

NV11
SEZIONE N. 2
DIST.PREC.: 20.000
DIST.SUCC.: 20.000

Movimenti Terra table with columns: Movimento, Superficie, etc.

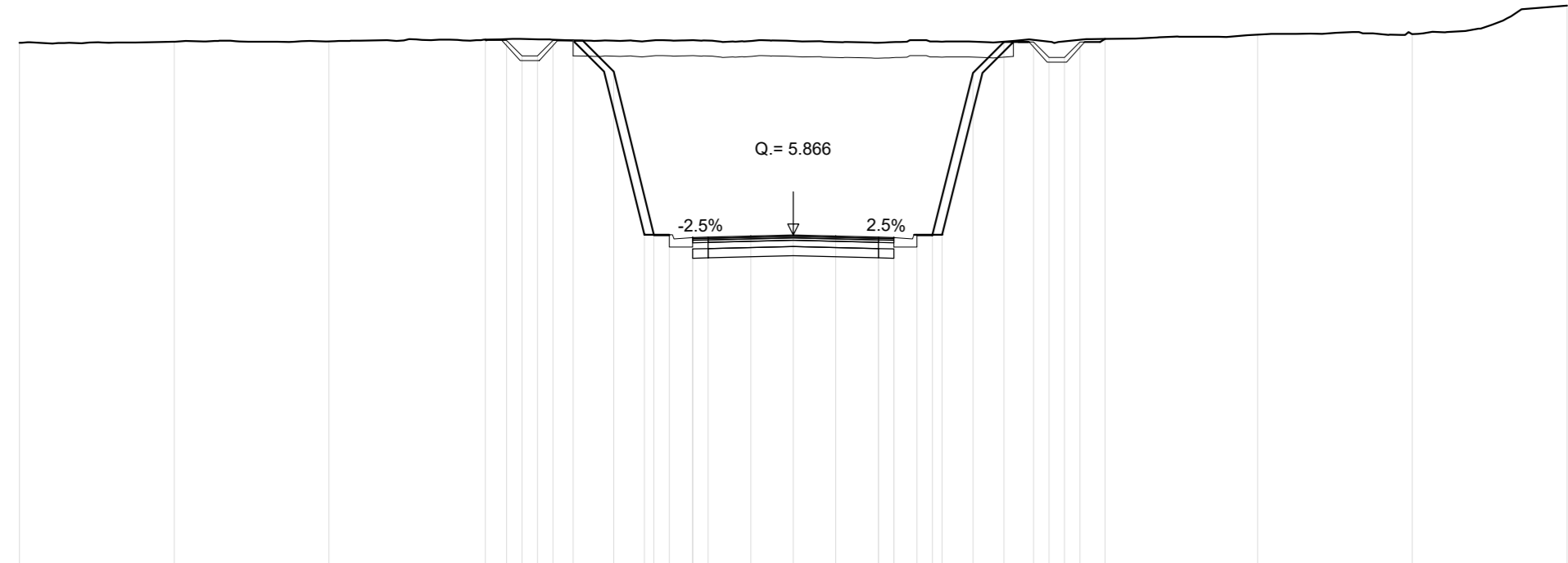

Table for Section 2 with columns: Quote Terreno, Quote Progetto, Dist. Progr. Progetto, Dist. Parziali

NV11
SEZIONE N. 3
DIST.PREC.: 20.000
DIST.SUCC.: 20.000

Movimenti Terra table for Section 3

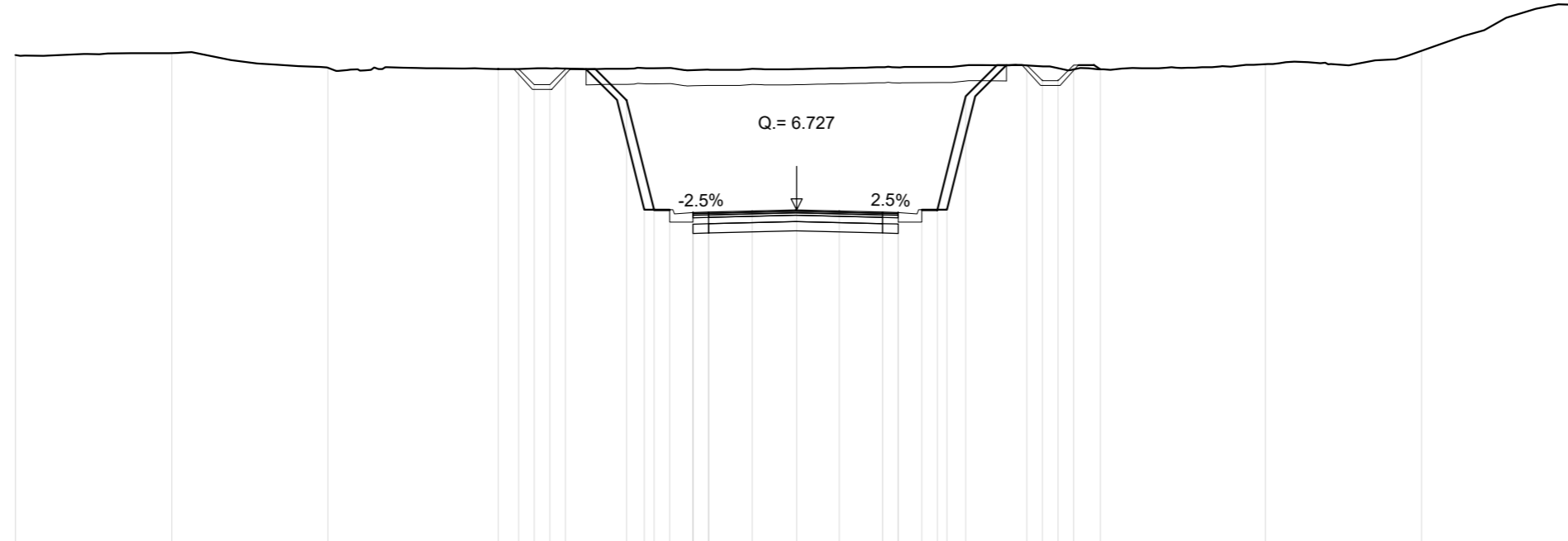

Table for Section 3 with columns: Quote Terreno, Quote Progetto, Dist. Progr. Progetto, Dist. Parziali

NV11
SEZIONE N. 4
DIST.PREC.: 20.000
DIST.SUCC.: 20.000

Movimenti Terra table for Section 4

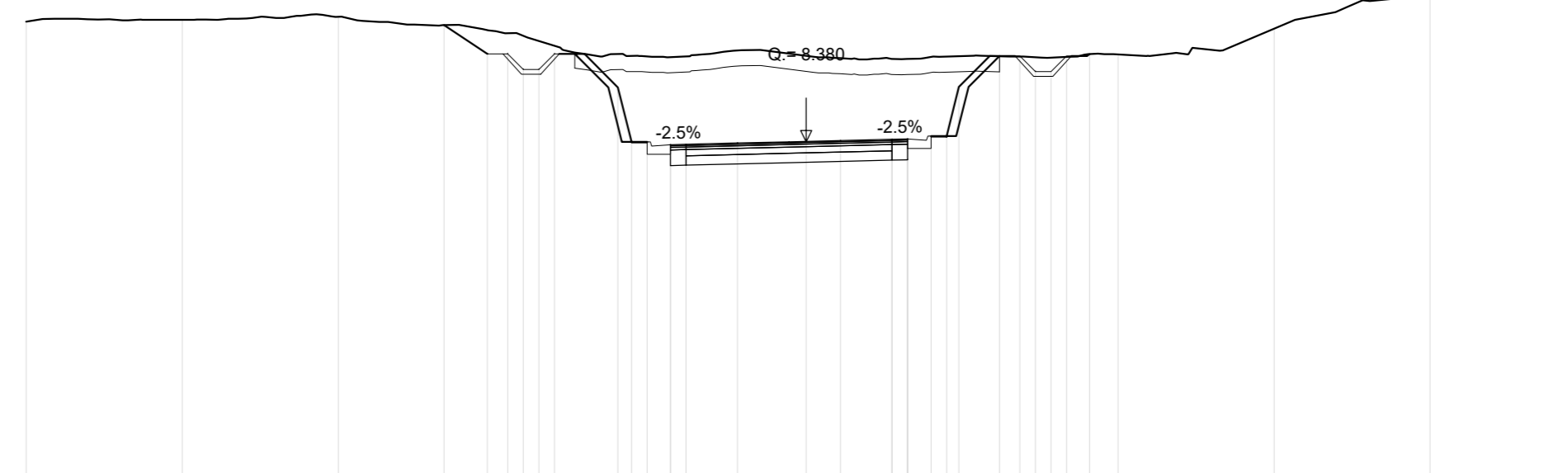

Table for Section 4 with columns: Quote Terreno, Quote Progetto, Dist. Progr. Progetto, Dist. Parziali

NV11
SEZIONE N. 5
DIST.PREC.: 20.000
DIST.SUCC.: 20.000

Movimenti Terra table for Section 5

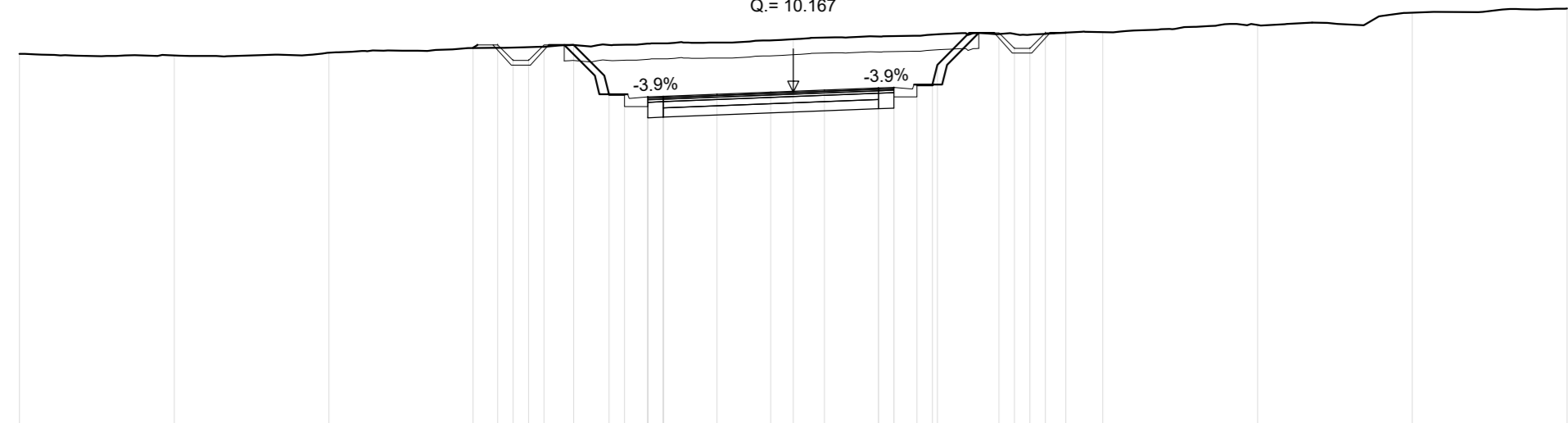

Table for Section 5 with columns: Quote Terreno, Quote Progetto, Dist. Progr. Progetto, Dist. Parziali

NV11
SEZIONE N. 6
DIST.PREC.: 20.000
DIST.SUCC.: 20.000

Movimenti Terra table for Section 6

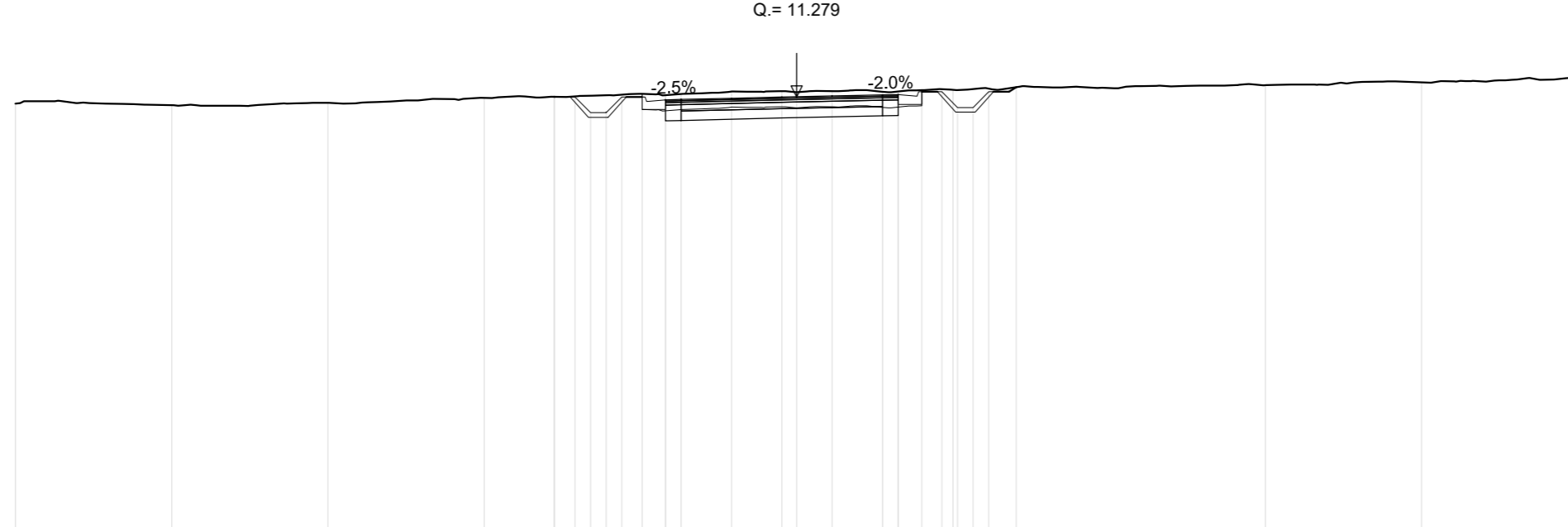

Table for Section 6 with columns: Quote Terreno, Quote Progetto, Dist. Progr. Progetto, Dist. Parziali

NV11
SEZIONE N. 7
DIST.PREC.: 20.000
DIST.SUCC.: 20.000

Movimenti Terra table for Section 7

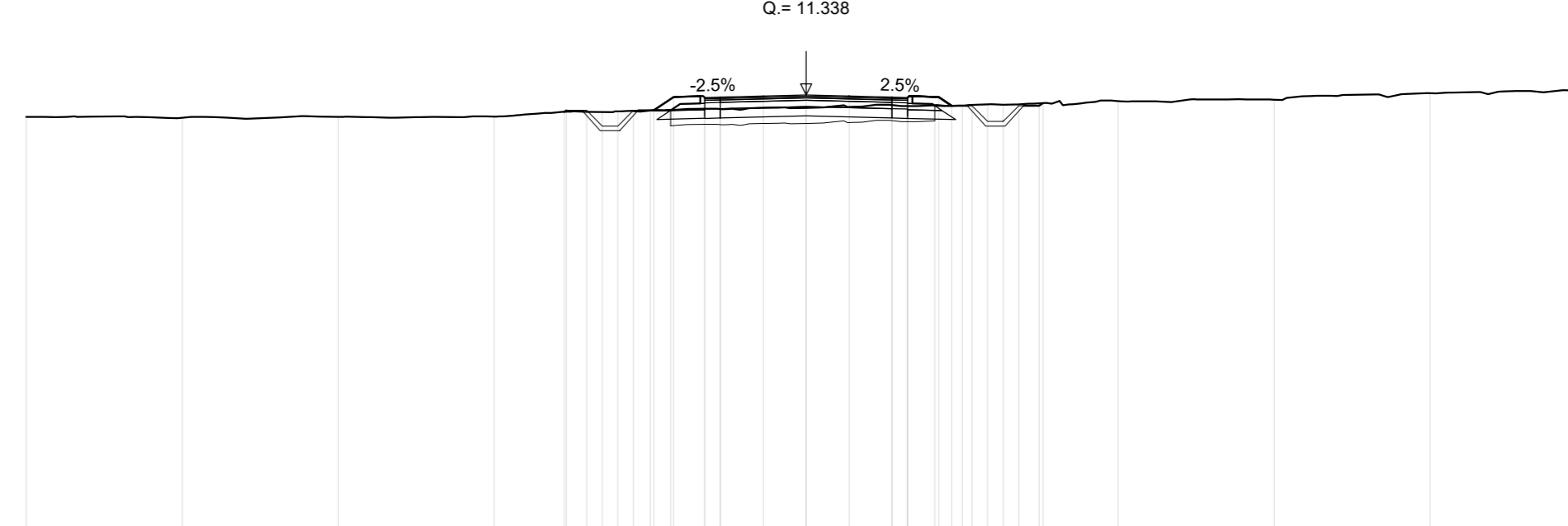

Table for Section 7 with columns: Quote Terreno, Quote Progetto, Dist. Progr. Progetto, Dist. Parziali

NV11
SEZIONE N. 8
DIST.PREC.: 20.000
DIST.SUCC.: 20.000

Movimenti Terra table for Section 8

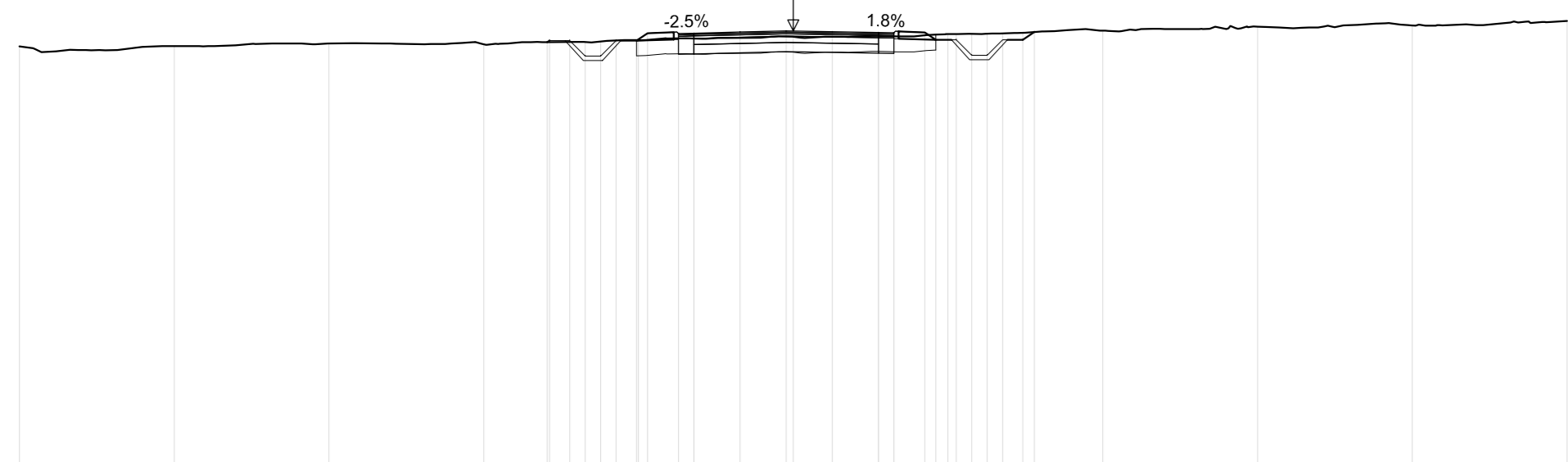

Table for Section 8 with columns: Quote Terreno, Quote Progetto, Dist. Progr. Progetto, Dist. Parziali

NV11
SEZIONE N. 9
DIST.PREC.: 20.000
DIST.SUCC.: 20.000

Movimenti Terra table for Section 9

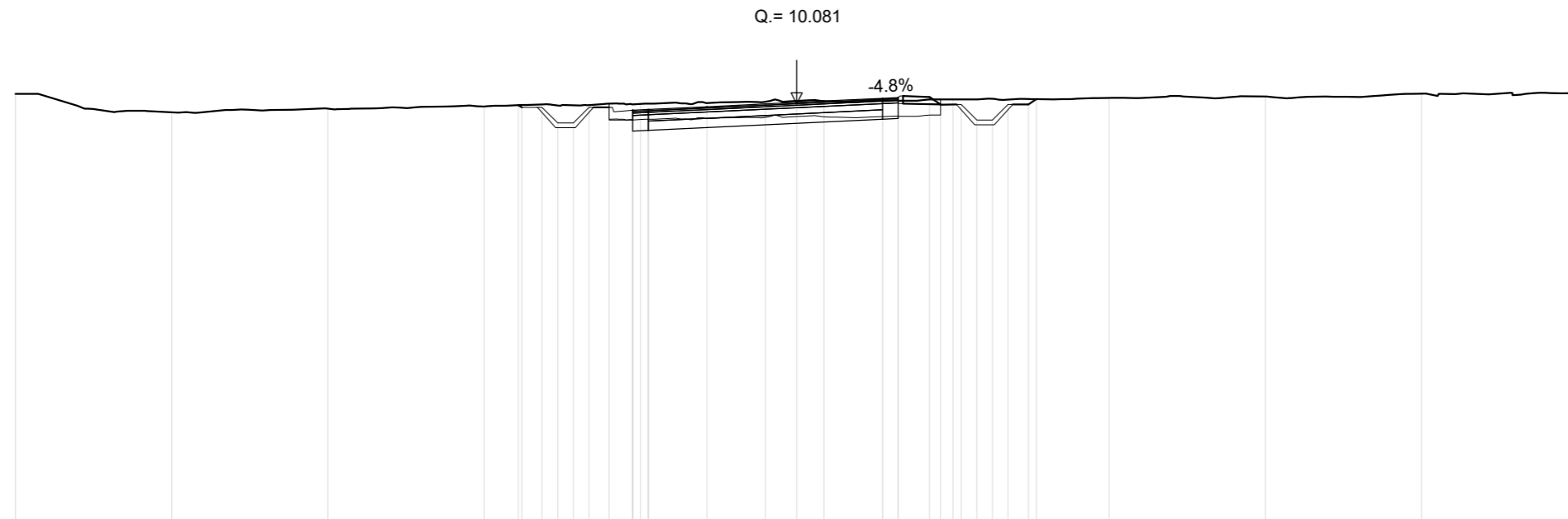

Table for Section 9 with columns: Quote Terreno, Quote Progetto, Dist. Progr. Progetto, Dist. Parziali

NV11
SEZIONE N. 10
DIST.PREC.: 20.000
DIST.SUCC.: 20.000

Movimenti Terra table for Section 10

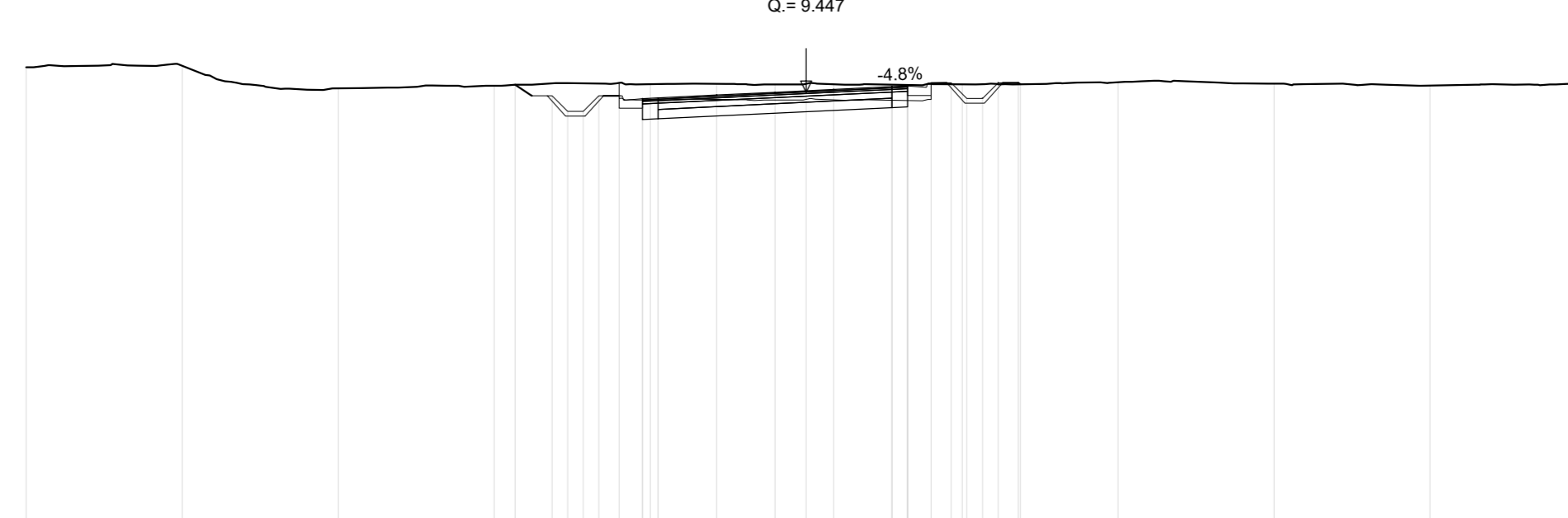

Table for Section 10 with columns: Quote Terreno, Quote Progetto, Dist. Progr. Progetto, Dist. Parziali

Project information including logos for RFI and ITALFER, project title 'INFRASTRUTTURE FERROVIARIE STRATEGICHE DEFINITE DALLA LEGGE OBIETTIVO N. 443/01 e s.m.i.', and a table for revision history.