



REGIONE PUGLIA



PROVINCIA di FOGGIA



COMUNE di San Severo

PROPONENTE



**RWE Renewables Italia S.r.l.**

Via Andrea Doria, 41/G

00192 Roma

P.IVA 06400370968

PROGETTAZIONE ESECUTIVA  
ELETTRICA -  
OPERE DI UTENZA



**STUDIO INGEGNERIA ELETTRICA**

MEZZINA dott. ing. Antonio

Via Tiberio Solis n.128 | 71016 San Severo (FG)

Tel. 0882.228072 | Fax 0882.243651

e-mail: info@studiomezzina.net | web: www.studiomezzina.net



OPERA

**IMPIANTO EOLICO COSTITUITO DA N. 12 AEROGENERATORI  
LOCALIZZATO NEL COMUNE DI SAN SEVERO (FG)**

**AUTORIZZATO CON D.D nr. 159 DEL 30 GIUGNO 2023**

OGGETTO

**PROGETTO ESECUTIVO**

Nome Elaborato:

Sottostazione Condivisa: Particolari fondazioni apparecchiature elettromeccaniche

Descrizione Elaborato:

Sottostazione Condivisa: Particolari fondazioni apparecchiature elettromeccaniche

00	Luglio 2023	Emissione per progetto esecutivo	Ing. S. Costa	Ing. A. Mezzina	RWE Srl
Rev.	Data	Oggetto della revisione	Elaborazione	Verifica	Approvazione
Scala: 1:50 Formato: A3		Codice Elaborato	TAV.E.61		

# Rif. 1 -2

## Fondazione per Sostegno a candelabro per terminale cavo + Scaricatore

Scala 1:50

SEZIONE A-A

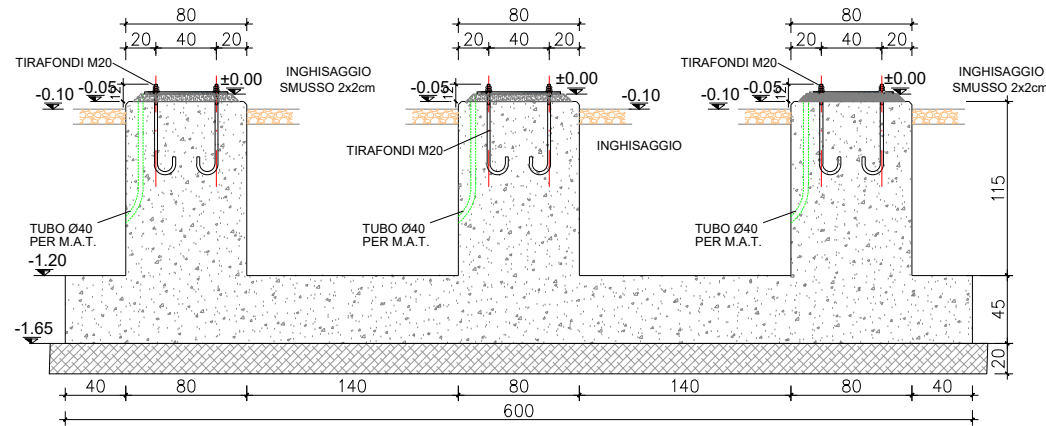

SEZIONE B-B

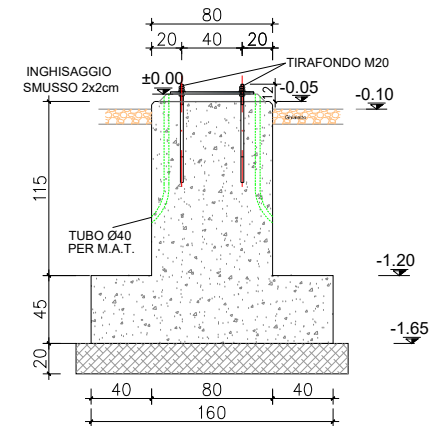

PIANTA

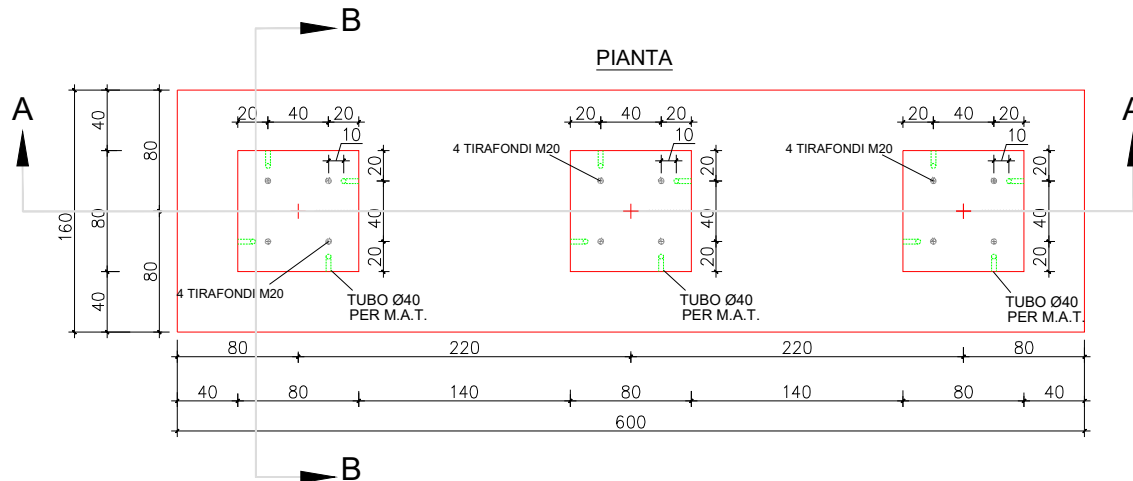

N.B. quota 0,00 quota di inghisaggio

**Rif. 3 - Sezionatore Orizzontale con L.T.**  
**Scala 1:50**

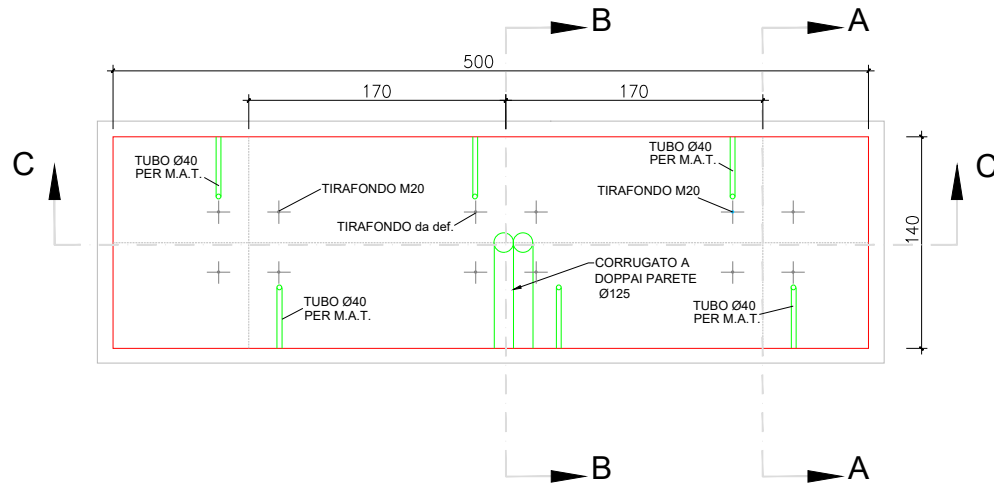

**SEZIONE A-A**

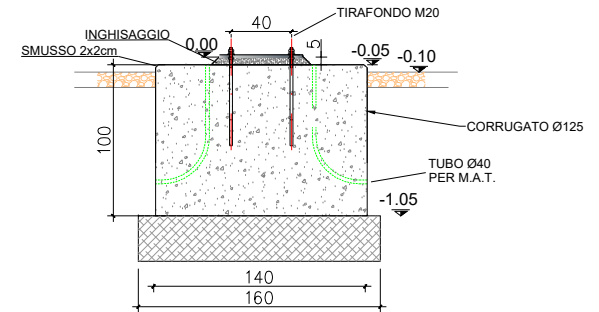

**SEZIONE C-C**

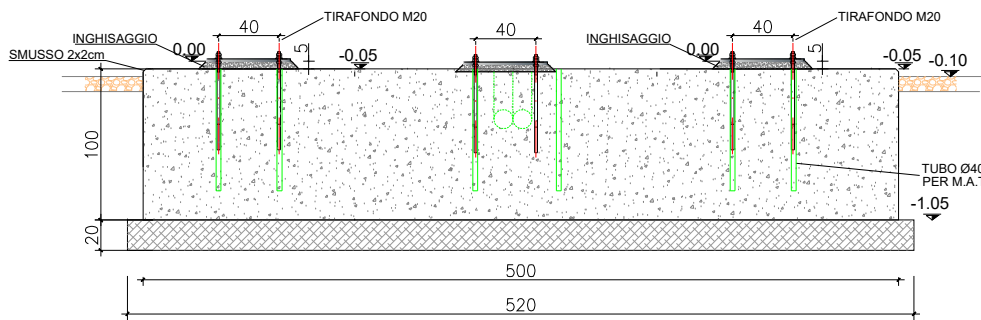

**SEZIONE B-B**

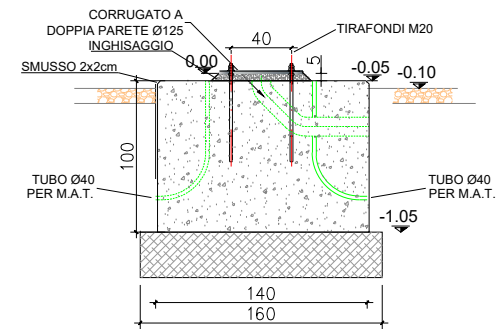

**N.B. quota 0,00 quota di inghisaggio**

Rif. 4a - TVI  
 Scala 1:50

SEZIONE A-A

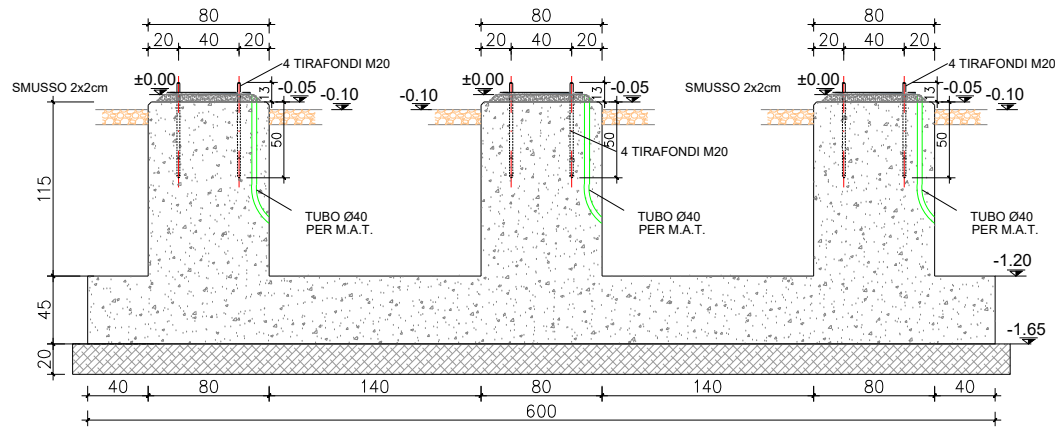

SEZIONE B-B

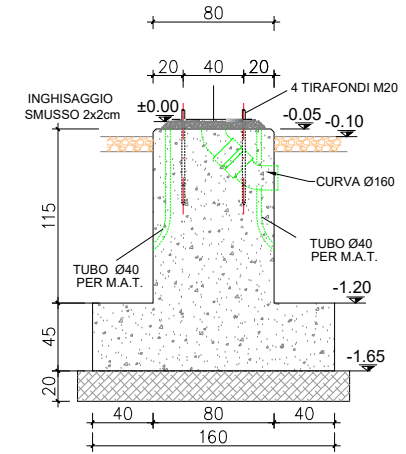

PIANTA

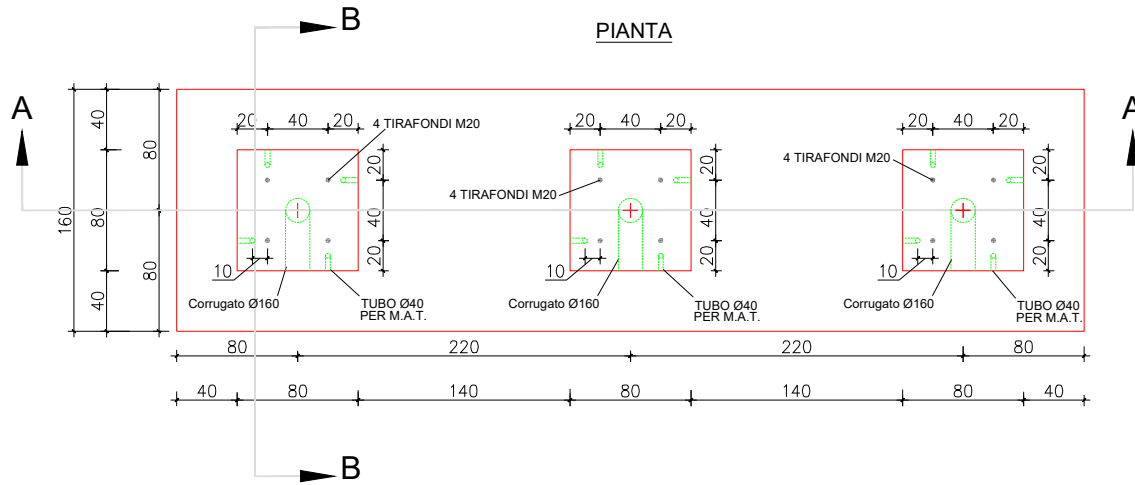

N.B. quota 0,00 quota di inghisaggio

**Rif. 4 Fondazione per TV**  
**Scala 1:50**

**SEZIONE A-A**

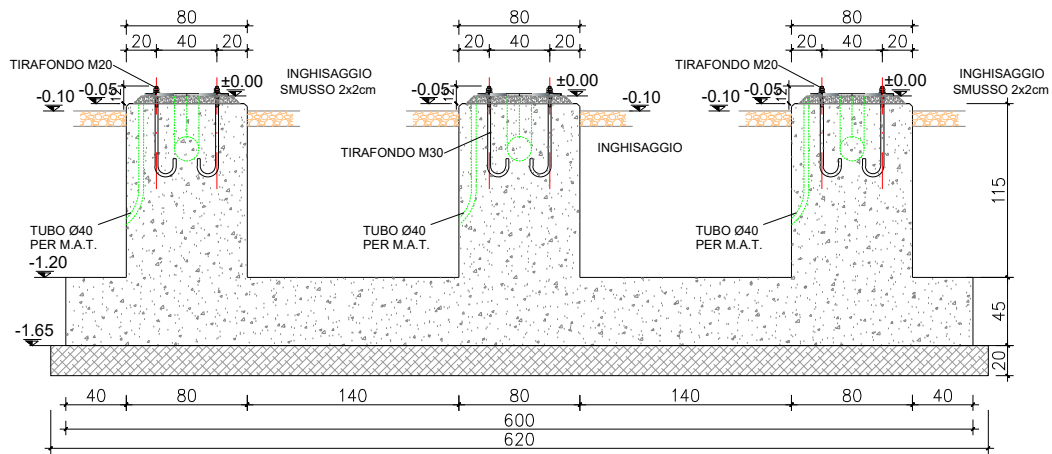

**SEZIONE B-B TV**

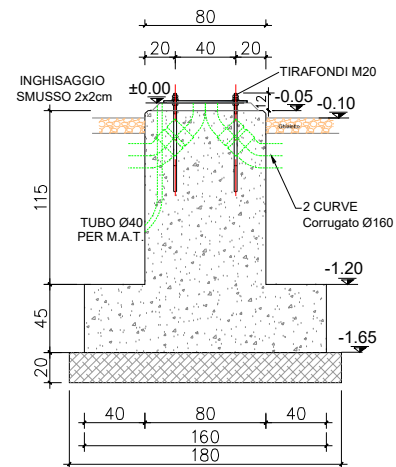

**PIANTA**

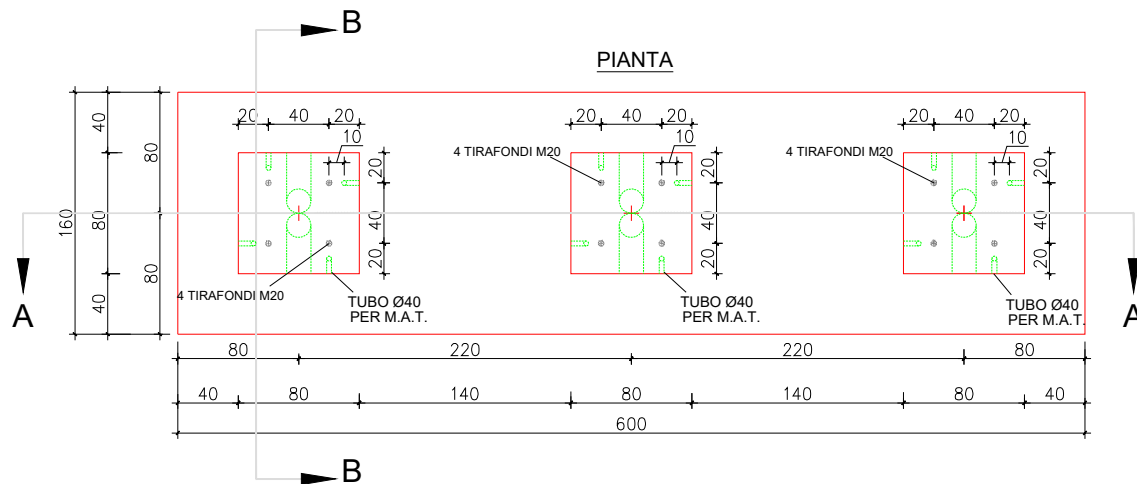

**Rif. 5 - Interruttore con TA integrato**  
Scala 1:50

**SEZIONE A-A**

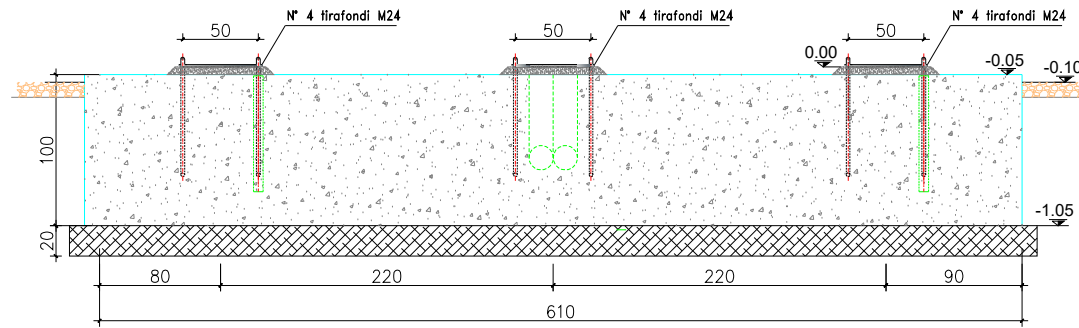

**SEZIONE B-B**

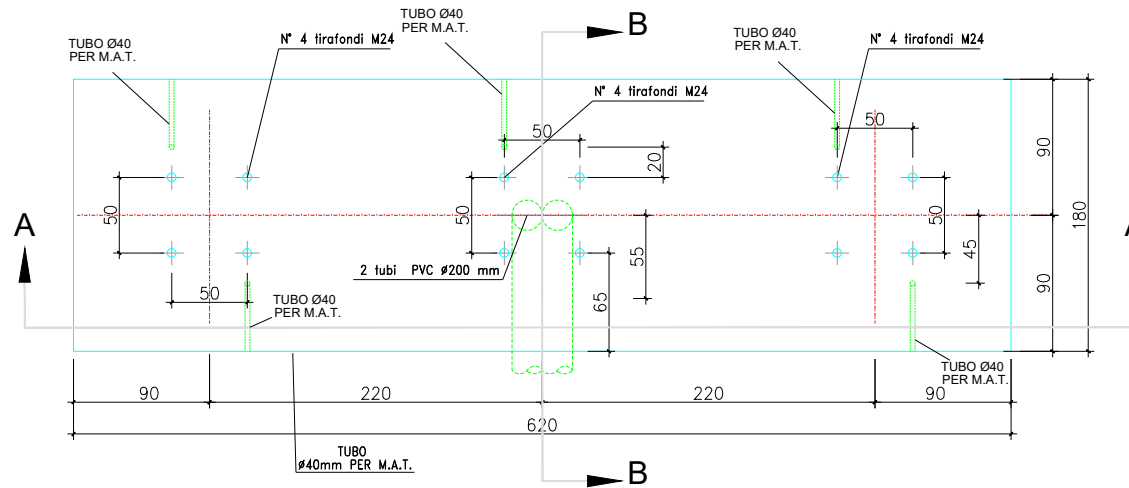
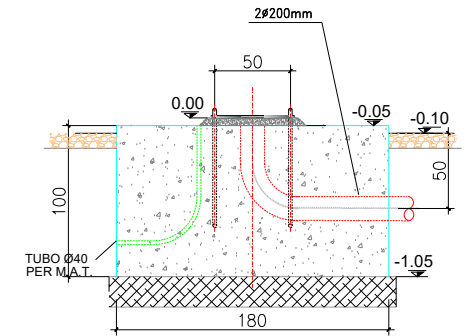

**Rif. 6 - Supporto sbarre unipolare**  
Scala 1:50

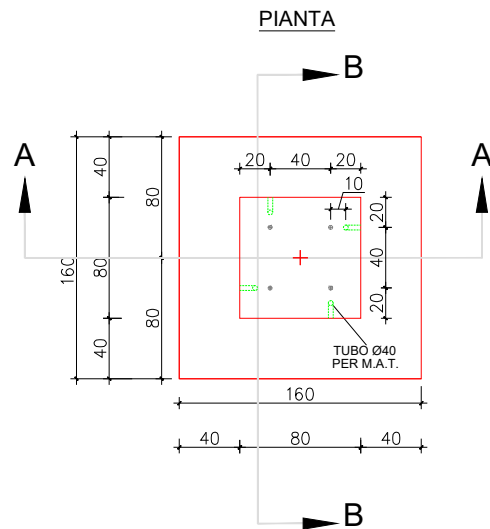
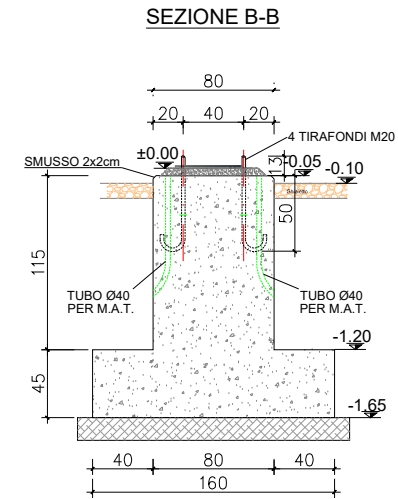
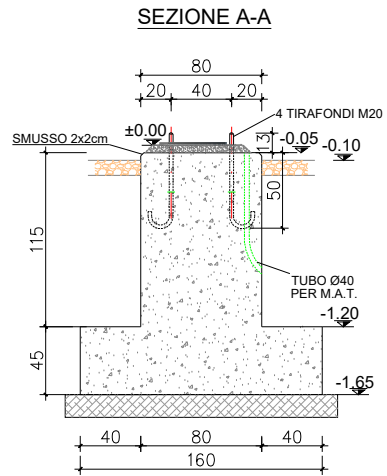

N.B. quota 0,00 quota di inghisaggio

**Rif. 7 - Supporto sbarre alto a portale**  
**Scala 1:50**

SEZIONE A-A

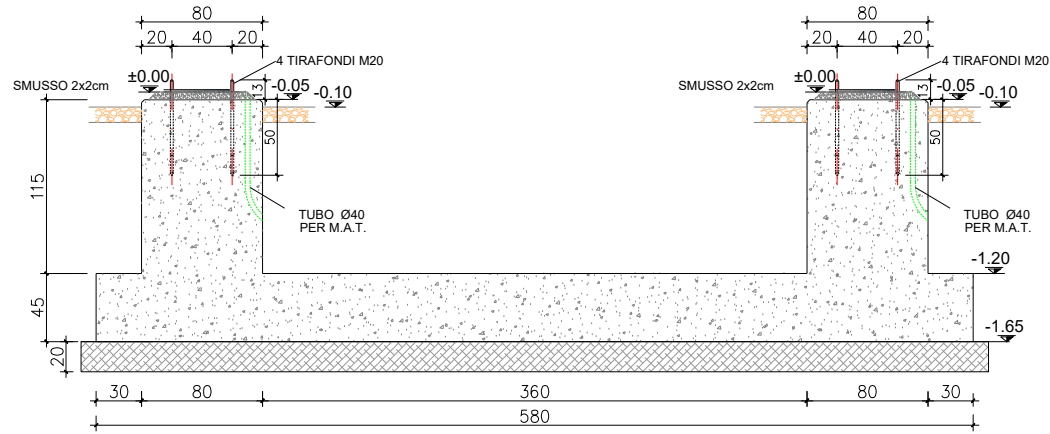

SEZIONE B-B

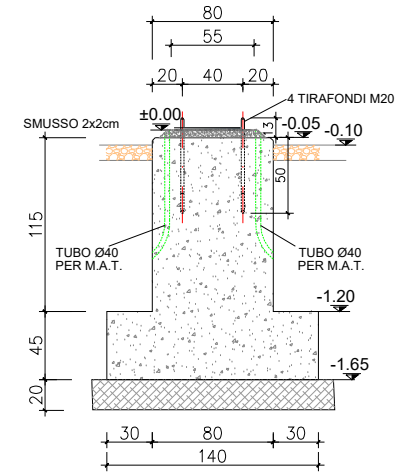

PIANTA

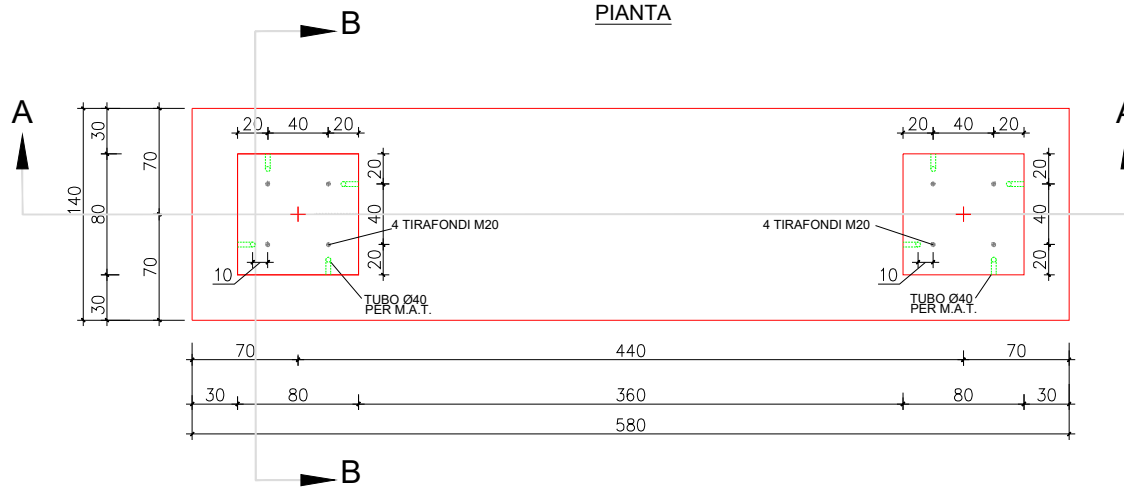

N.B. quota 0,00 quota di inghisaggio



# Rif. 12 - Palo Luce

## Scala 1:50

### PIANTA

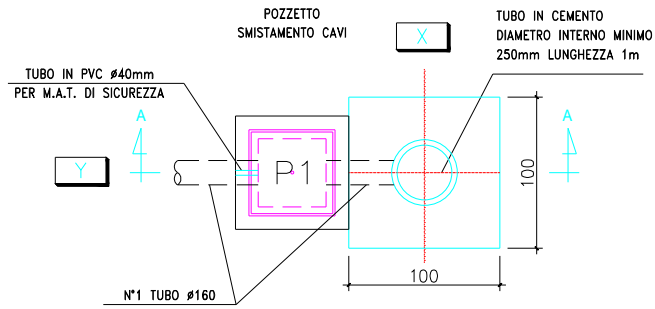

### SEZIONE A-A

