

# LEGENDA

-  INTERRUTTORE AT CON COMANDO MOTORIZZATO
-  SEZIONATORE MANUALE AT CON INTERBLOCCO LAME DI TERRA
-  SEZIONATORE MOTORIZZATO ROTATIVO AT CON INTERBLOCCO LAME DI TERRA
-  SCARICATORE
-  TRASFORMATORE DI TENSIONE
-  TRASFORMATORE DI CORRENTE
-  TRASFORMATORE DI POTENZA (COMMUTATORE SOTTO CARICO MOTORIZZATO)
-  TRASFORMATORE SERVIZI AUSILIARI
-  GENERATORE ASINCRONO
-  FUSIBILE
-  INTERRUTTORE MT ASPORTABILE CON COMANDO MOTORIZZATO
-  INDICATORE CAPACITIVO PRESENZA TENSIONE
-  LAME DI MESSA A TERRA
-  INTERRUTTORE AUTOMATICO
-  CONTATORE DI MANOVRA
-  SEZIONATORE ROTATIVO CON MESSA A TERRA
-  SEZIONATORE ROTATIVO SOTTOCARICO CON MESSA A TERRA
-  LAMPADA DI SEGNALAZIONE
-  BLOCCO A CHIAVE, CHIAVE LIBERA IN APERTO
-  BLOCCO A CHIAVE, CHIAVE LIBERA IN CHIUSO
-  CONTATORE DI ENERGIA ATTIVA/REATTIVA ENTRANTE-USCENTE PER MISURE FISCALI
-  TA A 3 NUCLEI
-  SEZIONATORE
-  TV CAPACITIVO
-  TERMINALE ARIA - CAVO

STAZIONE ELETTRICA CONDIVISA

STAZIONE TERNA

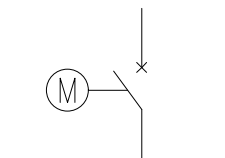
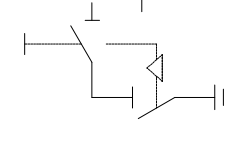
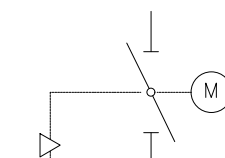
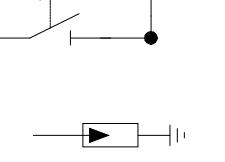
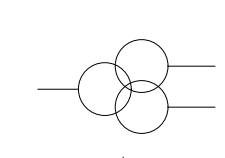
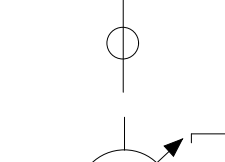
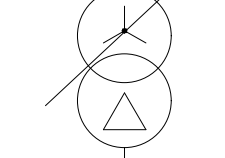
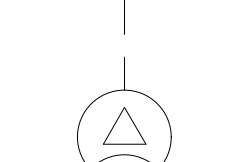
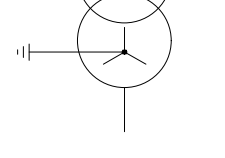
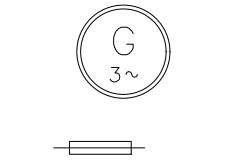
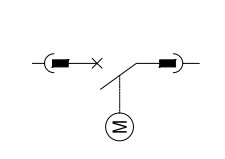
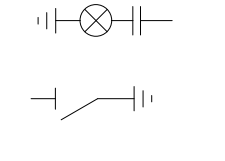
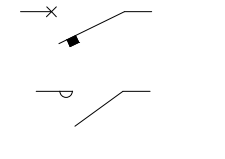
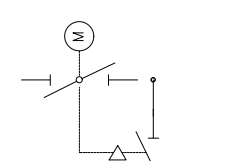
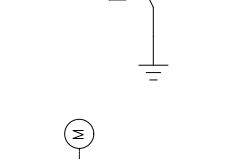
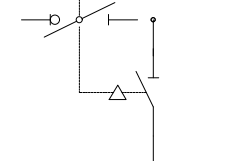
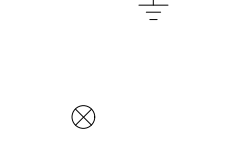
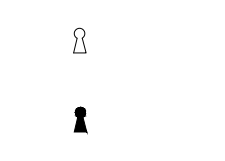
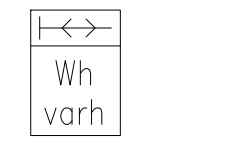
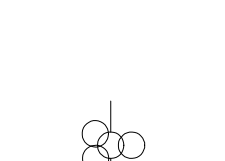
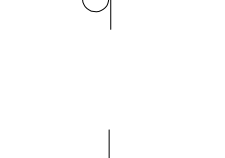
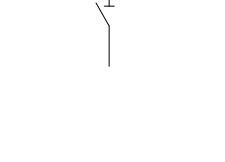
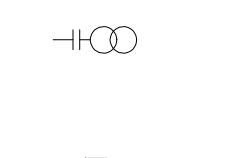
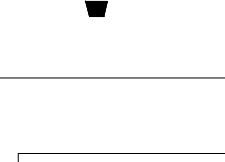
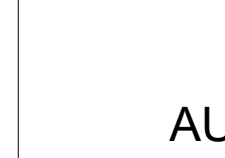
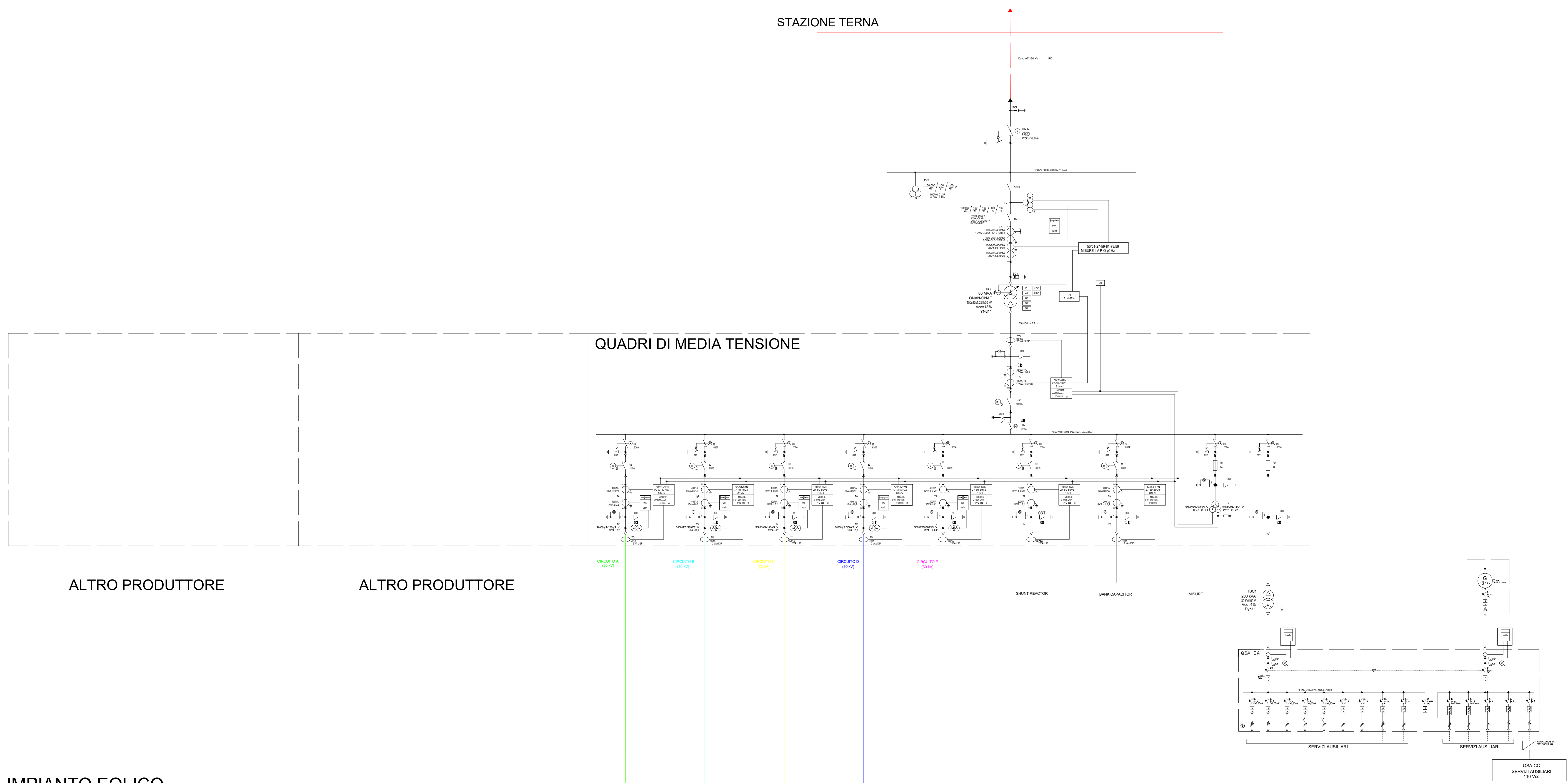

ALTRO PRODUTTORE

ALTRO PRODUTTORE

IMPIANTO EOLICO

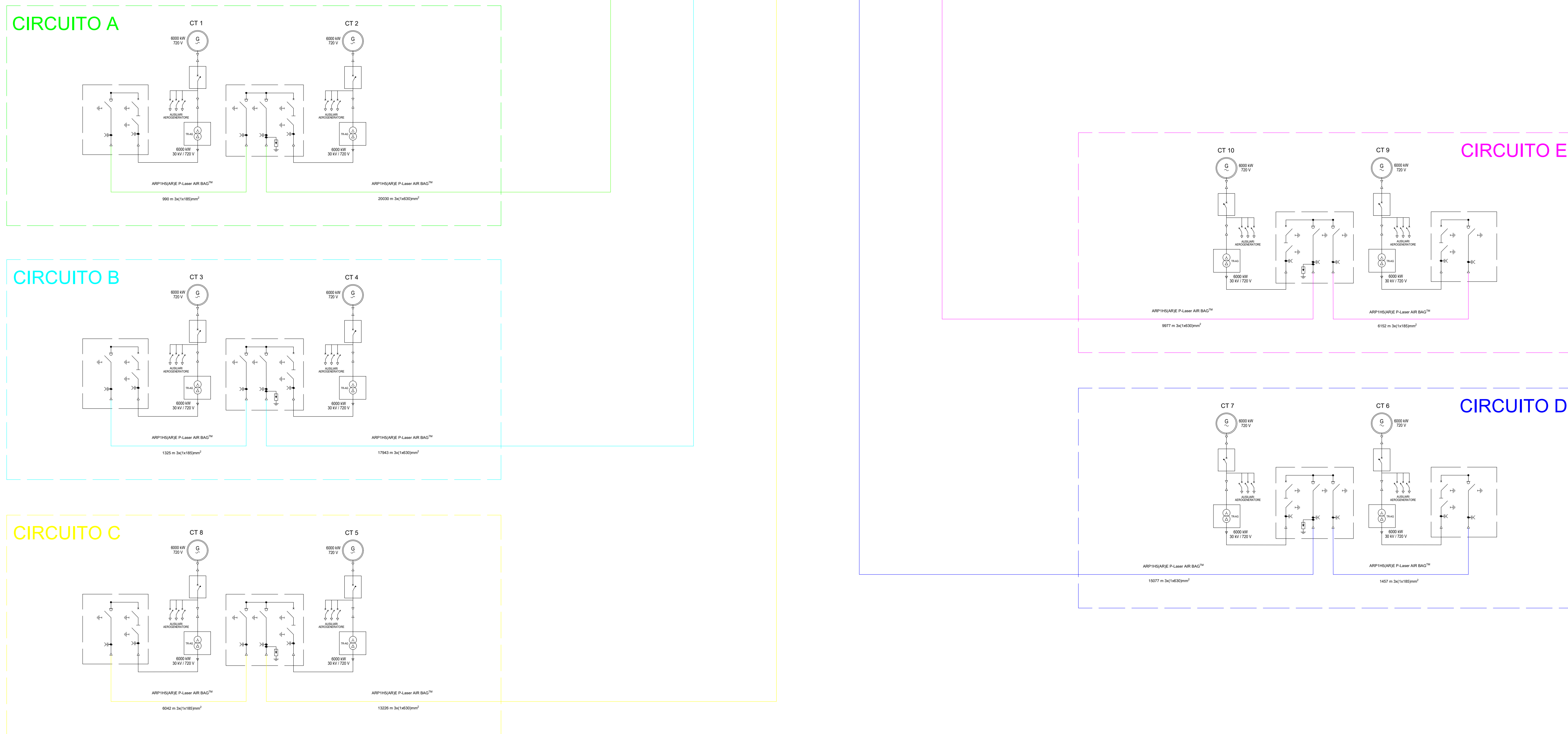

Dettaglio installazione a bordo torre di generazione eolica

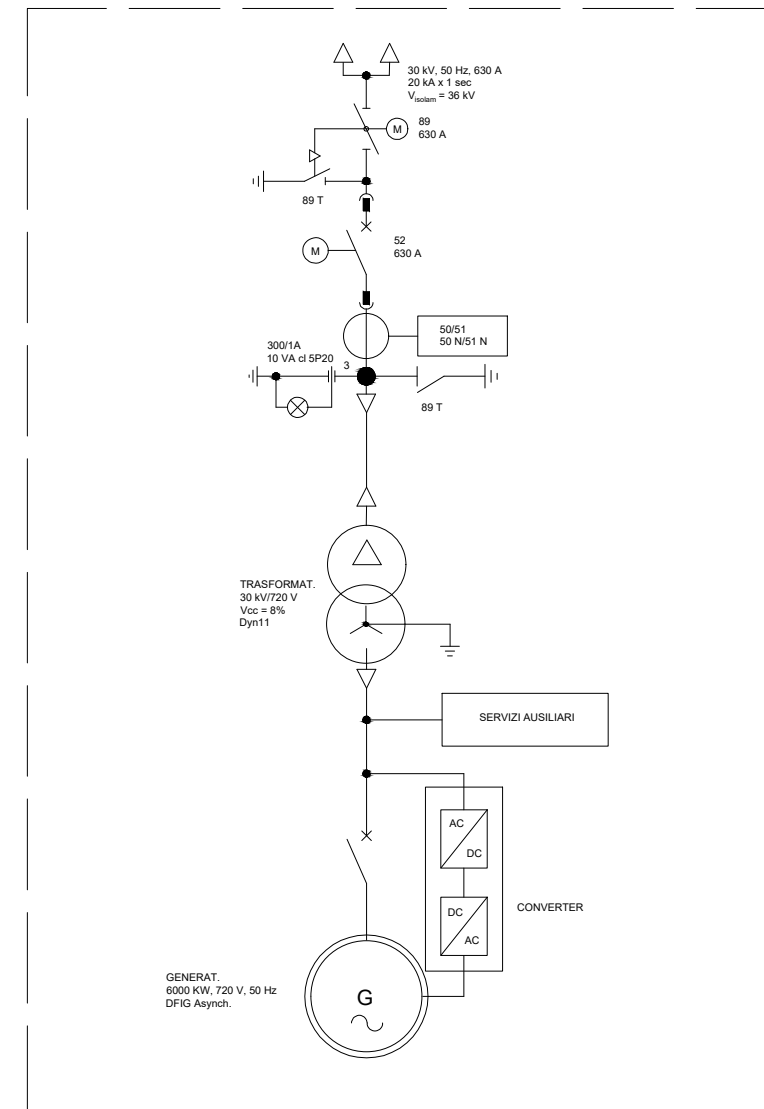

AUTORIZZAZIONE UNICA EX D. LGS. N. 387/2003



PROGETTO DEFINITIVO  
PARCO EOLICO COLOBRARO TURSI











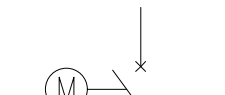
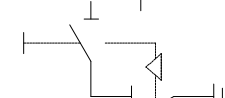
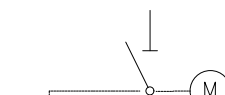
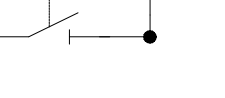

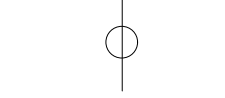
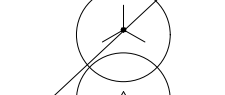
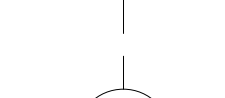
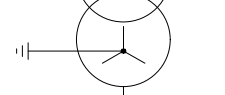

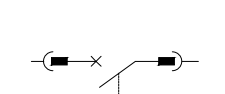
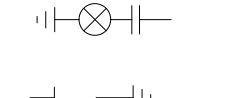
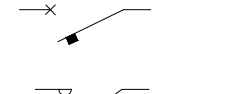
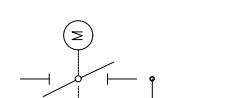
Titolo elaborato:

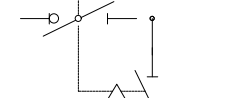
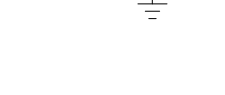
SOTTOSTAZIONE ELETTRICA UTENTE - SCHEMA ELETTRICO UNIFILARE

MT	LT	WPD	Prima emissione	10/01/2024	00
REDDATO	CONTR.	APPROV.	DESCRIZIONE REVISIONE DOCUMENTO	DATA	REV

<p><b>PROPONENTE</b></p>  <p>WPD MURGE s.r.l. Viale Luca Gaucico 9-11 00143 ROMA</p>	<p><b>CONSULENZA</b></p>  <p>GE.CO.D'OR S.R.L. Via A. De Gasperi n.8 74023 Grottaglie (TA)</p> <p><b>PROGETTISTA</b> Ing. Gaetano D'Oronzio Via Goito 14 - Colobraro (MT)</p>
---	--

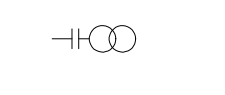
# LEGENDA

-  INTERRUTTORE AT CON COMANDO MOTORIZZATO
-  SEZIONATORE MANUALE AT CON INTERBLOCCO LAME DI TERRA
-  SEZIONATORE MOTORIZZATO ROTATIVO AT CON INTERBLOCCO LAME DI TERRA
-  SCARICATORE
-  TRASFORMATORE DI TENSIONE
-  TRASFORMATORE DI CORRENTE
-  TRASFORMATORE DI POTENZA (COMMUTATORE SOTTO CARICO MOTORIZZATO)
-  TRASFORMATORE SERVIZI AUSILIARI
-  GENERATORE ASINCRONO
-  FUSIBILE
-  INTERRUTTORE MT ASPORTABILE CON COMANDO MOTORIZZATO
-  INDICATORE CAPACITIVO PRESENZA TENSIONE
-  LAME DI MESSA A TERRA
-  INTERRUTTORE AUTOMATICO
-  CONTATORE DI MANOVRA
-  SEZIONATORE ROTATIVO CON MESSA A TERRA
-  SEZIONATORE ROTATIVO SOTTOCARICO CON MESSA A TERRA
-  LAMPADA DI SEGNALAZIONE
-  BLOCCO A CHIAVE, CHIAVE LIBERA IN APERTO
-  BLOCCO A CHIAVE, CHIAVE LIBERA IN CHIUSO
-  CONTATORE DI ENERGIA ATTIVA/REATTIVA ENTRANTE-USCENTE PER MISURE FISCALI
-  TA A 3 NUCLEI
-  SEZIONATORE
-  TV CAPACITIVO
-  TERMINALE ARIA - CAVO

## IMPIANTO EOLICO

Dettaglio installazione a bordo torre di generazione eolica

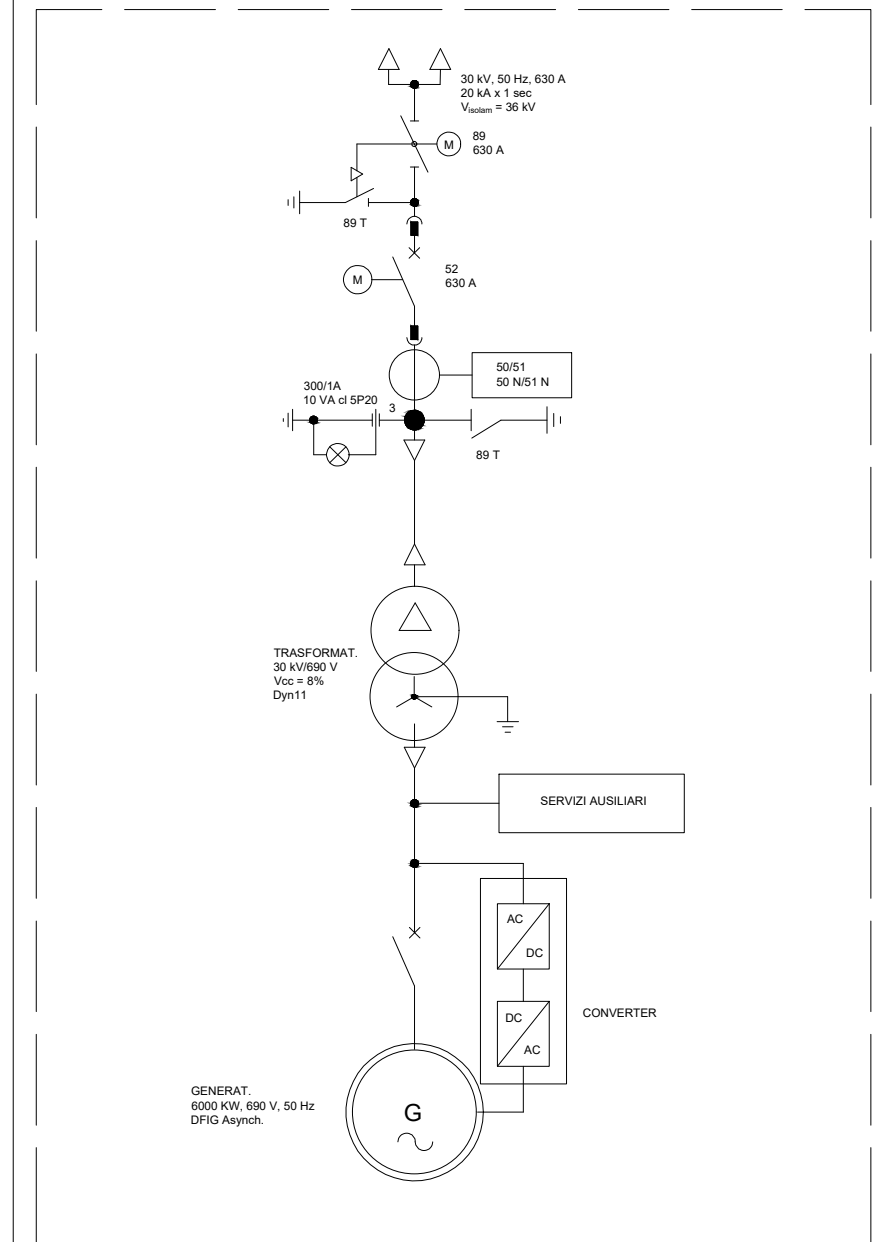

### CIRCUITO A

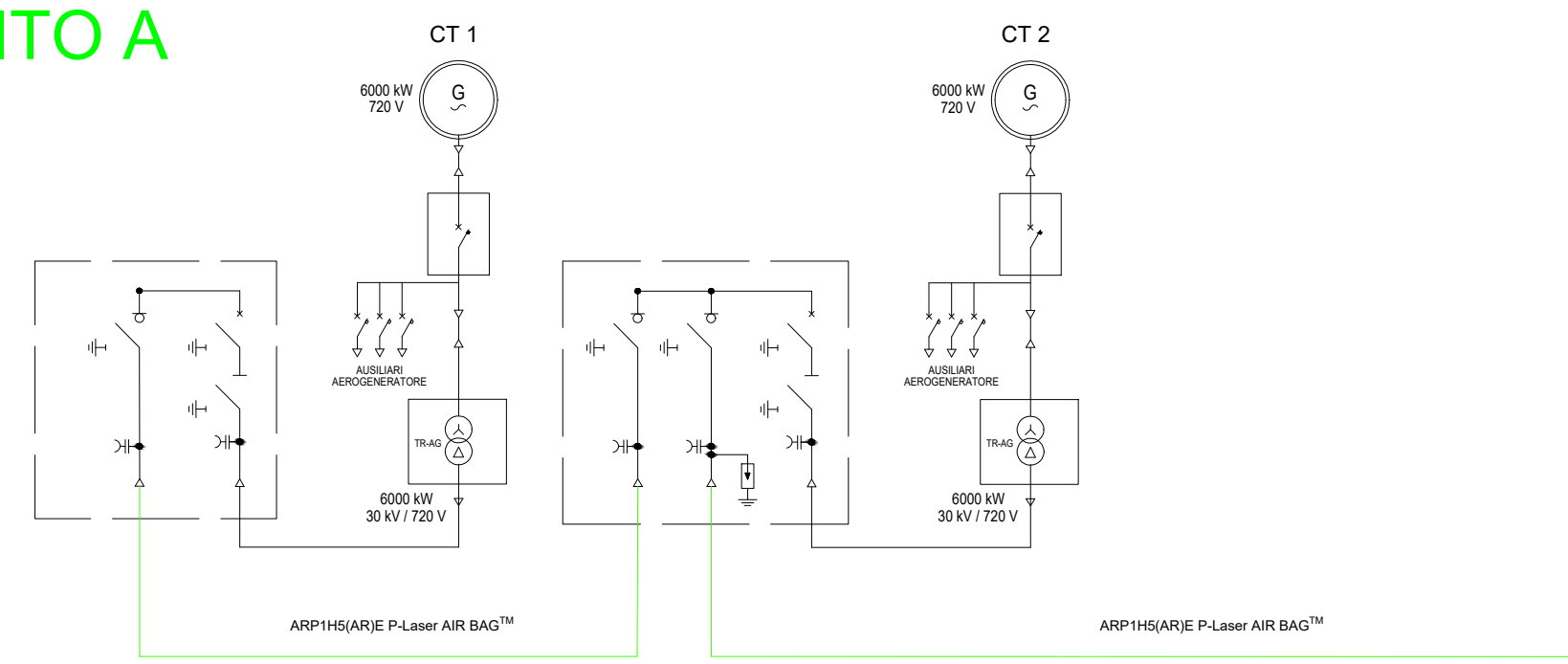

### CIRCUITO B

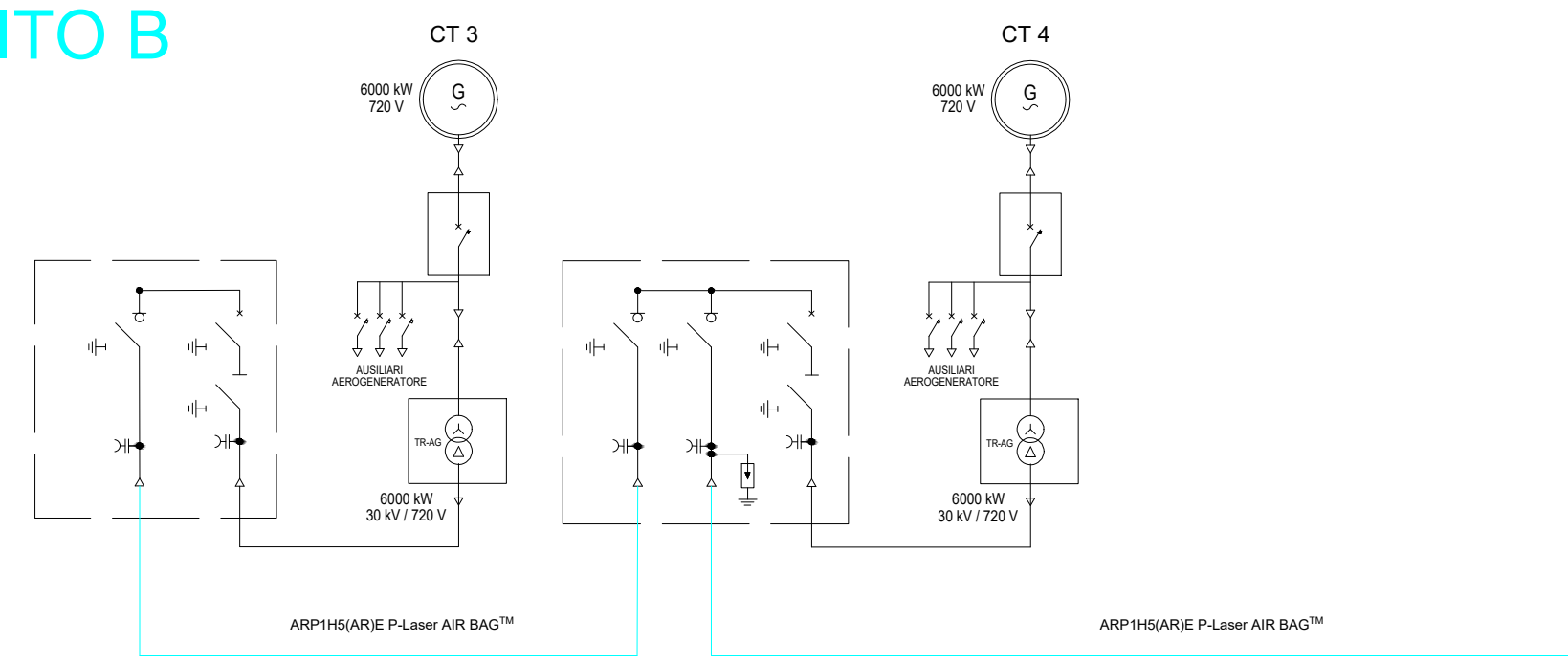

### CIRCUITO C

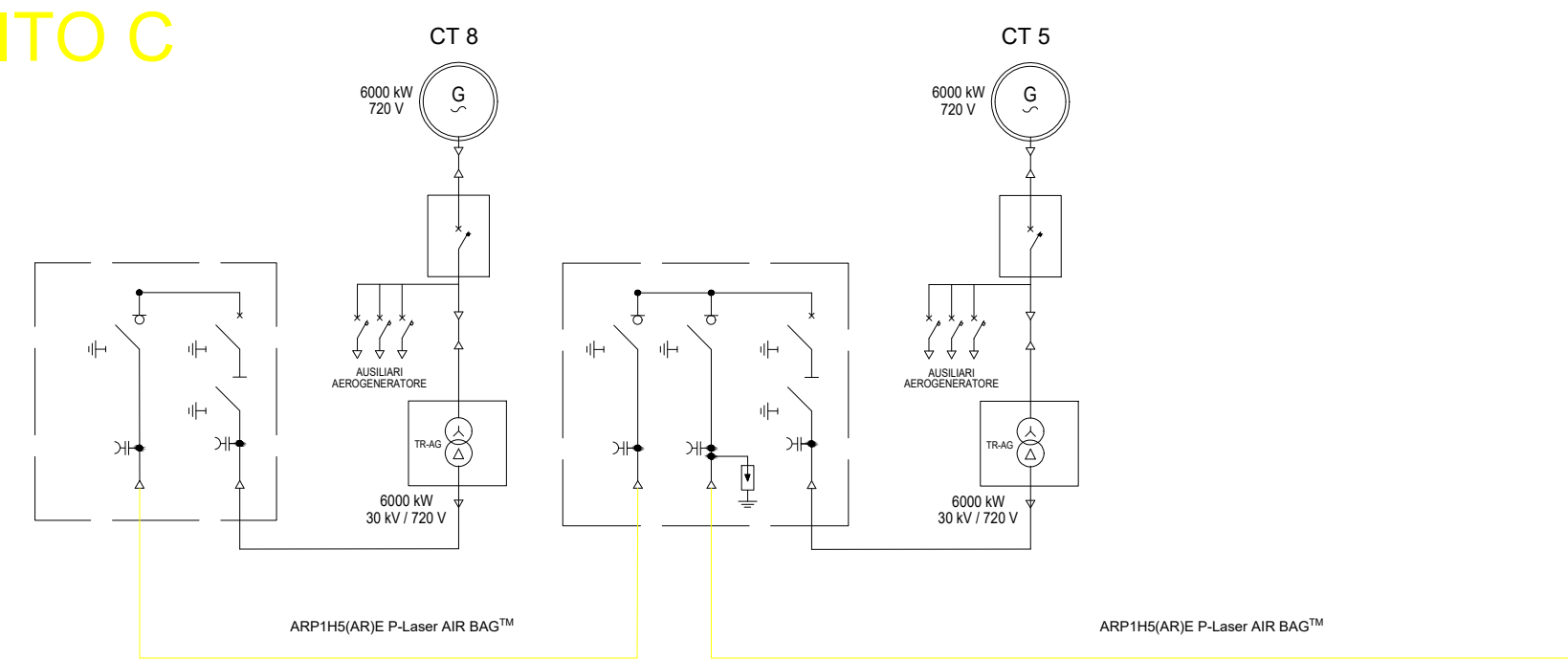

### CIRCUITO E

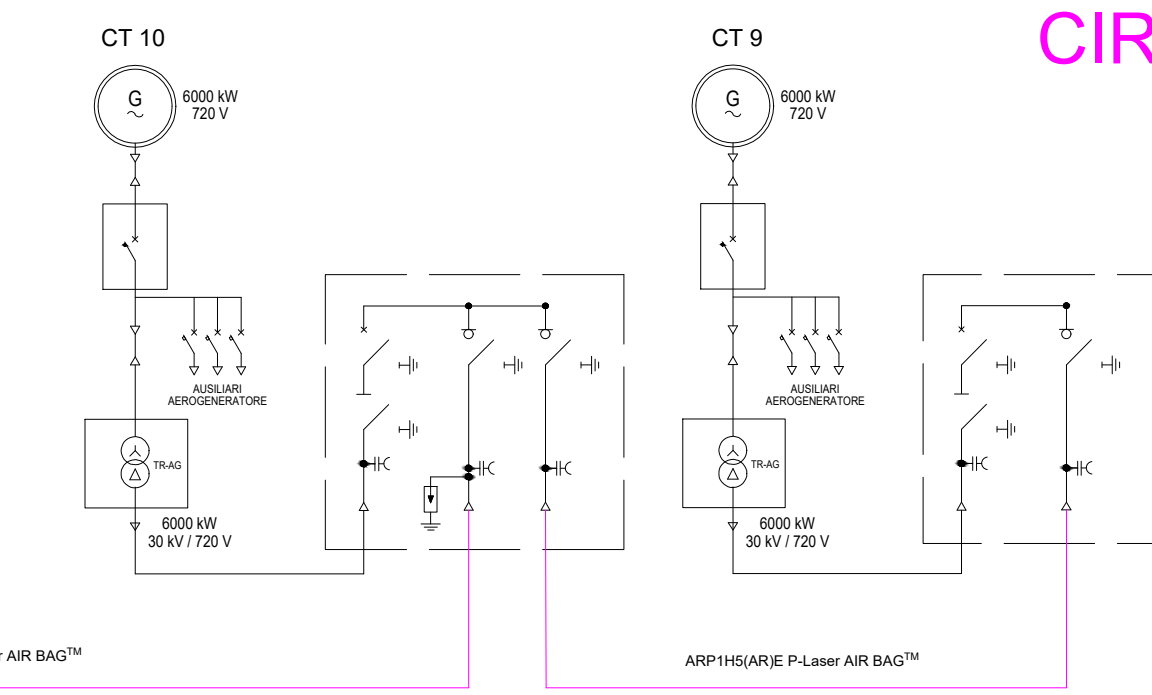

### CIRCUITO D

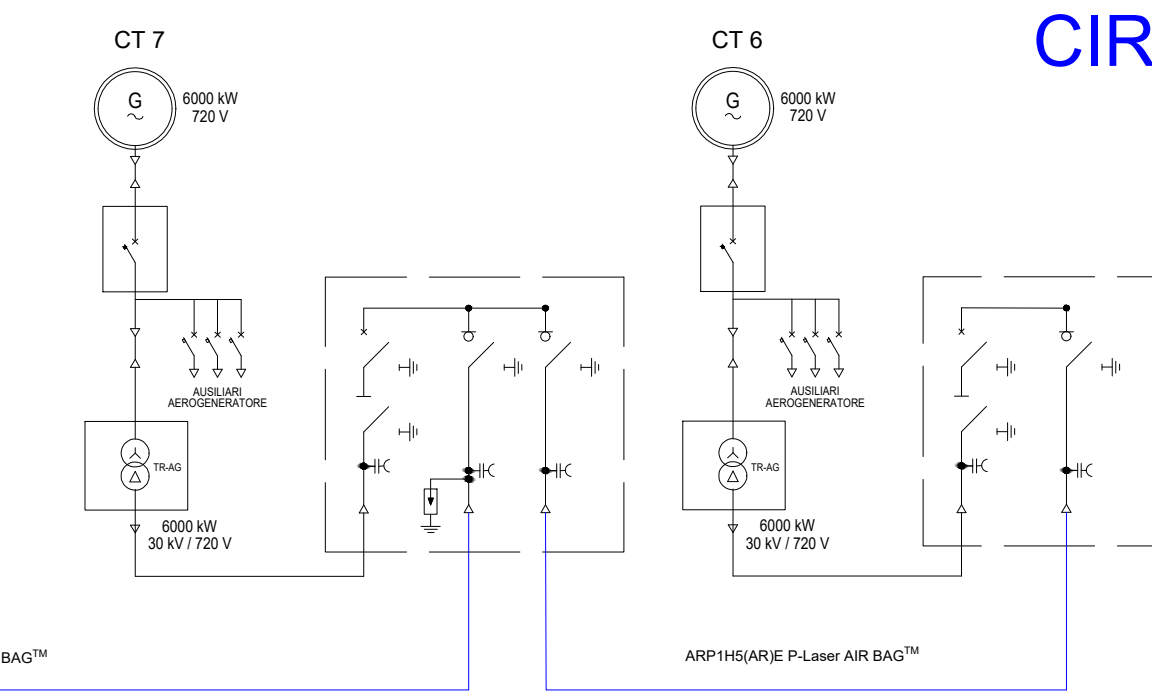

AUTORIZZAZIONE UNICA EX D. LGS. N. 387/2003



REGIONE BASILICATA  
 IL CHIAVE DI PIETRO  
**PROGETTO DEFINITIVO**  
**PARCO EOLICO COLOBRARO TURSI**

Titolo elaborato:

**SOTTOSTAZIONE ELETTRICA UTENTE - SCHEMA ELETTRICO UNIFILARE**

MT	LT	WPD	Prima emissione	10/01/2024	00
REDDATTO	CONTR.	APPROV.	DESCRIZIONE REVISIONE DOCUMENTO	DATA	REV

PROPONENTE	CONSULENZA
 <b>WPD MURGE s.r.l.</b> Viale Luca Gaurico 9-11 00143 ROMA	 <b>GE.CO.D'OR S.R.L.</b> Via A. De Gasperi n.8 74023 Grottaglie (TA)
	<b>PROGETTISTA</b> Ing. Gaetano D'Oronzio Via Goito 14 - Colobraro (MT)



# STAZIONE TERNA

## STALLO DI CONDIVISIONE

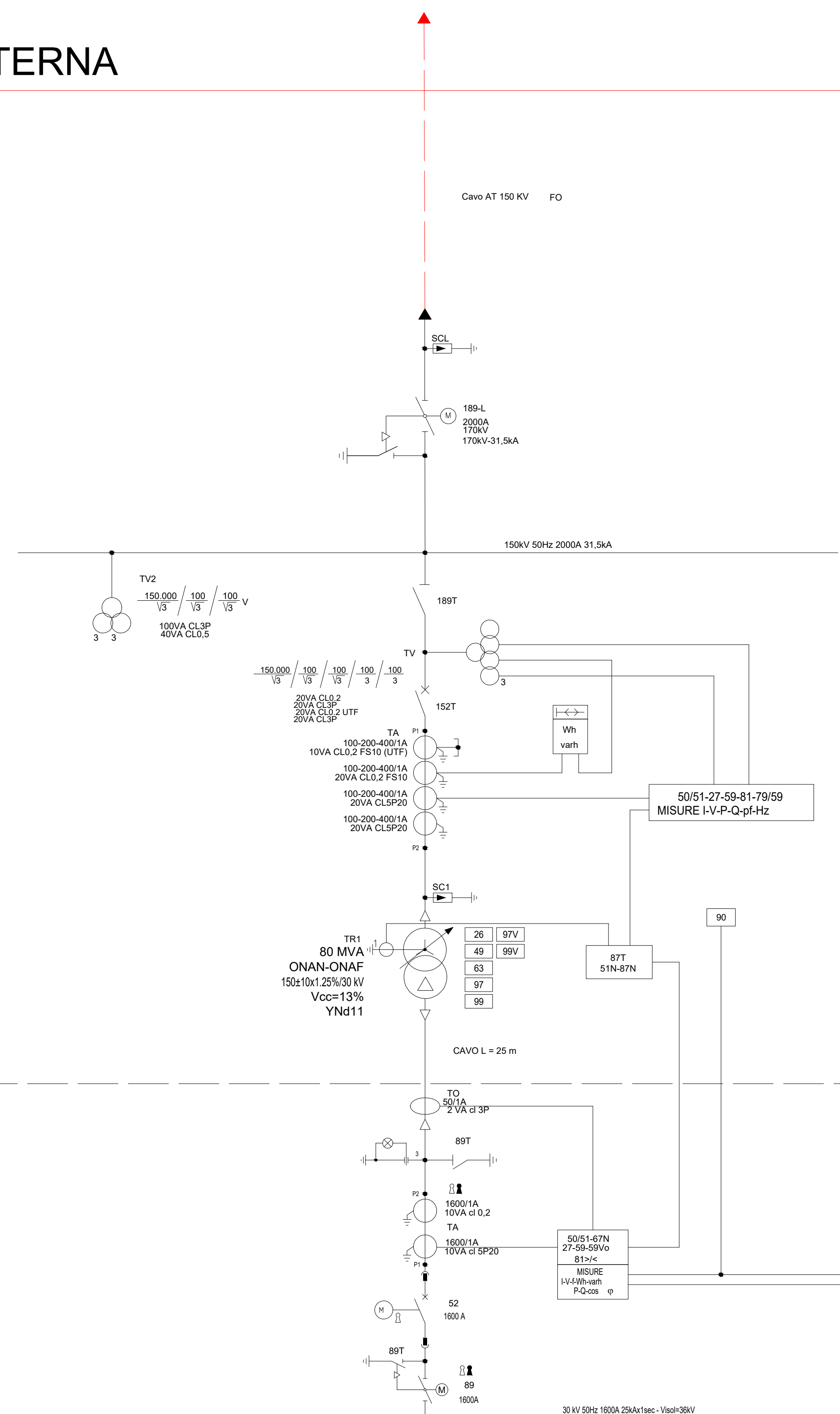

# QUADRI DI MEDIA TENSIONE

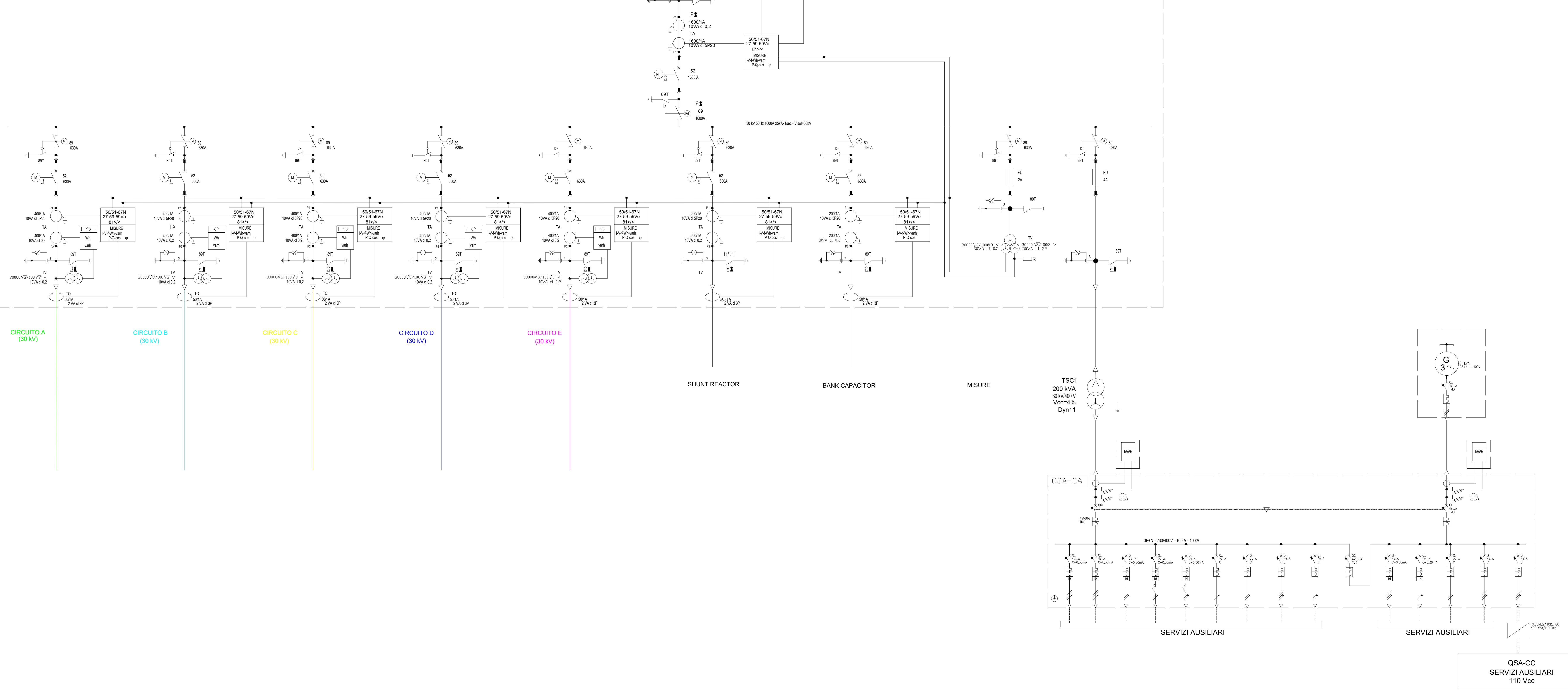

# LEGENDA

- INTERRUTTORE AT CON COMANDO MOTORIZZATO
- SEZIONATORE MANUALE AT CON INTERBLOCCO LAME DI TERRA
- SEZIONATORE MOTORIZZATO ROTATIVO AT CON INTERBLOCCO LAME DI TERRA
- SCARICATORE
- TRASFORMATORE DI TENSIONE
- TRASFORMATORE DI CORRENTE
- TRASFORMATORE DI POTENZA (COMMUTATORE SOTTO CARICO MOTORIZZATO)
- TRASFORMATORE SERVIZI AUSILIARI
- GENERATORE ASINCRONO
- FUSIBILE
- INTERRUTTORE MT ASPORTABILE CON COMANDO MOTORIZZATO
- INDICATORE CAPACITIVO PRESENZA TENSIONE
- LAME DI MESSA A TERRA
- INTERRUTTORE AUTOMATICO
- CONTATORE DI MANOVRA
- SEZIONATORE ROTATIVO CON MESSA A TERRA
- SEZIONATORE ROTATIVO SOTTOCARICO CON MESSA A TERRA
- LAMPADA DI SEGNALE
- BLOCCO A CHIAVE, CHIAVE LIBERA IN APERTO
- BLOCCO A CHIAVE, CHIAVE LIBERA IN CHIUSO
- CONTATORE DI ENERGIA ATTIVA/REATTIVA ENTRANTE-USCENTE PER MISURE FISCALI
- TA A 3 NUCLEI
- SEZIONATORE
- TV CAPACITIVO
- TERMINALE ARIA - CAVO

AUTORIZZAZIONE UNICA EX D. LGS. N. 387/2003



REGIONE BASILICATA  
 LA CHIAVE DI PIETRO

PROGETTO DEFINITIVO  
 PARCO EOLICO COLOBRARO TURSI

TITOLO ELABORATO:  
 SOTTOSTAZIONE ELETTRICA UTENTE - SCHEMA ELETTRICO UNIFILARE

MT	LT	WPD	Prima emissione	10/01/2024	00
REDDATTO	CONTR.	APPROV.	DESCRIZIONE REVISIONE DOCUMENTO	DATA	REV

<b>PROPONENTE</b>  WPD MURGE s.r.l. Viale Luca Gaunico 9-11 00143 ROMA	<b>CONSULENZA</b>  GE.CO.D'OR. S.R.L. Via A. De Gasperi n.8 74023 Grottaglie (TA)
<b>PROGETTISTA</b> Ing. Gaetano D'Oronzio Via Goito 14 - Colobraro (MT)	