

COMMITTENTE:



ALTA SORVEGLIANZA:



GENERAL CONTRACTOR:



INFRASTRUTTURE FERROVIARIE STRATEGICHE DEFINITE DALLA LEGGE OBIETTIVO N. 443/01

**LINEA A.V. /A.C. TORINO-VENEZIA Tratta VERONA-PADOVA
Lotto funzionale Verona-Bivio Vicenza**

PROGETTO ESECUTIVO

INTERFERENZE VIARIE

IN16 - INTERFERENZA CON SEDE AUTOSTRADALE AL Km 6+220.00

DEVIAZIONE PROVVISORIA E RIPRISTINO RACCORDO AUTOSTRADALE

SEZIONI TRASVERSALI RIPRISTINO VIABILITA'

GENERAL CONTRACTOR					DIRETTORE LAVORI			SCALA : 1:200
IL PROGETTISTA INTEGRATORE ing. Giovanni ... ENBA iscritto all'ordine degli ingegneri di Venezia n. 4289 Data: N. 4289					Consorzio Iricav Due Ing. Paolo CARMONA Data:			

COMMESSA	LOTTO	FASE	ENTE	TIPO DOC.	OPERA/DISCIPLINA	PROGR.	REV.	FOGLIO
IN17	12	E	12	W9	IN16C0	002	A	di

	VISTO CONSORZIO IRICAV DUE	
	Firma	Data
	ing. Alberto LEVORATO	

Progettazione :

Rev.	Descrizione	Redatto	Data	Verificato	Data	Approvato	Data	IL PROGETTISTA
A	EMISSIONE	<i>[Signature]</i>	12/04/2022	<i>[Signature]</i>	12/04/2022	<i>[Signature]</i>	12/04/2022	
B								
C								

CIG. 8377957CD1	CUP: J41E9100000009	File: IN1712E12W9IN16C0002A.DWG
		Cod. origine: CODICE

Progetto cofinanziato dalla Unione Europea

SEZIONI RACCORDO AUTOSTRADALE - RIPRISTINO

RACCORDO AUTOSTRADALE - RIPRISTINO

PROGRESSIVA 0+060.000

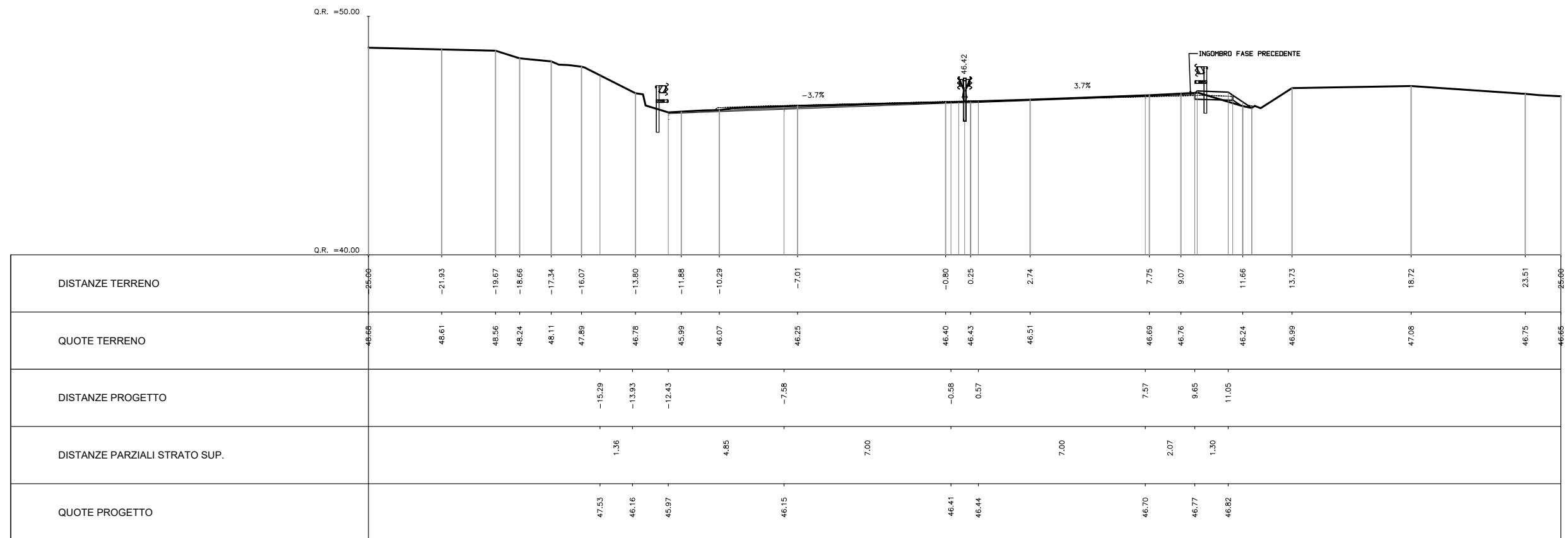

RACCORDO AUTOSTRADALE - RIPRISTINO

PROGRESSIVA 0+080.000

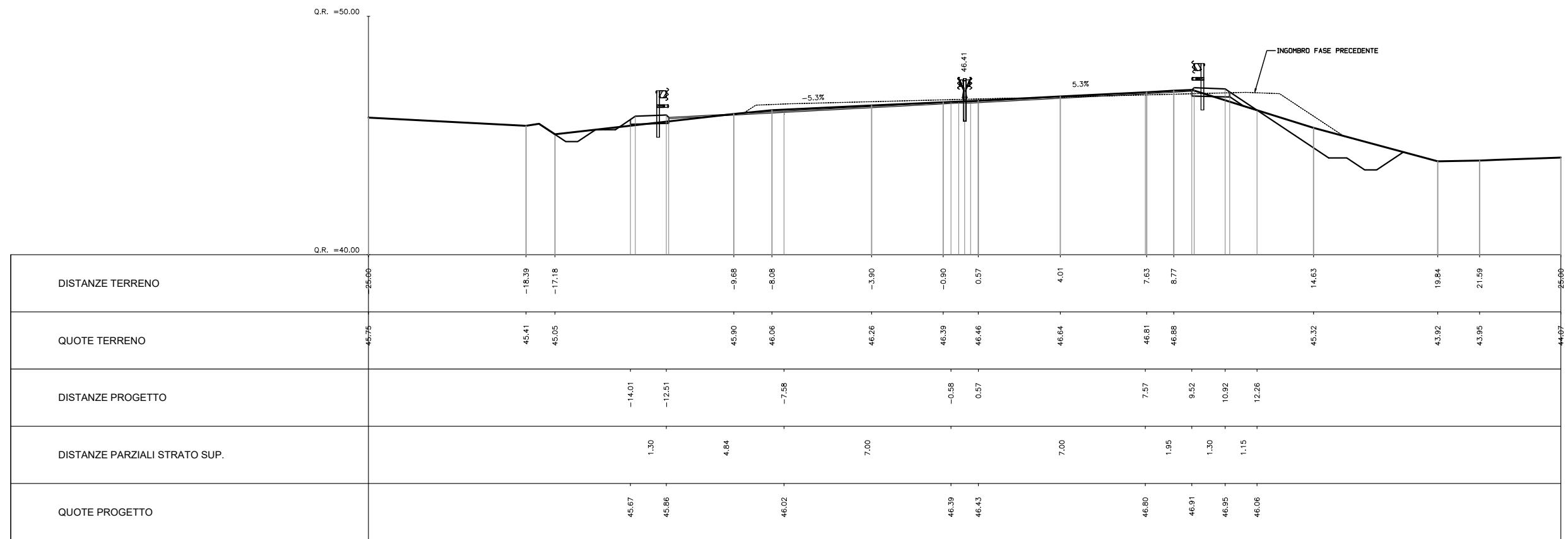

RACCORDO AUTOSTRADALE - RIPRISTINO

PROGRESSIVA 0+100.000

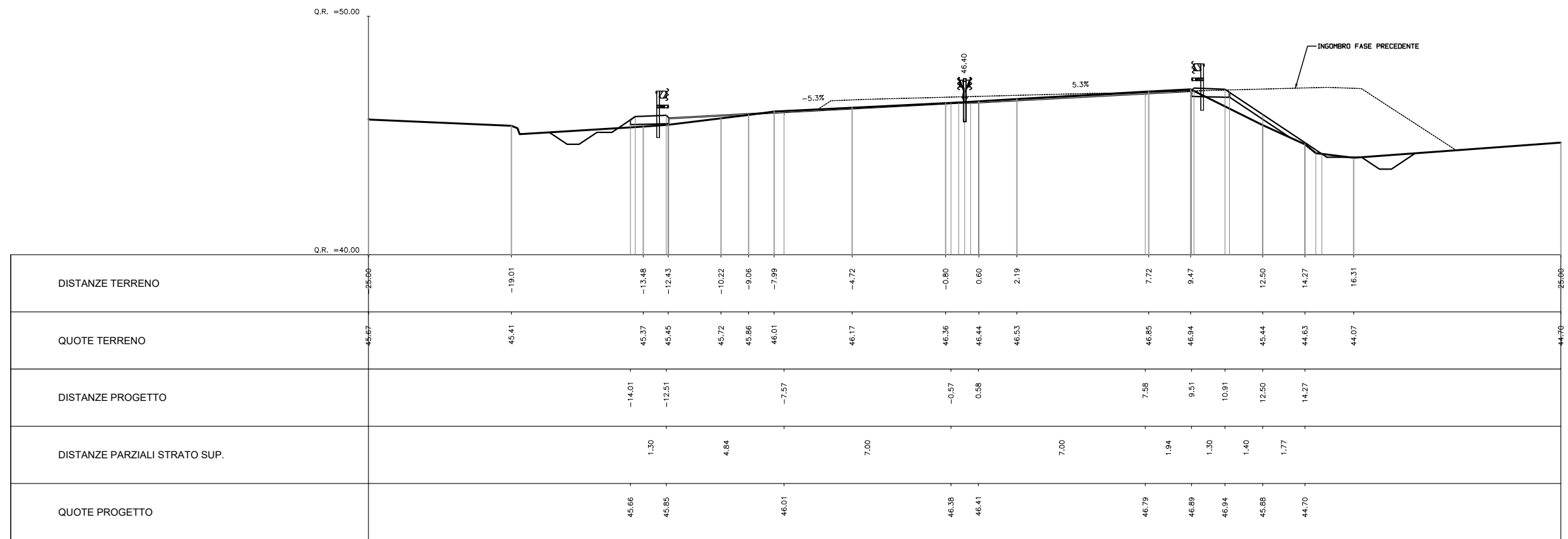

RACCORDO AUTOSTRADALE - RIPRISTINO

PROGRESSIVA 0+120.000

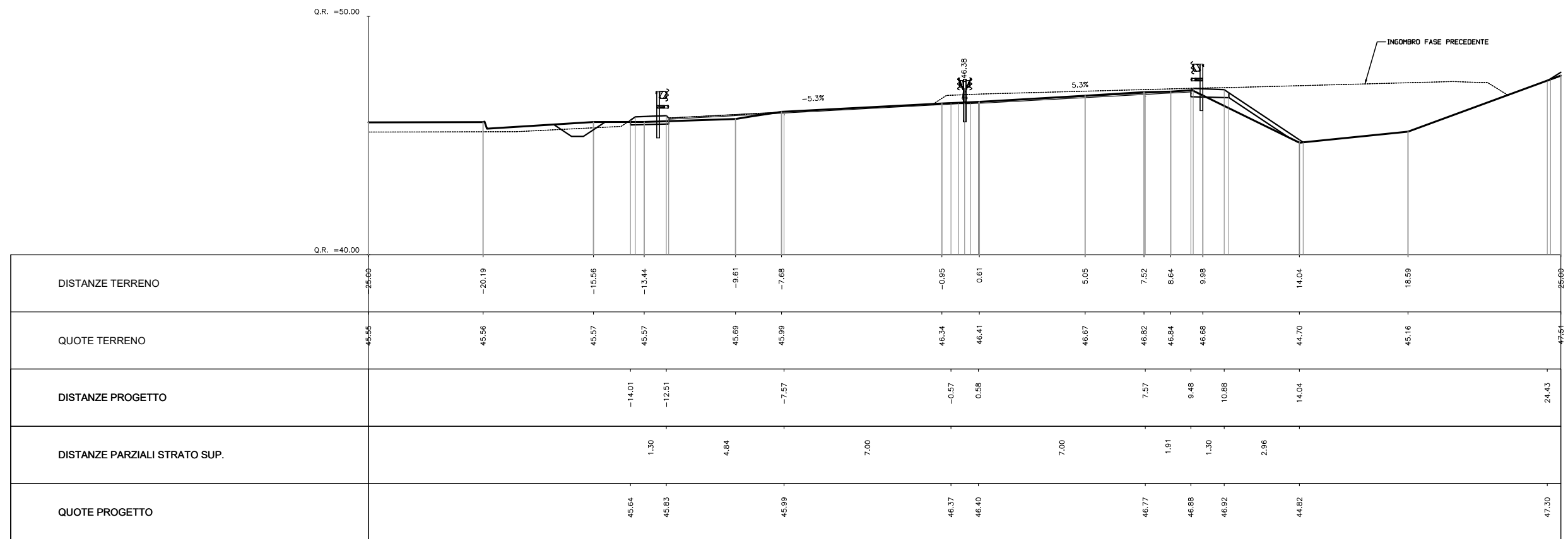

RACCORDO AUTOSTRADALE - RIPRISTINO

PROGRESSIVA 0+140.000

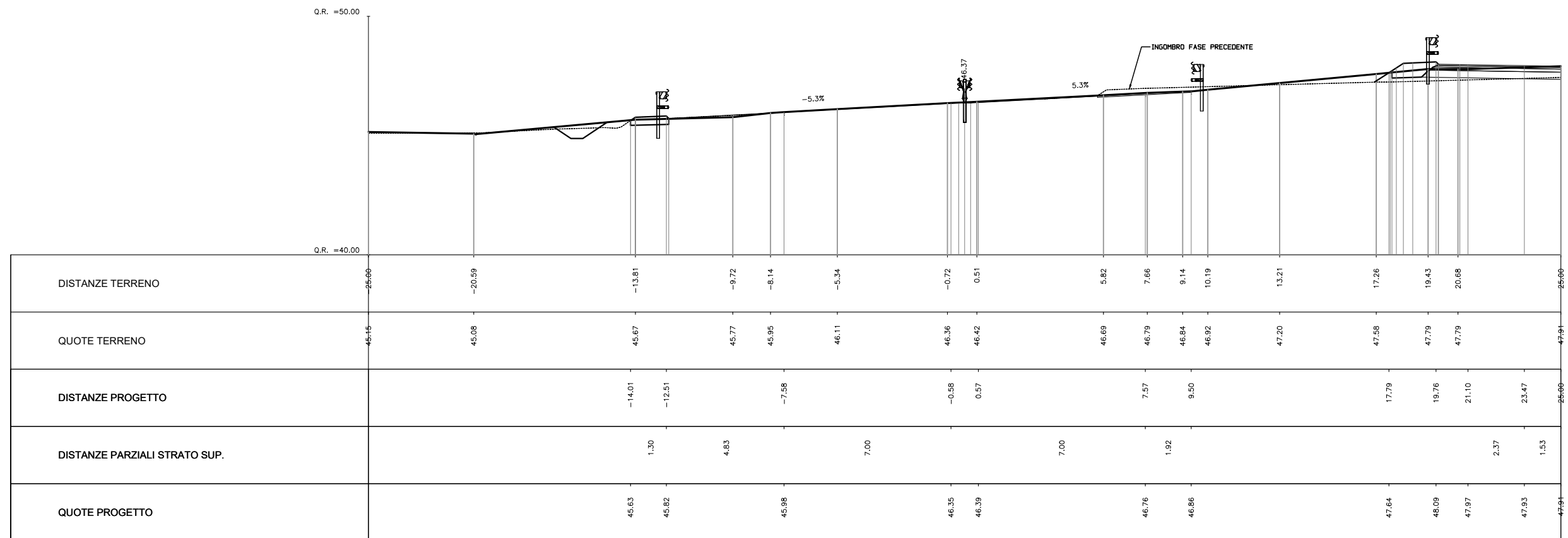

RACCORDO AUTOSTRADALE - RIPRISTINO

PROGRESSIVA 0+160.000

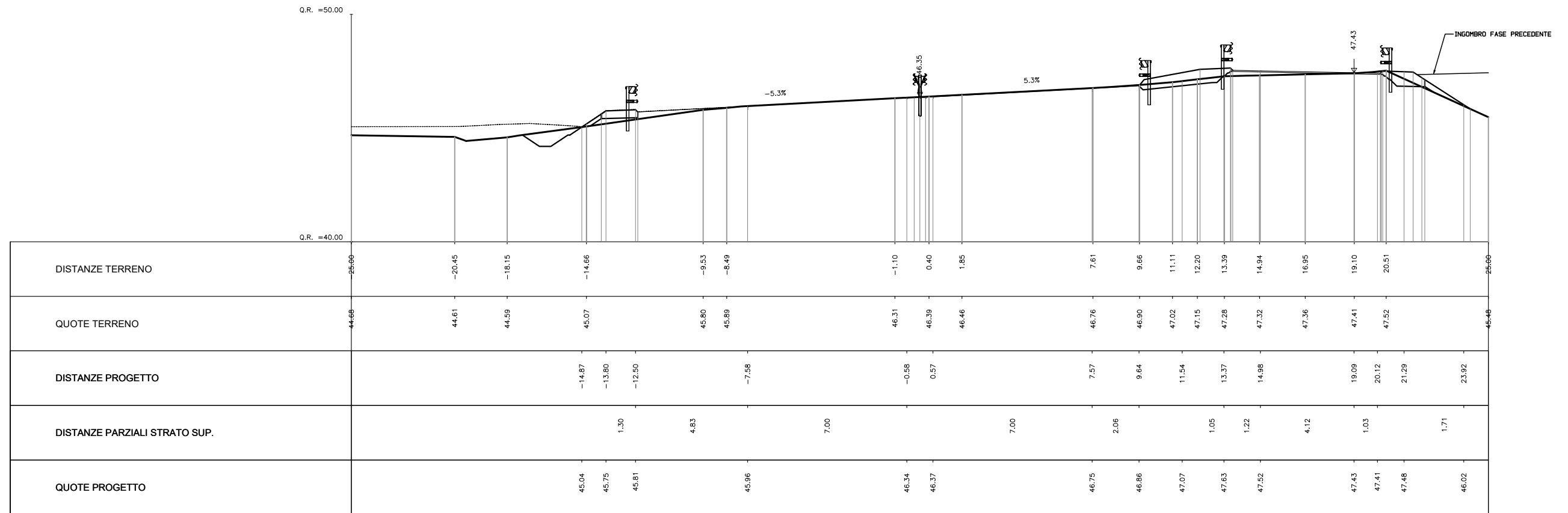

RACCORDO AUTOSTRADALE - RIPRISTINO

PROGRESSIVA 0+180.000

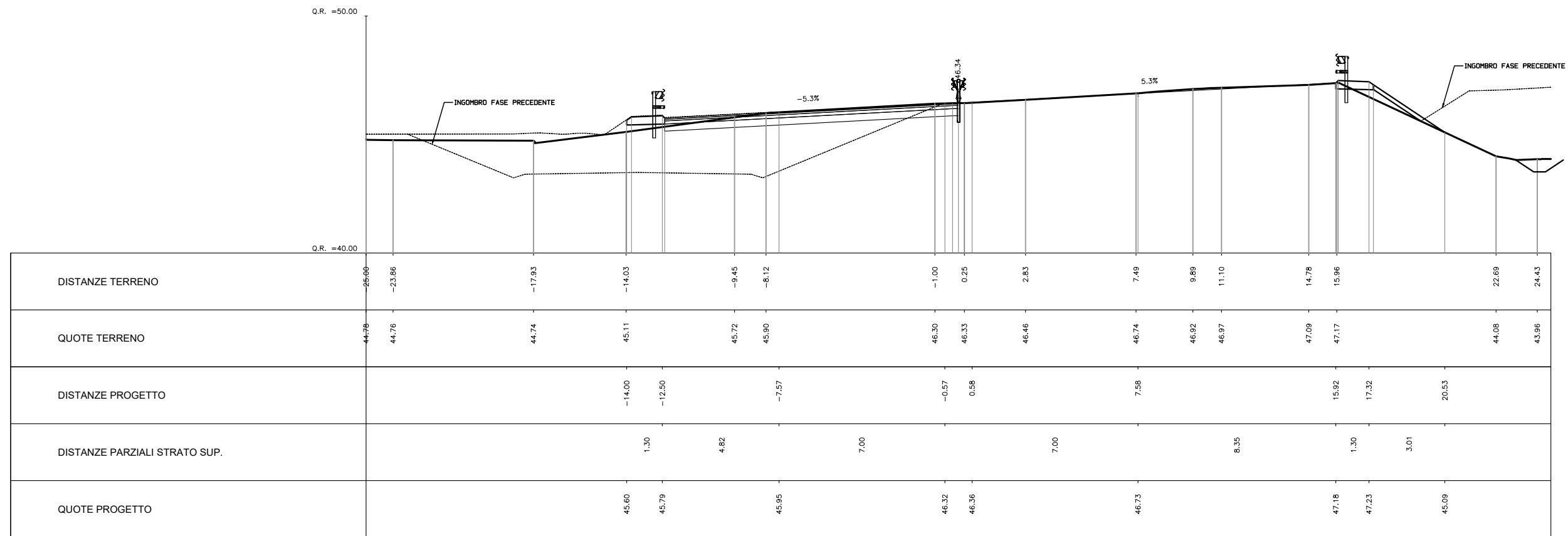

RACCORDO AUTOSTRADALE - RIPRISTINO

PROGRESSIVA 0+200.000

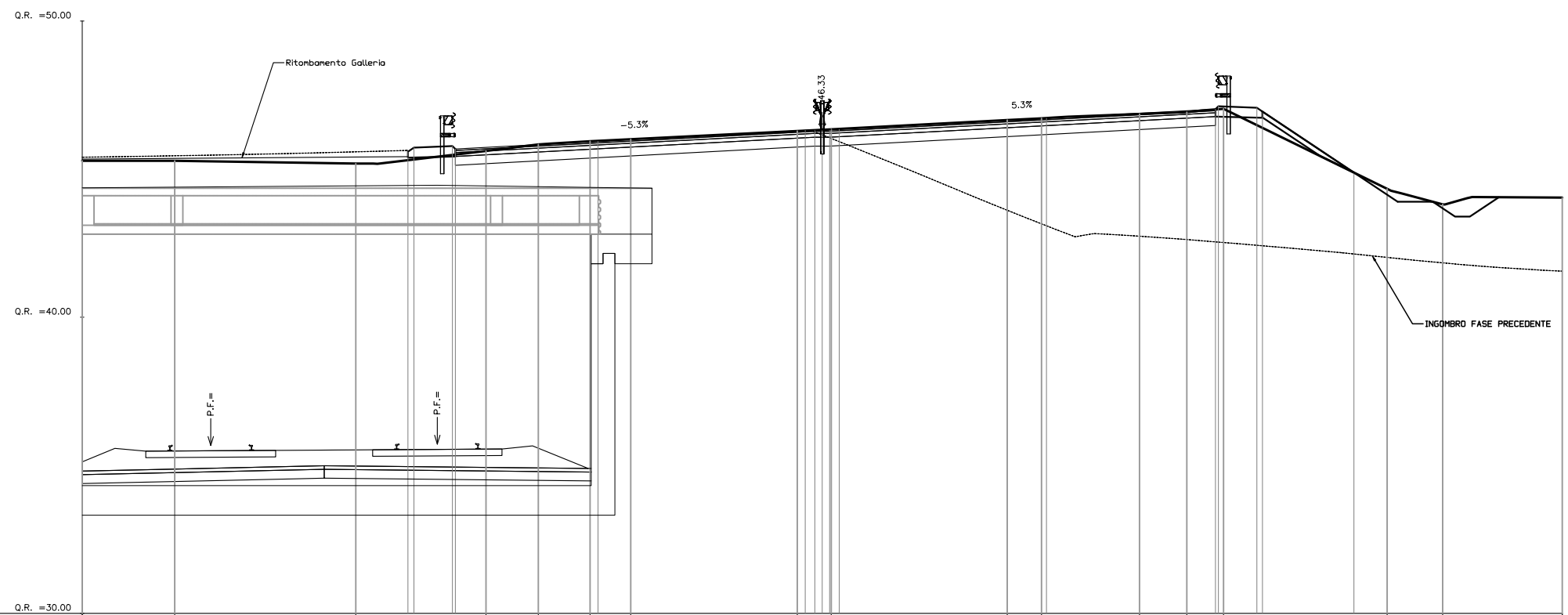

DISTANZE TERRENO	25.66	-21.87	-15.76	-11.36	-9.59	-7.84	-6.47	-0.84	0.30	6.25	7.41	10.72	12.32	13.56	19.08	20.96	25.66
QUOTE TERRENO	45.28	45.28	45.19	45.61	45.83	45.94	46.01	46.29	46.34	46.66	46.71	46.86	46.92	47.04	44.33	43.81	44.64
DISTANZE PROGETTO			-14.00	-12.49	-7.57	-0.57	0.58			7.58		13.28	14.68		17.96		
DISTANZE PARZIALI STRATO SUP.			1.30	4.82	7.00			7.00			5.71	1.30	3.09				
QUOTE PROGETTO			45.59	45.78	45.94	46.31	46.34	46.72		47.02	47.07	44.88					

RACCORDO AUTOSTRADALE - RIPRISTINO

PROGRESSIVA 0+220.000

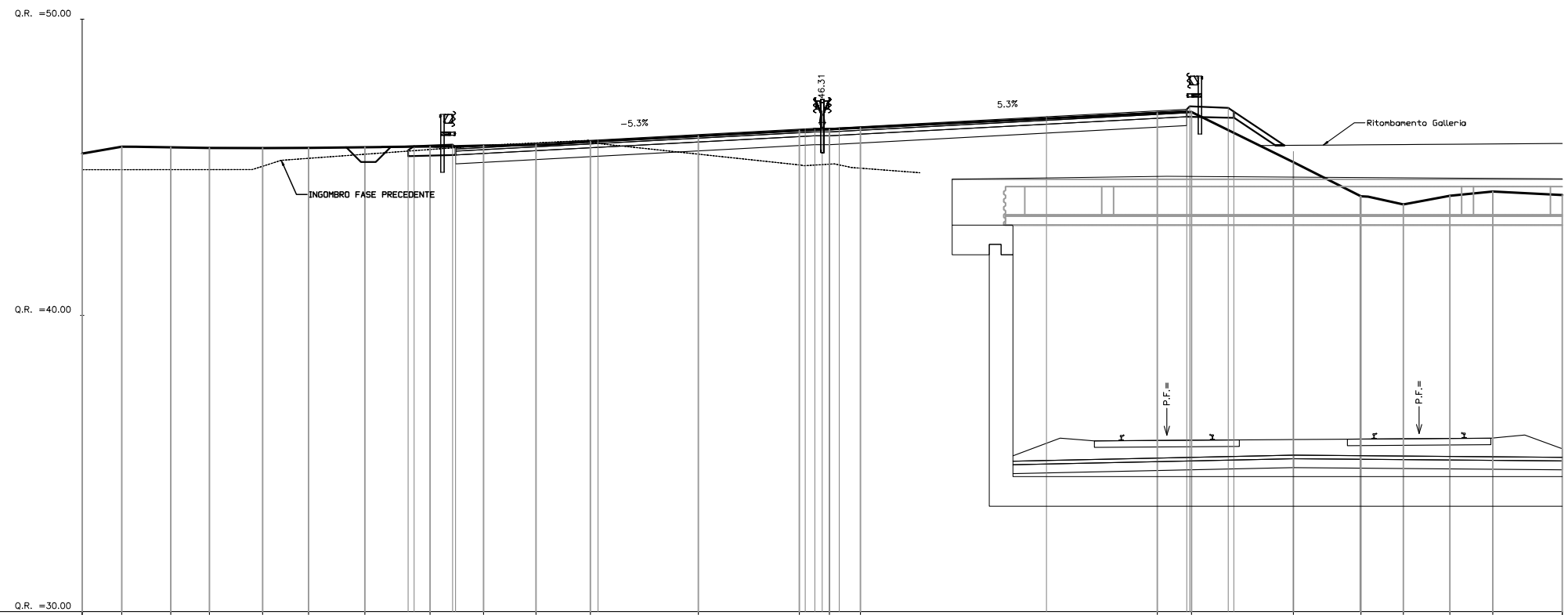

DISTANZE TERRENO	-25.66	-23.66	-22.01	-20.70	-18.90	-17.35	-15.45	-13.25	-11.44	-9.67	-7.83	-4.19	-0.77	0.24	1.29		11.32	12.48		15.92	18.20	19.63	21.20	22.65	25.66
QUOTE TERRENO	45.46	45.69	45.67	45.65	45.65	45.65	45.68	45.70	45.73	45.76	45.87	46.06	46.24	46.29	46.33		46.83	46.86		45.17	44.02	43.75	44.04	44.18	44.66
DISTANZE PROGETTO								-13.99	-12.49		-7.58		-0.58	0.57		7.57		12.31	13.71	15.92	18.17				
DISTANZE PARZIALI STRATO SUP.								1.30	4.81		7.00				7.00		4.74	1.30	2.01	2.25					
QUOTE PROGETTO							45.57	45.76		45.92		46.30	46.33		46.70		46.96	47.01	45.53	44.04					

RACCORDO AUTOSTRADALE - RIPRISTINO

PROGRESSIVA 0+240.000

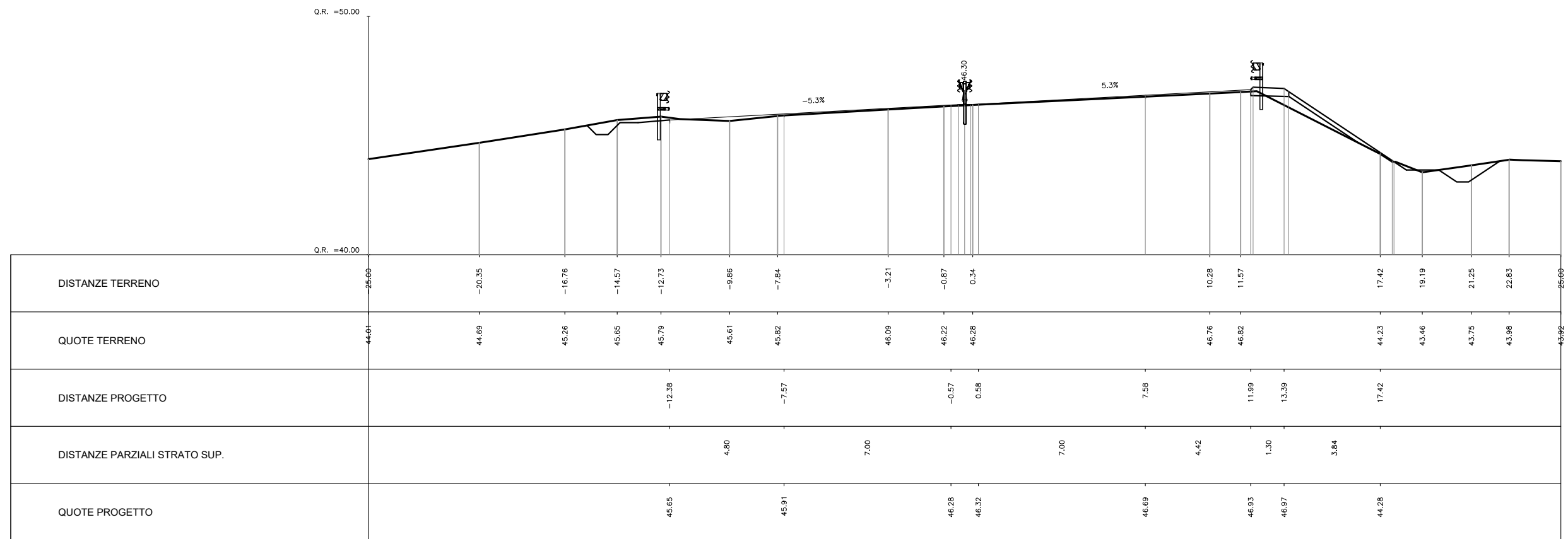

RACCORDO AUTOSTRADALE - RIPRISTINO

PROGRESSIVA 0+260.000

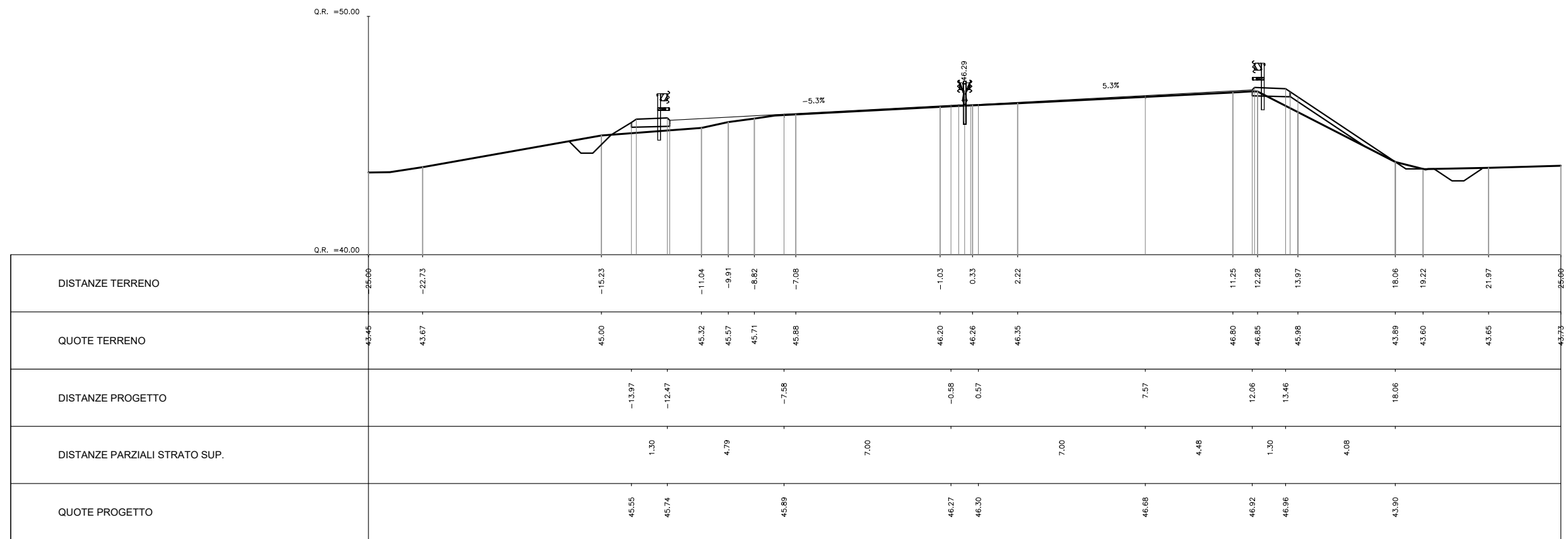

RACCORDO AUTOSTRADALE - RIPRISTINO

PROGRESSIVA 0+280.000

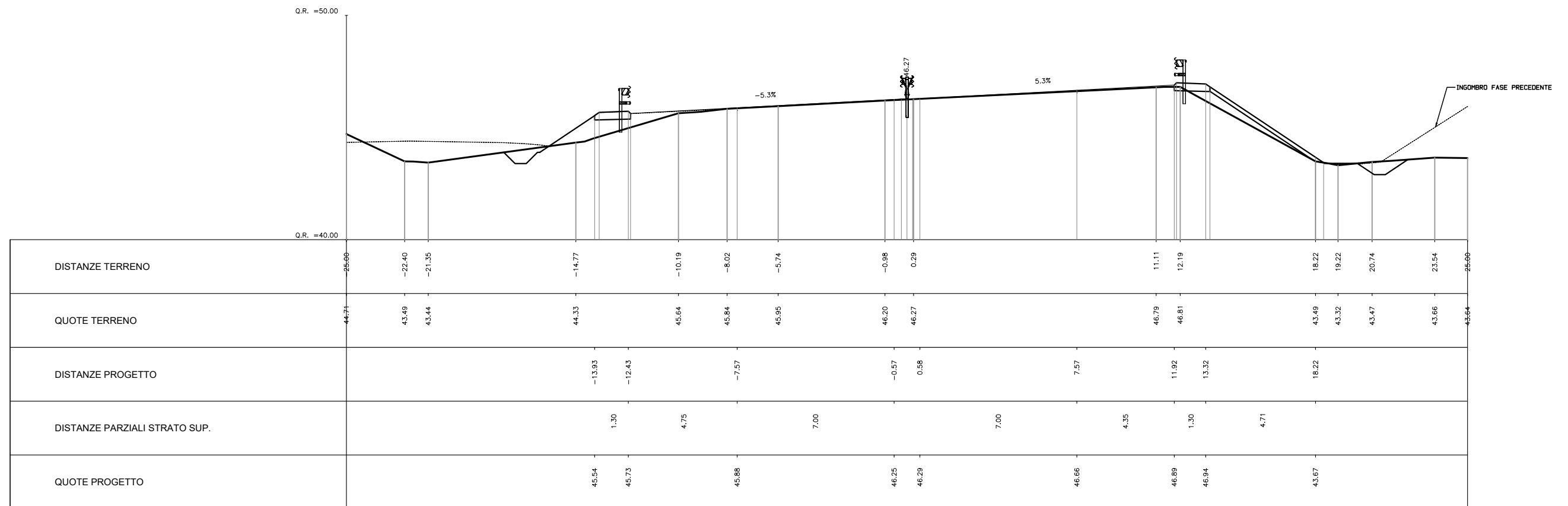

RACCORDO AUTOSTRADALE - RIPRISTINO

PROGRESSIVA 0+300.000

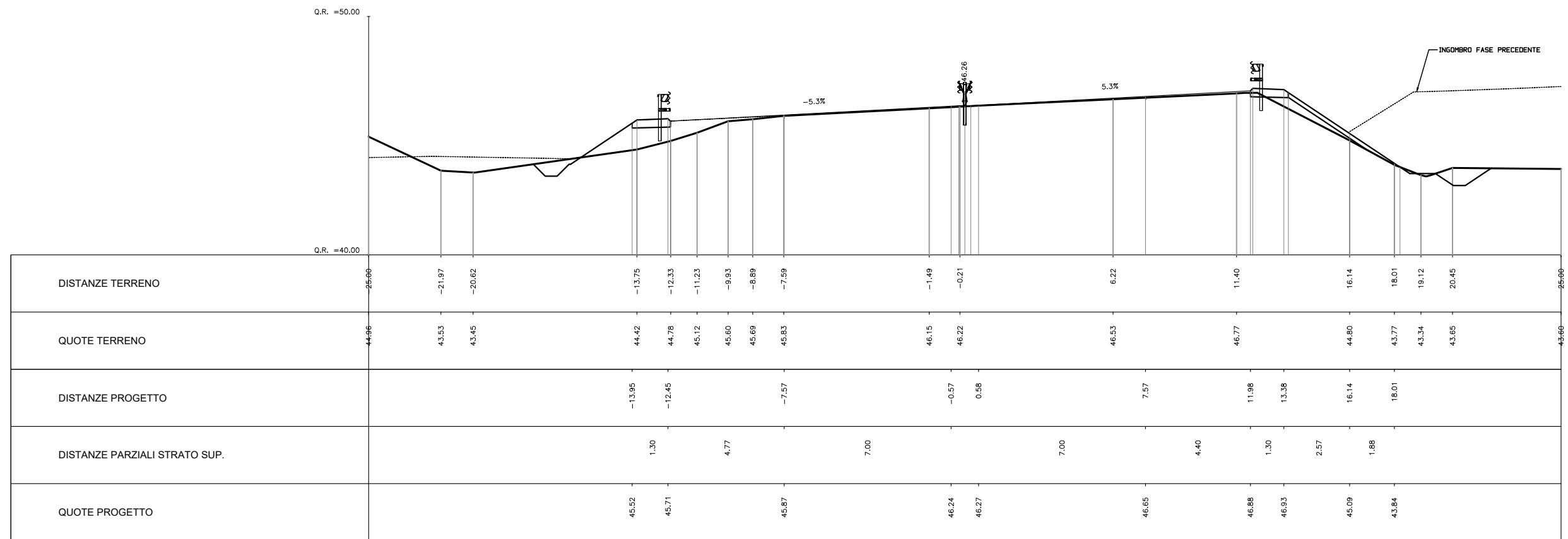

RACCORDO AUTOSTRADALE - RIPRISTINO

PROGRESSIVA 0+320.000

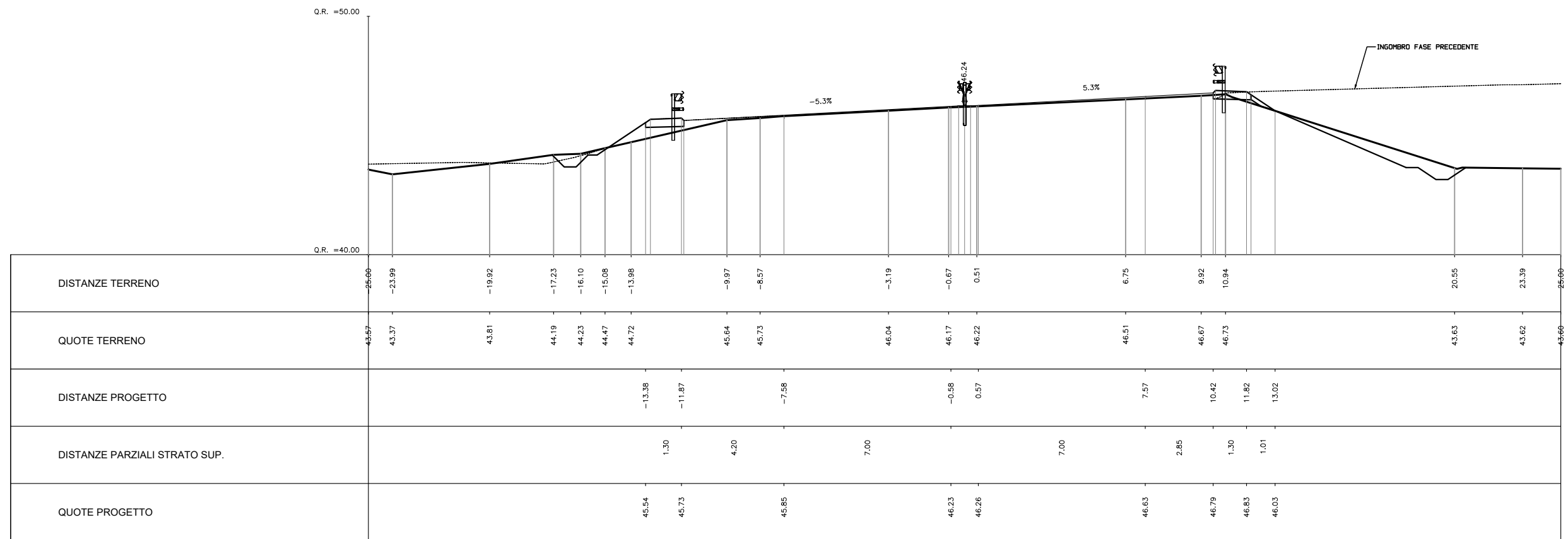

DISTANZE TERRENO	26.66	-23.99	-19.92	-17.23	-16.10	-15.08	-13.98	-9.97	-8.57	-3.19	-0.67	0.51	6.75	9.92	10.94	20.55	23.39	26.66
QUOTE TERRENO	45.57	45.37	45.81	44.19	44.23	44.47	44.72	45.64	45.73	46.04	46.17	46.22	46.51	46.67	46.73	45.63	45.62	45.66
DISTANZE PROGETTO							-13.38	-11.87	-7.58		-0.58	0.57	7.57	10.42	11.82	13.02		
DISTANZE PARZIALI STRATO SUP.							1.30	4.20	7.00		7.00	2.85	1.30	1.01				
QUOTE PROGETTO				45.54	45.73	45.85	46.23	46.26	46.63	46.79	46.83	46.03						

RACCORDO AUTOSTRADALE - RIPRISTINO

PROGRESSIVA 0+340.000

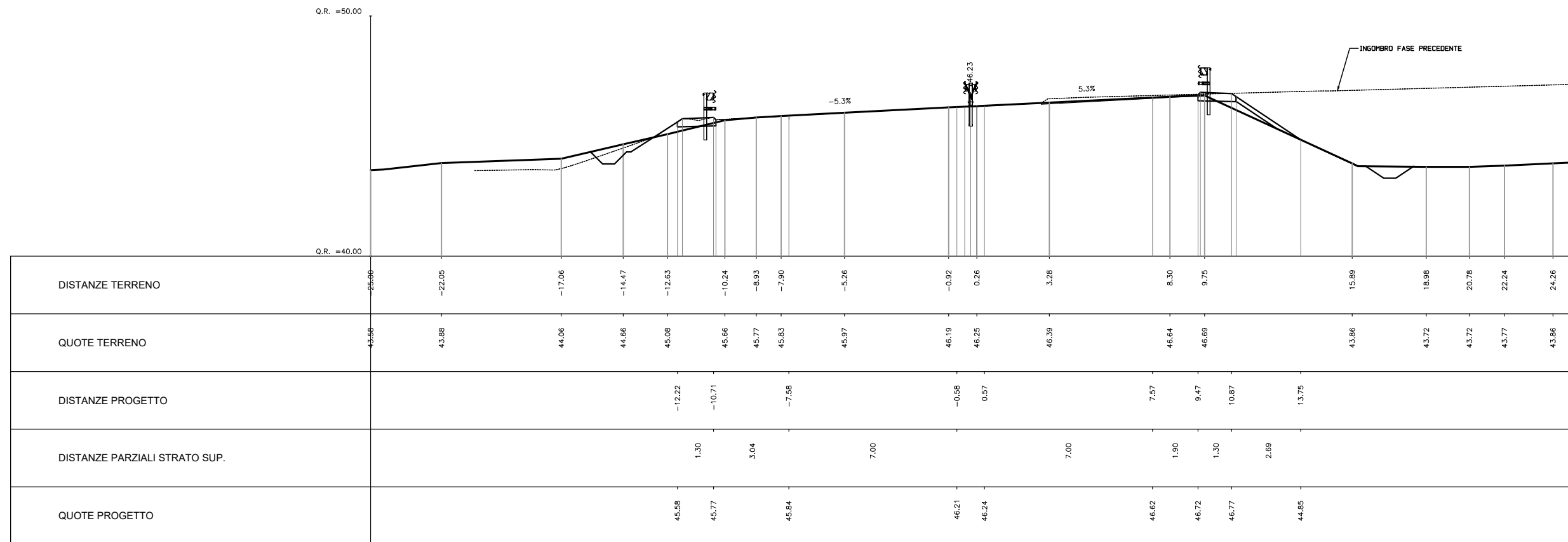

RACCORDO AUTOSTRADALE - RIPRISTINO

PROGRESSIVA 0+360.000

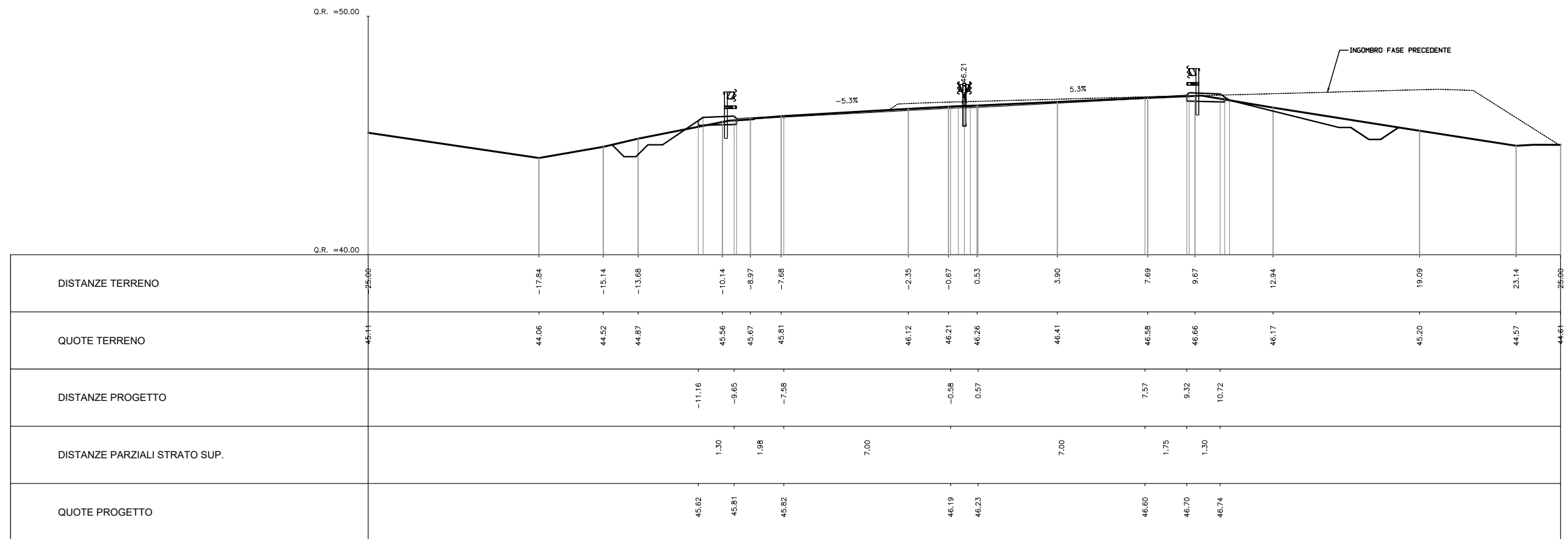

RACCORDO AUTOSTRADALE - RIPRISTINO

PROGRESSIVA 0+380.000

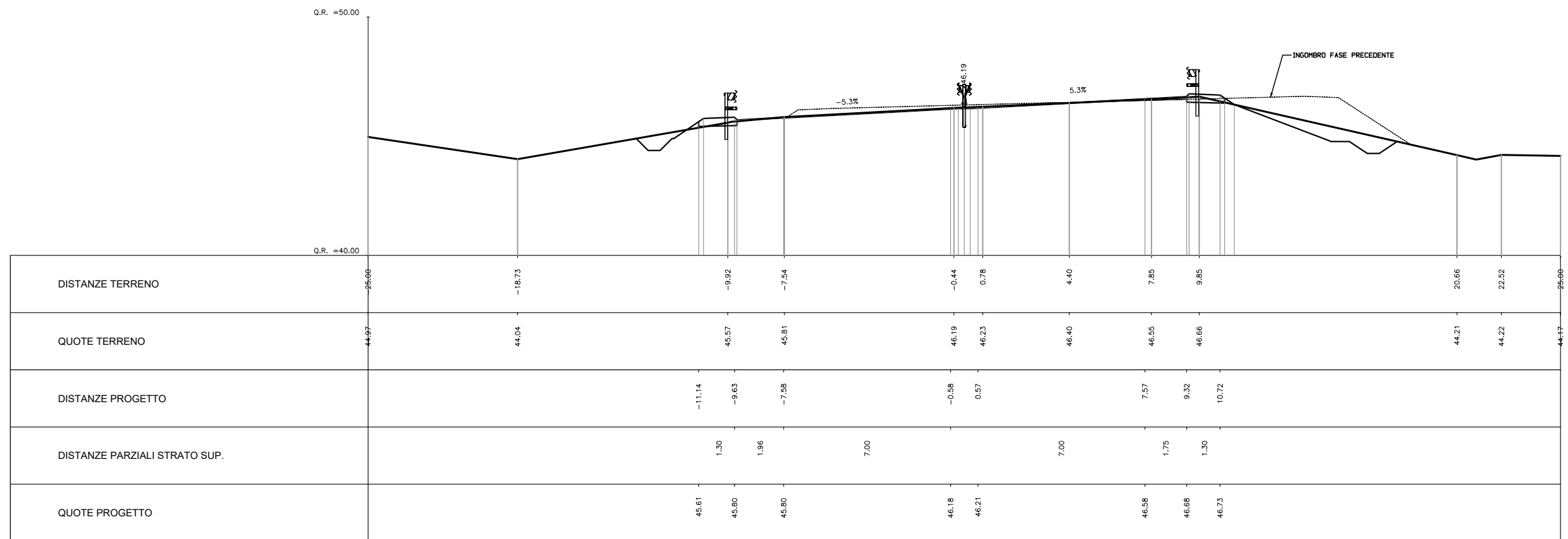

RACCORDO AUTOSTRADALE - RIPRISTINO

PROGRESSIVA 0+400.000

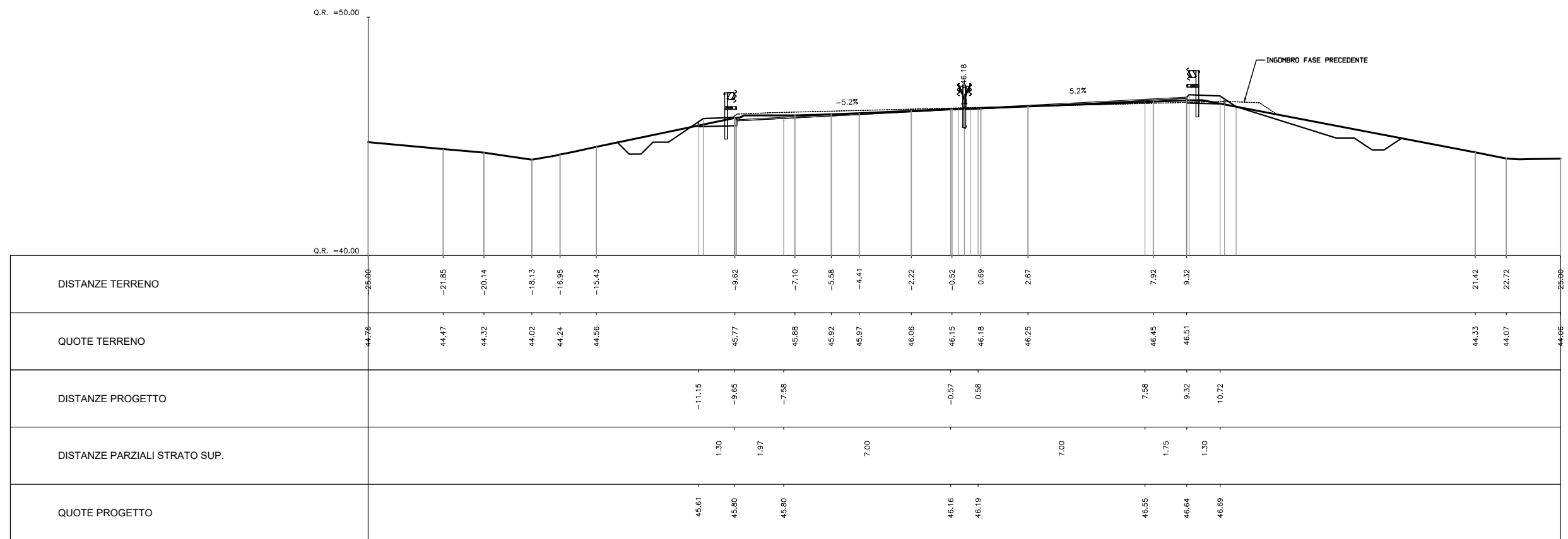

RACCORDO AUTOSTRADALE - RIPRISTINO

PROGRESSIVA 0+420.000

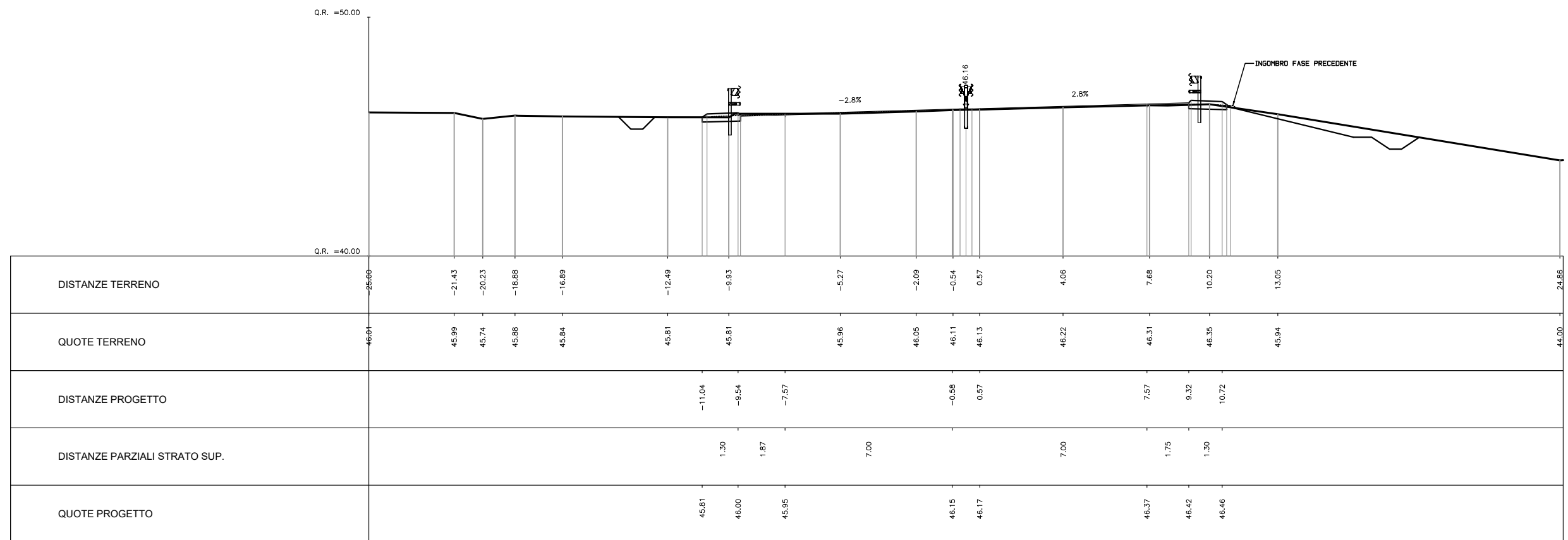

SEZIONI RAMPA RACCORDO

RAMPA RACCORDO -RIPRISTINO

PROGRESSIVA 0+060.000

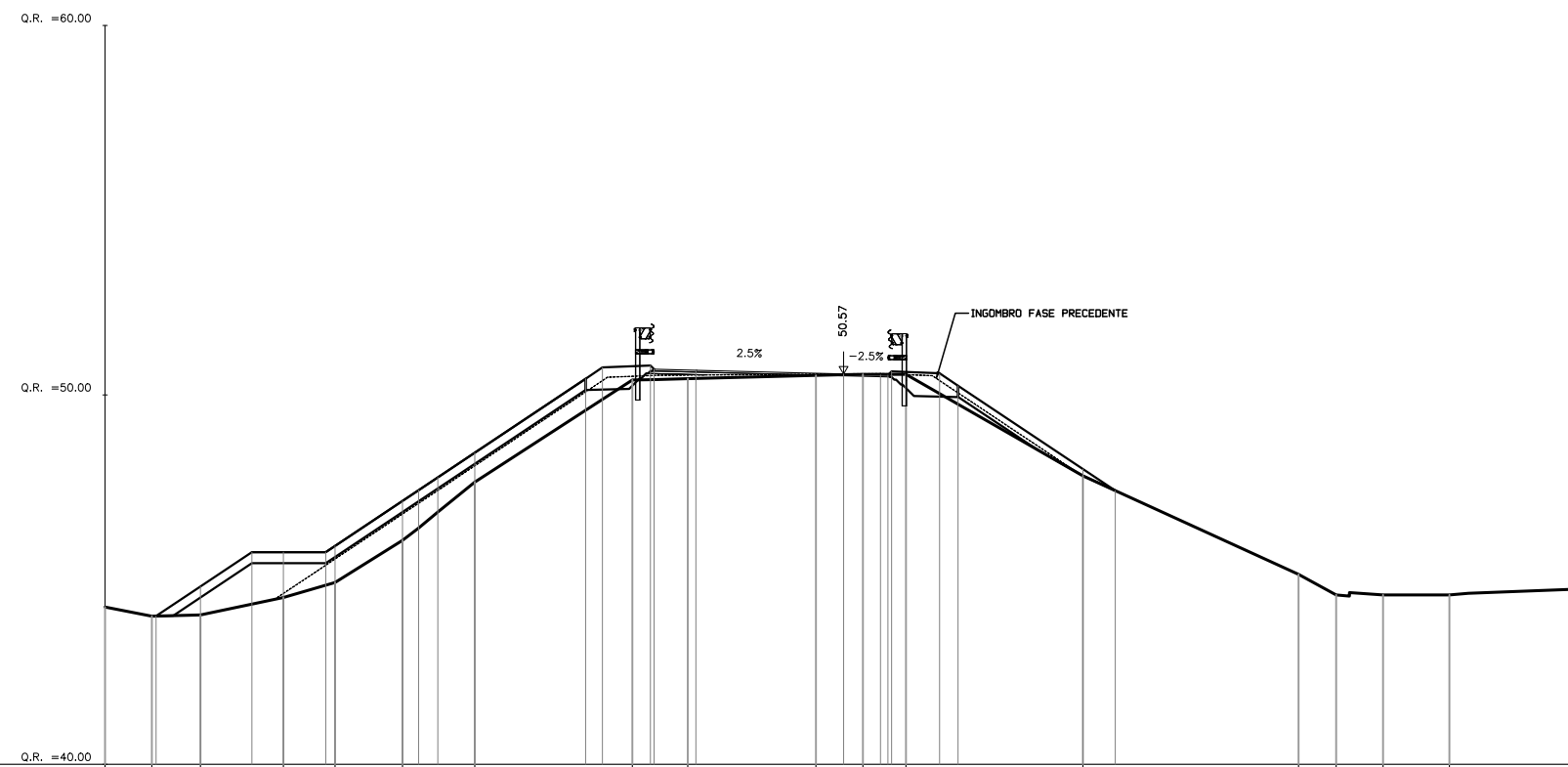

DISTANZE TERRENO	-26.66	-18.73	-17.42	-15.17	-13.77	-11.94	-9.99	-5.72	-4.22	-0.75	0.52	1.69	6.48	12.32	13.34	14.61	16.41	19.96
QUOTE TERRENO	44.26	44.01	44.04	44.51	44.92	46.06	47.64	50.40	50.44	50.53	50.56	50.56	47.81	45.14	44.58	44.58	44.59	44.74
DISTANZE PROGETTO		-18.62	-17.42	-16.02	-14.02	-11.94	-9.99	-6.99	-5.23	-4.00	-0.00	1.00	2.60	6.48				
DISTANZE PARZIALI STRATO SUP.		1.20	1.39	1.15	1.83	1.00	3.00	1.30	1.13	4.00	1.00	1.30	3.38					
QUOTE PROGETTO		44.01	44.81	45.74	45.74	47.13	48.43	50.44	50.80	50.67	50.57	50.54	50.98	47.99				

RAMPA RACCORDO -RIPRISTINO

PROGRESSIVA 0+075.000

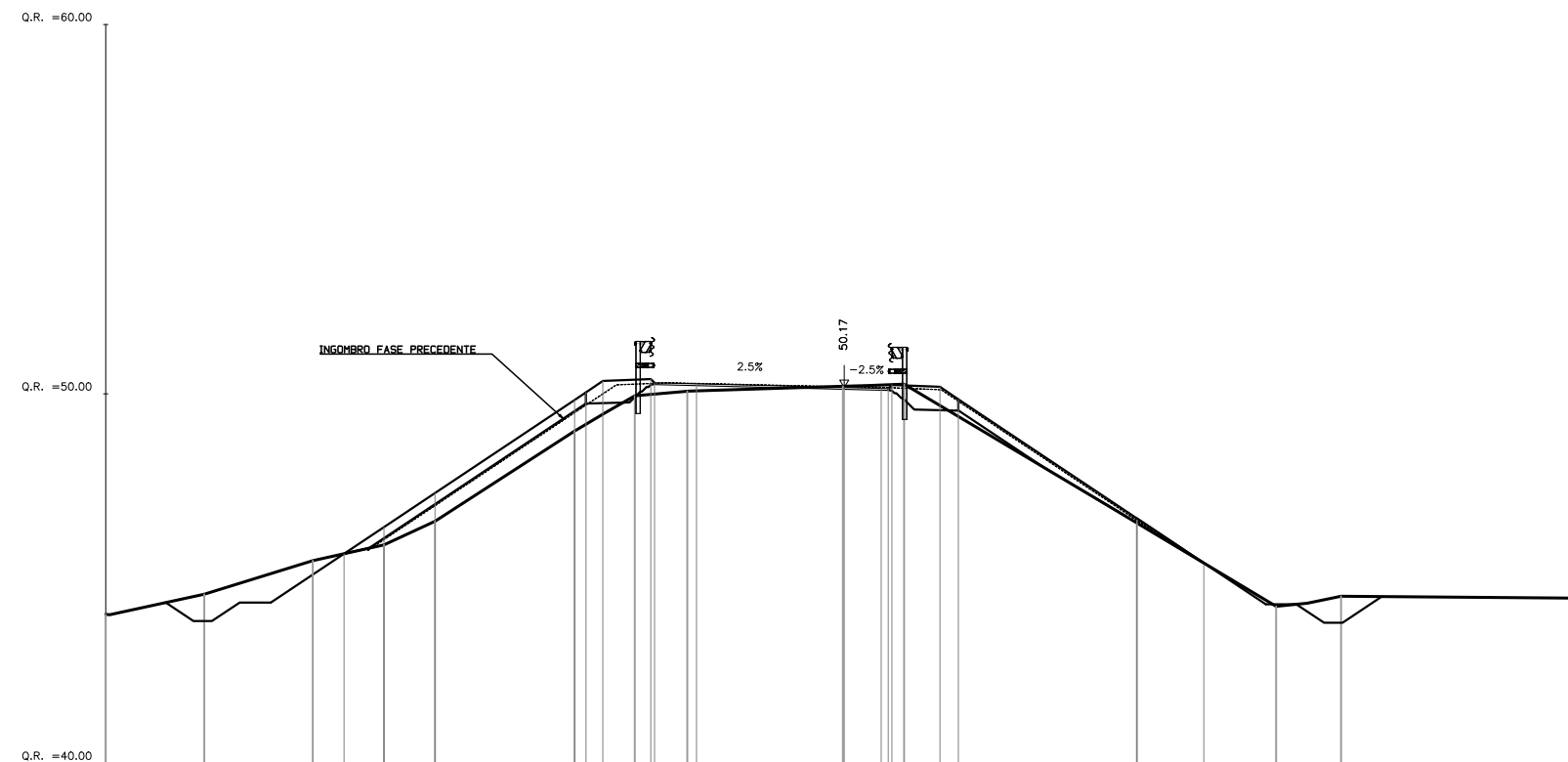

DISTANZE TERRENO	26+06	-17.33	-14.39	-12.46	-11.08	-7.30	-5.67	-4.25	-0.04	1.62	7.93	11.70	13.46	26+96
QUOTE TERRENO	44.83	44.58	45.48	45.91	46.55	48.99	49.95	50.07	50.21	50.26	46.51	44.25	44.52	44.47
DISTANZE PROGETTO			-13.55	-12.46	-11.08	-7.30	-5.24	-4.00	0.00	1.00	2.59	7.93	9.74	
DISTANZE PARZIALI STRATO SUP.			1.08	1.38	3.78	1.30	1.14	4.00	1.00	1.30	4.83	1.81		
QUOTE PROGETTO			45.67	46.39	47.31	49.83	50.40	50.27	50.17	50.15	50.19	46.63	45.42	

RAMPA RACCORDO -RIPRISTINO

PROGRESSIVA 0+090.000

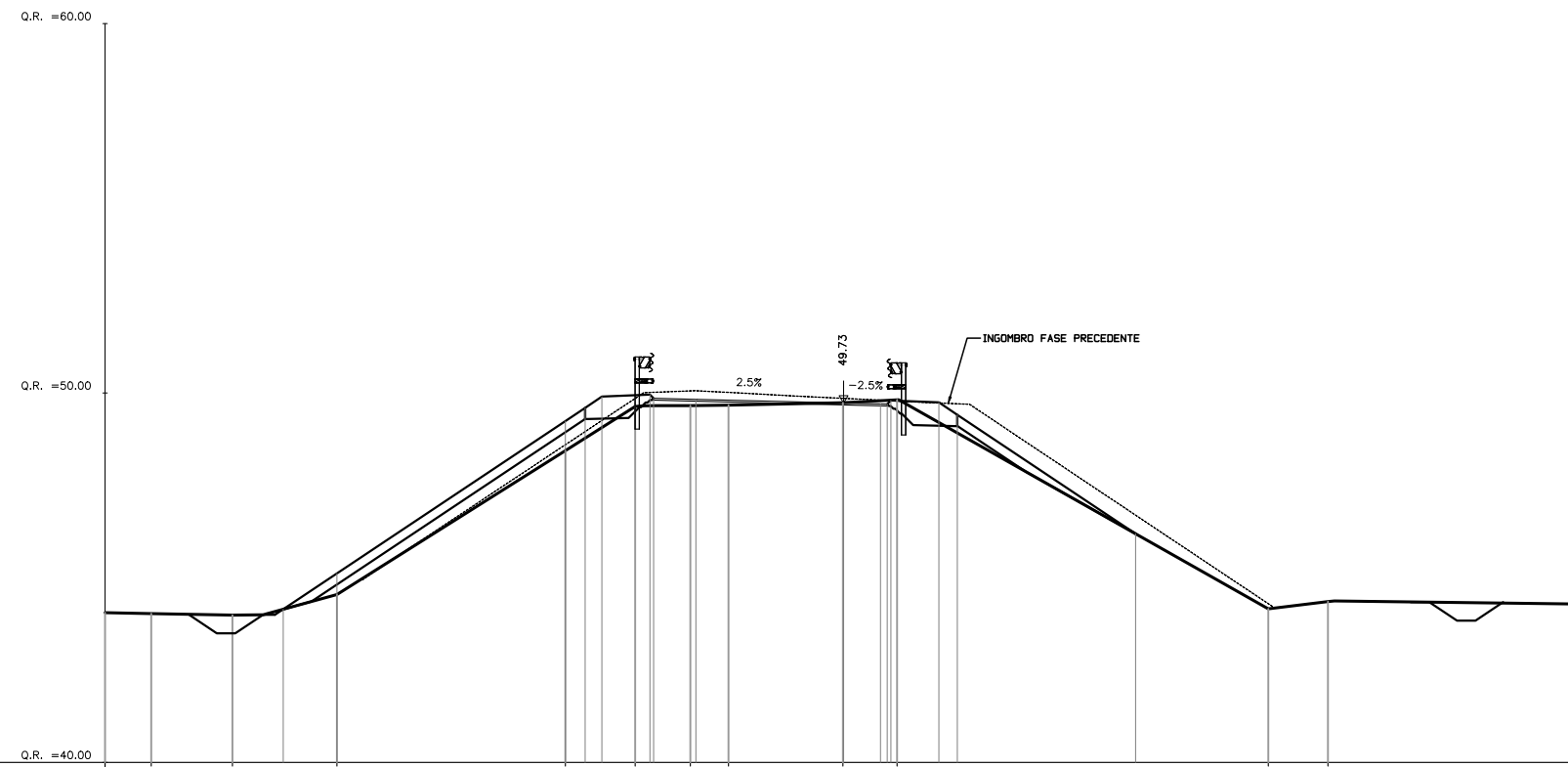

DISTANZE TERRENO	-26.66	-18.75	-16.55	-13.72	-7.53	-5.64	-4.15	-3.12	-0.02	1.45	11.50	13.12	26.66
QUOTE TERRENO	44.95	44.03	43.99	44.55	48.44	49.63	49.66	49.67	49.74	49.82	44.16	44.35	44.59
DISTANZE PROGETTO			-15.18	-13.72	-7.53	-5.24	-4.00		0.00	1.16	2.58	7.91	
DISTANZE PARZIALI STRATO SUP.			1.45	6.19	1.30	1.14	4.00		1.30	4.83			
QUOTE PROGETTO			44.15	45.11	49.24	49.96	49.83		49.73	49.70	49.75	46.19	

RAMPA RACCORDO -RIPRISTINO

PROGRESSIVA 0+105.000

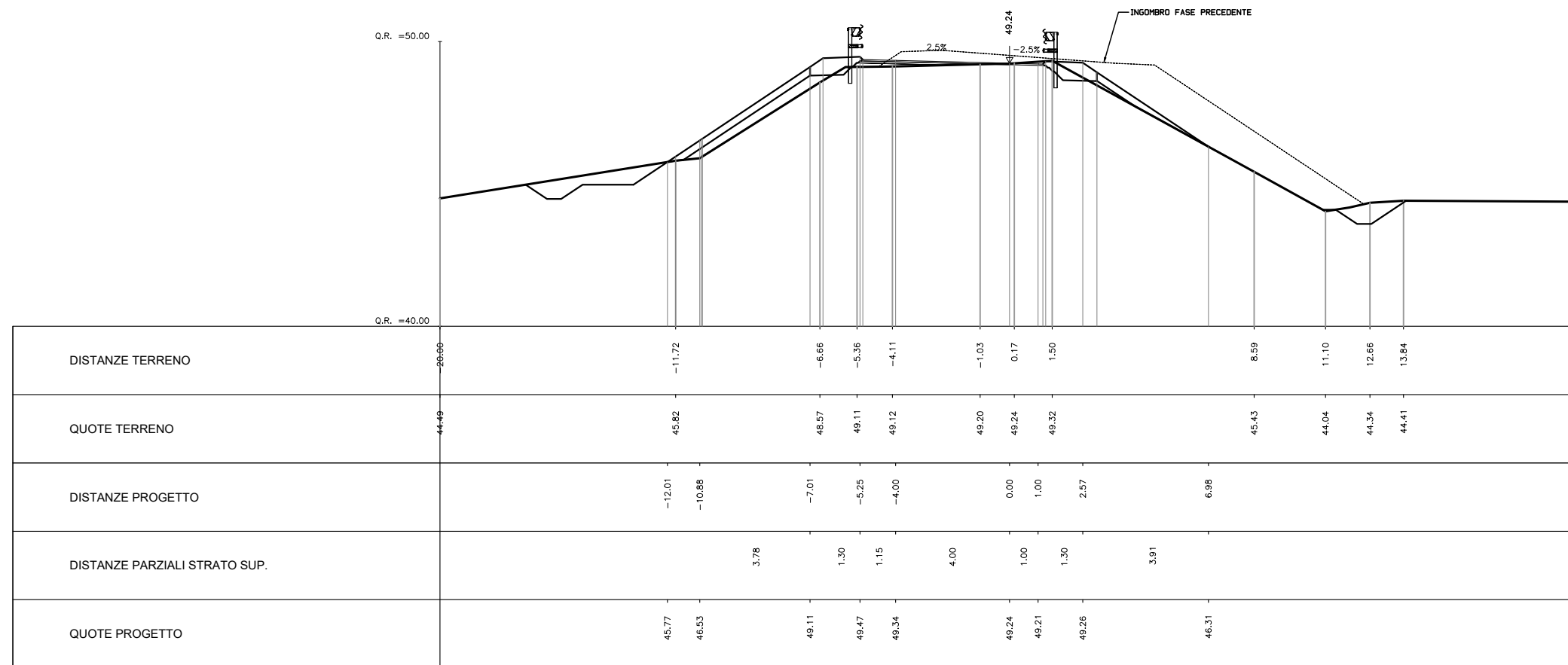

RAMPA RACCORDO -RIPRISTINO

PROGRESSIVA 0+120.000

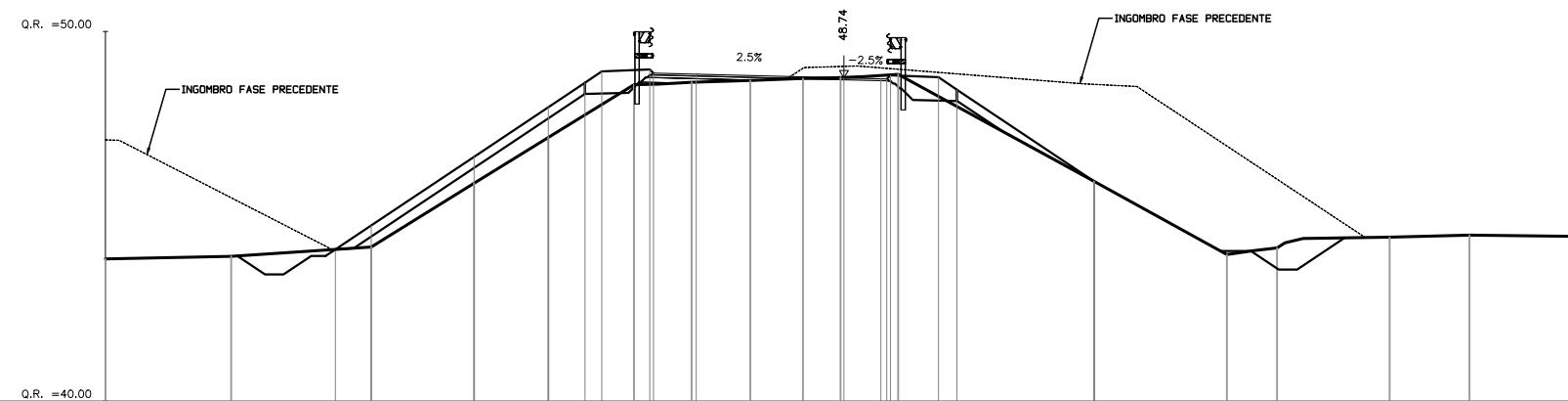

DISTANZE TERRENO	-26.66	-16.59	-12.80	-10.02	-8.01	-5.69	-4.12	-2.54	-1.11	-0.09	1.47	6.78	10.37	11.73	14.78	16.94	26.66
QUOTE TERRENO	43.85	43.92	44.17	45.90	47.14	48.56	48.63	48.67	48.73	48.75	48.84	45.95	43.97	44.15	44.44	44.49	44.46
DISTANZE PROGETTO			-13.77	-10.02	-8.01	-6.56	-5.26	-4.00		0.00	1.00	2.56					
DISTANZE PARZIALI STRATO SUP.				2.78	2.01	1.30	1.16	4.00		1.00	1.30	3.72					
QUOTE PROGETTO			44.11	46.61	47.95	48.92	48.97	48.84		48.74	48.72	48.76	45.95				

RAMPA RACCORDO -RIPRISTINO

PROGRESSIVA 0+135.000

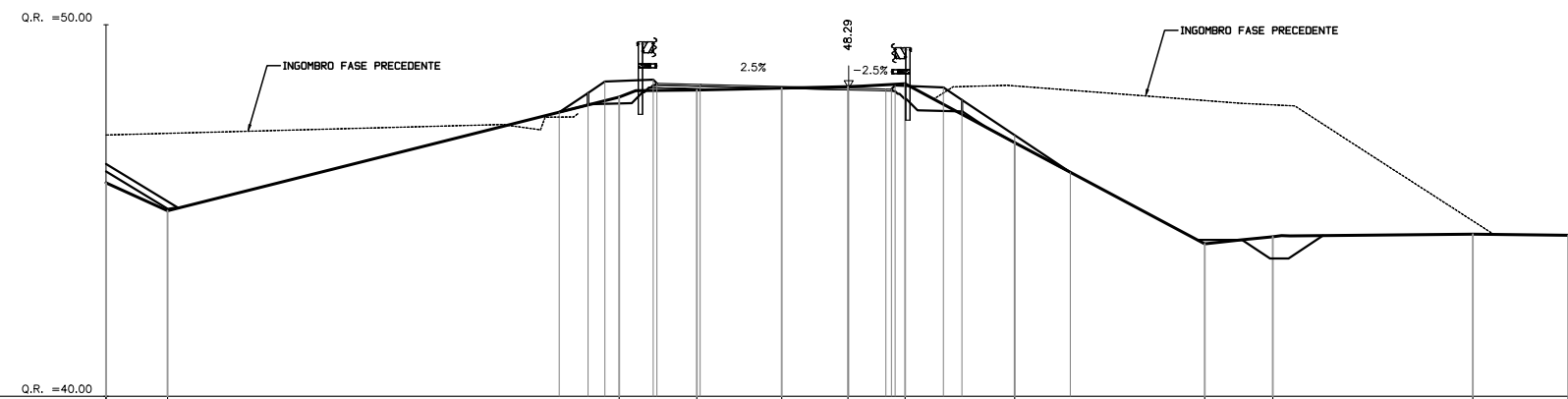

DISTANZE TERRENO	-26.66	-18.34		-6.18	-4.09	-1.80	-0.02	1.52	4.47		9.59	11.42	16.81	19.38
QUOTE TERRENO	45.75	44.99		48.05	48.24	48.29	48.33	48.41	46.83		44.10	44.29	44.36	44.33
DISTANZE PROGETTO				-7.80	-6.57	-5.27	-4.00		-0.00	1.00	2.55	4.47	5.97	
DISTANZE PARZIALI STRATO SUP.				1.30	1.17	4.00	1.00	1.30	1.42	1.50				
QUOTE PROGETTO				47.65	48.47	48.52	48.39		48.29	48.27	48.31	47.03	46.03	

RAMPA RACCORDO -RIPRISTINO

PROGRESSIVA 0+150.000

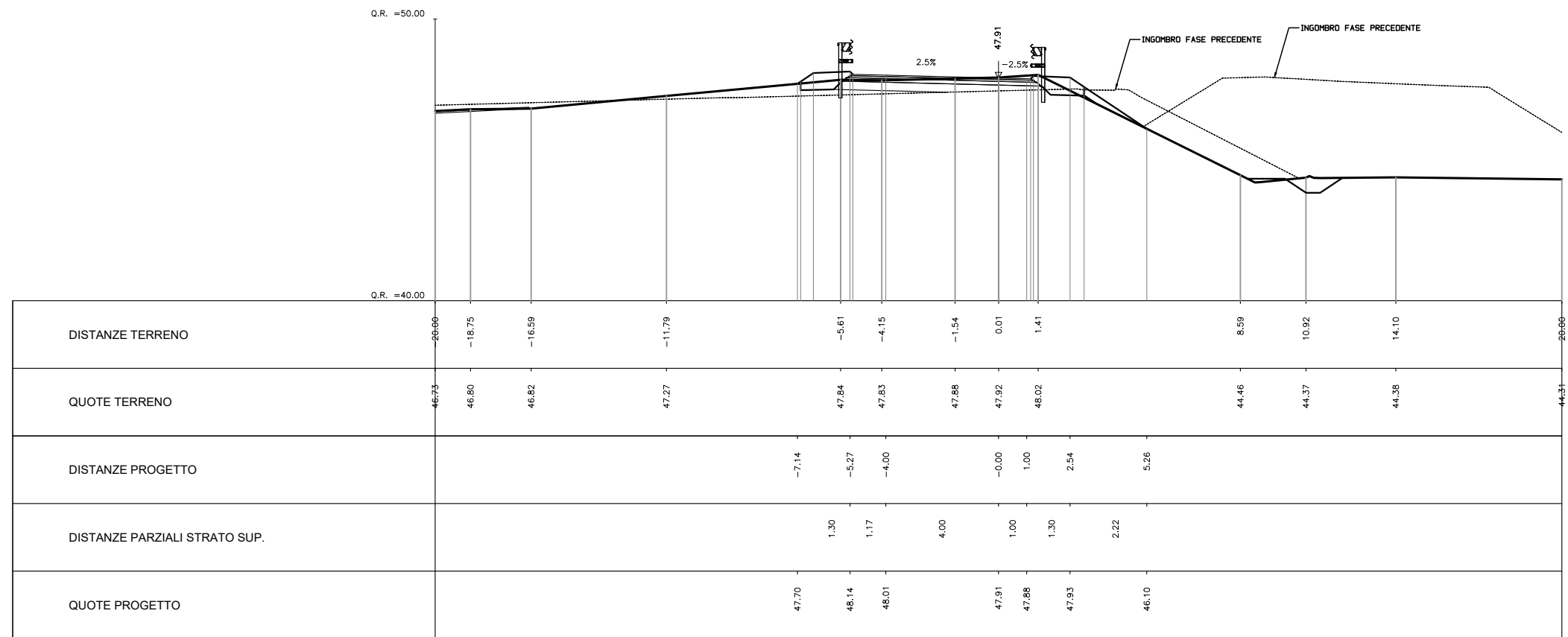

RAMPA RACCORDO -RIPRISTINO

PROGRESSIVA 0+165.000

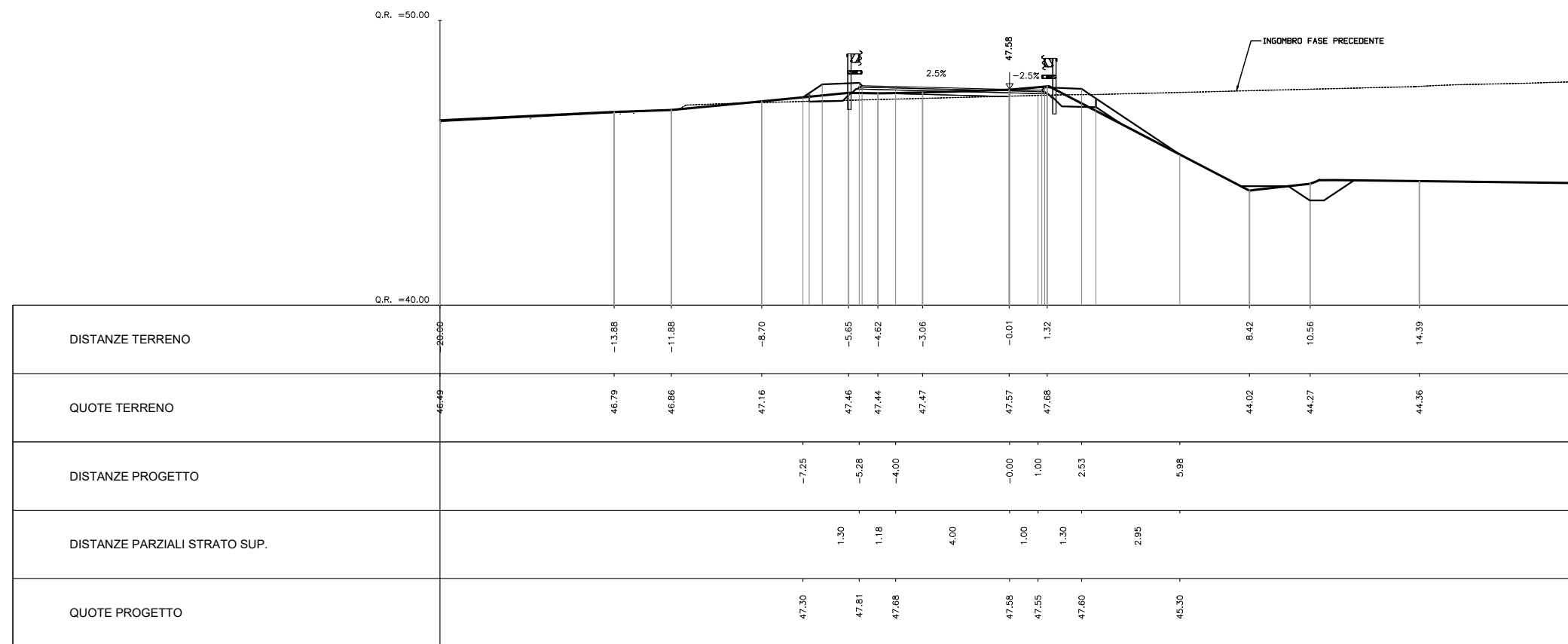

RAMPA RACCORDO -RIPRISTINO

PROGRESSIVA 0+180.000

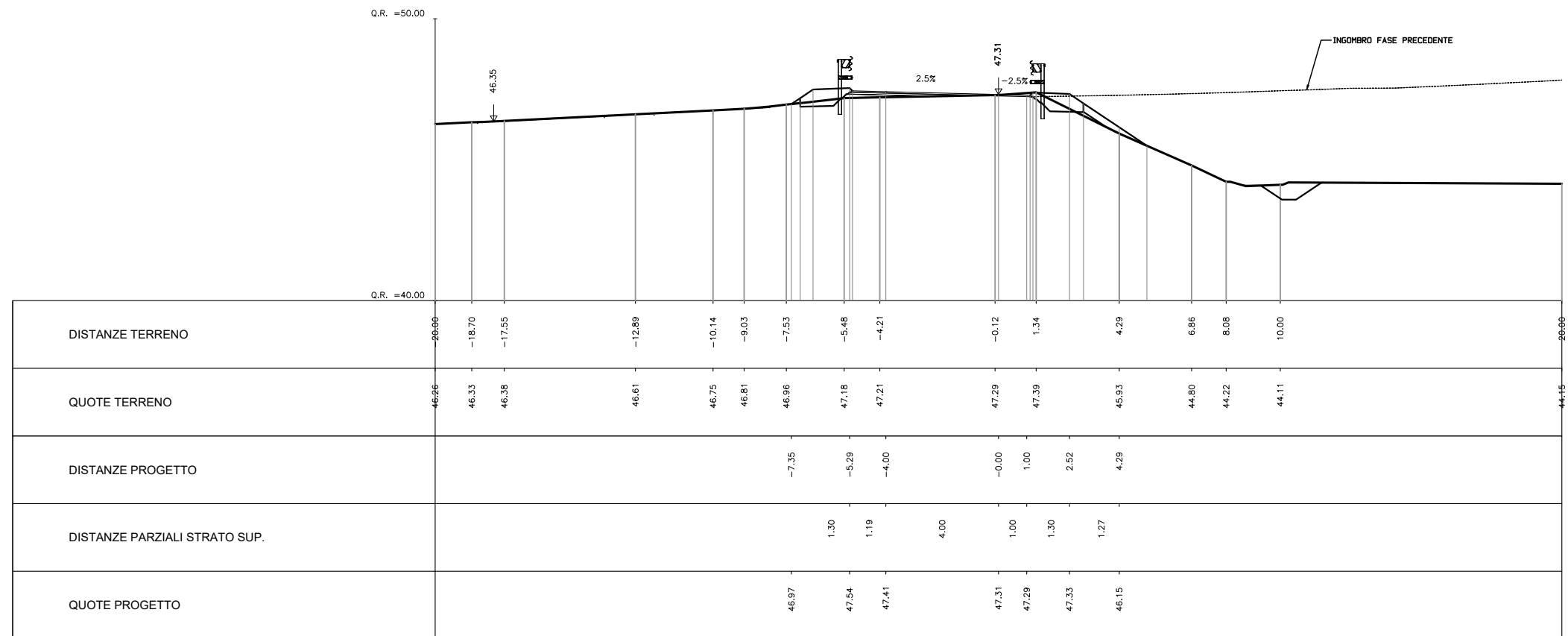

RAMPA RACCORDO -RIPRISTINO

PROGRESSIVA 0+190.000

