

Provincia di ENNA - Comune di ENNA

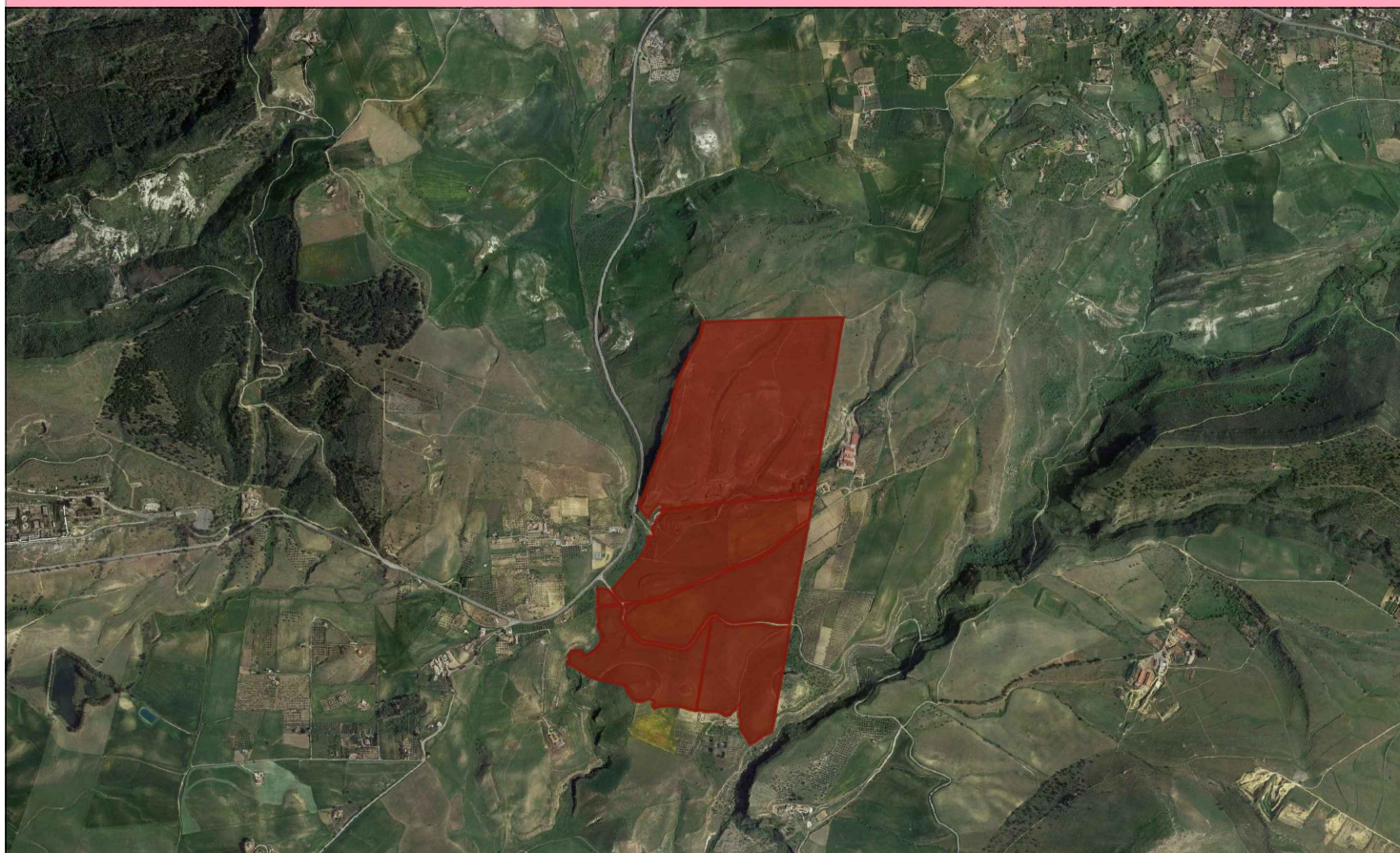

DATA	REV	OGGETTO REVISIONE

Committente:

X-ELIO

X-ELIO ENNA 2 S.R.L.

Corso Vittorio Emanuele II,349
00186 Roma
P.IVA:17129771006
www.x-elio.com

Sviluppo e Progettazione esecutiva:



GEOSTUDIOGROUP S.T.P. - S.R.L.

GEOSTUDIOGROUP STP S.r.l.

Via Dott. Lino Blundo n.3
97100 Ragusa (RG)
P.IVA:01635940883
www.geostudiogroup.net

OPERA:

Progetto per la realizzazione di un impiantoagrivoltaico denominato "ENNA 2" della potenza di 42 MW in A.C. e 50 MWp in D.C. con sistema di accumulo integrato da 21 MW e di tutte le opere connesse ed infrastrutture da realizzarsi nel Comune di Enna (EN).

UBICAZIONE IMPIANTO

**Contrada Salsello
Enna (EN)**

DATA:

08/08/2023

SCALA:

-

TITOLO: Schede tecniche componenti impianto FV

Progettista

Ing. Salvatore Camillieri



HIGH PERFORMANCE BIFACIAL PERC MONOCRYSTALLINE MODULE

Draft



RSM132-8-635BMDG-660BMDG

132 CELL

Mono PERC Module

635-660Wp

Power Output Range

1500VDC

Maximum System Voltage

21.2%

Maximum Efficiency

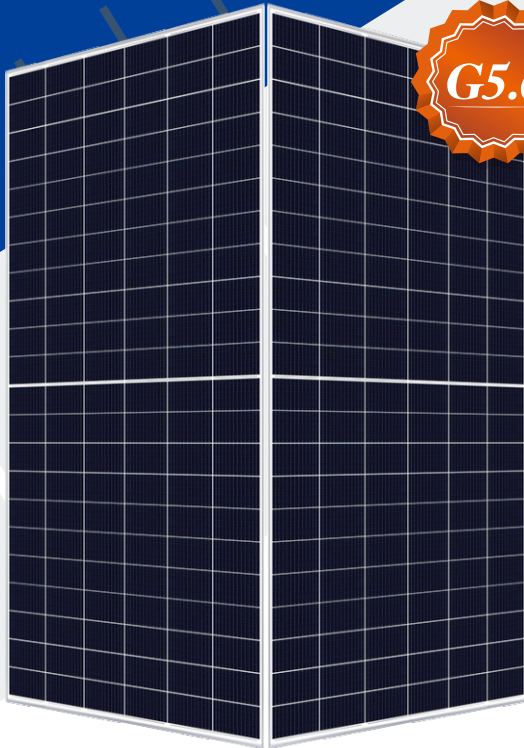

KEY SALIENT FEATURES



Global, Tier 1 bankable brand, with independently certified state-of-the-art automated manufacturing



Bifacial technology enables additional energy harvesting from rear side (up to 30%)



Industry leading lowest thermal co-efficient of power



Industry leading 12 years product warranty



Excellent low irradiance performance



Excellent PID resistance



Positive tight power tolerance



Dual stage 100% EL Inspection warranting defect-free product



Module Imp binning radically reduces string mismatch losses



Warranted reliability and stringent quality assurances well beyond certified requirements



Certified to withstand severe environmental conditions

- Anti-reflective & anti-soiling surface minimise power loss from dirt and dust
- Severe salt mist, ammonia & blown sand resistance, for seaside, farm and desert environments
- Excellent mechanical resistance: wind load 2400Pa & snow load 5400Pa



RISEN ENERGY CO., LTD.

Risen Energy is a leading, global tier 1 manufacturer of high-performance solar photovoltaic products and provider of total business solutions for residential, commercial and utility-scale power generation. The company, founded in 1986, and publicly listed in 2010, compels value generation for its chosen global customers. Techno-commercial innovation, underpinned by consummate quality and support, encircle Risen Energy's total Solar PV business solutions which are among the most powerful and cost-effective in the industry. With local market presence and strong financial bankability status, we are committed, and able, to building strategic, mutually beneficial collaborations with our partners, as together we capitalise on the rising value of green energy.

Tashan Industry Zone, Meilin, Ninghai 315609, Ningbo | PRC

Tel: +86-574-59953239 Fax: +86-574-59953599

E-mail: marketing@risenenergy.com Website: www.risenenergy.com

LINEAR PERFORMANCE WARRANTY

12 year Product Warranty / 30 year Linear Power Warranty

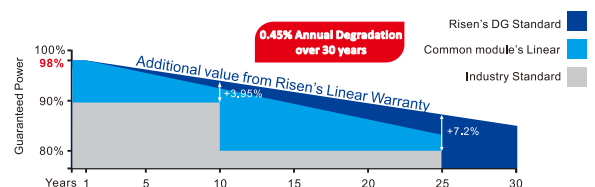

★ Please check the valid version of Limited Product Warranty which is officially released by Risen Energy Co., Ltd



Preliminary
For Global Market

Dimensions of PV Module Unit: mm

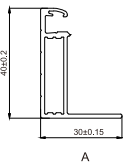
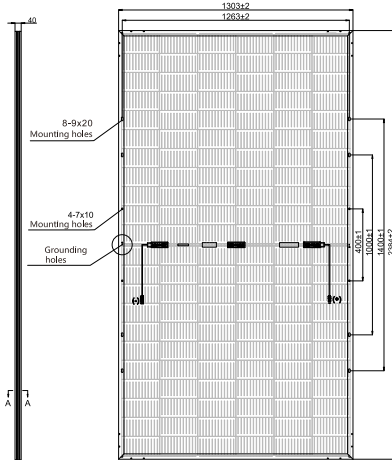

ELECTRICAL DATA (STC)

Model Number	RSM132-8-635BMDG	RSM132-8-640BMDG	RSM132-8-645BMDG	RSM132-8-650BMDG	RSM132-8-655BMDG	RSM132-8-660BMDG
Rated Power in Watts-Pmax(Wp)	635	640	645	650	655	660
Open Circuit Voltage-Voc(V)	44.89	45.09	45.29	45.49	45.69	45.89
Short Circuit Current-Isc(A)	18.03	18.08	18.13	18.18	18.23	18.28
Maximum Power Voltage-Vmpp(V)	37.32	37.51	37.69	37.87	38.05	38.23
Maximum Power Current-Imp(A)	17.02	17.07	17.12	17.17	17.22	17.27
Module Efficiency (%) ★	20.4	20.6	20.8	20.9	21.1	21.2

STC: Irradiance 1000 W/m², Cell Temperature 25°C, Air Mass AM1.5 according to EN 60904-3.
Bifacial factor: 70%±5 ★ Module Efficiency (%): Round-off to the nearest number

Electrical characteristics with 10% rear side power gain

	699	704	710	715	721	726
Total Equivalent power -Pmax (Wp)	699	704	710	715	721	726
Open Circuit Voltage-Voc(V)	44.89	45.09	45.29	45.49	45.69	45.89
Short Circuit Current-Isc(A)	19.83	19.89	19.94	20.00	20.05	20.11
Maximum Power Voltage-Vmpp(V)	37.32	37.51	37.69	37.87	38.05	38.23
Maximum Power Current-Imp(A)	18.72	18.78	18.83	18.89	18.94	19.00

Rear side power gain: The additional gain from the rear side compared to the power of the front side at the standard test condition. It depends on mounting (structure, height, tilt angle etc.) and albedo of the ground.

ELECTRICAL DATA (NMOT)

Model Number	RSM132-8-635BMDG	RSM132-8-640BMDG	RSM132-8-645BMDG	RSM132-8-650BMDG	RSM132-8-655BMDG	RSM132-8-660BMDG
Maximum Power-Pmax (Wp)	481.0	484.9	488.6	492.4	496.2	500.0
Open Circuit Voltage-Voc (V)	41.75	41.93	42.12	42.31	42.49	42.68
Short Circuit Current-Isc (A)	14.78	14.83	14.87	14.91	14.95	14.99
Maximum Power Voltage-Vmpp (V)	34.63	34.81	34.98	35.14	35.31	35.48
Maximum Power Current-Imp (A)	13.89	13.93	13.97	14.01	14.05	14.09

NMOT: Irradiance at 800 W/m², Ambient Temperature 20°C, Wind Speed 1 m/s.

MECHANICAL DATA

Solar cells	Monocrystalline
Cell configuration	132 cells (6×11×6×11)
Module dimensions	2384×1303×40mm
Weight	40kg
Substrate	Tempered Glass
Frame	Anodized Aluminium Alloy type 6005-2T6, Silver Color
J-Box	Potted, IP68, 1500VDC, 3 Schottky bypass diodes
Cables	4.0mm ² (12AWG), Positive(+)/350mm, Negative(-)/350mm (Connector Included)
Connector	Risen Twinsel PV-SY02, IP68

TEMPERATURE & MAXIMUM RATINGS

Nominal Module Operating Temperature (NMOT)	44°C±2°C
Temperature Coefficient of Voc	-0.25%/°C
Temperature Coefficient of Isc	0.04%/°C
Temperature Coefficient of Pmax	-0.34%/°C
Operational Temperature	-40°C~+85°C
Maximum System Voltage	1500VDC
Max Series Fuse Rating	35A
Limiting Reverse Current	35A

PACKAGING CONFIGURATION

	40ft(HQ)
Number of modules per container	459
Number of modules per pallet	27
Number of pallets per container	17
Box gross weight[kg]	1130

CAUTION: READ SAFETY AND INSTALLATION INSTRUCTIONS BEFORE USING THE PRODUCT.
©2021 Risen Energy. All rights reserved. Specifications included in this datasheet are subject to change without notice.

THE POWER OF RISING VALUE

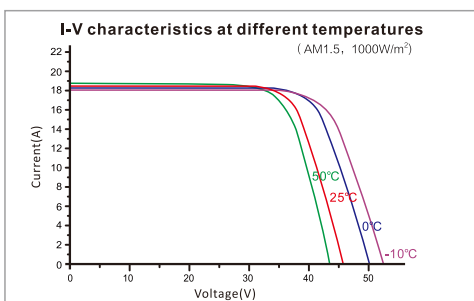
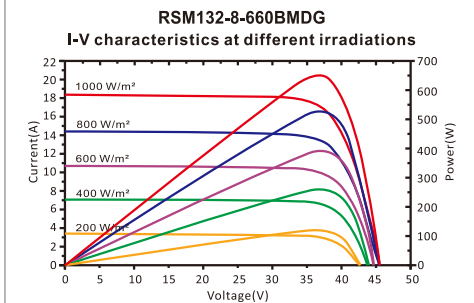

Our Partners:



**MEDIUM VOLTAGE
POWER STATION
CUSTOMIZED UP
TO 7.65 MVA,
WITH ALL THE
COMPONENTS
SUPPLIED ON TOP
OF THE SAME
SKID PLATFORM**

From 2500 up to 7650 kVA

This medium-voltage solution integrates all the necessary elements to develop a large-scale solar PV plant.

Maximize your investment with a minimal effort

Ingeteam's FSK power station is a compact, customizable and flexible solution that can be configured to suit each customer's requirements. It is supplied together with up to two photovoltaic inverters. All the equipment is suitable for outdoor installation, so there is no need of any kind of housing.

Higher adaptability and power density

This power station is now more versatile, as it presents the MV transformer integrated into a steel platform together with the LV and MV components, including the PV inverters. Moreover, it features one of the market's greatest power densities.

Plug & Play technology

This MV solution integrates power conversion equipment (up to 7.65 MVA), liquid-filled hermetically sealed transformer up to 36 kV and

provision for low voltage equipment. The MV Skid is delivered pre-assembled for a fast on-site connection with up to two PV inverters from Ingeteam's INGECON® SUN 3Power C Series inverter family.

Complete accessibility

Thanks to the lack of housing, the inverters, the switchgear and the transformer can have immediate access. Furthermore, the design of the 3Power C Series central inverters has been conceived to facilitate maintenance and repair works.

Maximum protection

Ingeteam's 3Power C Series central inverters feature an IP65 protection class for their power stacks thanks to a combined water and air cooling system that optimises the operating temperature of the power electronics.

Apart from that, they feature the main electrical protections and they deploy grid support functionalities, such as low voltage ride-through capability, reactive power deliverance and active power injection control.

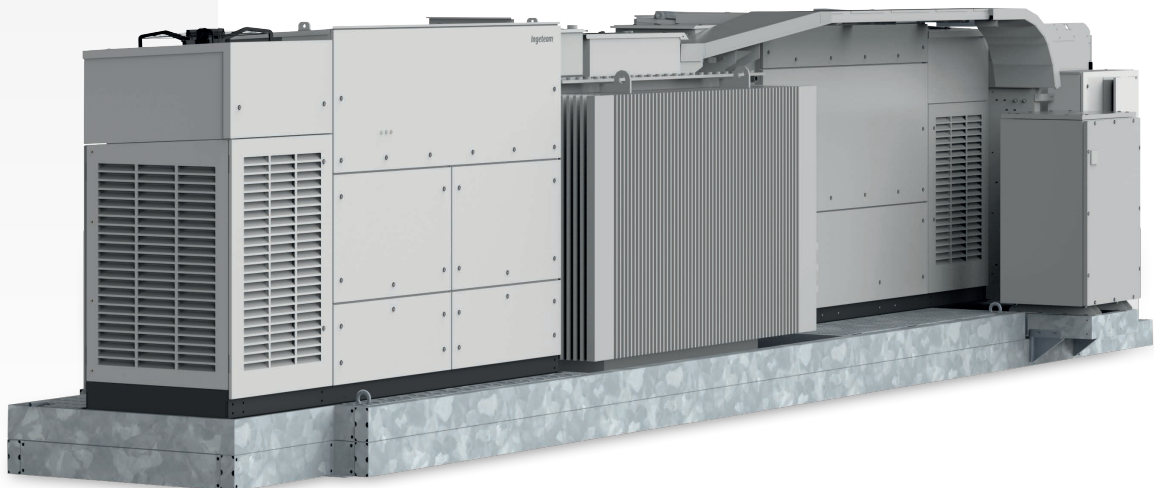

CONSTRUCTION

- Steel base frame.
- Suitable for slab or piers mounting.
- Compact design, minimising freight costs.
- Minimum installation at project site.

OPTIONAL ACCESSORIES

- Auxiliary services transformer (up to 50 kVA, Dyn11).
- UPS for monitoring (1.5 kVA, 30 min).
- LV Surge arresters type I+II.
- MV Surge arresters.
- Low voltage distribution panel (IP55).
- Power plant commissioning.
- High-speed Ethernet / fibre optic communication infrastructure for Plug & Play connection to the Power Plant Controller and/or SCADA systems.
- INGECON® SUN StringBox with 16 / 24 / 32 input channels. Intelligent or passive string combiner box.
- Energy meter for auxiliary services and/or energy production.
- Insulation monitoring relay for continuous monitoring of IS systems insulation.
- Reactive power regulation when there is no PV power available.
- Ground connection of the PV array.

STANDARD EQUIPMENT

- Up to two inverters with an output power of 7.65 MVA.
- Liquid-filled hermetically-sealed transformer up to 36 kV.
- 1L1A MV switchgear (2L1A optional).
- Oil-retention tank.
- Metal frame for installation of LV equipment.

COMPONENTS

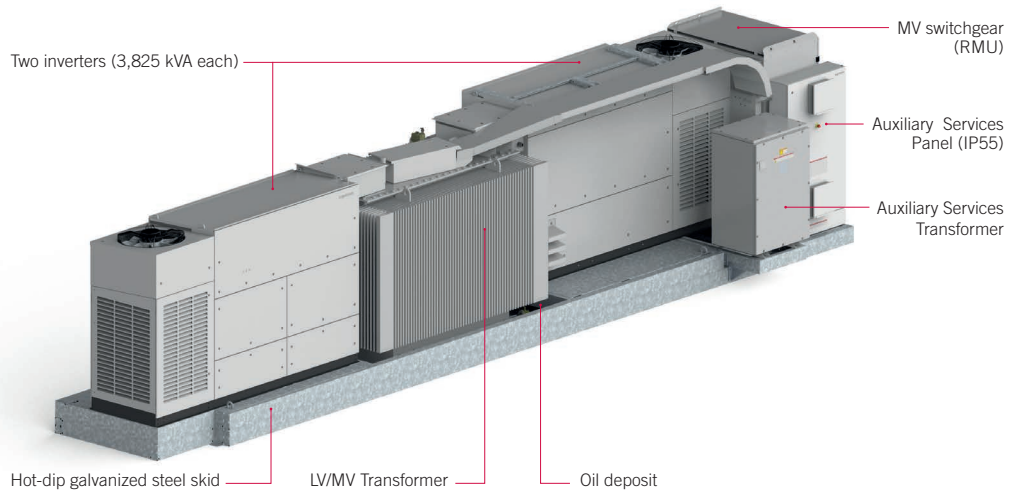

PLANT CONFIGURATION

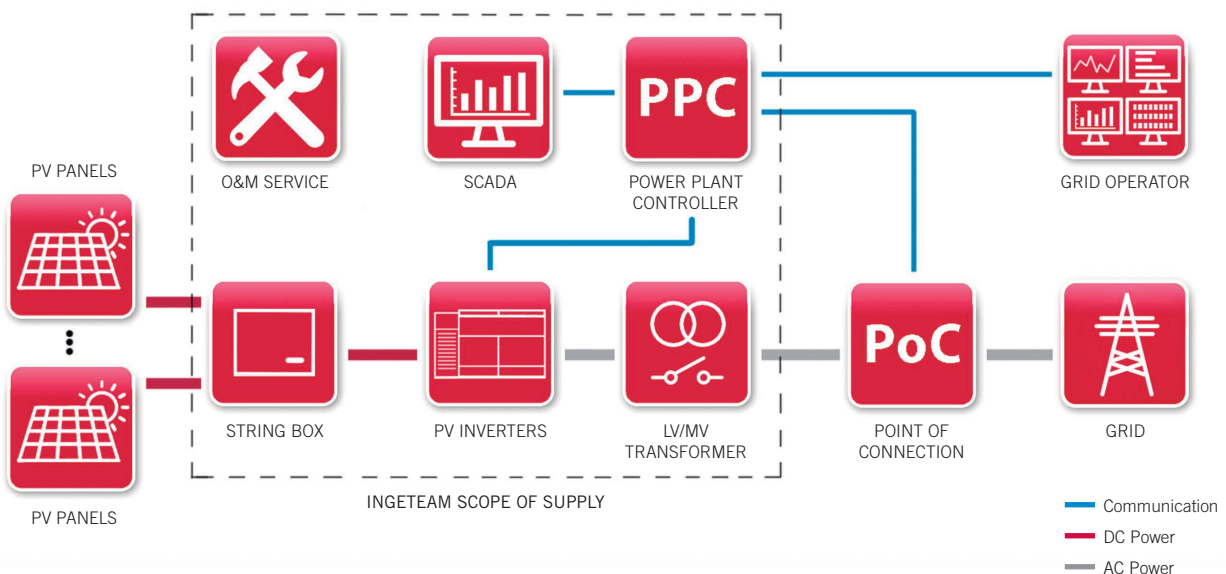

	3825 FSK C Series	7650 FSK C Series
General information		
Number of inverters	1	2
Max. power. @35 °C / 95 °F ⁽¹⁾	3,824 kVA	7,648 kVA
Operating temperature range	from -20 °C to +50 °C	
Relative humidity (non condensing)	0 - 100%	
Maximum altitude	3,000 m asl (power derating starting at 1,000 m asl)	
LV/MV Transformer		
Medium voltage	From 10 kV up to 35 kV, 50-60 Hz	
Cooling system	ONAN	
Minimum PEI (Peak Efficiency Index) ⁽²⁾	99.40%	
Protection degree	IP54	
MV Switchgear (RMU)		
Medium voltage	24 kV / 36 kV / 40.5 kV	
Rated current	630 A	
Cooling system	Natural air ventilation	
Protection degree	IP54	
Equipment		
LV-AUX Switchgear	Standard version (optional monitoring system)	
LV/MV transformer	Oil-immersed hermetically sealed transformer	
MV Switchgear	1L1A cells (2L1A optional)	
Mechanical information		
Structure type	Hot dip galvanized steel skid	
Dimensions Full Skid (W x D x H)	11,390 x 2,100 x 2,460 mm	11,390 x 2,100 x 2,460 mm
Full Skid	16 T	25 T
Standards	IEC 62271-212, IEC 62271-200, IEC 60076, IEC 61439-1	

Notes: ⁽¹⁾ Maximum power calculated with the inverter model INGECON® SUN 3800TL C690. For other inverter models, please contact Ingeteam's Solar sales department ⁽²⁾ For European installations, ECO design according to the EU 548/2014 and EU 2019/1783 standards.

Configuration with two C Series solar inverters

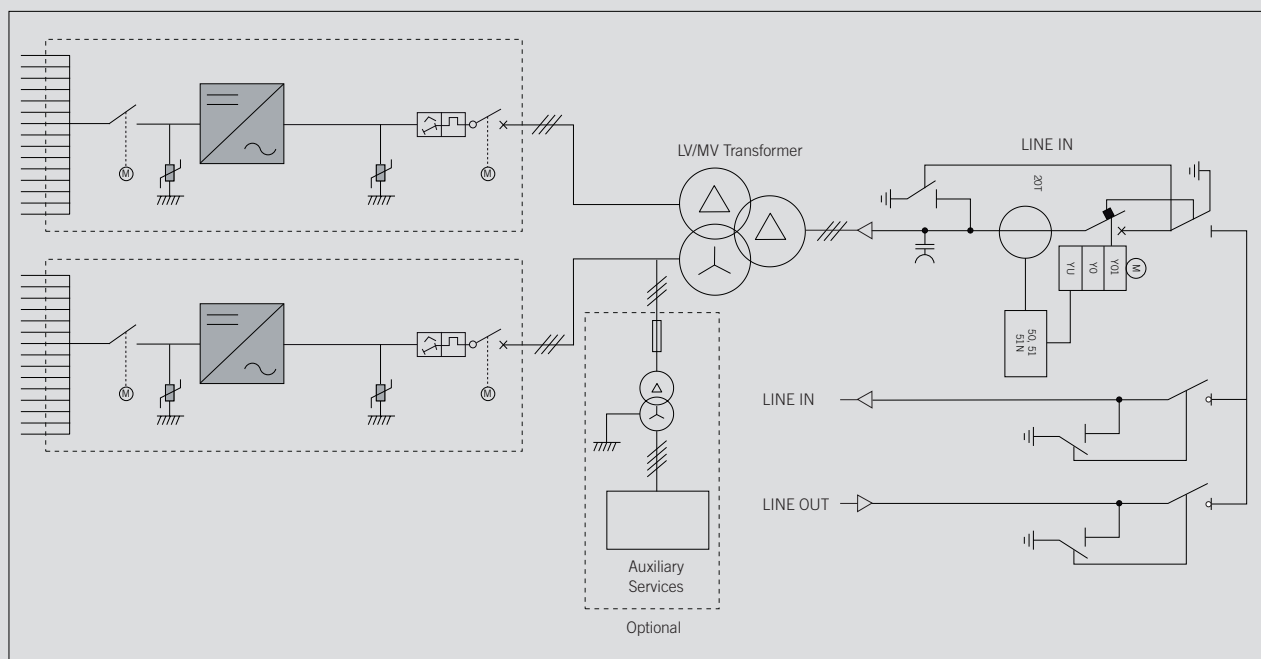

TURNKEY SOLUTION

for utility-scale PV plants with central inverters

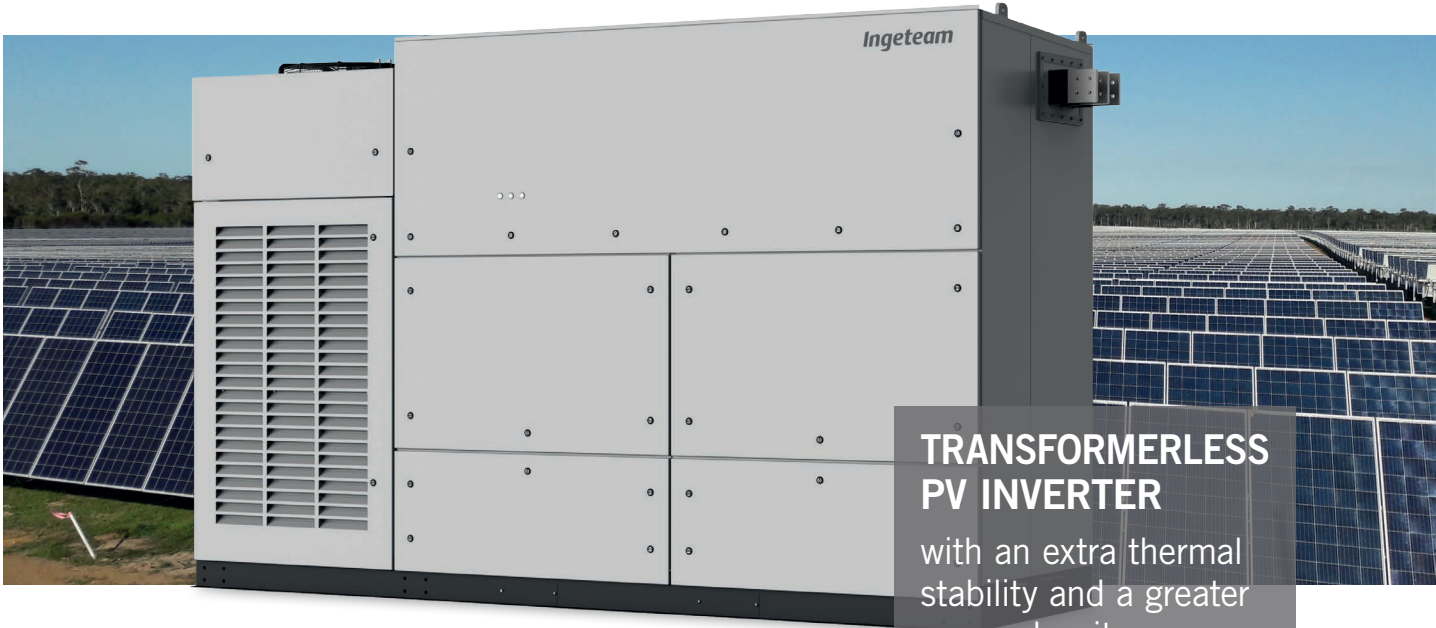

**TRANSFORMERLESS
PV INVERTER**
with an extra thermal
stability and a greater
power density

Up to 3.8 MVA at 1,500 V

Greater power density

This solar PV inverter achieves a market-leading power density of 492 kVA/m³, as it provides up to 3,825 kVA in just one power stack.

Latest generation electronics

The INGECON® SUN 3Power C Series PV inverter features an innovative control unit that performs a more efficient and sophisticated inverter control, as it uses a last-generation digital signal processor.

Liquid Cooling System (LCS)

Ingeteam has already supplied +52 GW of liquid-cooled wind power converters worldwide. It offers a greater thermal stability and a more optimized component usage. The LCS has been designed to refrigerate the IGBTs, the power phases and the IP65 compartment. It features less moving components, so it consumes a lower amount of power and it requires less maintenance works.

The LCS is a closed circuit supplied totally filled and purged, equipped with fast connectors with an anti-dripping system, so it offers zero risk of particle entrance. It has been designed to avoid siphons in order to easily purge it if necessary. The coolant used is a biodegradable glycol water mixture. There is no need of emptying the LCS in order to replace the phases, nor the sensors.

IP65 protection

A secondary liquid cooling system is used to refrigerate the air inside the IP65-protected compartment. A water-air heat exchanger is used for that. This compartment contains the power and control electronics, the DC fuses, the DC and AC protections, the busbars and the power phases.

Monitoring and communication

Dual Ethernet to communicate with the SCADA and the PPC (power plant controller). Moreover, it features Wi-Fi communication as access point to connect with the inverter during commissioning and O&M works. Ingeteam's advanced PV plant monitoring system INGECON® SUN Monitor is also available at no extra cost. The Smartphone application of the INGECON® SUN Monitor -available on the App Store and on the Play Store- makes it easier and more comfortable to monitor the PV plant.

Standard 5 year warranty, extendable for up to 25 years.

Advanced grid support



Low Voltage Ride Through



Fast Frequency Regulation



Reactive Power at Night



Voltage Droop Control



Active Power Reserve Without Batteries



Grid Following & Grid Forming



Black Start Capability



Automatic Voltage Regulation

INGECON® SUN 3825TL							
	C600	C615	C630	C645	C660	C675	C690
Input (DC)							
Recommended PV array power range ⁽¹⁾	3,144 - 4,188 kWp	3,222 - 4,293 kWp	3,301 - 4,398 kWp	3,379 - 4,502 kWp	3,458 - 4,607 kWp	3,537 - 4,712 kWp	3,615 - 4,816 kWp
Voltage Range MPP ⁽²⁾	853 - 1,300 V	874 - 1,300 V	895 - 1,300 V	916 - 1,300 V	937 - 1,300 V	958 - 1,300 V	979 - 1,300 V
Maximum voltage ⁽³⁾	1,500 V						
Maximum current	3,965 A						
N° inputs with fuse-holders	Up to 24						
Fuse dimensions	630 A / 1,500 V to 500 A / 1,500 V fuses (optional)						
Type of connection	Connection to copper bars						
Power blocks	1						
MPPT	1						
Input protections							
Overvoltage protections	Type II surge arresters (type I+II optional)						
DC switch	Motorized DC load break disconnect						
Other protections	Up to 24 pairs of DC fuses (optional) / Reverse polarity / Insulation failure monitoring / Anti-islanding protection / Emergency pushbutton						
Output (AC)							
Power @35 °C / @50 °C	3,326 kVA / 2,858 kVA	3,409 kVA / 2,929 kVA	3,492 kVA / 3,001 kVA	3,575 kVA / 3,072 kVA	3,658 kVA / 3,144 kVA	3,741 kVA / 3,215 kVA	3,824 kVA / 3,287 kVA
Current @35 °C / @50 °C	3,200 A / 2,750 A						
Rated voltage ⁽⁴⁾	600 V IT System	615 V IT System	630 V IT System	645 V IT System	660 V IT System	675 V IT System	690 V IT System
Frequency	50 / 60 Hz						
Power Factor ⁽⁵⁾	1						
Power Factor adjustable	Yes, 0 - 1 (leading / lagging)						
THD (Total Harmonic Distortion) ⁽⁶⁾	<3%						
Output protections							
Overvoltage protections	Type II surge arresters (type I+II optional)						
AC breaker	Motorized AC circuit breaker						
Anti-islanding protection	Yes, with automatic disconnection						
Other protections	AC short-circuits and overloads						
Features							
Operating efficiency	98.9%						
CEC	98.5%						
Max. consumption aux. services	9,000 W						
Stand-by or night consumption ⁽⁷⁾	< 180 W						
Average power consumption per day	2,500 W						
General Information							
Ambient temperature	-20 °C to +60 °C						
Relative humidity (non-condensing)	0-100% (Outdoor)						
Protection class	IP65						
Corrosion protection	External corrosion protection						
Maximum altitude	4,500 m (for installations beyond 1,000 m, please contact Ingeteam's solar sales department)						
Cooling system	Liquid cooling system and forced air cooling system with temperature control (400V 3 phase + neutral power supply, 50/60 Hz)						
Air flow range	0 - 18,000 m³/h						
Average air flow	12,000 m³/h						
Acoustic emission (100% / 50% load)	57 dB(A) at 10m / 49.7 dB(A) at 10m						
Marking	CE						
EMC and security standards	IEC 62920, IEC 61000-6-1, IEC 61000-6-2, IEC 61000-6-4, IEC 61000-3-11, IEC 61000-3-12, IEC 62109-1, IEC 62109-2, EN 50178, FCC Part 15, AS3100						
Grid connection standards	IEC 62116, EN 50530, IEC 61683, EU 631/2016 (EN 50549-2, P.O.12.2, CEI 0-16, VDE AR N 4120 ...), G99, South African Grid code, Mexican Grid Code, Chilean Grid Code, Ecuadorian Grid Code, Peruvian Grid code, Thailand PEA requirements, IEC61727, UNE 206007-1, ABNT NBR 16149, ABNT NBR 16150, IEEE 1547, IEEE1547.1, DEWA (Dubai) Grid code, Abu Dhabi Grid Code, Jordan Grid Code, Egyptian Grid Code, Saudi Arabia Grid Code, RETIE Colombia, Australian Grid Code						

Notes: ⁽¹⁾ Depending on the type of installation and geographical location. Data for STC conditions ⁽²⁾ V_{mpp}.min is for rated conditions (V_{ac}=1 p.u. and Power Factor=1) and floating systems ⁽³⁾ Consider the voltage increase of the 'V_{oc}' at low temperatures ⁽⁴⁾ Other AC voltages and powers available upon request ⁽⁵⁾ For P_{out}>25% of the rated power ⁽⁶⁾ For P_{out}>25% of the rated power and voltage in accordance with IEC 61000-3-4 ⁽⁷⁾ Consumption from PV field when there is PV power available.

TECHNICAL DATASHEET



Single-Axis Tracker

MAIN FEATURES

Tracking System	Horizontal Single-Axis with independent rows	
Tracking Range	up to $\pm 60^\circ$	
Drive System	Enclosed Slewing Drive, DC Motor	
Power Supply	AC/DC Universal Input Optional: Self-Powered PV Series	
Tracking Algorithm	Astronomical with TeamTrack Backtracking	
Communication	RS-485 cable not included in Soltec scope	
Wire	RS-485 Full Wired	
Wireless optional:	Hybrid Radio + RS-485 Cable Full Wireless	
Wind Resistance	Per Local Codes	
Land Use Features		
Independent Rows	YES	
Slope North-South	up to 17%	
Slope East-West	Unlimited	
Ground Coverage Ratio	Configurable. Typical range: 30-50%	
Foundation	Driven Pile Ground Screw Concrete	
Temperature Range		
Standard	- 4°F to +131°F -20°C to +55°C	
Extended	-40°F to +131°F -40°C to +55°C	
Availability	>99%	
Modules	Bifacial	

SPAIN / Headquarters
Pol. Ind. La Serreta
Gabriel Campillo, s/n, 30500
Molina de Segura, Murcia, Spain
info@soltec.com
+34 968 603 153

MADRID
Núñez de Balboa 33, 1ªA
28001 Madrid
emea@soltec.com
+34 91 449 72 03

UNITED STATES
usa@soltec.com
+1 510 440 9200

BRAZIL
brasil@soltec.com
+55 071 3026 4900

MEXICO
mexico@soltec.com
+52 1 55 5557 3144

CHILE
chile@soltec.com
+56 2 25738559

PERU
peru@soltec.com
+51 1422 7279

INDIA
india@soltec.com
+91 124 4568202

AUSTRALIA
australia@soltec.com
+61 2 9275 8806

CHINA
china@soltec.com
+86 21 66285799

ARGENTINA
argentina@soltec.com
+54 9 114 889 1476

EGYPT
egypt@soltec.com

B&V Bankability report
DNV GL Technology
Review available
RWDI WIND TUNNEL TESTED

2 year background industrial operation



MODULE CONFIGURATIONS Aproximate Dimentions

	Length	Height	Width		Length	Height	Width
2x27	28.1 m (92' 3")	4.21 m (13' 10")	4.17 m (13' 8")	2x40.5	42.4 m (139' 3")	4.21 m (13' 10")	4.17 m (13' 8")

SERVICES

Pull Test Plan	Commissioning Plan
Factory Support Plan	Operation & Maintenance Plan
Onsite Advisory Plan	Tracker Monitoring System Plan
Construction Plan	Solmate Customer Care

MAINTENANCE ADVANTAGES

Self-lubricating Bearings
Face to Face Cleaning Mode
2x Wider Aisles

WARRANTY

Structure 10 years (extendable)
Motor 5 years (extendable)
Electronics 5 years (extendable)

www.soltec.com

Contents subject to change without prior notice © Soltec Energías Renovables S.L. • SF7.200522.V4

SOLARFIX

Bifacial enhancement



pvhardware.com

STRUCTURAL & MECHANICAL SPECIFICATIONS

Ground coverage ratio	<i>30-50%, depending on configuration</i>
Modules supported	<i>All market available modules, including thin film and bifacial</i>
Slope tolerances	<i>N-S: unlimited, E-W: up to 14%</i>
Module configuration	<i>100% adaptable</i>
Module attachment	<i>Direct mount to panel rail (configurable for clamps)</i>
Structural materials	<i>Magnelis / Hot-dipped galvanized steel per ASTM A123 or ISO 1461</i>
Allowable wind load	<i>Specific conditions up to 120 mph/193 kph</i>
Grounding system	<i>Self-grounded via serrated fixation hardware</i>
In-field manufacturing	<i>No</i>
On-site training	<i>Yes</i>
Standard warranties	<i>Structure: 25 years</i>
Structural adaptation to local codes	<i>Yes, verified by third-party structural engineers if required</i>

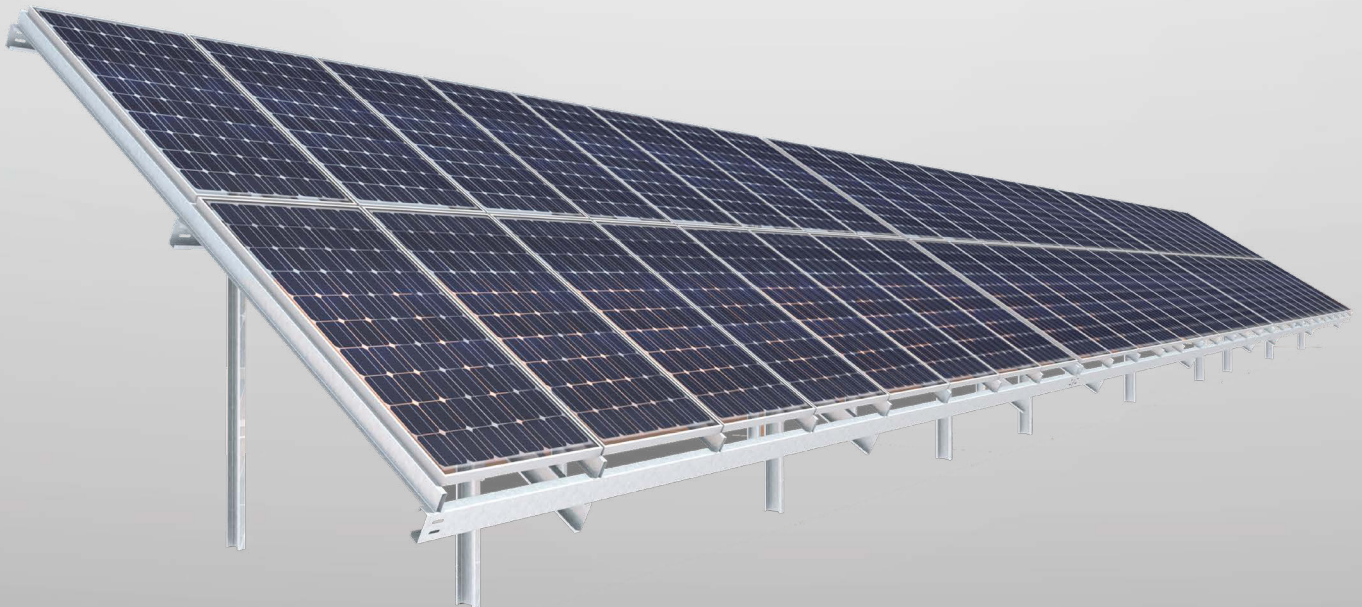

Intensium[®] Max 20 High Energy

2.3 MWh high energy lithium-ion battery storage container

The Intensium[®] Max 20 High Energy is Saft's unmanned and ready to install Energy Storage System (ESS) in a 20-foot container, enabling utility-scale storage solutions for grids, renewables and industries.



Built with advanced Lithium Iron Phosphate (LFP) technology, the **Intensium[®] Max 20 High Energy** is a fully integrated storage system, combining high energy density with high levels of safety, operational reliability and compliance with international standards.

The design choices of the **Intensium[®] Max 20 High Energy** are leveraging 10 years of technology and operational experience in multiple applications and environments to maximize the value of your next battery Energy Storage System asset.

Benefits

- 1 Flexible**
High energy density building blocks, suitable for storage assets ranging up to several hundreds of MWh
- 2 Project de-risking**
Quick and cost-effective installation of containers, 'plug and play' delivered and factory tested
- 3 Easy system integration**
Compatible with most Power Conversion Systems available in the market
- 4 Maximized energy storage economics**
 - Optimized energy and power availability over SoC
 - Multiple charge-discharge cycles per day with minimum auxiliary consumption
 - Long lifetime cells and optimum thermal management
 - High availability and serviceability
- 5 Low maintenance with Saft CUBE**
Real-time battery control, supervision and big-data publishing platform for enhanced analytics and services.
- 6 Safety driven design**
To guarantee safe behavior during operations and in case of an abusive event, protecting assets, operators and first responders

Applications

- Integration of renewables: smoothing, shifting, minimizing curtailment
- Peaking capacity
- Transmission & Distribution grid support
- Energy management in large C&I sites
- Microgrids

Features

Advanced industrial design offering highest safety and robustness:

- Unmanned container with external access, fully assembled and tested within Saft manufacturing hubs
- Single, easy access distribution cabinet integrating all power and control interfaces, supervision and safety devices

Proven architecture for high availability:

- Individually connectible strings with one Battery Management Module per string
- Master Battery Management for global charge and discharge management, auxiliary equipment monitoring and diagnostic functions
- CUBE platform for external communication, battery containers parallelization, remote monitoring and supervision, data management to lower operation and maintenance with a high cybersecurity level

Sophisticated battery management for enhanced operability:

- Monitoring and control of voltage, current and temperature
- Balancing of State of Charge (SoC) between cells and strings
- Real-time indication of State of Charge (SoC)
- Alarms and faults management
- Indication of State of Health (SoH) integrating cycling and calendar aging

Advanced thermal management system based on air conditioning unit and controllable fans:

- High cooling efficiency
- Temperature homogeneity within containers

Safety driven design to guarantee safe behavior in case of abuse usage or cell thermal runaway at module, string and container levels:

- UL9540A tested Lithium Iron Phosphate (LFP) technology
- Short-circuits, over-currents, over-temperature and over-voltages management
- Stop push button, disconnect switch, ground fault detection
- Fire detection and two levels of suppression systems (gas, water) to fight fires in their initial stages and prevent collateral damages
- Blast panels on the container roof
- Safety features focus to protect first line intervention personnel

Specifications

Electrical

Rated energy [C/5] ¹	2.3 MWh
Discharge duration range	1 – 4 hours
Voltage range	1040 V – 1400 V
Rated DC power	1.1 MW charge/discharge
Rated current	900 A charge/discharge
Maximum DC power	2.2 MW charge/discharge
Maximum current	1800 A charge/discharge

Mechanical

Dimensions (L, H, W) without HVAC	6.1m, 2.9m, 2.4m / 20ft, 9ft 6in, 8ft
Dimensions (L, H, W) with HVAC	6.7m, 2.9m, 2.4m / 22ft, 9ft 6in, 8ft
Weight	< 30,500 kg / 60,000 lbs
Container protection class	IP 54 (operation)

Operating & storage conditions

Ambient temperature	-25°C to +55°C
Design lifetime	≤ 20 years
Altitude above sea level	≤ 2000 m
Ambient relative humidity	Up to 100%
Storage temperature	-25°C to +55°C
Storage time	12 months (under conditions)

Saft CUBE platform

Features	Local HMI and cloud interface
External controllers	Sunspec MESA, Modbus TCP/IP

Standards

Safety	IEC 62619, IEC 62477 UL 1973, UL 9540, UL 9540A
Marking	CE, UL
Directives	REACH
Manufacturing hubs	ISO 9001, QS 9000, ISO 14000
Cybersecurity	IEC 62443-4-2
Transport (fully populated)	UN3536

¹ According to IEC 60620

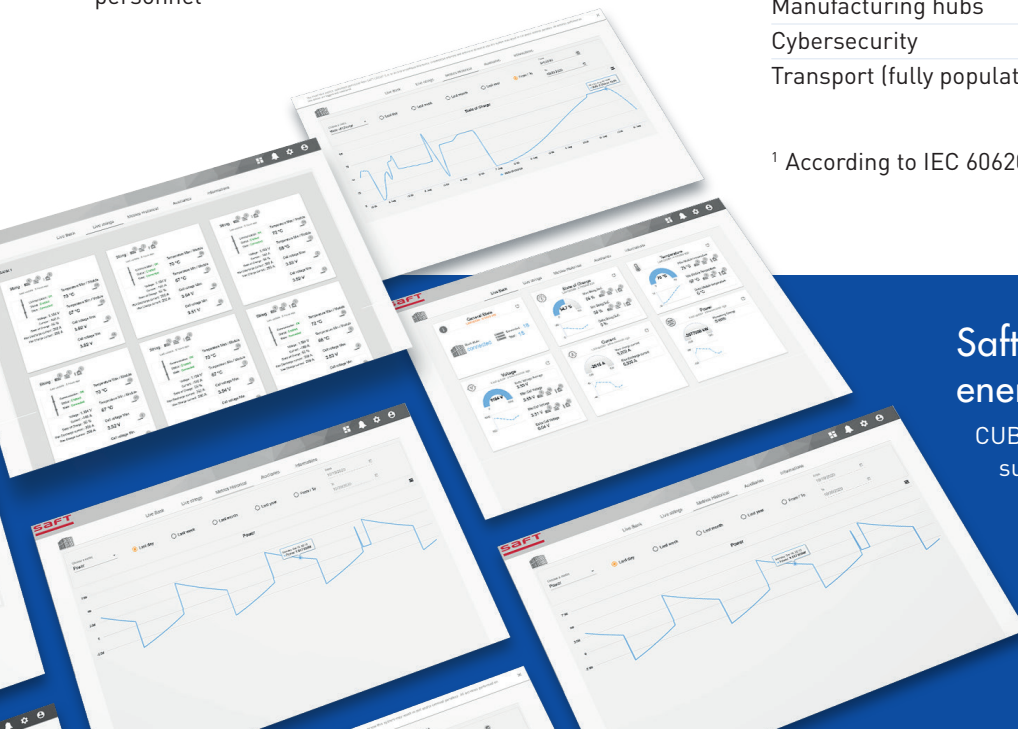

Saft CUBE: energy and asset performance

CUBE is Saft's real-time battery control, supervision and big-data publishing platform for enhanced analytics and services; it enables storage asset owners access to highly granular system data. Saft CUBE has a high level of cybersecurity ensuring data confidentiality, product availability and safety.

Saft

Energy Storage Solutions
26 quai Charles Pasqua
92300 Levallois-Perret - France
Tel. : +33 1 58 63 16 00
Fax : +33 1 58 63 16 18
www.saftbatteries.com

Document N°: 22133-0421-2
Edition: April 2021

Data in this document is subject to change without notice and becomes contractual only after written confirmation

Photo credits : Saft

©Saft- Société par Actions Simplifiée au capital de 31 944 000€ RCS Nanterre 383 703 877