

Blade storage area dimensions				
Rotor Ø	LB	LF	LCG	LT
V150	75.95 m	48.65 m	17.27 m	19.30 m
V162	81.60 m	53.35 m	21.63 m	20.25 m
V172	86.60 m	53.28 m	21.80 m	25.32 m

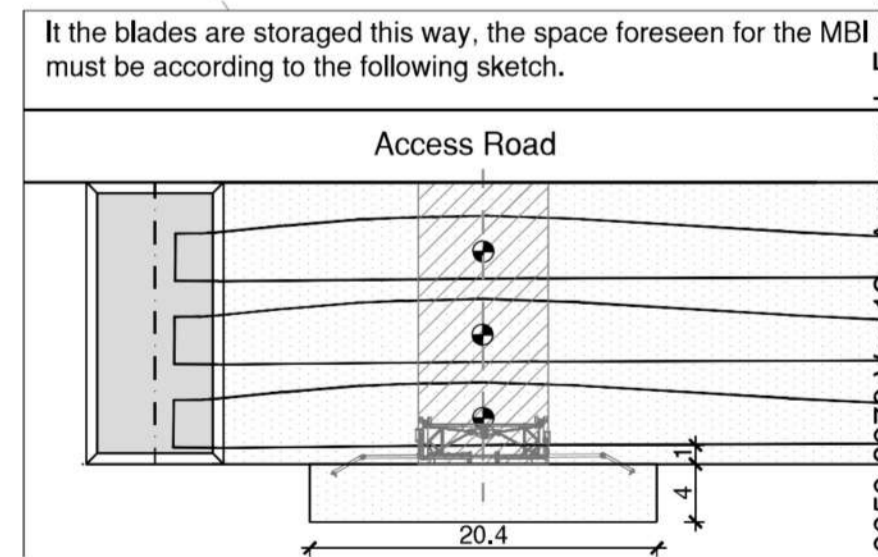

Notes:

- (1) The present drawing is supplied as a reference. It must be adapted to every real project according to the guidelines from the present document.
- (2) Pavement of graded aggregate:
 - Mandatory on cranes working area and nacelle storage area.
 - Necessary on tower sections and blades storage area, if slippery work conditions are expected.
- (3) Tower final dimensions to be confirmed by Vestas, specially in projects with site specific towers.
- (4) Crane pad design has considered Liebherr LR 1600 2W (SL2D config.) as a reference for main crane.
- (5) All units are in meters.
- (6) Side compartment not applicable if Mk0 A/B/C

Legend:

- Bearing capacity: Crane pressure + safety factor
- Bearing capacity: Auxiliary Crane pressure + safety factor (Min.2 Kg/cm²)
- Bearing capacity: 2 Kg/cm²
- Area free of obstacles.

Auxiliary pad detail:
-Every 40m aprox.

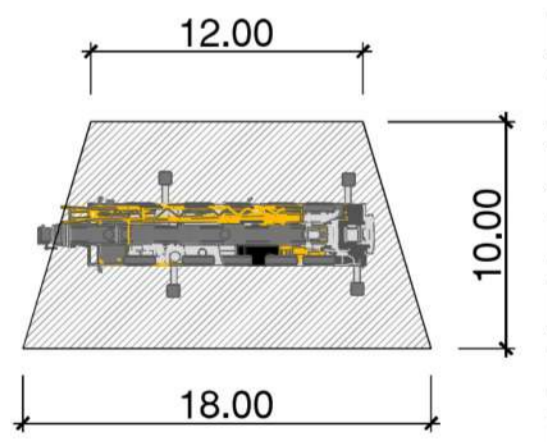

0050-8078_Ver.1.1 - Approved - Exported from DMS: 2022-12-01 by PIDEL

REGIONE PUGLIA
PROVINCIA DI BRINDISI
COMUNE DI BRINDISI

Parco Eolico "152 BRINDISI"
composto da 8 turbine da 6.2 MW ciascuna

T09

Tipico PIAZZOLE AEROGENERATORI

Pagina 1 di 1

Note:

Rev. 0 - Prima emissione, elaborato da ACS/MG, approvato da MG, data: 30/11/2023



Progettista: INTERPLAN s.r.l.
via Papa Giovanni Paolo I, n. 12 - 70124 Bari
c.f. 04767360722
info@interplan.it

Progettista:
Ing. Axel Ceglie Swoboda
via Messina n. 4
721017 Brindisi
c.f. CGLXLA63B16Z102C

Progettista: Ing. Marcello Gatto
Ord. Ing. Bari n. 3965
via Papa Giovanni Paolo I, n. 12 - 70124 Bari
c.f. GTTMCL63A27A662K
marcello.gatto@interplan.it

Committente: Cubico Lidia s.r.l.
Via Alessandro Manzoni, 43 - 20100 Milano
P.IVA e Codice Fiscale 12943230966
pec: cubicolidia@legalmail.it