

PIANTA (scala 1:1)

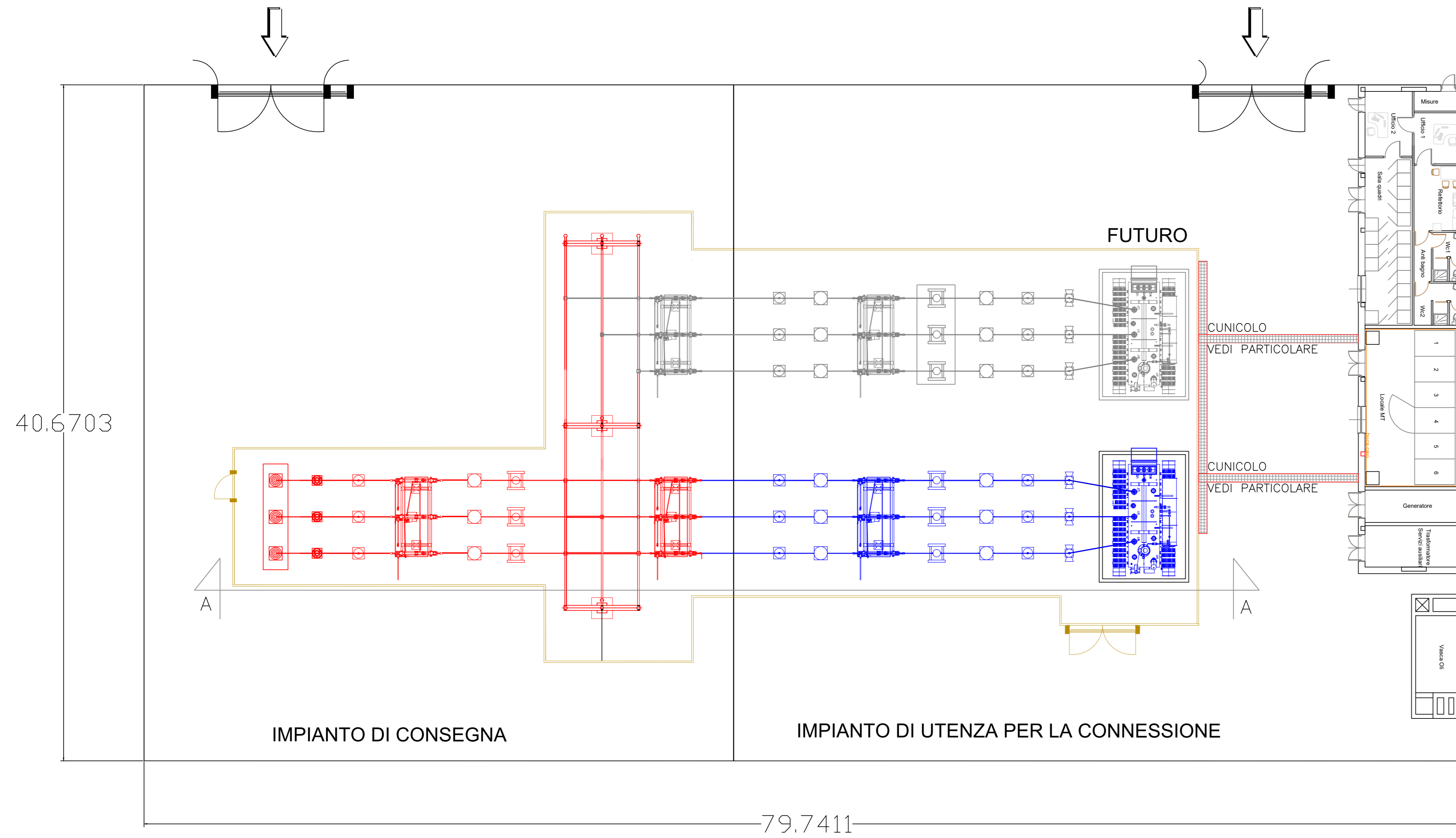

ESTRATTO PIANTA (scala 1:1)

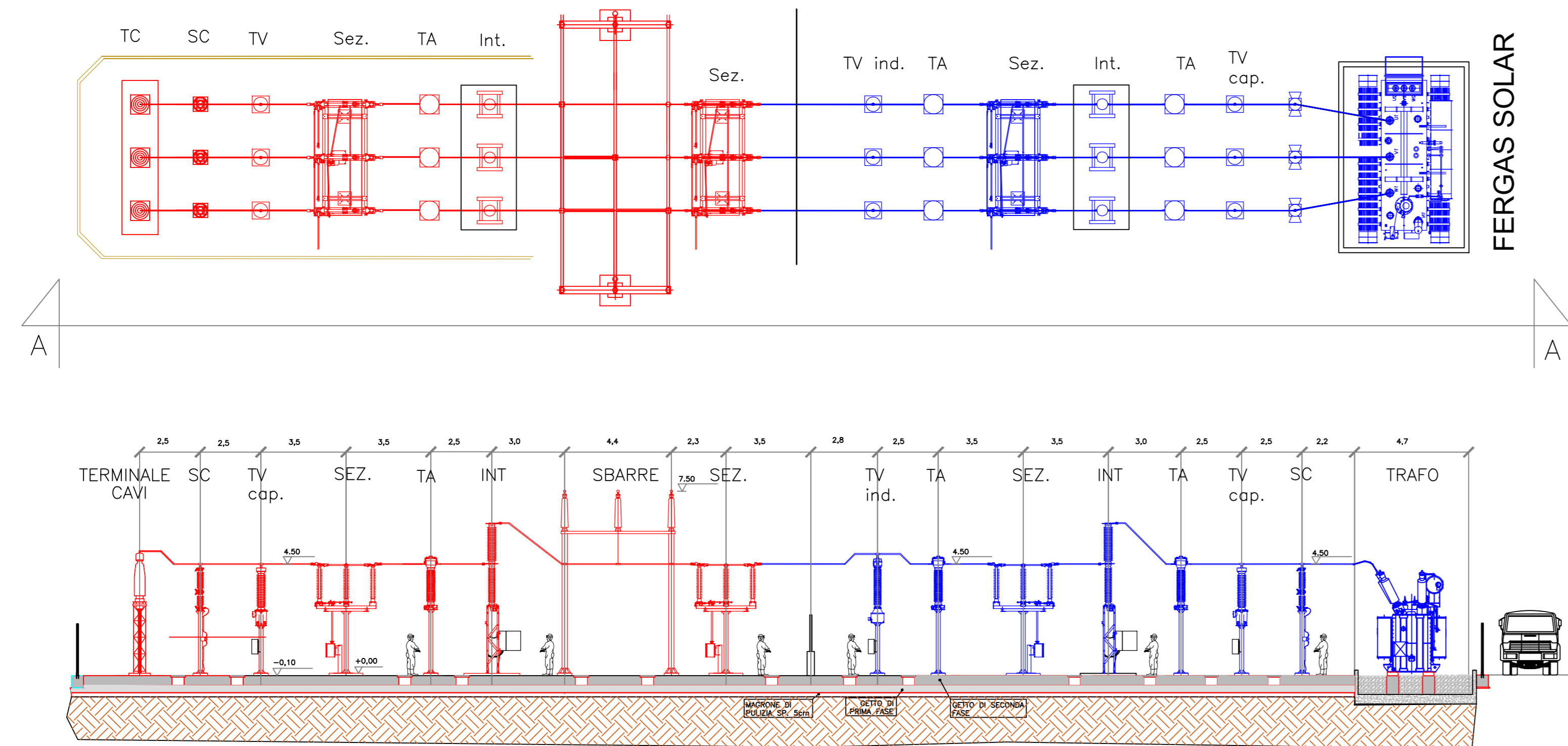

SOSTEGNO CON TV

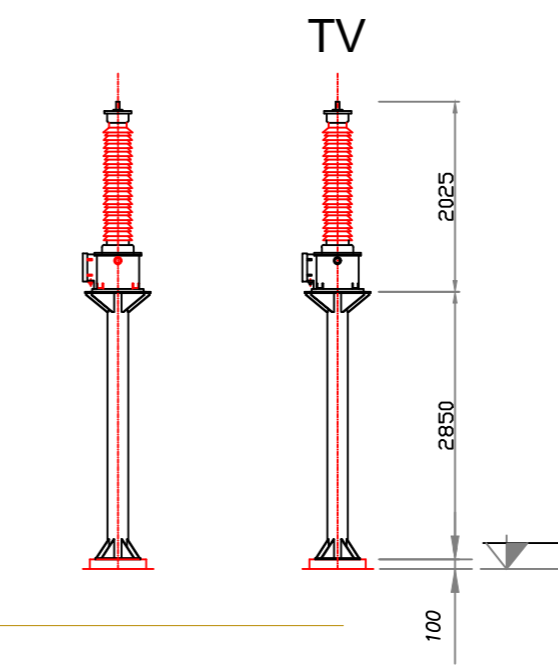

SOSTEGNO CON TA

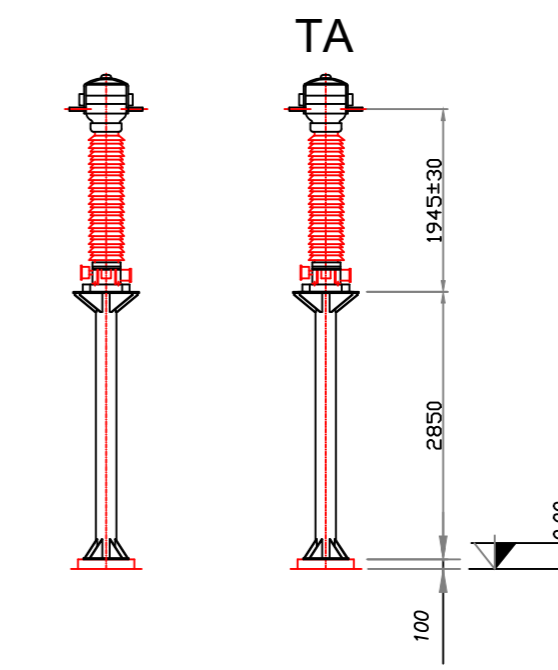

SOSTEGNO CON SCARICATORE

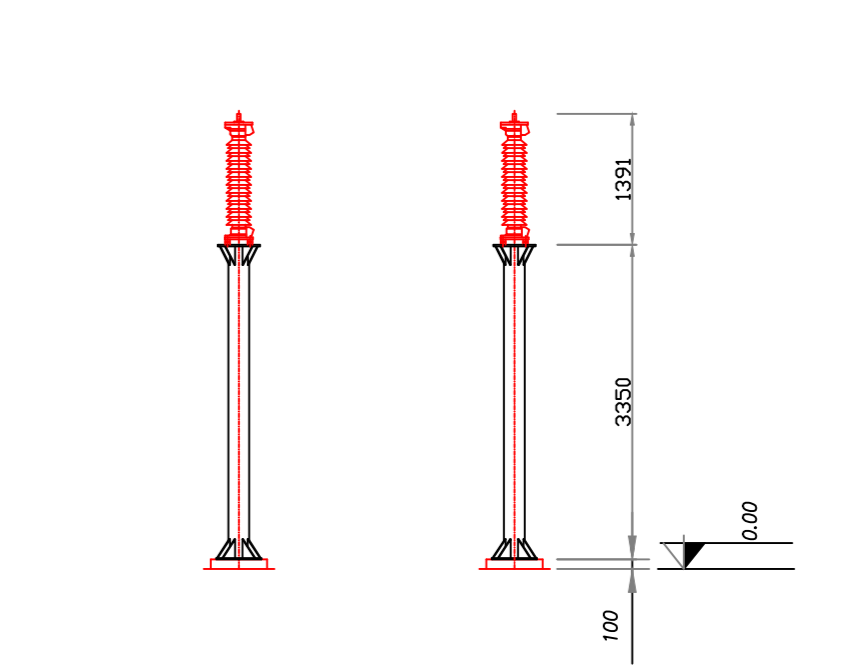

SOSTEGNO CON SEZIONATORE

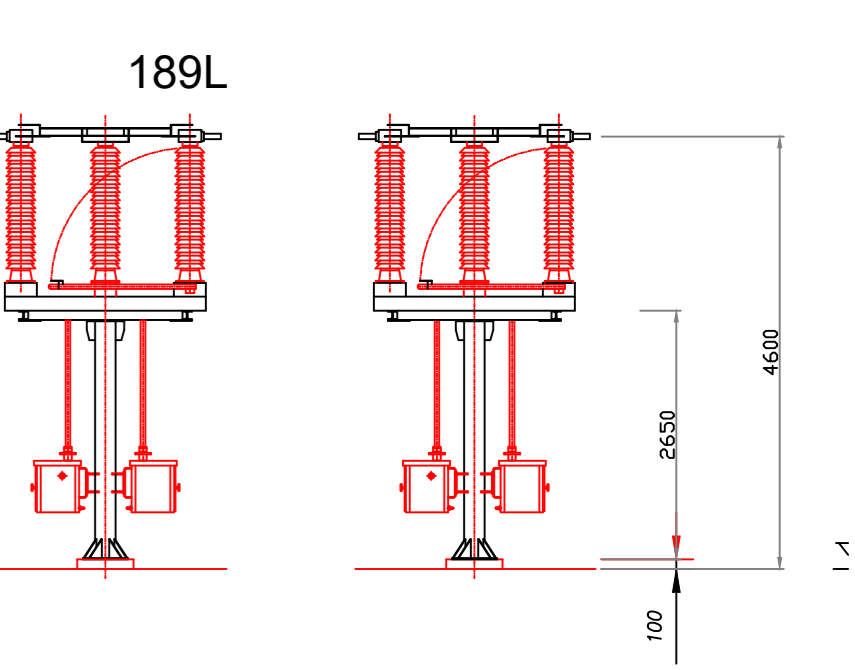

SOSTEGNO CON INTERRUTTORE

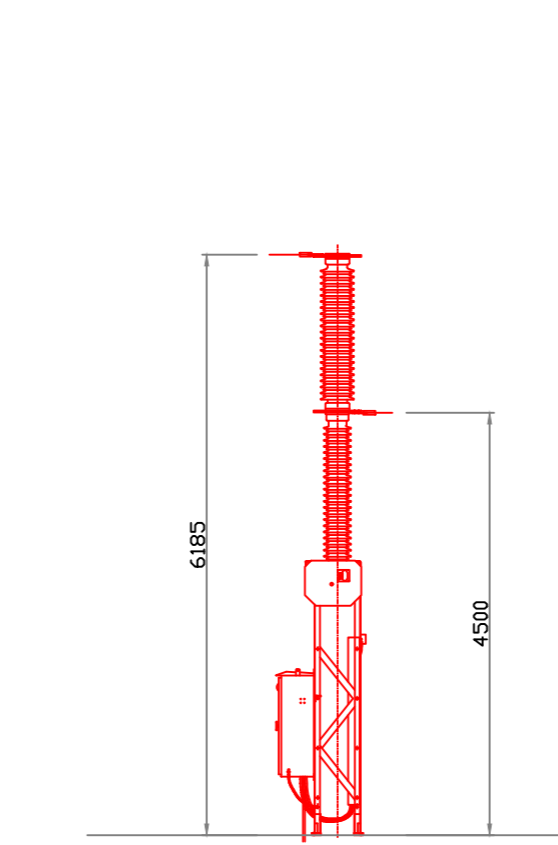

SOSTEGNO PORTALE SBARRE

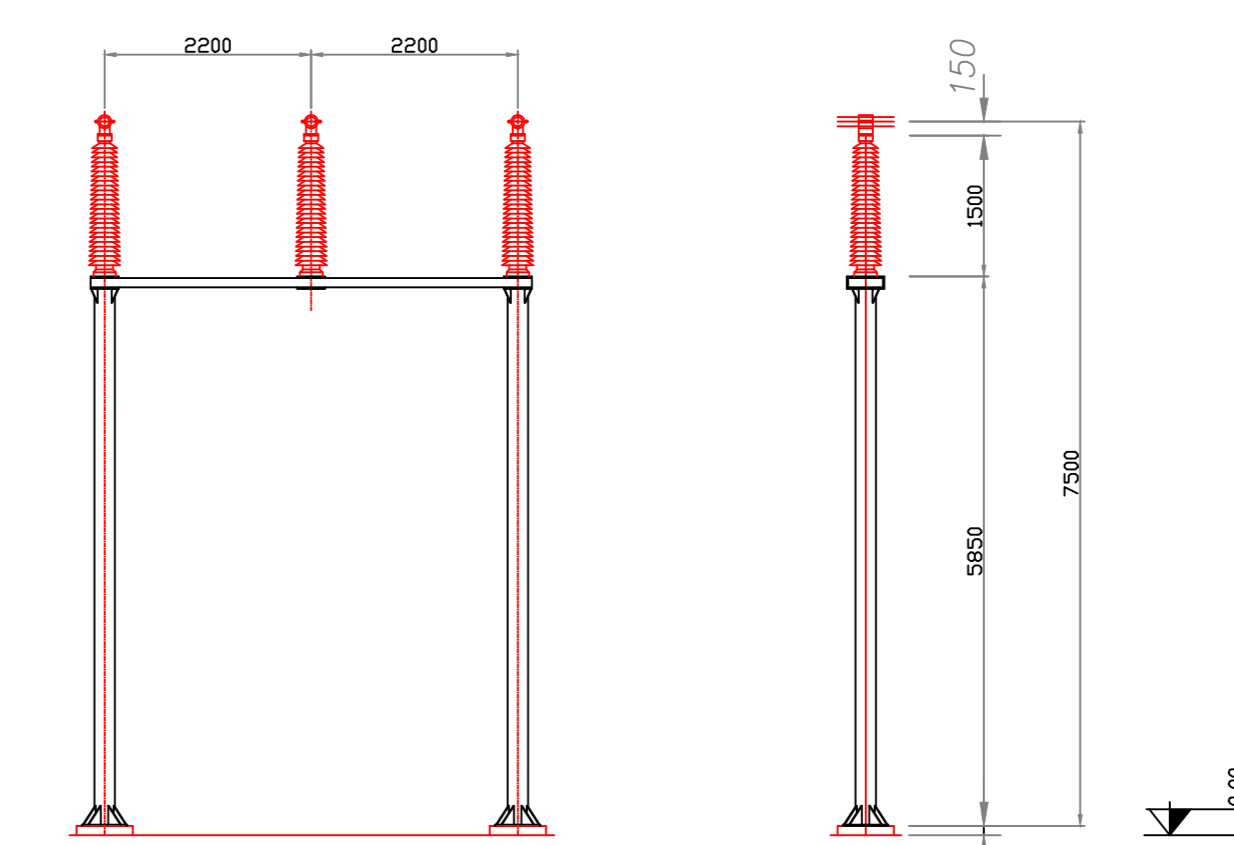

SOSTEGNO PORTALE SBARRE CON SEZIONATORE TERRA SBARRE

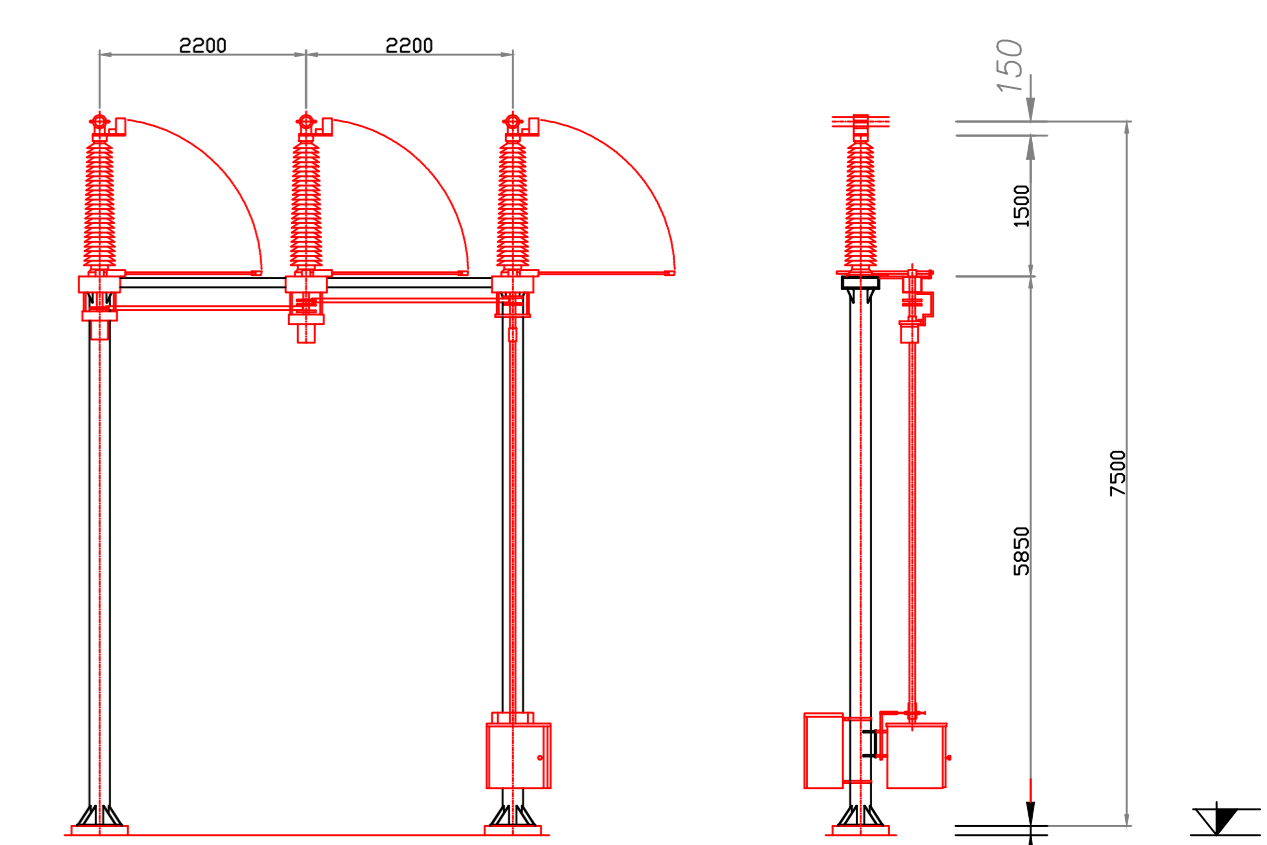

PIANTA (scala 1:200)

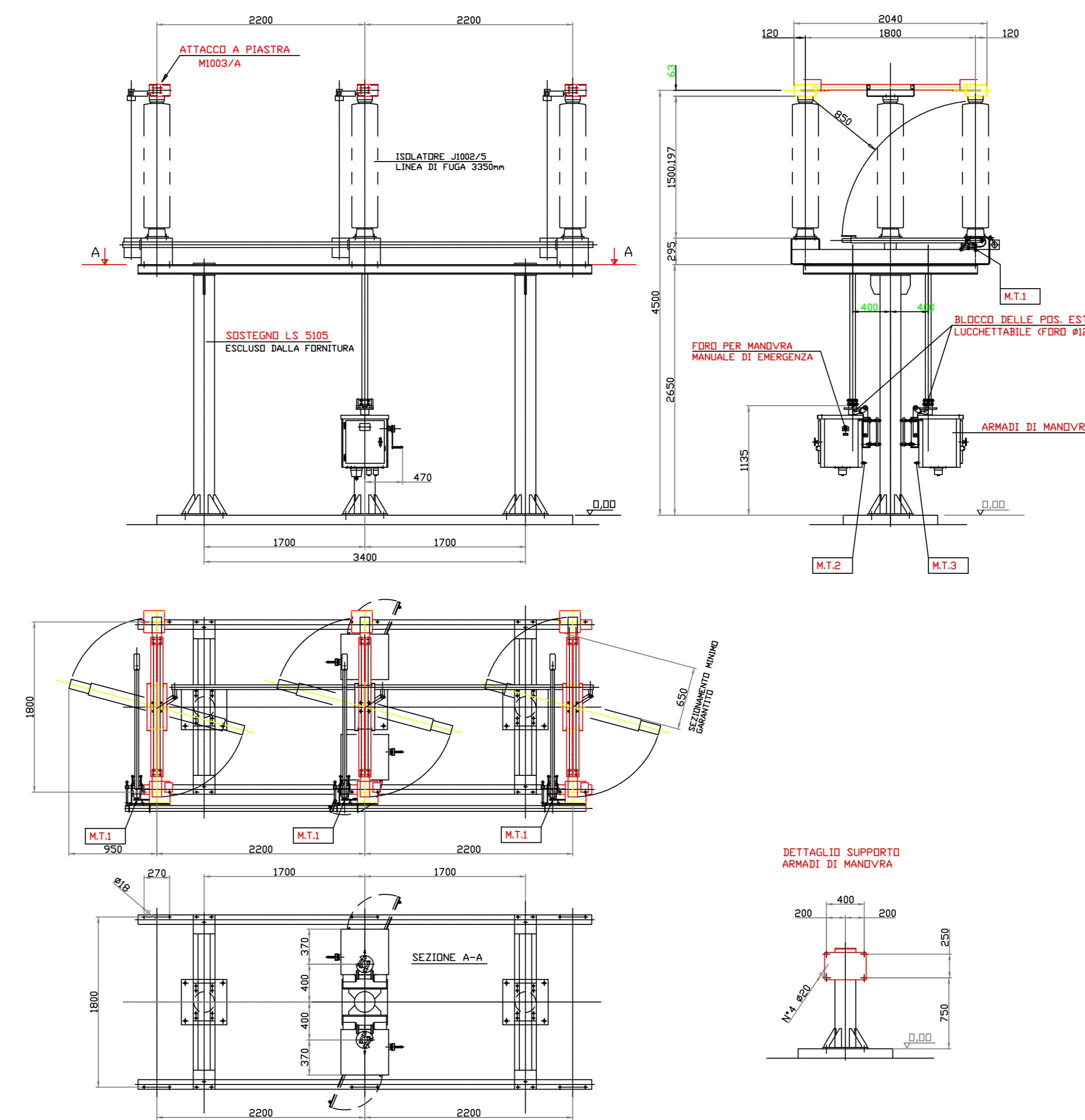

LEGENDA SIMBOLI

	SEZIONATORE TRIPOLARE ORIZZONTALE 145-170 kV CON LAME DI TERRA
	TERMINALI CAVI AT
	SCARICATORE A 150 kV CON SOSTEGNO
	INTERRUTTORE TRIPOLARE 170 kV
	a) TRASFORMATORE DI TENSIONE INDUTTIVO CON SOSTEGNO
	b) TRASFORMATORE DI TENSIONE CAPACITIVO CON BOBINA DI SBARRAMENTO
	TRASFORMATORE DI CORRENTE CON SOSTEGNO
	ARMADI SMISTAMENTO

Completatore: **RWE**

RWE RENEWABLES ITALIA S.R.L.
 Via Andrea Doria, 41/G - 00192 Roma
 P.IVA/C.F. 06420370968
 PEC: rwe.renewables@legalmail.it

Titolo del Progetto:
PROGETTO PER LA REALIZZAZIONE DI UN PARCO EOLICO DELLA POTENZA DI 72 MW DENOMINATO "MONTE BURANO" E UBICATO NEL COMUNE DI FOLIGNO (PG)

Documento: **PROGETTO DEFINITIVO OPERE CIVILI** N° Documento: **PEFO - 45**

ID PROGETTO: PEFO DISCIPLINA: TIPOLOGIA: D FORMATO:

Elaborato: **PARTICOLARI SSE LATO UTENTE**

Foglio: SCALA: Nome file: PEFO - 45, PARTICOLARI_SSE_LATO_UTENTE

Progettazione: **EGM PROJECT** Progettista:

EGM PROJECT S.R.L.
 VIA VERGATINO 15/A
 85100 - POTENZA (PZ)
 P.IVA 0204137076
 REA PZ 206983

Ing. Carmen Martone
 Nr. n. 1872
 VIA VERGATINO 15/A
 85100 - POTENZA (PZ)
 C.F. MTCNM735541703E

Genl. Raffaele Martone
 Nr. n. 243
 Ordine Ingegneri Potenza
 C.F. NBDPL71044509H

Rev.	Data Revisione	Descrizione Revisione	Redatto	Controllato	Approvato

