



PROGETTO DEFINITIVO DI UN IMPIANTO AGRO-FOTOVOLTAICO DELLA POTENZA COMPLESSIVA DI 104,4 MWp, E RELATIVE OPERE DI CONNESSIONE ALLA RETE, DOTATO DI SISTEMA DI ACCUMULO CON POTENZA DI 17,6 MW DA REALIZZARSI NEL COMUNE DI TORREMAGGIORE (FG)

PROGETTO DEFINITIVO

COMMITTENTE: EPSILON SOLAR s.r.l.

PROGETTISTA:

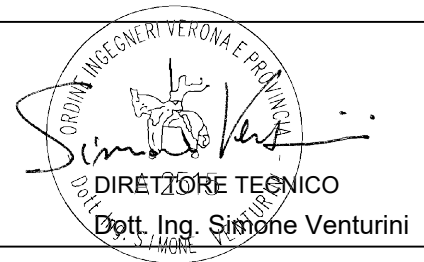

TITOLO ELABORATO:

BROCHURE INTERRUTTORE AT

ELABORATO n° :

BI035F-D-TM00-IMP-SH-07-00

NOME FILE :

SCALA : -

DATA : Marzo 2024

REVISIONE	N.	DATA	DESCRIZIONE	ELABORATO	CONTROLLATO	APPROVATO
	00	Marzo 2024	Emissione	N.Ostoich	M.Palvarini	S. Venturini
	01					
	02					
	03					
	04					

SIEMENS



www.siemens.com/energy

High Voltage Circuit Breakers 3AP type 72.5kV to 800kV

Answers for energy.

The 3AP High Voltage Circuit Breakers Available up to 800 kV

Decades of our experience in high-voltage switching technology go into the design and production of the 3AP circuit-breakers which set an international trend. We are a powerful partner for our customers and a competent supplier of attractive products and solutions at competitive prices with the high standard of quality that Siemens is known for. We comply with our customers' demands for reliability, safety and cost-effectiveness and serve them throughout the world. No matter what your application is, the 3AP circuit breakers provide the best solution for your requirements every time.

Our standard is reliability and safety at all times. The 3AP circuit-breaker family is available for rated voltages from 72.5 kV up to 800 kV. The latest development of our well established circuit-breakers completes our 3AP product range for rated voltages up to 800 kV. For the application of 420 kV to 800 kV the circuit-breakers can be equipped

with optional closing resistors. The circuit-breakers feature approved technology and ensures efficient operation. Based on our well proven modular design, we manufacture all of the core components ourselves, which include the stored-energy spring mechanism and the arc-assisted interrupter unit.

More than **50,000 nos. 3AP-circuit-breakers** have been delivered to over **120 countries** around the world in all climatic areas, proving on a daily basis the value and the reliability of the 3AP high-voltage switchgear. The 3AP high-voltage circuit-breaker operates safely and is capable of withstanding high mechanical loads. Particularly strong porcelain insulators and a circuit-breaker design optimized by using the latest mathematical techniques, give it very high seismic stability whilst in operation enabling it to perform to its full potential during its entire service life.



3AP2 FI 420 kV
Live-tank circuit-breaker in operation at a major power transmission and distribution company



3AP4 FI 800 kV Live-tank circuit-breaker

With High-Voltage Circuit-Breakers from Siemens you are always on the economically safe side

Great demands for highest quality. Our quality management system, certified in accordance with DIN EN ISO 9001, confirms that our quality always remains at the same high level. We carry out regular management reviews, internal audits in every department and the continuous development and maintenance of documentation for all processes. Most modern manufacturing technologies and investments in our worldwide production sites, assure reliable and **long-lasting products and process quality** according to Siemens' well-proven high standards.

The high quality, as well as excellent operating experience, is inherited by the 3AP series. The result is very high SF₆ tightness of our switchgear: **The SF₆ leakage rate is less than 0.5% per year.** This not only increases reliability and decreases operating costs as a result of long maintenance

intervals, but also has a positive impact on the environment, indicating our sense of responsibility. Our switchgear will fulfill your demands for low life-cycle-costs with highest availability and economical and continuous operation. We use strong materials under low mechanical loads in the construction of individual switchgear components; therefore **maintenance is not needed for 25 years or 10,000 operating cycles.** By standardizing our internal processes and systematically implementing module strategies for our 3AP product series, we can offer minimal **delivery times.**

The results are low service and investment costs which provide our customers competitive advantages worldwide, which equates to greater success for their own businesses.

The Modular Design

The self compression arc-quenching principle is applied in our 3AP circuit breakers.

The arc-assisted interrupter unit of the 3AP circuit-breaker utilizes the energy of the arc during opening for an optimal arc quenching, allowing reducing the operating energy to a minimum. Our circuit breakers for the voltage range 72.5 kV up to 245 kV have one interrupter unit per pole and up to 245 kV the circuit-breakers are available with a common or a single pole operating mechanism. 3AP high voltage circuit-breakers rated for 420 kV and 550 kV are equipped with two interrupter units per pole. At 800 kV voltage level, the breakers are available with four interrupter units.

The stored-energy spring mechanism: The compact design of this operating mechanism allows placing the stored-energy spring mechanism within the control cubicle. The main components such as the interrupter unit and the operating mechanism of our 3AP high-voltage circuit-breakers are identical to the ones in our 3AP dead tank circuit-breaker family. By applying this proven modular design we can fulfill the highest expectation with regard to availability, reliability, as well as economical performance. This results in continuously high customer satisfaction.

Distinct advantages with superior design.

- 'Ambient' temperature compensated density monitoring device
- Base frame - Robust & hot dip galvanized
- Lesser joints in gas piping – better limiting of gas leakage.
- Factory set closing & tripping springs - No adjustment required at site.
- 2 Trip coils per mechanism. Both magnetically & electrically separated from each other.

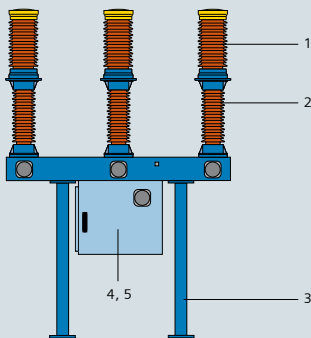

3AP1 FG up to 72.5 kV
One interrupter unit per pole.

Laterally stored-energy spring mechanism, circuit-breaker with common breaker base for three-pole operation

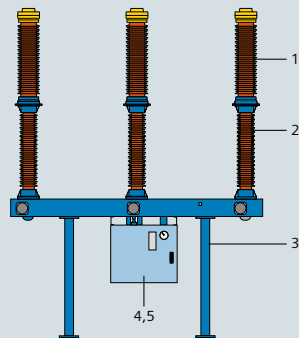

3AP1 FG up to 145 kV

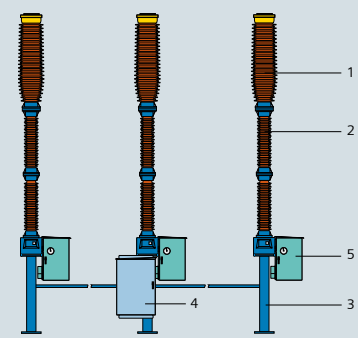

3AP1 FG up to 245 kV
One interrupter unit per pole.

Stored-energy spring mechanism, circuit-breaker with common breaker base for three-pole operation

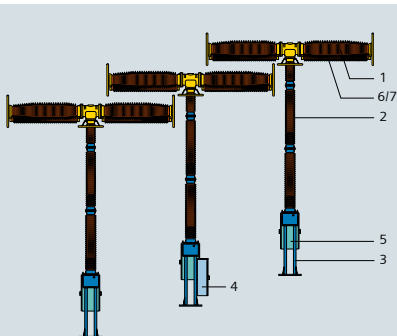

3AP2 FI up to 550 kV
Two interrupter units per pole.

Stored-energy spring mechanism, circuit-breaker with separate breaker base for one or three-pole operation

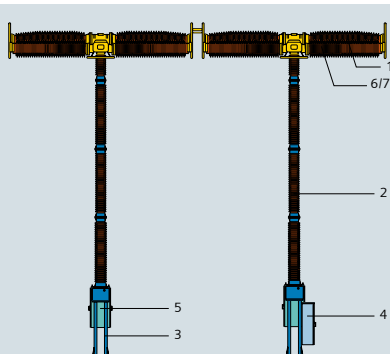

3AP4 FI up to 800 kV
Four interrupter units per pole.

Stored-energy spring mechanism, circuit breaker with separate breaker base for one or three pole operation

3AP circuit-breakers are available in different designs

- 1 Interrupter unit
- 2 Post insulator
- 3 Pillar
- 4 Control cabinet
- 5 Operating mechanism cubicle
- 6 Grading capacitor
- 7 Closing resistor (option al)

The Stored-Energy Spring Mechanism

There are a number of advantages to our stored-energy spring mechanism

Compact housing can be utilized by applying the most modern production techniques. Since the closing and opening springs are housed in the operating mechanism, a compact and sturdy structure is achieved. This design results in a small number of moving parts. The use of roller bearings and the maintenance-free spring mechanism are a prerequisite for decades of reliable operation. Proven design principles such as vibration-isolated latches and load-free isolation of the charging mechanism are retained.

The advantages of the stored-energy spring mechanism:

- Same principle for rated voltages from 72.5 up to 800 kV
- High reliability:- thanks to low operating energy requirement
- Simple principle of operation – minimum number of components
- Robust, durable & virtually maintenance free – Reduces life cycle cost.
- Lesser demand of auxiliary power.
- Low environmental impact

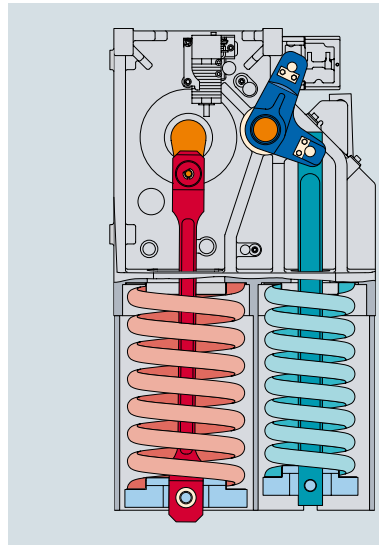

The Control

The control system includes all the secondary components required for operating the circuit-breaker, most of them are located in the control cabinet. The control, tripping, motor and heating power supplies are, to a great extent, selectable. Depending on customer requirements, two standard control variants are available.

Basic variant

The basic variant includes all control and monitoring elements that are needed for operation of the circuit-breaker. In addition to the elementary actuation functions, it includes:

- Total 20 NO + 19 NC Auxiliary switch contacts
- 4 wiper contact
- Switching operation counter
- Local actuator

Compact variant

In addition to the basic variant, this variant includes:-

- Spring monitoring by motor run time monitoring Heating monitoring
- Light and socket with a common circuit-breaker
- MCB for AC/DC protection, Motor protection
- MCB for heater protection

Special features

Above and beyond these two standard variants, a great number of further components and options are at our customers' disposal. Every control configuration of a circuit-breaker can therefore **be designed individually**. All control components have been type-tested for use on our circuit-breakers and are all located in a weatherproof cubicle (**IP 55** degree of protection). They are resistant to switching vibrations, and meet the requirements for electromagnetic compatibility (EMC).

The circuit-breaker documentation includes the wiring diagram of the control configuration. This diagram comprises the following documents:

- General Arrangement diagram
- Circuit diagram
- Technical data equipment part list
- Connection diagram

The circuit diagram documentation is in English.



Control cabinet with the stored-energy spring mechanism

Controlled Switching – Revolution in technology

Increased demand of controlled switching for some specific applications like

- Reactor switching
- Auto-transformer switching
- Power transformer switching
- Switching of capacitor bank
- Switching of unloaded lines

Kind of load	Switching Operation	Avoided load
Inductive load; Transformer; Shunt reactor	Opening	Re-strike; Over voltages.
Inductive load; Transformer; Shunt reactor	Closing	Inrush current
Capacitive load; Capacitor bank; Unloaded lines/cables; Filter	Opening	Re-strike; Over voltages.
Capacitive load; Capacitor bank; Unloaded lines/cables; Filter	Closing	Over voltages; Inrush current
Capacitive load; Unloaded lines/cables	Closing; Auto-reclosing	Over voltages; Inrush current

Overall achievements with PSD controller

- Effective reduction of inrush currents.
- Decrease in electromechanical stress on Operational equipment.
- Increase in life time expectancy of Circuit Breaker
- Minimization of stress caused of harmonics.
- Effective minimization of system over voltages = safety to system.
- Minimum dielectric stress = insulation protection (Slower aging of dielectrics)
- Increased system reliability.
- Advanced technology communicable device = Ready for future automations.
- Multifunctional substitute of closing resistors.

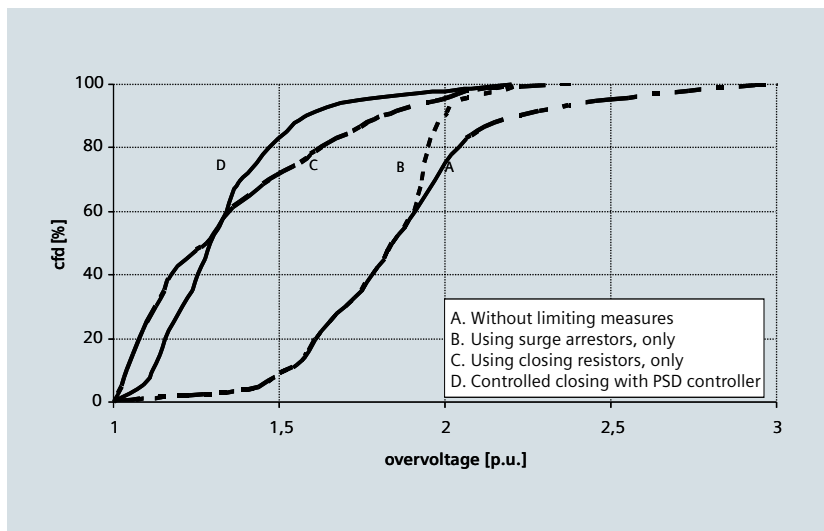

Cumulative frequency distribution for overvoltages

Value for switching overvoltages for different closing strategies	Closing Resistor	PSD Controller
95%	2.05 p.u.	1.95 p.u.
99%	2.38 p.u.	2.13 p.u.

Quality Right from the Start

Development

The foundation for the quality of Siemens high-voltage circuit-breakers is laid down right from the beginning of the development of a new product. Switching performance, high-voltage stability and performance under mechanical loads (wind and short circuits) and during an earthquake are simulated and optimized in the outline design phase using computer-aided calculations.

The use of common parts and assembled units in a large number of breaker types such as live-tank, dead-tank, as well as in the GIS means the production of a large number of the same type of main components. Steady and regular quantities of produced units allow a continuous production process and ensure the highest quality standards. Statistical quality control is based on large quantities. This results in a higher achieved validity.

All 3AP circuit-breakers can be used in earthquake areas up to 0.5 g without additional fittings.

Testing laboratories

Our state-of-the-art circuit-breaker plant has the most modern testing facilities:-

- High-voltage testing lab
- Mechanical testing lab
- Temperature rise testing laboratory

Type testing of all our 3AP type Circuit Breakers has been carried out at globally recognized premium test laboratories like PEHLA (Germany), CPRI (India) & ERDA (India). The 3AP circuit-breakers are fully type tested in accordance with the latest IEC 62271-100.

Routine testing

The main components of the circuit breakers are subjected to complete pre-acceptance testing before assembly. Based on this quality level, it is possible to confirm a leakage rate of less than 0.5% per year for the circuit-breaker. Each circuit-breaker is completely assembled in the test bay. The product specific inputs for computer-assisted routine testing are imported from the order processing tools. This ensures that in addition to the standard test procedure, the fulfillment of every customer requirement is checked before delivery.

Routine testing is performed in accordance with the latest IEC standards and it includes at least the following operations and measurements performed on each & every breaker:

- Mechanical operations test.
- Switching time determination – Speed travel characteristics.
- Gas leakage test
- Testing of control circuits in accordance with the circuit diagram
- Contact resistance measurement
- High voltage tests

The 3AP1 DTC

Complying with our Customers' demands

Decades of experience in high-voltage switching technology are the basis for the design and production of high-voltage circuit-breakers and disconnectors which are setting international trends. We are one of the leading suppliers of products and solutions with the highest standards in quality at competitive prices.

A further story of success has now been written with the new DTC Compact Switchgear from Siemens.

The DTC (Dead Tank Compact) Switchgear family is available for rated voltages up to 245 kV.

DTC is a compact arrangement of several functions needed in a substation. The elements of this new Siemens Compact Switchgear is a dead-tank circuit-breaker, fitted with one or two current transformers, one or more disconnectors, earthing switches and bushings as applicable for connection to the bus bar system.

Based on the well proven modular design, the core components of the main units have been adopted from our well established high-voltage circuit-breakers, disconnectors and GIS product family. These components are:

- Self-compression arc-quenching interrupter unit of the AIS 3AP-circuit-breaker

- Stored-energy spring drive mechanism
- SF₆-insulated disconnector/earthing switch from the GIS type 8DN9
- Outdoor earthing switch from the Ruhrtal range of disconnectors

Deliveries of more than 100,000 components to over 100 countries provide our customers with safety and competitive advantages worldwide, which equates to greater success for their own businesses.

Due to the compact design and the flexible use of predefined modules, different layouts can be realized with a minimum of engineering effort. The concept of DTC is to provide an economical compact design and create further options for our customers.



Experience you can rely on - at anytime, anywhere



The Concept

The concept of the DTC offers the following selected arrangements:

- In-/Out - Variant
- Single Bus Bar - Variant
- Double Bus Bar - Variant
- Circuit-Breaker with combined function and outdoor earthing switch

All parts, excluding the primary terminations are encapsulated in grounded cast aluminium housings. The circuit-breaker is based on our well established dead-tank design. The pole assemblies are filled with pressurised SF₆ and fixed on a common base frame.

Modular Design

The figures show typical arrangements with bushings on the incoming and outgoing side, the circuit-breaker and the three position switches for disconnection and earthing functions. The circuit-breaker has a common stored-energy spring drive mechanism. The control cabinet for the circuit-breaker, the three position switch and the terminals of the current transformers are located in front of the switchgear module. A linkage fitted between the poles connects the three position switches to the drive mechanism.

Circuit-Breaker

The self-compression arc-quenching principle is applied in the DTC circuit-breakers. The arc energy is used to interrupt the fault circuit breaking current. The required energy does not need to be provided by the operating mechanism. The components of the interrupter unit and the stored-energy spring drive mechanism are adopted from the well established 3AP circuit-breaker family.

Disconnect/Earthing Switch

The DTC disconnect/earthing switch is based on the design of GIS components with the same function. The main parts contain movable contacts, shafts and levers from GIS components. They have proved their reliability in operation over many years. The motor drive is an established reliable component from the GIS disconnect/earthing switches range of products.

Current Transformer

Current transformers for DTC are conventional types. The existing CT housing enables the placement of ring type cores in many combinations with different ratings. Cores for measuring and protection are available. The current transformer is located between the circuitbreaker and the disconnect/earthing switch. This is equivalent to the location of current transformers in Air Insulated Switchgear (AIS).

Air/SF₆-Bushings

DTC switchgear is connected to the overhead lines and bus bars by SF₆ insulated air bushings. A conductor and a shield electrode are fixed inside the bushing. The insulator is available in either porcelain or composite (epoxy impregnated fibre glass tube with silicon rubber sheds) materials. The variants with outdoor earthing switches are equipped with porcelain bushings.

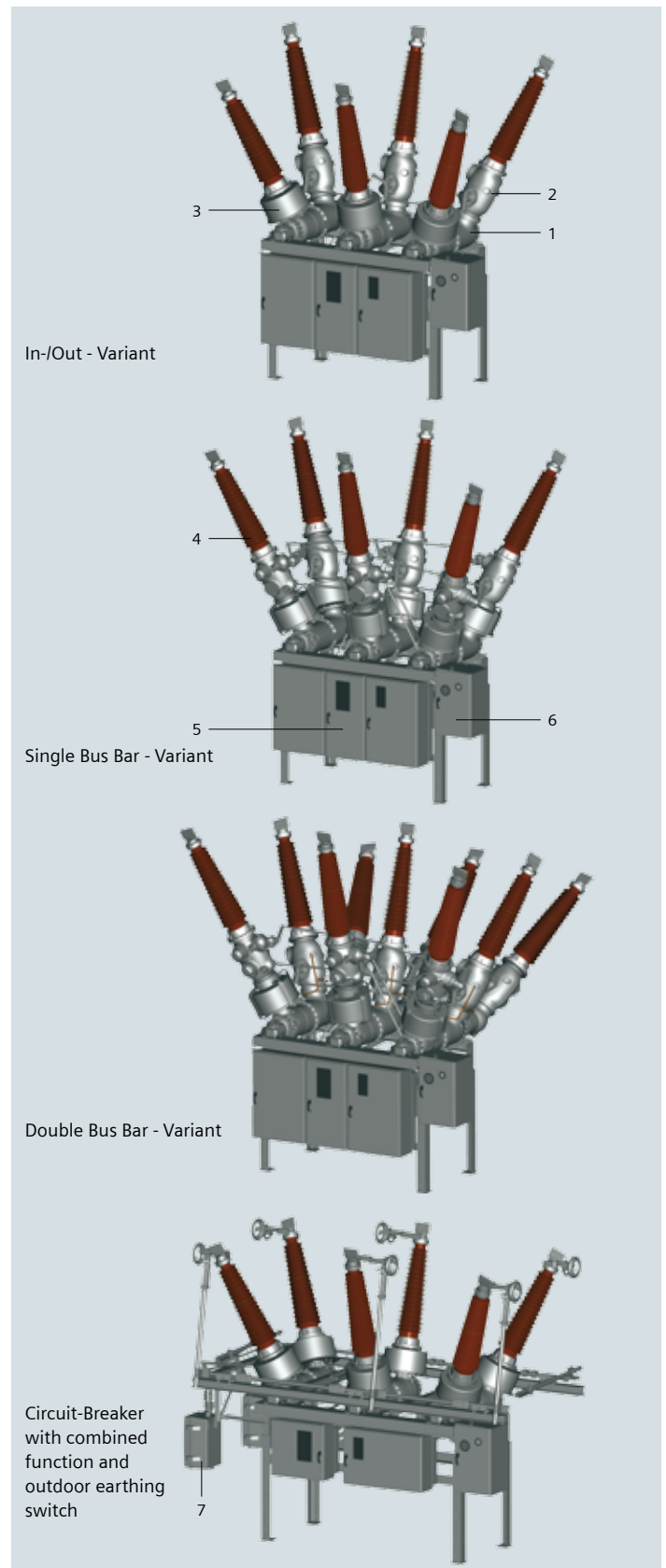

In-/Out - Variant

Single Bus Bar - Variant

Double Bus Bar - Variant

Circuit-Breaker with combined function and outdoor earthing switch

- | | |
|---------------------------------|---|
| 1 Circuit-breaker | 5 Control cabinets |
| 2 Disconnect/earthing switch | 6 Spring drive mechanism circuit-breaker |
| 3 Current transformer | 7 Drive mechanism for outdoor earthing switch |
| 4 Air/SF ₆ -Bushings | |

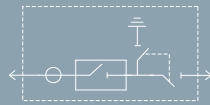
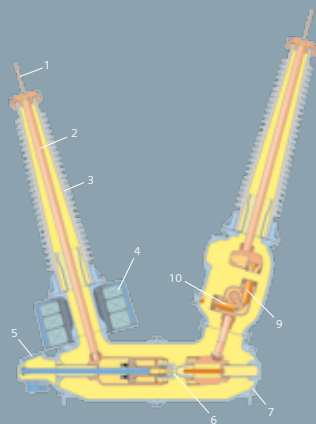

In-/Out – Variant

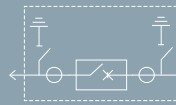
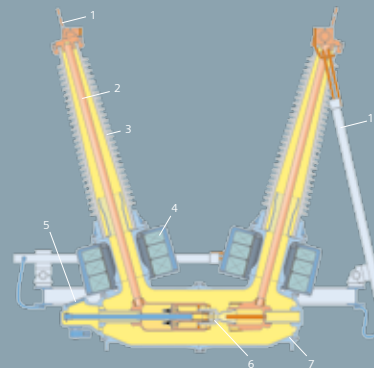

Circuit-Breaker with combined

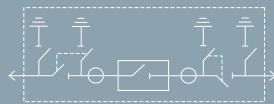
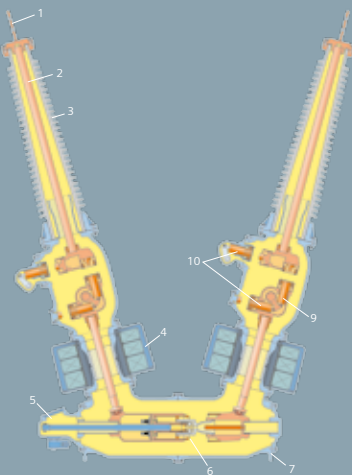

Single Bus Bar – Variant

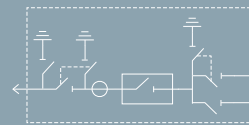
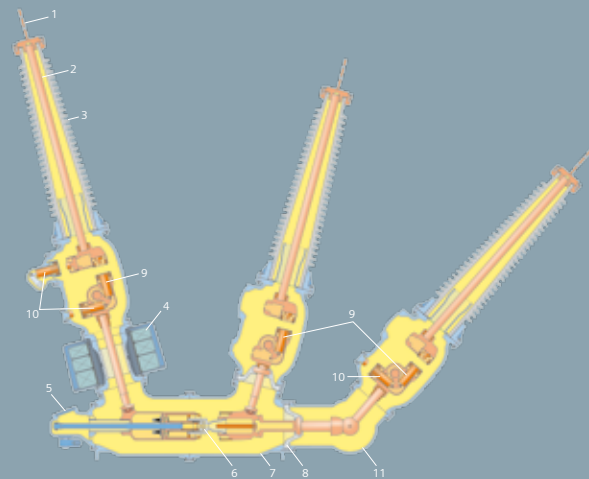

Double Bus Bar – Variant

1 Terminal plate	4 Current transformer	7 Metal housing	10 Earthing switch
2 Conductor	5 Rupture disc	8 Insulating partition	11 Angle housing
3 Bushing	6 Interrupter unit	9 Disconnector	12 Outdoor earthing switch

In-/Out - Variant

The DTC concept enables a flexible use for any substation layout. With its current transformers and disconnector/ earthing switches on the incoming and outgoing side, the new Compact Switchgear from Siemens features innovative technology and ensures efficient operation.

Single Bus Bar - Variant

If further disconnector/earthing switches on the line-side or bus bar-side are required, this variant offers the right solution. A combination of earthing switch/disconnecting and earthing switch is also available. They are located in one common housing.

Double Bus Bar - Variant

The DTC can also be used for a double bus bar layout. Gastight insulating partitions are available on request. They divide each device into functionally distinct gas compartments (circuit-breaker, disconnector). The gas compartments are under constant monitoring by means of density monitors with an integrated indicator; any nonconformity is immediately signalled. In case of a fault inside one disconnector, the other disconnector will not

be affected. The SF₆ bushing can be delivered in porcelain or epoxy design, which is the same as used in other GIS devices.

Circuit-Breaker with combined function and outdoor earthing switch

This version of the DTC offers the function of a combined disconnecting circuit-breaker. Additional elements in this arrangement are current transformers and earthing switches attached to both sides of the module.

The features are:

- A simple and compact substation layout
- A visible indication of the earthing contact position
- No creepage currents across the open device
- The use of conventional current transformers

Earthing Switch

The module can be equipped on both sides of the DTC with earthing switches which are adopted from well proven Siemens disconnector products. They can be operated either by motor or by hand. The earthing switches and drives are mounted on a common base frame.

Technical Data

A) 3AP - Live tank type

Type		3AP1 FG				3AP1 FI		3AP2/3 FI		3AP4/5 FI
Rated voltage (kV)	[kV]	72.5	72.5	145	245	145	245	420	550	800
Rated frequency	[Hz]	50	50	50	50	50	50	50	50	50
Rated current	[A]	2500	3150	3150	3150	3150	3150	4000	4000	4000
Interrupters / pole		1	1	1	1	1	1	2	2	4
Rated breaking	[kA]	31.5	40	40	50	40	50	50	63	63
Operating temperature	[°C]	-30 up to +55								
Rated making	[kAp]	78.75	100	100	125	100	125	125	158	158
Rated PF withstand Voltage	[kVr]	140	140	275	460	275	460	610	800	870
Lightning Impulse withstand	[kVp]	350	350	650	1050	650	1050	1425	1550	2100
Switching Impulse withstand	[kVp]							1050	1175	1550
Rated operating sequence	[kAp]	O - 0.3 sec - CO - 3 min - CO or CO - 15 sec - CO								
Rated S/C duration	[s]	3								

B) 3AP - Dead tank type

Type		3AP1 DTC 145kV	3AP1 DTC 245kV
Rated voltage	[kV]	145 kV	245 kV
Rated normal current	[A]	2500 A	3150 A
Rated frequency	[Hz]	50 Hz	50 Hz
Rated lightning impulse withstand voltage	[kVp]	650 kVp	1050 kVp
Rated power frequency withstand voltage	[kVr]	275 kV	460 kV
Rated breaking	[kA]	40 kA	50 kA
Rated peak withstand current	[kAp]	100 kAp	125 kAp
Ambient temperature range	[°C]	-30 ... +40°C	-30 ... +40°C

Values in accordance to IEC, other values on request

A worldwide **24 hours service** is available, which immediately sends out service personnel and/or delivers spare parts as needed.

Customer Support Center:-

- Toll free Phone no. in India: 1800 2667 480
- Email: energysupport.in@siemens.com

Siemens Ltd.
Energy Sector
Energy Transmission - High Voltage Breakers
E-76, Waluj MIDC, Aurangabad - 431 136
Maharashtra, INDIA
Fax: +91 240 255 4701
E-mail: circuit-breakers@siemens.com

XX-XX-XXX-XXX

www.siemens.com/energy

Product upgradation is a continuous process. Hence, data in this catalog is subject to change without prior notice. For the latest information, please get in touch with our Sales Offices.