

PARCO EOLICO IMPERIA MONTI MORO, GUARDIABELLA

Il Committente:



Sede Legale:

via Aldo Moro n. 28
25043, Breno (BS)
P.IVA e C.F. 04324170986

Oggetto:

PARTICOLARI COSTRUTTIVI

Titolo:

TIPOLOGICO TRALICCIO PER MONITORAGGIO ANEMOLOGICO

Il Progettista



Ing. Silvio Mario Bauducco

Data	Emis.	Aggiornamento	Data	Contr.	Data	Autor.
03/2023	SMB	Emissione	03/2023	SMB	03/2023	SMB

SCALA - N.A.

MARZO 2023

Commessa

Tip. impianto

Fase Progetto

Disciplina

Tip. Doc

Titolo

N. Elab

REV

22109

EO

DE

GN

DS

14

0002

A

PROGETTAZIONE EDILE, AMBIENTALE, STRUTTURALE ED IMPIANTISTICA A CURA DI:

I Tecnici:

Coord. gruppo di progettazione
Ing. Silvio Mario Bauducco

Collaboratori

Geom. Benzoni Manuel
Per. Ind. Biasin Emanuele
Ing. Occhiuto Felice
Arch. Ostino Paolo
Arch. Pelleri Martina

BAUTEL S.R.L.

Sede Amministrativa via Maroncelli, 23 10024 Moncalieri (TO)
tel 011.6052113 - 011.6059915 e-mail: amministrazione@bautel.it
Sede operativa Torino - via Maroncelli, 23 10024 Moncalieri (TO)
Sede operativa Genova - via Banderali, 2/4 16121 Genova (GE)

File: testalini relazioni.dwg

TUTTI I DIRITTI SONO RISERVATI - Questo documento è di proprietà esclusiva del progettista ivi indicato sul quale si riserva ogni diritto. Pertanto questo documento non può essere copiato, riprodotto, comunicato o divulgato ad altri o usato in qualsiasi maniera, nemmeno per fini sperimentali, senza autorizzazione scritta dallo stesso progettista.



ANEMOMETRIC STRUCTURES

self-supporting met mast

self-supporting met mast



The self-supporting met masts are triangular section structures composed by uprights and diagonals linked together by bolts. These structures have been designed and manufactured in compliance with the actual metallic constructions laws and have been specifically developed for the anemometer support of an eolic plant. Compared to the guyed solutions which are more indicated for more temporary uses, the self-supporting met masts allow a relevant reduction of the occupied spaces. They are available in two different series: light and heavy.

The stability of the structures is ensured by concrete casted foundations connected to the towers by means of anchor bolts down in the concrete cast and positioned thanks to a template included in the standard supply.

The towers are available for variable heights going 60 to 102 m with 6 m modules.

The towers are equipped with a climbing ladder provided with a rigid or flexible anchor line fall protection system compliant to the EN 353-1 and EN353-2 standards as well as arrangements for anchoring the cables along a tower leg.

At the top of structure it is possible to install a rod for the support of the top anemometer beside a higher rod supporting the lightning spike and connected to the base through an adequate grounding system. The dimensions of the instrumentation supports are fully compliant with the regulations of the IEC norm n. 61400-12-1 Annex G.

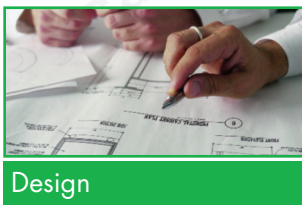

Design

Structural steel design according to the most recent European Standard. Designs to other International Standards (EIA, BS, NV65) available upon request.

- Design wind speed (Eurocode 1 - EN 1991) 28 m/s (serie leggera) ($q_{10}=1.1 \text{ kN/m}^2$)
Designed for wind zone 3 D II according to NTC08 standards until 500 meters height
- Design wind speed (Eurocode 1 - EN 1991) 40 m/s (serie pesante) ($q_{10}=2.4 \text{ kN/m}^2$)
Designed for wind zone 3 D III accordino to NTC08 standards until 1200 meters height



Materials

The materials comply with the requirements of European Standards (EURONORM).

- Structural parts S355J0 (Fe 510 C) EN 10025
- Nuts and bolts class 8.8 EN 20898-1

All steel materials are protected by hot-dip galvanizing in accordance to Euronorm EN 1461 and ASTM A123 Standards.



Supply

The standard supply provides the minimum configuration required for tower commissioning, excluding radiant systems and mounts.

- Foundation set
- Supporting structure, divided into sections
- Packing list with assembly and maintenance instructions
- Packing

For a description of the accessories and ordering information, please refer to the [Accessories](#) catalogue.





ANEMOMETRIC STRUCTURES

self-supporting met mast

All legal rights in this document are the exclusive property of calzavara and no part of it may be reproduced or communicated to any other party without our authorization. All data in this catalogue is for reference only and may be changed without notice, in line with our policy of continuous technical development.



ANEMOMETRIC STRUCTURES

self-supporting met mast



heavy tower
art. TMAP

light tower
art. TMAL

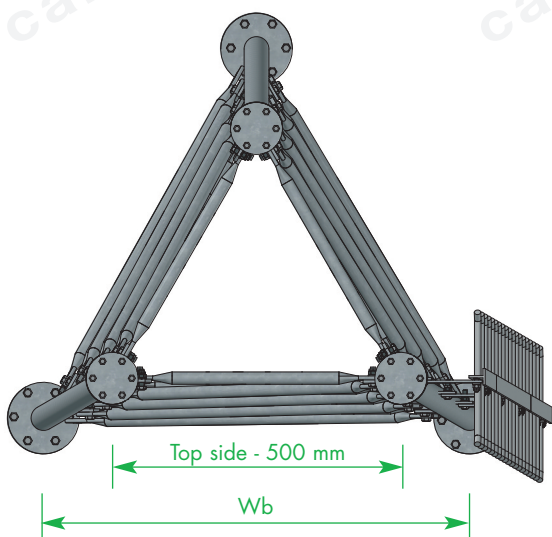
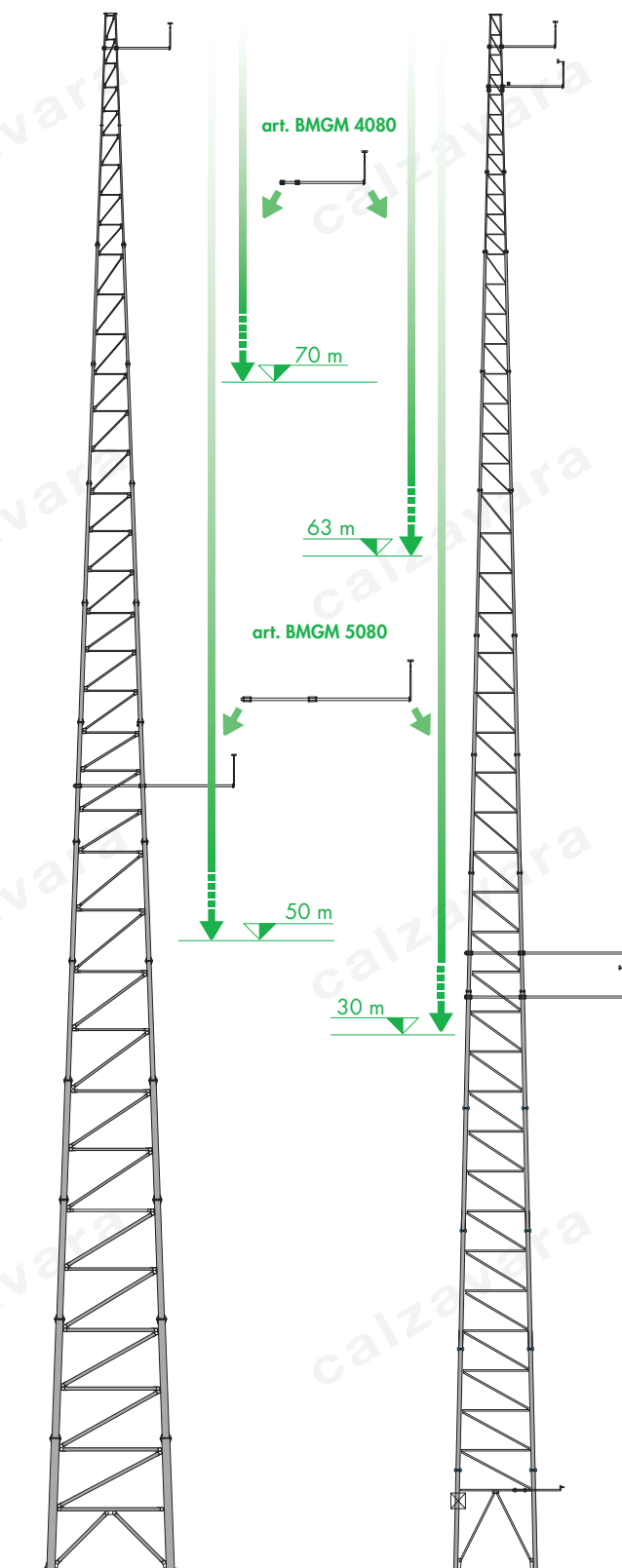

Article		Structure height*	Tower base side	Max wind	Gross	Packing	Foundation
		H	Wb	load	weight	volume	concrete volume
		m	m	m ²	tons	m ³	m ³
TMAL 56		54	2.9	2.1	6.2	30	55
TMAL 68		68	3.5	2.1	9.5	35	66
TMAL 80		80	4.0	2.1	13.9	40	78
TMAP 56		56	4.3	2.3	11.9	35	150
TMAP 68		68	5.2	2.3	18.3	42	180
TMAP 80		78	6.0	2.3	27.2	50	210

* La quota si intende a livello dell'anemometro di sommità

All legal rights in this document are the exclusive property of calzavara and no part of it may be reproduced or communicated to any other party without our authorization. All data in this catalogue is for reference only and may be changed without notice, in line with our policy of continuous technical development.

