

REGIONE SARDEGNA
Provincia del Sud Sardegna

PARCO EOLICO "SA CORONA"

COMUNI DI NURAMINIS, SAMATZAI E USSANA (SU)

Oggetto	PROGETTO DEFINITIVO	BLTX-NS-TC12
Titolo	SEZIONI TRASVERSALI RAPPRESENTATIVE VIABILITÀ DI IMPIANTO	Cod.elab. scala -

Data	Rev.	Descrizione	Eseg.	Contr.	Appr.
Maggio 2024	0	Prima emissione	MU	GF	BLTX

A cura di:
I.A.T. Consulenza e progetti S.r.l.
Dott. Ing. Giuseppe Frongia

Gruppo di progettazione:
Ing. Giuseppe Frongia
(coordinatore e responsabile)
Ing. Marianna Barbarino
Pian. Terr. Andrea Cappai
Ing. Gianfranco Corda
Ing. Paolo Desogus
Pian. Terr. Veronica Fais
Dott. Fabio Mancosu

Contributi specialistici:
Ing. Antonio Dedoni (acustica)
Dott. Geol. Maria Francesca Lobina (geologia)
Agr. Dott. Nat. Nicola Manis (pedologia)

Ing. Gianluca Melis
Dott. Fabrizio Murru
Dott. Nat. Alessio Musu
Ing. Andrea Onnis
Pian. Terr. Eleonora Re
Ing. Elisa Roych
Ing. Marco Utzeri

Agr. Dott. Nat. Mauro Casti (Flora)
Dott. Maurizio Medda (Fauna)
Dott.ssa Alice Nozza (Archeologia)
Dott. Matteo Tatti (Archeologia)

Progettazione:
Dott. Ing. Giuseppe Frongia



Il Committente:



BALTEX SARDEGNA 15 NURAMINIS S.R.L.

Corso XXII Marzo, 33
20129 Milano (MI)
P.IVA 13118320962 - PEC baltexsardegna15nuraminis@pec.it

A4	BLTX-NS-TC12_Sezioni trasversali rappresentative viabilità di impianto	BLTX-NS-TC12_Sezioni trasversali rappresentative viabilità di impianto	2023/0386
Formato	File origine	File di stampa	Codice pratica

Elaborazioni: I.A.T. Consulenza e progetti S.r.l. con socio unico - Via Michele Giua s.n.c. ZI CACIP , 09122 Cagliari, Tel./Fax +39.070.658297

Disegni, calcoli, specifiche e tutte le altre informazioni contenute nel presente documento sono di proprietà della I.A.T. Consulenza e progetti s.r.l. Al ricevimento di questo documento la stessa diffida pertanto di riprodurlo, in tutto o in parte, e di rivelarne il contenuto in assenza di esplicita autorizzazione.

SEZIONI TRASVERSALI

Profilo longitudinale tratto 1-2

Viabilità di impianto - Postazione aerogeneratore WTG01

Nota: Le canalette di deflusso delle acque meteoriche, non indicate nel presente elaborato, sono rappresentate graficamente nelle sezioni stradali tipo dell'elaborato "BLTX-NS-TC13_Piazzole aerogeneratori e strade di servizio - Particolari costruttivi", individuate planimetricamente nell'elaborato "BLTX-NS-TC14_Opere di regimazione acque superficiali - Planimetria generale" e quantificate nell'elaborato "BLTX-NS-RC6_Computo metrico estimativo opere civili".

DISEGNI DI RIFERIMENTO

TAVOLA	DESCRIZIONE
BLTX-NS-TC8	Viabilità e piazzole - Planimetria di progetto - Fase di cantiere
BLTX-NS-TC11	Profili longitudinali viabilità di impianto
BLTX-NS-TC13	Piazzole aerogeneratori e strade di servizio - Particolari costruttivi
BLTX-NS-TC14	Opere di regimazione acque superficiali - Planimetria generale

Sezione: 4
 Progressiva: 20.000
 Q. Progetto: 158.644

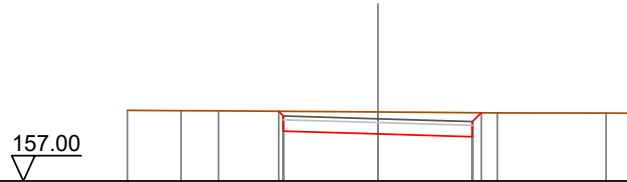

Quote Terreno	158.87	158.86	158.85		158.82	158.80	158.80	158.79
Quote Progetto			158.84	158.32	158.24	158.17	158.80	
Parziali			2.50		2.50			
Progressiva			-2.62	-2.50	0.00	2.50	2.73	
Dislivelli			0.00	-0.12	-0.58	-0.64	-0.00	

Sezione: 5
 Progressiva: 30.000
 Q. Progetto: 159.161

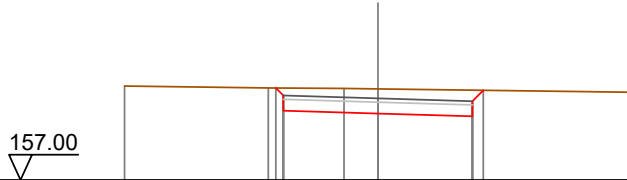

Quote Terreno	159.49	159.44	159.42	159.41		159.32
Quote Progetto		158.43	158.84	158.76	158.69	159.37
Parziali		2.50		2.50	0.28	
Progressiva		-2.70	-2.50	0.00	2.50	2.79
Dislivelli		-0.00	-0.20	-0.65	-0.69	0.00

Sezione: 6
 Progressiva: 38.660
 Q. Progetto: 159.493

158.00

Quote Terreno	159.90	159.87	159.86	159.84	159.79	159.76	159.74
Quote Progetto		159.86	159.17	159.09	159.02	159.80	
Parziali		0.30	2.50	2.50	0.39		
Progressiva		-2.80	-2.50	0.00	2.50	2.89	
Dislivelli		0.00	-0.30	-0.74	-0.79	0.00	

Sezione: 7
 Progressiva: 40.000
 Q. Progetto: 159.531

158.00

Quote Terreno	159.92	159.89	159.88	159.86	159.79	159.78
Quote Progetto		159.89	159.21	159.13	159.06	159.83
Parziali		0.28	2.50	2.50	0.38	
Progressiva		-2.78	-2.50	0.00	2.50	2.88
Dislivelli		0.00	-0.28	-0.73	-0.78	0.00

Sezione: 8
 Progressiva: 50.000
 Q. Progetto: 159.820

158.00

Quote Terreno	160.00	160.00	160.00	160.00	160.00	159.97
Quote Progetto		160.00	159.49	159.42	159.34	160.00
Parziali			2.50	2.50		
Progressiva		-2.61	-2.50	0.00	2.50	2.76
Dislivelli		0.00	-0.11	-0.58	-0.66	0.00

Sezione: 9
 Progressiva: 60.000
 Q. Progetto: 160.009

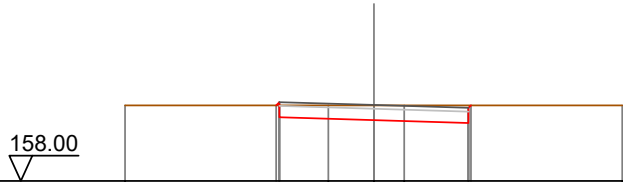

Quote Terreno	160.00	160.00	160.00	160.00	160.00
Quote Progetto		160.00 159.68		159.61 159.53	160.00
Parziali		2.50		2.50	
Progressiva		-2.58 -2.50		0.00 2.50	2.57
Dislivelli		0.00 0.08		-0.39 -0.47	0.00

Sezione: 10
 Progressiva: 70.000
 Q. Progetto: 160.026

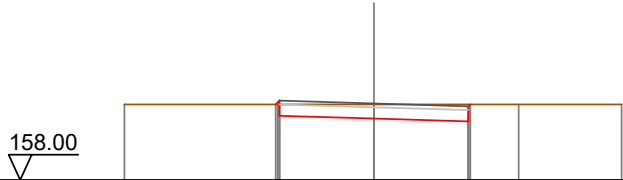

Quote Terreno	160.00	160.00	160.00	160.00	160.00
Quote Progetto		160.00 159.70		159.63 159.55	160.00
Parziali		2.50		2.50	
Progressiva		-2.60 -2.50		0.00 2.50	2.55
Dislivelli		0.00 0.10		-0.37 -0.45	0.00

Sezione: 11
 Progressiva: 75.731
 Q. Progetto: 160.022

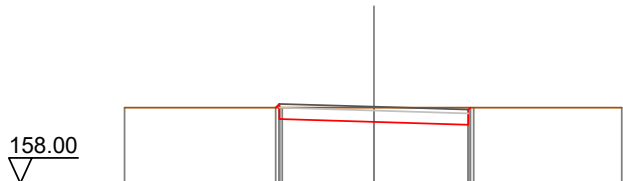

Quote Terreno	160.00	160.00	160.00	160.00	160.00
Quote Progetto		160.00 159.70		159.62 159.55	160.00
Parziali		2.50		2.50	
Progressiva		-2.60 -2.50		0.00 2.50	2.55
Dislivelli		0.00 0.10		-0.38 -0.45	0.00

Sezione: 12
 Progressiva: 80.000
 Q. Progetto: 160.019

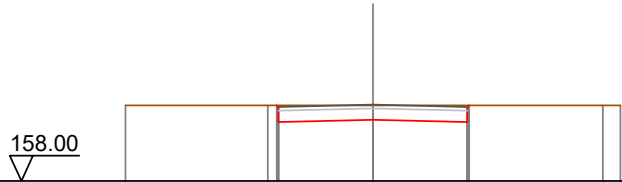

Quote Terreno	160.00	160.00	160.00	160.00	160.00
Quote Progetto		160.00 159.56	159.62	159.56 160.00	
Parziali		2.50	2.50		
Progressiva		-2.54 -2.50	0.00	2.50 2.54	
Dislivelli		0.00 -0.04	-0.38	-0.44 0.00	

Sezione: 13
 Progressiva: 100.000
 Q. Progetto: 160.015

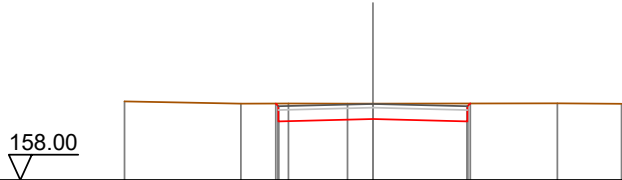

Quote Terreno	160.08	160.02	160.02	160.02	160.02	160.03	160.02
Quote Progetto		160.02 159.55	159.61	159.55 160.03			
Parziali		2.50	2.50				
Progressiva		-2.57 -2.50	0.00	2.50 2.57			
Dislivelli		0.00 -0.07	-0.41	-0.47 0.00			

Sezione: 14
 Progressiva: 120.000
 Q. Progetto: 160.366

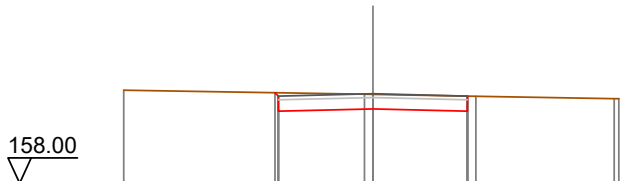

Quote Terreno	160.46	160.39	160.35	160.30	160.24	160.23
Quote Progetto		160.39 159.90	159.97	159.90		
Parziali		2.50	2.50			
Progressiva		-2.59 -2.50	0.00	2.50		
Dislivelli		0.00 -0.09	-0.38	-0.40		

Sezione: 15
 Progressiva: 129.482
 Q. Progetto: 160.560

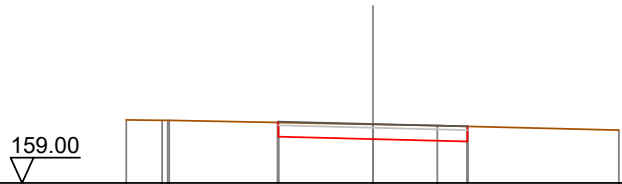

Quote Terreno	160.67	160.66	160.65			160.55	160.52	160.40
Quote Progetto				160.60	160.22	160.16	160.10	
Parziali				2.50	2.50			
Progressiva				-2.52	-2.50	0.00	2.50	
Dislivelli				0.00	0.02	-0.39	-0.40	

Sezione: 16
 Progressiva: 130.000
 Q. Progetto: 160.571

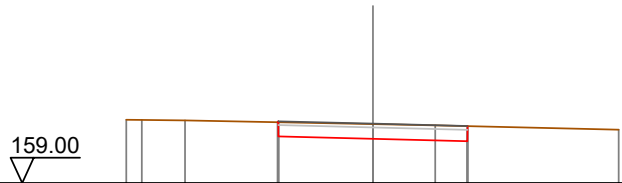

Quote Terreno	160.67	160.66				160.56	160.53	160.41
Quote Progetto				160.61	160.23	160.17	160.11	
Parziali				2.50	2.50			
Progressiva				-2.52	-2.50	0.00	2.50	
Dislivelli				0.00	0.02	-0.39	-0.40	

Sezione: 17
 Progressiva: 134.057
 Q. Progetto: 160.653



Quote Terreno	160.72					160.64	160.62	160.51	160.48
Quote Progetto				160.67	160.32	160.25	160.19		
Parziali				2.50	2.50				
Progressiva				-2.55	-2.50	0.00	2.50		
Dislivelli				0.00	0.05	-0.38	-0.39		

Sezione: 18
 Progressiva: 138.631
 Q. Progetto: 160.727

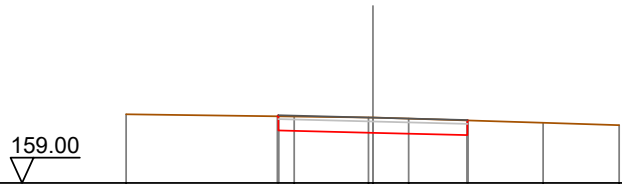

Quote Terreno	160.82	160.76	160.73	160.70	160.59	160.53
Quote Progetto		160.76 160.39	160.33	160.26		
Parziali		2.50	2.50			
Progressiva		-2.53 -2.50	0.00	2.50		
Dislivelli		0.00 0.03	-0.40	-0.39		

Sezione: 19
 Progressiva: 140.000
 Q. Progetto: 160.748

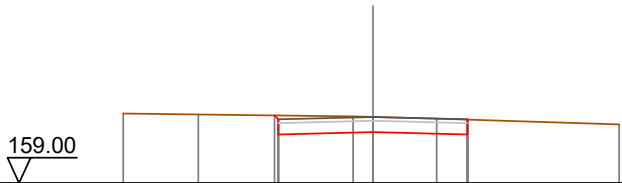

Quote Terreno	160.84	160.81	160.76	160.75	160.70	160.55
Quote Progetto			160.79 160.29	160.35	160.29	
Parziali			2.50	2.50		
Progressiva			-2.60 -2.50	0.00	2.50	
Dislivelli			0.00 -0.10	-0.40	-0.39	

Sezione: 20
 Progressiva: 160.000
 Q. Progetto: 161.062

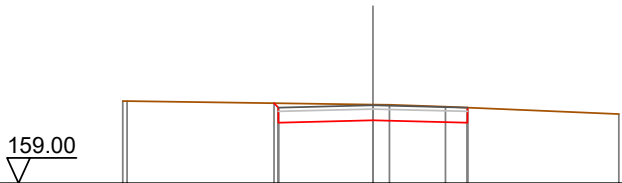

Quote Terreno	161.17	161.17	161.08	161.07	161.02	160.83
Quote Progetto			161.12 160.60	160.66	160.60	
Parziali			2.50	2.50		
Progressiva			-2.62 -2.50	0.00	2.50	
Dislivelli			0.00 -0.12	-0.42	-0.40	

Sezione: 21
 Progressiva: 180.000
 Q. Progetto: 161.345

159.00

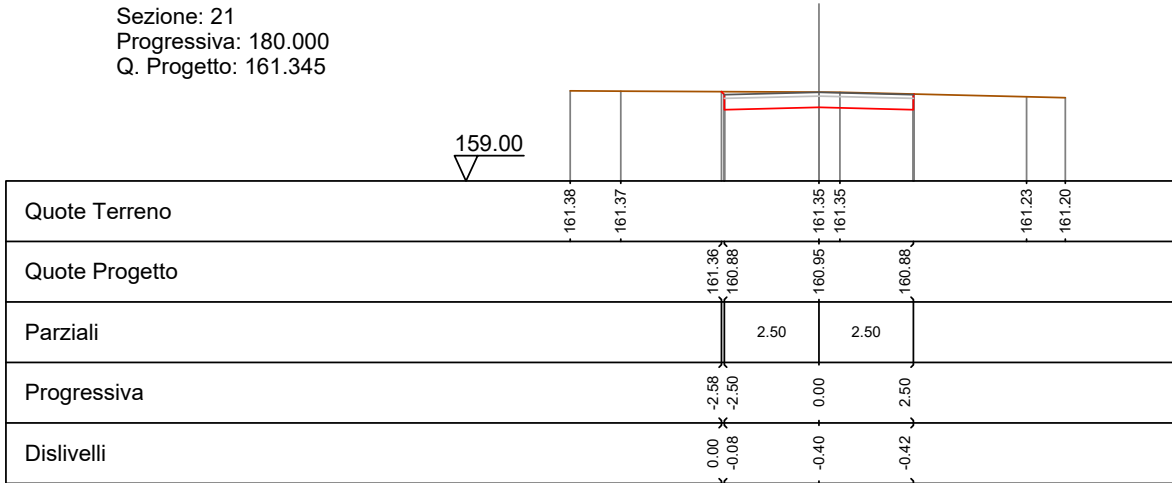

Sezione: 22
 Progressiva: 200.000
 Q. Progetto: 161.519

160.00

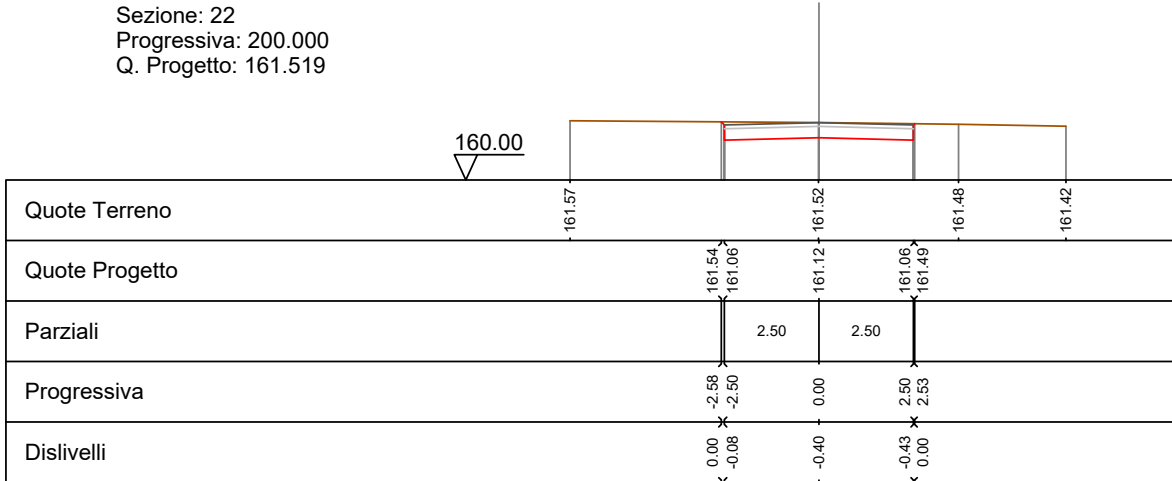

Sezione: 23
 Progressiva: 203.135
 Q. Progetto: 161.549

160.00

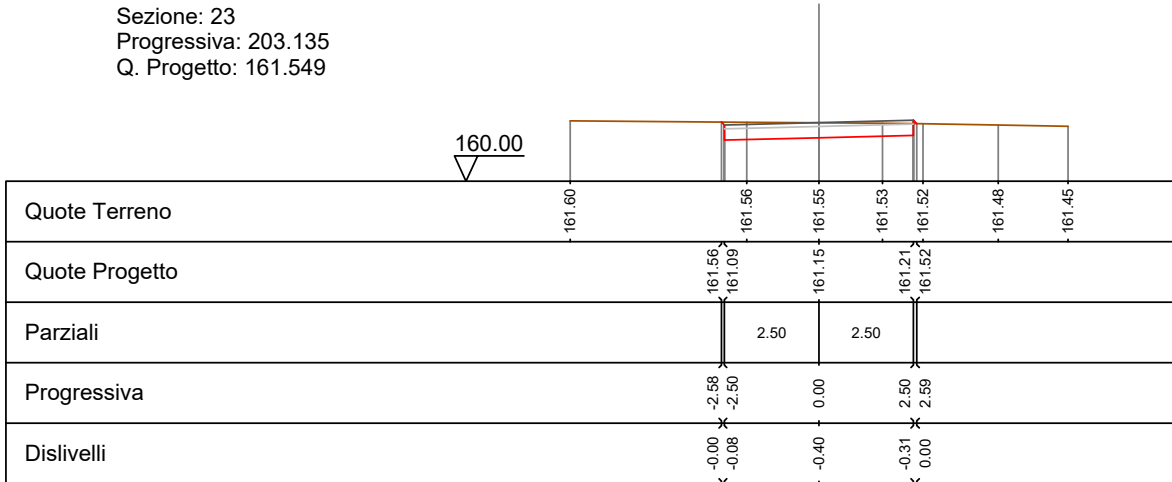

Sezione: 24
 Progressiva: 204.415
 Q. Progetto: 161.563

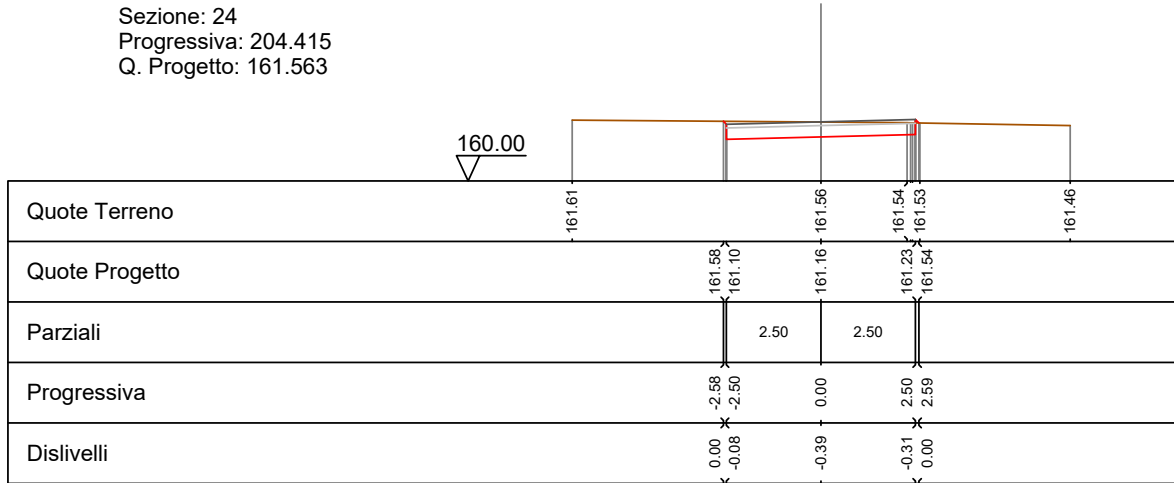

Sezione: 25
 Progressiva: 205.695
 Q. Progetto: 161.578

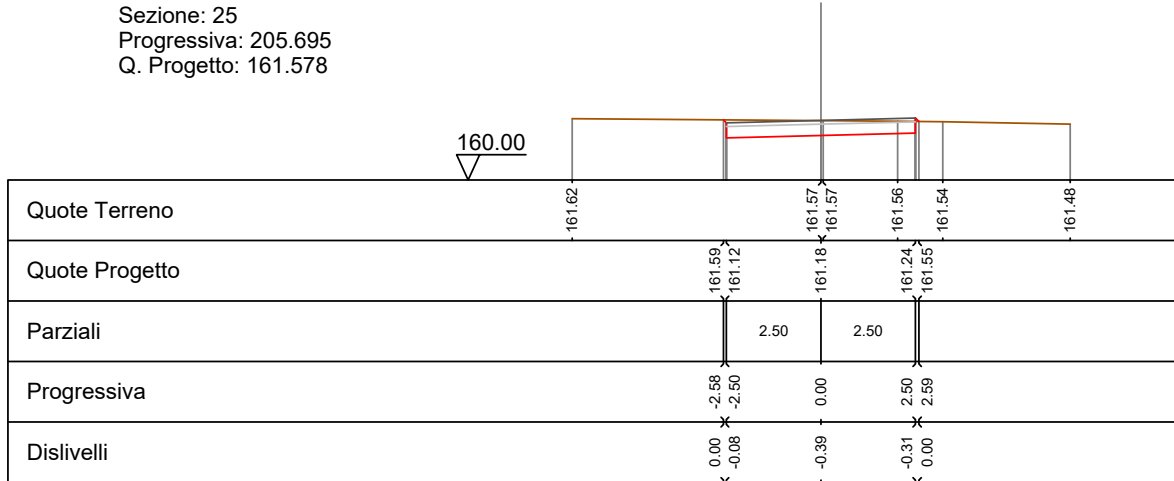

Sezione: 26
 Progressiva: 220.000
 Q. Progetto: 161.743

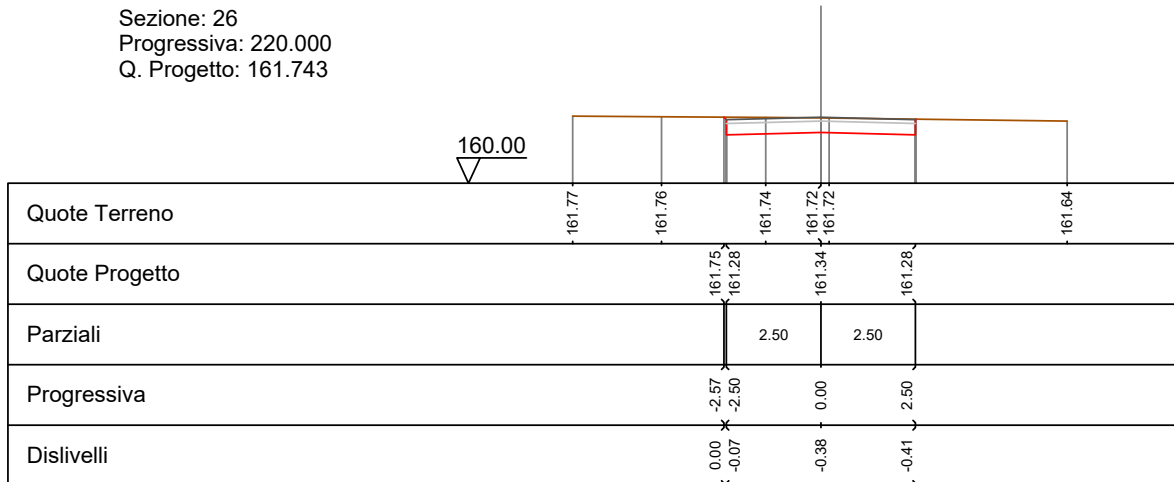

Sezione: 27
 Progressiva: 240.000
 Q. Progetto: 161.973

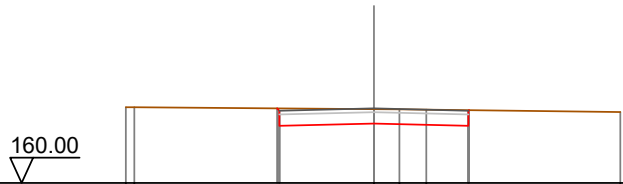

Quote Terreno	162.00	162.00			161.95	161.94	161.88
Quote Progetto		161.97	161.51		161.57	161.51	
Parziali		2.50		2.50			
Progressiva		-2.56	-2.50	0.00		2.50	
Dislivelli		0.00	-0.06	-0.38		-0.42	

Sezione: 28
 Progressiva: 260.000
 Q. Progetto: 162.203

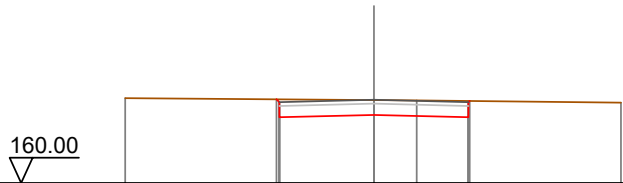

Quote Terreno	162.25				162.20	162.19	162.13
Quote Progetto		162.22	161.74		161.80	161.74	162.17
Parziali		2.50		2.50			
Progressiva		-2.58	-2.50	0.00		2.50	2.53
Dislivelli		-0.00	-0.08	-0.39		-0.43	0.00

Sezione: 29
 Progressiva: 280.000
 Q. Progetto: 162.464

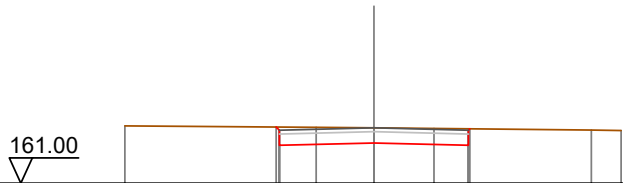

Quote Terreno	162.52				162.46	162.45	162.40	162.39
Quote Progetto		162.49	162.00		162.06	162.00	162.44	
Parziali		2.50		2.50				
Progressiva		-2.59	-2.50	0.00		2.50	2.54	
Dislivelli		0.00	-0.08	-0.40		-0.44	0.00	

Sezione: 30
 Progressiva: 300.000
 Q. Progetto: 162.735

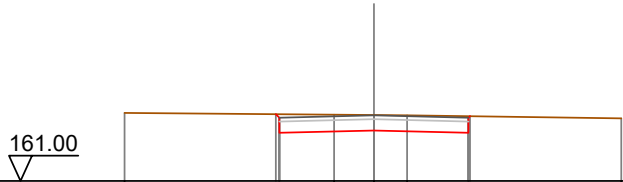

Quote Terreno	162.80		162.75	162.74	162.74	162.65
Quote Progetto		162.77	162.27	162.33	162.27	162.71
Parziali		2.50		2.50		
Progressiva		-2.59	-2.50	0.00	2.50	2.54
Dislivelli		0.00	-0.09	-0.41	-0.44	0.00

Sezione: 31
 Progressiva: 320.000
 Q. Progetto: 163.006

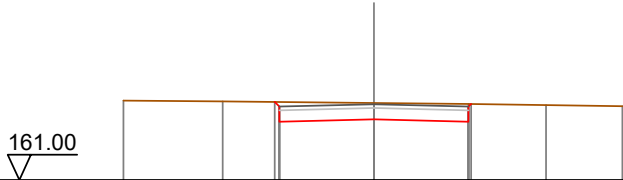

Quote Terreno	163.10	163.08		163.04	163.01	162.98	162.95
Quote Progetto			163.07	162.61	162.54	163.01	
Parziali			2.50		2.50		
Progressiva			-2.62	-2.50	0.00	2.50	2.57
Dislivelli			0.00	-0.12	-0.43	-0.47	0.00

Sezione: 32
 Progressiva: 320.284
 Q. Progetto: 163.010

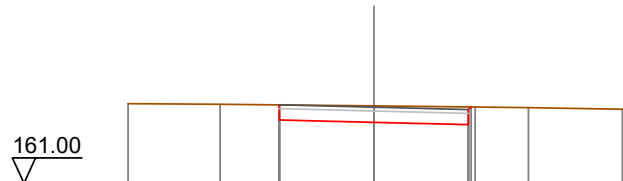

Quote Terreno	163.11	163.09		163.04	163.02	163.00	162.96
Quote Progetto			162.67	162.61	162.55	163.02	
Parziali			2.50		2.50		
Progressiva			-2.50	0.00	2.50	2.57	
Dislivelli			0.00	-0.43	-0.47	0.00	

Sezione: 33
 Progressiva: 330.000
 Q. Progetto: 163.141



Quote Terreno	163.27	163.23	163.17	163.08	163.06
Quote Progetto		162.80	162.74	162.68	163.13
Parziali		2.50	2.50		
Progressiva		-2.51	0.00	2.50	2.55
Dislivelli		0.00	-0.43	-0.45	0.00

Sezione: 34
 Progressiva: 334.305
 Q. Progetto: 163.200

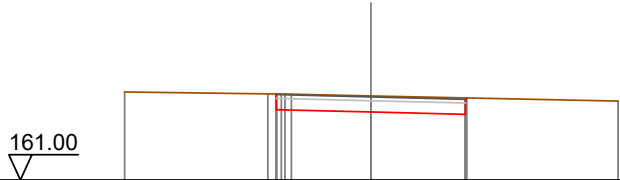

Quote Terreno	163.33	163.28	163.27	163.23	163.09
Quote Progetto		162.86	162.80	162.74	163.17
Parziali		2.50	2.50		
Progressiva		-2.52	0.00	2.50	2.54
Dislivelli		0.00	-0.43	-0.44	0.00

Sezione: 35
 Progressiva: 340.000
 Q. Progetto: 163.265

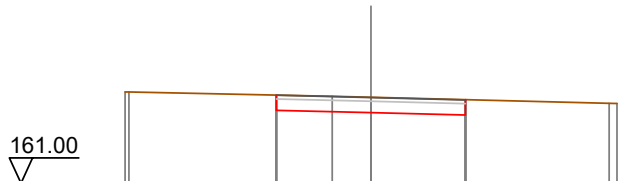

Quote Terreno	163.41	163.30	163.27	163.11
Quote Progetto		162.93	162.87	162.80
Parziali		2.50	2.50	
Progressiva		-2.50	0.00	2.50
Dislivelli		0.00	-0.41	-0.41

Sezione: 36
 Progressiva: 348.326
 Q. Progetto: 163.301



Quote Terreno	163.44	163.42	163.31	163.30	163.16	163.13
Quote Progetto			162.96	162.90	162.84	
Parziali			2.50	2.50		
Progressiva			-2.51	0.00	2.50	
Dislivelli			-0.00	-0.40	-0.39	

Sezione: 37
 Progressiva: 360.000
 Q. Progetto: 163.349

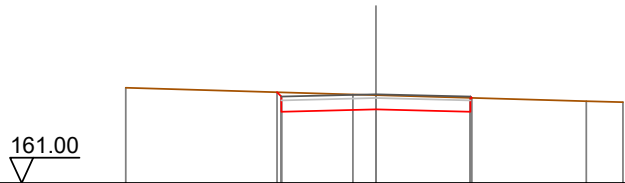

Quote Terreno	163.52		163.34	163.33	163.17	163.14
Quote Progetto			163.40	162.89	162.95	162.89
Parziali			2.50	2.50		
Progressiva			-2.62	-2.50	0.00	2.50
Dislivelli			0.00	-0.11	-0.38	-0.37
						2.53
						0.00

Sezione: 38
 Progressiva: 380.000
 Q. Progetto: 163.586

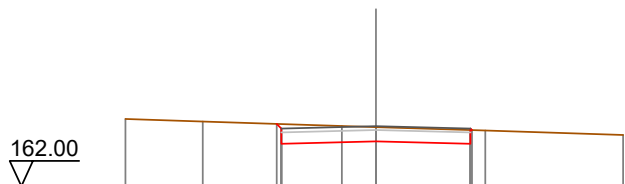

Quote Terreno	163.78	163.71	163.59	163.56	163.47	163.35
Quote Progetto			163.65	163.12	163.19	163.12
Parziali			2.50	2.50		
Progressiva			-2.62	-2.50	0.00	2.50
Dislivelli			0.00	-0.12	-0.38	-0.36
						2.54
						0.00

Sezione: 39
 Progressiva: 400.000
 Q. Progetto: 163.883

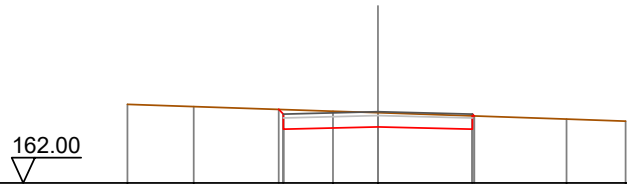

Quote Terreno	164.08	164.02		163.90	163.86		163.69	163.64
Quote Progetto			163.95	163.42	163.48	163.42	163.77	
Parziali			2.50	2.50				
Progressiva			-2.62	-2.50	0.00	2.50	2.55	
Dislivelli			-0.00	-0.12	-0.37	-0.35	0.00	

Sezione: 40
 Progressiva: 420.000
 Q. Progetto: 164.181

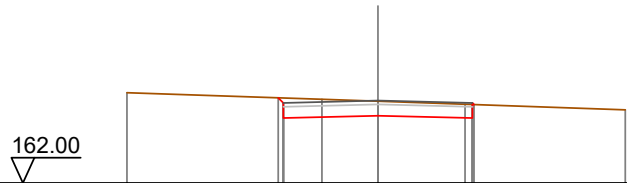

Quote Terreno	164.39		164.22	164.17	164.09		163.94
Quote Progetto		164.25	163.72	163.78	163.72	164.08	
Parziali		2.50	2.50				
Progressiva		-2.64	-2.50	0.00	2.50	2.54	
Dislivelli		0.00	-0.13	-0.38	-0.36	0.00	

Sezione: 41
 Progressiva: 422.124
 Q. Progetto: 164.213

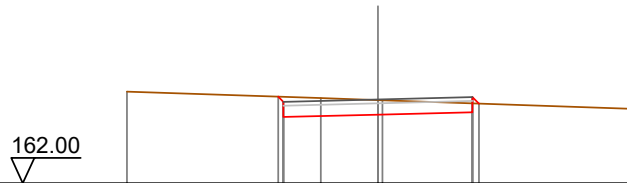

Quote Terreno	164.42		164.25	164.20	164.19		163.97
Quote Progetto		164.29	163.75	163.81	163.88	164.11	
Parziali		2.50	2.50				
Progressiva		-2.64	-2.50	0.00	2.50	2.67	
Dislivelli		0.00	-0.13	-0.39	-0.24	0.00	

Sezione: 42
 Progressiva: 428.920
 Q. Progetto: 164.327

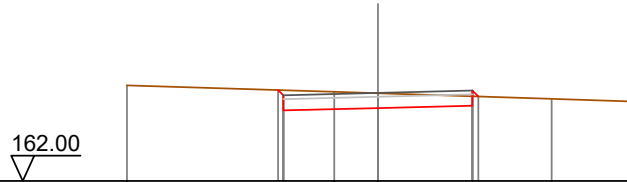

Quote Terreno	164.53		164.36	164.32		164.17	164.10
Quote Progetto		164.40	163.86	163.93	163.99	164.23	
Parziali		2.50	2.50				
Progressiva		-2.64	-2.50	0.00	2.50	2.66	
Dislivelli		0.00	-0.13	-0.39	-0.25	-0.00	

Sezione: 43
 Progressiva: 430.000
 Q. Progetto: 164.353

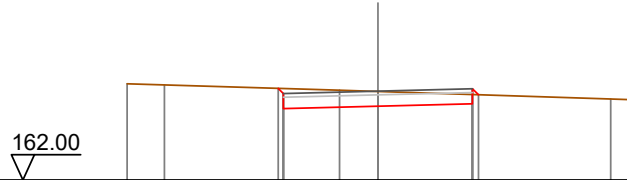

Quote Terreno	164.55	164.52	164.38	164.34		164.14	164.13
Quote Progetto		164.43	163.89	163.95	164.02	164.26	
Parziali		2.50	2.50				
Progressiva		-2.63	-2.50	0.00	2.50	2.66	
Dislivelli		0.00	-0.13	-0.39	-0.25	0.00	

Sezione: 44
 Progressiva: 435.716
 Q. Progetto: 164.493

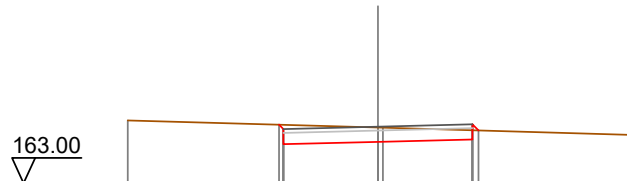

Quote Terreno	164.66		164.47	164.47		164.28	
Quote Progetto		164.55	164.03	164.09	164.16	164.40	
Parziali		2.50	2.50				
Progressiva		-2.62	-2.50	0.00	2.50	2.66	
Dislivelli		0.00	-0.11	-0.38	-0.24	0.00	

Sezione: 45
 Progressiva: 440.000
 Q. Progetto: 164.599

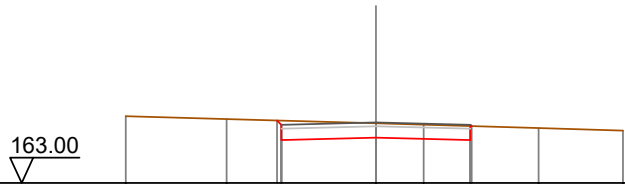

Quote Terreno	164.77	164.69	164.58	164.54	164.45	164.39
Quote Progetto		164.65 164.14	164.20	164.14 164.51		
Parziali		2.50	2.50			
Progressiva		-2.62 -2.50	0.00	2.50 2.53		
Dislivelli		-0.00 -0.11	-0.38	-0.37 0.00		

Sezione: 46
 Progressiva: 460.000
 Q. Progetto: 165.091

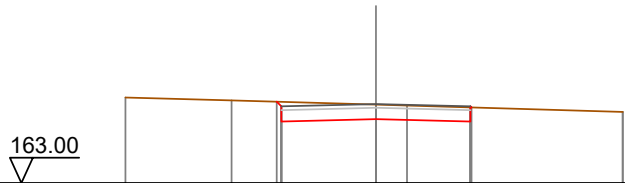

Quote Terreno	165.26	165.19	165.08	165.05	164.88
Quote Progetto		165.15 164.63	164.69	164.63 165.00	
Parziali		2.50	2.50		
Progressiva		-2.62 -2.50	0.00	2.50 2.53	
Dislivelli		0.00 -0.12	-0.38	-0.37 0.00	

Sezione: 47
 Progressiva: 480.000
 Q. Progetto: 165.583

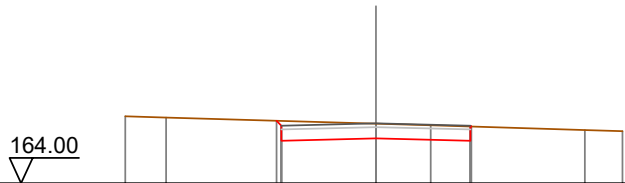

Quote Terreno	165.77	165.74	165.57	165.53	165.41	165.38
Quote Progetto		165.65 165.12	165.18	165.12 165.50		
Parziali		2.50	2.50			
Progressiva		-2.63 -2.50	0.00	2.50 2.52		
Dislivelli		0.00 -0.13	-0.39	-0.38 0.00		

Sezione: 48
 Progressiva: 480.789
 Q. Progetto: 165.603

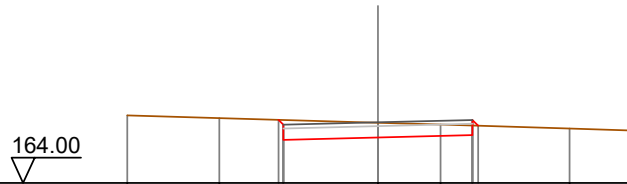

Quote Terreno	165.79	165.72		165.59	165.55		165.44	165.39
Quote Progetto			165.67	165.14	165.20		165.27	165.51
Parziali			2.50		2.50			
Progressiva			-2.63	-2.50	0.00		2.50	2.65
Dislivelli			0.00	-0.13	-0.39		-0.25	-0.00

Sezione: 49
 Progressiva: 487.802
 Q. Progetto: 165.790

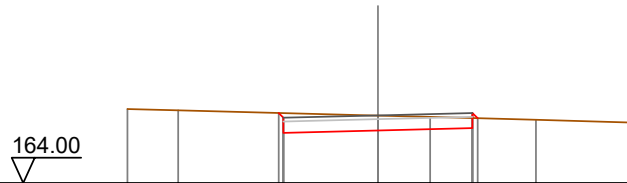

Quote Terreno	165.96	165.92		165.79	165.75		165.67	165.60
Quote Progetto			165.85	165.33	165.39		165.45	165.72
Parziali			2.50		2.50			
Progressiva			-2.63	-2.50	0.00		2.50	2.64
Dislivelli			0.00	-0.12	-0.40		-0.27	0.00

Sezione: 50
 Progressiva: 490.000
 Q. Progetto: 165.858

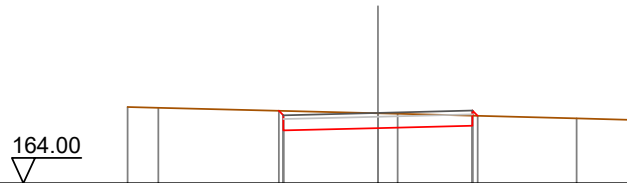

Quote Terreno	166.01	165.99		165.85	165.84		165.71	165.68
Quote Progetto			165.92	165.40	165.46		165.52	165.78
Parziali			2.50		2.50			
Progressiva			-2.62	-2.50	0.00		2.50	2.64
Dislivelli			0.00	-0.12	-0.39		-0.27	-0.00

Sezione: 51
 Progressiva: 494.815
 Q. Progetto: 166.006

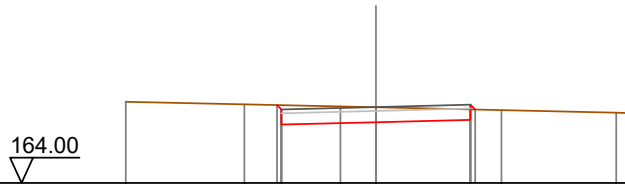

Quote Terreno	166.15	166.08	166.03	166.00	165.93	165.86	165.85
Quote Progetto		166.06	165.54	165.61	165.67	165.94	
Parziali			2.50	2.50			
Progressiva		-2.62	-2.50	0.00	2.50	2.63	
Dislivelli		0.00	-0.12	-0.40	-0.28	0.00	

Sezione: 52
 Progressiva: 495.153
 Q. Progetto: 166.017

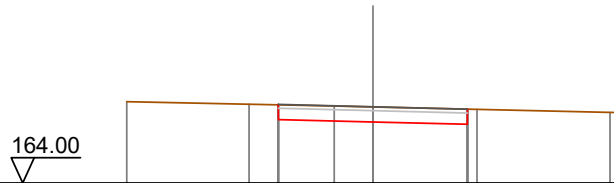

Quote Terreno	166.15	166.09	166.04	166.01	165.95	165.87	165.86
Quote Progetto		165.68		165.62	165.55		
Parziali			2.50	2.50			
Progressiva		-2.51	0.00	2.50			
Dislivelli		-0.00	-0.40	-0.40			

Sezione: 53
 Progressiva: 500.000
 Q. Progetto: 166.166

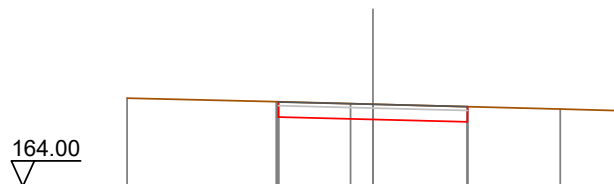

Quote Terreno	166.33	166.23	166.18	166.17	166.04	166.00
Quote Progetto		165.83	165.77	165.70		
Parziali			2.50	2.50		
Progressiva		-2.50	0.00	2.50		
Dislivelli		0.00	-0.40	-0.40		

Sezione: 54
 Progressiva: 500.987
 Q. Progetto: 166.197

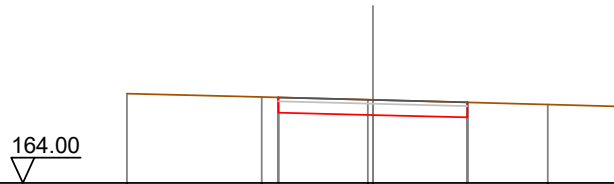

Quote Terreno	166.36	166.28	166.20	166.20	166.08	166.02
Quote Progetto		165.86	165.80	165.73		
Parziali			2.50	2.50		
Progressiva		-2.50	0.00	2.50		
Dislivelli		0.00	-0.40	-0.40		

Sezione: 55
 Progressiva: 506.822
 Q. Progetto: 166.363

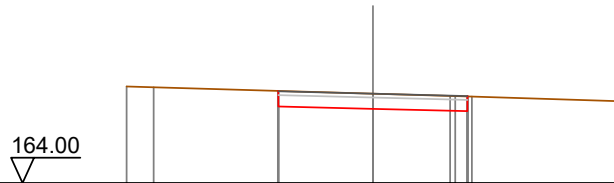

Quote Terreno	166.56	166.54	166.37	166.31	166.29	166.16
Quote Progetto			166.03	165.96	165.90	
Parziali			2.50	2.50		
Progressiva			-2.51	0.00	2.50	
Dislivelli			0.00	-0.40	-0.39	

Sezione: 56
 Progressiva: 520.000
 Q. Progetto: 166.725

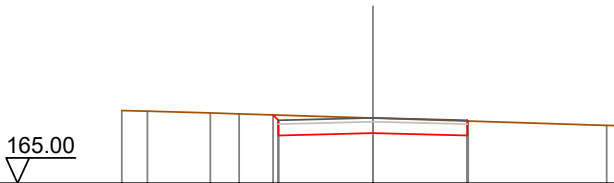

Quote Terreno	166.92	166.90	166.86	166.83	166.72	166.53	166.52
Quote Progetto				166.80	166.33	166.26	
Parziali				2.50	2.50		
Progressiva				-2.64	0.00	2.50	
Dislivelli				0.00	-0.40	-0.38	

Sezione: 57
 Progressiva: 533.233
 Q. Progetto: 167.088

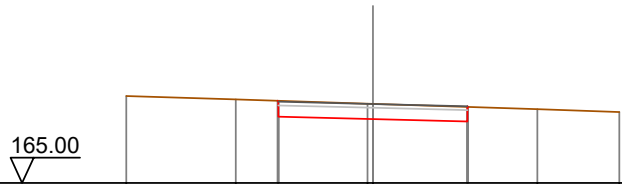

Quote Terreno	167.30	167.21	167.10	167.09	166.95	166.87
Quote Progetto		167.17 166.75	166.69	166.63		
Parziali			2.50	2.50		
Progressiva		-2.52 -2.50	0.00	2.50		
Dislivelli		0.00 -0.02	-0.40	-0.38		

Sezione: 58
 Progressiva: 534.850
 Q. Progetto: 167.133



Quote Terreno	167.35	167.29	167.14	167.12	167.02	166.91
Quote Progetto			167.22 166.80	166.73	166.67	
Parziali			2.50	2.50		
Progressiva			-2.53 -2.50	0.00	2.50	
Dislivelli			0.00 -0.02	-0.40	-0.38	

Sezione: 59
 Progressiva: 536.466
 Q. Progetto: 167.177



Quote Terreno	167.40	167.37	167.18	167.15	167.09	166.94
Quote Progetto			167.26 166.84	166.78	166.71 167.09	
Parziali			2.50	2.50		
Progressiva			-2.53 -2.50	0.00	2.50 2.52	
Dislivelli			0.00 -0.02	-0.40	-0.38 0.00	

Sezione: 60
 Progressiva: 540.000
 Q. Progetto: 167.266

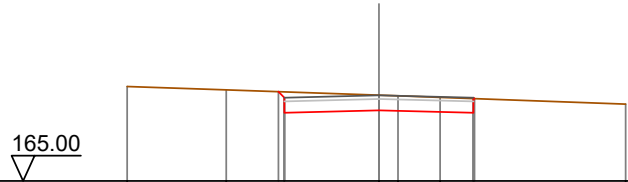

Quote Terreno	167.50	167.41		167.27	167.25	167.21	167.03
Quote Progetto			167.36	166.80	166.87	166.80	167.18
Parziali			2.50	2.50			
Progressiva			-2.66	-2.50	0.00	2.50	2.53
Dislivelli			0.00	-0.15	-0.40	-0.38	0.00

Sezione: 61
 Progressiva: 560.000
 Q. Progetto: 167.763

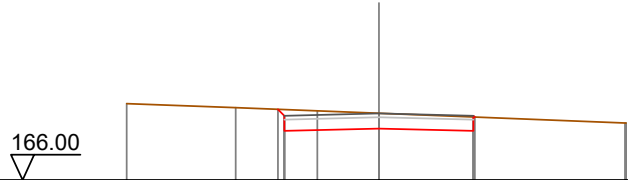

Quote Terreno	168.02	167.91	167.83	167.77		167.51	167.51
Quote Progetto			167.87	167.30	167.36	167.30	167.67
Parziali			2.50	2.50			
Progressiva			-2.67	-2.50	0.00	2.50	2.53
Dislivelli			0.00	-0.16	-0.40	-0.37	-0.00

Sezione: 62
 Progressiva: 575.858
 Q. Progetto: 168.156

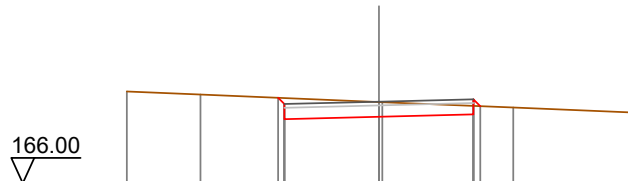

Quote Terreno	168.42	168.35		168.15	168.14	168.00	167.87
Quote Progetto			168.26	167.69	167.76	167.82	168.04
Parziali			2.50	2.50			
Progressiva			-2.67	-2.50	0.00	2.50	2.68
Dislivelli			0.00	-0.16	-0.39	-0.23	0.00

Sezione: 63
 Progressiva: 577.835
 Q. Progetto: 168.206

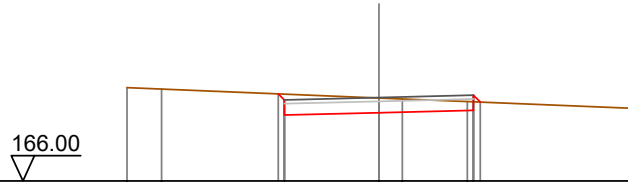

Quote Terreno	168.47	168.43		168.20	168.17	168.10	167.92
Quote Progetto			168.30	167.81	167.87	168.09	
Parziali			2.50	2.50			
Progressiva			-2.66	0.00	2.50	2.68	
Dislivelli			-0.00	-0.39	-0.23	0.00	

Sezione: 64
 Progressiva: 579.813
 Q. Progetto: 168.255

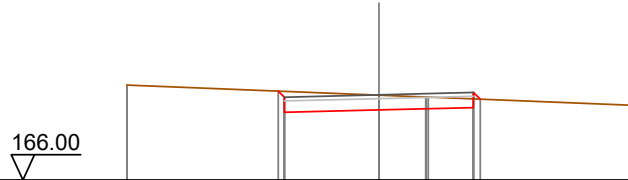

Quote Terreno	168.51			168.25	168.20	168.19	167.98
Quote Progetto			168.35	167.85	167.92	168.14	
Parziali			2.50	2.50			
Progressiva			-2.66	0.00	2.50	2.68	
Dislivelli			-0.00	-0.39	-0.23	0.00	

Sezione: 65
 Progressiva: 600.000
 Q. Progetto: 168.756

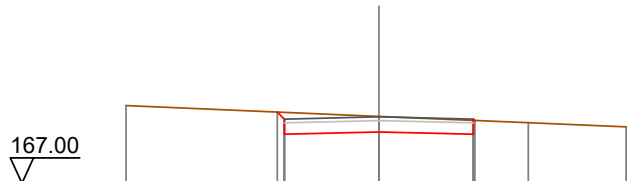

Quote Terreno	169.05			168.77		168.60	168.49
Quote Progetto			168.88	168.36	168.29	168.66	
Parziali			2.50	2.50			
Progressiva			-2.69	0.00	2.50	2.53	
Dislivelli			0.00	-0.41	-0.37	0.00	

Sezione: 66
 Progressiva: 620.000
 Q. Progetto: 169.234



Quote Terreno	169.52	169.51	169.36	169.23	169.03	168.96
Quote Progetto			169.34	168.83	168.77	169.13
Parziali			2.50	2.50		
Progressiva			-2.67	0.00	2.50	2.55
Dislivelli			0.00	-0.40	-0.36	-0.00

Sezione: 67
 Progressiva: 629.239
 Q. Progetto: 169.441

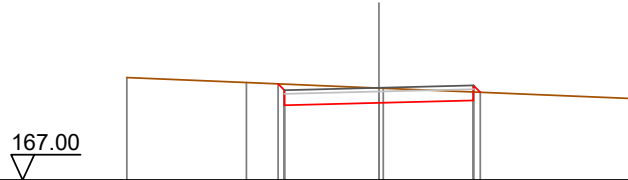

Quote Terreno	169.71	169.58	169.43	169.43	169.16
Quote Progetto		169.55	169.04	169.10	169.32
Parziali		2.50	2.50		
Progressiva		-2.67	0.00	2.50	2.68
Dislivelli		0.00	-0.39	-0.23	0.00

Sezione: 68
 Progressiva: 630.000
 Q. Progetto: 169.459

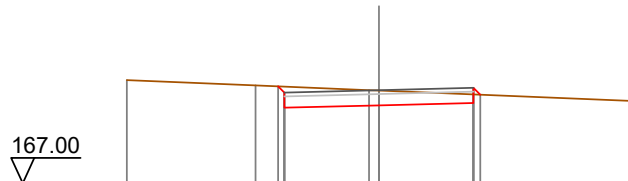

Quote Terreno	169.73	169.59	169.46	169.45	169.18
Quote Progetto		169.56	169.06	169.12	169.34
Parziali		2.50	2.50		
Progressiva		-2.67	0.00	2.50	2.68
Dislivelli		0.00	-0.39	-0.23	0.00

Sezione: 69
 Progressiva: 636.173
 Q. Progetto: 169.598

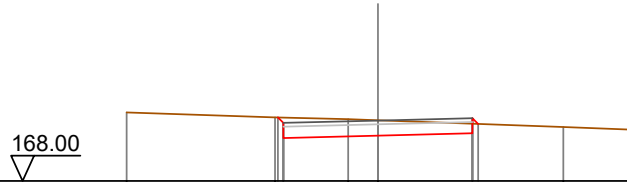

Quote Terreno	169.81	169.68	169.63	169.61	169.43	169.36
Quote Progetto		169.68	169.14	169.20	169.26	169.51
Parziali			2.50	2.50		
Progressiva		-2.64	-2.50	0.00	2.50	2.65
Dislivelli		-0.00	-0.14	-0.41	-0.25	0.00

Sezione: 70
 Progressiva: 640.000
 Q. Progetto: 169.684

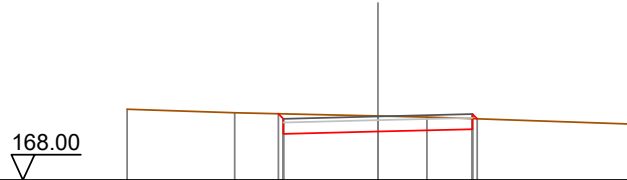

Quote Terreno	169.87	169.78	169.69	169.67	169.48	
Quote Progetto		169.75	169.22	169.28	169.35	169.62
Parziali			2.50	2.50		
Progressiva		-2.63	-2.50	0.00	2.50	2.63
Dislivelli		0.00	-0.13	-0.41	-0.28	0.00

Sezione: 71
 Progressiva: 643.107
 Q. Progetto: 169.754

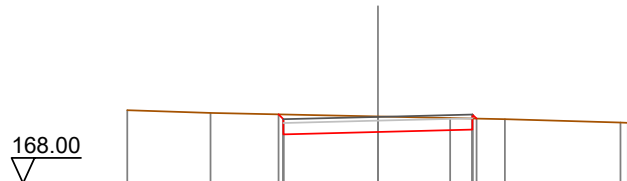

Quote Terreno	169.93	169.86	169.76	169.72	169.69	169.60	169.60
Quote Progetto		169.82	169.29	169.35	169.42	169.71	169.60
Parziali			2.50	2.50			
Progressiva		-2.63	-2.50	0.00	2.50	2.61	
Dislivelli		0.00	-0.13	-0.41	-0.30	-0.00	

Sezione: 72
 Progressiva: 660.000
 Q. Progetto: 169.980

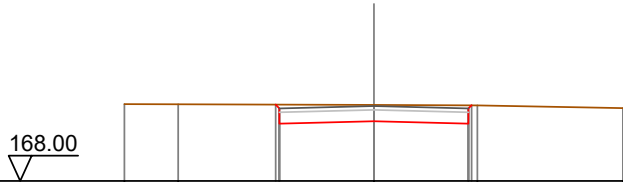

Quote Terreno	170.03	170.03		170.01	170.00	169.92
Quote Progetto			170.02	169.58	169.52	170.00
Parziali			2.50	2.50		
Progressiva			-2.60	0.00	2.50	2.58
Dislivelli			-0.00	-0.43	-0.48	0.00

Sezione: 73
 Progressiva: 680.000
 Q. Progetto: 170.084



Quote Terreno	170.02	170.02		170.01	170.01	170.00
Quote Progetto			169.62	169.68	169.62	
Parziali			2.50	2.50		
Progressiva			-2.50	0.00	2.50	
Dislivelli			0.00	-0.33	-0.39	

Sezione: 74
 Progressiva: 700.000
 Q. Progetto: 170.472



Quote Terreno	170.47	170.46		170.40	170.37	170.35	170.34
Quote Progetto			170.01	170.07	170.01	170.38	
Parziali			2.50	2.50			
Progressiva			-2.52	0.00	2.50	2.53	
Dislivelli			-0.00	-0.33	-0.37	0.00	

Sezione: 75
 Progressiva: 702.788
 Q. Progetto: 170.584

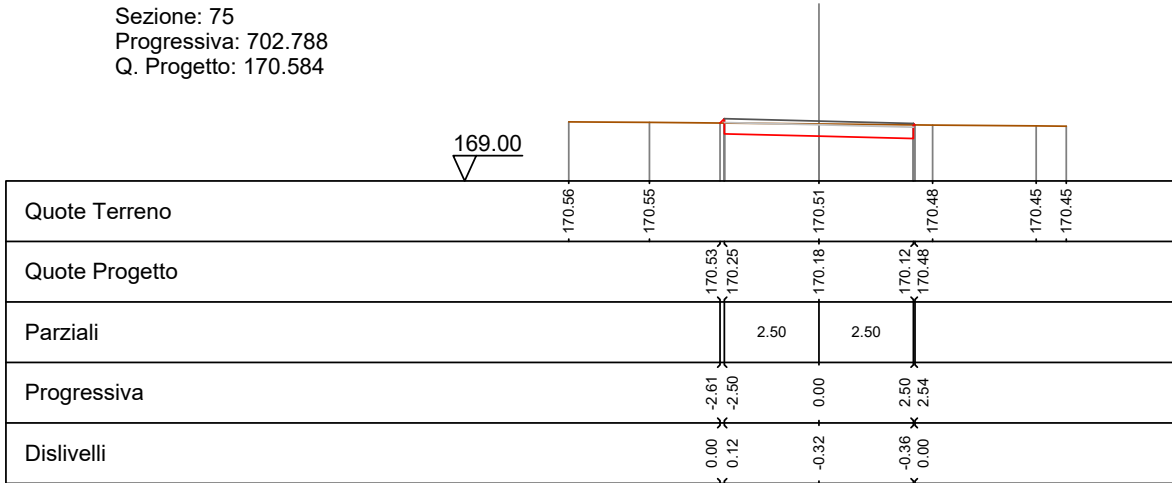

Sezione: 76
 Progressiva: 703.298
 Q. Progetto: 170.605

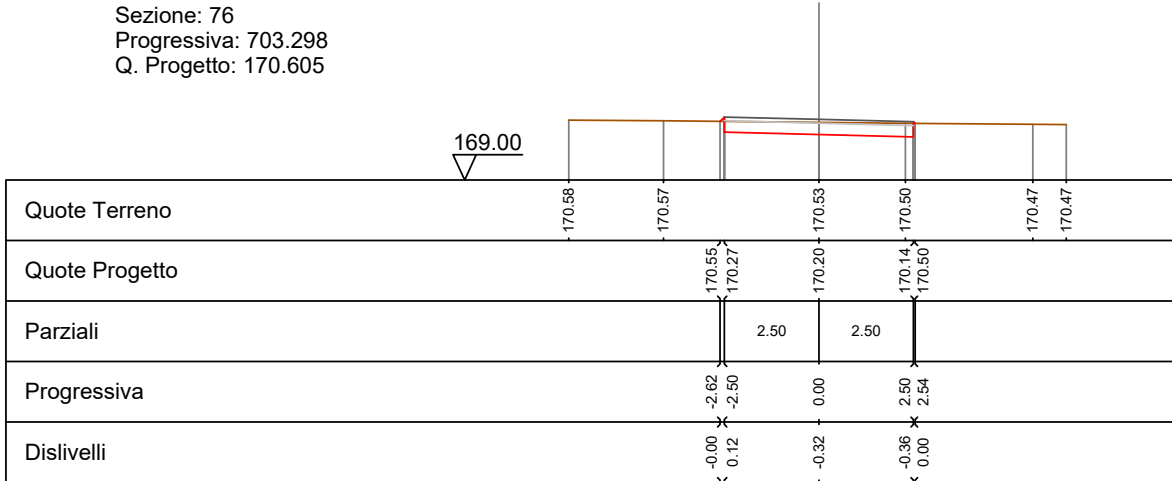

Sezione: 77
 Progressiva: 703.808
 Q. Progetto: 170.626

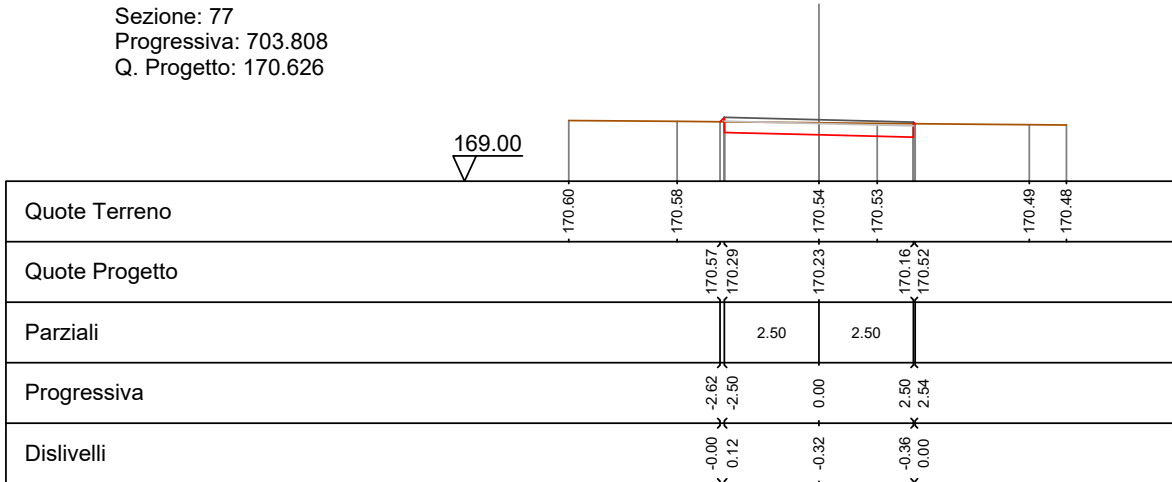

Sezione: 78
 Progressiva: 720.000
 Q. Progetto: 171.284

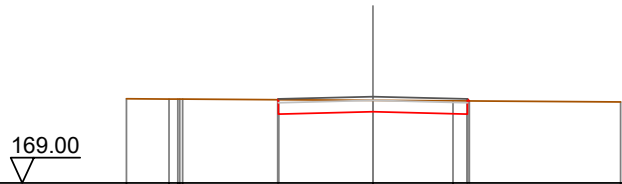

Quote Terreno	171.23	171.22	171.22		171.19	171.17	171.14
Quote Progetto			170.82		170.88	170.82	171.17
Parziali				2.50	2.50		
Progressiva			-2.52		0.00	2.50	2.55
Dislivelli			0.00		-0.30	-0.35	0.00

Sezione: 79
 Progressiva: 740.000
 Q. Progetto: 172.097

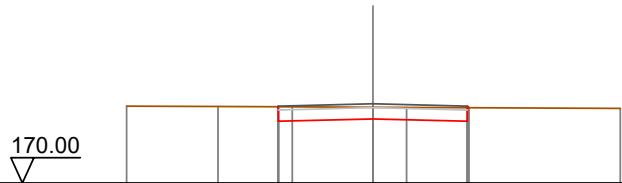

Quote Terreno	172.03	172.03	172.02		172.01	172.00	171.98
Quote Progetto			171.63		171.70	171.63	171.99
Parziali				2.50	2.50		
Progressiva			-2.52		0.00	2.50	2.54
Dislivelli			0.00		-0.31	-0.36	-0.00

Sezione: 80
 Progressiva: 760.000
 Q. Progetto: 172.909

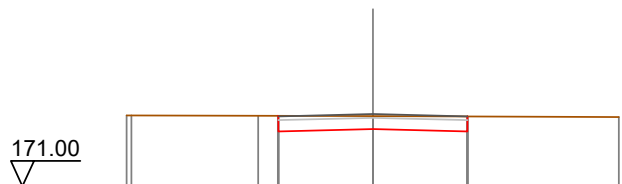

Quote Terreno	172.87	172.87	172.86		172.85		172.83
Quote Progetto			172.45		172.51	172.45	
Parziali				2.50	2.50		
Progressiva			-2.51		0.00	2.50	
Dislivelli			0.00		-0.34	-0.40	

Sezione: 81
 Progressiva: 776.006
 Q. Progetto: 173.560

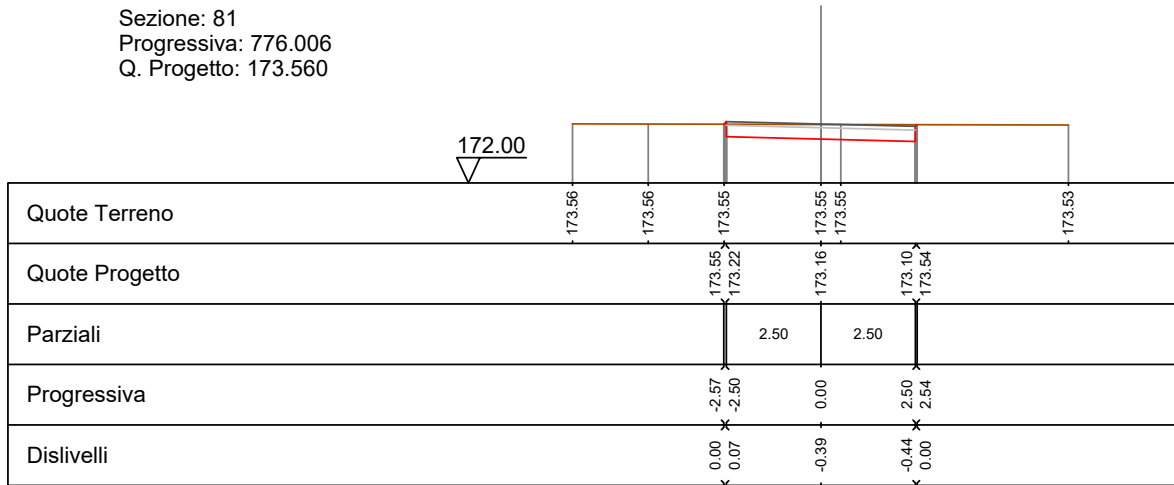

Sezione: 82
 Progressiva: 778.616
 Q. Progetto: 173.667

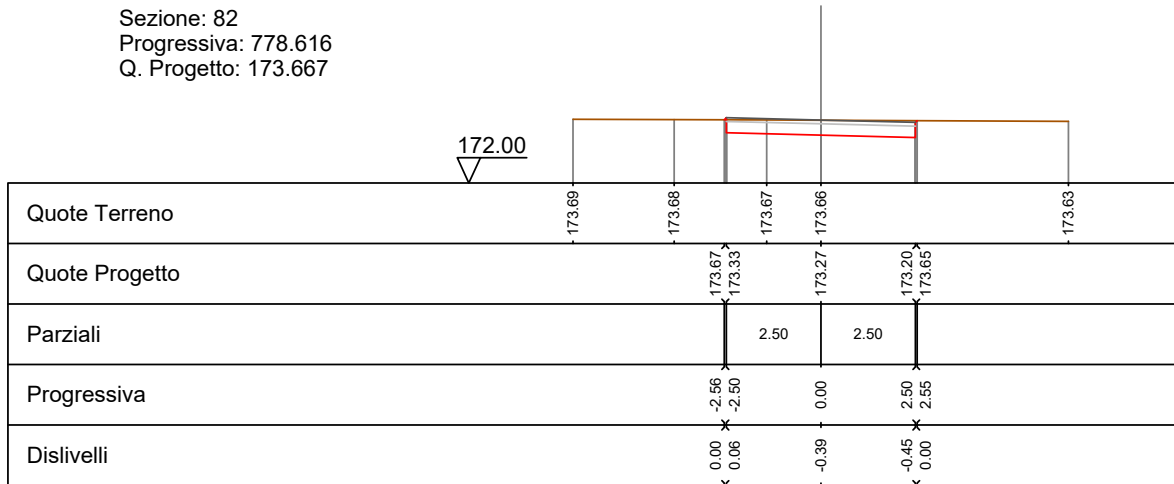

Sezione: 83
 Progressiva: 780.000
 Q. Progetto: 173.728

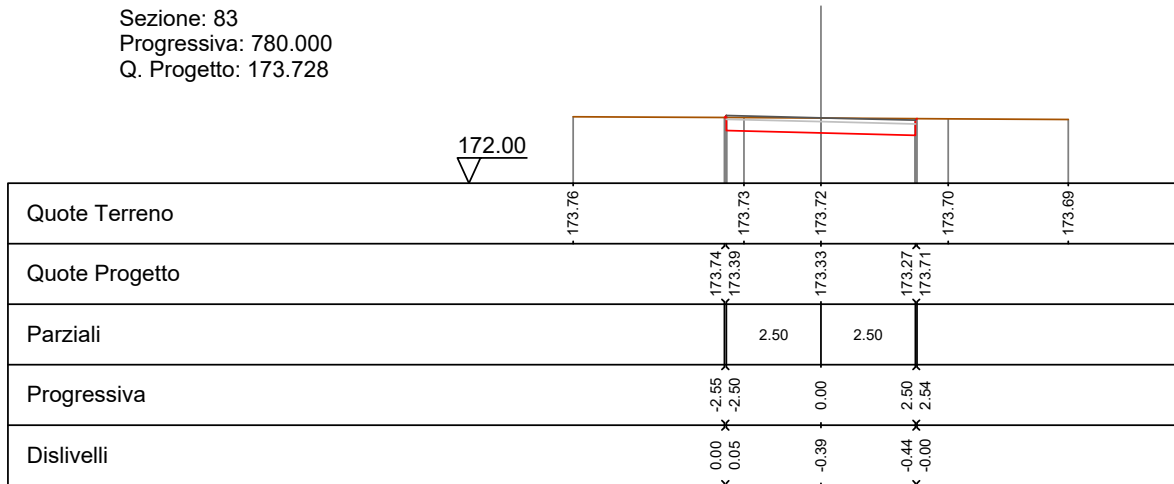

Sezione: 84
 Progressiva: 781.226
 Q. Progetto: 173.783

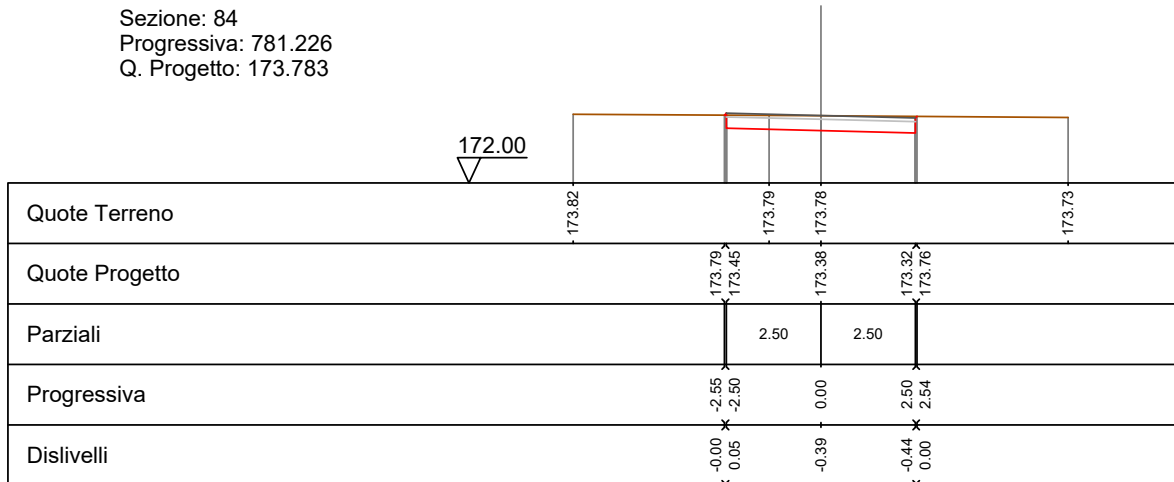

Sezione: 85
 Progressiva: 800.000
 Q. Progetto: 174.627

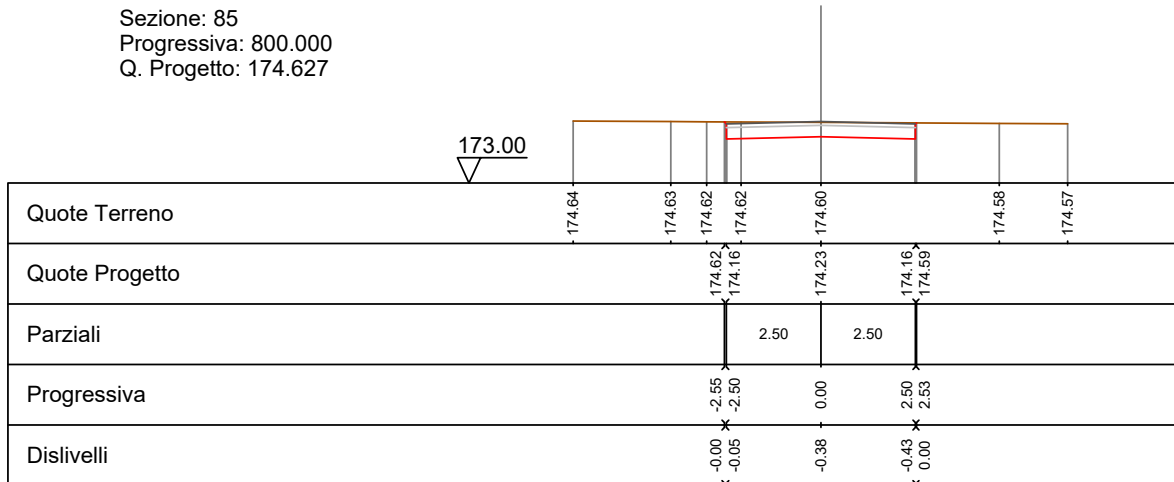

Sezione: 86
 Progressiva: 813.701
 Q. Progetto: 175.243

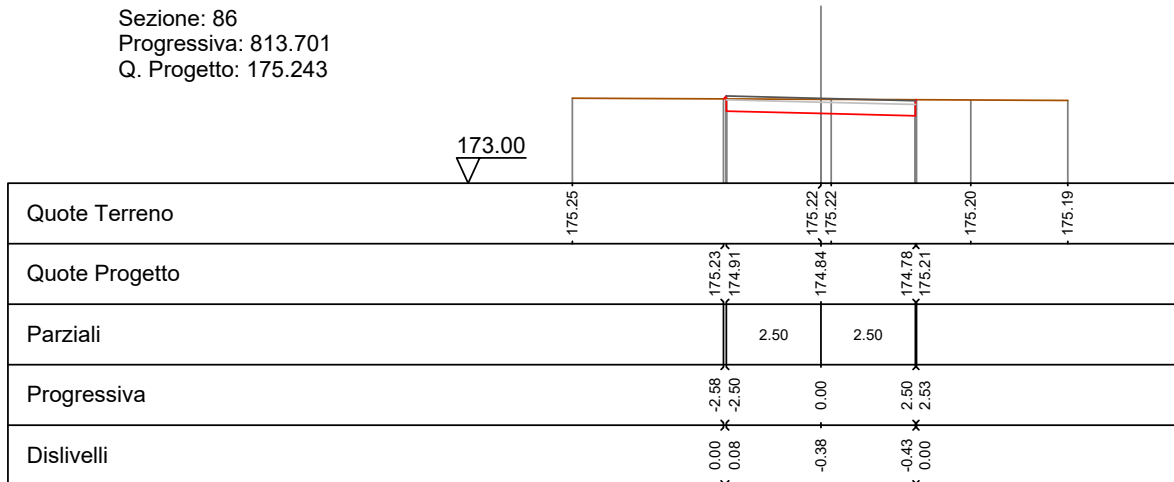

Sezione: 87
 Progressiva: 816.180
 Q. Progetto: 175.355

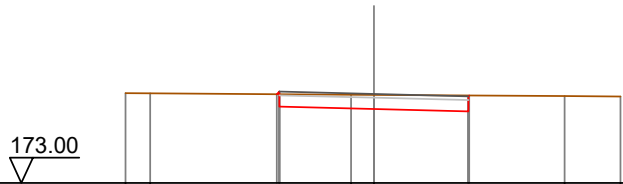

Quote Terreno	175.37	175.37		175.33	175.33		175.30	175.29
Quote Progetto			175.35	175.02	174.95		174.89	175.31
Parziali			2.50		2.50			
Progressiva			-2.57	-2.50	0.00		2.50	2.52
Dislivelli			0.00	0.07	-0.38		-0.42	0.00

Sezione: 88
 Progressiva: 818.658
 Q. Progetto: 175.466

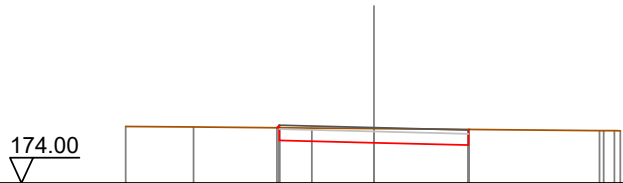

Quote Terreno	175.50	175.48		175.46	175.44		175.39	175.38	175.38
Quote Progetto			175.46	175.13	175.07		175.00		
Parziali			2.50		2.50				
Progressiva			-2.57	-2.50	0.00		2.50		
Dislivelli			0.00	0.07	-0.37		-0.41		

Sezione: 89
 Progressiva: 820.000
 Q. Progetto: 175.527

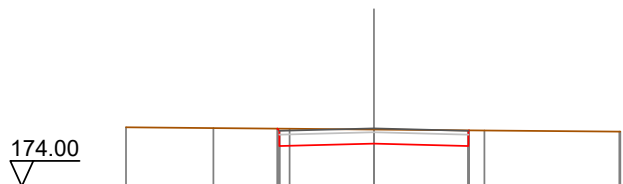

Quote Terreno	175.56	175.54		175.52	175.50		175.47	175.44	175.44
Quote Progetto			175.52	175.06	175.13		175.06		
Parziali			2.50		2.50				
Progressiva			-2.56	-2.50	0.00		2.50		
Dislivelli			0.00	-0.06	-0.37		-0.41		

Sezione: 90
 Progressiva: 840.000
 Q. Progetto: 176.426



Quote Terreno	176.45			176.40	176.39	176.38	176.35
Quote Progetto		176.42	175.96	176.03	175.96	176.38	
Parziali		2.50		2.50			
Progressiva		-2.56	-2.50	0.00	2.50	2.52	
Dislivelli		-0.06	-0.06	-0.38	-0.42	0.00	

Sezione: 91
 Progressiva: 841.056
 Q. Progetto: 176.473

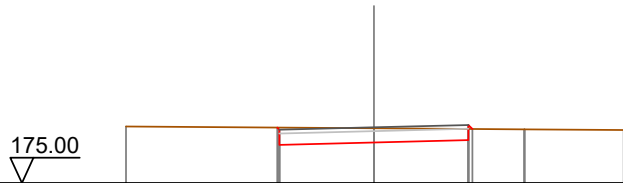

Quote Terreno	176.49			176.45		176.42	176.40
Quote Progetto		176.47	176.01	176.07	176.14	176.43	
Parziali		2.50		2.50			
Progressiva		-2.56	-2.50	0.00	2.50	2.60	
Dislivelli		0.00	-0.06	-0.38	-0.30	0.00	

Sezione: 92
 Progressiva: 843.140
 Q. Progetto: 176.567

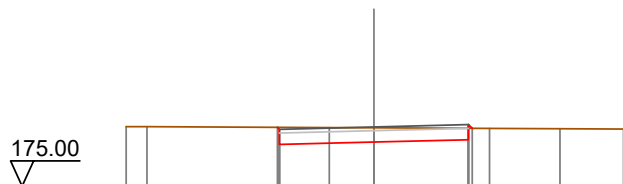

Quote Terreno	176.58	176.57		176.55	176.54	176.53	176.52	176.51
Quote Progetto			176.56	176.10	176.17	176.23	176.53	
Parziali			2.50		2.50			
Progressiva			-2.55	-2.50	0.00	2.50	2.60	
Dislivelli			-0.00	-0.05	-0.38	-0.30	0.00	

Sezione: 93
 Progressiva: 845.224
 Q. Progetto: 176.661

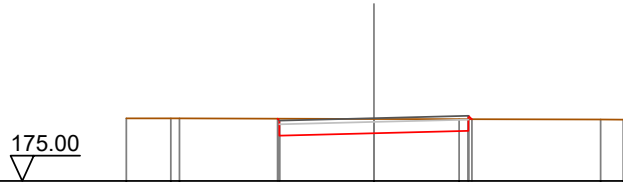

Quote Terreno	176.66	176.65	176.65		176.64	176.63	176.62	176.62
Quote Progetto			176.65	176.20	176.26	176.32	176.63	
Parziali			2.50		2.50			
Progressiva			-2.55	-2.50	0.00	2.50	2.59	
Dislivelli			0.00	-0.05	-0.38	-0.31	0.00	

Sezione: 94
 Progressiva: 860.000
 Q. Progetto: 177.325

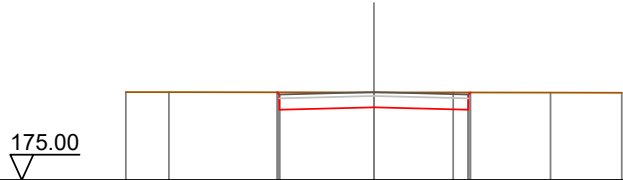

Quote Terreno	177.33	177.32			177.32	177.32	177.31	177.31
Quote Progetto			177.32	176.86	176.92	176.86	177.32	
Parziali			2.50		2.50			
Progressiva			-2.56	-2.50	0.00	2.50	2.55	
Dislivelli			-0.00	-0.06	-0.39	-0.45	0.00	

Sezione: 95
 Progressiva: 880.000
 Q. Progetto: 178.224

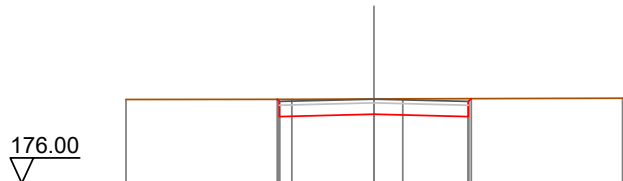

Quote Terreno	178.21		178.22		178.23	178.23		178.25
Quote Progetto			178.22	177.76	177.82	177.76	178.24	
Parziali			2.50		2.50			
Progressiva			-2.56	-2.50	0.00	2.50	2.57	
Dislivelli			0.00	-0.06	-0.40	-0.47	0.00	

Sezione: 96
 Progressiva: 900.000
 Q. Progetto: 179.098

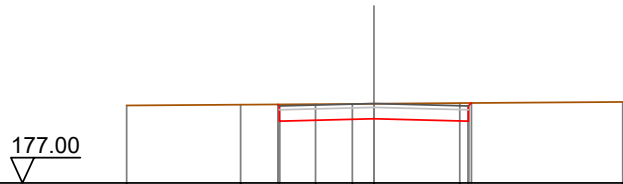

Quote Terreno	179.05	179.07	179.08	179.09	179.09	179.11	179.14
Quote Progetto		179.08	178.64	178.70	178.64	179.12	
Parziali			2.50	2.50			
Progressiva		-2.54	-2.50	0.00	2.50	2.58	
Dislivelli		0.00	-0.04	-0.40	-0.48	0.00	

Sezione: 97
 Progressiva: 903.712
 Q. Progetto: 179.255

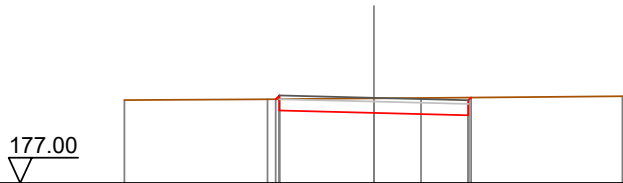

Quote Terreno	179.20	179.22	179.24	179.25	179.30
Quote Progetto		179.22	178.86	178.79	179.26
Parziali			2.50	2.50	
Progressiva		-2.60	-2.50	0.00	2.50
Dislivelli		0.00	0.10	-0.38	-0.47

Sezione: 98
 Progressiva: 910.000
 Q. Progetto: 179.521

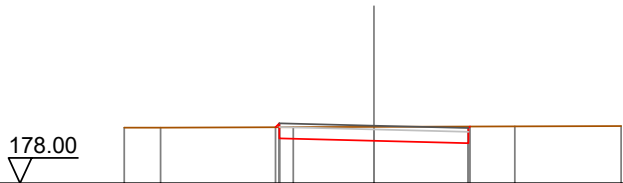

Quote Terreno	179.47	179.47	179.48	179.49	179.50	179.51
Quote Progetto		179.48	179.12	179.06	179.50	
Parziali			2.50	2.50		
Progressiva		-2.60	-2.50	0.00	2.50	2.54
Dislivelli		0.00	0.10	-0.37	-0.44	0.00

Sezione: 99
 Progressiva: 913.196
 Q. Progetto: 179.657

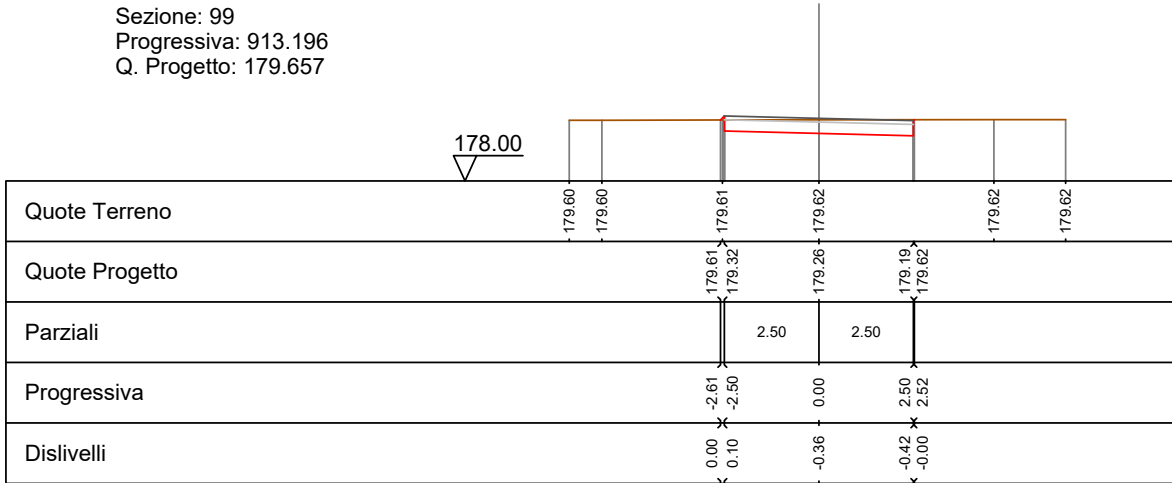

Sezione: 100
 Progressiva: 920.000
 Q. Progetto: 179.944

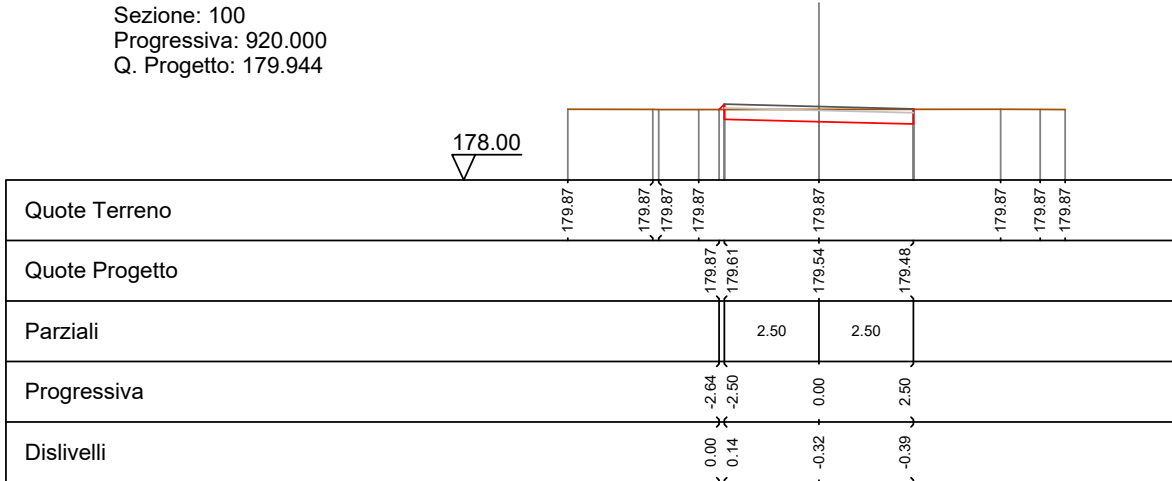

Sezione: 101
 Progressiva: 922.679
 Q. Progetto: 180.058

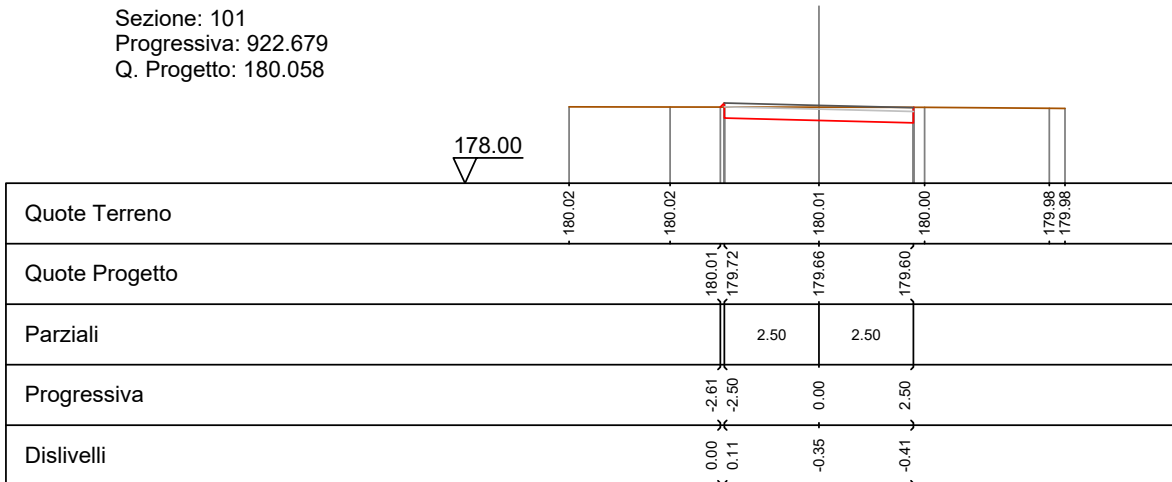

Sezione: 102
 Progressiva: 940.000
 Q. Progetto: 181.102

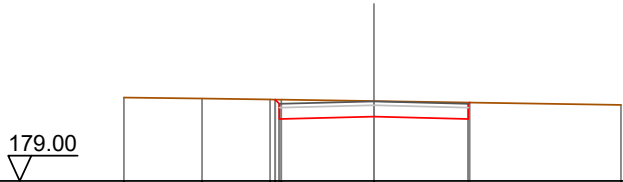

Quote Terreno	181.21	181.18	181.15	181.15	181.11	181.01
Quote Progetto			181.15	180.64	181.11	180.64
Parziali			2.50	2.50		
Progressiva			-2.61	-2.50	0.00	2.50
Dislivelli			0.00	-0.11	-0.41	-0.43

Sezione: 103
 Progressiva: 960.000
 Q. Progetto: 182.507

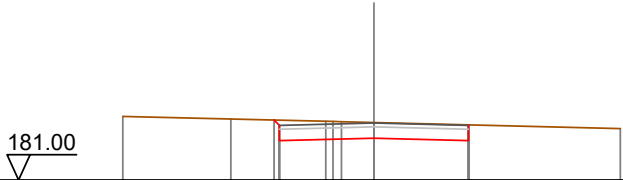

Quote Terreno	182.68	182.61	182.56	182.54	182.52	182.36
Quote Progetto			182.59	182.04	182.11	182.04
Parziali			2.50	2.50		
Progressiva			-2.64	-2.50	0.00	2.50
Dislivelli			0.00	-0.14	-0.42	-0.42

Sezione: 104
 Progressiva: 980.000
 Q. Progetto: 183.913

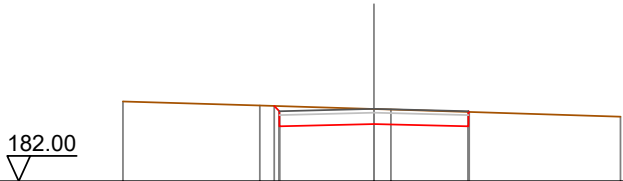

Quote Terreno	184.11	184.00	183.91	183.90	183.71
Quote Progetto		183.99	183.45	183.51	183.45
Parziali			2.50	2.50	
Progressiva			-2.64	-2.50	2.50
Dislivelli			0.00	-0.13	-0.40

Sezione: 105
 Progressiva: 983.665
 Q. Progetto: 184.170

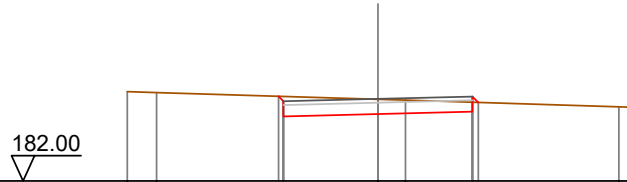

Quote Terreno	184.36	184.34		184.16	184.14		183.96	183.95
Quote Progetto			184.24	183.77		183.83	184.08	
Parziali			2.50	2.50				
Progressiva			-2.63	0.00		2.50	2.66	
Dislivelli			0.00	-0.39		-0.25	-0.00	

Sezione: 106
 Progressiva: 987.788
 Q. Progetto: 184.460



Quote Terreno	184.62		184.47	184.44	184.41	184.37	184.27
Quote Progetto		184.51	184.00	184.06	184.12	184.38	
Parziali		2.50	2.50				
Progressiva		-2.61	0.00		2.50	2.64	
Dislivelli		-0.00	-0.38		-0.26	0.00	

Sezione: 107
 Progressiva: 990.000
 Q. Progetto: 184.615

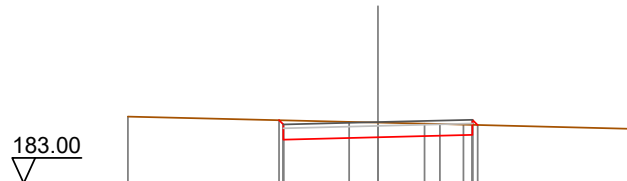

Quote Terreno	184.76		184.62	184.60	184.58	184.55	184.44
Quote Progetto		184.67	184.15	184.22	184.28	184.54	
Parziali		2.50	2.50				
Progressiva		-2.61	0.00		2.50	2.64	
Dislivelli		0.00	-0.39		-0.26	0.00	

Sezione: 108
 Progressiva: 991.911
 Q. Progetto: 184.749

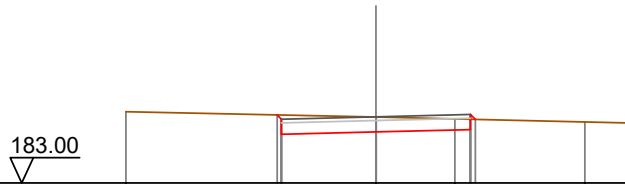

Quote Terreno	184.88			184.74	184.70	184.61	184.59
Quote Progetto		184.80	184.23	184.35	184.41	184.66	
Parziali		2.50		2.50			
Progressiva		-2.61	-2.50	0.00	2.50	2.63	
Dislivelli		0.00	-0.11	-0.40	-0.27	0.00	

Sezione: 109
 Progressiva: 1000.000
 Q. Progetto: 185.318

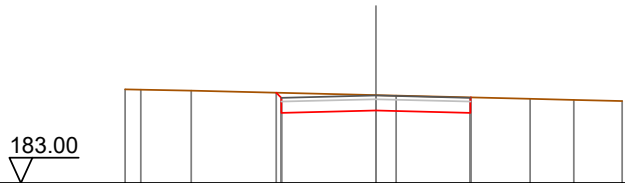

Quote Terreno	185.48	185.47	185.44		185.33	185.32	185.23	185.20	185.17
Quote Progetto				185.39	184.86	184.92	185.33	184.86	
Parziali				2.50		2.50			
Progressiva				-2.63	-2.50	0.00	2.50		
Dislivelli				-0.00	-0.13	-0.41	-0.41		

Sezione: 110
 Progressiva: 1020.000
 Q. Progetto: 186.723

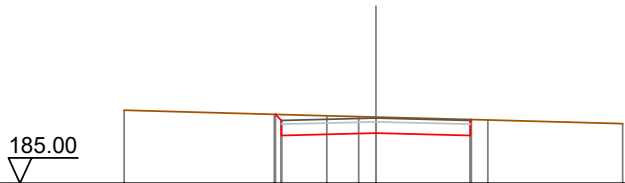

Quote Terreno	186.93			186.78	186.76	186.75	186.67	186.57
Quote Progetto		186.82	186.26	186.32	186.75	186.26	186.66	
Parziali		2.50		2.50				
Progressiva		-2.66	-2.50	0.00	2.50	2.52		
Dislivelli		-0.00	-0.16	-0.43	-0.42	0.00		

Sezione: 111
 Progressiva: 1040.000
 Q. Progetto: 188.128

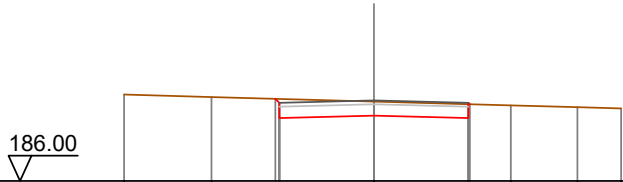

Quote Terreno	188.29	188.22		188.10		188.00	187.95	187.92
Quote Progetto			188.17	187.67	187.73	187.67	188.03	
Parziali			2.50	2.50				
Progressiva			-2.61	-2.50	0.00	2.50	2.54	
Dislivelli			0.00	-0.10	-0.37	-0.36	0.00	

Sezione: 112
 Progressiva: 1060.000
 Q. Progetto: 189.426

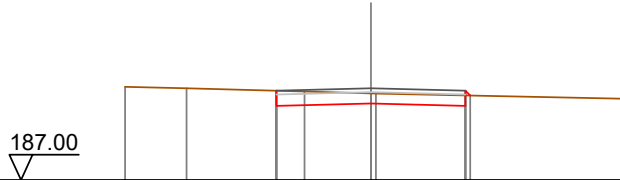

Quote Terreno	189.46	189.43		189.34	189.29	189.29		189.15
Quote Progetto			188.96		189.03	188.96	189.24	
Parziali			2.50	2.50				
Progressiva			-2.50	0.00	2.50	2.63		
Dislivelli			0.00	-0.27	-0.28	0.00		

Sezione: 113
 Progressiva: 1070.692
 Q. Progetto: 189.840

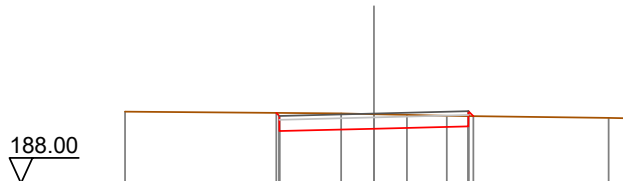

Quote Terreno	189.89			189.84	189.83	189.81	189.78	189.73	189.72
Quote Progetto			189.86	189.36	189.44	189.50	189.77		
Parziali			2.50	2.50					
Progressiva			-2.58	-2.50	0.00	2.50	2.63		
Dislivelli			0.00	-0.08	-0.39	-0.27	-0.00		

Sezione: 114
 Progressiva: 1074.573
 Q. Progetto: 189.934



Quote Terreno	189.97		189.89	189.89	189.90		189.91	189.91
Quote Progetto		189.92	189.47	189.53	189.60	189.90		
Parziali		2.50		2.50				
Progressiva		-2.55	-2.50	0.00	2.50	2.60		
Dislivelli		0.00	-0.05	-0.36	-0.30	0.00		

Sezione: 115
 Progressiva: 1078.454
 Q. Progetto: 189.998

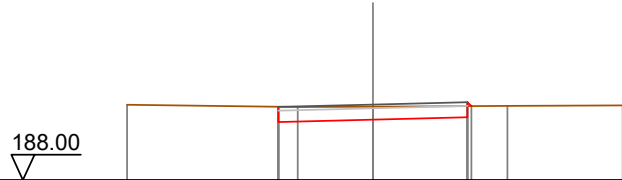

Quote Terreno	189.99		189.93	189.94		189.96		189.97
Quote Progetto		189.54		189.60	189.66	189.96		
Parziali		2.50		2.50				
Progressiva		-2.50	0.00	2.50	2.60			
Dislivelli		0.00	-0.34	-0.29	0.00			

Sezione: 116
 Progressiva: 1080.000
 Q. Progetto: 190.015

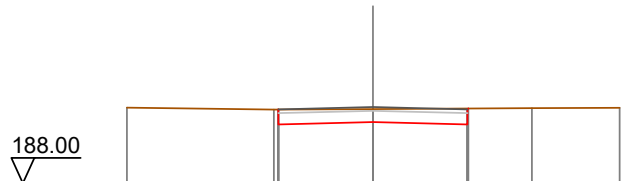

Quote Terreno	190.00		189.95	189.96		189.98		189.99
Quote Progetto		189.55		189.61	189.55	189.96		
Parziali		2.50		2.50				
Progressiva		-2.50	0.00	2.50	2.52			
Dislivelli		0.00	-0.35	-0.42	-0.00			

Sezione: 117
 Progressiva: 1100.000
 Q. Progetto: 190.182

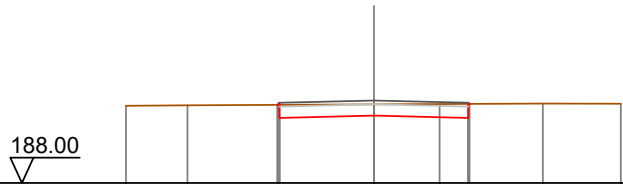

Quote Terreno	190.04	190.05		190.08	190.09	190.10	190.10
Quote Progetto			190.06 189.72	189.78	189.72 190.09		
Parziali			2.50	2.50			
Progressiva			-2.56 -2.50	0.00	2.50 2.53		
Dislivelli			0.00 0.06	-0.29	-0.37 -0.00		

Sezione: 118
 Progressiva: 1120.000
 Q. Progetto: 190.348

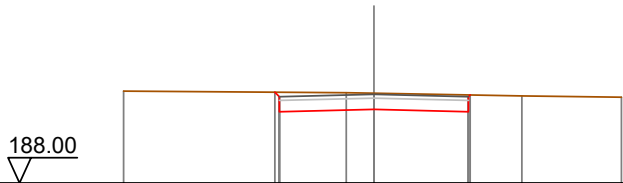

Quote Terreno	190.43		190.39	190.38	190.30	190.27
Quote Progetto		190.40 189.89	189.95	189.89 190.33		
Parziali		2.50	2.50			
Progressiva		-2.62 -2.50	0.00	2.50 2.54		
Dislivelli		-0.00 -0.12	-0.43	-0.45 -0.00		

Sezione: 119
 Progressiva: 1140.000
 Q. Progetto: 190.210

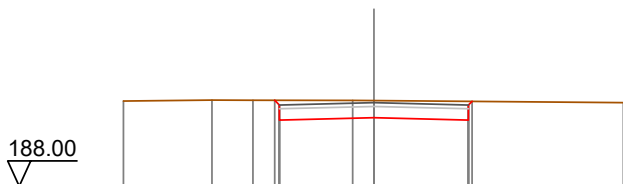

Quote Terreno	190.25	190.28	190.27	190.27	190.27	190.24	190.21
Quote Progetto			190.27 189.75	189.81	189.75 190.24		
Parziali			2.50	2.50			
Progressiva			-2.63 -2.50	0.00	2.50 2.60		
Dislivelli			0.00 -0.13	-0.46	-0.50 0.00		

Sezione: 120
 Progressiva: 1153.611
 Q. Progetto: 190.074

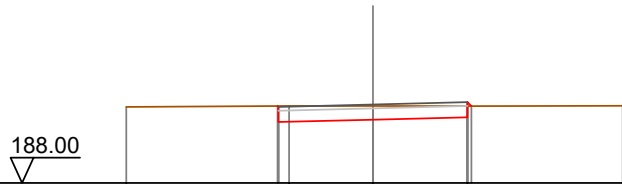

Quote Terreno	190.01	190.04	190.03	190.03	190.04
Quote Progetto		190.04 189.61	189.67	189.74 190.03	
Parziali		2.50	2.50		
Progressiva		-2.52 -2.50	0.00	2.50 2.61	
Dislivelli		0.00 -0.02	-0.36	-0.29 0.00	

Sezione: 121
 Progressiva: 1160.000
 Q. Progetto: 189.979

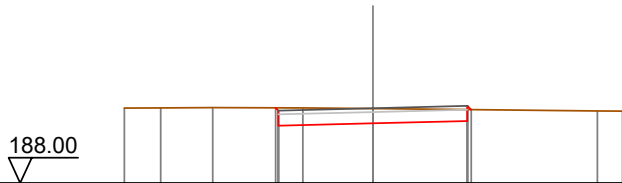

Quote Terreno	189.98	189.99	190.00	189.99	189.97	189.91	189.90
Quote Progetto				189.99 189.52	189.58	189.64 189.94	
Parziali				2.50	2.50		
Progressiva				-2.57 -2.50	0.00	2.50 2.60	
Dislivelli				0.00 -0.07	-0.39	-0.30 0.00	

Sezione: 122
 Progressiva: 1161.082
 Q. Progetto: 189.955

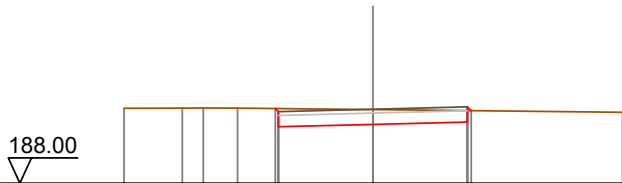

Quote Terreno	189.98	189.99	189.99	189.99	189.95	189.87
Quote Progetto				189.98 189.49	189.56	189.62 189.92
Parziali				2.50	2.50	
Progressiva				-2.58 -2.50	0.00	2.50 2.60
Dislivelli				-0.00 -0.08	-0.39	-0.30 0.00

Sezione: 123
 Progressiva: 1168.554
 Q. Progetto: 189.725

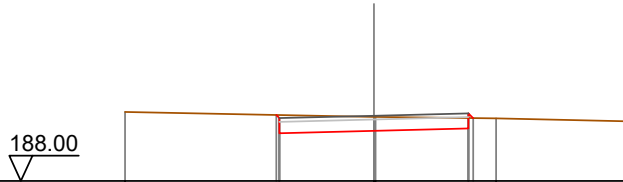

Quote Terreno	189.82		189.69	189.69	189.65	189.58
Quote Progetto		189.75	189.26	189.33	189.39	189.66
Parziali		2.50	2.50			
Progressiva		-2.58	-2.50	0.00	2.50	2.63
Dislivelli		-0.00	-0.08	-0.37	-0.28	0.00

Sezione: 124
 Progressiva: 1180.000
 Q. Progetto: 189.193

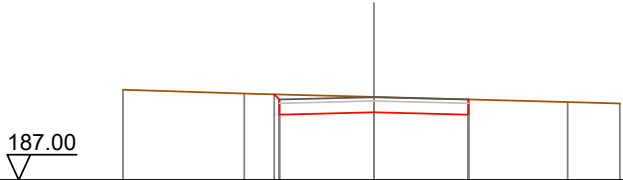

Quote Terreno	189.39	189.29	189.20	189.07	189.02
Quote Progetto		189.27	188.73	188.79	188.73
Parziali		2.50	2.50		
Progressiva		-2.64	-2.50	0.00	2.50
Dislivelli		0.00	-0.13	-0.41	-0.40

Sezione: 125
 Progressiva: 1200.000
 Q. Progetto: 188.212



Quote Terreno	188.47	188.34	188.26	188.21	188.20	188.00	187.97
Quote Progetto		188.32	187.75	187.81	187.75	188.12	
Parziali		2.50	2.50				
Progressiva		-2.67	-2.50	0.00	2.50	2.63	
Dislivelli		0.00	-0.16	-0.40	-0.37	0.00	

Sezione: 126
 Progressiva: 1220.082
 Q. Progetto: 186.825

185.00

Quote Terreno	187.48	187.30	187.16	186.99	186.87
Quote Progetto		187.29	186.36	186.42	186.49
Parziali		0.53	2.50	2.50	
Progressiva		-3.03	-2.50	0.00	2.50
Dislivelli		-0.00	-0.51	-0.74	-0.56

Sezione: 127
 Progressiva: 1223.129
 Q. Progetto: 186.543

185.00

Quote Terreno	187.35	187.16	187.00	186.99	186.68
Quote Progetto		187.15	186.08	186.14	186.21
Parziali		0.67	2.50	2.50	
Progressiva		-3.17	-2.50	0.00	2.50
Dislivelli		0.00	-0.64	-0.86	-0.68

Sezione: 128
 Progressiva: 1226.176
 Q. Progetto: 186.244

184.00

Quote Terreno	187.24	187.06	187.02	186.99	186.85	186.50
Quote Progetto		187.02	185.78	185.84	185.91	186.70
Parziali		0.84	2.50	2.50	0.40	
Progressiva		-3.34	-2.50	0.00	2.50	2.50
Dislivelli		0.00	-0.80	-1.01	-0.82	-0.00

Sezione: 129
 Progressiva: 1240.000
 Q. Progetto: 184.865

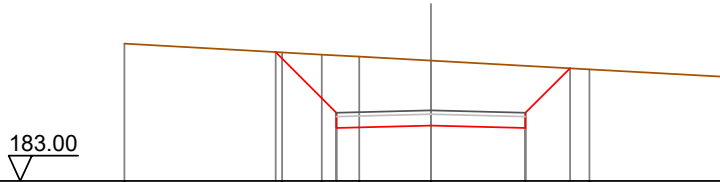

Quote Terreno	186.63	186.40	186.34	186.29	186.18	185.95	185.76
Quote Progetto		186.41	184.40	184.40	184.47	184.40	185.98
Parziali			1.61	2.50	2.50	1.18	
Progressiva		-4.11	-2.50	0.00	2.50	3.68	
Dislivelli		0.00	-1.52	-1.72	-1.64	0.00	

Sezione: 130
 Progressiva: 1242.657
 Q. Progetto: 184.600

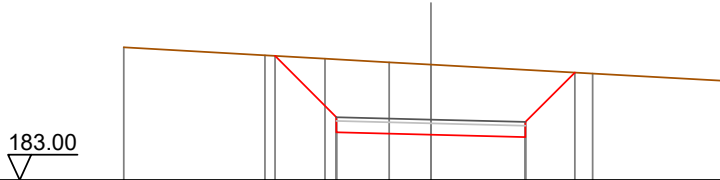

Quote Terreno	186.51	186.30	186.21	186.11	186.05	185.82	185.62
Quote Progetto		186.29	184.26	184.20	184.14	185.84	
Parziali			1.62	2.50	2.50	1.30	
Progressiva		-4.12	-2.50	0.00	2.50	3.80	
Dislivelli		0.00	-1.53	-1.85	-1.78	0.00	

Sezione: 131
 Progressiva: 1250.000
 Q. Progetto: 183.868

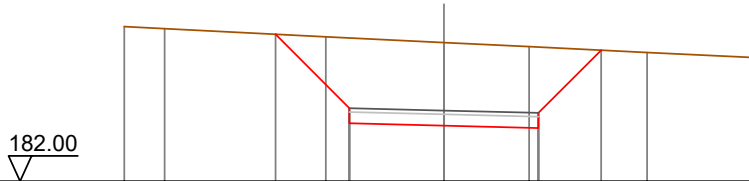

Quote Terreno	186.09	186.03	185.82	185.67	185.56	185.40	185.27
Quote Progetto			185.89	183.53	183.47	183.41	185.46
Parziali			1.96	2.50	2.50	1.66	
Progressiva		-4.46	-2.50	0.00	2.50	4.16	
Dislivelli		-0.00	-1.86	-2.20	-2.14	-0.00	

Sezione: 131
 Progressiva: 1250.000
 Q. Progetto: 183.868

182.00

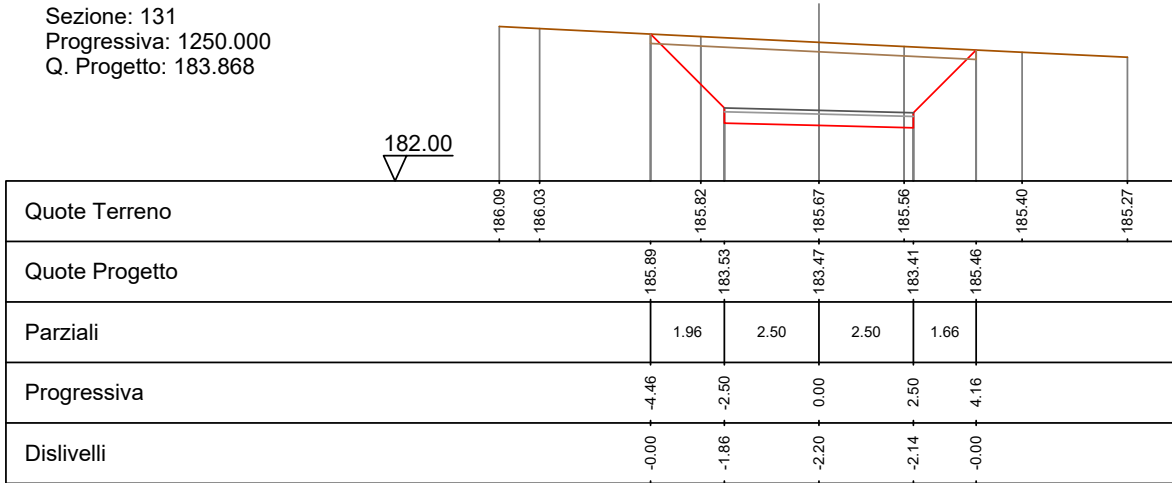

Sezione: 132
 Progressiva: 1260.000
 Q. Progetto: 182.871

181.00

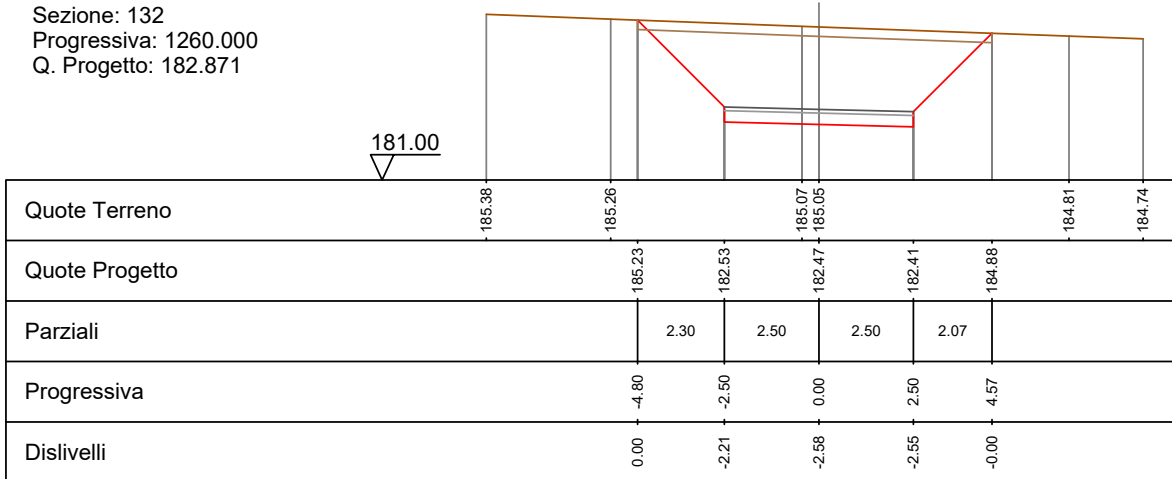

Sezione: 133
 Progressiva: 1270.000
 Q. Progetto: 181.909

180.00

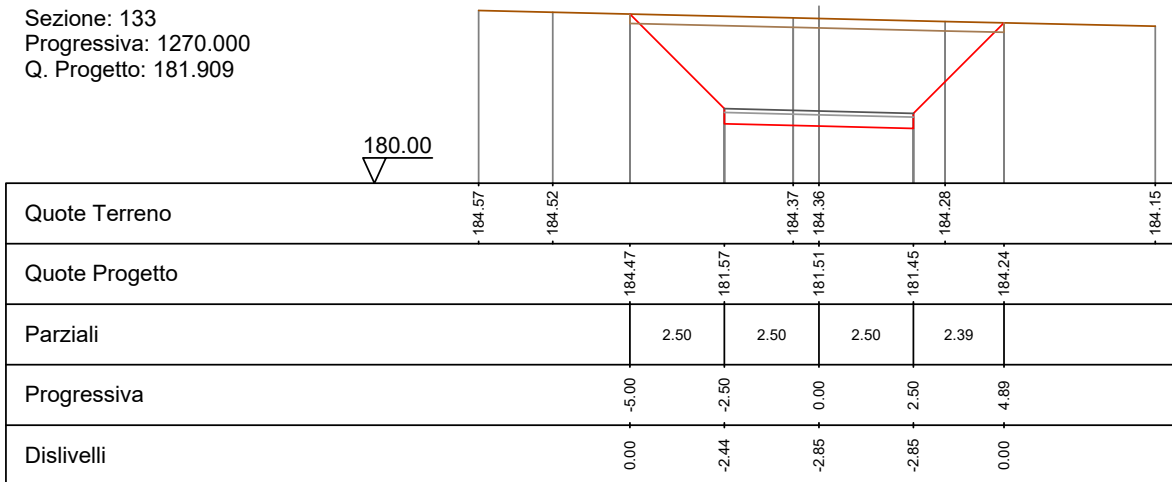

Sezione: 134
 Progressiva: 1280.000
 Q. Progetto: 181.134

179.00

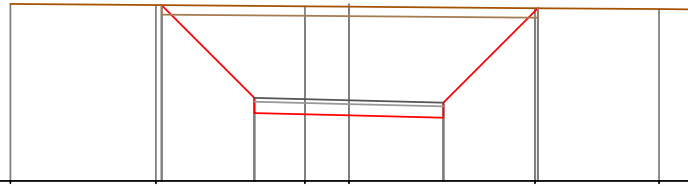

Quote Terreno	183.68	183.65	183.62	183.61	183.57	183.54	183.54
Quote Progetto		183.65	180.80	180.73	180.67	183.57	
Parziali		2.45	2.50	2.50	2.50		
Progressiva		-4.95	-2.50	0.00	2.50	5.00	
Dislivelli		0.00	-2.43	-2.88	-2.92	0.00	

Sezione: 135
 Progressiva: 1284.252
 Q. Progetto: 180.865

179.00

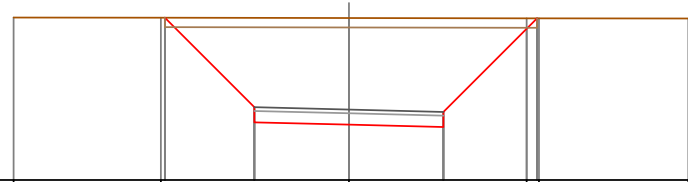

Quote Terreno	183.30	183.29	183.29	183.28	183.28	183.27
Quote Progetto		183.29	180.53	180.47	180.40	183.28
Parziali		2.37	2.50	2.50	2.48	
Progressiva		-4.87	-2.50	0.00	2.50	4.98
Dislivelli		0.00	-2.36	-2.82	-2.88	0.00

Sezione: 136
 Progressiva: 1290.000
 Q. Progetto: 180.560

179.00

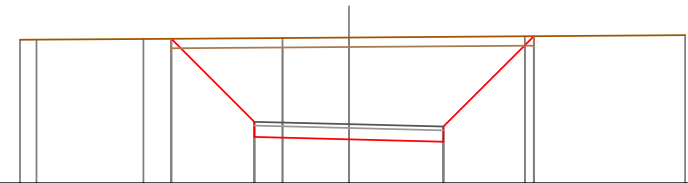

Quote Terreno	182.79	182.80	182.82	182.84	182.85	182.88	182.92
Quote Progetto			182.82	180.22	180.16	180.10	182.89
Parziali			2.20	2.50	2.50	2.39	
Progressiva			-4.70	-2.50	0.00	2.50	4.89
Dislivelli			0.00	-2.21	-2.69	-2.77	-0.00

Sezione: 137
 Progressiva: 1300.000
 Q. Progetto: 180.186

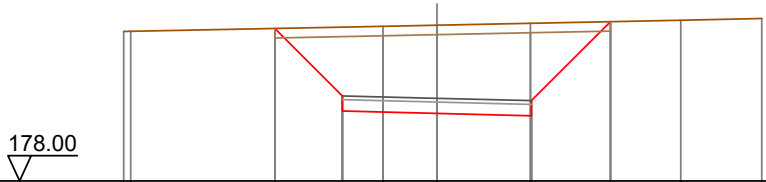

Quote Terreno	181.95	181.96		182.09	182.12	182.17		182.25	182.30
Quote Progetto			182.03	179.85	179.79	179.72	182.21		
Parziali			1.78	2.50	2.50	2.09			
Progressiva			-4.28	-2.50	0.00	2.50	4.59		
Dislivelli			0.00	-1.82	-2.33	-2.45	0.00		

Sezione: 138
 Progressiva: 1310.000
 Q. Progetto: 180.013

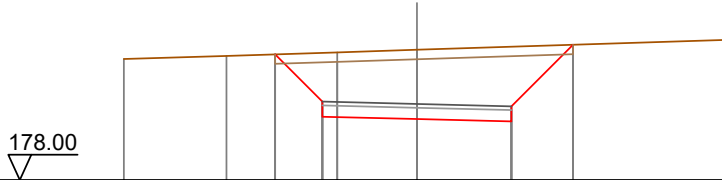

Quote Terreno	181.20	181.28	181.38	181.45				181.71
Quote Progetto			181.33	179.68	179.61	179.55	181.58	
Parziali			1.25	2.50	2.50	1.63		
Progressiva			-3.75	-2.50	0.00	2.50	4.13	
Dislivelli			0.00	-1.29	-1.83	-1.98	0.00	

Sezione: 139
 Progressiva: 1317.000
 Q. Progetto: 180.000

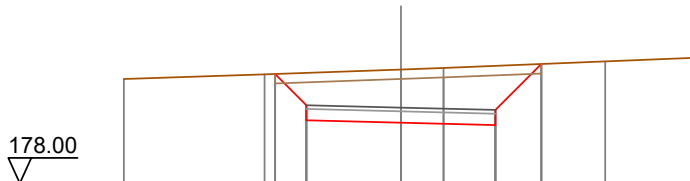

Quote Terreno	180.75	180.88		181.01	181.05		181.22	181.31
Quote Progetto		180.89	179.66	179.60	179.54	181.15		
Parziali		0.83	2.50	2.50	1.21			
Progressiva		-3.33	-2.50	0.00	2.50	3.71		
Dislivelli		0.00	-0.85	-1.41	-1.57	0.00		

SEZIONI TRASVERSALI
Profilo longitudinale tratto 3-4
Viabilità di impianto - Postazione aerogeneratore WTG02

Nota: Le canalette di deflusso delle acque meteoriche, non indicate nel presente elaborato, sono rappresentate graficamente nelle sezioni stradali tipo dell'elaborato "BLTX-NS-TC13_Piazzole aerogeneratori e strade di servizio - Particolari costruttivi", individuate planimetricamente nell'elaborato "BLTX-NS-TC14_Opere di regimazione acque superficiali - Planimetria generale" e quantificate nell'elaborato "BLTX-NS-RC6_Computo metrico estimativo opere civili".

DISEGNI DI RIFERIMENTO

TAVOLA	DESCRIZIONE
BLTX-NS-TC8	Viabilità e piazzole - Planimetria di progetto - Fase di cantiere
BLTX-NS-TC11	Profili longitudinali viabilità di impianto
BLTX-NS-TC13	Piazzole aerogeneratori e strade di servizio - Particolari costruttivi
BLTX-NS-TC14	Opere di regimazione acque superficiali - Planimetria generale

Sezione: 5
 Progressiva: 20.000
 Q. Progetto: 153.362

151.00

Quote Terreno	-152.92			152.99		-153.04	-153.07
Quote Progetto		152.96	153.02	152.96	152.90	153.01	
Parziali		0.47	2.50	2.50	0.29		
Progressiva		-2.97	-2.50	0.00	2.50	2.79	
Dislivelli		0.00	0.46	-0.02	-0.11	0.00	

Sezione: 6
 Progressiva: 30.000
 Q. Progetto: 153.113

151.00

Quote Terreno	-152.47	-152.51	-152.59	152.65	-152.76	-152.91
Quote Progetto		152.55	152.78	152.71	152.65	152.74
Parziali		0.63	2.50	2.50	0.31	
Progressiva		-3.13	-2.50	0.00	2.50	2.81
Dislivelli		0.00	0.60	0.06	-0.08	0.00

Sezione: 7
 Progressiva: 31.859
 Q. Progetto: 153.088

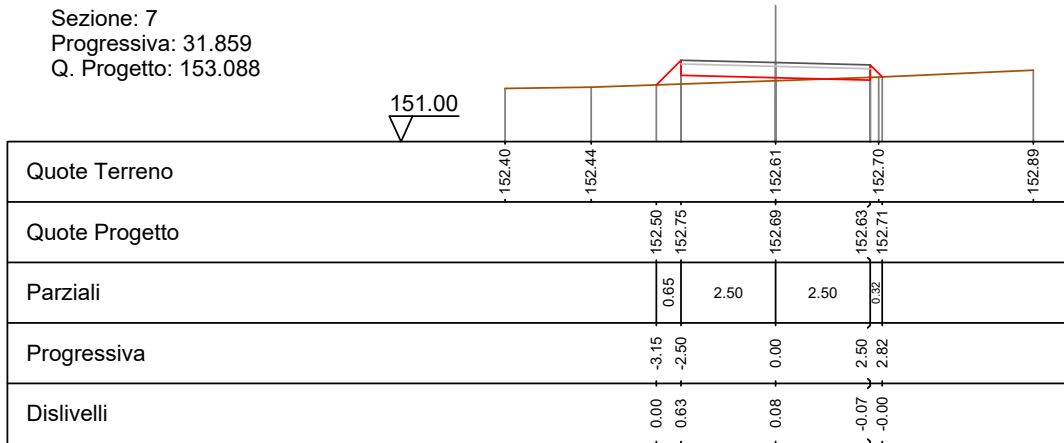

Sezione: 8
 Progressiva: 40.000
 Q. Progetto: 153.061

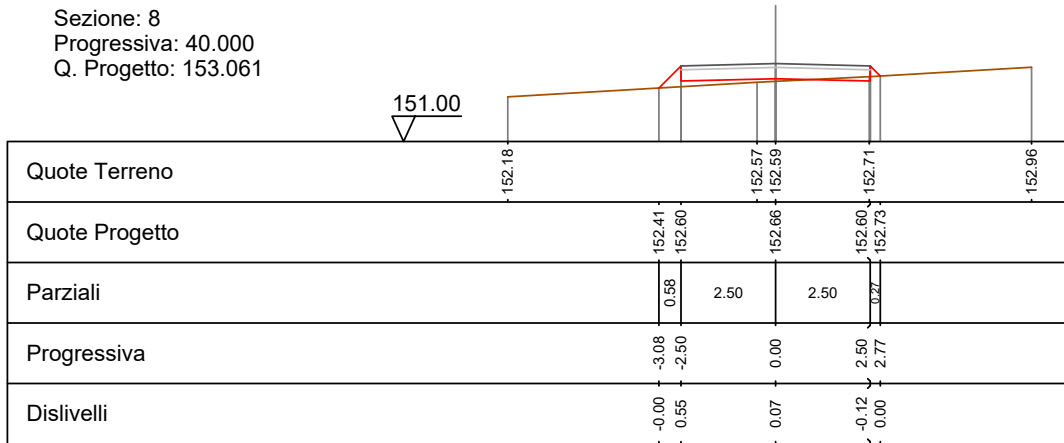

Sezione: 9
 Progressiva: 60.000
 Q. Progetto: 153.423

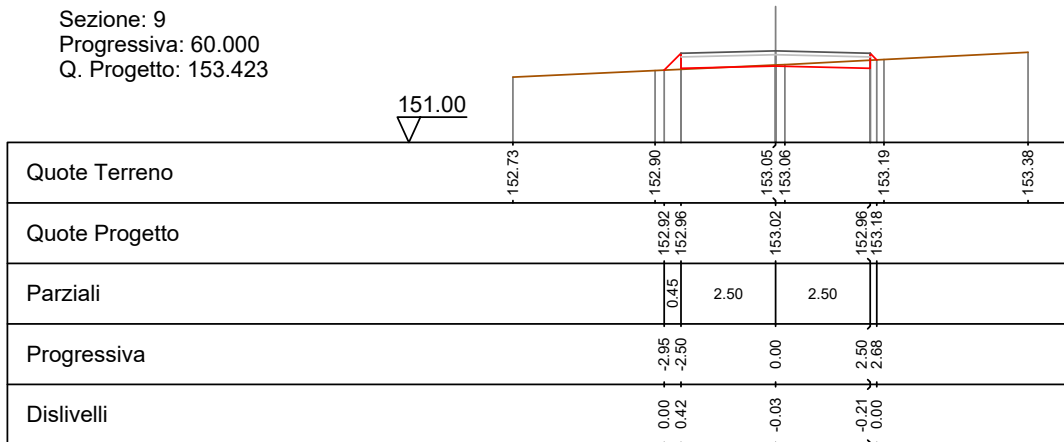

Sezione: 10
 Progressiva: 80.000
 Q. Progetto: 153.855

152.00

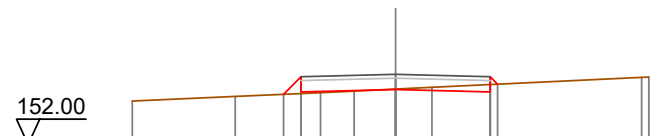

Quote Terreno	-153.15	-153.27	-153.33	-153.37	-153.41	-153.47	-153.51	-153.77	-153.78
Quote Progetto			153.33	153.39		153.46		153.39	153.59
Parziali			0.46	2.50		2.50			
Progressiva			-2.96	-2.50		0.00		2.50	2.70
Dislivelli			-0.00	0.44		-0.01		-0.19	0.00

Sezione: 11
 Progressiva: 88.278
 Q. Progetto: 154.021

152.00

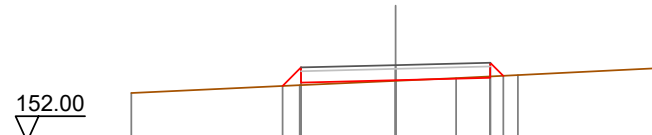

Quote Terreno	-153.28	-153.49	-153.49	-153.60	-153.68	-153.75	-153.93
Quote Progetto			153.47	153.56	153.62	153.68	153.74
Parziali			0.49	2.50		2.50	0.35
Progressiva			-2.99	-2.50	0.00	2.50	2.85
Dislivelli			0.00	0.47	0.02	-0.04	0.00

Sezione: 12
 Progressiva: 90.000
 Q. Progetto: 154.043

152.00

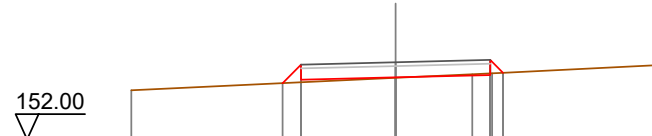

Quote Terreno	-153.30	-153.49	-153.58	-153.63	-153.73	-153.76	-153.96
Quote Progetto			153.49	153.58	153.64	153.71	153.76
Parziali			0.49	2.50		2.50	0.34
Progressiva			-2.99	-2.50	0.00	2.50	2.84
Dislivelli			0.00	0.47	0.01	-0.04	0.00

Sezione: 13
 Progressiva: 94.784
 Q. Progetto: 154.071

152.00

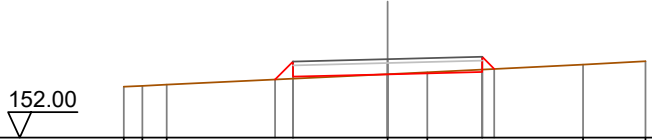

Quote Terreno	-153.34	-153.37	-153.40			153.67	153.72		153.93	154.02
Quote Progetto					153.53	153.61	153.67		153.73	153.81
Parziali					0.48	2.50		2.50	0.32	
Progressiva					-2.98	-2.50	0.00		2.50	2.82
Dislivelli					0.00	0.45	-0.00		-0.06	0.00

Sezione: 14
 Progressiva: 100.000
 Q. Progetto: 154.064

152.00

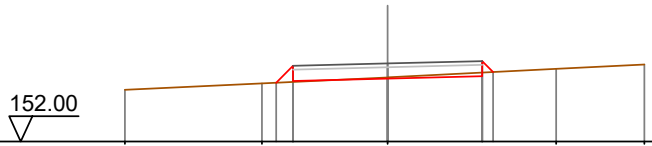

Quote Terreno	-153.37		-153.54			153.70			-153.92	154.04
Quote Progetto			153.55	153.60		153.66		153.73	153.84	
Parziali			0.45	2.50		2.50		0.29		
Progressiva			-2.95	-2.50		0.00		2.50	2.79	
Dislivelli			-0.00	0.43		-0.03		-0.10	0.00	

Sezione: 15
 Progressiva: 101.291
 Q. Progetto: 154.062

152.00

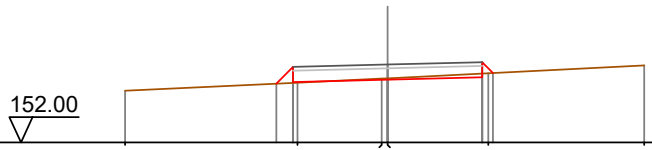

Quote Terreno	-153.37		-153.58			153.69	153.70		153.83	154.04
Quote Progetto			153.56	153.60		153.66		153.72	153.84	
Parziali			0.44	2.50		2.50		0.29		
Progressiva			-2.94	-2.50		0.00		2.50	2.79	
Dislivelli			0.00	0.42		-0.04		-0.10	0.00	

Sezione: 16
 Progressiva: 120.000
 Q. Progetto: 154.027

152.00

Quote Terreno	-153.33	-153.43	-153.54	-153.63	-153.65	-153.97
Quote Progetto			153.51	153.56	153.63	153.66
Parziali			0.45	2.50	2.50	
Progressiva			-2.95	-2.50	0.00	2.50
Dislivelli			0.00	0.43	-0.02	-0.20

Sezione: 17
 Progressiva: 127.140
 Q. Progetto: 154.013

152.00

Quote Terreno	-153.29	-153.46	-153.61	-153.71	-153.79	-153.93
Quote Progetto		153.47	153.61	153.55	153.74	
Parziali		0.61	2.50	2.50		
Progressiva		-3.11	-2.50	0.00	2.50	2.71
Dislivelli		0.00	0.58	0.00	-0.18	0.00

Sezione: 18
 Progressiva: 130.000
 Q. Progetto: 154.008

152.00

Quote Terreno	-153.27	-153.37	-153.43	-153.52	-153.60	-153.76	-153.91
Quote Progetto			153.45	153.67	153.61	153.55	153.72
Parziali			0.62	2.50	2.50		
Progressiva			-3.12	-2.50	0.00	2.50	2.73
Dislivelli			0.00	0.59	0.01	-0.16	0.00

Sezione: 19
 Progressiva: 140.092
 Q. Progetto: 153.989

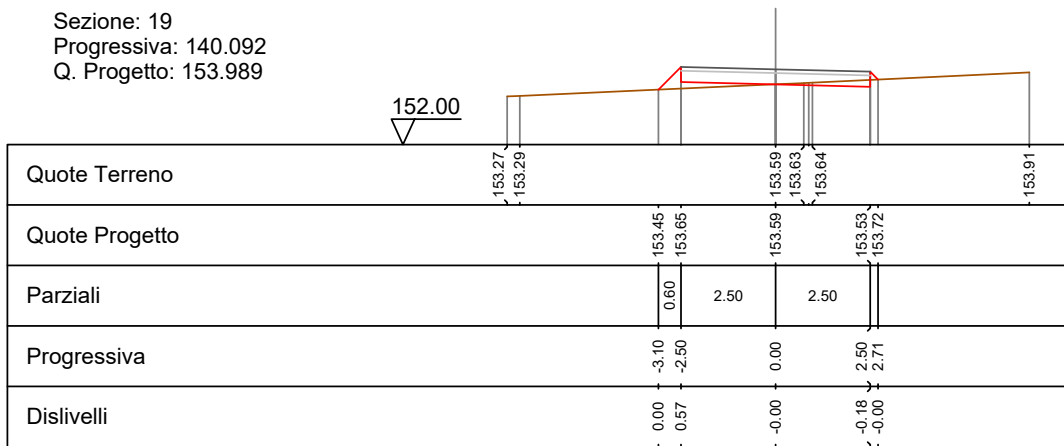

Sezione: 20
 Progressiva: 150.000
 Q. Progetto: 154.061

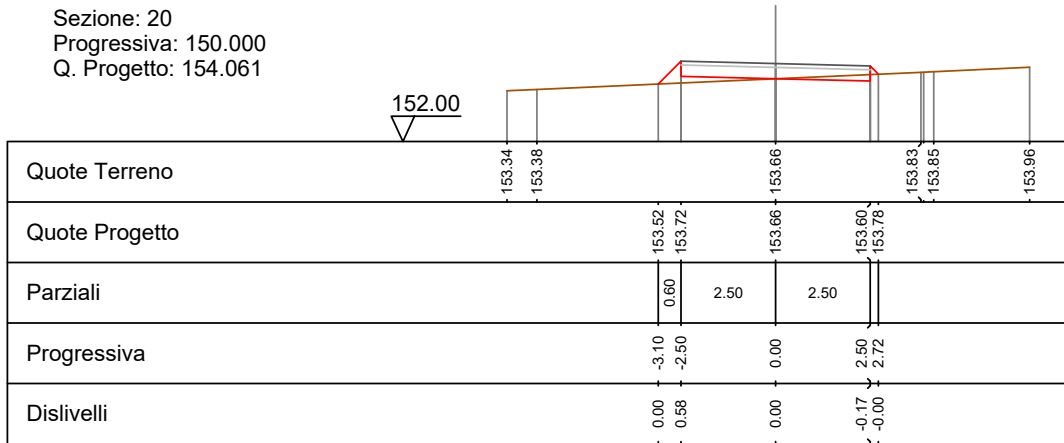

Sezione: 21
 Progressiva: 153.045
 Q. Progetto: 154.093

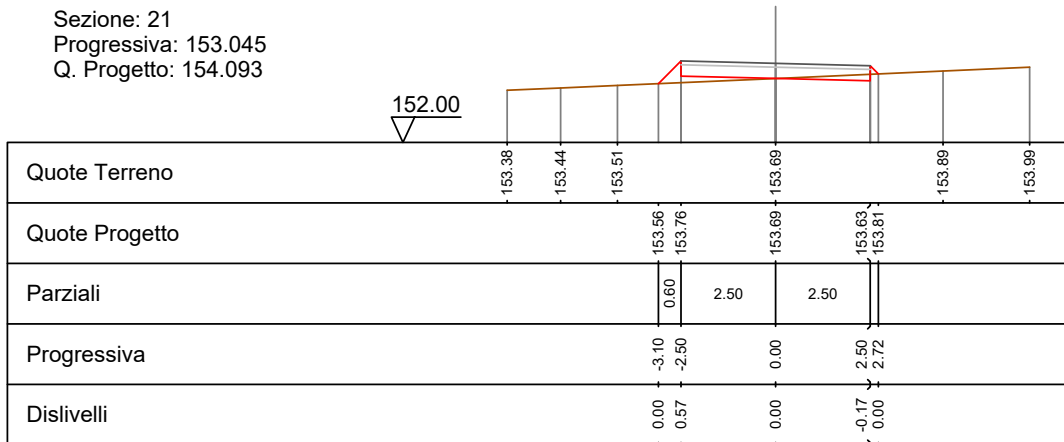

Sezione: 22
 Progressiva: 160.000
 Q. Progetto: 154.166

152.00

Quote Terreno		153.46	153.47		153.56		153.77		154.01	154.03	154.08
Quote Progetto					153.64	153.70	153.77		153.70	153.90	
Parziali					0.47	2.50	2.50				
Progressiva					-2.97	-2.50	0.00		2.50	2.71	
Dislivelli					-0.00	0.45	-0.01		-0.18	-0.00	

Sezione: 23
 Progressiva: 180.000
 Q. Progetto: 154.361

152.00

Quote Terreno		153.60			153.86	153.92	153.93				154.27
Quote Progetto					153.79	153.90	153.96		153.90	154.07	
Parziali					0.51	2.50	2.50				
Progressiva					-3.01	-2.50	0.00		2.50	2.73	
Dislivelli					0.00	0.48	0.03		-0.16	-0.00	

Sezione: 24
 Progressiva: 200.000
 Q. Progetto: 154.415

152.00

Quote Terreno		153.65			154.00	154.01	154.08		154.13		154.37
Quote Progetto					153.85	153.95	154.02		153.95	154.14	
Parziali					0.50	2.50	2.50				
Progressiva					-3.00	-2.50	0.00		2.50	2.71	
Dislivelli					-0.00	0.48	0.01		-0.18	0.00	

Sezione: 25
 Progressiva: 211.257
 Q. Progetto: 154.372

152.00

Quote Terreno	153.61	153.61	153.67		153.99	153.99	154.11	154.16	154.18	154.38
Quote Progetto				153.82	153.91	153.97	154.03	154.14	154.18	
Parziali				0.49	2.50	2.50	0.28			
Progressiva				-2.99	-2.50	0.00	2.50	2.79		
Dislivelli				0.00	0.46	-0.02	-0.09	0.00		

Sezione: 26
 Progressiva: 213.728
 Q. Progetto: 154.355

152.00

Quote Terreno	153.59	153.61			153.97	154.03		154.18	154.39
Quote Progetto			153.81	153.89	153.96	154.02	154.13		
Parziali			0.49	2.50	2.50	0.28			
Progressiva			-2.99	-2.50	0.00	2.50	2.79		
Dislivelli			0.00	0.46	-0.01	-0.09	0.00		

Sezione: 27
 Progressiva: 216.198
 Q. Progetto: 154.336

152.00

Quote Terreno	153.56	153.61			153.92	153.94		154.20	154.37
Quote Progetto			153.78	153.87	153.94	154.00	154.11		
Parziali			0.50	2.50	2.50	0.28			
Progressiva			-3.00	-2.50	0.00	2.50	2.79		
Dislivelli			0.00	0.47	-0.00	-0.09	0.00		

Sezione: 28
 Progressiva: 220.000
 Q. Progetto: 154.301

152.00

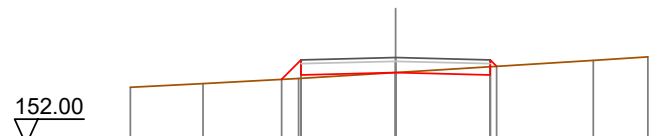

Quote Terreno	-153.51	-153.61	-153.75	-153.90	-154.22	-154.32
Quote Progetto			153.72 153.84	153.90	153.84 154.07	
Parziali			0.51 2.50	2.50		
Progressiva			-3.01 -2.50	0.00	2.50 2.67	
Dislivelli			-0.00 0.49	-0.00	-0.22 -0.00	

Sezione: 29
 Progressiva: 240.000
 Q. Progetto: 154.145

152.00

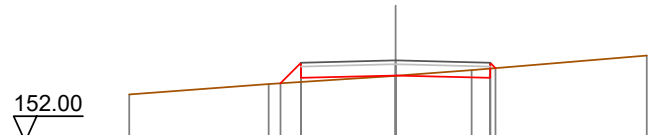

Quote Terreno	-153.24	-153.52	-153.74	-153.89	-154.27
Quote Progetto		153.54 153.68	153.75	153.68 153.94	
Parziali		0.54 2.50	2.50		
Progressiva		-3.04 -2.50	0.00	2.50 2.64	
Dislivelli		0.00 0.51	0.01	-0.25 0.00	

Sezione: 30
 Progressiva: 260.000
 Q. Progetto: 154.607

152.00

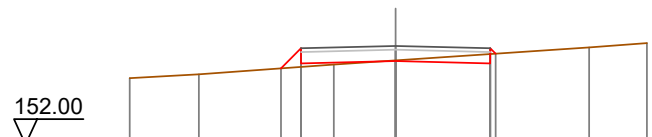

Quote Terreno	-153.75	-153.86	-154.11	-154.22	-154.57	-154.68
Quote Progetto			154.01 154.14	154.21	154.14 154.40	
Parziali			0.53 2.50	2.50		
Progressiva			-3.03 -2.50	0.00	2.50 2.64	
Dislivelli			0.00 0.49	-0.02	-0.25 0.00	

Sezione: 31
 Progressiva: 277.536
 Q. Progetto: 155.174

153.00

Quote Terreno	-154.34		-154.71	-154.75		-155.04	-155.19
Quote Progetto		154.57	154.71	154.77		154.84	154.94
Parziali		0.54	2.50	2.50		0.30	
Progressiva		-3.04	-2.50	0.00		2.50	2.80
Dislivelli		-0.00	0.51	0.02		-0.08	0.00

Sezione: 32
 Progressiva: 280.000
 Q. Progetto: 155.251

153.00

Quote Terreno	-154.40	-154.48		-154.82	-154.82		-155.01	-155.26
Quote Progetto			154.64	154.79	154.85		154.91	155.00
Parziali			0.55	2.50	2.50		0.31	
Progressiva			-3.05	-2.50	0.00		2.50	2.81
Dislivelli			0.00	0.52	0.03		-0.07	-0.00

Sezione: 33
 Progressiva: 284.187
 Q. Progetto: 155.355

153.00

Quote Terreno	-154.48		-154.88	-154.92	-154.97	-155.01	-155.10	-155.36
Quote Progetto		154.73	154.89	154.95		155.02	155.10	
Parziali		0.56	2.50	2.50		0.32		
Progressiva		-3.06	-2.50	0.00		2.50	2.82	
Dislivelli		0.00	0.53	0.04		-0.06	0.00	

Sezione: 34
 Progressiva: 290.000
 Q. Progetto: 155.440

153.00



Quote Terreno	154.56	154.56		154.93	155.00		155.28	155.45
Quote Progetto			154.81	154.98	155.04		155.10	155.18
Parziali			0.57	2.50		2.50	0.32	
Progressiva			-3.07	-2.50	0.00		2.50	2.82
Dislivelli			-0.00	0.53	0.04		-0.06	0.00

Sezione: 35
 Progressiva: 290.838
 Q. Progetto: 155.447

153.00

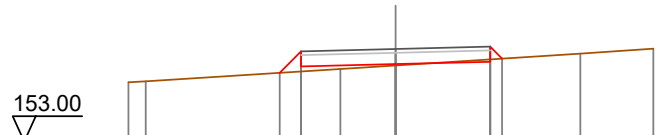

Quote Terreno	154.57	154.59		154.92	155.01		155.32	155.45
Quote Progetto			154.82	154.98	155.05		155.11	155.19
Parziali			0.57	2.50		2.50	0.32	
Progressiva			-3.07	-2.50	0.00		2.50	2.82
Dislivelli			0.00	0.53	0.03		-0.06	-0.00

Sezione: 36
 Progressiva: 300.000
 Q. Progetto: 155.512

153.00

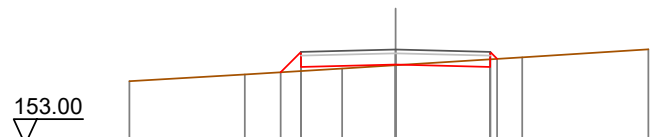

Quote Terreno	154.67	154.85		155.01	155.10		155.31	155.52
Quote Progetto			154.91	155.05	155.11		155.05	155.26
Parziali			0.54	2.50		2.50		
Progressiva			-3.04	-2.50	0.00		2.50	2.69
Dislivelli			0.00	0.51	0.02		-0.20	0.00

Sezione: 37
 Progressiva: 320.000
 Q. Progetto: 155.656

153.00

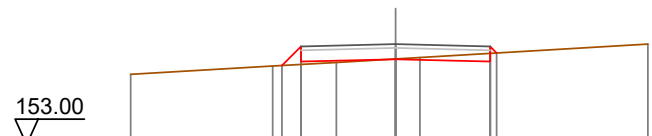

Quote Terreno	-154.86	155.07	155.17	155.26	155.30	155.66
Quote Progetto		155.09	155.19	155.26	155.19	155.42
Parziali		0.50	2.50	2.50		
Progressiva		-3.00	-2.50	0.00	2.60	2.67
Dislivelli		-0.00	0.48	-0.01	-0.22	0.00

Sezione: 38
 Progressiva: 333.956
 Q. Progetto: 155.756

153.00

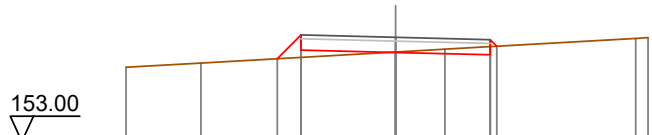

Quote Terreno	-154.96	155.07	155.37	155.44	155.73	155.75
Quote Progetto		155.19	155.42	155.36	155.29	155.52
Parziali		0.63	2.50	2.50		
Progressiva		-3.13	-2.50	0.00	2.60	2.67
Dislivelli		0.00	0.59	-0.01	-0.22	-0.00

Sezione: 39
 Progressiva: 337.347
 Q. Progetto: 155.780

154.00

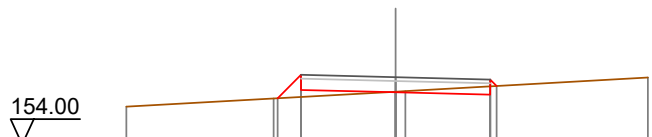

Quote Terreno	-155.00	155.22	155.41	155.40	155.77	
Quote Progetto		155.22	155.44	155.38	155.32	155.55
Parziali		0.62	2.50	2.50		
Progressiva		-3.12	-2.50	0.00	2.50	2.67
Dislivelli		0.00	0.59	-0.02	-0.22	-0.00

Sezione: 40
 Progressiva: 340.000
 Q. Progetto: 155.799

154.00

Quote Terreno	-155.04	-155.16	-155.26	-155.32	-155.39	-155.43	-155.55	-155.80
Quote Progetto			155.26	155.46		155.40	155.34	155.68
Parziali			0.60	2.50		2.50		
Progressiva			-3.10	-2.50		0.00	2.50	2.66
Dislivelli			-0.00	0.57		-0.03	-0.23	0.00

Sezione: 41
 Progressiva: 340.737
 Q. Progetto: 155.804

154.00

Quote Terreno	-155.05	-155.27	-155.35	-155.38	-155.44	-155.46	-155.80	-155.81
Quote Progetto		155.27	155.47		155.40	155.34	155.69	
Parziali		0.60	2.50		2.50			
Progressiva		-3.10	-2.50		0.00	2.50	2.66	
Dislivelli		0.00	0.56		-0.04	-0.24	0.00	

Sezione: 42
 Progressiva: 360.000
 Q. Progetto: 156.067

154.00

Quote Terreno	-155.32	-155.61	-155.70	-156.02	-156.03	-156.06	
Quote Progetto		155.54	155.60	155.67	155.60	155.84	
Parziali		0.47	2.50		2.50		
Progressiva		-2.97	-2.50		0.00	2.50	2.66
Dislivelli		-0.00	0.44		-0.03	-0.23	0.00

Sezione: 43
 Progressiva: 365.746
 Q. Progetto: 156.175

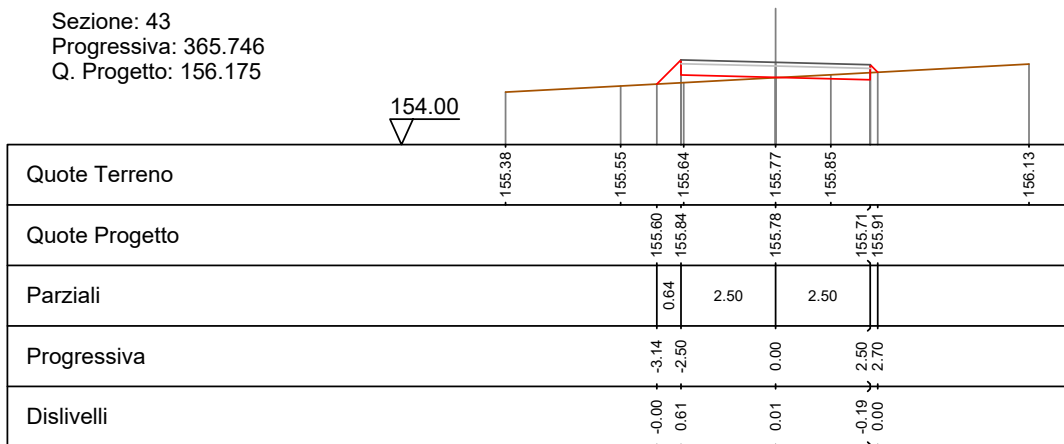

Sezione: 44
 Progressiva: 369.851
 Q. Progetto: 156.252

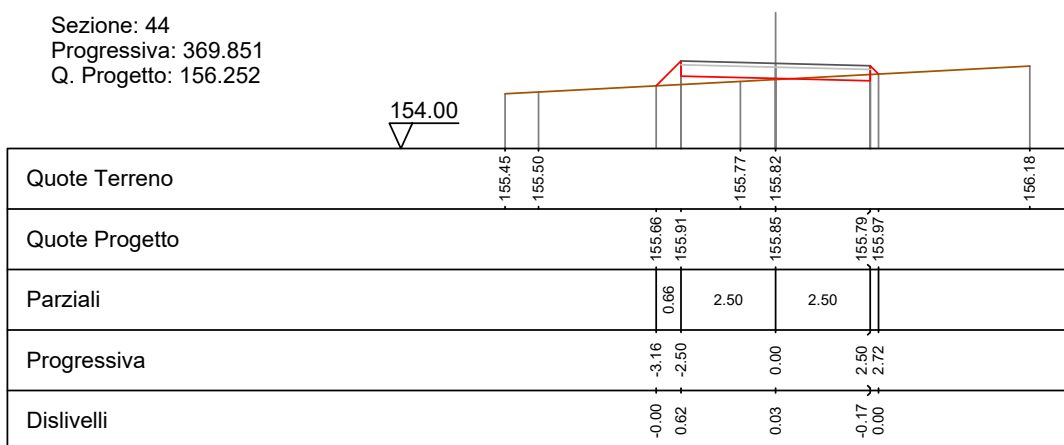

Sezione: 45
 Progressiva: 373.956
 Q. Progetto: 156.329

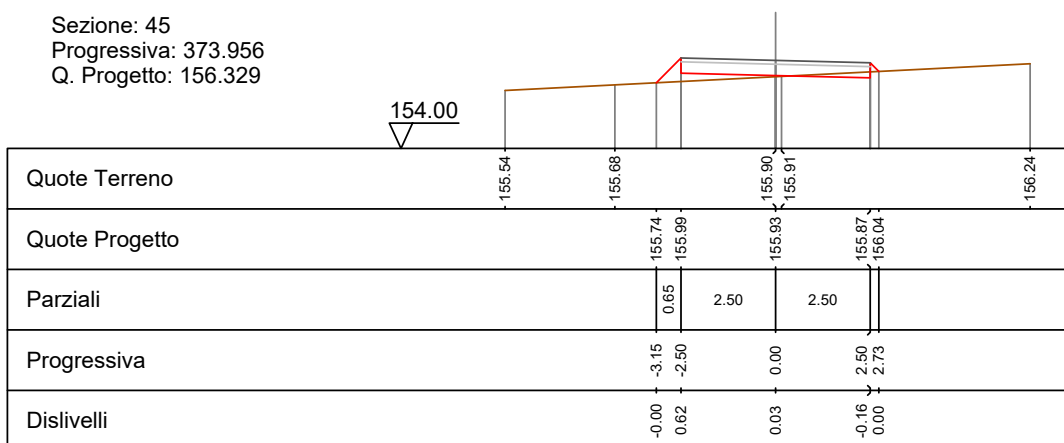

Sezione: 46
 Progressiva: 380.000
 Q. Progetto: 156.443

154.00

Quote Terreno	-155.66		155.86	155.90	156.02	156.09	156.21	156.36
Quote Progetto			155.86	155.98	156.04	155.98	156.16	
Parziali			0.52	2.50		2.50		
Progressiva			-3.02	-2.50	0.00	2.50	2.73	
Dislivelli			0.00	0.49	0.03	-0.16	-0.00	

Sezione: 47
 Progressiva: 400.000
 Q. Progetto: 156.819

155.00

Quote Terreno	-156.03	-156.17		156.36	156.39		156.69	156.73
Quote Progetto				156.24	156.36	156.42	156.36	156.53
Parziali				0.52	2.50		2.50	
Progressiva				-3.02	-2.50	0.00	2.50	2.73
Dislivelli				0.00	0.49	0.03	-0.16	0.00

Sezione: 48
 Progressiva: 400.525
 Q. Progetto: 156.829

155.00

Quote Terreno	-156.04	-156.18		156.35	156.40		156.71	156.75
Quote Progetto				156.24	156.37	156.43	156.49	156.54
Parziali				0.52	2.50		2.50	0.35
Progressiva				-3.02	-2.50	0.00	2.50	2.85
Dislivelli				0.00	0.50	0.03	-0.04	-0.00

Sezione: 49
 Progressiva: 404.944
 Q. Progetto: 156.912

155.00

Quote Terreno	-156.10	-156.27	-156.32	-156.47	-156.83
Quote Progetto			156.31 156.45	156.51	156.57 156.62
Parziali			0.54	2.50	2.50
Progressiva			-3.04 -2.50	0.00	2.50 2.88
Dislivelli			-0.00 0.51	0.05	-0.02 0.00

Sezione: 50
 Progressiva: 409.364
 Q. Progetto: 156.980

155.00

Quote Terreno	-156.13	-156.23	-156.42	-156.51	-156.88
Quote Progetto			156.35 156.52	156.58	156.64 156.66
Parziali			0.57	2.50	2.50
Progressiva			-3.07 -2.50	0.00	2.50 2.88
Dislivelli			0.00 0.54	0.07	-0.00 0.00

Sezione: 51
 Progressiva: 420.000
 Q. Progetto: 157.028

155.00

Quote Terreno	-156.21	-156.36	-156.58	-156.73	-156.89	-156.94
Quote Progetto			156.42 156.57	156.63	156.73 156.73	
Parziali			0.54	2.50	2.50	
Progressiva			-3.04 -2.50	0.00	2.50 2.74	
Dislivelli			0.00 0.51	0.04	-0.15 0.00	

Sezione: 52
 Progressiva: 440.000
 Q. Progetto: 157.089

155.00

Quote Terreno	-156.32			156.69	156.71		156.96	157.05
Quote Progetto			156.54	156.63	156.69		156.63	156.84
Parziali			0.49	2.50		2.50		
Progressiva			-2.99	-2.50	0.00		2.50	2.69
Dislivelli			0.00	0.47	-0.00		-0.20	0.00

Sezione: 53
 Progressiva: 460.000
 Q. Progetto: 157.151

155.00

Quote Terreno	-156.41	-156.49	156.60	156.65	156.77	156.77		157.12
Quote Progetto			156.62	156.69	156.75	156.75	156.69	156.91
Parziali			0.47	2.50		2.50		
Progressiva			-2.97	-2.50	0.00		2.50	2.67
Dislivelli			0.00	0.45	-0.02		-0.22	-0.00

Sezione: 54
 Progressiva: 480.000
 Q. Progetto: 157.212

155.00

Quote Terreno	-156.46	-156.57	156.63		156.75	156.83		157.14	157.17
Quote Progetto			156.67	156.75	156.81	156.83	156.75	156.96	
Parziali			0.48	2.50		2.50			
Progressiva			-2.98	-2.50	0.00		2.50	2.68	
Dislivelli			0.00	0.45	-0.01		-0.21	0.00	

Sezione: 55
 Progressiva: 498.831
 Q. Progetto: 157.249

155.00

Quote Terreno	-156.50			156.86	156.92	157.01	157.05	157.14	157.21
Quote Progetto		156.71	156.79	156.85		156.91	157.00		
Parziali		0.48	2.50		2.50	0.31			
Progressiva		-2.98	-2.50	0.00		2.50	2.81		
Dislivelli		0.00	0.46	-0.01		-0.08	0.00		

Sezione: 56
 Progressiva: 500.000
 Q. Progetto: 157.247

155.00

Quote Terreno	-156.50			156.86	156.99	157.03	157.04	157.09	157.21
Quote Progetto		156.71	156.78	156.85		156.91	157.01		
Parziali		0.48	2.50		2.50	0.30			
Progressiva		-2.98	-2.50	0.00		2.50	2.80		
Dislivelli		0.00	0.45	-0.01		-0.08	0.00		

Sezione: 57
 Progressiva: 506.446
 Q. Progetto: 157.220

155.00

Quote Terreno	-156.48	-156.52	-156.61		156.84	156.89			157.19
Quote Progetto				156.69	156.76	156.82		156.88	156.98
Parziali				0.47	2.50		2.50	0.30	
Progressiva				-2.97	-2.50	0.00		2.50	2.80
Dislivelli				0.00	0.45	-0.02		-0.08	0.00

Sezione: 58
 Progressiva: 510.000
 Q. Progetto: 157.194

155.00

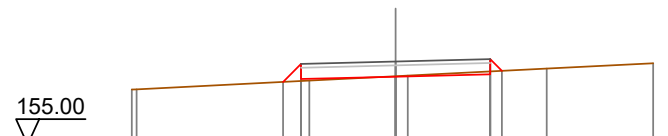

Quote Terreno	156.45	156.46		156.69	156.81	156.82		157.01	157.15
Quote Progetto			156.66	156.73	156.79	156.82	156.86	156.95	
Parziali			0.48	2.50	2.50	0.31			
Progressiva			-2.98	-2.50	0.00	2.50	2.81		
Dislivelli			0.00	0.45	-0.01	-0.08	0.00		

Sezione: 59
 Progressiva: 514.060
 Q. Progetto: 157.157

155.00

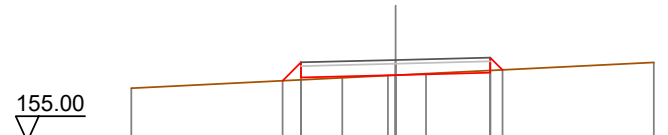

Quote Terreno	156.41		156.68	156.74	156.75	156.79		157.09
Quote Progetto		156.61	156.69	156.76	156.82	156.89		
Parziali		0.49	2.50	2.50	0.33			
Progressiva		-2.99	-2.50	0.00	2.50	2.83		
Dislivelli		-0.00	0.46	0.00	-0.06	0.00		

Sezione: 60
 Progressiva: 520.000
 Q. Progetto: 157.085

155.00

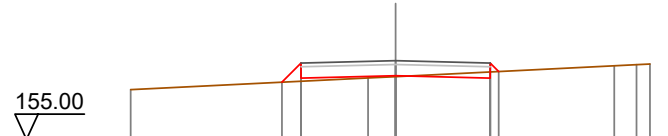

Quote Terreno	156.32		156.63	156.66		156.95	156.98	156.99
Quote Progetto		156.52	156.62	156.68	156.62	156.80		
Parziali		0.51	2.50	2.50				
Progressiva		-3.01	-2.50	0.00	2.50	2.73		
Dislivelli		0.00	0.48	0.02	-0.16	0.00		

Sezione: 61
 Progressiva: 540.000
 Q. Progetto: 156.755

155.00

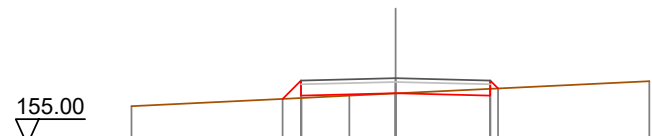

Quote Terreno	-156.01	156.21	156.23	156.29	156.35	156.29	156.48	156.68
Quote Progetto		156.21	156.29	156.36	156.36	156.29	156.48	
Parziali		0.49	2.50	2.50				
Progressiva		-2.99	-2.50	0.00	2.50	2.71		
Dislivelli		0.00	0.46	0.00	-0.18	0.00		

Sezione: 62
 Progressiva: 560.000
 Q. Progetto: 156.417

154.00

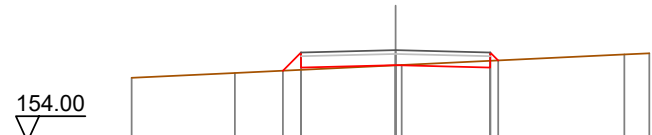

Quote Terreno	-155.69	155.81	155.87	155.95	156.01	156.02	155.95	156.30	156.33
Quote Progetto		155.87	155.95	156.02	156.02	155.95	156.14		
Parziali		0.48	2.50	2.50					
Progressiva		-2.98	-2.50	0.00	2.50	2.71			
Dislivelli		0.00	0.46	0.00	-0.18	0.00			

Sezione: 63
 Progressiva: 562.527
 Q. Progetto: 156.375

154.00



Quote Terreno	-155.64	155.76	155.82	156.04	155.97	156.08	156.11	156.29
Quote Progetto		155.82	156.04	155.97	155.97	155.91	156.10	
Parziali		0.61	2.50	2.50				
Progressiva		-3.11	-2.50	0.00	2.50	2.71		
Dislivelli		0.00	0.59	0.00	-0.18	0.00		

Sezione: 64
 Progressiva: 570.000
 Q. Progetto: 156.252

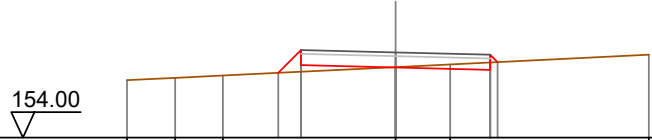

Quote Terreno	-155.52	-155.58	-155.64			155.86	-155.93	-156.19
Quote Progetto				155.71	155.91	155.85	155.79	155.99
Parziali				0.60	2.50		2.50	
Progressiva				-3.10	-2.50	0.00	2.50	2.70
Dislivelli				0.00	0.57	-0.01	-0.20	0.00

Sezione: 65
 Progressiva: 570.449
 Q. Progetto: 156.246

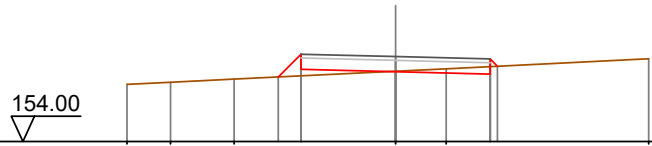

Quote Terreno	-155.51	-155.57	-155.65			155.86	-155.92	-156.19
Quote Progetto				155.71	155.91	155.85	155.78	155.99
Parziali				0.60	2.50		2.50	
Progressiva				-3.10	-2.50	0.00	2.50	2.69
Dislivelli				0.00	0.57	-0.01	-0.20	0.00

Sezione: 66
 Progressiva: 578.371
 Q. Progetto: 156.196

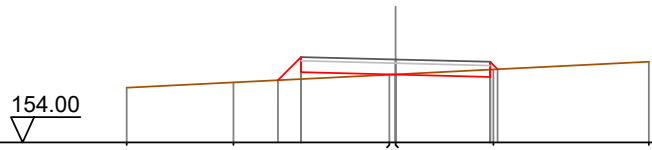

Quote Terreno	-155.45	-155.59				155.79	155.93	-156.14
Quote Progetto			155.65	155.86	155.80	155.80	155.73	155.94
Parziali			0.61	2.50		2.50		
Progressiva			-3.11	-2.50	0.00	2.50	2.70	
Dislivelli			0.00	0.58	-0.00	-0.19	0.00	

Sezione: 67
 Progressiva: 580.000
 Q. Progetto: 156.190

154.00

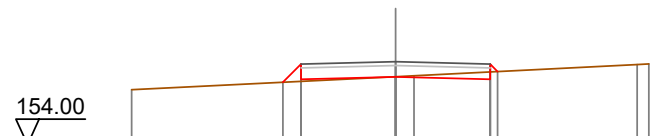

Quote Terreno	-155.45			155.79	155.82		156.12	156.13
Quote Progetto			155.65	155.73	155.79		155.73	155.93
Parziali			0.48	2.50	2.50			
Progressiva			-2.98	-2.50	0.00		2.50	2.70
Dislivelli			0.00	0.46	-0.00		-0.19	0.00

Sezione: 68
 Progressiva: 600.000
 Q. Progetto: 156.102

154.00

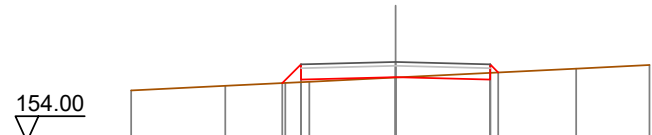

Quote Terreno	-155.35	-155.47	155.55	155.58	155.69		155.93	156.02
Quote Progetto			155.54	155.64	155.70		155.64	155.83
Parziali			0.50	2.50	2.50			
Progressiva			-3.00	-2.50	0.00		2.50	2.71
Dislivelli			-0.00	0.47	0.01		-0.18	0.00

Sezione: 69
 Progressiva: 620.000
 Q. Progetto: 155.936

154.00

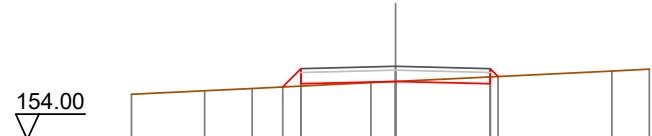

Quote Terreno	-155.20	-155.29	155.35		155.50	155.53		155.81	155.86
Quote Progetto			155.39	155.47	155.54		155.47	155.67	
Parziali			0.48	2.50	2.50				
Progressiva			-2.98	-2.50	0.00		2.50	2.71	
Dislivelli			0.00	0.46	0.00		-0.18	0.00	

Sezione: 70
 Progressiva: 629.178
 Q. Progetto: 155.828

154.00

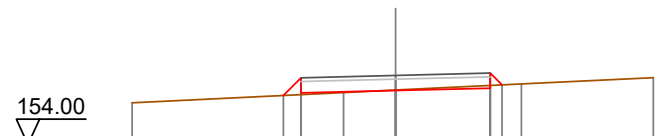

Quote Terreno	-155.10		-155.37	155.44		-155.60	-155.77
Quote Progetto		155.30 155.37		155.43		155.49 155.58	
Parziali		0.47	2.50		2.50	0.31	
Progressiva		-2.97 -2.50		0.00		2.50 2.81	
Dislivelli		-0.00 0.45		-0.01		-0.07 0.00	

Sezione: 71
 Progressiva: 630.000
 Q. Progetto: 155.817

154.00

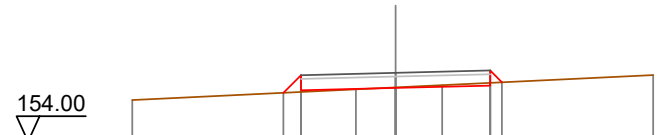

Quote Terreno	-155.10		-155.38	155.43		-155.49	-155.76
Quote Progetto		155.29 155.35		155.42		155.48 155.57	
Parziali		0.47	2.50		2.50	0.31	
Progressiva		-2.97 -2.50		0.00		2.50 2.81	
Dislivelli		-0.00 0.44		-0.01		-0.07 0.00	

Sezione: 72
 Progressiva: 630.912
 Q. Progetto: 155.805

154.00

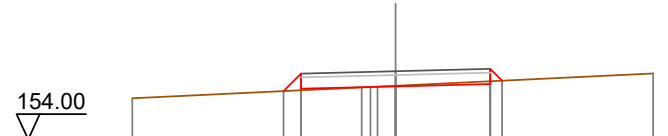

Quote Terreno	-155.09		-155.38	155.42		-155.49	-155.75
Quote Progetto		155.28 155.34		155.40		155.47 155.55	
Parziali		0.46	2.50		2.50	0.31	
Progressiva		-2.96 -2.50		0.00		2.50 2.81	
Dislivelli		-0.00 0.44		-0.02		-0.07 0.00	

Sezione: 73
 Progressiva: 632.646
 Q. Progetto: 155.782

154.00

Quote Terreno	-155.07	-155.19		155.40	155.40		-155.60	-155.72
Quote Progetto			155.26	155.38	155.44	155.63		
Parziali			0.46	2.50	2.50	0.32		
Progressiva			-2.96	-2.50	0.00	2.50	2.82	
Dislivelli			-0.00	0.44	-0.01	-0.07	0.00	

Sezione: 74
 Progressiva: 640.000
 Q. Progetto: 155.674

153.00

Quote Terreno	-154.96			155.29		155.44	155.46	-155.60
Quote Progetto			155.15	155.27	155.21	155.41		
Parziali			0.46	2.50	2.50			
Progressiva			-2.96	-2.50	0.00	2.50	2.70	
Dislivelli			0.00	0.44	-0.01	-0.19	0.00	

Sezione: 75
 Progressiva: 660.000
 Q. Progetto: 155.325

153.00

Quote Terreno	-154.63		154.81	154.95			155.13	-155.25
Quote Progetto			154.81	154.92	154.86	155.07		
Parziali			0.45	2.50	2.50			
Progressiva			-2.95	-2.50	0.00	2.50	2.69	
Dislivelli			0.00	0.43	-0.02	-0.20	-0.00	

Sezione: 76
 Progressiva: 680.000
 Q. Progetto: 154.957

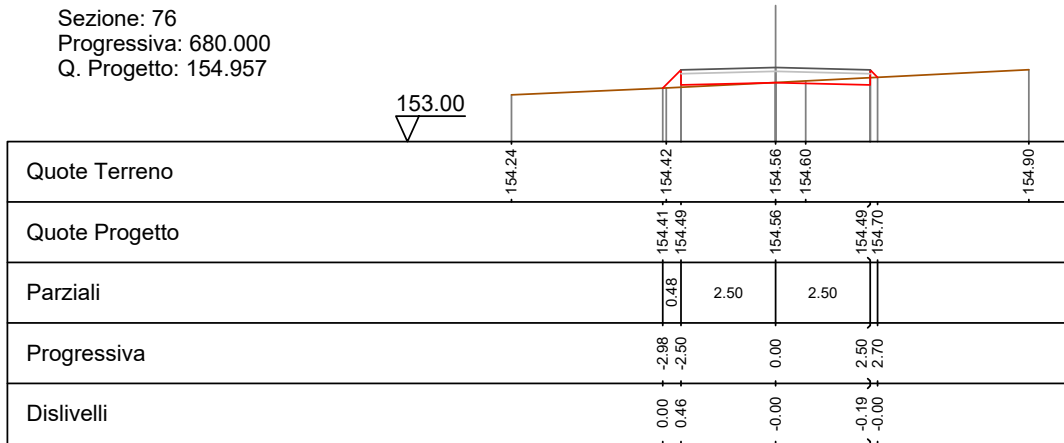

Sezione: 77
 Progressiva: 700.000
 Q. Progetto: 154.909

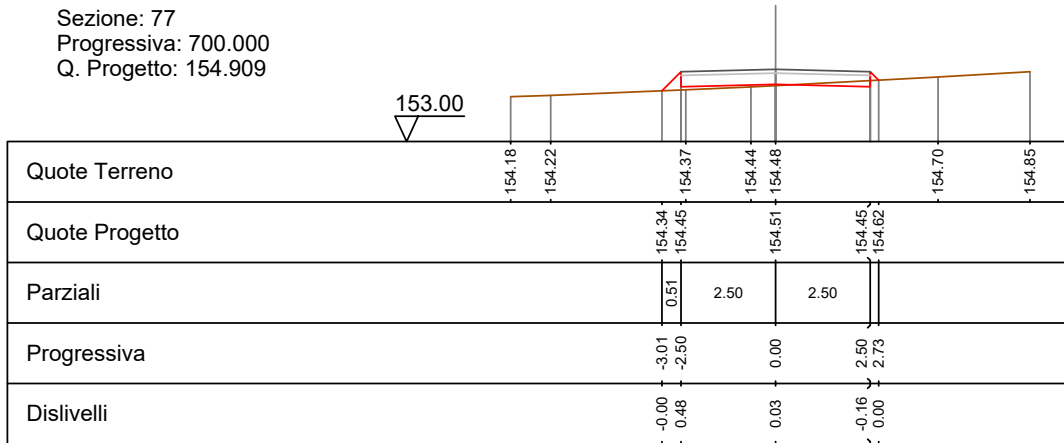

Sezione: 78
 Progressiva: 720.000
 Q. Progetto: 155.475

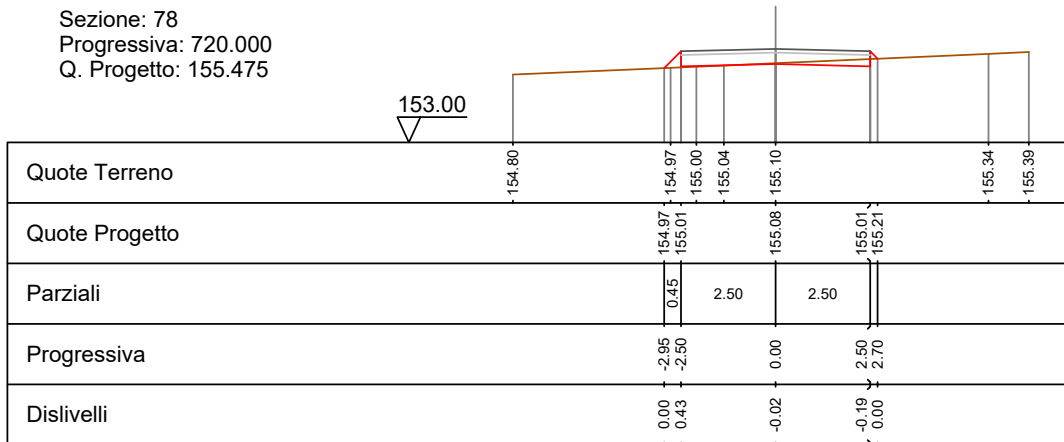

Sezione: 79
 Progressiva: 728.839
 Q. Progetto: 155.743

154.00

Quote Terreno	-155.04		155.35	155.40	155.44	155.46	155.50	-155.66
Quote Progetto		155.22	155.34		155.41	155.47		
Parziali		0.46	2.50	2.50	0.33			
Progressiva		-2.96	0.00		2.50	2.83		
Dislivelli		-0.00	-0.01		-0.05	0.00		

Sezione: 80
 Progressiva: 730.000
 Q. Progetto: 155.775

154.00

Quote Terreno	-155.07		155.38	155.42	155.47	155.50	-155.60	-155.69
Quote Progetto		155.25	155.38		155.44	155.51		
Parziali		0.47	2.50	2.50	0.33			
Progressiva		-2.97	0.00		2.50	2.83		
Dislivelli		0.00	-0.00		-0.05	-0.00		

Sezione: 81
 Progressiva: 740.000
 Q. Progetto: 155.979

154.00

Quote Terreno	-155.24	155.44	155.57	155.57	155.74	-155.91
Quote Progetto		155.43	155.58		155.64	155.72
Parziali		0.49	2.50	2.50	0.33	
Progressiva		-2.99	0.00		2.50	2.83
Dislivelli		0.00	0.01		-0.06	0.00

Sezione: 82
 Progressiva: 741.404
 Q. Progetto: 155.997

154.00

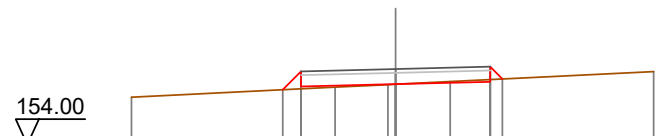

Quote Terreno	-155.25		-155.52	155.58	155.59	-155.67	-155.93
Quote Progetto		155.45	155.53	155.60		155.66	155.73
Parziali		0.49	2.50	2.50		0.33	
Progressiva		-2.99	-2.50	0.00		2.50	2.83
Dislivelli		0.00	0.46	0.00		-0.06	-0.00

Sezione: 83
 Progressiva: 750.000
 Q. Progetto: 156.049

154.00

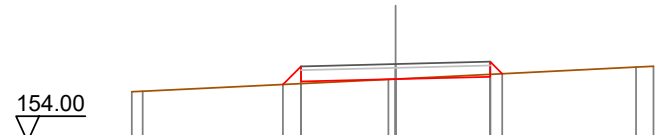

Quote Terreno	155.31	155.33		155.64	155.65		155.97	155.99
Quote Progetto			155.51	155.59	155.66		155.71	155.79
Parziali			0.48	2.50	2.50		0.32	
Progressiva			-2.98	-2.50	0.00		2.50	2.82
Dislivelli			0.00	0.46	-0.00		-0.06	0.00

Sezione: 84
 Progressiva: 753.968
 Q. Progetto: 156.042

154.00

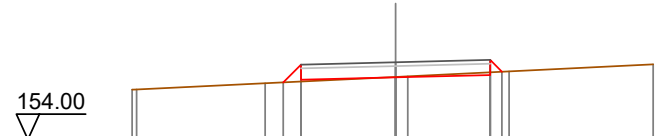

Quote Terreno	155.32	155.32	155.49	155.65	155.67	155.80	155.99
Quote Progetto			155.51	155.64	155.67	155.70	155.79
Parziali			0.47	2.50	2.50	0.31	
Progressiva			-2.97	-2.50	0.00	2.50	2.81
Dislivelli			0.00	0.45	-0.01	-0.07	-0.00

Sezione: 88
 Progressiva: 820.000
 Q. Progetto: 155.866

154.00

Quote Terreno	-155.16		155.46		-155.60	-155.65	-155.68	-155.75
Quote Progetto		155.33	155.47	155.40	155.58			
Parziali		0.47	2.50	2.50				
Progressiva		-2.97	0.00	2.50	2.72			
Dislivelli		-0.00	0.00	-0.17	-0.00			

Sezione: 89
 Progressiva: 840.000
 Q. Progetto: 155.812

154.00

Quote Terreno	-155.11	155.27	155.41		155.55		155.70
Quote Progetto		155.28	155.41	155.35	155.53		
Parziali		0.47	2.50	2.50			
Progressiva		-2.97	0.00	2.50	2.72		
Dislivelli		-0.00	0.00	-0.17	-0.00		

Sezione: 90
 Progressiva: 856.794
 Q. Progetto: 155.767

154.00

Quote Terreno	-155.08		155.39		155.52	155.53	155.67
Quote Progetto		155.25	155.37	155.30	155.50		
Parziali		0.58	2.50	2.50			
Progressiva		-3.08	0.00	2.50	2.70		
Dislivelli		0.00	-0.02	-0.19	0.00		

Sezione: 91
 Progressiva: 860.000
 Q. Progetto: 155.759

154.00

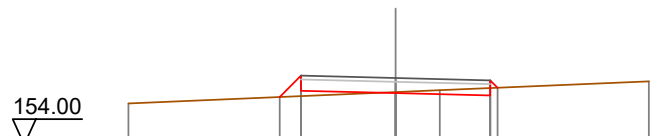

Quote Terreno	-155.08		155.39	155.44		-155.67
Quote Progetto		155.26	155.42	155.36	155.30	155.50
Parziali		0.57	2.50	2.50		
Progressiva		-3.07	-2.50	0.00	2.50	2.69
Dislivelli		0.00	0.54	-0.03	-0.20	0.00

Sezione: 92
 Progressiva: 864.231
 Q. Progetto: 155.772

154.00

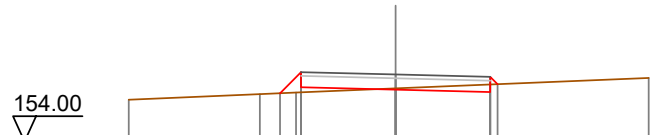

Quote Terreno	-155.11	-155.25	155.29	155.40		-155.68
Quote Progetto		155.28	155.43	155.37	155.31	155.52
Parziali		0.56	2.50	2.50		
Progressiva		-3.06	-2.50	0.00	2.50	2.69
Dislivelli		-0.00	0.53	-0.03	-0.20	0.00

Sezione: 93
 Progressiva: 870.000
 Q. Progetto: 155.843

154.00

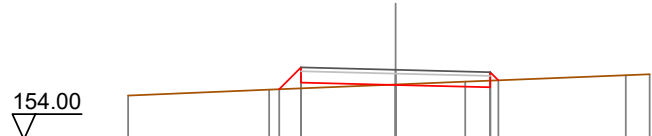

Quote Terreno	-155.16	-155.32	155.45	155.53		-155.70
Quote Progetto		155.33	155.51	155.44	155.38	155.56
Parziali		0.58	2.50	2.50		
Progressiva		-3.08	-2.50	0.00	2.50	2.72
Dislivelli		0.00	0.55	-0.01	-0.17	-0.00

Sezione: 94
 Progressiva: 871.667
 Q. Progetto: 155.868

154.00

Quote Terreno	-155.19	-155.33	-155.47	-155.60	-155.64	-155.74
Quote Progetto		155.35	155.47	155.41	155.58	
Parziali		0.58	2.50	2.50		
Progressiva		-3.08	-2.50	0.00	2.50	2.72
Dislivelli		0.00	0.56	-0.01	-0.17	0.00

Sezione: 95
 Progressiva: 880.000
 Q. Progetto: 155.992

154.00

Quote Terreno	-155.30	-155.31	-155.46	-155.58	-155.84
Quote Progetto			155.46	155.59	155.53
Parziali			0.47	2.50	2.50
Progressiva			-2.97	-2.50	0.00
Dislivelli			0.00	0.45	0.02
					-0.15
					0.00

Sezione: 96
 Progressiva: 900.000
 Q. Progetto: 156.290

154.00

Quote Terreno	-155.57	-155.73	-155.77	-155.84	-155.86	-156.11
Quote Progetto		155.73	155.83	155.89	155.83	155.96
Parziali		0.49	2.50	2.50	0.27	
Progressiva		-2.99	-2.50	0.00	2.50	2.77
Dislivelli		0.00	0.47	0.04	-0.12	0.00

Sezione: 97
 Progressiva: 920.000
 Q. Progetto: 156.589

154.00

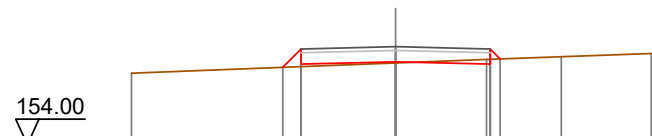

Quote Terreno	-155.89		156.16	156.25	-156.32	-156.41
Quote Progetto		156.04	156.19	156.13	156.26	
Parziali		0.48	2.50	2.50	0.28	
Progressiva		-2.98	0.00	2.50	2.76	
Dislivelli		-0.00	0.03	-0.13	-0.00	

Sezione: 98
 Progressiva: 931.417
 Q. Progetto: 156.759

155.00

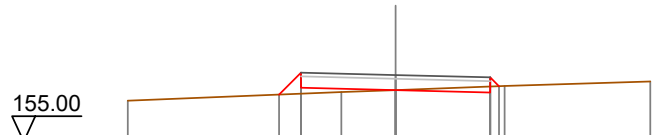

Quote Terreno	-156.08		156.36	156.47	-156.59
Quote Progetto		156.24	156.36	156.30	156.46
Parziali		0.58	2.50	2.50	0.00
Progressiva		-3.08	0.00	2.50	2.73
Dislivelli		0.00	-0.00	-0.16	0.00

Sezione: 99
 Progressiva: 937.591
 Q. Progetto: 156.851

155.00



Quote Terreno	-156.23		156.49	156.55	-156.67	-156.68
Quote Progetto		156.38	156.45	156.39	156.57	
Parziali		0.54	2.50	2.50	0.00	
Progressiva		-3.04	0.00	2.50	2.72	
Dislivelli		0.00	-0.04	-0.18	0.00	

Sezione: 100
 Progressiva: 940.000
 Q. Progetto: 156.887

155.00

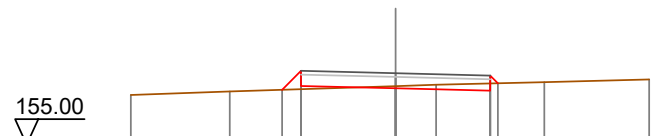

Quote Terreno	-156.31	-156.40	-156.45	-156.55	-156.58	-156.65	-156.72
Quote Progetto			156.45	156.55	156.49	156.42	156.62
Parziali			0.50	2.50	2.50		
Progressiva			-3.00	-2.50	0.00	2.50	2.70
Dislivelli			-0.00	0.49	-0.06	-0.19	0.00

Sezione: 101
 Progressiva: 943.764
 Q. Progetto: 156.940

155.00

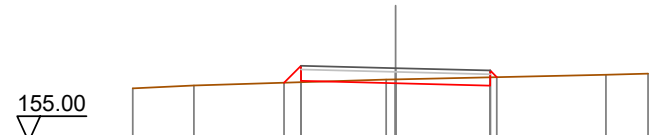

Quote Terreno	-156.41	-156.48	-156.55	-156.64	-156.64	-156.77	-156.79
Quote Progetto			156.55	156.60	156.54	156.48	156.70
Parziali			0.45	2.50	2.50		
Progressiva			-2.95	-2.50	0.00	2.50	2.68
Dislivelli			0.00	0.44	-0.10	-0.22	0.00

Sezione: 102
 Progressiva: 960.000
 Q. Progetto: 156.867

155.00

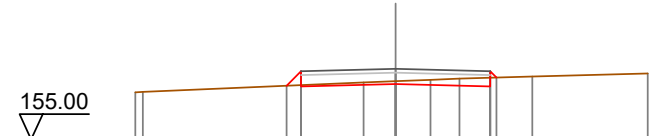

Quote Terreno	156.25	156.26	156.51	156.54	156.58	156.61	156.67	156.75
Quote Progetto			156.42	156.40	156.47	156.40	156.64	
Parziali			0.38	2.50	2.50			
Progressiva			-2.88	-2.50	0.00	2.50	2.67	
Dislivelli			0.00	0.37	-0.07	-0.23	0.00	

Sezione: 103
 Progressiva: 977.542
 Q. Progetto: 156.346

154.00

Quote Terreno	-155.56			155.88		-156.18
Quote Progetto		155.74	156.01	155.95	155.88	156.00
Parziali		0.67	2.50	2.50	0.28	
Progressiva		-3.17	-2.50	0.00	2.50	2.78
Dislivelli		0.00	0.64	0.07	-0.11	0.00

Sezione: 104
 Progressiva: 980.000
 Q. Progetto: 156.274

154.00

Quote Terreno	-155.48			155.82		-156.12
Quote Progetto		155.67	155.94	155.87	155.81	155.94
Parziali		0.67	2.50	2.50	0.27	
Progressiva		-3.17	-2.50	0.00	2.50	2.77
Dislivelli		0.00	0.63	0.05	-0.12	0.00

Sezione: 105
 Progressiva: 980.775
 Q. Progetto: 156.252

154.00

Quote Terreno	-155.44			155.80		-156.10
Quote Progetto		155.64	155.91	155.85	155.79	155.92
Parziali		0.67	2.50	2.50	0.27	
Progressiva		-3.17	-2.50	0.00	2.50	2.77
Dislivelli		0.00	0.64	0.05	-0.12	0.00

Sezione: 106
 Progressiva: 984.007
 Q. Progetto: 156.161

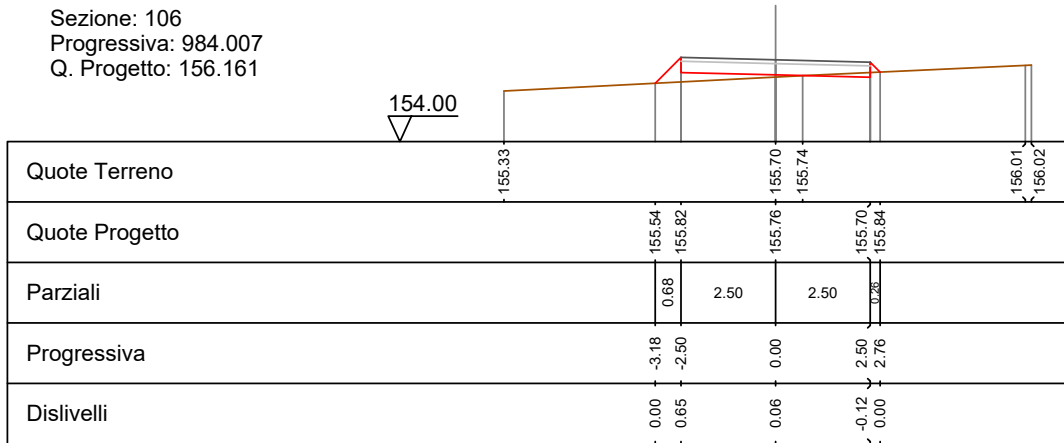

Sezione: 107
 Progressiva: 1000.000
 Q. Progetto: 155.761

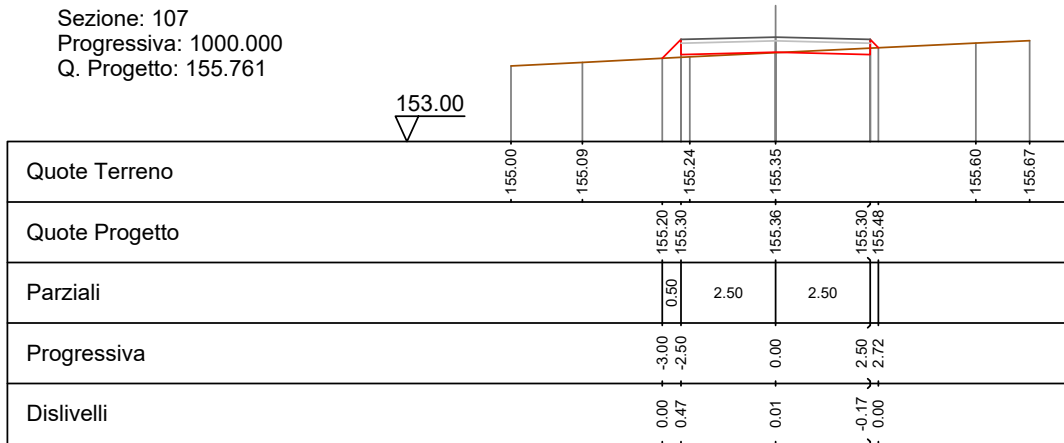

Sezione: 108
 Progressiva: 1001.457
 Q. Progetto: 155.729

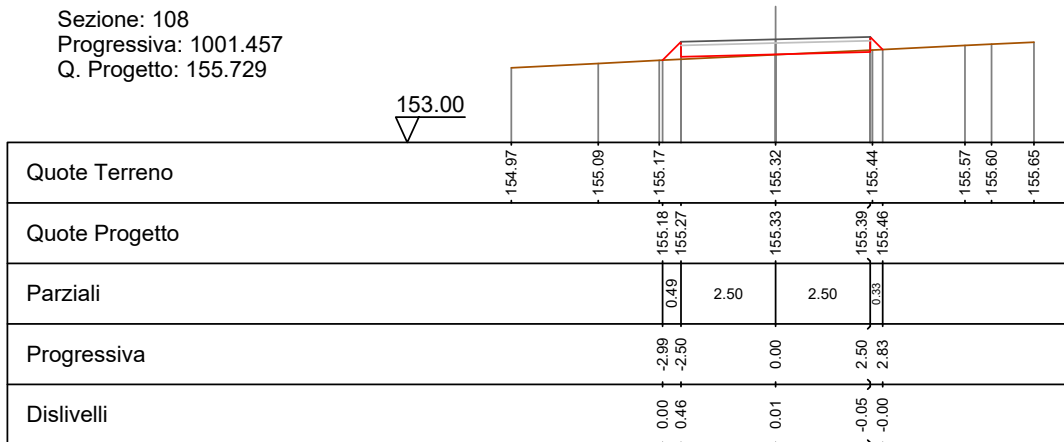

Sezione: 109
 Progressiva: 1007.611
 Q. Progetto: 155.600

153.00

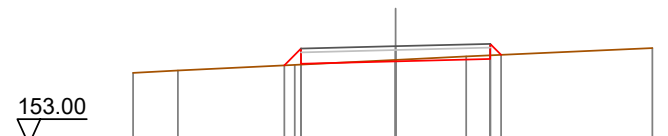

Quote Terreno	-154.89	-154.96	-155.11	-155.24	-155.33	-155.55
Quote Progetto			155.09 155.14	155.20	155.26 155.37	
Parziali			0.44 2.50	2.50	0.28 2.79	
Progressiva			-2.94 -2.50	0.00	2.50 2.79	
Dislivelli			-0.00 0.42	-0.04	-0.10 -0.00	

Sezione: 110
 Progressiva: 1010.000
 Q. Progetto: 155.553

153.00

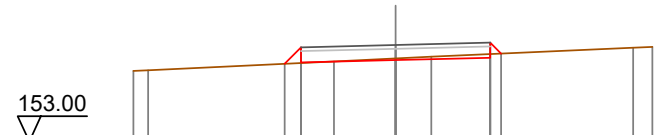

Quote Terreno	-154.87	-154.89	-155.12	-155.20	-155.24	-155.48	-155.50
Quote Progetto			155.06 155.09	155.15	155.22 155.32		
Parziali			0.43 2.50	2.50	0.28 2.79		
Progressiva			-2.93 -2.50	0.00	2.50 2.79		
Dislivelli			-0.00 0.41	-0.04	-0.10 -0.00		

Sezione: 111
 Progressiva: 1013.765
 Q. Progetto: 155.483

153.00

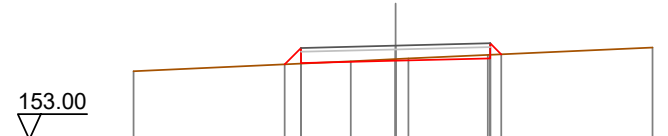

Quote Terreno	-154.80		-155.07	-155.13	-155.14	-155.24	-155.43
Quote Progetto			154.99 155.02	155.08	155.15 155.25		
Parziali			0.43 2.50	2.50	0.28 2.79		
Progressiva			-2.93 -2.50	0.00	2.50 2.79		
Dislivelli			0.00 0.41	-0.04	-0.09 0.00		

Sezione: 112
 Progressiva: 1020.000
 Q. Progetto: 155.376

153.00

Quote Terreno		-154.69		-154.94		-155.02		-155.21		-155.33
Quote Progetto			154.88 154.91		154.98		154.91 155.15			
Parziali			0.43	2.50		2.50				
Progressiva			-2.93 -2.50		0.00		2.50 2.66			
Dislivelli			0.00 0.41		-0.04		-0.23 0.00			

Sezione: 113
 Progressiva: 1040.000
 Q. Progetto: 155.119

153.00

Quote Terreno		154.50 154.51		154.84 154.85		155.02		155.15
Quote Progetto			154.70 154.66		154.72		154.66 154.96	
Parziali			0.36	2.50		2.50		
Progressiva			-2.86 -2.50		0.00		2.50 2.60	
Dislivelli			0.00 0.34		-0.12		-0.30 0.00	

Sezione: 114
 Progressiva: 1054.834
 Q. Progetto: 155.011

153.00

Quote Terreno		-154.47		-154.80		-154.85		-154.97		-155.11
Quote Progetto			154.67 154.55		154.61		154.67 154.93			
Parziali			0.28	2.50		2.50				
Progressiva			-2.78 -2.50		0.00		2.50 2.64			
Dislivelli			0.00 0.27		-0.19		-0.25 -0.00			

Sezione: 115
 Progressiva: 1059.684
 Q. Progetto: 154.990

153.00

Quote Terreno	-154.48		-154.78	-154.80	-154.91	-155.00	-155.10
Quote Progetto		154.67	154.53	154.59	154.65	154.92	
Parziali		0.28	2.50	2.50			
Progressiva		-2.76	-2.50	0.00	2.50	2.63	
Dislivelli		0.00	0.25	-0.21	-0.26	0.00	

Sezione: 116
 Progressiva: 1060.000
 Q. Progetto: 154.989

153.00

Quote Terreno	-154.48		-154.76	-154.80	-154.91	-155.01	-155.10
Quote Progetto		154.67	154.53	154.59	154.65	154.92	
Parziali		0.28	2.50	2.50			
Progressiva		-2.76	-2.50	0.00	2.50	2.63	
Dislivelli		0.00	0.25	-0.21	-0.26	-0.00	

Sezione: 117
 Progressiva: 1064.535
 Q. Progetto: 154.978

153.00

Quote Terreno	-154.46	-154.49	-154.56		-154.78	-154.87	-155.08
Quote Progetto				154.65	154.58	154.64	154.91
Parziali				0.28	2.50	2.50	
Progressiva				-2.76	-2.50	0.00	2.50
Dislivelli				0.00	0.25	-0.21	-0.26
							0.00

Sezione: 118
 Progressiva: 1080.000
 Q. Progetto: 154.988

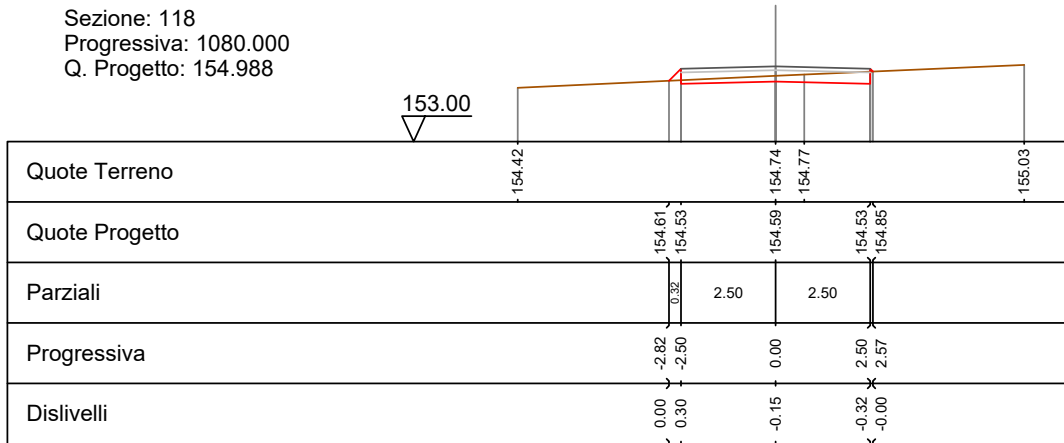

Sezione: 119
 Progressiva: 1093.213
 Q. Progetto: 155.056

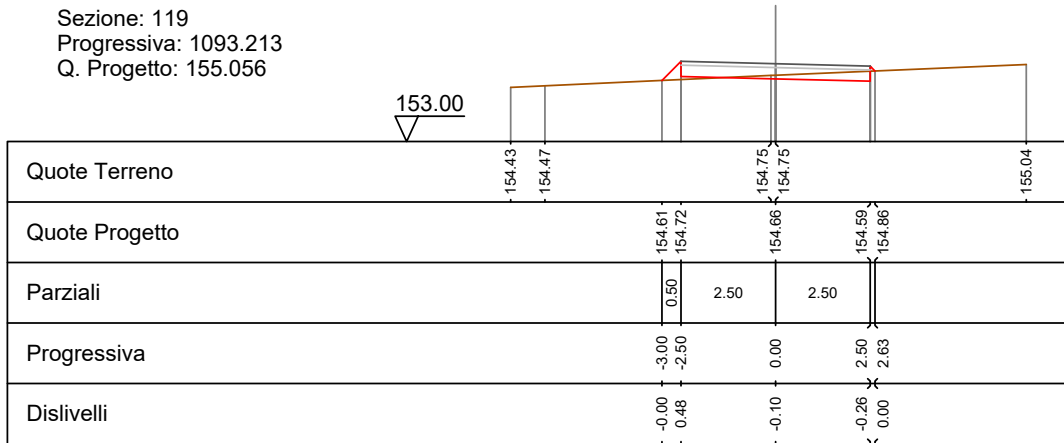

Sezione: 120
 Progressiva: 1098.892
 Q. Progetto: 155.103

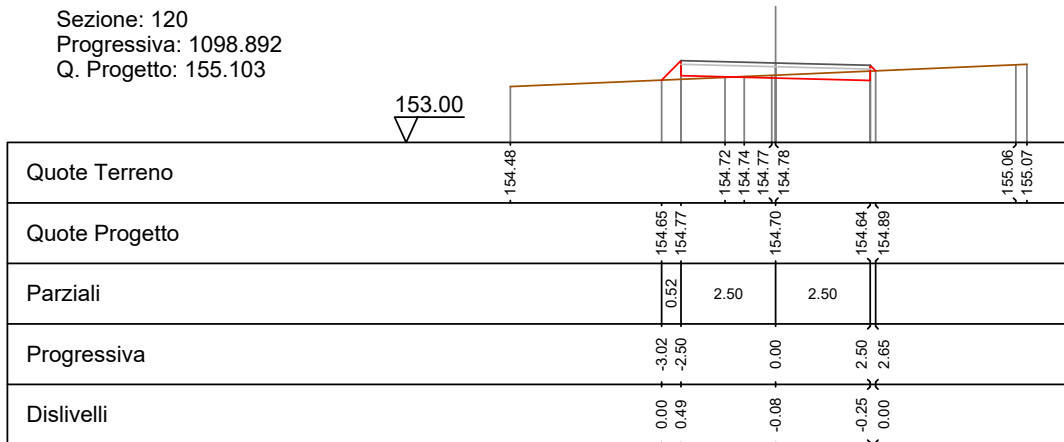

Sezione: 121
 Progressiva: 1100.000
 Q. Progetto: 155.114

153.00

Quote Terreno	-154.49		-154.71	-154.75	-154.77	-154.79		-155.06	-155.08
Quote Progetto		154.66	154.78			154.71		154.65	154.90
Parziali		0.51	2.50			2.50			
Progressiva		-3.01	-2.50			0.00		2.50	2.65
Dislivelli		0.00	0.49			-0.08		-0.25	0.00

Sezione: 122
 Progressiva: 1104.571
 Q. Progetto: 155.160

153.00

Quote Terreno	-154.56		-154.76	-154.85	-154.93		-155.06	-155.12
Quote Progetto		154.73	154.82	154.76	154.70	154.95		
Parziali		0.49	2.50		2.50			
Progressiva		-2.99	-2.50	0.00	2.50	2.64		
Dislivelli		0.00	0.47	-0.09	-0.25	0.00		

Sezione: 123
 Progressiva: 1120.000
 Q. Progetto: 155.343

153.00

Quote Terreno	-154.84		-155.06	-155.10	-155.22		-155.35
Quote Progetto		154.99	154.88	154.94	154.88	155.20	
Parziali		0.28	2.50		2.50		
Progressiva		-2.79	-2.50	0.00	2.50	2.58	
Dislivelli		0.00	0.28	-0.15	-0.31	0.00	

Sezione: 124
 Progressiva: 1132.567
 Q. Progetto: 155.493

154.00

Quote Terreno	-155.09	-155.13	-155.23	-155.33	-155.36	-155.48	-155.54	-155.57
Quote Progetto			155.23	155.09	155.36	155.16	155.43	
Parziali			2.50	2.50				
Progressiva			-2.70	0.00	2.50	2.63		
Dislivelli			0.00	-0.24	-0.27	-0.00		

Sezione: 125
 Progressiva: 1133.452
 Q. Progetto: 155.503

154.00

Quote Terreno	-155.11	-155.16	-155.25	-155.32	-155.35	-155.49	-155.57	-155.59
Quote Progetto			155.25	155.10	155.35	155.17	155.45	
Parziali			2.50	2.50				
Progressiva			-2.69	0.00	2.50	2.62		
Dislivelli			0.00	-0.25	-0.28	0.00		

Sezione: 126
 Progressiva: 1134.338
 Q. Progetto: 155.514

154.00

Quote Terreno	-155.12	-155.19	-155.27	-155.37	-155.50	-155.60		
Quote Progetto			155.27	155.11	155.18	155.46		
Parziali			2.50	2.50				
Progressiva			-2.68	0.00	2.50	2.61		
Dislivelli			0.00	-0.25	-0.28	-0.00		

Sezione: 127
 Progressiva: 1135.938
 Q. Progetto: 155.533

154.00

Quote Terreno	-155.15	-155.22	-155.26	-155.29	-155.20	-155.40	-155.51	-155.63
Quote Progetto				155.29	155.20	155.13	155.07	
Parziali				0.30	2.50	2.50		
Progressiva				-2.80	-2.50	0.00	2.50	
Dislivelli				0.00	0.29	-0.26	-0.42	

Sezione: 128
 Progressiva: 1140.000
 Q. Progetto: 155.581

154.00

Quote Terreno	-155.25	-155.39	-155.43	-155.48	-155.55	-155.70
Quote Progetto		155.39	155.24	155.18	155.12	155.57
Parziali		0.28	2.50	2.50		
Progressiva		-2.76	-2.50	0.00	2.50	2.55
Dislivelli		0.00	0.25	-0.30	-0.45	0.00

Sezione: 129
 Progressiva: 1150.000
 Q. Progetto: 155.701

154.00

Quote Terreno	-155.57	-155.65	-155.74	-155.80	-155.89	-155.92
Quote Progetto		155.67	155.36	155.30	155.24	155.81
Parziali			2.50	2.50		
Progressiva		-2.59	-2.50	0.00	2.50	2.68
Dislivelli		0.00	0.09	-0.44	-0.57	0.00

Sezione: 129
 Progressiva: 1150.000
 Q. Progetto: 155.701

154.00

Quote Terreno	-155.57	-155.65	-155.74	-155.80	-155.89	-155.92
Quote Progetto		155.67 155.36	155.30	155.24 155.81		
Parziali		2.50	2.50			
Progressiva		-2.99 -2.50	0.00	2.60 2.68		
Dislivelli		0.00 0.09	-0.44	-0.57 -0.00		

Sezione: 130
 Progressiva: 1160.000
 Q. Progetto: 155.900

154.00

Quote Terreno	-155.95	-155.95	-156.04	-156.07	-156.13	-156.19
Quote Progetto		156.02 155.56	155.50	155.44 156.12		
Parziali		2.50	2.50	0.78		
Progressiva		-2.56 -2.50	0.00	2.50 2.78		
Dislivelli		-0.00 -0.06	-0.57	-0.67 0.00		

Sezione: 131
 Progressiva: 1170.000
 Q. Progetto: 156.123

154.00

Quote Terreno	-156.36	-156.41	-156.42	-156.45	-156.49
Quote Progetto		156.39 155.79	155.72	155.66 156.45	
Parziali		2.50	2.50	0.39	
Progressiva		-2.71 -2.50	0.00	2.50 2.89	
Dislivelli		0.00 -0.21	-0.70	-0.79 0.00	

Sezione: 132
 Progressiva: 1180.000
 Q. Progetto: 156.345

154.00

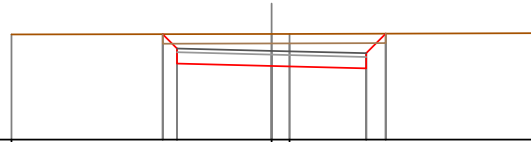

Quote Terreno	-156.78	-156.79	-156.79	-156.81
Quote Progetto		156.79	156.01	
Parziali		0.38	2.50	2.50
Progressiva		2.88	2.50	0.00
Dislivelli		0.00	-0.38	-0.84

Sezione: 133
 Progressiva: 1190.000
 Q. Progetto: 156.568

155.00

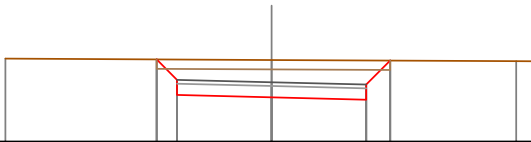

Quote Terreno	-157.19	-157.17	-157.16	-157.12
Quote Progetto		157.17	156.23	
Parziali		0.54	2.50	2.50
Progressiva		3.04	2.50	0.00
Dislivelli		0.00	-0.54	-0.99

Sezione: 134
 Progressiva: 1194.439
 Q. Progetto: 156.666

155.00

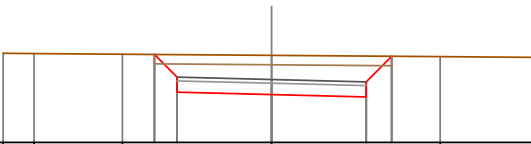

Quote Terreno	-157.36	-157.35	-157.34	-157.30	-157.27	-157.25
Quote Progetto			157.33	156.33	156.27	156.20
Parziali			0.60	2.50	2.50	0.68
Progressiva			-3.10	-2.50	0.00	2.50
Dislivelli			0.00	-0.60	-1.04	-1.08

Sezione: 135
 Progressiva: 1200.000
 Q. Progetto: 156.790

155.00



Quote Terreno	-157.57	-157.55			157.49	157.46	-157.41
Quote Progetto			157.52	156.45	156.39	156.33	157.45
Parziali			0.67	2.50	2.50	0.73	
Progressiva			-3.17	-2.50	0.00	2.50	3.23
Dislivelli			0.00	-0.66	-1.10	-1.13	0.00

Sezione: 136
 Progressiva: 1210.000
 Q. Progetto: 157.013

155.00

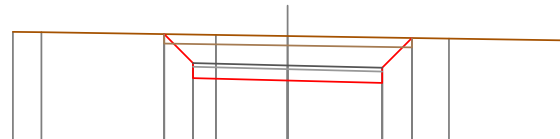

Quote Terreno	-157.90	-157.89			157.79		-157.72	-157.68
Quote Progetto			157.84	156.68	156.61	156.55	157.74	
Parziali			0.77	2.50	2.50	0.79		
Progressiva			-3.27	-2.50	0.00	2.50	3.29	
Dislivelli			-0.00	-0.75	-1.18	-1.20	0.00	

Sezione: 137
 Progressiva: 1220.000
 Q. Progetto: 157.235

155.00

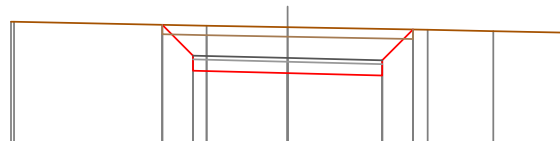

Quote Terreno	158.19	158.19			158.05		157.98	157.94	-157.91
Quote Progetto			158.11	156.90	156.84	156.77	157.99		
Parziali			0.82	2.50	2.50	0.82			
Progressiva			-3.32	-2.50	0.00	2.50	3.32		
Dislivelli			0.00	-0.80	-1.21	-1.23	0.00		

Sezione: 138
 Progressiva: 1230.000
 Q. Progetto: 157.458

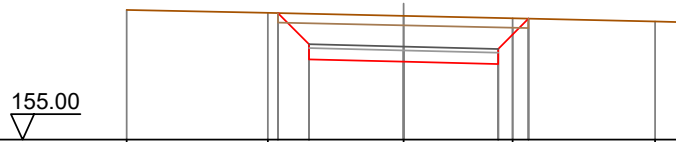

Quote Terreno	-158.43	-158.35	-158.27	-158.21	-158.12	-158.11
Quote Progetto		158.34	157.12	157.06	157.00	158.20
Parziali		0.82	2.50	2.50	0.80	
Progressiva		-3.32	-2.50	0.00	2.50	3.30
Dislivelli		0.00	-0.81	-1.21	-1.22	0.00

Sezione: 139
 Progressiva: 1240.000
 Q. Progetto: 157.680

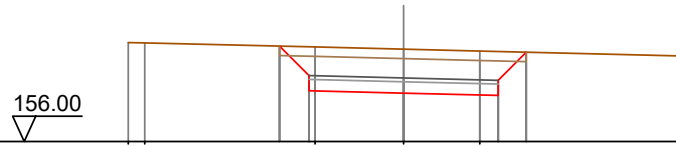

Quote Terreno	-158.62	-158.61	-158.50	-158.44	-158.39	-158.26
Quote Progetto			158.52	157.34	157.28	157.22
Parziali			0.78	2.50	2.50	0.74
Progressiva			-3.28	-2.50	0.00	2.50
Dislivelli			-0.00	-0.76	-1.16	-1.16

Sezione: 139
 Progressiva: 1240.000
 Q. Progetto: 157.680

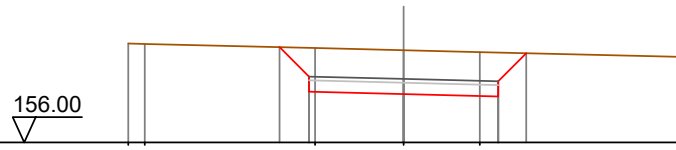

Quote Terreno	-158.62	-158.61	-158.50	-158.44	-158.39	-158.26
Quote Progetto			158.52	157.34	157.28	157.22
Parziali			0.78	2.50	2.50	0.74
Progressiva			-3.28	-2.50	0.00	2.50
Dislivelli			-0.00	-0.76	-1.16	-1.16

Sezione: 140
 Progressiva: 1250.000
 Q. Progetto: 157.902

156.00

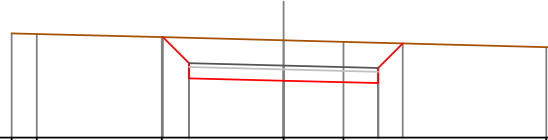

Quote Terreno	-158.75	-158.74	-158.66	-158.57	-158.53	-158.39	-158.39
Quote Progetto			158.66	157.50		157.44	158.49
Parziali			0.69	2.50	2.50	0.65	
Progressiva			-3.19	-2.50	0.00	2.50	3.15
Dislivelli			0.00	-0.67	-1.07	-1.07	0.00

Sezione: 141
 Progressiva: 1252.940
 Q. Progetto: 157.957

156.00

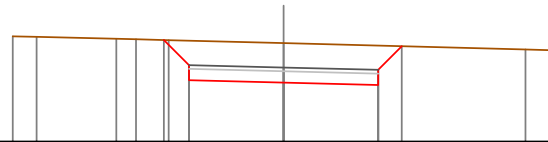

Quote Terreno	-158.78	-158.77	-158.72	-158.70	-158.68	-158.60	-158.43	-158.41
Quote Progetto			158.68	157.62		157.56	157.49	158.52
Parziali			0.66	2.50	2.50	0.62		
Progressiva			-3.16	-2.50	0.00	2.50	3.12	
Dislivelli			0.00	-0.65	-1.04	-1.04	-0.00	

Sezione: 142
 Progressiva: 1255.594
 Q. Progetto: 158.005

156.00

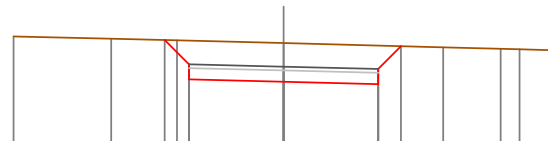

Quote Terreno	-158.81	-158.75	-158.70	-158.63	-158.52	-158.48	-158.46	-158.44
Quote Progetto			158.71	157.61		157.54	158.55	
Parziali			0.64	2.50	2.50	0.60		
Progressiva			-3.14	-2.50	0.00	2.50	3.10	
Dislivelli			0.00	-0.63	-1.02	-1.02	-0.00	

Sezione: 143
 Progressiva: 1258.811
 Q. Progetto: 158.063

156.00

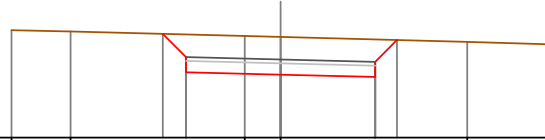

Quote Terreno	-158.84	-158.80		-158.69	-158.66		-158.53	-158.47
Quote Progetto			158.74	157.73	157.66		157.60	158.58
Parziali			0.62	2.50	2.50		0.58	
Progressiva			-3.12	-2.50	0.00		2.50	3.08
Dislivelli			-0.00	-0.60	-1.00		-0.99	0.00

Sezione: 144
 Progressiva: 1260.000
 Q. Progetto: 158.085

156.00

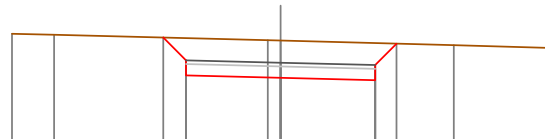

Quote Terreno	-158.85	-158.82		-158.68	-158.67		-158.55	-158.48
Quote Progetto			158.75	157.75	157.68		157.62	158.59
Parziali			0.60	2.50	2.50		0.57	
Progressiva			-3.10	-2.50	0.00		2.50	3.07
Dislivelli			0.00	-0.59	-0.99		-0.98	0.00

Sezione: 145
 Progressiva: 1262.027
 Q. Progetto: 158.121

156.00

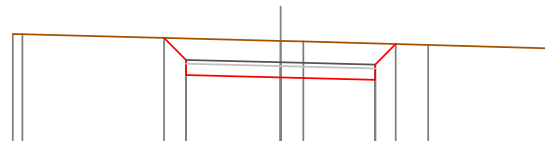

Quote Terreno	-158.87	-158.86		-158.69	-158.67		-158.58	-158.49
Quote Progetto			158.77	157.78	157.72		157.66	158.60
Parziali			0.58	2.50	2.50		0.55	
Progressiva			-3.08	-2.50	0.00		2.50	3.05
Dislivelli			0.00	-0.57	-0.97		-0.96	0.00

Sezione: 146
 Progressiva: 1280.000
 Q. Progetto: 158.445

156.00

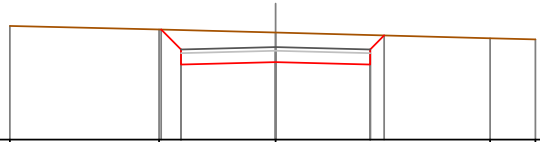

Quote Terreno	-159.00	158.91	158.83	158.68	158.65
Quote Progetto		158.91 157.98	158.05	157.98 158.75	
Parziali		0.53 2.50	2.50	0.37 2.50	
Progressiva		-3.03 -2.50	0.00	2.50 2.87	
Dislivelli		0.00 -0.51	-0.79	-0.78 -0.00	

Sezione: 147
 Progressiva: 1300.000
 Q. Progetto: 158.806

157.00

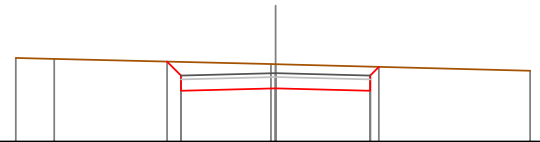

Quote Terreno	-159.21	158.19	159.05 159.04	158.87
Quote Progetto		159.11 158.34	158.41	158.34 158.97
Parziali		0.37 2.50	2.50	0.37 2.50
Progressiva		-2.87 -2.50	0.00	2.50 2.73
Dislivelli		-0.00 -0.36	-0.64	-0.64 -0.00

Sezione: 148
 Progressiva: 1320.000
 Q. Progetto: 159.167

157.00

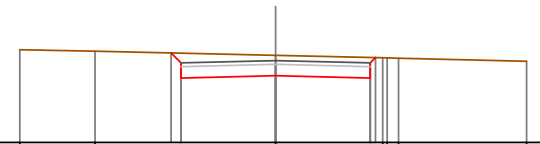

Quote Terreno	-159.45	159.41	159.30	159.24	159.23	159.15
Quote Progetto		159.37 158.70	158.77	158.70 159.24	159.23	
Parziali		0.26 2.50	2.50	0.37 2.50	2.50	
Progressiva		-2.76 -2.50	0.00	2.50 2.64		
Dislivelli		0.00 -0.26	-0.54	-0.54 -0.00		

Sezione: 149
 Progressiva: 1340.000
 Q. Progetto: 159.527

158.00

Quote Terreno	-159.73	-159.70	-159.69	-159.61	-159.49	-159.47
Quote Progetto			159.67 159.06	159.13	159.06 159.56	
Parziali			2.50	2.50		
Progressiva			-2.70 -2.50	0.00	2.50 2.59	
Dislivelli			0.00 -0.20	-0.48	-0.49 0.00	

Sezione: 150
 Progressiva: 1354.991
 Q. Progetto: 159.800

158.00

Quote Terreno	-159.92	-159.92	-159.85	-159.85	-159.74
Quote Progetto			159.88 159.46	159.40	159.34 159.81
Parziali			2.50	2.50	
Progressiva			-2.52 -2.50	0.00	2.50 2.57
Dislivelli			-0.00 -0.02	-0.45	-0.47 0.00

Sezione: 151
 Progressiva: 1359.377
 Q. Progetto: 159.886

158.00

Quote Terreno	-159.97	-159.96	-159.95	-159.94	-159.90	-159.88	-159.80
Quote Progetto			159.55 159.49	159.49	159.42 159.86		
Parziali			2.50	2.50			
Progressiva			-2.51	0.00	2.50 2.54		
Dislivelli			-0.00	-0.41	-0.44 -0.00		

Sezione: 152
 Progressiva: 1360.000
 Q. Progetto: 159.899

158.00

Quote Terreno	-159.97	-159.96	-159.96	-159.95	-159.93	-159.91	-159.82
Quote Progetto			159.86			159.50	159.44 159.87
Parziali			2.50		2.50		
Progressiva			-2.51		0.00		2.50 2.54
Dislivelli			0.00		-0.41		-0.44 -0.00

Sezione: 153
 Progressiva: 1363.763
 Q. Progetto: 159.980

158.00

Quote Terreno	-159.98	-159.98	-159.97	-159.96	-159.94	-159.88	
Quote Progetto			159.88 159.64			159.82 159.84	
Parziali			2.50		2.50		
Progressiva			-2.57 -2.50		0.00		2.50 2.53
Dislivelli			0.00 0.07		-0.38		-0.43 -0.00

Sezione: 154
 Progressiva: 1380.000
 Q. Progetto: 160.378

158.00

Quote Terreno	-160.26	-160.20	-160.16	-160.12	-160.06	
Quote Progetto		160.20 159.92		159.88 159.92	160.11 160.11	
Parziali		2.50		2.50		
Progressiva		-2.62 -2.50		0.00		2.50 2.71
Dislivelli		-0.00 0.12		-0.18		-0.20 0.00

Sezione: 155
 Progressiva: 1400.000
 Q. Progetto: 160.987

159.00

Quote Terreno	-160.92	-160.83	-160.73	-160.58	-160.53
Quote Progetto		160.81 160.52	160.59	160.52 160.65	
Parziali			2.50	2.50	0.28
Progressiva		-2.62 -2.50	0.00	2.50 2.78	
Dislivelli		-0.00 0.12	-0.14	-0.13 0.00	

Sezione: 156
 Progressiva: 1420.000
 Q. Progetto: 161.724

160.00

Quote Terreno	-161.68	-161.58	-161.47	-161.21
Quote Progetto		161.55 161.26	161.32	161.26 161.35
Parziali			2.50	2.50
Progressiva		-2.61 -2.50	0.00	2.50 2.81
Dislivelli		0.00 0.12	-0.13	-0.10 0.00

Sezione: 157
 Progressiva: 1440.000
 Q. Progetto: 162.592

160.00

Quote Terreno	-162.49	-162.43	-162.28	-161.97
Quote Progetto		162.35 162.13	162.19	162.13 162.13
Parziali			2.50	2.50
Progressiva		-2.68 -2.50	0.00	2.50 2.90
Dislivelli		0.00 0.19	-0.05	-0.01 0.00

Sezione: 158
 Progressiva: 1460.000
 Q. Progetto: 163.543

161.00

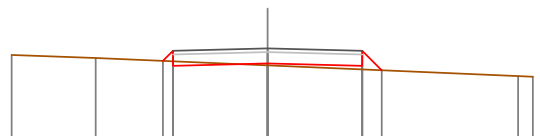

Quote Terreno	-163.37	-163.29	-163.21	-163.08	-163.09	-163.08	-162.81	-162.79
Quote Progetto			163.21	163.08	163.14	163.08	162.96	
Parziali			0.27	2.50	2.50	0.52		
Progressiva			-2.77	-2.50	0.00	2.50	3.02	
Dislivelli			0.00	0.28	0.05	0.09	0.00	

Sezione: 159
 Progressiva: 1473.661
 Q. Progetto: 164.194

162.00

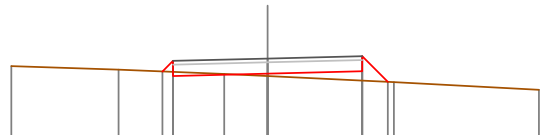

Quote Terreno	-164.00	-163.90	-163.79	-163.73	-163.79	-163.68	-163.57	-163.37
Quote Progetto			163.85	163.73	163.79	163.86	163.58	
Parziali			0.28	2.50	2.50	0.68		
Progressiva			-2.78	-2.50	0.00	2.50	3.18	
Dislivelli			-0.00	0.29	0.06	0.24	0.00	

Sezione: 160
 Progressiva: 1477.577
 Q. Progetto: 164.381

162.00

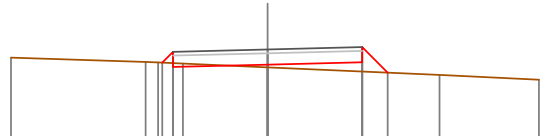

Quote Terreno	-164.17	-164.05	-164.04	-164.01	-163.91	-163.71	-163.58
Quote Progetto		164.03	163.92	163.98	164.04	163.77	
Parziali		0.28	2.50	2.50	0.67		
Progressiva		-2.79	-2.50	0.00	2.50	3.17	
Dislivelli		0.00	0.30	0.07	0.24	-0.00	

Sezione: 161
 Progressiva: 1480.000
 Q. Progetto: 164.496

162.00

Quote Terreno		164.28		164.20		164.12		164.03		163.90		163.80		163.74		163.71
Quote Progetto						164.15		164.10		164.16		163.89				
Parziali						0.28		2.50		2.50		0.67				
Progressiva						-2.78		-2.50		0.00		2.50		3.17		
Dislivelli						0.00		0.29		0.06		0.24		-0.00		

Sezione: 162
 Progressiva: 1481.493
 Q. Progetto: 164.567

162.00

Quote Terreno		164.35		164.29		164.18		164.11				163.86		163.82		163.80
Quote Progetto						164.22		164.17		164.23		163.88				
Parziali						0.28		2.50		2.50		0.65				
Progressiva						-2.78		-2.50		0.00		2.50		3.15		
Dislivelli						0.00		0.29		0.05		0.22		0.00		

Sezione: 163
 Progressiva: 1500.000
 Q. Progetto: 165.449

163.00

Quote Terreno		165.38				165.22		165.18		165.13				164.78		164.74
Quote Progetto						165.25		164.99		165.05		164.99		164.97		
Parziali						0.28		2.50		2.50		0.42				
Progressiva						-2.63		-2.50		0.00		2.50		2.92		
Dislivelli						0.00		0.14		-0.08		-0.00		0.00		

Sezione: 164
 Progressiva: 1520.000
 Q. Progetto: 166.309

164.00

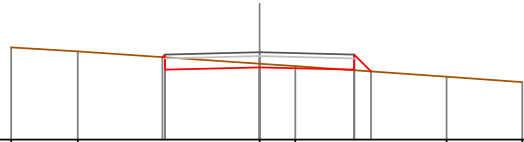

Quote Terreno	-166.44	-166.33		166.00	-165.94		-165.66	-165.52
Quote Progetto			166.18	165.91		165.85		
Parziali			2.50	2.50		0.45		
Progressiva			-2.57	0.00		2.50	2.95	
Dislivelli			0.00	-0.09		0.01	-0.00	

Sezione: 165
 Progressiva: 1522.933
 Q. Progetto: 166.384

164.00

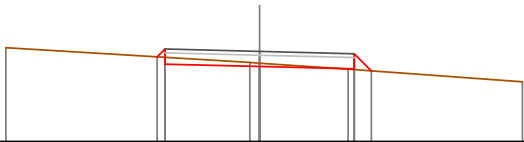

Quote Terreno	-166.48			166.09	166.07		165.91	-165.58
Quote Progetto			166.24	165.98		165.92	165.87	
Parziali			2.50	2.50		0.45		
Progressiva			-2.71	0.00		2.50	2.95	
Dislivelli			0.00	-0.09		0.02	0.00	

Sezione: 166
 Progressiva: 1530.000
 Q. Progetto: 166.492

164.00



Quote Terreno	-166.52	-166.46	-166.41	-166.37	-166.22	166.11		-165.64
Quote Progetto			166.29	166.15		166.09	166.03	165.90
Parziali			0.28	2.50	2.50		0.52	
Progressiva			-2.76	-2.50	0.00		2.50	3.02
Dislivelli			-0.00	-0.28	-0.01		0.09	-0.00

Sezione: 167
 Progressiva: 1532.187
 Q. Progetto: 166.506

164.00

Quote Terreno	-166.52	-166.46	-166.38	-166.23	-166.12	-165.68	-165.65
Quote Progetto			166.30	166.17	166.11	166.04	165.92
Parziali			0.27	2.50	2.50	0.53	
Progressiva			-2.77	-2.50	0.00	2.50	3.03
Dislivelli			-0.00	0.28	-0.01	0.09	-0.00

Sezione: 168
 Progressiva: 1540.000
 Q. Progetto: 166.486

164.00

Quote Terreno	-166.49	-166.27	-166.09	-166.03	-165.64	
Quote Progetto		166.27	166.15	166.09	166.02	165.90
Parziali		0.28	2.50	2.50	0.52	
Progressiva		-2.78	-2.50	0.00	2.50	3.02
Dislivelli		0.00	0.30	-0.01	0.09	-0.00

Sezione: 169
 Progressiva: 1541.441
 Q. Progetto: 166.478

164.00

Quote Terreno	-166.47	-166.39	-166.25	-166.10	-166.08	-165.63	
Quote Progetto			166.25	166.14	166.08	166.02	165.89
Parziali			0.28	2.50	2.50	0.53	
Progressiva			-2.79	-2.50	0.00	2.50	3.03
Dislivelli			-0.00	0.31	0.00	0.10	0.00

Sezione: 170
 Progressiva: 1560.000
 Q. Progetto: 166.385

164.00

Quote Terreno	-166.38	-166.23	-166.13	-166.01	-165.99	-165.70	-165.56
Quote Progetto			166.15 165.92	166.01 165.98		165.92 165.81	
Parziali			2.50	2.50		0.51	
Progressiva			-2.67 -2.50	0.00		2.50 3.01	
Dislivelli			0.00 0.18	-0.00		0.08 0.00	

Sezione: 171
 Progressiva: 1580.000
 Q. Progetto: 166.374

164.00

Quote Terreno	-166.40	-166.13	-166.03	-165.76	-165.65	-165.51
Quote Progetto		166.18 165.91	166.03 165.97	165.91 165.85		
Parziali		2.50	2.50	0.46		
Progressiva		-2.63 -2.50	0.00	2.50 2.96		
Dislivelli		0.00 0.14	-0.05	0.04 0.00		

Sezione: 172
 Progressiva: 1600.000
 Q. Progetto: 166.480

164.00

Quote Terreno	-166.56	-166.30	-166.28	-166.25	-166.21	-165.82
Quote Progetto		166.35 166.02	166.28 166.08	166.02 166.05		
Parziali		2.50	2.50	0.37		
Progressiva		-2.57 -2.50	0.00	2.50 2.87		
Dislivelli		0.00 0.07	-0.13	-0.05 -0.00		

Sezione: 173
 Progressiva: 1619.576
 Q. Progetto: 166.698

165.00

Quote Terreno	-166.86	-166.80	-166.57	-166.53	-166.30	-166.20	-166.17
Quote Progetto			166.66	166.36	166.30	166.24	166.38
Parziali			2.50	2.50			
Progressiva			-2.60	-2.50	0.00	2.50	2.75
Dislivelli			0.00	0.11	-0.23	-0.16	-0.00

Sezione: 174
 Progressiva: 1620.000
 Q. Progetto: 166.704

165.00

Quote Terreno	-166.87	-166.84	-166.57	-166.54	-166.29	-166.20	-166.18
Quote Progetto			166.67	166.37	166.30	166.24	166.39
Parziali			2.50	2.50			
Progressiva			-2.60	-2.50	0.00	2.50	2.75
Dislivelli			0.00	0.10	-0.23	-0.16	0.00

Sezione: 175
 Progressiva: 1622.829
 Q. Progetto: 166.745

165.00

Quote Terreno	-166.92	-166.91	-166.63	-166.59	-166.30	-166.22	
Quote Progetto			166.72	166.41	166.34	166.28	166.44
Parziali			2.50	2.50			
Progressiva			-2.59	-2.50	0.00	2.50	2.74
Dislivelli			0.00	0.09	-0.24	-0.17	0.00

Sezione: 176
 Progressiva: 1626.081
 Q. Progetto: 166.795

165.00

Quote Terreno	-166.97		-166.69	-166.63	-166.53	-166.27
Quote Progetto		166.77	166.46	166.39	166.33	166.48
Parziali			2.50		2.50	
Progressiva		-2.59	-2.50	0.00	2.50	2.75
Dislivelli		0.00	0.09	-0.24	-0.16	0.00

Sezione: 177
 Progressiva: 1640.000
 Q. Progetto: 167.010

165.00

Quote Terreno	-167.19	-167.11	-166.98	-166.86	-166.83	-166.51
Quote Progetto			166.99	166.61	166.55	166.72
Parziali			2.50		2.50	
Progressiva			-2.54	-2.50	0.00	2.50
Dislivelli			0.00	-0.04	-0.25	-0.18

Sezione: 178
 Progressiva: 1660.000
 Q. Progetto: 167.320

165.00

Quote Terreno	-167.60	-167.51	-167.36	-167.28		-166.94
Quote Progetto			167.41	166.86	166.92	166.86
Parziali			2.50		2.50	
Progressiva			-2.66	-2.50	0.00	2.50
Dislivelli			0.00	-0.15	-0.36	-0.29

Sezione: 179
 Progressiva: 1676.927
 Q. Progetto: 167.637

166.00

Quote Terreno	168.06	168.04		167.77	167.73	167.69	167.60	167.40
Quote Progetto			167.87	167.17	167.24	167.30	167.60	
Parziali			0.28	2.50	2.50			
Progressiva			-2.79	-2.50	0.00	2.50	2.60	
Dislivelli			0.00	-0.28	-0.49	-0.31	0.00	

Sezione: 180
 Progressiva: 1680.000
 Q. Progetto: 167.718

166.00

Quote Terreno	168.15	168.13		167.87	167.83	167.74	167.51
Quote Progetto			167.96	167.26	167.32	167.38	167.70
Parziali			0.30	2.50	2.50		
Progressiva			-2.80	-2.50	0.00	2.50	2.58
Dislivelli			0.00	-0.29	-0.51	-0.33	0.00

Sezione: 181
 Progressiva: 1685.420
 Q. Progetto: 167.880

166.00

Quote Terreno	168.31	168.30	168.27		168.02	167.90	167.75
Quote Progetto				168.14	167.48	167.54	167.91
Parziali				0.32	2.50	2.50	
Progressiva				-2.82	-2.50	0.00	2.50
Dislivelli				0.00	-0.31	-0.54	-0.37

Sezione: 182
 Progressiva: 1690.000
 Q. Progetto: 168.036

166.00

Quote Terreno	-168.48	-168.46	-168.30	-168.23	-168.10	-167.98
Quote Progetto			168.34 167.57	167.64	167.70 168.13	
Parziali			0.37 2.50	2.50		
Progressiva			-2.87 -2.50	0.00	2.50 2.54	
Dislivelli			-0.00 -0.35	-0.59	-0.44 0.00	

Sezione: 182
 Progressiva: 1690.000
 Q. Progetto: 168.036

166.00

Quote Terreno	-168.48	-168.46	-168.30	-168.23	-168.10	-167.98
Quote Progetto			168.34 167.57	167.64	167.70 168.13	
Parziali			0.37 2.50	2.50		
Progressiva			-2.87 -2.50	0.00	2.50 2.54	
Dislivelli			-0.00 -0.35	-0.59	-0.44 0.00	

Sezione: 183
 Progressiva: 1693.912
 Q. Progetto: 168.183

166.00

Quote Terreno	-168.64	-168.60	-168.42	-168.40	-168.29	-168.20
Quote Progetto			168.52 167.72	167.78	167.85 168.34	
Parziali			0.39 2.50	2.50		
Progressiva			-2.89 -2.50	0.00	2.50 2.59	
Dislivelli			-0.00 -0.38	-0.64	-0.49 -0.00	

Sezione: 184
 Progressiva: 1698.278
 Q. Progetto: 168.363

166.00

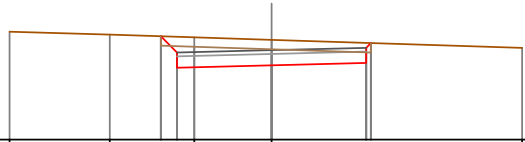

Quote Terreno	-168.85	-168.78	-168.70	-168.64	-168.42
Quote Progetto			168.73 167.90	167.96	168.03 168.55
Parziali			0.43 2.50	2.50	
Progressiva			-2.93 -2.50	0.00	2.50 2.63
Dislivelli			0.00 -0.42	-0.67	-0.53 0.00

Sezione: 185
 Progressiva: 1700.000
 Q. Progetto: 168.438

166.00

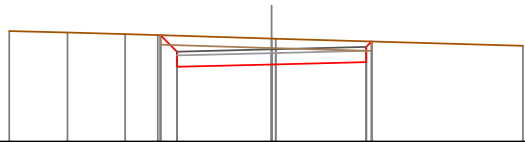

Quote Terreno	-168.92	-168.88	-168.84	-168.81	-168.72	-168.53
Quote Progetto				168.81 167.98	168.04	168.10 168.65
Parziali				0.44 2.50	2.50	
Progressiva				-2.94 -2.50	0.00	2.50 2.65
Dislivelli				0.00 -0.42	-0.68	-0.55 0.00

Sezione: 186
 Progressiva: 1710.000
 Q. Progetto: 168.925

167.00

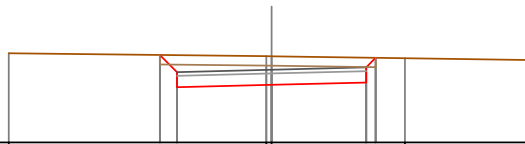

Quote Terreno	-169.36	-169.28	-169.28	-169.23	-169.18
Quote Progetto		169.32 168.46	168.52	168.59 169.24	
Parziali		0.45 2.50	2.50	2.50	
Progressiva				2.50 2.75	
Dislivelli		0.00 -0.45	-0.76	-0.66 -0.00	

Sezione: 187
 Progressiva: 1720.000
 Q. Progetto: 169.495

168.00

Quote Terreno		169.77	169.77		169.77	169.77	169.82
Quote Progetto			169.77	169.03	169.10	169.16	169.79
Parziali			0.34	2.50	2.50		
Progressiva			-2.84	-2.50	0.00	2.50	2.73
Dislivelli			0.00	-0.34	-0.68	-0.63	0.00

Sezione: 188
 Progressiva: 1724.039
 Q. Progetto: 169.750

168.00

Quote Terreno		169.94		169.96	169.96	169.97	170.03
Quote Progetto			169.95	169.29	169.35	169.41	169.99
Parziali			0.28	2.50	2.50		
Progressiva			-2.76	-2.50	0.00	2.50	2.68
Dislivelli			-0.00	-0.27	-0.61	-0.58	0.00

Sezione: 189
 Progressiva: 1730.000
 Q. Progetto: 170.151

168.00

Quote Terreno		170.27	170.29		170.42	170.45	170.65
Quote Progetto			170.34	169.69	169.75	169.81	170.51
Parziali				2.50	2.50	0.30	
Progressiva			-2.76	-2.50	0.00	2.50	2.80
Dislivelli			0.00	-0.26	-0.67	-0.69	0.00

Sezione: 190
 Progressiva: 1740.000
 Q. Progetto: 170.890

169.00

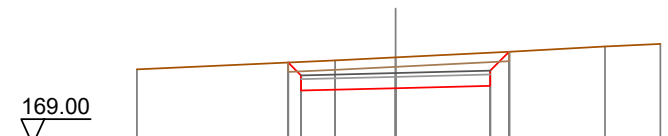

Quote Terreno	-170.99		-171.23	171.30		171.45	-171.59	-171.66
Quote Progetto		171.17	170.43	170.49		170.55	171.45	
Parziali		0.34	2.50	2.50		0.50		
Progressiva		-2.84	-2.50	0.00		2.50	3.00	
Dislivelli		0.00	-0.36	-0.81		-0.88	0.00	

Sezione: 191
 Progressiva: 1749.800
 Q. Progetto: 171.667

170.00

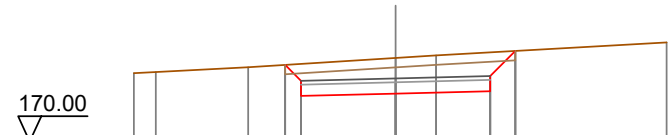

Quote Terreno	-171.81	-171.84	-171.97	172.21	-172.28		-172.62
Quote Progetto			172.03	171.27	171.33	172.39	
Parziali			0.42	2.50	2.50	0.67	
Progressiva			-2.92	-2.50	0.00	2.50	3.17
Dislivelli			-0.00	-0.45	-0.94	-1.03	-0.00

Sezione: 192
 Progressiva: 1750.395
 Q. Progetto: 171.714

170.00

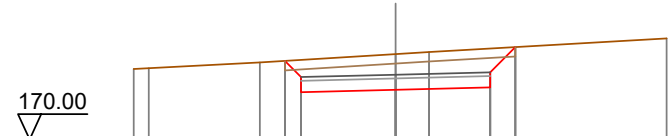

Quote Terreno	-171.86	-171.88	-172.04	172.26	-172.32		-172.67
Quote Progetto			172.08	171.31	171.38	172.44	
Parziali			0.43	2.50	2.50	0.67	
Progressiva			-2.83	-2.50	0.00	2.50	3.17
Dislivelli			0.00	-0.45	-0.95	-1.03	0.00

Sezione: 193
 Progressiva: 1760.000
 Q. Progetto: 172.476

171.00

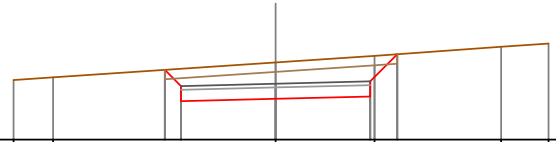

Quote Terreno	-172.57	-172.65			173.04	173.21		-173.45	-173.54
Quote Progetto			172.84	172.01	172.08	172.14	173.26		
Parziali			0.43	2.50	2.50	0.72			
Progressiva			-2.93	-2.50	0.00	2.50	3.22		
Dislivelli			0.00	-0.46	-0.96	-1.06	0.00		

Sezione: 194
 Progressiva: 1770.000
 Q. Progetto: 173.265

171.00

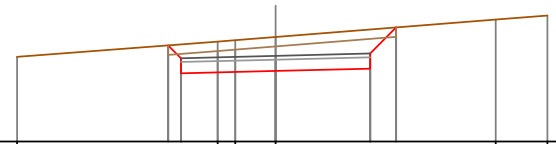

Quote Terreno	-173.24				-173.64	-173.68		-174.23	-174.33
Quote Progetto			173.54	172.80	172.86	172.83	174.02		
Parziali			0.34	2.50	2.50	0.69			
Progressiva			-2.84	-2.50	0.00	2.50	3.19		
Dislivelli			0.00	-0.36	-0.90	-1.03	0.00		

Sezione: 195
 Progressiva: 1770.585
 Q. Progetto: 173.308

171.00

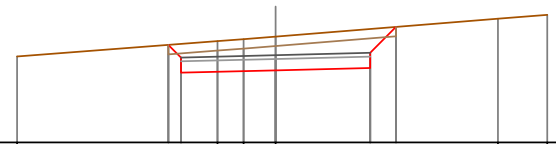

Quote Terreno	-173.27				-173.68	-173.73		-174.27	-174.37
Quote Progetto			173.58	172.85	172.91	172.87	174.06		
Parziali			0.33	2.50	2.50	0.69			
Progressiva			-2.83	-2.50	0.00	2.50	3.19		
Dislivelli			0.00	-0.36	-0.89	-1.03	0.00		

Sezione: 196
 Progressiva: 1780.000
 Q. Progetto: 173.915

172.00

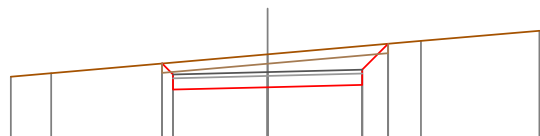

Quote Terreno	-173.79	-173.89		174.39		-174.74	-175.01
Quote Progetto			174.14 173.45	173.52		173.58 174.67	
Parziali			0.28 2.50	2.50		0.69	
Progressiva			-2.79 -2.50	0.00		2.50 3.19	
Dislivelli			0.00 -0.32	-0.87		-1.03 -0.00	

Sezione: 197
 Progressiva: 1790.000
 Q. Progetto: 174.375

172.00

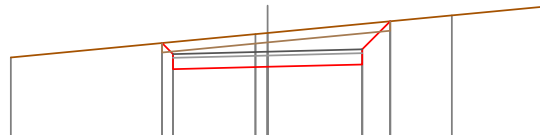

Quote Terreno	-174.22			174.84		-175.33	-175.56
Quote Progetto			174.60 173.91	173.97		174.04 175.18	
Parziali			0.28 2.50	2.50		0.74	
Progressiva			-2.79 -2.50	0.00		2.50 3.24	
Dislivelli			0.00 -0.32	-0.89		-1.07 0.00	

Sezione: 198
 Progressiva: 1790.775
 Q. Progetto: 174.407

172.00

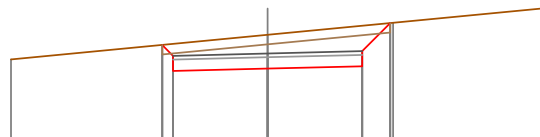

Quote Terreno	-174.25			174.90		175.22	-175.60
Quote Progetto			174.63 173.94	174.01		174.07 175.21	
Parziali			0.28 2.50	2.50		0.74	
Progressiva			-2.79 -2.50	0.00		2.50 3.24	
Dislivelli			0.00 -0.31	-0.89		-1.07 0.00	

Sezione: 199
 Progressiva: 1800.000
 Q. Progetto: 174.789

173.00

Quote Terreno	174.61	174.71	174.95	175.26	175.49	175.95
Quote Progetto			174.99	174.39	174.33	175.58
Parziali			0.27	2.50	2.50	0.85
Progressiva			-2.77	0.00	2.50	3.35
Dislivelli			-0.00	-0.87	-1.17	-0.00

Sezione: 200
 Progressiva: 1820.000
 Q. Progetto: 175.617

174.00

Quote Terreno	175.41	175.79	176.05	176.18	176.74
Quote Progetto		175.79	175.22	175.15	176.36
Parziali		2.50	2.50	0.81	
Progressiva		-2.74	0.00	2.50	3.31
Dislivelli		0.00	-0.83	-1.13	-0.00

Sezione: 201
 Progressiva: 1840.000
 Q. Progetto: 176.726

175.00

Quote Terreno	176.26	176.45	176.85	176.87	177.40	177.49
Quote Progetto			176.62	176.33	176.26	177.13
Parziali			0.36	2.50	2.50	0.46
Progressiva			-2.54	0.00	2.50	2.96
Dislivelli			0.00	-0.53	-0.82	0.00

Sezione: 202
 Progressiva: 1860.000
 Q. Progetto: 178.305

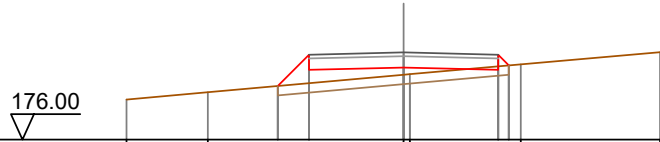

Quote Terreno	-177.06	-177.25			177.71	177.73		177.99	-178.31
Quote Progetto			177.42	177.84	177.91		177.84	177.96	
Parziali			0.83	2.50	2.50		0.28		
Progressiva			-3.33	-2.50	0.00		2.50	2.78	
Dislivelli			0.00	0.75	0.19		-0.09	0.00	

Sezione: 203
 Progressiva: 1867.281
 Q. Progetto: 178.850

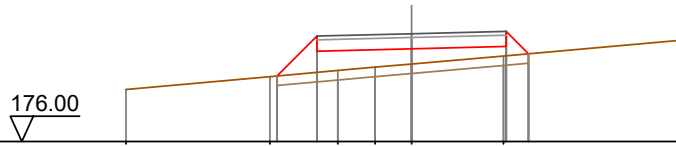

Quote Terreno	-177.38		177.72	-177.88	-177.97	178.05		178.26	-178.68
Quote Progetto			177.73	178.39		178.45		178.51	178.32
Parziali			1.05	2.50	2.50		0.59		
Progressiva			-3.55	-2.50	0.00		2.50	3.09	
Dislivelli			0.00	0.96	0.40		0.24	0.00	

Sezione: 204
 Progressiva: 1870.000
 Q. Progetto: 179.027

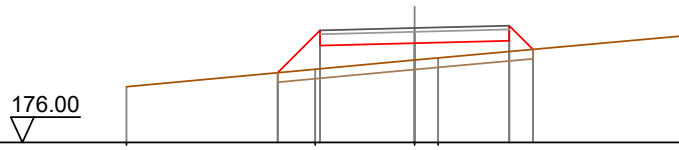

Quote Terreno	-177.48		177.94	178.18	-178.24				-178.82
Quote Progetto			177.85	178.56	178.63		178.69	178.46	
Parziali			1.12	2.50	2.50		0.63		
Progressiva			-3.62	-2.50	0.00		2.50	3.13	
Dislivelli			-0.00	1.02	0.45		0.28	-0.00	

Sezione: 205
 Progressiva: 1871.502
 Q. Progetto: 179.119

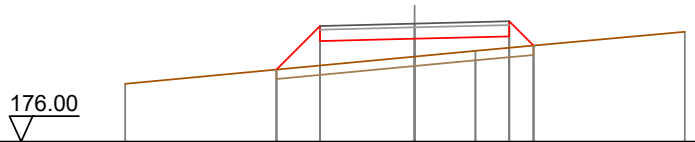

Quote Terreno		-177.53									-178.90
Quote Progetto			177.90	178.66		178.72		178.78	178.54		
Parziali			1.15	2.50		2.50		0.64			
Progressiva			-3.65	-2.50		0.00		2.50	3.14		
Dislivelli			0.00	1.05		0.47		0.30	0.00		

Sezione: 206
 Progressiva: 1875.723
 Q. Progetto: 179.352

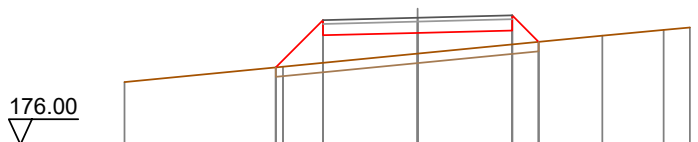

Quote Terreno		-177.65										-178.88	-179.03	-179.10
Quote Progetto			178.04	178.89		178.95		179.01	178.72					
Parziali			1.25	2.50		2.50		0.70						
Progressiva			-3.75	-2.50		0.00		2.50	3.20					
Dislivelli			0.00	1.13		0.55		0.37	0.00					

Sezione: 207
 Progressiva: 1880.000
 Q. Progetto: 179.552

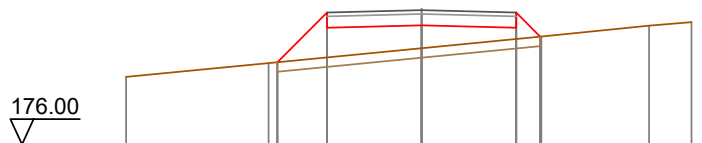

Quote Terreno		-177.79												-179.14	-179.24
Quote Progetto			178.18	179.09		179.15		179.09	178.85						
Parziali			1.31	2.50		2.50		0.64							
Progressiva			-3.81	-2.50		0.00		2.50	3.14						
Dislivelli			0.00	1.19		0.61		0.30	0.00						

Sezione: 208
 Progressiva: 1895.968
 Q. Progetto: 179.973

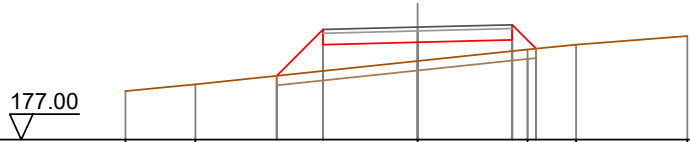

Quote Terreno	-178.28	-178.46				179.07		179.38	179.51	-179.74
Quote Progetto			178.68	179.51		179.57		179.64	179.40	
Parziali			1.23	2.50		2.50		0.63		
Progressiva			-3.73	-2.50		0.00		2.50	3.13	
Dislivelli			0.00	1.10		0.50		0.30	-0.00	

Sezione: 209
 Progressiva: 1899.000
 Q. Progetto: 179.995

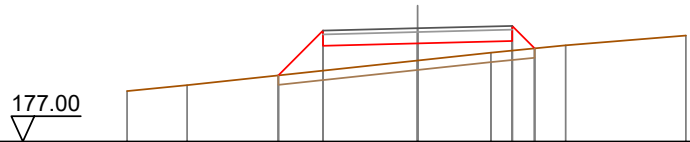

Quote Terreno	-178.33	-178.49				179.14		179.35	179.55	-179.80
Quote Progetto			178.75	179.53		179.60		179.66	179.46	
Parziali			1.18	2.50		2.50		0.59		
Progressiva			-3.68	-2.50		0.00		2.50	3.09	
Dislivelli			-0.00	1.06		0.45		0.25	0.00	

SEZIONI TRASVERSALI
Profilo longitudinale tratto 5-6
Viabilità di impianto - Postazione aerogeneratore WTG03

Nota: Le canalette di deflusso delle acque meteoriche, non indicate nel presente elaborato, sono rappresentate graficamente nelle sezioni stradali tipo dell'elaborato "BLTX-NS-TC13_Piazzole aerogeneratori e strade di servizio - Particolari costruttivi", individuate planimetricamente nell'elaborato "BLTX-NS-TC14_Opere di regimazione acque superficiali - Planimetria generale" e quantificate nell'elaborato "BLTX-NS-RC6_Computo metrico estimativo opere civili".

DISEGNI DI RIFERIMENTO

TAVOLA	DESCRIZIONE
BLTX-NS-TC8	Viabilità e piazzole - Planimetria di progetto - Fase di cantiere
BLTX-NS-TC11	Profili longitudinali viabilità di impianto
BLTX-NS-TC13	Piazzole aerogeneratori e strade di servizio - Particolari costruttivi
BLTX-NS-TC14	Opere di regimazione acque superficiali - Planimetria generale

Sezione: 4
 Progressiva: 20.000
 Q. Progetto: 130.882

129.00

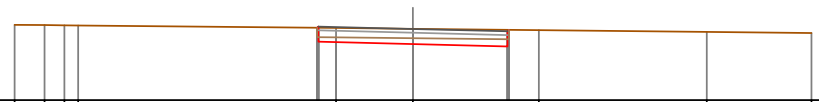

Quote Terreno	130.99	130.98	130.98	130.97	130.91	130.89	130.85	130.80	130.77
Quote Progetto					130.91	130.54	130.48	130.42	130.86
Parziali					2.50	2.50			
Progressiva					-2.53	-2.50	0.00	2.50	2.54
Dislivelli					0.00	0.03	-0.40	-0.44	0.00

Sezione: 5
 Progressiva: 25.671
 Q. Progetto: 130.955

129.00

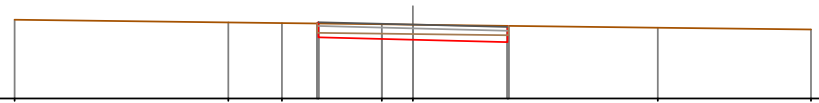

Quote Terreno	131.08	131.01	131.00	130.96	130.95	130.87	130.82	
Quote Progetto				130.99	130.66	130.49	130.92	
Parziali				2.50	2.50			
Progressiva				-2.53	-2.50	0.00	2.50	2.53
Dislivelli				0.00	0.03	-0.40	-0.43	0.00

Sezione: 6
 Progressiva: 30.000
 Q. Progetto: 130.997

129.00

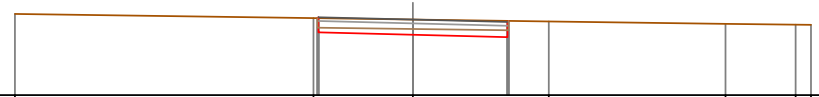

Quote Terreno	131.15	131.04	131.00	130.95	130.89	130.86
Quote Progetto		131.03 130.66	130.60	130.53 130.96		
Parziali		2.50	2.50			
Progressiva		-2.53 -2.50	0.00	2.50 2.53		
Dislivelli		0.00 0.03	-0.40	-0.43 0.00		

Sezione: 7
 Progressiva: 40.000
 Q. Progetto: 131.088

129.00

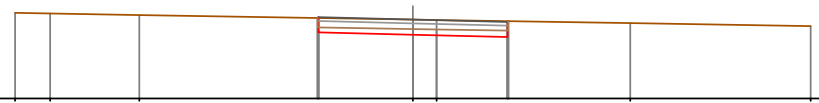

Quote Terreno	131.27	131.25	131.21	131.09	131.08	131.00	130.92
Quote Progetto				131.13 130.75	130.69	130.63 131.05	
Parziali				2.50	2.50		
Progressiva				-2.52 -2.50	0.00	2.50 2.52	
Dislivelli				0.00 0.02	-0.40	-0.42 0.00	

Sezione: 8
 Progressiva: 50.000
 Q. Progetto: 131.133

129.00

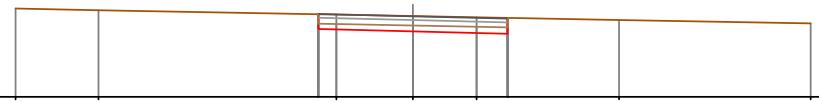

Quote Terreno	131.34	131.29	131.18	131.14	131.11	131.04	130.95
Quote Progetto			130.80	130.73	130.67		
Parziali			2.50	2.50			
Progressiva			-2.51	0.00	2.50		
Dislivelli			0.00	-0.41	-0.42		

Sezione: 9
 Progressiva: 50.897
 Q. Progetto: 131.135

129.00

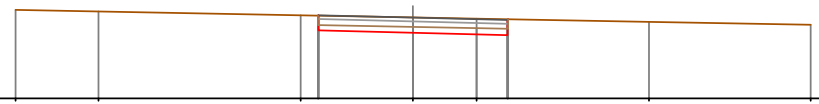

Quote Terreno	131.34	131.30	131.20	131.14	131.11	131.02	130.95
Quote Progetto			130.80	130.73	130.67		
Parziali			2.50	2.50			
Progressiva			-2.51	0.00	2.50		
Dislivelli			0.00	-0.41	-0.42		

Sezione: 10
 Progressiva: 51.260
 Q. Progetto: 131.135

129.00

Quote Terreno	131.34	131.30	131.20	131.14	131.11	131.02	130.95
Quote Progetto			131.19 130.67	130.74	130.80 131.09		
Parziali			2.50	2.50			
Progressiva			-2.62 -2.50	0.00	2.50 2.61		
Dislivelli			0.00 -0.12	-0.41	-0.30 -0.00		

Sezione: 11
 Progressiva: 60.000
 Q. Progetto: 131.077

129.00

Quote Terreno	131.38	131.36	131.32	131.19	131.12	131.03	130.97
Quote Progetto				131.22 130.61	130.74 131.12		
Parziali				2.50	2.50		
Progressiva				-2.71 -2.50	2.50		
Dislivelli				0.00 -0.20	-0.49	-0.38	

Sezione: 12
 Progressiva: 60.412
 Q. Progetto: 131.071

129.00

Quote Terreno	131.38	131.37		131.20	131.17	131.12	131.02	130.97
Quote Progetto				131.23 130.61	130.67 131.17	130.73 131.12		
Parziali				2.50	2.50			
Progressiva				-2.72 -2.50	0.00	2.50		
Dislivelli				0.00 -0.21	-0.50	-0.39		

Sezione: 13
 Progressiva: 69.700
 Q. Progetto: 131.000

129.00

Quote Terreno	131.44	131.40	131.34	131.30	131.23	131.13	131.06	131.03
Quote Progetto				131.28 130.54	130.60 131.23	130.54 131.18		
Parziali				0.35 2.50	2.50	2.50		
Progressiva				-2.85 -2.50	0.00	2.50 2.74		
Dislivelli				-0.00 -0.34	-0.63	-0.64 -0.00		

SEZIONI TRASVERSALI
Profilo longitudinale tratto 7-8
Viabilità di impianto - Postazione aerogeneratore WTG04

Nota: Le canalette di deflusso delle acque meteoriche, non indicate nel presente elaborato, sono rappresentate graficamente nelle sezioni stradali tipo dell'elaborato "BLTX-NS-TC13_Piazzole aerogeneratori e strade di servizio - Particolari costruttivi", individuate planimetricamente nell'elaborato "BLTX-NS-TC14_Opere di regimazione acque superficiali - Planimetria generale" e quantificate nell'elaborato "BLTX-NS-RC6_Computo metrico estimativo opere civili".

DISEGNI DI RIFERIMENTO

TAVOLA	DESCRIZIONE
BLTX-NS-TC8	Viabilità e piazzole - Planimetria di progetto - Fase di cantiere
BLTX-NS-TC11	Profili longitudinali viabilità di impianto
BLTX-NS-TC13	Piazzole aerogeneratori e strade di servizio - Particolari costruttivi
BLTX-NS-TC14	Opere di regimazione acque superficiali - Planimetria generale

Sezione: 3
 Progressiva: 20.000
 Q. Progetto: 130.408

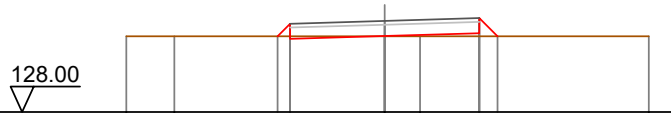

Quote Terreno	130.00	130.00			130.00	130.00			130.00	
Quote Progetto			130.00	129.93		130.01			130.08	130.00
Parziali			0.33	2.50		2.50			0.48	
Progressiva			-2.83	-2.50		0.00			2.50	2.98
Dislivelli			0.00	0.33		0.01			0.08	0.00

Sezione: 4
 Progressiva: 30.000
 Q. Progetto: 130.412

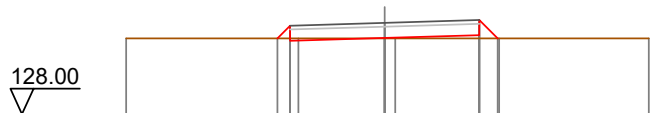

Quote Terreno	130.00	130.00			130.00	130.00			130.00	130.00
Quote Progetto			130.00	129.94		130.01			130.09	130.00
Parziali			0.34	2.50		2.50			0.49	
Progressiva			-2.84	-2.50		0.00			2.50	2.99
Dislivelli			0.00	0.34		0.01			0.09	0.00

Sezione: 5
 Progressiva: 39.681
 Q. Progetto: 130.416

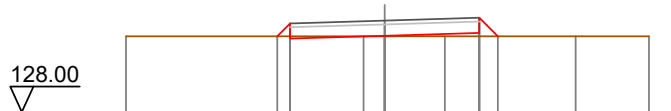

Quote Terreno	130.00		130.00	130.00	130.00	130.00	130.00
Quote Progetto		130.00	129.94	130.02		130.09	130.00
Parziali		0.34	2.50	2.50		0.49	
Progressiva		-2.84	-2.50	0.00		2.50	2.99
Dislivelli		0.00	0.34	0.02		0.09	0.00

Sezione: 6
 Progressiva: 40.000
 Q. Progetto: 130.416

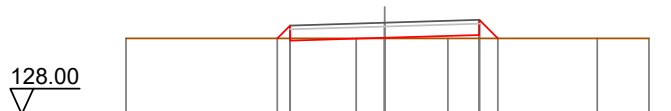

Quote Terreno	130.00		130.00	130.00	130.00	130.00	130.00
Quote Progetto		130.00	129.94	130.02		130.09	130.00
Parziali		0.34	2.50	2.50		0.49	
Progressiva		-2.84	-2.50	0.00		2.50	2.99
Dislivelli		0.00	0.34	0.02		0.09	0.00

Sezione: 7
 Progressiva: 50.000
 Q. Progetto: 130.420

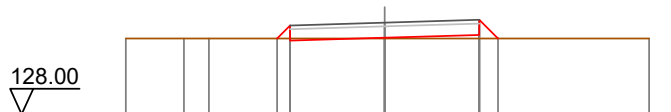

Quote Terreno	130.00	130.00	130.00		130.00		130.00
Quote Progetto				130.00	130.02	130.10	130.00
Parziali				0.35	2.50	2.50	0.50
Progressiva				-2.85	-2.50	0.00	2.50
Dislivelli				0.00	0.35	0.02	0.10
							0.00

Sezione: 8
 Progressiva: 60.000
 Q. Progetto: 130.424

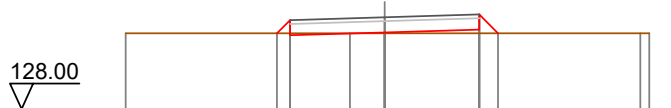

Quote Terreno	130.00	130.00	130.00	130.00
Quote Progetto	130.00	129.95	130.02	130.10
Parziali	0.35	2.50	2.50	0.50
Progressiva	2.85	-2.50	0.00	2.50
Dislivelli	0.00	0.35	0.02	0.10

Sezione: 9
 Progressiva: 68.742
 Q. Progetto: 130.428

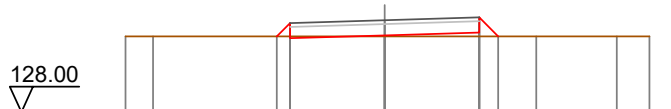

Quote Terreno	130.00	130.00	130.00	130.00
Quote Progetto	130.00	129.95	130.03	130.10
Parziali	0.35	2.50	2.50	0.50
Progressiva	2.85	-2.50	0.00	2.50
Dislivelli	0.00	0.35	0.03	0.10

Sezione: 10
 Progressiva: 70.172
 Q. Progetto: 130.428

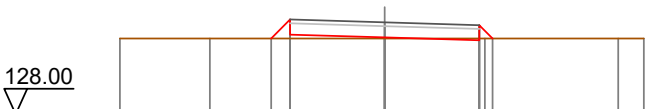

Quote Terreno	130.00	130.00	130.00	130.00
Quote Progetto	130.00	130.10	130.03	129.95
Parziali	0.50	2.50	2.50	0.35
Progressiva	-3.00	-2.50	0.00	2.50
Dislivelli	0.00	0.50	0.03	-0.05

Sezione: 11
 Progressiva: 74.714
 Q. Progetto: 130.430

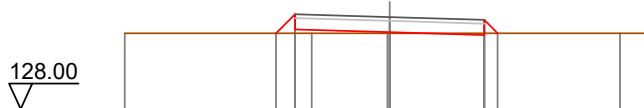

Quote Terreno	-130.00	-130.00	-130.00	-130.00	-130.00	-130.00
Quote Progetto		130.00 130.11	130.03	129.96 130.00		
Parziali		0.51	2.50	2.50	0.36	
Progressiva		-3.01 -2.50	0.00	2.50 2.86		
Dislivelli		0.00 0.51	0.03	-0.04 0.00		

Sezione: 12
 Progressiva: 79.256
 Q. Progetto: 130.432

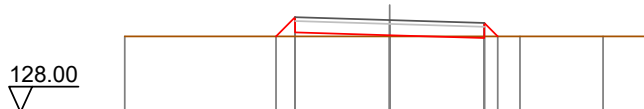

Quote Terreno	-130.00	-130.00	-130.00	-130.00	-130.00	-130.00
Quote Progetto		130.00 130.11	130.03	129.96 130.00		
Parziali		0.51	2.50	2.50	0.36	
Progressiva		-3.01 -2.50	0.00	2.50 2.86		
Dislivelli		0.00 0.51	0.03	-0.04 0.00		

Sezione: 13
 Progressiva: 80.000
 Q. Progetto: 130.432

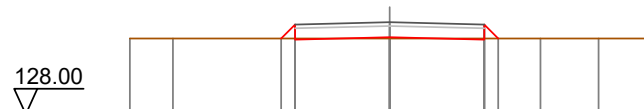

Quote Terreno	-130.00	-130.00	-130.00	-130.00	-130.00	-130.00
Quote Progetto		130.00 129.97	130.03	129.97 130.00		
Parziali		0.37	2.50	2.50	0.37	
Progressiva		2.87 -2.50	0.00	2.50 2.87		
Dislivelli		0.00 0.37	0.03	-0.03 0.00		

Sezione: 14
 Progressiva: 100.000
 Q. Progetto: 130.440

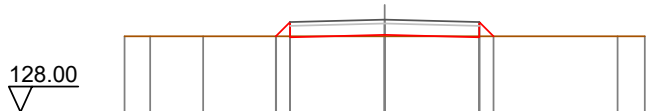

Quote Terreno	-130.00	-130.00	-130.00	-130.00	-130.00	-130.00	-130.00
Quote Progetto			130.00	129.96	130.04	129.98	130.00
Parziali			0.38	2.50	2.50	0.38	
Progressiva			-2.88	-2.50	0.00	2.50	2.88
Dislivelli			0.00	0.38	0.04	-0.02	0.00

Sezione: 15
 Progressiva: 120.000
 Q. Progetto: 130.449

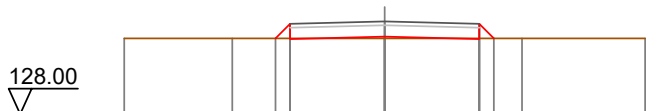

Quote Terreno	-130.00	-130.00	-130.00	-130.00	-130.00	-130.00	
Quote Progetto			130.00	129.99	130.05	129.99	130.00
Parziali			0.39	2.50	2.50	0.39	
Progressiva			-2.88	-2.50	0.00	2.50	2.88
Dislivelli			0.00	0.39	0.05	-0.01	0.00

Sezione: 16
 Progressiva: 140.000
 Q. Progetto: 130.457

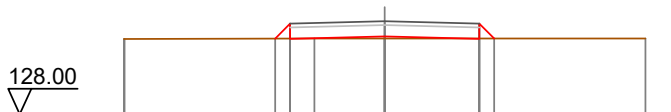

Quote Terreno	-129.99	-130.00	-130.00	-130.00	-130.00	
Quote Progetto		130.00	129.99	130.06	129.99	130.00
Parziali		0.40	2.50	2.50	0.39	
Progressiva		-2.80	-2.50	0.00	2.50	2.89
Dislivelli		0.00	0.40	0.06	-0.01	0.00

Sezione: 17
 Progressiva: 160.000
 Q. Progetto: 130.415

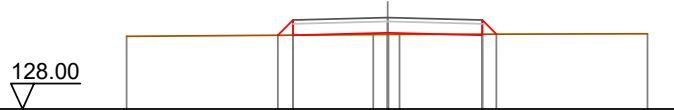

Quote Terreno	129.92		129.97	129.97	129.99
Quote Progetto		129.95 129.95	130.02	129.95 129.98	
Parziali		0.40	2.50	2.50	0.37
Progressiva		-2.90 -2.50	0.00	2.50 2.87	
Dislivelli		0.00 0.40	0.04	-0.03 0.00	

Sezione: 18
 Progressiva: 162.005
 Q. Progetto: 130.392

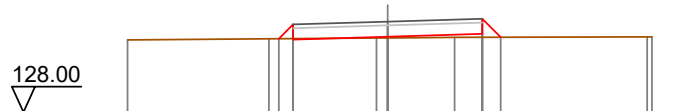

Quote Terreno	129.91	129.94	129.96	129.96	129.98	129.99	129.99
Quote Progetto		129.94 129.92	129.99	129.99	130.07 129.98		
Parziali		0.38	2.50	2.50	0.49		
Progressiva		-2.68 -2.50	0.00	0.00	2.50 2.99		
Dislivelli		0.00 0.38	0.03	0.03	0.09 0.00		

Sezione: 19
 Progressiva: 163.243
 Q. Progetto: 130.378

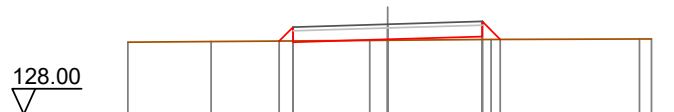

Quote Terreno	129.90	129.92	129.95	129.95	129.98	129.99	129.99
Quote Progetto			129.93 129.90	129.98	130.05 129.98		
Parziali			0.37	2.50	2.50	0.48	
Progressiva			-2.67 -2.50	0.00	2.50 2.98		
Dislivelli			0.00 0.37	0.02	0.08 0.00		

Sezione: 20
 Progressiva: 164.481
 Q. Progetto: 130.364

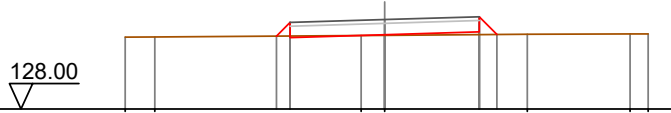

Quote Terreno	-129.90	-129.90	-129.94	-129.95	-129.98	-129.98	-129.99
Quote Progetto			129.89	129.96	130.04	129.97	
Parziali		0.36	2.50	2.50	0.47		
Progressiva		-2.86	-2.50	0.00	2.50	2.97	
Dislivelli		0.00	0.36	0.02	0.07	-0.00	

Sezione: 21
 Progressiva: 180.000
 Q. Progetto: 130.186

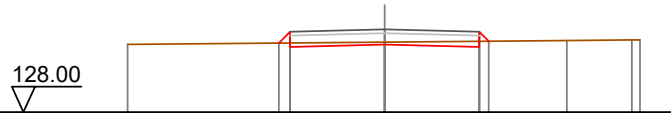

Quote Terreno	-129.79	-129.79	-129.85	-129.85	-129.89	-129.91	-129.91
Quote Progetto			129.82	129.72	129.72	129.87	
Parziali		0.30	2.50	2.50			
Progressiva		-2.80	-2.50	0.00	2.50	2.75	
Dislivelli		0.00	0.30	-0.06	-0.15	0.00	

Sezione: 22
 Progressiva: 200.000
 Q. Progetto: 129.957

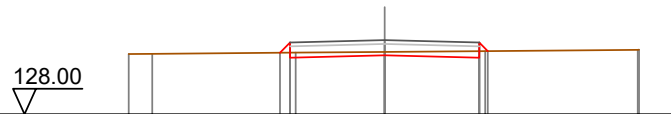

Quote Terreno	-129.59	-129.59	-129.63	-129.65	-129.67	-129.70	-129.70
Quote Progetto			129.62	129.56	129.49	129.67	
Parziali		0.27	2.50	2.50			
Progressiva		-2.77	-2.50	0.00	2.50	2.73	
Dislivelli		0.00	0.27	-0.09	-0.17	-0.00	

Sezione: 23
 Progressiva: 220.000
 Q. Progetto: 129.722

128.00

Quote Terreno	129.29	129.29		129.33	129.33		129.37	129.37
Quote Progetto			129.31	129.32	129.32		129.26	129.35
Parziali			0.35	2.50	2.50		0.31	
Progressiva			2.85	0.00	0.00		2.50	2.81
Dislivelli			-0.00	-0.01	-0.01		-0.09	-0.00

Sezione: 24
 Progressiva: 240.000
 Q. Progetto: 129.167

127.00

Quote Terreno	128.80	128.80	128.80	128.79	128.79		128.79	128.79
Quote Progetto			128.80	128.77	128.77		128.70	128.79
Parziali			0.31	2.50	2.50		0.31	
Progressiva			-2.81	0.00	0.00		2.50	2.81
Dislivelli			0.00	-0.03	-0.03		-0.09	0.00

Sezione: 25
 Progressiva: 260.000
 Q. Progetto: 128.560

127.00

Quote Terreno	128.17	128.16		128.14	128.12	128.12	128.10	128.10
Quote Progetto			128.16	128.16	128.10	128.12	128.12	
Parziali			0.34	2.50	2.50	0.38		
Progressiva			-2.84	0.00	0.00	2.50	2.88	
Dislivelli			-0.00	0.02	0.02	-0.03	0.00	

Sezione: 26
 Progressiva: 280.000
 Q. Progetto: 127.953

126.00

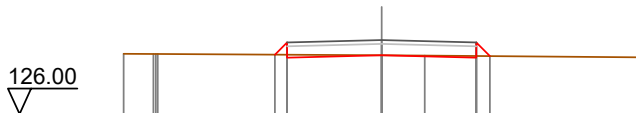

Quote Terreno	-127.59	-127.59	-127.59	-127.55	-127.54	-127.50
Quote Progetto			127.57 127.49	127.55		127.49 127.53
Parziali			0.32	2.50	2.50	0.36
Progressiva			-2.82 -2.50	0.00		2.50 2.88
Dislivelli			0.00 0.32	0.00		-0.04 0.00

Sezione: 27
 Progressiva: 300.000
 Q. Progetto: 127.481

125.00

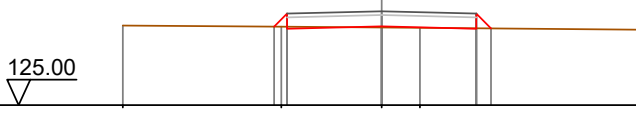

Quote Terreno	-127.10	-127.07	-127.05	-127.04	-126.99
Quote Progetto		127.07 127.02	127.08		127.02 127.03
Parziali		0.35	2.50	2.50	0.39
Progressiva		-2.95 -2.50	0.00		2.50 2.89
Dislivelli		0.00 0.35	0.03		-0.01 0.00

Sezione: 28
 Progressiva: 301.573
 Q. Progetto: 127.448

125.00

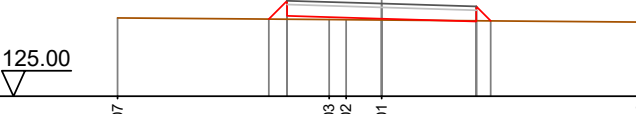

Quote Terreno	-127.07	-127.03	-127.02	-127.01	-126.96
Quote Progetto		127.04 127.12		127.05	126.97 126.99
Parziali		0.48	2.50	2.50	0.38
Progressiva		-2.98 -2.50	0.00		2.50 2.88
Dislivelli		0.00 0.48	0.03		-0.02 0.00

Sezione: 29
 Progressiva: 304.222
 Q. Progetto: 127.392

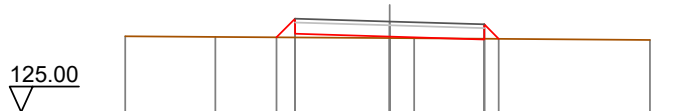

Quote Terreno	-127.00	-126.99			-126.96	-126.95			-126.90
Quote Progetto			126.98	127.07	126.99		126.92	126.94	
Parziali			0.49	2.50	2.50		0.38		
Progressiva			-2.98	-2.50	0.00		2.50	2.88	
Dislivelli			0.00	0.50	0.04		-0.02	0.00	

Sezione: 30
 Progressiva: 306.872
 Q. Progetto: 127.336

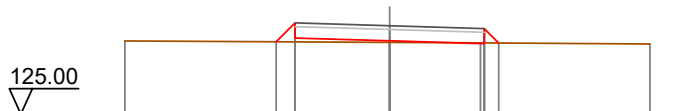

Quote Terreno	-126.93				-126.90		-126.88		-126.85
Quote Progetto			126.91	127.01	126.94		126.86	126.88	
Parziali			0.50	2.50	2.50		0.38		
Progressiva			-3.00	-2.50	0.00		2.50	2.88	
Dislivelli			0.00	0.50	0.04		-0.02	0.00	

Sezione: 31
 Progressiva: 320.000
 Q. Progetto: 127.059

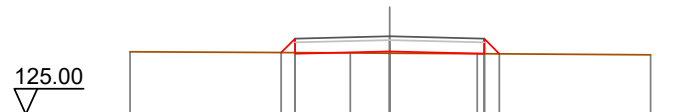

Quote Terreno	-126.65				-126.62	-126.61		-126.60	-126.57
Quote Progetto			126.63	126.60	126.66	126.61	126.60	126.60	
Parziali			0.37	2.50	2.50		0.40		
Progressiva			-2.87	-2.50	0.00		2.50	2.90	
Dislivelli			0.00	0.37	0.05		-0.00	0.00	

Sezione: 32
 Progressiva: 340.000
 Q. Progetto: 126.637

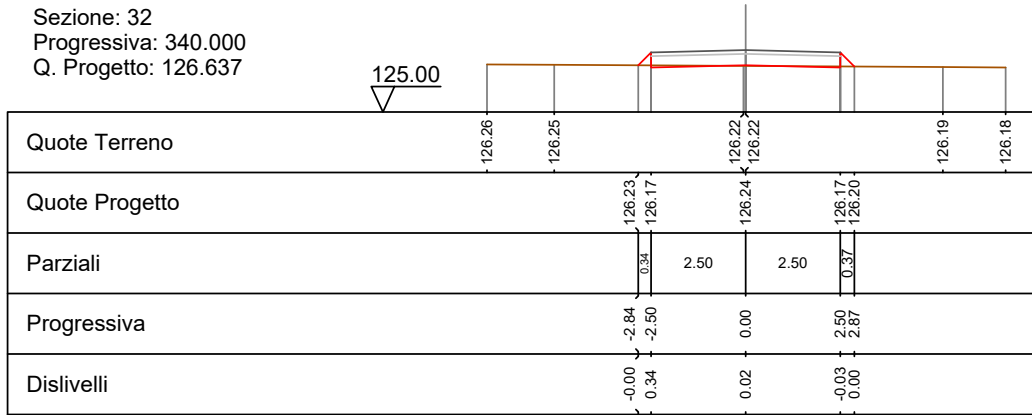

Sezione: 33
 Progressiva: 352.074
 Q. Progetto: 126.409

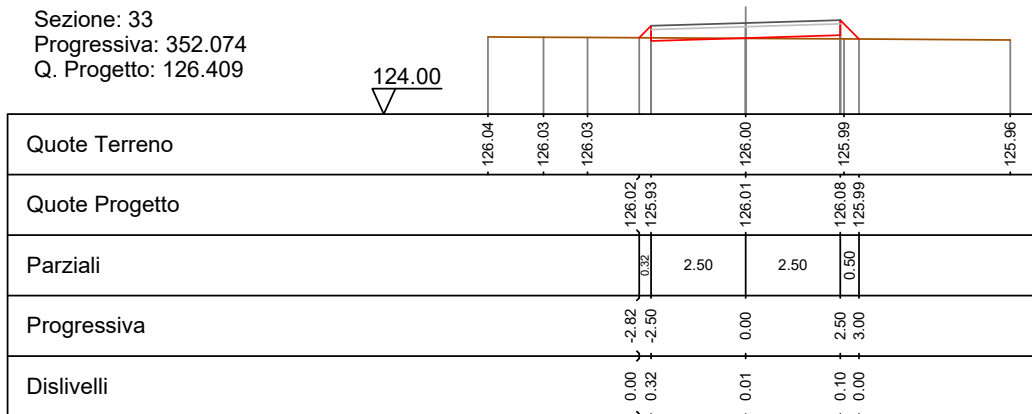

Sezione: 34
 Progressiva: 356.629
 Q. Progetto: 126.348

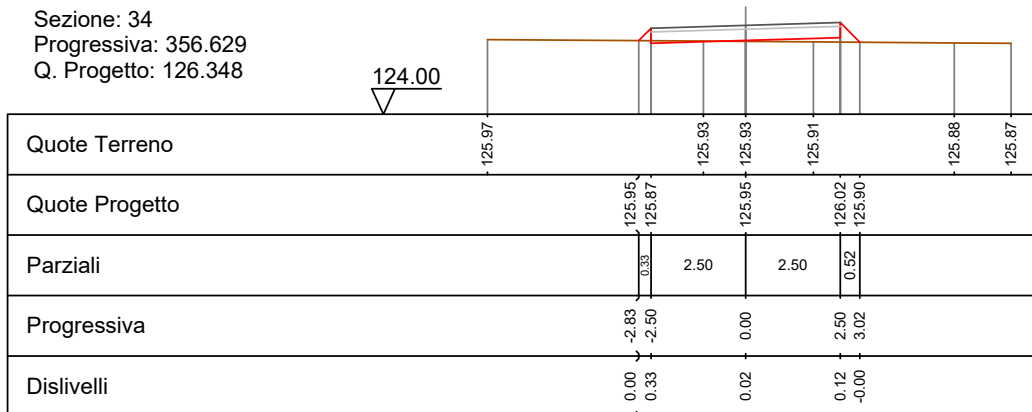

Sezione: 35
 Progressiva: 360.000
 Q. Progetto: 126.302

124.00

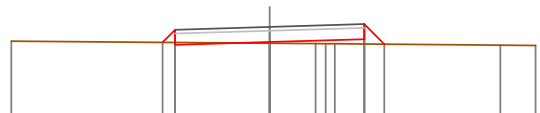

Quote Terreno	125.93			125.87	125.86	125.86		125.82	125.81
Quote Progetto			125.89	125.83	125.90		125.98	125.85	
Parziali			0.33	2.50		2.50	0.53		
Progressiva			-2.83	-2.50	0.00		2.50	3.03	
Dislivelli			0.00	0.34		0.03	0.13	-0.00	

Sezione: 36
 Progressiva: 361.184
 Q. Progetto: 126.286

124.00

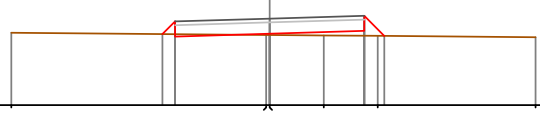

Quote Terreno	125.91			125.85	125.85	125.84		125.83	125.79
Quote Progetto			125.88	125.81	125.89		125.96	125.83	
Parziali			0.33	2.50		2.50	0.53		
Progressiva			-2.83	-2.50	0.00		2.50	3.03	
Dislivelli			0.00	0.34		0.03	0.13	0.00	

Sezione: 37
 Progressiva: 380.000
 Q. Progetto: 126.032

124.00



Quote Terreno	125.63	125.63	125.62		125.58	125.58		125.53	125.53
Quote Progetto				125.60	125.57	125.63	125.58	125.57	125.56
Parziali				0.37	2.50		2.50	0.41	
Progressiva				-2.87	-2.50	0.00		2.50	2.91
Dislivelli				0.00	0.37		0.05	0.00	0.00

Sezione: 38
 Progressiva: 397.877
 Q. Progetto: 125.790

124.00

Quote Terreno	125.39	125.37	125.35	125.35	125.31	125.30
Quote Progetto		125.37	125.32	125.39	125.47	125.33
Parziali		0.35	2.50	2.50	0.54	
Progressiva		2.85	2.50	0.00	2.50	3.04
Dislivelli		-0.00	0.35	0.04	0.14	-0.00

Sezione: 39
 Progressiva: 400.000
 Q. Progetto: 125.762

124.00

Quote Terreno	125.37		125.32	125.32	125.30	125.27
Quote Progetto		125.34	125.29	125.36	125.44	125.30
Parziali		0.35	2.50	2.50	0.54	
Progressiva		2.85	2.50	0.00	2.50	3.04
Dislivelli		-0.00	0.36	0.04	0.14	-0.00

Sezione: 40
 Progressiva: 400.578
 Q. Progetto: 125.754

124.00

Quote Terreno	125.36		125.32	125.31	125.31	125.30	125.26
Quote Progetto		125.33	125.28	125.35	125.31	125.43	125.29
Parziali		0.35	2.50	2.50	0.54		
Progressiva		2.85	2.50	0.00	2.50	3.04	
Dislivelli		0.00	0.35	0.04	0.13	0.00	

Sezione: 41
 Progressiva: 403.279
 Q. Progetto: 125.717

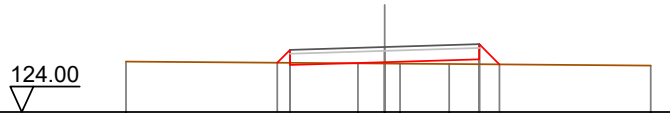

Quote Terreno	-125.33			-125.29	-125.28	-125.28	-125.27		-125.22
Quote Progetto		125.30	125.24		125.32		125.39	125.26	
Parziali		0.34	2.50		2.50		0.54		
Progressiva		-2.84	-2.50		0.00		2.50	3.04	
Dislivelli		-0.00	0.34		0.04		0.13	0.00	

Sezione: 42
 Progressiva: 420.000
 Q. Progetto: 125.491

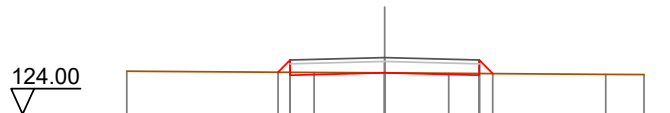

Quote Terreno	-125.13			-125.10	-125.09	-125.08		-125.05	-125.04
Quote Progetto		125.11	125.03		125.09		125.03	125.07	
Parziali		0.32	2.50		2.50		0.36		
Progressiva		-2.82	-2.50		0.00		2.50	2.86	
Dislivelli		-0.00	0.32		0.00		-0.04	-0.00	

Sezione: 43
 Progressiva: 440.000
 Q. Progetto: 125.237

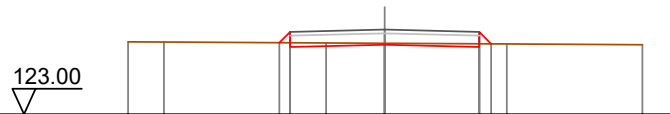

Quote Terreno	-124.91	-124.91		-124.88	-124.87		-124.86		-124.83
Quote Progetto		124.89	124.77		124.84	124.87	124.77	124.86	
Parziali		0.28	2.50		2.50		0.32		
Progressiva		-2.79	-2.50		0.00		2.50	2.82	
Dislivelli		0.00	0.29		-0.04		-0.09	0.00	

Sezione: 44
 Progressiva: 443.045
 Q. Progetto: 125.208

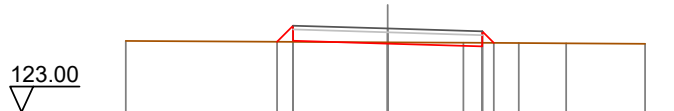

Quote Terreno	-124.88			124.84		124.83		124.82		124.82		-124.80
Quote Progetto			124.86		124.81		124.73		124.83			
Parziali			0.43	2.50		2.50		0.31				
Progressiva			-2.93	-2.50	0.00		2.50		2.81			
Dislivelli			0.00	0.43	-0.03		-0.10		0.00			

Sezione: 45
 Progressiva: 447.981
 Q. Progetto: 125.160

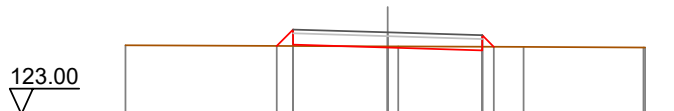

Quote Terreno	-124.82			124.79		124.79		124.77		124.76		124.76
Quote Progetto			124.80		124.76		124.69		124.78			
Parziali			0.43	2.50		2.50		0.31				
Progressiva			-2.93	-2.50	0.00		2.50		2.81			
Dislivelli			0.00	0.44	-0.03		-0.09		-0.00			

Sezione: 46
 Progressiva: 450.000
 Q. Progetto: 125.141

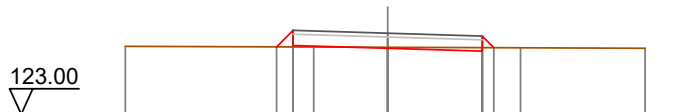

Quote Terreno	-124.79			124.77		124.77		124.76		124.74		124.74
Quote Progetto			124.78		124.74		124.67		124.76			
Parziali			0.44	2.50		2.50		0.31				
Progressiva			-2.94	-2.50	0.00		2.50		2.81			
Dislivelli			0.00	0.44	-0.03		-0.09		0.00			

Sezione: 47
 Progressiva: 452.917
 Q. Progetto: 125.112

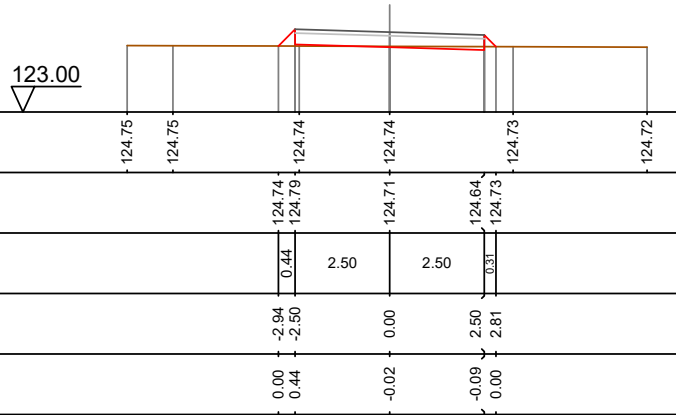

Sezione: 48
 Progressiva: 460.000
 Q. Progetto: 125.044

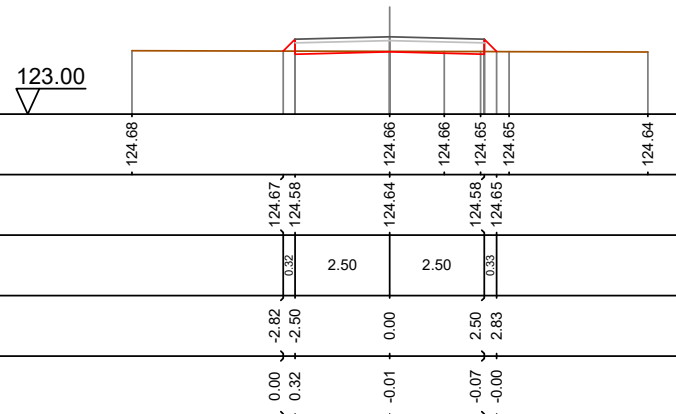

Sezione: 49
 Progressiva: 480.000
 Q. Progetto: 124.851

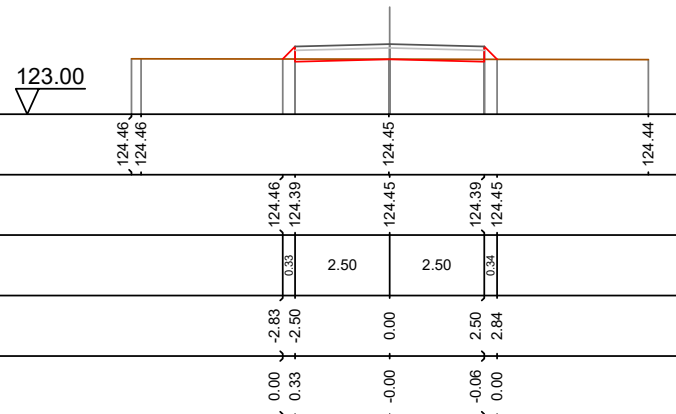

Sezione: 50
 Progressiva: 500.000
 Q. Progetto: 124.657

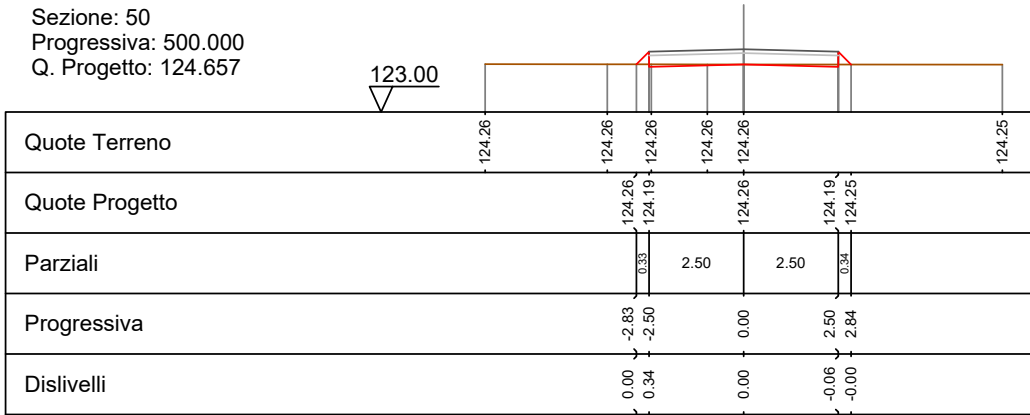

Sezione: 51
 Progressiva: 501.581
 Q. Progetto: 124.642

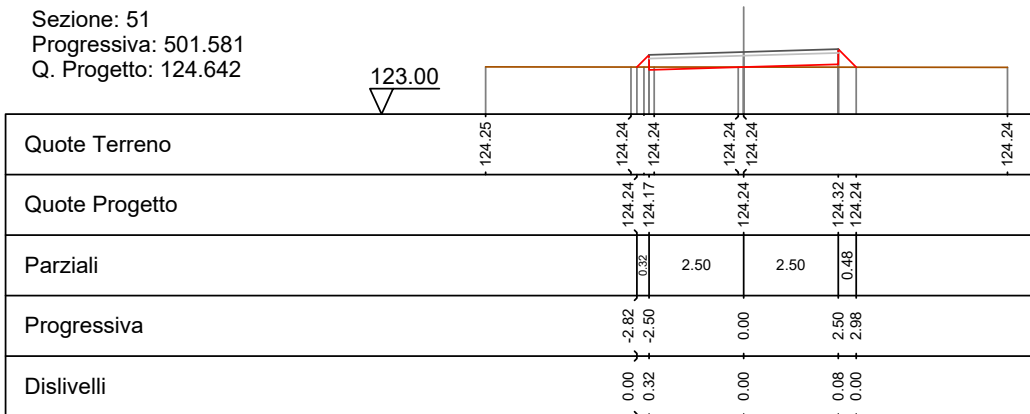

Sezione: 52
 Progressiva: 502.895
 Q. Progetto: 124.629

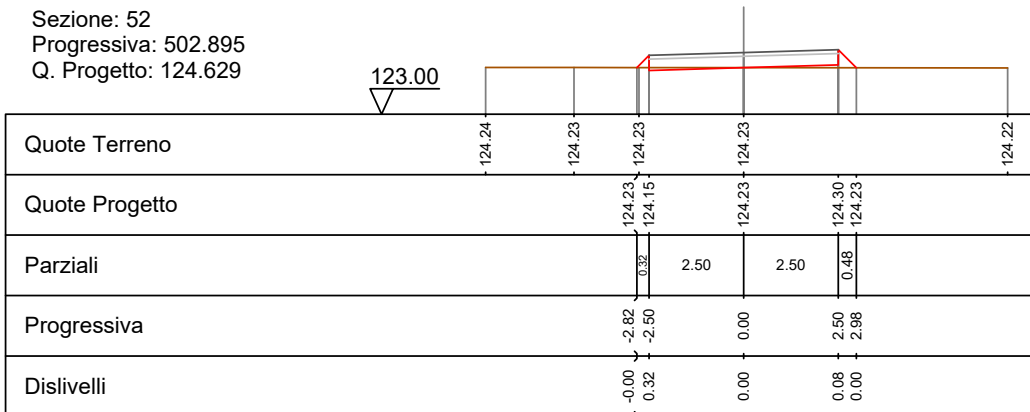

Sezione: 53
 Progressiva: 504.208
 Q. Progetto: 124.616

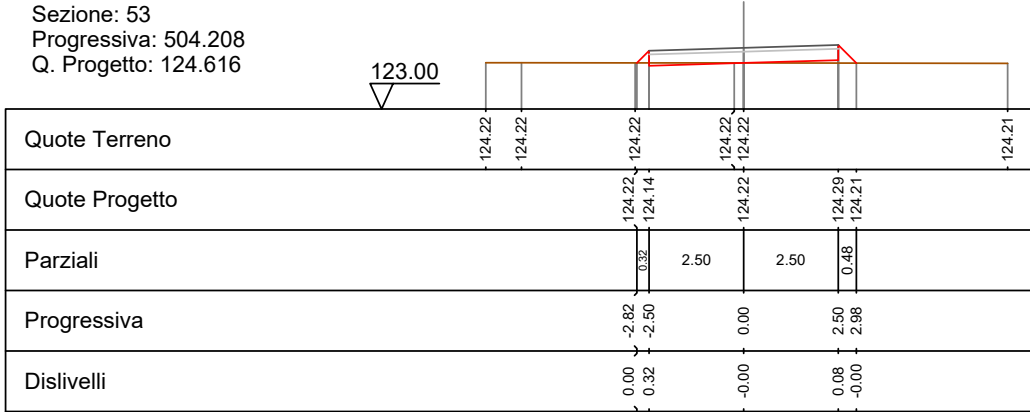

Sezione: 54
 Progressiva: 520.000
 Q. Progetto: 124.464

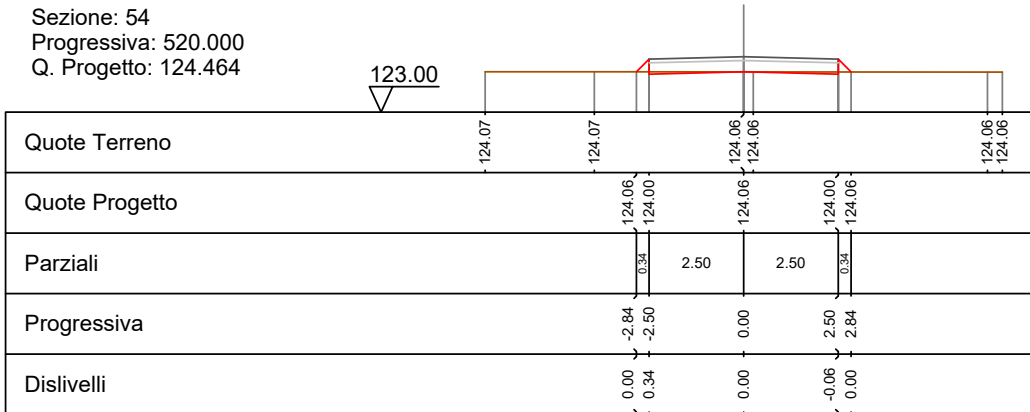

Sezione: 55
 Progressiva: 540.000
 Q. Progetto: 124.270

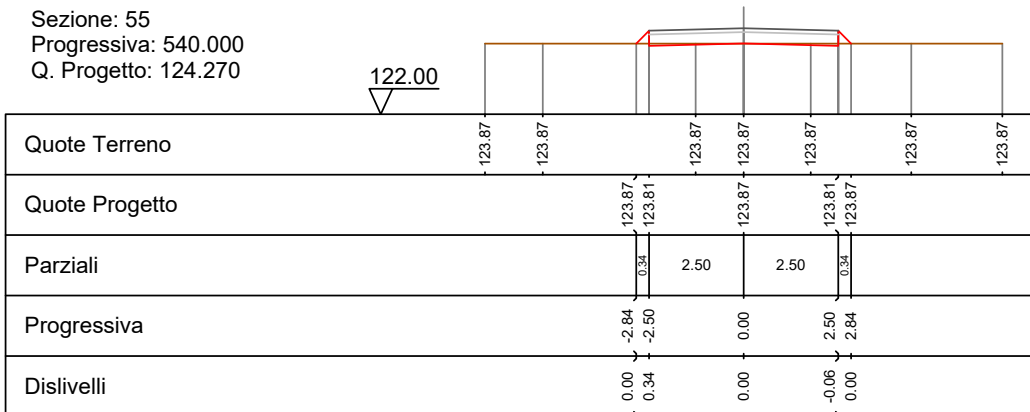

Sezione: 56
 Progressiva: 560.000
 Q. Progetto: 124.077

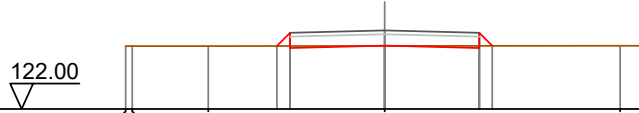

Quote Terreno	123.66	123.66	123.67	123.68	123.67	123.67	123.67
Quote Progetto			123.67	123.68	123.68	123.61	123.67
Parziali			0.35	2.50	2.50	0.34	
Progressiva			2.85	2.50	0.00	2.50	2.84
Dislivelli			0.00	0.35	0.01	-0.06	0.00

Sezione: 57
 Progressiva: 580.000
 Q. Progetto: 123.883

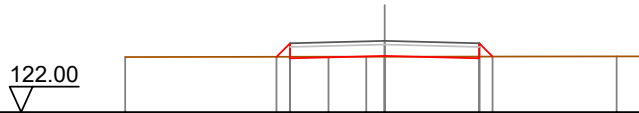

Quote Terreno	123.46	123.46	123.46	123.46	123.46	123.47	123.47
Quote Progetto		123.46	123.42	123.48	123.42	123.47	
Parziali		0.36	2.50	2.50	0.35		
Progressiva		2.86	2.50	0.00	2.50	2.85	
Dislivelli		0.00	0.36	0.02	-0.05	0.00	

Sezione: 58
 Progressiva: 584.866
 Q. Progetto: 123.836

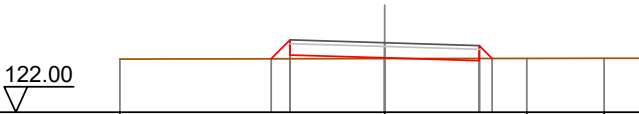

Quote Terreno	123.40	123.41	123.41	123.42	123.42	123.42
Quote Progetto		123.41	123.51	123.44	123.36	123.42
Parziali		0.50	2.50	2.50	0.34	
Progressiva		-3.00	-2.50	0.00	2.50	2.84
Dislivelli		0.00	0.50	0.02	-0.06	0.00

Sezione: 59
 Progressiva: 590.000
 Q. Progetto: 123.787

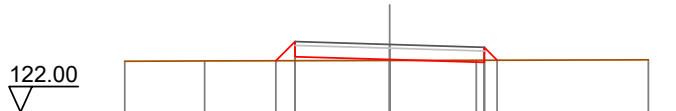

Quote Terreno	-123.34	-123.35			123.36		123.37	-123.38
Quote Progetto			123.35	123.46	123.39		123.31	123.37
Parziali			0.51	2.50	2.50		0.34	
Progressiva			-3.01	-2.50	0.00		2.50	2.84
Dislivelli			0.00	0.51	0.03		-0.06	0.00

Sezione: 60
 Progressiva: 595.023
 Q. Progetto: 123.738

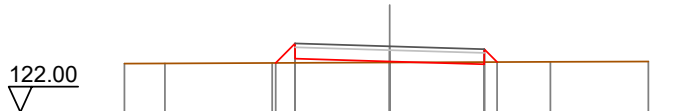

Quote Terreno	-123.28	-123.29			123.31		123.33	-123.34
Quote Progetto			123.30	123.41	123.34		123.26	123.32
Parziali			0.51	2.50	2.50		0.34	
Progressiva			-3.01	-2.50	0.00		2.50	2.84
Dislivelli			0.00	0.51	0.03		-0.06	0.00

Sezione: 61
 Progressiva: 600.000
 Q. Progetto: 123.690

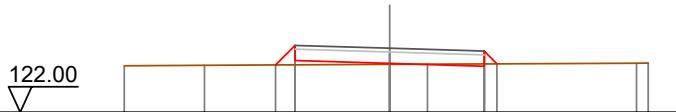

Quote Terreno	-123.23	-123.24			123.26		123.27	123.30
Quote Progetto			123.25	123.36	123.29		123.21	123.30
Parziali			0.52	2.50	2.50		0.34	
Progressiva			-3.02	-2.50	0.00		2.50	2.84
Dislivelli			0.00	0.51	0.03		-0.06	0.00

Sezione: 64
 Progressiva: 629.311
 Q. Progetto: 123.418

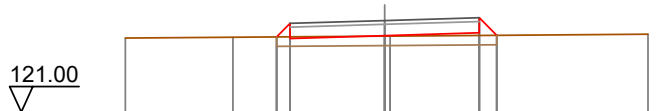

Quote Terreno	122.96	122.98	123.01	123.01	123.06
Quote Progetto			122.99	123.02	123.09
Parziali			0.36	2.50	0.47
Progressiva			2.86	0.00	2.50
Dislivelli			-0.00	0.01	0.07
			0.36		0.00
			-2.50		2.97

Sezione: 65
 Progressiva: 630.000
 Q. Progetto: 123.412

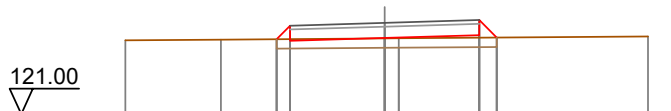

Quote Terreno	122.95	122.97	123.00	123.00	123.05
Quote Progetto			122.99	123.01	123.09
Parziali			0.36	2.50	0.47
Progressiva			2.86	0.00	2.50
Dislivelli			0.00	0.01	0.07
			0.36		-0.00
			-2.50		2.97

Sezione: 66
 Progressiva: 638.572
 Q. Progetto: 123.336

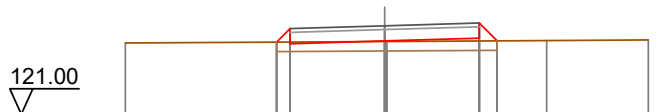

Quote Terreno	122.88		122.92	122.92	122.95	122.96
Quote Progetto			122.94	122.94	123.01	122.94
Parziali			0.36	2.50	0.47	
Progressiva			2.86	0.00	2.50	2.97
Dislivelli			0.00	0.01	0.07	-0.00
			0.36		-0.00	
			-2.50		2.97	

Sezione: 67
 Progressiva: 640.000
 Q. Progetto: 123.323

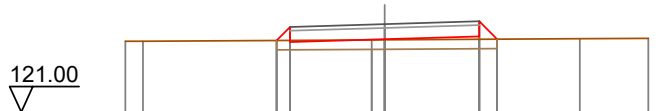

Quote Terreno	122.87	122.87		122.91	122.91		122.94	122.95
Quote Progetto			122.89	122.89	122.92	122.92	123.00	122.92
Parziali			0.36	2.50	2.50		0.47	
Progressiva			2.86	-2.50	0.00		2.50	2.97
Dislivelli			0.00	-0.35	0.02		0.08	-0.00

Sezione: 68
 Progressiva: 647.833
 Q. Progetto: 123.254

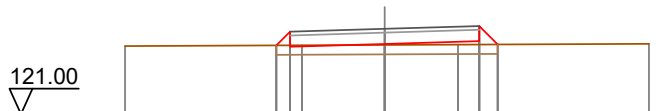

Quote Terreno	122.80		122.82	122.83		122.84		122.86
Quote Progetto			122.81	122.85		122.83		122.84
Parziali			0.36	2.50	2.50		0.49	
Progressiva			2.86	-2.50	0.00		2.50	2.99
Dislivelli			-0.00	-0.36	0.03		0.09	-0.00

Sezione: 69
 Progressiva: 660.000
 Q. Progetto: 123.146



Quote Terreno	122.66	122.67		122.69	122.69			122.73
Quote Progetto			122.68	122.75	122.75		122.68	122.71
Parziali			0.41	2.50	2.50		0.38	
Progressiva			2.91	-2.50	0.00		2.50	2.88
Dislivelli			0.00	-0.40	0.05		-0.02	-0.00

Sezione: 70
 Progressiva: 680.000
 Q. Progetto: 122.901

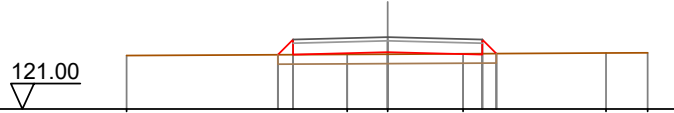

Quote Terreno	-122.41		-122.44	-122.45	-122.46	-122.48	-122.49
Quote Progetto		122.43 122.44		122.50	122.44 122.46		
Parziali		0.40	2.50	2.50	0.37		
Progressiva		-2.90 -2.50		0.00	2.50 2.87		
Dislivelli		-0.00 -0.40		0.05	-0.02 0.00		

Sezione: 71
 Progressiva: 700.000
 Q. Progetto: 122.581

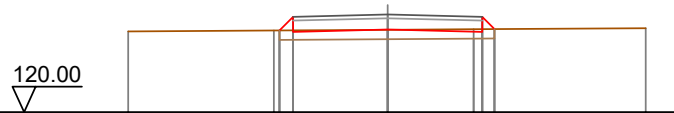

Quote Terreno	-122.13	122.16	122.18	122.19	122.22
Quote Progetto		122.16 122.12	122.18	122.12 122.19	
Parziali		0.36	2.50	2.50	0.32
Progressiva		-2.86 -2.50	0.00	2.50 2.82	
Dislivelli		0.00 -0.36	0.00	-0.07 -0.00	

Sezione: 72
 Progressiva: 720.000
 Q. Progetto: 122.262

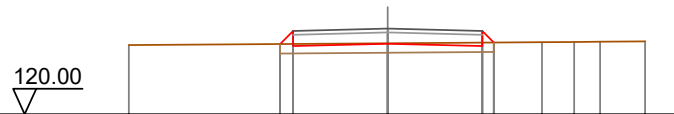

Quote Terreno	-121.83		121.87		121.90	121.91	121.91	121.92
Quote Progetto		121.85 121.80	121.86		121.80 121.89			
Parziali		0.35	2.50	2.50	0.31			
Progressiva		-2.85 -2.50	0.00		2.50 2.81			
Dislivelli		-0.00 -0.34	-0.01		-0.09 0.00			

Sezione: 73
 Progressiva: 727.672
 Q. Progetto: 122.140

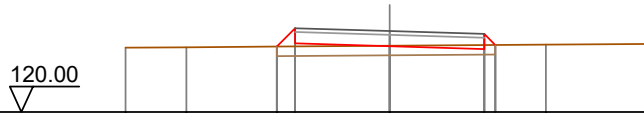

Quote Terreno	-121.70	-121.71	-121.73	-121.75	-121.78	-121.80
Quote Progetto			121.73 121.81	121.74	121.66 121.77	
Parziali			0.49	2.50	2.50	0.28
Progressiva			-2.99	-2.50	0.00	2.50 2.79
Dislivelli			-0.00 0.48	-0.01	-0.10 0.00	0.00

Sezione: 74
 Progressiva: 730.000
 Q. Progetto: 122.102

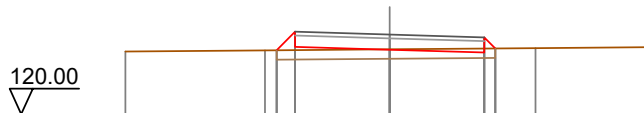

Quote Terreno	-121.66	-121.69	-121.71	-121.74	-121.77
Quote Progetto		121.69 121.78	121.70	121.63 121.73	
Parziali		0.49	2.50	2.50	0.28
Progressiva		-2.99	-2.50	0.00	2.50 2.79
Dislivelli		0.00 0.49	-0.01	-0.10 0.00	0.00

Sezione: 75
 Progressiva: 732.410
 Q. Progetto: 122.064

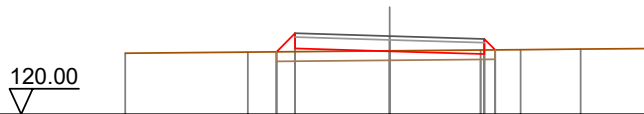

Quote Terreno	-121.61	-121.64	-121.67	-121.70	-121.71	-121.72	-121.73
Quote Progetto		121.65 121.74	121.66	121.59 121.70			
Parziali		0.49	2.50	2.50	0.28		
Progressiva		-2.99	-2.50	0.00	2.50	2.79	
Dislivelli		0.00 0.49	-0.01	-0.11 -0.00	0.00		

Sezione: 76
 Progressiva: 737.148
 Q. Progetto: 121.988

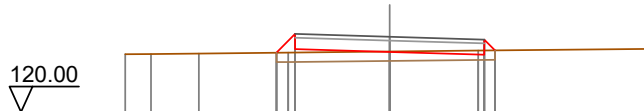

Quote Terreno	-121.53	-121.53	-121.55	-121.57	-121.60	-121.62	-121.67
Quote Progetto				121.57	121.59	121.51	121.63
Parziali				0.49	2.50	2.50	0.28
Progressiva				-2.98	-2.50	0.00	2.50
Dislivelli				-0.00	0.49	-0.01	-0.11

Sezione: 77
 Progressiva: 740.000
 Q. Progetto: 121.943

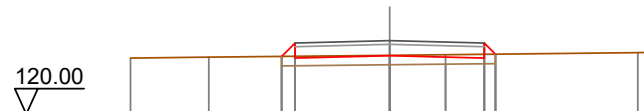

Quote Terreno	-121.48	-121.50		-121.55	-121.57	-121.62
Quote Progetto				121.52	121.48	121.63
Parziali				0.36	2.50	0.30
Progressiva				-2.86	-2.50	0.00
Dislivelli				0.00	0.36	-0.10

Sezione: 78
 Progressiva: 747.335
 Q. Progetto: 121.826

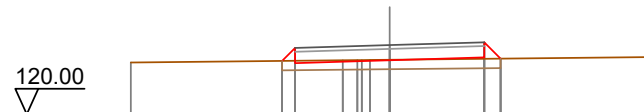

Quote Terreno	-121.36			-121.42	-121.43	-121.44	-121.51
Quote Progetto				121.41	121.35	121.43	121.50
Parziali				0.34	2.50	2.50	0.43
Progressiva				-2.84	-2.50	0.00	2.50
Dislivelli				0.00	0.34	-0.01	0.04

Sezione: 79
 Progressiva: 750.000
 Q. Progetto: 121.783

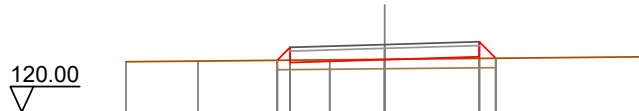

Quote Terreno	-121.33	-121.35	-121.38	-121.39	-121.46
Quote Progetto			121.37 121.31	121.38	121.46 121.42
Parziali			0.34 2.50	2.50	0.44
Progressiva			-2.84 -2.50	0.00	2.50 2.94
Dislivelli			-0.00 0.34	-0.01	0.04 0.00

Sezione: 79
 Progressiva: 750.000
 Q. Progetto: 121.783



Quote Terreno	-121.33	-121.35	-121.38	-121.39	-121.46
Quote Progetto			121.37 121.31	121.38	121.46 121.42
Parziali			0.34 2.50	2.50	0.44
Progressiva			-2.84 -2.50	0.00	2.50 2.94
Dislivelli			-0.00 0.34	-0.01	0.04 0.00

Sezione: 80
 Progressiva: 750.575
 Q. Progetto: 121.774



Quote Terreno	-121.32	-121.33	-121.37	-121.38	-121.39	-121.45
Quote Progetto			121.36 121.30	121.37	121.38	121.45 121.41
Parziali			0.34 2.50	2.50	0.44	
Progressiva			-2.84 -2.50	0.00	2.50	2.94
Dislivelli			0.00 0.34	-0.01	0.04	0.00

Sezione: 81
 Progressiva: 753.815
 Q. Progetto: 121.722

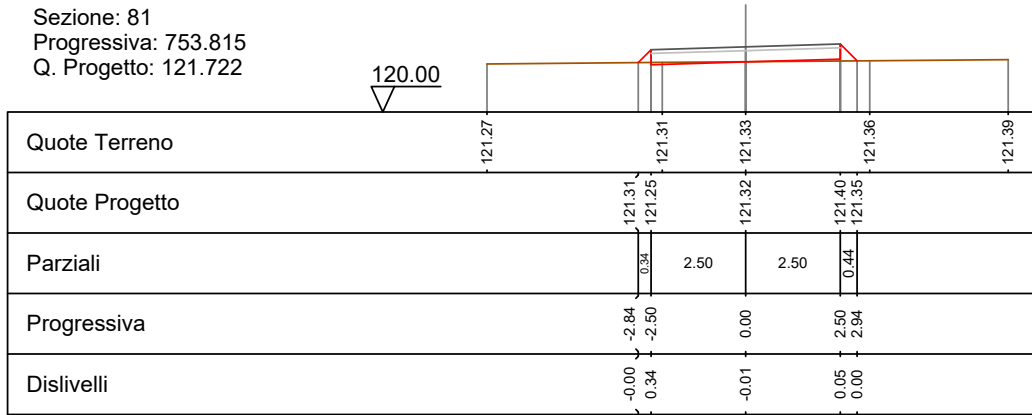

Sezione: 82
 Progressiva: 760.000
 Q. Progetto: 121.624

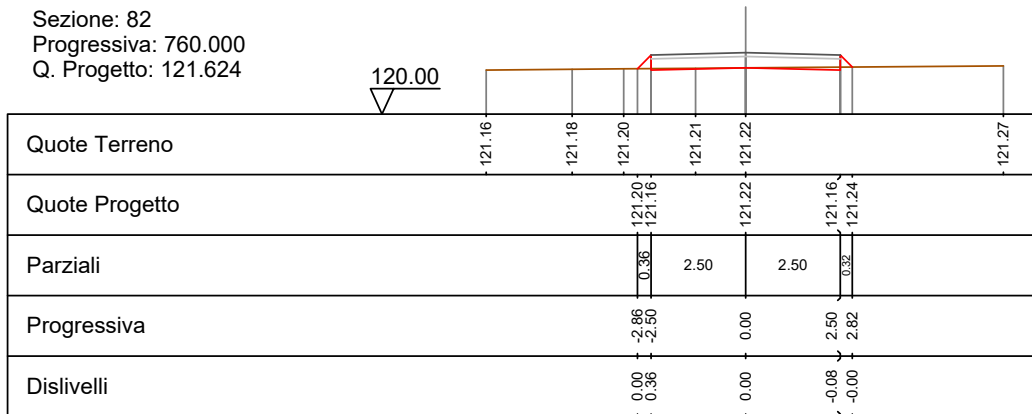

Sezione: 83
 Progressiva: 780.000
 Q. Progetto: 121.304

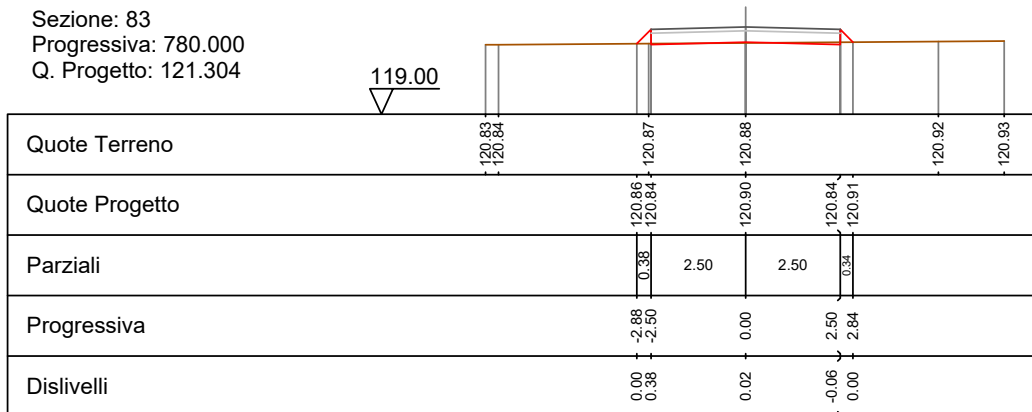

Sezione: 84
 Progressiva: 800.000
 Q. Progetto: 120.985

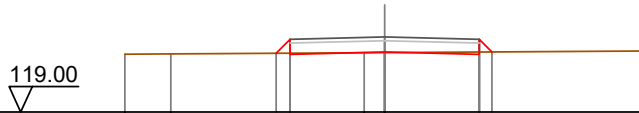

Quote Terreno	-120.53	-120.53	-120.57	-120.57	-120.61
Quote Progetto			120.55	120.58	120.52
Parziali			0.37	2.50	2.50
Progressiva			-2.87	0.00	2.50
Dislivelli			0.00	0.02	-0.06

Sezione: 85
 Progressiva: 820.000
 Q. Progetto: 120.666

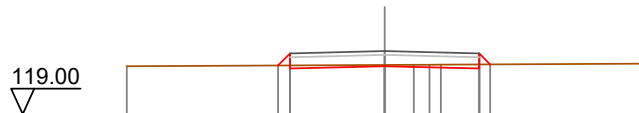

Quote Terreno	-120.27	-120.27	-120.30	-120.30	-120.31	-120.33
Quote Progetto			120.28	120.27	120.20	120.31
Parziali			0.32	2.50	2.50	0.29
Progressiva			-2.82	0.00	2.50	2.79
Dislivelli			0.00	-0.03	-0.11	0.00

Sezione: 86
 Progressiva: 840.000
 Q. Progetto: 120.374

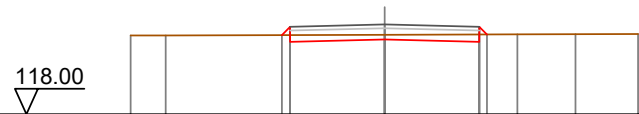

Quote Terreno	-120.08	-120.08	-120.10	-120.10	-120.11	-120.12	-120.12
Quote Progetto			120.09	119.97	119.91	120.11	
Parziali			0.22	2.50	2.50	0.00	
Progressiva			-2.72	0.00	2.50	2.70	
Dislivelli			0.00	-0.13	-0.20	0.00	

Sezione: 87
 Progressiva: 860.000
 Q. Progetto: 120.370

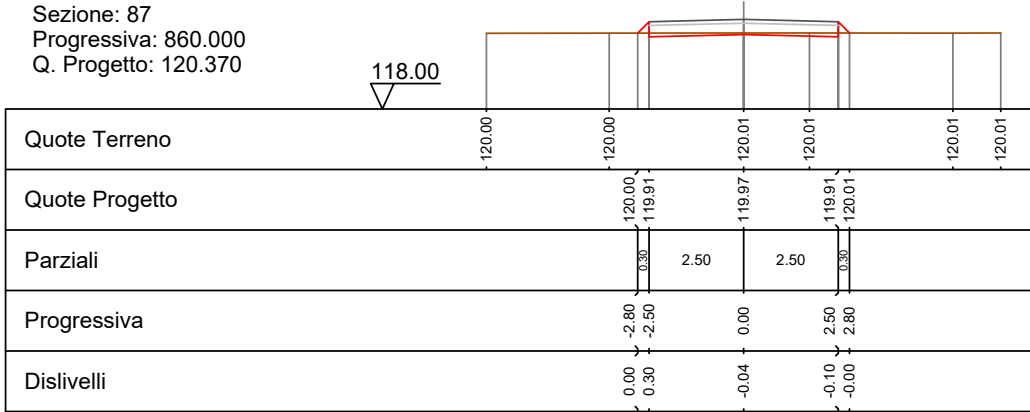

Sezione: 88
 Progressiva: 878.815
 Q. Progetto: 120.374

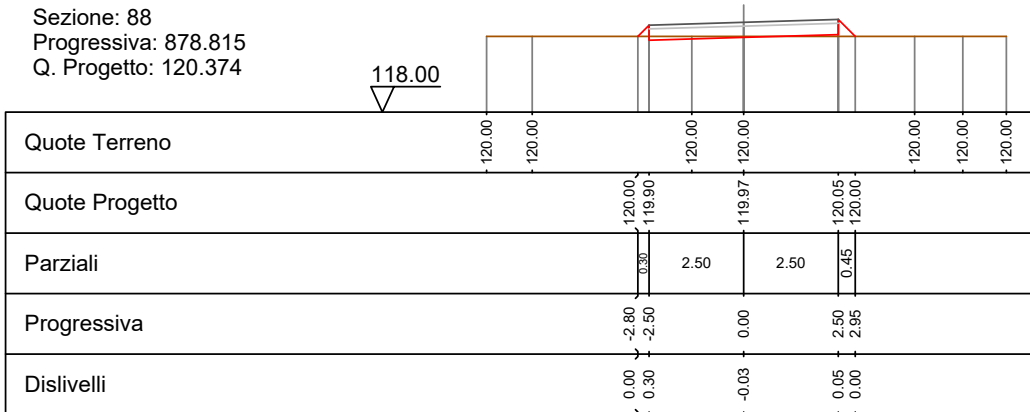

Sezione: 89
 Progressiva: 880.000
 Q. Progetto: 120.374

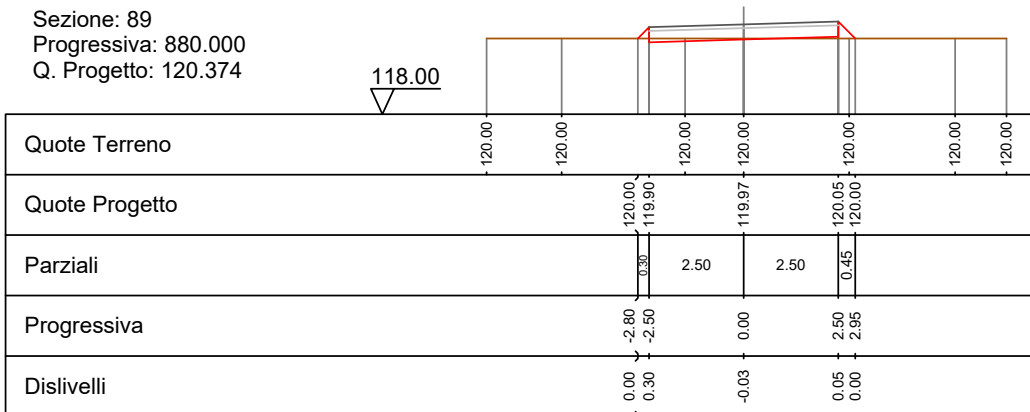

Sezione: 90
 Progressiva: 890.000
 Q. Progetto: 120.376

118.00

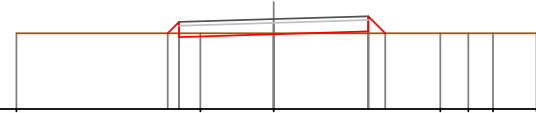

Quote Terreno	-120.00	-120.00	-120.00	-120.00	-120.00	-120.00	-120.00
Quote Progetto		120.00 119.90		119.98		120.05 120.00	
Parziali		0.30	2.50	2.50		0.45	
Progressiva		-2.80	-2.50	0.00		2.50	2.95
Dislivelli		0.00	0.30	-0.02		0.05	0.00

Sezione: 91
 Progressiva: 900.000
 Q. Progetto: 120.379

118.00

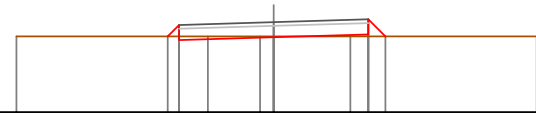

Quote Terreno	-120.00	-120.00	-120.00	-120.00	-120.00	-120.00	
Quote Progetto		120.00 119.90		119.98		120.05 120.00	
Parziali		0.30	2.50	2.50		0.45	
Progressiva		-2.80	-2.50	0.00		2.50	2.95
Dislivelli		0.00	0.30	-0.02		0.05	0.00

Sezione: 92
 Progressiva: 901.586
 Q. Progetto: 120.379

118.00

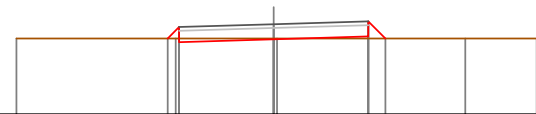

Quote Terreno	-120.00	-120.00	-120.00	-120.00	-120.00	-120.00	
Quote Progetto		120.00 119.90		119.98		120.05 120.00	
Parziali		0.30	2.50	2.50		0.45	
Progressiva		-2.80	-2.50	0.00		2.50	2.95
Dislivelli		0.00	0.30	-0.02		0.05	0.00

Sezione: 93
 Progressiva: 910.000
 Q. Progetto: 120.381

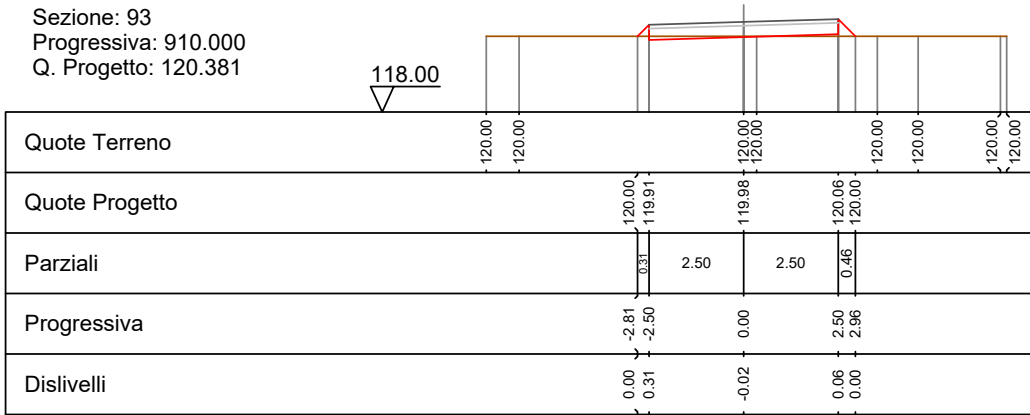

Sezione: 94
 Progressiva: 920.000
 Q. Progetto: 120.383

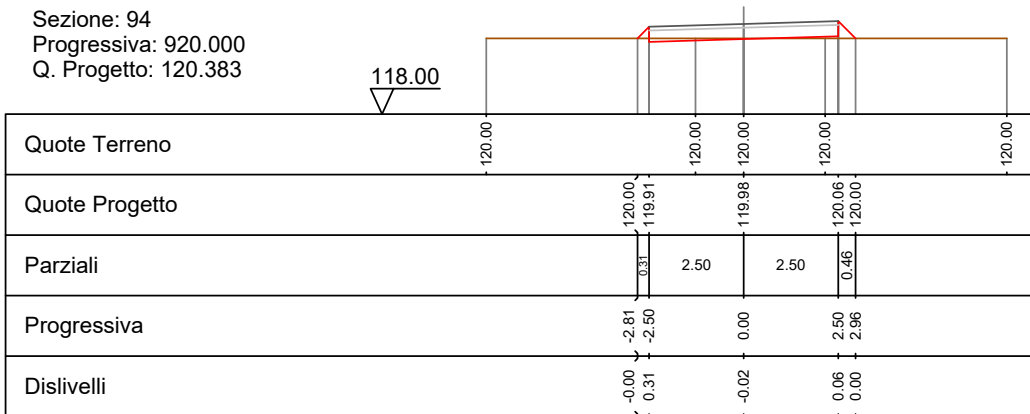

Sezione: 95
 Progressiva: 924.356
 Q. Progetto: 120.384

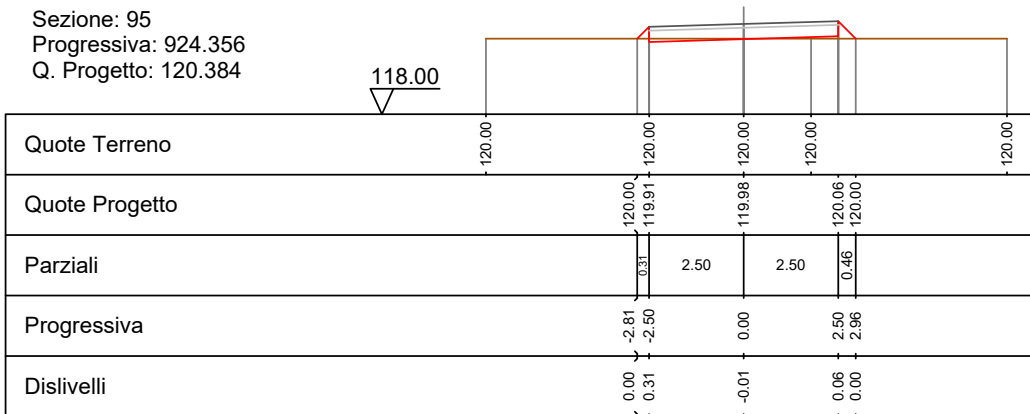

Sezione: 96
 Progressiva: 929.256
 Q. Progetto: 120.385

118.00

Quote Terreno	119.99			119.99	119.99	119.99	119.99
Quote Progetto		119.99	119.91	119.99		120.06	119.99
Parziali		0.32	2.50	2.50		0.47	
Progressiva		-2.82	-2.50	0.00		2.50	2.97
Dislivelli		-0.00	0.32	-0.01		0.07	-0.00

Sezione: 97
 Progressiva: 930.000
 Q. Progetto: 120.385

118.00

Quote Terreno	119.99			119.99	119.99	119.99	119.99
Quote Progetto		119.99	119.91	119.99		120.06	119.99
Parziali		0.32	2.50	2.50		0.47	
Progressiva		-2.82	-2.50	0.00		2.50	2.97
Dislivelli		0.00	0.32	-0.01		0.07	0.00

Sezione: 98
 Progressiva: 940.000
 Q. Progetto: 120.387

118.00

Quote Terreno	119.98	119.98		119.97	119.97	119.97	119.97
Quote Progetto		119.98	119.91	119.99		120.06	119.97
Parziali		0.34	2.50	2.50		0.49	
Progressiva		-2.84	-2.50	0.00		2.50	2.99
Dislivelli		0.00	0.34	0.01		0.09	0.00

Sezione: 99
 Progressiva: 943.159
 Q. Progetto: 120.388

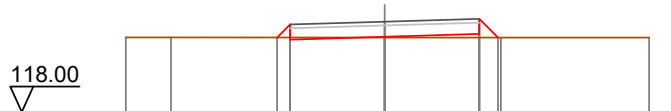

Quote Terreno	119.97	119.97			119.97		119.97	119.97	119.97
Quote Progetto			119.97	119.91	119.99		120.06	119.97	119.97
Parziali			0.34	2.50	2.50		0.50		
Progressiva			-2.84	-2.50	0.00		2.50	3.00	
Dislivelli			-0.00	0.34	0.02		0.10	-0.00	

Sezione: 100
 Progressiva: 950.000
 Q. Progetto: 120.390

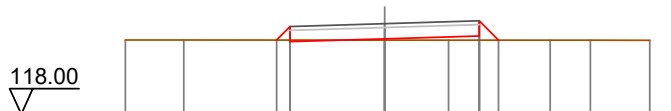

Quote Terreno	119.96	119.96			119.96		119.96	119.95	119.95
Quote Progetto			119.96	119.91	119.99		120.06	119.95	119.95
Parziali			0.36	2.50	2.50		0.51		
Progressiva			-2.86	-2.50	0.00		2.50	3.01	
Dislivelli			0.00	0.36	0.03		0.11	0.00	

Sezione: 101
 Progressiva: 957.061
 Q. Progetto: 120.391

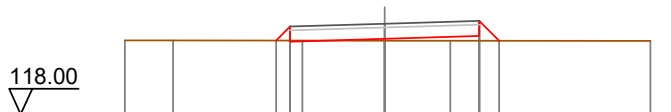

Quote Terreno	119.95	119.95			119.94		119.94	119.94	119.94
Quote Progetto			119.95	119.92	119.99		120.07	119.94	119.94
Parziali			0.37	2.50	2.50		0.53		
Progressiva			-2.87	-2.50	0.00		2.50	3.03	
Dislivelli			0.00	0.37	0.05		0.13	-0.00	

Sezione: 102
 Progressiva: 960.000
 Q. Progetto: 120.392

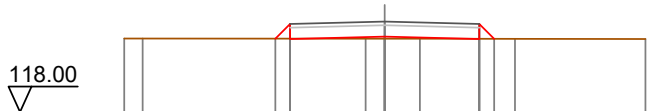

Quote Terreno	119.94	119.94		119.94	119.94	119.94	119.93	119.93
Quote Progetto			119.94	119.93		119.99	119.93	119.93
Parziali			0.39	2.50		2.50	0.40	
Progressiva			2.89	2.50		0.00	2.50	2.90
Dislivelli			0.00	0.39		0.05	-0.01	0.00

Sezione: 103
 Progressiva: 980.000
 Q. Progetto: 120.341

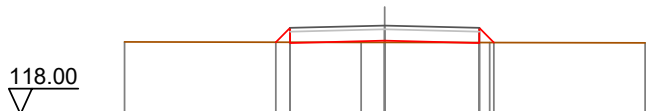

Quote Terreno	119.91			119.90	119.90		119.89	119.88
Quote Progetto			119.90	119.88		119.94	119.88	119.88
Parziali			0.38	2.50		2.50	0.39	
Progressiva			2.88	2.50		0.00	2.50	2.89
Dislivelli			0.00	0.38		0.04	-0.01	0.00

Sezione: 104
 Progressiva: 987.728
 Q. Progetto: 120.303

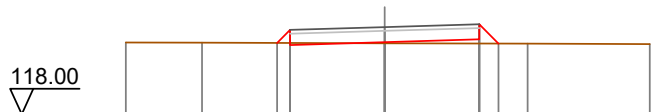

Quote Terreno	119.89	119.89		119.88	119.88		119.86	119.85
Quote Progetto			119.88	119.83		119.90	119.88	119.87
Parziali			0.34	2.50		2.50	0.51	
Progressiva			2.84	2.50		0.00	2.50	3.01
Dislivelli			0.00	0.35		0.03	0.11	0.00

Sezione: 105
 Progressiva: 989.132
 Q. Progetto: 120.296

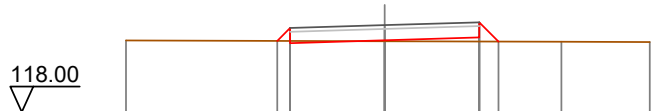

Quote Terreno	119.89			119.87			119.86	119.85
Quote Progetto		119.88	119.82	119.90		119.97	119.86	
Parziali		0.34	2.50	2.50		0.51		
Progressiva		-2.84	-2.50	0.00		2.50	3.01	
Dislivelli		0.00	0.34	0.03		0.11	-0.00	

Sezione: 106
 Progressiva: 990.000
 Q. Progetto: 120.292

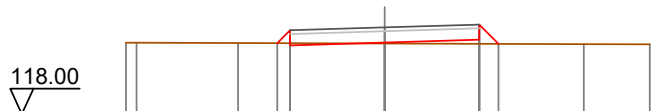

Quote Terreno	119.89	119.89	119.88		119.87		119.85	119.85
Quote Progetto			119.88	119.82	119.89		119.97	119.86
Parziali			0.34	2.50	2.50		0.51	
Progressiva			-2.84	-2.50	0.00		2.50	3.01
Dislivelli			0.00	0.34	0.02		0.11	0.00

Sezione: 107
 Progressiva: 990.535
 Q. Progetto: 120.289

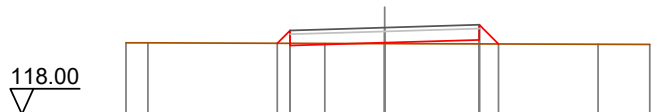

Quote Terreno	119.89	119.89		119.87	119.86		119.85	119.84
Quote Progetto			119.87	119.81	119.89		119.96	119.86
Parziali			0.34	2.50	2.50		0.51	
Progressiva			-2.84	-2.50	0.00		2.50	3.01
Dislivelli			-0.00	0.34	0.02		0.11	0.00

Sezione: 108
 Progressiva: 1000.000
 Q. Progetto: 120.242

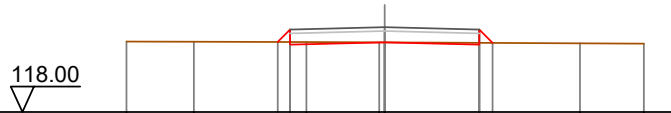

Quote Terreno	119.86	119.86	119.85	119.84	119.84	119.82	119.81
Quote Progetto			119.85	119.78	119.84	119.78	119.83
Parziali			0.33	2.50	2.50	0.35	
Progressiva			-2.83	-2.50	0.00	2.50	2.86
Dislivelli			0.00	0.33	0.00	-0.05	0.00

Sezione: 109
 Progressiva: 1020.000
 Q. Progetto: 120.143

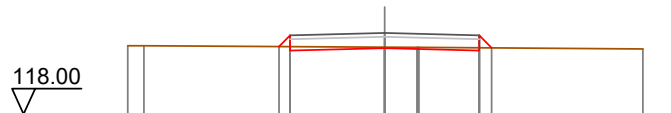

Quote Terreno	119.81	119.81	119.77	119.77	119.77	119.72	
Quote Progetto			119.79	119.68	119.74	119.68	119.75
Parziali			0.28	2.50	2.50	0.33	
Progressiva			-2.79	-2.50	0.00	2.50	2.83
Dislivelli			0.00	0.30	-0.03	-0.07	-0.00

Sezione: 110
 Progressiva: 1036.509
 Q. Progetto: 120.061

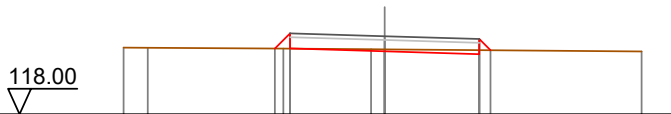

Quote Terreno	119.76	119.75	119.73	119.72	119.71	119.66	
Quote Progetto			119.73	119.74	119.66	119.59	119.69
Parziali			0.40	2.50	2.50	0.30	
Progressiva			-2.90	-2.50	0.00	2.50	2.80
Dislivelli			-0.00	0.41	-0.05	-0.11	-0.00

Sezione: 111
 Progressiva: 1040.000
 Q. Progetto: 120.044

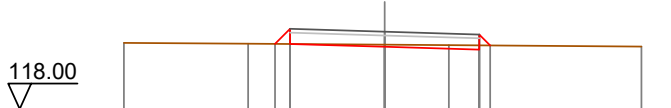

Quote Terreno	-119.75	-119.73	-119.70	-119.69	-119.65
Quote Progetto		119.72	119.64	119.57	119.66
Parziali		0.40	2.50	2.50	0.28
Progressiva		-2.90	0.00	2.50	2.79
Dislivelli		0.00	-0.06	-0.11	0.00

Sezione: 112
 Progressiva: 1043.692
 Q. Progetto: 120.026

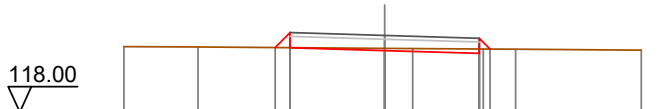

Quote Terreno	-119.73	-119.72	-119.69	-119.68	-119.67	-119.66	-119.63
Quote Progetto		119.71	119.63	119.55	119.67	119.66	
Parziali		0.40	2.50	2.50	0.28		
Progressiva		-2.90	0.00	2.50	2.78		
Dislivelli		0.00	-0.06	-0.12	0.00		

Sezione: 113
 Progressiva: 1050.000
 Q. Progetto: 119.995

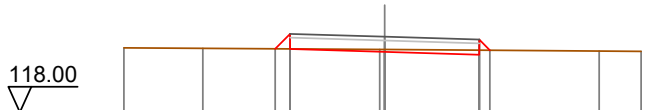

Quote Terreno	-119.70	-119.69	-119.66	-119.66	-119.61	-119.61
Quote Progetto		119.68	119.59	119.52	119.64	
Parziali		0.39	2.50	2.50	0.28	
Progressiva		-2.80	0.00	2.50	2.78	
Dislivelli		0.00	-0.06	-0.12	0.00	

Sezione: 114
 Progressiva: 1050.875
 Q. Progetto: 119.990

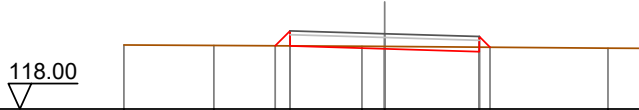

Quote Terreno	-119.69	-119.68		-119.66	-119.65		-119.61	-119.60
Quote Progetto			119.67	119.67		119.59	119.52	119.63
Parziali			0.39	2.50		2.50	0.28	
Progressiva			-2.89	-2.50		0.00	2.50	2.78
Dislivelli			0.00	0.40		-0.06	-0.12	0.00

Sezione: 115
 Progressiva: 1060.000
 Q. Progetto: 119.945

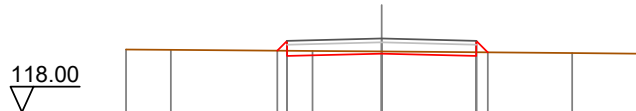

Quote Terreno	-119.65	-119.65		-119.62	-119.60		-119.56	-119.55
Quote Progetto			119.62	119.48		119.55	119.48	119.58
Parziali			0.26	2.50		2.50	0.30	
Progressiva			-2.76	-2.50		0.00	2.50	2.80
Dislivelli			-0.00	0.26		-0.06	-0.10	-0.00

Sezione: 116
 Progressiva: 1080.000
 Q. Progetto: 119.846

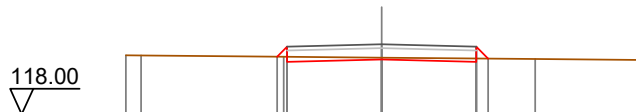

Quote Terreno	-119.56	-119.55		-119.52	-119.49		-119.46	-119.43
Quote Progetto			119.52	119.38		119.45	119.38	119.47
Parziali			0.27	2.50		2.50	0.32	
Progressiva			-2.77	-2.50		0.00	2.50	2.82
Dislivelli			-0.00	0.27		-0.05	-0.09	0.00

Sezione: 117
 Progressiva: 1091.101
 Q. Progetto: 119.791

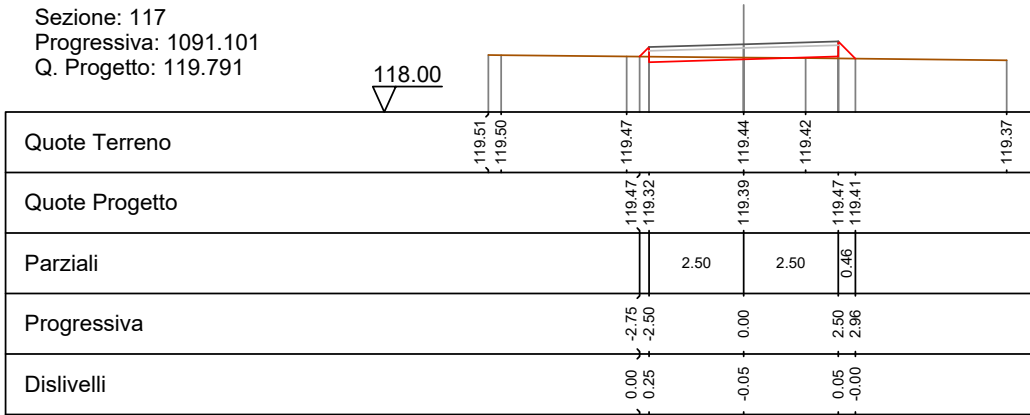

Sezione: 118
 Progressiva: 1093.230
 Q. Progetto: 119.781

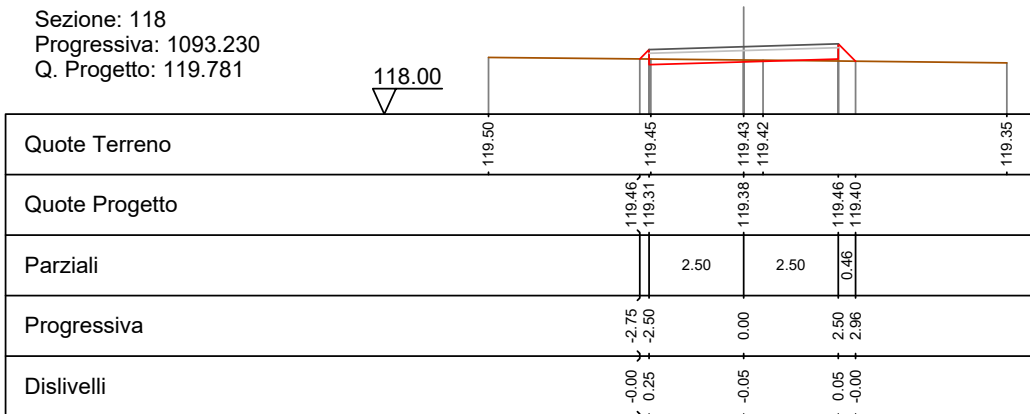

Sezione: 119
 Progressiva: 1095.359
 Q. Progetto: 119.770

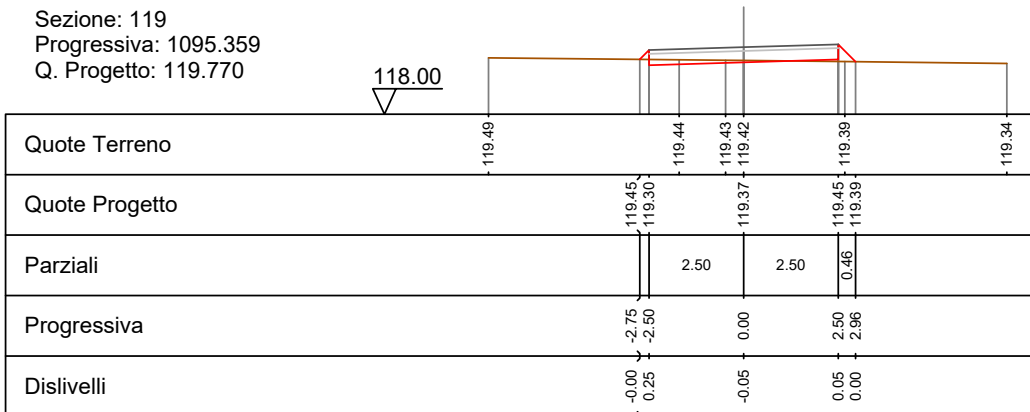

Sezione: 120
 Progressiva: 1100.000
 Q. Progetto: 119.748

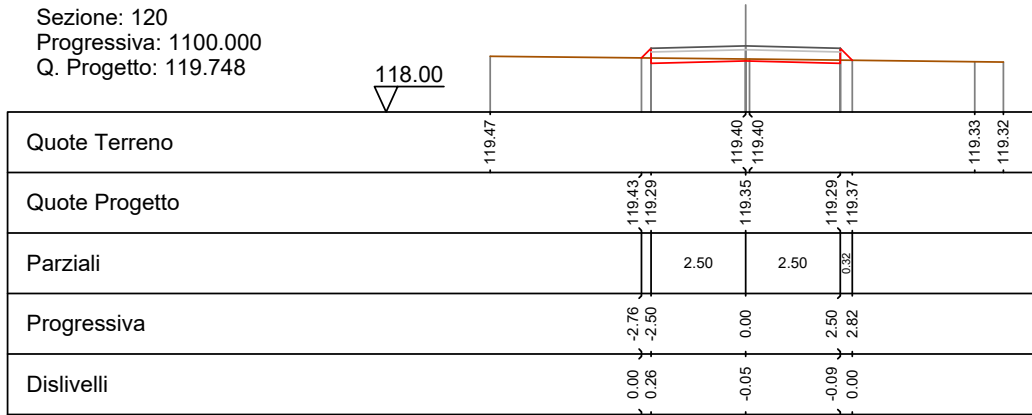

Sezione: 121
 Progressiva: 1120.000
 Q. Progetto: 119.707

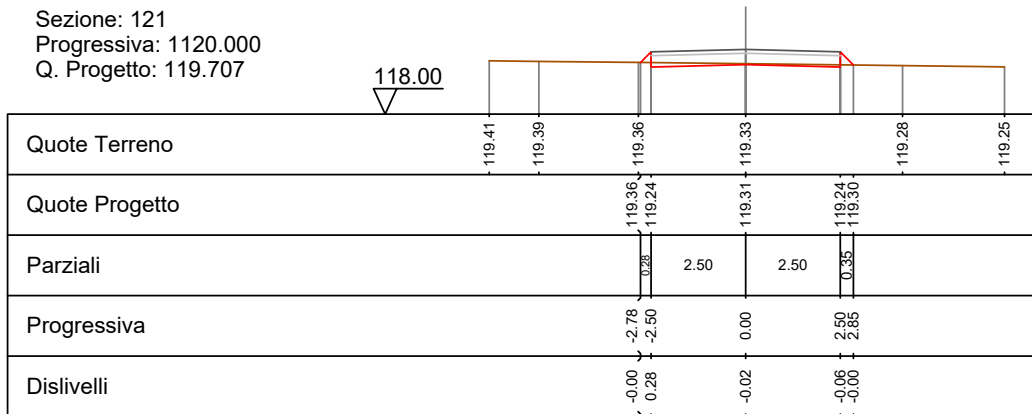

Sezione: 122
 Progressiva: 1140.000
 Q. Progetto: 119.666

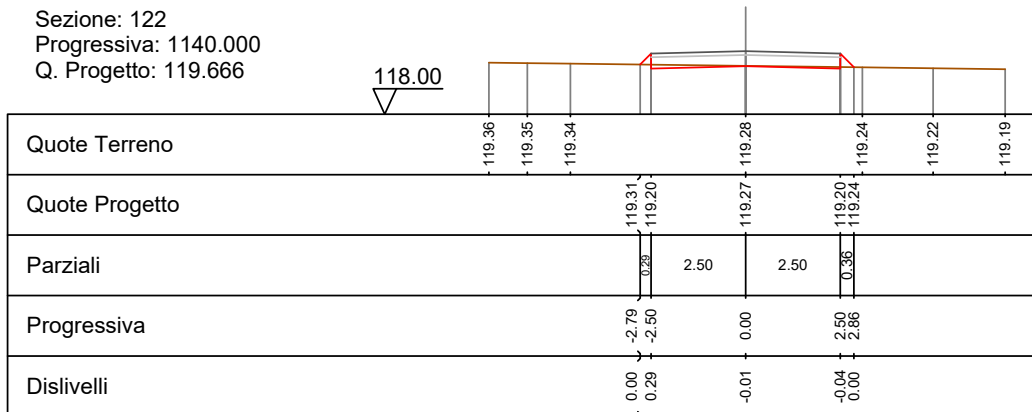

Sezione: 123
 Progressiva: 1149.654
 Q. Progetto: 119.647

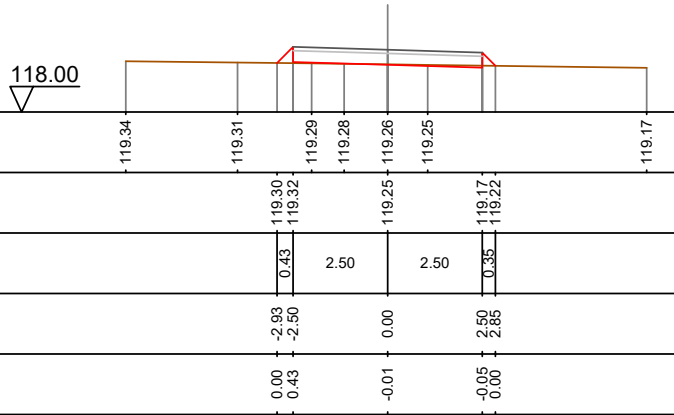

Sezione: 124
 Progressiva: 1150.000
 Q. Progetto: 119.646

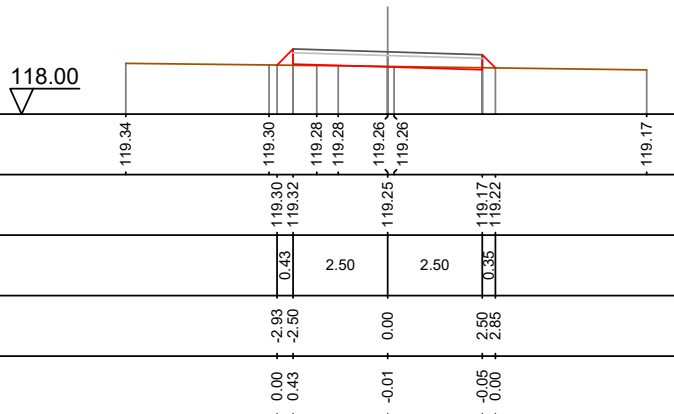

Sezione: 125
 Progressiva: 1155.224
 Q. Progetto: 119.636

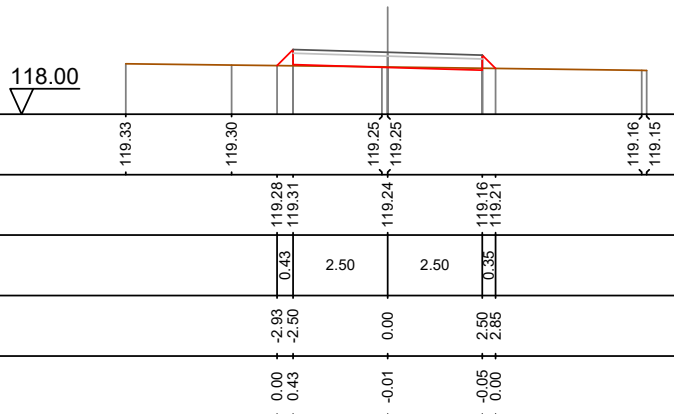

Sezione: 126
 Progressiva: 1160.000
 Q. Progetto: 119.626

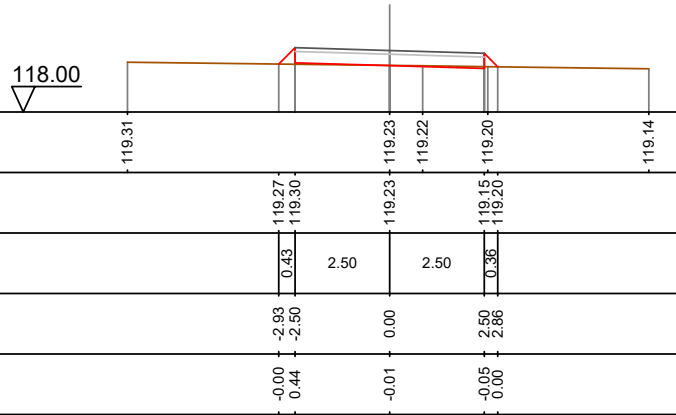

Sezione: 127
 Progressiva: 1160.794
 Q. Progetto: 119.624

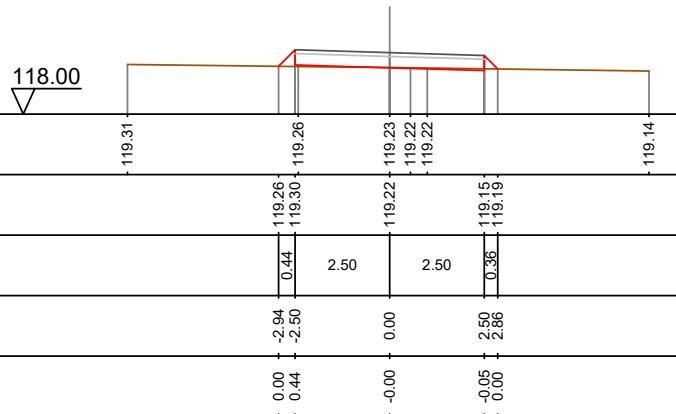

Sezione: 128
 Progressiva: 1180.000
 Q. Progetto: 119.585

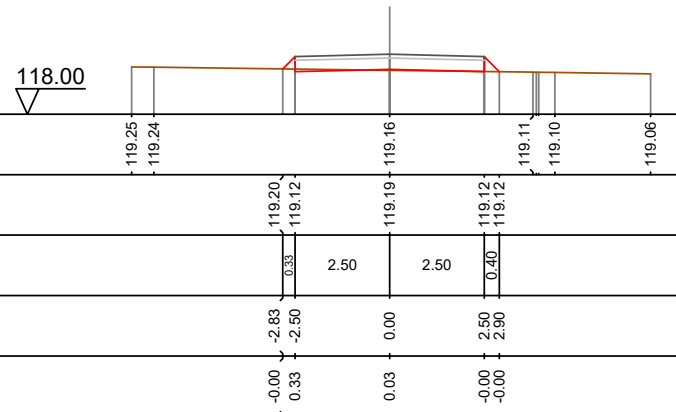

Sezione: 129
 Progressiva: 1200.000
 Q. Progetto: 119.545

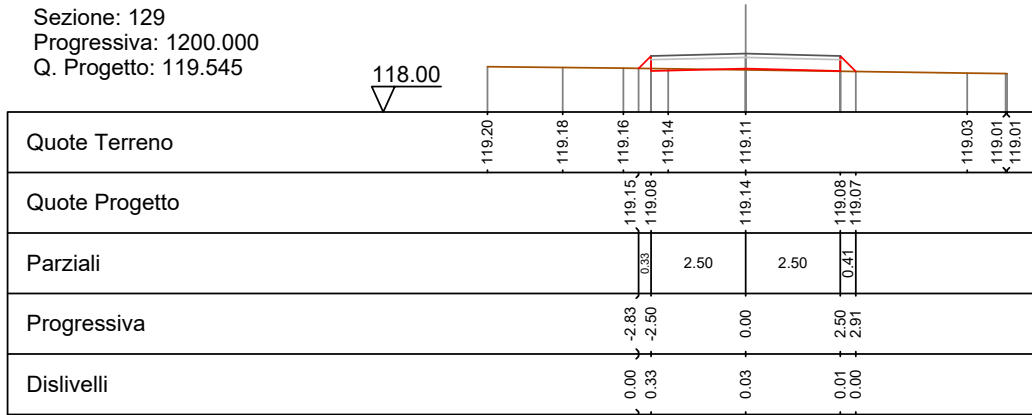

Sezione: 130
 Progressiva: 1218.015
 Q. Progetto: 119.504

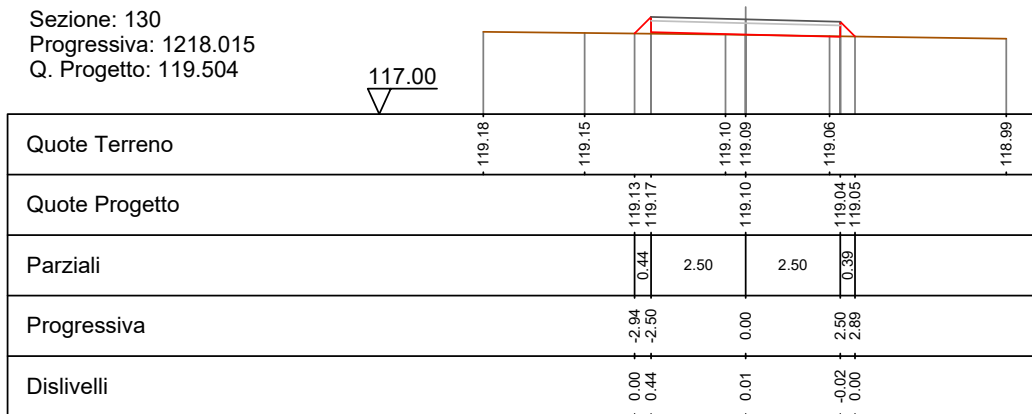

Sezione: 131
 Progressiva: 1220.000
 Q. Progetto: 119.489

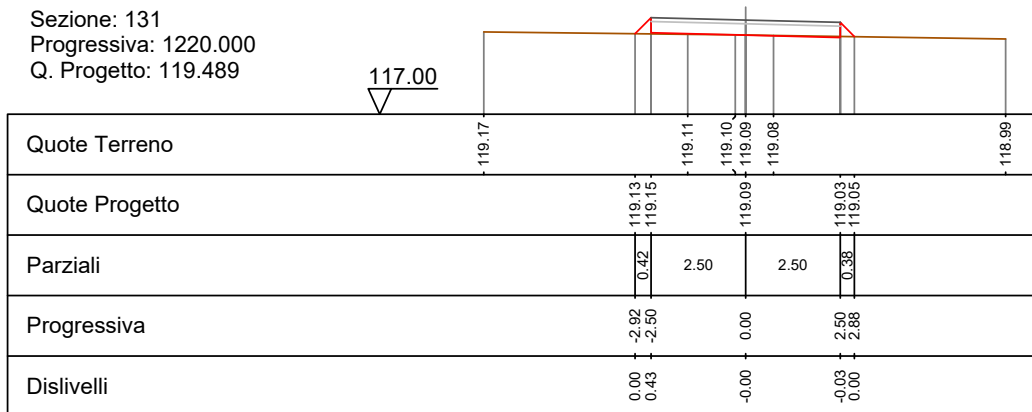

Sezione: 132
 Progressiva: 1222.401
 Q. Progetto: 119.465

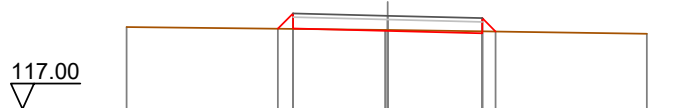

Quote Terreno	119.17		119.09		118.99
Quote Progetto		119.12	119.07	119.00	
Parziali		0.40	2.50	2.50	0.35
Progressiva		-2.90	0.00	2.50	-2.86
Dislivelli		-0.00	-0.03	-0.05	0.00

Sezione: 133
 Progressiva: 1226.787
 Q. Progetto: 119.422

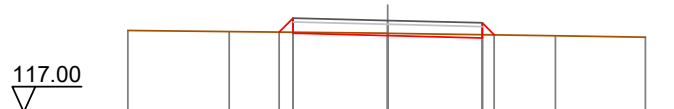

Quote Terreno	119.16	119.13	119.08	119.02	118.98
Quote Progetto			119.02	118.96	
Parziali		0.37	2.50	2.50	0.32
Progressiva		-2.87	0.00	2.50	-2.82
Dislivelli		0.00	-0.06	-0.09	-0.00

Sezione: 134
 Progressiva: 1240.000
 Q. Progetto: 119.290

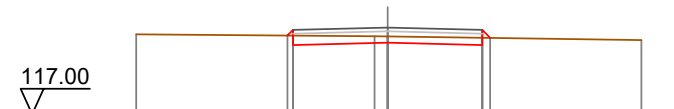

Quote Terreno	119.11		119.06		118.96
Quote Progetto		119.08	118.89	118.83	
Parziali		0.15	2.50	2.50	0.00
Progressiva		-2.65	0.00	2.50	-2.71
Dislivelli		0.00	-0.17	-0.19	0.00

Sezione: 135
 Progressiva: 1260.000
 Q. Progetto: 119.092

117.00

Quote Terreno	-119.06	-119.02	-119.01	-119.00	-119.00	-118.94
Quote Progetto		118.63		118.69	118.63	118.98
Parziali			2.50		2.50	
Progressiva		-2.51		0.00	2.50	2.55
Dislivelli		0.00		-0.31	-0.35	-0.00

Sezione: 136
 Progressiva: 1266.000
 Q. Progetto: 119.032

117.00

Quote Terreno	-119.07	-119.07	-119.02	-119.00	-119.00	-118.97	-118.94
Quote Progetto			119.03	118.57	118.63	118.57	
Parziali				2.50		2.50	
Progressiva			-2.56	-2.50	0.00	2.50	
Dislivelli			0.00	-0.06	-0.37	-0.41	

Sezione: 136
 Progressiva: 1266.000
 Q. Progetto: 119.032

117.00

Quote Terreno	-119.07	-119.07	-119.02	-119.00	-119.00	-118.97	-118.94
Quote Progetto			119.03	118.57	118.63	118.57	
Parziali				2.50		2.50	
Progressiva			-2.56	-2.50	0.00	2.50	
Dislivelli			0.00	-0.06	-0.37	-0.41	

Sezione: 137
 Progressiva: 1272.381
 Q. Progetto: 119.009

117.00

Quote Terreno	-119.09		-119.03	-119.02		-118.95
Quote Progetto		119.05 118.55		118.61		118.67 118.99
Parziali			2.50	2.50		
Progressiva		-2.60 -2.50		0.00		2.50 2.58
Dislivelli		-0.00 -0.10		-0.41		-0.32 0.00

Sezione: 138
 Progressiva: 1280.000
 Q. Progetto: 119.066

117.00

Quote Terreno	-119.12		-119.07	-119.06	-119.06	-118.99
Quote Progetto		119.09 118.60		118.67		118.73 119.04
Parziali			2.50	2.50		
Progressiva		-2.58 -2.50		0.00		2.50 2.59
Dislivelli		-0.00 -0.08		-0.40		-0.31 0.00

Sezione: 139
 Progressiva: 1290.000
 Q. Progetto: 119.152

117.00

Quote Terreno	-119.19		-119.15	-119.14	-119.14	-119.10	-119.07
Quote Progetto		119.17 118.69		118.75		118.81 119.13	
Parziali			2.50	2.50			
Progressiva		-2.58 -2.50		0.00		2.50 2.58	
Dislivelli		0.00 -0.08		-0.40		-0.32 0.00	

Sezione: 140
 Progressiva: 1296.155
 Q. Progetto: 119.205

117.00

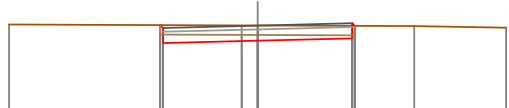

Quote Terreno	-119.23	-119.21	-119.21	-119.19	-119.15
Quote Progetto		119.22 118.74	118.80	118.87 119.20	
Parziali		2.50	2.50		
Progressiva		-2.58 -2.50	0.00	2.50 2.57	
Dislivelli		0.00 -0.08	-0.40	-0.33 0.00	

Sezione: 141
 Progressiva: 1300.000
 Q. Progetto: 119.244

117.00

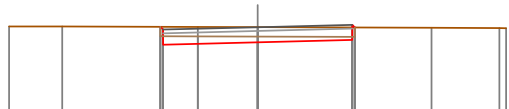

Quote Terreno	-119.27	-119.26	-119.25	-119.23	-119.22
Quote Progetto			119.25 118.78	118.84	118.91 119.24
Parziali			2.50	2.50	
Progressiva			-2.57 -2.50	0.00	2.50 2.57
Dislivelli			0.00 -0.07	-0.40	-0.33 0.00

Sezione: 142
 Progressiva: 1310.000
 Q. Progetto: 119.349

117.00

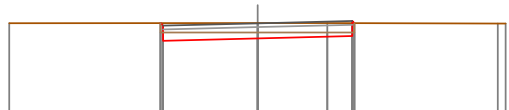

Quote Terreno	-119.35	-119.36	-119.36	-119.34	-119.34
Quote Progetto		119.36 118.89	118.95	119.01 119.35	
Parziali		2.50	2.50		
Progressiva		-2.57 -2.50	0.00	2.50 2.56	
Dislivelli		0.00 -0.07	-0.41	-0.34 0.00	

Sezione: 143
 Progressiva: 1319.929
 Q. Progetto: 119.453

117.00

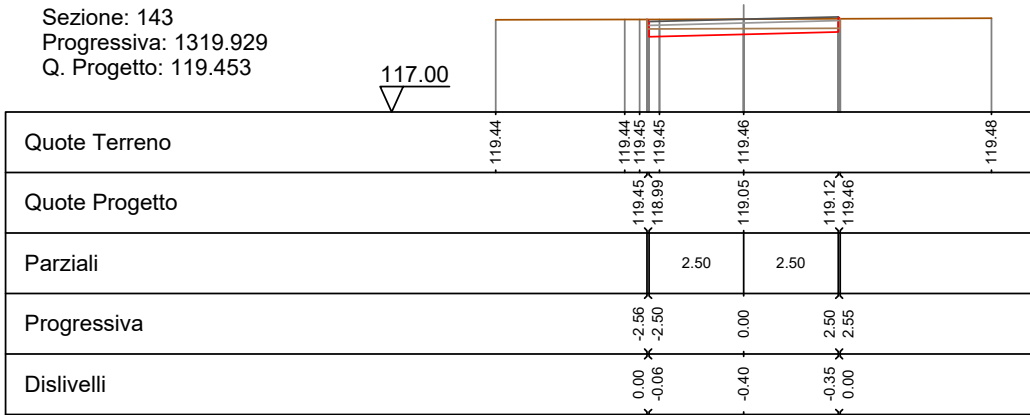

Sezione: 144
 Progressiva: 1320.807
 Q. Progetto: 119.463

118.00

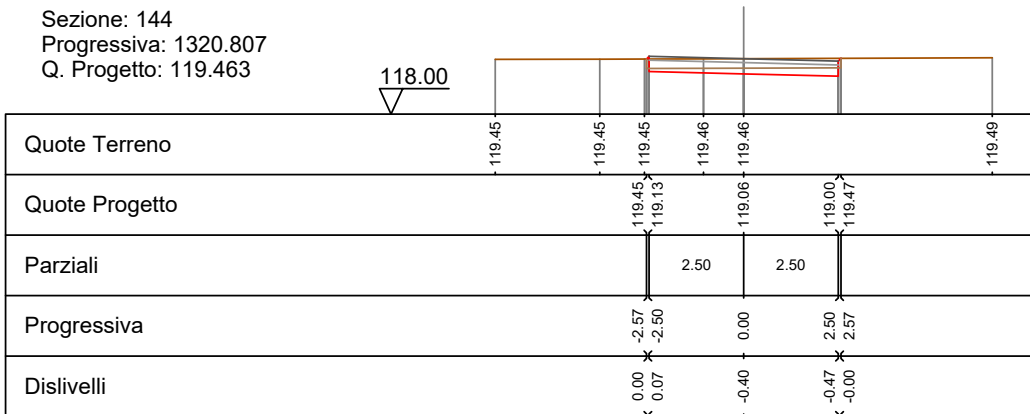

Sezione: 145
 Progressiva: 1330.000
 Q. Progetto: 119.559

118.00

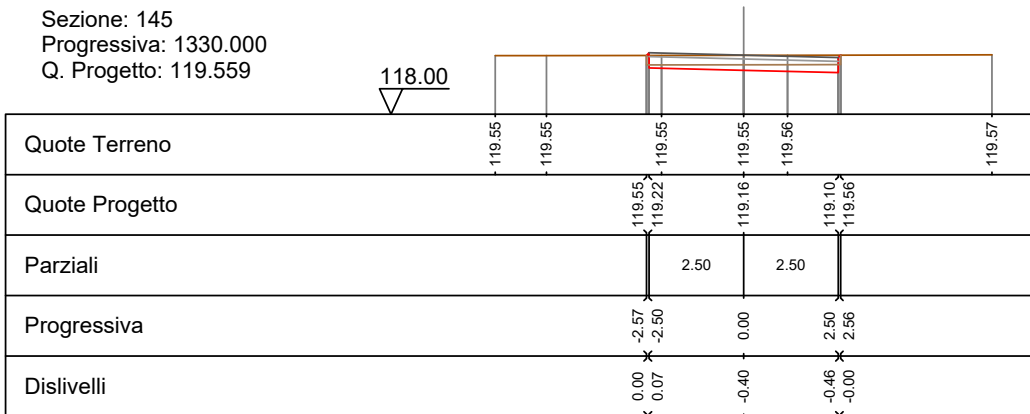

Sezione: 146
 Progressiva: 1334.839
 Q. Progetto: 119.610

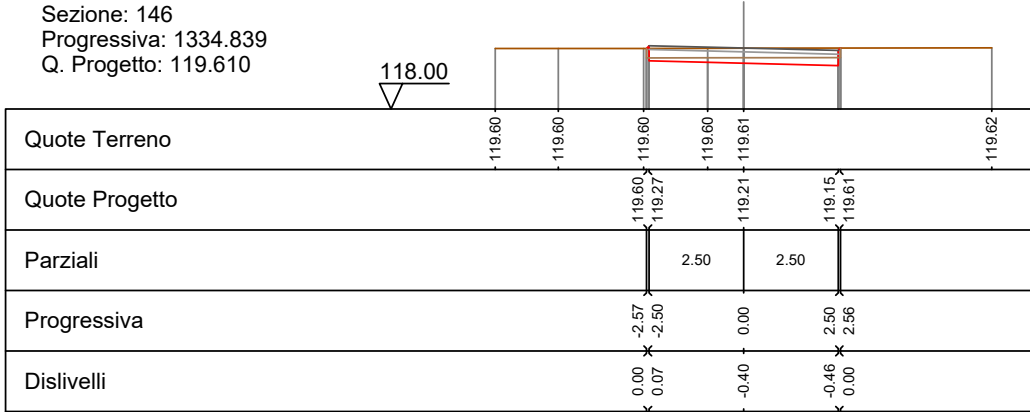

Sezione: 147
 Progressiva: 1340.000
 Q. Progetto: 119.664

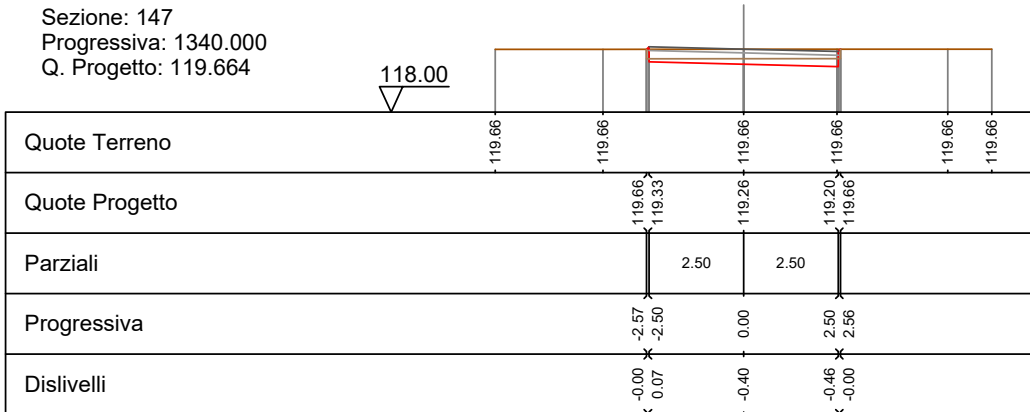

Sezione: 148
 Progressiva: 1348.870
 Q. Progetto: 119.758

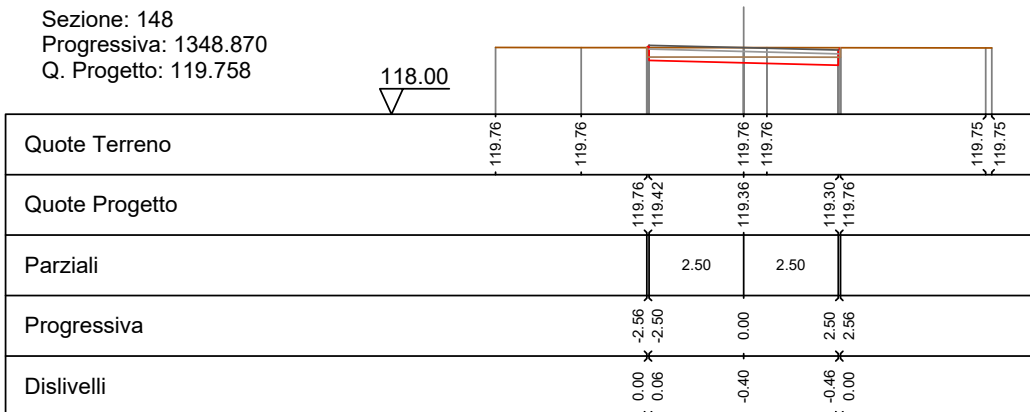

Sezione: 149
 Progressiva: 1350.000
 Q. Progetto: 119.769

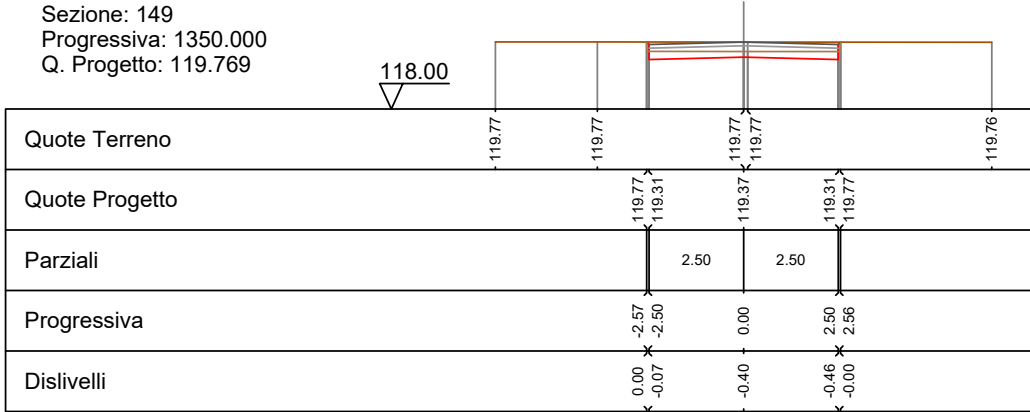

Sezione: 149
 Progressiva: 1350.000
 Q. Progetto: 119.769

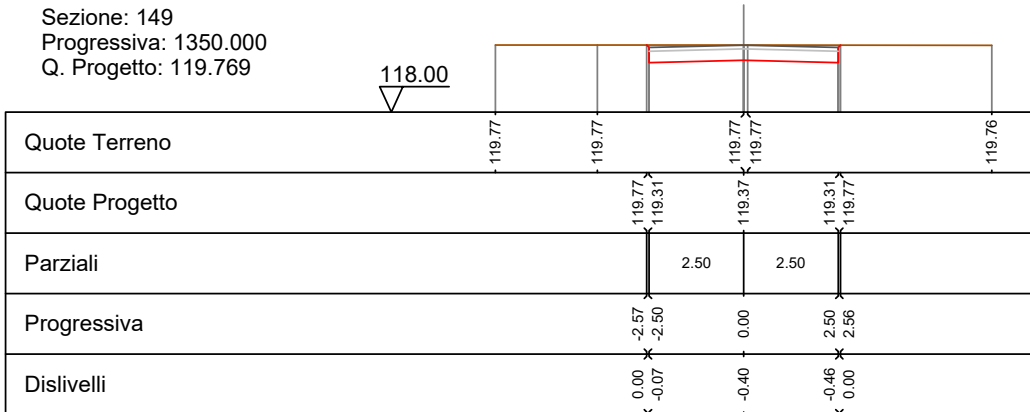

Sezione: 150
 Progressiva: 1351.193
 Q. Progetto: 119.782

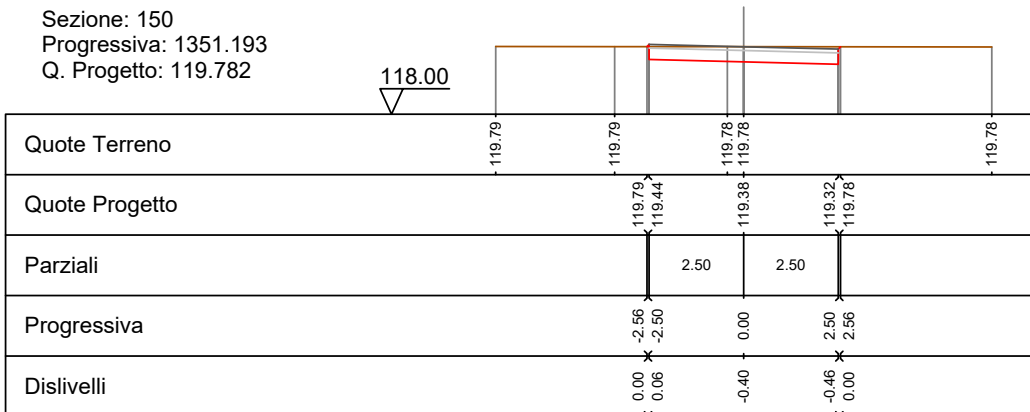

Sezione: 151
 Progressiva: 1359.266
 Q. Progetto: 119.867

118.00

Quote Terreno	119.89	119.89	119.88	119.87	119.86	119.85
Quote Progetto			119.88 119.53	119.47	119.40 119.87	
Parziali			2.50	2.50		
Progressiva			-2.55 -2.50	0.00	2.50 2.56	
Dislivelli			-0.00 0.05	-0.41	-0.46 0.00	

Sezione: 152
 Progressiva: 1360.000
 Q. Progetto: 119.875

118.00

Quote Terreno	119.90	119.90	119.88	119.88	119.86	119.86
Quote Progetto			119.89 119.54	119.47	119.41 119.87	
Parziali			2.50	2.50		
Progressiva			-2.55 -2.50	0.00	2.50 2.56	
Dislivelli			0.00 0.05	-0.41	-0.46 0.00	

Sezione: 153
 Progressiva: 1367.338
 Q. Progetto: 119.948

118.00

Quote Terreno	119.98		119.95	119.95	119.92	
Quote Progetto			119.96 119.61	119.55	119.49 119.94	
Parziali			2.50	2.50		
Progressiva			-2.55 -2.50	0.00	2.50 2.55	
Dislivelli			-0.00 0.05	-0.40	-0.45 0.00	

Sezione: 154
 Progressiva: 1380.000
 Q. Progetto: 120.062

118.00

Quote Terreno	-120.13	-120.09	-120.06	-120.06	-120.05	-120.03
Quote Progetto		120.08	119.60	119.66	119.60	120.06
Parziali			2.50	2.50		
Progressiva		-2.58	-2.50	0.00	2.50	2.56
Dislivelli		0.00	-0.08	-0.40	-0.46	0.00

Sezione: 155
 Progressiva: 1400.000
 Q. Progetto: 120.472

119.00

Quote Terreno	-120.62	-120.53	-120.46	-120.43	-120.36	-120.33
Quote Progetto		120.52	120.01	120.07	120.01	
Parziali			2.50	2.50		
Progressiva		-2.61	-2.50	0.00	2.50	
Dislivelli		0.00	-0.11	-0.39	-0.40	

Sezione: 156
 Progressiva: 1420.000
 Q. Progetto: 120.987

119.00

Quote Terreno	-121.18	-121.09	-120.98	-120.92	-120.78
Quote Progetto		121.07	120.52	120.59	120.52
Parziali			2.50	2.50	
Progressiva		-2.64	-2.50	0.00	2.50
Dislivelli		0.00	-0.14	-0.40	-0.38

Sezione: 157
 Progressiva: 1440.000
 Q. Progetto: 121.518

120.00

Quote Terreno	-121.75	-121.57	-121.53	-121.43	-121.31
Quote Progetto		121.62 121.06	121.12	121.06	
Parziali		2.50	2.50		
Progressiva		-2.66 -2.50	0.00	2.50	
Dislivelli		0.00 -0.16	-0.41	-0.39	

Sezione: 158
 Progressiva: 1444.816
 Q. Progetto: 121.646

120.00

Quote Terreno	-121.89	-121.67	-121.58	-121.56	-121.53	-121.44
Quote Progetto		121.75 121.31	121.25	121.18		
Parziali		2.50	2.50			
Progressiva		-2.55 -2.50	0.00	2.50		
Dislivelli		0.00 -0.04	-0.42	-0.40		

Sezione: 159
 Progressiva: 1445.346
 Q. Progetto: 121.660

120.00

Quote Terreno	-121.91	-121.68	-121.61	-121.57	-121.53	-121.45
Quote Progetto		121.77 121.32	121.26	121.20		
Parziali		2.50	2.50			
Progressiva		-2.55 -2.50	0.00	2.50		
Dislivelli		-0.00 -0.05	-0.42	-0.40		

Sezione: 160
 Progressiva: 1445.877
 Q. Progetto: 121.674

120.00

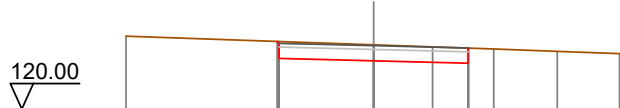

Quote Terreno	-121.93	-121.70	-121.64	-121.59	-121.52	-121.47
Quote Progetto		121.79 121.34	121.27	121.21		
Parziali		2.50	2.50			
Progressiva		-2.55 -2.50	0.00	2.50		
Dislivelli		0.00 -0.05	-0.42	-0.40		

Sezione: 161
 Progressiva: 1460.000
 Q. Progetto: 122.049

120.00

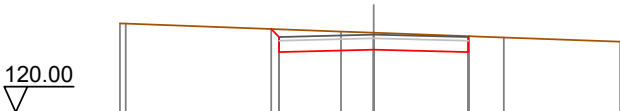

Quote Terreno	122.34 122.34	122.13	122.10	121.97	121.86
Quote Progetto		122.20 121.99	121.65	121.59 122.01	
Parziali		2.50	2.50		
Progressiva		-2.71 -2.50	0.00	2.50 2.52	
Dislivelli		0.00 -0.20	-0.45	-0.42 -0.00	

Sezione: 162
 Progressiva: 1467.139
 Q. Progetto: 122.238

120.00

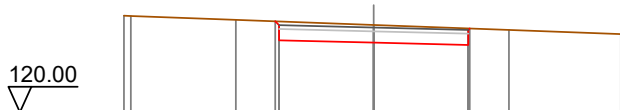

Quote Terreno	122.55 122.54	122.44	122.31	122.18	122.06
Quote Progetto		122.40 121.90	121.84	121.78 122.21	
Parziali		2.50	2.50		
Progressiva		-2.60 -2.50	0.00	2.50 2.54	
Dislivelli		-0.00 -0.10	-0.47	-0.44 -0.00	

Sezione: 163
 Progressiva: 1470.000
 Q. Progetto: 122.311

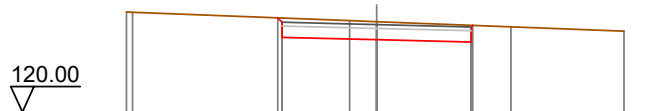

Quote Terreno	122.64	122.64		122.42	122.39		122.25		122.14
Quote Progetto			122.49	121.97		121.91		121.85	122.29
Parziali				2.50		2.50			
Progressiva			-2.62	-2.50		0.00		2.50	2.54
Dislivelli			0.00	-0.11		-0.48		-0.44	0.00

Sezione: 164
 Progressiva: 1480.000
 Q. Progetto: 122.492

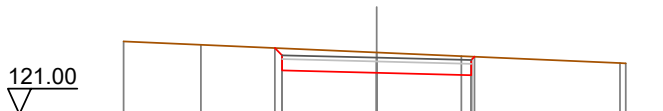

Quote Terreno	122.92	122.83		122.63		122.53		122.35	122.34
Quote Progetto			122.75	122.15		122.09		122.03	122.52
Parziali				2.50		2.50			
Progressiva			-2.69	-2.50		0.00		2.50	2.59
Dislivelli			0.00	-0.18		-0.54		-0.49	-0.00

Sezione: 164
 Progressiva: 1480.000
 Q. Progetto: 122.492

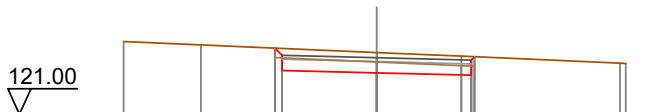

Quote Terreno	122.92	122.83		122.63		122.53		122.35	122.34
Quote Progetto			122.75	122.15		122.09		122.03	122.52
Parziali				2.50		2.50			
Progressiva			-2.69	-2.50		0.00		2.50	2.59
Dislivelli			0.00	-0.18		-0.54		-0.49	0.00

Sezione: 165
 Progressiva: 1490.000
 Q. Progetto: 122.639

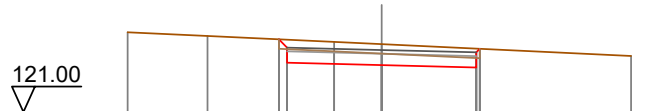

Quote Terreno	-123.11	-123.01	-122.85	-122.79	-122.48
Quote Progetto			122.92 122.30	122.24	122.18 122.67
Parziali			2.50	2.50	
Progressiva			-2.72 -2.50	0.00	2.50 2.59
Dislivelli			-0.00 -0.21	-0.55	-0.50 0.00

Sezione: 166
 Progressiva: 1500.000
 Q. Progetto: 122.692

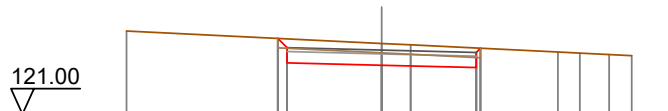

Quote Terreno	-123.20		-122.87	-122.83	-122.64	-122.61	-122.57	-122.55
Quote Progetto			123.00 122.35	122.29	122.23 122.74			
Parziali			2.50	2.50				
Progressiva			-2.75 -2.50	0.00	2.50 2.61			
Dislivelli			-0.00 -0.23	-0.58	-0.52 0.00			

Sezione: 167
 Progressiva: 1510.000
 Q. Progetto: 122.644

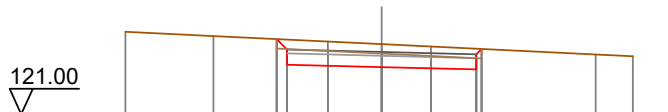

Quote Terreno	-123.18	-123.07	-122.92	-122.85	-122.79	-122.58	-122.53
Quote Progetto			122.99 122.31	122.24	122.18 122.72		
Parziali			2.50	2.50			
Progressiva			-2.78 -2.50	0.00	2.50 2.64		
Dislivelli			0.00 -0.27	-0.61	-0.55 0.00		

Sezione: 168
 Progressiva: 1518.747
 Q. Progetto: 122.521

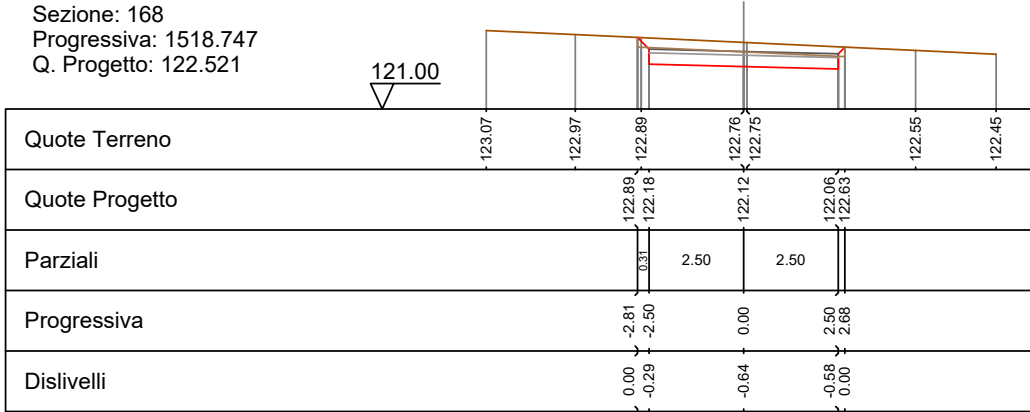

Sezione: 169
 Progressiva: 1520.000
 Q. Progetto: 122.497

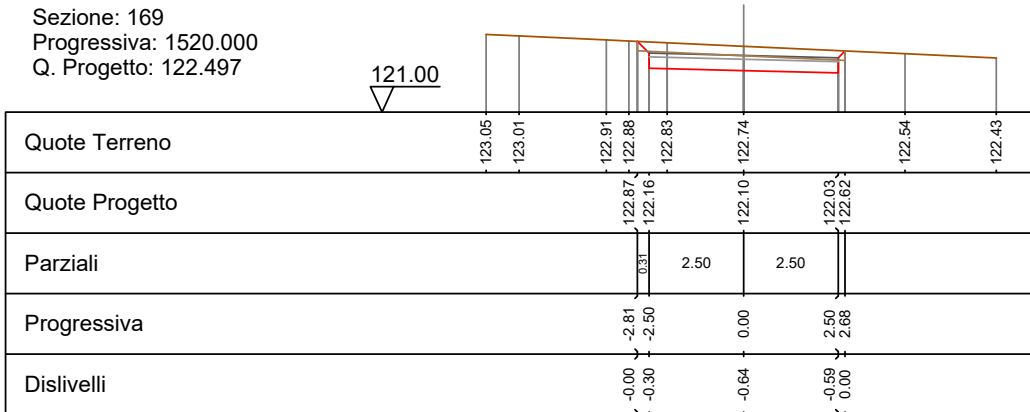

Sezione: 170
 Progressiva: 1530.000
 Q. Progetto: 122.251

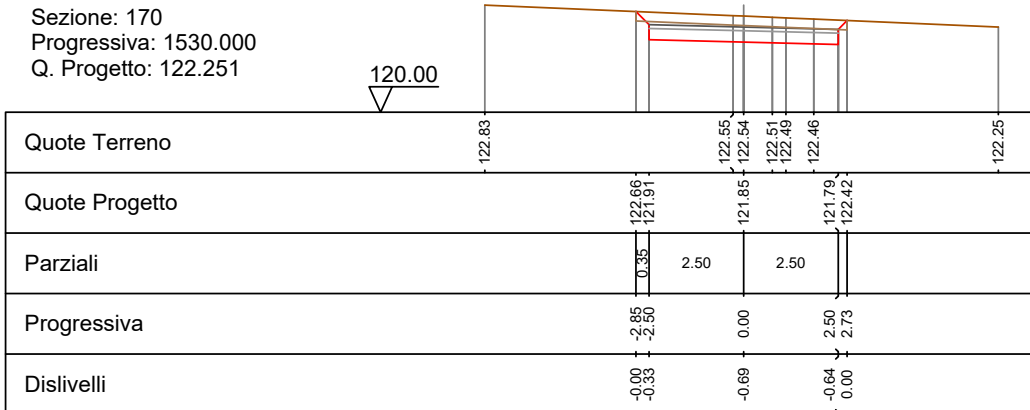

Sezione: 171
 Progressiva: 1540.000
 Q. Progetto: 121.975

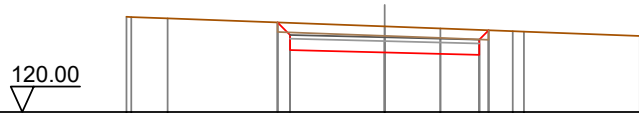

Quote Terreno	122.52	122.51	122.48			122.26	122.21	122.14	122.13	122.01
Quote Progetto				122.37	121.64	121.58	121.51	122.16		
Parziali				0.33	2.50	2.50				
Progressiva				-2.83	-2.50	0.00	2.50	2.75		
Dislivelli				-0.00	-0.32	-0.69	-0.66	0.00		

Sezione: 172
 Progressiva: 1550.000
 Q. Progetto: 121.680

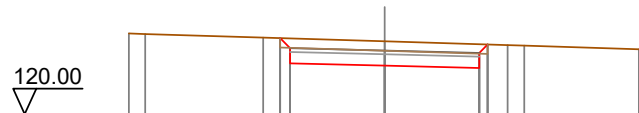

Quote Terreno	122.13	122.12	122.02			121.92	121.82	121.81	121.71
Quote Progetto			122.01	121.34		121.28	121.22	121.84	
Parziali			0.26	2.50	2.50				
Progressiva			-2.76	-2.50	0.00	2.50	2.72		
Dislivelli			0.00	-0.26	-0.64	-0.63	-0.00		

Sezione: 173
 Progressiva: 1560.000
 Q. Progetto: 121.330

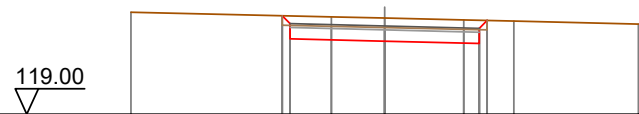

Quote Terreno	121.70		121.57	121.54		121.49	121.46	121.38
Quote Progetto		121.60	120.99	120.93		120.87	121.48	
Parziali			2.50	2.50				
Progressiva		-2.71	-2.50	0.00	2.50	2.71		
Dislivelli		0.00	-0.21	-0.61	-0.62	0.00		

Sezione: 174
 Progressiva: 1570.000
 Q. Progetto: 120.980

119.00

Quote Terreno	-121.23	-121.16	-121.16	-121.15	-121.13	-121.03
Quote Progetto		121.17	120.64		120.58	120.52
Parziali			2.50		2.50	
Progressiva		-2.63	-2.50		0.00	2.50
Dislivelli		-0.00	-0.12		-0.55	-0.57
						-0.00

Sezione: 175
 Progressiva: 1570.355
 Q. Progetto: 120.967

119.00

Quote Terreno	-121.21	-121.14	-121.14	-121.11	-121.01
Quote Progetto		121.15	120.63	120.57	120.50
Parziali			2.50		2.50
Progressiva		-2.62	-2.50	0.00	2.50
Dislivelli		-0.00	-0.12		-0.57
					0.00

Sezione: 176
 Progressiva: 1580.000
 Q. Progetto: 120.630

119.00

Quote Terreno	120.81	120.78	120.72	120.70	120.65	120.62
Quote Progetto			120.75	120.23	120.17	120.68
Parziali			2.50		2.50	
Progressiva			-2.60	0.00	2.50	2.61
Dislivelli			-0.00	-0.49	-0.51	0.00
						-0.18

Sezione: 177
 Progressiva: 1596.628
 Q. Progetto: 120.069

118.00

Quote Terreno	-120.17	-120.14	-120.10	-120.03	-120.02
Quote Progetto		120.12	119.61	119.73	120.07
Parziali		2.50	2.50		
Progressiva		-2.62	-2.50	0.00	2.50
Dislivelli		0.00	-0.12	-0.43	-0.34

Sezione: 178
 Progressiva: 1600.000
 Q. Progetto: 119.974

118.00

Quote Terreno	-120.07	-120.00	-119.99	-119.95	-119.94
Quote Progetto		120.02	119.51	119.64	119.97
Parziali		2.50	2.50		
Progressiva		-2.61	-2.50	0.00	2.50
Dislivelli		0.00	-0.10	-0.42	-0.33

Sezione: 179
 Progressiva: 1610.000
 Q. Progetto: 119.738

118.00

Quote Terreno	-119.84	-119.82	-119.74	-119.71	-119.65	-119.63
Quote Progetto		119.79	119.28	119.34	119.40	119.70
Parziali		2.50	2.50			
Progressiva		-2.61	-2.50	0.00	2.50	2.60
Dislivelli		0.00	-0.11	-0.40	-0.30	0.00

Sezione: 180
 Progressiva: 1620.000
 Q. Progetto: 119.503

118.00

Quote Terreno	-119.60	-119.54		119.45	119.43		-119.32	-119.30
Quote Progetto			119.51	119.10	119.17			
Parziali			2.50	2.50				
Progressiva			-2.57	0.00	2.50			
Dislivelli			-0.00	-0.35	-0.23			

Sezione: 181
 Progressiva: 1630.000
 Q. Progetto: 119.311

117.00

Quote Terreno	-119.38	-119.32		119.20	119.16		-119.02
Quote Progetto			119.27	118.91	118.97		
Parziali			2.50	2.50			
Progressiva			-2.52	0.00	2.50		
Dislivelli			0.00	-0.29	-0.16		

Sezione: 182
 Progressiva: 1632.776
 Q. Progetto: 119.266

117.00

Quote Terreno	-119.33			119.14	119.08		118.95
Quote Progetto			118.80	118.87	118.93		
Parziali			2.50	2.50			
Progressiva			-2.51	0.00	2.50		
Dislivelli			0.00	-0.28	-0.14		

Sezione: 183
 Progressiva: 1640.000
 Q. Progetto: 119.148

117.00

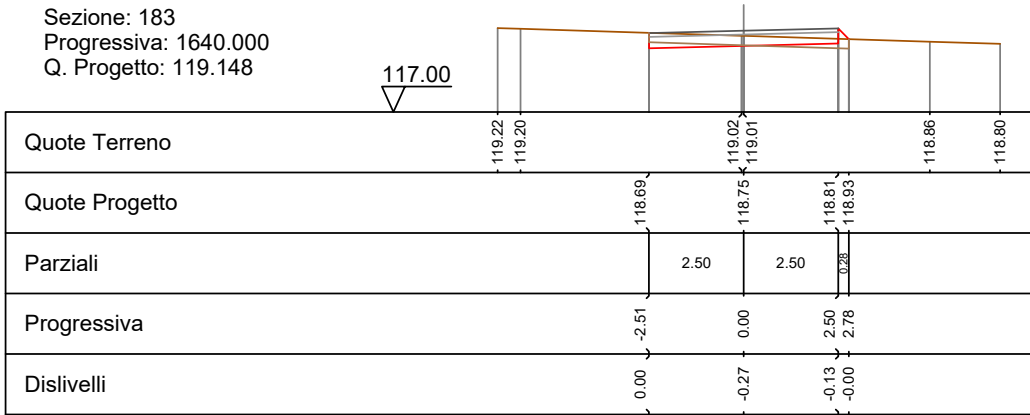

Sezione: 184
 Progressiva: 1650.000
 Q. Progetto: 119.078

117.00

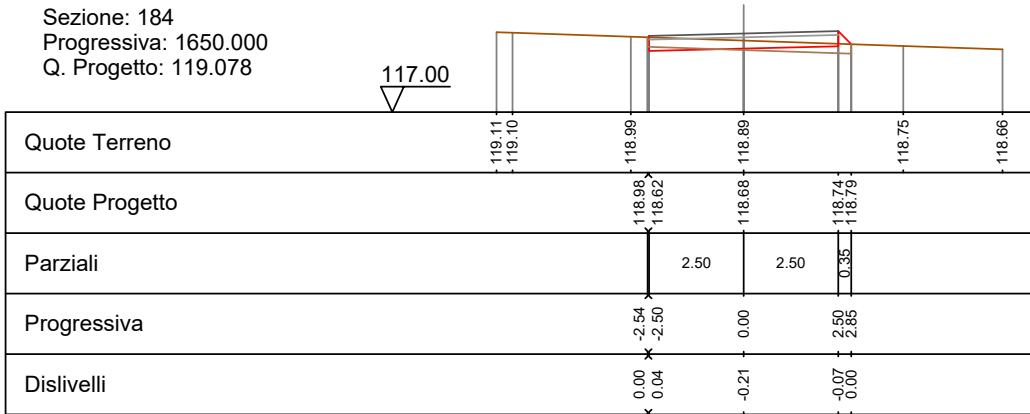

Sezione: 185
 Progressiva: 1660.000
 Q. Progetto: 119.052

117.00

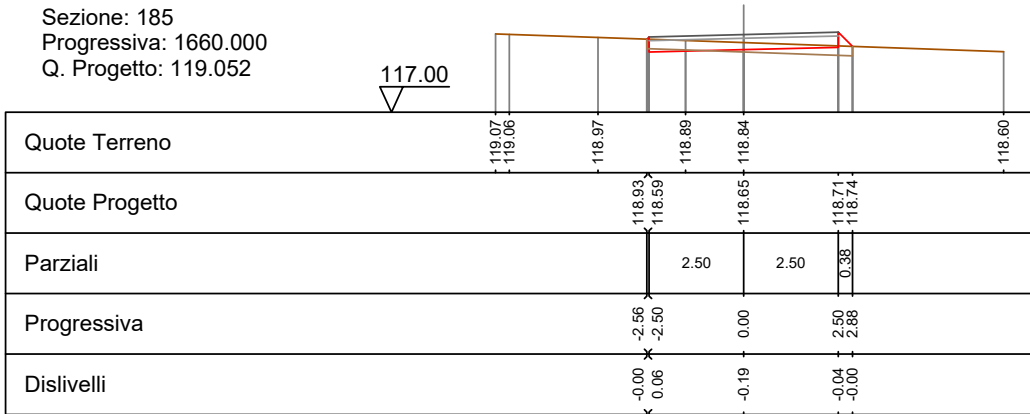

Sezione: 186
 Progressiva: 1668.925
 Q. Progetto: 119.029

117.00

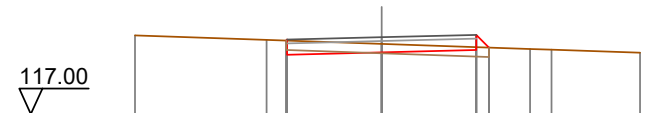

Quote Terreno	-119.08	-118.96	-118.86	-118.72	-118.70	-118.62
Quote Progetto		118.94 118.57	118.63	118.69 118.76		
Parziali		2.50	2.50	0.33		
Progressiva		-2.52 -2.50	0.00	2.50 2.83		
Dislivelli		0.00 0.03	-0.23	-0.08 0.00		

Sezione: 187
 Progressiva: 1680.000
 Q. Progetto: 119.001

117.00

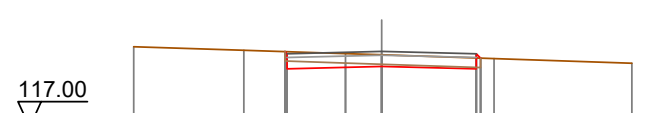

Quote Terreno	-119.12	-119.03	-118.94	-118.91	-118.81	-118.69
Quote Progetto		119.00 118.54	118.60	118.54 118.82		
Parziali		2.50	2.50			
Progressiva		-2.56 -2.50	0.00	2.50 2.62		
Dislivelli		-0.00 -0.05	-0.31	-0.28 0.00		

Sezione: 188
 Progressiva: 1687.702
 Q. Progetto: 119.038

117.00

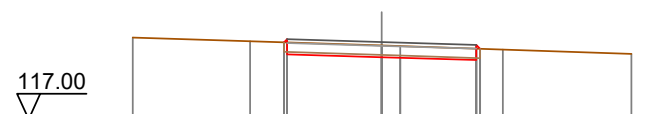

Quote Terreno	-119.16	-119.06	-118.95	-118.93	-118.84	-118.73
Quote Progetto		119.03 118.71	118.64	118.56 118.86		
Parziali		2.50	2.50			
Progressiva		-2.58 -2.50	0.00	2.50 2.60		
Dislivelli		0.00 0.08	-0.31	-0.30 0.00		

Sezione: 189
 Progressiva: 1690.000
 Q. Progetto: 119.072

117.00

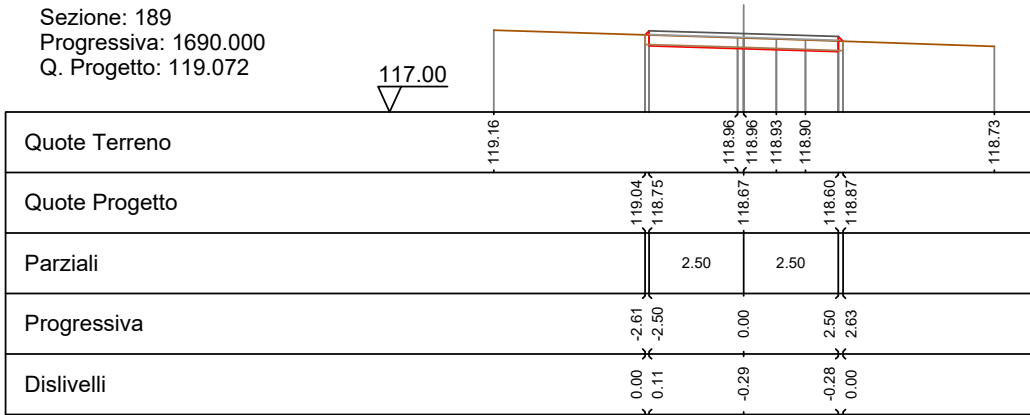

Sezione: 190
 Progressiva: 1698.077
 Q. Progetto: 119.200

117.00

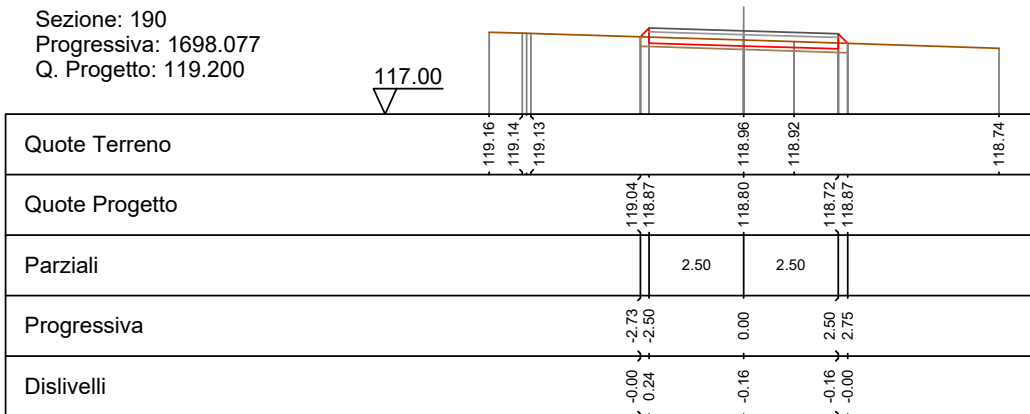

Sezione: 191
 Progressiva: 1700.000
 Q. Progetto: 119.230

117.00

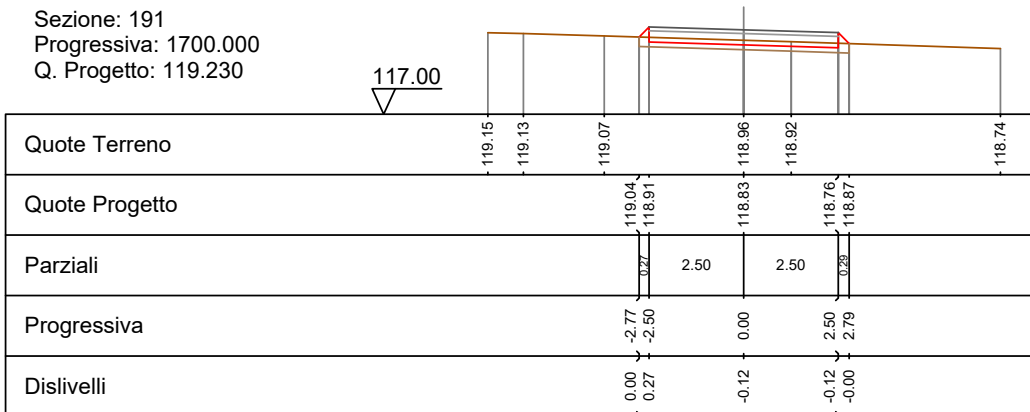

Sezione: 192
 Progressiva: 1702.600
 Q. Progetto: 119.272

117.00

Quote Terreno	119.14	119.12		118.99	118.94	118.91		118.81	118.73
Quote Progetto			119.03	118.95	118.87		118.80	118.85	
Parziali			0.32	2.50	2.50		0.34		
Progressiva			-2.82	-2.50	0.00		2.50	2.84	
Dislivelli			0.00	0.33	-0.07		-0.07	-0.00	

Sezione: 193
 Progressiva: 1708.451
 Q. Progetto: 119.365

117.00

Quote Terreno	119.09	119.02		118.90	118.90	118.83		118.69
Quote Progetto			118.98	119.04	118.96	118.89	118.82	
Parziali			0.46	2.50	2.50	0.47		
Progressiva			-2.96	-2.50	0.00	2.50	2.97	
Dislivelli			0.00	0.47	0.06	0.06	0.00	

Sezione: 194
 Progressiva: 1713.380
 Q. Progetto: 119.443

117.00

Quote Terreno	119.05	119.02		118.89	118.86			118.69	118.68	118.66	118.65
Quote Progetto			118.94	118.98	119.04	119.11	118.77				
Parziali			0.44	2.50	2.50	0.74					
Progressiva			-2.94	-2.50	0.00	2.50	3.24				
Dislivelli			0.00	0.45	0.18	0.32	0.00				

Sezione: 195
 Progressiva: 1714.593
 Q. Progetto: 119.460

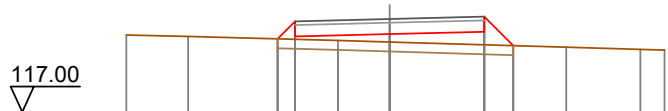

Quote Terreno	119.04	119.00		118.89	118.85		118.71	118.65	118.64
Quote Progetto			118.93	119.00		119.06	119.12	118.75	
Parziali			0.46	2.50	2.50	0.77			
Progressiva			-2.96	-2.50	0.00	2.50	3.27		
Dislivelli			-0.00	0.48	0.21	0.35	-0.00		

Sezione: 196
 Progressiva: 1715.806
 Q. Progetto: 119.474

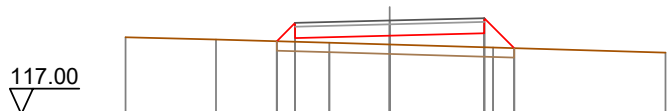

Quote Terreno	119.03	118.97		118.89	118.84		118.76	118.62
Quote Progetto			118.93	119.01		119.07	119.14	118.74
Parziali			0.49	2.50	2.50	0.79		
Progressiva			-2.99	-2.50	0.00	2.50	3.29	
Dislivelli			-0.00	0.50	0.23	0.37	0.00	

Sezione: 197
 Progressiva: 1717.000
 Q. Progetto: 119.485

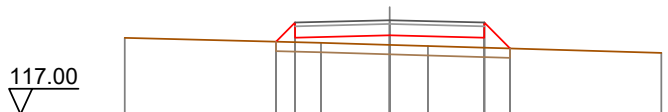

Quote Terreno	119.02		118.89	118.83	118.80		118.62
Quote Progetto		118.92	119.02		119.08	119.02	118.74
Parziali		0.51	2.50	2.50	0.68		
Progressiva		-3.01	-2.50	0.00	2.50	3.18	
Dislivelli		0.00	0.52	0.25	0.26	0.00	

SEZIONI TRASVERSALI
Profilo longitudinale tratto 9-10
Viabilità di impianto - Postazione aerogeneratore WTG05

Nota: Le canalette di deflusso delle acque meteoriche, non indicate nel presente elaborato, sono rappresentate graficamente nelle sezioni stradali tipo dell'elaborato "BLTX-NS-TC13_Piazzole aerogeneratori e strade di servizio - Particolari costruttivi", individuate planimetricamente nell'elaborato "BLTX-NS-TC14_Opere di regimazione acque superficiali - Planimetria generale" e quantificate nell'elaborato "BLTX-NS-RC6_Computo metrico estimativo opere civili".

DISEGNI DI RIFERIMENTO

TAVOLA	DESCRIZIONE
BLTX-NS-TC8	Viabilità e piazzole - Planimetria di progetto - Fase di cantiere
BLTX-NS-TC11	Profili longitudinali viabilità di impianto
BLTX-NS-TC13	Piazzole aerogeneratori e strade di servizio - Particolari costruttivi
BLTX-NS-TC14	Opere di regimazione acque superficiali - Planimetria generale

Sezione: 2
 Progressiva: 15.000
 Q. Progetto: 127.434

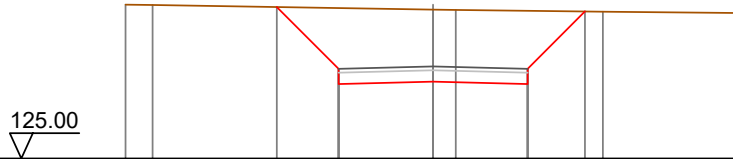

Quote Terreno	129.07	129.06				128.94	128.93		128.89	128.85
Quote Progetto			129.01	126.97	127.03	126.97	128.89			
Parziali			1.63	2.50	2.50	1.52				
Progressiva			-4.13	-2.50	0.00	2.50	4.02			
Dislivelli			0.00	-1.61	-1.90	-1.94	0.00			

Sezione: 3
 Progressiva: 20.000
 Q. Progetto: 127.266

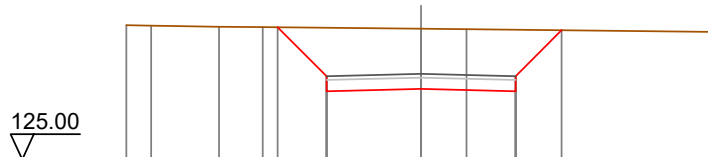

Quote Terreno	128.55	128.54	128.51	128.50		128.46	128.45		128.38
Quote Progetto				128.50	126.80	126.87	126.80	128.42	
Parziali				1.29	2.50	2.50	1.22		
Progressiva				-3.79	-2.50	0.00	2.50	3.72	
Dislivelli				0.00	-1.28	-1.59	-1.63	0.00	

Sezione: 4
 Progressiva: 40.000
 Q. Progetto: 126.593

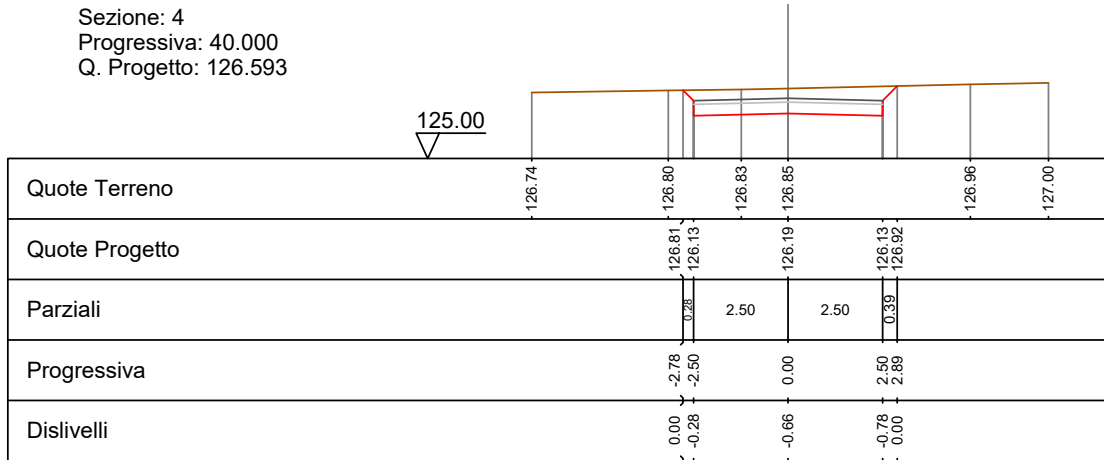

Sezione: 5
 Progressiva: 60.000
 Q. Progetto: 126.038

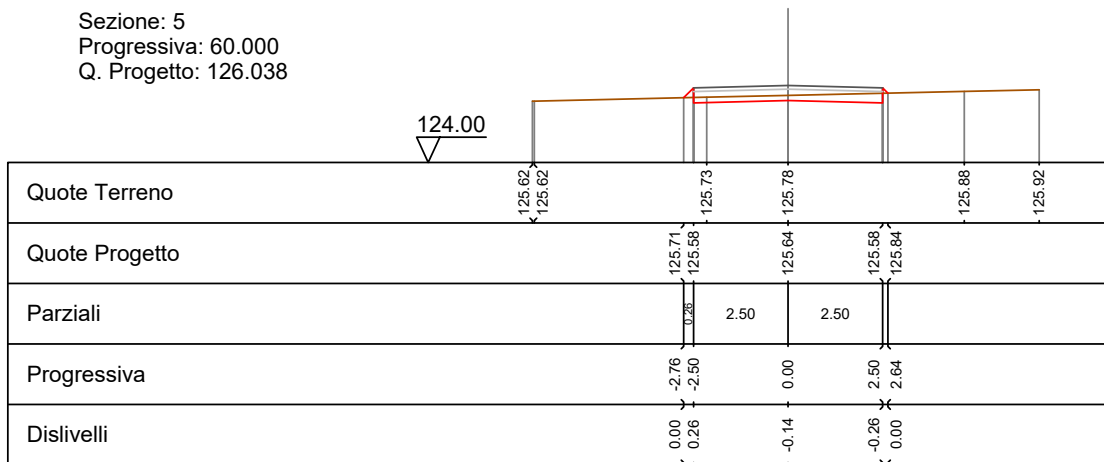

Sezione: 6
 Progressiva: 80.000
 Q. Progetto: 125.253

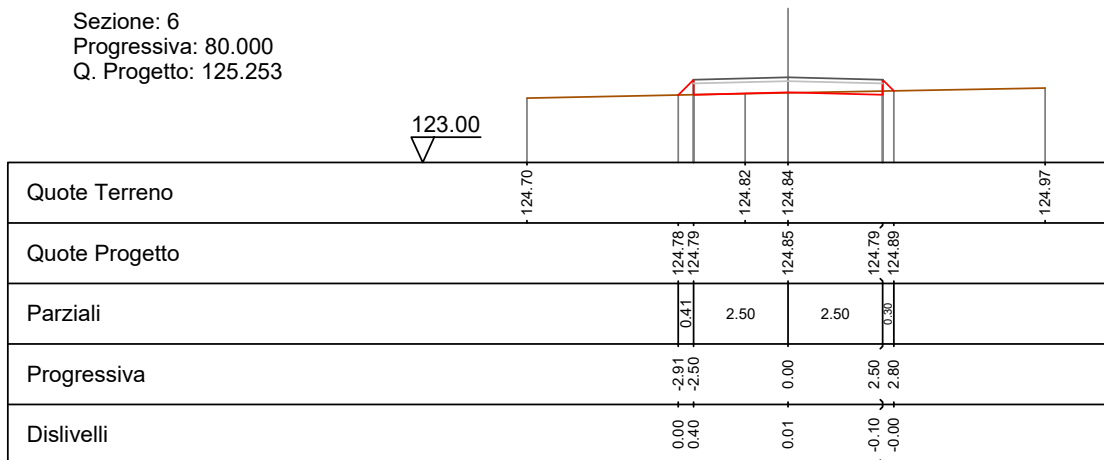

Sezione: 7
 Progressiva: 100.000
 Q. Progetto: 124.384

122.00

Quote Terreno	123.84		123.93	123.95	123.96	123.96		124.01		124.08
Quote Progetto			123.91	123.92		123.98		123.92	124.01	
Parziali			0.41	2.50		2.50		0.31		
Progressiva			-2.91	-2.50		0.00		2.50	2.81	
Dislivelli			0.00	0.41		0.02		-0.08	-0.00	

Sezione: 8
 Progressiva: 120.000
 Q. Progetto: 123.515

121.00

Quote Terreno	122.99		123.02		123.10	123.12	123.14		123.17	123.21
Quote Progetto			123.05	123.05	123.11	123.11	123.15	123.15		
Parziali			0.40	2.50		2.50		0.30		
Progressiva			-2.90	-2.50		0.00		2.50	2.80	
Dislivelli			-0.00	0.39		0.01		-0.09	0.00	

Sezione: 9
 Progressiva: 140.000
 Q. Progetto: 122.646

121.00

Quote Terreno	122.13			122.25		122.28		122.33		122.36
Quote Progetto			122.20	122.18	122.25	122.18	122.30			
Parziali			0.38	2.50		2.50		0.28		
Progressiva			-2.88	-2.50		0.00		2.50	2.79	
Dislivelli			0.00	0.38		-0.00		-0.11	-0.00	

Sezione: 10
 Progressiva: 160.000
 Q. Progetto: 121.777

120.00

Quote Terreno	121.28 121.28	121.35	121.39	121.45	121.52
Quote Progetto		121.34 121.31	121.38	121.31 121.44	
Parziali		0.37	2.50	2.50	0.27
Progressiva		-2.87 -2.50	0.00	2.50 2.77	
Dislivelli		0.00 0.36	-0.02	-0.12 0.00	

Sezione: 11
 Progressiva: 180.000
 Q. Progetto: 120.908

119.00

Quote Terreno	120.42	120.47	120.53	120.58	120.60	120.65
Quote Progetto		120.48 120.45	120.51	120.45 120.58		
Parziali		0.36	2.50	2.50	0.27	
Progressiva		-2.86 -2.50	0.00	2.50 2.77		
Dislivelli		0.00 0.36	-0.02	-0.13 0.00		

Sezione: 12
 Progressiva: 200.000
 Q. Progetto: 120.406

118.00

Quote Terreno	120.00	120.00	120.00	120.00	120.05	120.04
Quote Progetto		120.00 119.94	120.01	119.94 120.00		
Parziali		0.34	2.50	2.50	0.34	
Progressiva		-2.84 -2.50	0.00	2.50 2.84		
Dislivelli		0.00 0.34	0.01	-0.06 0.00		

Sezione: 13
 Progressiva: 220.000
 Q. Progetto: 120.401

118.00

Quote Terreno	120.00	120.00	120.00	120.00	120.00	120.00	120.00	120.00
Quote Progetto			120.00	119.94	120.00	120.00	119.94	120.00
Parziali			0.34	2.50	2.50	0.34		
Progressiva			-2.84	-2.50	0.00	2.50	2.84	
Dislivelli			0.00	0.34	0.00	-0.06	0.00	

Sezione: 14
 Progressiva: 240.000
 Q. Progetto: 120.403

118.00

Quote Terreno	120.00	120.00	120.00	120.00	120.00	120.01	120.02
Quote Progetto			120.00	119.94	120.00	120.00	120.00
Parziali			0.34	2.50	2.50	0.34	
Progressiva			-2.84	-2.50	0.00	2.50	2.84
Dislivelli			0.00	0.34	0.00	-0.06	0.00

Sezione: 15
 Progressiva: 260.000
 Q. Progetto: 120.612

119.00

Quote Terreno	120.12	120.13	120.16	120.23	120.23	120.15	120.35
Quote Progetto			120.18	120.21	120.21	120.15	120.28
Parziali			0.37	2.50	2.50	0.37	
Progressiva			-2.87	-2.50	0.00	2.50	2.77
Dislivelli			0.00	0.36	-0.02	-0.12	-0.00

Sezione: 16
 Progressiva: 280.000
 Q. Progetto: 121.021

119.00

Quote Terreno	120.52	120.56	120.58	120.59	120.64	120.65	120.80
Quote Progetto			120.59	120.56	120.62	120.65	120.71
Parziali			0.37	2.50	2.50		
Progressiva			-2.87	-2.50	0.00	2.50	2.75
Dislivelli			-0.00	0.36	-0.03	-0.15	0.00

Sezione: 17
 Progressiva: 300.000
 Q. Progetto: 121.430

119.00

Quote Terreno	120.89	120.98	121.00	121.03	121.04	121.08	121.21
Quote Progetto		120.98	120.97	121.03	121.04	121.07	121.11
Parziali		0.39	2.50	2.50		0.28	
Progressiva		-2.89	-2.50	0.00	2.50	2.76	
Dislivelli		0.00	0.38	-0.01	-0.13	0.00	

Sezione: 18
 Progressiva: 320.000
 Q. Progetto: 121.801

120.00

Quote Terreno	121.24	121.33	121.38	121.40	121.40	121.48	121.58
Quote Progetto		121.33	121.34	121.40	121.40	121.34	121.48
Parziali		0.40	2.50	2.50		0.28	
Progressiva		-2.90	-2.50	0.00	2.50	2.76	
Dislivelli		0.00	0.39	-0.00	-0.13	-0.00	

Sezione: 19
 Progressiva: 340.000
 Q. Progetto: 122.127

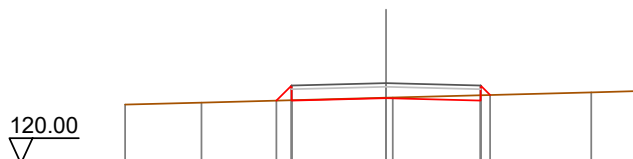

Quote Terreno	121.56	121.61		121.74	121.74		121.88	121.92
Quote Progetto			121.66	121.73	121.66	121.81		
Parziali			0.40	2.50	2.50			
Progressiva			-2.90	0.00	2.50	2.75		
Dislivelli			-0.00	-0.01	-0.14	0.00		

Sezione: 20
 Progressiva: 360.000
 Q. Progetto: 122.454

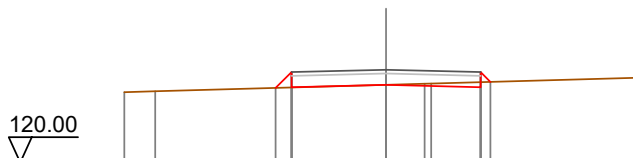

Quote Terreno	121.86	121.88		122.05	122.08	122.09		122.24
Quote Progetto			121.97	122.05	121.99	122.13		
Parziali			0.42	2.50	2.50	0.28		
Progressiva			-2.92	0.00	2.50	2.76		
Dislivelli			0.00	0.00	-0.13	-0.00		

Sezione: 21
 Progressiva: 380.000
 Q. Progetto: 122.781

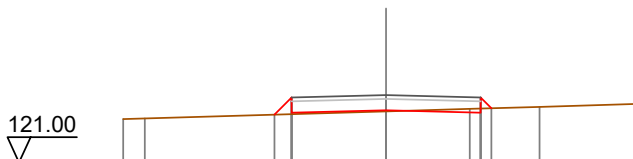

Quote Terreno	122.15	122.17		122.35	122.42	122.47		122.55
Quote Progetto			122.27	122.38	122.32	122.43		
Parziali			0.45	2.50	2.50	0.28		
Progressiva			-2.95	0.00	2.50	2.78		
Dislivelli			0.00	0.03	-0.11	0.00		

Sezione: 22
 Progressiva: 400.000
 Q. Progetto: 123.108

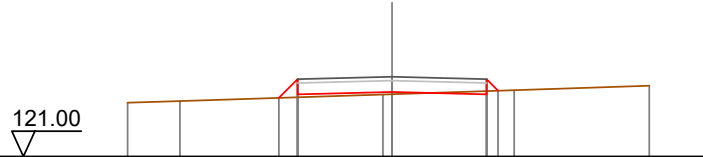

Quote Terreno	122.42	122.47		122.64	122.65		122.76	122.87
Quote Progetto			122.55	122.65	122.71	122.65	122.74	
Parziali			0.49	2.50	2.50	0.30		
Progressiva			-2.99	-2.50	0.00	2.50	2.80	
Dislivelli			0.00	0.48	0.06	-0.09	-0.00	

Sezione: 23
 Progressiva: 401.306
 Q. Progetto: 123.129



Quote Terreno	122.44			122.65	122.67		122.80	122.89
Quote Progetto			122.57	122.80	122.73	122.65	122.76	
Parziali			0.64	2.50	2.50	0.28		
Progressiva			-3.14	-2.50	0.00	2.50	2.79	
Dislivelli			-0.00	0.62	0.06	-0.10	0.00	

Sezione: 24
 Progressiva: 410.000
 Q. Progetto: 123.271

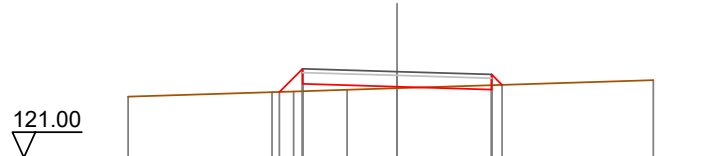

Quote Terreno	122.61		122.73	122.74	122.79	122.83		123.05
Quote Progetto			122.79	122.95	122.87	122.80	122.92	
Parziali			0.61	2.50	2.50	0.28		
Progressiva			-3.11	-2.50	0.00	2.50	2.78	
Dislivelli			0.00	0.59	0.04	-0.11	0.00	

Sezione: 25
 Progressiva: 420.000
 Q. Progetto: 123.434

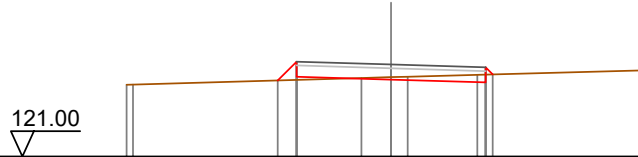

Quote Terreno	-122.90	-122.90			123.08	123.10	123.11			123.16		123.28
Quote Progetto			123.01	123.11		123.03	123.10			123.96	123.17	
Parziali			0.50	2.50		2.50						
Progressiva			-3.00	-2.50		0.00				2.50	2.69	
Dislivelli			0.00	0.48		-0.06				-0.21	-0.00	

Sezione: 26
 Progressiva: 421.114
 Q. Progetto: 123.453

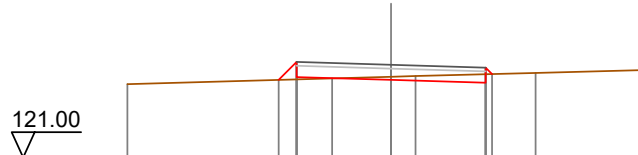

Quote Terreno	-122.94				123.09	123.14	123.15			123.24		123.31
Quote Progetto			123.05	123.13		123.05	123.14			123.98	123.21	
Parziali			0.47	2.50		2.50						
Progressiva			-2.97	-2.50		0.00				2.50	2.67	
Dislivelli			0.00	0.46		-0.08				-0.22	-0.00	

Sezione: 27
 Progressiva: 430.000
 Q. Progetto: 123.629

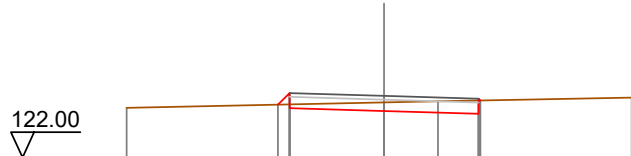

Quote Terreno	-123.31				123.46	123.49				123.59		
Quote Progetto			123.40	123.30		123.23	123.46			123.15	123.51	
Parziali			0.31	2.50		2.50						
Progressiva			-2.81	-2.50		0.00				2.50	2.55	
Dislivelli			0.00	0.30		-0.23				-0.35	0.00	

Sezione: 28
 Progressiva: 440.000
 Q. Progetto: 123.974

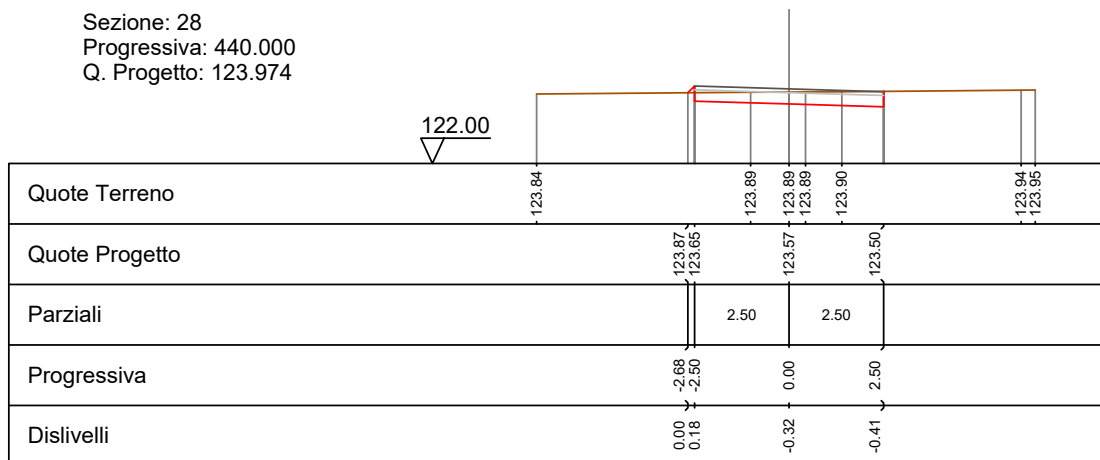

Sezione: 29
 Progressiva: 440.922
 Q. Progetto: 124.008

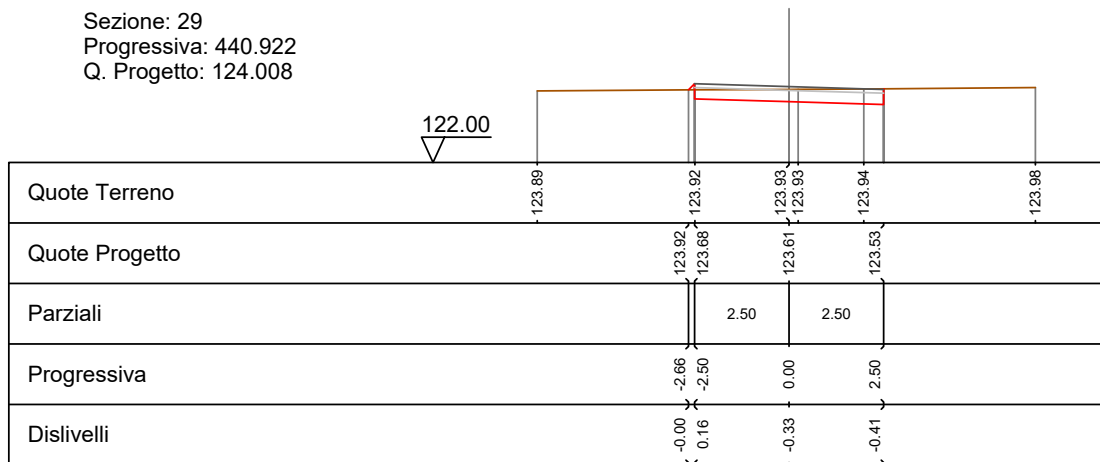

Sezione: 30
 Progressiva: 453.544
 Q. Progetto: 124.468

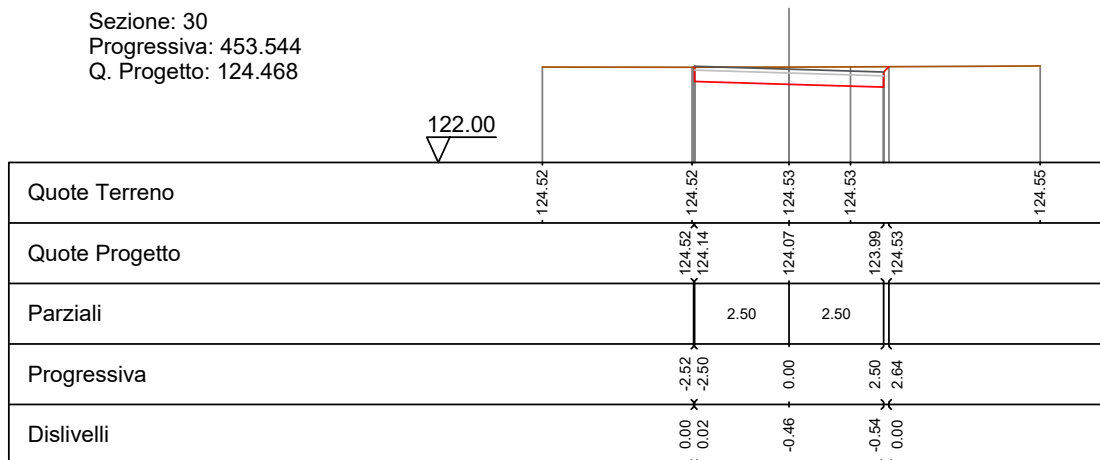

Sezione: 31
 Progressiva: 460.000
 Q. Progetto: 124.703

123.00

Quote Terreno	124.88	124.86		124.84	124.83	124.82	124.81	124.81
Quote Progetto			124.85	124.38	124.30	124.23	124.83	
Parziali			2.50		2.50			
Progressiva			-2.57	-2.50	0.00	2.50	2.70	
Dislivelli			-0.00	-0.07	-0.54	-0.60	0.00	

Sezione: 32
 Progressiva: 464.233
 Q. Progetto: 124.857

123.00

Quote Terreno	125.11	125.11		125.06	125.05	125.00	124.98
Quote Progetto			125.07	124.53	124.46	124.38	125.02
Parziali			2.50		2.50		
Progressiva			-2.64	-2.50	0.00	2.50	2.73
Dislivelli			0.00	-0.14	-0.59	-0.64	0.00

Sezione: 33
 Progressiva: 470.000
 Q. Progetto: 125.069

123.00

Quote Terreno	125.41	125.41		125.31	125.30	125.28	125.23	125.21
Quote Progetto			125.34	124.74	124.67	124.59	125.26	
Parziali			2.50		2.50	0.27		
Progressiva			-2.70	-2.50	0.00	2.50	2.77	
Dislivelli			0.00	-0.20	-0.63	-0.67	0.00	

Sezione: 34
 Progressiva: 474.922
 Q. Progetto: 125.285

123.00

Quote Terreno	125.65	125.62	125.55	125.51	125.48	125.40	125.39
Quote Progetto			125.57 124.96	124.89	124.81 125.46		
Parziali			2.50	2.50			
Progressiva			-2.71 -2.50	0.00	2.50 2.75		
Dislivelli			0.00 -0.20	-0.63	-0.65 -0.00		

Sezione: 35
 Progressiva: 480.000
 Q. Progetto: 125.559

124.00

Quote Terreno	125.87	125.84	125.82	125.80	125.72	125.67	125.60
Quote Progetto			125.78 125.10	125.16	125.10 125.67		
Parziali			0.28 2.50	2.50			
Progressiva			-2.79 -2.50	0.00	2.50 2.67		
Dislivelli			-0.00 -0.28	-0.56	-0.58 0.00		

Sezione: 36
 Progressiva: 500.000
 Q. Progetto: 126.734

125.00

Quote Terreno	126.66	126.56	126.52	126.44	126.41	126.40
Quote Progetto		126.57 126.27	126.33	126.27 126.47		
Parziali		2.50	2.50			
Progressiva		-2.60 -2.50	0.00	2.50 2.70		
Dislivelli		0.00 0.10	-0.19	-0.20 0.00		

Sezione: 37
 Progressiva: 520.000
 Q. Progetto: 127.663

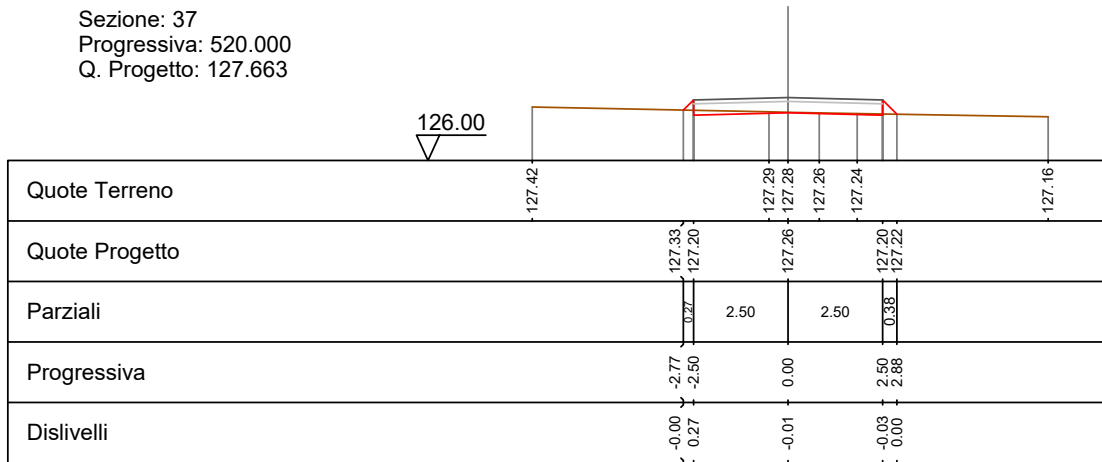

Sezione: 38
 Progressiva: 540.000
 Q. Progetto: 128.363

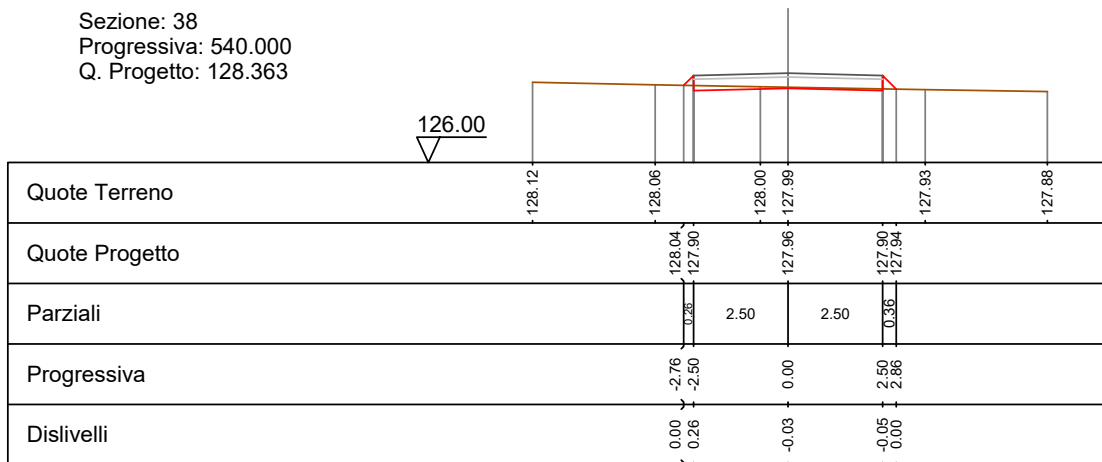

Sezione: 39
 Progressiva: 560.000
 Q. Progetto: 129.063

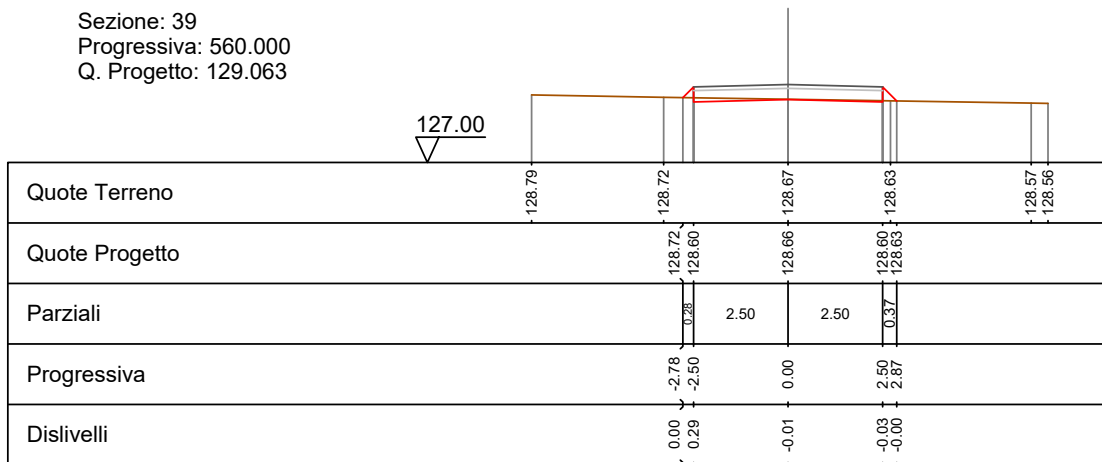

Sezione: 40
 Progressiva: 580.000
 Q. Progetto: 129.720

128.00

Quote Terreno	-129.39	-129.37	-129.35	-129.30	-129.21	-129.21
Quote Progetto			129.34 129.26	129.32	129.26 129.26	
Parziali			0.32 2.50	2.50	0.40	
Progressiva			-2.82 -2.50	0.00	2.50 2.90	
Dislivelli			0.00 0.33	0.02	-0.01 0.00	

Sezione: 41
 Progressiva: 599.715
 Q. Progetto: 130.157

128.00

Quote Terreno	-129.85		-129.80	-129.80	-129.77	-129.76	-129.75
Quote Progetto		129.82 129.68	129.76	129.80	129.83 129.78		
Parziali		0.26 2.50	2.50	2.50	0.45		
Progressiva		-2.76 -2.50	0.00		2.50 2.95		
Dislivelli		0.00 0.26	-0.04		0.05 0.00		

Sezione: 42
 Progressiva: 600.000
 Q. Progetto: 130.162

128.00

Quote Terreno	-129.86		-129.82	-129.81	-129.78	-129.77	-129.76
Quote Progetto		129.83 129.69	129.76	129.81	129.84 129.78		
Parziali		0.26 2.50	2.50	2.50	0.45		
Progressiva		-2.76 -2.50	0.00		2.50 2.95		
Dislivelli		-0.00 0.26	-0.05		0.05 0.00		

Sezione: 43
 Progressiva: 610.000
 Q. Progetto: 130.294

128.00

Quote Terreno	129.95	129.96	129.95	129.95	129.97	129.96
Quote Progetto		129.96	129.82	129.89	129.97	129.96
Parziali		0.26	2.50	2.50	0.41	
Progressiva		-2.76	-2.50	0.00	2.50	2.91
Dislivelli		0.00	0.26	-0.06	0.01	0.00

Sezione: 44
 Progressiva: 613.498
 Q. Progetto: 130.327

128.00

Quote Terreno	129.98	129.98	129.98	129.97	129.97	129.99
Quote Progetto			129.98	129.93	130.00	129.97
Parziali			0.27	2.50	2.50	0.43
Progressiva			-2.77	-2.50	0.00	2.50
Dislivelli			-0.00	0.27	-0.05	0.03

Sezione: 45
 Progressiva: 620.000
 Q. Progetto: 130.368

128.00

Quote Terreno	130.00	130.00	130.00	130.00	130.00	130.00
Quote Progetto			130.00	129.97	130.04	130.00
Parziali			0.29	2.50	2.50	0.44
Progressiva			-2.79	-2.50	0.00	2.50
Dislivelli			0.00	0.29	-0.03	0.04

Sezione: 46
 Progressiva: 627.281
 Q. Progetto: 130.385

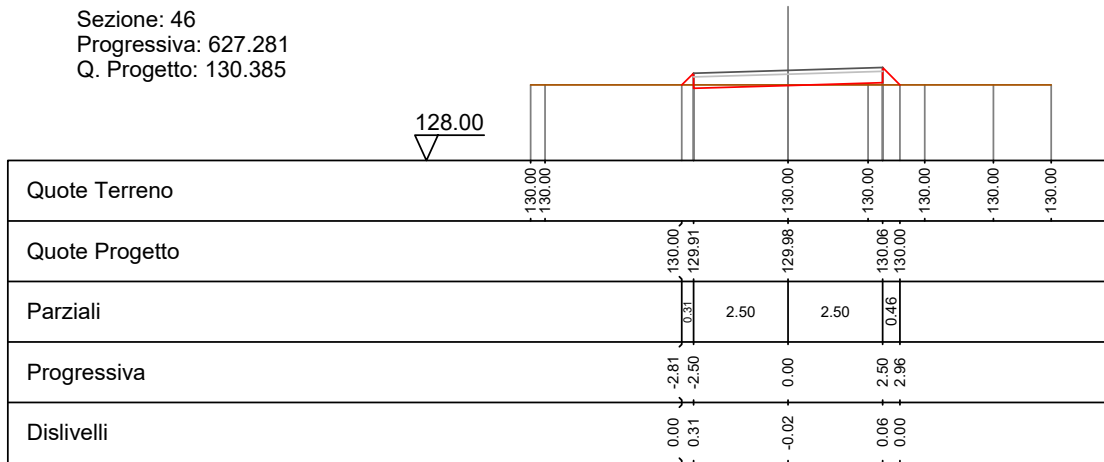

Sezione: 47
 Progressiva: 640.000
 Q. Progetto: 130.388

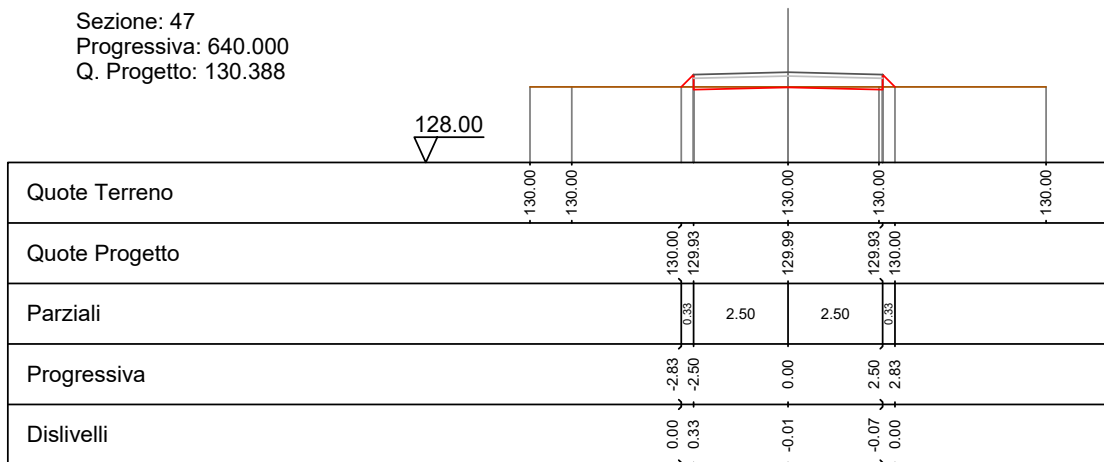

Sezione: 48
 Progressiva: 660.000
 Q. Progetto: 130.394

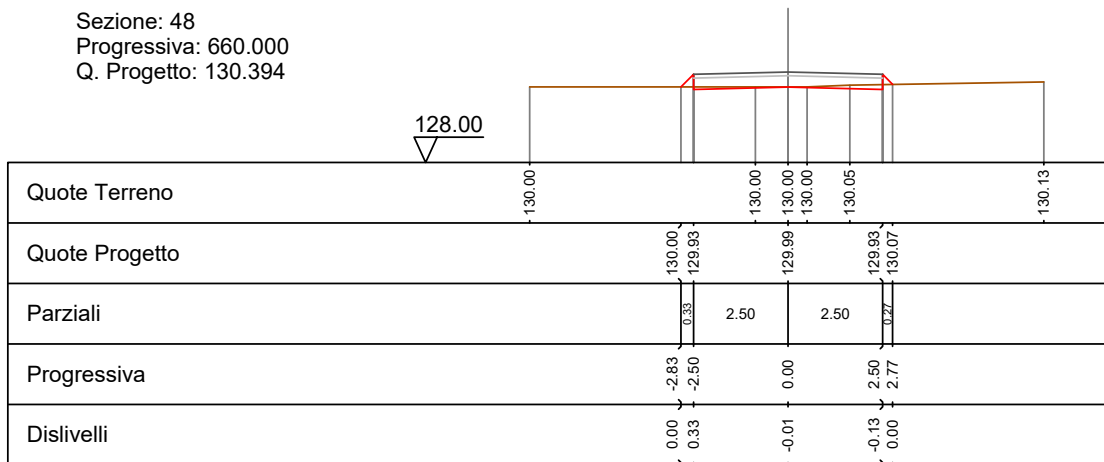

Sezione: 49
 Progressiva: 680.000
 Q. Progetto: 130.400

128.00

Quote Terreno	130.00	130.00	130.09	130.49
Quote Progetto		130.00 129.94	130.00 130.25	
Parziali		0.34 0.36	2.50	2.50
Progressiva		-2.84 -2.50	0.00	2.50 2.59
Dislivelli		0.00 0.34	-0.09	-0.30 0.00

Sezione: 50
 Progressiva: 700.000
 Q. Progetto: 130.722

129.00

Quote Terreno	130.09	130.05	130.37	130.98 131.01
Quote Progetto		130.07 130.26	130.32 130.62	
Parziali		0.59	2.50	2.50
Progressiva		-3.09 -2.50	0.00	2.50 2.54
Dislivelli		0.00 0.53	-0.05	-0.36 0.00

Sezione: 51
 Progressiva: 720.000
 Q. Progetto: 131.841

129.00

Quote Terreno	130.74 130.77	130.91	131.02	131.33	131.73	131.89
Quote Progetto			131.07 131.36	131.44	131.38 131.55	
Parziali			0.71	2.50	2.50	
Progressiva			-3.21 -2.50	0.00	2.50 2.72	
Dislivelli			-0.00 0.65	0.11	-0.16 -0.00	

Sezione: 52
 Progressiva: 740.000
 Q. Progetto: 133.746

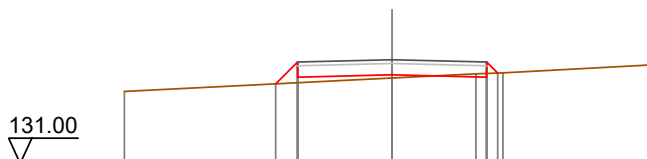

Quote Terreno	132.90		133.26	133.37	133.40	133.60
Quote Progetto		133.11 133.28	133.35	133.28 133.39	133.40	
Parziali		0.58 2.50	2.50	0.29		
Progressiva		-3.08 -2.50	0.00	2.50 2.79		
Dislivelli		0.00 0.55	0.09	-0.10 -0.00		

Sezione: 53
 Progressiva: 760.000
 Q. Progetto: 135.897

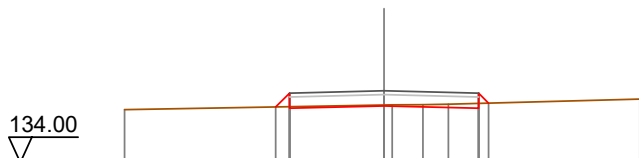

Quote Terreno	135.40		135.52 135.55	135.53 135.54	135.68
Quote Progetto		135.47 135.43	135.50	135.43 135.57	
Parziali		0.36 2.50	2.50	0.27	
Progressiva		-2.86 -2.50	0.00	2.50 2.77	
Dislivelli		0.00 0.36	-0.02	-0.13 0.00	

Sezione: 54
 Progressiva: 768.220
 Q. Progetto: 136.780

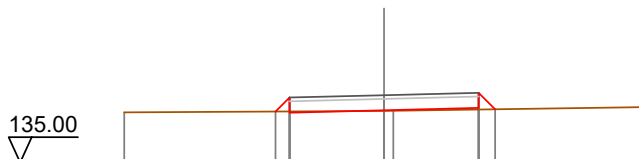

Quote Terreno	136.32		136.37 136.37	136.47
Quote Progetto		136.35 136.32	136.38	136.44 136.41
Parziali		0.37 2.50	2.50	0.44
Progressiva		-2.87 -2.50	0.00	2.50 2.94
Dislivelli		0.00 0.37	0.01	0.04 0.00

Sezione: 55
 Progressiva: 768.828
 Q. Progetto: 136.846

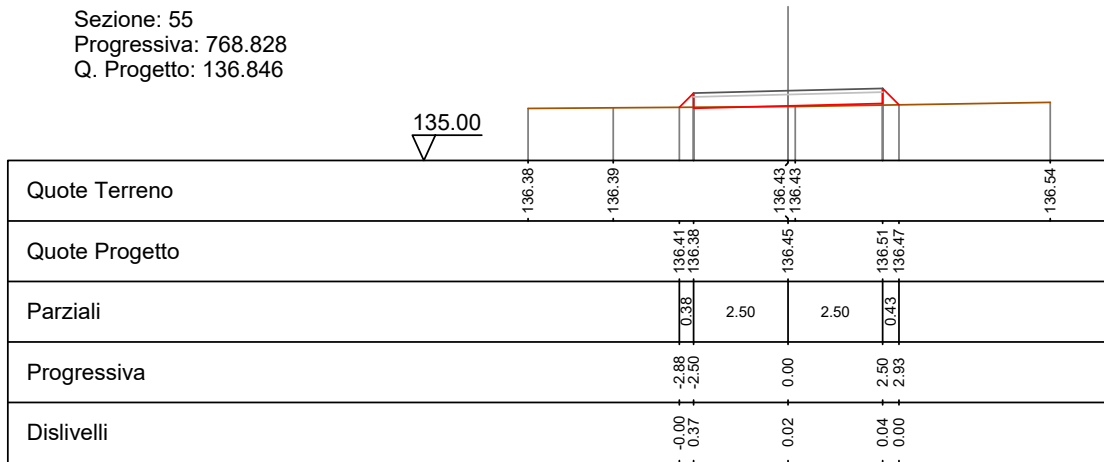

Sezione: 56
 Progressiva: 769.435
 Q. Progetto: 136.911

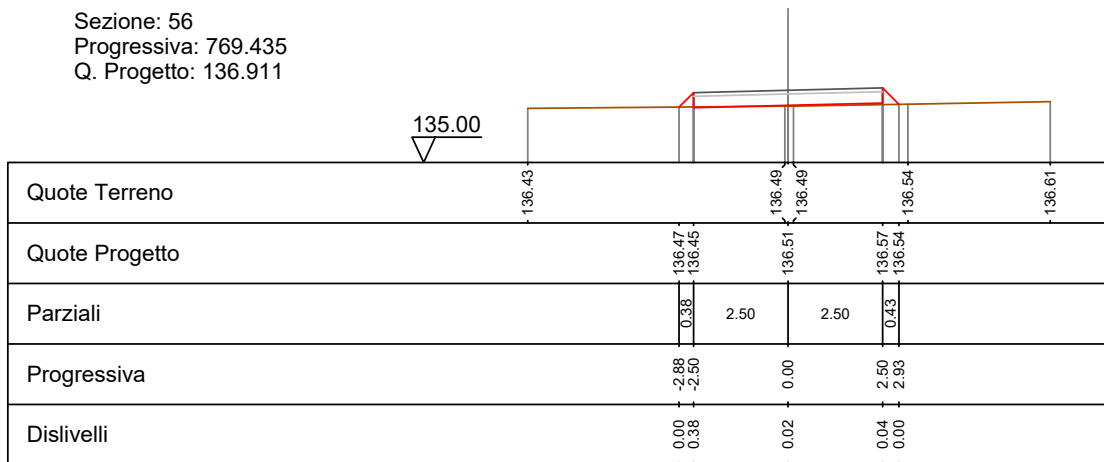

Sezione: 57
 Progressiva: 780.000
 Q. Progetto: 137.957

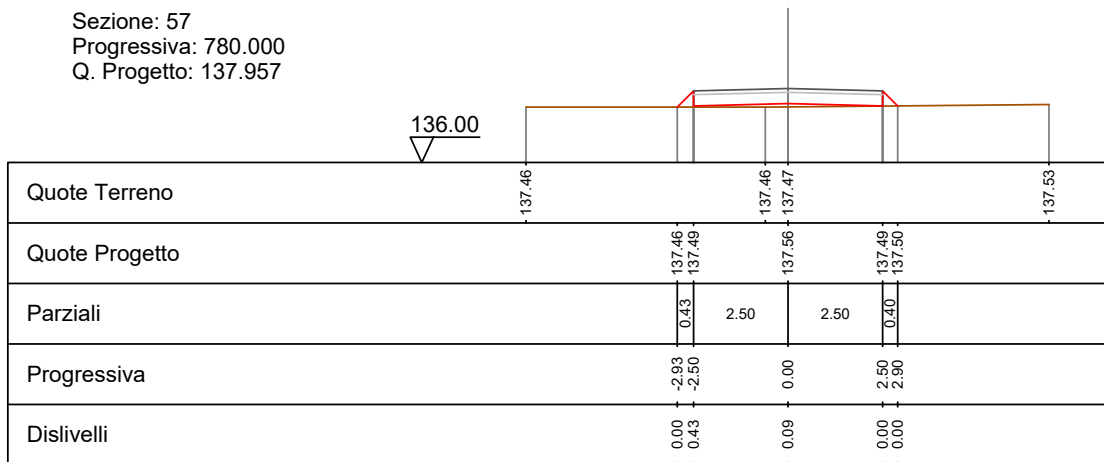

Sezione: 58
 Progressiva: 800.000
 Q. Progetto: 139.429

137.00

Quote Terreno	138.98	138.94	138.93	138.93	138.93	
Quote Progetto		138.94	138.97	139.03	138.97	138.93
Parziali		0.42	2.50	2.50	0.44	
Progressiva		-2.92	-2.50	0.00	2.50	2.94
Dislivelli		0.00	0.43	0.10	0.04	-0.00

Sezione: 59
 Progressiva: 820.000
 Q. Progetto: 140.243

138.00

Quote Terreno	139.81	139.79	139.79	139.78	139.77	139.77
Quote Progetto		139.79	139.78	139.84	139.78	139.78
Parziali		0.39	2.50	2.50	0.40	
Progressiva		-2.89	-2.50	0.00	2.50	2.90
Dislivelli		0.00	0.39	0.06	0.00	-0.00

Sezione: 60
 Progressiva: 829.015
 Q. Progetto: 140.394

138.00

Quote Terreno	139.97	139.97	139.96	139.96	139.94	139.94	139.94
Quote Progetto			139.96	140.06	139.99	139.93	139.95
Parziali			0.50	2.50	2.50	0.38	
Progressiva			-3.00	-2.50	0.00	2.50	2.88
Dislivelli			0.00	0.50	0.04	-0.02	0.00

Sezione: 61
 Progressiva: 830.000
 Q. Progetto: 140.403

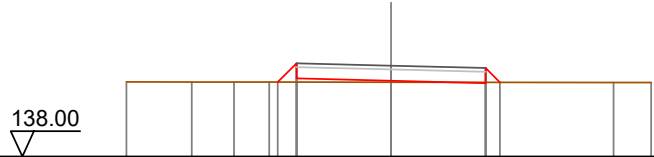

Quote Terreno	139.97	139.97	139.97	139.97	139.96	139.96
Quote Progetto			139.97	140.07	140.00	139.94
Parziali			0.50	2.50	2.50	0.38
Progressiva			-3.00	-2.50	0.00	2.50
Dislivelli			0.00	0.50	0.04	-0.02

Sezione: 62
 Progressiva: 840.000
 Q. Progetto: 140.423

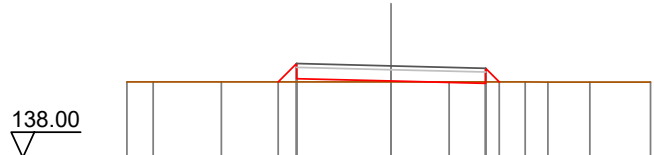

Quote Terreno	140.00	140.00	140.00	140.00	140.00	140.00
Quote Progetto			140.00	140.09	140.02	139.96
Parziali			0.49	2.50	2.50	0.38
Progressiva			-2.99	-2.50	0.00	2.50
Dislivelli			0.00	0.49	0.02	-0.04

Sezione: 63
 Progressiva: 842.754
 Q. Progetto: 140.423

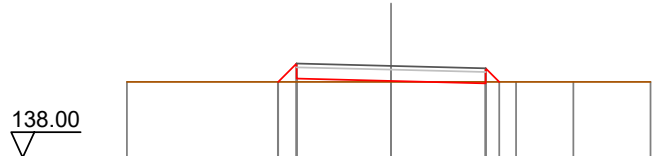

Quote Terreno	140.00	140.00	140.00	140.00	140.00	140.00
Quote Progetto		140.00	140.09	140.02	139.96	140.00
Parziali		0.49	2.50	2.50	0.38	
Progressiva		-2.99	-2.50	0.00	2.50	2.86
Dislivelli		0.00	0.49	0.02	-0.04	0.00

Sezione: 64
 Progressiva: 850.000
 Q. Progetto: 140.425

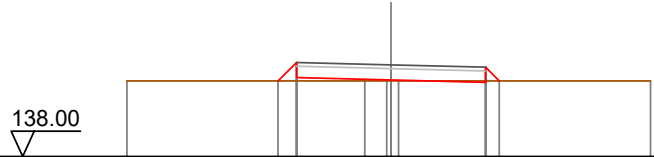

Quote Terreno	140.00	140.00	140.00	140.00
Quote Progetto		140.00 140.09	140.02	139.96 140.00
Parziali		0.49 2.50	2.50	0.36 140.00
Progressiva		-2.99 -2.50	0.00	2.50 2.86
Dislivelli		0.00 0.49	0.02	-0.04 0.00

Sezione: 65
 Progressiva: 856.494
 Q. Progetto: 140.426

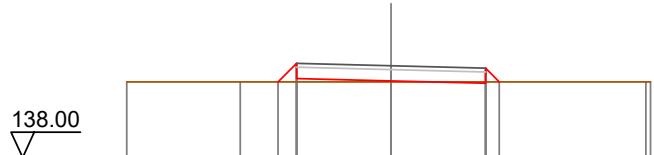

Quote Terreno	140.00	140.00	140.00	140.00
Quote Progetto		140.00 140.09	140.03	139.96 140.00
Parziali		0.49 2.50	2.50	0.36 140.00
Progressiva		-2.99 -2.50	0.00	2.50 2.86
Dislivelli		0.00 0.49	0.03	-0.04 0.00

Sezione: 66
 Progressiva: 860.000
 Q. Progetto: 140.427



Quote Terreno	140.00	140.00	140.00	140.00
Quote Progetto		140.00 139.96	140.03	139.96 140.00
Parziali		0.36 2.50	2.50	0.36 140.00
Progressiva		-2.86 -2.50	0.00	2.50 2.86
Dislivelli		0.00 0.36	0.03	-0.04 0.00

Sezione: 67
 Progressiva: 880.000
 Q. Progetto: 140.430

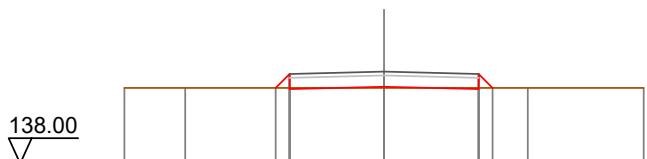

Quote Terreno	140.00	140.00		140.00		140.00	140.00
Quote Progetto			140.00 139.97	140.03		139.97 140.00	
Parziali			0.37	2.50	2.50	0.37	
Progressiva			-2.87 -2.50	0.00		2.50 2.87	
Dislivelli			0.00 0.37	0.03		-0.03 0.00	

Sezione: 68
 Progressiva: 892.313
 Q. Progetto: 140.433

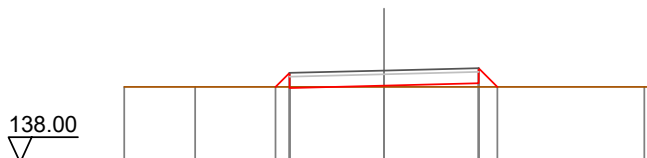

Quote Terreno	140.00	140.00		140.00		140.00	140.00
Quote Progetto			140.00 139.97	140.03		140.10 140.00	
Parziali			0.37	2.50	2.50	0.50	
Progressiva			-2.87 -2.50	0.00		2.50 3.00	
Dislivelli			0.00 0.37	0.03		0.10 0.00	

Sezione: 69
 Progressiva: 898.136
 Q. Progetto: 140.434

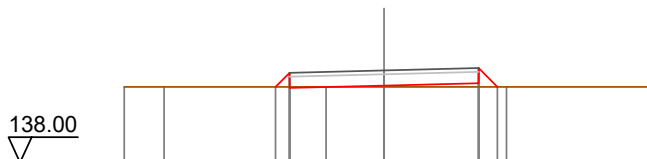

Quote Terreno	140.00	140.00		140.00		140.00	140.00
Quote Progetto			140.00 139.97	140.03		140.10 140.00	
Parziali			0.37	2.50	2.50	0.50	
Progressiva			-2.87 -2.50	0.00		2.50 3.00	
Dislivelli			0.00 0.37	0.03		0.10 0.00	

Sezione: 70
 Progressiva: 900.000
 Q. Progetto: 140.434

138.00

Quote Terreno	140.00	140.00	140.00	140.00	140.00	140.00
Quote Progetto			140.00	140.03	140.10	140.00
Parziali			0.37	2.50	2.50	0.50
Progressiva			-2.87	0.00	2.50	3.00
Dislivelli			0.00	0.03	0.10	0.00

Sezione: 71
 Progressiva: 903.958
 Q. Progetto: 140.435

138.00

Quote Terreno	140.00	140.00	140.00	140.00	140.00	140.00
Quote Progetto			140.00	140.04	140.10	140.00
Parziali			0.37	2.50	2.50	0.50
Progressiva			-2.87	0.00	2.50	3.00
Dislivelli			0.00	0.04	0.10	0.00

Sezione: 72
 Progressiva: 920.000
 Q. Progetto: 140.438

138.00

Quote Terreno	140.00	140.00	140.00	140.00	140.00	140.00	140.00	140.00
Quote Progetto			140.00	140.04	139.98	140.00		
Parziali			0.38	2.50	2.50	0.38		
Progressiva			-2.88	0.00	2.50	2.88		
Dislivelli			0.00	0.04	-0.02	0.00		

Sezione: 73
 Progressiva: 940.000
 Q. Progetto: 140.442

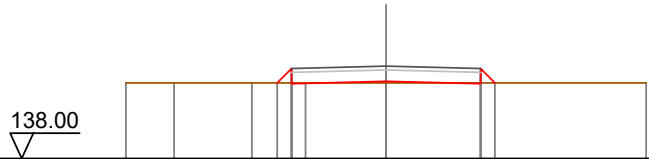

Quote Terreno	140.00	140.00	140.00	140.00	140.00	140.00
Quote Progetto			140.00	140.04	139.98	140.00
Parziali			0.38	2.50	2.50	0.38
Progressiva			-2.88	0.00	2.50	2.88
Dislivelli			0.00	0.04	-0.02	0.00

Sezione: 74
 Progressiva: 960.000
 Q. Progetto: 140.446

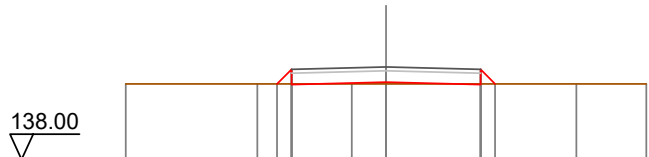

Quote Terreno	140.00	140.00	140.00	140.00	140.00	140.00
Quote Progetto			140.00	140.05	139.98	140.00
Parziali			0.38	2.50	2.50	0.38
Progressiva			-2.88	0.00	2.50	2.88
Dislivelli			0.00	0.05	-0.02	0.00

Sezione: 75
 Progressiva: 980.000
 Q. Progetto: 140.450



Quote Terreno	140.00	140.00	140.00	140.00	140.00	140.00
Quote Progetto			140.00	140.05	139.99	140.00
Parziali			0.39	2.50	2.50	0.39
Progressiva			-2.89	0.00	2.50	2.89
Dislivelli			0.00	0.05	-0.01	0.00

Sezione: 76
 Progressiva: 1000.000
 Q. Progetto: 140.454

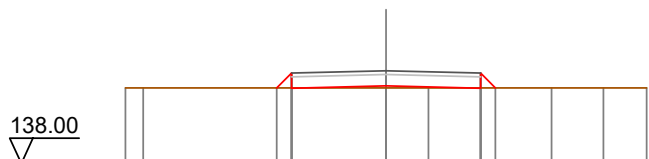

Quote Terreno	140.00	140.00		140.00	140.00	140.00	140.00	140.00
Quote Progetto			140.00	140.05	140.00	139.99	140.00	
Parziali			0.39	2.50	2.50	0.39		
Progressiva			-2.89	0.00	2.50	2.89		
Dislivelli			0.00	0.05	-0.01	0.00		

Sezione: 77
 Progressiva: 1020.000
 Q. Progetto: 140.458



Quote Terreno	140.00	140.00	140.00	140.00	140.00	140.00	140.00
Quote Progetto			140.00	140.06	140.00	140.00	
Parziali			0.40	2.50	2.50	0.40	
Progressiva			-2.90	0.00	2.50	2.90	
Dislivelli			0.00	0.06	-0.00	0.00	

Sezione: 78
 Progressiva: 1026.257
 Q. Progetto: 140.460

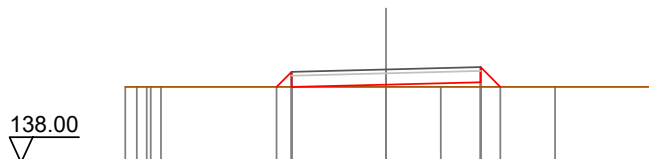

Quote Terreno	140.00	140.00	140.00	140.00	140.00	140.00	140.00
Quote Progetto			140.00	140.06	140.12	140.00	
Parziali			0.40	2.50	2.50	0.52	
Progressiva			-2.90	0.00	2.50	3.02	
Dislivelli			0.00	0.06	0.12	0.00	

Sezione: 79
 Progressiva: 1029.071
 Q. Progetto: 140.460

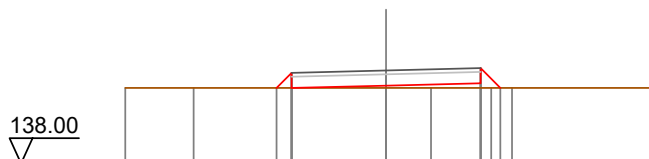

Quote Terreno	-140.00	-140.00		140.00	140.00	140.00	140.00	140.00
Quote Progetto			140.00	140.00	140.06	140.06	140.12	140.00
Parziali			0.40	2.50	2.50	0.52		
Progressiva			-2.90	-2.50	0.00	2.50	3.02	
Dislivelli			0.00	0.40	0.06	0.12	0.00	

Sezione: 80
 Progressiva: 1030.000
 Q. Progetto: 140.460

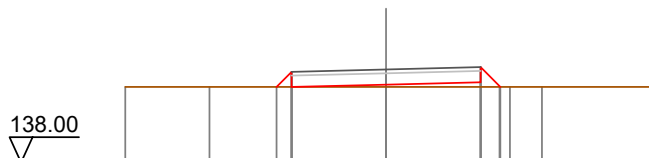

Quote Terreno	-140.00	-140.00		140.00	140.00	140.00	140.00	140.00
Quote Progetto			140.00	140.00	140.06	140.06	140.12	140.00
Parziali			0.40	2.50	2.50	0.52		
Progressiva			-2.90	-2.50	0.00	2.50	3.02	
Dislivelli			0.00	0.40	0.06	0.12	0.00	

Sezione: 81
 Progressiva: 1031.886
 Q. Progetto: 140.461

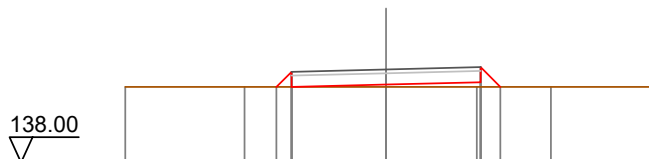

Quote Terreno	-140.00	-140.00		140.00	140.00	140.00	140.00	140.00
Quote Progetto			140.00	140.00	140.06	140.06	140.12	140.00
Parziali			0.40	2.50	2.50	0.52		
Progressiva			-2.90	-2.50	0.00	2.50	3.02	
Dislivelli			0.00	0.40	0.06	0.12	0.00	

Sezione: 82
 Progressiva: 1040.000
 Q. Progetto: 140.462



Quote Terreno	140.00	140.00	140.00	140.00	140.00
Quote Progetto		140.00	140.06	140.00	140.00
Parziali		0.40	2.50	0.40	
Progressiva		-2.90	0.00	2.50	2.90
Dislivelli		0.00	0.06	-0.00	0.00

Sezione: 83
 Progressiva: 1060.000
 Q. Progetto: 140.466



Quote Terreno	140.00	140.00	140.00	140.00	140.00	140.00	140.00
Quote Progetto		140.00	140.00	140.07	140.00	140.00	140.00
Parziali		0.40	2.50	0.40			
Progressiva		-2.90	0.00	2.50	2.90		
Dislivelli		0.00	0.07	0.00	0.00		

Sezione: 84
 Progressiva: 1071.746
 Q. Progetto: 140.469

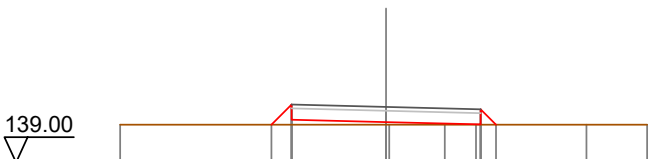

Quote Terreno	140.00	140.00	140.00	140.00	140.00	140.00
Quote Progetto		140.00	140.07	140.01	140.00	
Parziali		0.53	2.50	0.41		
Progressiva		-3.03	0.00	2.50	2.91	
Dislivelli		0.00	0.07	0.01	0.00	

Sezione: 85
 Progressiva: 1077.686
 Q. Progetto: 140.470

139.00

Quote Terreno	140.00		140.00	140.00	140.00	140.00
Quote Progetto		140.00	140.13	140.07	140.01	140.00
Parziali		0.53	2.50	2.50	0.41	
Progressiva		-3.03	-2.50	0.00	2.50	2.91
Dislivelli		0.00	0.53	0.07	0.01	0.00

Sezione: 86
 Progressiva: 1080.000
 Q. Progetto: 140.470

139.00

Quote Terreno	140.00		140.00	140.00	140.00	140.00
Quote Progetto		140.00	140.13	140.07	140.01	140.00
Parziali		0.53	2.50	2.50	0.41	
Progressiva		-3.03	-2.50	0.00	2.50	2.91
Dislivelli		0.00	0.53	0.07	0.01	0.00

Sezione: 87
 Progressiva: 1083.625
 Q. Progetto: 140.471

139.00

Quote Terreno	140.00	140.00	140.00	140.00	140.00	140.00
Quote Progetto		140.00	140.13	140.07	140.01	140.00
Parziali		0.53	2.50	2.50	0.41	
Progressiva		-3.03	-2.50	0.00	2.50	2.91
Dislivelli		0.00	0.53	0.07	0.01	0.00

Sezione: 88
 Progressiva: 1100.000
 Q. Progetto: 140.474

139.00

Quote Terreno	-140.00	-140.00	-140.00	-140.00	-140.00	-140.00
Quote Progetto		140.00	140.01	140.07	140.01	140.00
Parziali		0.41	2.50	2.50	0.41	
Progressiva		-2.91	-2.50	0.00	2.50	2.91
Dislivelli		0.00	0.41	0.07	0.01	0.00

Sezione: 89
 Progressiva: 1120.000
 Q. Progetto: 140.478

139.00

Quote Terreno	-140.00	-140.00	-140.00	-140.00	-140.00	
Quote Progetto		140.00	140.02	140.08	140.02	140.00
Parziali		0.42	2.50	2.50	0.42	
Progressiva		-2.92	-2.50	0.00	2.50	2.92
Dislivelli		0.00	0.42	0.08	0.02	0.00

Sezione: 90
 Progressiva: 1136.374
 Q. Progetto: 140.481

139.00

Quote Terreno	-140.00	-140.00	-140.00	-140.00	-140.00	
Quote Progetto		140.00	140.14	140.08	140.02	140.00
Parziali		0.54	2.50	2.50	0.42	
Progressiva		-3.04	-2.50	0.00	2.50	2.92
Dislivelli		0.00	0.54	0.08	0.02	0.00

Sezione: 91
 Progressiva: 1140.000
 Q. Progetto: 140.482

139.00

Quote Terreno	140.00	140.00	140.00	140.00	140.00	140.00	140.00		
Quote Progetto			140.00	140.14		140.08	140.00	140.02	140.00
Parziali			0.54	2.50		2.50		0.42	
Progressiva			-3.04	-2.50		0.00		2.50	2.92
Dislivelli			0.00	0.54		0.08		0.02	0.00

Sezione: 92
 Progressiva: 1141.780
 Q. Progetto: 140.483

139.00

Quote Terreno	140.00	140.00	140.00	140.00	140.00	140.00	140.00	140.00	
Quote Progetto			140.00	140.15		140.08	140.00	140.02	140.00
Parziali			0.55	2.50		2.50		0.42	
Progressiva			-3.05	-2.50		0.00		2.50	2.92
Dislivelli			0.00	0.55		0.08		0.02	0.00

Sezione: 93
 Progressiva: 1147.185
 Q. Progetto: 140.484

139.00

Quote Terreno	140.00	140.00	140.00	140.00	140.00	140.00	140.00	140.00	
Quote Progetto			140.00	140.15		140.08	140.00	140.02	140.00
Parziali			0.55	2.50		2.50		0.42	
Progressiva			-3.05	-2.50		0.00		2.50	2.92
Dislivelli			0.00	0.55		0.08		0.02	0.00

Sezione: 94
 Progressiva: 1160.000
 Q. Progetto: 140.486

139.00

Quote Terreno	140.00	140.00	140.00	140.00	140.00
Quote Progetto			140.00	140.09	140.02
Parziali			0.42	2.50	0.42
Progressiva			-2.92	0.00	2.50
Dislivelli			0.00	0.09	0.02

Sezione: 95
 Progressiva: 1180.000
 Q. Progetto: 140.490

139.00

Quote Terreno	140.00	140.00	140.00	140.00	140.00
Quote Progetto			140.00	140.09	140.03
Parziali			0.43	2.50	0.43
Progressiva			-2.93	0.00	2.50
Dislivelli			0.00	0.09	0.03

Sezione: 96
 Progressiva: 1200.000
 Q. Progetto: 140.547

139.00

Quote Terreno	141.00	140.92	140.85	140.85	140.85	140.87
Quote Progetto			140.85	140.15	140.08	140.85
Parziali			0.37	2.50	0.37	
Progressiva			-2.87	0.00	2.50	
Dislivelli			0.00	-0.70	-0.77	

Sezione: 97
 Progressiva: 1220.000
 Q. Progetto: 141.243

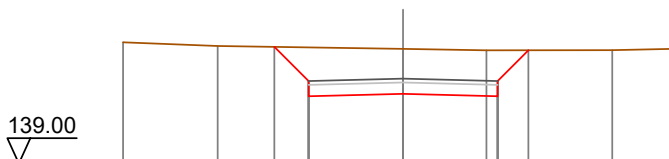

Quote Terreno	142.21	142.11		142.03	142.00	142.00	142.04
Quote Progetto			142.09	140.78	140.84	140.78	142.00
Parziali			0.91	2.50	2.50	0.82	
Progressiva			-3.41	-2.50	0.00	2.50	3.32
Dislivelli			-0.00	-0.89	-1.19	-1.21	0.00

Sezione: 98
 Progressiva: 1240.000
 Q. Progetto: 142.371

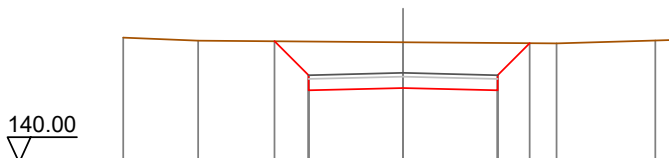

Quote Terreno	143.30	143.22		143.18		143.15	143.23	143.25
Quote Progetto			143.21	141.91	141.97	141.91	143.16	
Parziali			0.90	2.50	2.50	0.85		
Progressiva			-3.40	-2.50	0.00	2.50	3.35	
Dislivelli			0.00	-0.89	-1.21	-1.25	0.00	

Sezione: 99
 Progressiva: 1259.037
 Q. Progetto: 143.446

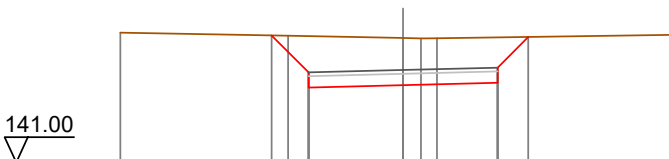

Quote Terreno	144.43		144.35	144.29	144.28	144.29		144.38
Quote Progetto		144.36	142.96	143.05	143.11	144.32		
Parziali		0.98	2.50	2.50	0.81			
Progressiva		-3.48	-2.50	0.00	2.50	3.31		
Dislivelli		0.00	-0.96	-1.25	-1.20	0.00		

Sezione: 100
 Progressiva: 1260.000
 Q. Progetto: 143.500

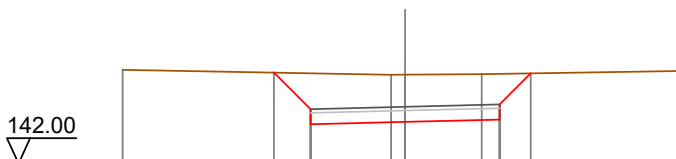

Quote Terreno	144.48			144.35	144.35	144.36	144.45
Quote Progetto		144.41	143.04	143.10	143.16	144.38	
Parziali		0.97	2.50	2.50	0.82		
Progressiva		-3.47	-2.50	0.00	2.50	3.32	
Dislivelli		0.00	-0.95	-1.25	-1.21	0.00	

Sezione: 101
 Progressiva: 1267.823
 Q. Progetto: 143.942

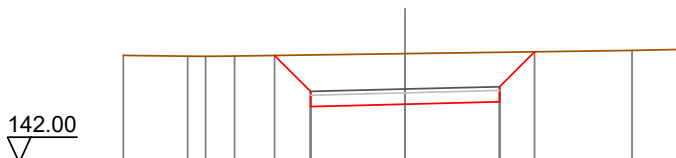

Quote Terreno	144.83	144.81	144.81	144.82	144.88	144.88	144.97	144.99
Quote Progetto			144.83	143.48	143.54	143.60	144.93	
Parziali			0.95	2.50	2.50	0.92		
Progressiva			-3.45	-2.50	0.00	2.50	3.42	
Dislivelli			0.00	-0.96	-1.34	-1.31	0.00	

Sezione: 102
 Progressiva: 1270.000
 Q. Progetto: 144.065

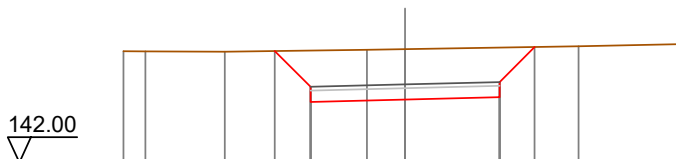

Quote Terreno	144.94	144.94	144.93	144.98	145.00	145.07	145.13
Quote Progetto			144.95	143.60	143.66	143.73	145.05
Parziali			0.95	2.50	2.50	0.93	
Progressiva			-3.45	-2.50	0.00	2.50	3.43
Dislivelli			0.00	-0.96	-1.33	-1.31	0.00

Sezione: 102
 Progressiva: 1270.000
 Q. Progetto: 144.065

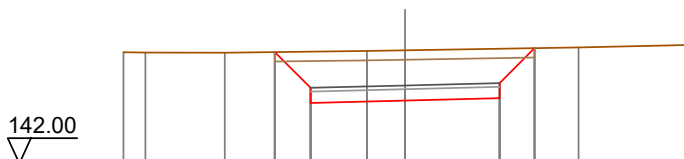

Quote Terreno	144.94	144.94	144.93	144.98	145.00	145.07	145.13
Quote Progetto			144.95	143.60	143.66	143.73	145.05
Parziali			0.95	2.50	2.50	0.93	
Progressiva			-3.45	-2.50	0.00	2.50	3.43
Dislivelli			0.00	-0.96	-1.33	-1.31	0.00

Sezione: 103
 Progressiva: 1276.609
 Q. Progetto: 144.438

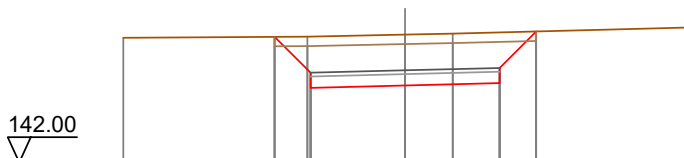

Quote Terreno	145.30	145.33	145.38	145.41	145.57	
Quote Progetto		145.32	143.98	144.04	144.10	145.47
Parziali		0.95	2.50	2.50	0.97	
Progressiva		-3.45	-2.50	0.00	2.50	3.47
Dislivelli		0.00	-0.96	-1.35	-1.34	0.00

Sezione: 104
 Progressiva: 1278.585
 Q. Progetto: 144.550

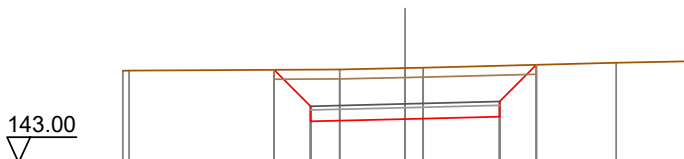

Quote Terreno	145.43	145.43	145.46	145.50	145.51	145.64	145.68
Quote Progetto			144.45	144.09	144.15	144.21	145.58
Parziali			0.96	2.50	2.50	0.97	
Progressiva			-3.46	-2.50	0.00	2.50	3.47
Dislivelli			0.00	-0.97	-1.35	-1.35	0.00

Sezione: 105
 Progressiva: 1280.000
 Q. Progetto: 144.629

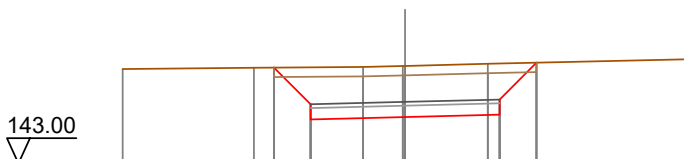

Quote Terreno	145.50	145.53	145.55	145.58	145.58	145.64	145.76
Quote Progetto		145.54	144.17	144.23	144.29	145.67	
Parziali		0.97	2.50	2.50	0.98		
Progressiva		-3.47	-2.50	0.00	2.50	3.48	
Dislivelli		0.00	-0.98	-1.35	-1.35	0.00	

Sezione: 106
 Progressiva: 1290.000
 Q. Progetto: 145.194

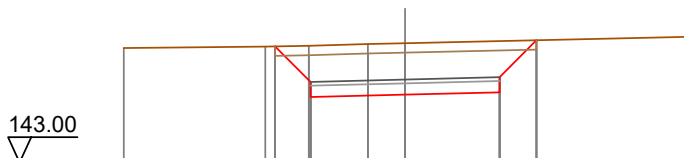

Quote Terreno	146.03	146.06	146.09	146.13	146.16		146.32
Quote Progetto		146.07	144.73	144.79	144.86	146.23	
Parziali		0.94	2.50	2.50	0.98		
Progressiva		-3.44	-2.50	0.00	2.50	3.48	
Dislivelli		0.00	-0.96	-1.36	-1.36	0.00	

Sezione: 107
 Progressiva: 1292.881
 Q. Progetto: 145.357

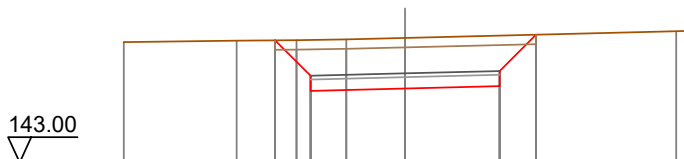

Quote Terreno	146.18	146.22	146.24	146.26	146.30		146.47
Quote Progetto		146.23	144.89	144.96	145.02	146.38	146.48
Parziali		0.94	2.50	2.50	0.96		
Progressiva		-3.44	-2.50	0.00	2.50	3.46	
Dislivelli		0.00	-0.95	-1.34	-1.34	-0.00	

Sezione: 108
 Progressiva: 1300.000
 Q. Progetto: 145.758

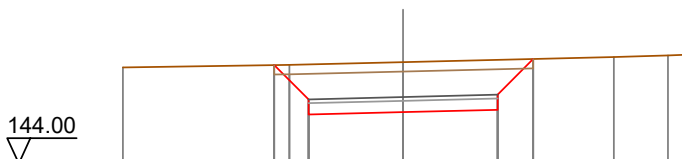

Quote Terreno	146.54	146.61	146.68	146.82	146.86	146.88
Quote Progetto		146.60	145.30	145.36	145.42	146.76
Parziali		0.91	2.50	2.50	0.94	
Progressiva		-3.41	-2.50	0.00	2.50	3.44
Dislivelli		-0.00	-0.93	-1.32	-1.32	0.00

Sezione: 109
 Progressiva: 1307.178
 Q. Progetto: 146.164

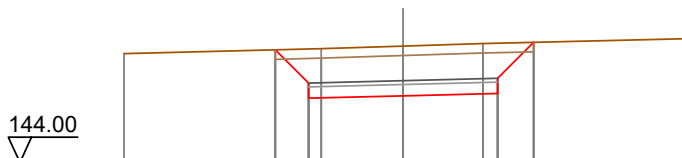

Quote Terreno	146.88	147.01	147.08	147.15	147.27	
Quote Progetto		146.98	145.70	145.76	145.83	147.18
Parziali		0.88	2.50	2.50	0.95	
Progressiva		-3.38	-2.50	0.00	2.50	3.45
Dislivelli		-0.00	-0.90	-1.31	-1.33	0.00

Sezione: 110
 Progressiva: 1318.972
 Q. Progetto: 146.829

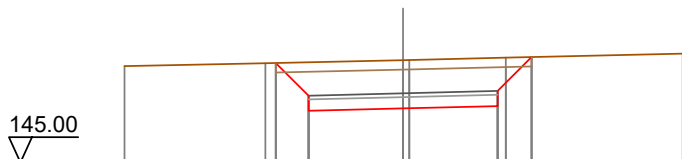

Quote Terreno	147.55	147.62	147.71	147.77	147.88	
Quote Progetto		147.63	146.37	146.43	146.49	147.79
Parziali		0.86	2.50	2.50	0.90	
Progressiva		-3.36	-2.50	0.00	2.50	3.40
Dislivelli		0.00	-0.88	-1.28	-1.28	0.00

Sezione: 111
 Progressiva: 1320.000
 Q. Progetto: 146.888

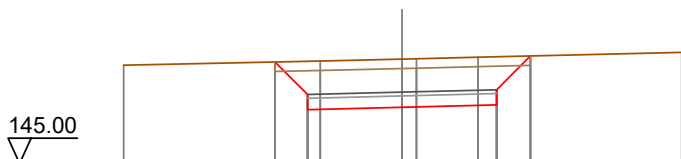

Quote Terreno	147.60		147.71	147.76	147.81	147.94
Quote Progetto		147.69	146.43	146.49	146.55	147.85
Parziali		0.86	2.50	2.50	0.90	
Progressiva		-3.36	-2.50	0.00	2.50	3.40
Dislivelli		0.00	-0.88	-1.27	-1.28	0.00

Sezione: 112
 Progressiva: 1324.325
 Q. Progetto: 147.132

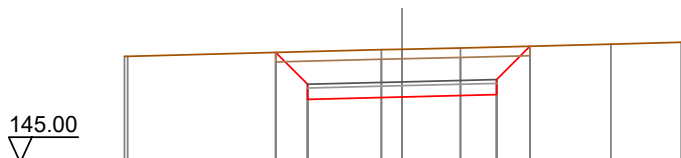

Quote Terreno	147.81		147.98	148.00	148.03	148.13	148.18
Quote Progetto		147.91	146.67	146.73	146.79	148.08	
Parziali		0.84	2.50	2.50	0.88		
Progressiva		-3.34	-2.50	0.00	2.50	3.38	
Dislivelli		0.00	-0.86	-1.26	-1.26	0.00	

Sezione: 113
 Progressiva: 1329.679
 Q. Progetto: 147.434

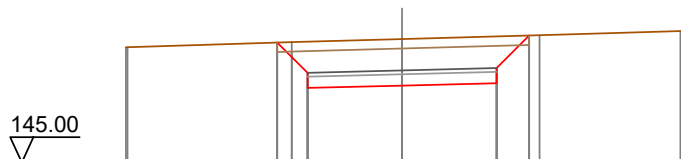

Quote Terreno	148.05		148.19	148.27	148.37	148.48
Quote Progetto		148.17	146.97	147.03	147.10	148.36
Parziali		0.80	2.50	2.50	0.86	
Progressiva		-3.30	-2.50	0.00	2.50	3.36
Dislivelli		0.00	-0.83	-1.23	-1.24	0.00

Sezione: 114
 Progressiva: 1340.000
 Q. Progetto: 148.017

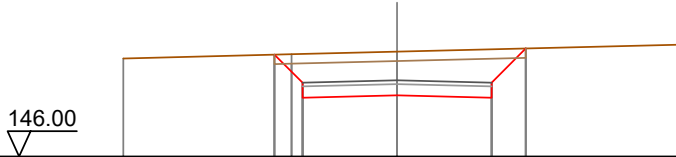

Quote Terreno	148.59	148.71	148.78	148.96
Quote Progetto		148.70	147.62	147.55
Parziali		0.74	2.50	0.90
Progressiva		-3.24	0.00	2.50
Dislivelli		0.00	-1.16	-1.28

Sezione: 115
 Progressiva: 1360.000
 Q. Progetto: 149.146

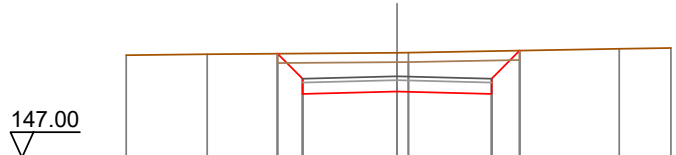

Quote Terreno	149.70	149.73	149.77	149.87
Quote Progetto		149.75	148.75	148.68
Parziali		0.66	2.50	0.74
Progressiva		-3.16	0.00	2.50
Dislivelli		0.00	-1.03	-1.13

Sezione: 116
 Progressiva: 1380.000
 Q. Progetto: 150.275

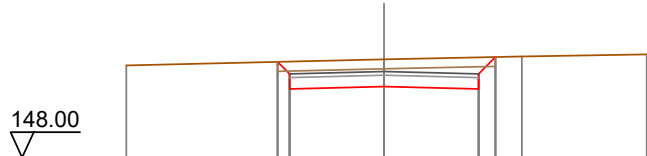

Quote Terreno	150.44	150.53	150.59	150.67
Quote Progetto		149.81	149.87	149.81
Parziali		0.32	2.50	0.75
Progressiva		-2.82	0.00	2.50
Dislivelli		-0.00	-0.72	-0.84

Sezione: 117
 Progressiva: 1400.000
 Q. Progetto: 151.709

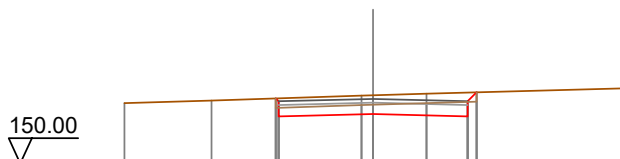

Quote Terreno	151.60	151.67	151.80	151.81	151.85	151.99
Quote Progetto			151.72	151.25	151.31	151.25
Parziali			2.50		2.50	
Progressiva			-2.58	-2.50	0.00	2.50
Dislivelli			0.00	-0.08	-0.50	-0.63
						0.00

Sezione: 118
 Progressiva: 1420.000
 Q. Progetto: 153.341

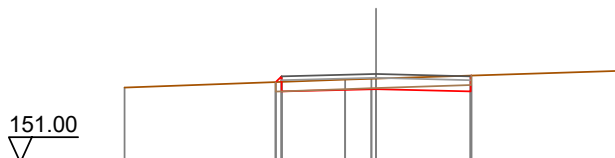

Quote Terreno	152.98		153.19	153.21	153.22	153.43
Quote Progetto			153.13	152.88	152.94	152.88
Parziali			2.50		2.50	
Progressiva			-2.65	-2.50	0.00	2.50
Dislivelli			0.00	0.15	-0.28	-0.42

Sezione: 119
 Progressiva: 1421.990
 Q. Progetto: 153.504

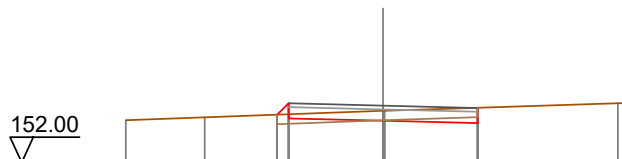

Quote Terreno	153.12	153.19	153.37	153.37	153.57	153.58
Quote Progetto			153.26	153.17	153.10	153.04
Parziali			2.50		2.50	
Progressiva			-2.80	-2.50	0.00	2.50
Dislivelli			0.00	0.29	-0.26	-0.41

Sezione: 120
 Progressiva: 1430.000
 Q. Progetto: 154.158

152.00

Quote Terreno	-153.81			153.97	154.03	154.04	154.12
Quote Progetto		153.91	153.82	153.76	153.70	154.04	
Parziali		0.31	2.50	2.50			
Progressiva		-2.81	-2.50	0.00	2.50	2.56	
Dislivelli		-0.00	0.31	-0.22	-0.34	0.00	

Sezione: 121
 Progressiva: 1440.000
 Q. Progetto: 154.974

153.00

Quote Terreno	-154.73	-154.75		154.79		154.82	154.83	154.84
Quote Progetto			154.77	154.64	154.57	154.51	154.82	
Parziali			0.27	2.50	2.50			
Progressiva			-2.77	-2.50	0.00	2.50	2.60	
Dislivelli			-0.00	0.26	-0.22	-0.30	0.00	

Sezione: 122
 Progressiva: 1450.000
 Q. Progetto: 155.790

154.00

Quote Terreno	-155.71	-155.71	-155.69		155.65	155.63	155.62	155.60	155.58
Quote Progetto				155.67	155.45	155.39	155.62		
Parziali				2.50	2.50				
Progressiva				-2.68	-2.50	0.00	2.50	2.60	
Dislivelli				0.00	0.18	-0.26	-0.30	0.00	

Sezione: 123
 Progressiva: 1452.483
 Q. Progetto: 155.993

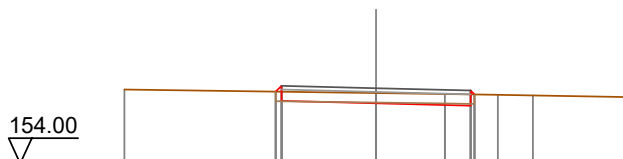

Quote Terreno	155.96			155.86	155.84	155.82	155.80	155.76
Quote Progetto		155.90	155.66	155.59	155.53	155.63		
Parziali			2.50		2.50			
Progressiva		-2.66	-2.50	0.00	2.50	2.60		
Dislivelli		0.00	0.16	-0.27	-0.30	0.00		

Sezione: 124
 Progressiva: 1460.000
 Q. Progetto: 156.607

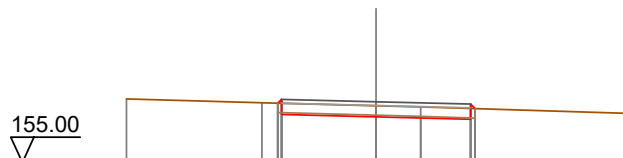

Quote Terreno	156.68	156.58		156.50	156.47		156.30
Quote Progetto		156.57	156.27	156.21	156.14	156.42	
Parziali			2.50		2.50		
Progressiva		-2.60	-2.50	0.00	2.50	2.62	
Dislivelli		0.00	0.10	-0.29	-0.28	-0.00	

Sezione: 125
 Progressiva: 1470.000
 Q. Progetto: 157.331

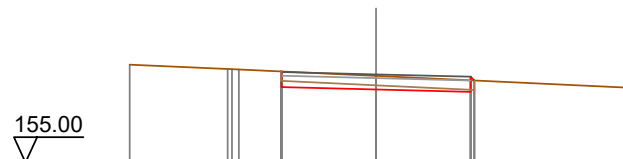

Quote Terreno	157.59	157.47	157.46		157.29		156.98
Quote Progetto			156.99		156.93	156.87	157.17
Parziali				2.50		2.50	
Progressiva			-2.52		0.00	2.50	2.60
Dislivelli			0.00		-0.36	-0.30	0.00

Sezione: 126
 Progressiva: 1480.000
 Q. Progetto: 157.854

156.00

Quote Terreno	158.39	158.35			157.98	157.92	157.69	157.58
Quote Progetto			158.15	157.52	157.45	157.39	157.82	
Parziali			2.50		2.50			
Progressiva			-2.73	-2.50	0.00	2.50	2.53	
Dislivelli			0.00	-0.22	-0.53	-0.44	0.00	

Sezione: 127
 Progressiva: 1482.975
 Q. Progetto: 157.971

156.00

Quote Terreno	158.60		158.34	158.29	158.16		157.86	157.73
Quote Progetto			158.34	157.63	157.57	157.51	157.99	
Parziali			0.31	2.50	2.50			
Progressiva			-2.81	-2.50	0.00	2.50	2.58	
Dislivelli			0.00	-0.29	-0.59	-0.49	0.00	

Sezione: 128
 Progressiva: 1496.849
 Q. Progetto: 158.282

156.00

Quote Terreno	159.41		159.18	159.10	158.96			158.51
Quote Progetto			159.18	157.94	157.88	157.82	158.77	
Parziali			0.83	2.50	2.50	0.55		
Progressiva			-3.33	-2.50	0.00	2.50	3.05	
Dislivelli			0.00	-0.78	-1.08	-0.98	-0.00	

Sezione: 129
 Progressiva: 1500.000
 Q. Progetto: 158.299

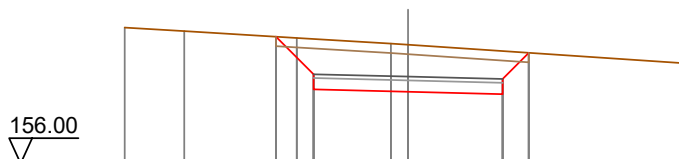

Quote Terreno	159.60	159.50	159.32	159.17	159.14	158.66	
Quote Progetto			159.35	157.96	157.90	157.84	158.93
Parziali			0.99	2.50	2.50	0.69	
Progressiva			-3.49	-2.50	0.00	2.50	3.19
Dislivelli			0.00	-0.93	-1.24	-1.14	0.00

Sezione: 130
 Progressiva: 1500.700
 Q. Progetto: 158.300

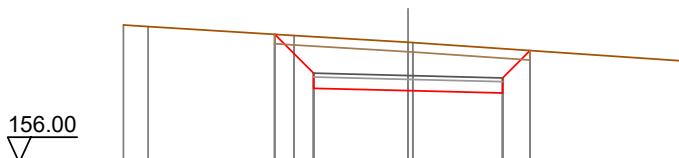

Quote Terreno	159.64	159.60	159.36	159.18	159.17	158.69	
Quote Progetto			159.39	157.96	157.90	157.84	158.96
Parziali			1.03	2.50	2.50	0.72	
Progressiva			-3.53	-2.50	0.00	2.50	3.22
Dislivelli			-0.00	-0.97	-1.28	-1.17	0.00

SEZIONI TRASVERSALI
Profilo longitudinale tratto 11-12
Viabilità di impianto - Postazione aerogeneratore WTG06

Nota: Le canalette di deflusso delle acque meteoriche, non indicate nel presente elaborato, sono rappresentate graficamente nelle sezioni stradali tipo dell'elaborato "BLTX-NS-TC13_Piazzole aerogeneratori e strade di servizio - Particolari costruttivi", individuate planimetricamente nell'elaborato "BLTX-NS-TC14_Opere di regimazione acque superficiali - Planimetria generale" e quantificate nell'elaborato "BLTX-NS-RC6_Computo metrico estimativo opere civili".

DISEGNI DI RIFERIMENTO

TAVOLA	DESCRIZIONE
BLTX-NS-TC8	Viabilità e piazzole - Planimetria di progetto - Fase di cantiere
BLTX-NS-TC11	Profili longitudinali viabilità di impianto
BLTX-NS-TC13	Piazzole aerogeneratori e strade di servizio - Particolari costruttivi
BLTX-NS-TC14	Opere di regimazione acque superficiali - Planimetria generale

Sezione: 3
 Progressiva: 30.000
 Q. Progetto: 136.134

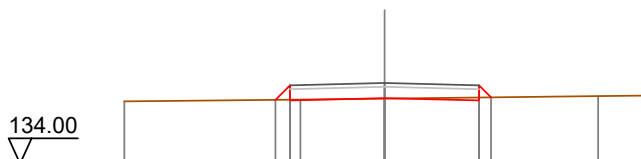

Quote Terreno	135.65	135.69	135.72	135.79	135.80
Quote Progetto		135.69 135.67	135.73	135.67 135.75	
Parziali		0.38	2.50	2.50	0.38
Progressiva		-2.88 -2.50	0.00	2.50 2.82	
Dislivelli		-0.00 -0.38	0.01	-0.08 -0.00	

Sezione: 4
 Progressiva: 40.000
 Q. Progetto: 135.976

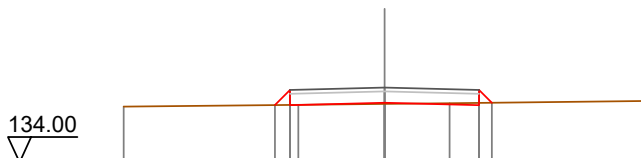

Quote Terreno	135.48	135.52	135.55	135.56	135.62
Quote Progetto		135.52 135.51	135.58	135.51 135.58	
Parziali		0.40	2.50	2.50	0.34
Progressiva		-2.90 -2.50	0.00	2.50 2.84	
Dislivelli		0.00 0.39	0.03	-0.06 0.00	

Sezione: 5
 Progressiva: 41.372
 Q. Progetto: 135.954

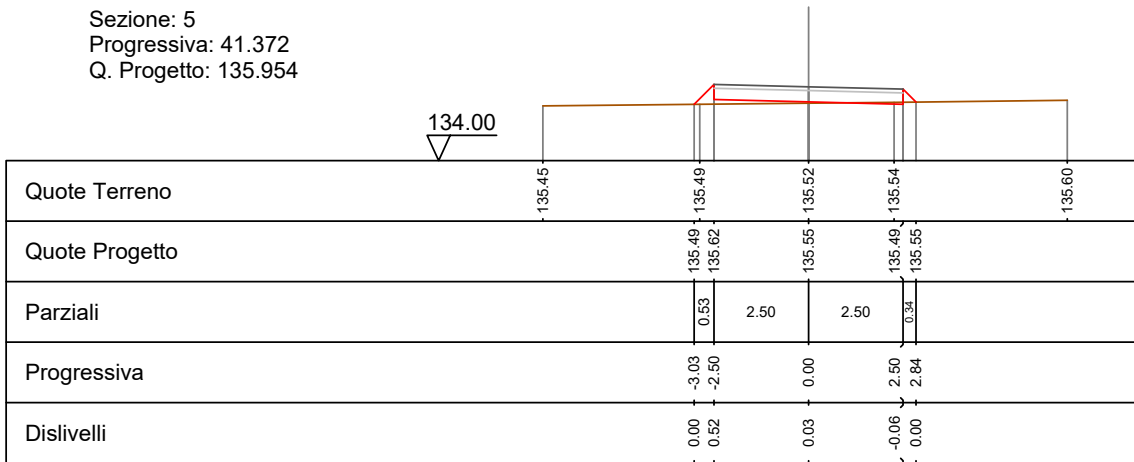

Sezione: 6
 Progressiva: 47.852
 Q. Progetto: 135.852

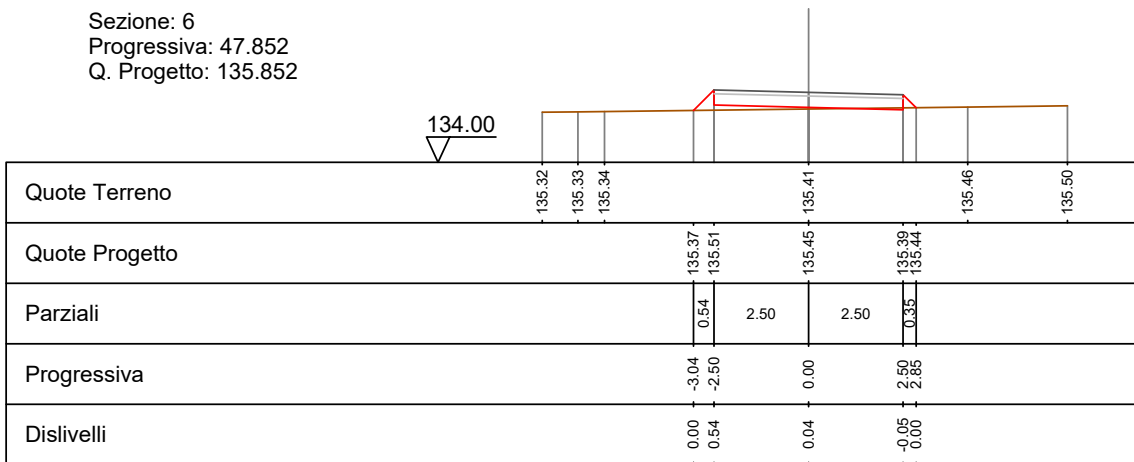

Sezione: 7
 Progressiva: 50.000
 Q. Progetto: 135.818

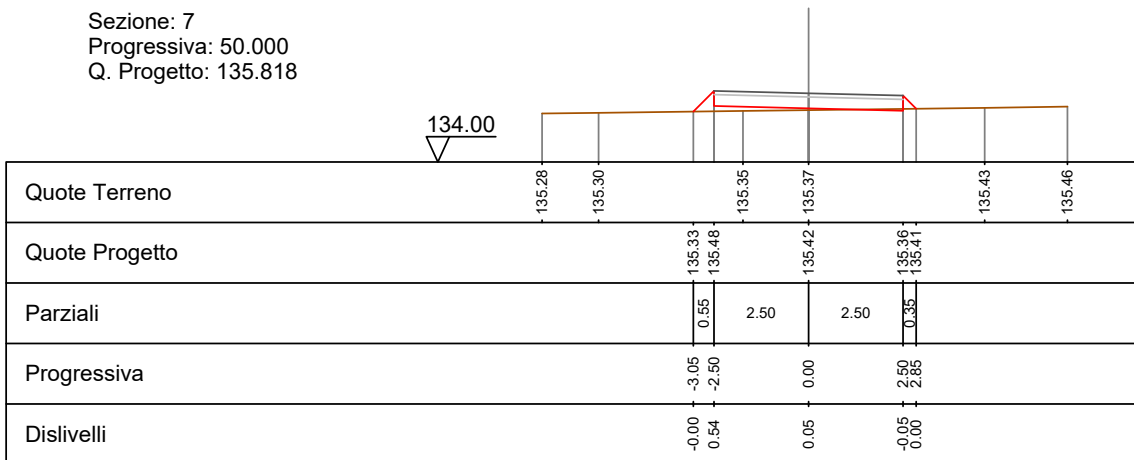

Sezione: 8
 Progressiva: 54.331
 Q. Progetto: 135.749

134.00

Quote Terreno	135.20	135.23		135.30		135.36	135.38	135.39	135.40
Quote Progetto			135.26	135.41	135.35	135.29	135.34		
Parziali			0.56	2.50	2.50	0.34			
Progressiva			-3.06	-2.50	0.00	2.50	2.84		
Dislivelli			0.00	0.55	0.05	-0.05	0.00		

Sezione: 9
 Progressiva: 60.000
 Q. Progetto: 135.660

134.00

Quote Terreno	135.11	135.14		135.21	135.21		135.30	135.31
Quote Progetto			135.16	135.20	135.26	135.20	135.25	
Parziali			0.44	2.50	2.50	0.34		
Progressiva			-2.94	-2.50	0.00	2.50	2.84	
Dislivelli			0.00	0.43	0.05	-0.05	0.00	

Sezione: 10
 Progressiva: 80.000
 Q. Progetto: 135.294

133.00

Quote Terreno	134.87		134.88	134.91	134.95		134.97
Quote Progetto		134.87	134.83	134.89	134.83	134.95	
Parziali		0.36	2.50	2.50	0.28		
Progressiva		-2.86	-2.50	0.00	2.50	2.78	
Dislivelli		0.00	0.36	-0.01	-0.12	0.00	

Sezione: 11
 Progressiva: 100.000
 Q. Progetto: 134.296

132.00

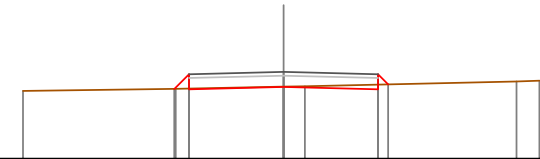

Quote Terreno	133.79	133.85	133.90	133.92	134.04	134.06
Quote Progetto		133.84 133.83	133.90	133.97	133.83 133.97	
Parziali		0.39	2.50	2.50	0.28	
Progressiva		-2.89 -2.50	0.00	0.00	2.50 2.77	
Dislivelli		0.00 0.38	-0.01	-0.01	-0.13 0.00	

Sezione: 12
 Progressiva: 120.000
 Q. Progetto: 132.940

131.00

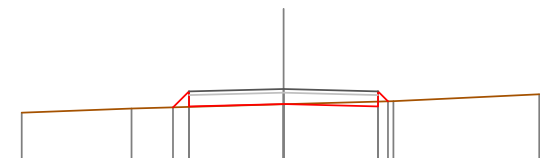

Quote Terreno	132.31	132.42	132.54	132.54	132.62	132.80
Quote Progetto		132.45 132.48	132.54	132.54	132.48 132.62	
Parziali		0.42	2.50	2.50	0.28	
Progressiva		-2.92 -2.50	0.00	0.00	2.50 2.76	
Dislivelli		0.00 0.41	0.00	0.00	-0.13 0.00	

Sezione: 13
 Progressiva: 140.000
 Q. Progetto: 131.584

129.00

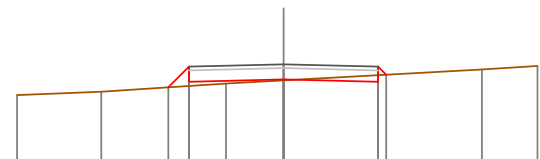

Quote Terreno	130.77	130.86	131.07	131.16	131.45	131.54
Quote Progetto		130.98 131.12	131.18	131.18	131.12 131.31	
Parziali		0.55	2.50	2.50	0.28	
Progressiva		-3.05 -2.50	0.00	0.00	2.50 2.71	
Dislivelli		-0.00 0.51	0.03	0.03	-0.17 0.00	

Sezione: 14
 Progressiva: 160.000
 Q. Progetto: 130.610

129.00

Quote Terreno	130.02	130.05	130.23	130.51	130.64
Quote Progetto		130.05 130.15	130.21	130.15 130.42	
Parziali		0.50	2.50	2.50	
Progressiva		-3.00 -2.50	0.00	2.50 2.63	
Dislivelli		0.00 0.50	-0.02	-0.27 0.00	

Sezione: 15
 Progressiva: 180.000
 Q. Progetto: 130.402

128.00

Quote Terreno	130.00	130.00	130.00	130.00	130.07
Quote Progetto		130.00 129.94	130.00	129.94 130.00	
Parziali		0.34	2.50	2.50	
Progressiva		-2.84 -2.50	0.00	2.50 2.84	
Dislivelli		0.00 0.34	0.00	-0.06 0.00	

Sezione: 16
 Progressiva: 200.000
 Q. Progetto: 130.390

128.00

Quote Terreno	130.00	130.00	130.00	130.00	130.00
Quote Progetto		130.00 129.93	129.99	129.93 130.00	
Parziali		0.33	2.50	2.50	
Progressiva		-2.83 -2.50	0.00	2.50 2.83	
Dislivelli		0.00 0.33	-0.01	-0.07 0.00	

Sezione: 17
 Progressiva: 220.000
 Q. Progetto: 130.378

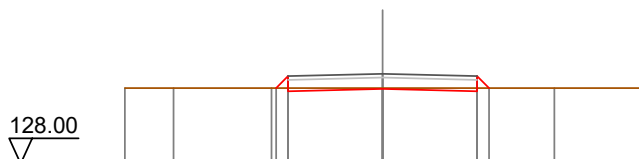

Quote Terreno	130.00	130.00	130.00	130.00	130.00	130.00
Quote Progetto			130.00	129.98	129.92	130.00
Parziali			0.32	2.50	2.50	0.32
Progressiva			-2.82	-2.50	0.00	2.50
Dislivelli			0.00	0.32	-0.02	-0.08

Sezione: 18
 Progressiva: 240.000
 Q. Progetto: 130.366

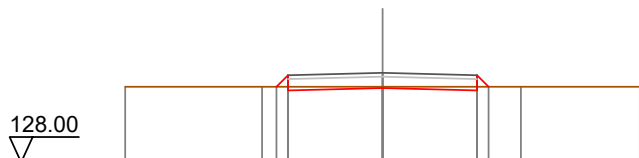

Quote Terreno	130.00	130.00	130.00	130.00	130.00	130.00
Quote Progetto			130.00	129.97	129.90	130.00
Parziali			0.30	2.50	2.50	0.30
Progressiva			-2.80	-2.50	0.00	2.50
Dislivelli			0.00	0.30	-0.03	-0.10

Sezione: 19
 Progressiva: 248.025
 Q. Progetto: 130.361

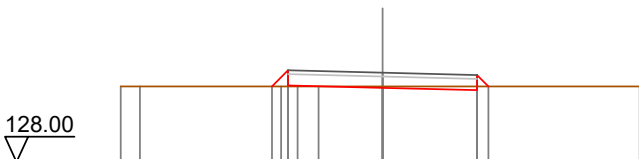

Quote Terreno	130.00	130.00	130.00	130.00	130.00	130.00
Quote Progetto			130.00	129.96	129.90	130.00
Parziali			0.42	2.50	2.50	0.30
Progressiva			-2.92	-2.50	0.00	2.50
Dislivelli			0.00	0.42	-0.04	-0.10

Sezione: 20
 Progressiva: 250.000
 Q. Progetto: 130.360

128.00

Quote Terreno	130.00	130.00	130.00	130.00	130.00	130.00
Quote Progetto			130.00 130.02	129.96	129.90	130.00
Parziali			0.42	2.50	2.50	0.30
Progressiva			-2.92 -2.50	0.00	2.50	2.80
Dislivelli			0.00 0.42	-0.04	-0.10	0.00

Sezione: 21
 Progressiva: 252.212
 Q. Progetto: 130.359

128.00

Quote Terreno	130.00	130.00	130.00	130.00	130.00	130.00
Quote Progetto			130.00 130.02	129.96	129.90	130.00
Parziali			0.42	2.50	2.50	0.30
Progressiva			-2.92 -2.50	0.00	2.50	2.80
Dislivelli			0.00 0.42	-0.04	-0.10	0.00

Sezione: 22
 Progressiva: 256.400
 Q. Progetto: 130.356

128.00

Quote Terreno	130.00	130.00	130.00	130.00	130.00	130.00
Quote Progetto			130.00 130.02	129.96	129.89	130.00
Parziali			0.42	2.50	2.50	0.29
Progressiva			-2.92 -2.50	0.00	2.50	2.79
Dislivelli			0.00 0.42	-0.04	-0.11	0.00

Sezione: 23
 Progressiva: 260.000
 Q. Progetto: 130.354

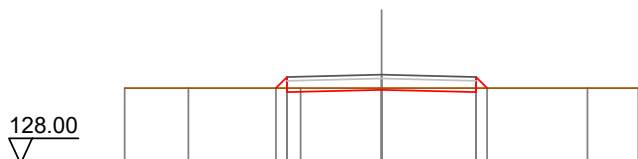

Quote Terreno	130.00	130.00	130.00	130.00	130.00	130.00	
Quote Progetto			130.00	129.89	129.95	129.89	130.00
Parziali			0.29	2.50	2.50	0.29	
Progressiva			-2.79	-2.50	0.00	2.50	2.79
Dislivelli			0.00	0.29	-0.05	-0.11	0.00

Sezione: 24
 Progressiva: 280.000
 Q. Progetto: 130.343

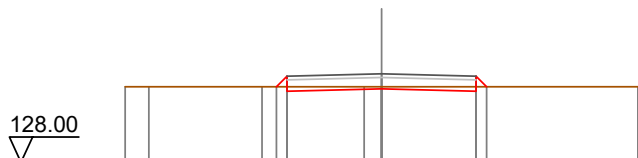

Quote Terreno	130.00	130.00	130.00	130.00	130.00	130.00	
Quote Progetto			130.00	129.88	129.94	129.88	130.00
Parziali			0.28	2.50	2.50	0.28	
Progressiva			-2.78	-2.50	0.00	2.50	2.78
Dislivelli			0.00	0.28	-0.06	-0.12	0.00

Sezione: 25
 Progressiva: 300.000
 Q. Progetto: 130.317

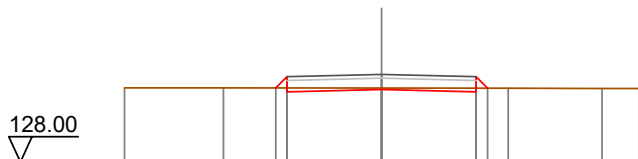

Quote Terreno	129.96	129.96	129.96	129.96	129.95	129.94	129.94
Quote Progetto			129.96	129.85	129.92	129.85	129.95
Parziali			0.30	2.50	2.50	0.30	
Progressiva			-2.80	-2.50	0.00	2.50	2.80
Dislivelli			0.00	0.30	-0.04	-0.10	0.00

Sezione: 26
 Progressiva: 316.240
 Q. Progetto: 130.066

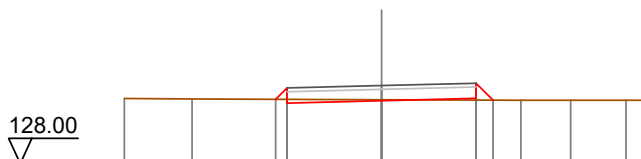

Quote Terreno	129.73	129.71		129.69		129.68	129.68	129.68	129.68
Quote Progetto			129.70	129.60	129.67	129.73	129.68		
Parziali			0.30	2.50	2.50	0.45			
Progressiva			-2.80	-2.50	0.00	2.50	2.95		
Dislivelli			0.00	0.30	-0.03	0.04	-0.00		

Sezione: 27
 Progressiva: 318.600
 Q. Progetto: 130.004

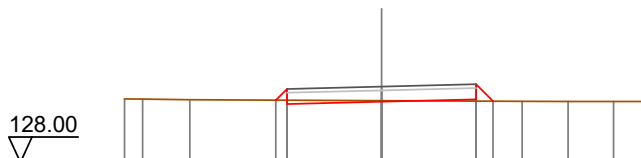

Quote Terreno	129.68	129.67	129.66		129.63		129.61	129.61	129.61	129.61
Quote Progetto				129.64	129.54	129.60	129.67	129.62		
Parziali				0.30	2.50	2.50	0.45			
Progressiva				-2.80	-2.50	0.00	2.50	2.95		
Dislivelli				-0.00	0.30	-0.03	0.05	0.00		

Sezione: 28
 Progressiva: 320.000
 Q. Progetto: 129.964

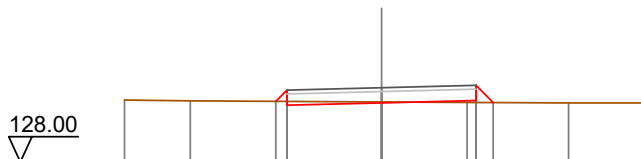

Quote Terreno	129.64	129.62		129.59		129.58	129.56	129.56	129.56
Quote Progetto			129.60	129.50	129.56	129.63	129.57		
Parziali			0.30	2.50	2.50	0.45			
Progressiva			-2.80	-2.50	0.00	2.50	2.95		
Dislivelli			0.00	0.30	-0.03	0.05	0.00		

Sezione: 29
 Progressiva: 320.960
 Q. Progetto: 129.935



Quote Terreno	129.61	129.59		129.56	129.55	129.53	129.53
Quote Progetto			129.58 129.47	129.54	129.60 129.54		
Parziali			0.30 2.50	2.50	0.46		
Progressiva			-2.80 -2.50	0.00	2.50 2.96		
Dislivelli			0.00 0.30	-0.02	0.05 0.00		

Sezione: 30
 Progressiva: 340.000
 Q. Progetto: 129.151

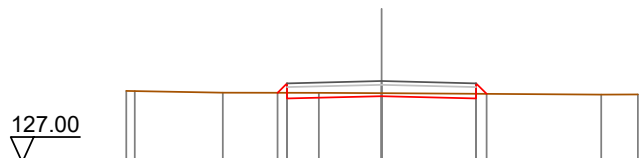

Quote Terreno	128.89 128.88	128.84	128.84	128.83		128.79	128.80
Quote Progetto			128.84 128.69	128.75	128.69 128.81		
Parziali			2.50	2.50	0.28		
Progressiva			-2.75 -2.50	0.00	2.50 2.78		
Dislivelli			0.00 0.25	-0.08	-0.12 0.00		

Sezione: 31
 Progressiva: 359.522
 Q. Progetto: 128.182

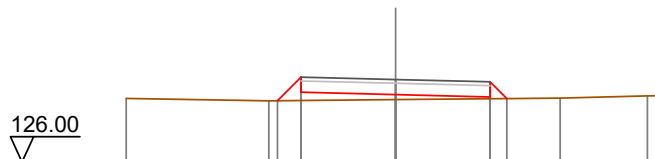

Quote Terreno	127.68	127.62	127.65	127.69	127.75	127.75
Quote Progetto		127.62 127.84	127.78	127.72 127.68		
Parziali		0.62 2.50	2.50	0.44		
Progressiva		-3.12 -2.50	0.00	2.50 2.94		
Dislivelli		0.00 0.62	0.13	0.05 -0.00		

Sezione: 32
 Progressiva: 360.000
 Q. Progetto: 128.158

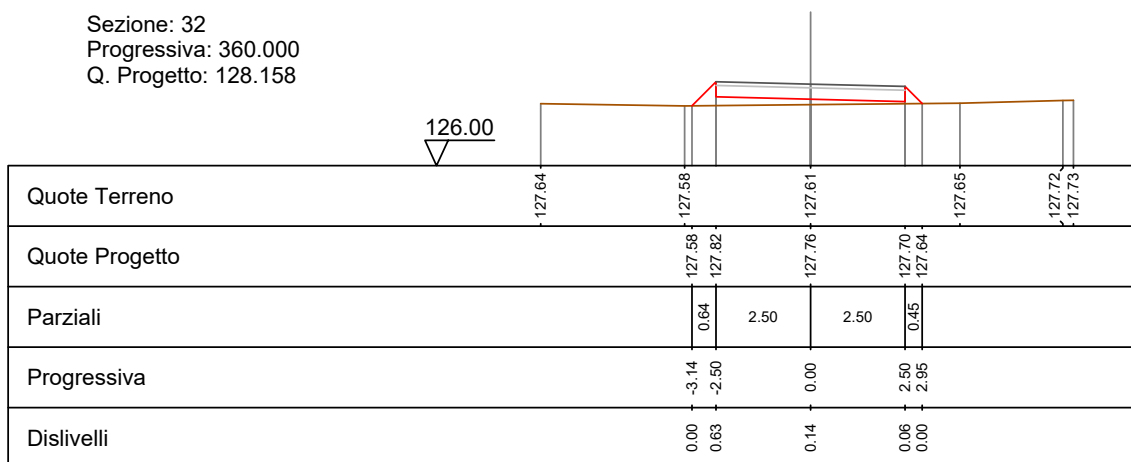

Sezione: 33
 Progressiva: 363.859
 Q. Progetto: 127.966

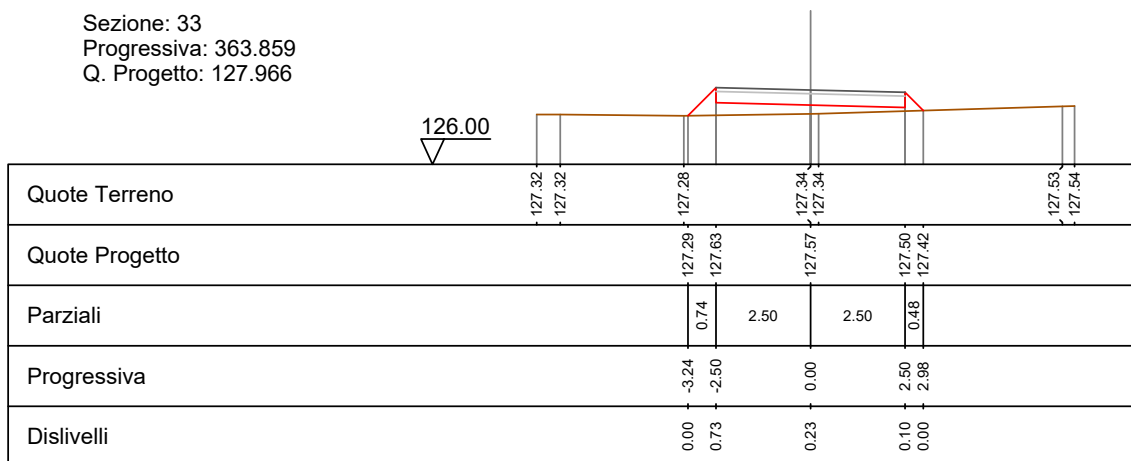

Sezione: 34
 Progressiva: 368.195
 Q. Progetto: 127.751

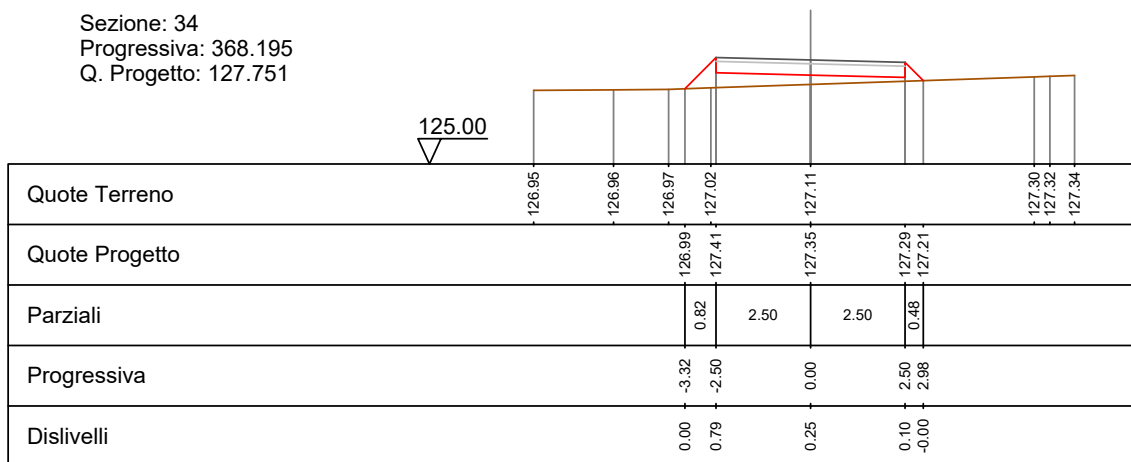

Sezione: 35
 Progressiva: 380.000
 Q. Progetto: 127.165

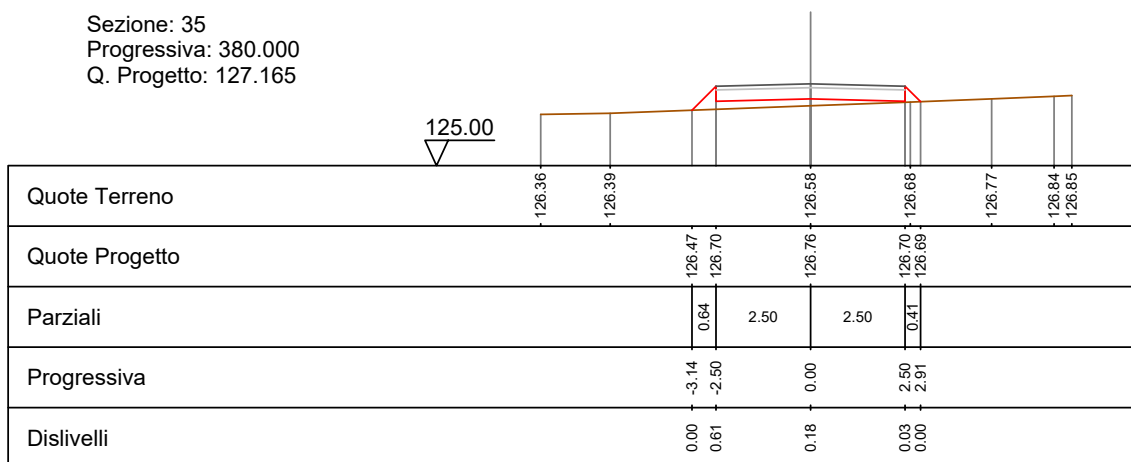

Sezione: 36
 Progressiva: 400.000
 Q. Progetto: 126.294

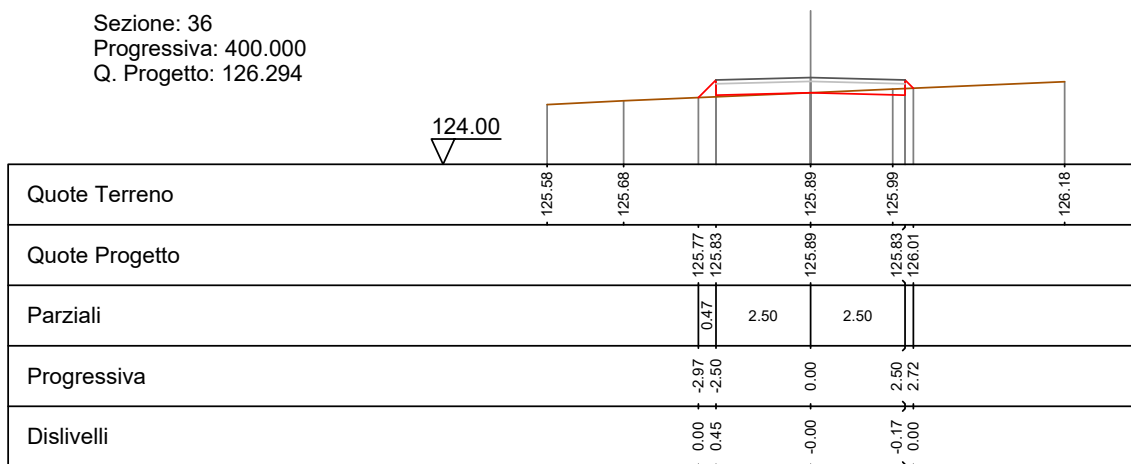

Sezione: 37
 Progressiva: 420.000
 Q. Progetto: 125.688

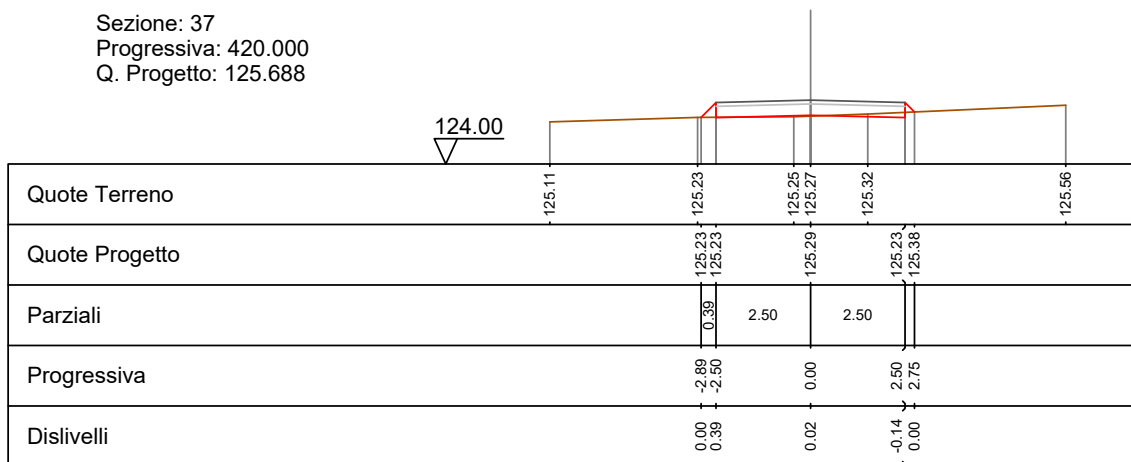

Sezione: 38
 Progressiva: 440.000
 Q. Progetto: 125.347

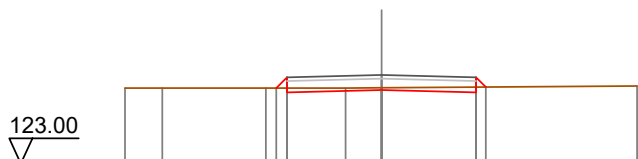

Quote Terreno	125.00	125.00	125.00	125.00	125.01	125.06	
Quote Progetto			125.00	124.88	124.95	124.88	125.03
Parziali			0.28	2.50	2.50		
Progressiva			-2.78	-2.50	0.00	2.50	2.76
Dislivelli			0.00	0.28	-0.06	-0.14	-0.00

Sezione: 39
 Progressiva: 460.000
 Q. Progetto: 125.265

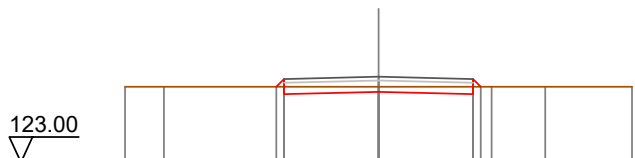

Quote Terreno	125.00	125.00	125.00	125.00	125.00	125.00	125.00
Quote Progetto			125.00	124.87	124.87	124.80	125.00
Parziali			0.20	2.50	2.50		
Progressiva			-2.70	-2.50	0.00	2.50	2.70
Dislivelli			0.00	0.20	-0.13	-0.20	0.00

Sezione: 40
 Progressiva: 480.000
 Q. Progetto: 125.264

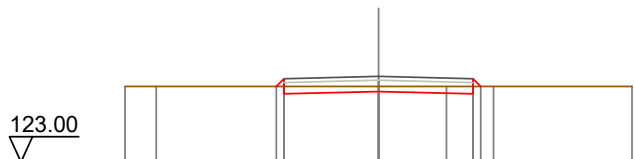

Quote Terreno	125.00	125.00	125.00	125.00	125.00	125.00	125.00
Quote Progetto			125.00	124.86	124.86	124.80	125.00
Parziali			0.20	2.50	2.50		
Progressiva			-2.70	-2.50	0.00	2.50	2.70
Dislivelli			0.00	0.20	-0.14	-0.20	0.00

Sezione: 41
 Progressiva: 500.000
 Q. Progetto: 125.264

123.00

Quote Terreno	125.00	125.00	125.00	125.00	125.00
Quote Progetto		125.00 124.80	124.86	124.80 125.00	
Parziali		2.50	2.50		
Progressiva		-2.70 -2.50	0.00	2.50 2.70	
Dislivelli		0.00 0.20	-0.14	-0.20 0.00	

Sezione: 42
 Progressiva: 508.615
 Q. Progetto: 125.263

123.00

Quote Terreno	125.00	125.00	125.00	125.00	125.00
Quote Progetto		125.00 124.80	124.86	124.93 125.00	
Parziali		2.50	2.50	0.33	
Progressiva		-2.70 -2.50	0.00	2.50 2.83	
Dislivelli		0.00 0.20	-0.14	-0.07 0.00	

Sezione: 43
 Progressiva: 509.483
 Q. Progetto: 125.263

123.00

Quote Terreno	125.00	125.00	125.00	125.00	125.00
Quote Progetto		125.00 124.80	124.86	124.93 125.00	
Parziali		2.50	2.50	0.33	
Progressiva		-2.70 -2.50	0.00	2.50 2.83	
Dislivelli		0.00 0.20	-0.14	-0.07 0.00	

Sezione: 44
 Progressiva: 510.000
 Q. Progetto: 125.263

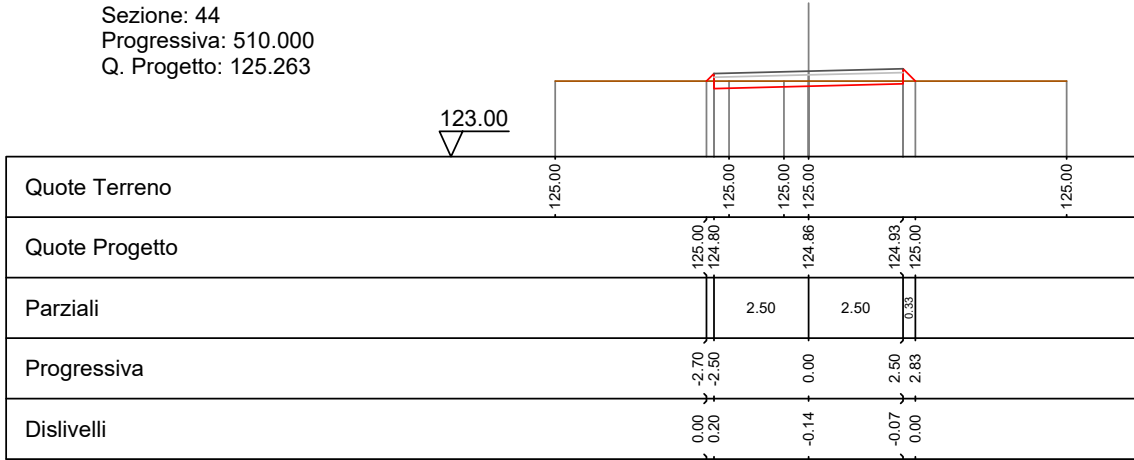

Sezione: 45
 Progressiva: 510.352
 Q. Progetto: 125.263

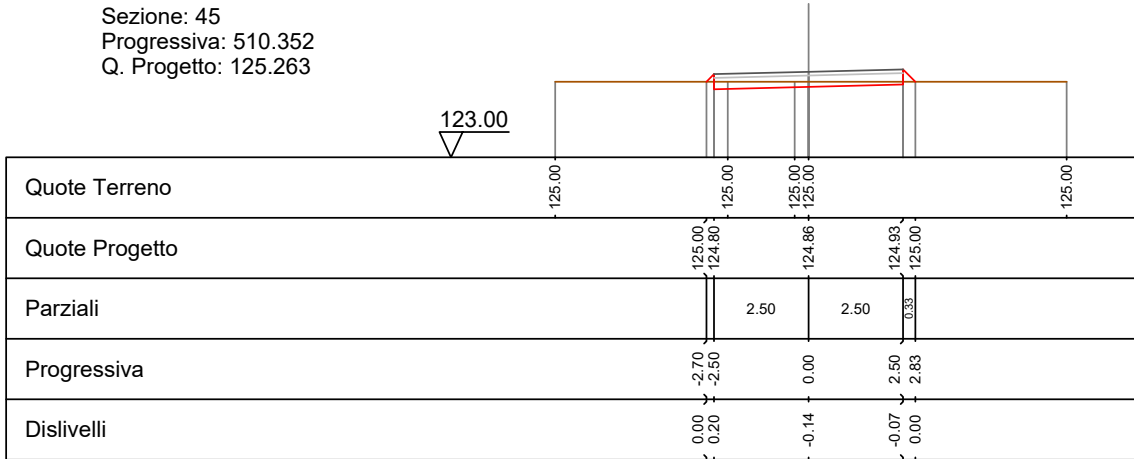

Sezione: 46
 Progressiva: 520.000
 Q. Progetto: 125.263

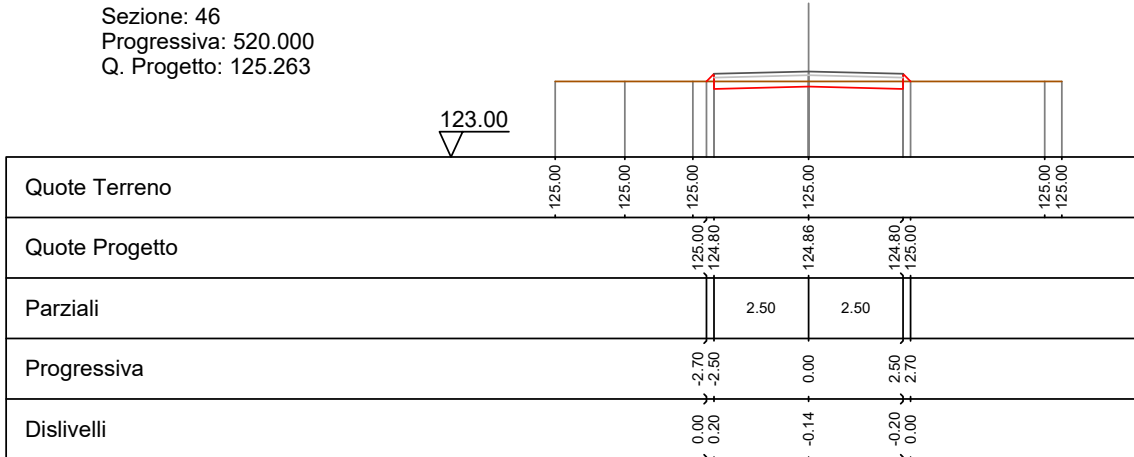

Sezione: 47
 Progressiva: 540.000
 Q. Progetto: 125.262

123.00

Quote Terreno	125.00	125.00	125.00	125.00	125.00	125.00
Quote Progetto			125.00 124.80	124.86	124.80 125.00	
Parziali			2.50	2.50		
Progressiva			-2.70 -2.50	0.00	2.50 2.70	
Dislivelli			0.00 0.20	-0.14	-0.20 0.00	

Sezione: 48
 Progressiva: 560.000
 Q. Progetto: 125.261

123.00

Quote Terreno	124.94	124.94	124.95	124.95	124.95	124.96
Quote Progetto			124.95 124.80	124.86	124.80 124.95	
Parziali			2.50	2.50		
Progressiva			-2.75 -2.50	0.00	2.50 2.75	
Dislivelli			0.00 0.25	-0.09	-0.15 -0.00	

Sezione: 49
 Progressiva: 580.000
 Q. Progetto: 124.924

123.00

Quote Terreno	124.59	124.59	124.59	124.59	124.61
Quote Progetto		124.59 124.46	124.52	124.46 124.60	
Parziali		0.27	2.50	2.50	0.27
Progressiva		-2.77 -2.50	0.00	2.50 2.77	
Dislivelli		-0.00 0.27	-0.07	-0.13 0.00	

Sezione: 50
 Progressiva: 600.000
 Q. Progetto: 124.241

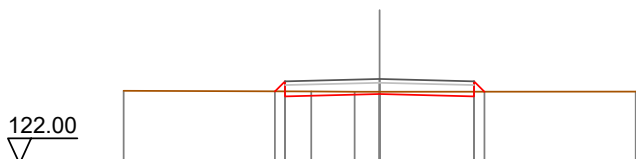

Quote Terreno	123.93	123.91	123.90	123.90	123.91
Quote Progetto		123.91 123.78	123.84	123.78 123.90	
Parziali		0.27 2.50	2.50	0.28 2.50	
Progressiva		-2.77 -2.50	0.00	2.50 2.78	
Dislivelli		-0.00 0.27	-0.06	-0.12 -0.00	

Sezione: 51
 Progressiva: 609.028
 Q. Progetto: 123.713

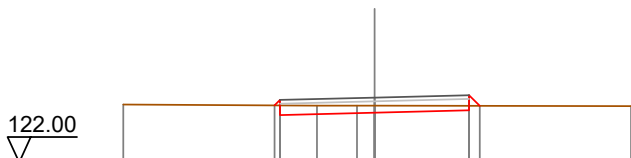

Quote Terreno	123.53	123.50	123.50	123.50	123.49
Quote Progetto		123.51 123.25	123.31	123.38 123.49	
Parziali		0.15 2.50	2.50	0.28 2.50	
Progressiva		-2.64 -2.50	0.00	2.50 2.78	
Dislivelli		0.00 0.15	-0.19	-0.12 -0.00	

Sezione: 52
 Progressiva: 610.000
 Q. Progetto: 123.653

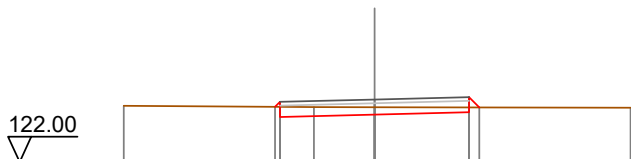

Quote Terreno	123.49	123.45	123.45	123.44
Quote Progetto		123.46 123.19	123.25	123.32 123.44
Parziali		0.27 2.50	2.50	0.27 2.50
Progressiva		-2.63 -2.50	0.00	2.50 2.77
Dislivelli		-0.00 0.13	-0.20	-0.13 0.00

Sezione: 53
 Progressiva: 610.837
 Q. Progetto: 123.602

122.00

Quote Terreno	123.45	123.41	123.41	123.39
Quote Progetto		123.42 123.14	123.20 123.41	123.26 123.40
Parziali		2.50	2.50	0.28
Progressiva		-2.62 -2.50	0.00	2.50 2.76
Dislivelli		0.00 0.12	-0.21	-0.14 -0.00

Sezione: 54
 Progressiva: 612.646
 Q. Progetto: 123.490

122.00

Quote Terreno	123.37	123.33	123.32	123.30	123.28
Quote Progetto		123.33 123.03	123.09 123.32	123.15 123.31	
Parziali		2.50	2.50		
Progressiva		-2.59 -2.50	0.00	2.50 2.75	
Dislivelli		0.00 0.09	-0.23	-0.15 0.00	

Sezione: 55
 Progressiva: 620.000
 Q. Progetto: 123.038

121.00

Quote Terreno	123.01	122.97	122.96	122.95	122.94	122.91
Quote Progetto		122.58 122.56	122.64 122.94	122.58 122.93		
Parziali		2.50	2.50			
Progressiva		-2.51	0.00	2.50 2.55		
Dislivelli		-0.00	-0.31	-0.35 -0.00		

Sezione: 56
 Progressiva: 640.000
 Q. Progetto: 121.809

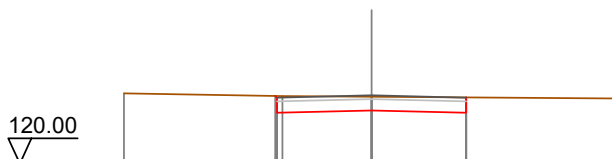

Quote Terreno	121.86	121.79	121.77	121.72
Quote Progetto		121.79 121.35	121.41	121.35
Parziali		2.50	2.50	
Progressiva		-2.55 -2.50	0.00	2.50
Dislivelli		0.00 -0.05	-0.36	-0.41

Sezione: 57
 Progressiva: 660.000
 Q. Progetto: 120.619



Quote Terreno	120.45	120.41	120.41	120.41	120.40	120.40
Quote Progetto		120.41	120.16	120.22	120.16	120.41
Parziali		2.50	2.50			
Progressiva		-2.64 -2.50	0.00	2.50	2.65	
Dislivelli		0.00 0.14	-0.19	-0.25 -0.00		

Sezione: 58
 Progressiva: 680.000
 Q. Progetto: 120.044

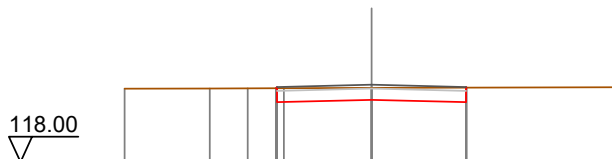

Quote Terreno	119.94	119.94	119.95	119.95	119.96	119.98
Quote Progetto		119.95	119.58	119.64	119.58	
Parziali		2.50	2.50			
Progressiva		-2.53 -2.50	0.00	2.50		
Dislivelli		0.00 0.03	-0.32	-0.39		

Sezione: 59
 Progressiva: 694.797
 Q. Progetto: 120.047

118.00

Quote Terreno	119.72	119.74	119.76	119.76	119.81	119.82
Quote Progetto		119.74 119.71	119.65	119.76	119.58 119.78	
Parziali		0.37	2.50	2.50		
Progressiva		-2.87 -2.50	0.00	0.00	2.50 2.70	
Dislivelli		0.00 0.37	-0.11	0.00	-0.19 -0.00	

Sezione: 60
 Progressiva: 696.810
 Q. Progetto: 120.035

118.00

Quote Terreno	119.68	119.70	119.71	119.73	119.79	119.79
Quote Progetto		119.70 119.70	119.63	119.73	119.57 119.75	
Parziali		0.39	2.50	2.50		
Progressiva		-2.89 -2.50	0.00	0.00	2.50 2.72	
Dislivelli		0.00 0.39	-0.09	0.00	-0.18 0.00	

Sezione: 61
 Progressiva: 698.823
 Q. Progetto: 120.015

118.00

Quote Terreno	119.64	119.66	119.67	119.70	119.76	119.77
Quote Progetto		119.67 119.68	119.61	119.70	119.55 119.73	
Parziali		0.41	2.50	2.50		
Progressiva		-2.91 -2.50	0.00	0.00	2.50 2.72	
Dislivelli		0.00 0.40	-0.08	0.00	-0.17 0.00	

Sezione: 62
 Progressiva: 700.000
 Q. Progetto: 120.000

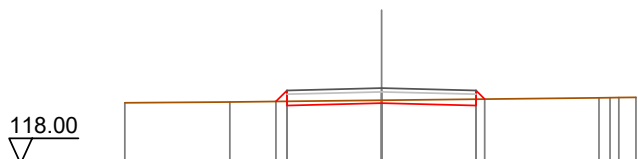

Quote Terreno	119.61	119.63	119.68	119.74	119.75	119.75
Quote Progetto		119.65 119.54	119.60 119.54	119.71	119.71	
Parziali		0.29 2.50	2.50	2.50		
Progressiva		-2.79 -2.50	0.00	2.50 2.73		
Dislivelli		-0.00 0.29	-0.08	-0.17 -0.00		

Sezione: 63
 Progressiva: 720.000
 Q. Progetto: 119.398

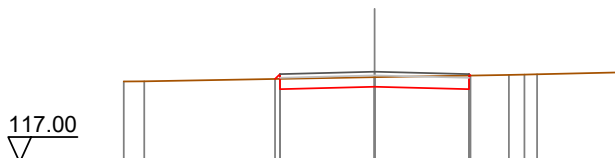

Quote Terreno	119.14	119.14	119.25	119.31	119.33	119.38
Quote Progetto		119.20 118.94	119.00 118.94	118.94 119.30	119.30	
Parziali		2.50	2.50	2.54		
Progressiva		-2.63 -2.50	0.00	2.50 2.54		
Dislivelli		0.00 0.13	-0.25	-0.36 -0.00		

Sezione: 64
 Progressiva: 732.070
 Q. Progetto: 118.963

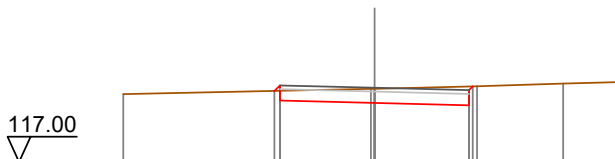

Quote Terreno	118.79	118.88 118.63	118.93 118.94	119.00	119.07	119.11
Quote Progetto		118.88 118.63	118.56 118.94	118.50 119.00	119.00	
Parziali		2.50	2.50	2.60		
Progressiva		-2.65 -2.50	0.00	2.50 2.60		
Dislivelli		-0.00 0.14	-0.37	-0.50 0.00		

Sezione: 65
 Progressiva: 740.000
 Q. Progetto: 118.678

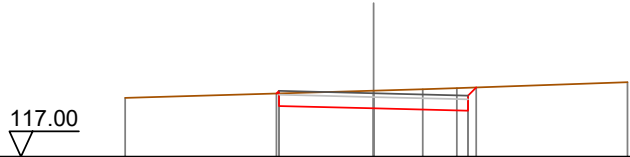

Quote Terreno	118.56		118.75	118.78	118.81	118.97
Quote Progetto		118.67 118.34	118.28	118.22	118.83	
Parziali		2.50	2.50			
Progressiva		-2.57 -2.50	0.00	2.50	2.72	
Dislivelli		-0.00 0.07	-0.47	-0.61	0.00	

Sezione: 65
 Progressiva: 740.000
 Q. Progetto: 118.678

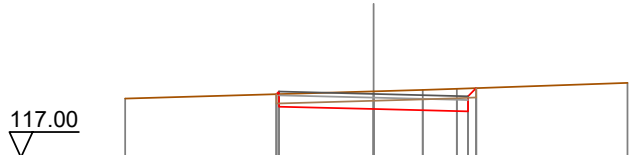

Quote Terreno	118.56		118.75	118.78	118.81	118.97
Quote Progetto		118.67 118.34	118.28	118.22	118.83	
Parziali		2.50	2.50			
Progressiva		-2.57 -2.50	0.00	2.50	2.72	
Dislivelli		0.00 0.07	-0.47	-0.61	0.00	

Sezione: 66
 Progressiva: 745.037
 Q. Progetto: 118.523

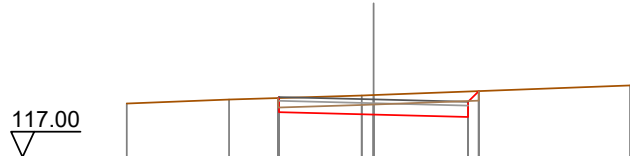

Quote Terreno	118.41	118.52	118.63	118.64		118.89
Quote Progetto		118.56 118.19	118.12	118.06	118.74	
Parziali		2.50	2.50	0.28		
Progressiva		-2.53 -2.50	0.00	2.50	2.78	
Dislivelli		-0.00 0.03	-0.52	-0.67	0.00	

Sezione: 67
 Progressiva: 750.000
 Q. Progetto: 118.419

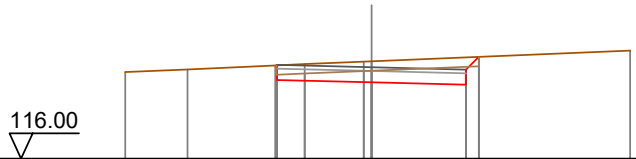

Quote Terreno	118.29	118.36	118.47	118.50	118.57	118.58		118.86
Quote Progetto			118.08		118.02		117.96	118.69
Parziali				2.50		2.50	0.34	
Progressiva			-2.51		0.00		2.50	2.84
Dislivelli			0.00		-0.56		-0.72	-0.00

Sezione: 68
 Progressiva: 758.003
 Q. Progetto: 118.356

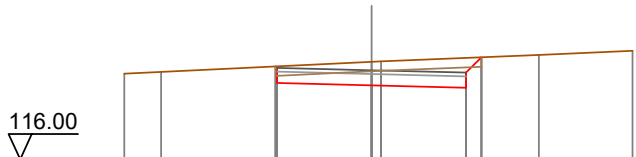

Quote Terreno	118.27	118.31		118.58	118.59		118.76	118.87
Quote Progetto			118.46	118.02	117.96		117.89	118.70
Parziali				2.50		2.50	0.40	
Progressiva			-2.54	-2.50	0.00		2.50	2.90
Dislivelli			0.00	-0.04	-0.62		-0.79	0.00

Sezione: 69
 Progressiva: 760.000
 Q. Progetto: 118.361

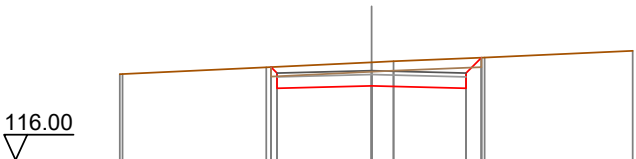

Quote Terreno	118.27	118.27	118.45	118.58	118.61	118.71	118.71	118.89
Quote Progetto			118.46	117.90	117.96		117.90	118.71
Parziali				2.50		2.50	0.41	
Progressiva			-2.66	-2.50	0.00		2.50	2.91
Dislivelli			0.00	-0.17	-0.62		-0.79	0.00

Sezione: 70
 Progressiva: 780.000
 Q. Progetto: 118.485

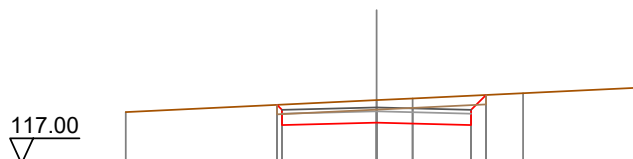

Quote Terreno	118.36		118.68	118.73	118.87	119.01
Quote Progetto		118.56 118.02	118.09		118.02 118.82	
Parziali		2.50	2.50		0.40	
Progressiva		-2.63 -2.50	0.00		2.50 2.90	
Dislivelli		0.00 -0.14	-0.60		-0.78 0.00	

Sezione: 71
 Progressiva: 800.000
 Q. Progetto: 118.611

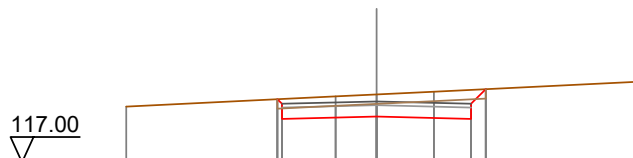

Quote Terreno	118.47		118.74	118.80	118.87	119.13
Quote Progetto		118.67 118.15	118.21		118.15 118.94	
Parziali		2.50	2.50		0.39	
Progressiva		-2.62 -2.50	0.00		2.50 2.89	
Dislivelli		-0.00 -0.13	-0.59		-0.77 0.00	

Sezione: 72
 Progressiva: 803.185
 Q. Progetto: 118.631

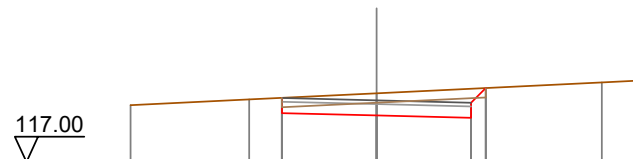

Quote Terreno	118.50	118.66	118.82		119.10	119.15
Quote Progetto		118.29	118.23		118.17 118.96	
Parziali		2.50	2.50		0.39	
Progressiva		-2.50	0.00		2.50 2.89	
Dislivelli		-0.00	-0.59		-0.77 0.00	

Sezione: 73
 Progressiva: 806.163
 Q. Progetto: 118.652

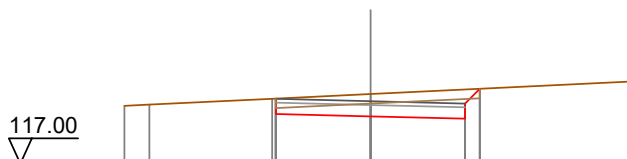

Quote Terreno	118.53	118.56	118.72	118.84	119.17
Quote Progetto			118.31	118.25	118.19
Parziali			2.50	2.50	0.39
Progressiva			-2.51	0.00	2.50
Dislivelli			0.00	-0.59	-0.77

Sezione: 74
 Progressiva: 809.141
 Q. Progetto: 118.688

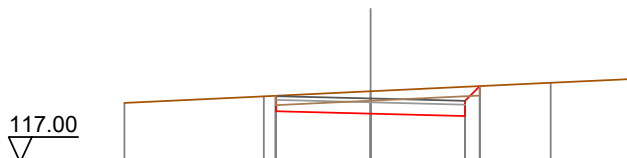

Quote Terreno	118.57	118.75	118.88	119.10	119.20
Quote Progetto		118.35	118.29	118.23	119.02
Parziali		2.50	2.50	0.39	
Progressiva		-2.51	0.00	2.50	2.89
Dislivelli		0.00	-0.59	-0.77	0.00

Sezione: 75
 Progressiva: 820.000
 Q. Progetto: 118.832

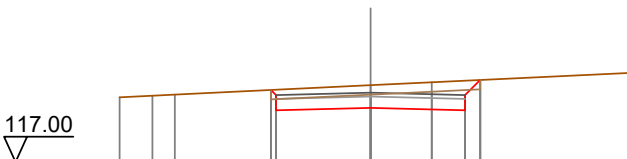

Quote Terreno	118.71	118.75	118.78	119.03	119.11	119.36
Quote Progetto			118.90	118.37	118.43	118.37
Parziali			2.50	2.50	0.40	
Progressiva			-2.63	-2.50	0.00	2.50
Dislivelli			0.00	-0.14	-0.60	-0.78

Sezione: 76
 Progressiva: 840.000
 Q. Progetto: 119.096

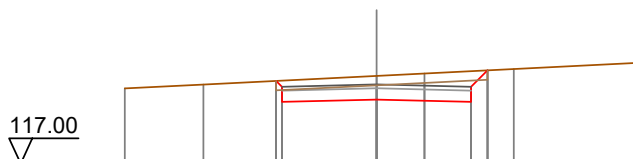

Quote Terreno	118.99	119.09	119.32	119.39	119.50	119.67
Quote Progetto		119.19	118.63	118.70	118.63	119.47
Parziali		2.50	2.50	0.44		
Progressiva		-2.66	-2.50	0.00	2.50	2.94
Dislivelli		-0.00	-0.16	-0.63	-0.81	-0.00

Sezione: 77
 Progressiva: 859.043
 Q. Progetto: 119.348

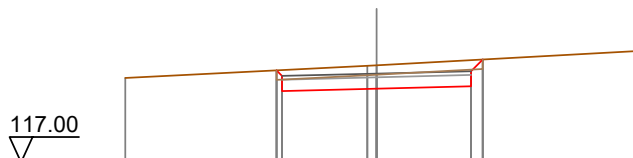

Quote Terreno	119.23		119.55		119.94	
Quote Progetto		119.43	118.89	118.95	119.01	119.72
Parziali		2.50	2.50	0.31		
Progressiva		-2.65	-2.50	0.00	2.50	2.81
Dislivelli		0.00	-0.15	-0.62	-0.89	0.00

Sezione: 78
 Progressiva: 860.000
 Q. Progetto: 119.360

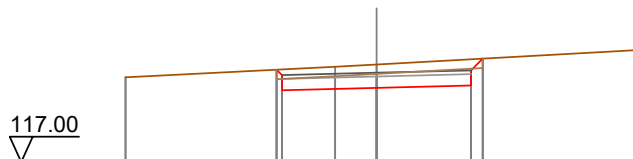

Quote Terreno	119.24		119.52		119.95	
Quote Progetto		119.44	118.90	118.96	119.02	119.73
Parziali		2.50	2.50	0.31		
Progressiva		-2.64	-2.50	0.00	2.50	2.81
Dislivelli		-0.00	-0.15	-0.62	-0.69	-0.00

Sezione: 79
 Progressiva: 870.000
 Q. Progetto: 119.421

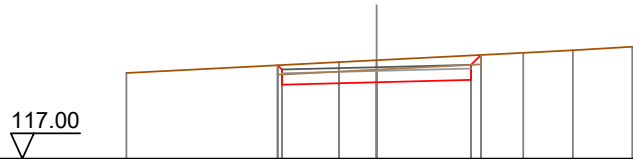

Quote Terreno	119.27		119.55	119.60		119.80	119.87	119.96
Quote Progetto		119.47	118.96	119.02		119.08	119.74	
Parziali		2.50		2.50		0.28		
Progressiva		-2.61	-2.50	0.00		2.50	2.76	
Dislivelli		0.00	-0.12	-0.58		-0.65	0.00	

Sezione: 80
 Progressiva: 873.547
 Q. Progetto: 119.395

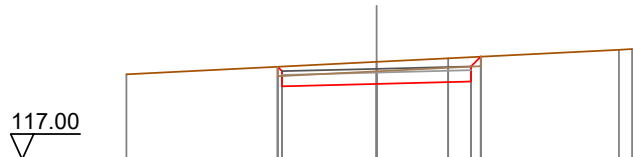

Quote Terreno	119.25		119.58		119.67		119.90	119.92
Quote Progetto		119.45	118.93	118.99	119.06	119.72		
Parziali		2.50		2.50		0.28		
Progressiva		-2.62	-2.50	0.00		2.50	2.76	
Dislivelli		0.00	-0.12	-0.58		-0.65	-0.00	

Sezione: 81
 Progressiva: 880.000
 Q. Progetto: 119.283

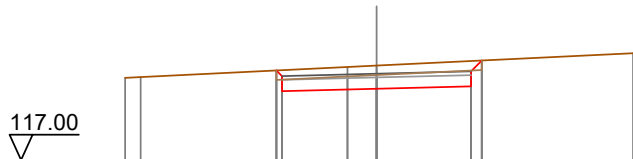

Quote Terreno	119.17	119.19		119.46	119.50			119.82
Quote Progetto		119.37	118.82	118.88	119.50	118.95	119.63	
Parziali		2.50		2.50		0.28		
Progressiva		-2.65	-2.50	0.00		2.50	2.78	
Dislivelli		0.00	-0.15	-0.61		-0.67	0.00	

Sezione: 82
 Progressiva: 888.050
 Q. Progetto: 119.075

117.00

Quote Terreno	119.04	119.16	119.21	119.24	119.32	119.48	119.60
Quote Progetto			119.21	118.61	118.67	118.74	119.43
Parziali			2.50	2.50	0.28		
Progressiva			-2.70	-2.50	0.00	2.50	2.79
Dislivelli			0.00	-0.20	-0.64	-0.68	-0.00

Sezione: 83
 Progressiva: 900.000
 Q. Progetto: 118.764

117.00

Quote Terreno	118.77	118.85	118.95	119.01	119.22	119.26	119.26
Quote Progetto			118.92	118.30	118.36	118.30	119.12
Parziali			2.50	2.50	0.42		
Progressiva			-2.71	-2.50	0.00	2.50	2.92
Dislivelli			0.00	-0.22	-0.65	-0.80	0.00

Sezione: 84
 Progressiva: 920.000
 Q. Progetto: 118.293

116.00

Quote Terreno	118.38	118.44	118.51	118.60	118.68	118.73	118.82
Quote Progetto			117.83	117.89	117.83	118.70	
Parziali			2.50	2.50	0.47		
Progressiva			-2.78	-2.50	0.00	2.50	2.97
Dislivelli			0.00	-0.29	-0.71	-0.85	0.00

Sezione: 85
 Progressiva: 940.000
 Q. Progetto: 117.973

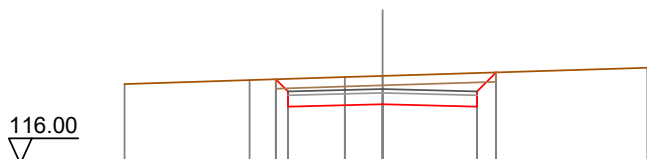

Quote Terreno	118.11	118.21	118.29	118.32	118.54
Quote Progetto		118.23 117.51	117.57	117.51 118.41	
Parziali		0.32 2.50	2.50	0.50	
Progressiva		-2.82 -2.50	0.00	2.50 3.00	
Dislivelli		0.00 -0.33	-0.75	-0.89 -0.00	

Sezione: 86
 Progressiva: 947.707
 Q. Progetto: 117.890

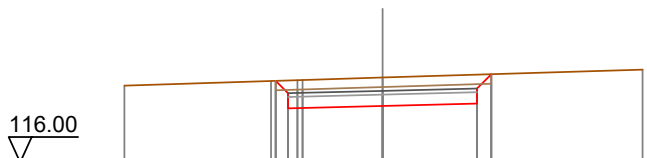

Quote Terreno	118.03	118.15 118.16 118.17 118.18	118.24	118.45
Quote Progetto		118.16 117.43	117.49	117.55 118.33
Parziali		0.33 2.50	2.50	0.38
Progressiva		-2.83 -2.50	0.00	2.50 2.88
Dislivelli		-0.00 -0.34	-0.75	-0.77 0.00

Sezione: 87
 Progressiva: 950.000
 Q. Progetto: 117.870

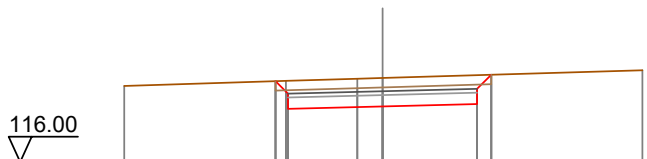

Quote Terreno	118.01	118.15	118.20 118.22	118.43
Quote Progetto		118.14 117.41	117.47	117.53 118.31
Parziali		0.33 2.50	2.50	0.37
Progressiva		-2.83 -2.50	0.00	2.50 2.87
Dislivelli		-0.00 -0.34	-0.75	-0.76 -0.00

Sezione: 88
 Progressiva: 950.696
 Q. Progetto: 117.865

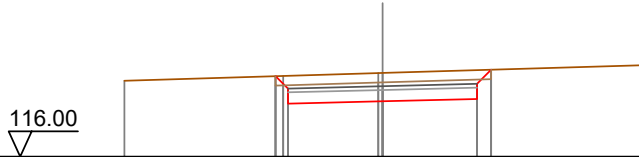

Quote Terreno	118.01	118.14	118.21	118.21	118.42
Quote Progetto		118.13 117.40	117.46	117.53 118.30	
Parziali		0.33 2.50	2.50	0.37 2.87	
Progressiva		-2.83 -2.50	0.00	2.50 2.87	
Dislivelli		0.00 -0.34	-0.75	-0.76 -0.00	

Sezione: 89
 Progressiva: 953.684
 Q. Progetto: 117.842

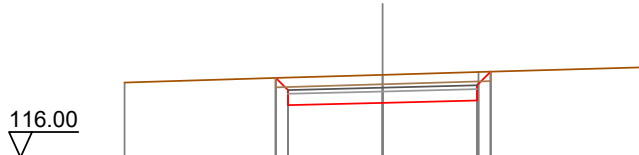

Quote Terreno	117.98	118.10	118.18	118.26	118.38
Quote Progetto		118.10 117.38	117.44	117.50 118.27	
Parziali		0.32 2.50	2.50	0.36 2.86	
Progressiva		-2.82 -2.50	0.00	2.50 2.86	
Dislivelli		0.00 -0.33	-0.74	-0.75 0.00	

Sezione: 90
 Progressiva: 960.000
 Q. Progetto: 117.806

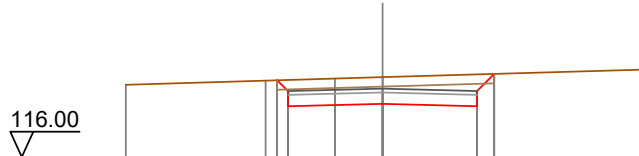

Quote Terreno	117.91	118.02	118.07	118.11	118.31
Quote Progetto		118.03 117.34	117.41	117.34 118.20	118.31
Parziali		0.28 2.50	2.50	0.45 2.95	
Progressiva		-2.79 -2.50	0.00	2.50 2.95	
Dislivelli		-0.00 -0.30	-0.71	-0.84 0.00	

Sezione: 91
 Progressiva: 977.646
 Q. Progetto: 117.785

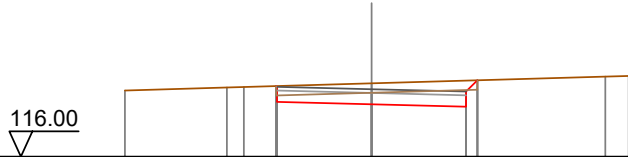

Quote Terreno	117.75	117.83	117.84	117.94	118.12	118.14
Quote Progetto			117.45	117.39	117.32	118.02
Parziali			2.50	2.50	0.30	
Progressiva			-2.52	0.00	2.50	2.80
Dislivelli			-0.00	-0.56	-0.69	-0.00

Sezione: 92
 Progressiva: 980.000
 Q. Progetto: 117.792

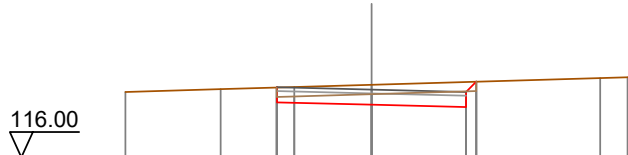

Quote Terreno	117.73	117.80	117.86	117.92	118.10	118.12
Quote Progetto			117.45	117.39	117.33	118.00
Parziali			2.50	2.50	0.27	
Progressiva			-2.51	0.00	2.50	2.77
Dislivelli			0.00	-0.53	-0.86	0.00

Sezione: 93
 Progressiva: 985.930
 Q. Progetto: 117.817

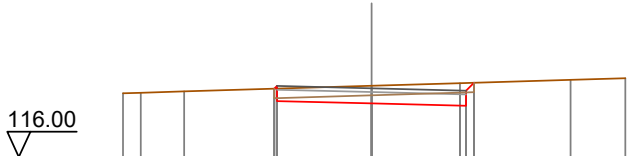

Quote Terreno	117.68	117.70	117.73	117.88	117.95	118.04	118.08
Quote Progetto				117.42	117.35	117.96	
Parziali				2.50	2.50		
Progressiva				-2.57	0.00	2.50	2.71
Dislivelli				-0.00	-0.47	-0.60	0.00

Sezione: 94
 Progressiva: 990.000
 Q. Progetto: 117.842

116.00

Quote Terreno	117.67	117.68	117.76	117.87	118.00	118.04	118.07
Quote Progetto			117.79	117.50	117.44	117.38	117.95
Parziali			2.50	2.50			
Progressiva			-2.61	-2.50	0.00	2.50	2.67
Dislivelli			0.00	0.11	-0.43	-0.57	0.00

Sezione: 95
 Progressiva: 994.213
 Q. Progetto: 117.875

116.00

Quote Terreno	117.66		117.83	117.87	117.96		118.07
Quote Progetto			117.78	117.54	117.47	117.41	117.95
Parziali			2.50	2.50			
Progressiva			-2.65	-2.50	0.00	2.50	2.63
Dislivelli			0.00	0.15	-0.39	-0.53	0.00

Sezione: 96
 Progressiva: 1000.000
 Q. Progetto: 117.931

116.00

Quote Terreno	117.67		117.85	117.87	117.89	117.90	117.94	118.07
Quote Progetto			117.79	117.47	117.53	117.47	117.95	
Parziali			2.50	2.50				
Progressiva			-2.58	-2.50	0.00	2.50	2.58	
Dislivelli			0.00	0.08	-0.34	-0.47	0.00	

Sezione: 97
 Progressiva: 1020.000
 Q. Progetto: 118.223

116.00

Quote Terreno		117.65		117.86		117.97		118.07
Quote Progetto			117.77	117.82	117.76		117.94	
Parziali			0.39	2.50	2.50			
Progressiva			-2.89	0.00	2.50		2.72	
Dislivelli			0.00	-0.04	-0.18		-0.00	

Sezione: 98
 Progressiva: 1040.000
 Q. Progetto: 118.668

116.00

Quote Terreno		117.60	117.67	117.70	117.71		117.83		118.04	118.06
Quote Progetto				117.72	118.21		118.27	118.21	117.93	
Parziali				0.88	2.50		2.50	0.67		
Progressiva				-3.38	-2.50		0.00	2.50	3.17	
Dislivelli				0.00	0.85		0.44	0.29	0.00	

Sezione: 99
 Progressiva: 1049.178
 Q. Progetto: 118.924

116.00

Quote Terreno		117.55		117.79		117.80		117.90		118.05
Quote Progetto			117.68	118.59	118.52	118.60	118.46	117.92		
Parziali			1.31	2.50	2.50	0.95				
Progressiva			-3.81	-2.50	0.00	2.50	3.45			
Dislivelli			0.00	1.26	0.72	0.58	0.00			

Sezione: 100
 Progressiva: 1050.000
 Q. Progetto: 118.948

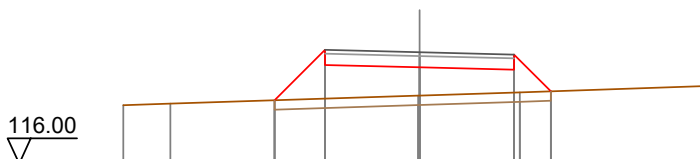

Quote Terreno	117.55	117.59			117.80	117.80	117.89	118.05
Quote Progetto			117.68	118.61	118.55	118.49	117.91	
Parziali			1.33	2.50	2.50	0.97		
Progressiva			-3.83	-2.50	0.00	2.50	3.47	
Dislivelli			0.00	1.29	0.75	0.60	-0.00	

Sezione: 101
 Progressiva: 1060.000
 Q. Progetto: 119.267

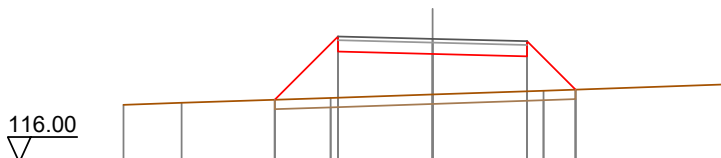

Quote Terreno	117.52	117.57		117.70	117.80	117.88	118.06
Quote Progetto			117.65	118.93	118.87	118.80	117.92
Parziali			1.67	2.50	2.50	1.28	
Progressiva			-4.17	-2.50	0.00	2.50	3.78
Dislivelli			0.00	1.62	1.07	0.92	0.00

Sezione: 102
 Progressiva: 1062.862
 Q. Progetto: 119.365

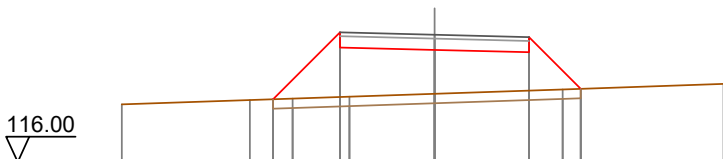

Quote Terreno	117.52	117.64	117.68	117.73	117.81	117.92	118.06
Quote Progetto		117.66	119.03	118.96	118.90	117.94	118.07
Parziali		1.77	2.50	2.50	1.37		
Progressiva		-4.27	-2.50	0.00	2.50	3.87	
Dislivelli		0.00	1.71	1.16	1.01	0.00	

Sezione: 103
 Progressiva: 1070.000
 Q. Progetto: 119.623

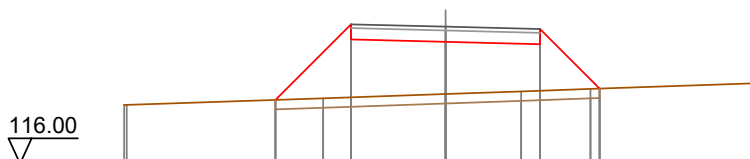

Quote Terreno		117.55	117.56		117.73		117.84		117.91		117.98		118.12
Quote Progetto					117.69		119.29		119.22		119.16		117.99
Parziali					2.00		2.50		2.50		1.58		
Progressiva					-4.50		-2.50		0.00		2.50		4.08
Dislivelli					-0.00		1.33		1.38		1.23		-0.00

Sezione: 104
 Progressiva: 1076.546
 Q. Progetto: 119.834

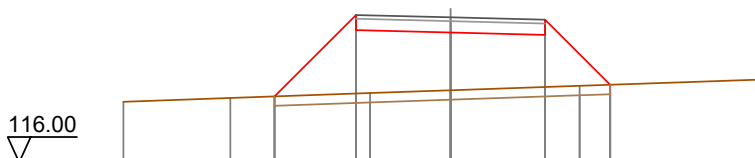

Quote Terreno		117.60		117.70		117.84		117.91		118.02		118.19
Quote Progetto				117.74		119.50		119.43		119.37		118.05
Parziali				2.15		2.50		2.50		1.72		
Progressiva				-4.65		-2.50		0.00		2.50		4.22
Dislivelli				0.00		2.08		1.53		1.38		0.00

Sezione: 105
 Progressiva: 1080.000
 Q. Progetto: 119.911

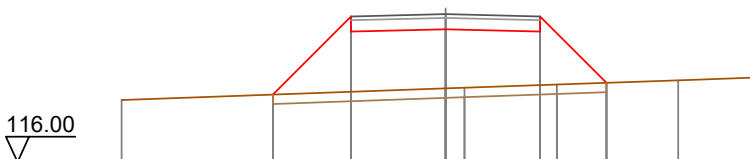

Quote Terreno		117.64						117.95		117.97		118.05		118.16		118.24
Quote Progetto								117.78		119.45		119.51		119.45		118.09
Parziali								2.07		2.50		2.50		1.75		
Progressiva								-4.57		-2.50		0.00		2.50		4.25
Dislivelli								0.00		1.99		1.56		1.42		0.00

Sezione: 106
 Progressiva: 1084.857
 Q. Progetto: 119.979

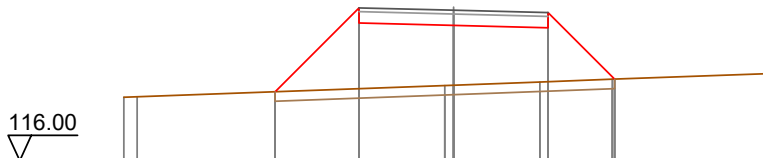

Quote Terreno		117.68	117.88		117.99	118.00	118.08	118.15	118.30
Quote Progetto			117.82	119.64	119.58	119.52	118.16		
Parziali			2.22	2.50	2.50	1.76			
Progressiva			-4.72	-2.50	0.00	2.50	4.26		
Dislivelli			0.00	2.14	1.58	1.43	0.00		

Sezione: 107
 Progressiva: 1090.000
 Q. Progetto: 120.000

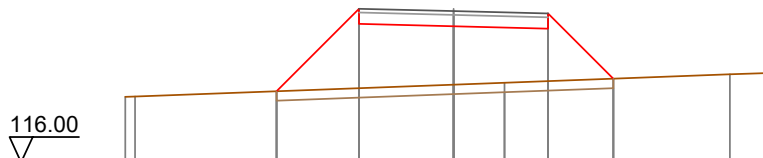

Quote Terreno		117.73	117.74		118.05	118.10		118.33	118.36
Quote Progetto			117.88	119.66	119.60	119.54	118.21		
Parziali			2.18	2.50	2.50	1.72			
Progressiva			-4.68	-2.50	0.00	2.50	4.22		
Dislivelli			0.00	2.10	1.55	1.39	0.00		

SEZIONI TRASVERSALI

Profilo longitudinale tratto 13-14

Viabilità di impianto - Postazione aerogeneratore WTG07

Nota: Le canalette di deflusso delle acque meteoriche, non indicate nel presente elaborato, sono rappresentate graficamente nelle sezioni stradali tipo dell'elaborato "BLTX-NS-TC13_Piazzole aerogeneratori e strade di servizio - Particolari costruttivi", individuate planimetricamente nell'elaborato "BLTX-NS-TC14_Opere di regimazione acque superficiali - Planimetria generale" e quantificate nell'elaborato "BLTX-NS-RC6_Computo metrico estimativo opere civili".

DISEGNI DI RIFERIMENTO

TAVOLA	DESCRIZIONE
BLTX-NS-TC8	Viabilità e piazzole - Planimetria di progetto - Fase di cantiere
BLTX-NS-TC11	Profili longitudinali viabilità di impianto
BLTX-NS-TC13	Piazzole aerogeneratori e strade di servizio - Particolari costruttivi
BLTX-NS-TC14	Opere di regimazione acque superficiali - Planimetria generale

Sezione: 7
 Progressiva: 25.000
 Q. Progetto: 140.127

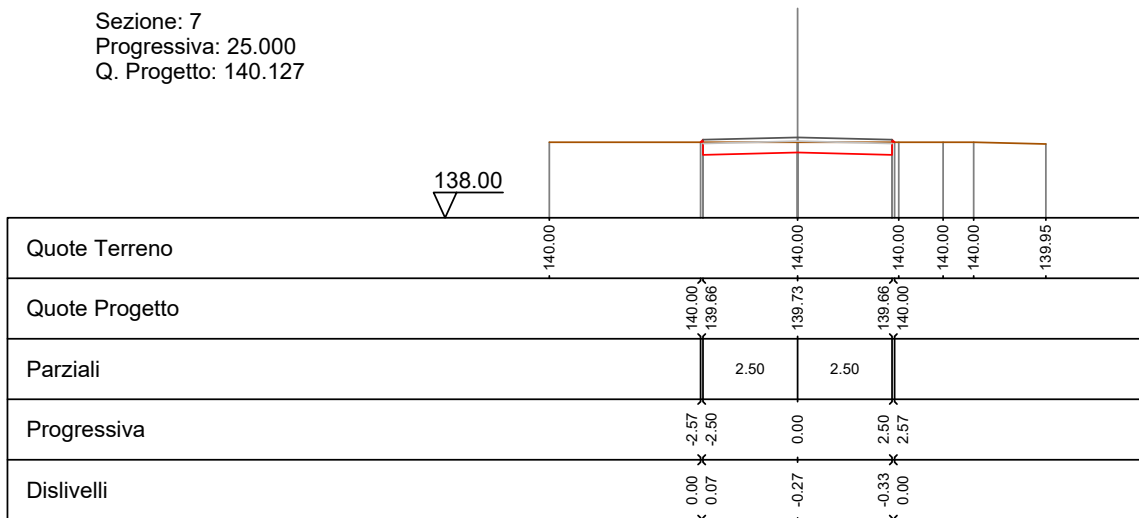

Sezione: 8
 Progressiva: 40.000
 Q. Progetto: 140.492

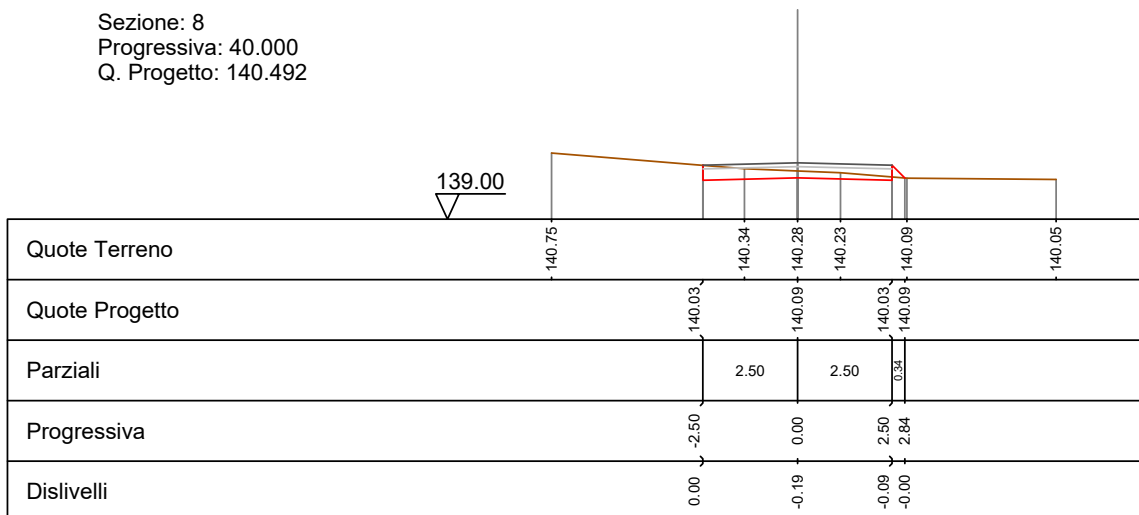

Sezione: 9
 Progressiva: 43.767
 Q. Progetto: 140.654

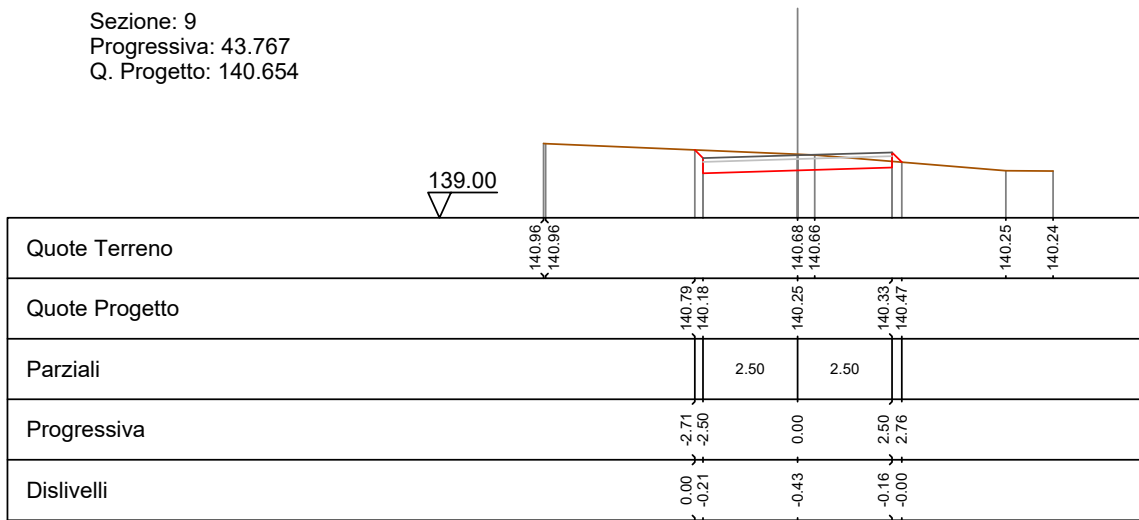

Sezione: 10
 Progressiva: 47.450
 Q. Progetto: 140.840

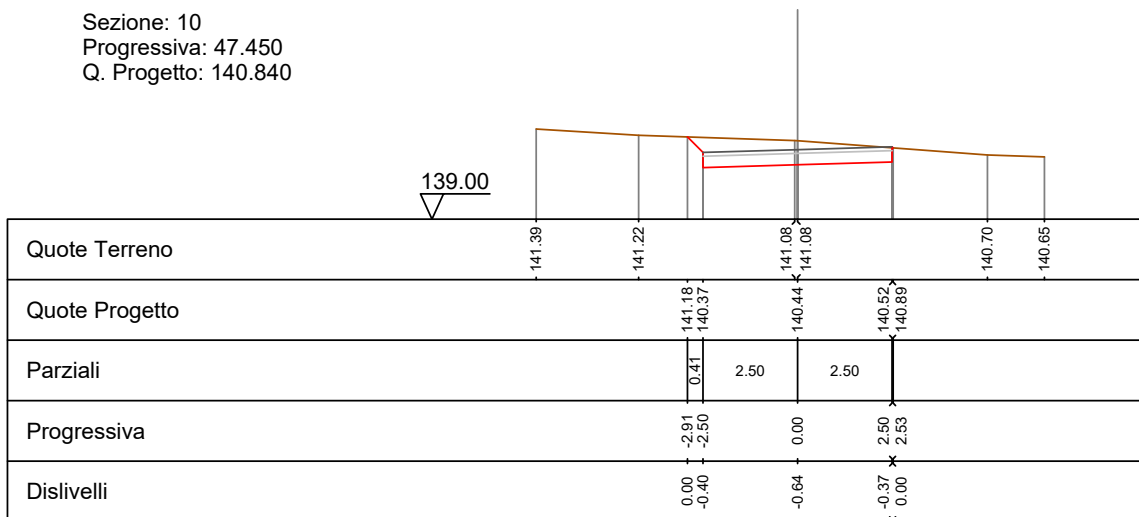

Sezione: 11
 Progressiva: 50.000
 Q. Progetto: 140.985

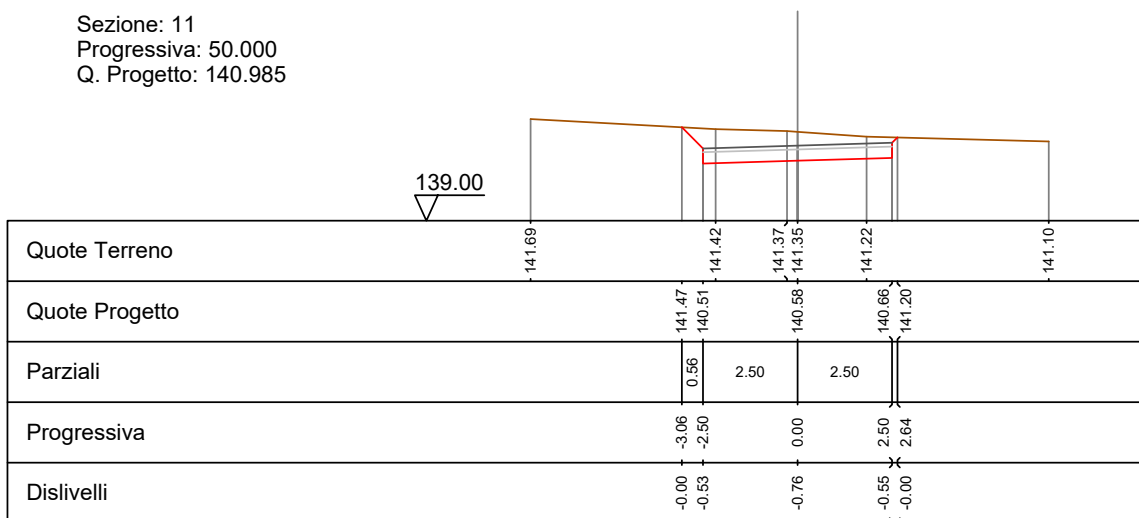

Sezione: 12
 Progressiva: 51.134
 Q. Progetto: 141.053

139.00

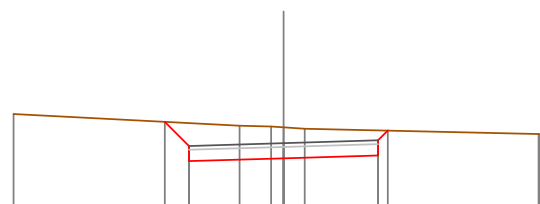

Quote Terreno		141.82		141.52	141.50	141.47	141.44		141.30
Quote Progetto			141.62	140.58		140.65		140.73	141.39
Parziali			0.64	2.50		2.50		0.28	
Progressiva			-3.14	-2.50		0.00		2.50	2.76
Dislivelli			0.00	-0.61		-0.82		-0.66	0.00

Sezione: 13
 Progressiva: 60.000
 Q. Progetto: 141.650

140.00

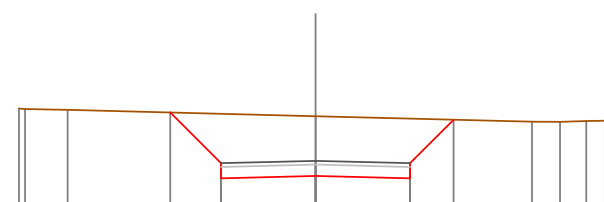

Quote Terreno		143.03	143.02	143.00			142.83			142.68	142.68	142.70	142.71
Quote Progetto					142.93	141.19	141.25	141.19	142.74				
Parziali					1.34	2.50	2.50	1.15					
Progressiva					-3.84	-2.50	0.00	2.50	3.65				
Dislivelli					-0.00	-1.31	-1.58	-1.58	0.00				

Sezione: 14
 Progressiva: 75.384
 Q. Progetto: 142.709

141.00

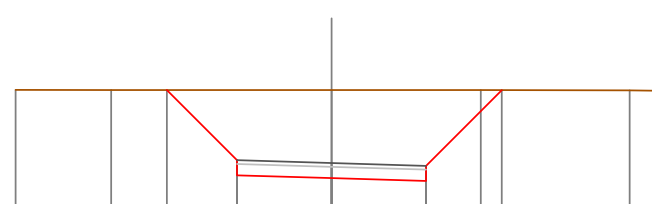

Quote Terreno				144.65	144.64		144.64	144.64	144.64		144.63	144.62
Quote Progetto				144.64	142.38		142.31	142.23	144.64			
Parziali				1.85	2.50		2.50	2.00				
Progressiva				-4.35	-2.50		0.00	2.50	4.50			
Dislivelli				0.00	-1.85		-2.33	-2.40	-0.00			

Sezione: 15
 Progressiva: 80.000
 Q. Progetto: 143.027

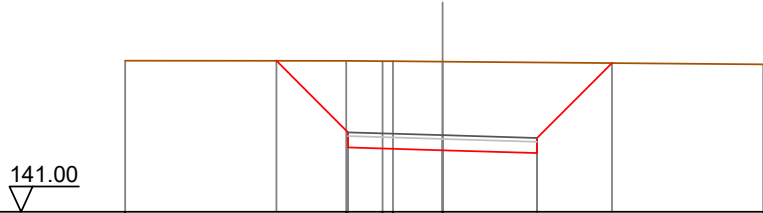

Quote Terreno		145.00		144.99	144.98	144.98	144.97		144.90
Quote Progetto			145.00	142.70			142.63	142.55	144.93
Parziali			1.89	2.50		2.50		1.98	
Progressiva			-4.39	-2.50		0.00		2.50	4.48
Dislivelli			0.00	-1.89		-2.34		-2.40	-0.00

Sezione: 16
 Progressiva: 90.000
 Q. Progetto: 143.716

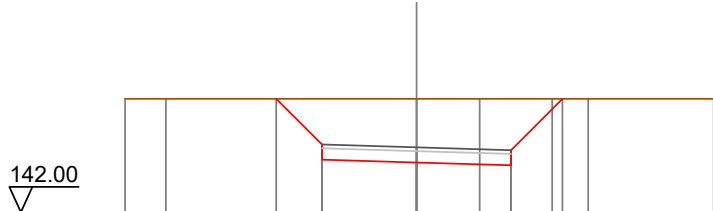

Quote Terreno		145.00	145.00		145.00	145.00	145.00	145.00	145.00
Quote Progetto				145.00	143.39		143.32	143.24	145.00
Parziali				1.21	2.50		2.50	1.36	
Progressiva				-3.71	-2.50		0.00	2.50	3.86
Dislivelli				0.00	-1.21		-1.68	-1.76	0.00

Sezione: 17
 Progressiva: 91.943
 Q. Progetto: 143.849

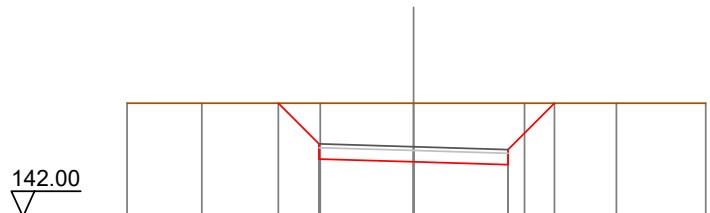

Quote Terreno		145.00	145.00	145.00	145.00	145.00	145.00	145.00	145.00
Quote Progetto				145.00	143.52		143.45	143.37	145.00
Parziali				1.08	2.50		2.50	1.23	
Progressiva				-3.58	-2.50		0.00	2.50	3.73
Dislivelli				0.00	-1.08		-1.55	-1.63	0.00

Sezione: 18
 Progressiva: 100.000
 Q. Progetto: 144.362

142.00

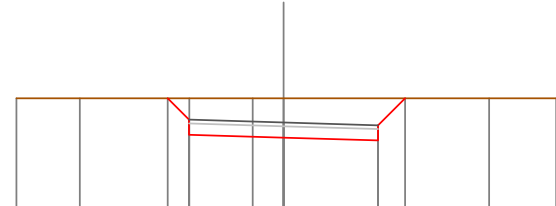

Quote Terreno	145.00	145.00	145.00	145.00	145.00	145.00	145.00
Quote Progetto			145.00	144.04	143.96	143.89	145.00
Parziali			0.56	2.50	2.50	0.71	
Progressiva			-3.06	-2.50	0.00	2.50	3.21
Dislivelli			0.00	-0.56	-1.04	-1.11	0.00

Sezione: 19
 Progressiva: 108.502
 Q. Progetto: 144.764

143.00

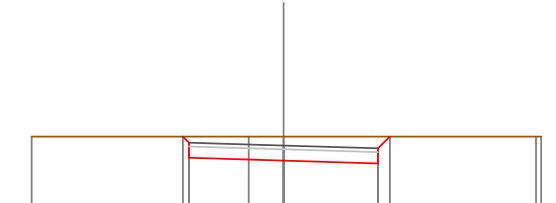

Quote Terreno	145.00	145.00	145.00	145.00	145.00	
Quote Progetto		145.00	144.44	144.36	144.29	145.00
Parziali			2.50	2.50	0.31	
Progressiva		-2.66	-2.50	0.00	2.50	2.81
Dislivelli		0.00	-0.16	-0.64	-0.71	0.00

Sezione: 20
 Progressiva: 120.000
 Q. Progetto: 145.078

143.00

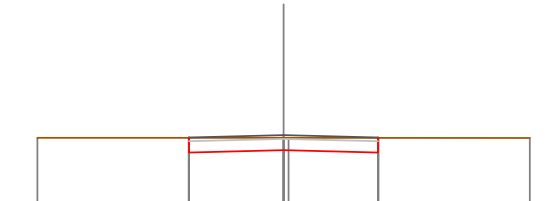

Quote Terreno	145.01	145.01	145.01	145.01	145.00
Quote Progetto		144.62	144.68	144.62	
Parziali			2.50	2.50	
Progressiva		-2.51	0.00	2.50	
Dislivelli		0.00	-0.33	-0.39	

Sezione: 21
 Progressiva: 134.959
 Q. Progetto: 145.177

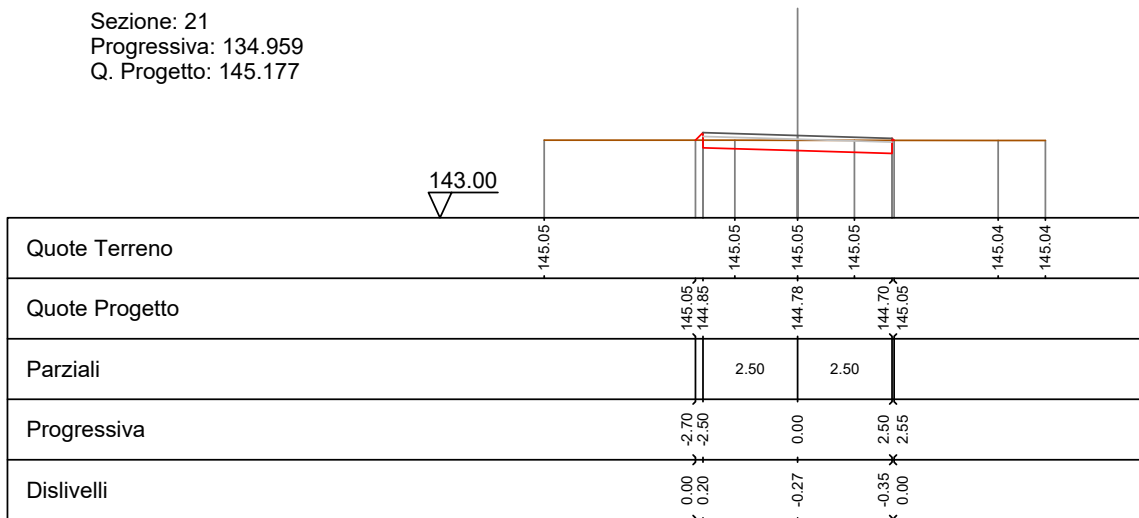

Sezione: 22
 Progressiva: 136.321
 Q. Progetto: 145.183

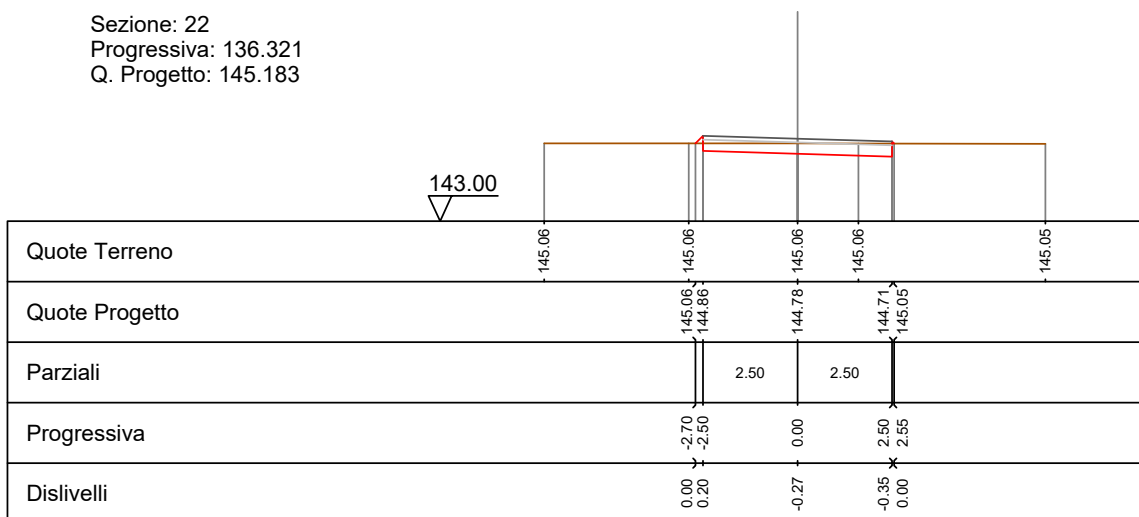

Sezione: 23
 Progressiva: 137.682
 Q. Progetto: 145.190

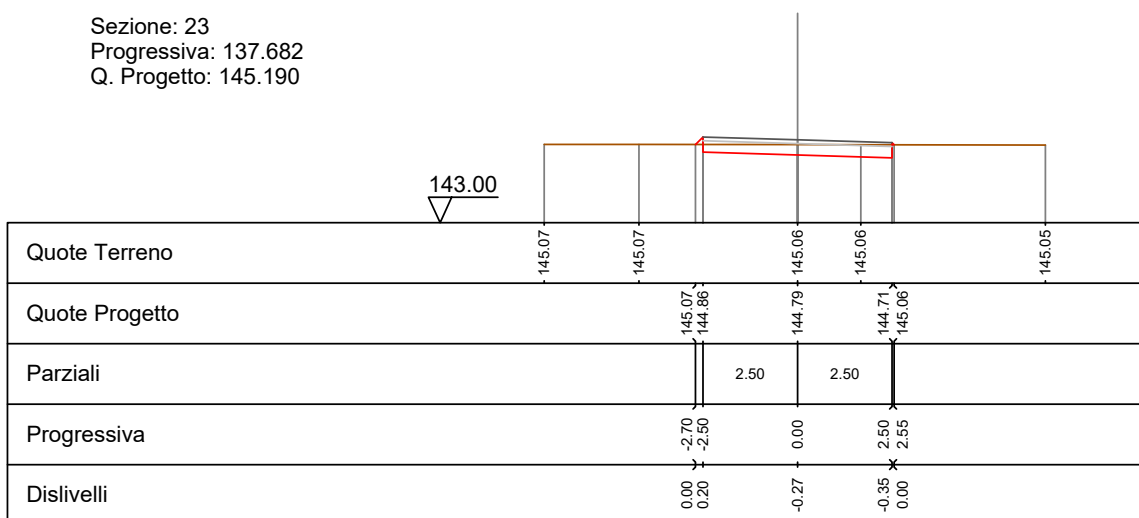

Sezione: 24
 Progressiva: 140.000
 Q. Progetto: 145.200

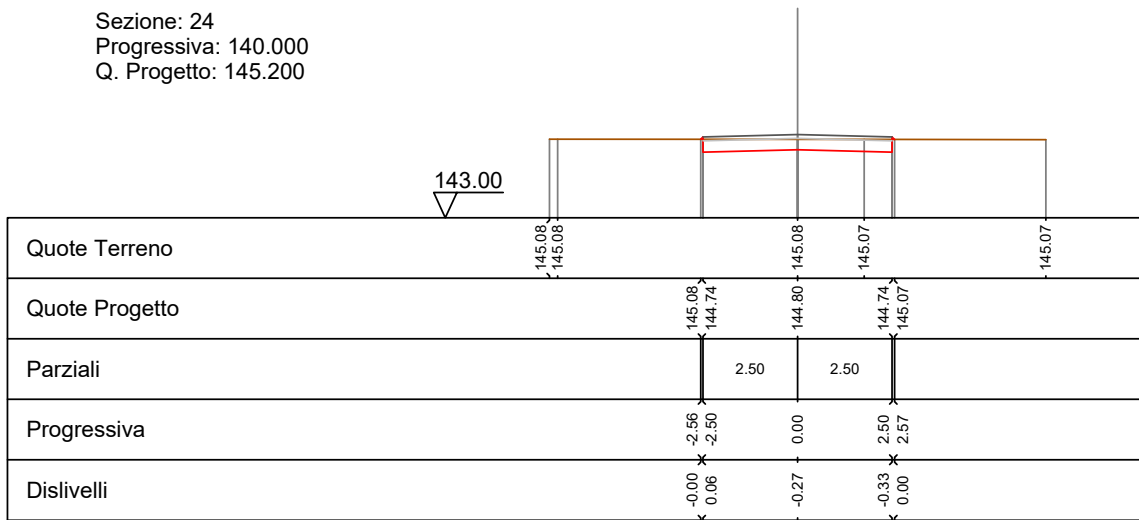

Sezione: 25
 Progressiva: 160.000
 Q. Progetto: 145.343

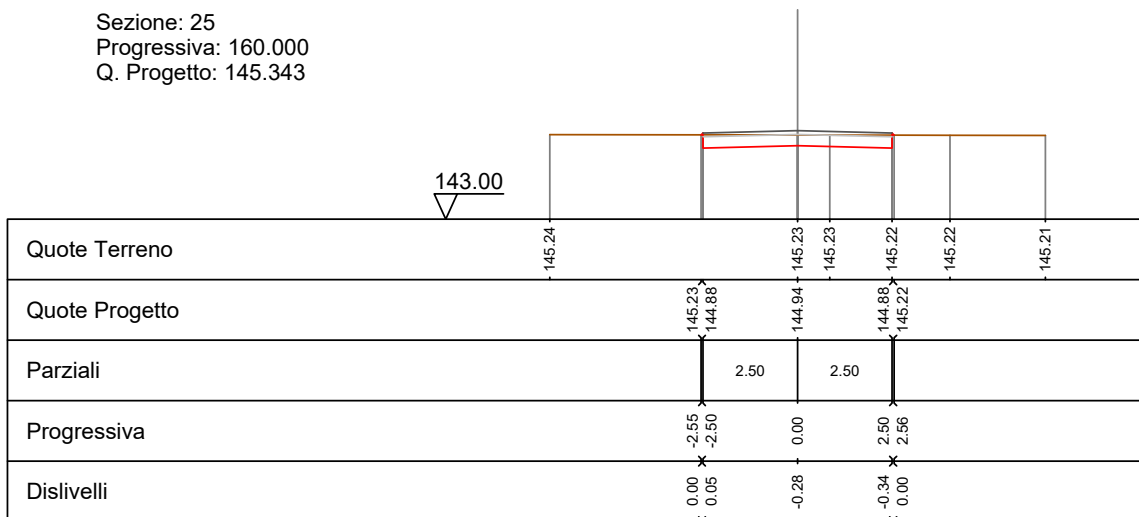

Sezione: 26
 Progressiva: 162.589
 Q. Progetto: 145.376

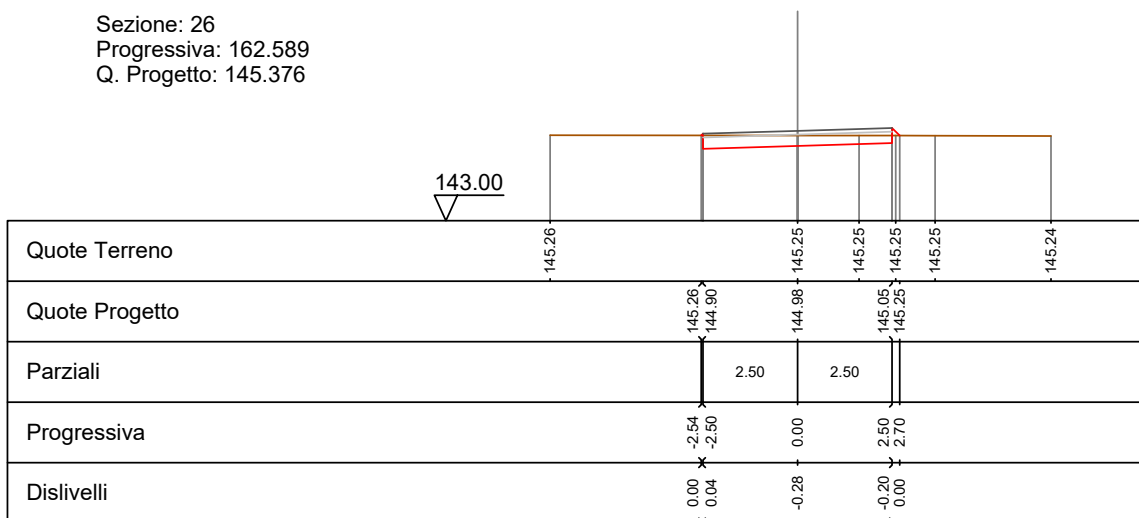

Sezione: 27
 Progressiva: 170.000
 Q. Progetto: 145.470

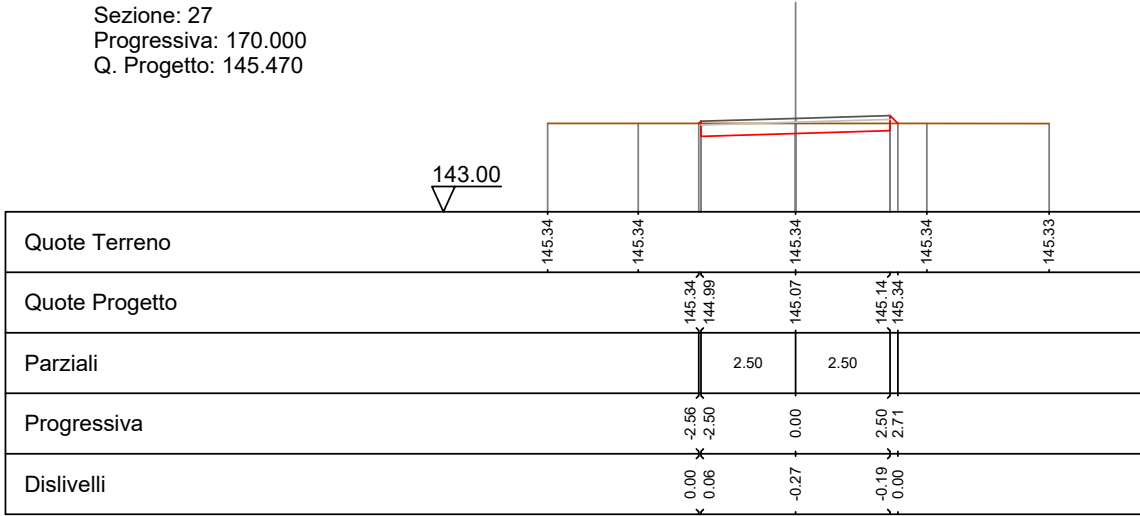

Sezione: 28
 Progressiva: 170.286
 Q. Progetto: 145.473

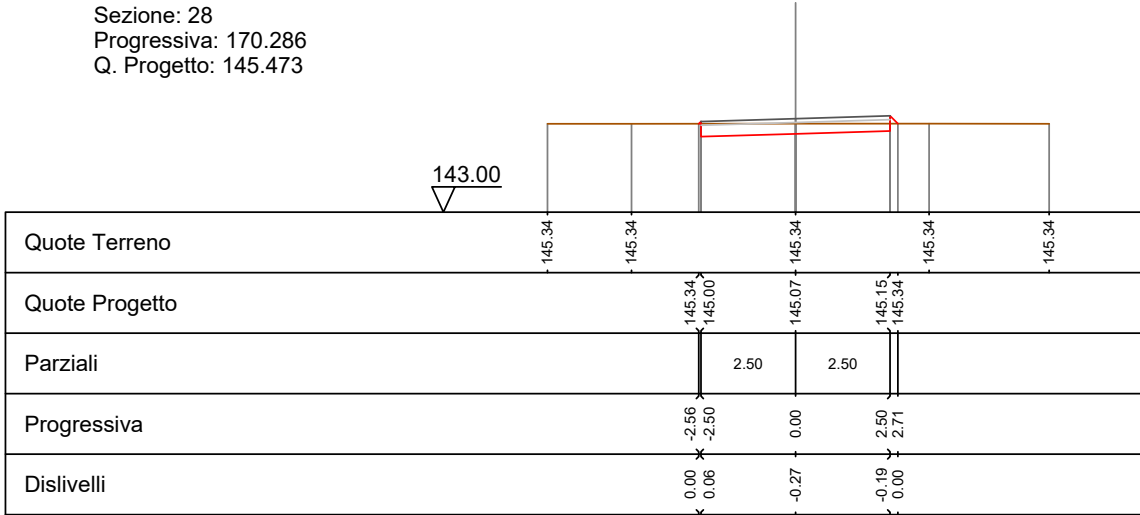

Sezione: 29
 Progressiva: 177.983
 Q. Progetto: 145.571

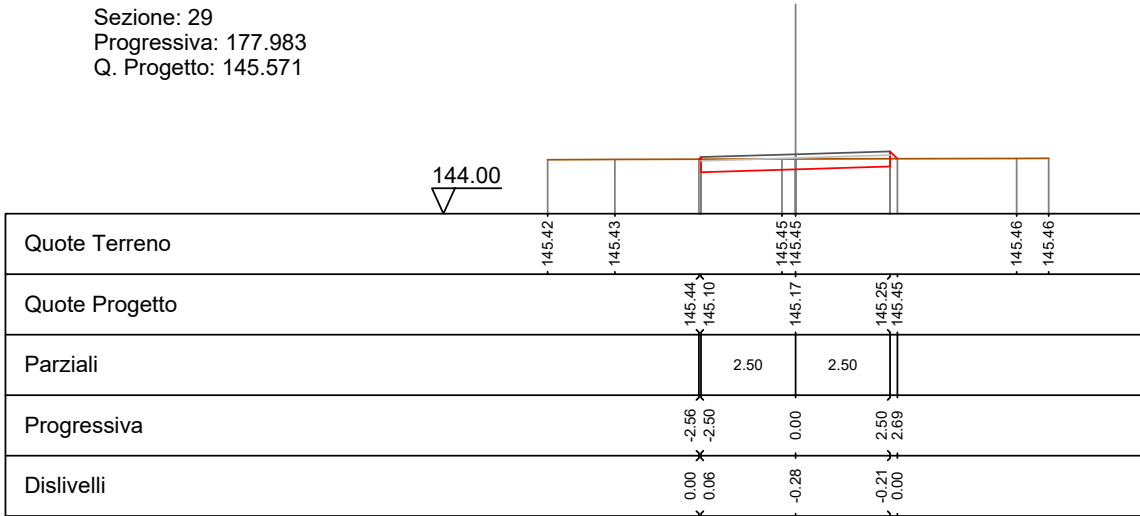

Sezione: 30
 Progressiva: 180.000
 Q. Progetto: 145.597

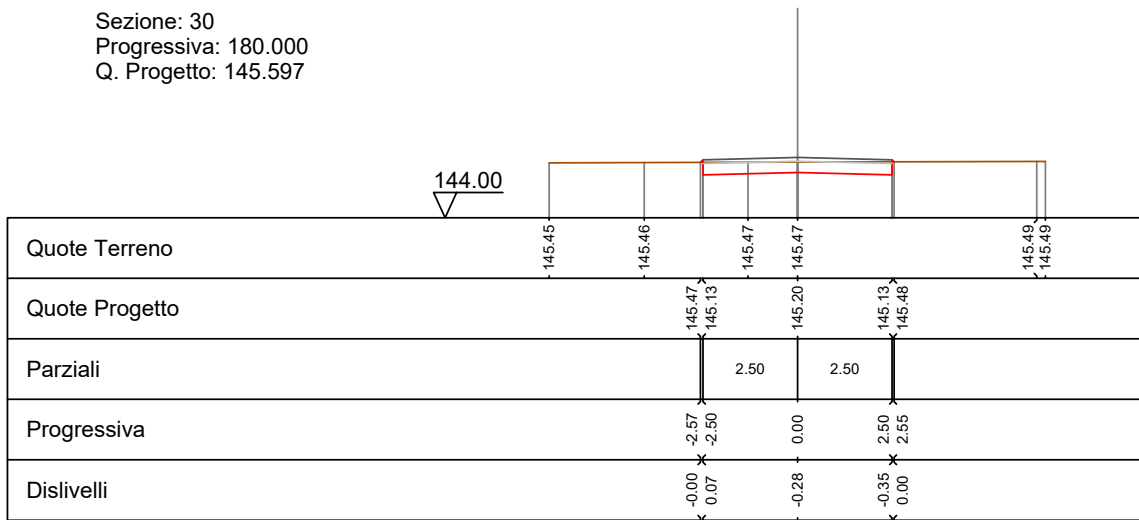

Sezione: 31
 Progressiva: 200.000
 Q. Progetto: 145.851

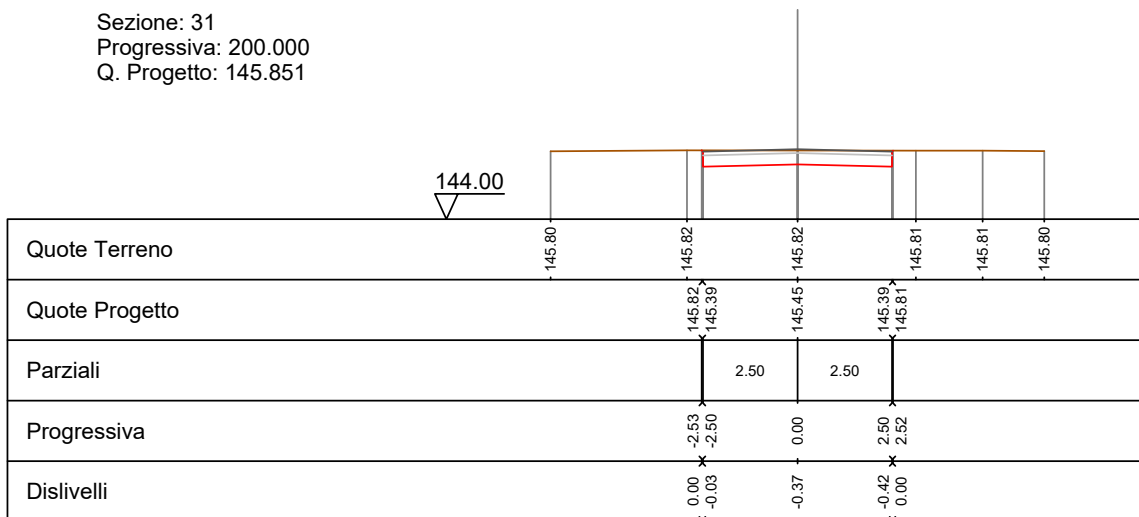

Sezione: 32
 Progressiva: 220.000
 Q. Progetto: 146.105

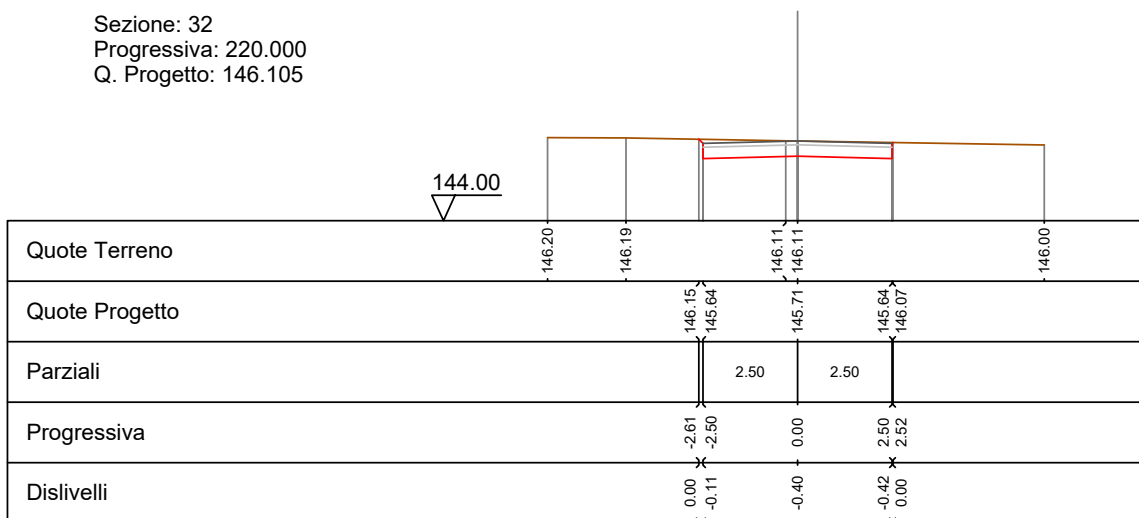

Sezione: 33
 Progressiva: 240.000
 Q. Progetto: 146.135

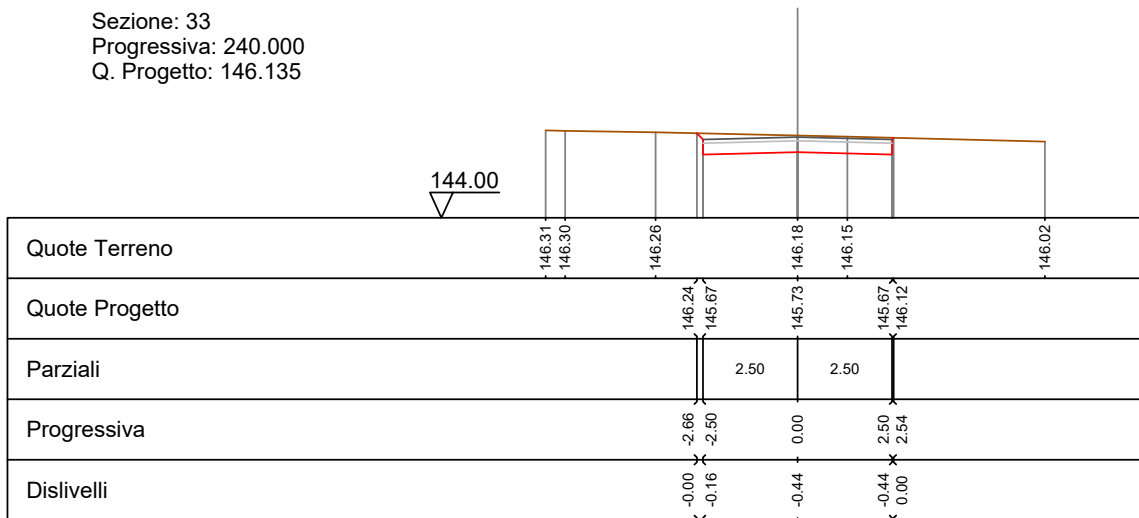

Sezione: 34
 Progressiva: 250.505
 Q. Progetto: 146.073

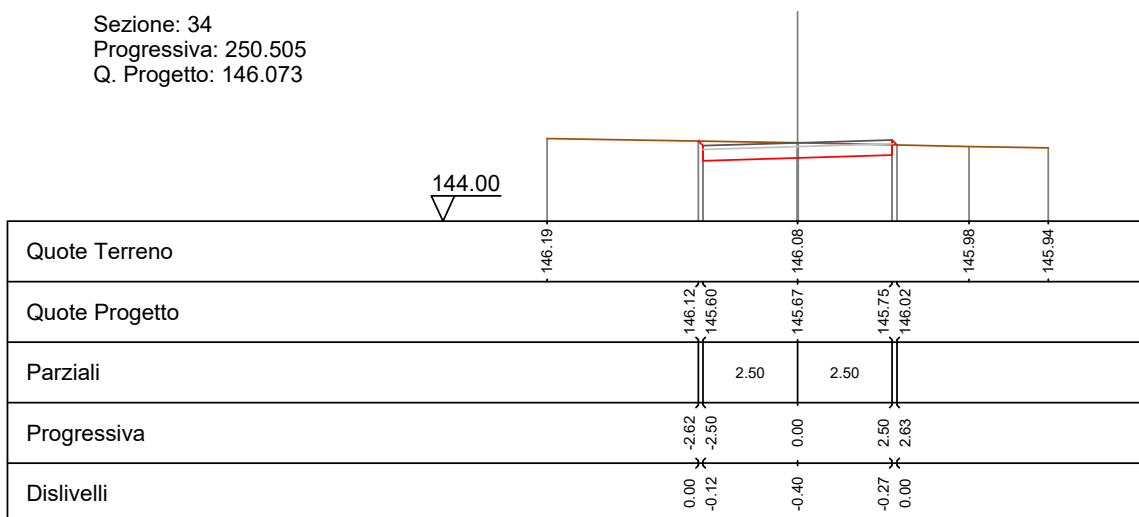

Sezione: 35
 Progressiva: 253.651
 Q. Progetto: 146.055

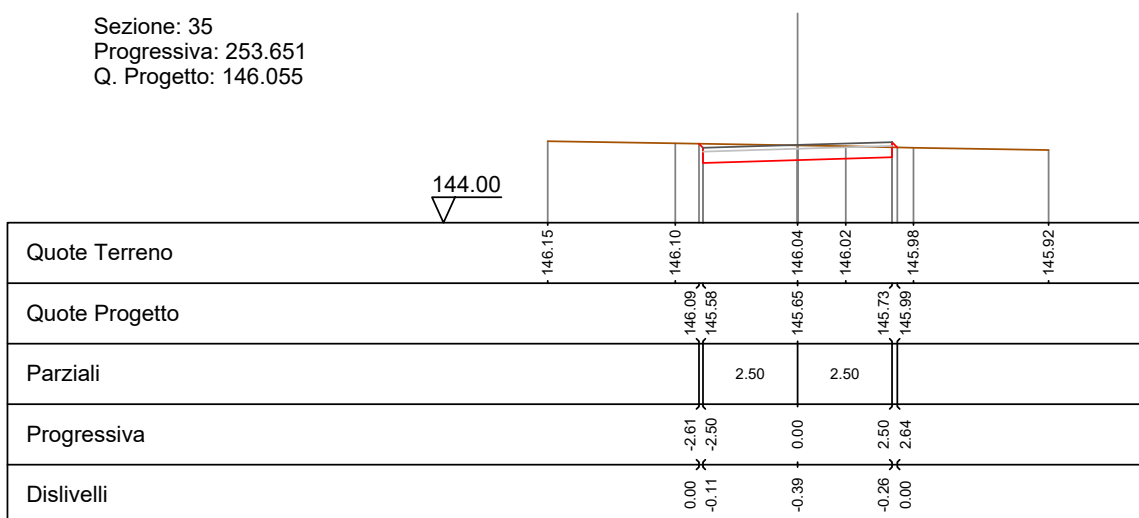

Sezione: 36
 Progressiva: 256.797
 Q. Progetto: 146.036

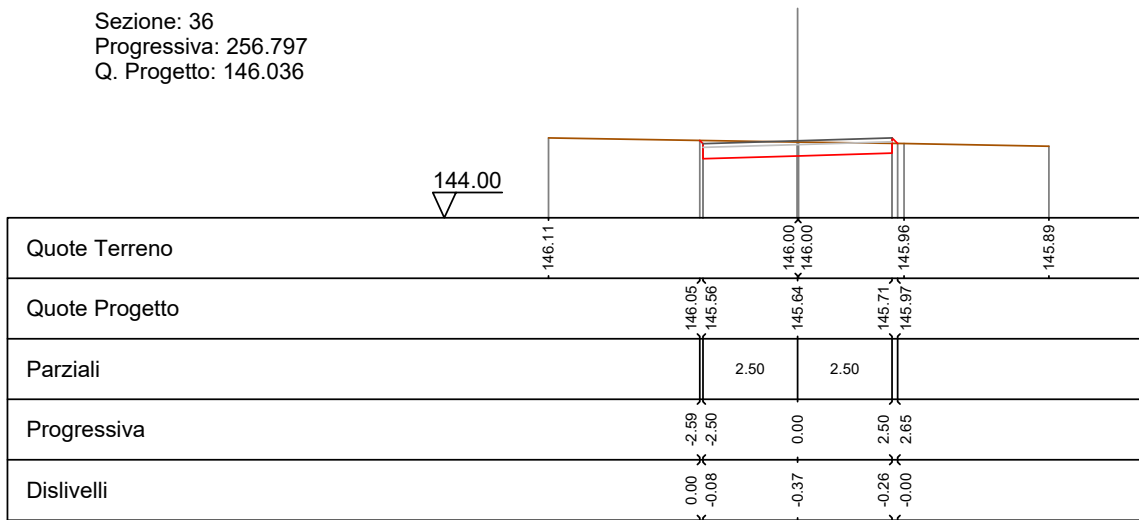

Sezione: 37
 Progressiva: 260.000
 Q. Progetto: 146.017

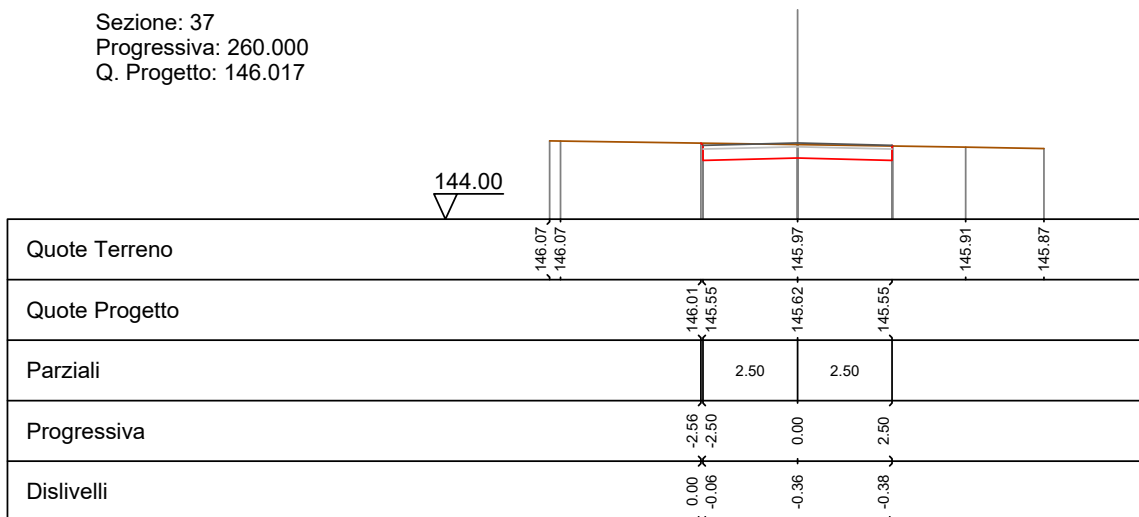

Sezione: 38
 Progressiva: 280.000
 Q. Progetto: 145.729

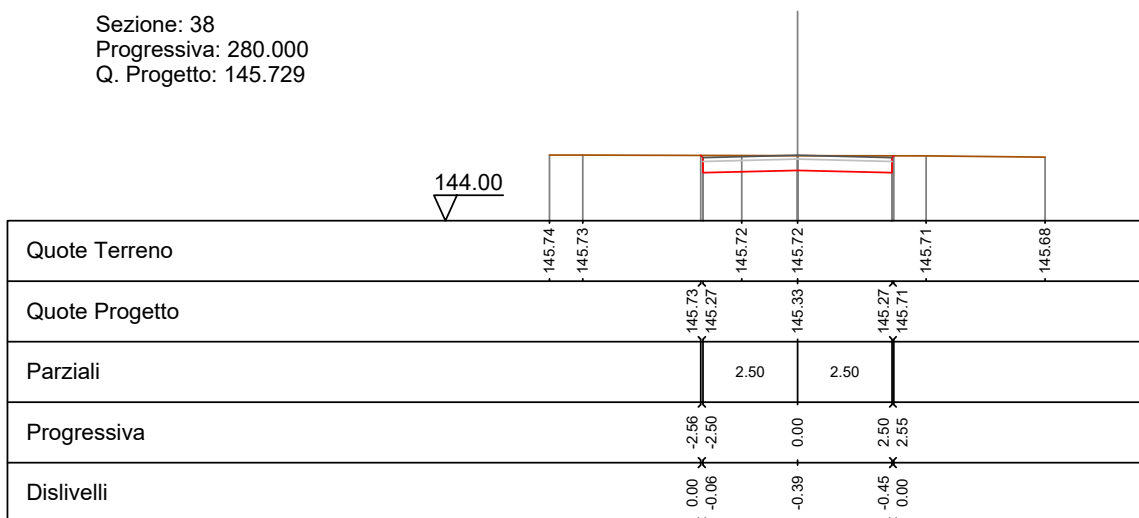

Sezione: 39
 Progressiva: 300.000
 Q. Progetto: 145.374

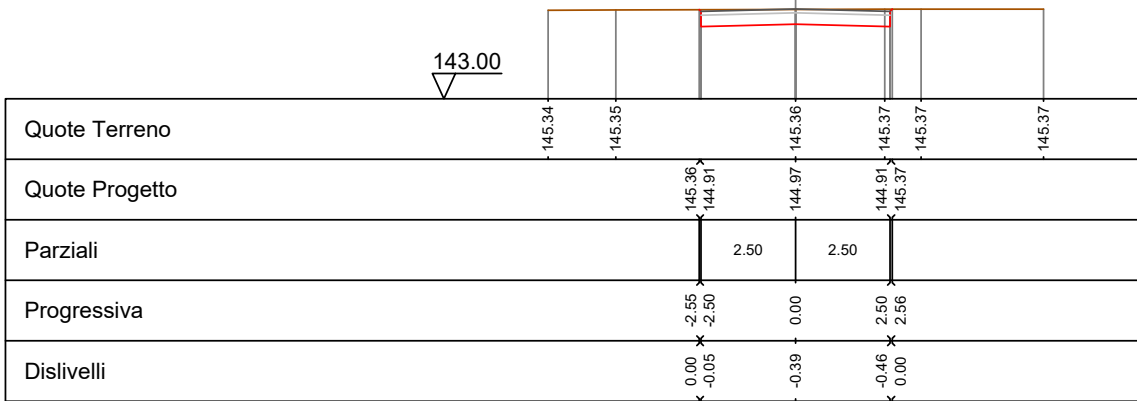

Sezione: 40
 Progressiva: 320.000
 Q. Progetto: 144.860

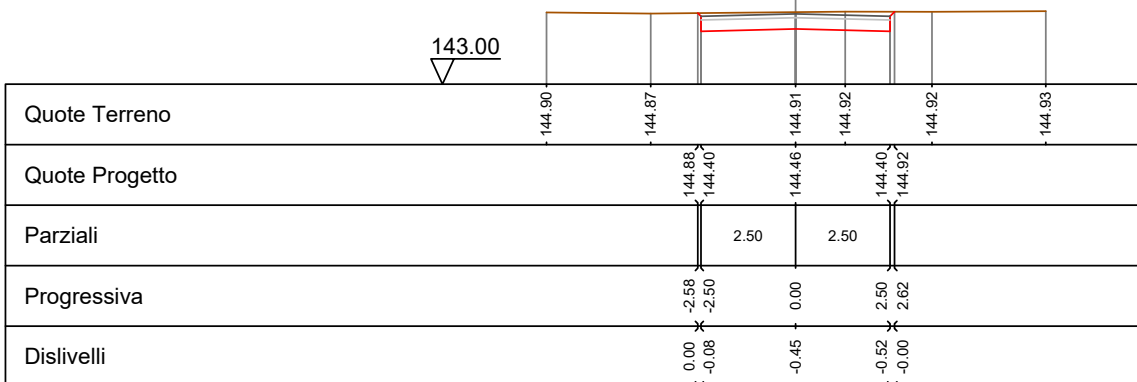

Sezione: 41
 Progressiva: 328.618
 Q. Progetto: 144.423

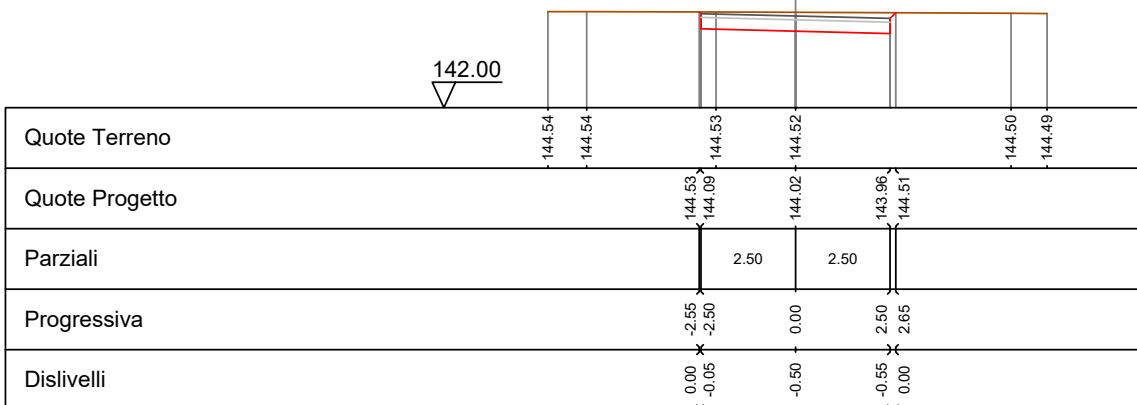

Sezione: 42
 Progressiva: 330.000
 Q. Progetto: 144.347

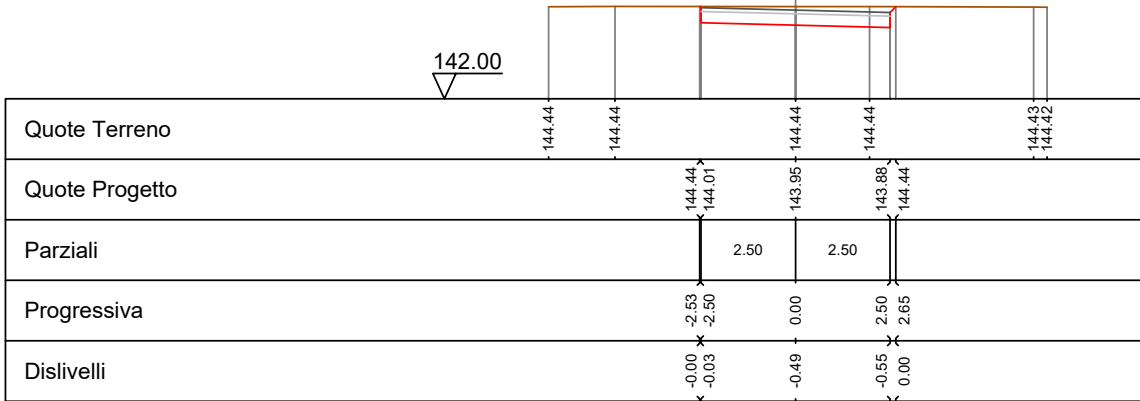

Sezione: 43
 Progressiva: 333.223
 Q. Progetto: 144.170

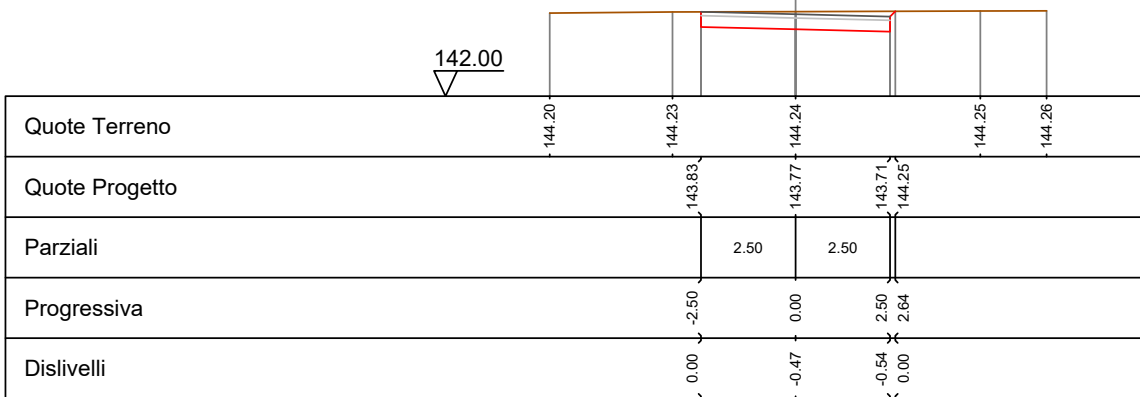

Sezione: 44
 Progressiva: 337.828
 Q. Progetto: 143.916

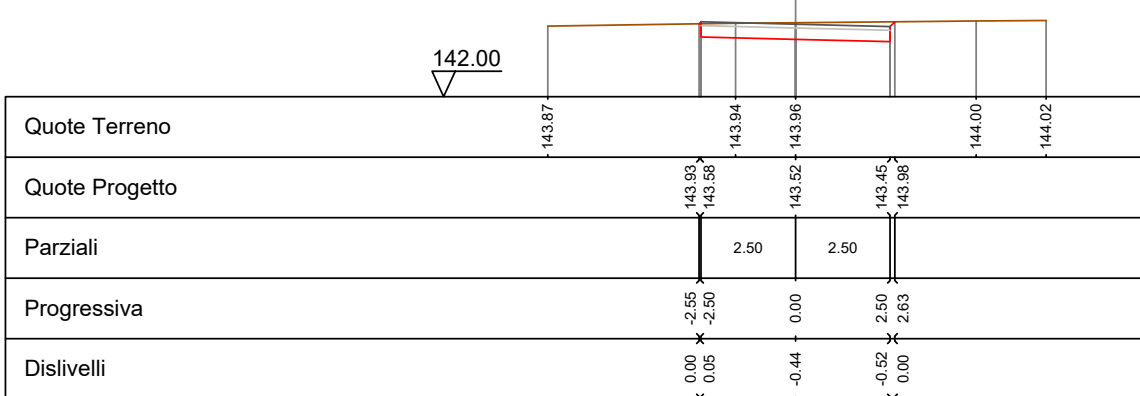

Sezione: 45
 Progressiva: 340.000
 Q. Progetto: 143.797

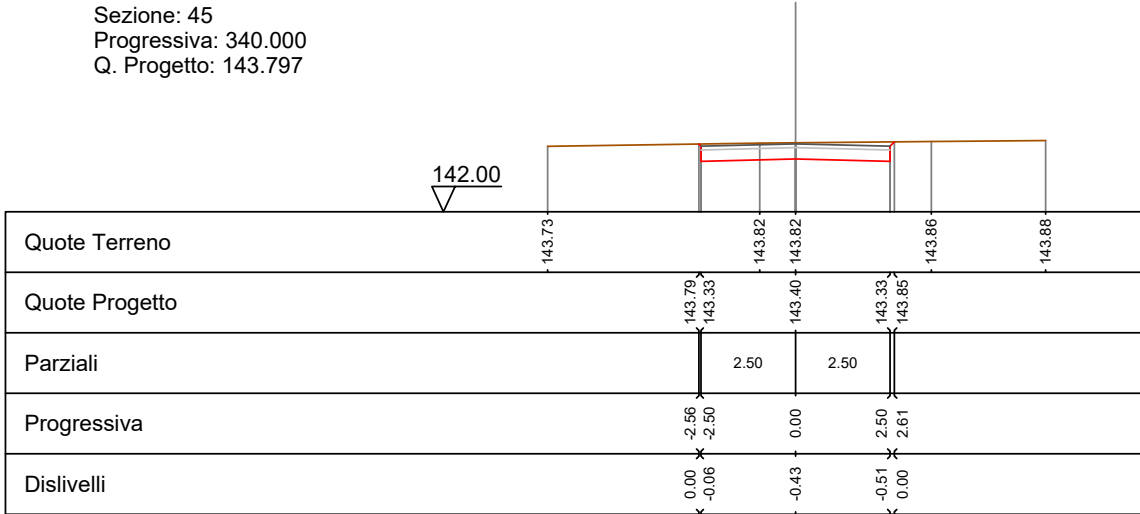

Sezione: 46
 Progressiva: 360.000
 Q. Progetto: 142.697

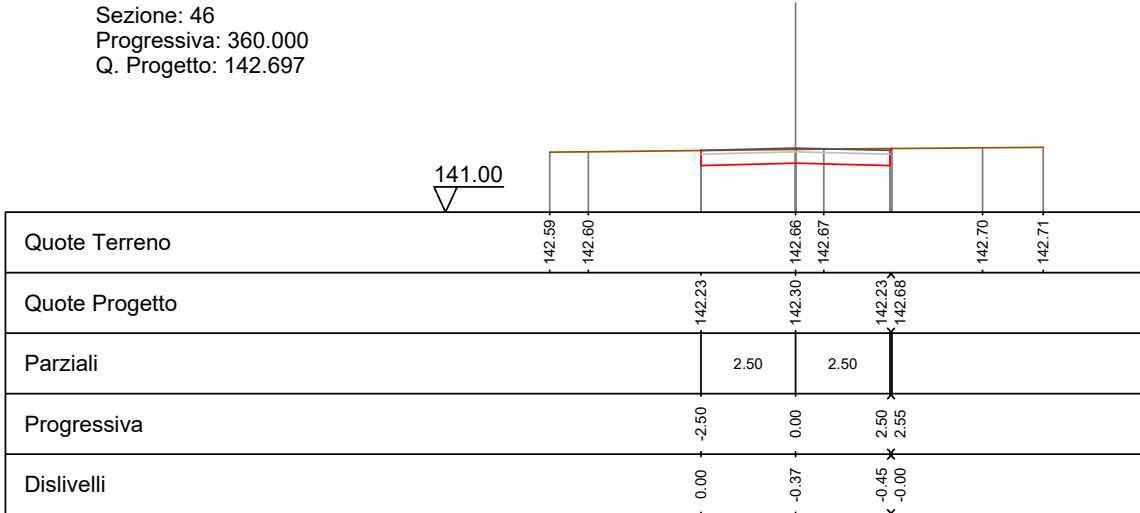

Sezione: 47
 Progressiva: 369.793
 Q. Progetto: 142.159

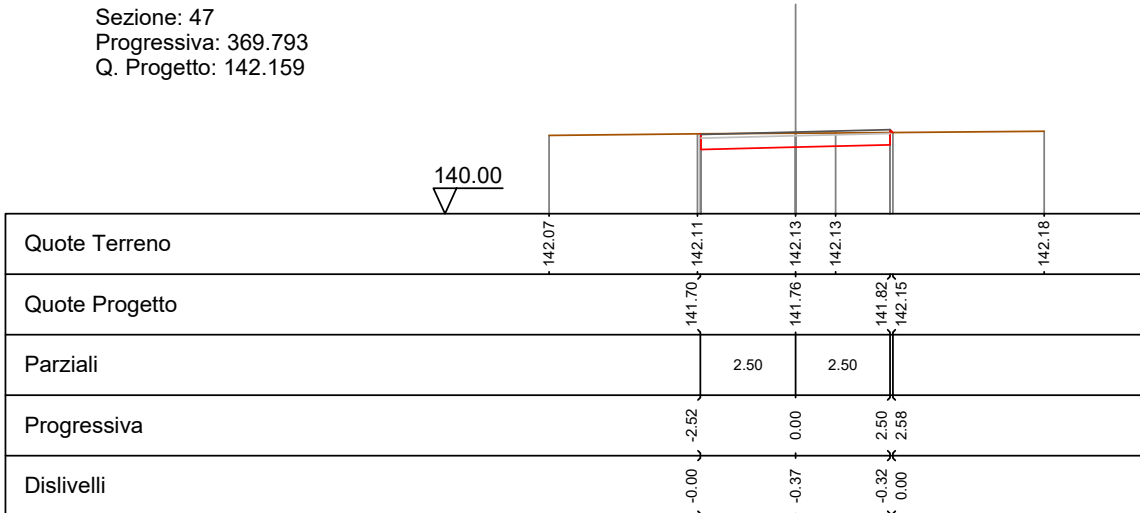

Sezione: 48
 Progressiva: 370.000
 Q. Progetto: 142.147

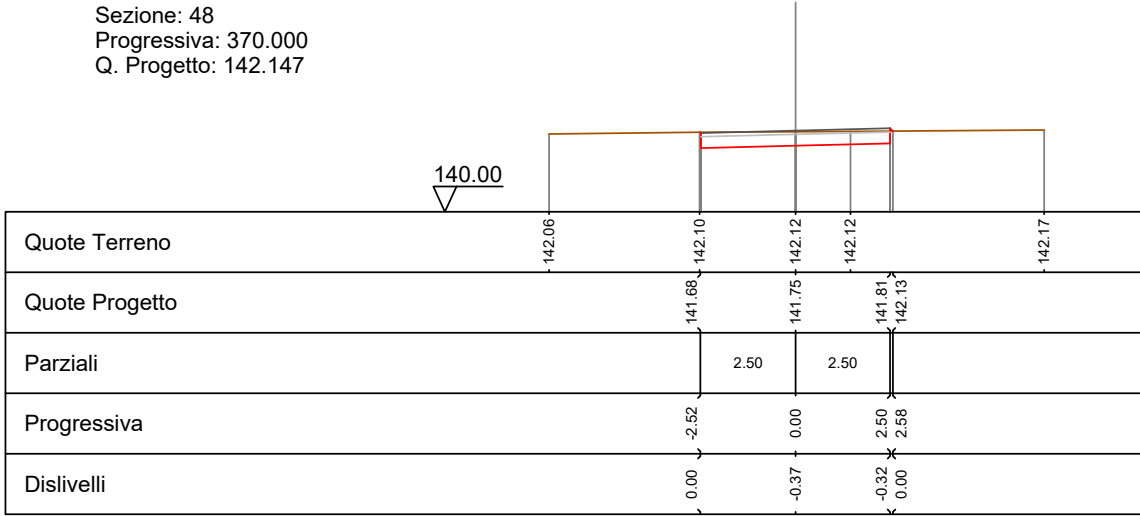

Sezione: 49
 Progressiva: 376.769
 Q. Progetto: 141.775

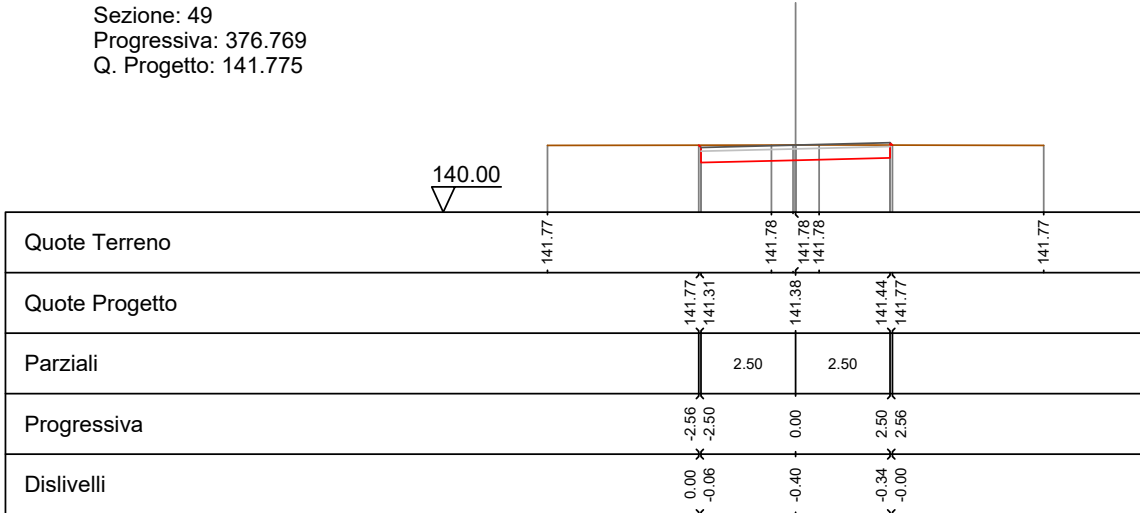

Sezione: 50
 Progressiva: 380.000
 Q. Progetto: 141.598

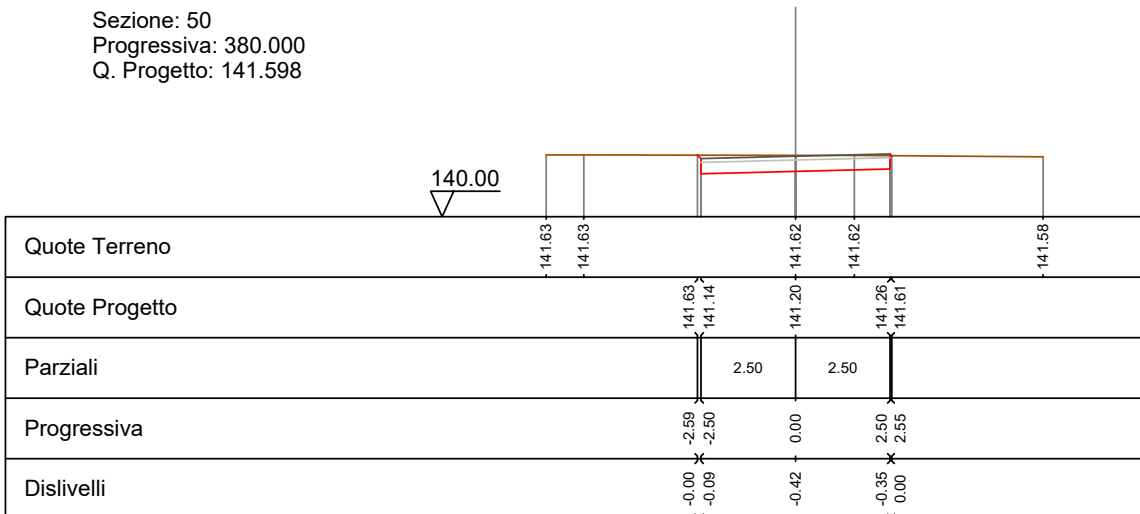

Sezione: 51
 Progressiva: 383.746
 Q. Progetto: 141.395

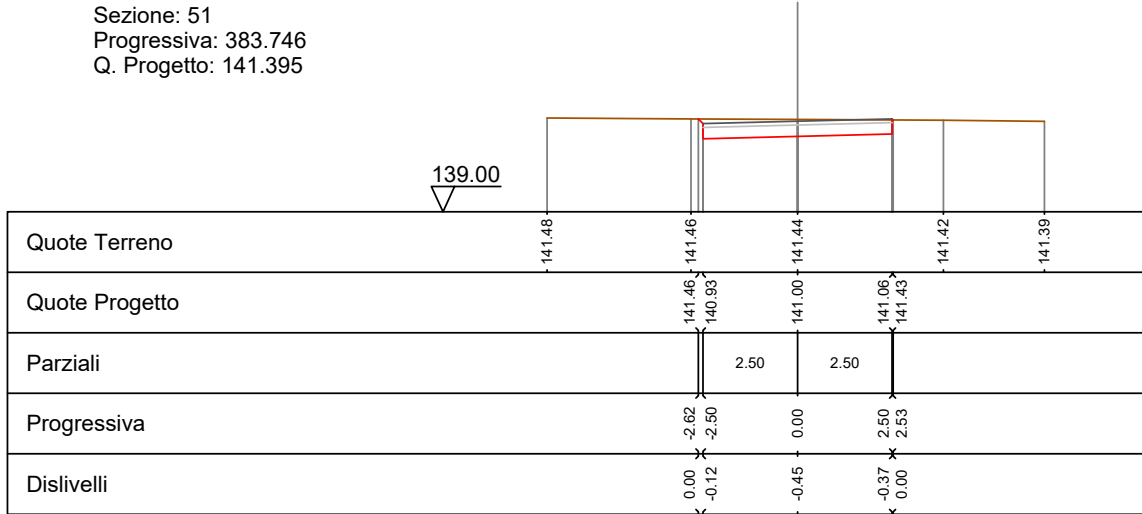

Sezione: 52
 Progressiva: 400.000
 Q. Progetto: 140.677

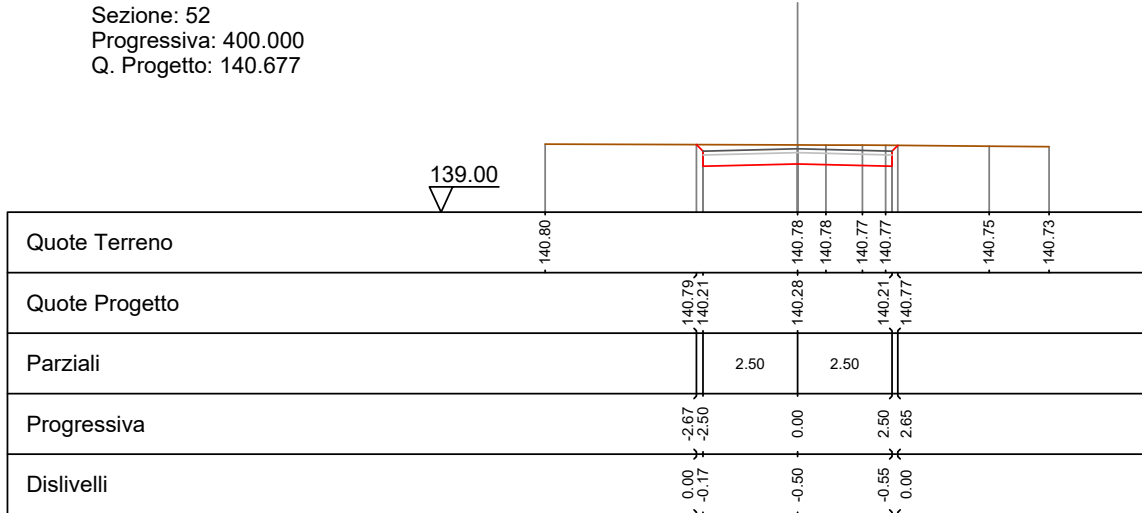

Sezione: 53
 Progressiva: 420.000
 Q. Progetto: 140.157

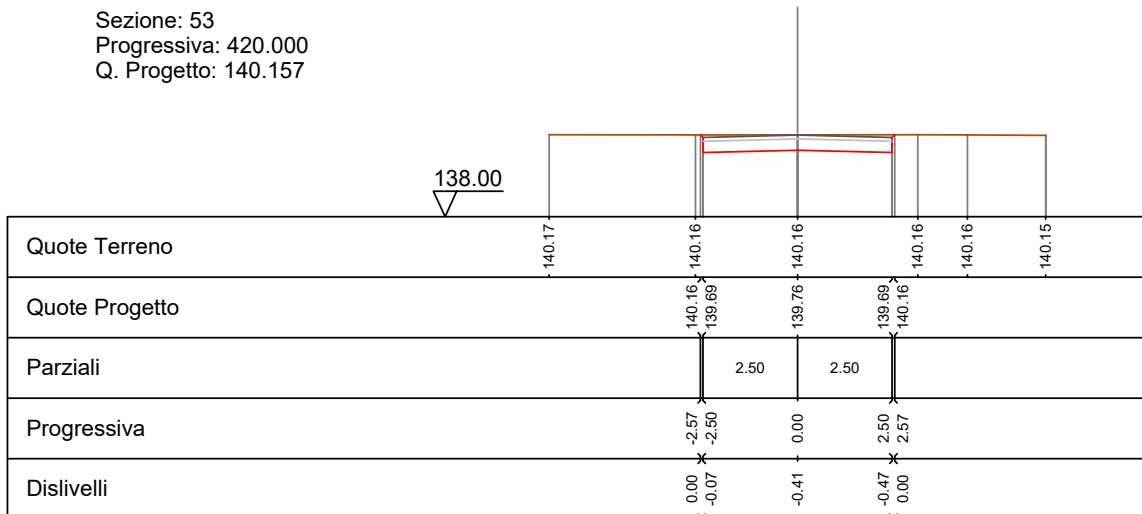

Sezione: 54
 Progressiva: 440.000
 Q. Progetto: 139.962

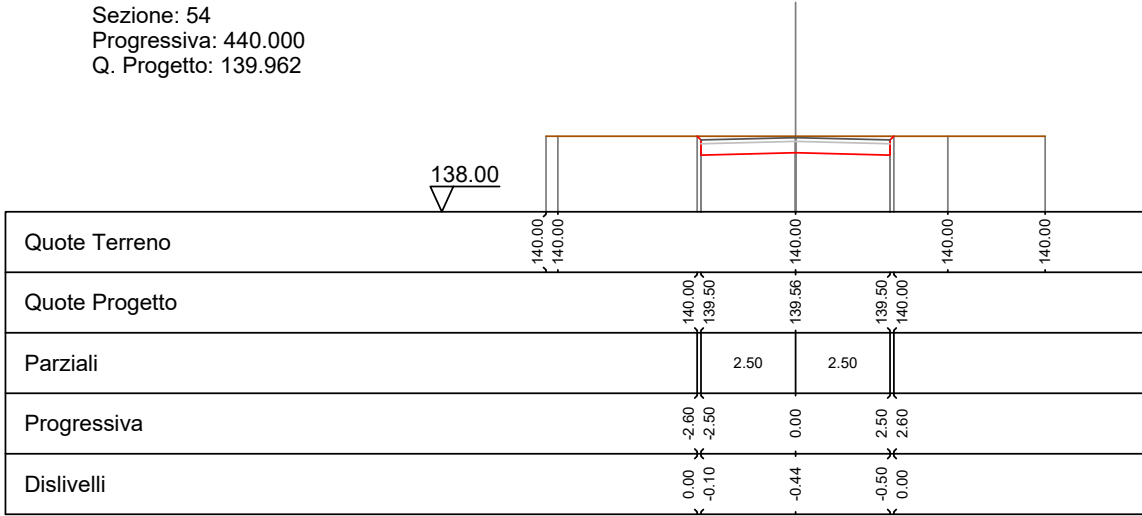

Sezione: 55
 Progressiva: 448.129
 Q. Progetto: 139.849

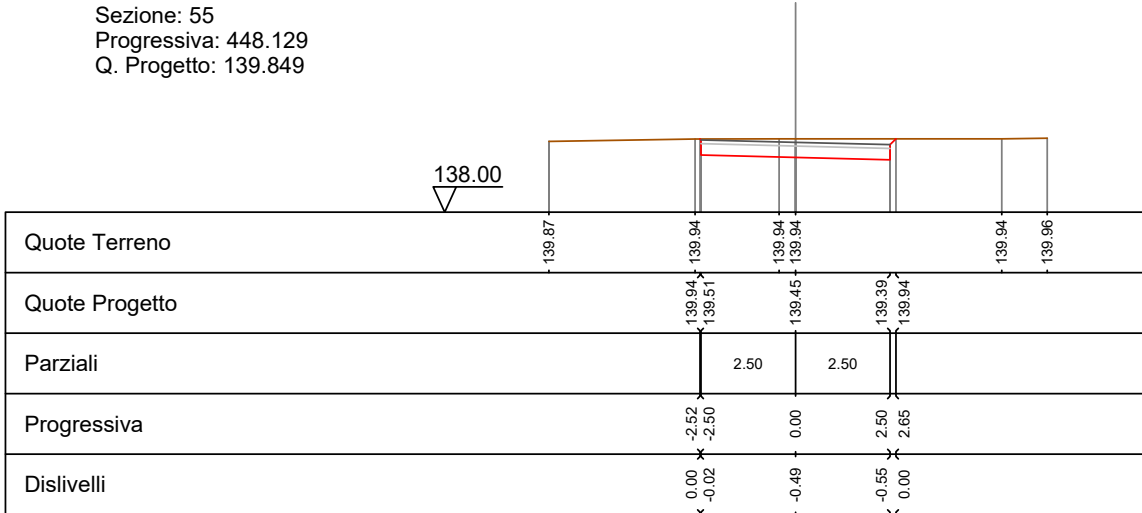

Sezione: 56
 Progressiva: 450.000
 Q. Progetto: 139.823

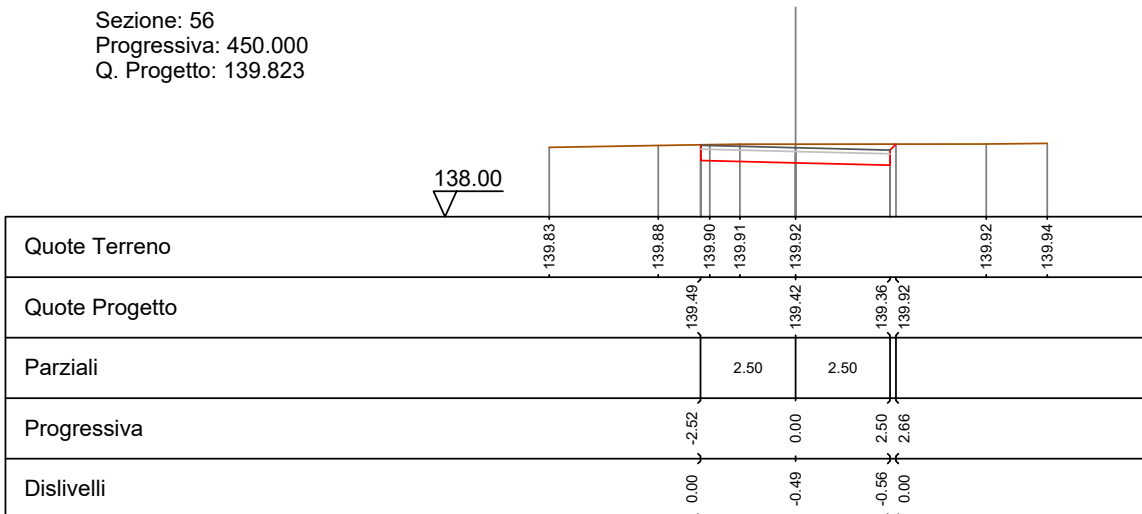

Sezione: 57
 Progressiva: 456.372
 Q. Progetto: 139.734

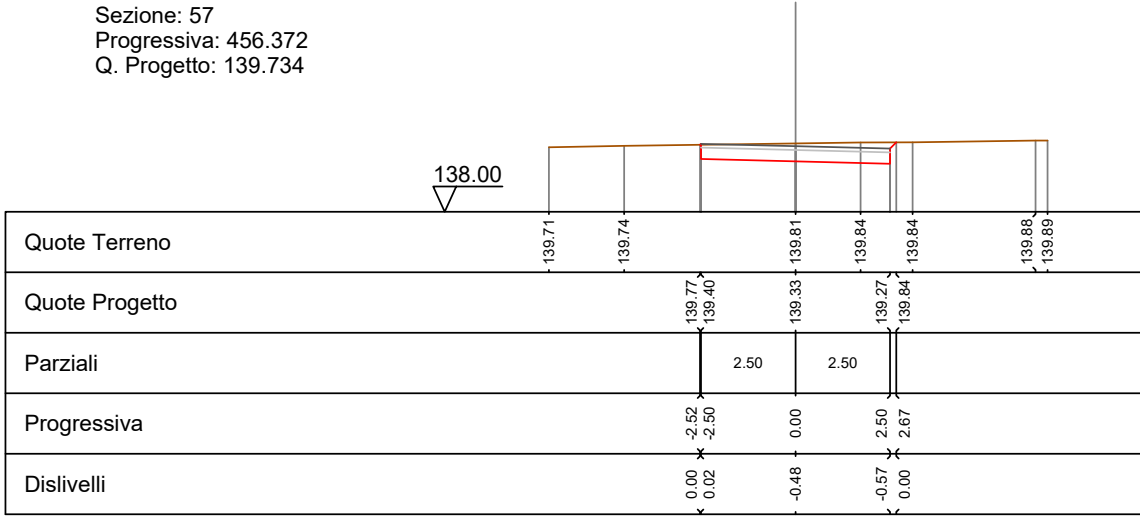

Sezione: 58
 Progressiva: 460.000
 Q. Progetto: 139.684

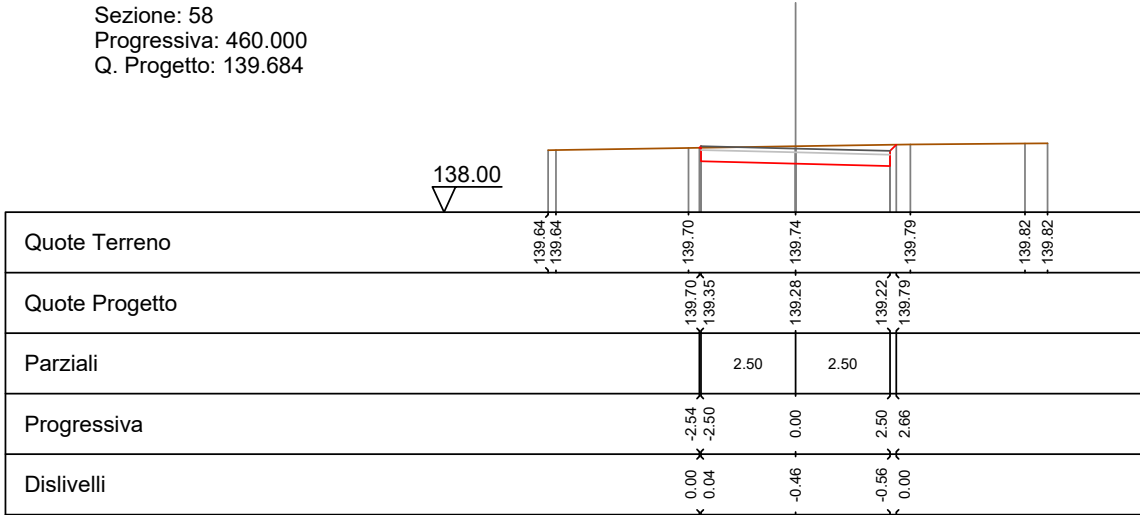

Sezione: 59
 Progressiva: 464.616
 Q. Progetto: 139.619

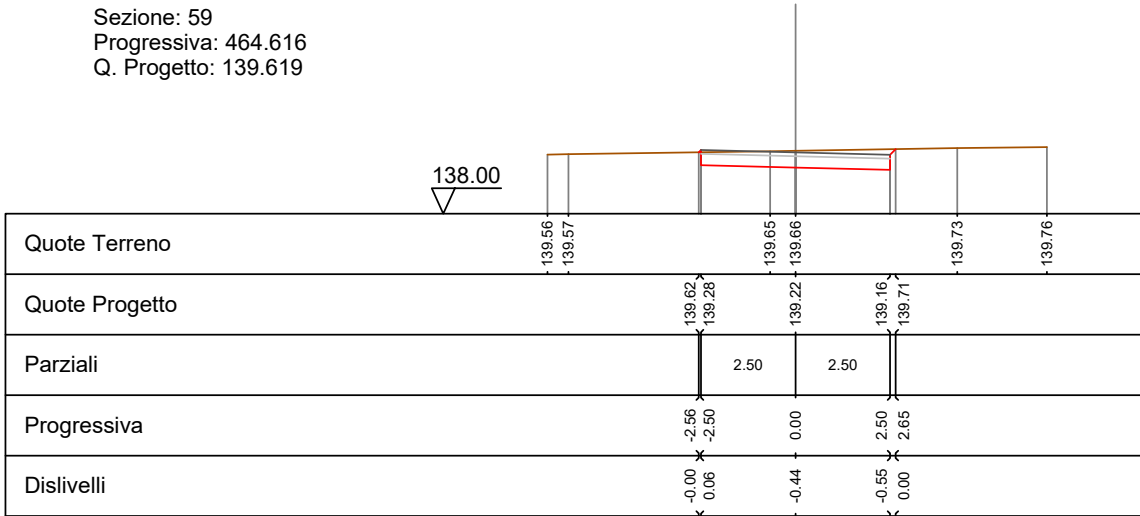

Sezione: 60
 Progressiva: 480.000
 Q. Progetto: 139.405

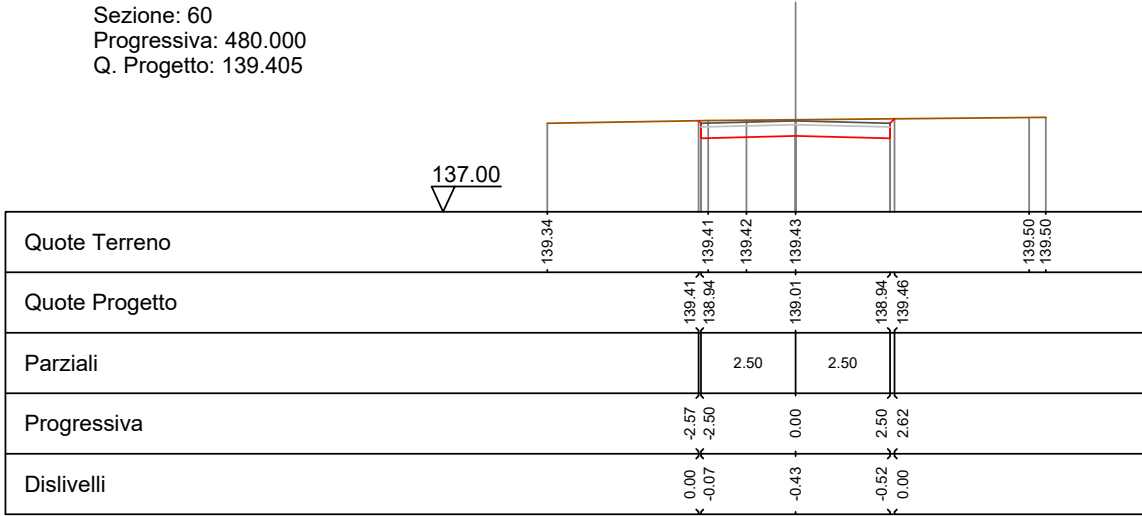

Sezione: 61
 Progressiva: 500.000
 Q. Progetto: 139.126

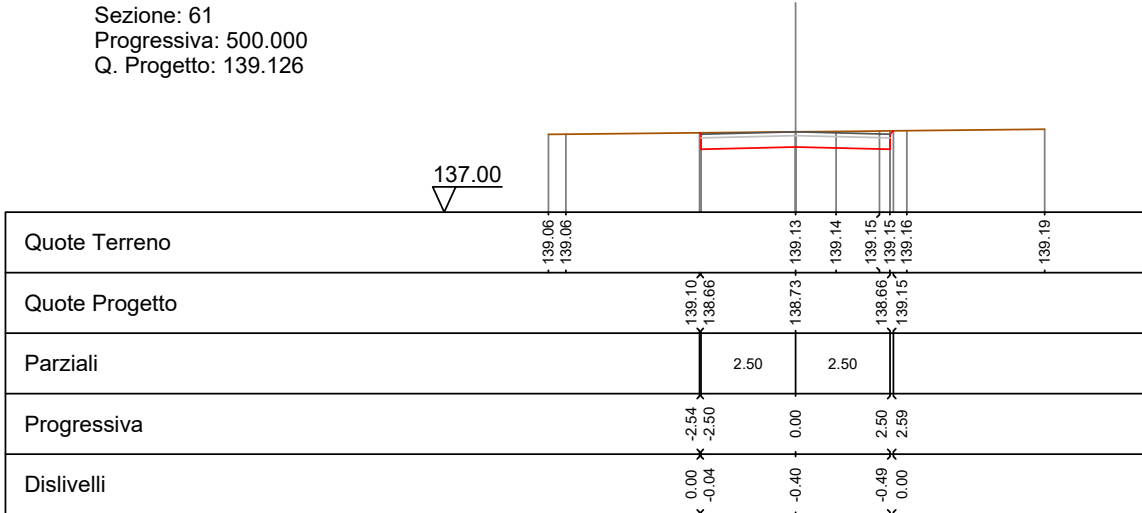

Sezione: 62
 Progressiva: 508.324
 Q. Progetto: 139.010

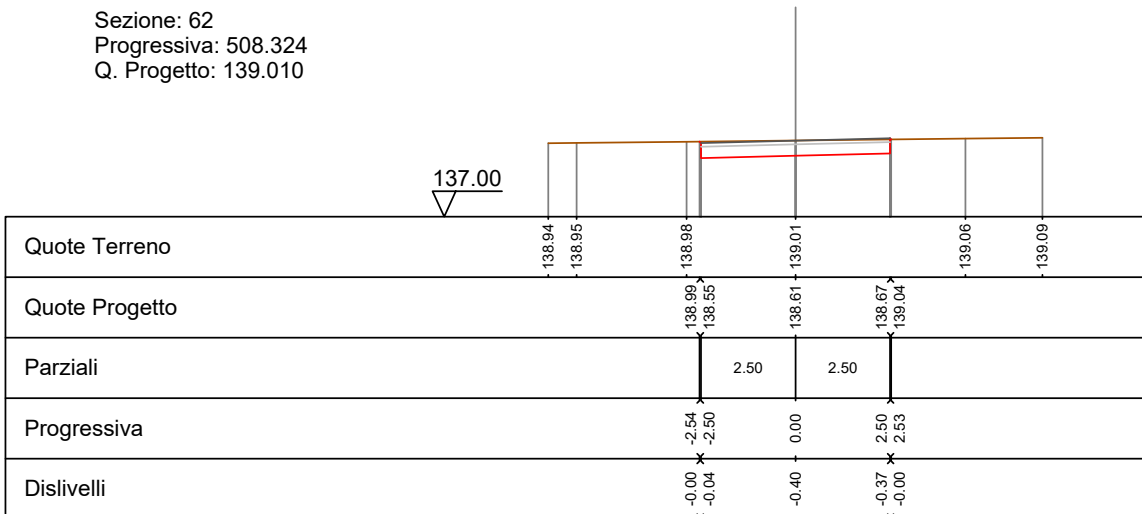

Sezione: 63
 Progressiva: 510.000
 Q. Progetto: 138.987

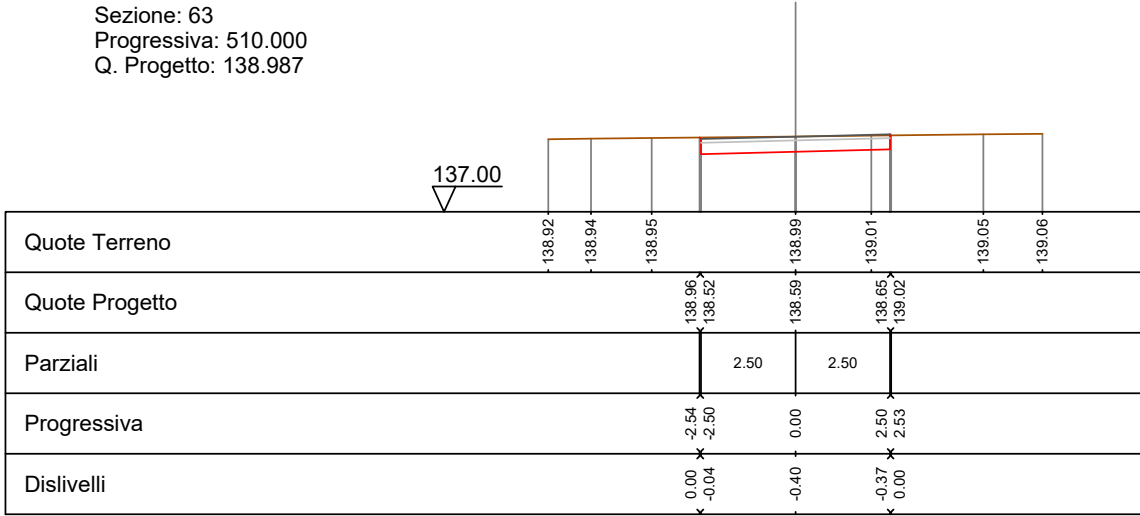

Sezione: 64
 Progressiva: 516.498
 Q. Progetto: 138.906

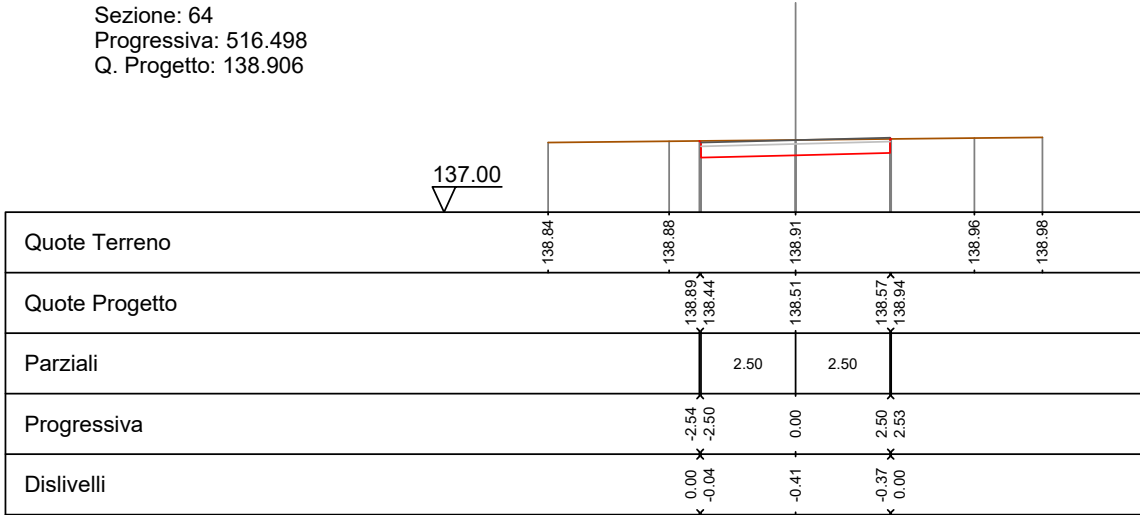

Sezione: 65
 Progressiva: 520.000
 Q. Progetto: 138.863

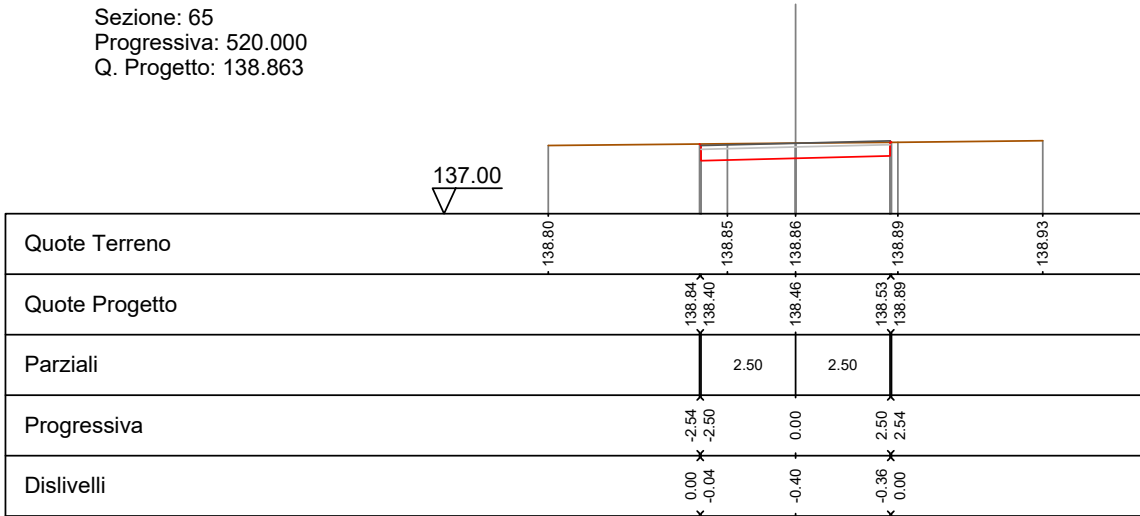

Sezione: 66
 Progressiva: 524.673
 Q. Progetto: 138.805

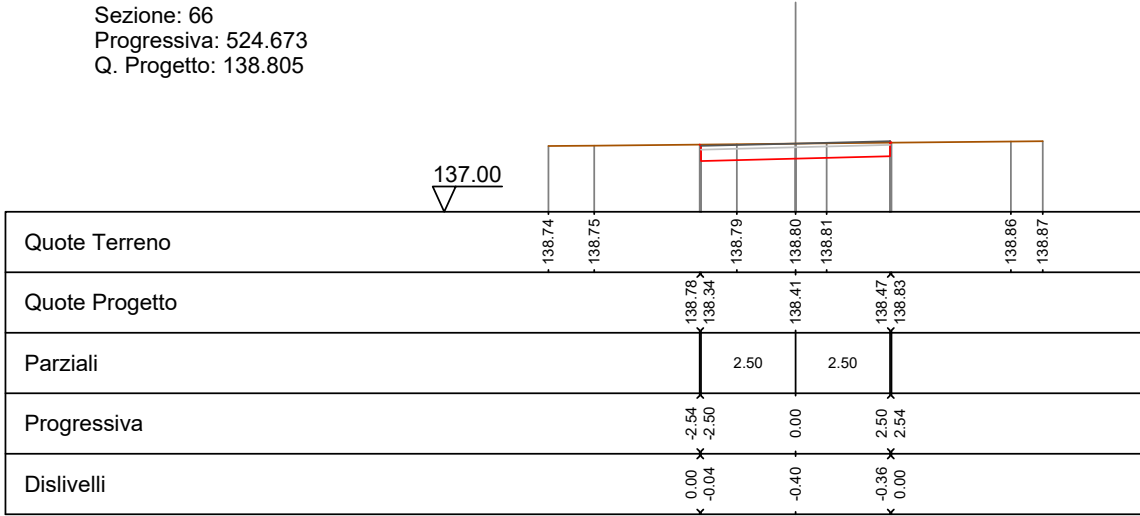

Sezione: 67
 Progressiva: 540.000
 Q. Progetto: 138.617

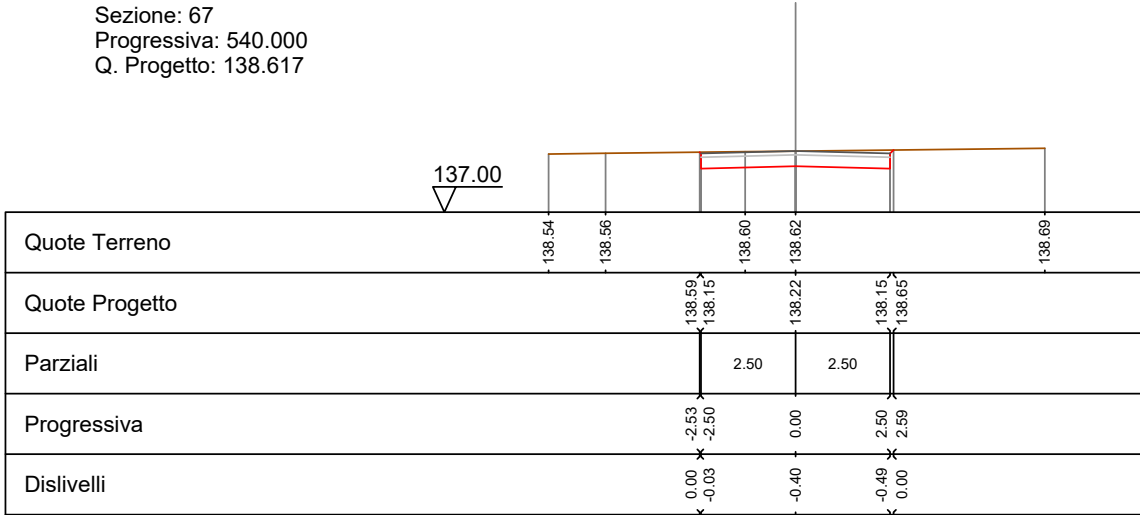

Sezione: 68
 Progressiva: 560.000
 Q. Progetto: 138.371

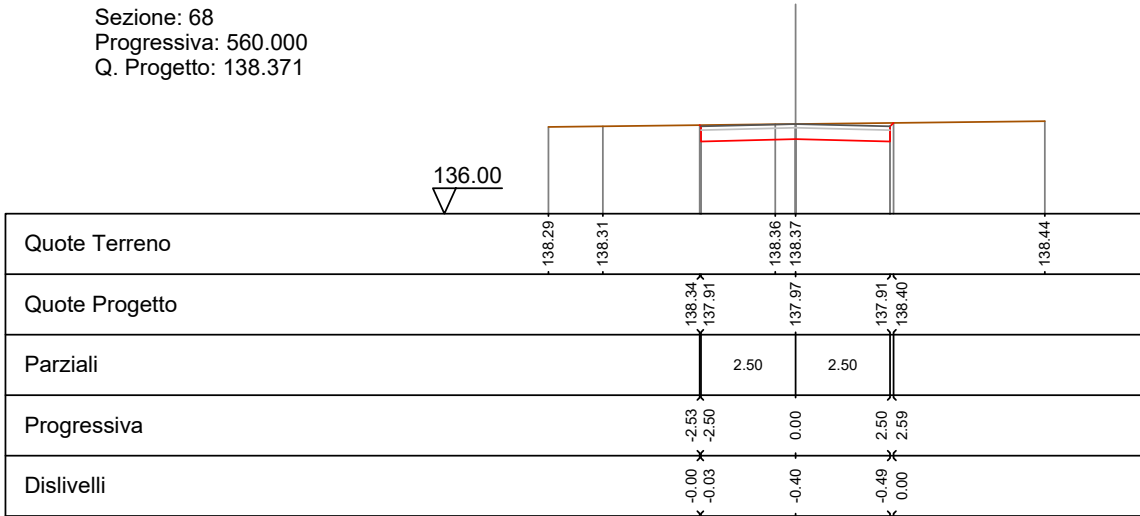

Sezione: 69
 Progressiva: 580.000
 Q. Progetto: 138.125

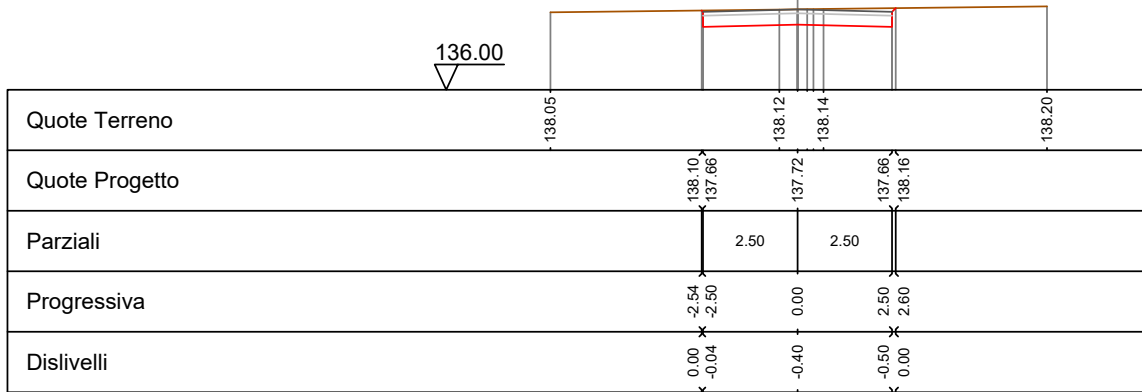

Sezione: 70
 Progressiva: 582.500
 Q. Progetto: 138.094

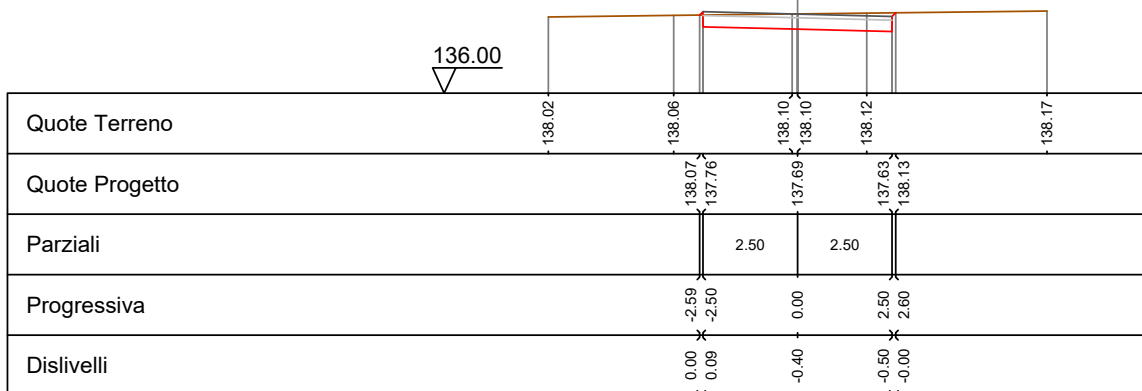

Sezione: 71
 Progressiva: 590.015
 Q. Progetto: 138.009

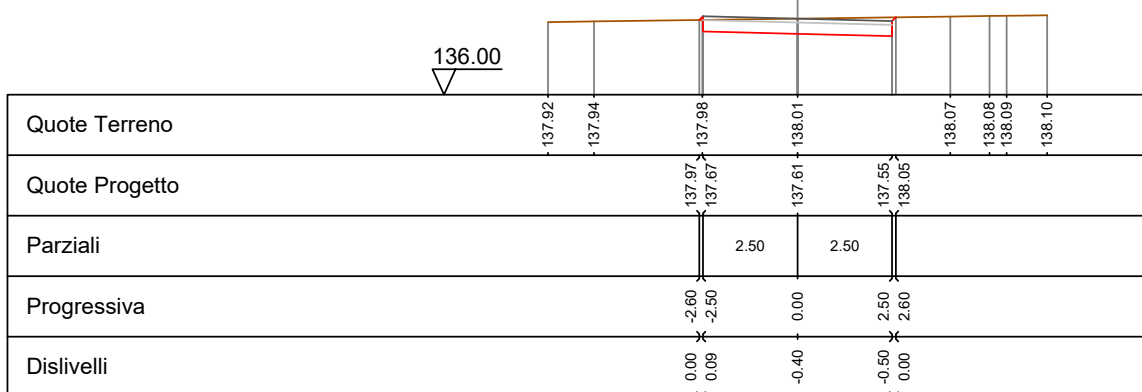

Sezione: 72
 Progressiva: 597.530
 Q. Progetto: 137.926

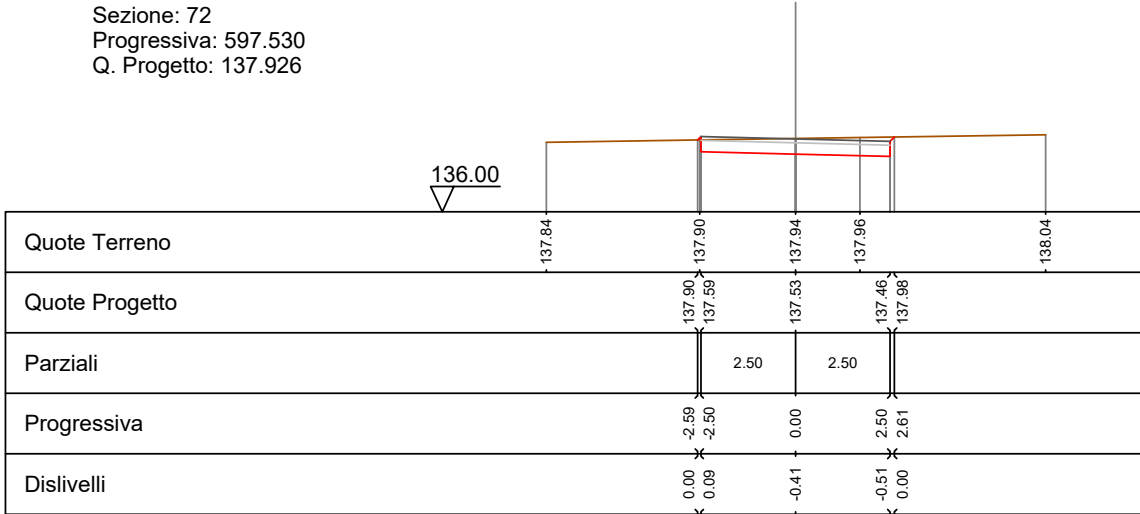

Sezione: 73
 Progressiva: 600.000
 Q. Progetto: 137.899

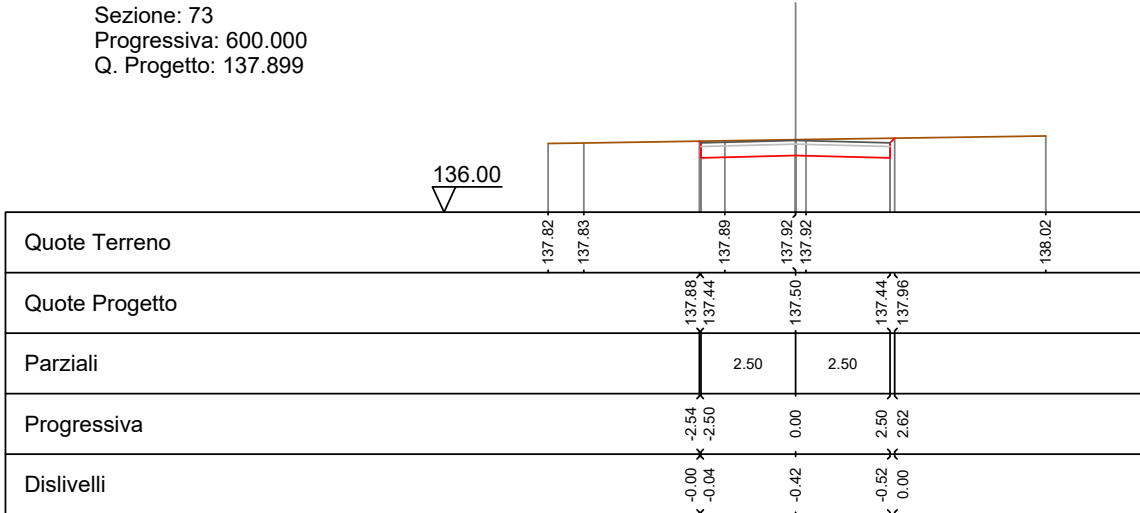

Sezione: 74
 Progressiva: 620.000
 Q. Progetto: 137.679

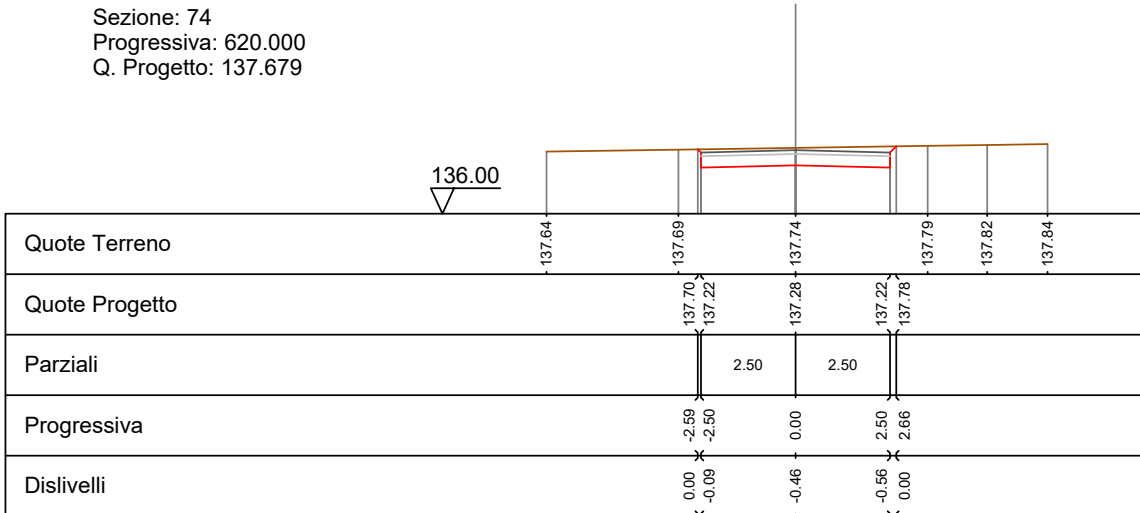

Sezione: 75
 Progressiva: 640.000
 Q. Progetto: 137.459

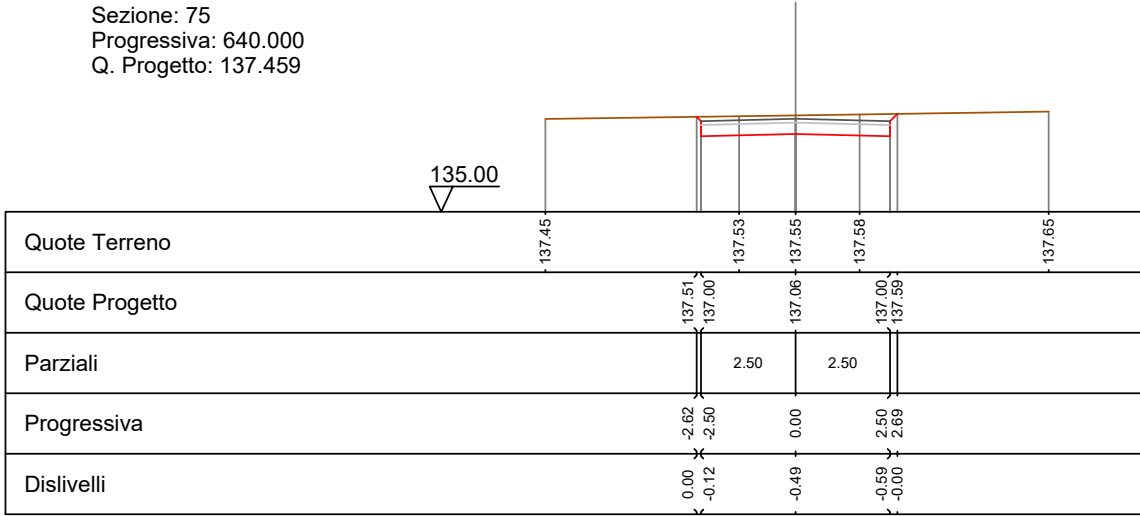

Sezione: 76
 Progressiva: 660.000
 Q. Progetto: 137.239

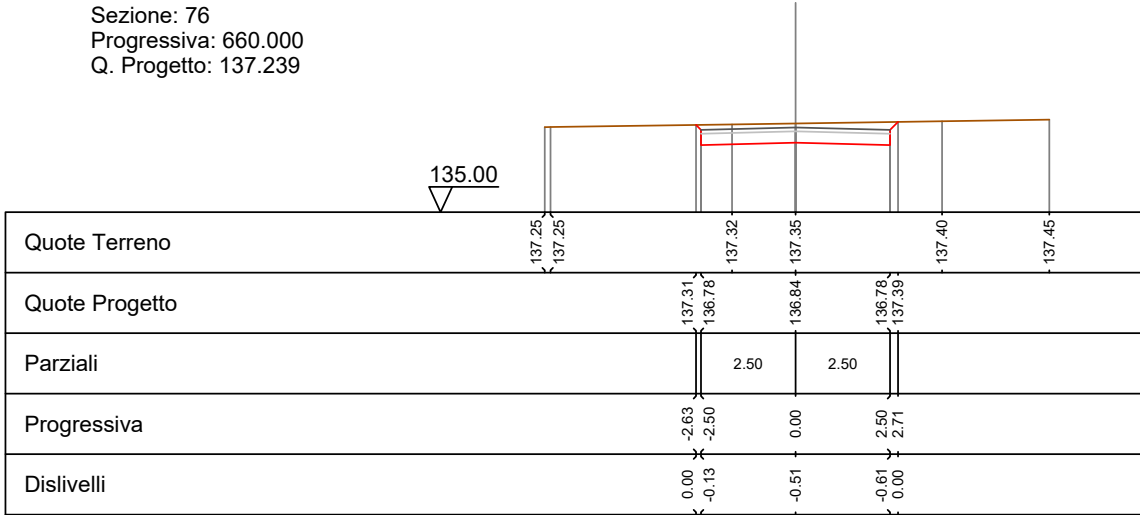

Sezione: 77
 Progressiva: 661.194
 Q. Progetto: 137.226

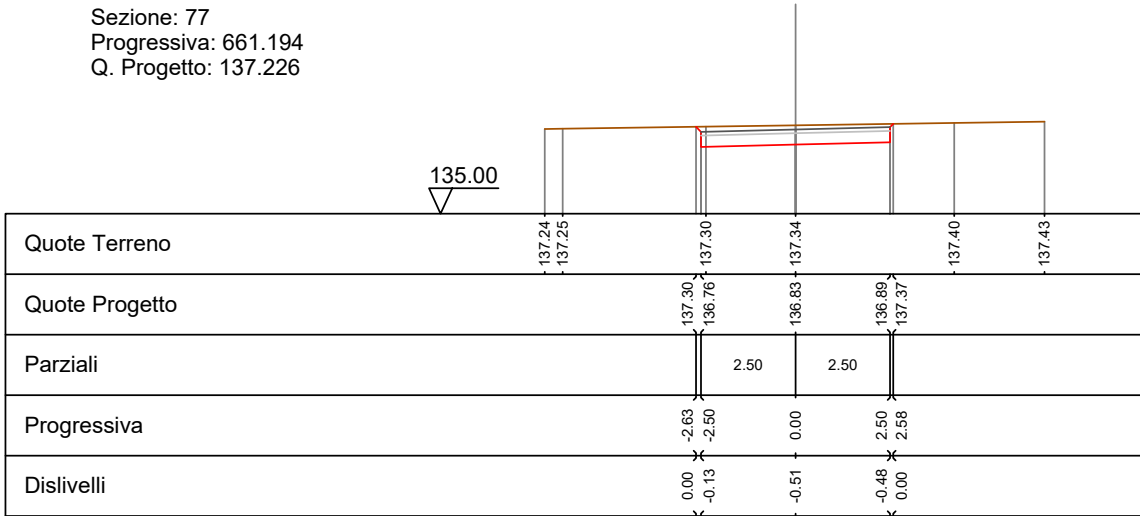

Sezione: 78
 Progressiva: 663.948
 Q. Progetto: 137.196

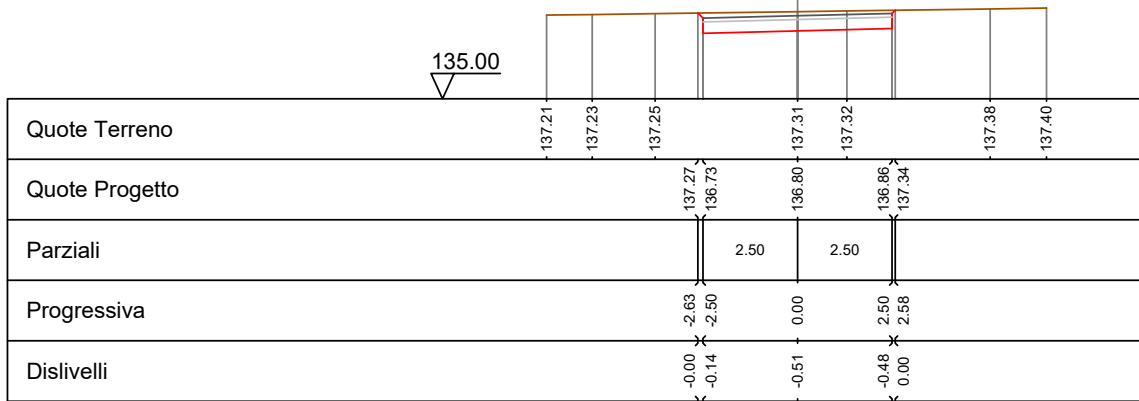

Sezione: 79
 Progressiva: 666.702
 Q. Progetto: 137.163

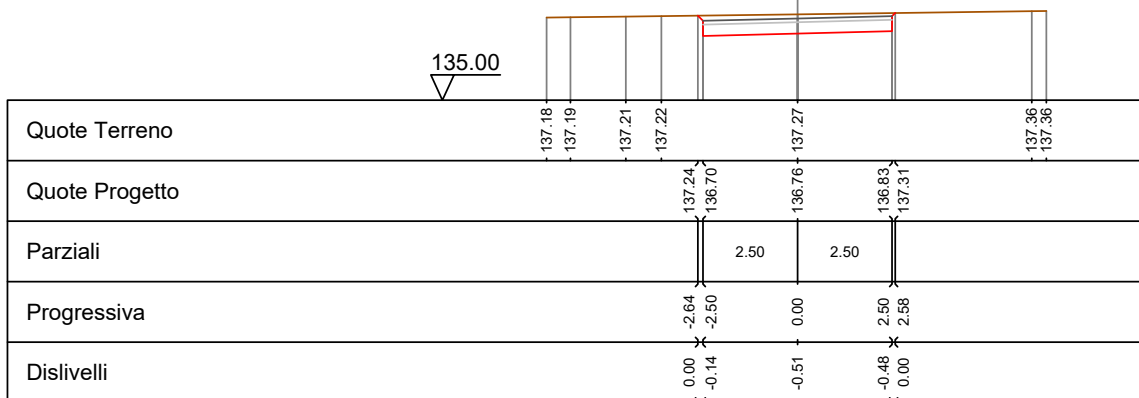

Sezione: 80
 Progressiva: 680.000
 Q. Progetto: 136.979

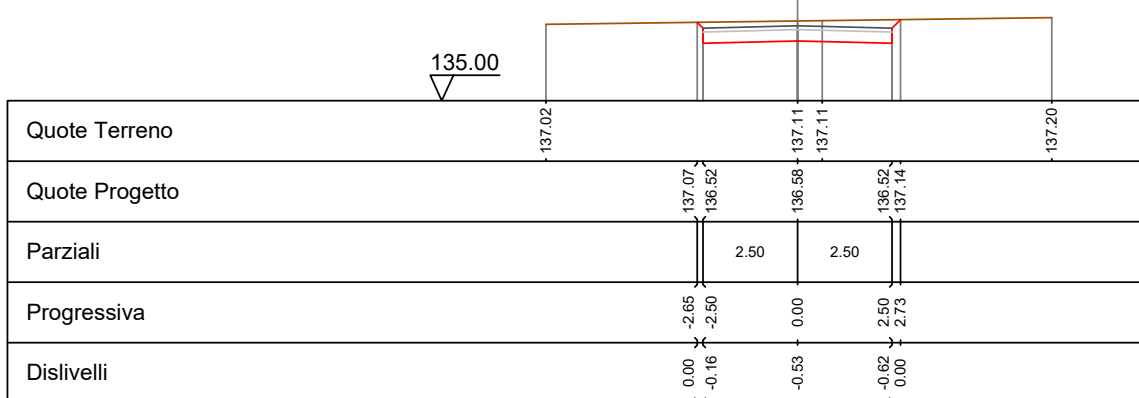

Sezione: 81
 Progressiva: 700.000
 Q. Progetto: 136.704

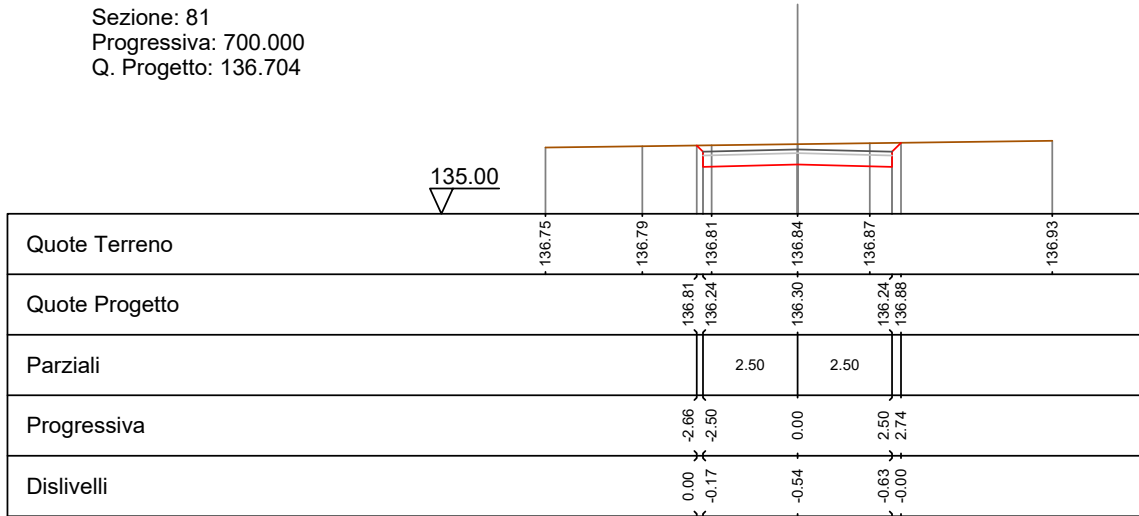

Sezione: 82
 Progressiva: 705.982
 Q. Progetto: 136.621

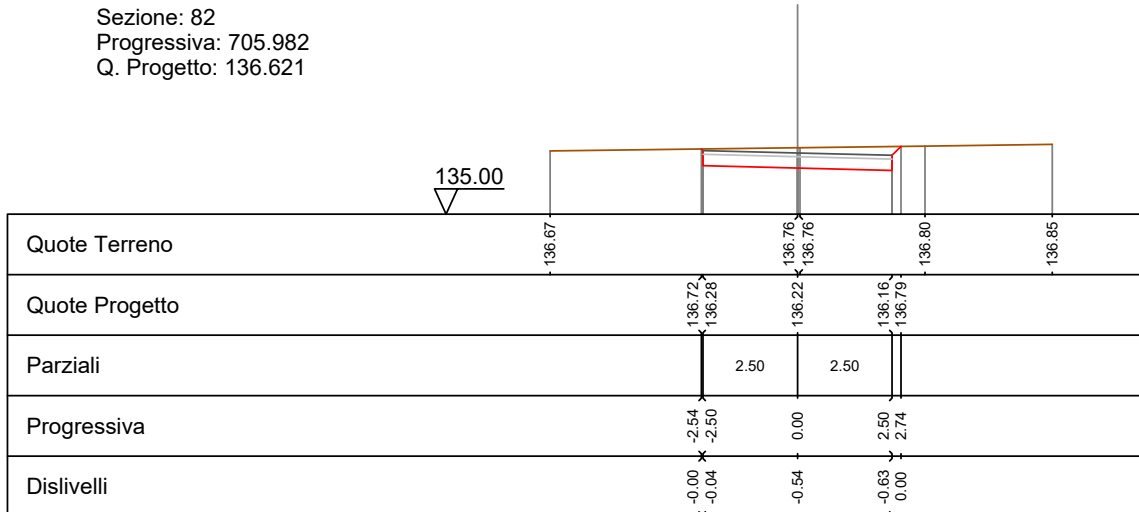

Sezione: 83
 Progressiva: 710.000
 Q. Progetto: 136.566

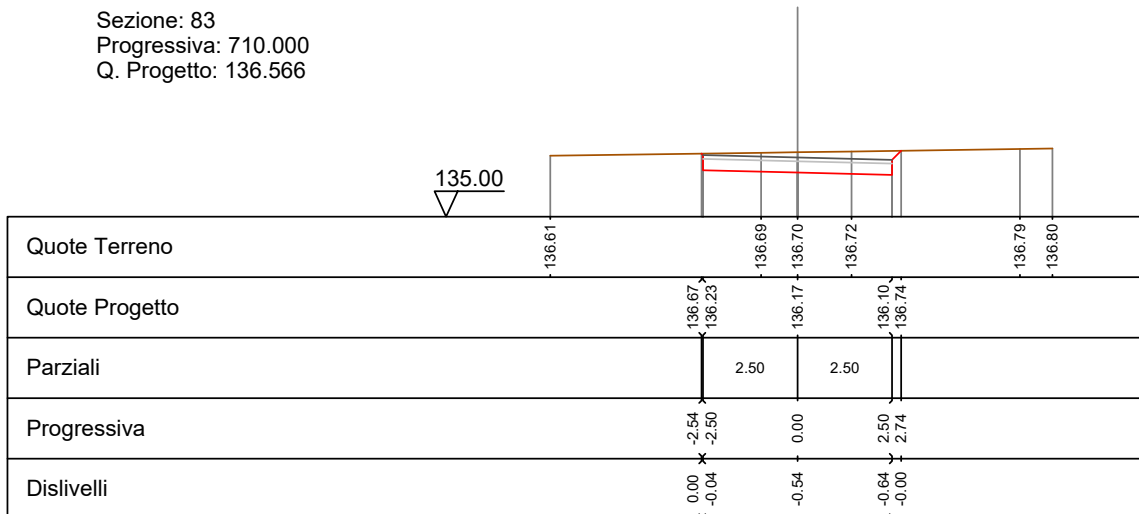

Sezione: 84
 Progressiva: 715.000
 Q. Progetto: 136.497

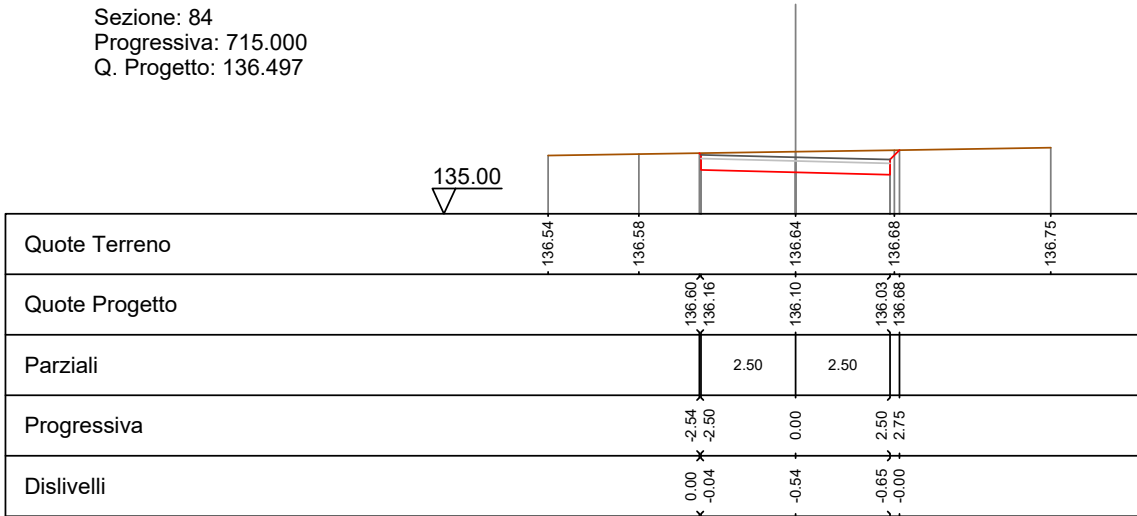

Sezione: 85
 Progressiva: 720.000
 Q. Progetto: 136.428

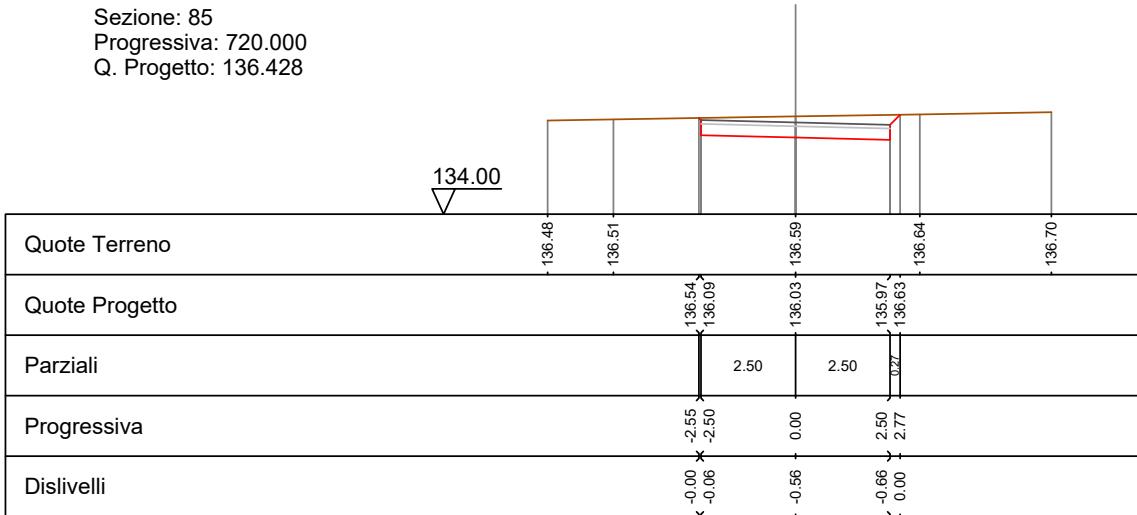

Sezione: 86
 Progressiva: 730.000
 Q. Progetto: 136.290

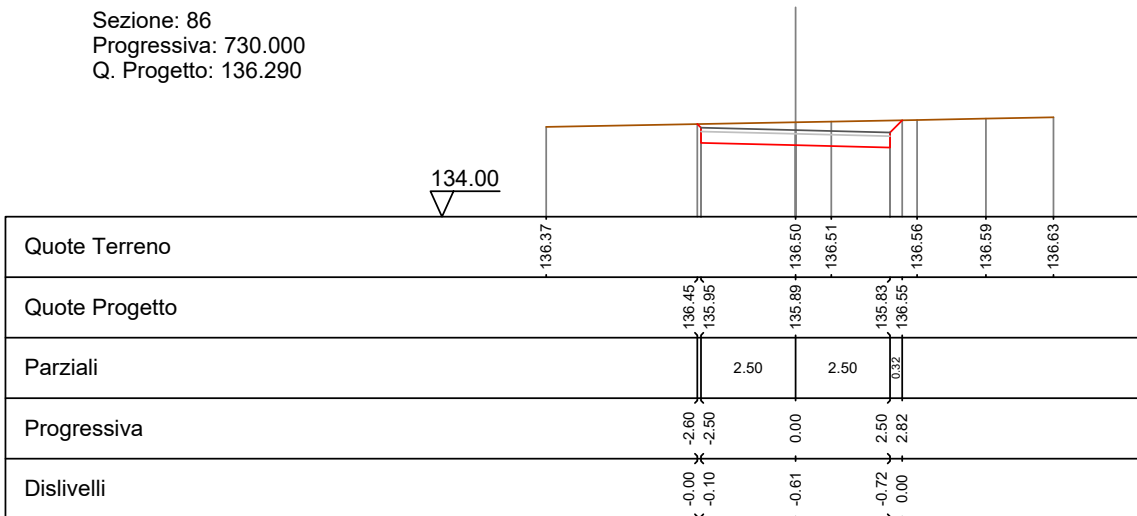

Sezione: 87
 Progressiva: 740.000
 Q. Progetto: 136.152

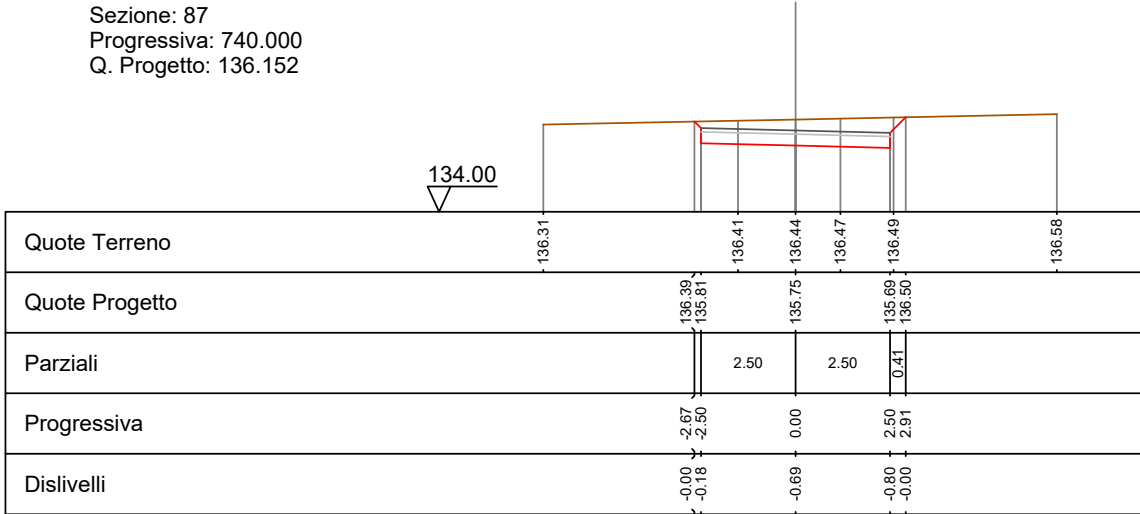

Sezione: 88
 Progressiva: 747.845
 Q. Progetto: 136.044

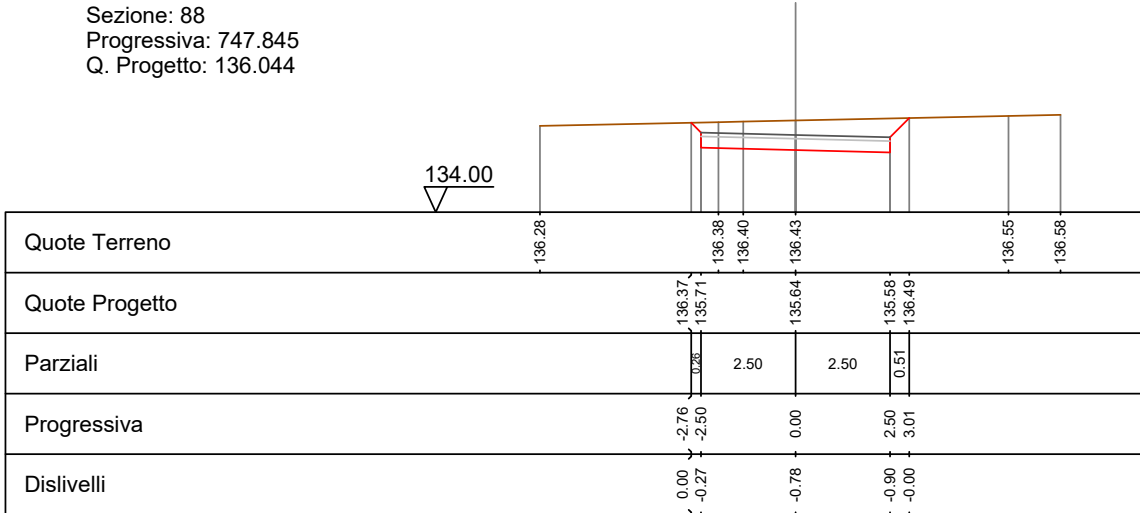

Sezione: 89
 Progressiva: 750.000
 Q. Progetto: 136.014

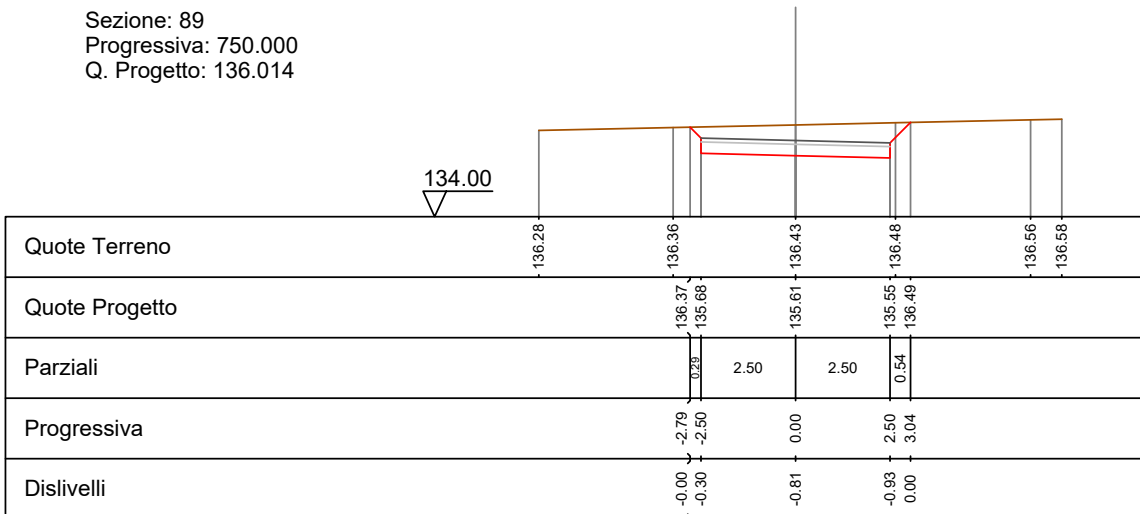

Sezione: 90
 Progressiva: 760.000
 Q. Progetto: 135.916

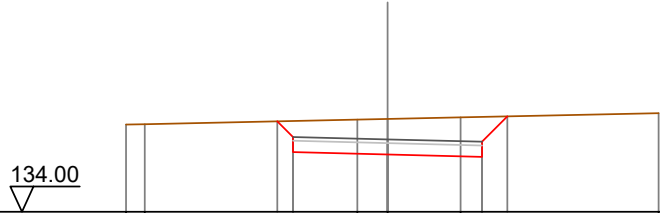

Quote Terreno	136.31	136.32		136.44	136.46	136.50	136.61
Quote Progetto			136.39	135.58	135.52	135.45	136.52
Parziali			0.41	2.50	2.50	0.67	
Progressiva			-2.91	-2.50	0.00	2.50	3.17
Dislivelli			0.00	-0.42	-0.94	-1.06	0.00

Sezione: 91
 Progressiva: 770.000
 Q. Progetto: 136.004

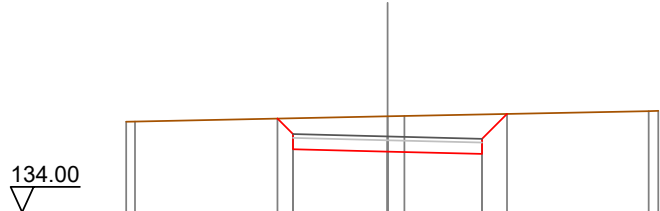

Quote Terreno	136.39	136.40		136.54	136.55	136.67	136.68
Quote Progetto			136.48	135.67	135.60	135.54	136.60
Parziali			0.41	2.50	2.50	0.66	
Progressiva			-2.91	-2.50	0.00	2.50	3.16
Dislivelli			0.00	-0.42	-0.93	-1.05	-0.00

Sezione: 92
 Progressiva: 780.000
 Q. Progetto: 136.285

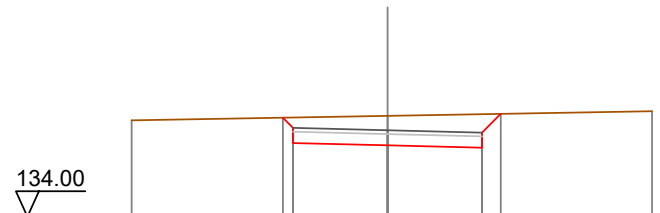

Quote Terreno	136.55			136.67		136.79	
Quote Progetto		136.62	135.95	135.89	135.82	136.72	
Parziali		0.27	2.50	2.50	0.50		
Progressiva		-2.77	-2.50	0.00	2.50	3.00	
Dislivelli		-0.00	-0.27	-0.78	-0.89	0.00	

Sezione: 93
 Progressiva: 789.708
 Q. Progetto: 136.610

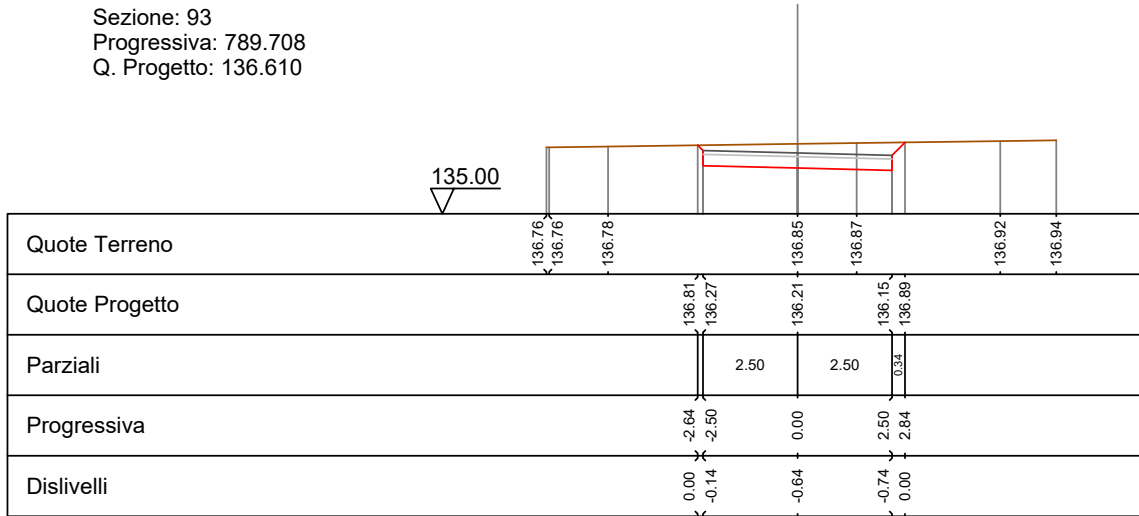

Sezione: 94
 Progressiva: 800.000
 Q. Progetto: 136.954

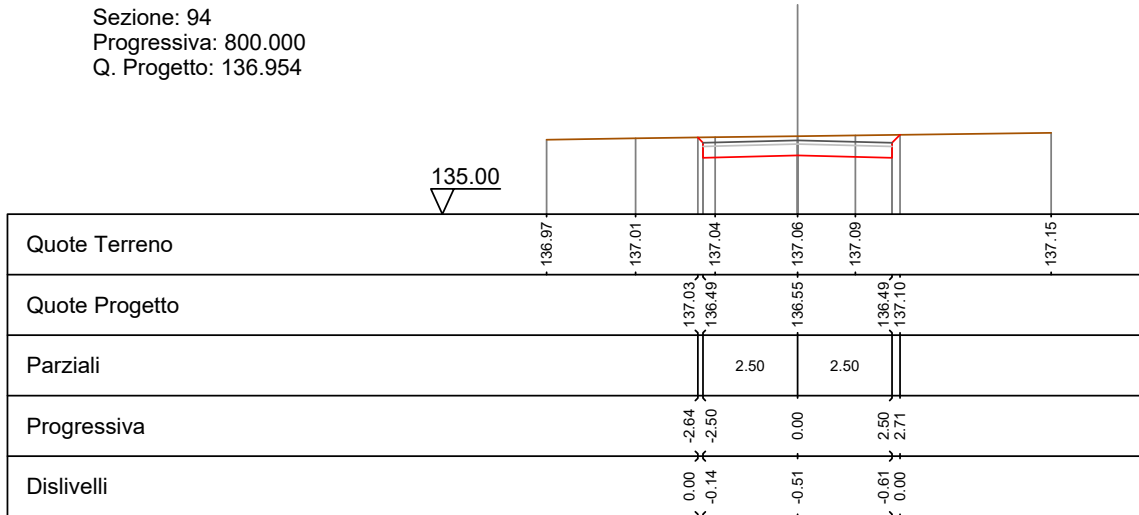

Sezione: 95
 Progressiva: 820.000
 Q. Progetto: 137.623

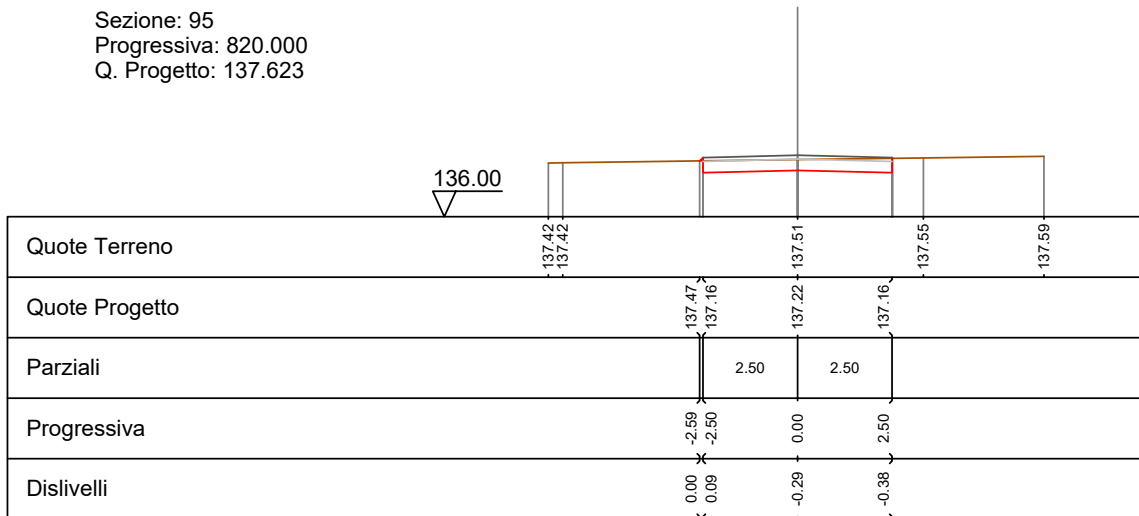

Sezione: 96
 Progressiva: 840.000
 Q. Progetto: 138.293

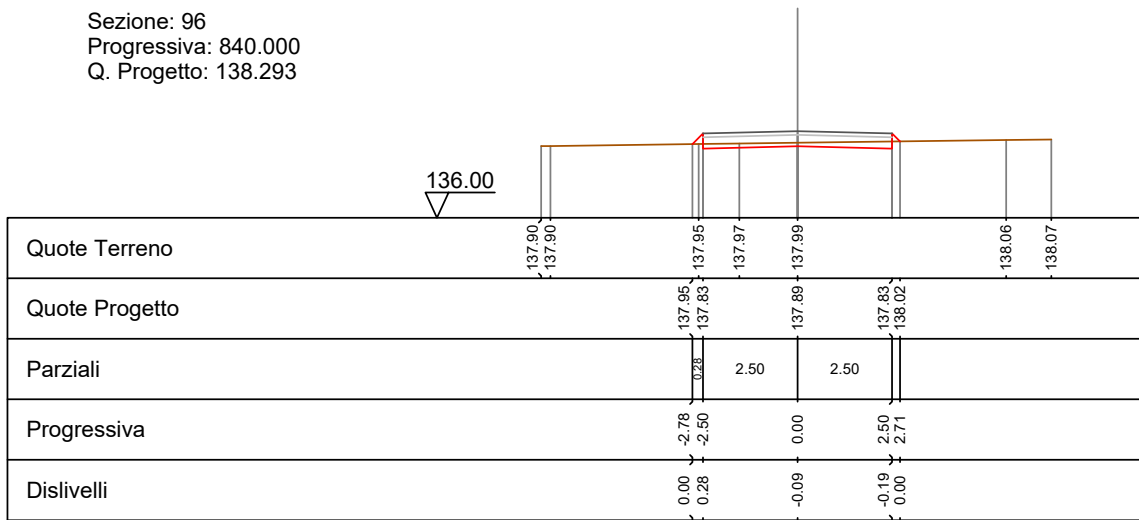

Sezione: 97
 Progressiva: 849.429
 Q. Progetto: 138.608

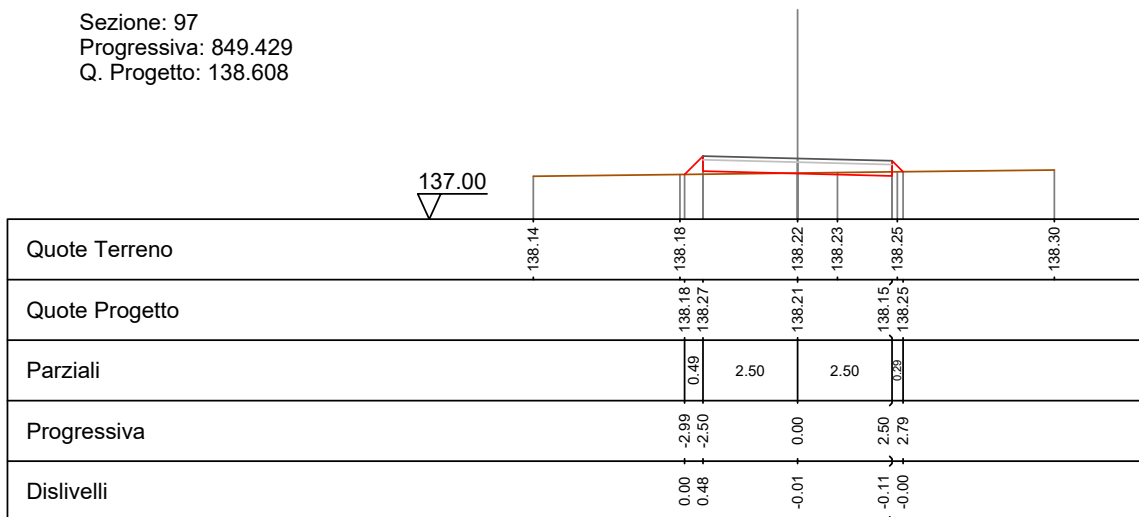

Sezione: 98
 Progressiva: 850.000
 Q. Progetto: 138.627

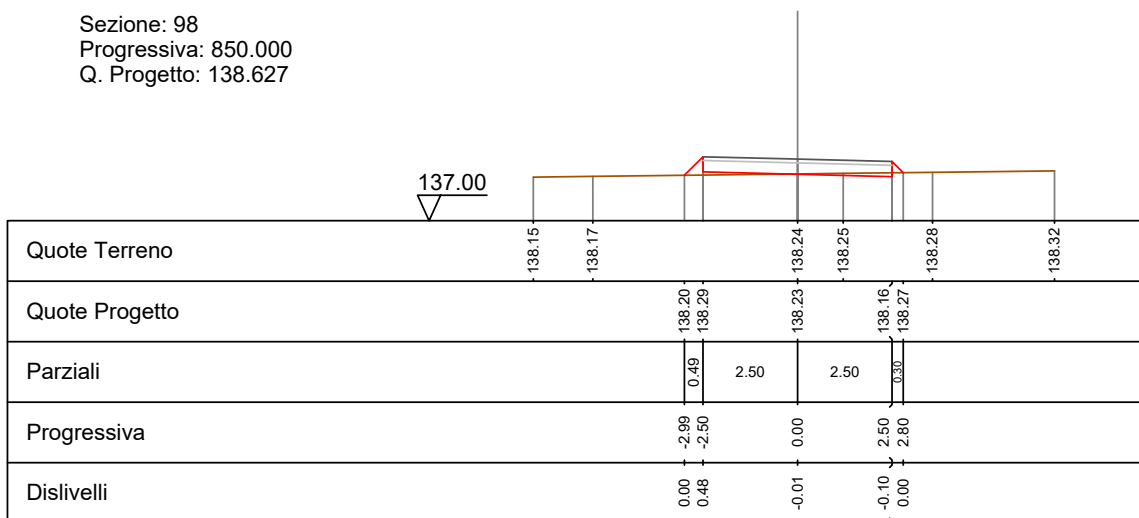

Sezione: 99
 Progressiva: 852.339
 Q. Progetto: 138.704

137.00

Quote Terreno	138.22	138.23		138.30	138.32	138.37
Quote Progetto			138.26	138.30	138.24	138.33
Parziali			0.50	2.50	2.50	0.31
Progressiva			-3.00	-2.50	0.00	2.50
Dislivelli			0.00	0.50	0.01	-0.08
						0.00

Sezione: 100
 Progressiva: 855.250
 Q. Progetto: 138.788

137.00

Quote Terreno	138.31		138.36	138.38	138.40	138.43
Quote Progetto			138.35	138.39	138.33	138.40
Parziali			0.50	2.50	2.50	0.32
Progressiva			-3.00	-2.50	0.00	2.50
Dislivelli			0.00	0.50	0.01	-0.07
						0.00

Sezione: 101
 Progressiva: 860.000
 Q. Progetto: 138.924

137.00

Quote Terreno	138.45			138.51	138.53	138.57
Quote Progetto			138.48	138.52	138.46	138.53
Parziali			0.38	2.50	2.50	0.33
Progressiva			-2.88	-2.50	0.00	2.50
Dislivelli			-0.00	0.37	0.02	-0.07
						0.00

Sezione: 102
 Progressiva: 880.000
 Q. Progetto: 139.495

138.00

Quote Terreno	139.04	139.04	139.05	139.05	139.06	139.03	139.08	139.08	139.11	139.12	139.13
Quote Progetto					139.06	139.03	139.09	139.09	139.03	139.10	
Parziali					0.37	2.50	2.50	2.50	0.33		
Progressiva					-2.87	-2.50	0.00	0.00	2.50	2.83	
Dislivelli					0.00	0.37	0.01	0.01	-0.07	-0.00	

Sezione: 103
 Progressiva: 900.000
 Q. Progetto: 140.066

138.00

Quote Terreno	139.66	139.66	139.67	139.67	139.68	139.68	139.68	139.68	139.69	139.69	139.71
Quote Progetto			139.67	139.60	139.67	139.67	139.67	139.67	139.60	139.69	
Parziali			0.33	2.50	2.50	2.50	2.50	2.50	0.33		
Progressiva			-2.83	-2.50	0.00	0.00	0.00	0.00	2.50	2.81	
Dislivelli			0.00	0.33	-0.01	-0.01	-0.01	-0.01	-0.09	0.00	

Sezione: 104
 Progressiva: 920.000
 Q. Progetto: 140.487

138.00

Quote Terreno	140.00	140.02	140.02	140.03	140.04	140.05	140.07	140.12
Quote Progetto		140.02	140.02	140.09	140.04	140.02	140.06	
Parziali		0.41	2.50	2.50	2.50	0.36		
Progressiva		-2.91	-2.50	0.00	0.00	2.50	2.86	
Dislivelli		0.00	0.41	0.06	0.06	-0.03	0.00	

Sezione: 105
 Progressiva: 929.886
 Q. Progetto: 140.631

139.00

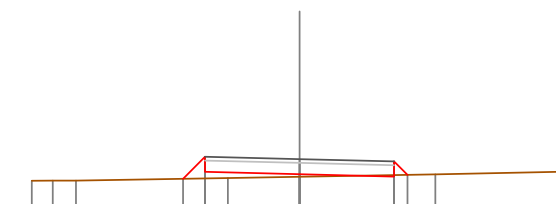

Quote Terreno	140.06	140.06	140.06	140.13	140.16	140.23	140.30
Quote Progetto			140.11	140.29	140.23	140.17	140.21
Parziali			0.58	2.50	2.50	0.35	
Progressiva			-3.08	-2.50	0.00	2.50	2.85
Dislivelli			0.00	0.57	0.07	-0.04	0.00

Sezione: 106
 Progressiva: 931.908
 Q. Progetto: 140.661

139.00

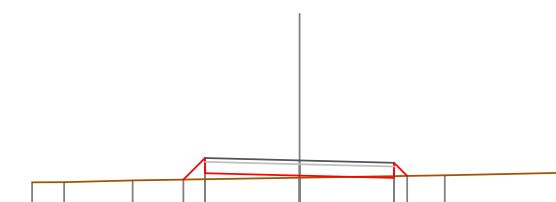

Quote Terreno	140.08	140.09	140.13		140.20		140.27	140.33
Quote Progetto			140.15	140.32	140.26	140.20	140.25	
Parziali			0.57	2.50	2.50	0.35		
Progressiva			-3.07	-2.50	0.00	2.50	2.85	
Dislivelli			0.00	0.56	0.06	-0.05	0.00	

Sezione: 107
 Progressiva: 933.930
 Q. Progetto: 140.691

139.00

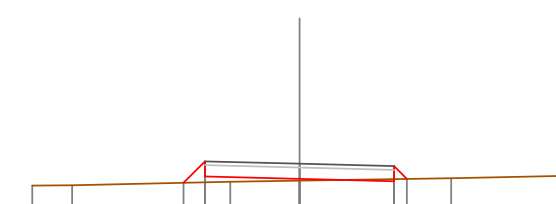

Quote Terreno	140.11	140.12		140.22	140.24		140.31	140.36
Quote Progetto			140.19	140.35	140.29	140.23	140.29	
Parziali			0.57	2.50	2.50	0.34		
Progressiva			-3.07	-2.50	0.00	2.50	2.84	
Dislivelli			0.00	0.55	0.05	-0.06	-0.00	

Sezione: 108
 Progressiva: 940.000
 Q. Progetto: 140.779

139.00

Quote Terreno	140.18	140.20	140.21	140.26	140.32	140.33	140.32	140.40	140.42	140.44	140.46	140.51
Quote Progetto				140.26	140.32	140.38	140.32	140.40				
Parziali				0.45	2.50	2.50	0.32					
Progressiva				-2.95	-2.50	0.00	2.50	2.82				
Dislivelli				0.00	0.44	0.05	-0.07	0.00				

Sezione: 109
 Progressiva: 960.000
 Q. Progetto: 141.071

139.00

Quote Terreno	140.43	140.52	140.53	140.57	140.61	140.67	140.69	140.61	140.79	140.91	140.95
Quote Progetto				140.57	140.61	140.67	140.69	140.61	140.79		
Parziali				0.44	2.50	2.50					
Progressiva				-2.94	-2.50	0.00	2.50	2.72			
Dislivelli				0.00	0.42	-0.01	-0.17	0.00			

Sezione: 110
 Progressiva: 980.000
 Q. Progetto: 141.364

139.00

Quote Terreno	140.61	140.78	140.81	140.82	140.83	140.98	140.90	141.13	141.37
Quote Progetto			140.81	140.90	140.98	140.98	140.90	141.13	
Parziali			0.49	2.50	2.50				
Progressiva			-2.99	-2.50	0.00	2.50	2.67		
Dislivelli			0.00	0.46	-0.02	-0.22	0.00		

Sezione: 111
 Progressiva: 990.742
 Q. Progetto: 141.485

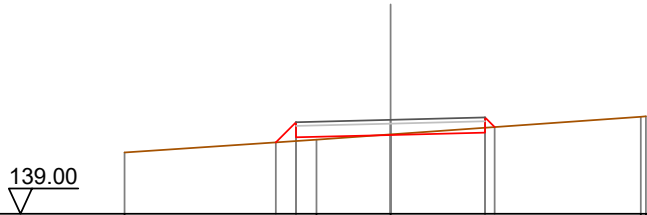

Quote Terreno	140.62	140.89	141.02	140.96	141.10	141.15	141.29	141.57	141.58
Quote Progetto		140.89	141.02		141.09	141.15	141.29		
Parziali		0.53	2.50		2.50				
Progressiva		-3.03	-2.50		0.00	2.50	2.75		
Dislivelli		0.00	0.50		-0.01	-0.13	0.00		

Sezione: 112
 Progressiva: 1000.000
 Q. Progetto: 141.425

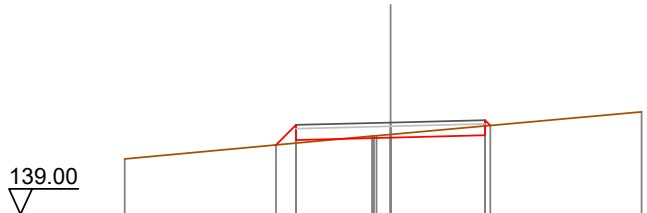

Quote Terreno	140.46	140.83	140.96	141.07	141.11	141.09	141.35	141.71
Quote Progetto		140.83	140.96	141.02	141.11	141.09	141.35	
Parziali		0.53	2.50		2.50			
Progressiva		-3.03	-2.50	0.00	2.50	2.64		
Dislivelli		0.00	0.48	-0.09	-0.25	0.00		

Sezione: 112
 Progressiva: 1000.000
 Q. Progetto: 141.425

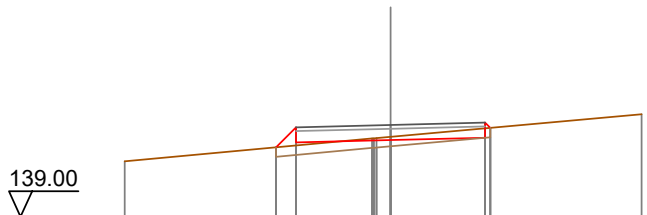

Quote Terreno	140.46	140.83	140.96	141.07	141.11	141.09	141.35	141.71
Quote Progetto		140.83	140.96	141.02	141.11	141.09	141.35	
Parziali		0.53	2.50		2.50			
Progressiva		-3.03	-2.50	0.00	2.50	2.64		
Dislivelli		0.00	0.48	-0.09	-0.25	0.00		

Sezione: 113
 Progressiva: 1005.900
 Q. Progetto: 141.297

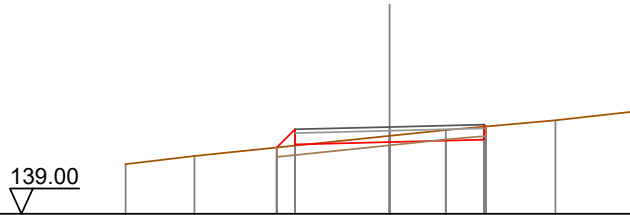

Quote Terreno	140.31	140.53			141.06	141.22	141.47	141.72
Quote Progetto			140.75	140.83	140.90	140.96	141.31	
Parziali			0.48	2.50	2.50			
Progressiva			-2.98	-2.50	0.00	2.50	2.55	
Dislivelli			0.00	0.43	-0.16	-0.35	0.00	

Sezione: 114
 Progressiva: 1010.000
 Q. Progetto: 141.167

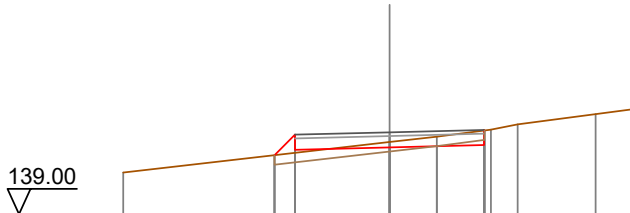

Quote Terreno	140.10				140.91	141.05	141.24	141.38	141.65	141.79
Quote Progetto			140.56	140.70	140.77	140.83				
Parziali			0.54	2.50	2.50					
Progressiva			-3.04	-2.50	0.00	2.50				
Dislivelli			-0.00	0.48	-0.14	-0.38				

Sezione: 115
 Progressiva: 1020.000
 Q. Progetto: 140.750

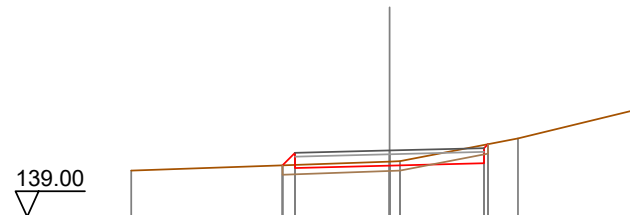

Quote Terreno	140.22				140.46	140.47	141.07	141.85
Quote Progetto			140.36	140.29	140.35	140.41	140.92	
Parziali			0.33	2.50	2.50			
Progressiva			-2.83	-2.50	0.00	2.50	2.60	
Dislivelli			0.00	0.32	-0.11	-0.48	-0.00	

Sezione: 116
 Progressiva: 1021.058
 Q. Progetto: 140.705

138.00

Quote Terreno	140.12	140.19	140.21	140.37	140.39	140.74	141.87
Quote Progetto		140.19	140.24	140.30	140.37	140.90	
Parziali		0.46	2.50		2.50		
Progressiva		-2.96	-2.50	0.00	2.50	2.63	
Dislivelli		-0.00	0.45	-0.07	-0.50	0.00	

Sezione: 117
 Progressiva: 1038.138
 Q. Progetto: 139.984

138.00

Quote Terreno	140.00	140.00	140.00	140.39	140.53		143.17
Quote Progetto		140.00	139.52	139.58	139.65	141.91	
Parziali			2.50	2.50	1.86		
Progressiva		-2.58	-2.50	0.00	2.50	4.36	
Dislivelli		0.00	-0.08	-0.94	-1.67	0.00	

Sezione: 118
 Progressiva: 1040.000
 Q. Progetto: 139.921

138.00

Quote Terreno	140.00	140.00	140.00	140.57	140.93		143.26
Quote Progetto		140.00	139.46	139.52	139.58	141.99	
Parziali			2.50	2.50	2.01		
Progressiva		-2.64	-2.50	0.00	2.50	4.51	
Dislivelli		0.00	-0.14	-1.05	-1.77	0.00	

Sezione: 119
 Progressiva: 1050.000
 Q. Progetto: 139.700

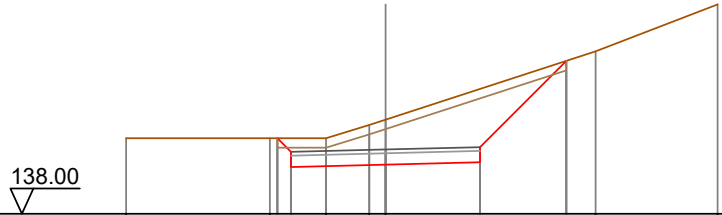

Quote Terreno	140.00	140.00	140.00	140.35	140.49	142.30	143.54
Quote Progetto		140.00 139.24		139.30	139.36	142.04	
Parziali		0.36	2.50	2.50	2.28		
Progressiva		2.86 2.50		0.00	2.50	4.78	
Dislivelli		0.00 -0.36		-1.19	-1.94	-0.00	

Sezione: 120
 Progressiva: 1060.000
 Q. Progetto: 139.662

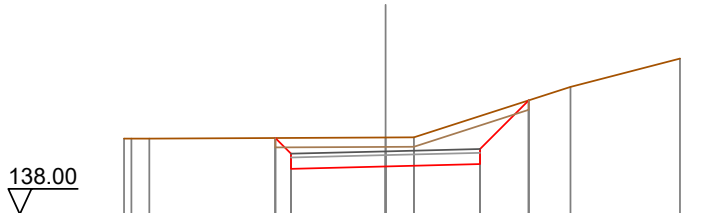

Quote Terreno	140.00	140.00	140.03	140.03	141.37	142.12
Quote Progetto		140.02 139.20	139.26	139.32	141.01	
Parziali		0.42	2.50	2.50	1.29	
Progressiva		2.92 2.50	0.00	2.50	3.79	
Dislivelli		0.00 -0.42	-0.77	-1.27	-0.00	

Sezione: 121
 Progressiva: 1066.047
 Q. Progetto: 139.660

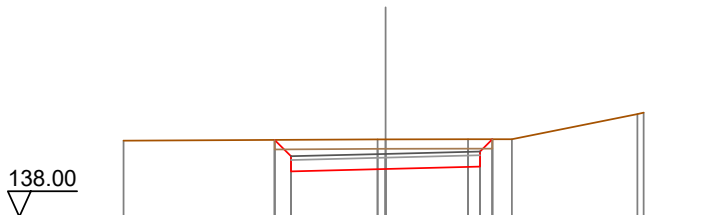

Quote Terreno	140.01	140.04	140.04	140.05	140.05	140.71	140.75
Quote Progetto		140.03 139.20	139.26	139.32 140.05	140.05		
Parziali		0.43	2.50	2.50	0.33		
Progressiva		2.93 2.50	0.00	2.50	2.83		
Dislivelli		0.00 -0.43	-0.78	-0.72	0.00		

Sezione: 122
 Progressiva: 1070.000
 Q. Progetto: 139.659

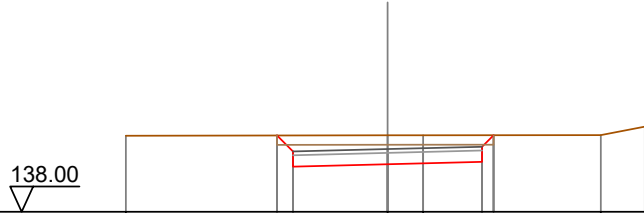

Quote Terreno	140.01		140.02	140.02	140.03	140.25
Quote Progetto		140.02	139.20	139.26	139.32	140.03
Parziali		0.42	2.50	2.50	0.30	
Progressiva		-2.92	-2.50	0.00	2.50	2.80
Dislivelli		-0.00	-0.42	-0.76	-0.70	0.00

Sezione: 123
 Progressiva: 1080.000
 Q. Progetto: 139.655

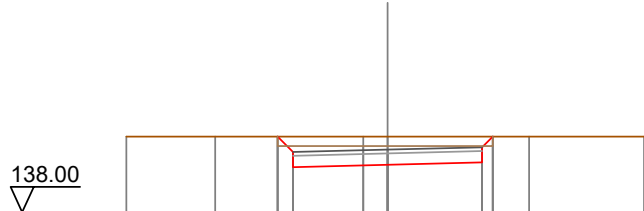

Quote Terreno	140.00	140.00	140.00	140.00	140.00	140.00
Quote Progetto			140.00	139.25	139.32	140.00
Parziali			0.41	2.50	2.50	0.28
Progressiva			-2.91	-2.50	0.00	2.50
Dislivelli			0.00	-0.41	-0.75	-0.68

Sezione: 124
 Progressiva: 1090.000
 Q. Progetto: 139.651

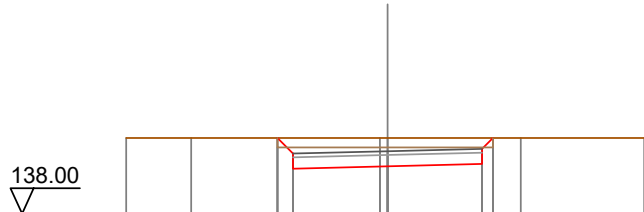

Quote Terreno	140.00	140.00	140.00	140.00	140.00	140.00
Quote Progetto			140.00	139.25	139.31	140.00
Parziali			0.41	2.50	2.50	0.29
Progressiva			-2.91	-2.50	0.00	2.50
Dislivelli			0.00	-0.41	-0.75	-0.69

Sezione: 125
 Progressiva: 1093.955
 Q. Progetto: 139.650

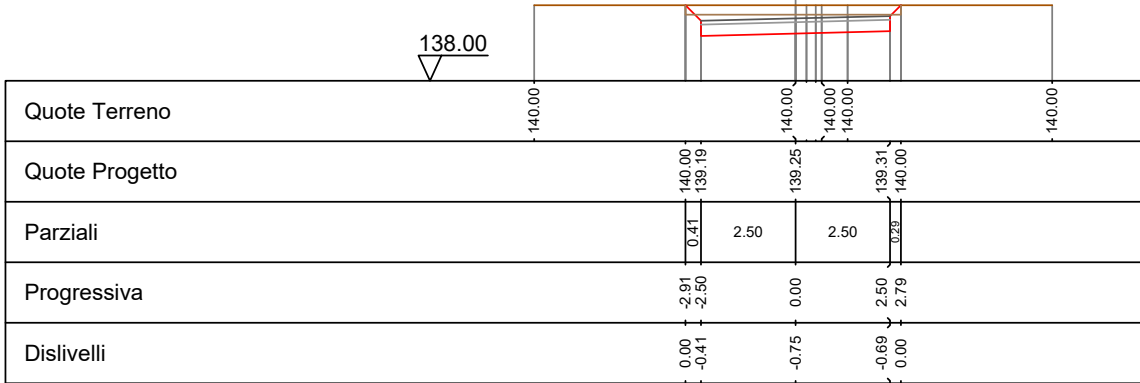

Sezione: 126
 Progressiva: 1100.000
 Q. Progetto: 139.647

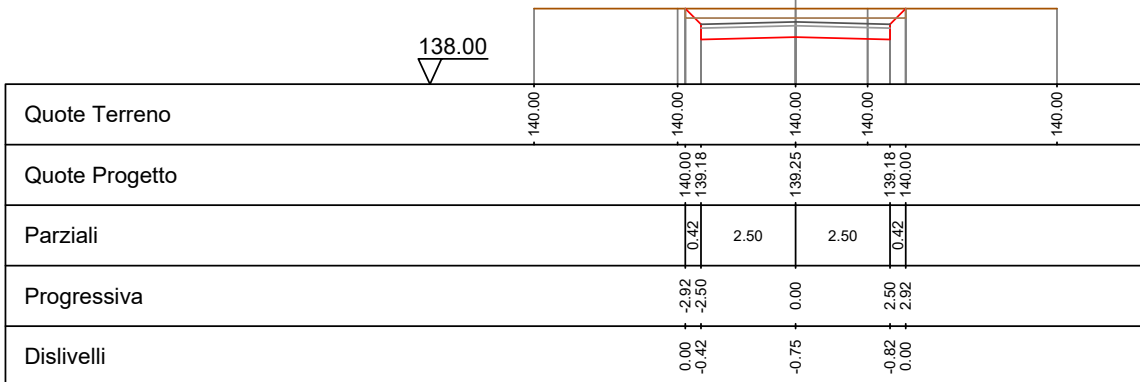

Sezione: 127
 Progressiva: 1120.000
 Q. Progetto: 139.640

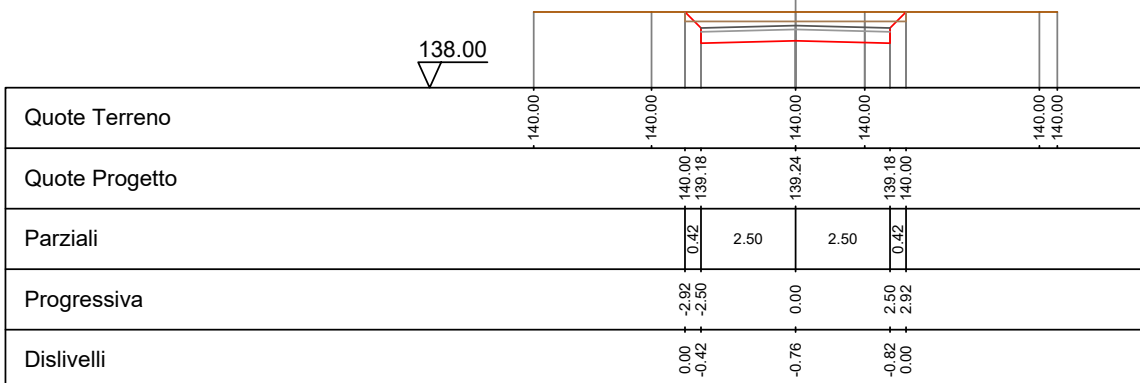

Sezione: 128
 Progressiva: 1138.813
 Q. Progetto: 139.633

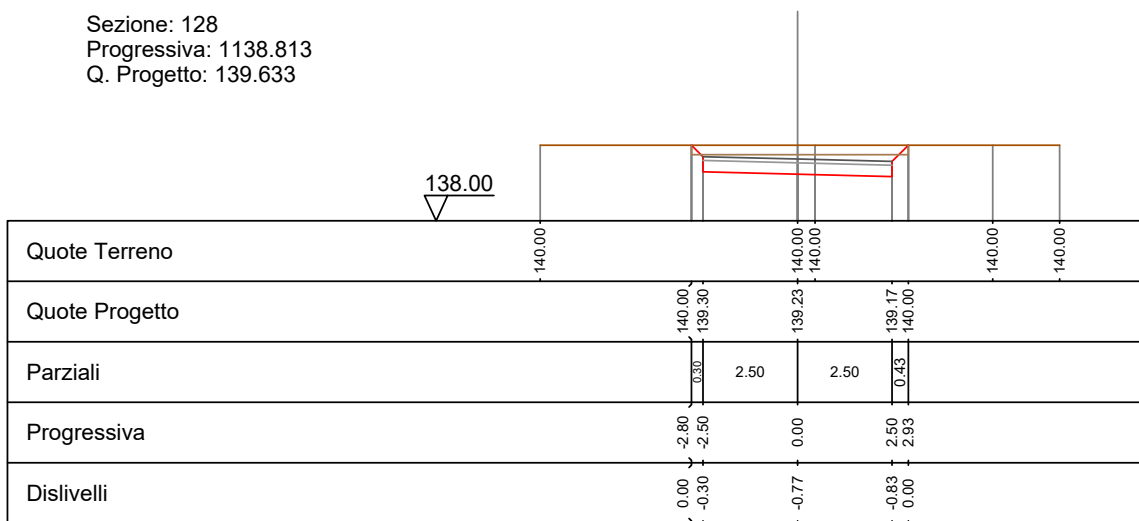

Sezione: 129
 Progressiva: 1140.000
 Q. Progetto: 139.632

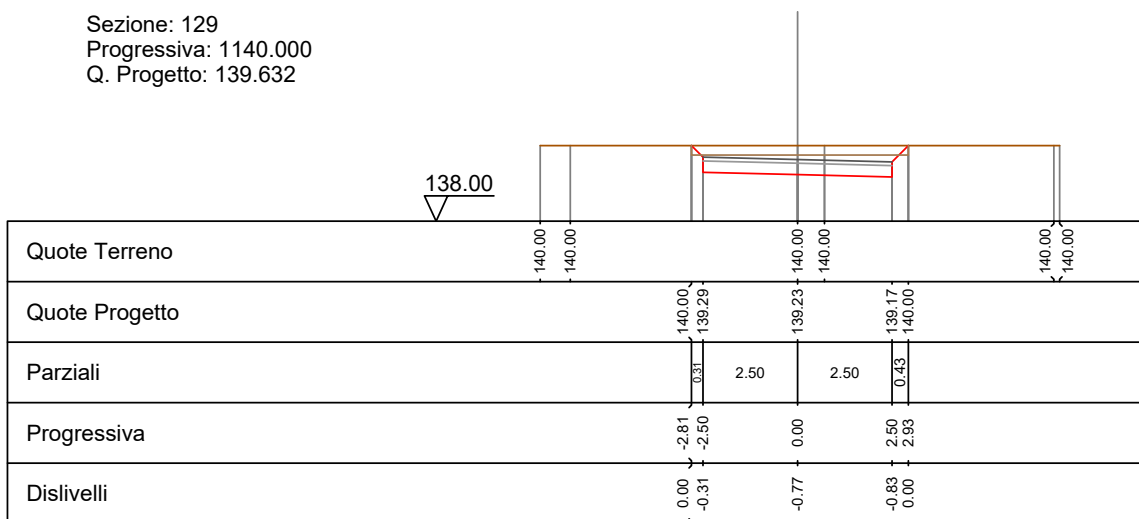

Sezione: 130
 Progressiva: 1150.000
 Q. Progetto: 139.629

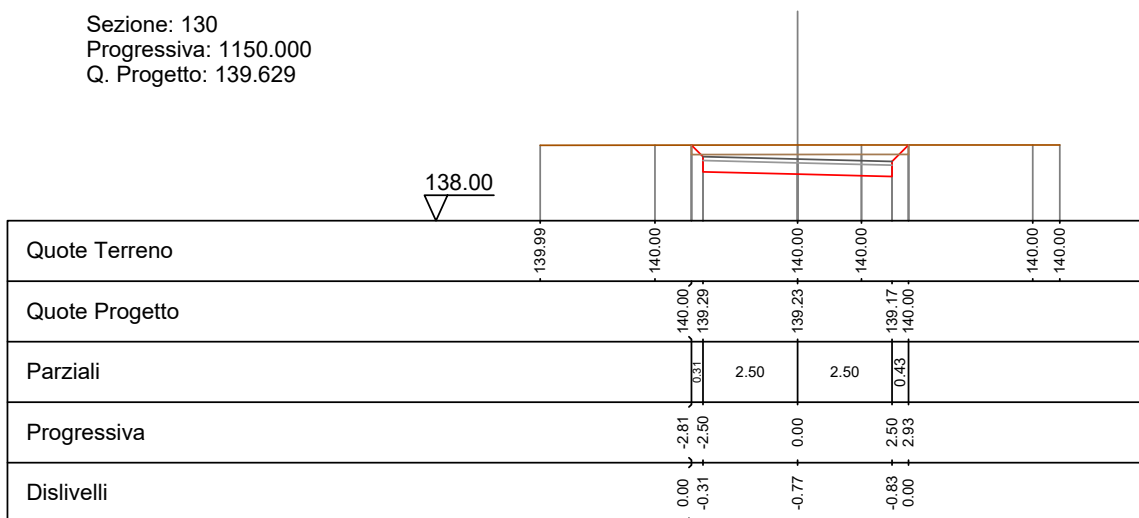

Sezione: 131
 Progressiva: 1160.000
 Q. Progetto: 139.625

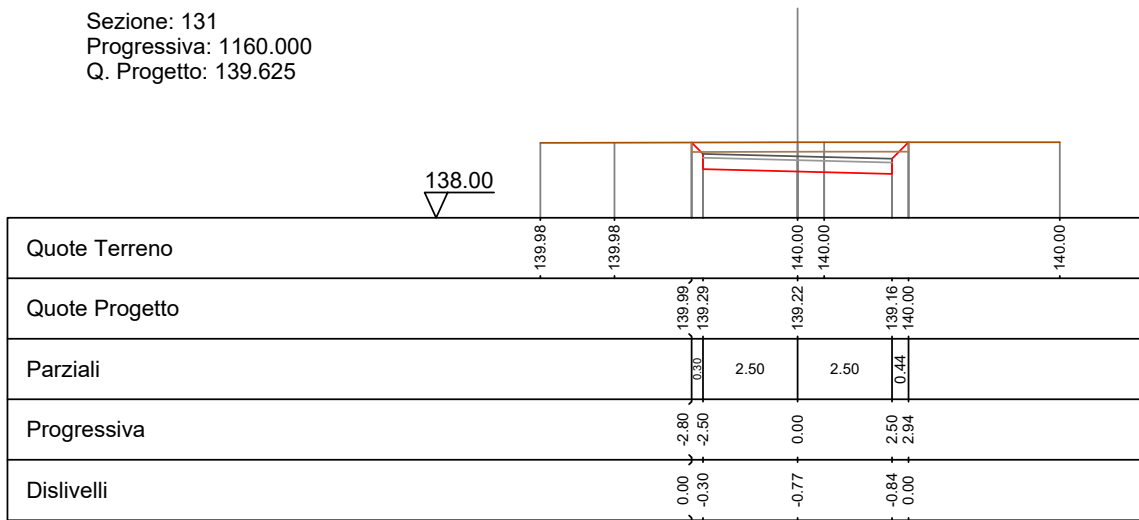

Sezione: 132
 Progressiva: 1161.723
 Q. Progetto: 139.624

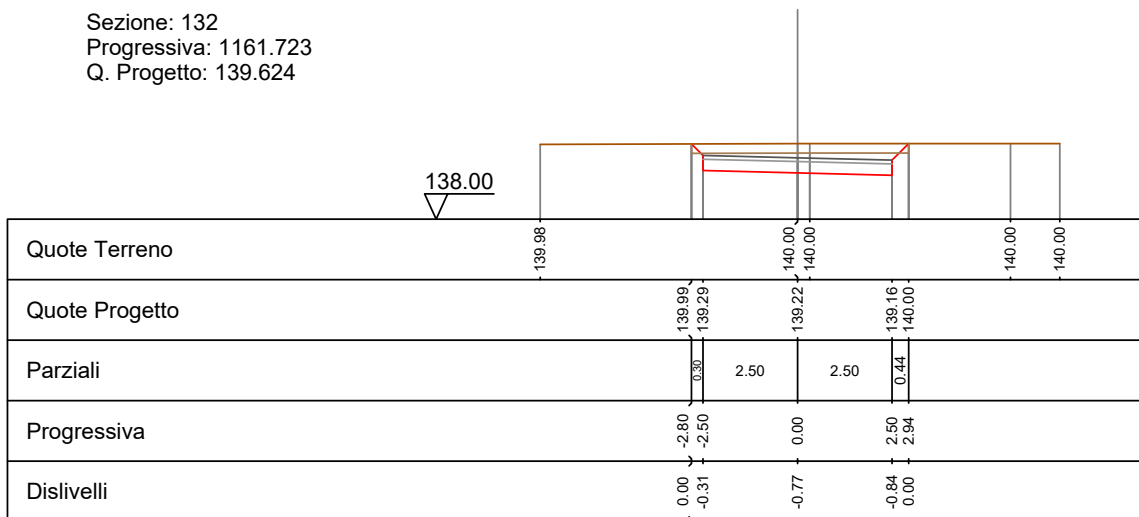

Sezione: 133
 Progressiva: 1170.000
 Q. Progetto: 139.621

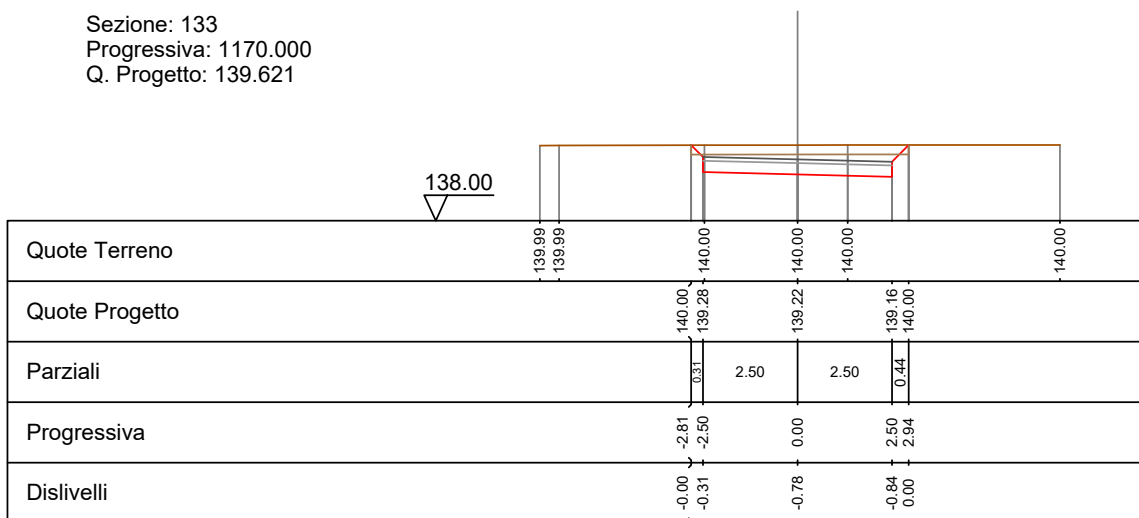

Sezione: 134
 Progressiva: 1180.000
 Q. Progetto: 139.617

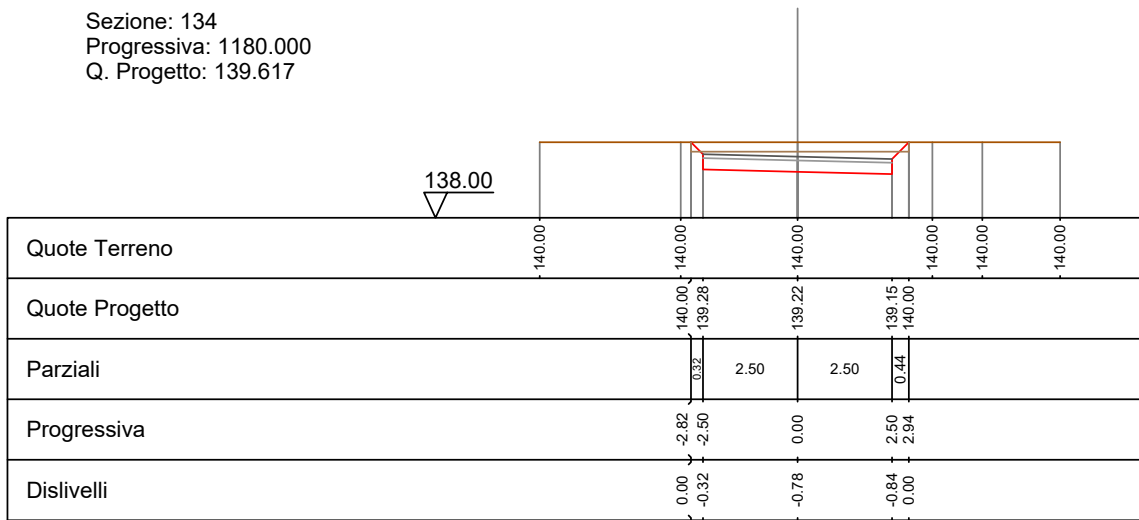

Sezione: 135
 Progressiva: 1184.634
 Q. Progetto: 139.616

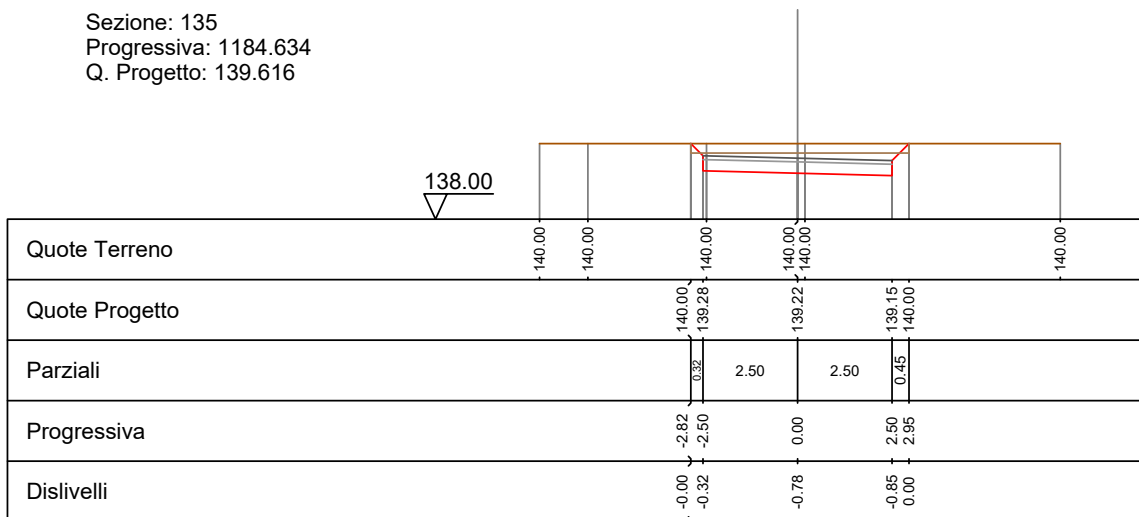

Sezione: 136
 Progressiva: 1200.000
 Q. Progetto: 139.617

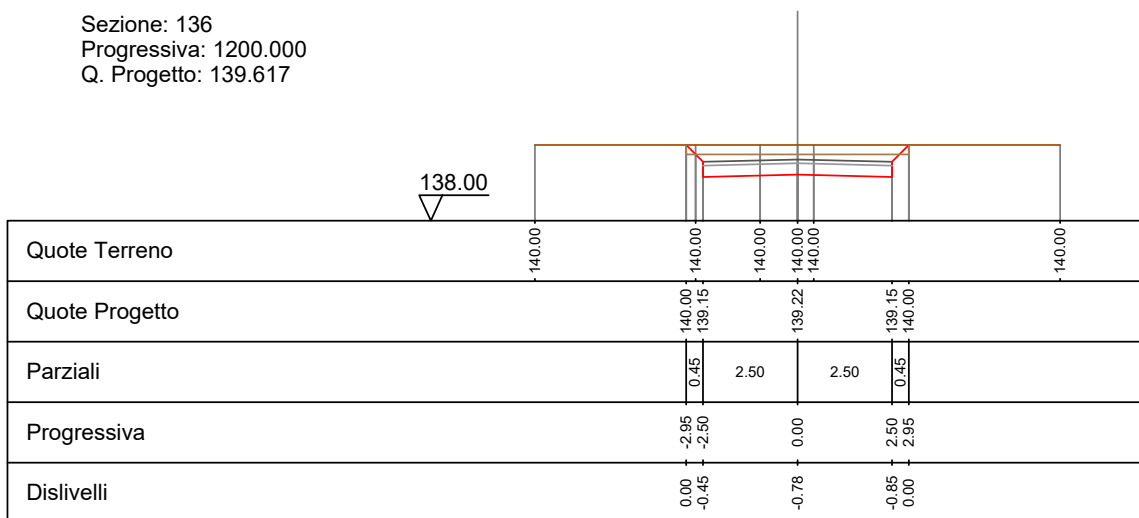

Sezione: 137
 Progressiva: 1211.523
 Q. Progetto: 139.809

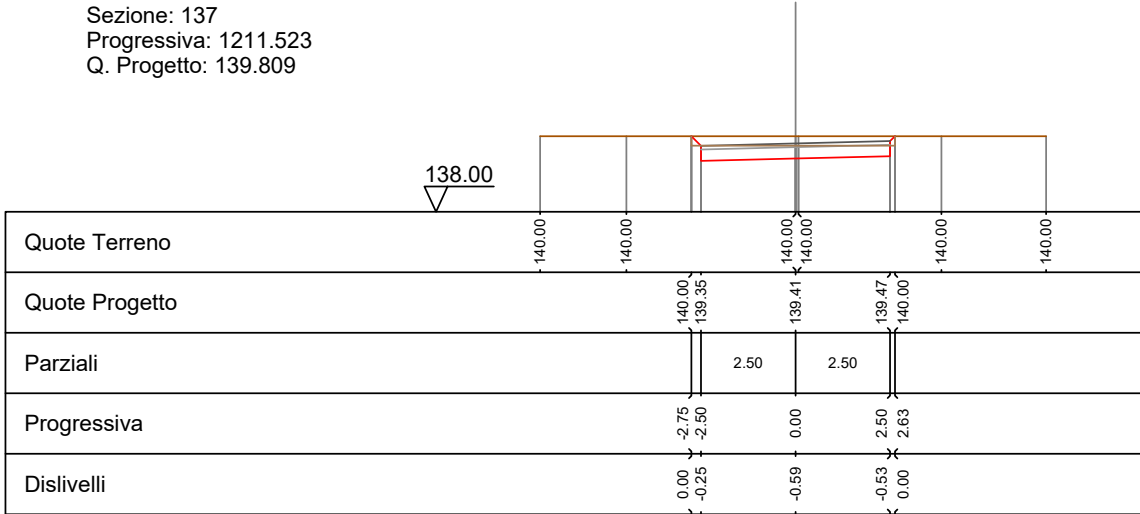

Sezione: 138
 Progressiva: 1220.000
 Q. Progetto: 140.119

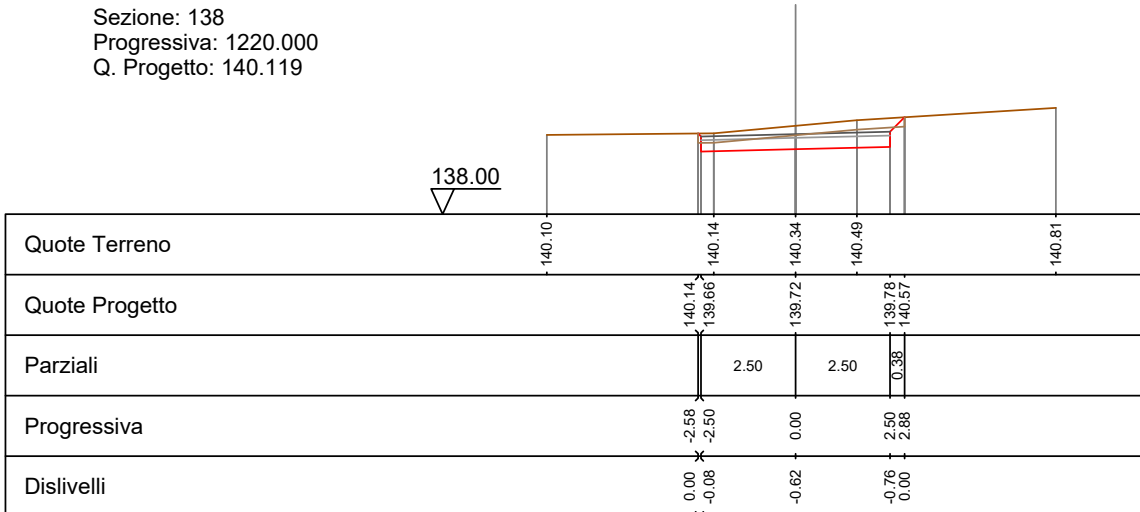

Sezione: 139
 Progressiva: 1230.000
 Q. Progetto: 140.634

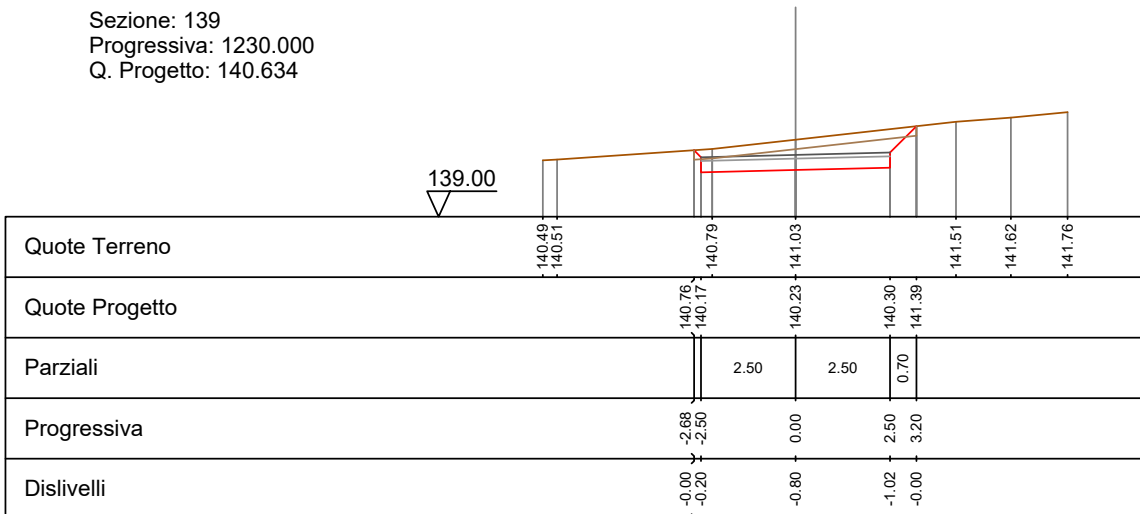

Sezione: 140
 Progressiva: 1231.026
 Q. Progetto: 140.688

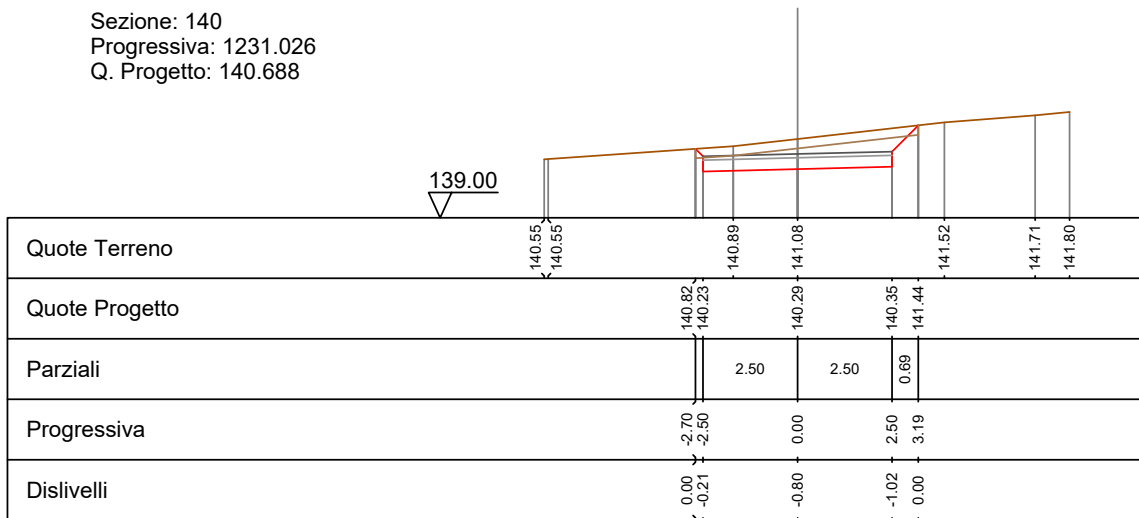

Sezione: 141
 Progressiva: 1240.000
 Q. Progetto: 141.074

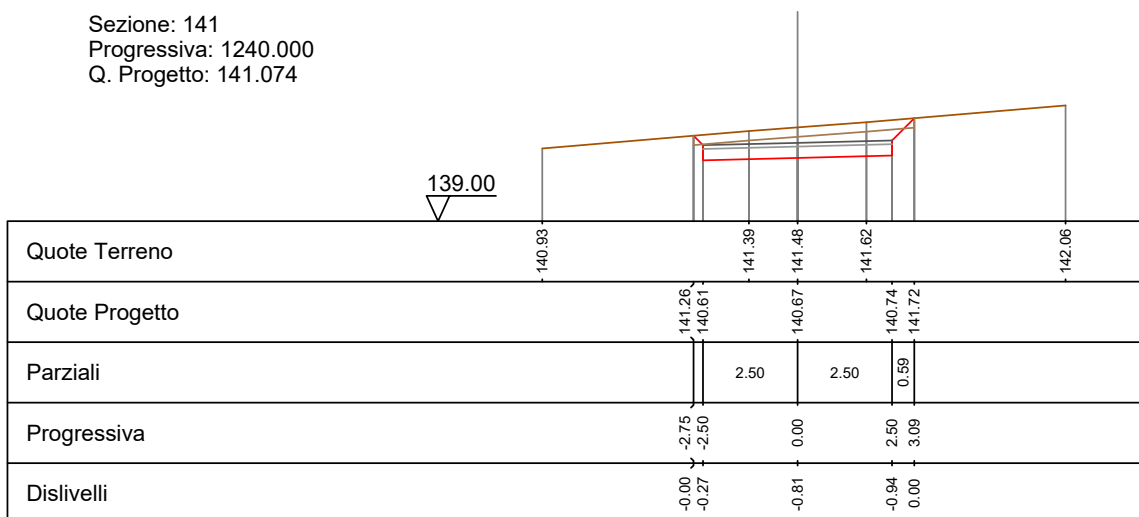

Sezione: 142
 Progressiva: 1250.000
 Q. Progetto: 141.314

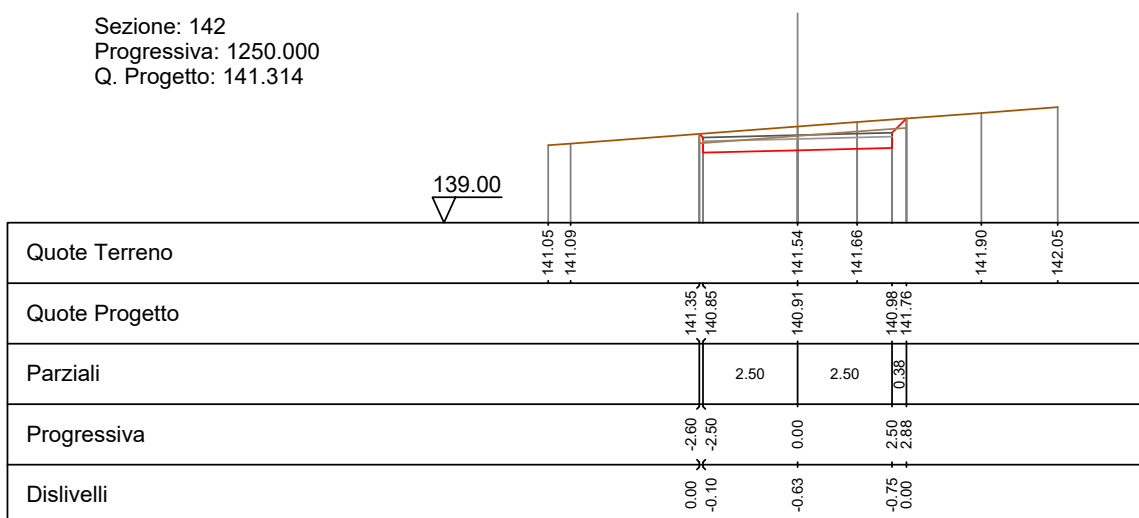

Sezione: 143
 Progressiva: 1250.529
 Q. Progetto: 141.321

139.00

Quote Terreno	141.05	141.13		141.54	141.66	141.95	142.05
Quote Progetto			141.35 140.86	140.92	140.98 141.75		
Parziali			2.50	2.50	0.37		
Progressiva			-2.59 -2.50	0.00	2.50 2.87		
Dislivelli			0.00 -0.09	-0.62	-0.74 0.00		

Sezione: 144
 Progressiva: 1253.861
 Q. Progetto: 141.353

139.00

Quote Terreno	141.06		141.41	141.52	141.67		142.02
Quote Progetto		141.34 140.89	140.95	141.02 141.73			
Parziali		2.50	2.50	0.32			
Progressiva		-2.55 -2.50	0.00	2.50 2.82			
Dislivelli		0.00 -0.05	-0.57	-0.70 0.00			

Sezione: 145
 Progressiva: 1254.796
 Q. Progetto: 141.358

139.00

Quote Terreno	141.06		141.49 141.52	141.67		142.02
Quote Progetto		141.34 140.90	140.96	141.02 141.73		
Parziali		2.50	2.50	0.31		
Progressiva		-2.54 -2.50	0.00	2.50 2.81		
Dislivelli		0.00 -0.05	-0.56	-0.68 -0.00		

Sezione: 146
 Progressiva: 1255.731
 Q. Progetto: 141.361

139.00

Quote Terreno	141.06	141.34	141.52	141.57	141.67	142.01
Quote Progetto		140.90	140.96		141.02	141.72
Parziali		2.50		2.50	0.30	
Progressiva		-2.54	0.00		2.50	2.80
Dislivelli		-0.00	-0.56		-0.68	0.00

Sezione: 147
 Progressiva: 1260.000
 Q. Progetto: 141.355

139.00

Quote Terreno	141.05	141.14	141.49	141.67	141.92	141.97
Quote Progetto			140.96	140.89	141.69	
Parziali			2.50	2.50	0.40	
Progressiva			0.00	2.50	2.90	
Dislivelli			-0.54	-0.77	0.00	

Sezione: 148
 Progressiva: 1269.052
 Q. Progetto: 141.322

139.00

Quote Terreno	141.01	141.03	141.43	141.55	141.67	141.88
Quote Progetto			140.92	140.86	141.61	
Parziali			2.50	2.50	0.35	
Progressiva			0.00	2.50	2.85	
Dislivelli			-0.51	-0.73	0.00	

Sezione: 149
 Progressiva: 1270.000
 Q. Progetto: 141.318

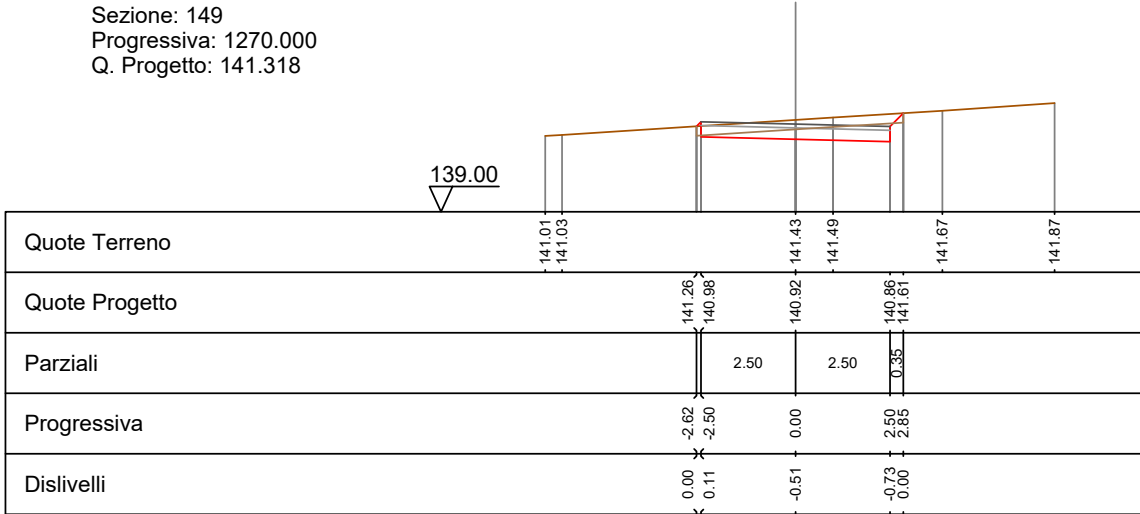

Sezione: 150
 Progressiva: 1275.788
 Q. Progetto: 141.303

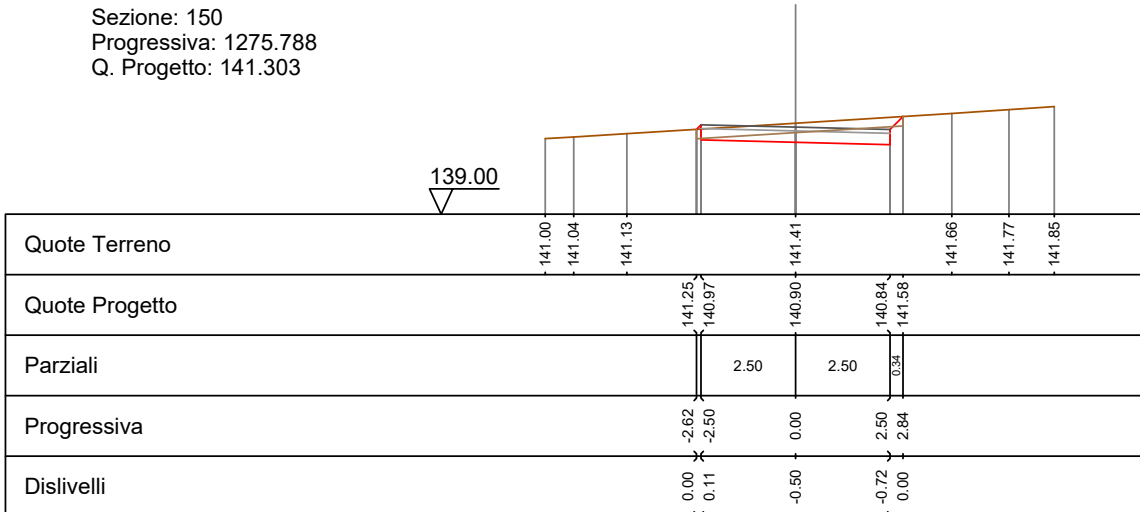

Sezione: 151
 Progressiva: 1280.000
 Q. Progetto: 141.314

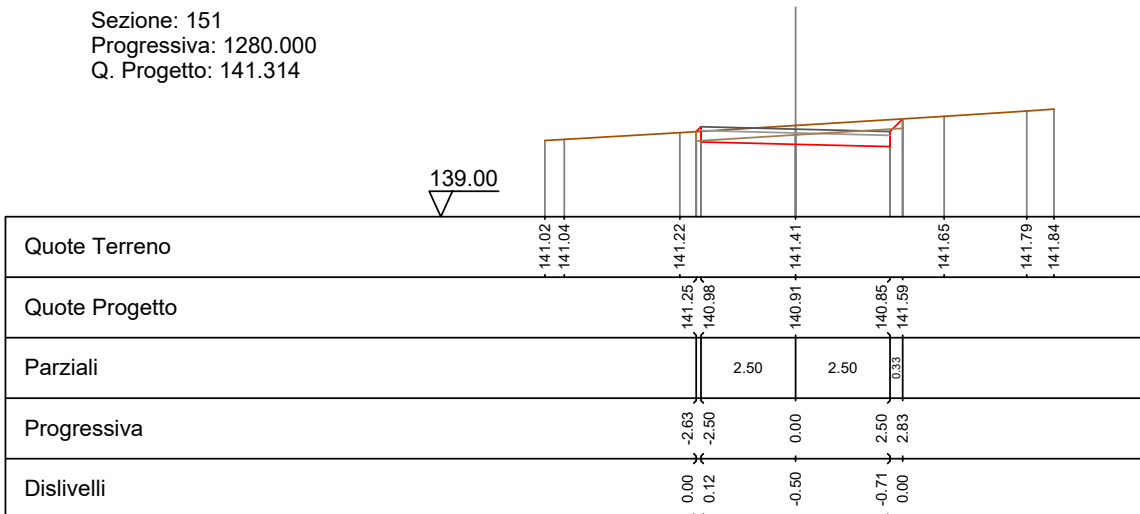

Sezione: 152
 Progressiva: 1282.525
 Q. Progetto: 141.321

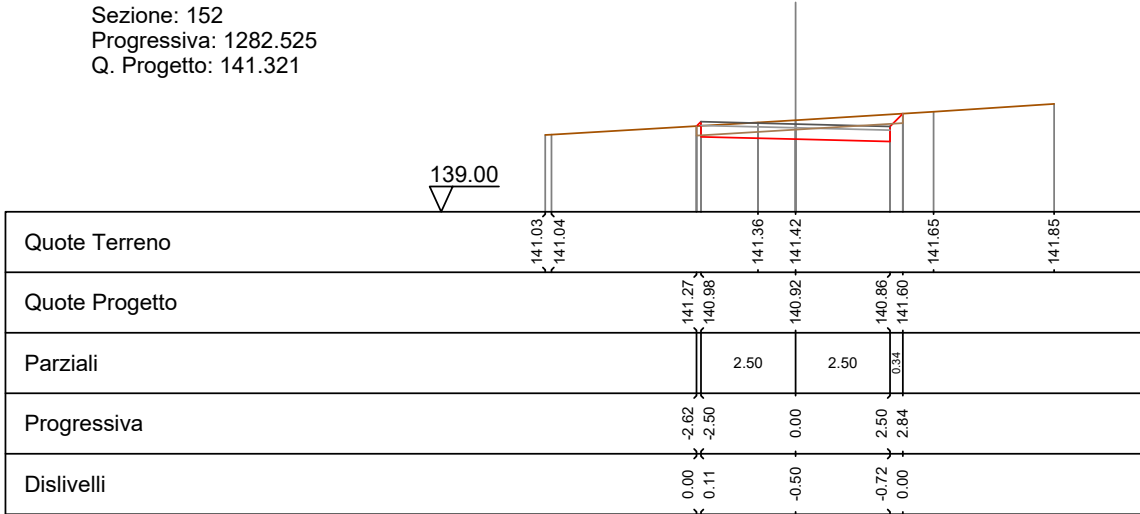

Sezione: 153
 Progressiva: 1300.000
 Q. Progetto: 141.370

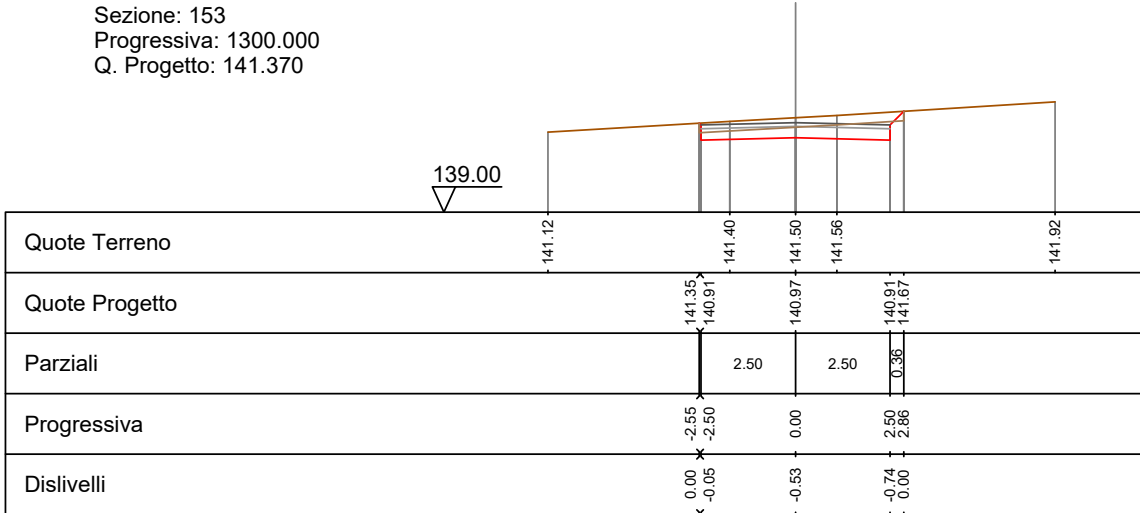

Sezione: 154
 Progressiva: 1300.807
 Q. Progetto: 141.372

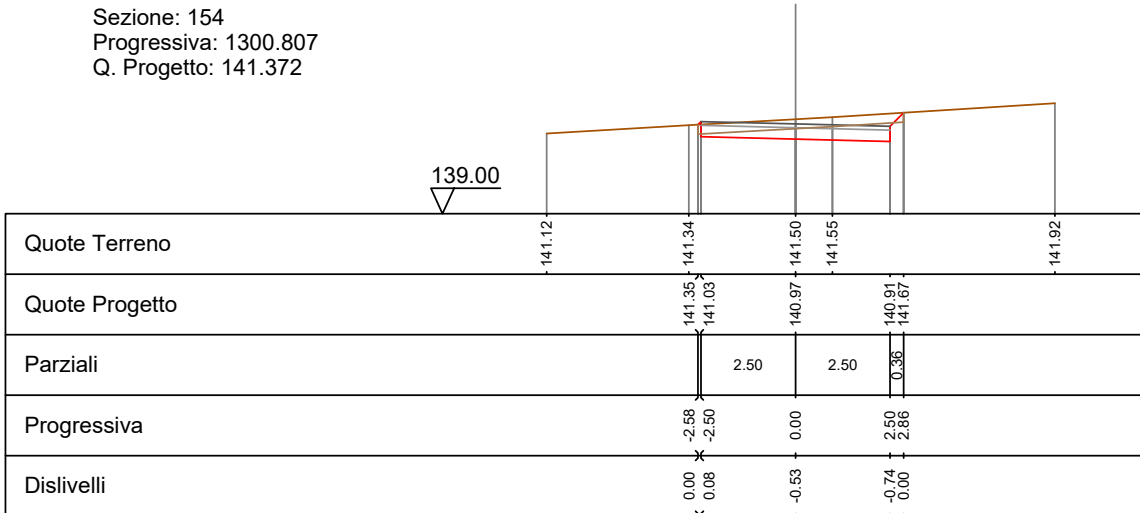

Sezione: 155
 Progressiva: 1307.257
 Q. Progetto: 141.400

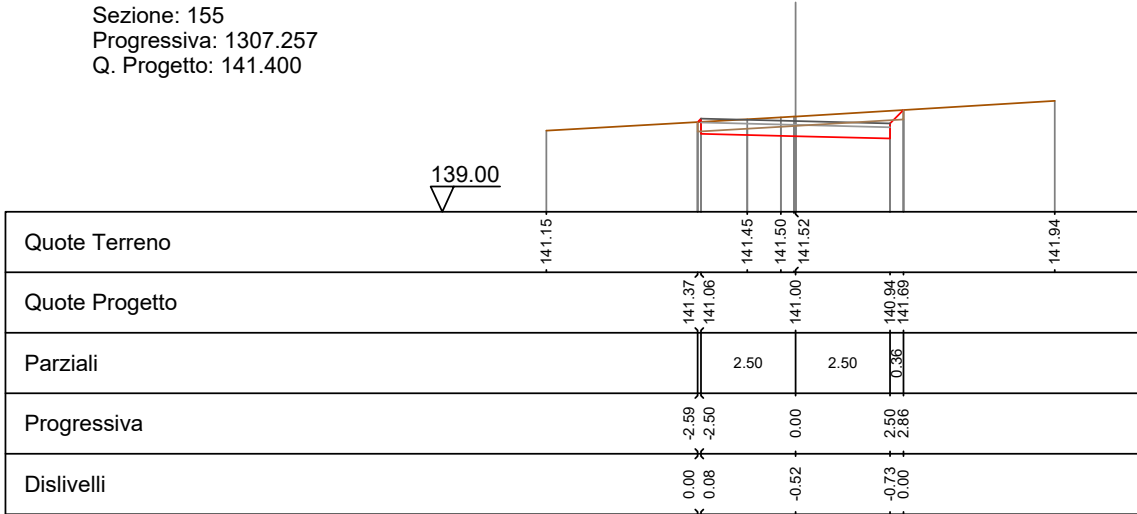

Sezione: 156
 Progressiva: 1310.000
 Q. Progetto: 141.433

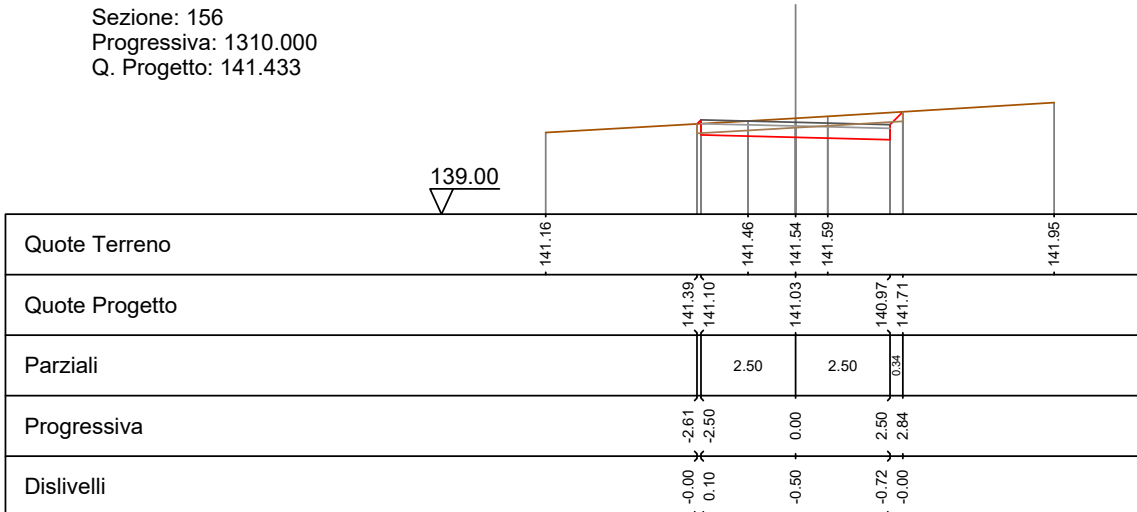

Sezione: 157
 Progressiva: 1313.707
 Q. Progetto: 141.501

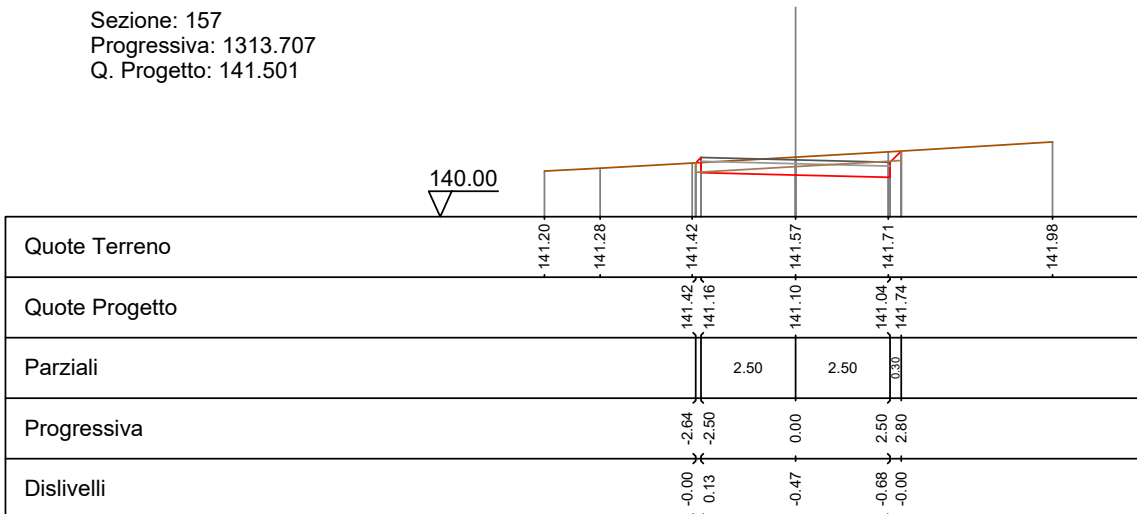

Sezione: 158
 Progressiva: 1320.000
 Q. Progetto: 141.675

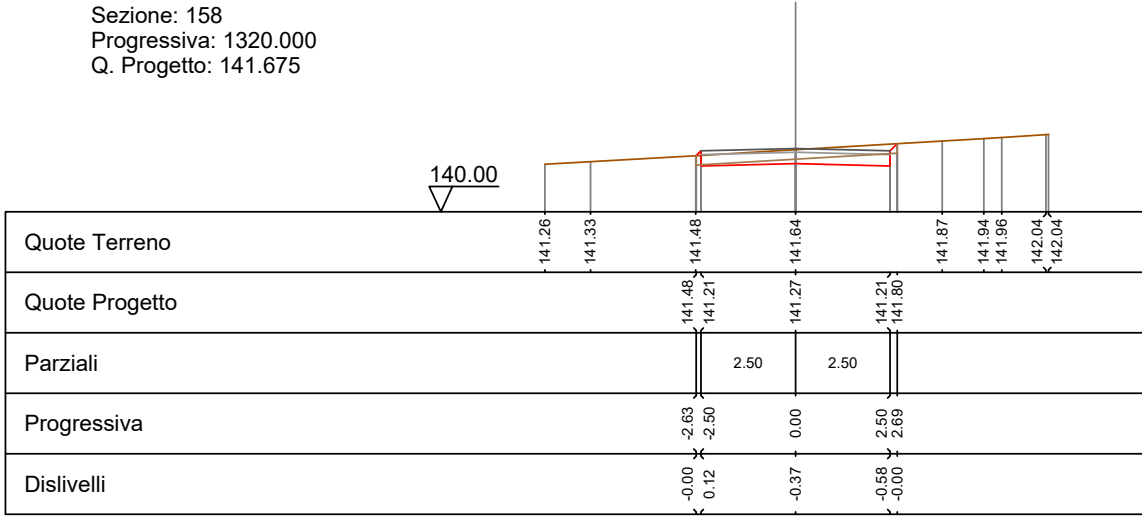

Sezione: 159
 Progressiva: 1336.004
 Q. Progetto: 142.069

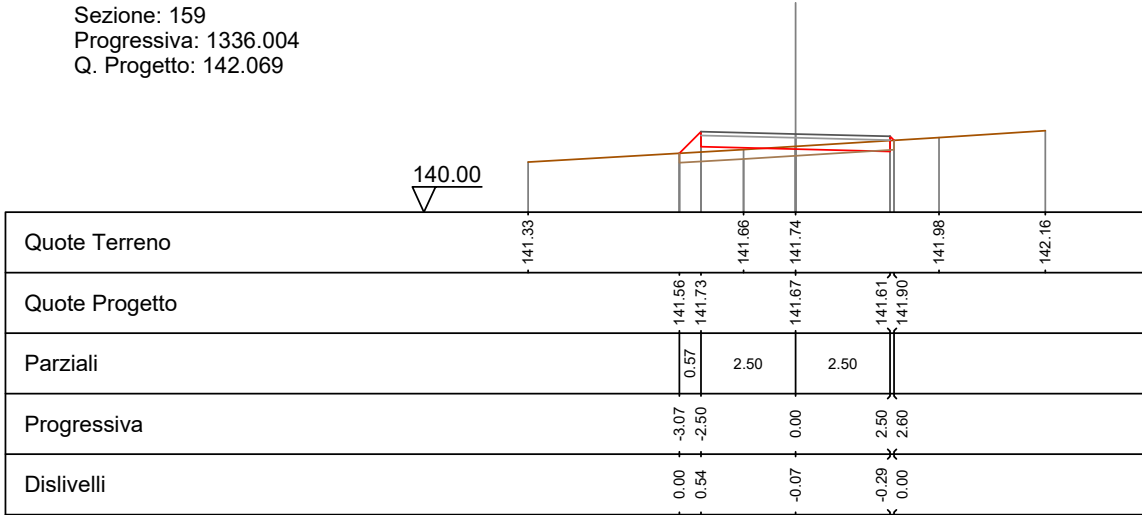

Sezione: 160
 Progressiva: 1340.000
 Q. Progetto: 142.097

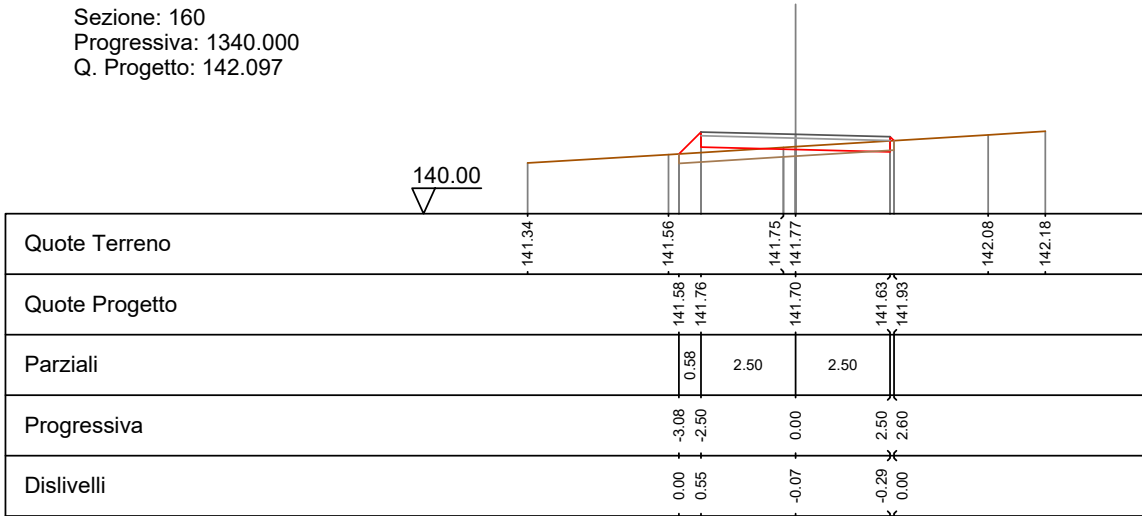

Sezione: 161
 Progressiva: 1341.253
 Q. Progetto: 142.100

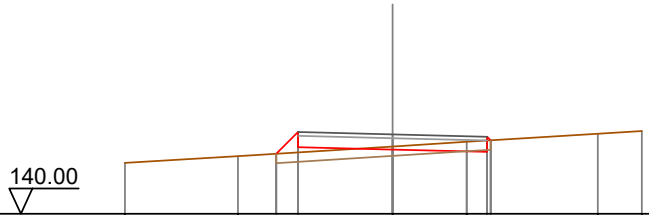

Quote Terreno	141.35	141.52	141.59	141.76	141.78	141.90	142.12	142.19
Quote Progetto			141.59	141.76	141.70	141.64	141.94	
Parziali			0.58	2.50		2.50		
Progressiva			-3.08	-2.50	0.00	2.50	2.59	
Dislivelli			0.00	0.54	-0.08	-0.30	0.00	

Sezione: 162
 Progressiva: 1343.400
 Q. Progetto: 142.100

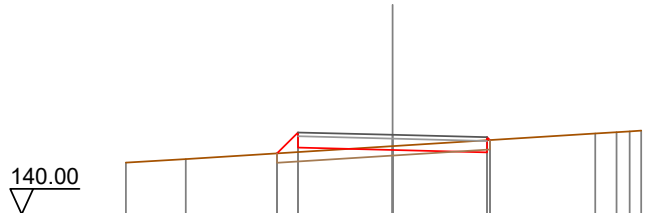

Quote Terreno	141.37	141.46	141.61	141.76	141.80	141.80	142.14	142.17	142.21
Quote Progetto			141.61	141.76	141.70	141.64	141.96		
Parziali			0.55	2.50		2.50			
Progressiva			-3.05	-2.50	0.00	2.50	2.58		
Dislivelli			0.00	0.52	-0.10	-0.32	-0.00		

SEZIONI TRASVERSALI
Profilo longitudinale tratto 15-16
Viabilità di impianto - Postazione aerogeneratore WTG08

Nota: Le canalette di deflusso delle acque meteoriche, non indicate nel presente elaborato, sono rappresentate graficamente nelle sezioni stradali tipo dell'elaborato "BLTX-NS-TC13_Piazzole aerogeneratori e strade di servizio - Particolari costruttivi", individuate planimetricamente nell'elaborato "BLTX-NS-TC14_Opere di regimazione acque superficiali - Planimetria generale" e quantificate nell'elaborato "BLTX-NS-RC6_Computo metrico estimativo opere civili".

DISEGNI DI RIFERIMENTO

TAVOLA	DESCRIZIONE
BLTX-NS-TC8	Viabilità e piazzole - Planimetria di progetto - Fase di cantiere
BLTX-NS-TC11	Profili longitudinali viabilità di impianto
BLTX-NS-TC13	Piazzole aerogeneratori e strade di servizio - Particolari costruttivi
BLTX-NS-TC14	Opere di regimazione acque superficiali - Planimetria generale

Sezione: 12
 Progressiva: 68.000
 Q. Progetto: 135.621

134.00

Quote Terreno	135.65			135.68	135.69		135.72
Quote Progetto		135.67	135.16	135.22		135.28	
Parziali			2.50		2.50		
Progressiva		-2.61	-2.50	0.00		2.50	
Dislivelli		0.00	-0.11	-0.46		-0.41	

Sezione: 13
 Progressiva: 80.000
 Q. Progetto: 135.410

133.00

Quote Terreno	135.43	135.43	135.44	135.45	135.46	135.47	
Quote Progetto			135.44	134.95	135.01	134.95	135.46
Parziali			2.50		2.50		
Progressiva		-2.59	-2.50	0.00		2.50	2.61
Dislivelli		0.00	-0.09	-0.44		-0.51	0.00

Sezione: 14
 Progressiva: 100.000
 Q. Progetto: 135.059

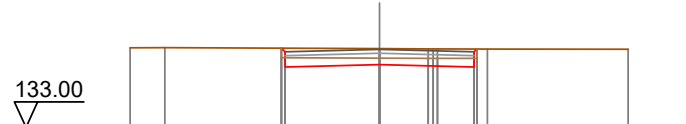

Quote Terreno	135.10	135.11		135.08	135.07	135.07	135.07	135.06
Quote Progetto			135.09	134.66	134.66	134.60	135.07	
Parziali			2.50	2.50				
Progressiva			-2.60	-2.50	0.00	2.50	2.58	
Dislivelli			-0.00	-0.10	-0.42	-0.48	0.00	

Sezione: 15
 Progressiva: 120.000
 Q. Progetto: 134.707

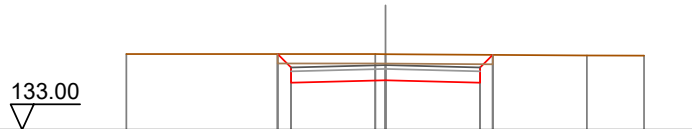

Quote Terreno	135.00			135.00			134.96	134.96
Quote Progetto		135.00	134.24	134.31	134.24	134.98		
Parziali		0.36	2.50	2.50	0.33			
Progressiva		-2.86	-2.50	0.00	2.50	2.83		
Dislivelli		0.00	-0.36	-0.69	-0.74	0.00		

Sezione: 16
 Progressiva: 140.000
 Q. Progetto: 134.356

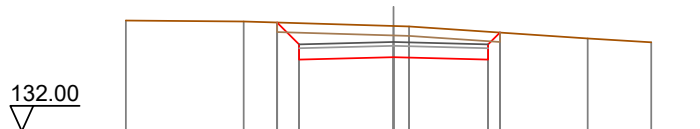

Quote Terreno	134.93	134.90		134.78	134.77		134.45	134.35
Quote Progetto			134.87	133.89	133.96	133.89	134.61	
Parziali			0.58	2.50	2.50	0.31		
Progressiva			-3.08	-2.50	0.00	2.50	2.81	
Dislivelli			0.00	-0.56	-0.82	-0.73	0.00	

Sezione: 17
 Progressiva: 149.950
 Q. Progetto: 134.283

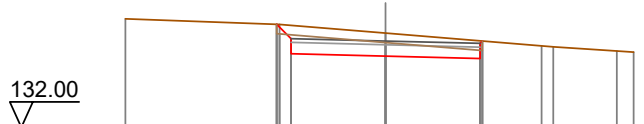

Quote Terreno	134.87	134.72	134.49	134.15	134.13	134.02	133.99
Quote Progetto		134.72	133.95	133.88	133.82	134.28	
Parziali		0.38	2.50	2.50			
Progressiva		-2.88	-2.50	0.00	2.50	2.56	
Dislivelli		0.00	-0.35	-0.61	-0.47	0.00	

Sezione: 18
 Progressiva: 156.225
 Q. Progetto: 134.338

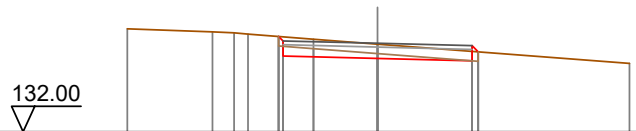

Quote Terreno	134.72	134.64	134.62	134.58	134.44	134.32	133.81
Quote Progetto			134.52	134.00	133.94	133.88	134.11
Parziali				2.50	2.50		
Progressiva		-2.62	-2.50	0.00	2.50	2.66	
Dislivelli		-0.00	-0.11	-0.38	-0.25	0.00	

Sezione: 19
 Progressiva: 160.000
 Q. Progetto: 134.410

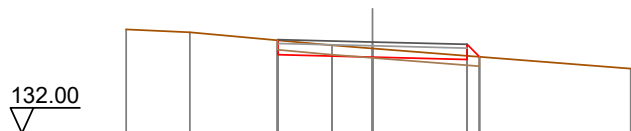

Quote Terreno	134.74	134.67	134.32	134.24	133.71	
Quote Progetto			134.07	134.01	133.95	134.02
Parziali			2.50	2.50	0.33	
Progressiva		-2.52	0.00	2.50	2.83	
Dislivelli		0.00	-0.23	-0.10	-0.00	

Sezione: 20
 Progressiva: 162.500
 Q. Progetto: 134.472

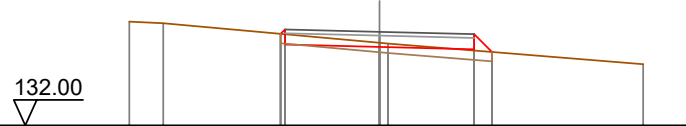

Quote Terreno	134.74	134.70		134.18	134.16		133.62
Quote Progetto			134.42	134.13		134.01	133.94
Parziali			2.50	2.50		0.47	
Progressiva			-2.62	-2.50	0.00	2.50	2.97
Dislivelli			0.00	0.13	-0.11	0.03	0.00

Sezione: 21
 Progressiva: 180.000
 Q. Progetto: 135.049

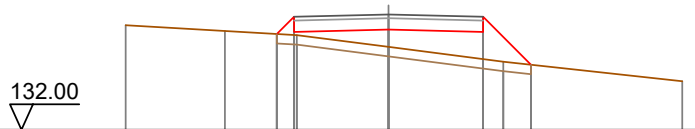

Quote Terreno	134.76	134.61	134.50	134.19	133.80	133.28	
Quote Progetto			134.53	134.65	134.59	133.72	
Parziali			0.45	2.50	2.50	1.27	
Progressiva			-2.95	-2.50	0.00	2.50	3.77
Dislivelli			0.00	0.48	0.46	0.72	0.00

Sezione: 22
 Progressiva: 185.313
 Q. Progetto: 135.226

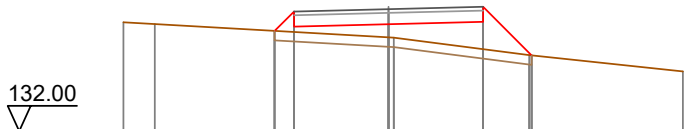

Quote Terreno	134.88	134.83		134.48	134.47		134.01	133.58
Quote Progetto			134.65	134.83	134.76		134.89	134.00
Parziali			0.51	2.50	2.50		1.29	
Progressiva			-3.01	-2.50	0.00	2.50	3.79	
Dislivelli			-0.00	0.54	0.35	0.72	0.00	

Sezione: 23
 Progressiva: 190.000
 Q. Progetto: 135.383

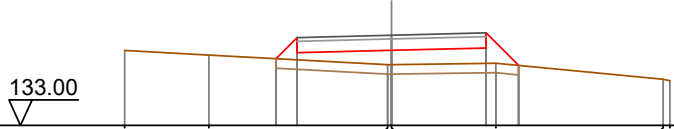

Quote Terreno	134.98	134.86		134.60	134.60	134.64	134.22	134.18
Quote Progetto			134.76	134.92	134.98	135.05	134.58	
Parziali			0.56	2.50	2.50	0.86		
Progressiva			-3.06	-2.50	0.00	2.50	3.36	
Dislivelli			0.00	0.59	0.38	0.41	0.00	

Sezione: 24
 Progressiva: 200.000
 Q. Progetto: 135.717

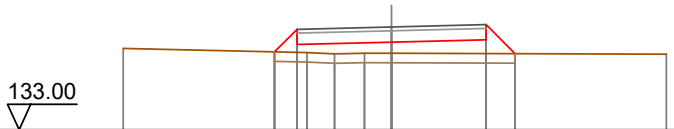

Quote Terreno	135.15		135.04	135.01	135.02	135.02		135.00
Quote Progetto			135.06	135.25	135.32	135.38	135.01	
Parziali			0.60	2.50	2.50	0.77		
Progressiva			-3.10	-2.50	0.00	2.50	3.27	
Dislivelli			0.00	0.61	0.30	0.37	-0.00	

Sezione: 25
 Progressiva: 210.000
 Q. Progetto: 136.003

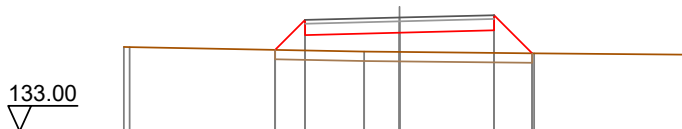

Quote Terreno	135.23	135.22		135.10	135.09		135.06	135.02
Quote Progetto			135.15	135.54	135.60	135.67	135.06	
Parziali			0.79	2.50	2.50	1.01		
Progressiva			-3.29	-2.50	0.00	2.50	3.51	
Dislivelli			0.00	0.81	0.51	0.60	0.00	

Sezione: 26
 Progressiva: 220.000
 Q. Progetto: 136.100

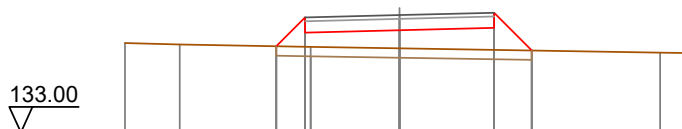

Quote Terreno		135.36	135.32		135.26		135.22		135.11	135.10
Quote Progetto				135.28	135.64		135.70		135.76	135.16
Parziali				0.76	2.50		2.50		1.00	
Progressiva				-3.26	-2.50		0.00		2.50	3.50
Dislivelli				0.00	0.77		0.48		0.58	-0.00

SEZIONI TRASVERSALI
Profilo longitudinale tratto 17-18
Viabilità di impianto - Postazione aerogeneratore WTG09

Nota: Le canalette di deflusso delle acque meteoriche, non indicate nel presente elaborato, sono rappresentate graficamente nelle sezioni stradali tipo dell'elaborato "BLTX-NS-TC13_Piazzole aerogeneratori e strade di servizio - Particolari costruttivi", individuate planimetricamente nell'elaborato "BLTX-NS-TC14_Opere di regimazione acque superficiali - Planimetria generale" e quantificate nell'elaborato "BLTX-NS-RC6_Computo metrico estimativo opere civili".

DISEGNI DI RIFERIMENTO

TAVOLA	DESCRIZIONE
BLTX-NS-TC8	Viabilità e piazzole - Planimetria di progetto - Fase di cantiere
BLTX-NS-TC11	Profili longitudinali viabilità di impianto
BLTX-NS-TC13	Piazzole aerogeneratori e strade di servizio - Particolari costruttivi
BLTX-NS-TC14	Opere di regimazione acque superficiali - Planimetria generale

Sezione: 4
 Progressiva: 20.000
 Q. Progetto: 102.648

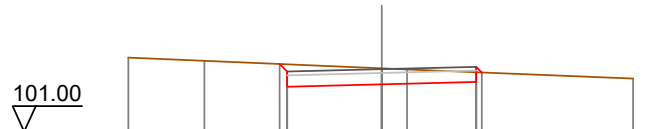

Quote Terreno	102.95	102.87		102.67	102.64		102.40
Quote Progetto			102.79	102.19	102.25	102.31	102.56
Parziali			2.50		2.50		
Progressiva			-2.70	-2.50	0.00	2.50	2.65
Dislivelli			0.00	-0.19	-0.42	-0.28	0.00

Sezione: 5
 Progressiva: 30.000
 Q. Progetto: 102.721

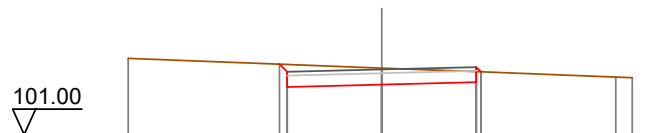

Quote Terreno	103.01			102.76		102.66	102.52	102.50
Quote Progetto			102.86	102.26	102.32	102.38	102.66	
Parziali			2.50		2.50			
Progressiva			-2.70	-2.50	0.00	2.50	2.63	
Dislivelli			0.00	-0.19	-0.44	-0.28	0.00	

Sezione: 6
 Progressiva: 34.253
 Q. Progetto: 102.781

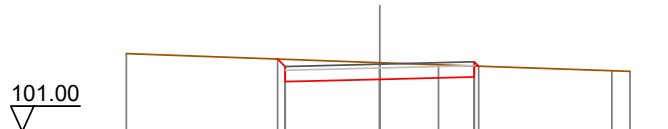

Quote Terreno	103.06		102.82	102.76	102.61	102.59
Quote Progetto		102.92	102.32	102.38	102.44	102.73
Parziali			2.50	2.50		
Progressiva		-2.70	-2.50	0.00	2.50	2.62
Dislivelli		0.00	-0.19	-0.44	-0.29	0.00

Sezione: 7
 Progressiva: 40.000
 Q. Progetto: 102.889

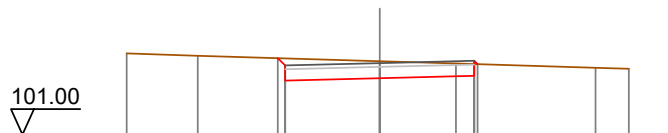

Quote Terreno	103.14	103.08	102.94	102.88	102.76	102.74
Quote Progetto		103.02	102.43	102.49	102.55	102.86
Parziali			2.50	2.50		
Progressiva		-2.69	-2.50	0.00	2.50	2.59
Dislivelli		0.00	-0.19	-0.45	-0.31	0.00

Sezione: 8
 Progressiva: 50.000
 Q. Progetto: 103.151

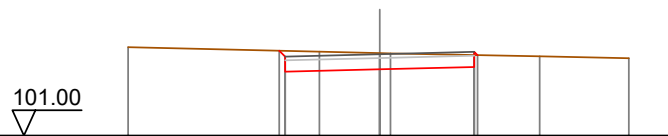

Quote Terreno	103.34	103.22	103.18	103.17	103.09	103.05
Quote Progetto		103.24	102.69	102.75	102.81	103.13
Parziali			2.50	2.50		
Progressiva		-2.66	-2.50	0.00	2.50	2.59
Dislivelli		0.00	-0.15	-0.43	-0.32	0.00

Sezione: 9
 Progressiva: 60.000
 Q. Progetto: 103.470

102.00

Quote Terreno	103.56	103.54	103.53		103.45	103.41	103.37	103.36
Quote Progetto				103.49	103.01	103.07	103.13	103.41
Parziali				2.50		2.50		
Progressiva				-2.59	-2.50	0.00	2.50	2.62
Dislivelli				0.00	-0.08	-0.38	-0.28	0.00

Sezione: 10
 Progressiva: 66.467
 Q. Progetto: 103.677

102.00

Quote Terreno	103.71		103.66		103.63		103.60	103.57
Quote Progetto			103.66	103.21	103.28		103.34	103.61
Parziali			2.50		2.50			
Progressiva			-2.55	-2.50	0.00	2.50	2.63	
Dislivelli			-0.00	-0.05	-0.36	-0.27	0.00	

Sezione: 11
 Progressiva: 80.000
 Q. Progetto: 104.087

102.00

Quote Terreno	104.06		104.01		103.99	103.99		103.96	103.93
Quote Progetto			103.62		103.69		103.62	103.97	
Parziali			2.50		2.50				
Progressiva			-2.51		0.00	2.50	2.56		
Dislivelli			0.00		-0.30	-0.34	0.00		

Sezione: 12
 Progressiva: 100.000
 Q. Progetto: 104.593

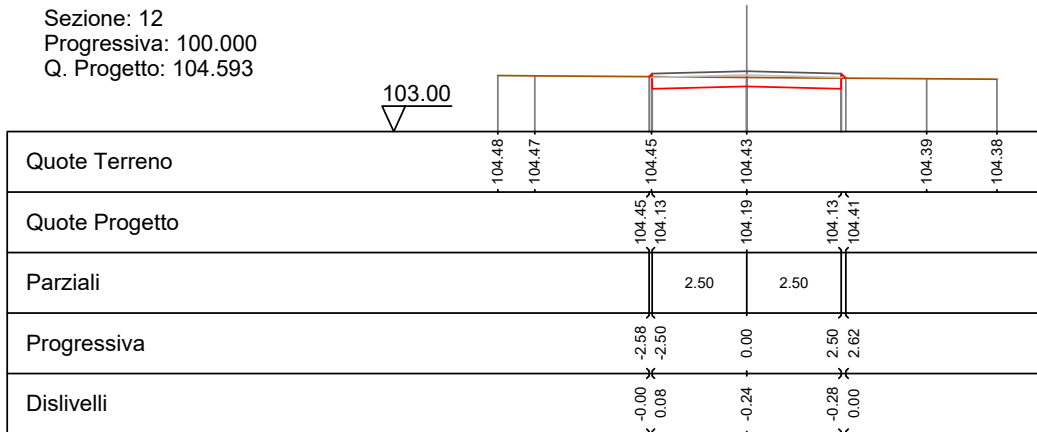

Sezione: 13
 Progressiva: 120.000
 Q. Progetto: 104.980

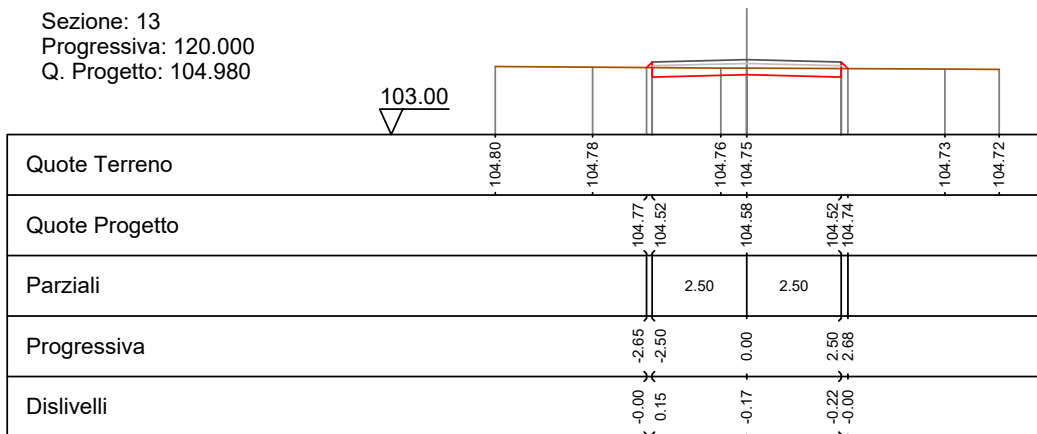

Sezione: 14
 Progressiva: 140.000
 Q. Progetto: 105.249

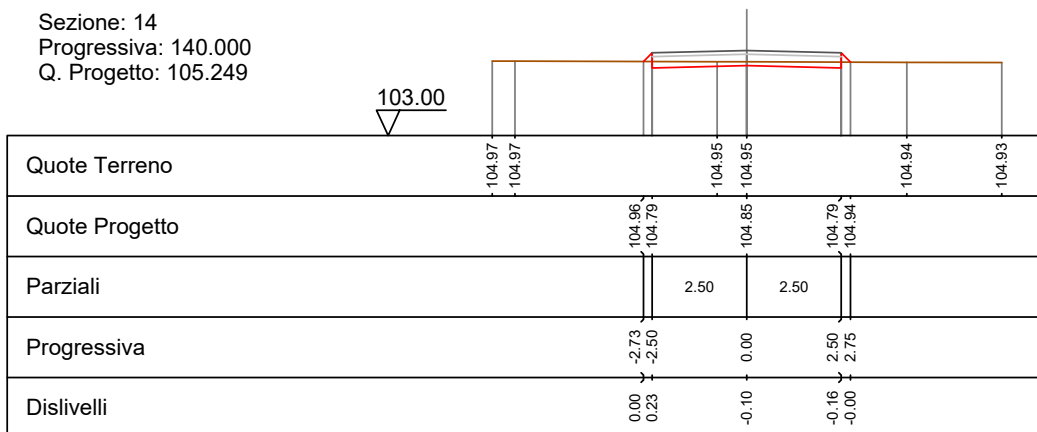

Sezione: 15
 Progressiva: 160.000
 Q. Progetto: 105.399



Quote Terreno	105.00	105.00	105.00	105.00	105.00	105.00
Quote Progetto			105.00 104.94	105.00	105.00	104.94 105.00
Parziali			0.34 2.50	2.50	2.50	0.34 105.00
Progressiva			-2.84 -2.50	0.00	2.50	2.84
Dislivelli			0.00 0.34	-0.00	-0.06	0.00

Sezione: 16
 Progressiva: 173.607
 Q. Progetto: 105.432

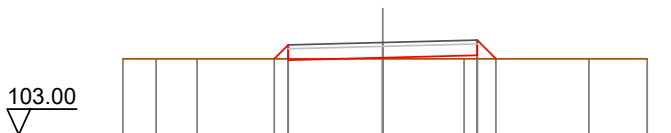

Quote Terreno	105.00	105.00	105.00	105.00	105.00	105.00
Quote Progetto			105.00 104.97	105.03	105.09	105.00
Parziali			0.37 2.50	2.50	0.49 2.50	105.00
Progressiva			-2.87 -2.50	0.00	2.50	2.99
Dislivelli			0.00 0.37	0.03	0.09	0.00

Sezione: 17
 Progressiva: 175.498
 Q. Progetto: 105.433

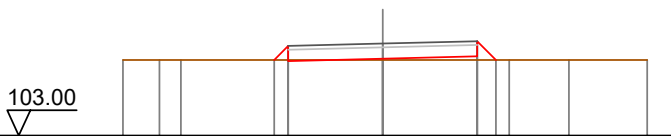

Quote Terreno	105.00	105.00	105.00	105.00	105.00	105.00
Quote Progetto			105.00 104.97	105.03	105.10	105.00
Parziali			0.37 2.50	2.50	0.50 2.50	105.00
Progressiva			-2.87 -2.50	0.00	2.50	3.00
Dislivelli			0.00 0.37	0.03	0.10	0.00

Sezione: 18
 Progressiva: 177.389
 Q. Progetto: 105.432

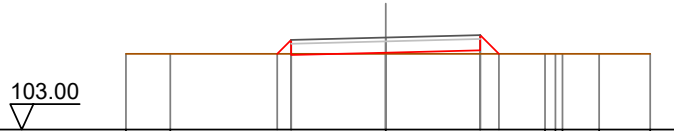

Quote Terreno	105.00	105.00		105.00		105.00	105.00	105.00	105.00
Quote Progetto			105.00 104.97		105.03		105.09 105.00		
Parziali			0.37	2.50	2.50		0.49		
Progressiva			-2.87 -2.50		0.00		2.50 2.99		
Dislivelli			0.00 0.37		0.03		0.09 0.00		

Sezione: 19
 Progressiva: 180.000
 Q. Progetto: 105.430

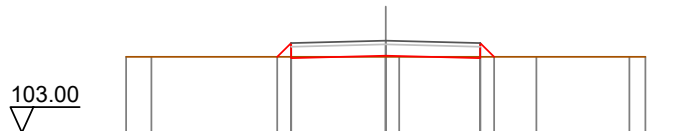

Quote Terreno	105.00	105.00		105.00		105.00	105.00	105.00	105.00
Quote Progetto			105.00 104.97		105.03		104.97 105.00		
Parziali			0.37	2.50	2.50		0.37		
Progressiva			-2.87 -2.50		0.00		2.50 2.87		
Dislivelli			0.00 0.37		0.03		-0.03 0.00		

Sezione: 20
 Progressiva: 200.000
 Q. Progetto: 105.411

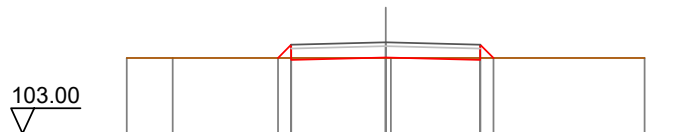

Quote Terreno	105.00	105.00		105.00		105.00	105.00	105.00	105.00
Quote Progetto			105.00 104.95		105.01		104.95 105.00		
Parziali			0.35	2.50	2.50		0.35		
Progressiva			-2.85 -2.50		0.00		2.50 2.85		
Dislivelli			0.00 0.35		0.01		-0.05 0.00		

Sezione: 21
 Progressiva: 220.000
 Q. Progetto: 105.392

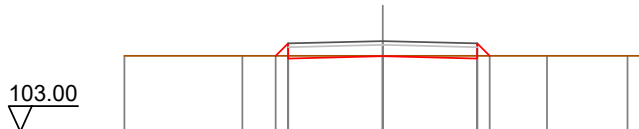

Quote Terreno	105.00	105.00	105.00	105.00	105.00
Quote Progetto		105.00 104.93	104.99	104.93 105.00	
Parziali		0.33	2.50	2.50	0.33
Progressiva		-2.83 -2.50	0.00	2.50 2.83	
Dislivelli		0.00 0.33	-0.01	-0.07 0.00	

Sezione: 22
 Progressiva: 240.000
 Q. Progetto: 105.598



Quote Terreno	105.26	105.19	105.13	105.09	105.05
Quote Progetto		105.17 105.14	105.20	105.14 105.09	
Parziali		0.36	2.50	2.50	0.45
Progressiva		-2.86 -2.50	0.00	2.50 2.95	
Dislivelli		-0.00 0.37	0.07	0.04 0.00	

Sezione: 23
 Progressiva: 253.309
 Q. Progetto: 105.796

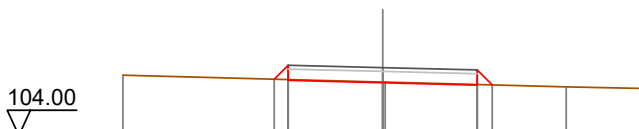

Quote Terreno	105.60		105.41 105.41		105.29	105.25
Quote Progetto		105.49 105.46	105.40	105.33 105.34		
Parziali		0.37	2.50	2.50	0.40	
Progressiva		-2.87 -2.50	0.00	2.50 2.90		
Dislivelli		0.00 0.38	-0.02	-0.01 -0.00		

Sezione: 24
 Progressiva: 258.186
 Q. Progetto: 105.869

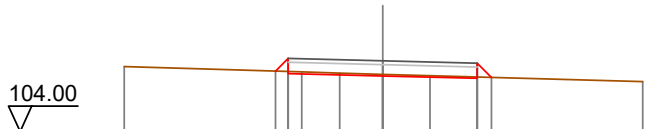

Quote Terreno	105.72	105.60	105.58	105.54	105.51	105.48	105.32
Quote Progetto		105.60	105.53		105.47		105.41
Parziali		0.33	2.50		2.50		0.38
Progressiva		-2.83	-2.50		0.00		2.50
Dislivelli		-0.00	0.34		-0.04		-0.03

Sezione: 25
 Progressiva: 260.000
 Q. Progetto: 105.896

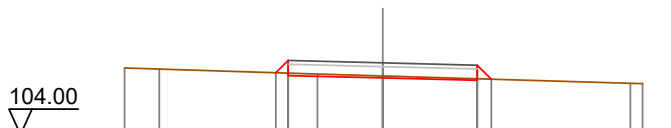

Quote Terreno	105.76	105.73	105.60	105.55	105.36	105.35
Quote Progetto		105.63	105.56	105.50	105.43	105.46
Parziali		0.33	2.50		2.50	0.37
Progressiva		-2.83	-2.50		0.00	2.50
Dislivelli		0.00	0.34		-0.05	-0.04

Sezione: 26
 Progressiva: 263.063
 Q. Progetto: 105.942

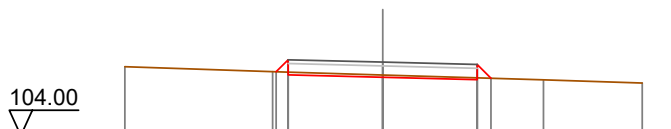

Quote Terreno	105.82	105.69	105.60	105.47	105.39
Quote Progetto		105.69	105.60	105.54	105.48
Parziali		0.32	2.50		2.50
Progressiva		-2.82	-2.50		0.00
Dislivelli		0.00	0.33		-0.06

Sezione: 27
 Progressiva: 280.000
 Q. Progetto: 106.194

104.00

Quote Terreno	106.08	106.07		105.85	105.81		105.60
Quote Progetto			105.94	105.73		105.79	105.73
Parziali			2.50		2.50		0.39
Progressiva			-2.69	-2.50	0.00	2.50	2.89
Dislivelli			0.00	0.20	-0.05	-0.03	0.00

Sezione: 28
 Progressiva: 300.000
 Q. Progetto: 106.492

104.00

Quote Terreno	106.36	106.32		106.19	106.11		106.04	105.98	105.85
Quote Progetto			106.21	106.03		106.09	106.03	106.00	
Parziali			2.50		2.50		0.43		
Progressiva			-2.72	-2.50	0.00	2.50	2.93		
Dislivelli			0.00	0.22	-0.02	0.01	0.00		

Sezione: 29
 Progressiva: 312.293
 Q. Progetto: 106.676

105.00

Quote Terreno	106.52		106.39		106.31		106.27		106.00
Quote Progetto			106.37		106.21		106.28		106.34
Parziali			2.50		2.50		0.59		
Progressiva			-2.74	-2.50	0.00	2.50	3.09		
Dislivelli			-0.00	0.25	0.01	0.16	-0.00		

Sezione: 30
 Progressiva: 313.453
 Q. Progetto: 106.693

105.00

Quote Terreno	106.53	106.49	106.35	106.28	106.11	106.02
Quote Progetto			106.38	106.29	106.36	106.17
Parziali			2.50	2.50	0.59	
Progressiva			-2.75	0.00	2.50	3.09
Dislivelli			0.00	0.01	0.17	-0.00

Sezione: 31
 Progressiva: 314.614
 Q. Progetto: 106.710

105.00

Quote Terreno	106.54	106.38	106.30	106.04
Quote Progetto		106.40	106.31	106.37
Parziali		2.50	2.50	0.59
Progressiva		-2.75	0.00	2.50
Dislivelli		-0.00	0.01	0.17

Sezione: 32
 Progressiva: 320.000
 Q. Progetto: 106.791

105.00

Quote Terreno	106.62	106.52	106.47	106.38	106.14	106.13
Quote Progetto			106.48	106.39	106.33	106.27
Parziali			2.50	2.50	0.46	
Progressiva			-2.75	0.00	2.50	2.96
Dislivelli			-0.00	0.01	0.04	0.00

Sezione: 33
 Progressiva: 340.000
 Q. Progetto: 107.089

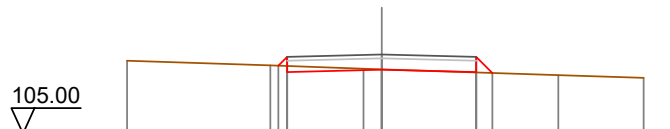

Quote Terreno	106.93	106.80	106.71	106.70	106.54	106.47
Quote Progetto		106.79	106.63	106.69	106.63	106.60
Parziali			2.50	2.50	0.43	
Progressiva		-2.73	-2.50	0.00	2.50	2.93
Dislivelli		-0.00	0.24	-0.01	0.01	-0.00

Sezione: 34
 Progressiva: 360.000
 Q. Progetto: 107.516

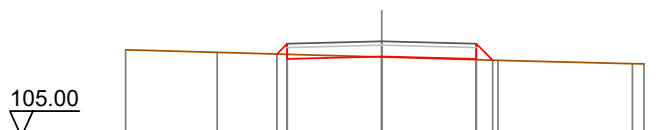

Quote Terreno	107.30	107.23	107.10	107.10	107.02	106.93	106.92
Quote Progetto			107.18	107.05	107.12	107.05	107.02
Parziali			0.27	2.50	2.50	0.43	
Progressiva			-2.77	-2.50	0.00	2.50	2.93
Dislivelli			0.00	0.28	0.01	0.02	0.00

Sezione: 35
 Progressiva: 380.000
 Q. Progetto: 107.973

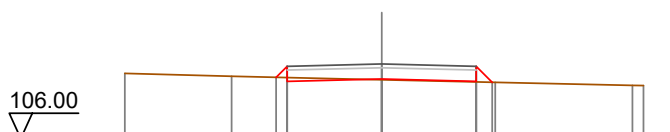

Quote Terreno	107.72	107.65	107.55	107.55	107.49	107.40	107.40
Quote Progetto			107.62	107.51	107.51	107.49	107.49
Parziali			0.28	2.50	2.50	0.42	
Progressiva			-2.79	-2.50	0.00	2.50	2.92
Dislivelli			0.00	0.30	0.02	0.01	0.00

Sezione: 36
 Progressiva: 396.381
 Q. Progetto: 108.346

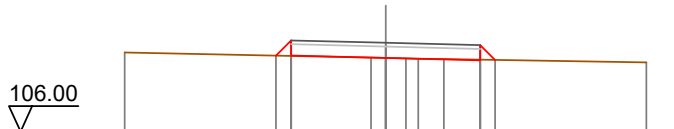

Quote Terreno	108.09			107.95	107.95	107.93	107.92		107.83
Quote Progetto		108.01	108.01		107.95			107.88	107.89
Parziali		0.40	2.50		2.50			0.39	
Progressiva		-2.90	-2.50		0.00			2.50	2.89
Dislivelli		0.00	0.41		0.00			-0.02	0.00

Sezione: 37
 Progressiva: 400.000
 Q. Progetto: 108.429

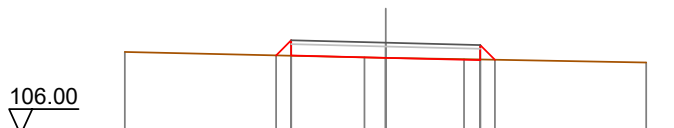

Quote Terreno	108.18			108.04	108.03			107.99	107.90
Quote Progetto		108.09	108.09		108.03			107.97	107.98
Parziali		0.40	2.50		2.50			0.39	
Progressiva		-2.90	-2.50		0.00			2.50	2.89
Dislivelli		0.00	0.41		-0.00			-0.02	0.00

Sezione: 38
 Progressiva: 402.153
 Q. Progetto: 108.478

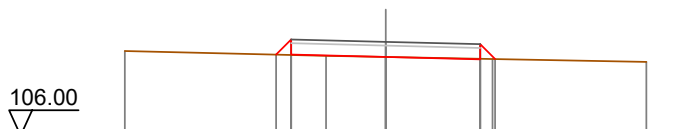

Quote Terreno	108.23			108.11	108.08			108.03	107.95
Quote Progetto		108.14	108.14		108.08			108.02	108.02
Parziali		0.40	2.50		2.50			0.39	
Progressiva		-2.90	-2.50		0.00			2.50	2.89
Dislivelli		0.00	0.41		-0.00			-0.02	0.00

Sezione: 39
 Progressiva: 407.925
 Q. Progetto: 108.602

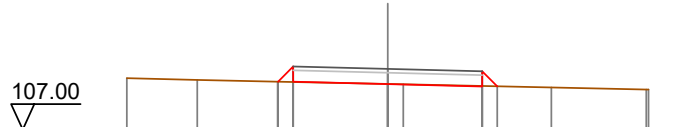

Quote Terreno	108.36	108.31	108.27	108.20	108.20	108.11	108.06	108.06
Quote Progetto			108.27	108.26	108.20	108.14	108.14	
Parziali			0.40	2.50	2.50	0.40		
Progressiva			-2.90	-2.50	0.00	2.50	2.90	
Dislivelli			0.00	0.41	-0.00	-0.01	0.00	

Sezione: 40
 Progressiva: 420.000
 Q. Progetto: 108.849

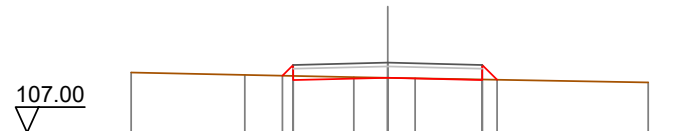

Quote Terreno	108.59	108.52	108.46	108.45	108.43	108.32	
Quote Progetto			108.50	108.39	108.45	108.39	108.40
Parziali			0.28	2.50	2.50	0.39	
Progressiva			-2.78	-2.50	0.00	2.50	2.89
Dislivelli			0.00	0.29	0.00	-0.02	-0.00

Sezione: 41
 Progressiva: 440.000
 Q. Progetto: 109.258



Quote Terreno	108.98	108.95	108.91	108.89	108.86	108.80	108.76
Quote Progetto			108.91	108.80	108.86	108.80	108.82
Parziali			0.28	2.50	2.50	0.37	
Progressiva			-2.79	-2.50	0.00	2.50	2.87
Dislivelli			0.00	0.29	-0.01	-0.03	0.00

Sezione: 42
 Progressiva: 460.000
 Q. Progetto: 109.667

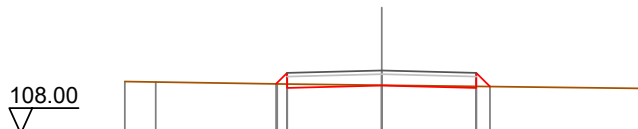

Quote Terreno	109.37	109.36	109.31	109.28	109.19
Quote Progetto			109.31	109.27	109.20
Parziali			0.28	2.50	0.36
Progressiva			-2.79	0.00	2.50
Dislivelli			-0.00	-0.01	-0.04

Sezione: 43
 Progressiva: 480.000
 Q. Progetto: 110.076

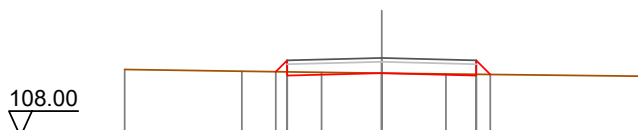

Quote Terreno	109.77	109.73	109.70	109.68	109.66	109.60
Quote Progetto			109.71	109.68	109.61	109.64
Parziali			0.30	2.50	0.37	
Progressiva			-2.80	0.00	2.50	2.87
Dislivelli			0.00	-0.00	-0.03	-0.00

Sezione: 44
 Progressiva: 481.707
 Q. Progetto: 110.111



Quote Terreno	109.81	109.78	109.73	109.71	109.66	109.63
Quote Progetto			109.75	109.71	109.65	109.68
Parziali			0.42	2.50	0.37	
Progressiva			-2.92	0.00	2.50	2.87
Dislivelli			0.00	-0.00	-0.03	0.00

Sezione: 45
 Progressiva: 484.613
 Q. Progetto: 110.171

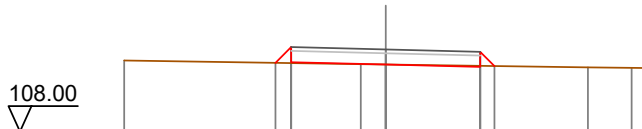

Quote Terreno	109.88		109.78	109.77		109.70	109.68	109.68
Quote Progetto		109.82	109.83	109.77		109.71	109.73	
Parziali		0.42	2.50	2.50		0.38		
Progressiva		-2.92	-2.50	0.00		2.50	2.88	
Dislivelli		0.00	0.42	-0.00		-0.03	0.00	

Sezione: 46
 Progressiva: 487.520
 Q. Progetto: 110.230

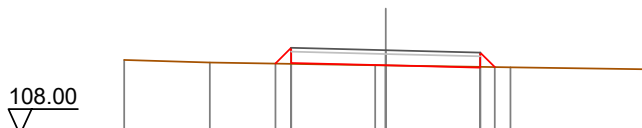

Quote Terreno	109.97	109.91		109.83	109.83		109.78	109.73	109.73
Quote Progetto			109.88	109.83	109.83		109.77	109.79	
Parziali			0.42	2.50	2.50		0.38		
Progressiva			-2.92	-2.50	0.00		2.50	2.88	
Dislivelli			0.00	0.42	0.00		-0.02	0.00	

Sezione: 47
 Progressiva: 500.000
 Q. Progetto: 110.593

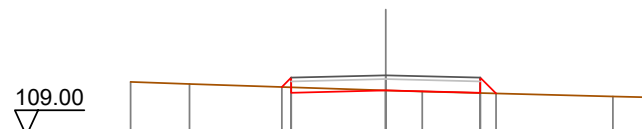

Quote Terreno	110.42	110.36		110.19	110.16		110.03	110.01
Quote Progetto			110.28	110.13	110.19		110.13	110.11
Parziali			0.42	2.50	2.50		0.42	
Progressiva			-2.75	-2.50	0.00		2.50	2.92
Dislivelli			0.00	0.25	-0.00		0.01	0.00

Sezione: 48
 Progressiva: 516.934
 Q. Progetto: 111.131

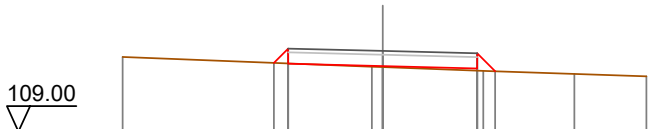

Quote Terreno	110.97		110.71	110.70	110.60	110.52	110.46
Quote Progetto		110.82	110.79				
Parziali		0.38	2.50	2.50	0.47		
Progressiva		-2.88	-2.50	0.00	2.50	2.97	
Dislivelli		0.00	0.39	0.03	0.06	-0.00	

Sezione: 49
 Progressiva: 518.506
 Q. Progetto: 111.170

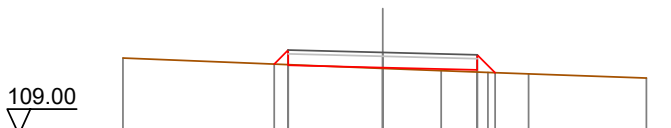

Quote Terreno	111.02		110.75	110.69	110.64	110.60	110.49
Quote Progetto		110.86	110.83				
Parziali		0.37	2.50	2.50	0.47		
Progressiva		-2.87	-2.50	0.00	2.50	2.97	
Dislivelli		-0.00	0.38	0.02	0.06	-0.00	

Sezione: 50
 Progressiva: 520.077
 Q. Progetto: 111.210

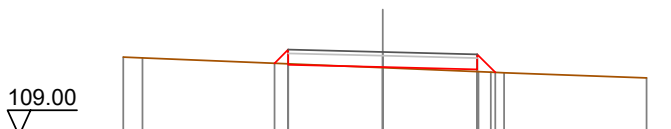

Quote Terreno	111.08	111.05		110.79	110.69	110.68	110.66	110.52
Quote Progetto			110.81	110.87				
Parziali			0.36	2.50	2.50	0.48		
Progressiva			-2.86	-2.50	0.00	2.50	2.98	
Dislivelli			-0.00	0.38	0.02	0.06	0.00	

Sezione: 51
 Progressiva: 540.000
 Q. Progetto: 111.715

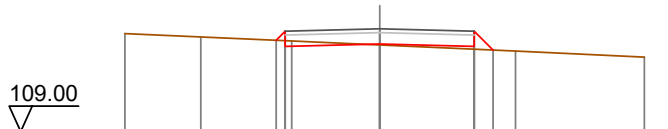

Quote Terreno	111.59	111.50	111.39	111.29	111.13	110.97
Quote Progetto			111.41 111.25	111.31	111.25 111.15	
Parziali			2.50	2.50	0.50	
Progressiva			-2.74 -2.50	0.00	2.50 3.00	
Dislivelli			0.00 0.25	0.03	0.08 0.00	

Sezione: 52
 Progressiva: 560.000
 Q. Progetto: 112.221

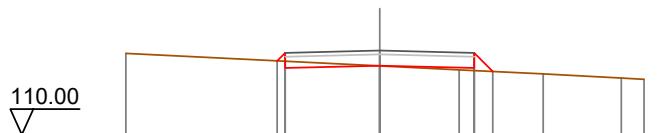

Quote Terreno	112.14			111.81	111.71	111.60	111.50	111.46
Quote Progetto			111.95 111.76	111.82	111.76 111.67			
Parziali			2.50	2.50	0.49			
Progressiva			-2.71 -2.50	0.00	2.50 2.99			
Dislivelli			-0.00 0.22	0.01	0.07 -0.00			

Sezione: 53
 Progressiva: 580.000
 Q. Progetto: 112.872

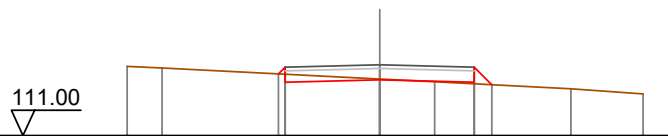

Quote Terreno	112.83	112.79		112.49	112.42		112.24	112.10
Quote Progetto			112.63 112.41	112.47	112.41 112.34			
Parziali			2.50	2.50	0.47			
Progressiva			-2.68 -2.50	0.00	2.50 2.97			
Dislivelli			-0.00 0.19	-0.02	0.04 0.00			

Sezione: 54
 Progressiva: 585.441
 Q. Progetto: 113.137

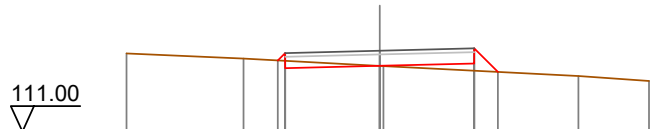

Quote Terreno	113.07	112.93	112.74	112.73	112.47	112.34
Quote Progetto		112.88	112.67	112.74	112.80	112.58
Parziali			2.50	2.50	0.62	
Progressiva		-2.70	-2.50	0.00	2.50	3.12
Dislivelli		0.00	0.21	0.00	0.19	0.00

Sezione: 55
 Progressiva: 590.000
 Q. Progetto: 113.389

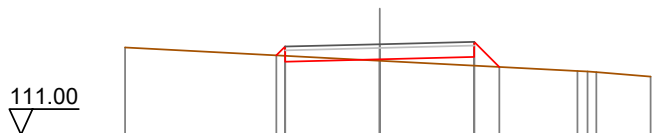

Quote Terreno	113.30	113.09	112.93	112.99	112.80	112.68	112.65	112.53
Quote Progetto		113.09	112.93	112.99	113.05	112.79		
Parziali			2.50	2.50	0.66			
Progressiva		-2.73	-2.50	0.00	2.50	3.16		
Dislivelli		0.00	0.25	0.04	0.23	0.00		

Sezione: 56
 Progressiva: 600.000
 Q. Progetto: 113.916

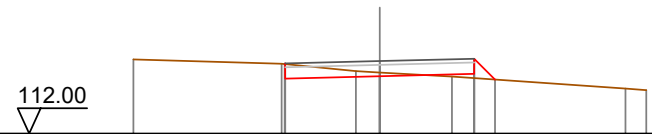

Quote Terreno	113.96	113.85	113.65	113.61	113.51	113.19	113.15
Quote Progetto		113.45	113.52	113.52	113.58	113.43	
Parziali			2.50	2.50	0.55		
Progressiva		-2.52	0.00	0.00	2.50	3.05	
Dislivelli		0.00	-0.10	0.00	0.11	0.00	

Sezione: 57
 Progressiva: 610.000
 Q. Progetto: 114.257

112.00



Quote Terreno	114.56		114.24	114.11	114.02	113.93	113.45
Quote Progetto		114.32	113.79	113.86		113.92	113.89
Parziali			2.50		2.50	0.43	
Progressiva		-2.62	-2.50	0.00		2.50	2.93
Dislivelli		0.00	-0.12	-0.25		-0.01	-0.00

Sezione: 58
 Progressiva: 620.000
 Q. Progetto: 114.398

112.00

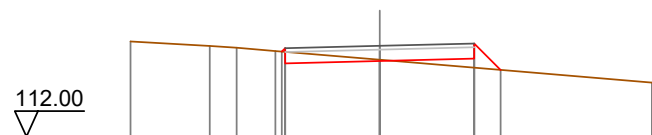

Quote Terreno	114.51	114.40	114.35	114.26	114.03		113.43
Quote Progetto				114.25	114.00	114.06	113.76
Parziali				2.50		2.50	0.70
Progressiva		-2.59	-2.50	0.00		2.50	3.20
Dislivelli		-0.00	0.10	-0.03		0.24	0.00

Sezione: 59
 Progressiva: 630.000
 Q. Progetto: 114.356

112.00

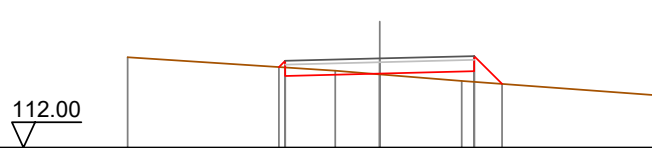

Quote Terreno	114.39		114.03	113.94	113.76		113.39
Quote Progetto		114.13	113.89	113.96	114.02	113.88	
Parziali			2.50		2.50	0.74	
Progressiva		-2.67	-2.50	0.00		2.50	3.24
Dislivelli		-0.00	0.18	0.02		0.28	0.00

Sezione: 60
 Progressiva: 633.008
 Q. Progetto: 114.337

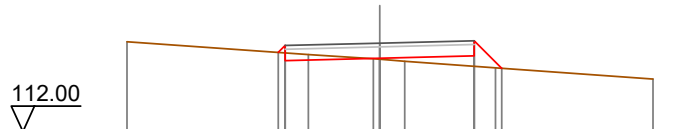

Quote Terreno	114.37	114.04	113.93	113.91	113.86	113.68	113.39
Quote Progetto		114.09	113.87	113.94	114.00	113.67	
Parziali		2.50	2.50	0.73			
Progressiva		-2.68	-2.50	0.00	2.50	3.23	
Dislivelli		0.00	0.19	0.03	0.28	0.00	

Sezione: 61
 Progressiva: 640.000
 Q. Progetto: 114.323

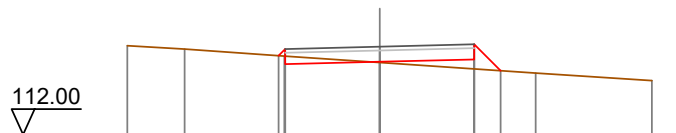

Quote Terreno	114.35	114.26	114.07	113.90		113.63	113.43
Quote Progetto			114.09	113.86	113.92	113.99	113.69
Parziali			2.50	2.50	0.70		
Progressiva			-2.68	-2.50	0.00	2.50	3.20
Dislivelli			0.00	0.19	0.02	0.25	0.00

Sezione: 62
 Progressiva: 650.000
 Q. Progetto: 114.379

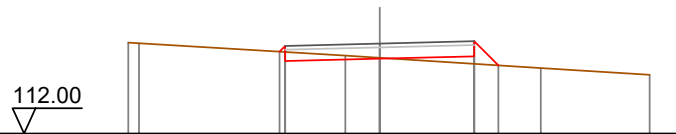

Quote Terreno	114.40	114.39		114.06	114.00		113.73	113.55
Quote Progetto			114.17	113.92	113.98	114.04	113.80	
Parziali			2.50	2.50	0.64			
Progressiva			-2.65	-2.50	0.00	2.50	3.14	
Dislivelli			0.00	0.16	-0.02	0.20	0.00	

Sezione: 63
 Progressiva: 660.000
 Q. Progetto: 114.524

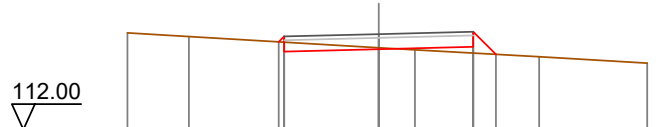

Quote Terreno	114.55	114.46		114.16	114.11		113.92	113.76
Quote Progetto			114.32	114.06	114.12		114.19	113.99
Parziali			2.50	2.50	0.60			
Progressiva			-2.64	-2.50	0.00		2.50	3.10
Dislivelli			-0.00	0.15	-0.04		0.17	-0.00

Sezione: 64
 Progressiva: 670.000
 Q. Progetto: 114.757

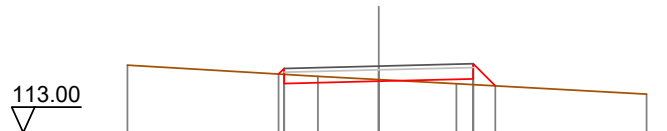

Quote Terreno	114.78		114.49	114.40	114.29		114.02
Quote Progetto		114.55	114.29	114.36	114.42	114.24	
Parziali		2.50	2.50	0.68			
Progressiva		-2.65	-2.50	0.00	2.50	3.08	
Dislivelli		0.00	0.16	-0.04	0.15	0.00	

Sezione: 65
 Progressiva: 680.000
 Q. Progetto: 115.079

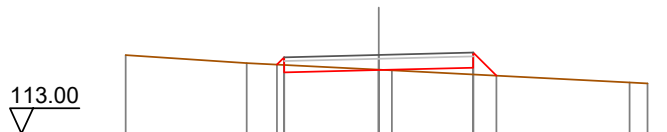

Quote Terreno	115.07	114.86		114.69	114.67		114.35	114.33
Quote Progetto		114.82	114.82	114.68	114.74	114.53		
Parziali		2.50	2.50	0.61				
Progressiva		-2.69	-2.50	0.00	2.50	3.11		
Dislivelli		0.00	0.20	-0.01	0.18	0.00		

Sezione: 66
 Progressiva: 680.575
 Q. Progetto: 115.100

113.00

Quote Terreno	115.09	114.89	114.71	114.67	114.37	114.35
Quote Progetto		114.84	114.64	114.70	114.76	114.55
Parziali			2.50	2.50	0.61	
Progressiva		-2.70	-2.50	0.00	2.50	3.11
Dislivelli		0.00	0.21	-0.01	0.18	-0.00

Sezione: 67
 Progressiva: 700.000
 Q. Progetto: 115.839

113.00

Quote Terreno	115.86	115.86	115.59	115.43	115.21	115.03	114.99
Quote Progetto			115.60	115.38	115.44	115.38	115.24
Parziali			2.50	2.50	0.54		
Progressiva		-2.68	-2.50	0.00	2.50	3.04	
Dislivelli		-0.00	0.19	0.01	0.10	0.00	

Sezione: 68
 Progressiva: 720.000
 Q. Progetto: 116.594

114.00

Quote Terreno	116.67	116.47	116.22	116.19	115.75	
Quote Progetto		116.40	116.13	116.19	116.13	116.02
Parziali			2.50	2.50	0.51	
Progressiva		-2.63	-2.50	0.00	2.50	3.01
Dislivelli		0.00	0.14	-0.02	0.08	0.00

Sezione: 69
 Progressiva: 740.000
 Q. Progetto: 117.197

115.00

Quote Terreno	117.29	117.00	116.79	116.76	116.27	
Quote Progetto		117.00	116.73	116.80	116.73	116.57
Parziali			2.50	2.50	0.57	
Progressiva		-2.64	-2.50	0.00	2.50	3.07
Dislivelli		-0.00	0.15	0.00	0.13	-0.00

Sezione: 70
 Progressiva: 760.000
 Q. Progetto: 117.592

115.00

Quote Terreno	117.71	117.64	117.36	117.17	116.82	116.60	
Quote Progetto			117.38	117.13	117.19	117.13	116.92
Parziali				2.50	2.50	0.61	
Progressiva			-2.65	-2.50	0.00	2.50	3.11
Dislivelli			-0.00	0.17	0.03	0.16	-0.00

Sezione: 71
 Progressiva: 775.417
 Q. Progetto: 117.764

115.00

Quote Terreno	117.93		117.36	117.36	117.20	116.99	116.77
Quote Progetto			117.59	117.43	117.36	117.30	117.11
Parziali				2.50	2.50	0.59	
Progressiva			-2.73	-2.50	0.00	2.50	3.09
Dislivelli			0.00	0.25	0.00	0.15	0.00

Sezione: 72
 Progressiva: 780.000
 Q. Progetto: 117.782

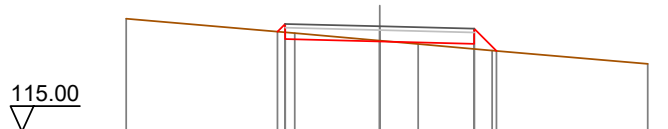

Quote Terreno	117.98	117.60	117.40	117.31	117.14	116.79
Quote Progetto		117.64 117.44	117.38 117.40	117.32 117.13		
Parziali		2.50	2.50	0.59		
Progressiva		-2.70 -2.50	0.00	2.50 3.09		
Dislivelli		0.00 0.22	-0.02	0.14 0.00		

Sezione: 73
 Progressiva: 780.954
 Q. Progetto: 117.783

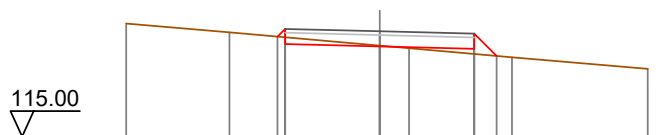

Quote Terreno	117.99	117.75	117.41	117.34	117.10	116.79
Quote Progetto		117.64 117.45	117.38 117.41	117.32 117.13		
Parziali		2.50	2.50	0.59		
Progressiva		-2.70 -2.50	0.00	2.50 3.09		
Dislivelli		0.00 0.22	-0.02	0.14 0.00		

Sezione: 74
 Progressiva: 786.491
 Q. Progetto: 117.772

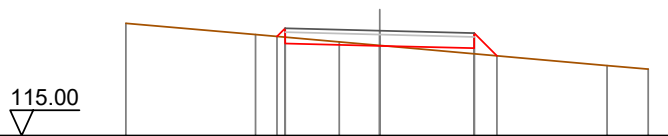

Quote Terreno	117.97	117.67	117.48	117.38	116.85	116.76
Quote Progetto		117.62 117.43	117.37 117.38	117.31 117.11		
Parziali		2.50	2.50	0.60		
Progressiva		-2.71 -2.50	0.00	2.50 3.10		
Dislivelli		0.00 0.23	-0.01	0.15 0.00		

Sezione: 75
 Progressiva: 800.000
 Q. Progetto: 117.615

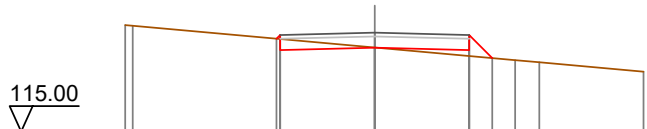

Quote Terreno	117.82	117.80		117.22		116.89	116.83	116.58
Quote Progetto			117.46	117.21	117.15	116.94		
Parziali			2.50	2.50	0.61			
Progressiva			-2.60	0.00	2.50	3.11		
Dislivelli			-0.00	-0.01	0.15	0.00		

Sezione: 76
 Progressiva: 801.019
 Q. Progetto: 117.596

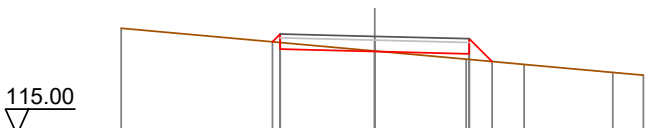

Quote Terreno	117.81			117.21		116.89	116.85	116.64	116.57
Quote Progetto			117.45	117.20	117.13	116.93			
Parziali			2.50	2.50	0.60				
Progressiva			-2.71	0.00	2.50	3.10			
Dislivelli			-0.00	-0.01	0.15	0.00			

Sezione: 77
 Progressiva: 807.322
 Q. Progetto: 117.454

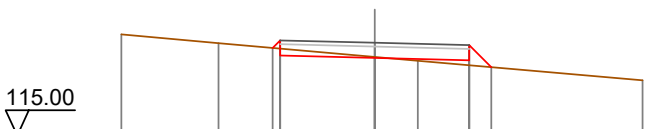

Quote Terreno	117.67	117.44		117.08	116.98		116.46
Quote Progetto			117.32	117.05	116.99	116.81	
Parziali			2.50	2.50	0.58		
Progressiva			-2.70	0.00	2.50	3.08	
Dislivelli			0.00	-0.03	0.13	-0.00	

Sezione: 78
 Progressiva: 810.000
 Q. Progetto: 117.381

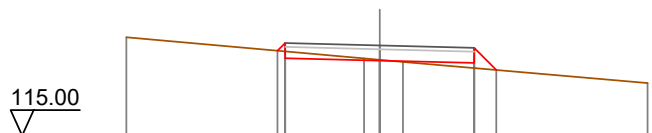

Quote Terreno	117.60		117.04	117.00	116.95	116.39
Quote Progetto		117.24	117.04	116.98	116.92	116.73
Parziali			2.50	2.50	0.59	
Progressiva		-2.70	-2.50	0.00	2.50	3.09
Dislivelli		0.00	0.22	-0.02	0.13	-0.00

Sezione: 79
 Progressiva: 813.626
 Q. Progetto: 117.272

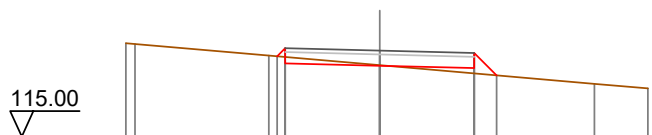

Quote Terreno	117.47	117.45	117.14	116.89	116.39	116.27	
Quote Progetto			117.12	116.87	116.81	116.62	
Parziali			2.50	2.50	0.59		
Progressiva			-2.71	-2.50	0.00	2.50	3.09
Dislivelli			-0.00	0.23	-0.01	0.14	0.00

Sezione: 80
 Progressiva: 820.000
 Q. Progetto: 117.064

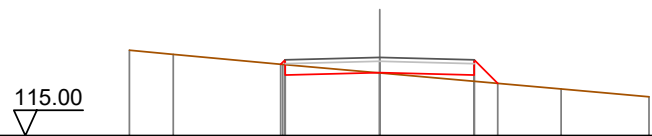

Quote Terreno	117.25	117.15	116.88	116.65	116.23	116.03	
Quote Progetto			116.88	116.66	116.60	116.38	
Parziali			2.50	2.50	0.62		
Progressiva			-2.62	-2.50	0.00	2.50	3.12
Dislivelli			-0.00	0.13	0.01	0.17	0.00

Sezione: 81
 Progressiva: 825.344
 Q. Progetto: 116.897

114.00

Quote Terreno	-117.10	-116.91	-116.72	-116.43	-116.50	-116.48	-116.40	-116.03	-115.80
Quote Progetto			116.72	116.43		116.50		116.56	116.17
Parziali				2.50		2.50		0.79	
Progressiva			-2.61	-2.50	0.00	0.00	2.50	3.29	
Dislivelli			0.00	0.12	0.02	0.02	0.31	0.00	

Sezione: 82
 Progressiva: 830.000
 Q. Progetto: 116.792

114.00

Quote Terreno	-116.89	-116.98	-116.72	-116.56	-116.36	-116.36	-115.95	-115.64
Quote Progetto			116.61	116.33	116.39	116.45	116.03	
Parziali				2.50		2.50	0.82	
Progressiva			-2.62	-2.50	0.00	2.50	3.32	
Dislivelli			-0.00	0.13	0.03	0.34	-0.00	

Sezione: 83
 Progressiva: 832.797
 Q. Progetto: 116.750

114.00

Quote Terreno	-116.97	-116.85	-116.67	-116.61	-116.48	-116.30	-115.97	-115.57
Quote Progetto			116.57	116.29	116.35	116.41	115.97	
Parziali				2.50		2.50	0.84	
Progressiva			-2.62	-2.50	0.00	2.50	3.34	
Dislivelli			0.00	0.13	0.05	0.36	0.00	

Sezione: 84
 Progressiva: 840.000
 Q. Progetto: 116.714

114.00

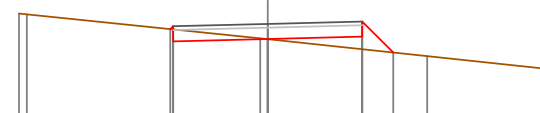

Quote Terreno	116.99	116.97		116.33	116.31		115.86	115.53
Quote Progetto			116.58	116.25		116.31	116.38	115.96
Parziali			2.50		2.50		0.82	
Progressiva			-2.58	-2.50	0.00		2.50	3.32
Dislivelli			0.00	0.08	0.00		0.33	0.00

Sezione: 85
 Progressiva: 840.250
 Q. Progetto: 116.714

114.00

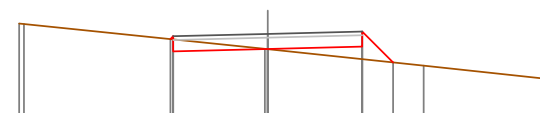

Quote Terreno	116.99	116.98		116.32	116.31		115.87	115.53
Quote Progetto			116.58	116.25		116.31	116.38	115.96
Parziali			2.50		2.50		0.82	
Progressiva			-2.57	-2.50	0.00		2.50	3.32
Dislivelli			0.00	0.08	0.00		0.33	-0.00

Sezione: 86
 Progressiva: 860.000
 Q. Progetto: 117.158

115.00

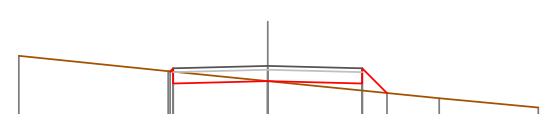

Quote Terreno	117.42		117.02		116.76		116.30	116.06
Quote Progetto			117.01	116.70		116.76	116.70	116.44
Parziali			2.50		2.50		0.65	
Progressiva			-2.58	-2.50	0.00		2.50	3.15
Dislivelli			-0.00	0.09	0.00		0.19	0.00

Sezione: 87
 Progressiva: 880.000
 Q. Progetto: 117.993

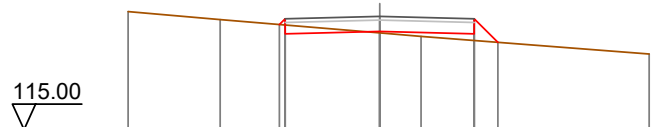

Quote Terreno	118.12	117.91		117.56	117.46	117.00
Quote Progetto			117.78	117.53	117.59	117.53
Parziali			2.50	2.50	0.62	
Progressiva			-2.65	-2.50	0.00	2.50
Dislivelli			0.00	0.17	0.04	0.18

Sezione: 88
 Progressiva: 883.725
 Q. Progetto: 118.100

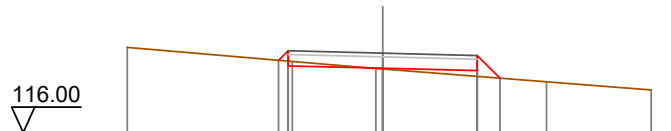

Quote Terreno	118.25		117.88	117.69		117.34	117.13
Quote Progetto			117.91	117.76	117.70	117.64	117.44
Parziali			2.50	2.50	0.60		
Progressiva			-2.75	-2.50	0.00	2.50	3.10
Dislivelli			0.00	0.28	0.02	0.15	-0.00

Sezione: 89
 Progressiva: 887.536
 Q. Progetto: 118.181

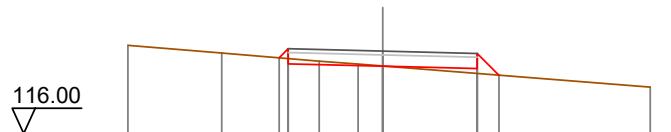

Quote Terreno	118.33	118.13		117.92	117.84	117.78	117.23
Quote Progetto			118.00	117.84		117.78	117.72
Parziali			2.50	2.50	0.58		
Progressiva			-2.74	-2.50	0.00	2.50	3.08
Dislivelli			0.00	0.26	-0.00	0.13	0.00

Sezione: 90
 Progressiva: 890.000
 Q. Progetto: 118.217

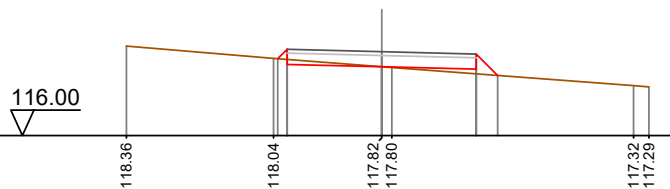

Quote Terreno	118.36	118.04	117.82	117.80	117.32	117.29
Quote Progetto		118.03	117.88	117.82	117.75	117.59
Parziali			2.50	2.50	0.57	
Progressiva		-2.75	-2.50	0.00	2.50	3.07
Dislivelli		0.00	0.27	0.00	0.13	-0.00

Sezione: 91
 Progressiva: 891.347
 Q. Progetto: 118.232

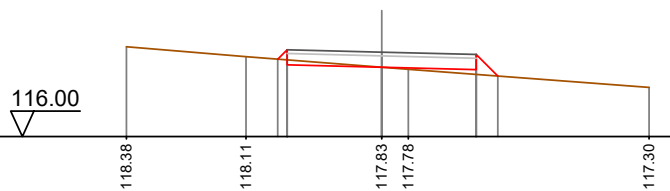

Quote Terreno	118.38	118.11	117.83	117.78	117.30	
Quote Progetto		118.04	117.88	117.83	117.77	117.60
Parziali			2.50	2.50	0.57	
Progressiva		-2.75	-2.50	0.00	2.50	3.07
Dislivelli		0.00	0.27	0.00	0.13	0.00

Sezione: 92
 Progressiva: 900.000
 Q. Progetto: 118.257

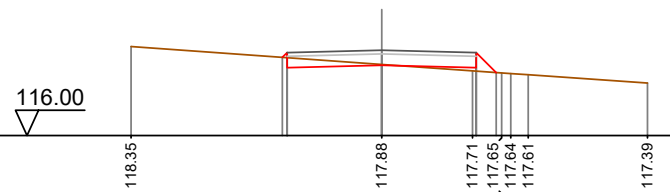

Quote Terreno	118.35		117.88	117.71	117.65	117.64	117.61	117.39
Quote Progetto		118.07	117.79	117.86	117.71	117.66	117.64	117.61
Parziali			2.50	2.50	0.53			
Progressiva		-2.63	-2.50	0.00	2.50	3.03		
Dislivelli		-0.00	0.14	-0.02	0.09	0.00		

Sezione: 93
 Progressiva: 920.000
 Q. Progetto: 118.262

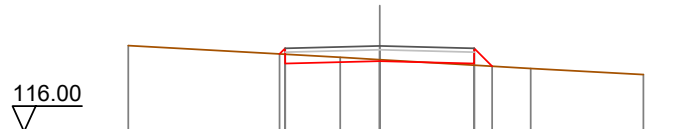

Quote Terreno	118.27		117.96	117.90		117.67	117.50
Quote Progetto		118.05	117.80	117.86	117.80	117.73	
Parziali		2.50	2.50	0.47			
Progressiva		-2.65	-2.50	0.00	2.50	2.97	
Dislivelli		-0.00	0.16	-0.04	0.05	0.00	

Sezione: 94
 Progressiva: 925.543
 Q. Progetto: 118.275

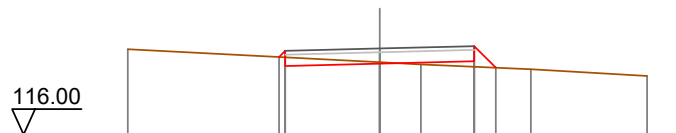

Quote Terreno	118.26		117.91	117.86		117.73	117.65
Quote Progetto		118.05	117.81	117.88	117.94	117.77	
Parziali		2.50	2.50	0.57			
Progressiva		-2.66	-2.50	0.00	2.50	3.07	
Dislivelli		0.00	0.17	-0.04	0.15	0.00	

Sezione: 95
 Progressiva: 929.499
 Q. Progetto: 118.319

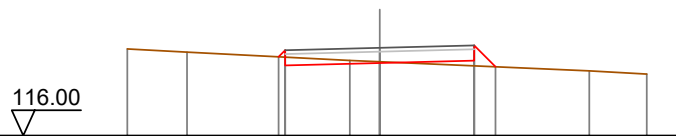

Quote Terreno	118.29	118.21		117.99	117.95		117.71	117.63
Quote Progetto			118.08	117.86	117.92	117.98	117.82	
Parziali			2.50	2.50	0.56			
Progressiva			-2.67	-2.50	0.00	2.50	3.06	
Dislivelli			0.00	0.18	-0.03	0.14	0.00	

Sezione: 96
 Progressiva: 930.000
 Q. Progetto: 118.326

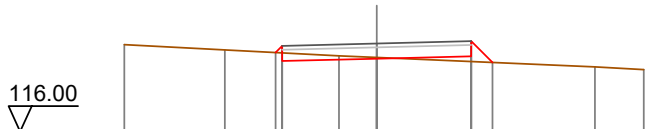

Quote Terreno	118.30	118.16	118.00	117.96	117.71	117.64
Quote Progetto			118.09	117.86	117.99	117.83
Parziali			2.50	2.50	0.56	
Progressiva			-2.68	-2.50	2.50	3.06
Dislivelli			-0.00	0.18	-0.03	0.14
						0.00

Sezione: 97
 Progressiva: 933.456
 Q. Progetto: 118.393

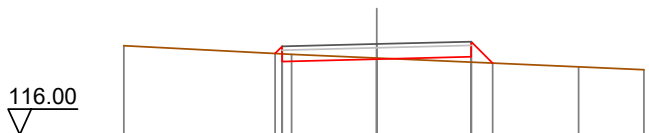

Quote Terreno	118.35	118.12	118.02	117.79	117.72
Quote Progetto		118.14	117.99	118.06	117.89
Parziali		2.50	2.50	0.57	
Progressiva		-2.69	-2.50	2.50	3.07
Dislivelli		0.00	0.20	-0.03	0.14
					0.00

Sezione: 98
 Progressiva: 940.000
 Q. Progetto: 118.575

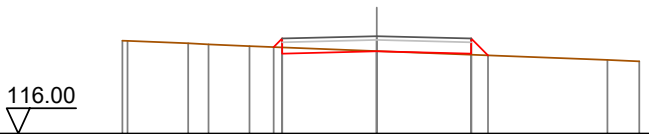

Quote Terreno	118.46	118.45	118.39	118.36	118.31	118.18	117.95	117.91
Quote Progetto			118.29	118.11	118.18	118.11	118.07	
Parziali			2.50	2.50	0.44			
Progressiva			-2.73	-2.50	0.00	2.50	2.94	
Dislivelli			0.00	0.23	-0.01	0.03	0.00	

Sezione: 99
 Progressiva: 960.000
 Q. Progetto: 119.161

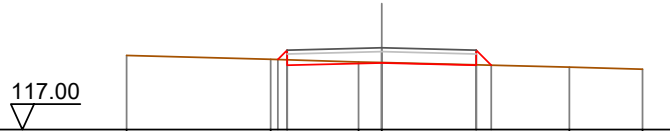

Quote Terreno	118.96	118.86	118.79	118.77	118.65	118.59
Quote Progetto		118.85	118.70	118.76	118.70	118.70
Parziali			2.50	2.50	0.40	
Progressiva		-2.75	-2.50	0.00	2.50	2.90
Dislivelli		0.00	0.25	-0.01	-0.01	0.00

Sezione: 100
 Progressiva: 980.000
 Q. Progetto: 119.661

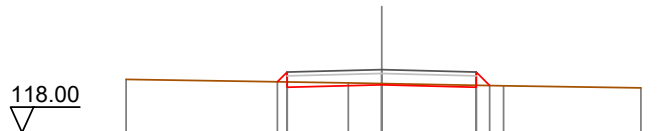

Quote Terreno	119.40	119.34	119.31	119.30	119.24	119.18
Quote Progetto		119.20	119.26	119.20	119.24	119.24
Parziali			2.50	2.50	0.36	
Progressiva		-2.76	-2.50	0.00	2.50	2.86
Dislivelli		-0.00	0.26	-0.03	-0.05	0.00

Sezione: 101
 Progressiva: 988.355
 Q. Progetto: 119.831

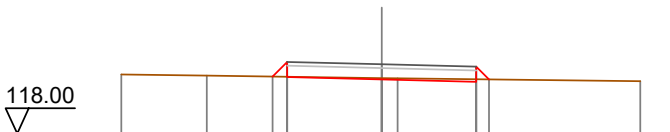

Quote Terreno	119.56	119.53	119.47	119.46	119.38	
Quote Progetto		119.51	119.43	119.37	119.43	
Parziali		0.39	2.50	2.50	0.34	
Progressiva		-2.89	-2.50	0.00	2.50	2.84
Dislivelli		0.00	0.39	-0.04	-0.07	0.00

Sezione: 102
 Progressiva: 990.000
 Q. Progetto: 119.862

118.00



Quote Terreno	119.59	119.55	119.50	119.50	119.41
Quote Progetto		119.54	119.52	119.46	119.40
Parziali		0.38	2.50	2.50	0.38
Progressiva		-2.88	-2.50	0.00	2.50
Dislivelli		-0.00	0.39	-0.03	-0.07

Sezione: 103
 Progressiva: 994.331
 Q. Progetto: 119.939

118.00

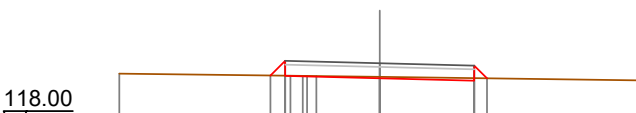

Quote Terreno	119.66	119.61	119.60	119.58	119.48
Quote Progetto		119.61	119.60	119.54	119.46
Parziali		0.39	2.50	2.50	0.34
Progressiva		-2.89	-2.50	0.00	2.50
Dislivelli		0.00	0.39	-0.04	-0.07

Sezione: 104
 Progressiva: 1000.000
 Q. Progetto: 120.031

118.00



Quote Terreno	119.74	119.72	119.66	119.66	119.57
Quote Progetto			119.69	119.63	119.57
Parziali			0.40	2.50	2.50
Progressiva			-2.90	-2.50	0.00
Dislivelli			-0.00	0.41	-0.03

Sezione: 105
 Progressiva: 1000.306
 Q. Progetto: 120.035

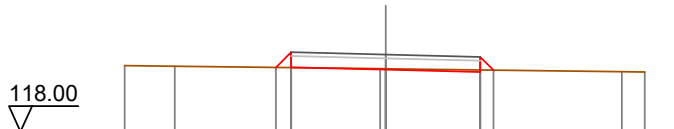

Quote Terreno	119.74	119.72		119.66	119.66		119.58	119.57
Quote Progetto			119.69	119.70		119.57	119.62	
Parziali			0.40	2.50		2.50	0.35	
Progressiva			-2.90	-2.50		0.00	2.50	2.85
Dislivelli			0.00	0.41		-0.02	-0.06	0.00

Sezione: 106
 Progressiva: 1020.000
 Q. Progetto: 120.271

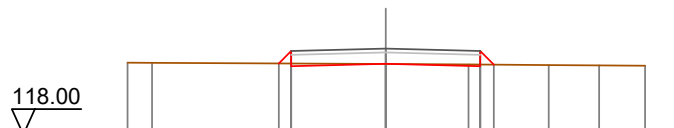

Quote Terreno	119.90	119.90		119.87	119.87		119.85	119.84	119.83	119.82
Quote Progetto			119.88	119.81		119.81	119.85			
Parziali			0.33	2.50		2.50	0.36			
Progressiva			-2.83	-2.50		0.00	2.50	2.86		
Dislivelli			-0.00	0.33		0.01	-0.04	0.00		

Sezione: 107
 Progressiva: 1040.000
 Q. Progetto: 120.381

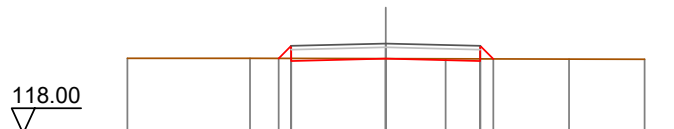

Quote Terreno	119.99	119.99		119.98	119.98		119.97	119.97
Quote Progetto			119.99	119.92		119.92	119.97	
Parziali			0.33	2.50		2.50	0.34	
Progressiva			-2.83	-2.50		0.00	2.50	2.84
Dislivelli			0.00	0.33		0.00	-0.06	0.00

Sezione: 108
 Progressiva: 1060.000
 Q. Progetto: 120.390

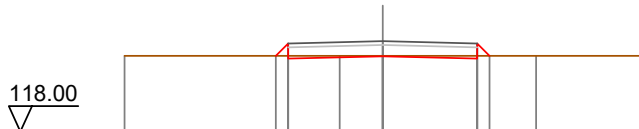

Quote Terreno	120.00		120.00	120.00		120.00		120.00		120.00
Quote Progetto		120.00	119.93		119.99		119.93	120.00		
Parziali		0.33	2.50		2.50		0.33			
Progressiva		-2.83	-2.50		0.00		2.50	2.83		
Dislivelli		0.00	0.33		-0.01		-0.07	0.00		

Sezione: 109
 Progressiva: 1080.000
 Q. Progetto: 120.391

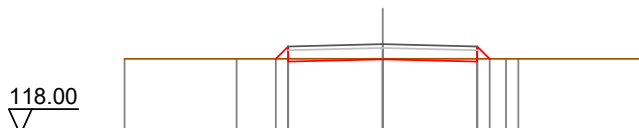

Quote Terreno	120.00		120.00	120.00		120.00		120.00		120.00
Quote Progetto		120.00	119.93		119.99		119.93	120.00		
Parziali		0.33	2.50		2.50		0.33			
Progressiva		-2.83	-2.50		0.00		2.50	2.83		
Dislivelli		0.00	0.33		-0.01		-0.07	0.00		

Sezione: 110
 Progressiva: 1100.000
 Q. Progetto: 120.393

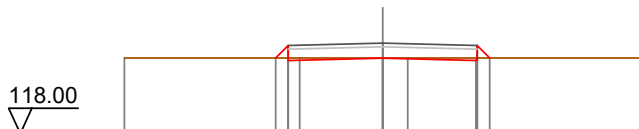

Quote Terreno	120.00		120.00	120.00		120.00		120.00		120.00
Quote Progetto		120.00	119.93		119.99		119.93	120.00		
Parziali		0.33	2.50		2.50		0.33			
Progressiva		-2.83	-2.50		0.00		2.50	2.83		
Dislivelli		0.00	0.33		-0.01		-0.07	0.00		

Sezione: 111
 Progressiva: 1106.627
 Q. Progetto: 120.393

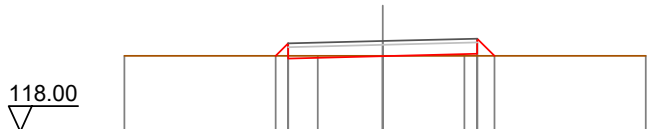

Quote Terreno	120.00	120.00	120.00	120.00	120.00	
Quote Progetto		120.00	119.93	119.99	120.06	120.00
Parziali		0.33	2.50	2.50	0.46	
Progressiva		-2.83	-2.50	0.00	2.50	2.96
Dislivelli		0.00	0.33	-0.01	0.06	0.00

Sezione: 112
 Progressiva: 1110.000
 Q. Progetto: 120.393

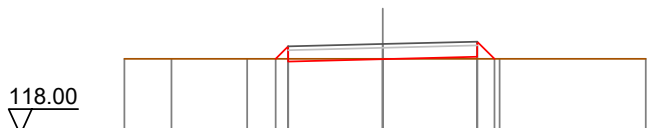

Quote Terreno	120.00	120.00	120.00	120.00	120.00	120.00	
Quote Progetto			120.00	119.93	119.99	120.06	120.00
Parziali			0.33	2.50	2.50	0.46	
Progressiva			-2.83	-2.50	0.00	2.50	2.96
Dislivelli			0.00	0.33	-0.01	0.06	0.00

Sezione: 113
 Progressiva: 1111.969
 Q. Progetto: 120.394

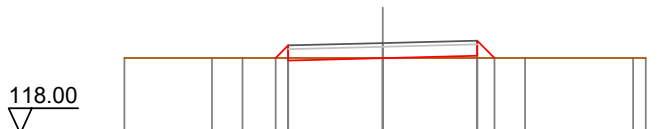

Quote Terreno	120.00	120.00	120.00	120.00	120.00	120.00	120.00
Quote Progetto			120.00	119.93	119.99	120.06	120.00
Parziali			0.33	2.50	2.50	0.46	
Progressiva			-2.83	-2.50	0.00	2.50	2.96
Dislivelli			0.00	0.33	-0.01	0.06	0.00

Sezione: 114
 Progressiva: 1117.311
 Q. Progetto: 120.394

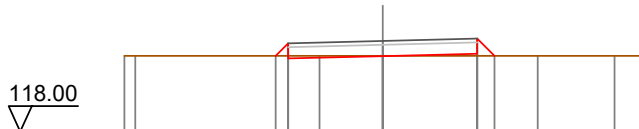

Quote Terreno	120.00	120.00	120.00	120.00	120.00	120.00	120.00
Quote Progetto		120.00	119.93	119.99	120.06	120.00	
Parziali		0.33	2.50	2.50	0.46		
Progressiva		-2.83	-2.50	0.00	2.50	2.96	
Dislivelli		0.00	0.33	-0.01	0.06	0.00	

Sezione: 115
 Progressiva: 1120.000
 Q. Progetto: 120.394

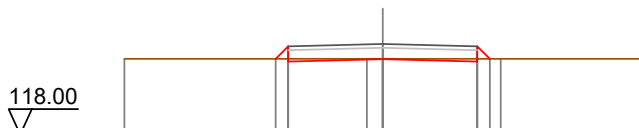

Quote Terreno	120.00	120.00	120.00	120.00	120.00	120.00
Quote Progetto		120.00	119.93	119.99	119.93	120.00
Parziali		0.33	2.50	2.50	0.33	
Progressiva		-2.83	-2.50	0.00	2.50	2.83
Dislivelli		0.00	0.33	-0.01	-0.07	0.00

Sezione: 116
 Progressiva: 1140.000
 Q. Progetto: 120.396

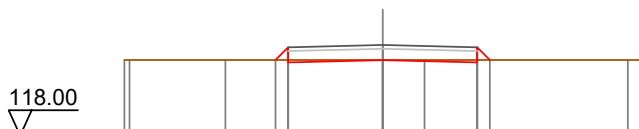

Quote Terreno	120.00	120.00	120.00	120.00	120.00	120.00
Quote Progetto		120.00	119.93	120.00	119.93	120.00
Parziali		0.33	2.50	2.50	0.33	
Progressiva		-2.83	-2.50	0.00	2.50	2.83
Dislivelli		0.00	0.33	-0.00	-0.07	0.00

Sezione: 117
 Progressiva: 1160.000
 Q. Progetto: 120.397

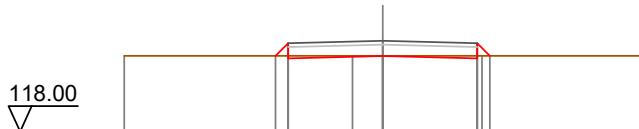

Quote Terreno	120.00		120.00	120.00	120.00	120.00
Quote Progetto		120.00	119.93	120.00	119.93	120.00
Parziali		0.33	2.50	2.50	0.33	
Progressiva		-2.83	-2.50	0.00	2.50	2.83
Dislivelli		0.00	0.33	-0.00	-0.07	0.00

Sezione: 118
 Progressiva: 1169.960
 Q. Progetto: 120.398

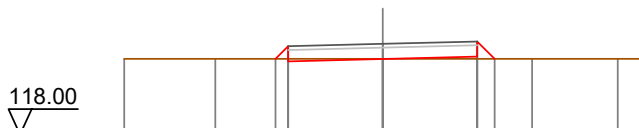

Quote Terreno	120.00	120.00		120.00		120.00	120.00	120.00	120.00
Quote Progetto			120.00	119.94	120.00	120.06	120.00		
Parziali			0.34	2.50	2.50	0.46			
Progressiva			-2.84	-2.50	0.00	2.50	2.96		
Dislivelli			0.00	0.34	-0.00	0.06	0.00		

Sezione: 119
 Progressiva: 1177.778
 Q. Progetto: 120.399

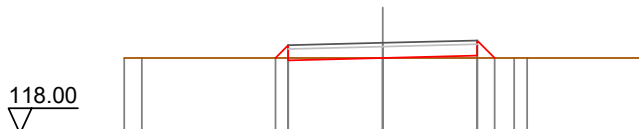

Quote Terreno	120.00	120.00		120.00		120.00	120.00	120.00	120.00
Quote Progetto			120.00	119.94	120.00	120.06	120.00		
Parziali			0.34	2.50	2.50	0.46			
Progressiva			-2.84	-2.50	0.00	2.50	2.96		
Dislivelli			0.00	0.34	-0.00	0.06	0.00		

Sezione: 120
 Progressiva: 1180.000
 Q. Progetto: 120.399

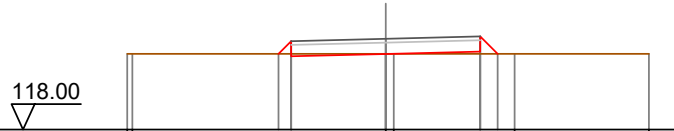

Quote Terreno	120.00	120.00		120.00	120.00	120.00	120.00
Quote Progetto			120.00	119.94	120.00	120.06	120.00
Parziali			0.34	2.50	2.50	0.46	
Progressiva			-2.84	-2.50	0.00	2.50	2.96
Dislivelli			0.00	0.34	-0.00	0.06	0.00

Sezione: 121
 Progressiva: 1185.596
 Q. Progetto: 120.399

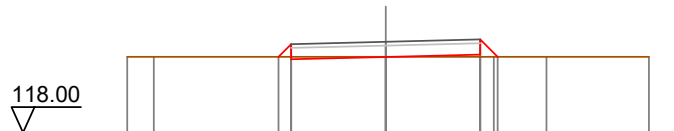

Quote Terreno	120.00	120.00		120.00	120.00	120.00	120.00
Quote Progetto			120.00	119.94	120.00	120.06	120.00
Parziali			0.34	2.50	2.50	0.46	
Progressiva			-2.84	-2.50	0.00	2.50	2.96
Dislivelli			0.00	0.34	-0.00	0.06	0.00

Sezione: 122
 Progressiva: 1200.000
 Q. Progetto: 120.412

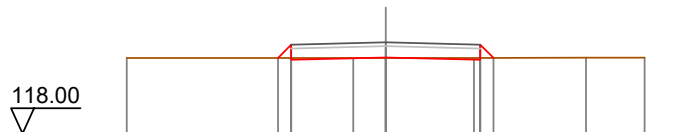

Quote Terreno	120.00		120.00	120.00	120.00	120.01	120.01
Quote Progetto			120.00	119.95	120.01	119.95	120.00
Parziali			0.35	2.50	2.50	0.35	
Progressiva			-2.85	-2.50	0.00	2.50	2.85
Dislivelli			0.00	0.35	0.01	-0.05	0.00

Sezione: 123
 Progressiva: 1220.000
 Q. Progetto: 120.952

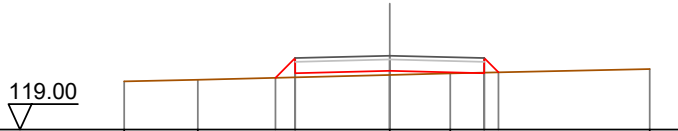

Quote Terreno	120.27	120.32			120.44	120.48	120.60
Quote Progetto			120.37	120.49	120.55	120.49	120.51
Parziali			0.52	2.50	2.50	0.38	
Progressiva			-3.02	-2.50	0.00	2.50	2.88
Dislivelli			-0.00	0.51	0.11	-0.02	-0.00

Sezione: 124
 Progressiva: 1222.149
 Q. Progetto: 121.057

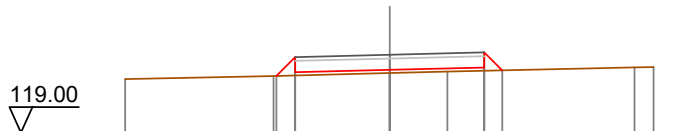

Quote Terreno	120.41	120.49			120.57	120.61	120.72	120.73
Quote Progetto		120.50	120.59		120.66	120.72	120.64	
Parziali		0.50	2.50		2.50	0.48		
Progressiva		-3.00	-2.50		0.00	2.50	2.98	
Dislivelli		-0.00	0.49		0.08	0.09	0.00	

Sezione: 125
 Progressiva: 1230.000
 Q. Progetto: 121.454

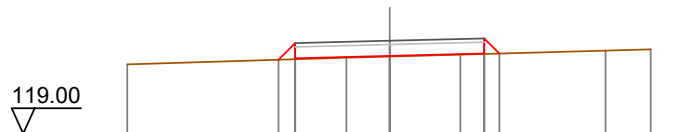

Quote Terreno	120.83	120.95	120.99	121.01	121.04	121.09	121.19	121.23
Quote Progetto		120.95	120.99		121.05	121.12	121.12	
Parziali		0.44	2.50		2.50	0.40		
Progressiva		-2.94	-2.50		0.00	2.50	2.90	
Dislivelli		0.00	0.43		0.02	0.01	0.00	

Sezione: 126
 Progressiva: 1230.297
 Q. Progetto: 121.469

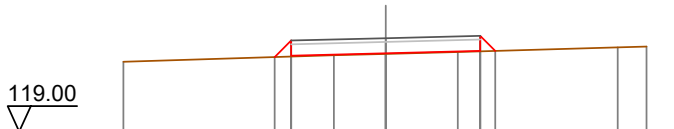

Quote Terreno	120.84		121.02	121.05	121.10		121.22	121.25
Quote Progetto			120.97	121.01			121.13	121.13
Parziali			0.44	2.50	2.50		0.40	
Progressiva			-2.94	-2.50	0.00		2.50	2.90
Dislivelli			-0.00	0.42	0.02		0.01	0.00

Sezione: 127
 Progressiva: 1238.444
 Q. Progetto: 121.880

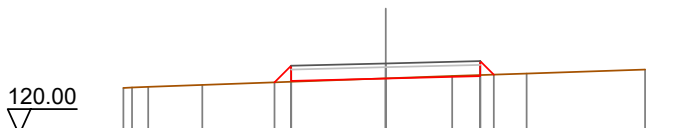

Quote Terreno	121.23	121.24	121.26	121.31		121.48	121.55	121.61	121.72
Quote Progetto						121.38	121.42		
Parziali						0.44	2.50	2.50	
Progressiva						-2.94	-2.50	0.00	
Dislivelli						0.00	0.42	-0.00	

Sezione: 128
 Progressiva: 1240.000
 Q. Progetto: 121.959

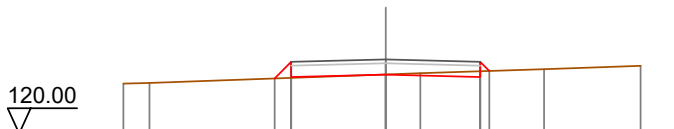

Quote Terreno	121.32	121.34				121.56	121.60	121.70	121.79
Quote Progetto						121.46	121.50		
Parziali						0.44	2.50	2.50	
Progressiva						-2.94	-2.50	0.00	
Dislivelli						0.00	0.42	-0.00	

Sezione: 129
 Progressiva: 1260.000
 Q. Progetto: 122.969

121.00



Quote Terreno	122.40	122.52	122.55	122.56	122.63	122.75
Quote Progetto		122.49	122.51	122.57	122.51	122.63
Parziali		0.41	2.50	2.50	0.27	
Progressiva		-2.91	-2.50	0.00	2.50	2.77
Dislivelli		0.00	0.40	0.01	-0.12	0.00

Sezione: 130
 Progressiva: 1280.000
 Q. Progetto: 123.979

122.00

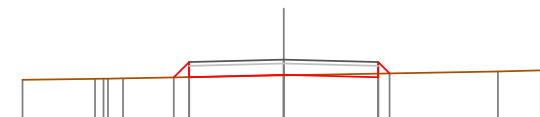

Quote Terreno	123.45	123.47	123.49	123.56	123.67	123.70
Quote Progetto		123.51	123.52	123.58	123.52	123.62
Parziali		0.41	2.50	2.50	0.30	
Progressiva		-2.91	-2.50	0.00	2.50	2.80
Dislivelli		-0.00	0.40	0.02	-0.09	0.00

Sezione: 131
 Progressiva: 1291.720
 Q. Progetto: 124.565

123.00



Quote Terreno	124.04	124.10	124.13	124.21	124.24
Quote Progetto		124.08	124.23	124.10	124.17
Parziali		0.54	2.50	2.50	0.33
Progressiva		-3.04	-2.50	0.00	2.50
Dislivelli		0.00	0.54	0.04	-0.06

Sezione: 132
 Progressiva: 1292.219
 Q. Progetto: 124.588

123.00

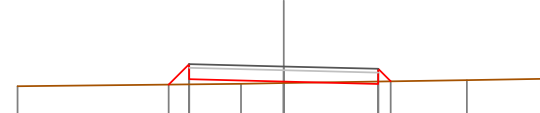

Quote Terreno	124.07		124.13	124.15		124.23	124.26
Quote Progetto		124.11	124.25	124.19	124.13	124.20	
Parziali		0.54	2.50	2.50	0.33		
Progressiva		-3.04	-2.50	0.00	2.50	2.83	
Dislivelli		0.00	0.54	0.04	-0.06	0.00	

Sezione: 133
 Progressiva: 1292.719
 Q. Progetto: 124.610

123.00



Quote Terreno	124.09		124.16	124.17		124.25	124.28
Quote Progetto		124.14	124.27	124.21	124.15	124.22	
Parziali		0.54	2.50	2.50	0.33		
Progressiva		-3.04	-2.50	0.00	2.50	2.83	
Dislivelli		0.00	0.53	0.04	-0.06	0.00	

Sezione: 134
 Progressiva: 1300.000
 Q. Progetto: 124.929

123.00



Quote Terreno	124.45		124.50	124.52	124.53		124.61
Quote Progetto		124.49	124.47	124.53	124.47	124.55	
Parziali		0.38	2.50	2.50	0.31		
Progressiva		-2.88	-2.50	0.00	2.50	2.81	
Dislivelli		0.00	0.37	0.01	-0.08	-0.00	

Sezione: 135
 Progressiva: 1320.000
 Q. Progetto: 125.804

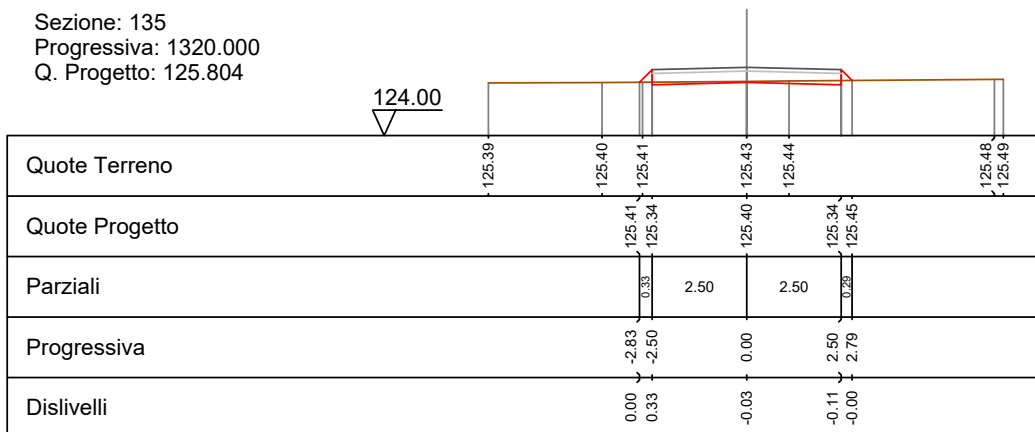

Sezione: 136
 Progressiva: 1334.955
 Q. Progetto: 126.458

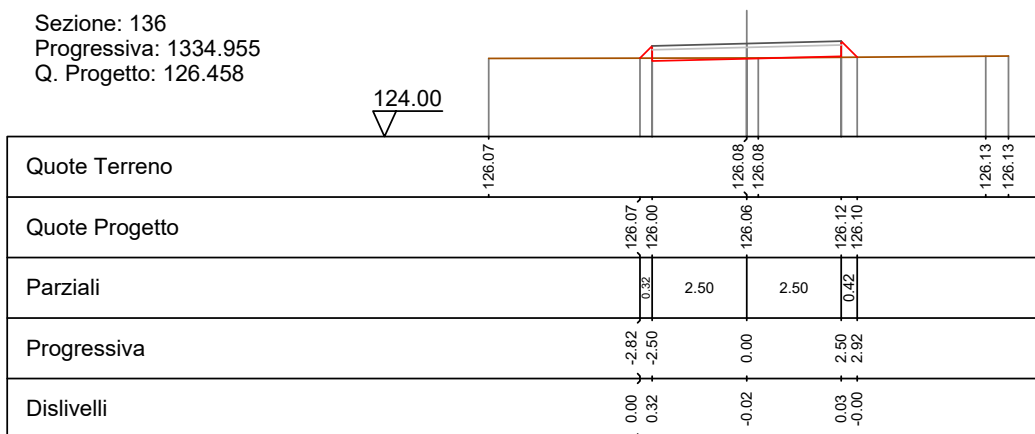

Sezione: 137
 Progressiva: 1338.201
 Q. Progetto: 126.600

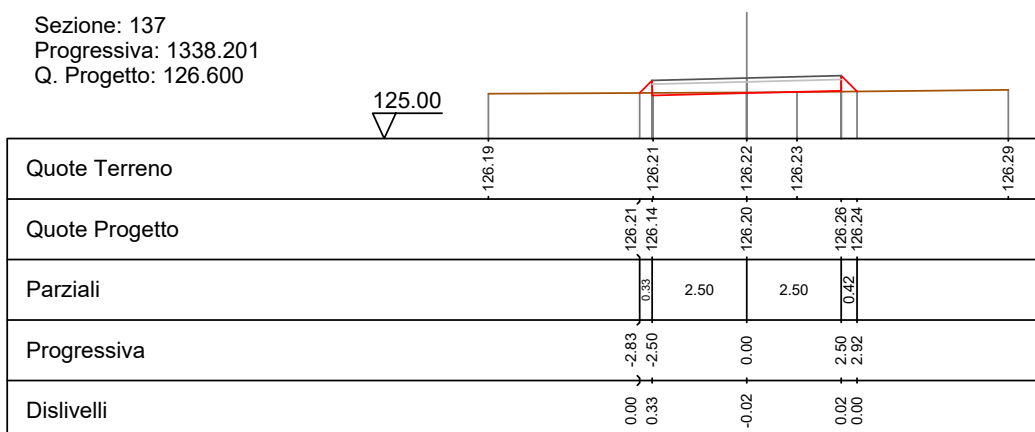

Sezione: 138
 Progressiva: 1340.000
 Q. Progetto: 126.679

125.00

Quote Terreno	126.25		126.30	126.31	126.31	126.37
Quote Progetto		126.28	126.22	126.28	126.34	126.32
Parziali		0.34	2.50	2.50	0.42	
Progressiva		-2.84	-2.50	0.00	2.50	2.92
Dislivelli		0.00	0.33	-0.02	0.02	-0.00

Sezione: 139
 Progressiva: 1341.447
 Q. Progetto: 126.742

125.00

Quote Terreno	126.31		126.35	126.36	126.37	126.38	126.44
Quote Progetto		126.34	126.28	126.34	126.40	126.38	
Parziali		0.34	2.50	2.50	0.42		
Progressiva		-2.84	-2.50	0.00	2.50	2.92	
Dislivelli		-0.00	0.34	-0.02	0.03	-0.00	

Sezione: 140
 Progressiva: 1360.000
 Q. Progetto: 127.554

126.00

Quote Terreno	127.13	127.13	127.14	127.15	127.15	127.20
Quote Progetto		127.14	127.09	127.15	127.09	127.17
Parziali		0.35	2.50	2.50	0.32	
Progressiva		-2.85	-2.50	0.00	2.50	2.82
Dislivelli		0.00	0.35	0.01	-0.07	-0.00

Sezione: 141
 Progressiva: 1380.000
 Q. Progetto: 128.365

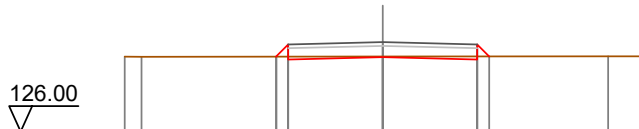

Quote Terreno	127.98	127.98	127.98	127.98	127.99	127.99
Quote Progetto		127.98	127.90	127.97	127.90	127.98
Parziali		0.32	2.50	2.50	0.32	
Progressiva		-2.82	-2.50	0.00	2.50	2.82
Dislivelli		0.00	0.32	-0.02	-0.08	0.00

Sezione: 142
 Progressiva: 1385.524
 Q. Progetto: 128.565



Quote Terreno	128.19	128.19	128.19	128.19	128.19	128.19
Quote Progetto		128.19	128.23	128.16	128.10	128.19
Parziali		0.43	2.50	2.50	0.31	
Progressiva		-2.93	-2.50	0.00	2.50	2.81
Dislivelli		0.00	0.43	-0.03	-0.09	0.00

Sezione: 143
 Progressiva: 1390.000
 Q. Progetto: 128.718

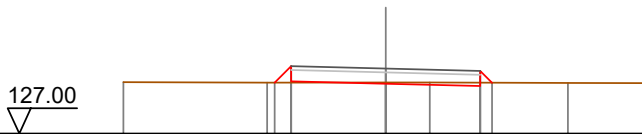

Quote Terreno	128.36	128.34	128.35	128.35	128.34	128.33
Quote Progetto		128.34	128.32	128.26	128.34	
Parziali		0.44	2.50	2.50	0.31	
Progressiva		-2.94	-2.50	0.00	2.50	2.81
Dislivelli		0.00	0.44	-0.03	-0.09	0.00

Sezione: 144
 Progressiva: 1391.670
 Q. Progetto: 128.773

127.00



Quote Terreno	128.42	128.40		128.41	128.41	128.39	128.39
Quote Progetto			128.40	128.44		128.31	128.40
Parziali			0.43	2.50	2.50	0.31	
Progressiva			-2.93	-2.50	0.00	2.50	2.81
Dislivelli			0.00	0.43	-0.03	-0.09	0.00

Sezione: 145
 Progressiva: 1397.815
 Q. Progetto: 128.969

127.00



Quote Terreno	128.63	128.63		128.60	128.59	128.56	
Quote Progetto			128.62	128.57	128.51	128.59	
Parziali			0.42	2.50	2.50	0.32	
Progressiva			-2.92	-2.50	0.00	2.50	2.82
Dislivelli			0.00	0.42	-0.03	-0.09	0.00

Sezione: 146
 Progressiva: 1400.000
 Q. Progetto: 129.035

127.00



Quote Terreno	128.70		128.68	128.67	128.65	128.62	
Quote Progetto			128.68	128.64	128.57	128.66	
Parziali			0.28	2.50	2.50	0.32	
Progressiva			-2.79	-2.50	0.00	2.50	2.82
Dislivelli			0.00	0.28	-0.03	-0.08	0.00

Sezione: 147
 Progressiva: 1420.000
 Q. Progetto: 129.588

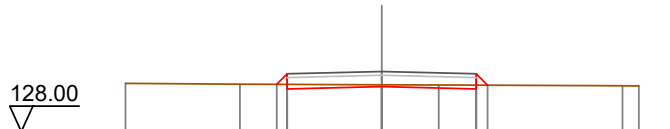

Quote Terreno	129.27	129.25	129.24	129.23	129.21	129.21
Quote Progetto		129.25 129.13	129.19	129.13	129.22	
Parziali		0.28	2.50	2.50	0.30	
Progressiva		-2.78 -2.50	0.00	2.50	2.80	
Dislivelli		-0.00 0.28	-0.05	-0.10	0.00	

Sezione: 148
 Progressiva: 1440.000
 Q. Progetto: 130.245

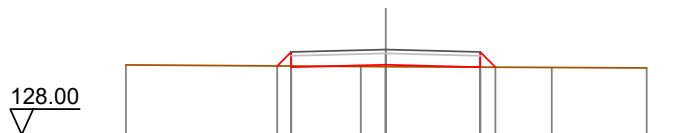

Quote Terreno	129.84	129.80	129.79	129.77	129.76
Quote Progetto		129.84 129.78	129.85	129.78 129.78	
Parziali		0.37	2.50	2.50	0.40
Progressiva		-2.87 -2.50	0.00	2.50	2.90
Dislivelli		-0.00 0.37	0.05	0.00	0.00

Sezione: 149
 Progressiva: 1442.680
 Q. Progetto: 130.383

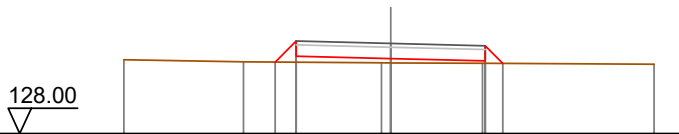

Quote Terreno	129.95	129.89	129.87	129.86	129.83
Quote Progetto		129.89 130.05	129.88	129.92 129.85	
Parziali		0.56	2.50	2.50	0.47
Progressiva		-3.06 -2.50	0.00	2.50	2.97
Dislivelli		0.00 0.56	0.11	0.06	0.00

Sezione: 150
 Progressiva: 1448.035
 Q. Progetto: 130.702

129.00

Quote Terreno	130.29		130.15	130.14		130.10
Quote Progetto		130.21	130.36	130.30	130.24	130.12
Parziali		0.56	2.50	2.50	0.51	
Progressiva		-3.06	-2.50	0.00	2.50	3.01
Dislivelli		0.00	0.57	0.16	0.11	0.00

Sezione: 151
 Progressiva: 1450.000
 Q. Progetto: 130.833

129.00

Quote Terreno	130.49	130.43		130.31	130.30		130.25	130.22
Quote Progetto			130.38	130.50	130.43	130.37	130.27	
Parziali			0.52	2.50	2.50	0.50		
Progressiva			-3.02	-2.50	0.00	2.50	3.00	
Dislivelli			0.00	0.53	0.13	0.09	-0.00	

Sezione: 152
 Progressiva: 1453.391
 Q. Progetto: 131.078

129.00

Quote Terreno	130.86		130.63	130.58	130.57	130.54		130.38
Quote Progetto		130.68	130.74	130.68	130.62	130.53		
Parziali		0.46	2.50	2.50	0.49			
Progressiva		-2.96	-2.50	0.00	2.50	2.99		
Dislivelli		0.00	0.48	0.10	0.08	0.00		

Sezione: 153
 Progressiva: 1460.000
 Q. Progetto: 131.586

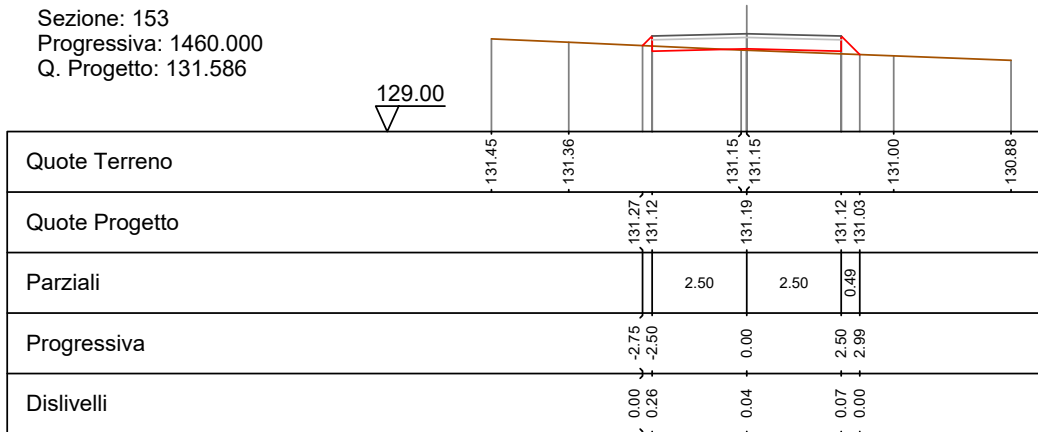

Sezione: 154
 Progressiva: 1475.300
 Q. Progetto: 132.765

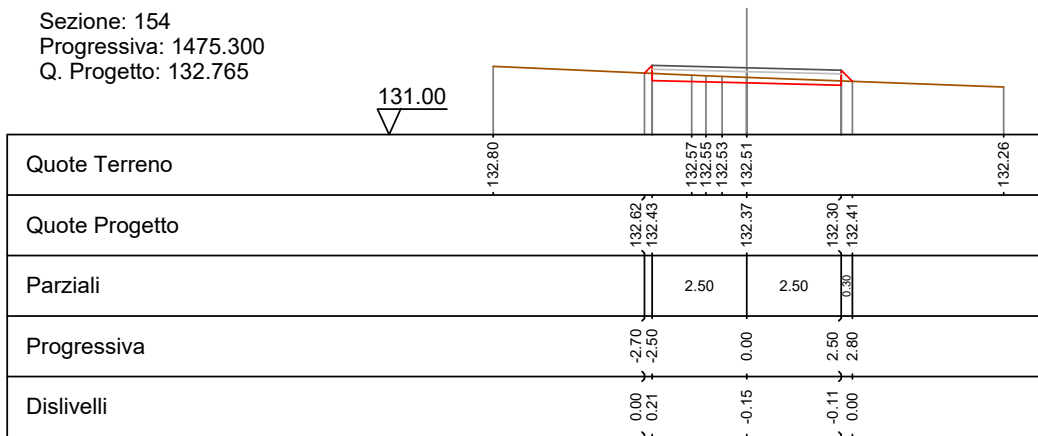

Sezione: 155
 Progressiva: 1480.000
 Q. Progetto: 133.127

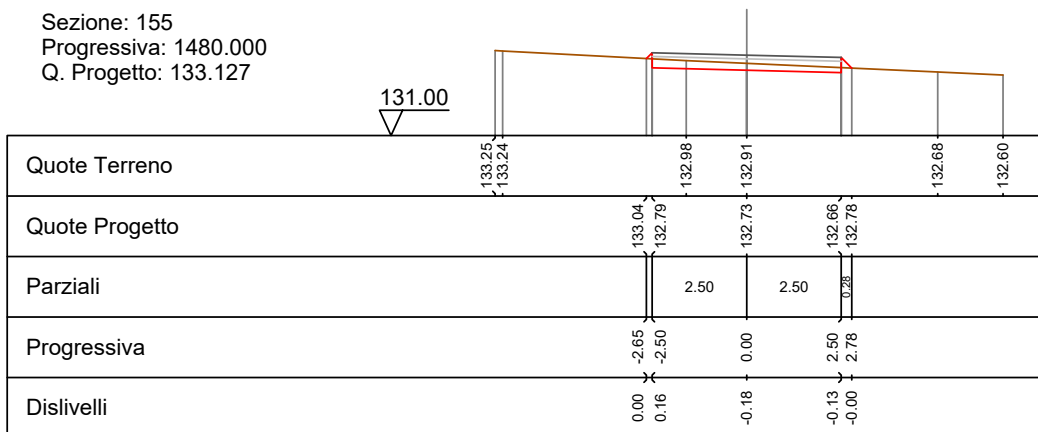

Sezione: 156
 Progressiva: 1482.781
 Q. Progetto: 133.341

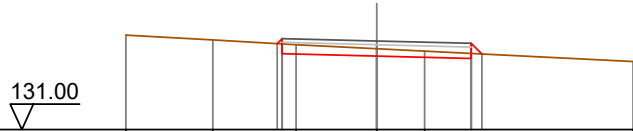

Quote Terreno	133.50	133.37	133.24	133.14	133.07	132.80
Quote Progetto			133.27	133.00	132.94	132.88
Parziali			2.50	2.50	0.28	
Progressiva			-2.63	-2.50	0.00	2.50
Dislivelli			0.00	0.14	-0.20	-0.13

Sezione: 157
 Progressiva: 1490.000
 Q. Progetto: 133.897

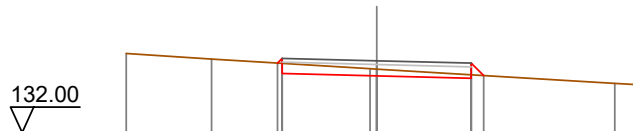

Quote Terreno	134.09	133.94	133.69	133.68	133.30	133.27
Quote Progetto			133.84	133.56	133.50	133.43
Parziali			2.50	2.50	0.33	
Progressiva			-2.62	-2.50	0.00	2.50
Dislivelli			0.00	0.13	-0.18	-0.09

Sezione: 158
 Progressiva: 1490.261
 Q. Progetto: 133.918

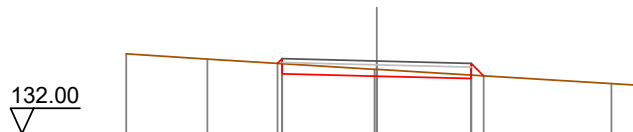

Quote Terreno	134.11	133.97	133.70	133.70	133.32	133.28
Quote Progetto			133.86	133.58	133.46	133.52
Parziali			2.50	2.50	0.33	
Progressiva			-2.62	-2.50	0.00	2.50
Dislivelli			0.00	0.13	-0.18	-0.09

Sezione: 159
 Progressiva: 1498.196
 Q. Progetto: 134.529

132.00

Quote Terreno	134.64		134.24	134.09	134.05	134.03	133.99	133.83
Quote Progetto		134.40	134.07	134.13	134.19	134.06		
Parziali			2.50	2.50	0.53			
Progressiva		-2.57	-2.50	0.00	2.50	3.03		
Dislivelli		0.00	0.07	-0.12	0.10	0.00		

Sezione: 160
 Progressiva: 1500.000
 Q. Progetto: 134.668

132.00

Quote Terreno	134.75		134.44	134.37	134.22		134.10	133.97
Quote Progetto		134.53	134.21	134.27	134.33	134.19		
Parziali			2.50	2.50	0.54			
Progressiva		-2.59	-2.50	0.00	2.50	3.04		
Dislivelli		0.00	0.09	-0.10	0.11	-0.00		

Sezione: 161
 Progressiva: 1509.946
 Q. Progetto: 135.434

133.00

Quote Terreno	135.39	135.23	135.08	135.08			134.77
Quote Progetto		135.21	134.97	135.03	135.10	134.95	
Parziali			2.50	2.50	0.55		
Progressiva		-2.66	-2.50	0.00	2.50	3.05	
Dislivelli		0.00	0.17	-0.05	0.12	0.00	

Sezione: 162
 Progressiva: 1520.000
 Q. Progetto: 136.208

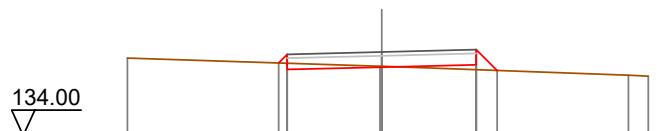

Quote Terreno	136.05		135.83	135.83		135.59	135.57
Quote Progetto		135.92	135.75		135.87	135.72	
Parziali		2.50	2.50		0.55		
Progressiva		-2.73	-2.50	0.00	2.50	3.05	
Dislivelli		0.00	0.23	-0.02	0.13	0.00	

Sezione: 163
 Progressiva: 1521.697
 Q. Progetto: 136.339

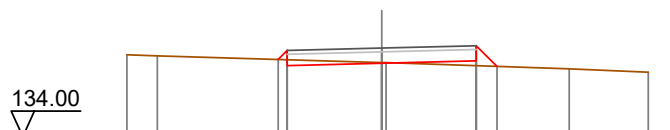

Quote Terreno	136.16	136.13		135.96	135.95		135.79	135.70
Quote Progetto			136.04	135.88		136.00	135.85	
Parziali			2.50	2.50		0.55		
Progressiva			-2.74	-2.50	0.00	2.50	3.05	
Dislivelli			0.00	0.25	-0.02	0.13	0.00	

Sezione: 164
 Progressiva: 1540.000
 Q. Progetto: 137.749

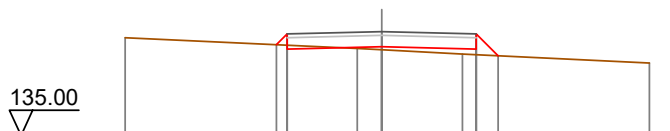

Quote Terreno	137.59		137.30	137.27		137.15		136.92
Quote Progetto		137.40	137.29		137.29	137.11		
Parziali		0.28	2.50	2.50	0.58			
Progressiva		-2.78	-2.50	0.00	2.50	3.08		
Dislivelli		0.00	0.30	0.08	0.15	0.00		

Sezione: 165
 Progressiva: 1556.179
 Q. Progetto: 138.925

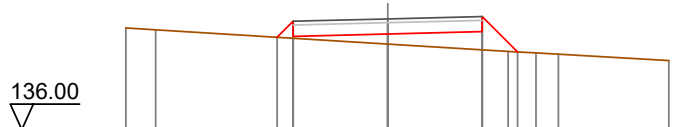

Quote Terreno	136.69	138.64		138.26		136.07	136.03	137.99	137.82
Quote Progetto			138.44	138.46	138.53	138.59	138.05		
Parziali			0.42	2.50	2.50	0.94			
Progressiva			-2.92	-2.50	0.00	2.50	3.44		
Dislivelli			0.00	0.45	0.26	0.48	0.00		

Sezione: 166
 Progressiva: 1560.000
 Q. Progetto: 139.141



Quote Terreno	138.69	138.81		138.48		138.39	138.20	138.04
Quote Progetto			138.65	138.68	138.74	138.80	138.27	
Parziali			0.43	2.50	2.50	0.93		
Progressiva			-2.93	-2.50	0.00	2.50	3.43	
Dislivelli			0.00	0.45	0.26	0.47	0.00	

Sezione: 167
 Progressiva: 1561.480
 Q. Progetto: 139.216



Quote Terreno	138.96	138.87		138.56	138.53		138.27	138.13
Quote Progetto			138.73	138.75	138.82	138.88	138.36	
Parziali			0.43	2.50	2.50	0.92		
Progressiva			-2.93	-2.50	0.00	2.50	3.42	
Dislivelli			0.00	0.45	0.25	0.47	0.00	

Sezione: 168
 Progressiva: 1566.781
 Q. Progetto: 139.451

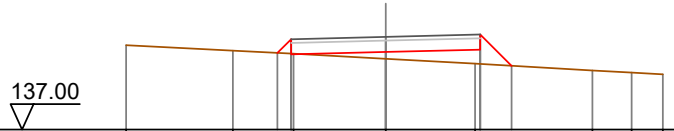

Quote Terreno	139.23	139.08	139.00	138.87	138.74	138.56	138.50	138.46
Quote Progetto			139.02 138.99	139.05	139.11	138.69		
Parziali			0.36 2.50	2.50	0.83			
Progressiva			-2.86 -2.50	0.00	2.50	3.33		
Dislivelli			-0.00 0.38	0.18	0.38	0.00		

Sezione: 169
 Progressiva: 1580.000
 Q. Progetto: 139.790

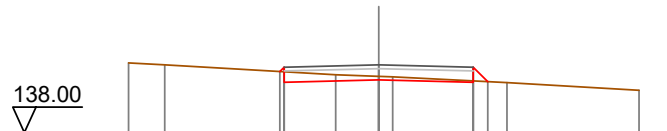

Quote Terreno	139.84	139.79	139.53	139.49	139.47	139.32	139.12
Quote Progetto			139.61 139.33	139.39	139.33	139.34	
Parziali			2.50	2.50	0.38		
Progressiva			-2.62 -2.50	0.00	2.50	2.88	
Dislivelli			0.00 0.12	-0.10	-0.04	-0.00	

Sezione: 170
 Progressiva: 1590.282
 Q. Progetto: 139.901

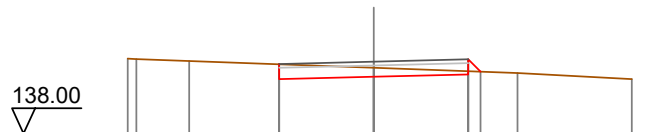

Quote Terreno	139.98	139.97	139.92	139.74	139.60	139.44
Quote Progetto			139.44	139.50	139.56 139.64	
Parziali			2.50	2.50	0.33	
Progressiva			-2.51	0.00	2.50	2.83
Dislivelli			0.00	-0.24	-0.09	0.00

Sezione: 171
 Progressiva: 1594.599
 Q. Progetto: 139.947

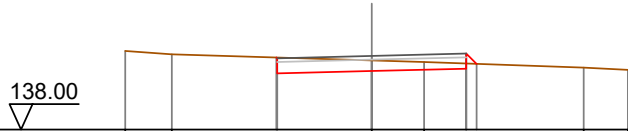

Quote Terreno	140.08	139.99		139.83	139.78	139.64	139.58
Quote Progetto			139.48	139.55	139.61	139.73	
Parziali			2.50	2.50	0.27		
Progressiva			-2.52	0.00	2.50	2.77	
Dislivelli			0.00	-0.28	-0.13	0.00	

Sezione: 172
 Progressiva: 1598.915
 Q. Progetto: 139.993

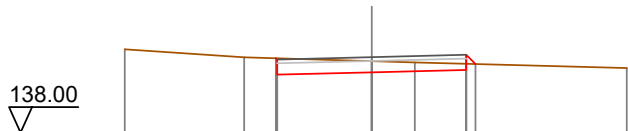

Quote Terreno	140.20	139.99		139.89	139.85	139.70
Quote Progetto			139.96	139.53	139.59	139.66
Parziali			2.50	2.50		
Progressiva			-2.53	0.00	2.50	2.74
Dislivelli			-0.00	-0.03	-0.29	-0.16

Sezione: 173
 Progressiva: 1600.000
 Q. Progetto: 140.005



Quote Terreno	140.19	140.14	139.99	139.93	139.91	139.73
Quote Progetto			139.98	139.54	139.60	139.54
Parziali			2.50	2.50		
Progressiva			-2.54	0.00	2.50	2.60
Dislivelli			0.00	-0.04	-0.30	-0.30

Sezione: 174
 Progressiva: 1600.688
 Q. Progetto: 140.012

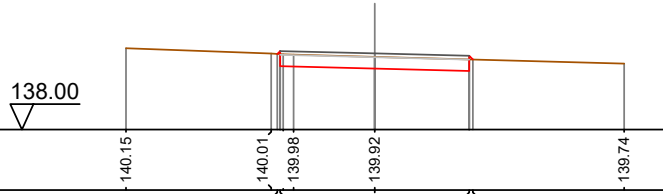

Quote Terreno	140.15	140.01	139.98	139.92	139.74
Quote Progetto		140.00	139.67	139.61	139.55
Parziali		2.50	2.50		
Progressiva		-2.58	-2.50	0.00	2.50
Dislivelli		0.00	0.08	-0.31	-0.31

Sezione: 175
 Progressiva: 1610.000
 Q. Progetto: 140.111

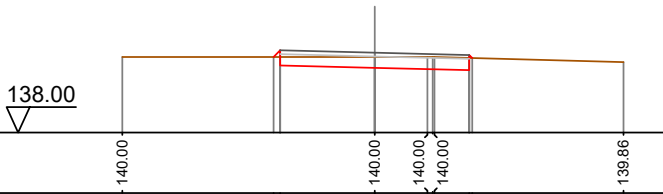

Quote Terreno	140.00	140.00	140.00	140.00	139.86
Quote Progetto		140.00	139.77	139.71	139.65
Parziali		2.50	2.50		
Progressiva		-2.68	-2.50	0.00	2.50
Dislivelli		-0.00	0.18	-0.29	-0.32

Sezione: 175
 Progressiva: 1610.000
 Q. Progetto: 140.111

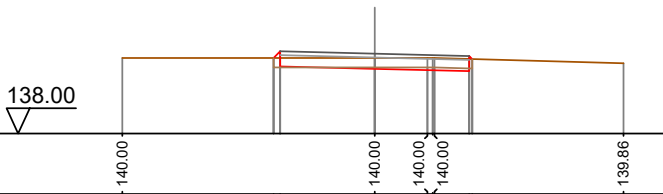

Quote Terreno	140.00	140.00	140.00	140.00	139.86
Quote Progetto		140.00	139.77	139.71	139.65
Parziali		2.50	2.50		
Progressiva		-2.68	-2.50	0.00	2.50
Dislivelli		0.00	0.18	-0.29	-0.32

Sezione: 176
 Progressiva: 1618.712
 Q. Progetto: 140.230

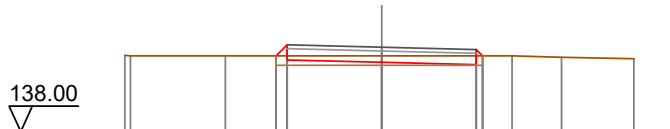

Quote Terreno	140.01	140.00	140.00	140.00	140.00	140.00	139.96	139.92
Quote Progetto	140.00	140.00	139.89	140.00	139.83	139.77	140.00	140.00
Parziali			0.29	2.50	2.50			
Progressiva			-2.79	-2.50	0.00	2.50	2.67	
Dislivelli			0.00	0.29	-0.17	-0.23	0.00	

Sezione: 177
 Progressiva: 1620.000
 Q. Progetto: 140.258

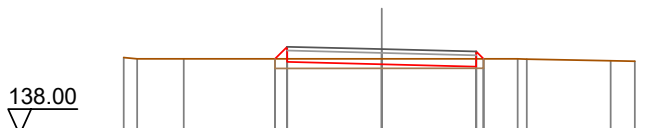

Quote Terreno	140.04	140.00	140.00	140.00	140.00	140.00	139.99	139.95
Quote Progetto	140.00	140.00	139.92	140.00	139.86	139.80	140.00	140.00
Parziali			0.32	2.50	2.50			
Progressiva			-2.82	-2.50	0.00	2.50	2.70	
Dislivelli			0.00	0.32	-0.14	-0.20	0.00	

Sezione: 178
 Progressiva: 1630.000
 Q. Progetto: 140.592

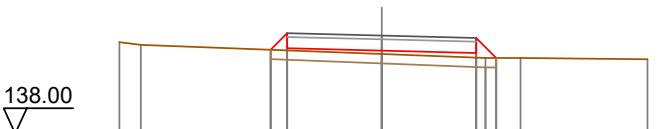

Quote Terreno	140.42	140.35	140.00	140.10	140.00	140.00	140.00	139.97
Quote Progetto	140.22	140.25	140.22	140.19	140.13	140.00	140.00	140.00
Parziali			0.44	2.50	2.50	0.53		
Progressiva			-2.94	-2.50	0.00	2.50	3.03	
Dislivelli			-0.00	0.45	0.09	0.12	0.00	

Sezione: 179
 Progressiva: 1636.736
 Q. Progetto: 140.930

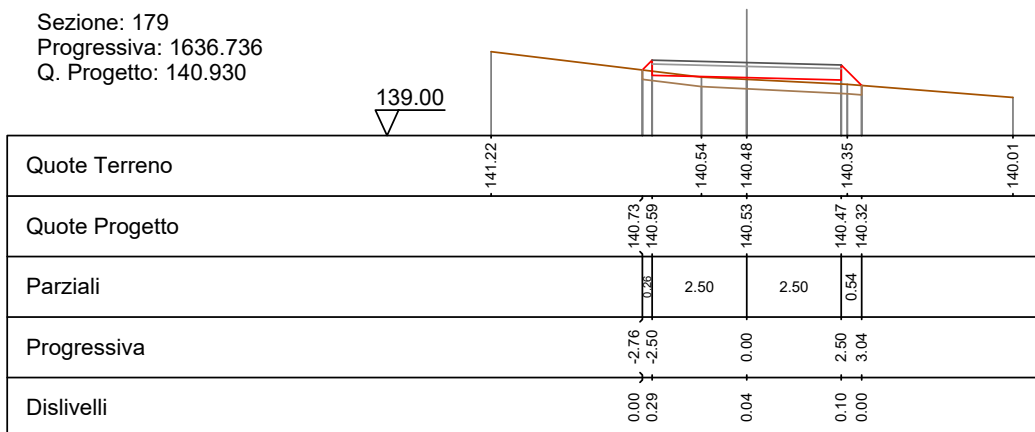

Sezione: 180
 Progressiva: 1640.000
 Q. Progetto: 141.123

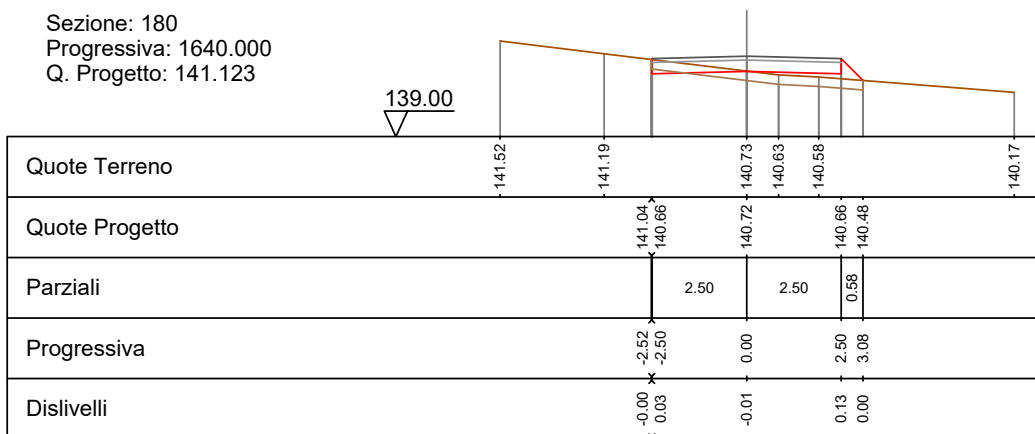

Sezione: 181
 Progressiva: 1660.000
 Q. Progetto: 142.163

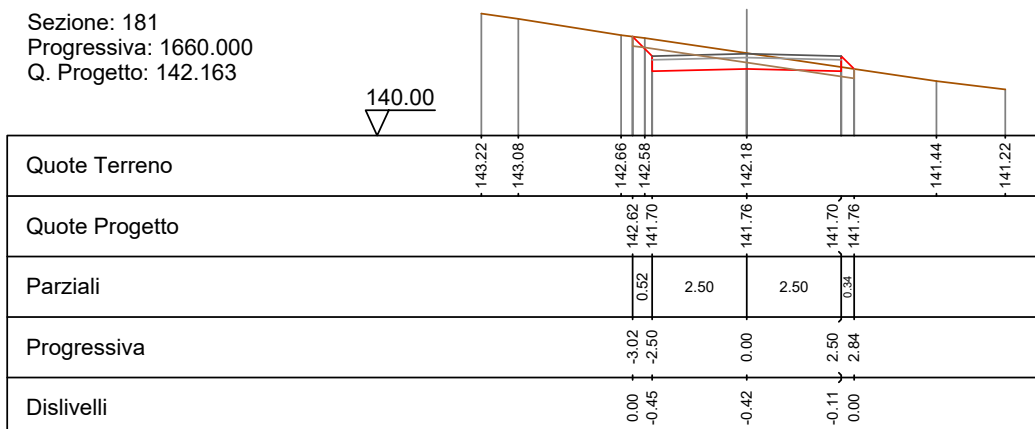

Sezione: 182
 Progressiva: 1667.125
 Q. Progetto: 142.416

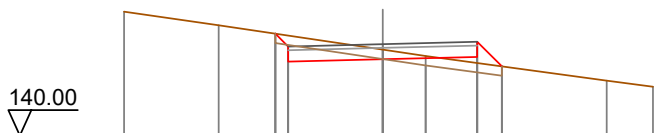

Quote Terreno	143.27	142.92	142.70	142.02	142.10	141.45	141.29
Quote Progetto			141.95	142.02	142.08	141.83	
Parziali			0.34	2.50	2.50	0.65	
Progressiva			-2.84	-2.50	0.00	2.50	3.15
Dislivelli			-0.00	-0.29	-0.26	0.16	0.00

Sezione: 183
 Progressiva: 1670.000
 Q. Progetto: 142.490

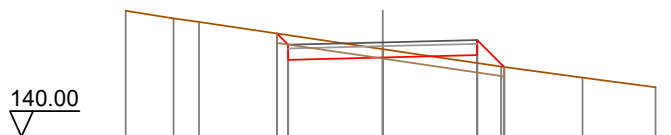

Quote Terreno	143.33	143.13	143.03	142.31	141.85	141.56	141.30
Quote Progetto			142.73	142.09	142.15	141.84	
Parziali			0.30	2.50	2.50	0.71	
Progressiva			-2.80	-2.50	0.00	2.50	3.21
Dislivelli			0.00	-0.25	-0.22	0.21	-0.00

Sezione: 184
 Progressiva: 1670.985
 Q. Progetto: 142.511

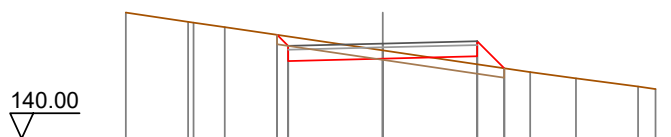

Quote Terreno	143.33	143.08	143.06	142.95	142.33	141.76	141.59	141.38	141.31
Quote Progetto			142.74	142.05	142.11	142.17	141.86		
Parziali			0.28	2.50	2.50	0.72			
Progressiva			-2.79	-2.50	0.00	2.50	3.22		
Dislivelli			0.00	-0.25	-0.22	0.21	0.00		

Sezione: 185
 Progressiva: 1674.845
 Q. Progetto: 142.577

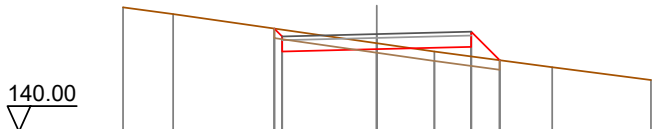

Quote Terreno	143.28	143.10		142.33	142.12	141.70	141.36
Quote Progetto			142.72	142.11	142.18	142.24	141.88
Parziali			2.50	2.50	0.75		
Progressiva			-2.71	-2.50	0.00	2.50	3.25
Dislivelli			0.00	-0.18	-0.16	0.25	0.00

Sezione: 186
 Progressiva: 1680.000
 Q. Progetto: 142.650

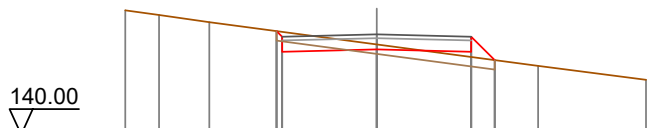

Quote Terreno	143.28	143.16	142.97	142.38		141.81	141.45
Quote Progetto			142.74	142.19	142.25	142.19	141.97
Parziali			2.50	2.50	0.62		
Progressiva			-2.65	-2.50	0.00	2.50	3.12
Dislivelli			0.00	-0.13	-0.13	0.14	0.00

Sezione: 187
 Progressiva: 1700.000
 Q. Progetto: 142.986

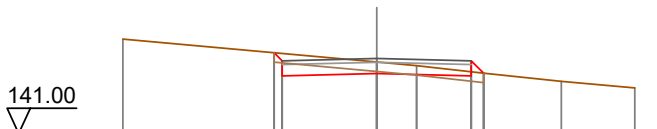

Quote Terreno	143.50			142.89	142.80	142.60	142.38	142.21
Quote Progetto		143.14	142.52	142.59	142.60	142.60		
Parziali		2.50	2.50	0.33				
Progressiva		-2.71	-2.50	0.00	2.50	2.83		
Dislivelli		-0.00	-0.19	-0.31	-0.11	-0.00		

Sezione: 188
 Progressiva: 1720.000
 Q. Progetto: 143.924

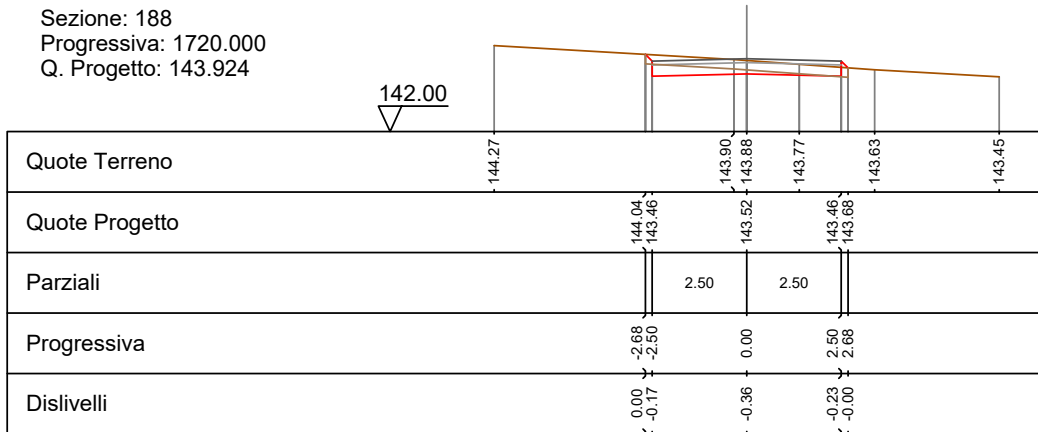

Sezione: 189
 Progressiva: 1740.000
 Q. Progetto: 144.901

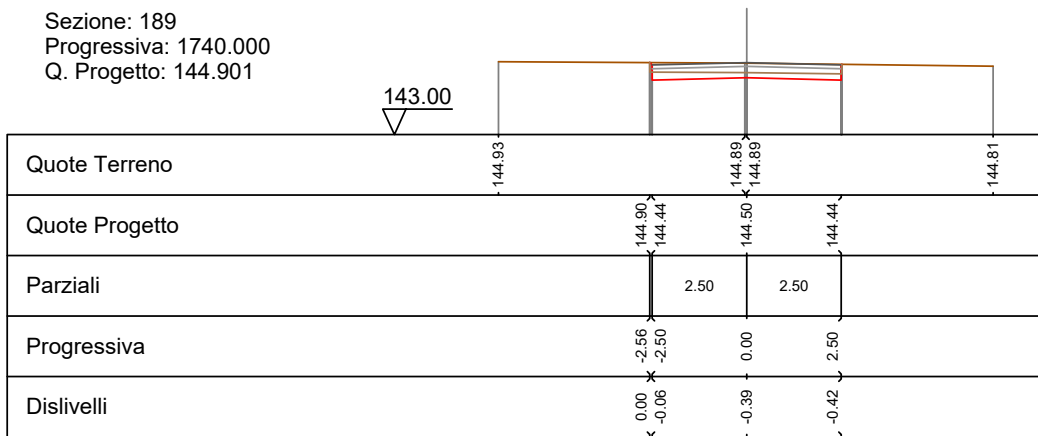

Sezione: 190
 Progressiva: 1760.000
 Q. Progetto: 145.497

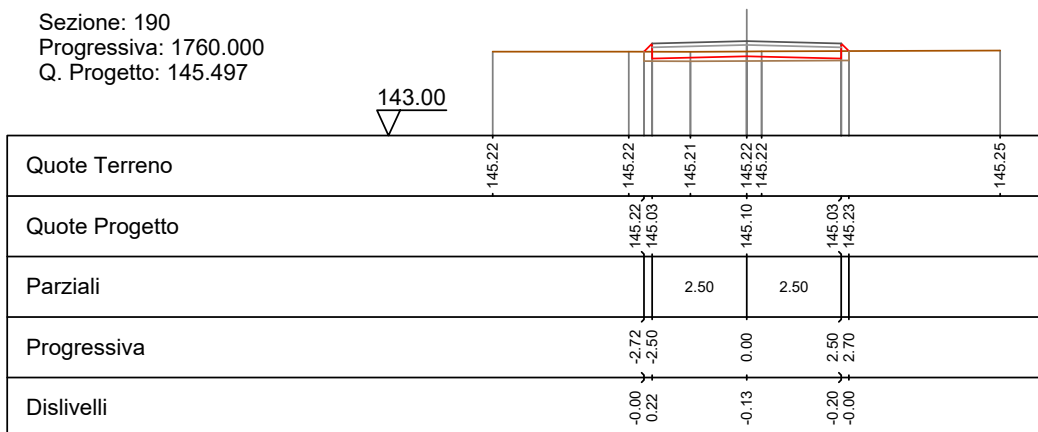

Sezione: 191
 Progressiva: 1780.000
 Q. Progetto: 146.056

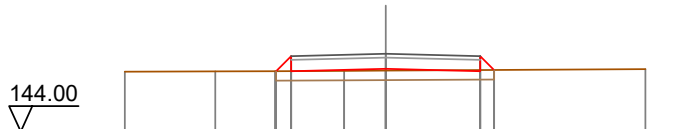

Quote Terreno	145.58	145.59	145.60	145.60	145.61	145.65
Quote Progetto			145.60 145.59	145.66	145.59 145.63	
Parziali			0.40	2.50	2.50	0.37
Progressiva			-2.90 -2.50	0.00	2.50 2.87	
Dislivelli			0.00 0.40	0.05	-0.03 0.00	

Sezione: 192
 Progressiva: 1800.000
 Q. Progetto: 146.492

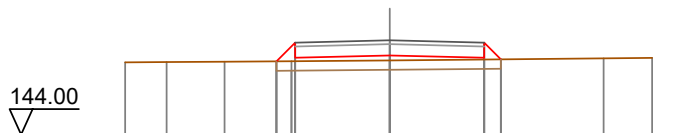

Quote Terreno	145.91	145.92	145.92	145.94	145.96	146.01	146.03
Quote Progetto				145.93 146.03	146.09	146.03 145.99	
Parziali				0.49	2.50	2.50	0.44
Progressiva				-2.99 -2.50	0.00	2.50 2.94	
Dislivelli				0.00 0.49	0.13	0.05 0.00	

Sezione: 193
 Progressiva: 1803.500
 Q. Progetto: 146.500

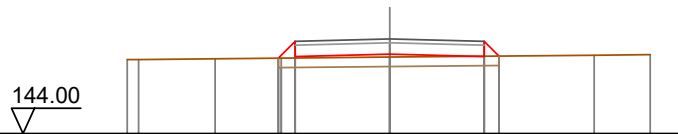

Quote Terreno	145.95	145.96	145.98	146.00	146.02	146.07	146.09
Quote Progetto				145.99 146.04	146.10	146.04 146.05	
Parziali				0.44	2.50	2.50	0.39
Progressiva				-2.94 -2.50	0.00	2.50 2.89	
Dislivelli				0.00 0.44	0.08	-0.01 0.00	

SEZIONI TRASVERSALI
Profilo longitudinale tratto 19-20
Viabilità di impianto - Postazione aerogeneratore WTG10

Nota: Le canalette di deflusso delle acque meteoriche, non indicate nel presente elaborato, sono rappresentate graficamente nelle sezioni stradali tipo dell'elaborato "BLTX-NS-TC13_Piazzole aerogeneratori e strade di servizio - Particolari costruttivi", individuate planimetricamente nell'elaborato "BLTX-NS-TC14_Opere di regimazione acque superficiali - Planimetria generale" e quantificate nell'elaborato "BLTX-NS-RC6_Computo metrico estimativo opere civili".

DISEGNI DI RIFERIMENTO

TAVOLA	DESCRIZIONE
BLTX-NS-TC8	Viabilità e piazzole - Planimetria di progetto - Fase di cantiere
BLTX-NS-TC11	Profili longitudinali viabilità di impianto
BLTX-NS-TC13	Piazzole aerogeneratori e strade di servizio - Particolari costruttivi
BLTX-NS-TC14	Opere di regimazione acque superficiali - Planimetria generale

Sezione: 4
 Progressiva: 20.000
 Q. Progetto: 111.318

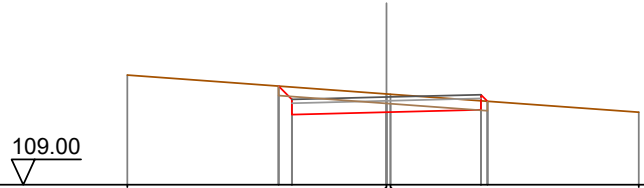

Quote Terreno		111.90		111.40		110.92
Quote Progetto			111.61 110.86		110.92 111.39	
Parziali			0.35 2.50		2.50	
Progressiva			-2.85 -2.50		0.00	2.50 2.67
Dislivelli			0.00 -0.33		-0.48	-0.24 0.00

Sezione: 5
 Progressiva: 30.000
 Q. Progetto: 111.325

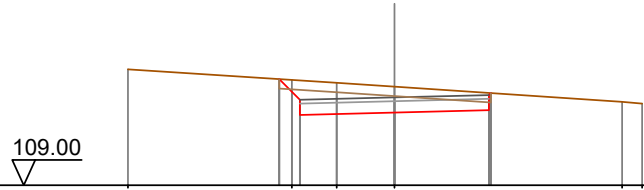

Quote Terreno		112.07		111.61		111.21
Quote Progetto			111.81 110.86		110.92 111.44	
Parziali			0.55 2.50		2.50	
Progressiva			-3.05 -2.50		0.00	2.50 2.55
Dislivelli			0.00 -0.51		-0.69	-0.46 -0.00

Sezione: 6
 Progressiva: 40.000
 Q. Progetto: 111.531

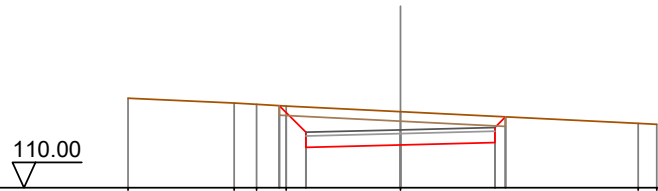

Quote Terreno	112.37	112.24	112.21	112.16	112.01	111.70	111.68
Quote Progetto			112.17	111.07	111.13	111.19	111.87
Parziali			0.70	2.50	2.50	0.28	
Progressiva			-3.20	-2.50	0.00	2.50	2.78
Dislivelli			0.00	-0.67	-0.88	-0.69	0.00

Sezione: 7
 Progressiva: 43.132
 Q. Progetto: 111.637

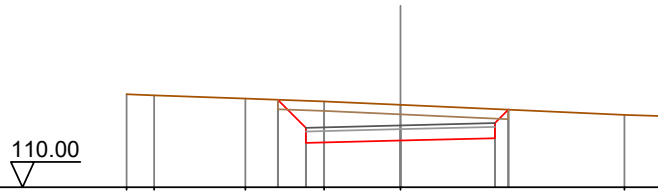

Quote Terreno	112.46	112.43	112.34	112.27	112.18	111.91	111.89
Quote Progetto			112.31	111.17	111.24	111.30	112.05
Parziali			0.74	2.50	2.50	0.35	
Progressiva			-3.24	-2.50	0.00	2.50	2.85
Dislivelli			-0.00	-0.72	-0.94	-0.77	0.00

Sezione: 8
 Progressiva: 50.000
 Q. Progetto: 111.937

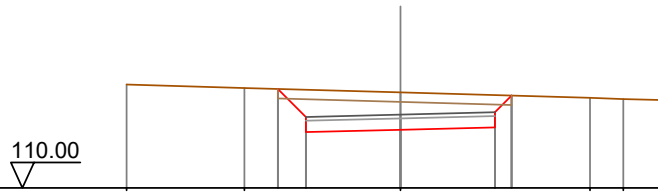

Quote Terreno	112.73	112.64	112.62	112.52	112.38	112.35	112.32
Quote Progetto			112.62	111.47	111.54	111.60	112.44
Parziali			0.74	2.50	2.50	0.44	
Progressiva			-3.24	-2.50	0.00	2.50	2.94
Dislivelli			0.00	-0.72	-0.99	-0.85	0.00

Sezione: 9
 Progressiva: 60.000
 Q. Progetto: 112.512

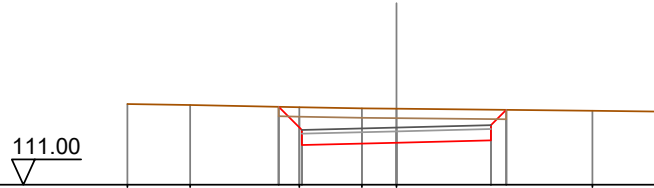

Quote Terreno		113.13		113.11		113.05		113.02		113.01		112.96		112.93
Quote Progetto						113.06		112.05		112.11		112.17		112.98
Parziali						0.61		2.50		2.50		0.41		112.98
Progressiva						-3.11		-2.50		0.00		2.50		2.91
Dislivelli						0.00		-0.80		-0.90		-0.81		-0.00

Sezione: 10
 Progressiva: 70.000
 Q. Progetto: 113.065

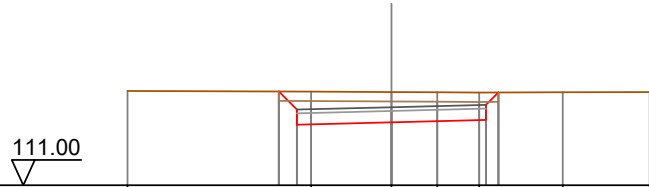

Quote Terreno		113.50				113.48		113.47		113.46		113.45		113.46
Quote Progetto						113.48		112.67		113.46		112.73		113.46
Parziali						0.48		2.50		2.50		0.33		113.46
Progressiva						-2.98		-2.50		0.00		2.50		2.83
Dislivelli						0.00		-0.48		-0.80		-0.73		0.00

Sezione: 10
 Progressiva: 70.000
 Q. Progetto: 113.065

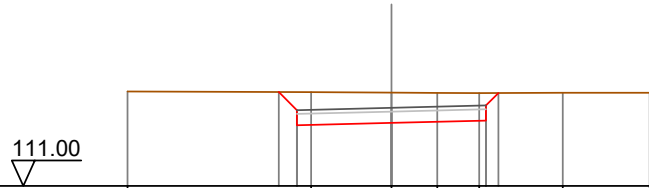

Quote Terreno		113.50				113.48		113.47		113.46		113.45		113.46
Quote Progetto						113.48		112.67		113.46		112.73		113.46
Parziali						0.48		2.50		2.50		0.33		113.46
Progressiva						-2.98		-2.50		0.00		2.50		2.83
Dislivelli						0.00		-0.48		-0.80		-0.73		0.00

Sezione: 11
 Progressiva: 80.000
 Q. Progetto: 113.559

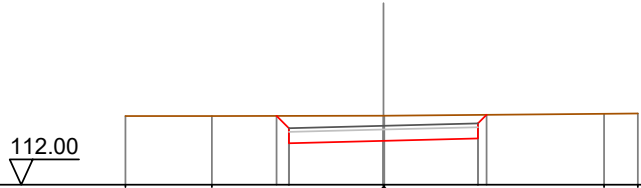

Quote Terreno	113.82	113.82		113.83	113.83		113.87	113.88
Quote Progetto			113.82	113.10	113.16	113.22	113.85	
Parziali			0.32	2.50	2.50			
Progressiva			-2.82	-2.50	0.00	2.50	2.73	
Dislivelli			0.00	-0.32	-0.67	-0.63	0.00	

Sezione: 12
 Progressiva: 85.674
 Q. Progetto: 113.813

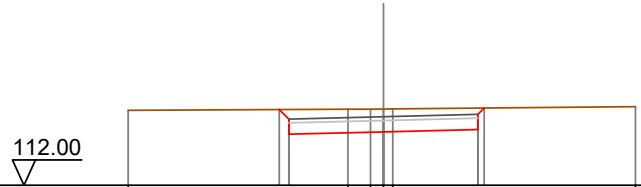

Quote Terreno	113.98			114.01	114.02	114.02		114.08
Quote Progetto			114.00	113.35	113.41	113.48	114.04	
Parziali			2.50	2.50				
Progressiva			-2.75	-2.50	0.00	2.50	2.67	
Dislivelli			-0.00	-0.25	-0.60	-0.56	0.00	

Sezione: 13
 Progressiva: 100.000
 Q. Progetto: 114.370

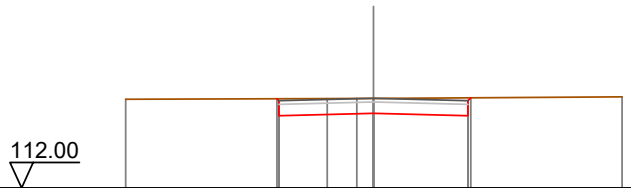

Quote Terreno	114.34			114.36	114.36	114.37		114.41
Quote Progetto			114.36	113.91	113.97	113.91	114.38	
Parziali			2.50	2.50				
Progressiva			-2.55	-2.50	0.00	2.50	2.57	
Dislivelli			-0.00	-0.05	-0.40	-0.47	-0.00	

Sezione: 14
 Progressiva: 120.000
 Q. Progetto: 114.944

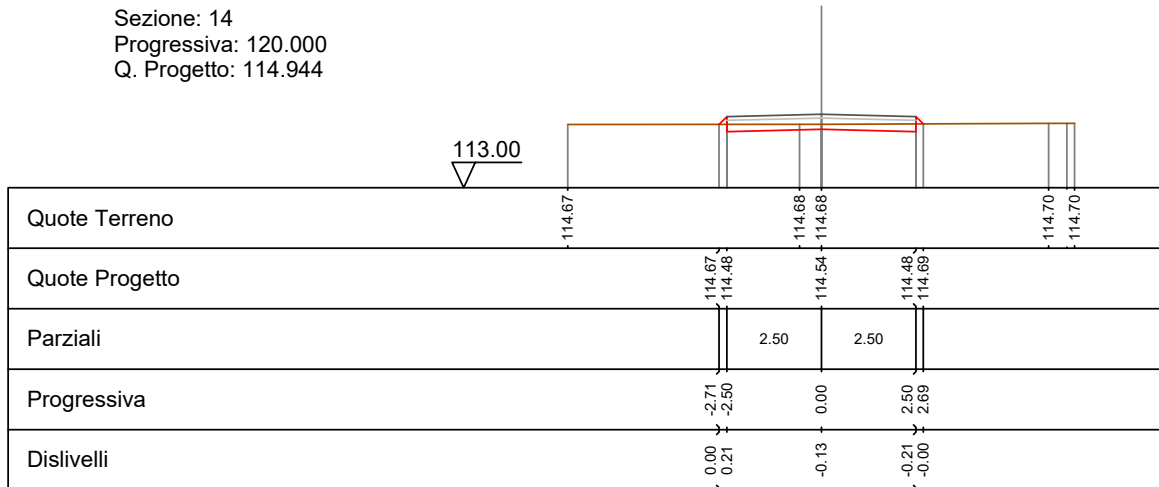

Sezione: 15
 Progressiva: 140.000
 Q. Progetto: 115.281

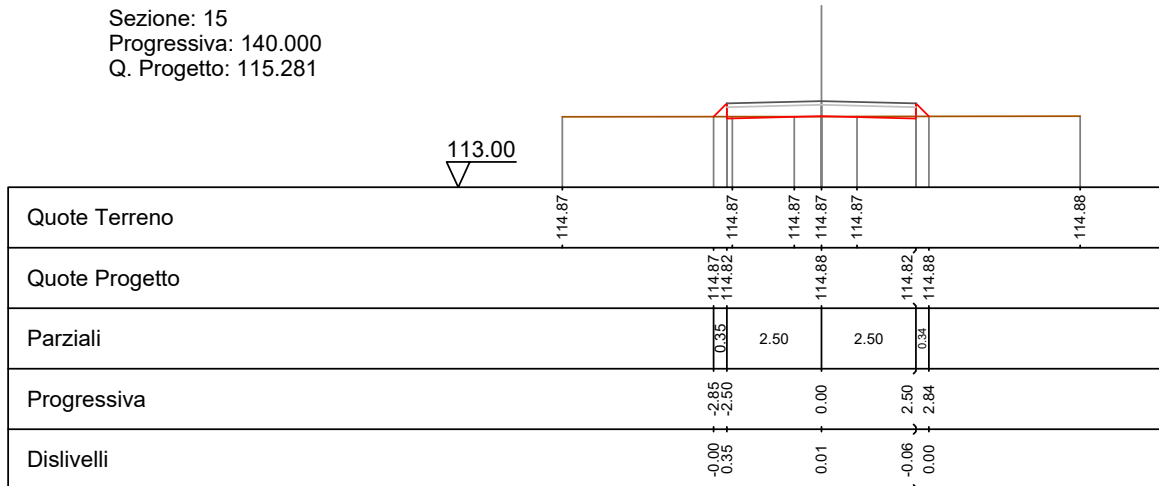

Sezione: 16
 Progressiva: 142.266
 Q. Progetto: 115.304

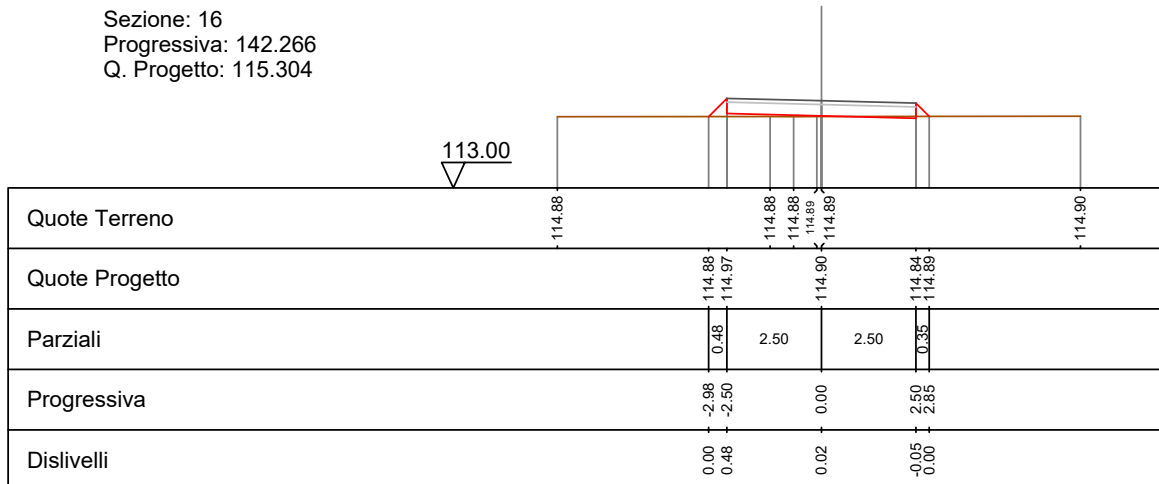

Sezione: 17
 Progressiva: 146.355
 Q. Progetto: 115.338

113.00

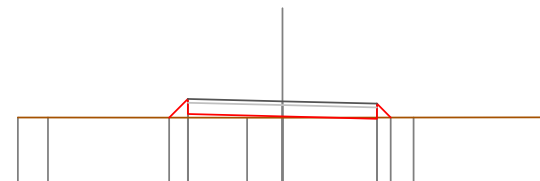

Quote Terreno	-114.91	-114.91	-114.91	-114.91	-114.91	-114.92
Quote Progetto		114.91	115.00	114.94	114.88	114.91
Parziali		0.49	2.50	2.50	0.37	
Progressiva		-2.99	-2.50	0.00	2.50	2.87
Dislivelli		0.00	0.49	0.03	-0.03	0.00

Sezione: 18
 Progressiva: 150.000
 Q. Progetto: 115.352

113.00

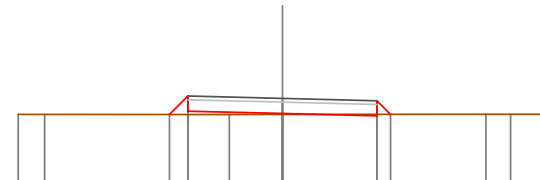

Quote Terreno	-114.93	-114.93	-114.93	-114.93	-114.93	-114.93
Quote Progetto		114.93	115.01	114.95	114.89	114.93
Parziali		0.49	2.50	2.50	0.36	
Progressiva		-2.99	-2.50	0.00	2.50	2.86
Dislivelli		0.00	0.49	0.03	-0.04	0.00

Sezione: 19
 Progressiva: 150.444
 Q. Progetto: 115.352

113.00

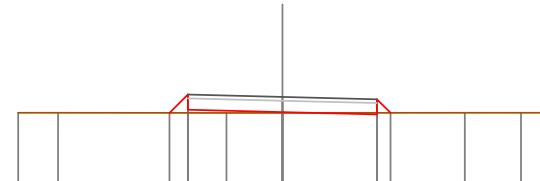

Quote Terreno	-114.93	-114.93	-114.93	-114.93	-114.93	-114.93
Quote Progetto		114.93	115.01	114.95	114.89	114.93
Parziali		0.49	2.50	2.50	0.36	
Progressiva		-2.99	-2.50	0.00	2.50	2.86
Dislivelli		-0.00	0.49	0.02	-0.04	-0.00

Sezione: 20
 Progressiva: 160.000
 Q. Progetto: 115.353

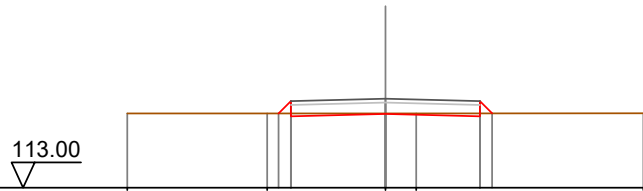

Quote Terreno	114.97	114.96	114.97	114.97	114.97
Quote Progetto		114.96 114.89	114.95	114.89 114.97	
Parziali		0.33 2.50	2.50	0.32	
Progressiva		-2.83 -2.50	0.00	2.50 2.82	
Dislivelli		0.00 0.33	-0.01	-0.08 0.00	

Sezione: 21
 Progressiva: 180.000
 Q. Progetto: 115.355

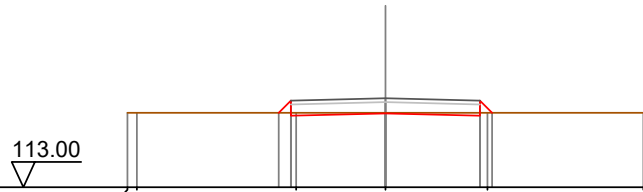

Quote Terreno	114.97	114.97	114.97	114.97	114.97
Quote Progetto		114.97 114.89	114.95	114.89 114.97	
Parziali		0.32 2.50	2.50	0.32	
Progressiva		-2.82 -2.50	0.00	2.50 2.82	
Dislivelli		-0.00 0.32	-0.02	-0.08 -0.00	

Sezione: 22
 Progressiva: 180.979
 Q. Progetto: 115.355

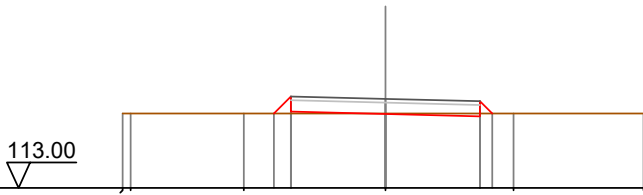

Quote Terreno	114.97	114.97	114.97	114.97	114.97
Quote Progetto		114.97 115.02	114.95	114.89 114.97	
Parziali		0.45 2.50	2.50	0.32	
Progressiva		-2.95 -2.50	0.00	2.50 2.82	
Dislivelli		0.00 0.45	-0.01	-0.08 -0.00	

Sezione: 23
 Progressiva: 183.303
 Q. Progetto: 115.355

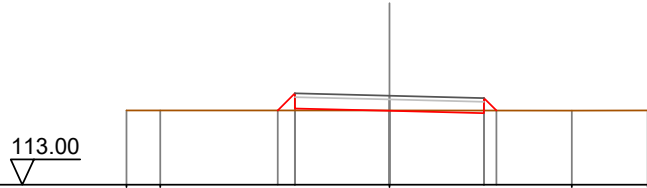

Quote Terreno	-114.96	-114.96	-114.96	-114.96	-114.96	-114.96
Quote Progetto			114.96 115.02	114.95 114.96	114.89 114.96	
Parziali			0.45	2.50	2.50	0.33
Progressiva			-2.95 -2.50	0.00	2.50 2.83	
Dislivelli			-0.00 0.45	-0.01	-0.07 0.00	

Sezione: 24
 Progressiva: 185.628
 Q. Progetto: 115.355

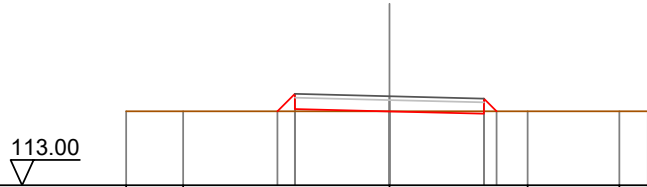

Quote Terreno	-114.96	-114.96	-114.96	-114.96	-114.96	-114.96
Quote Progetto			114.96 115.02	114.96 114.96	114.89 114.96	
Parziali			0.46	2.50	2.50	0.33
Progressiva			-2.96 -2.50	0.00	2.50 2.83	
Dislivelli			-0.00 0.46	-0.00	-0.07 0.00	

Sezione: 25
 Progressiva: 200.000
 Q. Progetto: 115.341

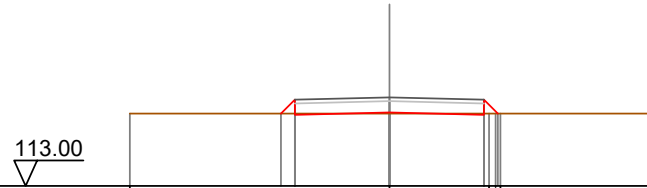

Quote Terreno	-114.91	-114.91	-114.91	-114.91	-114.91	-114.91
Quote Progetto			114.91 114.88	114.94 114.91	114.88 114.91	
Parziali			0.37	2.50	2.50	0.37
Progressiva			-2.87 -2.50	0.00	2.50 2.87	
Dislivelli			-0.00 0.37	0.03	-0.03 0.00	

Sezione: 26
 Progressiva: 220.000
 Q. Progetto: 115.205

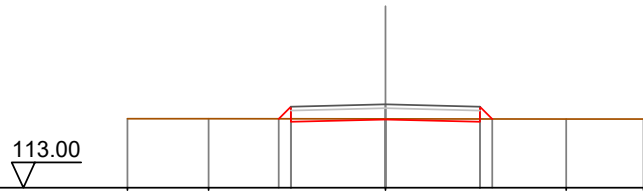

Quote Terreno	114.82	114.82	114.82	114.82	114.82	114.82
Quote Progetto		114.82	114.81	114.82	114.74	114.82
Parziali		0.32	2.50	2.50	0.33	
Progressiva		-2.82	0.00	0.00	2.50	2.83
Dislivelli		0.00	-0.01	-0.01	-0.07	0.00

Sezione: 27
 Progressiva: 240.000
 Q. Progetto: 115.069

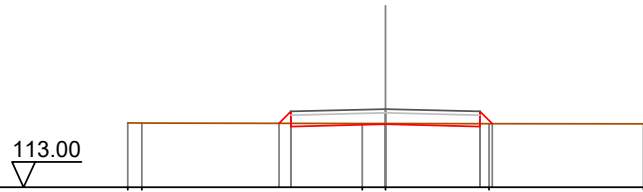

Quote Terreno	114.70	114.70	114.69	114.69	114.68	114.68
Quote Progetto		114.69	114.67	114.69	114.61	114.68
Parziali		0.31	2.50	2.50	0.33	
Progressiva		-2.81	0.00	0.00	2.50	2.83
Dislivelli		-0.00	-0.02	-0.02	-0.08	0.00

Sezione: 28
 Progressiva: 243.951
 Q. Progetto: 115.043

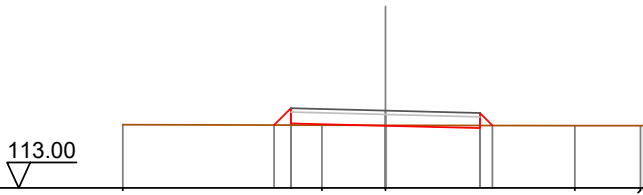

Quote Terreno	114.67	114.66	114.66	114.66	114.65	114.65
Quote Progetto		114.66	114.64	114.66	114.58	114.65
Parziali		0.44	2.50	2.50	0.33	
Progressiva		-2.94	0.00	0.00	2.50	2.83
Dislivelli		0.00	-0.01	-0.01	-0.07	-0.00

Sezione: 29
 Progressiva: 246.075
 Q. Progetto: 115.028

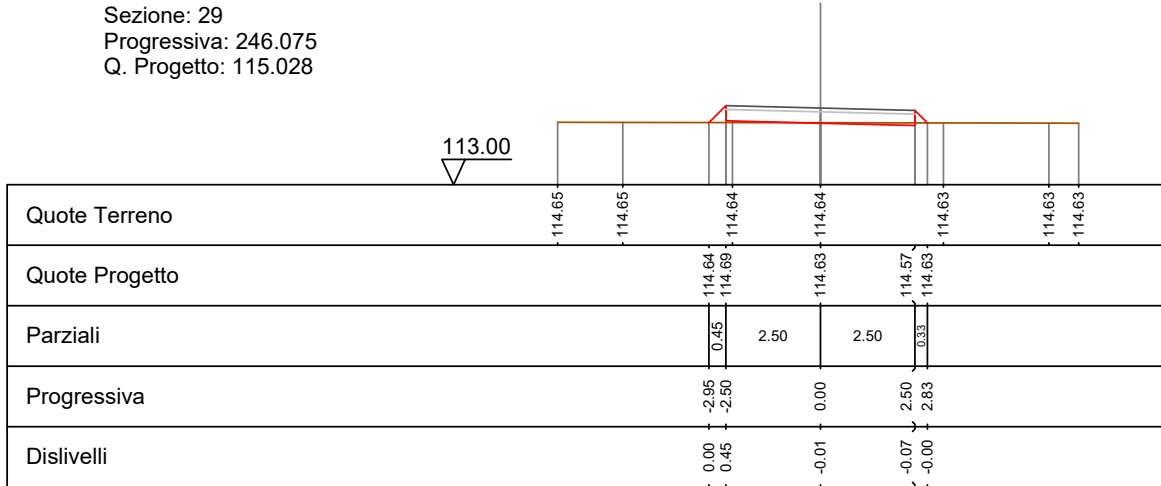

Sezione: 30
 Progressiva: 248.198
 Q. Progetto: 115.014

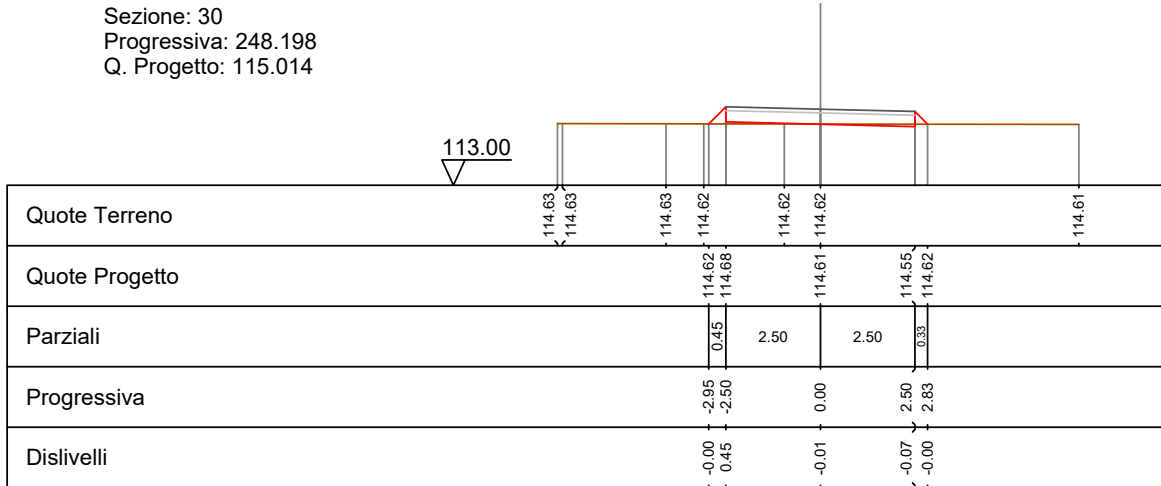

Sezione: 31
 Progressiva: 260.000
 Q. Progetto: 114.926

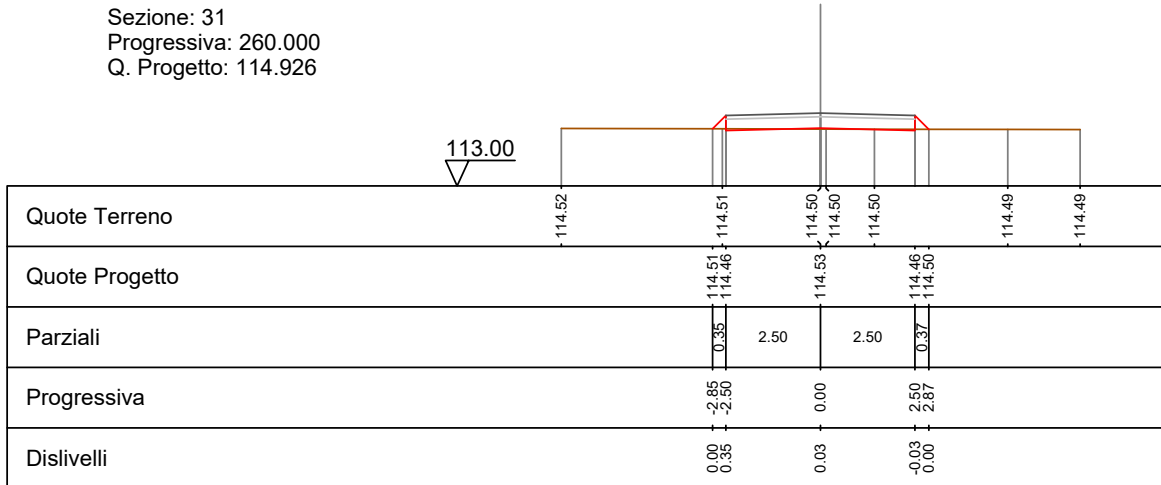

Sezione: 32
 Progressiva: 280.000
 Q. Progetto: 114.634

113.00

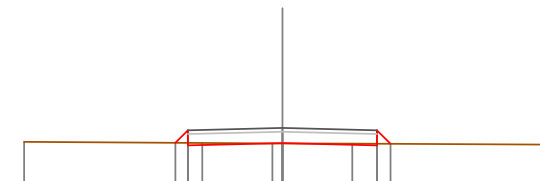

Quote Terreno	114.26	114.24	114.23	114.22	114.19
Quote Progetto		114.24	114.23	114.17	
Parziali		0.33	2.50	2.50	0.36
Progressiva		-2.83	-2.50	0.00	2.50
Dislivelli		-0.00	0.33	0.01	-0.04

Sezione: 33
 Progressiva: 289.685
 Q. Progetto: 114.452

112.00

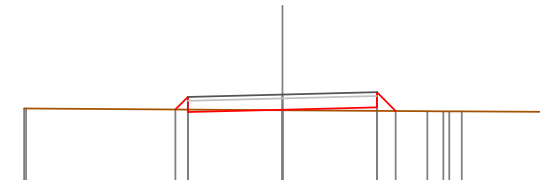

Quote Terreno	114.08	114.06	114.04	114.01	114.00
Quote Progetto		114.06	114.05	114.11	
Parziali		0.33	2.50	2.50	0.50
Progressiva		-2.83	-2.50	0.00	2.50
Dislivelli		-0.00	0.33	0.01	0.09

Sezione: 34
 Progressiva: 290.000
 Q. Progetto: 114.443

112.00

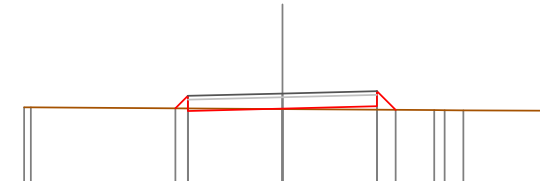

Quote Terreno	114.08	114.05	114.03	114.00	113.99
Quote Progetto		114.05	114.04	114.11	
Parziali		0.33	2.50	2.50	0.50
Progressiva		-2.83	-2.50	0.00	2.50
Dislivelli		-0.00	0.33	0.01	0.09

Sezione: 35
 Progressiva: 294.915
 Q. Progetto: 114.287

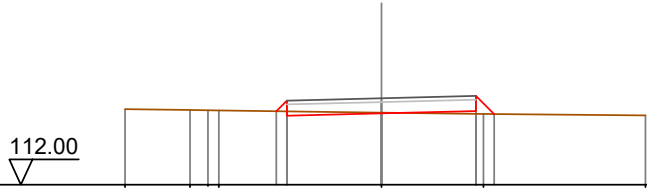

Quote Terreno	114.00	113.98	113.96			113.91		113.87	113.83
Quote Progetto				113.94	113.82	113.89	113.91	113.95	113.87
Parziali				0.28	2.50	2.50		0.48	
Progressiva				-2.78	-2.50	0.00		2.50	2.98
Dislivelli				-0.00	0.28	-0.02		0.08	0.00

Sezione: 36
 Progressiva: 300.146
 Q. Progetto: 114.114

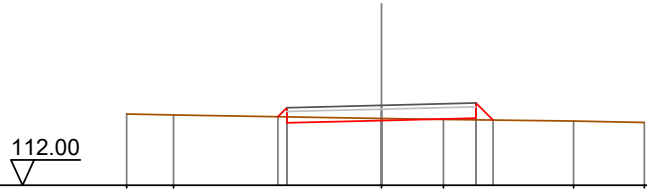

Quote Terreno	113.89	113.86				113.77		113.74	113.70	113.66
Quote Progetto				113.81	113.65	113.71	113.77	113.78	113.72	
Parziali				2.50	2.50			0.45		
Progressiva				-2.74	-2.50	0.00		2.50	2.95	
Dislivelli				-0.00	0.24	-0.05		0.05	-0.00	

Sezione: 37
 Progressiva: 320.000
 Q. Progetto: 113.485

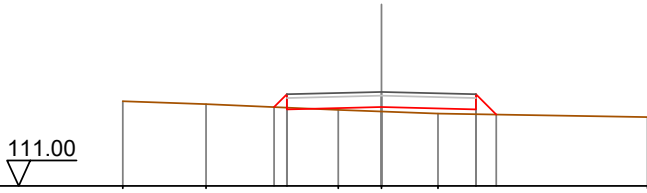

Quote Terreno	113.24	113.16				113.01	112.97	112.91		112.82
Quote Progetto				113.08	113.02	113.09	112.97	113.02	112.89	
Parziali				0.34	2.50	2.50		0.54		
Progressiva				-2.84	-2.50	0.00		2.50	3.04	
Dislivelli				0.00	0.35	-0.12		0.13	0.00	

Sezione: 38
 Progressiva: 334.659
 Q. Progetto: 113.371

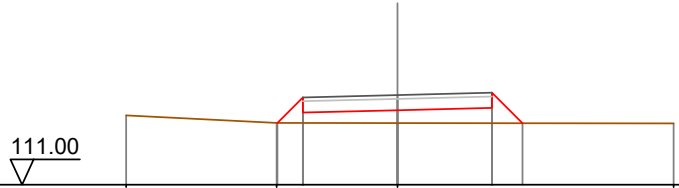

Quote Terreno	112.84	112.64	112.63	113.03	112.62
Quote Progetto		112.64	112.97	113.03	112.63
Parziali		0.67	2.50	2.50	0.81
Progressiva		-3.17	-2.50	0.00	2.50
Dislivelli		0.00	0.67	0.34	0.40

Sezione: 39
 Progressiva: 340.000
 Q. Progetto: 113.436

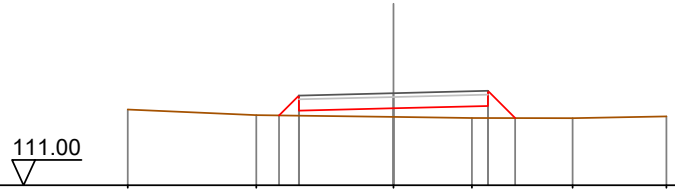

Quote Terreno	113.00	112.86	112.81	112.78	112.78	112.82
Quote Progetto		112.85	113.04	113.10	112.78	
Parziali		0.53	2.50	2.50	0.72	
Progressiva		-3.03	-2.50	0.00	2.50	3.22
Dislivelli		0.00	0.53	0.23	0.32	0.00

Sezione: 40
 Progressiva: 342.454
 Q. Progetto: 113.485

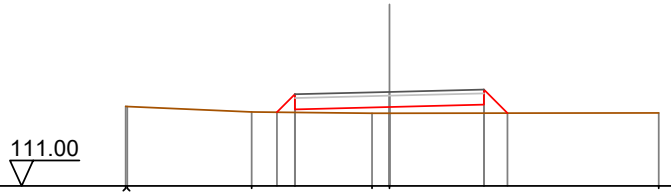

Quote Terreno	113.10	112.96	112.92	113.15	112.93
Quote Progetto	113.10	112.95	113.08	113.15	112.93
Parziali		0.47	2.50	2.50	0.62
Progressiva		-2.97	-2.50	0.00	2.50
Dislivelli		0.00	0.48	0.16	0.22

Sezione: 41
 Progressiva: 350.000
 Q. Progetto: 113.689

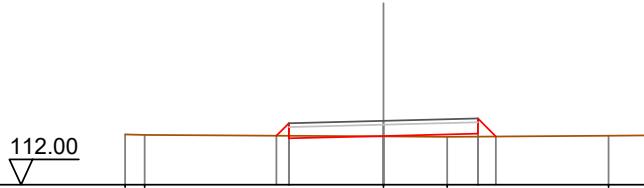

Quote Terreno	113.33	113.32		113.29	113.31
Quote Progetto			113.30	113.23	113.28
Parziali			0.33	2.50	2.50
Progressiva			-2.83	-2.50	0.00
Dislivelli			0.00	0.33	0.01

Sezione: 42
 Progressiva: 350.250
 Q. Progetto: 113.696

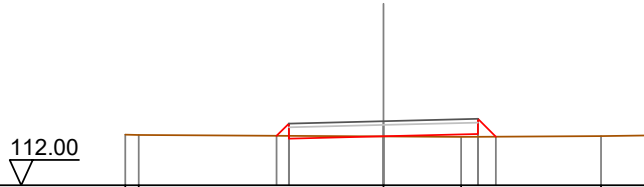

Quote Terreno	113.34	113.33		113.29	113.28	113.30	113.32
Quote Progetto			113.31	113.23	113.30	113.36	113.29
Parziali			0.33	2.50	2.50	0.47	
Progressiva			-2.83	-2.50	0.00	2.50	2.97
Dislivelli			0.00	0.33	0.00	0.08	0.00

Sezione: 43
 Progressiva: 360.000
 Q. Progetto: 113.969

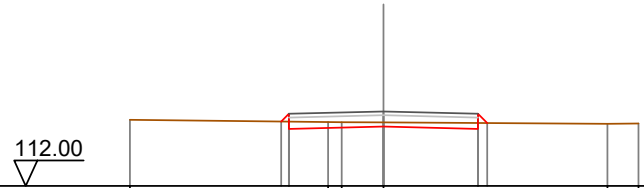

Quote Terreno	113.75		113.69	113.69	113.68		113.64	113.65
Quote Progetto		113.70	113.51		113.57		113.51	113.66
Parziali			2.50		2.50			
Progressiva		-2.70	-2.50		0.00		2.50	2.74
Dislivelli		-0.00	0.21		-0.11		-0.16	-0.00

Sezione: 44
 Progressiva: 380.000
 Q. Progetto: 114.530

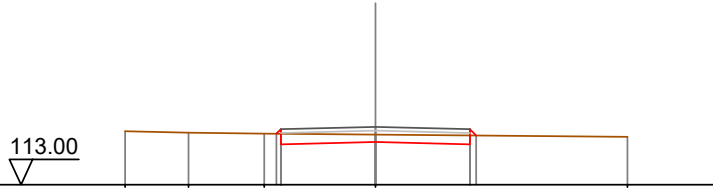

Quote Terreno	-114.41	-114.37	-114.35	-114.33	-114.26
Quote Progetto			114.35 114.07	114.13	114.07 114.30
Parziali			2.50	2.50	
Progressiva			-2.62 -2.50	0.00	2.50 2.67
Dislivelli			-0.00 0.12	-0.20	-0.24 0.00

Sezione: 45
 Progressiva: 400.000
 Q. Progetto: 115.091

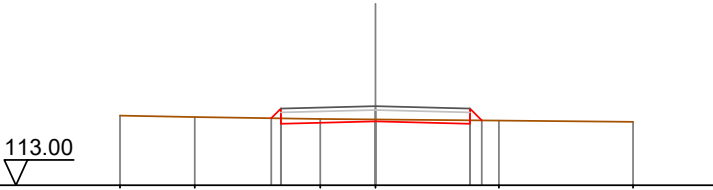

Quote Terreno	-114.84	-114.81	-114.75	-114.74	-114.71	-114.68
Quote Progetto			114.77 114.63	114.69	114.63 114.72	
Parziali			2.50	2.50	0.31	
Progressiva			-2.75 -2.50	0.00	2.50 2.81	
Dislivelli			-0.00 0.26	-0.05	-0.09 0.00	

Sezione: 46
 Progressiva: 420.000
 Q. Progetto: 115.381

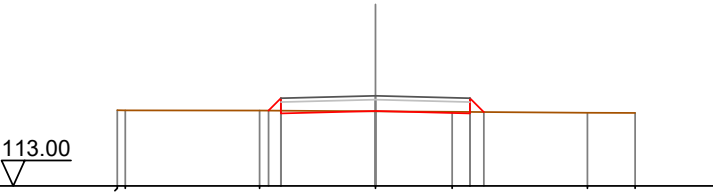

Quote Terreno	-115.00 -115.00	-114.99	-114.97	-114.96	-114.94	-114.93
Quote Progetto		114.99 114.92	114.98	114.92 114.95		
Parziali		0.33	2.50	2.50	0.37	
Progressiva		-2.83 -2.50	0.00	2.50 2.87		
Dislivelli		0.00 0.33	0.01	-0.04 0.00		

Sezione: 47
 Progressiva: 440.000
 Q. Progetto: 115.433

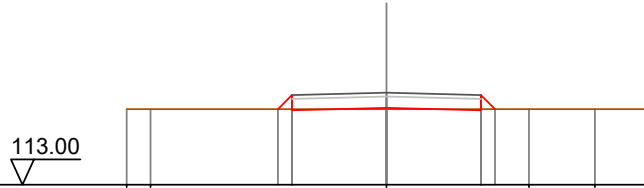

Quote Terreno	115.00	115.00		115.00	115.00	115.00	115.00	115.00
Quote Progetto			115.00	115.03	115.00	114.97	115.00	115.00
Parziali			0.37	2.50	2.50	0.37		
Progressiva			-2.87	0.00	0.00	2.50	2.87	
Dislivelli			0.00	0.03	0.00	-0.03	0.00	

Sezione: 48
 Progressiva: 460.000
 Q. Progetto: 115.500

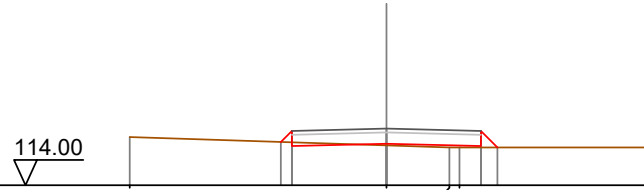

Quote Terreno	115.28			115.06	115.00	115.00	115.00	115.00
Quote Progetto			115.15	115.10	115.04	115.04	115.00	
Parziali			0.28	2.50	2.50	0.44		
Progressiva			-2.79	0.00	0.00	2.50	2.94	
Dislivelli			-0.00	0.04	0.00	0.04	0.00	

Sezione: 49
 Progressiva: 461.108
 Q. Progetto: 115.512

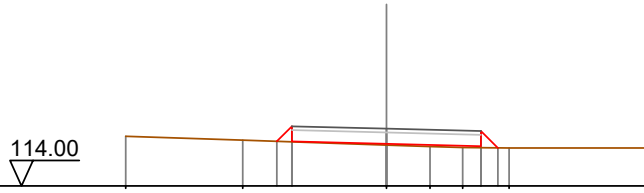

Quote Terreno	115.31	115.21		115.08	115.04	115.01	115.00	115.00
Quote Progetto			115.18	115.11	115.05	115.00	115.00	
Parziali			0.40	2.50	2.50	0.45		
Progressiva			-2.90	0.00	0.00	2.50	2.95	
Dislivelli			0.00	0.03	0.00	0.04	-0.00	

Sezione: 50
 Progressiva: 465.162
 Q. Progetto: 115.573

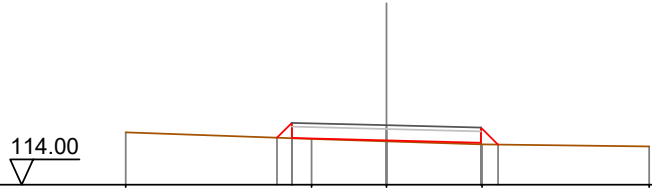

Quote Terreno	115.39	115.24	115.21	115.15	115.07	115.01
Quote Progetto		115.24	115.24	115.17	115.11	115.06
Parziali		0.38	2.50	2.50	0.45	
Progressiva		-2.89	-2.50	0.00	2.50	2.95
Dislivelli		0.00	0.41	0.03	0.04	0.00

Sezione: 51
 Progressiva: 469.216
 Q. Progetto: 115.637

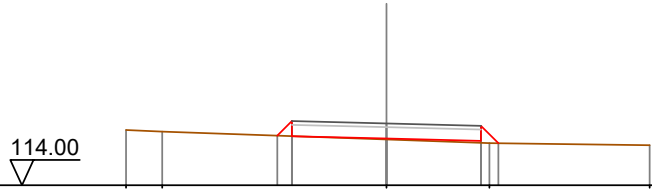

Quote Terreno	115.46	115.42	115.31	115.21	115.12	115.06
Quote Progetto			115.31	115.24	115.17	115.11
Parziali			0.38	2.50	2.50	0.46
Progressiva			-2.88	-2.50	0.00	2.50
Dislivelli			-0.00	0.40	0.02	0.05
						0.00

Sezione: 52
 Progressiva: 480.000
 Q. Progetto: 115.805

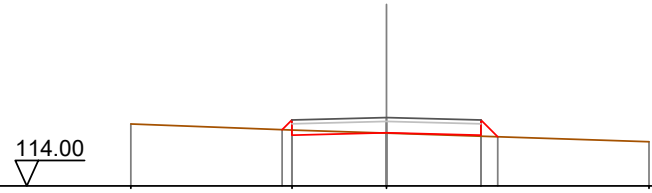

Quote Terreno	115.64	115.48	115.39	115.34	115.30	115.17
Quote Progetto		115.49	115.41	115.34	115.30	
Parziali			2.50	2.50	0.44	
Progressiva		-2.76	-2.50	0.00	2.50	2.94
Dislivelli		0.00	0.27	0.01	0.03	-0.00

Sezione: 53
 Progressiva: 500.000
 Q. Progetto: 116.118



Quote Terreno	115.94		115.70		115.50	115.46
Quote Progetto		115.80	115.72	115.66	115.60	
Parziali		2.50	2.50	0.46		
Progressiva		-2.75	0.00	2.50	2.96	
Dislivelli		-0.00	0.01	0.04	0.00	

Sezione: 54
 Progressiva: 504.800
 Q. Progetto: 116.193

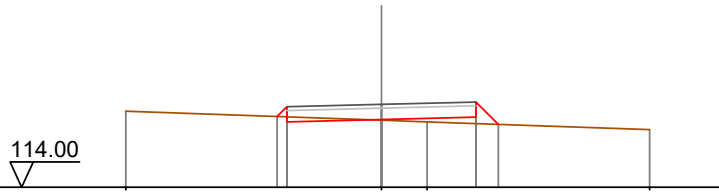

Quote Terreno	116.01		115.77		115.73	115.53
Quote Progetto		115.87	115.79	115.66	115.66	
Parziali		2.50	2.50	0.59		
Progressiva		-2.76	0.00	2.50	3.09	
Dislivelli		0.00	0.02	0.17	0.00	

Sezione: 55
 Progressiva: 510.000
 Q. Progetto: 116.275

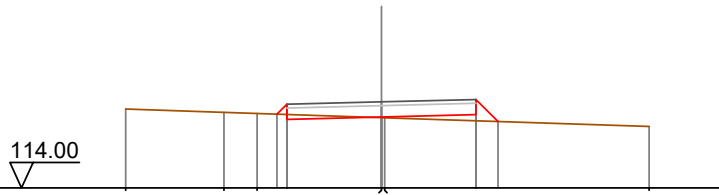

Quote Terreno	116.09	116.00	115.97	115.86	115.85	115.62
Quote Progetto		115.95	115.87	115.87	115.94	115.76
Parziali		2.50	2.50	0.58		
Progressiva		-2.76	0.00	2.50	3.08	
Dislivelli		0.00	0.02	0.16	0.00	

Sezione: 56
 Progressiva: 514.975
 Q. Progetto: 116.376

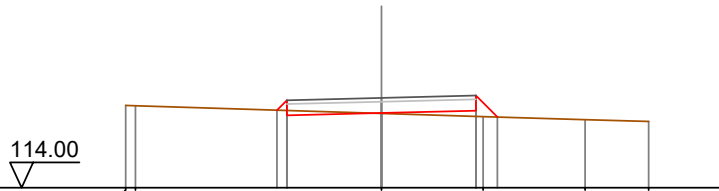

Quote Terreno	116.18	116.17								
Quote Progetto			116.05	115.91		115.98	115.97	116.04	115.88	
Parziali			0.28	2.50		2.50		0.57		
Progressiva			-2.76	-2.50		0.00		2.50	3.07	
Dislivelli			0.00	0.27		0.01		0.15	0.00	

Sezione: 57
 Progressiva: 520.000
 Q. Progetto: 116.528

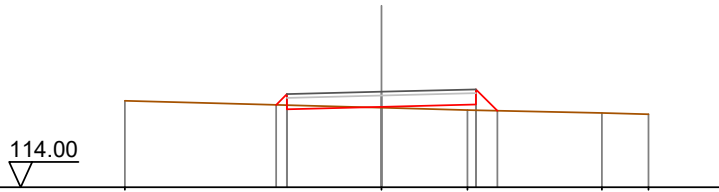

Quote Terreno	116.29									
Quote Progetto			116.18	116.07		116.13	116.10	116.04	116.03	
Parziali			0.29	2.50		2.50		0.56		
Progressiva			-2.79	-2.50		0.00		2.50	3.06	
Dislivelli			-0.00	0.29		0.02		0.15	-0.00	

Sezione: 58
 Progressiva: 525.149
 Q. Progetto: 116.706

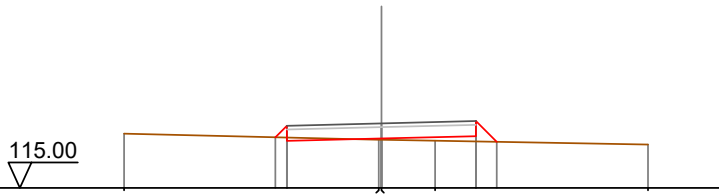

Quote Terreno	116.43									
Quote Progetto			116.34	116.24		116.31	116.27	116.25	116.22	
Parziali			0.31	2.50		2.50		0.55		
Progressiva			-2.81	-2.50		0.00		2.50	3.05	
Dislivelli			0.00	0.31		0.03		0.14	-0.00	

Sezione: 59
 Progressiva: 540.000
 Q. Progetto: 117.219

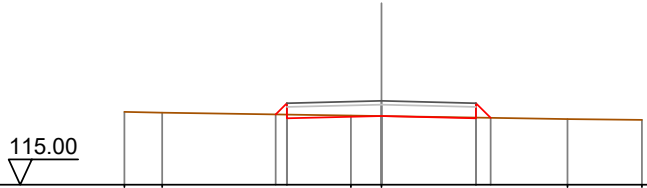

Quote Terreno	116.92	116.90		116.83	116.82		116.74	116.71
Quote Progetto			116.86	116.76	116.82	116.76	116.77	
Parziali			0.30	2.50	2.50	0.30		
Progressiva			-2.80	-2.50	0.00	2.50	2.89	
Dislivelli			0.00	0.30	0.00	-0.02	0.00	

Sezione: 60
 Progressiva: 560.000
 Q. Progetto: 117.910

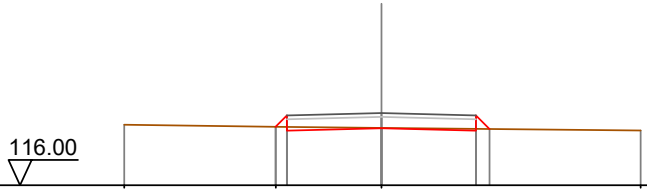

Quote Terreno	117.60		117.55		117.52			117.45
Quote Progetto			117.55	117.45	117.51	117.45	117.49	
Parziali			0.30	2.50	2.50	0.30		
Progressiva			-2.80	-2.50	0.00	2.50	2.86	
Dislivelli			-0.00	0.30	-0.01	-0.05	-0.00	

Sezione: 61
 Progressiva: 580.000
 Q. Progetto: 118.588

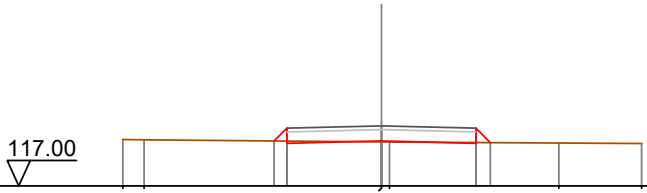

Quote Terreno	118.23	118.22		118.16	118.16		118.13	118.12
Quote Progetto			118.19	118.13	118.19	118.13	118.14	
Parziali			0.34	2.50	2.50	0.30		
Progressiva			-2.84	-2.50	0.00	2.50	2.88	
Dislivelli			0.00	0.34	0.03	-0.02	0.00	

Sezione: 62
 Progressiva: 591.974
 Q. Progetto: 118.950

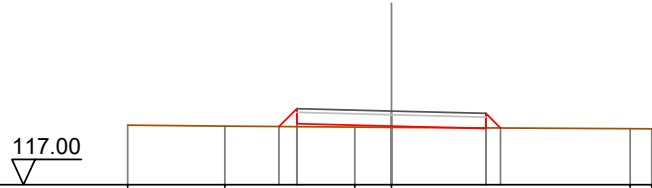

Quote Terreno	118.57	118.55	118.54	118.52	118.52	118.48	118.48
Quote Progetto			118.54	118.55	118.55	118.49	118.50
Parziali			0.47	2.50	2.50	0.39	
Progressiva			-2.97	-2.50	0.00	2.50	2.89
Dislivelli			0.00	0.48	0.03	-0.02	0.00

Sezione: 63
 Progressiva: 598.348
 Q. Progetto: 119.126

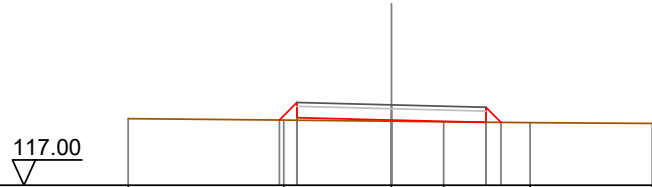

Quote Terreno	118.76	118.72	118.73	118.69	118.68	118.66	118.64
Quote Progetto			118.73	118.73	118.66	118.66	
Parziali			0.46	2.50	2.50	0.40	
Progressiva			-2.96	-2.50	0.00	2.50	2.90
Dislivelli			0.00	0.47	0.03	-0.00	0.00

Sezione: 64
 Progressiva: 600.000
 Q. Progetto: 119.170

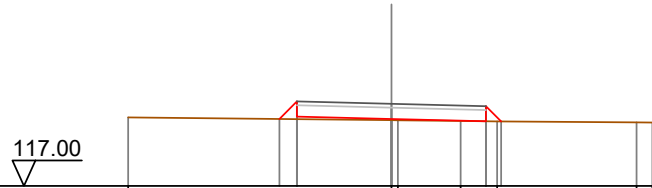

Quote Terreno	118.81	118.77	118.74	118.72	118.71	118.68	118.68
Quote Progetto		118.77	118.77	118.71	118.71		
Parziali			0.46	2.50	2.50	0.40	
Progressiva			-2.96	-2.50	0.00	2.50	2.90
Dislivelli			-0.00	0.47	0.03	-0.00	-0.00

Sezione: 65
 Progressiva: 604.722
 Q. Progetto: 119.291

117.00

Quote Terreno	118.94		118.85	118.82	118.78
Quote Progetto		118.89	118.89	118.83	
Parziali		0.47	2.50	2.50	0.41
Progressiva		-2.97	-2.50	0.00	2.50
Dislivelli		0.00	0.47	0.04	0.01

Sezione: 66
 Progressiva: 620.000
 Q. Progetto: 119.640

118.00

Quote Terreno	119.27	119.26	119.20	119.19	119.15	119.14
Quote Progetto		119.23	119.24	119.18	119.17	
Parziali		0.35	2.50	2.50	0.41	
Progressiva		-2.85	-2.50	0.00	2.50	2.91
Dislivelli		0.00	0.36	0.04	0.00	0.00

Sezione: 67
 Progressiva: 640.000
 Q. Progetto: 120.000

118.00

Quote Terreno	119.64		119.60	119.57	119.56
Quote Progetto		119.61	119.60	119.54	
Parziali		0.32	2.50	2.50	0.36
Progressiva		-2.82	-2.50	0.00	2.50
Dislivelli		0.00	0.33	0.01	-0.04

Sezione: 68
 Progressiva: 640.342
 Q. Progetto: 120.005

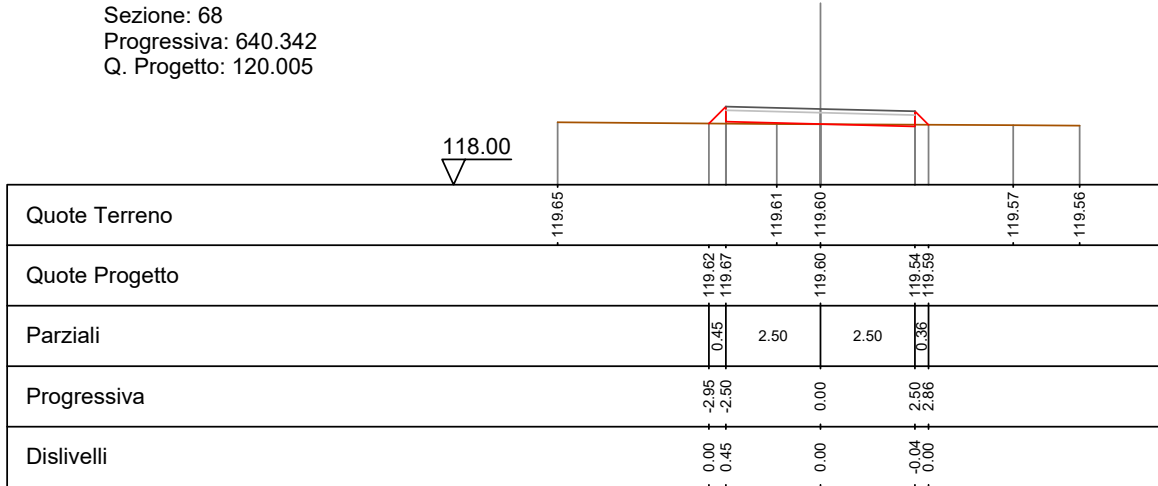

Sezione: 69
 Progressiva: 643.186
 Q. Progetto: 120.047

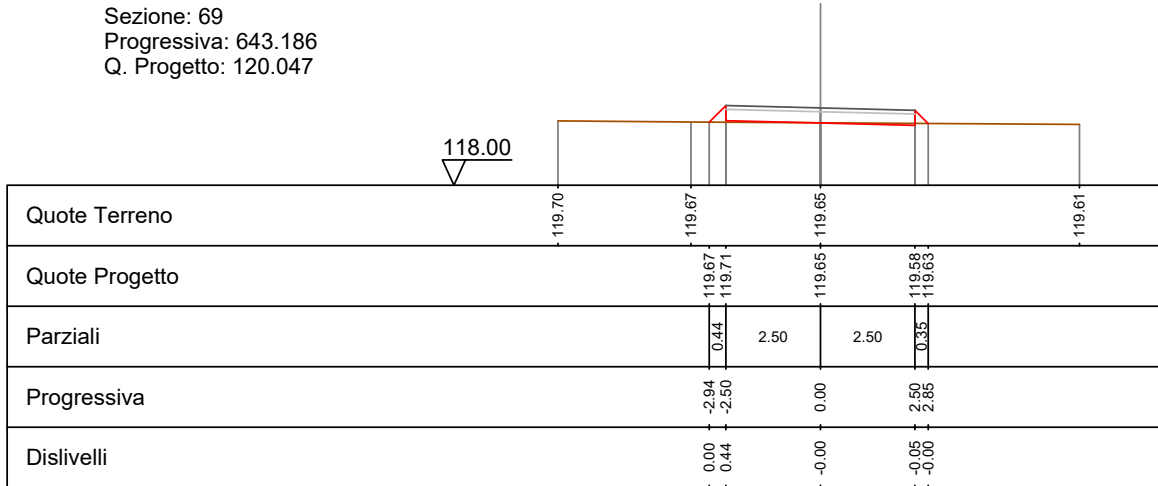

Sezione: 70
 Progressiva: 646.030
 Q. Progetto: 120.086

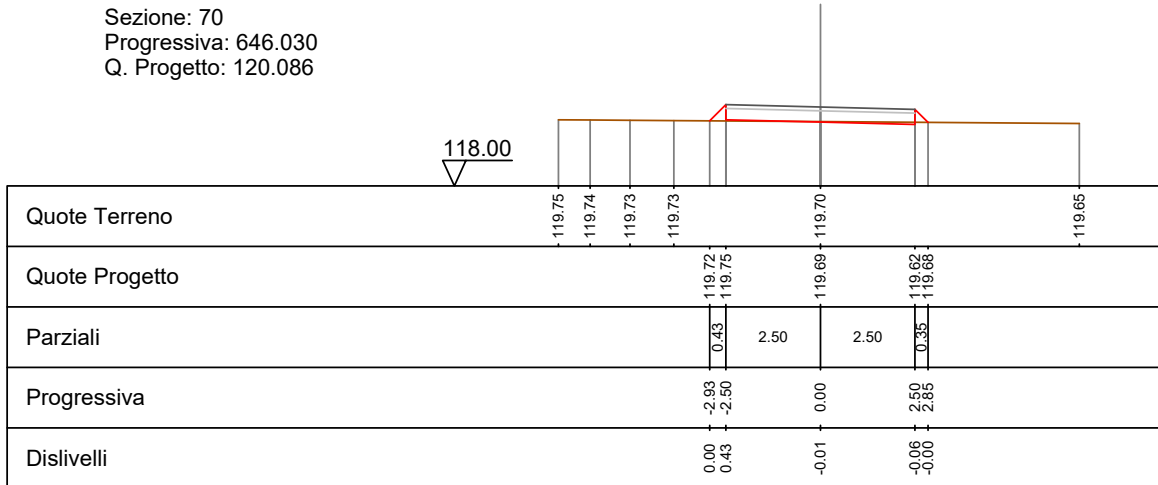

Sezione: 71
 Progressiva: 660.000
 Q. Progetto: 120.247

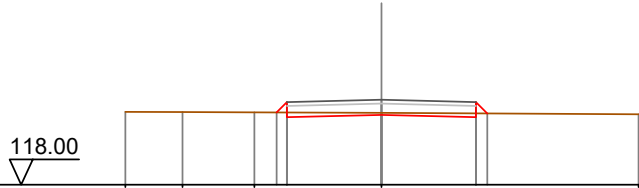

Quote Terreno	119.93	119.92	119.92	119.90	119.87
Quote Progetto		119.91	119.78	119.85	119.78
Parziali		0.27	2.50	2.50	0.30
Progressiva		-2.77	-2.50	0.00	2.50
Dislivelli		0.00	0.27	-0.05	-0.10

Sezione: 72
 Progressiva: 680.000
 Q. Progetto: 120.384

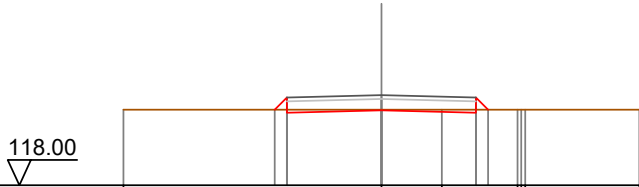

Quote Terreno	120.00	120.00	120.00	120.00	120.00
Quote Progetto		120.00	119.92	119.98	119.92
Parziali		0.32	2.50	2.50	0.32
Progressiva		-2.82	-2.50	0.00	2.50
Dislivelli		0.00	0.32	-0.02	-0.08

Sezione: 73
 Progressiva: 688.192
 Q. Progetto: 120.408

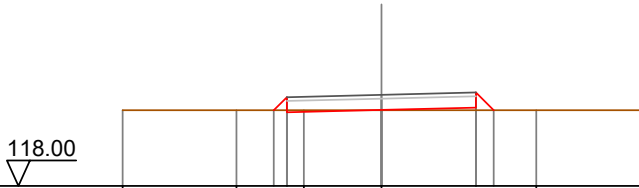

Quote Terreno	120.00	120.00	120.00	120.00	120.00
Quote Progetto		120.00	119.95	120.01	120.07
Parziali		0.35	2.50	2.50	0.47
Progressiva		-2.85	-2.50	0.00	2.50
Dislivelli		0.00	0.35	0.01	0.07

Sezione: 74
 Progressiva: 690.000
 Q. Progetto: 120.411

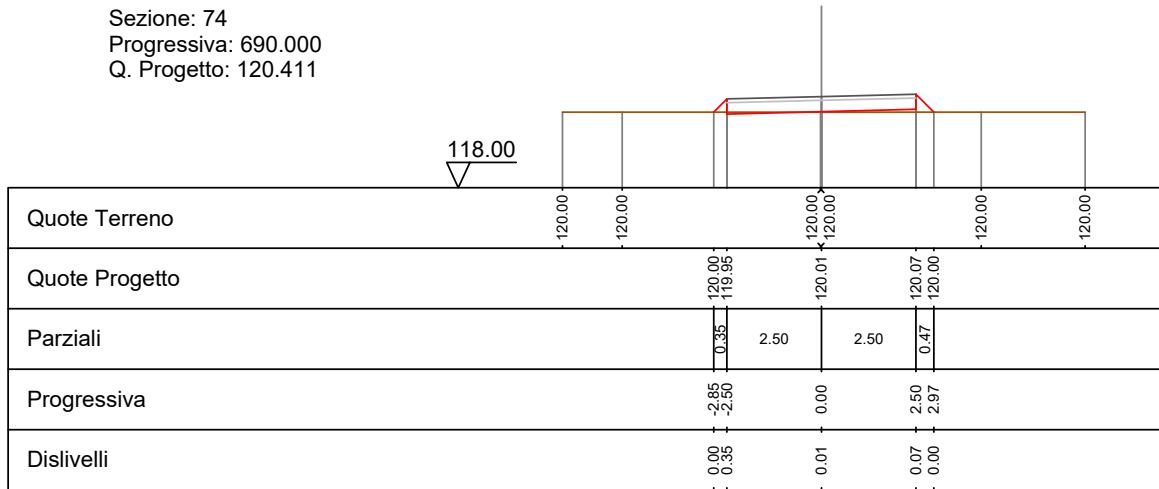

Sezione: 75
 Progressiva: 692.254
 Q. Progetto: 120.413

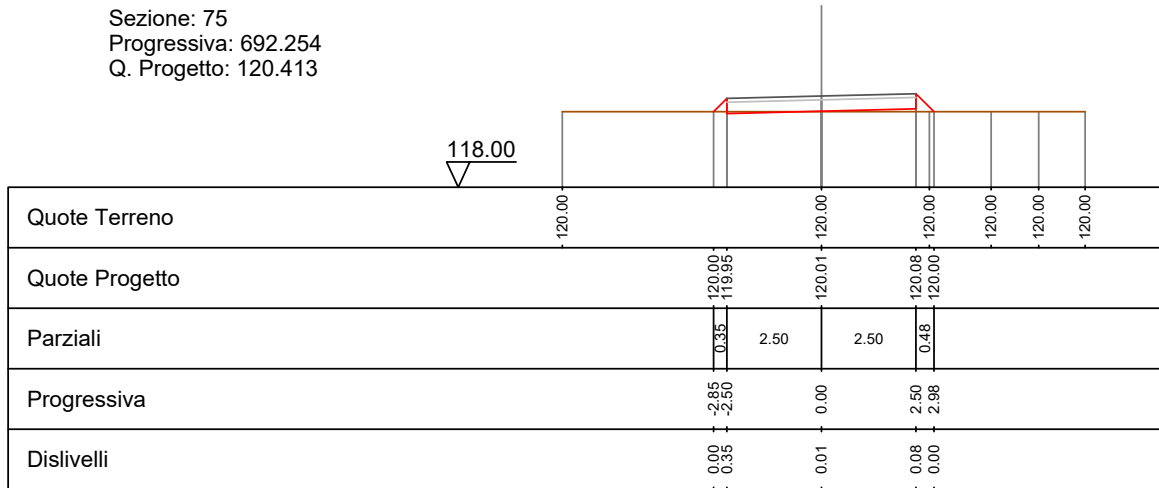

Sezione: 76
 Progressiva: 696.317
 Q. Progetto: 120.418

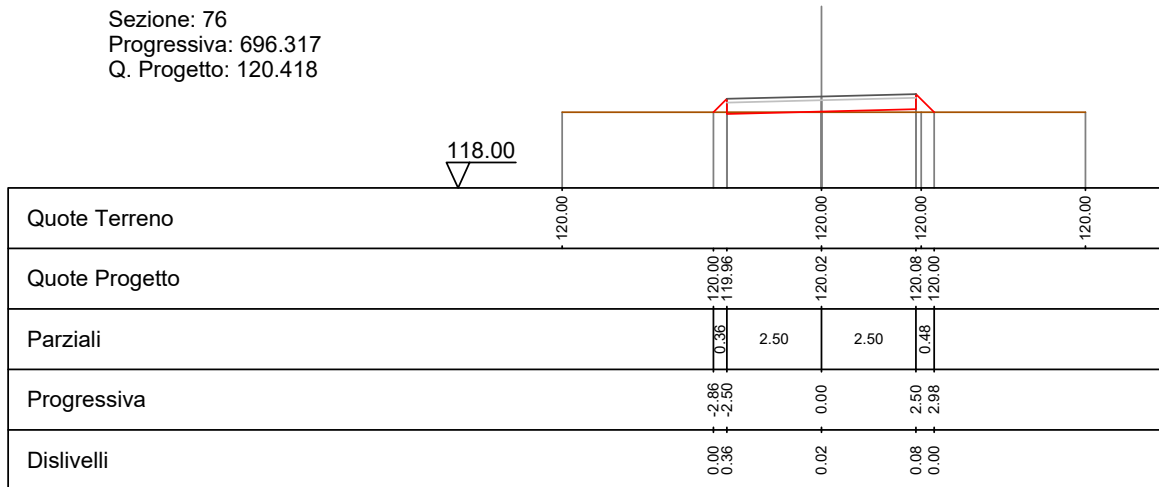

Sezione: 77
 Progressiva: 700.000
 Q. Progetto: 120.423

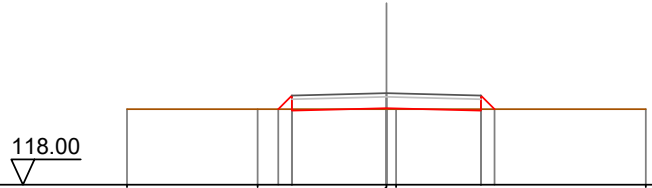

Quote Terreno	120.00	120.00	120.00	120.00	120.00
Quote Progetto		120.00 119.96	120.02	119.96 120.00	
Parziali		0.36	2.50	2.50	0.36
Progressiva		-2.86 -2.50	0.00	2.50 2.86	
Dislivelli		0.00 0.36	0.02	-0.04 0.00	

Sezione: 78
 Progressiva: 720.000
 Q. Progetto: 120.845

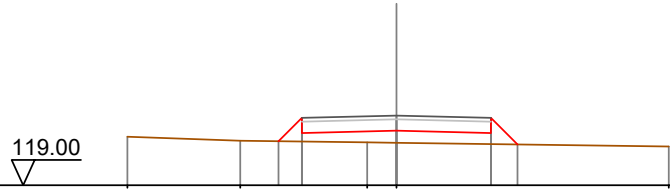

Quote Terreno	120.29	120.18	120.13	120.12	120.03
Quote Progetto		120.17 120.38	120.45	120.38 120.08	
Parziali		0.62	2.50	2.50	0.70
Progressiva		-3.12 -2.50	0.00	2.50 3.20	
Dislivelli		0.00 0.62	0.32	0.29 0.00	

Sezione: 79
 Progressiva: 740.000
 Q. Progetto: 122.070

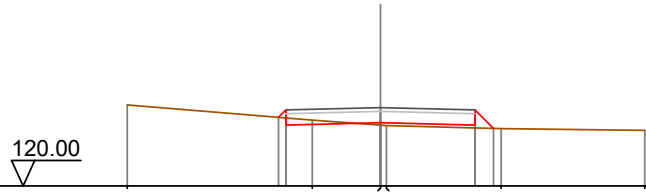

Quote Terreno	122.14	121.81 121.61	121.74	121.61 121.60	121.51 121.47
Quote Progetto		121.81 121.61	121.67	121.61 121.52	
Parziali		2.50	2.50	0.49	
Progressiva		-2.69 -2.50	0.00	2.50 2.99	
Dislivelli		0.00 0.21	0.06	0.08 0.00	

Sezione: 80
 Progressiva: 759.275
 Q. Progetto: 123.657

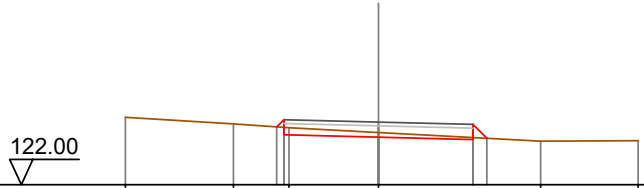

Quote Terreno	123.78	123.61	123.51	123.38	123.15	123.17
Quote Progetto		123.53	123.32	123.26	123.19	123.23
Parziali			2.50	2.50	0.37	
Progressiva		-2.69	-2.50	0.00	2.50	2.87
Dislivelli		-0.00	0.20	-0.12	-0.05	0.00

Sezione: 81
 Progressiva: 760.000
 Q. Progetto: 123.710

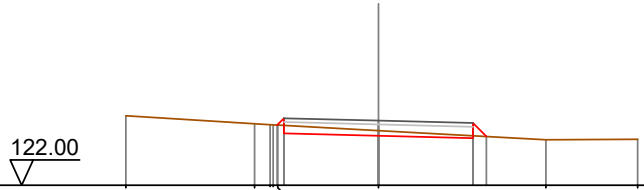

Quote Terreno	123.84	123.63	123.59	123.45	123.21	123.22
Quote Progetto		123.59	123.37	123.31	123.25	123.29
Parziali			2.50	2.50	0.36	
Progressiva		-2.68	-2.50	0.00	2.50	2.86
Dislivelli		0.00	0.19	-0.14	-0.06	0.00

Sezione: 82
 Progressiva: 764.766
 Q. Progetto: 124.048

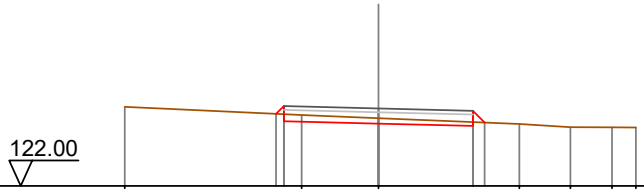

Quote Terreno	124.09	123.87	123.79	123.64	123.55	123.55	123.54
Quote Progetto		123.90	123.71	123.65	123.59	123.68	
Parziali			2.50	2.50	0.31		
Progressiva		-2.71	-2.50	0.00	2.50	2.81	
Dislivelli		0.00	0.22	-0.14	-0.10	0.00	

Sezione: 83
 Progressiva: 770.000
 Q. Progetto: 124.390

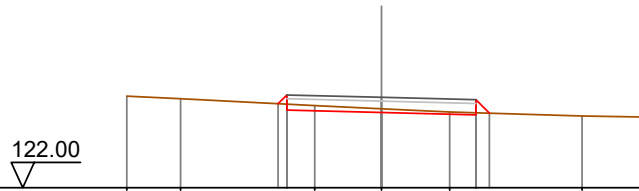

Quote Terreno	124.42	124.36		124.17	124.09	124.00		123.90	123.87
Quote Progetto			124.22	124.06					
Parziali					2.50		2.50		0.36
Progressiva			-2.73	-2.50		0.00		2.50	2.86
Dislivelli			0.00	0.24		-0.10		-0.05	-0.00

Sezione: 84
 Progressiva: 770.256
 Q. Progetto: 124.406

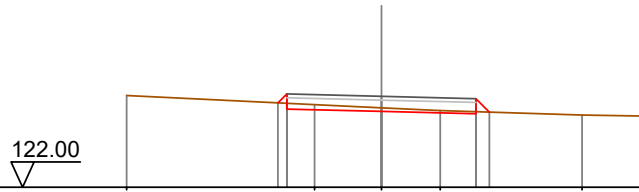

Quote Terreno	124.43			124.19	124.10	124.03		123.91	123.89
Quote Progetto			124.23	124.07					
Parziali					2.50		2.50		0.36
Progressiva			-2.74	-2.50		0.00		2.50	2.86
Dislivelli			0.00	0.25		-0.10		-0.06	-0.00

Sezione: 85
 Progressiva: 780.000
 Q. Progetto: 124.964

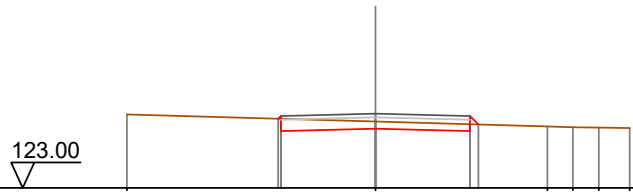

Quote Terreno	124.94				124.76			124.63	124.61	124.59	124.58
Quote Progetto			124.83	124.50				124.50	124.68		
Parziali					2.50		2.50				
Progressiva			-2.57	-2.50		0.00		2.50	2.72		
Dislivelli			0.00	0.07		-0.19		-0.18	-0.00		

Sezione: 86
 Progressiva: 783.483
 Q. Progetto: 125.139

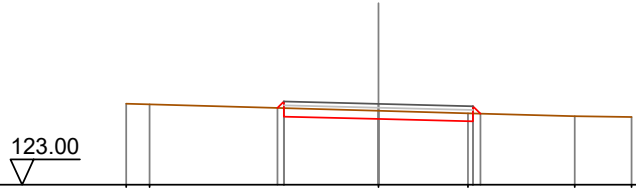

Quote Terreno	125.14	125.13			124.74	124.96			124.68	124.89		124.81	124.79
Quote Progetto			125.03	124.80		124.74	124.96		124.68	124.89			
Parziali					2.50		2.50						
Progressiva			-2.67	-2.50		0.00			2.50	2.70			
Dislivelli			-0.00	0.17		-0.22			-0.21	0.00			

Sezione: 87
 Progressiva: 790.000
 Q. Progetto: 125.431

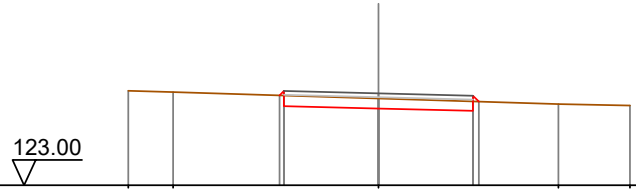

Quote Terreno	125.50	125.47			125.03	125.30			124.97	125.21		125.15	125.11
Quote Progetto			125.38	125.09		125.03	125.30		124.97	125.21			
Parziali					2.50		2.50						
Progressiva			-2.62	-2.50		0.00			2.50	2.65			
Dislivelli			-0.00	0.12		-0.27			-0.25	0.00			

Sezione: 87
 Progressiva: 790.000
 Q. Progetto: 125.431

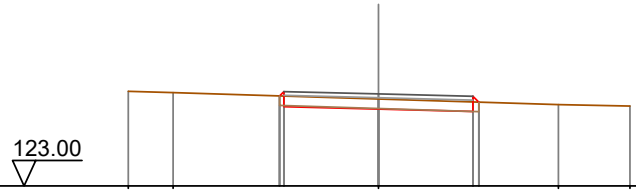

Quote Terreno	125.50	125.47			125.03	125.30			124.97	125.21		125.15	125.11
Quote Progetto			125.38	125.09		125.03	125.30		124.97	125.21			
Parziali					2.50		2.50						
Progressiva			-2.62	-2.50		0.00			2.50	2.65			
Dislivelli			0.00	0.12		-0.27			-0.25	0.00			

Sezione: 88
 Progressiva: 796.177
 Q. Progetto: 125.666

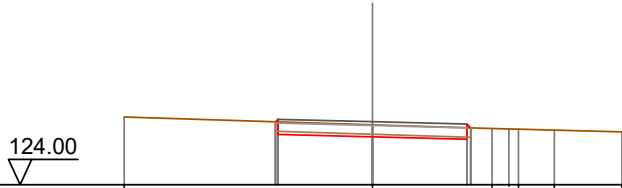

Quote Terreno	125.79									
Quote Progetto		125.67	125.33		125.27		125.20	125.50		
Parziali			2.50		2.50					
Progressiva		-2.56	-2.50		0.00		2.50	2.60		
Dislivelli		0.00	0.07		-0.32		-0.30	0.00		

Sezione: 89
 Progressiva: 800.000
 Q. Progetto: 125.792

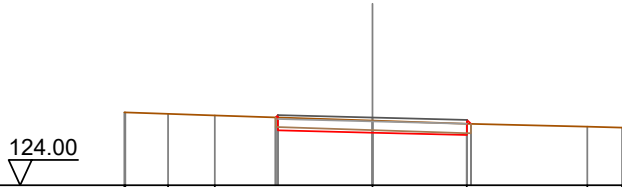

Quote Terreno	125.93	125.89	125.85		125.71		125.63		125.55	125.53
Quote Progetto				125.79	125.45		125.39	125.33	125.63	
Parziali				2.50			2.50			
Progressiva				-2.56	-2.50		0.00	2.50	2.60	
Dislivelli				0.00	0.06		-0.32	-0.30	0.00	

Sezione: 90
 Progressiva: 808.870
 Q. Progetto: 126.023

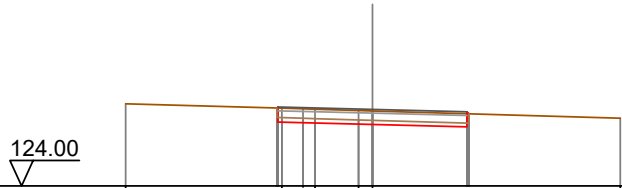

Quote Terreno	126.17			126.06	126.03		125.99	125.98		125.79
Quote Progetto				126.06	125.69		125.62	125.56	125.91	
Parziali				2.50			2.50			
Progressiva				-2.53	-2.50		0.00	2.50	2.55	
Dislivelli				-0.00	0.03		-0.36	-0.35	0.00	

Sezione: 91
 Progressiva: 809.756
 Q. Progetto: 126.042

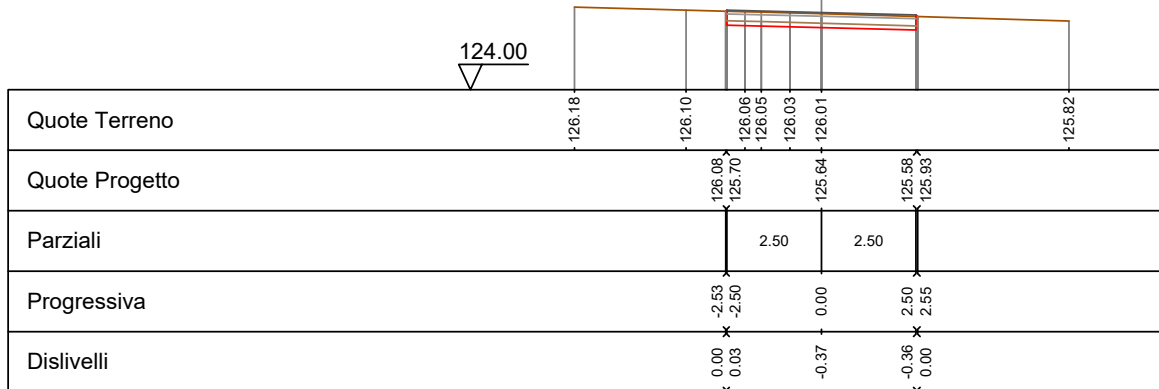

Sezione: 92
 Progressiva: 810.000
 Q. Progetto: 126.047

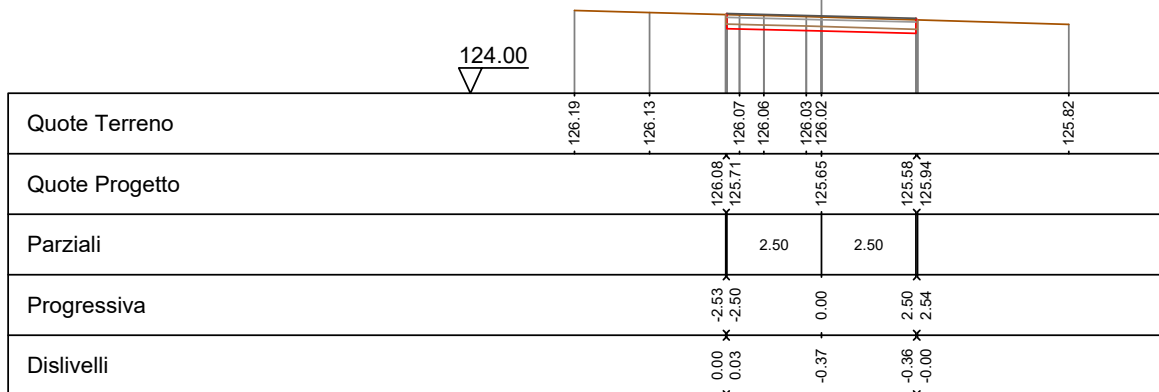

Sezione: 93
 Progressiva: 820.000
 Q. Progetto: 126.213

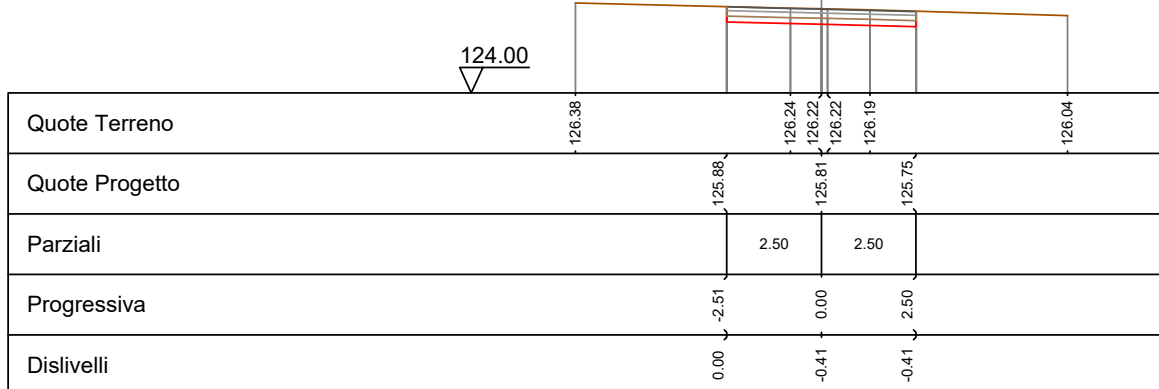

Sezione: 94
 Progressiva: 823.971
 Q. Progetto: 126.275

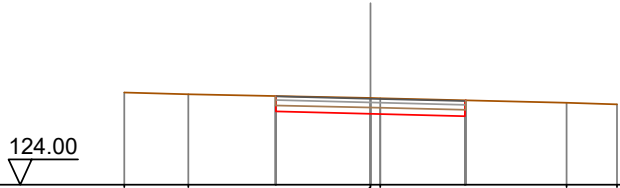

Quote Terreno		126.44	126.39		126.29	126.29		126.17	126.13
Quote Progetto				125.94		125.88		125.81	
Parziali				2.50		2.50			
Progressiva				-2.51		0.00		2.50	
Dislivelli				-0.00		-0.42		-0.42	

Sezione: 95
 Progressiva: 830.000
 Q. Progetto: 126.370

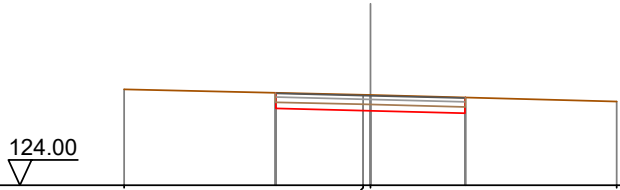

Quote Terreno		126.54		126.39	126.39		126.21
Quote Progetto			126.03		125.97		125.91
Parziali			2.50		2.50		
Progressiva			-2.51		0.00		2.50
Dislivelli			0.00		-0.42		-0.41

Sezione: 96
 Progressiva: 838.186
 Q. Progetto: 126.498

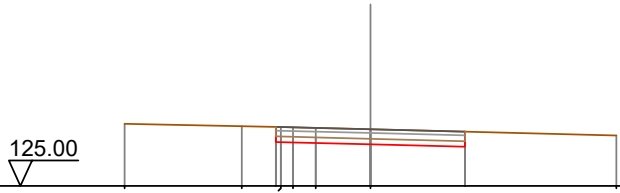

Quote Terreno		126.64	126.58	126.56	126.55	126.53	126.50		126.33
Quote Progetto				126.16			126.10		126.04
Parziali				2.50			2.50		
Progressiva				-2.50			0.00		2.50
Dislivelli				0.00			-0.40		-0.40

Sezione: 97
 Progressiva: 840.000
 Q. Progetto: 126.527

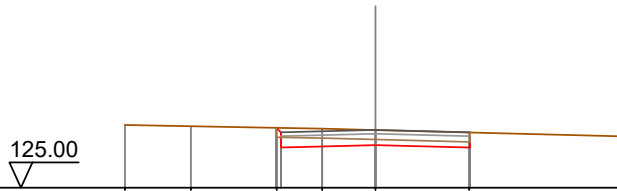

Quote Terreno	126.66	126.63	126.59	126.56	126.53	126.46	126.36
Quote Progetto			126.59	126.06	126.13	126.06	126.46
Parziali			2.50	2.50			
Progressiva			-2.62	-2.50	0.00	2.50	
Dislivelli			-0.00	-0.12	-0.40	-0.40	

Sezione: 98
 Progressiva: 852.611
 Q. Progetto: 126.724

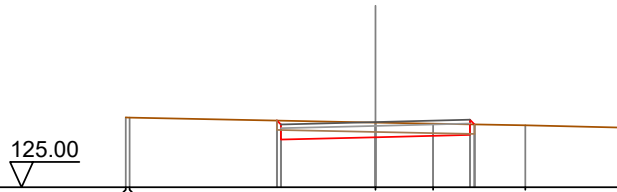

Quote Terreno	126.85	126.85	126.71	126.68	126.64	126.58
Quote Progetto			126.77	126.26	126.32	126.39
Parziali			2.50	2.50		
Progressiva			-2.60	-2.50	0.00	2.50
Dislivelli			0.00	-0.10	-0.39	-0.28

Sezione: 99
 Progressiva: 858.331
 Q. Progetto: 126.819

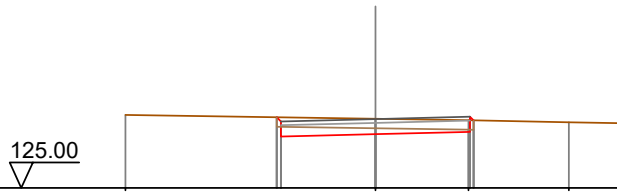

Quote Terreno	126.93	126.87	126.83	126.79	126.73	126.71
Quote Progetto		126.36	126.42	126.48	126.79	
Parziali		2.50	2.50			
Progressiva		-2.61	-2.50	0.00	2.50	2.60
Dislivelli		0.00	-0.11	-0.41	-0.31	0.00

Sezione: 100
 Progressiva: 860.000
 Q. Progetto: 126.856

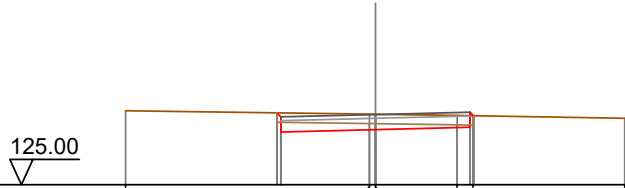

Quote Terreno	126.96		126.87	126.86	126.83	126.82	126.76
Quote Progetto		126.90	126.39	126.46	126.52	126.82	
Parziali			2.50		2.50		
Progressiva		-2.61	-2.50	0.00	2.50	2.59	
Dislivelli		0.00	-0.11	-0.41	-0.31	0.00	

Sezione: 101
 Progressiva: 864.051
 Q. Progetto: 126.948

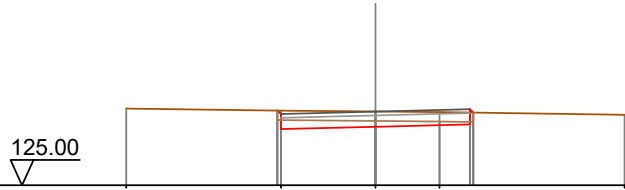

Quote Terreno	127.03		126.98	126.95	126.94		126.86
Quote Progetto		126.98	126.49	126.55	126.61	126.92	
Parziali			2.50		2.50		
Progressiva		-2.59	-2.50	0.00	2.50	2.59	
Dislivelli		0.00	-0.09	-0.40	-0.31	-0.00	

Sezione: 102
 Progressiva: 880.000
 Q. Progetto: 127.312

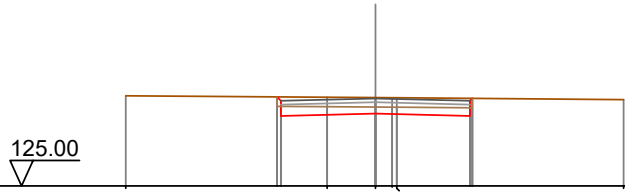

Quote Terreno	127.38		127.34	127.33	127.33		127.28
Quote Progetto		127.35	126.85	126.91	126.85	127.31	
Parziali			2.50		2.50		
Progressiva		-2.60	-2.50	0.00	2.50	2.56	
Dislivelli		0.00	-0.10	-0.42	-0.47	-0.00	

Sezione: 103
 Progressiva: 894.261
 Q. Progetto: 127.637

126.00

Quote Terreno	127.71	127.71	127.69	127.69	127.68	127.66
Quote Progetto			127.70	127.17	127.24	127.30
Parziali			2.50	2.50		
Progressiva			-2.62	-2.50	0.00	2.50
Dislivelli			0.00	-0.12	-0.46	-0.38

Sezione: 104
 Progressiva: 900.000
 Q. Progetto: 127.768

126.00

Quote Terreno	127.84	127.84	127.84	127.84	127.84	127.83
Quote Progetto			127.84	127.31	127.37	127.43
Parziali			2.50	2.50		
Progressiva			-2.63	-2.50	0.00	2.50
Dislivelli			0.00	-0.13	-0.47	-0.41

Sezione: 105
 Progressiva: 901.273
 Q. Progetto: 127.797

126.00

Quote Terreno	127.86	127.87	127.87	127.87	127.87	127.87
Quote Progetto			127.87	127.33	127.40	127.46
Parziali			2.50	2.50		
Progressiva			-2.63	-2.50	0.00	2.50
Dislivelli			0.00	-0.13	-0.48	-0.41

Sezione: 106
 Progressiva: 908.286
 Q. Progetto: 127.956

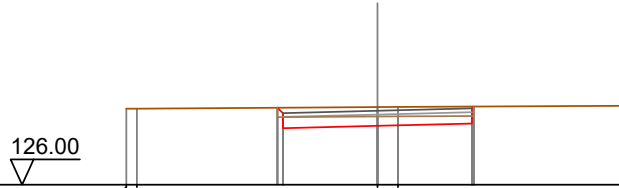

Quote Terreno	128.01	128.01			128.05	128.06		128.09
Quote Progetto			128.04	127.49	127.56		127.62	128.07
Parziali				2.50		2.50		
Progressiva			-2.64	-2.50	0.00		2.50	2.55
Dislivelli			0.00	-0.14	-0.50		-0.45	0.00

Sezione: 107
 Progressiva: 920.000
 Q. Progetto: 128.223

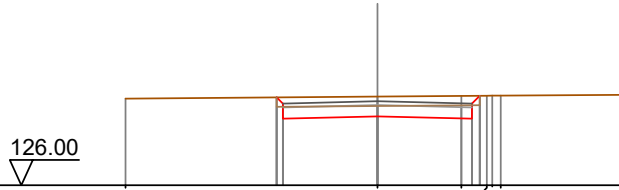

Quote Terreno	128.29				128.35		128.36	128.37	128.39
Quote Progetto			128.32	127.76	127.82		127.76	128.37	
Parziali				2.50		2.50			
Progressiva			-2.66	-2.50	0.00		2.50	2.71	
Dislivelli			0.00	-0.16	-0.52		-0.60	0.00	

Sezione: 108
 Progressiva: 923.292
 Q. Progetto: 128.299

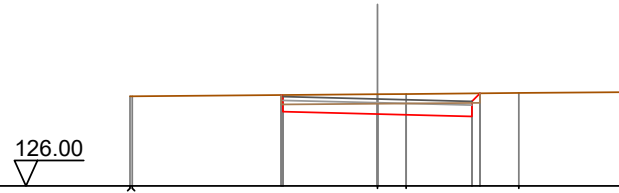

Quote Terreno	128.37	128.37			128.42	128.43		128.46	128.48
Quote Progetto			128.40	127.96	127.90		127.94	128.45	
Parziali				2.50		2.50			
Progressiva			-2.54	-2.50	0.00		2.50	2.71	
Dislivelli			0.00	-0.04	-0.52		-0.61	0.00	

Sezione: 109
 Progressiva: 925.281
 Q. Progetto: 128.344

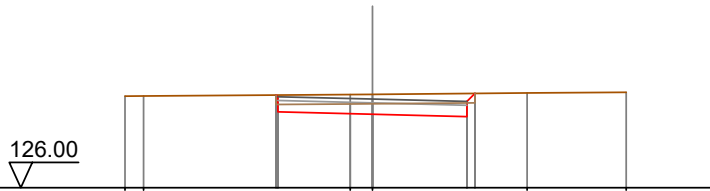

Quote Terreno	128.42	128.43		128.47	128.47	128.51	128.52
Quote Progetto			128.45	128.01	127.94	127.88	128.49
Parziali			2.50		2.50		
Progressiva			-2.54	-2.50	0.00	2.50	2.71
Dislivelli			0.00	-0.04	-0.53	-0.61	-0.00

Sezione: 110
 Progressiva: 927.270
 Q. Progetto: 128.389

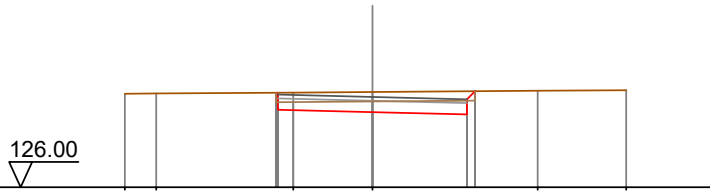

Quote Terreno	128.47	128.48		128.50	128.52	128.55	128.57
Quote Progetto			128.50	128.05	127.99	127.93	128.54
Parziali			2.50		2.50		
Progressiva			-2.55	-2.50	0.00	2.50	2.71
Dislivelli			0.00	-0.05	-0.53	-0.61	0.00

Sezione: 111
 Progressiva: 940.000
 Q. Progetto: 128.679

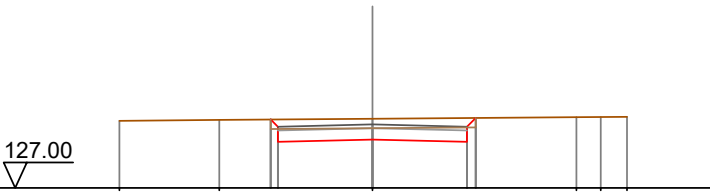

Quote Terreno	128.77	128.80		128.83		128.87	128.88	128.88
Quote Progetto			128.81	128.22	128.28	128.22	128.85	
Parziali			2.50		2.50			
Progressiva			-2.69	-2.50	0.00	2.50	2.73	
Dislivelli			0.00	-0.19	-0.55	-0.63	0.00	

Sezione: 112
 Progressiva: 960.000
 Q. Progetto: 129.135



Quote Terreno	129.24	129.27	129.28	129.29	129.29	129.33	129.33
Quote Progetto		129.27	128.67	128.74	128.67	129.31	
Parziali			2.50	2.50			
Progressiva		-2.70	-2.50	0.00	2.50	2.74	
Dislivelli		0.00	-0.20	-0.56	-0.63	-0.00	

Sezione: 113
 Progressiva: 975.497
 Q. Progetto: 129.488

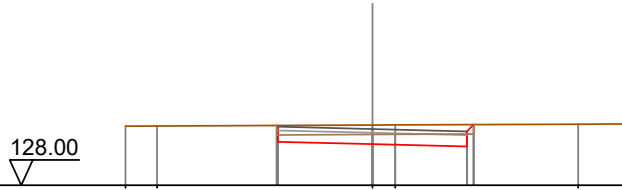

Quote Terreno	129.56	129.57	129.59	129.60	129.62	129.62
Quote Progetto		129.58	129.15	129.09	129.03	129.60
Parziali			2.50	2.50		
Progressiva		-2.53	-2.50	0.00	2.50	2.68
Dislivelli		-0.00	-0.03	-0.51	-0.56	0.00

Sezione: 114
 Progressiva: 977.159
 Q. Progetto: 129.526

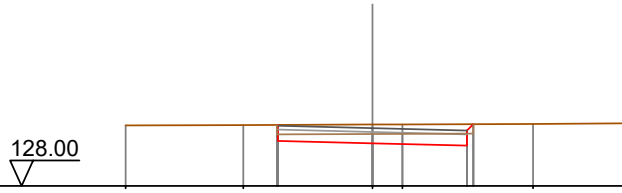

Quote Terreno	129.60	129.61	129.62	129.63	129.64	129.65
Quote Progetto		129.61	129.13	129.06	129.06	129.63
Parziali			2.50	2.50		
Progressiva		-2.52	-2.50	0.00	2.50	2.67
Dislivelli		0.00	-0.02	-0.50	-0.57	0.00

Sezione: 115
 Progressiva: 978.821
 Q. Progetto: 129.564

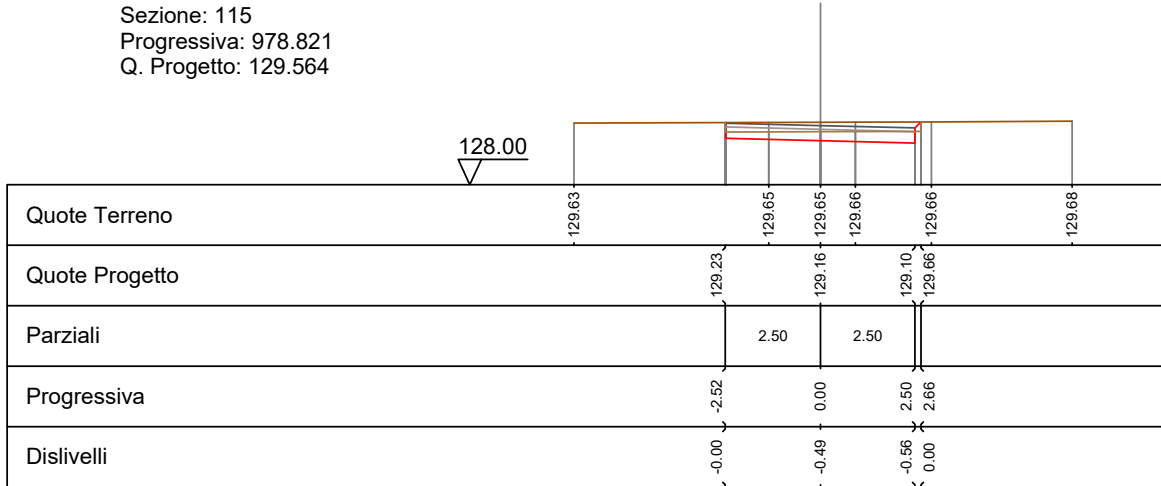

Sezione: 116
 Progressiva: 980.000
 Q. Progetto: 129.591

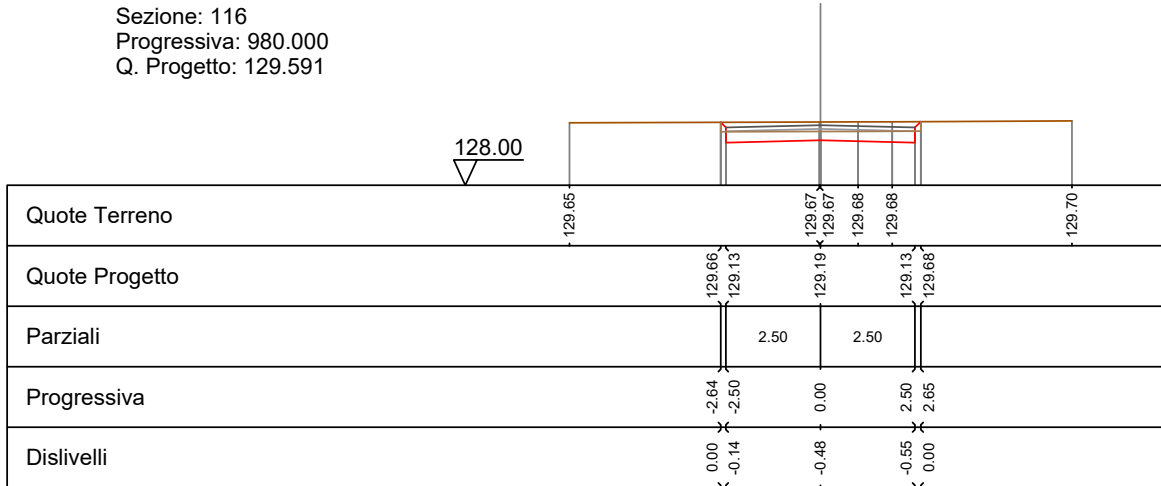

Sezione: 117
 Progressiva: 1000.000
 Q. Progetto: 130.047

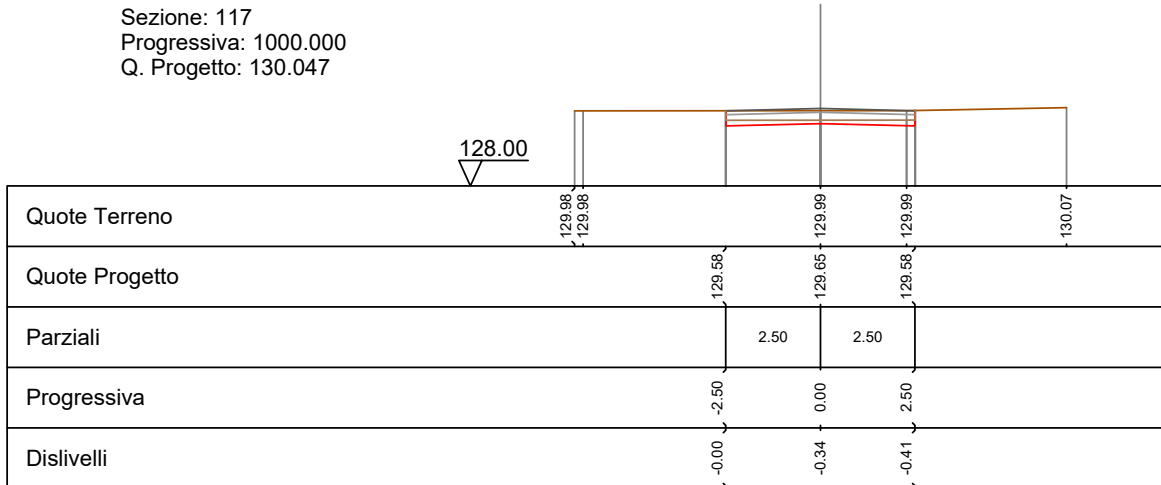

Sezione: 118
 Progressiva: 1011.928
 Q. Progetto: 130.417

128.00

Quote Terreno	130.10									
Quote Progetto		130.31	129.95	130.02	130.44	130.54	130.08	130.56	130.58	130.73
Parziali			2.50		2.50					
Progressiva		-2.55	-2.50	0.00		2.50	2.58			
Dislivelli		0.00	0.05	-0.42		-0.48	0.00			

Sezione: 119
 Progressiva: 1016.498
 Q. Progetto: 130.632

129.00

Quote Terreno	130.45	130.45	130.74	130.81		130.97	131.13
Quote Progetto		130.68	130.17	130.23	130.81	130.29	130.93
Parziali			2.50		2.50		
Progressiva		-2.61	-2.50	0.00		2.50	2.74
Dislivelli		0.00	-0.12	-0.58		-0.62	0.00

Sezione: 120
 Progressiva: 1020.000
 Q. Progetto: 130.826

129.00

Quote Terreno	130.72	130.74	130.87		131.06		131.27	131.28	131.33	131.41
Quote Progetto			130.93	130.36	130.43	131.06	130.49	131.20		
Parziali				2.50		2.50	0.31			
Progressiva			-2.67	-2.50	0.00		2.50	2.81		
Dislivelli			-0.00	-0.18	-0.64		-0.70	-0.00		

Sezione: 121
 Progressiva: 1021.069
 Q. Progetto: 130.890

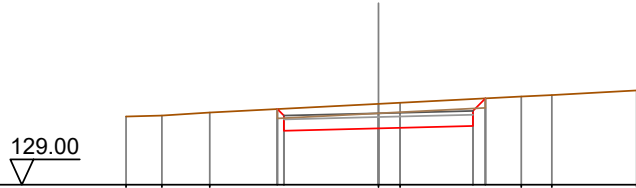

Quote Terreno	130.80	130.83	130.91	131.00	131.14	131.17	131.33	131.37	131.49
Quote Progetto				131.00	130.49	130.55	131.28		
Parziali				2.50	2.50	0.33			
Progressiva				-2.67	0.00	2.50	2.83		
Dislivelli				0.00	-0.65	-0.71	0.00		

Sezione: 122
 Progressiva: 1040.000
 Q. Progetto: 132.400

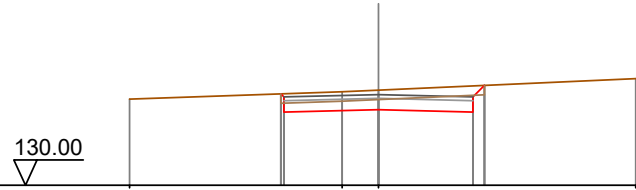

Quote Terreno	132.28			132.47	132.52				132.82
Quote Progetto				132.42	132.00	131.94	132.64		
Parziali				2.50	2.50	0.30			
Progressiva				-2.58	0.00	2.50	2.80		
Dislivelli				0.00	-0.52	-0.69	-0.00		

Sezione: 123
 Progressiva: 1060.000
 Q. Progetto: 134.289

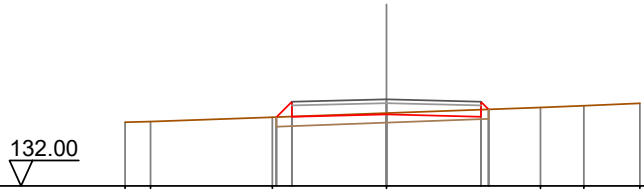

Quote Terreno	133.68	133.70	133.81	133.92	134.07	134.12	134.18
Quote Progetto			133.82	133.89	133.83	134.02	
Parziali			0.41	2.50	2.50		
Progressiva			-2.91	0.00	2.50	2.70	
Dislivelli			0.00	-0.03	-0.19	0.00	

Sezione: 124
 Progressiva: 1080.000
 Q. Progetto: 136.178

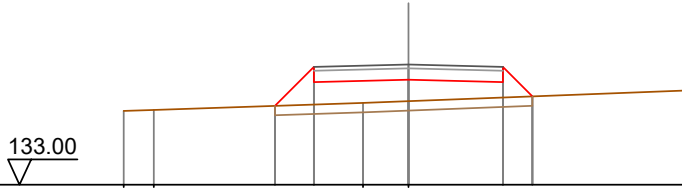

Quote Terreno		134.95	134.98		135.17	135.21		135.49
Quote Progetto				135.09	135.72	135.78	135.72	135.34
Parziali				1.03	2.50	2.50	0.78	
Progressiva				-3.53	-2.50	0.00	2.50	3.28
Dislivelli				-0.00	0.99	0.57	0.41	0.00

Sezione: 125
 Progressiva: 1090.806
 Q. Progetto: 137.199

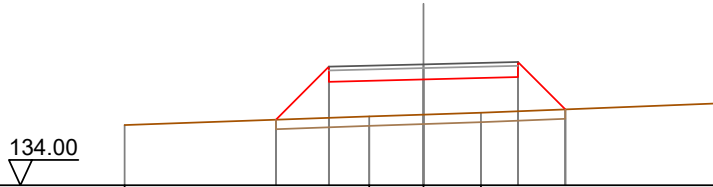

Quote Terreno		135.59		135.82	135.87	135.92		136.17
Quote Progetto			135.73	136.74	136.80	136.86	136.01	
Parziali			1.40	2.50	2.50	1.25		
Progressiva			-3.90	-2.50	0.00	2.50	3.75	
Dislivelli			-0.00	1.35	0.93	0.90	0.00	

Sezione: 126
 Progressiva: 1093.008
 Q. Progetto: 137.407

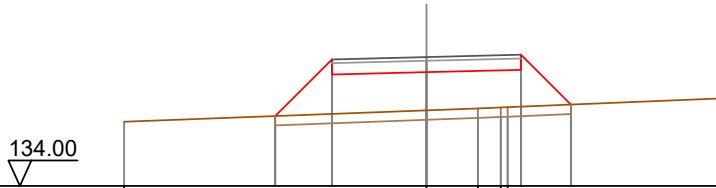

Quote Terreno		135.70		136.00	136.05	136.08		136.31
Quote Progetto			135.85	136.94	137.01	137.07	136.15	
Parziali			1.50	2.50	2.50	1.32		
Progressiva			-4.00	-2.50	0.00	2.50	3.82	
Dislivelli			0.00	1.44	1.01	0.98	0.00	

Sezione: 127
 Progressiva: 1095.211
 Q. Progetto: 137.615

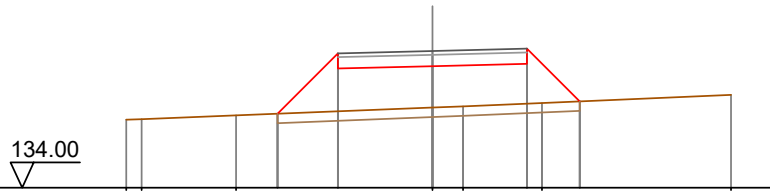

Quote Terreno		135.80	135.81		135.91		136.12	136.15	136.24	136.46
Quote Progetto				135.96	137.15	137.22	137.28	136.28		
Parziali				1.60	2.50	2.50	1.39			
Progressiva				-4.10	-2.50	0.00	2.50	3.89		
Dislivelli				0.00	1.53	1.10	1.06	0.00		

Sezione: 128
 Progressiva: 1100.000
 Q. Progetto: 138.068

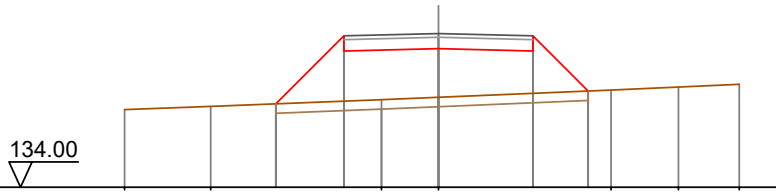

Quote Terreno		136.05	136.14		136.32	136.38		136.57	136.65	136.72
Quote Progetto				136.21	137.61	137.67	137.61	136.55		
Parziali				1.80	2.50	2.50	1.46			
Progressiva				-4.30	-2.50	0.00	2.50	3.96		
Dislivelli				-0.00	1.73	1.29	1.12	0.00		

Sezione: 129
 Progressiva: 1120.000
 Q. Progetto: 139.801

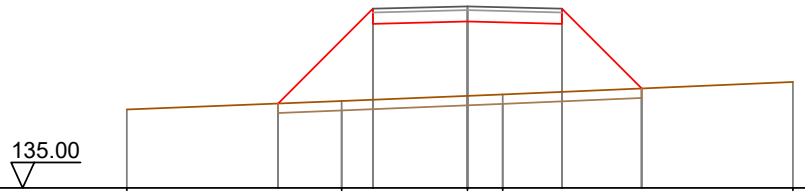

Quote Terreno		137.07		137.30		137.43	137.47		137.80
Quote Progetto			137.23	139.34	139.40	139.34	137.63		
Parziali			2.51	2.50	2.50	2.11			
Progressiva			-5.01	-2.50	0.00	2.50	4.61		
Dislivelli			0.00	2.41	1.97	1.80	-0.00		

Sezione: 130
 Progressiva: 1140.000
 Q. Progetto: 140.787

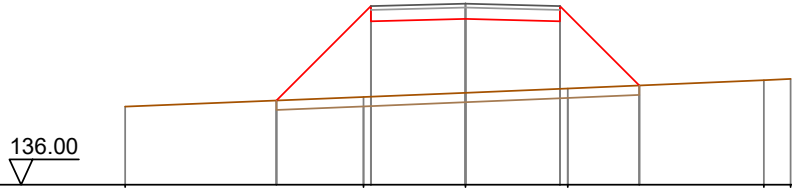

Quote Terreno		138.07		138.32	138.43	138.54		138.77	138.80
Quote Progetto			138.23	140.32	140.39	140.32		138.62	
Parziali			2.50	2.50	2.50	2.10			
Progressiva			-5.00	-2.50	0.00	2.50	4.60		
Dislivelli			0.00	2.40	1.96	1.79	-0.00		

Sezione: 131
 Progressiva: 1154.366
 Q. Progetto: 141.000

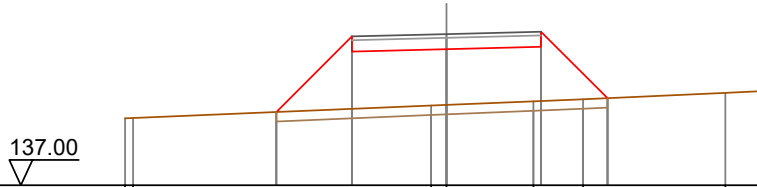

Quote Terreno		138.77	138.76		139.11	139.13	139.22	139.27	139.44	139.48
Quote Progetto				138.94	140.54	140.60	140.66	139.30		
Parziali				2.00	2.50	2.50	1.76			
Progressiva				-4.50	-2.50	0.00	2.50	4.26		
Dislivelli				0.00	1.92	1.47	1.43	-0.00		

Sezione: 132
 Progressiva: 1155.000
 Q. Progetto: 141.000

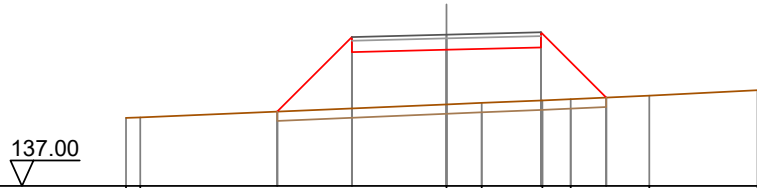

Quote Terreno		138.80	138.81		139.16	139.19	139.26	139.29	139.39	139.53
Quote Progetto				138.97	140.54	140.60	140.66	139.34		
Parziali				1.97	2.50	2.50	1.73			
Progressiva				-4.47	-2.50	0.00	2.50	4.23		
Dislivelli				0.00	1.89	1.44	1.40	0.00		

SEZIONI TRASVERSALI

Profilo longitudinale tratto 21-22

Viabilità di impianto - Postazione aerogeneratore WTG11

Nota: Le canalette di deflusso delle acque meteoriche, non indicate nel presente elaborato, sono rappresentate graficamente nelle sezioni stradali tipo dell'elaborato "BLTX-NS-TC13_Piazzole aerogeneratori e strade di servizio - Particolari costruttivi", individuate planimetricamente nell'elaborato "BLTX-NS-TC14_Opere di regimazione acque superficiali - Planimetria generale" e quantificate nell'elaborato "BLTX-NS-RC6_Computo metrico estimativo opere civili".

DISEGNI DI RIFERIMENTO

TAVOLA	DESCRIZIONE
BLTX-NS-TC8	Viabilità e piazzole - Planimetria di progetto - Fase di cantiere
BLTX-NS-TC11	Profili longitudinali viabilità di impianto
BLTX-NS-TC13	Piazzole aerogeneratori e strade di servizio - Particolari costruttivi
BLTX-NS-TC14	Opere di regimazione acque superficiali - Planimetria generale

Sezione: 9
 Progressiva: 33.300
 Q. Progetto: 125.882

124.00

Quote Terreno	126.00	125.97	125.93	125.88	125.82	125.79
Quote Progetto			125.93	125.48	125.54	125.83
Parziali			2.50	2.50		
Progressiva		-2.61	-2.50	0.00	2.50	2.61
Dislivelli		-0.00	-0.11	-0.40	-0.29	0.00

Sezione: 10
 Progressiva: 40.000
 Q. Progetto: 126.141

124.00

Quote Terreno	126.21		126.14	126.11	126.10	126.09
Quote Progetto		126.17	125.68	125.80	126.11	
Parziali		2.50	2.50			
Progressiva		-2.59	-2.50	0.00	2.50	2.59
Dislivelli		-0.00	-0.09	-0.40	-0.31	0.00

Sezione: 11
 Progressiva: 48.327
 Q. Progetto: 126.403

124.00

Quote Terreno	126.44	126.40	126.39	126.39	126.39	126.37	126.37
Quote Progetto		126.40	125.94	126.00	126.07	126.39	
Parziali			2.50		2.50		
Progressiva		-2.56	-2.50	0.00	2.50	2.58	
Dislivelli		0.00	-0.06	-0.39	-0.32	-0.00	

Sezione: 12
 Progressiva: 50.000
 Q. Progetto: 126.439

124.00

Quote Terreno	126.47	126.44	126.43	126.43	126.43	126.43	126.43
Quote Progetto		126.44	125.98	126.04	126.10	126.43	
Parziali			2.50		2.50		
Progressiva		-2.56	-2.50	0.00	2.50	2.57	
Dislivelli		0.00	-0.06	-0.39	-0.33	-0.00	

Sezione: 13
 Progressiva: 60.000
 Q. Progetto: 126.626

125.00

Quote Terreno	126.68	126.68	126.68	126.68	126.68	126.67	126.68
Quote Progetto		126.68	126.16	126.23	126.29		
Parziali			2.50		2.50		
Progressiva		-2.61	-2.50	0.00	2.50		
Dislivelli		0.00	-0.11	-0.45	-0.39		

Sezione: 14
 Progressiva: 70.000
 Q. Progetto: 126.813

125.00

Quote Terreno	126.85	126.84		126.84		126.84	126.84	126.84
Quote Progetto			126.84	126.35	126.41		126.48	126.84
Parziali			2.50		2.50			
Progressiva			-2.59	-2.50	0.00		2.50	2.54
Dislivelli			0.00	-0.09	-0.43		-0.36	-0.00

Sezione: 15
 Progressiva: 70.684
 Q. Progetto: 126.825

125.00

Quote Terreno	126.86	126.85		126.85		126.85	126.84	126.85
Quote Progetto			126.85	126.36	126.43		126.48	126.85
Parziali			2.50		2.50			
Progressiva			-2.59	-2.50	0.00		2.50	2.54
Dislivelli			0.00	-0.09	-0.42		-0.36	-0.00

Sezione: 16
 Progressiva: 80.000
 Q. Progetto: 126.927

125.00

Quote Terreno	126.99	126.99		126.96		126.94	126.94	126.93
Quote Progetto			126.97	126.46	126.53		126.46	126.94
Parziali			2.50		2.50			
Progressiva			-2.61	-2.50	0.00		2.50	2.58
Dislivelli			0.00	-0.11	-0.43		-0.46	0.00

Sezione: 17
 Progressiva: 100.000
 Q. Progetto: 126.990

125.00

Quote Terreno	127.12	127.12		127.03	127.00	126.99	126.96
Quote Progetto			127.07	126.53	126.59	126.53	127.00
Parziali			2.50		2.50		
Progressiva			-2.64	-2.50	0.00	2.50	2.57
Dislivelli			0.00	-0.14	-0.44	-0.47	-0.00

Sezione: 18
 Progressiva: 114.584
 Q. Progetto: 126.952

125.00

Quote Terreno	127.07			126.94	126.91		126.84
Quote Progetto		126.99	126.49	126.55	126.61	126.90	
Parziali			2.50		2.50		
Progressiva		-2.60	-2.50	0.00	2.50	2.61	
Dislivelli		0.00	-0.10	-0.39	-0.29	0.00	

Sezione: 19
 Progressiva: 120.000
 Q. Progetto: 126.897

125.00

Quote Terreno	127.04			126.89	126.85		126.78
Quote Progetto		126.95	126.43	126.50	126.56	126.84	
Parziali			2.50		2.50		
Progressiva		-2.62	-2.50	0.00	2.50	2.62	
Dislivelli		-0.00	-0.12	-0.40	-0.28	0.00	

Sezione: 19
 Progressiva: 120.000
 Q. Progetto: 126.897

125.00

Quote Terreno	127.04		126.90	126.89	126.85	126.78
Quote Progetto		126.95	126.43	126.50	126.56	126.84
Parziali			2.50		2.50	
Progressiva		-2.62	-2.50	0.00	2.50	2.62
Dislivelli		0.00	-0.12	-0.40	-0.28	0.00

Sezione: 20
 Progressiva: 130.000
 Q. Progetto: 126.793

125.00

Quote Terreno	126.97	126.96	126.92	126.79	126.68	126.62
Quote Progetto			126.87	126.33	126.46	126.72
Parziali			2.50		2.50	
Progressiva			-2.64	-2.50	0.00	2.50
Dislivelli			-0.00	-0.13	-0.40	-0.27

Sezione: 21
 Progressiva: 132.932
 Q. Progetto: 126.763

125.00

Quote Terreno	126.96	126.92	126.81	126.76	126.61	126.57
Quote Progetto			126.83	126.30	126.43	126.68
Parziali			2.50		2.50	
Progressiva			-2.63	-2.50	0.00	2.50
Dislivelli			0.00	-0.13	-0.39	-0.26

Sezione: 22
 Progressiva: 140.000
 Q. Progetto: 126.690

125.00

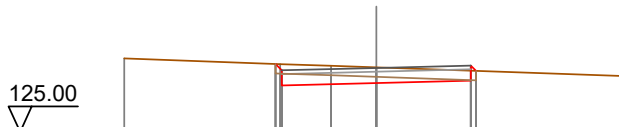

Quote Terreno	126.94	126.79	126.75	126.71		126.47
Quote Progetto		126.79	126.23	126.29	126.35	126.61
Parziali			2.50	2.50		
Progressiva		-2.67	-2.50	0.00	2.50	2.64
Dislivelli		0.00	-0.16	-0.42	-0.27	-0.00

Sezione: 23
 Progressiva: 150.000
 Q. Progetto: 126.667

125.00

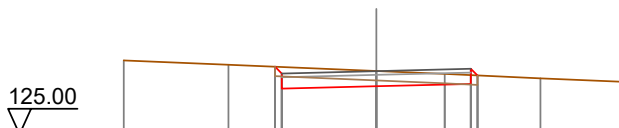

Quote Terreno	126.95	126.84	126.67	126.60	126.48	126.38
Quote Progetto		126.79	126.27	126.33	126.55	
Parziali			2.50	2.50		
Progressiva		-2.68	-2.50	0.00	2.50	2.68
Dislivelli		0.00	-0.17	-0.40	-0.23	0.00

Sezione: 24
 Progressiva: 151.281
 Q. Progetto: 126.668

125.00

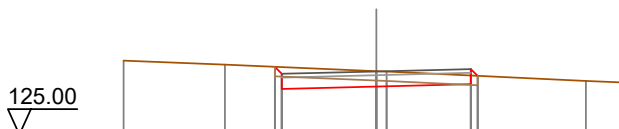

Quote Terreno	126.95	126.85	126.68	126.66	126.42	126.37
Quote Progetto		126.79	126.27	126.33	126.55	
Parziali			2.50	2.50		
Progressiva		-2.68	-2.50	0.00	2.50	2.68
Dislivelli		0.00	-0.18	-0.41	-0.23	-0.00

Sezione: 25
 Progressiva: 160.000
 Q. Progetto: 126.671

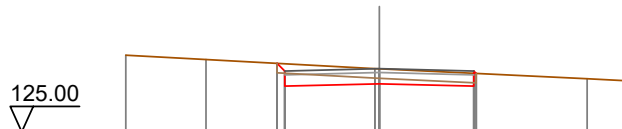

Quote Terreno	127.03	126.91		126.67	126.67		126.41	126.35
Quote Progetto			126.81	126.21		126.27	126.21	126.55
Parziali			2.50		2.50			
Progressiva			-2.70	-2.50	0.00		2.50	2.56
Dislivelli			0.00	-0.19	-0.40		-0.34	-0.00

Sezione: 26
 Progressiva: 180.000
 Q. Progetto: 126.583

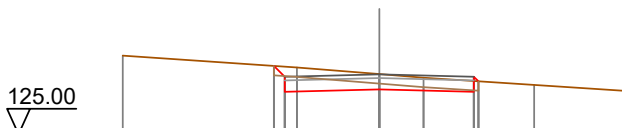

Quote Terreno	127.08		126.77	126.59	126.49		126.30	126.14
Quote Progetto			126.81	126.12		126.18	126.12	126.40
Parziali			2.50		2.50			
Progressiva			-2.79	-2.50	0.00		2.50	2.62
Dislivelli			-0.00	-0.27	-0.41		-0.29	0.00

Sezione: 27
 Progressiva: 200.000
 Q. Progetto: 126.129

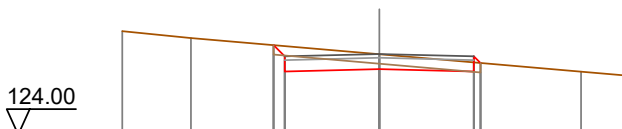

Quote Terreno	126.73	126.55		126.12		125.66	125.55
Quote Progetto			126.36	125.67		125.73	125.67
Parziali			2.50		2.50		
Progressiva			-2.80	-2.50	0.00		2.50
Dislivelli			0.00	-0.27	-0.39		-0.24

Sezione: 28
 Progressiva: 220.000
 Q. Progetto: 126.151

124.00

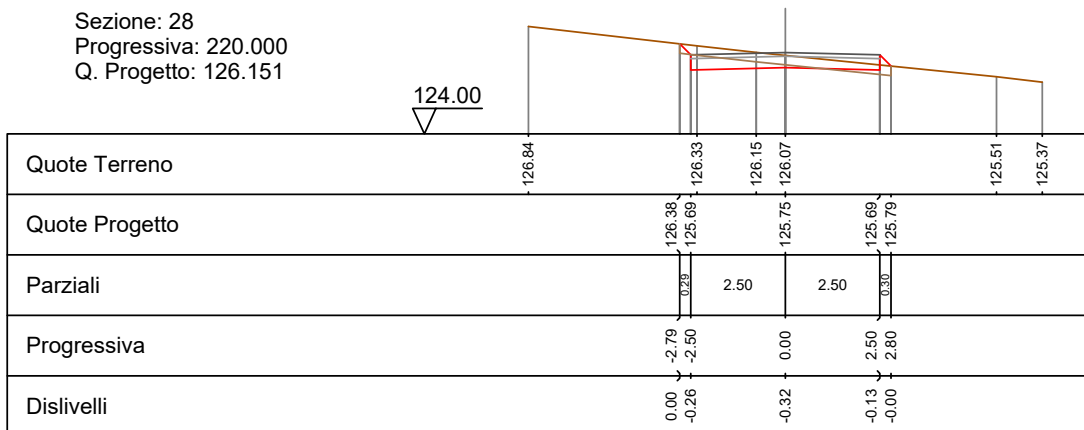

Sezione: 29
 Progressiva: 240.000
 Q. Progetto: 126.974

125.00

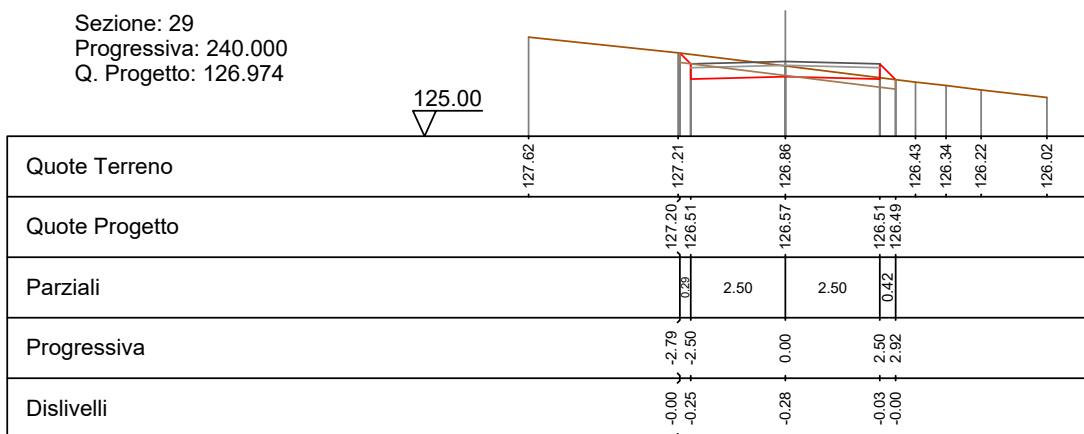

Sezione: 30
 Progressiva: 260.000
 Q. Progetto: 128.479

126.00

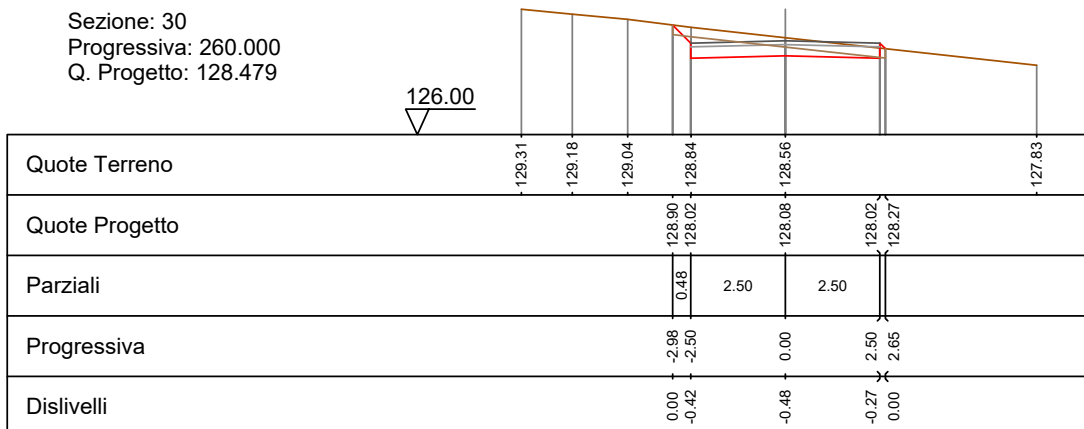

Sezione: 31
 Progressiva: 280.000
 Q. Progetto: 129.874

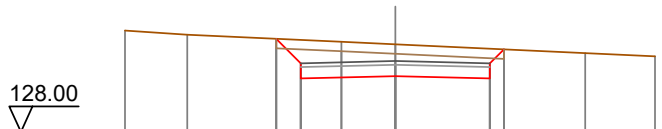

Quote Terreno	130.68	130.57	130.38	130.32	130.08	130.00
Quote Progetto			130.46	129.47	129.41	130.18
Parziali			0.65	2.50	2.50	0.37
Progressiva			-3.15	-2.50	0.00	2.50
Dislivelli			0.00	-0.62	-0.84	-0.79

Sezione: 32
 Progressiva: 300.000
 Q. Progetto: 130.505

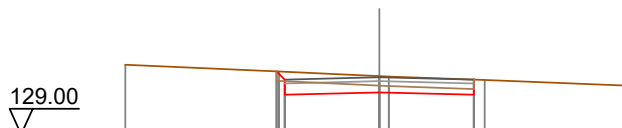

Quote Terreno	130.84	130.66	130.53	130.43	130.29
Quote Progetto		130.66	130.10	130.04	
Parziali			2.50	2.50	
Progressiva		-2.72	0.00	2.50	
Dislivelli		-0.00	-0.43	-0.40	

Sezione: 33
 Progressiva: 320.000
 Q. Progetto: 130.442

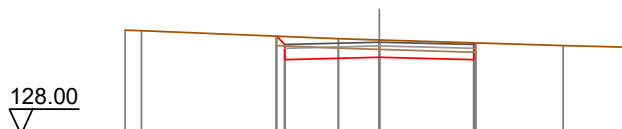

Quote Terreno	130.76	130.74	130.53	130.35	130.31
Quote Progetto			130.60	130.04	129.98
Parziali			2.50	2.50	
Progressiva			-2.72	0.00	2.50
Dislivelli			0.00	-0.46	-0.45

Sezione: 34
 Progressiva: 340.000
 Q. Progetto: 130.286

128.00

Quote Terreno	130.50	130.39	130.38	130.34	130.27	130.20
Quote Progetto		130.39	129.82	129.89	129.82	130.28
Parziali			2.50	2.50		
Progressiva		-2.67	-2.50	0.00	2.50	2.56
Dislivelli		0.00	-0.16	-0.45	-0.46	0.00

Sezione: 35
 Progressiva: 345.879
 Q. Progetto: 130.240

128.00

Quote Terreno	130.41	130.32	130.26	130.20	130.15	130.14
Quote Progetto		130.31	129.78	129.84	129.90	130.21
Parziali			2.50	2.50		
Progressiva		-2.63	-2.50	0.00	2.50	2.59
Dislivelli		0.00	-0.13	-0.42	-0.31	0.00

Sezione: 36
 Progressiva: 350.000
 Q. Progetto: 130.207

128.00

Quote Terreno	130.37	130.27	130.21	130.19	130.11	
Quote Progetto		130.26	129.74	129.81	129.87	130.17
Parziali			2.50	2.50		
Progressiva		-2.62	-2.50	0.00	2.50	2.60
Dislivelli		0.00	-0.12	-0.40	-0.30	0.00

Sezione: 37
 Progressiva: 360.000
 Q. Progetto: 130.128

128.00

Quote Terreno	130.25	130.25	130.16	130.13	130.05	130.05	130.05
Quote Progetto			130.18	129.67	129.73	129.79	130.10
Parziali			2.50	2.50			
Progressiva			-2.61	-2.50	0.00	2.50	2.60
Dislivelli			-0.00	-0.11	-0.41	-0.31	0.00

Sezione: 38
 Progressiva: 370.000
 Q. Progetto: 129.926

128.00

Quote Terreno	130.19	130.13	130.07	130.06	130.03	130.03
Quote Progetto		130.12	129.46	129.53	129.59	130.05
Parziali		2.50	2.50			
Progressiva		-2.75	-2.50	0.00	2.50	2.56
Dislivelli		-0.00	-0.25	-0.54	-0.46	0.00

Sezione: 39
 Progressiva: 380.000
 Q. Progetto: 129.532

128.00

Quote Terreno	130.14	130.10	130.06	130.04	130.00	
Quote Progetto		130.06	129.07	129.13	129.19	130.02
Parziali		0.59	2.50	2.50	0.43	
Progressiva		-3.09	-2.50	0.00	2.50	2.93
Dislivelli		0.00	-0.59	-0.91	-0.83	0.00

Sezione: 40
 Progressiva: 387.296
 Q. Progetto: 129.204

127.00

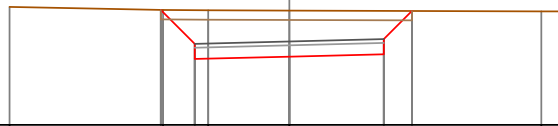

Quote Terreno	130.12	130.04	130.03	130.02	130.00	130.00
Quote Progetto		130.04	128.74	128.80	128.87	130.01
Parziali		0.90	2.50	2.50	0.75	
Progressiva		-3.40	-2.50	0.00	2.50	3.25
Dislivelli		0.00	-0.89	-1.22	-1.15	-0.00

Sezione: 41
 Progressiva: 390.000
 Q. Progetto: 129.083

127.00

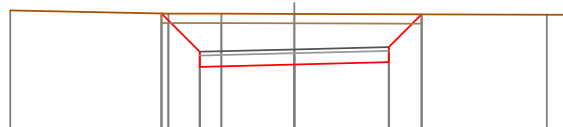

Quote Terreno	130.11	130.03	130.03	130.02	130.00	130.00
Quote Progetto		130.03	128.62	128.68	128.75	130.01
Parziali		1.01	2.50	2.50	0.87	
Progressiva		-3.51	-2.50	0.00	2.50	3.37
Dislivelli		0.00	-1.01	-1.34	-1.27	0.00

Sezione: 42
 Progressiva: 400.000
 Q. Progetto: 128.702

127.00

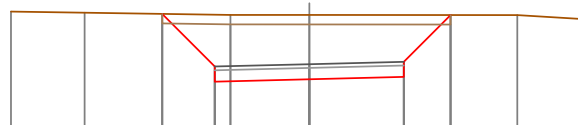

Quote Terreno	130.09	130.06	130.00	130.00	130.00	129.86
Quote Progetto			130.03	128.24	128.30	128.36
Parziali			1.39	2.50	2.50	1.24
Progressiva			-3.89	-2.50	0.00	2.50
Dislivelli			-0.00	-1.37	-1.70	-1.64
						0.00

Sezione: 43
 Progressiva: 410.000
 Q. Progetto: 128.518

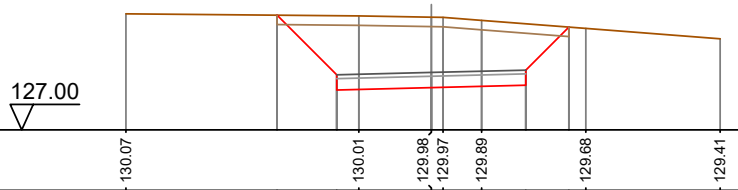

Quote Terreno		130.07		130.01		129.98		129.97		129.89		129.68		129.41
Quote Progetto			130.03		128.06		128.12		128.18		129.72			
Parziali				1.58		2.50		2.50		1.14				
Progressiva			-4.08		-2.50		0.00		2.50		3.64			
Dislivelli			0.00		-1.56		-1.86		-1.62		0.00			

Sezione: 44
 Progressiva: 414.400
 Q. Progetto: 128.500

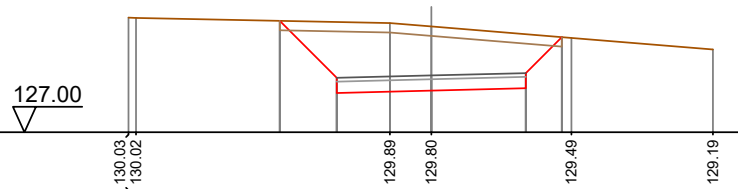

Quote Terreno		130.03		130.02		129.89		129.80		129.49		129.19
Quote Progetto			129.94		128.04		128.10		128.16		129.51	
Parziali				1.51		2.50		2.50		0.95		
Progressiva			-4.01		-2.50		0.00		2.50		3.45	
Dislivelli			0.00		-1.48		-1.70		-1.43		-0.00	

SEZIONI TRASVERSALI
Profilo longitudinale tratto 23-24
Viabilità di impianto - Asse di manovra WTG01 - A

Nota: Le canalette di deflusso delle acque meteoriche, non indicate nel presente elaborato, sono rappresentate graficamente nelle sezioni stradali tipo dell'elaborato "BLTX-NS-TC13_Piazzole aerogeneratori e strade di servizio - Particolari costruttivi", individuate planimetricamente nell'elaborato "BLTX-NS-TC14_Opere di regimazione acque superficiali - Planimetria generale" e quantificate nell'elaborato "BLTX-NS-RC6_Computo metrico estimativo opere civili".

DISEGNI DI RIFERIMENTO

TAVOLA	DESCRIZIONE
BLTX-NS-TC8	Viabilità e piazzole - Planimetria di progetto - Fase di cantiere
BLTX-NS-TC11	Profili longitudinali viabilità di impianto
BLTX-NS-TC13	Piazzole aerogeneratori e strade di servizio - Particolari costruttivi
BLTX-NS-TC14	Opere di regimazione acque superficiali - Planimetria generale

Sezione: 1
 Progressiva: 0.000
 Q. Progetto: 140.000

138.00



Quote Terreno	140.00	140.00	140.00	140.00	140.00	140.00
Quote Progetto			140.00	139.60	139.60	140.00
Parziali			2.50	2.50		
Progressiva			-2.56	0.00	2.50	2.56
Dislivelli			0.00	-0.40	-0.46	0.00

Sezione: 2
 Progressiva: 20.000
 Q. Progetto: 139.996

138.00



Quote Terreno	140.00	140.00	140.00	140.00	140.00	140.00
Quote Progetto			140.00	139.60	139.60	140.00
Parziali			2.50	2.50		
Progressiva			-2.57	0.00	2.50	2.57
Dislivelli			0.00	-0.40	-0.47	0.00

Sezione: 3
 Progressiva: 40.000
 Q. Progetto: 139.991

138.00

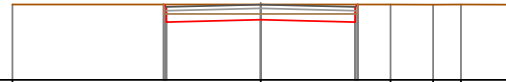

Quote Terreno	140.00		139.99		139.99		139.99		139.99
Quote Progetto		139.99	139.53		139.59		139.53	139.99	
Parziali		2.50		2.50					
Progressiva		-2.57	-2.50	0.00		2.50	2.56		
Dislivelli		0.00	-0.07	-0.40		-0.46	-0.00		

Sezione: 4
 Progressiva: 60.000
 Q. Progetto: 139.987

138.00

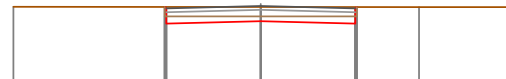

Quote Terreno	139.97		139.96		139.96		139.96		139.96
Quote Progetto		139.96	139.52		139.59		139.52	139.96	
Parziali		2.50		2.50					
Progressiva		-2.54	-2.50	0.00		2.50	2.54		
Dislivelli		0.00	-0.04	-0.38		-0.44	-0.00		

Sezione: 5
 Progressiva: 80.000
 Q. Progetto: 139.982

138.00

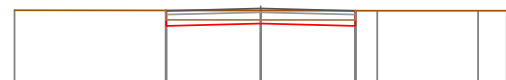

Quote Terreno	139.93		139.93		139.92		139.92		139.92
Quote Progetto		139.52		139.58		139.52			
Parziali		2.50		2.50					
Progressiva		-2.51		0.00		2.50			
Dislivelli		-0.00		-0.35		-0.41			

Sezione: 6
 Progressiva: 91.987
 Q. Progetto: 139.980

138.00

Quote Terreno	139.91	139.91	139.91	139.91	139.90	139.90
Quote Progetto			139.52	139.58	139.64	139.90
Parziali			2.50	2.50		
Progressiva			-2.51	0.00	2.50	2.64
Dislivelli			0.00	-0.33	-0.26	-0.00

Sezione: 7
 Progressiva: 100.000
 Q. Progetto: 139.978

138.00

Quote Terreno	139.90	139.90	139.89	139.89	139.88	139.88
Quote Progetto			139.52	139.58	139.64	139.89
Parziali			2.50	2.50		
Progressiva			-2.52	0.00	2.50	2.65
Dislivelli			-0.00	-0.31	-0.25	0.00

Sezione: 8
 Progressiva: 110.000
 Q. Progetto: 139.976

138.00

Quote Terreno	139.89	139.88	139.88	139.87	139.86	139.86
Quote Progetto		139.51	139.58	139.64	139.87	
Parziali		2.50	2.50			
Progressiva		-2.53	0.00	2.50	2.67	
Dislivelli		-0.00	-0.30	-0.23	0.00	

Sezione: 9
 Progressiva: 120.000
 Q. Progetto: 139.974

138.00

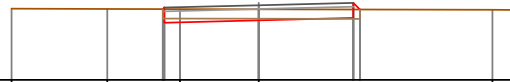

Quote Terreno	139.88	139.88	139.87	139.87	139.85	139.85
Quote Progetto			139.87 139.51	139.57	139.64 139.86	
Parziali			2.50	2.50		
Progressiva			-2.54 -2.50	0.00	2.50 2.68	
Dislivelli			0.00 0.04	-0.29	-0.22 -0.00	

Sezione: 10
 Progressiva: 130.000
 Q. Progetto: 139.971

138.00



Quote Terreno	139.88		139.87	139.86	139.86	139.85
Quote Progetto			139.87 139.51	139.57	139.63 139.86	
Parziali			2.50	2.50		
Progressiva			-2.54 -2.50	0.00	2.50 2.68	
Dislivelli			0.00 0.04	-0.29	-0.22 -0.00	

Sezione: 11
 Progressiva: 136.261
 Q. Progetto: 139.970

138.00



Quote Terreno	139.88	139.87	139.86	139.86	139.85
Quote Progetto		139.87 139.51	139.57	139.63 139.86	
Parziali		2.50	2.50		
Progressiva		-2.54 -2.50	0.00	2.50 2.68	
Dislivelli		0.00 0.04	-0.29	-0.22 0.00	

Sezione: 12
 Progressiva: 140.000
 Q. Progetto: 139.969

138.00

Quote Terreno	-139.88	-139.87	-139.87	-139.86	-139.85	-139.85
Quote Progetto		139.87 139.51	139.57	139.63 139.86		
Parziali		2.50	2.50			
Progressiva		-2.54 -2.50	0.00	2.50 2.67		
Dislivelli		-0.00 0.04	-0.30	-0.23 -0.00		

Sezione: 13
 Progressiva: 150.000
 Q. Progetto: 139.967

138.00

Quote Terreno	-139.89	-139.88	-139.88	-139.87	-139.87	-139.86
Quote Progetto		139.88 139.50	139.57	139.63 139.87		
Parziali		2.50	2.50			
Progressiva		-2.52 -2.50	0.00	2.50 2.66		
Dislivelli		0.00 0.02	-0.31	-0.24 -0.00		

Sezione: 14
 Progressiva: 160.000
 Q. Progetto: 139.965

138.00

Quote Terreno	-139.90	-139.89	-139.89	-139.88	-139.88	-139.88
Quote Progetto		139.50	139.56	139.63 139.88		
Parziali		2.50	2.50			
Progressiva		-2.51	0.00	2.50 2.64		
Dislivelli		0.00	-0.32	-0.26 0.00		

SEZIONI TRASVERSALI
Profilo longitudinale tratto 25-26
Viabilità di impianto - Asse di manovra WTG01 - B

Nota: Le canalette di deflusso delle acque meteoriche, non indicate nel presente elaborato, sono rappresentate graficamente nelle sezioni stradali tipo dell'elaborato "BLTX-NS-TC13_Piazzole aerogeneratori e strade di servizio - Particolari costruttivi", individuate planimetricamente nell'elaborato "BLTX-NS-TC14_Opere di regimazione acque superficiali - Planimetria generale" e quantificate nell'elaborato "BLTX-NS-RC6_Computo metrico estimativo opere civili".

DISEGNI DI RIFERIMENTO

TAVOLA	DESCRIZIONE
BLTX-NS-TC8	Viabilità e piazzole - Planimetria di progetto - Fase di cantiere
BLTX-NS-TC11	Profili longitudinali viabilità di impianto
BLTX-NS-TC13	Piazzole aerogeneratori e strade di servizio - Particolari costruttivi
BLTX-NS-TC14	Opere di regimazione acque superficiali - Planimetria generale

Sezione: 3
 Progressiva: 28.000
 Q. Progetto: 139.802

138.00

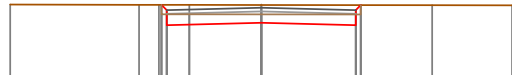

Quote Terreno	139.88	139.88	139.88	139.88	139.87	139.87
Quote Progetto		139.88	139.84	139.40	139.34	139.87
Parziali			2.50		2.50	
Progressiva		-2.64	-2.50	0.00	2.50	2.63
Dislivelli		-0.00	-0.14	-0.47	-0.53	0.00

Sezione: 4
 Progressiva: 31.775
 Q. Progetto: 139.785

138.00



Quote Terreno	139.88	139.88	139.87	139.87	139.86	139.86	139.86	139.86
Quote Progetto			139.87	139.45	139.39	139.32	139.86	
Parziali				2.50		2.50		
Progressiva		-2.52	-2.50	0.00	2.50	2.64		
Dislivelli		-0.00	-0.02	-0.48	-0.54	-0.00		

Sezione: 5
 Progressiva: 40.000
 Q. Progetto: 139.748

138.00

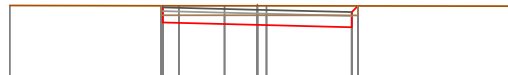

Quote Terreno	139.86	139.85	139.85	139.85	139.85	139.84
Quote Progetto		139.85	139.41	139.35	139.29	139.85
Parziali		2.50		2.50		
Progressiva		-2.54	-2.50	0.00	2.50	2.66
Dislivelli		0.00	-0.04	-0.50	-0.56	0.00

Sezione: 6
 Progressiva: 50.000
 Q. Progetto: 139.704

138.00

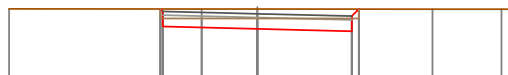

Quote Terreno	139.83	139.83	139.83	139.83	139.83	139.82
Quote Progetto		139.83	139.37	139.30	139.24	139.83
Parziali		2.50		2.50		
Progressiva		-2.56	-2.50	0.00	2.50	2.69
Dislivelli		0.00	-0.06	-0.53	-0.59	-0.00

Sezione: 7
 Progressiva: 60.000
 Q. Progetto: 139.659

138.00

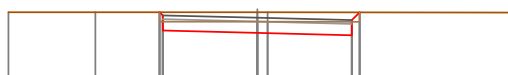

Quote Terreno	139.81	139.81	139.80	139.80	139.80	139.80
Quote Progetto		139.80	139.32	139.26	139.20	139.80
Parziali		2.50		2.50		
Progressiva		-2.58	-2.50	0.00	2.50	2.71
Dislivelli		0.00	-0.08	-0.55	-0.61	0.00

Sezione: 8
 Progressiva: 66.303
 Q. Progetto: 139.631

138.00



Quote Terreno	-139.79	-139.79			-139.79	-139.79	-139.78
Quote Progetto		139.79	139.29		139.23	139.17	139.79
Parziali			2.50		2.50		
Progressiva		-2.59	-2.50		0.00	2.50	2.72
Dislivelli		0.00	-0.09		-0.56	-0.62	0.00

Sezione: 9
 Progressiva: 70.000
 Q. Progetto: 139.614

138.00



Quote Terreno	-139.78	-139.77	-139.77	-139.77	-139.77	-139.77	-139.77
Quote Progetto		139.77	139.28		139.21	139.15	139.77
Parziali			2.50		2.50		
Progressiva		-2.60	-2.50		0.00	2.50	2.72
Dislivelli		0.00	-0.10		-0.56	-0.62	0.00

SEZIONI TRASVERSALI

Profilo longitudinale tratto 27-28

Viabilità di impianto - Asse di manovra WTG05

Nota: Le canalette di deflusso delle acque meteoriche, non indicate nel presente elaborato, sono rappresentate graficamente nelle sezioni stradali tipo dell'elaborato "BLTX-NS-TC13_Piazzole aerogeneratori e strade di servizio - Particolari costruttivi", individuate planimetricamente nell'elaborato "BLTX-NS-TC14_Opere di regimazione acque superficiali - Planimetria generale" e quantificate nell'elaborato "BLTX-NS-RC6_Computo metrico estimativo opere civili".

DISEGNI DI RIFERIMENTO

TAVOLA	DESCRIZIONE
BLTX-NS-TC8	Viabilità e piazzole - Planimetria di progetto - Fase di cantiere
BLTX-NS-TC11	Profili longitudinali viabilità di impianto
BLTX-NS-TC13	Piazzole aerogeneratori e strade di servizio - Particolari costruttivi
BLTX-NS-TC14	Opere di regimazione acque superficiali - Planimetria generale

Sezione: 1
 Progressiva: 0.000
 Q. Progetto: 127.168

125.00

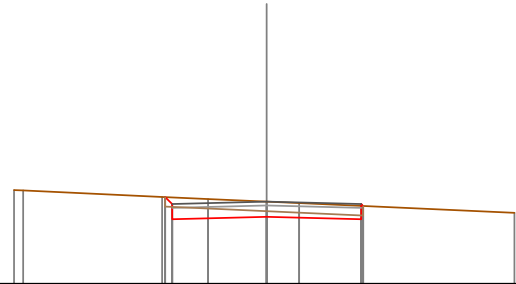

Quote Terreno	127.48	127.47	127.29	127.24	127.17	127.13	126.87
Quote Progetto			127.29	126.71	126.77	126.71	127.05
Parziali				2.50		2.50	
Progressiva			-2.68	-2.50	0.00	2.50	2.55
Dislivelli			0.00	-0.17	-0.40	-0.35	0.00

Sezione: 2
 Progressiva: 7.473
 Q. Progetto: 126.989

125.00

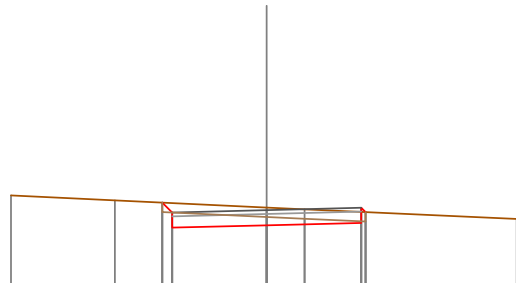

Quote Terreno	127.38	127.25	127.06	127.01	126.76		
Quote Progetto			127.19	126.53	126.65	126.94	
Parziali			2.50		2.50		
Progressiva			-2.76	-2.50	0.00	2.50	2.61
Dislivelli			0.00	-0.25	-0.47	-0.29	0.00

Sezione: 3
 Progressiva: 10.000
 Q. Progetto: 126.929

125.00

Quote Terreno	127.35	127.25		127.02	126.91	126.88	126.72
Quote Progetto			127.16	126.53	126.59	126.90	
Parziali			0.28	2.50	2.50		
Progressiva			-2.79	0.00	2.50	2.59	
Dislivelli			-0.00	-0.28	-0.50	-0.31	-0.00

Sezione: 4
 Progressiva: 20.000
 Q. Progetto: 126.747

125.00

Quote Terreno	127.30	127.26	127.09	126.95		126.69	126.62
Quote Progetto			127.09	126.35	126.41		
Parziali			0.41	2.50	2.50		
Progressiva			-2.91	0.00	2.50		
Dislivelli			0.00	-0.39	-0.60	-0.41	

Sezione: 5
 Progressiva: 30.000
 Q. Progetto: 126.652

125.00

Quote Terreno	127.33	127.27	127.19	126.97		126.62
Quote Progetto			127.12	126.25	126.31	126.83
Parziali			0.53	2.50	2.50	
Progressiva			-3.03	0.00	2.50	2.62
Dislivelli			0.00	-0.51	-0.71	-0.52

Sezione: 6
 Progressiva: 40.000
 Q. Progetto: 126.642

125.00

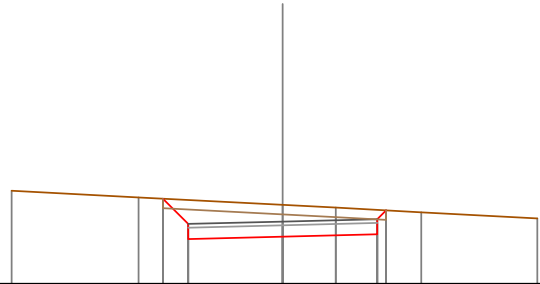

Quote Terreno	-127.46	-127.28	-127.08	-127.01	-126.89	-126.73
Quote Progetto		127.25	126.18	126.24	126.30	126.94
Parziali		0.67	2.50	2.50		
Progressiva		-3.17	-2.50	0.00	2.50	2.73
Dislivelli		-0.00	-0.63	-0.84	-0.65	-0.00

Sezione: 7
 Progressiva: 49.562
 Q. Progetto: 126.715

125.00

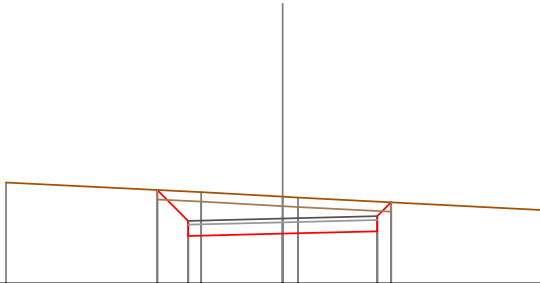

Quote Terreno	-127.67	-127.41	-127.29	-127.27	-126.94	
Quote Progetto		127.47	126.25	126.31	126.38	127.14
Parziali		0.82	2.50	2.50	0.37	
Progressiva		-3.32	-2.50	0.00	2.50	2.87
Dislivelli		0.00	-0.78	-0.98	-0.79	-0.00

Sezione: 8
 Progressiva: 50.000
 Q. Progetto: 126.720

125.00

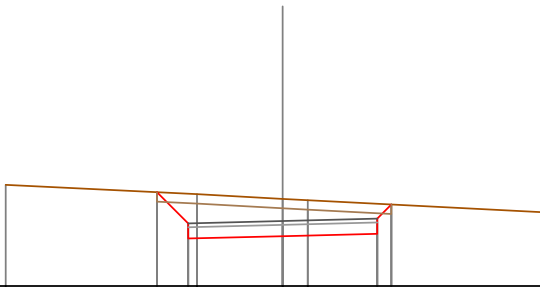

Quote Terreno	-127.68	-127.43	-127.31	-127.27	-126.95	
Quote Progetto		127.48	126.26	126.32	126.38	127.16
Parziali		0.82	2.50	2.50	0.37	
Progressiva		-3.32	-2.50	0.00	2.50	2.87
Dislivelli		0.00	-0.78	-0.99	-0.79	0.00

Sezione: 9
 Progressiva: 60.000
 Q. Progetto: 126.883

125.00

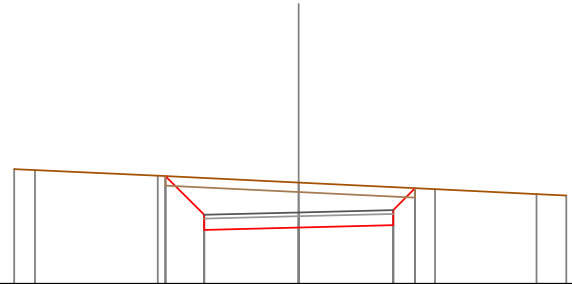

Quote Terreno	128.03	128.01	127.85	127.67	127.50	127.37	127.33
Quote Progetto			127.84	126.42	126.48	126.55	127.52
Parziali			1.02	2.50	2.50	0.58	
Progressiva			-3.52	-2.50	0.00	2.50	3.08
Dislivelli			-0.00	-0.97	-1.19	-1.01	-0.00

Sezione: 10
 Progressiva: 70.000
 Q. Progetto: 127.134

125.00

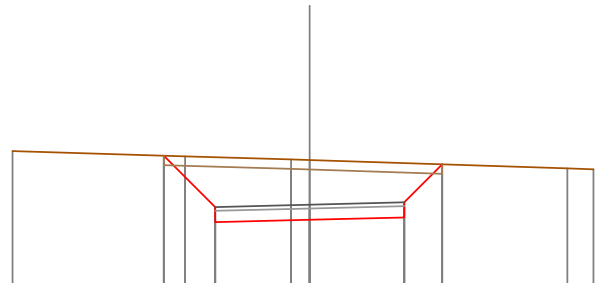

Quote Terreno	128.55	128.41	128.33	128.31	128.09	128.07
Quote Progetto		128.43	126.67	126.73	126.80	128.20
Parziali		1.36	2.50	2.50	1.00	
Progressiva		-3.86	-2.50	0.00	2.50	3.50
Dislivelli		0.00	-1.32	-1.58	-1.44	-0.00

Sezione: 11
 Progressiva: 80.000
 Q. Progetto: 127.471

126.00

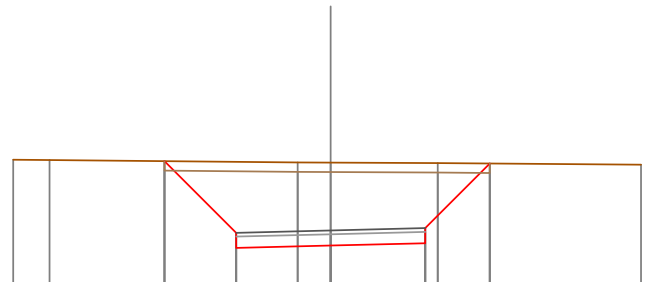

Quote Terreno	129.34	129.33	129.27	129.27	129.25	129.21
Quote Progetto		129.30	127.01	127.07	127.13	129.24
Parziali		1.90	2.50	2.50	1.71	
Progressiva		-4.40	-2.50	0.00	2.50	4.21
Dislivelli		0.00	-1.88	-2.20	-2.12	-0.00

Sezione: 12
 Progressiva: 90.000
 Q. Progetto: 127.887

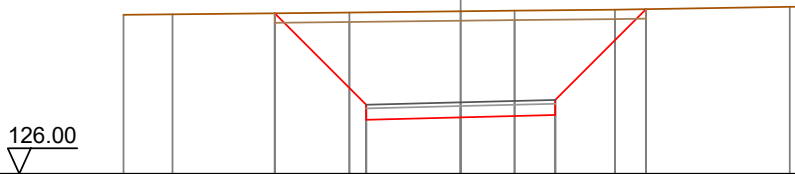

Quote Terreno		130.20	130.21		130.26	130.29	130.31	130.34	130.41	130.42
Quote Progetto				130.24	127.42	127.49	127.55	130.35		
Parziali				2.42	2.50	2.50	2.40			
Progressiva				-4.92	-2.50	0.00	2.50	4.90		
Dislivelli				0.00	-2.44	-2.81	-2.77	0.00		

Sezione: 13
 Progressiva: 91.651
 Q. Progetto: 127.959

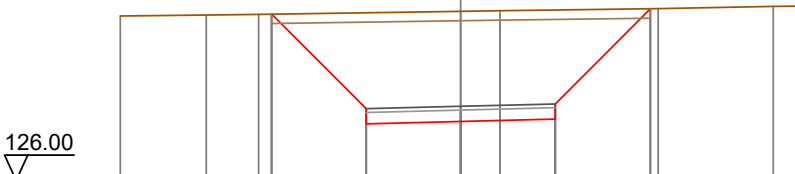

Quote Terreno		130.35	130.37	130.39		130.47	130.49	130.54	130.60	130.61
Quote Progetto				130.40	127.50	127.56	127.62	130.54		
Parziali				2.50	2.50	2.50	2.52			
Progressiva				-5.00	-2.50	0.00	2.50	5.02		
Dislivelli				0.00	-2.54	-2.91	-2.88	0.00		

Sezione: 14
 Progressiva: 100.000
 Q. Progetto: 128.320

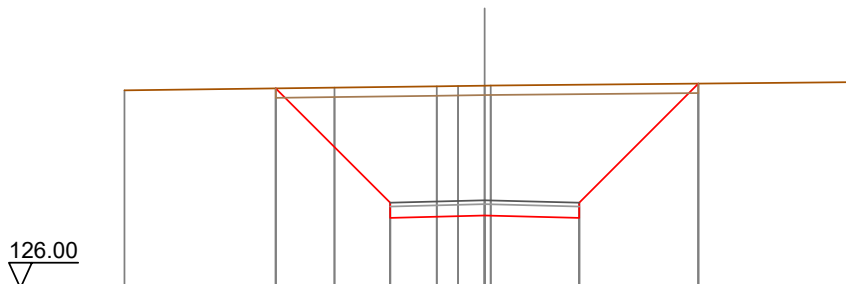

Quote Terreno		131.23		131.30	131.34	131.34	131.35	131.36		131.45
Quote Progetto			131.28	127.86	127.92	127.86	131.41			
Parziali			3.02	2.50	2.50	3.15				
Progressiva			-5.52	-2.50	0.00	2.50	5.65			
Dislivelli			0.00	-3.06	-3.43	-3.52	0.00			

Sezione: 15
 Progressiva: 120.000
 Q. Progetto: 129.185

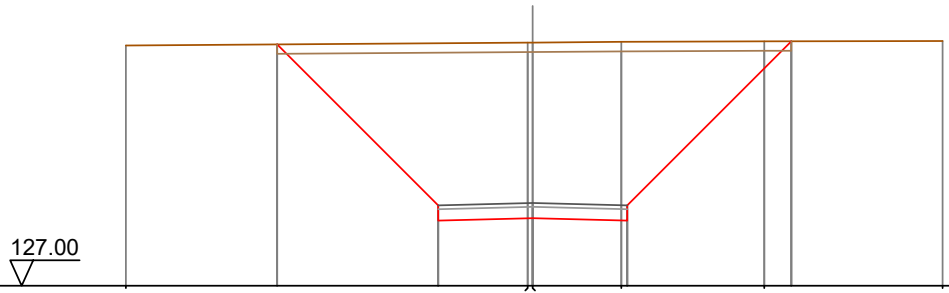

Quote Terreno		133.35		133.43	133.43	133.45		133.46		133.47
Quote Progetto		133.38		128.72	128.78	128.72		133.46		
Parziali			4.26		2.50	2.50		4.34		
Progressiva		-6.76		-2.50	0.00	2.50		6.84		
Dislivelli		-0.00		-4.29	-4.65	-4.73		0.00		

Sezione: 16
 Progressiva: 138.847
 Q. Progetto: 130.000

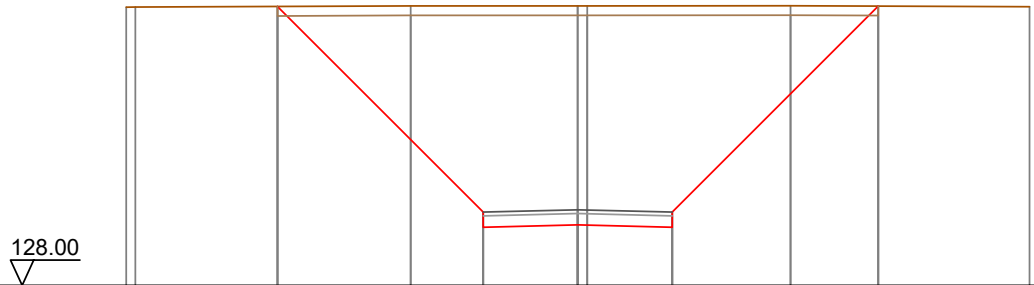

Quote Terreno		135.36		135.39	135.39	135.40		135.37		
Quote Progetto		135.38		129.54	129.60	129.54		135.39		
Parziali			5.44		2.50	2.50		5.45		
Progressiva		-7.94		-2.50	0.00	2.50		7.95		
Dislivelli		0.00		-5.45	-5.79	-5.86		-0.00		