

LEGENDA

- INTERRUTTORE AT CON COMANDO MOTORIZZATO
- SEZIONATORE MANUALE AT CON INTERBLOCCO LAME DI TERRA
- SEZIONATORE MOTORIZZATO ROTATIVO AT CON INTERBLOCCO LAME DI TERRA
- SCARICATORE
- TRASFORMATORE DI TENSIONE
- TRASFORMATORE DI CORRENTE
- TRASFORMATORE DI POTENZA (COMMUTATORE SOTTO CARICO MOTORIZZATO)
- TRASFORMATORE SERVIZI AUSILIARI
- GENERATORE ASINCRONO
- FUSIBILE
- INTERRUTTORE MT ASPORTABILE CON COMANDO MOTORIZZATO
- INDICATORE CAPACITIVO PRESENZA TENSIONE
- LAME DI MESSA A TERRA
- INTERRUTTORE AUTOMATICO
- CONTATORE DI MANOVRA
- SEZIONATORE ROTATIVO CON MESSA A TERRA
- SEZIONATORE ROTATIVO SOTTOCARICO CON MESSA A TERRA
- LAMPADA DI SEGNALAZIONE
- BLOCCO A CHIAVE, CHIAVE LIBERA IN APERTO
- BLOCCO A CHIAVE, CHIAVE LIBERA IN CHIUSO
- CONTATORE DI ENERGIA ATTIVA/REATTIVA ENTRANTE-USCENTE PER MISURE FISCALI
- MODULO IBRIDO MONOSTALLO ARIA-CAVO 145/170 kV
- 189 SA / 189 SB / SEZIONATORE DI SBARRA A E B
- B.O.C. BOBINA ONDE CONVOGLIATE
- TVC L TV CAPACITIVO LINEA

AUTORIZZAZIONE UNICA REGIONALE - ART. 12 DEL LGS. N. 387/2003











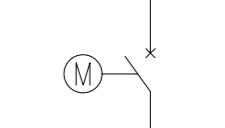
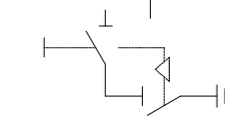
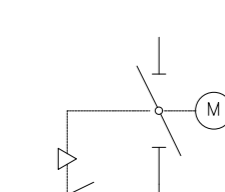
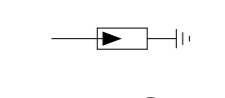

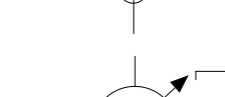
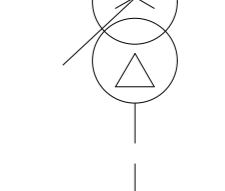
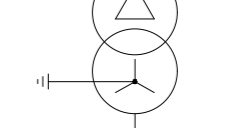
REGIONE BASILICATA
Progetto Definitivo
Parco Eolico Ischia Finata

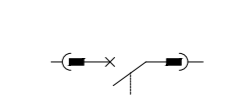
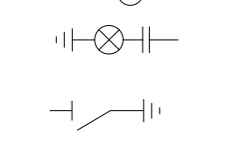
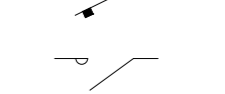
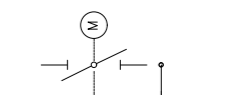
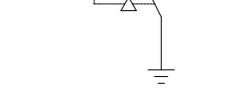
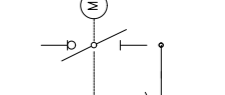
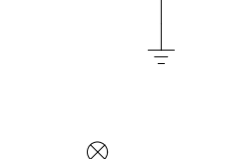
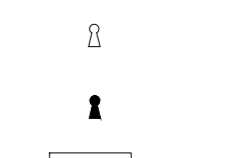
Titolo elaborato:
SCHEMA ELETTRICO UNIFILARE DEGLI IMPIANTI DI UTENTE E DI RTN (limitatamente allo stallo di competenza)

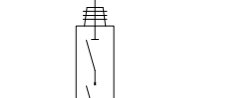
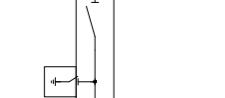
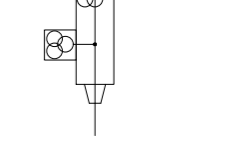
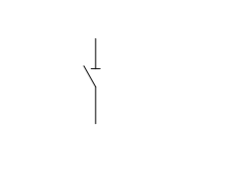
CG	TL	GD	Prima Emissione	01/07/2024	00
REDATTO	CONTR.	APPROV.	DESCRIZIONE REVISIONE DOCUMENTO	DATA	REV

<p>PROPONENTE</p> <p>ETESIA PRIME SRL Via A. De Gasperi n. 8 74023 Grottaglie (TA)</p>	<p>CONSULENZA</p> <p>ECODOR SRL Via A. De Gasperi n. 8 74023 Grottaglie (TA) PROGETTISTA Ing. Gaetano D'Oronzio</p>
--	--

-  INTERRUTTORE AT CON COMANDO MOTORIZZATO
-  SEZIONATORE MANUALE AT CON INTERBLOCCO LAME DI TERRA
-  SEZIONATORE MOTORIZZATO ROTATIVO AT CON INTERBLOCCO LAME DI TERRA
-  SCARICATORE
-  TRASFORMATORE DI TENSIONE
-  TRASFORMATORE DI CORRENTE
-  TRASFORMATORE DI POTENZA (COMMUTATORE SOTTO CARICO MOTORIZZATO)
-  TRASFORMATORE SERVIZI AUSILIARI
-  GENERATORE ASINCRONO
-  FUSIBILE
-  INTERRUTTORE MT ASPORTABILE CON COMANDO MOTORIZZATO
-  INDICATORE CAPACITIVO PRESENZA TENSIONE
-  LAME DI MESSA A TERRA
-  INTERRUTTORE AUTOMATICO
-  CONTATORE DI MANOVRA
-  SEZIONATORE ROTATIVO CON MESSA A TERRA
-  SEZIONATORE ROTATIVO SOTTOCARICO CON MESSA A TERRA
-  LAMPADA DI SEGNALAZIONE
-  BLOCCO A CHIAVE, CHIAVE LIBERA IN APERTO
-  BLOCCO A CHIAVE, CHIAVE LIBERA IN CHIUSO
-  CONTATORE DI ENERGIA ATTIVA/REATTIVA ENTRANTE-USCENTE PER MISURE FISCALI
-  MODULO IBRIDO MONOSTALLO ARIA-CAVO 145/170 kV
-  189 SA - 189 SB/ SEZIONATORE DI SBARRA A E B
-  B.O.C. BOBINA ONDE CONVOGLIATE
-  TVC L TV CAPACITIVO LINEA

Dettaglio installazione a bordo torre di generazione eolica

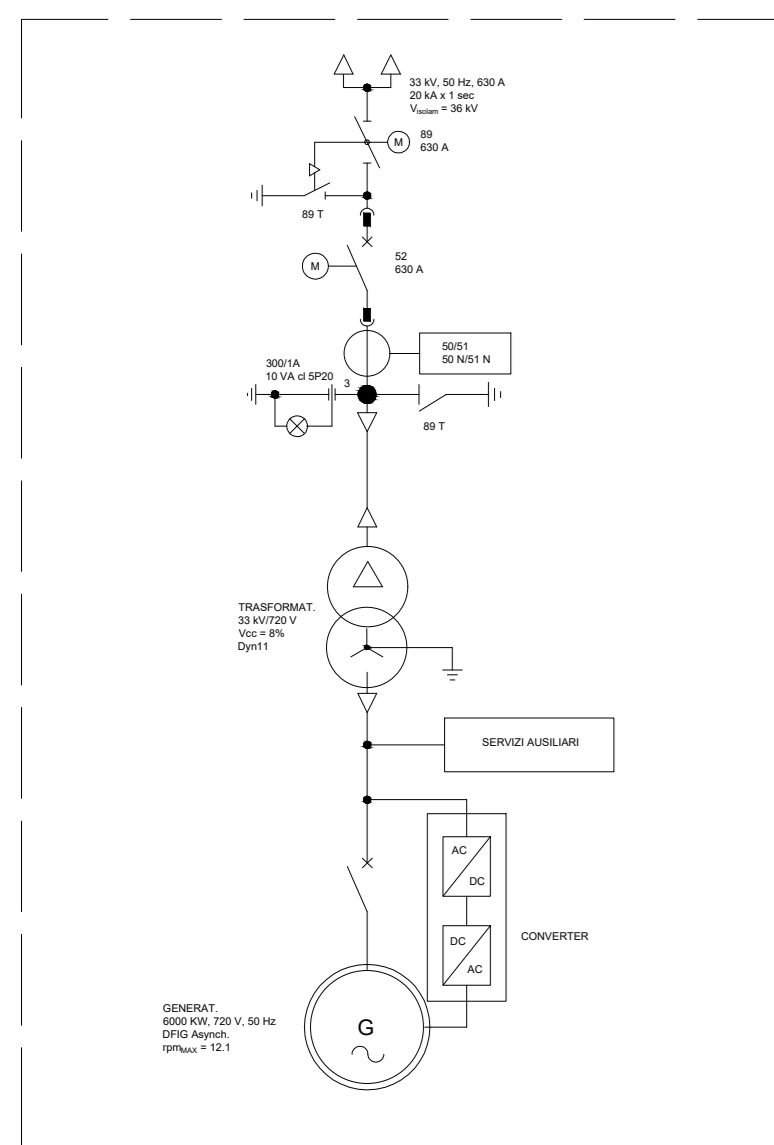

PARCO EOLICO ISCHIA FINATA

CIRCUITO A (33 kV) CIRCUITO B (33 kV) CIRCUITO C (33 kV) CIRCUITO D (33 kV)

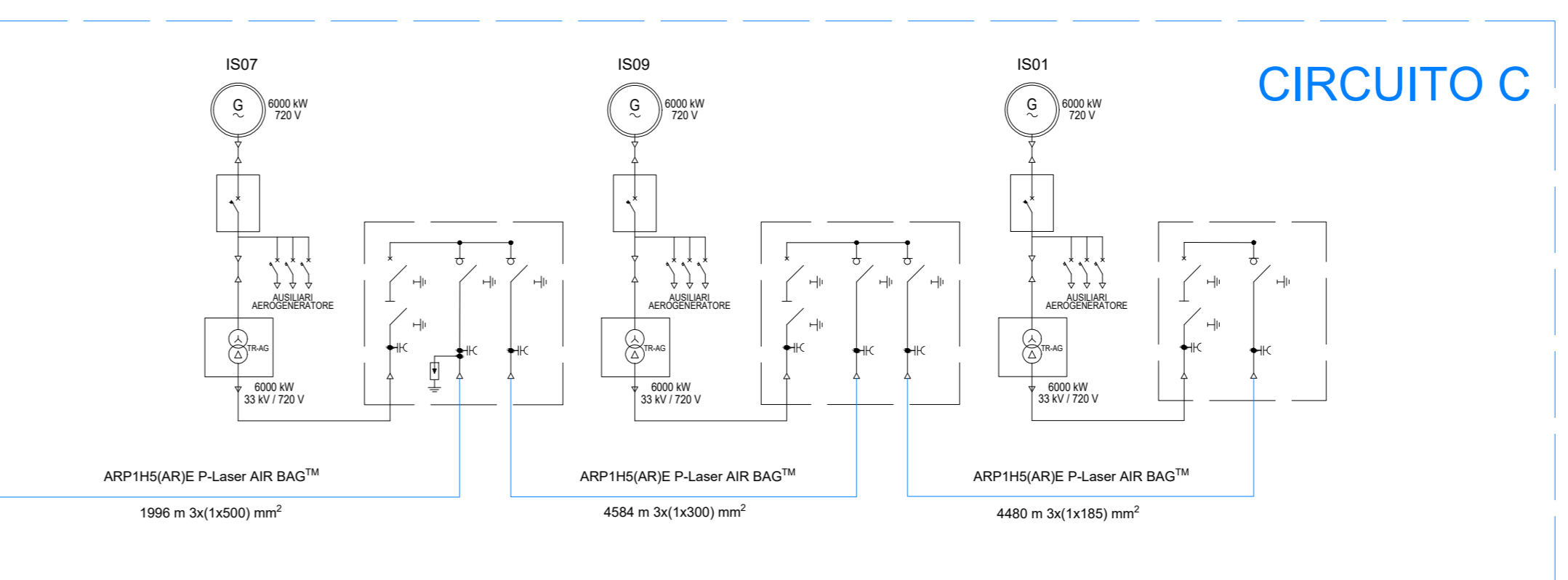
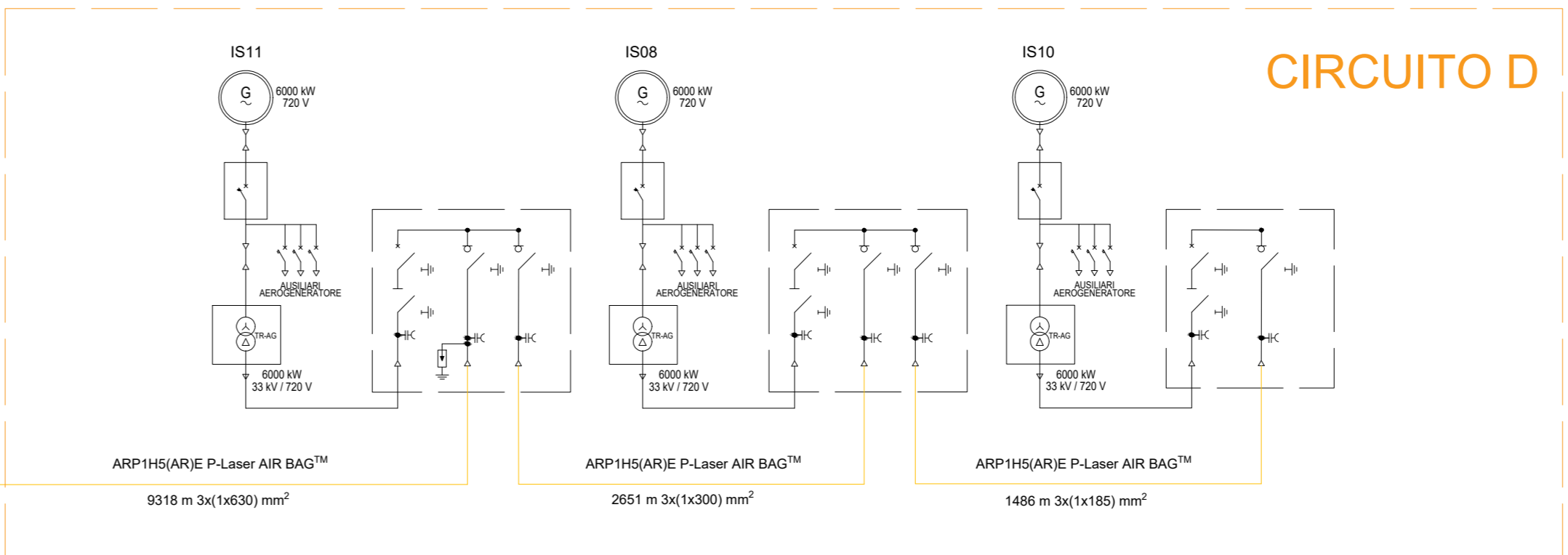
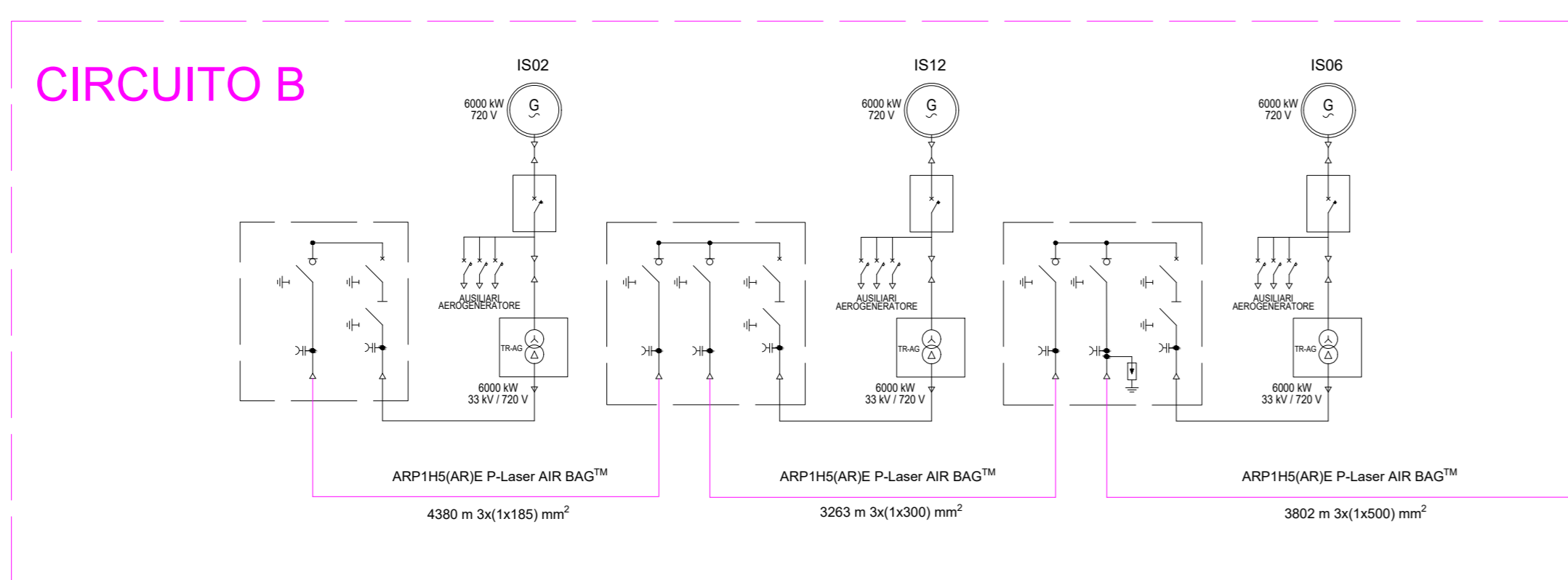
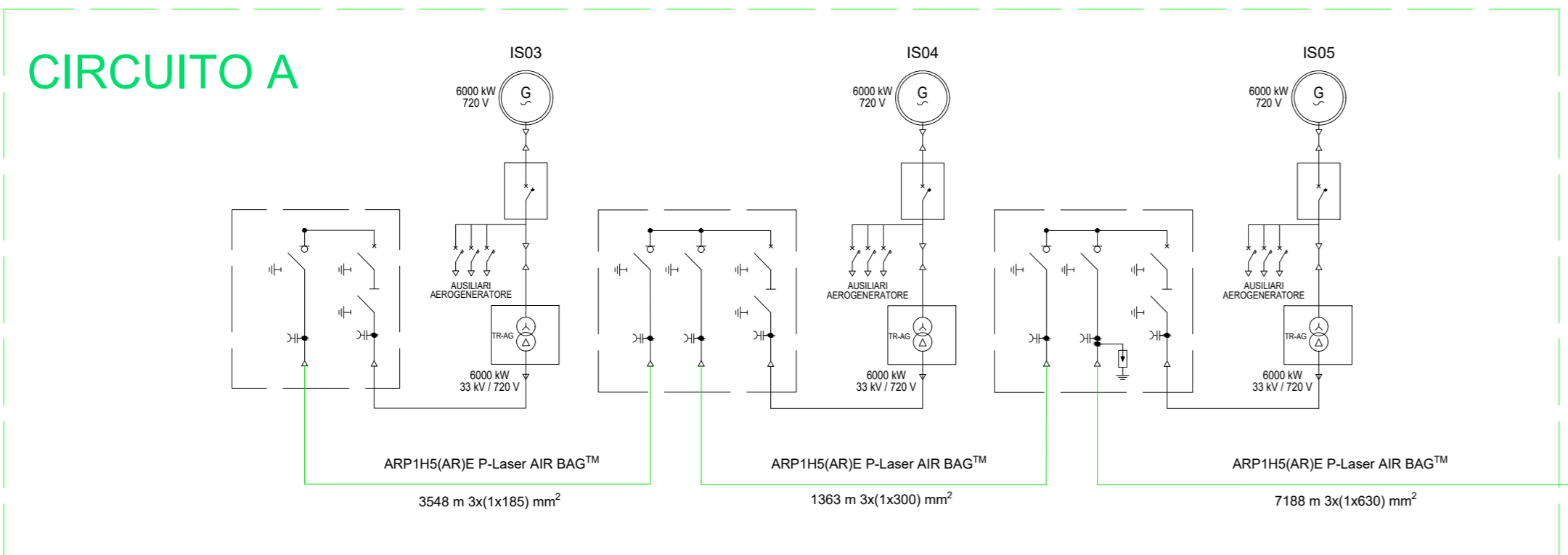

AUTORIZZAZIONE UNICA REGIONALE - ART. 12 DEL LGS. N. 387/2003



Progetto Definitivo
Parco Eolico Ischia Finata

Titolo elaborato:
SCHEMA ELETTRICO UNIFILARE DEGLI IMPIANTI DI UTENTE E DI RTN (limitatamente allo stallo di competenza)

CG	TL	GD	Prima Emissione	01/07/2024	00
REDATTO	CONTR.	APPROV.	DESCRIZIONE REVISIONE DOCUMENTO	DATA	REV

<p>PROPONENTE</p>  <p>ETESIA PRIME SRL Via A. De Gasperi n. 8 74023 Grottaglie (TA)</p>	<p>CONSULENZA</p>  <p>GECDOR SRL Via A. De Gasperi n. 8 74023 Grottaglie (TA) PROGETTISTA Ing. Gaetano D'Oronzio</p>
--	--

STAZIONE ELETTRICA UTENTE DI TRASFORMAZIONE 150/33 kV

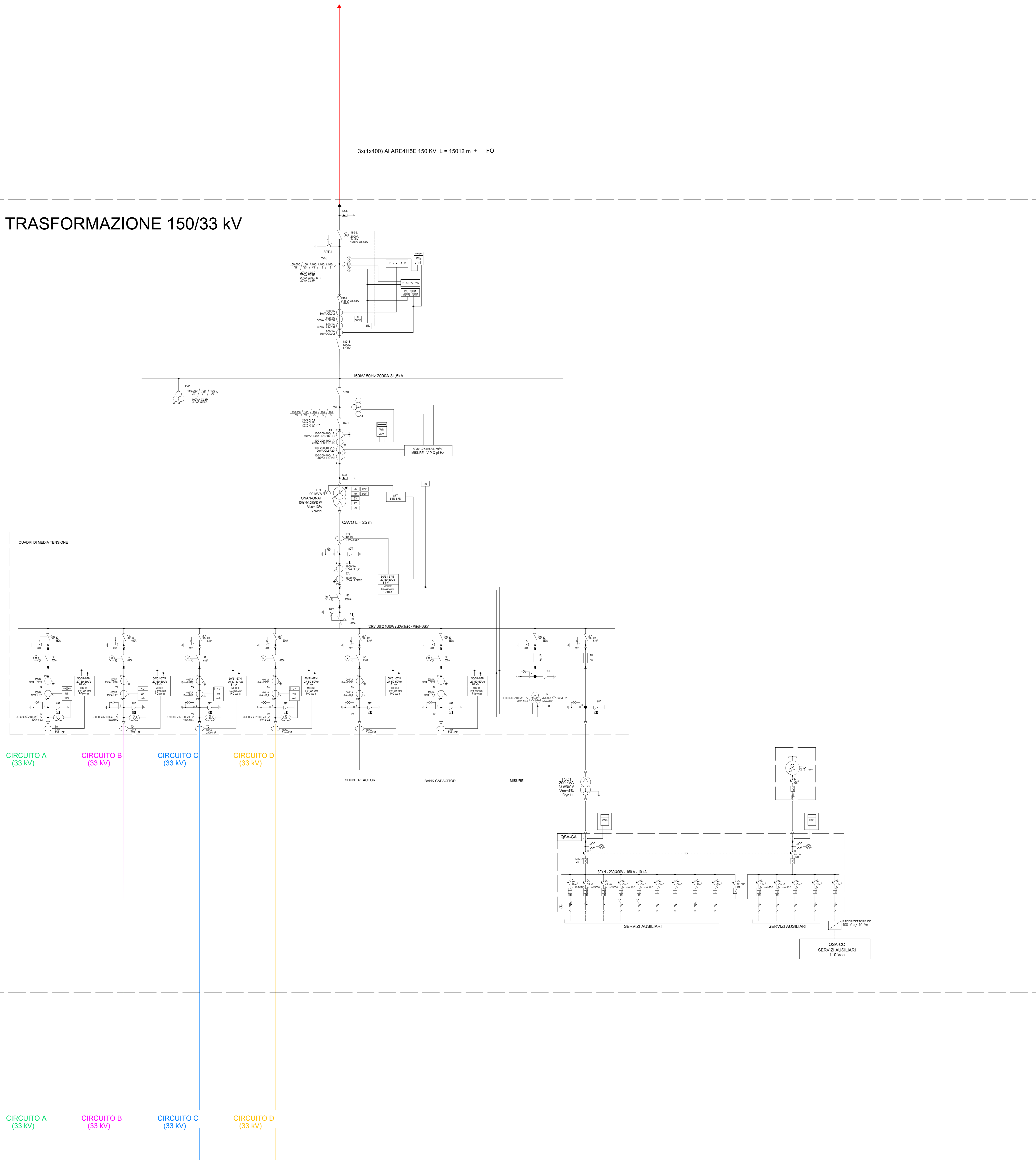

AUTORIZZAZIONE UNICA REGIONALE - ART. 12 DEL LGS. N. 387/2003











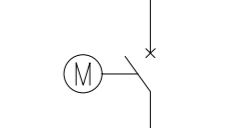
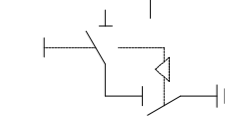
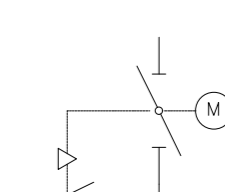
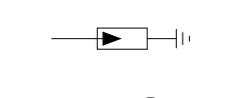

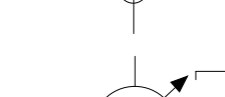
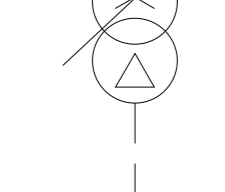
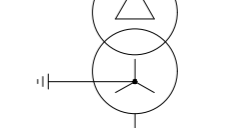

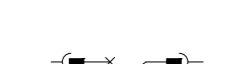
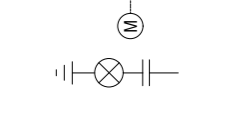
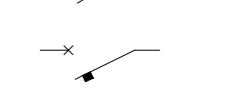
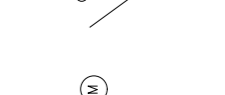

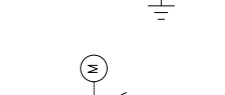
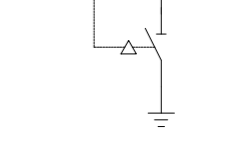
Parco Eolico Ischia Finata

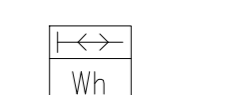
Titolo elaborato:
SCHEMA ELETTRICO UNIFILARE DEGLI IMPIANTI DI UTENTE E DI RTN (limitatamente allo stallo di competenza)

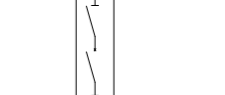
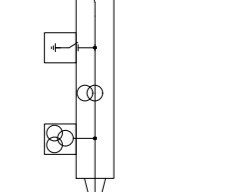
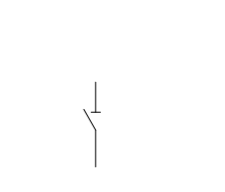
CG	TL	GD	Prima Emissione	01/07/2024	00
REDATTO	CONTR.	APPROV.	DESCRIZIONE REVISIONE DOCUMENTO	DATA	REV

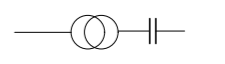
<p>PROPONENTE</p> <p>ETESIA PRIME SRL</p> <p>Via A. De Gasperi n. 8 74023 Grottaglie (TA)</p>	<p>CONSULENZA</p> <p>GECODOR SRL Via A. De Gasperi n. 8 74023 Grottaglie (TA)</p> <p>PROGETTISTA Ing. Gaetano D'Oronzio</p>
---	--

-  INTERRUTTORE AT CON COMANDO MOTORIZZATO
-  SEZIONATORE MANUALE AT CON INTERBLOCCO LAME DI TERRA
-  SEZIONATORE MOTORIZZATO ROTATIVO AT CON INTERBLOCCO LAME DI TERRA
-  SCARICATORE
-  TRASFORMATORE DI TENSIONE
-  TRASFORMATORE DI CORRENTE
-  TRASFORMATORE DI POTENZA (COMMUTATORE SOTTO CARICO MOTORIZZATO)
-  TRASFORMATORE SERVIZI AUSILIARI
-  GENERATORE ASINCRONO
-  FUSIBILE
-  INTERRUTTORE MT ASPORTABILE CON COMANDO MOTORIZZATO
-  INDICATORE CAPACITIVO PRESENZA TENSIONE
-  LAME DI MESSA A TERRA
-  INTERRUTTORE AUTOMATICO
-  CONTATORE DI MANOVRA
-  SEZIONATORE ROTATIVO CON MESSA A TERRA
-  SEZIONATORE ROTATIVO SOTTOCARICO CON MESSA A TERRA
-  LAMPADA DI SEGNALAZIONE
-  BLOCCO A CHIAVE, CHIAVE LIBERA IN APERTO
-  BLOCCO A CHIAVE, CHIAVE LIBERA IN CHIUSO
-  CONTATORE DI ENERGIA ATTIVA/REATTIVA ENTRANTE-USCENTE PER MISURE FISCALI
-  MODULO IBRIDO MONOSTALLO ARIA-CAVO 145/170 kV
-  189 SA - 189 SB/ SEZIONATORE DI SBARRA A E B
-  B.O.C. BOBINA ONDE CONVOGLIATE
-  TVC L TV CAPACITIVO LINEA

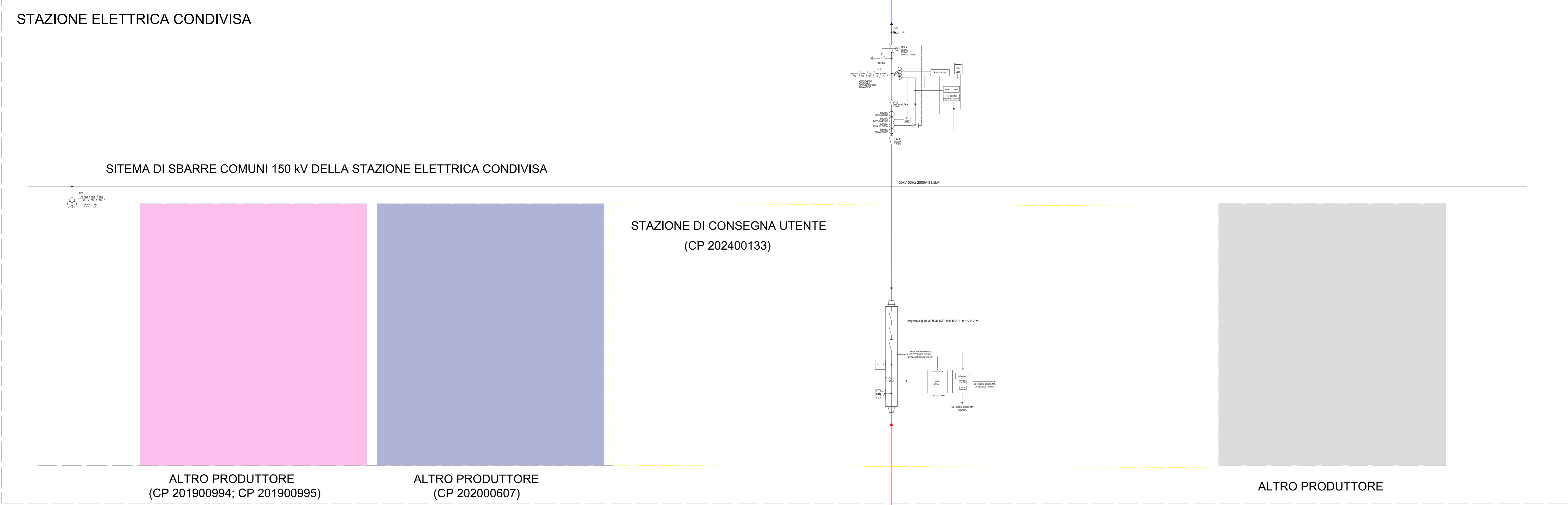

AUTORIZZAZIONE UNICA REGIONALE - ART. 12 DEL LGS. N. 387/2003





REGIONE BASILICATA
Progetto Definitivo
Comune di Poggioreale

Parco Eolico Ischia Finata







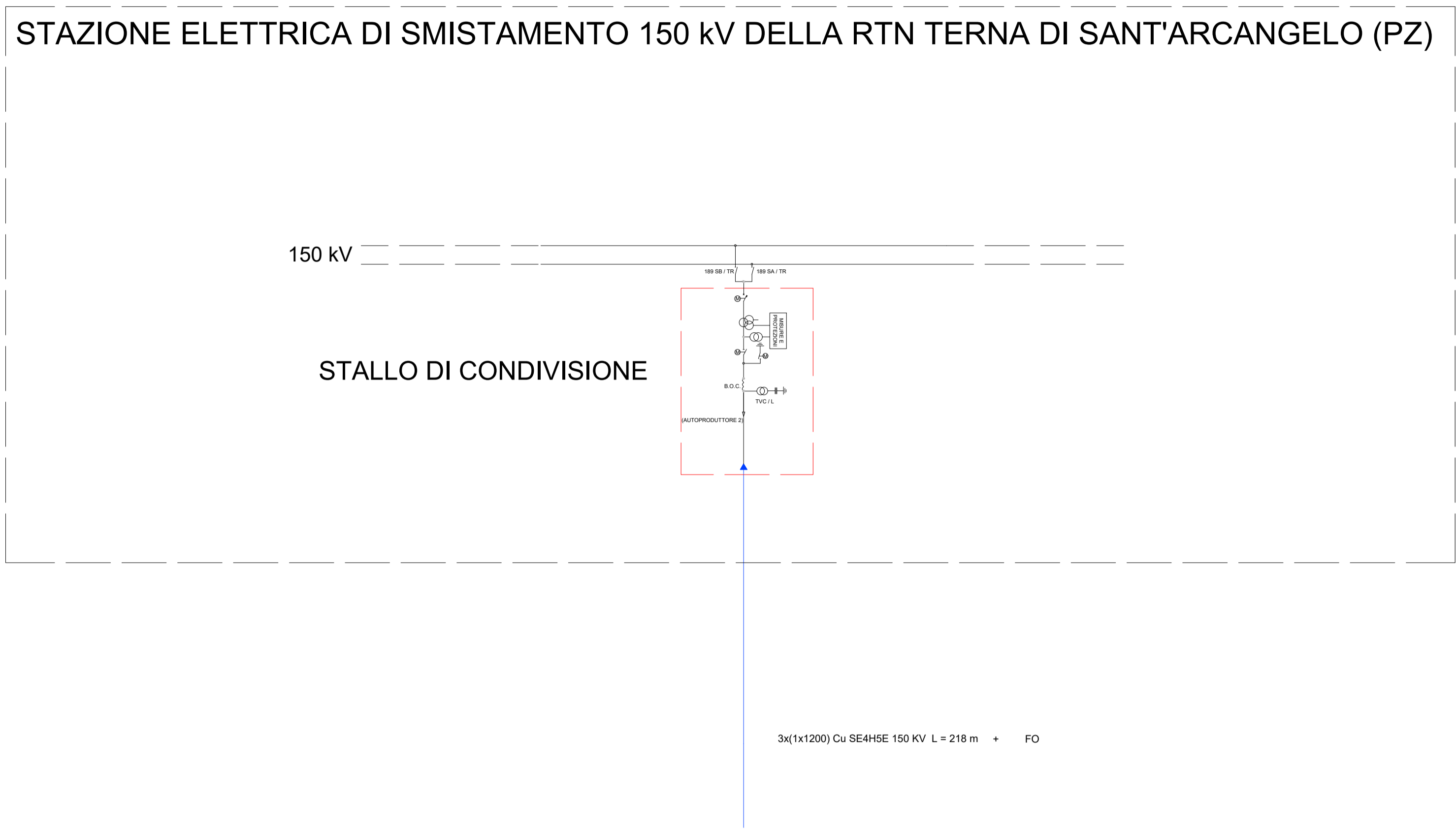



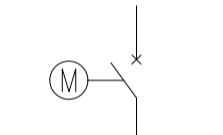
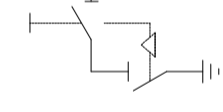
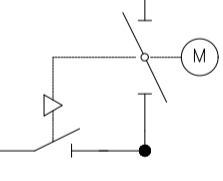
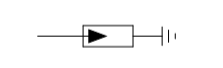
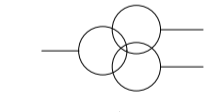

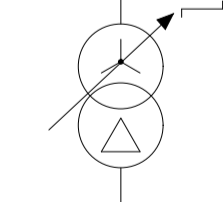
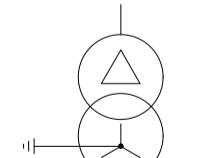
Titolo elaborato:
SCHEMA ELETTRICO UNIFILARE DEGLI IMPIANTI DI UTENTE E DI RTN (limitatamente allo stallo di competenza)

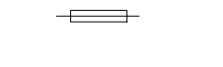
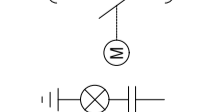
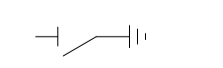
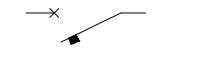
CG	TL	GD	Prima Emissione	01/07/2024	00
REDATTO	CONTR.	APPROV.	DESCRIZIONE REVISIONE DOCUMENTO	DATA	REV

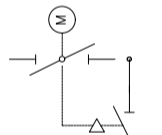
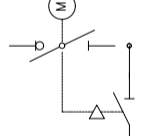
<p>PROPONENTE</p>  <p>ETESIA PRIME SRL Via A. De Gasperi n. 8 74023 Grottaglie (TA)</p>	<p>CONSULENZA</p>  <p>GECODOR SRL Via A. De Gasperi n. 8 74023 Grottaglie (TA)</p> <p>PROGETTISTA Ing. Gaetano D'Oronzio</p>
--	--

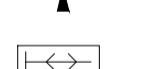

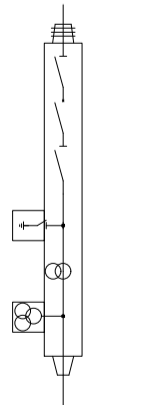
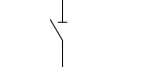
LEGENDA

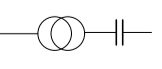
-  INTERRUTTORE AT CON COMANDO MOTORIZZATO
-  SEZIONATORE MANUALE AT CON INTERBLOCCO LAME DI TERRA
-  SEZIONATORE MOTORIZZATO ROTATIVO AT CON INTERBLOCCO LAME DI TERRA
-  SCARICATORE
-  TRASFORMATORE DI TENSIONE
-  TRASFORMATORE DI CORRENTE
-  TRASFORMATORE DI POTENZA (COMMUTATORE SOTTO CARICO MOTORIZZATO)
-  TRASFORMATORE SERVIZI AUSILIARI
-  GENERATORE ASINCRONO
-  FUSIBILE
-  INTERRUTTORE MT ASPORTABILE CON COMANDO MOTORIZZATO
-  INDICATORE CAPACITIVO PRESENZA TENSIONE
-  LAME DI MESSA A TERRA
-  INTERRUTTORE AUTOMATICO
-  CONTATORE DI MANOVRA
-  SEZIONATORE ROTATIVO CON MESSA A TERRA
-  SEZIONATORE ROTATIVO SOTTOCARICO CON MESSA A TERRA
-  LAMPADA DI SEGNALEZIONE
-  BLOCCO A CHIAVE, CHIAVE LIBERA IN APERTO
-  BLOCCO A CHIAVE, CHIAVE LIBERA IN CHIUSO
-  CONTATORE DI ENERGIA ATTIVA/REATTIVA ENTRANTE-USCENTE PER MISURE FISCALI
-  MODULO IBRIDO MONOSTALLO ARIA-CAVO 145/170 KV
-  189 SA/ - 189 SB/ SEZIONATORE DI SBARRA A E B
-  B.O.C. BOBINA ONDE CONVOGLIATE
-  TVC L TV CAPACITIVO LINEA

AUTORIZZAZIONE UNICA REGIONALE - ART. 12 DEL LGS. N. 387/2003



Progetto Definitivo

Parco Eolico Ischia Finata

Titolo elaborato:

SCHEMA ELETTRICO UNIFILARE DEGLI IMPIANTI DI UTENTE E DI RTN (limitatamente allo stallo di competenza)

CG	TL	GD	Prima Emissione	01/07/2024	00
REDATTO	CONTR.	APPROV.	DESCRIZIONE REVISIONE DOCUMENTO	DATA	REV

<p>PROPONENTE</p>  <p>ETESIA PRIME SRL</p> <p>Via A. De Gasperi n. 8 74023 Grottaglie (TA)</p>	<p>CONSULENZA</p>  <p>GECODOR SRL Via A. De Gasperi n. 8 74023 Grottaglie (TA)</p> <p>PROGETTISTA Ing. Gaetano D'Oronzio</p>
---	--