

PROPONENTE:**CUBICO CASALONE S.r.l.**

Via A. Manzoni 43
 20121 Milano (MI)
 c.f. e p.iva I3390000969
 cubicocasalone@legalmail.it



REALIZZAZIONE DI UN IMPIANTO AGRIVOLTAICO AVANZATO
 E OPERE DI CONNESSIONE ALLA R.T.N.
 DELLA POTENZA DI PICCOI MODULI FOTOVOLTAICI 36.287,68 kW_p
POTENZA NOMINALE INVERTER 34.240 kW
 POTENZA MASSIMA IN IMMISSIONE 29.000 kW

IMPIANTO AGRIVOLTAICO "CASALONE"
 COMUNE DI VITERBO (VT)
 REGIONE LAZIO

PROGETTO DEFINITIVO

DATASHEET DEI MATERIALI

Codifica Elaborato:
 CASA.35.DATASH

Data: 31/05/24

Scala



GSR TECH srl
 via del casale della castelluccia 39
 Roma 00123
 info@gsrtech.it
 gsrttech@pec.it



Ing. Giovanni Maria Giansanti Di Muzio
 ing.giansanti@gsrtech.com
 ing.giansanti@pec.ording.roma.it

Ordine degli Ingegneri di Roma A34380

PROGETTAZIONE E
 COORDINAMENTO

PROGETTAZIONE



FRONT

BACK

TOPBiHiKu7

N-type Bifacial TOPCon Technology

685 W ~ 715 W

CS7N-685 | 690 | 695 | 700 | 705 | 710 | 715TB-AG

MORE POWER



Module power up to 715 W
Module efficiency up to 23.0 %



Up to 85% Power Bifaciality,
more power from the back side



Excellent anti-LeTID & anti-PID performance.
Low power degradation, high energy yield



Lower temperature coefficient (Pmax): -0.29%/°C,
increases energy yield in hot climate



Lower LCOE & system cost

MORE RELIABLE



Minimizes micro-crack impacts



Heavy snow load up to 5400 Pa,
wind load up to 2400 Pa*



Enhanced Product Warranty on Materials and Workmanship*



Linear Power Performance Warranty*

**1st year power degradation no more than 1%
Subsequent annual power degradation no more than 0.4%**

*According to the applicable Canadian Solar Limited Warranty Statement.

MANAGEMENT SYSTEM CERTIFICATES*

ISO 9001: 2015 / Quality management system
ISO 14001: 2015 / Standards for environmental management system
ISO 45001: 2018 / International standards for occupational health & safety
IEC 62941: 2019 / Photovoltaic module manufacturing quality system

PRODUCT CERTIFICATES*

IEC 61215 / IEC 61730 / CE / INMETRO / MCS / UKCA / CGC
CEC listed (US California) / FSEC (US Florida)
UL 61730 / IEC 61701 / IEC 62716 / IEC 60068-2-68
UNI 9177 Reaction to Fire: Class 1 / Take-e-way



* The specific certificates applicable to different module types and markets will vary, and therefore not all of the certifications listed herein will simultaneously apply to the products you order or use. Please contact your local Canadian Solar sales representative to confirm the specific certificates available for your Product and applicable in the regions in which the products will be used.

CSI Solar Co., Ltd. is committed to providing high quality solar photovoltaic modules, solar energy and battery storage solutions to customers. The company was recognized as the No. 1 module supplier for quality and performance/price ratio in the IHS Module Customer Insight Survey. Over the past 22 years, it has successfully delivered over 110 GW of premium-quality solar modules across the world.

* For detailed information, please refer to the Installation Manual.

ENGINEERING DRAWING (mm)

Rear View

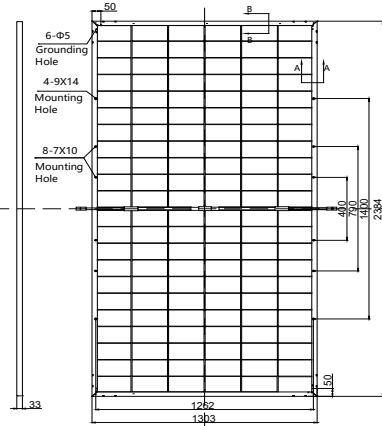

Frame Cross Section

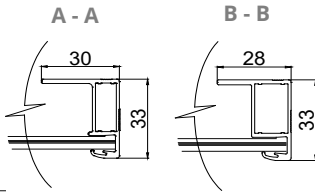

Mounting Hole

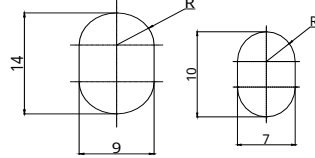

CS7N-695TB-AG / I-V CURVES

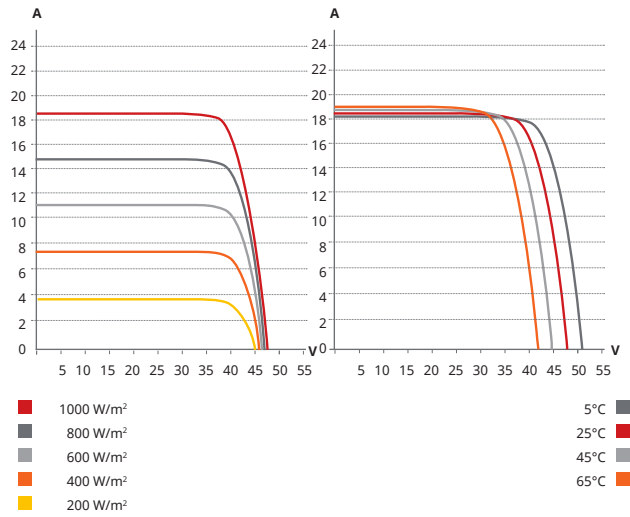

ELECTRICAL DATA | STC*

	Nominal Max. Power (Pmax)	Opt. Operating Voltage (Vmp)	Opt. Operating Current (Imp)	Open Circuit Voltage (Voc)	Short Circuit Current (Isc)	Module Efficiency
CS7N-685TB-AG	685 W	39.4 V	17.39 A	47.3 V	18.34 A	22.1%
Bifacial Gain**	5%	719 W	39.4 V	18.26 A	47.3 V	23.1%
	10%	754 W	39.4 V	19.13 A	47.3 V	24.3%
	20%	822 W	39.4 V	20.87 A	47.3 V	26.5%
CS7N-690TB-AG	690 W	39.6 V	17.43 A	47.5 V	18.39 A	22.2%
Bifacial Gain**	5%	725 W	39.6 V	18.30 A	47.5 V	23.3%
	10%	759 W	39.6 V	19.17 A	47.5 V	24.4%
	20%	828 W	39.6 V	20.92 A	47.5 V	26.7%
CS7N-695TB-AG	695 W	39.8 V	17.47 A	47.7 V	18.44 A	22.4%
Bifacial Gain**	5%	730 W	39.8 V	18.34 A	47.7 V	23.5%
	10%	765 W	39.8 V	19.22 A	47.7 V	24.6%
	20%	834 W	39.8 V	20.96 A	47.7 V	26.8%
CS7N-700TB-AG	700 W	40.0 V	17.51 A	47.9 V	18.49 A	22.5%
Bifacial Gain**	5%	735 W	40.0 V	18.39 A	47.9 V	23.7%
	10%	770 W	40.0 V	19.26 A	47.9 V	24.8%
	20%	840 W	40.0 V	21.01 A	47.9 V	27.0%
CS7N-705TB-AG	705 W	40.2 V	17.55 A	48.1 V	18.54 A	22.7%
Bifacial Gain**	5%	740 W	40.2 V	18.43 A	48.1 V	23.8%
	10%	776 W	40.2 V	19.31 A	48.1 V	25.0%
	20%	846 W	40.2 V	21.06 A	48.1 V	27.2%
CS7N-710TB-AG	710 W	40.4 V	17.59 A	48.3 V	18.59 A	22.9%
Bifacial Gain**	5%	746 W	40.4 V	18.47 A	48.3 V	24.0%
	10%	781 W	40.4 V	19.35 A	48.3 V	25.1%
	20%	852 W	40.4 V	21.11 A	48.3 V	27.4%
CS7N-715TB-AG	715 W	40.6 V	17.63 A	48.5 V	18.64 A	23.0%
Bifacial Gain**	5%	751 W	40.6 V	18.51 A	48.5 V	24.2%
	10%	787 W	40.6 V	19.39 A	48.5 V	25.3%
	20%	858 W	40.6 V	21.16 A	48.5 V	27.6%

* Under Standard Test Conditions (STC) of irradiance of 1000 W/m², spectrum AM 1.5 and cell temperature of 25°C.
** Bifacial Gain: The additional gain from the back side compared to the power of the front side at the standard test condition. It depends on mounting (structure, height, tilt angle etc.) and albedo of the ground.

ELECTRICAL DATA

Operating Temperature	-40°C ~ +85°C
Max. System Voltage	1500 V (IEC/UL) or 1000 V (IEC/UL)
Module Fire Performance	TYPE 29 (UL 61730) or CLASS C (IEC61730)
Max. Series Fuse Rating	35 A
Application Classification	Class A
Power Tolerance	0 ~ + 10 W
Power Bifaciality*	80 %

* Power Bifaciality = $\frac{P_{max_{rear}}}{P_{max_{front}}}$, both $P_{max_{rear}}$ and $P_{max_{front}}$ are tested under STC, Bifaciality Tolerance: ± 5 %

* The specifications and key features contained in this datasheet may deviate slightly from our actual products due to the on-going innovation and product enhancement. CSI Solar Co., Ltd. reserves the right to make necessary adjustment to the information described herein at any time without further notice.
Please be kindly advised that PV modules should be handled and installed by qualified people who have professional skills and please carefully read the safety and installation instructions before using our PV modules.

ELECTRICAL DATA | NMOT*

	Nominal Max. Power (Pmax)	Opt. Operating Voltage (Vmp)	Opt. Operating Current (Imp)	Open Circuit Voltage (Voc)	Short Circuit Current (Isc)
CS7N-685TB-AG	518 W	37.2 V	13.91 A	44.8 V	14.79 A
CS7N-690TB-AG	522 W	37.4 V	13.94 A	45.0 V	14.83 A
CS7N-695TB-AG	526 W	37.6 V	13.97 A	45.2 V	14.87 A
CS7N-700TB-AG	529 W	37.8 V	14.00 A	45.4 V	14.91 A
CS7N-705TB-AG	533 W	38.0 V	14.03 A	45.5 V	14.95 A
CS7N-710TB-AG	537 W	38.2 V	14.06 A	45.7 V	14.99 A
CS7N-715TB-AG	541 W	38.4 V	14.09 A	45.9 V	15.03 A

* Under Nominal Module Operating Temperature (NMOT), irradiance of 800 W/m² spectrum AM 1.5, ambient temperature 20°C, wind speed 1 m/s.

MECHANICAL DATA

Specification	Data
Cell Type	TOPCon cells
Cell Arrangement	132 [2 x (11 x 6)]
Dimensions	2384 x 1303 x 33 mm (93.9 x 51.3 x 1.30 in)
Weight	37.8 kg (83.3 lbs)
Front Glass	2.0 mm heat strengthened glass with anti-reflective coating
Back Glass	2.0 mm heat strengthened glass
Frame	Anodized aluminium alloy
J-Box	IP68, 3 bypass diodes
Cable	4.0 mm ² (IEC), 12 AWG (UL)
Cable Length (Including Connector)	410 mm (16.1 in) (+) / 250 mm (9.8 in) (-) or customized length*
Connector	T6 or MC4-EVO2 or MC4-EVO2A
Per Pallet	33 pieces
Per Container (40' HQ)	594 pieces or 495 pieces (only for US & Canada)

* For detailed information, please contact your local Canadian Solar sales and technical representatives.

TEMPERATURE CHARACTERISTICS

Specification	Data
Temperature Coefficient (Pmax)	-0.29 % / °C
Temperature Coefficient (Voc)	-0.25 % / °C
Temperature Coefficient (Isc)	0.05 % / °C
Nominal Module Operating Temperature	41 ± 3°C

PARTNER SECTION



SG350HX

Inverter di stringa multi-MPPT per sistemi a 1500 Vdc

NEW



RESA ELEVATA

- Fino a 16 MPPT con efficienza massima 99%
- 20 A per stringa, compatibilità con moduli da 500Wp+
- Scambio dati con sistema tracker, miglioramento della resa

BASSI COSTI

- Funzione Q at night, risparmio sull'investimento
- Power line communication (PLC)
- Diagnosi con Smart IV Curve*, O&M attivo

SUPPORTO ALLA RETE

- $SCR \geq 1.16$ funzionamento stabile in reti estremamente deboli
- Tempo di risposta della potenza reattiva <30ms
- Conforme al codice di rete globale

SICUREZZA

- 2 stringhe per MPPT, protezione del collegamento da inversione di polarità CC
- Interruttore CC integrato, spegnimento automatico in caso di guasti
- Monitoraggio dell'isolamento CA e CC in tempo reale 24 ore su 24

TOPOLOGIA

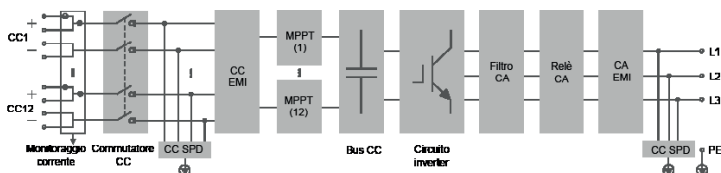

CURVA DI EFFICIENZA

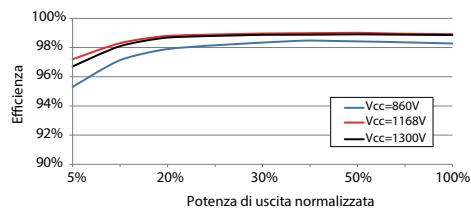

Designazione	SG350HX
Ingresso (CC)	
Tensione fotovoltaica in ingresso max.	1500 V
Tensione fotovoltaica in ingresso min. / Tensione di avvio	500 V / 550 V
Tensione nominale in ingresso	1080 V
Intervallo tensione MPP	500 V – 1500 V
Intervallo di tensione MPP per potenza nominale	860 V – 1300 V
N. di MPPT	12 (Opzionale: 14/16)
Numero max. stringhe fotovoltaiche per MPPT	2
Corrente max. in ingresso	12 * 40 A (Opzionale: 14 * 30 A / 16 * 30 A)
Corrente di cortocircuito max.	60 A
Uscita (CA)	
Potenza CA massima in uscita alla rete	352 kVA @ 30 °C / 320 kVA @ 40 °C / 295 kVA @ 50 °C
Potenza CA nominale in uscita	320 kW
Corrente CA max. in uscita	254 A
Tensione CA nominale	3 / PE, 800 V
Intervallo tensione CA	640 – 920 V
Frequenza di rete nominale / Intervallo f requenza di rete	50 Hz / 45 – 55 Hz, 60 Hz / 55 – 65 Hz
Distorsione armonica totale (THD)	< 3 % (alla potenza nominale)
Iniezione di corrente CC	< 0.5 % In
Fattore di potenza alla potenza nominale / regolabile	> 0.99 / 0.8 in anticipo – 0.8 in ritardo
Fasi di immissione / fasi di connessione	3 / 3
Efficienza	
Efficienza max. / Efficienza europea / Efficienza CEC	99.01 % / 98.8 % / 98.5 %
Protezione	
Protezione da collegamento inverso CC	Si
Protezione corto circuito CA	Si
Protezione da dispersione di corrente	Si
Monitoraggio della rete	Si
Monitoraggio dispersione verso terra	Si
Sezionatore CC / Sezionatore CA	Si / No
Monitoraggio corrente stringa fotovoltaica	Si
Funzione erogazione reattiva notturna (Q at night)	Si
Protezione anti-PID e PID-recovery	Opzionale
Protezione sovratensione	CC Tipo II / CA Tipo II
Dati Generali	
Dimensioni (L x A x P)	1136*870*361 mm
Peso	≤ 116 kg
Metodo di isolamento	Senza trasformatore
Grado di protezione	IP66 (NEMA 4X)
Consumo energetico notturno	< 6 W
Intervallo di temperature ambiente di funzionamento	-30 to 60 °C
Intervallo umidità relativa consentita (senza condensa)	0 – 100 %
Metodo di raffreddamento	Raffreddamento ad aria forzata intelligente
Altitudine massima di funzionamento	4000 m (> 3000 m derating)
Display	LED, Bluetooth+APP
Comunicazione	RS485 / PLC
Tipo di collegamento CC	MC4-Evo2 (Max. 6 mm ² , opzionale 10 mm ²)
Tipo di collegamento CA	Supporto terminali OT / DT (Max. 400 mm ²)
Conformità	IEC 62109, IEC 61727, IEC 62116, IEC 60068, IEC 61683, VDE-AR-N 4110:2018, VDE-AR-N 4120:2018, EN 50549-1/2, UNE 206007-1:2013, P.O.12.3, UTE C15-712-1:2013, UL1741, UL1741SA, IEEEE1547, IEEEE1547.1, CSA C22.2 107.1-01-2001, California Rule 21, UL1699B, CEI 0-16
Supporto rete	Funzione erogazione potenza reattiva notturna (Q at night), LVRT, HVRT, controllo potenza attiva e reattiva, velocità rampa di potenza, Q-U e P-f

*: Compatibile solo con logger Sungrow e iSolarCloud

**MEDIUM VOLTAGE
POWER STATION
CUSTOMIZED UP
TO 7.65 MVA,
WITH ALL THE
COMPONENTS
SUPPLIED ON TOP
OF THE SAME
SKID PLATFORM**

From 2500 up to 7650 kVA

This medium-voltage solution integrates all the necessary elements to develop a large-scale solar PV plant.

Maximize your investment with a minimal effort

Ingeteam's FSK power station is a compact, customizable and flexible solution that can be configured to suit each customer's requirements. It is supplied together with up to two photovoltaic inverters. All the equipment is suitable for outdoor installation, so there is no need of any kind of housing.

Higher adaptability and power density

This power station is now more versatile, as it presents the MV transformer integrated into a steel platform together with the LV and MV components, including the PV inverters. Moreover, it features one of the market's greatest power densities.

Plug & Play technology

This MV solution integrates power conversion equipment (up to 7.65 MVA), liquid-filled hermetically sealed transformer 36 kV class and

provision for low voltage equipment. The MV Skid is delivered pre-assembled for a fast on-site connection with up to two PV inverters from Ingeteam's INGECON® SUN 3Power C Series inverter family.

Complete accessibility

Thanks to the lack of housing, the inverters, the switchgear and the transformer can have immediate access. Furthermore, the design of the 3Power C Series central inverters has been conceived to facilitate maintenance and repair works.

Maximum protection

Ingeteam's 3Power C Series central inverters feature an IP65 protection class for their power stacks thanks to a combined water and air cooling system that optimises the operating temperature of the power electronics.

Apart from that, they feature the main electrical protections and they deploy grid support functionalities, such as low voltage ride-through capability, reactive power deliverance and active power injection control.

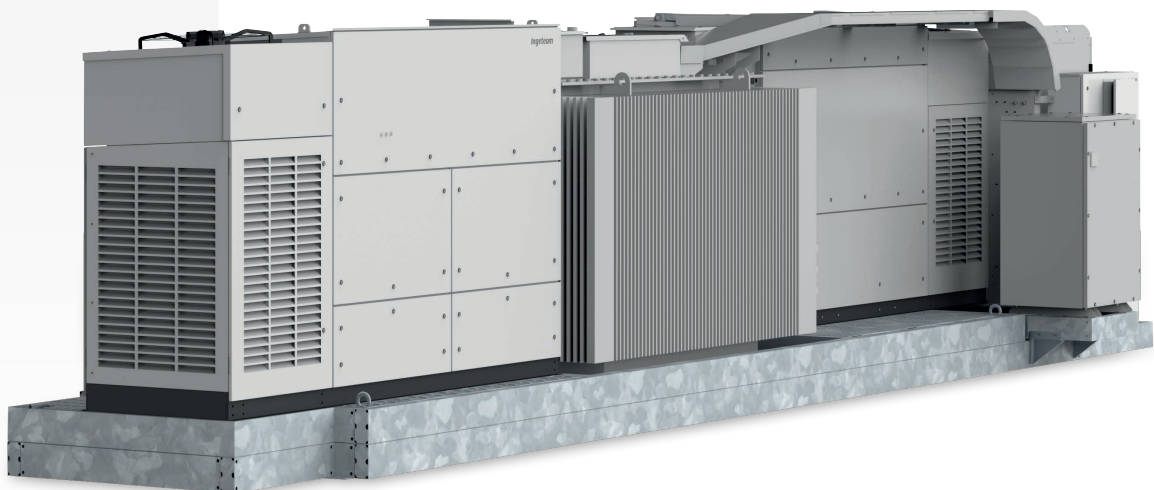

CONSTRUCTION

- Steel base frame.
- Suitable for slab or piers mounting.
- Compact design, minimising freight costs.
- Minimum installation at project site.

OPTIONAL ACCESSORIES

- Auxiliary services transformer (up to 60 kVA, Dyn11).
- MV Surge arresters.
- Self-power auxiliary services panel.
- High-speed Ethernet / fibre optic communication switch.
- INGECON® SUN StringBox with 16 / 24 / 32 input channels. Intelligent or passive string combiner box.
- Energy meter for energy production.
- Reactive power regulation when there is no PV power available.
- Ground connection of the PV array.

STANDARD EQUIPMENT

- Up to two inverters with an output power of 7.65 MVA.
- Liquid-filled hermetically-sealed transformer.
- 2L1A MV switchgear.
- Oil-retention tank.
- Metal frame for installation of LV equipment.

COMPONENTS

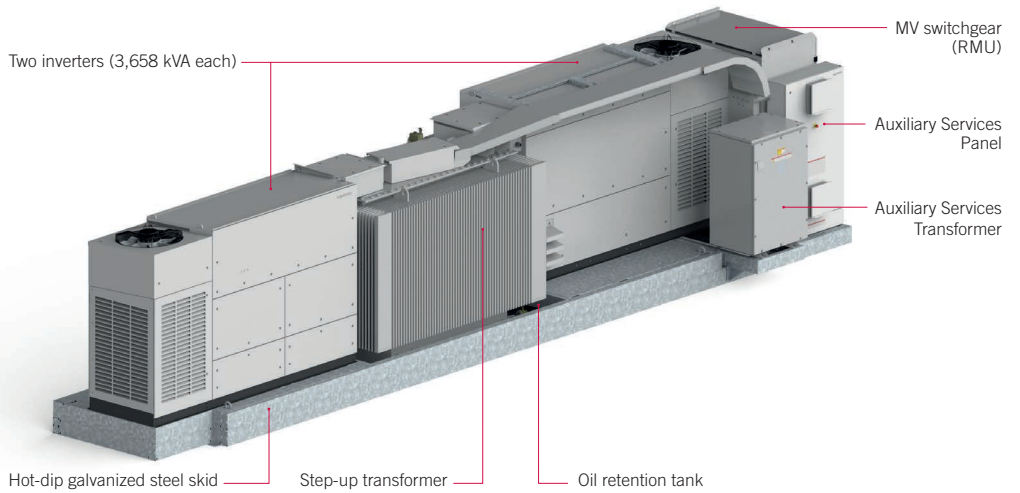

PLANT CONFIGURATION

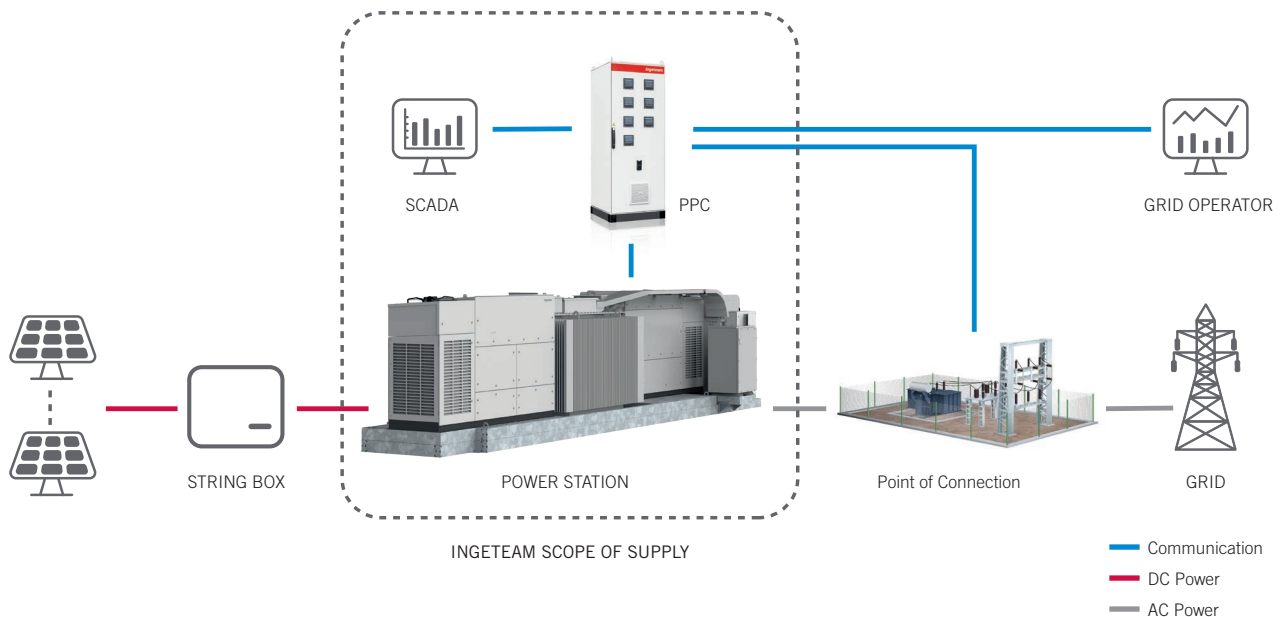

	3825 FSK C Series	7650 FSK C Series
General information		
Number of inverters	1	2
Max. power. @35 °C / 95 °F ⁽¹⁾	3,658 kVA	7,316 kVA
Operating temperature range	from -5 °C to +50 °C	
Relative humidity (non condensing)	0 - 100%	
Maximum altitude	4,500 masl (power derating starting at 1,000 masl)	
Step-up Transformer		
Medium voltage	36 kV class, 50 / 60 Hz	
Cooling system	ONAN (KNAN optionally)	
Minimum PEI (Peak Efficiency Index) ⁽²⁾	99,50%	
Installation	Readiness for outdoor installation	
MV Switchgear (RMU)		
Medium voltage	24 kV / 36 kV	
Rated current	630 A	
Cooling system	Natural air ventilation	
Protection degree	IP54	
Equipment		
Auxiliary services panel	IP54 self-powered LV panel	
Step-up transformer	Oil-immersed hermetically sealed transformer	
MV Switchgear	2L1A RMU as standard (0L1A1L, 1L1A & 0L1A optional)	
Mechanical information		
Structure type	Hot dip galvanized steel skid	
Dimensions Full Skid (W x D x H)	9,500 x 2,600 x 2,620 mm	11,390 x 2,600 x 2,620 mm
Full Skid	16 T	25 T
Standards	IEC 62271-202, IEC 62271-200, IEC 60076	

Notes: ⁽¹⁾ Maximum power calculated with the inverter model INGECON® SUN 3825TL C690. For other inverter models, please contact Ingeteam's Solar sales department ⁽²⁾ For European installations, ECO design according to the EU 548/2014 and EU 2019/1783 standards.

Configuration with two C Series solar inverters

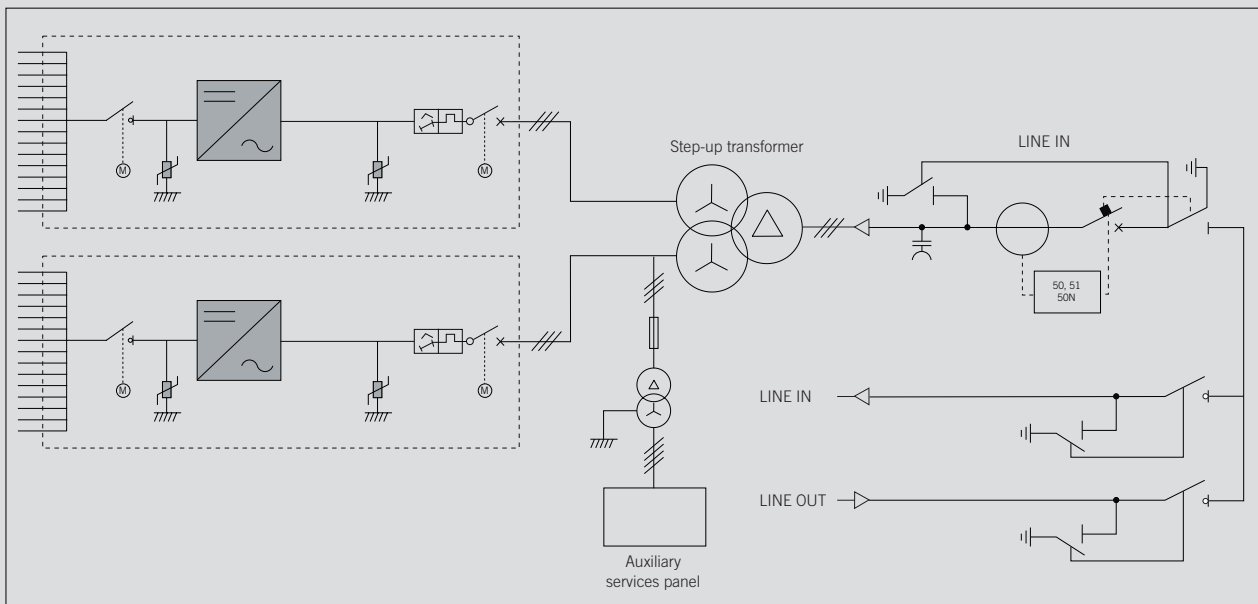



Ingeteam

Ingeteam Power Technology, S.A.
Avda. Ciudad de la Innovación, 13
31621 Sarriguren (Navarra) - Spain
Tel.: +34 948 288 000
Fax: +34 948 288 001
e-mail: solar.energy@ingeteam.com

Ingeteam S.r.l.
Via Emilia Ponente, 232
48014 Castel Bolognese (RA) - Italy
Tel.: +39 0546 651 490
Fax: +39 054 665 5391
e-mail: italia.energy@ingeteam.com

Ingeteam SAS
La Naurouze B - 140 rue Carmin
31670 Labège - France
Tel.: +33 (0)5 61 25 00 00
Fax: +33 (0)5 61 25 00 11
e-mail: france@ingeteam.com

Ingeteam INC.
3550 W. Canal St.
Milwaukee, WI 53208 - USA
Tel.: +1 (414) 934 4100 / +1 (855) 821 7190
Fax: +1 (414) 342 0736
e-mail: solar.us@ingeteam.com

Ingeteam, a.s.
Technologická 371/1
70800 Ostrava - Pustkovec
Czech Republic
Tel.: +420 59 747 6800
Fax: +420 59 732 6899
e-mail: czech@ingeteam.com

Ingeteam Shanghai, Co. Ltd.
Shanghai Trade Square, 1105
188 Si Ping Road
200086 Shanghai - P.R. China
Tel.: +86 21 65 07 76 36
Fax: +86 21 65 07 76 38
e-mail: shanghai@ingeteam.com

Ingeteam, S.A. de C.V.
Leibnitz Ext 13 Int 1102, Colonia Anzures
11590 - Miguel Hidalgo
Ciudad de México - Mexico
Tel.: +52 81 8311 4858
Fax: +52 81 8311 4859
e-mail: northamerica@ingeteam.com

Ingeteam Ltda.
Rua Estácio de Sá, 560
Jd. Santa Genebra
13080-010 Campinas/SP - Brazil
Tel.: +55 19 3037 3773
e-mail: brazil@ingeteam.com

Ingeteam Pty Ltd.
Unit 2 Alphen Square South
16th Road, Randjiespark
Midrand 1682 - South Africa
Tel.: +2711 314 3190
Fax: +2711 314 2420
e-mail: southafrica@ingeteam.com

Ingeteam SpA
Los militares 5890, Torre A, oficina 401
7560742 - Las Condes
Santiago de Chile - Chile
Tel.: +56 2 29574531
e-mail: chile@ingeteam.com

Ingeteam Power Technology India Pvt. Ltd.
2nd Floor, 431
Udyog Vihar, Phase III
122016 Gurgaon (Haryana) - India
Tel.: +91 124 420 6491-5
Fax: +91 124 420 6493
e-mail: india@ingeteam.com

Ingeteam Sp. z o.o.
Ul. Koszykowa 60/62 m 39
00-673 Warszawa - Poland
Tel.: +48 22 821 9930
Fax: +48 22 821 9931
e-mail: polska@ingeteam.com

Ingeteam Australia Pty Ltd.
iAccelerate Centre, Building 239
Innovation Campus, Squires Way
North Wollongong, NSW 2500 - Australia
Tel.: +61 429 111 190
e-mail: australia@ingeteam.com

Ingeteam Panama S.A.
Av. Manuel Espinosa Batista,
Ed. Torre Internacional
Business Center, Apto./Local 407
Urb.C45 Bella Vista
Bella Vista - Panama
Tel.: +50 761 329 467

Ingeteam Service S.R.L.
Bucuresti, Sector 2,
Bulevardul Dimitrie Pompeiu Nr 5-7
Cladirea Hermes Business
Campus 1, Birou 236, Etaj 2
Romania
Tel.: +40 728 993 202

Ingeteam Philippines Inc.
Office 2, Unit 330, Milelong Bldg.
Amorsolo St. corner Rufino St.
1230 Makati
Gran Manila - Philippines
Tel.: +63 0917 677 6039

Ingeteam Power Technology, S.A.
Level 1, Al Bateen Tower C6 Bainunah
ADIB Building, Street 34
PO BOX 30010 - Abu Dhabi
United Arab Emirates
Tel.: +971 50 125 8244

Ingeteam Vietnam Ltd.
Spaces - 28A Tran Hung Dao Street
Phan Chu Trinh Ward
Hoan Kiem District
Ha Noi City - Vietnam
Tel.: +84 24 71014057
e-mail: vietnam@ingeteam.com

Ingeteam Uruguay, S.A.
Avenida 18 de Julio, 1474, Piso 12
11200, Montevideo, Uruguay
Tel.: +598 934 92064

MEDIUM VOLTAGE INVERTER STATION, CUSTOMIZED UP TO 7.2 MVA

From 1.17 to 7.2 MVA

This brand new medium voltage solution integrates all the devices required for a multi-megawatt system.

Maximize your investment with a minimal effort

Ingeteam's Inverter Station is a compact, customizable and flexible solution that can be configured to suit each customer's requirements. It is supplied together with up to four photovoltaic inverters (two dual). All the equipment is suitable for outdoor installation, so there is no need of any kind of housing.

Higher adaptability and power density

This PowerStation is now more versatile, as it presents the MV transformer integrated into a steel base frame together with the MV switchgear. Moreover, it features the greatest power density on the market: 317 kW/m³.

Turnkey solution

This MV solution integrates power conversion equipment –up to 7.2 MVA–, liquid-filled hermetically sealed transformer up to 36 kV and provision for low voltage equipment.

A single steel skid integrating all the LV and MV components (except for the PV inverters) is delivered pre-assembled for a fast on-site connection with up to four PV inverters from Ingeteam's B Series central inverter family.

Complete accessibility

Thanks to the lack of housing, the inverters, the switchgear and the transformer can have immediate access. Furthermore, the design of the B Series central inverters has been conceived to facilitate maintenance and repair works.

Maximum protection

Ingeteam's B Series central inverters integrate the latest generation electronics and a much more efficient electronic protection. Apart from that, they feature the main electrical protections and they deploy grid support functionalities, such as low voltage ride-through capability, reactive power deliverance and active power injection control.

Furthermore, the electrical connection between the inverters and the transformer is fully protected from direct contact.

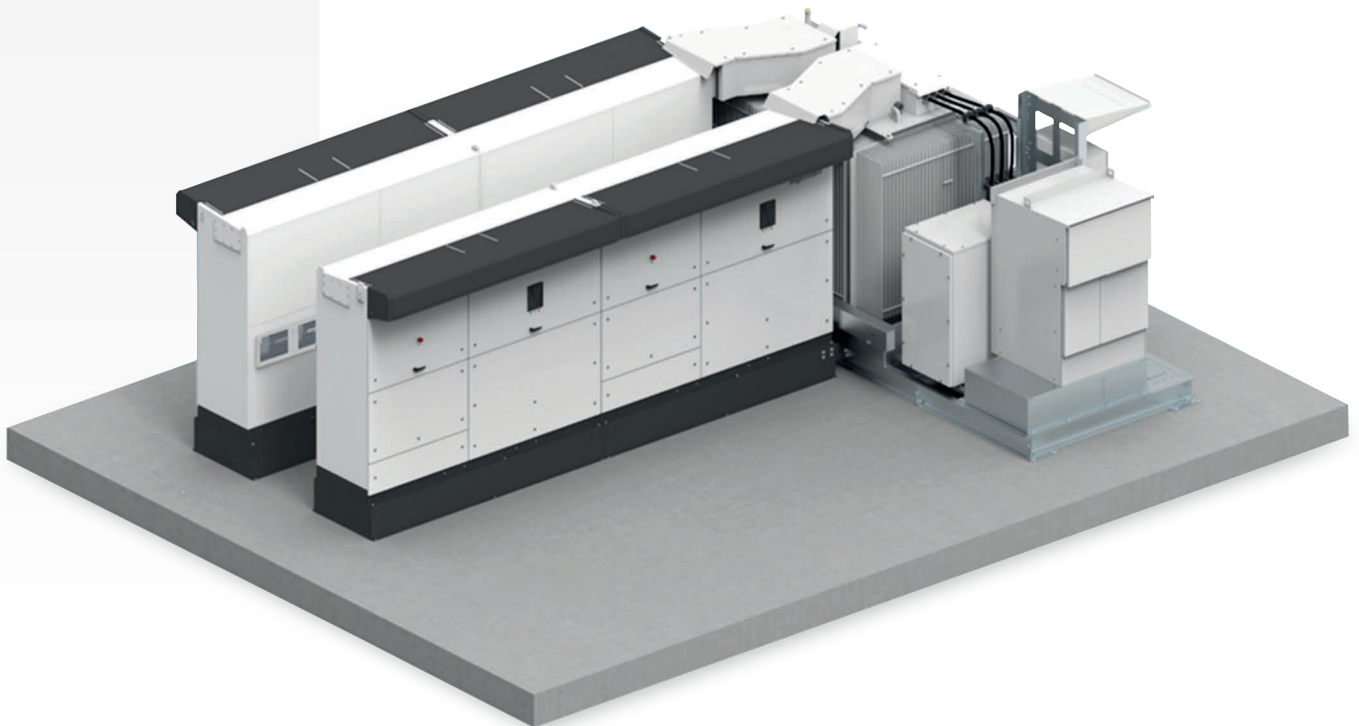

CONSTRUCTION

- Steel base frame.
- Suitable for slab or piers mounting.
- Compact design, minimizing freight costs.

STANDARD EQUIPMENT

- Up to four inverters with an output power of 7.2 MVA.
- Liquid-filled hermetically sealed transformer up to 36 kV.
- 1L1A MV switchgear (2L1A optional).
- Oil deposit.
- Frame for installation of LV equipment.
- Minimum installation at project site.

OPTIONAL ACCESORIES

- Auxiliary services transformer (up to 50 kVA, Dyn11).
- UPS for monitoring (1.5 kVA, 30 min).
- LV Surge arresters type I+II.
- MV Surge arresters.
- Low voltage distribution panel (IP55).
- Power plant commissioning.
- High-speed Ethernet / fibre optic communication infrastructure for Plug & Play connection to the Power Plant Controller and/or SCADA systems.
- INGECON® SUN StringBox with 16 / 24 / 32 input channels. Intelligent or passive string combiner box.
- Energy meter for auxiliary services and/or energy production.
- Insulation monitoring relay for continuous monitoring of IS systems insulation.
- Reactive power regulation when there is no PV power available.
- Ground connection of the PV array.

COMPONENTS

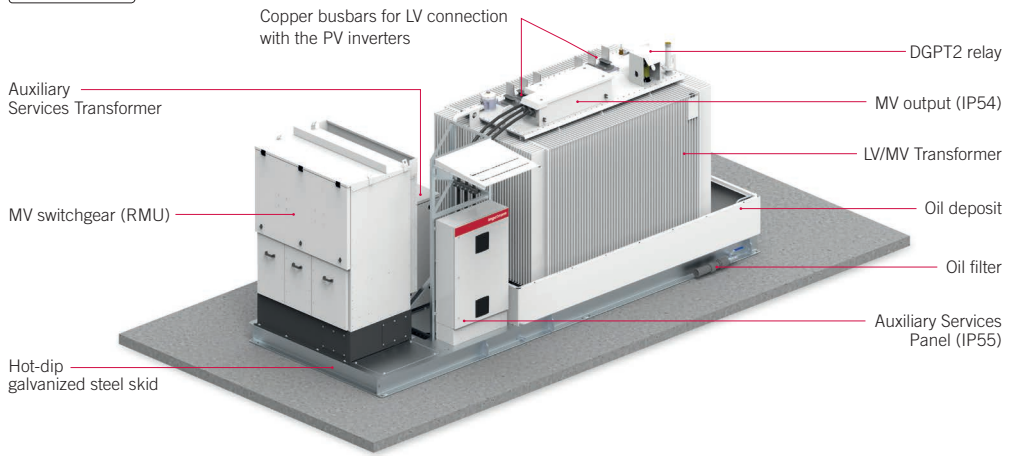

PV PLANT CONFIGURATION

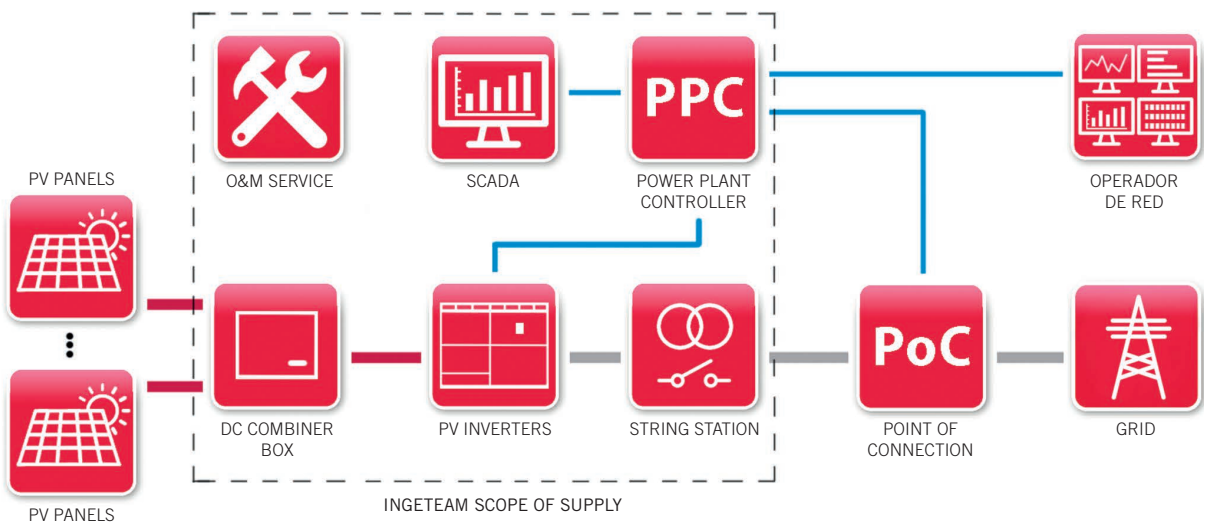

- Communication
- DC Power
- AC Power

	1800 MSK	3600 MSK	5400 MSK	7200 MSK
General data				
Number of inverters	1	2	3	4
Max. power @30 °C / 86 °F ⁽¹⁾	1,793 kVA	3,586 kVA	5,379 kVA	7,172 kVA
Operating temperature range	from -20 °C to +50 °C			
Relative humidity (non-condensing)	0 - 100%			
Maximum altitude	3,000 masl (power derating starting at 2,000 masl)			
LV / MV Transformer				
Medium voltage	From 20 kV up to 35 kV, 50-60 Hz			
Cooling system	ONAN			
Minimum PEI (Peak Efficiency Index) ⁽²⁾	99.40%			
Protection degree	IP54			
MV Switchgear				
Medium voltage	24 kV / 36 kV / 40.5 kV			
Rated current	630 A			
Cooling system	Natural air ventilation			
Protection degree	IP54			
Equipment				
LV-AUX Switchgear	Standard version (optional monitoring system)			
LV / MV Transformer	Oil-immersed hermetically sealed transformer			
MV Switchgear	1L1A cells (2L1A optional)			
Mechanical information				
Structure type	Hot dip galvanized steel skid			
Body dimensions	5,880 x 2,100 mm / 19 x 7 ft	5,880 x 2,100 mm / 19 x 7 ft	5,880 x 2,100 mm / 19 x 7 ft	5,880 x 2,100 mm / 19 x 7 ft
Max. estimated skid weight (without inverters)	11 T	12 T	13.5 T	17 T
Standards	IEC 62271-212, IEC 62271-200, IEC 60076, IEC 61439-1			

Notes: ⁽¹⁾ Maximum power calculated with the inverter model INGECON® SUN 1800TL B690. For other inverter models, please contact Ingeteam's Solar sales department ⁽²⁾ For European installations, ECO design according to the EU 548/2014 and EU 2019/1783 standards.

Configuration with four B Series PV inverters

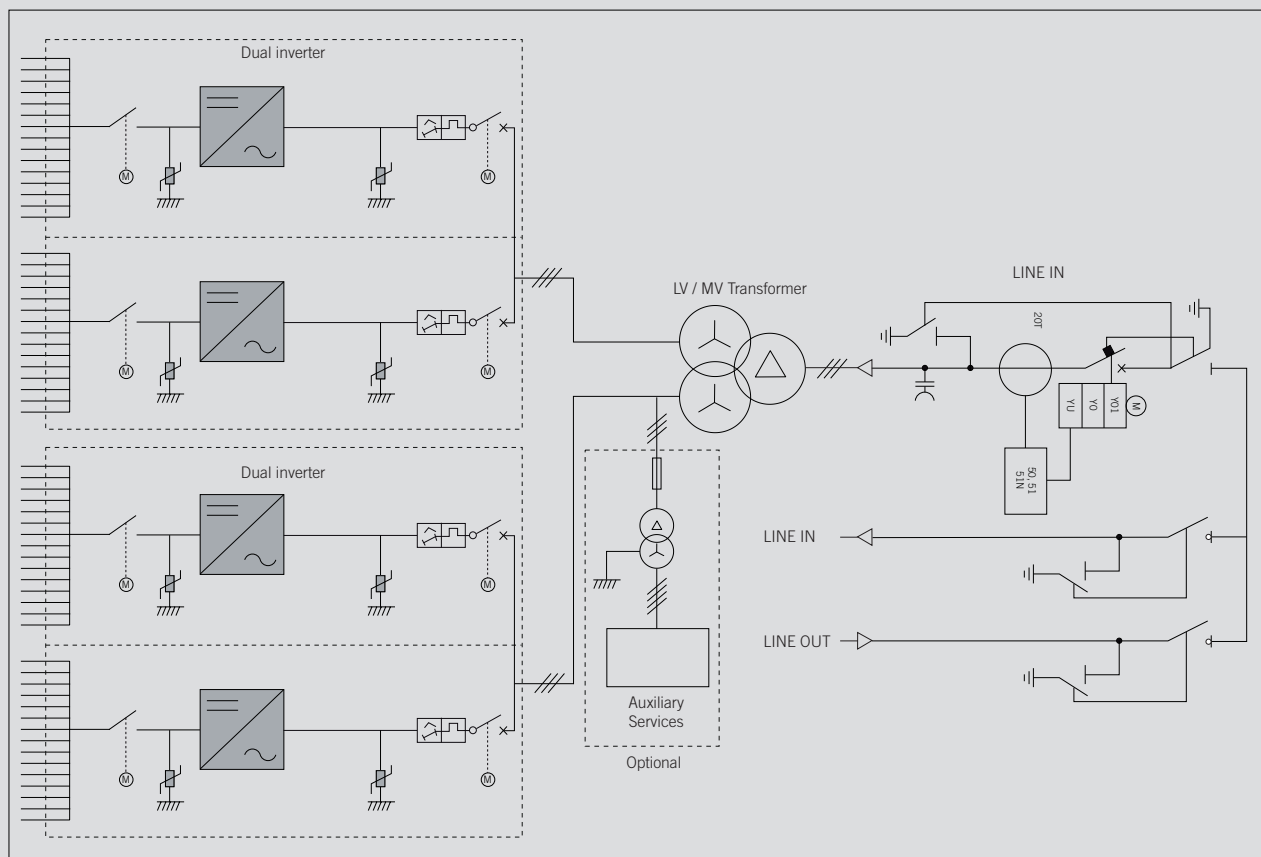



Ingeteam Power Technology, S.A.
Avda. Ciudad de la Innovación, 13
31621 Sarriguren (Navarra) - Spain
Tel.: +34 948 288 000 / Fax: +34 948 288 001
e-mail: solar.energy@ingeteam.com

Ingeteam S.r.l.
Via Emilia Ponente, 232
48014 Castel Bolognese (RA) - Italy
Tel.: +39 0546 651 490 / Fax: +39 054 665 5391
e-mail: italia.energy@ingeteam.com

Ingeteam SAS
La Naurouze B - 140 rue Carmin
31670 Labège - France
Tel: +33 (0)5 61 25 00 00 / Fax: +33 (0)5 61 25 00 11
e-mail: france@ingeteam.com

Ingeteam INC.
3550 W. Canal St.
Milwaukee, WI 53208 - USA
Tel.: +1 (414) 934 4100 / +1 (855) 821 7190 / Fax: +1 414 342 0779
e-mail: solar.us@ingeteam.com

Ingeteam, a.s.
Technologická 371/1
70800 Ostrava - Pustkovec
Czech Republic
Tel.: +420 59 732 6800 / Fax: +420 59 732 6899
e-mail: czech@ingeteam.com

Ingeteam, S.A. de C.V.
Leibniz 13 des 1101, Col. Anzures
Del. Miguel Hidalgo,
11590 - Mexico - CDMX
Tel +5255 6586 9930-31
e-mail: northamerica@ingeteam.com

Ingeteam Ltda.
Rua Estácio de Sá, 560
Jd. Santa Genebra
13080-010 Campinas/SP - Brazil
Tel.: +55 19 3037 3773
e-mail: brazil@ingeteam.com

Ingeteam Pty Ltd.
Unit 2 Alphen Square South
16th Road, Randjiespark
Midrand 1682 - South Africa
Tel.: +2711 314 3190 / Fax: +2711 314 2420
e-mail: southafrica@ingeteam.com

Ingeteam SpA
Los militares 5890, Torre A, oficina 401
7560742 - Las Condes
Santiago de Chile - Chile
Tel.: +56 2 29574531
e-mail: chile@ingeteam.com

Ingeteam Power Technology India Pvt. Ltd.
2nd Floor, 431
Udyog Vihar, Phase III
122016 Gurgaon (Haryana) - India
Tel.: +91 124 420 6491-5 / Fax: +91 124 420 6493
e-mail: india@ingeteam.com

Ingeteam Sp. z o.o.
Ul. Koszykowa 60/62 m 39
00-673 Warszawa - Poland
Tel.: +48 22 821 9930 / Fax: +48 22 821 9931
e-mail: polska@ingeteam.com

Ingeteam Australia Pty Ltd.
iAccelerate Centre, Building 239
Innovation Campus, Squires Way
North Wollongong, NSW 2500 - Australia
Tel.: +61 455 521 490
e-mail: australia@ingeteam.com

Ingeteam Panama S.A.
Av. Manuel Espinosa Batista, Ed. Torre Internacional
Business Center, Apto./Local 407 Urb.C45 Bella Vista
Bella Vista - Panama
Tel.: +50 761 329 467

Ingeteam Service S.R.L.
Bucuresti, Sector 2, Bulevardul
Dimitrie Pompeiu Nr 5-7
Cladirea Hermes Business Campus 1,
Birou 236, Etaj 2 - Romania
Tel.: +40 728 993 202

Ingeteam Philippines Inc.
Office 2, Unit 330, Milelong Bldg.
Amorsolo corner Rufin St.
1230 Makati
Gran Manila - Philippines
Tel.: +63 0917 677 6039

Ingeteam

TRACKER Agile™-1P

Dual-Row

TrinaTracker



About TrinaTracker

Excellent Bankability

Trina Solar was ranked top in the list of "Top Bankable Module Supplier" released by Bloomberg New Energy Finance (BNF) for five consecutive years

Multiple Product Lines For All Applications

Multiple product lines developed by experienced International R&D team for meeting market demands in all application scenarios

Superb Reliability and High Quality

Leading quality management system and over 20 years product quality control experience in the industry

Efficient Engineering Design Expert

Systematic and high efficient workflow for presales service to guarantee prompt engineering design

Unified Products Delivery Management

Global supply chain management of core equipments in solar farm (modules and trackers) with unified delivery channel



Two Rows per Tracker

Agile™-1P is a dual-row tracker with one primary slewing drive in one row and one secondary slewing drive in another row. Two slewing drives share one motor and one TCU.



Innovative SuperTrack Technology

According to real-time weather and actual terrain conditions, smart algorithm dynamically optimizes tracking angle, increases receiving radiation and reduces shading loss.

Up to **8%** yield gain



More Modules per Tracker

By adopting one in portrait (1P) design, Agile can install up to 60 modules per row.

Compatible with modules up to **670W+**



Designed for Challenging Conditions

The Agile™-1P has been designed for sites that have both challenging terrain and high wind conditions

Up to **20%** N-S slope.



Higher Reliability

The two slewing drives in Agile™-1P are connected by a transmission bar with a cardan design that improves the transmission efficiency, also has an optimized stow position and alarm strategy for a safer and more robust structure.

TRINA CLAMP

Trina Clamp is a proprietary product that is quick and easy to use with the 1P configuration, reducing the installation time and costs.



WIND TUNNEL TESTED BY CPP

Detailed wind tunnel test methodology to reproduce the most realistic tracker behavior and analyze the aerolastic effects that impact tracker structures.



Full aeroelastic model test.



TECHNICAL SPECIFICATIONS

GENERAL FEATURES

Solar tracker type	Horizontal Single-Axis with two rows
Tracking range	±60° (120°)
Driver	Cardan joined slewing drive
Configuration	One module in portrait (1P) up to 2 strings per row (1500 V string)
Solar module supported	Framed
Foundation options	Direct ramming, Pre-drilling + ramming, Micropile and PHC piles
Pile section	W, compatible with IPE, IPEA, HEA and HEB ⁽¹⁾
Modules attachment	Bolts, Rivets, Clamps (frameless)
Piles per MW (550Wp module)	~273 piles/MW ⁽²⁾ (60 modules per row)
(670 Wp module)	~248 piles/MW ⁽²⁾ (54 modules per row)
Terrain adaptability	20% N-S, 10% E-W ⁽³⁾
Wind and snow loads tolerance	Tailored to site requirement
Rear shading factor	1.27%
Critical wind speed	47m/s

STRUCTURE

Material	High Yield Strength Steel
Coating	HDG, Pregalvanized & ZM ⁽⁴⁾

ELECTRONIC CONTROLLER SPECIFICATIONS

Controller	Electronic board with microprocessor
Ingress protection marking	IP65
Tracking method	Astronomical algorithms + SuperTrack technology ⁽⁵⁾
Advanced wind control	Customizable
Anemometer	Cup / Ultrasonic
Night-time stow	Configurable
Communication with the tracker	Wired option: RS 485 Wireless option: LoRa/Zigbee
Operating conditions	Altitude < 4000 m ⁽⁶⁾ Temperature: -30°C to 60°C
Sensors	Digital inclinometer
Power (motor drive)	DC motor: 0.15kW ⁽⁷⁾
Power supply	Grid connection / String powered / Self-powered

WARRANTY

Structure	10 years
Driver and control components	5 years

(1) C shape piles under request

(2) Depending on layout

(3) N-S: max 20%, for slopes higher than 10% consult with TrinaTracker
E-W: max 10%, for slopes higher than 5% consult with TrinaTracker

(4) Standard configuration. Other coating under request, please consult TrinaTracker

(5) Includes smart tracking algorithm and smart backtracking algorithm

(6) Different conditions under request, please consult TrinaTracker

(7) Depending on external conditions

CAUTION: READ SAFETY AND INSTALLATION INSTRUCTIONS BEFORE USING THE PRODUCT.

© 2021 Trina Solar Co.,Ltd. All rights reserved. Specifications included in this datasheet are subject to change without notice.

Version number: DT-T-0003 B

PIANTA CABINA

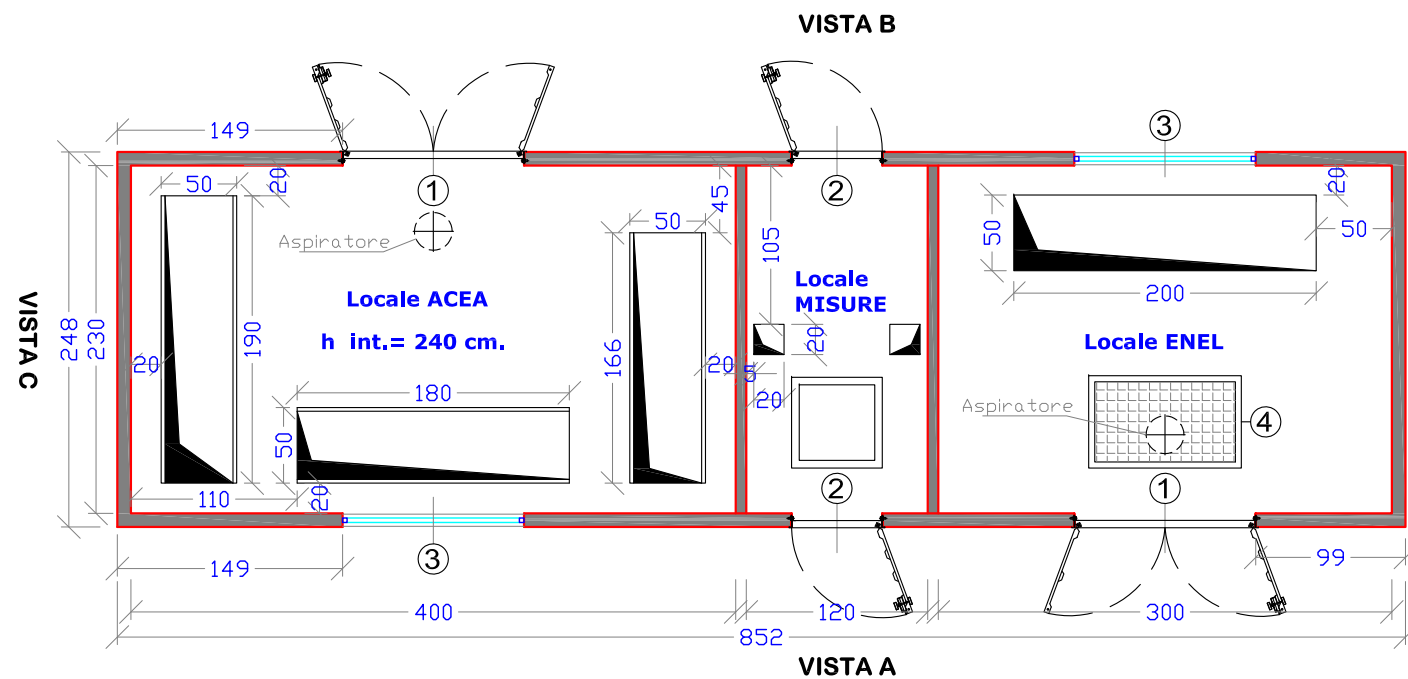

PIANTA VASCA DI FONDAZIONE

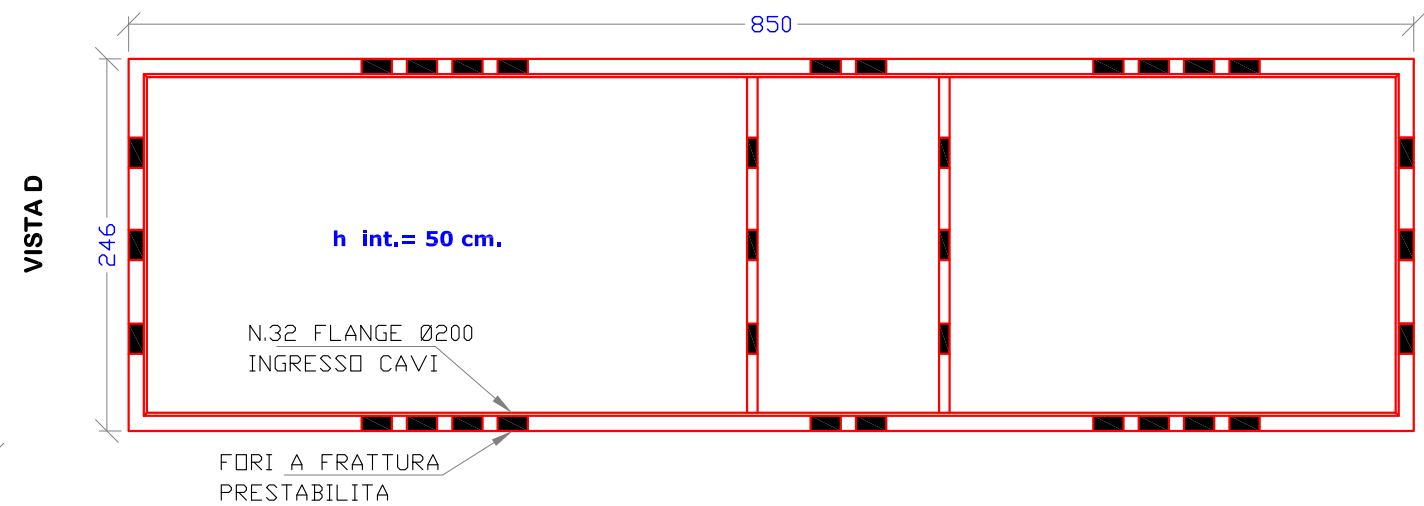

VISTA A

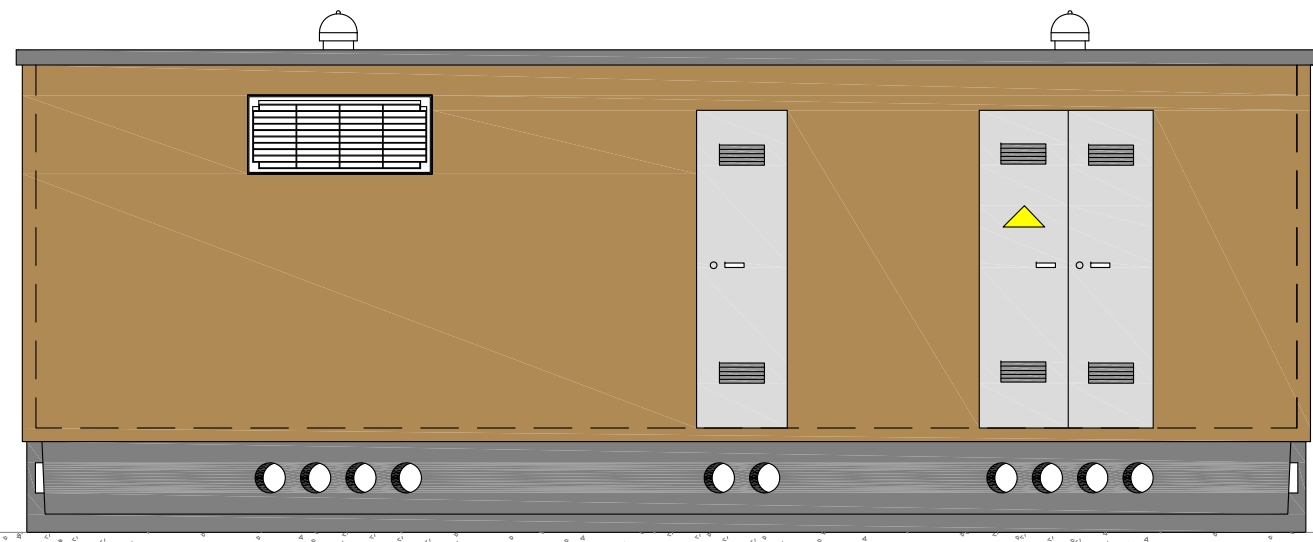

VISTA B

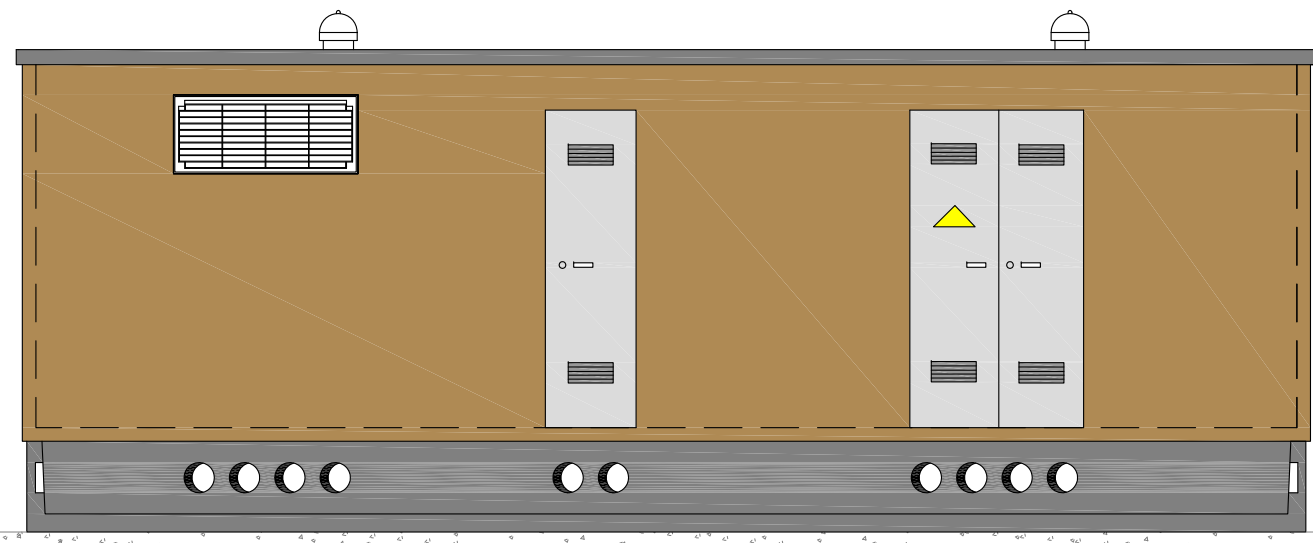

VISTA C-D

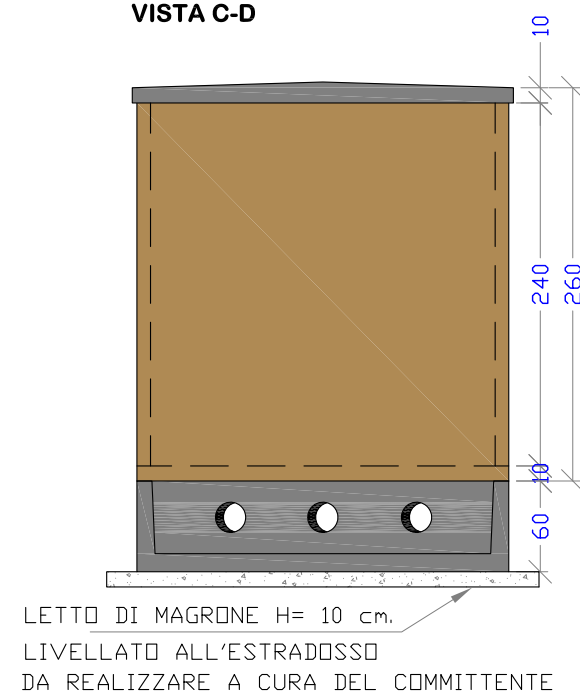

LEGENDA:

- ① PORTA A DUE ANTE in VTR o in acciaio (CM. 120X H215) omologata ENEL
- ② PORTA AD UNA ANTA in VTR (CM. 60X H215) omologata ENEL
- ③ GRIGLIA ALTA in VTR (CM. 120X H50) omologata ENEL
- ④ PLOTTA DI COP. CM. 100X60



EDILMETAS

MATERA

LEADING WORKSITE INNOVATION

“Soluzioni modulari
veloci e convenienti”



**ALLOGGI E
ABITAZIONI**

**UFFICI
MOBILI**

SERVIZI IGIENICI

- Profili preverniciati
- Flat Pack & RTA kit
- Modulari e Mobili
- Personalizzabili
- Rete internazionale
- Assistenza clienti

1. PREMESSA

Grazie per aver scelto un prodotto EDILMETAS, risultato di esperienza, miglioramento continuo, qualità assicurata, progettazione accurata. I nostri monoblocchi sono realizzati rispettando gli standard, l'ambiente e le persone.

Puntiamo ad offrire il miglior servizio per i nostri clienti, informandoli sul prodotto e corretto uso. Raccomandiamo di leggere attentamente le informazioni e prendere consapevolezza che le informazioni qui contenute possono cambiare senza preavviso.

I prefabbricati modulari EDILMETAS sono conosciuti in tutto il mondo per la facilità di assemblaggio, accesso semplice alle informazioni e grande attenzione ai dettagli.

by:
EDILMETAS SRL - VIA PIRELLI
MATERA - ITALY
75100

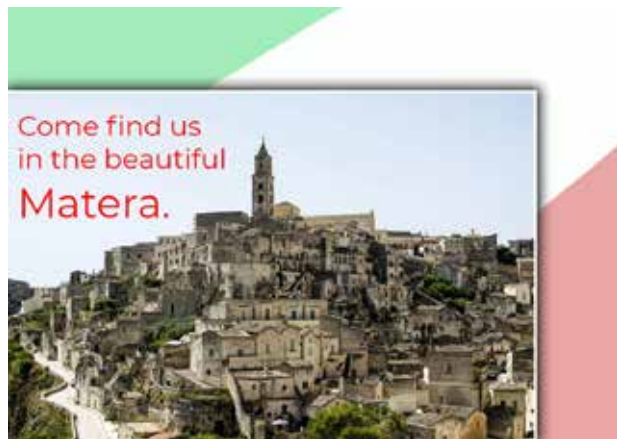

PROFILI
PREVERNICIATI

UNITA'
MODULARI

ASSEMBLAGGIO
FACILE



SISTEMA PROFILO PROPRIETARIO

marcato con asterisco (*)
significa su richiesta

1.1 Dimensioni (standard)

Ref.	Misure Esterne (mm)	Misure Interne (mm)	Peso (Kg)
MON214STAN	2140x2400xh2680	2000x2200xh2400	400
MON314STAN	3140x2400xh2680	3000x2200xh2400	600
MON414STAN	4140x2400xh2680	4000x2200xh2400	800
MON514STAN	5140x2400xh2680	5000x2200xh2400	1000
MON614STAN	6140x2400xh2680	6000x2200xh2400	1200
MON714STAN	7140x2400xh2680	7000x2200xh2400	1400
MON814STAN	8140x2400xh2680	8000x2200xh2400	1600
MON914STAN	9140x2400xh2680	9000x2200xh2400	1800
MON1014STAN	10140x2400xh2680	10000x2200xh2400	2000
MON1114STAN	11140x2400xh2680	11000x2200xh2400	2200
MON1214STAN	12140x2400xh2680	12000x2200xh2400	2400

Standard (esempio)

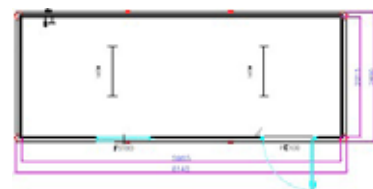

Altezze fuori standard

Ref.	Misure Esterne (mm)	Misure Interne (mm)
H3000	3280	3000
H2700	2980	2700
H2200	2480	2200

Servizi igienici

Ref.	Servizi igienici laterali	Peso (Kg)
V + L	Vaso WC e lavandino in ceramica; parete divisoria; porta interna cieca + serratura; finestra vasistas mm 650x500; impianto acqua fredda; punto luce ed interruttore.	+100
V + L + D	Vaso WC e lavandino in ceramica; doccia completa di accessori; parete divisoria; porta interna cieca + serratura; finestra vasistas mm 650x500; impianto acqua calda e boiler 30l; punto luce ed interruttore.	+150

Bagno laterale (esempio)

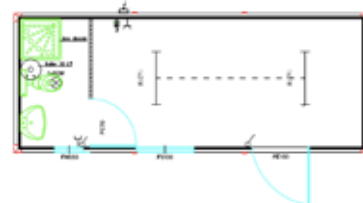

Ref.	Servizi igienici centrali	Peso (Kg)
V + L CEN	Vaso WC e lavandino in ceramica; (3x) parete divisoria; (3x) porta interna cieca + serratura; finestra vasistas mm 650x500; impianto acqua fredda; (2x) punto luce ed interruttore.	+200
V + L + D CEN	Vaso WC e lavandino in ceramica; doccia completa di accessori; (3x) parete divisoria; (3x) porta interna cieca + serratura; finestra vasistas mm 650x500; impianto acqua calda e boiler 30l; (2x) punto luce ed interruttore.	+250

Bagno Centrale (esempio)



*Altre dimensioni su richiesta

1.2 Informazioni Generali

Struttura:	I profili sono realizzati in acciaio preverniciato RAL 9002 (spessore 1,5mm), da coils zincati (standard: UNI 5753-75);
Base:	Standard: Il profilo della base è realizzato da acciaio zincato e preverniciato RAL 9002 (spessore 1,5mm); Lamiera da solaio zincata non collaborante (spessore 0,6mm). Sul solaio viene posta un pannello in truciolare 18mm su cui viene incollato, utilizzando apposite resine, un pavimento in PVC antiscivolo R10 spessore > 2mm. Su richiesta: Maggiore isolamento con pannelli coibentati o diverse pavimentazioni di tipo ignifugo/idrofugo sono su richiesta.
Pareti esterne ed interne	Standard: Realizzata in pannelli coibentati sp. 40 mm, composti con supporti in acciaio zincato preverniciato di colore bianco/grigio (spessore 0,4mm) secondo norme UNI EN 10169, con interposta coibentazione a base di schiuma poliuretana densità D=38-40 Kg/mc Trasmittanza U=0,55 W/mqK. Su richiesta: Pannello di spessori (50mm,60mm,80mm, 100mm) o isolanti diversi (Lana Minerale, Poliisocianurato).
Tetto	Standard: 1° livello) Realizzato in pannelli coibentati sp. 30 mm, composti con supporti in acciaio zincato preverniciato di colore bianco/grigio (spessore 0,4mm) secondo norme UNI EN 10169, con interposta coibentazione a base di schiuma poliuretana densità D=38-40 Kg/mc Trasmittanza U=0,62 W/mqK. 2° livello) Lamiera grecata zincata da copertura. Su richiesta: maggiore isolamento (Lana Minerale, EPS, etc.) da porre tra i due livelli fino ad un massimo di 40mm di spessore.
Serramenti, interni ed esterni	Standard: Profili in alluminio (Bianco RAL 9010) completi di tutti gli accessori per l'uso e vetro (4mm), barre anti-intrusione, maniglie e serrature. - Porta standard: mm 1050x2100 (890x2060); - Finestra scorrevole a due ante mm 1050x1100 - Finestra vasistas mm 650x500 (inclusa nell'opzione servizi igienici) Su richiesta: Possono essere previsti infissi con vetro camera; visarm 3+3; Sistemi oscuranti (tapparelle, scuretti, persiane); variante in PVC.

Note:

Sollevabile dal tetto mediante 4 golfari inclusi; Attacco forche su richiesta;

Scarichi delle acque piovane sui lati corti;

Impianto elettrico*	Standard: Una regletta led 1x13 ed una presa bipasso 10-16A. Su richiesta si possono aggiungere luci e prese o prevedere impianti trifase*.
Impianto Idrico*	Tubi e raccordi in PVC a vista. Gli scarichi sono tutti separati a pavimento o a parete. L'utente dovrà raccordarli e convogliarli nel pozzetto finale.



2 COMPONENTI

Ogni materiale utilizzato per la costruzione dei monoblocchi è certificato e garantito.

2.1 La Struttura

I nostri monoblocchi prefabbricati modulari sono fatti utilizzando uno speciale profilo leggero e resistente che rendono facile l'assemblaggio e l'accoppiamento.

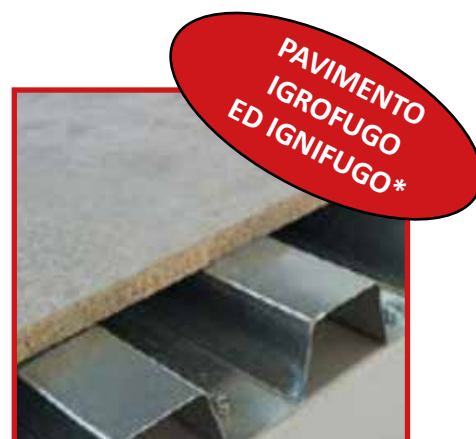
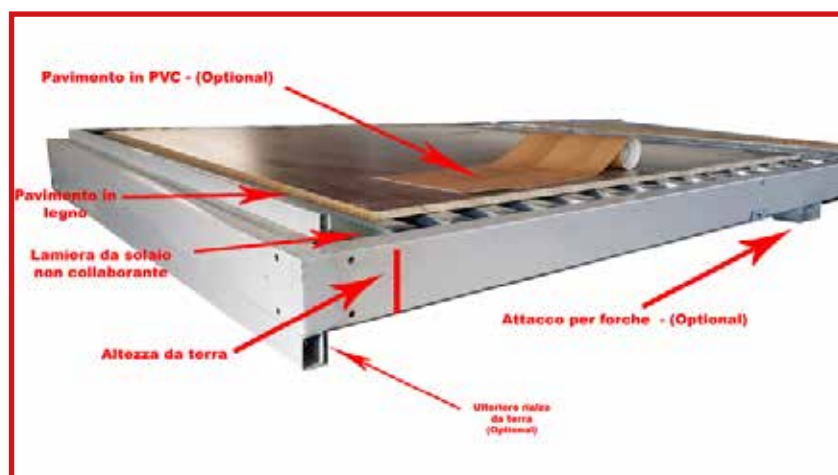
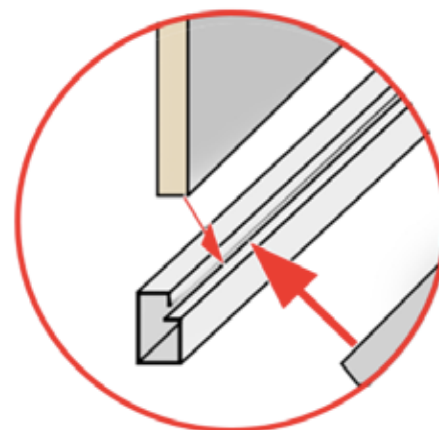
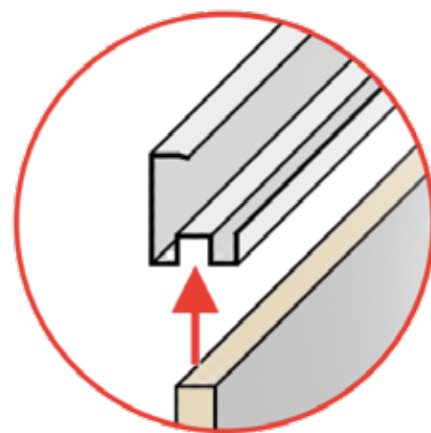
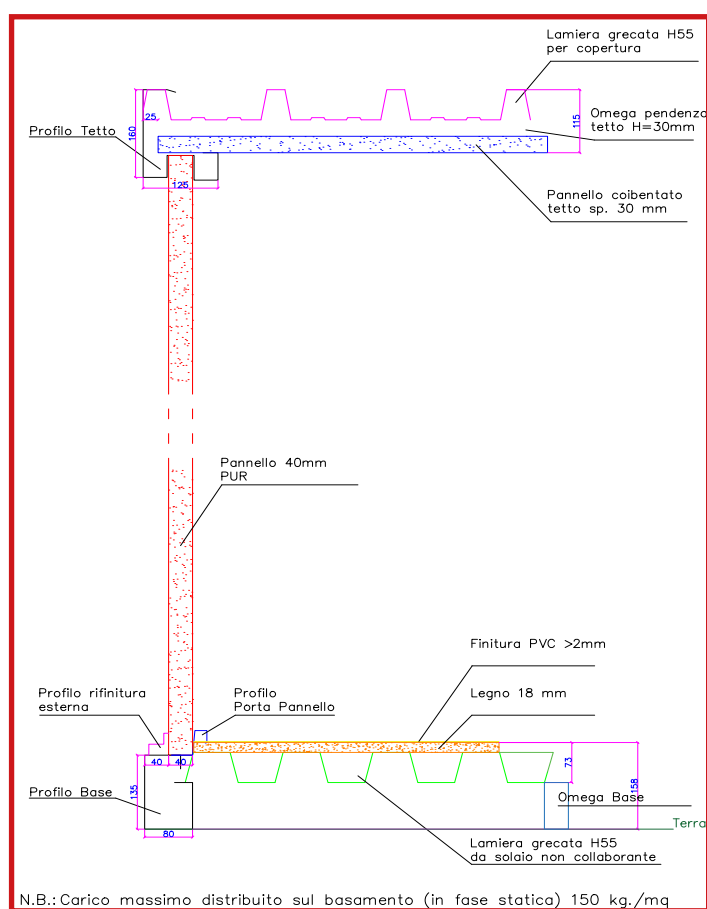

2.2 Pannelli

I nostri pannelli sono Made in Italy, il giusto compromesso per garantire efficienza e durabilità. Il pannello è di tipo autoportante (EN 14509:2013) colore bianco-grigio, verniciabile. Altre opzioni e colorazioni su richiesta (effetto legno, pietra)*.



Made in Italy

	Tetto	Parete		
	sp. 30mm	sp. 40mm	*sp. 50mm	*sp. 60mm
W/m2 K	0,62	0,55	0,44	0,37
Kcal/m2 h °C	0,53	0,47	0,38	0,24

Caratteristiche	Classe	Standards
Isolamento	PUR	EN 14509
Densità	40 Kg/m3	EN 14509
Reazione al fuoco	F	UNI EN 14509 EN 13501-1



Finitura effetto legno* su richiesta



Finitura effetto pietra* su richiesta

2.3a Pannello (poliisocianurato*)

Il pannello EI* (su richiesta) è un pannello sandwich piano con isolante in poliisocianurato progettato per l'impiego in pareti che necessitano di un alto grado di resistenza al fuoco.

Classe B-s1,d0; la resistenza al fuoco, invece, è in funzione dello spessore:

EI 15 per pannello sp. 60 mm

EI 30 per pannello sp. 100 mm



2.3b Pannelli speciali (Lana Minerale*)

ABBATTIMENTO DEL SUONO ED ELEVATA RESISTENZA AL FUOCO



RIVESTIMENTO SU RICHIESTA

Massa isolante

Densità: 100 kg/m3 ±10%.

Assorbimento acustico

Spessore mm 50: AW = 0,90

Spessore mm 80: AW = 0,95

Spessore mm 100: AW = 0,95

Isolamento acustico

Spessore mm 50: RW = 31 dB

Spessore mm 80: RW = 34 dB

Spessore mm 100: RW = 35 dB

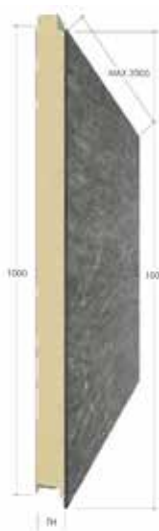

Made in Italy

3. Layout

Produciamo su misura e secondo vostre specifiche. Inoltre, potrete scegliere tra oltre 100 layout standard dal nostro catalogo dedicato.

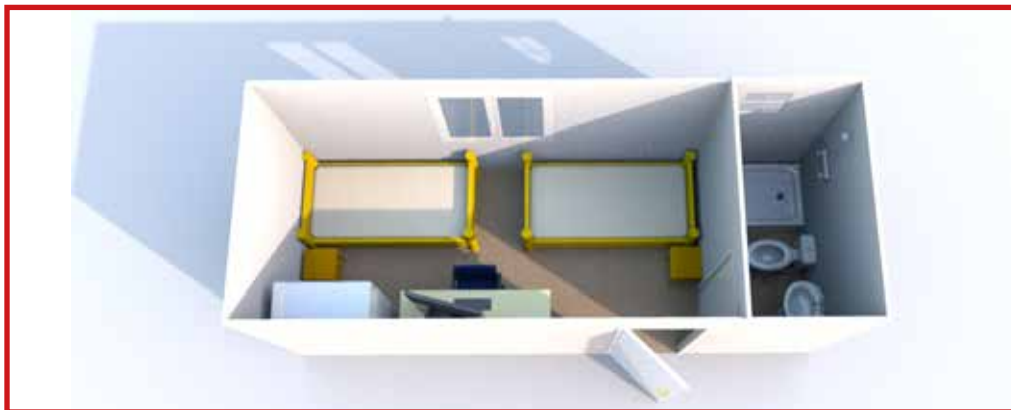

NOTE: Capacità di carico

Carico massimo del tetto in fase statica = 100 kg/mq - Non calpestabile

Carico massimo sul pavimento in fase statica = 200 kg/mq

*Le capacità di carico possono essere aumentate, se richiesto, attraverso apposite modifiche strutturali.**

Ambiente e smaltimento dei prodotti

In caso di smaltimento del prodotto, il proprietario o il detentore, devono provvedere ad un corretto smaltimento secondo le normative vigenti. Il monoblocco è completamente smontabile mantenendo separata la natura dei materiali. Suggeriamo di affidarsi ad una ditta specializzata. Abbi cura dell'ambiente.

_____ *Qualità italiana* _____

I nostri prefabbricati e sistemi modulari sono disegnati e prodotti nel nostro stabilimento di Matera. Rispettando tutti i regolamenti e norme sulla sicurezza

_____ *EU Standards* _____

Si consiglia di utilizzare ulteriori ancoraggi al terreno e di verificare le regole locali in quanto EDILMETAS non si riterrà responsabile per il mancato rispetto di queste o di negligenze.

I golfari di sollevamento forniti con il monoblocco sono per piccoli e non frequenti movimentazioni. Il tetto non è calpestabile. Per sovrapporre i monoblocchi si consiglia di consultare uno specialista e di verificare le regolamentazioni locali. Suggeriamo di non sovrapporre i monoblocchi senza una struttura verificata ed appositi accorgimenti.

4. Flat-pack

Il kit dei monoblocchi flat-pack include base e tetto pre-assemblati, pannelli, porte e finestre e tutto il necessario per l'assemblaggio sul posto. Può essere previsto l'impianto elettrico plug-in. Il tutto in soli 55cm di altezza per monoblocco standard!



1. Base pre-assemblata;



2. Tetto Preassemblato da fissare alle colonne;



3. Inserimento dei pannelli e degli infissi.

HAI BISOGNO DI PIU' SPAZIO? CHIEDI IL KIT PROFILI SMONTATI



4.1 Modularità

Moduli fino a 12000mm di lunghezza e semplici da assemblare.



profili da 1 a 12 metri

**DIVISORI
E STANZE**



IMPIANTI PLUG-IN

Una domanda crescente dell'export per costruzioni modulari e alloggi ci ha spinti ad innovare e trovare nuove soluzioni per rendere semplici la portabilità e la movimentazione.

Scegliendo i nostri monoblocchi prefabbricati flat-pack avrete una soluzione completa di impianto idrico pronto da assemblare.

Tutti i tubi e gli impianti sono già fissati sul pannello e la doccia già sul pavimento.

**FLAT PACK CON
IMPIANTO PLUG-IN**





**COSTRUZIONI
MODULARI**



**INCREMENTA
IL TUO BUSINESS**



**DEPENDANCE
HOTELS**



**ALLOGGI
TEMPORANEI**

**CONFIGURAZIONI
E CATALOGHI**



CONTATTI GENERALI:

**www.edilmetas.it
info@edilmetas.it**

Ph: +39 0 835 30 28 04

**EDILMETAS SRL - VIA PIRELLI
MATERA - ITALY 75100**



LEADING WORKSITE INNOVATION

**PREVANTIVI
GRATUITI**

