

**PIANTA FONDAZIONE**

SCALA 1:50

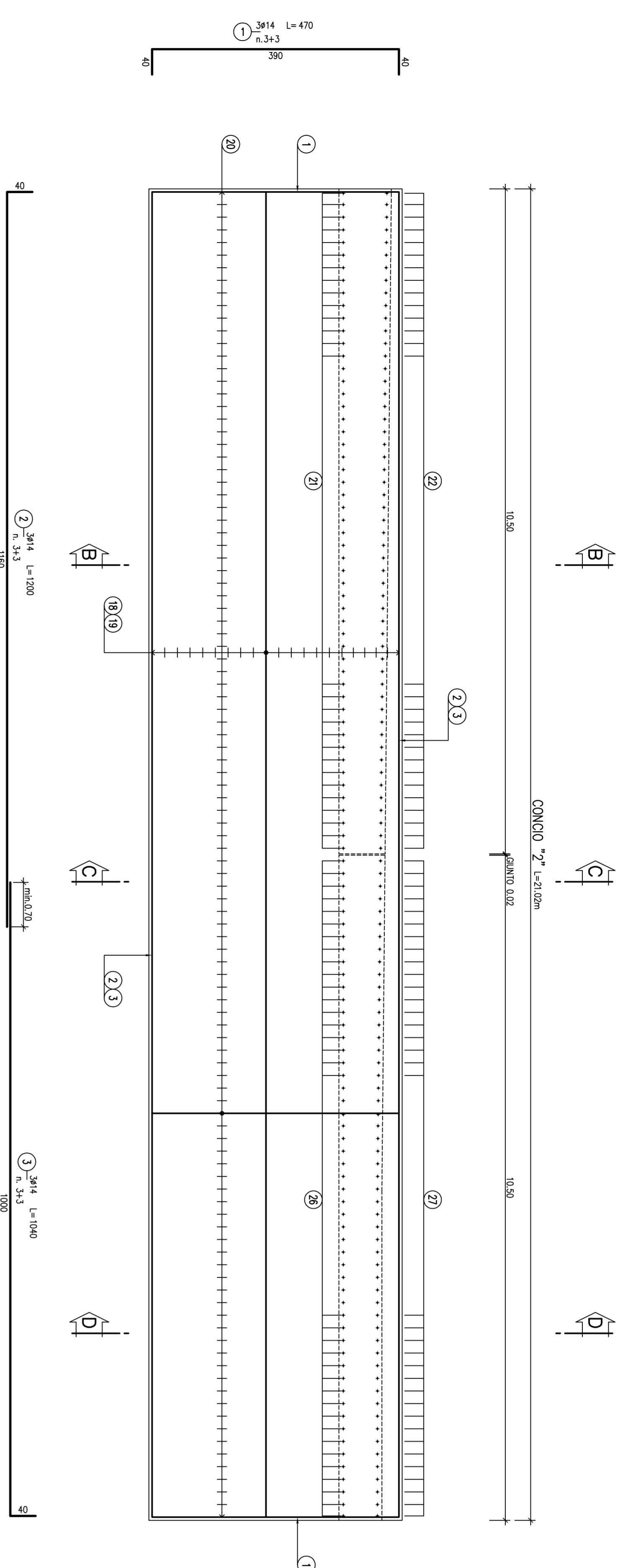

**SEZIONE TRASVERSALE B-B**

SCALA 1:50

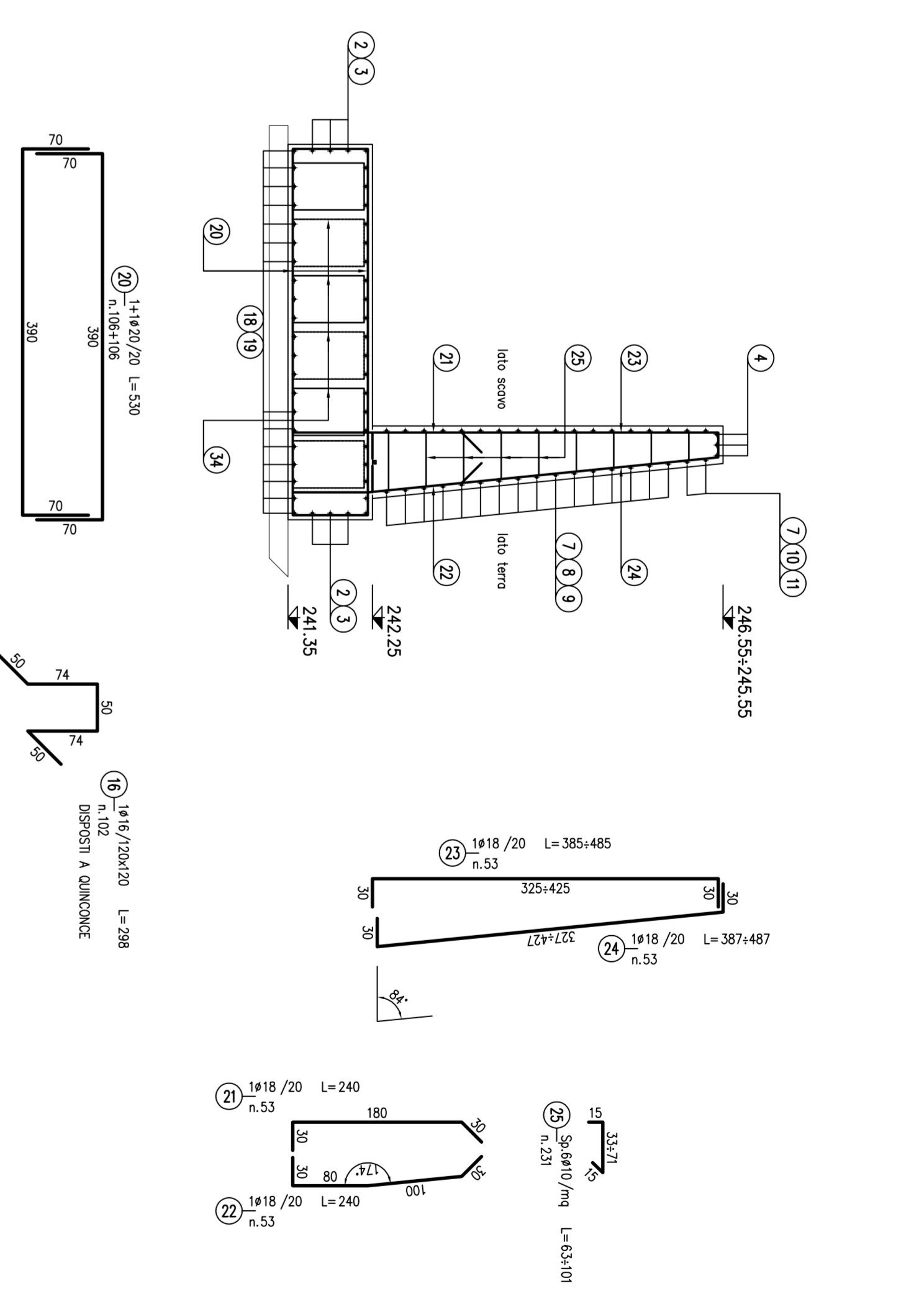

**SEZIONE ORIZZONTALE A-A**

SCALA 1:50

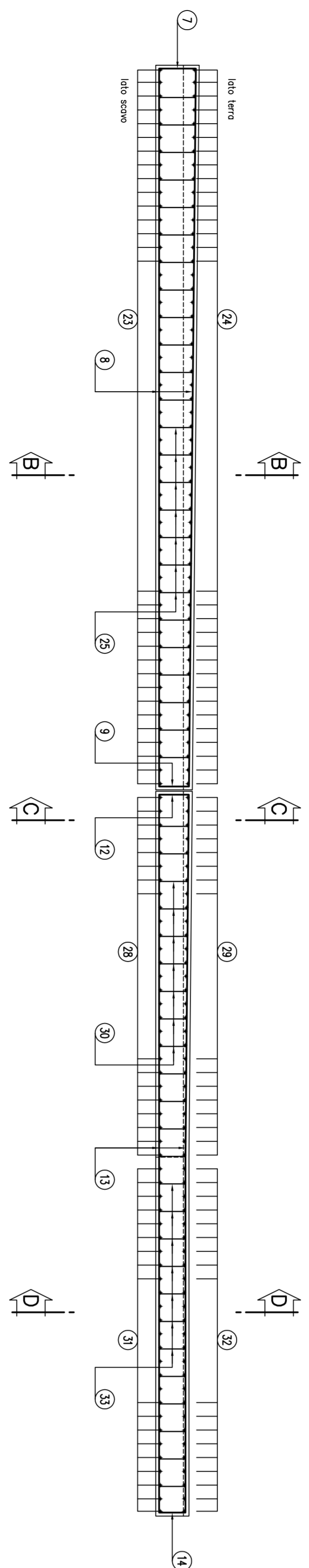

**PROFILO LONGITUDINALE**

SCALA 1:50

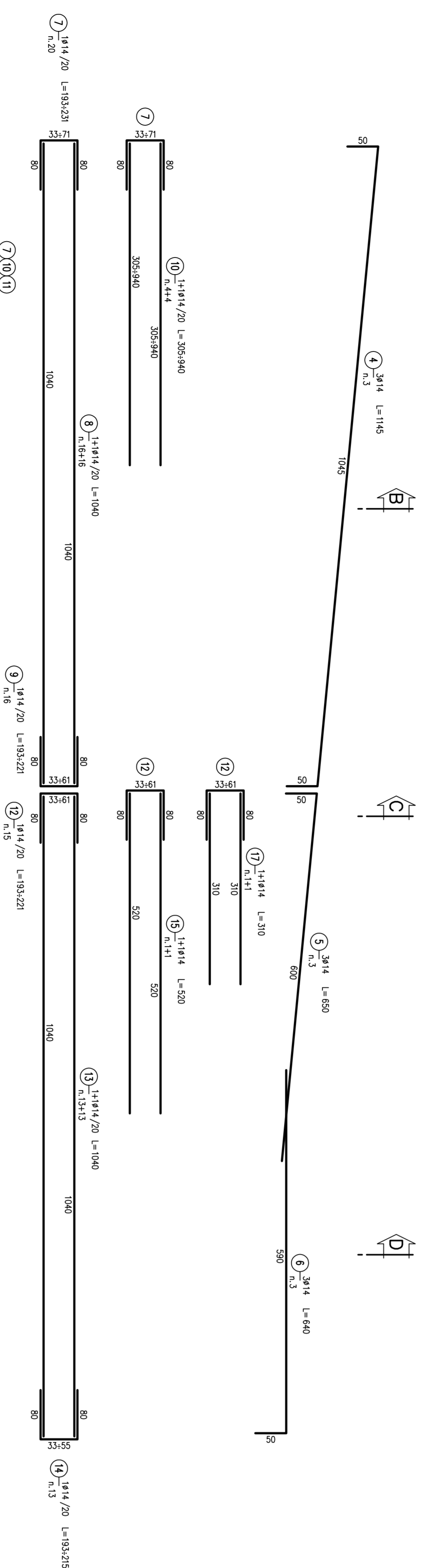

**SEZIONE TRASVERSALE D-D**

SCALA 1:50

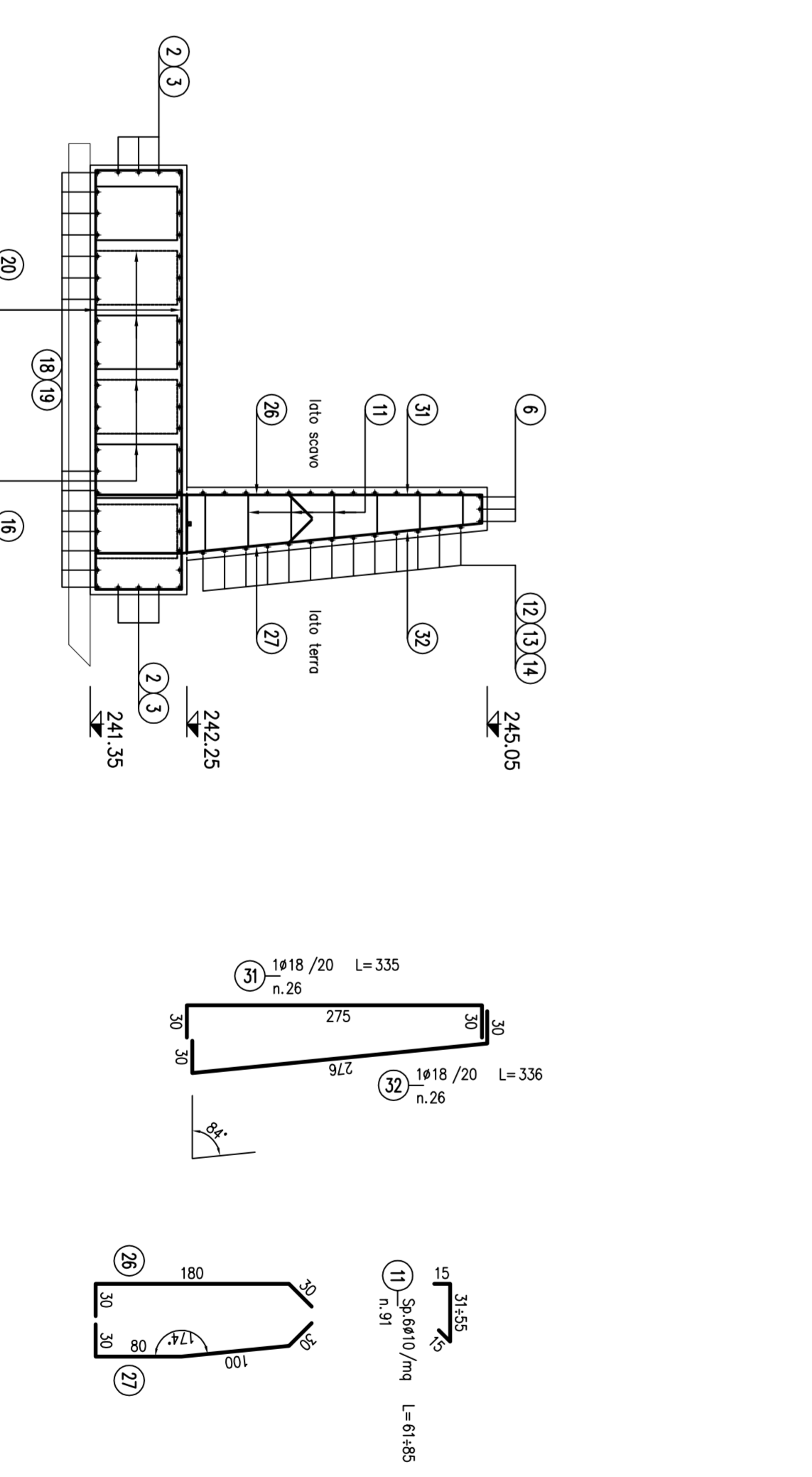

**SEZIONE TRASVERSALE C-C**

SCALA 1:50

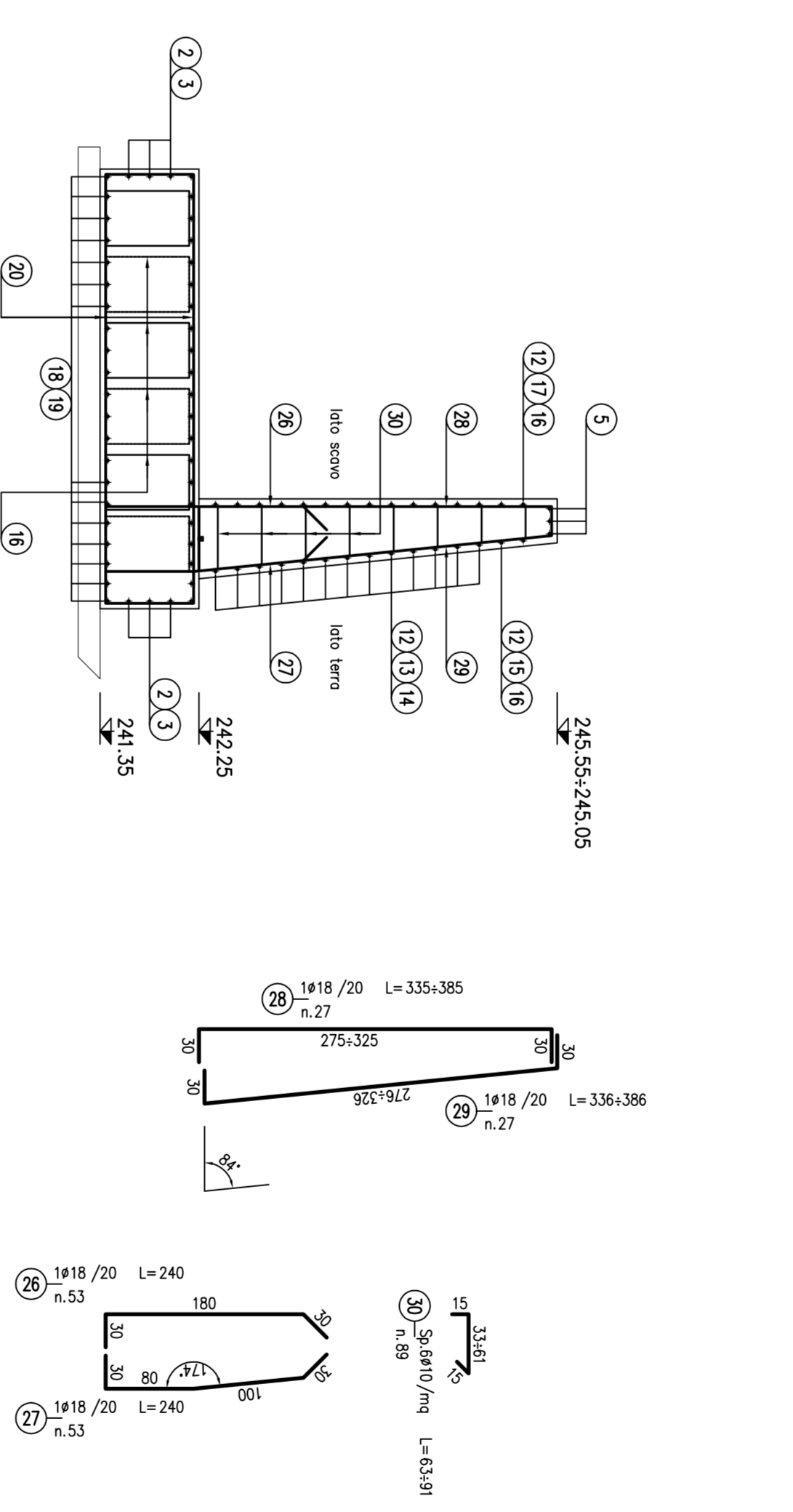

POS. N.	DATA	LAVORI SVOLTI	MIS. CONSUMI		LAVORI SVOLTI	PREZZO UNIT.	PREZZO TOT.
			QUANTITÀ	VALORE			
1	14	471	1.208	7200	28200	28200	39
2	14	1200	1.208	7200	7200	7200	81
3	14	1481	1.208	7200	9435	9435	42
4	14	1481	1.208	7200	18550	18550	26
5	14	650	1.208	7200	18550	18550	26
6	14	650	1.208	7200	4320	4320	2
7	14	650	1.208	7200	33350	33350	46
8	14	200	1.208	7200	2317	2317	4
9	14	200	1.208	7200	3105	3105	3
10	14	200	1.208	7200	2852	2852	3
11	14	200	1.208	7200	1040	1040	1
12	14	550	1.208	7200	3025	3025	4
13	14	550	1.208	7200	3025	3025	4
14	14	1200	1.208	7200	48820	48820	272
15	14	1100	1.208	7200	12720	12720	224
16	14	240	1.208	7200	234	234	1
17	14	437	1.208	7200	23181	23181	46
18	14	240	1.208	7200	18842	18842	117
19	14	86	0,917	18842	117	117	1
20	14	240	1.208	7200	18842	18842	117
21	14	240	1.208	7200	8720	8720	134
22	14	240	1.208	7200	8720	8720	134
23	14	358	1.208	7200	8710	8710	12
24	14	358	1.208	7200	8720	8720	134
25	14	358	1.208	7200	8720	8720	134
26	14	358	1.208	7200	8720	8720	134
27	14	358	1.208	7200	8720	8720	134
28	14	358	1.208	7200	8720	8720	134
29	14	358	1.208	7200	8720	8720	134
30	14	358	1.208	7200	8720	8720	134
31	14	358	1.208	7200	8720	8720	134
32	14	358	1.208	7200	8720	8720	134
33	14	358	1.208	7200	8720	8720	134
34	14	358	1.208	7200	8720	8720	134
35	14	358	1.208	7200	8720	8720	134
36	14	358	1.208	7200	8720	8720	134
37	14	358	1.208	7200	8720	8720	134
38	14	358	1.208	7200	8720	8720	134
39	14	358	1.208	7200	8720	8720	134
40	14	358	1.208	7200	8720	8720	134
41	14	358	1.208	7200	8720	8720	134
42	14	358	1.208	7200	8720	8720	134
43	14	358	1.208	7200	8720	8720	134
44	14	358	1.208	7200	8720	8720	134
45	14	358	1.208	7200	8720	8720	134
46	14	358	1.208	7200	8720	8720	134
47	14	358	1.208	7200	8720	8720	134
48	14	358	1.208	7200	8720	8720	134
49	14	358	1.208	7200	8720	8720	134
50	14	358	1.208	7200	8720	8720	134
51	14	358	1.208	7200	8720	8720	134
52	14	358	1.208	7200	8720	8720	134
53	14	358	1.208	7200	8720	8720	134
54	14	358	1.208	7200	8720	8720	134
55	14	358	1.208	7200	8720	8720	134
56	14	358	1.208	7200	8720	8720	134
57	14	358	1.208	7200	8720	8720	134
58	14	358	1.208	7200	8720	8720	134
59	14	358	1.208	7200	8720	8720	134
60	14	358	1.208	7200	8720	8720	134
61	14	358	1.208	7200	8720	8720	134
62	14	358	1.208	7200	8720	8720	134
63	14	358	1.208	7200	8720	8720	134
64	14	358	1.208	7200	8720	8720	134
65	14	358	1.208	7200	8720	8720	134
66	14	358	1.208	7200	8720	8720	134
67	14	358	1.208	7200	8720	8720	134
68	14	358	1.208	7200	8720	8720	134
69	14	358	1.208	7200	8720	8720	134
70	14	358	1.208	7200	8720	8720	134
71	14	358	1.208	7200	8720	8720	134
72	14	358	1.208	7200	8720	8720	134
73	14	358	1.208	7200	8720	8720	134
74	14	358	1.208	7200	8720	8720	134
75	14	358	1.208	7200	8720	8720	134
76	14	358	1.208	7200	8720	8720	134
77	14	358	1.208	7200	8720	8720	134
78	14	358	1.208	7200	8720	8720	134
79	14	358	1.208	7200	8720	8720	134
80	14	358	1.208	7200	8720	8720	134
81	14	358	1.208	7200	8720	8720	134
82	14	358	1.208	7200	8720	8720	134
83	14	358	1.208	7200	8720	8720	134
84	14	358	1.208	7200	8720	8720	134
85	14	358	1.208	7200	8720	8720	134
86	14	358	1.208	7200	8720	8720	134
87	14	358	1.208	7200	8720	8720	134
88	14	358	1.208	7200	8720	8720	134
89	14	358	1.208	7200	8720	8720	134
90	14	358	1.208	7200	8720	8720	134
91	14	358	1.208	7200	8720	8720	134
92	14	358	1.208	7200	8720	8720	134
93	14	358	1.208	7200	8720	8720	134
94	14	358	1.208	7200	8720	8720	134
95	14	358	1.208	7200	8720	8720	134
96	14	358	1.208	7200	8720	8720	134
97	14	358	1.208	7200	8720	8720	134
98	14	358	1.208	7200	8720	8720	134
99	14	358	1.208	7200	8720	8720	134
100	14	358	1.208	7200	8720	8720	134
101	14	358	1.208	7200	8720	8720	134
102	14	358	1.208	7200	8720	8720	134
103	14	358	1.208	7200	8720	8720	134
104	14	358	1.208	7200	8720	8720	134
105	14	358	1.208	7200	8720	8720	134
106	14	358	1.208	7200	8720	8720	134
107	14	358	1.208	7200	8720	8720	134
108	14	358	1.208	7200	8720	8720	134
109	14	358	1.208	7200	8720	8720	134
110	14	358	1.208	7200	8720	8720	134
111	14	358	1.208	7200	8720	8720	134
112	14	358	1.208	7200	8720	8720	134
113	14	358	1.208	7200	8720	8720	134
114	14	358	1.208	7200	8720	8720	134
115	14	358	1.208	7200	8720	8720	134
116	14	358	1.208	7200	8720	8720	134
117	14	358	1.208	7200	8720	8720	134
118	14	358	1.208	7200	8720	8720	134
119	14	358	1.208	7200	8720	8720	134
120	14	358	1.208	7200	8720	8720	134
121	14	358	1.208	7200	8720	8720	134
122	14	358	1.208	7200	8720	8720	134
123	14	358	1.208	7200	8720	8720	134
124	14	358	1.208	7200	8720	8720	134
125	14	358	1.208	7200	8720	8720	134
126	14	358	1.208	7200	8720	8720	134
127	14	358	1.208	7200	8720	8720	134
128	14	358	1.208	7200	8720	8720	134
129	14	358	1.208	7200	8720	8720	134
130	14	358	1.208	7200	8720	8720	134
131	14	358	1.208				