

**ELEVATION
CAISSON TYPE -3- (REINFORCED) Ø1.20**
SCALE 1:10

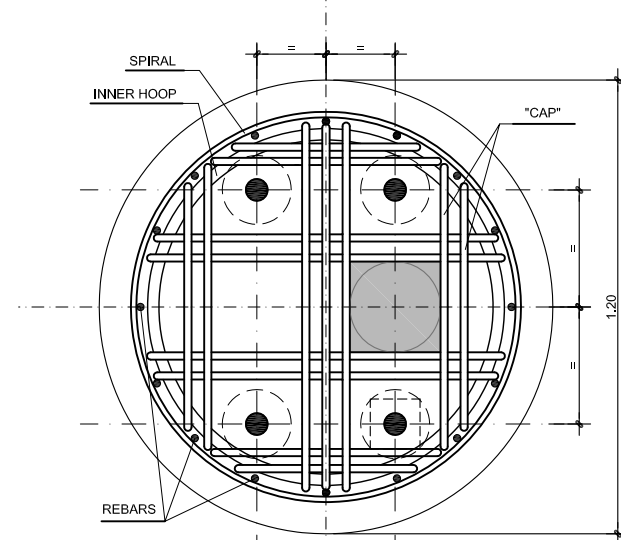

CAP DETAIL. PLAN
SCALE 1:10

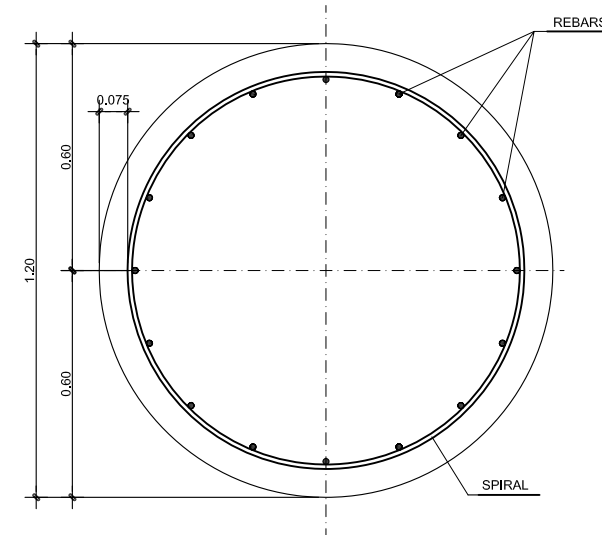
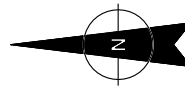

SECTION A-A
SCALE 1:10

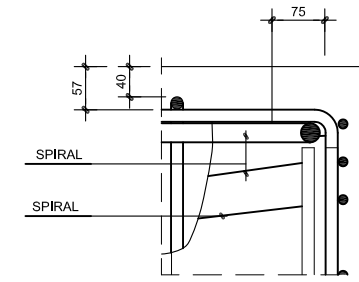

DETAIL-A
SCALE 1:5

MATERIALS	
CONCRETE	C 25/30
REINFORCEMENT	f _y =500 MPa
ANCHOR BOLTS	8.8 (UNE-ISO-898-1)
WASHER	S355 JR (UNE-EN-10025)
NUTS	GR.8 (UNE-ISO-898-6)

NOTES.-

- SEE TECH. SPECIFICATIONS
- PLASTIC COVER SPACERS SHALL BE PLACED ON VERTICAL REINFORCEMENT TO ENSURE CONCRETE COVER REQUIREMENTS
- ALL MATERIAL STUCK TO THE STEEL SHALL BE REMOVED FROM THE ANCHOR BOLTS. NO TRACE OF DIRT, WAX, OIL OR GREASE SHALL BE ALLOWED
- ANCHOR BOLT TEMPLATES SHALL REMAIN IN PLACE AT LEAST FOR THREE DAYS AFTER CONCRETE POURING
- ANCHOR BOLT TEMPLATES SHALL REMAIN IN PLACE AT LEAST FOR THREE DAYS AFTER CONCRETE POURING

CONCRETE CONSTRUCTION TOLERANCE NOTES:

- MAXIMUM PERMISSIBLE VARIATION OF THE CENTERLINE OF CAISSONS SHALL BE ± 40mm
- TOP OF CONCRETE ELEVATION SHALL NOT VARY MORE THAN ± 10mm FROM THE ELEVATIONS NOTED ON THE CAISSON SCHEDULES

ANCHOR BOLTS PLACEMENT TOLERANCE NOTES:

- MAXIMUM TOLERANCES IN THE BOLT ALIGNMENT WILL BE:
 - ± 5mm WITH RESPECT TO THE PROJECTION OF THE BOLT
 - ± 7mm WITH RESPECT TO THE MIRRORS DESIGN ALIGNMENT CENTERLINE (NORTH-SOUTH) AND THE PYLON DESIGN CENTERLINE (EAST-WEST)
 - ± 3mm WITH RESPECT TO RELATIVE DISTANCE BETWEEN BOLTS

REV.	DESCRIPTION	DATE	DRAWN	CHECKED	APPROVED
B	FOR INFORMATION	12/2014	A.B.H.	J.R.L.	P.A.Z.
A	FOR INFORMATION	03/2014	ILL	J.R.L.	P.A.Z.

REVISIONS

AUTHOR/OWNER: 		ENGINEERING: 		CONTRACTOR: 	
CAD FILE No: CER-SRCA-PC-9001-03-Rev B		PROJECT: GONNOSFANADIGA CSP PROJECT			
SCALE: 1:10		DRAWING TITLE: SOLAR FIELD COLLECTORS PILE FOUNDATIONS DETAILS TYPE 3- REINFORCED			
REFERENCE: C227A10		DRAWING No: CER-SRCA-PC-9001		SHEET: 03 OF 03	

