



Anas Spa

Direzione Centrale Progettazione

Nuova S.S.291

Lavori di costruzione del 1° lotto da Alghero ad Olmedo, in località bivio cantoniera di Rudas

PROGETTO DEFINITIVO

PROGETTAZIONE: ANAS - DIREZIONE CENTRALE PROGETTAZIONE

PROGETTISTI:

*Dott. Ing. ACHILLE DEVITOFRANCESCO/
Ordine Ing. di Roma n. 19116*
*Dott. Ing. ALESSANDRO MICHELI Dott. Ing. FULVIO MARIA SOCCODATO
Ordine Ing. di Roma n. 19654 Ordine Ing. di Roma n. 18861*

GRUPPO DI PROGETTAZIONE ANAS

<i>Dott. Ing. Piergiorgio D'Annini</i>	– Studio di traffico
<i>Dott. Ing. Gabriele Giovannini</i>	– Cartografia
<i>Arch. Barbara Bonchini</i>	– Ambiente
<i>Dott. Geol. Giuseppe Cardillo</i>	– Ambiente
<i>Dott. Geol. Stefano Serangei</i>	– Geologia
<i>Dott. Ing. Enrico Mitiga</i>	– Geotecnica
<i>Dott. Ing. Gianfranco Fusani</i>	– Idraulica
<i>Dott. Ing. Francesco Primieri</i>	– Strade
<i>Dott. Ing. Alessandro Piccarreto</i>	– Opere civili
<i>Dott. Ing. Francesco Baro</i>	– Opere civili
<i>Geom. Carmelo Zema</i>	– Espropri
<i>Dott. Ing. Pierluigi Fabbro</i>	– Interferenze
<i>Dott. Ing. Francesco Bezzi</i>	– Impianti
<i>Geom. Fabio Quondam</i>	– Comp., capitoli e sicurezza
<i>Geom. Pietro Tomasello</i>	– Opere civili

IL RESPONSABILE DEL S.I.A.

*Dott. Ing. FULVIO MARIA SOCCODATO
Ordine Ing. di Roma n. 18861*

COORDINATORE PER LA SICUREZZA IN FASE DI PROGETTAZIONE

Geom. FABIO QUONDAM

VISTO: IL RESP. DEL PROCEDIMENTO

Dott. Ing. ANTONIO SCALAMANDRE'

RESPONSABILI DI SERVIZI INGEGNERIA

<i>Dott. Ing. Fulvio Maria Soccodato</i>	– Territorio
<i>Dott. Ing. Alessandro Micheli</i>	– Geotecnica e Impianti
<i>Dott. Ing. Achille Devitofranceschi</i>	– Opere Civili
<i>Geom. Fabio Quondam</i>	– Compulti e capitoli
<i>Dott. Geol. Serena Mojetta</i>	– Caratterizzazione ambientale

PROTOCOLLO

DATA

PROGETTO STRADALE

Sezioni trasversali

Circ.ne Alghero tra la Rotatoria R2 e la Rotatoria R3

CODICE PROGETTO		NOME FILE	REVISIONE	SCALA:
PROGETTO	LIV. PROG. N. PROG.	T00PS00TRASZ03_B		
L O P L S C	D 1401	CODICE ELAB. T00P S00P S00T R A S Z 03	B	1:200
D				
C				
B	EMISSIONE PER PROCEDURE AUTORIZZATIVE	APR. 2015	Ing. F. Primieri	Ing. G. Fusani
A	EMISSIONE	APR. 2015	Ing. F. Primieri	Ing. G. Fusani
REV.	DESCRIZIONE	DATA	REDATTO	VERIFICATO APPROVATO

SEZIONE N. : 3
 QT. PROGETTO : 13.514
 DIST.PROG. : 25.000
 DIST.PREC. : 5.006
 DIST.SUCC. : 5.002

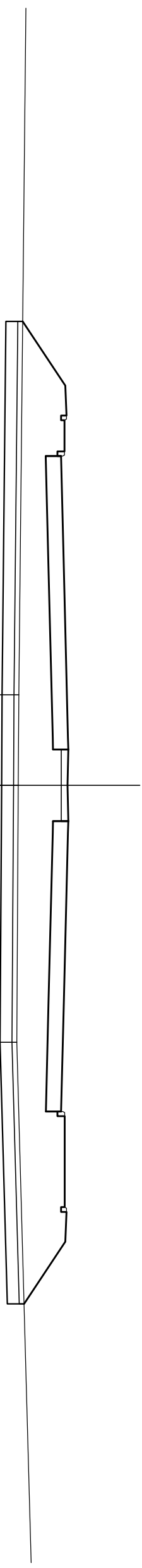

SCALA 1:200

QT.REF. -7.00

QUOTE TERRENO	DIST. PARZIALI TERRENO	QUOTE PROGETTO	DIST. PARZIALI PAVIMENTATO
	36,22	11,61	2,68
		13,40	1,25
		13,45	
		13,37	1,30
		13,37	
		13,22	4,76
		13,34	
	11,45		7,00
		13,51	0,50
		13,53	1,50
	3,78	13,50	1,50
		12,89	0,50
		13,51	7,00
	10,75		
		13,34	
		11,37	4,63
		13,22	
		13,07	3,80
		13,37	
		13,37	1,25
		13,45	
		13,40	2,60
		11,67	
	24,12		

SEZIONE N. : 5
 QT. PROGETTO : 13.168
 DIST.PROG. : 45.012
 DIST.PREC. : 15.010
 DIST.SUCC. : 15.003

SCALA 1:200

QT.REF. -3.00

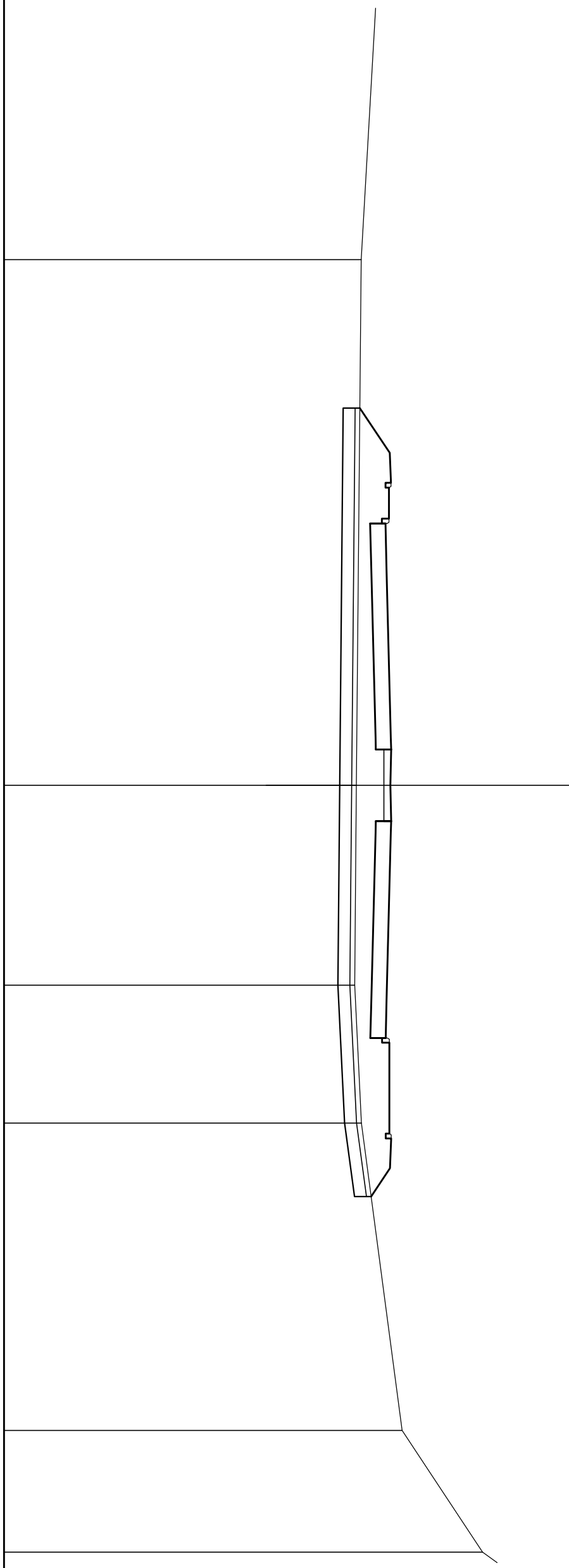

QUOTE TERRENO	DIST. PARZIALI TERRENO	QUOTE PROGETTO	DIST. PARZIALI PAVIMENTATO
11.93	13.02	11.87	1.88
11.73	21.98	13.12	1.25
11.66	8.36	13.17	1.30
11.94	5.76	13.09	1.95
13.65	12.86	12.94	7.00
17.00	5.08	12.99	7.00
	0.79	13.17	0.50
		13.18	1.50
		13.15	1.50
		12.54	0.50
		13.17	7.00
		12.99	1.56
		12.95	3.80
		12.80	1.25
		13.10	1.18
		13.18	12.35
		13.13	

SEZIONE N. : 6
 QT. PROGETTO : 13.034
 DIST.PROG. : 60.015
 DIST.PREC. : 15.003
 DIST.SUCC. : 14.995

SCALA 1:200

QT.REF. -5.00

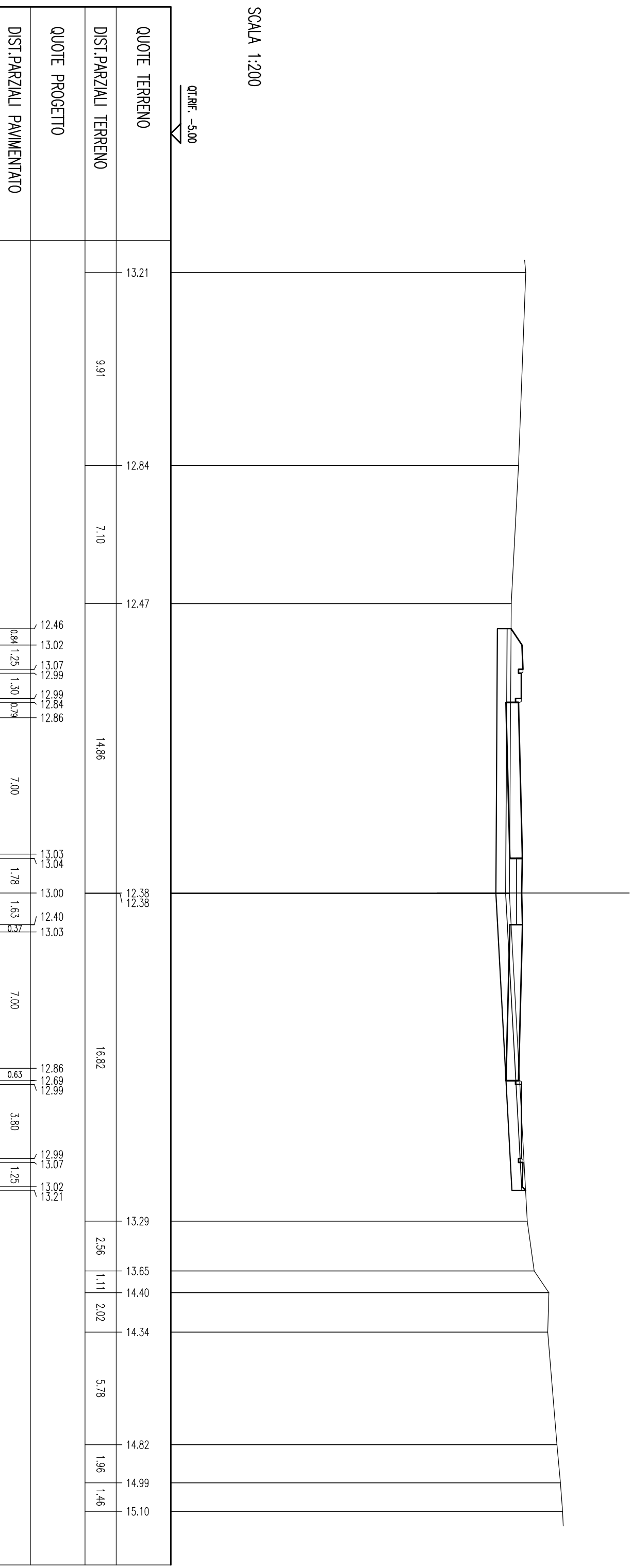

SEZIONE N. : 7
 QT. PROGETTO : 13.013
 DIST.PROG. : 75.010
 DIST.PREC. : 14.995
 DIST.SUCC. : 14.992

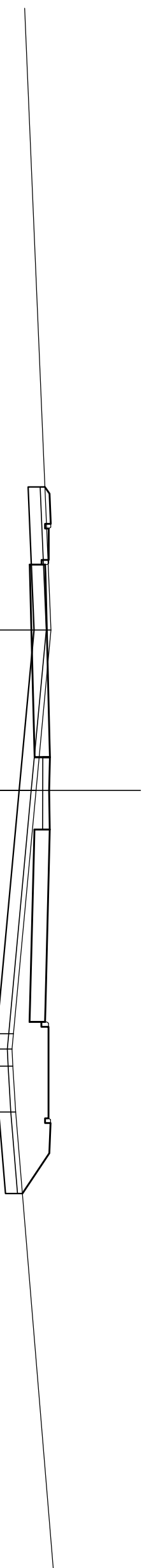

SCALA 1:200

QT.REF. -7.00

QUOTE TERRENO	DIST. PARZIALI TERRENO	QUOTE PROGETTO	DIST. PARZIALI PAVIMENTATO
	28.96		
13.07	6.66	12.82 13.01 13.06 12.98 12.98 12.84	1.25 1.30 0.38 7.00
12.45	10.11	13.01 13.03 12.99 12.38 13.01	0.29 1.38 1.62 0.38 7.00
11.51 11.45 11.49	0.63 0.71 1.90	12.84 12.67 12.97	0.62 3.80
11.60		12.97 13.05 13.00	1.25 1.68
	26.51	11.88	

SEZIONE N. : 8
 QT. PROGETTO : 13.104
 DIST.PROG. : 90.002
 DIST.PREC. : 14.992
 DIST.SUCC. : 14.998

SCALA 1:200

QT.RIF. -6.00

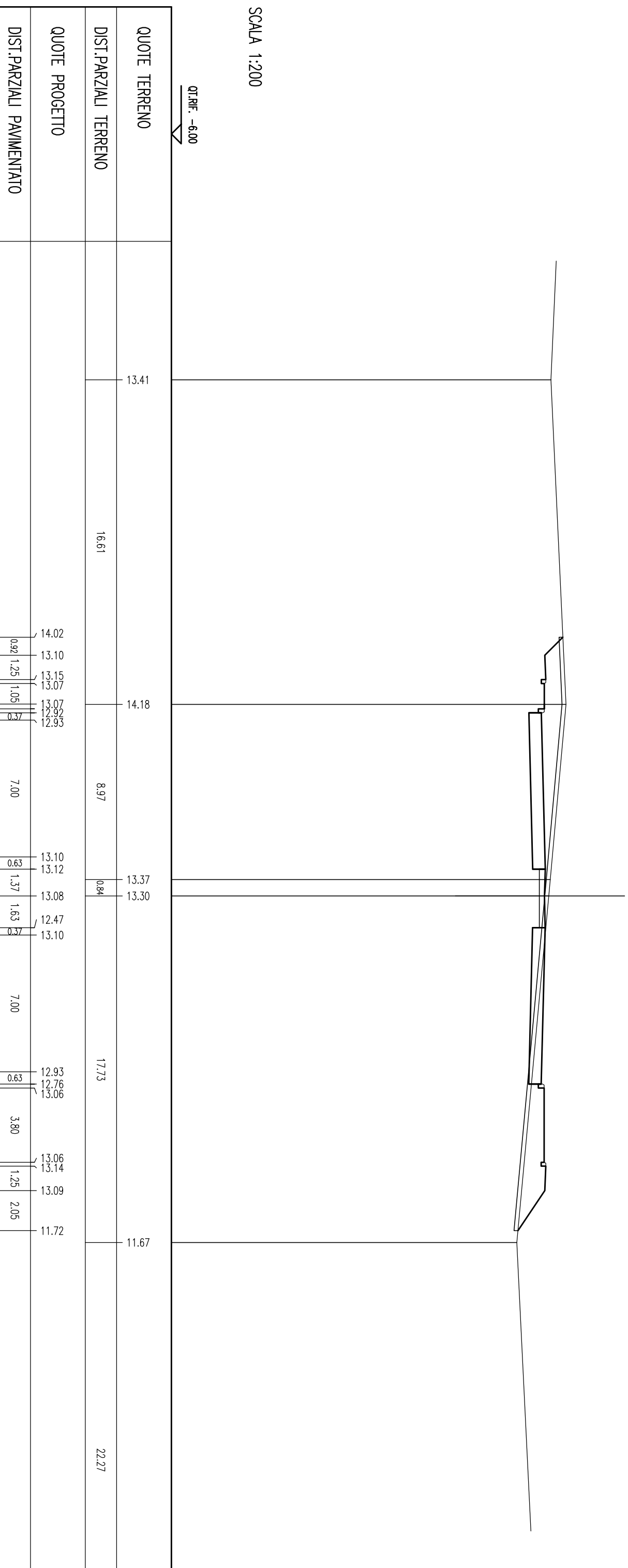

SEZIONE N. : 9
 QT. PROGETTO : 13.250
 DIST.PROG. : 105.000
 DIST.PREC. : 14.998
 DIST.SUCC. : 15.000

SCALA 1:200

QT.RIF. -5.00

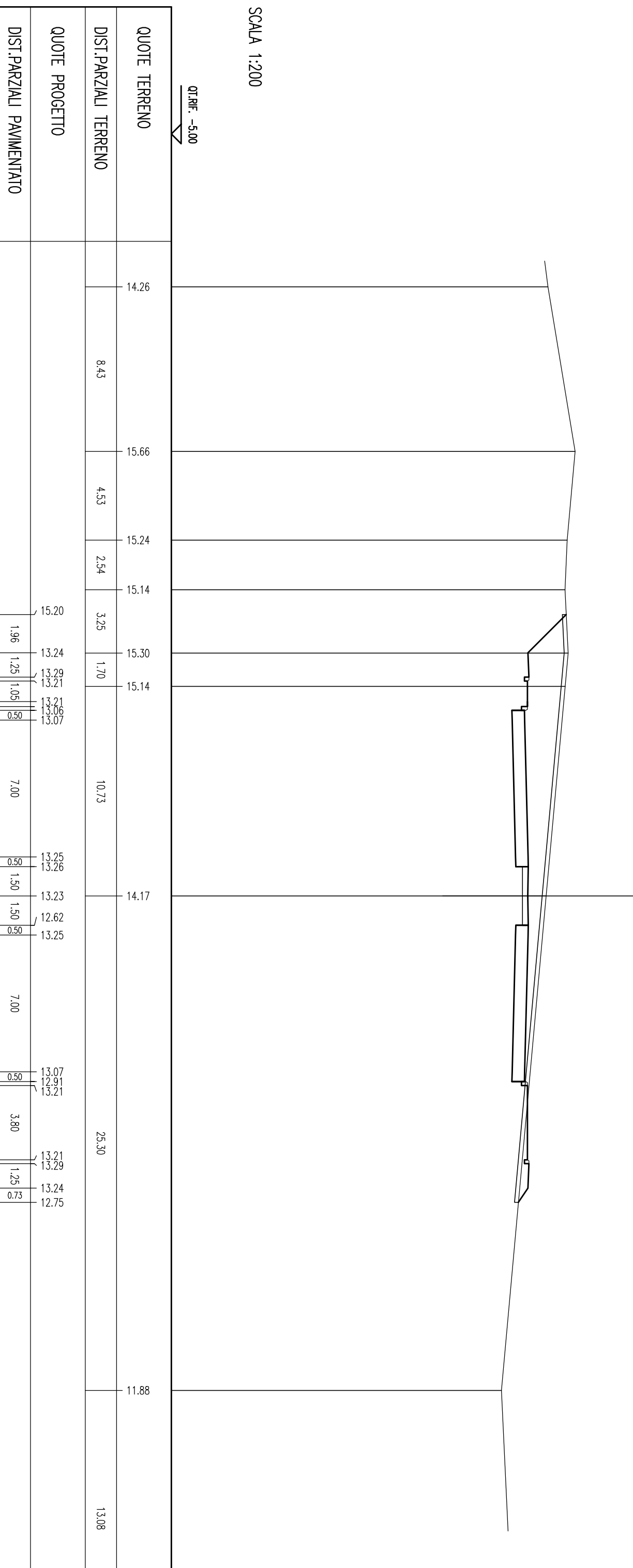

SEZIONE N. : 10
 QT. PROGETTO : 13.395
 DIST.PROG. : 120.000
 DIST.PREC. : 15.000
 DIST.SUCC. : 15.000

SCALA 1:200

QT.REF. -6.00

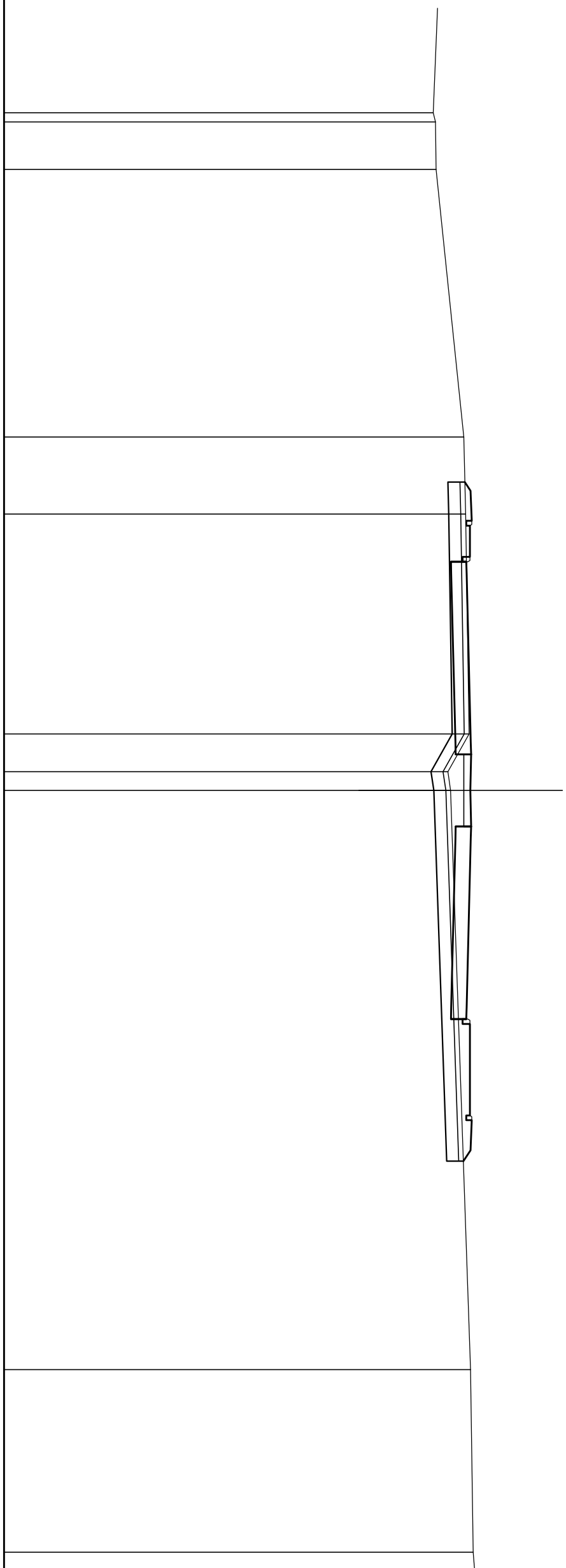

QUOTE TERRENO	DIST. PARZIALI TERRENO	QUOTE PROGETTO	DIST. PARZIALI PAVIMENTATO
11.84 11.93	7.71	11.97	
11.95	11.12		
13.10	3.20	13.18	
13.15 13.39	9.14	13.32	7.00
13.44 13.36	1.57	12.44	1.25
13.36 13.22	0.78	12.56	1.30
13.39 13.41	24.06	13.39	0.50
13.38 12.77 13.39		13.49	1.50
13.22 13.06 13.36			1.50
13.36 13.44			7.00
13.39 13.09			0.50
			1.25
			3.80
			0.45

SEZIONE N. : 11
 QT. PROGETTO : 13.540
 DIST.PROG. : 135.000
 DIST.PREC. : 15.000
 DIST.SUCC. : 15.000

SCALA 1:200

QT.REF. -7.00

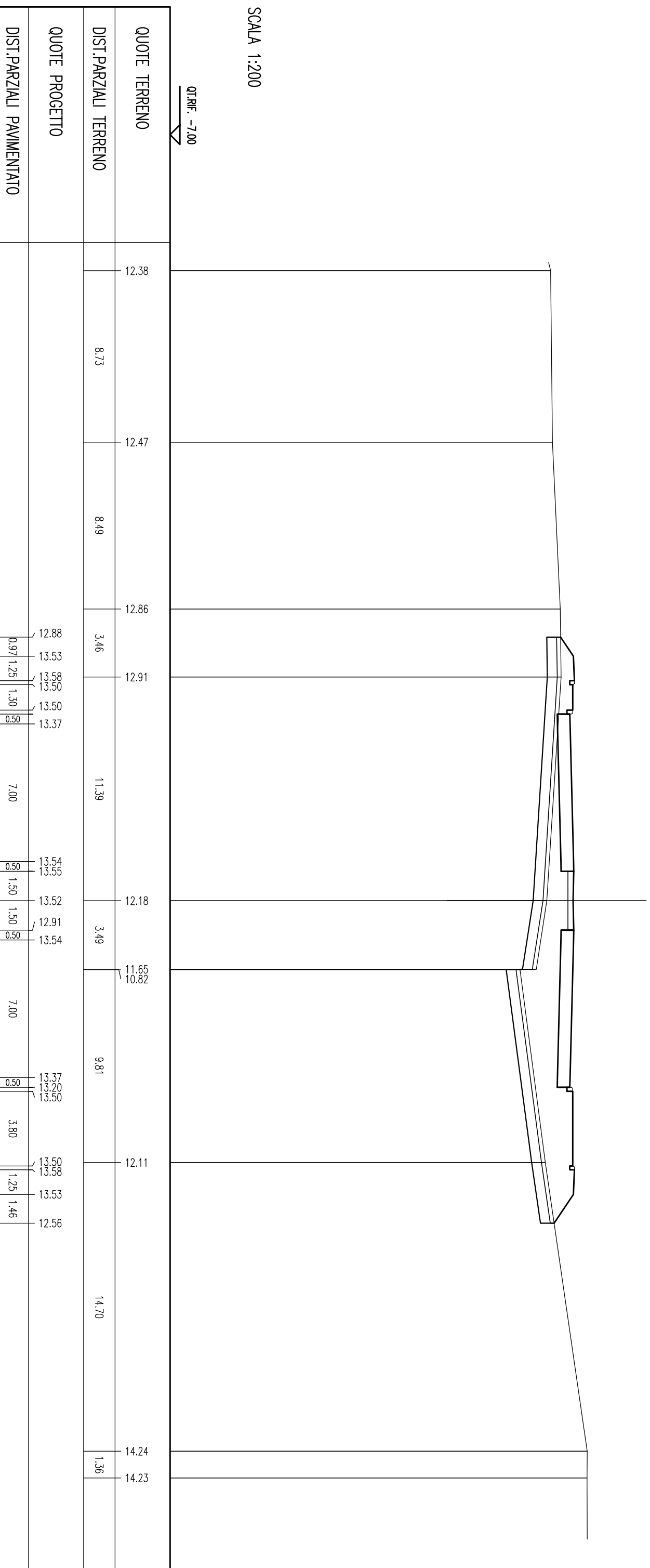

SEZIONE N. : 12
 QT. PROGETTO : 13.685
 DIST.PROG. : 150.000
 DIST.PREC. : 15.000
 DIST.SUCC. : 15.000

SCALA 1:200

QT.RIF. -6.00

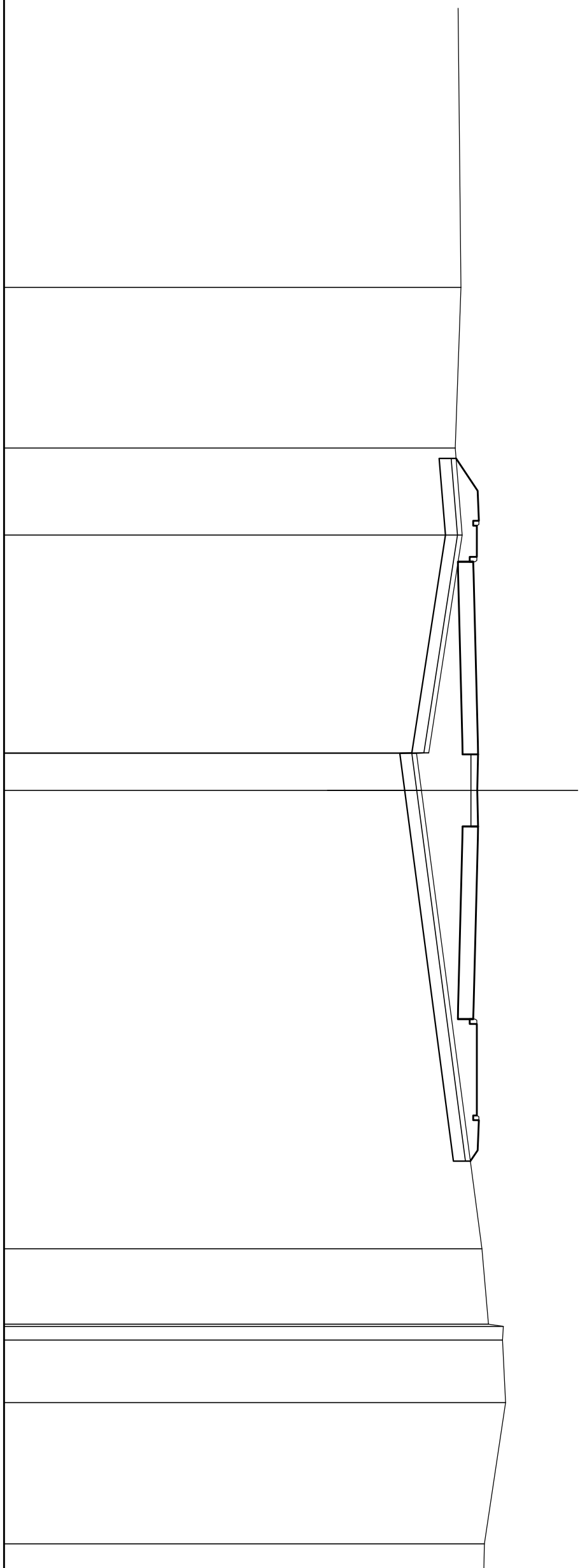

QUOTE TERRENO	DIST. PARZIALI TERRENO	QUOTE PROGETTO	DIST. PARZIALI PAVIMENTATO
12.99	6.67	12.78	1.35
12.75	3.61	13.68	1.25
13.04	9.05	13.73	1.30
13.04	9.05	13.65	0.50
13.51	9.05	13.51	7.00
11.65	1.54	13.69	0.50
11.14	1.54	13.70	1.50
11.35	1.54	13.67	1.50
11.35	1.54	13.06	0.50
11.35	1.54	13.69	7.00
13.51	19.04	13.51	0.50
13.35	19.04	13.35	3.80
13.65	19.04	13.65	1.25
13.65	19.04	13.65	0.45
13.73	19.04	13.73	1.25
13.68	19.04	13.68	0.45
13.38	19.04	13.38	0.45
13.85	3.13	14.13	0.57
14.13	3.13	14.75	2.60
14.72	3.13	14.72	5.87
14.84	5.87	14.84	5.87
13.96	13.96	13.96	13.96

SEZIONE N. : 13
 QT. PROGETTO : 13,831
 DIST.PROG. : 165,000
 DIST.PREC. : 15,000
 DIST.SUCC. : 15,000

SCALA 1:200

QT.RIF. -5,00

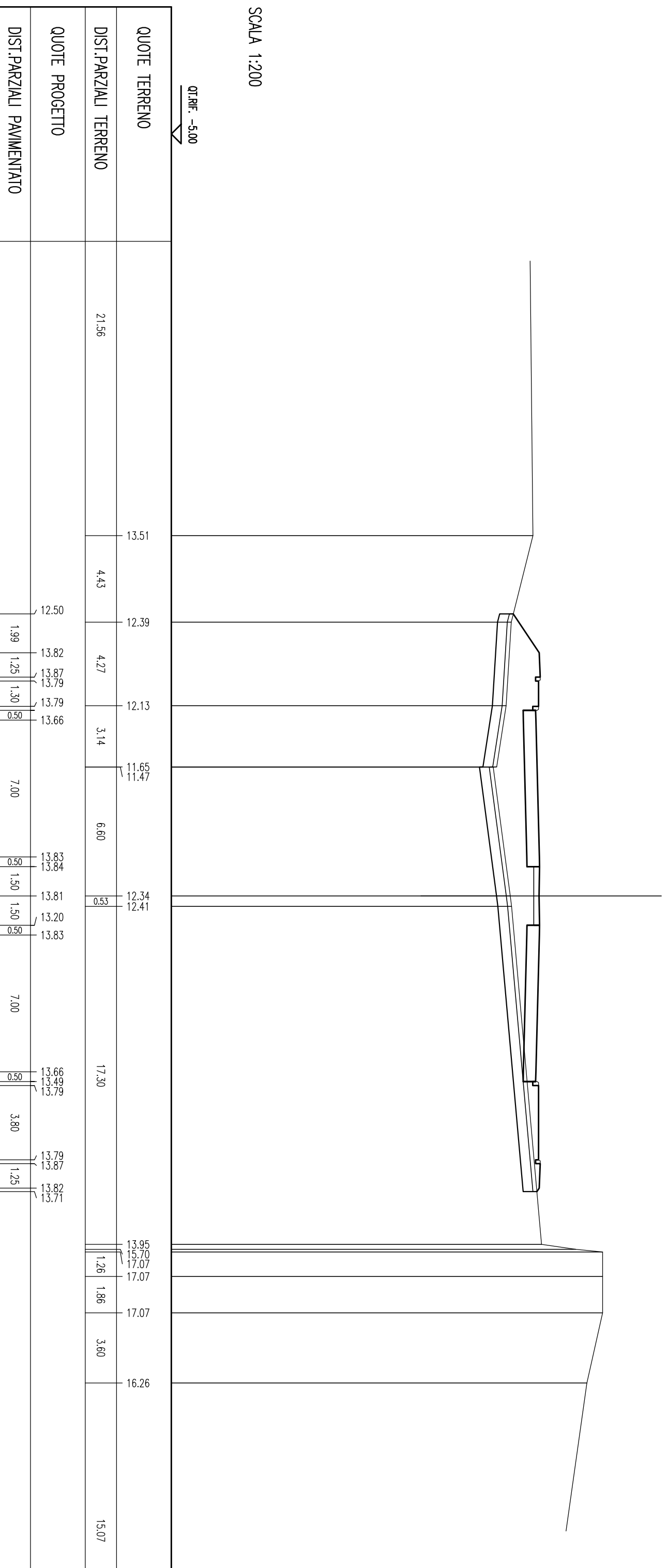

SEZIONE N. : 14
 QT. PROGETTO : 13.976
 DIST.PROG. : 180.000
 DIST.PREC. : 15.000
 DIST.SUCC. : 15.000

SCALA 1:200

QT.REF. -7.00

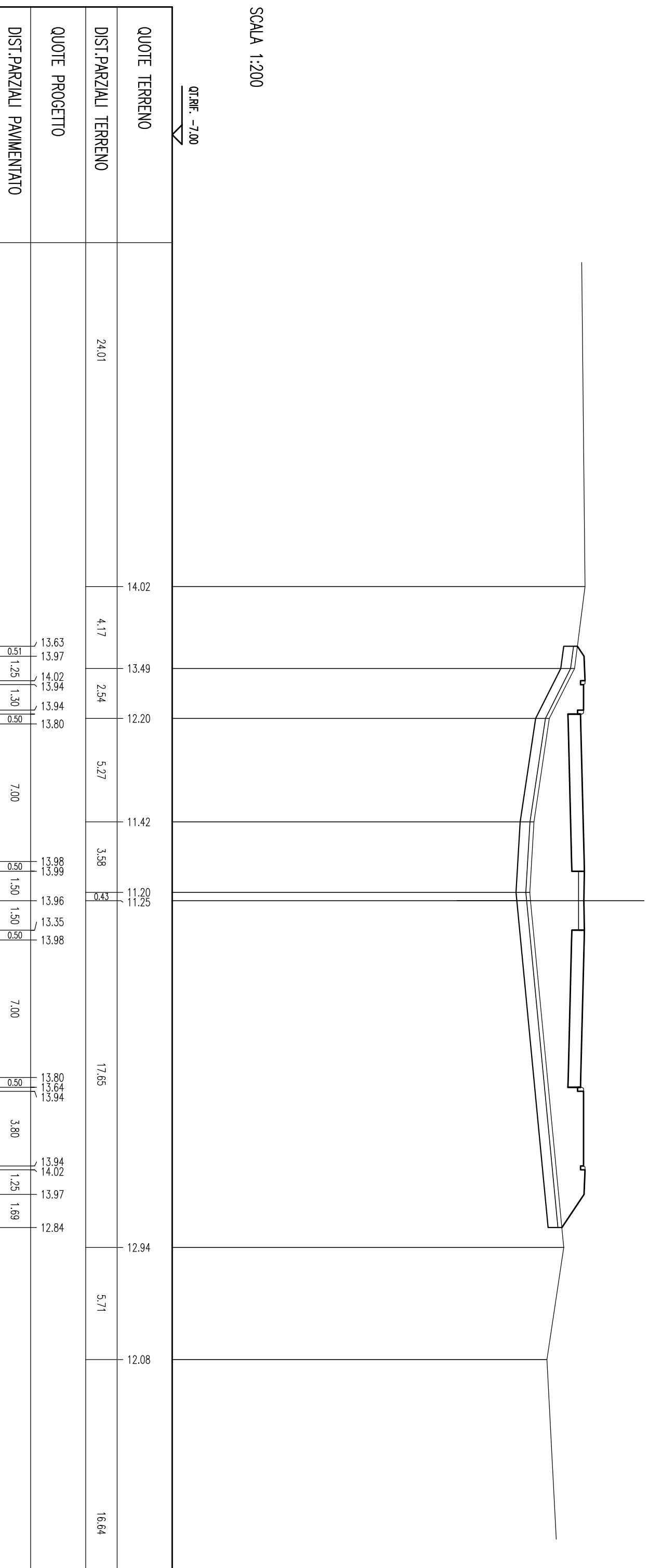

SEZIONE N. : 15
 QT. PROGETTO : 14.121
 DIST.PROG. : 195.000
 DIST.PREC. : 15.000
 DIST.SUCC. : 15.000

SCALA 1:200

QT.REF. -7.00

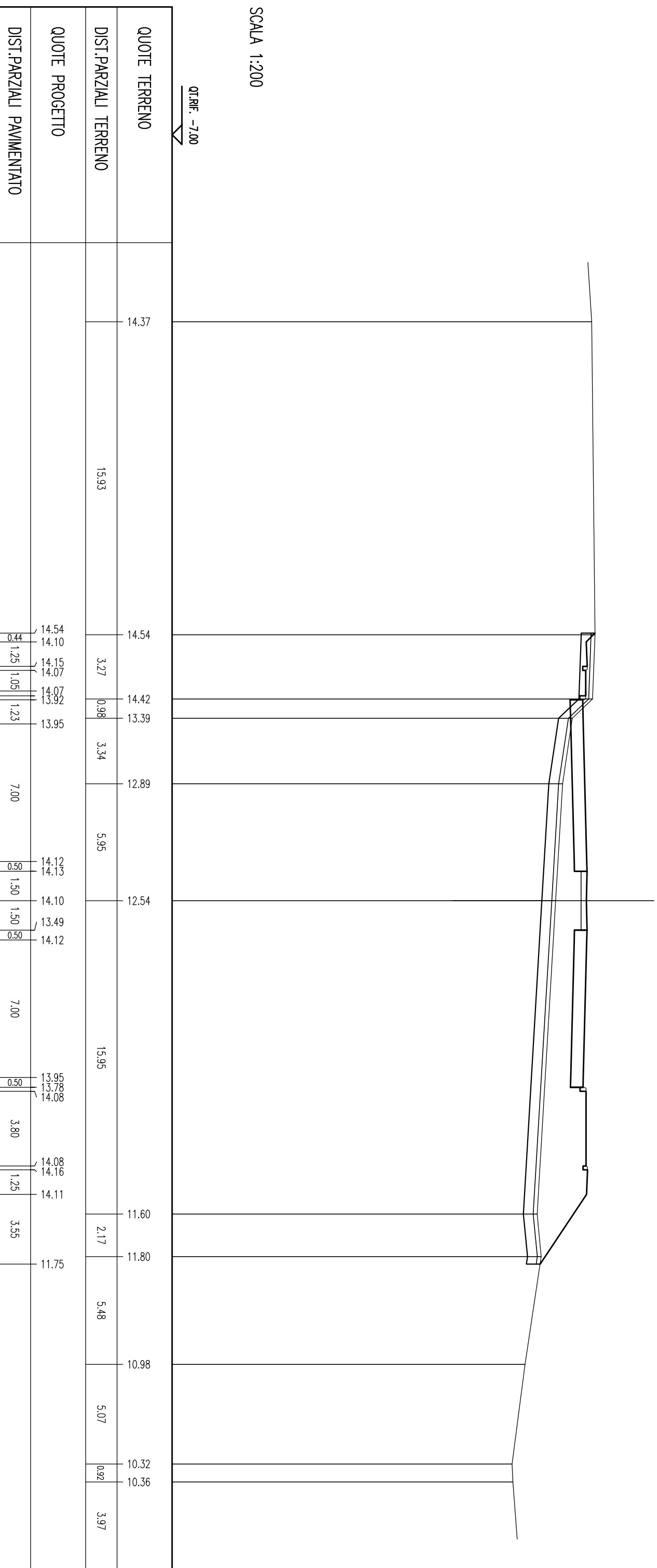

SEZIONE N. : 16
 QT. PROGETTO : 14.266
 DIST.PROG. : 210.000
 DIST.PREC. : 15.000
 DIST.SUCC. : 15.000

SCALA 1:200

QT.REF. -6.00

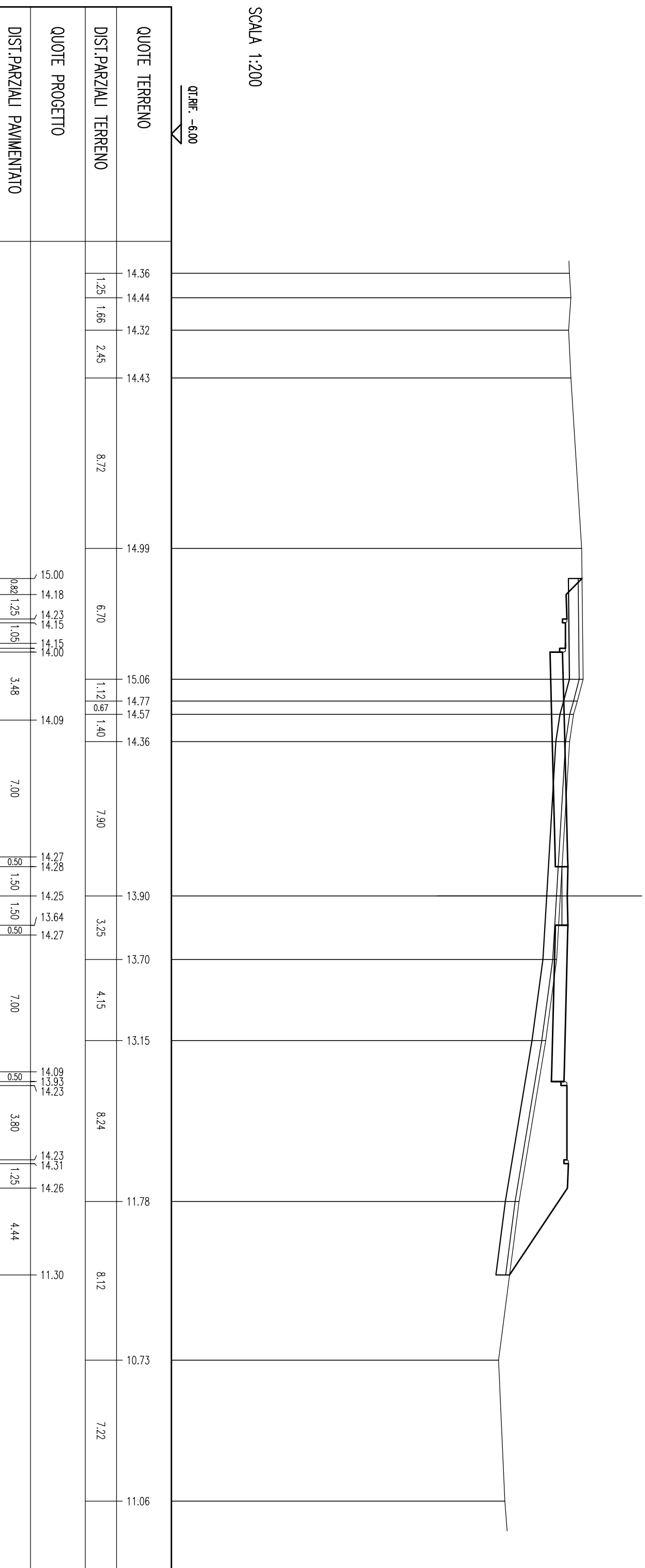

SEZIONE N. : 17
 QT. PROGETTO : 14.412
 DIST.PROG. : 225.000
 DIST.PREC. : 15.000
 DIST.SUCC. : 15.000

SCALA 1:200

QT.RIF. -6.00

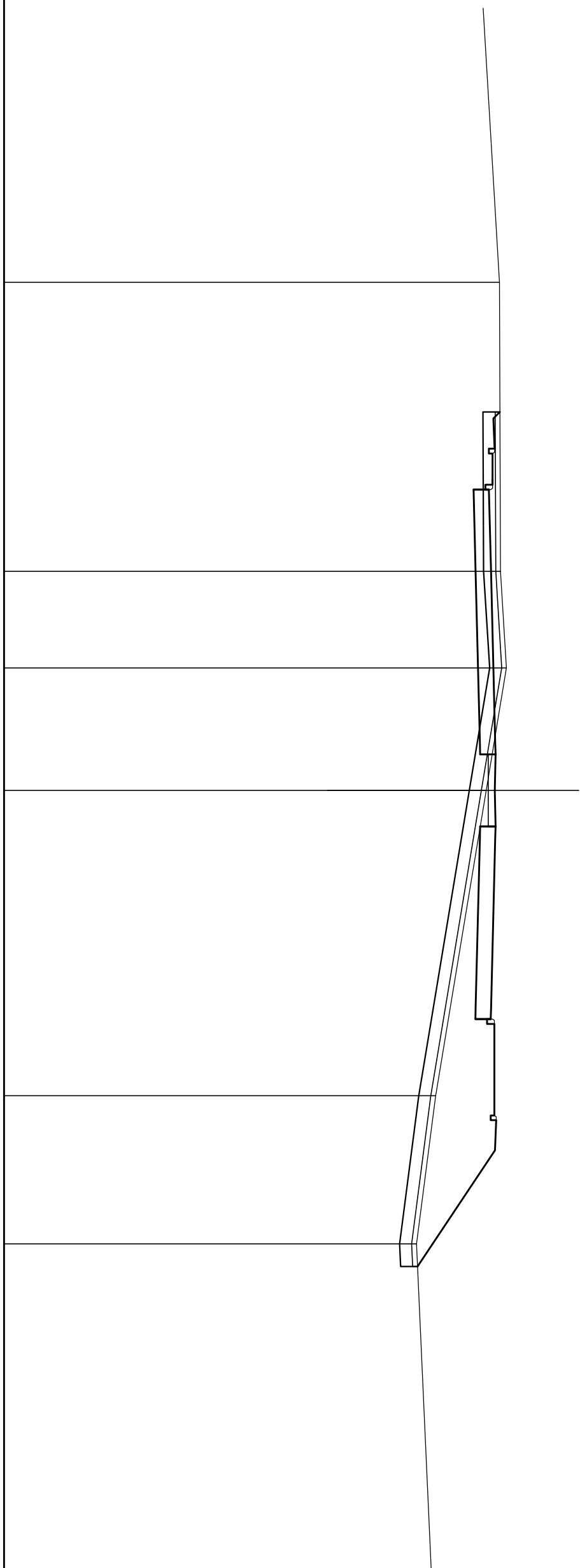

QUOTE TERRENO	DIST.PARZIALI TERRENO	QUOTE PROGETTO	DIST.PARZIALI PAVIMENTATO
14.58	18.89	14.60 14.53	1.25
14.63	12.01	14.38 14.30	1.05
14.88	4.01	14.30 14.15	3.50
14.04	5.09	14.24	7.00
11.94	12.69	14.41 14.42	0.50
11.14	6.15	14.39 13.78 14.41	1.50 1.50 0.50
11.18	13.52	14.24 14.07 14.37	0.50
		14.37 14.45	3.80
		14.40	1.25
			4.83

SEZIONE N. : 18
 QT. PROGETTO : 14.553
 DIST.PROG. : 240.000
 DIST.PREC. : 15.000
 DIST.SUCC. : 15.000

SCALA 1:200

QT.RIF. -6.00

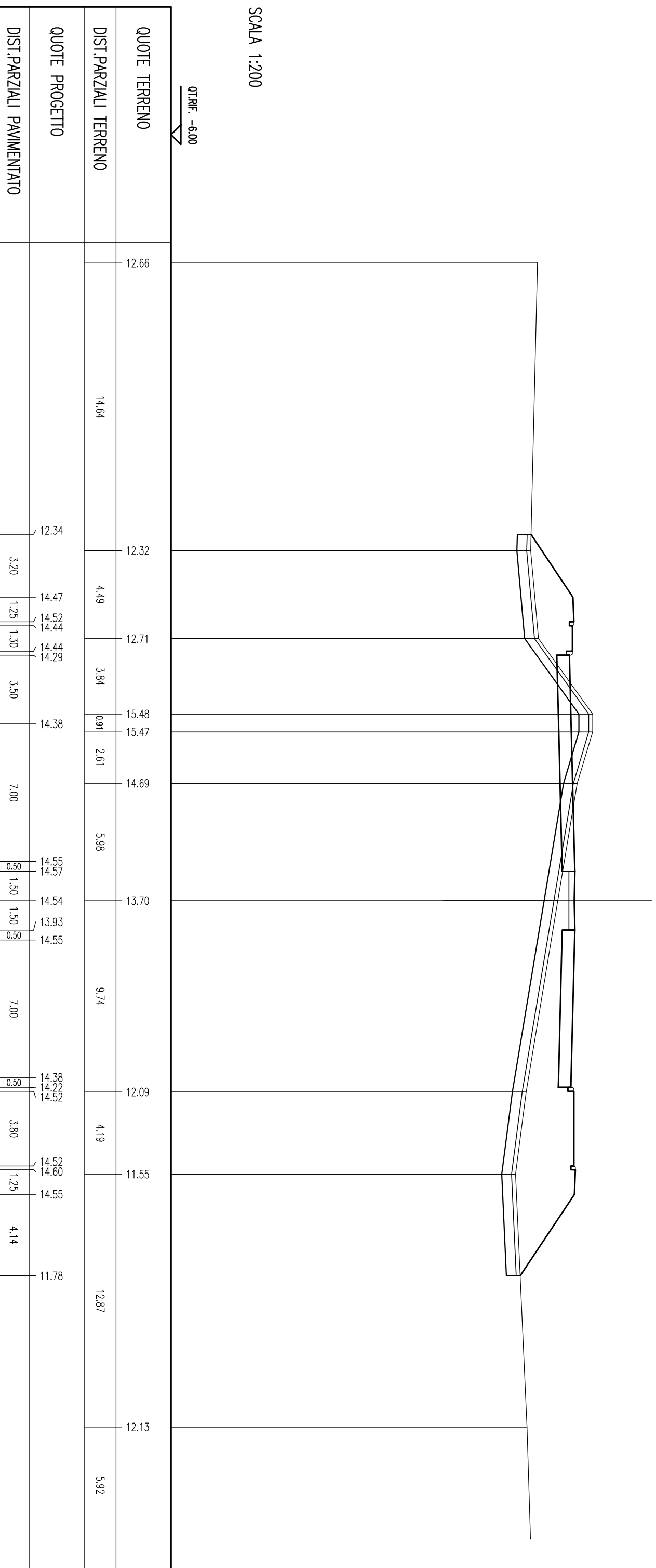

SEZIONE N. : 19
 QT. PROGETTO : 14.675
 DIST.PROG. : 255.000
 DIST.PREC. : 15.000
 DIST.SUCC. : 15.000

SCALA 1:200

QT.RIF. -6.00

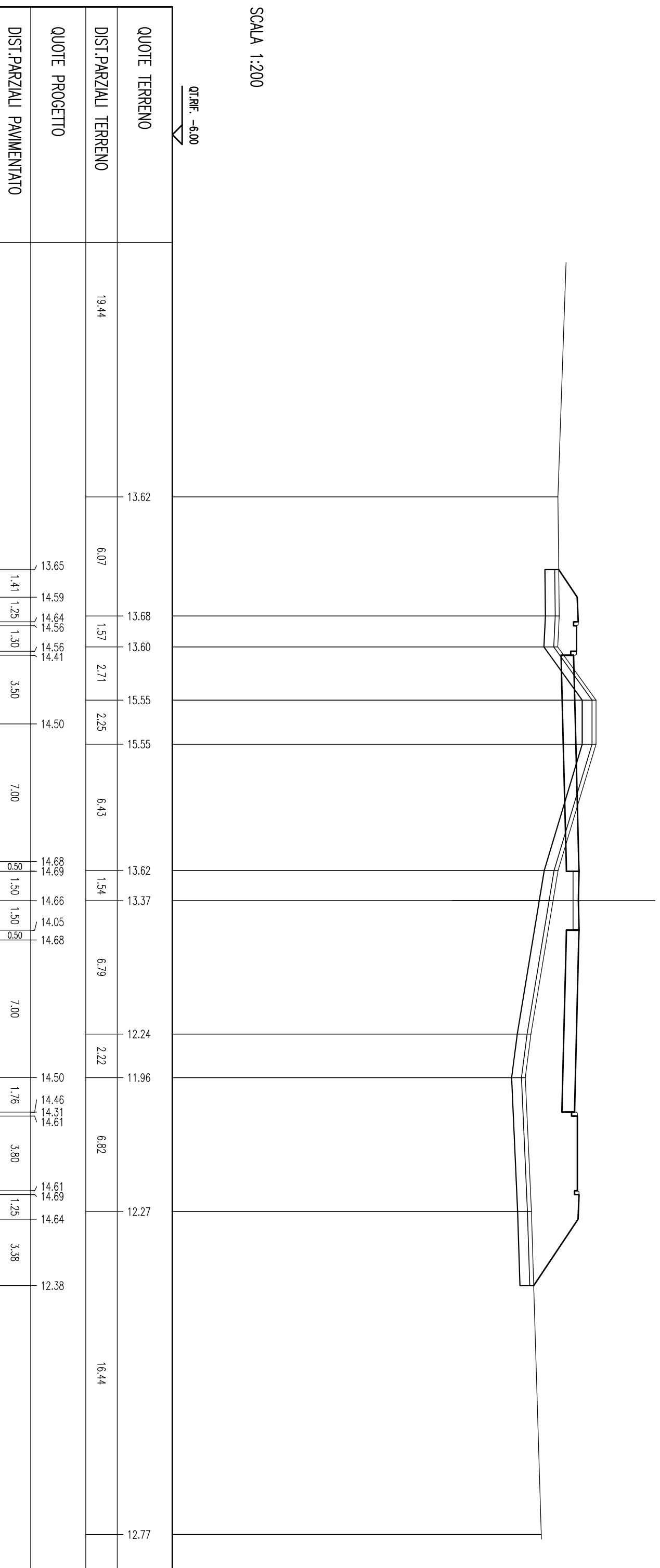

SEZIONE N. : 20
 QT. PROGETTO : 14.774
 DIST.PROG. : 270.000
 DIST.PREC. : 15.000
 DIST.SUCC. : 15.000

SCALA 1:200

QT.REF. -5.00

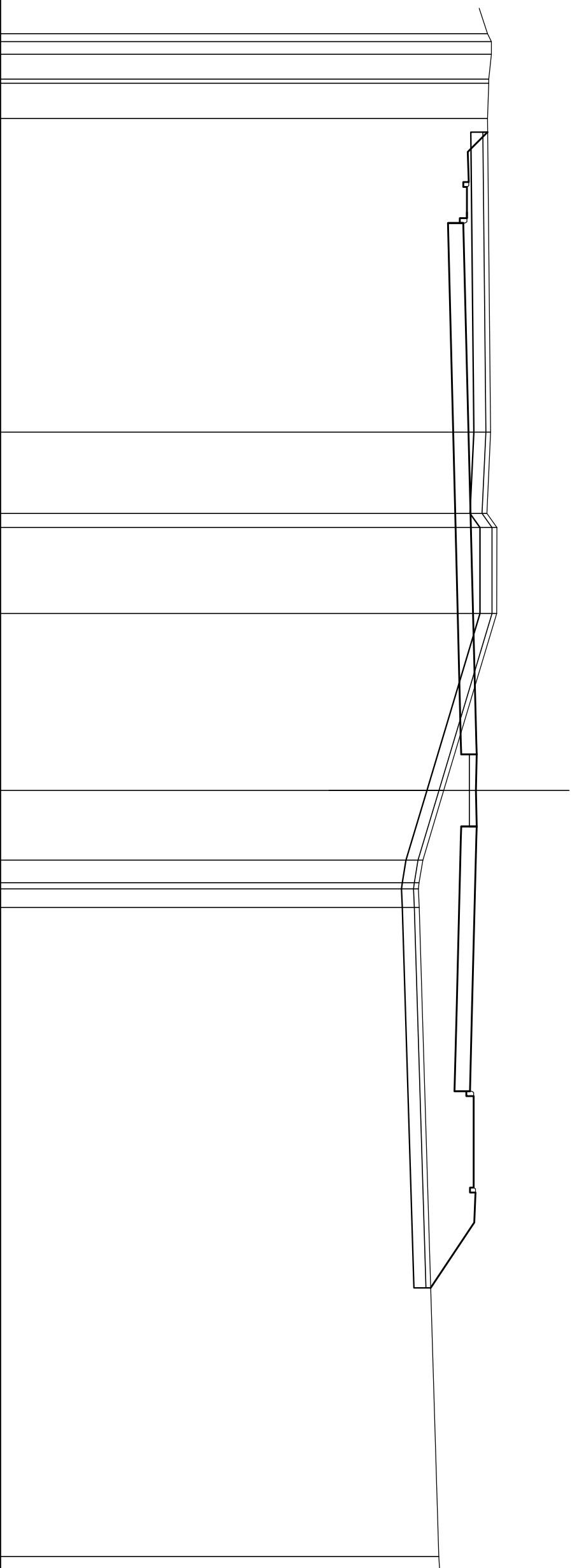

QUOTE TERRENO	DIST. PARZIALI TERRENO	QUOTE PROGETTO	DIST. PARZIALI PAVIMENTATO
15.24	0.00	15.24	0.00
15.40	0.00	14.41	0.83
15.40	1.03	14.46	1.25
15.29	1.47	14.38	1.05
15.29	13.03	14.23	14.57
15.24	15.37	14.60	7.00
15.37	3.38	14.77	1.50
15.21	0.98	14.79	1.50
15.63	3.58	14.76	0.94
15.62	7.35	14.15	0.77
15.62	2.90	14.77	7.00
13.42	0.94	14.60	3.50
12.55	0.77	14.51	3.80
12.40	26.96	14.36	1.25
12.37	14.66	14.66	2.71
12.40	14.74	14.69	12.88
13.22			

SEZIONE N. : 21
 QT. PROGETTO : 14.851
 DIST.PROG. : 285.000
 DIST.PREC. : 15.000
 DIST.SUCC. : 9.385

SCALA 1:200

QT.RIF. -5.00

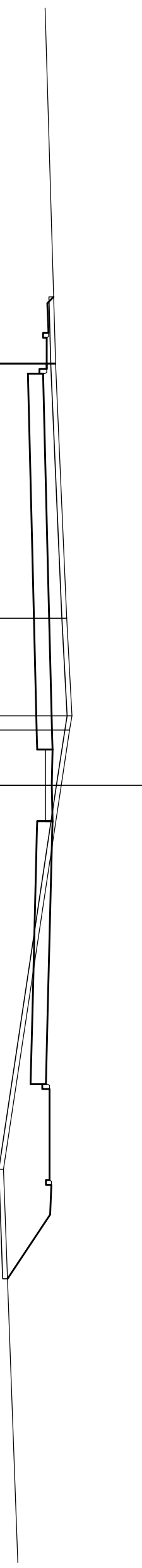

QUOTE TERRENO		14.99 14.99 14.99		15.68 15.58	15.23		12.81		
DIST.PARZIALI TERRENO	16.95	10.62	4.08	2.32	16.06	12.81	17.02		
QUOTE PROGETTO		14.91 14.65	14.70 14.62	14.62 14.47	14.85 14.86	14.83 14.22 14.85	14.59 14.44 14.74	14.74 14.82 14.77	12.98
DIST.PARZIALI PAVIMENTATO		1.25 1.05	8.21	7.00	1.50 1.50	7.00	3.50 3.80	1.25 2.68	

SEZIONE N. : 22
 QT. PROGETTO : 14.887
 DIST.PROG. : 294.385
 DIST.PREC. : 9.385
 DIST.SUCC. : 5.615

SCALA 1:200

QT.RIF. -5.00

QUOTE TERRENO	DIST.PARZIALI TERRENO	QUOTE PROGETTO	DIST.PARZIALI PAVIMENTATO
14.11	17.32	14.11	1.04
14.73	7.58	14.80	1.25
14.99	2.70	14.85	1.30
13.52	5.87	14.77	3.56
13.34	0.73	14.62	7.00
13.17	0.65	14.71	1.50
13.27	5.05	14.89	1.50
14.74	14.74	14.90	0.50
14.74	7.22	14.87	7.00
14.74	14.74	14.26	3.68
13.09	10.93	14.62	3.80
	9.64	14.47	1.25
		14.77	1.28

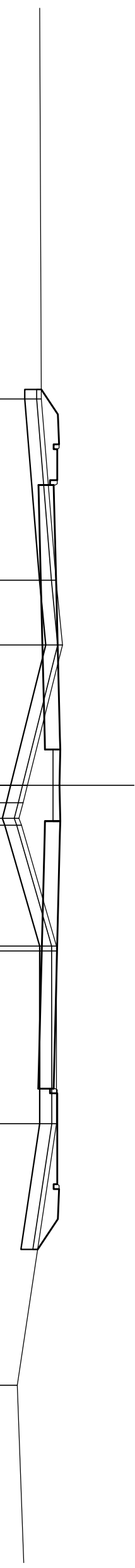

SEZIONE N. : 23
 QT. PROGETTO : 14.905
 DIST.PROG. : 300.000
 DIST.PREC. : 5.615
 DIST.SUCC. : 15.000

SCALA 1:200

QT.RIF. -5.00

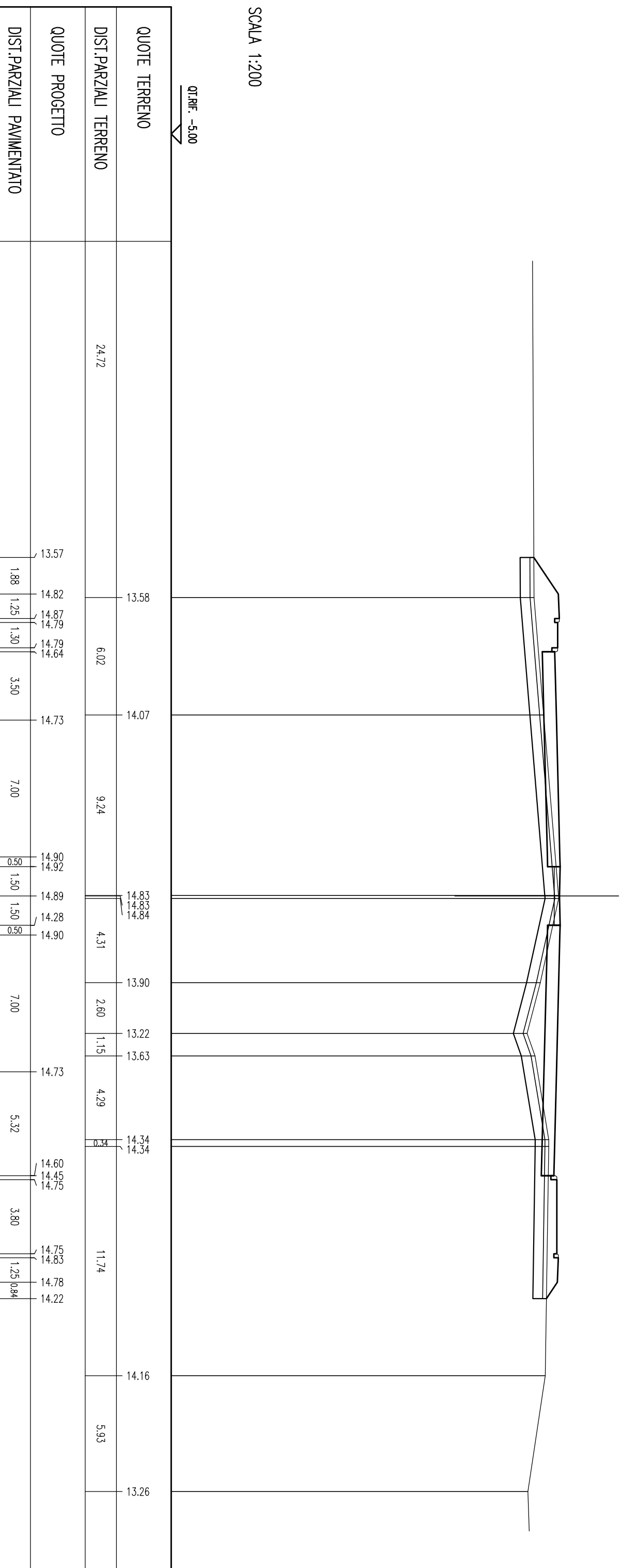

SEZIONE N. : 24
 QT. PROGETTO : 14.936
 DIST.PROG. : 315.000
 DIST.PREC. : 15.000
 DIST.SUCC. : 15.000

SCALA 1:200

QT.RIF. -6.00

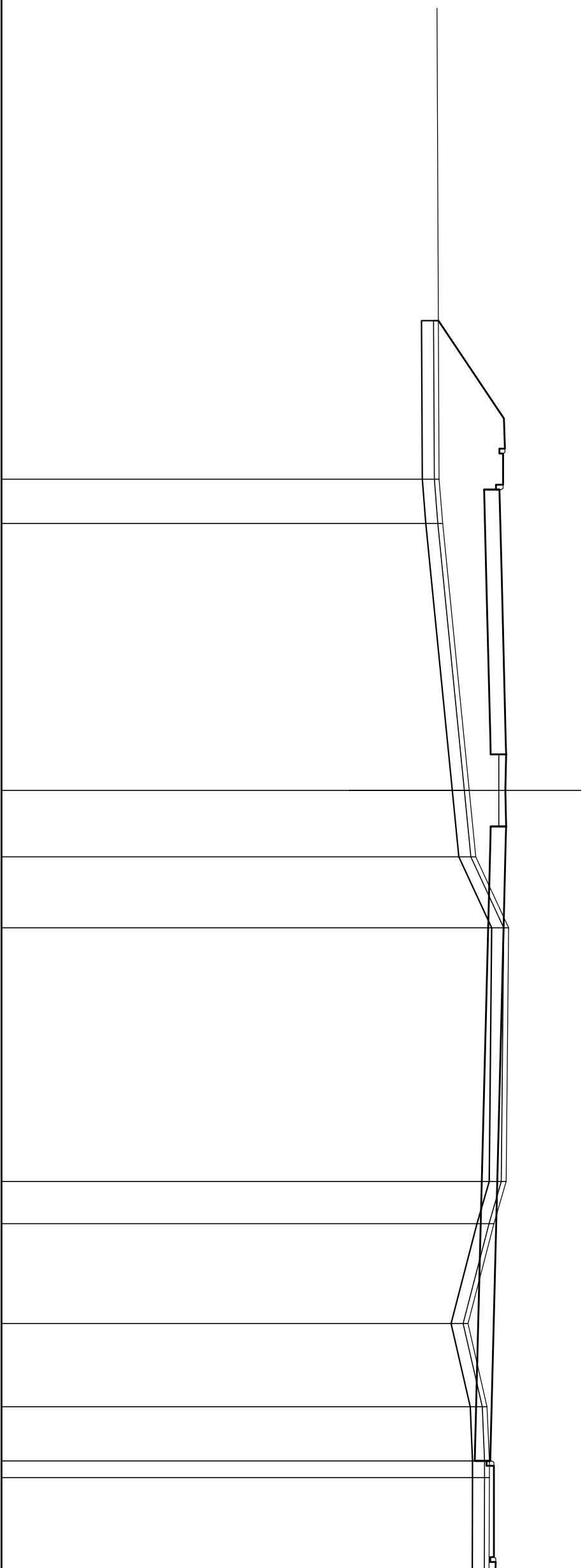

QUOTE TERRENO	DIST. PARZIALI TERRENO	QUOTE PROGETTO	DIST. PARZIALI PAVIMENTATO
	27.07		
	1.83	12.14	4.07
		14.85	1.25
		14.90	1.30
		14.82	
		14.82	3.50
		14.67	
		14.76	7.00
	11.09	14.94	0.50
		14.95	1.50
		14.92	1.50
		14.31	0.50
		14.94	7.00
	2.76		
	2.95		
	10.54		
		14.76	18.85
		14.95	
		14.44	1.76
			4.15
		13.37	3.45
		14.16	2.25
		14.26	0.80
		14.26	
		14.29	
		14.14	
		14.44	3.80
		14.44	
		14.52	1.25

SEZIONE N. : 25
 QT. PROGETTO : 14.945
 DIST.PROG. : 330.000
 DIST.PREC. : 15.000
 DIST.SUCC. : 15.000

SCALA 1:200

QT.RIF. -6.00

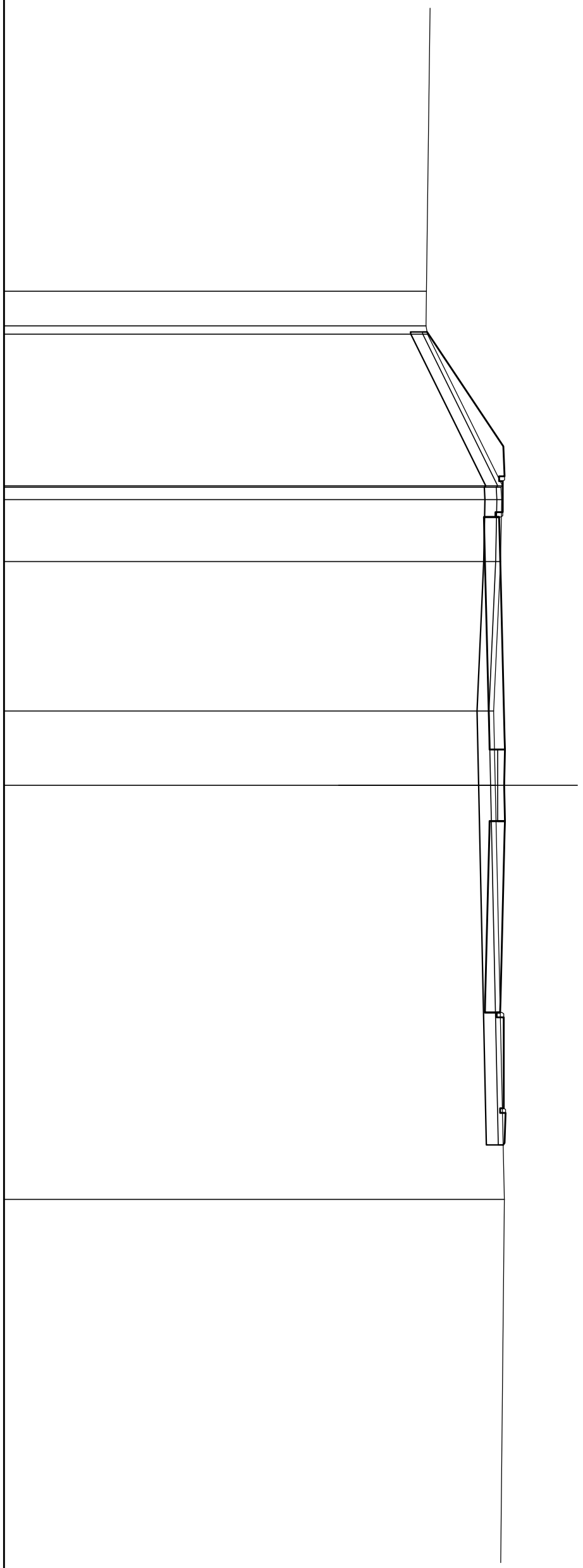

QUOTE TERRENO	DIST. PARZIALI TERRENO	QUOTE PROGETTO	DIST. PARZIALI PAVIMENTATO
11.68	19.34	11.70	4.79
11.65	1.44	14.89	1.25
11.72	6.35	14.94	1.30
14.86	0.52	14.86	2.22
14.79	2.59	14.86	7.00
14.82	14.77	14.71	14.77
14.49	6.25	14.77	14.49
14.56	3.11	14.95	14.56
14.93	17.31	14.96	14.93
14.91	14.93	14.93	14.93
14.91	14.32	14.32	14.32
14.99	14.95	14.95	14.95
14.88	14.77	14.77	14.77
	14.61	14.61	14.61
	14.91	14.91	14.91
	14.91	14.91	14.91
	14.99	14.99	14.99
	14.94	14.94	14.94
	14.88	14.88	14.88
	14.93	14.93	14.93
	15.98		15.98

SEZIONE N. : 26
 QT. PROGETTO : 14.932
 DIST.PROG. : 345.000
 DIST.PREC. : 15.000
 DIST.SUCC. : 15.000

SCALA 1:200

QT.REF. -5.00

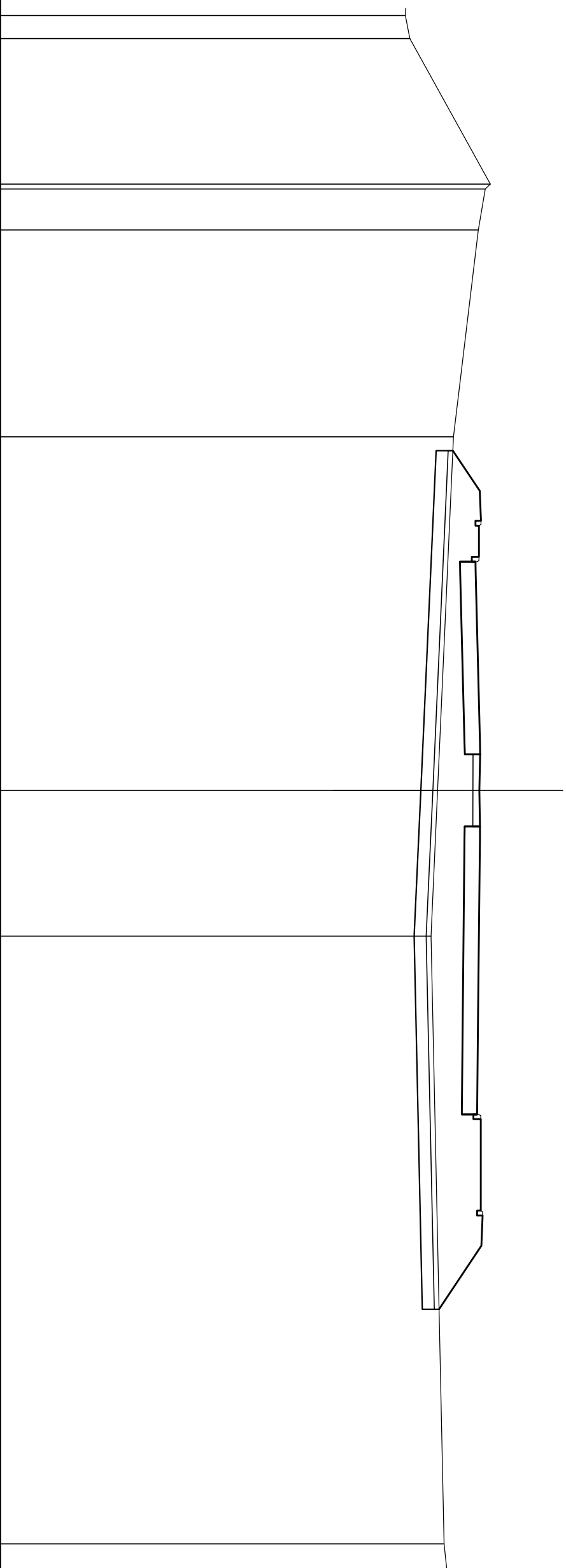

QUOTE TERRENO	DIST. PARZIALI TERRENO	QUOTE PROGETTO	DIST. PARZIALI PAVIMENTATO
11.84	0.96	13.81	1.67
12.02	6.04	14.92	1.25
15.37	1.71	14.97	1.30
15.15	8.59	14.89	0.50
14.87	13.84	14.89	14.76
	14.69	14.93	7.00
		14.94	0.50
		14.91	1.50
		14.30	1.50
		14.93	0.50
	6.05	14.86	7.00
		14.82	4.46
		14.67	3.80
		14.97	1.25
		15.05	2.64
		15.00	
		13.23	
	3.25	13.44	

SEZIONE N. : 27
 QT. PROGETTO : 14.896
 DIST.PROG. : 360.000
 DIST.PREC. : 15.000
 DIST.SUCC. : 15.000

SCALA 1:200

QT.RIF. -6.00

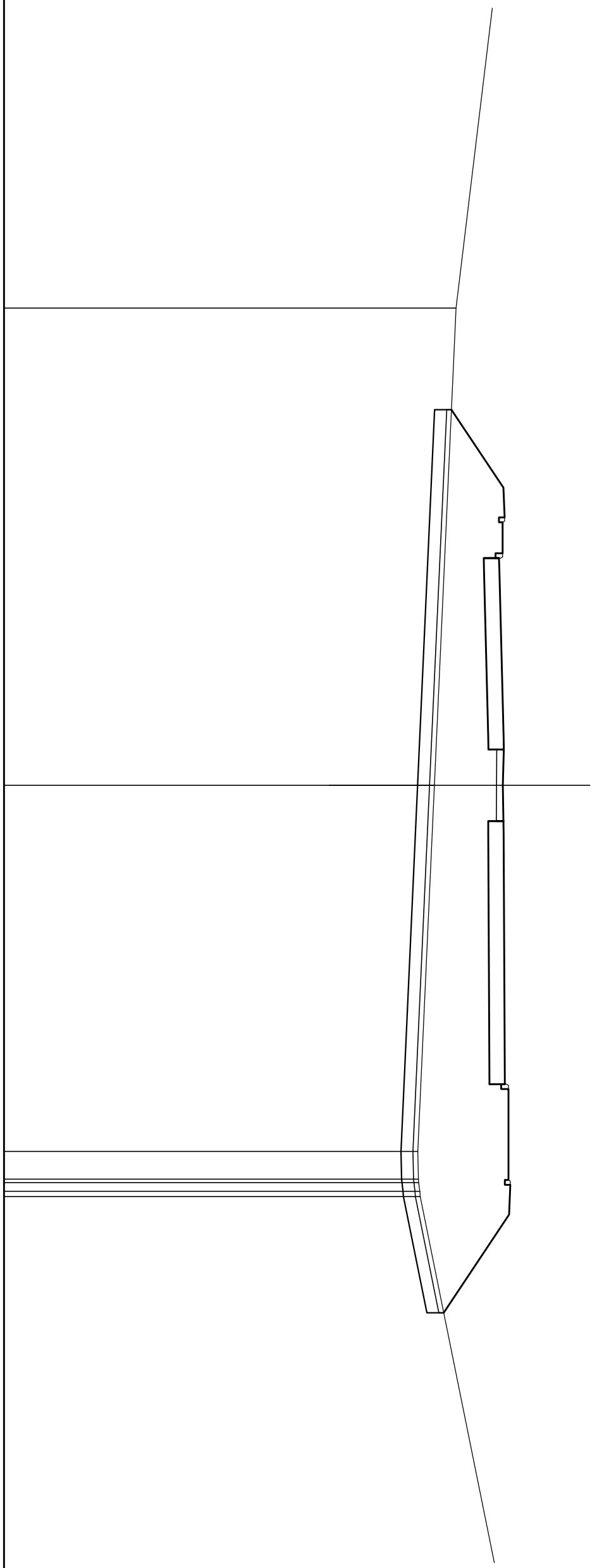

QUOTE TERRENO	DIST.PARZIALI TERRENO	QUOTE PROGETTO	DIST.PARZIALI PAVIMENTATO
	14.51	12.91	
	19.96	14.89	3.26
		14.94	1.25
		14.86	1.30
		14.86	0.50
		14.72	
		14.90	7.00
		14.91	0.50
		14.86	1.50
		14.25	1.50
		14.90	0.50
		14.93	7.00
		14.95	3.50
		14.80	
		15.10	3.80
		15.10	
		15.18	1.25
		15.13	
		12.39	4.10
	17.24		

SEZIONE N. : 28
 QT. PROGETTO : 14.851
 DIST.PROG. : 375.000
 DIST.PREC. : 15.000
 DIST.SUCC. : 15.000

SCALA 1:200

QT.REF. -5.00

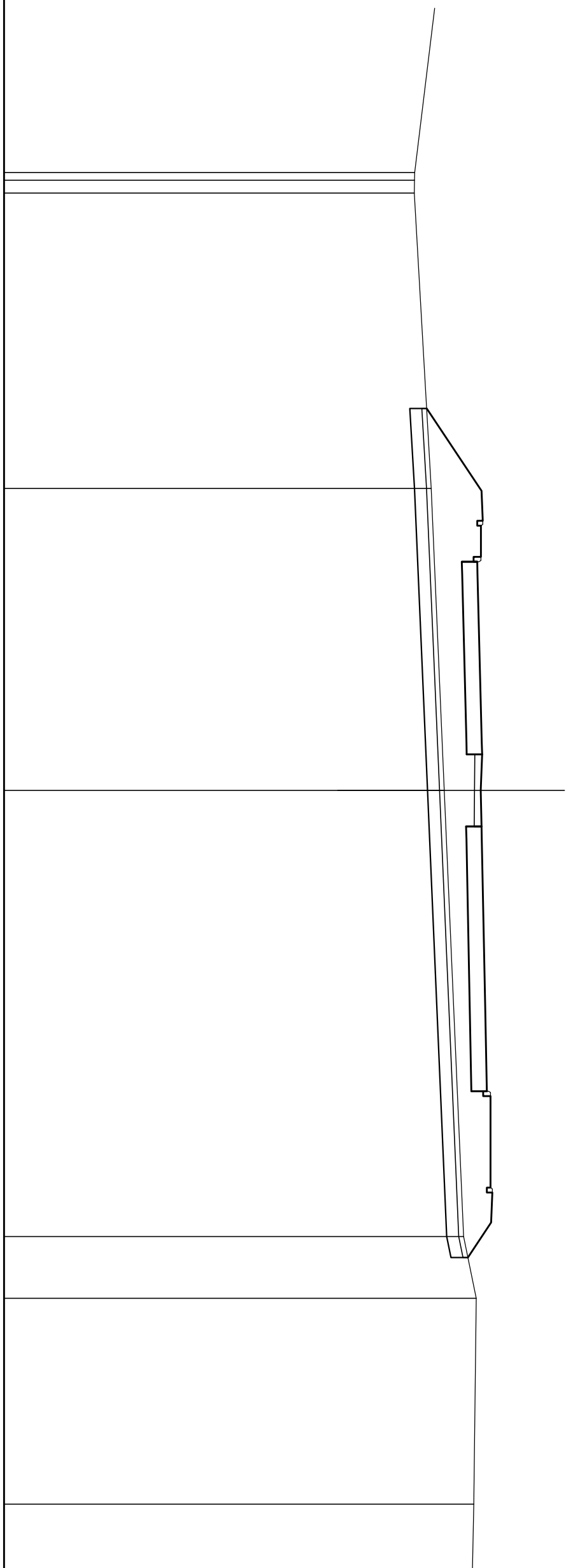

QUOTE TERRENO	DIST. PARZIALI TERRENO	QUOTE PROGETTO	DIST. PARZIALI PAVIMENTATO
12.06 12.05 12.05	12.27	12.56	3.42
12.75	12.55	14.84 14.89 14.81 14.81 14.68	1.25 1.30 0.50
13.30	18.53	14.85 14.86 14.81 14.20 14.85	0.50 1.50 1.50 0.50
14.10	2.57	14.99	7.00
14.62	8.55	15.06 14.91 15.21	3.50
14.52		15.21 15.29 15.24	3.80
		14.27	1.25 1.45

SEZIONE N. : 29
 QT. PROGETTO : 14.806
 DIST.PROG. : 390.000
 DIST.PREC. : 15.000
 DIST.SUCC. : 15.000

SCALA 1:200

QT.RIF. -5.00

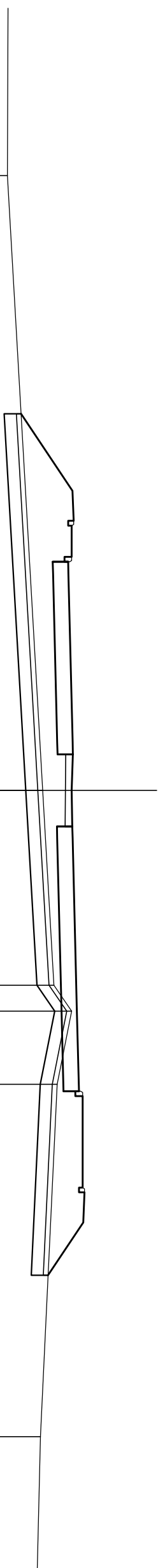

QUOTE TERRENO	DIST. PARZIALI TERRENO	QUOTE PROGETTO	DIST. PARZIALI PAVIMENTATO
	8.85	12.10	
	25.55	14.80	3.20
		14.85	1.25
		14.77	1.30
		14.77	0.50
		14.63	
		14.81	7.00
		14.82	0.50
		14.76	1.50
		14.15	1.50
		14.81	0.50
	8.09		7.00
		14.03	
		14.76	1.08
			3.04
		14.16	
		15.07	
		14.92	
		15.22	3.80
		15.22	
		15.30	1.25
		15.25	2.19
		13.78	
		14.63	
		13.47	

SEZIONE N. : 30
 QT. PROGETTO : 14.761
 DIST.PROG. : 405.000
 DIST.PREC. : 15.000
 DIST.SUCC. : 15.000

SCALA 1:200

QT.RIF. -5.00

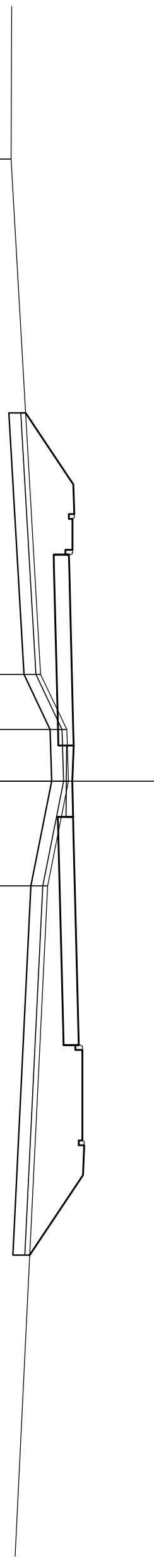

QUOTE TERRENO	DIST.PARZIALI TERRENO
12.15	21.61
13.39	2.31
14.48	2.17
14.55	4.39
13.68	
	31.46
QUOTE PROGETTO	DIST.PARZIALI PAVIMENTATO
12.76	2.99
14.75	1.25
14.80	1.30
14.72	0.50
14.72	
14.59	7.00
14.76	0.50
14.77	1.50
14.72	1.50
14.11	0.50
14.76	7.00
14.94	2.06
14.99	
14.84	3.80
15.14	
15.14	1.25
15.22	
15.17	3.36
12.93	

SEZIONE N. : 31
 QT. PROGETTO : 14.716
 DIST.PROG. : 420.000
 DIST.PREC. : 15.000
 DIST.SUCC. : 15.000

SCALA 1:200

QT.REF. -5.00

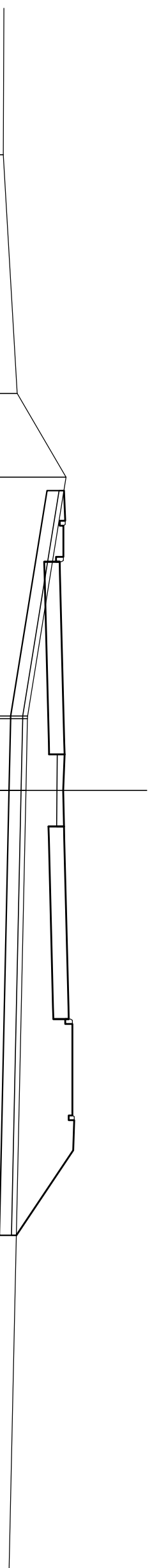

QUOTE TERRENO	DIST. PARZIALI TERRENO	QUOTE PROGETTO	DIST. PARZIALI PAVIMENTATO
12.20	9.91	14.70 14.71 14.76 14.68	1.25
12.77	3.48	14.68 14.54	1.30
14.79	9.92	14.72 14.73	0.50
13.20 13.19	2.98	14.67 14.06 14.72	0.50
13.13		14.89 14.75 15.05	0.50
		15.05 15.13 15.08	3.80
		12.73	1.25
	40.00		3.53

SEZIONE N. : 32
 QT. PROGETTO : 14.671
 DIST.PROG. : 435.000
 DIST.PREC. : 15.000
 DIST.SUCC. : 15.000

SCALA 1:200

QT.REF. -5.00

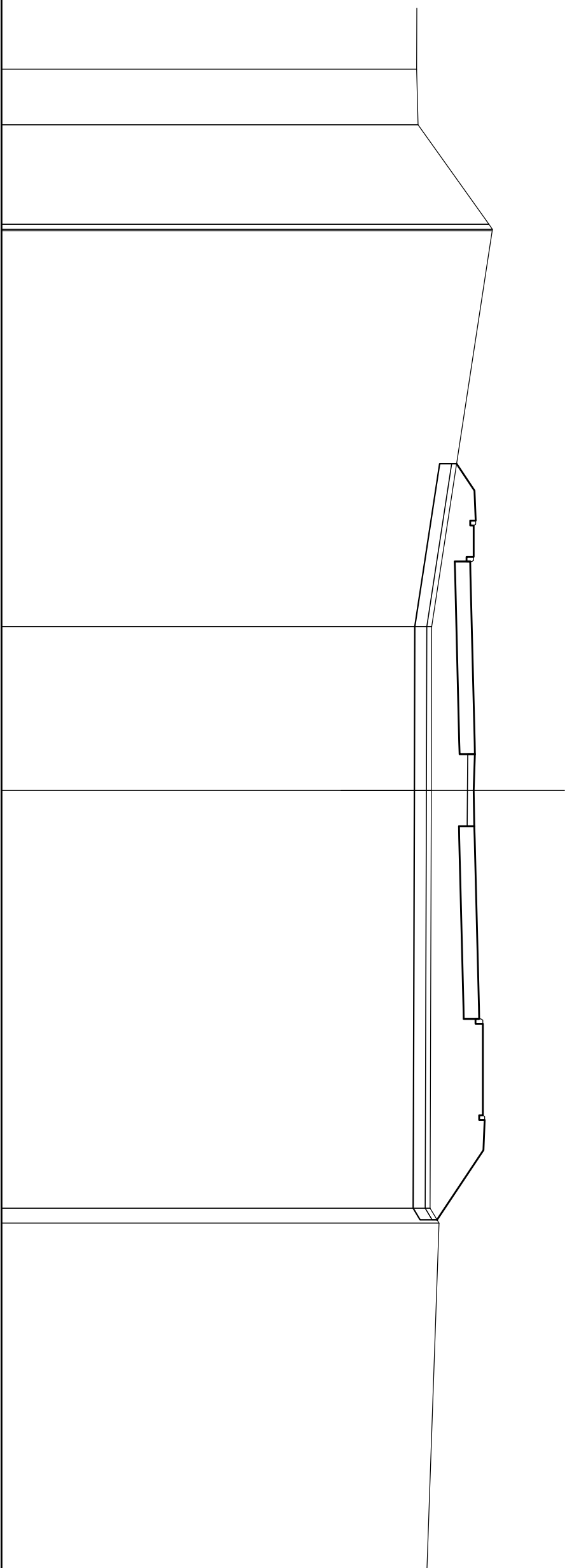

QUOTE TERRENO	DIST. PARZIALI TERRENO	QUOTE PROGETTO	DIST. PARZIALI PAVIMENTATO
12.26	2.31	13.92	1.12
12.32	4.14	14.66	1.25
15.26		14.71	1.30
15.41		14.63	0.51
15.40		14.63	7.00
	16.44	14.50	0.49
		12.89	1.51
		14.67	1.49
		14.68	0.51
	6.81	14.63	7.00
		14.02	0.49
		14.67	3.80
	17.35	14.85	1.25
		14.71	2.90
		15.01	13.11
		15.01	
		15.09	
		15.04	
	0.62	12.81	
		13.19	
	18.65		

SEZIONE N. : 33
 QT. PROGETTO : 14.626
 DIST.PROG. : 450.000
 DIST.PREC. : 15.000
 DIST.SUCC. : 15.000

SCALA 1:200

QT.RIF. -5.00

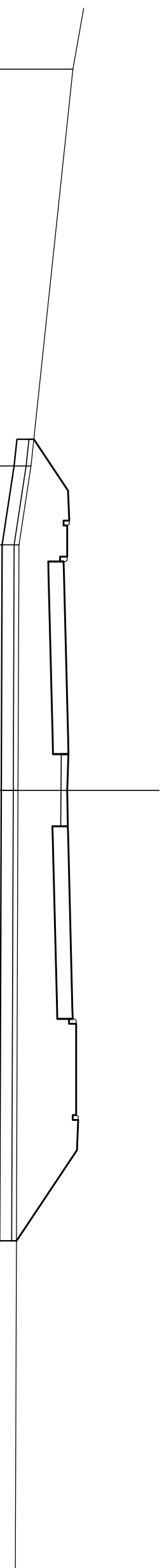

QUOTE TERRENO	DIST. PARZIALI TERRENO	QUOTE PROGETTO	DIST. PARZIALI PAVIMENTATO
14.83	3.34	13.20	2.13
16.48	3.28	14.62	1.25
13.08	12.58	14.67	1.30
12.58	10.20	14.59	0.51
14.45	12.54	14.63	0.49
14.63	14.58	14.64	1.51
14.64	13.97	14.63	0.51
14.63	14.63	14.63	7.00
14.80	14.80	14.80	0.49
14.66	14.66	14.66	3.80
14.96	14.96	14.96	1.25
14.96	15.04	14.99	3.77
12.48	39.30	12.48	

SEZIONE N. : 34
QI. PROGETTO : 14.581
DIST.PROG. : 465.000
DIST.PREC. : 15.000
DIST.SUCC. : 15.000

SCALA 1:200

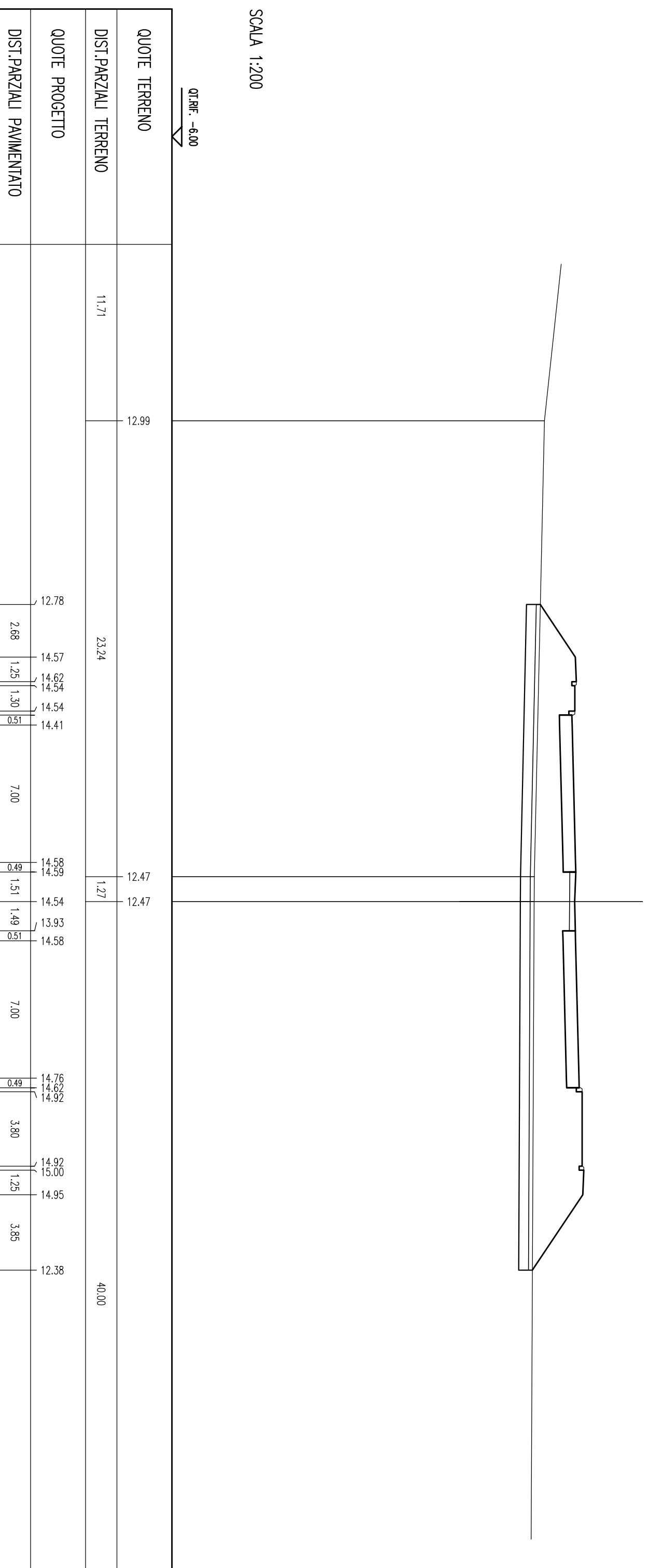

SEZIONE N. : 35
 QT. PROGETTO : 14.536
 DIST.PROG. : 480.000
 DIST.PREC. : 15.000
 DIST.SUCC. : 15.000

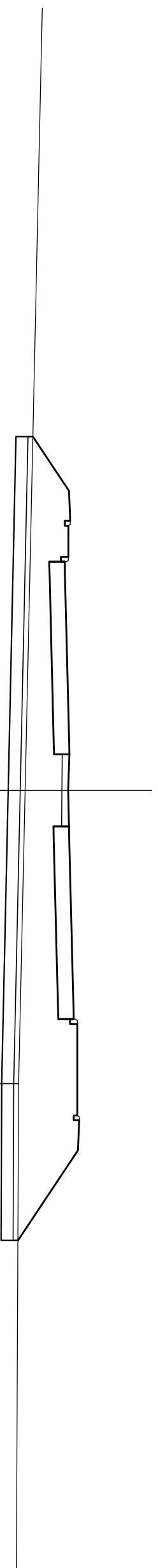

SCALA 1:200

QT.RIF. -6.00

QUOTE TERRENO																	
DIST.PARZIALI TERRENO	40.00																
QUOTE PROGETTO																	
DIST.PARZIALI PAVIMENTATO																	

		13.03	2.25	14.53	1.25	14.58	1.30	14.50	0.50	14.36	7.00	14.54	0.50	14.55	1.50	14.49	1.50	13.88	0.50	14.54	7.00	14.71	0.50	14.57	3.80	14.87	1.25	14.95	14.90	3.74	12.41
--	--	-------	------	-------	------	-------	------	-------	------	-------	------	-------	------	-------	------	-------	------	-------	------	-------	------	-------	------	-------	------	-------	------	-------	-------	------	-------

SEZIONE N. : 36
 QT. PROGETTO : 14.491
 DIST.PROG. : 495.000
 DIST.PREC. : 15.000
 DIST.SUCC. : 15.000

SCALA 1:200

QT.RIF. -6.00

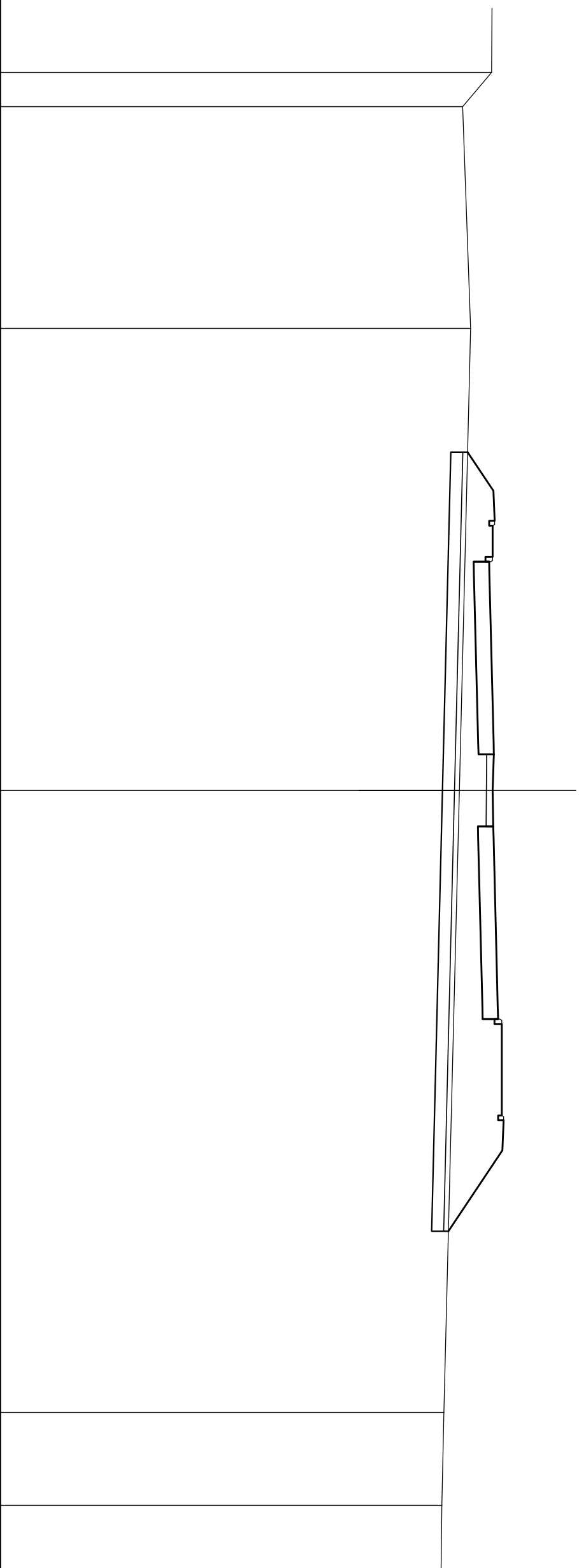

QUOTE TERRENO	DIST. PARZIALI TERRENO	QUOTE PROGETTO	DIST. PARZIALI PAVIMENTATO
14.41	1.43	13.41	1.60
13.21	9.21	14.48	1.25
13.54	19.20	14.53	1.30
		14.45	0.50
		14.45	7.00
		14.32	0.50
		13.07	14.49
		14.50	0.50
		14.45	1.50
		13.84	1.50
		14.49	0.50
		14.67	7.00
		14.53	0.50
		14.83	3.80
		14.83	1.25
		14.91	1.25
		14.86	3.36
		12.62	
		12.43	
		12.34	
			3.86

SEZIONE N. : 37
 QT. PROGETTO : 14.446
 DIST.PROG. : 510.000
 DIST.PREC. : 15.000
 DIST.SUCC. : 15.000

SCALA 1:200

QT.REF. -5.00

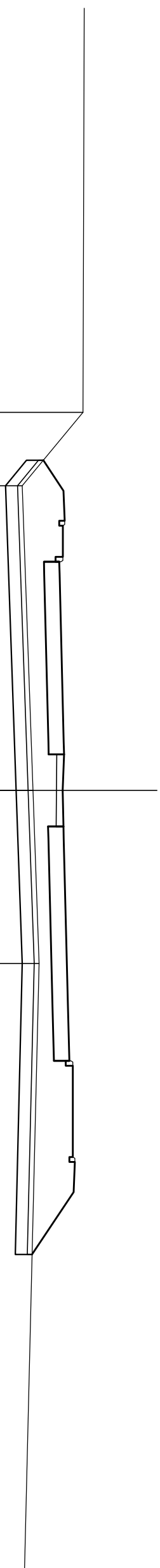

QUOTE TERRENO	DIST.PARZIALI TERRENO	15.25	12.72	13.16	13.42	
	24.29	3.04	12.66	7.19	13.42	27.80
QUOTE PROGETTO		13.59	14.44	14.49	14.41	14.41
		1.27	1.25	1.30	0.50	14.27
DIST.PARZIALI PAVIMENTATO		7.00	14.45	14.46	14.40	13.79
		0.50	1.50	1.50	0.50	14.45
		7.00	14.62	14.68	14.53	14.85
		2.23	3.80	14.85	14.91	14.86
		1.25	2.60	13.13		

SEZIONE N. : 38
 QT. PROGETTO : 14.401
 DIST.PROG. : 525.000
 DIST.PREC. : 15.000
 DIST.SUCC. : 15.000

SCALA 1:200

QT.RIF. -5.00

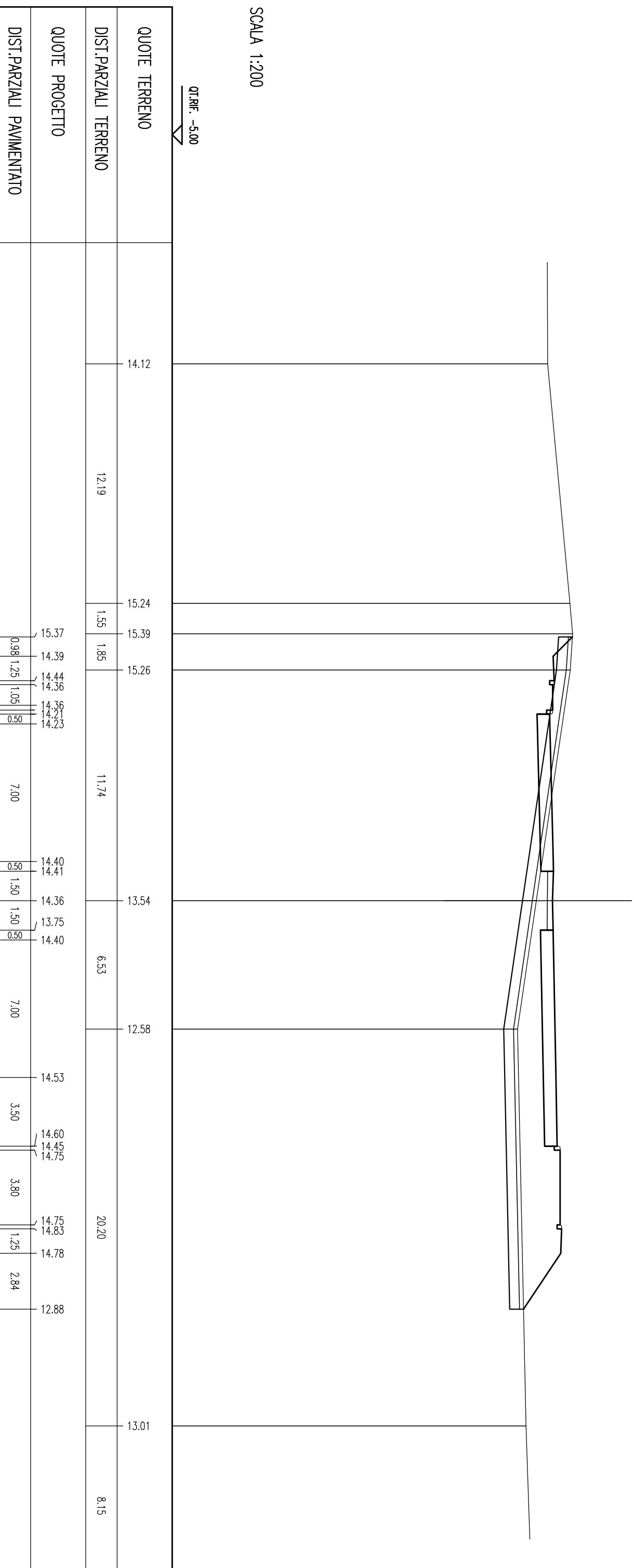

SEZIONE N. : 39
 QT. PROGETTO : 14.356
 DIST.PROG. : 540.000
 DIST.PREC. : 15.000
 DIST.SUCC. : 15.000

SCALA 1:200

QT.RIF. -5.00

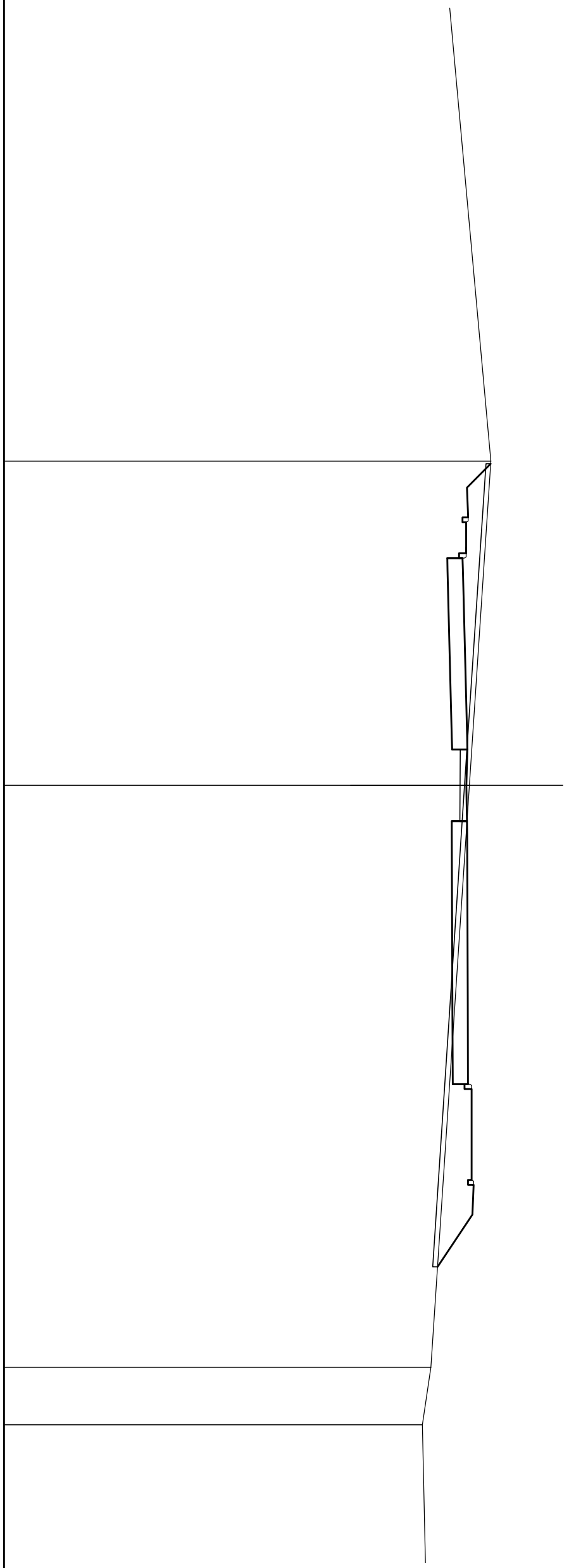

QUOTE TERRENO		15.35	14.45	12.84	12.49
DIST.PARZIALI TERRENO	26.44	13.56	24.33	2.41	7.42
QUOTE PROGETTO		15.34 14.35 14.40 14.32 14.32 14.17 14.18	14.36 14.37 14.32 13.71 14.36	14.38 14.40 14.25 14.55 14.55 14.63 14.58	13.12
DIST.PARZIALI PAVIMENTATO		1.00 1.25 1.05 0.50	0.50 1.50 1.50 0.50	3.50 3.80 1.25 2.18	
		7.00	7.00		

SEZIONE N. : 40
 QT. PROGETTO : 14.311
 DIST.PROG. : 555.000
 DIST.PREC. : 15.000
 DIST.SUCC. : 15.000

SCALA 1:200

QT.RIF. -5.00

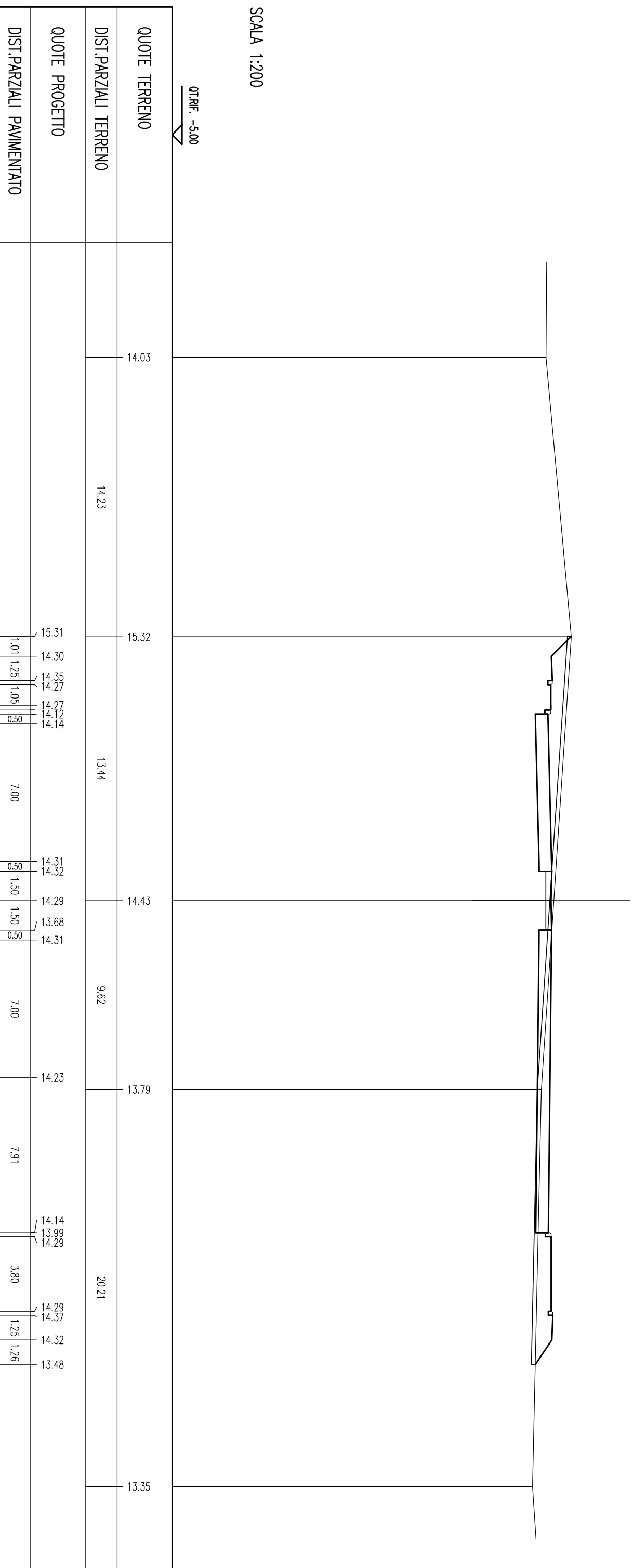

SEZIONE N. : 41
 QT. PROGETTO : 14.266
 DIST.PROG. : 570.000
 DIST.PREC. : 15.000
 DIST.SUCC. : 15.000

SCALA 1:200

QT.RIF. -5.00

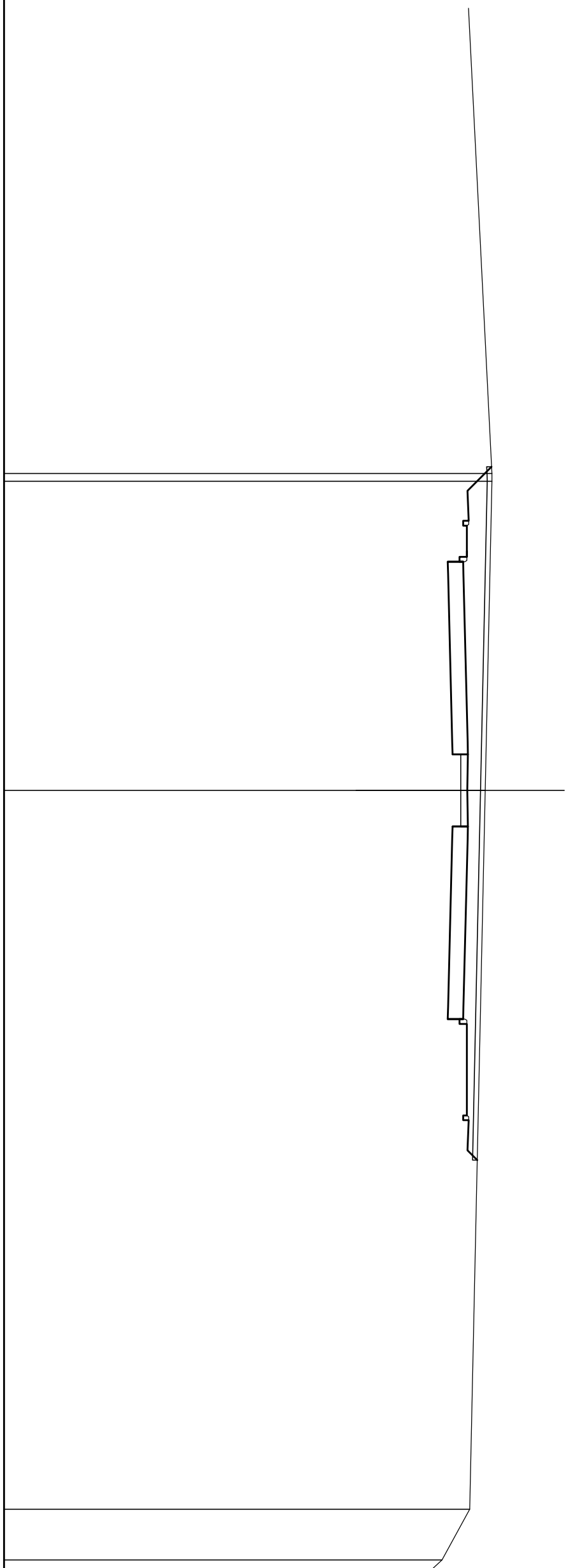

QUOTE TERRENO		15.27 15.28	15.00	14.35 13.20
DIST.PARZIALI TERRENO	23.67	0.32	12.84	29.86
QUOTE PROGETTO		15.26 14.26 14.31 14.23 14.23 14.08 14.09	14.27 14.28 14.25 13.64 14.27	14.09 13.93 14.23 14.23 14.31 14.26 14.67
DIST.PARZIALI PAVIMENTATO		1.00 1.25 1.05 0.50	0.50 1.50 1.50 0.50	0.50 3.80 1.25 0.41
		7.00	7.00	7.00

SEZIONE N. : 42
 QT. PROGETTO : 14.221
 DIST.PROG. : 585.000
 DIST.PREC. : 15.000
 DIST.SUCC. : 15.000

SCALA 1:200

QT.RIF. -5.00

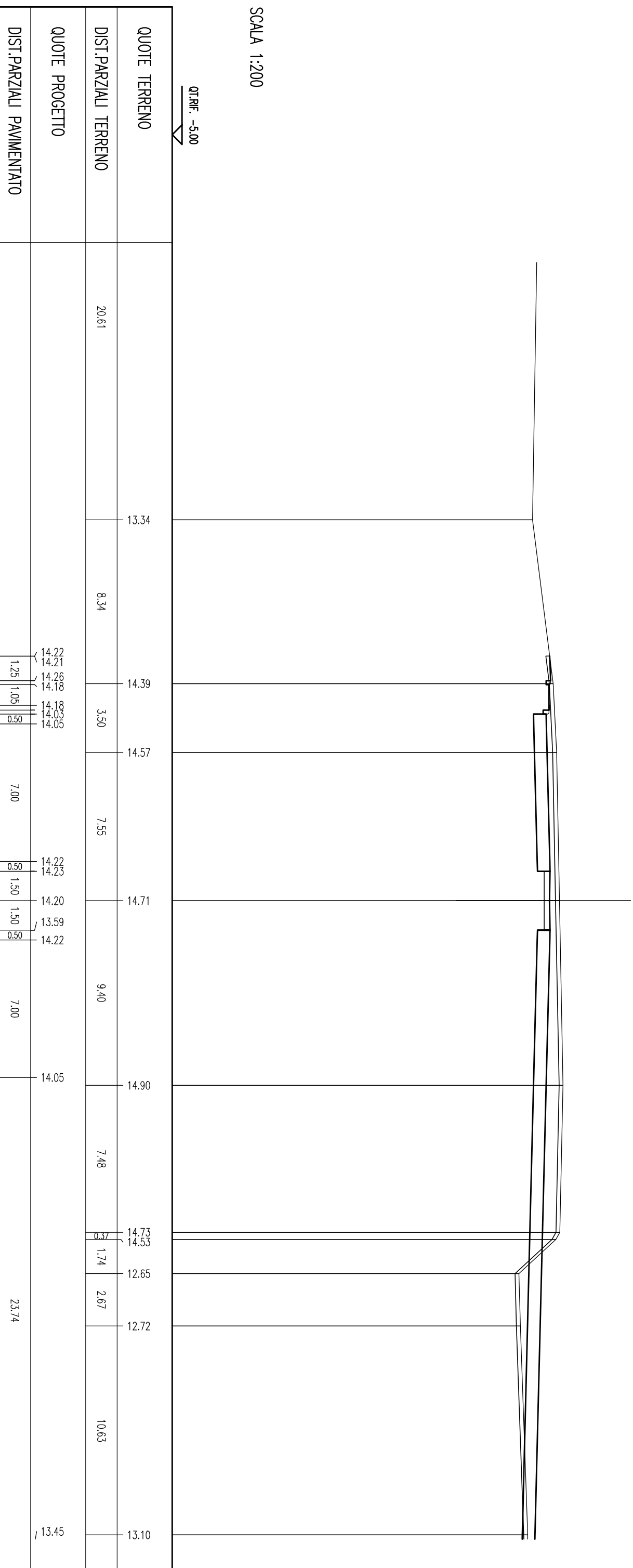

SEZIONE N. : 43
 QT. PROGETTO : 14.176
 DIST.PROG. : 600.000
 DIST.PREC. : 15.000
 DIST.SUCC. : 15.000

SCALA 1:200

QT.RIF. -5.00

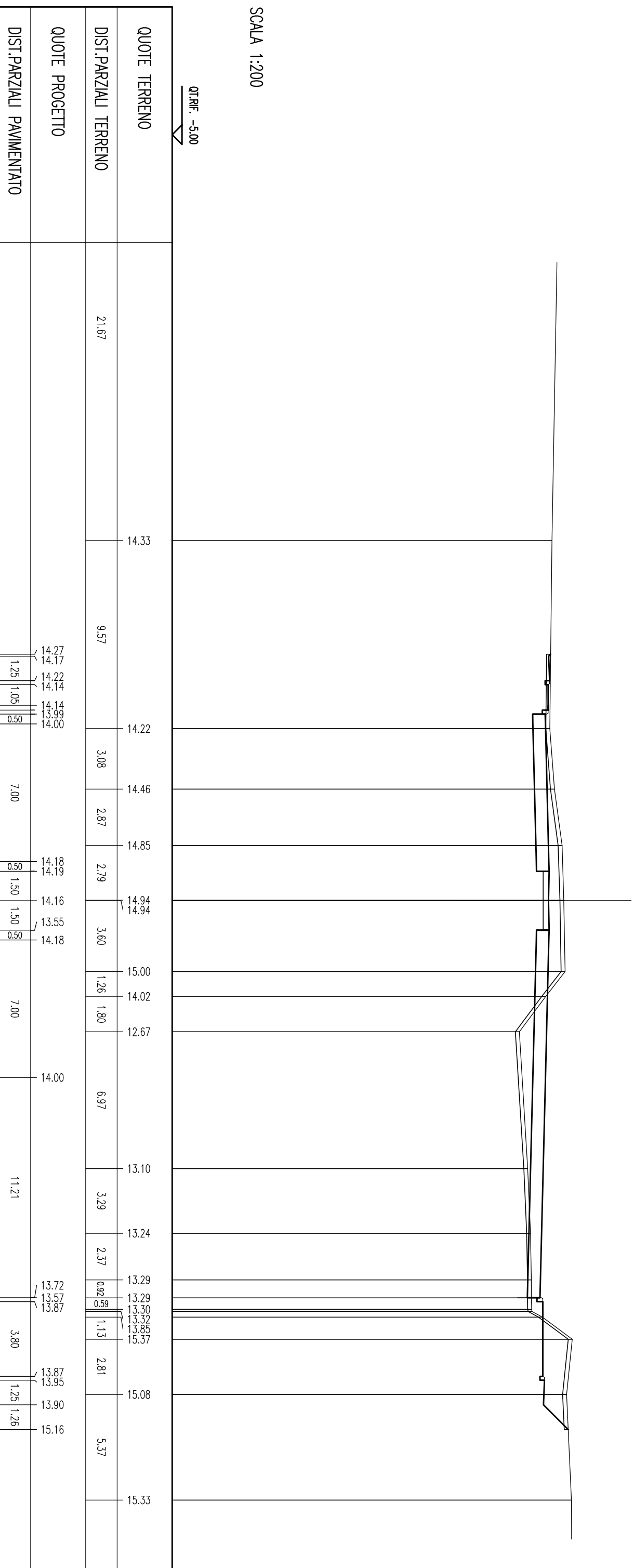

SEZIONE N. : 44
 QT. PROGETTO : 14.131
 DIST.PROG. : 615.000
 DIST.PREC. : 15.000
 DIST.SUCC. : 15.000

SCALA 1:200

QT.RIF. -5.00

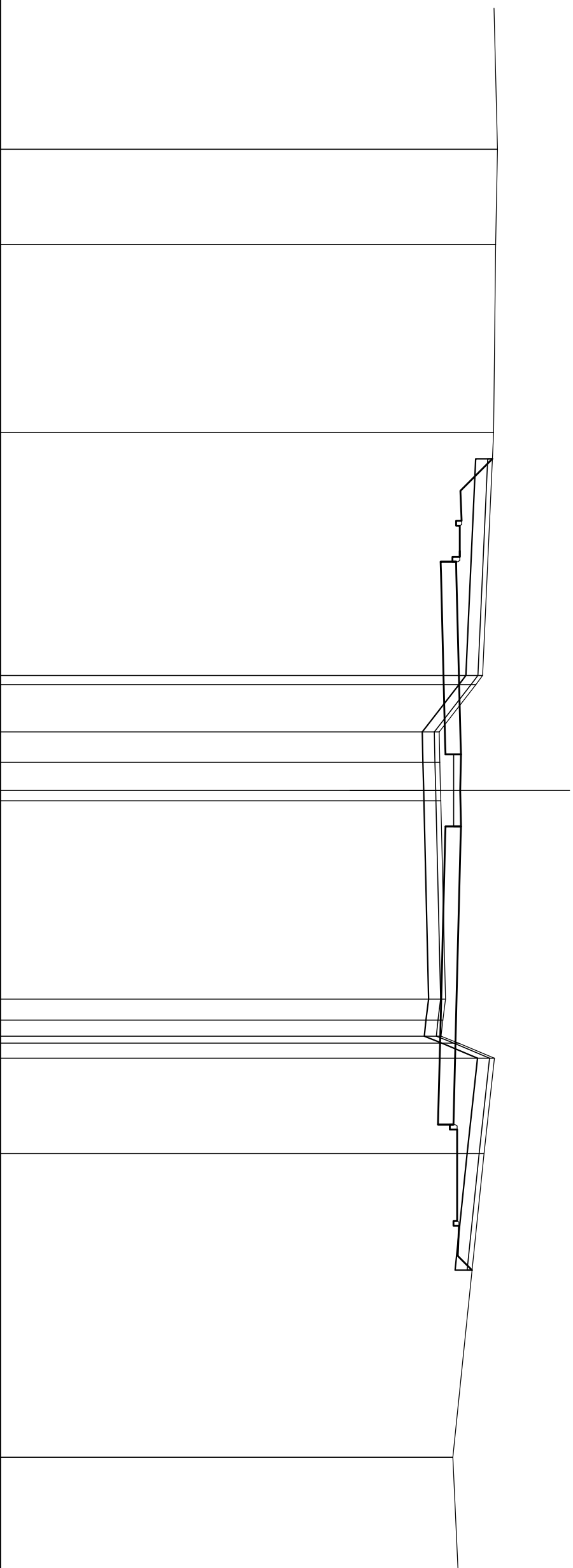

QUOTE TERRENO	DIST. PARZIALI TERRENO	QUOTE PROGETTO	DIST. PARZIALI PAVIMENTATO
15.66	3.96	15.45	1.33
15.59	7.81	14.12	1.25
15.50	10.10	14.17	1.05
		14.09	0.50
		14.09	
		13.94	
		13.96	
15.05	8.19	14.13	0.91
14.76	1.97	14.14	1.50
13.24	1.26	14.11	1.50
13.27	1.17	13.50	0.91
13.30	0.43	14.13	
13.31			
	8.24		7.00
13.50	0.87	13.96	4.89
13.39	0.97	13.83	
13.32	0.90	13.68	
14.05	3.96	13.98	
15.53			
	15.10		3.80
		13.98	1.25
		14.06	0.91
		14.01	
		14.60	
	12.62		
13.81			

SEZIONE N. : 45
 QT. PROGETTO : 14.086
 DIST.PROG. : 630.000
 DIST.PREC. : 15.000
 DIST.SUCC. : 15.000

SCALA 1:200

QT.RIF. -5.00

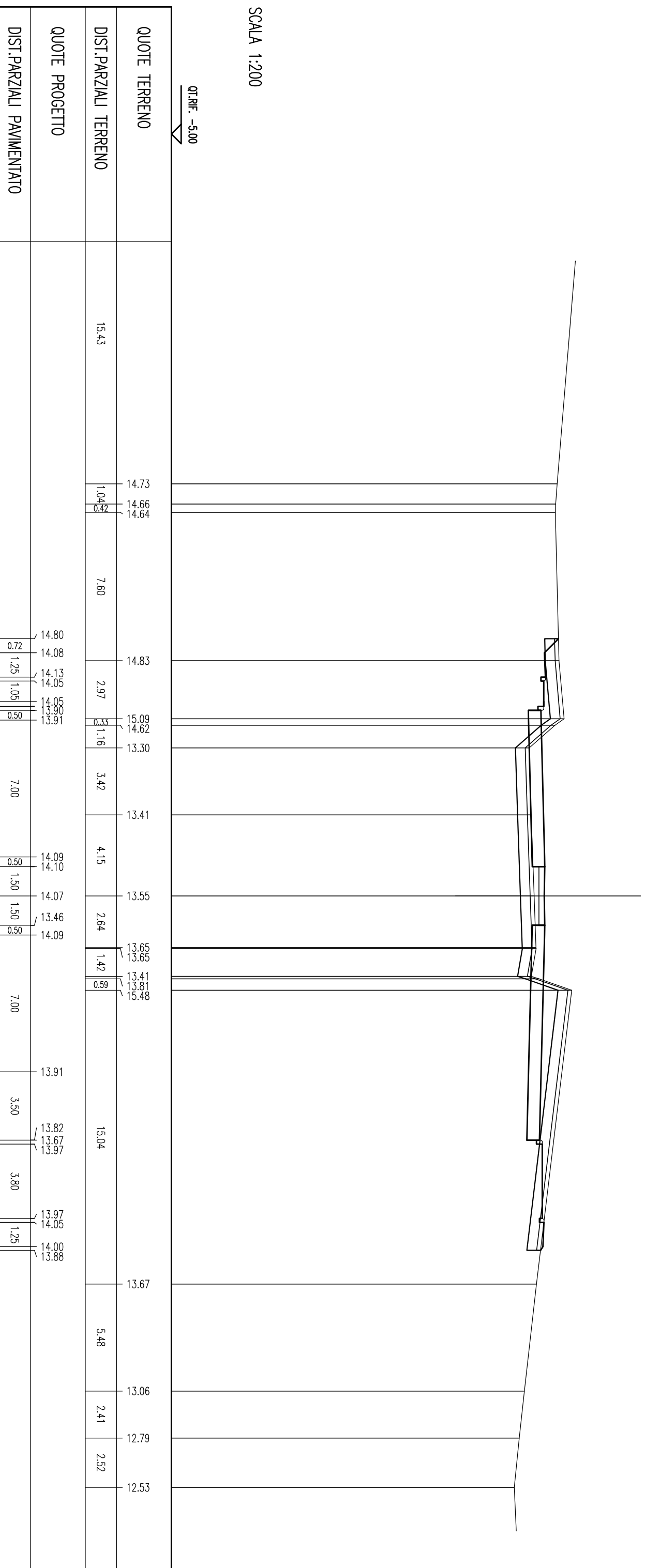

SEZIONE N. : 46
 QT. PROGETTO : 14.041
 DIST.PROG. : 645.000
 DIST.PREC. : 15.000
 DIST.SUCC. : 15.000

SCALA 1:200

QT.REF. -5.00

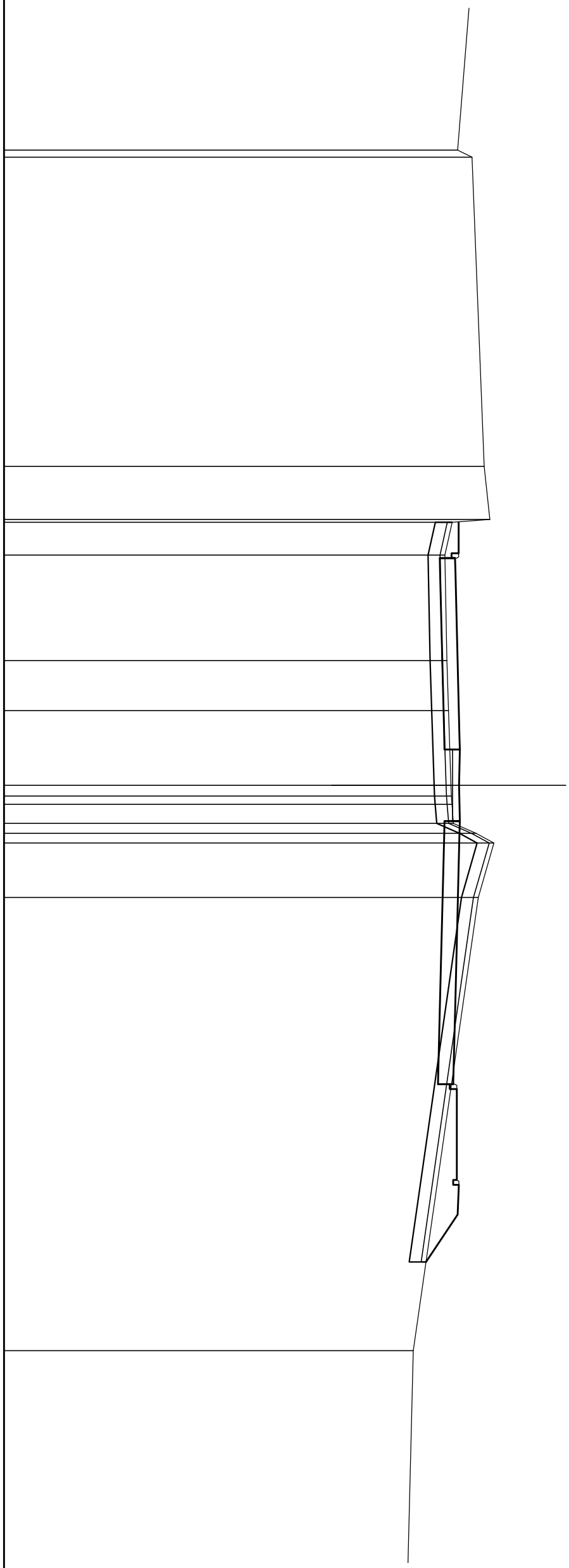

QUOTE TERRENO	DIST. PARZIALI TERRENO	QUOTE PROGETTO	DIST. PARZIALI PAVIMENTATO
13.96 14.56	12.92	15.07	
15.31 13.73	2.22	15.31 13.73	14.00
13.43	1.37	13.43	1.30 0.50
13.51	4.41	13.51	7.00
13.58	2.09	13.58	0.50
14.04 14.05	3.13	14.04 14.05	1.50
13.68 13.70 13.72 13.79 14.74 15.48	0.50 0.80 0.50 0.50 0.50	13.68 13.70 13.72 13.79 14.74 15.48	1.50 0.50
14.82	2.28	14.82	7.00
13.87	18.95	13.87	3.50
13.78 13.14 13.93		13.78 13.14 13.93	3.80
13.93 14.01		13.93 14.01	1.25
13.96		13.96	1.98
12.64		12.64	
12.11	16.36	12.11	

SEZIONE N. : 47
 QT. PROGETTO : 13.996
 DIST.PROG. : 660.000
 DIST.PREC. : 15.000
 DIST.SUCC. : 15.000

SCALA 1:200

QT.RIF. -6.00

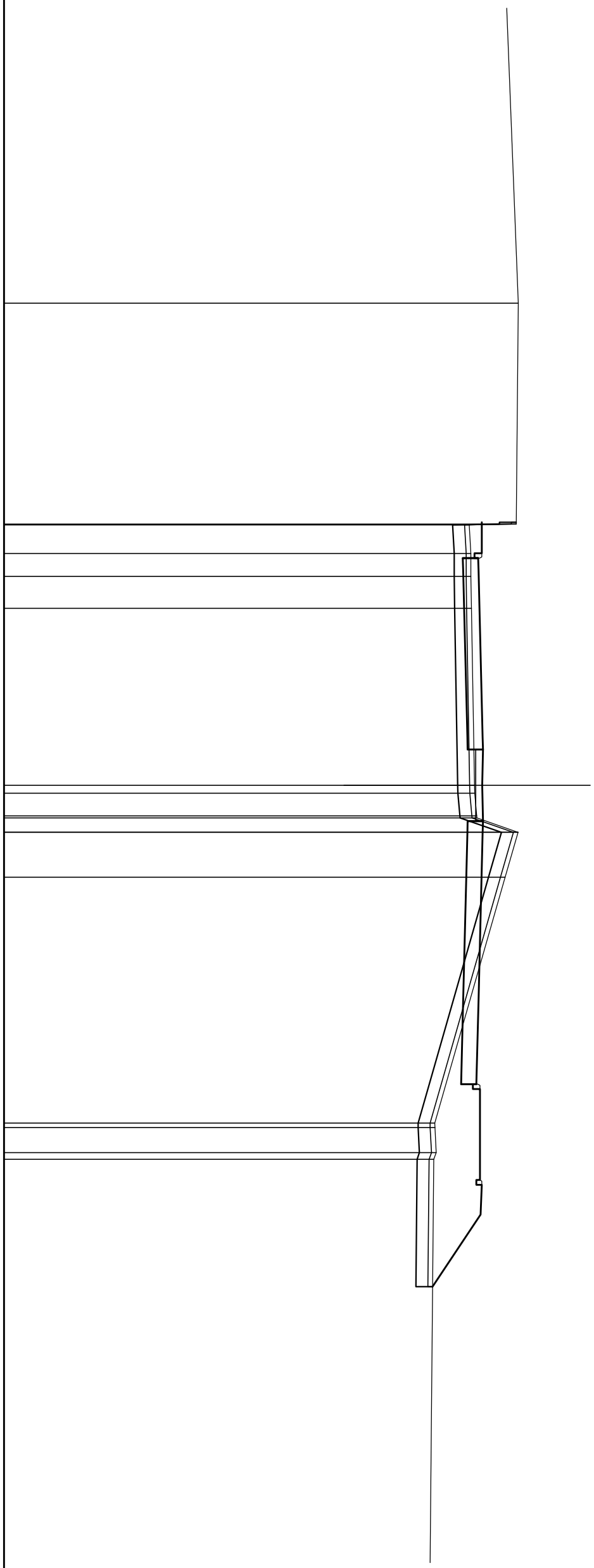

QUOTE TERRENO		
DIST.PARZIALI TERRENO	14.48	15.49
QUOTE PROGETTO	13.96	13.82
DIST.PARZIALI PAVIMENTATO	1.30	0.50
	7.00	7.00
	14.00	14.01
	13.98	13.37
	14.00	14.00
	13.82	13.73
	3.50	3.80
	13.88	13.96
	1.25	3.01
	11.91	
	12.00	12.06
	1.05	11.96
	10.28	
	13.66	13.66
	13.75	13.75
	15.47	15.48
	1.87	14.94
	30.95	
	1.96	1.34
	1.19	7.40
	15.40	13.44
	13.51	13.50
	9.24	13.53
	15.49	
	14.48	
	24.37	

SEZIONE N. : 48
 QT. PROGETTO : 13.951
 DIST.PROG. : 675.000
 DIST.PREC. : 15.000
 DIST.SUCC. : 15.000

SCALA 1:200

QT.RIF. -5.00

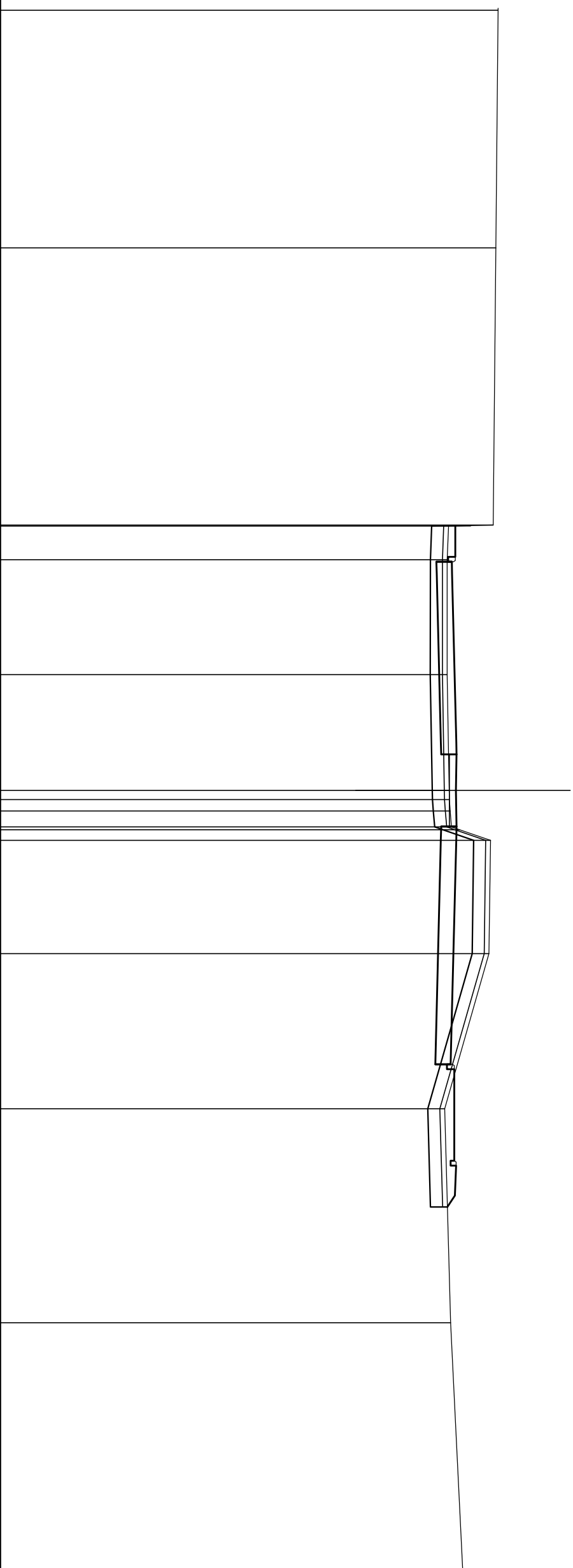

QUOTE TERRENO	DIST.PARZIALI TERRENO	QUOTE PROGETTO	DIST.PARZIALI PAVIMENTATO
15.69	9.87	13.91	1.30
15.60	11.52	13.91	0.50
15.48	1.40	13.78	7.00
13.58	4.77	13.95	0.50
13.57	4.81	13.96	1.50
13.66	0.47	13.93	1.50
13.70	0.66	13.32	0.50
14.09	0.44	13.95	7.00
15.31	4.70	13.72	2.38
13.78	6.45	13.08	3.80
13.47	8.89	13.87	1.25
13.71	17.89	13.90	0.47
		13.58	

SEZIONE N. : 49
 QT. PROGETTO : 13.906
 DIST.PROG. : 690.000
 DIST.PREC. : 15.000
 DIST.SUCC. : 15.000

SCALA 1:200

QT.RIF. -5.00

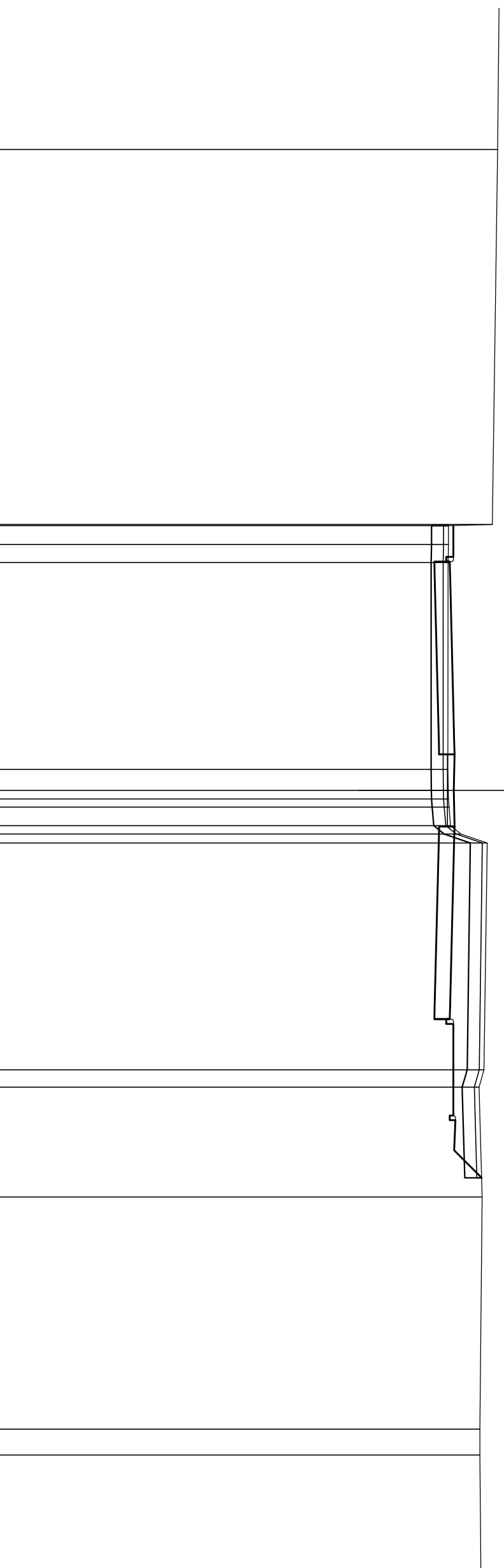

QUOTE TERRENO	DIST. PARZIALI TERRENO	QUOTE PROGETTO	DIST. PARZIALI PAVIMENTATO
15.70	15.58	13.87	1.30
15.48	0.780,75	13.87	0.50
13.66	8.59	13.73	7.00
13.66	13.64	13.91	0.50
13.65	13.66	13.92	1.50
15.48	13.66	13.89	1.50
13.66	13.66	13.28	0.50
13.69	13.69	13.91	7.00
13.75	13.75	13.73	0.50
14.18	14.18	13.08	3.80
15.27	15.27	13.87	1.25
15.14	15.14	13.95	1.14
14.94	0.71	13.90	
15.06	4.57	15.04	
14.97	9.64		
14.97	1.08		

SEZIONE N. : 50
 QT. PROGETTO : 13,861
 DIST.PROG. : 705,000
 DIST.PREC. : 15,000
 DIST.SUCC. : 15,000

SCALA 1:200

QT.RIF. -5,00

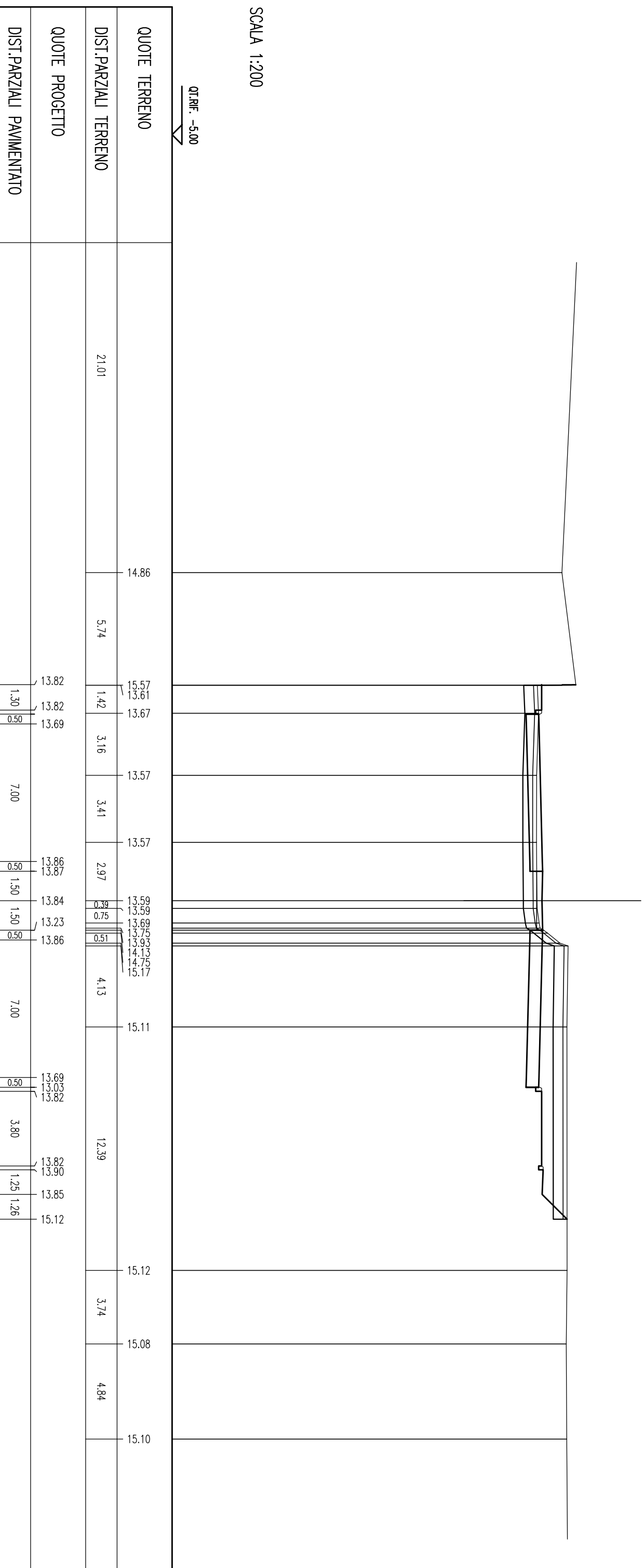

SEZIONE N. : 51
 QT. PROGETTO : 13.816
 DIST.PROG. : 720.000
 DIST.PREC. : 15.000
 DIST.SUCC. : 15.000

SCALA 1:200

QT.REF. -5.00

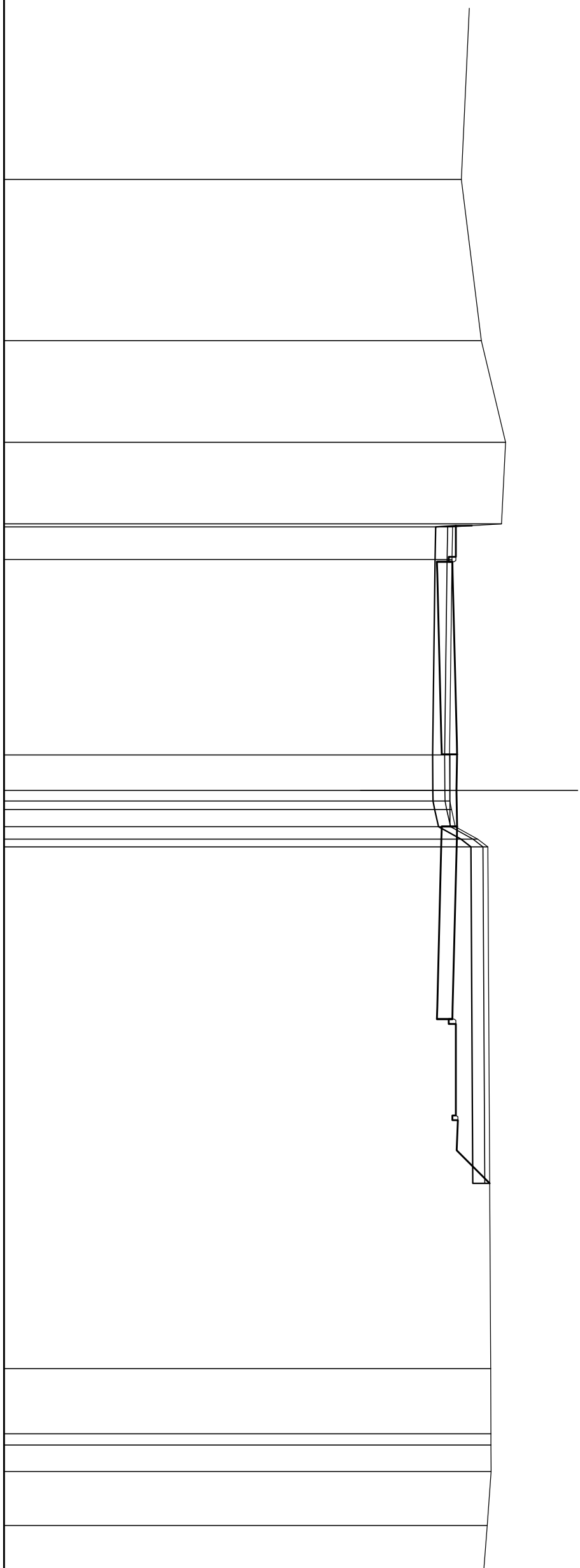

QUOTE TERRENO	DIST. PARZIALI TERRENO	QUOTE PROGETTO	DIST. PARZIALI PAVIMENTATO
14.00	6.69	13.78	1.30
14.83	4.23	13.78	0.50
15.84	3.39	13.64	7.00
15.67	1.36	13.82	0.50
13.64	8.12	13.83	1.50
13.61	1.47	13.80	1.50
13.51	0.38	13.19	0.50
13.52	0.38	13.82	7.00
13.52	0.38	13.64	0.50
13.60	0.38	12.99	3.80
13.75	0.38	13.78	1.25
14.68	0.38	13.81	1.37
15.10	21.67	15.18	
15.22	2.71		
15.23	0.47		
15.23	1.10		
15.24	2.24		
15.08			

SEZIONE N. : 52
 QT. PROGETTO : 13,831
 DIST.PROG. : 735,000
 DIST.PREC. : 15,000
 DIST.SUCC. : 15,000

SCALA 1:200

QT.REF. -4,00

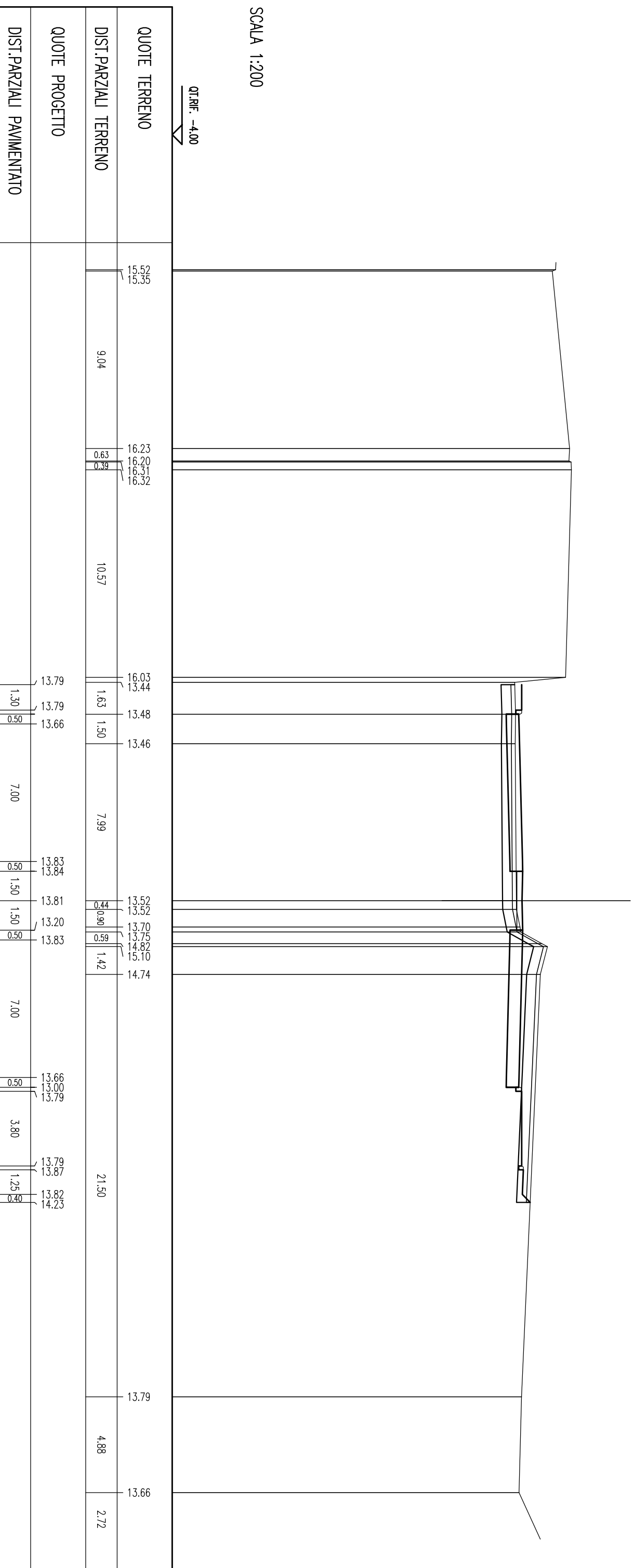

SEZIONE N. : 53
 QT. PROGETTO : 14.005
 DIST.PROG. : 750.000
 DIST.PREC. : 15.000
 DIST.SUCC. : 15.000

SCALA 1:200

QT.RIF. -4.00

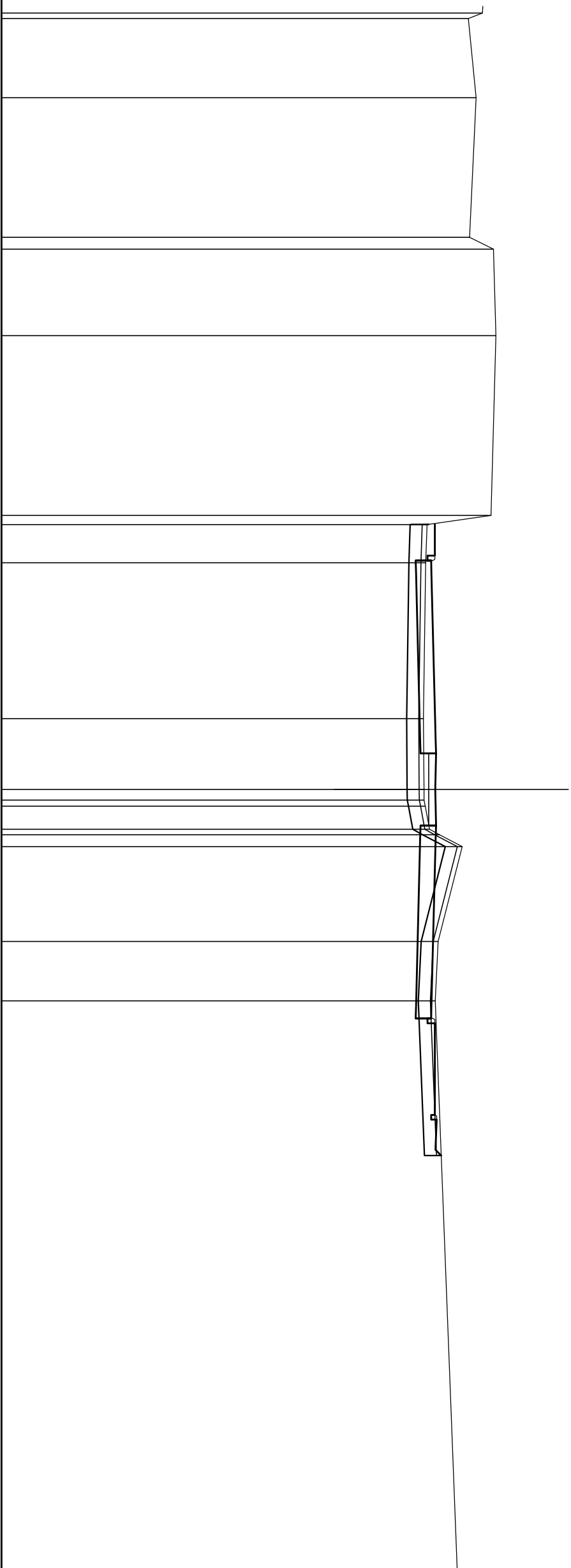

QUOTE TERRENO	DIST. PARZIALI TERRENO	QUOTE PROGETTO	DIST. PARZIALI PAVIMENTATO
15.94 15.36	3.29	15.68	
15.41 16.40	5.79	16.51	
16.30 13.65	7.46	13.59	
13.59	6.47	13.83	1.30
13.50	2.94	14.00 14.02	0.50
13.52 13.52 13.58	0.44	13.99	1.50
13.75 14.16 15.10	0.95	13.38	1.50
14.10	3.93	14.00	0.50
13.99	2.46	13.83 13.18 13.97	7.00
		13.97 14.05	0.50
		14.00 14.24	1.25
	25.47		3.80

SEZIONE N. : 54
 QT. PROGETTO : 14.340
 DIST.PROG. : 765.000
 DIST.PREC. : 15.000
 DIST.SUCC. : 15.000

SCALA 1:200

QT.REF. -4.00

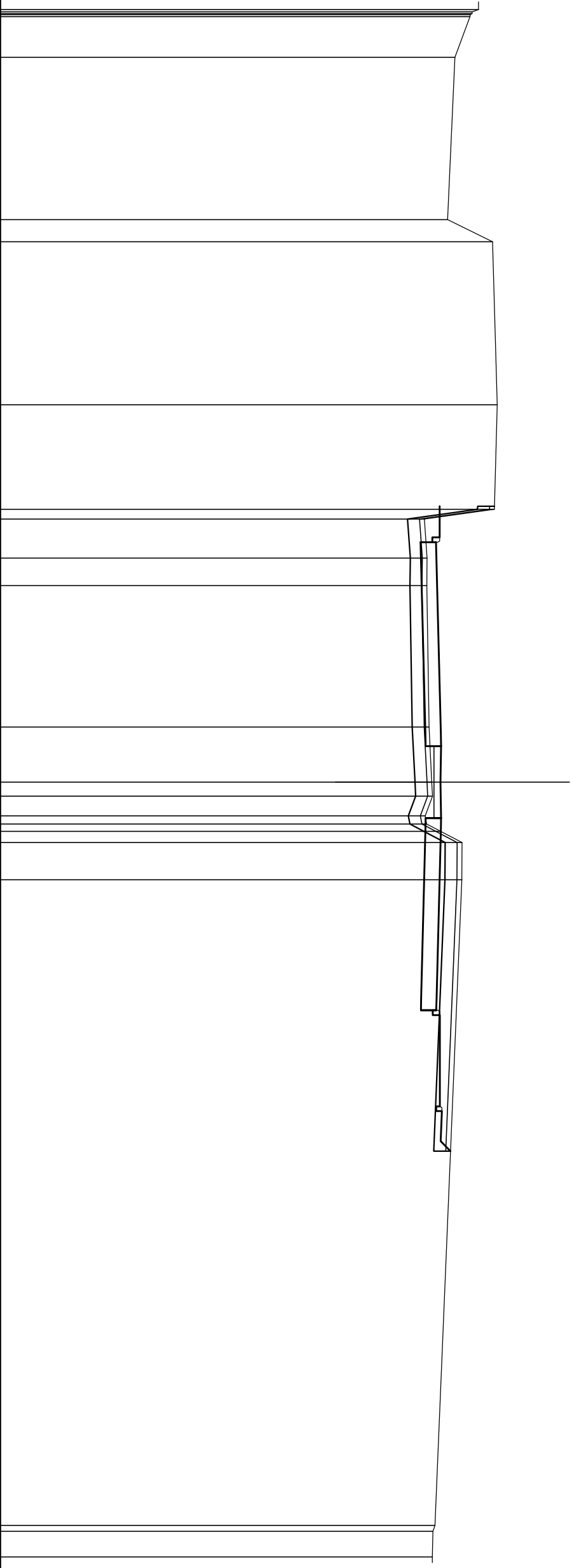

QUOTE TERRENO	DIST. PARZIALI TERRENO	QUOTE PROGETTO	DIST. PARZIALI PAVIMENTATO
15.91 15.64 15.64 15.55 14.93	1.70 6.75 0.93 6.79 4.35	14.29 14.29 14.14 14.16 13.77 13.75 16.57 13.66 13.85 13.96 13.99 13.69 13.75 14.34 15.22 15.21	1.30 0.99 7.00 0.50 1.50 1.50 0.50 7.00 0.50 3.80 1.25 0.41
	26.90		
		14.10 14.01 13.98	1.07

SEZIONE N. : 55
 QT. PROGETTO : 14.830
 DIST.PROG. : 780.000
 DIST.PREC. : 15.000
 DIST.SUCC. : 15.000

SCALA 1:200

QT.RIF. -4.00

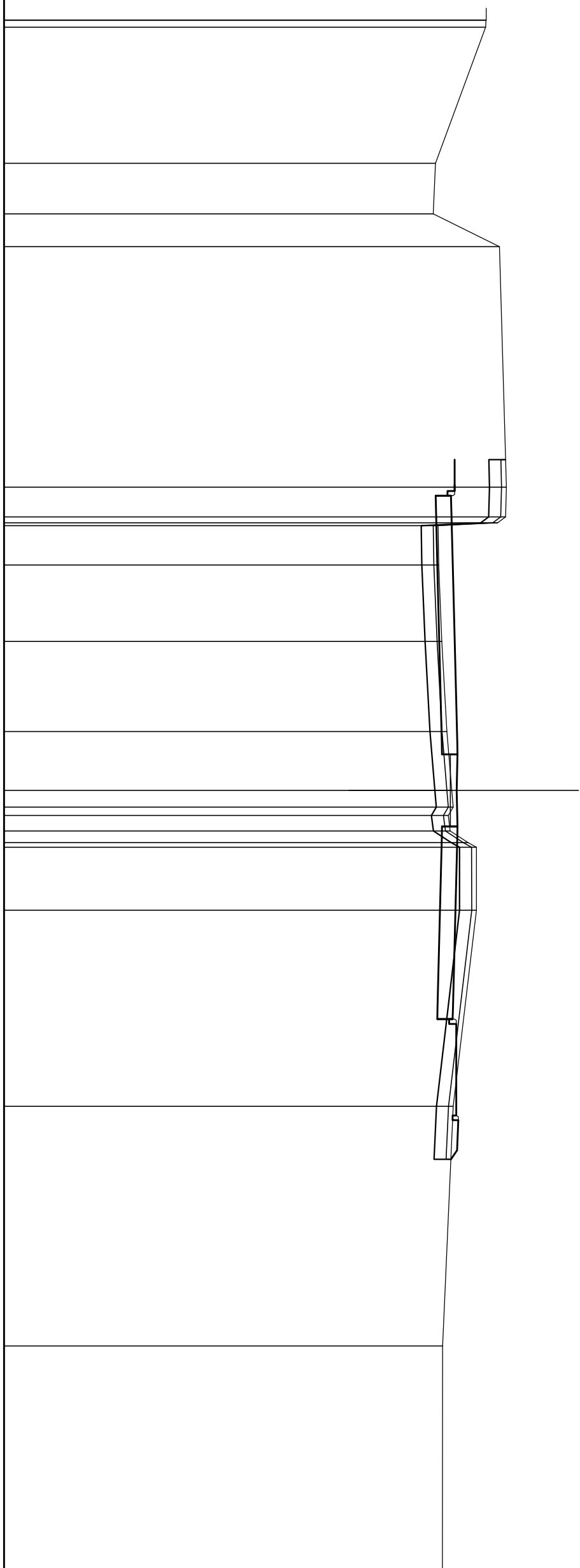

QUOTE TERRENO	DIST.PARZIALI TERRENO	QUOTE PROGETTO	DIST.PARZIALI PAVIMENTATO
16.04 16.03 16.01	5.66	13.93	
	2.10	13.83	
	1.36	16.59	
	9.99		
14.72		16.88	1.05
14.72 14.57	1.24	16.84 16.51 14.04	3.24
	1.63	14.06	
	3.17	14.19	7.00
	3.75	14.40	
14.83 14.84	2.45	14.61	0.50
14.81	0.93	14.66	1.50
14.20	0.39	14.46	0.50
14.83	0.48	14.54	
	2.61	15.28 15.63	7.00
	8.14	15.63	0.50
14.65 14.00 14.79		14.67	3.80
14.79 14.87		14.67	1.25
14.82 14.57	9.96		
	14.89	14.23	

SEZIONE N. : 56
 QT. PROGETTO : 15.308
 DIST.PROG. : 795.000
 DIST.PREC. : 15.000
 DIST.SUCC. : 15.000

SCALA 1:200

QT.REF. -4.00

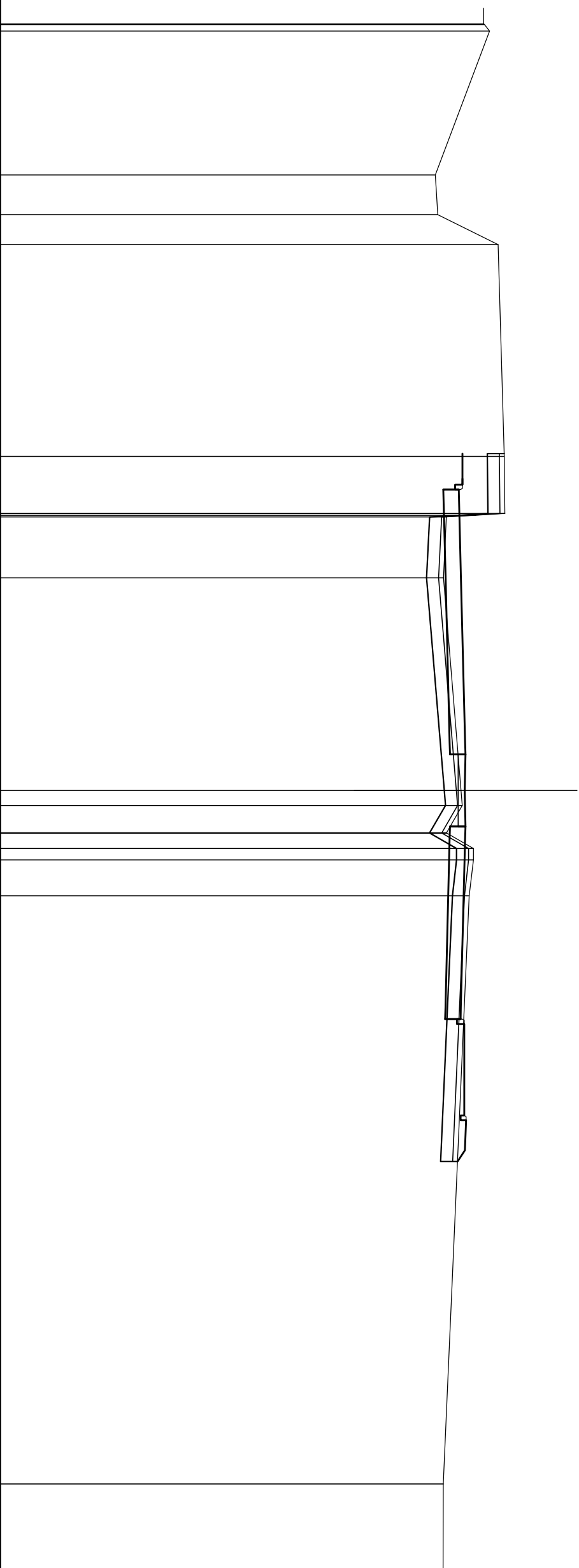

QUOTE TERRENO	DIST. PARZIALI TERRENO	QUOTE PROGETTO	DIST. PARZIALI PAVIMENTATO
16.08 16.12 16.32	5.98	14.07 14.17 16.68	
16.93	8.80	16.93	
16.96 15.75 14.53	2.37	15.20 15.20 15.05	1.05
14.41	2.54	15.13	3.50
15.14 15.19	8.83	15.31 15.32	7.00
14.54 14.54 14.55 15.66 15.66 15.48	0.62 1.14 0.63 0.88 1.49	15.29 14.68 15.31	0.50 1.50 1.50 0.50
15.13 14.48 15.27	24.43	15.13 14.48 15.27	7.00
15.27 15.35		15.27 15.35	3.80
15.30 14.99	7.42	15.30 14.99	1.25 0.46
14.40			

SEZIONE N. : 57
 QT. PROGETTO : 15,675
 DIST.PROG. : 810,000
 DIST.PREC. : 15,000
 DIST.SUCC. : 15,000

SCALA 1:200

QT.RIF. -3,00

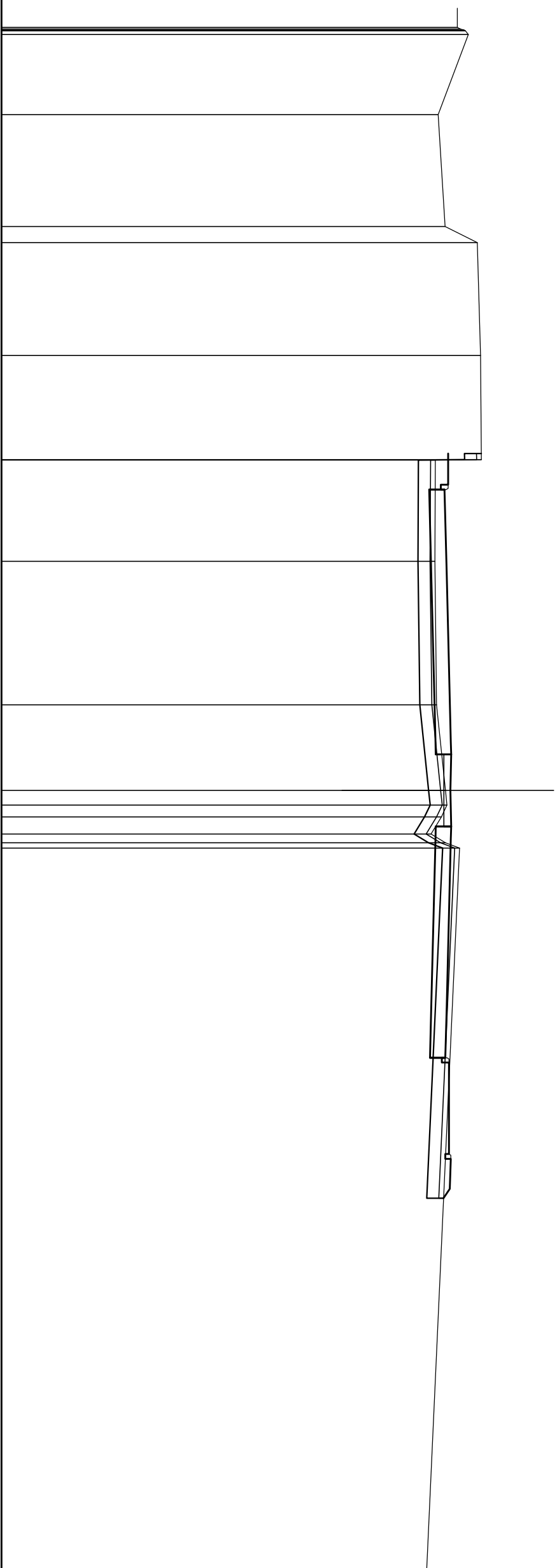

QUOTE TERRENO	DIST.PARZIALI TERRENO	QUOTE PROGETTO	DIST.PARZIALI PAVIMENTATO
15.95 16.07 16.23 16.28 16.40	3.33	15.15	
15.44 16.77	4.65 0.96	15.44	
16.91	4.69	16.91	
16.95 15.03	4.32	15.56 15.56 15.41	1.30 3.50
15.01	4.21	15.50	
15.08	5.96	15.50	7.00
15.45 15.52 15.28 14.85 15.45 16.03	3.56 0.61 0.70 0.70 0.70	15.67 15.69 15.66 15.05 15.67	0.50 1.50 1.50 0.50
15.50		15.50	7.00
15.45 14.81 15.60	2.10	15.45 14.81 15.60	3.80
15.60 15.68		15.60 15.68	1.25
15.63 15.37		15.63 15.37	0.80
	31.88		

SEZIONE N. : 58
 QT. PROGETTO : 15.933
 DIST.PROG. : 825.000
 DIST.PREC. : 15.000
 DIST.SUCC. : 15.000

SCALA 1:200

QT.REF. -3.00

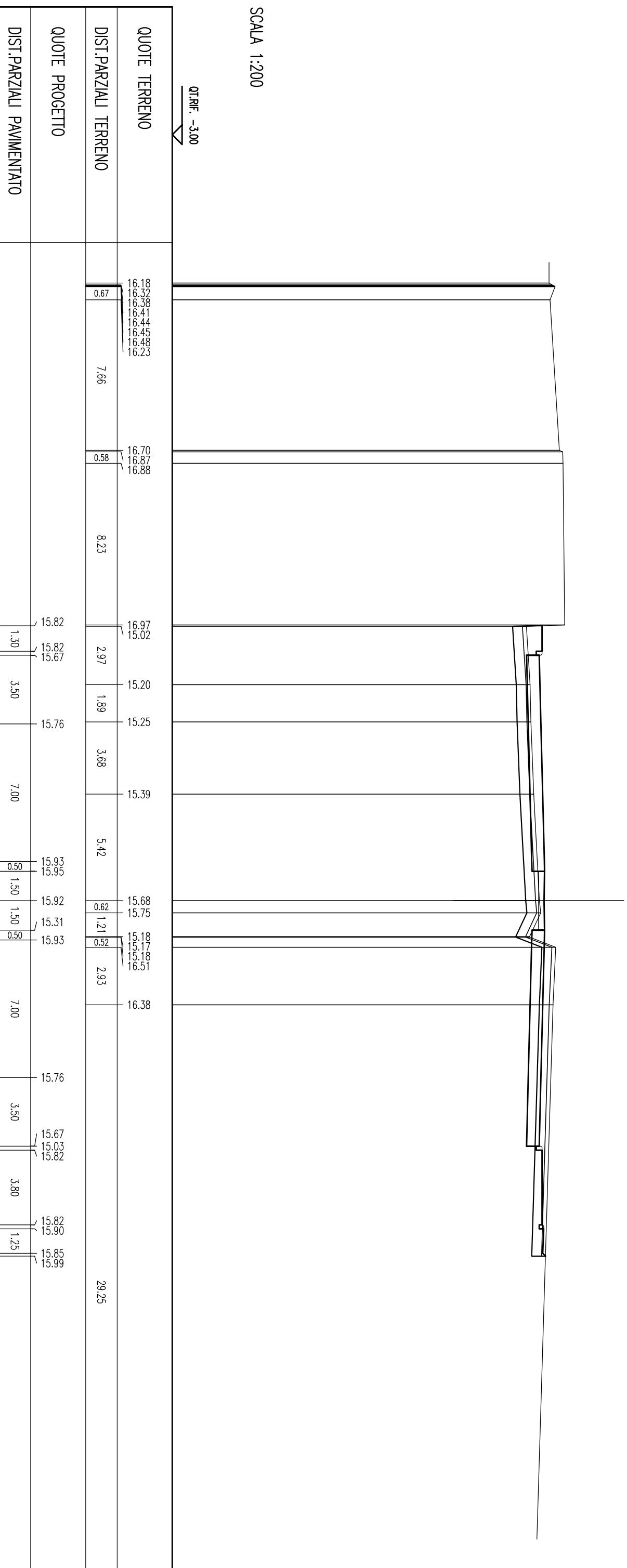

SEZIONE N. : 59
 QT. PROGETTO : 16.164
 DIST.PROG. : 840.000
 DIST.PREC. : 15.000
 DIST.SUCC. : 15.000

SCALA 1:200

QT.REF. -3.00

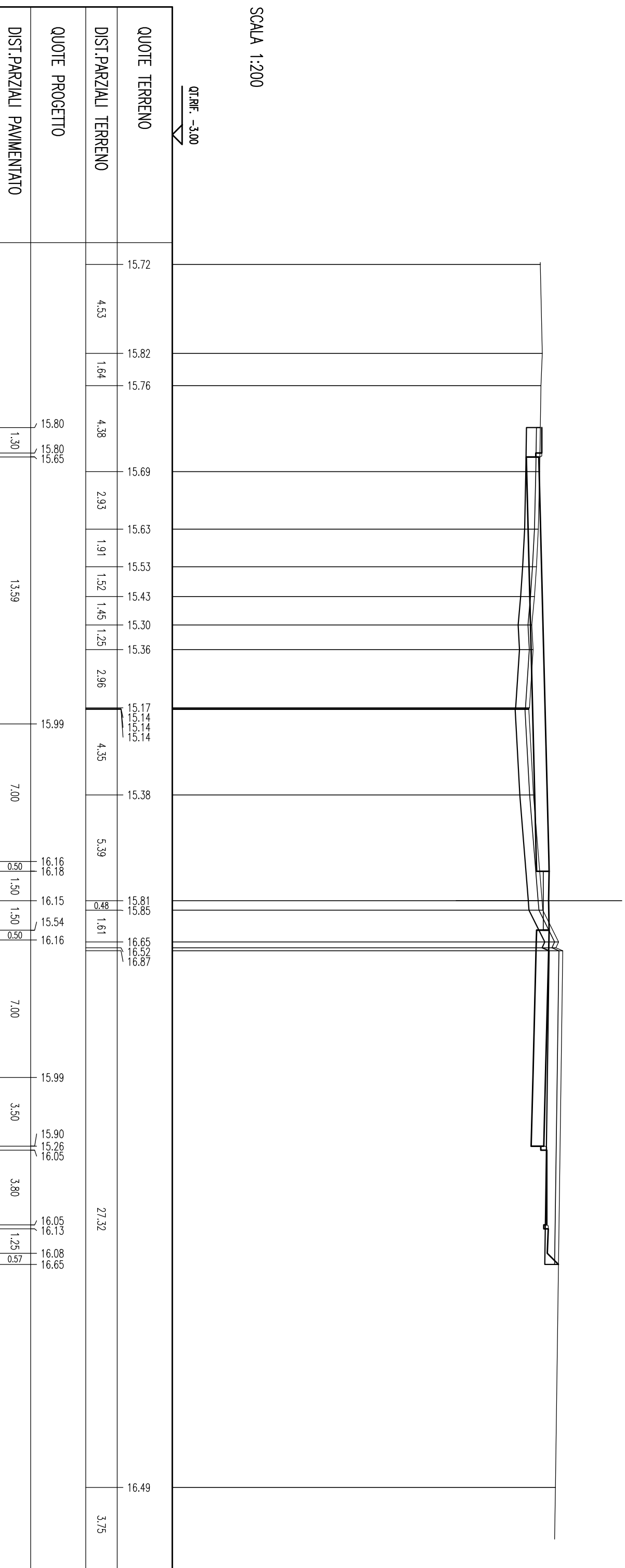

SEZIONE N. : 60
 QT. PROGETTO : 16.393
 DIST.PROG. : 855.000
 DIST.PREC. : 15.000
 DIST.SUCC. : 15.000

SCALA 1:200

QT.RIF. -2.00

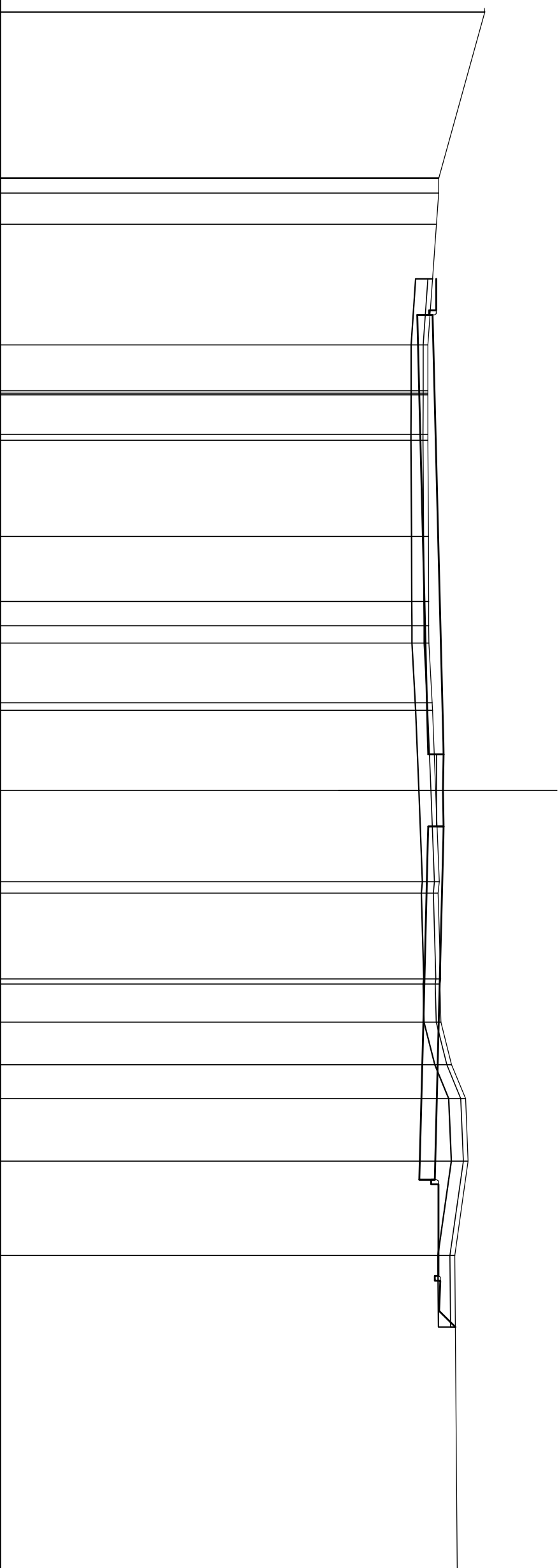

QUOTE TERRENO	DIST. PARZIALI TERRENO	QUOTE PROGETTO	DIST. PARZIALI PAVIMENTATO
18.11 18.11	6.89	16.10	1.30
16.20 16.20 16.20	1.30	16.10 15.95	10.75
16.10	5.02	16.10	7.00
15.75	1.90	16.22	16.39 16.41
15.75 15.75 15.75	1.64	16.07	1.50 1.50
15.75 15.75	4.00	16.39	7.00
15.77	2.70	16.23 16.18	16.22
15.78	1.01	16.28 16.25	7.17
15.79 15.79	0.75	16.29	16.04 15.40 16.19
15.93 15.94	2.48	16.74	3.80
16.07	3.33	17.31	16.19 16.27
16.38	3.79	17.42	16.22 16.89
15.77 16.39	0.50	16.87	
16.23 16.18	7.00		
16.28 16.25	3.57		
16.29	1.58		
16.74	1.77		
17.31	1.40		
17.42	2.61		
16.87	3.92		
	20.68		

SEZIONE N. : 61
 QT. PROGETTO : 16.568
 DIST.PROG. : 870.000
 DIST.PREC. : 15.000
 DIST.SUCC. : 15.000

SCALA 1:200

QT.RIF. 3.00

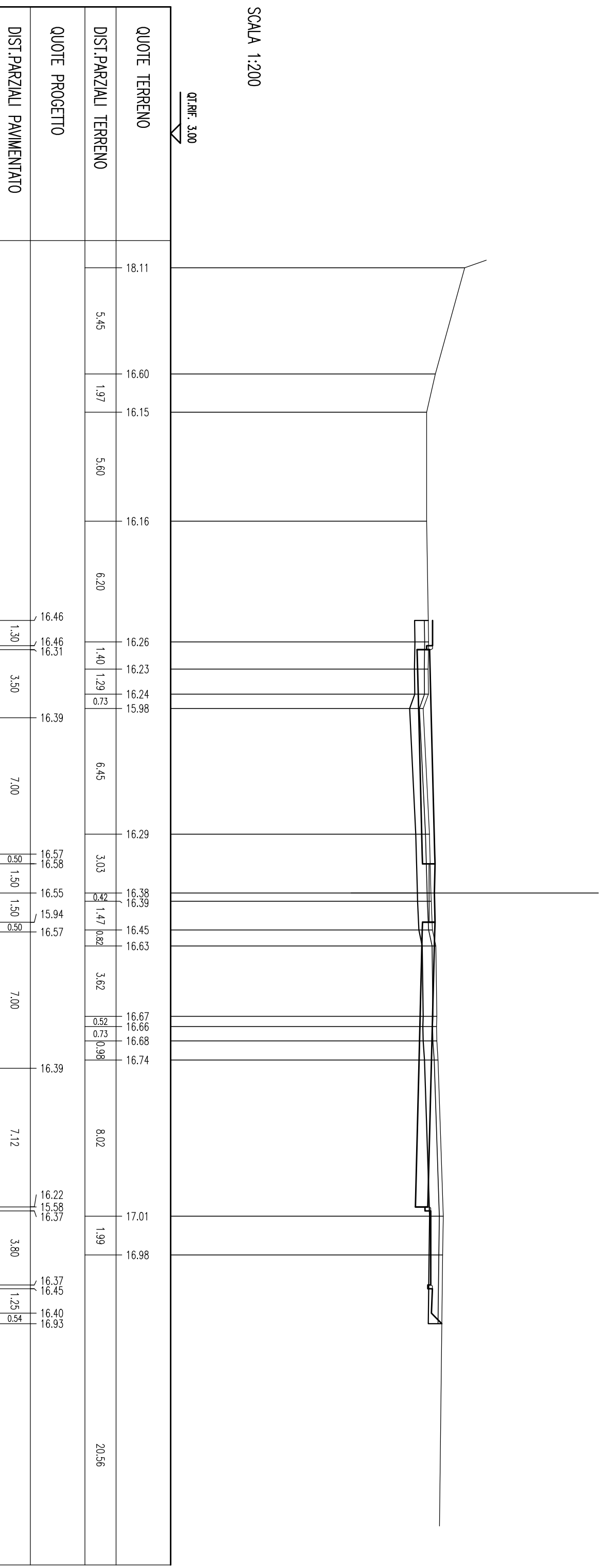

SEZIONE N. : 63
 QT. PROGETTO : 16,716
 DIST.PROG. : 900,000
 DIST.PREC. : 15,000
 DIST.SUCC. : 15,000

SCALA 1:200

QT.RIF. 0,000

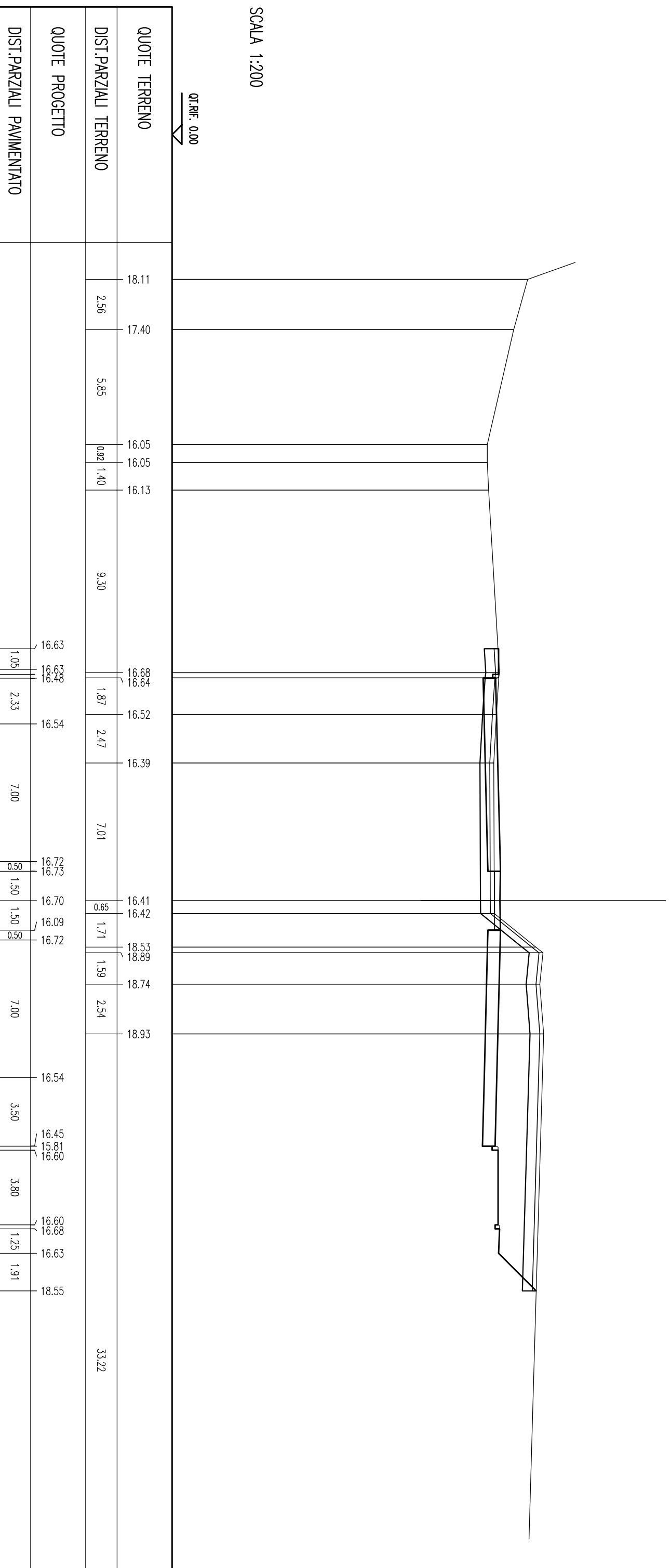

SEZIONE N. : 64
 QT. PROGETTO : 16,761
 DIST.PROG. : 915,000
 DIST.PREC. : 15,000
 DIST.SUCC. : 15,000

SCALA 1:200

QT.REF. -1,00

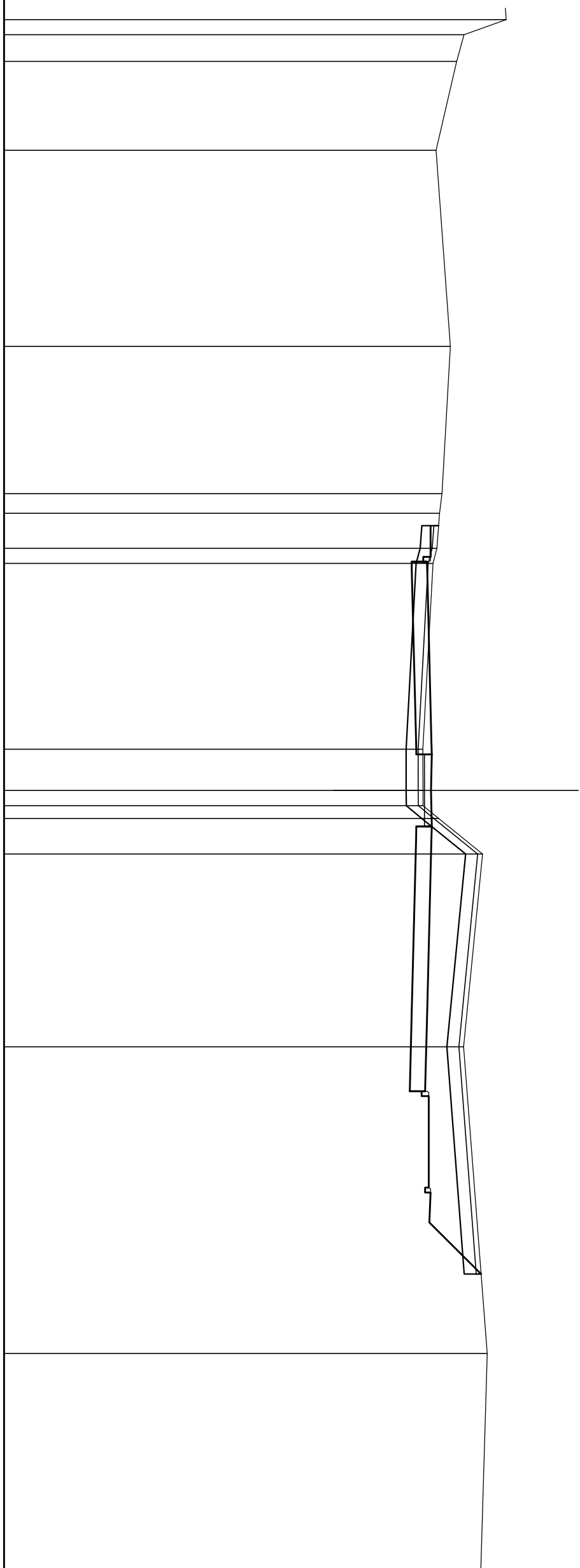

QUOTE TERRENO	DIST. PARZIALI TERRENO	QUOTE PROGETTO	DIST. PARZIALI PAVIMENTATO
19.86	0.63	16.72	1.05
18.11	1.11	16.72	0.50
17.80	3.69	16.57	7.00
16.95	8.15	16.59	0.50
17.54	6.12	16.76	1.50
17.20	0.81	16.77	1.50
17.10	1.46	16.74	0.50
16.99	0.93	16.13	7.00
16.82	7.72	16.76	7.00
16.41	1.71	16.59	3.50
16.41	0.64	16.50	3.80
16.42	2.50	16.65	1.25
17.06	1.48	16.73	2.14
18.88	8.01	16.68	18.82
18.10	12.74	18.82	19.08
16.50	16.61		
15.86			
16.65			

SEZIONE N. : 65
 QT. PROGETTO : 16.806
 DIST.PROG. : 930.000
 DIST.PREC. : 15.000
 DIST.SUCC. : 15.000

SCALA 1:200

QT.REF. -1.00

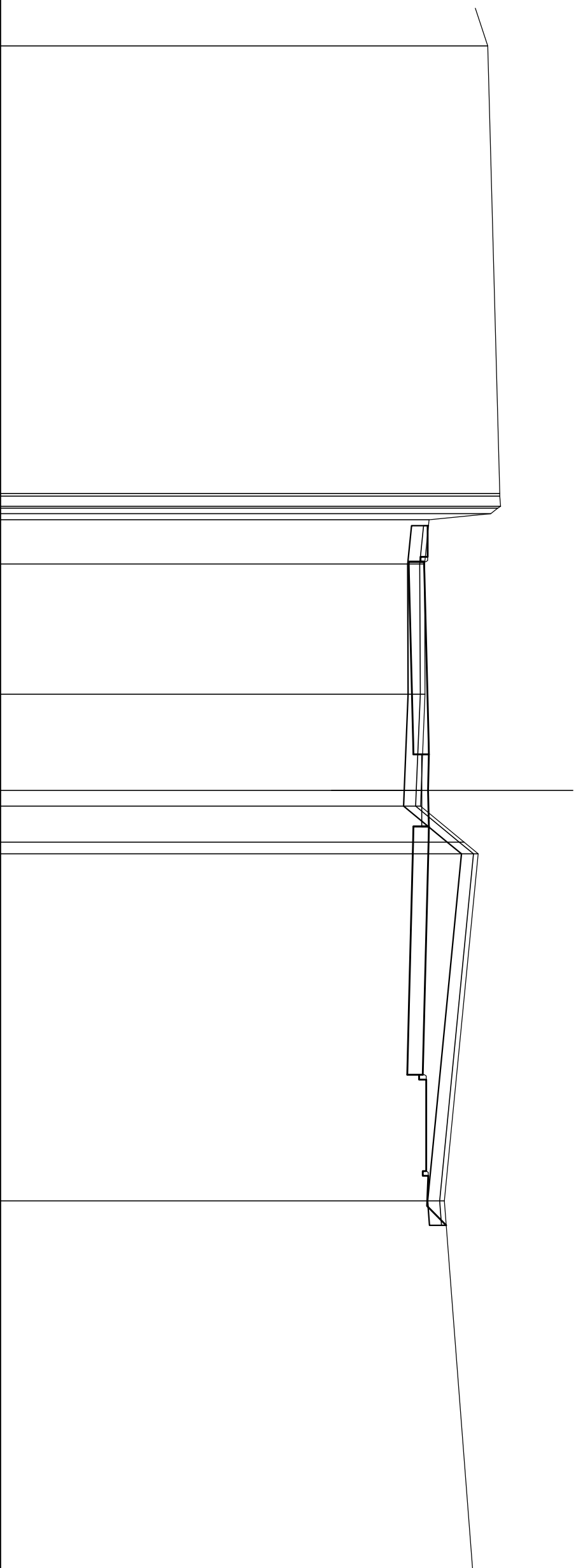

QUOTE TERRENO	DIST. PARZIALI TERRENO	QUOTE PROGETTO	DIST. PARZIALI PAVIMENTATO
19.26	18.59	16.77	1.30
19.76	0.42	16.77	0.50
19.76	1.84	16.63	
19.80	5.41		7.00
19.68	16.66	16.81	0.50
19.40	4.00	16.82	1.50
16.82	16.49	16.79	1.50
16.64	16.47	16.18	0.50
	18.28	16.81	7.00
	18.87		
	14.42	16.63	2.81
		16.56	
		15.92	3.80
		16.71	
	17.46	16.71	1.25
		16.79	0.80
		16.74	
		17.54	
	22.95		

SEZIONE N. : 66
QI. PROGETTO : 16.864
DIST.PROG. : 945.000
DIST.PREC. : 15.000
DIST.SUCC. : 15.000

SCALA 1:200

QI.REF. -1.00

QUOTE TERRENO	
18.55	19.41
19.71	19.71
19.63	16.62
16.61	16.72
16.83	16.59
16.83	16.56
16.69	17.05
16.86	18.89
16.88	16.69
16.85	16.04
16.24	16.83
16.86	16.83
16.83	16.91
16.91	16.86
17.59	17.49
17.49	17.19
17.19	17.30

DIST.PARZIALI TERRENO	
2.61	11.01
1.25	5.31
1.59	6.32
3.13	14.10
1.58	4.63
3.85	14.75

DIST.PARZIALI PAVIMENTATO	
1.30	7.00
0.50	1.50
0.50	1.50
0.50	1.50
0.56	3.80
1.25	0.74

SEZIONE N. : 67
 QT. PROGETTO : 17.021
 DIST.PROG. : 960.000
 DIST.PREC. : 15.000
 DIST.SUCC. : 15.000

SCALA 1:200

QT.REF. -1.00

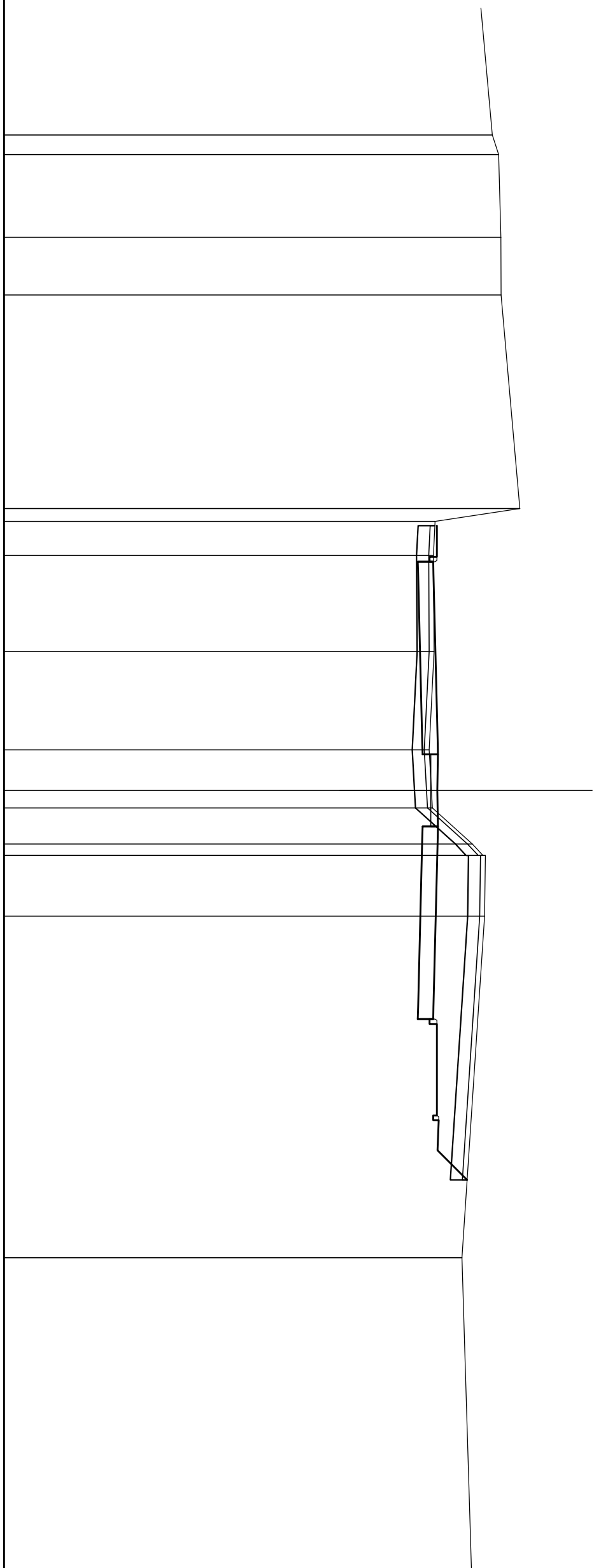

QUOTE TERRENO	DIST. PARZIALI TERRENO	QUOTE PROGETTO	DIST. PARZIALI PAVIMENTATO
19.29	0.81	16.98	1.30
19.56	3.44	16.98	0.50
19.65	2.39	16.85	7.00
19.65	8.88	17.02	0.50
20.44	0.53	17.03	1.50
16.91	1.42	17.00	1.50
16.84	4.00	16.39	0.50
16.87	4.08	17.02	7.00
16.67	1.68	18.46	0.50
16.76	0.73	18.90	3.80
16.80	1.50	19.00	1.25
18.46	0.47	18.97	1.23
18.90	2.52	18.03	
19.00			
16.85	14.19		
16.19			
16.98	19.61		
16.98			
17.06			
17.01			
18.24			

SEZIONE N. : 68
 QT. PROGETTO : 17.284
 DIST.PROG. : 975.000
 DIST.PREC. : 15.000
 DIST.SUCC. : 15.000

SCALA 1:200

QT.REF. -1.00

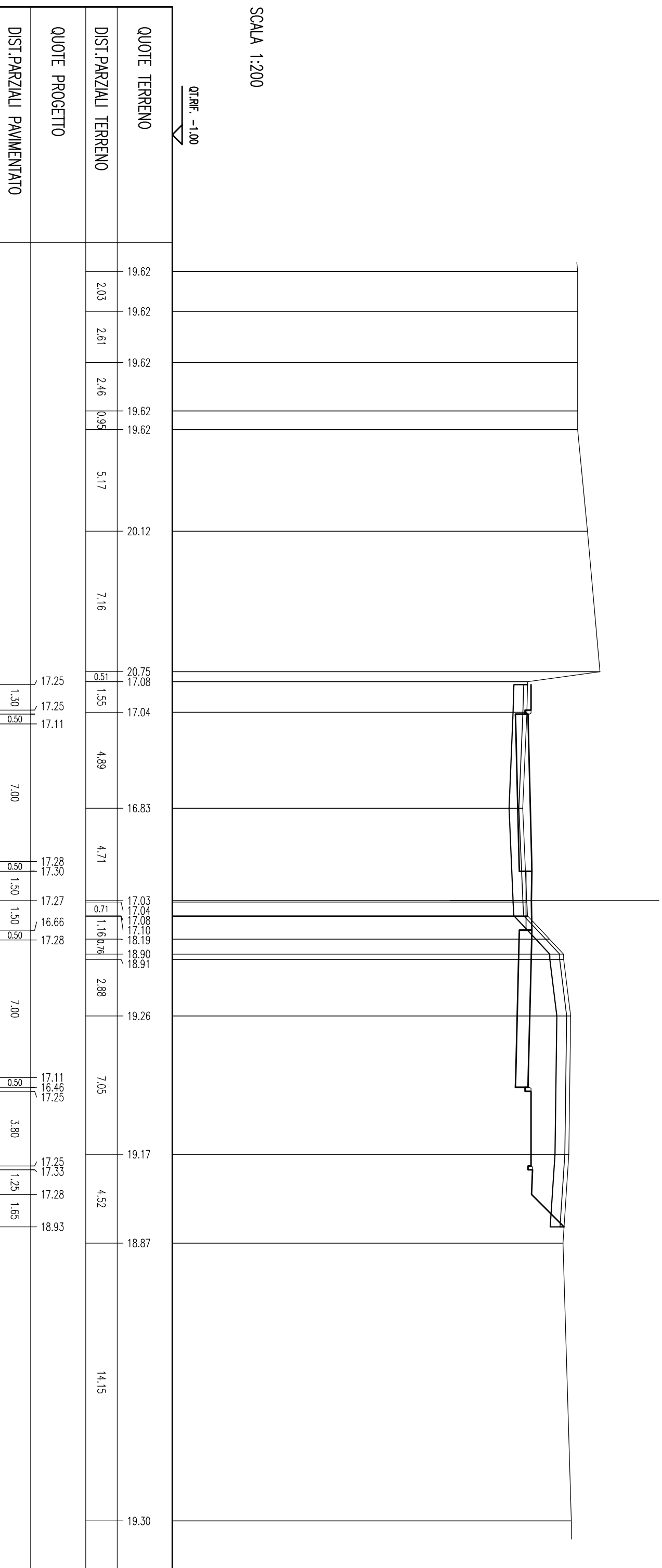

SEZIONE N. : 69
QT. PROGETTO : 17.568
DIST.PROG. : 990.000
DIST.PREC. : 15.000
DIST.SUCC. : 15.000

SCALA 1:200

QT.RIF. 0.000

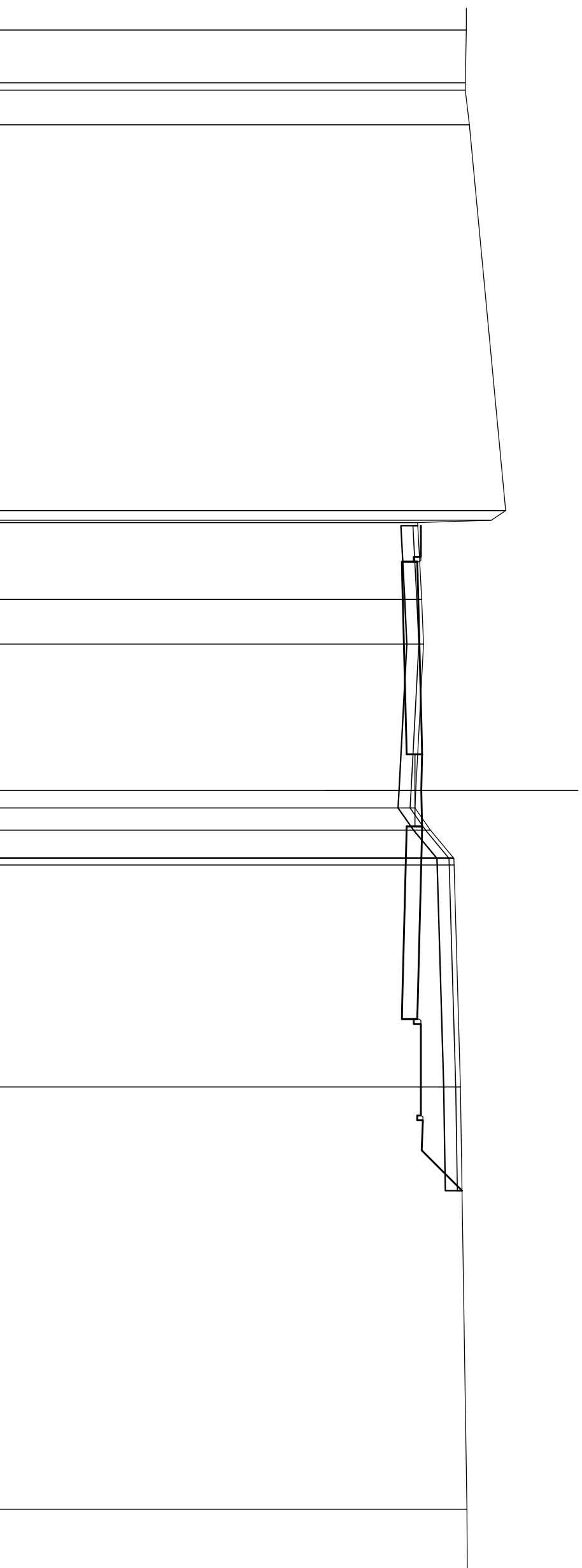

QUOTE TERRENO	DIST. PARZIALI TERRENO	QUOTE PROGETTO	DIST. PARZIALI PAVIMENTATO
19.42		17.53	1.30
19.42	2.19	17.53	0.50
19.37		17.39	
19.38	1.44	17.56	7.00
19.54	16.03	17.64	
21.05		17.57	0.50
20.46		17.58	1.50
17.40	3.20	17.55	1.50
17.56	1.85	16.94	0.50
17.64	6.08	17.57	7.00
17.32		17.39	0.50
17.28	0.72	16.74	
17.92	0.92	17.53	3.80
18.88		17.53	1.25
18.90		17.61	
18.91	1.16	17.56	1.68
19.18	9.22	19.24	
19.45	17.54		
	5.31		

SEZIONE N. : 70
 QT. PROGETTO : 17.774
 DIST.PROG. : 1005.000
 DIST.PREC. : 15.000
 DIST.SUCC. : 15.000

SCALA 1:200

QT.RIF. 0.000

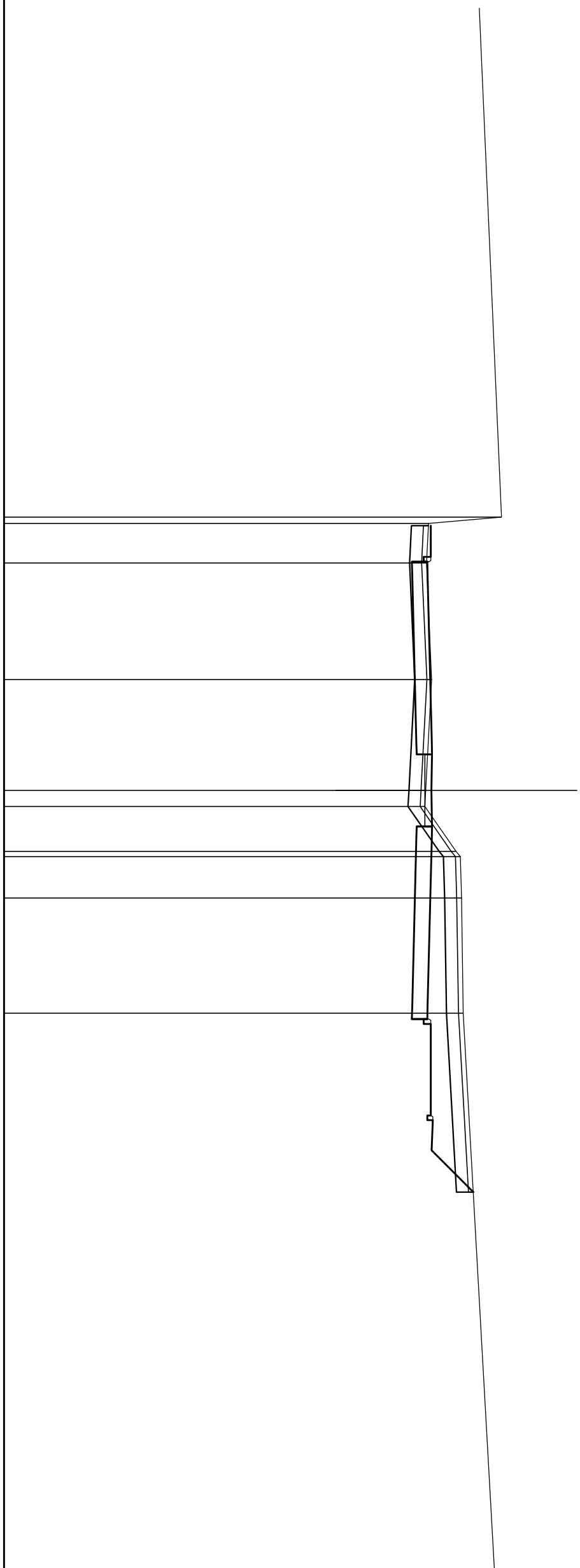

QUOTE TERRENO	DIST.PARZIALI TERRENO	QUOTE PROGETTO	DIST.PARZIALI PAVIMENTATO
20.68 17.64	21.68	17.74 17.74 17.60	1.30 0.50
17.55	1.65	17.74 17.60	0.50
17.77	4.84	17.77	7.00
17.52 17.49	4.61	17.77 17.79	0.50
18.78 18.96	0.67	17.76 17.15	1.50 1.50
19.01	1.86	17.77	0.50
19.08	1.72	17.60 16.95 17.74	7.00
19.50	4.78	17.74 17.82 17.77	0.50 3.80 1.25 1.73
	30.75		

SEZIONE N. : 71
 QT. PROGETTO : 17.868
 DIST.PROG. : 1020.000
 DIST.PREC. : 15.000
 DIST.SUCC. : 15.000

SCALA 1:200

QT.RIF. 0.00

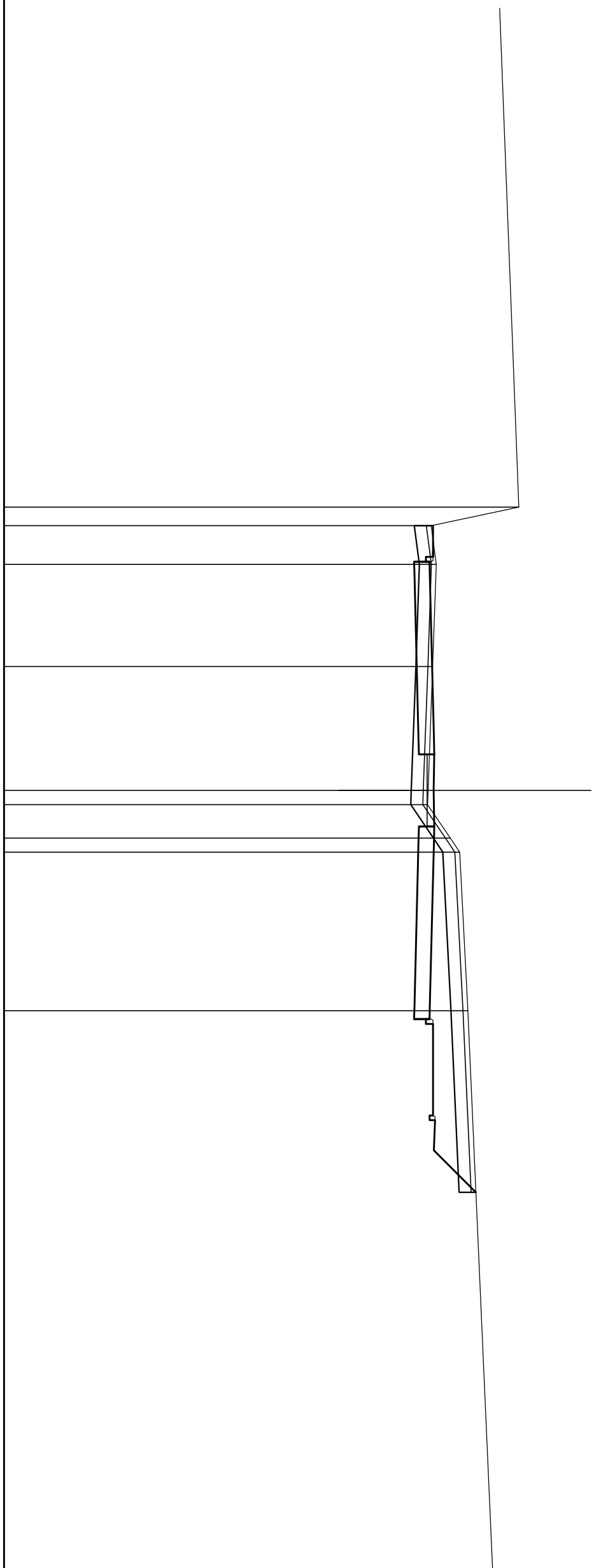

QUOTE TERRENO	DIST. PARZIALI TERRENO	QUOTE PROGETTO	DIST. PARZIALI PAVIMENTATO
21.39		17.83	
17.75	0.77	17.83	1.05
	1.61	17.68	0.50
17.96	4.24	17.69	
			7.00
17.81		17.87	
	5.15	17.88	0.50
		17.85	1.50
17.62	0.59	17.24	1.50
17.60	1.39	17.87	0.50
18.55	0.58		
18.94			7.00
	6.59		
19.27		17.69	0.50
		17.04	
		17.83	3.80
		17.83	
		17.91	1.25
		17.86	
			1.75
		19.61	
	30.85		

SEZIONE N. : 72
 QT. PROGETTO : 17,879
 DIST.PROG. : 1035,000
 DIST.PREC. : 15,000
 DIST.SUCC. : 15,000

SCALA 1:200

QT.RIF. 0,000

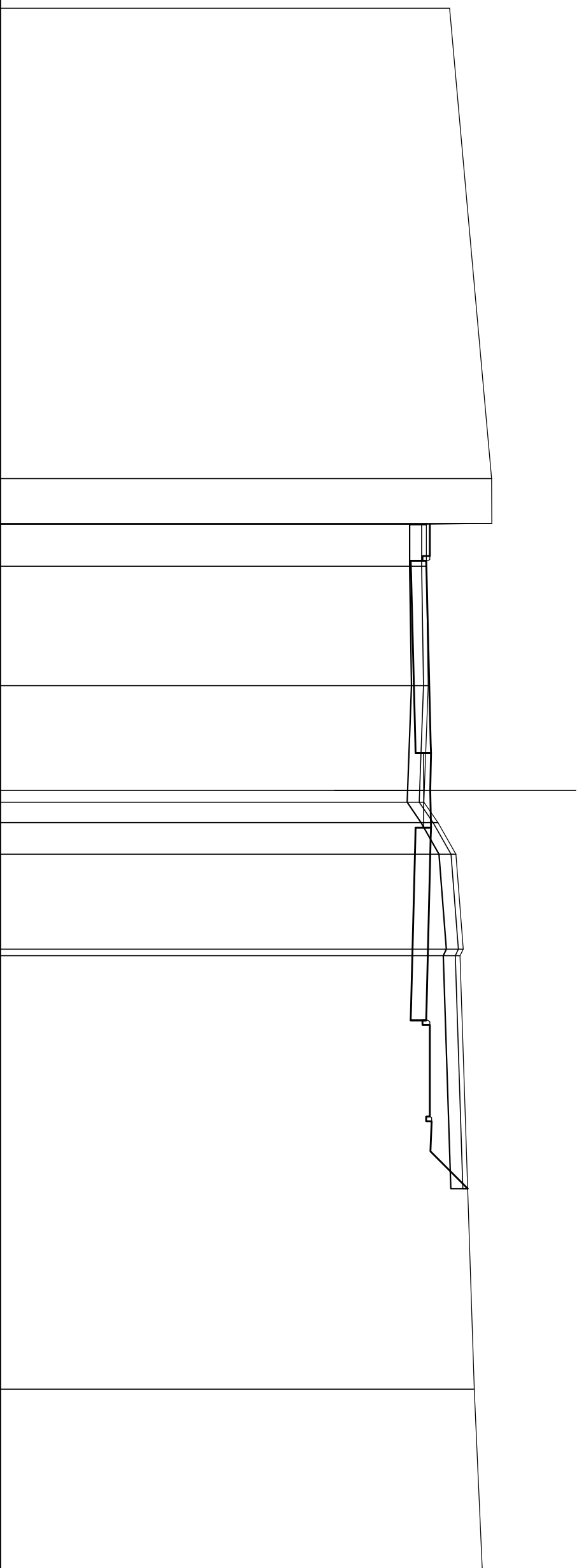

QUOTE TERRENO	DIST.PARZIALI TERRENO	QUOTE PROGETTO	DIST.PARZIALI PAVIMENTATO
18.66	19.54		
20.40	1.86	17.84	1.30
20.42	1.75	17.84	0.54
17.70	4.96	17.70	7.00
17.78	4.35	17.88	0.45
17.62	0.86	17.89	1.55
17.60	1.31	17.86	0.45
18.18	3.94	17.25	7.00
18.93		17.88	
19.23		17.70	
19.10		17.05	
		17.84	
		17.84	
		17.92	
		17.87	
	18.01	19.42	
19.69	15.13		

SEZIONE N. : 73
 QT. PROGETTO : 17,886
 DIST.PROG. : 1050,000
 DIST.PREC. : 15,000
 DIST.SUCC. : 15,000

SCALA 1:200

QT.RIF. 0,00

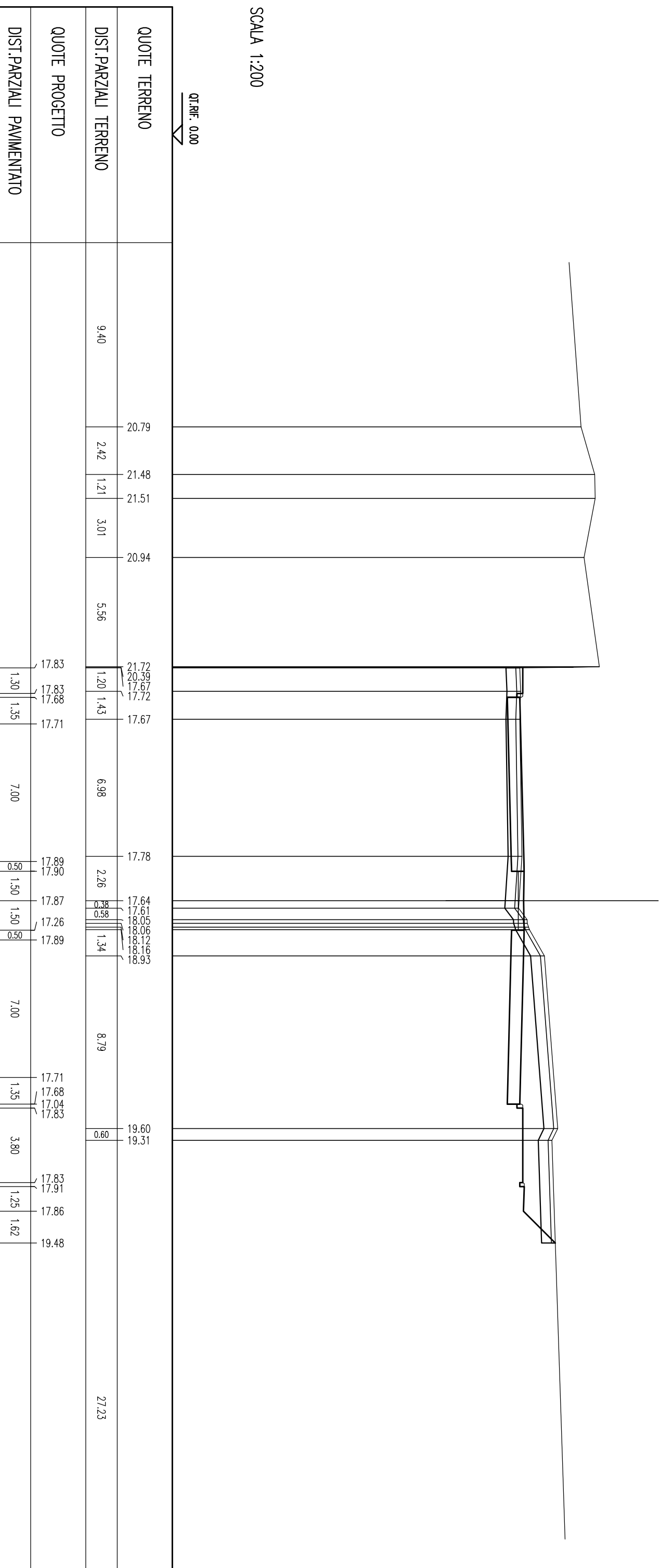

SEZIONE N. : 74
 QT. PROGETTO : 17.907
 DIST.PROG. : 1065.000
 DIST.PREC. : 15.000
 DIST.SUCC. : 10.834

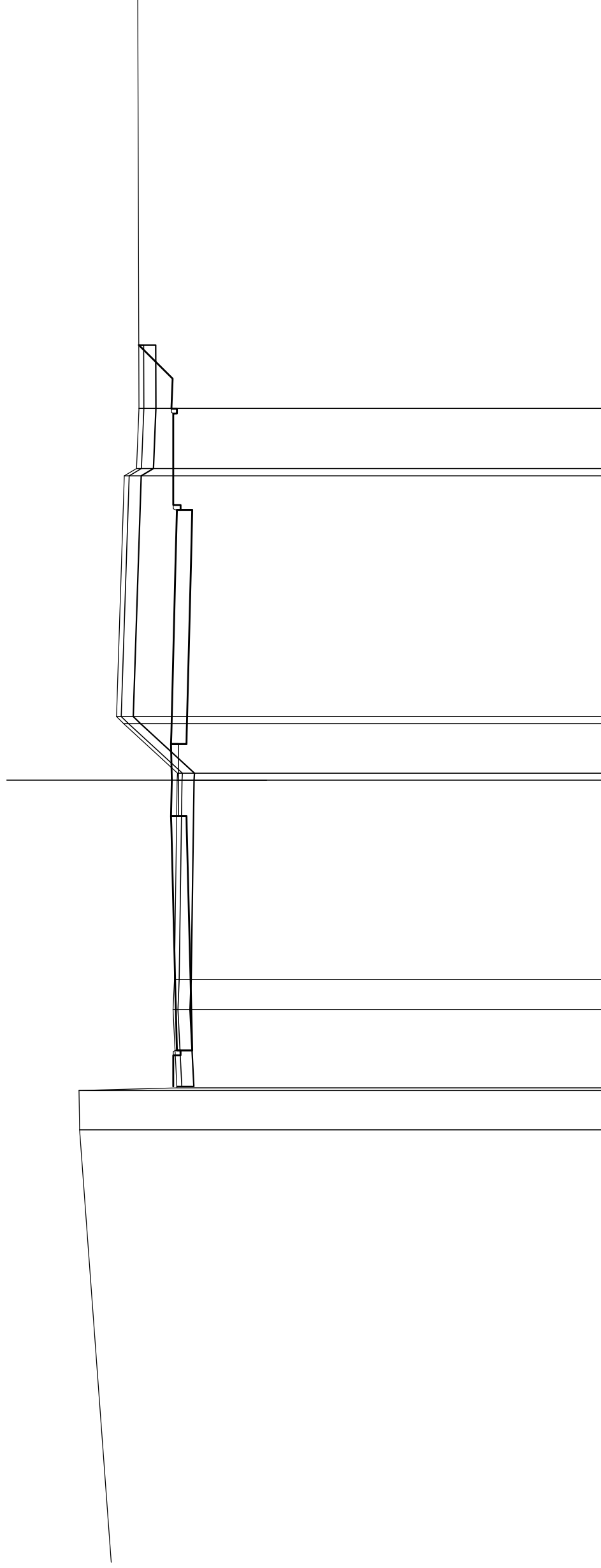

SCALA 1:200

QT.RIF. 0.00

QUOTE TERRENO	21.71	21.73	17.67	17.83	17.78	17.91	17.92	17.89	17.28	17.85	19.88	20.18	19.86	19.35	19.25
DIST.PARZIALI TERRENO	1.64	3.25	1.25	8.29	2.06	10.00	2.23	7.00	7.00	2.23	3.80	2.49	19.90		
QUOTE PROGETTO	17.83	17.83	17.73	17.91	17.89	17.73	17.83	17.04	17.83	17.83	17.83	17.91	17.86	19.25	
DIST.PARZIALI PAVIMENTATO	1.30	2.23	7.00	0.50	1.50	7.00	2.23	0.50	1.25	1.40	3.80	1.25	1.40		

