

PIANTA SCALA 1:1000

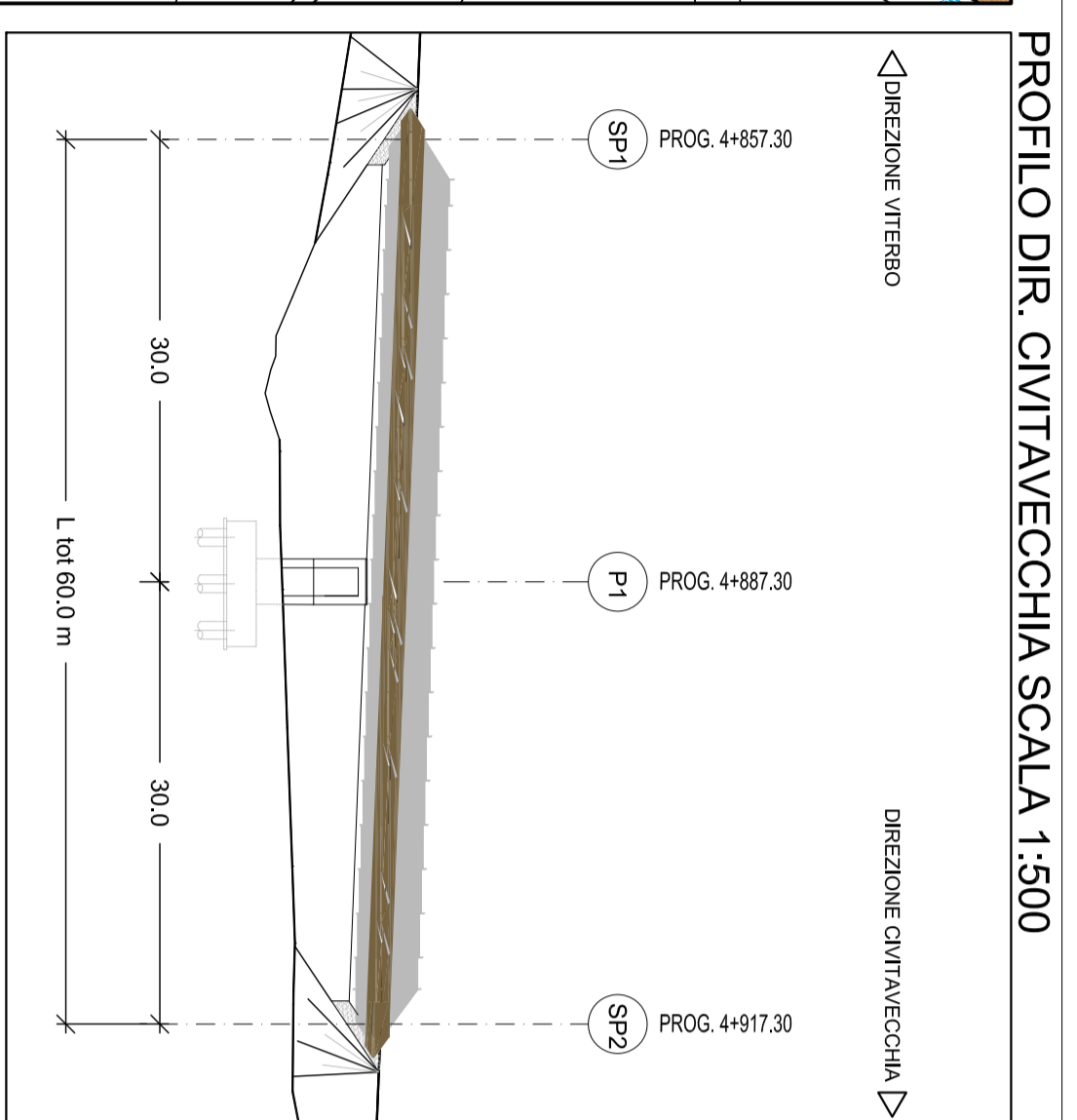

PROFILO DIR. CIVITAVECCHIA SCALA 1:500

CARREGGIATA CIVITAVECCHIA				CARREGGIATA VITERBO			
Nome	SP1	P1	SP2	Nome	SP1	P1	SP2
Progr.	4+857.30	4+887.30	4+917.30	Progr.	4+857.30	4+887.30	4+917.30
Altezza	3.58	6.45	3.95	Altezza	3.98	8.08	5.20

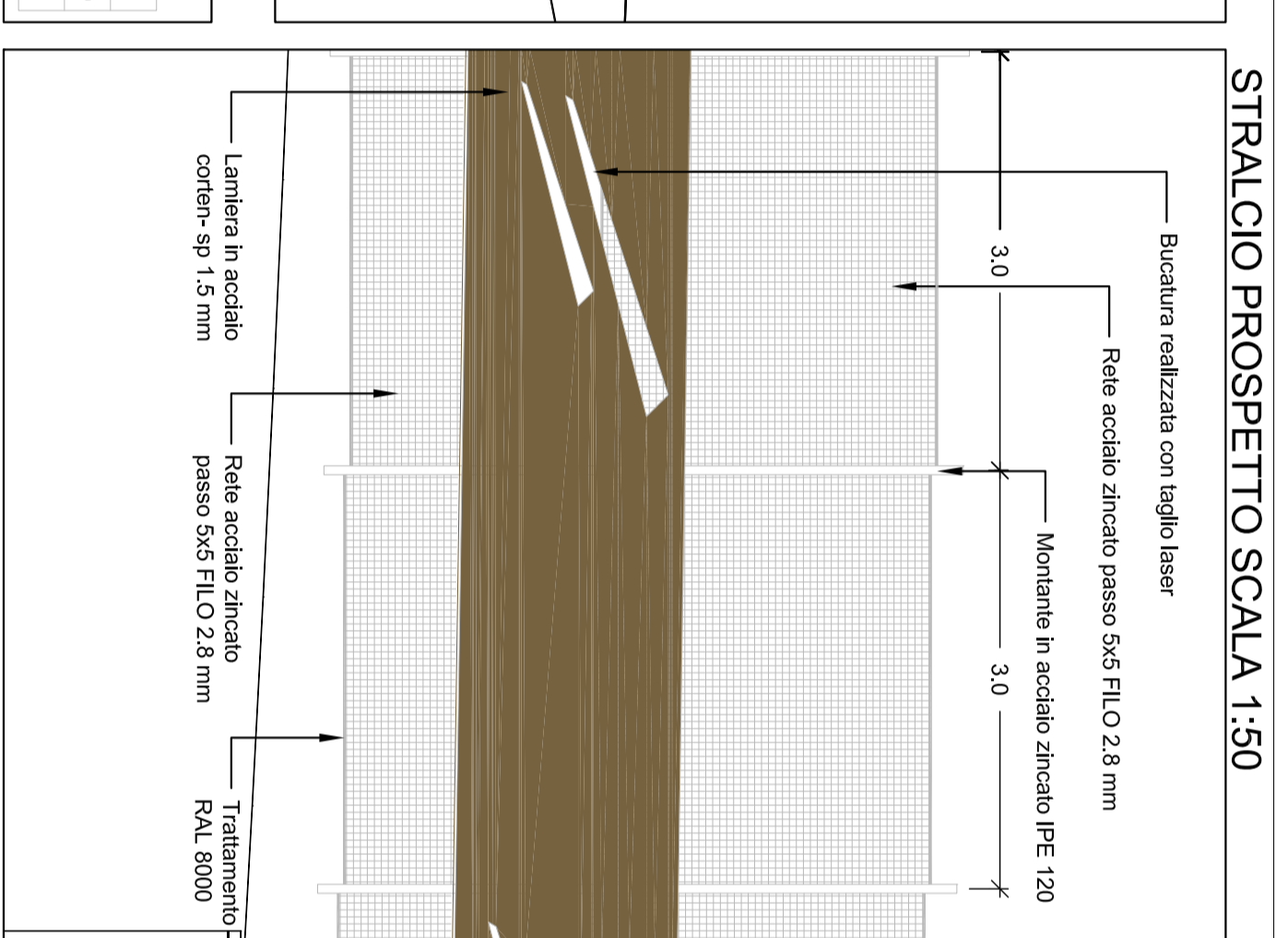

STRALCIO PROSPETTO SCALA 1:500

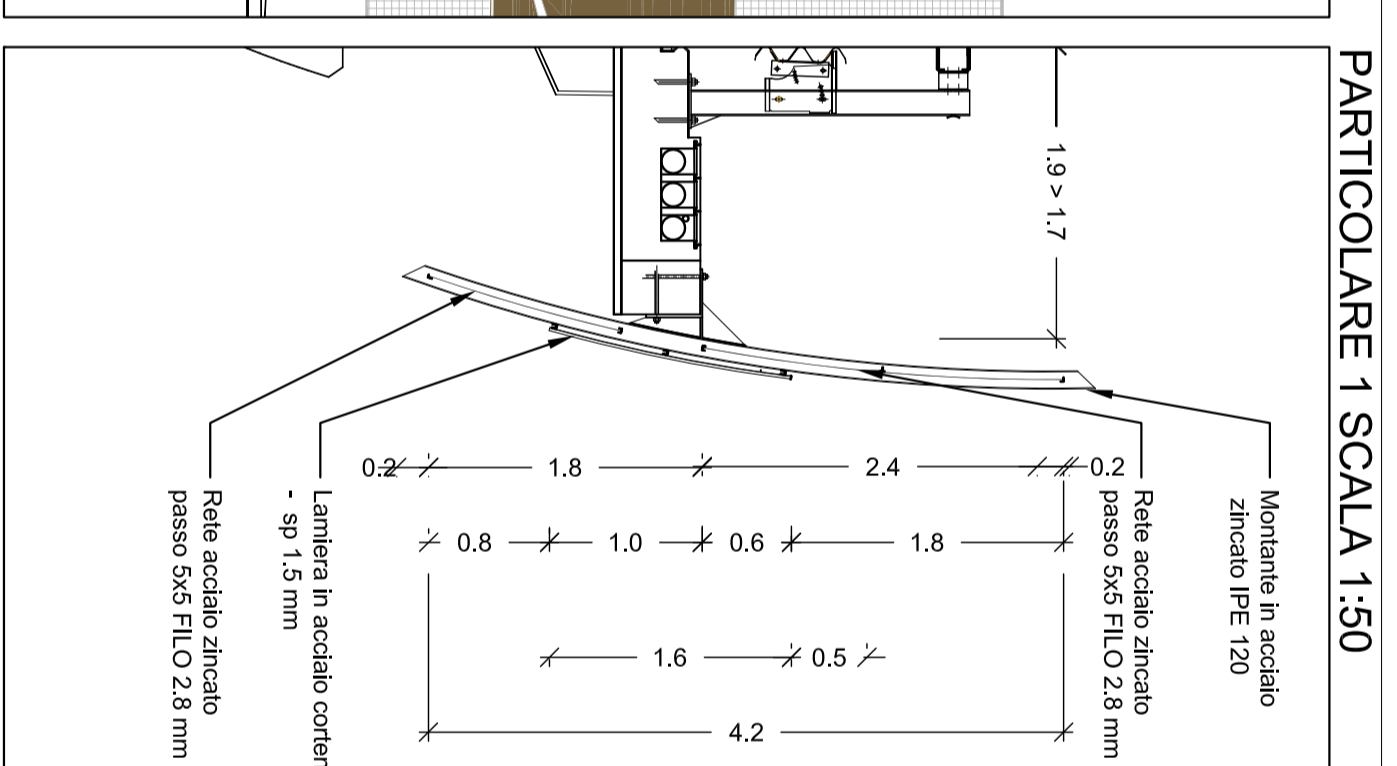

PARTICOLARE 1 SCALA 1:50

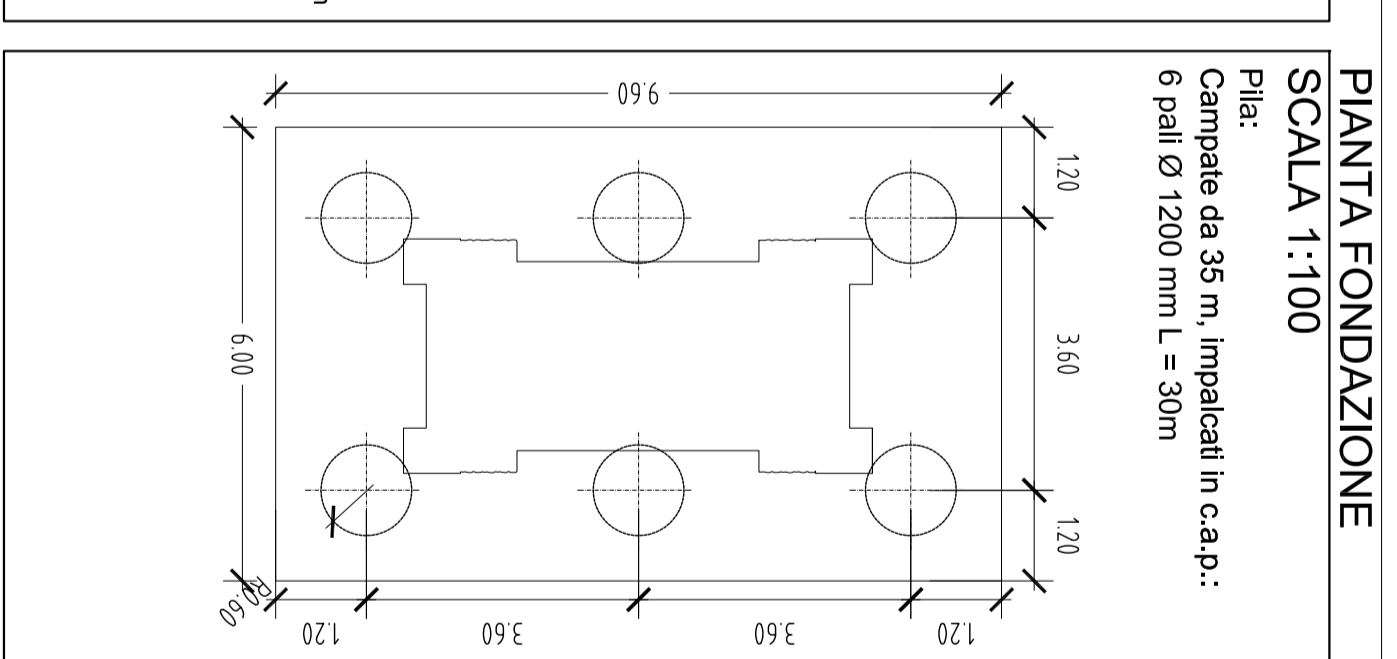

PIANTA FONDAZIONE SCALA 1:100

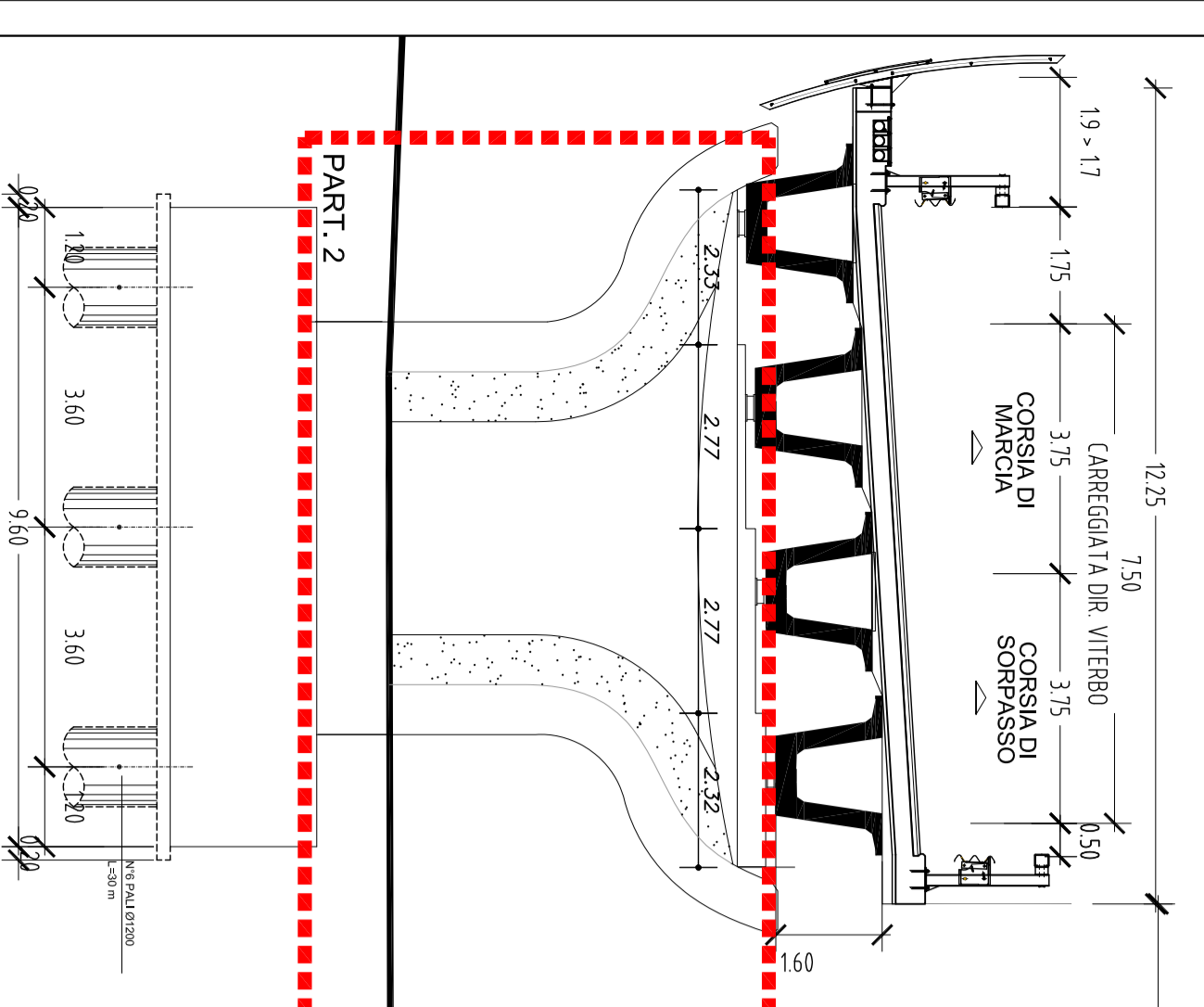

PART. 2

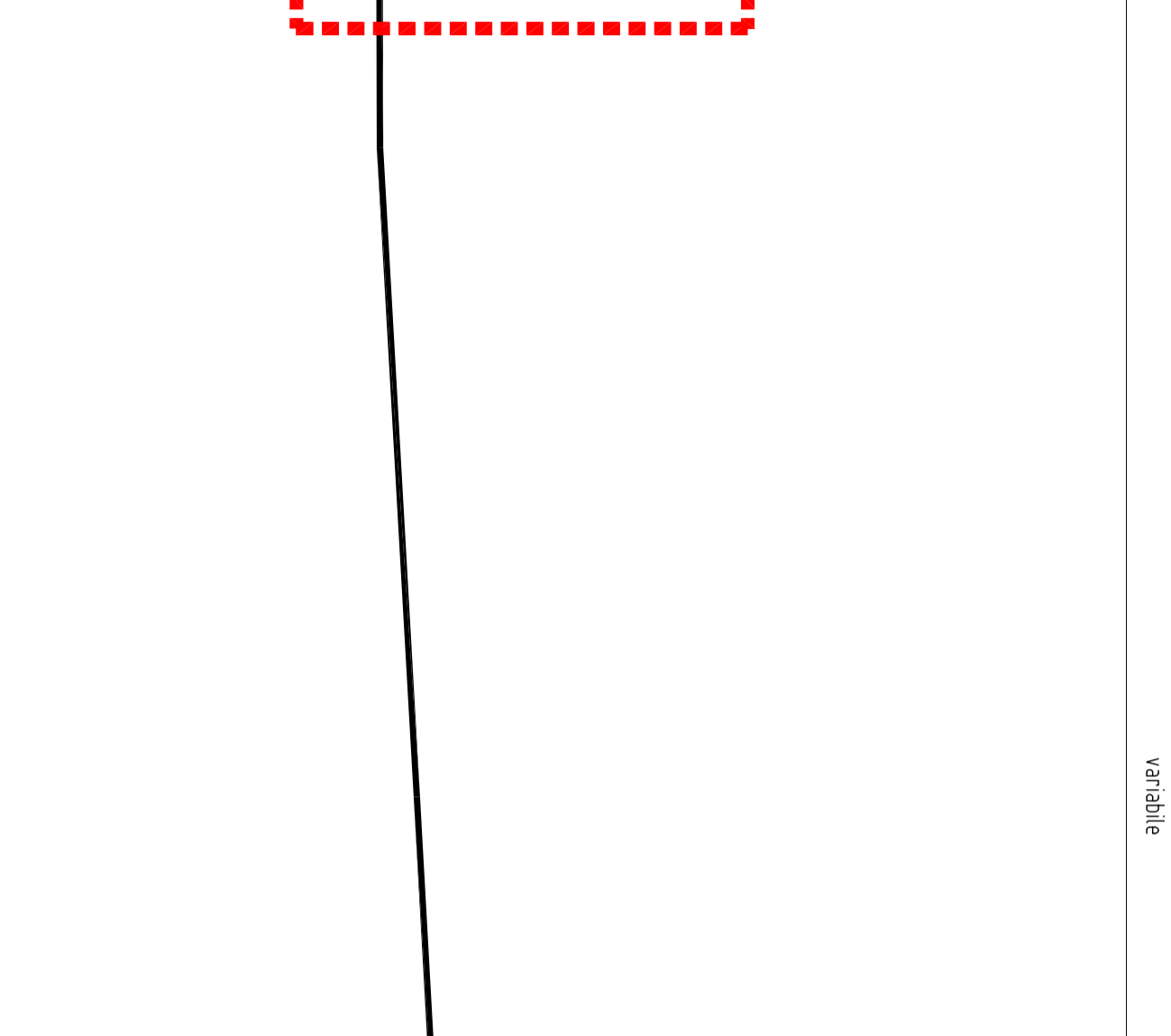

SEZIONE A-A SCALA 1:100

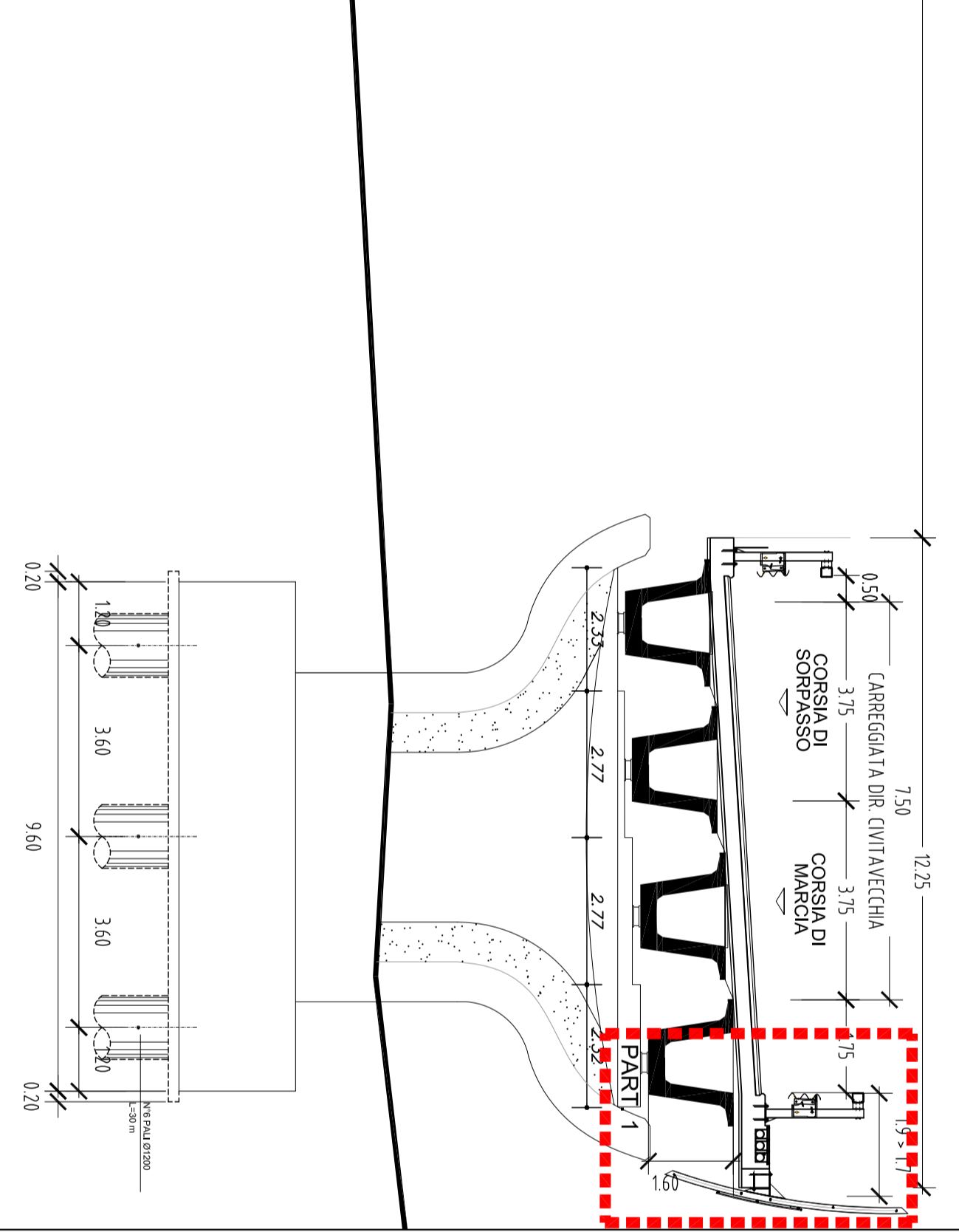

SEZIONE B-B SCALA 1:100

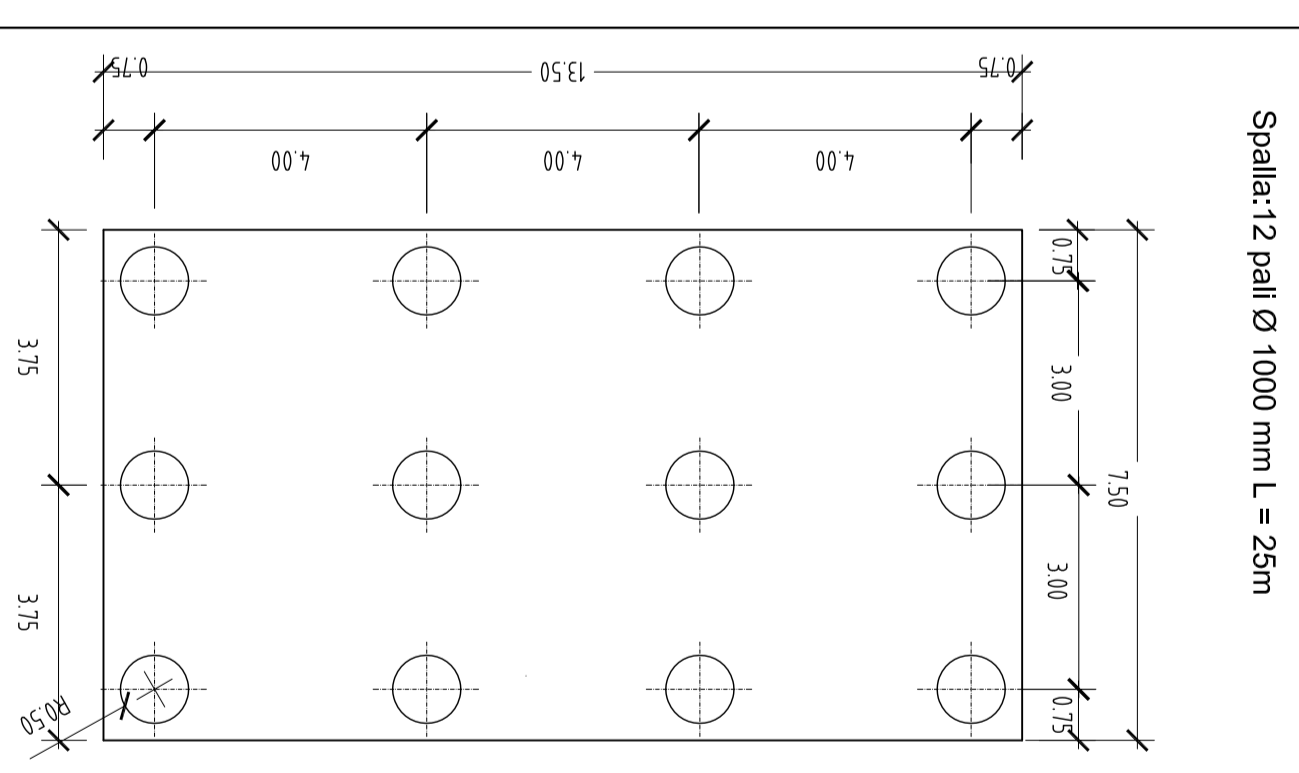

PIANTA FONDAZIONE SCALA 1:100

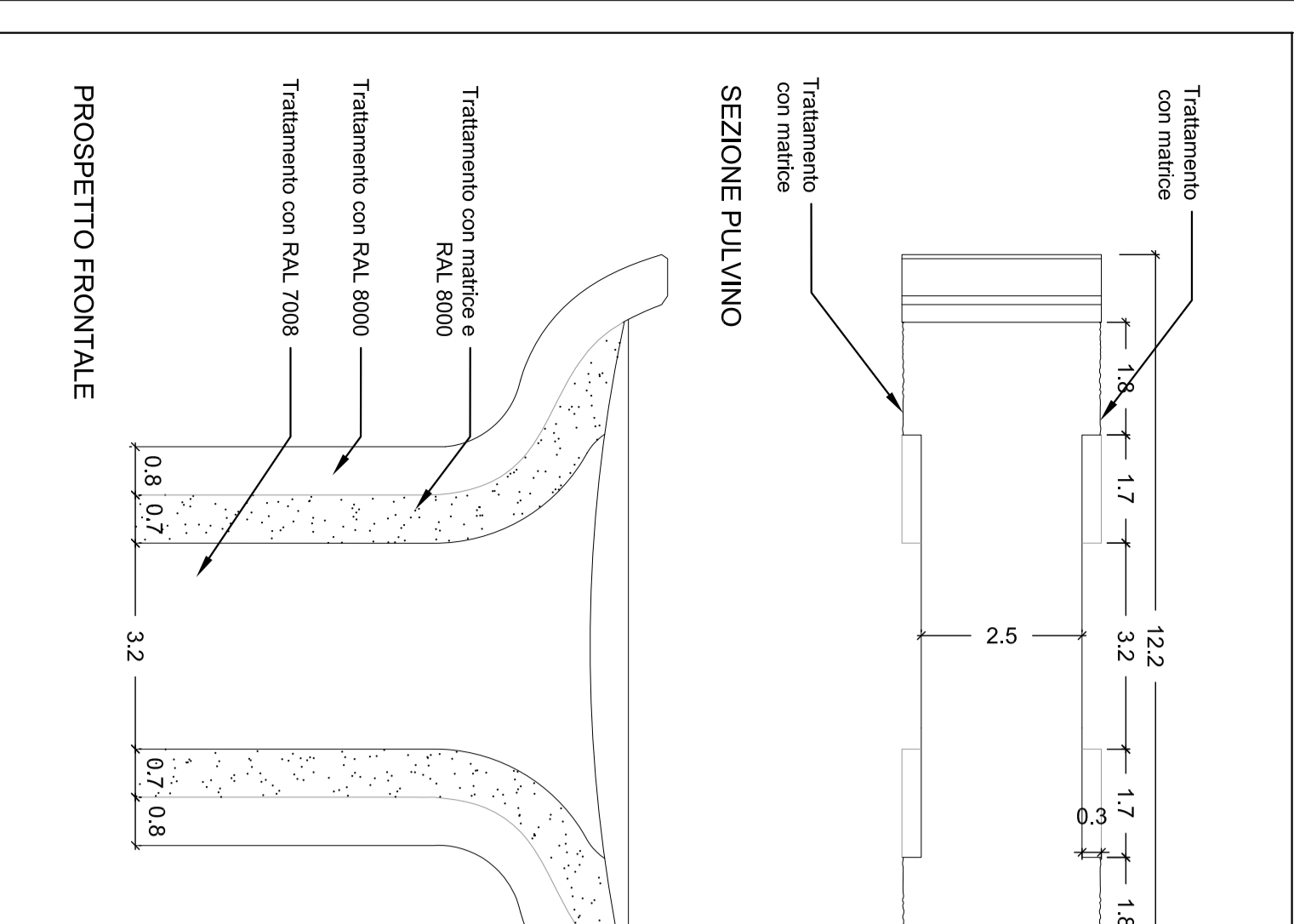

PROSPETTO FRONTALE

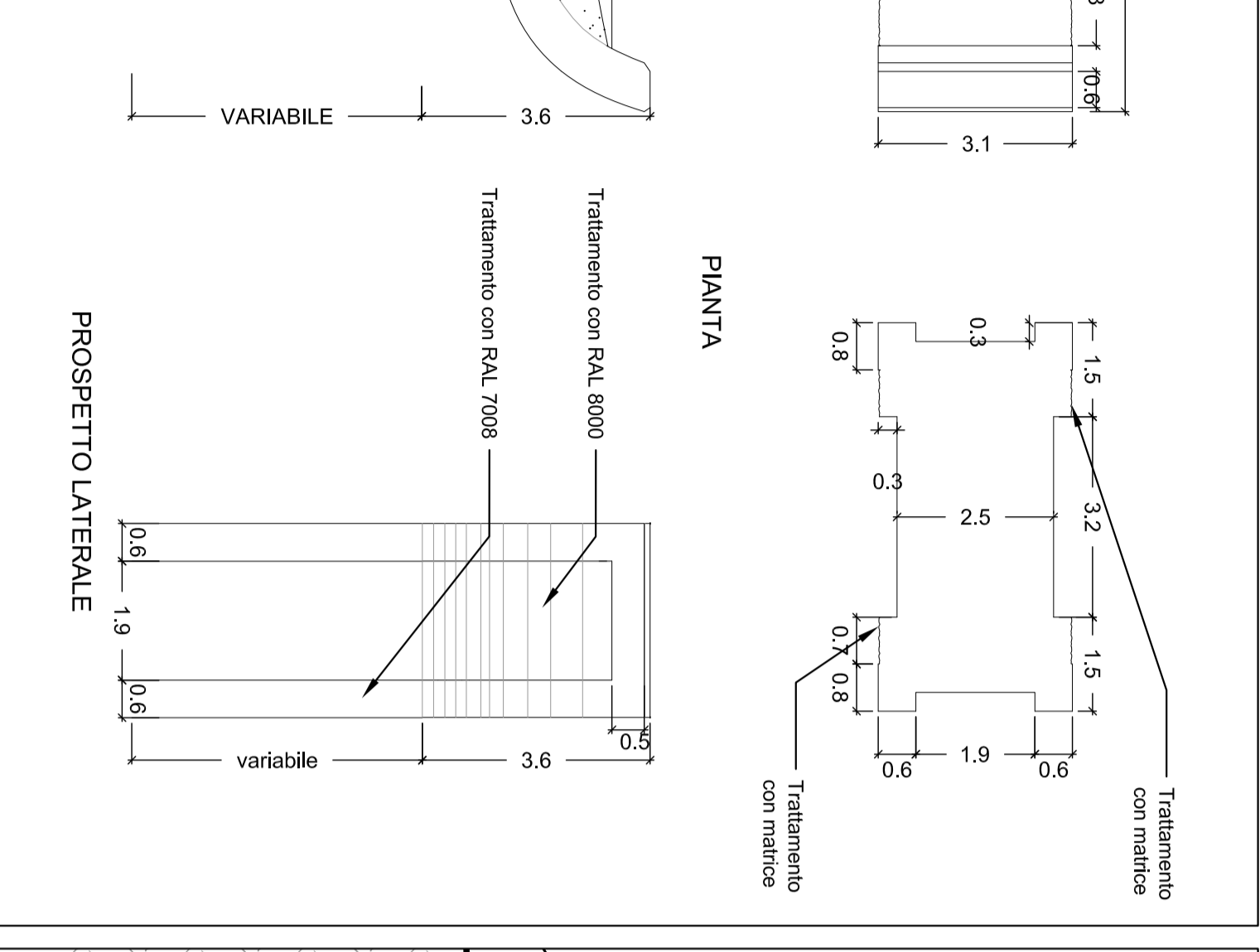

PIANTA

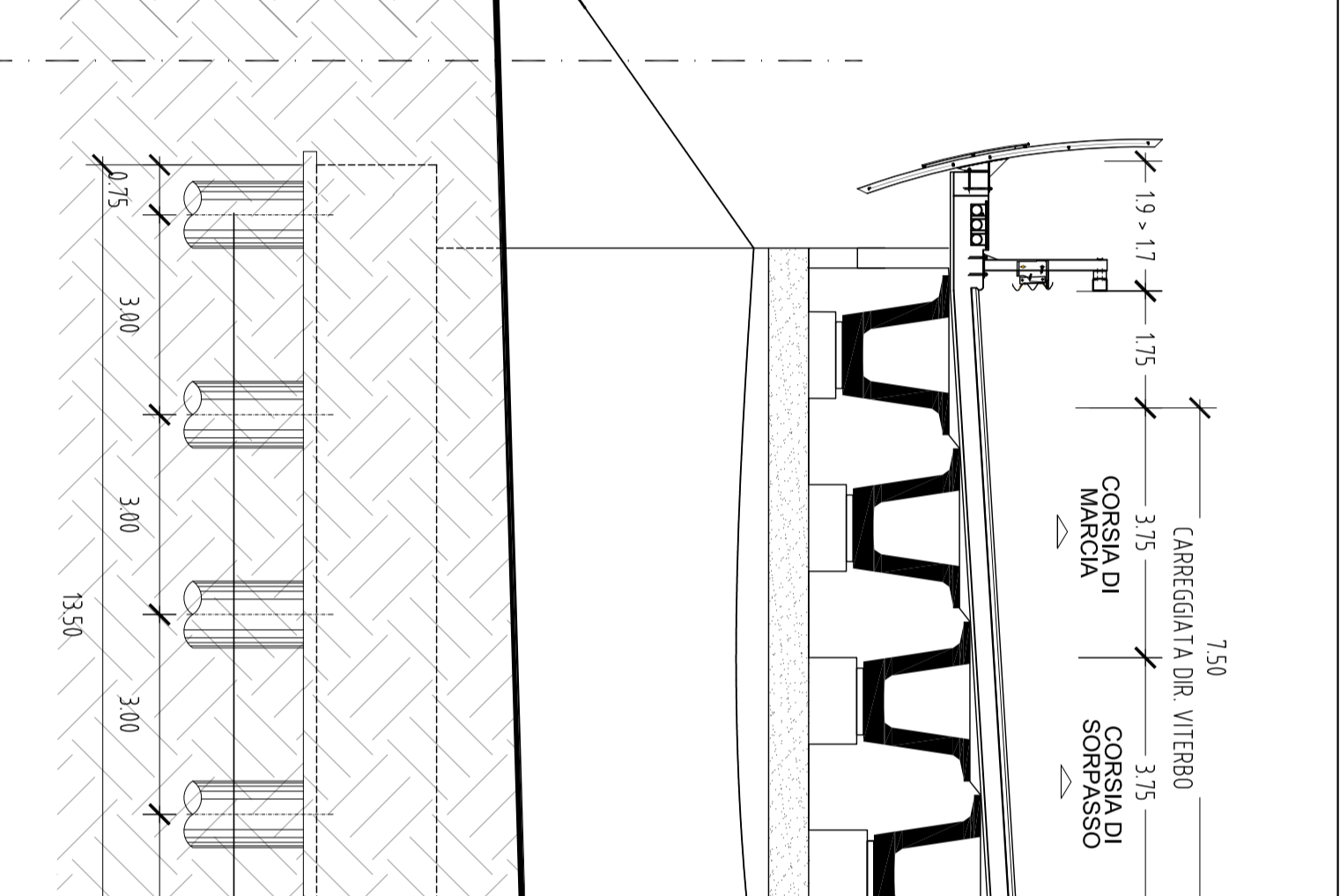

PROSPETTO LATERALE

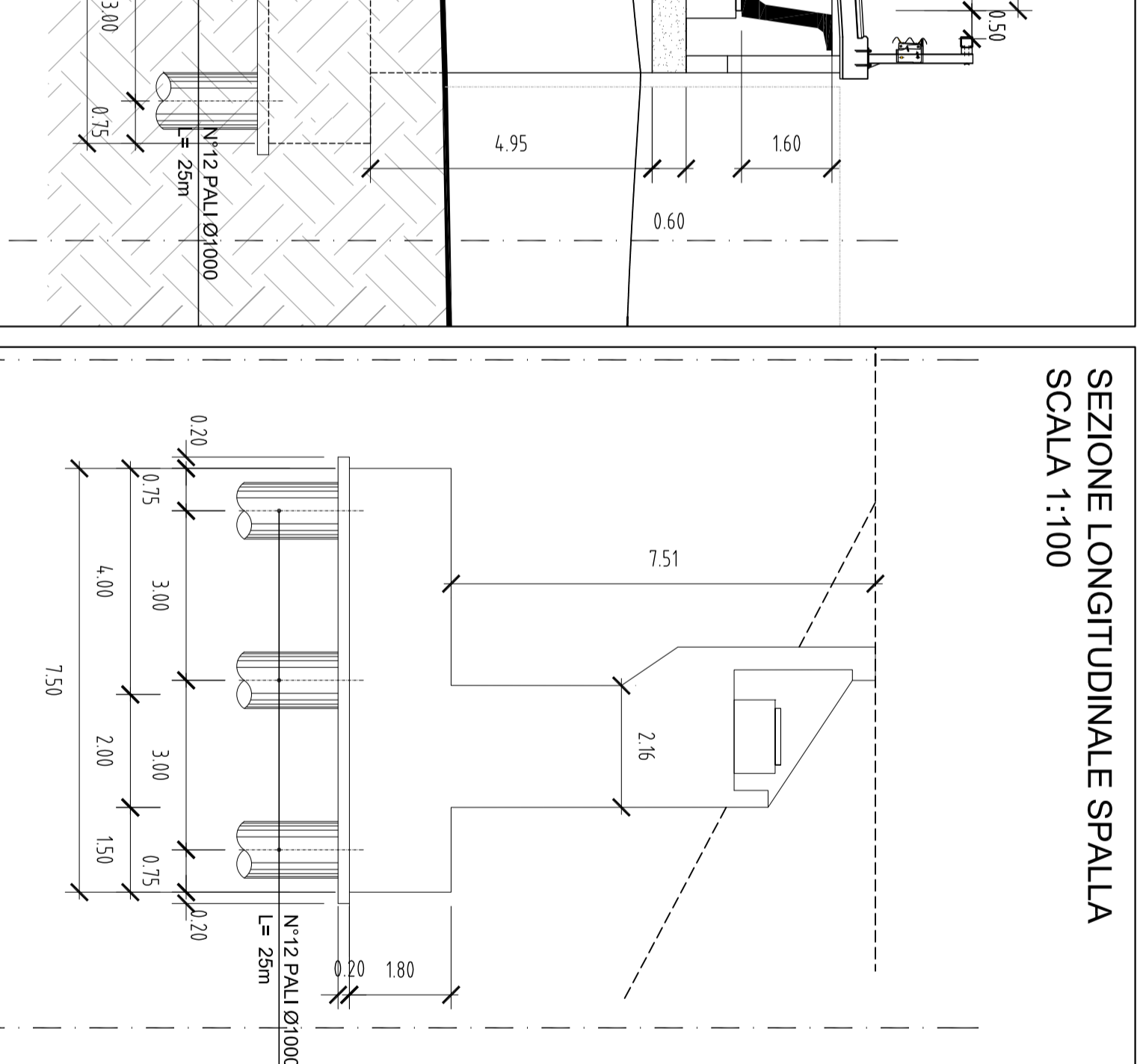

SEZIONE LONGITUDINALE SPALLA SCALA 1:100

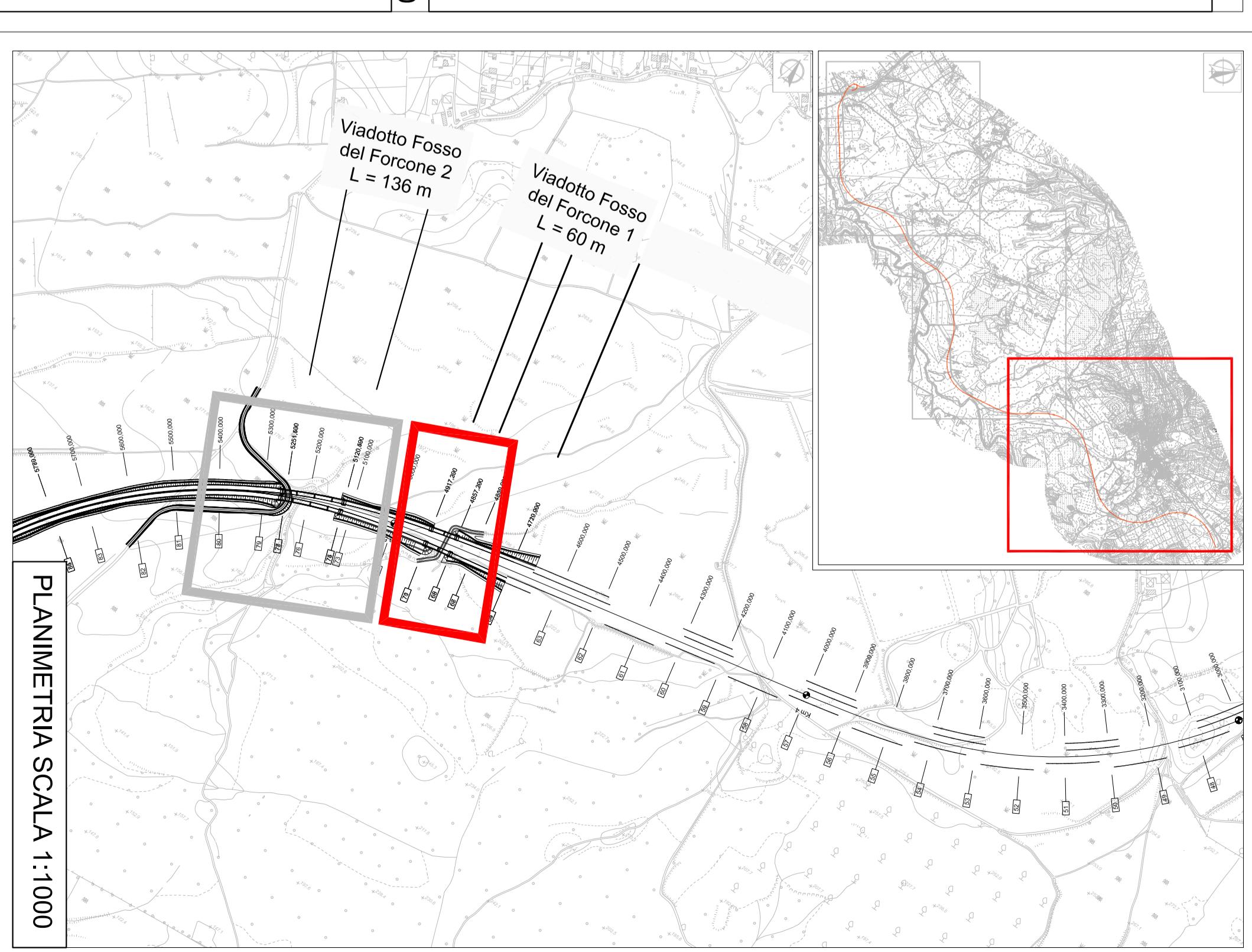

PLANIMETRIA SCALA 1:1000

TRATTA: MONTE ROMANO EST - CIVITAVECCHIA
PROGETTO PRELIMINARE
ANAS - DIREZIONE CENTRALE PROGETTAZIONE

PROGETTISTA: Ing. Maurizio Marchetti, Geol. Ing. di Roma n° 195068
IL GEOLOGO: Dott. Geol. Stefano Serragelli, Ordine Geol. Lazio n. 659
IL RESPONSABILE DEL S.I.A.: Ing. A. De Leo
COORDINATORE PER LA SICUREZZA IN FASE DI PROGETTAZIONE: Arch. Roberto Roggi
IL RESP. DEL PROCEDIMENTO: Ing. Mario Coppola

GRUPPO DI PROGETTAZIONE ANAS: Ing. F. Berto, Ing. F. Bezzi, Geol. G. Carrillo, Ing. L. Cedrone, Ing. P. G. D'Ammiri, Sig.ra A. M. D'Avverso, Ing. A. De Leo, Geom. E. De Masi, Geom. M. Diomonte, Ing. P. Fabro, Ing. G. Govanetti

SERVIZIO SUPPORTO ESTERNO: Geom. R. Izzo, Ing. E. Lucatelli, Geom. D. Maggi, Ing. E. Mitiga, Ing. M. Parolitto, Dott.ssa D. Perelli, Ing. A. Petrucci, Ing. F. Pisani, Arch. R. Roggi

PROTOCOLLO: DATA: VISTO DAL DIRETTORE CENTRALE Ing. Ugo Diemartino

VIADOTTO FOSSO DEL FORCONE 1
 Pianta - Prospetto - Sezione - Particolari

REV.	DESCRIZIONE	DATA	TECNICO/REVISIONE	MANCANTI	COMP.
A	EMMISSIONE				
B	REVISIONE				
C	REVISIONE				

CODICE PROGETTO: L4402D, L4402P, L4402R, L4402S, L4402T, L4402U, L4402V, L4402W, L4402X, L4402Y, L4402Z

PROGETTO: L4402D, L4402P, L4402R, L4402S, L4402T, L4402U, L4402V, L4402W, L4402X, L4402Y, L4402Z

REVISIONI: L4402D, L4402P, L4402R, L4402S, L4402T, L4402U, L4402V, L4402W, L4402X, L4402Y, L4402Z

REVISIONI: L4402D, L4402P, L4402R, L4402S, L4402T, L4402U, L4402V, L4402W, L4402X, L4402Y, L4402Z

REVISIONI: L4402D, L4402P, L4402R, L4402S, L4402T, L4402U, L4402V, L4402W, L4402X, L4402Y, L4402Z

REVISIONI: L4402D, L4402P, L4402R, L4402S, L4402T, L4402U, L4402V, L4402W, L4402X, L4402Y, L4402Z