

SEZIONE 1-1

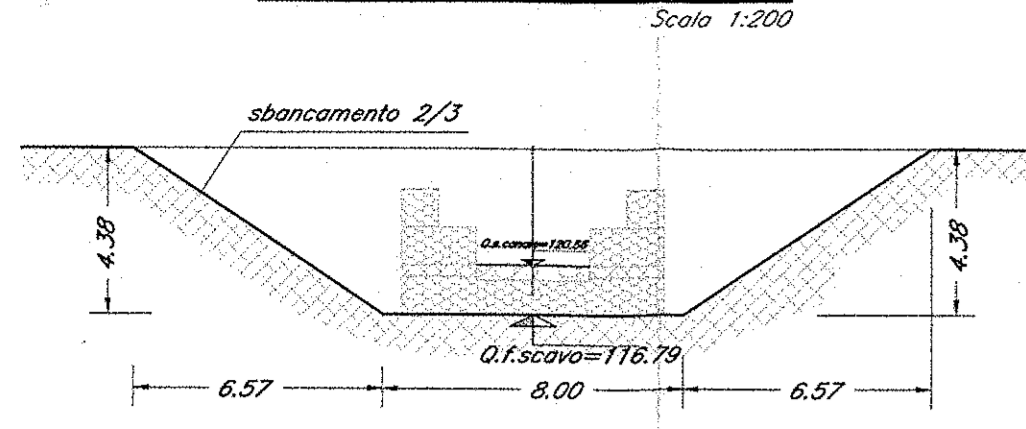

SEZIONE 2-2

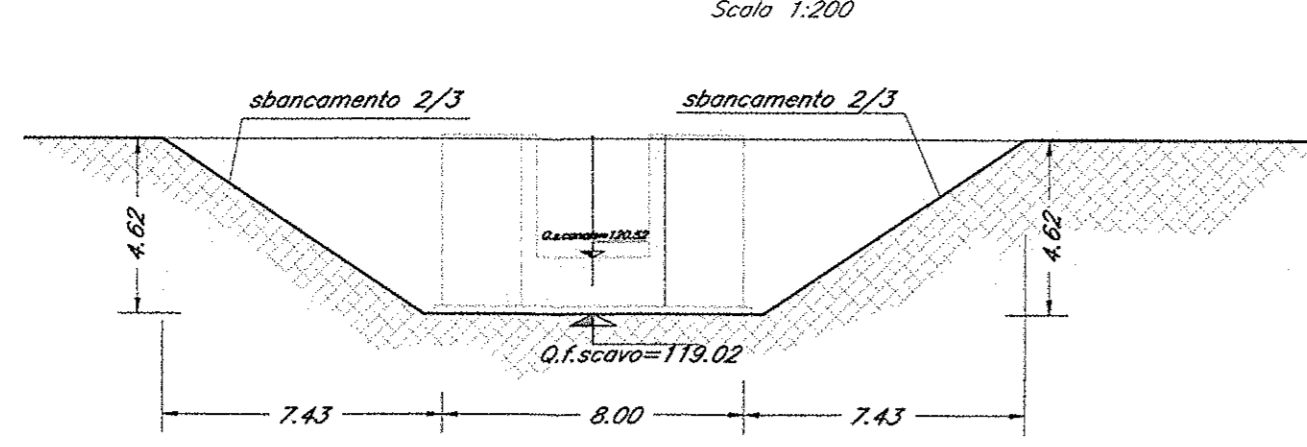

SEZIONE 3-3

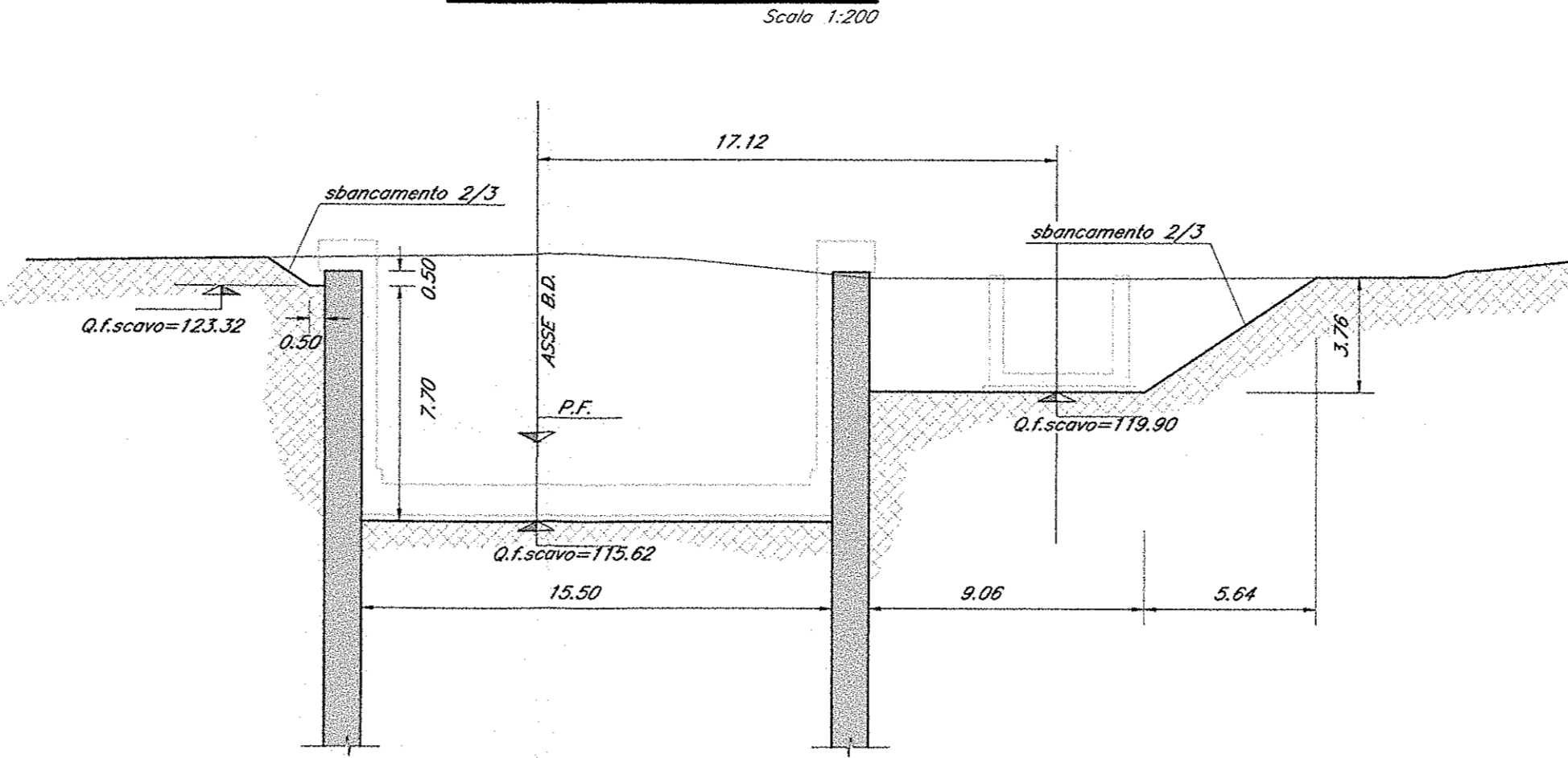

SEZIONE 4-4

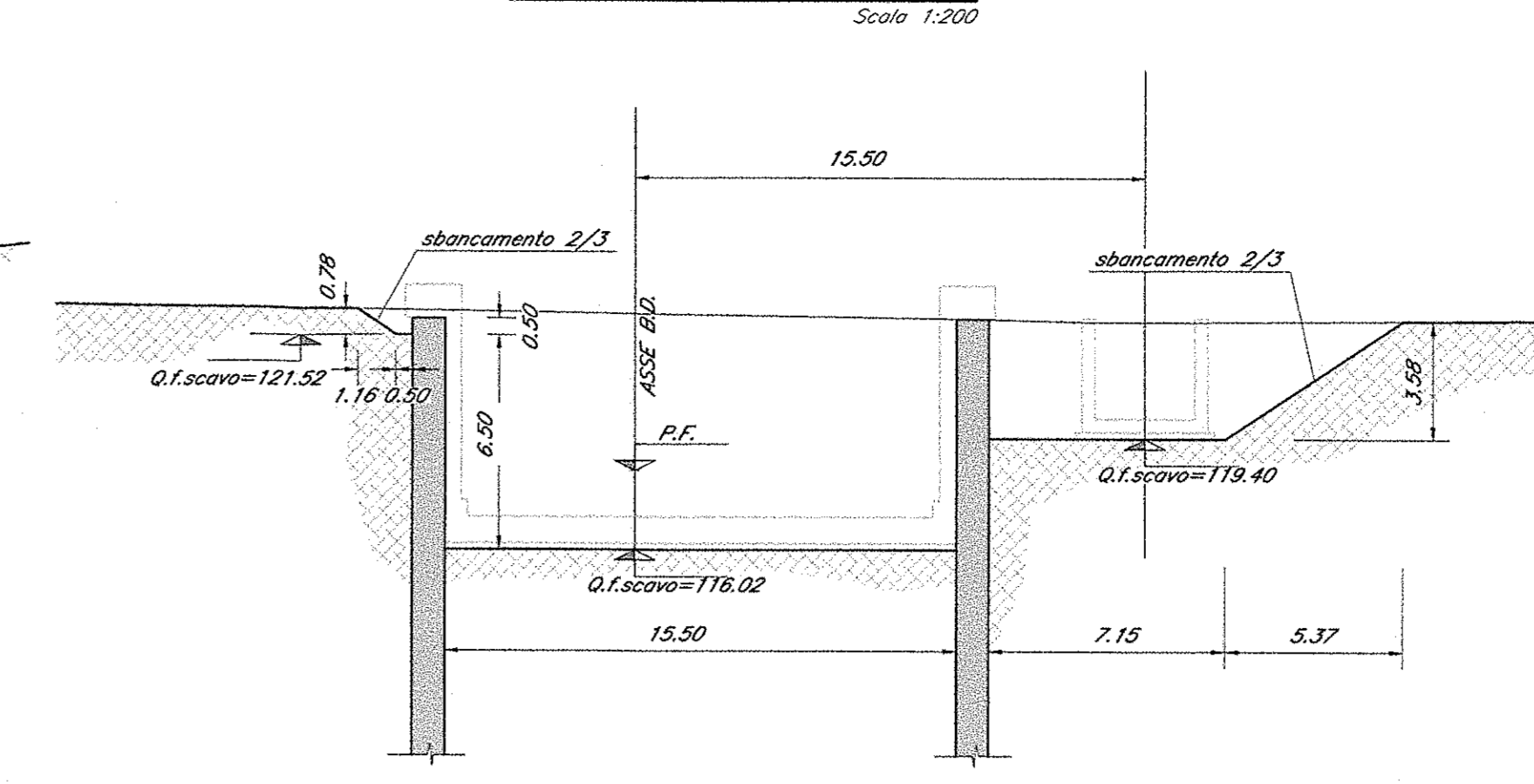

SEZIONE 5-5

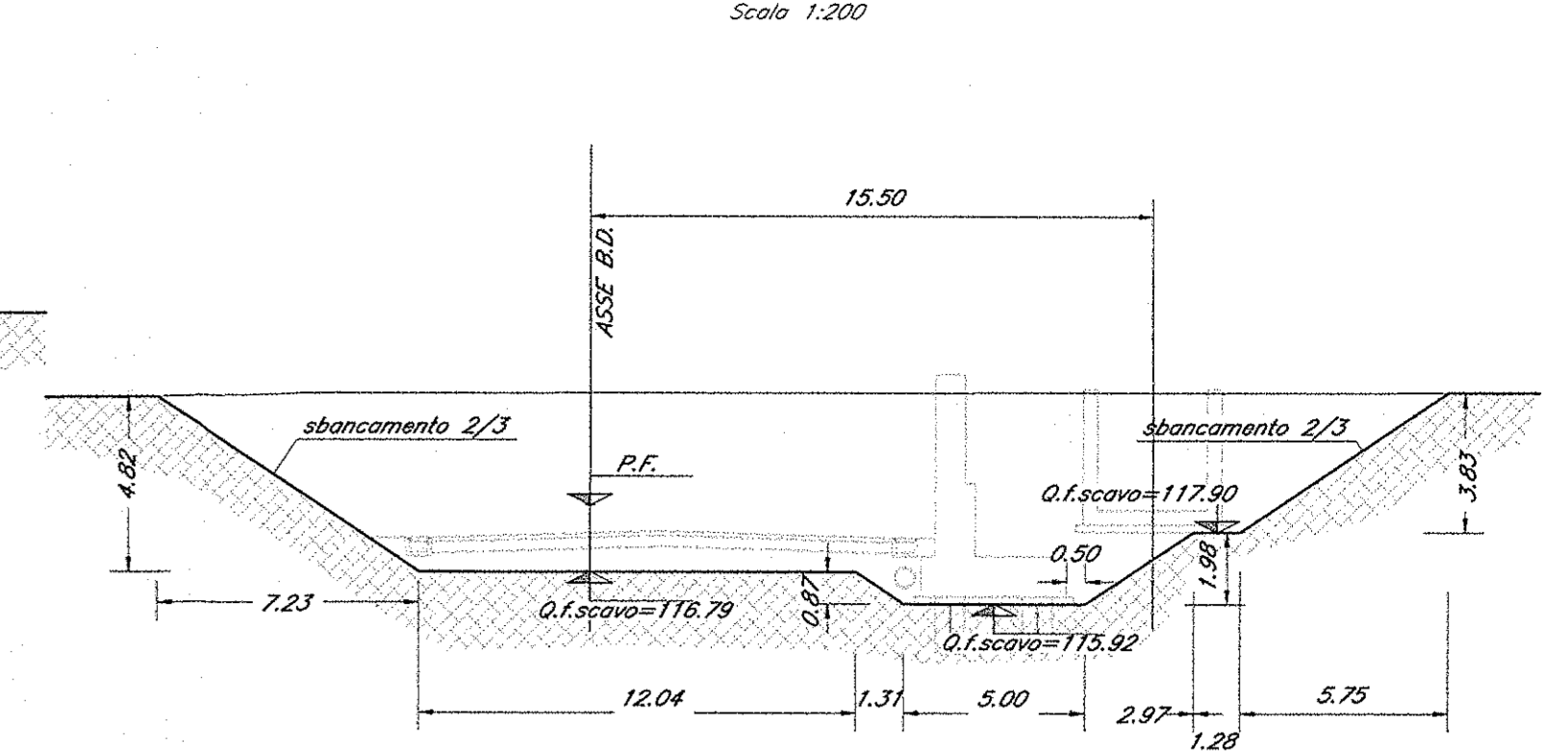

SEZIONE 6-6

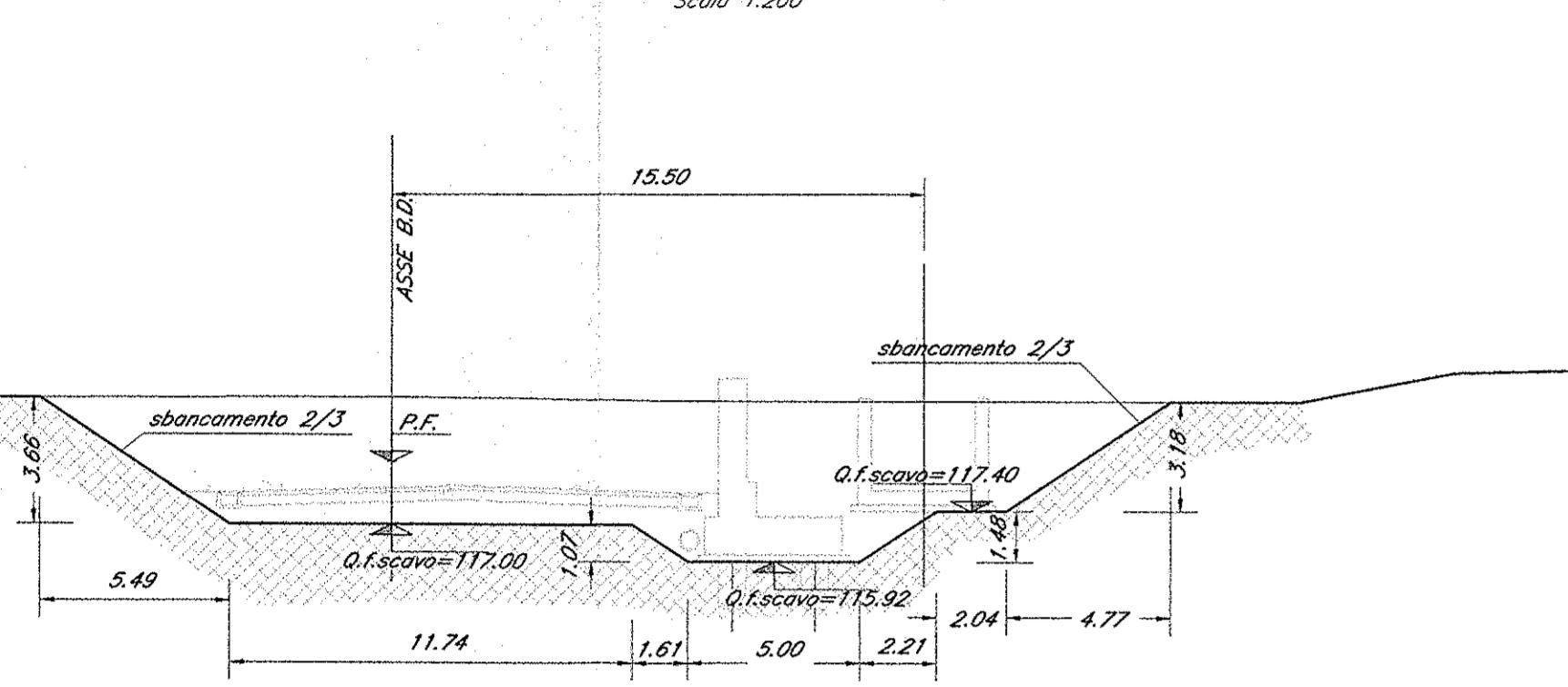

SEZIONE 7-7

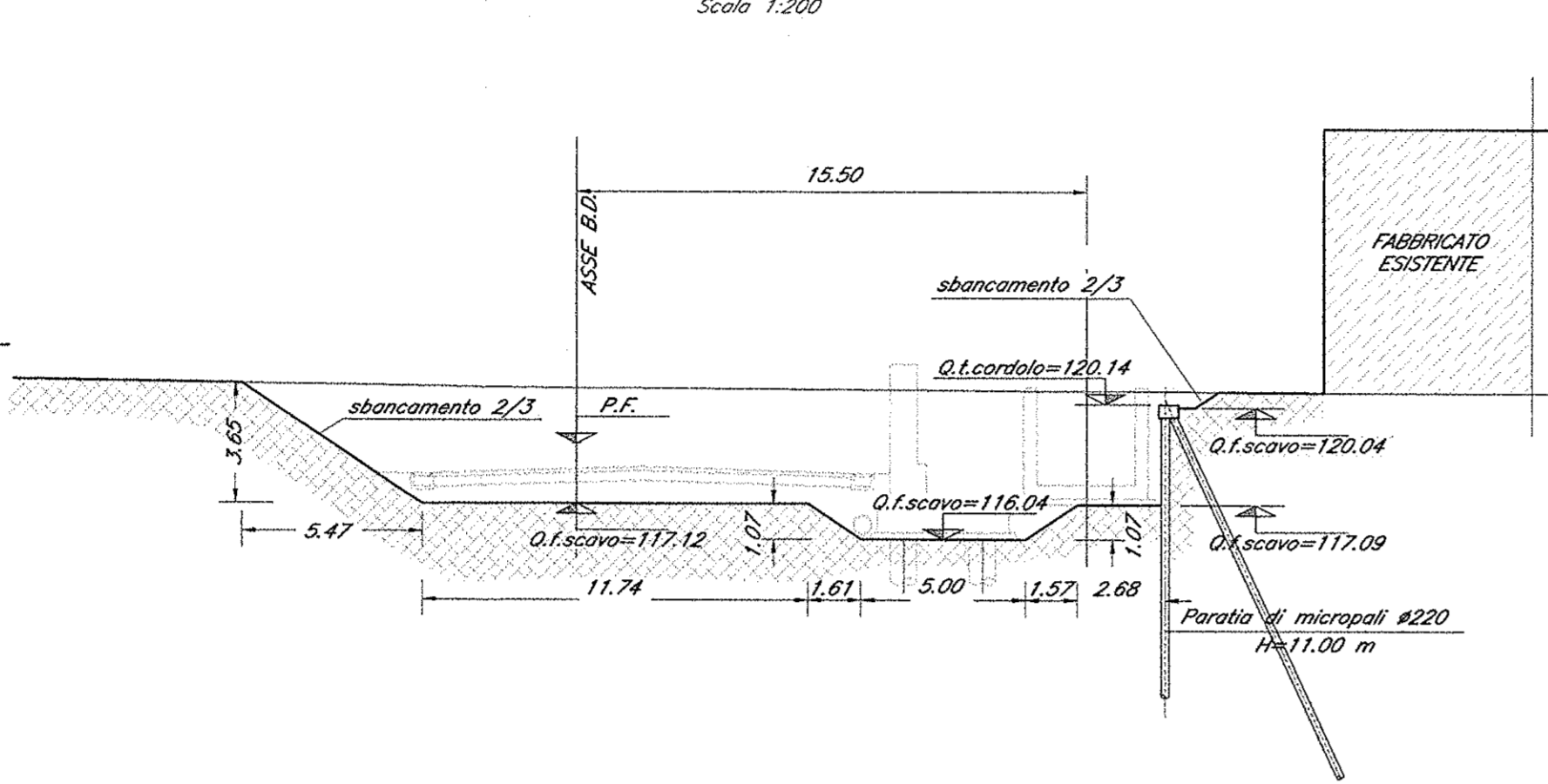

SEZIONE 8-8

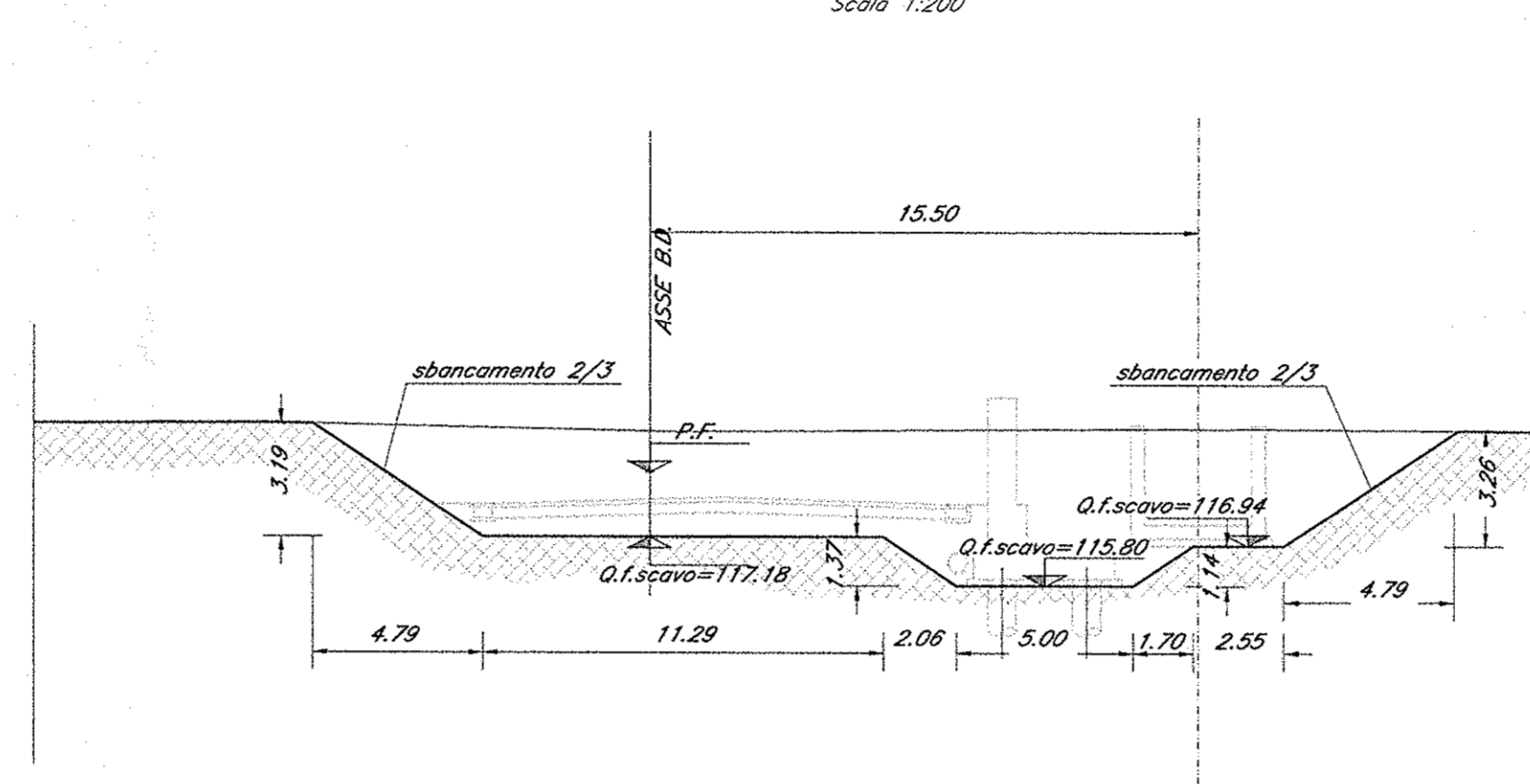

SEZIONE 9-9

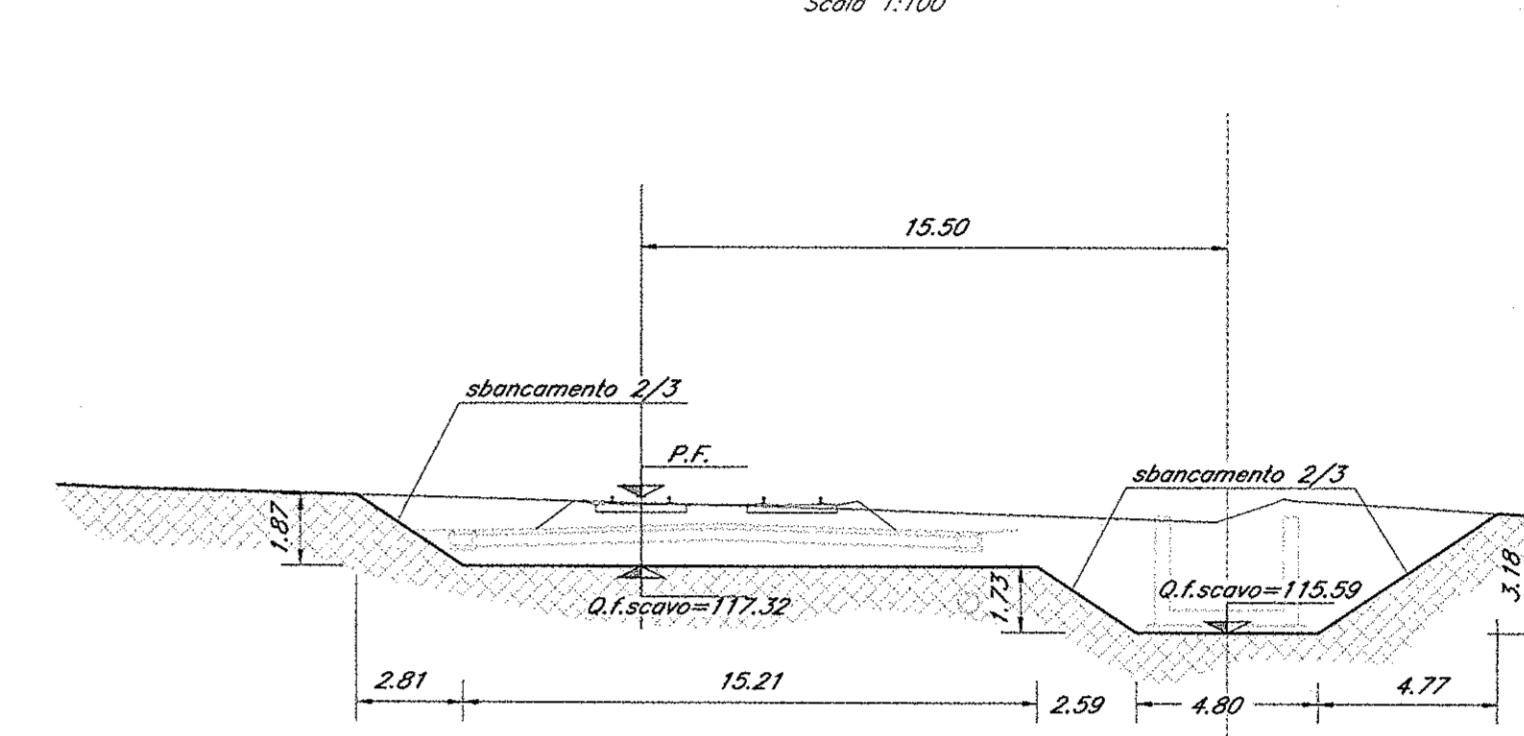

SEZIONE 1-1

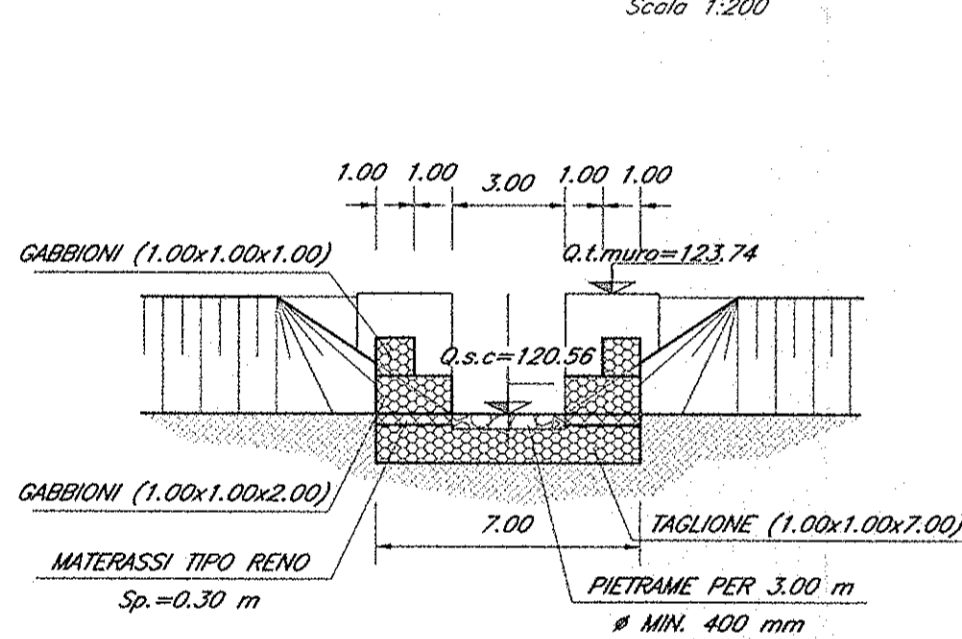

SEZIONE 2-2

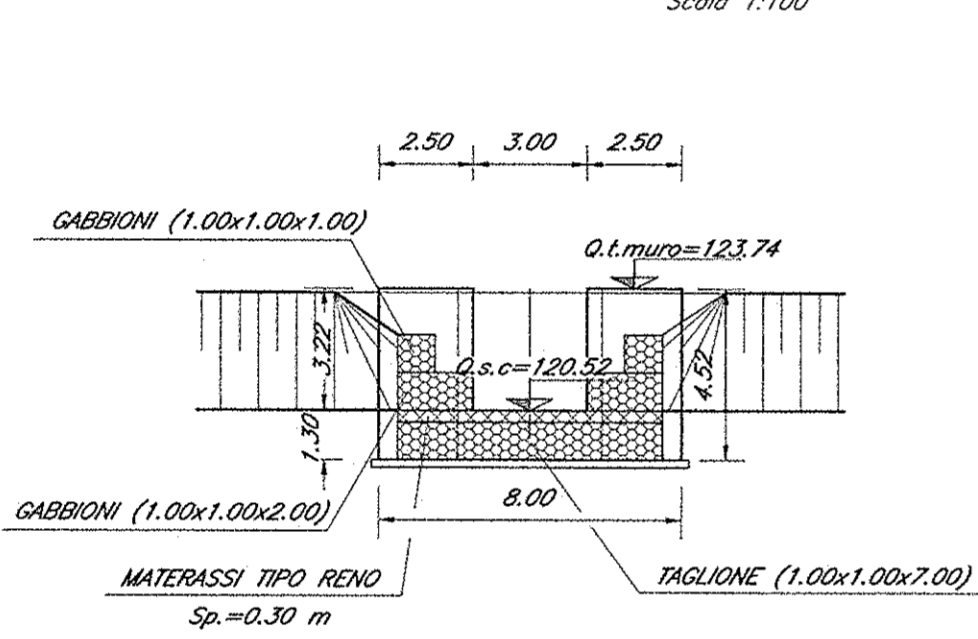

SEZIONE 3-3

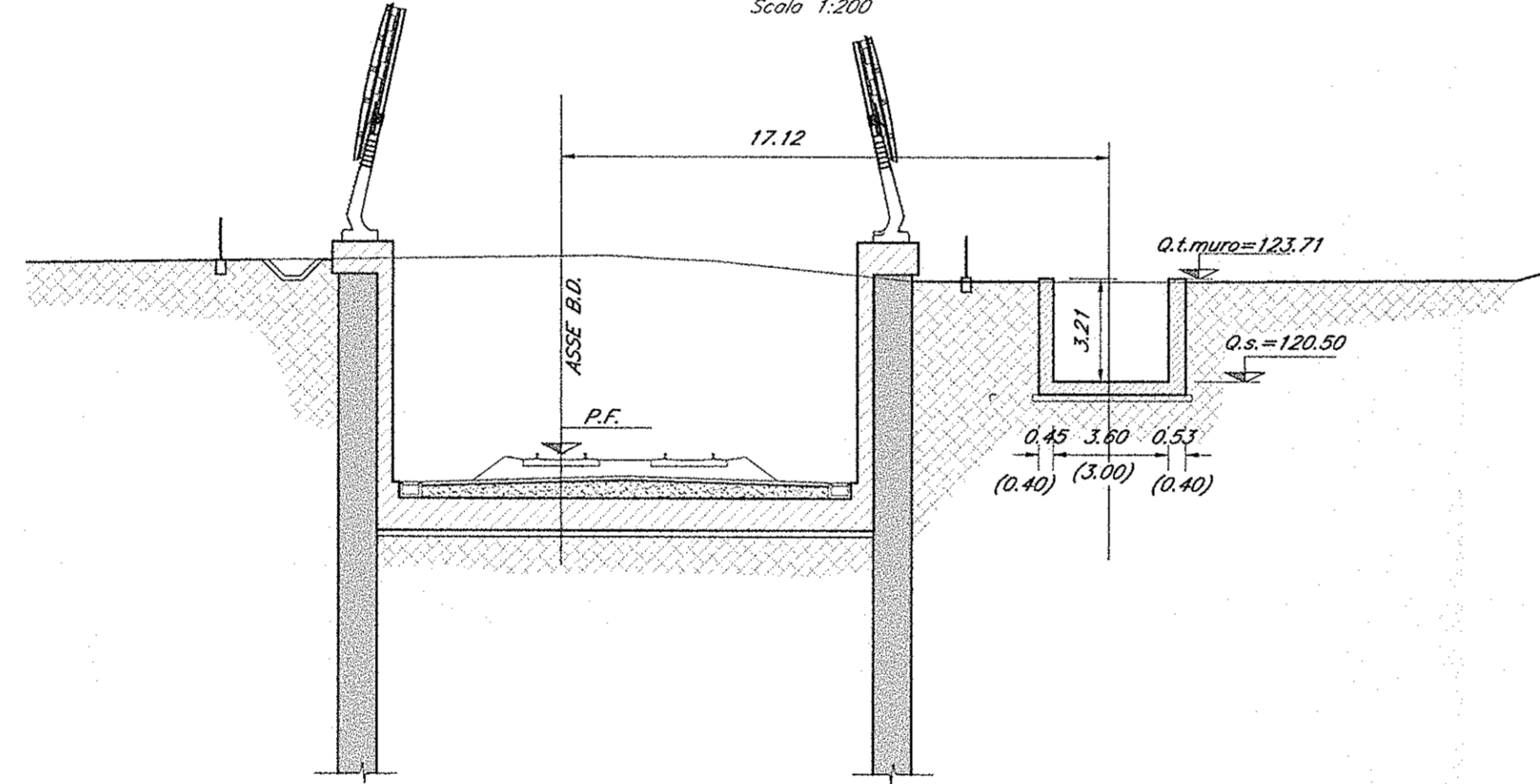

SEZIONE 4-4

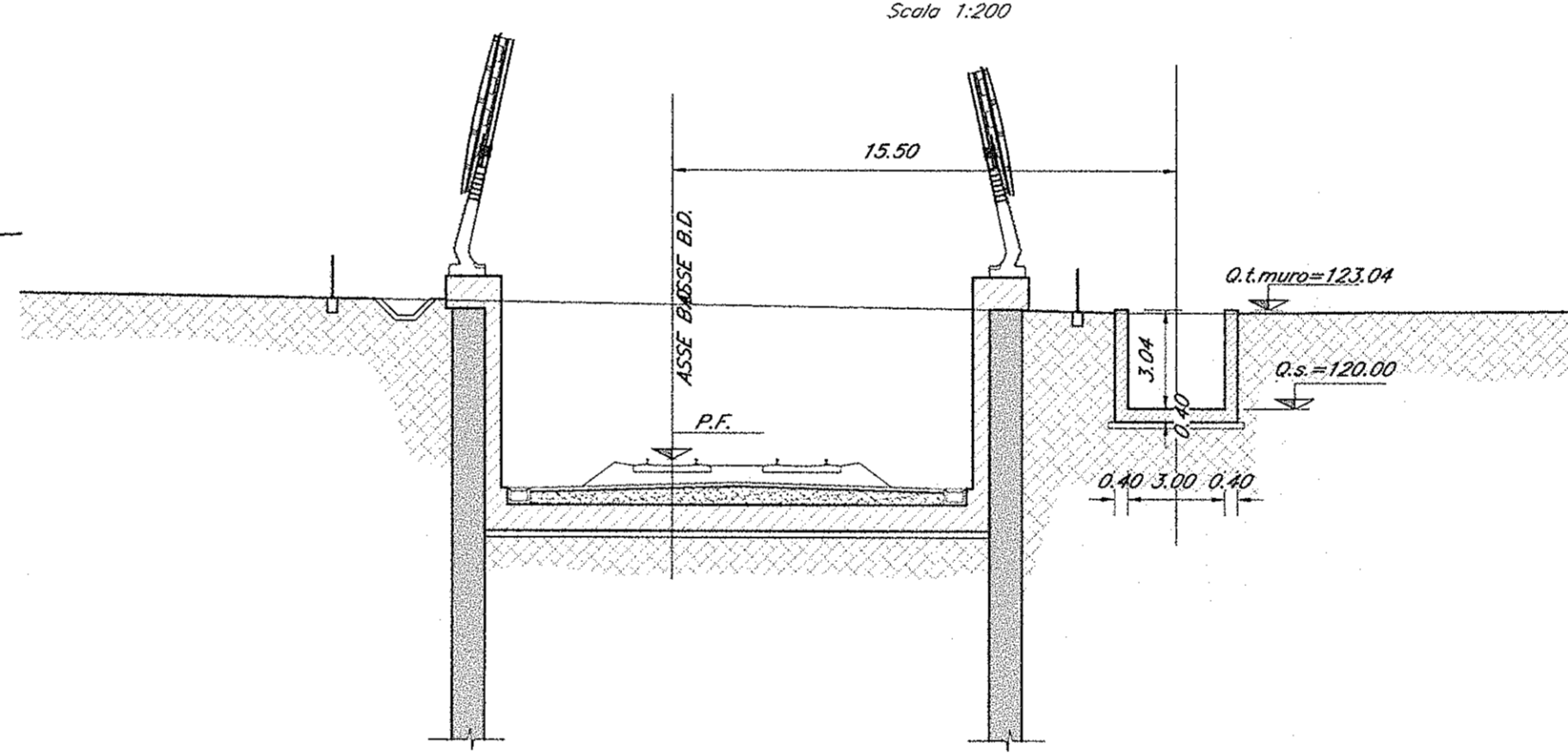

SEZIONE 5-5

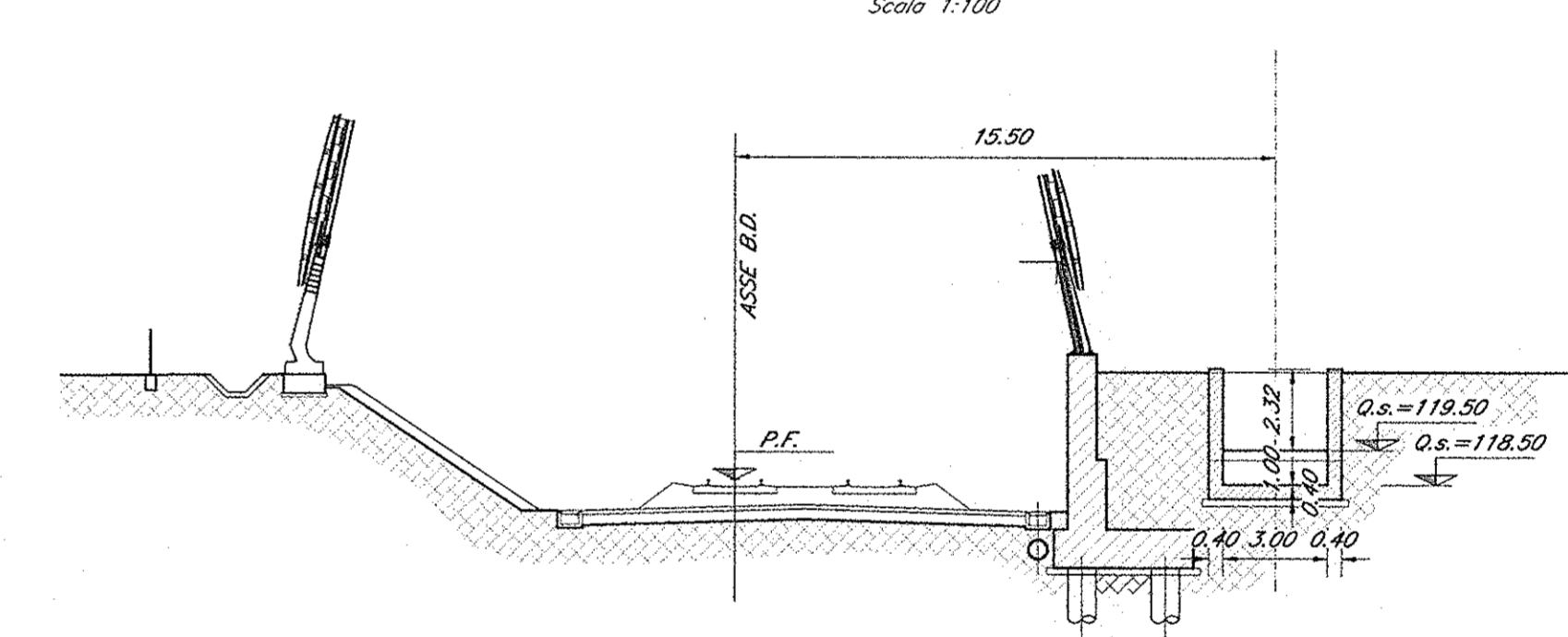

SEZIONE 10: Prog. 7+281.00

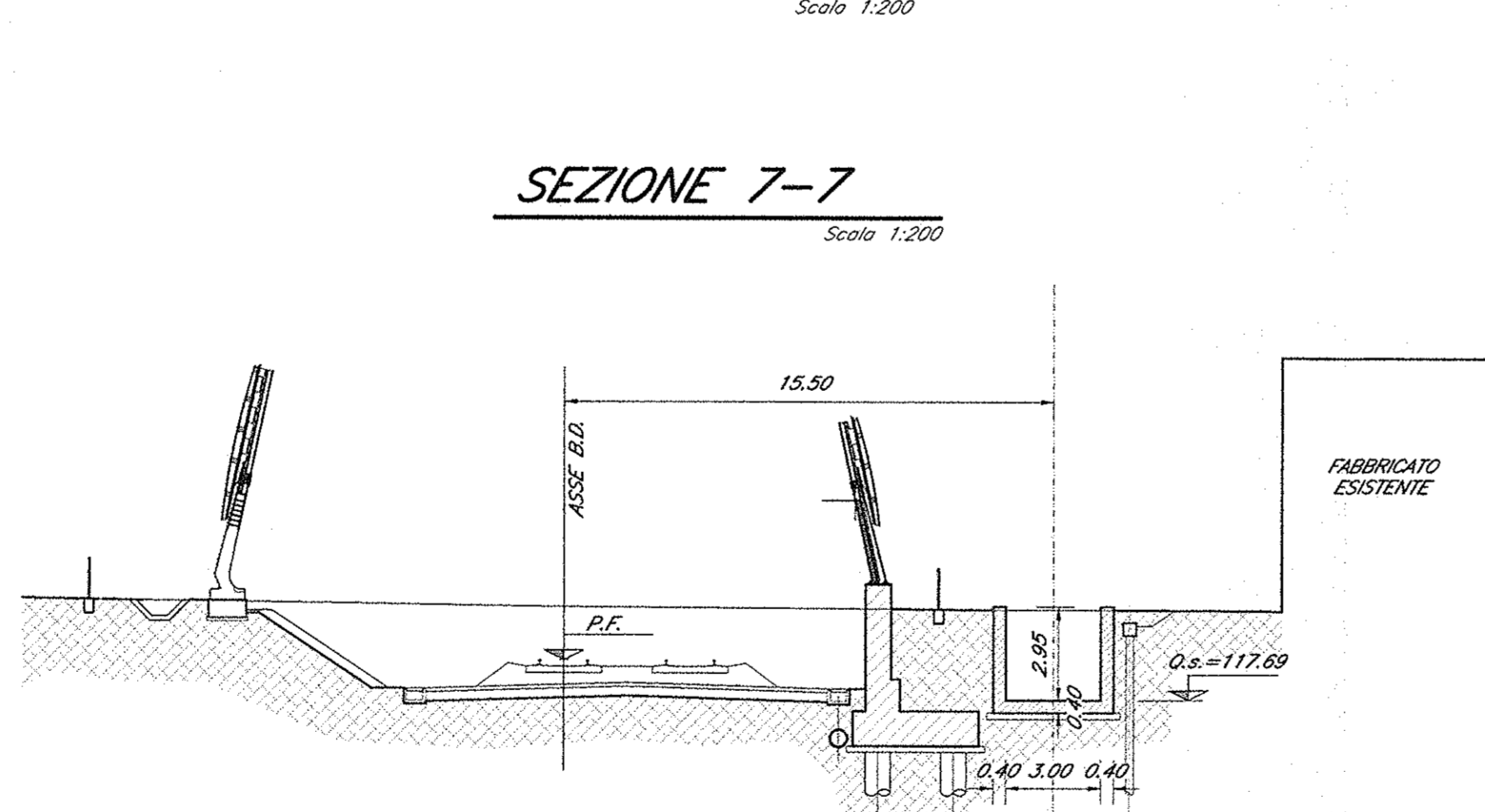

SEZIONE 11: Prog. 7+296.00

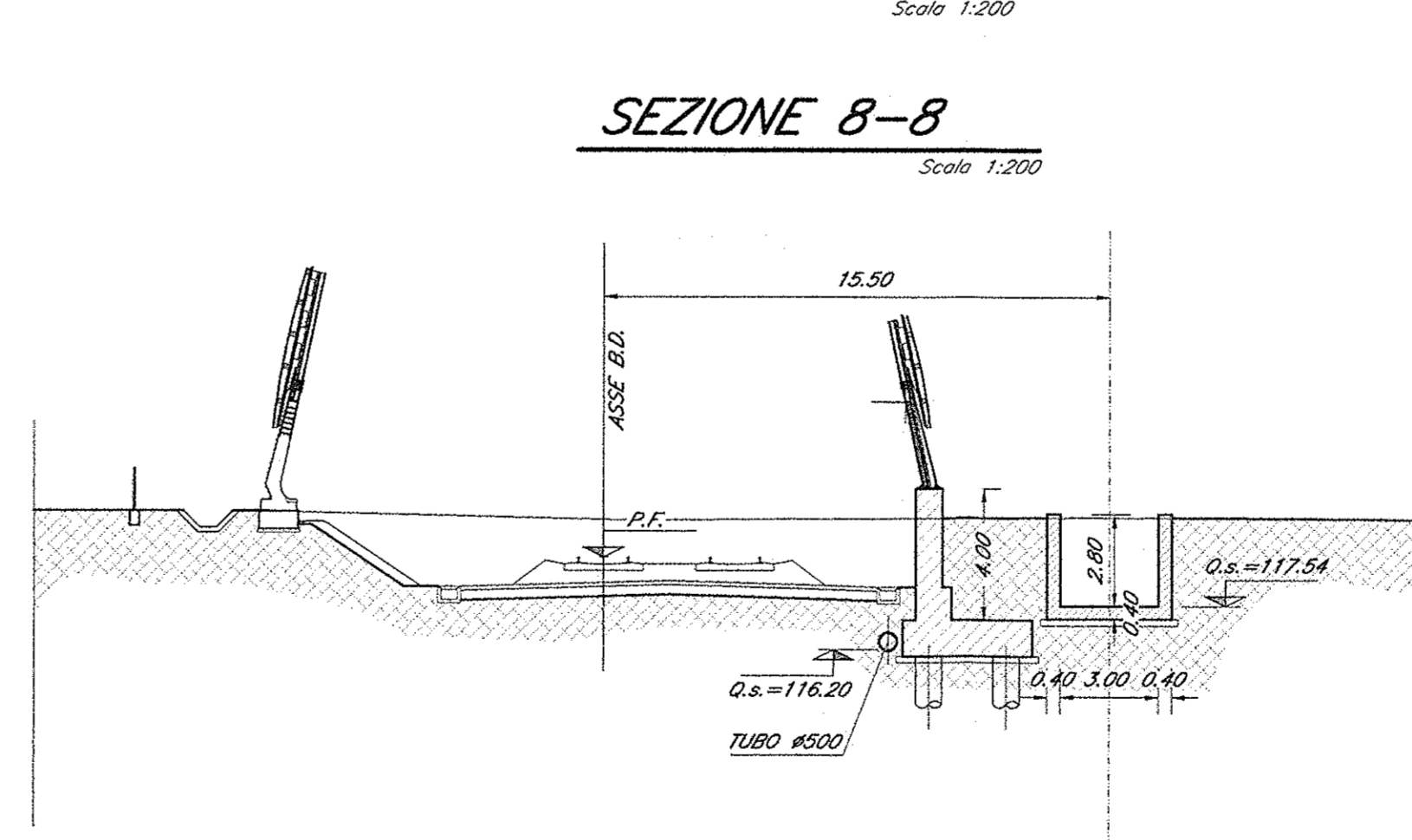

SEZIONE 6-6

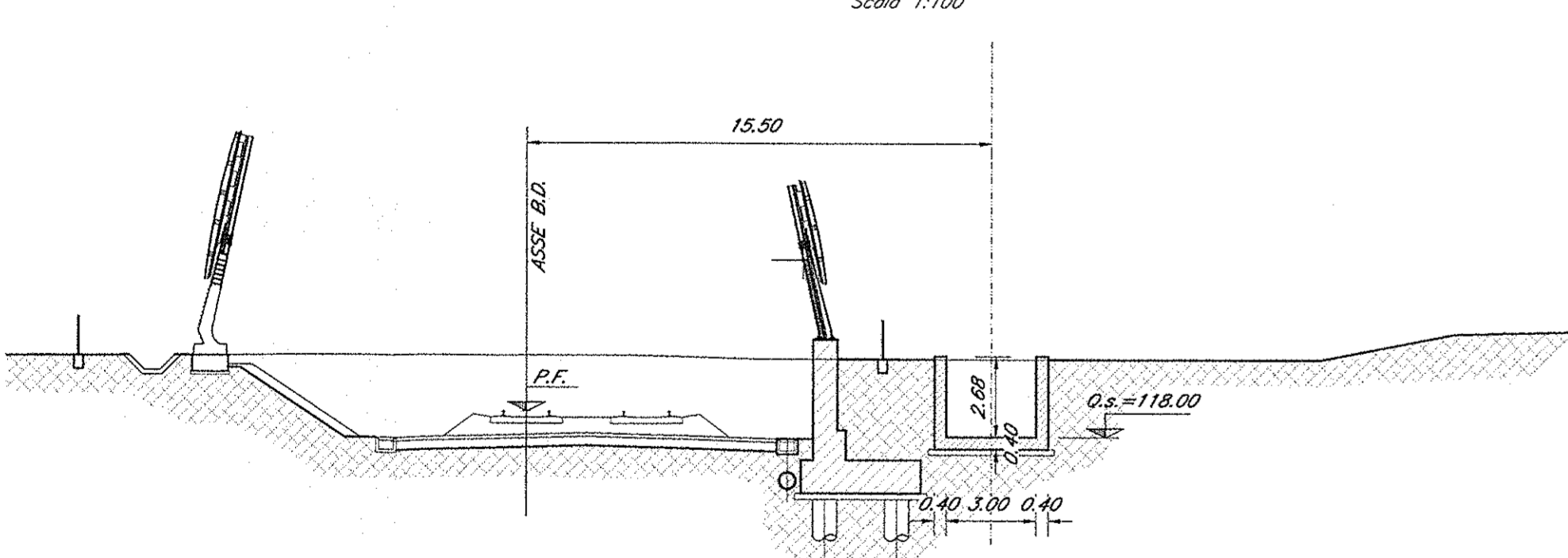

SEZIONE 7-7

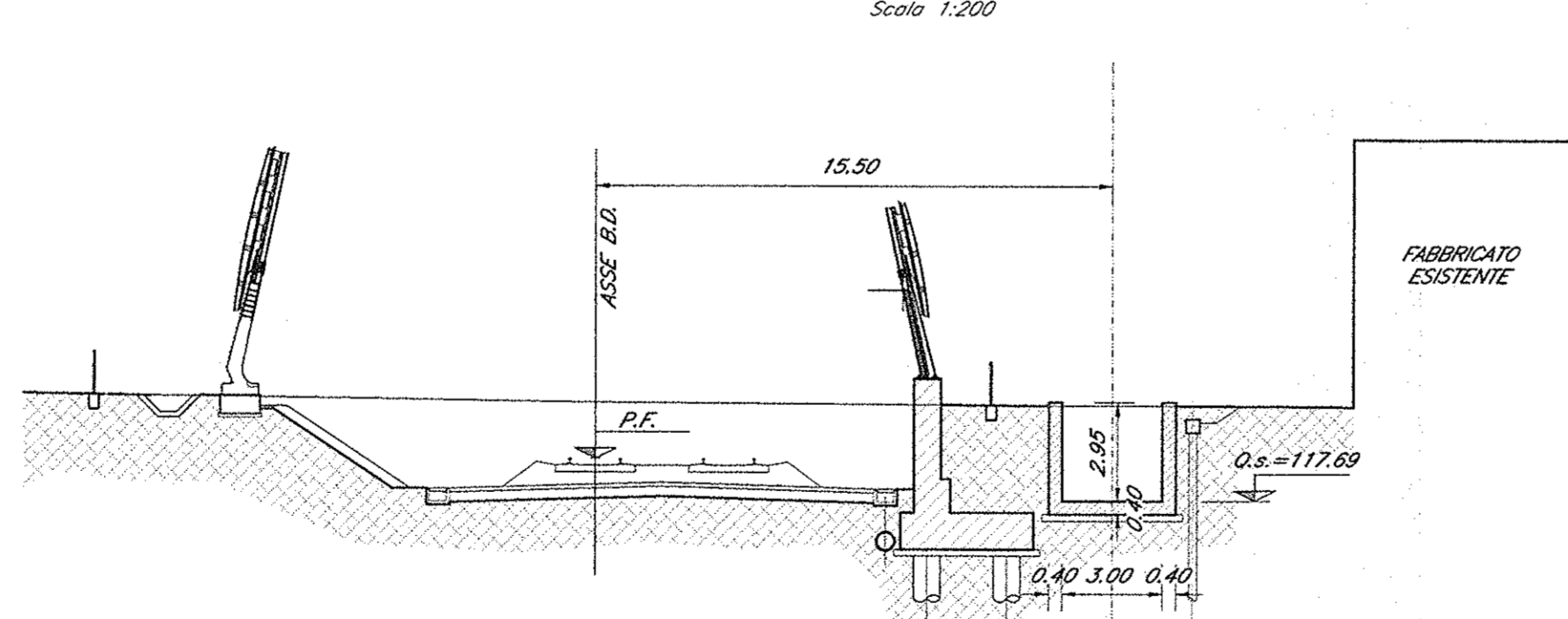

SEZIONE 8-8

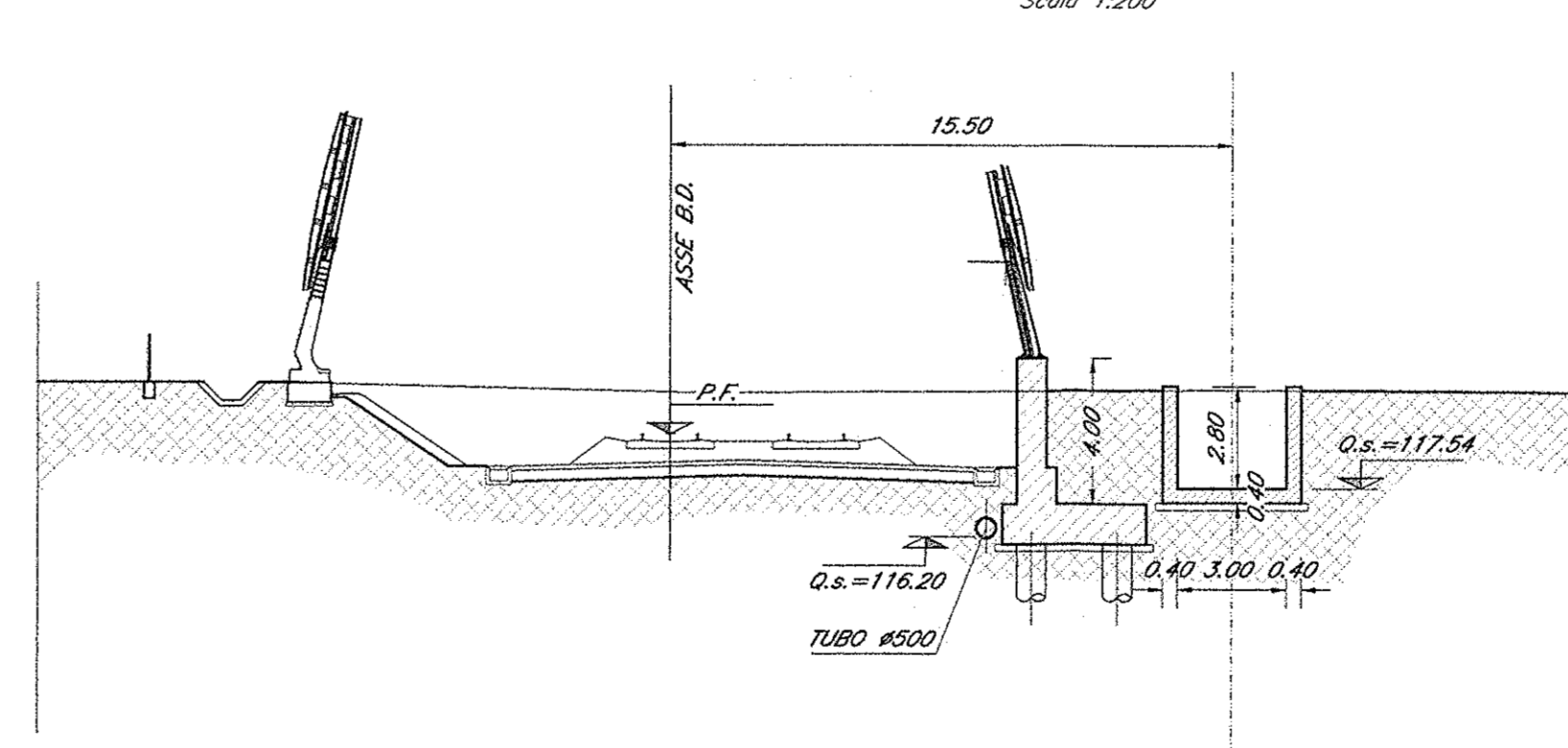

SEZIONE 12: Prog. 7+331.06

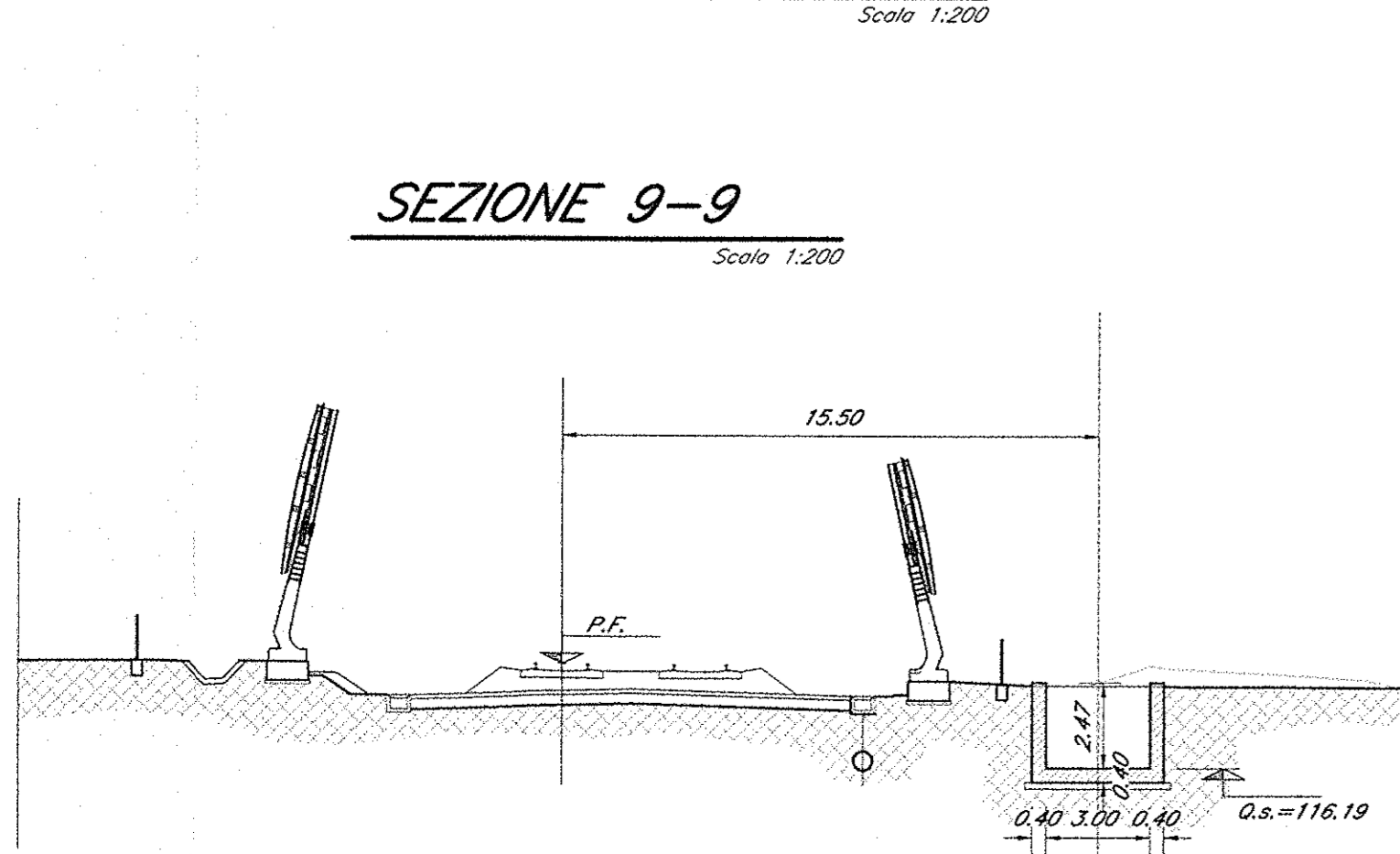

SEZIONE 10-10

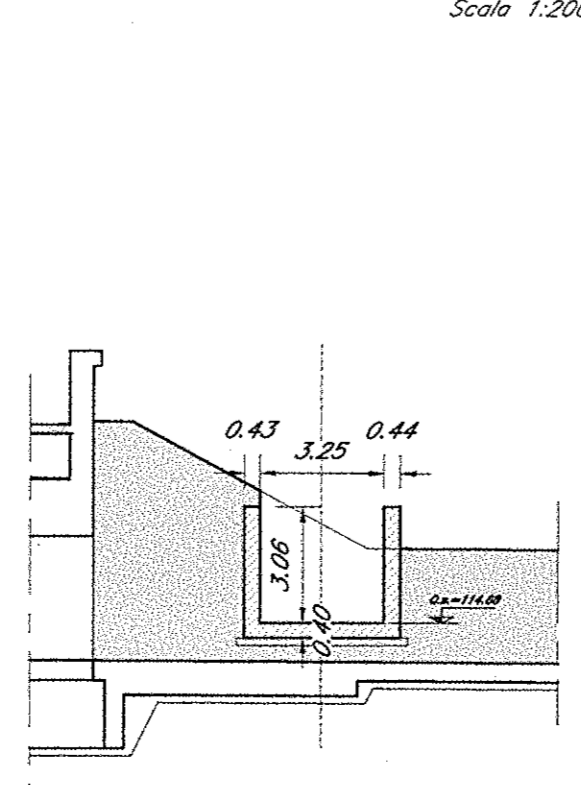

SEZIONE 9-9

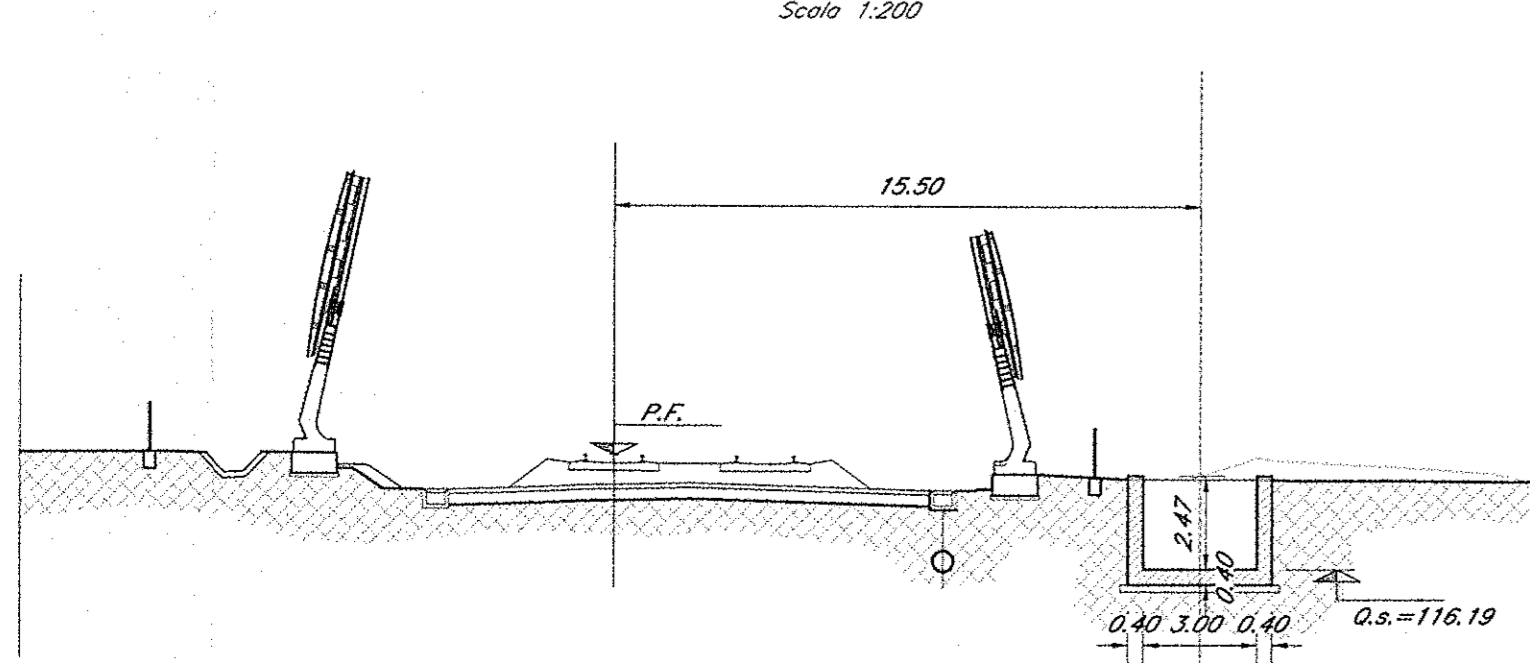

COMMITTENTE: RFI
 PROGETTAZIONE: ITALFERR
 DIREZIONE TECNICA
 UO CORPO STRADALE E GEOTECNICA
 PROGETTO DEFINITIVO
 ITINERARIO NAPOLI - BARI
 RADDOPPIO TRATTA CANCELLO - BENEVENTO
 I LOTTO FUNZIONALE CANCELLO - FRASSO TELESINO E VARIANTE
 ALLA LINEA ROMA NAPOLI VIA CASSINO NEL COMUNE DI MADDALONI
 TR03 - Deviazione affluente Votta
 Sezioni trasversali

SCALA: 1:200

COMMESSA LOTTO FASE ENTE TIPO DOC. OPERA/DISCIPLINA PROG. REV.
 IF0F 01 D 11 W9 TR0300 002 A

Revis	Descrizione	Redatto	Data	Verificato	Data	Approvato	Data	Autorizzato	Data
A	Emissione Esecutiva	A. Tosani	06.07.2015	P. Tagliore	07.07.2015	F. Corallo	08.07.2015	F. Scaroni	09.07.2015

File: PRFD11\WTR0300002A.dwg n. Elab: 227