

Committente:



AUTOCAMIONALE DELLA CISA S.P.A.

Via Camboara 26/A - Frazione Ponte Taro - 43015 NOCETO (PR)

Impresa Esecutrice:



**AUTOSTRADA DELLA CISA A15
RACCORDO AUTOSTRADALE A15/A22
CORRIDOIO PLURIMODALE TIRRENO-BRENNERO
RACCORDO AUTOSTRADALE FRA L' AUTOSTRADA DELLA CISA-FONTEVIVO (PR)
E L' AUTOSTRADA DEL BRENNERO-NOGAROLE ROCCA (VR). I LOTTO.**

C.U.P. G61B04000060008

C.I.G. 307068161E

PROGETTO ESECUTIVO

AUTOCAMIONALE DELLA CISA S.p.A.

Il Direttore TIBRE:

Il Responsabile del Procedimento:

Il Presidente:

IMPRESA PIZZAROTTI & C. S.p.A.

Il Direttore Tecnico:

IMPRESA PIZZAROTTI & C. S.p.A.
Il Responsabile di Progetto
Dott. Ing. Luca Bondanelli

Il Geologo:

NA

PROGETTAZIONE DI:



A.T.I.: **idroesse**
engineering
MANDATARIA

ROKSOIL S.p.A.
MANDANTE

VIA
INGEGNERIA S.r.l.
MANDANTE

Il Progettista:

Ing. Fabio Nigrelli

Ordine degli ingegneri della Provincia di Palermo n. 3581

Coordinatore per la Sicurezza in fase di Progettazione:

Ing. Giovanni Maria Cepparotti

Ordine degli Ingegneri della Provincia di Viterbo n. 392

Consulenza specialistica a cura di:

NA

Progettista Responsabile Integrazione Prestazioni Specialistiche:

Impresa Pizzarotti & C. S.p.A.

Ing. Pietro Mazzoli

Ordine degli Ingegneri della Provincia di Parma n. 821

Titolo Elaborato:

**Asse Principale
Sistemazioni idrauliche
Deviazioni canali**

Canale Otto Mulini - Album sezioni trasversali inalveazione

Data Emissione Progetto:

18/03/2014

Scala:

1:200

Identif. Elaborato:

N.RO IDENTIFICATIVO

CODICE COMMESSA

LOTTO

FASE

ENTE

AMBITO

CAT. OPERA

N.RO OPERA

PARTE OPERA

TIPO DOC.

N.RO PROGR. DOC.

REVISIONE

Rev.	Data	DESCRIZIONE REVISIONE	Redatto	Controllato	Approvato
C	30/01/2015	ISTRUTTORIA A15 NOVEMBRE 2014	MATALONE	NIGRELLI	MAZZOLI
B	10/12/2014	OSSERVAZIONI CONSORZIO DI BONIFICA PARMENSE prot. n°7978 del 04 dic. 2014	MATALONE	NIGRELLI	MAZZOLI
A	06.06.2014	RIEMMISSIONE PROGETTO ESECUTIVO	BORACCI	NIGRELLI	MAZZOLI

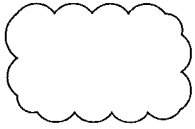

DESCRIZIONE DELLA MODIFICA:

modifica spessore del rivestimento in massi e inserimento nei tratti di ricucitura tra canale esistente e nuova inalveazione di un rivestimento in massi.

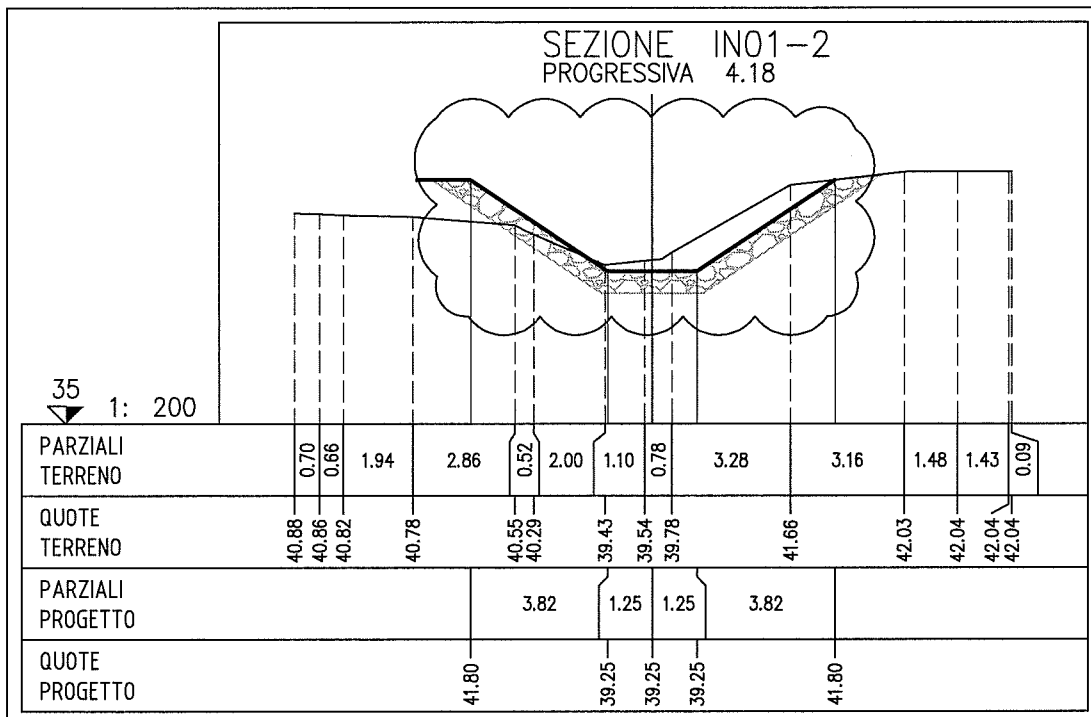
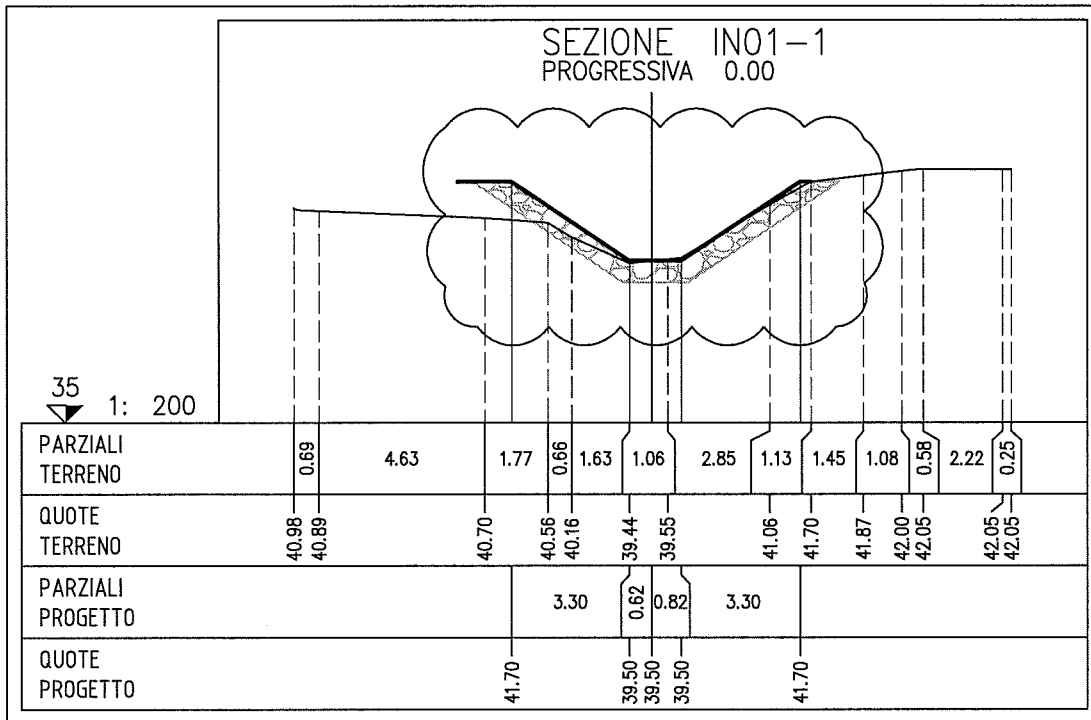

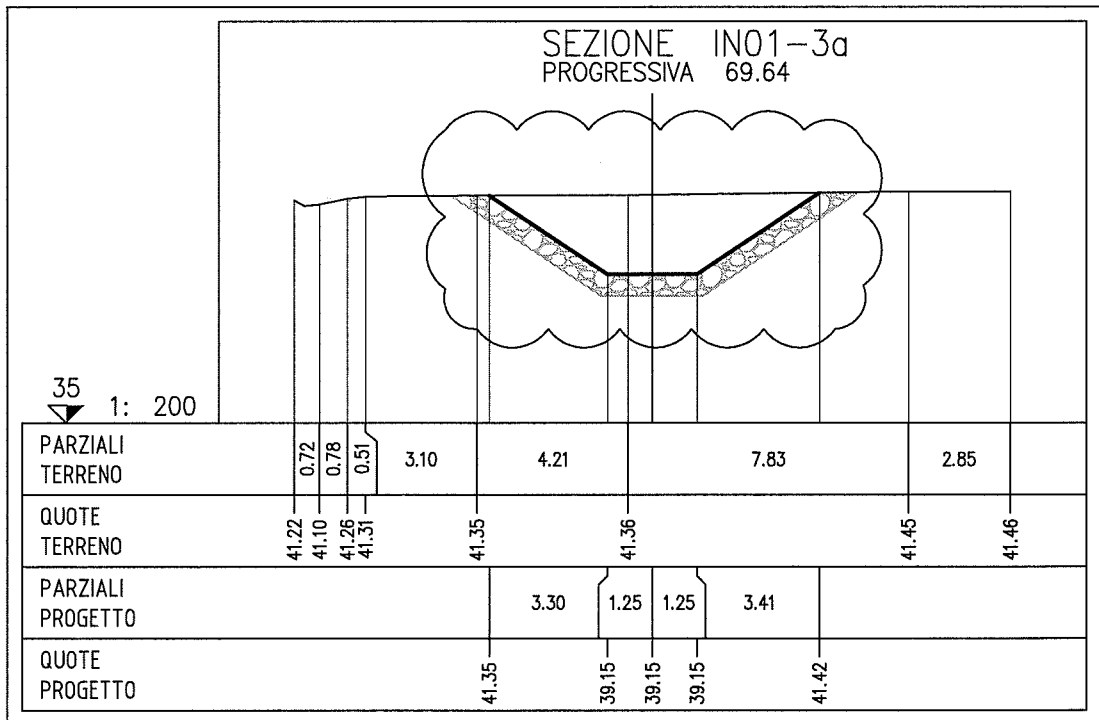
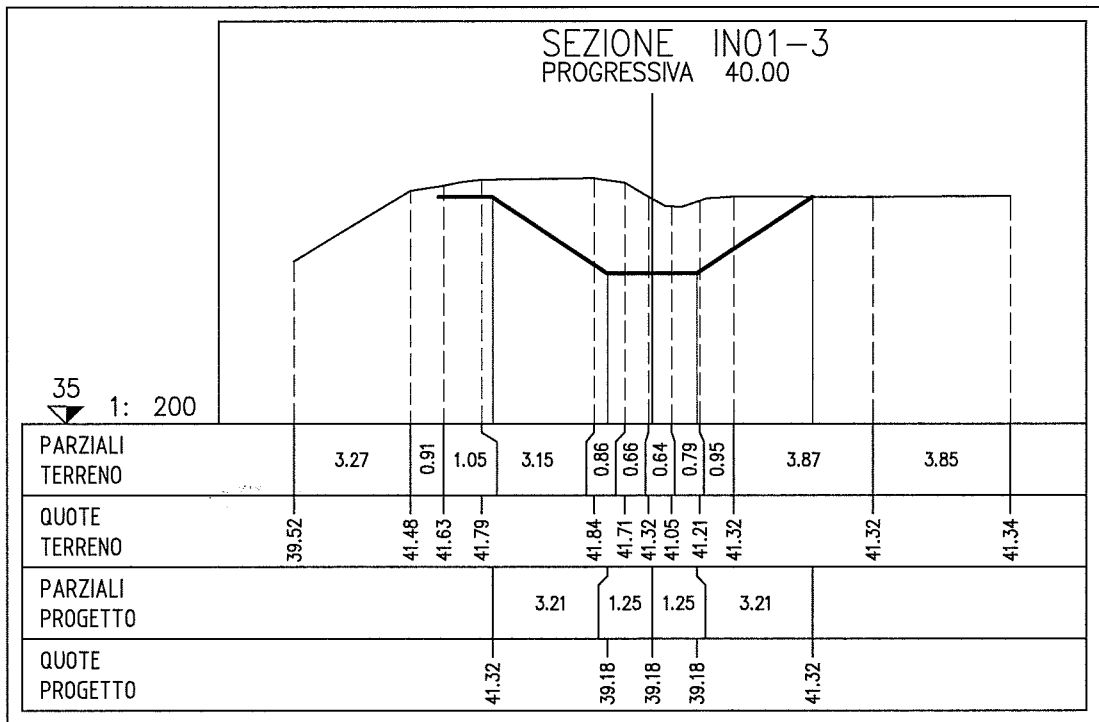

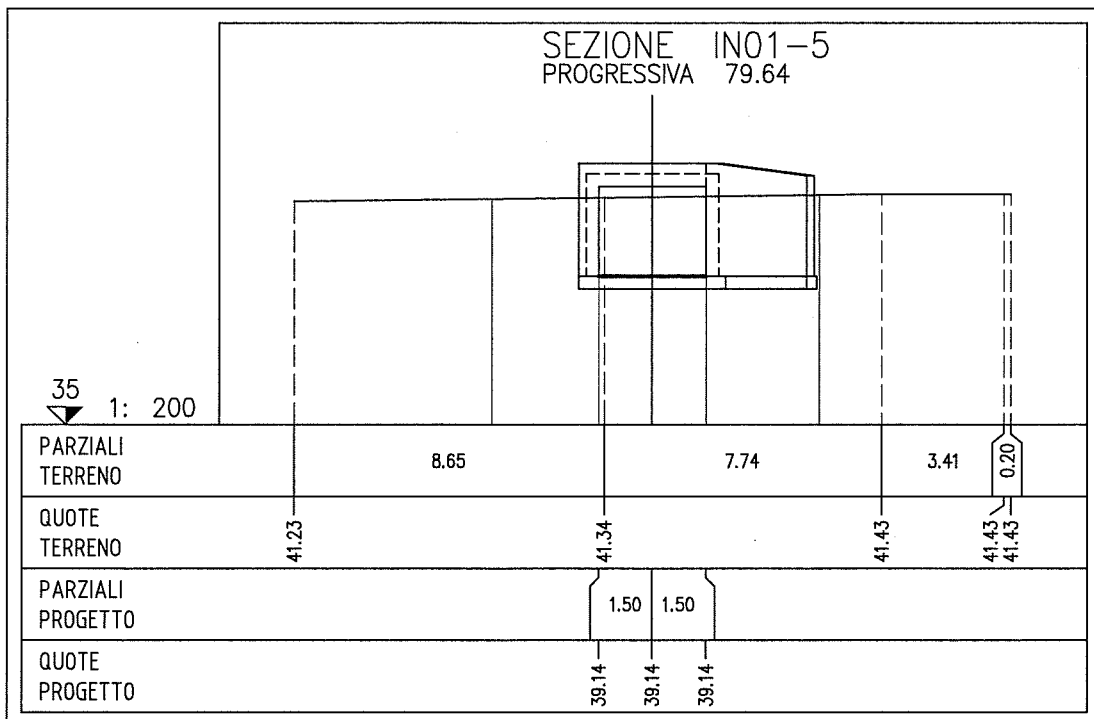
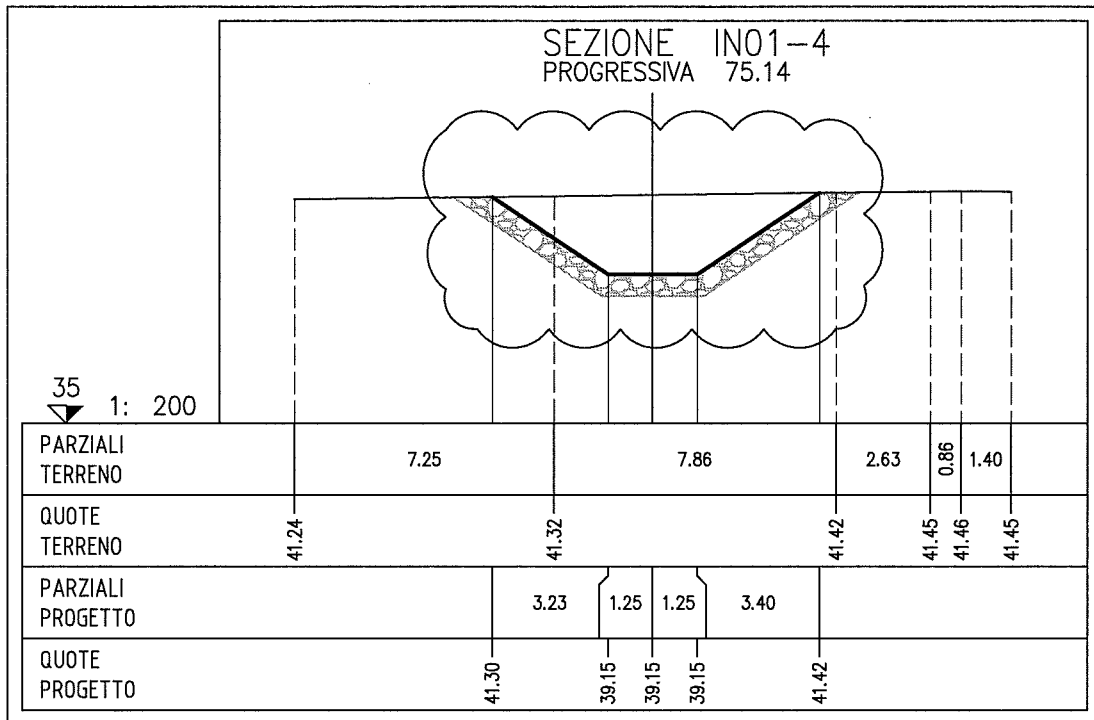

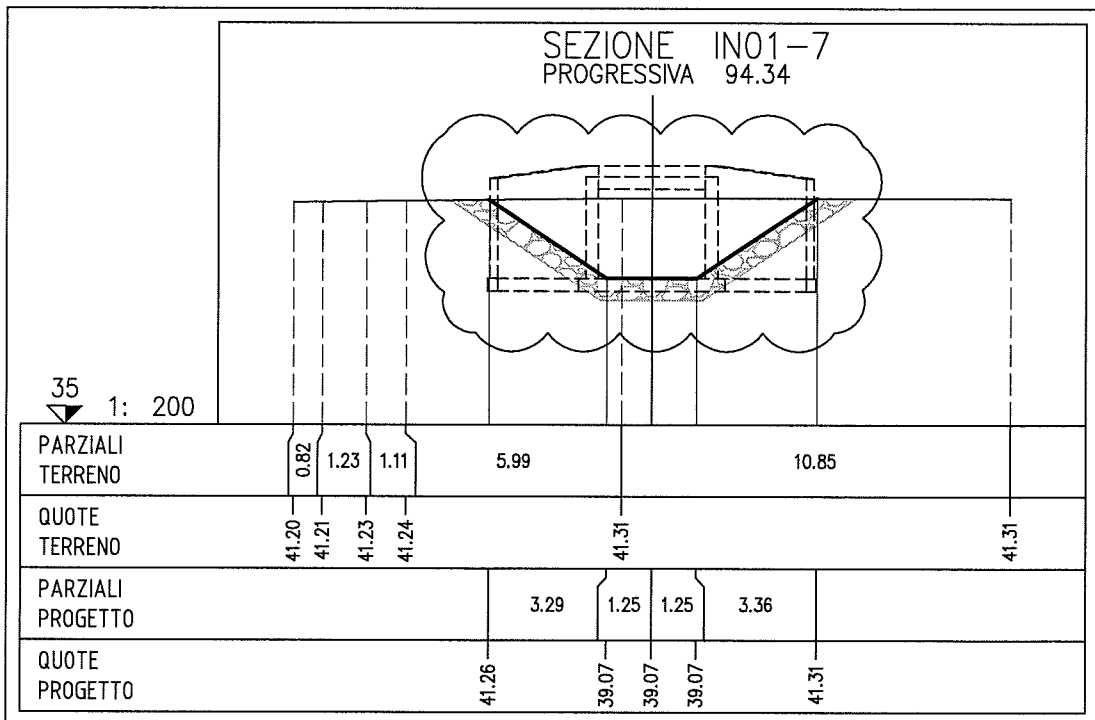
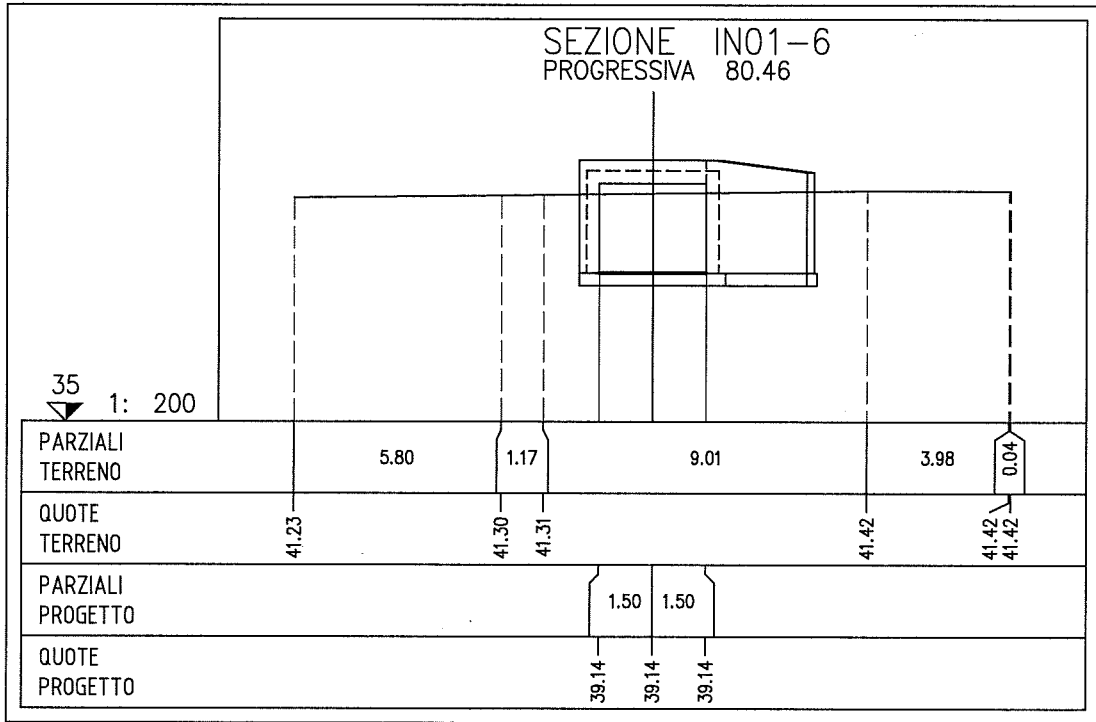

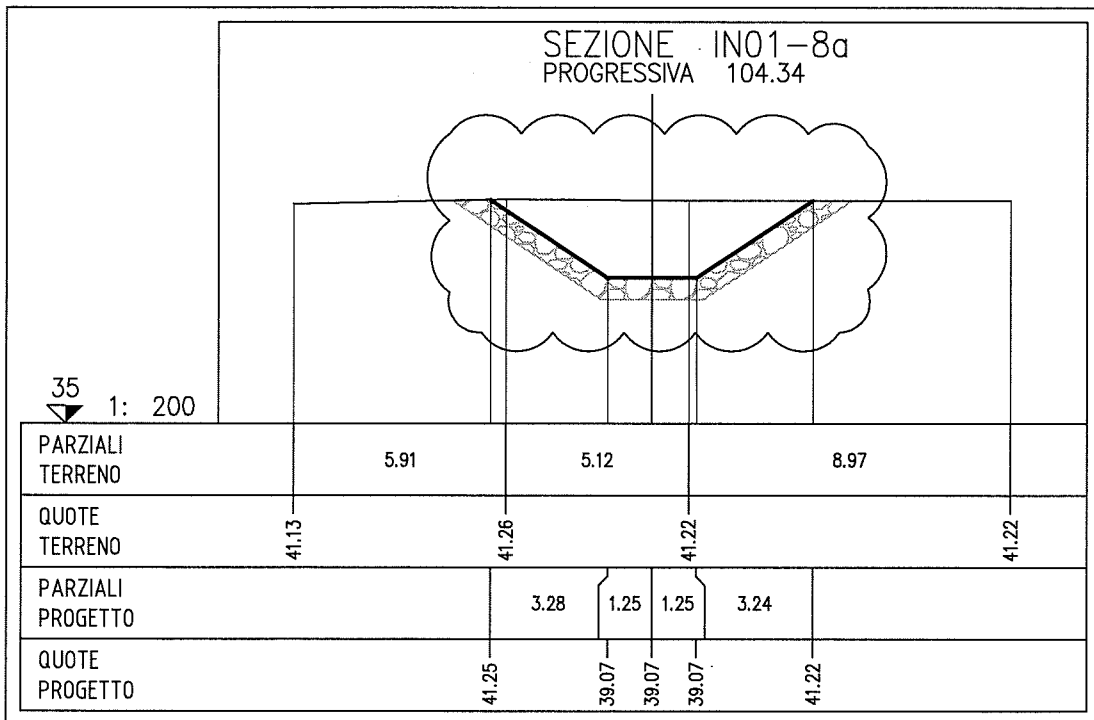
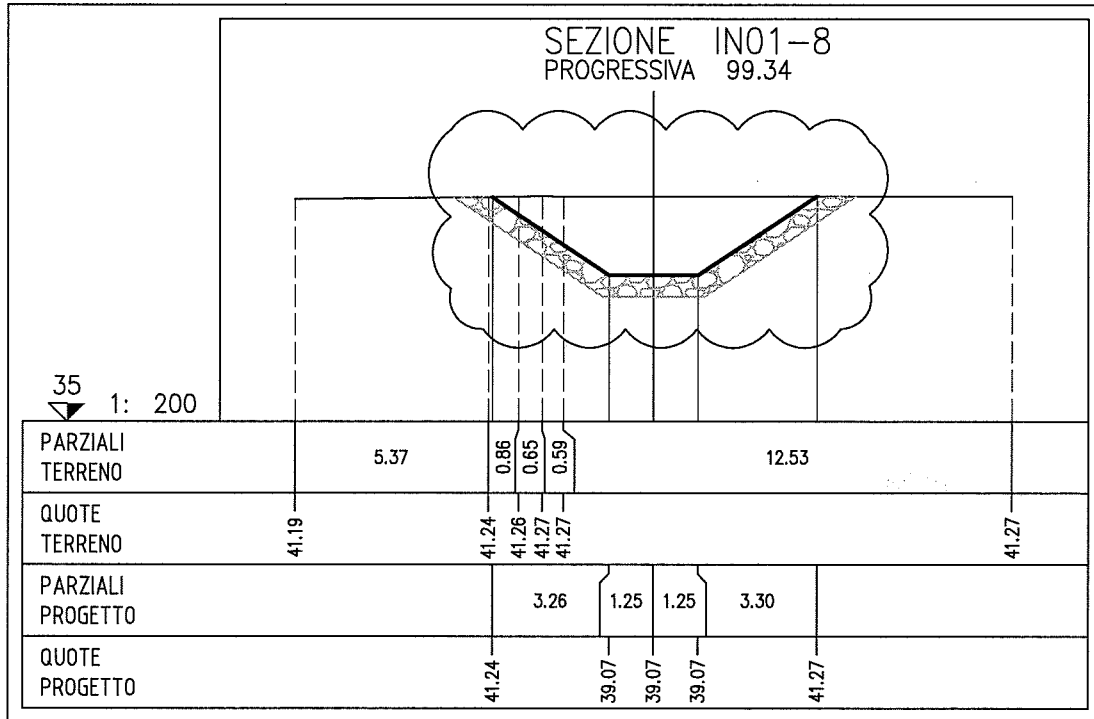

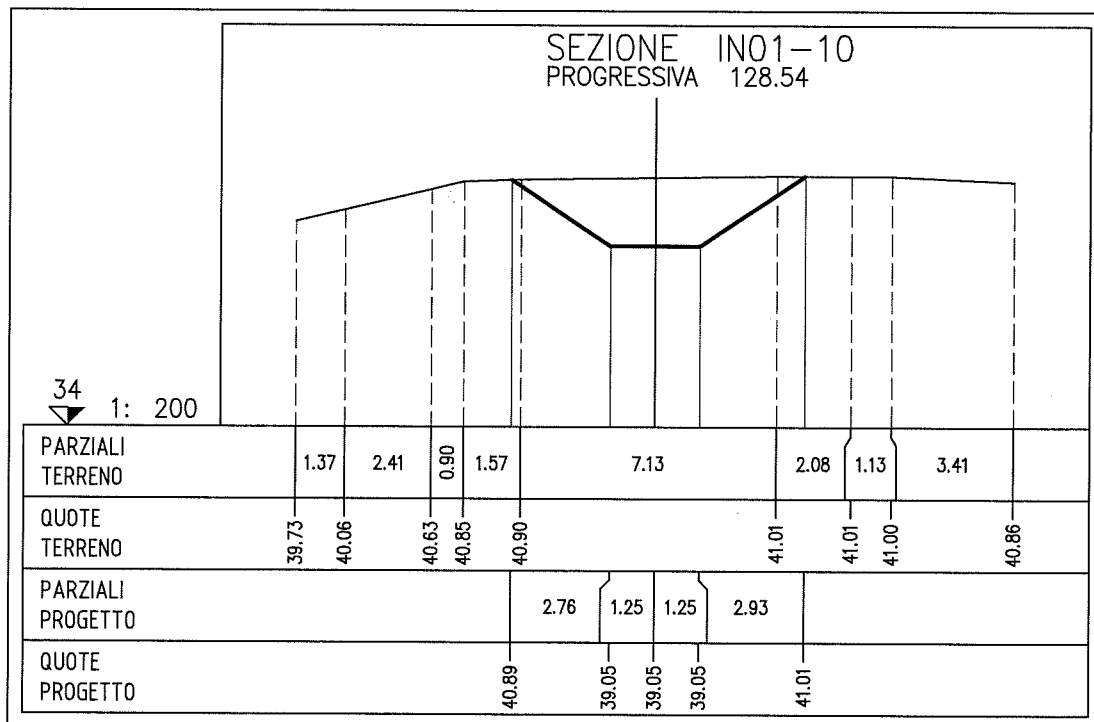
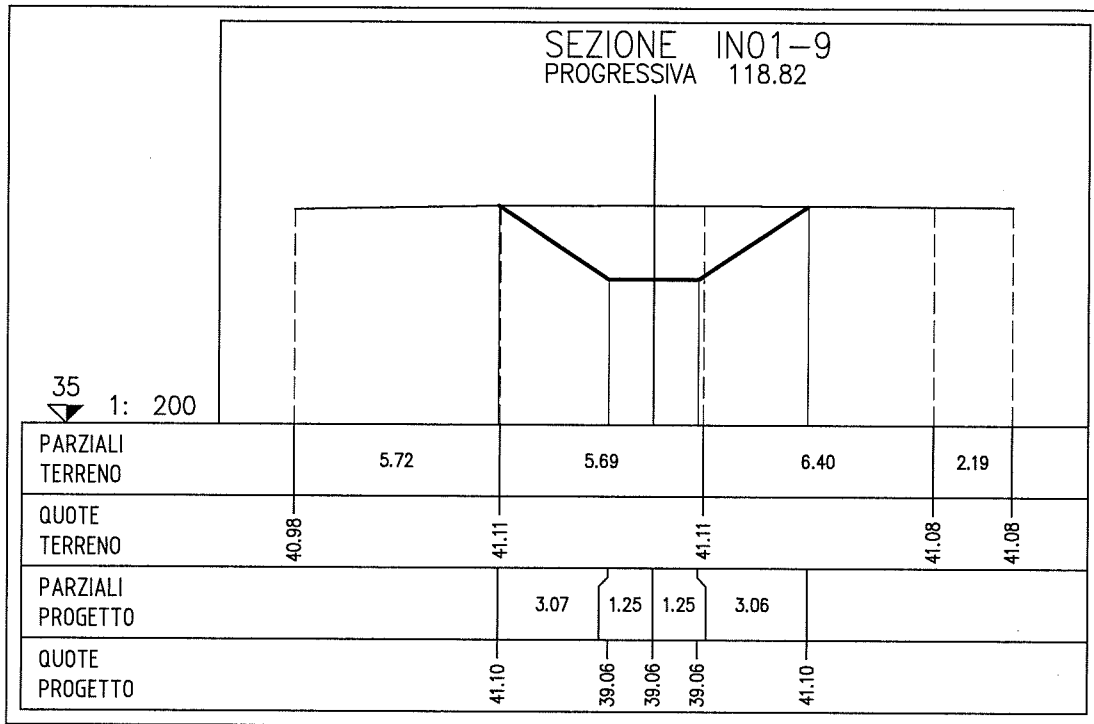

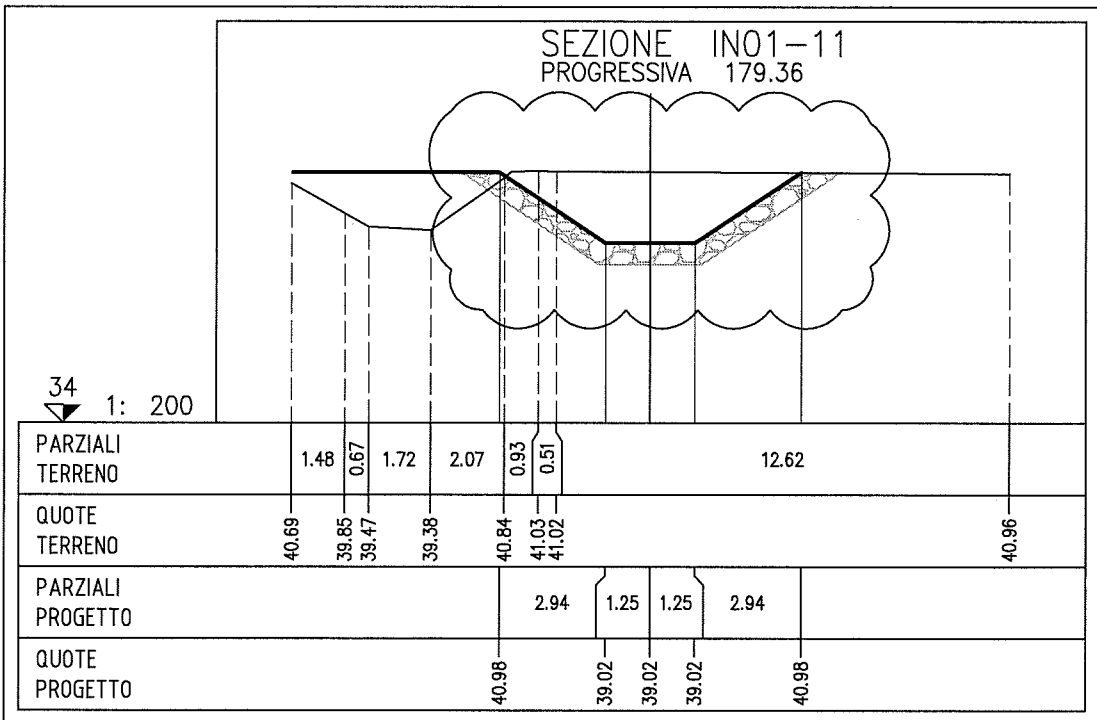
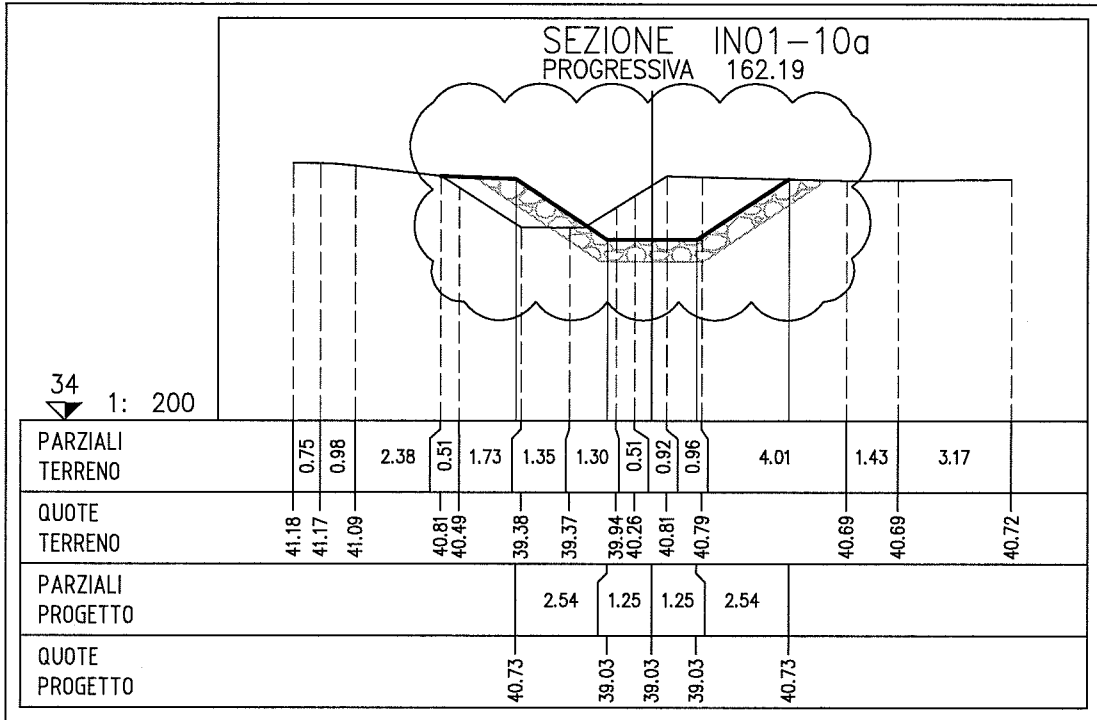

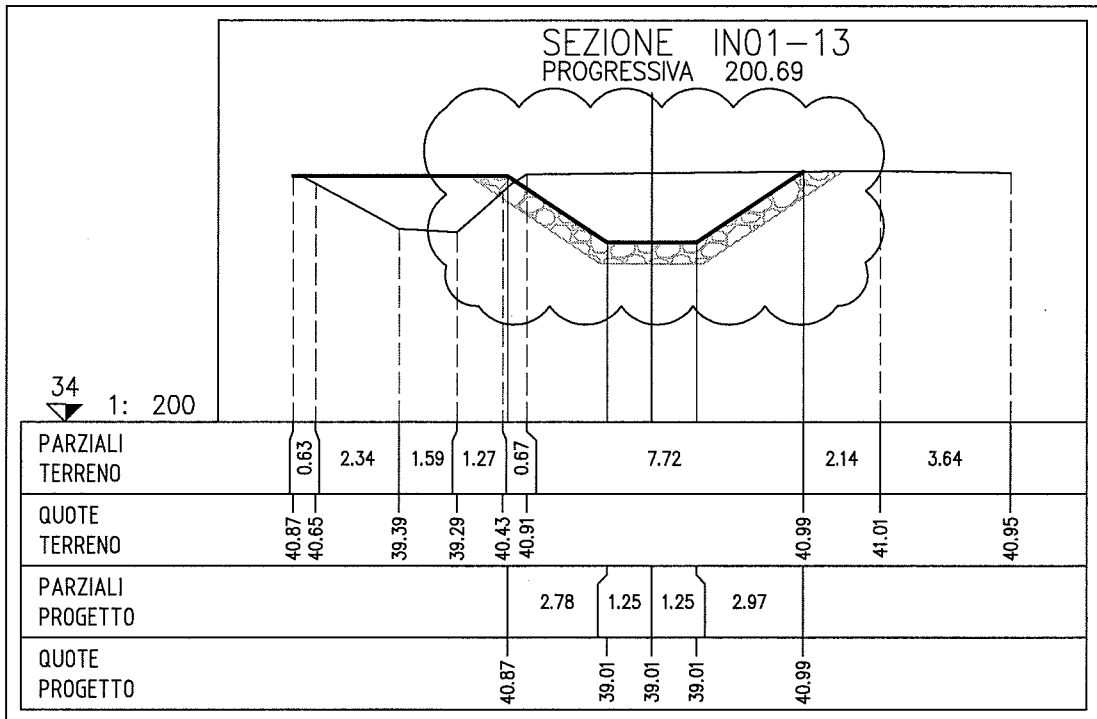
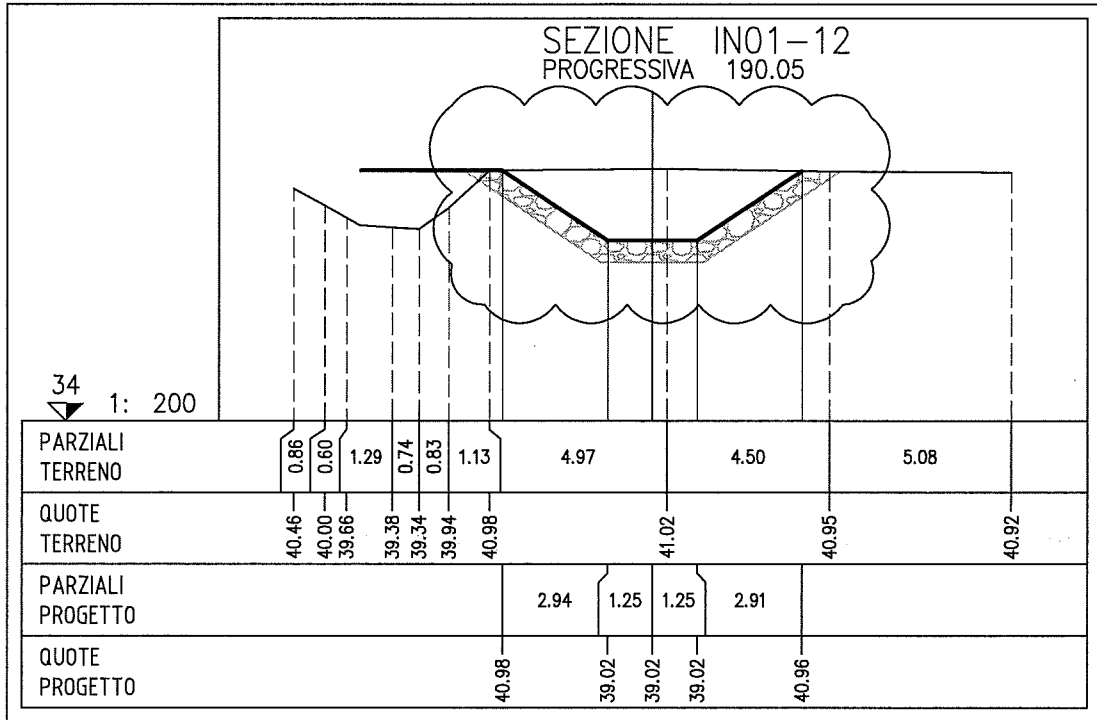

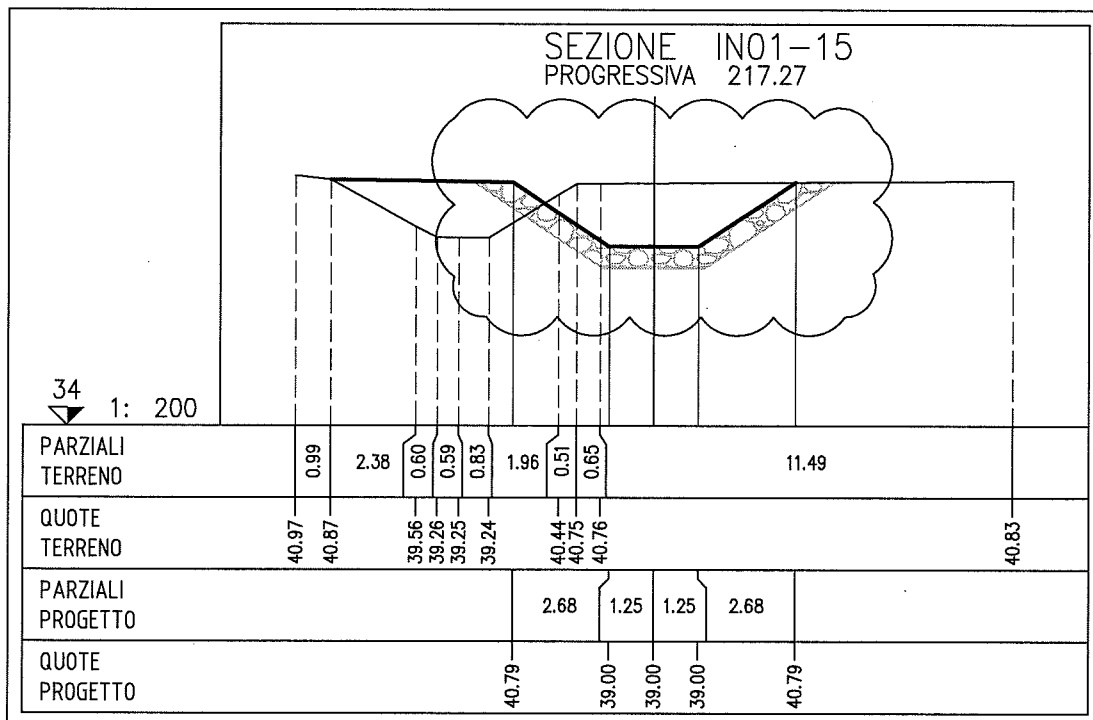
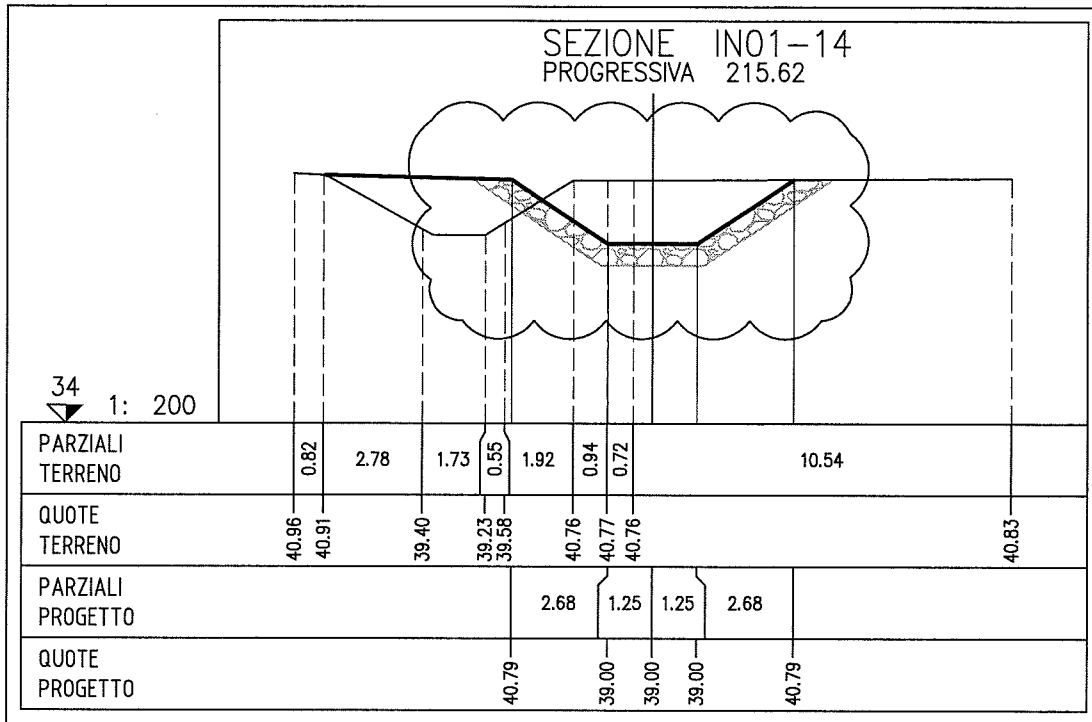

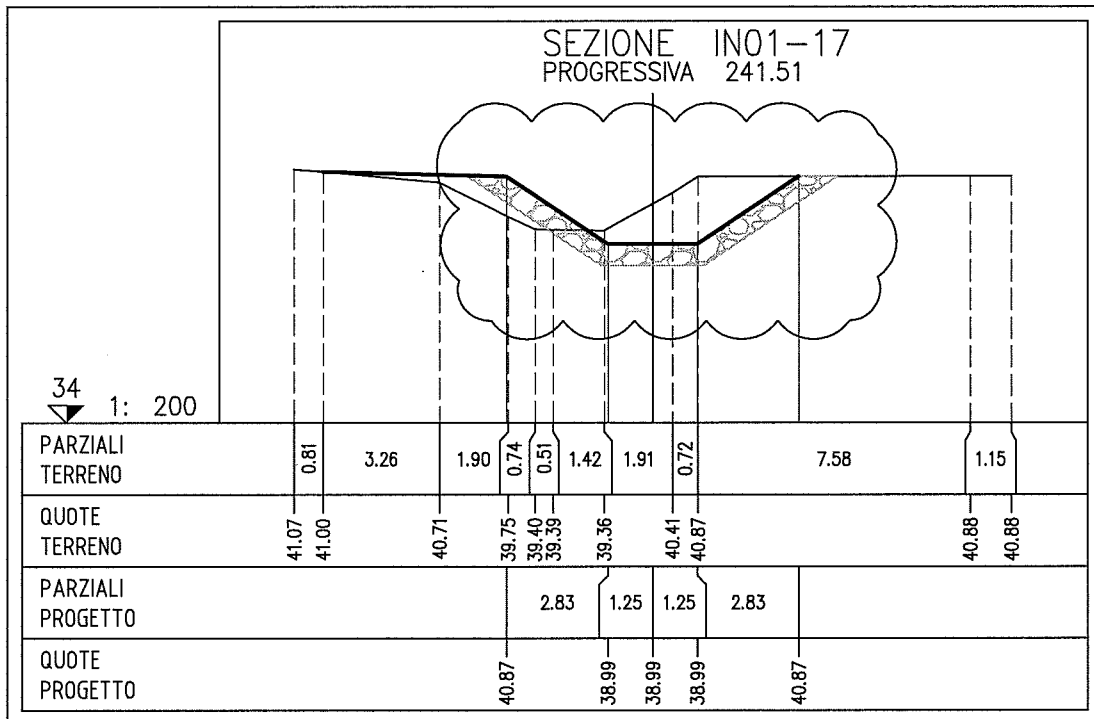
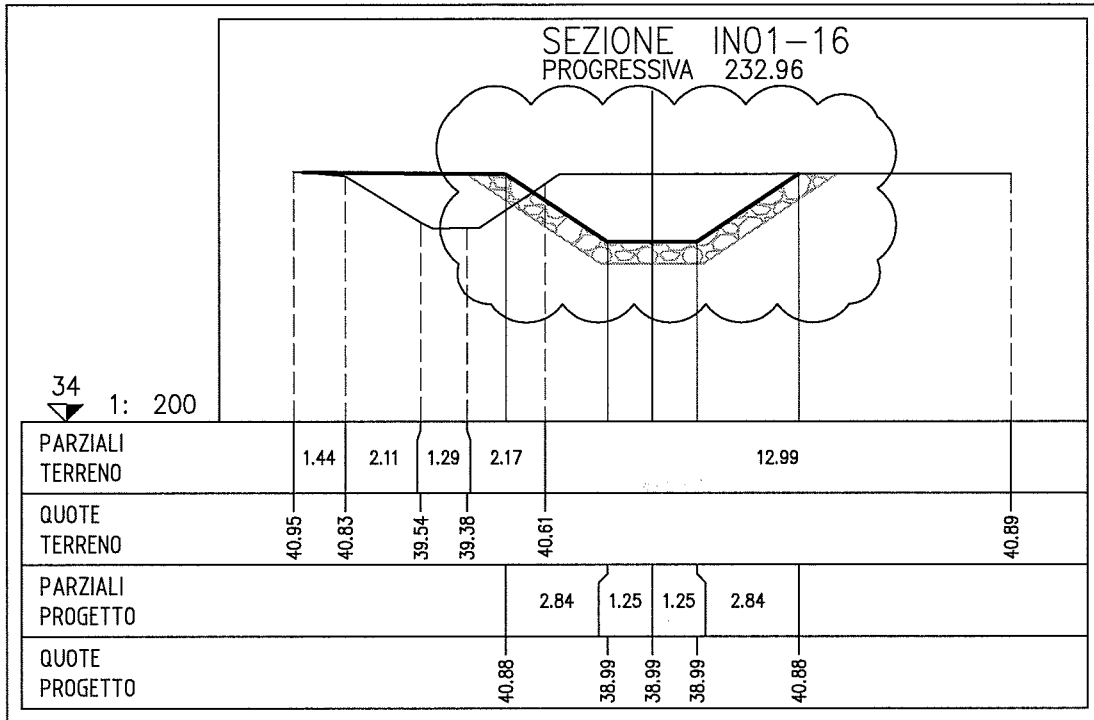

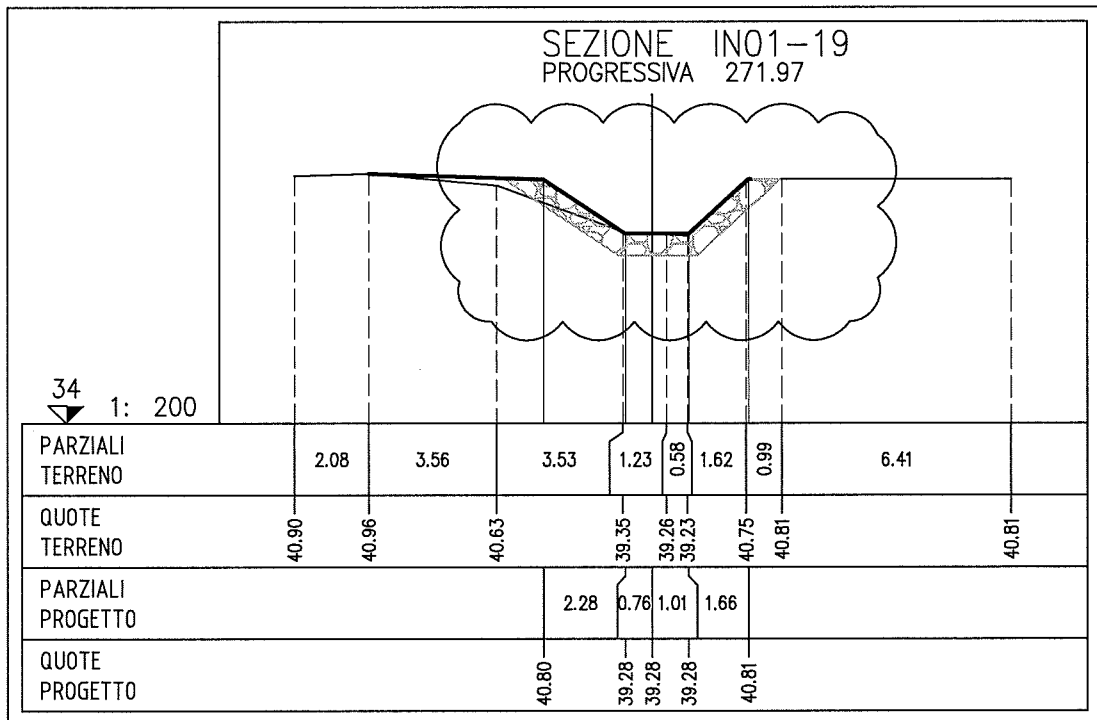
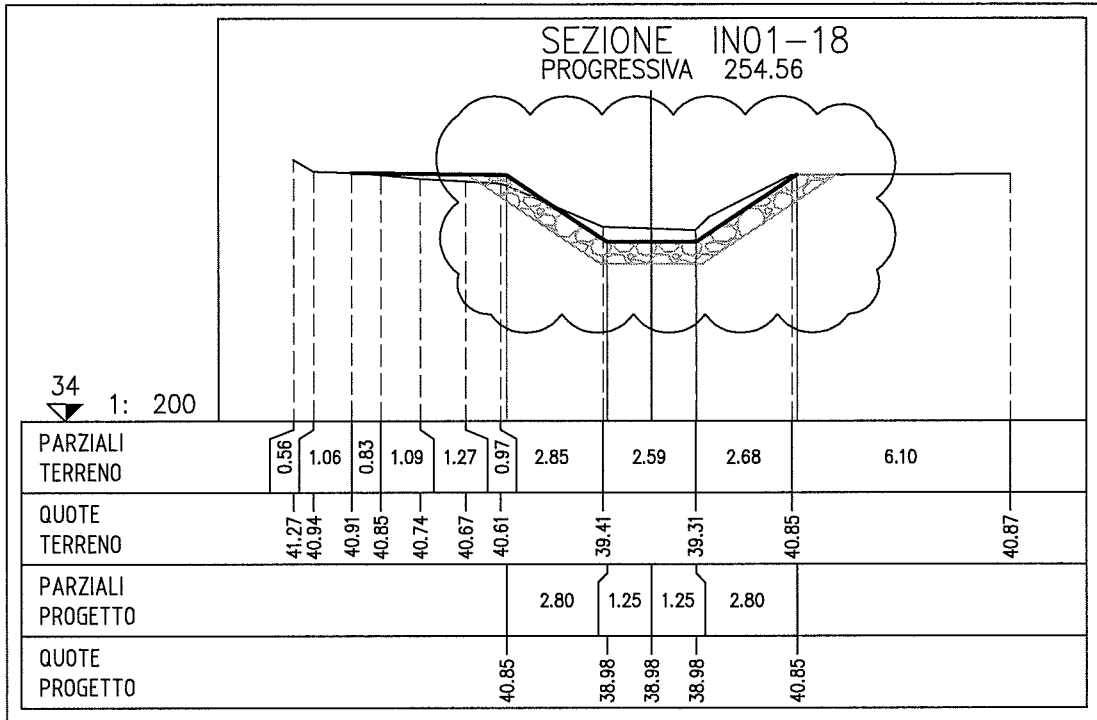

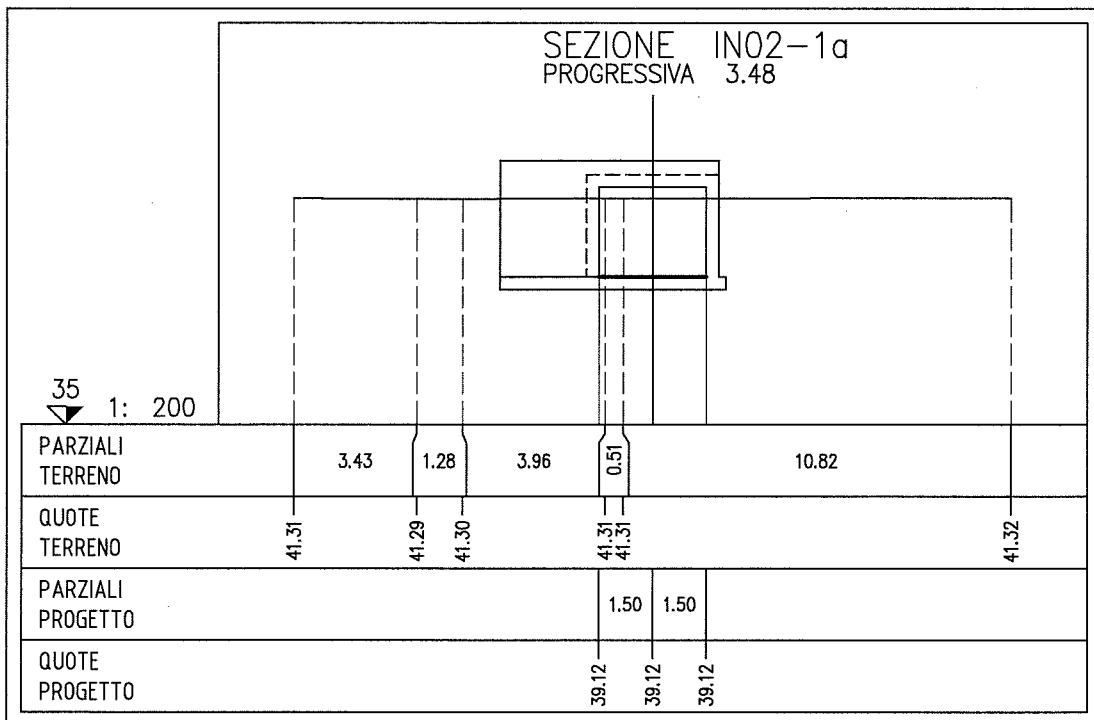
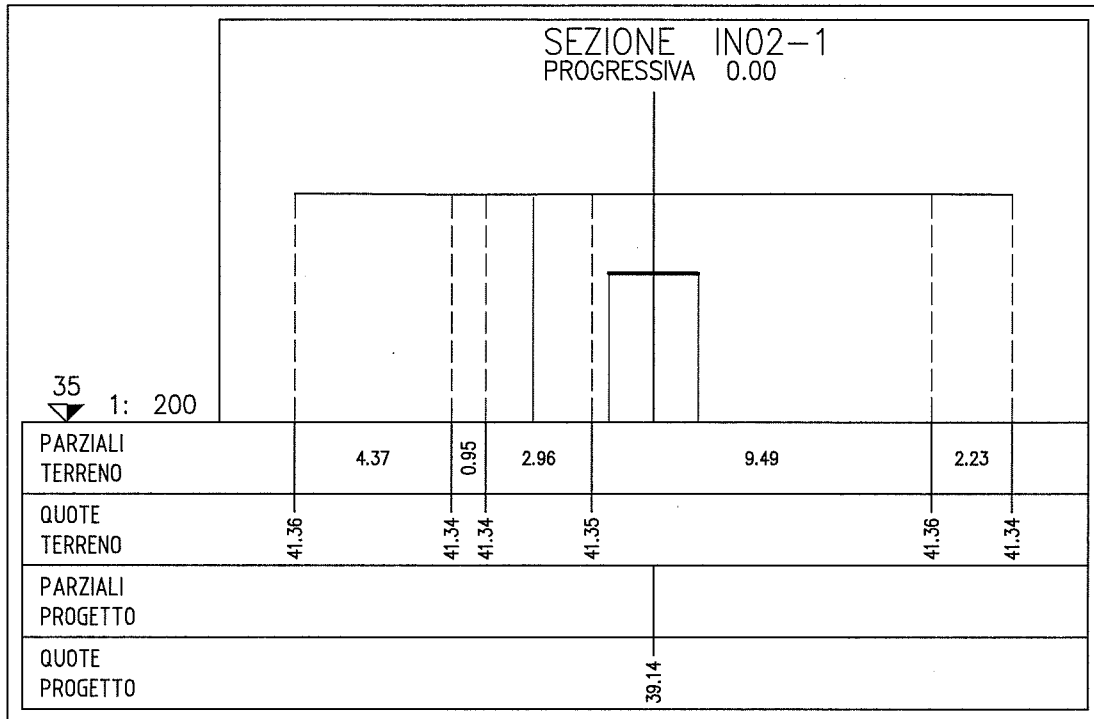

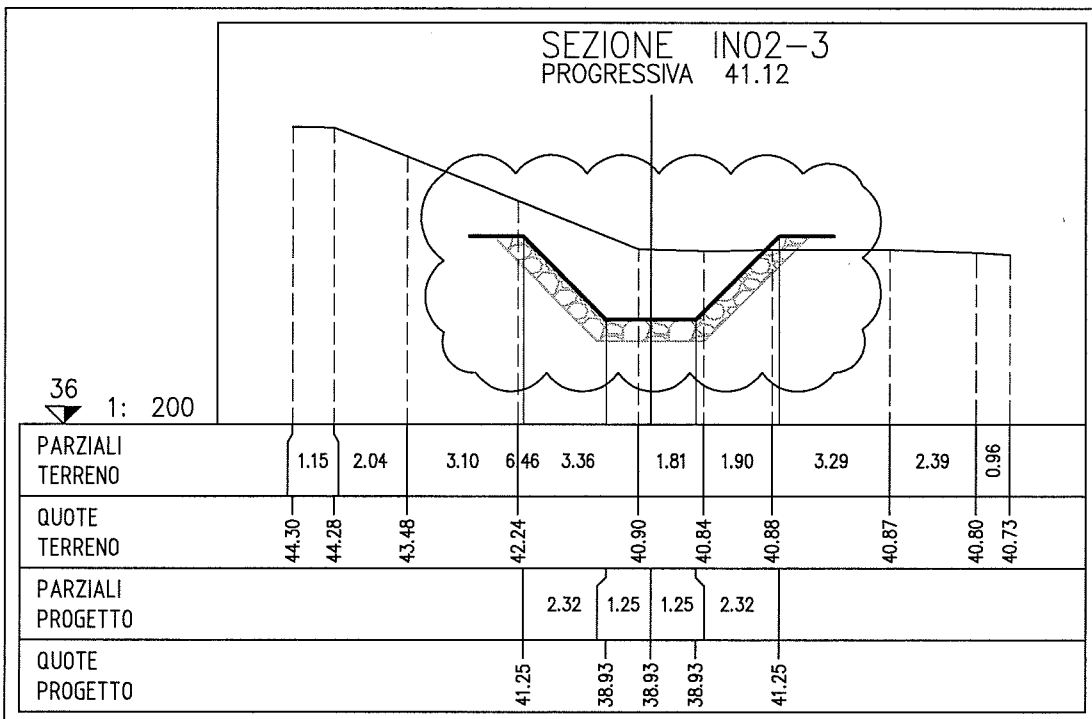
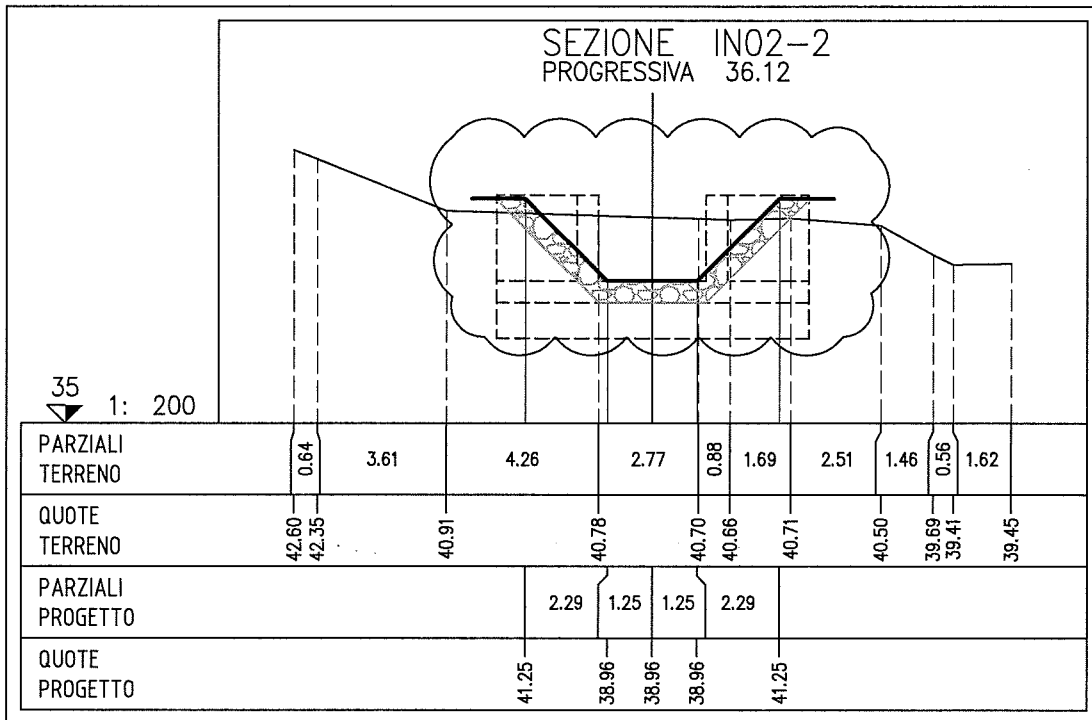

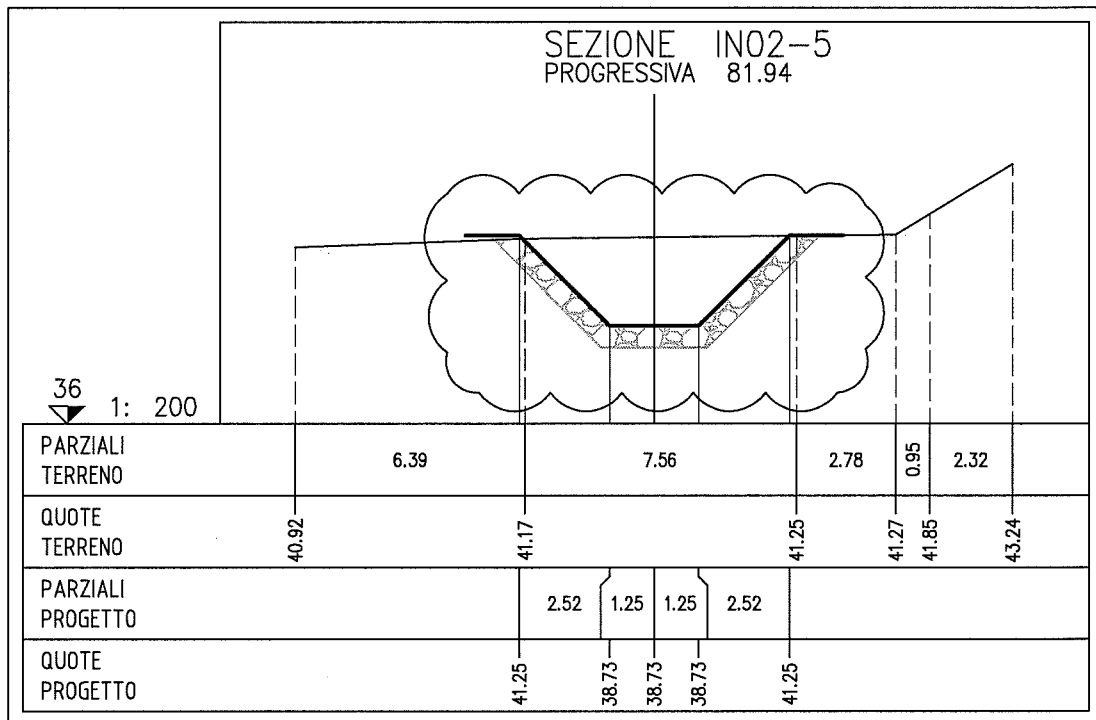
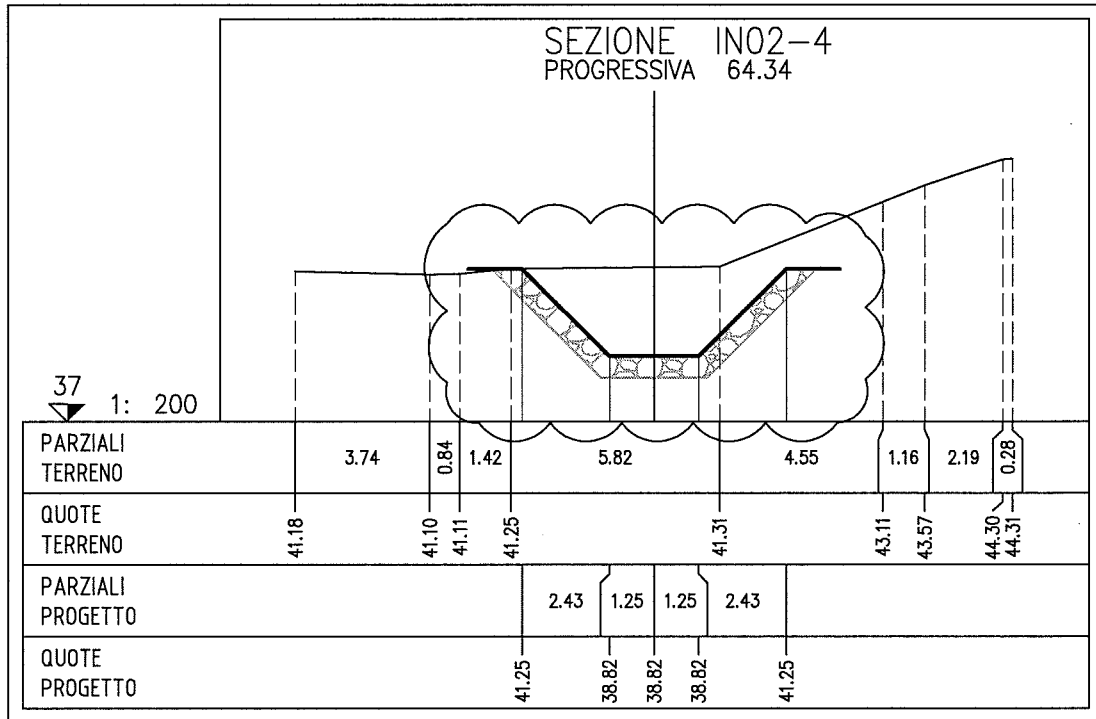

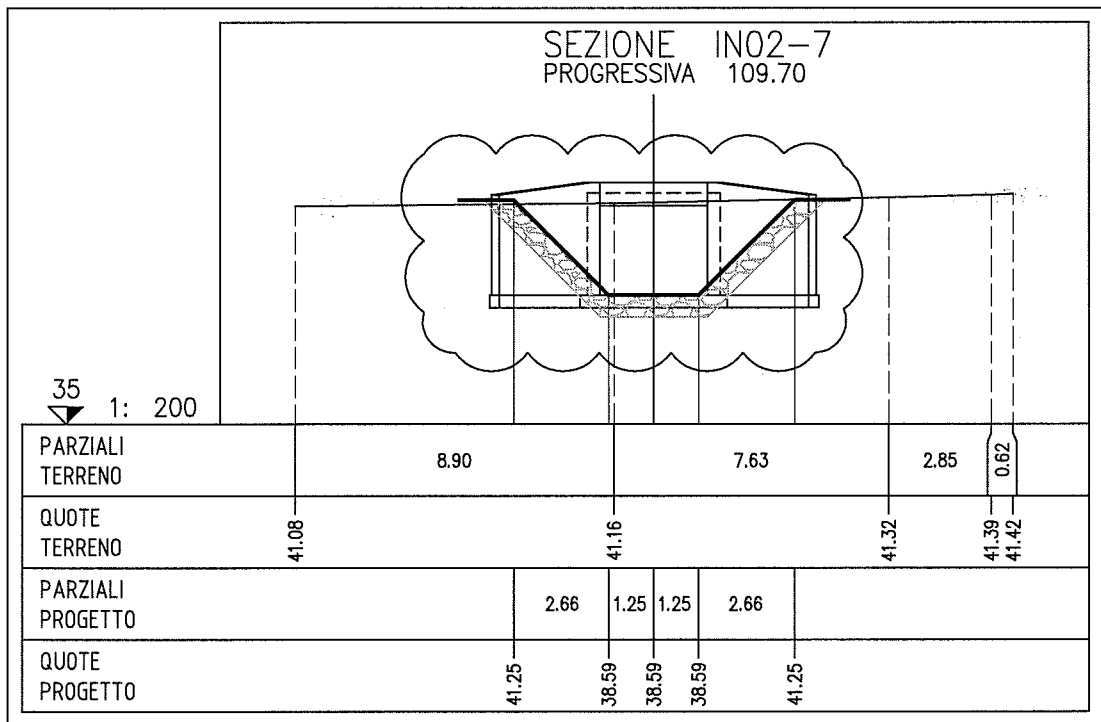
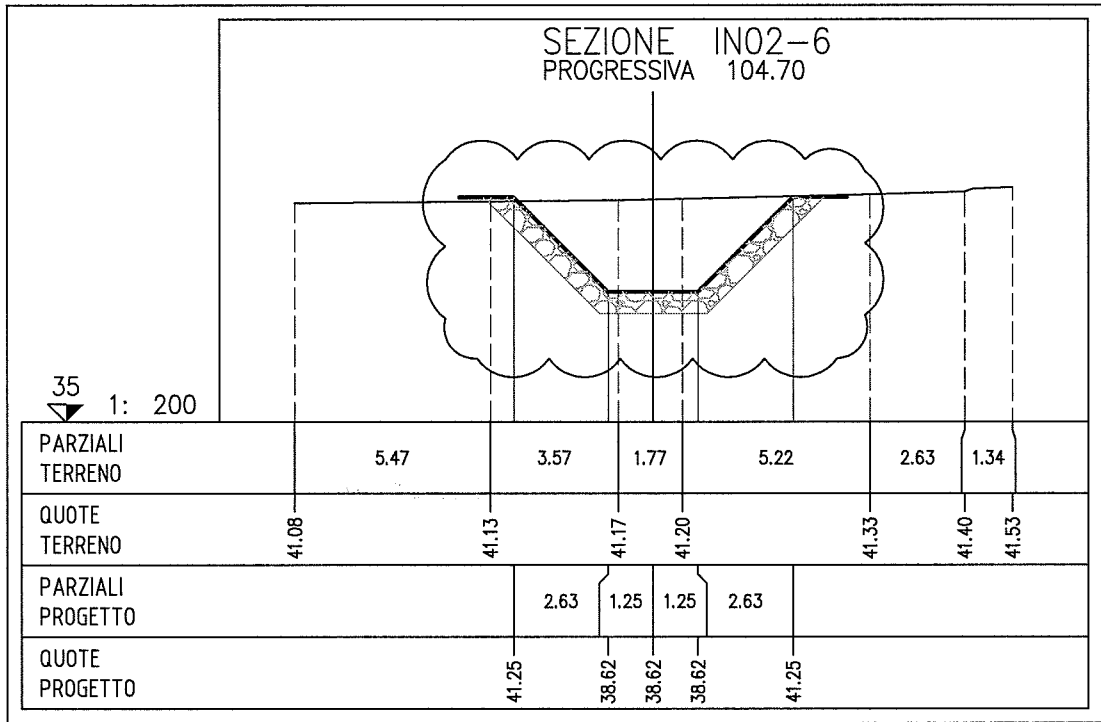

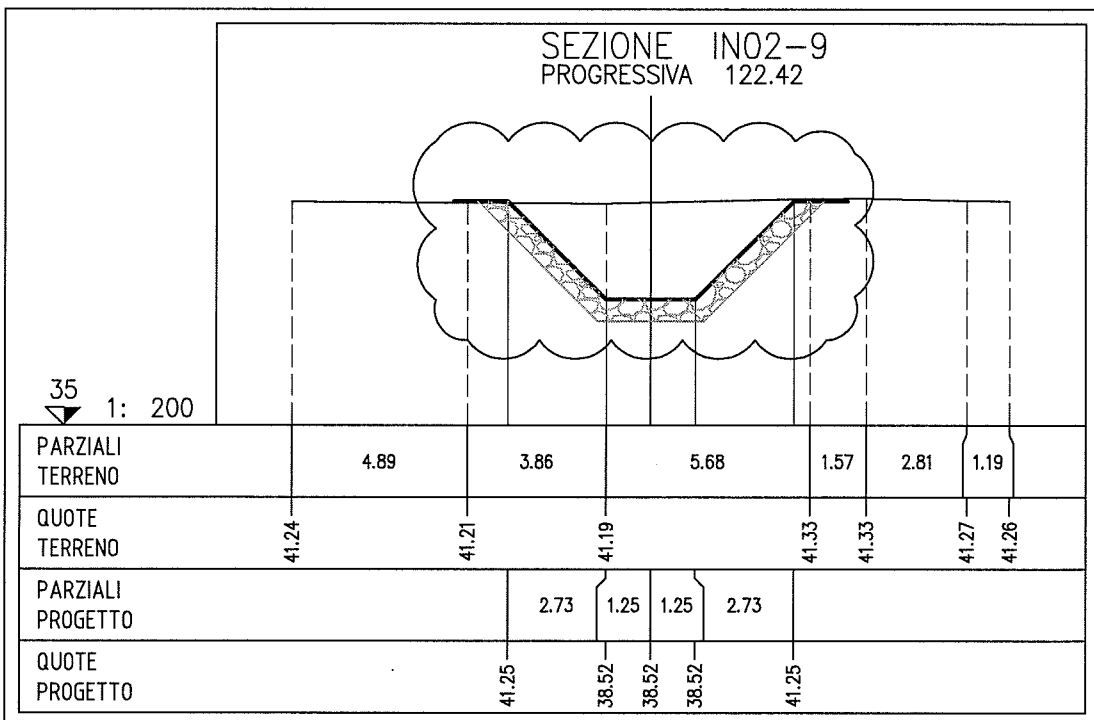
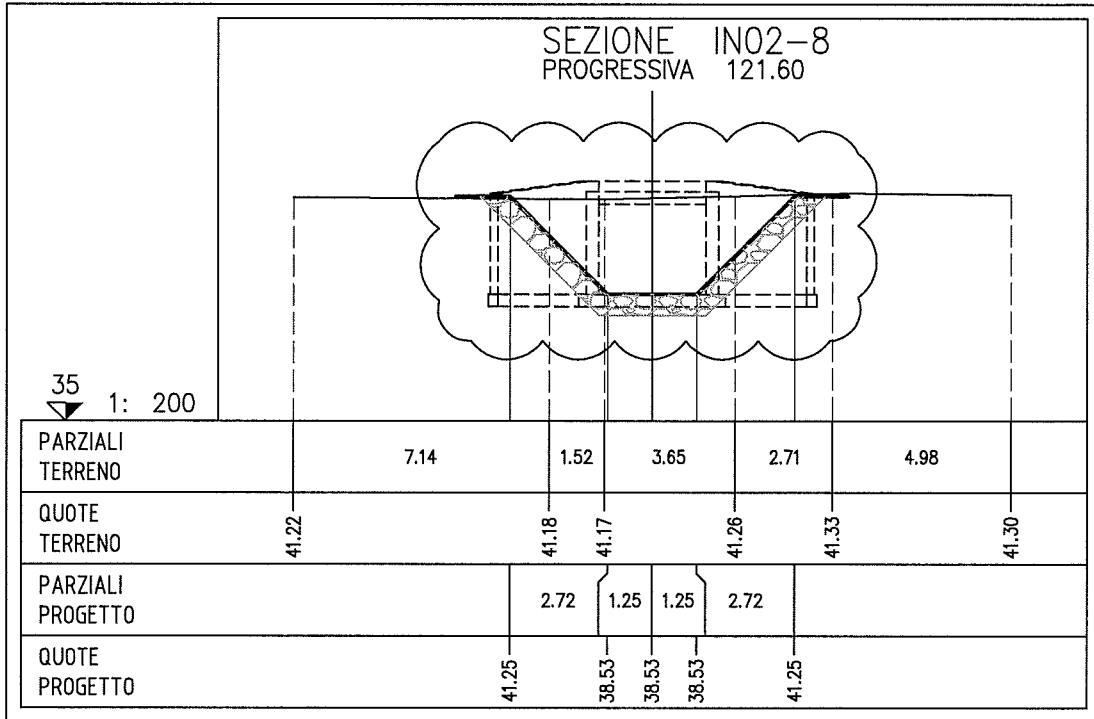

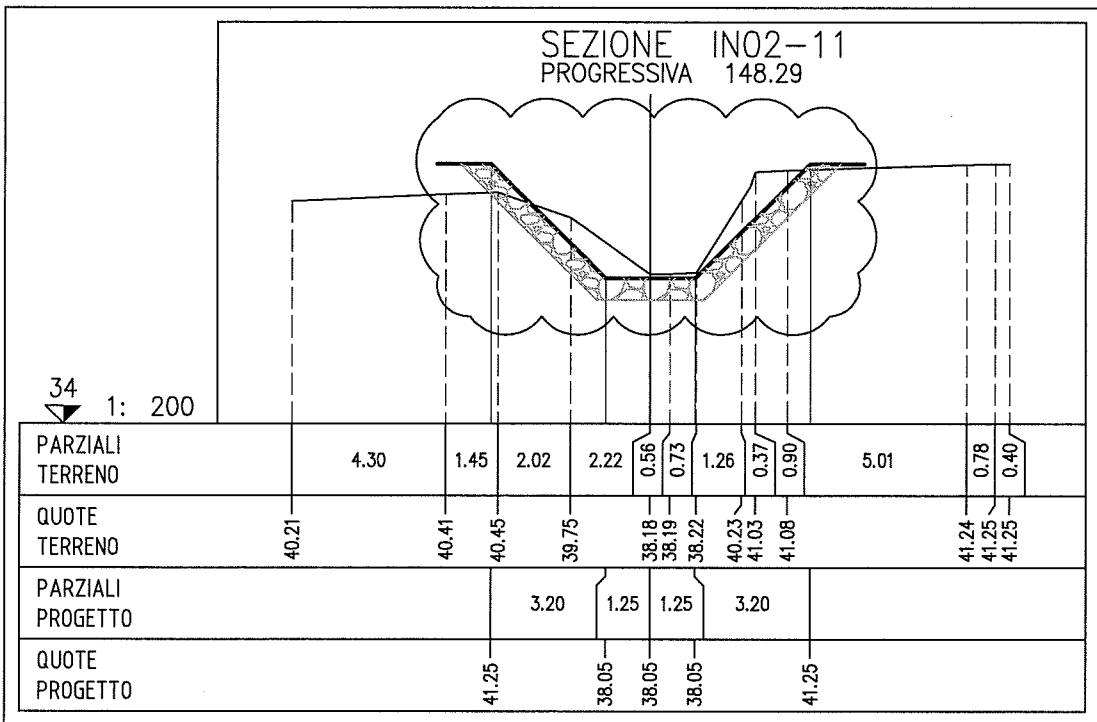
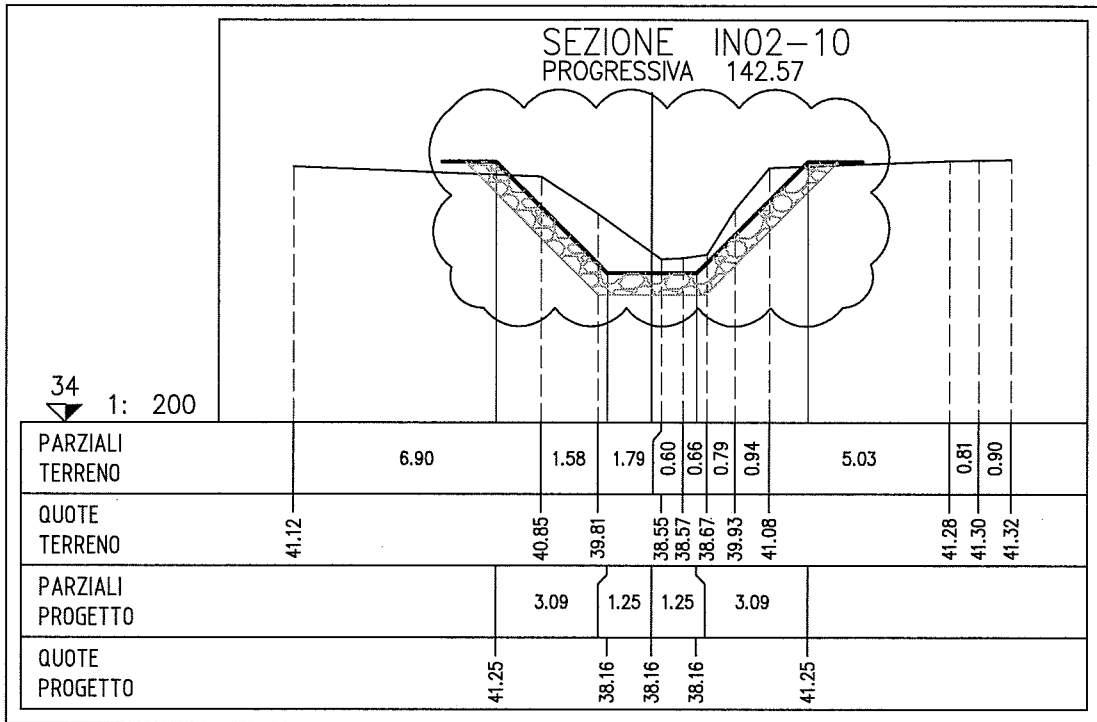

SEZIONE IN02-12
 PROGRESSIVA 150.92

34
 1: 200

PARZIALI TERRENO	0.69	4.66	4.23	1.59	1.02	5.52	0.97	1.32
QUOTE TERRENO	39.77 39.81	39.59	38.12	38.01	40.91	41.17	41.21	41.22
PARZIALI PROGETTO			0.13	1.17	3.24			
QUOTE PROGETTO			38.01 38.01	38.01	41.25			