

SCNITT 1-1 / SEZIONE 1-1
(1:50)

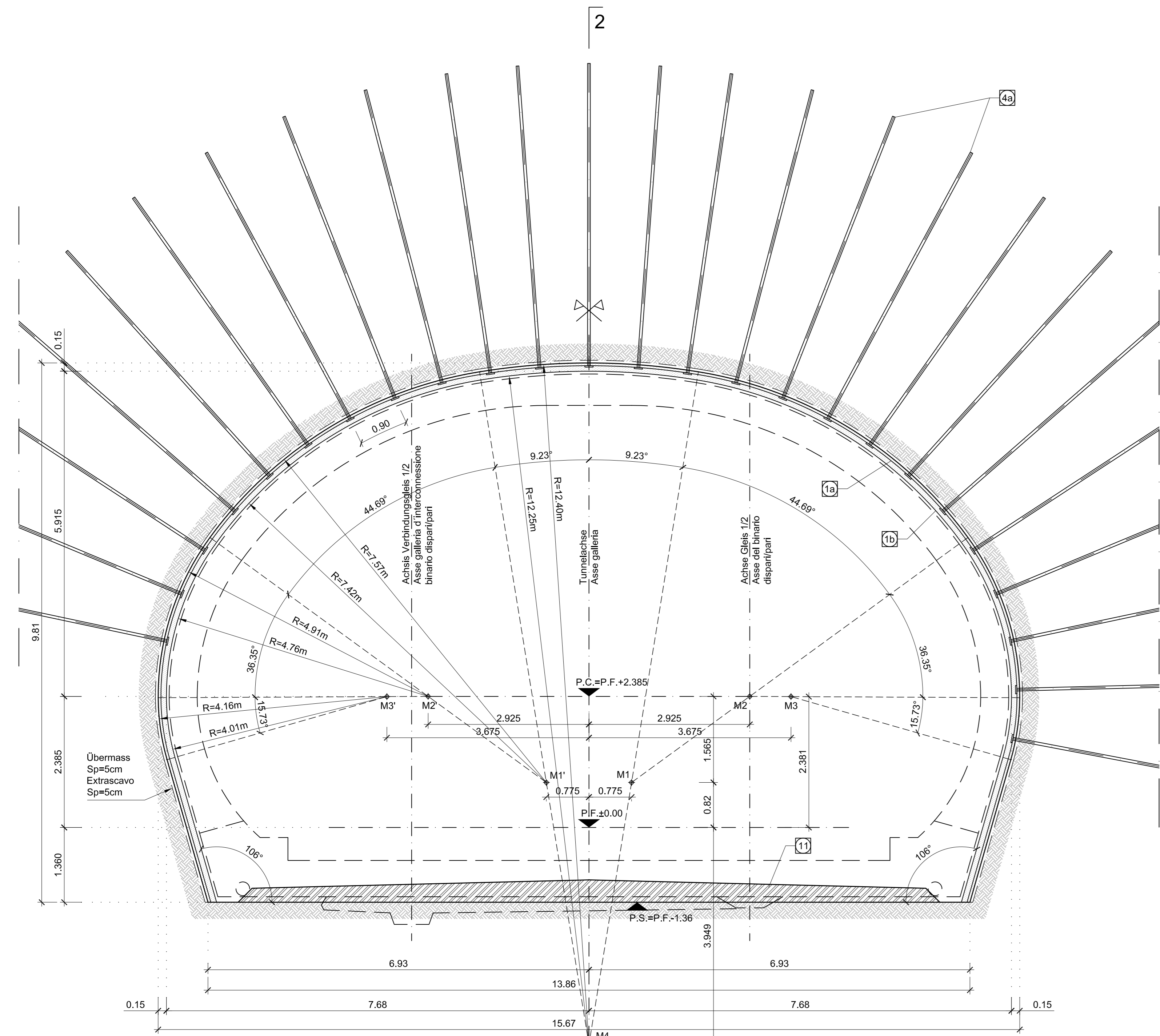
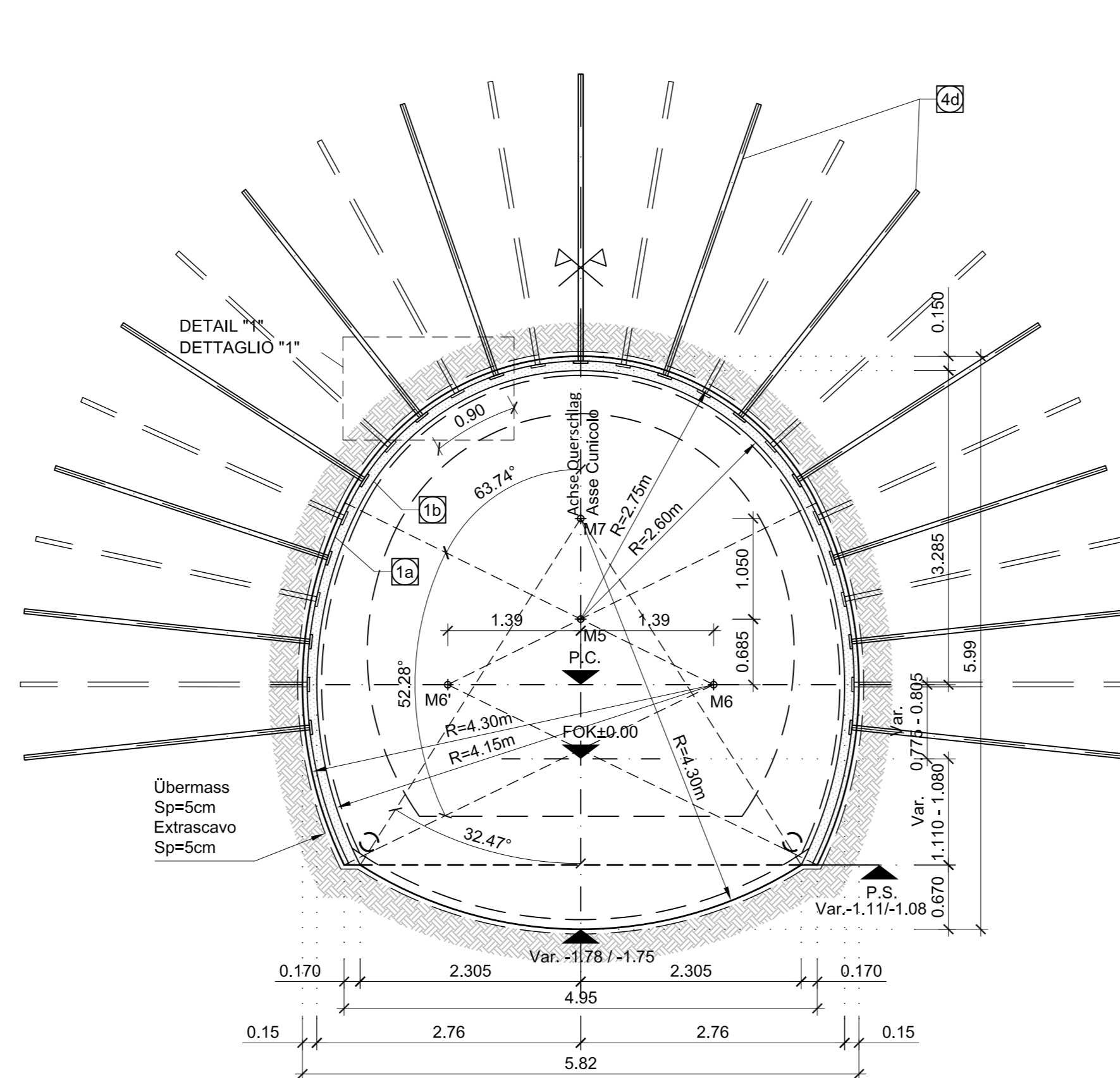

Table with 3 columns: P.T.No., X, Y. Lists coordinates for points M1 through M4.

QUERSCHNITT a / SEZIONE TIPO a
(1:50)



- BAUPHASEN: 1- AUSBAU DES TUNNELS MIT ANWENDUNG DER VERSTÄRKUNGSBANDER AN DER STREBE... 2- AUFBAU DER INNENWAND... 3- STÜTTEN DER INNENWAND... 4- VERSTÄRKUNG DER STREBE... 5- VERSTÄRKUNG DER STREBE... 6- VERSTÄRKUNG DER STREBE...

- FASI ESECUTIVE: 1- SCIAVO DELLA GALLERIA CORRENTE CON APPLICAZIONE DEI TRATTI DI RINFORZO... 2- SCIAVO DELLA GALLERIA CORRENTE CON APPLICAZIONE DEI TRATTI DI RINFORZO... 3- SCIAVO DELLA GALLERIA CORRENTE CON APPLICAZIONE DEI TRATTI DI RINFORZO...

Table with 4 columns: Quantità / Quantità, Unità, Valore, Note. Lists quantities for concrete and steel reinforcement.

QUERSCHNITT b / SEZIONE TIPO b
(1:50)

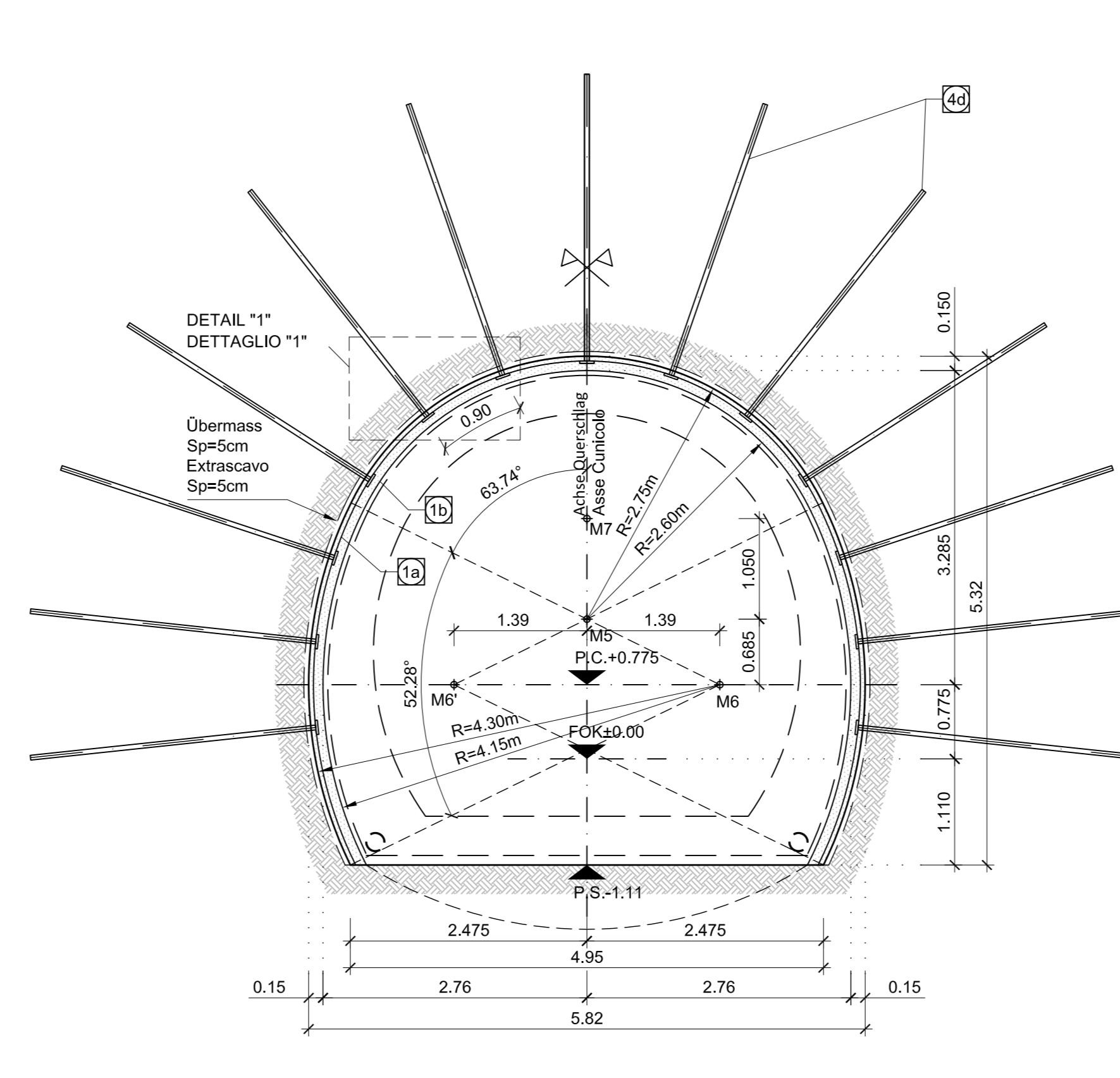

LÄNGSABLAUF / SVILUPPO LONGITUDINALE
(1:50)

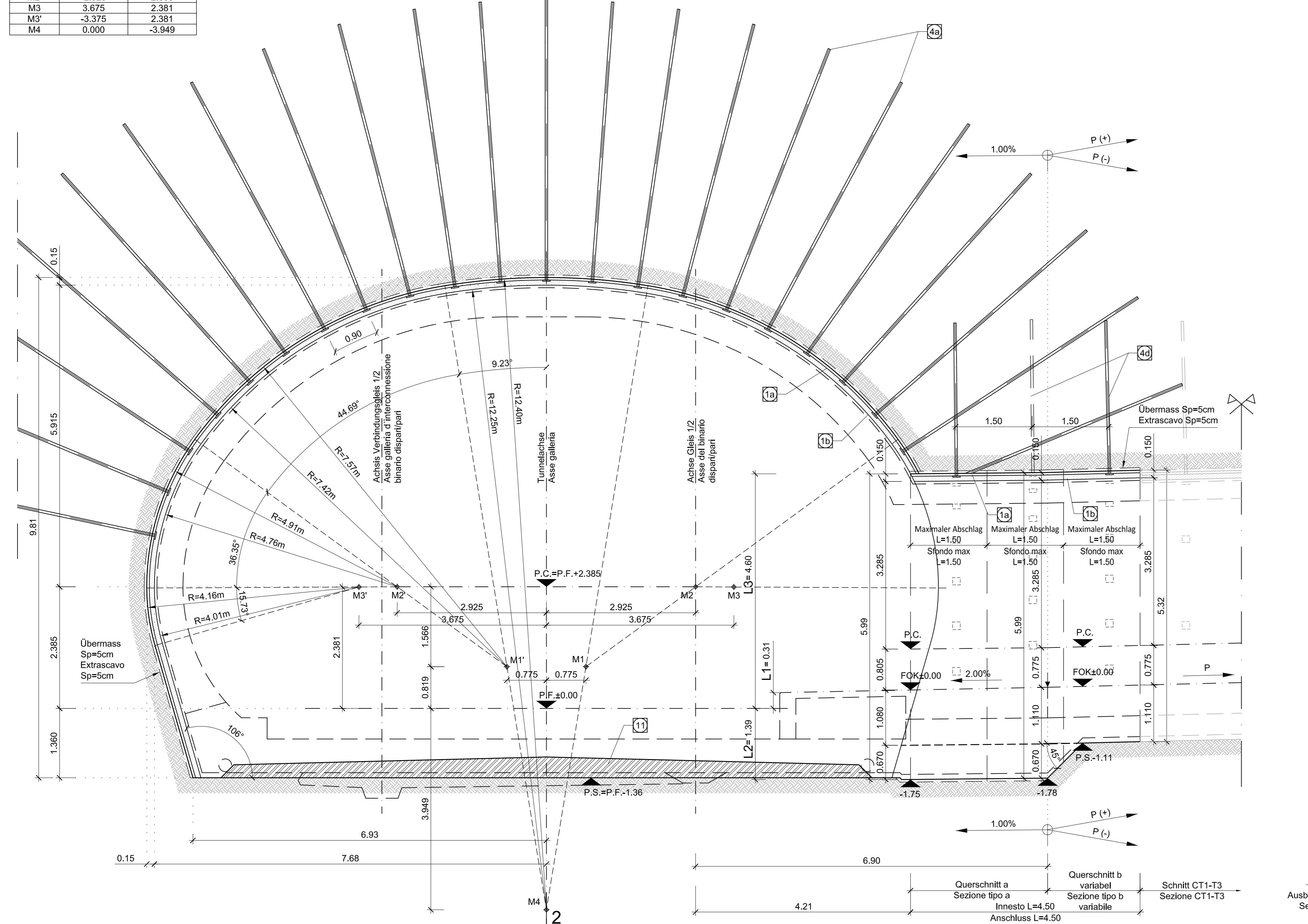

SCNITT 2-2 / SEZIONE 2-2
(1:50)

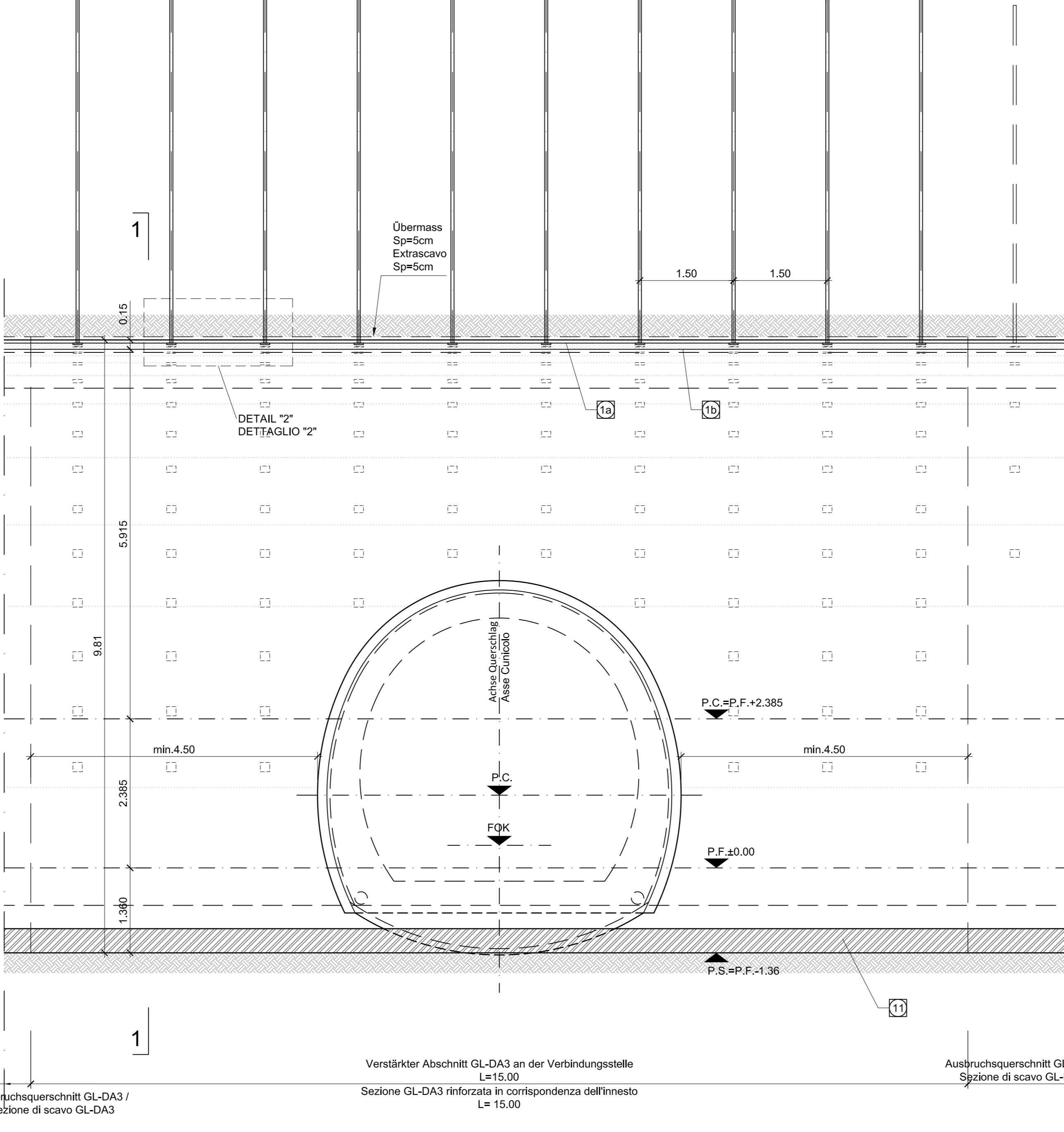

SCHEMA NIETUN
SCNITT CT1-IN-GL-DA3
SCHEMA CHIODATURA
SEZIONE CT1-IN-GL-DA3
(1:50)

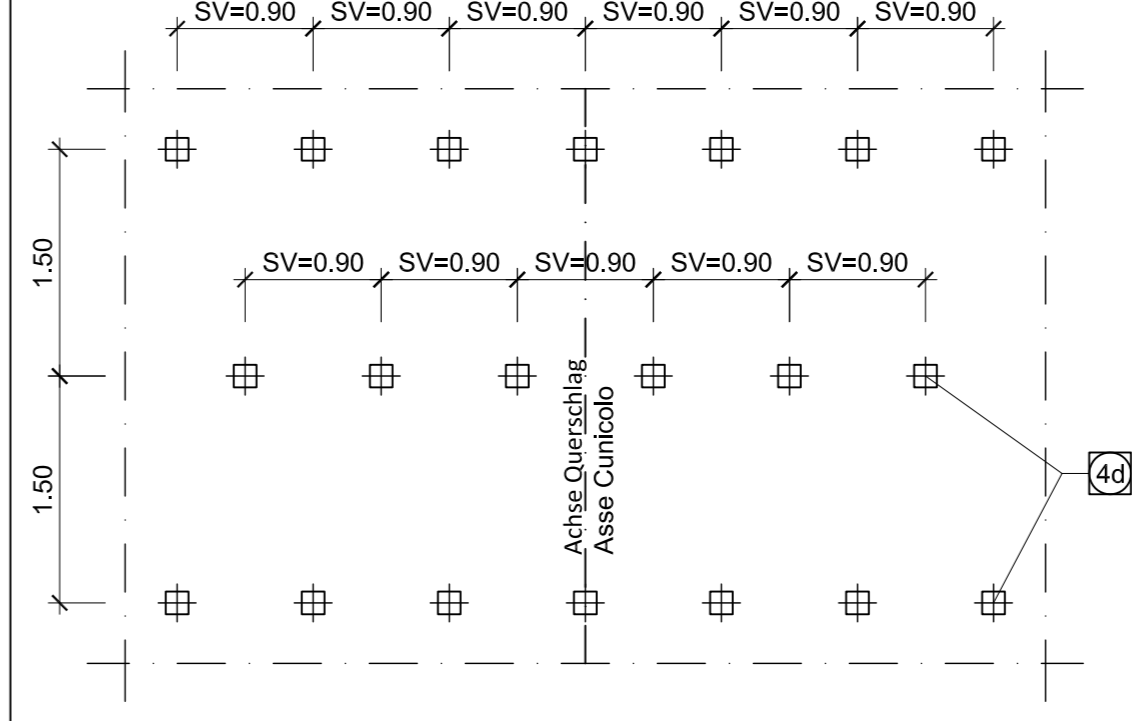

SCHEMA NIETUN
GL-D3 ANSCHLUSS
SCHEMA CHIODATURA
GL-DA3 INNESTO
(1:50)

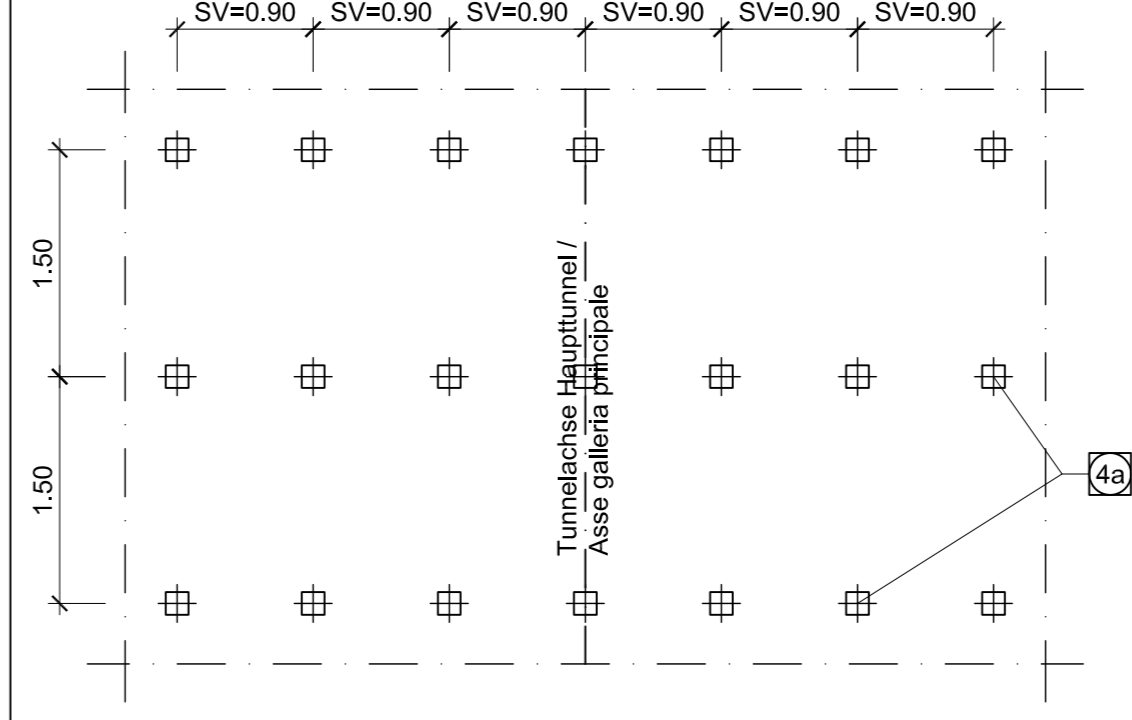

BERMerkUNGEN: 1- DER RECHENWERT... 2- BEI EINER... 3- DIE GEOMETRIE... LEGENDE: P.C. = EBENE DER KREISZENTREN... MATERIALEIGENSCHAFTEN UND TECHNISCHE SPEZIFIKATIONEN: SPRITZBETON MIT STAHLFASERN... RADIALE VERSTÄRKUNG... RADIALE VERSTÄRKUNG... PROJEKTIONEN...

NOTE: LA SEZIONE TIPO... CARATTERISTICHE DEI MATERIALI E SPECIFICHE TECNICHE: BENTONIT PROGETTATO... CARATTERISTICHE DEI MATERIALI E SPECIFICHE TECNICHE: BENTONIT PROGETTATO... CARATTERISTICHE DEI MATERIALI E SPECIFICHE TECNICHE: BENTONIT PROGETTATO...

GRUNDRISS / PIANTA
(1:200)

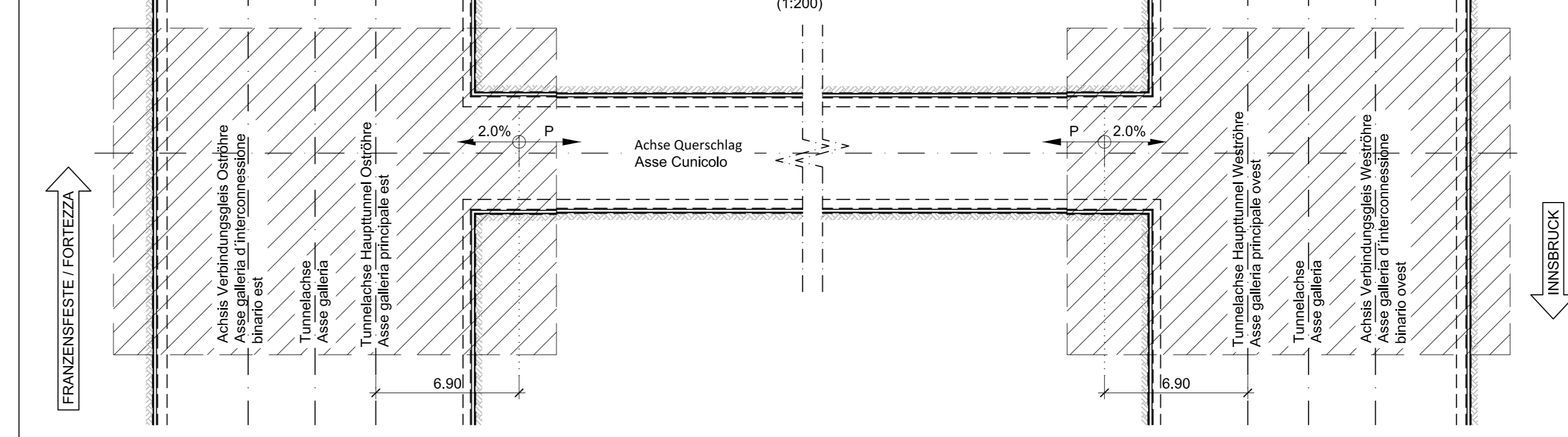

DETAIL 1 / DETTAGLIO 1
(1:20)

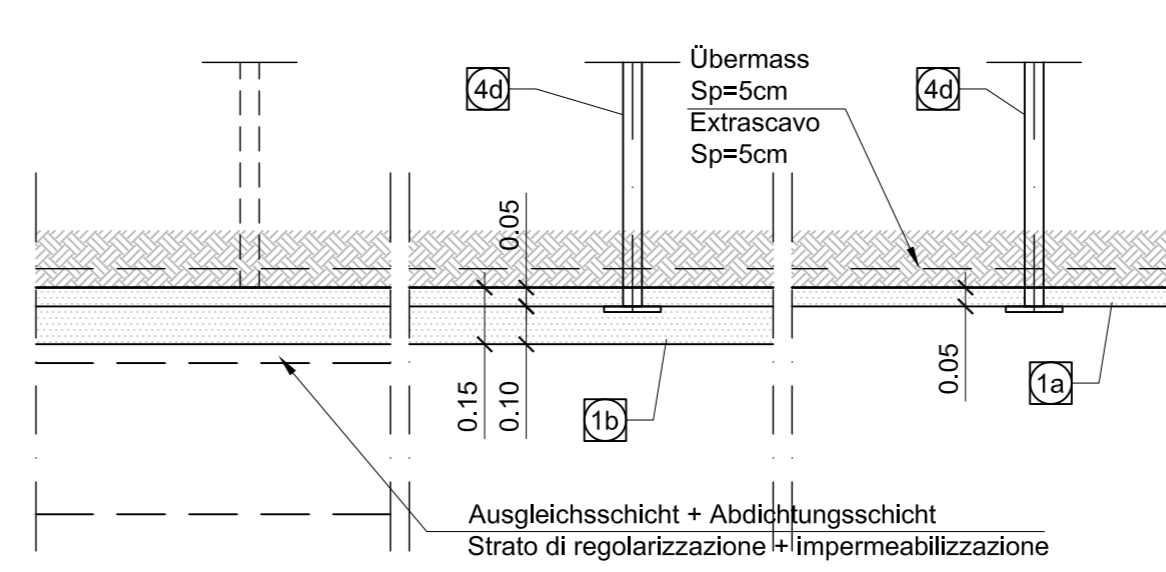

DETAIL 2 / DETTAGLIO 2
(1:20)

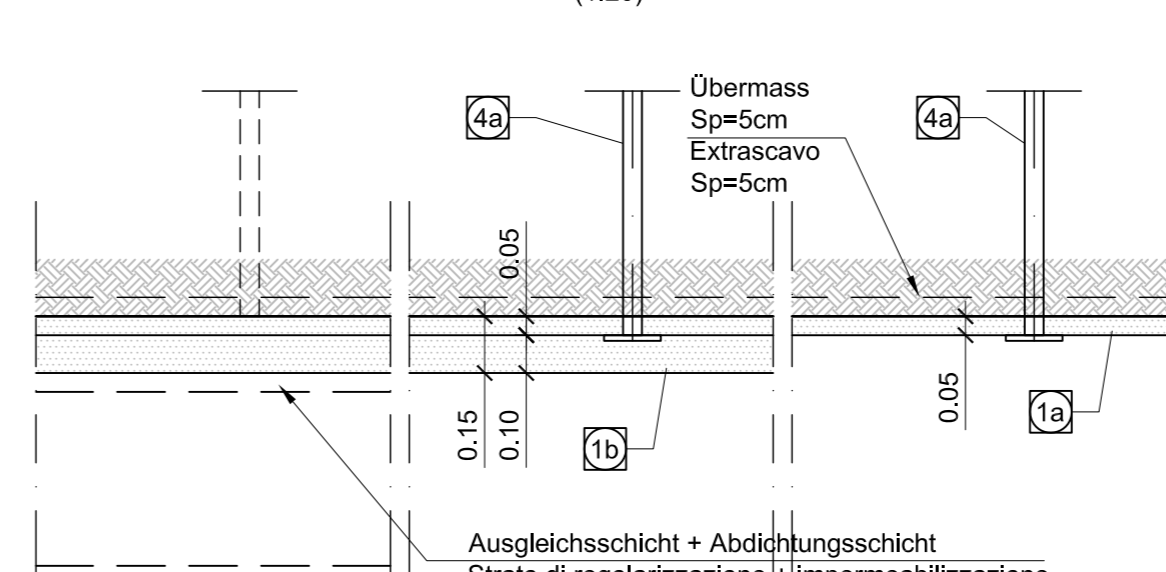

AUSHUBVOLUMEN
(INKL. EXTRAUSHUB)
VOLUME DI SCAVO
(INCLUSO EXTRASCAVO)
(1:200)

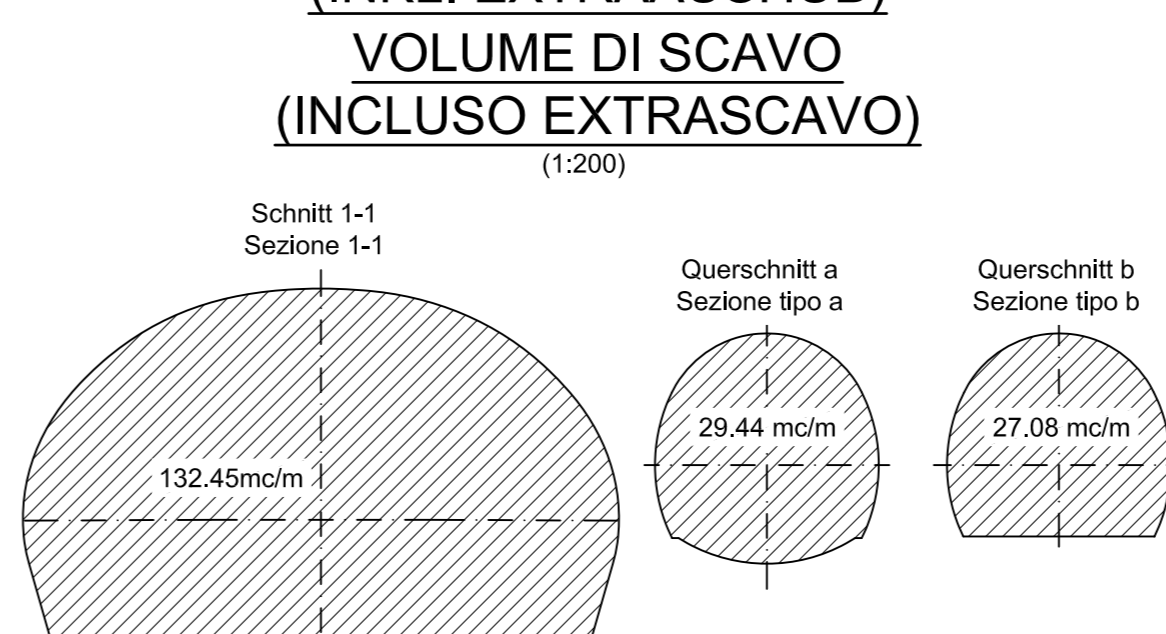

GRUNDRISS ANSCHLUSS / PIANTA INNESTO
(1:100)

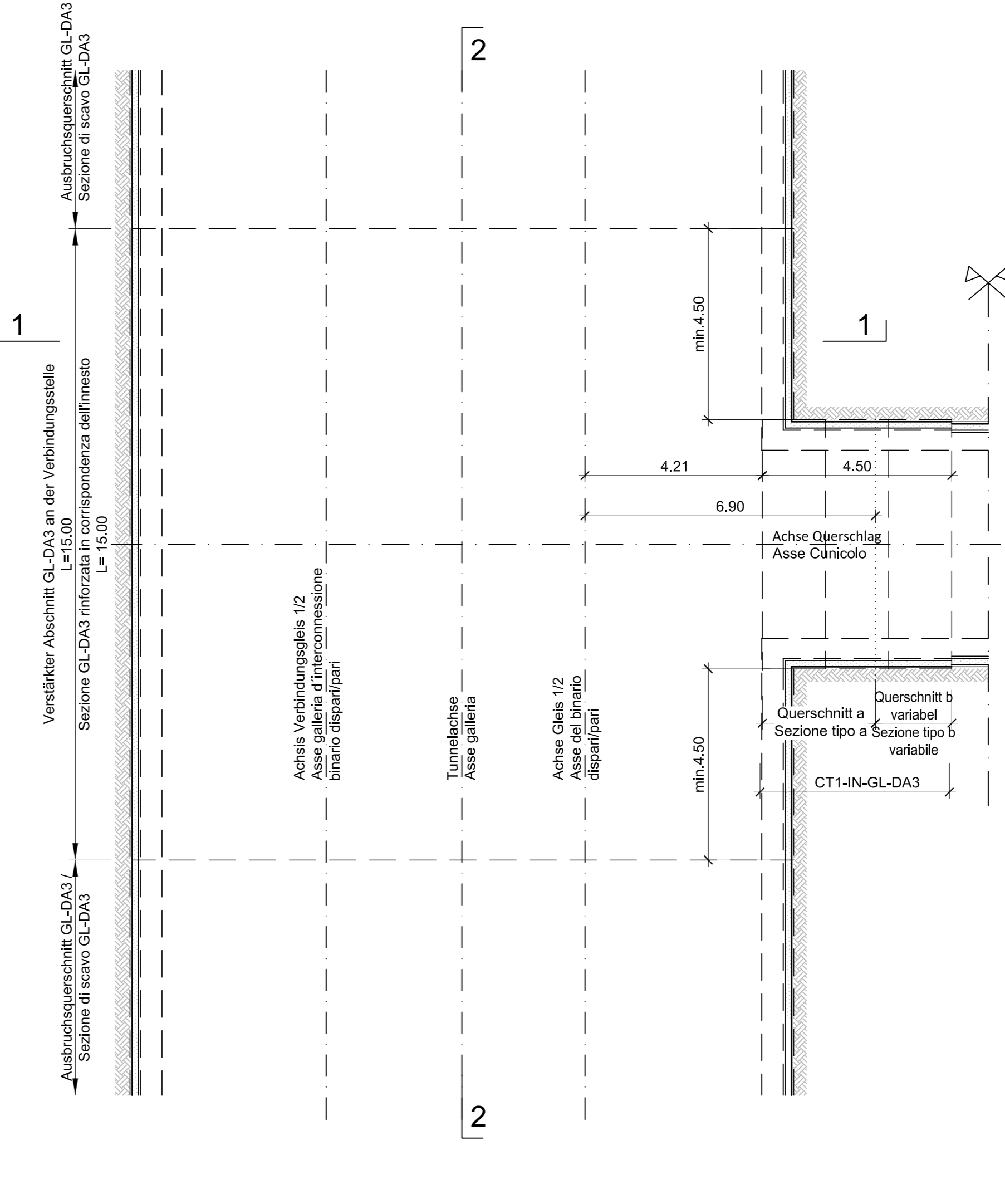

Referenzdokumente: 02_H61_EG_061_P_00700_10007... Bearbeitungsstand: 20.01.2014... Tabelle with columns for Revision, Beschreibung, Änderungen, Verantwortlicher, Änderung, Datum.

BRENNER BASISTUNNEL: GALLERIA DI BASE DEL BRENNERO... Project information including client, contractor, and technical details.