

QUERSCHNITT MGC-Ea-T / SEZIONE TIPO MGC-Ea-T

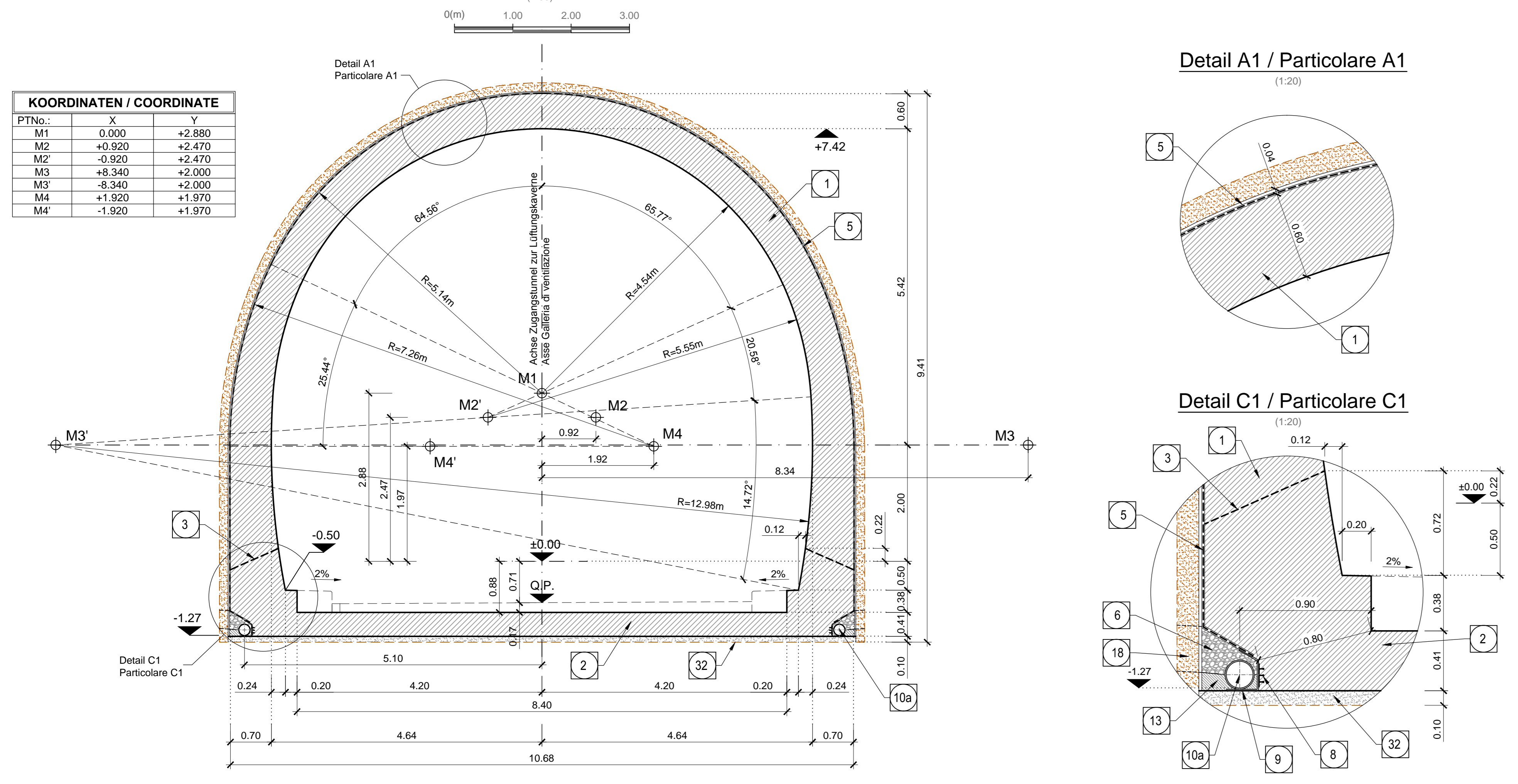

Darstellung der bestehenden Bauwerke  
Rappresentazione delle opere esistenti

ANMERKUNGEN / ANNOTAZIONI  
P.P. Projekthöhe Zugangstunnel zur Lüftungskammer und Lüftungskammer  
Quota di progetto Galleria e Camere di ventilazione

QUERSCHNITT MCV-E-T / SEZIONE TIPO MCV-E-T

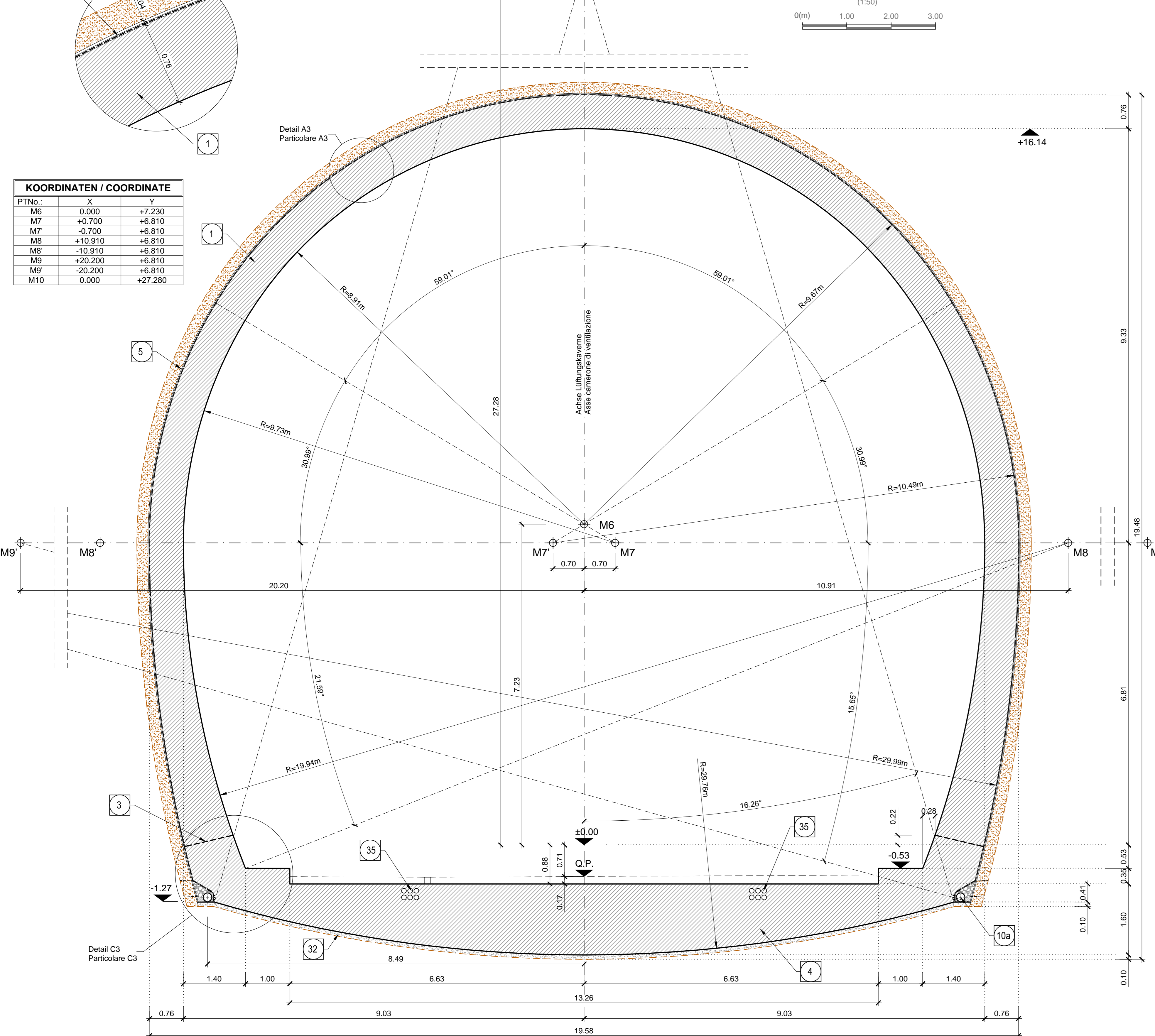

QUERSCHNITT MGC-Eb-T / SEZIONE TIPO MGC-Eb-T

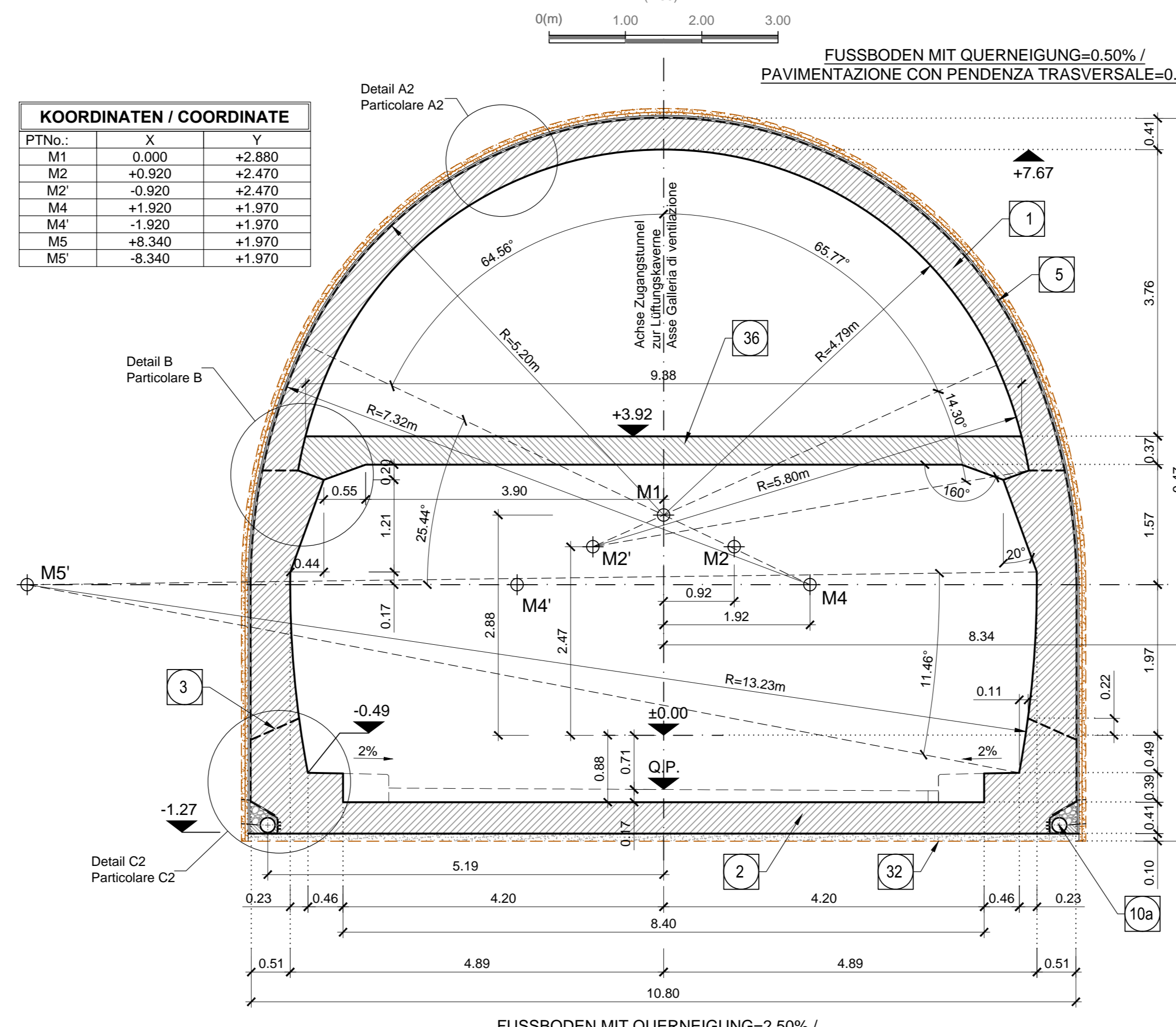

ANMERKUNGEN / ANNOTAZIONI  
P.P. Projekthöhe Zugangstunnel zur Lüftungskammer und Lüftungskammer  
Quota di progetto Galleria e Camere di ventilazione

QUERSCHNITT ANSAUGSCHACHT SEZIONE POZZO DI ASPIRAZIONE

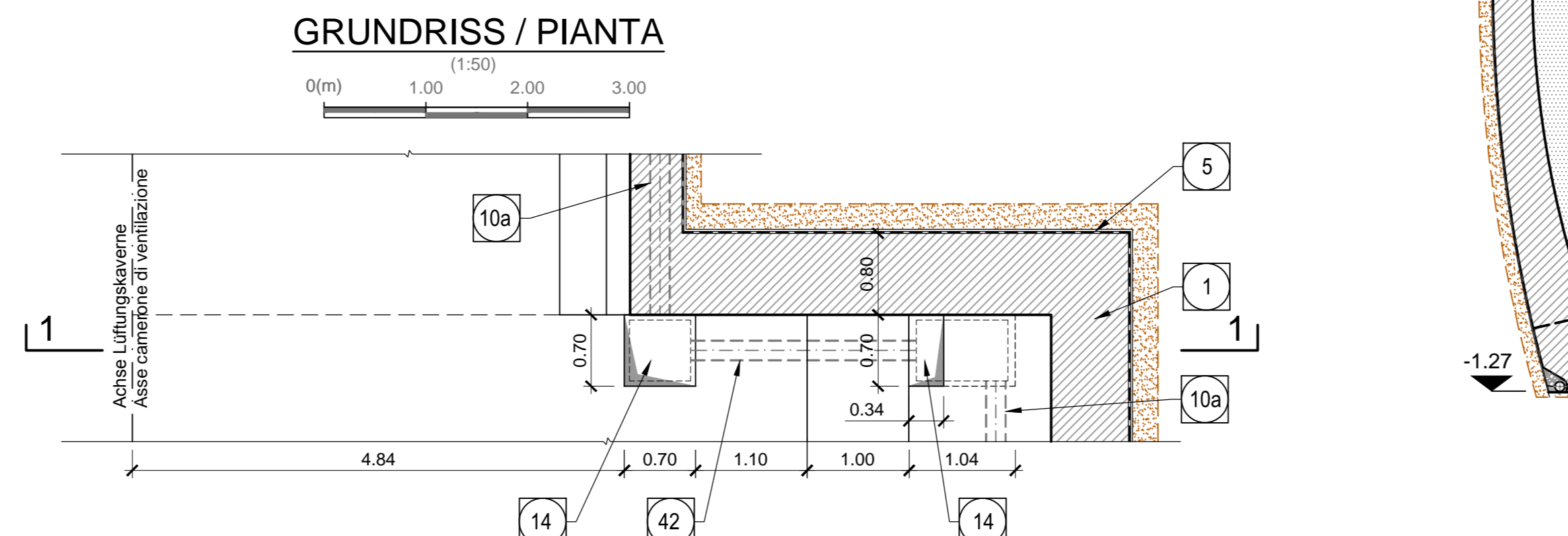
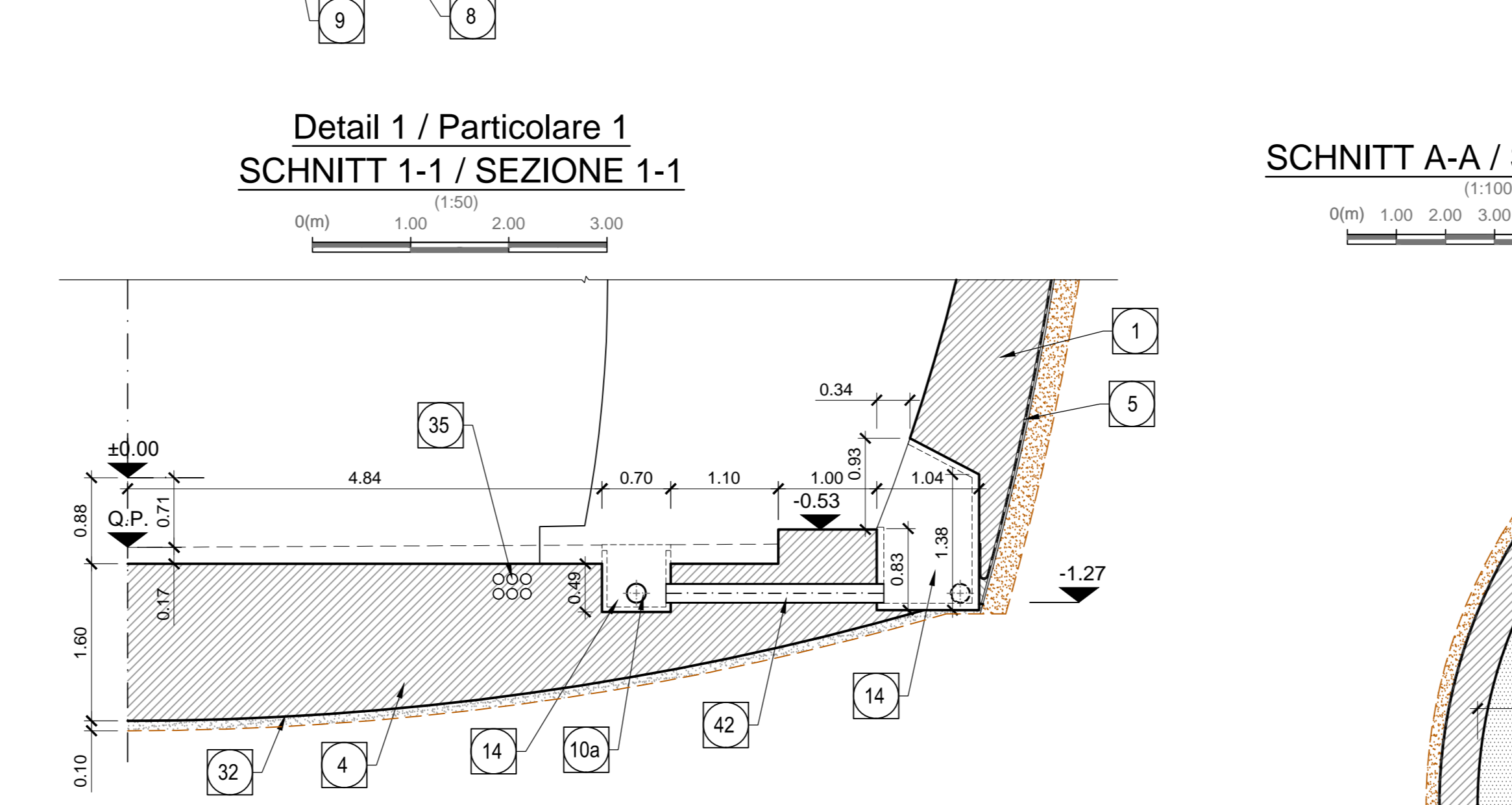
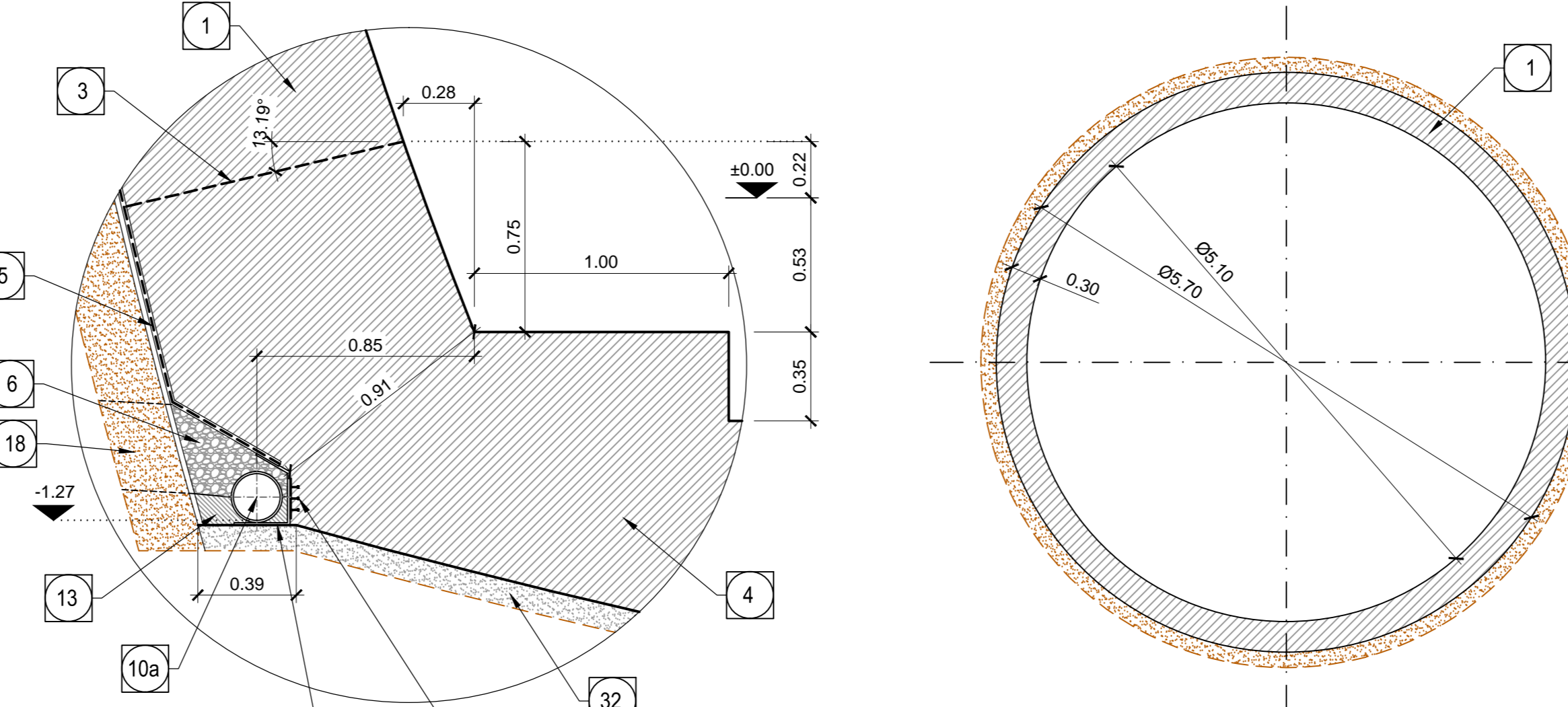
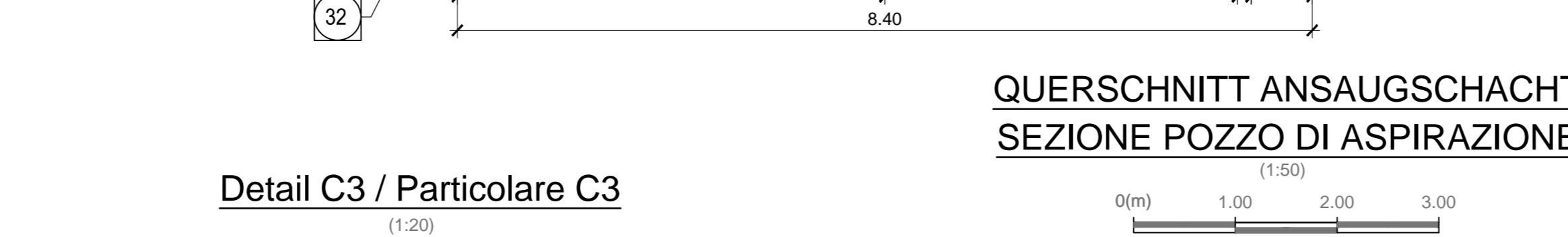

QUERSCHNITT MGC-Ea-T / SEZIONE TIPO MGC-Ea-T

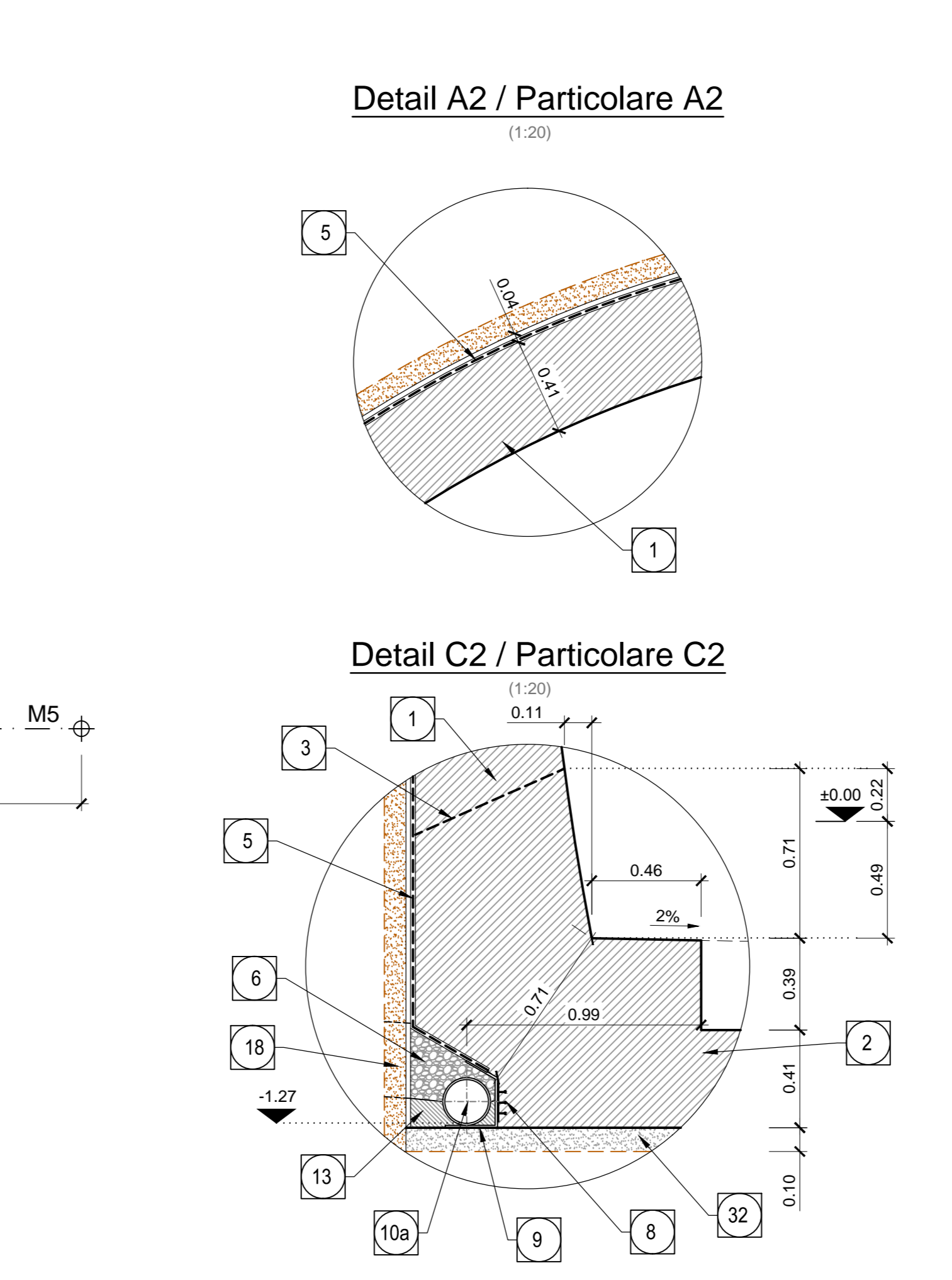

NOTE  
LE GEOMETRIE DEL RIVESTIMENTO DEFINITO SONO STATE DEFINITE SUL PROFILO TECNICO DI PROGETTO, CONSERVANDO UN PACCHETTO DI IMPERMEABILIZZAZIONE DI K<sub>10</sub>=1.5m DI BETONCINO DI REGULARIZZAZIONE E 1cm DI IMPERMEABILIZZAZIONE.

BEMERKUNGEN  
DIE INNEREN GEOMETRIEN SIND AUFGRUND DES THEORETISCHEN PLANUNGSPROFILS BESTIMMT WORDEN, UNTER BEWACHTUNG EINER ABDICHTUNGSMASSE VON K<sub>10</sub>=1.5m ANGLICHTERPREZISION (DÜSE, VON ABDICHTUNG).

SCHLÜSSELPLAN / PIANTA CHIAVE

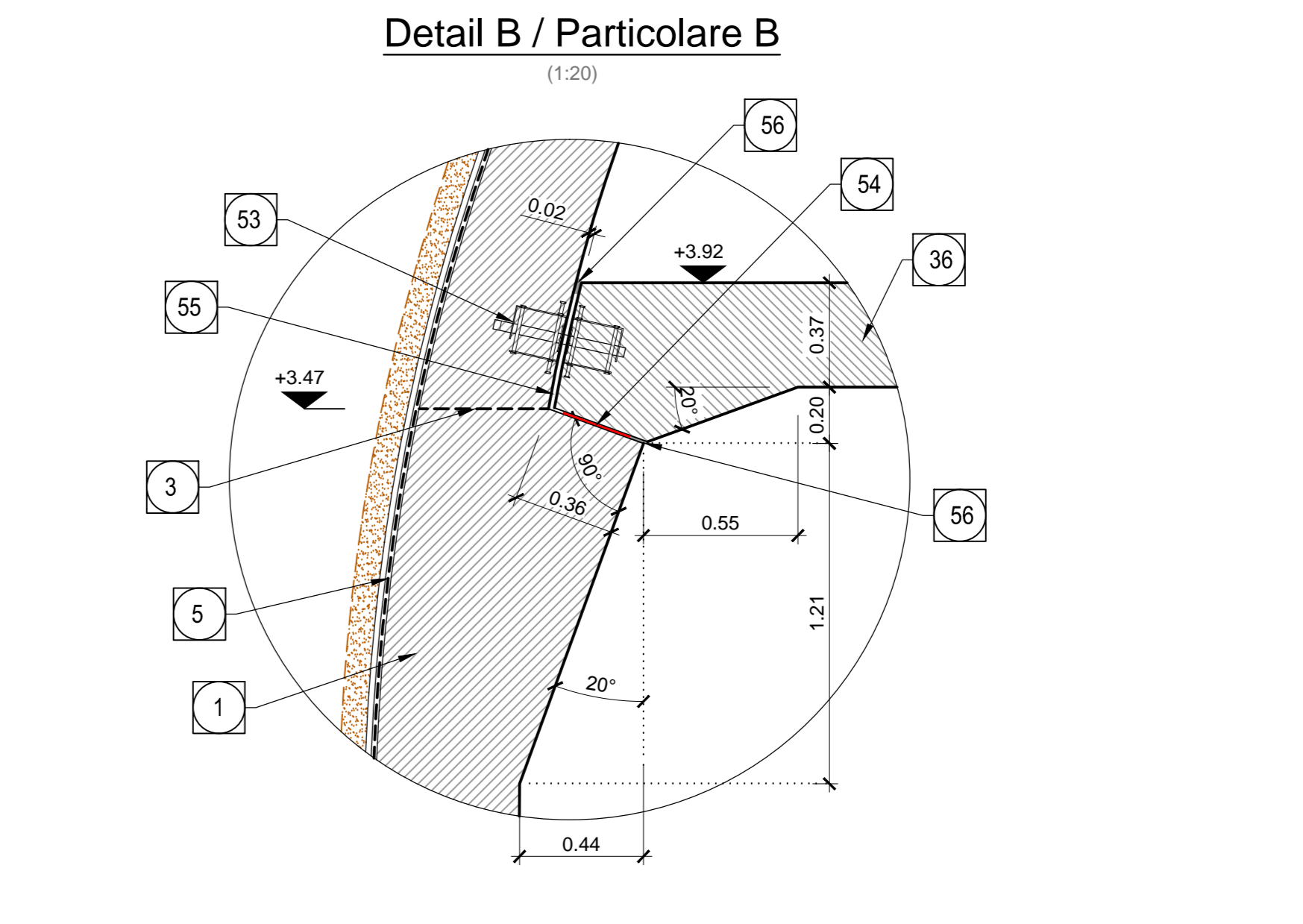
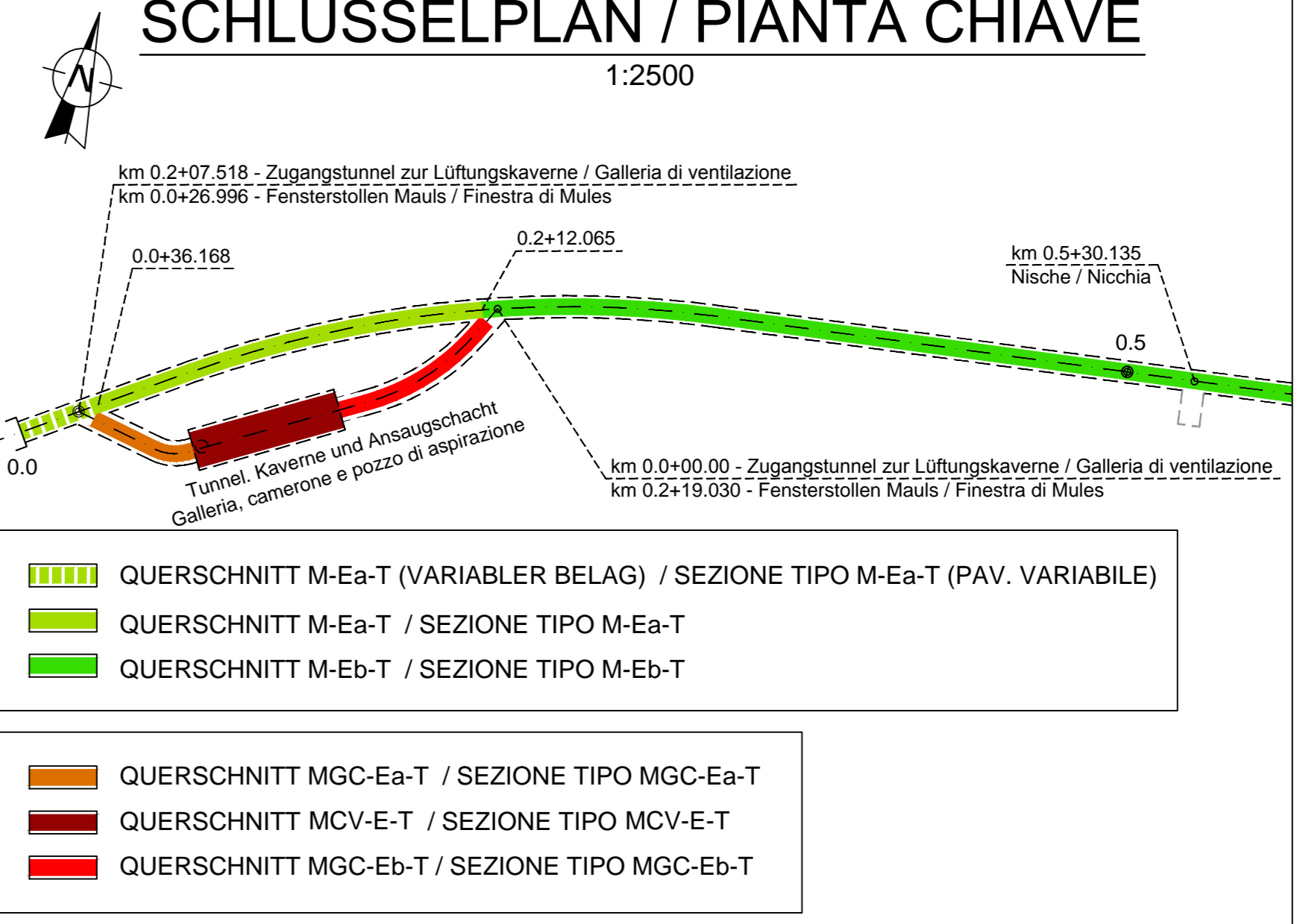

GRUNDRISS LÜFTUNGSKAVERNE / PIANTA CAMERONE DI VENTILAZIONE

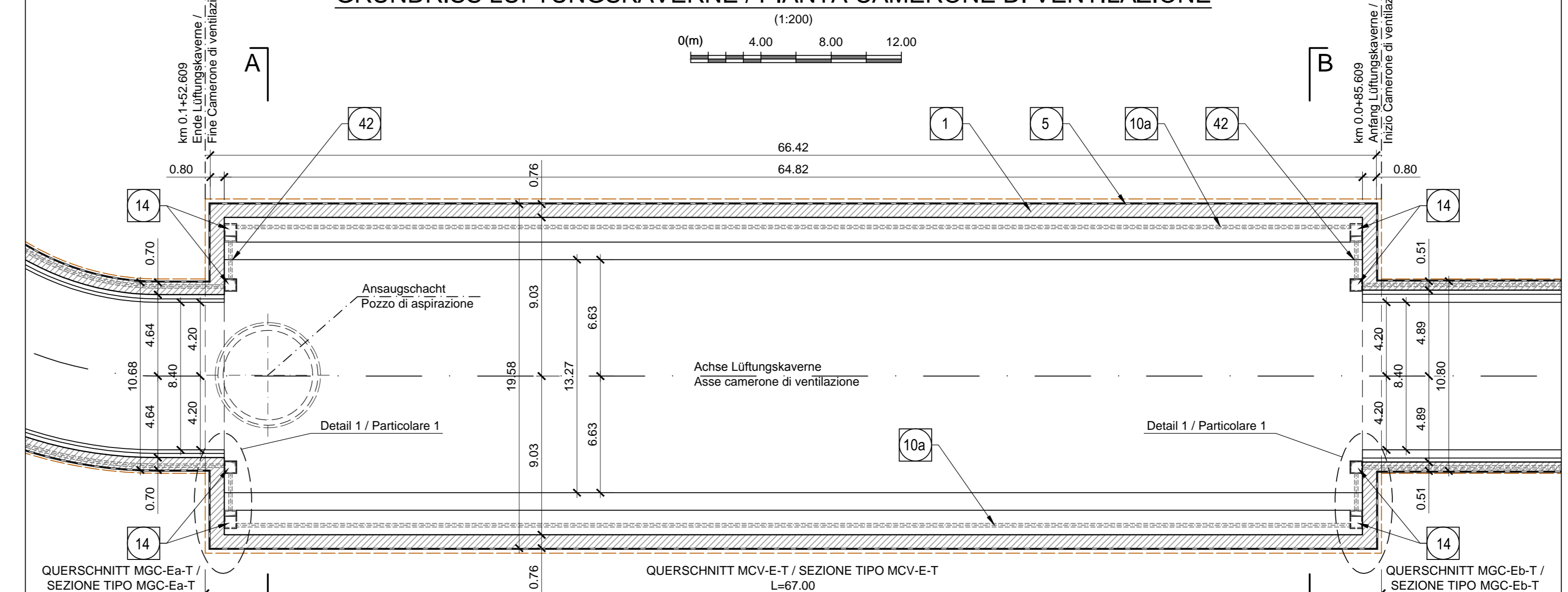

SCHNITT A-A / SEZIONE A-A

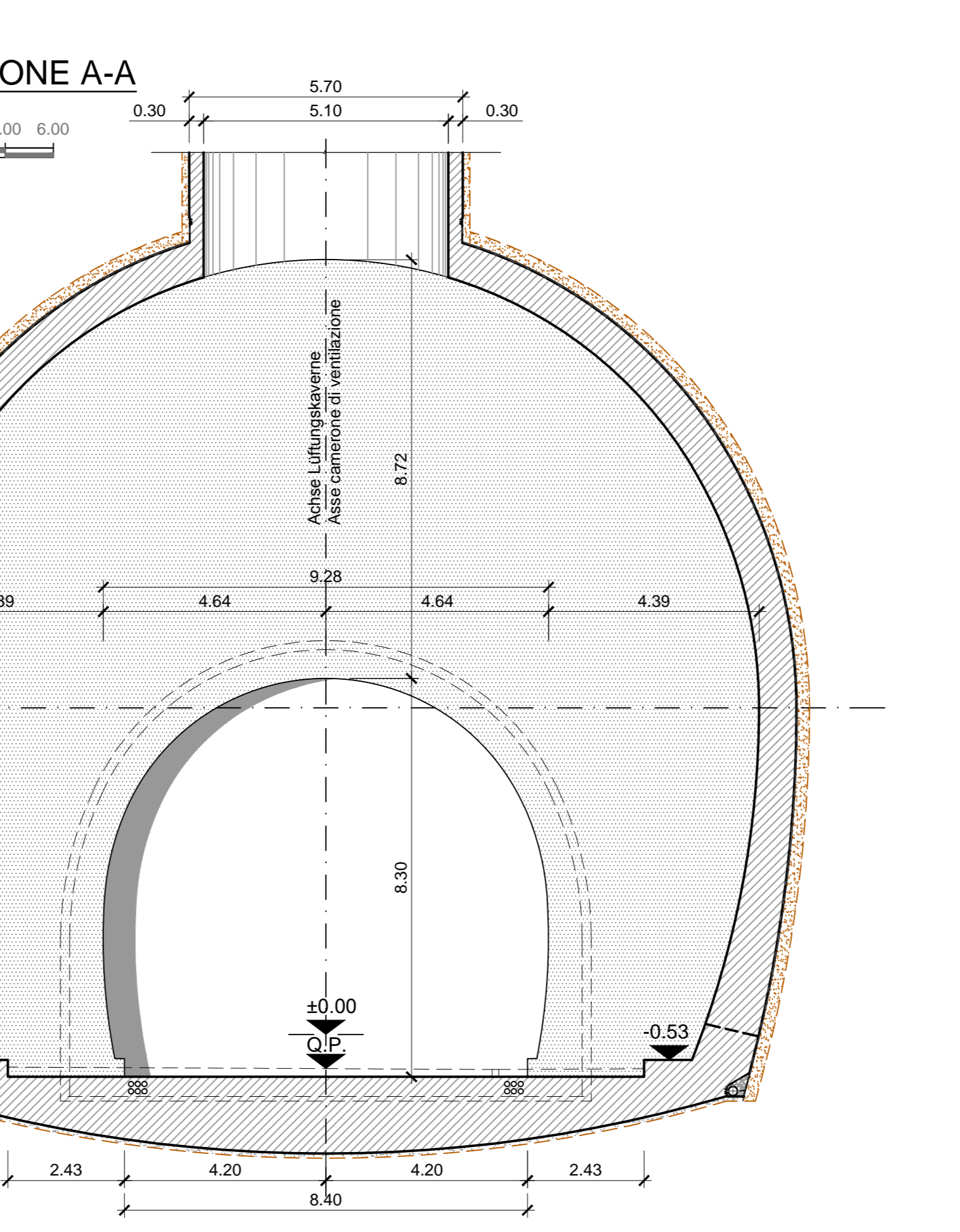

SCHNITT B-B / SEZIONE B-B

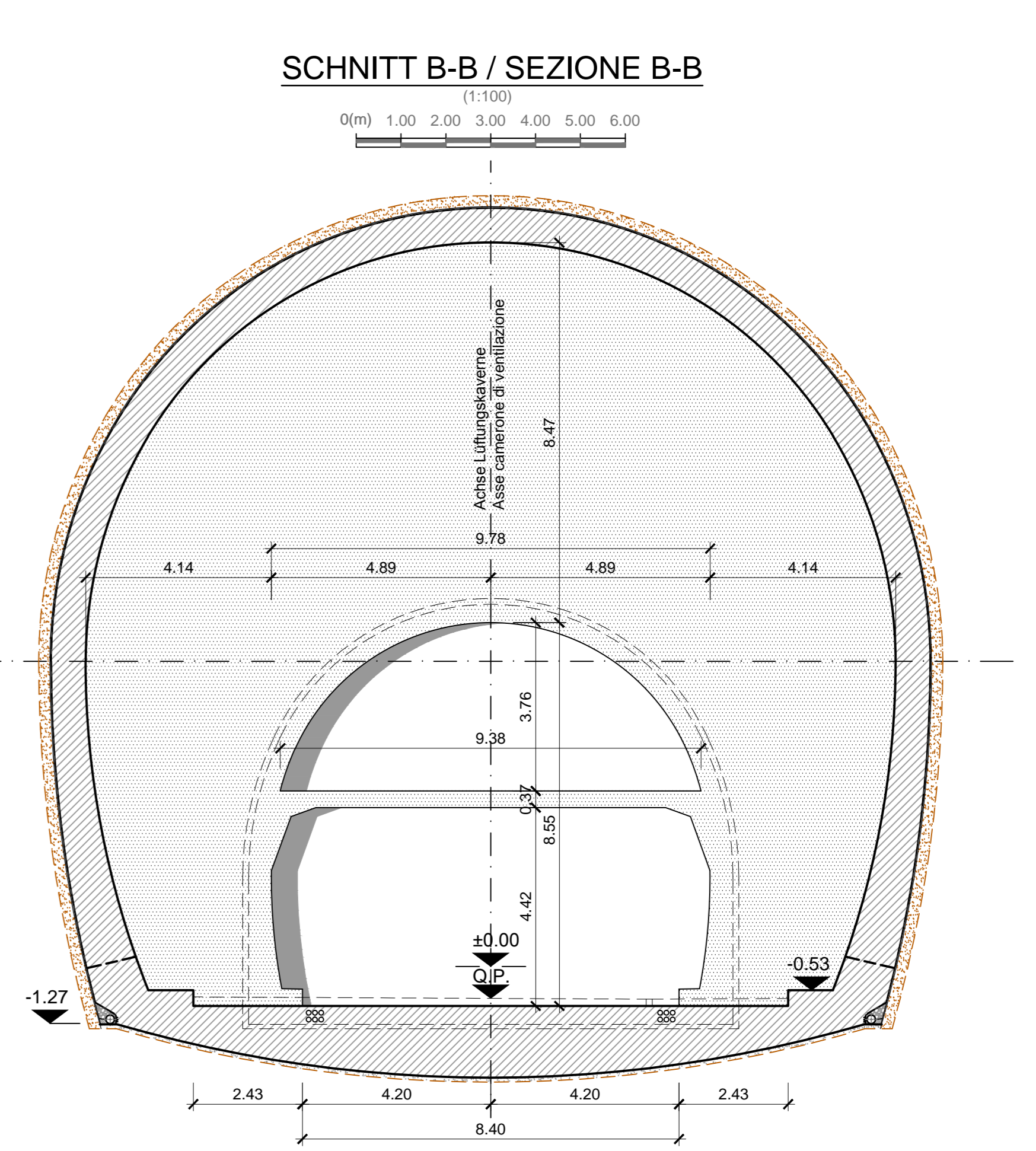

Legend for materials and components, numbered 1 to 56. Includes descriptions in Italian and German for various items like concrete, steel, and insulation.

Referenzdokumente (Reference documents) table listing standards and technical documents used in the project.

Stato di elaborazione (Status of elaboration) table showing revision history with columns for revision number, description, author, and date.

Project information and logos. Includes the BBT logo, project name 'BRENNER BASISTUNNEL GALLERIA DI BASE DEL BRENNERO', and logos of participating companies like PNY, Pöyry, and pini swiss.