

SCHNITT A-A / SEZIONE A-A  
(1:50)

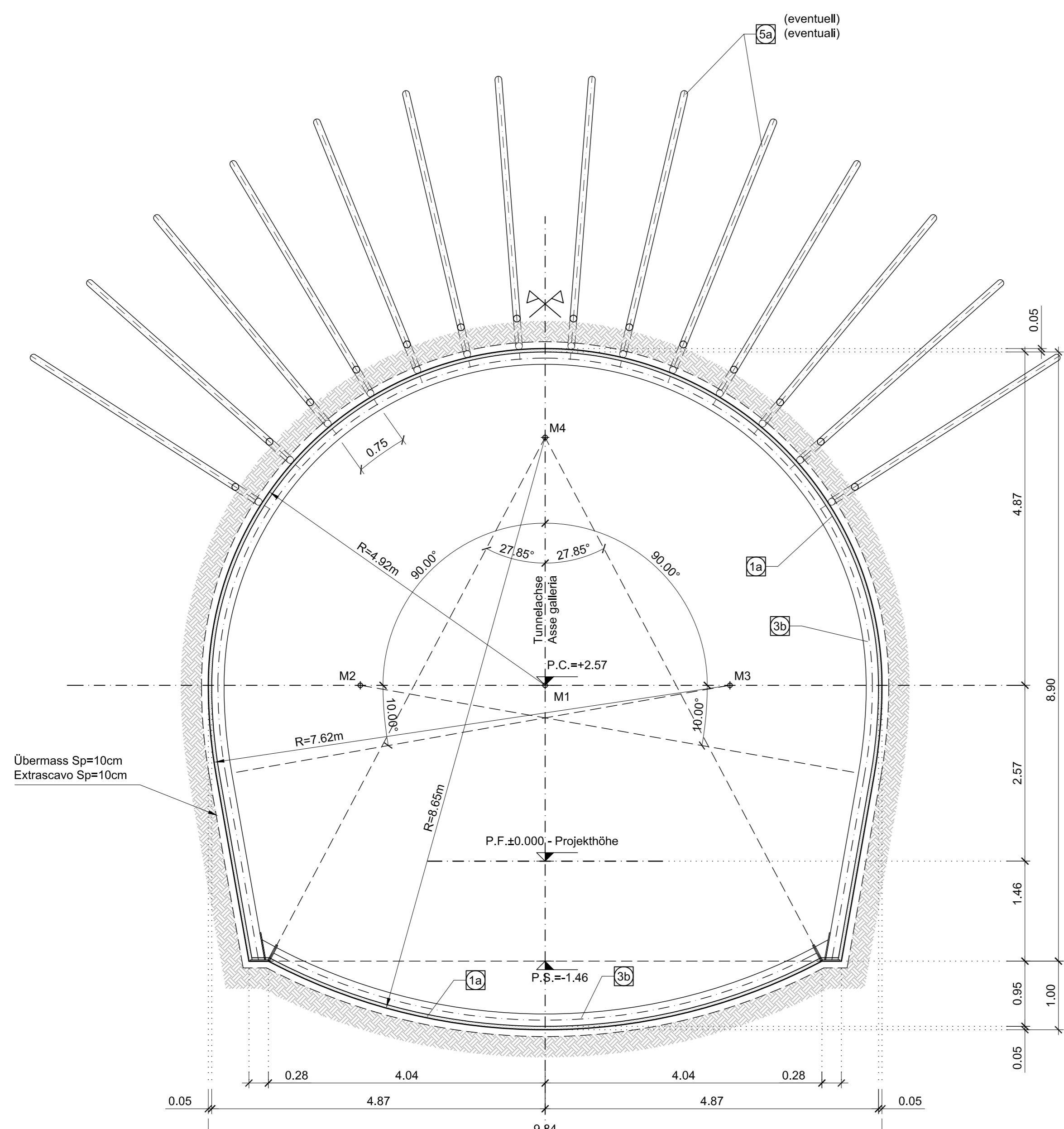

AUSHUBVOLUMEN  
(INKL. EXTRAUSHUB)  
VOLUME DI SCAVO  
(INCLUSO EXTRASCAVO)

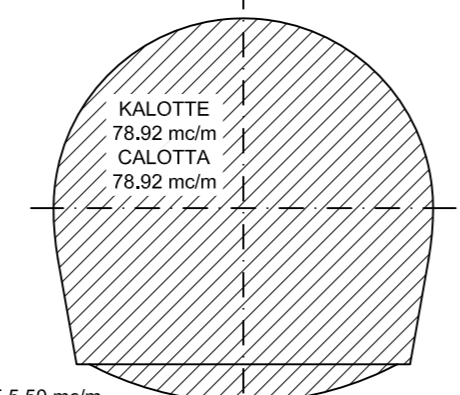
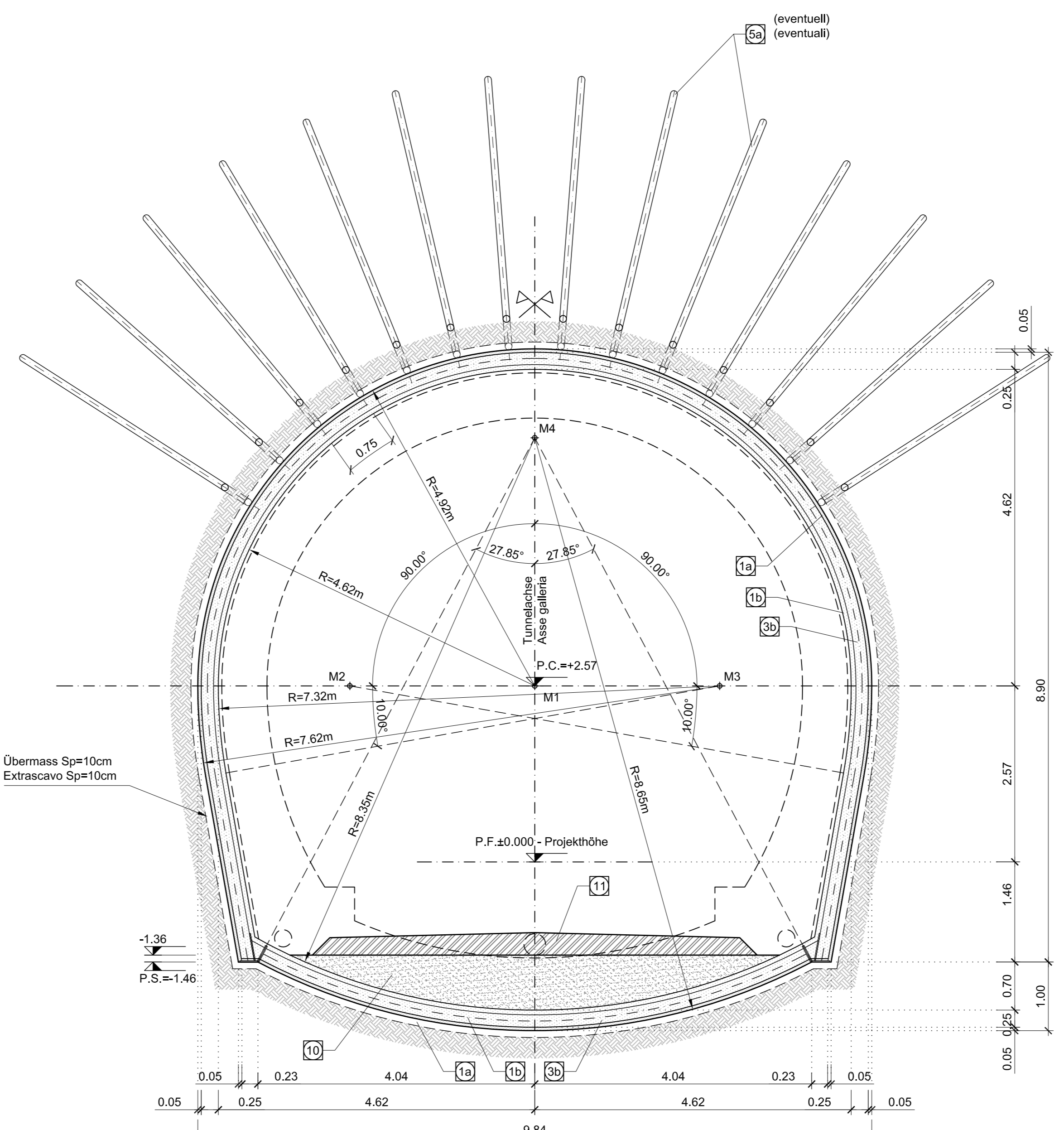
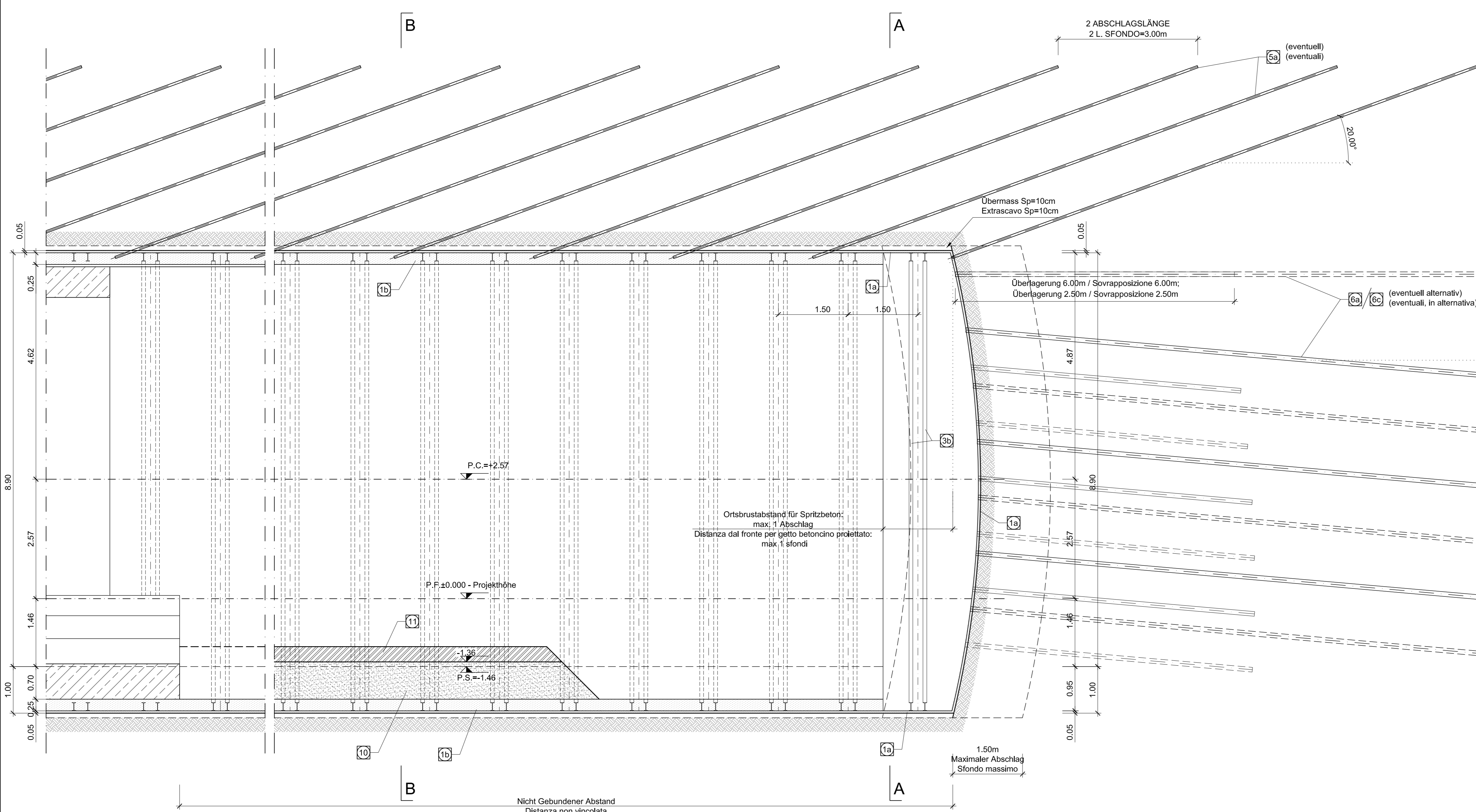

Table with 3 columns: P.No., X, Y. Coordinates for points M1, M2, M3, M4.

SCHNITT B-B / SEZIONE B-B  
(1:50)



LÄNGSABLAUF / SVILUPPO LONGITUDINALE  
(1:50)



SCHNITT A-A MIT SCHEMA DER VERGÜTUNG DER ORTSBRUST/  
SEZIONE A-A CON SCHEMA TRACCIAMENTO INTERVENTI  
DI CONSOLIDAMENTO AL FRONTE (EVENTUALI)

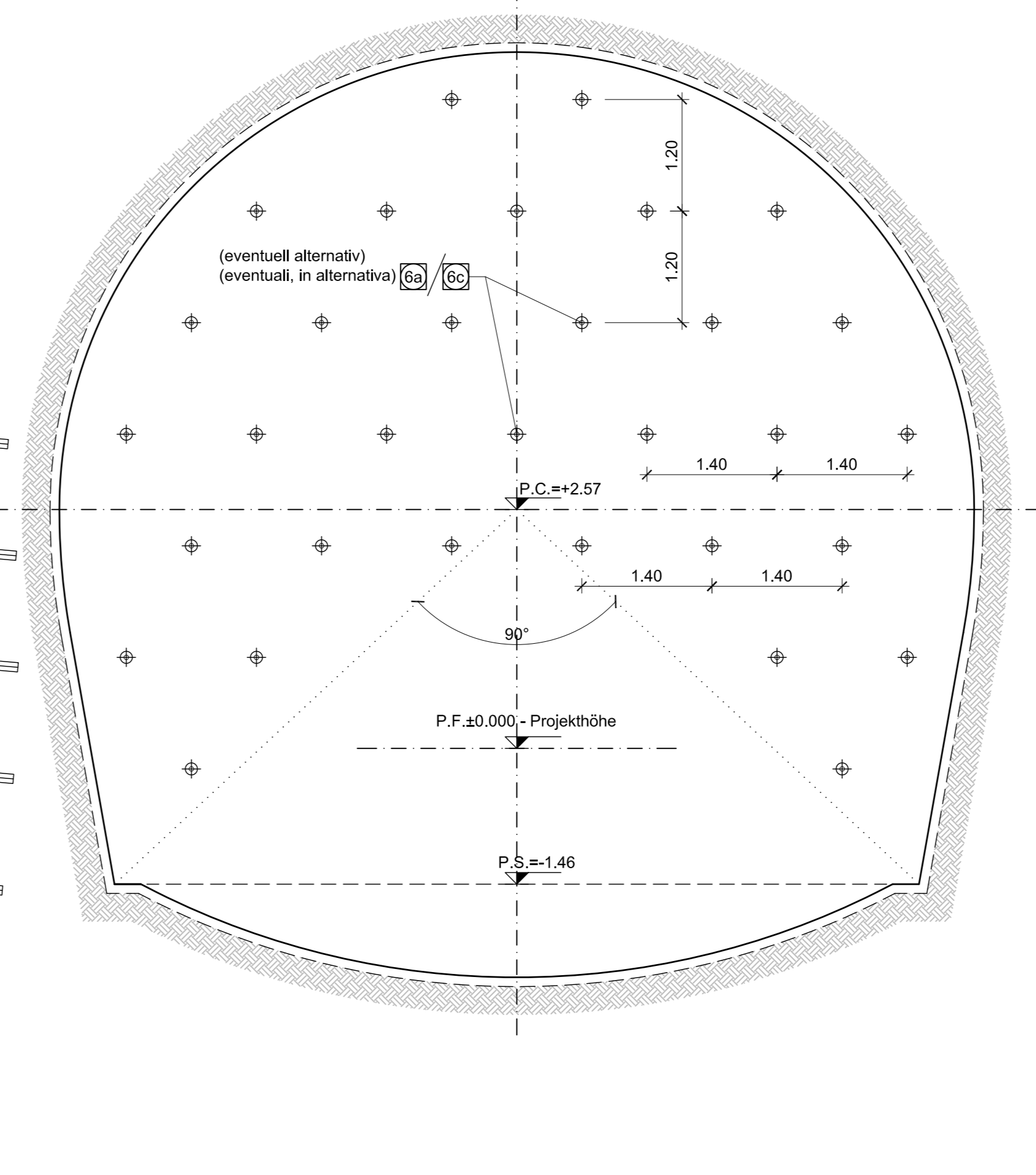

Technical notes, legend, and material specifications in Italian. Includes sections: BEMERKUNGEN, LEGENDE, BAUPHASEN, MATERIALEIGENSCHAFTEN UND TECHNISCHE SPEZIFIKATIONEN.

Notes, legend, and execution phases in German. Includes sections: NOTE, LEGENDE, FASI ESECUTIVE.

Material and technical characteristics table. Includes sections: CARATTERISTICHE DEI MATERIALI E SPECIFICHE TECNICHE.

Table with 4 columns: Bereich/Campo, Specificazione, Einheit/Unità, Dimensionen/Dimensioni. Lists various materials and their specifications.

Table with 3 columns: Revision, Änderungs-Modifizierung, Verantwortlicher Änderung/Responsabile modifica. Revision history table.

Table with 4 columns: Revision, Datum, Datum, Datum. Revision dates table.

Project information and contact details. Includes logos for BBT, Pöyry, and other partners. Contains project name: BRENNER BASISTUNNEL, GALLERIA DI BASE DEL BRENNERO.