

SCHNITT A-A / SEZIONE A-A

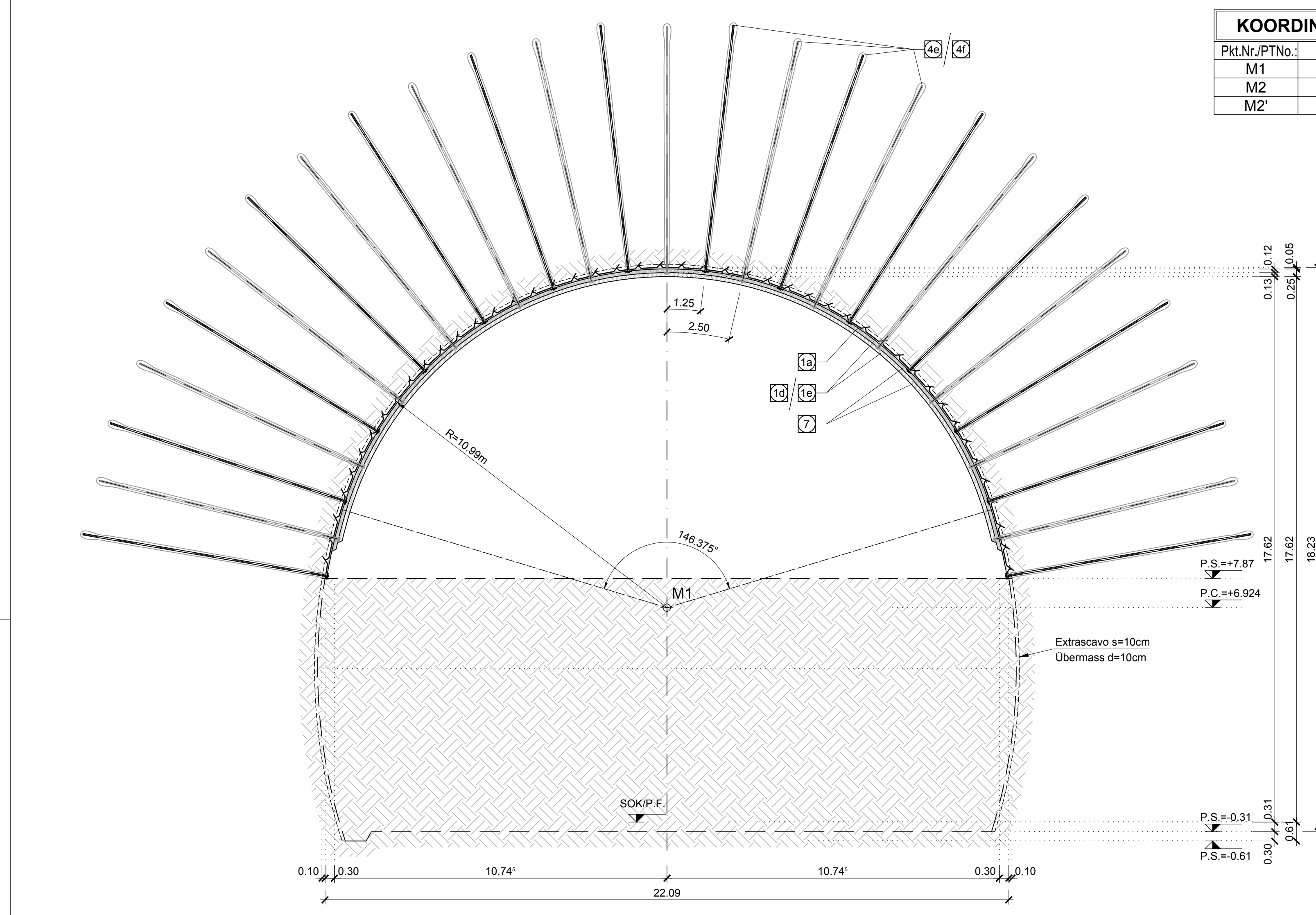
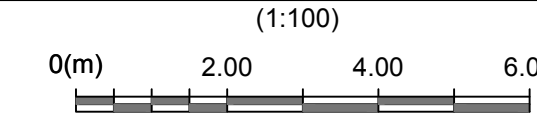
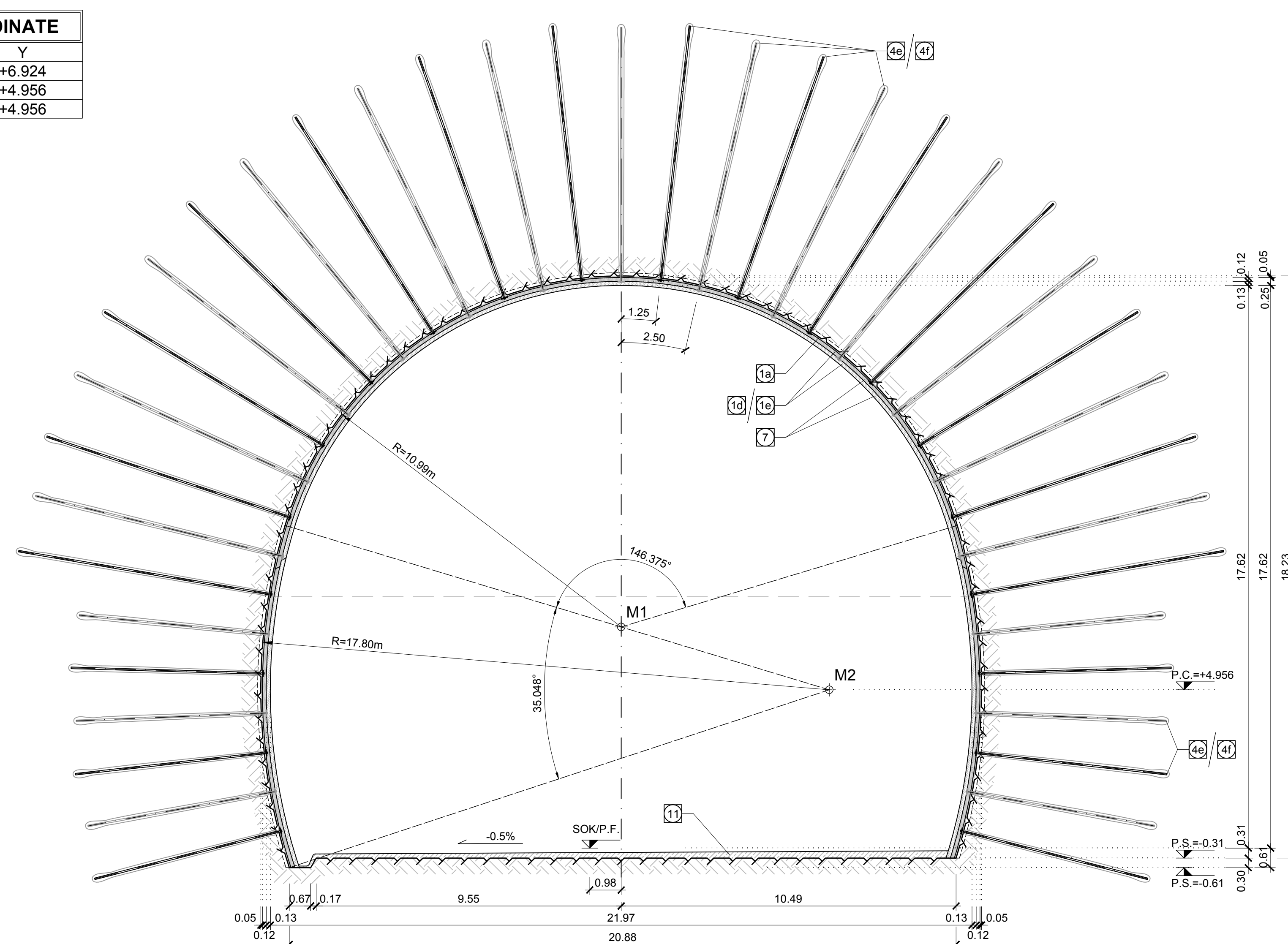
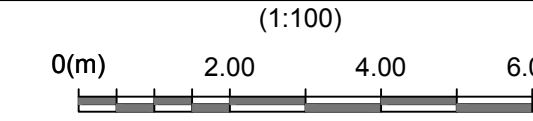
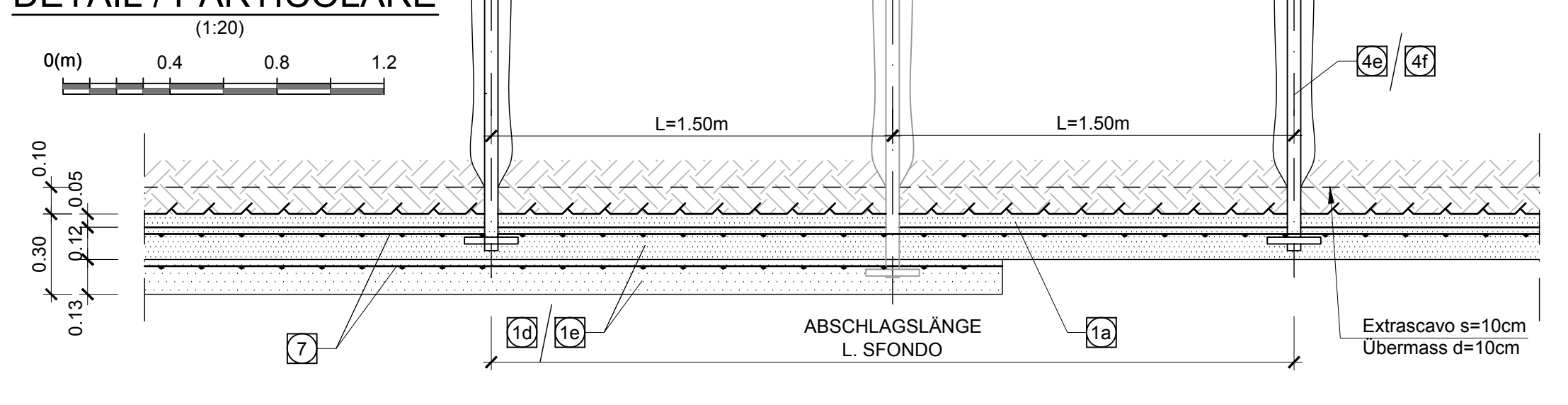

Table with 3 columns: PKL.N./PT.No., X, Y. Rows for points M1, M2, and M2'.

SCHNITT B-B / SEZIONE B-B



DETAIL / PARTICOLARE



LÄNGSABLAUF / SVILUPPO LONGITUDINALE

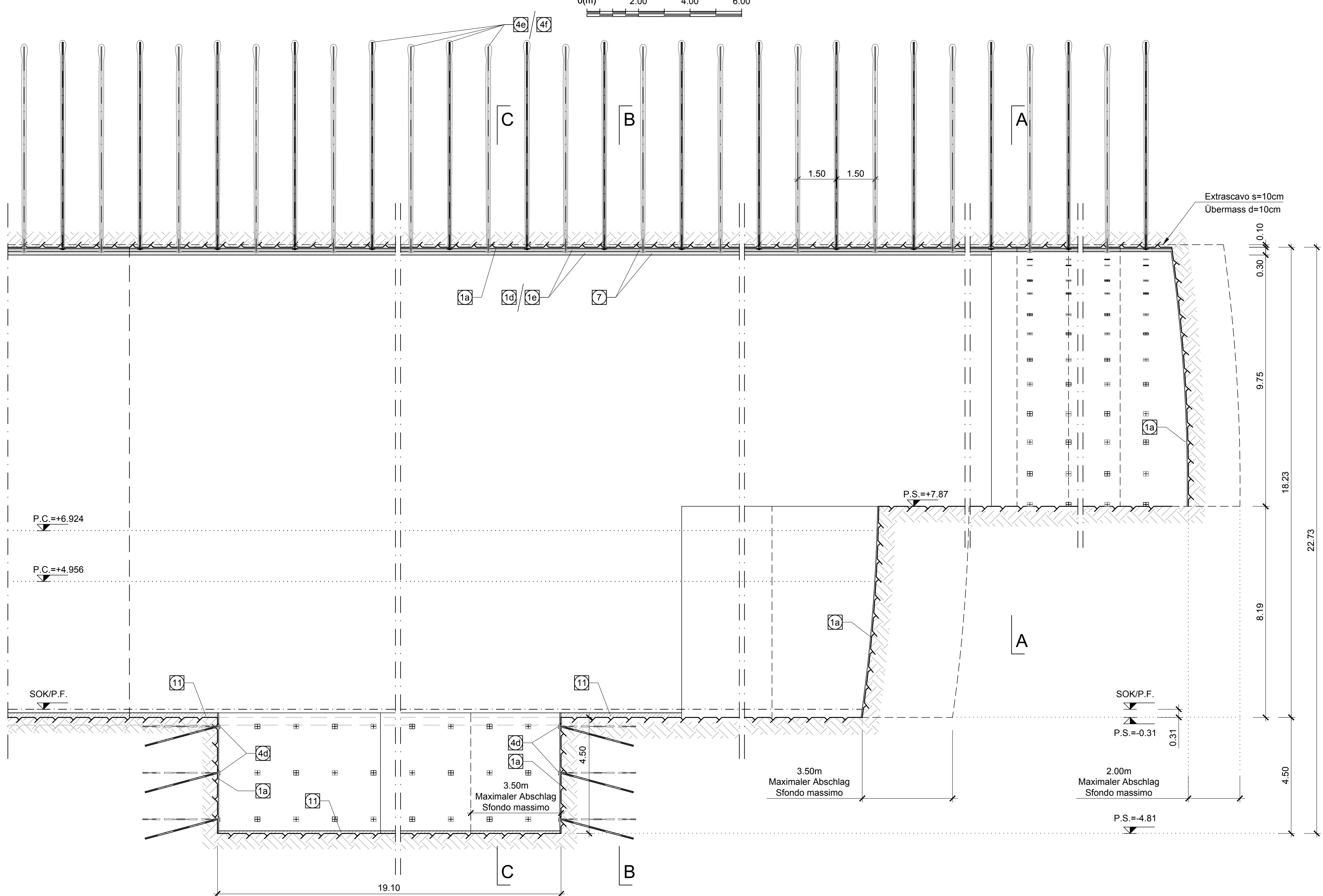
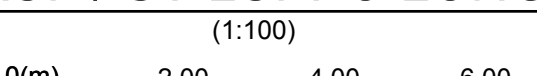

SCHNITT C-C / SEZIONE C-C

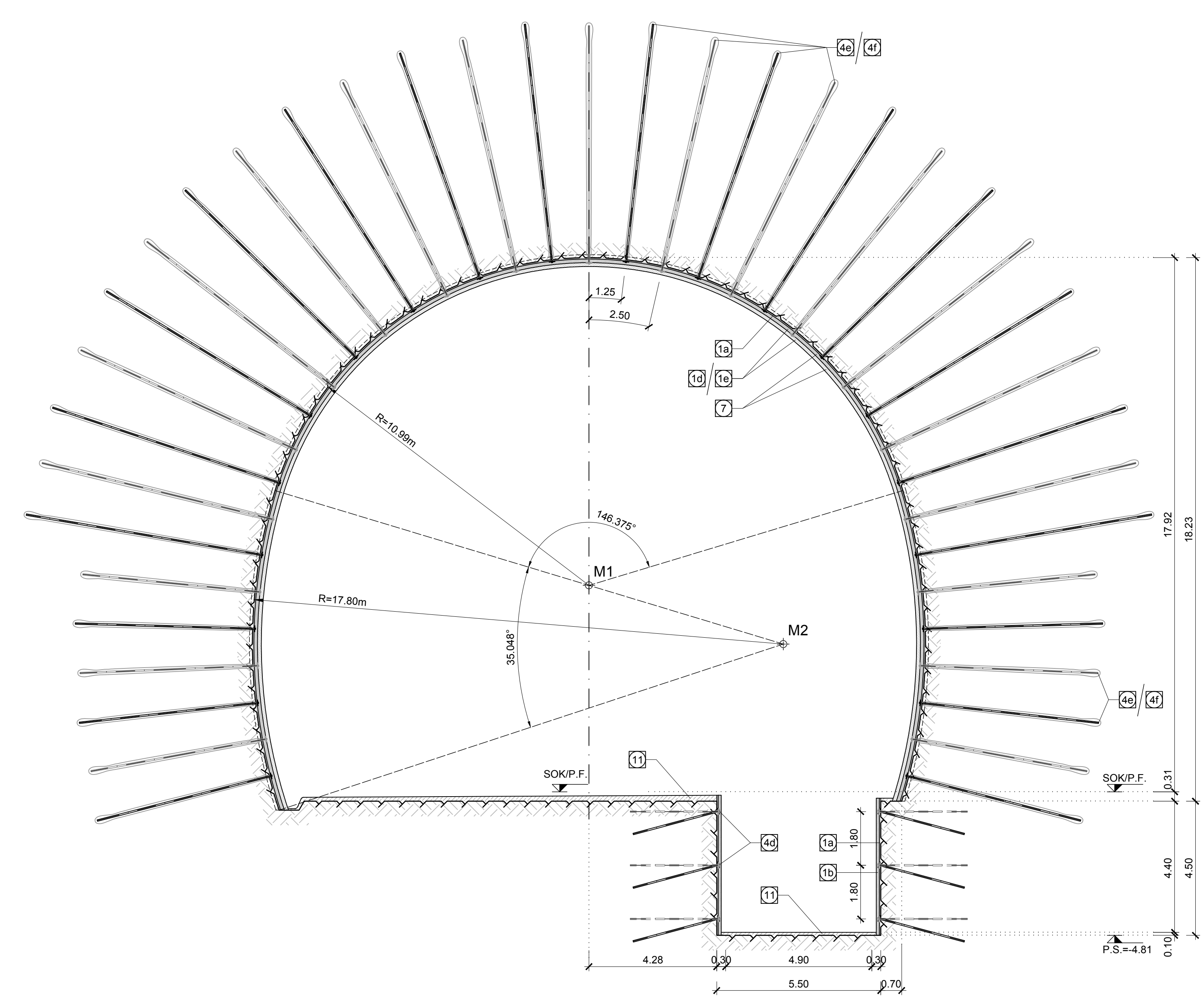
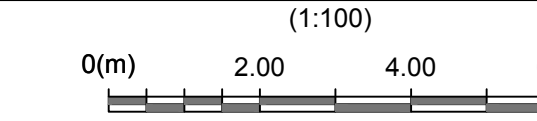

AUSBRUCHVOLUMEN (mit Übermaß) VOLUME DI SCAVO (incluso sovraccavo)

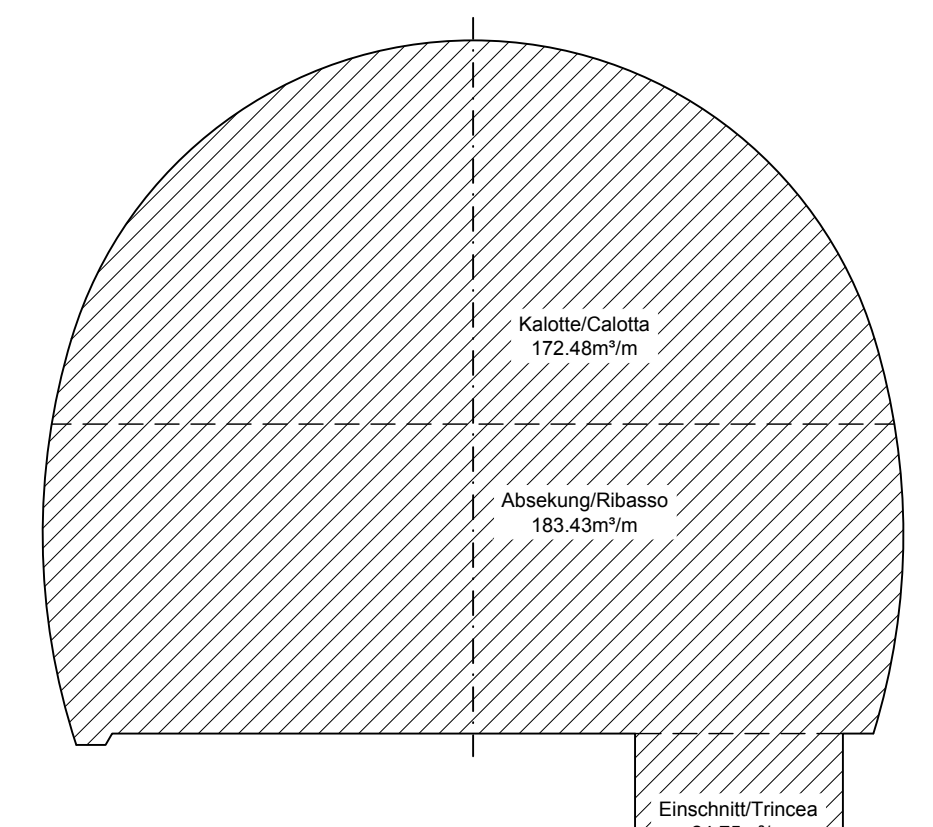
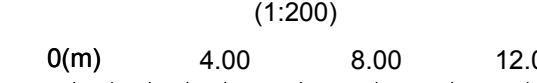

ANKERPLAN / PIANTA ANCORAGGI

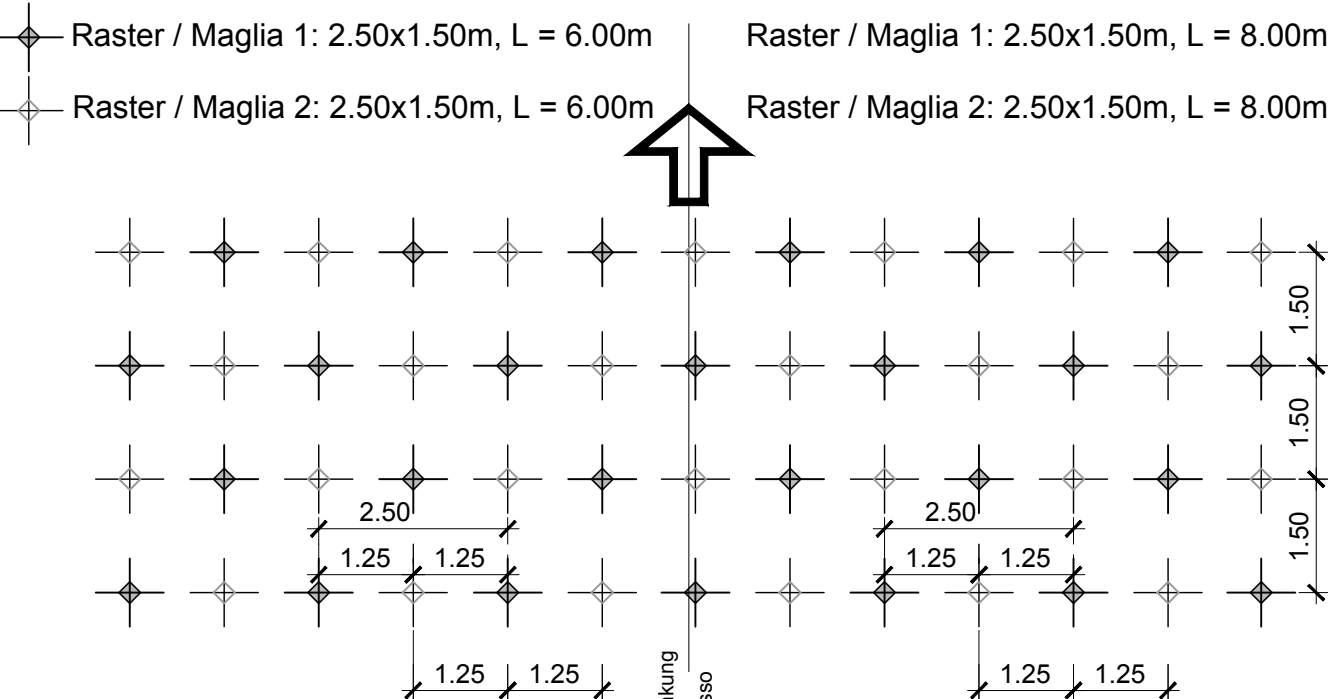
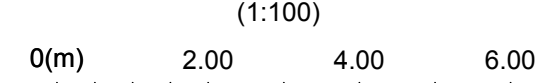

BEMERKUNGEN: DAS REGELPROFIL 'NL-C-T2' WIRD FÜR ÜBERBAU... (Technical notes in German regarding the tunnel profile and construction details.)

NOTE: LA SEZIONE TIPO 'NL-C-T2' VIENE APPLICATA... (Technical notes in Italian regarding the tunnel profile and construction details.)

BAUPHASEN: 1. SPRITZETON MIT TELLERBRICH... (Construction phases in German.)

FASI ESECUTIVE: 1. SCAVO A SEZIONE PARZIALIZZATA... (Construction phases in Italian.)

MATERIELEIGENSCHAFTEN UND TECHNISCHE SPEZIFIKATIONEN: 1. SPRITZETON MIT STAHNFASERN... (Material properties and technical specifications in German.)

CARATTERISTICHE DEI MATERIALI E SPECIFICHE TECNICHE: 1. BETONINO PROIETTATO FIBROFORZATO... (Material properties and technical specifications in Italian.)

LEGENDE / LEGENDA: .P.C. = EBENE DER KREISZENTREN... (Legend in German.)

LEGENDE / LEGENDA: .P.C. = EBENE DER KREISZENTREN... (Legend in Italian.)

Table with 6 columns: Bereich/ Campo, Spezifikation/ Specificazione, Einheit/ Unità, Beschreibung/ Descrizione, Dimensionen/ Dimensioni, Menge/ in Turni/ Quantità in galleria. Rows for concrete, reinforcement, and drainage.

Table with 6 columns: Bereich/ Campo, Spezifikation/ Specificazione, Einheit/ Unità, Beschreibung/ Descrizione, Dimensionen/ Dimensioni, Menge/ in Turni/ Quantità in galleria. Rows for concrete, reinforcement, and drainage.

ANMERKUNGEN / ANNOTAZIONI: SOK/P.F. Schienenoberkante (SOK+ ±0.00)... (Notes and annotations in German and Italian.)

M / SCALA 1 : 100: Scale bar for drawing M.

Referenzdokumente / Documenti di riferimento: Table listing various technical documents and standards.

Bearbeitungsstand / Stato di elaborazione: Table showing the status of the project at various stages.

Project information block including logos for BBT, RT4P, and other partners, project name 'GALLERIA DI BASE DEL BRENNERO', and contact details.