

FASE 1ter

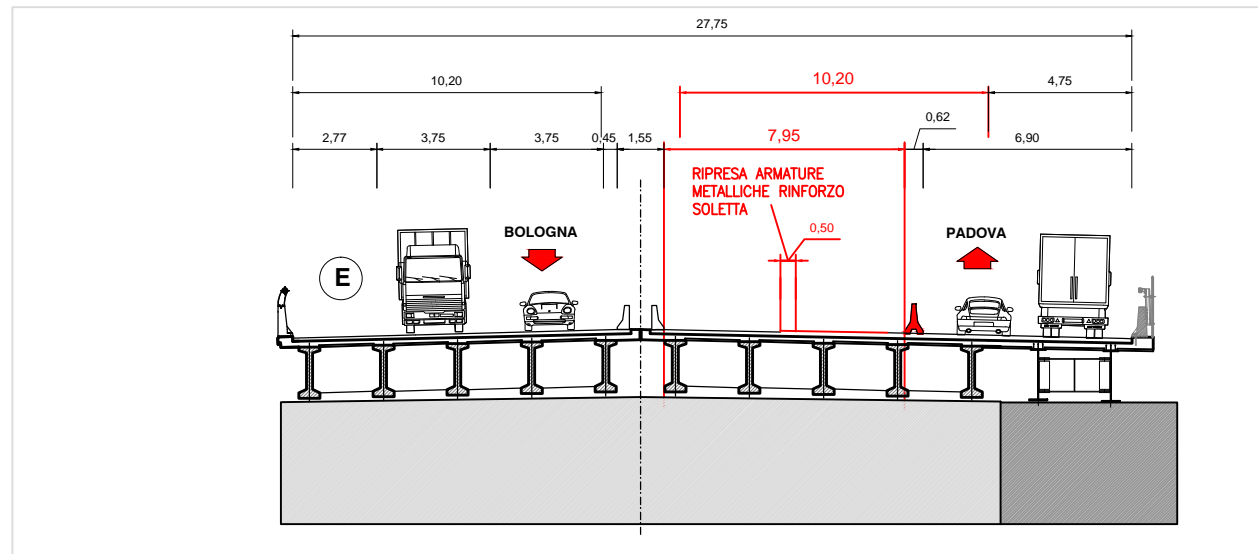

FASE 1quater

NESSUNA LAVORAZIONE

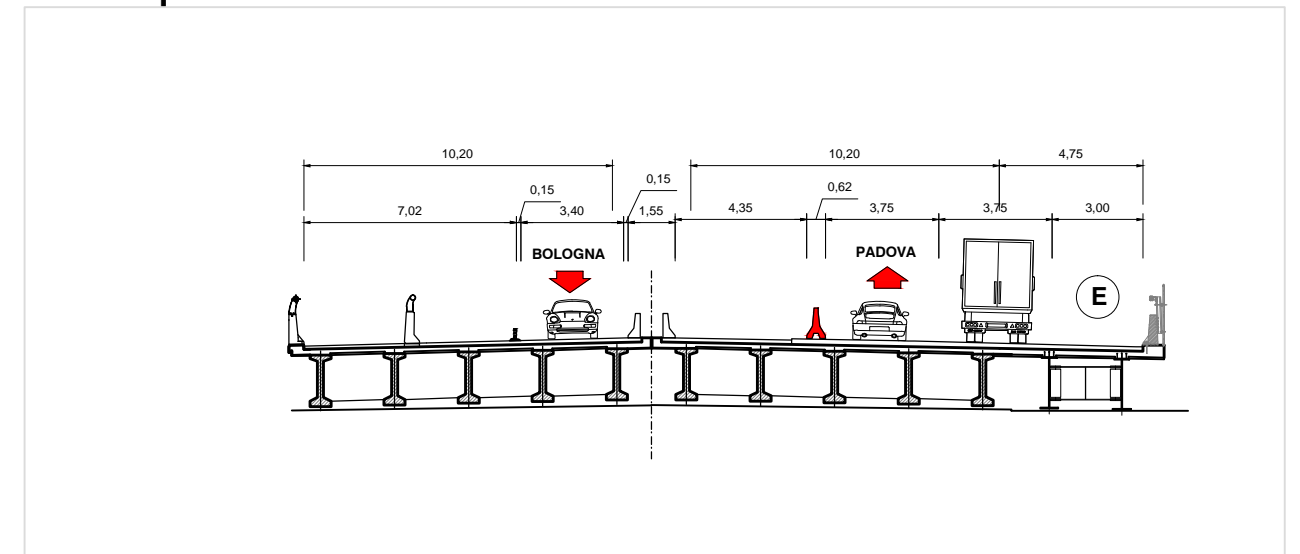

FASE 1quater

(fase notturna)

SOSTITUZIONE DRENANTE
 CON BINDER CHIUSO
 CORSIA DI SORPASSO

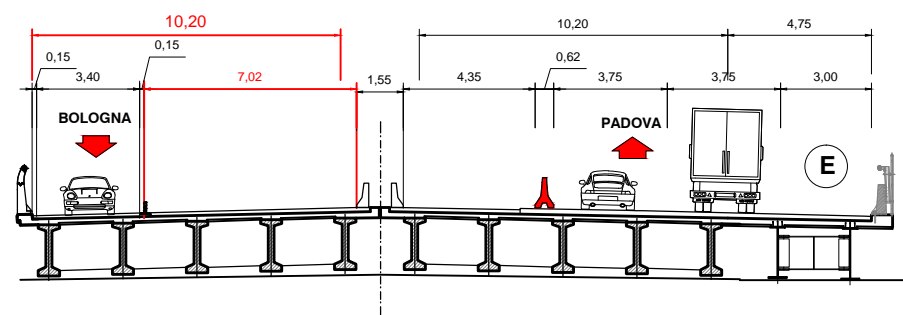

SOSTITUZIONE DRENANTE
 CON BINDER CHIUSO
 CORSIA DI MARCIA LENTA

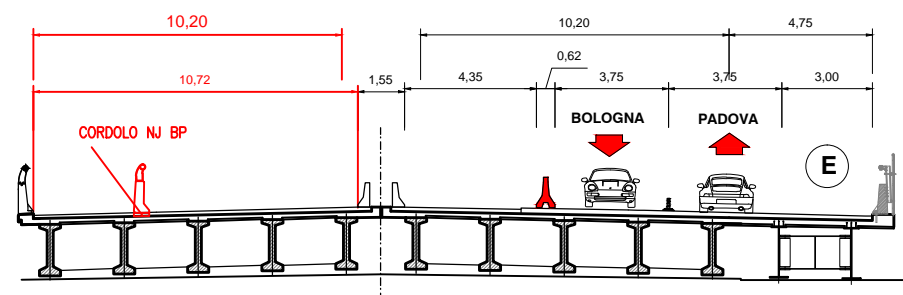

FASE 2

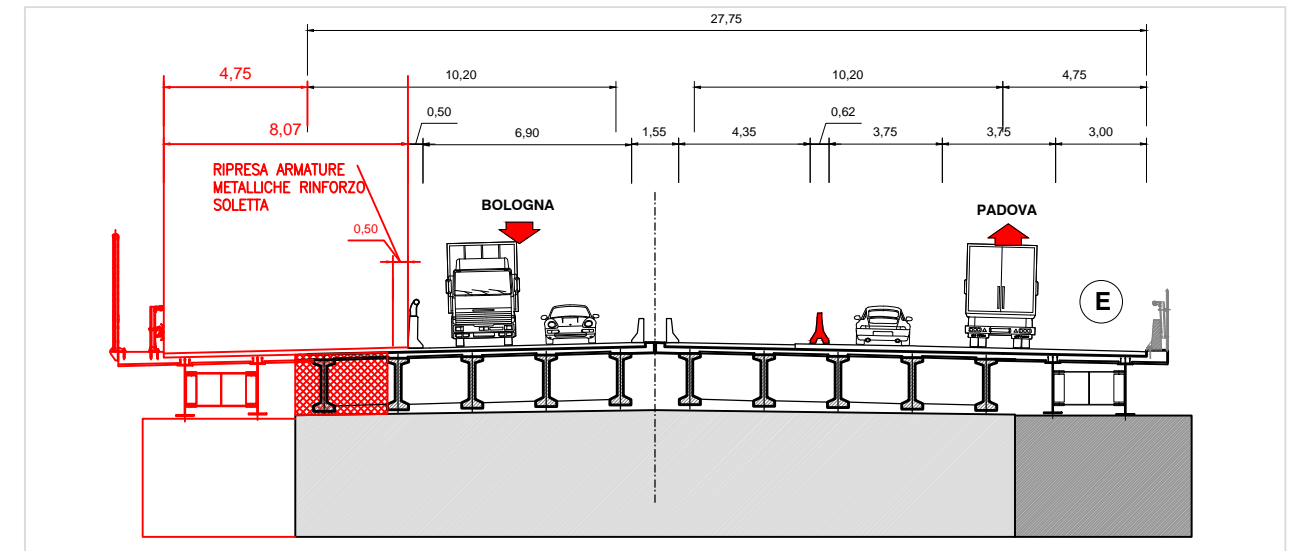

FASE 2

(fase notturna)

