

SEZIONE LONGITUDINALE IMPALCATO METALLICO scala (1:50)

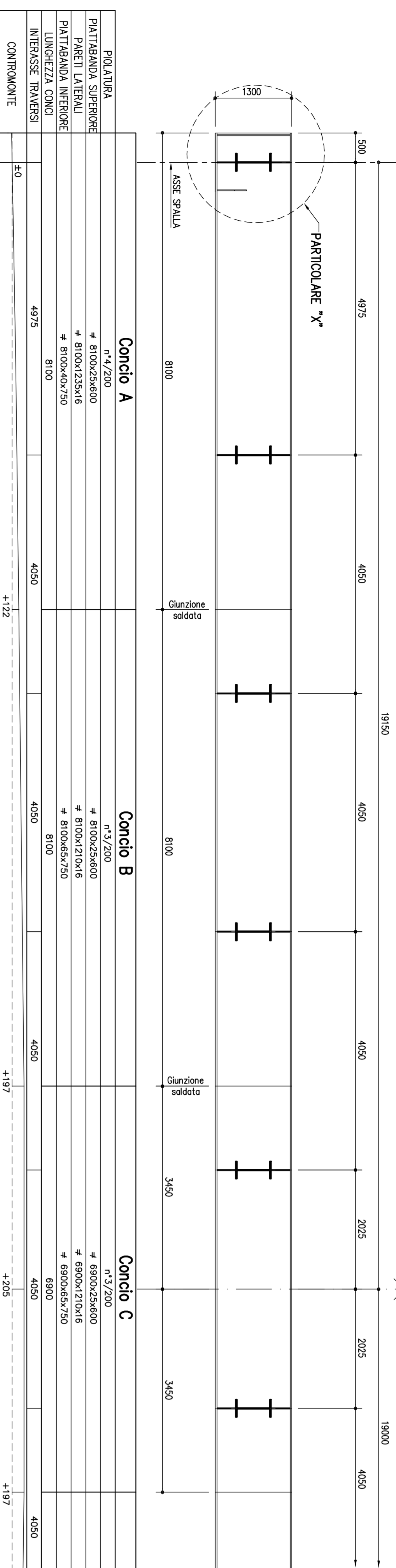

PIANTA IMPALCATO scala (1:50)

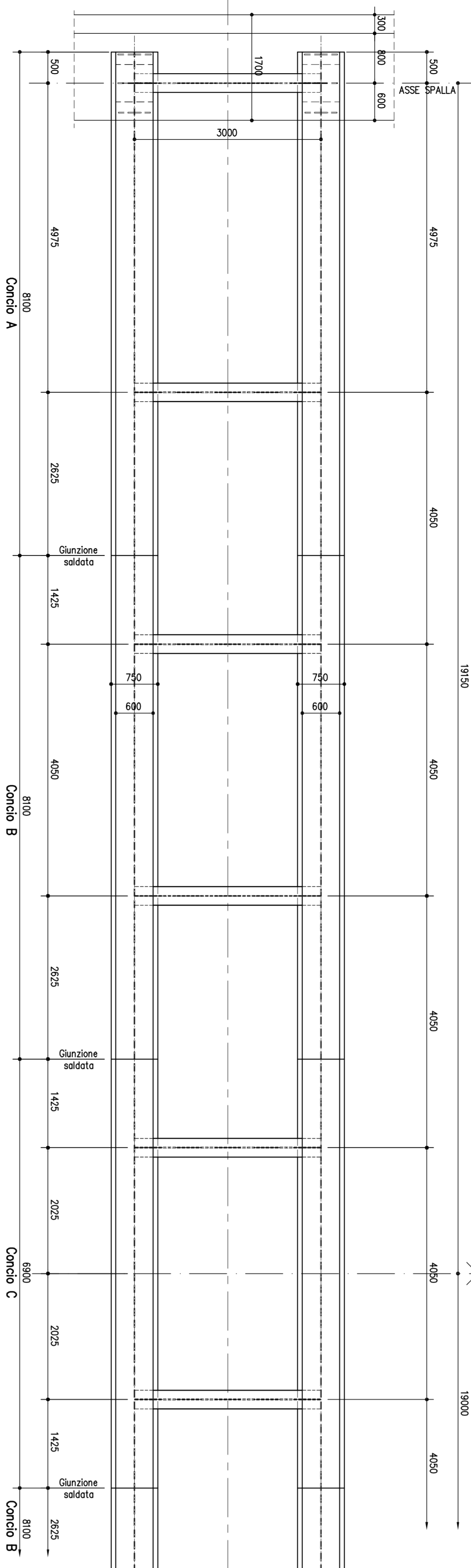

PIANTA CONTROVENTATURE DI MONTAGGIO SUPERIORE scala (1:100)

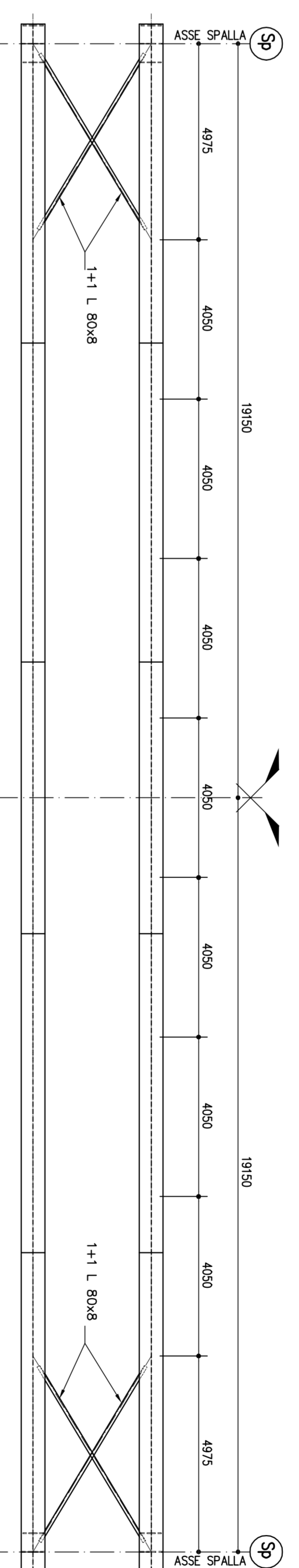

DISPOSIZIONE PIAZZI scala (1:20)

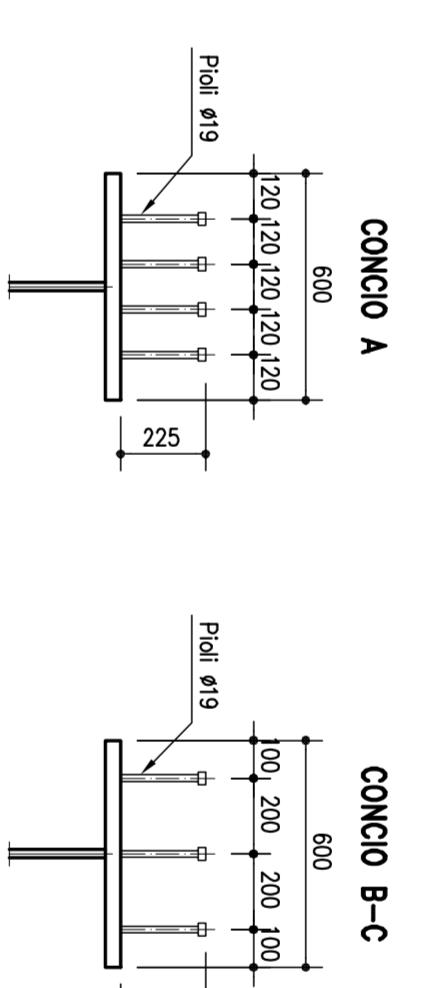

SALDATURE TIPO A CORDONE D'ANGOLO

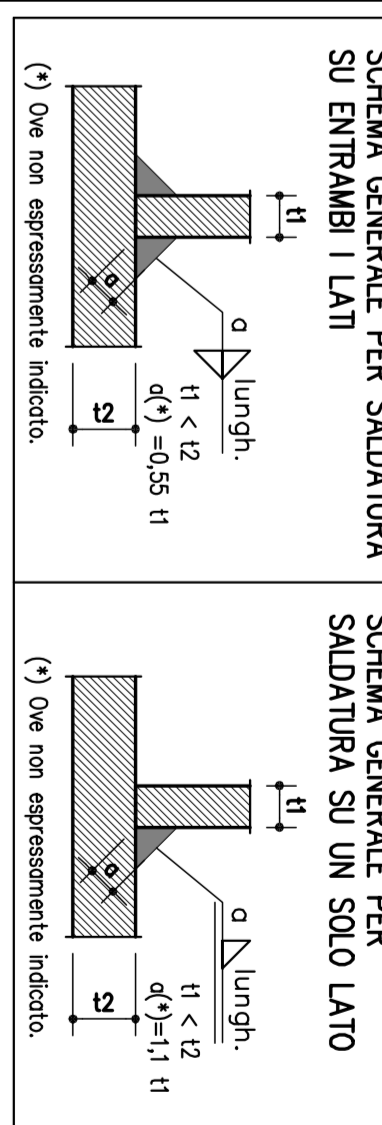

SALDATURE TIPO A PENA PENETRAZIONE

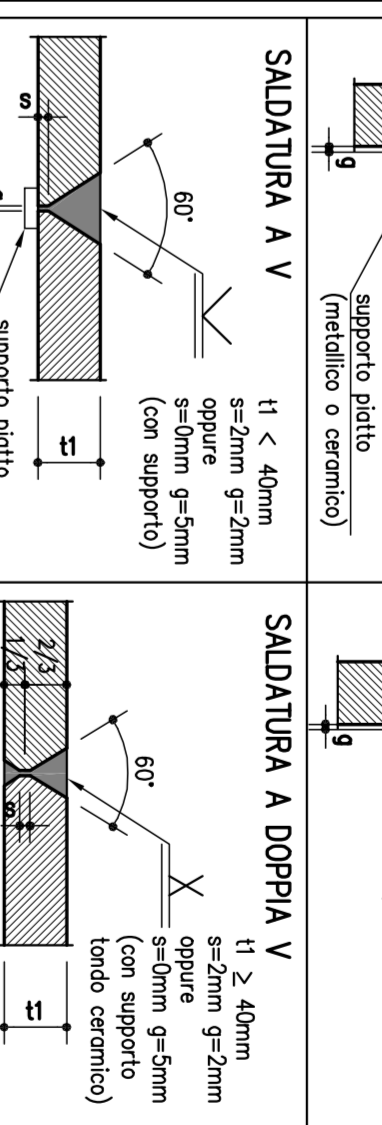

NOTE

1) Per la scelta dell'angolo di salda...  
2) Per la scelta dell'angolo di salda...  
3) Per la scelta dell'angolo di salda...

TRAVERSI TIPO scala (1:10)

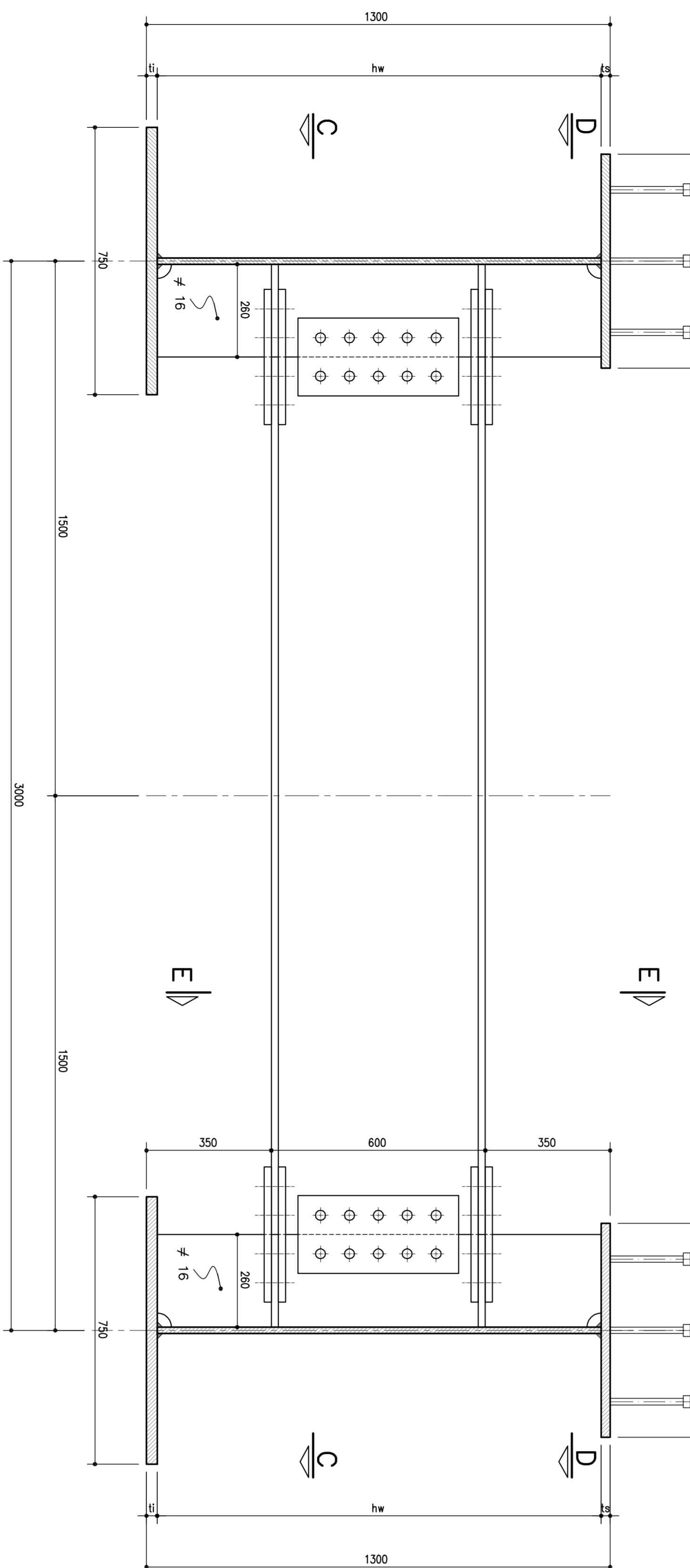

TRAVERSI SPALLA scala (1:10)

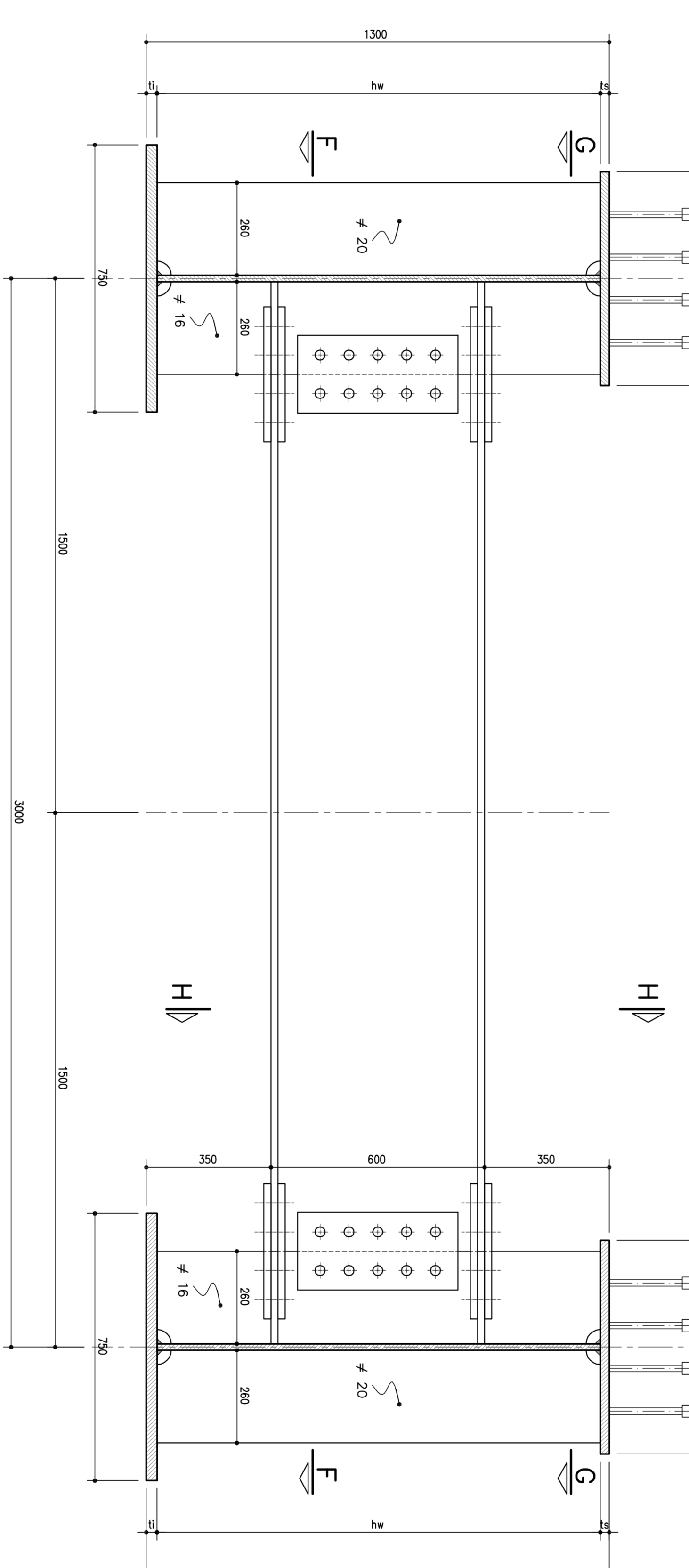

SEZIONE C-C scala (1:10)

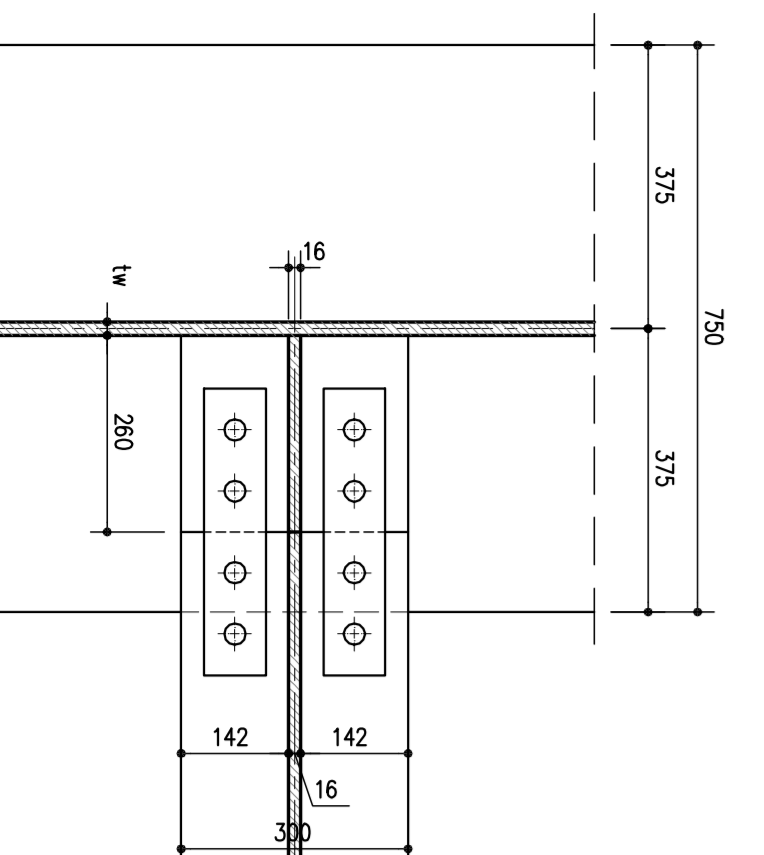

SEZIONE D-D scala (1:10)

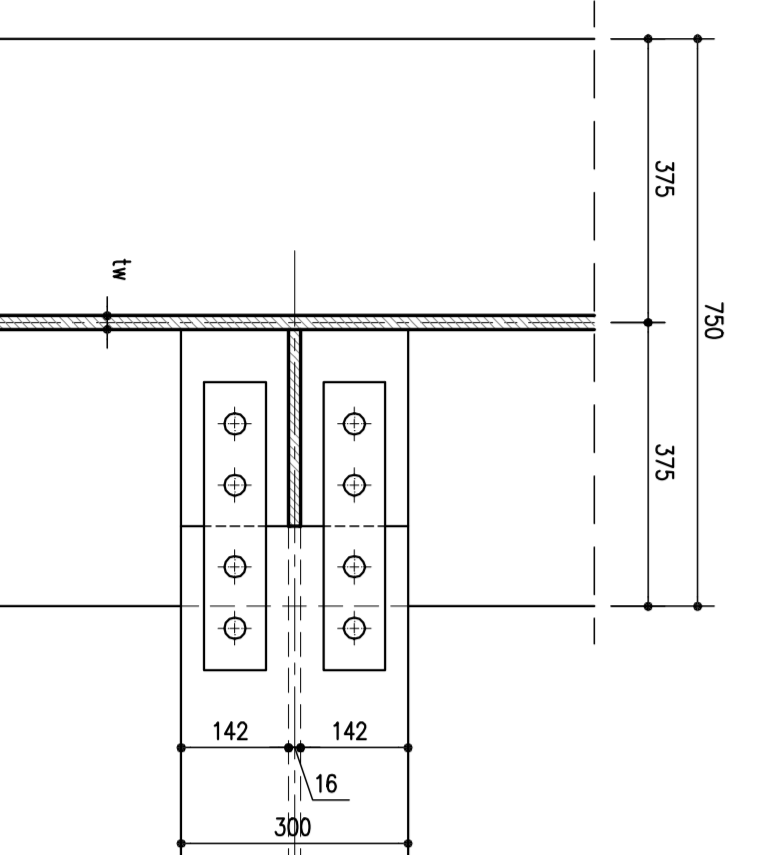

SEZIONE E-E scala (1:10)

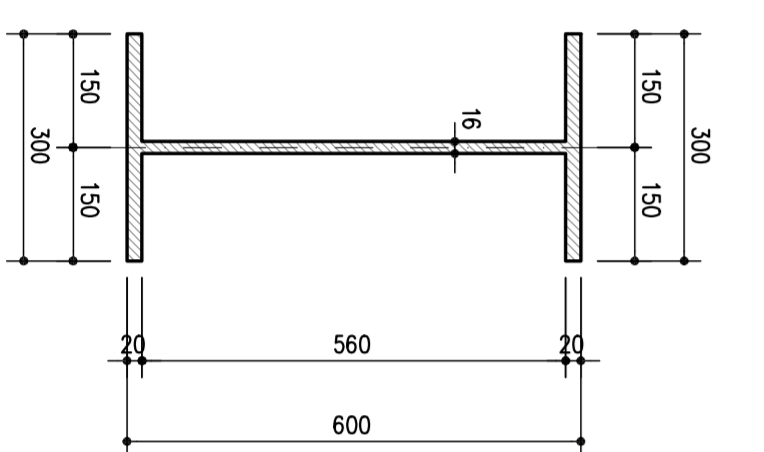

SEZIONE F-F scala (1:10)

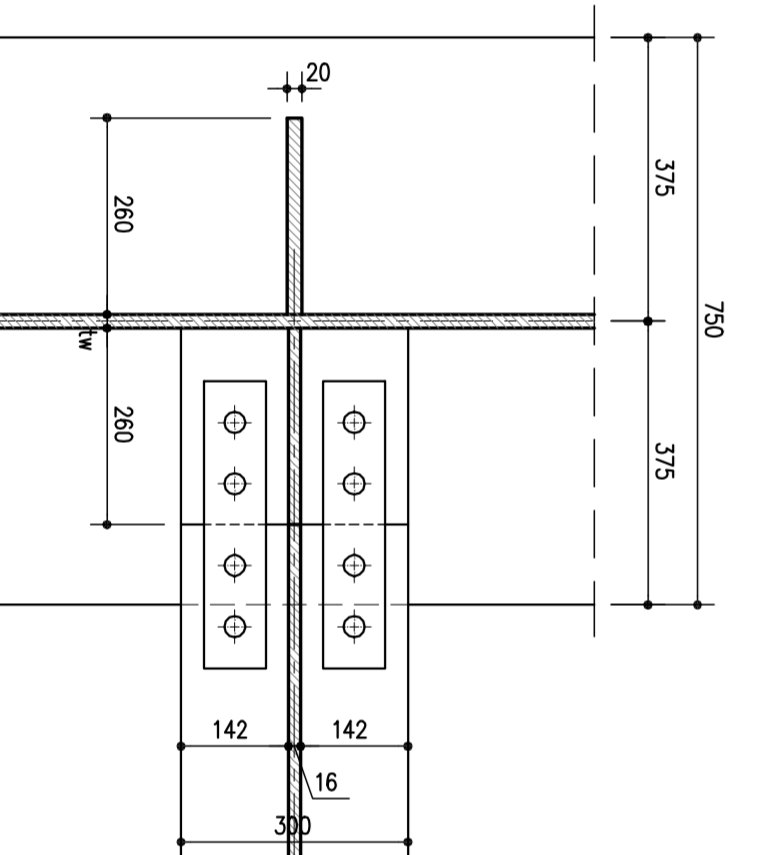

SEZIONE G-G scala (1:10)

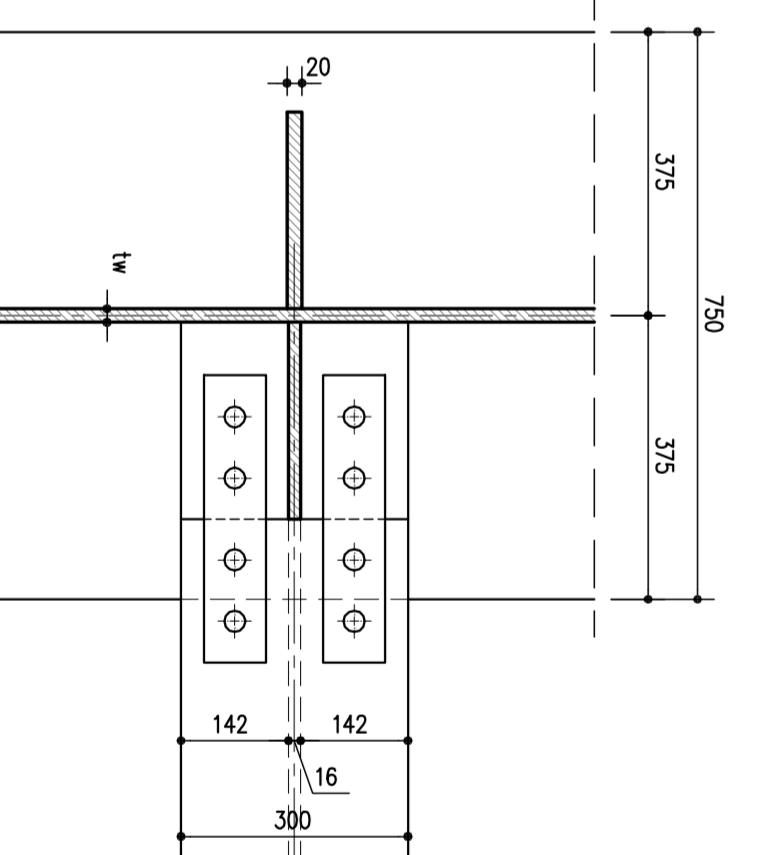

SEZIONE H-H scala (1:10)

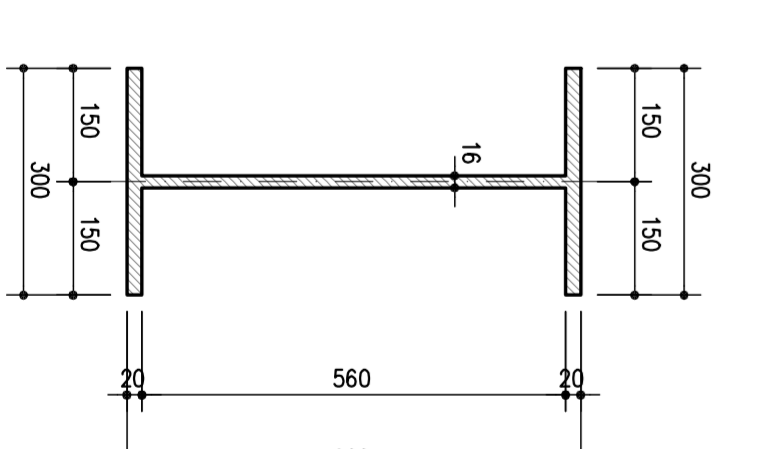

PARTICOLARE "X" scala (1:20)

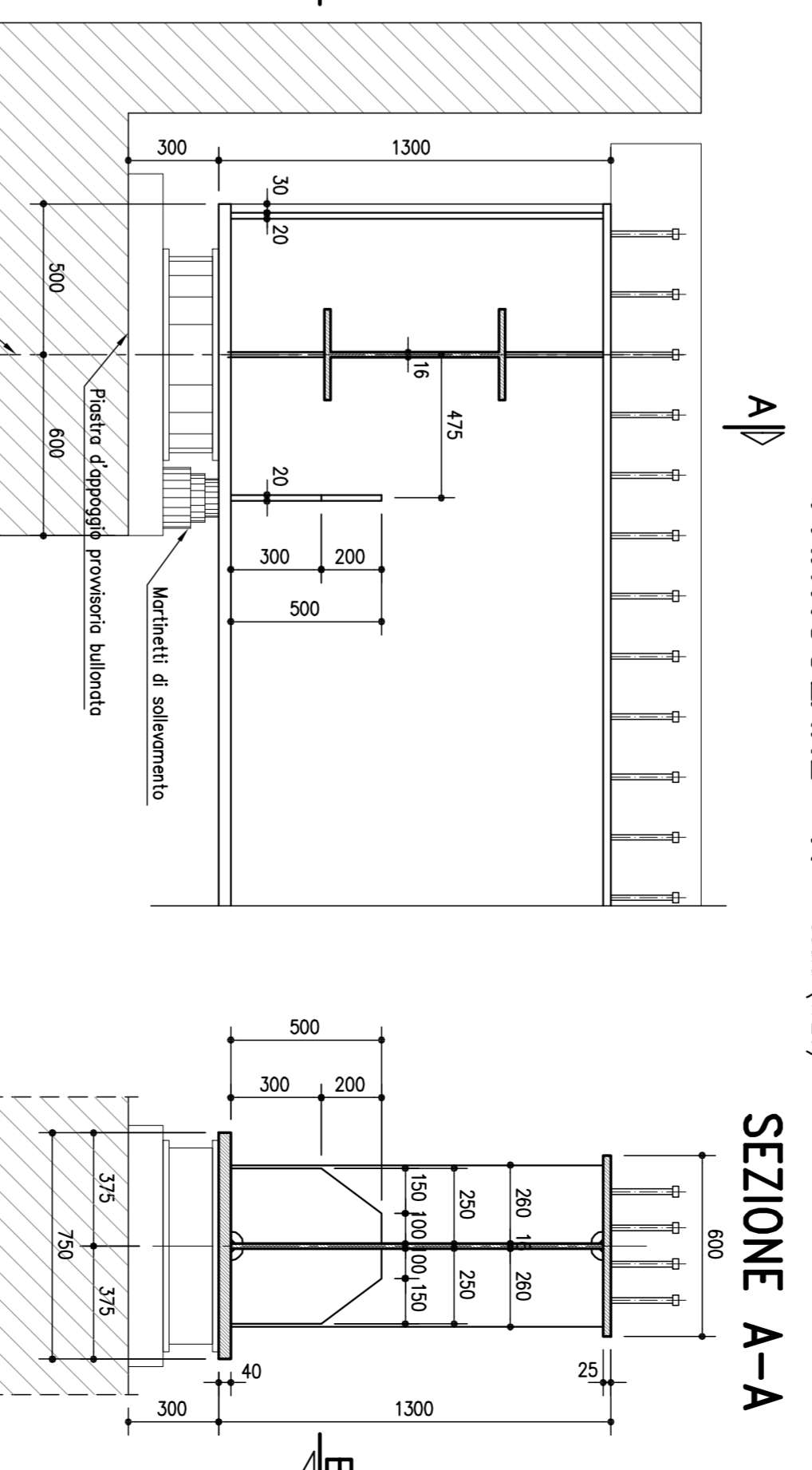

SEZIONE A-A

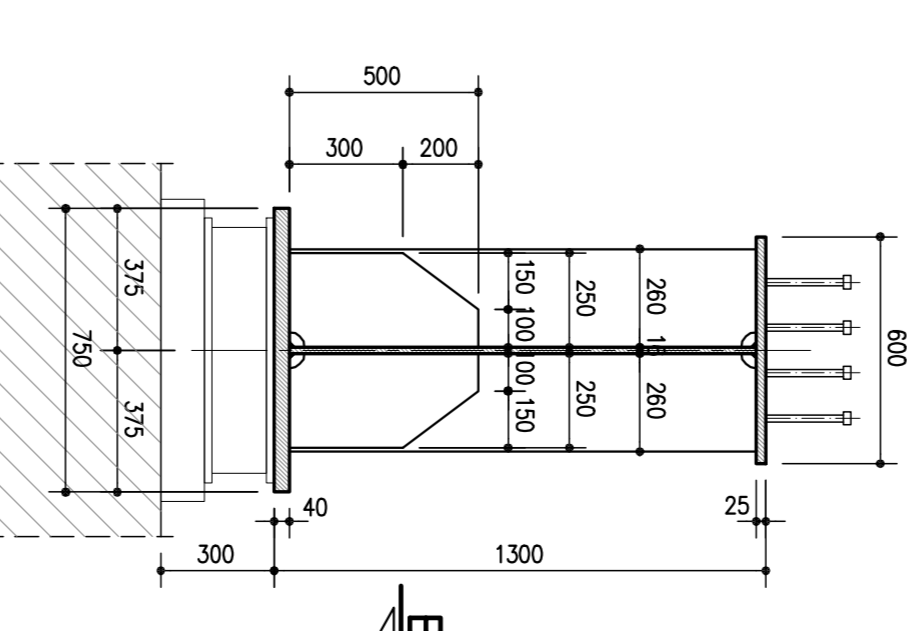

SEZIONE B-B

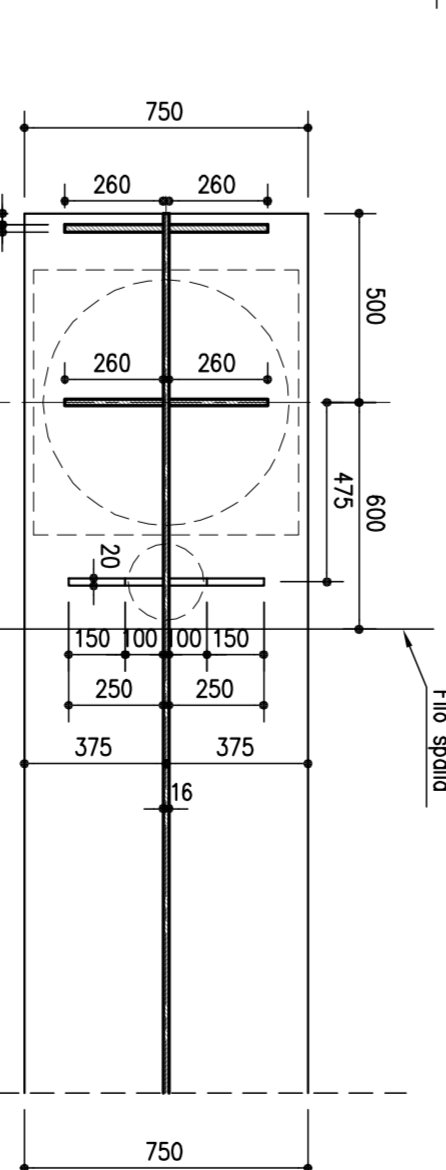

**autostrade // per l'Italia**  
 AUTOSTRADA (A13) : BOLOGNA-PADOVA

AMPLIAMENTO ALLA TERZA CORSA  
 TRATTO : MONSELICE - PADOVA SUD

PROGETTO DEFINITIVO

CORPO AUTOSTRADALE

OPERE D'ARTE MAGGIORI  
 CAVALCAVIA TIPOLOGICI

OP5-Tipologia impalcato L=5,40m-luce singola da 38,30 m  
 Carpenteria impalcato

<b>PROGETTAZIONE</b> Ing. Roberto Basso Ing. Roberto Basso		<b>PROGETTAZIONE</b> Ing. Roberto Basso Ing. Roberto Basso	
<b>VERBA DEI COMPONENTI</b> Ing. Roberto Basso Ing. Roberto Basso		<b>VERBA DEI COMPONENTI</b> Ing. Roberto Basso Ing. Roberto Basso	
<b>PROGETTO DEFINITIVO</b> Ing. Roberto Basso Ing. Roberto Basso		<b>PROGETTO DEFINITIVO</b> Ing. Roberto Basso Ing. Roberto Basso	