

PROFLO LONGITUDINALE TRAVI ACCOPPIATE

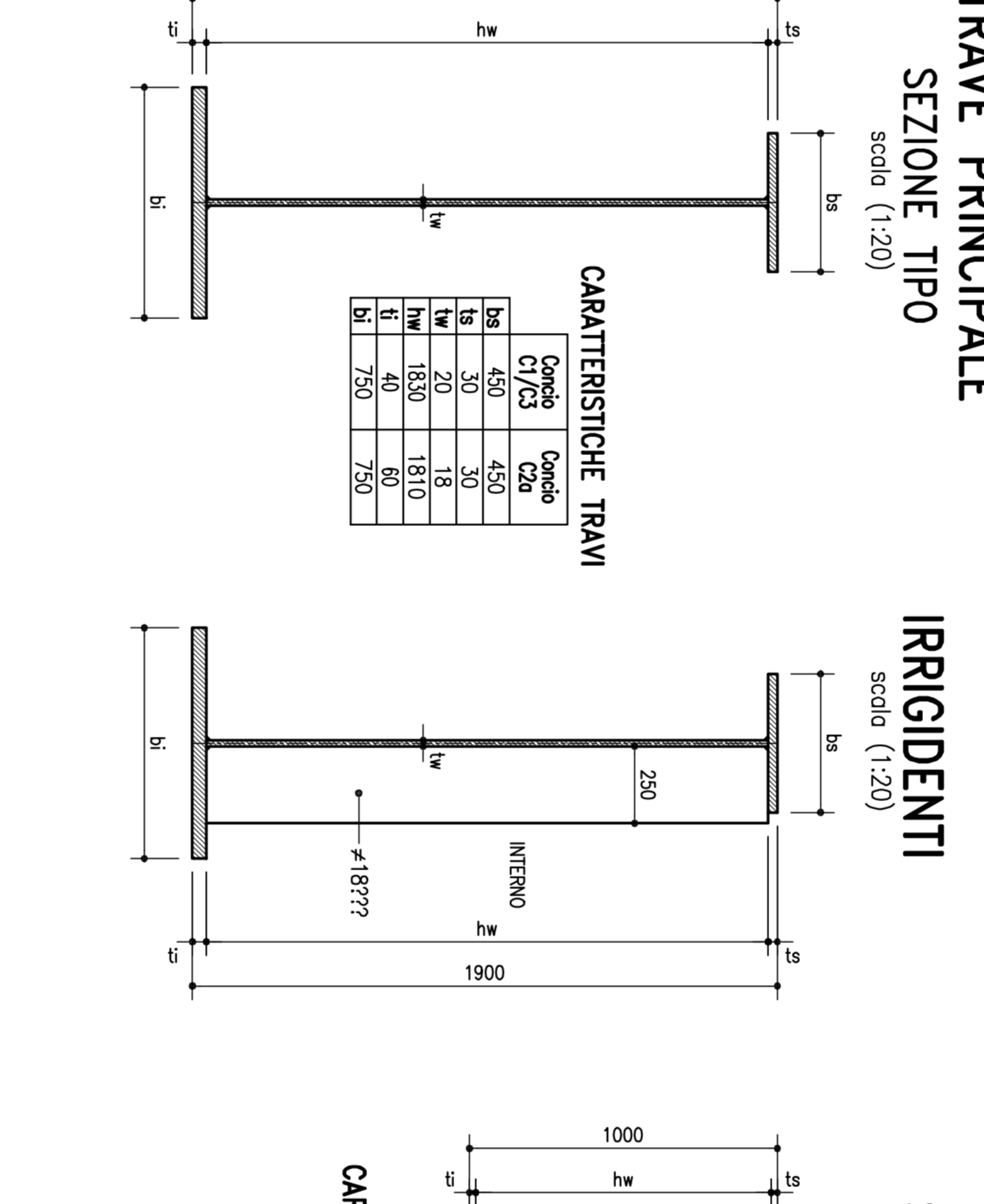

PROFLO LONGITUDINALE TRAVE SINGOLA

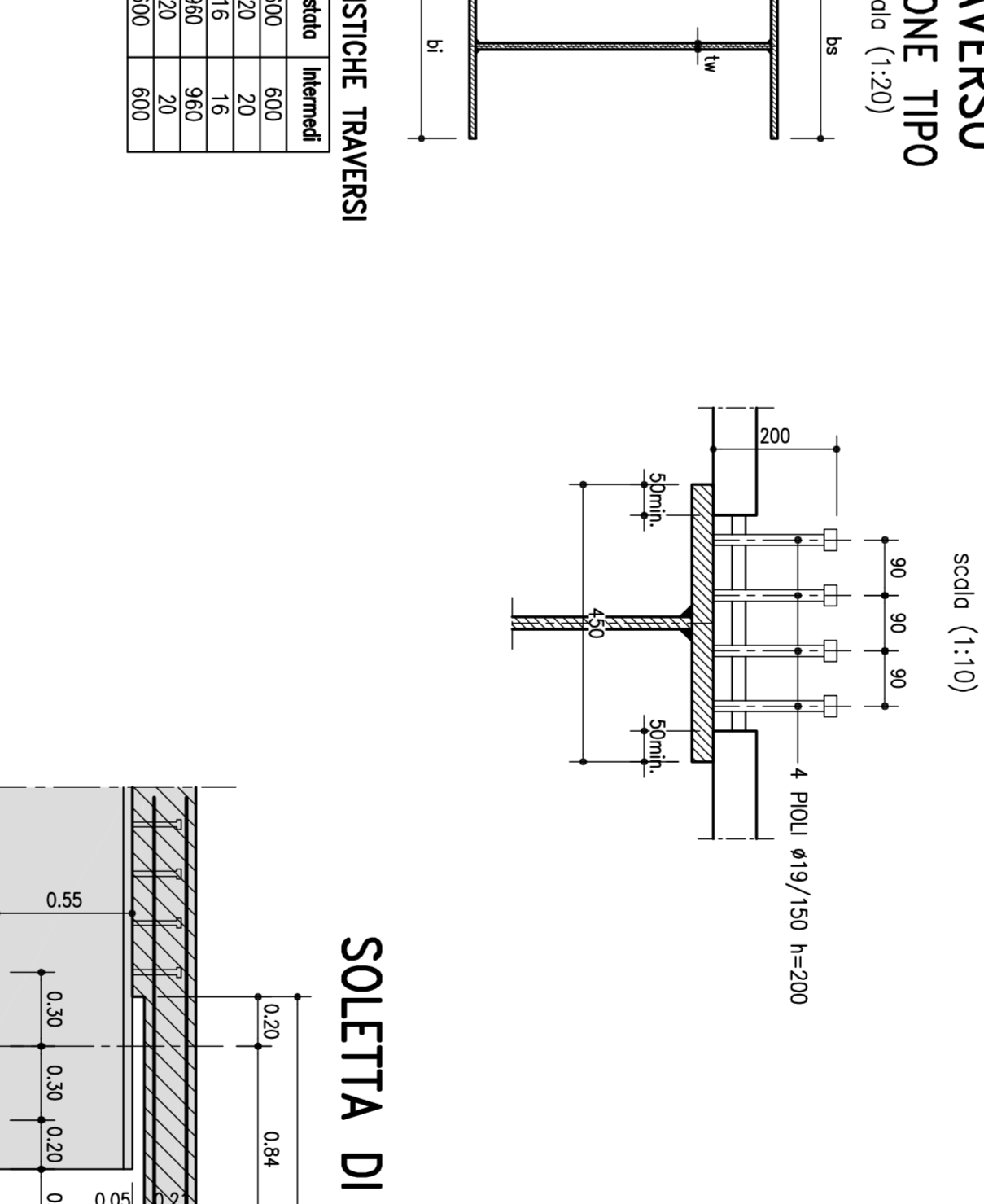

1/2 SEZIONE TRASVERSO DI TESTATA

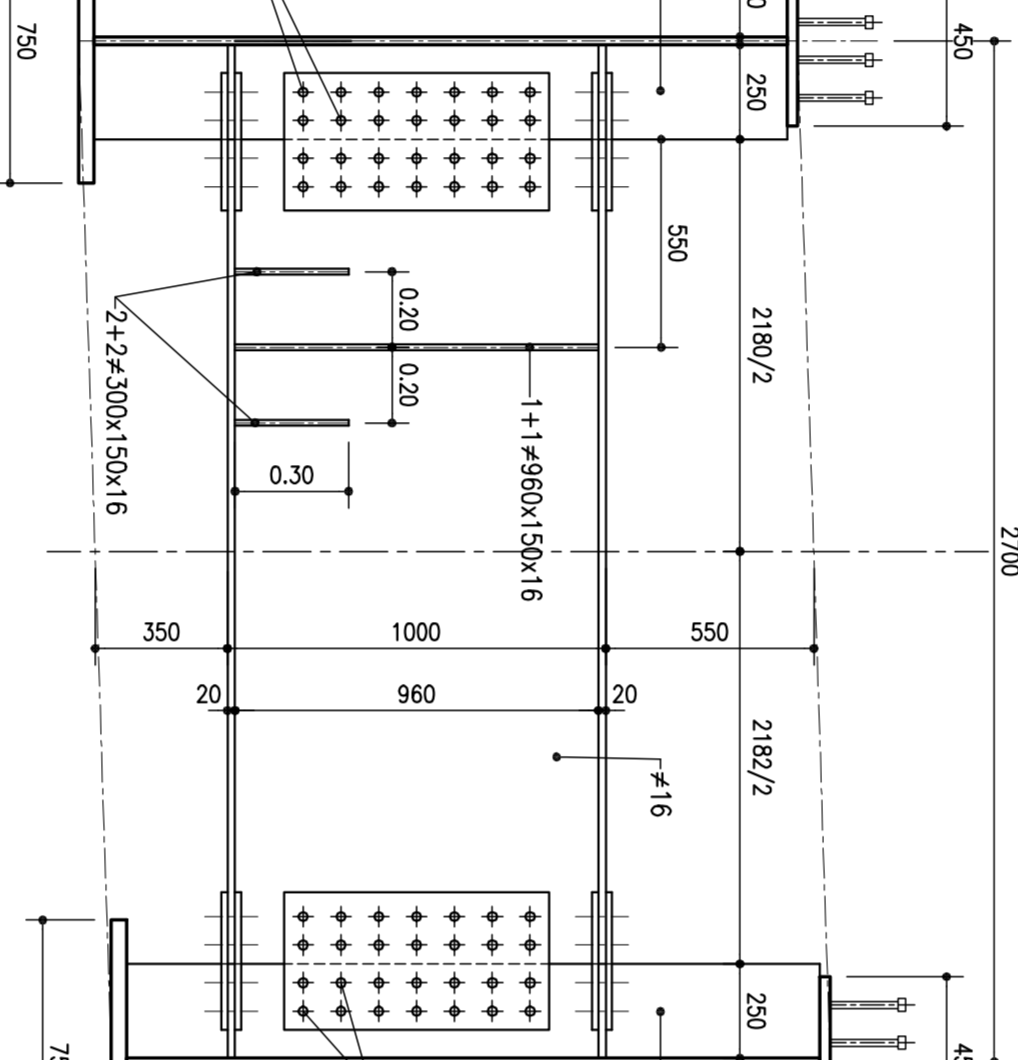

TRAVE PRINCIPALE SEZIONE TIPO

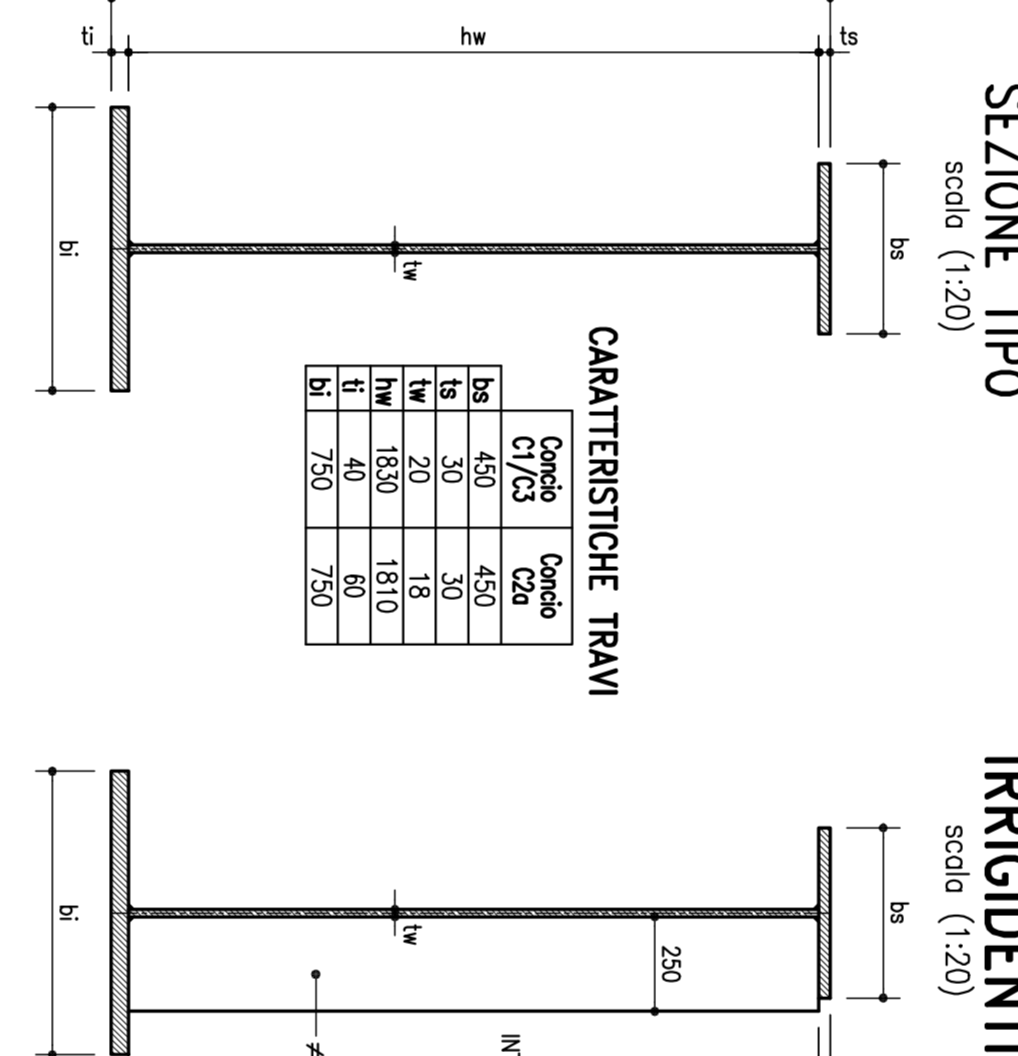

TRAVEIRO SEZIONE TIPO

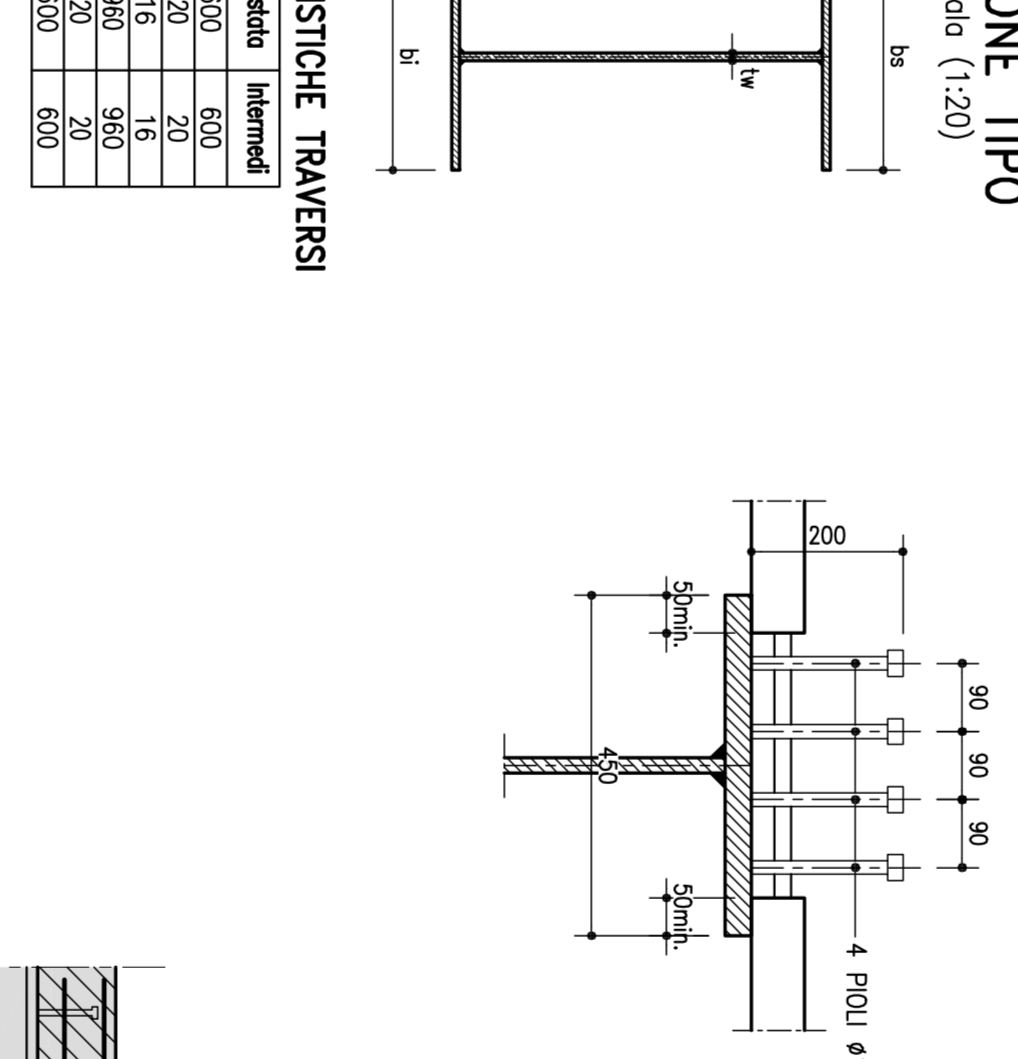

GUIDE METALLICHE DI VINCOLO TRASVERSALE

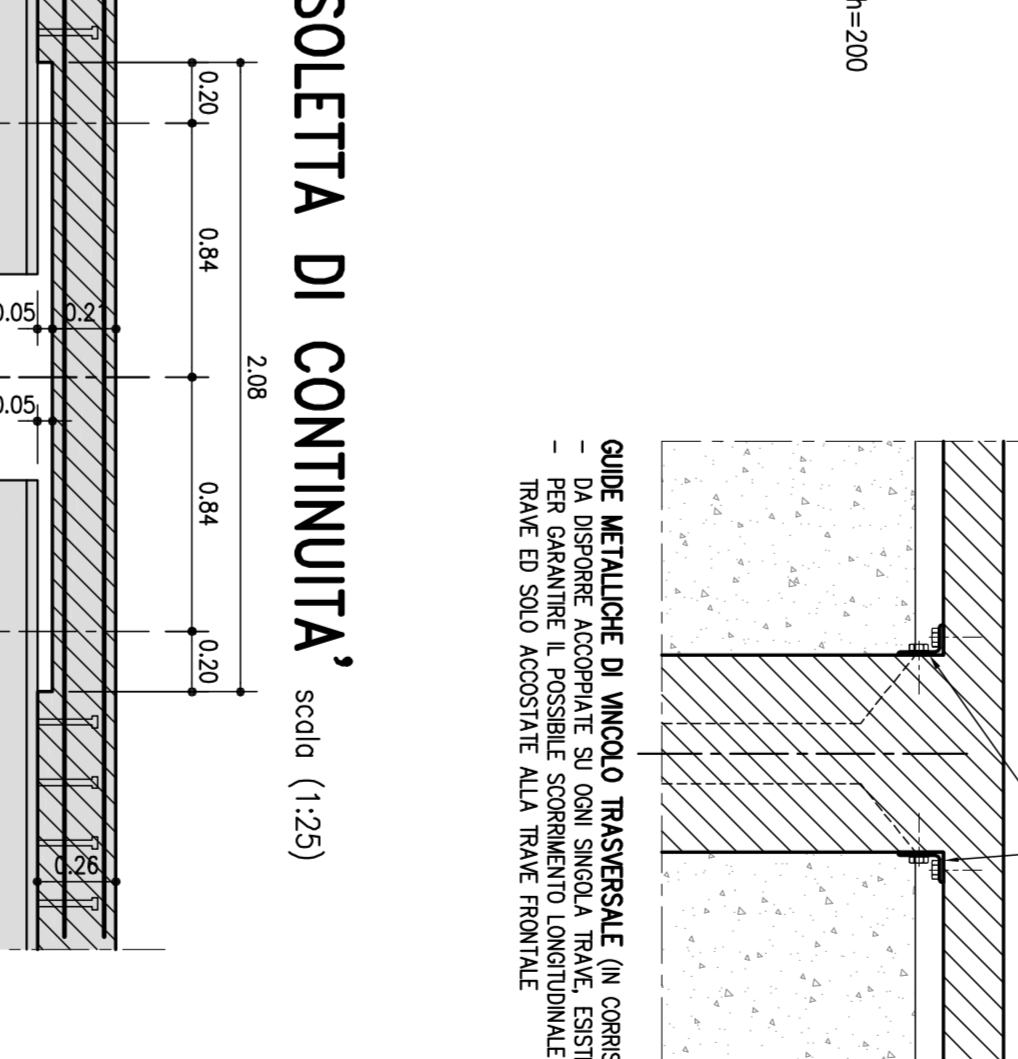

PARTICOLARE SHOCK-TRANSMITTER

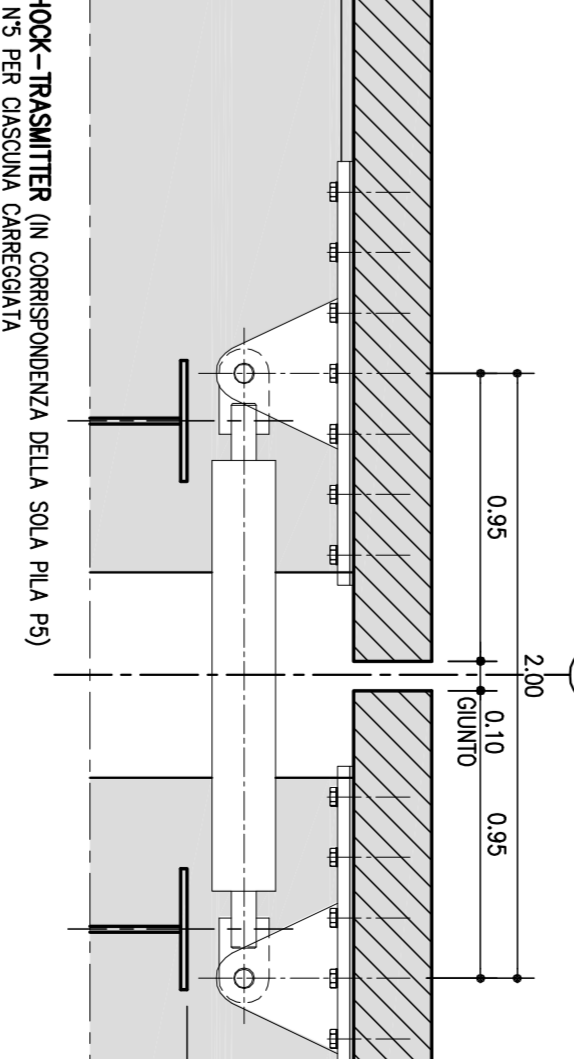
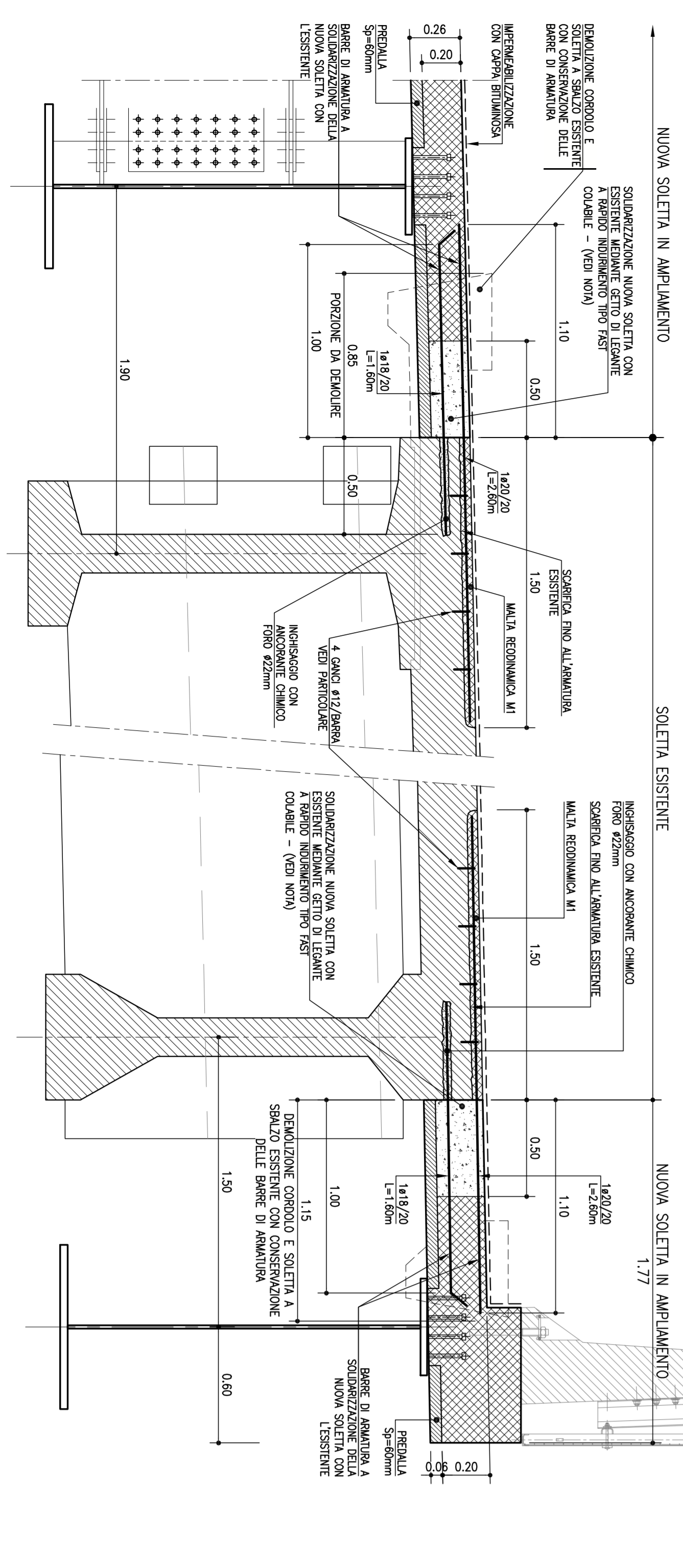
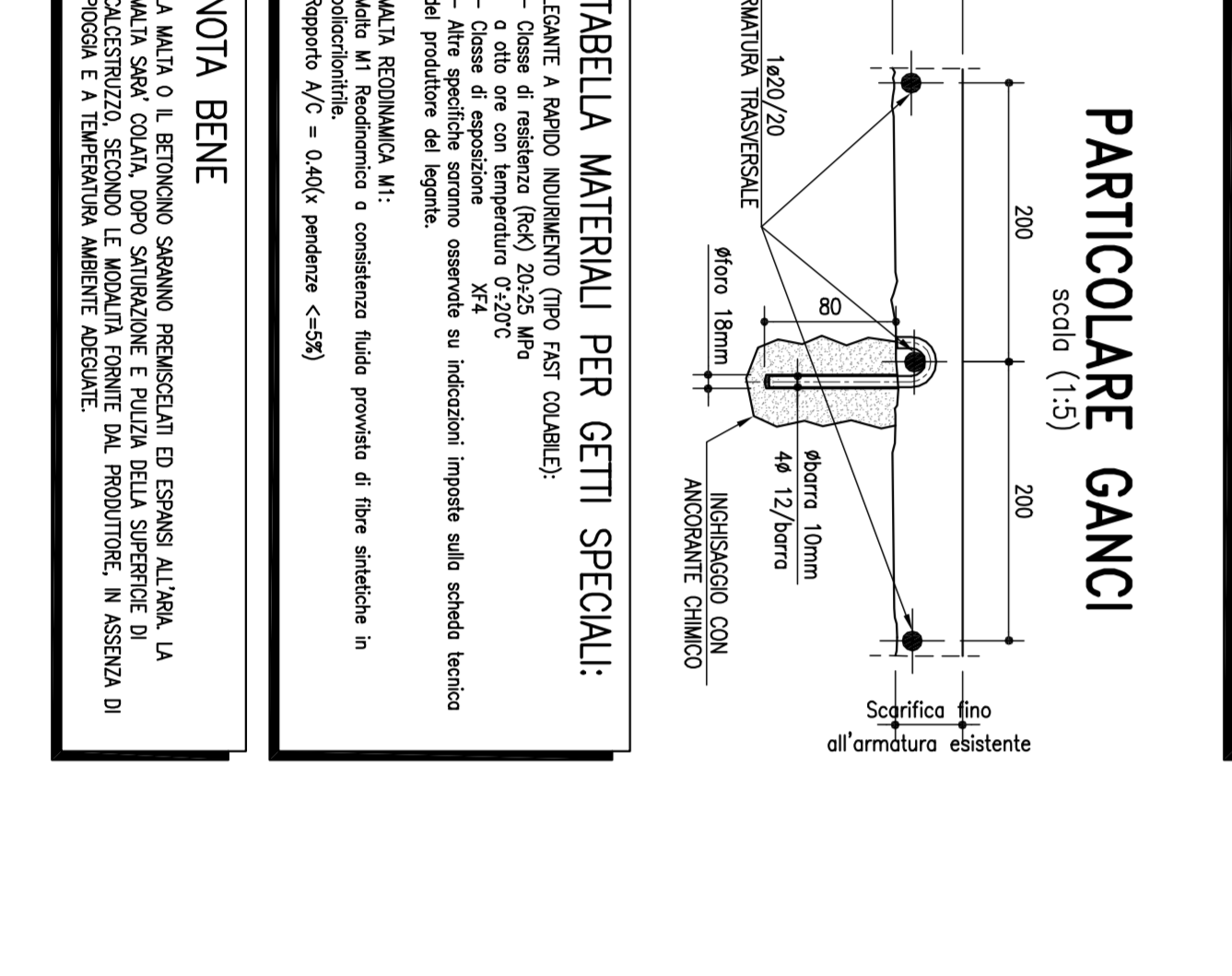

Table with 4 columns: SOLETTA, PIAZZOLE, TRAVE, and SOLETTA. It lists dimensions and material specifications for various components.

PARTICOLARE COLLEGAMENTO SOLETTE



PARTICOLARE GANCI



SCHEMA APPOGGI

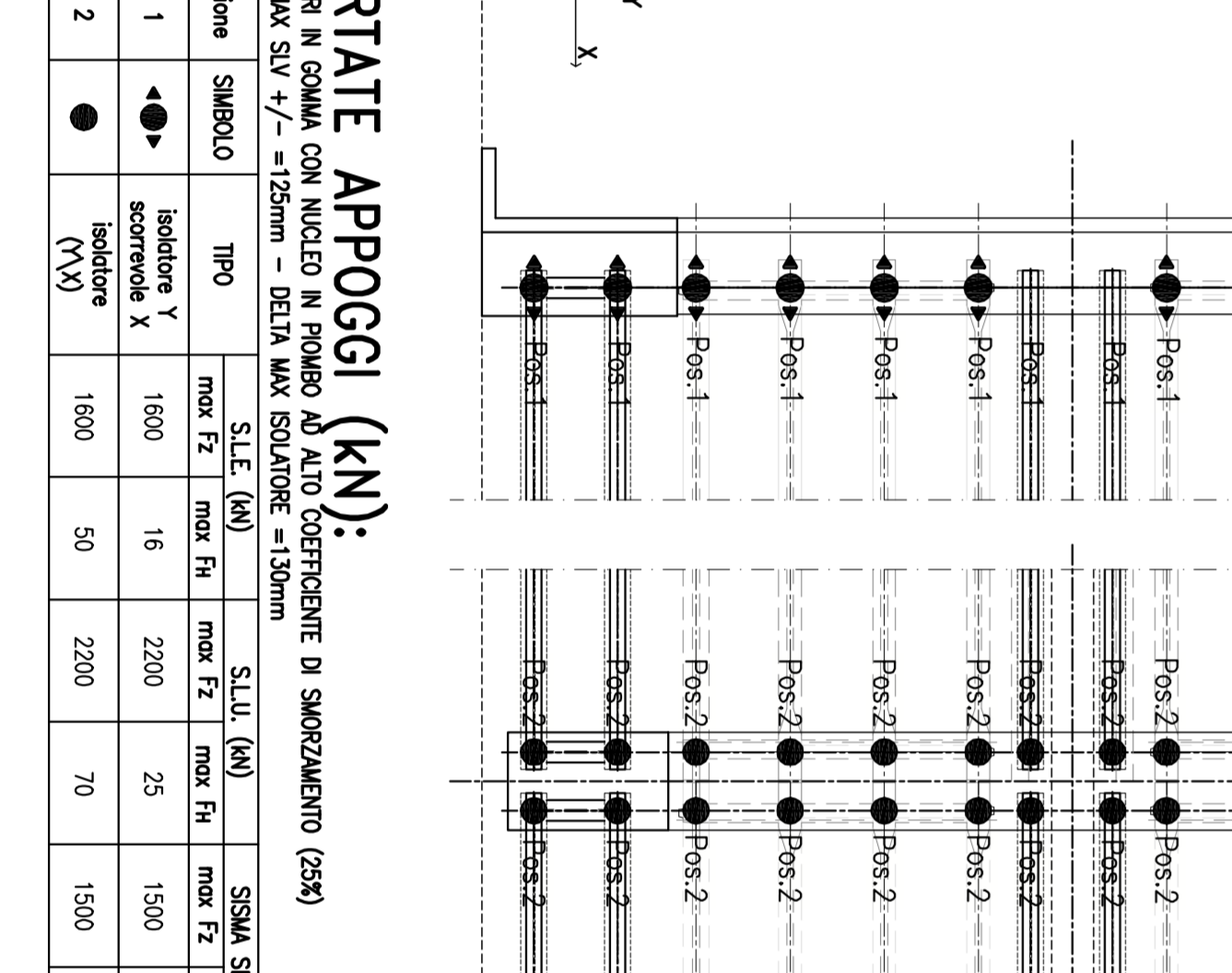

SCHEMA PILE TRAVI PRINCIPALI

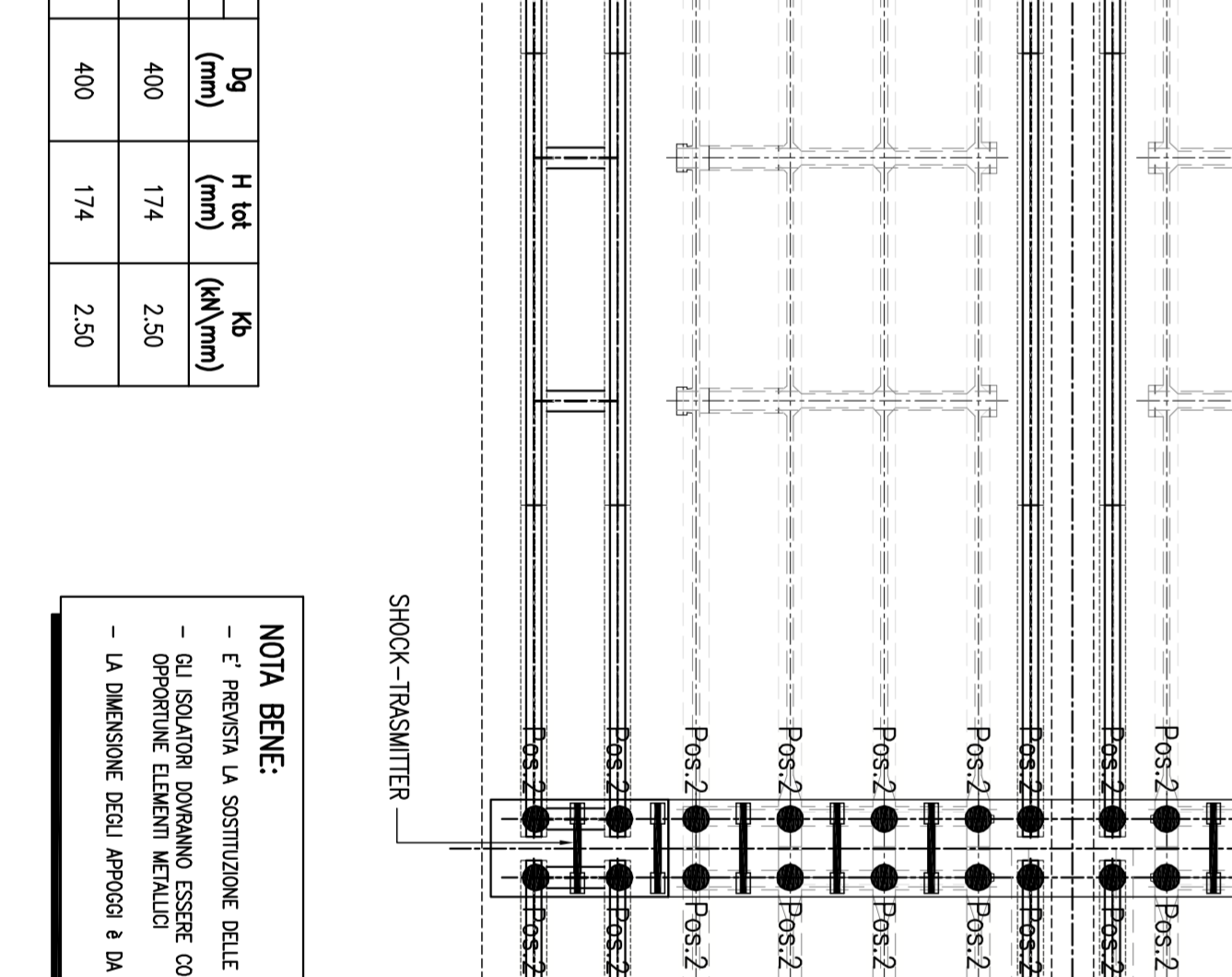

SOLETTA DI CONTINUITA'

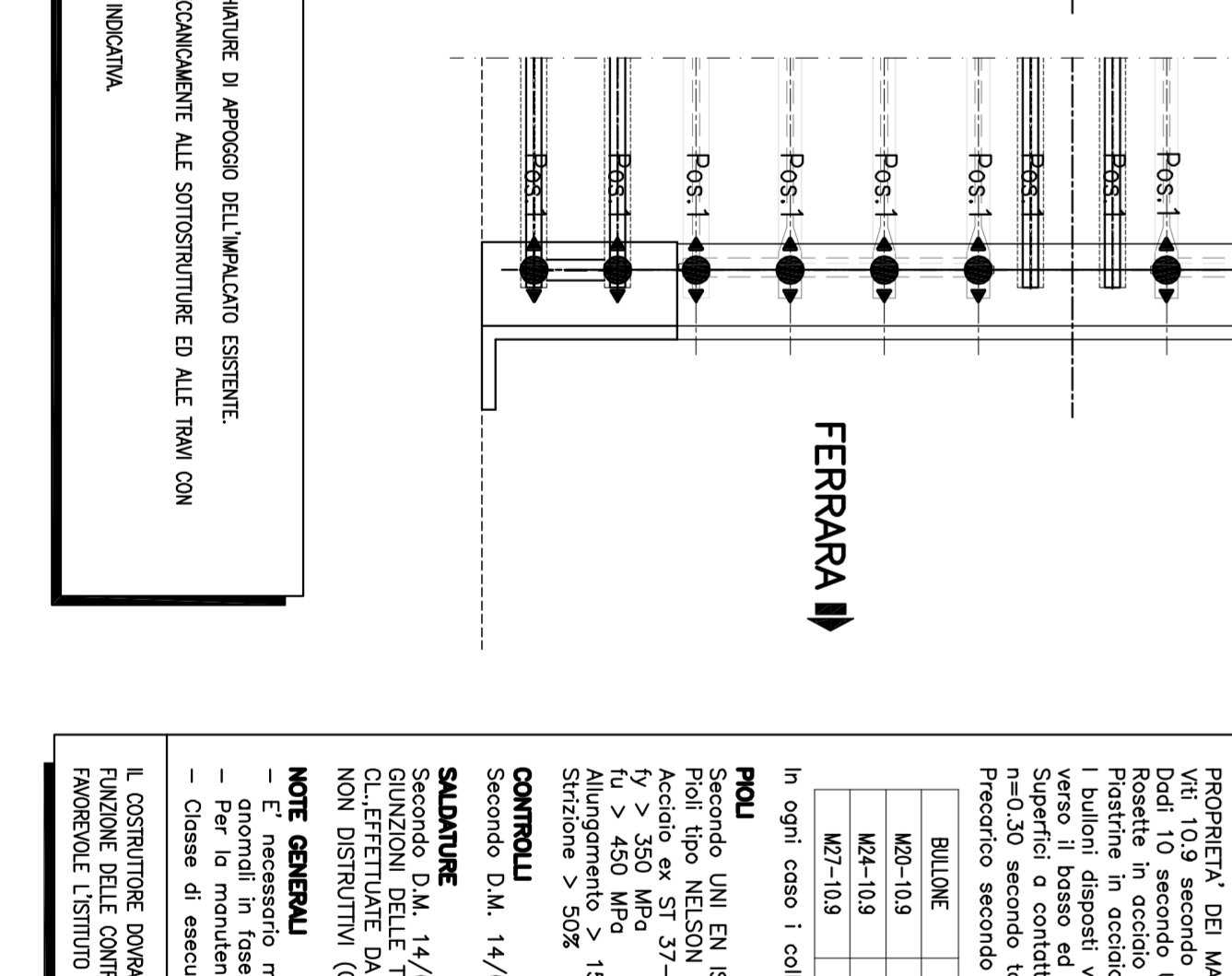

SEZIONE A-A

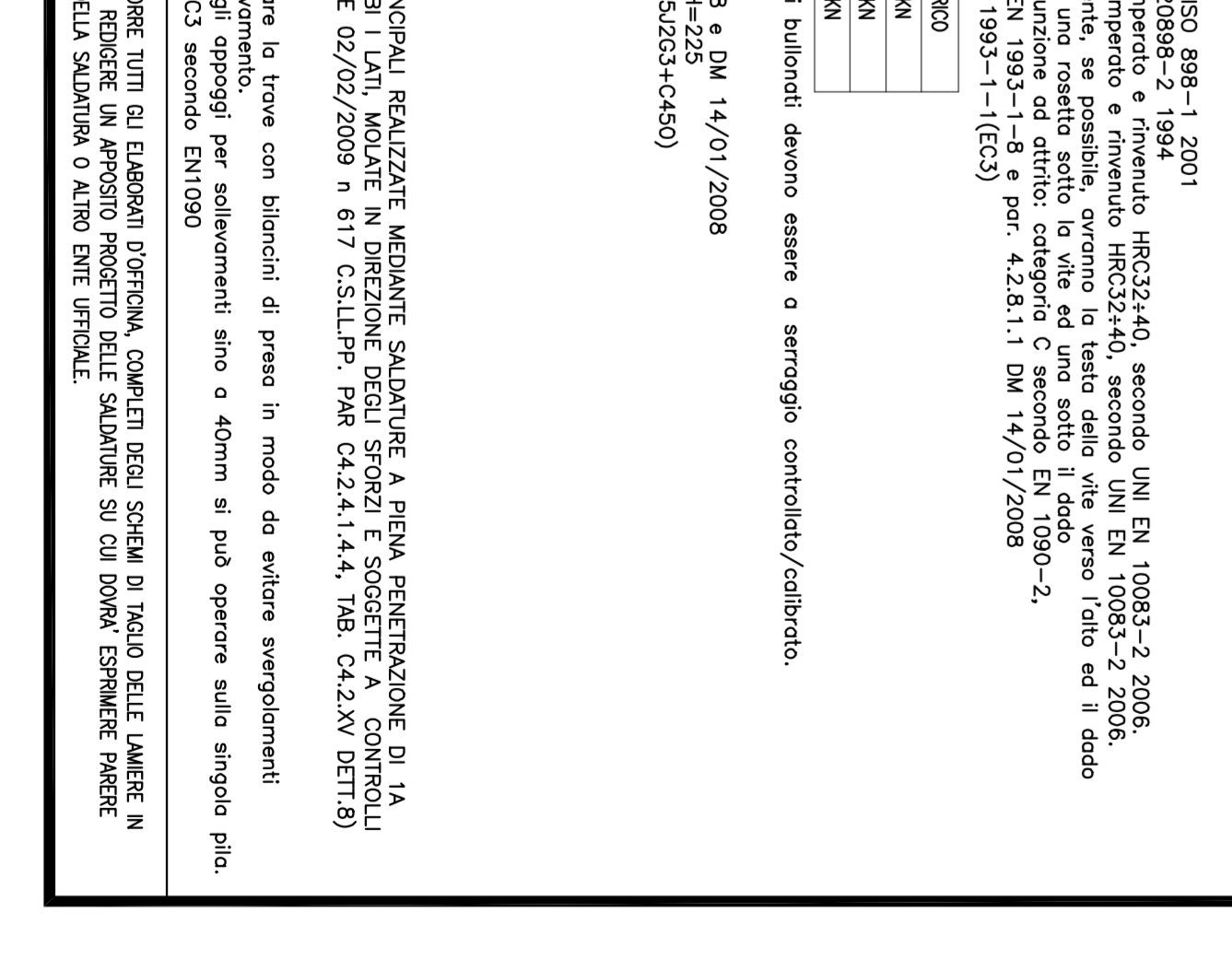

PROGETTO DEFINITIVO

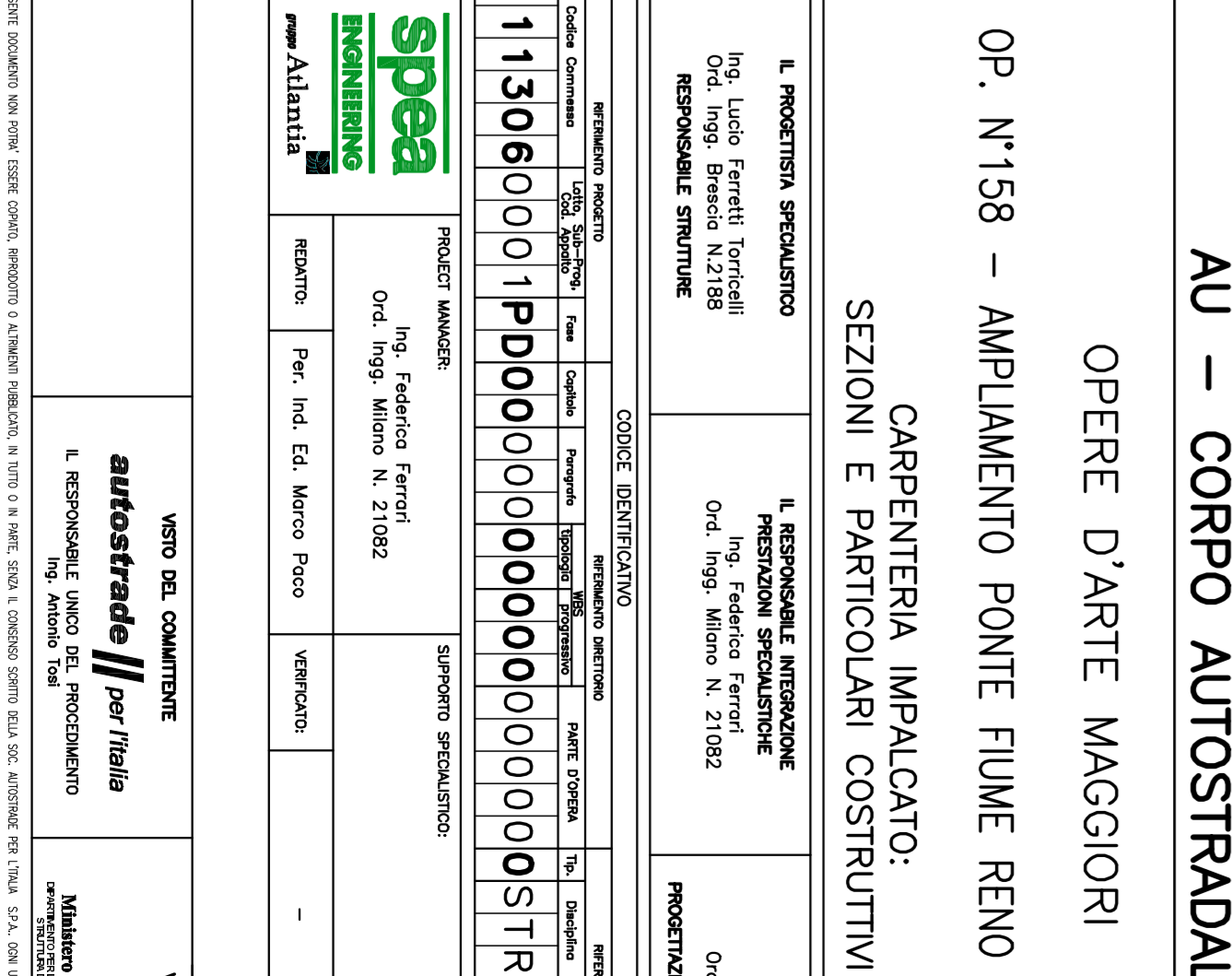

Project information block including: AUTOSTRADA (A13) - BOLOGNA-PADOVA, TRATTO: BOLOGNA ARCOVERSO - FERRARA SUD, and logos for SPEA and other stakeholders.