

AUTOSTRADA VALDASTICO

A31 NORD

1° LOTTO

Piovene Rocchette - Valle dell'Astico

PROGETTO DEFINITIVO

CUP	G21B1 30006 60005
WBS	B25.A31N.L1
COMMESSA	J16L1

COMMITTENTE



S.p.A. AUTOSTRADA BRESCIA VERONA VICENZA PADOVA
Area Costruzioni Autostradali

CAPO COMMESSA
PER LA PROGETTAZIONE
Dott. Ing. Gabriella Costantini

PRESTATORE DI SERVIZI:
CONSORZIO RAETIA



RAPPRESENTANTE: Dott. Ing. Alberto Scotti

RESPONSABILE DELL'INTEGRAZIONE
TRA LE PROGETTAZIONI SPECIALISTICHE:
Technital S.p.A. - Dott. Ing. Andrea Renzo



PROGETTAZIONE:

ING. FRANCESCO COCCIANTE
INGEGNERI
ROMA

Responsabile:
Dott. Ing. Francesco Cocciantè



ELABORATO: EDIFICI E STRUTTURE A CORREDO
CASELLO DI COGOLLO DEL CENGIO
STRUTTURALE
RELAZIONE TECNICA E DI CALCOLO PENSILINA

Progressivo	Rev.
09 01 02 001	02

Rev.	Data	Descrizione	Redazione	Controllo	Approvazione	SCALA:
00	MARZO 2017	PRIMA EMISSIONE	SINTEL ENGINEERING - G. ZOINO	M. BAFFA PACINI	F. COCCIANTE	-
01	GIUGNO 2017	REVISIONE PER VERIFICA	SINTEL ENGINEERING - G. ZOINO	M. BAFFA PACINI	F. COCCIANTE	NOME FILE: J16L1_09_01_02_001_0303_OPD_02.dwg
02	LUGLIO 2017	RECEPIMENTO OSSERVAZIONI	SINTEL ENGINEERING - G. ZOINO	M. BAFFA PACINI	F. COCCIANTE	CM. PROGR. FG. LIV. REV. J16L1_09_01_02_001_0303_OPD_02

AUTOSTRADA VALDASTICO A31 NORD
1° LOTTO
PIOVENE ROCCHETTE – VALLE DELL’ASTICO

Committente:



Progettazione:

CONSORZIO RAETIA



PROGETTO DEFINITIVO

EDIFICI E STRUTTURE A CORREDO
CASELLO COGOLLO DEL CENGIO
STRUTTURALE
RELAZIONE TECNICA E DI CALCOLO PENSILINA

INDICE

1	DESCRIZIONE GENERALE DELL'OPERA	5
2	NORMATIVA DI RIFERIMENTO	6
3	VITA NOMINALE , CLASSI D'USO E PERIODO DI RIFERIMENTO	7
4	MATERIALI IMPIEGATI E RESISTENZE DI CALCOLO	7
5	TERRENO DI FONDAZIONE	9
6	ANALISI DEI CARICHI	10
	o SOVRACCARICO NEVE	10
	o SOVRACCARICO VENTO	11
7	DIAGRAMMA DELLE DEFORMAZIONI E SOLLECITAZIONI	14
8	VALUTAZIONE DELL'AZIONE SISMICA	15
	8.1 SPETTRI DI RISPOSTA	15
9	ELEMENTI DI FONDAZIONE	19
10	METODO DI ANALISI E CRITERI DI VERIFICA	19
11	AZIONI SULLA STRUTTURA	21
12	CODICE DI CALCOLO IMPIEGATO	22
13	VERIFICA DEGLI ELEMENTI STRUTTURALI	24
	13.1 CRITERI DI VERIFICA	24
14	VALIDAZIONE DEL CALCOLO-INFORMAZIONI SULL'ELABORAZIONE	28
15	MODELLAZIONE	29
	15.1 AFFIDABILITA' DEI CODICI UTILIZZATI	31
16	PRESENTAZIONE DEI RISULTATI	31
17	TABULATI DI INPUT	35
	17.1 DATI GENERALI	35
	17.2 IMPALCATI	36
	17.3 PERCENTUALI DI SPOSTAMENTO MASSE IMPALCATI	36
	17.4 COMBINAZIONI DEL SISMA IN X E Y E VERTICALE	36
	17.5 SPETTRI DI RISPOSTA	37
	17.6 NODI - CARICHI	41
	17.7 PLINTI - GEOMETRIA E VINCOLI	43
18	TABULATI DI VERIFICA	43

19	VERIFICHE STATO LIMITE ULTIMO	43
	19.1 VERIFICA PLINTI	43
	19.2 VERIFICA RESISTENZA ASTE METALLICHE	54
20	VERIFICHE STATO LIMITE DI ESERCIZIO	488
	20.1 VERIFICA PLINTI	488
	20.1 VERIFICA SPOSTAMENTI VERTICALI DELLE ASTE IN ACCIAIO SECONDO NTC 2008	498
21	PIASTRA COLONNA PENSILINA	1117
	21.1 SEZIONE DELLA COLONNA	1120
	21.2 GEOMETRIA COSTOLE	1120
	21.3 GEOMETRIA TIRAFONDI	1120
	21.4 PROPRIETA' MATERIALI	1121
	21.5 PROPRIETA' SALDATURE	1121
	21.6 CARATTERISTICHE APPLICATE ALLA COLONNA	1122
22	CAPACITA' PORTANTE FONDAZIONE	1126
23	CALCOLI COMPARATIVI	1127
	23.1 CARATTERISTICHE DELLE SOLLECITAZIONI DELLE ASTE	1134
	23.2 VERIFICA DELLE ASTE (Profili tubolari)	1141
24	TABULATI DI INPUT- TETTOIA PARCHEGGIO	1147
	24.1 DATI GENERALI	1147
	24.2 IMPALCATI	1148
	24.3 PERCENTUALI SPOSTAMENTO MASSE IMPALCATI	1148
	24.4 ANALISI DEI CARICHI	1148
	o SOVRACCARICO NEVE	1148
	o SOVRACCARICO VENTO	1149
	24.5 COMBINAZIONI DEL SISMA IN X E Y E VERTICALE	1151
	24.6 SPETTRI DI RISPOSTA	1153
	24.7 NODI- GEOMETRIA E VINCOLI	1157
	24.8 IMPUT ASTE TABELLA SEZIONI TIPO	1158
	24.9 ASTE CARICHI	1158
	24.10 VERIFICA PORTANZA FONDAZIONE	1186
	24.11 VERIFICA DELLA SEZIONE	1188

Indice delle tabelle

Tabella 1: Percentuali spostamento masse impalcati	20
Tabella 2: Combinazioni del sisma in X e Y e Verticale.....	20
Tabella 3: Risultati Analisi Dinamica – Statistiche matrice di rigidezza	29

Indice delle figure

Figura 1 Vista 1	6
Figura 2 Vista 2	6
Figura 3 Diagrammi di calcolo tensione/deformazione del calcestruzzo.....	8
Figura 4 Diagrammi di calcolo tensione/deformazione dell'acciaio per calcestruzzo.....	9
Figura 5 Diagramma Deformazioni.....	14
Figura 6 Diagramma Sollecitazioni	14
Figura 7 Vista 1	1147
Figura 8 Diagramma Deformata tettoia parcheggio	1152
Figura 9 Diagramma Sollecitazioni tettoia parcheggio	1153

1 DESCRIZIONE GENERALE DELL'OPERA

La struttura oggetto del presente calcolo è ubicata in Cogollo del Cengio (prov. di Vicenza) . La struttura, che in pianta ha una forma rettangolare, ha dimensioni 27.00 m x 47.00 m ed una altezza totale strutturale massima pari a 9.30 m. La struttura è intelaiata in acciaio ed è costituita da pilastri binati di sezione pari a \varnothing 609.6 x 10 ed aste di sezioni pari a \varnothing 114.3 x 5.9 su plinti e pali in c.a. aventi dimensioni rispettivamente 2.60 x 2.80 x 1.20 m e pali di sezione 0.60 m e lunghezza 10 m.

Le aste in acciaio sono di tipo S 275 mentre la fondazione in c.a. utilizza calcestruzzo tipo C 25-30 ed acciaio tipo B 450 C.

Il manto di copertura è costituito da lastre tipo Riverclack.

Vengono riportate di seguito due viste assometriche contrapposte, allo scopo di consentire una migliore comprensione della struttura oggetto della presente relazione:



Figura 1 Vista 1



Figura 2 Vista 2

2 NORMATIVA DI RIFERIMENTO

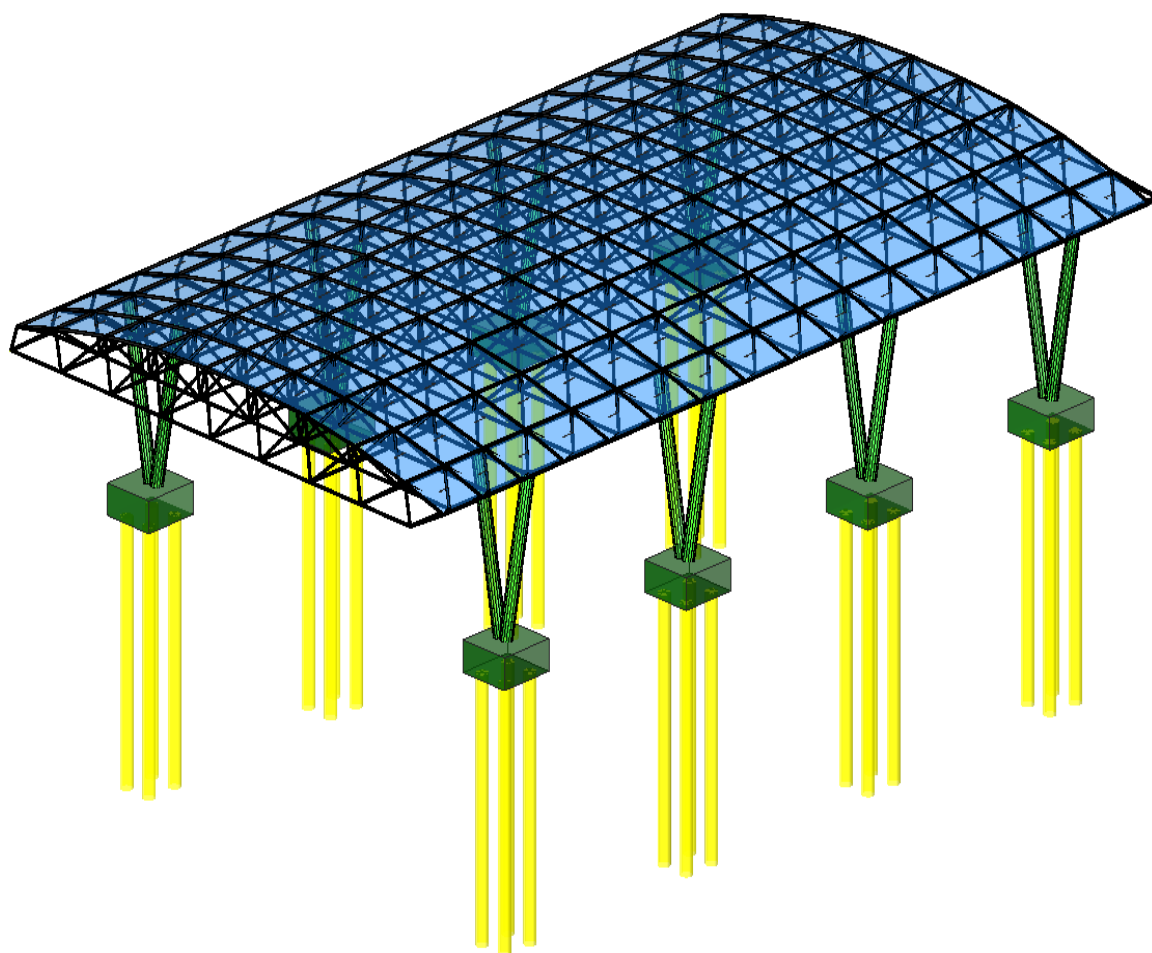
Nel seguente elenco sono riportate le norme di riferimento secondo le quali sono state condotte le fasi di calcolo e verifica degli elementi strutturali:

Legge 5 novembre 1971 n. 1086 (G. U. 21 dicembre 1971 n. 321)

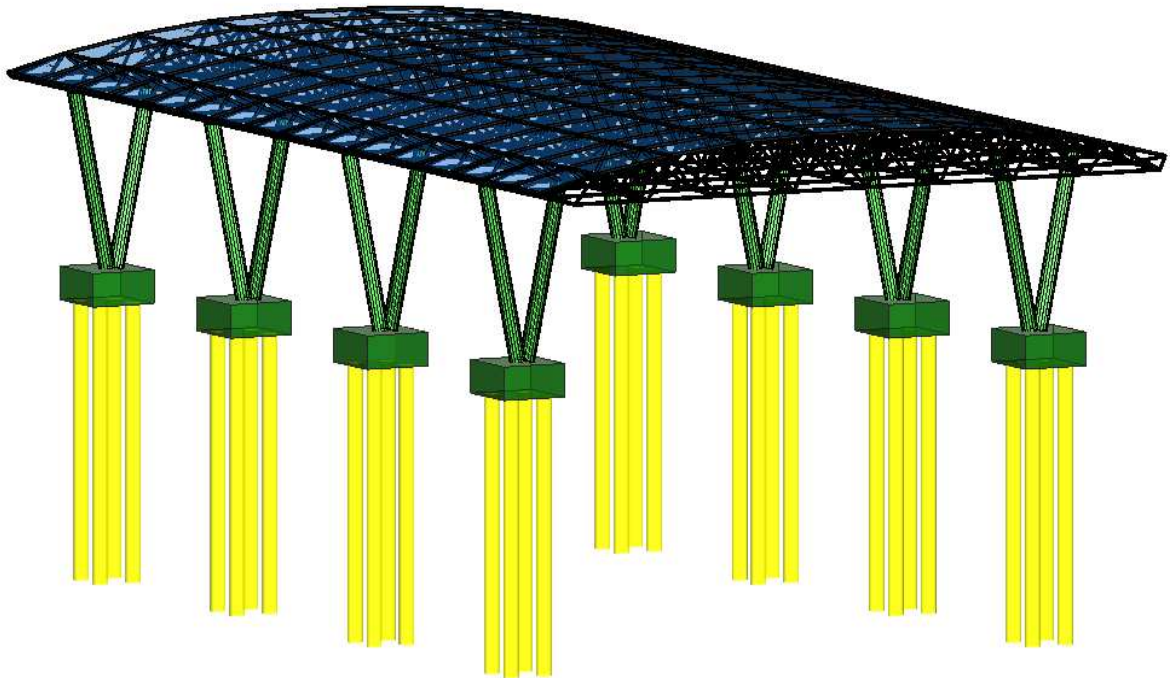
“Norme per la disciplina delle opere di conglomerato cementizio armato, normale e precompresso ed a struttura metallica”

Legge 2 febbraio 1974 n. 64 (G. U. 21 marzo 1974 n. 76)

“Provvedimenti per le costruzioni con particolari prescrizioni per le zone sismiche”

D.M. 14.01.2008 (nuove norme tecniche per le costruzioni)

Nel seguito denominate NT (norme tecniche)

Il calcolo delle sollecitazioni e la loro combinazione è stato eseguito seguendo le indicazioni delle NT secondo l'APPROCCIO 2.

3 VITA NOMINALE , CLASSI D'USO E PERIODO DI RIFERIMENTO

La costruzione in oggetto è definita dalla seguente tipologia (p.to 2.4 delle NT):

Vita della struttura	
Tipo	Opere ordinarie (50-100) 50 - 100 anni
Vita nominale(anni)	50.0
Classe d'uso	Classe II
Coefficiente d'uso	1.000
Periodo di riferimento(anni)	50.000
Stato limite di esercizio - SLD	PVR=63.0%
Stato limite ultimo - SLV	PVR=10.0%
Periodo di ritorno SLD(anni)	TR=50.3
Periodo di ritorno SLV(anni)	TR=474.6

Per maggiori dettagli riguardo l'azione sismica si veda la definizione degli spettri di risposta

4 MATERIALI IMPIEGATI E RESISTENZE DI CALCOLO

Per la realizzazione dell'opera in oggetto saranno impiegati i seguenti materiali, di cui si riportano nell'ordine le proprietà meccaniche adottate nel calcolo elastico e le resistenze di calcolo per le verifiche di sicurezza:

Parti in calcestruzzo armato		
Classe calcestruzzo		ClS C25/30
Resistenza cubica Rck	kg/cmq	300
Resistenza di calcolo fcd	kg/cmq	141
Resistenza a trazione di calcolo fctd	kg/cmq	12

Resistenza cilindrica f_{ck}	kg/cmq	249
Resistenza a trazione media f_{ctm}	kg/cmq	26
Classe acciaio		Acciaio B450C
Resistenza allo snervamento f_{yk}	kg/cmq	≥ 4500
Resistenza alla rottura f_{tk}	kg/cmq	≥ 5400
Parti in acciaio		
Classe acciaio		S275
f_{yd} (t<40mm)	kg/cmq	2750
f_{yd} (t>40mm)	kg/cmq	2550
f_t (t<40mm)	kg/cmq	4300
f_t (t>40mm)	kg/cmq	4100

I diagrammi costitutivi del calcestruzzo e dell'acciaio per calcestruzzo sono stati adottati in conformità alle indicazioni riportate al punto 4.1.2.1.2.2 del D.M. 14 gennaio 2008; in particolare per le verifiche delle sezioni in calcestruzzo armato è stato adottato il modello di calcestruzzo riportato in a) della figura seguente



Figura 3 Diagrammi di calcolo tensione/deformazione del calcestruzzo

ed il modello di acciaio riportato in a) o b) della figura seguente

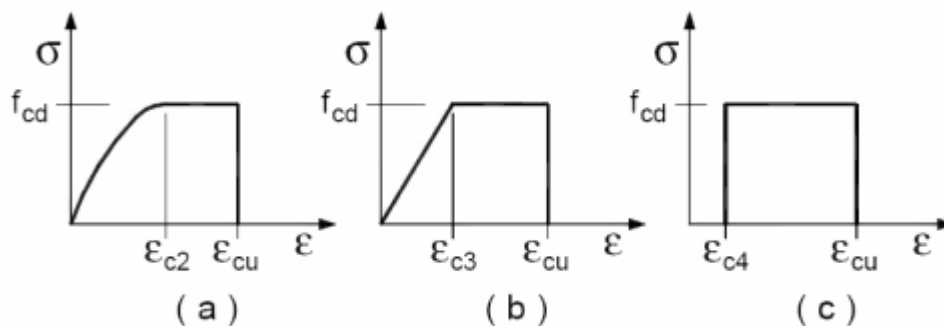

Figura 4 Diagrammi di calcolo tensione/deformazione dell'acciaio per calcestruzzo.

La resistenza di calcolo è data da f_{yk} / g_f . Il coefficiente di sicurezza è g_f .

Tutti i materiali impiegati dovranno essere comunque verificati con opportune prove di laboratorio secondo le prescrizioni della vigente Normativa. Riguardo ai coefficienti di sicurezza parziali, alle deformazioni del calcestruzzo e dell'acciaio per modello incrudente si faccia riferimento ai criteri di verifica nella sezione "Verifica Elementi Strutturali".

5 TERRENO DI FONDAZIONE

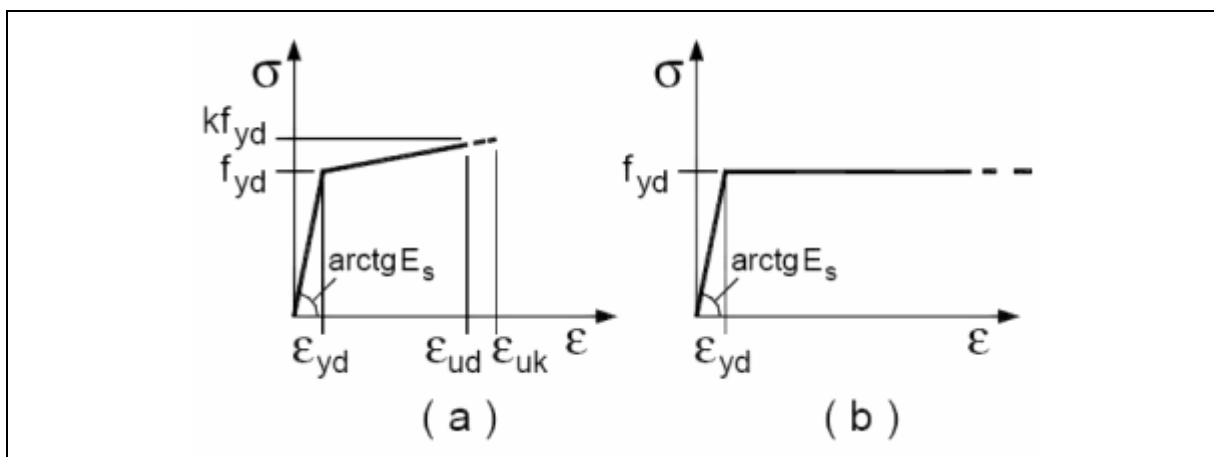
Le fondazioni del fabbricato in oggetto sono costituite da un insieme di:

plinti su pali in conglomerato cementizio armato.

La struttura di fondazione è posta ad una profondità media di m. 1.00 dal piano campagna e di dimensioni planimetriche massime pari a m. 27.00 x 47.00

I valori delle tensioni sul piano di posa e le sollecitazioni negli elementi di fondazione, sono riportati nell'allegato 'Calcoli Strutturali'. Dalla Relazione Geologica risulta che nell'area in oggetto, si ha un terreno di tipo B con la seguente stratigrafia:

Strato n°		1
Spessore	cm	20000
Peso spec.	kg/mc	2000
Peso spec. Sat.	kg/mc	0
Angolo attrito	°	38
Addensato		No
OCR		--
coesione	kg/cmq	0.00
cu	kg/cmq	0.00

Modulo edometrico	kg/cmq	2E02
Coeff. Poisson		0.3
Descrizione		Strato 1

Per la determinazione del carico limite del complesso terreno-fondazione, pertanto, si sono assunti i parametri fisico-meccanici precedentemente indicati. Per maggiori dettagli riguardo i parametri che caratterizzano il terreno si rimanda alla relazione geologica e a quella geotecnica.

6 ANALISI DEI CARICHI

La valutazione dei carichi e dei sovraccarichi è stata effettuata in accordo con le disposizioni contenute nel **D.M. 14.01.2008 (nuove norme tecniche per le costruzioni)**

I carichi adottati sono i seguenti:

I carichi relativi ai pesi propri vengono valutati in automatico in funzione della geometria degli elementi ed al loro peso specifico i tamponamenti vengono valutati per metro lineare di trave su cui insistono maggiori dettagli ad essi relativi sono riportati nel tabulato di calcolo alla sezione dei carichi relativi alle aste, nodi ed shell.

La valutazione dei carichi e dei sovraccarichi è stata effettuata in accordo con le disposizioni contenute nel **D.M. 14.01.2008 (nuove norme tecniche per le costruzioni)**

I carichi adottati sono i seguenti:

○ *SOVRACCARICO NEVE*

<u>Provincia</u> :	VICENZA
<u>Zona</u> :	1 - Alpina
<u>Altitudine a_s</u> :	305 m s.l.m.
<u>Esposizione</u> :	Normale
<u>Periodo di ritorno</u> :	50 anni

Il carico neve sulle coperture viene valutato con la seguente espressione:

$$q_s = m_i \cdot q_{sk} \cdot C_E \cdot C_t \text{ KN/m}^2$$

dove:

μ_i	Coefficiente di forma della copertura
$C_E = 1.0$	Coefficiente di esposizione
$C_t = 1.0$	Coefficiente termico
$q_{sk} = 1.82 \text{ KN/m}^2$	Carico neve al suolo

Nel caso in esame (copertura ad una falda), con

$$\alpha = 0.00^\circ$$

il coefficiente di forma vale:

$$\mu_i(\alpha) = 0.80 \Rightarrow q_s = 1.46 \text{ KN/m}^2$$

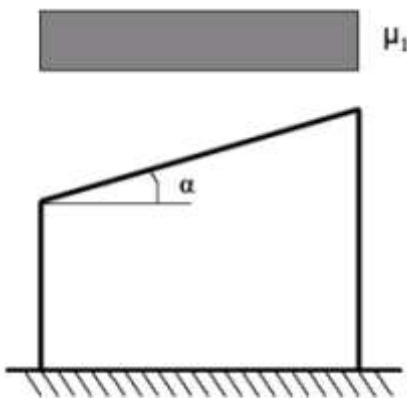

○ SOVRACCARICO VENTO

Zona Vento	$V_{b,0}$ (m/s)	a_0 (m)	K_a (1/s)
1	25	1000	0.010

Categoria di esposizione	K	z_0 (m)	z_{min} (m)
2	0.19	0.05	4

Altitudine: $a_s = 305 \text{ m s.l.m.}$

Distanza dalla costa: terra - oltre 40 Km

Classe di rugosità terreno: D

Altezza manufatto: h = 5.00 m

Periodo di ritorno: $T_R = 50.0$ anni =>
 $a_R = 0.75 \{1 - 0.2 \ln[-\ln(1 - 1/T_R)]\}^{0.5} = 1.00$

Velocità di riferimento del vento: $V_b = V_{b,0}$ per $a_s \leq a_0$
 $V_b = V_{b,0} + K_a (a_s - a_0)$ per $a_s > a_0$

$$V_b = 25.000 \text{ m/s}$$
$$V_b(T_R) = a_R V_b = 25.018 \text{ m/s}$$

Coefficiente dinamico: $C_d = 1.00$

Coefficiente di forma: $C_p = 1.20$

Coefficiente di attrito: $C_f = 0.02$

Coefficiente di topografia: $C_t = 1.00$

Coefficiente di esposizione: $C_e(z) = K^2 C_t \ln(z/z_0) [7 + C_t \ln(z/z_0)]$ per $z \geq z_{min}$

$$C_e(z) = C_e(z_{min}) \quad \text{per } z < z_{min}$$

$$C_e(z) = 1.93$$

Le azioni del vento si traducono in pressioni (positive) e depressioni (negative) agenti normalmente alla superficie degli elementi che compongono la costruzione. La pressione agente su un singolo elemento è data dall'espressione:

$$p = q_b C_e C_p C_d = 905.70 \text{ Pa}$$

dove,

$$q_b = 1/2 \rho v_b^2 \quad \text{è la pressione cinetica di riferimento;}$$

$$\rho = 1,25 \text{ Kg/m}^3 \quad \text{è la densità dell'aria.}$$

L'azione tangente per unità di superficie parallela alla direzione del vento è:

$$p_f = q_b C_e C_f = 15.09 \text{ Pa}$$

I carichi relativi ai pesi propri vengono valutati in automatico in funzione della geometria degli elementi ed al loro peso specifico i tamponamenti vengono valutati per metro lineare di trave su cui insistono maggiori dettagli ad essi relativi sono riportati nel tabulato di calcolo alla sezione dei carichi relativi alle aste, nodi ed shell.

Analisi carichi

SOLAIO copertura tipo Riverclack

PESO PROPRIO

Totale Pesi Propri: = 10 Kg/mq

SOVRACCARICHI FISSI

Accessori elementi

Copertura, etc : = 5 Kg/mq

Totale carichi permanenti = 15 Kg/mq

Carichi variabili = 146 Kg/mq

7 DIAGRAMMA DELLE DEFORMAZIONI E SOLLECITAZIONI



Figura 5 Diagramma Deformazioni



Figura 6 Diagramma Sollecitazioni

8 VALUTAZIONE DELL'AZIONE SISMICA

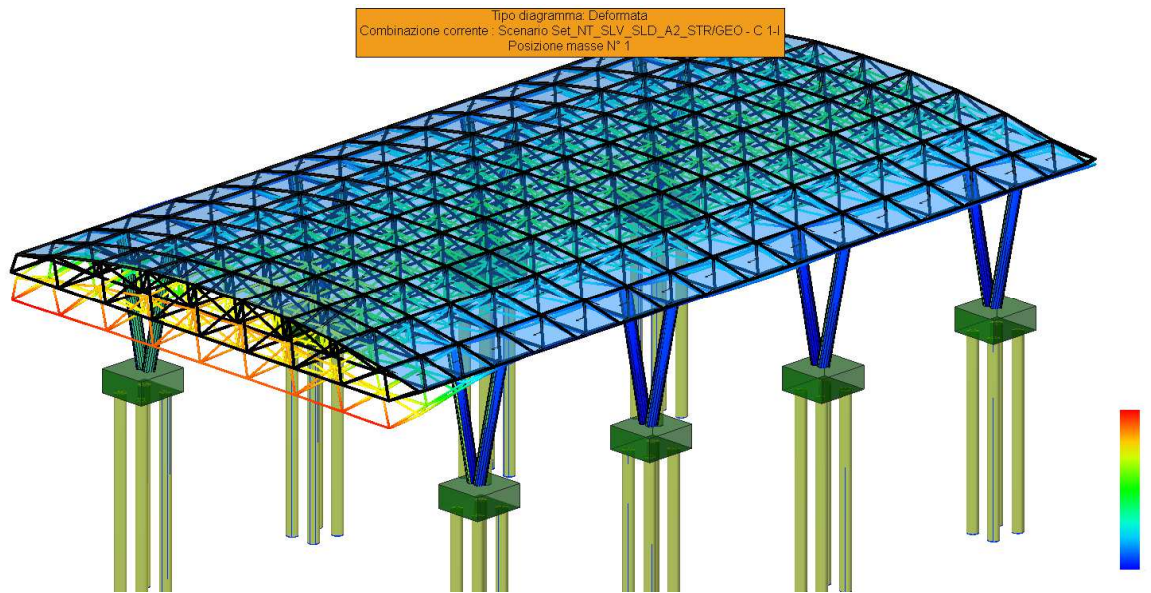
L'azione sismica è stata valutata in conformità alle indicazioni riportate al capitolo 3.2 del D.M. 14 gennaio 2008 "Norme tecniche per le Costruzioni"

La valutazione degli spettri di risposta per un dato Stato Limite avviene attraverso le seguenti fasi:

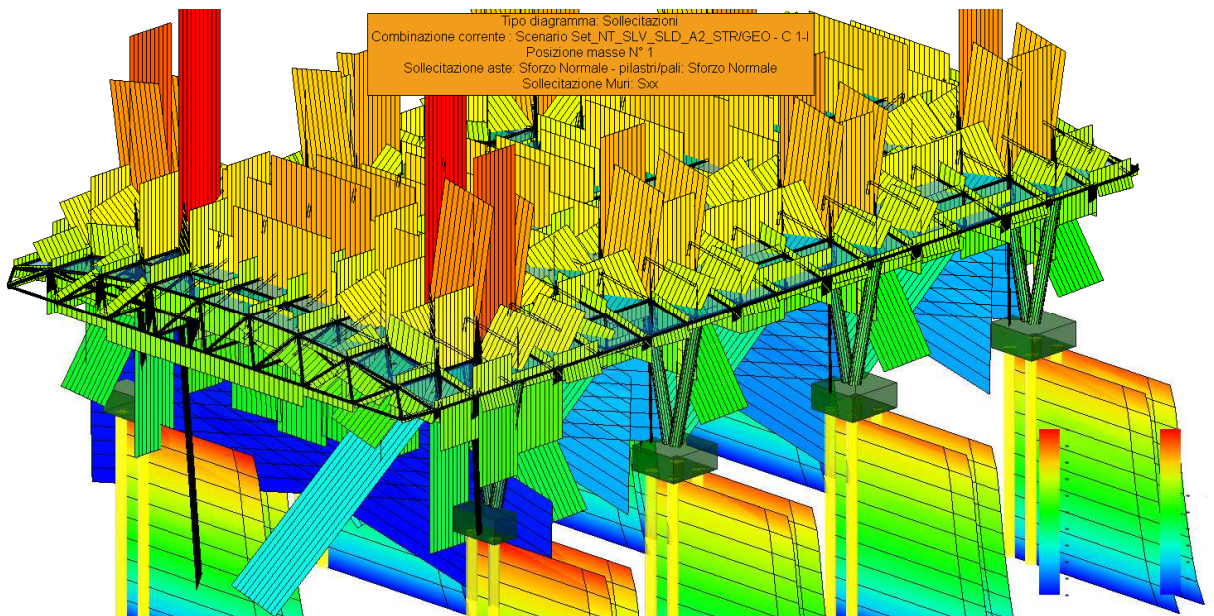
- definizione della Vita Nominale e della Classe d'Uso della struttura, in base ai quali si determina il Periodo di Riferimento dell'azione sismica.
- Determinazione attraverso latitudine e longitudine dei parametri sismici di base a_g , F_0 e T^*c per lo Stato Limite di interesse; l'individuazione è stata effettuata interpolando tra i 4 punti più vicini al punto di riferimento dell'edificio secondo quanto disposto dall'allegato alle NTC "Pericolosità Sismica", dove:
 - a_g accelerazione orizzontale massima al sito;
 - F_0 valore massimo del fattore di amplificazione dello spettro in accelerazione orizzontale.
 - T^*c periodo di inizio del tratto a velocità costante dello spettro in accelerazione orizzontale
- Determinazione dei coefficienti di amplificazione stratigrafica e topografica.
- Calcolo del periodo T_c corrispondente all'inizio del tratto a velocità costante dello Spettro.

I dati così calcolati sono stati utilizzati per determinare gli Spettri di Progetto nelle verifiche agli Stati Limite considerati, per ogni direzione dell'azione sismica.

Oltre alla determinazione dei parametri sismici del sito si è considerata la tipologia di terreno, la posizione topografica e la tipologia strutturale (classe di duttilità, regolarità, ecc..) che ha condotto alla determinazione dei seguenti spettri di risposta.

8.1 SPETTRI DI RISPOSTA

Spettro :SpettroNT

Il calcolo degli spettri e del fattore di struttura sono stati calcolati per la seguente tipologia di terreno e struttura

AUTOSTRADA VALDASTICO A31 NORD
1° LOTTO - PIOVENE ROCCHETTE – VALLE DELL'ASTICO

Vita della struttura	
Tipo	Opere ordinarie (50-100) 50 - 100 anni
Vita nominale(anni)	50.0
Classe d'uso	Classe II
Coefficiente d'uso	1.000
Periodo di riferimento(anni)	50.000
Stato limite di esercizio - SLD	PVR=63.0%
Stato limite ultimo - SLV	PVR=10.0%
Periodo di ritorno SLD(anni)	TR=50.3
Periodo di ritorno SLV(anni)	TR=474.6
Parametri del sito	
Comune	Cogollo del Cengio - (VI)
Longitudine	11.421
Latitudine	45.789
Id reticolo del sito	10961-10960-11182-11183
Valori di riferimento del sito	
Ag/g(TR=50.3) SLD	0.0559
F0(TR=50.3) SLD	2.4956
T* C(TR=50.3) SLD	0.250
Ag/g(TR=474.6) SLV	0.1533
F0(TR=474.6) SLV	2.4174
T* C(TR=474.6) SLV	0.290
Coefficiente Amplificazione Topografica	St=1.000
Categoria terreno B	
stato limite SLV	
	S=1.20
	TB=0.14
	TC=0.41
	TD=2.21
stato limite SLD	

AUTOSTRADA VALDASTICO A31 NORD
1° LOTTO - PIOVENE ROCCHETTE – VALLE DELL'ASTICO

	S=1.20
	TB=0.12
	TC=0.36
	TD=1.82
Fattore di struttura (SLV)	
Classe duttilità	B
Tipo struttura	Acciaio
Struttura regolare in altezza	Kr=1.000000
	Kw=1.000
Regolare in pianta	SI
Tipologia : Strutture a telaio	Ce=4.000
Fattore di struttura $q=Kw*Kr*Ce$	4.000

TSLV [s]	SLV[a/g]	TSLD [s]	SLD[a/g]
0.00000	0.18391	0.00000	0.06707
0.13620	0.11115	0.12101	0.16737
0.40860	0.11115	0.36304	0.16737
0.60909	0.07456	0.57169	0.10629
0.80958	0.05610	0.78033	0.07787
1.01007	0.04496	0.98898	0.06144
1.21057	0.03751	1.19762	0.05074
1.41106	0.03218	1.40626	0.04321
1.61155	0.03065	1.61491	0.03763
1.81204	0.03065	1.82355	0.03332
2.01253	0.03065	2.04120	0.02659
2.21302	0.03065	2.25884	0.02172
2.43639	0.03065	2.47649	0.01807
2.65977	0.03065	2.69413	0.01527

AUTOSTRADA VALDASTICO A31 NORD
1° LOTTO - PIOVENE ROCCHETTE – VALLE DELL'ASTICO

2.88314	0.03065	2.91178	0.01307
3.10651	0.03065	3.12942	0.01131
3.32988	0.03065	3.34707	0.00989
3.55326	0.03065	3.56471	0.00872
3.77663	0.03065	3.78236	0.00775
4.00000	0.03065	4.00000	0.00693

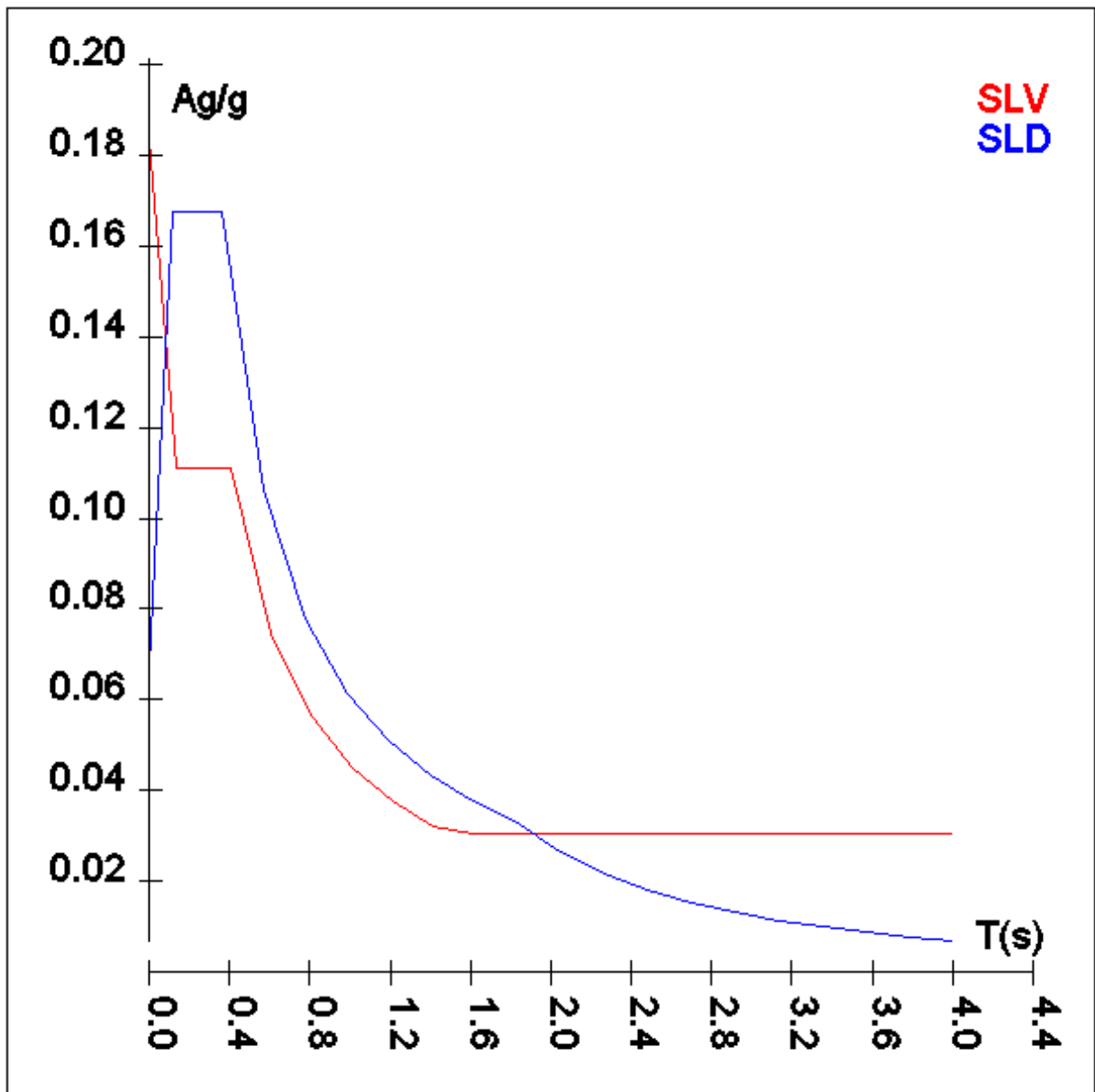

9 ELEMENTI DI FONDAZIONE

Il calcolo della struttura di fondazione è condotto considerando le azioni che la struttura sovrastante le trasmette amplificate per un $\tilde{a}R_d$ pari a 1,1 in CD “B” e 1,3 in CD “A”, e comunque non maggiori di quelle derivanti da una analisi elastica della struttura in elevazione eseguita con un fattore di struttura q pari a 1 e non maggiori delle resistenze degli elementi sovrastanti la fondazione.

10 METODO DI ANALISI E CRITERI DI VERIFICA

Il calcolo delle azioni sismiche è stato eseguito in analisi dinamica modale, considerando il comportamento della struttura in regime elastico lineare. Le masse sono applicate nei nodi del modello queste vengono generate attraverso i carichi agenti sulle membrature che collegano i nodi come la massa relativa alla azione di incastro perfetto del carico considerato. La risposta massima di una generica caratteristica E , conseguente alla sovrapposizione dei modi, è valutata con la tecnica della combinazione probabilistica definita CQC (Complete Quadratic Combination - Combinazione Quadratica Completa):

$$E = \sqrt{\sum_{i,j=1,n} \rho_{ij} \cdot E_i \cdot E_j}$$

con:

$$\rho_{ij} = \frac{8\xi^2 \cdot (1 + \beta_{ij}) \cdot \beta_{ij}^{\frac{3}{2}}}{(1 - \beta_{ij}^2)^2 + 4\xi^2 \cdot \beta_{ij} \cdot (1 + \beta_{ij}^2)} \quad \beta_{ij} = \frac{\omega_i}{\omega_j}$$

dove:

- n è il numero di modi di vibrazione considerati
- ξ è il coefficiente di smorzamento viscoso equivalente espresso in percentuale;
- β_{ij} è il rapporto tra le frequenze di ciascuna coppia i - j di modi di vibrazione.

Le sollecitazioni derivanti da tali azioni sono state calcolate per varie posizioni dei baricentri delle masse e composte secondo combinazioni di posizioni prestabilite, come riportato in seguito, il risultato di tali combinazioni sono state composte poi con quelle derivanti da carichi non sismici secondo le varie combinazioni di carico probabilistiche. Per tener conto della eccentricità accidentale delle masse si sono considerate varie posizioni delle masse ad ogni impalcato modificando la posizione del baricentro di una distanza, rispetto alla posizione originaria, come percentuale della dimensione della struttura nella direzione considerata. Le azioni risultanti dai calcoli per le varie posizioni delle masse, in fase di verifica

vengono combinati al fine di ottenere le azioni piu' sfavorevoli; di seguito vengono riportate sia le posizioni che le combinazioni delle masse, le due tabelle vanno lette nel seguente modo:

la prima indica la percentuale delle dimensione della struttura secondo cui viene spostato il baricentro ad ogni impalcato la percentuale è assegnata nelle due direzioni ortogonali secondo cui agisce il sisma, per ognuna di tali posizioni è eseguito un calcolo modale della struttura; la seconda tabella è usata in fase di verifica per la valutazione dell'azione sismica nel seguente modo l'effetto del sisma in una direzione è combinato con quello ortogonale di un'altra posizione con i fattori specificati nelle due colonne:

Posizione	% Spostamento direzione X	% Spostamento direzione Y
1	0	-5
2	5	0
3	0	5
4	-5	0

Tabella 1: Percentuali spostamento masse impalcati

Comb	Pos. Sisma X	Pos. Sisma Y	Fx	Fy	Fz
1	1	2	1	0.3	0
2	1	2	0.3	1	0
3	1	4	1	0.3	0
4	1	4	0.3	1	0
5	3	2	1	0.3	0
6	3	2	0.3	1	0
7	3	4	1	0.3	0
8	3	4	0.3	1	0

Tabella 2: Combinazioni del sisma in X e Y e Verticale

Comb. = Numero di combinazione dei sismi

Pos. SismaX = Posizione in cui viene scelto il sisma in direzione X

Pos. SismaY = Posizione in cui viene scelto il sisma in direzione Y

Fx = Fattore con cui il sisma X partecipa

Fy = Fattore con cui il sisma Y partecipa

Fz = Fattore con cui il sisma Verticale partecipa (quando richiesto)

Ogni combinazione genera al massimo 8 sotto-combinazioni in base a tutte le combinazioni possibili dei segni di Fx ed Fy ed Fz

Si è considerato un numero di modi di vibrazione sufficiente ad eccitare almeno l'85% della massa sismica in ogni posizione delle masse, di seguito si riportano i risultati salienti dell'analisi modale sia per il calcolo allo Stato Limite Ultimo che per quello di Esercizio.

11 AZIONI SULLA STRUTTURA

I calcoli e le verifiche sono condotti con il metodo semiprobabilistico degli stati limite secondo le indicazioni del D.M. 14 gennaio 2008. I carichi agenti sui solai, derivanti dall'analisi dei carichi, vengono assegnati alle aste in modo automatico in relazione all'influenza delle diverse aree di carico. I carichi dovuti ai tamponamenti, sia sulle travi di fondazione che su quelle di piano, sono schematizzati come carichi lineari agenti esclusivamente sulle aste. In presenza di platee il tamponamento è inserito considerando delle speciali aste (aste a sezione nulla) che hanno la sola funzione di riportare il carico su di esse agente nei nodi degli elementi della platea ad esse collegati. Su tutti gli elementi strutturali è inoltre possibile applicare direttamente ulteriori azioni concentrate e/o distribuite. Le azioni introdotte direttamente sono combinate con le altre (carichi permanenti, accidentali e sisma) mediante le combinazioni di carico di seguito descritte; da esse si ottengono i valori probabilistici da impiegare successivamente nelle verifiche.

I solai, oltre a generare le condizioni di carico per carichi fissi e variabili, generano anche altre condizioni di carico che derivano dal carico accidentale moltiplicati per i coefficienti γ_0 , γ_1 e γ_2 da utilizzare per le varie combinazioni di carico e per la determinazione delle masse sismiche.

Le azioni sono state assegnate su aste e piastre, definendo le seguenti condizioni di carico

Descrizione	Tipo
Peso Proprio	Automatica
QP Solai	Automatica
QFissi Solai	Automatica
QV Solai	Automatica
QV SolaiPsi0	Automatica
QV SolaiPsi1	Automatica
QV SolaiPsi2	Automatica
Tamponamento	Automatica
Neve	Utente
Vento X	Utente
Vento Y	Utente
Carichi termici	Utente

Spinta terreno	Utente
----------------	--------

In fase di combinazione delle condizioni di carico si è agito su coefficienti moltiplicatori delle condizioni per definirne l'esatto contributo sia in termini di carico che di massa, e sono stati infine definiti gli scenari di calcolo come gruppi omogenei di combinazioni di carico. Di seguito vengono riportate le combinazioni di carico usate per lo Stato Limite Ultimo e per lo Stato Limite di Esercizio. Le verifiche sono riportate nel fascicolo dei calcoli.

Le tabelle riportano nell'ordine:

- il nome della combinazione di carico
- il tipo di analisi svolta: STR=Strutturale, Statica STR=Sismica statica Strutturale, Modale STR=Sismica modale strutturale, SLE Rara=Stato Limite Esercizio combinazione rara, SLE Freq=Stato Limite Esercizio combinazione frequente, SLE Q.Perm=Stato Limite Esercizio combinazione quasi Permanente, GEO=Geotecnica, Statica GEO=Sismica Statica Geotecnica, Modale GEO=Sismica modale Geotecnica, STR+GEO=Strutturale+Geotecnica, Statica STR+GEO=Sismica Statica Strutturale+Geotecnica, Modale STR+GEO=Sismica modale Strutturale+Geotecnica, Modale SLE= Combinazione sismica modale con spettro di progetto SLD, Statica SLE=Combinazione sismica statica con spettro di progetto SLD. I termini "Strutturale", "Geotecnica" e "Strutturale+Geotecnica" indicano che la combinazione è usata dal programma per la determinazione delle verifiche di resistenza degli elementi strutturali, delle sole verifiche geotecniche, sia per le verifiche strutturali che geotecniche.
- lo spettro usato, se sismica
- il fattore amplificativo del sisma
- l'angolo di ingresso del sisma, se trattasi di analisi sismica
- il nome della condizione di carico e per ogni condizione di carico
- il fattore di combinazione per i carichi verticali
- se la condizione (con il suo coefficiente di peso) è inclusa nella combinazione (colonna Attiva)
- se la condizione partecipa alla formazione della massa (colonna Massa)
- il fattore con cui partecipa alla formazione della massa (se non è esclusa dalla formazione della massa)

12 CODICE DI CALCOLO IMPIEGATO

Autori:	dott. ing. Dario PICA prof. ing. Paolo BISEGNA
----------------	---

	dott. ing. Donato Sista
Produzione e distribuzione	SOFT.LAB srl via Borgo II - 82030 PONTE (BN) tel. ++39 (824) 874392 fax ++39 (824) 874431 internet: http://www.soft.lab.it e.mail: info@soft.lab.it
Sigla:	IperSpaceMax 7.0.0
Licenza n.	Concesso in licenza a SINTEL ENGINEERING SRL SINTEL ENGINEERING SRL codice utente C0084087

Il modello di calcolo assunto è di tipo spaziale e l'analisi condotta è una Analisi Elastica Lineare, esso è fondamentalmente definito dalla posizione dei nodi collegati da elementi di tipo Beam o elementi di tipo shell a comportamento sia flessionale che membranale, l'elemento finito shell utilizzato è anche in grado di esprimere una rigidezza rotazionale in direzione ortogonale al piano dello shell.

L'analisi sismica utilizzata è l'analisi modale con Combinazione Quadratica Completa degli effetti del sisma. Il modello è stato analizzato sia per le combinazioni dei carichi verticali sia per le combinazioni di carico verticale e sisma. Un particolare chiarimento richiede la definizione delle masse nell'analisi sismica. Pur avendo considerato il modello con impalcati rigidi non si rende necessario calcolare il modello con la metodologia del MASTER-SLAVE, in quanto gli impalcati rigidi sono stati modellati con elementi di tipo shell a comportamento membranale in corrispondenza dei campi di solaio. Per ottenere tale modellazione il programma inserisce in automatico elementi di tipo shell a comportamento membranale in corrispondenza del campo di solaio intercluso tra una maglia di travi, la loro rigidezza membranale è sufficientemente alta da rendere il campo di solaio rigido nel proprio piano, ma tale da non mal condizionare la matrice di rigidezza della struttura. Qualora una maglia di travi non è collegata da solaio lo shell non viene inserito rendendo tale campo libero di deformarsi con il solo vincolo dato dalle travi della. La loro rigidezza flessionale è trascurabile rispetto a quella degli elementi che contornano il campo, per cui lo shell impone un vincolo orizzontale solo nel piano dell'impalcato tra i nodi collegati, quindi non è necessario definire preventivamente definire il centro di massa e momento d'inerzia delle masse, questo perché le masse sono trasferite direttamente nei nodi del modello (modello Lumped Mass) dal codice di calcolo, il metodo per calcolare le masse nei nodi può essere quello per aree di influenza, ma questa richiederebbe l'intervento diretto dell'operatore; il codice di calcolo utilizza una metodologia leggermente più raffinata per tener conto del fatto che su un elemento il carico portato non è uniforme, quindi il codice di calcolo considera i carichi presenti sull'asta che sono stati indicati come quelli che contribuiscono alla formazione della massa (tipicamente $G + \gamma_2 * Q$) e calcola le reazioni di incastro perfetto verticali, tali reazioni divise per l'accelerazione di gravità g danno il contributo dell'elemento alla massa del nodo, sommando i contributi di tutti gli elementi che convergono nel nodo si ottiene la massa

complessiva nel nodo; per gli elementi shell invece si utilizza il metodo delle aree di influenza ossia in ognuno dei 3 oppure 4 nodi che definiscono lo shell si assegna $\frac{1}{3}$ oppure $\frac{1}{4}$ del peso dello shell e $\frac{1}{3}$ oppure $\frac{1}{4}$ dell’eventuale carico variabile ridotto, sommando su tutti gli shell che convergono nel nodo si ottiene la massa da assegnare al nodo.

13 VERIFICA DEGLI ELEMENTI STRUTTURALI

La verifiche di resistenza degli elementi è condotta considerando le sollecitazioni di calcolo ed imponendo che le resistenze siano superiori alle azioni. Gli elementi sono verificati e/o progettati applicando la gerarchia delle resistenze in particolare la gerarchia flessione-taglio per la verifica/progetto dell'elemento e la gerarchia pilastro-trave per la determinazione delle resistenze del pilastro. Le verifiche sono condotte secondo i seguenti criteri di verifica validi sia per lo SLU che per lo SLD, i criteri di verifica sono una raccolta di parametri che vengono usati in fase di verifica secondo le esigenze strutturali, ognuno di essi contiene i dati per tutti gli elementi, è sottointeso che nella verifica di un elemento (es. trave) non sono presi in considerazione i dati relativi agli altri elementi (ad es. se si verifica una trave non sono presi in considerazione i dati relativi a pilastri e shell, così come se si esegue una verifica agli SLU non sono presi in considerazione i dati relativi agli SLE). Ognuno di essi è identificato da un nome a scelta dell'operatore, per cui nei tabulati di verifica il nome del criterio ne identifica i parametri usati. Riguardo alle verifiche agli SLU le resistenze sono determinate in base a quanto specificato dalla norma attraverso il modello plastico-incrudente o elastico-perfettamente plastico, la verifica consiste nel verificare che assegnate le sollecitazioni di verifica le deformazioni massime nel calcestruzzo e nell'acciaio siano inferiori a quelle ultime cio' equivale ad affermare che nello spazio tridimensionale N,My,Mz il punto rappresentativo delle sollecitazioni è interno al dominio di resistenza della sezione.

Le verifiche agli SLE riguardano le verifiche di:

- deformabilità degli impalcati con $d \leq 0.0050 \cdot h$
- fessurazione
- tensioni in esercizio

13.1 CRITERI DI VERIFICA

Criterio di verifica: CLS Plinti		
Generici		
Resistenza caratteristica Rck	kg/cmq	300
Tensione caratteristica snervamento acciaio fyk	kg/cmq	4500

AUTOSTRADA VALDASTICO A31 NORD
1° LOTTO - PIOVENE ROCCHETTE – VALLE DELL'ASTICO

Deformazione unitaria ec0		0.002
Deformazione ultima ecu		0.0035
efu (solo incrudimento)		0.0019
Modulo elastico E acciaio	kg/cmq	2E06
Copriferro di calcolo	cm	4.1
Copriferro di disegno	cm	2.5
Coefficiente di sicurezza gClS		1.5
Coefficiente di sicurezza gAcc		1.15
Riduzione fcd calcestruzzo		0.85
Usa staffe minime di normativa in assenza di sisma		Si
Usa staffe minime di normativa in presenza di sisma		Si
Generici N.T.		
Inclinazione bielle compresse cotg(q)		1.00
Modello acciaio		Incrudente
Incrudimento Ey/E0		0.000
Elemento esistente		No
Generici D.M. 96 T.A.		
Tensione ammissibile sc	kg/cmq	97.5
Tensione ammissibile sc in trazione	kg/cmq	21.8
Tensione ammissibile sc acciaio	kg/cmq	2600.0
Tensione tangenziale ammissibile tc0	kg/cmq	6.0
Tensione tangenziale massima tc1	kg/cmq	18.3
Coefficiente di omogeneizzazione n		15
Coefficiente di omogeneizzazione n in trazione		0.5
Sezione interamente reagente		No
Fessurazioni		
Verifica a decompressione		No
Verifica formazione fessure		No
Verifica aperture fessure		Si
Classe di esposizione		XC2
Tipo armatura		Poco

AUTOSTRADA VALDASTICO A31 NORD
1° LOTTO - PIOVENE ROCCHETTE – VALLE DELL'ASTICO

		sensibile
Combinazione Rara		No
Combinazione QP		Si
W ammissibile Combinazione QP	mm	0.300
Combinazione Freq.		Si
W ammissibile Combinazione Freq.	mm	0.400
Valore caratteristico apertura fessure $w_k(*w_m)$		1
f_c efficace	kg/cmq	25.99
Coefficiente di breve o lunga durata k_t		0.40
Coefficiente di aderenza k_1		0.80
Tensioni ammissibili di esercizio		
Verifica Combinazione Rara		Si
Tensione ammissibile sCls	kg/cmq	149
Tensione ammissibile sAcciaio	kg/cmq	3600
Verifica Combinazione QP		Si
Tensione ammissibile sCls	kg/cmq	112
Tensione ammissibile sAcciaio	kg/cmq	3600
Verifica Combinazione Freq.		No
Coefficienti di omogeneizzazione		
Acciaio - Cls compresso		15
Cls teso - Cls compresso		0.5
Armatura pali		
Diametro ferri palo	mm	16
Minima percentuale armatura rispetto al Cls	%	1
Massima percentuale armatura rispetto al Cls	%	1
Incremento angolo di attrito strato alla punta per carico limite punta dei pali battuti	°	0
Pali singoli		
Vincola pali in testa in direzione X		No
Vincola pali in testa in direzione Y		No
Verifica plinti/pali		

AUTOSTRADA VALDASTICO A31 NORD
1° LOTTO - PIOVENE ROCCHETTE – VALLE DELL'ASTICO

Copriferro verifiche	cm	4.0
Step armatura di verifica	cmq	0.50
Resistenza a taglio per elementi non armati		No
Verifica a pressoflessione deviata		Si
Verifica D.M. 96 plinti/pali		
Coefficiente di sicurezza per carico limite verticale gV		3.000
Coefficiente di sicurezza per carico limite orizzontale gH		1.700
Coefficiente di gruppo per carico limite verticale hv		1.000
Coefficiente di gruppo per carico limite orizzontale hh		1.000
Verifica N.T. plinti/pali		
Tecnologia pali		Trivellati
Coefficiente parziale sicurezza alla base gb		1.350
Coefficiente parziale sicurezza laterale in compressione gs		1.150
Coefficiente parziale sicurezza laterale in trazione gst		1.250
Coefficiente parziale sicurezza per carico limite orizzontale gT		1.300
Coefficiente di gruppo per carico limite verticale hv		1.000
Coefficiente di gruppo per carico limite orizzontale hh		1.000
Parametri meccanici del terreno		Valori medi
Numero di verticali indagate		5
Coefficiente di correlazione in funzione delle verticali x3		1.500
Coefficiente di correlazione in funzione delle verticali x4		1.340
Stampa plinti/pali		
Stampa verifiche per tutte le combinazioni di carico		No
Stampa verifiche fusto pali		No
Stampa verifiche per tutti i pali		No

<u>Criterio di verifica: Acciaio Flessione</u>		
Verifiche		
Tipo di acciaio		S275
s amm (T<40mm)	kg/cmq	1800
s amm (T>40mm)	kg/cmq	1700

AUTOSTRADA VALDASTICO A31 NORD
1° LOTTO - PIOVENE ROCCHETTE – VALLE DELL'ASTICO

Fy (T<40mm)	kg/cmq	2750
Fy (T>40mm)	kg/cmq	2550
Ft (T<40mm)	kg/cmq	4300
Ft (T>40mm)	kg/cmq	4100
Piano di verifica		x
Tipo di instabilità		Nessuna
I Max		250
Coefficiente di sicurezza gs		1.5
Coefficiente di adattamento plastico Yx		1
Coefficiente di adattamento plastico Yy		1
Costante di ingobbimento Jw		1
Usa b		No
Escludi momento flettente trasversale Mz		No
Verifica come pendolo		No
Carichi estradossati		No
Verifiche N.T. SLU		
Coefficiente di sicurezza gM		1.05
Usa CNR 10011		No
Stampe		
Combinazioni di verifica		Più gravosa
Verifiche N.T. SLE		
Verifica degli spostamenti verticali		Si
Monta iniziale della trave dc	cm	0.0
Limite spostamento nello stato finale finale	mm	L/250.00
Limite spostamento dovuto ai soli carichi variabili	mm	L/300.00

14 VALIDAZIONE DEL CALCOLO-INFORMAZIONI SULL'ELABORAZIONE

Di seguito si riportano alcuni dati significativi del calcolo in base ai quali si ritiene che il codice di calcolo è affidabile ed i risultati accettati dal progettista.

Valutando a mano il peso complessivo della struttura è possibile determinare la massa sismica moltiplicandola per il valore dello spettro corrispondente al periodo fondamentale si

dovrebbe trovare un tagliante vicino a quello di calcolo, analogamente moltiplicando i vari pesi per i relativi coefficienti di combinazione si dovrebbe trovare un valore pressochè uguale a alle reazioni verticali totali (reazioni dei nodi + reazioni del terreno).

La valutazione sulla correttezza dei dati in ingresso e sulla accuratezza dei risultati è stata effettuata sia mediante le visualizzazioni grafiche del post processore sia mediante il controllo dei tabulati numerici. La verifica che la soluzione ottenuta non sia viziata da errori di tipo numerico, legati all'algoritmo risolutivo ed alle caratteristiche

he dell'elaboratore, è stata effettuata considerando che il numero di cifre è accettabile.

Si riporta la tabella relativa alle statistiche sulla matrice di rigidezza

Minimo della diag.	2.096804e+005
Massimo della diag.	1.639624e+008
Rapporto Max/Min	7.819633e+002
Media della diag.	2.191797e+007
Densita'	2.394487e+001

Tabella 3: Risultati Analisi Dinamica – Statistiche matrice di rigidezza

Scenario di calcolo : Set_NT_SLV_SLD_A2_STR/GEO

Pertanto i risultati si ritengono accettabili per quanto riguarda la correttezza del calcolo automatico.

15 MODELLAZIONE

La struttura è costituita da diversi elementi distinti, in base alla loro funzione, in:

- Fondazione in c.a. costituita da: plinti su pali
- I livelli di sicurezza scelti dal Committente e dal Progettista in funzione del tipo e dell'uso della struttura, nonché in funzione delle conseguenze del danno, con riguardo a persone, beni, e possibile turbativa sociale, compreso il costo delle opere necessarie per la riduzione del rischio di danno o di collasso, hanno indirizzato al progetto di una struttura con i seguenti requisiti:
 - sicurezza nei confronti degli Stati Limite Ultimi (SLU)
 - sicurezza nei confronti degli Stati Limite di Esercizio (SLE)
 - sicurezza nei confronti di deformazioni permanenti inaccettabili: Stato Limite di Danno (SLD).

La struttura è stata schematizzata con un modello spaziale agli elementi finiti che tengono conto dell'effettivo stato deformativo e di sollecitazione, secondo l'effettiva realizzazione. I vincoli esterni della struttura sono stati caratterizzati, a seconda degli elementi in fondazione se presenti, con: travi winkler, plinti diretti, plinti su pali, platee; ovvero con vincoli perfetti di incastro, appoggio, carrello, ecc. I vincoli interni sono stati schematizzati secondo le sollecitazioni mutuamente scambiate tra gli elementi strutturali, inserendo, ove opportuno, il rilascio di alcune caratteristiche della sollecitazione per schematizzare il comportamento di vincoli interni non iperstatici (cerniere, carrelli, ecc.). Il modello agli elementi finiti è stato calcolato tenendo conto dell'interazione tra strutture in fondazione e strutture in elevazione, consentendo un'accurata distribuzione delle azioni statiche e sismiche; il calcolo viene eseguito considerando il comportamento elastico lineare della struttura. I solai sono schematizzati come aree di carico, sulle quali vengono definiti i carichi permanenti (QP Solai), carichi fissi (QFissi Solai) e variabili (QV solai); tali carichi vengono assegnati alle aste in modo automatico in relazione all'influenza delle diverse aree di carico. Le masse corrispondenti ai carichi variabili sui solai nelle combinazioni sismiche vengono trattate in maniera automatica mediante un coefficiente moltiplicativo definito insieme alla tipologia del solaio.

Il modello utilizzato è stato valutato alla luce dei diversi scenari di carico a cui viene sottoposta la struttura durante la sua costruzione e la sua vita, atto a garantire la sicurezza e la durabilità della stessa. Per la tipologia strutturale affrontata non è stato necessario definire scenari di contingenza, quindi non è stata schematizzata la struttura durante le fasi costruttive, e si ritiene che non ci siano variazioni del modello di calcolo e degli schemi di vincolo, durante la vita dell'opera. Per il dettaglio degli scenari di calcolo si faccia riferimento alla "Relazione di Calcolo"

Il progetto e la verifica degli elementi strutturali è stato effettuato seguendo la teoria degli Stati limite. I parametri relativi alle verifiche effettuate sono riportati nella Relazione di Calcolo.

Il solutore agli elementi finiti impiegato nell'analisi è SpaceSolver, per il calcolo di strutture piane e spaziali schematizzabili da un insieme di elementi finiti tipo:

- BEAM,
- PLATE-SHELL,
- WINK,
- BOUNDARY,

interagenti tra loro attraverso i nodi, con la possibilità di tenere in conto tutti i possibili disassamenti, mediante l'introduzione di concetti rigidi e traslazioni degli elementi bidimensionali. Il solutore lavora in campo elastico lineare, si basa sulle routines di Matlab ed è stato sviluppato in collaborazione con l'Università di Roma – Tor Vergata. Il solutore offre la possibilità di risolvere anche travi su suolo alla Winkler con molle spalmate sull'intera suola, anziché sul solo asse, plinti diretti e su pali, pali singoli, platee, piastre sottili e spesse

con controllo delle rotazioni attorno all’asse normale alla piastra (drilling). Inoltre, per gli elementi BEAM considera il centro di taglio e non il baricentro.

L’affidabilità del solutore è stata testata su una serie di esempi campioni calcolati con altri procedimenti o con formule note, di cui si rende disponibile la documentazione.

15.1 AFFIDABILITA' DEI CODICI UTILIZZATI

Il programma è dotato di una serie di filtri di auto diagnostica che segnalano i seguenti eventi:

- labilità della struttura
- assenza di masse
- nodi collegati ad aste nulle
- mancanza di terreno sugli elementi in fondazione
- controllo sull'assegnazione dei nodi all'impalcato
- correttezza degli spettri di progetto
- fattori di partecipazione modali
- assegnazione dei criteri di verifica agli elementi
- numerazione degli elementi strutturali
- congruenza delle connessioni tra elementi shell
- congruenza delle aree di carico
- definizione delle caratteristiche d'inerzia delle sezioni
- presenza del magrone sotto la travi tipo wink
- elementi non verificati per semi progetto allo SLU, con inserimento automatico delle armature secondo i criteri di verifica.
- elementi non verificati allo SLU per armature già inserite nell'elemento strutturale
- elementi non verificati allo SLE per armature già inserite nell'elemento strutturale

16 PRESENTAZIONE DEI RISULTATI

I disegni dello schema statico adottato sono riportati nel fascicolo allegato alla presente relazione

E' stato impiegato il Sistema Internazionale per le unità di misura, con riferimento al daN per le forze.

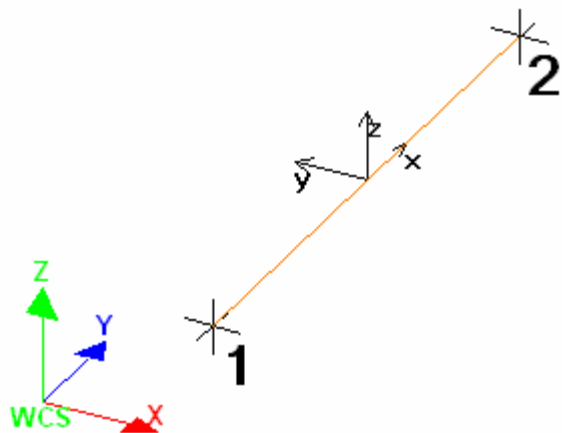

Il sistema di riferimento globale rispetto al quale è stata riferita l'intera struttura è una terna di assi cartesiani sinistrorsa OXYZ (X,Y, e Z sono disposti e orientati rispettivamente secondo il pollice, l'indice ed il medio della mano destra, una volta posizionati questi ultimi a 90° tra loro).

La terna di riferimento locale per un'asta è pure una terna sinistrorsa O'xyz che ha l'asse x orientato dal nodo iniziale I dell'asta verso il nodo finale J e gli assi y e z diretti secondo gli assi geometrici della sezione con l'asse y orizzontale e orientato in modo da portarsi a coincidere con l'asse x a mezzo di una rotazione oraria di 90° e l'asse z di conseguenza.

Per un'asta comunque disposta nello spazio la sua terna locale è orientata in modo tale da portarsi a coincidere con la terna globale a mezzo di rotazioni orarie degli assi locali inferiori a 180°.

- Le forze, sia sulle aste che sulle pareti o lastre, sono positive se opposte agli assi locali;
- Le forze nodali sono positive se opposte agli assi globali;
- Le coppie sono positive se sinistrorse.

Le caratteristiche di sollecitazione sono positive se sulla faccia di normale positiva sono rappresentate da vettori equiversi agli assi di riferimento locali; in particolare il vettore momento positivo rappresenta una coppia che ruota come le dita della mano destra che si chiudono quando il pollice è equi verso all'asse locale.

- Le traslazioni sono positive se concorde con gli assi globali;
- Le rotazioni sono positive se sinistrorse.

Il sistema di riferimento locale per gli elementi bidimensionali è quello riportato in figura

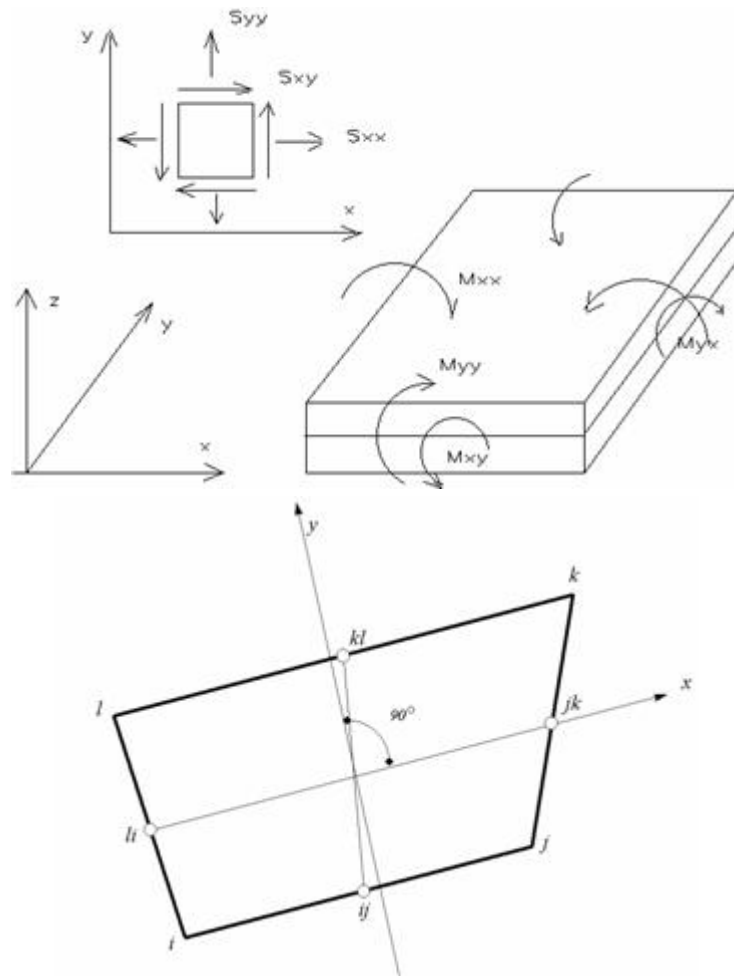

La terna locale per l'elemento shell è costituita dall'asse x locale che va dal nodo li al nodo jk , l'asse y è diretto secondo il piano dell'elemento e orientato verso il nodo l e l'asse z di conseguenza in modo da formare la solita terna sinistrorsa. L'asse z locale rappresenta la normale positiva all'elemento.

Le sollecitazioni dell'elemento sono:

a) sforzi membranali.

$$S_{xx} = s_x$$

$$S_{yy} = s_y$$

$$S_{xy} = t_{xy}$$

b) sforzi flessionali:

M_{xx} momento flettente che genera s_x , cioè intorno ad y.

M_{yy} momento flettente che genera s_y , cioè intorno ad x

M_{xy} momento torcente che genera t_{xy} .

Le sollecitazioni principali dell'elemento sono:

$$M_{1,2} = \frac{M_{xx} + M_{yy}}{2} \pm \sqrt{\left(\frac{M_{xx} - M_{yy}}{2}\right)^2 + M_{xy}^2}$$

$$S_{1,2} = \frac{S_{xx} + S_{yy}}{2} \pm \sqrt{\left(\frac{S_{xx} - S_{yy}}{2}\right)^2 + S_{xy}^2}$$

$$\operatorname{tg} 2\theta = \frac{M_{xy}}{M_{xx} - M_{yy}}$$

dove θ è l'angolo formato dagli assi principali di M_1 e M_2 con quelli di riferimento e

$$\operatorname{tg} 2\psi = \frac{S_{xy}}{S_{xx} - S_{yy}}$$

dove ψ è l'angolo formato dagli assi principali di S_1 e S_2 con quelli di riferimento

L'elemento shell usato come piastra dà i momenti flettenti e non i tagli in direzione ortogonale all'elemento che possono ottenersi come derivazione dei momenti flettenti;

$$T_{zx} = M_{xx,x} + M_{xy,y}$$

$$T_{zy} = M_{xy,y} + M_{yy,y}$$

quando invece viene usato come lastra ci restituisce una 's' costante ed una 't' costante non adatti a rappresentare momenti flettenti, ma solo sforzi normali e tagli nel piano della lastra.

I tabulati di calcolo contengono due sezioni principali: la descrizione del modello di calcolo e la presentazione dei risultati.

La descrizione del modello di calcolo contiene:

- i dati generali (dimensioni)
- le coordinate nodali;
- i vincoli dei nodi e i vincoli interni delle aste, con le eventuali sconnessioni;
- le caratteristiche sezionali;
- le caratteristiche dei solai;
- le caratteristiche delle aste;
- i carichi sulle aste, sui nodi e sui muri (inclusa la distribuzione delle distorsioni impresse, e delle variazioni e dei gradienti di temperatura);
- configurazione di sistemi che introducono stati coattivi;
- le caratteristiche dei materiali;
- legami costitutivi e criteri di verifica;
- le condizioni di carico;

La stampa dei risultati contiene:

- le combinazioni dei carichi;
- le forze sismiche agenti sulla struttura;
- gli spostamenti d'impalcato, se l'impalcato è rigido;
- gli spostamenti nodali;
- le sollecitazioni sulle membrature per ogni combinazione di carico;
- la sollecitazione sul terreno sotto travi di fondazione o platee;
- deformate;
- diagrammi sollecitazioni;

17 TABULATI DI INPUT

17.1 DATI GENERALI

Nome struttura	
Numero di frequenze	15
% Filtro masse libere	0.1
% Coefficiente di smorzamento viscoso	5
Spostamenti modali con segno	Si
Spostamento ammissibile impalcato	0.0050*h

17.2 IMPALCATI

N°	Quota	Rigido	Incr.Soll.Pil	Inc.Soll.Par.
	mm			
0	0	No	1.000	1.000
1	6400	No	1.000	1.000

17.3 PERCENTUALI DI SPOSTAMENTO MASSE IMPALCATI

Posizione	% Spostamento direzione X	% Spostamento direzione Y
1	0	-5
2	5	0
3	0	5
4	-5	0

17.4 COMBINAZIONI DEL SISMA IN X E Y E VERTICALE

Comb	Pos. SismaX	Pos. SismaY	Fx	Fy	Fz
1	1	2	1	0.3	0
2	1	2	0.3	1	0
3	1	4	1	0.3	0
4	1	4	0.3	1	0
5	3	2	1	0.3	0
6	3	2	0.3	1	0
7	3	4	1	0.3	0
8	3	4	0.3	1	0

Comb. = Numero di combinazione dei sismi

Pos. SismaX = Posizione in cui viene scelto il sisma in direzione X

Pos. SismaY = Posizione in cui viene scelto il sisma in direzione Y

Fx = Fattore con cui il sisma X partecipa

Fy = Fattore con cui il sisma Y partecipa

Fz = Fattore con cui il sisma Verticale partecipa (quando richiesto)

Ogni combinazione genera al massimo 8 sotto-combinazioni in base a tutte le combinazioni possibili dei segni di Fx ed Fy ed Fz.

17.5 SPETTRI DI RISPOSTA

Spettro :SpettroNT

Il calcolo degli spettri e del fattore di struttura sono stati calcolati per la seguente tipologia di terreno e struttura

Vita della struttura	
Tipo	Opere ordinarie (50-100) 50 - 100 anni
Vita nominale(anni)	50.0
Classe d'uso	Classe II
Coefficiente d'uso	1.000
Periodo di riferimento(anni)	50.000
Stato limite di esercizio - SLD	PVR=63.0%
Stato limite ultimo - SLV	PVR=10.0%
Periodo di ritorno SLD(anni)	TR=50.3
Periodo di ritorno SLV(anni)	TR=474.6
Parametri del sito	
Comune	Cogollo del Cengio - (VI)
Longitudine	11.421
Latitudine	45.789
Id reticolo del sito	10961-10960-11182- 11183

AUTOSTRADA VALDASTICO A31 NORD
1° LOTTO - PIOVENE ROCCHETTE – VALLE DELL'ASTICO

Valori di riferimento del sito	
Ag/g(TR=50.3) SLD	0.0559
F0(TR=50.3) SLD	2.4956
T* C(TR=50.3) SLD	0.250
Ag/g(TR=474.6) SLV	0.1533
F0(TR=474.6) SLV	2.4174
T* C(TR=474.6) SLV	0.290
Coefficiente Amplificazione Topografica	St=1.000
Categoria terreno B	
stato limite SLV	
	S=1.20
	TB=0.14
	TC=0.41
	TD=2.21
stato limite SLD	
	S=1.20
	TB=0.12
	TC=0.36
	TD=1.82
Fattore di struttura (SLV)	
Classe duttilità	B
Tipo struttura	Acciaio
Struttura regolare in altezza	Kr=1.000000
	Kw=1.000
Regolare in pianta	SI
Tipologia : Strutture a telaio	Ce=4.000
Fattore di struttura $q=Kw*Kr*Ce$	4.000

TSLV [s]	SLV[a/g]	TSLD [s]	SLD[a/g]
0.00000	0.18391	0.00000	0.06707

AUTOSTRADA VALDASTICO A31 NORD
1° LOTTO - PIOVENE ROCCHETTE – VALLE DELL'ASTICO

0.13620	0.11115	0.12101	0.16737
0.40860	0.11115	0.36304	0.16737
0.60909	0.07456	0.57169	0.10629
0.80958	0.05610	0.78033	0.07787
1.01007	0.04496	0.98898	0.06144
1.21057	0.03751	1.19762	0.05074
1.41106	0.03218	1.40626	0.04321
1.61155	0.03065	1.61491	0.03763
1.81204	0.03065	1.82355	0.03332
2.01253	0.03065	2.04120	0.02659
2.21302	0.03065	2.25884	0.02172
2.43639	0.03065	2.47649	0.01807
2.65977	0.03065	2.69413	0.01527
2.88314	0.03065	2.91178	0.01307
3.10651	0.03065	3.12942	0.01131
3.32988	0.03065	3.34707	0.00989
3.55326	0.03065	3.56471	0.00872
3.77663	0.03065	3.78236	0.00775
4.00000	0.03065	4.00000	0.00693

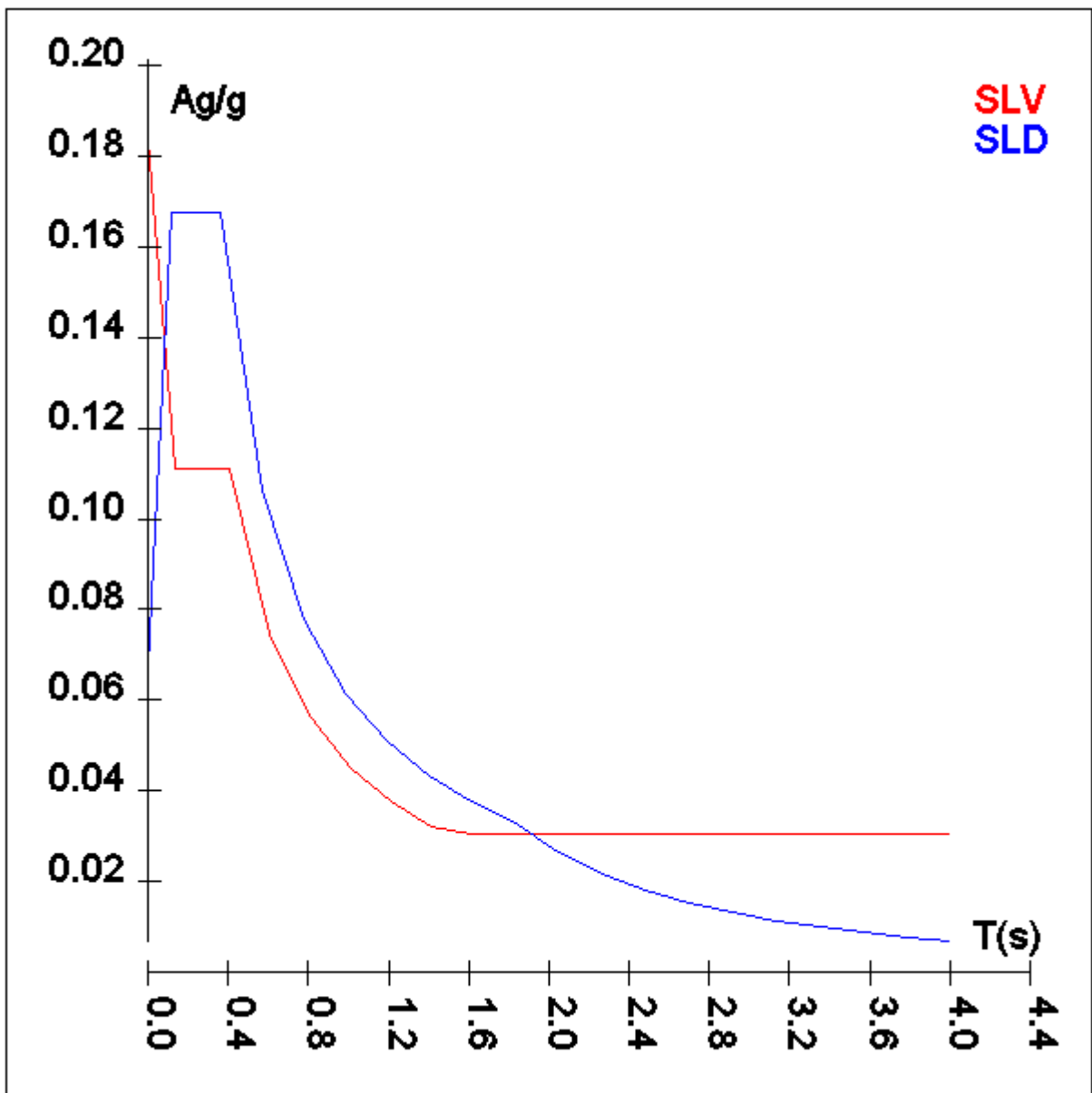

AUTOSTRADA VALDASTICO A31 NORD
1° LOTTO - PIOVENE ROCCHETTE – VALLE DELL'ASTICO

17.6 NODI - CARICHI

N°	C.Car.	Fx	Fy	Fz	Mx	My	Mz
		kg			kg*m		
172	Peso Proprio	0	0	21840	0	0	0
172	Neve	25396	50	100	-54	-1160	-339
173	Peso Proprio	0	0	21840	0	0	0
173	Neve	25396	50	100	-54	-1160	-339
174	Peso Proprio	0	0	21840	0	0	0
174	Neve	25396	50	100	-54	-1160	-339
175	Peso Proprio	0	0	21840	0	0	0
175	Neve	25396	50	100	-54	-1160	-339
184	Peso Proprio	0	0	21840	0	0	0
184	Neve	25396	50	100	-54	-1160	-339
185	Peso Proprio	0	0	21840	0	0	0
185	Neve	25396	50	100	-54	-1160	-339
186	Peso Proprio	0	0	21840	0	0	0
186	Neve	25396	50	100	-54	-1160	-339
187	Peso Proprio	0	0	21840	0	0	0
187	Neve	25396	50	100	-54	-1160	-339
486	Neve	0	50	100	0	0	0
487	Neve	0	50	100	0	0	0
488	Neve	0	50	100	0	0	0
489	Neve	0	50	100	0	0	0
490	Neve	0	50	100	0	0	0
491	Neve	0	50	100	0	0	0
492	Neve	0	50	100	0	0	0
493	Neve	0	50	100	0	0	0
494	Neve	0	50	100	0	0	0
495	Neve	0	50	100	0	0	0
496	Neve	0	50	100	0	0	0
497	Neve	0	50	100	0	0	0

AUTOSTRADA VALDASTICO A31 NORD
1° LOTTO - PIOVENE ROCCHETTE – VALLE DELL'ASTICO

N°	C.Car.	Fx	Fy	Fz	Mx	My	Mz
498	Neve	0	50	100	0	0	0
499	Neve	0	50	100	0	0	0
500	Neve	0	50	100	0	0	0
501	Neve	0	50	100	0	0	0
502	Neve	0	50	100	0	0	0
503	Neve	0	50	100	0	0	0
504	Neve	0	50	100	0	0	0
505	Neve	0	50	100	0	0	0
506	Neve	0	50	100	0	0	0
507	Neve	0	50	100	0	0	0
508	Neve	0	50	100	0	0	0
509	Neve	0	50	100	0	0	0
510	Neve	0	50	100	0	0	0
511	Neve	0	50	100	0	0	0
512	Neve	0	50	100	0	0	0
513	Neve	0	50	100	0	0	0
514	Neve	0	50	100	0	0	0
515	Neve	0	50	100	0	0	0
516	Neve	0	50	100	0	0	0
517	Neve	0	50	100	0	0	0
518	Neve	0	50	100	0	0	0
519	Neve	0	50	100	0	0	0

17.7 PLINTI - GEOMETRIA E VINCOLI

N.	Nodo	X	Y	Z	Tipo	Materiale	Criterio	f.f.	F.Rig.Ass	F.Rig.Rot
		mm	mm	mm						
0	173	18850	1380	0	4PALI	C25/30	CLS_Plinti	55	1.000	1.000
0	174	30290	1380	0	4PALI	C25/30	CLS_Plinti	55	1.000	1.000
0	175	41730	1380	0	4PALI	C25/30	CLS_Plinti	55	1.000	1.000
0	184	7410	23760	0	4PALI	C25/30	CLS_Plinti	55	1.000	1.000
0	185	18850	23760	0	4PALI	C25/30	CLS_Plinti	55	1.000	1.000
0	186	30290	23760	0	4PALI	C25/30	CLS_Plinti	55	1.000	1.000
0	187	41730	23760	0	4PALI	C25/30	CLS_Plinti	55	1.000	1.000
0	172	7410	1380	0	4PALI	C25/30	CLS_Plinti	55	1.000	1.000

18 TABULATI DI VERIFICA

L'esito di ogni elaborazione viene sintetizzato nei disegni e schemi grafici allegati, che evidenziano i valori numerici nei punti e/o nelle sezioni significative, ai fini della valutazione del comportamento complessivo della struttura, e quelli necessari ai fini delle verifiche di misura della sicurezza.

Di seguito si riportano le tabelle relative allo stato limite ultimo.

19 VERIFICHE STATO LIMITE ULTIMO

19.1 VERIFICA PLINTI

Plinto n°: 172

Descrizione	Plinto Rettangolare su 4 pali
Criterio di verifica	CLS_Plinti
Terreno	Terreno1

Rp	Lp	H	HSup	Bx	By	BxSup	BySup	TR.X	TR.Y	Rot
cm	cm	cm	cm	cm	cm	cm	cm	cm	cm	°
30.0	1000.0	120.0	0.0	280.0	260.0	280.0	260.0	0.0	0.0	0

AUTOSTRADA VALDASTICO A31 NORD
1° LOTTO - PIOVENE ROCCHETTE – VALLE DELL'ASTICO

Peso plinto	F punz	Res. punz	Arm. punz	Afx	Afy	Afincl	Apx	Apy	Apincl	Arm.palo
kg	kg	kg	cmq	cmq	cmq	cmq	cmq	cmq	cmq	
21840	1134(C. (12+13)-VIII-1)	360047	0.00	4.71	4.71	4.62	3.08	3.08	3.08	31.42

C.	Mx	My	MIncl	Mrx	Mry	MrIncl	csx	csy	csIncl
	kg*m	kg*m	kg*m	kg*m	kg*m	kg*m			
4	11552	10108	7675	20917	20934	20563	1.81	2.07	2.68

C.	Nmin	Nmax	Plim	Slim	Ql_Comp	Ql_Traz
	t	t	t	t	t	t
4	13.87	14.29	357.62	88.36	227.83	47.13

C.	Hx	Hy	ecc.X	ecc.Y	N	vinc.X	vinc.Y	Mult	HlimX	HlimY	Cs
	kg	kg	cm	cm	kg			kg*m	kg	kg	
(12+13)-III-2	321	147	--	--	4635	Vinc	Vinc	19936	22299	22299	69.4

Plinto:**Verificato**

Tipo palo a rottura:

N° palo	TipoXmin	ZXmin	TipoXmax	ZXmax	TipoYmin	ZYmin	TipoYmax	ZYmax
		cm		cm		cm		cm
1	lungo	160	lungo	161	lungo	160	lungo	161
2	lungo	160	lungo	161	lungo	160	lungo	161
3	lungo	160	lungo	161	lungo	160	lungo	161
4	lungo	160	lungo	161	lungo	160	lungo	161

AUTOSTRADA VALDASTICO A31 NORD
1° LOTTO - PIOVENE ROCCHETTE – VALLE DELL'ASTICO

Plinto n°: 173

Descrizione	Plinto Rettangolare su 4 pali
Criterio di verifica	CLS_Plinti
Terreno	Terreno1

Rp	Lp	H	HSup	Bx	By	BxSup	BySup	TR.X	TR.Y	Rot
cm	cm	cm	cm	cm	cm	cm	cm	cm	cm	°
30.0	1000.0	120.0	0.0	280.0	260.0	280.0	260.0	0.0	0.0	0

Peso plinto	F punz	Res. punz	Arm. punz	Afx	Afy	Afincl	Apx	Apy	Apincl	Arm.palo
kg	kg	kg	cmq	cmq	cmq	cmq	cmq	cmq	cmq	
21840	1101(C. (12+13)-VIII-3)	360047	0.00	4.71	4.71	4.62	3.08	3.08	3.08	31.42

C.	Mx	My	MIncl	Mrx	Mry	MrIncl	csx	csy	csIncl
	kg*m	kg*m	kg*m	kg*m	kg*m	kg*m			
4	11790	10316	7833	20917	20934	20563	1.77	2.03	2.63

C.	Nmin	Nmax	Plim	Slim	Ql_Comp	Ql_Traz
	t	t	t	t	t	t
4	14.12	14.44	357.62	88.36	227.83	47.13

C.	Hx	Hy	ecc.X	ecc.Y	N	vinc.X	vinc.Y	Mult	HlimX	HlimY	Cs
	kg	kg	cm	cm	kg			kg*m	kg	kg	
(12+13)-III-3	324	5	--	--	5153	Vinc	Vinc	20020	22353	22353	68.9

Plinto:**Verificato**

AUTOSTRADA VALDASTICO A31 NORD
1° LOTTO - PIOVENE ROCCHETTE – VALLE DELL'ASTICO

Tipo palo a rottura:

N° palo	TipoXmin	ZXmin	TipoXmax	ZXmax	TipoYmin	ZYmin	TipoYmax	ZYmax
		cm		cm		cm		cm
1	lungo	160	lungo	161	lungo	160	lungo	161
2	lungo	160	lungo	161	lungo	160	lungo	161
3	lungo	160	lungo	161	lungo	160	lungo	161
4	lungo	160	lungo	161	lungo	160	lungo	161

Plinto n°: 174

Descrizione	Plinto Rettangolare su 4 pali
Criterio di verifica	CLS_Plinti
Terreno	Terreno1

Rp	Lp	H	HSup	Bx	By	BxSup	BySup	TR.X	TR.Y	Rot
cm	cm	cm	cm	cm	cm	cm	cm	cm	cm	°
30.0	1000.0	120.0	0.0	280.0	260.0	280.0	260.0	0.0	0.0	0

Peso plinto	F punz	Res. punz	Arm. punz	Afx	Afy	Afincl	Apx	Apy	Apincl	Arm.palo
kg	kg	kg	cmq	cmq	cmq	cmq	cmq	cmq	cmq	
21840	1231(C. (12+13)-VI-1)	360047	0.00	4.71	4.71	4.62	3.08	3.08	3.08	31.42

C.	Mx	My	MIncl	Mrx	Mry	MrIncl	csx	csy	csIncl
	kg*m	kg*m	kg*m	kg*m	kg*m	kg*m			
4	11840	10360	7867	20917	20934	20563	1.77	2.02	2.61

AUTOSTRADA VALDASTICO A31 NORD
1° LOTTO - PIOVENE ROCCHETTE – VALLE DELL'ASTICO

C.	Nmin	Nmax	Plim	Slim	Ql_Comp	Ql_Traz
	t	t	t	t	t	t
4	14.13	14.47	357.62	88.36	227.83	47.13

C.	Hx	Hy	ecc.X	ecc.Y	N	vinc.X	vinc.Y	Mult	HlimX	HlimY	Cs
	kg	kg	cm	cm	kg			kg*m	kg	kg	
(12+13)-III-3	316	22	--	--	5201	Vinc	Vinc	20028	22358	22358	70.7

Plinto:**Verificato**

Tipo palo a rottura:

N° palo	TipoXmin	ZXmin	TipoXmax	ZXmax	TipoYmin	ZYmin	TipoYmax	ZYmax
		cm		cm		cm		cm
1	lungo	160	lungo	161	lungo	160	lungo	161
2	lungo	160	lungo	161	lungo	160	lungo	161
3	lungo	160	lungo	161	lungo	160	lungo	161
4	lungo	160	lungo	161	lungo	160	lungo	161

Plinto n°: 175

Descrizione	Plinto Rettangolare su 4 pali
Criterio di verifica	CLS_Plinti
Terreno	Terreno1

AUTOSTRADA VALDASTICO A31 NORD
1° LOTTO - PIOVENE ROCCHETTE – VALLE DELL'ASTICO

Rp	Lp	H	HSup	Bx	By	BxSup	BySup	TR.X	TR.Y	Rot
cm	cm	cm	cm	cm	cm	cm	cm	cm	cm	°
30.0	1000.0	120.0	0.0	280.0	260.0	280.0	260.0	0.0	0.0	0

Peso plinto	F punz	Res. punz	Arm. punz	Afx	Afy	Afincl	Apx	Apy	Apincl	Arm.palo
kg	kg	kg	cmq	cmq	cmq	cmq	cmq	cmq	cmq	
21840	1395(C. (12+13)-VI-3)	360047	0.00	4.71	4.71	4.62	3.08	3.08	3.08	31.42

C.	Mx	My	MIncl	Mrx	Mry	MrIncl	csx	csy	csIncl
	kg*m	kg*m	kg*m	kg*m	kg*m	kg*m			
4	11781	10309	7827	20917	20934	20563	1.78	2.03	2.63

C.	Nmin	Nmax	Plim	Slim	Ql_Comp	Ql_Traz
	t	t	t	t	t	t
4	14.10	14.43	357.62	88.36	227.83	47.13

C.	Hx	Hy	ecc.X	ecc.Y	N	vinc.X	vinc.Y	Mult	HlimX	HlimY	Cs
	kg	kg	cm	cm	kg			kg*m	kg	kg	
(12+13)-III-3	311	23	--	--	5101	Vinc	Vinc	20012	22348	22348	71.9

Plinto:**Verificato**

Tipo palo a rottura:

N° palo	TipoXmin	ZXmin	TipoXmax	ZXmax	TipoYmin	ZYmin	TipoYmax	ZYmax

AUTOSTRADA VALDASTICO A31 NORD
1° LOTTO - PIOVENE ROCCHETTE – VALLE DELL'ASTICO

N° palo	TipoXmin	ZXmin	TipoXmax	ZXmax	TipoYmin	ZYmin	TipoYmax	ZYmax
		cm		cm		cm		cm
1	lungo	160	lungo	161	lungo	160	lungo	161
2	lungo	160	lungo	161	lungo	160	lungo	161
3	lungo	160	lungo	161	lungo	160	lungo	161
4	lungo	160	lungo	161	lungo	160	lungo	161

Plinto n°: 184

Descrizione	Plinto Rettangolare su 4 pali
Criterio di verifica	CLS_Plinti
Terreno	Terreno1

Rp	Lp	H	HSup	Bx	By	BxSup	BySup	TR.X	TR.Y	Rot
cm	cm	cm	cm	cm	cm	cm	cm	cm	cm	°
30.0	1000.0	120.0	0.0	280.0	260.0	280.0	260.0	0.0	0.0	0

Peso plinto	F punz	Res. punz	Arm. punz	Afx	Afy	Afincl	Apx	Apy	Apincl	Arm.palo
kg	kg	kg	cmq	cmq	cmq	cmq	cmq	cmq	cmq	
21840	1142(C. (12+13)-IV-2)	360047	0.00	4.71	4.71	4.62	3.08	3.08	3.08	31.42

C.	Mx	My	MIncl	Mrx	Mry	MIncl	csx	csy	csIncl
	kg*m	kg*m	kg*m	kg*m	kg*m	kg*m			
4	11628	10174	7725	20917	20934	20563	1.80	2.06	2.66

C.	Nmin	Nmax	Plim	Slim	QI_Comp	QI_Traz

AUTOSTRADA VALDASTICO A31 NORD
1° LOTTO - PIOVENE ROCCHETTE – VALLE DELL'ASTICO

C.	Nmin	Nmax	Plim	Slim	QI_Comp	QI_Traz
	t	t	t	t	t	t
4	14.10	14.34	357.62	88.36	227.83	47.13

C.	Hx	Hy	ecc.X	ecc.Y	N	vinc.X	vinc.Y	Mult	HlimX	HlimY	Cs
	kg	kg	cm	cm	kg			kg*m	kg	kg	
(12+13)-VII-1	320	141	--	--	4643	Vinc	Vinc	19937	22300	22300	69.7

Plinto:**Verificato**

Tipo palo a rottura:

N° palo	TipoXmin	ZXmin	TipoXmax	ZXmax	TipoYmin	ZYmin	TipoYmax	ZYmax
		cm		cm		cm		cm
1	lungo	160	lungo	161	lungo	160	lungo	161
2	lungo	160	lungo	161	lungo	160	lungo	161
3	lungo	160	lungo	161	lungo	160	lungo	161
4	lungo	160	lungo	161	lungo	160	lungo	161

Plinto n°: 185

Descrizione	Plinto Rettangolare su 4 pali
Criterio di verifica	CLS_Plinti
Terreno	Terreno1

Rp	Lp	H	HSup	Bx	By	BxSup	BySup	TR.X	TR.Y	Rot
----	----	---	------	----	----	-------	-------	------	------	-----

AUTOSTRADA VALDASTICO A31 NORD
1° LOTTO - PIOVENE ROCCHETTE – VALLE DELL'ASTICO

Rp	Lp	H	HSup	Bx	By	BxSup	BySup	TR.X	TR.Y	Rot
cm	cm	cm	cm	cm	cm	cm	cm	cm	cm	°
30.0	1000.0	120.0	0.0	280.0	260.0	280.0	260.0	0.0	0.0	0

Peso plinto	F punz	Res. punz	Arm. punz	Afx	Afy	Afincl	Apx	Apy	Apincl	Arm.palo
kg	kg	kg	cmq	cmq	cmq	cmq	cmq	cmq	cmq	
21840	1141(C. (12+13)-IV-4)	360047	0.00	4.71	4.71	4.62	3.08	3.08	3.08	31.42

C.	Mx	My	MIncl	Mrx	Mry	MIncl	csx	csy	csIncl
	kg*m	kg*m	kg*m	kg*m	kg*m	kg*m			
4	11898	10411	7905	20917	20934	20563	1.76	2.01	2.60

C.	Nmin	Nmax	Plim	Slim	QI_Comp	QI_Traz
	t	t	t	t	t	t
4	14.32	14.50	357.62	88.36	227.83	47.13

C.	Hx	Hy	ecc.X	ecc.Y	N	vinc.X	vinc.Y	Mult	HlimX	HlimY	Cs
	kg	kg	cm	cm	kg			kg*m	kg	kg	
(12+13)-VII-4	325	0	--	--	5166	Vinc	Vinc	20022	22355	0	68.7

Plinto: **Verificato**

Tipo palo a rottura:

N° palo	TipoXmin	ZXmin	TipoXmax	ZXmax	TipoYmin	ZYmin	TipoYmax	ZYmax
		cm		cm		cm		cm
1	lungo	160	lungo	161	lungo	160	lungo	161
2	lungo	160	lungo	161	lungo	160	lungo	161
3	lungo	160	lungo	161	lungo	160	lungo	161

AUTOSTRADA VALDASTICO A31 NORD
1° LOTTO - PIOVENE ROCCHETTE – VALLE DELL'ASTICO

N° palo	TipoXmin	ZXmin	TipoXmax	ZXmax	TipoYmin	ZYmin	TipoYmax	ZYmax
4	lungo	160	lungo	161	lungo	160	lungo	161

Plinto n°: 186

Descrizione	Plinto Rettangolare su 4 pali
Criterio di verifica	CLS_Plinti
Terreno	Terreno1

Rp	Lp	H	HSup	Bx	By	BxSup	BySup	TR.X	TR.Y	Rot
cm	cm	cm	cm	cm	cm	cm	cm	cm	cm	°
30.0	1000.0	120.0	0.0	280.0	260.0	280.0	260.0	0.0	0.0	0

Peso plinto	F punz	Res. punz	Arm. punz	Afx	Afy	Afincl	Apx	Apy	Apincl	Arm.palo
kg	kg	kg	cmq	cmq	cmq	cmq	cmq	cmq	cmq	
21840	1266(C. (12+13)-II-2)	360047	0.00	4.71	4.71	4.62	3.08	3.08	3.08	31.42

C.	Mx	My	MIncl	Mrx	Mry	MrIncl	csx	csy	csIncl
	kg*m	kg*m	kg*m	kg*m	kg*m	kg*m			
4	11931	10440	7927	20917	20934	20563	1.75	2.01	2.59

C.	Nmin	Nmax	Plim	Slim	Ql_Comp	Ql_Traz
	t	t	t	t	t	t
4	14.33	14.53	357.62	88.36	227.83	47.13

C.	Hx	Hy	ecc.X	ecc.Y	N	vinc.X	vinc.Y	Mult	HlimX	HlimY	Cs
----	----	----	-------	-------	---	--------	--------	------	-------	-------	----

AUTOSTRADA VALDASTICO A31 NORD
1° LOTTO - PIOVENE ROCCHETTE – VALLE DELL'ASTICO

C.	Hx	Hy	ecc.X	ecc.Y	N	vinc.X	vinc.Y	Mult	HlimX	HlimY	Cs
	kg	kg	cm	cm	kg			kg*m	kg	kg	
(12+13)-VII-4	317	27	--	--	5203	Vinc	Vinc	20028	22358	22358	70.5

Plinto: **Verificato**

Tipo palo a rottura:

N° palo	TipoXmin	ZXmin	TipoXmin	ZXmax	TipoYmin	ZYmin	TipoYmax	ZYmax
		cm		cm		cm		cm
1	lungo	160	lungo	161	lungo	160	lungo	161
2	lungo	160	lungo	161	lungo	160	lungo	161
3	lungo	160	lungo	161	lungo	160	lungo	161
4	lungo	160	lungo	161	lungo	160	lungo	161

Plinto n°: 187

Descrizione	Plinto Rettangolare su 4 pali
Criterio di verifica	CLS_Plinti
Terreno	Terreno1

Rp	Lp	H	HSup	Bx	By	BxSup	BySup	TR.X	TR.Y	Rot
cm	cm	cm	cm	cm	cm	cm	cm	cm	cm	°
30.0	1000.0	120.0	0.0	280.0	260.0	280.0	260.0	0.0	0.0	0

Peso plinto	F punz	Res. punz	Arm. punz	Afx	Afy	Afincl	Apx	Apy	Apincl	Arm.palo
kg	kg	kg	cmq	cmq	cmq	cmq	cmq	cmq	cmq	
21840	1430(C. (12+13)-II-4)	360047	0.00	4.71	4.71	4.62	3.08	3.08	3.08	31.42

AUTOSTRADA VALDASTICO A31 NORD
1° LOTTO - PIOVENE ROCCHETTE – VALLE DELL'ASTICO

C.	Mx	My	MIncl	Mrx	Mry	MrIncl	csx	csy	csIncl
	kg*m	kg*m	kg*m	kg*m	kg*m	kg*m			
4	11872	10388	7888	20917	20934	20563	1.76	2.02	2.61

C.	Nmin	Nmax	Plim	Slim	Ql_Comp	Ql_Traz
	t	t	t	t	t	t
4	14.28	14.49	357.62	88.36	227.83	47.13

C.	Hx	Hy	ecc.X	ecc.Y	N	vinc.X	vinc.Y	Mult	HlimX	HlimY	Cs
	kg	kg	cm	cm	kg			kg*m	kg	kg	
(12+13)-VII-4	312	18	--	--	5112	Vinc	Vinc	20013	22349	22349	71.6

Plinto: **Verificato**

Tipo palo a rottura:

N° palo	TipoXmin	ZXmin	TipoXmax	ZXmax	TipoYmin	ZYmin	TipoYmax	ZYmax
		cm		cm		cm		cm
1	lungo	160	lungo	161	lungo	160	lungo	161
2	lungo	160	lungo	161	lungo	160	lungo	161
3	lungo	160	lungo	161	lungo	160	lungo	161
4	lungo	160	lungo	161	lungo	160	lungo	161

19.2 VERIFICA RESISTENZA ASTE METALLICHE

Asta : 1 [196 , 203]

Sez. G: O 114.3x5.9 L=229.9 cm Crit.: Acciaio_Flessione $\gamma_M=1.05$ $f_{yk}/\gamma_M=2619$ kg/cm² $f_t=4300$ kg/cm²

: **Verificato**

X	cls	N	TY	TZ	MT	MY	MZ	My4	Mz4	Comb.
cm		kg	kg	kg	kg*m	kg*m	kg*m			

AUTOSTRADA VALDASTICO A31 NORD
1° LOTTO - PIOVENE ROCCHETTE – VALLE DELL'ASTICO

X	cls	N	TY	TZ	MT	MY	MZ	My4	Mz4	Comb.
230	1	3727	-34	93	11	121	30	--	--	2

X	cls	Nr	Vyr	Vzr	Mry	Mrz	MTrd	SF_V.	SF_M	SF_Mt	SF
cm		kg	kg	kg	kg*m	kg*m	kg*m				
230	1	52623	19211	19211	1818	1818	1566	>100	6.50	>100	6.50

Asta : 2 [206 , 195]

Sez. G: O 114.3x5.9 L=286.0 cm Crit.: Acciaio_Flessione $\gamma_M=1.05$ $f_{yk}/\gamma_M=2619$ kg/cm² $f_t=4300$ kg/cm²

:Verificato

X	cls	N	TY	TZ	MT	MY	MZ	My4	Mz4	Comb.
cm		kg	kg	kg	kg*m	kg*m	kg*m			
286	1	-17603	-2	107	42	154	5	--	--	2

X	cls	Nr	Vyr	Vzr	Mry	Mrz	MTrd	SF_V.	SF_M	SF_Mt	SF
cm		kg	kg	kg	kg*m	kg*m	kg*m				
286	1	52623	18817	18817	1818	1818	1566	>100	2.37	36.9	2.37

Asta : 3 [195 , 196]

Sez. G: O 114.3x5.9 L=314.0 cm Crit.: Acciaio_Flessione $\gamma_M=1.05$ $f_{yk}/\gamma_M=2619$ kg/cm² $f_t=4300$ kg/cm²

:Verificato

X	cls	N	TY	TZ	MT	MY	MZ	My4	Mz4	Comb.
cm		kg	kg	kg	kg*m	kg*m	kg*m			
314	1	-10022	2	50	-0	43	-5	--	--	2

X	cls	Nr	Vyr	Vzr	Mry	Mrz	MTrd	SF_V.	SF_M	SF_Mt	SF
cm		kg	kg	kg	kg*m	kg*m	kg*m				
314	1	52623	19339	19339	1818	1818	1566	>100	4.61	>100	4.61

Asta : 4 [205 , 203]

Sez. G: O 114.3x5.9 L=229.9 cm Crit.: Acciaio_Flessione $\gamma_M=1.05$ $f_{yk}/\gamma_M=2619$ kg/cm² $f_t=4300$ kg/cm²

:Verificato

AUTOSTRADA VALDASTICO A31 NORD
1° LOTTO - PIOVENE ROCCHETTE – VALLE DELL'ASTICO

X	cls	N	TY	TZ	MT	MY	MZ	My4	Mz4	Comb.
cm		kg	kg	kg	kg*m	kg*m	kg*m			
230	1	7642	-2	55	5	43	-2	--	--	2

X	cls	Nr	Vyr	Vzr	Mry	Mrz	MTrd	SF_V.	SF_M	SF_Mt	SF
cm		kg	kg	kg	kg*m	kg*m	kg*m				
230	1	52623	19283	19283	1818	1818	1566	>100	5.88	>100	5.88

Asta : 5 [203 , 195]

Sez. G: O 114.3x5.9 L=229.9 cm Crit.: Acciaio_Flessione $\gamma_M=1.05$ $f_{yk}/\gamma_M=2619$ kg/cm² $f_t=4300$ kg/cm²

:Verificato

X	cls	N	TY	TZ	MT	MY	MZ	My4	Mz4	Comb.
cm		kg	kg	kg	kg*m	kg*m	kg*m			
230	1	-23556	-0	-5	19	-43	16	--	--	2

X	cls	Nr	Vyr	Vzr	Mry	Mrz	MTrd	SF_V.	SF_M	SF_Mt	SF
cm		kg	kg	kg	kg*m	kg*m	kg*m				
230	1	52623	19101	19101	1818	1818	1566	>100	2.08	80.3	2.08

Asta : 6 [203 , 206]

Sez. G: O 114.3x5.9 L=229.9 cm Crit.: Acciaio_Flessione $\gamma_M=1.05$ $f_{yk}/\gamma_M=2619$ kg/cm² $f_t=4300$ kg/cm²

:Verificato

X	cls	N	TY	TZ	MT	MY	MZ	My4	Mz4	Comb.
cm		kg	kg	kg	kg*m	kg*m	kg*m			
0	1	10425	18	-66	1	102	23	--	--	2

X	cls	Nr	Vyr	Vzr	Mry	Mrz	MTrd	SF_V.	SF_M	SF_Mt	SF
cm		kg	kg	kg	kg*m	kg*m	kg*m				
0	1	52623	19325	19325	1818	1818	1566	>100	3.74	>100	3.74

Asta : 7 [205 , 196]

AUTOSTRADA VALDASTICO A31 NORD
1° LOTTO - PIOVENE ROCCHETTE – VALLE DELL'ASTICO

Sez. G: O 114.3x5.9 L=286.0 cm Crit.: Acciaio_Flessione $\gamma_M=1.05$ $f_{yk}/\gamma_M=2619$ kg/cmq $f_t=4300$ kg/cmq

:Verificato

X	cls	N	TY	TZ	MT	MY	MZ	My4	Mz4	Comb.
cm		kg	kg	kg	kg*m	kg*m	kg*m			
0	1	-8939	15	-78	26	93	22	--	--	2

X	cls	Nr	Vyr	Vzr	Mry	Mrz	MTrd	SF_V.	SF_M	SF_Mt	SF
cm		kg	kg	kg	kg*m	kg*m	kg*m				
0	1	52623	19026	19026	1818	1818	1566	>100	4.29	61.2	4.29

Asta : 8 [207 , 194]

Sez. G: O 114.3x5.9 L=286.0 cm Crit.: Acciaio_Flessione $\gamma_M=1.05$ $f_{yk}/\gamma_M=2619$ kg/cmq $f_t=4300$ kg/cmq

:Verificato

X	cls	N	TY	TZ	MT	MY	MZ	My4	Mz4	Comb.
cm		kg	kg	kg	kg*m	kg*m	kg*m			
286	1	-11023	-15	50	-17	71	22	--	--	2

X	cls	Nr	Vyr	Vzr	Mry	Mrz	MTrd	SF_V.	SF_M	SF_Mt	SF
cm		kg	kg	kg	kg*m	kg*m	kg*m				
286	1	52623	19130	19130	1818	1818	1566	>100	3.84	91.4	3.84

Asta : 9 [194 , 195]

Sez. G: O 114.3x5.9 L=314.0 cm Crit.: Acciaio_Flessione $\gamma_M=1.05$ $f_{yk}/\gamma_M=2619$ kg/cmq $f_t=4300$ kg/cmq

:Verificato

X	cls	N	TY	TZ	MT	MY	MZ	My4	Mz4	Comb.
cm		kg	kg	kg	kg*m	kg*m	kg*m			
314	1	-4395	-5	241	18	425	8	--	--	2

X	cls	Nr	Vyr	Vzr	Mry	Mrz	MTrd	SF_V.	SF_M	SF_Mt	SF
cm		kg	kg	kg	kg*m	kg*m	kg*m				
314	1	52623	19124	19124	1818	1818	1566	79.3	3.11	88.8	3.11

AUTOSTRADA VALDASTICO A31 NORD
1° LOTTO - PIOVENE ROCCHETTE – VALLE DELL'ASTICO

Asta : 10 [195 , 202]

Sez. G: O 114.3x7.1 L=254.4 cm Crit.: Acciaio_Flessione $\gamma_M=1.05$ $f_{yk}/\gamma_M=2619$ kg/cmq $f_t=4300$ kg/cmq

:Verificato

X	cls	N	TY	TZ	MT	MY	MZ	My4	Mz4	Comb.
cm		kg	kg	kg	kg*m	kg*m	kg*m			
0	1	-41281	-101	-237	40	373	-171	--	--	2

X	cls	Nr	Vyr	Vzr	Mry	Mrz	MTrd	SF_V.	SF_M	SF_Mt	SF
cm		kg	kg	kg	kg*m	kg*m	kg*m				
0	1	62625	22507	22507	2140	2140	1826	94.9	1.10	45.1	1.10

Asta : 11 [202 , 207]

Sez. G: O 114.3x5.9 L=254.4 cm Crit.: Acciaio_Flessione $\gamma_M=1.05$ $f_{yk}/\gamma_M=2619$ kg/cmq $f_t=4300$ kg/cmq

:Verificato

X	cls	N	TY	TZ	MT	MY	MZ	My4	Mz4	Comb.
cm		kg	kg	kg	kg*m	kg*m	kg*m			
51	1	11811	10	-9	-8	-26	6	--	--	2

X	cls	Nr	Vyr	Vzr	Mry	Mrz	MTrd	SF_V.	SF_M	SF_Mt	SF
cm		kg	kg	kg	kg*m	kg*m	kg*m				
51	1	52623	19243	19243	1818	1818	1566	>100	4.13	>100	4.13

Asta : 12 [206 , 202]

Sez. G: O 114.3x5.9 L=254.4 cm Crit.: Acciaio_Flessione $\gamma_M=1.05$ $f_{yk}/\gamma_M=2619$ kg/cmq $f_t=4300$ kg/cmq

:Verificato

X	cls	N	TY	TZ	MT	MY	MZ	My4	Mz4	Comb.
cm		kg	kg	kg	kg*m	kg*m	kg*m			
0	1	9309	-23	-26	-7	56	-27	--	--	2

X	cls	Nr	Vyr	Vzr	Mry	Mrz	MTrd	SF_V.	SF_M	SF_Mt	SF

AUTOSTRADA VALDASTICO A31 NORD
1° LOTTO - PIOVENE ROCCHETTE – VALLE DELL'ASTICO

X	cls	Nr	Vyr	Vzr	Mry	Mrz	MTrd	SF_V.	SF_M	SF_Mt	SF
cm		kg	kg	kg	kg*m	kg*m	kg*m				
0	1	52623	19261	19261	1818	1818	1566	>100	4.50	>100	4.50

Asta : 13 [202 , 194]

Sez. G: O 114.3x5.9 L=254.4 cm Crit.: Acciaio_Flessione $\gamma_M=1.05$ $f_{yk}/\gamma_M=2619$ kg/cm² $f_t=4300$ kg/cm²

:Verificato

X	cls	N	TY	TZ	MT	MY	MZ	My4	Mz4	Comb.
cm		kg	kg	kg	kg*m	kg*m	kg*m			
0	1	7345	40	-23	16	38	71	--	--	2

X	cls	Nr	Vyr	Vzr	Mry	Mrz	MTrd	SF_V.	SF_M	SF_Mt	SF
cm		kg	kg	kg	kg*m	kg*m	kg*m				
0	1	52623	19144	19144	1818	1818	1566	>100	5.00	98.1	5.00

Asta : 14 [208 , 193]

Sez. G: O 114.3x5.9 L=286.0 cm Crit.: Acciaio_Flessione $\gamma_M=1.05$ $f_{yk}/\gamma_M=2619$ kg/cm² $f_t=4300$ kg/cm²

:Verificato

X	cls	N	TY	TZ	MT	MY	MZ	My4	Mz4	Comb.
cm		kg	kg	kg	kg*m	kg*m	kg*m			
286	1	-4032	-6	30	-2	24	8	--	--	2

X	cls	Nr	Vyr	Vzr	Mry	Mrz	MTrd	SF_V.	SF_M	SF_Mt	SF
cm		kg	kg	kg	kg*m	kg*m	kg*m				
286	1	52623	19322	19322	1818	1818	1566	>100	10.6	>100	10.6

Asta : 15 [193 , 194]

Sez. G: O 114.3x5.9 L=314.0 cm Crit.: Acciaio_Flessione $\gamma_M=1.05$ $f_{yk}/\gamma_M=2619$ kg/cm² $f_t=4300$ kg/cm²

:Verificato

X	cls	N	TY	TZ	MT	MY	MZ	My4	Mz4	Comb.
cm		kg	kg	kg	kg*m	kg*m	kg*m			

AUTOSTRADA VALDASTICO A31 NORD
1° LOTTO - PIOVENE ROCCHETTE – VALLE DELL'ASTICO

X	cls	N	TY	TZ	MT	MY	MZ	My4	Mz4	Comb.
220	1	15287	-7	6	-4	-51	5	--	--	2

X	cls	Nr	Vyr	Vzr	Mry	Mrz	MTrd	SF_V.	SF_M	SF_Mt	SF
cm		kg	kg	kg	kg*m	kg*m	kg*m				
220	1	52623	19294	19294	1818	1818	1566	>100	3.11	>100	3.11

Asta : 16 [207 , 201]

Sez. G: O 114.3x5.9 L=273.9 cm Crit.: Acciaio_Flessione $\gamma_M=1.05$ $f_{yk}/\gamma_M=2619$ kg/cmq $f_t=4300$ kg/cmq

:Verificato

X	cls	N	TY	TZ	MT	MY	MZ	My4	Mz4	Comb.
cm		kg	kg	kg	kg*m	kg*m	kg*m			
0	1	-1070	-15	-28	10	24	-31	--	--	2

X	cls	Nr	Vyr	Vzr	Mry	Mrz	MTrd	SF_V.	SF_M	SF_Mt	SF
cm		kg	kg	kg	kg*m	kg*m	kg*m				
0	1	52623	19216	19216	1818	1818	1566	>100	19.7	>100	19.7

Asta : 17 [201 , 193]

Sez. G: O 114.3x5.9 L=273.9 cm Crit.: Acciaio_Flessione $\gamma_M=1.05$ $f_{yk}/\gamma_M=2619$ kg/cmq $f_t=4300$ kg/cmq

:Verificato

X	cls	N	TY	TZ	MT	MY	MZ	My4	Mz4	Comb.
cm		kg	kg	kg	kg*m	kg*m	kg*m			
164	1	1757	0	-3	10	-15	11	--	--	2

X	cls	Nr	Vyr	Vzr	Mry	Mrz	MTrd	SF_V.	SF_M	SF_Mt	SF
cm		kg	kg	kg	kg*m	kg*m	kg*m				
164	1	52623	19216	19216	1818	1818	1566	>100	21.1	>100	21.1

Asta : 18 [194 , 201]

AUTOSTRADA VALDASTICO A31 NORD
1° LOTTO - PIOVENE ROCCHETTE – VALLE DELL'ASTICO

Sez. G: O 114.3x5.9 L=273.9 cm Crit.: Acciaio_Flessione $\gamma_M=1.05$ $f_{yk}/\gamma_M=2619$ kg/cm² $f_t=4300$ kg/cm²

:Verificato

X	cls	N	TY	TZ	MT	MY	MZ	My4	Mz4	Comb.
cm		kg	kg	kg	kg*m	kg*m	kg*m			
0	1	-7677	15	-13	-19	-17	39	--	--	2

X	cls	Nr	Vyr	Vzr	Mry	Mrz	MTrd	SF_V.	SF_M	SF_Mt	SF
cm		kg	kg	kg	kg*m	kg*m	kg*m				
0	1	52623	19113	19113	1818	1818	1566	>100	5.66	84.6	5.66

Asta : 19 [201 , 208]

Sez. G: O 114.3x5.9 L=273.9 cm Crit.: Acciaio_Flessione $\gamma_M=1.05$ $f_{yk}/\gamma_M=2619$ kg/cm² $f_t=4300$ kg/cm²

:Verificato

X	cls	N	TY	TZ	MT	MY	MZ	My4	Mz4	Comb.
cm		kg	kg	kg	kg*m	kg*m	kg*m			
164	1	3407	2	3	-9	-18	-10	--	--	2

X	cls	Nr	Vyr	Vzr	Mry	Mrz	MTrd	SF_V.	SF_M	SF_Mt	SF
cm		kg	kg	kg	kg*m	kg*m	kg*m				
164	1	52623	19227	19227	1818	1818	1566	>100	12.5	>100	12.5

Asta : 20 [209 , 192]

Sez. G: O 114.3x5.9 L=286.0 cm Crit.: Acciaio_Flessione $\gamma_M=1.05$ $f_{yk}/\gamma_M=2619$ kg/cm² $f_t=4300$ kg/cm²

:Verificato

X	cls	N	TY	TZ	MT	MY	MZ	My4	Mz4	Comb.
cm		kg	kg	kg	kg*m	kg*m	kg*m			
0	1	-1858	0	-33	0	24	0	--	--	2

X	cls	Nr	Vyr	Vzr	Mry	Mrz	MTrd	SF_V.	SF_M	SF_Mt	SF
cm		kg	kg	kg	kg*m	kg*m	kg*m				
0	1	52623	19340	19340	1818	1818	1566	>100	20.6	>100	20.6

AUTOSTRADA VALDASTICO A31 NORD
1° LOTTO - PIOVENE ROCCHETTE – VALLE DELL'ASTICO

Asta : 21 [192 , 193]

Sez. G: O 114.3x5.9 L=314.0 cm Crit.: Acciaio_Flessione $\gamma_M=1.05$ $f_{yk}/\gamma_M=2619$ kg/cm² $f_t=4300$ kg/cm²

:Verificato

X	cls	N	TY	TZ	MT	MY	MZ	My4	Mz4	Comb.
cm		kg	kg	kg	kg*m	kg*m	kg*m			
157	1	19055	-3	2	-2	-42	0	--	--	2

X	cls	Nr	Vyr	Vzr	Mry	Mrz	MTrd	SF_V.	SF_M	SF_Mt	SF
cm		kg	kg	kg	kg*m	kg*m	kg*m				
157	1	52623	19320	19320	1818	1818	1566	>100	2.60	>100	2.60

Asta : 22 [208 , 200]

Sez. G: O 114.3x5.9 L=281.6 cm Crit.: Acciaio_Flessione $\gamma_M=1.05$ $f_{yk}/\gamma_M=2619$ kg/cm² $f_t=4300$ kg/cm²

:Verificato

X	cls	N	TY	TZ	MT	MY	MZ	My4	Mz4	Comb.
cm		kg	kg	kg	kg*m	kg*m	kg*m			
113	1	-2086	-5	-6	8	-12	-11	--	--	2

X	cls	Nr	Vyr	Vzr	Mry	Mrz	MTrd	SF_V.	SF_M	SF_Mt	SF
cm		kg	kg	kg	kg*m	kg*m	kg*m				
113	1	52623	19239	19239	1818	1818	1566	>100	19.1	>100	19.1

Asta : 23 [200 , 209]

Sez. G: O 114.3x5.9 L=281.6 cm Crit.: Acciaio_Flessione $\gamma_M=1.05$ $f_{yk}/\gamma_M=2619$ kg/cm² $f_t=4300$ kg/cm²

:Verificato

X	cls	N	TY	TZ	MT	MY	MZ	My4	Mz4	Comb.
cm		kg	kg	kg	kg*m	kg*m	kg*m			
141	1	-589	1	0	-8	-17	-10	--	--	2

X	cls	Nr	Vyr	Vzr	Mry	Mrz	MTrd	SF_V.	SF_M	SF_Mt	SF
cm		kg	kg	kg	kg*m	kg*m	kg*m				

AUTOSTRADA VALDASTICO A31 NORD
1° LOTTO - PIOVENE ROCCHETTE – VALLE DELL'ASTICO

X	cls	Nr	Vyr	Vzr	Mry	Mrz	MTrd	SF_V.	SF_M	SF_Mt	SF
141	1	52623	19238	19238	1818	1818	1566	>100	38.5	>100	38.5

Asta : 24 [193 , 200]

Sez. G: O 114.3x5.9 L=281.6 cm Crit.: Acciaio_Flessione $\gamma_M=1.05$ $f_{yk}/\gamma_M=2619$ kg/cmq $f_t=4300$ kg/cmq

:Verificato

X	cls	N	TY	TZ	MT	MY	MZ	My4	Mz4	Comb.
cm		kg	kg	kg	kg*m	kg*m	kg*m			
141	1	-988	3	-2	-9	-15	10	--	--	2

X	cls	Nr	Vyr	Vzr	Mry	Mrz	MTrd	SF_V.	SF_M	SF_Mt	SF
cm		kg	kg	kg	kg*m	kg*m	kg*m				
141	1	52623	19228	19228	1818	1818	1566	>100	30.6	>100	30.6

Asta : 25 [200 , 192]

Sez. G: O 114.3x5.9 L=281.6 cm Crit.: Acciaio_Flessione $\gamma_M=1.05$ $f_{yk}/\gamma_M=2619$ kg/cmq $f_t=4300$ kg/cmq

:Verificato

X	cls	N	TY	TZ	MT	MY	MZ	My4	Mz4	Comb.
cm		kg	kg	kg	kg*m	kg*m	kg*m			
169	1	653	-3	3	8	-17	10	--	--	2

X	cls	Nr	Vyr	Vzr	Mry	Mrz	MTrd	SF_V.	SF_M	SF_Mt	SF
cm		kg	kg	kg	kg*m	kg*m	kg*m				
169	1	52623	19239	19239	1818	1818	1566	>100	36.3	>100	36.3

Asta : 26 [192 , 199]

Sez. G: O 114.3x5.9 L=281.6 cm Crit.: Acciaio_Flessione $\gamma_M=1.05$ $f_{yk}/\gamma_M=2619$ kg/cmq $f_t=4300$ kg/cmq

:Verificato

X	cls	N	TY	TZ	MT	MY	MZ	My4	Mz4	Comb.
cm		kg	kg	kg	kg*m	kg*m	kg*m			
113	1	679	2	-3	-8	-17	10	--	--	2

AUTOSTRADA VALDASTICO A31 NORD
1° LOTTO - PIOVENE ROCCHETTE – VALLE DELL'ASTICO

X	cls	Nr	Vyr	Vzr	Mry	Mrz	MTrd	SF_V.	SF_M	SF_Mt	SF
cm		kg	kg	kg	kg*m	kg*m	kg*m				
113	1	52623	19239	19239	1818	1818	1566	>100	35.9	>100	35.9

Asta : 27 [199 , 210]

Sez. G: O 114.3x5.9 L=281.6 cm Crit.: Acciaio_Flessione $\gamma M=1.05$ $f_y k/\gamma M=2619$ kg/cmq $f_t=4300$ kg/cmq

:Verificato

X	cls	N	TY	TZ	MT	MY	MZ	My4	Mz4	Comb.
cm		kg	kg	kg	kg*m	kg*m	kg*m			
169	1	-2118	5	6	-8	-12	-11	--	--	2

X	cls	Nr	Vyr	Vzr	Mry	Mrz	MTrd	SF_V.	SF_M	SF_Mt	SF
cm		kg	kg	kg	kg*m	kg*m	kg*m				
169	1	52623	19240	19240	1818	1818	1566	>100	18.9	>100	18.9

Asta : 28 [210 , 191]

Sez. G: O 114.3x5.9 L=286.0 cm Crit.: Acciaio_Flessione $\gamma M=1.05$ $f_y k/\gamma M=2619$ kg/cmq $f_t=4300$ kg/cmq

:Verificato

X	cls	N	TY	TZ	MT	MY	MZ	My4	Mz4	Comb.
cm		kg	kg	kg	kg*m	kg*m	kg*m			
286	1	-3943	6	30	2	24	-9	--	--	2

X	cls	Nr	Vyr	Vzr	Mry	Mrz	MTrd	SF_V.	SF_M	SF_Mt	SF
cm		kg	kg	kg	kg*m	kg*m	kg*m				
286	1	52623	19319	19319	1818	1818	1566	>100	10.8	>100	10.8

Asta : 29 [191 , 192]

Sez. G: O 114.3x5.9 L=314.0 cm Crit.: Acciaio_Flessione $\gamma M=1.05$ $f_y k/\gamma M=2619$ kg/cmq $f_t=4300$ kg/cmq

:Verificato

AUTOSTRADA VALDASTICO A31 NORD
1° LOTTO - PIOVENE ROCCHETTE – VALLE DELL'ASTICO

X	cls	N	TY	TZ	MT	MY	MZ	My4	Mz4	Comb.
cm		kg	kg	kg	kg*m	kg*m	kg*m			
157	1	18977	2	-2	1	-41	0	--	--	2

X	cls	Nr	Vyr	Vzr	Mry	Mrz	MTrd	SF_V.	SF_M	SF_Mt	SF
cm		kg	kg	kg	kg*m	kg*m	kg*m				
157	1	52623	19323	19323	1818	1818	1566	>100	2.61	>100	2.61

Asta : 30 [209 , 199]

Sez. G: O 114.3x5.9 L=281.6 cm Crit.: Acciaio_Flessione $\gamma_M=1.05$ $f_{yk}/\gamma_M=2619$ kg/cm² $f_t=4300$ kg/cm²

:Verificato

X	cls	N	TY	TZ	MT	MY	MZ	My4	Mz4	Comb.
cm		kg	kg	kg	kg*m	kg*m	kg*m			
141	1	-533	-1	-0	8	-17	-10	--	--	2

X	cls	Nr	Vyr	Vzr	Mry	Mrz	MTrd	SF_V.	SF_M	SF_Mt	SF
cm		kg	kg	kg	kg*m	kg*m	kg*m				
141	1	52623	19238	19238	1818	1818	1566	>100	40.0	>100	40.0

Asta : 31 [199 , 191]

Sez. G: O 114.3x5.9 L=281.6 cm Crit.: Acciaio_Flessione $\gamma_M=1.05$ $f_{yk}/\gamma_M=2619$ kg/cm² $f_t=4300$ kg/cm²

:Verificato

X	cls	N	TY	TZ	MT	MY	MZ	My4	Mz4	Comb.
cm		kg	kg	kg	kg*m	kg*m	kg*m			
141	1	-1042	-3	2	9	-16	10	--	--	2

X	cls	Nr	Vyr	Vzr	Mry	Mrz	MTrd	SF_V.	SF_M	SF_Mt	SF
cm		kg	kg	kg	kg*m	kg*m	kg*m				
141	1	52623	19230	19230	1818	1818	1566	>100	29.6	>100	29.6

Asta : 32 [211 , 190]

AUTOSTRADA VALDASTICO A31 NORD
1° LOTTO - PIOVENE ROCCHETTE – VALLE DELL'ASTICO

Sez. G: O 114.3x5.9 L=286.0 cm Crit.: Acciaio_Flessione $\gamma_M=1.05$ $f_{yk}/\gamma_M=2619$ kg/cmq $f_t=4300$ kg/cmq

:Verificato

X	cls	N	TY	TZ	MT	MY	MZ	My4	Mz4	Comb.
cm		kg	kg	kg	kg*m	kg*m	kg*m			
286	1	-10818	14	50	17	71	-21	--	--	2

X	cls	Nr	Vyr	Vzr	Mry	Mrz	MTrd	SF_V.	SF_M	SF_Mt	SF
cm		kg	kg	kg	kg*m	kg*m	kg*m				
286	1	52623	19128	19128	1818	1818	1566	>100	3.90	90.7	3.90

Asta : 33 [190 , 191]

Sez. G: O 114.3x5.9 L=314.0 cm Crit.: Acciaio_Flessione $\gamma_M=1.05$ $f_{yk}/\gamma_M=2619$ kg/cmq $f_t=4300$ kg/cmq

:Verificato

X	cls	N	TY	TZ	MT	MY	MZ	My4	Mz4	Comb.
cm		kg	kg	kg	kg*m	kg*m	kg*m			
94	1	15025	6	-6	4	-51	4	--	--	2

X	cls	Nr	Vyr	Vzr	Mry	Mrz	MTrd	SF_V.	SF_M	SF_Mt	SF
cm		kg	kg	kg	kg*m	kg*m	kg*m				
94	1	52623	19296	19296	1818	1818	1566	>100	3.16	>100	3.16

Asta : 34 [191 , 198]

Sez. G: O 114.3x5.9 L=273.9 cm Crit.: Acciaio_Flessione $\gamma_M=1.05$ $f_{yk}/\gamma_M=2619$ kg/cmq $f_t=4300$ kg/cmq

:Verificato

X	cls	N	TY	TZ	MT	MY	MZ	My4	Mz4	Comb.
cm		kg	kg	kg	kg*m	kg*m	kg*m			
110	1	1759	-0	3	-10	-14	11	--	--	2

X	cls	Nr	Vyr	Vzr	Mry	Mrz	MTrd	SF_V.	SF_M	SF_Mt	SF
cm		kg	kg	kg	kg*m	kg*m	kg*m				
110	1	52623	19216	19216	1818	1818	1566	>100	21.1	>100	21.1

AUTOSTRADA VALDASTICO A31 NORD
1° LOTTO - PIOVENE ROCCHETTE – VALLE DELL'ASTICO

Asta : 35 [198 , 211]

Sez. G: O 114.3x5.9 L=273.9 cm Crit.: Acciaio_Flessione $\gamma_M=1.05$ $f_{yk}/\gamma_M=2619$ kg/cmq $f_t=4300$ kg/cmq

:Verificato

X	cls	N	TY	TZ	MT	MY	MZ	My4	Mz4	Comb.
cm		kg	kg	kg	kg*m	kg*m	kg*m			
274	1	-1070	16	28	-10	23	-32	--	--	2

X	cls	Nr	Vyr	Vzr	Mry	Mrz	MTrd	SF_V.	SF_M	SF_Mt	SF
cm		kg	kg	kg	kg*m	kg*m	kg*m				
274	1	52623	19218	19218	1818	1818	1566	>100	19.8	>100	19.8

Asta : 36 [210 , 198]

Sez. G: O 114.3x5.9 L=273.9 cm Crit.: Acciaio_Flessione $\gamma_M=1.05$ $f_{yk}/\gamma_M=2619$ kg/cmq $f_t=4300$ kg/cmq

:Verificato

X	cls	N	TY	TZ	MT	MY	MZ	My4	Mz4	Comb.
cm		kg	kg	kg	kg*m	kg*m	kg*m			
110	1	3445	-2	-3	9	-18	-10	--	--	2

X	cls	Nr	Vyr	Vzr	Mry	Mrz	MTrd	SF_V.	SF_M	SF_Mt	SF
cm		kg	kg	kg	kg*m	kg*m	kg*m				
110	1	52623	19228	19228	1818	1818	1566	>100	12.4	>100	12.4

Asta : 37 [198 , 190]

Sez. G: O 114.3x5.9 L=273.9 cm Crit.: Acciaio_Flessione $\gamma_M=1.05$ $f_{yk}/\gamma_M=2619$ kg/cmq $f_t=4300$ kg/cmq

:Verificato

X	cls	N	TY	TZ	MT	MY	MZ	My4	Mz4	Comb.
cm		kg	kg	kg	kg*m	kg*m	kg*m			
274	1	-7737	-16	12	18	-17	40	--	--	2

X	cls	Nr	Vyr	Vzr	Mry	Mrz	MTrd	SF_V.	SF_M	SF_Mt	SF
cm		kg	kg	kg	kg*m	kg*m	kg*m				

AUTOSTRADA VALDASTICO A31 NORD
1° LOTTO - PIOVENE ROCCHETTE – VALLE DELL'ASTICO

X	cls	Nr	Vyr	Vzr	Mry	Mrz	MTrd	SF_V.	SF_M	SF_Mt	SF
cm		kg	kg	kg	kg*m	kg*m	kg*m				
274	1	52623	19115	19115	1818	1818	1566	>100	5.60	85.4	5.60

Asta : 38 [190 , 189]

Sez. G: O 114.3x5.9 L=314.0 cm Crit.: Acciaio_Flessione $\gamma_M=1.05$ $f_{yk}/\gamma_M=2619$ kg/cm² $f_t=4300$ kg/cm²

:Verificato

X	cls	N	TY	TZ	MT	MY	MZ	My4	Mz4	Comb.
cm		kg	kg	kg	kg*m	kg*m	kg*m			
314	1	-4953	5	247	-17	439	-9	--	--	2

X	cls	Nr	Vyr	Vzr	Mry	Mrz	MTrd	SF_V.	SF_M	SF_Mt	SF
cm		kg	kg	kg	kg*m	kg*m	kg*m				
314	1	52623	19127	19127	1818	1818	1566	77.3	2.94	90.2	2.94

Asta : 39 [189 , 212]

Sez. G: O 114.3x5.9 L=286.0 cm Crit.: Acciaio_Flessione $\gamma_M=1.05$ $f_{yk}/\gamma_M=2619$ kg/cm² $f_t=4300$ kg/cm²

:Verificato

X	cls	N	TY	TZ	MT	MY	MZ	My4	Mz4	Comb.
cm		kg	kg	kg	kg*m	kg*m	kg*m			
0	1	-17465	1	-108	-46	154	4	--	--	2

X	cls	Nr	Vyr	Vzr	Mry	Mrz	MTrd	SF_V.	SF_M	SF_Mt	SF
cm		kg	kg	kg	kg*m	kg*m	kg*m				
0	1	52623	18779	18779	1818	1818	1566	>100	2.39	34.4	2.39

Asta : 40 [211 , 197]

Sez. G: O 114.3x5.9 L=254.4 cm Crit.: Acciaio_Flessione $\gamma_M=1.05$ $f_{yk}/\gamma_M=2619$ kg/cm² $f_t=4300$ kg/cm²

:Verificato

X	cls	N	TY	TZ	MT	MY	MZ	My4	Mz4	Comb.
cm		kg	kg	kg	kg*m	kg*m	kg*m			

AUTOSTRADA VALDASTICO A31 NORD
1° LOTTO - PIOVENE ROCCHETTE – VALLE DELL'ASTICO

X	cls	N	TY	TZ	MT	MY	MZ	My4	Mz4	Comb.
203	1	11757	-11	10	8	-26	7	--	--	2

X	cls	Nr	Vyr	Vzr	Mry	Mrz	MTrd	SF_V.	SF_M	SF_Mt	SF
cm		kg	kg	kg	kg*m	kg*m	kg*m				
203	1	52623	19248	19248	1818	1818	1566	>100	4.15	>100	4.15

Asta : 41 [197 , 212]

Sez. G: O 114.3x5.9 L=254.4 cm Crit.: Acciaio_Flessione $\gamma_M=1.05$ $f_{yk}/\gamma_M=2619$ kg/cm² $f_t=4300$ kg/cm²

:Verificato

X	cls	N	TY	TZ	MT	MY	MZ	My4	Mz4	Comb.
cm		kg	kg	kg	kg*m	kg*m	kg*m			
254	1	9270	21	27	7	56	-23	--	--	2

X	cls	Nr	Vyr	Vzr	Mry	Mrz	MTrd	SF_V.	SF_M	SF_Mt	SF
cm		kg	kg	kg	kg*m	kg*m	kg*m				
254	1	52623	19255	19255	1818	1818	1566	>100	4.55	>100	4.55

Asta : 42 [190 , 197]

Sez. G: O 114.3x5.9 L=254.4 cm Crit.: Acciaio_Flessione $\gamma_M=1.05$ $f_{yk}/\gamma_M=2619$ kg/cm² $f_t=4300$ kg/cm²

:Verificato

X	cls	N	TY	TZ	MT	MY	MZ	My4	Mz4	Comb.
cm		kg	kg	kg	kg*m	kg*m	kg*m			
254	1	7381	-41	24	-16	40	71	--	--	2

X	cls	Nr	Vyr	Vzr	Mry	Mrz	MTrd	SF_V.	SF_M	SF_Mt	SF
cm		kg	kg	kg	kg*m	kg*m	kg*m				
254	1	52623	19149	19149	1818	1818	1566	>100	4.97	>100	4.97

Asta : 43 [197 , 189]

Sez. G: O 114.3x7.1 L=254.4 cm Crit.: Acciaio_Flessione $\gamma_M=1.05$ $f_{yk}/\gamma_M=2619$ kg/cm² $f_t=4300$ kg/cm²

:Verificato

AUTOSTRADA VALDASTICO A31 NORD
1° LOTTO - PIOVENE ROCCHETTE – VALLE DELL'ASTICO

X	cls	N	TY	TZ	MT	MY	MZ	My4	Mz4	Comb.
cm		kg	kg	kg	kg*m	kg*m	kg*m			
254	1	-41248	105	246	-42	388	-178	--	--	2

X	cls	Nr	Vyr	Vzr	Mry	Mrz	MTrd	SF_V.	SF_M	SF_Mt	SF
cm		kg	kg	kg	kg*m	kg*m	kg*m				
254	1	62625	22485	22485	2140	2140	1826	91.4	1.08	43.2	1.08

Asta : 44 [213 , 188]

Sez. G: O 114.3x5.9 L=286.0 cm Crit.: Acciaio_Flessione $\gamma_M=1.05$ $f_{yk}/\gamma_M=2619$ kg/cm² $f_t=4300$ kg/cm²

:Verificato

X	cls	N	TY	TZ	MT	MY	MZ	My4	Mz4	Comb.
cm		kg	kg	kg	kg*m	kg*m	kg*m			
0	1	-9135	-17	-91	-29	113	-25	--	--	2

X	cls	Nr	Vyr	Vzr	Mry	Mrz	MTrd	SF_V.	SF_M	SF_Mt	SF
cm		kg	kg	kg	kg*m	kg*m	kg*m				
0	1	52623	18987	18987	1818	1818	1566	>100	4.02	54.6	4.02

Asta : 45 [188 , 189]

Sez. G: O 114.3x5.9 L=314.0 cm Crit.: Acciaio_Flessione $\gamma_M=1.05$ $f_{yk}/\gamma_M=2619$ kg/cm² $f_t=4300$ kg/cm²

:Verificato

X	cls	N	TY	TZ	MT	MY	MZ	My4	Mz4	Comb.
cm		kg	kg	kg	kg*m	kg*m	kg*m			
0	1	-10493	-2	-56	0	53	-5	--	--	2

X	cls	Nr	Vyr	Vzr	Mry	Mrz	MTrd	SF_V.	SF_M	SF_Mt	SF
cm		kg	kg	kg	kg*m	kg*m	kg*m				
0	1	52623	19336	19336	1818	1818	1566	>100	4.33	>100	4.33

Asta : 46 [212 , 204]

AUTOSTRADA VALDASTICO A31 NORD
1° LOTTO - PIOVENE ROCCHETTE – VALLE DELL'ASTICO

Sez. G: O 114.3x5.9 L=229.9 cm Crit.: Acciaio_Flessione $\gamma_M=1.05$ $f_{yk}/\gamma_M=2619$ kg/cmq $f_t=4300$ kg/cmq

:Verificato

X	cls	N	TY	TZ	MT	MY	MZ	My4	Mz4	Comb.
cm		kg	kg	kg	kg*m	kg*m	kg*m			
230	1	10393	-11	51	4	78	12	--	--	2

X	cls	Nr	Vyr	Vzr	Mry	Mrz	MTrd	SF_V.	SF_M	SF_Mt	SF
cm		kg	kg	kg	kg*m	kg*m	kg*m				
230	1	52623	19289	19289	1818	1818	1566	>100	4.05	>100	4.05

Asta : 47 [204 , 188]

Sez. G: O 114.3x5.9 L=229.9 cm Crit.: Acciaio_Flessione $\gamma_M=1.05$ $f_{yk}/\gamma_M=2619$ kg/cmq $f_t=4300$ kg/cmq

:Verificato

X	cls	N	TY	TZ	MT	MY	MZ	My4	Mz4	Comb.
cm		kg	kg	kg	kg*m	kg*m	kg*m			
0	1	4926	26	-120	-19	162	17	--	--	2

X	cls	Nr	Vyr	Vzr	Mry	Mrz	MTrd	SF_V.	SF_M	SF_Mt	SF
cm		kg	kg	kg	kg*m	kg*m	kg*m				
0	1	52623	19108	19108	1818	1818	1566	>100	5.21	82.7	5.21

Asta : 48 [204 , 213]

Sez. G: O 114.3x5.9 L=229.9 cm Crit.: Acciaio_Flessione $\gamma_M=1.05$ $f_{yk}/\gamma_M=2619$ kg/cmq $f_t=4300$ kg/cmq

:Verificato

X	cls	N	TY	TZ	MT	MY	MZ	My4	Mz4	Comb.
cm		kg	kg	kg	kg*m	kg*m	kg*m			
0	1	7584	10	-74	-1	74	8	--	--	2

X	cls	Nr	Vyr	Vzr	Mry	Mrz	MTrd	SF_V.	SF_M	SF_Mt	SF
cm		kg	kg	kg	kg*m	kg*m	kg*m				
0	1	52623	19328	19328	1818	1818	1566	>100	5.29	>100	5.29

AUTOSTRADA VALDASTICO A31 NORD
1° LOTTO - PIOVENE ROCCHETTE – VALLE DELL'ASTICO

Asta : 49 [203 , 202]

Sez. G: O 114.3x5.9 L=318.3 cm Crit.: Acciaio_Flessione $\gamma_M=1.05$ $f_{yk}/\gamma_M=2619$ kg/cmq $f_t=4300$ kg/cmq

:Verificato

X	cls	N	TY	TZ	MT	MY	MZ	My4	Mz4	Comb.
cm		kg	kg	kg	kg*m	kg*m	kg*m			
0	1	18847	3	-1309	-2	766	4	--	--	2

X	cls	Nr	Vyr	Vzr	Mry	Mrz	MTrd	SF_V.	SF_M	SF_Mt	SF
cm		kg	kg	kg	kg*m	kg*m	kg*m				
0	1	52623	19313	19313	1818	1818	1566	14.8	1.28	>100	1.28

Asta : 50 [202 , 201]

Sez. G: O 114.3x5.9 L=315.7 cm Crit.: Acciaio_Flessione $\gamma_M=1.05$ $f_{yk}/\gamma_M=2619$ kg/cmq $f_t=4300$ kg/cmq

:Verificato

X	cls	N	TY	TZ	MT	MY	MZ	My4	Mz4	Comb.
cm		kg	kg	kg	kg*m	kg*m	kg*m			
0	1	-12777	-10	-1310	16	682	-14	--	--	2

X	cls	Nr	Vyr	Vzr	Mry	Mrz	MTrd	SF_V.	SF_M	SF_Mt	SF
cm		kg	kg	kg	kg*m	kg*m	kg*m				
0	1	52623	19144	19144	1818	1818	1566	14.6	1.60	97.8	1.60

Asta : 51 [201 , 200]

Sez. G: O 114.3x5.9 L=314.2 cm Crit.: Acciaio_Flessione $\gamma_M=1.05$ $f_{yk}/\gamma_M=2619$ kg/cmq $f_t=4300$ kg/cmq

:Verificato

X	cls	N	TY	TZ	MT	MY	MZ	My4	Mz4	Comb.
cm		kg	kg	kg	kg*m	kg*m	kg*m			
0	1	-20584	0	-1299	2	657	-0	--	--	2

X	cls	Nr	Vyr	Vzr	Mry	Mrz	MTrd	SF_V.	SF_M	SF_Mt	SF
cm		kg	kg	kg	kg*m	kg*m	kg*m				
0	1	52623	19144	19144	1818	1818	1566	14.6	1.60	97.8	1.60

AUTOSTRADA VALDASTICO A31 NORD
1° LOTTO - PIOVENE ROCCHETTE – VALLE DELL'ASTICO

X	cls	Nr	Vyr	Vzr	Mry	Mrz	MTrd	SF_V.	SF_M	SF_Mt	SF
cm		kg	kg	kg	kg*m	kg*m	kg*m				
0	1	52623	19322	19322	1818	1818	1566	14.9	1.33	>100	1.33

Asta : 52 [200 , 199]

Sez. G: O 114.3x5.9 L=314.0 cm Crit.: Acciaio_Flessione $\gamma_M=1.05$ $f_{yk}/\gamma_M=2619$ kg/cm² $f_t=4300$ kg/cm²

:Verificato

X	cls	N	TY	TZ	MT	MY	MZ	My4	Mz4	Comb.
cm		kg	kg	kg	kg*m	kg*m	kg*m			
314	1	-22263	0	1294	-0	647	-0	--	--	2

X	cls	Nr	Vyr	Vzr	Mry	Mrz	MTrd	SF_V.	SF_M	SF_Mt	SF
cm		kg	kg	kg	kg*m	kg*m	kg*m				
314	1	52623	19340	19340	1818	1818	1566	14.9	1.28	>100	1.28

Asta : 53 [199 , 198]

Sez. G: O 114.3x5.9 L=314.2 cm Crit.: Acciaio_Flessione $\gamma_M=1.05$ $f_{yk}/\gamma_M=2619$ kg/cm² $f_t=4300$ kg/cm²

:Verificato

X	cls	N	TY	TZ	MT	MY	MZ	My4	Mz4	Comb.
cm		kg	kg	kg	kg*m	kg*m	kg*m			
314	1	-20491	0	1299	-2	657	-1	--	--	2

X	cls	Nr	Vyr	Vzr	Mry	Mrz	MTrd	SF_V.	SF_M	SF_Mt	SF
cm		kg	kg	kg	kg*m	kg*m	kg*m				
314	1	52623	19319	19319	1818	1818	1566	14.9	1.33	>100	1.33

Asta : 54 [198 , 197]

Sez. G: O 114.3x5.9 L=315.7 cm Crit.: Acciaio_Flessione $\gamma_M=1.05$ $f_{yk}/\gamma_M=2619$ kg/cm² $f_t=4300$ kg/cm²

:Verificato

X	cls	N	TY	TZ	MT	MY	MZ	My4	Mz4	Comb.
cm		kg	kg	kg	kg*m	kg*m	kg*m			

AUTOSTRADA VALDASTICO A31 NORD
1° LOTTO - PIOVENE ROCCHETTE – VALLE DELL'ASTICO

X	cls	N	TY	TZ	MT	MY	MZ	My4	Mz4	Comb.
316	1	-12624	10	1311	-16	684	-14	--	--	2

X	cls	Nr	Vyr	Vzr	Mry	Mrz	MTrd	SF_V.	SF_M	SF_Mt	SF
cm		kg	kg	kg	kg*m	kg*m	kg*m				
316	1	52623	19142	19142	1818	1818	1566	14.6	1.60	96.7	1.60

Asta : 55 [197 , 204]

Sez. G: O 114.3x5.9 L=318.3 cm Crit.: Acciaio_Flessione $\gamma_M=1.05$ $f_{yk}/\gamma_M=2619$ kg/cm² $f_t=4300$ kg/cm²

:Verificato

X	cls	N	TY	TZ	MT	MY	MZ	My4	Mz4	Comb.
cm		kg	kg	kg	kg*m	kg*m	kg*m			
0	1	19414	-4	-1294	4	734	-6	--	--	2

X	cls	Nr	Vyr	Vzr	Mry	Mrz	MTrd	SF_V.	SF_M	SF_Mt	SF
cm		kg	kg	kg	kg*m	kg*m	kg*m				
0	1	52623	19295	19295	1818	1818	1566	14.9	1.29	>100	1.29

Asta : 56 [205 , 220]

Sez. G: O 114.3x5.9 L=229.9 cm Crit.: Acciaio_Flessione $\gamma_M=1.05$ $f_{yk}/\gamma_M=2619$ kg/cm² $f_t=4300$ kg/cm²

:Verificato

X	cls	N	TY	TZ	MT	MY	MZ	My4	Mz4	Comb.
cm		kg	kg	kg	kg*m	kg*m	kg*m			
0	1	-4219	-4	-27	5	43	-9	--	--	2

X	cls	Nr	Vyr	Vzr	Mry	Mrz	MTrd	SF_V.	SF_M	SF_Mt	SF
cm		kg	kg	kg	kg*m	kg*m	kg*m				
0	1	52623	19281	19281	1818	1818	1566	>100	9.20	>100	9.20

Asta : 57 [223 , 206]

AUTOSTRADA VALDASTICO A31 NORD
1° LOTTO - PIOVENE ROCCHETTE – VALLE DELL'ASTICO

Sez. G: O 114.3x5.9 L=286.0 cm Crit.: Acciaio_Flessione $\gamma_M=1.05$ $f_{yk}/\gamma_M=2619$ kg/cmq $f_t=4300$ kg/cmq

:Verificato

X	cls	N	TY	TZ	MT	MY	MZ	My4	Mz4	Comb.
cm		kg	kg	kg	kg*m	kg*m	kg*m			
57	1	4758	-5	-5	-4	-33	-5	--	--	2

X	cls	Nr	Vyr	Vzr	Mry	Mrz	MTrd	SF_V.	SF_M	SF_Mt	SF
cm		kg	kg	kg	kg*m	kg*m	kg*m				
57	1	52623	19293	19293	1818	1818	1566	>100	8.99	>100	8.99

Asta : 58 [206 , 205]

Sez. G: O 114.3x5.9 L=314.0 cm Crit.: Acciaio_Flessione $\gamma_M=1.05$ $f_{yk}/\gamma_M=2619$ kg/cmq $f_t=4300$ kg/cmq

:Verificato

X	cls	N	TY	TZ	MT	MY	MZ	My4	Mz4	Comb.
cm		kg	kg	kg	kg*m	kg*m	kg*m			
0	1	-4375	-6	-41	-14	49	-10	--	--	2

X	cls	Nr	Vyr	Vzr	Mry	Mrz	MTrd	SF_V.	SF_M	SF_Mt	SF
cm		kg	kg	kg	kg*m	kg*m	kg*m				
0	1	52623	19172	19172	1818	1818	1566	>100	8.65	>100	8.65

Asta : 59 [222 , 220]

Sez. G: O 114.3x5.9 L=229.9 cm Crit.: Acciaio_Flessione $\gamma_M=1.05$ $f_{yk}/\gamma_M=2619$ kg/cmq $f_t=4300$ kg/cmq

:Verificato

X	cls	N	TY	TZ	MT	MY	MZ	My4	Mz4	Comb.
cm		kg	kg	kg	kg*m	kg*m	kg*m			
230	1	2232	-9	33	-15	24	17	--	--	2

X	cls	Nr	Vyr	Vzr	Mry	Mrz	MTrd	SF_V.	SF_M	SF_Mt	SF
cm		kg	kg	kg	kg*m	kg*m	kg*m				
230	1	52623	19155	19155	1818	1818	1566	>100	15.4	>100	15.4

AUTOSTRADA VALDASTICO A31 NORD
1° LOTTO - PIOVENE ROCCHETTE – VALLE DELL'ASTICO

Asta : 60 [220 , 206]

Sez. G: O 114.3x5.9 L=229.9 cm Crit.: Acciaio_Flessione $\gamma_M=1.05$ $f_{yk}/\gamma_M=2619$ kg/cm² $f_t=4300$ kg/cm²

:Verificato

X	cls	N	TY	TZ	MT	MY	MZ	My4	Mz4	Comb.
cm		kg	kg	kg	kg*m	kg*m	kg*m			
230	1	-6532	25	56	-6	41	-30	--	--	2

X	cls	Nr	Vyr	Vzr	Mry	Mrz	MTrd	SF_V.	SF_M	SF_Mt	SF
cm		kg	kg	kg	kg*m	kg*m	kg*m				
230	1	52623	19270	19270	1818	1818	1566	>100	6.13	>100	6.13

Asta : 61 [220 , 223]

Sez. G: O 114.3x5.9 L=229.9 cm Crit.: Acciaio_Flessione $\gamma_M=1.05$ $f_{yk}/\gamma_M=2619$ kg/cm² $f_t=4300$ kg/cm²

:Verificato

X	cls	N	TY	TZ	MT	MY	MZ	My4	Mz4	Comb.
cm		kg	kg	kg	kg*m	kg*m	kg*m			
0	1	2188	3	0	6	-34	9	--	--	2

X	cls	Nr	Vyr	Vzr	Mry	Mrz	MTrd	SF_V.	SF_M	SF_Mt	SF
cm		kg	kg	kg	kg*m	kg*m	kg*m				
0	1	52623	19272	19272	1818	1818	1566	>100	15.3	>100	15.3

Asta : 62 [222 , 205]

Sez. G: O 114.3x5.9 L=286.0 cm Crit.: Acciaio_Flessione $\gamma_M=1.05$ $f_{yk}/\gamma_M=2619$ kg/cm² $f_t=4300$ kg/cm²

:Verificato

X	cls	N	TY	TZ	MT	MY	MZ	My4	Mz4	Comb.
cm		kg	kg	kg	kg*m	kg*m	kg*m			
286	1	-450	4	55	7	51	-5	--	--	2

X	cls	Nr	Vyr	Vzr	Mry	Mrz	MTrd	SF_V.	SF_M	SF_Mt	SF

AUTOSTRADA VALDASTICO A31 NORD
1° LOTTO - PIOVENE ROCCHETTE – VALLE DELL'ASTICO

X	cls	Nr	Vyr	Vzr	Mry	Mrz	MTrd	SF_V.	SF_M	SF_Mt	SF
cm		kg	kg	kg	kg*m	kg*m	kg*m				
286	1	52623	19261	19261	1818	1818	1566	>100	25.5	>100	25.5

Asta : 63 [224 , 207]

Sez. G: O 114.3x5.9 L=286.0 cm Crit.: Acciaio_Flessione $\gamma_M=1.05$ $f_{yk}/\gamma_M=2619$ kg/cm² $f_t=4300$ kg/cm²

:Verificato

X	cls	N	TY	TZ	MT	MY	MZ	My4	Mz4	Comb.
cm		kg	kg	kg	kg*m	kg*m	kg*m			
286	1	-158	-13	42	-11	30	19	--	--	2

X	cls	Nr	Vyr	Vzr	Mry	Mrz	MTrd	SF_V.	SF_M	SF_Mt	SF
cm		kg	kg	kg	kg*m	kg*m	kg*m				
286	1	52623	19211	19211	1818	1818	1566	>100	33.5	>100	33.5

Asta : 64 [207 , 206]

Sez. G: O 114.3x5.9 L=314.0 cm Crit.: Acciaio_Flessione $\gamma_M=1.05$ $f_{yk}/\gamma_M=2619$ kg/cm² $f_t=4300$ kg/cm²

:Verificato

X	cls	N	TY	TZ	MT	MY	MZ	My4	Mz4	Comb.
cm		kg	kg	kg	kg*m	kg*m	kg*m			
314	1	-275	12	60	19	69	-20	--	--	2

X	cls	Nr	Vyr	Vzr	Mry	Mrz	MTrd	SF_V.	SF_M	SF_Mt	SF
cm		kg	kg	kg	kg*m	kg*m	kg*m				
314	1	52623	19113	19113	1818	1818	1566	>100	18.3	84.7	18.3

Asta : 65 [206 , 219]

Sez. G: O 114.3x5.9 L=254.4 cm Crit.: Acciaio_Flessione $\gamma_M=1.05$ $f_{yk}/\gamma_M=2619$ kg/cm² $f_t=4300$ kg/cm²

:Verificato

X	cls	N	TY	TZ	MT	MY	MZ	My4	Mz4	Comb.
cm		kg	kg	kg	kg*m	kg*m	kg*m			

AUTOSTRADA VALDASTICO A31 NORD
1° LOTTO - PIOVENE ROCCHETTE – VALLE DELL'ASTICO

X	cls	N	TY	TZ	MT	MY	MZ	My4	Mz4	Comb.
0	1	-11683	-20	-35	11	15	-33	--	--	2

X	cls	Nr	Vyr	Vzr	Mry	Mrz	MTrd	SF_V.	SF_M	SF_Mt	SF
cm		kg	kg	kg	kg*m	kg*m	kg*m				
0	1	52623	19204	19204	1818	1818	1566	>100	4.02	>100	4.02

Asta : 66 [219 , 224]

Sez. G: O 114.3x5.9 L=254.4 cm Crit.: Acciaio_Flessione $\gamma_M=1.05$ $f_{yk}/\gamma_M=2619$ kg/cmq $f_t=4300$ kg/cmq

:Verificato

X	cls	N	TY	TZ	MT	MY	MZ	My4	Mz4	Comb.
cm		kg	kg	kg	kg*m	kg*m	kg*m			
102	1	4477	-1	1	3	-19	2	--	--	2

X	cls	Nr	Vyr	Vzr	Mry	Mrz	MTrd	SF_V.	SF_M	SF_Mt	SF
cm		kg	kg	kg	kg*m	kg*m	kg*m				
102	1	52623	19304	19304	1818	1818	1566	>100	10.3	>100	10.3

Asta : 67 [223 , 219]

Sez. G: O 114.3x5.9 L=254.4 cm Crit.: Acciaio_Flessione $\gamma_M=1.05$ $f_{yk}/\gamma_M=2619$ kg/cmq $f_t=4300$ kg/cmq

:Verificato

X	cls	N	TY	TZ	MT	MY	MZ	My4	Mz4	Comb.
cm		kg	kg	kg	kg*m	kg*m	kg*m			
254	1	991	-9	17	-7	5	18	--	--	2

X	cls	Nr	Vyr	Vzr	Mry	Mrz	MTrd	SF_V.	SF_M	SF_Mt	SF
cm		kg	kg	kg	kg*m	kg*m	kg*m				
254	1	52623	19259	19259	1818	1818	1566	>100	31.8	>100	31.8

Asta : 68 [219 , 207]

AUTOSTRADA VALDASTICO A31 NORD
1° LOTTO - PIOVENE ROCCHETTE – VALLE DELL'ASTICO

Sez. G: O 114.3x5.9 L=254.4 cm Crit.: Acciaio_Flessione $\gamma_M=1.05$ $f_{yk}/\gamma_M=2619$ kg/cmq $f_t=4300$ kg/cmq

:Verificato

X	cls	N	TY	TZ	MT	MY	MZ	My4	Mz4	Comb.
cm		kg	kg	kg	kg*m	kg*m	kg*m			
254	1	-945	16	30	1	32	-19	--	--	2

X	cls	Nr	Vyr	Vzr	Mry	Mrz	MTrd	SF_V.	SF_M	SF_Mt	SF
cm		kg	kg	kg	kg*m	kg*m	kg*m				
254	1	52623	19330	19330	1818	1818	1566	>100	21.5	>100	21.5

Asta : 69 [225 , 208]

Sez. G: O 114.3x5.9 L=286.0 cm Crit.: Acciaio_Flessione $\gamma_M=1.05$ $f_{yk}/\gamma_M=2619$ kg/cmq $f_t=4300$ kg/cmq

:Verificato

X	cls	N	TY	TZ	MT	MY	MZ	My4	Mz4	Comb.
cm		kg	kg	kg	kg*m	kg*m	kg*m			
286	1	-2926	-7	32	-4	23	11	--	--	2

X	cls	Nr	Vyr	Vzr	Mry	Mrz	MTrd	SF_V.	SF_M	SF_Mt	SF
cm		kg	kg	kg	kg*m	kg*m	kg*m				
286	1	52623	19291	19291	1818	1818	1566	>100	13.5	>100	13.5

Asta : 70 [208 , 207]

Sez. G: O 114.3x5.9 L=314.0 cm Crit.: Acciaio_Flessione $\gamma_M=1.05$ $f_{yk}/\gamma_M=2619$ kg/cmq $f_t=4300$ kg/cmq

:Verificato

X	cls	N	TY	TZ	MT	MY	MZ	My4	Mz4	Comb.
cm		kg	kg	kg	kg*m	kg*m	kg*m			
94	1	11690	7	-4	9	-34	4	--	--	2

X	cls	Nr	Vyr	Vzr	Mry	Mrz	MTrd	SF_V.	SF_M	SF_Mt	SF
cm		kg	kg	kg	kg*m	kg*m	kg*m				
94	1	52623	19236	19236	1818	1818	1566	>100	4.11	>100	4.11

AUTOSTRADA VALDASTICO A31 NORD
1° LOTTO - PIOVENE ROCCHETTE – VALLE DELL'ASTICO

Asta : 71 [224 , 218]

Sez. G: O 114.3x5.9 L=273.9 cm Crit.: Acciaio_Flessione $\gamma_M=1.05$ $f_{yk}/\gamma_M=2619$ kg/cmq $f_t=4300$ kg/cmq

:Verificato

X	cls	N	TY	TZ	MT	MY	MZ	My4	Mz4	Comb.
cm		kg	kg	kg	kg*m	kg*m	kg*m			
0	1	-1618	-11	-22	4	9	-18	--	--	2

X	cls	Nr	Vyr	Vzr	Mry	Mrz	MTrd	SF_V.	SF_M	SF_Mt	SF
cm		kg	kg	kg	kg*m	kg*m	kg*m				
0	1	52623	19298	19298	1818	1818	1566	>100	21.8	>100	21.8

Asta : 72 [218 , 208]

Sez. G: O 114.3x5.9 L=273.9 cm Crit.: Acciaio_Flessione $\gamma_M=1.05$ $f_{yk}/\gamma_M=2619$ kg/cmq $f_t=4300$ kg/cmq

:Verificato

X	cls	N	TY	TZ	MT	MY	MZ	My4	Mz4	Comb.
cm		kg	kg	kg	kg*m	kg*m	kg*m			
0	1	1778	7	-22	7	9	16	--	--	2

X	cls	Nr	Vyr	Vzr	Mry	Mrz	MTrd	SF_V.	SF_M	SF_Mt	SF
cm		kg	kg	kg	kg*m	kg*m	kg*m				
0	1	52623	19260	19260	1818	1818	1566	>100	21.0	>100	21.0

Asta : 73 [207 , 218]

Sez. G: O 114.3x5.9 L=273.9 cm Crit.: Acciaio_Flessione $\gamma_M=1.05$ $f_{yk}/\gamma_M=2619$ kg/cmq $f_t=4300$ kg/cmq

:Verificato

X	cls	N	TY	TZ	MT	MY	MZ	My4	Mz4	Comb.
cm		kg	kg	kg	kg*m	kg*m	kg*m			
110	1	-8082	2	-1	-5	-23	6	--	--	2

X	cls	Nr	Vyr	Vzr	Mry	Mrz	MTrd	SF_V.	SF_M	SF_Mt	SF
cm		kg	kg	kg	kg*m	kg*m	kg*m				

AUTOSTRADA VALDASTICO A31 NORD
1° LOTTO - PIOVENE ROCCHETTE – VALLE DELL'ASTICO

X	cls	Nr	Vyr	Vzr	Mry	Mrz	MTrd	SF_V.	SF_M	SF_Mt	SF
cm		kg	kg	kg	kg*m	kg*m	kg*m				
110	1	52623	19278	19278	1818	1818	1566	>100	5.90	>100	5.90

Asta : 74 [218 , 225]

Sez. G: O 114.3x5.9 L=273.9 cm Crit.: Acciaio_Flessione $\gamma_M=1.05$ $f_{yk}/\gamma_M=2619$ kg/cm² $f_t=4300$ kg/cm²

:Verificato

X	cls	N	TY	TZ	MT	MY	MZ	My4	Mz4	Comb.
cm		kg	kg	kg	kg*m	kg*m	kg*m			
110	1	3526	-1	-1	-5	-16	-6	--	--	2

X	cls	Nr	Vyr	Vzr	Mry	Mrz	MTrd	SF_V.	SF_M	SF_Mt	SF
cm		kg	kg	kg	kg*m	kg*m	kg*m				
110	1	52623	19277	19277	1818	1818	1566	>100	12.6	>100	12.6

Asta : 75 [226 , 209]

Sez. G: O 114.3x5.9 L=286.0 cm Crit.: Acciaio_Flessione $\gamma_M=1.05$ $f_{yk}/\gamma_M=2619$ kg/cm² $f_t=4300$ kg/cm²

:Verificato

X	cls	N	TY	TZ	MT	MY	MZ	My4	Mz4	Comb.
cm		kg	kg	kg	kg*m	kg*m	kg*m			
0	1	-3175	0	-30	0	22	0	--	--	2

X	cls	Nr	Vyr	Vzr	Mry	Mrz	MTrd	SF_V.	SF_M	SF_Mt	SF
cm		kg	kg	kg	kg*m	kg*m	kg*m				
0	1	52623	19341	19341	1818	1818	1566	>100	13.8	>100	13.8

Asta : 76 [209 , 208]

Sez. G: O 114.3x5.9 L=314.0 cm Crit.: Acciaio_Flessione $\gamma_M=1.05$ $f_{yk}/\gamma_M=2619$ kg/cm² $f_t=4300$ kg/cm²

:Verificato

X	cls	N	TY	TZ	MT	MY	MZ	My4	Mz4	Comb.
cm		kg	kg	kg	kg*m	kg*m	kg*m			

AUTOSTRADA VALDASTICO A31 NORD
1° LOTTO - PIOVENE ROCCHETTE – VALLE DELL'ASTICO

X	cls	N	TY	TZ	MT	MY	MZ	My4	Mz4	Comb.
126	1	17233	1	-3	2	-39	1	--	--	2

X	cls	Nr	Vyr	Vzr	Mry	Mrz	MTrd	SF_V.	SF_M	SF_Mt	SF
cm		kg	kg	kg	kg*m	kg*m	kg*m				
126	1	52623	19321	19321	1818	1818	1566	>100	2.86	>100	2.86

Asta : 77 [225 , 217]

Sez. G: O 114.3x5.9 L=281.6 cm Crit.: Acciaio_Flessione $\gamma_M=1.05$ $f_{yk}/\gamma_M=2619$ kg/cmq $f_t=4300$ kg/cmq

:Verificato

X	cls	N	TY	TZ	MT	MY	MZ	My4	Mz4	Comb.
cm		kg	kg	kg	kg*m	kg*m	kg*m			
0	1	-2067	-6	-23	7	5	-16	--	--	2

X	cls	Nr	Vyr	Vzr	Mry	Mrz	MTrd	SF_V.	SF_M	SF_Mt	SF
cm		kg	kg	kg	kg*m	kg*m	kg*m				
0	1	52623	19254	19254	1818	1818	1566	>100	19.7	>100	19.7

Asta : 78 [217 , 226]

Sez. G: O 114.3x5.9 L=281.6 cm Crit.: Acciaio_Flessione $\gamma_M=1.05$ $f_{yk}/\gamma_M=2619$ kg/cmq $f_t=4300$ kg/cmq

:Verificato

X	cls	N	TY	TZ	MT	MY	MZ	My4	Mz4	Comb.
cm		kg	kg	kg	kg*m	kg*m	kg*m			
141	1	365	1	2	-8	-15	-9	--	--	2

X	cls	Nr	Vyr	Vzr	Mry	Mrz	MTrd	SF_V.	SF_M	SF_Mt	SF
cm		kg	kg	kg	kg*m	kg*m	kg*m				
141	1	52623	19248	19248	1818	1818	1566	>100	50.0	>100	50.0

Asta : 79 [208 , 217]

AUTOSTRADA VALDASTICO A31 NORD
1° LOTTO - PIOVENE ROCCHETTE – VALLE DELL'ASTICO

Sez. G: O 114.3x5.9 L=281.6 cm Crit.: Acciaio_Flessione $\gamma_M=1.05$ $f_{yk}/\gamma_M=2619$ kg/cmq $f_t=4300$ kg/cmq

:Verificato

X	cls	N	TY	TZ	MT	MY	MZ	My4	Mz4	Comb.
cm		kg	kg	kg	kg*m	kg*m	kg*m			
113	1	-2539	3	-3	-8	-17	10	--	--	2

X	cls	Nr	Vyr	Vzr	Mry	Mrz	MTrd	SF_V.	SF_M	SF_Mt	SF
cm		kg	kg	kg	kg*m	kg*m	kg*m				
113	1	52623	19243	19243	1818	1818	1566	>100	15.8	>100	15.8

Asta : 80 [217 , 209]

Sez. G: O 114.3x5.9 L=281.6 cm Crit.: Acciaio_Flessione $\gamma_M=1.05$ $f_{yk}/\gamma_M=2619$ kg/cmq $f_t=4300$ kg/cmq

:Verificato

X	cls	N	TY	TZ	MT	MY	MZ	My4	Mz4	Comb.
cm		kg	kg	kg	kg*m	kg*m	kg*m			
141	1	731	-0	-0	8	-14	9	--	--	2

X	cls	Nr	Vyr	Vzr	Mry	Mrz	MTrd	SF_V.	SF_M	SF_Mt	SF
cm		kg	kg	kg	kg*m	kg*m	kg*m				
141	1	52623	19241	19241	1818	1818	1566	>100	37.3	>100	37.3

Asta : 81 [209 , 216]

Sez. G: O 114.3x5.9 L=281.6 cm Crit.: Acciaio_Flessione $\gamma_M=1.05$ $f_{yk}/\gamma_M=2619$ kg/cmq $f_t=4300$ kg/cmq

:Verificato

X	cls	N	TY	TZ	MT	MY	MZ	My4	Mz4	Comb.
cm		kg	kg	kg	kg*m	kg*m	kg*m			
141	1	748	0	0	-8	-14	9	--	--	2

X	cls	Nr	Vyr	Vzr	Mry	Mrz	MTrd	SF_V.	SF_M	SF_Mt	SF
cm		kg	kg	kg	kg*m	kg*m	kg*m				

AUTOSTRADA VALDASTICO A31 NORD
1° LOTTO - PIOVENE ROCCHETTE – VALLE DELL'ASTICO

X	cls	Nr	Vyr	Vzr	Mry	Mrz	MTrd	SF_V.	SF_M	SF_Mt	SF
141	1	52623	19241	19241	1818	1818	1566	>100	37.0	>100	37.0

Asta : 82 [216 , 227]

Sez. G: O 114.3x5.9 L=281.6 cm Crit.: Acciaio_Flessione $\gamma_M=1.05$ $f_{yk}/\gamma_M=2619$ kg/cm² $f_t=4300$ kg/cm²

:Verificato

X	cls	N	TY	TZ	MT	MY	MZ	My4	Mz4	Comb.
cm		kg	kg	kg	kg*m	kg*m	kg*m			
282	1	-2104	6	23	-7	5	-16	--	--	2

X	cls	Nr	Vyr	Vzr	Mry	Mrz	MTrd	SF_V.	SF_M	SF_Mt	SF
cm		kg	kg	kg	kg*m	kg*m	kg*m				
282	1	52623	19254	19254	1818	1818	1566	>100	19.4	>100	19.4

Asta : 83 [227 , 210]

Sez. G: O 114.3x5.9 L=286.0 cm Crit.: Acciaio_Flessione $\gamma_M=1.05$ $f_{yk}/\gamma_M=2619$ kg/cm² $f_t=4300$ kg/cm²

:Verificato

X	cls	N	TY	TZ	MT	MY	MZ	My4	Mz4	Comb.
cm		kg	kg	kg	kg*m	kg*m	kg*m			
286	1	-2831	7	32	4	23	-11	--	--	2

X	cls	Nr	Vyr	Vzr	Mry	Mrz	MTrd	SF_V.	SF_M	SF_Mt	SF
cm		kg	kg	kg	kg*m	kg*m	kg*m				
286	1	52623	19290	19290	1818	1818	1566	>100	13.8	>100	13.8

Asta : 84 [210 , 209]

Sez. G: O 114.3x5.9 L=314.0 cm Crit.: Acciaio_Flessione $\gamma_M=1.05$ $f_{yk}/\gamma_M=2619$ kg/cm² $f_t=4300$ kg/cm²

:Verificato

X	cls	N	TY	TZ	MT	MY	MZ	My4	Mz4	Comb.
cm		kg	kg	kg	kg*m	kg*m	kg*m			
188	1	17193	-1	3	-2	-39	1	--	--	2

AUTOSTRADA VALDASTICO A31 NORD
1° LOTTO - PIOVENE ROCCHETTE – VALLE DELL'ASTICO

X	cls	Nr	Vyr	Vzr	Mry	Mrz	MTrd	SF_V.	SF_M	SF_Mt	SF
cm		kg	kg	kg	kg*m	kg*m	kg*m				
188	1	52623	19319	19319	1818	1818	1566	>100	2.87	>100	2.87

Asta : 85 [226 , 216]

Sez. G: O 114.3x5.9 L=281.6 cm Crit.: Acciaio_Flessione $\gamma_M=1.05$ $f_{yk}/\gamma_M=2619$ kg/cm² $f_t=4300$ kg/cm²

:Verificato

X	cls	N	TY	TZ	MT	MY	MZ	My4	Mz4	Comb.
cm		kg	kg	kg	kg*m	kg*m	kg*m			
141	1	391	-1	-2	8	-15	-9	--	--	2

X	cls	Nr	Vyr	Vzr	Mry	Mrz	MTrd	SF_V.	SF_M	SF_Mt	SF
cm		kg	kg	kg	kg*m	kg*m	kg*m				
141	1	52623	19248	19248	1818	1818	1566	>100	48.7	>100	48.7

Asta : 86 [216 , 210]

Sez. G: O 114.3x5.9 L=281.6 cm Crit.: Acciaio_Flessione $\gamma_M=1.05$ $f_{yk}/\gamma_M=2619$ kg/cm² $f_t=4300$ kg/cm²

:Verificato

X	cls	N	TY	TZ	MT	MY	MZ	My4	Mz4	Comb.
cm		kg	kg	kg	kg*m	kg*m	kg*m			
169	1	-2547	-3	3	8	-17	10	--	--	2

X	cls	Nr	Vyr	Vzr	Mry	Mrz	MTrd	SF_V.	SF_M	SF_Mt	SF
cm		kg	kg	kg	kg*m	kg*m	kg*m				
169	1	52623	19244	19244	1818	1818	1566	>100	15.8	>100	15.8

Asta : 87 [228 , 211]

Sez. G: O 114.3x5.9 L=286.0 cm Crit.: Acciaio_Flessione $\gamma_M=1.05$ $f_{yk}/\gamma_M=2619$ kg/cm² $f_t=4300$ kg/cm²

:Verificato

X	cls	N	TY	TZ	MT	MY	MZ	My4	Mz4	Comb.
cm		kg	kg	kg	kg*m	kg*m	kg*m			
169	1	-2547	-3	3	8	-17	10	--	--	2

AUTOSTRADA VALDASTICO A31 NORD
1° LOTTO - PIOVENE ROCCHETTE – VALLE DELL'ASTICO

X	cls	N	TY	TZ	MT	MY	MZ	My4	Mz4	Comb.
cm		kg	kg	kg	kg*m	kg*m	kg*m			
286	1	-8	13	42	11	30	-19	--	--	2

X	cls	Nr	Vyr	Vzr	Mry	Mrz	MTrd	SF_V.	SF_M	SF_Mt	SF
cm		kg	kg	kg	kg*m	kg*m	kg*m				
286	1	52623	19210	19210	1818	1818	1566	>100	37.3	>100	37.3

Asta : 88 [211 , 210]

Sez. G: O 114.3x5.9 L=314.0 cm Crit.: Acciaio_Flessione $\gamma_M=1.05$ $f_{yk}/\gamma_M=2619$ kg/cm² $f_t=4300$ kg/cm²

:Verificato

X	cls	N	TY	TZ	MT	MY	MZ	My4	Mz4	Comb.
cm		kg	kg	kg	kg*m	kg*m	kg*m			
220	1	11603	-7	4	-9	-34	4	--	--	2

X	cls	Nr	Vyr	Vzr	Mry	Mrz	MTrd	SF_V.	SF_M	SF_Mt	SF
cm		kg	kg	kg	kg*m	kg*m	kg*m				
220	1	52623	19235	19235	1818	1818	1566	>100	4.14	>100	4.14

Asta : 89 [210 , 215]

Sez. G: O 114.3x5.9 L=273.9 cm Crit.: Acciaio_Flessione $\gamma_M=1.05$ $f_{yk}/\gamma_M=2619$ kg/cm² $f_t=4300$ kg/cm²

:Verificato

X	cls	N	TY	TZ	MT	MY	MZ	My4	Mz4	Comb.
cm		kg	kg	kg	kg*m	kg*m	kg*m			
274	1	1781	-7	22	-7	9	16	--	--	2

X	cls	Nr	Vyr	Vzr	Mry	Mrz	MTrd	SF_V.	SF_M	SF_Mt	SF
cm		kg	kg	kg	kg*m	kg*m	kg*m				
274	1	52623	19261	19261	1818	1818	1566	>100	21.0	>100	21.0

Asta : 90 [215 , 228]

AUTOSTRADA VALDASTICO A31 NORD
1° LOTTO - PIOVENE ROCCHETTE – VALLE DELL'ASTICO

Sez. G: O 114.3x5.9 L=273.9 cm Crit.: Acciaio_Flessione $\gamma_M=1.05$ $f_{yk}/\gamma_M=2619$ kg/cmq $f_t=4300$ kg/cmq

:Verificato

X	cls	N	TY	TZ	MT	MY	MZ	My4	Mz4	Comb.
cm		kg	kg	kg	kg*m	kg*m	kg*m			
274	1	-1656	11	22	-3	9	-18	--	--	2

X	cls	Nr	Vyr	Vzr	Mry	Mrz	MTrd	SF_V.	SF_M	SF_Mt	SF
cm		kg	kg	kg	kg*m	kg*m	kg*m				
274	1	52623	19299	19299	1818	1818	1566	>100	21.6	>100	21.6

Asta : 91 [227 , 215]

Sez. G: O 114.3x5.9 L=273.9 cm Crit.: Acciaio_Flessione $\gamma_M=1.05$ $f_{yk}/\gamma_M=2619$ kg/cmq $f_t=4300$ kg/cmq

:Verificato

X	cls	N	TY	TZ	MT	MY	MZ	My4	Mz4	Comb.
cm		kg	kg	kg	kg*m	kg*m	kg*m			
164	1	3517	1	1	5	-17	-6	--	--	2

X	cls	Nr	Vyr	Vzr	Mry	Mrz	MTrd	SF_V.	SF_M	SF_Mt	SF
cm		kg	kg	kg	kg*m	kg*m	kg*m				
164	1	52623	19278	19278	1818	1818	1566	>100	12.6	>100	12.6

Asta : 92 [215 , 211]

Sez. G: O 114.3x5.9 L=273.9 cm Crit.: Acciaio_Flessione $\gamma_M=1.05$ $f_{yk}/\gamma_M=2619$ kg/cmq $f_t=4300$ kg/cmq

:Verificato

X	cls	N	TY	TZ	MT	MY	MZ	My4	Mz4	Comb.
cm		kg	kg	kg	kg*m	kg*m	kg*m			
164	1	-8043	-2	1	5	-23	6	--	--	2

X	cls	Nr	Vyr	Vzr	Mry	Mrz	MTrd	SF_V.	SF_M	SF_Mt	SF
cm		kg	kg	kg	kg*m	kg*m	kg*m				
164	1	52623	19279	19279	1818	1818	1566	>100	5.92	>100	5.92

AUTOSTRADA VALDASTICO A31 NORD
1° LOTTO - PIOVENE ROCCHETTE – VALLE DELL'ASTICO

Asta : 93 [211 , 212]

Sez. G: O 114.3x5.9 L=314.0 cm Crit.: Acciaio_Flessione $\gamma_M=1.05$ $f_{yk}/\gamma_M=2619$ kg/cmq $f_t=4300$ kg/cmq

:Verificato

X	cls	N	TY	TZ	MT	MY	MZ	My4	Mz4	Comb.
cm		kg	kg	kg	kg*m	kg*m	kg*m			
314	1	-309	-12	60	-18	71	21	--	--	2

X	cls	Nr	Vyr	Vzr	Mry	Mrz	MTrd	SF_V.	SF_M	SF_Mt	SF
cm		kg	kg	kg	kg*m	kg*m	kg*m				
314	1	52623	19119	19119	1818	1818	1566	>100	17.7	86.9	17.7

Asta : 94 [212 , 229]

Sez. G: O 114.3x5.9 L=286.0 cm Crit.: Acciaio_Flessione $\gamma_M=1.05$ $f_{yk}/\gamma_M=2619$ kg/cmq $f_t=4300$ kg/cmq

:Verificato

X	cls	N	TY	TZ	MT	MY	MZ	My4	Mz4	Comb.
cm		kg	kg	kg	kg*m	kg*m	kg*m			
229	1	4796	4	5	4	-33	-5	--	--	2

X	cls	Nr	Vyr	Vzr	Mry	Mrz	MTrd	SF_V.	SF_M	SF_Mt	SF
cm		kg	kg	kg	kg*m	kg*m	kg*m				
229	1	52623	19298	19298	1818	1818	1566	>100	8.93	>100	8.93

Asta : 95 [228 , 214]

Sez. G: O 114.3x5.9 L=254.4 cm Crit.: Acciaio_Flessione $\gamma_M=1.05$ $f_{yk}/\gamma_M=2619$ kg/cmq $f_t=4300$ kg/cmq

:Verificato

X	cls	N	TY	TZ	MT	MY	MZ	My4	Mz4	Comb.
cm		kg	kg	kg	kg*m	kg*m	kg*m			
153	1	4438	1	-1	-3	-19	2	--	--	2

X	cls	Nr	Vyr	Vzr	Mry	Mrz	MTrd	SF_V.	SF_M	SF_Mt	SF
cm		kg	kg	kg	kg*m	kg*m	kg*m				
153	1	4438	1	-1	-3	-19	2	--	--	2	

AUTOSTRADA VALDASTICO A31 NORD
1° LOTTO - PIOVENE ROCCHETTE – VALLE DELL'ASTICO

X	cls	Nr	Vyr	Vzr	Mry	Mrz	MTrd	SF_V.	SF_M	SF_Mt	SF
cm		kg	kg	kg	kg*m	kg*m	kg*m				
153	1	52623	19303	19303	1818	1818	1566	>100	10.4	>100	10.4

Asta : 96 [214 , 229]

Sez. G: O 114.3x5.9 L=254.4 cm Crit.: Acciaio_Flessione $\gamma M=1.05$ $f_{yk}/\gamma M=2619$ kg/cm² $f_t=4300$ kg/cm²

:Verificato

X	cls	N	TY	TZ	MT	MY	MZ	My4	Mz4	Comb.
cm		kg	kg	kg	kg*m	kg*m	kg*m			
0	1	958	9	-17	7	5	18	--	--	2

X	cls	Nr	Vyr	Vzr	Mry	Mrz	MTrd	SF_V.	SF_M	SF_Mt	SF
cm		kg	kg	kg	kg*m	kg*m	kg*m				
0	1	52623	19258	19258	1818	1818	1566	>100	32.6	>100	32.6

Asta : 97 [211 , 214]

Sez. G: O 114.3x5.9 L=254.4 cm Crit.: Acciaio_Flessione $\gamma M=1.05$ $f_{yk}/\gamma M=2619$ kg/cm² $f_t=4300$ kg/cm²

:Verificato

X	cls	N	TY	TZ	MT	MY	MZ	My4	Mz4	Comb.
cm		kg	kg	kg	kg*m	kg*m	kg*m			
0	1	-939	-16	-30	-1	32	-19	--	--	2

X	cls	Nr	Vyr	Vzr	Mry	Mrz	MTrd	SF_V.	SF_M	SF_Mt	SF
cm		kg	kg	kg	kg*m	kg*m	kg*m				
0	1	52623	19331	19331	1818	1818	1566	>100	21.6	>100	21.6

Asta : 98 [214 , 212]

Sez. G: O 114.3x5.9 L=254.4 cm Crit.: Acciaio_Flessione $\gamma M=1.05$ $f_{yk}/\gamma M=2619$ kg/cm² $f_t=4300$ kg/cm²

:Verificato

X	cls	N	TY	TZ	MT	MY	MZ	My4	Mz4	Comb.
cm		kg	kg	kg	kg*m	kg*m	kg*m			

AUTOSTRADA VALDASTICO A31 NORD
1° LOTTO - PIOVENE ROCCHETTE – VALLE DELL'ASTICO

X	cls	N	TY	TZ	MT	MY	MZ	My4	Mz4	Comb.
254	1	-11607	20	37	-11	18	-33	--	--	2

X	cls	Nr	Vyr	Vzr	Mry	Mrz	MTrd	SF_V.	SF_M	SF_Mt	SF
cm		kg	kg	kg	kg*m	kg*m	kg*m				
254	1	52623	19203	19203	1818	1818	1566	>100	4.02	>100	4.02

Asta : 99 [230 , 213]

Sez. G: O 114.3x5.9 L=286.0 cm Crit.: Acciaio_Flessione $\gamma_M=1.05$ $f_{yk}/\gamma_M=2619$ kg/cm² $f_t=4300$ kg/cm²

:Verificato

X	cls	N	TY	TZ	MT	MY	MZ	My4	Mz4	Comb.
cm		kg	kg	kg	kg*m	kg*m	kg*m			
286	1	-680	-3	53	-7	47	4	--	--	2

X	cls	Nr	Vyr	Vzr	Mry	Mrz	MTrd	SF_V.	SF_M	SF_Mt	SF
cm		kg	kg	kg	kg*m	kg*m	kg*m				
286	1	52623	19258	19258	1818	1818	1566	>100	24.4	>100	24.4

Asta : 100 [213 , 212]

Sez. G: O 114.3x5.9 L=314.0 cm Crit.: Acciaio_Flessione $\gamma_M=1.05$ $f_{yk}/\gamma_M=2619$ kg/cm² $f_t=4300$ kg/cm²

:Verificato

X	cls	N	TY	TZ	MT	MY	MZ	My4	Mz4	Comb.
cm		kg	kg	kg	kg*m	kg*m	kg*m			
314	1	-4382	7	39	13	47	-10	--	--	2

X	cls	Nr	Vyr	Vzr	Mry	Mrz	MTrd	SF_V.	SF_M	SF_Mt	SF
cm		kg	kg	kg	kg*m	kg*m	kg*m				
314	1	52623	19182	19182	1818	1818	1566	>100	8.73	>100	8.73

Asta : 101 [229 , 221]

AUTOSTRADA VALDASTICO A31 NORD
1° LOTTO - PIOVENE ROCCHETTE – VALLE DELL'ASTICO

Sez. G: O 114.3x5.9 L=229.9 cm Crit.: Acciaio_Flessione $\gamma_M=1.05$ $f_{yk}/\gamma_M=2619$ kg/cmq $f_t=4300$ kg/cmq

:Verificato

X	cls	N	TY	TZ	MT	MY	MZ	My4	Mz4	Comb.
cm		kg	kg	kg	kg*m	kg*m	kg*m			
230	1	2203	-3	-1	-5	-36	9	--	--	2

X	cls	Nr	Vyr	Vzr	Mry	Mrz	MTrd	SF_V.	SF_M	SF_Mt	SF
cm		kg	kg	kg	kg*m	kg*m	kg*m				
230	1	52623	19275	19275	1818	1818	1566	>100	15.1	>100	15.1

Asta : 102 [221 , 213]

Sez. G: O 114.3x5.9 L=229.9 cm Crit.: Acciaio_Flessione $\gamma_M=1.05$ $f_{yk}/\gamma_M=2619$ kg/cmq $f_t=4300$ kg/cmq

:Verificato

X	cls	N	TY	TZ	MT	MY	MZ	My4	Mz4	Comb.
cm		kg	kg	kg	kg*m	kg*m	kg*m			
230	1	-4275	6	25	-6	41	-12	--	--	2

X	cls	Nr	Vyr	Vzr	Mry	Mrz	MTrd	SF_V.	SF_M	SF_Mt	SF
cm		kg	kg	kg	kg*m	kg*m	kg*m				
230	1	52623	19272	19272	1818	1818	1566	>100	9.07	>100	9.07

Asta : 103 [221 , 230]

Sez. G: O 114.3x5.9 L=229.9 cm Crit.: Acciaio_Flessione $\gamma_M=1.05$ $f_{yk}/\gamma_M=2619$ kg/cmq $f_t=4300$ kg/cmq

:Verificato

X	cls	N	TY	TZ	MT	MY	MZ	My4	Mz4	Comb.
cm		kg	kg	kg	kg*m	kg*m	kg*m			
0	1	2226	9	-33	15	25	17	--	--	2

X	cls	Nr	Vyr	Vzr	Mry	Mrz	MTrd	SF_V.	SF_M	SF_Mt	SF
cm		kg	kg	kg	kg*m	kg*m	kg*m				

AUTOSTRADA VALDASTICO A31 NORD
1° LOTTO - PIOVENE ROCCHETTE – VALLE DELL'ASTICO

X	cls	Nr	Vyr	Vzr	Mry	Mrz	MTrd	SF_V.	SF_M	SF_Mt	SF
0	1	52623	19154	19154	1818	1818	1566	>100	15.4	>100	15.4

Asta : 104 [220 , 219]

Sez. G: O 114.3x5.9 L=318.3 cm Crit.: Acciaio_Flessione $\gamma_M=1.05$ $f_{yk}/\gamma_M=2619$ kg/cm² $f_t=4300$ kg/cm²

:Verificato

X	cls	N	TY	TZ	MT	MY	MZ	My4	Mz4	Comb.
cm		kg	kg	kg	kg*m	kg*m	kg*m			
318	1	3117	-7	1348	6	730	12	--	--	2

X	cls	Nr	Vyr	Vzr	Mry	Mrz	MTrd	SF_V.	SF_M	SF_Mt	SF
cm		kg	kg	kg	kg*m	kg*m	kg*m				
318	1	52623	19265	19265	1818	1818	1566	14.3	2.14	>100	2.14

Asta : 105 [219 , 218]

Sez. G: O 114.3x5.9 L=315.7 cm Crit.: Acciaio_Flessione $\gamma_M=1.05$ $f_{yk}/\gamma_M=2619$ kg/cm² $f_t=4300$ kg/cm²

:Verificato

X	cls	N	TY	TZ	MT	MY	MZ	My4	Mz4	Comb.
cm		kg	kg	kg	kg*m	kg*m	kg*m			
0	1	-6136	-13	-1351	10	717	-22	--	--	2

X	cls	Nr	Vyr	Vzr	Mry	Mrz	MTrd	SF_V.	SF_M	SF_Mt	SF
cm		kg	kg	kg	kg*m	kg*m	kg*m				
0	1	52623	19219	19219	1818	1818	1566	14.2	1.91	>100	1.91

Asta : 106 [218 , 217]

Sez. G: O 114.3x5.9 L=314.2 cm Crit.: Acciaio_Flessione $\gamma_M=1.05$ $f_{yk}/\gamma_M=2619$ kg/cm² $f_t=4300$ kg/cm²

:Verificato

X	cls	N	TY	TZ	MT	MY	MZ	My4	Mz4	Comb.
cm		kg	kg	kg	kg*m	kg*m	kg*m			
0	1	-14628	-4	-1346	4	692	-6	--	--	2

AUTOSTRADA VALDASTICO A31 NORD
1° LOTTO - PIOVENE ROCCHETTE – VALLE DELL'ASTICO

X	cls	Nr	Vyr	Vzr	Mry	Mrz	MTrd	SF_V.	SF_M	SF_Mt	SF
cm		kg	kg	kg	kg*m	kg*m	kg*m				
0	1	52623	19295	19295	1818	1818	1566	14.3	1.51	>100	1.51

Asta : 107 [217 , 216]

Sez. G: O 114.3x5.9 L=314.0 cm Crit.: Acciaio_Flessione $\gamma_M=1.05$ $f_{yk}/\gamma_M=2619$ kg/cm² $f_t=4300$ kg/cm²

:Verificato

X	cls	N	TY	TZ	MT	MY	MZ	My4	Mz4	Comb.
cm		kg	kg	kg	kg*m	kg*m	kg*m			
314	1	-17741	0	1339	-0	675	-0	--	--	2

X	cls	Nr	Vyr	Vzr	Mry	Mrz	MTrd	SF_V.	SF_M	SF_Mt	SF
cm		kg	kg	kg	kg*m	kg*m	kg*m				
314	1	52623	19341	19341	1818	1818	1566	14.4	1.41	>100	1.41

Asta : 108 [216 , 215]

Sez. G: O 114.3x5.9 L=314.2 cm Crit.: Acciaio_Flessione $\gamma_M=1.05$ $f_{yk}/\gamma_M=2619$ kg/cm² $f_t=4300$ kg/cm²

:Verificato

X	cls	N	TY	TZ	MT	MY	MZ	My4	Mz4	Comb.
cm		kg	kg	kg	kg*m	kg*m	kg*m			
314	1	-14579	4	1346	-4	692	-7	--	--	2

X	cls	Nr	Vyr	Vzr	Mry	Mrz	MTrd	SF_V.	SF_M	SF_Mt	SF
cm		kg	kg	kg	kg*m	kg*m	kg*m				
314	1	52623	19294	19294	1818	1818	1566	14.3	1.51	>100	1.51

Asta : 109 [215 , 214]

Sez. G: O 114.3x5.9 L=315.7 cm Crit.: Acciaio_Flessione $\gamma_M=1.05$ $f_{yk}/\gamma_M=2619$ kg/cm² $f_t=4300$ kg/cm²

:Verificato

X	cls	N	TY	TZ	MT	MY	MZ	My4	Mz4	Comb.
cm		kg	kg	kg	kg*m	kg*m	kg*m			
314	1	-14579	4	1346	-4	692	-7	--	--	2

AUTOSTRADA VALDASTICO A31 NORD
1° LOTTO - PIOVENE ROCCHETTE – VALLE DELL'ASTICO

X	cls	N	TY	TZ	MT	MY	MZ	My4	Mz4	Comb.
cm		kg	kg	kg	kg*m	kg*m	kg*m			
316	1	-6090	13	1351	-10	717	-22	--	--	2

X	cls	Nr	Vyr	Vzr	Mry	Mrz	MTrd	SF_V.	SF_M	SF_Mt	SF
cm		kg	kg	kg	kg*m	kg*m	kg*m				
316	1	52623	19218	19218	1818	1818	1566	14.2	1.91	>100	1.91

Asta : 110 [214 , 221]

Sez. G: O 114.3x5.9 L=318.3 cm Crit.: Acciaio_Flessione $\gamma_M=1.05$ $f_{yk}/\gamma_M=2619$ kg/cm² $f_t=4300$ kg/cm²

:Verificato

X	cls	N	TY	TZ	MT	MY	MZ	My4	Mz4	Comb.
cm		kg	kg	kg	kg*m	kg*m	kg*m			
0	1	3116	7	-1349	-6	731	12	--	--	2

X	cls	Nr	Vyr	Vzr	Mry	Mrz	MTrd	SF_V.	SF_M	SF_Mt	SF
cm		kg	kg	kg	kg*m	kg*m	kg*m				
0	1	52623	19266	19266	1818	1818	1566	14.3	2.14	>100	2.14

Asta : 111 [222 , 237]

Sez. G: O 114.3x5.9 L=229.9 cm Crit.: Acciaio_Flessione $\gamma_M=1.05$ $f_{yk}/\gamma_M=2619$ kg/cm² $f_t=4300$ kg/cm²

:Verificato

X	cls	N	TY	TZ	MT	MY	MZ	My4	Mz4	Comb.
cm		kg	kg	kg	kg*m	kg*m	kg*m			
230	1	-954	3	35	18	18	-11	--	--	2

X	cls	Nr	Vyr	Vzr	Mry	Mrz	MTrd	SF_V.	SF_M	SF_Mt	SF
cm		kg	kg	kg	kg*m	kg*m	kg*m				
230	1	52623	19121	19121	1818	1818	1566	>100	29.2	87.6	29.2

Asta : 112 [240 , 223]

AUTOSTRADA VALDASTICO A31 NORD
1° LOTTO - PIOVENE ROCCHETTE – VALLE DELL'ASTICO

Sez. G: O 114.3x5.9 L=286.0 cm Crit.: Acciaio_Flessione $\gamma_M=1.05$ $f_{yk}/\gamma_M=2619$ kg/cmq $f_t=4300$ kg/cmq

:Verificato

X	cls	N	TY	TZ	MT	MY	MZ	My4	Mz4	Comb.
cm		kg	kg	kg	kg*m	kg*m	kg*m			
143	1	7704	0	1	-1	-39	-1	--	--	2

X	cls	Nr	Vyr	Vzr	Mry	Mrz	MTrd	SF_V.	SF_M	SF_Mt	SF
cm		kg	kg	kg	kg*m	kg*m	kg*m				
143	1	52623	19329	19329	1818	1818	1566	>100	5.93	>100	5.93

Asta : 113 [223 , 222]

Sez. G: O 114.3x5.9 L=314.0 cm Crit.: Acciaio_Flessione $\gamma_M=1.05$ $f_{yk}/\gamma_M=2619$ kg/cmq $f_t=4300$ kg/cmq

:Verificato

X	cls	N	TY	TZ	MT	MY	MZ	My4	Mz4	Comb.
cm		kg	kg	kg	kg*m	kg*m	kg*m			
314	1	-1101	1	33	3	24	-2	--	--	2

X	cls	Nr	Vyr	Vzr	Mry	Mrz	MTrd	SF_V.	SF_M	SF_Mt	SF
cm		kg	kg	kg	kg*m	kg*m	kg*m				
314	1	52623	19310	19310	1818	1818	1566	>100	28.4	>100	28.4

Asta : 114 [239 , 237]

Sez. G: O 114.3x5.9 L=229.9 cm Crit.: Acciaio_Flessione $\gamma_M=1.05$ $f_{yk}/\gamma_M=2619$ kg/cmq $f_t=4300$ kg/cmq

:Verificato

X	cls	N	TY	TZ	MT	MY	MZ	My4	Mz4	Comb.
cm		kg	kg	kg	kg*m	kg*m	kg*m			
230	1	-1652	4	26	-13	33	4	--	--	2

X	cls	Nr	Vyr	Vzr	Mry	Mrz	MTrd	SF_V.	SF_M	SF_Mt	SF
cm		kg	kg	kg	kg*m	kg*m	kg*m				

AUTOSTRADA VALDASTICO A31 NORD
1° LOTTO - PIOVENE ROCCHETTE – VALLE DELL'ASTICO

X	cls	Nr	Vyr	Vzr	Mry	Mrz	MTrd	SF_V.	SF_M	SF_Mt	SF
230	1	52623	19184	19184	1818	1818	1566	>100	19.2	>100	19.2

Asta : 115 [237 , 223]

Sez. G: O 114.3x5.9 L=229.9 cm Crit.: Acciaio_Flessione $\gamma M=1.05$ $f_{yk}/\gamma M=2619$ kg/cm² $f_t=4300$ kg/cm²

:Verificato

X	cls	N	TY	TZ	MT	MY	MZ	My4	Mz4	Comb.
cm		kg	kg	kg	kg*m	kg*m	kg*m			
0	1	382	3	6	-6	-37	-1	--	--	2

X	cls	Nr	Vyr	Vzr	Mry	Mrz	MTrd	SF_V.	SF_M	SF_Mt	SF
cm		kg	kg	kg	kg*m	kg*m	kg*m				
0	1	52623	19262	19262	1818	1818	1566	>100	35.1	>100	35.1

Asta : 116 [237 , 240]

Sez. G: O 114.3x5.9 L=229.9 cm Crit.: Acciaio_Flessione $\gamma M=1.05$ $f_{yk}/\gamma M=2619$ kg/cm² $f_t=4300$ kg/cm²

:Verificato

X	cls	N	TY	TZ	MT	MY	MZ	My4	Mz4	Comb.
cm		kg	kg	kg	kg*m	kg*m	kg*m			
0	1	-4391	-19	5	9	-42	-16	--	--	2

X	cls	Nr	Vyr	Vzr	Mry	Mrz	MTrd	SF_V.	SF_M	SF_Mt	SF
cm		kg	kg	kg	kg*m	kg*m	kg*m				
0	1	52623	19226	19226	1818	1818	1566	>100	8.64	>100	8.64

Asta : 117 [239 , 222]

Sez. G: O 114.3x5.9 L=286.0 cm Crit.: Acciaio_Flessione $\gamma M=1.05$ $f_{yk}/\gamma M=2619$ kg/cm² $f_t=4300$ kg/cm²

:Verificato

X	cls	N	TY	TZ	MT	MY	MZ	My4	Mz4	Comb.
cm		kg	kg	kg	kg*m	kg*m	kg*m			
200	1	2156	-2	3	-9	-26	1	--	--	2

AUTOSTRADA VALDASTICO A31 NORD
1° LOTTO - PIOVENE ROCCHETTE – VALLE DELL'ASTICO

X	cls	Nr	Vyr	Vzr	Mry	Mrz	MTrd	SF_V.	SF_M	SF_Mt	SF
cm		kg	kg	kg	kg*m	kg*m	kg*m				
200	1	52623	19228	19228	1818	1818	1566	>100	18.1	>100	18.1

Asta : 118 [241 , 224]

Sez. G: O 114.3x5.9 L=286.0 cm Crit.: Acciaio_Flessione $\gamma_M=1.05$ $f_{yk}/\gamma_M=2619$ kg/cm² $f_t=4300$ kg/cm²

:Verificato

X	cls	N	TY	TZ	MT	MY	MZ	My4	Mz4	Comb.
cm		kg	kg	kg	kg*m	kg*m	kg*m			
0	1	2325	4	-33	4	13	6	--	--	2

X	cls	Nr	Vyr	Vzr	Mry	Mrz	MTrd	SF_V.	SF_M	SF_Mt	SF
cm		kg	kg	kg	kg*m	kg*m	kg*m				
0	1	52623	19295	19295	1818	1818	1566	>100	18.3	>100	18.3

Asta : 119 [224 , 223]

Sez. G: O 114.3x5.9 L=314.0 cm Crit.: Acciaio_Flessione $\gamma_M=1.05$ $f_{yk}/\gamma_M=2619$ kg/cm² $f_t=4300$ kg/cm²

:Verificato

X	cls	N	TY	TZ	MT	MY	MZ	My4	Mz4	Comb.
cm		kg	kg	kg	kg*m	kg*m	kg*m			
314	1	1453	3	43	4	35	-6	--	--	2

X	cls	Nr	Vyr	Vzr	Mry	Mrz	MTrd	SF_V.	SF_M	SF_Mt	SF
cm		kg	kg	kg	kg*m	kg*m	kg*m				
314	1	52623	19296	19296	1818	1818	1566	>100	20.0	>100	20.0

Asta : 120 [223 , 236]

Sez. G: O 114.3x5.9 L=254.4 cm Crit.: Acciaio_Flessione $\gamma_M=1.05$ $f_{yk}/\gamma_M=2619$ kg/cm² $f_t=4300$ kg/cm²

:Verificato

X	cls	N	TY	TZ	MT	MY	MZ	My4	Mz4	Comb.

AUTOSTRADA VALDASTICO A31 NORD
1° LOTTO - PIOVENE ROCCHETTE – VALLE DELL'ASTICO

X	cls	N	TY	TZ	MT	MY	MZ	My4	Mz4	Comb.
cm		kg	kg	kg	kg*m	kg*m	kg*m			
153	1	-2251	1	1	8	-12	-7	--	--	2

X	cls	Nr	Vyr	Vzr	Mry	Mrz	MTrd	SF_V.	SF_M	SF_Mt	SF
cm		kg	kg	kg	kg*m	kg*m	kg*m				
153	1	52623	19238	19238	1818	1818	1566	>100	18.7	>100	18.7

Asta : 121 [236 , 241]

Sez. G: O 114.3x5.9 L=254.4 cm Crit.: Acciaio_Flessione $\gamma_M=1.05$ $f_{yk}/\gamma_M=2619$ kg/cm² $f_t=4300$ kg/cm²

:Verificato

X	cls	N	TY	TZ	MT	MY	MZ	My4	Mz4	Comb.
cm		kg	kg	kg	kg*m	kg*m	kg*m			
254	1	769	-10	28	2	21	14	--	--	2

X	cls	Nr	Vyr	Vzr	Mry	Mrz	MTrd	SF_V.	SF_M	SF_Mt	SF
cm		kg	kg	kg	kg*m	kg*m	kg*m				
254	1	52623	19322	19322	1818	1818	1566	>100	29.7	>100	29.7

Asta : 122 [240 , 236]

Sez. G: O 114.3x5.9 L=254.4 cm Crit.: Acciaio_Flessione $\gamma_M=1.05$ $f_{yk}/\gamma_M=2619$ kg/cm² $f_t=4300$ kg/cm²

:Verificato

X	cls	N	TY	TZ	MT	MY	MZ	My4	Mz4	Comb.
cm		kg	kg	kg	kg*m	kg*m	kg*m			
0	1	-7518	15	-29	-13	7	28	--	--	2

X	cls	Nr	Vyr	Vzr	Mry	Mrz	MTrd	SF_V.	SF_M	SF_Mt	SF
cm		kg	kg	kg	kg*m	kg*m	kg*m				
0	1	52623	19182	19182	1818	1818	1566	>100	6.15	>100	6.15

Asta : 123 [236 , 224]

AUTOSTRADA VALDASTICO A31 NORD
1° LOTTO - PIOVENE ROCCHETTE – VALLE DELL'ASTICO

Sez. G: O 114.3x5.9 L=254.4 cm Crit.: Acciaio_Flessione $\gamma_M=1.05$ $f_{yk}/\gamma_M=2619$ kg/cmq $f_t=4300$ kg/cmq

:Verificato

X	cls	N	TY	TZ	MT	MY	MZ	My4	Mz4	Comb.
cm		kg	kg	kg	kg*m	kg*m	kg*m			
254	1	2055	6	27	-3	10	-11	--	--	2

X	cls	Nr	Vyr	Vzr	Mry	Mrz	MTrd	SF_V.	SF_M	SF_Mt	SF
cm		kg	kg	kg	kg*m	kg*m	kg*m				
254	1	52623	19301	19301	1818	1818	1566	>100	19.9	>100	19.9

Asta : 124 [242 , 225]

Sez. G: O 114.3x5.9 L=286.0 cm Crit.: Acciaio_Flessione $\gamma_M=1.05$ $f_{yk}/\gamma_M=2619$ kg/cmq $f_t=4300$ kg/cmq

:Verificato

X	cls	N	TY	TZ	MT	MY	MZ	My4	Mz4	Comb.
cm		kg	kg	kg	kg*m	kg*m	kg*m			
286	1	-1687	1	31	0	20	-1	--	--	2

X	cls	Nr	Vyr	Vzr	Mry	Mrz	MTrd	SF_V.	SF_M	SF_Mt	SF
cm		kg	kg	kg	kg*m	kg*m	kg*m				
286	1	52623	19337	19337	1818	1818	1566	>100	22.9	>100	22.9

Asta : 125 [225 , 224]

Sez. G: O 114.3x5.9 L=314.0 cm Crit.: Acciaio_Flessione $\gamma_M=1.05$ $f_{yk}/\gamma_M=2619$ kg/cmq $f_t=4300$ kg/cmq

:Verificato

X	cls	N	TY	TZ	MT	MY	MZ	My4	Mz4	Comb.
cm		kg	kg	kg	kg*m	kg*m	kg*m			
94	1	8599	4	-4	3	-26	2	--	--	2

X	cls	Nr	Vyr	Vzr	Mry	Mrz	MTrd	SF_V.	SF_M	SF_Mt	SF
cm		kg	kg	kg	kg*m	kg*m	kg*m				

AUTOSTRADA VALDASTICO A31 NORD
1° LOTTO - PIOVENE ROCCHETTE – VALLE DELL'ASTICO

X	cls	Nr	Vyr	Vzr	Mry	Mrz	MTrd	SF_V.	SF_M	SF_Mt	SF
94	1	52623	19306	19306	1818	1818	1566	>100	5.59	>100	5.59

Asta : 126 [241 , 235]

Sez. G: O 114.3x5.9 L=273.9 cm Crit.: Acciaio_Flessione $\gamma M=1.05$ $f_y k/\gamma M=2619$ kg/cm² $f_t=4300$ kg/cm²

:Verificato

X	cls	N	TY	TZ	MT	MY	MZ	My4	Mz4	Comb.
cm		kg	kg	kg	kg*m	kg*m	kg*m			
82	1	-5168	-5	-5	4	-18	-6	--	--	2

X	cls	Nr	Vyr	Vzr	Mry	Mrz	MTrd	SF_V.	SF_M	SF_Mt	SF
cm		kg	kg	kg	kg*m	kg*m	kg*m				
82	1	52623	19298	19298	1818	1818	1566	>100	8.96	>100	8.96

Asta : 127 [235 , 225]

Sez. G: O 114.3x5.9 L=273.9 cm Crit.: Acciaio_Flessione $\gamma M=1.05$ $f_y k/\gamma M=2619$ kg/cm² $f_t=4300$ kg/cm²

:Verificato

X	cls	N	TY	TZ	MT	MY	MZ	My4	Mz4	Comb.
cm		kg	kg	kg	kg*m	kg*m	kg*m			
82	1	1882	4	-6	5	-11	8	--	--	2

X	cls	Nr	Vyr	Vzr	Mry	Mrz	MTrd	SF_V.	SF_M	SF_Mt	SF
cm		kg	kg	kg	kg*m	kg*m	kg*m				
82	1	52623	19283	19283	1818	1818	1566	>100	21.8	>100	21.8

Asta : 128 [224 , 235]

Sez. G: O 114.3x5.9 L=273.9 cm Crit.: Acciaio_Flessione $\gamma M=1.05$ $f_y k/\gamma M=2619$ kg/cm² $f_t=4300$ kg/cm²

:Verificato

X	cls	N	TY	TZ	MT	MY	MZ	My4	Mz4	Comb.
cm		kg	kg	kg	kg*m	kg*m	kg*m			

AUTOSTRADA VALDASTICO A31 NORD
1° LOTTO - PIOVENE ROCCHETTE – VALLE DELL'ASTICO

X	cls	N	TY	TZ	MT	MY	MZ	My4	Mz4	Comb.
82	1	-3760	6	-7	-2	-11	6	--	--	2

X	cls	Nr	Vyr	Vzr	Mry	Mrz	MTrd	SF_V.	SF_M	SF_Mt	SF
cm		kg	kg	kg	kg*m	kg*m	kg*m				
82	1	52623	19316	19316	1818	1818	1566	>100	12.3	>100	12.3

Asta : 129 [235 , 242]

Sez. G: O 114.3x5.9 L=273.9 cm Crit.: Acciaio_Flessione $\gamma_M=1.05$ $f_{yk}/\gamma_M=2619$ kg/cmq $f_t=4300$ kg/cmq

:Verificato

X	cls	N	TY	TZ	MT	MY	MZ	My4	Mz4	Comb.
cm		kg	kg	kg	kg*m	kg*m	kg*m			
110	1	2662	-3	-3	-5	-10	-6	--	--	2

X	cls	Nr	Vyr	Vzr	Mry	Mrz	MTrd	SF_V.	SF_M	SF_Mt	SF
cm		kg	kg	kg	kg*m	kg*m	kg*m				
110	1	52623	19281	19281	1818	1818	1566	>100	16.7	>100	16.7

Asta : 130 [243 , 226]

Sez. G: O 114.3x5.9 L=286.0 cm Crit.: Acciaio_Flessione $\gamma_M=1.05$ $f_{yk}/\gamma_M=2619$ kg/cmq $f_t=4300$ kg/cmq

:Verificato

X	cls	N	TY	TZ	MT	MY	MZ	My4	Mz4	Comb.
cm		kg	kg	kg	kg*m	kg*m	kg*m			
286	1	-2586	0	32	-0	24	-0	--	--	2

X	cls	Nr	Vyr	Vzr	Mry	Mrz	MTrd	SF_V.	SF_M	SF_Mt	SF
cm		kg	kg	kg	kg*m	kg*m	kg*m				
286	1	52623	19342	19342	1818	1818	1566	>100	16.1	>100	16.1

Asta : 131 [226 , 225]

AUTOSTRADA VALDASTICO A31 NORD
1° LOTTO - PIOVENE ROCCHETTE – VALLE DELL'ASTICO

Sez. G: O 114.3x5.9 L=314.0 cm Crit.: Acciaio_Flessione $\gamma_M=1.05$ $f_{yk}/\gamma_M=2619$ kg/cmq $f_t=4300$ kg/cmq

:Verificato

X	cls	N	TY	TZ	MT	MY	MZ	My4	Mz4	Comb.
cm		kg	kg	kg	kg*m	kg*m	kg*m			
126	1	14403	1	-3	1	-35	0	--	--	2

X	cls	Nr	Vyr	Vzr	Mry	Mrz	MTrd	SF_V.	SF_M	SF_Mt	SF
cm		kg	kg	kg	kg*m	kg*m	kg*m				
126	1	52623	19330	19330	1818	1818	1566	>100	3.41	>100	3.41

Asta : 132 [242 , 234]

Sez. G: O 114.3x5.9 L=281.6 cm Crit.: Acciaio_Flessione $\gamma_M=1.05$ $f_{yk}/\gamma_M=2619$ kg/cmq $f_t=4300$ kg/cmq

:Verificato

X	cls	N	TY	TZ	MT	MY	MZ	My4	Mz4	Comb.
cm		kg	kg	kg	kg*m	kg*m	kg*m			
113	1	-1640	-5	-4	7	-15	-9	--	--	2

X	cls	Nr	Vyr	Vzr	Mry	Mrz	MTrd	SF_V.	SF_M	SF_Mt	SF
cm		kg	kg	kg	kg*m	kg*m	kg*m				
113	1	52623	19259	19259	1818	1818	1566	>100	22.8	>100	22.8

Asta : 133 [234 , 243]

Sez. G: O 114.3x5.9 L=281.6 cm Crit.: Acciaio_Flessione $\gamma_M=1.05$ $f_{yk}/\gamma_M=2619$ kg/cmq $f_t=4300$ kg/cmq

:Verificato

X	cls	N	TY	TZ	MT	MY	MZ	My4	Mz4	Comb.
cm		kg	kg	kg	kg*m	kg*m	kg*m			
141	1	1059	2	0	-7	-14	-8	--	--	2

X	cls	Nr	Vyr	Vzr	Mry	Mrz	MTrd	SF_V.	SF_M	SF_Mt	SF
cm		kg	kg	kg	kg*m	kg*m	kg*m				
141	1	52623	19256	19256	1818	1818	1566	>100	31.0	>100	31.0

AUTOSTRADA VALDASTICO A31 NORD
1° LOTTO - PIOVENE ROCCHETTE – VALLE DELL'ASTICO

Asta : 134 [225 , 234]

Sez. G: O 114.3x5.9 L=281.6 cm Crit.: Acciaio_Flessione $\gamma_M=1.05$ $f_{yk}/\gamma_M=2619$ kg/cmq $f_t=4300$ kg/cmq

:Verificato

X	cls	N	TY	TZ	MT	MY	MZ	My4	Mz4	Comb.
cm		kg	kg	kg	kg*m	kg*m	kg*m			
113	1	-2784	3	-4	-6	-14	8	--	--	2

X	cls	Nr	Vyr	Vzr	Mry	Mrz	MTrd	SF_V.	SF_M	SF_Mt	SF
cm		kg	kg	kg	kg*m	kg*m	kg*m				
113	1	52623	19262	19262	1818	1818	1566	>100	15.4	>100	15.4

Asta : 135 [234 , 226]

Sez. G: O 114.3x5.9 L=281.6 cm Crit.: Acciaio_Flessione $\gamma_M=1.05$ $f_{yk}/\gamma_M=2619$ kg/cmq $f_t=4300$ kg/cmq

:Verificato

X	cls	N	TY	TZ	MT	MY	MZ	My4	Mz4	Comb.
cm		kg	kg	kg	kg*m	kg*m	kg*m			
141	1	-201	1	1	7	-14	8	--	--	2

X	cls	Nr	Vyr	Vzr	Mry	Mrz	MTrd	SF_V.	SF_M	SF_Mt	SF
cm		kg	kg	kg	kg*m	kg*m	kg*m				
141	1	52623	19253	19253	1818	1818	1566	>100	62.6	>100	62.6

Asta : 136 [226 , 233]

Sez. G: O 114.3x5.9 L=281.6 cm Crit.: Acciaio_Flessione $\gamma_M=1.05$ $f_{yk}/\gamma_M=2619$ kg/cmq $f_t=4300$ kg/cmq

:Verificato

X	cls	N	TY	TZ	MT	MY	MZ	My4	Mz4	Comb.
cm		kg	kg	kg	kg*m	kg*m	kg*m			
141	1	-193	-1	-1	-7	-14	8	--	--	2

X	cls	Nr	Vyr	Vzr	Mry	Mrz	MTrd	SF_V.	SF_M	SF_Mt	SF
cm		kg	kg	kg	kg*m	kg*m	kg*m				

AUTOSTRADA VALDASTICO A31 NORD
1° LOTTO - PIOVENE ROCCHETTE – VALLE DELL'ASTICO

X	cls	Nr	Vyr	Vzr	Mry	Mrz	MTrd	SF_V.	SF_M	SF_Mt	SF
cm		kg	kg	kg	kg*m	kg*m	kg*m				
141	1	52623	19253	19253	1818	1818	1566	>100	63.3	>100	63.3

Asta : 137 [233 , 244]

Sez. G: O 114.3x5.9 L=281.6 cm Crit.: Acciaio_Flessione $\gamma_M=1.05$ $f_{yk}/\gamma_M=2619$ kg/cm² $f_t=4300$ kg/cm²

:Verificato

X	cls	N	TY	TZ	MT	MY	MZ	My4	Mz4	Comb.
cm		kg	kg	kg	kg*m	kg*m	kg*m			
169	1	-1700	5	3	-7	-15	-9	--	--	2

X	cls	Nr	Vyr	Vzr	Mry	Mrz	MTrd	SF_V.	SF_M	SF_Mt	SF
cm		kg	kg	kg	kg*m	kg*m	kg*m				
169	1	52623	19259	19259	1818	1818	1566	>100	22.2	>100	22.2

Asta : 138 [244 , 227]

Sez. G: O 114.3x5.9 L=286.0 cm Crit.: Acciaio_Flessione $\gamma_M=1.05$ $f_{yk}/\gamma_M=2619$ kg/cm² $f_t=4300$ kg/cm²

:Verificato

X	cls	N	TY	TZ	MT	MY	MZ	My4	Mz4	Comb.
cm		kg	kg	kg	kg*m	kg*m	kg*m			
286	1	-1641	-1	31	-0	20	1	--	--	2

X	cls	Nr	Vyr	Vzr	Mry	Mrz	MTrd	SF_V.	SF_M	SF_Mt	SF
cm		kg	kg	kg	kg*m	kg*m	kg*m				
286	1	52623	19336	19336	1818	1818	1566	>100	23.4	>100	23.4

Asta : 139 [227 , 226]

Sez. G: O 114.3x5.9 L=314.0 cm Crit.: Acciaio_Flessione $\gamma_M=1.05$ $f_{yk}/\gamma_M=2619$ kg/cm² $f_t=4300$ kg/cm²

:Verificato

X	cls	N	TY	TZ	MT	MY	MZ	My4	Mz4	Comb.
cm		kg	kg	kg	kg*m	kg*m	kg*m			

AUTOSTRADA VALDASTICO A31 NORD
1° LOTTO - PIOVENE ROCCHETTE – VALLE DELL'ASTICO

X	cls	N	TY	TZ	MT	MY	MZ	My4	Mz4	Comb.
188	1	14384	-1	2	-1	-35	0	--	--	2

X	cls	Nr	Vyr	Vzr	Mry	Mrz	MTrd	SF_V.	SF_M	SF_Mt	SF
cm		kg	kg	kg	kg*m	kg*m	kg*m				
188	1	52623	19329	19329	1818	1818	1566	>100	3.42	>100	3.42

Asta : 140 [243 , 233]

Sez. G: O 114.3x5.9 L=281.6 cm Crit.: Acciaio_Flessione $\gamma_M=1.05$ $f_{yk}/\gamma_M=2619$ kg/cm² $f_t=4300$ kg/cm²

:Verificato

X	cls	N	TY	TZ	MT	MY	MZ	My4	Mz4	Comb.
cm		kg	kg	kg	kg*m	kg*m	kg*m			
141	1	1086	-2	-1	7	-14	-8	--	--	2

X	cls	Nr	Vyr	Vzr	Mry	Mrz	MTrd	SF_V.	SF_M	SF_Mt	SF
cm		kg	kg	kg	kg*m	kg*m	kg*m				
141	1	52623	19257	19257	1818	1818	1566	>100	30.5	>100	30.5

Asta : 141 [233 , 227]

Sez. G: O 114.3x5.9 L=281.6 cm Crit.: Acciaio_Flessione $\gamma_M=1.05$ $f_{yk}/\gamma_M=2619$ kg/cm² $f_t=4300$ kg/cm²

:Verificato

X	cls	N	TY	TZ	MT	MY	MZ	My4	Mz4	Comb.
cm		kg	kg	kg	kg*m	kg*m	kg*m			
169	1	-2762	-3	4	6	-14	8	--	--	2

X	cls	Nr	Vyr	Vzr	Mry	Mrz	MTrd	SF_V.	SF_M	SF_Mt	SF
cm		kg	kg	kg	kg*m	kg*m	kg*m				
169	1	52623	19263	19263	1818	1818	1566	>100	15.5	>100	15.5

Asta : 142 [245 , 228]

AUTOSTRADA VALDASTICO A31 NORD
1° LOTTO - PIOVENE ROCCHETTE – VALLE DELL'ASTICO

Sez. G: O 114.3x5.9 L=286.0 cm Crit.: Acciaio_Flessione $\gamma_M=1.05$ $f_{yk}/\gamma_M=2619$ kg/cmq $f_t=4300$ kg/cmq

:Verificato

X	cls	N	TY	TZ	MT	MY	MZ	My4	Mz4	Comb.
cm		kg	kg	kg	kg*m	kg*m	kg*m			
0	1	2395	-4	-34	-4	13	-6	--	--	2

X	cls	Nr	Vyr	Vzr	Mry	Mrz	MTrd	SF_V.	SF_M	SF_Mt	SF
cm		kg	kg	kg	kg*m	kg*m	kg*m				
0	1	52623	19295	19295	1818	1818	1566	>100	17.8	>100	17.8

Asta : 143 [228 , 227]

Sez. G: O 114.3x5.9 L=314.0 cm Crit.: Acciaio_Flessione $\gamma_M=1.05$ $f_{yk}/\gamma_M=2619$ kg/cmq $f_t=4300$ kg/cmq

:Verificato

X	cls	N	TY	TZ	MT	MY	MZ	My4	Mz4	Comb.
cm		kg	kg	kg	kg*m	kg*m	kg*m			
220	1	8562	-4	4	-3	-26	2	--	--	2

X	cls	Nr	Vyr	Vzr	Mry	Mrz	MTrd	SF_V.	SF_M	SF_Mt	SF
cm		kg	kg	kg	kg*m	kg*m	kg*m				
220	1	52623	19306	19306	1818	1818	1566	>100	5.61	>100	5.61

Asta : 144 [227 , 232]

Sez. G: O 114.3x5.9 L=273.9 cm Crit.: Acciaio_Flessione $\gamma_M=1.05$ $f_{yk}/\gamma_M=2619$ kg/cmq $f_t=4300$ kg/cmq

:Verificato

X	cls	N	TY	TZ	MT	MY	MZ	My4	Mz4	Comb.
cm		kg	kg	kg	kg*m	kg*m	kg*m			
192	1	1906	-4	6	-5	-11	8	--	--	2

X	cls	Nr	Vyr	Vzr	Mry	Mrz	MTrd	SF_V.	SF_M	SF_Mt	SF
cm		kg	kg	kg	kg*m	kg*m	kg*m				

AUTOSTRADA VALDASTICO A31 NORD
1° LOTTO - PIOVENE ROCCHETTE – VALLE DELL'ASTICO

X	cls	Nr	Vyr	Vzr	Mry	Mrz	MTrd	SF_V.	SF_M	SF_Mt	SF
192	1	52623	19284	19284	1818	1818	1566	>100	21.6	>100	21.6

Asta : 145 [232 , 245]

Sez. G: O 114.3x5.9 L=273.9 cm Crit.: Acciaio_Flessione $\gamma_M=1.05$ $f_{yk}/\gamma_M=2619$ kg/cm² $f_t=4300$ kg/cm²

:Verificato

X	cls	N	TY	TZ	MT	MY	MZ	My4	Mz4	Comb.
cm		kg	kg	kg	kg*m	kg*m	kg*m			
192	1	-5273	5	5	-4	-18	-6	--	--	2

X	cls	Nr	Vyr	Vzr	Mry	Mrz	MTrd	SF_V.	SF_M	SF_Mt	SF
cm		kg	kg	kg	kg*m	kg*m	kg*m				
192	1	52623	19298	19298	1818	1818	1566	>100	8.81	>100	8.81

Asta : 146 [244 , 232]

Sez. G: O 114.3x5.9 L=273.9 cm Crit.: Acciaio_Flessione $\gamma_M=1.05$ $f_{yk}/\gamma_M=2619$ kg/cm² $f_t=4300$ kg/cm²

:Verificato

X	cls	N	TY	TZ	MT	MY	MZ	My4	Mz4	Comb.
cm		kg	kg	kg	kg*m	kg*m	kg*m			
164	1	2667	3	3	5	-10	-6	--	--	2

X	cls	Nr	Vyr	Vzr	Mry	Mrz	MTrd	SF_V.	SF_M	SF_Mt	SF
cm		kg	kg	kg	kg*m	kg*m	kg*m				
164	1	52623	19282	19282	1818	1818	1566	>100	16.7	>100	16.7

Asta : 147 [232 , 228]

Sez. G: O 114.3x5.9 L=273.9 cm Crit.: Acciaio_Flessione $\gamma_M=1.05$ $f_{yk}/\gamma_M=2619$ kg/cm² $f_t=4300$ kg/cm²

:Verificato

X	cls	N	TY	TZ	MT	MY	MZ	My4	Mz4	Comb.
cm		kg	kg	kg	kg*m	kg*m	kg*m			
192	1	-3696	-6	7	2	-12	6	--	--	2

AUTOSTRADA VALDASTICO A31 NORD
1° LOTTO - PIOVENE ROCCHETTE – VALLE DELL'ASTICO

X	cls	Nr	Vyr	Vzr	Mry	Mrz	MTrd	SF_V.	SF_M	SF_Mt	SF
cm		kg	kg	kg	kg*m	kg*m	kg*m				
192	1	52623	19317	19317	1818	1818	1566	>100	12.5	>100	12.5

Asta : 148 [228 , 229]

Sez. G: O 114.3x5.9 L=314.0 cm Crit.: Acciaio_Flessione $\gamma_M=1.05$ $f_{yk}/\gamma_M=2619$ kg/cm² $f_t=4300$ kg/cm²

:Verificato

X	cls	N	TY	TZ	MT	MY	MZ	My4	Mz4	Comb.
cm		kg	kg	kg	kg*m	kg*m	kg*m			
314	1	1449	-3	43	-4	35	6	--	--	2

X	cls	Nr	Vyr	Vzr	Mry	Mrz	MTrd	SF_V.	SF_M	SF_Mt	SF
cm		kg	kg	kg	kg*m	kg*m	kg*m				
314	1	52623	19295	19295	1818	1818	1566	>100	20.0	>100	20.0

Asta : 149 [229 , 246]

Sez. G: O 114.3x5.9 L=286.0 cm Crit.: Acciaio_Flessione $\gamma_M=1.05$ $f_{yk}/\gamma_M=2619$ kg/cm² $f_t=4300$ kg/cm²

:Verificato

X	cls	N	TY	TZ	MT	MY	MZ	My4	Mz4	Comb.
cm		kg	kg	kg	kg*m	kg*m	kg*m			
143	1	7733	0	-1	1	-39	-1	--	--	2

X	cls	Nr	Vyr	Vzr	Mry	Mrz	MTrd	SF_V.	SF_M	SF_Mt	SF
cm		kg	kg	kg	kg*m	kg*m	kg*m				
143	1	52623	19324	19324	1818	1818	1566	>100	5.91	>100	5.91

Asta : 150 [245 , 231]

Sez. G: O 114.3x5.9 L=254.4 cm Crit.: Acciaio_Flessione $\gamma_M=1.05$ $f_{yk}/\gamma_M=2619$ kg/cm² $f_t=4300$ kg/cm²

:Verificato

X	cls	N	TY	TZ	MT	MY	MZ	My4	Mz4	Comb.
cm		kg	kg	kg	kg*m	kg*m	kg*m			
143	1	7733	0	-1	1	-39	-1	--	--	2

AUTOSTRADA VALDASTICO A31 NORD
1° LOTTO - PIOVENE ROCCHETTE – VALLE DELL'ASTICO

X	cls	N	TY	TZ	MT	MY	MZ	My4	Mz4	Comb.
cm		kg	kg	kg	kg*m	kg*m	kg*m			
0	1	772	10	-28	-2	21	14	--	--	2

X	cls	Nr	Vyr	Vzr	Mry	Mrz	MTrd	SF_V.	SF_M	SF_Mt	SF
cm		kg	kg	kg	kg*m	kg*m	kg*m				
0	1	52623	19321	19321	1818	1818	1566	>100	29.4	>100	29.4

Asta : 151 [231 , 246]

Sez. G: O 114.3x5.9 L=254.4 cm Crit.: Acciaio_Flessione $\gamma_M=1.05$ $f_{yk}/\gamma_M=2619$ kg/cm² $f_t=4300$ kg/cm²

:Verificato

X	cls	N	TY	TZ	MT	MY	MZ	My4	Mz4	Comb.
cm		kg	kg	kg	kg*m	kg*m	kg*m			
254	1	-7602	-15	29	13	8	29	--	--	2

X	cls	Nr	Vyr	Vzr	Mry	Mrz	MTrd	SF_V.	SF_M	SF_Mt	SF
cm		kg	kg	kg	kg*m	kg*m	kg*m				
254	1	52623	19178	19178	1818	1818	1566	>100	6.06	>100	6.06

Asta : 152 [228 , 231]

Sez. G: O 114.3x5.9 L=254.4 cm Crit.: Acciaio_Flessione $\gamma_M=1.05$ $f_{yk}/\gamma_M=2619$ kg/cm² $f_t=4300$ kg/cm²

:Verificato

X	cls	N	TY	TZ	MT	MY	MZ	My4	Mz4	Comb.
cm		kg	kg	kg	kg*m	kg*m	kg*m			
0	1	2065	-6	-27	3	10	-11	--	--	2

X	cls	Nr	Vyr	Vzr	Mry	Mrz	MTrd	SF_V.	SF_M	SF_Mt	SF
cm		kg	kg	kg	kg*m	kg*m	kg*m				
0	1	52623	19299	19299	1818	1818	1566	>100	19.8	>100	19.8

Asta : 153 [231 , 229]

AUTOSTRADA VALDASTICO A31 NORD
1° LOTTO - PIOVENE ROCCHETTE – VALLE DELL'ASTICO

Sez. G: O 114.3x5.9 L=254.4 cm Crit.: Acciaio_Flessione $\gamma_M=1.05$ $f_{yk}/\gamma_M=2619$ kg/cmq $f_t=4300$ kg/cmq

:Verificato

X	cls	N	TY	TZ	MT	MY	MZ	My4	Mz4	Comb.
cm		kg	kg	kg	kg*m	kg*m	kg*m			
102	1	-2196	-1	-1	-9	-12	-7	--	--	2

X	cls	Nr	Vyr	Vzr	Mry	Mrz	MTrd	SF_V.	SF_M	SF_Mt	SF
cm		kg	kg	kg	kg*m	kg*m	kg*m				
102	1	52623	19236	19236	1818	1818	1566	>100	19.1	>100	19.1

Asta : 154 [247 , 230]

Sez. G: O 114.3x5.9 L=286.0 cm Crit.: Acciaio_Flessione $\gamma_M=1.05$ $f_{yk}/\gamma_M=2619$ kg/cmq $f_t=4300$ kg/cmq

:Verificato

X	cls	N	TY	TZ	MT	MY	MZ	My4	Mz4	Comb.
cm		kg	kg	kg	kg*m	kg*m	kg*m			
200	1	2029	3	3	10	-25	-1	--	--	2

X	cls	Nr	Vyr	Vzr	Mry	Mrz	MTrd	SF_V.	SF_M	SF_Mt	SF
cm		kg	kg	kg	kg*m	kg*m	kg*m				
200	1	52623	19218	19218	1818	1818	1566	>100	19.0	>100	19.0

Asta : 155 [230 , 229]

Sez. G: O 114.3x5.9 L=314.0 cm Crit.: Acciaio_Flessione $\gamma_M=1.05$ $f_{yk}/\gamma_M=2619$ kg/cmq $f_t=4300$ kg/cmq

:Verificato

X	cls	N	TY	TZ	MT	MY	MZ	My4	Mz4	Comb.
cm		kg	kg	kg	kg*m	kg*m	kg*m			
0	1	-1068	-1	-33	-3	25	-2	--	--	2

X	cls	Nr	Vyr	Vzr	Mry	Mrz	MTrd	SF_V.	SF_M	SF_Mt	SF
cm		kg	kg	kg	kg*m	kg*m	kg*m				
0	1	52623	19307	19307	1818	1818	1566	>100	28.5	>100	28.5

AUTOSTRADA VALDASTICO A31 NORD
1° LOTTO - PIOVENE ROCCHETTE – VALLE DELL'ASTICO

Asta : 156 [246 , 238]

Sez. G: O 114.3x5.9 L=229.9 cm Crit.: Acciaio_Flessione $\gamma_M=1.05$ $f_{yk}/\gamma_M=2619$ kg/cmq $f_t=4300$ kg/cmq

:Verificato

X	cls	N	TY	TZ	MT	MY	MZ	My4	Mz4	Comb.
cm		kg	kg	kg	kg*m	kg*m	kg*m			
230	1	-4373	19	-5	-10	-43	-16	--	--	2

X	cls	Nr	Vyr	Vzr	Mry	Mrz	MTrd	SF_V.	SF_M	SF_Mt	SF
cm		kg	kg	kg	kg*m	kg*m	kg*m				
230	1	52623	19224	19224	1818	1818	1566	>100	8.64	>100	8.64

Asta : 157 [238 , 230]

Sez. G: O 114.3x5.9 L=229.9 cm Crit.: Acciaio_Flessione $\gamma_M=1.05$ $f_{yk}/\gamma_M=2619$ kg/cmq $f_t=4300$ kg/cmq

:Verificato

X	cls	N	TY	TZ	MT	MY	MZ	My4	Mz4	Comb.
cm		kg	kg	kg	kg*m	kg*m	kg*m			
0	1	-967	-3	-34	-18	17	-11	--	--	2

X	cls	Nr	Vyr	Vzr	Mry	Mrz	MTrd	SF_V.	SF_M	SF_Mt	SF
cm		kg	kg	kg	kg*m	kg*m	kg*m				
0	1	52623	19121	19121	1818	1818	1566	>100	29.5	87.8	29.5

Asta : 158 [238 , 247]

Sez. G: O 114.3x5.9 L=229.9 cm Crit.: Acciaio_Flessione $\gamma_M=1.05$ $f_{yk}/\gamma_M=2619$ kg/cmq $f_t=4300$ kg/cmq

:Verificato

X	cls	N	TY	TZ	MT	MY	MZ	My4	Mz4	Comb.
cm		kg	kg	kg	kg*m	kg*m	kg*m			
230	1	-1608	-4	19	13	27	13	--	--	2

X	cls	Nr	Vyr	Vzr	Mry	Mrz	MTrd	SF_V.	SF_M	SF_Mt	SF
cm		kg	kg	kg	kg*m	kg*m	kg*m				
230	1	52623	19121	19121	1818	1818	1566	>100	29.5	87.8	29.5

AUTOSTRADA VALDASTICO A31 NORD
1° LOTTO - PIOVENE ROCCHETTE – VALLE DELL'ASTICO

X	cls	Nr	Vyr	Vzr	Mry	Mrz	MTrd	SF_V.	SF_M	SF_Mt	SF
cm		kg	kg	kg	kg*m	kg*m	kg*m				
230	1	52623	19186	19186	1818	1818	1566	>100	19.1	>100	19.1

Asta : 159 [237 , 236]

Sez. G: O 114.3x5.9 L=318.3 cm Crit.: Acciaio_Flessione $\gamma_M=1.05$ $f_{yk}/\gamma_M=2619$ kg/cm² $f_t=4300$ kg/cm²

:Verificato

X	cls	N	TY	TZ	MT	MY	MZ	My4	Mz4	Comb.
cm		kg	kg	kg	kg*m	kg*m	kg*m			
318	1	2450	0	1350	-1	730	-1	--	--	2

X	cls	Nr	Vyr	Vzr	Mry	Mrz	MTrd	SF_V.	SF_M	SF_Mt	SF
cm		kg	kg	kg	kg*m	kg*m	kg*m				
318	1	52623	19335	19335	1818	1818	1566	14.3	2.23	>100	2.23

Asta : 160 [236 , 235]

Sez. G: O 114.3x5.9 L=315.7 cm Crit.: Acciaio_Flessione $\gamma_M=1.05$ $f_{yk}/\gamma_M=2619$ kg/cm² $f_t=4300$ kg/cm²

:Verificato

X	cls	N	TY	TZ	MT	MY	MZ	My4	Mz4	Comb.
cm		kg	kg	kg	kg*m	kg*m	kg*m			
0	1	-5788	4	-1350	-3	716	7	--	--	2

X	cls	Nr	Vyr	Vzr	Mry	Mrz	MTrd	SF_V.	SF_M	SF_Mt	SF
cm		kg	kg	kg	kg*m	kg*m	kg*m				
0	1	52623	19302	19302	1818	1818	1566	14.3	1.97	>100	1.97

Asta : 161 [235 , 234]

Sez. G: O 114.3x5.9 L=314.2 cm Crit.: Acciaio_Flessione $\gamma_M=1.05$ $f_{yk}/\gamma_M=2619$ kg/cm² $f_t=4300$ kg/cm²

:Verificato

X	cls	N	TY	TZ	MT	MY	MZ	My4	Mz4	Comb.
cm		kg	kg	kg	kg*m	kg*m	kg*m			

AUTOSTRADA VALDASTICO A31 NORD
1° LOTTO - PIOVENE ROCCHETTE – VALLE DELL'ASTICO

X	cls	N	TY	TZ	MT	MY	MZ	My4	Mz4	Comb.
0	1	-13415	0	-1346	-0	693	0	--	--	2

X	cls	Nr	Vyr	Vzr	Mry	Mrz	MTrd	SF_V.	SF_M	SF_Mt	SF
cm		kg	kg	kg	kg*m	kg*m	kg*m				
0	1	52623	19338	19338	1818	1818	1566	14.4	1.57	>100	1.57

Asta : 162 [234 , 233]

Sez. G: O 114.3x5.9 L=314.0 cm Crit.: Acciaio_Flessione $\gamma_M=1.05$ $f_{yk}/\gamma_M=2619$ kg/cm² $f_t=4300$ kg/cm²

:Verificato

X	cls	N	TY	TZ	MT	MY	MZ	My4	Mz4	Comb.
cm		kg	kg	kg	kg*m	kg*m	kg*m			
314	1	-16305	-0	1339	0	677	0	--	--	2

X	cls	Nr	Vyr	Vzr	Mry	Mrz	MTrd	SF_V.	SF_M	SF_Mt	SF
cm		kg	kg	kg	kg*m	kg*m	kg*m				
314	1	52623	19342	19342	1818	1818	1566	14.4	1.46	>100	1.46

Asta : 163 [233 , 232]

Sez. G: O 114.3x5.9 L=314.2 cm Crit.: Acciaio_Flessione $\gamma_M=1.05$ $f_{yk}/\gamma_M=2619$ kg/cm² $f_t=4300$ kg/cm²

:Verificato

X	cls	N	TY	TZ	MT	MY	MZ	My4	Mz4	Comb.
cm		kg	kg	kg	kg*m	kg*m	kg*m			
314	1	-13375	-0	1346	0	693	0	--	--	2

X	cls	Nr	Vyr	Vzr	Mry	Mrz	MTrd	SF_V.	SF_M	SF_Mt	SF
cm		kg	kg	kg	kg*m	kg*m	kg*m				
314	1	52623	19338	19338	1818	1818	1566	14.4	1.57	>100	1.57

Asta : 164 [232 , 231]

AUTOSTRADA VALDASTICO A31 NORD
1° LOTTO - PIOVENE ROCCHETTE – VALLE DELL'ASTICO

Sez. G: O 114.3x5.9 L=315.7 cm Crit.: Acciaio_Flessione $\gamma_M=1.05$ $f_{yk}/\gamma_M=2619$ kg/cmq $f_t=4300$ kg/cmq

:Verificato

X	cls	N	TY	TZ	MT	MY	MZ	My4	Mz4	Comb.
cm		kg	kg	kg	kg*m	kg*m	kg*m			
316	1	-5705	-4	1350	3	716	7	--	--	2

X	cls	Nr	Vyr	Vzr	Mry	Mrz	MTrd	SF_V.	SF_M	SF_Mt	SF
cm		kg	kg	kg	kg*m	kg*m	kg*m				
316	1	52623	19302	19302	1818	1818	1566	14.3	1.97	>100	1.97

Asta : 165 [231 , 238]

Sez. G: O 114.3x5.9 L=318.3 cm Crit.: Acciaio_Flessione $\gamma_M=1.05$ $f_{yk}/\gamma_M=2619$ kg/cmq $f_t=4300$ kg/cmq

:Verificato

X	cls	N	TY	TZ	MT	MY	MZ	My4	Mz4	Comb.
cm		kg	kg	kg	kg*m	kg*m	kg*m			
0	1	2559	-0	-1350	0	730	-1	--	--	2

X	cls	Nr	Vyr	Vzr	Mry	Mrz	MTrd	SF_V.	SF_M	SF_Mt	SF
cm		kg	kg	kg	kg*m	kg*m	kg*m				
0	1	52623	19338	19338	1818	1818	1566	14.3	2.22	>100	2.22

Asta : 166 [239 , 254]

Sez. G: O 114.3x5.9 L=229.9 cm Crit.: Acciaio_Flessione $\gamma_M=1.05$ $f_{yk}/\gamma_M=2619$ kg/cmq $f_t=4300$ kg/cmq

:Verificato

X	cls	N	TY	TZ	MT	MY	MZ	My4	Mz4	Comb.
cm		kg	kg	kg	kg*m	kg*m	kg*m			
230	1	4450	8	62	8	51	-10	--	--	2

X	cls	Nr	Vyr	Vzr	Mry	Mrz	MTrd	SF_V.	SF_M	SF_Mt	SF
cm		kg	kg	kg	kg*m	kg*m	kg*m				
230	1	52623	19242	19242	1818	1818	1566	>100	8.46	>100	8.46

AUTOSTRADA VALDASTICO A31 NORD
1° LOTTO - PIOVENE ROCCHETTE – VALLE DELL'ASTICO

Asta : 167 [257 , 240]

Sez. G: O 114.3x5.9 L=286.0 cm Crit.: Acciaio_Flessione $\gamma_M=1.05$ $f_{yk}/\gamma_M=2619$ kg/cm² $f_t=4300$ kg/cm²

:Verificato

X	cls	N	TY	TZ	MT	MY	MZ	My4	Mz4	Comb.
cm		kg	kg	kg	kg*m	kg*m	kg*m			
0	1	-7229	-2	-133	-36	188	-1	--	--	2

X	cls	Nr	Vyr	Vzr	Mry	Mrz	MTrd	SF_V.	SF_M	SF_Mt	SF
cm		kg	kg	kg	kg*m	kg*m	kg*m				
0	1	52623	18892	18892	1818	1818	1566	>100	4.14	43.0	4.14

Asta : 168 [240 , 239]

Sez. G: O 114.3x5.9 L=314.0 cm Crit.: Acciaio_Flessione $\gamma_M=1.05$ $f_{yk}/\gamma_M=2619$ kg/cm² $f_t=4300$ kg/cm²

:Verificato

X	cls	N	TY	TZ	MT	MY	MZ	My4	Mz4	Comb.
cm		kg	kg	kg	kg*m	kg*m	kg*m			
0	1	-3566	6	-36	13	40	9	--	--	2

X	cls	Nr	Vyr	Vzr	Mry	Mrz	MTrd	SF_V.	SF_M	SF_Mt	SF
cm		kg	kg	kg	kg*m	kg*m	kg*m				
0	1	52623	19178	19178	1818	1818	1566	>100	10.6	>100	10.6

Asta : 169 [256 , 254]

Sez. G: O 114.3x5.9 L=229.9 cm Crit.: Acciaio_Flessione $\gamma_M=1.05$ $f_{yk}/\gamma_M=2619$ kg/cm² $f_t=4300$ kg/cm²

:Verificato

X	cls	N	TY	TZ	MT	MY	MZ	My4	Mz4	Comb.
cm		kg	kg	kg	kg*m	kg*m	kg*m			
230	1	4609	1	66	-9	101	5	--	--	2

X	cls	Nr	Vyr	Vzr	Mry	Mrz	MTrd	SF_V.	SF_M	SF_Mt	SF
cm		kg	kg	kg	kg*m	kg*m	kg*m				

AUTOSTRADA VALDASTICO A31 NORD
1° LOTTO - PIOVENE ROCCHETTE – VALLE DELL'ASTICO

X	cls	Nr	Vyr	Vzr	Mry	Mrz	MTrd	SF_V.	SF_M	SF_Mt	SF
230	1	52623	19227	19227	1818	1818	1566	>100	6.87	>100	6.87

Asta : 170 [254 , 240]

Sez. G: O 114.3x5.9 L=229.9 cm Crit.: Acciaio_Flessione $\gamma_M=1.05$ $f_{yk}/\gamma_M=2619$ kg/cmq $f_t=4300$ kg/cmq

:Verificato

X	cls	N	TY	TZ	MT	MY	MZ	My4	Mz4	Comb.
cm		kg	kg	kg	kg*m	kg*m	kg*m			
0	1	7966	-8	-31	-1	41	-11	--	--	2

X	cls	Nr	Vyr	Vzr	Mry	Mrz	MTrd	SF_V.	SF_M	SF_Mt	SF
cm		kg	kg	kg	kg*m	kg*m	kg*m				
0	1	52623	19329	19329	1818	1818	1566	>100	5.55	>100	5.55

Asta : 171 [254 , 257]

Sez. G: O 114.3x5.9 L=229.9 cm Crit.: Acciaio_Flessione $\gamma_M=1.05$ $f_{yk}/\gamma_M=2619$ kg/cmq $f_t=4300$ kg/cmq

:Verificato

X	cls	N	TY	TZ	MT	MY	MZ	My4	Mz4	Comb.
cm		kg	kg	kg	kg*m	kg*m	kg*m			
230	1	-18733	13	73	-28	49	-34	--	--	2

X	cls	Nr	Vyr	Vzr	Mry	Mrz	MTrd	SF_V.	SF_M	SF_Mt	SF
cm		kg	kg	kg	kg*m	kg*m	kg*m				
230	1	52623	18999	18999	1818	1818	1566	>100	2.49	56.4	2.49

Asta : 172 [256 , 239]

Sez. G: O 114.3x5.9 L=286.0 cm Crit.: Acciaio_Flessione $\gamma_M=1.05$ $f_{yk}/\gamma_M=2619$ kg/cmq $f_t=4300$ kg/cmq

:Verificato

X	cls	N	TY	TZ	MT	MY	MZ	My4	Mz4	Comb.
cm		kg	kg	kg	kg*m	kg*m	kg*m			
286	1	-2165	-12	41	-22	37	16	--	--	2

AUTOSTRADA VALDASTICO A31 NORD
1° LOTTO - PIOVENE ROCCHETTE – VALLE DELL'ASTICO

X	cls	Nr	Vyr	Vzr	Mry	Mrz	MTrd	SF_V.	SF_M	SF_Mt	SF
cm		kg	kg	kg	kg*m	kg*m	kg*m				
286	1	52623	19069	19069	1818	1818	1566	>100	14.2	70.8	14.2

Asta : 173 [258 , 241]

Sez. G: O 114.3x5.9 L=286.0 cm Crit.: Acciaio_Flessione $\gamma_M=1.05$ $f_{yk}/\gamma_M=2619$ kg/cm² $f_t=4300$ kg/cm²

:Verificato

X	cls	N	TY	TZ	MT	MY	MZ	My4	Mz4	Comb.
cm		kg	kg	kg	kg*m	kg*m	kg*m			
0	1	-3313	9	-43	14	45	13	--	--	2

X	cls	Nr	Vyr	Vzr	Mry	Mrz	MTrd	SF_V.	SF_M	SF_Mt	SF
cm		kg	kg	kg	kg*m	kg*m	kg*m				
0	1	52623	19166	19166	1818	1818	1566	>100	10.5	>100	10.5

Asta : 174 [241 , 240]

Sez. G: O 114.3x5.9 L=314.0 cm Crit.: Acciaio_Flessione $\gamma_M=1.05$ $f_{yk}/\gamma_M=2619$ kg/cm² $f_t=4300$ kg/cm²

:Verificato

X	cls	N	TY	TZ	MT	MY	MZ	My4	Mz4	Comb.
cm		kg	kg	kg	kg*m	kg*m	kg*m			
314	1	202	-8	55	-14	61	13	--	--	2

X	cls	Nr	Vyr	Vzr	Mry	Mrz	MTrd	SF_V.	SF_M	SF_Mt	SF
cm		kg	kg	kg	kg*m	kg*m	kg*m				
314	1	52623	19172	19172	1818	1818	1566	>100	22.6	>100	22.6

Asta : 175 [240 , 253]

Sez. G: O 114.3x5.9 L=254.4 cm Crit.: Acciaio_Flessione $\gamma_M=1.05$ $f_{yk}/\gamma_M=2619$ kg/cm² $f_t=4300$ kg/cm²

:Verificato

X	cls	N	TY	TZ	MT	MY	MZ	My4	Mz4	Comb.
cm		kg	kg	kg	kg*m	kg*m	kg*m			
254	1	202	-8	55	-14	61	13	--	--	2

AUTOSTRADA VALDASTICO A31 NORD
1° LOTTO - PIOVENE ROCCHETTE – VALLE DELL'ASTICO

X	cls	N	TY	TZ	MT	MY	MZ	My4	Mz4	Comb.
cm		kg	kg	kg	kg*m	kg*m	kg*m			
0	1	5332	19	-30	9	47	19	--	--	2

X	cls	Nr	Vyr	Vzr	Mry	Mrz	MTrd	SF_V.	SF_M	SF_Mt	SF
cm		kg	kg	kg	kg*m	kg*m	kg*m				
0	1	52623	19236	19236	1818	1818	1566	>100	7.29	>100	7.29

Asta : 176 [253 , 258]

Sez. G: O 114.3x5.9 L=254.4 cm Crit.: Acciaio_Flessione $\gamma_M=1.05$ $f_{yk}/\gamma_M=2619$ kg/cm² $f_t=4300$ kg/cm²

:Verificato

X	cls	N	TY	TZ	MT	MY	MZ	My4	Mz4	Comb.
cm		kg	kg	kg	kg*m	kg*m	kg*m			
0	1	7361	-31	-18	-11	24	-52	--	--	2

X	cls	Nr	Vyr	Vzr	Mry	Mrz	MTrd	SF_V.	SF_M	SF_Mt	SF
cm		kg	kg	kg	kg*m	kg*m	kg*m				
0	1	52623	19210	19210	1818	1818	1566	>100	5.51	>100	5.51

Asta : 177 [257 , 253]

Sez. G: O 114.3x5.9 L=254.4 cm Crit.: Acciaio_Flessione $\gamma_M=1.05$ $f_{yk}/\gamma_M=2619$ kg/cm² $f_t=4300$ kg/cm²

:Verificato

X	cls	N	TY	TZ	MT	MY	MZ	My4	Mz4	Comb.
cm		kg	kg	kg	kg*m	kg*m	kg*m			
0	1	-32074	50	-217	-25	330	89	--	--	2

X	cls	Nr	Vyr	Vzr	Mry	Mrz	MTrd	SF_V.	SF_M	SF_Mt	SF
cm		kg	kg	kg	kg*m	kg*m	kg*m				
0	1	52623	19036	19036	1818	1818	1566	87.9	1.19	63.2	1.19

Asta : 178 [253 , 241]

AUTOSTRADA VALDASTICO A31 NORD
1° LOTTO - PIOVENE ROCCHETTE – VALLE DELL'ASTICO

Sez. G: O 114.3x5.9 L=254.4 cm Crit.: Acciaio_Flessione $\gamma_M=1.05$ $f_{yk}/\gamma_M=2619$ kg/cmq $f_t=4300$ kg/cmq

:Verificato

X	cls	N	TY	TZ	MT	MY	MZ	My4	Mz4	Comb.
cm		kg	kg	kg	kg*m	kg*m	kg*m			
51	1	7877	-3	-5	3	-28	-3	--	--	2

X	cls	Nr	Vyr	Vzr	Mry	Mrz	MTrd	SF_V.	SF_M	SF_Mt	SF
cm		kg	kg	kg	kg*m	kg*m	kg*m				
51	1	52623	19302	19302	1818	1818	1566	>100	5.99	>100	5.99

Asta : 179 [259 , 242]

Sez. G: O 114.3x5.9 L=286.0 cm Crit.: Acciaio_Flessione $\gamma_M=1.05$ $f_{yk}/\gamma_M=2619$ kg/cmq $f_t=4300$ kg/cmq

:Verificato

X	cls	N	TY	TZ	MT	MY	MZ	My4	Mz4	Comb.
cm		kg	kg	kg	kg*m	kg*m	kg*m			
286	1	-905	3	31	1	20	-5	--	--	2

X	cls	Nr	Vyr	Vzr	Mry	Mrz	MTrd	SF_V.	SF_M	SF_Mt	SF
cm		kg	kg	kg	kg*m	kg*m	kg*m				
286	1	52623	19331	19331	1818	1818	1566	>100	32.4	>100	32.4

Asta : 180 [242 , 241]

Sez. G: O 114.3x5.9 L=314.0 cm Crit.: Acciaio_Flessione $\gamma_M=1.05$ $f_{yk}/\gamma_M=2619$ kg/cmq $f_t=4300$ kg/cmq

:Verificato

X	cls	N	TY	TZ	MT	MY	MZ	My4	Mz4	Comb.
cm		kg	kg	kg	kg*m	kg*m	kg*m			
126	1	9692	-2	1	-5	-30	-1	--	--	2

X	cls	Nr	Vyr	Vzr	Mry	Mrz	MTrd	SF_V.	SF_M	SF_Mt	SF
cm		kg	kg	kg	kg*m	kg*m	kg*m				
126	1	52623	19285	19285	1818	1818	1566	>100	4.97	>100	4.97

AUTOSTRADA VALDASTICO A31 NORD
1° LOTTO - PIOVENE ROCCHETTE – VALLE DELL'ASTICO

Asta : 181 [258 , 252]

Sez. G: O 114.3x5.9 L=273.9 cm Crit.: Acciaio_Flessione $\gamma_M=1.05$ $f_{yk}/\gamma_M=2619$ kg/cmq $f_t=4300$ kg/cmq

:Verificato

X	cls	N	TY	TZ	MT	MY	MZ	My4	Mz4	Comb.
cm		kg	kg	kg	kg*m	kg*m	kg*m			
0	1	-5526	-18	-11	13	-22	-38	--	--	2

X	cls	Nr	Vyr	Vzr	Mry	Mrz	MTrd	SF_V.	SF_M	SF_Mt	SF
cm		kg	kg	kg	kg*m	kg*m	kg*m				
0	1	52623	19179	19179	1818	1818	1566	>100	7.25	>100	7.25

Asta : 182 [252 , 242]

Sez. G: O 114.3x5.9 L=273.9 cm Crit.: Acciaio_Flessione $\gamma_M=1.05$ $f_{yk}/\gamma_M=2619$ kg/cmq $f_t=4300$ kg/cmq

:Verificato

X	cls	N	TY	TZ	MT	MY	MZ	My4	Mz4	Comb.
cm		kg	kg	kg	kg*m	kg*m	kg*m			
137	1	1743	0	-1	7	-16	7	--	--	2

X	cls	Nr	Vyr	Vzr	Mry	Mrz	MTrd	SF_V.	SF_M	SF_Mt	SF
cm		kg	kg	kg	kg*m	kg*m	kg*m				
137	1	52623	19261	19261	1818	1818	1566	>100	21.9	>100	21.9

Asta : 183 [241 , 252]

Sez. G: O 114.3x5.9 L=273.9 cm Crit.: Acciaio_Flessione $\gamma_M=1.05$ $f_{yk}/\gamma_M=2619$ kg/cmq $f_t=4300$ kg/cmq

:Verificato

X	cls	N	TY	TZ	MT	MY	MZ	My4	Mz4	Comb.
cm		kg	kg	kg	kg*m	kg*m	kg*m			
0	1	-2051	11	-25	-6	14	22	--	--	2

X	cls	Nr	Vyr	Vzr	Mry	Mrz	MTrd	SF_V.	SF_M	SF_Mt	SF
cm		kg	kg	kg	kg*m	kg*m	kg*m				
0	1	52623	19261	19261	1818	1818	1566	>100	21.9	>100	21.9

AUTOSTRADA VALDASTICO A31 NORD
1° LOTTO - PIOVENE ROCCHETTE – VALLE DELL'ASTICO

X	cls	Nr	Vyr	Vzr	Mry	Mrz	MTrd	SF_V.	SF_M	SF_Mt	SF
cm		kg	kg	kg	kg*m	kg*m	kg*m				
0	1	52623	19263	19263	1818	1818	1566	>100	17.1	>100	17.1

Asta : 184 [252 , 259]

Sez. G: O 114.3x5.9 L=273.9 cm Crit.: Acciaio_Flessione $\gamma_M=1.05$ $f_{yk}/\gamma_M=2619$ kg/cm² $f_t=4300$ kg/cm²

:Verificato

X	cls	N	TY	TZ	MT	MY	MZ	My4	Mz4	Comb.
cm		kg	kg	kg	kg*m	kg*m	kg*m			
164	1	2012	1	-0	-7	-14	-8	--	--	2

X	cls	Nr	Vyr	Vzr	Mry	Mrz	MTrd	SF_V.	SF_M	SF_Mt	SF
cm		kg	kg	kg	kg*m	kg*m	kg*m				
164	1	52623	19252	19252	1818	1818	1566	>100	19.9	>100	19.9

Asta : 185 [260 , 243]

Sez. G: O 114.3x5.9 L=286.0 cm Crit.: Acciaio_Flessione $\gamma_M=1.05$ $f_{yk}/\gamma_M=2619$ kg/cm² $f_t=4300$ kg/cm²

:Verificato

X	cls	N	TY	TZ	MT	MY	MZ	My4	Mz4	Comb.
cm		kg	kg	kg	kg*m	kg*m	kg*m			
286	1	-586	0	33	-0	21	-0	--	--	2

X	cls	Nr	Vyr	Vzr	Mry	Mrz	MTrd	SF_V.	SF_M	SF_Mt	SF
cm		kg	kg	kg	kg*m	kg*m	kg*m				
286	1	52623	19341	19341	1818	1818	1566	>100	44.1	>100	44.1

Asta : 186 [243 , 242]

Sez. G: O 114.3x5.9 L=314.0 cm Crit.: Acciaio_Flessione $\gamma_M=1.05$ $f_{yk}/\gamma_M=2619$ kg/cm² $f_t=4300$ kg/cm²

:Verificato

X	cls	N	TY	TZ	MT	MY	MZ	My4	Mz4	Comb.
cm		kg	kg	kg	kg*m	kg*m	kg*m			

AUTOSTRADA VALDASTICO A31 NORD
1° LOTTO - PIOVENE ROCCHETTE – VALLE DELL'ASTICO

X	cls	N	TY	TZ	MT	MY	MZ	My4	Mz4	Comb.
157	1	14388	0	3	-1	-35	-0	--	--	2

X	cls	Nr	Vyr	Vzr	Mry	Mrz	MTrd	SF_V.	SF_M	SF_Mt	SF
cm		kg	kg	kg	kg*m	kg*m	kg*m				
157	1	52623	19335	19335	1818	1818	1566	>100	3.41	>100	3.41

Asta : 187 [259 , 251]

Sez. G: O 114.3x5.9 L=281.6 cm Crit.: Acciaio_Flessione $\gamma_M=1.05$ $f_{yk}/\gamma_M=2619$ kg/cm² $f_t=4300$ kg/cm²

:Verificato

X	cls	N	TY	TZ	MT	MY	MZ	My4	Mz4	Comb.
cm		kg	kg	kg	kg*m	kg*m	kg*m			
113	1	-776	-4	-5	7	-14	-9	--	--	2

X	cls	Nr	Vyr	Vzr	Mry	Mrz	MTrd	SF_V.	SF_M	SF_Mt	SF
cm		kg	kg	kg	kg*m	kg*m	kg*m				
113	1	52623	19260	19260	1818	1818	1566	>100	36.5	>100	36.5

Asta : 188 [251 , 260]

Sez. G: O 114.3x5.9 L=281.6 cm Crit.: Acciaio_Flessione $\gamma_M=1.05$ $f_{yk}/\gamma_M=2619$ kg/cm² $f_t=4300$ kg/cm²

:Verificato

X	cls	N	TY	TZ	MT	MY	MZ	My4	Mz4	Comb.
cm		kg	kg	kg	kg*m	kg*m	kg*m			
169	1	582	3	4	-7	-16	-8	--	--	2

X	cls	Nr	Vyr	Vzr	Mry	Mrz	MTrd	SF_V.	SF_M	SF_Mt	SF
cm		kg	kg	kg	kg*m	kg*m	kg*m				
169	1	52623	19261	19261	1818	1818	1566	>100	41.3	>100	41.3

Asta : 189 [242 , 251]

Sez. G: O 114.3x5.9 L=281.6 cm Crit.: Acciaio_Flessione $\gamma_M=1.05$ $f_{yk}/\gamma_M=2619$ kg/cm² $f_t=4300$ kg/cm²

:Verificato

AUTOSTRADA VALDASTICO A31 NORD
1° LOTTO - PIOVENE ROCCHETTE – VALLE DELL'ASTICO

X	cls	N	TY	TZ	MT	MY	MZ	My4	Mz4	Comb.
cm		kg	kg	kg	kg*m	kg*m	kg*m			
113	1	-2247	4	-5	-6	-13	9	--	--	2

X	cls	Nr	Vyr	Vzr	Mry	Mrz	MTrd	SF_V.	SF_M	SF_Mt	SF
cm		kg	kg	kg	kg*m	kg*m	kg*m				
113	1	52623	19264	19264	1818	1818	1566	>100	18.3	>100	18.3

Asta : 190 [251 , 243]

Sez. G: O 114.3x5.9 L=281.6 cm Crit.: Acciaio_Flessione $\gamma_M=1.05$ $f_{yk}/\gamma_M=2619$ kg/cm² $f_t=4300$ kg/cm²

:Verificato

X	cls	N	TY	TZ	MT	MY	MZ	My4	Mz4	Comb.
cm		kg	kg	kg	kg*m	kg*m	kg*m			
141	1	-896	-0	0	7	-16	8	--	--	2

X	cls	Nr	Vyr	Vzr	Mry	Mrz	MTrd	SF_V.	SF_M	SF_Mt	SF
cm		kg	kg	kg	kg*m	kg*m	kg*m				
141	1	52623	19258	19258	1818	1818	1566	>100	33.4	>100	33.4

Asta : 191 [243 , 250]

Sez. G: O 114.3x5.9 L=281.6 cm Crit.: Acciaio_Flessione $\gamma_M=1.05$ $f_{yk}/\gamma_M=2619$ kg/cm² $f_t=4300$ kg/cm²

:Verificato

X	cls	N	TY	TZ	MT	MY	MZ	My4	Mz4	Comb.
cm		kg	kg	kg	kg*m	kg*m	kg*m			
141	1	-891	0	-0	-7	-16	8	--	--	2

X	cls	Nr	Vyr	Vzr	Mry	Mrz	MTrd	SF_V.	SF_M	SF_Mt	SF
cm		kg	kg	kg	kg*m	kg*m	kg*m				
141	1	52623	19258	19258	1818	1818	1566	>100	33.5	>100	33.5

Asta : 192 [250 , 261]

AUTOSTRADA VALDASTICO A31 NORD
1° LOTTO - PIOVENE ROCCHETTE – VALLE DELL'ASTICO

Sez. G: O 114.3x5.9 L=281.6 cm Crit.: Acciaio_Flessione $\gamma_M=1.05$ $f_{yk}/\gamma_M=2619$ kg/cmq $f_t=4300$ kg/cmq

:Verificato

X	cls	N	TY	TZ	MT	MY	MZ	My4	Mz4	Comb.
cm		kg	kg	kg	kg*m	kg*m	kg*m			
169	1	-827	4	5	-7	-14	-9	--	--	2

X	cls	Nr	Vyr	Vzr	Mry	Mrz	MTrd	SF_V.	SF_M	SF_Mt	SF
cm		kg	kg	kg	kg*m	kg*m	kg*m				
169	1	52623	19260	19260	1818	1818	1566	>100	35.3	>100	35.3

Asta : 193 [261 , 244]

Sez. G: O 114.3x5.9 L=286.0 cm Crit.: Acciaio_Flessione $\gamma_M=1.05$ $f_{yk}/\gamma_M=2619$ kg/cmq $f_t=4300$ kg/cmq

:Verificato

X	cls	N	TY	TZ	MT	MY	MZ	My4	Mz4	Comb.
cm		kg	kg	kg	kg*m	kg*m	kg*m			
286	1	-916	-3	31	-1	20	5	--	--	2

X	cls	Nr	Vyr	Vzr	Mry	Mrz	MTrd	SF_V.	SF_M	SF_Mt	SF
cm		kg	kg	kg	kg*m	kg*m	kg*m				
286	1	52623	19331	19331	1818	1818	1566	>100	32.3	>100	32.3

Asta : 194 [244 , 243]

Sez. G: O 114.3x5.9 L=314.0 cm Crit.: Acciaio_Flessione $\gamma_M=1.05$ $f_{yk}/\gamma_M=2619$ kg/cmq $f_t=4300$ kg/cmq

:Verificato

X	cls	N	TY	TZ	MT	MY	MZ	My4	Mz4	Comb.
cm		kg	kg	kg	kg*m	kg*m	kg*m			
157	1	14370	-0	-3	1	-35	-0	--	--	2

X	cls	Nr	Vyr	Vzr	Mry	Mrz	MTrd	SF_V.	SF_M	SF_Mt	SF
cm		kg	kg	kg	kg*m	kg*m	kg*m				
157	1	52623	19335	19335	1818	1818	1566	>100	3.42	>100	3.42

AUTOSTRADA VALDASTICO A31 NORD
1° LOTTO - PIOVENE ROCCHETTE – VALLE DELL'ASTICO

Asta : 195 [260 , 250]

Sez. G: O 114.3x5.9 L=281.6 cm Crit.: Acciaio_Flessione $\gamma_M=1.05$ $f_{yk}/\gamma_M=2619$ kg/cmq $f_t=4300$ kg/cmq

:Verificato

X	cls	N	TY	TZ	MT	MY	MZ	My4	Mz4	Comb.
cm		kg	kg	kg	kg*m	kg*m	kg*m			
113	1	609	-3	-4	7	-16	-8	--	--	2

X	cls	Nr	Vyr	Vzr	Mry	Mrz	MTrd	SF_V.	SF_M	SF_Mt	SF
cm		kg	kg	kg	kg*m	kg*m	kg*m				
113	1	52623	19261	19261	1818	1818	1566	>100	40.5	>100	40.5

Asta : 196 [250 , 244]

Sez. G: O 114.3x5.9 L=281.6 cm Crit.: Acciaio_Flessione $\gamma_M=1.05$ $f_{yk}/\gamma_M=2619$ kg/cmq $f_t=4300$ kg/cmq

:Verificato

X	cls	N	TY	TZ	MT	MY	MZ	My4	Mz4	Comb.
cm		kg	kg	kg	kg*m	kg*m	kg*m			
169	1	-2229	-4	5	6	-13	9	--	--	2

X	cls	Nr	Vyr	Vzr	Mry	Mrz	MTrd	SF_V.	SF_M	SF_Mt	SF
cm		kg	kg	kg	kg*m	kg*m	kg*m				
169	1	52623	19265	19265	1818	1818	1566	>100	18.4	>100	18.4

Asta : 197 [262 , 245]

Sez. G: O 114.3x5.9 L=286.0 cm Crit.: Acciaio_Flessione $\gamma_M=1.05$ $f_{yk}/\gamma_M=2619$ kg/cmq $f_t=4300$ kg/cmq

:Verificato

X	cls	N	TY	TZ	MT	MY	MZ	My4	Mz4	Comb.
cm		kg	kg	kg	kg*m	kg*m	kg*m			
0	1	-3360	-9	-43	-14	46	-13	--	--	2

X	cls	Nr	Vyr	Vzr	Mry	Mrz	MTrd	SF_V.	SF_M	SF_Mt	SF
cm		kg	kg	kg	kg*m	kg*m	kg*m				

AUTOSTRADA VALDASTICO A31 NORD
1° LOTTO - PIOVENE ROCCHETTE – VALLE DELL'ASTICO

X	cls	Nr	Vyr	Vzr	Mry	Mrz	MTrd	SF_V.	SF_M	SF_Mt	SF
0	1	52623	19163	19163	1818	1818	1566	>100	10.4	>100	10.4

Asta : 198 [245 , 244]

Sez. G: O 114.3x5.9 L=314.0 cm Crit.: Acciaio_Flessione $\gamma_M=1.05$ $f_{yk}/\gamma_M=2619$ kg/cm² $f_t=4300$ kg/cm²

:Verificato

X	cls	N	TY	TZ	MT	MY	MZ	My4	Mz4	Comb.
cm		kg	kg	kg	kg*m	kg*m	kg*m			
220	1	9625	2	6	5	-29	-2	--	--	2

X	cls	Nr	Vyr	Vzr	Mry	Mrz	MTrd	SF_V.	SF_M	SF_Mt	SF
cm		kg	kg	kg	kg*m	kg*m	kg*m				
220	1	52623	19285	19285	1818	1818	1566	>100	5.00	>100	5.00

Asta : 199 [244 , 249]

Sez. G: O 114.3x5.9 L=273.9 cm Crit.: Acciaio_Flessione $\gamma_M=1.05$ $f_{yk}/\gamma_M=2619$ kg/cm² $f_t=4300$ kg/cm²

:Verificato

X	cls	N	TY	TZ	MT	MY	MZ	My4	Mz4	Comb.
cm		kg	kg	kg	kg*m	kg*m	kg*m			
137	1	1782	-0	1	-7	-16	7	--	--	2

X	cls	Nr	Vyr	Vzr	Mry	Mrz	MTrd	SF_V.	SF_M	SF_Mt	SF
cm		kg	kg	kg	kg*m	kg*m	kg*m				
137	1	52623	19261	19261	1818	1818	1566	>100	21.6	>100	21.6

Asta : 200 [249 , 262]

Sez. G: O 114.3x5.9 L=273.9 cm Crit.: Acciaio_Flessione $\gamma_M=1.05$ $f_{yk}/\gamma_M=2619$ kg/cm² $f_t=4300$ kg/cm²

:Verificato

X	cls	N	TY	TZ	MT	MY	MZ	My4	Mz4	Comb.
cm		kg	kg	kg	kg*m	kg*m	kg*m			
274	1	-5658	18	11	-13	-22	-39	--	--	2

AUTOSTRADA VALDASTICO A31 NORD
1° LOTTO - PIOVENE ROCCHETTE – VALLE DELL'ASTICO

X	cls	Nr	Vyr	Vzr	Mry	Mrz	MTrd	SF_V.	SF_M	SF_Mt	SF
cm		kg	kg	kg	kg*m	kg*m	kg*m				
274	1	52623	19177	19177	1818	1818	1566	>100	7.08	>100	7.08

Asta : 201 [261 , 249]

Sez. G: O 114.3x5.9 L=273.9 cm Crit.: Acciaio_Flessione $\gamma_M=1.05$ $f_{yk}/\gamma_M=2619$ kg/cm² $f_t=4300$ kg/cm²

:Verificato

X	cls	N	TY	TZ	MT	MY	MZ	My4	Mz4	Comb.
cm		kg	kg	kg	kg*m	kg*m	kg*m			
110	1	2053	-1	1	7	-14	-8	--	--	2

X	cls	Nr	Vyr	Vzr	Mry	Mrz	MTrd	SF_V.	SF_M	SF_Mt	SF
cm		kg	kg	kg	kg*m	kg*m	kg*m				
110	1	52623	19252	19252	1818	1818	1566	>100	19.6	>100	19.6

Asta : 202 [249 , 245]

Sez. G: O 114.3x5.9 L=273.9 cm Crit.: Acciaio_Flessione $\gamma_M=1.05$ $f_{yk}/\gamma_M=2619$ kg/cm² $f_t=4300$ kg/cm²

:Verificato

X	cls	N	TY	TZ	MT	MY	MZ	My4	Mz4	Comb.
cm		kg	kg	kg	kg*m	kg*m	kg*m			
274	1	-2020	-11	25	6	14	22	--	--	2

X	cls	Nr	Vyr	Vzr	Mry	Mrz	MTrd	SF_V.	SF_M	SF_Mt	SF
cm		kg	kg	kg	kg*m	kg*m	kg*m				
274	1	52623	19263	19263	1818	1818	1566	>100	17.2	>100	17.2

Asta : 203 [245 , 246]

Sez. G: O 114.3x5.9 L=314.0 cm Crit.: Acciaio_Flessione $\gamma_M=1.05$ $f_{yk}/\gamma_M=2619$ kg/cm² $f_t=4300$ kg/cm²

:Verificato

X	cls	N	TY	TZ	MT	MY	MZ	My4	Mz4	Comb.
cm		kg	kg	kg	kg*m	kg*m	kg*m			
314	1	40	7	56	14	62	-13	--	--	2

AUTOSTRADA VALDASTICO A31 NORD
1° LOTTO - PIOVENE ROCCHETTE – VALLE DELL'ASTICO

X	cls	Nr	Vyr	Vzr	Mry	Mrz	MTrd	SF_V.	SF_M	SF_Mt	SF
cm		kg	kg	kg	kg*m	kg*m	kg*m				
314	1	52623	19172	19172	1818	1818	1566	>100	24.0	>100	24.0

Asta : 204 [246 , 263]

Sez. G: O 114.3x5.9 L=286.0 cm Crit.: Acciaio_Flessione $\gamma_M=1.05$ $f_{yk}/\gamma_M=2619$ kg/cm² $f_t=4300$ kg/cm²

:Verificato

X	cls	N	TY	TZ	MT	MY	MZ	My4	Mz4	Comb.
cm		kg	kg	kg	kg*m	kg*m	kg*m			
286	1	-7265	3	135	39	190	-3	--	--	2

X	cls	Nr	Vyr	Vzr	Mry	Mrz	MTrd	SF_V.	SF_M	SF_Mt	SF
cm		kg	kg	kg	kg*m	kg*m	kg*m				
286	1	52623	18857	18857	1818	1818	1566	>100	4.09	39.9	4.09

Asta : 205 [262 , 248]

Sez. G: O 114.3x5.9 L=254.4 cm Crit.: Acciaio_Flessione $\gamma_M=1.05$ $f_{yk}/\gamma_M=2619$ kg/cm² $f_t=4300$ kg/cm²

:Verificato

X	cls	N	TY	TZ	MT	MY	MZ	My4	Mz4	Comb.
cm		kg	kg	kg	kg*m	kg*m	kg*m			
254	1	7497	32	18	11	23	-53	--	--	2

X	cls	Nr	Vyr	Vzr	Mry	Mrz	MTrd	SF_V.	SF_M	SF_Mt	SF
cm		kg	kg	kg	kg*m	kg*m	kg*m				
254	1	52623	19210	19210	1818	1818	1566	>100	5.42	>100	5.42

Asta : 206 [248 , 263]

Sez. G: O 114.3x5.9 L=254.4 cm Crit.: Acciaio_Flessione $\gamma_M=1.05$ $f_{yk}/\gamma_M=2619$ kg/cm² $f_t=4300$ kg/cm²

:Verificato

X	cls	N	TY	TZ	MT	MY	MZ	My4	Mz4	Comb.
cm		kg	kg	kg	kg*m	kg*m	kg*m			

AUTOSTRADA VALDASTICO A31 NORD
1° LOTTO - PIOVENE ROCCHETTE – VALLE DELL'ASTICO

X	cls	N	TY	TZ	MT	MY	MZ	My4	Mz4	Comb.
254	1	-32490	-52	224	27	343	93	--	--	2

X	cls	Nr	Vyr	Vzr	Mry	Mrz	MTrd	SF_V.	SF_M	SF_Mt	SF
cm		kg	kg	kg	kg*m	kg*m	kg*m				
254	1	52623	19014	19014	1818	1818	1566	85.0	1.17	59.0	1.17

Asta : 207 [245 , 248]

Sez. G: O 114.3x5.9 L=254.4 cm Crit.: Acciaio_Flessione $\gamma_M=1.05$ $f_{yk}/\gamma_M=2619$ kg/cm² $f_t=4300$ kg/cm²

:Verificato

X	cls	N	TY	TZ	MT	MY	MZ	My4	Mz4	Comb.
cm		kg	kg	kg	kg*m	kg*m	kg*m			
203	1	7959	3	5	-3	-29	-3	--	--	2

X	cls	Nr	Vyr	Vzr	Mry	Mrz	MTrd	SF_V.	SF_M	SF_Mt	SF
cm		kg	kg	kg	kg*m	kg*m	kg*m				
203	1	52623	19304	19304	1818	1818	1566	>100	5.92	>100	5.92

Asta : 208 [248 , 246]

Sez. G: O 114.3x5.9 L=254.4 cm Crit.: Acciaio_Flessione $\gamma_M=1.05$ $f_{yk}/\gamma_M=2619$ kg/cm² $f_t=4300$ kg/cm²

:Verificato

X	cls	N	TY	TZ	MT	MY	MZ	My4	Mz4	Comb.
cm		kg	kg	kg	kg*m	kg*m	kg*m			
254	1	5429	-19	30	-9	47	19	--	--	2

X	cls	Nr	Vyr	Vzr	Mry	Mrz	MTrd	SF_V.	SF_M	SF_Mt	SF
cm		kg	kg	kg	kg*m	kg*m	kg*m				
254	1	52623	19229	19229	1818	1818	1566	>100	7.18	>100	7.18

Asta : 209 [264 , 247]

Sez. G: O 114.3x5.9 L=286.0 cm Crit.: Acciaio_Flessione $\gamma_M=1.05$ $f_{yk}/\gamma_M=2619$ kg/cm² $f_t=4300$ kg/cm²

:Verificato

AUTOSTRADA VALDASTICO A31 NORD
1° LOTTO - PIOVENE ROCCHETTE – VALLE DELL'ASTICO

X	cls	N	TY	TZ	MT	MY	MZ	My4	Mz4	Comb.
cm		kg	kg	kg	kg*m	kg*m	kg*m			
286	1	-1994	13	43	24	39	-17	--	--	2

X	cls	Nr	Vyr	Vzr	Mry	Mrz	MTrd	SF_V.	SF_M	SF_Mt	SF
cm		kg	kg	kg	kg*m	kg*m	kg*m				
286	1	52623	19042	19042	1818	1818	1566	>100	14.5	64.5	14.5

Asta : 210 [247 , 246]

Sez. G: O 114.3x5.9 L=314.0 cm Crit.: Acciaio_Flessione $\gamma_M=1.05$ $f_{yk}/\gamma_M=2619$ kg/cm² $f_t=4300$ kg/cm²

:Verificato

X	cls	N	TY	TZ	MT	MY	MZ	My4	Mz4	Comb.
cm		kg	kg	kg	kg*m	kg*m	kg*m			
314	1	-3704	-7	36	-14	40	10	--	--	2

X	cls	Nr	Vyr	Vzr	Mry	Mrz	MTrd	SF_V.	SF_M	SF_Mt	SF
cm		kg	kg	kg	kg*m	kg*m	kg*m				
314	1	52623	19166	19166	1818	1818	1566	>100	10.2	>100	10.2

Asta : 211 [263 , 255]

Sez. G: O 114.3x5.9 L=229.9 cm Crit.: Acciaio_Flessione $\gamma_M=1.05$ $f_{yk}/\gamma_M=2619$ kg/cm² $f_t=4300$ kg/cm²

:Verificato

X	cls	N	TY	TZ	MT	MY	MZ	My4	Mz4	Comb.
cm		kg	kg	kg	kg*m	kg*m	kg*m			
0	1	-18918	-15	-69	29	41	-37	--	--	2

X	cls	Nr	Vyr	Vzr	Mry	Mrz	MTrd	SF_V.	SF_M	SF_Mt	SF
cm		kg	kg	kg	kg*m	kg*m	kg*m				
0	1	52623	18980	18980	1818	1818	1566	>100	2.49	53.5	2.49

Asta : 212 [255 , 247]

AUTOSTRADA VALDASTICO A31 NORD
1° LOTTO - PIOVENE ROCCHETTE – VALLE DELL'ASTICO

Sez. G: O 114.3x5.9 L=229.9 cm Crit.: Acciaio_Flessione $\gamma_M=1.05$ $f_{yk}/\gamma_M=2619$ kg/cmq $f_t=4300$ kg/cmq

:Verificato

X	cls	N	TY	TZ	MT	MY	MZ	My4	Mz4	Comb.
cm		kg	kg	kg	kg*m	kg*m	kg*m			
0	1	4471	-7	-63	-9	51	-10	--	--	2

X	cls	Nr	Vyr	Vzr	Mry	Mrz	MTrd	SF_V.	SF_M	SF_Mt	SF
cm		kg	kg	kg	kg*m	kg*m	kg*m				
0	1	52623	19237	19237	1818	1818	1566	>100	8.45	>100	8.45

Asta : 213 [255 , 264]

Sez. G: O 114.3x5.9 L=229.9 cm Crit.: Acciaio_Flessione $\gamma_M=1.05$ $f_{yk}/\gamma_M=2619$ kg/cmq $f_t=4300$ kg/cmq

:Verificato

X	cls	N	TY	TZ	MT	MY	MZ	My4	Mz4	Comb.
cm		kg	kg	kg	kg*m	kg*m	kg*m			
0	1	4963	-2	-66	11	103	5	--	--	2

X	cls	Nr	Vyr	Vzr	Mry	Mrz	MTrd	SF_V.	SF_M	SF_Mt	SF
cm		kg	kg	kg	kg*m	kg*m	kg*m				
0	1	52623	19208	19208	1818	1818	1566	>100	6.50	>100	6.50

Asta : 214 [254 , 253]

Sez. G: O 114.3x5.9 L=318.3 cm Crit.: Acciaio_Flessione $\gamma_M=1.05$ $f_{yk}/\gamma_M=2619$ kg/cmq $f_t=4300$ kg/cmq

:Verificato

X	cls	N	TY	TZ	MT	MY	MZ	My4	Mz4	Comb.
cm		kg	kg	kg	kg*m	kg*m	kg*m			
318	1	15337	-1	1340	2	749	2	--	--	2

X	cls	Nr	Vyr	Vzr	Mry	Mrz	MTrd	SF_V.	SF_M	SF_Mt	SF
cm		kg	kg	kg	kg*m	kg*m	kg*m				
318	1	52623	19317	19317	1818	1818	1566	14.4	1.42	>100	1.42

AUTOSTRADA VALDASTICO A31 NORD
1° LOTTO - PIOVENE ROCCHETTE – VALLE DELL'ASTICO

Asta : 215 [253 , 252]

Sez. G: O 114.3x5.9 L=315.7 cm Crit.: Acciaio_Flessione $\gamma_M=1.05$ $f_{yk}/\gamma_M=2619$ kg/cm² $f_t=4300$ kg/cm²

:Verificato

X	cls	N	TY	TZ	MT	MY	MZ	My4	Mz4	Comb.
cm		kg	kg	kg	kg*m	kg*m	kg*m			
0	1	-11066	10	-1350	-13	703	15	--	--	2

X	cls	Nr	Vyr	Vzr	Mry	Mrz	MTrd	SF_V.	SF_M	SF_Mt	SF
cm		kg	kg	kg	kg*m	kg*m	kg*m				
0	1	52623	19180	19180	1818	1818	1566	14.2	1.65	>100	1.65

Asta : 216 [252 , 251]

Sez. G: O 114.3x5.9 L=314.2 cm Crit.: Acciaio_Flessione $\gamma_M=1.05$ $f_{yk}/\gamma_M=2619$ kg/cm² $f_t=4300$ kg/cm²

:Verificato

X	cls	N	TY	TZ	MT	MY	MZ	My4	Mz4	Comb.
cm		kg	kg	kg	kg*m	kg*m	kg*m			
0	1	-17411	1	-1344	-1	685	1	--	--	2

X	cls	Nr	Vyr	Vzr	Mry	Mrz	MTrd	SF_V.	SF_M	SF_Mt	SF
cm		kg	kg	kg	kg*m	kg*m	kg*m				
0	1	52623	19327	19327	1818	1818	1566	14.4	1.41	>100	1.41

Asta : 217 [251 , 250]

Sez. G: O 114.3x5.9 L=314.0 cm Crit.: Acciaio_Flessione $\gamma_M=1.05$ $f_{yk}/\gamma_M=2619$ kg/cm² $f_t=4300$ kg/cm²

:Verificato

X	cls	N	TY	TZ	MT	MY	MZ	My4	Mz4	Comb.
cm		kg	kg	kg	kg*m	kg*m	kg*m			
314	1	-18854	-0	1339	0	676	0	--	--	2

X	cls	Nr	Vyr	Vzr	Mry	Mrz	MTrd	SF_V.	SF_M	SF_Mt	SF
cm		kg	kg	kg	kg*m	kg*m	kg*m				
314	1	52623	19342	19342	1818	1818	1566	14.4	1.37	>100	1.37

AUTOSTRADA VALDASTICO A31 NORD
1° LOTTO - PIOVENE ROCCHETTE – VALLE DELL'ASTICO

Asta : 218 [250 , 249]

Sez. G: O 114.3x5.9 L=314.2 cm Crit.: Acciaio_Flessione $\gamma_M=1.05$ $f_{yk}/\gamma_M=2619$ kg/cmq $f_t=4300$ kg/cmq

:Verificato

X	cls	N	TY	TZ	MT	MY	MZ	My4	Mz4	Comb.
cm		kg	kg	kg	kg*m	kg*m	kg*m			
314	1	-17376	-1	1344	1	686	1	--	--	2

X	cls	Nr	Vyr	Vzr	Mry	Mrz	MTrd	SF_V.	SF_M	SF_Mt	SF
cm		kg	kg	kg	kg*m	kg*m	kg*m				
314	1	52623	19327	19327	1818	1818	1566	14.4	1.41	>100	1.41

Asta : 219 [249 , 248]

Sez. G: O 114.3x5.9 L=315.7 cm Crit.: Acciaio_Flessione $\gamma_M=1.05$ $f_{yk}/\gamma_M=2619$ kg/cmq $f_t=4300$ kg/cmq

:Verificato

X	cls	N	TY	TZ	MT	MY	MZ	My4	Mz4	Comb.
cm		kg	kg	kg	kg*m	kg*m	kg*m			
316	1	-10926	-10	1351	13	703	15	--	--	2

X	cls	Nr	Vyr	Vzr	Mry	Mrz	MTrd	SF_V.	SF_M	SF_Mt	SF
cm		kg	kg	kg	kg*m	kg*m	kg*m				
316	1	52623	19177	19177	1818	1818	1566	14.2	1.66	>100	1.66

Asta : 220 [248 , 255]

Sez. G: O 114.3x5.9 L=318.3 cm Crit.: Acciaio_Flessione $\gamma_M=1.05$ $f_{yk}/\gamma_M=2619$ kg/cmq $f_t=4300$ kg/cmq

:Verificato

X	cls	N	TY	TZ	MT	MY	MZ	My4	Mz4	Comb.
cm		kg	kg	kg	kg*m	kg*m	kg*m			
0	1	15812	2	-1340	-3	751	2	--	--	2

X	cls	Nr	Vyr	Vzr	Mry	Mrz	MTrd	SF_V.	SF_M	SF_Mt	SF
cm		kg	kg	kg	kg*m	kg*m	kg*m				

AUTOSTRADA VALDASTICO A31 NORD
1° LOTTO - PIOVENE ROCCHETTE – VALLE DELL'ASTICO

X	cls	Nr	Vyr	Vzr	Mry	Mrz	MTrd	SF_V.	SF_M	SF_Mt	SF
0	1	52623	19309	19309	1818	1818	1566	14.4	1.40	>100	1.40

Asta : 221 [256 , 271]

Sez. G: O 114.3x5.9 L=229.9 cm Crit.: Acciaio_Flessione $\gamma_M=1.05$ $f_{yk}/\gamma_M=2619$ kg/cm² $f_t=4300$ kg/cm²

:Verificato

X	cls	N	TY	TZ	MT	MY	MZ	My4	Mz4	Comb.
cm		kg	kg	kg	kg*m	kg*m	kg*m			
230	1	3341	8	24	-6	68	-12	--	--	2

X	cls	Nr	Vyr	Vzr	Mry	Mrz	MTrd	SF_V.	SF_M	SF_Mt	SF
cm		kg	kg	kg	kg*m	kg*m	kg*m				
230	1	52623	19268	19268	1818	1818	1566	>100	9.31	>100	9.31

Asta : 222 [274 , 257]

Sez. G: O 114.3x5.9 L=286.0 cm Crit.: Acciaio_Flessione $\gamma_M=1.05$ $f_{yk}/\gamma_M=2619$ kg/cm² $f_t=4300$ kg/cm²

:Verificato

X	cls	N	TY	TZ	MT	MY	MZ	My4	Mz4	Comb.
cm		kg	kg	kg	kg*m	kg*m	kg*m			
286	1	-6640	2	171	33	259	-3	--	--	2

X	cls	Nr	Vyr	Vzr	Mry	Mrz	MTrd	SF_V.	SF_M	SF_Mt	SF
cm		kg	kg	kg	kg*m	kg*m	kg*m				
286	1	52623	18933	18933	1818	1818	1566	>100	3.70	47.3	3.70

Asta : 223 [257 , 256]

Sez. G: O 114.3x5.9 L=314.0 cm Crit.: Acciaio_Flessione $\gamma_M=1.05$ $f_{yk}/\gamma_M=2619$ kg/cm² $f_t=4300$ kg/cm²

:Verificato

X	cls	N	TY	TZ	MT	MY	MZ	My4	Mz4	Comb.
cm		kg	kg	kg	kg*m	kg*m	kg*m			
314	1	-7389	-1	42	0	31	4	--	--	2

AUTOSTRADA VALDASTICO A31 NORD
1° LOTTO - PIOVENE ROCCHETTE – VALLE DELL'ASTICO

X	cls	Nr	Vyr	Vzr	Mry	Mrz	MTrd	SF_V.	SF_M	SF_Mt	SF
cm		kg	kg	kg	kg*m	kg*m	kg*m				
314	1	52623	19337	19337	1818	1818	1566	>100	6.27	>100	6.27

Asta : 224 [273 , 271]

Sez. G: O 114.3x5.9 L=229.9 cm Crit.: Acciaio_Flessione $\gamma_M=1.05$ $f_{yk}/\gamma_M=2619$ kg/cm² $f_t=4300$ kg/cm²

:Verificato

X	cls	N	TY	TZ	MT	MY	MZ	My4	Mz4	Comb.
cm		kg	kg	kg	kg*m	kg*m	kg*m			
230	1	5951	-11	55	-9	48	15	--	--	2

X	cls	Nr	Vyr	Vzr	Mry	Mrz	MTrd	SF_V.	SF_M	SF_Mt	SF
cm		kg	kg	kg	kg*m	kg*m	kg*m				
230	1	52623	19236	19236	1818	1818	1566	>100	6.78	>100	6.78

Asta : 225 [271 , 257]

Sez. G: O 114.3x5.9 L=229.9 cm Crit.: Acciaio_Flessione $\gamma_M=1.05$ $f_{yk}/\gamma_M=2619$ kg/cm² $f_t=4300$ kg/cm²

:Verificato

X	cls	N	TY	TZ	MT	MY	MZ	My4	Mz4	Comb.
cm		kg	kg	kg	kg*m	kg*m	kg*m			
230	1	-18501	-24	112	41	113	53	--	--	2

X	cls	Nr	Vyr	Vzr	Mry	Mrz	MTrd	SF_V.	SF_M	SF_Mt	SF
cm		kg	kg	kg	kg*m	kg*m	kg*m				
230	1	52623	18835	18835	1818	1818	1566	>100	2.26	38.2	2.26

Asta : 226 [271 , 274]

Sez. G: O 114.3x5.9 L=229.9 cm Crit.: Acciaio_Flessione $\gamma_M=1.05$ $f_{yk}/\gamma_M=2619$ kg/cm² $f_t=4300$ kg/cm²

:Verificato

X	cls	N	TY	TZ	MT	MY	MZ	My4	Mz4	Comb.
cm		kg	kg	kg	kg*m	kg*m	kg*m			
0	1	7804	12	-26	1	30	17	--	--	2

AUTOSTRADA VALDASTICO A31 NORD
1° LOTTO - PIOVENE ROCCHETTE – VALLE DELL'ASTICO

X	cls	Nr	Vyr	Vzr	Mry	Mrz	MTrd	SF_V.	SF_M	SF_Mt	SF
cm		kg	kg	kg	kg*m	kg*m	kg*m				
0	1	52623	19325	19325	1818	1818	1566	>100	5.75	>100	5.75

Asta : 227 [273 , 256]

Sez. G: O 114.3x5.9 L=286.0 cm Crit.: Acciaio_Flessione $\gamma_M=1.05$ $f_{yk}/\gamma_M=2619$ kg/cm² $f_t=4300$ kg/cm²

:Verificato

X	cls	N	TY	TZ	MT	MY	MZ	My4	Mz4	Comb.
cm		kg	kg	kg	kg*m	kg*m	kg*m			
286	1	-1727	7	61	19	88	-8	--	--	2

X	cls	Nr	Vyr	Vzr	Mry	Mrz	MTrd	SF_V.	SF_M	SF_Mt	SF
cm		kg	kg	kg	kg*m	kg*m	kg*m				
286	1	52623	19112	19112	1818	1818	1566	>100	11.7	84.3	11.7

Asta : 228 [275 , 258]

Sez. G: O 114.3x5.9 L=286.0 cm Crit.: Acciaio_Flessione $\gamma_M=1.05$ $f_{yk}/\gamma_M=2619$ kg/cm² $f_t=4300$ kg/cm²

:Verificato

X	cls	N	TY	TZ	MT	MY	MZ	My4	Mz4	Comb.
cm		kg	kg	kg	kg*m	kg*m	kg*m			
286	1	-2407	-11	47	-17	50	16	--	--	2

X	cls	Nr	Vyr	Vzr	Mry	Mrz	MTrd	SF_V.	SF_M	SF_Mt	SF
cm		kg	kg	kg	kg*m	kg*m	kg*m				
286	1	52623	19130	19130	1818	1818	1566	>100	12.2	91.6	12.2

Asta : 229 [258 , 257]

Sez. G: O 114.3x5.9 L=314.0 cm Crit.: Acciaio_Flessione $\gamma_M=1.05$ $f_{yk}/\gamma_M=2619$ kg/cm² $f_t=4300$ kg/cm²

:Verificato

X	cls	N	TY	TZ	MT	MY	MZ	My4	Mz4	Comb.
cm		kg	kg	kg	kg*m	kg*m	kg*m			

AUTOSTRADA VALDASTICO A31 NORD
1° LOTTO - PIOVENE ROCCHETTE – VALLE DELL'ASTICO

X	cls	N	TY	TZ	MT	MY	MZ	My4	Mz4	Comb.
314	1	-4232	1	215	-5	371	-2	--	--	2

X	cls	Nr	Vyr	Vzr	Mry	Mrz	MTrd	SF_V.	SF_M	SF_Mt	SF
cm		kg	kg	kg	kg*m	kg*m	kg*m				
314	1	52623	19285	19285	1818	1818	1566	89.6	3.49	>100	3.49

Asta : 230 [257 , 270]

Sez. G: O 114.3x5.9 L=254.4 cm Crit.: Acciaio_Flessione $\gamma_M=1.05$ $f_{yk}/\gamma_M=2619$ kg/cm² $f_t=4300$ kg/cm²

:Verificato

X	cls	N	TY	TZ	MT	MY	MZ	My4	Mz4	Comb.
cm		kg	kg	kg	kg*m	kg*m	kg*m			
0	1	-33755	-33	-244	16	376	-58	--	--	2

X	cls	Nr	Vyr	Vzr	Mry	Mrz	MTrd	SF_V.	SF_M	SF_Mt	SF
cm		kg	kg	kg	kg*m	kg*m	kg*m				
0	1	52623	19139	19139	1818	1818	1566	78.5	1.14	95.4	1.14

Asta : 231 [270 , 275]

Sez. G: O 114.3x5.9 L=254.4 cm Crit.: Acciaio_Flessione $\gamma_M=1.05$ $f_{yk}/\gamma_M=2619$ kg/cm² $f_t=4300$ kg/cm²

:Verificato

X	cls	N	TY	TZ	MT	MY	MZ	My4	Mz4	Comb.
cm		kg	kg	kg	kg*m	kg*m	kg*m			
51	1	7999	4	-4	-2	-35	4	--	--	2

X	cls	Nr	Vyr	Vzr	Mry	Mrz	MTrd	SF_V.	SF_M	SF_Mt	SF
cm		kg	kg	kg	kg*m	kg*m	kg*m				
51	1	52623	19316	19316	1818	1818	1566	>100	5.77	>100	5.77

Asta : 232 [274 , 270]

Sez. G: O 114.3x5.9 L=254.4 cm Crit.: Acciaio_Flessione $\gamma_M=1.05$ $f_{yk}/\gamma_M=2619$ kg/cm² $f_t=4300$ kg/cm²

:Verificato

AUTOSTRADA VALDASTICO A31 NORD
1° LOTTO - PIOVENE ROCCHETTE – VALLE DELL'ASTICO

X	cls	N	TY	TZ	MT	MY	MZ	My4	Mz4	Comb.
cm		kg	kg	kg	kg*m	kg*m	kg*m			
0	1	7168	-25	-34	-9	55	-25	--	--	2

X	cls	Nr	Vyr	Vzr	Mry	Mrz	MTrd	SF_V.	SF_M	SF_Mt	SF
cm		kg	kg	kg	kg*m	kg*m	kg*m				
0	1	52623	19234	19234	1818	1818	1566	>100	5.54	>100	5.54

Asta : 233 [270 , 258]

Sez. G: O 114.3x5.9 L=254.4 cm Crit.: Acciaio_Flessione $\gamma_M=1.05$ $f_{yk}/\gamma_M=2619$ kg/cm² $f_t=4300$ kg/cm²

:Verificato

X	cls	N	TY	TZ	MT	MY	MZ	My4	Mz4	Comb.
cm		kg	kg	kg	kg*m	kg*m	kg*m			
0	1	7155	32	-16	12	24	54	--	--	2

X	cls	Nr	Vyr	Vzr	Mry	Mrz	MTrd	SF_V.	SF_M	SF_Mt	SF
cm		kg	kg	kg	kg*m	kg*m	kg*m				
0	1	52623	19196	19196	1818	1818	1566	>100	5.60	>100	5.60

Asta : 234 [276 , 259]

Sez. G: O 114.3x5.9 L=286.0 cm Crit.: Acciaio_Flessione $\gamma_M=1.05$ $f_{yk}/\gamma_M=2619$ kg/cm² $f_t=4300$ kg/cm²

:Verificato

X	cls	N	TY	TZ	MT	MY	MZ	My4	Mz4	Comb.
cm		kg	kg	kg	kg*m	kg*m	kg*m			
286	1	123	-5	32	-3	19	7	--	--	2

X	cls	Nr	Vyr	Vzr	Mry	Mrz	MTrd	SF_V.	SF_M	SF_Mt	SF
cm		kg	kg	kg	kg*m	kg*m	kg*m				
286	1	52623	19310	19310	1818	1818	1566	>100	59.1	>100	59.1

Asta : 235 [259 , 258]

AUTOSTRADA VALDASTICO A31 NORD
1° LOTTO - PIOVENE ROCCHETTE – VALLE DELL'ASTICO

Sez. G: O 114.3x5.9 L=314.0 cm Crit.: Acciaio_Flessione $\gamma_M=1.05$ $f_{yk}/\gamma_M=2619$ kg/cm² $f_t=4300$ kg/cm²

:Verificato

X	cls	N	TY	TZ	MT	MY	MZ	My4	Mz4	Comb.
cm		kg	kg	kg	kg*m	kg*m	kg*m			
188	1	11948	1	-1	1	-46	-1	--	--	2

X	cls	Nr	Vyr	Vzr	Mry	Mrz	MTrd	SF_V.	SF_M	SF_Mt	SF
cm		kg	kg	kg	kg*m	kg*m	kg*m				
188	1	52623	19329	19329	1818	1818	1566	>100	3.96	>100	3.96

Asta : 236 [275 , 269]

Sez. G: O 114.3x5.9 L=273.9 cm Crit.: Acciaio_Flessione $\gamma_M=1.05$ $f_{yk}/\gamma_M=2619$ kg/cm² $f_t=4300$ kg/cm²

:Verificato

X	cls	N	TY	TZ	MT	MY	MZ	My4	Mz4	Comb.
cm		kg	kg	kg	kg*m	kg*m	kg*m			
0	1	-339	-12	-27	6	18	-23	--	--	2

X	cls	Nr	Vyr	Vzr	Mry	Mrz	MTrd	SF_V.	SF_M	SF_Mt	SF
cm		kg	kg	kg	kg*m	kg*m	kg*m				
0	1	52623	19268	19268	1818	1818	1566	>100	34.5	>100	34.5

Asta : 237 [269 , 259]

Sez. G: O 114.3x5.9 L=273.9 cm Crit.: Acciaio_Flessione $\gamma_M=1.05$ $f_{yk}/\gamma_M=2619$ kg/cm² $f_t=4300$ kg/cm²

:Verificato

X	cls	N	TY	TZ	MT	MY	MZ	My4	Mz4	Comb.
cm		kg	kg	kg	kg*m	kg*m	kg*m			
0	1	1247	1	-26	7	10	9	--	--	2

X	cls	Nr	Vyr	Vzr	Mry	Mrz	MTrd	SF_V.	SF_M	SF_Mt	SF
cm		kg	kg	kg	kg*m	kg*m	kg*m				
0	1	52623	19256	19256	1818	1818	1566	>100	29.4	>100	29.4

AUTOSTRADA VALDASTICO A31 NORD
1° LOTTO - PIOVENE ROCCHETTE – VALLE DELL'ASTICO

Asta : 238 [258 , 269]

Sez. G: O 114.3x5.9 L=273.9 cm Crit.: Acciaio_Flessione $\gamma_M=1.05$ $f_{yk}/\gamma_M=2619$ kg/cm² $f_t=4300$ kg/cm²

:Verificato

X	cls	N	TY	TZ	MT	MY	MZ	My4	Mz4	Comb.
cm		kg	kg	kg	kg*m	kg*m	kg*m			
0	1	-7035	16	-10	-13	-25	36	--	--	2

X	cls	Nr	Vyr	Vzr	Mry	Mrz	MTrd	SF_V.	SF_M	SF_Mt	SF
cm		kg	kg	kg	kg*m	kg*m	kg*m				
0	1	52623	19183	19183	1818	1818	1566	>100	5.99	>100	5.99

Asta : 239 [269 , 276]

Sez. G: O 114.3x5.9 L=273.9 cm Crit.: Acciaio_Flessione $\gamma_M=1.05$ $f_{yk}/\gamma_M=2619$ kg/cm² $f_t=4300$ kg/cm²

:Verificato

X	cls	N	TY	TZ	MT	MY	MZ	My4	Mz4	Comb.
cm		kg	kg	kg	kg*m	kg*m	kg*m			
164	1	2319	3	2	-6	-18	-6	--	--	2

X	cls	Nr	Vyr	Vzr	Mry	Mrz	MTrd	SF_V.	SF_M	SF_Mt	SF
cm		kg	kg	kg	kg*m	kg*m	kg*m				
164	1	52623	19272	19272	1818	1818	1566	>100	17.4	>100	17.4

Asta : 240 [277 , 260]

Sez. G: O 114.3x5.9 L=286.0 cm Crit.: Acciaio_Flessione $\gamma_M=1.05$ $f_{yk}/\gamma_M=2619$ kg/cm² $f_t=4300$ kg/cm²

:Verificato

X	cls	N	TY	TZ	MT	MY	MZ	My4	Mz4	Comb.
cm		kg	kg	kg	kg*m	kg*m	kg*m			
286	1	459	0	30	0	15	-0	--	--	2

X	cls	Nr	Vyr	Vzr	Mry	Mrz	MTrd	SF_V.	SF_M	SF_Mt	SF
cm		kg	kg	kg	kg*m	kg*m	kg*m				
286	1	52623	19342	19342	1818	1818	1566	>100	58.6	>100	58.6

AUTOSTRADA VALDASTICO A31 NORD
1° LOTTO - PIOVENE ROCCHETTE – VALLE DELL'ASTICO

Asta : 241 [260 , 259]

Sez. G: O 114.3x5.9 L=314.0 cm Crit.: Acciaio_Flessione $\gamma_M=1.05$ $f_{yk}/\gamma_M=2619$ kg/cmq $f_t=4300$ kg/cmq

:Verificato

X	cls	N	TY	TZ	MT	MY	MZ	My4	Mz4	Comb.
cm		kg	kg	kg	kg*m	kg*m	kg*m			
157	1	15333	1	2	0	-36	-0	--	--	2

X	cls	Nr	Vyr	Vzr	Mry	Mrz	MTrd	SF_V.	SF_M	SF_Mt	SF
cm		kg	kg	kg	kg*m	kg*m	kg*m				
157	1	52623	19336	19336	1818	1818	1566	>100	3.21	>100	3.21

Asta : 242 [276 , 268]

Sez. G: O 114.3x5.9 L=281.6 cm Crit.: Acciaio_Flessione $\gamma_M=1.05$ $f_{yk}/\gamma_M=2619$ kg/cmq $f_t=4300$ kg/cmq

:Verificato

X	cls	N	TY	TZ	MT	MY	MZ	My4	Mz4	Comb.
cm		kg	kg	kg	kg*m	kg*m	kg*m			
113	1	-944	-6	-6	6	-12	-8	--	--	2

X	cls	Nr	Vyr	Vzr	Mry	Mrz	MTrd	SF_V.	SF_M	SF_Mt	SF
cm		kg	kg	kg	kg*m	kg*m	kg*m				
113	1	52623	19273	19273	1818	1818	1566	>100	34.5	>100	34.5

Asta : 243 [268 , 277]

Sez. G: O 114.3x5.9 L=281.6 cm Crit.: Acciaio_Flessione $\gamma_M=1.05$ $f_{yk}/\gamma_M=2619$ kg/cmq $f_t=4300$ kg/cmq

:Verificato

X	cls	N	TY	TZ	MT	MY	MZ	My4	Mz4	Comb.
cm		kg	kg	kg	kg*m	kg*m	kg*m			
141	1	6	3	0	-6	-16	-7	--	--	2

X	cls	Nr	Vyr	Vzr	Mry	Mrz	MTrd	SF_V.	SF_M	SF_Mt	SF
cm		kg	kg	kg	kg*m	kg*m	kg*m				

AUTOSTRADA VALDASTICO A31 NORD
1° LOTTO - PIOVENE ROCCHETTE – VALLE DELL'ASTICO

X	cls	Nr	Vyr	Vzr	Mry	Mrz	MTrd	SF_V.	SF_M	SF_Mt	SF
141	1	52623	19269	19269	1818	1818	1566	>100	78.3	>100	78.3

Asta : 244 [259 , 268]

Sez. G: O 114.3x5.9 L=281.6 cm Crit.: Acciaio_Flessione $\gamma_M=1.05$ $f_{yk}/\gamma_M=2619$ kg/cm² $f_t=4300$ kg/cm²

:Verificato

X	cls	N	TY	TZ	MT	MY	MZ	My4	Mz4	Comb.
cm		kg	kg	kg	kg*m	kg*m	kg*m			
113	1	-1984	2	-4	-6	-16	8	--	--	2

X	cls	Nr	Vyr	Vzr	Mry	Mrz	MTrd	SF_V.	SF_M	SF_Mt	SF
cm		kg	kg	kg	kg*m	kg*m	kg*m				
113	1	52623	19266	19266	1818	1818	1566	>100	19.7	>100	19.7

Asta : 245 [268 , 260]

Sez. G: O 114.3x5.9 L=281.6 cm Crit.: Acciaio_Flessione $\gamma_M=1.05$ $f_{yk}/\gamma_M=2619$ kg/cm² $f_t=4300$ kg/cm²

:Verificato

X	cls	N	TY	TZ	MT	MY	MZ	My4	Mz4	Comb.
cm		kg	kg	kg	kg*m	kg*m	kg*m			
169	1	-439	-1	3	6	-16	7	--	--	2

X	cls	Nr	Vyr	Vzr	Mry	Mrz	MTrd	SF_V.	SF_M	SF_Mt	SF
cm		kg	kg	kg	kg*m	kg*m	kg*m				
169	1	52623	19265	19265	1818	1818	1566	>100	47.8	>100	47.8

Asta : 246 [260 , 267]

Sez. G: O 114.3x5.9 L=281.6 cm Crit.: Acciaio_Flessione $\gamma_M=1.05$ $f_{yk}/\gamma_M=2619$ kg/cm² $f_t=4300$ kg/cm²

:Verificato

X	cls	N	TY	TZ	MT	MY	MZ	My4	Mz4	Comb.
cm		kg	kg	kg	kg*m	kg*m	kg*m			
141	1	-415	1	1	-6	-16	7	--	--	2

AUTOSTRADA VALDASTICO A31 NORD
1° LOTTO - PIOVENE ROCCHETTE – VALLE DELL'ASTICO

X	cls	Nr	Vyr	Vzr	Mry	Mrz	MTrd	SF_V.	SF_M	SF_Mt	SF
cm		kg	kg	kg	kg*m	kg*m	kg*m				
141	1	52623	19265	19265	1818	1818	1566	>100	48.7	>100	48.7

Asta : 247 [267 , 278]

Sez. G: O 114.3x5.9 L=281.6 cm Crit.: Acciaio_Flessione $\gamma_M=1.05$ $f_{yk}/\gamma_M=2619$ kg/cm² $f_t=4300$ kg/cm²

:Verificato

X	cls	N	TY	TZ	MT	MY	MZ	My4	Mz4	Comb.
cm		kg	kg	kg	kg*m	kg*m	kg*m			
169	1	-965	6	6	-6	-12	-8	--	--	2

X	cls	Nr	Vyr	Vzr	Mry	Mrz	MTrd	SF_V.	SF_M	SF_Mt	SF
cm		kg	kg	kg	kg*m	kg*m	kg*m				
169	1	52623	19273	19273	1818	1818	1566	>100	34.1	>100	34.1

Asta : 248 [278 , 261]

Sez. G: O 114.3x5.9 L=286.0 cm Crit.: Acciaio_Flessione $\gamma_M=1.05$ $f_{yk}/\gamma_M=2619$ kg/cm² $f_t=4300$ kg/cm²

:Verificato

X	cls	N	TY	TZ	MT	MY	MZ	My4	Mz4	Comb.
cm		kg	kg	kg	kg*m	kg*m	kg*m			
286	1	101	5	32	3	19	-7	--	--	2

X	cls	Nr	Vyr	Vzr	Mry	Mrz	MTrd	SF_V.	SF_M	SF_Mt	SF
cm		kg	kg	kg	kg*m	kg*m	kg*m				
286	1	52623	19310	19310	1818	1818	1566	>100	60.4	>100	60.4

Asta : 249 [261 , 260]

Sez. G: O 114.3x5.9 L=314.0 cm Crit.: Acciaio_Flessione $\gamma_M=1.05$ $f_{yk}/\gamma_M=2619$ kg/cm² $f_t=4300$ kg/cm²

:Verificato

X	cls	N	TY	TZ	MT	MY	MZ	My4	Mz4	Comb.
cm		kg	kg	kg	kg*m	kg*m	kg*m			
157	1	15307	-1	-2	-0	-36	-0	--	--	2

AUTOSTRADA VALDASTICO A31 NORD
1° LOTTO - PIOVENE ROCCHETTE – VALLE DELL'ASTICO

X	cls	Nr	Vyr	Vzr	Mry	Mrz	MTrd	SF_V.	SF_M	SF_Mt	SF
cm		kg	kg	kg	kg*m	kg*m	kg*m				
157	1	52623	19336	19336	1818	1818	1566	>100	3.22	>100	3.22

Asta : 250 [277 , 267]

Sez. G: O 114.3x5.9 L=281.6 cm Crit.: Acciaio_Flessione $\gamma_M=1.05$ $f_{yk}/\gamma_M=2619$ kg/cm² $f_t=4300$ kg/cm²

:Verificato

X	cls	N	TY	TZ	MT	MY	MZ	My4	Mz4	Comb.
cm		kg	kg	kg	kg*m	kg*m	kg*m			
141	1	30	-3	-0	6	-16	-7	--	--	2

X	cls	Nr	Vyr	Vzr	Mry	Mrz	MTrd	SF_V.	SF_M	SF_Mt	SF
cm		kg	kg	kg	kg*m	kg*m	kg*m				
141	1	52623	19269	19269	1818	1818	1566	>100	75.6	>100	75.6

Asta : 251 [267 , 261]

Sez. G: O 114.3x5.9 L=281.6 cm Crit.: Acciaio_Flessione $\gamma_M=1.05$ $f_{yk}/\gamma_M=2619$ kg/cm² $f_t=4300$ kg/cm²

:Verificato

X	cls	N	TY	TZ	MT	MY	MZ	My4	Mz4	Comb.
cm		kg	kg	kg	kg*m	kg*m	kg*m			
169	1	-2010	-2	4	6	-16	8	--	--	2

X	cls	Nr	Vyr	Vzr	Mry	Mrz	MTrd	SF_V.	SF_M	SF_Mt	SF
cm		kg	kg	kg	kg*m	kg*m	kg*m				
169	1	52623	19266	19266	1818	1818	1566	>100	19.5	>100	19.5

Asta : 252 [279 , 262]

Sez. G: O 114.3x5.9 L=286.0 cm Crit.: Acciaio_Flessione $\gamma_M=1.05$ $f_{yk}/\gamma_M=2619$ kg/cm² $f_t=4300$ kg/cm²

:Verificato

X	cls	N	TY	TZ	MT	MY	MZ	My4	Mz4	Comb.
cm		kg	kg	kg	kg*m	kg*m	kg*m			

AUTOSTRADA VALDASTICO A31 NORD
1° LOTTO - PIOVENE ROCCHETTE – VALLE DELL'ASTICO

X	cls	N	TY	TZ	MT	MY	MZ	My4	Mz4	Comb.
286	1	-2462	11	47	17	50	-16	--	--	2

X	cls	Nr	Vyr	Vzr	Mry	Mrz	MTrd	SF_V.	SF_M	SF_Mt	SF
cm		kg	kg	kg	kg*m	kg*m	kg*m				
286	1	52623	19127	19127	1818	1818	1566	>100	12.0	89.9	12.0

Asta : 253 [262 , 261]

Sez. G: O 114.3x5.9 L=314.0 cm Crit.: Acciaio_Flessione $\gamma_M=1.05$ $f_{yk}/\gamma_M=2619$ kg/cm² $f_t=4300$ kg/cm²

:Verificato

X	cls	N	TY	TZ	MT	MY	MZ	My4	Mz4	Comb.
cm		kg	kg	kg	kg*m	kg*m	kg*m			
126	1	11834	-1	1	-1	-46	-1	--	--	2

X	cls	Nr	Vyr	Vzr	Mry	Mrz	MTrd	SF_V.	SF_M	SF_Mt	SF
cm		kg	kg	kg	kg*m	kg*m	kg*m				
126	1	52623	19328	19328	1818	1818	1566	>100	3.99	>100	3.99

Asta : 254 [261 , 266]

Sez. G: O 114.3x5.9 L=273.9 cm Crit.: Acciaio_Flessione $\gamma_M=1.05$ $f_{yk}/\gamma_M=2619$ kg/cm² $f_t=4300$ kg/cm²

:Verificato

X	cls	N	TY	TZ	MT	MY	MZ	My4	Mz4	Comb.
cm		kg	kg	kg	kg*m	kg*m	kg*m			
274	1	1286	-1	27	-7	10	9	--	--	2

X	cls	Nr	Vyr	Vzr	Mry	Mrz	MTrd	SF_V.	SF_M	SF_Mt	SF
cm		kg	kg	kg	kg*m	kg*m	kg*m				
274	1	52623	19256	19256	1818	1818	1566	>100	28.7	>100	28.7

Asta : 255 [266 , 279]

Sez. G: O 114.3x5.9 L=273.9 cm Crit.: Acciaio_Flessione $\gamma_M=1.05$ $f_{yk}/\gamma_M=2619$ kg/cm² $f_t=4300$ kg/cm²

:Verificato

AUTOSTRADA VALDASTICO A31 NORD
1° LOTTO - PIOVENE ROCCHETTE – VALLE DELL'ASTICO

X	cls	N	TY	TZ	MT	MY	MZ	My4	Mz4	Comb.
cm		kg	kg	kg	kg*m	kg*m	kg*m			
274	1	-353	13	27	-6	18	-23	--	--	2

X	cls	Nr	Vyr	Vzr	Mry	Mrz	MTrd	SF_V.	SF_M	SF_Mt	SF
cm		kg	kg	kg	kg*m	kg*m	kg*m				
274	1	52623	19269	19269	1818	1818	1566	>100	34.0	>100	34.0

Asta : 256 [278 , 266]

Sez. G: O 114.3x5.9 L=273.9 cm Crit.: Acciaio_Flessione $\gamma_M=1.05$ $f_{yk}/\gamma_M=2619$ kg/cm² $f_t=4300$ kg/cm²

:Verificato

X	cls	N	TY	TZ	MT	MY	MZ	My4	Mz4	Comb.
cm		kg	kg	kg	kg*m	kg*m	kg*m			
110	1	2364	-2	-2	6	-18	-6	--	--	2

X	cls	Nr	Vyr	Vzr	Mry	Mrz	MTrd	SF_V.	SF_M	SF_Mt	SF
cm		kg	kg	kg	kg*m	kg*m	kg*m				
110	1	52623	19272	19272	1818	1818	1566	>100	17.1	>100	17.1

Asta : 257 [266 , 262]

Sez. G: O 114.3x5.9 L=273.9 cm Crit.: Acciaio_Flessione $\gamma_M=1.05$ $f_{yk}/\gamma_M=2619$ kg/cm² $f_t=4300$ kg/cm²

:Verificato

X	cls	N	TY	TZ	MT	MY	MZ	My4	Mz4	Comb.
cm		kg	kg	kg	kg*m	kg*m	kg*m			
274	1	-7130	-16	10	13	-26	36	--	--	2

X	cls	Nr	Vyr	Vzr	Mry	Mrz	MTrd	SF_V.	SF_M	SF_Mt	SF
cm		kg	kg	kg	kg*m	kg*m	kg*m				
274	1	52623	19182	19182	1818	1818	1566	>100	5.89	>100	5.89

Asta : 258 [262 , 263]

AUTOSTRADA VALDASTICO A31 NORD
1° LOTTO - PIOVENE ROCCHETTE – VALLE DELL'ASTICO

Sez. G: O 114.3x5.9 L=314.0 cm Crit.: Acciaio_Flessione $\gamma_M=1.05$ $f_{yk}/\gamma_M=2619$ kg/cm² $f_t=4300$ kg/cm²

:Verificato

X	cls	N	TY	TZ	MT	MY	MZ	My4	Mz4	Comb.
cm		kg	kg	kg	kg*m	kg*m	kg*m			
314	1	-4634	-1	222	4	386	2	--	--	2

X	cls	Nr	Vyr	Vzr	Mry	Mrz	MTrd	SF_V.	SF_M	SF_Mt	SF
cm		kg	kg	kg	kg*m	kg*m	kg*m				
314	1	52623	19288	19288	1818	1818	1566	87.0	3.32	>100	3.32

Asta : 259 [263 , 280]

Sez. G: O 114.3x5.9 L=286.0 cm Crit.: Acciaio_Flessione $\gamma_M=1.05$ $f_{yk}/\gamma_M=2619$ kg/cm² $f_t=4300$ kg/cm²

:Verificato

X	cls	N	TY	TZ	MT	MY	MZ	My4	Mz4	Comb.
cm		kg	kg	kg	kg*m	kg*m	kg*m			
0	1	-6668	-2	-171	-36	260	-3	--	--	2

X	cls	Nr	Vyr	Vzr	Mry	Mrz	MTrd	SF_V.	SF_M	SF_Mt	SF
cm		kg	kg	kg	kg*m	kg*m	kg*m				
0	1	52623	18900	18900	1818	1818	1566	>100	3.69	43.8	3.69

Asta : 260 [279 , 265]

Sez. G: O 114.3x5.9 L=254.4 cm Crit.: Acciaio_Flessione $\gamma_M=1.05$ $f_{yk}/\gamma_M=2619$ kg/cm² $f_t=4300$ kg/cm²

:Verificato

X	cls	N	TY	TZ	MT	MY	MZ	My4	Mz4	Comb.
cm		kg	kg	kg	kg*m	kg*m	kg*m			
203	1	8096	-4	4	2	-35	5	--	--	2

X	cls	Nr	Vyr	Vzr	Mry	Mrz	MTrd	SF_V.	SF_M	SF_Mt	SF
cm		kg	kg	kg	kg*m	kg*m	kg*m				
203	1	52623	19318	19318	1818	1818	1566	>100	5.69	>100	5.69

AUTOSTRADA VALDASTICO A31 NORD
1° LOTTO - PIOVENE ROCCHETTE – VALLE DELL'ASTICO

Asta : 261 [265 , 280]

Sez. G: O 114.3x5.9 L=254.4 cm Crit.: Acciaio_Flessione $\gamma_M=1.05$ $f_{yk}/\gamma_M=2619$ kg/cm² $f_t=4300$ kg/cm²

:Verificato

X	cls	N	TY	TZ	MT	MY	MZ	My4	Mz4	Comb.
cm		kg	kg	kg	kg*m	kg*m	kg*m			
254	1	7232	25	34	9	56	-25	--	--	2

X	cls	Nr	Vyr	Vzr	Mry	Mrz	MTrd	SF_V.	SF_M	SF_Mt	SF
cm		kg	kg	kg	kg*m	kg*m	kg*m				
254	1	52623	19228	19228	1818	1818	1566	>100	5.50	>100	5.50

Asta : 262 [262 , 265]

Sez. G: O 114.3x5.9 L=254.4 cm Crit.: Acciaio_Flessione $\gamma_M=1.05$ $f_{yk}/\gamma_M=2619$ kg/cm² $f_t=4300$ kg/cm²

:Verificato

X	cls	N	TY	TZ	MT	MY	MZ	My4	Mz4	Comb.
cm		kg	kg	kg	kg*m	kg*m	kg*m			
254	1	7269	-33	15	-12	24	56	--	--	2

X	cls	Nr	Vyr	Vzr	Mry	Mrz	MTrd	SF_V.	SF_M	SF_Mt	SF
cm		kg	kg	kg	kg*m	kg*m	kg*m				
254	1	52623	19196	19196	1818	1818	1566	>100	5.50	>100	5.50

Asta : 263 [265 , 263]

Sez. G: O 114.3x5.9 L=254.4 cm Crit.: Acciaio_Flessione $\gamma_M=1.05$ $f_{yk}/\gamma_M=2619$ kg/cm² $f_t=4300$ kg/cm²

:Verificato

X	cls	N	TY	TZ	MT	MY	MZ	My4	Mz4	Comb.
cm		kg	kg	kg	kg*m	kg*m	kg*m			
254	1	-34133	36	250	-18	388	-64	--	--	2

X	cls	Nr	Vyr	Vzr	Mry	Mrz	MTrd	SF_V.	SF_M	SF_Mt	SF
cm		kg	kg	kg	kg*m	kg*m	kg*m				
254	1	52623	19116	19116	1818	1818	1566	76.3	1.11	85.8	1.11

AUTOSTRADA VALDASTICO A31 NORD
1° LOTTO - PIOVENE ROCCHETTE – VALLE DELL'ASTICO

Asta : 264 [281 , 264]

Sez. G: O 114.3x5.9 L=286.0 cm Crit.: Acciaio_Flessione $\gamma_M=1.05$ $f_{yk}/\gamma_M=2619$ kg/cmq $f_t=4300$ kg/cmq

:Verificato

X	cls	N	TY	TZ	MT	MY	MZ	My4	Mz4	Comb.
cm		kg	kg	kg	kg*m	kg*m	kg*m			
286	1	-919	5	69	-3	108	-12	--	--	(12+13)-III-3

X	cls	Nr	Vyr	Vzr	Mry	Mrz	MTrd	SF_V.	SF_M	SF_Mt	SF
cm		kg	kg	kg	kg*m	kg*m	kg*m				
286	1	52623	19301	19301	1818	1818	1566	>100	12.0	>100	12.0

Asta : 265 [264 , 263]

Sez. G: O 114.3x5.9 L=314.0 cm Crit.: Acciaio_Flessione $\gamma_M=1.05$ $f_{yk}/\gamma_M=2619$ kg/cmq $f_t=4300$ kg/cmq

:Verificato

X	cls	N	TY	TZ	MT	MY	MZ	My4	Mz4	Comb.
cm		kg	kg	kg	kg*m	kg*m	kg*m			
0	1	-7854	2	-48	-0	40	4	--	--	2

X	cls	Nr	Vyr	Vzr	Mry	Mrz	MTrd	SF_V.	SF_M	SF_Mt	SF
cm		kg	kg	kg	kg*m	kg*m	kg*m				
0	1	52623	19337	19337	1818	1818	1566	>100	5.76	>100	5.76

Asta : 266 [280 , 272]

Sez. G: O 114.3x5.9 L=229.9 cm Crit.: Acciaio_Flessione $\gamma_M=1.05$ $f_{yk}/\gamma_M=2619$ kg/cmq $f_t=4300$ kg/cmq

:Verificato

X	cls	N	TY	TZ	MT	MY	MZ	My4	Mz4	Comb.
cm		kg	kg	kg	kg*m	kg*m	kg*m			
230	1	7783	-12	27	-2	32	17	--	--	2

X	cls	Nr	Vyr	Vzr	Mry	Mrz	MTrd	SF_V.	SF_M	SF_Mt	SF
cm		kg	kg	kg	kg*m	kg*m	kg*m				

AUTOSTRADA VALDASTICO A31 NORD
1° LOTTO - PIOVENE ROCCHETTE – VALLE DELL'ASTICO

X	cls	Nr	Vyr	Vzr	Mry	Mrz	MTrd	SF_V.	SF_M	SF_Mt	SF
230	1	52623	19323	19323	1818	1818	1566	>100	5.71	>100	5.71

Asta : 267 [272 , 264]

Sez. G: O 114.3x5.9 L=229.9 cm Crit.: Acciaio_Flessione $\gamma_M=1.05$ $f_{yk}/\gamma_M=2619$ kg/cm² $f_t=4300$ kg/cm²

:Verificato

X	cls	N	TY	TZ	MT	MY	MZ	My4	Mz4	Comb.
cm		kg	kg	kg	kg*m	kg*m	kg*m			
0	1	3725	-7	-25	4	71	-12	--	--	2

X	cls	Nr	Vyr	Vzr	Mry	Mrz	MTrd	SF_V.	SF_M	SF_Mt	SF
cm		kg	kg	kg	kg*m	kg*m	kg*m				
0	1	52623	19291	19291	1818	1818	1566	>100	8.61	>100	8.61

Asta : 268 [272 , 281]

Sez. G: O 114.3x5.9 L=229.9 cm Crit.: Acciaio_Flessione $\gamma_M=1.05$ $f_{yk}/\gamma_M=2619$ kg/cm² $f_t=4300$ kg/cm²

:Verificato

X	cls	N	TY	TZ	MT	MY	MZ	My4	Mz4	Comb.
cm		kg	kg	kg	kg*m	kg*m	kg*m			
0	1	5950	11	-56	9	48	14	--	--	2

X	cls	Nr	Vyr	Vzr	Mry	Mrz	MTrd	SF_V.	SF_M	SF_Mt	SF
cm		kg	kg	kg	kg*m	kg*m	kg*m				
0	1	52623	19230	19230	1818	1818	1566	>100	6.79	>100	6.79

Asta : 269 [271 , 270]

Sez. G: O 114.3x5.9 L=318.3 cm Crit.: Acciaio_Flessione $\gamma_M=1.05$ $f_{yk}/\gamma_M=2619$ kg/cm² $f_t=4300$ kg/cm²

:Verificato

X	cls	N	TY	TZ	MT	MY	MZ	My4	Mz4	Comb.
cm		kg	kg	kg	kg*m	kg*m	kg*m			
318	1	15351	-6	1342	2	754	9	--	--	2

AUTOSTRADA VALDASTICO A31 NORD
1° LOTTO - PIOVENE ROCCHETTE – VALLE DELL'ASTICO

X	cls	Nr	Vyr	Vzr	Mry	Mrz	MTrd	SF_V.	SF_M	SF_Mt	SF
cm		kg	kg	kg	kg*m	kg*m	kg*m				
318	1	52623	19320	19320	1818	1818	1566	14.4	1.41	>100	1.41

Asta : 270 [270 , 269]

Sez. G: O 114.3x5.9 L=315.7 cm Crit.: Acciaio_Flessione $\gamma_M=1.05$ $f_{yk}/\gamma_M=2619$ kg/cm² $f_t=4300$ kg/cm²

:Verificato

X	cls	N	TY	TZ	MT	MY	MZ	My4	Mz4	Comb.
cm		kg	kg	kg	kg*m	kg*m	kg*m			
0	1	-10908	-16	-1349	17	700	-26	--	--	2

X	cls	Nr	Vyr	Vzr	Mry	Mrz	MTrd	SF_V.	SF_M	SF_Mt	SF
cm		kg	kg	kg	kg*m	kg*m	kg*m				
0	1	52623	19137	19137	1818	1818	1566	14.2	1.65	94.6	1.65

Asta : 271 [269 , 268]

Sez. G: O 114.3x5.9 L=314.2 cm Crit.: Acciaio_Flessione $\gamma_M=1.05$ $f_{yk}/\gamma_M=2619$ kg/cm² $f_t=4300$ kg/cm²

:Verificato

X	cls	N	TY	TZ	MT	MY	MZ	My4	Mz4	Comb.
cm		kg	kg	kg	kg*m	kg*m	kg*m			
0	1	-17017	-4	-1343	3	686	-6	--	--	2

X	cls	Nr	Vyr	Vzr	Mry	Mrz	MTrd	SF_V.	SF_M	SF_Mt	SF
cm		kg	kg	kg	kg*m	kg*m	kg*m				
0	1	52623	19306	19306	1818	1818	1566	14.4	1.42	>100	1.42

Asta : 272 [268 , 267]

Sez. G: O 114.3x5.9 L=314.0 cm Crit.: Acciaio_Flessione $\gamma_M=1.05$ $f_{yk}/\gamma_M=2619$ kg/cm² $f_t=4300$ kg/cm²

:Verificato

X	cls	N	TY	TZ	MT	MY	MZ	My4	Mz4	Comb.
cm		kg	kg	kg	kg*m	kg*m	kg*m			
314	1	-18341	-0	1339	-0	677	0	--	--	2

AUTOSTRADA VALDASTICO A31 NORD
1° LOTTO - PIOVENE ROCCHETTE – VALLE DELL'ASTICO

X	cls	Nr	Vyr	Vzr	Mry	Mrz	MTrd	SF_V.	SF_M	SF_Mt	SF
cm		kg	kg	kg	kg*m	kg*m	kg*m				
314	1	52623	19342	19342	1818	1818	1566	14.4	1.39	>100	1.39

Asta : 273 [267 , 266]

Sez. G: O 114.3x5.9 L=314.2 cm Crit.: Acciaio_Flessione $\gamma_M=1.05$ $f_{yk}/\gamma_M=2619$ kg/cm² $f_t=4300$ kg/cm²

:Verificato

X	cls	N	TY	TZ	MT	MY	MZ	My4	Mz4	Comb.
cm		kg	kg	kg	kg*m	kg*m	kg*m			
314	1	-16967	4	1344	-3	686	-6	--	--	2

X	cls	Nr	Vyr	Vzr	Mry	Mrz	MTrd	SF_V.	SF_M	SF_Mt	SF
cm		kg	kg	kg	kg*m	kg*m	kg*m				
314	1	52623	19305	19305	1818	1818	1566	14.4	1.42	>100	1.42

Asta : 274 [266 , 265]

Sez. G: O 114.3x5.9 L=315.7 cm Crit.: Acciaio_Flessione $\gamma_M=1.05$ $f_{yk}/\gamma_M=2619$ kg/cm² $f_t=4300$ kg/cm²

:Verificato

X	cls	N	TY	TZ	MT	MY	MZ	My4	Mz4	Comb.
cm		kg	kg	kg	kg*m	kg*m	kg*m			
316	1	-10745	16	1349	-17	700	-26	--	--	2

X	cls	Nr	Vyr	Vzr	Mry	Mrz	MTrd	SF_V.	SF_M	SF_Mt	SF
cm		kg	kg	kg	kg*m	kg*m	kg*m				
316	1	52623	19134	19134	1818	1818	1566	14.2	1.66	93.1	1.66

Asta : 275 [265 , 272]

Sez. G: O 114.3x5.9 L=318.3 cm Crit.: Acciaio_Flessione $\gamma_M=1.05$ $f_{yk}/\gamma_M=2619$ kg/cm² $f_t=4300$ kg/cm²

:Verificato

X	cls	N	TY	TZ	MT	MY	MZ	My4	Mz4	Comb.
cm		kg	kg	kg	kg*m	kg*m	kg*m			

AUTOSTRADA VALDASTICO A31 NORD
1° LOTTO - PIOVENE ROCCHETTE – VALLE DELL'ASTICO

X	cls	N	TY	TZ	MT	MY	MZ	My4	Mz4	Comb.
0	1	15839	5	-1342	-1	755	9	--	--	2

X	cls	Nr	Vyr	Vzr	Mry	Mrz	MTrd	SF_V.	SF_M	SF_Mt	SF
cm		kg	kg	kg	kg*m	kg*m	kg*m				
0	1	52623	19326	19326	1818	1818	1566	14.4	1.39	>100	1.39

Asta : 276 [273 , 288]

Sez. G: O 114.3x5.9 L=229.9 cm Crit.: Acciaio_Flessione $\gamma_M=1.05$ $f_{yk}/\gamma_M=2619$ kg/cm² $f_t=4300$ kg/cm²

:Verificato

X	cls	N	TY	TZ	MT	MY	MZ	My4	Mz4	Comb.
cm		kg	kg	kg	kg*m	kg*m	kg*m			
0	1	-3204	-7	-15	17	13	-18	--	--	2

X	cls	Nr	Vyr	Vzr	Mry	Mrz	MTrd	SF_V.	SF_M	SF_Mt	SF
cm		kg	kg	kg	kg*m	kg*m	kg*m				
0	1	52623	19129	19129	1818	1818	1566	>100	12.8	91.1	12.8

Asta : 277 [291 , 274]

Sez. G: O 114.3x5.9 L=286.0 cm Crit.: Acciaio_Flessione $\gamma_M=1.05$ $f_{yk}/\gamma_M=2619$ kg/cm² $f_t=4300$ kg/cm²

:Verificato

X	cls	N	TY	TZ	MT	MY	MZ	My4	Mz4	Comb.
cm		kg	kg	kg	kg*m	kg*m	kg*m			
143	1	10289	-1	-1	-2	-47	-2	--	--	2

X	cls	Nr	Vyr	Vzr	Mry	Mrz	MTrd	SF_V.	SF_M	SF_Mt	SF
cm		kg	kg	kg	kg*m	kg*m	kg*m				
143	1	52623	19323	19323	1818	1818	1566	>100	4.50	>100	4.50

Asta : 278 [274 , 273]

Sez. G: O 114.3x5.9 L=314.0 cm Crit.: Acciaio_Flessione $\gamma_M=1.05$ $f_{yk}/\gamma_M=2619$ kg/cm² $f_t=4300$ kg/cm²

:Verificato

AUTOSTRADA VALDASTICO A31 NORD
1° LOTTO - PIOVENE ROCCHETTE – VALLE DELL'ASTICO

X	cls	N	TY	TZ	MT	MY	MZ	My4	Mz4	Comb.
cm		kg	kg	kg	kg*m	kg*m	kg*m			
0	1	-3596	-5	-36	-10	39	-7	--	--	2

X	cls	Nr	Vyr	Vzr	Mry	Mrz	MTrd	SF_V.	SF_M	SF_Mt	SF
cm		kg	kg	kg	kg*m	kg*m	kg*m				
0	1	52623	19224	19224	1818	1818	1566	>100	10.7	>100	10.7

Asta : 279 [290 , 288]

Sez. G: O 114.3x5.9 L=229.9 cm Crit.: Acciaio_Flessione $\gamma_M=1.05$ $f_{yk}/\gamma_M=2619$ kg/cm² $f_t=4300$ kg/cm²

:Verificato

X	cls	N	TY	TZ	MT	MY	MZ	My4	Mz4	Comb.
cm		kg	kg	kg	kg*m	kg*m	kg*m			
230	1	667	-4	34	-21	17	14	--	--	2

X	cls	Nr	Vyr	Vzr	Mry	Mrz	MTrd	SF_V.	SF_M	SF_Mt	SF
cm		kg	kg	kg	kg*m	kg*m	kg*m				
230	1	52623	19079	19079	1818	1818	1566	>100	34.1	73.7	34.1

Asta : 280 [288 , 274]

Sez. G: O 114.3x5.9 L=229.9 cm Crit.: Acciaio_Flessione $\gamma_M=1.05$ $f_{yk}/\gamma_M=2619$ kg/cm² $f_t=4300$ kg/cm²

:Verificato

X	cls	N	TY	TZ	MT	MY	MZ	My4	Mz4	Comb.
cm		kg	kg	kg	kg*m	kg*m	kg*m			
0	1	-4585	21	5	-12	-43	18	--	--	2

X	cls	Nr	Vyr	Vzr	Mry	Mrz	MTrd	SF_V.	SF_M	SF_Mt	SF
cm		kg	kg	kg	kg*m	kg*m	kg*m				
0	1	52623	19190	19190	1818	1818	1566	>100	8.29	>100	8.29

Asta : 281 [288 , 291]

AUTOSTRADA VALDASTICO A31 NORD
1° LOTTO - PIOVENE ROCCHETTE – VALLE DELL'ASTICO

Sez. G: O 114.3x5.9 L=229.9 cm Crit.: Acciaio_Flessione $\gamma_M=1.05$ $f_{yk}/\gamma_M=2619$ kg/cm² $f_t=4300$ kg/cm²

:Verificato

X	cls	N	TY	TZ	MT	MY	MZ	My4	Mz4	Comb.
cm		kg	kg	kg	kg*m	kg*m	kg*m			
0	1	520	-0	4	9	-41	6	--	--	2

X	cls	Nr	Vyr	Vzr	Mry	Mrz	MTrd	SF_V.	SF_M	SF_Mt	SF
cm		kg	kg	kg	kg*m	kg*m	kg*m				
0	1	52623	19230	19230	1818	1818	1566	>100	27.6	>100	27.6

Asta : 282 [290 , 273]

Sez. G: O 114.3x5.9 L=286.0 cm Crit.: Acciaio_Flessione $\gamma_M=1.05$ $f_{yk}/\gamma_M=2619$ kg/cm² $f_t=4300$ kg/cm²

:Verificato

X	cls	N	TY	TZ	MT	MY	MZ	My4	Mz4	Comb.
cm		kg	kg	kg	kg*m	kg*m	kg*m			
114	1	4709	3	3	7	-37	-1	--	--	2

X	cls	Nr	Vyr	Vzr	Mry	Mrz	MTrd	SF_V.	SF_M	SF_Mt	SF
cm		kg	kg	kg	kg*m	kg*m	kg*m				
114	1	52623	19261	19261	1818	1818	1566	>100	9.09	>100	9.09

Asta : 283 [292 , 275]

Sez. G: O 114.3x5.9 L=286.0 cm Crit.: Acciaio_Flessione $\gamma_M=1.05$ $f_{yk}/\gamma_M=2619$ kg/cm² $f_t=4300$ kg/cm²

:Verificato

X	cls	N	TY	TZ	MT	MY	MZ	My4	Mz4	Comb.
cm		kg	kg	kg	kg*m	kg*m	kg*m			
86	1	5215	-7	-4	-6	-21	-4	--	--	2

X	cls	Nr	Vyr	Vzr	Mry	Mrz	MTrd	SF_V.	SF_M	SF_Mt	SF
cm		kg	kg	kg	kg*m	kg*m	kg*m				
86	1	52623	19262	19262	1818	1818	1566	>100	8.86	>100	8.86

AUTOSTRADA VALDASTICO A31 NORD
1° LOTTO - PIOVENE ROCCHETTE – VALLE DELL'ASTICO

Asta : 284 [275 , 274]

Sez. G: O 114.3x5.9 L=314.0 cm Crit.: Acciaio_Flessione $\gamma_M=1.05$ $f_{yk}/\gamma_M=2619$ kg/cm² $f_t=4300$ kg/cm²

:Verificato

X	cls	N	TY	TZ	MT	MY	MZ	My4	Mz4	Comb.
cm		kg	kg	kg	kg*m	kg*m	kg*m			
314	1	-187	9	55	18	61	-16	--	--	2

X	cls	Nr	Vyr	Vzr	Mry	Mrz	MTrd	SF_V.	SF_M	SF_Mt	SF
cm		kg	kg	kg	kg*m	kg*m	kg*m				
314	1	52623	19118	19118	1818	1818	1566	>100	21.8	86.5	21.8

Asta : 285 [274 , 287]

Sez. G: O 114.3x5.9 L=254.4 cm Crit.: Acciaio_Flessione $\gamma_M=1.05$ $f_{yk}/\gamma_M=2619$ kg/cm² $f_t=4300$ kg/cm²

:Verificato

X	cls	N	TY	TZ	MT	MY	MZ	My4	Mz4	Comb.
cm		kg	kg	kg	kg*m	kg*m	kg*m			
25	1	-9164	-19	-20	16	-10	-31	--	--	2

X	cls	Nr	Vyr	Vzr	Mry	Mrz	MTrd	SF_V.	SF_M	SF_Mt	SF
cm		kg	kg	kg	kg*m	kg*m	kg*m				
25	1	52623	19146	19146	1818	1818	1566	>100	5.07	98.8	5.07

Asta : 286 [287 , 292]

Sez. G: O 114.3x5.9 L=254.4 cm Crit.: Acciaio_Flessione $\gamma_M=1.05$ $f_{yk}/\gamma_M=2619$ kg/cm² $f_t=4300$ kg/cm²

:Verificato

X	cls	N	TY	TZ	MT	MY	MZ	My4	Mz4	Comb.
cm		kg	kg	kg	kg*m	kg*m	kg*m			
127	1	2338	-3	3	5	-16	5	--	--	2

X	cls	Nr	Vyr	Vzr	Mry	Mrz	MTrd	SF_V.	SF_M	SF_Mt	SF
cm		kg	kg	kg	kg*m	kg*m	kg*m				
127	1	52623	19275	19275	1818	1818	1566	>100	17.8	>100	17.8

AUTOSTRADA VALDASTICO A31 NORD
1° LOTTO - PIOVENE ROCCHETTE – VALLE DELL'ASTICO

Asta : 287 [291 , 287]

Sez. G: O 114.3x5.9 L=254.4 cm Crit.: Acciaio_Flessione $\gamma_M=1.05$ $f_{yk}/\gamma_M=2619$ kg/cmq $f_t=4300$ kg/cmq

:Verificato

X	cls	N	TY	TZ	MT	MY	MZ	My4	Mz4	Comb.
cm		kg	kg	kg	kg*m	kg*m	kg*m			
153	1	-205	-3	2	-10	-12	9	--	--	2

X	cls	Nr	Vyr	Vzr	Mry	Mrz	MTrd	SF_V.	SF_M	SF_Mt	SF
cm		kg	kg	kg	kg*m	kg*m	kg*m				
153	1	52623	19218	19218	1818	1818	1566	>100	66.4	>100	66.4

Asta : 288 [287 , 275]

Sez. G: O 114.3x5.9 L=254.4 cm Crit.: Acciaio_Flessione $\gamma_M=1.05$ $f_{yk}/\gamma_M=2619$ kg/cmq $f_t=4300$ kg/cmq

:Verificato

X	cls	N	TY	TZ	MT	MY	MZ	My4	Mz4	Comb.
cm		kg	kg	kg	kg*m	kg*m	kg*m			
254	1	165	12	29	-3	23	-17	--	--	2

X	cls	Nr	Vyr	Vzr	Mry	Mrz	MTrd	SF_V.	SF_M	SF_Mt	SF
cm		kg	kg	kg	kg*m	kg*m	kg*m				
254	1	52623	19303	19303	1818	1818	1566	>100	39.6	>100	39.6

Asta : 289 [293 , 276]

Sez. G: O 114.3x5.9 L=286.0 cm Crit.: Acciaio_Flessione $\gamma_M=1.05$ $f_{yk}/\gamma_M=2619$ kg/cmq $f_t=4300$ kg/cmq

:Verificato

X	cls	N	TY	TZ	MT	MY	MZ	My4	Mz4	Comb.
cm		kg	kg	kg	kg*m	kg*m	kg*m			
286	1	1293	-3	31	-2	14	4	--	--	2

X	cls	Nr	Vyr	Vzr	Mry	Mrz	MTrd	SF_V.	SF_M	SF_Mt	SF
cm		kg	kg	kg	kg*m	kg*m	kg*m				

AUTOSTRADA VALDASTICO A31 NORD
1° LOTTO - PIOVENE ROCCHETTE – VALLE DELL'ASTICO

X	cls	Nr	Vyr	Vzr	Mry	Mrz	MTrd	SF_V.	SF_M	SF_Mt	SF
286	1	52623	19316	19316	1818	1818	1566	>100	28.7	>100	28.7

Asta : 290 [276 , 275]

Sez. G: O 114.3x5.9 L=314.0 cm Crit.: Acciaio_Flessione $\gamma_M=1.05$ $f_{yk}/\gamma_M=2619$ kg/cm² $f_t=4300$ kg/cm²

:Verificato

X	cls	N	TY	TZ	MT	MY	MZ	My4	Mz4	Comb.
cm		kg	kg	kg	kg*m	kg*m	kg*m			
94	1	8767	5	-6	7	-28	3	--	--	2

X	cls	Nr	Vyr	Vzr	Mry	Mrz	MTrd	SF_V.	SF_M	SF_Mt	SF
cm		kg	kg	kg	kg*m	kg*m	kg*m				
94	1	52623	19254	19254	1818	1818	1566	>100	5.46	>100	5.46

Asta : 291 [292 , 286]

Sez. G: O 114.3x5.9 L=273.9 cm Crit.: Acciaio_Flessione $\gamma_M=1.05$ $f_{yk}/\gamma_M=2619$ kg/cm² $f_t=4300$ kg/cm²

:Verificato

X	cls	N	TY	TZ	MT	MY	MZ	My4	Mz4	Comb.
cm		kg	kg	kg	kg*m	kg*m	kg*m			
82	1	-1853	-8	-7	0	-11	-5	--	--	2

X	cls	Nr	Vyr	Vzr	Mry	Mrz	MTrd	SF_V.	SF_M	SF_Mt	SF
cm		kg	kg	kg	kg*m	kg*m	kg*m				
82	1	52623	19336	19336	1818	1818	1566	>100	22.9	>100	22.9

Asta : 292 [286 , 276]

Sez. G: O 114.3x5.9 L=273.9 cm Crit.: Acciaio_Flessione $\gamma_M=1.05$ $f_{yk}/\gamma_M=2619$ kg/cm² $f_t=4300$ kg/cm²

:Verificato

X	cls	N	TY	TZ	MT	MY	MZ	My4	Mz4	Comb.
cm		kg	kg	kg	kg*m	kg*m	kg*m			
0	1	1683	5	-21	3	4	11	--	--	2

AUTOSTRADA VALDASTICO A31 NORD
1° LOTTO - PIOVENE ROCCHETTE – VALLE DELL'ASTICO

X	cls	Nr	Vyr	Vzr	Mry	Mrz	MTrd	SF_V.	SF_M	SF_Mt	SF
cm		kg	kg	kg	kg*m	kg*m	kg*m				
0	1	52623	19300	19300	1818	1818	1566	>100	24.9	>100	24.9

Asta : 293 [275 , 286]

Sez. G: O 114.3x5.9 L=273.9 cm Crit.: Acciaio_Flessione $\gamma_M=1.05$ $f_{yk}/\gamma_M=2619$ kg/cm² $f_t=4300$ kg/cm²

:Verificato

X	cls	N	TY	TZ	MT	MY	MZ	My4	Mz4	Comb.
cm		kg	kg	kg	kg*m	kg*m	kg*m			
82	1	-6462	2	-3	-2	-23	3	--	--	2

X	cls	Nr	Vyr	Vzr	Mry	Mrz	MTrd	SF_V.	SF_M	SF_Mt	SF
cm		kg	kg	kg	kg*m	kg*m	kg*m				
82	1	52623	19322	19322	1818	1818	1566	>100	7.29	>100	7.29

Asta : 294 [286 , 293]

Sez. G: O 114.3x5.9 L=273.9 cm Crit.: Acciaio_Flessione $\gamma_M=1.05$ $f_{yk}/\gamma_M=2619$ kg/cm² $f_t=4300$ kg/cm²

:Verificato

X	cls	N	TY	TZ	MT	MY	MZ	My4	Mz4	Comb.
cm		kg	kg	kg	kg*m	kg*m	kg*m			
110	1	2240	-2	-3	-3	-15	-3	--	--	2

X	cls	Nr	Vyr	Vzr	Mry	Mrz	MTrd	SF_V.	SF_M	SF_Mt	SF
cm		kg	kg	kg	kg*m	kg*m	kg*m				
110	1	52623	19308	19308	1818	1818	1566	>100	19.1	>100	19.1

Asta : 295 [294 , 277]

Sez. G: O 114.3x5.9 L=286.0 cm Crit.: Acciaio_Flessione $\gamma_M=1.05$ $f_{yk}/\gamma_M=2619$ kg/cm² $f_t=4300$ kg/cm²

:Verificato

X	cls	N	TY	TZ	MT	MY	MZ	My4	Mz4	Comb.
cm		kg	kg	kg	kg*m	kg*m	kg*m			
286	1	322	0	29	0	15	-0	--	--	2

AUTOSTRADA VALDASTICO A31 NORD
1° LOTTO - PIOVENE ROCCHETTE – VALLE DELL'ASTICO

X	cls	Nr	Vyr	Vzr	Mry	Mrz	MTrd	SF_V.	SF_M	SF_Mt	SF
cm		kg	kg	kg	kg*m	kg*m	kg*m				
286	1	52623	19342	19342	1818	1818	1566	>100	70.5	>100	70.5

Asta : 296 [277 , 276]

Sez. G: O 114.3x5.9 L=314.0 cm Crit.: Acciaio_Flessione $\gamma_M=1.05$ $f_{yk}/\gamma_M=2619$ kg/cm² $f_t=4300$ kg/cm²

:Verificato

X	cls	N	TY	TZ	MT	MY	MZ	My4	Mz4	Comb.
cm		kg	kg	kg	kg*m	kg*m	kg*m			
157	1	13004	1	2	1	-33	0	--	--	2

X	cls	Nr	Vyr	Vzr	Mry	Mrz	MTrd	SF_V.	SF_M	SF_Mt	SF
cm		kg	kg	kg	kg*m	kg*m	kg*m				
157	1	52623	19324	19324	1818	1818	1566	>100	3.77	>100	3.77

Asta : 297 [293 , 285]

Sez. G: O 114.3x5.9 L=281.6 cm Crit.: Acciaio_Flessione $\gamma_M=1.05$ $f_{yk}/\gamma_M=2619$ kg/cm² $f_t=4300$ kg/cm²

:Verificato

X	cls	N	TY	TZ	MT	MY	MZ	My4	Mz4	Comb.
cm		kg	kg	kg	kg*m	kg*m	kg*m			
113	1	-1598	-5	-4	5	-13	-6	--	--	2

X	cls	Nr	Vyr	Vzr	Mry	Mrz	MTrd	SF_V.	SF_M	SF_Mt	SF
cm		kg	kg	kg	kg*m	kg*m	kg*m				
113	1	52623	19286	19286	1818	1818	1566	>100	24.3	>100	24.3

Asta : 298 [285 , 294]

Sez. G: O 114.3x5.9 L=281.6 cm Crit.: Acciaio_Flessione $\gamma_M=1.05$ $f_{yk}/\gamma_M=2619$ kg/cm² $f_t=4300$ kg/cm²

:Verificato

X	cls	N	TY	TZ	MT	MY	MZ	My4	Mz4	Comb.
cm		kg	kg	kg	kg*m	kg*m	kg*m			

AUTOSTRADA VALDASTICO A31 NORD
1° LOTTO - PIOVENE ROCCHETTE – VALLE DELL'ASTICO

X	cls	N	TY	TZ	MT	MY	MZ	My4	Mz4	Comb.
141	1	362	1	0	-5	-15	-6	--	--	2

X	cls	Nr	Vyr	Vzr	Mry	Mrz	MTrd	SF_V.	SF_M	SF_Mt	SF
cm		kg	kg	kg	kg*m	kg*m	kg*m				
141	1	52623	19278	19278	1818	1818	1566	>100	55.1	>100	55.1

Asta : 299 [276 , 285]

Sez. G: O 114.3x5.9 L=281.6 cm Crit.: Acciaio_Flessione $\gamma_M=1.05$ $f_{yk}/\gamma_M=2619$ kg/cm² $f_t=4300$ kg/cm²

:Verificato

X	cls	N	TY	TZ	MT	MY	MZ	My4	Mz4	Comb.
cm		kg	kg	kg	kg*m	kg*m	kg*m			
113	1	-2548	3	-2	-5	-17	6	--	--	2

X	cls	Nr	Vyr	Vzr	Mry	Mrz	MTrd	SF_V.	SF_M	SF_Mt	SF
cm		kg	kg	kg	kg*m	kg*m	kg*m				
113	1	52623	19280	19280	1818	1818	1566	>100	16.3	>100	16.3

Asta : 300 [285 , 277]

Sez. G: O 114.3x5.9 L=281.6 cm Crit.: Acciaio_Flessione $\gamma_M=1.05$ $f_{yk}/\gamma_M=2619$ kg/cm² $f_t=4300$ kg/cm²

:Verificato

X	cls	N	TY	TZ	MT	MY	MZ	My4	Mz4	Comb.
cm		kg	kg	kg	kg*m	kg*m	kg*m			
141	1	143	-0	-0	5	-14	6	--	--	2

X	cls	Nr	Vyr	Vzr	Mry	Mrz	MTrd	SF_V.	SF_M	SF_Mt	SF
cm		kg	kg	kg	kg*m	kg*m	kg*m				
141	1	52623	19276	19276	1818	1818	1566	>100	71.5	>100	71.5

Asta : 301 [277 , 284]

Sez. G: O 114.3x5.9 L=281.6 cm Crit.: Acciaio_Flessione $\gamma_M=1.05$ $f_{yk}/\gamma_M=2619$ kg/cm² $f_t=4300$ kg/cm²

:Verificato

AUTOSTRADA VALDASTICO A31 NORD
1° LOTTO - PIOVENE ROCCHETTE – VALLE DELL'ASTICO

X	cls	N	TY	TZ	MT	MY	MZ	My4	Mz4	Comb.
cm		kg	kg	kg	kg*m	kg*m	kg*m			
141	1	176	-0	0	-5	-14	6	--	--	2

X	cls	Nr	Vyr	Vzr	Mry	Mrz	MTrd	SF_V.	SF_M	SF_Mt	SF
cm		kg	kg	kg	kg*m	kg*m	kg*m				
141	1	52623	19276	19276	1818	1818	1566	>100	68.6	>100	68.6

Asta : 302 [284 , 295]

Sez. G: O 114.3x5.9 L=281.6 cm Crit.: Acciaio_Flessione $\gamma_M=1.05$ $f_{yk}/\gamma_M=2619$ kg/cm² $f_t=4300$ kg/cm²

:Verificato

X	cls	N	TY	TZ	MT	MY	MZ	My4	Mz4	Comb.
cm		kg	kg	kg	kg*m	kg*m	kg*m			
169	1	-1625	5	4	-4	-13	-6	--	--	2

X	cls	Nr	Vyr	Vzr	Mry	Mrz	MTrd	SF_V.	SF_M	SF_Mt	SF
cm		kg	kg	kg	kg*m	kg*m	kg*m				
169	1	52623	19286	19286	1818	1818	1566	>100	24.0	>100	24.0

Asta : 303 [295 , 278]

Sez. G: O 114.3x5.9 L=286.0 cm Crit.: Acciaio_Flessione $\gamma_M=1.05$ $f_{yk}/\gamma_M=2619$ kg/cm² $f_t=4300$ kg/cm²

:Verificato

X	cls	N	TY	TZ	MT	MY	MZ	My4	Mz4	Comb.
cm		kg	kg	kg	kg*m	kg*m	kg*m			
286	1	1295	3	31	2	14	-4	--	--	2

X	cls	Nr	Vyr	Vzr	Mry	Mrz	MTrd	SF_V.	SF_M	SF_Mt	SF
cm		kg	kg	kg	kg*m	kg*m	kg*m				
286	1	52623	19315	19315	1818	1818	1566	>100	28.7	>100	28.7

Asta : 304 [278 , 277]

AUTOSTRADA VALDASTICO A31 NORD
1° LOTTO - PIOVENE ROCCHETTE – VALLE DELL'ASTICO

Sez. G: O 114.3x5.9 L=314.0 cm Crit.: Acciaio_Flessione $\gamma_M=1.05$ $f_{yk}/\gamma_M=2619$ kg/cm² $f_t=4300$ kg/cm²

:Verificato

X	cls	N	TY	TZ	MT	MY	MZ	My4	Mz4	Comb.
cm		kg	kg	kg	kg*m	kg*m	kg*m			
157	1	12973	-1	-2	-1	-33	0	--	--	2

X	cls	Nr	Vyr	Vzr	Mry	Mrz	MTrd	SF_V.	SF_M	SF_Mt	SF
cm		kg	kg	kg	kg*m	kg*m	kg*m				
157	1	52623	19324	19324	1818	1818	1566	>100	3.78	>100	3.78

Asta : 305 [294 , 284]

Sez. G: O 114.3x5.9 L=281.6 cm Crit.: Acciaio_Flessione $\gamma_M=1.05$ $f_{yk}/\gamma_M=2619$ kg/cm² $f_t=4300$ kg/cm²

:Verificato

X	cls	N	TY	TZ	MT	MY	MZ	My4	Mz4	Comb.
cm		kg	kg	kg	kg*m	kg*m	kg*m			
141	1	394	-1	-1	5	-15	-6	--	--	2

X	cls	Nr	Vyr	Vzr	Mry	Mrz	MTrd	SF_V.	SF_M	SF_Mt	SF
cm		kg	kg	kg	kg*m	kg*m	kg*m				
141	1	52623	19278	19278	1818	1818	1566	>100	53.3	>100	53.3

Asta : 306 [284 , 278]

Sez. G: O 114.3x5.9 L=281.6 cm Crit.: Acciaio_Flessione $\gamma_M=1.05$ $f_{yk}/\gamma_M=2619$ kg/cm² $f_t=4300$ kg/cm²

:Verificato

X	cls	N	TY	TZ	MT	MY	MZ	My4	Mz4	Comb.
cm		kg	kg	kg	kg*m	kg*m	kg*m			
169	1	-2590	-3	2	5	-17	6	--	--	2

X	cls	Nr	Vyr	Vzr	Mry	Mrz	MTrd	SF_V.	SF_M	SF_Mt	SF
cm		kg	kg	kg	kg*m	kg*m	kg*m				
169	1	52623	19281	19281	1818	1818	1566	>100	16.1	>100	16.1

AUTOSTRADA VALDASTICO A31 NORD
1° LOTTO - PIOVENE ROCCHETTE – VALLE DELL'ASTICO

Asta : 307 [296 , 279]

Sez. G: O 114.3x5.9 L=286.0 cm Crit.: Acciaio_Flessione $\gamma_M=1.05$ $f_{yk}/\gamma_M=2619$ kg/cm² $f_t=4300$ kg/cm²

:Verificato

X	cls	N	TY	TZ	MT	MY	MZ	My4	Mz4	Comb.
cm		kg	kg	kg	kg*m	kg*m	kg*m			
86	1	5245	7	-4	7	-21	4	--	--	2

X	cls	Nr	Vyr	Vzr	Mry	Mrz	MTrd	SF_V.	SF_M	SF_Mt	SF
cm		kg	kg	kg	kg*m	kg*m	kg*m				
86	1	52623	19261	19261	1818	1818	1566	>100	8.81	>100	8.81

Asta : 308 [279 , 278]

Sez. G: O 114.3x5.9 L=314.0 cm Crit.: Acciaio_Flessione $\gamma_M=1.05$ $f_{yk}/\gamma_M=2619$ kg/cm² $f_t=4300$ kg/cm²

:Verificato

X	cls	N	TY	TZ	MT	MY	MZ	My4	Mz4	Comb.
cm		kg	kg	kg	kg*m	kg*m	kg*m			
220	1	8662	-5	6	-7	-28	3	--	--	2

X	cls	Nr	Vyr	Vzr	Mry	Mrz	MTrd	SF_V.	SF_M	SF_Mt	SF
cm		kg	kg	kg	kg*m	kg*m	kg*m				
220	1	52623	19254	19254	1818	1818	1566	>100	5.52	>100	5.52

Asta : 309 [278 , 283]

Sez. G: O 114.3x5.9 L=273.9 cm Crit.: Acciaio_Flessione $\gamma_M=1.05$ $f_{yk}/\gamma_M=2619$ kg/cm² $f_t=4300$ kg/cm²

:Verificato

X	cls	N	TY	TZ	MT	MY	MZ	My4	Mz4	Comb.
cm		kg	kg	kg	kg*m	kg*m	kg*m			
274	1	1703	-5	21	-3	4	11	--	--	2

X	cls	Nr	Vyr	Vzr	Mry	Mrz	MTrd	SF_V.	SF_M	SF_Mt	SF
cm		kg	kg	kg	kg*m	kg*m	kg*m				
274	1	52623	19300	19300	1818	1818	1566	>100	24.6	>100	24.6

AUTOSTRADA VALDASTICO A31 NORD
1° LOTTO - PIOVENE ROCCHETTE – VALLE DELL'ASTICO

Asta : 310 [283 , 296]

Sez. G: O 114.3x5.9 L=273.9 cm Crit.: Acciaio_Flessione $\gamma_M=1.05$ $f_{yk}/\gamma_M=2619$ kg/cmq $f_t=4300$ kg/cmq

:Verificato

X	cls	N	TY	TZ	MT	MY	MZ	My4	Mz4	Comb.
cm		kg	kg	kg	kg*m	kg*m	kg*m			
192	1	-1861	8	7	-0	-10	-5	--	--	2

X	cls	Nr	Vyr	Vzr	Mry	Mrz	MTrd	SF_V.	SF_M	SF_Mt	SF
cm		kg	kg	kg	kg*m	kg*m	kg*m				
192	1	52623	19337	19337	1818	1818	1566	>100	22.9	>100	22.9

Asta : 311 [295 , 283]

Sez. G: O 114.3x5.9 L=273.9 cm Crit.: Acciaio_Flessione $\gamma_M=1.05$ $f_{yk}/\gamma_M=2619$ kg/cmq $f_t=4300$ kg/cmq

:Verificato

X	cls	N	TY	TZ	MT	MY	MZ	My4	Mz4	Comb.
cm		kg	kg	kg	kg*m	kg*m	kg*m			
164	1	2271	2	3	3	-14	-3	--	--	2

X	cls	Nr	Vyr	Vzr	Mry	Mrz	MTrd	SF_V.	SF_M	SF_Mt	SF
cm		kg	kg	kg	kg*m	kg*m	kg*m				
164	1	52623	19309	19309	1818	1818	1566	>100	18.9	>100	18.9

Asta : 312 [283 , 279]

Sez. G: O 114.3x5.9 L=273.9 cm Crit.: Acciaio_Flessione $\gamma_M=1.05$ $f_{yk}/\gamma_M=2619$ kg/cmq $f_t=4300$ kg/cmq

:Verificato

X	cls	N	TY	TZ	MT	MY	MZ	My4	Mz4	Comb.
cm		kg	kg	kg	kg*m	kg*m	kg*m			
192	1	-6526	-2	3	2	-23	3	--	--	2

X	cls	Nr	Vyr	Vzr	Mry	Mrz	MTrd	SF_V.	SF_M	SF_Mt	SF
cm		kg	kg	kg	kg*m	kg*m	kg*m				

AUTOSTRADA VALDASTICO A31 NORD
1° LOTTO - PIOVENE ROCCHETTE – VALLE DELL'ASTICO

X	cls	Nr	Vyr	Vzr	Mry	Mrz	MTrd	SF_V.	SF_M	SF_Mt	SF
192	1	52623	19322	19322	1818	1818	1566	>100	7.23	>100	7.23

Asta : 313 [279 , 280]

Sez. G: O 114.3x5.9 L=314.0 cm Crit.: Acciaio_Flessione $\gamma_M=1.05$ $f_{yk}/\gamma_M=2619$ kg/cm² $f_t=4300$ kg/cm²

:Verificato

X	cls	N	TY	TZ	MT	MY	MZ	My4	Mz4	Comb.
cm		kg	kg	kg	kg*m	kg*m	kg*m			
314	1	-392	-9	56	-18	62	16	--	--	2

X	cls	Nr	Vyr	Vzr	Mry	Mrz	MTrd	SF_V.	SF_M	SF_Mt	SF
cm		kg	kg	kg	kg*m	kg*m	kg*m				
314	1	52623	19118	19118	1818	1818	1566	>100	19.8	86.3	19.8

Asta : 314 [280 , 297]

Sez. G: O 114.3x5.9 L=286.0 cm Crit.: Acciaio_Flessione $\gamma_M=1.05$ $f_{yk}/\gamma_M=2619$ kg/cm² $f_t=4300$ kg/cm²

:Verificato

X	cls	N	TY	TZ	MT	MY	MZ	My4	Mz4	Comb.
cm		kg	kg	kg	kg*m	kg*m	kg*m			
143	1	10318	1	1	1	-47	-2	--	--	2

X	cls	Nr	Vyr	Vzr	Mry	Mrz	MTrd	SF_V.	SF_M	SF_Mt	SF
cm		kg	kg	kg	kg*m	kg*m	kg*m				
143	1	52623	19326	19326	1818	1818	1566	>100	4.48	>100	4.48

Asta : 315 [296 , 282]

Sez. G: O 114.3x5.9 L=254.4 cm Crit.: Acciaio_Flessione $\gamma_M=1.05$ $f_{yk}/\gamma_M=2619$ kg/cm² $f_t=4300$ kg/cm²

:Verificato

X	cls	N	TY	TZ	MT	MY	MZ	My4	Mz4	Comb.
cm		kg	kg	kg	kg*m	kg*m	kg*m			
127	1	2347	3	-3	-6	-16	5	--	--	2

AUTOSTRADA VALDASTICO A31 NORD
1° LOTTO - PIOVENE ROCCHETTE – VALLE DELL'ASTICO

X	cls	Nr	Vyr	Vzr	Mry	Mrz	MTrd	SF_V.	SF_M	SF_Mt	SF
cm		kg	kg	kg	kg*m	kg*m	kg*m				
127	1	52623	19274	19274	1818	1818	1566	>100	17.8	>100	17.8

Asta : 316 [282 , 297]

Sez. G: O 114.3x5.9 L=254.4 cm Crit.: Acciaio_Flessione $\gamma_M=1.05$ $f_{yk}/\gamma_M=2619$ kg/cm² $f_t=4300$ kg/cm²

:Verificato

X	cls	N	TY	TZ	MT	MY	MZ	My4	Mz4	Comb.
cm		kg	kg	kg	kg*m	kg*m	kg*m			
102	1	-191	3	-2	10	-11	9	--	--	2

X	cls	Nr	Vyr	Vzr	Mry	Mrz	MTrd	SF_V.	SF_M	SF_Mt	SF
cm		kg	kg	kg	kg*m	kg*m	kg*m				
102	1	52623	19216	19216	1818	1818	1566	>100	67.6	>100	67.6

Asta : 317 [279 , 282]

Sez. G: O 114.3x5.9 L=254.4 cm Crit.: Acciaio_Flessione $\gamma_M=1.05$ $f_{yk}/\gamma_M=2619$ kg/cm² $f_t=4300$ kg/cm²

:Verificato

X	cls	N	TY	TZ	MT	MY	MZ	My4	Mz4	Comb.
cm		kg	kg	kg	kg*m	kg*m	kg*m			
0	1	159	-12	-29	3	23	-17	--	--	2

X	cls	Nr	Vyr	Vzr	Mry	Mrz	MTrd	SF_V.	SF_M	SF_Mt	SF
cm		kg	kg	kg	kg*m	kg*m	kg*m				
0	1	52623	19302	19302	1818	1818	1566	>100	39.3	>100	39.3

Asta : 318 [282 , 280]

Sez. G: O 114.3x5.9 L=254.4 cm Crit.: Acciaio_Flessione $\gamma_M=1.05$ $f_{yk}/\gamma_M=2619$ kg/cm² $f_t=4300$ kg/cm²

:Verificato

X	cls	N	TY	TZ	MT	MY	MZ	My4	Mz4	Comb.
cm		kg	kg	kg	kg*m	kg*m	kg*m			
229	1	-9200	19	21	-16	-10	-32	--	--	2

AUTOSTRADA VALDASTICO A31 NORD
1° LOTTO - PIOVENE ROCCHETTE – VALLE DELL'ASTICO

X	cls	Nr	Vyr	Vzr	Mry	Mrz	MTrd	SF_V.	SF_M	SF_Mt	SF
cm		kg	kg	kg	kg*m	kg*m	kg*m				
229	1	52623	19142	19142	1818	1818	1566	>100	5.06	96.9	5.06

Asta : 319 [298 , 281]

Sez. G: O 114.3x5.9 L=286.0 cm Crit.: Acciaio_Flessione $\gamma_M=1.05$ $f_{yk}/\gamma_M=2619$ kg/cm² $f_t=4300$ kg/cm²

:Verificato

X	cls	N	TY	TZ	MT	MY	MZ	My4	Mz4	Comb.
cm		kg	kg	kg	kg*m	kg*m	kg*m			
86	1	4556	-3	-3	-7	-36	-1	--	--	2

X	cls	Nr	Vyr	Vzr	Mry	Mrz	MTrd	SF_V.	SF_M	SF_Mt	SF
cm		kg	kg	kg	kg*m	kg*m	kg*m				
86	1	52623	19254	19254	1818	1818	1566	>100	9.39	>100	9.39

Asta : 320 [281 , 280]

Sez. G: O 114.3x5.9 L=314.0 cm Crit.: Acciaio_Flessione $\gamma_M=1.05$ $f_{yk}/\gamma_M=2619$ kg/cm² $f_t=4300$ kg/cm²

:Verificato

X	cls	N	TY	TZ	MT	MY	MZ	My4	Mz4	Comb.
cm		kg	kg	kg	kg*m	kg*m	kg*m			
314	1	-3753	6	36	10	39	-8	--	--	2

X	cls	Nr	Vyr	Vzr	Mry	Mrz	MTrd	SF_V.	SF_M	SF_Mt	SF
cm		kg	kg	kg	kg*m	kg*m	kg*m				
314	1	52623	19214	19214	1818	1818	1566	>100	10.3	>100	10.3

Asta : 321 [297 , 289]

Sez. G: O 114.3x5.9 L=229.9 cm Crit.: Acciaio_Flessione $\gamma_M=1.05$ $f_{yk}/\gamma_M=2619$ kg/cm² $f_t=4300$ kg/cm²

:Verificato

X	cls	N	TY	TZ	MT	MY	MZ	My4	Mz4	Comb.
cm		kg	kg	kg	kg*m	kg*m	kg*m			

AUTOSTRADA VALDASTICO A31 NORD
1° LOTTO - PIOVENE ROCCHETTE – VALLE DELL'ASTICO

X	cls	N	TY	TZ	MT	MY	MZ	My4	Mz4	Comb.
230	1	485	0	-4	-9	-41	6	--	--	2

X	cls	Nr	Vyr	Vzr	Mry	Mrz	MTrd	SF_V.	SF_M	SF_Mt	SF
cm		kg	kg	kg	kg*m	kg*m	kg*m				
230	1	52623	19229	19229	1818	1818	1566	>100	28.4	>100	28.4

Asta : 322 [289 , 281]

Sez. G: O 114.3x5.9 L=229.9 cm Crit.: Acciaio_Flessione $\gamma_M=1.05$ $f_{yk}/\gamma_M=2619$ kg/cm² $f_t=4300$ kg/cm²

:Verificato

X	cls	N	TY	TZ	MT	MY	MZ	My4	Mz4	Comb.
cm		kg	kg	kg	kg*m	kg*m	kg*m			
230	1	-3106	7	16	-17	16	-18	--	--	2

X	cls	Nr	Vyr	Vzr	Mry	Mrz	MTrd	SF_V.	SF_M	SF_Mt	SF
cm		kg	kg	kg	kg*m	kg*m	kg*m				
230	1	52623	19132	19132	1818	1818	1566	>100	12.9	92.2	12.9

Asta : 323 [289 , 298]

Sez. G: O 114.3x5.9 L=229.9 cm Crit.: Acciaio_Flessione $\gamma_M=1.05$ $f_{yk}/\gamma_M=2619$ kg/cm² $f_t=4300$ kg/cm²

:Verificato

X	cls	N	TY	TZ	MT	MY	MZ	My4	Mz4	Comb.
cm		kg	kg	kg	kg*m	kg*m	kg*m			
0	1	667	4	-34	21	16	13	--	--	2

X	cls	Nr	Vyr	Vzr	Mry	Mrz	MTrd	SF_V.	SF_M	SF_Mt	SF
cm		kg	kg	kg	kg*m	kg*m	kg*m				
0	1	52623	19080	19080	1818	1818	1566	>100	34.5	74.0	34.5

Asta : 324 [288 , 287]

Sez. G: O 114.3x5.9 L=318.3 cm Crit.: Acciaio_Flessione $\gamma_M=1.05$ $f_{yk}/\gamma_M=2619$ kg/cm² $f_t=4300$ kg/cm²

:Verificato

AUTOSTRADA VALDASTICO A31 NORD
1° LOTTO - PIOVENE ROCCHETTE – VALLE DELL'ASTICO

X	cls	N	TY	TZ	MT	MY	MZ	My4	Mz4	Comb.
cm		kg	kg	kg	kg*m	kg*m	kg*m			
318	1	2537	-5	1350	3	731	8	--	--	2

X	cls	Nr	Vyr	Vzr	Mry	Mrz	MTrd	SF_V.	SF_M	SF_Mt	SF
cm		kg	kg	kg	kg*m	kg*m	kg*m				
318	1	52623	19299	19299	1818	1818	1566	14.3	2.20	>100	2.20

Asta : 325 [287 , 286]

Sez. G: O 114.3x5.9 L=315.7 cm Crit.: Acciaio_Flessione $\gamma_M=1.05$ $f_{yk}/\gamma_M=2619$ kg/cm² $f_t=4300$ kg/cm²

:Verificato

X	cls	N	TY	TZ	MT	MY	MZ	My4	Mz4	Comb.
cm		kg	kg	kg	kg*m	kg*m	kg*m			
0	1	-5246	-9	-1349	6	716	-15	--	--	2

X	cls	Nr	Vyr	Vzr	Mry	Mrz	MTrd	SF_V.	SF_M	SF_Mt	SF
cm		kg	kg	kg	kg*m	kg*m	kg*m				
0	1	52623	19268	19268	1818	1818	1566	14.3	1.99	>100	1.99

Asta : 326 [286 , 285]

Sez. G: O 114.3x5.9 L=314.2 cm Crit.: Acciaio_Flessione $\gamma_M=1.05$ $f_{yk}/\gamma_M=2619$ kg/cm² $f_t=4300$ kg/cm²

:Verificato

X	cls	N	TY	TZ	MT	MY	MZ	My4	Mz4	Comb.
cm		kg	kg	kg	kg*m	kg*m	kg*m			
0	1	-12164	-3	-1345	2	694	-5	--	--	2

X	cls	Nr	Vyr	Vzr	Mry	Mrz	MTrd	SF_V.	SF_M	SF_Mt	SF
cm		kg	kg	kg	kg*m	kg*m	kg*m				
0	1	52623	19317	19317	1818	1818	1566	14.4	1.62	>100	1.62

Asta : 327 [285 , 284]

AUTOSTRADA VALDASTICO A31 NORD
1° LOTTO - PIOVENE ROCCHETTE – VALLE DELL'ASTICO

Sez. G: O 114.3x5.9 L=314.0 cm Crit.: Acciaio_Flessione $\gamma_M=1.05$ $f_{yk}/\gamma_M=2619$ kg/cmq $f_t=4300$ kg/cmq

:Verificato

X	cls	N	TY	TZ	MT	MY	MZ	My4	Mz4	Comb.
cm		kg	kg	kg	kg*m	kg*m	kg*m			
314	1	-14702	0	1339	-0	681	0	--	--	2

X	cls	Nr	Vyr	Vzr	Mry	Mrz	MTrd	SF_V.	SF_M	SF_Mt	SF
cm		kg	kg	kg	kg*m	kg*m	kg*m				
314	1	52623	19342	19342	1818	1818	1566	14.4	1.53	>100	1.53

Asta : 328 [284 , 283]

Sez. G: O 114.3x5.9 L=314.2 cm Crit.: Acciaio_Flessione $\gamma_M=1.05$ $f_{yk}/\gamma_M=2619$ kg/cmq $f_t=4300$ kg/cmq

:Verificato

X	cls	N	TY	TZ	MT	MY	MZ	My4	Mz4	Comb.
cm		kg	kg	kg	kg*m	kg*m	kg*m			
314	1	-12089	3	1345	-2	695	-5	--	--	2

X	cls	Nr	Vyr	Vzr	Mry	Mrz	MTrd	SF_V.	SF_M	SF_Mt	SF
cm		kg	kg	kg	kg*m	kg*m	kg*m				
314	1	52623	19317	19317	1818	1818	1566	14.4	1.63	>100	1.63

Asta : 329 [283 , 282]

Sez. G: O 114.3x5.9 L=315.7 cm Crit.: Acciaio_Flessione $\gamma_M=1.05$ $f_{yk}/\gamma_M=2619$ kg/cmq $f_t=4300$ kg/cmq

:Verificato

X	cls	N	TY	TZ	MT	MY	MZ	My4	Mz4	Comb.
cm		kg	kg	kg	kg*m	kg*m	kg*m			
316	1	-5101	9	1349	-6	716	-15	--	--	2

X	cls	Nr	Vyr	Vzr	Mry	Mrz	MTrd	SF_V.	SF_M	SF_Mt	SF
cm		kg	kg	kg	kg*m	kg*m	kg*m				
316	1	52623	19268	19268	1818	1818	1566	14.3	2.00	>100	2.00

AUTOSTRADA VALDASTICO A31 NORD
1° LOTTO - PIOVENE ROCCHETTE – VALLE DELL'ASTICO

Asta : 330 [282 , 289]

Sez. G: O 114.3x5.9 L=318.3 cm Crit.: Acciaio_Flessione $\gamma_M=1.05$ $f_{yk}/\gamma_M=2619$ kg/cm² $f_t=4300$ kg/cm²

:Verificato

X	cls	N	TY	TZ	MT	MY	MZ	My4	Mz4	Comb.
cm		kg	kg	kg	kg*m	kg*m	kg*m			
0	1	2699	4	-1351	-3	732	7	--	--	2

X	cls	Nr	Vyr	Vzr	Mry	Mrz	MTrd	SF_V.	SF_M	SF_Mt	SF
cm		kg	kg	kg	kg*m	kg*m	kg*m				
0	1	52623	19301	19301	1818	1818	1566	14.3	2.18	>100	2.18

Asta : 331 [290 , 305]

Sez. G: O 114.3x5.9 L=229.9 cm Crit.: Acciaio_Flessione $\gamma_M=1.05$ $f_{yk}/\gamma_M=2619$ kg/cm² $f_t=4300$ kg/cm²

:Verificato

X	cls	N	TY	TZ	MT	MY	MZ	My4	Mz4	Comb.
cm		kg	kg	kg	kg*m	kg*m	kg*m			
230	1	624	5	34	21	19	-15	--	--	2

X	cls	Nr	Vyr	Vzr	Mry	Mrz	MTrd	SF_V.	SF_M	SF_Mt	SF
cm		kg	kg	kg	kg*m	kg*m	kg*m				
230	1	52623	19086	19086	1818	1818	1566	>100	32.8	75.6	32.8

Asta : 332 [308 , 291]

Sez. G: O 114.3x5.9 L=286.0 cm Crit.: Acciaio_Flessione $\gamma_M=1.05$ $f_{yk}/\gamma_M=2619$ kg/cm² $f_t=4300$ kg/cm²

:Verificato

X	cls	N	TY	TZ	MT	MY	MZ	My4	Mz4	Comb.
cm		kg	kg	kg	kg*m	kg*m	kg*m			
172	1	9944	5	5	3	-46	-3	--	--	2

X	cls	Nr	Vyr	Vzr	Mry	Mrz	MTrd	SF_V.	SF_M	SF_Mt	SF
cm		kg	kg	kg	kg*m	kg*m	kg*m				
172	1	52623	19301	19301	1818	1818	1566	>100	4.64	>100	4.64

AUTOSTRADA VALDASTICO A31 NORD
1° LOTTO - PIOVENE ROCCHETTE – VALLE DELL'ASTICO

Asta : 333 [291 , 290]

Sez. G: O 114.3x5.9 L=314.0 cm Crit.: Acciaio_Flessione $\gamma_M=1.05$ $f_{yk}/\gamma_M=2619$ kg/cmq $f_t=4300$ kg/cmq

:Verificato

X	cls	N	TY	TZ	MT	MY	MZ	My4	Mz4	Comb.
cm		kg	kg	kg	kg*m	kg*m	kg*m			
314	1	-1039	-1	34	-1	27	2	--	--	2

X	cls	Nr	Vyr	Vzr	Mry	Mrz	MTrd	SF_V.	SF_M	SF_Mt	SF
cm		kg	kg	kg	kg*m	kg*m	kg*m				
314	1	52623	19330	19330	1818	1818	1566	>100	28.1	>100	28.1

Asta : 334 [307 , 305]

Sez. G: O 114.3x5.9 L=229.9 cm Crit.: Acciaio_Flessione $\gamma_M=1.05$ $f_{yk}/\gamma_M=2619$ kg/cmq $f_t=4300$ kg/cmq

:Verificato

X	cls	N	TY	TZ	MT	MY	MZ	My4	Mz4	Comb.
cm		kg	kg	kg	kg*m	kg*m	kg*m			
0	1	-3068	7	-19	-16	19	17	--	--	2

X	cls	Nr	Vyr	Vzr	Mry	Mrz	MTrd	SF_V.	SF_M	SF_Mt	SF
cm		kg	kg	kg	kg*m	kg*m	kg*m				
0	1	52623	19146	19146	1818	1818	1566	>100	12.8	99.0	12.8

Asta : 335 [305 , 291]

Sez. G: O 114.3x5.9 L=229.9 cm Crit.: Acciaio_Flessione $\gamma_M=1.05$ $f_{yk}/\gamma_M=2619$ kg/cmq $f_t=4300$ kg/cmq

:Verificato

X	cls	N	TY	TZ	MT	MY	MZ	My4	Mz4	Comb.
cm		kg	kg	kg	kg*m	kg*m	kg*m			
0	1	1490	-1	5	-9	-44	-8	--	--	2

X	cls	Nr	Vyr	Vzr	Mry	Mrz	MTrd	SF_V.	SF_M	SF_Mt	SF
cm		kg	kg	kg	kg*m	kg*m	kg*m				

AUTOSTRADA VALDASTICO A31 NORD
1° LOTTO - PIOVENE ROCCHETTE – VALLE DELL'ASTICO

X	cls	Nr	Vyr	Vzr	Mry	Mrz	MTrd	SF_V.	SF_M	SF_Mt	SF
0	1	52623	19231	19231	1818	1818	1566	>100	17.5	>100	17.5

Asta : 336 [305 , 308]

Sez. G: O 114.3x5.9 L=229.9 cm Crit.: Acciaio_Flessione $\gamma_M=1.05$ $f_{yk}/\gamma_M=2619$ kg/cm² $f_t=4300$ kg/cm²

:Verificato

X	cls	N	TY	TZ	MT	MY	MZ	My4	Mz4	Comb.
cm		kg	kg	kg	kg*m	kg*m	kg*m			
0	1	-5589	-22	6	12	-41	-19	--	--	2

X	cls	Nr	Vyr	Vzr	Mry	Mrz	MTrd	SF_V.	SF_M	SF_Mt	SF
cm		kg	kg	kg	kg*m	kg*m	kg*m				
0	1	52623	19198	19198	1818	1818	1566	>100	7.18	>100	7.18

Asta : 337 [307 , 290]

Sez. G: O 114.3x5.9 L=286.0 cm Crit.: Acciaio_Flessione $\gamma_M=1.05$ $f_{yk}/\gamma_M=2619$ kg/cm² $f_t=4300$ kg/cm²

:Verificato

X	cls	N	TY	TZ	MT	MY	MZ	My4	Mz4	Comb.
cm		kg	kg	kg	kg*m	kg*m	kg*m			
200	1	4330	-1	-1	-5	-35	-0	--	--	2

X	cls	Nr	Vyr	Vzr	Mry	Mrz	MTrd	SF_V.	SF_M	SF_Mt	SF
cm		kg	kg	kg	kg*m	kg*m	kg*m				
200	1	52623	19275	19275	1818	1818	1566	>100	9.81	>100	9.81

Asta : 338 [309 , 292]

Sez. G: O 114.3x5.9 L=286.0 cm Crit.: Acciaio_Flessione $\gamma_M=1.05$ $f_{yk}/\gamma_M=2619$ kg/cm² $f_t=4300$ kg/cm²

:Verificato

X	cls	N	TY	TZ	MT	MY	MZ	My4	Mz4	Comb.
cm		kg	kg	kg	kg*m	kg*m	kg*m			
229	1	5152	11	10	8	-19	-10	--	--	2

AUTOSTRADA VALDASTICO A31 NORD
1° LOTTO - PIOVENE ROCCHETTE – VALLE DELL'ASTICO

X	cls	Nr	Vyr	Vzr	Mry	Mrz	MTrd	SF_V.	SF_M	SF_Mt	SF
cm		kg	kg	kg	kg*m	kg*m	kg*m				
229	1	52623	19239	19239	1818	1818	1566	>100	8.81	>100	8.81

Asta : 339 [292 , 291]

Sez. G: O 114.3x5.9 L=314.0 cm Crit.: Acciaio_Flessione $\gamma_M=1.05$ $f_{yk}/\gamma_M=2619$ kg/cm² $f_t=4300$ kg/cm²

:Verificato

X	cls	N	TY	TZ	MT	MY	MZ	My4	Mz4	Comb.
cm		kg	kg	kg	kg*m	kg*m	kg*m			
314	1	886	-2	41	-1	33	3	--	--	2

X	cls	Nr	Vyr	Vzr	Mry	Mrz	MTrd	SF_V.	SF_M	SF_Mt	SF
cm		kg	kg	kg	kg*m	kg*m	kg*m				
314	1	52623	19329	19329	1818	1818	1566	>100	27.2	>100	27.2

Asta : 340 [291 , 304]

Sez. G: O 114.3x5.9 L=254.4 cm Crit.: Acciaio_Flessione $\gamma_M=1.05$ $f_{yk}/\gamma_M=2619$ kg/cm² $f_t=4300$ kg/cm²

:Verificato

X	cls	N	TY	TZ	MT	MY	MZ	My4	Mz4	Comb.
cm		kg	kg	kg	kg*m	kg*m	kg*m			
153	1	-665	4	3	10	-9	-9	--	--	2

X	cls	Nr	Vyr	Vzr	Mry	Mrz	MTrd	SF_V.	SF_M	SF_Mt	SF
cm		kg	kg	kg	kg*m	kg*m	kg*m				
153	1	52623	19222	19222	1818	1818	1566	>100	44.4	>100	44.4

Asta : 341 [304 , 309]

Sez. G: O 114.3x5.9 L=254.4 cm Crit.: Acciaio_Flessione $\gamma_M=1.05$ $f_{yk}/\gamma_M=2619$ kg/cm² $f_t=4300$ kg/cm²

:Verificato

X	cls	N	TY	TZ	MT	MY	MZ	My4	Mz4	Comb.
cm		kg	kg	kg	kg*m	kg*m	kg*m			
254	1	-399	-12	27	3	23	17	--	--	2

AUTOSTRADA VALDASTICO A31 NORD
1° LOTTO - PIOVENE ROCCHETTE – VALLE DELL'ASTICO

X	cls	Nr	Vyr	Vzr	Mry	Mrz	MTrd	SF_V.	SF_M	SF_Mt	SF
cm		kg	kg	kg	kg*m	kg*m	kg*m				
254	1	52623	19306	19306	1818	1818	1566	>100	33.6	>100	33.6

Asta : 342 [308 , 304]

Sez. G: O 114.3x5.9 L=254.4 cm Crit.: Acciaio_Flessione $\gamma_M=1.05$ $f_{yk}/\gamma_M=2619$ kg/cm² $f_t=4300$ kg/cm²

:Verificato

X	cls	N	TY	TZ	MT	MY	MZ	My4	Mz4	Comb.
cm		kg	kg	kg	kg*m	kg*m	kg*m			
51	1	-8967	19	-19	-16	-14	26	--	--	2

X	cls	Nr	Vyr	Vzr	Mry	Mrz	MTrd	SF_V.	SF_M	SF_Mt	SF
cm		kg	kg	kg	kg*m	kg*m	kg*m				
51	1	52623	19148	19148	1818	1818	1566	>100	5.19	99.7	5.19

Asta : 343 [304 , 292]

Sez. G: O 114.3x5.9 L=254.4 cm Crit.: Acciaio_Flessione $\gamma_M=1.05$ $f_{yk}/\gamma_M=2619$ kg/cm² $f_t=4300$ kg/cm²

:Verificato

X	cls	N	TY	TZ	MT	MY	MZ	My4	Mz4	Comb.
cm		kg	kg	kg	kg*m	kg*m	kg*m			
102	1	3111	3	0	-5	-19	-4	--	--	2

X	cls	Nr	Vyr	Vzr	Mry	Mrz	MTrd	SF_V.	SF_M	SF_Mt	SF
cm		kg	kg	kg	kg*m	kg*m	kg*m				
102	1	52623	19274	19274	1818	1818	1566	>100	13.9	>100	13.9

Asta : 344 [310 , 293]

Sez. G: O 114.3x5.9 L=286.0 cm Crit.: Acciaio_Flessione $\gamma_M=1.05$ $f_{yk}/\gamma_M=2619$ kg/cm² $f_t=4300$ kg/cm²

:Verificato

X	cls	N	TY	TZ	MT	MY	MZ	My4	Mz4	Comb.
cm		kg	kg	kg	kg*m	kg*m	kg*m			

AUTOSTRADA VALDASTICO A31 NORD
1° LOTTO - PIOVENE ROCCHETTE – VALLE DELL'ASTICO

X	cls	N	TY	TZ	MT	MY	MZ	My4	Mz4	Comb.
286	1	1673	6	30	3	12	-8	--	--	2

X	cls	Nr	Vyr	Vzr	Mry	Mrz	MTrd	SF_V.	SF_M	SF_Mt	SF
cm		kg	kg	kg	kg*m	kg*m	kg*m				
286	1	52623	19305	19305	1818	1818	1566	>100	23.5	>100	23.5

Asta : 345 [293 , 292]

Sez. G: O 114.3x5.9 L=314.0 cm Crit.: Acciaio_Flessione $\gamma_M=1.05$ $f_{yk}/\gamma_M=2619$ kg/cm² $f_t=4300$ kg/cm²

:Verificato

X	cls	N	TY	TZ	MT	MY	MZ	My4	Mz4	Comb.
cm		kg	kg	kg	kg*m	kg*m	kg*m			
126	1	6808	-2	1	-1	-24	-1	--	--	2

X	cls	Nr	Vyr	Vzr	Mry	Mrz	MTrd	SF_V.	SF_M	SF_Mt	SF
cm		kg	kg	kg	kg*m	kg*m	kg*m				
126	1	52623	19333	19333	1818	1818	1566	>100	7.01	>100	7.01

Asta : 346 [309 , 303]

Sez. G: O 114.3x5.9 L=273.9 cm Crit.: Acciaio_Flessione $\gamma_M=1.05$ $f_{yk}/\gamma_M=2619$ kg/cm² $f_t=4300$ kg/cm²

:Verificato

X	cls	N	TY	TZ	MT	MY	MZ	My4	Mz4	Comb.
cm		kg	kg	kg	kg*m	kg*m	kg*m			
82	1	-5891	-3	-4	2	-24	-4	--	--	2

X	cls	Nr	Vyr	Vzr	Mry	Mrz	MTrd	SF_V.	SF_M	SF_Mt	SF
cm		kg	kg	kg	kg*m	kg*m	kg*m				
82	1	52623	19319	19319	1818	1818	1566	>100	7.86	>100	7.86

Asta : 347 [303 , 293]

Sez. G: O 114.3x5.9 L=273.9 cm Crit.: Acciaio_Flessione $\gamma_M=1.05$ $f_{yk}/\gamma_M=2619$ kg/cm² $f_t=4300$ kg/cm²

:Verificato

AUTOSTRADA VALDASTICO A31 NORD
1° LOTTO - PIOVENE ROCCHETTE – VALLE DELL'ASTICO

X	cls	N	TY	TZ	MT	MY	MZ	My4	Mz4	Comb.
cm		kg	kg	kg	kg*m	kg*m	kg*m			
110	1	2312	2	-2	3	-16	4	--	--	2

X	cls	Nr	Vyr	Vzr	Mry	Mrz	MTrd	SF_V.	SF_M	SF_Mt	SF
cm		kg	kg	kg	kg*m	kg*m	kg*m				
110	1	52623	19310	19310	1818	1818	1566	>100	18.3	>100	18.3

Asta : 348 [292 , 303]

Sez. G: O 114.3x5.9 L=273.9 cm Crit.: Acciaio_Flessione $\gamma_M=1.05$ $f_{yk}/\gamma_M=2619$ kg/cm² $f_t=4300$ kg/cm²

:Verificato

X	cls	N	TY	TZ	MT	MY	MZ	My4	Mz4	Comb.
cm		kg	kg	kg	kg*m	kg*m	kg*m			
274	1	-2537	8	24	-1	7	-10	--	--	2

X	cls	Nr	Vyr	Vzr	Mry	Mrz	MTrd	SF_V.	SF_M	SF_Mt	SF
cm		kg	kg	kg	kg*m	kg*m	kg*m				
274	1	52623	19334	19334	1818	1818	1566	>100	17.3	>100	17.3

Asta : 349 [303 , 310]

Sez. G: O 114.3x5.9 L=273.9 cm Crit.: Acciaio_Flessione $\gamma_M=1.05$ $f_{yk}/\gamma_M=2619$ kg/cm² $f_t=4300$ kg/cm²

:Verificato

X	cls	N	TY	TZ	MT	MY	MZ	My4	Mz4	Comb.
cm		kg	kg	kg	kg*m	kg*m	kg*m			
0	1	1760	-4	-23	-4	7	-10	--	--	2

X	cls	Nr	Vyr	Vzr	Mry	Mrz	MTrd	SF_V.	SF_M	SF_Mt	SF
cm		kg	kg	kg	kg*m	kg*m	kg*m				
0	1	52623	19298	19298	1818	1818	1566	>100	23.5	>100	23.5

Asta : 350 [311 , 294]

AUTOSTRADA VALDASTICO A31 NORD
1° LOTTO - PIOVENE ROCCHETTE – VALLE DELL'ASTICO

Sez. G: O 114.3x5.9 L=286.0 cm Crit.: Acciaio_Flessione $\gamma_M=1.05$ $f_{yk}/\gamma_M=2619$ kg/cm² $f_t=4300$ kg/cm²

:Verificato

X	cls	N	TY	TZ	MT	MY	MZ	My4	Mz4	Comb.
cm		kg	kg	kg	kg*m	kg*m	kg*m			
286	1	907	0	32	-0	17	-0	--	--	2

X	cls	Nr	Vyr	Vzr	Mry	Mrz	MTrd	SF_V.	SF_M	SF_Mt	SF
cm		kg	kg	kg	kg*m	kg*m	kg*m				
286	1	52623	19342	19342	1818	1818	1566	>100	37.9	>100	37.9

Asta : 351 [294 , 293]

Sez. G: O 114.3x5.9 L=314.0 cm Crit.: Acciaio_Flessione $\gamma_M=1.05$ $f_{yk}/\gamma_M=2619$ kg/cm² $f_t=4300$ kg/cm²

:Verificato

X	cls	N	TY	TZ	MT	MY	MZ	My4	Mz4	Comb.
cm		kg	kg	kg	kg*m	kg*m	kg*m			
126	1	11670	-1	-3	-0	-31	-0	--	--	2

X	cls	Nr	Vyr	Vzr	Mry	Mrz	MTrd	SF_V.	SF_M	SF_Mt	SF
cm		kg	kg	kg	kg*m	kg*m	kg*m				
126	1	52623	19339	19339	1818	1818	1566	>100	4.19	>100	4.19

Asta : 352 [310 , 302]

Sez. G: O 114.3x5.9 L=281.6 cm Crit.: Acciaio_Flessione $\gamma_M=1.05$ $f_{yk}/\gamma_M=2619$ kg/cm² $f_t=4300$ kg/cm²

:Verificato

X	cls	N	TY	TZ	MT	MY	MZ	My4	Mz4	Comb.
cm		kg	kg	kg	kg*m	kg*m	kg*m			
113	1	-1738	-4	-2	5	-18	-6	--	--	2

X	cls	Nr	Vyr	Vzr	Mry	Mrz	MTrd	SF_V.	SF_M	SF_Mt	SF
cm		kg	kg	kg	kg*m	kg*m	kg*m				
113	1	52623	19280	19280	1818	1818	1566	>100	21.5	>100	21.5

AUTOSTRADA VALDASTICO A31 NORD
1° LOTTO - PIOVENE ROCCHETTE – VALLE DELL'ASTICO

Asta : 353 [302 , 311]

Sez. G: O 114.3x5.9 L=281.6 cm Crit.: Acciaio_Flessione $\gamma_M=1.05$ $f_{yk}/\gamma_M=2619$ kg/cm² $f_t=4300$ kg/cm²

:Verificato

X	cls	N	TY	TZ	MT	MY	MZ	My4	Mz4	Comb.
cm		kg	kg	kg	kg*m	kg*m	kg*m			
141	1	753	1	-1	-5	-15	-6	--	--	2

X	cls	Nr	Vyr	Vzr	Mry	Mrz	MTrd	SF_V.	SF_M	SF_Mt	SF
cm		kg	kg	kg	kg*m	kg*m	kg*m				
141	1	52623	19277	19277	1818	1818	1566	>100	38.8	>100	38.8

Asta : 354 [293 , 302]

Sez. G: O 114.3x5.9 L=281.6 cm Crit.: Acciaio_Flessione $\gamma_M=1.05$ $f_{yk}/\gamma_M=2619$ kg/cm² $f_t=4300$ kg/cm²

:Verificato

X	cls	N	TY	TZ	MT	MY	MZ	My4	Mz4	Comb.
cm		kg	kg	kg	kg*m	kg*m	kg*m			
113	1	-2423	4	-4	-4	-13	6	--	--	2

X	cls	Nr	Vyr	Vzr	Mry	Mrz	MTrd	SF_V.	SF_M	SF_Mt	SF
cm		kg	kg	kg	kg*m	kg*m	kg*m				
113	1	52623	19287	19287	1818	1818	1566	>100	17.7	>100	17.7

Asta : 355 [302 , 294]

Sez. G: O 114.3x5.9 L=281.6 cm Crit.: Acciaio_Flessione $\gamma_M=1.05$ $f_{yk}/\gamma_M=2619$ kg/cm² $f_t=4300$ kg/cm²

:Verificato

X	cls	N	TY	TZ	MT	MY	MZ	My4	Mz4	Comb.
cm		kg	kg	kg	kg*m	kg*m	kg*m			
141	1	-213	-0	1	5	-15	6	--	--	2

X	cls	Nr	Vyr	Vzr	Mry	Mrz	MTrd	SF_V.	SF_M	SF_Mt	SF
cm		kg	kg	kg	kg*m	kg*m	kg*m				
141	1	52623	19280	19280	1818	1818	1566	>100	63.9	>100	63.9

AUTOSTRADA VALDASTICO A31 NORD
1° LOTTO - PIOVENE ROCCHETTE – VALLE DELL'ASTICO

Asta : 356 [294 , 301]

Sez. G: O 114.3x5.9 L=281.6 cm Crit.: Acciaio_Flessione $\gamma_M=1.05$ $f_{yk}/\gamma_M=2619$ kg/cmq $f_t=4300$ kg/cmq

:Verificato

X	cls	N	TY	TZ	MT	MY	MZ	My4	Mz4	Comb.
cm		kg	kg	kg	kg*m	kg*m	kg*m			
141	1	-183	-0	-1	-5	-15	6	--	--	2

X	cls	Nr	Vyr	Vzr	Mry	Mrz	MTrd	SF_V.	SF_M	SF_Mt	SF
cm		kg	kg	kg	kg*m	kg*m	kg*m				
141	1	52623	19281	19281	1818	1818	1566	>100	66.3	>100	66.3

Asta : 357 [301 , 312]

Sez. G: O 114.3x5.9 L=281.6 cm Crit.: Acciaio_Flessione $\gamma_M=1.05$ $f_{yk}/\gamma_M=2619$ kg/cmq $f_t=4300$ kg/cmq

:Verificato

X	cls	N	TY	TZ	MT	MY	MZ	My4	Mz4	Comb.
cm		kg	kg	kg	kg*m	kg*m	kg*m			
169	1	-1781	4	2	-5	-18	-6	--	--	2

X	cls	Nr	Vyr	Vzr	Mry	Mrz	MTrd	SF_V.	SF_M	SF_Mt	SF
cm		kg	kg	kg	kg*m	kg*m	kg*m				
169	1	52623	19280	19280	1818	1818	1566	>100	21.1	>100	21.1

Asta : 358 [312 , 295]

Sez. G: O 114.3x5.9 L=286.0 cm Crit.: Acciaio_Flessione $\gamma_M=1.05$ $f_{yk}/\gamma_M=2619$ kg/cmq $f_t=4300$ kg/cmq

:Verificato

X	cls	N	TY	TZ	MT	MY	MZ	My4	Mz4	Comb.
cm		kg	kg	kg	kg*m	kg*m	kg*m			
286	1	1679	-6	30	-3	12	8	--	--	2

X	cls	Nr	Vyr	Vzr	Mry	Mrz	MTrd	SF_V.	SF_M	SF_Mt	SF
cm		kg	kg	kg	kg*m	kg*m	kg*m				

AUTOSTRADA VALDASTICO A31 NORD
1° LOTTO - PIOVENE ROCCHETTE – VALLE DELL'ASTICO

X	cls	Nr	Vyr	Vzr	Mry	Mrz	MTrd	SF_V.	SF_M	SF_Mt	SF
286	1	52623	19305	19305	1818	1818	1566	>100	23.5	>100	23.5

Asta : 359 [295 , 294]

Sez. G: O 114.3x5.9 L=314.0 cm Crit.: Acciaio_Flessione $\gamma_M=1.05$ $f_{yk}/\gamma_M=2619$ kg/cm² $f_t=4300$ kg/cm²

:Verificato

X	cls	N	TY	TZ	MT	MY	MZ	My4	Mz4	Comb.
cm		kg	kg	kg	kg*m	kg*m	kg*m			
188	1	11636	1	3	0	-31	-0	--	--	2

X	cls	Nr	Vyr	Vzr	Mry	Mrz	MTrd	SF_V.	SF_M	SF_Mt	SF
cm		kg	kg	kg	kg*m	kg*m	kg*m				
188	1	52623	19339	19339	1818	1818	1566	>100	4.20	>100	4.20

Asta : 360 [311 , 301]

Sez. G: O 114.3x5.9 L=281.6 cm Crit.: Acciaio_Flessione $\gamma_M=1.05$ $f_{yk}/\gamma_M=2619$ kg/cm² $f_t=4300$ kg/cm²

:Verificato

X	cls	N	TY	TZ	MT	MY	MZ	My4	Mz4	Comb.
cm		kg	kg	kg	kg*m	kg*m	kg*m			
141	1	788	-1	1	5	-15	-6	--	--	2

X	cls	Nr	Vyr	Vzr	Mry	Mrz	MTrd	SF_V.	SF_M	SF_Mt	SF
cm		kg	kg	kg	kg*m	kg*m	kg*m				
141	1	52623	19277	19277	1818	1818	1566	>100	37.9	>100	37.9

Asta : 361 [301 , 295]

Sez. G: O 114.3x5.9 L=281.6 cm Crit.: Acciaio_Flessione $\gamma_M=1.05$ $f_{yk}/\gamma_M=2619$ kg/cm² $f_t=4300$ kg/cm²

:Verificato

X	cls	N	TY	TZ	MT	MY	MZ	My4	Mz4	Comb.
cm		kg	kg	kg	kg*m	kg*m	kg*m			
169	1	-2448	-4	4	4	-13	6	--	--	2

AUTOSTRADA VALDASTICO A31 NORD
1° LOTTO - PIOVENE ROCCHETTE – VALLE DELL'ASTICO

X	cls	Nr	Vyr	Vzr	Mry	Mrz	MTrd	SF_V.	SF_M	SF_Mt	SF
cm		kg	kg	kg	kg*m	kg*m	kg*m				
169	1	52623	19288	19288	1818	1818	1566	>100	17.5	>100	17.5

Asta : 362 [313 , 296]

Sez. G: O 114.3x5.9 L=286.0 cm Crit.: Acciaio_Flessione $\gamma_M=1.05$ $f_{yk}/\gamma_M=2619$ kg/cm² $f_t=4300$ kg/cm²

:Verificato

X	cls	N	TY	TZ	MT	MY	MZ	My4	Mz4	Comb.
cm		kg	kg	kg	kg*m	kg*m	kg*m			
229	1	5183	-11	10	-8	-19	10	--	--	2

X	cls	Nr	Vyr	Vzr	Mry	Mrz	MTrd	SF_V.	SF_M	SF_Mt	SF
cm		kg	kg	kg	kg*m	kg*m	kg*m				
229	1	52623	19239	19239	1818	1818	1566	>100	8.76	>100	8.76

Asta : 363 [296 , 295]

Sez. G: O 114.3x5.9 L=314.0 cm Crit.: Acciaio_Flessione $\gamma_M=1.05$ $f_{yk}/\gamma_M=2619$ kg/cm² $f_t=4300$ kg/cm²

:Verificato

X	cls	N	TY	TZ	MT	MY	MZ	My4	Mz4	Comb.
cm		kg	kg	kg	kg*m	kg*m	kg*m			
188	1	6714	2	-1	1	-23	-1	--	--	2

X	cls	Nr	Vyr	Vzr	Mry	Mrz	MTrd	SF_V.	SF_M	SF_Mt	SF
cm		kg	kg	kg	kg*m	kg*m	kg*m				
188	1	52623	19333	19333	1818	1818	1566	>100	7.11	>100	7.11

Asta : 364 [295 , 300]

Sez. G: O 114.3x5.9 L=273.9 cm Crit.: Acciaio_Flessione $\gamma_M=1.05$ $f_{yk}/\gamma_M=2619$ kg/cm² $f_t=4300$ kg/cm²

:Verificato

X	cls	N	TY	TZ	MT	MY	MZ	My4	Mz4	Comb.
cm		kg	kg	kg	kg*m	kg*m	kg*m			
164	1	2335	-2	2	-3	-16	4	--	--	2

AUTOSTRADA VALDASTICO A31 NORD
1° LOTTO - PIOVENE ROCCHETTE – VALLE DELL'ASTICO

X	cls	Nr	Vyr	Vzr	Mry	Mrz	MTrd	SF_V.	SF_M	SF_Mt	SF
cm		kg	kg	kg	kg*m	kg*m	kg*m				
164	1	52623	19310	19310	1818	1818	1566	>100	18.1	>100	18.1

Asta : 365 [300 , 313]

Sez. G: O 114.3x5.9 L=273.9 cm Crit.: Acciaio_Flessione $\gamma_M=1.05$ $f_{yk}/\gamma_M=2619$ kg/cm² $f_t=4300$ kg/cm²

:Verificato

X	cls	N	TY	TZ	MT	MY	MZ	My4	Mz4	Comb.
cm		kg	kg	kg	kg*m	kg*m	kg*m			
192	1	-5956	3	4	-2	-24	-4	--	--	2

X	cls	Nr	Vyr	Vzr	Mry	Mrz	MTrd	SF_V.	SF_M	SF_Mt	SF
cm		kg	kg	kg	kg*m	kg*m	kg*m				
192	1	52623	19320	19320	1818	1818	1566	>100	7.78	>100	7.78

Asta : 366 [312 , 300]

Sez. G: O 114.3x5.9 L=273.9 cm Crit.: Acciaio_Flessione $\gamma_M=1.05$ $f_{yk}/\gamma_M=2619$ kg/cm² $f_t=4300$ kg/cm²

:Verificato

X	cls	N	TY	TZ	MT	MY	MZ	My4	Mz4	Comb.
cm		kg	kg	kg	kg*m	kg*m	kg*m			
274	1	1784	4	23	3	7	-10	--	--	2

X	cls	Nr	Vyr	Vzr	Mry	Mrz	MTrd	SF_V.	SF_M	SF_Mt	SF
cm		kg	kg	kg	kg*m	kg*m	kg*m				
274	1	52623	19299	19299	1818	1818	1566	>100	23.2	>100	23.2

Asta : 367 [300 , 296]

Sez. G: O 114.3x5.9 L=273.9 cm Crit.: Acciaio_Flessione $\gamma_M=1.05$ $f_{yk}/\gamma_M=2619$ kg/cm² $f_t=4300$ kg/cm²

:Verificato

X	cls	N	TY	TZ	MT	MY	MZ	My4	Mz4	Comb.
cm		kg	kg	kg	kg*m	kg*m	kg*m			

AUTOSTRADA VALDASTICO A31 NORD
1° LOTTO - PIOVENE ROCCHETTE – VALLE DELL'ASTICO

X	cls	N	TY	TZ	MT	MY	MZ	My4	Mz4	Comb.
0	1	-2538	-8	-24	1	7	-10	--	--	2

X	cls	Nr	Vyr	Vzr	Mry	Mrz	MTrd	SF_V.	SF_M	SF_Mt	SF
cm		kg	kg	kg	kg*m	kg*m	kg*m				
0	1	52623	19335	19335	1818	1818	1566	>100	17.3	>100	17.3

Asta : 368 [296 , 297]

Sez. G: O 114.3x5.9 L=314.0 cm Crit.: Acciaio_Flessione $\gamma_M=1.05$ $f_{yk}/\gamma_M=2619$ kg/cm² $f_t=4300$ kg/cm²

:Verificato

X	cls	N	TY	TZ	MT	MY	MZ	My4	Mz4	Comb.
cm		kg	kg	kg	kg*m	kg*m	kg*m			
314	1	783	2	41	1	33	-3	--	--	2

X	cls	Nr	Vyr	Vzr	Mry	Mrz	MTrd	SF_V.	SF_M	SF_Mt	SF
cm		kg	kg	kg	kg*m	kg*m	kg*m				
314	1	52623	19328	19328	1818	1818	1566	>100	28.6	>100	28.6

Asta : 369 [297 , 314]

Sez. G: O 114.3x5.9 L=286.0 cm Crit.: Acciaio_Flessione $\gamma_M=1.05$ $f_{yk}/\gamma_M=2619$ kg/cm² $f_t=4300$ kg/cm²

:Verificato

X	cls	N	TY	TZ	MT	MY	MZ	My4	Mz4	Comb.
cm		kg	kg	kg	kg*m	kg*m	kg*m			
114	1	9961	-5	-5	-3	-46	-3	--	--	2

X	cls	Nr	Vyr	Vzr	Mry	Mrz	MTrd	SF_V.	SF_M	SF_Mt	SF
cm		kg	kg	kg	kg*m	kg*m	kg*m				
114	1	52623	19303	19303	1818	1818	1566	>100	4.63	>100	4.63

Asta : 370 [313 , 299]

Sez. G: O 114.3x5.9 L=254.4 cm Crit.: Acciaio_Flessione $\gamma_M=1.05$ $f_{yk}/\gamma_M=2619$ kg/cm² $f_t=4300$ kg/cm²

:Verificato

AUTOSTRADA VALDASTICO A31 NORD
1° LOTTO - PIOVENE ROCCHETTE – VALLE DELL'ASTICO

X	cls	N	TY	TZ	MT	MY	MZ	My4	Mz4	Comb.
cm		kg	kg	kg	kg*m	kg*m	kg*m			
0	1	-399	12	-27	-3	23	18	--	--	2

X	cls	Nr	Vyr	Vzr	Mry	Mrz	MTrd	SF_V.	SF_M	SF_Mt	SF
cm		kg	kg	kg	kg*m	kg*m	kg*m				
0	1	52623	19305	19305	1818	1818	1566	>100	33.2	>100	33.2

Asta : 371 [299 , 314]

Sez. G: O 114.3x5.9 L=254.4 cm Crit.: Acciaio_Flessione $\gamma_M=1.05$ $f_{yk}/\gamma_M=2619$ kg/cm² $f_t=4300$ kg/cm²

:Verificato

X	cls	N	TY	TZ	MT	MY	MZ	My4	Mz4	Comb.
cm		kg	kg	kg	kg*m	kg*m	kg*m			
203	1	-9016	-20	19	16	-14	27	--	--	2

X	cls	Nr	Vyr	Vzr	Mry	Mrz	MTrd	SF_V.	SF_M	SF_Mt	SF
cm		kg	kg	kg	kg*m	kg*m	kg*m				
203	1	52623	19144	19144	1818	1818	1566	>100	5.17	98.0	5.17

Asta : 372 [296 , 299]

Sez. G: O 114.3x5.9 L=254.4 cm Crit.: Acciaio_Flessione $\gamma_M=1.05$ $f_{yk}/\gamma_M=2619$ kg/cm² $f_t=4300$ kg/cm²

:Verificato

X	cls	N	TY	TZ	MT	MY	MZ	My4	Mz4	Comb.
cm		kg	kg	kg	kg*m	kg*m	kg*m			
153	1	3111	-3	-0	6	-19	-4	--	--	2

X	cls	Nr	Vyr	Vzr	Mry	Mrz	MTrd	SF_V.	SF_M	SF_Mt	SF
cm		kg	kg	kg	kg*m	kg*m	kg*m				
153	1	52623	19272	19272	1818	1818	1566	>100	13.9	>100	13.9

Asta : 373 [299 , 297]

AUTOSTRADA VALDASTICO A31 NORD
1° LOTTO - PIOVENE ROCCHETTE – VALLE DELL'ASTICO

Sez. G: O 114.3x5.9 L=254.4 cm Crit.: Acciaio_Flessione $\gamma_M=1.05$ $f_{yk}/\gamma_M=2619$ kg/cmq $f_t=4300$ kg/cmq

:Verificato

X	cls	N	TY	TZ	MT	MY	MZ	My4	Mz4	Comb.
cm		kg	kg	kg	kg*m	kg*m	kg*m			
102	1	-633	-3	-3	-10	-9	-9	--	--	2

X	cls	Nr	Vyr	Vzr	Mry	Mrz	MTrd	SF_V.	SF_M	SF_Mt	SF
cm		kg	kg	kg	kg*m	kg*m	kg*m				
102	1	52623	19221	19221	1818	1818	1566	>100	45.7	>100	45.7

Asta : 374 [315 , 298]

Sez. G: O 114.3x5.9 L=286.0 cm Crit.: Acciaio_Flessione $\gamma_M=1.05$ $f_{yk}/\gamma_M=2619$ kg/cmq $f_t=4300$ kg/cmq

:Verificato

X	cls	N	TY	TZ	MT	MY	MZ	My4	Mz4	Comb.
cm		kg	kg	kg	kg*m	kg*m	kg*m			
200	1	4164	1	-1	6	-34	0	--	--	2

X	cls	Nr	Vyr	Vzr	Mry	Mrz	MTrd	SF_V.	SF_M	SF_Mt	SF
cm		kg	kg	kg	kg*m	kg*m	kg*m				
200	1	52623	19269	19269	1818	1818	1566	>100	10.2	>100	10.2

Asta : 375 [298 , 297]

Sez. G: O 114.3x5.9 L=314.0 cm Crit.: Acciaio_Flessione $\gamma_M=1.05$ $f_{yk}/\gamma_M=2619$ kg/cmq $f_t=4300$ kg/cmq

:Verificato

X	cls	N	TY	TZ	MT	MY	MZ	My4	Mz4	Comb.
cm		kg	kg	kg	kg*m	kg*m	kg*m			
0	1	-1068	1	-34	1	27	2	--	--	2

X	cls	Nr	Vyr	Vzr	Mry	Mrz	MTrd	SF_V.	SF_M	SF_Mt	SF
cm		kg	kg	kg	kg*m	kg*m	kg*m				
0	1	52623	19330	19330	1818	1818	1566	>100	27.6	>100	27.6

AUTOSTRADA VALDASTICO A31 NORD
1° LOTTO - PIOVENE ROCCHETTE – VALLE DELL'ASTICO

Asta : 376 [314 , 306]

Sez. G: O 114.3x5.9 L=229.9 cm Crit.: Acciaio_Flessione $\gamma_M=1.05$ $f_{yk}/\gamma_M=2619$ kg/cm² $f_t=4300$ kg/cm²

:Verificato

X	cls	N	TY	TZ	MT	MY	MZ	My4	Mz4	Comb.
cm		kg	kg	kg	kg*m	kg*m	kg*m			
230	1	-5609	22	-6	-12	-41	-19	--	--	2

X	cls	Nr	Vyr	Vzr	Mry	Mrz	MTrd	SF_V.	SF_M	SF_Mt	SF
cm		kg	kg	kg	kg*m	kg*m	kg*m				
230	1	52623	19197	19197	1818	1818	1566	>100	7.16	>100	7.16

Asta : 377 [306 , 298]

Sez. G: O 114.3x5.9 L=229.9 cm Crit.: Acciaio_Flessione $\gamma_M=1.05$ $f_{yk}/\gamma_M=2619$ kg/cm² $f_t=4300$ kg/cm²

:Verificato

X	cls	N	TY	TZ	MT	MY	MZ	My4	Mz4	Comb.
cm		kg	kg	kg	kg*m	kg*m	kg*m			
0	1	638	-5	-34	-21	19	-14	--	--	2

X	cls	Nr	Vyr	Vzr	Mry	Mrz	MTrd	SF_V.	SF_M	SF_Mt	SF
cm		kg	kg	kg	kg*m	kg*m	kg*m				
0	1	52623	19087	19087	1818	1818	1566	>100	32.8	76.0	32.8

Asta : 378 [306 , 315]

Sez. G: O 114.3x5.9 L=229.9 cm Crit.: Acciaio_Flessione $\gamma_M=1.05$ $f_{yk}/\gamma_M=2619$ kg/cm² $f_t=4300$ kg/cm²

:Verificato

X	cls	N	TY	TZ	MT	MY	MZ	My4	Mz4	Comb.
cm		kg	kg	kg	kg*m	kg*m	kg*m			
230	1	-2997	-7	20	16	21	17	--	--	2

X	cls	Nr	Vyr	Vzr	Mry	Mrz	MTrd	SF_V.	SF_M	SF_Mt	SF
cm		kg	kg	kg	kg*m	kg*m	kg*m				
230	1	52623	19148	19148	1818	1818	1566	>100	12.8	>100	12.8

AUTOSTRADA VALDASTICO A31 NORD
1° LOTTO - PIOVENE ROCCHETTE – VALLE DELL'ASTICO

Asta : 379 [305 , 304]

Sez. G: O 114.3x5.9 L=318.3 cm Crit.: Acciaio_Flessione $\gamma_M=1.05$ $f_{yk}/\gamma_M=2619$ kg/cmq $f_t=4300$ kg/cmq

:Verificato

X	cls	N	TY	TZ	MT	MY	MZ	My4	Mz4	Comb.
cm		kg	kg	kg	kg*m	kg*m	kg*m			
318	1	2624	5	1350	-5	731	-8	--	--	2

X	cls	Nr	Vyr	Vzr	Mry	Mrz	MTrd	SF_V.	SF_M	SF_Mt	SF
cm		kg	kg	kg	kg*m	kg*m	kg*m				
318	1	52623	19276	19276	1818	1818	1566	14.3	2.19	>100	2.19

Asta : 380 [304 , 303]

Sez. G: O 114.3x5.9 L=315.7 cm Crit.: Acciaio_Flessione $\gamma_M=1.05$ $f_{yk}/\gamma_M=2619$ kg/cmq $f_t=4300$ kg/cmq

:Verificato

X	cls	N	TY	TZ	MT	MY	MZ	My4	Mz4	Comb.
cm		kg	kg	kg	kg*m	kg*m	kg*m			
0	1	-5454	9	-1349	-8	716	16	--	--	2

X	cls	Nr	Vyr	Vzr	Mry	Mrz	MTrd	SF_V.	SF_M	SF_Mt	SF
cm		kg	kg	kg	kg*m	kg*m	kg*m				
0	1	52623	19247	19247	1818	1818	1566	14.3	1.98	>100	1.98

Asta : 381 [303 , 302]

Sez. G: O 114.3x5.9 L=314.2 cm Crit.: Acciaio_Flessione $\gamma_M=1.05$ $f_{yk}/\gamma_M=2619$ kg/cmq $f_t=4300$ kg/cmq

:Verificato

X	cls	N	TY	TZ	MT	MY	MZ	My4	Mz4	Comb.
cm		kg	kg	kg	kg*m	kg*m	kg*m			
0	1	-12534	3	-1345	-3	694	5	--	--	2

X	cls	Nr	Vyr	Vzr	Mry	Mrz	MTrd	SF_V.	SF_M	SF_Mt	SF
cm		kg	kg	kg	kg*m	kg*m	kg*m				

AUTOSTRADA VALDASTICO A31 NORD
1° LOTTO - PIOVENE ROCCHETTE – VALLE DELL'ASTICO

X	cls	Nr	Vyr	Vzr	Mry	Mrz	MTrd	SF_V.	SF_M	SF_Mt	SF
0	1	52623	19308	19308	1818	1818	1566	14.4	1.61	>100	1.61

Asta : 382 [302 , 301]

Sez. G: O 114.3x5.9 L=314.0 cm Crit.: Acciaio_Flessione $\gamma_M=1.05$ $f_{yk}/\gamma_M=2619$ kg/cm² $f_t=4300$ kg/cm²

:Verificato

X	cls	N	TY	TZ	MT	MY	MZ	My4	Mz4	Comb.
cm		kg	kg	kg	kg*m	kg*m	kg*m			
314	1	-15100	-0	1339	0	680	0	--	--	2

X	cls	Nr	Vyr	Vzr	Mry	Mrz	MTrd	SF_V.	SF_M	SF_Mt	SF
cm		kg	kg	kg	kg*m	kg*m	kg*m				
314	1	52623	19342	19342	1818	1818	1566	14.4	1.51	>100	1.51

Asta : 383 [301 , 300]

Sez. G: O 114.3x5.9 L=314.2 cm Crit.: Acciaio_Flessione $\gamma_M=1.05$ $f_{yk}/\gamma_M=2619$ kg/cm² $f_t=4300$ kg/cm²

:Verificato

X	cls	N	TY	TZ	MT	MY	MZ	My4	Mz4	Comb.
cm		kg	kg	kg	kg*m	kg*m	kg*m			
314	1	-12461	-3	1345	3	694	5	--	--	2

X	cls	Nr	Vyr	Vzr	Mry	Mrz	MTrd	SF_V.	SF_M	SF_Mt	SF
cm		kg	kg	kg	kg*m	kg*m	kg*m				
314	1	52623	19308	19308	1818	1818	1566	14.4	1.61	>100	1.61

Asta : 384 [300 , 299]

Sez. G: O 114.3x5.9 L=315.7 cm Crit.: Acciaio_Flessione $\gamma_M=1.05$ $f_{yk}/\gamma_M=2619$ kg/cm² $f_t=4300$ kg/cm²

:Verificato

X	cls	N	TY	TZ	MT	MY	MZ	My4	Mz4	Comb.
cm		kg	kg	kg	kg*m	kg*m	kg*m			
316	1	-5316	-10	1349	8	716	16	--	--	2

AUTOSTRADA VALDASTICO A31 NORD
1° LOTTO - PIOVENE ROCCHETTE – VALLE DELL'ASTICO

X	cls	Nr	Vyr	Vzr	Mry	Mrz	MTrd	SF_V.	SF_M	SF_Mt	SF
cm		kg	kg	kg	kg*m	kg*m	kg*m				
316	1	52623	19247	19247	1818	1818	1566	14.3	1.99	>100	1.99

Asta : 385 [299 , 306]

Sez. G: O 114.3x5.9 L=318.3 cm Crit.: Acciaio_Flessione $\gamma_M=1.05$ $f_{yk}/\gamma_M=2619$ kg/cm² $f_t=4300$ kg/cm²

:Verificato

X	cls	N	TY	TZ	MT	MY	MZ	My4	Mz4	Comb.
cm		kg	kg	kg	kg*m	kg*m	kg*m			
0	1	2773	-5	-1350	5	732	-8	--	--	2

X	cls	Nr	Vyr	Vzr	Mry	Mrz	MTrd	SF_V.	SF_M	SF_Mt	SF
cm		kg	kg	kg	kg*m	kg*m	kg*m				
0	1	52623	19278	19278	1818	1818	1566	14.3	2.18	>100	2.18

Asta : 386 [324 , 331]

Sez. G: O 114.3x5.9 L=229.9 cm Crit.: Acciaio_Flessione $\gamma_M=1.05$ $f_{yk}/\gamma_M=2619$ kg/cm² $f_t=4300$ kg/cm²

:Verificato

X	cls	N	TY	TZ	MT	MY	MZ	My4	Mz4	Comb.
cm		kg	kg	kg	kg*m	kg*m	kg*m			
230	1	3842	3	40	-1	83	-7	--	--	2

X	cls	Nr	Vyr	Vzr	Mry	Mrz	MTrd	SF_V.	SF_M	SF_Mt	SF
cm		kg	kg	kg	kg*m	kg*m	kg*m				
230	1	52623	19331	19331	1818	1818	1566	>100	8.15	>100	8.15

Asta : 387 [334 , 323]

Sez. G: O 114.3x5.9 L=286.0 cm Crit.: Acciaio_Flessione $\gamma_M=1.05$ $f_{yk}/\gamma_M=2619$ kg/cm² $f_t=4300$ kg/cm²

:Verificato

X	cls	N	TY	TZ	MT	MY	MZ	My4	Mz4	Comb.
cm		kg	kg	kg	kg*m	kg*m	kg*m			
286	1	-8209	2	162	35	242	-1	--	--	2

AUTOSTRADA VALDASTICO A31 NORD
1° LOTTO - PIOVENE ROCCHETTE – VALLE DELL'ASTICO

X	cls	Nr	Vyr	Vzr	Mry	Mrz	MTrd	SF_V.	SF_M	SF_Mt	SF
cm		kg	kg	kg	kg*m	kg*m	kg*m				
286	1	52623	18905	18905	1818	1818	1566	>100	3.45	44.2	3.45

Asta : 388 [323 , 324]

Sez. G: O 114.3x5.9 L=314.0 cm Crit.: Acciaio_Flessione $\gamma_M=1.05$ $f_{yk}/\gamma_M=2619$ kg/cmq $f_t=4300$ kg/cmq

:Verificato

X	cls	N	TY	TZ	MT	MY	MZ	My4	Mz4	Comb.
cm		kg	kg	kg	kg*m	kg*m	kg*m			
314	1	-7645	-0	43	0	34	1	--	--	2

X	cls	Nr	Vyr	Vzr	Mry	Mrz	MTrd	SF_V.	SF_M	SF_Mt	SF
cm		kg	kg	kg	kg*m	kg*m	kg*m				
314	1	52623	19341	19341	1818	1818	1566	>100	6.08	>100	6.08

Asta : 389 [333 , 331]

Sez. G: O 114.3x5.9 L=229.9 cm Crit.: Acciaio_Flessione $\gamma_M=1.05$ $f_{yk}/\gamma_M=2619$ kg/cmq $f_t=4300$ kg/cmq

:Verificato

X	cls	N	TY	TZ	MT	MY	MZ	My4	Mz4	Comb.
cm		kg	kg	kg	kg*m	kg*m	kg*m			
230	1	6134	-11	57	-7	52	14	--	--	2

X	cls	Nr	Vyr	Vzr	Mry	Mrz	MTrd	SF_V.	SF_M	SF_Mt	SF
cm		kg	kg	kg	kg*m	kg*m	kg*m				
230	1	52623	19259	19259	1818	1818	1566	>100	6.56	>100	6.56

Asta : 390 [331 , 323]

Sez. G: O 114.3x5.9 L=229.9 cm Crit.: Acciaio_Flessione $\gamma_M=1.05$ $f_{yk}/\gamma_M=2619$ kg/cmq $f_t=4300$ kg/cmq

:Verificato

X	cls	N	TY	TZ	MT	MY	MZ	My4	Mz4	Comb.
cm		kg	kg	kg	kg*m	kg*m	kg*m			

AUTOSTRADA VALDASTICO A31 NORD
1° LOTTO - PIOVENE ROCCHETTE – VALLE DELL'ASTICO

X	cls	N	TY	TZ	MT	MY	MZ	My4	Mz4	Comb.
230	1	-19703	-19	97	38	89	46	--	--	2

X	cls	Nr	Vyr	Vzr	Mry	Mrz	MTrd	SF_V.	SF_M	SF_Mt	SF
cm		kg	kg	kg	kg*m	kg*m	kg*m				
230	1	52623	18873	18873	1818	1818	1566	>100	2.23	41.3	2.23

Asta : 391 [331 , 334]

Sez. G: O 114.3x5.9 L=229.9 cm Crit.: Acciaio_Flessione $\gamma_M=1.05$ $f_{yk}/\gamma_M=2619$ kg/cm² $f_t=4300$ kg/cm²

:Verificato

X	cls	N	TY	TZ	MT	MY	MZ	My4	Mz4	Comb.
cm		kg	kg	kg	kg*m	kg*m	kg*m			
0	1	8543	12	-31	1	39	16	--	--	2

X	cls	Nr	Vyr	Vzr	Mry	Mrz	MTrd	SF_V.	SF_M	SF_Mt	SF
cm		kg	kg	kg	kg*m	kg*m	kg*m				
0	1	52623	19334	19334	1818	1818	1566	>100	5.20	>100	5.20

Asta : 392 [333 , 324]

Sez. G: O 114.3x5.9 L=286.0 cm Crit.: Acciaio_Flessione $\gamma_M=1.05$ $f_{yk}/\gamma_M=2619$ kg/cm² $f_t=4300$ kg/cm²

:Verificato

X	cls	N	TY	TZ	MT	MY	MZ	My4	Mz4	Comb.
cm		kg	kg	kg	kg*m	kg*m	kg*m			
286	1	-2772	9	43	20	59	-11	--	--	2

X	cls	Nr	Vyr	Vzr	Mry	Mrz	MTrd	SF_V.	SF_M	SF_Mt	SF
cm		kg	kg	kg	kg*m	kg*m	kg*m				
286	1	52623	19093	19093	1818	1818	1566	>100	10.9	77.7	10.9

Asta : 393 [335 , 322]

Sez. G: O 114.3x5.9 L=286.0 cm Crit.: Acciaio_Flessione $\gamma_M=1.05$ $f_{yk}/\gamma_M=2619$ kg/cm² $f_t=4300$ kg/cm²

:Verificato

AUTOSTRADA VALDASTICO A31 NORD
1° LOTTO - PIOVENE ROCCHETTE – VALLE DELL'ASTICO

X	cls	N	TY	TZ	MT	MY	MZ	My4	Mz4	Comb.
cm		kg	kg	kg	kg*m	kg*m	kg*m			
286	1	-2526	-12	47	-18	49	17	--	--	2

X	cls	Nr	Vyr	Vzr	Mry	Mrz	MTrd	SF_V.	SF_M	SF_Mt	SF
cm		kg	kg	kg	kg*m	kg*m	kg*m				
286	1	52623	19124	19124	1818	1818	1566	>100	11.8	88.8	11.8

Asta : 394 [322 , 323]

Sez. G: O 114.3x5.9 L=314.0 cm Crit.: Acciaio_Flessione $\gamma_M=1.05$ $f_{yk}/\gamma_M=2619$ kg/cm² $f_t=4300$ kg/cm²

:Verificato

X	cls	N	TY	TZ	MT	MY	MZ	My4	Mz4	Comb.
cm		kg	kg	kg	kg*m	kg*m	kg*m			
314	1	-4379	-0	226	-0	392	1	--	--	2

X	cls	Nr	Vyr	Vzr	Mry	Mrz	MTrd	SF_V.	SF_M	SF_Mt	SF
cm		kg	kg	kg	kg*m	kg*m	kg*m				
314	1	52623	19337	19337	1818	1818	1566	85.4	3.34	>100	3.34

Asta : 395 [323 , 330]

Sez. G: O 114.3x5.9 L=254.4 cm Crit.: Acciaio_Flessione $\gamma_M=1.05$ $f_{yk}/\gamma_M=2619$ kg/cm² $f_t=4300$ kg/cm²

:Verificato

X	cls	N	TY	TZ	MT	MY	MZ	My4	Mz4	Comb.
cm		kg	kg	kg	kg*m	kg*m	kg*m			
0	1	-35351	-43	-244	21	375	-76	--	--	2

X	cls	Nr	Vyr	Vzr	Mry	Mrz	MTrd	SF_V.	SF_M	SF_Mt	SF
cm		kg	kg	kg	kg*m	kg*m	kg*m				
0	1	52623	19083	19083	1818	1818	1566	78.2	1.09	74.7	1.09

Asta : 396 [330 , 335]

AUTOSTRADA VALDASTICO A31 NORD
1° LOTTO - PIOVENE ROCCHETTE – VALLE DELL'ASTICO

Sez. G: O 114.3x5.9 L=254.4 cm Crit.: Acciaio_Flessione $\gamma_M=1.05$ $f_{yk}/\gamma_M=2619$ kg/cmq $f_t=4300$ kg/cmq

:Verificato

X	cls	N	TY	TZ	MT	MY	MZ	My4	Mz4	Comb.
cm		kg	kg	kg	kg*m	kg*m	kg*m			
51	1	8428	5	-6	-3	-34	5	--	--	2

X	cls	Nr	Vyr	Vzr	Mry	Mrz	MTrd	SF_V.	SF_M	SF_Mt	SF
cm		kg	kg	kg	kg*m	kg*m	kg*m				
51	1	52623	19310	19310	1818	1818	1566	>100	5.51	>100	5.51

Asta : 397 [334 , 330]

Sez. G: O 114.3x5.9 L=254.4 cm Crit.: Acciaio_Flessione $\gamma_M=1.05$ $f_{yk}/\gamma_M=2619$ kg/cmq $f_t=4300$ kg/cmq

:Verificato

X	cls	N	TY	TZ	MT	MY	MZ	My4	Mz4	Comb.
cm		kg	kg	kg	kg*m	kg*m	kg*m			
0	1	7208	-24	-33	-8	57	-24	--	--	2

X	cls	Nr	Vyr	Vzr	Mry	Mrz	MTrd	SF_V.	SF_M	SF_Mt	SF
cm		kg	kg	kg	kg*m	kg*m	kg*m				
0	1	52623	19237	19237	1818	1818	1566	>100	5.51	>100	5.51

Asta : 398 [330 , 322]

Sez. G: O 114.3x5.9 L=254.4 cm Crit.: Acciaio_Flessione $\gamma_M=1.05$ $f_{yk}/\gamma_M=2619$ kg/cmq $f_t=4300$ kg/cmq

:Verificato

X	cls	N	TY	TZ	MT	MY	MZ	My4	Mz4	Comb.
cm		kg	kg	kg	kg*m	kg*m	kg*m			
0	1	7866	33	-18	12	26	56	--	--	2

X	cls	Nr	Vyr	Vzr	Mry	Mrz	MTrd	SF_V.	SF_M	SF_Mt	SF
cm		kg	kg	kg	kg*m	kg*m	kg*m				
0	1	52623	19193	19193	1818	1818	1566	>100	5.14	>100	5.14

AUTOSTRADA VALDASTICO A31 NORD
1° LOTTO - PIOVENE ROCCHETTE – VALLE DELL'ASTICO

Asta : 399 [336 , 321]

Sez. G: O 114.3x5.9 L=286.0 cm Crit.: Acciaio_Flessione $\gamma_M=1.05$ $f_{yk}/\gamma_M=2619$ kg/cm² $f_t=4300$ kg/cm²

:Verificato

X	cls	N	TY	TZ	MT	MY	MZ	My4	Mz4	Comb.
cm		kg	kg	kg	kg*m	kg*m	kg*m			
286	1	1561	-5	30	-2	15	7	--	--	2

X	cls	Nr	Vyr	Vzr	Mry	Mrz	MTrd	SF_V.	SF_M	SF_Mt	SF
cm		kg	kg	kg	kg*m	kg*m	kg*m				
286	1	52623	19312	19312	1818	1818	1566	>100	24.1	>100	24.1

Asta : 400 [321 , 322]

Sez. G: O 114.3x5.9 L=314.0 cm Crit.: Acciaio_Flessione $\gamma_M=1.05$ $f_{yk}/\gamma_M=2619$ kg/cm² $f_t=4300$ kg/cm²

:Verificato

X	cls	N	TY	TZ	MT	MY	MZ	My4	Mz4	Comb.
cm		kg	kg	kg	kg*m	kg*m	kg*m			
188	1	12569	-1	-2	-0	-48	0	--	--	2

X	cls	Nr	Vyr	Vzr	Mry	Mrz	MTrd	SF_V.	SF_M	SF_Mt	SF
cm		kg	kg	kg	kg*m	kg*m	kg*m				
188	1	52623	19340	19340	1818	1818	1566	>100	3.76	>100	3.76

Asta : 401 [335 , 329]

Sez. G: O 114.3x5.9 L=273.9 cm Crit.: Acciaio_Flessione $\gamma_M=1.05$ $f_{yk}/\gamma_M=2619$ kg/cm² $f_t=4300$ kg/cm²

:Verificato

X	cls	N	TY	TZ	MT	MY	MZ	My4	Mz4	Comb.
cm		kg	kg	kg	kg*m	kg*m	kg*m			
0	1	-646	-12	-27	6	18	-23	--	--	2

X	cls	Nr	Vyr	Vzr	Mry	Mrz	MTrd	SF_V.	SF_M	SF_Mt	SF
cm		kg	kg	kg	kg*m	kg*m	kg*m				
0	1	52623	19266	19266	1818	1818	1566	>100	28.9	>100	28.9

AUTOSTRADA VALDASTICO A31 NORD
1° LOTTO - PIOVENE ROCCHETTE – VALLE DELL'ASTICO

Asta : 402 [329 , 321]

Sez. G: O 114.3x5.9 L=273.9 cm Crit.: Acciaio_Flessione $\gamma_M=1.05$ $f_{yk}/\gamma_M=2619$ kg/cmq $f_t=4300$ kg/cmq

:Verificato

X	cls	N	TY	TZ	MT	MY	MZ	My4	Mz4	Comb.
cm		kg	kg	kg	kg*m	kg*m	kg*m			
164	1	1687	-0	-1	7	-14	7	--	--	2

X	cls	Nr	Vyr	Vzr	Mry	Mrz	MTrd	SF_V.	SF_M	SF_Mt	SF
cm		kg	kg	kg	kg*m	kg*m	kg*m				
164	1	52623	19259	19259	1818	1818	1566	>100	22.7	>100	22.7

Asta : 403 [322 , 329]

Sez. G: O 114.3x5.9 L=273.9 cm Crit.: Acciaio_Flessione $\gamma_M=1.05$ $f_{yk}/\gamma_M=2619$ kg/cmq $f_t=4300$ kg/cmq

:Verificato

X	cls	N	TY	TZ	MT	MY	MZ	My4	Mz4	Comb.
cm		kg	kg	kg	kg*m	kg*m	kg*m			
0	1	-6896	17	-10	-13	-27	37	--	--	2

X	cls	Nr	Vyr	Vzr	Mry	Mrz	MTrd	SF_V.	SF_M	SF_Mt	SF
cm		kg	kg	kg	kg*m	kg*m	kg*m				
0	1	52623	19176	19176	1818	1818	1566	>100	6.01	>100	6.01

Asta : 404 [329 , 336]

Sez. G: O 114.3x5.9 L=273.9 cm Crit.: Acciaio_Flessione $\gamma_M=1.05$ $f_{yk}/\gamma_M=2619$ kg/cmq $f_t=4300$ kg/cmq

:Verificato

X	cls	N	TY	TZ	MT	MY	MZ	My4	Mz4	Comb.
cm		kg	kg	kg	kg*m	kg*m	kg*m			
164	1	2093	2	1	-6	-20	-6	--	--	2

X	cls	Nr	Vyr	Vzr	Mry	Mrz	MTrd	SF_V.	SF_M	SF_Mt	SF
cm		kg	kg	kg	kg*m	kg*m	kg*m				

AUTOSTRADA VALDASTICO A31 NORD
1° LOTTO - PIOVENE ROCCHETTE – VALLE DELL'ASTICO

X	cls	Nr	Vyr	Vzr	Mry	Mrz	MTrd	SF_V.	SF_M	SF_Mt	SF
164	1	52623	19273	19273	1818	1818	1566	>100	18.5	>100	18.5

Asta : 405 [337 , 320]

Sez. G: O 114.3x5.9 L=286.0 cm Crit.: Acciaio_Flessione $\gamma M=1.05$ fyk/ $\gamma M=2619$ kg/cm² ft=4300 kg/cm²

:Verificato

X	cls	N	TY	TZ	MT	MY	MZ	My4	Mz4	Comb.
cm		kg	kg	kg	kg*m	kg*m	kg*m			
0	1	2498	0	-30	0	12	0	--	--	2

X	cls	Nr	Vyr	Vzr	Mry	Mrz	MTrd	SF_V.	SF_M	SF_Mt	SF
cm		kg	kg	kg	kg*m	kg*m	kg*m				
0	1	52623	19342	19342	1818	1818	1566	>100	18.4	>100	18.4

Asta : 406 [320 , 321]

Sez. G: O 114.3x5.9 L=314.0 cm Crit.: Acciaio_Flessione $\gamma M=1.05$ fyk/ $\gamma M=2619$ kg/cm² ft=4300 kg/cm²

:Verificato

X	cls	N	TY	TZ	MT	MY	MZ	My4	Mz4	Comb.
cm		kg	kg	kg	kg*m	kg*m	kg*m			
157	1	15850	-0	2	-0	-37	-0	--	--	2

X	cls	Nr	Vyr	Vzr	Mry	Mrz	MTrd	SF_V.	SF_M	SF_Mt	SF
cm		kg	kg	kg	kg*m	kg*m	kg*m				
157	1	52623	19341	19341	1818	1818	1566	>100	3.11	>100	3.11

Asta : 407 [336 , 328]

Sez. G: O 114.3x5.9 L=281.6 cm Crit.: Acciaio_Flessione $\gamma M=1.05$ fyk/ $\gamma M=2619$ kg/cm² ft=4300 kg/cm²

:Verificato

X	cls	N	TY	TZ	MT	MY	MZ	My4	Mz4	Comb.
cm		kg	kg	kg	kg*m	kg*m	kg*m			
113	1	-1276	-5	-5	5	-13	-8	--	--	2

AUTOSTRADA VALDASTICO A31 NORD
1° LOTTO - PIOVENE ROCCHETTE – VALLE DELL'ASTICO

X	cls	Nr	Vyr	Vzr	Mry	Mrz	MTrd	SF_V.	SF_M	SF_Mt	SF
cm		kg	kg	kg	kg*m	kg*m	kg*m				
113	1	52623	19277	19277	1818	1818	1566	>100	28.0	>100	28.0

Asta : 408 [328 , 337]

Sez. G: O 114.3x5.9 L=281.6 cm Crit.: Acciaio_Flessione $\gamma_M=1.05$ $f_{yk}/\gamma_M=2619$ kg/cm² $f_t=4300$ kg/cm²

:Verificato

X	cls	N	TY	TZ	MT	MY	MZ	My4	Mz4	Comb.
cm		kg	kg	kg	kg*m	kg*m	kg*m			
169	1	-388	2	4	-5	-18	-7	--	--	2

X	cls	Nr	Vyr	Vzr	Mry	Mrz	MTrd	SF_V.	SF_M	SF_Mt	SF
cm		kg	kg	kg	kg*m	kg*m	kg*m				
169	1	52623	19274	19274	1818	1818	1566	>100	48.4	>100	48.4

Asta : 409 [321 , 328]

Sez. G: O 114.3x5.9 L=281.6 cm Crit.: Acciaio_Flessione $\gamma_M=1.05$ $f_{yk}/\gamma_M=2619$ kg/cm² $f_t=4300$ kg/cm²

:Verificato

X	cls	N	TY	TZ	MT	MY	MZ	My4	Mz4	Comb.
cm		kg	kg	kg	kg*m	kg*m	kg*m			
113	1	-1607	2	-4	-6	-17	7	--	--	2

X	cls	Nr	Vyr	Vzr	Mry	Mrz	MTrd	SF_V.	SF_M	SF_Mt	SF
cm		kg	kg	kg	kg*m	kg*m	kg*m				
113	1	52623	19271	19271	1818	1818	1566	>100	22.7	>100	22.7

Asta : 410 [328 , 320]

Sez. G: O 114.3x5.9 L=281.6 cm Crit.: Acciaio_Flessione $\gamma_M=1.05$ $f_{yk}/\gamma_M=2619$ kg/cm² $f_t=4300$ kg/cm²

:Verificato

X	cls	N	TY	TZ	MT	MY	MZ	My4	Mz4	Comb.
cm		kg	kg	kg	kg*m	kg*m	kg*m			
169	1	-36	-1	3	6	-18	7	--	--	2

AUTOSTRADA VALDASTICO A31 NORD
1° LOTTO - PIOVENE ROCCHETTE – VALLE DELL'ASTICO

X	cls	Nr	Vyr	Vzr	Mry	Mrz	MTrd	SF_V.	SF_M	SF_Mt	SF
cm		kg	kg	kg	kg*m	kg*m	kg*m				
169	1	52623	19273	19273	1818	1818	1566	>100	70.8	>100	70.8

Asta : 411 [320 , 327]

Sez. G: O 114.3x5.9 L=281.6 cm Crit.: Acciaio_Flessione $\gamma_M=1.05$ $f_{yk}/\gamma_M=2619$ kg/cm² $f_t=4300$ kg/cm²

:Verificato

X	cls	N	TY	TZ	MT	MY	MZ	My4	Mz4	Comb.
cm		kg	kg	kg	kg*m	kg*m	kg*m			
113	1	-6	1	-3	-6	-18	7	--	--	2

X	cls	Nr	Vyr	Vzr	Mry	Mrz	MTrd	SF_V.	SF_M	SF_Mt	SF
cm		kg	kg	kg	kg*m	kg*m	kg*m				
113	1	52623	19273	19273	1818	1818	1566	>100	73.9	>100	73.9

Asta : 412 [327 , 338]

Sez. G: O 114.3x5.9 L=281.6 cm Crit.: Acciaio_Flessione $\gamma_M=1.05$ $f_{yk}/\gamma_M=2619$ kg/cm² $f_t=4300$ kg/cm²

:Verificato

X	cls	N	TY	TZ	MT	MY	MZ	My4	Mz4	Comb.
cm		kg	kg	kg	kg*m	kg*m	kg*m			
169	1	-1288	5	6	-5	-13	-8	--	--	2

X	cls	Nr	Vyr	Vzr	Mry	Mrz	MTrd	SF_V.	SF_M	SF_Mt	SF
cm		kg	kg	kg	kg*m	kg*m	kg*m				
169	1	52623	19277	19277	1818	1818	1566	>100	27.8	>100	27.8

Asta : 413 [338 , 319]

Sez. G: O 114.3x5.9 L=286.0 cm Crit.: Acciaio_Flessione $\gamma_M=1.05$ $f_{yk}/\gamma_M=2619$ kg/cm² $f_t=4300$ kg/cm²

:Verificato

X	cls	N	TY	TZ	MT	MY	MZ	My4	Mz4	Comb.
cm		kg	kg	kg	kg*m	kg*m	kg*m			

AUTOSTRADA VALDASTICO A31 NORD
1° LOTTO - PIOVENE ROCCHETTE – VALLE DELL'ASTICO

X	cls	N	TY	TZ	MT	MY	MZ	My4	Mz4	Comb.
286	1	1548	5	30	2	15	-7	--	--	2

X	cls	Nr	Vyr	Vzr	Mry	Mrz	MTrd	SF_V.	SF_M	SF_Mt	SF
cm		kg	kg	kg	kg*m	kg*m	kg*m				
286	1	52623	19312	19312	1818	1818	1566	>100	24.2	>100	24.2

Asta : 414 [319 , 320]

Sez. G: O 114.3x5.9 L=314.0 cm Crit.: Acciaio_Flessione $\gamma_M=1.05$ $f_{yk}/\gamma_M=2619$ kg/cm² $f_t=4300$ kg/cm²

:Verificato

X	cls	N	TY	TZ	MT	MY	MZ	My4	Mz4	Comb.
cm		kg	kg	kg	kg*m	kg*m	kg*m			
157	1	15820	0	-2	0	-37	-0	--	--	2

X	cls	Nr	Vyr	Vzr	Mry	Mrz	MTrd	SF_V.	SF_M	SF_Mt	SF
cm		kg	kg	kg	kg*m	kg*m	kg*m				
157	1	52623	19341	19341	1818	1818	1566	>100	3.11	>100	3.11

Asta : 415 [337 , 327]

Sez. G: O 114.3x5.9 L=281.6 cm Crit.: Acciaio_Flessione $\gamma_M=1.05$ $f_{yk}/\gamma_M=2619$ kg/cm² $f_t=4300$ kg/cm²

:Verificato

X	cls	N	TY	TZ	MT	MY	MZ	My4	Mz4	Comb.
cm		kg	kg	kg	kg*m	kg*m	kg*m			
113	1	-371	-2	-4	5	-18	-7	--	--	2

X	cls	Nr	Vyr	Vzr	Mry	Mrz	MTrd	SF_V.	SF_M	SF_Mt	SF
cm		kg	kg	kg	kg*m	kg*m	kg*m				
113	1	52623	19274	19274	1818	1818	1566	>100	49.2	>100	49.2

Asta : 416 [327 , 319]

Sez. G: O 114.3x5.9 L=281.6 cm Crit.: Acciaio_Flessione $\gamma_M=1.05$ $f_{yk}/\gamma_M=2619$ kg/cm² $f_t=4300$ kg/cm²

:Verificato

AUTOSTRADA VALDASTICO A31 NORD
1° LOTTO - PIOVENE ROCCHETTE – VALLE DELL'ASTICO

X	cls	N	TY	TZ	MT	MY	MZ	My4	Mz4	Comb.
cm		kg	kg	kg	kg*m	kg*m	kg*m			
169	1	-1645	-3	4	6	-17	7	--	--	2

X	cls	Nr	Vyr	Vzr	Mry	Mrz	MTrd	SF_V.	SF_M	SF_Mt	SF
cm		kg	kg	kg	kg*m	kg*m	kg*m				
169	1	52623	19272	19272	1818	1818	1566	>100	22.3	>100	22.3

Asta : 417 [339 , 318]

Sez. G: O 114.3x5.9 L=286.0 cm Crit.: Acciaio_Flessione $\gamma_M=1.05$ $f_{yk}/\gamma_M=2619$ kg/cm² $f_t=4300$ kg/cm²

:Verificato

X	cls	N	TY	TZ	MT	MY	MZ	My4	Mz4	Comb.
cm		kg	kg	kg	kg*m	kg*m	kg*m			
286	1	-2570	12	47	18	50	-17	--	--	2

X	cls	Nr	Vyr	Vzr	Mry	Mrz	MTrd	SF_V.	SF_M	SF_Mt	SF
cm		kg	kg	kg	kg*m	kg*m	kg*m				
286	1	52623	19120	19120	1818	1818	1566	>100	11.7	87.4	11.7

Asta : 418 [318 , 319]

Sez. G: O 114.3x5.9 L=314.0 cm Crit.: Acciaio_Flessione $\gamma_M=1.05$ $f_{yk}/\gamma_M=2619$ kg/cm² $f_t=4300$ kg/cm²

:Verificato

X	cls	N	TY	TZ	MT	MY	MZ	My4	Mz4	Comb.
cm		kg	kg	kg	kg*m	kg*m	kg*m			
126	1	12454	1	2	0	-49	0	--	--	2

X	cls	Nr	Vyr	Vzr	Mry	Mrz	MTrd	SF_V.	SF_M	SF_Mt	SF
cm		kg	kg	kg	kg*m	kg*m	kg*m				
126	1	52623	19340	19340	1818	1818	1566	>100	3.79	>100	3.79

Asta : 419 [319 , 326]

AUTOSTRADA VALDASTICO A31 NORD
1° LOTTO - PIOVENE ROCCHETTE – VALLE DELL'ASTICO

Sez. G: O 114.3x5.9 L=273.9 cm Crit.: Acciaio_Flessione $\gamma_M=1.05$ $f_{yk}/\gamma_M=2619$ kg/cmq $f_t=4300$ kg/cmq

:Verificato

X	cls	N	TY	TZ	MT	MY	MZ	My4	Mz4	Comb.
cm		kg	kg	kg	kg*m	kg*m	kg*m			
110	1	1726	0	2	-7	-14	7	--	--	2

X	cls	Nr	Vyr	Vzr	Mry	Mrz	MTrd	SF_V.	SF_M	SF_Mt	SF
cm		kg	kg	kg	kg*m	kg*m	kg*m				
110	1	52623	19259	19259	1818	1818	1566	>100	22.4	>100	22.4

Asta : 420 [326 , 339]

Sez. G: O 114.3x5.9 L=273.9 cm Crit.: Acciaio_Flessione $\gamma_M=1.05$ $f_{yk}/\gamma_M=2619$ kg/cmq $f_t=4300$ kg/cmq

:Verificato

X	cls	N	TY	TZ	MT	MY	MZ	My4	Mz4	Comb.
cm		kg	kg	kg	kg*m	kg*m	kg*m			
274	1	-649	12	27	-6	18	-23	--	--	2

X	cls	Nr	Vyr	Vzr	Mry	Mrz	MTrd	SF_V.	SF_M	SF_Mt	SF
cm		kg	kg	kg	kg*m	kg*m	kg*m				
274	1	52623	19266	19266	1818	1818	1566	>100	28.7	>100	28.7

Asta : 421 [338 , 326]

Sez. G: O 114.3x5.9 L=273.9 cm Crit.: Acciaio_Flessione $\gamma_M=1.05$ $f_{yk}/\gamma_M=2619$ kg/cmq $f_t=4300$ kg/cmq

:Verificato

X	cls	N	TY	TZ	MT	MY	MZ	My4	Mz4	Comb.
cm		kg	kg	kg	kg*m	kg*m	kg*m			
110	1	2129	-2	-1	5	-20	-6	--	--	2

X	cls	Nr	Vyr	Vzr	Mry	Mrz	MTrd	SF_V.	SF_M	SF_Mt	SF
cm		kg	kg	kg	kg*m	kg*m	kg*m				
110	1	52623	19274	19274	1818	1818	1566	>100	18.2	>100	18.2

AUTOSTRADA VALDASTICO A31 NORD
1° LOTTO - PIOVENE ROCCHETTE – VALLE DELL'ASTICO

Asta : 422 [326 , 318]

Sez. G: O 114.3x5.9 L=273.9 cm Crit.: Acciaio_Flessione $\gamma_M=1.05$ $f_{yk}/\gamma_M=2619$ kg/cm² $f_t=4300$ kg/cm²

:Verificato

X	cls	N	TY	TZ	MT	MY	MZ	My4	Mz4	Comb.
cm		kg	kg	kg	kg*m	kg*m	kg*m			
274	1	-6992	-17	9	13	-28	38	--	--	2

X	cls	Nr	Vyr	Vzr	Mry	Mrz	MTrd	SF_V.	SF_M	SF_Mt	SF
cm		kg	kg	kg	kg*m	kg*m	kg*m				
274	1	52623	19175	19175	1818	1818	1566	>100	5.92	>100	5.92

Asta : 423 [318 , 317]

Sez. G: O 114.3x5.9 L=314.0 cm Crit.: Acciaio_Flessione $\gamma_M=1.05$ $f_{yk}/\gamma_M=2619$ kg/cm² $f_t=4300$ kg/cm²

:Verificato

X	cls	N	TY	TZ	MT	MY	MZ	My4	Mz4	Comb.
cm		kg	kg	kg	kg*m	kg*m	kg*m			
314	1	-4739	1	232	0	405	-1	--	--	2

X	cls	Nr	Vyr	Vzr	Mry	Mrz	MTrd	SF_V.	SF_M	SF_Mt	SF
cm		kg	kg	kg	kg*m	kg*m	kg*m				
314	1	52623	19339	19339	1818	1818	1566	83.3	3.19	>100	3.19

Asta : 424 [317 , 340]

Sez. G: O 114.3x5.9 L=286.0 cm Crit.: Acciaio_Flessione $\gamma_M=1.05$ $f_{yk}/\gamma_M=2619$ kg/cm² $f_t=4300$ kg/cm²

:Verificato

X	cls	N	TY	TZ	MT	MY	MZ	My4	Mz4	Comb.
cm		kg	kg	kg	kg*m	kg*m	kg*m			
0	1	-8247	-2	-162	-38	243	-1	--	--	2

X	cls	Nr	Vyr	Vzr	Mry	Mrz	MTrd	SF_V.	SF_M	SF_Mt	SF
cm		kg	kg	kg	kg*m	kg*m	kg*m				
0	1	52623	18875	18875	1818	1818	1566	>100	3.44	41.4	3.44

AUTOSTRADA VALDASTICO A31 NORD
1° LOTTO - PIOVENE ROCCHETTE – VALLE DELL'ASTICO

Asta : 425 [339 , 325]

Sez. G: O 114.3x5.9 L=254.4 cm Crit.: Acciaio_Flessione $\gamma_M=1.05$ $f_{yk}/\gamma_M=2619$ kg/cmq $f_t=4300$ kg/cmq

:Verificato

X	cls	N	TY	TZ	MT	MY	MZ	My4	Mz4	Comb.
cm		kg	kg	kg	kg*m	kg*m	kg*m			
203	1	8508	-5	5	2	-35	5	--	--	2

X	cls	Nr	Vyr	Vzr	Mry	Mrz	MTrd	SF_V.	SF_M	SF_Mt	SF
cm		kg	kg	kg	kg*m	kg*m	kg*m				
203	1	52623	19311	19311	1818	1818	1566	>100	5.45	>100	5.45

Asta : 426 [325 , 340]

Sez. G: O 114.3x5.9 L=254.4 cm Crit.: Acciaio_Flessione $\gamma_M=1.05$ $f_{yk}/\gamma_M=2619$ kg/cmq $f_t=4300$ kg/cmq

:Verificato

X	cls	N	TY	TZ	MT	MY	MZ	My4	Mz4	Comb.
cm		kg	kg	kg	kg*m	kg*m	kg*m			
254	1	7274	24	33	9	57	-24	--	--	2

X	cls	Nr	Vyr	Vzr	Mry	Mrz	MTrd	SF_V.	SF_M	SF_Mt	SF
cm		kg	kg	kg	kg*m	kg*m	kg*m				
254	1	52623	19231	19231	1818	1818	1566	>100	5.47	>100	5.47

Asta : 427 [318 , 325]

Sez. G: O 114.3x5.9 L=254.4 cm Crit.: Acciaio_Flessione $\gamma_M=1.05$ $f_{yk}/\gamma_M=2619$ kg/cmq $f_t=4300$ kg/cmq

:Verificato

X	cls	N	TY	TZ	MT	MY	MZ	My4	Mz4	Comb.
cm		kg	kg	kg	kg*m	kg*m	kg*m			
254	1	7970	-34	17	-12	26	57	--	--	2

X	cls	Nr	Vyr	Vzr	Mry	Mrz	MTrd	SF_V.	SF_M	SF_Mt	SF
cm		kg	kg	kg	kg*m	kg*m	kg*m				

AUTOSTRADA VALDASTICO A31 NORD
1° LOTTO - PIOVENE ROCCHETTE – VALLE DELL'ASTICO

X	cls	Nr	Vyr	Vzr	Mry	Mrz	MTrd	SF_V.	SF_M	SF_Mt	SF
254	1	52623	19193	19193	1818	1818	1566	>100	5.07	>100	5.07

Asta : 428 [325 , 317]

Sez. G: O 114.3x5.9 L=254.4 cm Crit.: Acciaio_Flessione $\gamma_M=1.05$ $f_{yk}/\gamma_M=2619$ kg/cm² $f_t=4300$ kg/cm²

:Verificato

X	cls	N	TY	TZ	MT	MY	MZ	My4	Mz4	Comb.
cm		kg	kg	kg	kg*m	kg*m	kg*m			
254	1	-35692	47	250	-23	386	-82	--	--	2

X	cls	Nr	Vyr	Vzr	Mry	Mrz	MTrd	SF_V.	SF_M	SF_Mt	SF
cm		kg	kg	kg	kg*m	kg*m	kg*m				
254	1	52623	19062	19062	1818	1818	1566	76.3	1.07	69.1	1.07

Asta : 429 [341 , 316]

Sez. G: O 114.3x5.9 L=286.0 cm Crit.: Acciaio_Flessione $\gamma_M=1.05$ $f_{yk}/\gamma_M=2619$ kg/cm² $f_t=4300$ kg/cm²

:Verificato

X	cls	N	TY	TZ	MT	MY	MZ	My4	Mz4	Comb.
cm		kg	kg	kg	kg*m	kg*m	kg*m			
286	1	-2648	-10	40	-22	54	12	--	--	2

X	cls	Nr	Vyr	Vzr	Mry	Mrz	MTrd	SF_V.	SF_M	SF_Mt	SF
cm		kg	kg	kg	kg*m	kg*m	kg*m				
286	1	52623	19070	19070	1818	1818	1566	>100	11.5	71.3	11.5

Asta : 430 [316 , 317]

Sez. G: O 114.3x5.9 L=314.0 cm Crit.: Acciaio_Flessione $\gamma_M=1.05$ $f_{yk}/\gamma_M=2619$ kg/cm² $f_t=4300$ kg/cm²

:Verificato

X	cls	N	TY	TZ	MT	MY	MZ	My4	Mz4	Comb.
cm		kg	kg	kg	kg*m	kg*m	kg*m			
0	1	-8066	1	-49	-0	42	2	--	--	2

AUTOSTRADA VALDASTICO A31 NORD
1° LOTTO - PIOVENE ROCCHETTE – VALLE DELL'ASTICO

X	cls	Nr	Vyr	Vzr	Mry	Mrz	MTrd	SF_V.	SF_M	SF_Mt	SF
cm		kg	kg	kg	kg*m	kg*m	kg*m				
0	1	52623	19341	19341	1818	1818	1566	>100	5.64	>100	5.64

Asta : 431 [340 , 332]

Sez. G: O 114.3x5.9 L=229.9 cm Crit.: Acciaio_Flessione $\gamma_M=1.05$ $f_{yk}/\gamma_M=2619$ kg/cm² $f_t=4300$ kg/cm²

:Verificato

X	cls	N	TY	TZ	MT	MY	MZ	My4	Mz4	Comb.
cm		kg	kg	kg	kg*m	kg*m	kg*m			
230	1	8524	-12	32	-1	41	16	--	--	2

X	cls	Nr	Vyr	Vzr	Mry	Mrz	MTrd	SF_V.	SF_M	SF_Mt	SF
cm		kg	kg	kg	kg*m	kg*m	kg*m				
230	1	52623	19332	19332	1818	1818	1566	>100	5.18	>100	5.18

Asta : 432 [332 , 316]

Sez. G: O 114.3x5.9 L=229.9 cm Crit.: Acciaio_Flessione $\gamma_M=1.05$ $f_{yk}/\gamma_M=2619$ kg/cm² $f_t=4300$ kg/cm²

:Verificato

X	cls	N	TY	TZ	MT	MY	MZ	My4	Mz4	Comb.
cm		kg	kg	kg	kg*m	kg*m	kg*m			
0	1	4174	-2	-40	-1	86	-7	--	--	2

X	cls	Nr	Vyr	Vzr	Mry	Mrz	MTrd	SF_V.	SF_M	SF_Mt	SF
cm		kg	kg	kg	kg*m	kg*m	kg*m				
0	1	52623	19332	19332	1818	1818	1566	>100	7.67	>100	7.67

Asta : 433 [332 , 341]

Sez. G: O 114.3x5.9 L=229.9 cm Crit.: Acciaio_Flessione $\gamma_M=1.05$ $f_{yk}/\gamma_M=2619$ kg/cm² $f_t=4300$ kg/cm²

:Verificato

X	cls	N	TY	TZ	MT	MY	MZ	My4	Mz4	Comb.
cm		kg	kg	kg	kg*m	kg*m	kg*m			
0	1	6140	10	-58	7	52	13	--	--	2

AUTOSTRADA VALDASTICO A31 NORD
1° LOTTO - PIOVENE ROCCHETTE – VALLE DELL'ASTICO

X	cls	Nr	Vyr	Vzr	Mry	Mrz	MTrd	SF_V.	SF_M	SF_Mt	SF
cm		kg	kg	kg	kg*m	kg*m	kg*m				
0	1	52623	19255	19255	1818	1818	1566	>100	6.56	>100	6.56

Asta : 434 [331 , 330]

Sez. G: O 114.3x5.9 L=318.3 cm Crit.: Acciaio_Flessione $\gamma_M=1.05$ $f_{yk}/\gamma_M=2619$ kg/cm² $f_t=4300$ kg/cm²

:Verificato

X	cls	N	TY	TZ	MT	MY	MZ	My4	Mz4	Comb.
cm		kg	kg	kg	kg*m	kg*m	kg*m			
318	1	16216	-4	1341	1	753	7	--	--	2

X	cls	Nr	Vyr	Vzr	Mry	Mrz	MTrd	SF_V.	SF_M	SF_Mt	SF
cm		kg	kg	kg	kg*m	kg*m	kg*m				
318	1	52623	19326	19326	1818	1818	1566	14.4	1.38	>100	1.38

Asta : 435 [330 , 329]

Sez. G: O 114.3x5.9 L=315.7 cm Crit.: Acciaio_Flessione $\gamma_M=1.05$ $f_{yk}/\gamma_M=2619$ kg/cm² $f_t=4300$ kg/cm²

:Verificato

X	cls	N	TY	TZ	MT	MY	MZ	My4	Mz4	Comb.
cm		kg	kg	kg	kg*m	kg*m	kg*m			
0	1	-11711	-16	-1350	17	701	-25	--	--	2

X	cls	Nr	Vyr	Vzr	Mry	Mrz	MTrd	SF_V.	SF_M	SF_Mt	SF
cm		kg	kg	kg	kg*m	kg*m	kg*m				
0	1	52623	19134	19134	1818	1818	1566	14.2	1.61	93.1	1.61

Asta : 436 [329 , 328]

Sez. G: O 114.3x5.9 L=314.2 cm Crit.: Acciaio_Flessione $\gamma_M=1.05$ $f_{yk}/\gamma_M=2619$ kg/cm² $f_t=4300$ kg/cm²

:Verificato

X	cls	N	TY	TZ	MT	MY	MZ	My4	Mz4	Comb.
cm		kg	kg	kg	kg*m	kg*m	kg*m			

AUTOSTRADA VALDASTICO A31 NORD
1° LOTTO - PIOVENE ROCCHETTE – VALLE DELL'ASTICO

X	cls	N	TY	TZ	MT	MY	MZ	My4	Mz4	Comb.
0	1	-18043	-4	-1343	3	684	-6	--	--	2

X	cls	Nr	Vyr	Vzr	Mry	Mrz	MTrd	SF_V.	SF_M	SF_Mt	SF
cm		kg	kg	kg	kg*m	kg*m	kg*m				
0	1	52623	19308	19308	1818	1818	1566	14.4	1.38	>100	1.38

Asta : 437 [328 , 327]

Sez. G: O 114.3x5.9 L=314.0 cm Crit.: Acciaio_Flessione $\gamma_M=1.05$ $f_{yk}/\gamma_M=2619$ kg/cm² $f_t=4300$ kg/cm²

:Verificato

X	cls	N	TY	TZ	MT	MY	MZ	My4	Mz4	Comb.
cm		kg	kg	kg	kg*m	kg*m	kg*m			
314	1	-19346	0	1339	-0	675	0	--	--	2

X	cls	Nr	Vyr	Vzr	Mry	Mrz	MTrd	SF_V.	SF_M	SF_Mt	SF
cm		kg	kg	kg	kg*m	kg*m	kg*m				
314	1	52623	19342	19342	1818	1818	1566	14.4	1.35	>100	1.35

Asta : 438 [327 , 326]

Sez. G: O 114.3x5.9 L=314.2 cm Crit.: Acciaio_Flessione $\gamma_M=1.05$ $f_{yk}/\gamma_M=2619$ kg/cm² $f_t=4300$ kg/cm²

:Verificato

X	cls	N	TY	TZ	MT	MY	MZ	My4	Mz4	Comb.
cm		kg	kg	kg	kg*m	kg*m	kg*m			
314	1	-17989	4	1344	-3	685	-6	--	--	2

X	cls	Nr	Vyr	Vzr	Mry	Mrz	MTrd	SF_V.	SF_M	SF_Mt	SF
cm		kg	kg	kg	kg*m	kg*m	kg*m				
314	1	52623	19308	19308	1818	1818	1566	14.4	1.39	>100	1.39

Asta : 439 [326 , 325]

Sez. G: O 114.3x5.9 L=315.7 cm Crit.: Acciaio_Flessione $\gamma_M=1.05$ $f_{yk}/\gamma_M=2619$ kg/cm² $f_t=4300$ kg/cm²

:Verificato

AUTOSTRADA VALDASTICO A31 NORD
1° LOTTO - PIOVENE ROCCHETTE – VALLE DELL'ASTICO

X	cls	N	TY	TZ	MT	MY	MZ	My4	Mz4	Comb.
cm		kg	kg	kg	kg*m	kg*m	kg*m			
316	1	-11555	16	1350	-17	701	-25	--	--	2

X	cls	Nr	Vyr	Vzr	Mry	Mrz	MTrd	SF_V.	SF_M	SF_Mt	SF
cm		kg	kg	kg	kg*m	kg*m	kg*m				
316	1	52623	19131	19131	1818	1818	1566	14.2	1.62	91.9	1.62

Asta : 440 [325 , 332]

Sez. G: O 114.3x5.9 L=318.3 cm Crit.: Acciaio_Flessione $\gamma_M=1.05$ $f_{yk}/\gamma_M=2619$ kg/cm² $f_t=4300$ kg/cm²

:Verificato

X	cls	N	TY	TZ	MT	MY	MZ	My4	Mz4	Comb.
cm		kg	kg	kg	kg*m	kg*m	kg*m			
0	1	16655	4	-1341	-1	755	6	--	--	2

X	cls	Nr	Vyr	Vzr	Mry	Mrz	MTrd	SF_V.	SF_M	SF_Mt	SF
cm		kg	kg	kg	kg*m	kg*m	kg*m				
0	1	52623	19331	19331	1818	1818	1566	14.4	1.36	>100	1.36

Asta : 441 [307 , 348]

Sez. G: O 114.3x5.9 L=229.9 cm Crit.: Acciaio_Flessione $\gamma_M=1.05$ $f_{yk}/\gamma_M=2619$ kg/cm² $f_t=4300$ kg/cm²

:Verificato

X	cls	N	TY	TZ	MT	MY	MZ	My4	Mz4	Comb.
cm		kg	kg	kg	kg*m	kg*m	kg*m			
230	1	5936	11	58	7	53	-14	--	--	2

X	cls	Nr	Vyr	Vzr	Mry	Mrz	MTrd	SF_V.	SF_M	SF_Mt	SF
cm		kg	kg	kg	kg*m	kg*m	kg*m				
230	1	52623	19256	19256	1818	1818	1566	>100	6.69	>100	6.69

Asta : 442 [323 , 308]

AUTOSTRADA VALDASTICO A31 NORD
1° LOTTO - PIOVENE ROCCHETTE – VALLE DELL'ASTICO

Sez. G: O 114.3x5.9 L=286.0 cm Crit.: Acciaio_Flessione $\gamma_M=1.05$ $f_{yk}/\gamma_M=2619$ kg/cmq $f_t=4300$ kg/cmq

:Verificato

X	cls	N	TY	TZ	MT	MY	MZ	My4	Mz4	Comb.
cm		kg	kg	kg	kg*m	kg*m	kg*m			
0	1	-8074	1	-161	-35	240	3	--	--	2

X	cls	Nr	Vyr	Vzr	Mry	Mrz	MTrd	SF_V.	SF_M	SF_Mt	SF
cm		kg	kg	kg	kg*m	kg*m	kg*m				
0	1	52623	18907	18907	1818	1818	1566	>100	3.49	44.5	3.49

Asta : 443 [308 , 307]

Sez. G: O 114.3x5.9 L=314.0 cm Crit.: Acciaio_Flessione $\gamma_M=1.05$ $f_{yk}/\gamma_M=2619$ kg/cmq $f_t=4300$ kg/cmq

:Verificato

X	cls	N	TY	TZ	MT	MY	MZ	My4	Mz4	Comb.
cm		kg	kg	kg	kg*m	kg*m	kg*m			
0	1	-3747	4	-36	9	39	5	--	--	2

X	cls	Nr	Vyr	Vzr	Mry	Mrz	MTrd	SF_V.	SF_M	SF_Mt	SF
cm		kg	kg	kg	kg*m	kg*m	kg*m				
0	1	52623	19228	19228	1818	1818	1566	>100	10.4	>100	10.4

Asta : 444 [324 , 348]

Sez. G: O 114.3x5.9 L=229.9 cm Crit.: Acciaio_Flessione $\gamma_M=1.05$ $f_{yk}/\gamma_M=2619$ kg/cmq $f_t=4300$ kg/cmq

:Verificato

X	cls	N	TY	TZ	MT	MY	MZ	My4	Mz4	Comb.
cm		kg	kg	kg	kg*m	kg*m	kg*m			
230	1	4021	-4	40	0	83	8	--	--	2

X	cls	Nr	Vyr	Vzr	Mry	Mrz	MTrd	SF_V.	SF_M	SF_Mt	SF
cm		kg	kg	kg	kg*m	kg*m	kg*m				
230	1	52623	19337	19337	1818	1818	1566	>100	7.93	>100	7.93

AUTOSTRADA VALDASTICO A31 NORD
1° LOTTO - PIOVENE ROCCHETTE – VALLE DELL'ASTICO

Asta : 445 [348 , 308]

Sez. G: O 114.3x5.9 L=229.9 cm Crit.: Acciaio_Flessione $\gamma_M=1.05$ $f_{yk}/\gamma_M=2619$ kg/cm² $f_t=4300$ kg/cm²

:Verificato

X	cls	N	TY	TZ	MT	MY	MZ	My4	Mz4	Comb.
cm		kg	kg	kg	kg*m	kg*m	kg*m			
0	1	9041	-12	-30	-1	38	-16	--	--	2

X	cls	Nr	Vyr	Vzr	Mry	Mrz	MTrd	SF_V.	SF_M	SF_Mt	SF
cm		kg	kg	kg	kg*m	kg*m	kg*m				
0	1	52623	19332	19332	1818	1818	1566	>100	4.96	>100	4.96

Asta : 446 [348 , 323]

Sez. G: O 114.3x5.9 L=229.9 cm Crit.: Acciaio_Flessione $\gamma_M=1.05$ $f_{yk}/\gamma_M=2619$ kg/cm² $f_t=4300$ kg/cm²

:Verificato

X	cls	N	TY	TZ	MT	MY	MZ	My4	Mz4	Comb.
cm		kg	kg	kg	kg*m	kg*m	kg*m			
230	1	-20197	20	95	-37	86	-47	--	--	2

X	cls	Nr	Vyr	Vzr	Mry	Mrz	MTrd	SF_V.	SF_M	SF_Mt	SF
cm		kg	kg	kg	kg*m	kg*m	kg*m				
230	1	52623	18882	18882	1818	1818	1566	>100	2.19	42.1	2.19

Asta : 447 [324 , 307]

Sez. G: O 114.3x5.9 L=286.0 cm Crit.: Acciaio_Flessione $\gamma_M=1.05$ $f_{yk}/\gamma_M=2619$ kg/cm² $f_t=4300$ kg/cm²

:Verificato

X	cls	N	TY	TZ	MT	MY	MZ	My4	Mz4	Comb.
cm		kg	kg	kg	kg*m	kg*m	kg*m			
0	1	-2688	-9	-43	-20	59	-12	--	--	2

X	cls	Nr	Vyr	Vzr	Mry	Mrz	MTrd	SF_V.	SF_M	SF_Mt	SF
cm		kg	kg	kg	kg*m	kg*m	kg*m				
0	1	52623	19095	19095	1818	1818	1566	>100	11.1	78.3	11.1

AUTOSTRADA VALDASTICO A31 NORD
1° LOTTO - PIOVENE ROCCHETTE – VALLE DELL'ASTICO

Asta : 448 [322 , 309]

Sez. G: O 114.3x5.9 L=286.0 cm Crit.: Acciaio_Flessione $\gamma_M=1.05$ $f_{yk}/\gamma_M=2619$ kg/cmq $f_t=4300$ kg/cmq

:Verificato

X	cls	N	TY	TZ	MT	MY	MZ	My4	Mz4	Comb.
cm		kg	kg	kg	kg*m	kg*m	kg*m			
0	1	-2548	14	-46	18	49	20	--	--	2

X	cls	Nr	Vyr	Vzr	Mry	Mrz	MTrd	SF_V.	SF_M	SF_Mt	SF
cm		kg	kg	kg	kg*m	kg*m	kg*m				
0	1	52623	19121	19121	1818	1818	1566	>100	11.6	87.6	11.6

Asta : 449 [309 , 308]

Sez. G: O 114.3x5.9 L=314.0 cm Crit.: Acciaio_Flessione $\gamma_M=1.05$ $f_{yk}/\gamma_M=2619$ kg/cmq $f_t=4300$ kg/cmq

:Verificato

X	cls	N	TY	TZ	MT	MY	MZ	My4	Mz4	Comb.
cm		kg	kg	kg	kg*m	kg*m	kg*m			
314	1	-92	-13	56	-19	63	21	--	--	2

X	cls	Nr	Vyr	Vzr	Mry	Mrz	MTrd	SF_V.	SF_M	SF_Mt	SF
cm		kg	kg	kg	kg*m	kg*m	kg*m				
314	1	52623	19102	19102	1818	1818	1566	>100	20.9	80.8	20.9

Asta : 450 [308 , 347]

Sez. G: O 114.3x5.9 L=254.4 cm Crit.: Acciaio_Flessione $\gamma_M=1.05$ $f_{yk}/\gamma_M=2619$ kg/cmq $f_t=4300$ kg/cmq

:Verificato

X	cls	N	TY	TZ	MT	MY	MZ	My4	Mz4	Comb.
cm		kg	kg	kg	kg*m	kg*m	kg*m			
0	1	6829	24	-32	9	56	24	--	--	2

X	cls	Nr	Vyr	Vzr	Mry	Mrz	MTrd	SF_V.	SF_M	SF_Mt	SF
cm		kg	kg	kg	kg*m	kg*m	kg*m				

AUTOSTRADA VALDASTICO A31 NORD
1° LOTTO - PIOVENE ROCCHETTE – VALLE DELL'ASTICO

X	cls	Nr	Vyr	Vzr	Mry	Mrz	MTrd	SF_V.	SF_M	SF_Mt	SF
0	1	52623	19236	19236	1818	1818	1566	>100	5.77	>100	5.77

Asta : 451 [347 , 322]

Sez. G: O 114.3x5.9 L=254.4 cm Crit.: Acciaio_Flessione $\gamma_M=1.05$ $f_{yk}/\gamma_M=2619$ kg/cm² $f_t=4300$ kg/cm²

:Verificato

X	cls	N	TY	TZ	MT	MY	MZ	My4	Mz4	Comb.
cm		kg	kg	kg	kg*m	kg*m	kg*m			
0	1	7330	-34	-19	-12	28	-56	--	--	2

X	cls	Nr	Vyr	Vzr	Mry	Mrz	MTrd	SF_V.	SF_M	SF_Mt	SF
cm		kg	kg	kg	kg*m	kg*m	kg*m				
0	1	52623	19194	19194	1818	1818	1566	>100	5.39	>100	5.39

Asta : 452 [323 , 347]

Sez. G: O 114.3x5.9 L=254.4 cm Crit.: Acciaio_Flessione $\gamma_M=1.05$ $f_{yk}/\gamma_M=2619$ kg/cm² $f_t=4300$ kg/cm²

:Verificato

X	cls	N	TY	TZ	MT	MY	MZ	My4	Mz4	Comb.
cm		kg	kg	kg	kg*m	kg*m	kg*m			
0	1	-34938	45	-244	-21	374	79	--	--	2

X	cls	Nr	Vyr	Vzr	Mry	Mrz	MTrd	SF_V.	SF_M	SF_Mt	SF
cm		kg	kg	kg	kg*m	kg*m	kg*m				
0	1	52623	19079	19079	1818	1818	1566	78.3	1.10	73.7	1.10

Asta : 453 [347 , 309]

Sez. G: O 114.3x5.9 L=254.4 cm Crit.: Acciaio_Flessione $\gamma_M=1.05$ $f_{yk}/\gamma_M=2619$ kg/cm² $f_t=4300$ kg/cm²

:Verificato

X	cls	N	TY	TZ	MT	MY	MZ	My4	Mz4	Comb.
cm		kg	kg	kg	kg*m	kg*m	kg*m			
51	1	8938	-5	-5	3	-35	-5	--	--	2

AUTOSTRADA VALDASTICO A31 NORD
1° LOTTO - PIOVENE ROCCHETTE – VALLE DELL'ASTICO

X	cls	Nr	Vyr	Vzr	Mry	Mrz	MTrd	SF_V.	SF_M	SF_Mt	SF
cm		kg	kg	kg	kg*m	kg*m	kg*m				
51	1	52623	19310	19310	1818	1818	1566	>100	5.21	>100	5.21

Asta : 454 [321 , 310]

Sez. G: O 114.3x5.9 L=286.0 cm Crit.: Acciaio_Flessione $\gamma_M=1.05$ $f_{yk}/\gamma_M=2619$ kg/cm² $f_t=4300$ kg/cm²

:Verificato

X	cls	N	TY	TZ	MT	MY	MZ	My4	Mz4	Comb.
cm		kg	kg	kg	kg*m	kg*m	kg*m			
0	1	1406	6	-30	3	14	9	--	--	2

X	cls	Nr	Vyr	Vzr	Mry	Mrz	MTrd	SF_V.	SF_M	SF_Mt	SF
cm		kg	kg	kg	kg*m	kg*m	kg*m				
0	1	52623	19310	19310	1818	1818	1566	>100	25.4	>100	25.4

Asta : 455 [310 , 309]

Sez. G: O 114.3x5.9 L=314.0 cm Crit.: Acciaio_Flessione $\gamma_M=1.05$ $f_{yk}/\gamma_M=2619$ kg/cm² $f_t=4300$ kg/cm²

:Verificato

X	cls	N	TY	TZ	MT	MY	MZ	My4	Mz4	Comb.
cm		kg	kg	kg	kg*m	kg*m	kg*m			
94	1	9279	-7	-6	-8	-29	-4	--	--	2

X	cls	Nr	Vyr	Vzr	Mry	Mrz	MTrd	SF_V.	SF_M	SF_Mt	SF
cm		kg	kg	kg	kg*m	kg*m	kg*m				
94	1	52623	19244	19244	1818	1818	1566	>100	5.14	>100	5.14

Asta : 456 [322 , 346]

Sez. G: O 114.3x5.9 L=273.9 cm Crit.: Acciaio_Flessione $\gamma_M=1.05$ $f_{yk}/\gamma_M=2619$ kg/cm² $f_t=4300$ kg/cm²

:Verificato

X	cls	N	TY	TZ	MT	MY	MZ	My4	Mz4	Comb.
cm		kg	kg	kg	kg*m	kg*m	kg*m			
0	1	-6277	-17	-10	13	-26	-38	--	--	2

AUTOSTRADA VALDASTICO A31 NORD
1° LOTTO - PIOVENE ROCCHETTE – VALLE DELL'ASTICO

X	cls	Nr	Vyr	Vzr	Mry	Mrz	MTrd	SF_V.	SF_M	SF_Mt	SF
cm		kg	kg	kg	kg*m	kg*m	kg*m				
0	1	52623	19176	19176	1818	1818	1566	>100	6.47	>100	6.47

Asta : 457 [346 , 310]

Sez. G: O 114.3x5.9 L=273.9 cm Crit.: Acciaio_Flessione $\gamma_M=1.05$ $f_{yk}/\gamma_M=2619$ kg/cm² $f_t=4300$ kg/cm²

:Verificato

X	cls	N	TY	TZ	MT	MY	MZ	My4	Mz4	Comb.
cm		kg	kg	kg	kg*m	kg*m	kg*m			
164	1	2293	-2	2	6	-20	6	--	--	2

X	cls	Nr	Vyr	Vzr	Mry	Mrz	MTrd	SF_V.	SF_M	SF_Mt	SF
cm		kg	kg	kg	kg*m	kg*m	kg*m				
164	1	52623	19273	19273	1818	1818	1566	>100	17.3	>100	17.3

Asta : 458 [309 , 346]

Sez. G: O 114.3x5.9 L=273.9 cm Crit.: Acciaio_Flessione $\gamma_M=1.05$ $f_{yk}/\gamma_M=2619$ kg/cm² $f_t=4300$ kg/cm²

:Verificato

X	cls	N	TY	TZ	MT	MY	MZ	My4	Mz4	Comb.
cm		kg	kg	kg	kg*m	kg*m	kg*m			
0	1	-1239	12	-26	-6	17	23	--	--	2

X	cls	Nr	Vyr	Vzr	Mry	Mrz	MTrd	SF_V.	SF_M	SF_Mt	SF
cm		kg	kg	kg	kg*m	kg*m	kg*m				
0	1	52623	19265	19265	1818	1818	1566	>100	22.2	>100	22.2

Asta : 459 [346 , 321]

Sez. G: O 114.3x5.9 L=273.9 cm Crit.: Acciaio_Flessione $\gamma_M=1.05$ $f_{yk}/\gamma_M=2619$ kg/cm² $f_t=4300$ kg/cm²

:Verificato

X	cls	N	TY	TZ	MT	MY	MZ	My4	Mz4	Comb.
cm		kg	kg	kg	kg*m	kg*m	kg*m			

AUTOSTRADA VALDASTICO A31 NORD
1° LOTTO - PIOVENE ROCCHETTE – VALLE DELL'ASTICO

X	cls	N	TY	TZ	MT	MY	MZ	My4	Mz4	Comb.
192	1	1457	0	2	-7	-14	-7	--	--	2

X	cls	Nr	Vyr	Vzr	Mry	Mrz	MTrd	SF_V.	SF_M	SF_Mt	SF
cm		kg	kg	kg	kg*m	kg*m	kg*m				
192	1	52623	19257	19257	1818	1818	1566	>100	25.2	>100	25.2

Asta : 460 [320 , 311]

Sez. G: O 114.3x5.9 L=286.0 cm Crit.: Acciaio_Flessione $\gamma_M=1.05$ $f_{yk}/\gamma_M=2619$ kg/cm² $f_t=4300$ kg/cm²

:Verificato

X	cls	N	TY	TZ	MT	MY	MZ	My4	Mz4	Comb.
cm		kg	kg	kg	kg*m	kg*m	kg*m			
286	1	2288	-0	31	-0	14	0	--	--	2

X	cls	Nr	Vyr	Vzr	Mry	Mrz	MTrd	SF_V.	SF_M	SF_Mt	SF
cm		kg	kg	kg	kg*m	kg*m	kg*m				
286	1	52623	19342	19342	1818	1818	1566	>100	19.5	>100	19.5

Asta : 461 [311 , 310]

Sez. G: O 114.3x5.9 L=314.0 cm Crit.: Acciaio_Flessione $\gamma_M=1.05$ $f_{yk}/\gamma_M=2619$ kg/cm² $f_t=4300$ kg/cm²

:Verificato

X	cls	N	TY	TZ	MT	MY	MZ	My4	Mz4	Comb.
cm		kg	kg	kg	kg*m	kg*m	kg*m			
126	1	13572	-1	-4	-2	-34	-1	--	--	2

X	cls	Nr	Vyr	Vzr	Mry	Mrz	MTrd	SF_V.	SF_M	SF_Mt	SF
cm		kg	kg	kg	kg*m	kg*m	kg*m				
126	1	52623	19321	19321	1818	1818	1566	>100	3.61	>100	3.61

Asta : 462 [321 , 345]

Sez. G: O 114.3x5.9 L=281.6 cm Crit.: Acciaio_Flessione $\gamma_M=1.05$ $f_{yk}/\gamma_M=2619$ kg/cm² $f_t=4300$ kg/cm²

:Verificato

AUTOSTRADA VALDASTICO A31 NORD
1° LOTTO - PIOVENE ROCCHETTE – VALLE DELL'ASTICO

X	cls	N	TY	TZ	MT	MY	MZ	My4	Mz4	Comb.
cm		kg	kg	kg	kg*m	kg*m	kg*m			
113	1	-1069	-3	-5	6	-17	-7	--	--	2

X	cls	Nr	Vyr	Vzr	Mry	Mrz	MTrd	SF_V.	SF_M	SF_Mt	SF
cm		kg	kg	kg	kg*m	kg*m	kg*m				
113	1	52623	19270	19270	1818	1818	1566	>100	29.6	>100	29.6

Asta : 463 [345 , 320]

Sez. G: O 114.3x5.9 L=281.6 cm Crit.: Acciaio_Flessione $\gamma_M=1.05$ $f_{yk}/\gamma_M=2619$ kg/cm² $f_t=4300$ kg/cm²

:Verificato

X	cls	N	TY	TZ	MT	MY	MZ	My4	Mz4	Comb.
cm		kg	kg	kg	kg*m	kg*m	kg*m			
169	1	173	2	3	-6	-17	-7	--	--	2

X	cls	Nr	Vyr	Vzr	Mry	Mrz	MTrd	SF_V.	SF_M	SF_Mt	SF
cm		kg	kg	kg	kg*m	kg*m	kg*m				
169	1	52623	19271	19271	1818	1818	1566	>100	59.9	>100	59.9

Asta : 464 [310 , 345]

Sez. G: O 114.3x5.9 L=281.6 cm Crit.: Acciaio_Flessione $\gamma_M=1.05$ $f_{yk}/\gamma_M=2619$ kg/cm² $f_t=4300$ kg/cm²

:Verificato

X	cls	N	TY	TZ	MT	MY	MZ	My4	Mz4	Comb.
cm		kg	kg	kg	kg*m	kg*m	kg*m			
113	1	-1805	5	-5	-5	-13	8	--	--	2

X	cls	Nr	Vyr	Vzr	Mry	Mrz	MTrd	SF_V.	SF_M	SF_Mt	SF
cm		kg	kg	kg	kg*m	kg*m	kg*m				
113	1	52623	19277	19277	1818	1818	1566	>100	21.9	>100	21.9

Asta : 465 [345 , 311]

AUTOSTRADA VALDASTICO A31 NORD
1° LOTTO - PIOVENE ROCCHETTE – VALLE DELL'ASTICO

Sez. G: O 114.3x5.9 L=281.6 cm Crit.: Acciaio_Flessione $\gamma_M=1.05$ $f_{yk}/\gamma_M=2619$ kg/cmq $f_t=4300$ kg/cmq

:Verificato

X	cls	N	TY	TZ	MT	MY	MZ	My4	Mz4	Comb.
cm		kg	kg	kg	kg*m	kg*m	kg*m			
141	1	-605	-2	0	5	-18	6	--	--	2

X	cls	Nr	Vyr	Vzr	Mry	Mrz	MTrd	SF_V.	SF_M	SF_Mt	SF
cm		kg	kg	kg	kg*m	kg*m	kg*m				
141	1	52623	19274	19274	1818	1818	1566	>100	40.4	>100	40.4

Asta : 466 [311 , 344]

Sez. G: O 114.3x5.9 L=281.6 cm Crit.: Acciaio_Flessione $\gamma_M=1.05$ $f_{yk}/\gamma_M=2619$ kg/cmq $f_t=4300$ kg/cmq

:Verificato

X	cls	N	TY	TZ	MT	MY	MZ	My4	Mz4	Comb.
cm		kg	kg	kg	kg*m	kg*m	kg*m			
141	1	-583	2	-0	-5	-18	6	--	--	2

X	cls	Nr	Vyr	Vzr	Mry	Mrz	MTrd	SF_V.	SF_M	SF_Mt	SF
cm		kg	kg	kg	kg*m	kg*m	kg*m				
141	1	52623	19274	19274	1818	1818	1566	>100	41.1	>100	41.1

Asta : 467 [344 , 319]

Sez. G: O 114.3x5.9 L=281.6 cm Crit.: Acciaio_Flessione $\gamma_M=1.05$ $f_{yk}/\gamma_M=2619$ kg/cmq $f_t=4300$ kg/cmq

:Verificato

X	cls	N	TY	TZ	MT	MY	MZ	My4	Mz4	Comb.
cm		kg	kg	kg	kg*m	kg*m	kg*m			
169	1	-1104	3	5	-6	-17	-7	--	--	2

X	cls	Nr	Vyr	Vzr	Mry	Mrz	MTrd	SF_V.	SF_M	SF_Mt	SF
cm		kg	kg	kg	kg*m	kg*m	kg*m				
169	1	52623	19270	19270	1818	1818	1566	>100	29.0	>100	29.0

AUTOSTRADA VALDASTICO A31 NORD
1° LOTTO - PIOVENE ROCCHETTE – VALLE DELL'ASTICO

Asta : 468 [319 , 312]

Sez. G: O 114.3x5.9 L=286.0 cm Crit.: Acciaio_Flessione $\gamma_M=1.05$ $f_{yk}/\gamma_M=2619$ kg/cm² $f_t=4300$ kg/cm²

:Verificato

X	cls	N	TY	TZ	MT	MY	MZ	My4	Mz4	Comb.
cm		kg	kg	kg	kg*m	kg*m	kg*m			
0	1	1392	-6	-30	-3	14	-9	--	--	2

X	cls	Nr	Vyr	Vzr	Mry	Mrz	MTrd	SF_V.	SF_M	SF_Mt	SF
cm		kg	kg	kg	kg*m	kg*m	kg*m				
0	1	52623	19310	19310	1818	1818	1566	>100	25.5	>100	25.5

Asta : 469 [312 , 311]

Sez. G: O 114.3x5.9 L=314.0 cm Crit.: Acciaio_Flessione $\gamma_M=1.05$ $f_{yk}/\gamma_M=2619$ kg/cm² $f_t=4300$ kg/cm²

:Verificato

X	cls	N	TY	TZ	MT	MY	MZ	My4	Mz4	Comb.
cm		kg	kg	kg	kg*m	kg*m	kg*m			
188	1	13541	1	4	2	-34	-1	--	--	2

X	cls	Nr	Vyr	Vzr	Mry	Mrz	MTrd	SF_V.	SF_M	SF_Mt	SF
cm		kg	kg	kg	kg*m	kg*m	kg*m				
188	1	52623	19321	19321	1818	1818	1566	>100	3.62	>100	3.62

Asta : 470 [320 , 344]

Sez. G: O 114.3x5.9 L=281.6 cm Crit.: Acciaio_Flessione $\gamma_M=1.05$ $f_{yk}/\gamma_M=2619$ kg/cm² $f_t=4300$ kg/cm²

:Verificato

X	cls	N	TY	TZ	MT	MY	MZ	My4	Mz4	Comb.
cm		kg	kg	kg	kg*m	kg*m	kg*m			
113	1	198	-2	-3	6	-17	-7	--	--	2

X	cls	Nr	Vyr	Vzr	Mry	Mrz	MTrd	SF_V.	SF_M	SF_Mt	SF
cm		kg	kg	kg	kg*m	kg*m	kg*m				
113	1	52623	19271	19271	1818	1818	1566	>100	58.3	>100	58.3

AUTOSTRADA VALDASTICO A31 NORD
1° LOTTO - PIOVENE ROCCHETTE – VALLE DELL'ASTICO

Asta : 471 [344 , 312]

Sez. G: O 114.3x5.9 L=281.6 cm Crit.: Acciaio_Flessione $\gamma_M=1.05$ $f_{yk}/\gamma_M=2619$ kg/cmq $f_t=4300$ kg/cmq

:Verificato

X	cls	N	TY	TZ	MT	MY	MZ	My4	Mz4	Comb.
cm		kg	kg	kg	kg*m	kg*m	kg*m			
169	1	-1820	-5	5	5	-13	8	--	--	2

X	cls	Nr	Vyr	Vzr	Mry	Mrz	MTrd	SF_V.	SF_M	SF_Mt	SF
cm		kg	kg	kg	kg*m	kg*m	kg*m				
169	1	52623	19277	19277	1818	1818	1566	>100	21.7	>100	21.7

Asta : 472 [318 , 313]

Sez. G: O 114.3x5.9 L=286.0 cm Crit.: Acciaio_Flessione $\gamma_M=1.05$ $f_{yk}/\gamma_M=2619$ kg/cmq $f_t=4300$ kg/cmq

:Verificato

X	cls	N	TY	TZ	MT	MY	MZ	My4	Mz4	Comb.
cm		kg	kg	kg	kg*m	kg*m	kg*m			
0	1	-2594	-14	-47	-18	49	-20	--	--	2

X	cls	Nr	Vyr	Vzr	Mry	Mrz	MTrd	SF_V.	SF_M	SF_Mt	SF
cm		kg	kg	kg	kg*m	kg*m	kg*m				
0	1	52623	19117	19117	1818	1818	1566	>100	11.4	86.3	11.4

Asta : 473 [313 , 312]

Sez. G: O 114.3x5.9 L=314.0 cm Crit.: Acciaio_Flessione $\gamma_M=1.05$ $f_{yk}/\gamma_M=2619$ kg/cmq $f_t=4300$ kg/cmq

:Verificato

X	cls	N	TY	TZ	MT	MY	MZ	My4	Mz4	Comb.
cm		kg	kg	kg	kg*m	kg*m	kg*m			
220	1	9180	7	6	8	-29	-4	--	--	2

X	cls	Nr	Vyr	Vzr	Mry	Mrz	MTrd	SF_V.	SF_M	SF_Mt	SF
cm		kg	kg	kg	kg*m	kg*m	kg*m				

AUTOSTRADA VALDASTICO A31 NORD
1° LOTTO - PIOVENE ROCCHETTE – VALLE DELL'ASTICO

X	cls	Nr	Vyr	Vzr	Mry	Mrz	MTrd	SF_V.	SF_M	SF_Mt	SF
220	1	52623	19243	19243	1818	1818	1566	>100	5.19	>100	5.19

Asta : 474 [312 , 343]

Sez. G: O 114.3x5.9 L=273.9 cm Crit.: Acciaio_Flessione $\gamma_M=1.05$ $f_{yk}/\gamma_M=2619$ kg/cm² $f_t=4300$ kg/cm²

:Verificato

X	cls	N	TY	TZ	MT	MY	MZ	My4	Mz4	Comb.
cm		kg	kg	kg	kg*m	kg*m	kg*m			
110	1	2330	2	-2	-6	-20	6	--	--	2

X	cls	Nr	Vyr	Vzr	Mry	Mrz	MTrd	SF_V.	SF_M	SF_Mt	SF
cm		kg	kg	kg	kg*m	kg*m	kg*m				
110	1	52623	19274	19274	1818	1818	1566	>100	17.1	>100	17.1

Asta : 475 [343 , 318]

Sez. G: O 114.3x5.9 L=273.9 cm Crit.: Acciaio_Flessione $\gamma_M=1.05$ $f_{yk}/\gamma_M=2619$ kg/cm² $f_t=4300$ kg/cm²

:Verificato

X	cls	N	TY	TZ	MT	MY	MZ	My4	Mz4	Comb.
cm		kg	kg	kg	kg*m	kg*m	kg*m			
274	1	-6374	18	10	-14	-27	-38	--	--	2

X	cls	Nr	Vyr	Vzr	Mry	Mrz	MTrd	SF_V.	SF_M	SF_Mt	SF
cm		kg	kg	kg	kg*m	kg*m	kg*m				
274	1	52623	19175	19175	1818	1818	1566	>100	6.37	>100	6.37

Asta : 476 [319 , 343]

Sez. G: O 114.3x5.9 L=273.9 cm Crit.: Acciaio_Flessione $\gamma_M=1.05$ $f_{yk}/\gamma_M=2619$ kg/cm² $f_t=4300$ kg/cm²

:Verificato

X	cls	N	TY	TZ	MT	MY	MZ	My4	Mz4	Comb.
cm		kg	kg	kg	kg*m	kg*m	kg*m			
82	1	1494	-0	-2	7	-14	-7	--	--	2

AUTOSTRADA VALDASTICO A31 NORD
1° LOTTO - PIOVENE ROCCHETTE – VALLE DELL'ASTICO

X	cls	Nr	Vyr	Vzr	Mry	Mrz	MTrd	SF_V.	SF_M	SF_Mt	SF
cm		kg	kg	kg	kg*m	kg*m	kg*m				
82	1	52623	19257	19257	1818	1818	1566	>100	24.8	>100	24.8

Asta : 477 [343 , 313]

Sez. G: O 114.3x5.9 L=273.9 cm Crit.: Acciaio_Flessione $\gamma_M=1.05$ $f_{yk}/\gamma_M=2619$ kg/cm² $f_t=4300$ kg/cm²

:Verificato

X	cls	N	TY	TZ	MT	MY	MZ	My4	Mz4	Comb.
cm		kg	kg	kg	kg*m	kg*m	kg*m			
274	1	-1239	-12	26	6	17	23	--	--	2

X	cls	Nr	Vyr	Vzr	Mry	Mrz	MTrd	SF_V.	SF_M	SF_Mt	SF
cm		kg	kg	kg	kg*m	kg*m	kg*m				
274	1	52623	19266	19266	1818	1818	1566	>100	22.1	>100	22.1

Asta : 478 [313 , 314]

Sez. G: O 114.3x5.9 L=314.0 cm Crit.: Acciaio_Flessione $\gamma_M=1.05$ $f_{yk}/\gamma_M=2619$ kg/cm² $f_t=4300$ kg/cm²

:Verificato

X	cls	N	TY	TZ	MT	MY	MZ	My4	Mz4	Comb.
cm		kg	kg	kg	kg*m	kg*m	kg*m			
314	1	-273	13	57	19	64	-21	--	--	2

X	cls	Nr	Vyr	Vzr	Mry	Mrz	MTrd	SF_V.	SF_M	SF_Mt	SF
cm		kg	kg	kg	kg*m	kg*m	kg*m				
314	1	52623	19102	19102	1818	1818	1566	>100	19.2	80.5	19.2

Asta : 479 [314 , 317]

Sez. G: O 114.3x5.9 L=286.0 cm Crit.: Acciaio_Flessione $\gamma_M=1.05$ $f_{yk}/\gamma_M=2619$ kg/cm² $f_t=4300$ kg/cm²

:Verificato

X	cls	N	TY	TZ	MT	MY	MZ	My4	Mz4	Comb.
cm		kg	kg	kg	kg*m	kg*m	kg*m			
286	1	-8125	0	162	38	242	1	--	--	2

AUTOSTRADA VALDASTICO A31 NORD
1° LOTTO - PIOVENE ROCCHETTE – VALLE DELL'ASTICO

X	cls	Nr	Vyr	Vzr	Mry	Mrz	MTrd	SF_V.	SF_M	SF_Mt	SF
cm		kg	kg	kg	kg*m	kg*m	kg*m				
286	1	52623	18878	18878	1818	1818	1566	>100	3.47	41.7	3.47

Asta : 480 [318 , 342]

Sez. G: O 114.3x5.9 L=254.4 cm Crit.: Acciaio_Flessione $\gamma_M=1.05$ $f_{yk}/\gamma_M=2619$ kg/cmq $f_t=4300$ kg/cmq

:Verificato

X	cls	N	TY	TZ	MT	MY	MZ	My4	Mz4	Comb.
cm		kg	kg	kg	kg*m	kg*m	kg*m			
254	1	7438	35	18	12	28	-58	--	--	2

X	cls	Nr	Vyr	Vzr	Mry	Mrz	MTrd	SF_V.	SF_M	SF_Mt	SF
cm		kg	kg	kg	kg*m	kg*m	kg*m				
254	1	52623	19194	19194	1818	1818	1566	>100	5.31	>100	5.31

Asta : 481 [342 , 317]

Sez. G: O 114.3x5.9 L=254.4 cm Crit.: Acciaio_Flessione $\gamma_M=1.05$ $f_{yk}/\gamma_M=2619$ kg/cmq $f_t=4300$ kg/cmq

:Verificato

X	cls	N	TY	TZ	MT	MY	MZ	My4	Mz4	Comb.
cm		kg	kg	kg	kg*m	kg*m	kg*m			
254	1	-35287	-47	250	23	386	83	--	--	2

X	cls	Nr	Vyr	Vzr	Mry	Mrz	MTrd	SF_V.	SF_M	SF_Mt	SF
cm		kg	kg	kg	kg*m	kg*m	kg*m				
254	1	52623	19060	19060	1818	1818	1566	76.2	1.08	68.7	1.08

Asta : 482 [313 , 342]

Sez. G: O 114.3x5.9 L=254.4 cm Crit.: Acciaio_Flessione $\gamma_M=1.05$ $f_{yk}/\gamma_M=2619$ kg/cmq $f_t=4300$ kg/cmq

:Verificato

X	cls	N	TY	TZ	MT	MY	MZ	My4	Mz4	Comb.
cm		kg	kg	kg	kg*m	kg*m	kg*m			

AUTOSTRADA VALDASTICO A31 NORD
1° LOTTO - PIOVENE ROCCHETTE – VALLE DELL'ASTICO

X	cls	N	TY	TZ	MT	MY	MZ	My4	Mz4	Comb.
203	1	9012	5	4	-2	-36	-5	--	--	2

X	cls	Nr	Vyr	Vzr	Mry	Mrz	MTrd	SF_V.	SF_M	SF_Mt	SF
cm		kg	kg	kg	kg*m	kg*m	kg*m				
203	1	52623	19311	19311	1818	1818	1566	>100	5.16	>100	5.16

Asta : 483 [342 , 314]

Sez. G: O 114.3x5.9 L=254.4 cm Crit.: Acciaio_Flessione $\gamma_M=1.05$ $f_{yk}/\gamma_M=2619$ kg/cm² $f_t=4300$ kg/cm²

:Verificato

X	cls	N	TY	TZ	MT	MY	MZ	My4	Mz4	Comb.
cm		kg	kg	kg	kg*m	kg*m	kg*m			
254	1	6905	-24	32	-9	56	24	--	--	2

X	cls	Nr	Vyr	Vzr	Mry	Mrz	MTrd	SF_V.	SF_M	SF_Mt	SF
cm		kg	kg	kg	kg*m	kg*m	kg*m				
254	1	52623	19231	19231	1818	1818	1566	>100	5.71	>100	5.71

Asta : 484 [316 , 315]

Sez. G: O 114.3x5.9 L=286.0 cm Crit.: Acciaio_Flessione $\gamma_M=1.05$ $f_{yk}/\gamma_M=2619$ kg/cm² $f_t=4300$ kg/cm²

:Verificato

X	cls	N	TY	TZ	MT	MY	MZ	My4	Mz4	Comb.
cm		kg	kg	kg	kg*m	kg*m	kg*m			
0	1	-2586	10	-41	22	56	13	--	--	2

X	cls	Nr	Vyr	Vzr	Mry	Mrz	MTrd	SF_V.	SF_M	SF_Mt	SF
cm		kg	kg	kg	kg*m	kg*m	kg*m				
0	1	52623	19072	19072	1818	1818	1566	>100	11.5	71.7	11.5

Asta : 485 [315 , 314]

Sez. G: O 114.3x5.9 L=314.0 cm Crit.: Acciaio_Flessione $\gamma_M=1.05$ $f_{yk}/\gamma_M=2619$ kg/cm² $f_t=4300$ kg/cm²

:Verificato

AUTOSTRADA VALDASTICO A31 NORD
1° LOTTO - PIOVENE ROCCHETTE – VALLE DELL'ASTICO

X	cls	N	TY	TZ	MT	MY	MZ	My4	Mz4	Comb.
cm		kg	kg	kg	kg*m	kg*m	kg*m			
314	1	-3881	-4	36	-10	40	6	--	--	2

X	cls	Nr	Vyr	Vzr	Mry	Mrz	MTrd	SF_V.	SF_M	SF_Mt	SF
cm		kg	kg	kg	kg*m	kg*m	kg*m				
314	1	52623	19219	19219	1818	1818	1566	>100	10.1	>100	10.1

Asta : 486 [317 , 349]

Sez. G: O 114.3x5.9 L=229.9 cm Crit.: Acciaio_Flessione $\gamma_M=1.05$ $f_{yk}/\gamma_M=2619$ kg/cm² $f_t=4300$ kg/cm²

:Verificato

X	cls	N	TY	TZ	MT	MY	MZ	My4	Mz4	Comb.
cm		kg	kg	kg	kg*m	kg*m	kg*m			
0	1	-20378	-22	-91	39	80	-50	--	--	2

X	cls	Nr	Vyr	Vzr	Mry	Mrz	MTrd	SF_V.	SF_M	SF_Mt	SF
cm		kg	kg	kg	kg*m	kg*m	kg*m				
0	1	52623	18865	18865	1818	1818	1566	>100	2.18	40.5	2.18

Asta : 487 [349 , 315]

Sez. G: O 114.3x5.9 L=229.9 cm Crit.: Acciaio_Flessione $\gamma_M=1.05$ $f_{yk}/\gamma_M=2619$ kg/cm² $f_t=4300$ kg/cm²

:Verificato

X	cls	N	TY	TZ	MT	MY	MZ	My4	Mz4	Comb.
cm		kg	kg	kg	kg*m	kg*m	kg*m			
0	1	5945	-10	-59	-7	53	-13	--	--	2

X	cls	Nr	Vyr	Vzr	Mry	Mrz	MTrd	SF_V.	SF_M	SF_Mt	SF
cm		kg	kg	kg	kg*m	kg*m	kg*m				
0	1	52623	19253	19253	1818	1818	1566	>100	6.69	>100	6.69

Asta : 488 [349 , 316]

AUTOSTRADA VALDASTICO A31 NORD
1° LOTTO - PIOVENE ROCCHETTE – VALLE DELL'ASTICO

Sez. G: O 114.3x5.9 L=229.9 cm Crit.: Acciaio_Flessione $\gamma_M=1.05$ $f_{yk}/\gamma_M=2619$ kg/cmq $f_t=4300$ kg/cmq

:Verificato

X	cls	N	TY	TZ	MT	MY	MZ	My4	Mz4	Comb.
cm		kg	kg	kg	kg*m	kg*m	kg*m			
0	1	4354	3	-39	1	84	8	--	--	2

X	cls	Nr	Vyr	Vzr	Mry	Mrz	MTrd	SF_V.	SF_M	SF_Mt	SF
cm		kg	kg	kg	kg*m	kg*m	kg*m				
0	1	52623	19330	19330	1818	1818	1566	>100	7.48	>100	7.48

Asta : 489 [348 , 347]

Sez. G: O 114.3x5.9 L=318.3 cm Crit.: Acciaio_Flessione $\gamma_M=1.05$ $f_{yk}/\gamma_M=2619$ kg/cmq $f_t=4300$ kg/cmq

:Verificato

X	cls	N	TY	TZ	MT	MY	MZ	My4	Mz4	Comb.
cm		kg	kg	kg	kg*m	kg*m	kg*m			
318	1	16198	3	1341	-2	753	-5	--	--	2

X	cls	Nr	Vyr	Vzr	Mry	Mrz	MTrd	SF_V.	SF_M	SF_Mt	SF
cm		kg	kg	kg	kg*m	kg*m	kg*m				
318	1	52623	19322	19322	1818	1818	1566	14.4	1.38	>100	1.38

Asta : 490 [347 , 346]

Sez. G: O 114.3x5.9 L=315.7 cm Crit.: Acciaio_Flessione $\gamma_M=1.05$ $f_{yk}/\gamma_M=2619$ kg/cmq $f_t=4300$ kg/cmq

:Verificato

X	cls	N	TY	TZ	MT	MY	MZ	My4	Mz4	Comb.
cm		kg	kg	kg	kg*m	kg*m	kg*m			
0	1	-11690	14	-1350	-17	701	23	--	--	2

X	cls	Nr	Vyr	Vzr	Mry	Mrz	MTrd	SF_V.	SF_M	SF_Mt	SF
cm		kg	kg	kg	kg*m	kg*m	kg*m				
0	1	52623	19132	19132	1818	1818	1566	14.2	1.61	92.2	1.61

AUTOSTRADA VALDASTICO A31 NORD
1° LOTTO - PIOVENE ROCCHETTE – VALLE DELL'ASTICO

Asta : 491 [346 , 345]

Sez. G: O 114.3x5.9 L=314.2 cm Crit.: Acciaio_Flessione $\gamma_M=1.05$ $f_{yk}/\gamma_M=2619$ kg/cm² $f_t=4300$ kg/cm²

:Verificato

X	cls	N	TY	TZ	MT	MY	MZ	My4	Mz4	Comb.
cm		kg	kg	kg	kg*m	kg*m	kg*m			
0	1	-17994	3	-1343	-3	684	4	--	--	2

X	cls	Nr	Vyr	Vzr	Mry	Mrz	MTrd	SF_V.	SF_M	SF_Mt	SF
cm		kg	kg	kg	kg*m	kg*m	kg*m				
0	1	52623	19307	19307	1818	1818	1566	14.4	1.39	>100	1.39

Asta : 492 [345 , 344]

Sez. G: O 114.3x5.9 L=314.0 cm Crit.: Acciaio_Flessione $\gamma_M=1.05$ $f_{yk}/\gamma_M=2619$ kg/cm² $f_t=4300$ kg/cm²

:Verificato

X	cls	N	TY	TZ	MT	MY	MZ	My4	Mz4	Comb.
cm		kg	kg	kg	kg*m	kg*m	kg*m			
314	1	-19285	-0	1339	0	676	0	--	--	2

X	cls	Nr	Vyr	Vzr	Mry	Mrz	MTrd	SF_V.	SF_M	SF_Mt	SF
cm		kg	kg	kg	kg*m	kg*m	kg*m				
314	1	52623	19342	19342	1818	1818	1566	14.4	1.35	>100	1.35

Asta : 493 [344 , 343]

Sez. G: O 114.3x5.9 L=314.2 cm Crit.: Acciaio_Flessione $\gamma_M=1.05$ $f_{yk}/\gamma_M=2619$ kg/cm² $f_t=4300$ kg/cm²

:Verificato

X	cls	N	TY	TZ	MT	MY	MZ	My4	Mz4	Comb.
cm		kg	kg	kg	kg*m	kg*m	kg*m			
314	1	-17939	-3	1343	3	685	4	--	--	2

X	cls	Nr	Vyr	Vzr	Mry	Mrz	MTrd	SF_V.	SF_M	SF_Mt	SF
cm		kg	kg	kg	kg*m	kg*m	kg*m				
314	1	52623	19307	19307	1818	1818	1566	14.4	1.39	>100	1.39

AUTOSTRADA VALDASTICO A31 NORD
1° LOTTO - PIOVENE ROCCHETTE – VALLE DELL'ASTICO

Asta : 494 [343 , 342]

Sez. G: O 114.3x5.9 L=315.7 cm Crit.: Acciaio_Flessione $\gamma_M=1.05$ $f_{yk}/\gamma_M=2619$ kg/cmq $f_t=4300$ kg/cmq

:Verificato

X	cls	N	TY	TZ	MT	MY	MZ	My4	Mz4	Comb.
cm		kg	kg	kg	kg*m	kg*m	kg*m			
316	1	-11537	-14	1350	17	701	23	--	--	2

X	cls	Nr	Vyr	Vzr	Mry	Mrz	MTrd	SF_V.	SF_M	SF_Mt	SF
cm		kg	kg	kg	kg*m	kg*m	kg*m				
316	1	52623	19129	19129	1818	1818	1566	14.2	1.62	91.0	1.62

Asta : 495 [342 , 349]

Sez. G: O 114.3x5.9 L=318.3 cm Crit.: Acciaio_Flessione $\gamma_M=1.05$ $f_{yk}/\gamma_M=2619$ kg/cmq $f_t=4300$ kg/cmq

:Verificato

X	cls	N	TY	TZ	MT	MY	MZ	My4	Mz4	Comb.
cm		kg	kg	kg	kg*m	kg*m	kg*m			
0	1	16635	-3	-1341	1	755	-5	--	--	2

X	cls	Nr	Vyr	Vzr	Mry	Mrz	MTrd	SF_V.	SF_M	SF_Mt	SF
cm		kg	kg	kg	kg*m	kg*m	kg*m				
0	1	52623	19328	19328	1818	1818	1566	14.4	1.36	>100	1.36

Asta : 496 [333 , 356]

Sez. G: O 114.3x5.9 L=229.9 cm Crit.: Acciaio_Flessione $\gamma_M=1.05$ $f_{yk}/\gamma_M=2619$ kg/cmq $f_t=4300$ kg/cmq

:Verificato

X	cls	N	TY	TZ	MT	MY	MZ	My4	Mz4	Comb.
cm		kg	kg	kg	kg*m	kg*m	kg*m			
0	1	-3250	-6	-20	15	20	-16	--	--	2

X	cls	Nr	Vyr	Vzr	Mry	Mrz	MTrd	SF_V.	SF_M	SF_Mt	SF
cm		kg	kg	kg	kg*m	kg*m	kg*m				

AUTOSTRADA VALDASTICO A31 NORD
1° LOTTO - PIOVENE ROCCHETTE – VALLE DELL'ASTICO

X	cls	Nr	Vyr	Vzr	Mry	Mrz	MTrd	SF_V.	SF_M	SF_Mt	SF
0	1	52623	19151	19151	1818	1818	1566	>100	12.2	>100	12.2

Asta : 497 [359 , 334]

Sez. G: O 114.3x5.9 L=286.0 cm Crit.: Acciaio_Flessione $\gamma_M=1.05$ $f_{yk}/\gamma_M=2619$ kg/cm² $f_t=4300$ kg/cm²

:Verificato

X	cls	N	TY	TZ	MT	MY	MZ	My4	Mz4	Comb.
cm		kg	kg	kg	kg*m	kg*m	kg*m			
114	1	9613	-4	-5	-4	-45	-3	--	--	2

X	cls	Nr	Vyr	Vzr	Mry	Mrz	MTrd	SF_V.	SF_M	SF_Mt	SF
cm		kg	kg	kg	kg*m	kg*m	kg*m				
114	1	52623	19298	19298	1818	1818	1566	>100	4.79	>100	4.79

Asta : 498 [334 , 333]

Sez. G: O 114.3x5.9 L=314.0 cm Crit.: Acciaio_Flessione $\gamma_M=1.05$ $f_{yk}/\gamma_M=2619$ kg/cm² $f_t=4300$ kg/cm²

:Verificato

X	cls	N	TY	TZ	MT	MY	MZ	My4	Mz4	Comb.
cm		kg	kg	kg	kg*m	kg*m	kg*m			
0	1	-3767	-4	-35	-9	39	-6	--	--	2

X	cls	Nr	Vyr	Vzr	Mry	Mrz	MTrd	SF_V.	SF_M	SF_Mt	SF
cm		kg	kg	kg	kg*m	kg*m	kg*m				
0	1	52623	19227	19227	1818	1818	1566	>100	10.3	>100	10.3

Asta : 499 [358 , 356]

Sez. G: O 114.3x5.9 L=229.9 cm Crit.: Acciaio_Flessione $\gamma_M=1.05$ $f_{yk}/\gamma_M=2619$ kg/cm² $f_t=4300$ kg/cm²

:Verificato

X	cls	N	TY	TZ	MT	MY	MZ	My4	Mz4	Comb.
cm		kg	kg	kg	kg*m	kg*m	kg*m			
230	1	853	-5	33	-20	19	15	--	--	2

AUTOSTRADA VALDASTICO A31 NORD
1° LOTTO - PIOVENE ROCCHETTE – VALLE DELL'ASTICO

X	cls	Nr	Vyr	Vzr	Mry	Mrz	MTrd	SF_V.	SF_M	SF_Mt	SF
cm		kg	kg	kg	kg*m	kg*m	kg*m				
230	1	52623	19091	19091	1818	1818	1566	>100	29.0	77.3	29.0

Asta : 500 [356 , 334]

Sez. G: O 114.3x5.9 L=229.9 cm Crit.: Acciaio_Flessione $\gamma_M=1.05$ fyk/ $\gamma_M=2619$ kg/cm² ft=4300 kg/cm²

:Verificato

X	cls	N	TY	TZ	MT	MY	MZ	My4	Mz4	Comb.
cm		kg	kg	kg	kg*m	kg*m	kg*m			
0	1	-5073	22	6	-11	-41	19	--	--	2

X	cls	Nr	Vyr	Vzr	Mry	Mrz	MTrd	SF_V.	SF_M	SF_Mt	SF
cm		kg	kg	kg	kg*m	kg*m	kg*m				
0	1	52623	19201	19201	1818	1818	1566	>100	7.74	>100	7.74

Asta : 501 [356 , 359]

Sez. G: O 114.3x5.9 L=229.9 cm Crit.: Acciaio_Flessione $\gamma_M=1.05$ fyk/ $\gamma_M=2619$ kg/cm² ft=4300 kg/cm²

:Verificato

X	cls	N	TY	TZ	MT	MY	MZ	My4	Mz4	Comb.
cm		kg	kg	kg	kg*m	kg*m	kg*m			
0	1	952	0	4	9	-44	7	--	--	2

X	cls	Nr	Vyr	Vzr	Mry	Mrz	MTrd	SF_V.	SF_M	SF_Mt	SF
cm		kg	kg	kg	kg*m	kg*m	kg*m				
0	1	52623	19235	19235	1818	1818	1566	>100	21.8	>100	21.8

Asta : 502 [358 , 333]

Sez. G: O 114.3x5.9 L=286.0 cm Crit.: Acciaio_Flessione $\gamma_M=1.05$ fyk/ $\gamma_M=2619$ kg/cm² ft=4300 kg/cm²

:Verificato

X	cls	N	TY	TZ	MT	MY	MZ	My4	Mz4	Comb.
cm		kg	kg	kg	kg*m	kg*m	kg*m			
86	1	4226	2	0	5	-33	0	--	--	2

AUTOSTRADA VALDASTICO A31 NORD
1° LOTTO - PIOVENE ROCCHETTE – VALLE DELL'ASTICO

X	cls	Nr	Vyr	Vzr	Mry	Mrz	MTrd	SF_V.	SF_M	SF_Mt	SF
cm		kg	kg	kg	kg*m	kg*m	kg*m				
86	1	52623	19278	19278	1818	1818	1566	>100	10.1	>100	10.1

Asta : 503 [360 , 335]

Sez. G: O 114.3x5.9 L=286.0 cm Crit.: Acciaio_Flessione $\gamma_M=1.05$ $f_{yk}/\gamma_M=2619$ kg/cm² $f_t=4300$ kg/cm²

:Verificato

X	cls	N	TY	TZ	MT	MY	MZ	My4	Mz4	Comb.
cm		kg	kg	kg	kg*m	kg*m	kg*m			
57	1	5213	-9	-10	-9	-19	-8	--	--	2

X	cls	Nr	Vyr	Vzr	Mry	Mrz	MTrd	SF_V.	SF_M	SF_Mt	SF
cm		kg	kg	kg	kg*m	kg*m	kg*m				
57	1	52623	19236	19236	1818	1818	1566	>100	8.77	>100	8.77

Asta : 504 [335 , 334]

Sez. G: O 114.3x5.9 L=314.0 cm Crit.: Acciaio_Flessione $\gamma_M=1.05$ $f_{yk}/\gamma_M=2619$ kg/cm² $f_t=4300$ kg/cm²

:Verificato

X	cls	N	TY	TZ	MT	MY	MZ	My4	Mz4	Comb.
cm		kg	kg	kg	kg*m	kg*m	kg*m			
314	1	-93	11	57	19	63	-19	--	--	2

X	cls	Nr	Vyr	Vzr	Mry	Mrz	MTrd	SF_V.	SF_M	SF_Mt	SF
cm		kg	kg	kg	kg*m	kg*m	kg*m				
314	1	52623	19102	19102	1818	1818	1566	>100	21.3	80.7	21.3

Asta : 505 [334 , 355]

Sez. G: O 114.3x5.9 L=254.4 cm Crit.: Acciaio_Flessione $\gamma_M=1.05$ $f_{yk}/\gamma_M=2619$ kg/cm² $f_t=4300$ kg/cm²

:Verificato

X	cls	N	TY	TZ	MT	MY	MZ	My4	Mz4	Comb.
cm		kg	kg	kg	kg*m	kg*m	kg*m			

AUTOSTRADA VALDASTICO A31 NORD
1° LOTTO - PIOVENE ROCCHETTE – VALLE DELL'ASTICO

X	cls	N	TY	TZ	MT	MY	MZ	My4	Mz4	Comb.
51	1	-9360	-19	-18	16	-14	-26	--	--	2

X	cls	Nr	Vyr	Vzr	Mry	Mrz	MTrd	SF_V.	SF_M	SF_Mt	SF
cm		kg	kg	kg	kg*m	kg*m	kg*m				
51	1	52623	19149	19149	1818	1818	1566	>100	4.99	>100	4.99

Asta : 506 [355 , 360]

Sez. G: O 114.3x5.9 L=254.4 cm Crit.: Acciaio_Flessione $\gamma_M=1.05$ $f_{yk}/\gamma_M=2619$ kg/cm² $f_t=4300$ kg/cm²

:Verificato

X	cls	N	TY	TZ	MT	MY	MZ	My4	Mz4	Comb.
cm		kg	kg	kg	kg*m	kg*m	kg*m			
127	1	2558	-3	3	6	-19	5	--	--	2

X	cls	Nr	Vyr	Vzr	Mry	Mrz	MTrd	SF_V.	SF_M	SF_Mt	SF
cm		kg	kg	kg	kg*m	kg*m	kg*m				
127	1	52623	19272	19272	1818	1818	1566	>100	16.2	>100	16.2

Asta : 507 [359 , 355]

Sez. G: O 114.3x5.9 L=254.4 cm Crit.: Acciaio_Flessione $\gamma_M=1.05$ $f_{yk}/\gamma_M=2619$ kg/cm² $f_t=4300$ kg/cm²

:Verificato

X	cls	N	TY	TZ	MT	MY	MZ	My4	Mz4	Comb.
cm		kg	kg	kg	kg*m	kg*m	kg*m			
153	1	-325	-3	2	-9	-8	9	--	--	2

X	cls	Nr	Vyr	Vzr	Mry	Mrz	MTrd	SF_V.	SF_M	SF_Mt	SF
cm		kg	kg	kg	kg*m	kg*m	kg*m				
153	1	52623	19225	19225	1818	1818	1566	>100	64.0	>100	64.0

Asta : 508 [355 , 335]

Sez. G: O 114.3x5.9 L=254.4 cm Crit.: Acciaio_Flessione $\gamma_M=1.05$ $f_{yk}/\gamma_M=2619$ kg/cm² $f_t=4300$ kg/cm²

:Verificato

AUTOSTRADA VALDASTICO A31 NORD
1° LOTTO - PIOVENE ROCCHETTE – VALLE DELL'ASTICO

X	cls	N	TY	TZ	MT	MY	MZ	My4	Mz4	Comb.
cm		kg	kg	kg	kg*m	kg*m	kg*m			
254	1	188	12	28	-3	24	-17	--	--	2

X	cls	Nr	Vyr	Vzr	Mry	Mrz	MTrd	SF_V.	SF_M	SF_Mt	SF
cm		kg	kg	kg	kg*m	kg*m	kg*m				
254	1	52623	19307	19307	1818	1818	1566	>100	38.2	>100	38.2

Asta : 509 [361 , 336]

Sez. G: O 114.3x5.9 L=286.0 cm Crit.: Acciaio_Flessione $\gamma_M=1.05$ $f_{yk}/\gamma_M=2619$ kg/cm² $f_t=4300$ kg/cm²

:Verificato

X	cls	N	TY	TZ	MT	MY	MZ	My4	Mz4	Comb.
cm		kg	kg	kg	kg*m	kg*m	kg*m			
286	1	2154	-4	30	-3	11	7	--	--	2

X	cls	Nr	Vyr	Vzr	Mry	Mrz	MTrd	SF_V.	SF_M	SF_Mt	SF
cm		kg	kg	kg	kg*m	kg*m	kg*m				
286	1	52623	19304	19304	1818	1818	1566	>100	19.7	>100	19.7

Asta : 510 [336 , 335]

Sez. G: O 114.3x5.9 L=314.0 cm Crit.: Acciaio_Flessione $\gamma_M=1.05$ $f_{yk}/\gamma_M=2619$ kg/cm² $f_t=4300$ kg/cm²

:Verificato

X	cls	N	TY	TZ	MT	MY	MZ	My4	Mz4	Comb.
cm		kg	kg	kg	kg*m	kg*m	kg*m			
94	1	9364	6	-6	8	-29	3	--	--	2

X	cls	Nr	Vyr	Vzr	Mry	Mrz	MTrd	SF_V.	SF_M	SF_Mt	SF
cm		kg	kg	kg	kg*m	kg*m	kg*m				
94	1	52623	19244	19244	1818	1818	1566	>100	5.11	>100	5.11

Asta : 511 [360 , 354]

AUTOSTRADA VALDASTICO A31 NORD
1° LOTTO - PIOVENE ROCCHETTE – VALLE DELL'ASTICO

Sez. G: O 114.3x5.9 L=273.9 cm Crit.: Acciaio_Flessione $\gamma_M=1.05$ $f_{yk}/\gamma_M=2619$ kg/cmq $f_t=4300$ kg/cmq

:Verificato

X	cls	N	TY	TZ	MT	MY	MZ	My4	Mz4	Comb.
cm		kg	kg	kg	kg*m	kg*m	kg*m			
274	1	-1929	-8	23	1	6	10	--	--	2

X	cls	Nr	Vyr	Vzr	Mry	Mrz	MTrd	SF_V.	SF_M	SF_Mt	SF
cm		kg	kg	kg	kg*m	kg*m	kg*m				
274	1	52623	19335	19335	1818	1818	1566	>100	21.9	>100	21.9

Asta : 512 [354 , 336]

Sez. G: O 114.3x5.9 L=273.9 cm Crit.: Acciaio_Flessione $\gamma_M=1.05$ $f_{yk}/\gamma_M=2619$ kg/cmq $f_t=4300$ kg/cmq

:Verificato

X	cls	N	TY	TZ	MT	MY	MZ	My4	Mz4	Comb.
cm		kg	kg	kg	kg*m	kg*m	kg*m			
0	1	2006	5	-22	3	6	10	--	--	2

X	cls	Nr	Vyr	Vzr	Mry	Mrz	MTrd	SF_V.	SF_M	SF_Mt	SF
cm		kg	kg	kg	kg*m	kg*m	kg*m				
0	1	52623	19301	19301	1818	1818	1566	>100	21.3	>100	21.3

Asta : 513 [335 , 354]

Sez. G: O 114.3x5.9 L=273.9 cm Crit.: Acciaio_Flessione $\gamma_M=1.05$ $f_{yk}/\gamma_M=2619$ kg/cmq $f_t=4300$ kg/cmq

:Verificato

X	cls	N	TY	TZ	MT	MY	MZ	My4	Mz4	Comb.
cm		kg	kg	kg	kg*m	kg*m	kg*m			
82	1	-6553	2	-3	-2	-25	3	--	--	2

X	cls	Nr	Vyr	Vzr	Mry	Mrz	MTrd	SF_V.	SF_M	SF_Mt	SF
cm		kg	kg	kg	kg*m	kg*m	kg*m				
82	1	52623	19321	19321	1818	1818	1566	>100	7.14	>100	7.14

AUTOSTRADA VALDASTICO A31 NORD
1° LOTTO - PIOVENE ROCCHETTE – VALLE DELL'ASTICO

Asta : 514 [354 , 361]

Sez. G: O 114.3x5.9 L=273.9 cm Crit.: Acciaio_Flessione $\gamma_M=1.05$ $f_{yk}/\gamma_M=2619$ kg/cm² $f_t=4300$ kg/cm²

:Verificato

X	cls	N	TY	TZ	MT	MY	MZ	My4	Mz4	Comb.
cm		kg	kg	kg	kg*m	kg*m	kg*m			
110	1	2116	-2	-3	-2	-16	-3	--	--	2

X	cls	Nr	Vyr	Vzr	Mry	Mrz	MTrd	SF_V.	SF_M	SF_Mt	SF
cm		kg	kg	kg	kg*m	kg*m	kg*m				
110	1	52623	19312	19312	1818	1818	1566	>100	19.6	>100	19.6

Asta : 515 [362 , 337]

Sez. G: O 114.3x5.9 L=286.0 cm Crit.: Acciaio_Flessione $\gamma_M=1.05$ $f_{yk}/\gamma_M=2619$ kg/cm² $f_t=4300$ kg/cm²

:Verificato

X	cls	N	TY	TZ	MT	MY	MZ	My4	Mz4	Comb.
cm		kg	kg	kg	kg*m	kg*m	kg*m			
0	1	1561	-0	-31	0	14	-0	--	--	2

X	cls	Nr	Vyr	Vzr	Mry	Mrz	MTrd	SF_V.	SF_M	SF_Mt	SF
cm		kg	kg	kg	kg*m	kg*m	kg*m				
0	1	52623	19342	19342	1818	1818	1566	>100	26.9	>100	26.9

Asta : 516 [337 , 336]

Sez. G: O 114.3x5.9 L=314.0 cm Crit.: Acciaio_Flessione $\gamma_M=1.05$ $f_{yk}/\gamma_M=2619$ kg/cm² $f_t=4300$ kg/cm²

:Verificato

X	cls	N	TY	TZ	MT	MY	MZ	My4	Mz4	Comb.
cm		kg	kg	kg	kg*m	kg*m	kg*m			
157	1	13707	1	2	2	-34	0	--	--	2

X	cls	Nr	Vyr	Vzr	Mry	Mrz	MTrd	SF_V.	SF_M	SF_Mt	SF
cm		kg	kg	kg	kg*m	kg*m	kg*m				
157	1	52623	19321	19321	1818	1818	1566	>100	3.58	>100	3.58

AUTOSTRADA VALDASTICO A31 NORD
1° LOTTO - PIOVENE ROCCHETTE – VALLE DELL'ASTICO

Asta : 517 [361 , 353]

Sez. G: O 114.3x5.9 L=281.6 cm Crit.: Acciaio_Flessione $\gamma_M=1.05$ $f_{yk}/\gamma_M=2619$ kg/cmq $f_t=4300$ kg/cmq

:Verificato

X	cls	N	TY	TZ	MT	MY	MZ	My4	Mz4	Comb.
cm		kg	kg	kg	kg*m	kg*m	kg*m			
113	1	-1873	-4	-4	4	-13	-6	--	--	2

X	cls	Nr	Vyr	Vzr	Mry	Mrz	MTrd	SF_V.	SF_M	SF_Mt	SF
cm		kg	kg	kg	kg*m	kg*m	kg*m				
113	1	52623	19289	19289	1818	1818	1566	>100	21.7	>100	21.7

Asta : 518 [353 , 362]

Sez. G: O 114.3x5.9 L=281.6 cm Crit.: Acciaio_Flessione $\gamma_M=1.05$ $f_{yk}/\gamma_M=2619$ kg/cmq $f_t=4300$ kg/cmq

:Verificato

X	cls	N	TY	TZ	MT	MY	MZ	My4	Mz4	Comb.
cm		kg	kg	kg	kg*m	kg*m	kg*m			
141	1	34	0	0	-5	-16	-5	--	--	2

X	cls	Nr	Vyr	Vzr	Mry	Mrz	MTrd	SF_V.	SF_M	SF_Mt	SF
cm		kg	kg	kg	kg*m	kg*m	kg*m				
141	1	52623	19283	19283	1818	1818	1566	>100	81.1	>100	81.1

Asta : 519 [336 , 353]

Sez. G: O 114.3x5.9 L=281.6 cm Crit.: Acciaio_Flessione $\gamma_M=1.05$ $f_{yk}/\gamma_M=2619$ kg/cmq $f_t=4300$ kg/cmq

:Verificato

X	cls	N	TY	TZ	MT	MY	MZ	My4	Mz4	Comb.
cm		kg	kg	kg	kg*m	kg*m	kg*m			
113	1	-2312	3	-2	-5	-19	6	--	--	2

X	cls	Nr	Vyr	Vzr	Mry	Mrz	MTrd	SF_V.	SF_M	SF_Mt	SF
cm		kg	kg	kg	kg*m	kg*m	kg*m				

AUTOSTRADA VALDASTICO A31 NORD
1° LOTTO - PIOVENE ROCCHETTE – VALLE DELL'ASTICO

X	cls	Nr	Vyr	Vzr	Mry	Mrz	MTrd	SF_V.	SF_M	SF_Mt	SF
cm		kg	kg	kg	kg*m	kg*m	kg*m				
113	1	52623	19284	19284	1818	1818	1566	>100	17.4	>100	17.4

Asta : 520 [353 , 337]

Sez. G: O 114.3x5.9 L=281.6 cm Crit.: Acciaio_Flessione $\gamma_M=1.05$ $f_{yk}/\gamma_M=2619$ kg/cm² $f_t=4300$ kg/cm²

:Verificato

X	cls	N	TY	TZ	MT	MY	MZ	My4	Mz4	Comb.
cm		kg	kg	kg	kg*m	kg*m	kg*m			
141	1	533	-0	-1	5	-16	6	--	--	2

X	cls	Nr	Vyr	Vzr	Mry	Mrz	MTrd	SF_V.	SF_M	SF_Mt	SF
cm		kg	kg	kg	kg*m	kg*m	kg*m				
141	1	52623	19281	19281	1818	1818	1566	>100	45.9	>100	45.9

Asta : 521 [337 , 352]

Sez. G: O 114.3x5.9 L=281.6 cm Crit.: Acciaio_Flessione $\gamma_M=1.05$ $f_{yk}/\gamma_M=2619$ kg/cm² $f_t=4300$ kg/cm²

:Verificato

X	cls	N	TY	TZ	MT	MY	MZ	My4	Mz4	Comb.
cm		kg	kg	kg	kg*m	kg*m	kg*m			
141	1	571	0	1	-5	-16	6	--	--	2

X	cls	Nr	Vyr	Vzr	Mry	Mrz	MTrd	SF_V.	SF_M	SF_Mt	SF
cm		kg	kg	kg	kg*m	kg*m	kg*m				
141	1	52623	19281	19281	1818	1818	1566	>100	44.5	>100	44.5

Asta : 522 [352 , 363]

Sez. G: O 114.3x5.9 L=281.6 cm Crit.: Acciaio_Flessione $\gamma_M=1.05$ $f_{yk}/\gamma_M=2619$ kg/cm² $f_t=4300$ kg/cm²

:Verificato

X	cls	N	TY	TZ	MT	MY	MZ	My4	Mz4	Comb.
cm		kg	kg	kg	kg*m	kg*m	kg*m			
169	1	-1892	4	4	-4	-13	-6	--	--	2

AUTOSTRADA VALDASTICO A31 NORD
1° LOTTO - PIOVENE ROCCHETTE – VALLE DELL'ASTICO

X	cls	Nr	Vyr	Vzr	Mry	Mrz	MTrd	SF_V.	SF_M	SF_Mt	SF
cm		kg	kg	kg	kg*m	kg*m	kg*m				
169	1	52623	19290	19290	1818	1818	1566	>100	21.6	>100	21.6

Asta : 523 [363 , 338]

Sez. G: O 114.3x5.9 L=286.0 cm Crit.: Acciaio_Flessione $\gamma_M=1.05$ $f_{yk}/\gamma_M=2619$ kg/cm² $f_t=4300$ kg/cm²

:Verificato

X	cls	N	TY	TZ	MT	MY	MZ	My4	Mz4	Comb.
cm		kg	kg	kg	kg*m	kg*m	kg*m			
286	1	2165	4	30	3	11	-7	--	--	2

X	cls	Nr	Vyr	Vzr	Mry	Mrz	MTrd	SF_V.	SF_M	SF_Mt	SF
cm		kg	kg	kg	kg*m	kg*m	kg*m				
286	1	52623	19303	19303	1818	1818	1566	>100	19.6	>100	19.6

Asta : 524 [338 , 337]

Sez. G: O 114.3x5.9 L=314.0 cm Crit.: Acciaio_Flessione $\gamma_M=1.05$ $f_{yk}/\gamma_M=2619$ kg/cm² $f_t=4300$ kg/cm²

:Verificato

X	cls	N	TY	TZ	MT	MY	MZ	My4	Mz4	Comb.
cm		kg	kg	kg	kg*m	kg*m	kg*m			
157	1	13676	-1	-2	-2	-34	0	--	--	2

X	cls	Nr	Vyr	Vzr	Mry	Mrz	MTrd	SF_V.	SF_M	SF_Mt	SF
cm		kg	kg	kg	kg*m	kg*m	kg*m				
157	1	52623	19321	19321	1818	1818	1566	>100	3.59	>100	3.59

Asta : 525 [362 , 352]

Sez. G: O 114.3x5.9 L=281.6 cm Crit.: Acciaio_Flessione $\gamma_M=1.05$ $f_{yk}/\gamma_M=2619$ kg/cm² $f_t=4300$ kg/cm²

:Verificato

X	cls	N	TY	TZ	MT	MY	MZ	My4	Mz4	Comb.
cm		kg	kg	kg	kg*m	kg*m	kg*m			

AUTOSTRADA VALDASTICO A31 NORD
1° LOTTO - PIOVENE ROCCHETTE – VALLE DELL'ASTICO

X	cls	N	TY	TZ	MT	MY	MZ	My4	Mz4	Comb.
141	1	57	-0	-0	5	-16	-5	--	--	2

X	cls	Nr	Vyr	Vzr	Mry	Mrz	MTrd	SF_V.	SF_M	SF_Mt	SF
cm		kg	kg	kg	kg*m	kg*m	kg*m				
141	1	52623	19283	19283	1818	1818	1566	>100	78.3	>100	78.3

Asta : 526 [352 , 338]

Sez. G: O 114.3x5.9 L=281.6 cm Crit.: Acciaio_Flessione $\gamma_M=1.05$ $f_{yk}/\gamma_M=2619$ kg/cm² $f_t=4300$ kg/cm²

:Verificato

X	cls	N	TY	TZ	MT	MY	MZ	My4	Mz4	Comb.
cm		kg	kg	kg	kg*m	kg*m	kg*m			
169	1	-2358	-3	2	5	-19	6	--	--	2

X	cls	Nr	Vyr	Vzr	Mry	Mrz	MTrd	SF_V.	SF_M	SF_Mt	SF
cm		kg	kg	kg	kg*m	kg*m	kg*m				
169	1	52623	19284	19284	1818	1818	1566	>100	17.1	>100	17.1

Asta : 527 [364 , 339]

Sez. G: O 114.3x5.9 L=286.0 cm Crit.: Acciaio_Flessione $\gamma_M=1.05$ $f_{yk}/\gamma_M=2619$ kg/cm² $f_t=4300$ kg/cm²

:Verificato

X	cls	N	TY	TZ	MT	MY	MZ	My4	Mz4	Comb.
cm		kg	kg	kg	kg*m	kg*m	kg*m			
57	1	5249	9	-10	9	-19	8	--	--	2

X	cls	Nr	Vyr	Vzr	Mry	Mrz	MTrd	SF_V.	SF_M	SF_Mt	SF
cm		kg	kg	kg	kg*m	kg*m	kg*m				
57	1	52623	19236	19236	1818	1818	1566	>100	8.71	>100	8.71

Asta : 528 [339 , 338]

Sez. G: O 114.3x5.9 L=314.0 cm Crit.: Acciaio_Flessione $\gamma_M=1.05$ $f_{yk}/\gamma_M=2619$ kg/cm² $f_t=4300$ kg/cm²

:Verificato

AUTOSTRADA VALDASTICO A31 NORD
1° LOTTO - PIOVENE ROCCHETTE – VALLE DELL'ASTICO

X	cls	N	TY	TZ	MT	MY	MZ	My4	Mz4	Comb.
cm		kg	kg	kg	kg*m	kg*m	kg*m			
220	1	9265	-6	6	-8	-29	3	--	--	2

X	cls	Nr	Vyr	Vzr	Mry	Mrz	MTrd	SF_V.	SF_M	SF_Mt	SF
cm		kg	kg	kg	kg*m	kg*m	kg*m				
220	1	52623	19244	19244	1818	1818	1566	>100	5.16	>100	5.16

Asta : 529 [338 , 351]

Sez. G: O 114.3x5.9 L=273.9 cm Crit.: Acciaio_Flessione $\gamma_M=1.05$ $f_{yk}/\gamma_M=2619$ kg/cm² $f_t=4300$ kg/cm²

:Verificato

X	cls	N	TY	TZ	MT	MY	MZ	My4	Mz4	Comb.
cm		kg	kg	kg	kg*m	kg*m	kg*m			
274	1	2031	-5	22	-3	6	10	--	--	2

X	cls	Nr	Vyr	Vzr	Mry	Mrz	MTrd	SF_V.	SF_M	SF_Mt	SF
cm		kg	kg	kg	kg*m	kg*m	kg*m				
274	1	52623	19301	19301	1818	1818	1566	>100	21.1	>100	21.1

Asta : 530 [351 , 364]

Sez. G: O 114.3x5.9 L=273.9 cm Crit.: Acciaio_Flessione $\gamma_M=1.05$ $f_{yk}/\gamma_M=2619$ kg/cm² $f_t=4300$ kg/cm²

:Verificato

X	cls	N	TY	TZ	MT	MY	MZ	My4	Mz4	Comb.
cm		kg	kg	kg	kg*m	kg*m	kg*m			
0	1	-1929	8	-23	-0	6	10	--	--	2

X	cls	Nr	Vyr	Vzr	Mry	Mrz	MTrd	SF_V.	SF_M	SF_Mt	SF
cm		kg	kg	kg	kg*m	kg*m	kg*m				
0	1	52623	19336	19336	1818	1818	1566	>100	21.9	>100	21.9

Asta : 531 [363 , 351]

AUTOSTRADA VALDASTICO A31 NORD
1° LOTTO - PIOVENE ROCCHETTE – VALLE DELL'ASTICO

Sez. G: O 114.3x5.9 L=273.9 cm Crit.: Acciaio_Flessione $\gamma_M=1.05$ $f_{yk}/\gamma_M=2619$ kg/cm² $f_t=4300$ kg/cm²

:Verificato

X	cls	N	TY	TZ	MT	MY	MZ	My4	Mz4	Comb.
cm		kg	kg	kg	kg*m	kg*m	kg*m			
164	1	2137	2	3	2	-16	-3	--	--	2

X	cls	Nr	Vyr	Vzr	Mry	Mrz	MTrd	SF_V.	SF_M	SF_Mt	SF
cm		kg	kg	kg	kg*m	kg*m	kg*m				
164	1	52623	19313	19313	1818	1818	1566	>100	19.4	>100	19.4

Asta : 532 [351 , 339]

Sez. G: O 114.3x5.9 L=273.9 cm Crit.: Acciaio_Flessione $\gamma_M=1.05$ $f_{yk}/\gamma_M=2619$ kg/cm² $f_t=4300$ kg/cm²

:Verificato

X	cls	N	TY	TZ	MT	MY	MZ	My4	Mz4	Comb.
cm		kg	kg	kg	kg*m	kg*m	kg*m			
192	1	-6616	-2	3	2	-25	3	--	--	2

X	cls	Nr	Vyr	Vzr	Mry	Mrz	MTrd	SF_V.	SF_M	SF_Mt	SF
cm		kg	kg	kg	kg*m	kg*m	kg*m				
192	1	52623	19322	19322	1818	1818	1566	>100	7.08	>100	7.08

Asta : 533 [339 , 340]

Sez. G: O 114.3x5.9 L=314.0 cm Crit.: Acciaio_Flessione $\gamma_M=1.05$ $f_{yk}/\gamma_M=2619$ kg/cm² $f_t=4300$ kg/cm²

:Verificato

X	cls	N	TY	TZ	MT	MY	MZ	My4	Mz4	Comb.
cm		kg	kg	kg	kg*m	kg*m	kg*m			
314	1	-277	-11	57	-19	64	19	--	--	2

X	cls	Nr	Vyr	Vzr	Mry	Mrz	MTrd	SF_V.	SF_M	SF_Mt	SF
cm		kg	kg	kg	kg*m	kg*m	kg*m				
314	1	52623	19102	19102	1818	1818	1566	>100	19.6	80.6	19.6

AUTOSTRADA VALDASTICO A31 NORD
1° LOTTO - PIOVENE ROCCHETTE – VALLE DELL'ASTICO

Asta : 534 [340 , 365]

Sez. G: O 114.3x5.9 L=286.0 cm Crit.: Acciaio_Flessione $\gamma_M=1.05$ $f_{yk}/\gamma_M=2619$ kg/cmq $f_t=4300$ kg/cmq

:Verificato

X	cls	N	TY	TZ	MT	MY	MZ	My4	Mz4	Comb.
cm		kg	kg	kg	kg*m	kg*m	kg*m			
172	1	9635	4	5	3	-45	-3	--	--	2

X	cls	Nr	Vyr	Vzr	Mry	Mrz	MTrd	SF_V.	SF_M	SF_Mt	SF
cm		kg	kg	kg	kg*m	kg*m	kg*m				
172	1	52623	19300	19300	1818	1818	1566	>100	4.78	>100	4.78

Asta : 535 [364 , 350]

Sez. G: O 114.3x5.9 L=254.4 cm Crit.: Acciaio_Flessione $\gamma_M=1.05$ $f_{yk}/\gamma_M=2619$ kg/cmq $f_t=4300$ kg/cmq

:Verificato

X	cls	N	TY	TZ	MT	MY	MZ	My4	Mz4	Comb.
cm		kg	kg	kg	kg*m	kg*m	kg*m			
127	1	2562	3	-3	-6	-19	5	--	--	2

X	cls	Nr	Vyr	Vzr	Mry	Mrz	MTrd	SF_V.	SF_M	SF_Mt	SF
cm		kg	kg	kg	kg*m	kg*m	kg*m				
127	1	52623	19271	19271	1818	1818	1566	>100	16.2	>100	16.2

Asta : 536 [350 , 365]

Sez. G: O 114.3x5.9 L=254.4 cm Crit.: Acciaio_Flessione $\gamma_M=1.05$ $f_{yk}/\gamma_M=2619$ kg/cmq $f_t=4300$ kg/cmq

:Verificato

X	cls	N	TY	TZ	MT	MY	MZ	My4	Mz4	Comb.
cm		kg	kg	kg	kg*m	kg*m	kg*m			
102	1	-305	3	-1	10	-8	9	--	--	2

X	cls	Nr	Vyr	Vzr	Mry	Mrz	MTrd	SF_V.	SF_M	SF_Mt	SF
cm		kg	kg	kg	kg*m	kg*m	kg*m				
102	1	52623	19224	19224	1818	1818	1566	>100	65.5	>100	65.5

AUTOSTRADA VALDASTICO A31 NORD
1° LOTTO - PIOVENE ROCCHETTE – VALLE DELL'ASTICO

Asta : 537 [339 , 350]

Sez. G: O 114.3x5.9 L=254.4 cm Crit.: Acciaio_Flessione $\gamma_M=1.05$ $f_{yk}/\gamma_M=2619$ kg/cm² $f_t=4300$ kg/cm²

:Verificato

X	cls	N	TY	TZ	MT	MY	MZ	My4	Mz4	Comb.
cm		kg	kg	kg	kg*m	kg*m	kg*m			
0	1	185	-12	-28	3	24	-17	--	--	2

X	cls	Nr	Vyr	Vzr	Mry	Mrz	MTrd	SF_V.	SF_M	SF_Mt	SF
cm		kg	kg	kg	kg*m	kg*m	kg*m				
0	1	52623	19306	19306	1818	1818	1566	>100	37.9	>100	37.9

Asta : 538 [350 , 340]

Sez. G: O 114.3x5.9 L=254.4 cm Crit.: Acciaio_Flessione $\gamma_M=1.05$ $f_{yk}/\gamma_M=2619$ kg/cm² $f_t=4300$ kg/cm²

:Verificato

X	cls	N	TY	TZ	MT	MY	MZ	My4	Mz4	Comb.
cm		kg	kg	kg	kg*m	kg*m	kg*m			
203	1	-9398	20	18	-16	-14	-27	--	--	2

X	cls	Nr	Vyr	Vzr	Mry	Mrz	MTrd	SF_V.	SF_M	SF_Mt	SF
cm		kg	kg	kg	kg*m	kg*m	kg*m				
203	1	52623	19146	19146	1818	1818	1566	>100	4.98	98.9	4.98

Asta : 539 [366 , 341]

Sez. G: O 114.3x5.9 L=286.0 cm Crit.: Acciaio_Flessione $\gamma_M=1.05$ $f_{yk}/\gamma_M=2619$ kg/cm² $f_t=4300$ kg/cm²

:Verificato

X	cls	N	TY	TZ	MT	MY	MZ	My4	Mz4	Comb.
cm		kg	kg	kg	kg*m	kg*m	kg*m			
86	1	4078	-2	0	-6	-33	-0	--	--	2

X	cls	Nr	Vyr	Vzr	Mry	Mrz	MTrd	SF_V.	SF_M	SF_Mt	SF
cm		kg	kg	kg	kg*m	kg*m	kg*m				
86	1	52623	19271	19271	1818	1818	1566	>100	10.5	>100	10.5

AUTOSTRADA VALDASTICO A31 NORD
1° LOTTO - PIOVENE ROCCHETTE – VALLE DELL'ASTICO

Asta : 540 [341 , 340]

Sez. G: O 114.3x5.9 L=314.0 cm Crit.: Acciaio_Flessione $\gamma_M=1.05$ $f_{yk}/\gamma_M=2619$ kg/cmq $f_t=4300$ kg/cmq

:Verificato

X	cls	N	TY	TZ	MT	MY	MZ	My4	Mz4	Comb.
cm		kg	kg	kg	kg*m	kg*m	kg*m			
314	1	-3904	5	35	10	40	-7	--	--	2

X	cls	Nr	Vyr	Vzr	Mry	Mrz	MTrd	SF_V.	SF_M	SF_Mt	SF
cm		kg	kg	kg	kg*m	kg*m	kg*m				
314	1	52623	19218	19218	1818	1818	1566	>100	10.0	>100	10.0

Asta : 541 [365 , 357]

Sez. G: O 114.3x5.9 L=229.9 cm Crit.: Acciaio_Flessione $\gamma_M=1.05$ $f_{yk}/\gamma_M=2619$ kg/cmq $f_t=4300$ kg/cmq

:Verificato

X	cls	N	TY	TZ	MT	MY	MZ	My4	Mz4	Comb.
cm		kg	kg	kg	kg*m	kg*m	kg*m			
230	1	925	-0	-4	-9	-43	7	--	--	2

X	cls	Nr	Vyr	Vzr	Mry	Mrz	MTrd	SF_V.	SF_M	SF_Mt	SF
cm		kg	kg	kg	kg*m	kg*m	kg*m				
230	1	52623	19235	19235	1818	1818	1566	>100	22.1	>100	22.1

Asta : 542 [357 , 341]

Sez. G: O 114.3x5.9 L=229.9 cm Crit.: Acciaio_Flessione $\gamma_M=1.05$ $f_{yk}/\gamma_M=2619$ kg/cmq $f_t=4300$ kg/cmq

:Verificato

X	cls	N	TY	TZ	MT	MY	MZ	My4	Mz4	Comb.
cm		kg	kg	kg	kg*m	kg*m	kg*m			
230	1	-3172	6	20	-15	22	-17	--	--	2

X	cls	Nr	Vyr	Vzr	Mry	Mrz	MTrd	SF_V.	SF_M	SF_Mt	SF
cm		kg	kg	kg	kg*m	kg*m	kg*m				

AUTOSTRADA VALDASTICO A31 NORD
1° LOTTO - PIOVENE ROCCHETTE – VALLE DELL'ASTICO

X	cls	Nr	Vyr	Vzr	Mry	Mrz	MTrd	SF_V.	SF_M	SF_Mt	SF
230	1	52623	19154	19154	1818	1818	1566	>100	12.2	>100	12.2

Asta : 543 [357 , 366]

Sez. G: O 114.3x5.9 L=229.9 cm Crit.: Acciaio_Flessione $\gamma_M=1.05$ $f_{yk}/\gamma_M=2619$ kg/cm² $f_t=4300$ kg/cm²

:Verificato

X	cls	N	TY	TZ	MT	MY	MZ	My4	Mz4	Comb.
cm		kg	kg	kg	kg*m	kg*m	kg*m			
0	1	861	5	-32	20	18	14	--	--	2

X	cls	Nr	Vyr	Vzr	Mry	Mrz	MTrd	SF_V.	SF_M	SF_Mt	SF
cm		kg	kg	kg	kg*m	kg*m	kg*m				
0	1	52623	19093	19093	1818	1818	1566	>100	29.1	77.7	29.1

Asta : 544 [356 , 355]

Sez. G: O 114.3x5.9 L=318.3 cm Crit.: Acciaio_Flessione $\gamma_M=1.05$ $f_{yk}/\gamma_M=2619$ kg/cm² $f_t=4300$ kg/cm²

:Verificato

X	cls	N	TY	TZ	MT	MY	MZ	My4	Mz4	Comb.
cm		kg	kg	kg	kg*m	kg*m	kg*m			
318	1	2670	-6	1350	6	731	10	--	--	2

X	cls	Nr	Vyr	Vzr	Mry	Mrz	MTrd	SF_V.	SF_M	SF_Mt	SF
cm		kg	kg	kg	kg*m	kg*m	kg*m				
318	1	52623	19273	19273	1818	1818	1566	14.3	2.18	>100	2.18

Asta : 545 [355 , 354]

Sez. G: O 114.3x5.9 L=315.7 cm Crit.: Acciaio_Flessione $\gamma_M=1.05$ $f_{yk}/\gamma_M=2619$ kg/cm² $f_t=4300$ kg/cm²

:Verificato

X	cls	N	TY	TZ	MT	MY	MZ	My4	Mz4	Comb.
cm		kg	kg	kg	kg*m	kg*m	kg*m			
0	1	-5461	-12	-1349	8	716	-19	--	--	2

AUTOSTRADA VALDASTICO A31 NORD
1° LOTTO - PIOVENE ROCCHETTE – VALLE DELL'ASTICO

X	cls	Nr	Vyr	Vzr	Mry	Mrz	MTrd	SF_V.	SF_M	SF_Mt	SF
cm		kg	kg	kg	kg*m	kg*m	kg*m				
0	1	52623	19244	19244	1818	1818	1566	14.3	1.97	>100	1.97

Asta : 546 [354 , 353]

Sez. G: O 114.3x5.9 L=314.2 cm Crit.: Acciaio_Flessione $\gamma_M=1.05$ $f_{yk}/\gamma_M=2619$ kg/cm² $f_t=4300$ kg/cm²

:Verificato

X	cls	N	TY	TZ	MT	MY	MZ	My4	Mz4	Comb.
cm		kg	kg	kg	kg*m	kg*m	kg*m			
0	1	-12599	-4	-1345	3	694	-7	--	--	2

X	cls	Nr	Vyr	Vzr	Mry	Mrz	MTrd	SF_V.	SF_M	SF_Mt	SF
cm		kg	kg	kg	kg*m	kg*m	kg*m				
0	1	52623	19306	19306	1818	1818	1566	14.4	1.60	>100	1.60

Asta : 547 [353 , 352]

Sez. G: O 114.3x5.9 L=314.0 cm Crit.: Acciaio_Flessione $\gamma_M=1.05$ $f_{yk}/\gamma_M=2619$ kg/cm² $f_t=4300$ kg/cm²

:Verificato

X	cls	N	TY	TZ	MT	MY	MZ	My4	Mz4	Comb.
cm		kg	kg	kg	kg*m	kg*m	kg*m			
314	1	-15191	0	1339	-0	680	-0	--	--	2

X	cls	Nr	Vyr	Vzr	Mry	Mrz	MTrd	SF_V.	SF_M	SF_Mt	SF
cm		kg	kg	kg	kg*m	kg*m	kg*m				
314	1	52623	19342	19342	1818	1818	1566	14.4	1.51	>100	1.51

Asta : 548 [352 , 351]

Sez. G: O 114.3x5.9 L=314.2 cm Crit.: Acciaio_Flessione $\gamma_M=1.05$ $f_{yk}/\gamma_M=2619$ kg/cm² $f_t=4300$ kg/cm²

:Verificato

X	cls	N	TY	TZ	MT	MY	MZ	My4	Mz4	Comb.
cm		kg	kg	kg	kg*m	kg*m	kg*m			
314	1	-12527	4	1345	-3	694	-7	--	--	2

AUTOSTRADA VALDASTICO A31 NORD
1° LOTTO - PIOVENE ROCCHETTE – VALLE DELL'ASTICO

X	cls	Nr	Vyr	Vzr	Mry	Mrz	MTrd	SF_V.	SF_M	SF_Mt	SF
cm		kg	kg	kg	kg*m	kg*m	kg*m				
314	1	52623	19306	19306	1818	1818	1566	14.4	1.60	>100	1.60

Asta : 549 [351 , 350]

Sez. G: O 114.3x5.9 L=315.7 cm Crit.: Acciaio_Flessione $\gamma_M=1.05$ $f_{yk}/\gamma_M=2619$ kg/cm² $f_t=4300$ kg/cm²

:Verificato

X	cls	N	TY	TZ	MT	MY	MZ	My4	Mz4	Comb.
cm		kg	kg	kg	kg*m	kg*m	kg*m			
316	1	-5326	12	1349	-8	716	-19	--	--	2

X	cls	Nr	Vyr	Vzr	Mry	Mrz	MTrd	SF_V.	SF_M	SF_Mt	SF
cm		kg	kg	kg	kg*m	kg*m	kg*m				
316	1	52623	19243	19243	1818	1818	1566	14.3	1.98	>100	1.98

Asta : 550 [350 , 357]

Sez. G: O 114.3x5.9 L=318.3 cm Crit.: Acciaio_Flessione $\gamma_M=1.05$ $f_{yk}/\gamma_M=2619$ kg/cm² $f_t=4300$ kg/cm²

:Verificato

X	cls	N	TY	TZ	MT	MY	MZ	My4	Mz4	Comb.
cm		kg	kg	kg	kg*m	kg*m	kg*m			
0	1	2818	6	-1350	-5	732	9	--	--	2

X	cls	Nr	Vyr	Vzr	Mry	Mrz	MTrd	SF_V.	SF_M	SF_Mt	SF
cm		kg	kg	kg	kg*m	kg*m	kg*m				
0	1	52623	19275	19275	1818	1818	1566	14.3	2.17	>100	2.17

Asta : 551 [358 , 373]

Sez. G: O 114.3x5.9 L=229.9 cm Crit.: Acciaio_Flessione $\gamma_M=1.05$ $f_{yk}/\gamma_M=2619$ kg/cm² $f_t=4300$ kg/cm²

:Verificato

X	cls	N	TY	TZ	MT	MY	MZ	My4	Mz4	Comb.
cm		kg	kg	kg	kg*m	kg*m	kg*m			

AUTOSTRADA VALDASTICO A31 NORD
1° LOTTO - PIOVENE ROCCHETTE – VALLE DELL'ASTICO

X	cls	N	TY	TZ	MT	MY	MZ	My4	Mz4	Comb.
230	1	461	5	33	21	16	-15	--	--	2

X	cls	Nr	Vyr	Vzr	Mry	Mrz	MTrd	SF_V.	SF_M	SF_Mt	SF
cm		kg	kg	kg	kg*m	kg*m	kg*m				
230	1	52623	19088	19088	1818	1818	1566	>100	39.4	76.3	39.4

Asta : 552 [376 , 359]

Sez. G: O 114.3x5.9 L=286.0 cm Crit.: Acciaio_Flessione $\gamma_M=1.05$ $f_{yk}/\gamma_M=2619$ kg/cm² $f_t=4300$ kg/cm²

:Verificato

X	cls	N	TY	TZ	MT	MY	MZ	My4	Mz4	Comb.
cm		kg	kg	kg	kg*m	kg*m	kg*m			
172	1	9675	2	4	1	-44	-2	--	--	2

X	cls	Nr	Vyr	Vzr	Mry	Mrz	MTrd	SF_V.	SF_M	SF_Mt	SF
cm		kg	kg	kg	kg*m	kg*m	kg*m				
172	1	52623	19335	19335	1818	1818	1566	>100	4.78	>100	4.78

Asta : 553 [359 , 358]

Sez. G: O 114.3x5.9 L=314.0 cm Crit.: Acciaio_Flessione $\gamma_M=1.05$ $f_{yk}/\gamma_M=2619$ kg/cm² $f_t=4300$ kg/cm²

:Verificato

X	cls	N	TY	TZ	MT	MY	MZ	My4	Mz4	Comb.
cm		kg	kg	kg	kg*m	kg*m	kg*m			
314	1	-1061	1	34	1	27	-1	--	--	2

X	cls	Nr	Vyr	Vzr	Mry	Mrz	MTrd	SF_V.	SF_M	SF_Mt	SF
cm		kg	kg	kg	kg*m	kg*m	kg*m				
314	1	52623	19324	19324	1818	1818	1566	>100	27.9	>100	27.9

Asta : 554 [375 , 373]

Sez. G: O 114.3x5.9 L=229.9 cm Crit.: Acciaio_Flessione $\gamma_M=1.05$ $f_{yk}/\gamma_M=2619$ kg/cm² $f_t=4300$ kg/cm²

:Verificato

AUTOSTRADA VALDASTICO A31 NORD
1° LOTTO - PIOVENE ROCCHETTE – VALLE DELL'ASTICO

X	cls	N	TY	TZ	MT	MY	MZ	My4	Mz4	Comb.
cm		kg	kg	kg	kg*m	kg*m	kg*m			
0	1	-3040	6	-18	-16	18	17	--	--	2

X	cls	Nr	Vyr	Vzr	Mry	Mrz	MTrd	SF_V.	SF_M	SF_Mt	SF
cm		kg	kg	kg	kg*m	kg*m	kg*m				
0	1	52623	19145	19145	1818	1818	1566	>100	13.0	98.1	13.0

Asta : 555 [373 , 359]

Sez. G: O 114.3x5.9 L=229.9 cm Crit.: Acciaio_Flessione $\gamma_M=1.05$ $f_{yk}/\gamma_M=2619$ kg/cm² $f_t=4300$ kg/cm²

:Verificato

X	cls	N	TY	TZ	MT	MY	MZ	My4	Mz4	Comb.
cm		kg	kg	kg	kg*m	kg*m	kg*m			
0	1	1034	-0	5	-8	-41	-7	--	--	2

X	cls	Nr	Vyr	Vzr	Mry	Mrz	MTrd	SF_V.	SF_M	SF_Mt	SF
cm		kg	kg	kg	kg*m	kg*m	kg*m				
0	1	52623	19239	19239	1818	1818	1566	>100	21.7	>100	21.7

Asta : 556 [373 , 376]

Sez. G: O 114.3x5.9 L=229.9 cm Crit.: Acciaio_Flessione $\gamma_M=1.05$ $f_{yk}/\gamma_M=2619$ kg/cm² $f_t=4300$ kg/cm²

:Verificato

X	cls	N	TY	TZ	MT	MY	MZ	My4	Mz4	Comb.
cm		kg	kg	kg	kg*m	kg*m	kg*m			
0	1	-5062	-21	7	11	-44	-18	--	--	2

X	cls	Nr	Vyr	Vzr	Mry	Mrz	MTrd	SF_V.	SF_M	SF_Mt	SF
cm		kg	kg	kg	kg*m	kg*m	kg*m				
0	1	52623	19208	19208	1818	1818	1566	>100	7.66	>100	7.66

Asta : 557 [375 , 358]

AUTOSTRADA VALDASTICO A31 NORD
1° LOTTO - PIOVENE ROCCHETTE – VALLE DELL'ASTICO

Sez. G: O 114.3x5.9 L=286.0 cm Crit.: Acciaio_Flessione $\gamma_M=1.05$ $f_{yk}/\gamma_M=2619$ kg/cm² $f_t=4300$ kg/cm²

:Verificato

X	cls	N	TY	TZ	MT	MY	MZ	My4	Mz4	Comb.
cm		kg	kg	kg	kg*m	kg*m	kg*m			
200	1	4646	-2	2	-7	-35	0	--	--	2

X	cls	Nr	Vyr	Vzr	Mry	Mrz	MTrd	SF_V.	SF_M	SF_Mt	SF
cm		kg	kg	kg	kg*m	kg*m	kg*m				
200	1	52623	19258	19258	1818	1818	1566	>100	9.29	>100	9.29

Asta : 558 [377 , 360]

Sez. G: O 114.3x5.9 L=286.0 cm Crit.: Acciaio_Flessione $\gamma_M=1.05$ $f_{yk}/\gamma_M=2619$ kg/cm² $f_t=4300$ kg/cm²

:Verificato

X	cls	N	TY	TZ	MT	MY	MZ	My4	Mz4	Comb.
cm		kg	kg	kg	kg*m	kg*m	kg*m			
200	1	5286	7	4	5	-21	-4	--	--	2

X	cls	Nr	Vyr	Vzr	Mry	Mrz	MTrd	SF_V.	SF_M	SF_Mt	SF
cm		kg	kg	kg	kg*m	kg*m	kg*m				
200	1	52623	19279	19279	1818	1818	1566	>100	8.74	>100	8.74

Asta : 559 [360 , 359]

Sez. G: O 114.3x5.9 L=314.0 cm Crit.: Acciaio_Flessione $\gamma_M=1.05$ $f_{yk}/\gamma_M=2619$ kg/cm² $f_t=4300$ kg/cm²

:Verificato

X	cls	N	TY	TZ	MT	MY	MZ	My4	Mz4	Comb.
cm		kg	kg	kg	kg*m	kg*m	kg*m			
314	1	836	2	41	2	33	-3	--	--	2

X	cls	Nr	Vyr	Vzr	Mry	Mrz	MTrd	SF_V.	SF_M	SF_Mt	SF
cm		kg	kg	kg	kg*m	kg*m	kg*m				
314	1	52623	19320	19320	1818	1818	1566	>100	28.0	>100	28.0

AUTOSTRADA VALDASTICO A31 NORD
1° LOTTO - PIOVENE ROCCHETTE – VALLE DELL'ASTICO

Asta : 560 [359 , 372]

Sez. G: O 114.3x5.9 L=254.4 cm Crit.: Acciaio_Flessione $\gamma_M=1.05$ $f_{yk}/\gamma_M=2619$ kg/cm² $f_t=4300$ kg/cm²

:Verificato

X	cls	N	TY	TZ	MT	MY	MZ	My4	Mz4	Comb.
cm		kg	kg	kg	kg*m	kg*m	kg*m			
153	1	-530	3	2	10	-12	-9	--	--	2

X	cls	Nr	Vyr	Vzr	Mry	Mrz	MTrd	SF_V.	SF_M	SF_Mt	SF
cm		kg	kg	kg	kg*m	kg*m	kg*m				
153	1	52623	19221	19221	1818	1818	1566	>100	46.4	>100	46.4

Asta : 561 [372 , 377]

Sez. G: O 114.3x5.9 L=254.4 cm Crit.: Acciaio_Flessione $\gamma_M=1.05$ $f_{yk}/\gamma_M=2619$ kg/cm² $f_t=4300$ kg/cm²

:Verificato

X	cls	N	TY	TZ	MT	MY	MZ	My4	Mz4	Comb.
cm		kg	kg	kg	kg*m	kg*m	kg*m			
254	1	-601	-12	27	3	19	17	--	--	2

X	cls	Nr	Vyr	Vzr	Mry	Mrz	MTrd	SF_V.	SF_M	SF_Mt	SF
cm		kg	kg	kg	kg*m	kg*m	kg*m				
254	1	52623	19300	19300	1818	1818	1566	>100	31.8	>100	31.8

Asta : 562 [376 , 372]

Sez. G: O 114.3x5.9 L=254.4 cm Crit.: Acciaio_Flessione $\gamma_M=1.05$ $f_{yk}/\gamma_M=2619$ kg/cm² $f_t=4300$ kg/cm²

:Verificato

X	cls	N	TY	TZ	MT	MY	MZ	My4	Mz4	Comb.
cm		kg	kg	kg	kg*m	kg*m	kg*m			
51	1	-8641	19	-18	-14	-11	25	--	--	2

X	cls	Nr	Vyr	Vzr	Mry	Mrz	MTrd	SF_V.	SF_M	SF_Mt	SF
cm		kg	kg	kg	kg*m	kg*m	kg*m				
51	1	52623	19164	19164	1818	1818	1566	>100	5.44	>100	5.44

AUTOSTRADA VALDASTICO A31 NORD
1° LOTTO - PIOVENE ROCCHETTE – VALLE DELL'ASTICO

Asta : 563 [372 , 360]

Sez. G: O 114.3x5.9 L=254.4 cm Crit.: Acciaio_Flessione $\gamma_M=1.05$ $f_{yk}/\gamma_M=2619$ kg/cmq $f_t=4300$ kg/cmq

:Verificato

X	cls	N	TY	TZ	MT	MY	MZ	My4	Mz4	Comb.
cm		kg	kg	kg	kg*m	kg*m	kg*m			
127	1	2959	2	4	-5	-15	-5	--	--	2

X	cls	Nr	Vyr	Vzr	Mry	Mrz	MTrd	SF_V.	SF_M	SF_Mt	SF
cm		kg	kg	kg	kg*m	kg*m	kg*m				
127	1	52623	19277	19277	1818	1818	1566	>100	14.9	>100	14.9

Asta : 564 [378 , 361]

Sez. G: O 114.3x5.9 L=286.0 cm Crit.: Acciaio_Flessione $\gamma_M=1.05$ $f_{yk}/\gamma_M=2619$ kg/cmq $f_t=4300$ kg/cmq

:Verificato

X	cls	N	TY	TZ	MT	MY	MZ	My4	Mz4	Comb.
cm		kg	kg	kg	kg*m	kg*m	kg*m			
0	1	2128	3	-30	1	11	5	--	--	2

X	cls	Nr	Vyr	Vzr	Mry	Mrz	MTrd	SF_V.	SF_M	SF_Mt	SF
cm		kg	kg	kg	kg*m	kg*m	kg*m				
0	1	52623	19324	19324	1818	1818	1566	>100	20.3	>100	20.3

Asta : 565 [361 , 360]

Sez. G: O 114.3x5.9 L=314.0 cm Crit.: Acciaio_Flessione $\gamma_M=1.05$ $f_{yk}/\gamma_M=2619$ kg/cmq $f_t=4300$ kg/cmq

:Verificato

X	cls	N	TY	TZ	MT	MY	MZ	My4	Mz4	Comb.
cm		kg	kg	kg	kg*m	kg*m	kg*m			
126	1	6835	1	1	1	-24	0	--	--	2

X	cls	Nr	Vyr	Vzr	Mry	Mrz	MTrd	SF_V.	SF_M	SF_Mt	SF
cm		kg	kg	kg	kg*m	kg*m	kg*m				

AUTOSTRADA VALDASTICO A31 NORD
1° LOTTO - PIOVENE ROCCHETTE – VALLE DELL'ASTICO

X	cls	Nr	Vyr	Vzr	Mry	Mrz	MTrd	SF_V.	SF_M	SF_Mt	SF
126	1	52623	19326	19326	1818	1818	1566	>100	7.00	>100	7.00

Asta : 566 [377 , 371]

Sez. G: O 114.3x5.9 L=273.9 cm Crit.: Acciaio_Flessione $\gamma_M=1.05$ $f_{yk}/\gamma_M=2619$ kg/cm² $f_t=4300$ kg/cm²

:Verificato

X	cls	N	TY	TZ	MT	MY	MZ	My4	Mz4	Comb.
cm		kg	kg	kg	kg*m	kg*m	kg*m			
82	1	-5768	-2	-5	1	-20	-3	--	--	2

X	cls	Nr	Vyr	Vzr	Mry	Mrz	MTrd	SF_V.	SF_M	SF_Mt	SF
cm		kg	kg	kg	kg*m	kg*m	kg*m				
82	1	52623	19323	19323	1818	1818	1566	>100	8.17	>100	8.17

Asta : 567 [371 , 361]

Sez. G: O 114.3x5.9 L=273.9 cm Crit.: Acciaio_Flessione $\gamma_M=1.05$ $f_{yk}/\gamma_M=2619$ kg/cm² $f_t=4300$ kg/cm²

:Verificato

X	cls	N	TY	TZ	MT	MY	MZ	My4	Mz4	Comb.
cm		kg	kg	kg	kg*m	kg*m	kg*m			
110	1	2490	2	-3	2	-14	3	--	--	2

X	cls	Nr	Vyr	Vzr	Mry	Mrz	MTrd	SF_V.	SF_M	SF_Mt	SF
cm		kg	kg	kg	kg*m	kg*m	kg*m				
110	1	52623	19313	19313	1818	1818	1566	>100	17.5	>100	17.5

Asta : 568 [360 , 371]

Sez. G: O 114.3x5.9 L=273.9 cm Crit.: Acciaio_Flessione $\gamma_M=1.05$ $f_{yk}/\gamma_M=2619$ kg/cm² $f_t=4300$ kg/cm²

:Verificato

X	cls	N	TY	TZ	MT	MY	MZ	My4	Mz4	Comb.
cm		kg	kg	kg	kg*m	kg*m	kg*m			
82	1	-2524	7	-6	-0	-12	4	--	--	2

AUTOSTRADA VALDASTICO A31 NORD
1° LOTTO - PIOVENE ROCCHETTE – VALLE DELL'ASTICO

X	cls	Nr	Vyr	Vzr	Mry	Mrz	MTrd	SF_V.	SF_M	SF_Mt	SF
cm		kg	kg	kg	kg*m	kg*m	kg*m				
82	1	52623	19341	19341	1818	1818	1566	>100	17.6	>100	17.6

Asta : 569 [371 , 378]

Sez. G: O 114.3x5.9 L=273.9 cm Crit.: Acciaio_Flessione $\gamma_M=1.05$ $f_{yk}/\gamma_M=2619$ kg/cm² $f_t=4300$ kg/cm²

:Verificato

X	cls	N	TY	TZ	MT	MY	MZ	My4	Mz4	Comb.
cm		kg	kg	kg	kg*m	kg*m	kg*m			
0	1	1396	-5	-22	-3	5	-10	--	--	2

X	cls	Nr	Vyr	Vzr	Mry	Mrz	MTrd	SF_V.	SF_M	SF_Mt	SF
cm		kg	kg	kg	kg*m	kg*m	kg*m				
0	1	52623	19306	19306	1818	1818	1566	>100	29.1	>100	29.1

Asta : 570 [379 , 362]

Sez. G: O 114.3x5.9 L=286.0 cm Crit.: Acciaio_Flessione $\gamma_M=1.05$ $f_{yk}/\gamma_M=2619$ kg/cm² $f_t=4300$ kg/cm²

:Verificato

X	cls	N	TY	TZ	MT	MY	MZ	My4	Mz4	Comb.
cm		kg	kg	kg	kg*m	kg*m	kg*m			
286	1	1473	-0	30	-0	13	0	--	--	2

X	cls	Nr	Vyr	Vzr	Mry	Mrz	MTrd	SF_V.	SF_M	SF_Mt	SF
cm		kg	kg	kg	kg*m	kg*m	kg*m				
286	1	52623	19342	19342	1818	1818	1566	>100	28.3	>100	28.3

Asta : 571 [362 , 361]

Sez. G: O 114.3x5.9 L=314.0 cm Crit.: Acciaio_Flessione $\gamma_M=1.05$ $f_{yk}/\gamma_M=2619$ kg/cm² $f_t=4300$ kg/cm²

:Verificato

X	cls	N	TY	TZ	MT	MY	MZ	My4	Mz4	Comb.
cm		kg	kg	kg	kg*m	kg*m	kg*m			
157	1	11756	0	3	0	-31	-0	--	--	2

AUTOSTRADA VALDASTICO A31 NORD
1° LOTTO - PIOVENE ROCCHETTE – VALLE DELL'ASTICO

X	cls	Nr	Vyr	Vzr	Mry	Mrz	MTrd	SF_V.	SF_M	SF_Mt	SF
cm		kg	kg	kg	kg*m	kg*m	kg*m				
157	1	52623	19337	19337	1818	1818	1566	>100	4.16	>100	4.16

Asta : 572 [378 , 370]

Sez. G: O 114.3x5.9 L=281.6 cm Crit.: Acciaio_Flessione $\gamma_M=1.05$ $f_{yk}/\gamma_M=2619$ kg/cm² $f_t=4300$ kg/cm²

:Verificato

X	cls	N	TY	TZ	MT	MY	MZ	My4	Mz4	Comb.
cm		kg	kg	kg	kg*m	kg*m	kg*m			
113	1	-1971	-3	-3	5	-17	-6	--	--	2

X	cls	Nr	Vyr	Vzr	Mry	Mrz	MTrd	SF_V.	SF_M	SF_Mt	SF
cm		kg	kg	kg	kg*m	kg*m	kg*m				
113	1	52623	19286	19286	1818	1818	1566	>100	20.1	>100	20.1

Asta : 573 [370 , 379]

Sez. G: O 114.3x5.9 L=281.6 cm Crit.: Acciaio_Flessione $\gamma_M=1.05$ $f_{yk}/\gamma_M=2619$ kg/cm² $f_t=4300$ kg/cm²

:Verificato

X	cls	N	TY	TZ	MT	MY	MZ	My4	Mz4	Comb.
cm		kg	kg	kg	kg*m	kg*m	kg*m			
141	1	404	0	-1	-5	-15	-5	--	--	2

X	cls	Nr	Vyr	Vzr	Mry	Mrz	MTrd	SF_V.	SF_M	SF_Mt	SF
cm		kg	kg	kg	kg*m	kg*m	kg*m				
141	1	52623	19283	19283	1818	1818	1566	>100	52.8	>100	52.8

Asta : 574 [361 , 370]

Sez. G: O 114.3x5.9 L=281.6 cm Crit.: Acciaio_Flessione $\gamma_M=1.05$ $f_{yk}/\gamma_M=2619$ kg/cm² $f_t=4300$ kg/cm²

:Verificato

X	cls	N	TY	TZ	MT	MY	MZ	My4	Mz4	Comb.
cm		kg	kg	kg	kg*m	kg*m	kg*m			

AUTOSTRADA VALDASTICO A31 NORD
1° LOTTO - PIOVENE ROCCHETTE – VALLE DELL'ASTICO

X	cls	N	TY	TZ	MT	MY	MZ	My4	Mz4	Comb.
113	1	-2202	4	-3	-4	-15	6	--	--	2

X	cls	Nr	Vyr	Vzr	Mry	Mrz	MTrd	SF_V.	SF_M	SF_Mt	SF
cm		kg	kg	kg	kg*m	kg*m	kg*m				
113	1	52623	19293	19293	1818	1818	1566	>100	18.9	>100	18.9

Asta : 575 [370 , 362]

Sez. G: O 114.3x5.9 L=281.6 cm Crit.: Acciaio_Flessione $\gamma_M=1.05$ $f_{yk}/\gamma_M=2619$ kg/cm² $f_t=4300$ kg/cm²

:Verificato

X	cls	N	TY	TZ	MT	MY	MZ	My4	Mz4	Comb.
cm		kg	kg	kg	kg*m	kg*m	kg*m			
141	1	115	-0	0	5	-15	5	--	--	2

X	cls	Nr	Vyr	Vzr	Mry	Mrz	MTrd	SF_V.	SF_M	SF_Mt	SF
cm		kg	kg	kg	kg*m	kg*m	kg*m				
141	1	52623	19286	19286	1818	1818	1566	>100	73.7	>100	73.7

Asta : 576 [362 , 369]

Sez. G: O 114.3x5.9 L=281.6 cm Crit.: Acciaio_Flessione $\gamma_M=1.05$ $f_{yk}/\gamma_M=2619$ kg/cm² $f_t=4300$ kg/cm²

:Verificato

X	cls	N	TY	TZ	MT	MY	MZ	My4	Mz4	Comb.
cm		kg	kg	kg	kg*m	kg*m	kg*m			
141	1	151	-0	-0	-5	-15	5	--	--	2

X	cls	Nr	Vyr	Vzr	Mry	Mrz	MTrd	SF_V.	SF_M	SF_Mt	SF
cm		kg	kg	kg	kg*m	kg*m	kg*m				
141	1	52623	19286	19286	1818	1818	1566	>100	70.2	>100	70.2

Asta : 577 [369 , 380]

Sez. G: O 114.3x5.9 L=281.6 cm Crit.: Acciaio_Flessione $\gamma_M=1.05$ $f_{yk}/\gamma_M=2619$ kg/cm² $f_t=4300$ kg/cm²

:Verificato

AUTOSTRADA VALDASTICO A31 NORD
1° LOTTO - PIOVENE ROCCHETTE – VALLE DELL'ASTICO

X	cls	N	TY	TZ	MT	MY	MZ	My4	Mz4	Comb.
cm		kg	kg	kg	kg*m	kg*m	kg*m			
169	1	-2007	3	3	-5	-17	-6	--	--	2

X	cls	Nr	Vyr	Vzr	Mry	Mrz	MTrd	SF_V.	SF_M	SF_Mt	SF
cm		kg	kg	kg	kg*m	kg*m	kg*m				
169	1	52623	19286	19286	1818	1818	1566	>100	19.9	>100	19.9

Asta : 578 [380 , 363]

Sez. G: O 114.3x5.9 L=286.0 cm Crit.: Acciaio_Flessione $\gamma_M=1.05$ $f_{yk}/\gamma_M=2619$ kg/cm² $f_t=4300$ kg/cm²

:Verificato

X	cls	N	TY	TZ	MT	MY	MZ	My4	Mz4	Comb.
cm		kg	kg	kg	kg*m	kg*m	kg*m			
0	1	2140	-3	-30	-1	11	-5	--	--	2

X	cls	Nr	Vyr	Vzr	Mry	Mrz	MTrd	SF_V.	SF_M	SF_Mt	SF
cm		kg	kg	kg	kg*m	kg*m	kg*m				
0	1	52623	19323	19323	1818	1818	1566	>100	20.2	>100	20.2

Asta : 579 [363 , 362]

Sez. G: O 114.3x5.9 L=314.0 cm Crit.: Acciaio_Flessione $\gamma_M=1.05$ $f_{yk}/\gamma_M=2619$ kg/cm² $f_t=4300$ kg/cm²

:Verificato

X	cls	N	TY	TZ	MT	MY	MZ	My4	Mz4	Comb.
cm		kg	kg	kg	kg*m	kg*m	kg*m			
157	1	11722	-0	-3	-0	-31	-0	--	--	2

X	cls	Nr	Vyr	Vzr	Mry	Mrz	MTrd	SF_V.	SF_M	SF_Mt	SF
cm		kg	kg	kg	kg*m	kg*m	kg*m				
157	1	52623	19337	19337	1818	1818	1566	>100	4.17	>100	4.17

Asta : 580 [379 , 369]

AUTOSTRADA VALDASTICO A31 NORD
1° LOTTO - PIOVENE ROCCHETTE – VALLE DELL'ASTICO

Sez. G: O 114.3x5.9 L=281.6 cm Crit.: Acciaio_Flessione $\gamma_M=1.05$ $f_{yk}/\gamma_M=2619$ kg/cm² $f_t=4300$ kg/cm²

:Verificato

X	cls	N	TY	TZ	MT	MY	MZ	My4	Mz4	Comb.
cm		kg	kg	kg	kg*m	kg*m	kg*m			
141	1	430	-0	1	5	-15	-5	--	--	2

X	cls	Nr	Vyr	Vzr	Mry	Mrz	MTrd	SF_V.	SF_M	SF_Mt	SF
cm		kg	kg	kg	kg*m	kg*m	kg*m				
141	1	52623	19283	19283	1818	1818	1566	>100	51.5	>100	51.5

Asta : 581 [369 , 363]

Sez. G: O 114.3x5.9 L=281.6 cm Crit.: Acciaio_Flessione $\gamma_M=1.05$ $f_{yk}/\gamma_M=2619$ kg/cm² $f_t=4300$ kg/cm²

:Verificato

X	cls	N	TY	TZ	MT	MY	MZ	My4	Mz4	Comb.
cm		kg	kg	kg	kg*m	kg*m	kg*m			
169	1	-2232	-4	3	4	-15	5	--	--	2

X	cls	Nr	Vyr	Vzr	Mry	Mrz	MTrd	SF_V.	SF_M	SF_Mt	SF
cm		kg	kg	kg	kg*m	kg*m	kg*m				
169	1	52623	19294	19294	1818	1818	1566	>100	18.7	>100	18.7

Asta : 582 [381 , 364]

Sez. G: O 114.3x5.9 L=286.0 cm Crit.: Acciaio_Flessione $\gamma_M=1.05$ $f_{yk}/\gamma_M=2619$ kg/cm² $f_t=4300$ kg/cm²

:Verificato

X	cls	N	TY	TZ	MT	MY	MZ	My4	Mz4	Comb.
cm		kg	kg	kg	kg*m	kg*m	kg*m			
200	1	5326	-7	4	-5	-21	4	--	--	2

X	cls	Nr	Vyr	Vzr	Mry	Mrz	MTrd	SF_V.	SF_M	SF_Mt	SF
cm		kg	kg	kg	kg*m	kg*m	kg*m				
200	1	52623	19278	19278	1818	1818	1566	>100	8.68	>100	8.68

AUTOSTRADA VALDASTICO A31 NORD
1° LOTTO - PIOVENE ROCCHETTE – VALLE DELL'ASTICO

Asta : 583 [364 , 363]

Sez. G: O 114.3x5.9 L=314.0 cm Crit.: Acciaio_Flessione $\gamma_M=1.05$ $f_{yk}/\gamma_M=2619$ kg/cm² $f_t=4300$ kg/cm²

:Verificato

X	cls	N	TY	TZ	MT	MY	MZ	My4	Mz4	Comb.
cm		kg	kg	kg	kg*m	kg*m	kg*m			
188	1	6745	-1	-1	-1	-23	0	--	--	2

X	cls	Nr	Vyr	Vzr	Mry	Mrz	MTrd	SF_V.	SF_M	SF_Mt	SF
cm		kg	kg	kg	kg*m	kg*m	kg*m				
188	1	52623	19326	19326	1818	1818	1566	>100	7.08	>100	7.08

Asta : 584 [363 , 368]

Sez. G: O 114.3x5.9 L=273.9 cm Crit.: Acciaio_Flessione $\gamma_M=1.05$ $f_{yk}/\gamma_M=2619$ kg/cm² $f_t=4300$ kg/cm²

:Verificato

X	cls	N	TY	TZ	MT	MY	MZ	My4	Mz4	Comb.
cm		kg	kg	kg	kg*m	kg*m	kg*m			
164	1	2520	-2	3	-2	-14	3	--	--	2

X	cls	Nr	Vyr	Vzr	Mry	Mrz	MTrd	SF_V.	SF_M	SF_Mt	SF
cm		kg	kg	kg	kg*m	kg*m	kg*m				
164	1	52623	19314	19314	1818	1818	1566	>100	17.4	>100	17.4

Asta : 585 [368 , 381]

Sez. G: O 114.3x5.9 L=273.9 cm Crit.: Acciaio_Flessione $\gamma_M=1.05$ $f_{yk}/\gamma_M=2619$ kg/cm² $f_t=4300$ kg/cm²

:Verificato

X	cls	N	TY	TZ	MT	MY	MZ	My4	Mz4	Comb.
cm		kg	kg	kg	kg*m	kg*m	kg*m			
192	1	-5824	2	5	-1	-20	-3	--	--	2

X	cls	Nr	Vyr	Vzr	Mry	Mrz	MTrd	SF_V.	SF_M	SF_Mt	SF
cm		kg	kg	kg	kg*m	kg*m	kg*m				
192	1	52623	19324	19324	1818	1818	1566	>100	8.11	>100	8.11

AUTOSTRADA VALDASTICO A31 NORD
1° LOTTO - PIOVENE ROCCHETTE – VALLE DELL'ASTICO

Asta : 586 [380 , 368]

Sez. G: O 114.3x5.9 L=273.9 cm Crit.: Acciaio_Flessione $\gamma_M=1.05$ $f_{yk}/\gamma_M=2619$ kg/cmq $f_t=4300$ kg/cmq

:Verificato

X	cls	N	TY	TZ	MT	MY	MZ	My4	Mz4	Comb.
cm		kg	kg	kg	kg*m	kg*m	kg*m			
274	1	1410	5	22	3	5	-10	--	--	2

X	cls	Nr	Vyr	Vzr	Mry	Mrz	MTrd	SF_V.	SF_M	SF_Mt	SF
cm		kg	kg	kg	kg*m	kg*m	kg*m				
274	1	52623	19307	19307	1818	1818	1566	>100	28.8	>100	28.8

Asta : 587 [368 , 364]

Sez. G: O 114.3x5.9 L=273.9 cm Crit.: Acciaio_Flessione $\gamma_M=1.05$ $f_{yk}/\gamma_M=2619$ kg/cmq $f_t=4300$ kg/cmq

:Verificato

X	cls	N	TY	TZ	MT	MY	MZ	My4	Mz4	Comb.
cm		kg	kg	kg	kg*m	kg*m	kg*m			
192	1	-2529	-7	6	0	-12	4	--	--	2

X	cls	Nr	Vyr	Vzr	Mry	Mrz	MTrd	SF_V.	SF_M	SF_Mt	SF
cm		kg	kg	kg	kg*m	kg*m	kg*m				
192	1	52623	19341	19341	1818	1818	1566	>100	17.6	>100	17.6

Asta : 588 [364 , 365]

Sez. G: O 114.3x5.9 L=314.0 cm Crit.: Acciaio_Flessione $\gamma_M=1.05$ $f_{yk}/\gamma_M=2619$ kg/cmq $f_t=4300$ kg/cmq

:Verificato

X	cls	N	TY	TZ	MT	MY	MZ	My4	Mz4	Comb.
cm		kg	kg	kg	kg*m	kg*m	kg*m			
314	1	739	-2	41	-2	34	3	--	--	2

X	cls	Nr	Vyr	Vzr	Mry	Mrz	MTrd	SF_V.	SF_M	SF_Mt	SF
cm		kg	kg	kg	kg*m	kg*m	kg*m				

AUTOSTRADA VALDASTICO A31 NORD
1° LOTTO - PIOVENE ROCCHETTE – VALLE DELL'ASTICO

X	cls	Nr	Vyr	Vzr	Mry	Mrz	MTrd	SF_V.	SF_M	SF_Mt	SF
314	1	52623	19320	19320	1818	1818	1566	>100	29.3	>100	29.3

Asta : 589 [365 , 382]

Sez. G: O 114.3x5.9 L=286.0 cm Crit.: Acciaio_Flessione $\gamma_M=1.05$ $f_{yk}/\gamma_M=2619$ kg/cm² $f_t=4300$ kg/cm²

:Verificato

X	cls	N	TY	TZ	MT	MY	MZ	My4	Mz4	Comb.
cm		kg	kg	kg	kg*m	kg*m	kg*m			
143	1	9702	-1	1	-0	-45	-1	--	--	2

X	cls	Nr	Vyr	Vzr	Mry	Mrz	MTrd	SF_V.	SF_M	SF_Mt	SF
cm		kg	kg	kg	kg*m	kg*m	kg*m				
143	1	52623	19338	19338	1818	1818	1566	>100	4.77	>100	4.77

Asta : 590 [381 , 367]

Sez. G: O 114.3x5.9 L=254.4 cm Crit.: Acciaio_Flessione $\gamma_M=1.05$ $f_{yk}/\gamma_M=2619$ kg/cm² $f_t=4300$ kg/cm²

:Verificato

X	cls	N	TY	TZ	MT	MY	MZ	My4	Mz4	Comb.
cm		kg	kg	kg	kg*m	kg*m	kg*m			
0	1	-605	12	-27	-3	19	17	--	--	2

X	cls	Nr	Vyr	Vzr	Mry	Mrz	MTrd	SF_V.	SF_M	SF_Mt	SF
cm		kg	kg	kg	kg*m	kg*m	kg*m				
0	1	52623	19299	19299	1818	1818	1566	>100	31.5	>100	31.5

Asta : 591 [367 , 382]

Sez. G: O 114.3x5.9 L=254.4 cm Crit.: Acciaio_Flessione $\gamma_M=1.05$ $f_{yk}/\gamma_M=2619$ kg/cm² $f_t=4300$ kg/cm²

:Verificato

X	cls	N	TY	TZ	MT	MY	MZ	My4	Mz4	Comb.
cm		kg	kg	kg	kg*m	kg*m	kg*m			
254	1	-8686	-19	27	15	1	35	--	--	2

AUTOSTRADA VALDASTICO A31 NORD
1° LOTTO - PIOVENE ROCCHETTE – VALLE DELL'ASTICO

X	cls	Nr	Vyr	Vzr	Mry	Mrz	MTrd	SF_V.	SF_M	SF_Mt	SF
cm		kg	kg	kg	kg*m	kg*m	kg*m				
254	1	52623	19160	19160	1818	1818	1566	>100	5.40	>100	5.40

Asta : 592 [364 , 367]

Sez. G: O 114.3x5.9 L=254.4 cm Crit.: Acciaio_Flessione $\gamma_M=1.05$ $f_{yk}/\gamma_M=2619$ kg/cm² $f_t=4300$ kg/cm²

:Verificato

X	cls	N	TY	TZ	MT	MY	MZ	My4	Mz4	Comb.
cm		kg	kg	kg	kg*m	kg*m	kg*m			
127	1	2961	-2	-4	5	-15	-5	--	--	2

X	cls	Nr	Vyr	Vzr	Mry	Mrz	MTrd	SF_V.	SF_M	SF_Mt	SF
cm		kg	kg	kg	kg*m	kg*m	kg*m				
127	1	52623	19275	19275	1818	1818	1566	>100	14.9	>100	14.9

Asta : 593 [367 , 365]

Sez. G: O 114.3x5.9 L=254.4 cm Crit.: Acciaio_Flessione $\gamma_M=1.05$ $f_{yk}/\gamma_M=2619$ kg/cm² $f_t=4300$ kg/cm²

:Verificato

X	cls	N	TY	TZ	MT	MY	MZ	My4	Mz4	Comb.
cm		kg	kg	kg	kg*m	kg*m	kg*m			
102	1	-505	-3	-2	-10	-12	-9	--	--	2

X	cls	Nr	Vyr	Vzr	Mry	Mrz	MTrd	SF_V.	SF_M	SF_Mt	SF
cm		kg	kg	kg	kg*m	kg*m	kg*m				
102	1	52623	19220	19220	1818	1818	1566	>100	47.4	>100	47.4

Asta : 594 [383 , 366]

Sez. G: O 114.3x5.9 L=286.0 cm Crit.: Acciaio_Flessione $\gamma_M=1.05$ $f_{yk}/\gamma_M=2619$ kg/cm² $f_t=4300$ kg/cm²

:Verificato

X	cls	N	TY	TZ	MT	MY	MZ	My4	Mz4	Comb.
cm		kg	kg	kg	kg*m	kg*m	kg*m			
200	1	4506	3	2	7	-34	-1	--	--	2

AUTOSTRADA VALDASTICO A31 NORD
1° LOTTO - PIOVENE ROCCHETTE – VALLE DELL'ASTICO

X	cls	Nr	Vyr	Vzr	Mry	Mrz	MTrd	SF_V.	SF_M	SF_Mt	SF
cm		kg	kg	kg	kg*m	kg*m	kg*m				
200	1	52623	19252	19252	1818	1818	1566	>100	9.55	>100	9.55

Asta : 595 [366 , 365]

Sez. G: O 114.3x5.9 L=314.0 cm Crit.: Acciaio_Flessione $\gamma_M=1.05$ $f_{yk}/\gamma_M=2619$ kg/cm² $f_t=4300$ kg/cm²

:Verificato

X	cls	N	TY	TZ	MT	MY	MZ	My4	Mz4	Comb.
cm		kg	kg	kg	kg*m	kg*m	kg*m			
0	1	-1086	-1	-34	-1	27	-1	--	--	2

X	cls	Nr	Vyr	Vzr	Mry	Mrz	MTrd	SF_V.	SF_M	SF_Mt	SF
cm		kg	kg	kg	kg*m	kg*m	kg*m				
0	1	52623	19324	19324	1818	1818	1566	>100	27.5	>100	27.5

Asta : 596 [382 , 374]

Sez. G: O 114.3x5.9 L=229.9 cm Crit.: Acciaio_Flessione $\gamma_M=1.05$ $f_{yk}/\gamma_M=2619$ kg/cm² $f_t=4300$ kg/cm²

:Verificato

X	cls	N	TY	TZ	MT	MY	MZ	My4	Mz4	Comb.
cm		kg	kg	kg	kg*m	kg*m	kg*m			
230	1	-5072	21	-6	-11	-44	-18	--	--	2

X	cls	Nr	Vyr	Vzr	Mry	Mrz	MTrd	SF_V.	SF_M	SF_Mt	SF
cm		kg	kg	kg	kg*m	kg*m	kg*m				
230	1	52623	19207	19207	1818	1818	1566	>100	7.65	>100	7.65

Asta : 597 [374 , 366]

Sez. G: O 114.3x5.9 L=229.9 cm Crit.: Acciaio_Flessione $\gamma_M=1.05$ $f_{yk}/\gamma_M=2619$ kg/cm² $f_t=4300$ kg/cm²

:Verificato

X	cls	N	TY	TZ	MT	MY	MZ	My4	Mz4	Comb.
cm		kg	kg	kg	kg*m	kg*m	kg*m			

AUTOSTRADA VALDASTICO A31 NORD
1° LOTTO - PIOVENE ROCCHETTE – VALLE DELL'ASTICO

X	cls	N	TY	TZ	MT	MY	MZ	My4	Mz4	Comb.
0	1	466	-5	-32	-20	15	-14	--	--	2

X	cls	Nr	Vyr	Vzr	Mry	Mrz	MTrd	SF_V.	SF_M	SF_Mt	SF
cm		kg	kg	kg	kg*m	kg*m	kg*m				
0	1	52623	19089	19089	1818	1818	1566	>100	39.7	76.7	39.7

Asta : 598 [374 , 383]

Sez. G: O 114.3x5.9 L=229.9 cm Crit.: Acciaio_Flessione $\gamma_M=1.05$ $f_{yk}/\gamma_M=2619$ kg/cm² $f_t=4300$ kg/cm²

:Verificato

X	cls	N	TY	TZ	MT	MY	MZ	My4	Mz4	Comb.
cm		kg	kg	kg	kg*m	kg*m	kg*m			
230	1	-2967	-6	18	16	20	17	--	--	2

X	cls	Nr	Vyr	Vzr	Mry	Mrz	MTrd	SF_V.	SF_M	SF_Mt	SF
cm		kg	kg	kg	kg*m	kg*m	kg*m				
230	1	52623	19146	19146	1818	1818	1566	>100	13.1	99.0	13.1

Asta : 599 [373 , 372]

Sez. G: O 114.3x5.9 L=318.3 cm Crit.: Acciaio_Flessione $\gamma_M=1.05$ $f_{yk}/\gamma_M=2619$ kg/cm² $f_t=4300$ kg/cm²

:Verificato

X	cls	N	TY	TZ	MT	MY	MZ	My4	Mz4	Comb.
cm		kg	kg	kg	kg*m	kg*m	kg*m			
318	1	2469	3	1351	-2	731	-5	--	--	2

X	cls	Nr	Vyr	Vzr	Mry	Mrz	MTrd	SF_V.	SF_M	SF_Mt	SF
cm		kg	kg	kg	kg*m	kg*m	kg*m				
318	1	52623	19313	19313	1818	1818	1566	14.3	2.21	>100	2.21

Asta : 600 [372 , 371]

Sez. G: O 114.3x5.9 L=315.7 cm Crit.: Acciaio_Flessione $\gamma_M=1.05$ $f_{yk}/\gamma_M=2619$ kg/cm² $f_t=4300$ kg/cm²

:Verificato

AUTOSTRADA VALDASTICO A31 NORD
1° LOTTO - PIOVENE ROCCHETTE – VALLE DELL'ASTICO

X	cls	N	TY	TZ	MT	MY	MZ	My4	Mz4	Comb.
cm		kg	kg	kg	kg*m	kg*m	kg*m			
0	1	-5099	5	-1349	-5	716	9	--	--	2

X	cls	Nr	Vyr	Vzr	Mry	Mrz	MTrd	SF_V.	SF_M	SF_Mt	SF
cm		kg	kg	kg	kg*m	kg*m	kg*m				
0	1	52623	19285	19285	1818	1818	1566	14.3	2.02	>100	2.02

Asta : 601 [371 , 370]

Sez. G: O 114.3x5.9 L=314.2 cm Crit.: Acciaio_Flessione $\gamma_M=1.05$ $f_{yk}/\gamma_M=2619$ kg/cm² $f_t=4300$ kg/cm²

:Verificato

X	cls	N	TY	TZ	MT	MY	MZ	My4	Mz4	Comb.
cm		kg	kg	kg	kg*m	kg*m	kg*m			
0	1	-11979	0	-1345	-1	695	1	--	--	2

X	cls	Nr	Vyr	Vzr	Mry	Mrz	MTrd	SF_V.	SF_M	SF_Mt	SF
cm		kg	kg	kg	kg*m	kg*m	kg*m				
0	1	52623	19326	19326	1818	1818	1566	14.4	1.64	>100	1.64

Asta : 602 [370 , 369]

Sez. G: O 114.3x5.9 L=314.0 cm Crit.: Acciaio_Flessione $\gamma_M=1.05$ $f_{yk}/\gamma_M=2619$ kg/cm² $f_t=4300$ kg/cm²

:Verificato

X	cls	N	TY	TZ	MT	MY	MZ	My4	Mz4	Comb.
cm		kg	kg	kg	kg*m	kg*m	kg*m			
314	1	-14539	0	1339	0	681	0	--	--	2

X	cls	Nr	Vyr	Vzr	Mry	Mrz	MTrd	SF_V.	SF_M	SF_Mt	SF
cm		kg	kg	kg	kg*m	kg*m	kg*m				
314	1	52623	19342	19342	1818	1818	1566	14.4	1.54	>100	1.54

Asta : 603 [369 , 368]

AUTOSTRADA VALDASTICO A31 NORD
1° LOTTO - PIOVENE ROCCHETTE – VALLE DELL'ASTICO

Sez. G: O 114.3x5.9 L=314.2 cm Crit.: Acciaio_Flessione $\gamma_M=1.05$ $f_{yk}/\gamma_M=2619$ kg/cmq $f_t=4300$ kg/cmq

:Verificato

X	cls	N	TY	TZ	MT	MY	MZ	My4	Mz4	Comb.
cm		kg	kg	kg	kg*m	kg*m	kg*m			
314	1	-11908	-1	1345	1	695	1	--	--	2

X	cls	Nr	Vyr	Vzr	Mry	Mrz	MTrd	SF_V.	SF_M	SF_Mt	SF
cm		kg	kg	kg	kg*m	kg*m	kg*m				
314	1	52623	19326	19326	1818	1818	1566	14.4	1.64	>100	1.64

Asta : 604 [368 , 367]

Sez. G: O 114.3x5.9 L=315.7 cm Crit.: Acciaio_Flessione $\gamma_M=1.05$ $f_{yk}/\gamma_M=2619$ kg/cmq $f_t=4300$ kg/cmq

:Verificato

X	cls	N	TY	TZ	MT	MY	MZ	My4	Mz4	Comb.
cm		kg	kg	kg	kg*m	kg*m	kg*m			
316	1	-4967	-5	1349	5	716	9	--	--	2

X	cls	Nr	Vyr	Vzr	Mry	Mrz	MTrd	SF_V.	SF_M	SF_Mt	SF
cm		kg	kg	kg	kg*m	kg*m	kg*m				
316	1	52623	19285	19285	1818	1818	1566	14.3	2.03	>100	2.03

Asta : 605 [367 , 374]

Sez. G: O 114.3x5.9 L=318.3 cm Crit.: Acciaio_Flessione $\gamma_M=1.05$ $f_{yk}/\gamma_M=2619$ kg/cmq $f_t=4300$ kg/cmq

:Verificato

X	cls	N	TY	TZ	MT	MY	MZ	My4	Mz4	Comb.
cm		kg	kg	kg	kg*m	kg*m	kg*m			
0	1	2610	-3	-1351	2	732	-5	--	--	2

X	cls	Nr	Vyr	Vzr	Mry	Mrz	MTrd	SF_V.	SF_M	SF_Mt	SF
cm		kg	kg	kg	kg*m	kg*m	kg*m				
0	1	52623	19314	19314	1818	1818	1566	14.3	2.20	>100	2.20

AUTOSTRADA VALDASTICO A31 NORD
1° LOTTO - PIOVENE ROCCHETTE – VALLE DELL'ASTICO

Asta : 606 [375 , 390]

Sez. G: O 114.3x5.9 L=229.9 cm Crit.: Acciaio_Flessione $\gamma_M=1.05$ $f_{yk}/\gamma_M=2619$ kg/cm² $f_t=4300$ kg/cm²

:Verificato

X	cls	N	TY	TZ	MT	MY	MZ	My4	Mz4	Comb.
cm		kg	kg	kg	kg*m	kg*m	kg*m			
230	1	5734	13	52	8	44	-16	--	--	2

X	cls	Nr	Vyr	Vzr	Mry	Mrz	MTrd	SF_V.	SF_M	SF_Mt	SF
cm		kg	kg	kg	kg*m	kg*m	kg*m				
230	1	52623	19246	19246	1818	1818	1566	>100	7.03	>100	7.03

Asta : 607 [393 , 376]

Sez. G: O 114.3x5.9 L=286.0 cm Crit.: Acciaio_Flessione $\gamma_M=1.05$ $f_{yk}/\gamma_M=2619$ kg/cm² $f_t=4300$ kg/cm²

:Verificato

X	cls	N	TY	TZ	MT	MY	MZ	My4	Mz4	Comb.
cm		kg	kg	kg	kg*m	kg*m	kg*m			
0	1	-7231	-3	-154	-32	230	-3	--	--	2

X	cls	Nr	Vyr	Vzr	Mry	Mrz	MTrd	SF_V.	SF_M	SF_Mt	SF
cm		kg	kg	kg	kg*m	kg*m	kg*m				
0	1	52623	18949	18949	1818	1818	1566	>100	3.76	49.3	3.76

Asta : 608 [376 , 375]

Sez. G: O 114.3x5.9 L=314.0 cm Crit.: Acciaio_Flessione $\gamma_M=1.05$ $f_{yk}/\gamma_M=2619$ kg/cm² $f_t=4300$ kg/cm²

:Verificato

X	cls	N	TY	TZ	MT	MY	MZ	My4	Mz4	Comb.
cm		kg	kg	kg	kg*m	kg*m	kg*m			
0	1	-3444	5	-35	10	36	7	--	--	2

X	cls	Nr	Vyr	Vzr	Mry	Mrz	MTrd	SF_V.	SF_M	SF_Mt	SF
cm		kg	kg	kg	kg*m	kg*m	kg*m				
0	1	52623	19220	19220	1818	1818	1566	>100	11.2	>100	11.2

AUTOSTRADA VALDASTICO A31 NORD
1° LOTTO - PIOVENE ROCCHETTE – VALLE DELL'ASTICO

Asta : 609 [392 , 390]

Sez. G: O 114.3x5.9 L=229.9 cm Crit.: Acciaio_Flessione $\gamma_M=1.05$ $f_{yk}/\gamma_M=2619$ kg/cmq $f_t=4300$ kg/cmq

:Verificato

X	cls	N	TY	TZ	MT	MY	MZ	My4	Mz4	Comb.
cm		kg	kg	kg	kg*m	kg*m	kg*m			
230	1	2537	-7	35	3	75	9	--	--	2

X	cls	Nr	Vyr	Vzr	Mry	Mrz	MTrd	SF_V.	SF_M	SF_Mt	SF
cm		kg	kg	kg	kg*m	kg*m	kg*m				
230	1	52623	19307	19307	1818	1818	1566	>100	10.5	>100	10.5

Asta : 610 [390 , 376]

Sez. G: O 114.3x5.9 L=229.9 cm Crit.: Acciaio_Flessione $\gamma_M=1.05$ $f_{yk}/\gamma_M=2619$ kg/cmq $f_t=4300$ kg/cmq

:Verificato

X	cls	N	TY	TZ	MT	MY	MZ	My4	Mz4	Comb.
cm		kg	kg	kg	kg*m	kg*m	kg*m			
0	1	8067	-13	-25	-1	30	-17	--	--	2

X	cls	Nr	Vyr	Vzr	Mry	Mrz	MTrd	SF_V.	SF_M	SF_Mt	SF
cm		kg	kg	kg	kg*m	kg*m	kg*m				
0	1	52623	19332	19332	1818	1818	1566	>100	5.58	>100	5.58

Asta : 611 [390 , 393]

Sez. G: O 114.3x5.9 L=229.9 cm Crit.: Acciaio_Flessione $\gamma_M=1.05$ $f_{yk}/\gamma_M=2619$ kg/cmq $f_t=4300$ kg/cmq

:Verificato

X	cls	N	TY	TZ	MT	MY	MZ	My4	Mz4	Comb.
cm		kg	kg	kg	kg*m	kg*m	kg*m			
230	1	-18126	16	98	-36	93	-41	--	--	2

X	cls	Nr	Vyr	Vzr	Mry	Mrz	MTrd	SF_V.	SF_M	SF_Mt	SF
cm		kg	kg	kg	kg*m	kg*m	kg*m				

AUTOSTRADA VALDASTICO A31 NORD
1° LOTTO - PIOVENE ROCCHETTE – VALLE DELL'ASTICO

X	cls	Nr	Vyr	Vzr	Mry	Mrz	MTrd	SF_V.	SF_M	SF_Mt	SF
230	1	52623	18896	18896	1818	1818	1566	>100	2.39	43.4	2.39

Asta : 612 [392 , 375]

Sez. G: O 114.3x5.9 L=286.0 cm Crit.: Acciaio_Flessione $\gamma_M=1.05$ $f_{yk}/\gamma_M=2619$ kg/cm² $f_t=4300$ kg/cm²

:Verificato

X	cls	N	TY	TZ	MT	MY	MZ	My4	Mz4	Comb.
cm		kg	kg	kg	kg*m	kg*m	kg*m			
0	1	-1800	4	-58	-4	90	9	--	--	(12+13)-V-2

X	cls	Nr	Vyr	Vzr	Mry	Mrz	MTrd	SF_V.	SF_M	SF_Mt	SF
cm		kg	kg	kg	kg*m	kg*m	kg*m				
0	1	52623	19298	19298	1818	1818	1566	>100	11.3	>100	11.3

Asta : 613 [394 , 377]

Sez. G: O 114.3x5.9 L=286.0 cm Crit.: Acciaio_Flessione $\gamma_M=1.05$ $f_{yk}/\gamma_M=2619$ kg/cm² $f_t=4300$ kg/cm²

:Verificato

X	cls	N	TY	TZ	MT	MY	MZ	My4	Mz4	Comb.
cm		kg	kg	kg	kg*m	kg*m	kg*m			
0	1	-2448	10	-47	14	49	15	--	--	2

X	cls	Nr	Vyr	Vzr	Mry	Mrz	MTrd	SF_V.	SF_M	SF_Mt	SF
cm		kg	kg	kg	kg*m	kg*m	kg*m				
0	1	52623	19173	19173	1818	1818	1566	>100	12.3	>100	12.3

Asta : 614 [377 , 376]

Sez. G: O 114.3x5.9 L=314.0 cm Crit.: Acciaio_Flessione $\gamma_M=1.05$ $f_{yk}/\gamma_M=2619$ kg/cm² $f_t=4300$ kg/cm²

:Verificato

X	cls	N	TY	TZ	MT	MY	MZ	My4	Mz4	Comb.
cm		kg	kg	kg	kg*m	kg*m	kg*m			
314	1	-295	-8	54	-15	58	14	--	--	2

AUTOSTRADA VALDASTICO A31 NORD
1° LOTTO - PIOVENE ROCCHETTE – VALLE DELL'ASTICO

X	cls	Nr	Vyr	Vzr	Mry	Mrz	MTrd	SF_V.	SF_M	SF_Mt	SF
cm		kg	kg	kg	kg*m	kg*m	kg*m				
314	1	52623	19156	19156	1818	1818	1566	>100	22.1	>100	22.1

Asta : 615 [376 , 389]

Sez. G: O 114.3x5.9 L=254.4 cm Crit.: Acciaio_Flessione $\gamma_M=1.05$ $f_{yk}/\gamma_M=2619$ kg/cm² $f_t=4300$ kg/cm²

:Verificato

X	cls	N	TY	TZ	MT	MY	MZ	My4	Mz4	Comb.
cm		kg	kg	kg	kg*m	kg*m	kg*m			
0	1	6830	24	-33	8	50	25	--	--	2

X	cls	Nr	Vyr	Vzr	Mry	Mrz	MTrd	SF_V.	SF_M	SF_Mt	SF
cm		kg	kg	kg	kg*m	kg*m	kg*m				
0	1	52623	19243	19243	1818	1818	1566	>100	5.85	>100	5.85

Asta : 616 [389 , 394]

Sez. G: O 114.3x5.9 L=254.4 cm Crit.: Acciaio_Flessione $\gamma_M=1.05$ $f_{yk}/\gamma_M=2619$ kg/cm² $f_t=4300$ kg/cm²

:Verificato

X	cls	N	TY	TZ	MT	MY	MZ	My4	Mz4	Comb.
cm		kg	kg	kg	kg*m	kg*m	kg*m			
0	1	5303	-31	-19	-10	24	-51	--	--	2

X	cls	Nr	Vyr	Vzr	Mry	Mrz	MTrd	SF_V.	SF_M	SF_Mt	SF
cm		kg	kg	kg	kg*m	kg*m	kg*m				
0	1	52623	19213	19213	1818	1818	1566	>100	7.05	>100	7.05

Asta : 617 [393 , 389]

Sez. G: O 114.3x5.9 L=254.4 cm Crit.: Acciaio_Flessione $\gamma_M=1.05$ $f_{yk}/\gamma_M=2619$ kg/cm² $f_t=4300$ kg/cm²

:Verificato

X	cls	N	TY	TZ	MT	MY	MZ	My4	Mz4	Comb.
cm		kg	kg	kg	kg*m	kg*m	kg*m			
0	1	-31545	36	-219	-16	338	62	--	--	2

AUTOSTRADA VALDASTICO A31 NORD
1° LOTTO - PIOVENE ROCCHETTE – VALLE DELL'ASTICO

X	cls	Nr	Vyr	Vzr	Mry	Mrz	MTrd	SF_V.	SF_M	SF_Mt	SF
cm		kg	kg	kg	kg*m	kg*m	kg*m				
0	1	52623	19149	19149	1818	1818	1566	87.4	1.22	>100	1.22

Asta : 618 [389 , 377]

Sez. G: O 114.3x5.9 L=254.4 cm Crit.: Acciaio_Flessione $\gamma_M=1.05$ $f_{yk}/\gamma_M=2619$ kg/cm² $f_t=4300$ kg/cm²

:Verificato

X	cls	N	TY	TZ	MT	MY	MZ	My4	Mz4	Comb.
cm		kg	kg	kg	kg*m	kg*m	kg*m			
51	1	8541	-6	-5	2	-29	-5	--	--	2

X	cls	Nr	Vyr	Vzr	Mry	Mrz	MTrd	SF_V.	SF_M	SF_Mt	SF
cm		kg	kg	kg	kg*m	kg*m	kg*m				
51	1	52623	19318	19318	1818	1818	1566	>100	5.51	>100	5.51

Asta : 619 [395 , 378]

Sez. G: O 114.3x5.9 L=286.0 cm Crit.: Acciaio_Flessione $\gamma_M=1.05$ $f_{yk}/\gamma_M=2619$ kg/cm² $f_t=4300$ kg/cm²

:Verificato

X	cls	N	TY	TZ	MT	MY	MZ	My4	Mz4	Comb.
cm		kg	kg	kg	kg*m	kg*m	kg*m			
0	1	1247	4	-31	1	15	6	--	--	2

X	cls	Nr	Vyr	Vzr	Mry	Mrz	MTrd	SF_V.	SF_M	SF_Mt	SF
cm		kg	kg	kg	kg*m	kg*m	kg*m				
0	1	52623	19326	19326	1818	1818	1566	>100	28.3	>100	28.3

Asta : 620 [378 , 377]

Sez. G: O 114.3x5.9 L=314.0 cm Crit.: Acciaio_Flessione $\gamma_M=1.05$ $f_{yk}/\gamma_M=2619$ kg/cm² $f_t=4300$ kg/cm²

:Verificato

X	cls	N	TY	TZ	MT	MY	MZ	My4	Mz4	Comb.
cm		kg	kg	kg	kg*m	kg*m	kg*m			

AUTOSTRADA VALDASTICO A31 NORD
1° LOTTO - PIOVENE ROCCHETTE – VALLE DELL'ASTICO

X	cls	N	TY	TZ	MT	MY	MZ	My4	Mz4	Comb.
94	1	8405	-4	-6	-5	-27	-2	--	--	2

X	cls	Nr	Vyr	Vzr	Mry	Mrz	MTrd	SF_V.	SF_M	SF_Mt	SF
cm		kg	kg	kg	kg*m	kg*m	kg*m				
94	1	52623	19275	19275	1818	1818	1566	>100	5.69	>100	5.69

Asta : 621 [394 , 388]

Sez. G: O 114.3x5.9 L=273.9 cm Crit.: Acciaio_Flessione $\gamma_M=1.05$ $f_{yk}/\gamma_M=2619$ kg/cm² $f_t=4300$ kg/cm²

:Verificato

X	cls	N	TY	TZ	MT	MY	MZ	My4	Mz4	Comb.
cm		kg	kg	kg	kg*m	kg*m	kg*m			
0	1	-6436	-13	-13	12	-18	-30	--	--	2

X	cls	Nr	Vyr	Vzr	Mry	Mrz	MTrd	SF_V.	SF_M	SF_Mt	SF
cm		kg	kg	kg	kg*m	kg*m	kg*m				
0	1	52623	19194	19194	1818	1818	1566	>100	6.72	>100	6.72

Asta : 622 [388 , 378]

Sez. G: O 114.3x5.9 L=273.9 cm Crit.: Acciaio_Flessione $\gamma_M=1.05$ $f_{yk}/\gamma_M=2619$ kg/cm² $f_t=4300$ kg/cm²

:Verificato

X	cls	N	TY	TZ	MT	MY	MZ	My4	Mz4	Comb.
cm		kg	kg	kg	kg*m	kg*m	kg*m			
164	1	2622	-2	2	5	-17	5	--	--	2

X	cls	Nr	Vyr	Vzr	Mry	Mrz	MTrd	SF_V.	SF_M	SF_Mt	SF
cm		kg	kg	kg	kg*m	kg*m	kg*m				
164	1	52623	19282	19282	1818	1818	1566	>100	16.0	>100	16.0

Asta : 623 [377 , 388]

Sez. G: O 114.3x5.9 L=273.9 cm Crit.: Acciaio_Flessione $\gamma_M=1.05$ $f_{yk}/\gamma_M=2619$ kg/cm² $f_t=4300$ kg/cm²

:Verificato

AUTOSTRADA VALDASTICO A31 NORD
1° LOTTO - PIOVENE ROCCHETTE – VALLE DELL'ASTICO

X	cls	N	TY	TZ	MT	MY	MZ	My4	Mz4	Comb.
cm		kg	kg	kg	kg*m	kg*m	kg*m			
0	1	-838	12	-25	-5	14	21	--	--	2

X	cls	Nr	Vyr	Vzr	Mry	Mrz	MTrd	SF_V.	SF_M	SF_Mt	SF
cm		kg	kg	kg	kg*m	kg*m	kg*m				
0	1	52623	19280	19280	1818	1818	1566	>100	28.5	>100	28.5

Asta : 624 [388 , 395]

Sez. G: O 114.3x5.9 L=273.9 cm Crit.: Acciaio_Flessione $\gamma_M=1.05$ $f_{yk}/\gamma_M=2619$ kg/cm² $f_t=4300$ kg/cm²

:Verificato

X	cls	N	TY	TZ	MT	MY	MZ	My4	Mz4	Comb.
cm		kg	kg	kg	kg*m	kg*m	kg*m			
164	1	828	-1	-2	-6	-15	-6	--	--	2

X	cls	Nr	Vyr	Vzr	Mry	Mrz	MTrd	SF_V.	SF_M	SF_Mt	SF
cm		kg	kg	kg	kg*m	kg*m	kg*m				
164	1	52623	19271	19271	1818	1818	1566	>100	37.0	>100	37.0

Asta : 625 [396 , 379]

Sez. G: O 114.3x5.9 L=286.0 cm Crit.: Acciaio_Flessione $\gamma_M=1.05$ $f_{yk}/\gamma_M=2619$ kg/cm² $f_t=4300$ kg/cm²

:Verificato

X	cls	N	TY	TZ	MT	MY	MZ	My4	Mz4	Comb.
cm		kg	kg	kg	kg*m	kg*m	kg*m			
286	1	2139	-0	30	-0	12	0	--	--	2

X	cls	Nr	Vyr	Vzr	Mry	Mrz	MTrd	SF_V.	SF_M	SF_Mt	SF
cm		kg	kg	kg	kg*m	kg*m	kg*m				
286	1	52623	19342	19342	1818	1818	1566	>100	21.1	>100	21.1

Asta : 626 [379 , 378]

AUTOSTRADA VALDASTICO A31 NORD
1° LOTTO - PIOVENE ROCCHETTE – VALLE DELL'ASTICO

Sez. G: O 114.3x5.9 L=314.0 cm Crit.: Acciaio_Flessione $\gamma_M=1.05$ $f_{yk}/\gamma_M=2619$ kg/cmq $f_t=4300$ kg/cmq

:Verificato

X	cls	N	TY	TZ	MT	MY	MZ	My4	Mz4	Comb.
cm		kg	kg	kg	kg*m	kg*m	kg*m			
157	1	12659	-0	2	-1	-32	-0	--	--	2

X	cls	Nr	Vyr	Vzr	Mry	Mrz	MTrd	SF_V.	SF_M	SF_Mt	SF
cm		kg	kg	kg	kg*m	kg*m	kg*m				
157	1	52623	19331	19331	1818	1818	1566	>100	3.87	>100	3.87

Asta : 627 [395 , 387]

Sez. G: O 114.3x5.9 L=281.6 cm Crit.: Acciaio_Flessione $\gamma_M=1.05$ $f_{yk}/\gamma_M=2619$ kg/cmq $f_t=4300$ kg/cmq

:Verificato

X	cls	N	TY	TZ	MT	MY	MZ	My4	Mz4	Comb.
cm		kg	kg	kg	kg*m	kg*m	kg*m			
113	1	-1390	-2	-4	5	-15	-6	--	--	2

X	cls	Nr	Vyr	Vzr	Mry	Mrz	MTrd	SF_V.	SF_M	SF_Mt	SF
cm		kg	kg	kg	kg*m	kg*m	kg*m				
113	1	52623	19277	19277	1818	1818	1566	>100	26.1	>100	26.1

Asta : 628 [387 , 396]

Sez. G: O 114.3x5.9 L=281.6 cm Crit.: Acciaio_Flessione $\gamma_M=1.05$ $f_{yk}/\gamma_M=2619$ kg/cmq $f_t=4300$ kg/cmq

:Verificato

X	cls	N	TY	TZ	MT	MY	MZ	My4	Mz4	Comb.
cm		kg	kg	kg	kg*m	kg*m	kg*m			
169	1	-152	1	2	-5	-17	-6	--	--	2

X	cls	Nr	Vyr	Vzr	Mry	Mrz	MTrd	SF_V.	SF_M	SF_Mt	SF
cm		kg	kg	kg	kg*m	kg*m	kg*m				
169	1	52623	19281	19281	1818	1818	1566	>100	65.5	>100	65.5

AUTOSTRADA VALDASTICO A31 NORD
1° LOTTO - PIOVENE ROCCHETTE – VALLE DELL'ASTICO

Asta : 629 [378 , 387]

Sez. G: O 114.3x5.9 L=281.6 cm Crit.: Acciaio_Flessione $\gamma_M=1.05$ $f_{yk}/\gamma_M=2619$ kg/cm² $f_t=4300$ kg/cm²

:Verificato

X	cls	N	TY	TZ	MT	MY	MZ	My4	Mz4	Comb.
cm		kg	kg	kg	kg*m	kg*m	kg*m			
113	1	-1538	4	-4	-4	-14	7	--	--	2

X	cls	Nr	Vyr	Vzr	Mry	Mrz	MTrd	SF_V.	SF_M	SF_Mt	SF
cm		kg	kg	kg	kg*m	kg*m	kg*m				
113	1	52623	19286	19286	1818	1818	1566	>100	24.7	>100	24.7

Asta : 630 [387 , 379]

Sez. G: O 114.3x5.9 L=281.6 cm Crit.: Acciaio_Flessione $\gamma_M=1.05$ $f_{yk}/\gamma_M=2619$ kg/cm² $f_t=4300$ kg/cm²

:Verificato

X	cls	N	TY	TZ	MT	MY	MZ	My4	Mz4	Comb.
cm		kg	kg	kg	kg*m	kg*m	kg*m			
169	1	-260	-1	4	5	-16	6	--	--	2

X	cls	Nr	Vyr	Vzr	Mry	Mrz	MTrd	SF_V.	SF_M	SF_Mt	SF
cm		kg	kg	kg	kg*m	kg*m	kg*m				
169	1	52623	19282	19282	1818	1818	1566	>100	57.9	>100	57.9

Asta : 631 [379 , 386]

Sez. G: O 114.3x5.9 L=281.6 cm Crit.: Acciaio_Flessione $\gamma_M=1.05$ $f_{yk}/\gamma_M=2619$ kg/cm² $f_t=4300$ kg/cm²

:Verificato

X	cls	N	TY	TZ	MT	MY	MZ	My4	Mz4	Comb.
cm		kg	kg	kg	kg*m	kg*m	kg*m			
113	1	-229	1	-4	-5	-16	6	--	--	2

X	cls	Nr	Vyr	Vzr	Mry	Mrz	MTrd	SF_V.	SF_M	SF_Mt	SF
cm		kg	kg	kg	kg*m	kg*m	kg*m				
113	1	52623	19282	19282	1818	1818	1566	>100	60.0	>100	60.0

AUTOSTRADA VALDASTICO A31 NORD
1° LOTTO - PIOVENE ROCCHETTE – VALLE DELL'ASTICO

Asta : 632 [386 , 397]

Sez. G: O 114.3x5.9 L=281.6 cm Crit.: Acciaio_Flessione $\gamma_M=1.05$ $f_{yk}/\gamma_M=2619$ kg/cmq $f_t=4300$ kg/cmq

:Verificato

X	cls	N	TY	TZ	MT	MY	MZ	My4	Mz4	Comb.
cm		kg	kg	kg	kg*m	kg*m	kg*m			
169	1	-1420	2	4	-5	-15	-6	--	--	2

X	cls	Nr	Vyr	Vzr	Mry	Mrz	MTrd	SF_V.	SF_M	SF_Mt	SF
cm		kg	kg	kg	kg*m	kg*m	kg*m				
169	1	52623	19277	19277	1818	1818	1566	>100	25.8	>100	25.8

Asta : 633 [397 , 380]

Sez. G: O 114.3x5.9 L=286.0 cm Crit.: Acciaio_Flessione $\gamma_M=1.05$ $f_{yk}/\gamma_M=2619$ kg/cmq $f_t=4300$ kg/cmq

:Verificato

X	cls	N	TY	TZ	MT	MY	MZ	My4	Mz4	Comb.
cm		kg	kg	kg	kg*m	kg*m	kg*m			
0	1	1236	-4	-31	-1	15	-6	--	--	2

X	cls	Nr	Vyr	Vzr	Mry	Mrz	MTrd	SF_V.	SF_M	SF_Mt	SF
cm		kg	kg	kg	kg*m	kg*m	kg*m				
0	1	52623	19326	19326	1818	1818	1566	>100	28.4	>100	28.4

Asta : 634 [380 , 379]

Sez. G: O 114.3x5.9 L=314.0 cm Crit.: Acciaio_Flessione $\gamma_M=1.05$ $f_{yk}/\gamma_M=2619$ kg/cmq $f_t=4300$ kg/cmq

:Verificato

X	cls	N	TY	TZ	MT	MY	MZ	My4	Mz4	Comb.
cm		kg	kg	kg	kg*m	kg*m	kg*m			
157	1	12627	0	-2	1	-32	-0	--	--	2

X	cls	Nr	Vyr	Vzr	Mry	Mrz	MTrd	SF_V.	SF_M	SF_Mt	SF
cm		kg	kg	kg	kg*m	kg*m	kg*m				

AUTOSTRADA VALDASTICO A31 NORD
1° LOTTO - PIOVENE ROCCHETTE – VALLE DELL'ASTICO

X	cls	Nr	Vyr	Vzr	Mry	Mrz	MTrd	SF_V.	SF_M	SF_Mt	SF
157	1	52623	19331	19331	1818	1818	1566	>100	3.88	>100	3.88

Asta : 635 [396 , 386]

Sez. G: O 114.3x5.9 L=281.6 cm Crit.: Acciaio_Flessione $\gamma_M=1.05$ $f_{yk}/\gamma_M=2619$ kg/cm² $f_t=4300$ kg/cm²

:Verificato

X	cls	N	TY	TZ	MT	MY	MZ	My4	Mz4	Comb.
cm		kg	kg	kg	kg*m	kg*m	kg*m			
113	1	-135	-1	-2	5	-17	-6	--	--	2

X	cls	Nr	Vyr	Vzr	Mry	Mrz	MTrd	SF_V.	SF_M	SF_Mt	SF
cm		kg	kg	kg	kg*m	kg*m	kg*m				
113	1	52623	19281	19281	1818	1818	1566	>100	67.0	>100	67.0

Asta : 636 [386 , 380]

Sez. G: O 114.3x5.9 L=281.6 cm Crit.: Acciaio_Flessione $\gamma_M=1.05$ $f_{yk}/\gamma_M=2619$ kg/cm² $f_t=4300$ kg/cm²

:Verificato

X	cls	N	TY	TZ	MT	MY	MZ	My4	Mz4	Comb.
cm		kg	kg	kg	kg*m	kg*m	kg*m			
169	1	-1560	-4	4	4	-14	7	--	--	2

X	cls	Nr	Vyr	Vzr	Mry	Mrz	MTrd	SF_V.	SF_M	SF_Mt	SF
cm		kg	kg	kg	kg*m	kg*m	kg*m				
169	1	52623	19286	19286	1818	1818	1566	>100	24.4	>100	24.4

Asta : 637 [398 , 381]

Sez. G: O 114.3x5.9 L=286.0 cm Crit.: Acciaio_Flessione $\gamma_M=1.05$ $f_{yk}/\gamma_M=2619$ kg/cm² $f_t=4300$ kg/cm²

:Verificato

X	cls	N	TY	TZ	MT	MY	MZ	My4	Mz4	Comb.
cm		kg	kg	kg	kg*m	kg*m	kg*m			
0	1	-2478	-10	-47	-14	49	-15	--	--	2

AUTOSTRADA VALDASTICO A31 NORD
1° LOTTO - PIOVENE ROCCHETTE – VALLE DELL'ASTICO

X	cls	Nr	Vyr	Vzr	Mry	Mrz	MTrd	SF_V.	SF_M	SF_Mt	SF
cm		kg	kg	kg	kg*m	kg*m	kg*m				
0	1	52623	19170	19170	1818	1818	1566	>100	12.2	>100	12.2

Asta : 638 [381 , 380]

Sez. G: O 114.3x5.9 L=314.0 cm Crit.: Acciaio_Flessione $\gamma_M=1.05$ $f_{yk}/\gamma_M=2619$ kg/cm² $f_t=4300$ kg/cm²

:Verificato

X	cls	N	TY	TZ	MT	MY	MZ	My4	Mz4	Comb.
cm		kg	kg	kg	kg*m	kg*m	kg*m			
220	1	8306	4	6	5	-27	-2	--	--	2

X	cls	Nr	Vyr	Vzr	Mry	Mrz	MTrd	SF_V.	SF_M	SF_Mt	SF
cm		kg	kg	kg	kg*m	kg*m	kg*m				
220	1	52623	19274	19274	1818	1818	1566	>100	5.75	>100	5.75

Asta : 639 [380 , 385]

Sez. G: O 114.3x5.9 L=273.9 cm Crit.: Acciaio_Flessione $\gamma_M=1.05$ $f_{yk}/\gamma_M=2619$ kg/cm² $f_t=4300$ kg/cm²

:Verificato

X	cls	N	TY	TZ	MT	MY	MZ	My4	Mz4	Comb.
cm		kg	kg	kg	kg*m	kg*m	kg*m			
110	1	2669	2	-2	-5	-17	5	--	--	2

X	cls	Nr	Vyr	Vzr	Mry	Mrz	MTrd	SF_V.	SF_M	SF_Mt	SF
cm		kg	kg	kg	kg*m	kg*m	kg*m				
110	1	52623	19282	19282	1818	1818	1566	>100	15.8	>100	15.8

Asta : 640 [385 , 398]

Sez. G: O 114.3x5.9 L=273.9 cm Crit.: Acciaio_Flessione $\gamma_M=1.05$ $f_{yk}/\gamma_M=2619$ kg/cm² $f_t=4300$ kg/cm²

:Verificato

X	cls	N	TY	TZ	MT	MY	MZ	My4	Mz4	Comb.
cm		kg	kg	kg	kg*m	kg*m	kg*m			
274	1	-6526	13	12	-12	-19	-30	--	--	2

AUTOSTRADA VALDASTICO A31 NORD
1° LOTTO - PIOVENE ROCCHETTE – VALLE DELL'ASTICO

X	cls	Nr	Vyr	Vzr	Mry	Mrz	MTrd	SF_V.	SF_M	SF_Mt	SF
cm		kg	kg	kg	kg*m	kg*m	kg*m				
274	1	52623	19193	19193	1818	1818	1566	>100	6.62	>100	6.62

Asta : 641 [397 , 385]

Sez. G: O 114.3x5.9 L=273.9 cm Crit.: Acciaio_Flessione $\gamma_M=1.05$ $f_{yk}/\gamma_M=2619$ kg/cm² $f_t=4300$ kg/cm²

:Verificato

X	cls	N	TY	TZ	MT	MY	MZ	My4	Mz4	Comb.
cm		kg	kg	kg	kg*m	kg*m	kg*m			
110	1	854	1	2	6	-15	-6	--	--	2

X	cls	Nr	Vyr	Vzr	Mry	Mrz	MTrd	SF_V.	SF_M	SF_Mt	SF
cm		kg	kg	kg	kg*m	kg*m	kg*m				
110	1	52623	19271	19271	1818	1818	1566	>100	36.4	>100	36.4

Asta : 642 [385 , 381]

Sez. G: O 114.3x5.9 L=273.9 cm Crit.: Acciaio_Flessione $\gamma_M=1.05$ $f_{yk}/\gamma_M=2619$ kg/cm² $f_t=4300$ kg/cm²

:Verificato

X	cls	N	TY	TZ	MT	MY	MZ	My4	Mz4	Comb.
cm		kg	kg	kg	kg*m	kg*m	kg*m			
274	1	-842	-12	25	5	14	21	--	--	2

X	cls	Nr	Vyr	Vzr	Mry	Mrz	MTrd	SF_V.	SF_M	SF_Mt	SF
cm		kg	kg	kg	kg*m	kg*m	kg*m				
274	1	52623	19280	19280	1818	1818	1566	>100	28.4	>100	28.4

Asta : 643 [381 , 382]

Sez. G: O 114.3x5.9 L=314.0 cm Crit.: Acciaio_Flessione $\gamma_M=1.05$ $f_{yk}/\gamma_M=2619$ kg/cm² $f_t=4300$ kg/cm²

:Verificato

X	cls	N	TY	TZ	MT	MY	MZ	My4	Mz4	Comb.
cm		kg	kg	kg	kg*m	kg*m	kg*m			

AUTOSTRADA VALDASTICO A31 NORD
1° LOTTO - PIOVENE ROCCHETTE – VALLE DELL'ASTICO

X	cls	N	TY	TZ	MT	MY	MZ	My4	Mz4	Comb.
314	1	-470	8	54	15	60	-14	--	--	2

X	cls	Nr	Vyr	Vzr	Mry	Mrz	MTrd	SF_V.	SF_M	SF_Mt	SF
cm		kg	kg	kg	kg*m	kg*m	kg*m				
314	1	52623	19155	19155	1818	1818	1566	>100	20.4	>100	20.4

Asta : 644 [382 , 399]

Sez. G: O 114.3x5.9 L=286.0 cm Crit.: Acciaio_Flessione $\gamma_M=1.05$ $f_{yk}/\gamma_M=2619$ kg/cm² $f_t=4300$ kg/cm²

:Verificato

X	cls	N	TY	TZ	MT	MY	MZ	My4	Mz4	Comb.
cm		kg	kg	kg	kg*m	kg*m	kg*m			
286	1	-7249	3	156	34	233	-4	--	--	2

X	cls	Nr	Vyr	Vzr	Mry	Mrz	MTrd	SF_V.	SF_M	SF_Mt	SF
cm		kg	kg	kg	kg*m	kg*m	kg*m				
286	1	52623	18922	18922	1818	1818	1566	>100	3.73	46.1	3.73

Asta : 645 [398 , 384]

Sez. G: O 114.3x5.9 L=254.4 cm Crit.: Acciaio_Flessione $\gamma_M=1.05$ $f_{yk}/\gamma_M=2619$ kg/cm² $f_t=4300$ kg/cm²

:Verificato

X	cls	N	TY	TZ	MT	MY	MZ	My4	Mz4	Comb.
cm		kg	kg	kg	kg*m	kg*m	kg*m			
254	1	5389	32	18	10	23	-52	--	--	2

X	cls	Nr	Vyr	Vzr	Mry	Mrz	MTrd	SF_V.	SF_M	SF_Mt	SF
cm		kg	kg	kg	kg*m	kg*m	kg*m				
254	1	52623	19213	19213	1818	1818	1566	>100	6.94	>100	6.94

Asta : 646 [384 , 399]

Sez. G: O 114.3x5.9 L=254.4 cm Crit.: Acciaio_Flessione $\gamma_M=1.05$ $f_{yk}/\gamma_M=2619$ kg/cm² $f_t=4300$ kg/cm²

:Verificato

AUTOSTRADA VALDASTICO A31 NORD
1° LOTTO - PIOVENE ROCCHETTE – VALLE DELL'ASTICO

X	cls	N	TY	TZ	MT	MY	MZ	My4	Mz4	Comb.
cm		kg	kg	kg	kg*m	kg*m	kg*m			
254	1	-31851	-38	225	17	349	65	--	--	2

X	cls	Nr	Vyr	Vzr	Mry	Mrz	MTrd	SF_V.	SF_M	SF_Mt	SF
cm		kg	kg	kg	kg*m	kg*m	kg*m				
254	1	52623	19132	19132	1818	1818	1566	85.0	1.20	92.3	1.20

Asta : 647 [381 , 384]

Sez. G: O 114.3x5.9 L=254.4 cm Crit.: Acciaio_Flessione $\gamma_M=1.05$ $f_{yk}/\gamma_M=2619$ kg/cm² $f_t=4300$ kg/cm²

:Verificato

X	cls	N	TY	TZ	MT	MY	MZ	My4	Mz4	Comb.
cm		kg	kg	kg	kg*m	kg*m	kg*m			
203	1	8614	6	5	-2	-30	-6	--	--	2

X	cls	Nr	Vyr	Vzr	Mry	Mrz	MTrd	SF_V.	SF_M	SF_Mt	SF
cm		kg	kg	kg	kg*m	kg*m	kg*m				
203	1	52623	19320	19320	1818	1818	1566	>100	5.46	>100	5.46

Asta : 648 [384 , 382]

Sez. G: O 114.3x5.9 L=254.4 cm Crit.: Acciaio_Flessione $\gamma_M=1.05$ $f_{yk}/\gamma_M=2619$ kg/cm² $f_t=4300$ kg/cm²

:Verificato

X	cls	N	TY	TZ	MT	MY	MZ	My4	Mz4	Comb.
cm		kg	kg	kg	kg*m	kg*m	kg*m			
254	1	6900	-25	33	-8	50	25	--	--	2

X	cls	Nr	Vyr	Vzr	Mry	Mrz	MTrd	SF_V.	SF_M	SF_Mt	SF
cm		kg	kg	kg	kg*m	kg*m	kg*m				
254	1	52623	19238	19238	1818	1818	1566	>100	5.79	>100	5.79

Asta : 649 [400 , 383]

AUTOSTRADA VALDASTICO A31 NORD
1° LOTTO - PIOVENE ROCCHETTE – VALLE DELL'ASTICO

Sez. G: O 114.3x5.9 L=286.0 cm Crit.: Acciaio_Flessione $\gamma_M=1.05$ $f_{yk}/\gamma_M=2619$ kg/cmq $f_t=4300$ kg/cmq

:Verificato

X	cls	N	TY	TZ	MT	MY	MZ	My4	Mz4	Comb.
cm		kg	kg	kg	kg*m	kg*m	kg*m			
0	1	-1775	-4	-58	4	90	-9	--	--	(12+13)-I-1

X	cls	Nr	Vyr	Vzr	Mry	Mrz	MTrd	SF_V.	SF_M	SF_Mt	SF
cm		kg	kg	kg	kg*m	kg*m	kg*m				
0	1	52623	19297	19297	1818	1818	1566	>100	11.3	>100	11.3

Asta : 650 [383 , 382]

Sez. G: O 114.3x5.9 L=314.0 cm Crit.: Acciaio_Flessione $\gamma_M=1.05$ $f_{yk}/\gamma_M=2619$ kg/cmq $f_t=4300$ kg/cmq

:Verificato

X	cls	N	TY	TZ	MT	MY	MZ	My4	Mz4	Comb.
cm		kg	kg	kg	kg*m	kg*m	kg*m			
314	1	-3567	-5	35	-10	37	8	--	--	2

X	cls	Nr	Vyr	Vzr	Mry	Mrz	MTrd	SF_V.	SF_M	SF_Mt	SF
cm		kg	kg	kg	kg*m	kg*m	kg*m				
314	1	52623	19212	19212	1818	1818	1566	>100	10.8	>100	10.8

Asta : 651 [399 , 391]

Sez. G: O 114.3x5.9 L=229.9 cm Crit.: Acciaio_Flessione $\gamma_M=1.05$ $f_{yk}/\gamma_M=2619$ kg/cmq $f_t=4300$ kg/cmq

:Verificato

X	cls	N	TY	TZ	MT	MY	MZ	My4	Mz4	Comb.
cm		kg	kg	kg	kg*m	kg*m	kg*m			
0	1	-18273	-17	-95	37	88	-43	--	--	2

X	cls	Nr	Vyr	Vzr	Mry	Mrz	MTrd	SF_V.	SF_M	SF_Mt	SF
cm		kg	kg	kg	kg*m	kg*m	kg*m				
0	1	52623	18880	18880	1818	1818	1566	>100	2.39	41.9	2.39

AUTOSTRADA VALDASTICO A31 NORD
1° LOTTO - PIOVENE ROCCHETTE – VALLE DELL'ASTICO

Asta : 652 [391 , 383]

Sez. G: O 114.3x5.9 L=229.9 cm Crit.: Acciaio_Flessione $\gamma_M=1.05$ $f_{yk}/\gamma_M=2619$ kg/cm² $f_t=4300$ kg/cm²

:Verificato

X	cls	N	TY	TZ	MT	MY	MZ	My4	Mz4	Comb.
cm		kg	kg	kg	kg*m	kg*m	kg*m			
0	1	5735	-12	-53	-8	44	-16	--	--	2

X	cls	Nr	Vyr	Vzr	Mry	Mrz	MTrd	SF_V.	SF_M	SF_Mt	SF
cm		kg	kg	kg	kg*m	kg*m	kg*m				
0	1	52623	19242	19242	1818	1818	1566	>100	7.04	>100	7.04

Asta : 653 [391 , 400]

Sez. G: O 114.3x5.9 L=229.9 cm Crit.: Acciaio_Flessione $\gamma_M=1.05$ $f_{yk}/\gamma_M=2619$ kg/cm² $f_t=4300$ kg/cm²

:Verificato

X	cls	N	TY	TZ	MT	MY	MZ	My4	Mz4	Comb.
cm		kg	kg	kg	kg*m	kg*m	kg*m			
0	1	2846	6	-35	-2	76	10	--	--	2

X	cls	Nr	Vyr	Vzr	Mry	Mrz	MTrd	SF_V.	SF_M	SF_Mt	SF
cm		kg	kg	kg	kg*m	kg*m	kg*m				
0	1	52623	19321	19321	1818	1818	1566	>100	9.84	>100	9.84

Asta : 654 [390 , 389]

Sez. G: O 114.3x5.9 L=318.3 cm Crit.: Acciaio_Flessione $\gamma_M=1.05$ $f_{yk}/\gamma_M=2619$ kg/cm² $f_t=4300$ kg/cm²

:Verificato

X	cls	N	TY	TZ	MT	MY	MZ	My4	Mz4	Comb.
cm		kg	kg	kg	kg*m	kg*m	kg*m			
318	1	14185	3	1316	0	737	-6	--	--	2

X	cls	Nr	Vyr	Vzr	Mry	Mrz	MTrd	SF_V.	SF_M	SF_Mt	SF
cm		kg	kg	kg	kg*m	kg*m	kg*m				
318	1	52623	19340	19340	1818	1818	1566	14.7	1.47	>100	1.47

AUTOSTRADA VALDASTICO A31 NORD
1° LOTTO - PIOVENE ROCCHETTE – VALLE DELL'ASTICO

Asta : 655 [389 , 388]

Sez. G: O 114.3x5.9 L=315.7 cm Crit.: Acciaio_Flessione $\gamma_M=1.05$ $f_{yk}/\gamma_M=2619$ kg/cmq $f_t=4300$ kg/cmq

:Verificato

X	cls	N	TY	TZ	MT	MY	MZ	My4	Mz4	Comb.
cm		kg	kg	kg	kg*m	kg*m	kg*m			
0	1	-10089	10	-1323	-13	689	16	--	--	2

X	cls	Nr	Vyr	Vzr	Mry	Mrz	MTrd	SF_V.	SF_M	SF_Mt	SF
cm		kg	kg	kg	kg*m	kg*m	kg*m				
0	1	52623	19180	19180	1818	1818	1566	14.5	1.73	>100	1.73

Asta : 656 [388 , 387]

Sez. G: O 114.3x5.9 L=314.2 cm Crit.: Acciaio_Flessione $\gamma_M=1.05$ $f_{yk}/\gamma_M=2619$ kg/cmq $f_t=4300$ kg/cmq

:Verificato

X	cls	N	TY	TZ	MT	MY	MZ	My4	Mz4	Comb.
cm		kg	kg	kg	kg*m	kg*m	kg*m			
0	1	-16090	0	-1317	-1	673	0	--	--	2

X	cls	Nr	Vyr	Vzr	Mry	Mrz	MTrd	SF_V.	SF_M	SF_Mt	SF
cm		kg	kg	kg	kg*m	kg*m	kg*m				
0	1	52623	19325	19325	1818	1818	1566	14.7	1.48	>100	1.48

Asta : 657 [387 , 386]

Sez. G: O 114.3x5.9 L=314.0 cm Crit.: Acciaio_Flessione $\gamma_M=1.05$ $f_{yk}/\gamma_M=2619$ kg/cmq $f_t=4300$ kg/cmq

:Verificato

X	cls	N	TY	TZ	MT	MY	MZ	My4	Mz4	Comb.
cm		kg	kg	kg	kg*m	kg*m	kg*m			
314	1	-17428	0	1313	0	665	0	--	--	2

X	cls	Nr	Vyr	Vzr	Mry	Mrz	MTrd	SF_V.	SF_M	SF_Mt	SF
cm		kg	kg	kg	kg*m	kg*m	kg*m				

AUTOSTRADA VALDASTICO A31 NORD
1° LOTTO - PIOVENE ROCCHETTE – VALLE DELL'ASTICO

X	cls	Nr	Vyr	Vzr	Mry	Mrz	MTrd	SF_V.	SF_M	SF_Mt	SF
314	1	52623	19342	19342	1818	1818	1566	14.7	1.43	>100	1.43

Asta : 658 [386 , 385]

Sez. G: O 114.3x5.9 L=314.2 cm Crit.: Acciaio_Flessione $\gamma_M=1.05$ $f_{yk}/\gamma_M=2619$ kg/cm² $f_t=4300$ kg/cm²

:Verificato

X	cls	N	TY	TZ	MT	MY	MZ	My4	Mz4	Comb.
cm		kg	kg	kg	kg*m	kg*m	kg*m			
314	1	-16033	-0	1318	1	674	1	--	--	2

X	cls	Nr	Vyr	Vzr	Mry	Mrz	MTrd	SF_V.	SF_M	SF_Mt	SF
cm		kg	kg	kg	kg*m	kg*m	kg*m				
314	1	52623	19325	19325	1818	1818	1566	14.7	1.48	>100	1.48

Asta : 659 [385 , 384]

Sez. G: O 114.3x5.9 L=315.7 cm Crit.: Acciaio_Flessione $\gamma_M=1.05$ $f_{yk}/\gamma_M=2619$ kg/cm² $f_t=4300$ kg/cm²

:Verificato

X	cls	N	TY	TZ	MT	MY	MZ	My4	Mz4	Comb.
cm		kg	kg	kg	kg*m	kg*m	kg*m			
316	1	-9936	-10	1323	13	689	16	--	--	2

X	cls	Nr	Vyr	Vzr	Mry	Mrz	MTrd	SF_V.	SF_M	SF_Mt	SF
cm		kg	kg	kg	kg*m	kg*m	kg*m				
316	1	52623	19178	19178	1818	1818	1566	14.5	1.73	>100	1.73

Asta : 660 [384 , 391]

Sez. G: O 114.3x5.9 L=318.3 cm Crit.: Acciaio_Flessione $\gamma_M=1.05$ $f_{yk}/\gamma_M=2619$ kg/cm² $f_t=4300$ kg/cm²

:Verificato

X	cls	N	TY	TZ	MT	MY	MZ	My4	Mz4	Comb.
cm		kg	kg	kg	kg*m	kg*m	kg*m			
0	1	14583	-3	-1317	-1	738	-5	--	--	2

AUTOSTRADA VALDASTICO A31 NORD
1° LOTTO - PIOVENE ROCCHETTE – VALLE DELL'ASTICO

X	cls	Nr	Vyr	Vzr	Mry	Mrz	MTrd	SF_V.	SF_M	SF_Mt	SF
cm		kg	kg	kg	kg*m	kg*m	kg*m				
0	1	52623	19335	19335	1818	1818	1566	14.7	1.46	>100	1.46

Asta : 661 [409 , 416]

Sez. G: O 114.3x5.9 L=218.3 cm Crit.: Acciaio_Flessione $\gamma_M=1.05$ $f_{yk}/\gamma_M=2619$ kg/cm² $f_t=4300$ kg/cm²

:Verificato

X	cls	N	TY	TZ	MT	MY	MZ	My4	Mz4	Comb.
cm		kg	kg	kg	kg*m	kg*m	kg*m			
218	1	232	-5	52	1	53	2	--	--	2

X	cls	Nr	Vyr	Vzr	Mry	Mrz	MTrd	SF_V.	SF_M	SF_Mt	SF
cm		kg	kg	kg	kg*m	kg*m	kg*m				
218	1	52623	19333	19333	1818	1818	1566	>100	28.5	>100	28.5

Asta : 662 [419 , 408]

Sez. G: O 114.3x5.9 L=247.0 cm Crit.: Acciaio_Flessione $\gamma_M=1.05$ $f_{yk}/\gamma_M=2619$ kg/cm² $f_t=4300$ kg/cm²

:Verificato

X	cls	N	TY	TZ	MT	MY	MZ	My4	Mz4	Comb.
cm		kg	kg	kg	kg*m	kg*m	kg*m			
0	1	119	30	-32	20	13	36	--	--	2

X	cls	Nr	Vyr	Vzr	Mry	Mrz	MTrd	SF_V.	SF_M	SF_Mt	SF
cm		kg	kg	kg	kg*m	kg*m	kg*m				
0	1	52623	19097	19097	1818	1818	1566	>100	34.5	79.1	34.5

Asta : 663 [408 , 409]

Sez. G: O 114.3x5.9 L=314.0 cm Crit.: Acciaio_Flessione $\gamma_M=1.05$ $f_{yk}/\gamma_M=2619$ kg/cm² $f_t=4300$ kg/cm²

:Verificato

X	cls	N	TY	TZ	MT	MY	MZ	My4	Mz4	Comb.
cm		kg	kg	kg	kg*m	kg*m	kg*m			
0	1	-87	-9	-41	-15	26	-11	--	--	2

AUTOSTRADA VALDASTICO A31 NORD
1° LOTTO - PIOVENE ROCCHETTE – VALLE DELL'ASTICO

X	cls	Nr	Vyr	Vzr	Mry	Mrz	MTrd	SF_V.	SF_M	SF_Mt	SF
cm		kg	kg	kg	kg*m	kg*m	kg*m				
0	1	52623	19157	19157	1818	1818	1566	>100	45.9	>100	45.9

Asta : 664 [418 , 416]

Sez. G: O 114.3x5.9 L=218.3 cm Crit.: Acciaio_Flessione $\gamma_M=1.05$ $f_{yk}/\gamma_M=2619$ kg/cmq $f_t=4300$ kg/cmq

:Verificato

X	cls	N	TY	TZ	MT	MY	MZ	My4	Mz4	Comb.
cm		kg	kg	kg	kg*m	kg*m	kg*m			
153	1	-2205	-7	6	-5	-13	5	--	--	2

X	cls	Nr	Vyr	Vzr	Mry	Mrz	MTrd	SF_V.	SF_M	SF_Mt	SF
cm		kg	kg	kg	kg*m	kg*m	kg*m				
153	1	52623	19275	19275	1818	1818	1566	>100	19.3	>100	19.3

Asta : 665 [416 , 408]

Sez. G: O 114.3x5.9 L=218.3 cm Crit.: Acciaio_Flessione $\gamma_M=1.05$ $f_{yk}/\gamma_M=2619$ kg/cmq $f_t=4300$ kg/cmq

:Verificato

X	cls	N	TY	TZ	MT	MY	MZ	My4	Mz4	Comb.
cm		kg	kg	kg	kg*m	kg*m	kg*m			
153	1	-926	13	15	-4	-26	-12	--	--	2

X	cls	Nr	Vyr	Vzr	Mry	Mrz	MTrd	SF_V.	SF_M	SF_Mt	SF
cm		kg	kg	kg	kg*m	kg*m	kg*m				
153	1	52623	19297	19297	1818	1818	1566	>100	26.0	>100	26.0

Asta : 666 [416 , 419]

Sez. G: O 114.3x5.9 L=218.3 cm Crit.: Acciaio_Flessione $\gamma_M=1.05$ $f_{yk}/\gamma_M=2619$ kg/cmq $f_t=4300$ kg/cmq

:Verificato

X	cls	N	TY	TZ	MT	MY	MZ	My4	Mz4	Comb.
cm		kg	kg	kg	kg*m	kg*m	kg*m			

AUTOSTRADA VALDASTICO A31 NORD
1° LOTTO - PIOVENE ROCCHETTE – VALLE DELL'ASTICO

X	cls	N	TY	TZ	MT	MY	MZ	My4	Mz4	Comb.
218	1	-468	-3	38	-2	46	-1	--	--	2

X	cls	Nr	Vyr	Vzr	Mry	Mrz	MTrd	SF_V.	SF_M	SF_Mt	SF
cm		kg	kg	kg	kg*m	kg*m	kg*m				
218	1	52623	19312	19312	1818	1818	1566	>100	29.0	>100	29.0

Asta : 667 [418 , 409]

Sez. G: O 114.3x5.9 L=247.0 cm Crit.: Acciaio_Flessione $\gamma_M=1.05$ $f_{yk}/\gamma_M=2619$ kg/cm² $f_t=4300$ kg/cm²

:Verificato

X	cls	N	TY	TZ	MT	MY	MZ	My4	Mz4	Comb.
cm		kg	kg	kg	kg*m	kg*m	kg*m			
0	1	-141	5	-49	10	34	8	--	--	2

X	cls	Nr	Vyr	Vzr	Mry	Mrz	MTrd	SF_V.	SF_M	SF_Mt	SF
cm		kg	kg	kg	kg*m	kg*m	kg*m				
0	1	52623	19221	19221	1818	1818	1566	>100	39.0	>100	39.0

Asta : 668 [420 , 407]

Sez. G: O 114.3x5.9 L=247.0 cm Crit.: Acciaio_Flessione $\gamma_M=1.05$ $f_{yk}/\gamma_M=2619$ kg/cm² $f_t=4300$ kg/cm²

:Verificato

X	cls	N	TY	TZ	MT	MY	MZ	My4	Mz4	Comb.
cm		kg	kg	kg	kg*m	kg*m	kg*m			
0	1	-5	41	-30	21	13	48	--	--	2

X	cls	Nr	Vyr	Vzr	Mry	Mrz	MTrd	SF_V.	SF_M	SF_Mt	SF
cm		kg	kg	kg	kg*m	kg*m	kg*m				
0	1	52623	19077	19077	1818	1818	1566	>100	29.9	73.1	29.9

Asta : 669 [407 , 408]

Sez. G: O 114.3x5.9 L=314.0 cm Crit.: Acciaio_Flessione $\gamma_M=1.05$ $f_{yk}/\gamma_M=2619$ kg/cm² $f_t=4300$ kg/cm²

:Verificato

AUTOSTRADA VALDASTICO A31 NORD
1° LOTTO - PIOVENE ROCCHETTE – VALLE DELL'ASTICO

X	cls	N	TY	TZ	MT	MY	MZ	My4	Mz4	Comb.
cm		kg	kg	kg	kg*m	kg*m	kg*m			
0	1	-1258	-25	-46	-25	40	-37	--	--	2

X	cls	Nr	Vyr	Vzr	Mry	Mrz	MTrd	SF_V.	SF_M	SF_Mt	SF
cm		kg	kg	kg	kg*m	kg*m	kg*m				
0	1	52623	19036	19036	1818	1818	1566	>100	15.1	63.2	15.1

Asta : 670 [408 , 415]

Sez. G: O 114.3x5.9 L=243.9 cm Crit.: Acciaio_Flessione $\gamma_M=1.05$ $f_{yk}/\gamma_M=2619$ kg/cm² $f_t=4300$ kg/cm²

:Verificato

X	cls	N	TY	TZ	MT	MY	MZ	My4	Mz4	Comb.
cm		kg	kg	kg	kg*m	kg*m	kg*m			
244	1	872	-3	34	-4	45	8	--	--	2

X	cls	Nr	Vyr	Vzr	Mry	Mrz	MTrd	SF_V.	SF_M	SF_Mt	SF
cm		kg	kg	kg	kg*m	kg*m	kg*m				
244	1	52623	19293	19293	1818	1818	1566	>100	21.8	>100	21.8

Asta : 671 [415 , 420]

Sez. G: O 114.3x5.9 L=243.9 cm Crit.: Acciaio_Flessione $\gamma_M=1.05$ $f_{yk}/\gamma_M=2619$ kg/cm² $f_t=4300$ kg/cm²

:Verificato

X	cls	N	TY	TZ	MT	MY	MZ	My4	Mz4	Comb.
cm		kg	kg	kg	kg*m	kg*m	kg*m			
0	1	346	-8	-19	-3	31	-13	--	--	2

X	cls	Nr	Vyr	Vzr	Mry	Mrz	MTrd	SF_V.	SF_M	SF_Mt	SF
cm		kg	kg	kg	kg*m	kg*m	kg*m				
0	1	52623	19305	19305	1818	1818	1566	>100	32.2	>100	32.2

Asta : 672 [419 , 415]

AUTOSTRADA VALDASTICO A31 NORD
1° LOTTO - PIOVENE ROCCHETTE – VALLE DELL'ASTICO

Sez. G: O 114.3x5.9 L=243.9 cm Crit.: Acciaio_Flessione $\gamma_M=1.05$ $f_{yk}/\gamma_M=2619$ kg/cmq $f_t=4300$ kg/cmq

:Verificato

X	cls	N	TY	TZ	MT	MY	MZ	My4	Mz4	Comb.
cm		kg	kg	kg	kg*m	kg*m	kg*m			
146	1	-2591	-3	2	-7	-30	6	--	--	2

X	cls	Nr	Vyr	Vzr	Mry	Mrz	MTrd	SF_V.	SF_M	SF_Mt	SF
cm		kg	kg	kg	kg*m	kg*m	kg*m				
146	1	52623	19252	19252	1818	1818	1566	>100	14.5	>100	14.5

Asta : 673 [415 , 407]

Sez. G: O 114.3x5.9 L=243.9 cm Crit.: Acciaio_Flessione $\gamma_M=1.05$ $f_{yk}/\gamma_M=2619$ kg/cmq $f_t=4300$ kg/cmq

:Verificato

X	cls	N	TY	TZ	MT	MY	MZ	My4	Mz4	Comb.
cm		kg	kg	kg	kg*m	kg*m	kg*m			
122	1	-1051	6	4	-5	-28	-9	--	--	2

X	cls	Nr	Vyr	Vzr	Mry	Mrz	MTrd	SF_V.	SF_M	SF_Mt	SF
cm		kg	kg	kg	kg*m	kg*m	kg*m				
122	1	52623	19275	19275	1818	1818	1566	>100	24.7	>100	24.7

Asta : 674 [421 , 406]

Sez. G: O 114.3x5.9 L=247.0 cm Crit.: Acciaio_Flessione $\gamma_M=1.05$ $f_{yk}/\gamma_M=2619$ kg/cmq $f_t=4300$ kg/cmq

:Verificato

X	cls	N	TY	TZ	MT	MY	MZ	My4	Mz4	Comb.
cm		kg	kg	kg	kg*m	kg*m	kg*m			
0	1	-124	28	-30	12	15	34	--	--	2

X	cls	Nr	Vyr	Vzr	Mry	Mrz	MTrd	SF_V.	SF_M	SF_Mt	SF
cm		kg	kg	kg	kg*m	kg*m	kg*m				
0	1	52623	19192	19192	1818	1818	1566	>100	34.6	>100	34.6

AUTOSTRADA VALDASTICO A31 NORD
1° LOTTO - PIOVENE ROCCHETTE – VALLE DELL'ASTICO

Asta : 675 [406 , 407]

Sez. G: O 114.3x5.9 L=314.0 cm Crit.: Acciaio_Flessione $\gamma_M=1.05$ $f_{yk}/\gamma_M=2619$ kg/cm² $f_t=4300$ kg/cm²

:Verificato

X	cls	N	TY	TZ	MT	MY	MZ	My4	Mz4	Comb.
cm		kg	kg	kg	kg*m	kg*m	kg*m			
0	1	-2561	-21	-40	-19	31	-33	--	--	2

X	cls	Nr	Vyr	Vzr	Mry	Mrz	MTrd	SF_V.	SF_M	SF_Mt	SF
cm		kg	kg	kg	kg*m	kg*m	kg*m				
0	1	52623	19103	19103	1818	1818	1566	>100	11.9	80.9	11.9

Asta : 676 [420 , 414]

Sez. G: O 114.3x5.9 L=264.3 cm Crit.: Acciaio_Flessione $\gamma_M=1.05$ $f_{yk}/\gamma_M=2619$ kg/cm² $f_t=4300$ kg/cm²

:Verificato

X	cls	N	TY	TZ	MT	MY	MZ	My4	Mz4	Comb.
cm		kg	kg	kg	kg*m	kg*m	kg*m			
106	1	-3833	-2	2	-4	-29	3	--	--	2

X	cls	Nr	Vyr	Vzr	Mry	Mrz	MTrd	SF_V.	SF_M	SF_Mt	SF
cm		kg	kg	kg	kg*m	kg*m	kg*m				
106	1	52623	19293	19293	1818	1818	1566	>100	11.0	>100	11.0

Asta : 677 [414 , 406]

Sez. G: O 114.3x5.9 L=264.3 cm Crit.: Acciaio_Flessione $\gamma_M=1.05$ $f_{yk}/\gamma_M=2619$ kg/cm² $f_t=4300$ kg/cm²

:Verificato

X	cls	N	TY	TZ	MT	MY	MZ	My4	Mz4	Comb.
cm		kg	kg	kg	kg*m	kg*m	kg*m			
106	1	248	-1	-1	-2	-20	-6	--	--	2

X	cls	Nr	Vyr	Vzr	Mry	Mrz	MTrd	SF_V.	SF_M	SF_Mt	SF
cm		kg	kg	kg	kg*m	kg*m	kg*m				
106	1	52623	19318	19318	1818	1818	1566	>100	52.7	>100	52.7

AUTOSTRADA VALDASTICO A31 NORD
1° LOTTO - PIOVENE ROCCHETTE – VALLE DELL'ASTICO

Asta : 678 [407 , 414]

Sez. G: O 114.3x5.9 L=264.3 cm Crit.: Acciaio_Flessione $\gamma_M=1.05$ $f_{yk}/\gamma_M=2619$ kg/cmq $f_t=4300$ kg/cmq

:Verificato

X	cls	N	TY	TZ	MT	MY	MZ	My4	Mz4	Comb.
cm		kg	kg	kg	kg*m	kg*m	kg*m			
264	1	1160	6	24	-2	33	-2	--	--	2

X	cls	Nr	Vyr	Vzr	Mry	Mrz	MTrd	SF_V.	SF_M	SF_Mt	SF
cm		kg	kg	kg	kg*m	kg*m	kg*m				
264	1	52623	19311	19311	1818	1818	1566	>100	24.2	>100	24.2

Asta : 679 [414 , 421]

Sez. G: O 114.3x5.9 L=264.3 cm Crit.: Acciaio_Flessione $\gamma_M=1.05$ $f_{yk}/\gamma_M=2619$ kg/cmq $f_t=4300$ kg/cmq

:Verificato

X	cls	N	TY	TZ	MT	MY	MZ	My4	Mz4	Comb.
cm		kg	kg	kg	kg*m	kg*m	kg*m			
0	1	390	-8	-22	-2	24	-16	--	--	2

X	cls	Nr	Vyr	Vzr	Mry	Mrz	MTrd	SF_V.	SF_M	SF_Mt	SF
cm		kg	kg	kg	kg*m	kg*m	kg*m				
0	1	52623	19312	19312	1818	1818	1566	>100	34.5	>100	34.5

Asta : 680 [422 , 405]

Sez. G: O 114.3x5.9 L=247.0 cm Crit.: Acciaio_Flessione $\gamma_M=1.05$ $f_{yk}/\gamma_M=2619$ kg/cmq $f_t=4300$ kg/cmq

:Verificato

X	cls	N	TY	TZ	MT	MY	MZ	My4	Mz4	Comb.
cm		kg	kg	kg	kg*m	kg*m	kg*m			
0	1	-116	1	-29	0	14	1	--	--	2

X	cls	Nr	Vyr	Vzr	Mry	Mrz	MTrd	SF_V.	SF_M	SF_Mt	SF
cm		kg	kg	kg	kg*m	kg*m	kg*m				

AUTOSTRADA VALDASTICO A31 NORD
1° LOTTO - PIOVENE ROCCHETTE – VALLE DELL'ASTICO

X	cls	Nr	Vyr	Vzr	Mry	Mrz	MTrd	SF_V.	SF_M	SF_Mt	SF
0	1	52623	19339	19339	1818	1818	1566	>100	98.6	>100	98.6

Asta : 681 [405 , 406]

Sez. G: O 114.3x5.9 L=314.0 cm Crit.: Acciaio_Flessione $\gamma_M=1.05$ $f_{yk}/\gamma_M=2619$ kg/cm² $f_t=4300$ kg/cm²

:Verificato

X	cls	N	TY	TZ	MT	MY	MZ	My4	Mz4	Comb.
cm		kg	kg	kg	kg*m	kg*m	kg*m			
0	1	-2372	-8	-34	-7	20	-12	--	--	2

X	cls	Nr	Vyr	Vzr	Mry	Mrz	MTrd	SF_V.	SF_M	SF_Mt	SF
cm		kg	kg	kg	kg*m	kg*m	kg*m				
0	1	52623	19257	19257	1818	1818	1566	>100	15.9	>100	15.9

Asta : 682 [421 , 413]

Sez. G: O 114.3x5.9 L=272.3 cm Crit.: Acciaio_Flessione $\gamma_M=1.05$ $f_{yk}/\gamma_M=2619$ kg/cm² $f_t=4300$ kg/cm²

:Verificato

X	cls	N	TY	TZ	MT	MY	MZ	My4	Mz4	Comb.
cm		kg	kg	kg	kg*m	kg*m	kg*m			
109	1	-1878	0	1	-0	-19	-0	--	--	2

X	cls	Nr	Vyr	Vzr	Mry	Mrz	MTrd	SF_V.	SF_M	SF_Mt	SF
cm		kg	kg	kg	kg*m	kg*m	kg*m				
109	1	52623	19338	19338	1818	1818	1566	>100	21.7	>100	21.7

Asta : 683 [413 , 422]

Sez. G: O 114.3x5.9 L=272.3 cm Crit.: Acciaio_Flessione $\gamma_M=1.05$ $f_{yk}/\gamma_M=2619$ kg/cm² $f_t=4300$ kg/cm²

:Verificato

X	cls	N	TY	TZ	MT	MY	MZ	My4	Mz4	Comb.
cm		kg	kg	kg	kg*m	kg*m	kg*m			
0	1	-63	-4	-24	-2	13	-8	--	--	2

AUTOSTRADA VALDASTICO A31 NORD
1° LOTTO - PIOVENE ROCCHETTE – VALLE DELL'ASTICO

X	cls	Nr	Vyr	Vzr	Mry	Mrz	MTrd	SF_V.	SF_M	SF_Mt	SF
cm		kg	kg	kg	kg*m	kg*m	kg*m				
0	1	52623	19323	19323	1818	1818	1566	>100	77.2	>100	77.2

Asta : 684 [406 , 413]

Sez. G: O 114.3x5.9 L=272.3 cm Crit.: Acciaio_Flessione $\gamma_M=1.05$ $f_{yk}/\gamma_M=2619$ kg/cm² $f_t=4300$ kg/cm²

:Verificato

X	cls	N	TY	TZ	MT	MY	MZ	My4	Mz4	Comb.
cm		kg	kg	kg	kg*m	kg*m	kg*m			
0	1	-38	5	-19	-1	14	10	--	--	2

X	cls	Nr	Vyr	Vzr	Mry	Mrz	MTrd	SF_V.	SF_M	SF_Mt	SF
cm		kg	kg	kg	kg*m	kg*m	kg*m				
0	1	52623	19326	19326	1818	1818	1566	>100	72.6	>100	72.6

Asta : 685 [413 , 405]

Sez. G: O 114.3x5.9 L=272.3 cm Crit.: Acciaio_Flessione $\gamma_M=1.05$ $f_{yk}/\gamma_M=2619$ kg/cm² $f_t=4300$ kg/cm²

:Verificato

X	cls	N	TY	TZ	MT	MY	MZ	My4	Mz4	Comb.
cm		kg	kg	kg	kg*m	kg*m	kg*m			
109	1	171	-3	-4	0	-9	-2	--	--	2

X	cls	Nr	Vyr	Vzr	Mry	Mrz	MTrd	SF_V.	SF_M	SF_Mt	SF
cm		kg	kg	kg	kg*m	kg*m	kg*m				
109	1	52623	19340	19340	1818	1818	1566	>100	>100	>100	>100

Asta : 686 [405 , 412]

Sez. G: O 114.3x5.9 L=272.3 cm Crit.: Acciaio_Flessione $\gamma_M=1.05$ $f_{yk}/\gamma_M=2619$ kg/cm² $f_t=4300$ kg/cm²

:Verificato

X	cls	N	TY	TZ	MT	MY	MZ	My4	Mz4	Comb.
cm		kg	kg	kg	kg*m	kg*m	kg*m			
272	1	108	-1	23	0	10	-0	--	--	1

AUTOSTRADA VALDASTICO A31 NORD
1° LOTTO - PIOVENE ROCCHETTE – VALLE DELL'ASTICO

X	cls	Nr	Vyr	Vzr	Mry	Mrz	MTrd	SF_V.	SF_M	SF_Mt	SF
cm		kg	kg	kg	kg*m	kg*m	kg*m				
272	1	52623	19336	19336	1818	1818	1566	>100	>100	>100	>100

Asta : 687 [412 , 423]

Sez. G: O 114.3x5.9 L=272.3 cm Crit.: Acciaio_Flessione $\gamma_M=1.05$ $f_{yk}/\gamma_M=2619$ kg/cm² $f_t=4300$ kg/cm²

:Verificato

X	cls	N	TY	TZ	MT	MY	MZ	My4	Mz4	Comb.
cm		kg	kg	kg	kg*m	kg*m	kg*m			
163	1	-1880	-1	-1	0	-19	-0	--	--	2

X	cls	Nr	Vyr	Vzr	Mry	Mrz	MTrd	SF_V.	SF_M	SF_Mt	SF
cm		kg	kg	kg	kg*m	kg*m	kg*m				
163	1	52623	19339	19339	1818	1818	1566	>100	21.8	>100	21.8

Asta : 688 [423 , 404]

Sez. G: O 114.3x5.9 L=247.0 cm Crit.: Acciaio_Flessione $\gamma_M=1.05$ $f_{yk}/\gamma_M=2619$ kg/cm² $f_t=4300$ kg/cm²

:Verificato

X	cls	N	TY	TZ	MT	MY	MZ	My4	Mz4	Comb.
cm		kg	kg	kg	kg*m	kg*m	kg*m			
0	1	-120	-27	-30	-12	15	-32	--	--	2

X	cls	Nr	Vyr	Vzr	Mry	Mrz	MTrd	SF_V.	SF_M	SF_Mt	SF
cm		kg	kg	kg	kg*m	kg*m	kg*m				
0	1	52623	19198	19198	1818	1818	1566	>100	36.0	>100	36.0

Asta : 689 [404 , 405]

Sez. G: O 114.3x5.9 L=314.0 cm Crit.: Acciaio_Flessione $\gamma_M=1.05$ $f_{yk}/\gamma_M=2619$ kg/cm² $f_t=4300$ kg/cm²

:Verificato

X	cls	N	TY	TZ	MT	MY	MZ	My4	Mz4	Comb.
cm		kg	kg	kg	kg*m	kg*m	kg*m			

AUTOSTRADA VALDASTICO A31 NORD
1° LOTTO - PIOVENE ROCCHETTE – VALLE DELL'ASTICO

X	cls	N	TY	TZ	MT	MY	MZ	My4	Mz4	Comb.
314	1	-2301	7	34	6	20	-11	--	--	2

X	cls	Nr	Vyr	Vzr	Mry	Mrz	MTrd	SF_V.	SF_M	SF_Mt	SF
cm		kg	kg	kg	kg*m	kg*m	kg*m				
314	1	52623	19262	19262	1818	1818	1566	>100	16.4	>100	16.4

Asta : 690 [422 , 412]

Sez. G: O 114.3x5.9 L=272.3 cm Crit.: Acciaio_Flessione $\gamma_M=1.05$ $f_{yk}/\gamma_M=2619$ kg/cm² $f_t=4300$ kg/cm²

:Verificato

X	cls	N	TY	TZ	MT	MY	MZ	My4	Mz4	Comb.
cm		kg	kg	kg	kg*m	kg*m	kg*m			
272	1	-43	4	24	1	13	-8	--	--	2

X	cls	Nr	Vyr	Vzr	Mry	Mrz	MTrd	SF_V.	SF_M	SF_Mt	SF
cm		kg	kg	kg	kg*m	kg*m	kg*m				
272	1	52623	19323	19323	1818	1818	1566	>100	82.5	>100	82.5

Asta : 691 [412 , 404]

Sez. G: O 114.3x5.9 L=272.3 cm Crit.: Acciaio_Flessione $\gamma_M=1.05$ $f_{yk}/\gamma_M=2619$ kg/cm² $f_t=4300$ kg/cm²

:Verificato

X	cls	N	TY	TZ	MT	MY	MZ	My4	Mz4	Comb.
cm		kg	kg	kg	kg*m	kg*m	kg*m			
0	1	109	-5	-22	1	19	-4	--	--	2

X	cls	Nr	Vyr	Vzr	Mry	Mrz	MTrd	SF_V.	SF_M	SF_Mt	SF
cm		kg	kg	kg	kg*m	kg*m	kg*m				
0	1	52623	19326	19326	1818	1818	1566	>100	68.3	>100	68.3

Asta : 692 [424 , 403]

Sez. G: O 114.3x5.9 L=247.0 cm Crit.: Acciaio_Flessione $\gamma_M=1.05$ $f_{yk}/\gamma_M=2619$ kg/cm² $f_t=4300$ kg/cm²

:Verificato

AUTOSTRADA VALDASTICO A31 NORD
1° LOTTO - PIOVENE ROCCHETTE – VALLE DELL'ASTICO

X	cls	N	TY	TZ	MT	MY	MZ	My4	Mz4	Comb.
cm		kg	kg	kg	kg*m	kg*m	kg*m			
0	1	2	-39	-30	-21	13	-46	--	--	2

X	cls	Nr	Vyr	Vzr	Mry	Mrz	MTrd	SF_V.	SF_M	SF_Mt	SF
cm		kg	kg	kg	kg*m	kg*m	kg*m				
0	1	52623	19086	19086	1818	1818	1566	>100	31.2	75.7	31.2

Asta : 693 [403 , 404]

Sez. G: O 114.3x5.9 L=314.0 cm Crit.: Acciaio_Flessione $\gamma_M=1.05$ $f_{yk}/\gamma_M=2619$ kg/cm² $f_t=4300$ kg/cm²

:Verificato

X	cls	N	TY	TZ	MT	MY	MZ	My4	Mz4	Comb.
cm		kg	kg	kg	kg*m	kg*m	kg*m			
314	1	-2358	21	40	19	31	-31	--	--	2

X	cls	Nr	Vyr	Vzr	Mry	Mrz	MTrd	SF_V.	SF_M	SF_Mt	SF
cm		kg	kg	kg	kg*m	kg*m	kg*m				
314	1	52623	19111	19111	1818	1818	1566	>100	12.7	83.8	12.7

Asta : 694 [404 , 411]

Sez. G: O 114.3x5.9 L=264.3 cm Crit.: Acciaio_Flessione $\gamma_M=1.05$ $f_{yk}/\gamma_M=2619$ kg/cm² $f_t=4300$ kg/cm²

:Verificato

X	cls	N	TY	TZ	MT	MY	MZ	My4	Mz4	Comb.
cm		kg	kg	kg	kg*m	kg*m	kg*m			
159	1	134	1	1	2	-19	-6	--	--	2

X	cls	Nr	Vyr	Vzr	Mry	Mrz	MTrd	SF_V.	SF_M	SF_Mt	SF
cm		kg	kg	kg	kg*m	kg*m	kg*m				
159	1	52623	19319	19319	1818	1818	1566	>100	60.9	>100	60.9

Asta : 695 [411 , 424]

AUTOSTRADA VALDASTICO A31 NORD
1° LOTTO - PIOVENE ROCCHETTE – VALLE DELL'ASTICO

Sez. G: O 114.3x5.9 L=264.3 cm Crit.: Acciaio_Flessione $\gamma_M=1.05$ $f_{yk}/\gamma_M=2619$ kg/cm² $f_t=4300$ kg/cm²

:Verificato

X	cls	N	TY	TZ	MT	MY	MZ	My4	Mz4	Comb.
cm		kg	kg	kg	kg*m	kg*m	kg*m			
159	1	-3773	1	-2	4	-29	3	--	--	2

X	cls	Nr	Vyr	Vzr	Mry	Mrz	MTrd	SF_V.	SF_M	SF_Mt	SF
cm		kg	kg	kg	kg*m	kg*m	kg*m				
159	1	52623	19296	19296	1818	1818	1566	>100	11.2	>100	11.2

Asta : 696 [423 , 411]

Sez. G: O 114.3x5.9 L=264.3 cm Crit.: Acciaio_Flessione $\gamma_M=1.05$ $f_{yk}/\gamma_M=2619$ kg/cm² $f_t=4300$ kg/cm²

:Verificato

X	cls	N	TY	TZ	MT	MY	MZ	My4	Mz4	Comb.
cm		kg	kg	kg	kg*m	kg*m	kg*m			
264	1	422	8	22	2	23	-15	--	--	2

X	cls	Nr	Vyr	Vzr	Mry	Mrz	MTrd	SF_V.	SF_M	SF_Mt	SF
cm		kg	kg	kg	kg*m	kg*m	kg*m				
264	1	52623	19313	19313	1818	1818	1566	>100	34.6	>100	34.6

Asta : 697 [411 , 403]

Sez. G: O 114.3x5.9 L=264.3 cm Crit.: Acciaio_Flessione $\gamma_M=1.05$ $f_{yk}/\gamma_M=2619$ kg/cm² $f_t=4300$ kg/cm²

:Verificato

X	cls	N	TY	TZ	MT	MY	MZ	My4	Mz4	Comb.
cm		kg	kg	kg	kg*m	kg*m	kg*m			
0	1	1211	-5	-24	2	32	-2	--	--	2

X	cls	Nr	Vyr	Vzr	Mry	Mrz	MTrd	SF_V.	SF_M	SF_Mt	SF
cm		kg	kg	kg	kg*m	kg*m	kg*m				
0	1	52623	19311	19311	1818	1818	1566	>100	24.0	>100	24.0

AUTOSTRADA VALDASTICO A31 NORD
1° LOTTO - PIOVENE ROCCHETTE – VALLE DELL'ASTICO

Asta : 698 [403 , 402]

Sez. G: O 114.3x5.9 L=314.0 cm Crit.: Acciaio_Flessione $\gamma_M=1.05$ $f_{yk}/\gamma_M=2619$ kg/cm² $f_t=4300$ kg/cm²

:Verificato

X	cls	N	TY	TZ	MT	MY	MZ	My4	Mz4	Comb.
cm		kg	kg	kg	kg*m	kg*m	kg*m			
0	1	-983	24	-46	24	39	35	--	--	2

X	cls	Nr	Vyr	Vzr	Mry	Mrz	MTrd	SF_V.	SF_M	SF_Mt	SF
cm		kg	kg	kg	kg*m	kg*m	kg*m				
0	1	52623	19049	19049	1818	1818	1566	>100	16.9	66.1	16.9

Asta : 699 [402 , 425]

Sez. G: O 114.3x5.9 L=247.0 cm Crit.: Acciaio_Flessione $\gamma_M=1.05$ $f_{yk}/\gamma_M=2619$ kg/cm² $f_t=4300$ kg/cm²

:Verificato

X	cls	N	TY	TZ	MT	MY	MZ	My4	Mz4	Comb.
cm		kg	kg	kg	kg*m	kg*m	kg*m			
247	1	100	-28	34	-18	16	33	--	--	2

X	cls	Nr	Vyr	Vzr	Mry	Mrz	MTrd	SF_V.	SF_M	SF_Mt	SF
cm		kg	kg	kg	kg*m	kg*m	kg*m				
247	1	52623	19117	19117	1818	1818	1566	>100	34.8	86.2	34.8

Asta : 700 [424 , 410]

Sez. G: O 114.3x5.9 L=243.9 cm Crit.: Acciaio_Flessione $\gamma_M=1.05$ $f_{yk}/\gamma_M=2619$ kg/cm² $f_t=4300$ kg/cm²

:Verificato

X	cls	N	TY	TZ	MT	MY	MZ	My4	Mz4	Comb.
cm		kg	kg	kg	kg*m	kg*m	kg*m			
244	1	412	7	19	3	30	-13	--	--	2

X	cls	Nr	Vyr	Vzr	Mry	Mrz	MTrd	SF_V.	SF_M	SF_Mt	SF
cm		kg	kg	kg	kg*m	kg*m	kg*m				
244	1	52623	19306	19306	1818	1818	1566	>100	31.9	>100	31.9

AUTOSTRADA VALDASTICO A31 NORD
1° LOTTO - PIOVENE ROCCHETTE – VALLE DELL'ASTICO

Asta : 701 [410 , 425]

Sez. G: O 114.3x5.9 L=243.9 cm Crit.: Acciaio_Flessione $\gamma_M=1.05$ $f_{yk}/\gamma_M=2619$ kg/cmq $f_t=4300$ kg/cmq

:Verificato

X	cls	N	TY	TZ	MT	MY	MZ	My4	Mz4	Comb.
cm		kg	kg	kg	kg*m	kg*m	kg*m			
73	1	-2490	4	-4	7	-28	6	--	--	2

X	cls	Nr	Vyr	Vzr	Mry	Mrz	MTrd	SF_V.	SF_M	SF_Mt	SF
cm		kg	kg	kg	kg*m	kg*m	kg*m				
73	1	52623	19259	19259	1818	1818	1566	>100	15.1	>100	15.1

Asta : 702 [403 , 410]

Sez. G: O 114.3x5.9 L=243.9 cm Crit.: Acciaio_Flessione $\gamma_M=1.05$ $f_{yk}/\gamma_M=2619$ kg/cmq $f_t=4300$ kg/cmq

:Verificato

X	cls	N	TY	TZ	MT	MY	MZ	My4	Mz4	Comb.
cm		kg	kg	kg	kg*m	kg*m	kg*m			
98	1	-1114	-6	-8	5	-26	-10	--	--	2

X	cls	Nr	Vyr	Vzr	Mry	Mrz	MTrd	SF_V.	SF_M	SF_Mt	SF
cm		kg	kg	kg	kg*m	kg*m	kg*m				
98	1	52623	19277	19277	1818	1818	1566	>100	24.3	>100	24.3

Asta : 703 [410 , 402]

Sez. G: O 114.3x5.9 L=243.9 cm Crit.: Acciaio_Flessione $\gamma_M=1.05$ $f_{yk}/\gamma_M=2619$ kg/cmq $f_t=4300$ kg/cmq

:Verificato

X	cls	N	TY	TZ	MT	MY	MZ	My4	Mz4	Comb.
cm		kg	kg	kg	kg*m	kg*m	kg*m			
0	1	799	3	-33	4	44	7	--	--	2

X	cls	Nr	Vyr	Vzr	Mry	Mrz	MTrd	SF_V.	SF_M	SF_Mt	SF
cm		kg	kg	kg	kg*m	kg*m	kg*m				

AUTOSTRADA VALDASTICO A31 NORD
1° LOTTO - PIOVENE ROCCHETTE – VALLE DELL'ASTICO

X	cls	Nr	Vyr	Vzr	Mry	Mrz	MTrd	SF_V.	SF_M	SF_Mt	SF
0	1	52623	19294	19294	1818	1818	1566	>100	23.2	>100	23.2

Asta : 704 [426 , 401]

Sez. G: O 114.3x5.9 L=247.0 cm Crit.: Acciaio_Flessione $\gamma M=1.05$ fyk/ $\gamma M=2619$ kg/cm² ft=4300 kg/cm²

:Verificato

X	cls	N	TY	TZ	MT	MY	MZ	My4	Mz4	Comb.
cm		kg	kg	kg	kg*m	kg*m	kg*m			
0	1	-241	-5	-44	-9	26	-8	--	--	2

X	cls	Nr	Vyr	Vzr	Mry	Mrz	MTrd	SF_V.	SF_M	SF_Mt	SF
cm		kg	kg	kg	kg*m	kg*m	kg*m				
0	1	52623	19235	19235	1818	1818	1566	>100	43.3	>100	43.3

Asta : 705 [401 , 402]

Sez. G: O 114.3x5.9 L=314.0 cm Crit.: Acciaio_Flessione $\gamma M=1.05$ fyk/ $\gamma M=2619$ kg/cm² ft=4300 kg/cm²

:Verificato

X	cls	N	TY	TZ	MT	MY	MZ	My4	Mz4	Comb.
cm		kg	kg	kg	kg*m	kg*m	kg*m			
314	1	73	8	39	13	23	-9	--	--	2

X	cls	Nr	Vyr	Vzr	Mry	Mrz	MTrd	SF_V.	SF_M	SF_Mt	SF
cm		kg	kg	kg	kg*m	kg*m	kg*m				
314	1	52623	19177	19177	1818	1818	1566	>100	52.2	>100	52.2

Asta : 706 [425 , 417]

Sez. G: O 114.3x5.9 L=218.3 cm Crit.: Acciaio_Flessione $\gamma M=1.05$ fyk/ $\gamma M=2619$ kg/cm² ft=4300 kg/cm²

:Verificato

X	cls	N	TY	TZ	MT	MY	MZ	My4	Mz4	Comb.
cm		kg	kg	kg	kg*m	kg*m	kg*m			
0	1	-408	3	-39	3	45	-1	--	--	2

AUTOSTRADA VALDASTICO A31 NORD
1° LOTTO - PIOVENE ROCCHETTE – VALLE DELL'ASTICO

X	cls	Nr	Vyr	Vzr	Mry	Mrz	MTrd	SF_V.	SF_M	SF_Mt	SF
cm		kg	kg	kg	kg*m	kg*m	kg*m				
0	1	52623	19300	19300	1818	1818	1566	>100	30.5	>100	30.5

Asta : 707 [417 , 401]

Sez. G: O 114.3x5.9 L=218.3 cm Crit.: Acciaio_Flessione $\gamma_M=1.05$ $f_{yk}/\gamma_M=2619$ kg/cmq $f_t=4300$ kg/cmq

:Verificato

X	cls	N	TY	TZ	MT	MY	MZ	My4	Mz4	Comb.
cm		kg	kg	kg	kg*m	kg*m	kg*m			
0	1	148	5	-51	-2	51	2	--	--	2

X	cls	Nr	Vyr	Vzr	Mry	Mrz	MTrd	SF_V.	SF_M	SF_Mt	SF
cm		kg	kg	kg	kg*m	kg*m	kg*m				
0	1	52623	19323	19323	1818	1818	1566	>100	30.8	>100	30.8

Asta : 708 [417 , 426]

Sez. G: O 114.3x5.9 L=218.3 cm Crit.: Acciaio_Flessione $\gamma_M=1.05$ $f_{yk}/\gamma_M=2619$ kg/cmq $f_t=4300$ kg/cmq

:Verificato

X	cls	N	TY	TZ	MT	MY	MZ	My4	Mz4	Comb.
cm		kg	kg	kg	kg*m	kg*m	kg*m			
109	1	-2418	4	-2	6	-14	3	--	--	2

X	cls	Nr	Vyr	Vzr	Mry	Mrz	MTrd	SF_V.	SF_M	SF_Mt	SF
cm		kg	kg	kg	kg*m	kg*m	kg*m				
109	1	52623	19263	19263	1818	1818	1566	>100	18.1	>100	18.1

Asta : 709 [416 , 415]

Sez. G: O 114.3x5.9 L=318.3 cm Crit.: Acciaio_Flessione $\gamma_M=1.05$ $f_{yk}/\gamma_M=2619$ kg/cmq $f_t=4300$ kg/cmq

:Verificato

X	cls	N	TY	TZ	MT	MY	MZ	My4	Mz4	Comb.
cm		kg	kg	kg	kg*m	kg*m	kg*m			
318	1	99	18	603	-22	327	-26	--	--	2

AUTOSTRADA VALDASTICO A31 NORD
1° LOTTO - PIOVENE ROCCHETTE – VALLE DELL'ASTICO

X	cls	Nr	Vyr	Vzr	Mry	Mrz	MTrd	SF_V.	SF_M	SF_Mt	SF
cm		kg	kg	kg	kg*m	kg*m	kg*m				
318	1	52623	19066	19066	1818	1818	1566	31.6	5.10	70.2	5.10

Asta : 710 [415 , 414]

Sez. G: O 114.3x5.9 L=315.7 cm Crit.: Acciaio_Flessione $\gamma_M=1.05$ $f_{yk}/\gamma_M=2619$ kg/cm² $f_t=4300$ kg/cm²

:Verificato

X	cls	N	TY	TZ	MT	MY	MZ	My4	Mz4	Comb.
cm		kg	kg	kg	kg*m	kg*m	kg*m			
0	1	-785	31	-597	-24	317	50	--	--	2

X	cls	Nr	Vyr	Vzr	Mry	Mrz	MTrd	SF_V.	SF_M	SF_Mt	SF
cm		kg	kg	kg	kg*m	kg*m	kg*m				
0	1	52623	19042	19042	1818	1818	1566	31.9	4.62	64.5	4.62

Asta : 711 [414 , 413]

Sez. G: O 114.3x5.9 L=314.2 cm Crit.: Acciaio_Flessione $\gamma_M=1.05$ $f_{yk}/\gamma_M=2619$ kg/cm² $f_t=4300$ kg/cm²

:Verificato

X	cls	N	TY	TZ	MT	MY	MZ	My4	Mz4	Comb.
cm		kg	kg	kg	kg*m	kg*m	kg*m			
0	1	-2768	17	-597	-14	312	26	--	--	2

X	cls	Nr	Vyr	Vzr	Mry	Mrz	MTrd	SF_V.	SF_M	SF_Mt	SF
cm		kg	kg	kg	kg*m	kg*m	kg*m				
0	1	52623	19174	19174	1818	1818	1566	32.1	4.19	>100	4.19

Asta : 712 [413 , 412]

Sez. G: O 114.3x5.9 L=314.0 cm Crit.: Acciaio_Flessione $\gamma_M=1.05$ $f_{yk}/\gamma_M=2619$ kg/cm² $f_t=4300$ kg/cm²

:Verificato

X	cls	N	TY	TZ	MT	MY	MZ	My4	Mz4	Comb.
cm		kg	kg	kg	kg*m	kg*m	kg*m			

AUTOSTRADA VALDASTICO A31 NORD
1° LOTTO - PIOVENE ROCCHETTE – VALLE DELL'ASTICO

X	cls	N	TY	TZ	MT	MY	MZ	My4	Mz4	Comb.
314	1	-3908	0	596	-0	308	-2	--	--	2

X	cls	Nr	Vyr	Vzr	Mry	Mrz	MTrd	SF_V.	SF_M	SF_Mt	SF
cm		kg	kg	kg	kg*m	kg*m	kg*m				
314	1	52623	19339	19339	1818	1818	1566	32.4	4.09	>100	4.09

Asta : 713 [412 , 411]

Sez. G: O 114.3x5.9 L=314.2 cm Crit.: Acciaio_Flessione $\gamma_M=1.05$ $f_{yk}/\gamma_M=2619$ kg/cm² $f_t=4300$ kg/cm²

:Verificato

X	cls	N	TY	TZ	MT	MY	MZ	My4	Mz4	Comb.
cm		kg	kg	kg	kg*m	kg*m	kg*m			
314	1	-2889	-17	597	13	312	25	--	--	2

X	cls	Nr	Vyr	Vzr	Mry	Mrz	MTrd	SF_V.	SF_M	SF_Mt	SF
cm		kg	kg	kg	kg*m	kg*m	kg*m				
314	1	52623	19180	19180	1818	1818	1566	32.1	4.16	>100	4.16

Asta : 714 [411 , 410]

Sez. G: O 114.3x5.9 L=315.7 cm Crit.: Acciaio_Flessione $\gamma_M=1.05$ $f_{yk}/\gamma_M=2619$ kg/cm² $f_t=4300$ kg/cm²

:Verificato

X	cls	N	TY	TZ	MT	MY	MZ	My4	Mz4	Comb.
cm		kg	kg	kg	kg*m	kg*m	kg*m			
316	1	-1024	-30	597	23	316	49	--	--	2

X	cls	Nr	Vyr	Vzr	Mry	Mrz	MTrd	SF_V.	SF_M	SF_Mt	SF
cm		kg	kg	kg	kg*m	kg*m	kg*m				
316	1	52623	19052	19052	1818	1818	1566	31.9	4.54	66.7	4.54

Asta : 715 [410 , 417]

Sez. G: O 114.3x5.9 L=318.3 cm Crit.: Acciaio_Flessione $\gamma_M=1.05$ $f_{yk}/\gamma_M=2619$ kg/cm² $f_t=4300$ kg/cm²

:Verificato

AUTOSTRADA VALDASTICO A31 NORD
1° LOTTO - PIOVENE ROCCHETTE – VALLE DELL'ASTICO

X	cls	N	TY	TZ	MT	MY	MZ	My4	Mz4	Comb.
cm		kg	kg	kg	kg*m	kg*m	kg*m			
0	1	-157	-17	-604	21	326	-25	--	--	2

X	cls	Nr	Vyr	Vzr	Mry	Mrz	MTrd	SF_V.	SF_M	SF_Mt	SF
cm		kg	kg	kg	kg*m	kg*m	kg*m				
0	1	52623	19083	19083	1818	1818	1566	31.6	5.10	74.8	5.10

Asta : 716 [427 , 418]

Sez. G: O 114.3x5.9 L=247.0 cm Crit.: Acciaio_Flessione $\gamma_M=1.05$ $f_{yk}/\gamma_M=2619$ kg/cm² $f_t=4300$ kg/cm²

:Verificato

X	cls	N	TY	TZ	MT	MY	MZ	My4	Mz4	Comb.
cm		kg	kg	kg	kg*m	kg*m	kg*m			
0	1	-4734	3	-36	5	29	8	--	--	2

X	cls	Nr	Vyr	Vzr	Mry	Mrz	MTrd	SF_V.	SF_M	SF_Mt	SF
cm		kg	kg	kg	kg*m	kg*m	kg*m				
0	1	52623	19277	19277	1818	1818	1566	>100	9.10	>100	9.10

Asta : 717 [428 , 419]

Sez. G: O 114.3x5.9 L=218.3 cm Crit.: Acciaio_Flessione $\gamma_M=1.05$ $f_{yk}/\gamma_M=2619$ kg/cm² $f_t=4300$ kg/cm²

:Verificato

X	cls	N	TY	TZ	MT	MY	MZ	My4	Mz4	Comb.
cm		kg	kg	kg	kg*m	kg*m	kg*m			
109	1	1366	-7	-9	-8	-19	-7	--	--	2

X	cls	Nr	Vyr	Vzr	Mry	Mrz	MTrd	SF_V.	SF_M	SF_Mt	SF
cm		kg	kg	kg	kg*m	kg*m	kg*m				
109	1	52623	19245	19245	1818	1818	1566	>100	25.0	>100	25.0

Asta : 718 [419 , 418]

AUTOSTRADA VALDASTICO A31 NORD
1° LOTTO - PIOVENE ROCCHETTE – VALLE DELL'ASTICO

Sez. G: O 114.3x5.9 L=314.0 cm Crit.: Acciaio_Flessione $\gamma_M=1.05$ $f_{yk}/\gamma_M=2619$ kg/cm² $f_t=4300$ kg/cm²

:Verificato

X	cls	N	TY	TZ	MT	MY	MZ	My4	Mz4	Comb.
cm		kg	kg	kg	kg*m	kg*m	kg*m			
314	1	-1279	-9	32	-15	22	17	--	--	2

X	cls	Nr	Vyr	Vzr	Mry	Mrz	MTrd	SF_V.	SF_M	SF_Mt	SF
cm		kg	kg	kg	kg*m	kg*m	kg*m				
314	1	52623	19161	19161	1818	1818	1566	>100	21.8	>100	21.8

Asta : 719 [419 , 429]

Sez. G: O 114.3x5.9 L=243.9 cm Crit.: Acciaio_Flessione $\gamma_M=1.05$ $f_{yk}/\gamma_M=2619$ kg/cm² $f_t=4300$ kg/cm²

:Verificato

X	cls	N	TY	TZ	MT	MY	MZ	My4	Mz4	Comb.
cm		kg	kg	kg	kg*m	kg*m	kg*m			
0	1	2351	10	-24	-4	43	10	--	--	2

X	cls	Nr	Vyr	Vzr	Mry	Mrz	MTrd	SF_V.	SF_M	SF_Mt	SF
cm		kg	kg	kg	kg*m	kg*m	kg*m				
0	1	52623	19295	19295	1818	1818	1566	>100	13.5	>100	13.5

Asta : 720 [428 , 430]

Sez. G: O 114.3x5.9 L=218.3 cm Crit.: Acciaio_Flessione $\gamma_M=1.05$ $f_{yk}/\gamma_M=2619$ kg/cm² $f_t=4300$ kg/cm²

:Verificato

X	cls	N	TY	TZ	MT	MY	MZ	My4	Mz4	Comb.
cm		kg	kg	kg	kg*m	kg*m	kg*m			
0	1	-6173	-28	-23	7	33	-28	--	--	2

X	cls	Nr	Vyr	Vzr	Mry	Mrz	MTrd	SF_V.	SF_M	SF_Mt	SF
cm		kg	kg	kg	kg*m	kg*m	kg*m				
0	1	52623	19252	19252	1818	1818	1566	>100	6.63	>100	6.63

AUTOSTRADA VALDASTICO A31 NORD
1° LOTTO - PIOVENE ROCCHETTE – VALLE DELL'ASTICO

Asta : 721 [428 , 429]

Sez. G: O 114.3x5.9 L=318.3 cm Crit.: Acciaio_Flessione $\gamma_M=1.05$ $f_{yk}/\gamma_M=2619$ kg/cm² $f_t=4300$ kg/cm²

:Verificato

X	cls	N	TY	TZ	MT	MY	MZ	My4	Mz4	Comb.
cm		kg	kg	kg	kg*m	kg*m	kg*m			
0	1	4105	24	-1167	-23	643	39	--	--	2

X	cls	Nr	Vyr	Vzr	Mry	Mrz	MTrd	SF_V.	SF_M	SF_Mt	SF
cm		kg	kg	kg	kg*m	kg*m	kg*m				
0	1	52623	19062	19062	1818	1818	1566	16.3	2.21	69.1	2.21

Asta : 722 [418 , 428]

Sez. G: O 114.3x5.9 L=218.3 cm Crit.: Acciaio_Flessione $\gamma_M=1.05$ $f_{yk}/\gamma_M=2619$ kg/cm² $f_t=4300$ kg/cm²

:Verificato

X	cls	N	TY	TZ	MT	MY	MZ	My4	Mz4	Comb.
cm		kg	kg	kg	kg*m	kg*m	kg*m			
0	1	3637	-1	-25	0	27	-3	--	--	2

X	cls	Nr	Vyr	Vzr	Mry	Mrz	MTrd	SF_V.	SF_M	SF_Mt	SF
cm		kg	kg	kg	kg*m	kg*m	kg*m				
0	1	52623	19338	19338	1818	1818	1566	>100	11.7	>100	11.7

Asta : 723 [427 , 428]

Sez. G: O 114.3x5.9 L=218.3 cm Crit.: Acciaio_Flessione $\gamma_M=1.05$ $f_{yk}/\gamma_M=2619$ kg/cm² $f_t=4300$ kg/cm²

:Verificato

X	cls	N	TY	TZ	MT	MY	MZ	My4	Mz4	Comb.
cm		kg	kg	kg	kg*m	kg*m	kg*m			
0	1	-4958	27	-30	-3	20	33	--	--	2

X	cls	Nr	Vyr	Vzr	Mry	Mrz	MTrd	SF_V.	SF_M	SF_Mt	SF
cm		kg	kg	kg	kg*m	kg*m	kg*m				
0	1	52623	19307	19307	1818	1818	1566	>100	8.11	>100	8.11

AUTOSTRADA VALDASTICO A31 NORD
1° LOTTO - PIOVENE ROCCHETTE – VALLE DELL'ASTICO

Asta : 724 [430 , 419]

Sez. G: O 114.3x5.9 L=247.0 cm Crit.: Acciaio_Flessione $\gamma_M=1.05$ $f_{yk}/\gamma_M=2619$ kg/cmq $f_t=4300$ kg/cmq

:Verificato

X	cls	N	TY	TZ	MT	MY	MZ	My4	Mz4	Comb.
cm		kg	kg	kg	kg*m	kg*m	kg*m			
222	1	-3410	22	20	19	-7	-22	--	--	2

X	cls	Nr	Vyr	Vzr	Mry	Mrz	MTrd	SF_V.	SF_M	SF_Mt	SF
cm		kg	kg	kg	kg*m	kg*m	kg*m				
222	1	52623	19110	19110	1818	1818	1566	>100	12.4	83.5	12.4

Asta : 725 [430 , 429]

Sez. G: O 114.3x5.9 L=243.9 cm Crit.: Acciaio_Flessione $\gamma_M=1.05$ $f_{yk}/\gamma_M=2619$ kg/cmq $f_t=4300$ kg/cmq

:Verificato

X	cls	N	TY	TZ	MT	MY	MZ	My4	Mz4	Comb.
cm		kg	kg	kg	kg*m	kg*m	kg*m			
0	1	-11954	30	-29	-17	-4	46	--	--	2

X	cls	Nr	Vyr	Vzr	Mry	Mrz	MTrd	SF_V.	SF_M	SF_Mt	SF
cm		kg	kg	kg	kg*m	kg*m	kg*m				
0	1	52623	19130	19130	1818	1818	1566	>100	3.93	91.5	3.93

Asta : 726 [429 , 431]

Sez. G: O 114.3x5.9 L=315.7 cm Crit.: Acciaio_Flessione $\gamma_M=1.05$ $f_{yk}/\gamma_M=2619$ kg/cmq $f_t=4300$ kg/cmq

:Verificato

X	cls	N	TY	TZ	MT	MY	MZ	My4	Mz4	Comb.
cm		kg	kg	kg	kg*m	kg*m	kg*m			
0	1	-4227	42	-1168	-27	619	68	--	--	2

X	cls	Nr	Vyr	Vzr	Mry	Mrz	MTrd	SF_V.	SF_M	SF_Mt	SF
cm		kg	kg	kg	kg*m	kg*m	kg*m				

AUTOSTRADA VALDASTICO A31 NORD
1° LOTTO - PIOVENE ROCCHETTE – VALLE DELL'ASTICO

X	cls	Nr	Vyr	Vzr	Mry	Mrz	MTrd	SF_V.	SF_M	SF_Mt	SF
0	1	52623	19013	19013	1818	1818	1566	16.3	2.18	58.8	2.18

Asta : 727 [429 , 432]

Sez. G: O 114.3x5.9 L=243.9 cm Crit.: Acciaio_Flessione $\gamma_M=1.05$ $f_{yk}/\gamma_M=2619$ kg/cm² $f_t=4300$ kg/cm²

:Verificato

X	cls	N	TY	TZ	MT	MY	MZ	My4	Mz4	Comb.
cm		kg	kg	kg	kg*m	kg*m	kg*m			
244	1	229	-14	27	-8	48	11	--	--	2

X	cls	Nr	Vyr	Vzr	Mry	Mrz	MTrd	SF_V.	SF_M	SF_Mt	SF
cm		kg	kg	kg	kg*m	kg*m	kg*m				
244	1	52623	19248	19248	1818	1818	1566	>100	27.1	>100	27.1

Asta : 728 [429 , 420]

Sez. G: O 114.3x5.9 L=243.9 cm Crit.: Acciaio_Flessione $\gamma_M=1.05$ $f_{yk}/\gamma_M=2619$ kg/cm² $f_t=4300$ kg/cm²

:Verificato

X	cls	N	TY	TZ	MT	MY	MZ	My4	Mz4	Comb.
cm		kg	kg	kg	kg*m	kg*m	kg*m			
98	1	3098	-3	-2	-5	-33	-3	--	--	2

X	cls	Nr	Vyr	Vzr	Mry	Mrz	MTrd	SF_V.	SF_M	SF_Mt	SF
cm		kg	kg	kg	kg*m	kg*m	kg*m				
98	1	52623	19281	19281	1818	1818	1566	>100	12.7	>100	12.7

Asta : 729 [420 , 419]

Sez. G: O 114.3x5.9 L=314.0 cm Crit.: Acciaio_Flessione $\gamma_M=1.05$ $f_{yk}/\gamma_M=2619$ kg/cm² $f_t=4300$ kg/cm²

:Verificato

X	cls	N	TY	TZ	MT	MY	MZ	My4	Mz4	Comb.
cm		kg	kg	kg	kg*m	kg*m	kg*m			
314	1	-482	-31	38	-26	28	50	--	--	2

AUTOSTRADA VALDASTICO A31 NORD
1° LOTTO - PIOVENE ROCCHETTE – VALLE DELL'ASTICO

X	cls	Nr	Vyr	Vzr	Mry	Mrz	MTrd	SF_V.	SF_M	SF_Mt	SF
cm		kg	kg	kg	kg*m	kg*m	kg*m				
314	1	52623	19017	19017	1818	1818	1566	>100	19.0	59.6	19.0

Asta : 730 [432 , 420]

Sez. G: O 114.3x5.9 L=247.0 cm Crit.: Acciaio_Flessione $\gamma_M=1.05$ $f_{yk}/\gamma_M=2619$ kg/cm² $f_t=4300$ kg/cm²

:Verificato

X	cls	N	TY	TZ	MT	MY	MZ	My4	Mz4	Comb.
cm		kg	kg	kg	kg*m	kg*m	kg*m			
0	1	-3757	39	-40	28	34	49	--	--	2

X	cls	Nr	Vyr	Vzr	Mry	Mrz	MTrd	SF_V.	SF_M	SF_Mt	SF
cm		kg	kg	kg	kg*m	kg*m	kg*m				
0	1	52623	19001	19001	1818	1818	1566	>100	8.52	56.7	8.52

Asta : 731 [420 , 431]

Sez. G: O 114.3x5.9 L=264.3 cm Crit.: Acciaio_Flessione $\gamma_M=1.05$ $f_{yk}/\gamma_M=2619$ kg/cm² $f_t=4300$ kg/cm²

:Verificato

X	cls	N	TY	TZ	MT	MY	MZ	My4	Mz4	Comb.
cm		kg	kg	kg	kg*m	kg*m	kg*m			
0	1	1132	12	-28	-8	39	20	--	--	2

X	cls	Nr	Vyr	Vzr	Mry	Mrz	MTrd	SF_V.	SF_M	SF_Mt	SF
cm		kg	kg	kg	kg*m	kg*m	kg*m				
0	1	52623	19243	19243	1818	1818	1566	>100	18.6	>100	18.6

Asta : 732 [432 , 431]

Sez. G: O 114.3x5.9 L=264.3 cm Crit.: Acciaio_Flessione $\gamma_M=1.05$ $f_{yk}/\gamma_M=2619$ kg/cm² $f_t=4300$ kg/cm²

:Verificato

X	cls	N	TY	TZ	MT	MY	MZ	My4	Mz4	Comb.
cm		kg	kg	kg	kg*m	kg*m	kg*m			
106	1	-8372	5	3	1	-35	-3	--	--	2

AUTOSTRADA VALDASTICO A31 NORD
1° LOTTO - PIOVENE ROCCHETTE – VALLE DELL'ASTICO

X	cls	Nr	Vyr	Vzr	Mry	Mrz	MTrd	SF_V.	SF_M	SF_Mt	SF
cm		kg	kg	kg	kg*m	kg*m	kg*m				
106	1	52623	19333	19333	1818	1818	1566	>100	5.57	>100	5.57

Asta : 733 [421 , 420]

Sez. G: O 114.3x5.9 L=314.0 cm Crit.: Acciaio_Flessione $\gamma_M=1.05$ $f_{yk}/\gamma_M=2619$ kg/cm² $f_t=4300$ kg/cm²

:Verificato

X	cls	N	TY	TZ	MT	MY	MZ	My4	Mz4	Comb.
cm		kg	kg	kg	kg*m	kg*m	kg*m			
314	1	3326	-28	37	-20	17	45	--	--	2

X	cls	Nr	Vyr	Vzr	Mry	Mrz	MTrd	SF_V.	SF_M	SF_Mt	SF
cm		kg	kg	kg	kg*m	kg*m	kg*m				
314	1	52623	19089	19089	1818	1818	1566	>100	10.2	76.5	10.2

Asta : 734 [431 , 421]

Sez. G: O 114.3x5.9 L=264.3 cm Crit.: Acciaio_Flessione $\gamma_M=1.05$ $f_{yk}/\gamma_M=2619$ kg/cm² $f_t=4300$ kg/cm²

:Verificato

X	cls	N	TY	TZ	MT	MY	MZ	My4	Mz4	Comb.
cm		kg	kg	kg	kg*m	kg*m	kg*m			
132	1	2244	-4	2	0	-25	2	--	--	2

X	cls	Nr	Vyr	Vzr	Mry	Mrz	MTrd	SF_V.	SF_M	SF_Mt	SF
cm		kg	kg	kg	kg*m	kg*m	kg*m				
132	1	52623	19337	19337	1818	1818	1566	>100	17.3	>100	17.3

Asta : 735 [431 , 433]

Sez. G: O 114.3x5.9 L=264.3 cm Crit.: Acciaio_Flessione $\gamma_M=1.05$ $f_{yk}/\gamma_M=2619$ kg/cm² $f_t=4300$ kg/cm²

:Verificato

X	cls	N	TY	TZ	MT	MY	MZ	My4	Mz4	Comb.
cm		kg	kg	kg	kg*m	kg*m	kg*m			

AUTOSTRADA VALDASTICO A31 NORD
1° LOTTO - PIOVENE ROCCHETTE – VALLE DELL'ASTICO

X	cls	N	TY	TZ	MT	MY	MZ	My4	Mz4	Comb.
0	1	1255	-6	-23	-7	22	-16	--	--	2

X	cls	Nr	Vyr	Vzr	Mry	Mrz	MTrd	SF_V.	SF_M	SF_Mt	SF
cm		kg	kg	kg	kg*m	kg*m	kg*m				
0	1	52623	19250	19250	1818	1818	1566	>100	22.5	>100	22.5

Asta : 736 [431 , 434]

Sez. G: O 114.3x5.9 L=314.2 cm Crit.: Acciaio_Flessione $\gamma_M=1.05$ $f_{yk}/\gamma_M=2619$ kg/cm² $f_t=4300$ kg/cm²

:Verificato

X	cls	N	TY	TZ	MT	MY	MZ	My4	Mz4	Comb.
cm		kg	kg	kg	kg*m	kg*m	kg*m			
0	1	-10495	22	-1164	-13	600	35	--	--	2

X	cls	Nr	Vyr	Vzr	Mry	Mrz	MTrd	SF_V.	SF_M	SF_Mt	SF
cm		kg	kg	kg	kg*m	kg*m	kg*m				
0	1	52623	19179	19179	1818	1818	1566	16.5	1.82	>100	1.82

Asta : 737 [433 , 421]

Sez. G: O 114.3x5.9 L=247.0 cm Crit.: Acciaio_Flessione $\gamma_M=1.05$ $f_{yk}/\gamma_M=2619$ kg/cm² $f_t=4300$ kg/cm²

:Verificato

X	cls	N	TY	TZ	MT	MY	MZ	My4	Mz4	Comb.
cm		kg	kg	kg	kg*m	kg*m	kg*m			
0	1	-1744	24	-29	14	19	31	--	--	2

X	cls	Nr	Vyr	Vzr	Mry	Mrz	MTrd	SF_V.	SF_M	SF_Mt	SF
cm		kg	kg	kg	kg*m	kg*m	kg*m				
0	1	52623	19172	19172	1818	1818	1566	>100	16.6	>100	16.6

Asta : 738 [421 , 434]

Sez. G: O 114.3x5.9 L=272.3 cm Crit.: Acciaio_Flessione $\gamma_M=1.05$ $f_{yk}/\gamma_M=2619$ kg/cm² $f_t=4300$ kg/cm²

:Verificato

AUTOSTRADA VALDASTICO A31 NORD
1° LOTTO - PIOVENE ROCCHETTE – VALLE DELL'ASTICO

X	cls	N	TY	TZ	MT	MY	MZ	My4	Mz4	Comb.
cm		kg	kg	kg	kg*m	kg*m	kg*m			
0	1	-335	7	-26	-6	20	14	--	--	2

X	cls	Nr	Vyr	Vzr	Mry	Mrz	MTrd	SF_V.	SF_M	SF_Mt	SF
cm		kg	kg	kg	kg*m	kg*m	kg*m				
0	1	52623	19273	19273	1818	1818	1566	>100	39.6	>100	39.6

Asta : 739 [433 , 434]

Sez. G: O 114.3x5.9 L=272.3 cm Crit.: Acciaio_Flessione $\gamma_M=1.05$ $f_yk/\gamma_M=2619$ kg/cm² $f_t=4300$ kg/cm²

:Verificato

X	cls	N	TY	TZ	MT	MY	MZ	My4	Mz4	Comb.
cm		kg	kg	kg	kg*m	kg*m	kg*m			
109	1	-2907	2	1	4	-23	-5	--	--	2

X	cls	Nr	Vyr	Vzr	Mry	Mrz	MTrd	SF_V.	SF_M	SF_Mt	SF
cm		kg	kg	kg	kg*m	kg*m	kg*m				
109	1	52623	19298	19298	1818	1818	1566	>100	14.1	>100	14.1

Asta : 740 [434 , 422]

Sez. G: O 114.3x5.9 L=272.3 cm Crit.: Acciaio_Flessione $\gamma_M=1.05$ $f_yk/\gamma_M=2619$ kg/cm² $f_t=4300$ kg/cm²

:Verificato

X	cls	N	TY	TZ	MT	MY	MZ	My4	Mz4	Comb.
cm		kg	kg	kg	kg*m	kg*m	kg*m			
136	1	257	-4	3	3	-15	4	--	--	2

X	cls	Nr	Vyr	Vzr	Mry	Mrz	MTrd	SF_V.	SF_M	SF_Mt	SF
cm		kg	kg	kg	kg*m	kg*m	kg*m				
136	1	52623	19304	19304	1818	1818	1566	>100	66.5	>100	66.5

Asta : 741 [434 , 436]

AUTOSTRADA VALDASTICO A31 NORD
1° LOTTO - PIOVENE ROCCHETTE – VALLE DELL'ASTICO

Sez. G: O 114.3x5.9 L=272.3 cm Crit.: Acciaio_Flessione $\gamma_M=1.05$ $f_{yk}/\gamma_M=2619$ kg/cm² $f_t=4300$ kg/cm²

:Verificato

X	cls	N	TY	TZ	MT	MY	MZ	My4	Mz4	Comb.
cm		kg	kg	kg	kg*m	kg*m	kg*m			
136	1	-97	-2	-4	-5	-11	-6	--	--	2

X	cls	Nr	Vyr	Vzr	Mry	Mrz	MTrd	SF_V.	SF_M	SF_Mt	SF
cm		kg	kg	kg	kg*m	kg*m	kg*m				
136	1	52623	19276	19276	1818	1818	1566	>100	87.2	>100	87.2

Asta : 742 [422 , 435]

Sez. G: O 114.3x5.9 L=272.3 cm Crit.: Acciaio_Flessione $\gamma_M=1.05$ $f_{yk}/\gamma_M=2619$ kg/cm² $f_t=4300$ kg/cm²

:Verificato

X	cls	N	TY	TZ	MT	MY	MZ	My4	Mz4	Comb.
cm		kg	kg	kg	kg*m	kg*m	kg*m			
136	1	220	4	-3	-3	-14	4	--	--	2

X	cls	Nr	Vyr	Vzr	Mry	Mrz	MTrd	SF_V.	SF_M	SF_Mt	SF
cm		kg	kg	kg	kg*m	kg*m	kg*m				
136	1	52623	19303	19303	1818	1818	1566	>100	70.7	>100	70.7

Asta : 743 [435 , 437]

Sez. G: O 114.3x5.9 L=272.3 cm Crit.: Acciaio_Flessione $\gamma_M=1.05$ $f_{yk}/\gamma_M=2619$ kg/cm² $f_t=4300$ kg/cm²

:Verificato

X	cls	N	TY	TZ	MT	MY	MZ	My4	Mz4	Comb.
cm		kg	kg	kg	kg*m	kg*m	kg*m			
163	1	-2963	-2	-1	-4	-23	-5	--	--	2

X	cls	Nr	Vyr	Vzr	Mry	Mrz	MTrd	SF_V.	SF_M	SF_Mt	SF
cm		kg	kg	kg	kg*m	kg*m	kg*m				
163	1	52623	19297	19297	1818	1818	1566	>100	13.9	>100	13.9

AUTOSTRADA VALDASTICO A31 NORD
1° LOTTO - PIOVENE ROCCHETTE – VALLE DELL'ASTICO

Asta : 744 [436 , 435]

Sez. G: O 114.3x5.9 L=272.3 cm Crit.: Acciaio_Flessione $\gamma_M=1.05$ $f_{yk}/\gamma_M=2619$ kg/cm² $f_t=4300$ kg/cm²

:Verificato

X	cls	N	TY	TZ	MT	MY	MZ	My4	Mz4	Comb.
cm		kg	kg	kg	kg*m	kg*m	kg*m			
272	1	-283	1	17	1	8	-3	--	--	(12+13)-IV-3

X	cls	Nr	Vyr	Vzr	Mry	Mrz	MTrd	SF_V.	SF_M	SF_Mt	SF
cm		kg	kg	kg	kg*m	kg*m	kg*m				
272	1	52623	19324	19324	1818	1818	1566	>100	90.0	>100	90.0

Asta : 745 [435 , 423]

Sez. G: O 114.3x5.9 L=272.3 cm Crit.: Acciaio_Flessione $\gamma_M=1.05$ $f_{yk}/\gamma_M=2619$ kg/cm² $f_t=4300$ kg/cm²

:Verificato

X	cls	N	TY	TZ	MT	MY	MZ	My4	Mz4	Comb.
cm		kg	kg	kg	kg*m	kg*m	kg*m			
272	1	-306	-7	26	5	20	14	--	--	2

X	cls	Nr	Vyr	Vzr	Mry	Mrz	MTrd	SF_V.	SF_M	SF_Mt	SF
cm		kg	kg	kg	kg*m	kg*m	kg*m				
272	1	52623	19275	19275	1818	1818	1566	>100	40.9	>100	40.9

Asta : 746 [434 , 435]

Sez. G: O 114.3x5.9 L=314.0 cm Crit.: Acciaio_Flessione $\gamma_M=1.05$ $f_{yk}/\gamma_M=2619$ kg/cm² $f_t=4300$ kg/cm²

:Verificato

X	cls	N	TY	TZ	MT	MY	MZ	My4	Mz4	Comb.
cm		kg	kg	kg	kg*m	kg*m	kg*m			
0	1	-12391	0	-1160	-0	590	1	--	--	2

X	cls	Nr	Vyr	Vzr	Mry	Mrz	MTrd	SF_V.	SF_M	SF_Mt	SF
cm		kg	kg	kg	kg*m	kg*m	kg*m				
0	1	52623	19339	19339	1818	1818	1566	16.7	1.78	>100	1.78

AUTOSTRADA VALDASTICO A31 NORD
1° LOTTO - PIOVENE ROCCHETTE – VALLE DELL'ASTICO

Asta : 747 [435 , 438]

Sez. G: O 114.3x5.9 L=314.2 cm Crit.: Acciaio_Flessione $\gamma_M=1.05$ $f_{yk}/\gamma_M=2619$ kg/cmq $f_t=4300$ kg/cmq

:Verificato

X	cls	N	TY	TZ	MT	MY	MZ	My4	Mz4	Comb.
cm		kg	kg	kg	kg*m	kg*m	kg*m			
314	1	-10465	-21	1164	13	600	34	--	--	2

X	cls	Nr	Vyr	Vzr	Mry	Mrz	MTrd	SF_V.	SF_M	SF_Mt	SF
cm		kg	kg	kg	kg*m	kg*m	kg*m				
314	1	52623	19184	19184	1818	1818	1566	16.5	1.83	>100	1.83

Asta : 748 [436 , 422]

Sez. G: O 114.3x5.9 L=247.0 cm Crit.: Acciaio_Flessione $\gamma_M=1.05$ $f_{yk}/\gamma_M=2619$ kg/cmq $f_t=4300$ kg/cmq

:Verificato

X	cls	N	TY	TZ	MT	MY	MZ	My4	Mz4	Comb.
cm		kg	kg	kg	kg*m	kg*m	kg*m			
247	1	-435	1	25	0	12	-1	--	--	2

X	cls	Nr	Vyr	Vzr	Mry	Mrz	MTrd	SF_V.	SF_M	SF_Mt	SF
cm		kg	kg	kg	kg*m	kg*m	kg*m				
247	1	52623	19339	19339	1818	1818	1566	>100	65.2	>100	65.2

Asta : 749 [422 , 421]

Sez. G: O 114.3x5.9 L=314.0 cm Crit.: Acciaio_Flessione $\gamma_M=1.05$ $f_{yk}/\gamma_M=2619$ kg/cmq $f_t=4300$ kg/cmq

:Verificato

X	cls	N	TY	TZ	MT	MY	MZ	My4	Mz4	Comb.
cm		kg	kg	kg	kg*m	kg*m	kg*m			
314	1	6147	-10	34	-7	8	17	--	--	2

X	cls	Nr	Vyr	Vzr	Mry	Mrz	MTrd	SF_V.	SF_M	SF_Mt	SF
cm		kg	kg	kg	kg*m	kg*m	kg*m				

AUTOSTRADA VALDASTICO A31 NORD
1° LOTTO - PIOVENE ROCCHETTE – VALLE DELL'ASTICO

X	cls	Nr	Vyr	Vzr	Mry	Mrz	MTrd	SF_V.	SF_M	SF_Mt	SF
314	1	52623	19255	19255	1818	1818	1566	>100	7.66	>100	7.66

Asta : 750 [423 , 422]

Sez. G: O 114.3x5.9 L=314.0 cm Crit.: Acciaio_Flessione $\gamma_M=1.05$ $f_{yk}/\gamma_M=2619$ kg/cm² $f_t=4300$ kg/cm²

:Verificato

X	cls	N	TY	TZ	MT	MY	MZ	My4	Mz4	Comb.
cm		kg	kg	kg	kg*m	kg*m	kg*m			
0	1	6156	9	-34	7	8	15	--	--	2

X	cls	Nr	Vyr	Vzr	Mry	Mrz	MTrd	SF_V.	SF_M	SF_Mt	SF
cm		kg	kg	kg	kg*m	kg*m	kg*m				
0	1	52623	19260	19260	1818	1818	1566	>100	7.69	>100	7.69

Asta : 751 [423 , 438]

Sez. G: O 114.3x5.9 L=264.3 cm Crit.: Acciaio_Flessione $\gamma_M=1.05$ $f_{yk}/\gamma_M=2619$ kg/cm² $f_t=4300$ kg/cm²

:Verificato

X	cls	N	TY	TZ	MT	MY	MZ	My4	Mz4	Comb.
cm		kg	kg	kg	kg*m	kg*m	kg*m			
132	1	2184	4	-2	-0	-25	2	--	--	2

X	cls	Nr	Vyr	Vzr	Mry	Mrz	MTrd	SF_V.	SF_M	SF_Mt	SF
cm		kg	kg	kg	kg*m	kg*m	kg*m				
132	1	52623	19336	19336	1818	1818	1566	>100	17.8	>100	17.8

Asta : 752 [437 , 423]

Sez. G: O 114.3x5.9 L=247.0 cm Crit.: Acciaio_Flessione $\gamma_M=1.05$ $f_{yk}/\gamma_M=2619$ kg/cm² $f_t=4300$ kg/cm²

:Verificato

X	cls	N	TY	TZ	MT	MY	MZ	My4	Mz4	Comb.
cm		kg	kg	kg	kg*m	kg*m	kg*m			
0	1	-1711	-23	-29	-13	19	-29	--	--	2

AUTOSTRADA VALDASTICO A31 NORD
1° LOTTO - PIOVENE ROCCHETTE – VALLE DELL'ASTICO

X	cls	Nr	Vyr	Vzr	Mry	Mrz	MTrd	SF_V.	SF_M	SF_Mt	SF
cm		kg	kg	kg	kg*m	kg*m	kg*m				
0	1	52623	19178	19178	1818	1818	1566	>100	17.0	>100	17.0

Asta : 753 [437 , 438]

Sez. G: O 114.3x5.9 L=264.3 cm Crit.: Acciaio_Flessione $\gamma_M=1.05$ $f_{yk}/\gamma_M=2619$ kg/cm² $f_t=4300$ kg/cm²

:Verificato

X	cls	N	TY	TZ	MT	MY	MZ	My4	Mz4	Comb.
cm		kg	kg	kg	kg*m	kg*m	kg*m			
264	1	1316	6	23	7	21	-16	--	--	2

X	cls	Nr	Vyr	Vzr	Mry	Mrz	MTrd	SF_V.	SF_M	SF_Mt	SF
cm		kg	kg	kg	kg*m	kg*m	kg*m				
264	1	52623	19252	19252	1818	1818	1566	>100	22.2	>100	22.2

Asta : 754 [438 , 424]

Sez. G: O 114.3x5.9 L=264.3 cm Crit.: Acciaio_Flessione $\gamma_M=1.05$ $f_{yk}/\gamma_M=2619$ kg/cm² $f_t=4300$ kg/cm²

:Verificato

X	cls	N	TY	TZ	MT	MY	MZ	My4	Mz4	Comb.
cm		kg	kg	kg	kg*m	kg*m	kg*m			
264	1	1146	-12	28	8	37	20	--	--	2

X	cls	Nr	Vyr	Vzr	Mry	Mrz	MTrd	SF_V.	SF_M	SF_Mt	SF
cm		kg	kg	kg	kg*m	kg*m	kg*m				
264	1	52623	19246	19246	1818	1818	1566	>100	18.7	>100	18.7

Asta : 755 [424 , 423]

Sez. G: O 114.3x5.9 L=314.0 cm Crit.: Acciaio_Flessione $\gamma_M=1.05$ $f_{yk}/\gamma_M=2619$ kg/cm² $f_t=4300$ kg/cm²

:Verificato

X	cls	N	TY	TZ	MT	MY	MZ	My4	Mz4	Comb.
cm		kg	kg	kg	kg*m	kg*m	kg*m			
0	1	3368	27	-37	20	17	44	--	--	2

AUTOSTRADA VALDASTICO A31 NORD
1° LOTTO - PIOVENE ROCCHETTE – VALLE DELL'ASTICO

X	cls	Nr	Vyr	Vzr	Mry	Mrz	MTrd	SF_V.	SF_M	SF_Mt	SF
cm		kg	kg	kg	kg*m	kg*m	kg*m				
0	1	52623	19097	19097	1818	1818	1566	>100	10.3	79.0	10.3

Asta : 756 [439 , 424]

Sez. G: O 114.3x5.9 L=247.0 cm Crit.: Acciaio_Flessione $\gamma_M=1.05$ $f_{yk}/\gamma_M=2619$ kg/cmq $f_t=4300$ kg/cmq

:Verificato

X	cls	N	TY	TZ	MT	MY	MZ	My4	Mz4	Comb.
cm		kg	kg	kg	kg*m	kg*m	kg*m			
0	1	-3615	-37	-40	-27	34	-47	--	--	2

X	cls	Nr	Vyr	Vzr	Mry	Mrz	MTrd	SF_V.	SF_M	SF_Mt	SF
cm		kg	kg	kg	kg*m	kg*m	kg*m				
0	1	52623	19013	19013	1818	1818	1566	>100	8.85	58.9	8.85

Asta : 757 [440 , 441]

Sez. G: O 114.3x5.9 L=243.9 cm Crit.: Acciaio_Flessione $\gamma_M=1.05$ $f_{yk}/\gamma_M=2619$ kg/cmq $f_t=4300$ kg/cmq

:Verificato

X	cls	N	TY	TZ	MT	MY	MZ	My4	Mz4	Comb.
cm		kg	kg	kg	kg*m	kg*m	kg*m			
244	1	-11761	-33	28	17	-5	51	--	--	2

X	cls	Nr	Vyr	Vzr	Mry	Mrz	MTrd	SF_V.	SF_M	SF_Mt	SF
cm		kg	kg	kg	kg*m	kg*m	kg*m				
244	1	52623	19127	19127	1818	1818	1566	>100	3.93	90.1	3.93

Asta : 758 [440 , 425]

Sez. G: O 114.3x5.9 L=243.9 cm Crit.: Acciaio_Flessione $\gamma_M=1.05$ $f_{yk}/\gamma_M=2619$ kg/cmq $f_t=4300$ kg/cmq

:Verificato

X	cls	N	TY	TZ	MT	MY	MZ	My4	Mz4	Comb.
cm		kg	kg	kg	kg*m	kg*m	kg*m			

AUTOSTRADA VALDASTICO A31 NORD
1° LOTTO - PIOVENE ROCCHETTE – VALLE DELL'ASTICO

X	cls	N	TY	TZ	MT	MY	MZ	My4	Mz4	Comb.
244	1	2267	-7	25	3	42	6	--	--	2

X	cls	Nr	Vyr	Vzr	Mry	Mrz	MTrd	SF_V.	SF_M	SF_Mt	SF
cm		kg	kg	kg	kg*m	kg*m	kg*m				
244	1	52623	19300	19300	1818	1818	1566	>100	14.4	>100	14.4

Asta : 759 [438 , 440]

Sez. G: O 114.3x5.9 L=315.7 cm Crit.: Acciaio_Flessione $\gamma_M=1.05$ $f_{yk}/\gamma_M=2619$ kg/cm² $f_t=4300$ kg/cm²

:Verificato

X	cls	N	TY	TZ	MT	MY	MZ	My4	Mz4	Comb.
cm		kg	kg	kg	kg*m	kg*m	kg*m			
316	1	-4194	-41	1169	26	621	66	--	--	2

X	cls	Nr	Vyr	Vzr	Mry	Mrz	MTrd	SF_V.	SF_M	SF_Mt	SF
cm		kg	kg	kg	kg*m	kg*m	kg*m				
316	1	52623	19024	19024	1818	1818	1566	16.3	2.18	61.0	2.18

Asta : 760 [440 , 442]

Sez. G: O 114.3x5.9 L=318.3 cm Crit.: Acciaio_Flessione $\gamma_M=1.05$ $f_{yk}/\gamma_M=2619$ kg/cm² $f_t=4300$ kg/cm²

:Verificato

X	cls	N	TY	TZ	MT	MY	MZ	My4	Mz4	Comb.
cm		kg	kg	kg	kg*m	kg*m	kg*m			
0	1	4381	-22	-1167	21	634	-36	--	--	2

X	cls	Nr	Vyr	Vzr	Mry	Mrz	MTrd	SF_V.	SF_M	SF_Mt	SF
cm		kg	kg	kg	kg*m	kg*m	kg*m				
0	1	52623	19088	19088	1818	1818	1566	16.4	2.21	76.3	2.21

Asta : 761 [424 , 440]

Sez. G: O 114.3x5.9 L=243.9 cm Crit.: Acciaio_Flessione $\gamma_M=1.05$ $f_{yk}/\gamma_M=2619$ kg/cm² $f_t=4300$ kg/cm²

:Verificato

AUTOSTRADA VALDASTICO A31 NORD
1° LOTTO - PIOVENE ROCCHETTE – VALLE DELL'ASTICO

X	cls	N	TY	TZ	MT	MY	MZ	My4	Mz4	Comb.
cm		kg	kg	kg	kg*m	kg*m	kg*m			
146	1	2943	3	4	5	-31	-3	--	--	2

X	cls	Nr	Vyr	Vzr	Mry	Mrz	MTrd	SF_V.	SF_M	SF_Mt	SF
cm		kg	kg	kg	kg*m	kg*m	kg*m				
146	1	52623	19279	19279	1818	1818	1566	>100	13.4	>100	13.4

Asta : 762 [438 , 439]

Sez. G: O 114.3x5.9 L=264.3 cm Crit.: Acciaio_Flessione $\gamma_M=1.05$ $f_{yk}/\gamma_M=2619$ kg/cm² $f_t=4300$ kg/cm²

:Verificato

X	cls	N	TY	TZ	MT	MY	MZ	My4	Mz4	Comb.
cm		kg	kg	kg	kg*m	kg*m	kg*m			
159	1	-8388	-5	-3	-1	-34	-3	--	--	2

X	cls	Nr	Vyr	Vzr	Mry	Mrz	MTrd	SF_V.	SF_M	SF_Mt	SF
cm		kg	kg	kg	kg*m	kg*m	kg*m				
159	1	52623	19334	19334	1818	1818	1566	>100	5.57	>100	5.57

Asta : 763 [439 , 440]

Sez. G: O 114.3x5.9 L=243.9 cm Crit.: Acciaio_Flessione $\gamma_M=1.05$ $f_{yk}/\gamma_M=2619$ kg/cm² $f_t=4300$ kg/cm²

:Verificato

X	cls	N	TY	TZ	MT	MY	MZ	My4	Mz4	Comb.
cm		kg	kg	kg	kg*m	kg*m	kg*m			
0	1	281	13	-26	7	46	11	--	--	2

X	cls	Nr	Vyr	Vzr	Mry	Mrz	MTrd	SF_V.	SF_M	SF_Mt	SF
cm		kg	kg	kg	kg*m	kg*m	kg*m				
0	1	52623	19256	19256	1818	1818	1566	>100	27.2	>100	27.2

Asta : 764 [424 , 425]

AUTOSTRADA VALDASTICO A31 NORD
1° LOTTO - PIOVENE ROCCHETTE – VALLE DELL'ASTICO

Sez. G: O 114.3x5.9 L=314.0 cm Crit.: Acciaio_Flessione $\gamma_M=1.05$ $f_{yk}/\gamma_M=2619$ kg/cm² $f_t=4300$ kg/cm²

:Verificato

X	cls	N	TY	TZ	MT	MY	MZ	My4	Mz4	Comb.
cm		kg	kg	kg	kg*m	kg*m	kg*m			
314	1	-338	30	38	25	29	-49	--	--	2

X	cls	Nr	Vyr	Vzr	Mry	Mrz	MTrd	SF_V.	SF_M	SF_Mt	SF
cm		kg	kg	kg	kg*m	kg*m	kg*m				
314	1	52623	19038	19038	1818	1818	1566	>100	20.3	63.7	20.3

Asta : 765 [425 , 441]

Sez. G: O 114.3x5.9 L=247.0 cm Crit.: Acciaio_Flessione $\gamma_M=1.05$ $f_{yk}/\gamma_M=2619$ kg/cm² $f_t=4300$ kg/cm²

:Verificato

X	cls	N	TY	TZ	MT	MY	MZ	My4	Mz4	Comb.
cm		kg	kg	kg	kg*m	kg*m	kg*m			
247	1	-3288	-20	22	-17	-7	25	--	--	2

X	cls	Nr	Vyr	Vzr	Mry	Mrz	MTrd	SF_V.	SF_M	SF_Mt	SF
cm		kg	kg	kg	kg*m	kg*m	kg*m				
247	1	52623	19129	19129	1818	1818	1566	>100	12.4	90.9	12.4

Asta : 766 [441 , 442]

Sez. G: O 114.3x5.9 L=218.3 cm Crit.: Acciaio_Flessione $\gamma_M=1.05$ $f_{yk}/\gamma_M=2619$ kg/cm² $f_t=4300$ kg/cm²

:Verificato

X	cls	N	TY	TZ	MT	MY	MZ	My4	Mz4	Comb.
cm		kg	kg	kg	kg*m	kg*m	kg*m			
0	1	-5705	35	-39	-4	36	38	--	--	2

X	cls	Nr	Vyr	Vzr	Mry	Mrz	MTrd	SF_V.	SF_M	SF_Mt	SF
cm		kg	kg	kg	kg*m	kg*m	kg*m				
0	1	52623	19290	19290	1818	1818	1566	>100	6.70	>100	6.70

AUTOSTRADA VALDASTICO A31 NORD
1° LOTTO - PIOVENE ROCCHETTE – VALLE DELL'ASTICO

Asta : 767 [442 , 426]

Sez. G: O 114.3x5.9 L=218.3 cm Crit.: Acciaio_Flessione $\gamma_M=1.05$ $f_{yk}/\gamma_M=2619$ kg/cm² $f_t=4300$ kg/cm²

:Verificato

X	cls	N	TY	TZ	MT	MY	MZ	My4	Mz4	Comb.
cm		kg	kg	kg	kg*m	kg*m	kg*m			
0	1	3627	-10	-37	-3	51	-15	--	--	2

X	cls	Nr	Vyr	Vzr	Mry	Mrz	MTrd	SF_V.	SF_M	SF_Mt	SF
cm		kg	kg	kg	kg*m	kg*m	kg*m				
0	1	52623	19299	19299	1818	1818	1566	>100	9.54	>100	9.54

Asta : 768 [442 , 443]

Sez. G: O 114.3x5.9 L=218.3 cm Crit.: Acciaio_Flessione $\gamma_M=1.05$ $f_{yk}/\gamma_M=2619$ kg/cm² $f_t=4300$ kg/cm²

:Verificato

X	cls	N	TY	TZ	MT	MY	MZ	My4	Mz4	Comb.
cm		kg	kg	kg	kg*m	kg*m	kg*m			
0	1	-3922	-10	-27	3	36	-7	--	--	2

X	cls	Nr	Vyr	Vzr	Mry	Mrz	MTrd	SF_V.	SF_M	SF_Mt	SF
cm		kg	kg	kg	kg*m	kg*m	kg*m				
0	1	52623	19303	19303	1818	1818	1566	>100	10.2	>100	10.2

Asta : 769 [426 , 425]

Sez. G: O 114.3x5.9 L=314.0 cm Crit.: Acciaio_Flessione $\gamma_M=1.05$ $f_{yk}/\gamma_M=2619$ kg/cm² $f_t=4300$ kg/cm²

:Verificato

X	cls	N	TY	TZ	MT	MY	MZ	My4	Mz4	Comb.
cm		kg	kg	kg	kg*m	kg*m	kg*m			
0	1	-1168	8	-33	15	24	14	--	--	2

X	cls	Nr	Vyr	Vzr	Mry	Mrz	MTrd	SF_V.	SF_M	SF_Mt	SF
cm		kg	kg	kg	kg*m	kg*m	kg*m				
0	1	52623	19156	19156	1818	1818	1566	>100	23.3	>100	23.3

AUTOSTRADA VALDASTICO A31 NORD
1° LOTTO - PIOVENE ROCCHETTE – VALLE DELL'ASTICO

Asta : 770 [443 , 426]

Sez. G: O 114.3x5.9 L=247.0 cm Crit.: Acciaio_Flessione $\gamma_M=1.05$ $f_{yk}/\gamma_M=2619$ kg/cmq $f_t=4300$ kg/cmq

:Verificato

X	cls	N	TY	TZ	MT	MY	MZ	My4	Mz4	Comb.
cm		kg	kg	kg	kg*m	kg*m	kg*m			
0	1	-5154	-1	-41	-2	48	-4	--	--	2

X	cls	Nr	Vyr	Vzr	Mry	Mrz	MTrd	SF_V.	SF_M	SF_Mt	SF
cm		kg	kg	kg	kg*m	kg*m	kg*m				
0	1	52623	19320	19320	1818	1818	1566	>100	7.92	>100	7.92

Asta : 771 [196 , 427]

Sez. G: O 114.3x5.9 L=247.0 cm Crit.: Acciaio_Flessione $\gamma_M=1.05$ $f_{yk}/\gamma_M=2619$ kg/cmq $f_t=4300$ kg/cmq

:Verificato

X	cls	N	TY	TZ	MT	MY	MZ	My4	Mz4	Comb.
cm		kg	kg	kg	kg*m	kg*m	kg*m			
0	1	-14242	-5	-98	-18	233	1	--	--	2

X	cls	Nr	Vyr	Vzr	Mry	Mrz	MTrd	SF_V.	SF_M	SF_Mt	SF
cm		kg	kg	kg	kg*m	kg*m	kg*m				
0	1	52623	19114	19114	1818	1818	1566	>100	2.51	84.8	2.51

Asta : 772 [444 , 430]

Sez. G: O 114.3x5.9 L=218.3 cm Crit.: Acciaio_Flessione $\gamma_M=1.05$ $f_{yk}/\gamma_M=2619$ kg/cmq $f_t=4300$ kg/cmq

:Verificato

X	cls	N	TY	TZ	MT	MY	MZ	My4	Mz4	Comb.
cm		kg	kg	kg	kg*m	kg*m	kg*m			
218	1	9477	-5	51	23	54	19	--	--	2

X	cls	Nr	Vyr	Vzr	Mry	Mrz	MTrd	SF_V.	SF_M	SF_Mt	SF
cm		kg	kg	kg	kg*m	kg*m	kg*m				

AUTOSTRADA VALDASTICO A31 NORD
1° LOTTO - PIOVENE ROCCHETTE – VALLE DELL'ASTICO

X	cls	Nr	Vyr	Vzr	Mry	Mrz	MTrd	SF_V.	SF_M	SF_Mt	SF
218	1	52623	19062	19062	1818	1818	1566	>100	4.54	69.2	4.54

Asta : 773 [430 , 427]

Sez. G: O 114.3x5.9 L=314.0 cm Crit.: Acciaio_Flessione $\gamma_M=1.05$ $f_{yk}/\gamma_M=2619$ kg/cm² $f_t=4300$ kg/cm²

:Verificato

X	cls	N	TY	TZ	MT	MY	MZ	My4	Mz4	Comb.
cm		kg	kg	kg	kg*m	kg*m	kg*m			
0	1	-4908	-3	-37	-5	44	-5	--	--	2

X	cls	Nr	Vyr	Vzr	Mry	Mrz	MTrd	SF_V.	SF_M	SF_Mt	SF
cm		kg	kg	kg	kg*m	kg*m	kg*m				
0	1	52623	19284	19284	1818	1818	1566	>100	8.33	>100	8.33

Asta : 774 [430 , 445]

Sez. G: O 114.3x5.9 L=243.9 cm Crit.: Acciaio_Flessione $\gamma_M=1.05$ $f_{yk}/\gamma_M=2619$ kg/cm² $f_t=4300$ kg/cm²

:Verificato

X	cls	N	TY	TZ	MT	MY	MZ	My4	Mz4	Comb.
cm		kg	kg	kg	kg*m	kg*m	kg*m			
0	1	9639	37	-41	-4	99	44	--	--	2

X	cls	Nr	Vyr	Vzr	Mry	Mrz	MTrd	SF_V.	SF_M	SF_Mt	SF
cm		kg	kg	kg	kg*m	kg*m	kg*m				
0	1	52623	19296	19296	1818	1818	1566	>100	3.82	>100	3.82

Asta : 775 [444 , 195]

Sez. G: O 114.3x5.9 L=218.3 cm Crit.: Acciaio_Flessione $\gamma_M=1.05$ $f_{yk}/\gamma_M=2619$ kg/cm² $f_t=4300$ kg/cm²

:Verificato

X	cls	N	TY	TZ	MT	MY	MZ	My4	Mz4	Comb.
cm		kg	kg	kg	kg*m	kg*m	kg*m			
218	1	-20810	50	190	-87	207	-111	--	--	2

AUTOSTRADA VALDASTICO A31 NORD
1° LOTTO - PIOVENE ROCCHETTE – VALLE DELL'ASTICO

X	cls	Nr	Vyr	Vzr	Mry	Mrz	MTrd	SF_V.	SF_M	SF_Mt	SF
cm		kg	kg	kg	kg*m	kg*m	kg*m				
218	1	52623	18272	18272	1818	1818	1566	96.2	1.75	18.1	1.75

Asta : 776 [444 , 445]

Sez. G: O 114.3x5.9 L=318.3 cm Crit.: Acciaio_Flessione $\gamma_M=1.05$ $f_{yk}/\gamma_M=2619$ kg/cm² $f_t=4300$ kg/cm²

:Verificato

X	cls	N	TY	TZ	MT	MY	MZ	My4	Mz4	Comb.
cm		kg	kg	kg	kg*m	kg*m	kg*m			
318	1	20010	14	1238	-8	726	-23	--	--	2

X	cls	Nr	Vyr	Vzr	Mry	Mrz	MTrd	SF_V.	SF_M	SF_Mt	SF
cm		kg	kg	kg	kg*m	kg*m	kg*m				
318	1	52623	19243	19243	1818	1818	1566	15.5	1.26	>100	1.26

Asta : 777 [427 , 444]

Sez. G: O 114.3x5.9 L=218.3 cm Crit.: Acciaio_Flessione $\gamma_M=1.05$ $f_{yk}/\gamma_M=2619$ kg/cm² $f_t=4300$ kg/cm²

:Verificato

X	cls	N	TY	TZ	MT	MY	MZ	My4	Mz4	Comb.
cm		kg	kg	kg	kg*m	kg*m	kg*m			
218	1	8005	42	93	-7	143	-41	--	--	2

X	cls	Nr	Vyr	Vzr	Mry	Mrz	MTrd	SF_V.	SF_M	SF_Mt	SF
cm		kg	kg	kg	kg*m	kg*m	kg*m				
218	1	52623	19259	19259	1818	1818	1566	>100	3.95	>100	3.95

Asta : 778 [196 , 444]

Sez. G: O 114.3x5.9 L=218.3 cm Crit.: Acciaio_Flessione $\gamma_M=1.05$ $f_{yk}/\gamma_M=2619$ kg/cm² $f_t=4300$ kg/cm²

:Verificato

X	cls	N	TY	TZ	MT	MY	MZ	My4	Mz4	Comb.
cm		kg	kg	kg	kg*m	kg*m	kg*m			
218	1	7593	-58	30	34	135	53	--	--	2

AUTOSTRADA VALDASTICO A31 NORD
1° LOTTO - PIOVENE ROCCHETTE – VALLE DELL'ASTICO

X	cls	Nr	Vyr	Vzr	Mry	Mrz	MTrd	SF_V.	SF_M	SF_Mt	SF
cm		kg	kg	kg	kg*m	kg*m	kg*m				
218	1	52623	18926	18926	1818	1818	1566	>100	4.04	46.5	4.04

Asta : 779 [195 , 430]

Sez. G: O 114.3x5.9 L=247.0 cm Crit.: Acciaio_Flessione $\gamma_M=1.05$ $f_{yk}/\gamma_M=2619$ kg/cm² $f_t=4300$ kg/cm²

:Verificato

X	cls	N	TY	TZ	MT	MY	MZ	My4	Mz4	Comb.
cm		kg	kg	kg	kg*m	kg*m	kg*m			
0	1	-23271	7	-300	-39	475	14	--	--	2

X	cls	Nr	Vyr	Vzr	Mry	Mrz	MTrd	SF_V.	SF_M	SF_Mt	SF
cm		kg	kg	kg	kg*m	kg*m	kg*m				
0	1	52623	18865	18865	1818	1818	1566	62.8	1.41	40.5	1.41

Asta : 780 [195 , 445]

Sez. G: O 114.3x7.1 L=243.9 cm Crit.: Acciaio_Flessione $\gamma_M=1.05$ $f_{yk}/\gamma_M=2619$ kg/cm² $f_t=4300$ kg/cm²

:Verificato

X	cls	N	TY	TZ	MT	MY	MZ	My4	Mz4	Comb.
cm		kg	kg	kg	kg*m	kg*m	kg*m			
0	1	-41151	18	-391	3	609	21	--	--	2

X	cls	Nr	Vyr	Vzr	Mry	Mrz	MTrd	SF_V.	SF_M	SF_Mt	SF
cm		kg	kg	kg	kg*m	kg*m	kg*m				
0	1	62625	22976	22976	2140	2140	1826	58.7	1.05	>100	1.05

Asta : 781 [445 , 446]

Sez. G: O 114.3x5.9 L=315.7 cm Crit.: Acciaio_Flessione $\gamma_M=1.05$ $f_{yk}/\gamma_M=2619$ kg/cm² $f_t=4300$ kg/cm²

:Verificato

X	cls	N	TY	TZ	MT	MY	MZ	My4	Mz4	Comb.
cm		kg	kg	kg	kg*m	kg*m	kg*m			

AUTOSTRADA VALDASTICO A31 NORD
1° LOTTO - PIOVENE ROCCHETTE – VALLE DELL'ASTICO

X	cls	N	TY	TZ	MT	MY	MZ	My4	Mz4	Comb.
0	1	-13175	33	-1214	-27	623	54	--	--	2

X	cls	Nr	Vyr	Vzr	Mry	Mrz	MTrd	SF_V.	SF_M	SF_Mt	SF
cm		kg	kg	kg	kg*m	kg*m	kg*m				
0	1	52623	19002	19002	1818	1818	1566	15.6	1.61	57.0	1.61

Asta : 782 [445 , 194]

Sez. G: O 114.3x5.9 L=243.9 cm Crit.: Acciaio_Flessione $\gamma_M=1.05$ $f_{yk}/\gamma_M=2619$ kg/cm² $f_t=4300$ kg/cm²

:Verificato

X	cls	N	TY	TZ	MT	MY	MZ	My4	Mz4	Comb.
cm		kg	kg	kg	kg*m	kg*m	kg*m			
0	1	9887	-33	-14	-25	36	-65	--	--	2

X	cls	Nr	Vyr	Vzr	Mry	Mrz	MTrd	SF_V.	SF_M	SF_Mt	SF
cm		kg	kg	kg	kg*m	kg*m	kg*m				
0	1	52623	19035	19035	1818	1818	1566	>100	4.11	63.1	4.11

Asta : 783 [445 , 432]

Sez. G: O 114.3x5.9 L=243.9 cm Crit.: Acciaio_Flessione $\gamma_M=1.05$ $f_{yk}/\gamma_M=2619$ kg/cm² $f_t=4300$ kg/cm²

:Verificato

X	cls	N	TY	TZ	MT	MY	MZ	My4	Mz4	Comb.
cm		kg	kg	kg	kg*m	kg*m	kg*m			
24	1	9500	-8	-7	5	-44	-4	--	--	2

X	cls	Nr	Vyr	Vzr	Mry	Mrz	MTrd	SF_V.	SF_M	SF_Mt	SF
cm		kg	kg	kg	kg*m	kg*m	kg*m				
24	1	52623	19283	19283	1818	1818	1566	>100	4.83	>100	4.83

Asta : 784 [432 , 430]

Sez. G: O 114.3x5.9 L=314.0 cm Crit.: Acciaio_Flessione $\gamma_M=1.05$ $f_{yk}/\gamma_M=2619$ kg/cm² $f_t=4300$ kg/cm²

:Verificato

AUTOSTRADA VALDASTICO A31 NORD
1° LOTTO - PIOVENE ROCCHETTE – VALLE DELL'ASTICO

X	cls	N	TY	TZ	MT	MY	MZ	My4	Mz4	Comb.
cm		kg	kg	kg	kg*m	kg*m	kg*m			
314	1	-1061	-30	63	-36	77	51	--	--	2

X	cls	Nr	Vyr	Vzr	Mry	Mrz	MTrd	SF_V.	SF_M	SF_Mt	SF
cm		kg	kg	kg	kg*m	kg*m	kg*m				
314	1	52623	18891	18891	1818	1818	1566	>100	11.1	42.9	11.1

Asta : 785 [194 , 432]

Sez. G: O 114.3x5.9 L=247.0 cm Crit.: Acciaio_Flessione $\gamma_M=1.05$ $f_{yk}/\gamma_M=2619$ kg/cm² $f_t=4300$ kg/cm²

:Verificato

X	cls	N	TY	TZ	MT	MY	MZ	My4	Mz4	Comb.
cm		kg	kg	kg	kg*m	kg*m	kg*m			
0	1	-12468	29	-51	28	77	37	--	--	2

X	cls	Nr	Vyr	Vzr	Mry	Mrz	MTrd	SF_V.	SF_M	SF_Mt	SF
cm		kg	kg	kg	kg*m	kg*m	kg*m				
0	1	52623	18991	18991	1818	1818	1566	>100	3.34	55.1	3.34

Asta : 786 [432 , 446]

Sez. G: O 114.3x5.9 L=264.3 cm Crit.: Acciaio_Flessione $\gamma_M=1.05$ $f_{yk}/\gamma_M=2619$ kg/cm² $f_t=4300$ kg/cm²

:Verificato

X	cls	N	TY	TZ	MT	MY	MZ	My4	Mz4	Comb.
cm		kg	kg	kg	kg*m	kg*m	kg*m			
0	1	126	15	-32	-14	39	33	--	--	2

X	cls	Nr	Vyr	Vzr	Mry	Mrz	MTrd	SF_V.	SF_M	SF_Mt	SF
cm		kg	kg	kg	kg*m	kg*m	kg*m				
0	1	52623	19173	19173	1818	1818	1566	>100	23.8	>100	23.8

Asta : 787 [194 , 446]

AUTOSTRADA VALDASTICO A31 NORD
1° LOTTO - PIOVENE ROCCHETTE – VALLE DELL'ASTICO

Sez. G: O 114.3x5.9 L=264.3 cm Crit.: Acciaio_Flessione $\gamma_M=1.05$ $f_{yk}/\gamma_M=2619$ kg/cm² $f_t=4300$ kg/cm²

:Verificato

X	cls	N	TY	TZ	MT	MY	MZ	My4	Mz4	Comb.
cm		kg	kg	kg	kg*m	kg*m	kg*m			
0	1	-7381	-18	-9	16	-31	-43	--	--	2

X	cls	Nr	Vyr	Vzr	Mry	Mrz	MTrd	SF_V.	SF_M	SF_Mt	SF
cm		kg	kg	kg	kg*m	kg*m	kg*m				
0	1	52623	19144	19144	1818	1818	1566	>100	5.54	97.9	5.54

Asta : 788 [433 , 432]

Sez. G: O 114.3x5.9 L=314.0 cm Crit.: Acciaio_Flessione $\gamma_M=1.05$ $f_{yk}/\gamma_M=2619$ kg/cm² $f_t=4300$ kg/cm²

:Verificato

X	cls	N	TY	TZ	MT	MY	MZ	My4	Mz4	Comb.
cm		kg	kg	kg	kg*m	kg*m	kg*m			
31	1	10093	-22	-19	-19	-22	-26	--	--	2

X	cls	Nr	Vyr	Vzr	Mry	Mrz	MTrd	SF_V.	SF_M	SF_Mt	SF
cm		kg	kg	kg	kg*m	kg*m	kg*m				
31	1	52623	19102	19102	1818	1818	1566	>100	4.58	80.8	4.58

Asta : 789 [446 , 433]

Sez. G: O 114.3x5.9 L=264.3 cm Crit.: Acciaio_Flessione $\gamma_M=1.05$ $f_{yk}/\gamma_M=2619$ kg/cm² $f_t=4300$ kg/cm²

:Verificato

X	cls	N	TY	TZ	MT	MY	MZ	My4	Mz4	Comb.
cm		kg	kg	kg	kg*m	kg*m	kg*m			
185	1	2398	-6	5	6	-25	11	--	--	2

X	cls	Nr	Vyr	Vzr	Mry	Mrz	MTrd	SF_V.	SF_M	SF_Mt	SF
cm		kg	kg	kg	kg*m	kg*m	kg*m				
185	1	52623	19262	19262	1818	1818	1566	>100	15.3	>100	15.3

AUTOSTRADA VALDASTICO A31 NORD
1° LOTTO - PIOVENE ROCCHETTE – VALLE DELL'ASTICO

Asta : 790 [446 , 193]

Sez. G: O 114.3x5.9 L=264.3 cm Crit.: Acciaio_Flessione $\gamma_M=1.05$ $f_{yk}/\gamma_M=2619$ kg/cm² $f_t=4300$ kg/cm²

:Verificato

X	cls	N	TY	TZ	MT	MY	MZ	My4	Mz4	Comb.
cm		kg	kg	kg	kg*m	kg*m	kg*m			
0	1	1794	0	-28	-11	16	-12	--	--	2

X	cls	Nr	Vyr	Vzr	Mry	Mrz	MTrd	SF_V.	SF_M	SF_Mt	SF
cm		kg	kg	kg	kg*m	kg*m	kg*m				
0	1	52623	19207	19207	1818	1818	1566	>100	20.2	>100	20.2

Asta : 791 [446 , 447]

Sez. G: O 114.3x5.9 L=314.2 cm Crit.: Acciaio_Flessione $\gamma_M=1.05$ $f_{yk}/\gamma_M=2619$ kg/cm² $f_t=4300$ kg/cm²

:Verificato

X	cls	N	TY	TZ	MT	MY	MZ	My4	Mz4	Comb.
cm		kg	kg	kg	kg*m	kg*m	kg*m			
0	1	-19778	13	-1209	-8	610	20	--	--	2

X	cls	Nr	Vyr	Vzr	Mry	Mrz	MTrd	SF_V.	SF_M	SF_Mt	SF
cm		kg	kg	kg	kg*m	kg*m	kg*m				
0	1	52623	19242	19242	1818	1818	1566	15.9	1.38	>100	1.38

Asta : 792 [193 , 433]

Sez. G: O 114.3x5.9 L=247.0 cm Crit.: Acciaio_Flessione $\gamma_M=1.05$ $f_{yk}/\gamma_M=2619$ kg/cm² $f_t=4300$ kg/cm²

:Verificato

X	cls	N	TY	TZ	MT	MY	MZ	My4	Mz4	Comb.
cm		kg	kg	kg	kg*m	kg*m	kg*m			
0	1	-3510	16	-29	8	25	20	--	--	2

X	cls	Nr	Vyr	Vzr	Mry	Mrz	MTrd	SF_V.	SF_M	SF_Mt	SF
cm		kg	kg	kg	kg*m	kg*m	kg*m				
0	1	52623	19248	19248	1818	1818	1566	>100	11.0	>100	11.0

AUTOSTRADA VALDASTICO A31 NORD
1° LOTTO - PIOVENE ROCCHETTE – VALLE DELL'ASTICO

Asta : 793 [433 , 447]

Sez. G: O 114.3x5.9 L=272.3 cm Crit.: Acciaio_Flessione $\gamma_M=1.05$ $f_{yk}/\gamma_M=2619$ kg/cmq $f_t=4300$ kg/cmq

:Verificato

X	cls	N	TY	TZ	MT	MY	MZ	My4	Mz4	Comb.
cm		kg	kg	kg	kg*m	kg*m	kg*m			
0	1	-311	7	-25	-8	11	19	--	--	2

X	cls	Nr	Vyr	Vzr	Mry	Mrz	MTrd	SF_V.	SF_M	SF_Mt	SF
cm		kg	kg	kg	kg*m	kg*m	kg*m				
0	1	52623	19241	19241	1818	1818	1566	>100	44.8	>100	44.8

Asta : 794 [193 , 447]

Sez. G: O 114.3x5.9 L=272.3 cm Crit.: Acciaio_Flessione $\gamma_M=1.05$ $f_{yk}/\gamma_M=2619$ kg/cmq $f_t=4300$ kg/cmq

:Verificato

X	cls	N	TY	TZ	MT	MY	MZ	My4	Mz4	Comb.
cm		kg	kg	kg	kg*m	kg*m	kg*m			
136	1	-2047	-1	0	7	-21	-9	--	--	2

X	cls	Nr	Vyr	Vzr	Mry	Mrz	MTrd	SF_V.	SF_M	SF_Mt	SF
cm		kg	kg	kg	kg*m	kg*m	kg*m				
136	1	52623	19254	19254	1818	1818	1566	>100	18.1	>100	18.1

Asta : 795 [447 , 436]

Sez. G: O 114.3x5.9 L=272.3 cm Crit.: Acciaio_Flessione $\gamma_M=1.05$ $f_{yk}/\gamma_M=2619$ kg/cmq $f_t=4300$ kg/cmq

:Verificato

X	cls	N	TY	TZ	MT	MY	MZ	My4	Mz4	Comb.
cm		kg	kg	kg	kg*m	kg*m	kg*m			
163	1	203	-5	5	6	-18	9	--	--	2

X	cls	Nr	Vyr	Vzr	Mry	Mrz	MTrd	SF_V.	SF_M	SF_Mt	SF
cm		kg	kg	kg	kg*m	kg*m	kg*m				

AUTOSTRADA VALDASTICO A31 NORD
1° LOTTO - PIOVENE ROCCHETTE – VALLE DELL'ASTICO

X	cls	Nr	Vyr	Vzr	Mry	Mrz	MTrd	SF_V.	SF_M	SF_Mt	SF
163	1	52623	19265	19265	1818	1818	1566	>100	53.9	>100	53.9

Asta : 796 [447 , 192]

Sez. G: O 114.3x5.9 L=272.3 cm Crit.: Acciaio_Flessione $\gamma_M=1.05$ $f_{yk}/\gamma_M=2619$ kg/cm² $f_t=4300$ kg/cm²

:Verificato

X	cls	N	TY	TZ	MT	MY	MZ	My4	Mz4	Comb.
cm		kg	kg	kg	kg*m	kg*m	kg*m			
163	1	-544	-0	2	-8	-17	-9	--	--	2

X	cls	Nr	Vyr	Vzr	Mry	Mrz	MTrd	SF_V.	SF_M	SF_Mt	SF
cm		kg	kg	kg	kg*m	kg*m	kg*m				
163	1	52623	19249	19249	1818	1818	1566	>100	40.6	>100	40.6

Asta : 797 [436 , 448]

Sez. G: O 114.3x5.9 L=272.3 cm Crit.: Acciaio_Flessione $\gamma_M=1.05$ $f_{yk}/\gamma_M=2619$ kg/cm² $f_t=4300$ kg/cm²

:Verificato

X	cls	N	TY	TZ	MT	MY	MZ	My4	Mz4	Comb.
cm		kg	kg	kg	kg*m	kg*m	kg*m			
109	1	242	5	-5	-6	-18	9	--	--	2

X	cls	Nr	Vyr	Vzr	Mry	Mrz	MTrd	SF_V.	SF_M	SF_Mt	SF
cm		kg	kg	kg	kg*m	kg*m	kg*m				
109	1	52623	19264	19264	1818	1818	1566	>100	52.4	>100	52.4

Asta : 798 [448 , 191]

Sez. G: O 114.3x5.9 L=272.3 cm Crit.: Acciaio_Flessione $\gamma_M=1.05$ $f_{yk}/\gamma_M=2619$ kg/cm² $f_t=4300$ kg/cm²

:Verificato

X	cls	N	TY	TZ	MT	MY	MZ	My4	Mz4	Comb.
cm		kg	kg	kg	kg*m	kg*m	kg*m			
136	1	-2148	1	-0	-7	-20	-9	--	--	2

AUTOSTRADA VALDASTICO A31 NORD
1° LOTTO - PIOVENE ROCCHETTE – VALLE DELL'ASTICO

X	cls	Nr	Vyr	Vzr	Mry	Mrz	MTrd	SF_V.	SF_M	SF_Mt	SF
cm		kg	kg	kg	kg*m	kg*m	kg*m				
136	1	52623	19254	19254	1818	1818	1566	>100	17.6	>100	17.6

Asta : 799 [192 , 448]

Sez. G: O 114.3x5.9 L=272.3 cm Crit.: Acciaio_Flessione $\gamma_M=1.05$ $f_{yk}/\gamma_M=2619$ kg/cm² $f_t=4300$ kg/cm²

:Verificato

X	cls	N	TY	TZ	MT	MY	MZ	My4	Mz4	Comb.
cm		kg	kg	kg	kg*m	kg*m	kg*m			
109	1	-433	0	-2	7	-17	-9	--	--	2

X	cls	Nr	Vyr	Vzr	Mry	Mrz	MTrd	SF_V.	SF_M	SF_Mt	SF
cm		kg	kg	kg	kg*m	kg*m	kg*m				
109	1	52623	19249	19249	1818	1818	1566	>100	44.3	>100	44.3

Asta : 800 [448 , 437]

Sez. G: O 114.3x5.9 L=272.3 cm Crit.: Acciaio_Flessione $\gamma_M=1.05$ $f_{yk}/\gamma_M=2619$ kg/cm² $f_t=4300$ kg/cm²

:Verificato

X	cls	N	TY	TZ	MT	MY	MZ	My4	Mz4	Comb.
cm		kg	kg	kg	kg*m	kg*m	kg*m			
272	1	-371	-7	25	8	11	19	--	--	2

X	cls	Nr	Vyr	Vzr	Mry	Mrz	MTrd	SF_V.	SF_M	SF_Mt	SF
cm		kg	kg	kg	kg*m	kg*m	kg*m				
272	1	52623	19243	19243	1818	1818	1566	>100	42.8	>100	42.8

Asta : 801 [447 , 448]

Sez. G: O 114.3x5.9 L=314.0 cm Crit.: Acciaio_Flessione $\gamma_M=1.05$ $f_{yk}/\gamma_M=2619$ kg/cm² $f_t=4300$ kg/cm²

:Verificato

X	cls	N	TY	TZ	MT	MY	MZ	My4	Mz4	Comb.
cm		kg	kg	kg	kg*m	kg*m	kg*m			
314	1	-20860	0	1205	-0	602	-0	--	--	2

AUTOSTRADA VALDASTICO A31 NORD
1° LOTTO - PIOVENE ROCCHETTE – VALLE DELL'ASTICO

X	cls	Nr	Vyr	Vzr	Mry	Mrz	MTrd	SF_V.	SF_M	SF_Mt	SF
cm		kg	kg	kg	kg*m	kg*m	kg*m				
314	1	52623	19340	19340	1818	1818	1566	16.1	1.37	>100	1.37

Asta : 802 [448 , 449]

Sez. G: O 114.3x5.9 L=314.2 cm Crit.: Acciaio_Flessione $\gamma_M=1.05$ $f_{yk}/\gamma_M=2619$ kg/cm² $f_t=4300$ kg/cm²

:Verificato

X	cls	N	TY	TZ	MT	MY	MZ	My4	Mz4	Comb.
cm		kg	kg	kg	kg*m	kg*m	kg*m			
314	1	-19597	-12	1209	8	611	20	--	--	2

X	cls	Nr	Vyr	Vzr	Mry	Mrz	MTrd	SF_V.	SF_M	SF_Mt	SF
cm		kg	kg	kg	kg*m	kg*m	kg*m				
314	1	52623	19246	19246	1818	1818	1566	15.9	1.39	>100	1.39

Asta : 803 [192 , 436]

Sez. G: O 114.3x5.9 L=247.0 cm Crit.: Acciaio_Flessione $\gamma_M=1.05$ $f_{yk}/\gamma_M=2619$ kg/cm² $f_t=4300$ kg/cm²

:Verificato

X	cls	N	TY	TZ	MT	MY	MZ	My4	Mz4	Comb.
cm		kg	kg	kg	kg*m	kg*m	kg*m			
0	1	-729	0	-27	0	16	1	--	--	2

X	cls	Nr	Vyr	Vzr	Mry	Mrz	MTrd	SF_V.	SF_M	SF_Mt	SF
cm		kg	kg	kg	kg*m	kg*m	kg*m				
0	1	52623	19340	19340	1818	1818	1566	>100	43.4	>100	43.4

Asta : 804 [436 , 433]

Sez. G: O 114.3x5.9 L=314.0 cm Crit.: Acciaio_Flessione $\gamma_M=1.05$ $f_{yk}/\gamma_M=2619$ kg/cm² $f_t=4300$ kg/cm²

:Verificato

X	cls	N	TY	TZ	MT	MY	MZ	My4	Mz4	Comb.
cm		kg	kg	kg	kg*m	kg*m	kg*m			

AUTOSTRADA VALDASTICO A31 NORD
1° LOTTO - PIOVENE ROCCHETTE – VALLE DELL'ASTICO

X	cls	N	TY	TZ	MT	MY	MZ	My4	Mz4	Comb.
188	1	14091	-7	8	-6	-32	3	--	--	2

X	cls	Nr	Vyr	Vzr	Mry	Mrz	MTrd	SF_V.	SF_M	SF_Mt	SF
cm		kg	kg	kg	kg*m	kg*m	kg*m				
188	1	52623	19271	19271	1818	1818	1566	>100	3.48	>100	3.48

Asta : 805 [437 , 436]

Sez. G: O 114.3x5.9 L=314.0 cm Crit.: Acciaio_Flessione $\gamma_M=1.05$ $f_{yk}/\gamma_M=2619$ kg/cm² $f_t=4300$ kg/cm²

:Verificato

X	cls	N	TY	TZ	MT	MY	MZ	My4	Mz4	Comb.
cm		kg	kg	kg	kg*m	kg*m	kg*m			
126	1	14032	6	-8	5	-32	3	--	--	2

X	cls	Nr	Vyr	Vzr	Mry	Mrz	MTrd	SF_V.	SF_M	SF_Mt	SF
cm		kg	kg	kg	kg*m	kg*m	kg*m				
126	1	52623	19275	19275	1818	1818	1566	>100	3.50	>100	3.50

Asta : 806 [437 , 449]

Sez. G: O 114.3x5.9 L=264.3 cm Crit.: Acciaio_Flessione $\gamma_M=1.05$ $f_{yk}/\gamma_M=2619$ kg/cm² $f_t=4300$ kg/cm²

:Verificato

X	cls	N	TY	TZ	MT	MY	MZ	My4	Mz4	Comb.
cm		kg	kg	kg	kg*m	kg*m	kg*m			
79	1	2458	6	-4	-6	-24	11	--	--	2

X	cls	Nr	Vyr	Vzr	Mry	Mrz	MTrd	SF_V.	SF_M	SF_Mt	SF
cm		kg	kg	kg	kg*m	kg*m	kg*m				
79	1	52623	19263	19263	1818	1818	1566	>100	15.2	>100	15.2

Asta : 807 [191 , 437]

Sez. G: O 114.3x5.9 L=247.0 cm Crit.: Acciaio_Flessione $\gamma_M=1.05$ $f_{yk}/\gamma_M=2619$ kg/cm² $f_t=4300$ kg/cm²

:Verificato

AUTOSTRADA VALDASTICO A31 NORD
1° LOTTO - PIOVENE ROCCHETTE – VALLE DELL'ASTICO

X	cls	N	TY	TZ	MT	MY	MZ	My4	Mz4	Comb.
cm		kg	kg	kg	kg*m	kg*m	kg*m			
0	1	-3474	-15	-29	-7	25	-18	--	--	2

X	cls	Nr	Vyr	Vzr	Mry	Mrz	MTrd	SF_V.	SF_M	SF_Mt	SF
cm		kg	kg	kg	kg*m	kg*m	kg*m				
0	1	52623	19253	19253	1818	1818	1566	>100	11.1	>100	11.1

Asta : 808 [191 , 449]

Sez. G: O 114.3x5.9 L=264.3 cm Crit.: Acciaio_Flessione $\gamma_M=1.05$ $f_{yk}/\gamma_M=2619$ kg/cm² $f_t=4300$ kg/cm²

:Verificato

X	cls	N	TY	TZ	MT	MY	MZ	My4	Mz4	Comb.
cm		kg	kg	kg	kg*m	kg*m	kg*m			
264	1	1950	-0	28	11	16	-12	--	--	2

X	cls	Nr	Vyr	Vzr	Mry	Mrz	MTrd	SF_V.	SF_M	SF_Mt	SF
cm		kg	kg	kg	kg*m	kg*m	kg*m				
264	1	52623	19209	19209	1818	1818	1566	>100	19.1	>100	19.1

Asta : 809 [449 , 439]

Sez. G: O 114.3x5.9 L=264.3 cm Crit.: Acciaio_Flessione $\gamma_M=1.05$ $f_{yk}/\gamma_M=2619$ kg/cm² $f_t=4300$ kg/cm²

:Verificato

X	cls	N	TY	TZ	MT	MY	MZ	My4	Mz4	Comb.
cm		kg	kg	kg	kg*m	kg*m	kg*m			
264	1	4	-15	32	13	38	32	--	--	2

X	cls	Nr	Vyr	Vzr	Mry	Mrz	MTrd	SF_V.	SF_M	SF_Mt	SF
cm		kg	kg	kg	kg*m	kg*m	kg*m				
264	1	52623	19176	19176	1818	1818	1566	>100	25.6	>100	25.6

Asta : 810 [439 , 437]

AUTOSTRADA VALDASTICO A31 NORD
1° LOTTO - PIOVENE ROCCHETTE – VALLE DELL'ASTICO

Sez. G: O 114.3x5.9 L=314.0 cm Crit.: Acciaio_Flessione $\gamma_M=1.05$ $f_{yk}/\gamma_M=2619$ kg/cm² $f_t=4300$ kg/cm²

:Verificato

X	cls	N	TY	TZ	MT	MY	MZ	My4	Mz4	Comb.
cm		kg	kg	kg	kg*m	kg*m	kg*m			
283	1	9895	21	18	19	-22	-25	--	--	2

X	cls	Nr	Vyr	Vzr	Mry	Mrz	MTrd	SF_V.	SF_M	SF_Mt	SF
cm		kg	kg	kg	kg*m	kg*m	kg*m				
283	1	52623	19109	19109	1818	1818	1566	>100	4.67	83.3	4.67

Asta : 811 [190 , 439]

Sez. G: O 114.3x5.9 L=247.0 cm Crit.: Acciaio_Flessione $\gamma_M=1.05$ $f_{yk}/\gamma_M=2619$ kg/cm² $f_t=4300$ kg/cm²

:Verificato

X	cls	N	TY	TZ	MT	MY	MZ	My4	Mz4	Comb.
cm		kg	kg	kg	kg*m	kg*m	kg*m			
0	1	-12303	-28	-51	-28	77	-36	--	--	2

X	cls	Nr	Vyr	Vzr	Mry	Mrz	MTrd	SF_V.	SF_M	SF_Mt	SF
cm		kg	kg	kg	kg*m	kg*m	kg*m				
0	1	52623	18993	18993	1818	1818	1566	>100	3.38	55.5	3.38

Asta : 812 [450 , 189]

Sez. G: O 114.3x7.1 L=243.9 cm Crit.: Acciaio_Flessione $\gamma_M=1.05$ $f_{yk}/\gamma_M=2619$ kg/cm² $f_t=4300$ kg/cm²

:Verificato

X	cls	N	TY	TZ	MT	MY	MZ	My4	Mz4	Comb.
cm		kg	kg	kg	kg*m	kg*m	kg*m			
244	1	-41480	-19	395	0	619	25	--	--	2

X	cls	Nr	Vyr	Vzr	Mry	Mrz	MTrd	SF_V.	SF_M	SF_Mt	SF
cm		kg	kg	kg	kg*m	kg*m	kg*m				
244	1	62625	23014	23014	2140	2140	1826	58.3	1.04	>100	1.04

AUTOSTRADA VALDASTICO A31 NORD
1° LOTTO - PIOVENE ROCCHETTE – VALLE DELL'ASTICO

Asta : 813 [450 , 441]

Sez. G: O 114.3x5.9 L=243.9 cm Crit.: Acciaio_Flessione $\gamma_M=1.05$ $f_{yk}/\gamma_M=2619$ kg/cm² $f_t=4300$ kg/cm²

:Verificato

X	cls	N	TY	TZ	MT	MY	MZ	My4	Mz4	Comb.
cm		kg	kg	kg	kg*m	kg*m	kg*m			
244	1	9513	-42	39	2	98	50	--	--	2

X	cls	Nr	Vyr	Vzr	Mry	Mrz	MTrd	SF_V.	SF_M	SF_Mt	SF
cm		kg	kg	kg	kg*m	kg*m	kg*m				
244	1	52623	19311	19311	1818	1818	1566	>100	3.82	>100	3.82

Asta : 814 [449 , 450]

Sez. G: O 114.3x5.9 L=315.7 cm Crit.: Acciaio_Flessione $\gamma_M=1.05$ $f_{yk}/\gamma_M=2619$ kg/cm² $f_t=4300$ kg/cm²

:Verificato

X	cls	N	TY	TZ	MT	MY	MZ	My4	Mz4	Comb.
cm		kg	kg	kg	kg*m	kg*m	kg*m			
316	1	-12691	-32	1213	27	620	52	--	--	2

X	cls	Nr	Vyr	Vzr	Mry	Mrz	MTrd	SF_V.	SF_M	SF_Mt	SF
cm		kg	kg	kg	kg*m	kg*m	kg*m				
316	1	52623	19006	19006	1818	1818	1566	15.7	1.64	57.7	1.64

Asta : 815 [450 , 451]

Sez. G: O 114.3x5.9 L=318.3 cm Crit.: Acciaio_Flessione $\gamma_M=1.05$ $f_{yk}/\gamma_M=2619$ kg/cm² $f_t=4300$ kg/cm²

:Verificato

X	cls	N	TY	TZ	MT	MY	MZ	My4	Mz4	Comb.
cm		kg	kg	kg	kg*m	kg*m	kg*m			
0	1	21009	-13	-1212	7	703	-21	--	--	2

X	cls	Nr	Vyr	Vzr	Mry	Mrz	MTrd	SF_V.	SF_M	SF_Mt	SF
cm		kg	kg	kg	kg*m	kg*m	kg*m				
0	1	52623	19255	19255	1818	1818	1566	15.9	1.25	>100	1.25

AUTOSTRADA VALDASTICO A31 NORD
1° LOTTO - PIOVENE ROCCHETTE – VALLE DELL'ASTICO

Asta : 816 [439 , 450]

Sez. G: O 114.3x5.9 L=243.9 cm Crit.: Acciaio_Flessione $\gamma_M=1.05$ $f_{yk}/\gamma_M=2619$ kg/cmq $f_t=4300$ kg/cmq

:Verificato

X	cls	N	TY	TZ	MT	MY	MZ	My4	Mz4	Comb.
cm		kg	kg	kg	kg*m	kg*m	kg*m			
244	1	9613	7	8	-5	-46	-5	--	--	2

X	cls	Nr	Vyr	Vzr	Mry	Mrz	MTrd	SF_V.	SF_M	SF_Mt	SF
cm		kg	kg	kg	kg*m	kg*m	kg*m				
244	1	52623	19280	19280	1818	1818	1566	>100	4.75	>100	4.75

Asta : 817 [449 , 190]

Sez. G: O 114.3x5.9 L=264.3 cm Crit.: Acciaio_Flessione $\gamma_M=1.05$ $f_{yk}/\gamma_M=2619$ kg/cmq $f_t=4300$ kg/cmq

:Verificato

X	cls	N	TY	TZ	MT	MY	MZ	My4	Mz4	Comb.
cm		kg	kg	kg	kg*m	kg*m	kg*m			
264	1	-7545	18	8	-16	-31	-42	--	--	2

X	cls	Nr	Vyr	Vzr	Mry	Mrz	MTrd	SF_V.	SF_M	SF_Mt	SF
cm		kg	kg	kg	kg*m	kg*m	kg*m				
264	1	52623	19144	19144	1818	1818	1566	>100	5.44	97.9	5.44

Asta : 818 [190 , 450]

Sez. G: O 114.3x5.9 L=243.9 cm Crit.: Acciaio_Flessione $\gamma_M=1.05$ $f_{yk}/\gamma_M=2619$ kg/cmq $f_t=4300$ kg/cmq

:Verificato

X	cls	N	TY	TZ	MT	MY	MZ	My4	Mz4	Comb.
cm		kg	kg	kg	kg*m	kg*m	kg*m			
244	1	10099	36	11	25	31	-69	--	--	2

X	cls	Nr	Vyr	Vzr	Mry	Mrz	MTrd	SF_V.	SF_M	SF_Mt	SF
cm		kg	kg	kg	kg*m	kg*m	kg*m				

AUTOSTRADA VALDASTICO A31 NORD
1° LOTTO - PIOVENE ROCCHETTE – VALLE DELL'ASTICO

X	cls	Nr	Vyr	Vzr	Mry	Mrz	MTrd	SF_V.	SF_M	SF_Mt	SF
244	1	52623	19037	19037	1818	1818	1566	>100	4.06	63.4	4.06

Asta : 819 [439 , 441]

Sez. G: O 114.3x5.9 L=314.0 cm Crit.: Acciaio_Flessione $\gamma_M=1.05$ $f_{yk}/\gamma_M=2619$ kg/cm² $f_t=4300$ kg/cm²

:Verificato

X	cls	N	TY	TZ	MT	MY	MZ	My4	Mz4	Comb.
cm		kg	kg	kg	kg*m	kg*m	kg*m			
314	1	-1449	28	63	36	77	-46	--	--	2

X	cls	Nr	Vyr	Vzr	Mry	Mrz	MTrd	SF_V.	SF_M	SF_Mt	SF
cm		kg	kg	kg	kg*m	kg*m	kg*m				
314	1	52623	18893	18893	1818	1818	1566	>100	10.5	43.1	10.5

Asta : 820 [441 , 189]

Sez. G: O 114.3x5.9 L=247.0 cm Crit.: Acciaio_Flessione $\gamma_M=1.05$ $f_{yk}/\gamma_M=2619$ kg/cm² $f_t=4300$ kg/cm²

:Verificato

X	cls	N	TY	TZ	MT	MY	MZ	My4	Mz4	Comb.
cm		kg	kg	kg	kg*m	kg*m	kg*m			
247	1	-22367	-6	296	43	468	12	--	--	2

X	cls	Nr	Vyr	Vzr	Mry	Mrz	MTrd	SF_V.	SF_M	SF_Mt	SF
cm		kg	kg	kg	kg*m	kg*m	kg*m				
247	1	52623	18817	18817	1818	1818	1566	63.6	1.45	36.8	1.45

Asta : 821 [189 , 451]

Sez. G: O 114.3x5.9 L=218.3 cm Crit.: Acciaio_Flessione $\gamma_M=1.05$ $f_{yk}/\gamma_M=2619$ kg/cm² $f_t=4300$ kg/cm²

:Verificato

X	cls	N	TY	TZ	MT	MY	MZ	My4	Mz4	Comb.
cm		kg	kg	kg	kg*m	kg*m	kg*m			
0	1	-21434	-67	-139	76	166	-123	--	--	2

AUTOSTRADA VALDASTICO A31 NORD
1° LOTTO - PIOVENE ROCCHETTE – VALLE DELL'ASTICO

X	cls	Nr	Vyr	Vzr	Mry	Mrz	MTrd	SF_V.	SF_M	SF_Mt	SF
cm		kg	kg	kg	kg*m	kg*m	kg*m				
0	1	52623	18397	18397	1818	1818	1566	>100	1.77	20.5	1.77

Asta : 822 [451 , 443]

Sez. G: O 114.3x5.9 L=218.3 cm Crit.: Acciaio_Flessione $\gamma_M=1.05$ $f_{yk}/\gamma_M=2619$ kg/cm² $f_t=4300$ kg/cm²

:Verificato

X	cls	N	TY	TZ	MT	MY	MZ	My4	Mz4	Comb.
cm		kg	kg	kg	kg*m	kg*m	kg*m			
0	1	7244	-19	-57	9	74	-14	--	--	2

X	cls	Nr	Vyr	Vzr	Mry	Mrz	MTrd	SF_V.	SF_M	SF_Mt	SF
cm		kg	kg	kg	kg*m	kg*m	kg*m				
0	1	52623	19235	19235	1818	1818	1566	>100	5.37	>100	5.37

Asta : 823 [451 , 188]

Sez. G: O 114.3x5.9 L=218.3 cm Crit.: Acciaio_Flessione $\gamma_M=1.05$ $f_{yk}/\gamma_M=2619$ kg/cm² $f_t=4300$ kg/cm²

:Verificato

X	cls	N	TY	TZ	MT	MY	MZ	My4	Mz4	Comb.
cm		kg	kg	kg	kg*m	kg*m	kg*m			
218	1	7065	41	66	-41	157	-59	--	--	2

X	cls	Nr	Vyr	Vzr	Mry	Mrz	MTrd	SF_V.	SF_M	SF_Mt	SF
cm		kg	kg	kg	kg*m	kg*m	kg*m				
218	1	52623	18839	18839	1818	1818	1566	>100	3.95	38.5	3.95

Asta : 824 [443 , 441]

Sez. G: O 114.3x5.9 L=314.0 cm Crit.: Acciaio_Flessione $\gamma_M=1.05$ $f_{yk}/\gamma_M=2619$ kg/cm² $f_t=4300$ kg/cm²

:Verificato

X	cls	N	TY	TZ	MT	MY	MZ	My4	Mz4	Comb.
cm		kg	kg	kg	kg*m	kg*m	kg*m			
314	1	-5149	-0	38	-4	46	-0	--	--	2

AUTOSTRADA VALDASTICO A31 NORD
1° LOTTO - PIOVENE ROCCHETTE – VALLE DELL'ASTICO

X	cls	Nr	Vyr	Vzr	Mry	Mrz	MTrd	SF_V.	SF_M	SF_Mt	SF
cm		kg	kg	kg	kg*m	kg*m	kg*m				
314	1	52623	19289	19289	1818	1818	1566	>100	8.10	>100	8.10

Asta : 825 [188 , 443]

Sez. G: O 114.3x5.9 L=247.0 cm Crit.: Acciaio_Flessione $\gamma_M=1.05$ $f_{yk}/\gamma_M=2619$ kg/cm² $f_t=4300$ kg/cm²

:Verificato

X	cls	N	TY	TZ	MT	MY	MZ	My4	Mz4	Comb.
cm		kg	kg	kg	kg*m	kg*m	kg*m			
0	1	-12071	6	-118	21	240	1	--	--	2

X	cls	Nr	Vyr	Vzr	Mry	Mrz	MTrd	SF_V.	SF_M	SF_Mt	SF
cm		kg	kg	kg	kg*m	kg*m	kg*m				
0	1	52623	19083	19083	1818	1818	1566	>100	2.76	74.7	2.76

Asta : 826 [402 , 417]

Sez. G: O 114.3x5.9 L=218.3 cm Crit.: Acciaio_Flessione $\gamma_M=1.05$ $f_{yk}/\gamma_M=2619$ kg/cm² $f_t=4300$ kg/cm²

:Verificato

X	cls	N	TY	TZ	MT	MY	MZ	My4	Mz4	Comb.
cm		kg	kg	kg	kg*m	kg*m	kg*m			
87	1	-826	-13	-11	3	-28	-9	--	--	2

X	cls	Nr	Vyr	Vzr	Mry	Mrz	MTrd	SF_V.	SF_M	SF_Mt	SF
cm		kg	kg	kg	kg*m	kg*m	kg*m				
87	1	52623	19307	19307	1818	1818	1566	>100	27.9	>100	27.9

Asta : 827 [425 , 442]

Sez. G: O 114.3x5.9 L=218.3 cm Crit.: Acciaio_Flessione $\gamma_M=1.05$ $f_{yk}/\gamma_M=2619$ kg/cm² $f_t=4300$ kg/cm²

:Verificato

X	cls	N	TY	TZ	MT	MY	MZ	My4	Mz4	Comb.
cm		kg	kg	kg	kg*m	kg*m	kg*m			

AUTOSTRADA VALDASTICO A31 NORD
1° LOTTO - PIOVENE ROCCHETTE – VALLE DELL'ASTICO

X	cls	N	TY	TZ	MT	MY	MZ	My4	Mz4	Comb.
153	1	1354	-2	-3	2	-30	-2	--	--	2

X	cls	Nr	Vyr	Vzr	Mry	Mrz	MTrd	SF_V.	SF_M	SF_Mt	SF
cm		kg	kg	kg	kg*m	kg*m	kg*m				
153	1	52623	19316	19316	1818	1818	1566	>100	23.1	>100	23.1

Asta : 828 [441 , 451]

Sez. G: O 114.3x5.9 L=218.3 cm Crit.: Acciaio_Flessione $\gamma_M=1.05$ $f_{yk}/\gamma_M=2619$ kg/cm² $f_t=4300$ kg/cm²

:Verificato

X	cls	N	TY	TZ	MT	MY	MZ	My4	Mz4	Comb.
cm		kg	kg	kg	kg*m	kg*m	kg*m			
218	1	8873	19	29	-12	51	-15	--	--	2

X	cls	Nr	Vyr	Vzr	Mry	Mrz	MTrd	SF_V.	SF_M	SF_Mt	SF
cm		kg	kg	kg	kg*m	kg*m	kg*m				
218	1	52623	19190	19190	1818	1818	1566	>100	4.89	>100	4.89

Asta : 829 [189 , 204]

Sez. G: O 114.3x5.9 L=229.9 cm Crit.: Acciaio_Flessione $\gamma_M=1.05$ $f_{yk}/\gamma_M=2619$ kg/cm² $f_t=4300$ kg/cm²

:Verificato

X	cls	N	TY	TZ	MT	MY	MZ	My4	Mz4	Comb.
cm		kg	kg	kg	kg*m	kg*m	kg*m			
46	1	-23191	-2	0	-26	-42	18	--	--	2

X	cls	Nr	Vyr	Vzr	Mry	Mrz	MTrd	SF_V.	SF_M	SF_Mt	SF
cm		kg	kg	kg	kg*m	kg*m	kg*m				
46	1	52623	19024	19024	1818	1818	1566	>100	2.11	60.9	2.11

Asta : 830 [212 , 221]

Sez. G: O 114.3x5.9 L=229.9 cm Crit.: Acciaio_Flessione $\gamma_M=1.05$ $f_{yk}/\gamma_M=2619$ kg/cm² $f_t=4300$ kg/cm²

:Verificato

AUTOSTRADA VALDASTICO A31 NORD
1° LOTTO - PIOVENE ROCCHETTE – VALLE DELL'ASTICO

X	cls	N	TY	TZ	MT	MY	MZ	My4	Mz4	Comb.
cm		kg	kg	kg	kg*m	kg*m	kg*m			
0	1	-6514	-25	-57	5	41	-30	--	--	2

X	cls	Nr	Vyr	Vzr	Mry	Mrz	MTrd	SF_V.	SF_M	SF_Mt	SF
cm		kg	kg	kg	kg*m	kg*m	kg*m				
0	1	52623	19282	19282	1818	1818	1566	>100	6.14	>100	6.14

Asta : 831 [229 , 238]

Sez. G: O 114.3x5.9 L=229.9 cm Crit.: Acciaio_Flessione $\gamma_M=1.05$ $f_{yk}/\gamma_M=2619$ kg/cm² $f_t=4300$ kg/cm²

:Verificato

X	cls	N	TY	TZ	MT	MY	MZ	My4	Mz4	Comb.
cm		kg	kg	kg	kg*m	kg*m	kg*m			
230	1	334	-3	-5	6	-37	-1	--	--	2

X	cls	Nr	Vyr	Vzr	Mry	Mrz	MTrd	SF_V.	SF_M	SF_Mt	SF
cm		kg	kg	kg	kg*m	kg*m	kg*m				
230	1	52623	19262	19262	1818	1818	1566	>100	36.9	>100	36.9

Asta : 832 [246 , 255]

Sez. G: O 114.3x5.9 L=229.9 cm Crit.: Acciaio_Flessione $\gamma_M=1.05$ $f_{yk}/\gamma_M=2619$ kg/cm² $f_t=4300$ kg/cm²

:Verificato

X	cls	N	TY	TZ	MT	MY	MZ	My4	Mz4	Comb.
cm		kg	kg	kg	kg*m	kg*m	kg*m			
230	1	7925	8	32	1	43	-11	--	--	2

X	cls	Nr	Vyr	Vzr	Mry	Mrz	MTrd	SF_V.	SF_M	SF_Mt	SF
cm		kg	kg	kg	kg*m	kg*m	kg*m				
230	1	52623	19328	19328	1818	1818	1566	>100	5.53	>100	5.53

Asta : 833 [263 , 272]

AUTOSTRADA VALDASTICO A31 NORD
1° LOTTO - PIOVENE ROCCHETTE – VALLE DELL'ASTICO

Sez. G: O 114.3x5.9 L=229.9 cm Crit.: Acciaio_Flessione $\gamma_M=1.05$ $f_{yk}/\gamma_M=2619$ kg/cmq $f_t=4300$ kg/cmq

:Verificato

X	cls	N	TY	TZ	MT	MY	MZ	My4	Mz4	Comb.
cm		kg	kg	kg	kg*m	kg*m	kg*m			
0	1	-18713	27	-107	-42	104	57	--	--	2

X	cls	Nr	Vyr	Vzr	Mry	Mrz	MTrd	SF_V.	SF_M	SF_Mt	SF
cm		kg	kg	kg	kg*m	kg*m	kg*m				
0	1	52623	18822	18822	1818	1818	1566	>100	2.25	37.2	2.25

Asta : 834 [280 , 289]

Sez. G: O 114.3x5.9 L=229.9 cm Crit.: Acciaio_Flessione $\gamma_M=1.05$ $f_{yk}/\gamma_M=2619$ kg/cmq $f_t=4300$ kg/cmq

:Verificato

X	cls	N	TY	TZ	MT	MY	MZ	My4	Mz4	Comb.
cm		kg	kg	kg	kg*m	kg*m	kg*m			
230	1	-4608	-21	-5	12	-43	17	--	--	2

X	cls	Nr	Vyr	Vzr	Mry	Mrz	MTrd	SF_V.	SF_M	SF_Mt	SF
cm		kg	kg	kg	kg*m	kg*m	kg*m				
230	1	52623	19188	19188	1818	1818	1566	>100	8.26	>100	8.26

Asta : 835 [297 , 306]

Sez. G: O 114.3x5.9 L=229.9 cm Crit.: Acciaio_Flessione $\gamma_M=1.05$ $f_{yk}/\gamma_M=2619$ kg/cmq $f_t=4300$ kg/cmq

:Verificato

X	cls	N	TY	TZ	MT	MY	MZ	My4	Mz4	Comb.
cm		kg	kg	kg	kg*m	kg*m	kg*m			
230	1	1458	1	-5	9	-44	-8	--	--	2

X	cls	Nr	Vyr	Vzr	Mry	Mrz	MTrd	SF_V.	SF_M	SF_Mt	SF
cm		kg	kg	kg	kg*m	kg*m	kg*m				
230	1	52623	19231	19231	1818	1818	1566	>100	17.8	>100	17.8

AUTOSTRADA VALDASTICO A31 NORD
1° LOTTO - PIOVENE ROCCHETTE – VALLE DELL'ASTICO

Asta : 836 [314 , 349]

Sez. G: O 114.3x5.9 L=229.9 cm Crit.: Acciaio_Flessione $\gamma_M=1.05$ $f_{yk}/\gamma_M=2619$ kg/cmq $f_t=4300$ kg/cmq

:Verificato

X	cls	N	TY	TZ	MT	MY	MZ	My4	Mz4	Comb.
cm		kg	kg	kg	kg*m	kg*m	kg*m			
230	1	9018	12	31	1	40	-16	--	--	2

X	cls	Nr	Vyr	Vzr	Mry	Mrz	MTrd	SF_V.	SF_M	SF_Mt	SF
cm		kg	kg	kg	kg*m	kg*m	kg*m				
230	1	52623	19330	19330	1818	1818	1566	>100	4.95	>100	4.95

Asta : 837 [317 , 332]

Sez. G: O 114.3x5.9 L=229.9 cm Crit.: Acciaio_Flessione $\gamma_M=1.05$ $f_{yk}/\gamma_M=2619$ kg/cmq $f_t=4300$ kg/cmq

:Verificato

X	cls	N	TY	TZ	MT	MY	MZ	My4	Mz4	Comb.
cm		kg	kg	kg	kg*m	kg*m	kg*m			
0	1	-19892	22	-92	-39	81	50	--	--	2

X	cls	Nr	Vyr	Vzr	Mry	Mrz	MTrd	SF_V.	SF_M	SF_Mt	SF
cm		kg	kg	kg	kg*m	kg*m	kg*m				
0	1	52623	18862	18862	1818	1818	1566	>100	2.22	40.3	2.22

Asta : 838 [340 , 357]

Sez. G: O 114.3x5.9 L=229.9 cm Crit.: Acciaio_Flessione $\gamma_M=1.05$ $f_{yk}/\gamma_M=2619$ kg/cmq $f_t=4300$ kg/cmq

:Verificato

X	cls	N	TY	TZ	MT	MY	MZ	My4	Mz4	Comb.
cm		kg	kg	kg	kg*m	kg*m	kg*m			
230	1	-5096	-22	-6	11	-41	19	--	--	2

X	cls	Nr	Vyr	Vzr	Mry	Mrz	MTrd	SF_V.	SF_M	SF_Mt	SF
cm		kg	kg	kg	kg*m	kg*m	kg*m				
230	1	52623	19200	19200	1818	1818	1566	>100	7.71	>100	7.71

AUTOSTRADA VALDASTICO A31 NORD
1° LOTTO - PIOVENE ROCCHETTE – VALLE DELL'ASTICO

Asta : 839 [365 , 374]

Sez. G: O 114.3x5.9 L=229.9 cm Crit.: Acciaio_Flessione $\gamma_M=1.05$ $f_{yk}/\gamma_M=2619$ kg/cmq $f_t=4300$ kg/cmq

:Verificato

X	cls	N	TY	TZ	MT	MY	MZ	My4	Mz4	Comb.
cm		kg	kg	kg	kg*m	kg*m	kg*m			
230	1	997	0	-5	8	-41	-7	--	--	2

X	cls	Nr	Vyr	Vzr	Mry	Mrz	MTrd	SF_V.	SF_M	SF_Mt	SF
cm		kg	kg	kg	kg*m	kg*m	kg*m				
230	1	52623	19238	19238	1818	1818	1566	>100	22.1	>100	22.1

Asta : 840 [382 , 391]

Sez. G: O 114.3x5.9 L=229.9 cm Crit.: Acciaio_Flessione $\gamma_M=1.05$ $f_{yk}/\gamma_M=2619$ kg/cmq $f_t=4300$ kg/cmq

:Verificato

X	cls	N	TY	TZ	MT	MY	MZ	My4	Mz4	Comb.
cm		kg	kg	kg	kg*m	kg*m	kg*m			
230	1	8030	13	26	1	32	-17	--	--	2

X	cls	Nr	Vyr	Vzr	Mry	Mrz	MTrd	SF_V.	SF_M	SF_Mt	SF
cm		kg	kg	kg	kg*m	kg*m	kg*m				
230	1	52623	19330	19330	1818	1818	1566	>100	5.57	>100	5.57

Asta : 841 [392 , 461]

Sez. G: O 114.3x5.9 L=263.5 cm Crit.: Acciaio_Flessione $\gamma_M=1.05$ $f_{yk}/\gamma_M=2619$ kg/cmq $f_t=4300$ kg/cmq

:Verificato

X	cls	N	TY	TZ	MT	MY	MZ	My4	Mz4	Comb.
cm		kg	kg	kg	kg*m	kg*m	kg*m			
263	1	-3781	9	29	17	38	-14	--	--	2

X	cls	Nr	Vyr	Vzr	Mry	Mrz	MTrd	SF_V.	SF_M	SF_Mt	SF
cm		kg	kg	kg	kg*m	kg*m	kg*m				

AUTOSTRADA VALDASTICO A31 NORD
1° LOTTO - PIOVENE ROCCHETTE – VALLE DELL'ASTICO

X	cls	Nr	Vyr	Vzr	Mry	Mrz	MTrd	SF_V.	SF_M	SF_Mt	SF
263	1	52623	19128	19128	1818	1818	1566	>100	9.96	90.7	9.96

Asta : 842 [461 , 478]

Sez. G: O 114.3x5.9 L=263.5 cm Crit.: Acciaio_Flessione $\gamma_M=1.05$ $f_{yk}/\gamma_M=2619$ kg/cm² $f_t=4300$ kg/cm²

:Verificato

X	cls	N	TY	TZ	MT	MY	MZ	My4	Mz4	Comb.
cm		kg	kg	kg	kg*m	kg*m	kg*m			
0	1	-499	4	-47	9	38	4	--	--	2

X	cls	Nr	Vyr	Vzr	Mry	Mrz	MTrd	SF_V.	SF_M	SF_Mt	SF
cm		kg	kg	kg	kg*m	kg*m	kg*m				
0	1	52623	19236	19236	1818	1818	1566	>100	30.7	>100	30.7

Asta : 843 [393 , 460]

Sez. G: O 114.3x5.9 L=263.5 cm Crit.: Acciaio_Flessione $\gamma_M=1.05$ $f_{yk}/\gamma_M=2619$ kg/cm² $f_t=4300$ kg/cm²

:Verificato

X	cls	N	TY	TZ	MT	MY	MZ	My4	Mz4	Comb.
cm		kg	kg	kg	kg*m	kg*m	kg*m			
0	1	-11249	-1	-144	32	206	-4	--	--	2

X	cls	Nr	Vyr	Vzr	Mry	Mrz	MTrd	SF_V.	SF_M	SF_Mt	SF
cm		kg	kg	kg	kg*m	kg*m	kg*m				
0	1	52623	18947	18947	1818	1818	1566	>100	3.04	49.0	3.04

Asta : 844 [460 , 477]

Sez. G: O 114.3x5.9 L=263.5 cm Crit.: Acciaio_Flessione $\gamma_M=1.05$ $f_{yk}/\gamma_M=2619$ kg/cm² $f_t=4300$ kg/cm²

:Verificato

X	cls	N	TY	TZ	MT	MY	MZ	My4	Mz4	Comb.
cm		kg	kg	kg	kg*m	kg*m	kg*m			
211	1	-340	-11	13	-6	-17	9	--	--	2

AUTOSTRADA VALDASTICO A31 NORD
1° LOTTO - PIOVENE ROCCHETTE – VALLE DELL'ASTICO

X	cls	Nr	Vyr	Vzr	Mry	Mrz	MTrd	SF_V.	SF_M	SF_Mt	SF
cm		kg	kg	kg	kg*m	kg*m	kg*m				
211	1	52623	19271	19271	1818	1818	1566	>100	48.6	>100	48.6

Asta : 845 [460 , 461]

Sez. G: O 114.3x5.9 L=314.0 cm Crit.: Acciaio_Flessione $\gamma_M=1.05$ $f_{yk}/\gamma_M=2619$ kg/cm² $f_t=4300$ kg/cm²

:Verificato

X	cls	N	TY	TZ	MT	MY	MZ	My4	Mz4	Comb.
cm		kg	kg	kg	kg*m	kg*m	kg*m			
0	1	-3726	-4	-36	-10	37	-6	--	--	2

X	cls	Nr	Vyr	Vzr	Mry	Mrz	MTrd	SF_V.	SF_M	SF_Mt	SF
cm		kg	kg	kg	kg*m	kg*m	kg*m				
0	1	52623	19219	19219	1818	1818	1566	>100	10.5	>100	10.5

Asta : 846 [477 , 478]

Sez. G: O 114.3x5.9 L=314.0 cm Crit.: Acciaio_Flessione $\gamma_M=1.05$ $f_{yk}/\gamma_M=2619$ kg/cm² $f_t=4300$ kg/cm²

:Verificato

X	cls	N	TY	TZ	MT	MY	MZ	My4	Mz4	Comb.
cm		kg	kg	kg	kg*m	kg*m	kg*m			
314	1	365	-2	35	-1	21	1	--	--	2

X	cls	Nr	Vyr	Vzr	Mry	Mrz	MTrd	SF_V.	SF_M	SF_Mt	SF
cm		kg	kg	kg	kg*m	kg*m	kg*m				
314	1	52623	19332	19332	1818	1818	1566	>100	52.0	>100	52.0

Asta : 847 [393 , 392]

Sez. G: O 114.3x5.9 L=314.0 cm Crit.: Acciaio_Flessione $\gamma_M=1.05$ $f_{yk}/\gamma_M=2619$ kg/cm² $f_t=4300$ kg/cm²

:Verificato

X	cls	N	TY	TZ	MT	MY	MZ	My4	Mz4	Comb.
cm		kg	kg	kg	kg*m	kg*m	kg*m			
314	1	-6987	-1	40	0	28	1	--	--	2

AUTOSTRADA VALDASTICO A31 NORD
1° LOTTO - PIOVENE ROCCHETTE – VALLE DELL'ASTICO

X	cls	Nr	Vyr	Vzr	Mry	Mrz	MTrd	SF_V.	SF_M	SF_Mt	SF
cm		kg	kg	kg	kg*m	kg*m	kg*m				
314	1	52623	19341	19341	1818	1818	1566	>100	6.72	>100	6.72

Asta : 848 [392 , 462]

Sez. G: O 114.3x5.9 L=223.0 cm Crit.: Acciaio_Flessione $\gamma_M=1.05$ fyk/ $\gamma_M=2619$ kg/cmq ft=4300 kg/cmq

:Verificato

X	cls	N	TY	TZ	MT	MY	MZ	My4	Mz4	Comb.
cm		kg	kg	kg	kg*m	kg*m	kg*m			
223	1	4858	5	53	-0	88	-9	--	--	2

X	cls	Nr	Vyr	Vzr	Mry	Mrz	MTrd	SF_V.	SF_M	SF_Mt	SF
cm		kg	kg	kg	kg*m	kg*m	kg*m				
223	1	52623	19337	19337	1818	1818	1566	>100	6.86	>100	6.86

Asta : 849 [462 , 461]

Sez. G: O 114.3x5.9 L=223.0 cm Crit.: Acciaio_Flessione $\gamma_M=1.05$ fyk/ $\gamma_M=2619$ kg/cmq ft=4300 kg/cmq

:Verificato

X	cls	N	TY	TZ	MT	MY	MZ	My4	Mz4	Comb.
cm		kg	kg	kg	kg*m	kg*m	kg*m			
0	1	3818	-8	-60	-3	58	-9	--	--	2

X	cls	Nr	Vyr	Vzr	Mry	Mrz	MTrd	SF_V.	SF_M	SF_Mt	SF
cm		kg	kg	kg	kg*m	kg*m	kg*m				
0	1	52623	19301	19301	1818	1818	1566	>100	9.12	>100	9.12

Asta : 850 [393 , 462]

Sez. G: O 114.3x5.9 L=223.0 cm Crit.: Acciaio_Flessione $\gamma_M=1.05$ fyk/ $\gamma_M=2619$ kg/cmq ft=4300 kg/cmq

:Verificato

X	cls	N	TY	TZ	MT	MY	MZ	My4	Mz4	Comb.
cm		kg	kg	kg	kg*m	kg*m	kg*m			

AUTOSTRADA VALDASTICO A31 NORD
1° LOTTO - PIOVENE ROCCHETTE – VALLE DELL'ASTICO

X	cls	N	TY	TZ	MT	MY	MZ	My4	Mz4	Comb.
0	1	-16235	-18	-76	30	60	-41	--	--	2

X	cls	Nr	Vyr	Vzr	Mry	Mrz	MTrd	SF_V.	SF_M	SF_Mt	SF
cm		kg	kg	kg	kg*m	kg*m	kg*m				
0	1	52623	18972	18972	1818	1818	1566	>100	2.75	52.4	2.75

Asta : 851 [462 , 460]

Sez. G: O 114.3x5.9 L=223.0 cm Crit.: Acciaio_Flessione $\gamma_M=1.05$ $f_{yk}/\gamma_M=2619$ kg/cm² $f_t=4300$ kg/cm²

:Verificato

X	cls	N	TY	TZ	MT	MY	MZ	My4	Mz4	Comb.
cm		kg	kg	kg	kg*m	kg*m	kg*m			
0	1	6211	4	-27	-4	38	3	--	--	2

X	cls	Nr	Vyr	Vzr	Mry	Mrz	MTrd	SF_V.	SF_M	SF_Mt	SF
cm		kg	kg	kg	kg*m	kg*m	kg*m				
0	1	52623	19288	19288	1818	1818	1566	>100	7.13	>100	7.13

Asta : 852 [461 , 479]

Sez. G: O 114.3x5.9 L=223.6 cm Crit.: Acciaio_Flessione $\gamma_M=1.05$ $f_{yk}/\gamma_M=2619$ kg/cm² $f_t=4300$ kg/cm²

:Verificato

X	cls	N	TY	TZ	MT	MY	MZ	My4	Mz4	Comb.
cm		kg	kg	kg	kg*m	kg*m	kg*m			
0	1	-1103	-0	-26	2	35	-3	--	--	2

X	cls	Nr	Vyr	Vzr	Mry	Mrz	MTrd	SF_V.	SF_M	SF_Mt	SF
cm		kg	kg	kg	kg*m	kg*m	kg*m				
0	1	52623	19320	19320	1818	1818	1566	>100	23.9	>100	23.9

Asta : 853 [479 , 478]

Sez. G: O 114.3x5.9 L=222.5 cm Crit.: Acciaio_Flessione $\gamma_M=1.05$ $f_{yk}/\gamma_M=2619$ kg/cm² $f_t=4300$ kg/cm²

:Verificato

AUTOSTRADA VALDASTICO A31 NORD
1° LOTTO - PIOVENE ROCCHETTE – VALLE DELL'ASTICO

X	cls	N	TY	TZ	MT	MY	MZ	My4	Mz4	Comb.
cm		kg	kg	kg	kg*m	kg*m	kg*m			
0	1	-11	1	-38	-9	24	-4	--	--	2

X	cls	Nr	Vyr	Vzr	Mry	Mrz	MTrd	SF_V.	SF_M	SF_Mt	SF
cm		kg	kg	kg	kg*m	kg*m	kg*m				
0	1	52623	19235	19235	1818	1818	1566	>100	64.1	>100	64.1

Asta : 854 [460 , 479]

Sez. G: O 114.3x5.9 L=223.6 cm Crit.: Acciaio_Flessione $\gamma_M=1.05$ $f_{yk}/\gamma_M=2619$ kg/cm² $f_t=4300$ kg/cm²

:Verificato

X	cls	N	TY	TZ	MT	MY	MZ	My4	Mz4	Comb.
cm		kg	kg	kg	kg*m	kg*m	kg*m			
0	1	-3236	15	-33	-6	19	19	--	--	2

X	cls	Nr	Vyr	Vzr	Mry	Mrz	MTrd	SF_V.	SF_M	SF_Mt	SF
cm		kg	kg	kg	kg*m	kg*m	kg*m				
0	1	52623	19272	19272	1818	1818	1566	>100	12.2	>100	12.2

Asta : 855 [479 , 477]

Sez. G: O 114.3x5.9 L=222.5 cm Crit.: Acciaio_Flessione $\gamma_M=1.05$ $f_{yk}/\gamma_M=2619$ kg/cm² $f_t=4300$ kg/cm²

:Verificato

X	cls	N	TY	TZ	MT	MY	MZ	My4	Mz4	Comb.
cm		kg	kg	kg	kg*m	kg*m	kg*m			
156	1	1191	-9	9	2	-13	8	--	--	2

X	cls	Nr	Vyr	Vzr	Mry	Mrz	MTrd	SF_V.	SF_M	SF_Mt	SF
cm		kg	kg	kg	kg*m	kg*m	kg*m				
156	1	52623	19313	19313	1818	1818	1566	>100	29.6	>100	29.6

Asta : 856 [393 , 394]

AUTOSTRADA VALDASTICO A31 NORD
1° LOTTO - PIOVENE ROCCHETTE – VALLE DELL'ASTICO

Sez. G: O 114.3x5.9 L=314.0 cm Crit.: Acciaio_Flessione $\gamma_M=1.05$ $f_{yk}/\gamma_M=2619$ kg/cm² $f_t=4300$ kg/cm²

:Verificato

X	cls	N	TY	TZ	MT	MY	MZ	My4	Mz4	Comb.
cm		kg	kg	kg	kg*m	kg*m	kg*m			
0	1	-4227	2	-199	5	340	3	--	--	2

X	cls	Nr	Vyr	Vzr	Mry	Mrz	MTrd	SF_V.	SF_M	SF_Mt	SF
cm		kg	kg	kg	kg*m	kg*m	kg*m				
0	1	52623	19282	19282	1818	1818	1566	97.0	3.72	>100	3.72

Asta : 857 [394 , 459]

Sez. G: O 114.3x5.9 L=263.5 cm Crit.: Acciaio_Flessione $\gamma_M=1.05$ $f_{yk}/\gamma_M=2619$ kg/cm² $f_t=4300$ kg/cm²

:Verificato

X	cls	N	TY	TZ	MT	MY	MZ	My4	Mz4	Comb.
cm		kg	kg	kg	kg*m	kg*m	kg*m			
0	1	-4571	-14	-38	-18	41	-19	--	--	2

X	cls	Nr	Vyr	Vzr	Mry	Mrz	MTrd	SF_V.	SF_M	SF_Mt	SF
cm		kg	kg	kg	kg*m	kg*m	kg*m				
0	1	52623	19118	19118	1818	1818	1566	>100	8.32	86.4	8.32

Asta : 858 [459 , 476]

Sez. G: O 114.3x5.9 L=263.5 cm Crit.: Acciaio_Flessione $\gamma_M=1.05$ $f_{yk}/\gamma_M=2619$ kg/cm² $f_t=4300$ kg/cm²

:Verificato

X	cls	N	TY	TZ	MT	MY	MZ	My4	Mz4	Comb.
cm		kg	kg	kg	kg*m	kg*m	kg*m			
0	1	-280	-24	-34	-14	19	-31	--	--	2

X	cls	Nr	Vyr	Vzr	Mry	Mrz	MTrd	SF_V.	SF_M	SF_Mt	SF
cm		kg	kg	kg	kg*m	kg*m	kg*m				
0	1	52623	19168	19168	1818	1818	1566	>100	30.4	>100	30.4

AUTOSTRADA VALDASTICO A31 NORD
1° LOTTO - PIOVENE ROCCHETTE – VALLE DELL'ASTICO

Asta : 859 [476 , 477]

Sez. G: O 114.3x5.9 L=314.0 cm Crit.: Acciaio_Flessione $\gamma_M=1.05$ $f_{yk}/\gamma_M=2619$ kg/cm² $f_t=4300$ kg/cm²

:Verificato

X	cls	N	TY	TZ	MT	MY	MZ	My4	Mz4	Comb.
cm		kg	kg	kg	kg*m	kg*m	kg*m			
0	1	1626	17	-38	13	23	26	--	--	2

X	cls	Nr	Vyr	Vzr	Mry	Mrz	MTrd	SF_V.	SF_M	SF_Mt	SF
cm		kg	kg	kg	kg*m	kg*m	kg*m				
0	1	52623	19180	19180	1818	1818	1566	>100	17.3	>100	17.3

Asta : 860 [460 , 459]

Sez. G: O 114.3x5.9 L=314.0 cm Crit.: Acciaio_Flessione $\gamma_M=1.05$ $f_{yk}/\gamma_M=2619$ kg/cm² $f_t=4300$ kg/cm²

:Verificato

X	cls	N	TY	TZ	MT	MY	MZ	My4	Mz4	Comb.
cm		kg	kg	kg	kg*m	kg*m	kg*m			
0	1	-474	18	-54	21	57	29	--	--	2

X	cls	Nr	Vyr	Vzr	Mry	Mrz	MTrd	SF_V.	SF_M	SF_Mt	SF
cm		kg	kg	kg	kg*m	kg*m	kg*m				
0	1	52623	19084	19084	1818	1818	1566	>100	17.7	75.0	17.7

Asta : 861 [394 , 463]

Sez. G: O 114.3x5.9 L=248.2 cm Crit.: Acciaio_Flessione $\gamma_M=1.05$ $f_{yk}/\gamma_M=2619$ kg/cm² $f_t=4300$ kg/cm²

:Verificato

X	cls	N	TY	TZ	MT	MY	MZ	My4	Mz4	Comb.
cm		kg	kg	kg	kg*m	kg*m	kg*m			
248	1	8041	25	17	12	25	-44	--	--	2

X	cls	Nr	Vyr	Vzr	Mry	Mrz	MTrd	SF_V.	SF_M	SF_Mt	SF
cm		kg	kg	kg	kg*m	kg*m	kg*m				
248	1	52623	19191	19191	1818	1818	1566	>100	5.25	>100	5.25

AUTOSTRADA VALDASTICO A31 NORD
1° LOTTO - PIOVENE ROCCHETTE – VALLE DELL'ASTICO

Asta : 862 [463 , 393]

Sez. G: O 114.3x5.9 L=248.2 cm Crit.: Acciaio_Flessione $\gamma_M=1.05$ $f_{yk}/\gamma_M=2619$ kg/cmq $f_t=4300$ kg/cmq

:Verificato

X	cls	N	TY	TZ	MT	MY	MZ	My4	Mz4	Comb.
cm		kg	kg	kg	kg*m	kg*m	kg*m			
248	1	-28982	-41	216	19	322	70	--	--	2

X	cls	Nr	Vyr	Vzr	Mry	Mrz	MTrd	SF_V.	SF_M	SF_Mt	SF
cm		kg	kg	kg	kg*m	kg*m	kg*m				
248	1	52623	19107	19107	1818	1818	1566	88.3	1.30	82.5	1.30

Asta : 863 [459 , 463]

Sez. G: O 114.3x5.9 L=248.2 cm Crit.: Acciaio_Flessione $\gamma_M=1.05$ $f_{yk}/\gamma_M=2619$ kg/cmq $f_t=4300$ kg/cmq

:Verificato

X	cls	N	TY	TZ	MT	MY	MZ	My4	Mz4	Comb.
cm		kg	kg	kg	kg*m	kg*m	kg*m			
174	1	6194	3	3	-3	-30	-1	--	--	2

X	cls	Nr	Vyr	Vzr	Mry	Mrz	MTrd	SF_V.	SF_M	SF_Mt	SF
cm		kg	kg	kg	kg*m	kg*m	kg*m				
174	1	52623	19305	19305	1818	1818	1566	>100	7.42	>100	7.42

Asta : 864 [463 , 460]

Sez. G: O 114.3x5.9 L=248.2 cm Crit.: Acciaio_Flessione $\gamma_M=1.05$ $f_{yk}/\gamma_M=2619$ kg/cmq $f_t=4300$ kg/cmq

:Verificato

X	cls	N	TY	TZ	MT	MY	MZ	My4	Mz4	Comb.
cm		kg	kg	kg	kg*m	kg*m	kg*m			
248	1	4060	-17	31	-2	58	19	--	--	2

X	cls	Nr	Vyr	Vzr	Mry	Mrz	MTrd	SF_V.	SF_M	SF_Mt	SF
cm		kg	kg	kg	kg*m	kg*m	kg*m				

AUTOSTRADA VALDASTICO A31 NORD
1° LOTTO - PIOVENE ROCCHETTE – VALLE DELL'ASTICO

X	cls	Nr	Vyr	Vzr	Mry	Mrz	MTrd	SF_V.	SF_M	SF_Mt	SF
248	1	52623	19314	19314	1818	1818	1566	>100	8.39	>100	8.39

Asta : 865 [459 , 480]

Sez. G: O 114.3x5.9 L=248.7 cm Crit.: Acciaio_Flessione $\gamma_M=1.05$ $f_{yk}/\gamma_M=2619$ kg/cm² $f_t=4300$ kg/cm²

:Verificato

X	cls	N	TY	TZ	MT	MY	MZ	My4	Mz4	Comb.
cm		kg	kg	kg	kg*m	kg*m	kg*m			
249	1	1140	8	19	3	22	-13	--	--	2

X	cls	Nr	Vyr	Vzr	Mry	Mrz	MTrd	SF_V.	SF_M	SF_Mt	SF
cm		kg	kg	kg	kg*m	kg*m	kg*m				
249	1	52623	19311	19311	1818	1818	1566	>100	24.4	>100	24.4

Asta : 866 [480 , 460]

Sez. G: O 114.3x5.9 L=248.7 cm Crit.: Acciaio_Flessione $\gamma_M=1.05$ $f_{yk}/\gamma_M=2619$ kg/cm² $f_t=4300$ kg/cm²

:Verificato

X	cls	N	TY	TZ	MT	MY	MZ	My4	Mz4	Comb.
cm		kg	kg	kg	kg*m	kg*m	kg*m			
149	1	-5919	-11	12	10	-16	10	--	--	2

X	cls	Nr	Vyr	Vzr	Mry	Mrz	MTrd	SF_V.	SF_M	SF_Mt	SF
cm		kg	kg	kg	kg*m	kg*m	kg*m				
149	1	52623	19219	19219	1818	1818	1566	>100	7.87	>100	7.87

Asta : 867 [476 , 480]

Sez. G: O 114.3x5.9 L=247.7 cm Crit.: Acciaio_Flessione $\gamma_M=1.05$ $f_{yk}/\gamma_M=2619$ kg/cm² $f_t=4300$ kg/cm²

:Verificato

X	cls	N	TY	TZ	MT	MY	MZ	My4	Mz4	Comb.
cm		kg	kg	kg	kg*m	kg*m	kg*m			
124	1	1666	-6	-4	4	-22	-4	--	--	2

AUTOSTRADA VALDASTICO A31 NORD
1° LOTTO - PIOVENE ROCCHETTE – VALLE DELL'ASTICO

X	cls	Nr	Vyr	Vzr	Mry	Mrz	MTrd	SF_V.	SF_M	SF_Mt	SF
cm		kg	kg	kg	kg*m	kg*m	kg*m				
124	1	52623	19296	19296	1818	1818	1566	>100	21.6	>100	21.6

Asta : 868 [480 , 477]

Sez. G: O 114.3x5.9 L=247.7 cm Crit.: Acciaio_Flessione $\gamma_M=1.05$ fyk/ $\gamma_M=2619$ kg/cm² ft=4300 kg/cm²

:Verificato

X	cls	N	TY	TZ	MT	MY	MZ	My4	Mz4	Comb.
cm		kg	kg	kg	kg*m	kg*m	kg*m			
0	1	-611	2	-33	0	32	2	--	--	2

X	cls	Nr	Vyr	Vzr	Mry	Mrz	MTrd	SF_V.	SF_M	SF_Mt	SF
cm		kg	kg	kg	kg*m	kg*m	kg*m				
0	1	52623	19341	19341	1818	1818	1566	>100	33.2	>100	33.2

Asta : 869 [394 , 395]

Sez. G: O 114.3x5.9 L=314.0 cm Crit.: Acciaio_Flessione $\gamma_M=1.05$ fyk/ $\gamma_M=2619$ kg/cm² ft=4300 kg/cm²

:Verificato

X	cls	N	TY	TZ	MT	MY	MZ	My4	Mz4	Comb.
cm		kg	kg	kg	kg*m	kg*m	kg*m			
126	1	10842	3	-0	2	-42	1	--	--	2

X	cls	Nr	Vyr	Vzr	Mry	Mrz	MTrd	SF_V.	SF_M	SF_Mt	SF
cm		kg	kg	kg	kg*m	kg*m	kg*m				
126	1	52623	19319	19319	1818	1818	1566	>100	4.35	>100	4.35

Asta : 870 [395 , 458]

Sez. G: O 114.3x5.9 L=263.5 cm Crit.: Acciaio_Flessione $\gamma_M=1.05$ fyk/ $\gamma_M=2619$ kg/cm² ft=4300 kg/cm²

:Verificato

X	cls	N	TY	TZ	MT	MY	MZ	My4	Mz4	Comb.
cm		kg	kg	kg	kg*m	kg*m	kg*m			
263	1	471	-7	29	-4	15	9	--	--	2

AUTOSTRADA VALDASTICO A31 NORD
1° LOTTO - PIOVENE ROCCHETTE – VALLE DELL'ASTICO

X	cls	Nr	Vyr	Vzr	Mry	Mrz	MTrd	SF_V.	SF_M	SF_Mt	SF
cm		kg	kg	kg	kg*m	kg*m	kg*m				
263	1	52623	19294	19294	1818	1818	1566	>100	44.9	>100	44.9

Asta : 871 [458 , 459]

Sez. G: O 114.3x5.9 L=314.0 cm Crit.: Acciaio_Flessione $\gamma_M=1.05$ $f_{yk}/\gamma_M=2619$ kg/cmq $f_t=4300$ kg/cmq

:Verificato

X	cls	N	TY	TZ	MT	MY	MZ	My4	Mz4	Comb.
cm		kg	kg	kg	kg*m	kg*m	kg*m			
63	1	7707	12	-14	11	-22	10	--	--	2

X	cls	Nr	Vyr	Vzr	Mry	Mrz	MTrd	SF_V.	SF_M	SF_Mt	SF
cm		kg	kg	kg	kg*m	kg*m	kg*m				
63	1	52623	19209	19209	1818	1818	1566	>100	6.09	>100	6.09

Asta : 872 [394 , 464]

Sez. G: O 114.3x5.9 L=268.2 cm Crit.: Acciaio_Flessione $\gamma_M=1.05$ $f_{yk}/\gamma_M=2619$ kg/cmq $f_t=4300$ kg/cmq

:Verificato

X	cls	N	TY	TZ	MT	MY	MZ	My4	Mz4	Comb.
cm		kg	kg	kg	kg*m	kg*m	kg*m			
0	1	-5151	16	-10	-11	-26	34	--	--	2

X	cls	Nr	Vyr	Vzr	Mry	Mrz	MTrd	SF_V.	SF_M	SF_Mt	SF
cm		kg	kg	kg	kg*m	kg*m	kg*m				
0	1	52623	19208	19208	1818	1818	1566	>100	7.66	>100	7.66

Asta : 873 [464 , 458]

Sez. G: O 114.3x5.9 L=268.2 cm Crit.: Acciaio_Flessione $\gamma_M=1.05$ $f_{yk}/\gamma_M=2619$ kg/cmq $f_t=4300$ kg/cmq

:Verificato

X	cls	N	TY	TZ	MT	MY	MZ	My4	Mz4	Comb.
cm		kg	kg	kg	kg*m	kg*m	kg*m			

AUTOSTRADA VALDASTICO A31 NORD
1° LOTTO - PIOVENE ROCCHETTE – VALLE DELL'ASTICO

X	cls	N	TY	TZ	MT	MY	MZ	My4	Mz4	Comb.
161	1	1023	2	1	-5	-20	-6	--	--	2

X	cls	Nr	Vyr	Vzr	Mry	Mrz	MTrd	SF_V.	SF_M	SF_Mt	SF
cm		kg	kg	kg	kg*m	kg*m	kg*m				
161	1	52623	19286	19286	1818	1818	1566	>100	29.9	>100	29.9

Asta : 874 [395 , 464]

Sez. G: O 114.3x5.9 L=268.2 cm Crit.: Acciaio_Flessione $\gamma_M=1.05$ $f_{yk}/\gamma_M=2619$ kg/cm² $f_t=4300$ kg/cm²

:Verificato

X	cls	N	TY	TZ	MT	MY	MZ	My4	Mz4	Comb.
cm		kg	kg	kg	kg*m	kg*m	kg*m			
80	1	2055	-2	-2	6	-12	-8	--	--	2

X	cls	Nr	Vyr	Vzr	Mry	Mrz	MTrd	SF_V.	SF_M	SF_Mt	SF
cm		kg	kg	kg	kg*m	kg*m	kg*m				
80	1	52623	19263	19263	1818	1818	1566	>100	20.1	>100	20.1

Asta : 875 [464 , 459]

Sez. G: O 114.3x5.9 L=268.2 cm Crit.: Acciaio_Flessione $\gamma_M=1.05$ $f_{yk}/\gamma_M=2619$ kg/cm² $f_t=4300$ kg/cm²

:Verificato

X	cls	N	TY	TZ	MT	MY	MZ	My4	Mz4	Comb.
cm		kg	kg	kg	kg*m	kg*m	kg*m			
268	1	-1458	-9	27	8	23	20	--	--	2

X	cls	Nr	Vyr	Vzr	Mry	Mrz	MTrd	SF_V.	SF_M	SF_Mt	SF
cm		kg	kg	kg	kg*m	kg*m	kg*m				
268	1	52623	19245	19245	1818	1818	1566	>100	19.6	>100	19.6

Asta : 876 [458 , 475]

Sez. G: O 114.3x5.9 L=263.5 cm Crit.: Acciaio_Flessione $\gamma_M=1.05$ $f_{yk}/\gamma_M=2619$ kg/cm² $f_t=4300$ kg/cm²

:Verificato

AUTOSTRADA VALDASTICO A31 NORD
1° LOTTO - PIOVENE ROCCHETTE – VALLE DELL'ASTICO

X	cls	N	TY	TZ	MT	MY	MZ	My4	Mz4	Comb.
cm		kg	kg	kg	kg*m	kg*m	kg*m			
0	1	-163	-14	-30	-6	14	-18	--	--	2

X	cls	Nr	Vyr	Vzr	Mry	Mrz	MTrd	SF_V.	SF_M	SF_Mt	SF
cm		kg	kg	kg	kg*m	kg*m	kg*m				
0	1	52623	19269	19269	1818	1818	1566	>100	48.5	>100	48.5

Asta : 877 [475 , 476]

Sez. G: O 114.3x5.9 L=314.0 cm Crit.: Acciaio_Flessione $\gamma_M=1.05$ $f_{yk}/\gamma_M=2619$ kg/cm² $f_t=4300$ kg/cm²

:Verificato

X	cls	N	TY	TZ	MT	MY	MZ	My4	Mz4	Comb.
cm		kg	kg	kg	kg*m	kg*m	kg*m			
314	1	3443	12	33	10	10	-19	--	--	2

X	cls	Nr	Vyr	Vzr	Mry	Mrz	MTrd	SF_V.	SF_M	SF_Mt	SF
cm		kg	kg	kg	kg*m	kg*m	kg*m				
314	1	52623	19215	19215	1818	1818	1566	>100	12.3	>100	12.3

Asta : 878 [459 , 481]

Sez. G: O 114.3x5.9 L=268.7 cm Crit.: Acciaio_Flessione $\gamma_M=1.05$ $f_{yk}/\gamma_M=2619$ kg/cm² $f_t=4300$ kg/cm²

:Verificato

X	cls	N	TY	TZ	MT	MY	MZ	My4	Mz4	Comb.
cm		kg	kg	kg	kg*m	kg*m	kg*m			
81	1	-4641	4	-3	-2	-25	3	--	--	2

X	cls	Nr	Vyr	Vzr	Mry	Mrz	MTrd	SF_V.	SF_M	SF_Mt	SF
cm		kg	kg	kg	kg*m	kg*m	kg*m				
81	1	52623	19319	19319	1818	1818	1566	>100	9.61	>100	9.61

Asta : 879 [481 , 458]

AUTOSTRADA VALDASTICO A31 NORD
1° LOTTO - PIOVENE ROCCHETTE – VALLE DELL'ASTICO

Sez. G: O 114.3x5.9 L=268.7 cm Crit.: Acciaio_Flessione $\gamma_M=1.05$ $f_{yk}/\gamma_M=2619$ kg/cm² $f_t=4300$ kg/cm²

:Verificato

X	cls	N	TY	TZ	MT	MY	MZ	My4	Mz4	Comb.
cm		kg	kg	kg	kg*m	kg*m	kg*m			
0	1	1974	4	-24	3	15	11	--	--	2

X	cls	Nr	Vyr	Vzr	Mry	Mrz	MTrd	SF_V.	SF_M	SF_Mt	SF
cm		kg	kg	kg	kg*m	kg*m	kg*m				
0	1	52623	19302	19302	1818	1818	1566	>100	19.4	>100	19.4

Asta : 880 [476 , 481]

Sez. G: O 114.3x5.9 L=267.7 cm Crit.: Acciaio_Flessione $\gamma_M=1.05$ $f_{yk}/\gamma_M=2619$ kg/cm² $f_t=4300$ kg/cm²

:Verificato

X	cls	N	TY	TZ	MT	MY	MZ	My4	Mz4	Comb.
cm		kg	kg	kg	kg*m	kg*m	kg*m			
268	1	-1219	-5	25	3	22	3	--	--	2

X	cls	Nr	Vyr	Vzr	Mry	Mrz	MTrd	SF_V.	SF_M	SF_Mt	SF
cm		kg	kg	kg	kg*m	kg*m	kg*m				
268	1	52623	19304	19304	1818	1818	1566	>100	27.2	>100	27.2

Asta : 881 [481 , 475]

Sez. G: O 114.3x5.9 L=267.7 cm Crit.: Acciaio_Flessione $\gamma_M=1.05$ $f_{yk}/\gamma_M=2619$ kg/cm² $f_t=4300$ kg/cm²

:Verificato

X	cls	N	TY	TZ	MT	MY	MZ	My4	Mz4	Comb.
cm		kg	kg	kg	kg*m	kg*m	kg*m			
134	1	1856	-2	-1	-1	-18	-0	--	--	2

X	cls	Nr	Vyr	Vzr	Mry	Mrz	MTrd	SF_V.	SF_M	SF_Mt	SF
cm		kg	kg	kg	kg*m	kg*m	kg*m				
134	1	52623	19324	19324	1818	1818	1566	>100	22.1	>100	22.1

AUTOSTRADA VALDASTICO A31 NORD
1° LOTTO - PIOVENE ROCCHETTE – VALLE DELL'ASTICO

Asta : 882 [395 , 396]

Sez. G: O 114.3x5.9 L=314.0 cm Crit.: Acciaio_Flessione $\gamma_M=1.05$ $f_{yk}/\gamma_M=2619$ kg/cm² $f_t=4300$ kg/cm²

:Verificato

X	cls	N	TY	TZ	MT	MY	MZ	My4	Mz4	Comb.
cm		kg	kg	kg	kg*m	kg*m	kg*m			
157	1	13890	1	-2	1	-34	0	--	--	2

X	cls	Nr	Vyr	Vzr	Mry	Mrz	MTrd	SF_V.	SF_M	SF_Mt	SF
cm		kg	kg	kg	kg*m	kg*m	kg*m				
157	1	52623	19333	19333	1818	1818	1566	>100	3.54	>100	3.54

Asta : 883 [396 , 457]

Sez. G: O 114.3x5.9 L=263.5 cm Crit.: Acciaio_Flessione $\gamma_M=1.05$ $f_{yk}/\gamma_M=2619$ kg/cm² $f_t=4300$ kg/cm²

:Verificato

X	cls	N	TY	TZ	MT	MY	MZ	My4	Mz4	Comb.
cm		kg	kg	kg	kg*m	kg*m	kg*m			
263	1	1709	-0	30	0	14	0	--	--	2

X	cls	Nr	Vyr	Vzr	Mry	Mrz	MTrd	SF_V.	SF_M	SF_Mt	SF
cm		kg	kg	kg	kg*m	kg*m	kg*m				
263	1	52623	19342	19342	1818	1818	1566	>100	25.0	>100	25.0

Asta : 884 [457 , 458]

Sez. G: O 114.3x5.9 L=314.0 cm Crit.: Acciaio_Flessione $\gamma_M=1.05$ $f_{yk}/\gamma_M=2619$ kg/cm² $f_t=4300$ kg/cm²

:Verificato

X	cls	N	TY	TZ	MT	MY	MZ	My4	Mz4	Comb.
cm		kg	kg	kg	kg*m	kg*m	kg*m			
157	1	10890	3	2	3	-30	-0	--	--	2

X	cls	Nr	Vyr	Vzr	Mry	Mrz	MTrd	SF_V.	SF_M	SF_Mt	SF
cm		kg	kg	kg	kg*m	kg*m	kg*m				
157	1	52623	19307	19307	1818	1818	1566	>100	4.47	>100	4.47

AUTOSTRADA VALDASTICO A31 NORD
1° LOTTO - PIOVENE ROCCHETTE – VALLE DELL'ASTICO

Asta : 885 [395 , 465]

Sez. G: O 114.3x5.9 L=276.1 cm Crit.: Acciaio_Flessione $\gamma_M=1.05$ $f_{yk}/\gamma_M=2619$ kg/cmq $f_t=4300$ kg/cmq

:Verificato

X	cls	N	TY	TZ	MT	MY	MZ	My4	Mz4	Comb.
cm		kg	kg	kg	kg*m	kg*m	kg*m			
110	1	-1069	3	-3	-5	-17	6	--	--	2

X	cls	Nr	Vyr	Vzr	Mry	Mrz	MTrd	SF_V.	SF_M	SF_Mt	SF
cm		kg	kg	kg	kg*m	kg*m	kg*m				
110	1	52623	19285	19285	1818	1818	1566	>100	30.0	>100	30.0

Asta : 886 [465 , 457]

Sez. G: O 114.3x5.9 L=276.1 cm Crit.: Acciaio_Flessione $\gamma_M=1.05$ $f_{yk}/\gamma_M=2619$ kg/cmq $f_t=4300$ kg/cmq

:Verificato

X	cls	N	TY	TZ	MT	MY	MZ	My4	Mz4	Comb.
cm		kg	kg	kg	kg*m	kg*m	kg*m			
166	1	-871	1	4	-5	-16	-6	--	--	2

X	cls	Nr	Vyr	Vzr	Mry	Mrz	MTrd	SF_V.	SF_M	SF_Mt	SF
cm		kg	kg	kg	kg*m	kg*m	kg*m				
166	1	52623	19285	19285	1818	1818	1566	>100	35.3	>100	35.3

Asta : 887 [396 , 465]

Sez. G: O 114.3x5.9 L=276.1 cm Crit.: Acciaio_Flessione $\gamma_M=1.05$ $f_{yk}/\gamma_M=2619$ kg/cmq $f_t=4300$ kg/cmq

:Verificato

X	cls	N	TY	TZ	MT	MY	MZ	My4	Mz4	Comb.
cm		kg	kg	kg	kg*m	kg*m	kg*m			
110	1	282	-2	-2	5	-16	-6	--	--	2

X	cls	Nr	Vyr	Vzr	Mry	Mrz	MTrd	SF_V.	SF_M	SF_Mt	SF
cm		kg	kg	kg	kg*m	kg*m	kg*m				

AUTOSTRADA VALDASTICO A31 NORD
1° LOTTO - PIOVENE ROCCHETTE – VALLE DELL'ASTICO

X	cls	Nr	Vyr	Vzr	Mry	Mrz	MTrd	SF_V.	SF_M	SF_Mt	SF
110	1	52623	19284	19284	1818	1818	1566	>100	56.9	>100	56.9

Asta : 888 [465 , 458]

Sez. G: O 114.3x5.9 L=276.1 cm Crit.: Acciaio_Flessione $\gamma_M=1.05$ $f_{yk}/\gamma_M=2619$ kg/cm² $f_t=4300$ kg/cm²

:Verificato

X	cls	N	TY	TZ	MT	MY	MZ	My4	Mz4	Comb.
cm		kg	kg	kg	kg*m	kg*m	kg*m			
276	1	-1488	-4	22	5	6	11	--	--	2

X	cls	Nr	Vyr	Vzr	Mry	Mrz	MTrd	SF_V.	SF_M	SF_Mt	SF
cm		kg	kg	kg	kg*m	kg*m	kg*m				
276	1	52623	19278	19278	1818	1818	1566	>100	26.9	>100	26.9

Asta : 889 [457 , 474]

Sez. G: O 114.3x5.9 L=263.5 cm Crit.: Acciaio_Flessione $\gamma_M=1.05$ $f_{yk}/\gamma_M=2619$ kg/cm² $f_t=4300$ kg/cm²

:Verificato

X	cls	N	TY	TZ	MT	MY	MZ	My4	Mz4	Comb.
cm		kg	kg	kg	kg*m	kg*m	kg*m			
0	1	-92	-0	-31	-0	14	-0	--	--	1

X	cls	Nr	Vyr	Vzr	Mry	Mrz	MTrd	SF_V.	SF_M	SF_Mt	SF
cm		kg	kg	kg	kg*m	kg*m	kg*m				
0	1	52623	19342	19342	1818	1818	1566	>100	>100	>100	>100

Asta : 890 [474 , 475]

Sez. G: O 114.3x5.9 L=314.0 cm Crit.: Acciaio_Flessione $\gamma_M=1.05$ $f_{yk}/\gamma_M=2619$ kg/cm² $f_t=4300$ kg/cm²

:Verificato

X	cls	N	TY	TZ	MT	MY	MZ	My4	Mz4	Comb.
cm		kg	kg	kg	kg*m	kg*m	kg*m			
157	1	5451	3	1	3	-23	-1	--	--	2

AUTOSTRADA VALDASTICO A31 NORD
1° LOTTO - PIOVENE ROCCHETTE – VALLE DELL'ASTICO

X	cls	Nr	Vyr	Vzr	Mry	Mrz	MTrd	SF_V.	SF_M	SF_Mt	SF
cm		kg	kg	kg	kg*m	kg*m	kg*m				
157	1	52623	19306	19306	1818	1818	1566	>100	8.57	>100	8.57

Asta : 891 [457 , 482]

Sez. G: O 114.3x5.9 L=276.6 cm Crit.: Acciaio_Flessione $\gamma_M=1.05$ $f_{yk}/\gamma_M=2619$ kg/cm² $f_t=4300$ kg/cm²

:Verificato

X	cls	N	TY	TZ	MT	MY	MZ	My4	Mz4	Comb.
cm		kg	kg	kg	kg*m	kg*m	kg*m			
111	1	1016	-1	-0	3	-13	-5	--	--	2

X	cls	Nr	Vyr	Vzr	Mry	Mrz	MTrd	SF_V.	SF_M	SF_Mt	SF
cm		kg	kg	kg	kg*m	kg*m	kg*m				
111	1	52623	19299	19299	1818	1818	1566	>100	34.1	>100	34.1

Asta : 892 [482 , 458]

Sez. G: O 114.3x5.9 L=276.6 cm Crit.: Acciaio_Flessione $\gamma_M=1.05$ $f_{yk}/\gamma_M=2619$ kg/cm² $f_t=4300$ kg/cm²

:Verificato

X	cls	N	TY	TZ	MT	MY	MZ	My4	Mz4	Comb.
cm		kg	kg	kg	kg*m	kg*m	kg*m			
194	1	-1076	3	4	-3	-18	-5	--	--	2

X	cls	Nr	Vyr	Vzr	Mry	Mrz	MTrd	SF_V.	SF_M	SF_Mt	SF
cm		kg	kg	kg	kg*m	kg*m	kg*m				
194	1	52623	19300	19300	1818	1818	1566	>100	29.8	>100	29.8

Asta : 893 [474 , 482]

Sez. G: O 114.3x5.9 L=275.6 cm Crit.: Acciaio_Flessione $\gamma_M=1.05$ $f_{yk}/\gamma_M=2619$ kg/cm² $f_t=4300$ kg/cm²

:Verificato

X	cls	N	TY	TZ	MT	MY	MZ	My4	Mz4	Comb.
cm		kg	kg	kg	kg*m	kg*m	kg*m			
110	1	88	-1	1	-3	-15	3	--	--	2

AUTOSTRADA VALDASTICO A31 NORD
1° LOTTO - PIOVENE ROCCHETTE – VALLE DELL'ASTICO

X	cls	Nr	Vyr	Vzr	Mry	Mrz	MTrd	SF_V.	SF_M	SF_Mt	SF
cm		kg	kg	kg	kg*m	kg*m	kg*m				
110	1	52623	19301	19301	1818	1818	1566	>100	88.2	>100	88.2

Asta : 894 [482 , 475]

Sez. G: O 114.3x5.9 L=275.6 cm Crit.: Acciaio_Flessione $\gamma_M=1.05$ $f_{yk}/\gamma_M=2619$ kg/cmq $f_t=4300$ kg/cmq

:Verificato

X	cls	N	TY	TZ	MT	MY	MZ	My4	Mz4	Comb.
cm		kg	kg	kg	kg*m	kg*m	kg*m			
193	1	-1587	-3	2	4	-9	6	--	--	2

X	cls	Nr	Vyr	Vzr	Mry	Mrz	MTrd	SF_V.	SF_M	SF_Mt	SF
cm		kg	kg	kg	kg*m	kg*m	kg*m				
193	1	52623	19297	19297	1818	1818	1566	>100	26.1	>100	26.1

Asta : 895 [396 , 397]

Sez. G: O 114.3x5.9 L=314.0 cm Crit.: Acciaio_Flessione $\gamma_M=1.05$ $f_{yk}/\gamma_M=2619$ kg/cmq $f_t=4300$ kg/cmq

:Verificato

X	cls	N	TY	TZ	MT	MY	MZ	My4	Mz4	Comb.
cm		kg	kg	kg	kg*m	kg*m	kg*m			
157	1	13861	-1	2	-1	-34	0	--	--	2

X	cls	Nr	Vyr	Vzr	Mry	Mrz	MTrd	SF_V.	SF_M	SF_Mt	SF
cm		kg	kg	kg	kg*m	kg*m	kg*m				
157	1	52623	19333	19333	1818	1818	1566	>100	3.54	>100	3.54

Asta : 896 [397 , 456]

Sez. G: O 114.3x5.9 L=263.5 cm Crit.: Acciaio_Flessione $\gamma_M=1.05$ $f_{yk}/\gamma_M=2619$ kg/cmq $f_t=4300$ kg/cmq

:Verificato

X	cls	N	TY	TZ	MT	MY	MZ	My4	Mz4	Comb.
cm		kg	kg	kg	kg*m	kg*m	kg*m			

AUTOSTRADA VALDASTICO A31 NORD
1° LOTTO - PIOVENE ROCCHETTE – VALLE DELL'ASTICO

X	cls	N	TY	TZ	MT	MY	MZ	My4	Mz4	Comb.
263	1	454	7	29	4	15	-9	--	--	2

X	cls	Nr	Vyr	Vzr	Mry	Mrz	MTrd	SF_V.	SF_M	SF_Mt	SF
cm		kg	kg	kg	kg*m	kg*m	kg*m				
263	1	52623	19294	19294	1818	1818	1566	>100	45.7	>100	45.7

Asta : 897 [456 , 457]

Sez. G: O 114.3x5.9 L=314.0 cm Crit.: Acciaio_Flessione $\gamma_M=1.05$ $f_{yk}/\gamma_M=2619$ kg/cm² $f_t=4300$ kg/cm²

:Verificato

X	cls	N	TY	TZ	MT	MY	MZ	My4	Mz4	Comb.
cm		kg	kg	kg	kg*m	kg*m	kg*m			
157	1	10869	-3	-2	-3	-30	-0	--	--	2

X	cls	Nr	Vyr	Vzr	Mry	Mrz	MTrd	SF_V.	SF_M	SF_Mt	SF
cm		kg	kg	kg	kg*m	kg*m	kg*m				
157	1	52623	19307	19307	1818	1818	1566	>100	4.48	>100	4.48

Asta : 898 [397 , 466]

Sez. G: O 114.3x5.9 L=276.1 cm Crit.: Acciaio_Flessione $\gamma_M=1.05$ $f_{yk}/\gamma_M=2619$ kg/cm² $f_t=4300$ kg/cm²

:Verificato

X	cls	N	TY	TZ	MT	MY	MZ	My4	Mz4	Comb.
cm		kg	kg	kg	kg*m	kg*m	kg*m			
110	1	-1108	-3	-3	5	-17	-6	--	--	2

X	cls	Nr	Vyr	Vzr	Mry	Mrz	MTrd	SF_V.	SF_M	SF_Mt	SF
cm		kg	kg	kg	kg*m	kg*m	kg*m				
110	1	52623	19285	19285	1818	1818	1566	>100	29.4	>100	29.4

Asta : 899 [466 , 396]

Sez. G: O 114.3x5.9 L=276.1 cm Crit.: Acciaio_Flessione $\gamma_M=1.05$ $f_{yk}/\gamma_M=2619$ kg/cm² $f_t=4300$ kg/cm²

:Verificato

AUTOSTRADA VALDASTICO A31 NORD
1° LOTTO - PIOVENE ROCCHETTE – VALLE DELL'ASTICO

X	cls	N	TY	TZ	MT	MY	MZ	My4	Mz4	Comb.
cm		kg	kg	kg	kg*m	kg*m	kg*m			
166	1	315	2	2	-5	-16	-6	--	--	2

X	cls	Nr	Vyr	Vzr	Mry	Mrz	MTrd	SF_V.	SF_M	SF_Mt	SF
cm		kg	kg	kg	kg*m	kg*m	kg*m				
166	1	52623	19284	19284	1818	1818	1566	>100	55.0	>100	55.0

Asta : 900 [457 , 466]

Sez. G: O 114.3x5.9 L=276.1 cm Crit.: Acciaio_Flessione $\gamma_M=1.05$ $f_{yk}/\gamma_M=2619$ kg/cm² $f_t=4300$ kg/cm²

:Verificato

X	cls	N	TY	TZ	MT	MY	MZ	My4	Mz4	Comb.
cm		kg	kg	kg	kg*m	kg*m	kg*m			
110	1	-862	-1	-4	5	-16	-6	--	--	2

X	cls	Nr	Vyr	Vzr	Mry	Mrz	MTrd	SF_V.	SF_M	SF_Mt	SF
cm		kg	kg	kg	kg*m	kg*m	kg*m				
110	1	52623	19285	19285	1818	1818	1566	>100	35.5	>100	35.5

Asta : 901 [466 , 456]

Sez. G: O 114.3x5.9 L=276.1 cm Crit.: Acciaio_Flessione $\gamma_M=1.05$ $f_{yk}/\gamma_M=2619$ kg/cm² $f_t=4300$ kg/cm²

:Verificato

X	cls	N	TY	TZ	MT	MY	MZ	My4	Mz4	Comb.
cm		kg	kg	kg	kg*m	kg*m	kg*m			
276	1	-1493	4	22	-5	6	-11	--	--	2

X	cls	Nr	Vyr	Vzr	Mry	Mrz	MTrd	SF_V.	SF_M	SF_Mt	SF
cm		kg	kg	kg	kg*m	kg*m	kg*m				
276	1	52623	19278	19278	1818	1818	1566	>100	26.8	>100	26.8

Asta : 902 [456 , 473]

AUTOSTRADA VALDASTICO A31 NORD
1° LOTTO - PIOVENE ROCCHETTE – VALLE DELL'ASTICO

Sez. G: O 114.3x5.9 L=263.5 cm Crit.: Acciaio_Flessione $\gamma_M=1.05$ $f_{yk}/\gamma_M=2619$ kg/cmq $f_t=4300$ kg/cmq

:Verificato

X	cls	N	TY	TZ	MT	MY	MZ	My4	Mz4	Comb.
cm		kg	kg	kg	kg*m	kg*m	kg*m			
0	1	-164	14	-30	6	14	18	--	--	2

X	cls	Nr	Vyr	Vzr	Mry	Mrz	MTrd	SF_V.	SF_M	SF_Mt	SF
cm		kg	kg	kg	kg*m	kg*m	kg*m				
0	1	52623	19268	19268	1818	1818	1566	>100	48.2	>100	48.2

Asta : 903 [473 , 474]

Sez. G: O 114.3x5.9 L=314.0 cm Crit.: Acciaio_Flessione $\gamma_M=1.05$ $f_{yk}/\gamma_M=2619$ kg/cmq $f_t=4300$ kg/cmq

:Verificato

X	cls	N	TY	TZ	MT	MY	MZ	My4	Mz4	Comb.
cm		kg	kg	kg	kg*m	kg*m	kg*m			
157	1	5440	-3	-2	-3	-23	-1	--	--	2

X	cls	Nr	Vyr	Vzr	Mry	Mrz	MTrd	SF_V.	SF_M	SF_Mt	SF
cm		kg	kg	kg	kg*m	kg*m	kg*m				
157	1	52623	19306	19306	1818	1818	1566	>100	8.59	>100	8.59

Asta : 904 [456 , 483]

Sez. G: O 114.3x5.9 L=276.6 cm Crit.: Acciaio_Flessione $\gamma_M=1.05$ $f_{yk}/\gamma_M=2619$ kg/cmq $f_t=4300$ kg/cmq

:Verificato

X	cls	N	TY	TZ	MT	MY	MZ	My4	Mz4	Comb.
cm		kg	kg	kg	kg*m	kg*m	kg*m			
83	1	-1114	-3	-4	3	-18	-5	--	--	2

X	cls	Nr	Vyr	Vzr	Mry	Mrz	MTrd	SF_V.	SF_M	SF_Mt	SF
cm		kg	kg	kg	kg*m	kg*m	kg*m				
83	1	52623	19300	19300	1818	1818	1566	>100	29.2	>100	29.2

AUTOSTRADA VALDASTICO A31 NORD
1° LOTTO - PIOVENE ROCCHETTE – VALLE DELL'ASTICO

Asta : 905 [483 , 457]

Sez. G: O 114.3x5.9 L=276.6 cm Crit.: Acciaio_Flessione $\gamma_M=1.05$ $f_{yk}/\gamma_M=2619$ kg/cm² $f_t=4300$ kg/cm²

:Verificato

X	cls	N	TY	TZ	MT	MY	MZ	My4	Mz4	Comb.
cm		kg	kg	kg	kg*m	kg*m	kg*m			
166	1	1044	1	0	-3	-13	-5	--	--	2

X	cls	Nr	Vyr	Vzr	Mry	Mrz	MTrd	SF_V.	SF_M	SF_Mt	SF
cm		kg	kg	kg	kg*m	kg*m	kg*m				
166	1	52623	19299	19299	1818	1818	1566	>100	33.6	>100	33.6

Asta : 906 [473 , 483]

Sez. G: O 114.3x5.9 L=275.6 cm Crit.: Acciaio_Flessione $\gamma_M=1.05$ $f_{yk}/\gamma_M=2619$ kg/cm² $f_t=4300$ kg/cm²

:Verificato

X	cls	N	TY	TZ	MT	MY	MZ	My4	Mz4	Comb.
cm		kg	kg	kg	kg*m	kg*m	kg*m			
83	1	-1600	3	-2	-4	-9	6	--	--	2

X	cls	Nr	Vyr	Vzr	Mry	Mrz	MTrd	SF_V.	SF_M	SF_Mt	SF
cm		kg	kg	kg	kg*m	kg*m	kg*m				
83	1	52623	19298	19298	1818	1818	1566	>100	25.9	>100	25.9

Asta : 907 [483 , 474]

Sez. G: O 114.3x5.9 L=275.6 cm Crit.: Acciaio_Flessione $\gamma_M=1.05$ $f_{yk}/\gamma_M=2619$ kg/cm² $f_t=4300$ kg/cm²

:Verificato

X	cls	N	TY	TZ	MT	MY	MZ	My4	Mz4	Comb.
cm		kg	kg	kg	kg*m	kg*m	kg*m			
165	1	107	1	-1	3	-15	3	--	--	2

X	cls	Nr	Vyr	Vzr	Mry	Mrz	MTrd	SF_V.	SF_M	SF_Mt	SF
cm		kg	kg	kg	kg*m	kg*m	kg*m				
165	1	52623	19301	19301	1818	1818	1566	>100	85.5	>100	85.5

AUTOSTRADA VALDASTICO A31 NORD
1° LOTTO - PIOVENE ROCCHETTE – VALLE DELL'ASTICO

Asta : 908 [397 , 398]

Sez. G: O 114.3x5.9 L=314.0 cm Crit.: Acciaio_Flessione $\gamma_M=1.05$ $f_{yk}/\gamma_M=2619$ kg/cmq $f_t=4300$ kg/cmq

:Verificato

X	cls	N	TY	TZ	MT	MY	MZ	My4	Mz4	Comb.
cm		kg	kg	kg	kg*m	kg*m	kg*m			
188	1	10731	-3	-0	-2	-43	1	--	--	2

X	cls	Nr	Vyr	Vzr	Mry	Mrz	MTrd	SF_V.	SF_M	SF_Mt	SF
cm		kg	kg	kg	kg*m	kg*m	kg*m				
188	1	52623	19319	19319	1818	1818	1566	>100	4.39	>100	4.39

Asta : 909 [398 , 455]

Sez. G: O 114.3x5.9 L=263.5 cm Crit.: Acciaio_Flessione $\gamma_M=1.05$ $f_{yk}/\gamma_M=2619$ kg/cmq $f_t=4300$ kg/cmq

:Verificato

X	cls	N	TY	TZ	MT	MY	MZ	My4	Mz4	Comb.
cm		kg	kg	kg	kg*m	kg*m	kg*m			
0	1	-4615	14	-38	18	41	19	--	--	2

X	cls	Nr	Vyr	Vzr	Mry	Mrz	MTrd	SF_V.	SF_M	SF_Mt	SF
cm		kg	kg	kg	kg*m	kg*m	kg*m				
0	1	52623	19115	19115	1818	1818	1566	>100	8.26	85.4	8.26

Asta : 910 [455 , 456]

Sez. G: O 114.3x5.9 L=314.0 cm Crit.: Acciaio_Flessione $\gamma_M=1.05$ $f_{yk}/\gamma_M=2619$ kg/cmq $f_t=4300$ kg/cmq

:Verificato

X	cls	N	TY	TZ	MT	MY	MZ	My4	Mz4	Comb.
cm		kg	kg	kg	kg*m	kg*m	kg*m			
251	1	7635	-11	14	-11	-22	10	--	--	2

X	cls	Nr	Vyr	Vzr	Mry	Mrz	MTrd	SF_V.	SF_M	SF_Mt	SF
cm		kg	kg	kg	kg*m	kg*m	kg*m				

AUTOSTRADA VALDASTICO A31 NORD
1° LOTTO - PIOVENE ROCCHETTE – VALLE DELL'ASTICO

X	cls	Nr	Vyr	Vzr	Mry	Mrz	MTrd	SF_V.	SF_M	SF_Mt	SF
251	1	52623	19208	19208	1818	1818	1566	>100	6.14	>100	6.14

Asta : 911 [397 , 454]

Sez. G: O 114.3x5.9 L=268.2 cm Crit.: Acciaio_Flessione $\gamma_M=1.05$ $f_{yk}/\gamma_M=2619$ kg/cm² $f_t=4300$ kg/cm²

:Verificato

X	cls	N	TY	TZ	MT	MY	MZ	My4	Mz4	Comb.
cm		kg	kg	kg	kg*m	kg*m	kg*m			
80	1	2103	2	-2	-6	-12	8	--	--	2

X	cls	Nr	Vyr	Vzr	Mry	Mrz	MTrd	SF_V.	SF_M	SF_Mt	SF
cm		kg	kg	kg	kg*m	kg*m	kg*m				
80	1	52623	19263	19263	1818	1818	1566	>100	19.7	>100	19.7

Asta : 912 [454 , 398]

Sez. G: O 114.3x5.9 L=268.2 cm Crit.: Acciaio_Flessione $\gamma_M=1.05$ $f_{yk}/\gamma_M=2619$ kg/cm² $f_t=4300$ kg/cm²

:Verificato

X	cls	N	TY	TZ	MT	MY	MZ	My4	Mz4	Comb.
cm		kg	kg	kg	kg*m	kg*m	kg*m			
268	1	-5237	-16	9	11	-26	34	--	--	2

X	cls	Nr	Vyr	Vzr	Mry	Mrz	MTrd	SF_V.	SF_M	SF_Mt	SF
cm		kg	kg	kg	kg*m	kg*m	kg*m				
268	1	52623	19207	19207	1818	1818	1566	>100	7.52	>100	7.52

Asta : 913 [456 , 454]

Sez. G: O 114.3x5.9 L=268.2 cm Crit.: Acciaio_Flessione $\gamma_M=1.05$ $f_{yk}/\gamma_M=2619$ kg/cm² $f_t=4300$ kg/cm²

:Verificato

X	cls	N	TY	TZ	MT	MY	MZ	My4	Mz4	Comb.
cm		kg	kg	kg	kg*m	kg*m	kg*m			
107	1	1046	-2	-1	4	-20	-6	--	--	2

AUTOSTRADA VALDASTICO A31 NORD
1° LOTTO - PIOVENE ROCCHETTE – VALLE DELL'ASTICO

X	cls	Nr	Vyr	Vzr	Mry	Mrz	MTrd	SF_V.	SF_M	SF_Mt	SF
cm		kg	kg	kg	kg*m	kg*m	kg*m				
107	1	52623	19286	19286	1818	1818	1566	>100	29.5	>100	29.5

Asta : 914 [454 , 455]

Sez. G: O 114.3x5.9 L=268.2 cm Crit.: Acciaio_Flessione $\gamma_M=1.05$ $f_{yk}/\gamma_M=2619$ kg/cm² $f_t=4300$ kg/cm²

:Verificato

X	cls	N	TY	TZ	MT	MY	MZ	My4	Mz4	Comb.
cm		kg	kg	kg	kg*m	kg*m	kg*m			
268	1	-1465	9	27	-8	23	-20	--	--	2

X	cls	Nr	Vyr	Vzr	Mry	Mrz	MTrd	SF_V.	SF_M	SF_Mt	SF
cm		kg	kg	kg	kg*m	kg*m	kg*m				
268	1	52623	19245	19245	1818	1818	1566	>100	19.5	>100	19.5

Asta : 915 [455 , 472]

Sez. G: O 114.3x5.9 L=263.5 cm Crit.: Acciaio_Flessione $\gamma_M=1.05$ $f_{yk}/\gamma_M=2619$ kg/cm² $f_t=4300$ kg/cm²

:Verificato

X	cls	N	TY	TZ	MT	MY	MZ	My4	Mz4	Comb.
cm		kg	kg	kg	kg*m	kg*m	kg*m			
0	1	-273	23	-35	14	19	31	--	--	2

X	cls	Nr	Vyr	Vzr	Mry	Mrz	MTrd	SF_V.	SF_M	SF_Mt	SF
cm		kg	kg	kg	kg*m	kg*m	kg*m				
0	1	52623	19169	19169	1818	1818	1566	>100	30.6	>100	30.6

Asta : 916 [472 , 473]

Sez. G: O 114.3x5.9 L=314.0 cm Crit.: Acciaio_Flessione $\gamma_M=1.05$ $f_{yk}/\gamma_M=2619$ kg/cm² $f_t=4300$ kg/cm²

:Verificato

X	cls	N	TY	TZ	MT	MY	MZ	My4	Mz4	Comb.
cm		kg	kg	kg	kg*m	kg*m	kg*m			
0	1	3416	-12	-33	-10	9	-20	--	--	2

AUTOSTRADA VALDASTICO A31 NORD
1° LOTTO - PIOVENE ROCCHETTE – VALLE DELL'ASTICO

X	cls	Nr	Vyr	Vzr	Mry	Mrz	MTrd	SF_V.	SF_M	SF_Mt	SF
cm		kg	kg	kg	kg*m	kg*m	kg*m				
0	1	52623	19217	19217	1818	1818	1566	>100	12.3	>100	12.3

Asta : 917 [456 , 471]

Sez. G: O 114.3x5.9 L=268.7 cm Crit.: Acciaio_Flessione $\gamma_M=1.05$ $f_{yk}/\gamma_M=2619$ kg/cm² $f_t=4300$ kg/cm²

:Verificato

X	cls	N	TY	TZ	MT	MY	MZ	My4	Mz4	Comb.
cm		kg	kg	kg	kg*m	kg*m	kg*m			
269	1	1996	-4	24	-3	15	11	--	--	2

X	cls	Nr	Vyr	Vzr	Mry	Mrz	MTrd	SF_V.	SF_M	SF_Mt	SF
cm		kg	kg	kg	kg*m	kg*m	kg*m				
269	1	52623	19302	19302	1818	1818	1566	>100	19.2	>100	19.2

Asta : 918 [471 , 455]

Sez. G: O 114.3x5.9 L=268.7 cm Crit.: Acciaio_Flessione $\gamma_M=1.05$ $f_{yk}/\gamma_M=2619$ kg/cm² $f_t=4300$ kg/cm²

:Verificato

X	cls	N	TY	TZ	MT	MY	MZ	My4	Mz4	Comb.
cm		kg	kg	kg	kg*m	kg*m	kg*m			
188	1	-4696	-4	3	2	-25	3	--	--	2

X	cls	Nr	Vyr	Vzr	Mry	Mrz	MTrd	SF_V.	SF_M	SF_Mt	SF
cm		kg	kg	kg	kg*m	kg*m	kg*m				
188	1	52623	19319	19319	1818	1818	1566	>100	9.53	>100	9.53

Asta : 919 [472 , 471]

Sez. G: O 114.3x5.9 L=267.7 cm Crit.: Acciaio_Flessione $\gamma_M=1.05$ $f_{yk}/\gamma_M=2619$ kg/cm² $f_t=4300$ kg/cm²

:Verificato

X	cls	N	TY	TZ	MT	MY	MZ	My4	Mz4	Comb.
cm		kg	kg	kg	kg*m	kg*m	kg*m			

AUTOSTRADA VALDASTICO A31 NORD
1° LOTTO - PIOVENE ROCCHETTE – VALLE DELL'ASTICO

X	cls	N	TY	TZ	MT	MY	MZ	My4	Mz4	Comb.
268	1	-1214	5	26	-3	22	-3	--	--	2

X	cls	Nr	Vyr	Vzr	Mry	Mrz	MTrd	SF_V.	SF_M	SF_Mt	SF
cm		kg	kg	kg	kg*m	kg*m	kg*m				
268	1	52623	19303	19303	1818	1818	1566	>100	27.2	>100	27.2

Asta : 920 [471 , 473]

Sez. G: O 114.3x5.9 L=267.7 cm Crit.: Acciaio_Flessione $\gamma_M=1.05$ $f_{yk}/\gamma_M=2619$ kg/cm² $f_t=4300$ kg/cm²

:Verificato

X	cls	N	TY	TZ	MT	MY	MZ	My4	Mz4	Comb.
cm		kg	kg	kg	kg*m	kg*m	kg*m			
161	1	1866	3	3	1	-18	-1	--	--	2

X	cls	Nr	Vyr	Vzr	Mry	Mrz	MTrd	SF_V.	SF_M	SF_Mt	SF
cm		kg	kg	kg	kg*m	kg*m	kg*m				
161	1	52623	19325	19325	1818	1818	1566	>100	22.0	>100	22.0

Asta : 921 [398 , 399]

Sez. G: O 114.3x5.9 L=314.0 cm Crit.: Acciaio_Flessione $\gamma_M=1.05$ $f_{yk}/\gamma_M=2619$ kg/cm² $f_t=4300$ kg/cm²

:Verificato

X	cls	N	TY	TZ	MT	MY	MZ	My4	Mz4	Comb.
cm		kg	kg	kg	kg*m	kg*m	kg*m			
314	1	-4563	-2	204	-5	351	3	--	--	2

X	cls	Nr	Vyr	Vzr	Mry	Mrz	MTrd	SF_V.	SF_M	SF_Mt	SF
cm		kg	kg	kg	kg*m	kg*m	kg*m				
314	1	52623	19279	19279	1818	1818	1566	94.5	3.55	>100	3.55

Asta : 922 [399 , 453]

Sez. G: O 114.3x5.9 L=263.5 cm Crit.: Acciaio_Flessione $\gamma_M=1.05$ $f_{yk}/\gamma_M=2619$ kg/cm² $f_t=4300$ kg/cm²

:Verificato

AUTOSTRADA VALDASTICO A31 NORD
1° LOTTO - PIOVENE ROCCHETTE – VALLE DELL'ASTICO

X	cls	N	TY	TZ	MT	MY	MZ	My4	Mz4	Comb.
cm		kg	kg	kg	kg*m	kg*m	kg*m			
0	1	-11261	1	-145	-34	206	4	--	--	2

X	cls	Nr	Vyr	Vzr	Mry	Mrz	MTrd	SF_V.	SF_M	SF_Mt	SF
cm		kg	kg	kg	kg*m	kg*m	kg*m				
0	1	52623	18917	18917	1818	1818	1566	>100	3.04	45.6	3.04

Asta : 923 [453 , 455]

Sez. G: O 114.3x5.9 L=314.0 cm Crit.: Acciaio_Flessione $\gamma_M=1.05$ $f_{yk}/\gamma_M=2619$ kg/cm² $f_t=4300$ kg/cm²

:Verificato

X	cls	N	TY	TZ	MT	MY	MZ	My4	Mz4	Comb.
cm		kg	kg	kg	kg*m	kg*m	kg*m			
0	1	-628	-18	-54	-21	58	-29	--	--	2

X	cls	Nr	Vyr	Vzr	Mry	Mrz	MTrd	SF_V.	SF_M	SF_Mt	SF
cm		kg	kg	kg	kg*m	kg*m	kg*m				
0	1	52623	19085	19085	1818	1818	1566	>100	16.7	75.4	16.7

Asta : 924 [398 , 467]

Sez. G: O 114.3x5.9 L=248.2 cm Crit.: Acciaio_Flessione $\gamma_M=1.05$ $f_{yk}/\gamma_M=2619$ kg/cm² $f_t=4300$ kg/cm²

:Verificato

X	cls	N	TY	TZ	MT	MY	MZ	My4	Mz4	Comb.
cm		kg	kg	kg	kg*m	kg*m	kg*m			
248	1	8148	-26	16	-12	24	45	--	--	2

X	cls	Nr	Vyr	Vzr	Mry	Mrz	MTrd	SF_V.	SF_M	SF_Mt	SF
cm		kg	kg	kg	kg*m	kg*m	kg*m				
248	1	52623	19192	19192	1818	1818	1566	>100	5.18	>100	5.18

Asta : 925 [467 , 399]

AUTOSTRADA VALDASTICO A31 NORD
1° LOTTO - PIOVENE ROCCHETTE – VALLE DELL'ASTICO

Sez. G: O 114.3x5.9 L=248.2 cm Crit.: Acciaio_Flessione $\gamma_M=1.05$ $f_{yk}/\gamma_M=2619$ kg/cm² $f_t=4300$ kg/cm²

:Verificato

X	cls	N	TY	TZ	MT	MY	MZ	My4	Mz4	Comb.
cm		kg	kg	kg	kg*m	kg*m	kg*m			
248	1	-29270	44	222	-21	332	-76	--	--	2

X	cls	Nr	Vyr	Vzr	Mry	Mrz	MTrd	SF_V.	SF_M	SF_Mt	SF
cm		kg	kg	kg	kg*m	kg*m	kg*m				
248	1	52623	19088	19088	1818	1818	1566	86.0	1.28	76.4	1.28

Asta : 926 [453 , 467]

Sez. G: O 114.3x5.9 L=248.2 cm Crit.: Acciaio_Flessione $\gamma_M=1.05$ $f_{yk}/\gamma_M=2619$ kg/cm² $f_t=4300$ kg/cm²

:Verificato

X	cls	N	TY	TZ	MT	MY	MZ	My4	Mz4	Comb.
cm		kg	kg	kg	kg*m	kg*m	kg*m			
0	1	4097	17	-31	3	58	18	--	--	2

X	cls	Nr	Vyr	Vzr	Mry	Mrz	MTrd	SF_V.	SF_M	SF_Mt	SF
cm		kg	kg	kg	kg*m	kg*m	kg*m				
0	1	52623	19308	19308	1818	1818	1566	>100	8.35	>100	8.35

Asta : 927 [467 , 455]

Sez. G: O 114.3x5.9 L=248.2 cm Crit.: Acciaio_Flessione $\gamma_M=1.05$ $f_{yk}/\gamma_M=2619$ kg/cm² $f_t=4300$ kg/cm²

:Verificato

X	cls	N	TY	TZ	MT	MY	MZ	My4	Mz4	Comb.
cm		kg	kg	kg	kg*m	kg*m	kg*m			
74	1	6255	-4	-3	3	-31	-1	--	--	2

X	cls	Nr	Vyr	Vzr	Mry	Mrz	MTrd	SF_V.	SF_M	SF_Mt	SF
cm		kg	kg	kg	kg*m	kg*m	kg*m				
74	1	52623	19305	19305	1818	1818	1566	>100	7.34	>100	7.34

AUTOSTRADA VALDASTICO A31 NORD
1° LOTTO - PIOVENE ROCCHETTE – VALLE DELL'ASTICO

Asta : 928 [453 , 470]

Sez. G: O 114.3x5.9 L=263.5 cm Crit.: Acciaio_Flessione $\gamma_M=1.05$ $f_{yk}/\gamma_M=2619$ kg/cm² $f_t=4300$ kg/cm²

:Verificato

X	cls	N	TY	TZ	MT	MY	MZ	My4	Mz4	Comb.
cm		kg	kg	kg	kg*m	kg*m	kg*m			
184	1	-334	10	8	5	-19	-5	--	--	2

X	cls	Nr	Vyr	Vzr	Mry	Mrz	MTrd	SF_V.	SF_M	SF_Mt	SF
cm		kg	kg	kg	kg*m	kg*m	kg*m				
184	1	52623	19277	19277	1818	1818	1566	>100	50.8	>100	50.8

Asta : 929 [470 , 472]

Sez. G: O 108x5.9 L=314.0 cm Crit.: Acciaio_Flessione $\gamma_M=1.05$ $f_{yk}/\gamma_M=2619$ kg/cm² $f_t=4300$ kg/cm²

:Verificato

X	cls	N	TY	TZ	MT	MY	MZ	My4	Mz4	Comb.
cm		kg	kg	kg	kg*m	kg*m	kg*m			
314	1	1611	-15	35	-11	22	23	--	--	2

X	cls	Nr	Vyr	Vzr	Mry	Mrz	MTrd	SF_V.	SF_M	SF_Mt	SF
cm		kg	kg	kg	kg*m	kg*m	kg*m				
314	1	49565	18072	18072	1613	1613	1386	>100	16.6	>100	16.6

Asta : 930 [453 , 484]

Sez. G: O 114.3x5.9 L=248.7 cm Crit.: Acciaio_Flessione $\gamma_M=1.05$ $f_{yk}/\gamma_M=2619$ kg/cm² $f_t=4300$ kg/cm²

:Verificato

X	cls	N	TY	TZ	MT	MY	MZ	My4	Mz4	Comb.
cm		kg	kg	kg	kg*m	kg*m	kg*m			
0	1	-5954	11	-29	-10	5	22	--	--	2

X	cls	Nr	Vyr	Vzr	Mry	Mrz	MTrd	SF_V.	SF_M	SF_Mt	SF
cm		kg	kg	kg	kg*m	kg*m	kg*m				
0	1	52623	19217	19217	1818	1818	1566	>100	7.83	>100	7.83

AUTOSTRADA VALDASTICO A31 NORD
1° LOTTO - PIOVENE ROCCHETTE – VALLE DELL'ASTICO

Asta : 931 [484 , 455]

Sez. G: O 114.3x5.9 L=248.7 cm Crit.: Acciaio_Flessione $\gamma_M=1.05$ $f_{yk}/\gamma_M=2619$ kg/cmq $f_t=4300$ kg/cmq

:Verificato

X	cls	N	TY	TZ	MT	MY	MZ	My4	Mz4	Comb.
cm		kg	kg	kg	kg*m	kg*m	kg*m			
0	1	1150	-8	-19	-2	22	-13	--	--	2

X	cls	Nr	Vyr	Vzr	Mry	Mrz	MTrd	SF_V.	SF_M	SF_Mt	SF
cm		kg	kg	kg	kg*m	kg*m	kg*m				
0	1	52623	19311	19311	1818	1818	1566	>100	24.5	>100	24.5

Asta : 932 [470 , 484]

Sez. G: O 114.3x5.9 L=247.7 cm Crit.: Acciaio_Flessione $\gamma_M=1.05$ $f_{yk}/\gamma_M=2619$ kg/cmq $f_t=4300$ kg/cmq

:Verificato

X	cls	N	TY	TZ	MT	MY	MZ	My4	Mz4	Comb.
cm		kg	kg	kg	kg*m	kg*m	kg*m			
248	1	-598	-2	33	-0	32	2	--	--	2

X	cls	Nr	Vyr	Vzr	Mry	Mrz	MTrd	SF_V.	SF_M	SF_Mt	SF
cm		kg	kg	kg	kg*m	kg*m	kg*m				
248	1	52623	19339	19339	1818	1818	1566	>100	33.4	>100	33.4

Asta : 933 [484 , 472]

Sez. G: O 114.3x5.9 L=247.7 cm Crit.: Acciaio_Flessione $\gamma_M=1.05$ $f_{yk}/\gamma_M=2619$ kg/cmq $f_t=4300$ kg/cmq

:Verificato

X	cls	N	TY	TZ	MT	MY	MZ	My4	Mz4	Comb.
cm		kg	kg	kg	kg*m	kg*m	kg*m			
124	1	1655	6	4	-4	-22	-4	--	--	2

X	cls	Nr	Vyr	Vzr	Mry	Mrz	MTrd	SF_V.	SF_M	SF_Mt	SF
cm		kg	kg	kg	kg*m	kg*m	kg*m				

AUTOSTRADA VALDASTICO A31 NORD
1° LOTTO - PIOVENE ROCCHETTE – VALLE DELL'ASTICO

X	cls	Nr	Vyr	Vzr	Mry	Mrz	MTrd	SF_V.	SF_M	SF_Mt	SF
124	1	52623	19291	19291	1818	1818	1566	>100	21.8	>100	21.8

Asta : 934 [399 , 400]

Sez. G: O 114.3x5.9 L=314.0 cm Crit.: Acciaio_Flessione $\gamma M=1.05$ $f_{yk}/\gamma M=2619$ kg/cm² $f_t=4300$ kg/cm²

:Verificato

X	cls	N	TY	TZ	MT	MY	MZ	My4	Mz4	Comb.
cm		kg	kg	kg	kg*m	kg*m	kg*m			
314	1	-7368	1	45	-0	36	-1	--	--	2

X	cls	Nr	Vyr	Vzr	Mry	Mrz	MTrd	SF_V.	SF_M	SF_Mt	SF
cm		kg	kg	kg	kg*m	kg*m	kg*m				
314	1	52623	19340	19340	1818	1818	1566	>100	6.24	>100	6.24

Asta : 935 [400 , 452]

Sez. G: O 114.3x5.9 L=263.5 cm Crit.: Acciaio_Flessione $\gamma M=1.05$ $f_{yk}/\gamma M=2619$ kg/cm² $f_t=4300$ kg/cm²

:Verificato

X	cls	N	TY	TZ	MT	MY	MZ	My4	Mz4	Comb.
cm		kg	kg	kg	kg*m	kg*m	kg*m			
263	1	-3577	-10	32	-19	41	15	--	--	2

X	cls	Nr	Vyr	Vzr	Mry	Mrz	MTrd	SF_V.	SF_M	SF_Mt	SF
cm		kg	kg	kg	kg*m	kg*m	kg*m				
263	1	52623	19105	19105	1818	1818	1566	>100	10.2	81.7	10.2

Asta : 936 [452 , 453]

Sez. G: O 114.3x5.9 L=314.0 cm Crit.: Acciaio_Flessione $\gamma M=1.05$ $f_{yk}/\gamma M=2619$ kg/cm² $f_t=4300$ kg/cm²

:Verificato

X	cls	N	TY	TZ	MT	MY	MZ	My4	Mz4	Comb.
cm		kg	kg	kg	kg*m	kg*m	kg*m			
314	1	-3858	5	36	11	38	-7	--	--	2

AUTOSTRADA VALDASTICO A31 NORD
1° LOTTO - PIOVENE ROCCHETTE – VALLE DELL'ASTICO

X	cls	Nr	Vyr	Vzr	Mry	Mrz	MTrd	SF_V.	SF_M	SF_Mt	SF
cm		kg	kg	kg	kg*m	kg*m	kg*m				
314	1	52623	19208	19208	1818	1818	1566	>100	10.2	>100	10.2

Asta : 937 [400 , 468]

Sez. G: O 114.3x5.9 L=223.0 cm Crit.: Acciaio_Flessione $\gamma_M=1.05$ $f_{yk}/\gamma_M=2619$ kg/cm² $f_t=4300$ kg/cm²

:Verificato

X	cls	N	TY	TZ	MT	MY	MZ	My4	Mz4	Comb.
cm		kg	kg	kg	kg*m	kg*m	kg*m			
223	1	5153	-4	54	-1	90	9	--	--	2

X	cls	Nr	Vyr	Vzr	Mry	Mrz	MTrd	SF_V.	SF_M	SF_Mt	SF
cm		kg	kg	kg	kg*m	kg*m	kg*m				
223	1	52623	19326	19326	1818	1818	1566	>100	6.55	>100	6.55

Asta : 938 [468 , 399]

Sez. G: O 114.3x5.9 L=223.0 cm Crit.: Acciaio_Flessione $\gamma_M=1.05$ $f_{yk}/\gamma_M=2619$ kg/cm² $f_t=4300$ kg/cm²

:Verificato

X	cls	N	TY	TZ	MT	MY	MZ	My4	Mz4	Comb.
cm		kg	kg	kg	kg*m	kg*m	kg*m			
223	1	-16407	20	71	-31	51	-44	--	--	2

X	cls	Nr	Vyr	Vzr	Mry	Mrz	MTrd	SF_V.	SF_M	SF_Mt	SF
cm		kg	kg	kg	kg*m	kg*m	kg*m				
223	1	52623	18964	18964	1818	1818	1566	>100	2.75	51.2	2.75

Asta : 939 [452 , 468]

Sez. G: O 114.3x5.9 L=223.0 cm Crit.: Acciaio_Flessione $\gamma_M=1.05$ $f_{yk}/\gamma_M=2619$ kg/cm² $f_t=4300$ kg/cm²

:Verificato

X	cls	N	TY	TZ	MT	MY	MZ	My4	Mz4	Comb.
cm		kg	kg	kg	kg*m	kg*m	kg*m			
223	1	3831	7	62	4	59	-9	--	--	2

AUTOSTRADA VALDASTICO A31 NORD
1° LOTTO - PIOVENE ROCCHETTE – VALLE DELL'ASTICO

X	cls	Nr	Vyr	Vzr	Mry	Mrz	MTrd	SF_V.	SF_M	SF_Mt	SF
cm		kg	kg	kg	kg*m	kg*m	kg*m				
223	1	52623	19294	19294	1818	1818	1566	>100	9.10	>100	9.10

Asta : 940 [468 , 453]

Sez. G: O 114.3x5.9 L=223.0 cm Crit.: Acciaio_Flessione $\gamma_M=1.05$ $f_{yk}/\gamma_M=2619$ kg/cmq $f_t=4300$ kg/cmq

:Verificato

X	cls	N	TY	TZ	MT	MY	MZ	My4	Mz4	Comb.
cm		kg	kg	kg	kg*m	kg*m	kg*m			
0	1	6190	-4	-28	4	40	-3	--	--	2

X	cls	Nr	Vyr	Vzr	Mry	Mrz	MTrd	SF_V.	SF_M	SF_Mt	SF
cm		kg	kg	kg	kg*m	kg*m	kg*m				
0	1	52623	19289	19289	1818	1818	1566	>100	7.09	>100	7.09

Asta : 941 [452 , 469]

Sez. G: O 114.3x5.9 L=263.5 cm Crit.: Acciaio_Flessione $\gamma_M=1.05$ $f_{yk}/\gamma_M=2619$ kg/cmq $f_t=4300$ kg/cmq

:Verificato

X	cls	N	TY	TZ	MT	MY	MZ	My4	Mz4	Comb.
cm		kg	kg	kg	kg*m	kg*m	kg*m			
0	1	-493	-4	-47	-9	39	-4	--	--	2

X	cls	Nr	Vyr	Vzr	Mry	Mrz	MTrd	SF_V.	SF_M	SF_Mt	SF
cm		kg	kg	kg	kg*m	kg*m	kg*m				
0	1	52623	19227	19227	1818	1818	1566	>100	30.5	>100	30.5

Asta : 942 [469 , 470]

Sez. G: O 108x5.9 L=314.0 cm Crit.: Acciaio_Flessione $\gamma_M=1.05$ $f_{yk}/\gamma_M=2619$ kg/cmq $f_t=4300$ kg/cmq

:Verificato

X	cls	N	TY	TZ	MT	MY	MZ	My4	Mz4	Comb.
cm		kg	kg	kg	kg*m	kg*m	kg*m			

AUTOSTRADA VALDASTICO A31 NORD
1° LOTTO - PIOVENE ROCCHETTE – VALLE DELL'ASTICO

X	cls	N	TY	TZ	MT	MY	MZ	My4	Mz4	Comb.
0	1	378	2	-33	1	20	2	--	--	2

X	cls	Nr	Vyr	Vzr	Mry	Mrz	MTrd	SF_V.	SF_M	SF_Mt	SF
cm		kg	kg	kg	kg*m	kg*m	kg*m				
0	1	49565	18200	18200	1613	1613	1386	>100	46.7	>100	46.7

Asta : 943 [452 , 485]

Sez. G: O 114.3x5.9 L=223.6 cm Crit.: Acciaio_Flessione $\gamma_M=1.05$ $f_{yk}/\gamma_M=2619$ kg/cm² $f_t=4300$ kg/cm²

:Verificato

X	cls	N	TY	TZ	MT	MY	MZ	My4	Mz4	Comb.
cm		kg	kg	kg	kg*m	kg*m	kg*m			
0	1	-1035	0	-26	-2	36	4	--	--	2

X	cls	Nr	Vyr	Vzr	Mry	Mrz	MTrd	SF_V.	SF_M	SF_Mt	SF
cm		kg	kg	kg	kg*m	kg*m	kg*m				
0	1	52623	19322	19322	1818	1818	1566	>100	24.0	>100	24.0

Asta : 944 [485 , 453]

Sez. G: O 114.3x5.9 L=223.6 cm Crit.: Acciaio_Flessione $\gamma_M=1.05$ $f_{yk}/\gamma_M=2619$ kg/cm² $f_t=4300$ kg/cm²

:Verificato

X	cls	N	TY	TZ	MT	MY	MZ	My4	Mz4	Comb.
cm		kg	kg	kg	kg*m	kg*m	kg*m			
224	1	-3235	-15	34	6	19	19	--	--	2

X	cls	Nr	Vyr	Vzr	Mry	Mrz	MTrd	SF_V.	SF_M	SF_Mt	SF
cm		kg	kg	kg	kg*m	kg*m	kg*m				
224	1	52623	19270	19270	1818	1818	1566	>100	12.2	>100	12.2

Asta : 945 [469 , 485]

Sez. G: O 108x5.9 L=222.5 cm Crit.: Acciaio_Flessione $\gamma_M=1.05$ $f_{yk}/\gamma_M=2619$ kg/cm² $f_t=4300$ kg/cm²

:Verificato

AUTOSTRADA VALDASTICO A31 NORD
1° LOTTO - PIOVENE ROCCHETTE – VALLE DELL'ASTICO

X	cls	N	TY	TZ	MT	MY	MZ	My4	Mz4	Comb.
cm		kg	kg	kg	kg*m	kg*m	kg*m			
222	1	-30	-0	34	8	20	-3	--	--	2

X	cls	Nr	Vyr	Vzr	Mry	Mrz	MTrd	SF_V.	SF_M	SF_Mt	SF
cm		kg	kg	kg	kg*m	kg*m	kg*m				
222	1	49565	18118	18118	1613	1613	1386	>100	66.4	>100	66.4

Asta : 946 [485 , 470]

Sez. G: O 114.3x5.9 L=222.5 cm Crit.: Acciaio_Flessione $\gamma_M=1.05$ $f_{yk}/\gamma_M=2619$ kg/cm² $f_t=4300$ kg/cm²

:Verificato

X	cls	N	TY	TZ	MT	MY	MZ	My4	Mz4	Comb.
cm		kg	kg	kg	kg*m	kg*m	kg*m			
156	1	1165	9	9	-2	-12	-7	--	--	2

X	cls	Nr	Vyr	Vzr	Mry	Mrz	MTrd	SF_V.	SF_M	SF_Mt	SF
cm		kg	kg	kg	kg*m	kg*m	kg*m				
156	1	52623	19315	19315	1818	1818	1566	>100	30.9	>100	30.9

Asta : 947 [462 , 463]

Sez. G: O 114.3x5.9 L=318.3 cm Crit.: Acciaio_Flessione $\gamma_M=1.05$ $f_{yk}/\gamma_M=2619$ kg/cm² $f_t=4300$ kg/cm²

:Verificato

X	cls	N	TY	TZ	MT	MY	MZ	My4	Mz4	Comb.
cm		kg	kg	kg	kg*m	kg*m	kg*m			
318	1	14807	-3	1265	2	709	5	--	--	2

X	cls	Nr	Vyr	Vzr	Mry	Mrz	MTrd	SF_V.	SF_M	SF_Mt	SF
cm		kg	kg	kg	kg*m	kg*m	kg*m				
318	1	52623	19315	19315	1818	1818	1566	15.3	1.48	>100	1.48

Asta : 948 [463 , 464]

AUTOSTRADA VALDASTICO A31 NORD
1° LOTTO - PIOVENE ROCCHETTE – VALLE DELL'ASTICO

Sez. G: O 114.3x5.9 L=315.7 cm Crit.: Acciaio_Flessione $\gamma_M=1.05$ $f_{yk}/\gamma_M=2619$ kg/cm² $f_t=4300$ kg/cm²

:Verificato

X	cls	N	TY	TZ	MT	MY	MZ	My4	Mz4	Comb.
cm		kg	kg	kg	kg*m	kg*m	kg*m			
0	1	-10404	-18	-1273	17	662	-29	--	--	2

X	cls	Nr	Vyr	Vzr	Mry	Mrz	MTrd	SF_V.	SF_M	SF_Mt	SF
cm		kg	kg	kg	kg*m	kg*m	kg*m				
0	1	52623	19136	19136	1818	1818	1566	15.0	1.73	93.8	1.73

Asta : 949 [464 , 465]

Sez. G: O 114.3x5.9 L=314.2 cm Crit.: Acciaio_Flessione $\gamma_M=1.05$ $f_{yk}/\gamma_M=2619$ kg/cm² $f_t=4300$ kg/cm²

:Verificato

X	cls	N	TY	TZ	MT	MY	MZ	My4	Mz4	Comb.
cm		kg	kg	kg	kg*m	kg*m	kg*m			
0	1	-15918	-7	-1267	4	647	-11	--	--	2

X	cls	Nr	Vyr	Vzr	Mry	Mrz	MTrd	SF_V.	SF_M	SF_Mt	SF
cm		kg	kg	kg	kg*m	kg*m	kg*m				
0	1	52623	19290	19290	1818	1818	1566	15.2	1.50	>100	1.50

Asta : 950 [465 , 466]

Sez. G: O 114.3x5.9 L=314.0 cm Crit.: Acciaio_Flessione $\gamma_M=1.05$ $f_{yk}/\gamma_M=2619$ kg/cm² $f_t=4300$ kg/cm²

:Verificato

X	cls	N	TY	TZ	MT	MY	MZ	My4	Mz4	Comb.
cm		kg	kg	kg	kg*m	kg*m	kg*m			
0	1	-16961	0	-1264	-0	640	0	--	--	2

X	cls	Nr	Vyr	Vzr	Mry	Mrz	MTrd	SF_V.	SF_M	SF_Mt	SF
cm		kg	kg	kg	kg*m	kg*m	kg*m				
0	1	52623	19342	19342	1818	1818	1566	15.3	1.48	>100	1.48

AUTOSTRADA VALDASTICO A31 NORD
1° LOTTO - PIOVENE ROCCHETTE – VALLE DELL'ASTICO

Asta : 951 [466 , 454]

Sez. G: O 114.3x5.9 L=314.2 cm Crit.: Acciaio_Flessione $\gamma_M=1.05$ $f_{yk}/\gamma_M=2619$ kg/cmq $f_t=4300$ kg/cmq

:Verificato

X	cls	N	TY	TZ	MT	MY	MZ	My4	Mz4	Comb.
cm		kg	kg	kg	kg*m	kg*m	kg*m			
314	1	-15869	7	1267	-4	647	-11	--	--	2

X	cls	Nr	Vyr	Vzr	Mry	Mrz	MTrd	SF_V.	SF_M	SF_Mt	SF
cm		kg	kg	kg	kg*m	kg*m	kg*m				
314	1	52623	19290	19290	1818	1818	1566	15.2	1.51	>100	1.51

Asta : 952 [454 , 467]

Sez. G: O 114.3x5.9 L=315.7 cm Crit.: Acciaio_Flessione $\gamma_M=1.05$ $f_{yk}/\gamma_M=2619$ kg/cmq $f_t=4300$ kg/cmq

:Verificato

X	cls	N	TY	TZ	MT	MY	MZ	My4	Mz4	Comb.
cm		kg	kg	kg	kg*m	kg*m	kg*m			
316	1	-10258	18	1273	-17	662	-29	--	--	2

X	cls	Nr	Vyr	Vzr	Mry	Mrz	MTrd	SF_V.	SF_M	SF_Mt	SF
cm		kg	kg	kg	kg*m	kg*m	kg*m				
316	1	52623	19134	19134	1818	1818	1566	15.0	1.74	92.9	1.74

Asta : 953 [467 , 468]

Sez. G: O 114.3x5.9 L=318.3 cm Crit.: Acciaio_Flessione $\gamma_M=1.05$ $f_{yk}/\gamma_M=2619$ kg/cmq $f_t=4300$ kg/cmq

:Verificato

X	cls	N	TY	TZ	MT	MY	MZ	My4	Mz4	Comb.
cm		kg	kg	kg	kg*m	kg*m	kg*m			
0	1	15221	2	-1265	-2	710	4	--	--	2

X	cls	Nr	Vyr	Vzr	Mry	Mrz	MTrd	SF_V.	SF_M	SF_Mt	SF
cm		kg	kg	kg	kg*m	kg*m	kg*m				
0	1	52623	19321	19321	1818	1818	1566	15.3	1.47	>100	1.47

AUTOSTRADA VALDASTICO A31 NORD
1° LOTTO - PIOVENE ROCCHETTE – VALLE DELL'ASTICO

Asta : 954 [479 , 480]

Sez. G: O 114.3x5.9 L=318.3 cm Crit.: Acciaio_Flessione $\gamma_M=1.05$ $f_{yk}/\gamma_M=2619$ kg/cmq $f_t=4300$ kg/cmq

:Verificato

X	cls	N	TY	TZ	MT	MY	MZ	My4	Mz4	Comb.
cm		kg	kg	kg	kg*m	kg*m	kg*m			
318	1	1405	-6	640	9	346	9	--	--	2

X	cls	Nr	Vyr	Vzr	Mry	Mrz	MTrd	SF_V.	SF_M	SF_Mt	SF
cm		kg	kg	kg	kg*m	kg*m	kg*m				
318	1	52623	19235	19235	1818	1818	1566	30.1	4.51	>100	4.51

Asta : 955 [480 , 481]

Sez. G: O 114.3x5.9 L=315.7 cm Crit.: Acciaio_Flessione $\gamma_M=1.05$ $f_{yk}/\gamma_M=2619$ kg/cmq $f_t=4300$ kg/cmq

:Verificato

X	cls	N	TY	TZ	MT	MY	MZ	My4	Mz4	Comb.
cm		kg	kg	kg	kg*m	kg*m	kg*m			
0	1	-4750	-19	-642	15	338	-33	--	--	2

X	cls	Nr	Vyr	Vzr	Mry	Mrz	MTrd	SF_V.	SF_M	SF_Mt	SF
cm		kg	kg	kg	kg*m	kg*m	kg*m				
0	1	52623	19153	19153	1818	1818	1566	29.8	3.40	>100	3.40

Asta : 956 [481 , 482]

Sez. G: O 114.3x5.9 L=314.2 cm Crit.: Acciaio_Flessione $\gamma_M=1.05$ $f_{yk}/\gamma_M=2619$ kg/cmq $f_t=4300$ kg/cmq

:Verificato

X	cls	N	TY	TZ	MT	MY	MZ	My4	Mz4	Comb.
cm		kg	kg	kg	kg*m	kg*m	kg*m			
0	1	-10393	-7	-640	6	325	-11	--	--	2

X	cls	Nr	Vyr	Vzr	Mry	Mrz	MTrd	SF_V.	SF_M	SF_Mt	SF
cm		kg	kg	kg	kg*m	kg*m	kg*m				

AUTOSTRADA VALDASTICO A31 NORD
1° LOTTO - PIOVENE ROCCHETTE – VALLE DELL'ASTICO

X	cls	Nr	Vyr	Vzr	Mry	Mrz	MTrd	SF_V.	SF_M	SF_Mt	SF
0	1	52623	19262	19262	1818	1818	1566	30.1	2.62	>100	2.62

Asta : 957 [482 , 483]

Sez. G: O 114.3x5.9 L=314.0 cm Crit.: Acciaio_Flessione $\gamma_M=1.05$ $f_{yk}/\gamma_M=2619$ kg/cm² $f_t=4300$ kg/cm²

:Verificato

X	cls	N	TY	TZ	MT	MY	MZ	My4	Mz4	Comb.
cm		kg	kg	kg	kg*m	kg*m	kg*m			
0	1	-12510	0	-636	-0	316	1	--	--	2

X	cls	Nr	Vyr	Vzr	Mry	Mrz	MTrd	SF_V.	SF_M	SF_Mt	SF
cm		kg	kg	kg	kg*m	kg*m	kg*m				
0	1	52623	19341	19341	1818	1818	1566	30.4	2.43	>100	2.43

Asta : 958 [483 , 471]

Sez. G: O 114.3x5.9 L=314.2 cm Crit.: Acciaio_Flessione $\gamma_M=1.05$ $f_{yk}/\gamma_M=2619$ kg/cm² $f_t=4300$ kg/cm²

:Verificato

X	cls	N	TY	TZ	MT	MY	MZ	My4	Mz4	Comb.
cm		kg	kg	kg	kg*m	kg*m	kg*m			
314	1	-10336	7	640	-7	325	-11	--	--	2

X	cls	Nr	Vyr	Vzr	Mry	Mrz	MTrd	SF_V.	SF_M	SF_Mt	SF
cm		kg	kg	kg	kg*m	kg*m	kg*m				
314	1	52623	19261	19261	1818	1818	1566	30.1	2.62	>100	2.62

Asta : 959 [471 , 484]

Sez. G: O 114.3x5.9 L=315.7 cm Crit.: Acciaio_Flessione $\gamma_M=1.05$ $f_{yk}/\gamma_M=2619$ kg/cm² $f_t=4300$ kg/cm²

:Verificato

X	cls	N	TY	TZ	MT	MY	MZ	My4	Mz4	Comb.
cm		kg	kg	kg	kg*m	kg*m	kg*m			
316	1	-4643	19	642	-15	338	-33	--	--	2

AUTOSTRADA VALDASTICO A31 NORD
1° LOTTO - PIOVENE ROCCHETTE – VALLE DELL'ASTICO

X	cls	Nr	Vyr	Vzr	Mry	Mrz	MTrd	SF_V.	SF_M	SF_Mt	SF
cm		kg	kg	kg	kg*m	kg*m	kg*m				
316	1	52623	19153	19153	1818	1818	1566	29.8	3.42	>100	3.42

Asta : 960 [484 , 485]

Sez. G: O 114.3x5.9 L=318.3 cm Crit.: Acciaio_Flessione $\gamma_M=1.05$ $f_{yk}/\gamma_M=2619$ kg/cm² $f_t=4300$ kg/cm²

:Verificato

X	cls	N	TY	TZ	MT	MY	MZ	My4	Mz4	Comb.
cm		kg	kg	kg	kg*m	kg*m	kg*m			
0	1	1517	5	-640	-8	346	8	--	--	2

X	cls	Nr	Vyr	Vzr	Mry	Mrz	MTrd	SF_V.	SF_M	SF_Mt	SF
cm		kg	kg	kg	kg*m	kg*m	kg*m				
0	1	52623	19240	19240	1818	1818	1566	30.1	4.47	>100	4.47

Asta : 961 [416 , 428]

Sez. G: O 114.3x5.9 L=247.0 cm Crit.: Acciaio_Flessione $\gamma_M=1.05$ $f_{yk}/\gamma_M=2619$ kg/cm² $f_t=4300$ kg/cm²

:Verificato

X	cls	N	TY	TZ	MT	MY	MZ	My4	Mz4	Comb.
cm		kg	kg	kg	kg*m	kg*m	kg*m			
247	1	1074	-24	30	11	13	30	--	--	2

X	cls	Nr	Vyr	Vzr	Mry	Mrz	MTrd	SF_V.	SF_M	SF_Mt	SF
cm		kg	kg	kg	kg*m	kg*m	kg*m				
247	1	52623	19204	19204	1818	1818	1566	>100	22.9	>100	22.9

Asta : 962 [428 , 444]

Sez. G: O 114.3x5.9 L=247.0 cm Crit.: Acciaio_Flessione $\gamma_M=1.05$ $f_{yk}/\gamma_M=2619$ kg/cm² $f_t=4300$ kg/cm²

:Verificato

X	cls	N	TY	TZ	MT	MY	MZ	My4	Mz4	Comb.
cm		kg	kg	kg	kg*m	kg*m	kg*m			
247	1	10245	-5	94	22	130	4	--	--	2

AUTOSTRADA VALDASTICO A31 NORD
1° LOTTO - PIOVENE ROCCHETTE – VALLE DELL'ASTICO

X	cls	Nr	Vyr	Vzr	Mry	Mrz	MTrd	SF_V.	SF_M	SF_Mt	SF
cm		kg	kg	kg	kg*m	kg*m	kg*m				
247	1	52623	19066	19066	1818	1818	1566	>100	3.72	70.3	3.72

Asta : 963 [444 , 203]

Sez. G: O 114.3x5.9 L=266.5 cm Crit.: Acciaio_Flessione $\gamma_M=1.05$ $f_{yk}/\gamma_M=2619$ kg/cm² $f_t=4300$ kg/cm²

:Verificato

X	cls	N	TY	TZ	MT	MY	MZ	My4	Mz4	Comb.
cm		kg	kg	kg	kg*m	kg*m	kg*m			
0	1	27497	-5	-59	-19	149	-16	--	--	2

X	cls	Nr	Vyr	Vzr	Mry	Mrz	MTrd	SF_V.	SF_M	SF_Mt	SF
cm		kg	kg	kg	kg*m	kg*m	kg*m				
0	1	52623	19111	19111	1818	1818	1566	>100	1.63	83.7	1.63

Asta : 964 [203 , 220]

Sez. G: O 114.3x5.9 L=286.0 cm Crit.: Acciaio_Flessione $\gamma_M=1.05$ $f_{yk}/\gamma_M=2619$ kg/cm² $f_t=4300$ kg/cm²

:Verificato

X	cls	N	TY	TZ	MT	MY	MZ	My4	Mz4	Comb.
cm		kg	kg	kg	kg*m	kg*m	kg*m			
0	1	3891	-9	-78	21	98	-12	--	--	2

X	cls	Nr	Vyr	Vzr	Mry	Mrz	MTrd	SF_V.	SF_M	SF_Mt	SF
cm		kg	kg	kg	kg*m	kg*m	kg*m				
0	1	52623	19080	19080	1818	1818	1566	>100	7.46	73.8	7.46

Asta : 965 [220 , 237]

Sez. G: O 114.3x5.9 L=286.0 cm Crit.: Acciaio_Flessione $\gamma_M=1.05$ $f_{yk}/\gamma_M=2619$ kg/cm² $f_t=4300$ kg/cm²

:Verificato

X	cls	N	TY	TZ	MT	MY	MZ	My4	Mz4	Comb.
cm		kg	kg	kg	kg*m	kg*m	kg*m			

AUTOSTRADA VALDASTICO A31 NORD
1° LOTTO - PIOVENE ROCCHETTE – VALLE DELL'ASTICO

X	cls	N	TY	TZ	MT	MY	MZ	My4	Mz4	Comb.
143	1	-5545	3	-5	-2	-35	3	--	--	2

X	cls	Nr	Vyr	Vzr	Mry	Mrz	MTrd	SF_V.	SF_M	SF_Mt	SF
cm		kg	kg	kg	kg*m	kg*m	kg*m				
143	1	52623	19320	19320	1818	1818	1566	>100	7.93	>100	7.93

Asta : 966 [237 , 254]

Sez. G: O 114.3x5.9 L=286.0 cm Crit.: Acciaio_Flessione $\gamma_M=1.05$ $f_{yk}/\gamma_M=2619$ kg/cm² $f_t=4300$ kg/cm²

:Verificato

X	cls	N	TY	TZ	MT	MY	MZ	My4	Mz4	Comb.
cm		kg	kg	kg	kg*m	kg*m	kg*m			
286	1	-2132	11	64	-15	56	-14	--	--	2

X	cls	Nr	Vyr	Vzr	Mry	Mrz	MTrd	SF_V.	SF_M	SF_Mt	SF
cm		kg	kg	kg	kg*m	kg*m	kg*m				
286	1	52623	19162	19162	1818	1818	1566	>100	12.7	>100	12.7

Asta : 967 [254 , 271]

Sez. G: O 114.3x5.9 L=286.0 cm Crit.: Acciaio_Flessione $\gamma_M=1.05$ $f_{yk}/\gamma_M=2619$ kg/cm² $f_t=4300$ kg/cm²

:Verificato

X	cls	N	TY	TZ	MT	MY	MZ	My4	Mz4	Comb.
cm		kg	kg	kg	kg*m	kg*m	kg*m			
286	1	14347	3	31	-1	66	-9	--	--	2

X	cls	Nr	Vyr	Vzr	Mry	Mrz	MTrd	SF_V.	SF_M	SF_Mt	SF
cm		kg	kg	kg	kg*m	kg*m	kg*m				
286	1	52623	19328	19328	1818	1818	1566	>100	3.19	>100	3.19

Asta : 968 [271 , 288]

Sez. G: O 114.3x5.9 L=286.0 cm Crit.: Acciaio_Flessione $\gamma_M=1.05$ $f_{yk}/\gamma_M=2619$ kg/cm² $f_t=4300$ kg/cm²

:Verificato

AUTOSTRADA VALDASTICO A31 NORD
1° LOTTO - PIOVENE ROCCHETTE – VALLE DELL'ASTICO

X	cls	N	TY	TZ	MT	MY	MZ	My4	Mz4	Comb.
cm		kg	kg	kg	kg*m	kg*m	kg*m			
286	1	-3581	-6	-8	11	-53	10	--	--	2

X	cls	Nr	Vyr	Vzr	Mry	Mrz	MTrd	SF_V.	SF_M	SF_Mt	SF
cm		kg	kg	kg	kg*m	kg*m	kg*m				
286	1	52623	19207	19207	1818	1818	1566	>100	9.74	>100	9.74

Asta : 969 [288 , 305]

Sez. G: O 114.3x5.9 L=286.0 cm Crit.: Acciaio_Flessione $\gamma_M=1.05$ $f_{yk}/\gamma_M=2619$ kg/cm² $f_t=4300$ kg/cm²

:Verificato

X	cls	N	TY	TZ	MT	MY	MZ	My4	Mz4	Comb.
cm		kg	kg	kg	kg*m	kg*m	kg*m			
143	1	-9173	-0	0	1	-46	3	--	--	2

X	cls	Nr	Vyr	Vzr	Mry	Mrz	MTrd	SF_V.	SF_M	SF_Mt	SF
cm		kg	kg	kg	kg*m	kg*m	kg*m				
143	1	52623	19331	19331	1818	1818	1566	>100	4.96	>100	4.96

Asta : 970 [305 , 348]

Sez. G: O 114.3x5.9 L=286.0 cm Crit.: Acciaio_Flessione $\gamma_M=1.05$ $f_{yk}/\gamma_M=2619$ kg/cm² $f_t=4300$ kg/cm²

:Verificato

X	cls	N	TY	TZ	MT	MY	MZ	My4	Mz4	Comb.
cm		kg	kg	kg	kg*m	kg*m	kg*m			
286	1	-2464	7	70	-11	62	-9	--	--	2

X	cls	Nr	Vyr	Vzr	Mry	Mrz	MTrd	SF_V.	SF_M	SF_Mt	SF
cm		kg	kg	kg	kg*m	kg*m	kg*m				
286	1	52623	19208	19208	1818	1818	1566	>100	11.6	>100	11.6

Asta : 971 [348 , 331]

AUTOSTRADA VALDASTICO A31 NORD
1° LOTTO - PIOVENE ROCCHETTE – VALLE DELL'ASTICO

Sez. G: O 114.3x5.9 L=286.0 cm Crit.: Acciaio_Flessione $\gamma_M=1.05$ $f_{yk}/\gamma_M=2619$ kg/cmq $f_t=4300$ kg/cmq

:Verificato

X	cls	N	TY	TZ	MT	MY	MZ	My4	Mz4	Comb.
cm		kg	kg	kg	kg*m	kg*m	kg*m			
286	1	16871	0	30	0	72	-7	--	--	2

X	cls	Nr	Vyr	Vzr	Mry	Mrz	MTrd	SF_V.	SF_M	SF_Mt	SF
cm		kg	kg	kg	kg*m	kg*m	kg*m				
286	1	52623	19340	19340	1818	1818	1566	>100	2.75	>100	2.75

Asta : 972 [331 , 356]

Sez. G: O 114.3x5.9 L=286.0 cm Crit.: Acciaio_Flessione $\gamma_M=1.05$ $f_{yk}/\gamma_M=2619$ kg/cmq $f_t=4300$ kg/cmq

:Verificato

X	cls	N	TY	TZ	MT	MY	MZ	My4	Mz4	Comb.
cm		kg	kg	kg	kg*m	kg*m	kg*m			
0	1	-2081	-6	-70	11	63	-8	--	--	2

X	cls	Nr	Vyr	Vzr	Mry	Mrz	MTrd	SF_V.	SF_M	SF_Mt	SF
cm		kg	kg	kg	kg*m	kg*m	kg*m				
0	1	52623	19207	19207	1818	1818	1566	>100	12.8	>100	12.8

Asta : 973 [356 , 373]

Sez. G: O 114.3x5.9 L=286.0 cm Crit.: Acciaio_Flessione $\gamma_M=1.05$ $f_{yk}/\gamma_M=2619$ kg/cmq $f_t=4300$ kg/cmq

:Verificato

X	cls	N	TY	TZ	MT	MY	MZ	My4	Mz4	Comb.
cm		kg	kg	kg	kg*m	kg*m	kg*m			
143	1	-8389	1	-0	-1	-44	3	--	--	2

X	cls	Nr	Vyr	Vzr	Mry	Mrz	MTrd	SF_V.	SF_M	SF_Mt	SF
cm		kg	kg	kg	kg*m	kg*m	kg*m				
143	1	52623	19325	19325	1818	1818	1566	>100	5.39	>100	5.39

AUTOSTRADA VALDASTICO A31 NORD
1° LOTTO - PIOVENE ROCCHETTE – VALLE DELL'ASTICO

Asta : 974 [373 , 390]

Sez. G: O 114.3x5.9 L=286.0 cm Crit.: Acciaio_Flessione $\gamma_M=1.05$ $f_{yk}/\gamma_M=2619$ kg/cm² $f_t=4300$ kg/cm²

:Verificato

X	cls	N	TY	TZ	MT	MY	MZ	My4	Mz4	Comb.
cm		kg	kg	kg	kg*m	kg*m	kg*m			
286	1	-2409	7	66	-12	54	-9	--	--	2

X	cls	Nr	Vyr	Vzr	Mry	Mrz	MTrd	SF_V.	SF_M	SF_Mt	SF
cm		kg	kg	kg	kg*m	kg*m	kg*m				
286	1	52623	19198	19198	1818	1818	1566	>100	12.4	>100	12.4

Asta : 975 [390 , 462]

Sez. G: O 114.3x5.9 L=274.8 cm Crit.: Acciaio_Flessione $\gamma_M=1.05$ $f_{yk}/\gamma_M=2619$ kg/cm² $f_t=4300$ kg/cm²

:Verificato

X	cls	N	TY	TZ	MT	MY	MZ	My4	Mz4	Comb.
cm		kg	kg	kg	kg*m	kg*m	kg*m			
275	1	15834	1	35	-2	75	-7	--	--	2

X	cls	Nr	Vyr	Vzr	Mry	Mrz	MTrd	SF_V.	SF_M	SF_Mt	SF
cm		kg	kg	kg	kg*m	kg*m	kg*m				
275	1	52623	19319	19319	1818	1818	1566	>100	2.89	>100	2.89

Asta : 976 [462 , 479]

Sez. G: O 114.3x5.9 L=264.5 cm Crit.: Acciaio_Flessione $\gamma_M=1.05$ $f_{yk}/\gamma_M=2619$ kg/cm² $f_t=4300$ kg/cm²

:Verificato

X	cls	N	TY	TZ	MT	MY	MZ	My4	Mz4	Comb.
cm		kg	kg	kg	kg*m	kg*m	kg*m			
0	1	3239	-8	-58	7	63	-11	--	--	2

X	cls	Nr	Vyr	Vzr	Mry	Mrz	MTrd	SF_V.	SF_M	SF_Mt	SF
cm		kg	kg	kg	kg*m	kg*m	kg*m				
0	1	52623	19257	19257	1818	1818	1566	>100	9.77	>100	9.77

AUTOSTRADA VALDASTICO A31 NORD
1° LOTTO - PIOVENE ROCCHETTE – VALLE DELL'ASTICO

Asta : 977 [415 , 429]

Sez. G: O 114.3x5.9 L=247.0 cm Crit.: Acciaio_Flessione $\gamma_M=1.05$ $f_{yk}/\gamma_M=2619$ kg/cmq $f_t=4300$ kg/cmq

:Verificato

X	cls	N	TY	TZ	MT	MY	MZ	My4	Mz4	Comb.
cm		kg	kg	kg	kg*m	kg*m	kg*m			
247	1	1027	-47	32	27	16	55	--	--	2

X	cls	Nr	Vyr	Vzr	Mry	Mrz	MTrd	SF_V.	SF_M	SF_Mt	SF
cm		kg	kg	kg	kg*m	kg*m	kg*m				
247	1	52623	19011	19011	1818	1818	1566	>100	17.0	58.4	17.0

Asta : 978 [429 , 445]

Sez. G: O 114.3x5.9 L=247.0 cm Crit.: Acciaio_Flessione $\gamma_M=1.05$ $f_{yk}/\gamma_M=2619$ kg/cmq $f_t=4300$ kg/cmq

:Verificato

X	cls	N	TY	TZ	MT	MY	MZ	My4	Mz4	Comb.
cm		kg	kg	kg	kg*m	kg*m	kg*m			
247	1	9737	-65	62	40	66	82	--	--	2

X	cls	Nr	Vyr	Vzr	Mry	Mrz	MTrd	SF_V.	SF_M	SF_Mt	SF
cm		kg	kg	kg	kg*m	kg*m	kg*m				
247	1	52623	18852	18852	1818	1818	1566	>100	3.75	39.5	3.75

Asta : 979 [445 , 202]

Sez. G: O 114.3x5.9 L=266.5 cm Crit.: Acciaio_Flessione $\gamma_M=1.05$ $f_{yk}/\gamma_M=2619$ kg/cmq $f_t=4300$ kg/cmq

:Verificato

X	cls	N	TY	TZ	MT	MY	MZ	My4	Mz4	Comb.
cm		kg	kg	kg	kg*m	kg*m	kg*m			
0	1	35190	3	-44	1	121	-2	--	--	2

X	cls	Nr	Vyr	Vzr	Mry	Mrz	MTrd	SF_V.	SF_M	SF_Mt	SF
cm		kg	kg	kg	kg*m	kg*m	kg*m				

AUTOSTRADA VALDASTICO A31 NORD
1° LOTTO - PIOVENE ROCCHETTE – VALLE DELL'ASTICO

X	cls	Nr	Vyr	Vzr	Mry	Mrz	MTrd	SF_V.	SF_M	SF_Mt	SF
0	1	52623	19327	19327	1818	1818	1566	>100	1.36	>100	1.36

Asta : 980 [202 , 219]

Sez. G: O 114.3x5.9 L=286.0 cm Crit.: Acciaio_Flessione $\gamma M=1.05$ $f_{yk}/\gamma M=2619$ kg/cm² $f_t=4300$ kg/cm²

:Verificato

X	cls	N	TY	TZ	MT	MY	MZ	My4	Mz4	Comb.
cm		kg	kg	kg	kg*m	kg*m	kg*m			
0	1	4195	32	-61	-22	60	50	--	--	2

X	cls	Nr	Vyr	Vzr	Mry	Mrz	MTrd	SF_V.	SF_M	SF_Mt	SF
cm		kg	kg	kg	kg*m	kg*m	kg*m				
0	1	52623	19065	19065	1818	1818	1566	>100	7.13	70.0	7.13

Asta : 981 [219 , 236]

Sez. G: O 114.3x5.9 L=286.0 cm Crit.: Acciaio_Flessione $\gamma M=1.05$ $f_{yk}/\gamma M=2619$ kg/cm² $f_t=4300$ kg/cm²

:Verificato

X	cls	N	TY	TZ	MT	MY	MZ	My4	Mz4	Comb.
cm		kg	kg	kg	kg*m	kg*m	kg*m			
200	1	-5976	5	7	-4	-25	-3	--	--	2

X	cls	Nr	Vyr	Vzr	Mry	Mrz	MTrd	SF_V.	SF_M	SF_Mt	SF
cm		kg	kg	kg	kg*m	kg*m	kg*m				
200	1	52623	19297	19297	1818	1818	1566	>100	7.77	>100	7.77

Asta : 982 [236 , 253]

Sez. G: O 114.3x5.9 L=286.0 cm Crit.: Acciaio_Flessione $\gamma M=1.05$ $f_{yk}/\gamma M=2619$ kg/cm² $f_t=4300$ kg/cm²

:Verificato

X	cls	N	TY	TZ	MT	MY	MZ	My4	Mz4	Comb.
cm		kg	kg	kg	kg*m	kg*m	kg*m			
286	1	-2292	-21	47	16	28	32	--	--	2

AUTOSTRADA VALDASTICO A31 NORD
1° LOTTO - PIOVENE ROCCHETTE – VALLE DELL'ASTICO

X	cls	Nr	Vyr	Vzr	Mry	Mrz	MTrd	SF_V.	SF_M	SF_Mt	SF
cm		kg	kg	kg	kg*m	kg*m	kg*m				
286	1	52623	19146	19146	1818	1818	1566	>100	13.0	99.0	13.0

Asta : 983 [253 , 270]

Sez. G: O 114.3x5.9 L=286.0 cm Crit.: Acciaio_Flessione $\gamma_M=1.05$ $f_{yk}/\gamma_M=2619$ kg/cm² $f_t=4300$ kg/cm²

:Verificato

X	cls	N	TY	TZ	MT	MY	MZ	My4	Mz4	Comb.
cm		kg	kg	kg	kg*m	kg*m	kg*m			
286	1	19029	2	29	-1	64	-7	--	--	2

X	cls	Nr	Vyr	Vzr	Mry	Mrz	MTrd	SF_V.	SF_M	SF_Mt	SF
cm		kg	kg	kg	kg*m	kg*m	kg*m				
286	1	52623	19331	19331	1818	1818	1566	>100	2.50	>100	2.50

Asta : 984 [270 , 287]

Sez. G: O 114.3x5.9 L=286.0 cm Crit.: Acciaio_Flessione $\gamma_M=1.05$ $f_{yk}/\gamma_M=2619$ kg/cm² $f_t=4300$ kg/cm²

:Verificato

X	cls	N	TY	TZ	MT	MY	MZ	My4	Mz4	Comb.
cm		kg	kg	kg	kg*m	kg*m	kg*m			
286	1	-4437	26	9	-20	-31	-36	--	--	2

X	cls	Nr	Vyr	Vzr	Mry	Mrz	MTrd	SF_V.	SF_M	SF_Mt	SF
cm		kg	kg	kg	kg*m	kg*m	kg*m				
286	1	52623	19099	19099	1818	1818	1566	>100	8.25	79.8	8.25

Asta : 985 [287 , 304]

Sez. G: O 114.3x5.9 L=286.0 cm Crit.: Acciaio_Flessione $\gamma_M=1.05$ $f_{yk}/\gamma_M=2619$ kg/cm² $f_t=4300$ kg/cm²

:Verificato

X	cls	N	TY	TZ	MT	MY	MZ	My4	Mz4	Comb.
cm		kg	kg	kg	kg*m	kg*m	kg*m			
143	1	-10697	-0	0	1	-34	1	--	--	2

AUTOSTRADA VALDASTICO A31 NORD
1° LOTTO - PIOVENE ROCCHETTE – VALLE DELL'ASTICO

X	cls	Nr	Vyr	Vzr	Mry	Mrz	MTrd	SF_V.	SF_M	SF_Mt	SF
cm		kg	kg	kg	kg*m	kg*m	kg*m				
143	1	52623	19329	19329	1818	1818	1566	>100	4.50	>100	4.50

Asta : 986 [304 , 347]

Sez. G: O 114.3x5.9 L=286.0 cm Crit.: Acciaio_Flessione $\gamma_M=1.05$ $f_{yk}/\gamma_M=2619$ kg/cm² $f_t=4300$ kg/cm²

:Verificato

X	cls	N	TY	TZ	MT	MY	MZ	My4	Mz4	Comb.
cm		kg	kg	kg	kg*m	kg*m	kg*m			
286	1	-4055	-27	51	21	30	41	--	--	2

X	cls	Nr	Vyr	Vzr	Mry	Mrz	MTrd	SF_V.	SF_M	SF_Mt	SF
cm		kg	kg	kg	kg*m	kg*m	kg*m				
286	1	52623	19079	19079	1818	1818	1566	>100	8.59	73.7	8.59

Asta : 987 [347 , 330]

Sez. G: O 114.3x5.9 L=286.0 cm Crit.: Acciaio_Flessione $\gamma_M=1.05$ $f_{yk}/\gamma_M=2619$ kg/cm² $f_t=4300$ kg/cm²

:Verificato

X	cls	N	TY	TZ	MT	MY	MZ	My4	Mz4	Comb.
cm		kg	kg	kg	kg*m	kg*m	kg*m			
286	1	20325	0	29	0	68	-6	--	--	2

X	cls	Nr	Vyr	Vzr	Mry	Mrz	MTrd	SF_V.	SF_M	SF_Mt	SF
cm		kg	kg	kg	kg*m	kg*m	kg*m				
286	1	52623	19339	19339	1818	1818	1566	>100	2.34	>100	2.34

Asta : 988 [330 , 355]

Sez. G: O 114.3x5.9 L=286.0 cm Crit.: Acciaio_Flessione $\gamma_M=1.05$ $f_{yk}/\gamma_M=2619$ kg/cm² $f_t=4300$ kg/cm²

:Verificato

X	cls	N	TY	TZ	MT	MY	MZ	My4	Mz4	Comb.
cm		kg	kg	kg	kg*m	kg*m	kg*m			

AUTOSTRADA VALDASTICO A31 NORD
1° LOTTO - PIOVENE ROCCHETTE – VALLE DELL'ASTICO

X	cls	N	TY	TZ	MT	MY	MZ	My4	Mz4	Comb.
0	1	-3909	29	-51	-21	30	43	--	--	2

X	cls	Nr	Vyr	Vzr	Mry	Mrz	MTrd	SF_V.	SF_M	SF_Mt	SF
cm		kg	kg	kg	kg*m	kg*m	kg*m				
0	1	52623	19079	19079	1818	1818	1566	>100	8.73	73.8	8.73

Asta : 989 [355 , 372]

Sez. G: O 114.3x5.9 L=286.0 cm Crit.: Acciaio_Flessione $\gamma_M=1.05$ $f_{yk}/\gamma_M=2619$ kg/cm² $f_t=4300$ kg/cm²

:Verificato

X	cls	N	TY	TZ	MT	MY	MZ	My4	Mz4	Comb.
cm		kg	kg	kg	kg*m	kg*m	kg*m			
143	1	-10322	3	0	-2	-33	0	--	--	2

X	cls	Nr	Vyr	Vzr	Mry	Mrz	MTrd	SF_V.	SF_M	SF_Mt	SF
cm		kg	kg	kg	kg*m	kg*m	kg*m				
143	1	52623	19319	19319	1818	1818	1566	>100	4.66	>100	4.66

Asta : 990 [372 , 389]

Sez. G: O 114.3x5.9 L=286.0 cm Crit.: Acciaio_Flessione $\gamma_M=1.05$ $f_{yk}/\gamma_M=2619$ kg/cm² $f_t=4300$ kg/cm²

:Verificato

X	cls	N	TY	TZ	MT	MY	MZ	My4	Mz4	Comb.
cm		kg	kg	kg	kg*m	kg*m	kg*m			
286	1	-3756	-21	50	17	29	32	--	--	2

X	cls	Nr	Vyr	Vzr	Mry	Mrz	MTrd	SF_V.	SF_M	SF_Mt	SF
cm		kg	kg	kg	kg*m	kg*m	kg*m				
286	1	52623	19137	19137	1818	1818	1566	>100	9.54	94.4	9.54

Asta : 991 [389 , 463]

Sez. G: O 114.3x5.9 L=274.8 cm Crit.: Acciaio_Flessione $\gamma_M=1.05$ $f_{yk}/\gamma_M=2619$ kg/cm² $f_t=4300$ kg/cm²

:Verificato

AUTOSTRADA VALDASTICO A31 NORD
1° LOTTO - PIOVENE ROCCHETTE – VALLE DELL'ASTICO

X	cls	N	TY	TZ	MT	MY	MZ	My4	Mz4	Comb.
cm		kg	kg	kg	kg*m	kg*m	kg*m			
275	1	19640	0	34	-1	71	-5	--	--	2

X	cls	Nr	Vyr	Vzr	Mry	Mrz	MTrd	SF_V.	SF_M	SF_Mt	SF
cm		kg	kg	kg	kg*m	kg*m	kg*m				
275	1	52623	19328	19328	1818	1818	1566	>100	2.41	>100	2.41

Asta : 992 [463 , 480]

Sez. G: O 114.3x5.9 L=264.5 cm Crit.: Acciaio_Flessione $\gamma_M=1.05$ $f_{yk}/\gamma_M=2619$ kg/cm² $f_t=4300$ kg/cm²

:Verificato

X	cls	N	TY	TZ	MT	MY	MZ	My4	Mz4	Comb.
cm		kg	kg	kg	kg*m	kg*m	kg*m			
0	1	3094	35	-43	-23	33	47	--	--	2

X	cls	Nr	Vyr	Vzr	Mry	Mrz	MTrd	SF_V.	SF_M	SF_Mt	SF
cm		kg	kg	kg	kg*m	kg*m	kg*m				
0	1	52623	19060	19060	1818	1818	1566	>100	9.73	68.6	9.73

Asta : 993 [414 , 431]

Sez. G: O 114.3x5.9 L=247.0 cm Crit.: Acciaio_Flessione $\gamma_M=1.05$ $f_{yk}/\gamma_M=2619$ kg/cm² $f_t=4300$ kg/cm²

:Verificato

X	cls	N	TY	TZ	MT	MY	MZ	My4	Mz4	Comb.
cm		kg	kg	kg	kg*m	kg*m	kg*m			
247	1	2290	-47	35	20	23	55	--	--	2

X	cls	Nr	Vyr	Vzr	Mry	Mrz	MTrd	SF_V.	SF_M	SF_Mt	SF
cm		kg	kg	kg	kg*m	kg*m	kg*m				
247	1	52623	19099	19099	1818	1818	1566	>100	11.6	79.6	11.6

Asta : 994 [431 , 446]

AUTOSTRADA VALDASTICO A31 NORD
1° LOTTO - PIOVENE ROCCHETTE – VALLE DELL'ASTICO

Sez. G: O 114.3x5.9 L=247.0 cm Crit.: Acciaio_Flessione $\gamma_M=1.05$ $f_{yk}/\gamma_M=2619$ kg/cmq $f_t=4300$ kg/cmq

:Verificato

X	cls	N	TY	TZ	MT	MY	MZ	My4	Mz4	Comb.
cm		kg	kg	kg	kg*m	kg*m	kg*m			
247	1	7259	-47	41	19	42	59	--	--	2

X	cls	Nr	Vyr	Vzr	Mry	Mrz	MTrd	SF_V.	SF_M	SF_Mt	SF
cm		kg	kg	kg	kg*m	kg*m	kg*m				
247	1	52623	19113	19113	1818	1818	1566	>100	5.17	84.7	5.17

Asta : 995 [446 , 201]

Sez. G: O 114.3x5.9 L=266.5 cm Crit.: Acciaio_Flessione $\gamma_M=1.05$ $f_{yk}/\gamma_M=2619$ kg/cmq $f_t=4300$ kg/cmq

:Verificato

X	cls	N	TY	TZ	MT	MY	MZ	My4	Mz4	Comb.
cm		kg	kg	kg	kg*m	kg*m	kg*m			
0	1	11095	-6	-29	3	34	-8	--	--	2

X	cls	Nr	Vyr	Vzr	Mry	Mrz	MTrd	SF_V.	SF_M	SF_Mt	SF
cm		kg	kg	kg	kg*m	kg*m	kg*m				
0	1	52623	19299	19299	1818	1818	1566	>100	4.28	>100	4.28

Asta : 996 [201 , 218]

Sez. G: O 114.3x5.9 L=286.0 cm Crit.: Acciaio_Flessione $\gamma_M=1.05$ $f_{yk}/\gamma_M=2619$ kg/cmq $f_t=4300$ kg/cmq

:Verificato

X	cls	N	TY	TZ	MT	MY	MZ	My4	Mz4	Comb.
cm		kg	kg	kg	kg*m	kg*m	kg*m			
0	1	6762	18	-40	-8	39	25	--	--	2

X	cls	Nr	Vyr	Vzr	Mry	Mrz	MTrd	SF_V.	SF_M	SF_Mt	SF
cm		kg	kg	kg	kg*m	kg*m	kg*m				
0	1	52623	19239	19239	1818	1818	1566	>100	6.11	>100	6.11

AUTOSTRADA VALDASTICO A31 NORD
1° LOTTO - PIOVENE ROCCHETTE – VALLE DELL'ASTICO

Asta : 997 [218 , 235]

Sez. G: O 114.3x5.9 L=286.0 cm Crit.: Acciaio_Flessione $\gamma_M=1.05$ $f_{yk}/\gamma_M=2619$ kg/cm² $f_t=4300$ kg/cm²

:Verificato

X	cls	N	TY	TZ	MT	MY	MZ	My4	Mz4	Comb.
cm		kg	kg	kg	kg*m	kg*m	kg*m			
0	1	2437	5	-33	-3	19	6	--	--	2

X	cls	Nr	Vyr	Vzr	Mry	Mrz	MTrd	SF_V.	SF_M	SF_Mt	SF
cm		kg	kg	kg	kg*m	kg*m	kg*m				
0	1	52623	19306	19306	1818	1818	1566	>100	16.6	>100	16.6

Asta : 998 [235 , 252]

Sez. G: O 114.3x5.9 L=286.0 cm Crit.: Acciaio_Flessione $\gamma_M=1.05$ $f_{yk}/\gamma_M=2619$ kg/cm² $f_t=4300$ kg/cm²

:Verificato

X	cls	N	TY	TZ	MT	MY	MZ	My4	Mz4	Comb.
cm		kg	kg	kg	kg*m	kg*m	kg*m			
286	1	2769	-11	34	4	24	16	--	--	2

X	cls	Nr	Vyr	Vzr	Mry	Mrz	MTrd	SF_V.	SF_M	SF_Mt	SF
cm		kg	kg	kg	kg*m	kg*m	kg*m				
286	1	52623	19291	19291	1818	1818	1566	>100	13.5	>100	13.5

Asta : 999 [252 , 269]

Sez. G: O 114.3x5.9 L=286.0 cm Crit.: Acciaio_Flessione $\gamma_M=1.05$ $f_{yk}/\gamma_M=2619$ kg/cm² $f_t=4300$ kg/cm²

:Verificato

X	cls	N	TY	TZ	MT	MY	MZ	My4	Mz4	Comb.
cm		kg	kg	kg	kg*m	kg*m	kg*m			
0	1	4450	3	-31	-1	24	4	--	--	2

X	cls	Nr	Vyr	Vzr	Mry	Mrz	MTrd	SF_V.	SF_M	SF_Mt	SF
cm		kg	kg	kg	kg*m	kg*m	kg*m				
0	1	52623	19327	19327	1818	1818	1566	>100	10.0	>100	10.0

AUTOSTRADA VALDASTICO A31 NORD
1° LOTTO - PIOVENE ROCCHETTE – VALLE DELL'ASTICO

Asta : 1000 [269 , 286]

Sez. G: O 114.3x5.9 L=286.0 cm Crit.: Acciaio_Flessione $\gamma_M=1.05$ $f_{yk}/\gamma_M=2619$ kg/cmq $f_t=4300$ kg/cmq

:Verificato

X	cls	N	TY	TZ	MT	MY	MZ	My4	Mz4	Comb.
cm		kg	kg	kg	kg*m	kg*m	kg*m			
0	1	363	16	-38	-6	25	23	--	--	2

X	cls	Nr	Vyr	Vzr	Mry	Mrz	MTrd	SF_V.	SF_M	SF_Mt	SF
cm		kg	kg	kg	kg*m	kg*m	kg*m				
0	1	52623	19262	19262	1818	1818	1566	>100	30.0	>100	30.0

Asta : 1001 [286 , 303]

Sez. G: O 114.3x5.9 L=286.0 cm Crit.: Acciaio_Flessione $\gamma_M=1.05$ $f_{yk}/\gamma_M=2619$ kg/cmq $f_t=4300$ kg/cmq

:Verificato

X	cls	N	TY	TZ	MT	MY	MZ	My4	Mz4	Comb.
cm		kg	kg	kg	kg*m	kg*m	kg*m			
143	1	-2356	-0	-0	1	-14	-0	--	--	2

X	cls	Nr	Vyr	Vzr	Mry	Mrz	MTrd	SF_V.	SF_M	SF_Mt	SF
cm		kg	kg	kg	kg*m	kg*m	kg*m				
143	1	52623	19333	19333	1818	1818	1566	>100	19.0	>100	19.0

Asta : 1002 [303 , 346]

Sez. G: O 114.3x5.9 L=286.0 cm Crit.: Acciaio_Flessione $\gamma_M=1.05$ $f_{yk}/\gamma_M=2619$ kg/cmq $f_t=4300$ kg/cmq

:Verificato

X	cls	N	TY	TZ	MT	MY	MZ	My4	Mz4	Comb.
cm		kg	kg	kg	kg*m	kg*m	kg*m			
286	1	-308	-16	37	7	23	23	--	--	2

X	cls	Nr	Vyr	Vzr	Mry	Mrz	MTrd	SF_V.	SF_M	SF_Mt	SF
cm		kg	kg	kg	kg*m	kg*m	kg*m				

AUTOSTRADA VALDASTICO A31 NORD
1° LOTTO - PIOVENE ROCCHETTE – VALLE DELL'ASTICO

X	cls	Nr	Vyr	Vzr	Mry	Mrz	MTrd	SF_V.	SF_M	SF_Mt	SF
286	1	52623	19251	19251	1818	1818	1566	>100	32.1	>100	32.1

Asta : 1003 [346 , 329]

Sez. G: O 114.3x5.9 L=286.0 cm Crit.: Acciaio_Flessione $\gamma_M=1.05$ $f_{yk}/\gamma_M=2619$ kg/cm² $f_t=4300$ kg/cm²

:Verificato

X	cls	N	TY	TZ	MT	MY	MZ	My4	Mz4	Comb.
cm		kg	kg	kg	kg*m	kg*m	kg*m			
0	1	2774	1	-30	0	20	1	--	--	2

X	cls	Nr	Vyr	Vzr	Mry	Mrz	MTrd	SF_V.	SF_M	SF_Mt	SF
cm		kg	kg	kg	kg*m	kg*m	kg*m				
0	1	52623	19340	19340	1818	1818	1566	>100	15.6	>100	15.6

Asta : 1004 [329 , 354]

Sez. G: O 114.3x5.9 L=286.0 cm Crit.: Acciaio_Flessione $\gamma_M=1.05$ $f_{yk}/\gamma_M=2619$ kg/cm² $f_t=4300$ kg/cm²

:Verificato

X	cls	N	TY	TZ	MT	MY	MZ	My4	Mz4	Comb.
cm		kg	kg	kg	kg*m	kg*m	kg*m			
0	1	-719	17	-38	-7	24	25	--	--	2

X	cls	Nr	Vyr	Vzr	Mry	Mrz	MTrd	SF_V.	SF_M	SF_Mt	SF
cm		kg	kg	kg	kg*m	kg*m	kg*m				
0	1	52623	19251	19251	1818	1818	1566	>100	24.8	>100	24.8

Asta : 1005 [354 , 371]

Sez. G: O 114.3x5.9 L=286.0 cm Crit.: Acciaio_Flessione $\gamma_M=1.05$ $f_{yk}/\gamma_M=2619$ kg/cm² $f_t=4300$ kg/cm²

:Verificato

X	cls	N	TY	TZ	MT	MY	MZ	My4	Mz4	Comb.
cm		kg	kg	kg	kg*m	kg*m	kg*m			
172	1	-3201	3	6	-1	-14	-1	--	--	2

AUTOSTRADA VALDASTICO A31 NORD
1° LOTTO - PIOVENE ROCCHETTE – VALLE DELL'ASTICO

X	cls	Nr	Vyr	Vzr	Mry	Mrz	MTrd	SF_V.	SF_M	SF_Mt	SF
cm		kg	kg	kg	kg*m	kg*m	kg*m				
172	1	52623	19326	19326	1818	1818	1566	>100	14.4	>100	14.4

Asta : 1006 [371 , 388]

Sez. G: O 114.3x5.9 L=286.0 cm Crit.: Acciaio_Flessione $\gamma_M=1.05$ $f_{yk}/\gamma_M=2619$ kg/cm² $f_t=4300$ kg/cm²

:Verificato

X	cls	N	TY	TZ	MT	MY	MZ	My4	Mz4	Comb.
cm		kg	kg	kg	kg*m	kg*m	kg*m			
286	1	-917	-11	37	5	22	16	--	--	2

X	cls	Nr	Vyr	Vzr	Mry	Mrz	MTrd	SF_V.	SF_M	SF_Mt	SF
cm		kg	kg	kg	kg*m	kg*m	kg*m				
286	1	52623	19280	19280	1818	1818	1566	>100	25.8	>100	25.8

Asta : 1007 [388 , 464]

Sez. G: O 114.3x5.9 L=274.8 cm Crit.: Acciaio_Flessione $\gamma_M=1.05$ $f_{yk}/\gamma_M=2619$ kg/cm² $f_t=4300$ kg/cm²

:Verificato

X	cls	N	TY	TZ	MT	MY	MZ	My4	Mz4	Comb.
cm		kg	kg	kg	kg*m	kg*m	kg*m			
275	1	2961	2	31	-1	22	-3	--	--	2

X	cls	Nr	Vyr	Vzr	Mry	Mrz	MTrd	SF_V.	SF_M	SF_Mt	SF
cm		kg	kg	kg	kg*m	kg*m	kg*m				
275	1	52623	19326	19326	1818	1818	1566	>100	14.3	>100	14.3

Asta : 1008 [464 , 481]

Sez. G: O 114.3x5.9 L=264.5 cm Crit.: Acciaio_Flessione $\gamma_M=1.05$ $f_{yk}/\gamma_M=2619$ kg/cm² $f_t=4300$ kg/cm²

:Verificato

X	cls	N	TY	TZ	MT	MY	MZ	My4	Mz4	Comb.
cm		kg	kg	kg	kg*m	kg*m	kg*m			
0	1	1642	26	-33	-10	22	33	--	--	2

AUTOSTRADA VALDASTICO A31 NORD
1° LOTTO - PIOVENE ROCCHETTE – VALLE DELL'ASTICO

X	cls	Nr	Vyr	Vzr	Mry	Mrz	MTrd	SF_V.	SF_M	SF_Mt	SF
cm		kg	kg	kg	kg*m	kg*m	kg*m				
0	1	52623	19218	19218	1818	1818	1566	>100	16.4	>100	16.4

Asta : 1009 [413 , 434]

Sez. G: O 114.3x5.9 L=247.0 cm Crit.: Acciaio_Flessione $\gamma_M=1.05$ $f_{yk}/\gamma_M=2619$ kg/cmq $f_t=4300$ kg/cmq

:Verificato

X	cls	N	TY	TZ	MT	MY	MZ	My4	Mz4	Comb.
cm		kg	kg	kg	kg*m	kg*m	kg*m			
247	1	984	-18	28	7	14	21	--	--	2

X	cls	Nr	Vyr	Vzr	Mry	Mrz	MTrd	SF_V.	SF_M	SF_Mt	SF
cm		kg	kg	kg	kg*m	kg*m	kg*m				
247	1	52623	19256	19256	1818	1818	1566	>100	26.4	>100	26.4

Asta : 1010 [434 , 447]

Sez. G: O 114.3x5.9 L=247.0 cm Crit.: Acciaio_Flessione $\gamma_M=1.05$ $f_{yk}/\gamma_M=2619$ kg/cmq $f_t=4300$ kg/cmq

:Verificato

X	cls	N	TY	TZ	MT	MY	MZ	My4	Mz4	Comb.
cm		kg	kg	kg	kg*m	kg*m	kg*m			
247	1	2359	-16	29	6	18	19	--	--	2

X	cls	Nr	Vyr	Vzr	Mry	Mrz	MTrd	SF_V.	SF_M	SF_Mt	SF
cm		kg	kg	kg	kg*m	kg*m	kg*m				
247	1	52623	19269	19269	1818	1818	1566	>100	15.3	>100	15.3

Asta : 1011 [447 , 200]

Sez. G: O 114.3x5.9 L=266.5 cm Crit.: Acciaio_Flessione $\gamma_M=1.05$ $f_{yk}/\gamma_M=2619$ kg/cmq $f_t=4300$ kg/cmq

:Verificato

X	cls	N	TY	TZ	MT	MY	MZ	My4	Mz4	Comb.
cm		kg	kg	kg	kg*m	kg*m	kg*m			

AUTOSTRADA VALDASTICO A31 NORD
1° LOTTO - PIOVENE ROCCHETTE – VALLE DELL'ASTICO

X	cls	N	TY	TZ	MT	MY	MZ	My4	Mz4	Comb.
266	1	3519	-3	29	1	20	4	--	--	2

X	cls	Nr	Vyr	Vzr	Mry	Mrz	MTrd	SF_V.	SF_M	SF_Mt	SF
cm		kg	kg	kg	kg*m	kg*m	kg*m				
266	1	52623	19324	19324	1818	1818	1566	>100	12.5	>100	12.5

Asta : 1012 [200 , 217]

Sez. G: O 114.3x5.9 L=286.0 cm Crit.: Acciaio_Flessione $\gamma_M=1.05$ $f_{yk}/\gamma_M=2619$ kg/cm² $f_t=4300$ kg/cm²

:Verificato

X	cls	N	TY	TZ	MT	MY	MZ	My4	Mz4	Comb.
cm		kg	kg	kg	kg*m	kg*m	kg*m			
286	1	4706	5	30	-2	22	-7	--	--	2

X	cls	Nr	Vyr	Vzr	Mry	Mrz	MTrd	SF_V.	SF_M	SF_Mt	SF
cm		kg	kg	kg	kg*m	kg*m	kg*m				
286	1	52623	19318	19318	1818	1818	1566	>100	9.51	>100	9.51

Asta : 1013 [217 , 234]

Sez. G: O 114.3x5.9 L=286.0 cm Crit.: Acciaio_Flessione $\gamma_M=1.05$ $f_{yk}/\gamma_M=2619$ kg/cm² $f_t=4300$ kg/cm²

:Verificato

X	cls	N	TY	TZ	MT	MY	MZ	My4	Mz4	Comb.
cm		kg	kg	kg	kg*m	kg*m	kg*m			
0	1	4636	2	-31	-1	22	2	--	--	2

X	cls	Nr	Vyr	Vzr	Mry	Mrz	MTrd	SF_V.	SF_M	SF_Mt	SF
cm		kg	kg	kg	kg*m	kg*m	kg*m				
0	1	52623	19329	19329	1818	1818	1566	>100	9.86	>100	9.86

Asta : 1014 [234 , 251]

Sez. G: O 114.3x5.9 L=286.0 cm Crit.: Acciaio_Flessione $\gamma_M=1.05$ $f_{yk}/\gamma_M=2619$ kg/cm² $f_t=4300$ kg/cm²

:Verificato

AUTOSTRADA VALDASTICO A31 NORD
1° LOTTO - PIOVENE ROCCHETTE – VALLE DELL'ASTICO

X	cls	N	TY	TZ	MT	MY	MZ	My4	Mz4	Comb.
cm		kg	kg	kg	kg*m	kg*m	kg*m			
0	1	3413	-3	-32	1	21	-4	--	--	2

X	cls	Nr	Vyr	Vzr	Mry	Mrz	MTrd	SF_V.	SF_M	SF_Mt	SF
cm		kg	kg	kg	kg*m	kg*m	kg*m				
0	1	52623	19333	19333	1818	1818	1566	>100	12.7	>100	12.7

Asta : 1015 [251 , 268]

Sez. G: O 114.3x5.9 L=286.0 cm Crit.: Acciaio_Flessione $\gamma_M=1.05$ $f_{yk}/\gamma_M=2619$ kg/cm² $f_t=4300$ kg/cm²

:Verificato

X	cls	N	TY	TZ	MT	MY	MZ	My4	Mz4	Comb.
cm		kg	kg	kg	kg*m	kg*m	kg*m			
0	1	1913	1	-31	-0	18	1	--	--	2

X	cls	Nr	Vyr	Vzr	Mry	Mrz	MTrd	SF_V.	SF_M	SF_Mt	SF
cm		kg	kg	kg	kg*m	kg*m	kg*m				
0	1	52623	19336	19336	1818	1818	1566	>100	21.2	>100	21.2

Asta : 1016 [268 , 285]

Sez. G: O 114.3x5.9 L=286.0 cm Crit.: Acciaio_Flessione $\gamma_M=1.05$ $f_{yk}/\gamma_M=2619$ kg/cm² $f_t=4300$ kg/cm²

:Verificato

X	cls	N	TY	TZ	MT	MY	MZ	My4	Mz4	Comb.
cm		kg	kg	kg	kg*m	kg*m	kg*m			
0	1	1151	4	-30	-2	16	6	--	--	2

X	cls	Nr	Vyr	Vzr	Mry	Mrz	MTrd	SF_V.	SF_M	SF_Mt	SF
cm		kg	kg	kg	kg*m	kg*m	kg*m				
0	1	52623	19322	19322	1818	1818	1566	>100	29.4	>100	29.4

Asta : 1017 [285 , 302]

AUTOSTRADA VALDASTICO A31 NORD
1° LOTTO - PIOVENE ROCCHETTE – VALLE DELL'ASTICO

Sez. G: O 114.3x5.9 L=286.0 cm Crit.: Acciaio_Flessione $\gamma_M=1.05$ $f_{yk}/\gamma_M=2619$ kg/cm² $f_t=4300$ kg/cm²

:Verificato

X	cls	N	TY	TZ	MT	MY	MZ	My4	Mz4	Comb.
cm		kg	kg	kg	kg*m	kg*m	kg*m			
0	1	551	-0	-30	0	15	-0	--	--	2

X	cls	Nr	Vyr	Vzr	Mry	Mrz	MTrd	SF_V.	SF_M	SF_Mt	SF
cm		kg	kg	kg	kg*m	kg*m	kg*m				
0	1	52623	19339	19339	1818	1818	1566	>100	52.7	>100	52.7

Asta : 1018 [302 , 345]

Sez. G: O 114.3x5.9 L=286.0 cm Crit.: Acciaio_Flessione $\gamma_M=1.05$ $f_{yk}/\gamma_M=2619$ kg/cm² $f_t=4300$ kg/cm²

:Verificato

X	cls	N	TY	TZ	MT	MY	MZ	My4	Mz4	Comb.
cm		kg	kg	kg	kg*m	kg*m	kg*m			
0	1	-283	-4	-31	2	14	-6	--	--	2

X	cls	Nr	Vyr	Vzr	Mry	Mrz	MTrd	SF_V.	SF_M	SF_Mt	SF
cm		kg	kg	kg	kg*m	kg*m	kg*m				
0	1	52623	19319	19319	1818	1818	1566	>100	60.1	>100	60.1

Asta : 1019 [345 , 328]

Sez. G: O 114.3x5.9 L=286.0 cm Crit.: Acciaio_Flessione $\gamma_M=1.05$ $f_{yk}/\gamma_M=2619$ kg/cm² $f_t=4300$ kg/cm²

:Verificato

X	cls	N	TY	TZ	MT	MY	MZ	My4	Mz4	Comb.
cm		kg	kg	kg	kg*m	kg*m	kg*m			
0	1	-1049	0	-30	0	12	0	--	--	2

X	cls	Nr	Vyr	Vzr	Mry	Mrz	MTrd	SF_V.	SF_M	SF_Mt	SF
cm		kg	kg	kg	kg*m	kg*m	kg*m				
0	1	52623	19341	19341	1818	1818	1566	>100	37.2	>100	37.2

AUTOSTRADA VALDASTICO A31 NORD
1° LOTTO - PIOVENE ROCCHETTE – VALLE DELL'ASTICO

Asta : 1020 [328 , 353]

Sez. G: O 114.3x5.9 L=286.0 cm Crit.: Acciaio_Flessione $\gamma_M=1.05$ $f_{yk}/\gamma_M=2619$ kg/cm² $f_t=4300$ kg/cm²

:Verificato

X	cls	N	TY	TZ	MT	MY	MZ	My4	Mz4	Comb.
cm		kg	kg	kg	kg*m	kg*m	kg*m			
286	1	-1045	5	30	-2	12	-7	--	--	2

X	cls	Nr	Vyr	Vzr	Mry	Mrz	MTrd	SF_V.	SF_M	SF_Mt	SF
cm		kg	kg	kg	kg*m	kg*m	kg*m				
286	1	52623	19319	19319	1818	1818	1566	>100	33.1	>100	33.1

Asta : 1021 [353 , 370]

Sez. G: O 114.3x5.9 L=286.0 cm Crit.: Acciaio_Flessione $\gamma_M=1.05$ $f_{yk}/\gamma_M=2619$ kg/cm² $f_t=4300$ kg/cm²

:Verificato

X	cls	N	TY	TZ	MT	MY	MZ	My4	Mz4	Comb.
cm		kg	kg	kg	kg*m	kg*m	kg*m			
0	1	-1022	1	-29	-0	12	1	--	--	2

X	cls	Nr	Vyr	Vzr	Mry	Mrz	MTrd	SF_V.	SF_M	SF_Mt	SF
cm		kg	kg	kg	kg*m	kg*m	kg*m				
0	1	52623	19337	19337	1818	1818	1566	>100	37.4	>100	37.4

Asta : 1022 [370 , 387]

Sez. G: O 114.3x5.9 L=286.0 cm Crit.: Acciaio_Flessione $\gamma_M=1.05$ $f_{yk}/\gamma_M=2619$ kg/cm² $f_t=4300$ kg/cm²

:Verificato

X	cls	N	TY	TZ	MT	MY	MZ	My4	Mz4	Comb.
cm		kg	kg	kg	kg*m	kg*m	kg*m			
0	1	-1284	-3	-30	1	12	-4	--	--	2

X	cls	Nr	Vyr	Vzr	Mry	Mrz	MTrd	SF_V.	SF_M	SF_Mt	SF
cm		kg	kg	kg	kg*m	kg*m	kg*m				
0	1	52623	19329	19329	1818	1818	1566	>100	30.2	>100	30.2

AUTOSTRADA VALDASTICO A31 NORD
1° LOTTO - PIOVENE ROCCHETTE – VALLE DELL'ASTICO

Asta : 1023 [387 , 465]

Sez. G: O 114.3x5.9 L=274.8 cm Crit.: Acciaio_Flessione $\gamma_M=1.05$ $f_{yk}/\gamma_M=2619$ kg/cmq $f_t=4300$ kg/cmq

:Verificato

X	cls	N	TY	TZ	MT	MY	MZ	My4	Mz4	Comb.
cm		kg	kg	kg	kg*m	kg*m	kg*m			
275	1	-1412	1	29	-1	11	-2	--	--	2

X	cls	Nr	Vyr	Vzr	Mry	Mrz	MTrd	SF_V.	SF_M	SF_Mt	SF
cm		kg	kg	kg	kg*m	kg*m	kg*m				
275	1	52623	19334	19334	1818	1818	1566	>100	29.4	>100	29.4

Asta : 1024 [465 , 482]

Sez. G: O 114.3x5.9 L=264.5 cm Crit.: Acciaio_Flessione $\gamma_M=1.05$ $f_{yk}/\gamma_M=2619$ kg/cmq $f_t=4300$ kg/cmq

:Verificato

X	cls	N	TY	TZ	MT	MY	MZ	My4	Mz4	Comb.
cm		kg	kg	kg	kg*m	kg*m	kg*m			
265	1	-677	8	30	-3	14	-11	--	--	2

X	cls	Nr	Vyr	Vzr	Mry	Mrz	MTrd	SF_V.	SF_M	SF_Mt	SF
cm		kg	kg	kg	kg*m	kg*m	kg*m				
265	1	52623	19306	19306	1818	1818	1566	>100	37.3	>100	37.3

Asta : 1025 [412 , 435]

Sez. G: O 114.3x5.9 L=247.0 cm Crit.: Acciaio_Flessione $\gamma_M=1.05$ $f_{yk}/\gamma_M=2619$ kg/cmq $f_t=4300$ kg/cmq

:Verificato

X	cls	N	TY	TZ	MT	MY	MZ	My4	Mz4	Comb.
cm		kg	kg	kg	kg*m	kg*m	kg*m			
247	1	970	17	28	-6	14	-20	--	--	2

X	cls	Nr	Vyr	Vzr	Mry	Mrz	MTrd	SF_V.	SF_M	SF_Mt	SF
cm		kg	kg	kg	kg*m	kg*m	kg*m				

AUTOSTRADA VALDASTICO A31 NORD
1° LOTTO - PIOVENE ROCCHETTE – VALLE DELL'ASTICO

X	cls	Nr	Vyr	Vzr	Mry	Mrz	MTrd	SF_V.	SF_M	SF_Mt	SF
247	1	52623	19261	19261	1818	1818	1566	>100	27.0	>100	27.0

Asta : 1026 [435 , 448]

Sez. G: O 114.3x5.9 L=247.0 cm Crit.: Acciaio_Flessione $\gamma_M=1.05$ $f_{yk}/\gamma_M=2619$ kg/cm² $f_t=4300$ kg/cm²

:Verificato

X	cls	N	TY	TZ	MT	MY	MZ	My4	Mz4	Comb.
cm		kg	kg	kg	kg*m	kg*m	kg*m			
247	1	2338	15	29	-6	18	-19	--	--	2

X	cls	Nr	Vyr	Vzr	Mry	Mrz	MTrd	SF_V.	SF_M	SF_Mt	SF
cm		kg	kg	kg	kg*m	kg*m	kg*m				
247	1	52623	19273	19273	1818	1818	1566	>100	15.5	>100	15.5

Asta : 1027 [448 , 199]

Sez. G: O 114.3x5.9 L=266.5 cm Crit.: Acciaio_Flessione $\gamma_M=1.05$ $f_{yk}/\gamma_M=2619$ kg/cm² $f_t=4300$ kg/cm²

:Verificato

X	cls	N	TY	TZ	MT	MY	MZ	My4	Mz4	Comb.
cm		kg	kg	kg	kg*m	kg*m	kg*m			
266	1	3483	2	29	-1	20	-3	--	--	2

X	cls	Nr	Vyr	Vzr	Mry	Mrz	MTrd	SF_V.	SF_M	SF_Mt	SF
cm		kg	kg	kg	kg*m	kg*m	kg*m				
266	1	52623	19327	19327	1818	1818	1566	>100	12.7	>100	12.7

Asta : 1028 [199 , 216]

Sez. G: O 114.3x5.9 L=286.0 cm Crit.: Acciaio_Flessione $\gamma_M=1.05$ $f_{yk}/\gamma_M=2619$ kg/cm² $f_t=4300$ kg/cm²

:Verificato

X	cls	N	TY	TZ	MT	MY	MZ	My4	Mz4	Comb.
cm		kg	kg	kg	kg*m	kg*m	kg*m			
286	1	4644	-5	30	2	22	7	--	--	2

AUTOSTRADA VALDASTICO A31 NORD
1° LOTTO - PIOVENE ROCCHETTE – VALLE DELL'ASTICO

X	cls	Nr	Vyr	Vzr	Mry	Mrz	MTrd	SF_V.	SF_M	SF_Mt	SF
cm		kg	kg	kg	kg*m	kg*m	kg*m				
286	1	52623	19316	19316	1818	1818	1566	>100	9.60	>100	9.60

Asta : 1029 [216 , 233]

Sez. G: O 114.3x5.9 L=286.0 cm Crit.: Acciaio_Flessione $\gamma_M=1.05$ $f_{yk}/\gamma_M=2619$ kg/cm² $f_t=4300$ kg/cm²

:Verificato

X	cls	N	TY	TZ	MT	MY	MZ	My4	Mz4	Comb.
cm		kg	kg	kg	kg*m	kg*m	kg*m			
0	1	4585	-2	-31	1	22	-2	--	--	2

X	cls	Nr	Vyr	Vzr	Mry	Mrz	MTrd	SF_V.	SF_M	SF_Mt	SF
cm		kg	kg	kg	kg*m	kg*m	kg*m				
0	1	52623	19329	19329	1818	1818	1566	>100	9.96	>100	9.96

Asta : 1030 [233 , 250]

Sez. G: O 114.3x5.9 L=286.0 cm Crit.: Acciaio_Flessione $\gamma_M=1.05$ $f_{yk}/\gamma_M=2619$ kg/cm² $f_t=4300$ kg/cm²

:Verificato

X	cls	N	TY	TZ	MT	MY	MZ	My4	Mz4	Comb.
cm		kg	kg	kg	kg*m	kg*m	kg*m			
0	1	3394	3	-32	-1	21	4	--	--	2

X	cls	Nr	Vyr	Vzr	Mry	Mrz	MTrd	SF_V.	SF_M	SF_Mt	SF
cm		kg	kg	kg	kg*m	kg*m	kg*m				
0	1	52623	19333	19333	1818	1818	1566	>100	12.8	>100	12.8

Asta : 1031 [250 , 267]

Sez. G: O 114.3x5.9 L=286.0 cm Crit.: Acciaio_Flessione $\gamma_M=1.05$ $f_{yk}/\gamma_M=2619$ kg/cm² $f_t=4300$ kg/cm²

:Verificato

X	cls	N	TY	TZ	MT	MY	MZ	My4	Mz4	Comb.
cm		kg	kg	kg	kg*m	kg*m	kg*m			
0	1	1917	-1	-31	0	18	-1	--	--	2

AUTOSTRADA VALDASTICO A31 NORD
1° LOTTO - PIOVENE ROCCHETTE – VALLE DELL'ASTICO

X	cls	Nr	Vyr	Vzr	Mry	Mrz	MTrd	SF_V.	SF_M	SF_Mt	SF
cm		kg	kg	kg	kg*m	kg*m	kg*m				
0	1	52623	19336	19336	1818	1818	1566	>100	21.2	>100	21.2

Asta : 1032 [267 , 284]

Sez. G: O 114.3x5.9 L=286.0 cm Crit.: Acciaio_Flessione $\gamma_M=1.05$ $f_{yk}/\gamma_M=2619$ kg/cm² $f_t=4300$ kg/cm²

:Verificato

X	cls	N	TY	TZ	MT	MY	MZ	My4	Mz4	Comb.
cm		kg	kg	kg	kg*m	kg*m	kg*m			
0	1	1151	-5	-30	2	16	-7	--	--	2

X	cls	Nr	Vyr	Vzr	Mry	Mrz	MTrd	SF_V.	SF_M	SF_Mt	SF
cm		kg	kg	kg	kg*m	kg*m	kg*m				
0	1	52623	19322	19322	1818	1818	1566	>100	29.3	>100	29.3

Asta : 1033 [284 , 301]

Sez. G: O 114.3x5.9 L=286.0 cm Crit.: Acciaio_Flessione $\gamma_M=1.05$ $f_{yk}/\gamma_M=2619$ kg/cm² $f_t=4300$ kg/cm²

:Verificato

X	cls	N	TY	TZ	MT	MY	MZ	My4	Mz4	Comb.
cm		kg	kg	kg	kg*m	kg*m	kg*m			
0	1	543	0	-30	-0	15	0	--	--	2

X	cls	Nr	Vyr	Vzr	Mry	Mrz	MTrd	SF_V.	SF_M	SF_Mt	SF
cm		kg	kg	kg	kg*m	kg*m	kg*m				
0	1	52623	19339	19339	1818	1818	1566	>100	53.1	>100	53.1

Asta : 1034 [301 , 344]

Sez. G: O 114.3x5.9 L=286.0 cm Crit.: Acciaio_Flessione $\gamma_M=1.05$ $f_{yk}/\gamma_M=2619$ kg/cm² $f_t=4300$ kg/cm²

:Verificato

X	cls	N	TY	TZ	MT	MY	MZ	My4	Mz4	Comb.
cm		kg	kg	kg	kg*m	kg*m	kg*m			

AUTOSTRADA VALDASTICO A31 NORD
1° LOTTO - PIOVENE ROCCHETTE – VALLE DELL'ASTICO

X	cls	N	TY	TZ	MT	MY	MZ	My4	Mz4	Comb.
0	1	-285	4	-31	-2	14	6	--	--	2

X	cls	Nr	Vyr	Vzr	Mry	Mrz	MTrd	SF_V.	SF_M	SF_Mt	SF
cm		kg	kg	kg	kg*m	kg*m	kg*m				
0	1	52623	19319	19319	1818	1818	1566	>100	59.8	>100	59.8

Asta : 1035 [344 , 327]

Sez. G: O 114.3x5.9 L=286.0 cm Crit.: Acciaio_Flessione $\gamma_M=1.05$ $f_{yk}/\gamma_M=2619$ kg/cm² $f_t=4300$ kg/cm²

:Verificato

X	cls	N	TY	TZ	MT	MY	MZ	My4	Mz4	Comb.
cm		kg	kg	kg	kg*m	kg*m	kg*m			
0	1	-1042	-0	-30	-0	12	-0	--	--	2

X	cls	Nr	Vyr	Vzr	Mry	Mrz	MTrd	SF_V.	SF_M	SF_Mt	SF
cm		kg	kg	kg	kg*m	kg*m	kg*m				
0	1	52623	19341	19341	1818	1818	1566	>100	37.4	>100	37.4

Asta : 1036 [327 , 352]

Sez. G: O 114.3x5.9 L=286.0 cm Crit.: Acciaio_Flessione $\gamma_M=1.05$ $f_{yk}/\gamma_M=2619$ kg/cm² $f_t=4300$ kg/cm²

:Verificato

X	cls	N	TY	TZ	MT	MY	MZ	My4	Mz4	Comb.
cm		kg	kg	kg	kg*m	kg*m	kg*m			
286	1	-1046	-5	30	2	12	7	--	--	2

X	cls	Nr	Vyr	Vzr	Mry	Mrz	MTrd	SF_V.	SF_M	SF_Mt	SF
cm		kg	kg	kg	kg*m	kg*m	kg*m				
286	1	52623	19319	19319	1818	1818	1566	>100	33.0	>100	33.0

Asta : 1037 [352 , 369]

Sez. G: O 114.3x5.9 L=286.0 cm Crit.: Acciaio_Flessione $\gamma_M=1.05$ $f_{yk}/\gamma_M=2619$ kg/cm² $f_t=4300$ kg/cm²

:Verificato

AUTOSTRADA VALDASTICO A31 NORD
1° LOTTO - PIOVENE ROCCHETTE – VALLE DELL'ASTICO

X	cls	N	TY	TZ	MT	MY	MZ	My4	Mz4	Comb.
cm		kg	kg	kg	kg*m	kg*m	kg*m			
0	1	-1029	-1	-29	0	12	-1	--	--	2

X	cls	Nr	Vyr	Vzr	Mry	Mrz	MTrd	SF_V.	SF_M	SF_Mt	SF
cm		kg	kg	kg	kg*m	kg*m	kg*m				
0	1	52623	19337	19337	1818	1818	1566	>100	37.2	>100	37.2

Asta : 1038 [369 , 386]

Sez. G: O 114.3x5.9 L=286.0 cm Crit.: Acciaio_Flessione $\gamma_M=1.05$ $f_{yk}/\gamma_M=2619$ kg/cm² $f_t=4300$ kg/cm²

:Verificato

X	cls	N	TY	TZ	MT	MY	MZ	My4	Mz4	Comb.
cm		kg	kg	kg	kg*m	kg*m	kg*m			
0	1	-1284	3	-30	-1	12	4	--	--	2

X	cls	Nr	Vyr	Vzr	Mry	Mrz	MTrd	SF_V.	SF_M	SF_Mt	SF
cm		kg	kg	kg	kg*m	kg*m	kg*m				
0	1	52623	19328	19328	1818	1818	1566	>100	30.2	>100	30.2

Asta : 1039 [386 , 466]

Sez. G: O 114.3x5.9 L=274.8 cm Crit.: Acciaio_Flessione $\gamma_M=1.05$ $f_{yk}/\gamma_M=2619$ kg/cm² $f_t=4300$ kg/cm²

:Verificato

X	cls	N	TY	TZ	MT	MY	MZ	My4	Mz4	Comb.
cm		kg	kg	kg	kg*m	kg*m	kg*m			
275	1	-1399	-1	29	1	11	2	--	--	2

X	cls	Nr	Vyr	Vzr	Mry	Mrz	MTrd	SF_V.	SF_M	SF_Mt	SF
cm		kg	kg	kg	kg*m	kg*m	kg*m				
275	1	52623	19334	19334	1818	1818	1566	>100	29.6	>100	29.6

Asta : 1040 [466 , 483]

AUTOSTRADA VALDASTICO A31 NORD
1° LOTTO - PIOVENE ROCCHETTE – VALLE DELL'ASTICO

Sez. G: O 114.3x5.9 L=264.5 cm Crit.: Acciaio_Flessione $\gamma_M=1.05$ $f_{yk}/\gamma_M=2619$ kg/cm² $f_t=4300$ kg/cm²

:Verificato

X	cls	N	TY	TZ	MT	MY	MZ	My4	Mz4	Comb.
cm		kg	kg	kg	kg*m	kg*m	kg*m			
265	1	-669	-8	30	3	14	11	--	--	2

X	cls	Nr	Vyr	Vzr	Mry	Mrz	MTrd	SF_V.	SF_M	SF_Mt	SF
cm		kg	kg	kg	kg*m	kg*m	kg*m				
265	1	52623	19305	19305	1818	1818	1566	>100	37.4	>100	37.4

Asta : 1041 [411 , 438]

Sez. G: O 114.3x5.9 L=247.0 cm Crit.: Acciaio_Flessione $\gamma_M=1.05$ $f_{yk}/\gamma_M=2619$ kg/cm² $f_t=4300$ kg/cm²

:Verificato

X	cls	N	TY	TZ	MT	MY	MZ	My4	Mz4	Comb.
cm		kg	kg	kg	kg*m	kg*m	kg*m			
247	1	2217	46	35	-19	23	-53	--	--	2

X	cls	Nr	Vyr	Vzr	Mry	Mrz	MTrd	SF_V.	SF_M	SF_Mt	SF
cm		kg	kg	kg	kg*m	kg*m	kg*m				
247	1	52623	19106	19106	1818	1818	1566	>100	11.9	82.2	11.9

Asta : 1042 [438 , 449]

Sez. G: O 114.3x5.9 L=247.0 cm Crit.: Acciaio_Flessione $\gamma_M=1.05$ $f_{yk}/\gamma_M=2619$ kg/cm² $f_t=4300$ kg/cm²

:Verificato

X	cls	N	TY	TZ	MT	MY	MZ	My4	Mz4	Comb.
cm		kg	kg	kg	kg*m	kg*m	kg*m			
247	1	7142	46	41	-18	41	-57	--	--	2

X	cls	Nr	Vyr	Vzr	Mry	Mrz	MTrd	SF_V.	SF_M	SF_Mt	SF
cm		kg	kg	kg	kg*m	kg*m	kg*m				
247	1	52623	19122	19122	1818	1818	1566	>100	5.26	87.9	5.26

AUTOSTRADA VALDASTICO A31 NORD
1° LOTTO - PIOVENE ROCCHETTE – VALLE DELL'ASTICO

Asta : 1043 [449 , 198]

Sez. G: O 114.3x5.9 L=266.5 cm Crit.: Acciaio_Flessione $\gamma_M=1.05$ $f_{yk}/\gamma_M=2619$ kg/cm² $f_t=4300$ kg/cm²

:Verificato

X	cls	N	TY	TZ	MT	MY	MZ	My4	Mz4	Comb.
cm		kg	kg	kg	kg*m	kg*m	kg*m			
0	1	10952	5	-29	-3	34	7	--	--	2

X	cls	Nr	Vyr	Vzr	Mry	Mrz	MTrd	SF_V.	SF_M	SF_Mt	SF
cm		kg	kg	kg	kg*m	kg*m	kg*m				
0	1	52623	19301	19301	1818	1818	1566	>100	4.33	>100	4.33

Asta : 1044 [198 , 215]

Sez. G: O 114.3x5.9 L=286.0 cm Crit.: Acciaio_Flessione $\gamma_M=1.05$ $f_{yk}/\gamma_M=2619$ kg/cm² $f_t=4300$ kg/cm²

:Verificato

X	cls	N	TY	TZ	MT	MY	MZ	My4	Mz4	Comb.
cm		kg	kg	kg	kg*m	kg*m	kg*m			
0	1	6571	-18	-40	8	39	-25	--	--	2

X	cls	Nr	Vyr	Vzr	Mry	Mrz	MTrd	SF_V.	SF_M	SF_Mt	SF
cm		kg	kg	kg	kg*m	kg*m	kg*m				
0	1	52623	19238	19238	1818	1818	1566	>100	6.25	>100	6.25

Asta : 1045 [215 , 232]

Sez. G: O 114.3x5.9 L=286.0 cm Crit.: Acciaio_Flessione $\gamma_M=1.05$ $f_{yk}/\gamma_M=2619$ kg/cm² $f_t=4300$ kg/cm²

:Verificato

X	cls	N	TY	TZ	MT	MY	MZ	My4	Mz4	Comb.
cm		kg	kg	kg	kg*m	kg*m	kg*m			
0	1	2293	-5	-33	3	19	-6	--	--	2

X	cls	Nr	Vyr	Vzr	Mry	Mrz	MTrd	SF_V.	SF_M	SF_Mt	SF
cm		kg	kg	kg	kg*m	kg*m	kg*m				
0	1	52623	19306	19306	1818	1818	1566	>100	17.4	>100	17.4

AUTOSTRADA VALDASTICO A31 NORD
1° LOTTO - PIOVENE ROCCHETTE – VALLE DELL'ASTICO

Asta : 1046 [232 , 249]

Sez. G: O 114.3x5.9 L=286.0 cm Crit.: Acciaio_Flessione $\gamma_M=1.05$ $f_{yk}/\gamma_M=2619$ kg/cmq $f_t=4300$ kg/cmq

:Verificato

X	cls	N	TY	TZ	MT	MY	MZ	My4	Mz4	Comb.
cm		kg	kg	kg	kg*m	kg*m	kg*m			
286	1	2723	11	34	-4	24	-16	--	--	2

X	cls	Nr	Vyr	Vzr	Mry	Mrz	MTrd	SF_V.	SF_M	SF_Mt	SF
cm		kg	kg	kg	kg*m	kg*m	kg*m				
286	1	52623	19290	19290	1818	1818	1566	>100	13.6	>100	13.6

Asta : 1047 [249 , 266]

Sez. G: O 114.3x5.9 L=286.0 cm Crit.: Acciaio_Flessione $\gamma_M=1.05$ $f_{yk}/\gamma_M=2619$ kg/cmq $f_t=4300$ kg/cmq

:Verificato

X	cls	N	TY	TZ	MT	MY	MZ	My4	Mz4	Comb.
cm		kg	kg	kg	kg*m	kg*m	kg*m			
0	1	4489	-3	-31	1	24	-4	--	--	2

X	cls	Nr	Vyr	Vzr	Mry	Mrz	MTrd	SF_V.	SF_M	SF_Mt	SF
cm		kg	kg	kg	kg*m	kg*m	kg*m				
0	1	52623	19327	19327	1818	1818	1566	>100	9.95	>100	9.95

Asta : 1048 [266 , 283]

Sez. G: O 114.3x5.9 L=286.0 cm Crit.: Acciaio_Flessione $\gamma_M=1.05$ $f_{yk}/\gamma_M=2619$ kg/cmq $f_t=4300$ kg/cmq

:Verificato

X	cls	N	TY	TZ	MT	MY	MZ	My4	Mz4	Comb.
cm		kg	kg	kg	kg*m	kg*m	kg*m			
0	1	356	-16	-38	7	25	-23	--	--	2

X	cls	Nr	Vyr	Vzr	Mry	Mrz	MTrd	SF_V.	SF_M	SF_Mt	SF
cm		kg	kg	kg	kg*m	kg*m	kg*m				

AUTOSTRADA VALDASTICO A31 NORD
1° LOTTO - PIOVENE ROCCHETTE – VALLE DELL'ASTICO

X	cls	Nr	Vyr	Vzr	Mry	Mrz	MTrd	SF_V.	SF_M	SF_Mt	SF
0	1	52623	19261	19261	1818	1818	1566	>100	29.9	>100	29.9

Asta : 1049 [283 , 300]

Sez. G: O 114.3x5.9 L=286.0 cm Crit.: Acciaio_Flessione $\gamma_M=1.05$ $f_{yk}/\gamma_M=2619$ kg/cm² $f_t=4300$ kg/cm²

:Verificato

X	cls	N	TY	TZ	MT	MY	MZ	My4	Mz4	Comb.
cm		kg	kg	kg	kg*m	kg*m	kg*m			
143	1	-2398	0	-0	-1	-14	0	--	--	2

X	cls	Nr	Vyr	Vzr	Mry	Mrz	MTrd	SF_V.	SF_M	SF_Mt	SF
cm		kg	kg	kg	kg*m	kg*m	kg*m				
143	1	52623	19333	19333	1818	1818	1566	>100	18.7	>100	18.7

Asta : 1050 [300 , 343]

Sez. G: O 114.3x5.9 L=286.0 cm Crit.: Acciaio_Flessione $\gamma_M=1.05$ $f_{yk}/\gamma_M=2619$ kg/cm² $f_t=4300$ kg/cm²

:Verificato

X	cls	N	TY	TZ	MT	MY	MZ	My4	Mz4	Comb.
cm		kg	kg	kg	kg*m	kg*m	kg*m			
286	1	-317	16	37	-7	23	-23	--	--	2

X	cls	Nr	Vyr	Vzr	Mry	Mrz	MTrd	SF_V.	SF_M	SF_Mt	SF
cm		kg	kg	kg	kg*m	kg*m	kg*m				
286	1	52623	19250	19250	1818	1818	1566	>100	31.8	>100	31.8

Asta : 1051 [343 , 326]

Sez. G: O 114.3x5.9 L=286.0 cm Crit.: Acciaio_Flessione $\gamma_M=1.05$ $f_{yk}/\gamma_M=2619$ kg/cm² $f_t=4300$ kg/cm²

:Verificato

X	cls	N	TY	TZ	MT	MY	MZ	My4	Mz4	Comb.
cm		kg	kg	kg	kg*m	kg*m	kg*m			
0	1	2815	-1	-30	-0	20	-1	--	--	2

AUTOSTRADA VALDASTICO A31 NORD
1° LOTTO - PIOVENE ROCCHETTE – VALLE DELL'ASTICO

X	cls	Nr	Vyr	Vzr	Mry	Mrz	MTrd	SF_V.	SF_M	SF_Mt	SF
cm		kg	kg	kg	kg*m	kg*m	kg*m				
0	1	52623	19340	19340	1818	1818	1566	>100	15.4	>100	15.4

Asta : 1052 [326 , 351]

Sez. G: O 114.3x5.9 L=286.0 cm Crit.: Acciaio_Flessione $\gamma_M=1.05$ $f_{yk}/\gamma_M=2619$ kg/cm² $f_t=4300$ kg/cm²

:Verificato

X	cls	N	TY	TZ	MT	MY	MZ	My4	Mz4	Comb.
cm		kg	kg	kg	kg*m	kg*m	kg*m			
0	1	-725	-18	-38	7	24	-25	--	--	2

X	cls	Nr	Vyr	Vzr	Mry	Mrz	MTrd	SF_V.	SF_M	SF_Mt	SF
cm		kg	kg	kg	kg*m	kg*m	kg*m				
0	1	52623	19251	19251	1818	1818	1566	>100	24.6	>100	24.6

Asta : 1053 [351 , 368]

Sez. G: O 114.3x5.9 L=286.0 cm Crit.: Acciaio_Flessione $\gamma_M=1.05$ $f_{yk}/\gamma_M=2619$ kg/cm² $f_t=4300$ kg/cm²

:Verificato

X	cls	N	TY	TZ	MT	MY	MZ	My4	Mz4	Comb.
cm		kg	kg	kg	kg*m	kg*m	kg*m			
172	1	-3239	-3	6	1	-14	1	--	--	2

X	cls	Nr	Vyr	Vzr	Mry	Mrz	MTrd	SF_V.	SF_M	SF_Mt	SF
cm		kg	kg	kg	kg*m	kg*m	kg*m				
172	1	52623	19326	19326	1818	1818	1566	>100	14.3	>100	14.3

Asta : 1054 [368 , 385]

Sez. G: O 114.3x5.9 L=286.0 cm Crit.: Acciaio_Flessione $\gamma_M=1.05$ $f_{yk}/\gamma_M=2619$ kg/cm² $f_t=4300$ kg/cm²

:Verificato

X	cls	N	TY	TZ	MT	MY	MZ	My4	Mz4	Comb.
cm		kg	kg	kg	kg*m	kg*m	kg*m			
286	1	-920	12	37	-5	23	-16	--	--	2

AUTOSTRADA VALDASTICO A31 NORD
1° LOTTO - PIOVENE ROCCHETTE – VALLE DELL'ASTICO

X	cls	Nr	Vyr	Vzr	Mry	Mrz	MTrd	SF_V.	SF_M	SF_Mt	SF
cm		kg	kg	kg	kg*m	kg*m	kg*m				
286	1	52623	19280	19280	1818	1818	1566	>100	25.6	>100	25.6

Asta : 1055 [385 , 454]

Sez. G: O 114.3x5.9 L=274.8 cm Crit.: Acciaio_Flessione $\gamma_M=1.05$ $f_{yk}/\gamma_M=2619$ kg/cmq $f_t=4300$ kg/cmq

:Verificato

X	cls	N	TY	TZ	MT	MY	MZ	My4	Mz4	Comb.
cm		kg	kg	kg	kg*m	kg*m	kg*m			
275	1	3013	-2	31	1	22	3	--	--	2

X	cls	Nr	Vyr	Vzr	Mry	Mrz	MTrd	SF_V.	SF_M	SF_Mt	SF
cm		kg	kg	kg	kg*m	kg*m	kg*m				
275	1	52623	19326	19326	1818	1818	1566	>100	14.1	>100	14.1

Asta : 1056 [454 , 471]

Sez. G: O 114.3x5.9 L=264.5 cm Crit.: Acciaio_Flessione $\gamma_M=1.05$ $f_{yk}/\gamma_M=2619$ kg/cmq $f_t=4300$ kg/cmq

:Verificato

X	cls	N	TY	TZ	MT	MY	MZ	My4	Mz4	Comb.
cm		kg	kg	kg	kg*m	kg*m	kg*m			
0	1	1667	-26	-33	10	22	-33	--	--	2

X	cls	Nr	Vyr	Vzr	Mry	Mrz	MTrd	SF_V.	SF_M	SF_Mt	SF
cm		kg	kg	kg	kg*m	kg*m	kg*m				
0	1	52623	19218	19218	1818	1818	1566	>100	16.2	>100	16.2

Asta : 1057 [410 , 440]

Sez. G: O 114.3x5.9 L=247.0 cm Crit.: Acciaio_Flessione $\gamma_M=1.05$ $f_{yk}/\gamma_M=2619$ kg/cmq $f_t=4300$ kg/cmq

:Verificato

X	cls	N	TY	TZ	MT	MY	MZ	My4	Mz4	Comb.
cm		kg	kg	kg	kg*m	kg*m	kg*m			

AUTOSTRADA VALDASTICO A31 NORD
1° LOTTO - PIOVENE ROCCHETTE – VALLE DELL'ASTICO

X	cls	N	TY	TZ	MT	MY	MZ	My4	Mz4	Comb.
247	1	874	45	32	-25	16	-53	--	--	2

X	cls	Nr	Vyr	Vzr	Mry	Mrz	MTrd	SF_V.	SF_M	SF_Mt	SF
cm		kg	kg	kg	kg*m	kg*m	kg*m				
247	1	52623	19033	19033	1818	1818	1566	>100	18.4	62.6	18.4

Asta : 1058 [440 , 450]

Sez. G: O 114.3x5.9 L=247.0 cm Crit.: Acciaio_Flessione $\gamma_M=1.05$ $f_{yk}/\gamma_M=2619$ kg/cm² $f_t=4300$ kg/cm²

:Verificato

X	cls	N	TY	TZ	MT	MY	MZ	My4	Mz4	Comb.
cm		kg	kg	kg	kg*m	kg*m	kg*m			
247	1	9338	63	61	-40	64	-79	--	--	2

X	cls	Nr	Vyr	Vzr	Mry	Mrz	MTrd	SF_V.	SF_M	SF_Mt	SF
cm		kg	kg	kg	kg*m	kg*m	kg*m				
247	1	52623	18844	18844	1818	1818	1566	>100	3.90	38.9	3.90

Asta : 1059 [450 , 197]

Sez. G: O 114.3x5.9 L=266.5 cm Crit.: Acciaio_Flessione $\gamma_M=1.05$ $f_{yk}/\gamma_M=2619$ kg/cm² $f_t=4300$ kg/cm²

:Verificato

X	cls	N	TY	TZ	MT	MY	MZ	My4	Mz4	Comb.
cm		kg	kg	kg	kg*m	kg*m	kg*m			
0	1	34846	-2	-43	0	119	4	--	--	2

X	cls	Nr	Vyr	Vzr	Mry	Mrz	MTrd	SF_V.	SF_M	SF_Mt	SF
cm		kg	kg	kg	kg*m	kg*m	kg*m				
0	1	52623	19340	19340	1818	1818	1566	>100	1.37	>100	1.37

Asta : 1060 [197 , 214]

Sez. G: O 114.3x5.9 L=286.0 cm Crit.: Acciaio_Flessione $\gamma_M=1.05$ $f_{yk}/\gamma_M=2619$ kg/cm² $f_t=4300$ kg/cm²

:Verificato

AUTOSTRADA VALDASTICO A31 NORD
1° LOTTO - PIOVENE ROCCHETTE – VALLE DELL'ASTICO

X	cls	N	TY	TZ	MT	MY	MZ	My4	Mz4	Comb.
cm		kg	kg	kg	kg*m	kg*m	kg*m			
0	1	3943	-32	-60	22	59	-50	--	--	2

X	cls	Nr	Vyr	Vzr	Mry	Mrz	MTrd	SF_V.	SF_M	SF_Mt	SF
cm		kg	kg	kg	kg*m	kg*m	kg*m				
0	1	52623	19071	19071	1818	1818	1566	>100	7.42	71.5	7.42

Asta : 1061 [214 , 231]

Sez. G: O 114.3x5.9 L=286.0 cm Crit.: Acciaio_Flessione $\gamma_M=1.05$ $f_{yk}/\gamma_M=2619$ kg/cm² $f_t=4300$ kg/cm²

:Verificato

X	cls	N	TY	TZ	MT	MY	MZ	My4	Mz4	Comb.
cm		kg	kg	kg	kg*m	kg*m	kg*m			
200	1	-6139	-5	7	4	-25	3	--	--	2

X	cls	Nr	Vyr	Vzr	Mry	Mrz	MTrd	SF_V.	SF_M	SF_Mt	SF
cm		kg	kg	kg	kg*m	kg*m	kg*m				
200	1	52623	19296	19296	1818	1818	1566	>100	7.58	>100	7.58

Asta : 1062 [231 , 248]

Sez. G: O 114.3x5.9 L=286.0 cm Crit.: Acciaio_Flessione $\gamma_M=1.05$ $f_{yk}/\gamma_M=2619$ kg/cm² $f_t=4300$ kg/cm²

:Verificato

X	cls	N	TY	TZ	MT	MY	MZ	My4	Mz4	Comb.
cm		kg	kg	kg	kg*m	kg*m	kg*m			
286	1	-2374	21	47	-16	27	-33	--	--	2

X	cls	Nr	Vyr	Vzr	Mry	Mrz	MTrd	SF_V.	SF_M	SF_Mt	SF
cm		kg	kg	kg	kg*m	kg*m	kg*m				
286	1	52623	19145	19145	1818	1818	1566	>100	12.8	98.3	12.8

Asta : 1063 [248 , 265]

AUTOSTRADA VALDASTICO A31 NORD
1° LOTTO - PIOVENE ROCCHETTE – VALLE DELL'ASTICO

Sez. G: O 114.3x5.9 L=286.0 cm Crit.: Acciaio_Flessione $\gamma_M=1.05$ $f_{yk}/\gamma_M=2619$ kg/cm² $f_t=4300$ kg/cm²

:Verificato

X	cls	N	TY	TZ	MT	MY	MZ	My4	Mz4	Comb.
cm		kg	kg	kg	kg*m	kg*m	kg*m			
286	1	19205	-2	29	1	65	7	--	--	2

X	cls	Nr	Vyr	Vzr	Mry	Mrz	MTrd	SF_V.	SF_M	SF_Mt	SF
cm		kg	kg	kg	kg*m	kg*m	kg*m				
286	1	52623	19330	19330	1818	1818	1566	>100	2.47	>100	2.47

Asta : 1064 [265 , 282]

Sez. G: O 114.3x5.9 L=286.0 cm Crit.: Acciaio_Flessione $\gamma_M=1.05$ $f_{yk}/\gamma_M=2619$ kg/cm² $f_t=4300$ kg/cm²

:Verificato

X	cls	N	TY	TZ	MT	MY	MZ	My4	Mz4	Comb.
cm		kg	kg	kg	kg*m	kg*m	kg*m			
286	1	-4501	-26	9	20	-31	36	--	--	2

X	cls	Nr	Vyr	Vzr	Mry	Mrz	MTrd	SF_V.	SF_M	SF_Mt	SF
cm		kg	kg	kg	kg*m	kg*m	kg*m				
286	1	52623	19097	19097	1818	1818	1566	>100	8.16	79.0	8.16

Asta : 1065 [282 , 299]

Sez. G: O 114.3x5.9 L=286.0 cm Crit.: Acciaio_Flessione $\gamma_M=1.05$ $f_{yk}/\gamma_M=2619$ kg/cm² $f_t=4300$ kg/cm²

:Verificato

X	cls	N	TY	TZ	MT	MY	MZ	My4	Mz4	Comb.
cm		kg	kg	kg	kg*m	kg*m	kg*m			
143	1	-10796	0	0	-1	-34	-1	--	--	2

X	cls	Nr	Vyr	Vzr	Mry	Mrz	MTrd	SF_V.	SF_M	SF_Mt	SF
cm		kg	kg	kg	kg*m	kg*m	kg*m				
143	1	52623	19328	19328	1818	1818	1566	>100	4.46	>100	4.46

AUTOSTRADA VALDASTICO A31 NORD
1° LOTTO - PIOVENE ROCCHETTE – VALLE DELL'ASTICO

Asta : 1066 [299 , 342]

Sez. G: O 114.3x5.9 L=286.0 cm Crit.: Acciaio_Flessione $\gamma_M=1.05$ $f_{yk}/\gamma_M=2619$ kg/cm² $f_t=4300$ kg/cm²

:Verificato

X	cls	N	TY	TZ	MT	MY	MZ	My4	Mz4	Comb.
cm		kg	kg	kg	kg*m	kg*m	kg*m			
286	1	-4109	27	51	-21	30	-42	--	--	2

X	cls	Nr	Vyr	Vzr	Mry	Mrz	MTrd	SF_V.	SF_M	SF_Mt	SF
cm		kg	kg	kg	kg*m	kg*m	kg*m				
286	1	52623	19077	19077	1818	1818	1566	>100	8.52	73.1	8.52

Asta : 1067 [342 , 325]

Sez. G: O 114.3x5.9 L=286.0 cm Crit.: Acciaio_Flessione $\gamma_M=1.05$ $f_{yk}/\gamma_M=2619$ kg/cm² $f_t=4300$ kg/cm²

:Verificato

X	cls	N	TY	TZ	MT	MY	MZ	My4	Mz4	Comb.
cm		kg	kg	kg	kg*m	kg*m	kg*m			
286	1	20491	-1	29	-0	68	6	--	--	2

X	cls	Nr	Vyr	Vzr	Mry	Mrz	MTrd	SF_V.	SF_M	SF_Mt	SF
cm		kg	kg	kg	kg*m	kg*m	kg*m				
286	1	52623	19340	19340	1818	1818	1566	>100	2.32	>100	2.32

Asta : 1068 [325 , 350]

Sez. G: O 114.3x5.9 L=286.0 cm Crit.: Acciaio_Flessione $\gamma_M=1.05$ $f_{yk}/\gamma_M=2619$ kg/cm² $f_t=4300$ kg/cm²

:Verificato

X	cls	N	TY	TZ	MT	MY	MZ	My4	Mz4	Comb.
cm		kg	kg	kg	kg*m	kg*m	kg*m			
0	1	-3960	-29	-51	21	30	-44	--	--	2

X	cls	Nr	Vyr	Vzr	Mry	Mrz	MTrd	SF_V.	SF_M	SF_Mt	SF
cm		kg	kg	kg	kg*m	kg*m	kg*m				
0	1	52623	19078	19078	1818	1818	1566	>100	8.65	73.2	8.65

AUTOSTRADA VALDASTICO A31 NORD
1° LOTTO - PIOVENE ROCCHETTE – VALLE DELL'ASTICO

Asta : 1069 [350 , 367]

Sez. G: O 114.3x5.9 L=286.0 cm Crit.: Acciaio_Flessione $\gamma_M=1.05$ $f_{yk}/\gamma_M=2619$ kg/cmq $f_t=4300$ kg/cmq

:Verificato

X	cls	N	TY	TZ	MT	MY	MZ	My4	Mz4	Comb.
cm		kg	kg	kg	kg*m	kg*m	kg*m			
143	1	-10410	-3	0	2	-33	-0	--	--	2

X	cls	Nr	Vyr	Vzr	Mry	Mrz	MTrd	SF_V.	SF_M	SF_Mt	SF
cm		kg	kg	kg	kg*m	kg*m	kg*m				
143	1	52623	19319	19319	1818	1818	1566	>100	4.62	>100	4.62

Asta : 1070 [367 , 384]

Sez. G: O 114.3x5.9 L=286.0 cm Crit.: Acciaio_Flessione $\gamma_M=1.05$ $f_{yk}/\gamma_M=2619$ kg/cmq $f_t=4300$ kg/cmq

:Verificato

X	cls	N	TY	TZ	MT	MY	MZ	My4	Mz4	Comb.
cm		kg	kg	kg	kg*m	kg*m	kg*m			
286	1	-3804	21	50	-17	28	-32	--	--	2

X	cls	Nr	Vyr	Vzr	Mry	Mrz	MTrd	SF_V.	SF_M	SF_Mt	SF
cm		kg	kg	kg	kg*m	kg*m	kg*m				
286	1	52623	19135	19135	1818	1818	1566	>100	9.47	93.6	9.47

Asta : 1071 [384 , 467]

Sez. G: O 114.3x5.9 L=274.8 cm Crit.: Acciaio_Flessione $\gamma_M=1.05$ $f_{yk}/\gamma_M=2619$ kg/cmq $f_t=4300$ kg/cmq

:Verificato

X	cls	N	TY	TZ	MT	MY	MZ	My4	Mz4	Comb.
cm		kg	kg	kg	kg*m	kg*m	kg*m			
275	1	19795	-0	34	1	72	5	--	--	2

X	cls	Nr	Vyr	Vzr	Mry	Mrz	MTrd	SF_V.	SF_M	SF_Mt	SF
cm		kg	kg	kg	kg*m	kg*m	kg*m				

AUTOSTRADA VALDASTICO A31 NORD
1° LOTTO - PIOVENE ROCCHETTE – VALLE DELL'ASTICO

X	cls	Nr	Vyr	Vzr	Mry	Mrz	MTrd	SF_V.	SF_M	SF_Mt	SF
275	1	52623	19328	19328	1818	1818	1566	>100	2.39	>100	2.39

Asta : 1072 [467 , 484]

Sez. G: O 114.3x5.9 L=264.5 cm Crit.: Acciaio_Flessione $\gamma_M=1.05$ $f_{yk}/\gamma_M=2619$ kg/cm² $f_t=4300$ kg/cm²

:Verificato

X	cls	N	TY	TZ	MT	MY	MZ	My4	Mz4	Comb.
cm		kg	kg	kg	kg*m	kg*m	kg*m			
0	1	3101	-35	-43	23	33	-47	--	--	2

X	cls	Nr	Vyr	Vzr	Mry	Mrz	MTrd	SF_V.	SF_M	SF_Mt	SF
cm		kg	kg	kg	kg*m	kg*m	kg*m				
0	1	52623	19059	19059	1818	1818	1566	>100	9.72	68.4	9.72

Asta : 1073 [417 , 442]

Sez. G: O 114.3x5.9 L=247.0 cm Crit.: Acciaio_Flessione $\gamma_M=1.05$ $f_{yk}/\gamma_M=2619$ kg/cm² $f_t=4300$ kg/cm²

:Verificato

X	cls	N	TY	TZ	MT	MY	MZ	My4	Mz4	Comb.
cm		kg	kg	kg	kg*m	kg*m	kg*m			
247	1	1172	23	32	-17	17	-27	--	--	2

X	cls	Nr	Vyr	Vzr	Mry	Mrz	MTrd	SF_V.	SF_M	SF_Mt	SF
cm		kg	kg	kg	kg*m	kg*m	kg*m				
247	1	52623	19129	19129	1818	1818	1566	>100	21.4	90.9	21.4

Asta : 1074 [442 , 451]

Sez. G: O 114.3x5.9 L=247.0 cm Crit.: Acciaio_Flessione $\gamma_M=1.05$ $f_{yk}/\gamma_M=2619$ kg/cm² $f_t=4300$ kg/cm²

:Verificato

X	cls	N	TY	TZ	MT	MY	MZ	My4	Mz4	Comb.
cm		kg	kg	kg	kg*m	kg*m	kg*m			
247	1	9458	-0	84	5	114	2	--	--	2

AUTOSTRADA VALDASTICO A31 NORD
1° LOTTO - PIOVENE ROCCHETTE – VALLE DELL'ASTICO

X	cls	Nr	Vyr	Vzr	Mry	Mrz	MTrd	SF_V.	SF_M	SF_Mt	SF
cm		kg	kg	kg	kg*m	kg*m	kg*m				
247	1	52623	19285	19285	1818	1818	1566	>100	4.11	>100	4.11

Asta : 1075 [451 , 204]

Sez. G: O 114.3x5.9 L=266.5 cm Crit.: Acciaio_Flessione $\gamma_M=1.05$ $f_{yk}/\gamma_M=2619$ kg/cmq $f_t=4300$ kg/cmq

:Verificato

X	cls	N	TY	TZ	MT	MY	MZ	My4	Mz4	Comb.
cm		kg	kg	kg	kg*m	kg*m	kg*m			
0	1	26560	6	-51	-4	135	17	--	--	2

X	cls	Nr	Vyr	Vzr	Mry	Mrz	MTrd	SF_V.	SF_M	SF_Mt	SF
cm		kg	kg	kg	kg*m	kg*m	kg*m				
0	1	52623	19288	19288	1818	1818	1566	>100	1.70	>100	1.70

Asta : 1076 [204 , 221]

Sez. G: O 114.3x5.9 L=286.0 cm Crit.: Acciaio_Flessione $\gamma_M=1.05$ $f_{yk}/\gamma_M=2619$ kg/cmq $f_t=4300$ kg/cmq

:Verificato

X	cls	N	TY	TZ	MT	MY	MZ	My4	Mz4	Comb.
cm		kg	kg	kg	kg*m	kg*m	kg*m			
0	1	3984	9	-81	-15	102	12	--	--	2

X	cls	Nr	Vyr	Vzr	Mry	Mrz	MTrd	SF_V.	SF_M	SF_Mt	SF
cm		kg	kg	kg	kg*m	kg*m	kg*m				
0	1	52623	19151	19151	1818	1818	1566	>100	7.22	>100	7.22

Asta : 1077 [221 , 238]

Sez. G: O 114.3x5.9 L=286.0 cm Crit.: Acciaio_Flessione $\gamma_M=1.05$ $f_{yk}/\gamma_M=2619$ kg/cmq $f_t=4300$ kg/cmq

:Verificato

X	cls	N	TY	TZ	MT	MY	MZ	My4	Mz4	Comb.
cm		kg	kg	kg	kg*m	kg*m	kg*m			
143	1	-5483	-3	-5	2	-35	-3	--	--	2

AUTOSTRADA VALDASTICO A31 NORD
1° LOTTO - PIOVENE ROCCHETTE – VALLE DELL'ASTICO

X	cls	Nr	Vyr	Vzr	Mry	Mrz	MTrd	SF_V.	SF_M	SF_Mt	SF
cm		kg	kg	kg	kg*m	kg*m	kg*m				
143	1	52623	19314	19314	1818	1818	1566	>100	8.01	>100	8.01

Asta : 1078 [238 , 255]

Sez. G: O 114.3x5.9 L=286.0 cm Crit.: Acciaio_Flessione $\gamma_M=1.05$ $f_{yk}/\gamma_M=2619$ kg/cm² $f_t=4300$ kg/cm²

:Verificato

X	cls	N	TY	TZ	MT	MY	MZ	My4	Mz4	Comb.
cm		kg	kg	kg	kg*m	kg*m	kg*m			
286	1	-2159	-11	64	15	56	15	--	--	2

X	cls	Nr	Vyr	Vzr	Mry	Mrz	MTrd	SF_V.	SF_M	SF_Mt	SF
cm		kg	kg	kg	kg*m	kg*m	kg*m				
286	1	52623	19150	19150	1818	1818	1566	>100	12.5	>100	12.5

Asta : 1079 [255 , 272]

Sez. G: O 114.3x5.9 L=286.0 cm Crit.: Acciaio_Flessione $\gamma_M=1.05$ $f_{yk}/\gamma_M=2619$ kg/cm² $f_t=4300$ kg/cm²

:Verificato

X	cls	N	TY	TZ	MT	MY	MZ	My4	Mz4	Comb.
cm		kg	kg	kg	kg*m	kg*m	kg*m			
286	1	14202	-3	31	1	65	9	--	--	2

X	cls	Nr	Vyr	Vzr	Mry	Mrz	MTrd	SF_V.	SF_M	SF_Mt	SF
cm		kg	kg	kg	kg*m	kg*m	kg*m				
286	1	52623	19327	19327	1818	1818	1566	>100	3.22	>100	3.22

Asta : 1080 [272 , 289]

Sez. G: O 114.3x5.9 L=286.0 cm Crit.: Acciaio_Flessione $\gamma_M=1.05$ $f_{yk}/\gamma_M=2619$ kg/cm² $f_t=4300$ kg/cm²

:Verificato

X	cls	N	TY	TZ	MT	MY	MZ	My4	Mz4	Comb.
cm		kg	kg	kg	kg*m	kg*m	kg*m			

AUTOSTRADA VALDASTICO A31 NORD
1° LOTTO - PIOVENE ROCCHETTE – VALLE DELL'ASTICO

X	cls	N	TY	TZ	MT	MY	MZ	My4	Mz4	Comb.
286	1	-3604	6	-8	-12	-53	-11	--	--	2

X	cls	Nr	Vyr	Vzr	Mry	Mrz	MTrd	SF_V.	SF_M	SF_Mt	SF
cm		kg	kg	kg	kg*m	kg*m	kg*m				
286	1	52623	19198	19198	1818	1818	1566	>100	9.66	>100	9.66

Asta : 1081 [289 , 306]

Sez. G: O 114.3x5.9 L=286.0 cm Crit.: Acciaio_Flessione $\gamma_M=1.05$ $f_{yk}/\gamma_M=2619$ kg/cm² $f_t=4300$ kg/cm²

:Verificato

X	cls	N	TY	TZ	MT	MY	MZ	My4	Mz4	Comb.
cm		kg	kg	kg	kg*m	kg*m	kg*m			
143	1	-9127	0	1	-1	-46	-3	--	--	2

X	cls	Nr	Vyr	Vzr	Mry	Mrz	MTrd	SF_V.	SF_M	SF_Mt	SF
cm		kg	kg	kg	kg*m	kg*m	kg*m				
143	1	52623	19330	19330	1818	1818	1566	>100	4.99	>100	4.99

Asta : 1082 [306 , 349]

Sez. G: O 114.3x5.9 L=286.0 cm Crit.: Acciaio_Flessione $\gamma_M=1.05$ $f_{yk}/\gamma_M=2619$ kg/cm² $f_t=4300$ kg/cm²

:Verificato

X	cls	N	TY	TZ	MT	MY	MZ	My4	Mz4	Comb.
cm		kg	kg	kg	kg*m	kg*m	kg*m			
286	1	-2460	-8	70	11	63	10	--	--	2

X	cls	Nr	Vyr	Vzr	Mry	Mrz	MTrd	SF_V.	SF_M	SF_Mt	SF
cm		kg	kg	kg	kg*m	kg*m	kg*m				
286	1	52623	19200	19200	1818	1818	1566	>100	11.6	>100	11.6

Asta : 1083 [349 , 332]

Sez. G: O 114.3x5.9 L=286.0 cm Crit.: Acciaio_Flessione $\gamma_M=1.05$ $f_{yk}/\gamma_M=2619$ kg/cm² $f_t=4300$ kg/cm²

:Verificato

AUTOSTRADA VALDASTICO A31 NORD
1° LOTTO - PIOVENE ROCCHETTE – VALLE DELL'ASTICO

X	cls	N	TY	TZ	MT	MY	MZ	My4	Mz4	Comb.
cm		kg	kg	kg	kg*m	kg*m	kg*m			
286	1	16769	-0	29	-0	71	7	--	--	2

X	cls	Nr	Vyr	Vzr	Mry	Mrz	MTrd	SF_V.	SF_M	SF_Mt	SF
cm		kg	kg	kg	kg*m	kg*m	kg*m				
286	1	52623	19340	19340	1818	1818	1566	>100	2.77	>100	2.77

Asta : 1084 [332 , 357]

Sez. G: O 114.3x5.9 L=286.0 cm Crit.: Acciaio_Flessione $\gamma_M=1.05$ $f_{yk}/\gamma_M=2619$ kg/cm² $f_t=4300$ kg/cm²

:Verificato

X	cls	N	TY	TZ	MT	MY	MZ	My4	Mz4	Comb.
cm		kg	kg	kg	kg*m	kg*m	kg*m			
0	1	-2085	7	-70	-12	63	8	--	--	2

X	cls	Nr	Vyr	Vzr	Mry	Mrz	MTrd	SF_V.	SF_M	SF_Mt	SF
cm		kg	kg	kg	kg*m	kg*m	kg*m				
0	1	52623	19199	19199	1818	1818	1566	>100	12.7	>100	12.7

Asta : 1085 [357 , 374]

Sez. G: O 114.3x5.9 L=286.0 cm Crit.: Acciaio_Flessione $\gamma_M=1.05$ $f_{yk}/\gamma_M=2619$ kg/cm² $f_t=4300$ kg/cm²

:Verificato

X	cls	N	TY	TZ	MT	MY	MZ	My4	Mz4	Comb.
cm		kg	kg	kg	kg*m	kg*m	kg*m			
143	1	-8346	-1	-0	1	-44	-3	--	--	2

X	cls	Nr	Vyr	Vzr	Mry	Mrz	MTrd	SF_V.	SF_M	SF_Mt	SF
cm		kg	kg	kg	kg*m	kg*m	kg*m				
143	1	52623	19325	19325	1818	1818	1566	>100	5.42	>100	5.42

Asta : 1086 [374 , 391]

AUTOSTRADA VALDASTICO A31 NORD
1° LOTTO - PIOVENE ROCCHETTE – VALLE DELL'ASTICO

Sez. G: O 114.3x5.9 L=286.0 cm Crit.: Acciaio_Flessione $\gamma_M=1.05$ $f_{yk}/\gamma_M=2619$ kg/cm² $f_t=4300$ kg/cm²

:Verificato

X	cls	N	TY	TZ	MT	MY	MZ	My4	Mz4	Comb.
cm		kg	kg	kg	kg*m	kg*m	kg*m			
286	1	-2426	-8	66	12	55	10	--	--	2

X	cls	Nr	Vyr	Vzr	Mry	Mrz	MTrd	SF_V.	SF_M	SF_Mt	SF
cm		kg	kg	kg	kg*m	kg*m	kg*m				
286	1	52623	19191	19191	1818	1818	1566	>100	12.3	>100	12.3

Asta : 1087 [391 , 468]

Sez. G: O 114.3x5.9 L=274.8 cm Crit.: Acciaio_Flessione $\gamma_M=1.05$ $f_{yk}/\gamma_M=2619$ kg/cm² $f_t=4300$ kg/cm²

:Verificato

X	cls	N	TY	TZ	MT	MY	MZ	My4	Mz4	Comb.
cm		kg	kg	kg	kg*m	kg*m	kg*m			
275	1	15692	-1	35	2	74	7	--	--	2

X	cls	Nr	Vyr	Vzr	Mry	Mrz	MTrd	SF_V.	SF_M	SF_Mt	SF
cm		kg	kg	kg	kg*m	kg*m	kg*m				
275	1	52623	19319	19319	1818	1818	1566	>100	2.92	>100	2.92

Asta : 1088 [468 , 485]

Sez. G: O 114.3x5.9 L=264.5 cm Crit.: Acciaio_Flessione $\gamma_M=1.05$ $f_{yk}/\gamma_M=2619$ kg/cm² $f_t=4300$ kg/cm²

:Verificato

X	cls	N	TY	TZ	MT	MY	MZ	My4	Mz4	Comb.
cm		kg	kg	kg	kg*m	kg*m	kg*m			
0	1	3174	8	-58	-8	64	12	--	--	2

X	cls	Nr	Vyr	Vzr	Mry	Mrz	MTrd	SF_V.	SF_M	SF_Mt	SF
cm		kg	kg	kg	kg*m	kg*m	kg*m				
0	1	52623	19246	19246	1818	1818	1566	>100	9.83	>100	9.83

AUTOSTRADA VALDASTICO A31 NORD
1° LOTTO - PIOVENE ROCCHETTE – VALLE DELL'ASTICO

Asta : 1089 [185 , 256]

Sez. G: O 609.6x10. L=654.3 cm Crit.: Acciaio_Flessione $\gamma_M=1.05$ $f_{yk}/\gamma_M=2619$ kg/cm² $f_t=4300$ kg/cm²

:Verificato

X	cls	N	TY	TZ	MT	MY	MZ	My4	Mz4	Comb.
cm		kg	kg	kg	kg*m	kg*m	kg*m			
0	3	404	976	-337	30	1483	5855	--	--	(12+13)-V-3

X	cls	Nr	Vyr	Vzr	Mry	Mrz	MTrd	SF_V.	SF_M	SF_Mt	SF
cm		kg	kg	kg	kg*m	kg*m	kg*m				
0	3	493350	181267	181267	72760	72760	84016	>100	9.84	>100	9.84

Asta : 1090 [181 , 257]

Sez. G: O 609.6x10. L=655.1 cm Crit.: Acciaio_Flessione $\gamma_M=1.05$ $f_{yk}/\gamma_M=2619$ kg/cm² $f_t=4300$ kg/cm²

:Verificato

X	cls	N	TY	TZ	MT	MY	MZ	My4	Mz4	Comb.
cm		kg	kg	kg	kg*m	kg*m	kg*m			
0	3	-54151	-168	268	-28	-1651	-919	--	--	2

X	cls	Nr	Vyr	Vzr	Mry	Mrz	MTrd	SF_V.	SF_M	SF_Mt	SF
cm		kg	kg	kg	kg*m	kg*m	kg*m				
0	3	493350	181272	181272	72760	72760	84016	>100	6.89	>100	6.89

Asta : 1091 [186 , 324]

Sez. G: O 609.6x10. L=654.3 cm Crit.: Acciaio_Flessione $\gamma_M=1.05$ $f_{yk}/\gamma_M=2619$ kg/cm² $f_t=4300$ kg/cm²

:Verificato

X	cls	N	TY	TZ	MT	MY	MZ	My4	Mz4	Comb.
cm		kg	kg	kg	kg*m	kg*m	kg*m			
0	3	248	-938	-302	-31	1262	-5674	--	--	(12+13)-VII-1

X	cls	Nr	Vyr	Vzr	Mry	Mrz	MTrd	SF_V.	SF_M	SF_Mt	SF
cm		kg	kg	kg	kg*m	kg*m	kg*m				
0	3	493350	181266	181266	72760	72760	84016	>100	10.4	>100	10.4

AUTOSTRADA VALDASTICO A31 NORD
1° LOTTO - PIOVENE ROCCHETTE – VALLE DELL'ASTICO

Asta : 1092 [182 , 323]

Sez. G: O 609.6x10. L=655.1 cm Crit.: Acciaio_Flessione $\gamma_M=1.05$ $f_{yk}/\gamma_M=2619$ kg/cmq $f_t=4300$ kg/cmq

:Verificato

X	cls	N	TY	TZ	MT	MY	MZ	My4	Mz4	Comb.
cm		kg	kg	kg	kg*m	kg*m	kg*m			
0	3	-57775	-58	300	5	-1805	-374	--	--	2

X	cls	Nr	Vyr	Vzr	Mry	Mrz	MTrd	SF_V.	SF_M	SF_Mt	SF
cm		kg	kg	kg	kg*m	kg*m	kg*m				
0	3	493350	181322	181322	72760	72760	84016	>100	6.80	>100	6.80

Asta : 1093 [184 , 196]

Sez. G: O 609.6x10. L=654.3 cm Crit.: Acciaio_Flessione $\gamma_M=1.05$ $f_{yk}/\gamma_M=2619$ kg/cmq $f_t=4300$ kg/cmq

:Verificato

X	cls	N	TY	TZ	MT	MY	MZ	My4	Mz4	Comb.
cm		kg	kg	kg	kg*m	kg*m	kg*m			
0	3	1436	-1003	-489	-42	2428	-5922	--	--	(12+13)-VII-1

X	cls	Nr	Vyr	Vzr	Mry	Mrz	MTrd	SF_V.	SF_M	SF_Mt	SF
cm		kg	kg	kg	kg*m	kg*m	kg*m				
0	3	493350	181240	181240	72760	72760	84016	>100	8.50	>100	8.50

Asta : 1094 [180 , 195]

Sez. G: O 609.6x10. L=655.1 cm Crit.: Acciaio_Flessione $\gamma_M=1.05$ $f_{yk}/\gamma_M=2619$ kg/cmq $f_t=4300$ kg/cmq

:Verificato

X	cls	N	TY	TZ	MT	MY	MZ	My4	Mz4	Comb.
cm		kg	kg	kg	kg*m	kg*m	kg*m			
0	3	-68019	208	424	129	-2332	582	--	--	2

X	cls	Nr	Vyr	Vzr	Mry	Mrz	MTrd	SF_V.	SF_M	SF_Mt	SF
cm		kg	kg	kg	kg*m	kg*m	kg*m				

AUTOSTRADA VALDASTICO A31 NORD
1° LOTTO - PIOVENE ROCCHETTE – VALLE DELL'ASTICO

X	cls	Nr	Vyr	Vzr	Mry	Mrz	MTrd	SF_V.	SF_M	SF_Mt	SF
0	3	493350	181054	181054	72760	72760	84016	>100	5.62	>100	5.62

Asta : 1095 [187 , 392]

Sez. G: O 609.6x10. L=654.3 cm Crit.: Acciaio_Flessione $\gamma_M=1.05$ $f_{yk}/\gamma_M=2619$ kg/cm² $f_t=4300$ kg/cm²

:Verificato

X	cls	N	TY	TZ	MT	MY	MZ	My4	Mz4	Comb.
cm		kg	kg	kg	kg*m	kg*m	kg*m			
0	3	727	924	-420	-0	2018	5626	--	--	(12+13)-V-3

X	cls	Nr	Vyr	Vzr	Mry	Mrz	MTrd	SF_V.	SF_M	SF_Mt	SF
cm		kg	kg	kg	kg*m	kg*m	kg*m				
0	3	493350	181331	181331	72760	72760	84016	>100	9.39	>100	9.39

Asta : 1096 [183 , 393]

Sez. G: O 609.6x10. L=655.1 cm Crit.: Acciaio_Flessione $\gamma_M=1.05$ $f_{yk}/\gamma_M=2619$ kg/cm² $f_t=4300$ kg/cm²

:Verificato

X	cls	N	TY	TZ	MT	MY	MZ	My4	Mz4	Comb.
cm		kg	kg	kg	kg*m	kg*m	kg*m			
0	3	-15047	-938	277	66	-2147	-5728	--	--	(12+13)-V-3

X	cls	Nr	Vyr	Vzr	Mry	Mrz	MTrd	SF_V.	SF_M	SF_Mt	SF
cm		kg	kg	kg	kg*m	kg*m	kg*m				
0	3	493350	181189	181189	72760	72760	84016	>100	7.21	>100	7.21

Asta : 1097 [176 , 189]

Sez. G: O 609.6x10. L=654.7 cm Crit.: Acciaio_Flessione $\gamma_M=1.05$ $f_{yk}/\gamma_M=2619$ kg/cm² $f_t=4300$ kg/cm²

:Verificato

X	cls	N	TY	TZ	MT	MY	MZ	My4	Mz4	Comb.
cm		kg	kg	kg	kg*m	kg*m	kg*m			
0	3	-68279	-206	620	-127	-3515	-620	--	--	2

AUTOSTRADA VALDASTICO A31 NORD
1° LOTTO - PIOVENE ROCCHETTE – VALLE DELL'ASTICO

X	cls	Nr	Vyr	Vzr	Mry	Mrz	MTrd	SF_V.	SF_M	SF_Mt	SF
cm		kg	kg	kg	kg*m	kg*m	kg*m				
0	3	493350	181058	181058	72760	72760	84016	>100	5.12	>100	5.12

Asta : 1098 [172 , 188]

Sez. G: O 609.6x10. L=654.7 cm Crit.: Acciaio_Flessione $\gamma_M=1.05$ fyk/ $\gamma_M=2619$ kg/cmq ft=4300 kg/cmq

:Verificato

X	cls	N	TY	TZ	MT	MY	MZ	My4	Mz4	Comb.
cm		kg	kg	kg	kg*m	kg*m	kg*m			
0	3	1447	1012	-506	51	2527	5947	--	--	(12+13)-III-2

X	cls	Nr	Vyr	Vzr	Mry	Mrz	MTrd	SF_V.	SF_M	SF_Mt	SF
cm		kg	kg	kg	kg*m	kg*m	kg*m				
0	3	493350	181222	181222	72760	72760	84016	>100	8.37	>100	8.37

Asta : 1099 [177 , 263]

Sez. G: O 609.6x10. L=654.7 cm Crit.: Acciaio_Flessione $\gamma_M=1.05$ fyk/ $\gamma_M=2619$ kg/cmq ft=4300 kg/cmq

:Verificato

X	cls	N	TY	TZ	MT	MY	MZ	My4	Mz4	Comb.
cm		kg	kg	kg	kg*m	kg*m	kg*m			
0	3	-54761	156	443	32	-2712	843	--	--	2

X	cls	Nr	Vyr	Vzr	Mry	Mrz	MTrd	SF_V.	SF_M	SF_Mt	SF
cm		kg	kg	kg	kg*m	kg*m	kg*m				
0	3	493350	181263	181263	72760	72760	84016	>100	6.26	>100	6.26

Asta : 1100 [173 , 264]

Sez. G: O 609.6x10. L=654.7 cm Crit.: Acciaio_Flessione $\gamma_M=1.05$ fyk/ $\gamma_M=2619$ kg/cmq ft=4300 kg/cmq

:Verificato

X	cls	N	TY	TZ	MT	MY	MZ	My4	Mz4	Comb.
cm		kg	kg	kg	kg*m	kg*m	kg*m			
0	3	449	-972	-353	-29	1574	-5838	--	--	(12+13)-I-4

AUTOSTRADA VALDASTICO A31 NORD
1° LOTTO - PIOVENE ROCCHETTE – VALLE DELL'ASTICO

X	cls	Nr	Vyr	Vzr	Mry	Mrz	MTrd	SF_V.	SF_M	SF_Mt	SF
cm		kg	kg	kg	kg*m	kg*m	kg*m				
0	3	493350	181268	181268	72760	72760	84016	>100	9.73	>100	9.73

Asta : 1101 [178 , 317]

Sez. G: O 609.6x10. L=654.7 cm Crit.: Acciaio_Flessione $\gamma_M=1.05$ fyk/ $\gamma_M=2619$ kg/cmq ft=4300 kg/cmq

:Verificato

X	cls	N	TY	TZ	MT	MY	MZ	My4	Mz4	Comb.
cm		kg	kg	kg	kg*m	kg*m	kg*m			
0	3	-58308	46	459	-1	-2768	300	--	--	2

X	cls	Nr	Vyr	Vzr	Mry	Mrz	MTrd	SF_V.	SF_M	SF_Mt	SF
cm		kg	kg	kg	kg*m	kg*m	kg*m				
0	3	493350	181330	181330	72760	72760	84016	>100	6.24	>100	6.24

Asta : 1102 [174 , 316]

Sez. G: O 609.6x10. L=654.7 cm Crit.: Acciaio_Flessione $\gamma_M=1.05$ fyk/ $\gamma_M=2619$ kg/cmq ft=4300 kg/cmq

:Verificato

X	cls	N	TY	TZ	MT	MY	MZ	My4	Mz4	Comb.
cm		kg	kg	kg	kg*m	kg*m	kg*m			
0	3	287	938	-317	31	1345	5678	--	--	(12+13)-III-2

X	cls	Nr	Vyr	Vzr	Mry	Mrz	MTrd	SF_V.	SF_M	SF_Mt	SF
cm		kg	kg	kg	kg*m	kg*m	kg*m				
0	3	493350	181266	181266	72760	72760	84016	>100	10.3	>100	10.3

Asta : 1103 [179 , 399]

Sez. G: O 609.6x10. L=654.7 cm Crit.: Acciaio_Flessione $\gamma_M=1.05$ fyk/ $\gamma_M=2619$ kg/cmq ft=4300 kg/cmq

:Verificato

X	cls	N	TY	TZ	MT	MY	MZ	My4	Mz4	Comb.
cm		kg	kg	kg	kg*m	kg*m	kg*m			

AUTOSTRADA VALDASTICO A31 NORD
1° LOTTO - PIOVENE ROCCHETTE – VALLE DELL'ASTICO

X	cls	N	TY	TZ	MT	MY	MZ	My4	Mz4	Comb.
0	3	-15077	938	292	-65	-2232	5725	--	--	(12+13)-I-4

X	cls	Nr	Vyr	Vzr	Mry	Mrz	MTrd	SF_V.	SF_M	SF_Mt	SF
cm		kg	kg	kg	kg*m	kg*m	kg*m				
0	3	493350	181191	181191	72760	72760	84016	>100	7.15	>100	7.15

Asta : 1104 [175 , 400]

Sez. G: O 609.6x10. L=654.7 cm Crit.: Acciaio_Flessione $\gamma_M=1.05$ $f_{yk}/\gamma_M=2619$ kg/cm² $f_t=4300$ kg/cm²

:Verificato

X	cls	N	TY	TZ	MT	MY	MZ	My4	Mz4	Comb.
cm		kg	kg	kg	kg*m	kg*m	kg*m			
0	3	765	-920	-433	1	2089	-5607	--	--	(12+13)-I-4

X	cls	Nr	Vyr	Vzr	Mry	Mrz	MTrd	SF_V.	SF_M	SF_Mt	SF
cm		kg	kg	kg	kg*m	kg*m	kg*m				
0	3	493350	181330	181330	72760	72760	84016	>100	9.32	>100	9.32

Asta : 1105 [479 , 502]

Sez. G: O 114.3x5.9 L=248.8 cm Crit.: Acciaio_Flessione $\gamma_M=1.05$ $f_{yk}/\gamma_M=2619$ kg/cm² $f_t=4300$ kg/cm²

:Verificato

X	cls	N	TY	TZ	MT	MY	MZ	My4	Mz4	Comb.
cm		kg	kg	kg	kg*m	kg*m	kg*m			
0	1	800	3	-555	-6	274	4	--	--	2

X	cls	Nr	Vyr	Vzr	Mry	Mrz	MTrd	SF_V.	SF_M	SF_Mt	SF
cm		kg	kg	kg	kg*m	kg*m	kg*m				
0	1	52623	19267	19267	1818	1818	1566	34.7	5.95	>100	5.95

Asta : 1106 [502 , 501]

Sez. G: O 114.3x5.9 L=263.5 cm Crit.: Acciaio_Flessione $\gamma_M=1.05$ $f_{yk}/\gamma_M=2619$ kg/cm² $f_t=4300$ kg/cm²

:Verificato

AUTOSTRADA VALDASTICO A31 NORD
1° LOTTO - PIOVENE ROCCHETTE – VALLE DELL'ASTICO

X	cls	N	TY	TZ	MT	MY	MZ	My4	Mz4	Comb.
cm		kg	kg	kg	kg*m	kg*m	kg*m			
263	1	2150	-4	36	-4	41	7	--	--	2

X	cls	Nr	Vyr	Vzr	Mry	Mrz	MTrd	SF_V.	SF_M	SF_Mt	SF
cm		kg	kg	kg	kg*m	kg*m	kg*m				
263	1	52623	19297	19297	1818	1818	1566	>100	14.8	>100	14.8

Asta : 1107 [501 , 462]

Sez. G: O 114.3x5.9 L=248.8 cm Crit.: Acciaio_Flessione $\gamma_M=1.05$ $f_{yk}/\gamma_M=2619$ kg/cm² $f_t=4300$ kg/cm²

:Verificato

X	cls	N	TY	TZ	MT	MY	MZ	My4	Mz4	Comb.
cm		kg	kg	kg	kg*m	kg*m	kg*m			
249	1	1577	8	1116	-12	556	-10	--	--	2

X	cls	Nr	Vyr	Vzr	Mry	Mrz	MTrd	SF_V.	SF_M	SF_Mt	SF
cm		kg	kg	kg	kg*m	kg*m	kg*m				
249	1	52623	19190	19190	1818	1818	1566	17.2	2.93	>100	2.93

Asta : 1108 [501 , 461]

Sez. G: O 114.3x5.9 L=160.6 cm Crit.: Acciaio_Flessione $\gamma_M=1.05$ $f_{yk}/\gamma_M=2619$ kg/cm² $f_t=4300$ kg/cm²

:Verificato

X	cls	N	TY	TZ	MT	MY	MZ	My4	Mz4	Comb.
cm		kg	kg	kg	kg*m	kg*m	kg*m			
0	1	-1526	-22	109	-42	-102	-33	--	--	2

X	cls	Nr	Vyr	Vzr	Mry	Mrz	MTrd	SF_V.	SF_M	SF_Mt	SF
cm		kg	kg	kg	kg*m	kg*m	kg*m				
0	1	52623	18824	18824	1818	1818	1566	>100	9.68	37.4	9.68

Asta : 1109 [461 , 502]

AUTOSTRADA VALDASTICO A31 NORD
1° LOTTO - PIOVENE ROCCHETTE – VALLE DELL'ASTICO

Sez. G: O 114.3x5.9 L=160.5 cm Crit.: Acciaio_Flessione $\gamma_M=1.05$ $f_{yk}/\gamma_M=2619$ kg/cm² $f_t=4300$ kg/cm²

:Verificato

X	cls	N	TY	TZ	MT	MY	MZ	My4	Mz4	Comb.
cm		kg	kg	kg	kg*m	kg*m	kg*m			
160	1	-1989	16	-65	29	-81	-21	--	--	2

X	cls	Nr	Vyr	Vzr	Mry	Mrz	MTrd	SF_V.	SF_M	SF_Mt	SF
cm		kg	kg	kg	kg*m	kg*m	kg*m				
160	1	52623	18987	18987	1818	1818	1566	>100	10.7	54.6	10.7

Asta : 1110 [501 , 500]

Sez. G: O 114.3x5.9 L=274.7 cm Crit.: Acciaio_Flessione $\gamma_M=1.05$ $f_{yk}/\gamma_M=2619$ kg/cm² $f_t=4300$ kg/cm²

:Verificato

X	cls	N	TY	TZ	MT	MY	MZ	My4	Mz4	Comb.
cm		kg	kg	kg	kg*m	kg*m	kg*m			
0	1	1804	1	-30	-3	40	0	--	--	2

X	cls	Nr	Vyr	Vzr	Mry	Mrz	MTrd	SF_V.	SF_M	SF_Mt	SF
cm		kg	kg	kg	kg*m	kg*m	kg*m				
0	1	52623	19307	19307	1818	1818	1566	>100	17.8	>100	17.8

Asta : 1111 [500 , 390]

Sez. G: O 114.3x5.9 L=248.8 cm Crit.: Acciaio_Flessione $\gamma_M=1.05$ $f_{yk}/\gamma_M=2619$ kg/cm² $f_t=4300$ kg/cm²

:Verificato

X	cls	N	TY	TZ	MT	MY	MZ	My4	Mz4	Comb.
cm		kg	kg	kg	kg*m	kg*m	kg*m			
249	1	1604	-2	1163	13	581	3	--	--	2

X	cls	Nr	Vyr	Vzr	Mry	Mrz	MTrd	SF_V.	SF_M	SF_Mt	SF
cm		kg	kg	kg	kg*m	kg*m	kg*m				
249	1	52623	19184	19184	1818	1818	1566	16.5	2.84	>100	2.84

AUTOSTRADA VALDASTICO A31 NORD
1° LOTTO - PIOVENE ROCCHETTE – VALLE DELL'ASTICO

Asta : 1112 [500 , 392]

Sez. G: O 114.3x5.9 L=169.9 cm Crit.: Acciaio_Flessione $\gamma_M=1.05$ $f_{yk}/\gamma_M=2619$ kg/cm² $f_t=4300$ kg/cm²

:Verificato

X	cls	N	TY	TZ	MT	MY	MZ	My4	Mz4	Comb.
cm		kg	kg	kg	kg*m	kg*m	kg*m			
0	1	-1770	-22	99	-68	-117	-35	--	--	2

X	cls	Nr	Vyr	Vzr	Mry	Mrz	MTrd	SF_V.	SF_M	SF_Mt	SF
cm		kg	kg	kg	kg*m	kg*m	kg*m				
0	1	52623	18508	18508	1818	1818	1566	>100	8.52	23.2	8.52

Asta : 1113 [392 , 501]

Sez. G: O 114.3x5.9 L=160.5 cm Crit.: Acciaio_Flessione $\gamma_M=1.05$ $f_{yk}/\gamma_M=2619$ kg/cm² $f_t=4300$ kg/cm²

:Verificato

X	cls	N	TY	TZ	MT	MY	MZ	My4	Mz4	Comb.
cm		kg	kg	kg	kg*m	kg*m	kg*m			
160	1	-1082	25	-64	61	-96	-36	--	--	2

X	cls	Nr	Vyr	Vzr	Mry	Mrz	MTrd	SF_V.	SF_M	SF_Mt	SF
cm		kg	kg	kg	kg*m	kg*m	kg*m				
160	1	52623	18588	18588	1818	1818	1566	>100	10.7	25.7	10.7

Asta : 1114 [500 , 499]

Sez. G: O 114.3x5.9 L=286.0 cm Crit.: Acciaio_Flessione $\gamma_M=1.05$ $f_{yk}/\gamma_M=2619$ kg/cm² $f_t=4300$ kg/cm²

:Verificato

X	cls	N	TY	TZ	MT	MY	MZ	My4	Mz4	Comb.
cm		kg	kg	kg	kg*m	kg*m	kg*m			
0	1	1140	3	-47	-10	36	6	--	--	2

X	cls	Nr	Vyr	Vzr	Mry	Mrz	MTrd	SF_V.	SF_M	SF_Mt	SF
cm		kg	kg	kg	kg*m	kg*m	kg*m				
0	1	52623	19224	19224	1818	1818	1566	>100	22.4	>100	22.4

AUTOSTRADA VALDASTICO A31 NORD
1° LOTTO - PIOVENE ROCCHETTE – VALLE DELL'ASTICO

Asta : 1115 [499 , 373]

Sez. G: O 114.3x5.9 L=248.8 cm Crit.: Acciaio_Flessione $\gamma_M=1.05$ $f_{yk}/\gamma_M=2619$ kg/cmq $f_t=4300$ kg/cmq

:Verificato

X	cls	N	TY	TZ	MT	MY	MZ	My4	Mz4	Comb.
cm		kg	kg	kg	kg*m	kg*m	kg*m			
249	1	1537	1	1166	5	572	-2	--	--	2

X	cls	Nr	Vyr	Vzr	Mry	Mrz	MTrd	SF_V.	SF_M	SF_Mt	SF
cm		kg	kg	kg	kg*m	kg*m	kg*m				
249	1	52623	19281	19281	1818	1818	1566	16.5	2.90	>100	2.90

Asta : 1116 [499 , 375]

Sez. G: O 114.3x5.9 L=169.9 cm Crit.: Acciaio_Flessione $\gamma_M=1.05$ $f_{yk}/\gamma_M=2619$ kg/cmq $f_t=4300$ kg/cmq

:Verificato

X	cls	N	TY	TZ	MT	MY	MZ	My4	Mz4	Comb.
cm		kg	kg	kg	kg*m	kg*m	kg*m			
0	1	-2301	-22	128	-38	-171	-27	--	--	2

X	cls	Nr	Vyr	Vzr	Mry	Mrz	MTrd	SF_V.	SF_M	SF_Mt	SF
cm		kg	kg	kg	kg*m	kg*m	kg*m				
0	1	52623	18869	18869	1818	1818	1566	>100	6.55	40.9	6.55

Asta : 1117 [375 , 500]

Sez. G: O 114.3x5.9 L=169.9 cm Crit.: Acciaio_Flessione $\gamma_M=1.05$ $f_{yk}/\gamma_M=2619$ kg/cmq $f_t=4300$ kg/cmq

:Verificato

X	cls	N	TY	TZ	MT	MY	MZ	My4	Mz4	Comb.
cm		kg	kg	kg	kg*m	kg*m	kg*m			
170	1	-994	10	-108	37	-115	-20	--	--	2

X	cls	Nr	Vyr	Vzr	Mry	Mrz	MTrd	SF_V.	SF_M	SF_Mt	SF
cm		kg	kg	kg	kg*m	kg*m	kg*m				

AUTOSTRADA VALDASTICO A31 NORD
1° LOTTO - PIOVENE ROCCHETTE – VALLE DELL'ASTICO

X	cls	Nr	Vyr	Vzr	Mry	Mrz	MTrd	SF_V.	SF_M	SF_Mt	SF
170	1	52623	18884	18884	1818	1818	1566	>100	10.7	42.2	10.7

Asta : 1118 [499 , 498]

Sez. G: O 114.3x5.9 L=286.0 cm Crit.: Acciaio_Flessione $\gamma_M=1.05$ $f_{yk}/\gamma_M=2619$ kg/cm² $f_t=4300$ kg/cm²

:Verificato

X	cls	N	TY	TZ	MT	MY	MZ	My4	Mz4	Comb.
cm		kg	kg	kg	kg*m	kg*m	kg*m			
143	1	-515	0	2	-1	-35	-1	--	--	2

X	cls	Nr	Vyr	Vzr	Mry	Mrz	MTrd	SF_V.	SF_M	SF_Mt	SF
cm		kg	kg	kg	kg*m	kg*m	kg*m				
143	1	52623	19326	19326	1818	1818	1566	>100	33.7	>100	33.7

Asta : 1119 [498 , 356]

Sez. G: O 114.3x5.9 L=248.8 cm Crit.: Acciaio_Flessione $\gamma_M=1.05$ $f_{yk}/\gamma_M=2619$ kg/cm² $f_t=4300$ kg/cm²

:Verificato

X	cls	N	TY	TZ	MT	MY	MZ	My4	Mz4	Comb.
cm		kg	kg	kg	kg*m	kg*m	kg*m			
249	1	1547	-3	1166	-3	572	3	--	--	2

X	cls	Nr	Vyr	Vzr	Mry	Mrz	MTrd	SF_V.	SF_M	SF_Mt	SF
cm		kg	kg	kg	kg*m	kg*m	kg*m				
249	1	52623	19303	19303	1818	1818	1566	16.5	2.89	>100	2.89

Asta : 1120 [498 , 358]

Sez. G: O 114.3x5.9 L=169.9 cm Crit.: Acciaio_Flessione $\gamma_M=1.05$ $f_{yk}/\gamma_M=2619$ kg/cm² $f_t=4300$ kg/cm²

:Verificato

X	cls	N	TY	TZ	MT	MY	MZ	My4	Mz4	Comb.
cm		kg	kg	kg	kg*m	kg*m	kg*m			
0	1	-126	-14	120	-28	-162	-19	--	--	2

AUTOSTRADA VALDASTICO A31 NORD
1° LOTTO - PIOVENE ROCCHETTE – VALLE DELL'ASTICO

X	cls	Nr	Vyr	Vzr	Mry	Mrz	MTrd	SF_V.	SF_M	SF_Mt	SF
cm		kg	kg	kg	kg*m	kg*m	kg*m				
0	1	52623	18990	18990	1818	1818	1566	>100	9.82	55.1	9.82

Asta : 1121 [358 , 499]

Sez. G: O 114.3x5.9 L=169.9 cm Crit.: Acciaio_Flessione $\gamma_M=1.05$ $f_{yk}/\gamma_M=2619$ kg/cm² $f_t=4300$ kg/cm²

:Verificato

X	cls	N	TY	TZ	MT	MY	MZ	My4	Mz4	Comb.
cm		kg	kg	kg	kg*m	kg*m	kg*m			
170	1	-337	14	-124	27	-164	-18	--	--	2

X	cls	Nr	Vyr	Vzr	Mry	Mrz	MTrd	SF_V.	SF_M	SF_Mt	SF
cm		kg	kg	kg	kg*m	kg*m	kg*m				
170	1	52623	19012	19012	1818	1818	1566	>100	9.38	58.8	9.38

Asta : 1122 [331 , 497]

Sez. G: O 114.3x5.9 L=248.8 cm Crit.: Acciaio_Flessione $\gamma_M=1.05$ $f_{yk}/\gamma_M=2619$ kg/cm² $f_t=4300$ kg/cm²

:Verificato

X	cls	N	TY	TZ	MT	MY	MZ	My4	Mz4	Comb.
cm		kg	kg	kg	kg*m	kg*m	kg*m			
0	1	1690	5	-1191	-14	598	6	--	--	2

X	cls	Nr	Vyr	Vzr	Mry	Mrz	MTrd	SF_V.	SF_M	SF_Mt	SF
cm		kg	kg	kg	kg*m	kg*m	kg*m				
0	1	52623	19172	19172	1818	1818	1566	16.1	2.75	>100	2.75

Asta : 1123 [497 , 498]

Sez. G: O 114.3x5.9 L=286.0 cm Crit.: Acciaio_Flessione $\gamma_M=1.05$ $f_{yk}/\gamma_M=2619$ kg/cm² $f_t=4300$ kg/cm²

:Verificato

X	cls	N	TY	TZ	MT	MY	MZ	My4	Mz4	Comb.
cm		kg	kg	kg	kg*m	kg*m	kg*m			
0	1	1508	-3	-50	8	46	-6	--	--	2

AUTOSTRADA VALDASTICO A31 NORD
1° LOTTO - PIOVENE ROCCHETTE – VALLE DELL'ASTICO

X	cls	Nr	Vyr	Vzr	Mry	Mrz	MTrd	SF_V.	SF_M	SF_Mt	SF
cm		kg	kg	kg	kg*m	kg*m	kg*m				
0	1	52623	19249	19249	1818	1818	1566	>100	17.4	>100	17.4

Asta : 1124 [498 , 333]

Sez. G: O 114.3x5.9 L=169.9 cm Crit.: Acciaio_Flessione $\gamma_M=1.05$ $f_{yk}/\gamma_M=2619$ kg/cm² $f_t=4300$ kg/cm²

:Verificato

X	cls	N	TY	TZ	MT	MY	MZ	My4	Mz4	Comb.
cm		kg	kg	kg	kg*m	kg*m	kg*m			
0	1	-2530	22	127	39	-166	28	--	--	2

X	cls	Nr	Vyr	Vzr	Mry	Mrz	MTrd	SF_V.	SF_M	SF_Mt	SF
cm		kg	kg	kg	kg*m	kg*m	kg*m				
0	1	52623	18855	18855	1818	1818	1566	>100	6.47	39.8	6.47

Asta : 1125 [333 , 497]

Sez. G: O 114.3x5.9 L=169.9 cm Crit.: Acciaio_Flessione $\gamma_M=1.05$ $f_{yk}/\gamma_M=2619$ kg/cm² $f_t=4300$ kg/cm²

:Verificato

X	cls	N	TY	TZ	MT	MY	MZ	My4	Mz4	Comb.
cm		kg	kg	kg	kg*m	kg*m	kg*m			
170	1	-1149	-11	-103	-41	-107	23	--	--	2

X	cls	Nr	Vyr	Vzr	Mry	Mrz	MTrd	SF_V.	SF_M	SF_Mt	SF
cm		kg	kg	kg	kg*m	kg*m	kg*m				
170	1	52623	18830	18830	1818	1818	1566	>100	10.7	37.8	10.7

Asta : 1126 [497 , 496]

Sez. G: O 114.3x5.9 L=286.0 cm Crit.: Acciaio_Flessione $\gamma_M=1.05$ $f_{yk}/\gamma_M=2619$ kg/cm² $f_t=4300$ kg/cm²

:Verificato

X	cls	N	TY	TZ	MT	MY	MZ	My4	Mz4	Comb.
cm		kg	kg	kg	kg*m	kg*m	kg*m			

AUTOSTRADA VALDASTICO A31 NORD
1° LOTTO - PIOVENE ROCCHETTE – VALLE DELL'ASTICO

X	cls	N	TY	TZ	MT	MY	MZ	My4	Mz4	Comb.
0	1	2037	0	-30	0	42	-1	--	--	2

X	cls	Nr	Vyr	Vzr	Mry	Mrz	MTrd	SF_V.	SF_M	SF_Mt	SF
cm		kg	kg	kg	kg*m	kg*m	kg*m				
0	1	52623	19341	19341	1818	1818	1566	>100	16.0	>100	16.0

Asta : 1127 [496 , 348]

Sez. G: O 114.3x5.9 L=248.8 cm Crit.: Acciaio_Flessione $\gamma_M=1.05$ $f_{yk}/\gamma_M=2619$ kg/cm² $f_t=4300$ kg/cm²

:Verificato

X	cls	N	TY	TZ	MT	MY	MZ	My4	Mz4	Comb.
cm		kg	kg	kg	kg*m	kg*m	kg*m			
249	1	1690	-5	1191	14	598	6	--	--	2

X	cls	Nr	Vyr	Vzr	Mry	Mrz	MTrd	SF_V.	SF_M	SF_Mt	SF
cm		kg	kg	kg	kg*m	kg*m	kg*m				
249	1	52623	19175	19175	1818	1818	1566	16.1	2.74	>100	2.74

Asta : 1128 [497 , 324]

Sez. G: O 114.3x5.9 L=169.9 cm Crit.: Acciaio_Flessione $\gamma_M=1.05$ $f_{yk}/\gamma_M=2619$ kg/cm² $f_t=4300$ kg/cm²

:Verificato

X	cls	N	TY	TZ	MT	MY	MZ	My4	Mz4	Comb.
cm		kg	kg	kg	kg*m	kg*m	kg*m			
0	1	-1763	19	77	72	-105	34	--	--	2

X	cls	Nr	Vyr	Vzr	Mry	Mrz	MTrd	SF_V.	SF_M	SF_Mt	SF
cm		kg	kg	kg	kg*m	kg*m	kg*m				
0	1	52623	18451	18451	1818	1818	1566	>100	9.11	21.7	9.11

Asta : 1129 [324 , 496]

Sez. G: O 114.3x5.9 L=169.9 cm Crit.: Acciaio_Flessione $\gamma_M=1.05$ $f_{yk}/\gamma_M=2619$ kg/cm² $f_t=4300$ kg/cm²

:Verificato

AUTOSTRADA VALDASTICO A31 NORD
1° LOTTO - PIOVENE ROCCHETTE – VALLE DELL'ASTICO

X	cls	N	TY	TZ	MT	MY	MZ	My4	Mz4	Comb.
cm		kg	kg	kg	kg*m	kg*m	kg*m			
170	1	-1927	-20	-77	-72	-105	34	--	--	2

X	cls	Nr	Vyr	Vzr	Mry	Mrz	MTrd	SF_V.	SF_M	SF_Mt	SF
cm		kg	kg	kg	kg*m	kg*m	kg*m				
170	1	52623	18455	18455	1818	1818	1566	>100	8.83	21.8	8.83

Asta : 1130 [305 , 495]

Sez. G: O 114.3x5.9 L=248.8 cm Crit.: Acciaio_Flessione $\gamma_M=1.05$ $f_{yk}/\gamma_M=2619$ kg/cm² $f_t=4300$ kg/cm²

:Verificato

X	cls	N	TY	TZ	MT	MY	MZ	My4	Mz4	Comb.
cm		kg	kg	kg	kg*m	kg*m	kg*m			
0	1	1548	2	-1167	3	572	3	--	--	2

X	cls	Nr	Vyr	Vzr	Mry	Mrz	MTrd	SF_V.	SF_M	SF_Mt	SF
cm		kg	kg	kg	kg*m	kg*m	kg*m				
0	1	52623	19301	19301	1818	1818	1566	16.5	2.89	>100	2.89

Asta : 1131 [495 , 496]

Sez. G: O 114.3x5.9 L=286.0 cm Crit.: Acciaio_Flessione $\gamma_M=1.05$ $f_{yk}/\gamma_M=2619$ kg/cm² $f_t=4300$ kg/cm²

:Verificato

X	cls	N	TY	TZ	MT	MY	MZ	My4	Mz4	Comb.
cm		kg	kg	kg	kg*m	kg*m	kg*m			
286	1	1234	3	50	-8	45	-6	--	--	2

X	cls	Nr	Vyr	Vzr	Mry	Mrz	MTrd	SF_V.	SF_M	SF_Mt	SF
cm		kg	kg	kg	kg*m	kg*m	kg*m				
286	1	52623	19247	19247	1818	1818	1566	>100	19.3	>100	19.3

Asta : 1132 [496 , 307]

AUTOSTRADA VALDASTICO A31 NORD
1° LOTTO - PIOVENE ROCCHETTE – VALLE DELL'ASTICO

Sez. G: O 114.3x5.9 L=169.9 cm Crit.: Acciaio_Flessione $\gamma_M=1.05$ $f_{yk}/\gamma_M=2619$ kg/cm² $f_t=4300$ kg/cm²

:Verificato

X	cls	N	TY	TZ	MT	MY	MZ	My4	Mz4	Comb.
cm		kg	kg	kg	kg*m	kg*m	kg*m			
0	1	-988	12	102	41	-107	24	--	--	2

X	cls	Nr	Vyr	Vzr	Mry	Mrz	MTrd	SF_V.	SF_M	SF_Mt	SF
cm		kg	kg	kg	kg*m	kg*m	kg*m				
0	1	52623	18833	18833	1818	1818	1566	>100	11.0	38.0	11.0

Asta : 1133 [307 , 495]

Sez. G: O 114.3x5.9 L=169.9 cm Crit.: Acciaio_Flessione $\gamma_M=1.05$ $f_{yk}/\gamma_M=2619$ kg/cm² $f_t=4300$ kg/cm²

:Verificato

X	cls	N	TY	TZ	MT	MY	MZ	My4	Mz4	Comb.
cm		kg	kg	kg	kg*m	kg*m	kg*m			
170	1	-2674	-22	-126	-39	-167	28	--	--	2

X	cls	Nr	Vyr	Vzr	Mry	Mrz	MTrd	SF_V.	SF_M	SF_Mt	SF
cm		kg	kg	kg	kg*m	kg*m	kg*m				
170	1	52623	18858	18858	1818	1818	1566	>100	6.34	40.0	6.34

Asta : 1134 [288 , 494]

Sez. G: O 114.3x5.9 L=248.8 cm Crit.: Acciaio_Flessione $\gamma_M=1.05$ $f_{yk}/\gamma_M=2619$ kg/cm² $f_t=4300$ kg/cm²

:Verificato

X	cls	N	TY	TZ	MT	MY	MZ	My4	Mz4	Comb.
cm		kg	kg	kg	kg*m	kg*m	kg*m			
0	1	1551	-2	-1167	-5	572	-2	--	--	2

X	cls	Nr	Vyr	Vzr	Mry	Mrz	MTrd	SF_V.	SF_M	SF_Mt	SF
cm		kg	kg	kg	kg*m	kg*m	kg*m				
0	1	52623	19284	19284	1818	1818	1566	16.5	2.89	>100	2.89

AUTOSTRADA VALDASTICO A31 NORD
1° LOTTO - PIOVENE ROCCHETTE – VALLE DELL'ASTICO

Asta : 1135 [494 , 495]

Sez. G: O 114.3x5.9 L=286.0 cm Crit.: Acciaio_Flessione $\gamma_M=1.05$ $f_{yk}/\gamma_M=2619$ kg/cm² $f_t=4300$ kg/cm²

:Verificato

X	cls	N	TY	TZ	MT	MY	MZ	My4	Mz4	Comb.
cm		kg	kg	kg	kg*m	kg*m	kg*m			
143	1	-1029	-0	1	1	-37	1	--	--	2

X	cls	Nr	Vyr	Vzr	Mry	Mrz	MTrd	SF_V.	SF_M	SF_Mt	SF
cm		kg	kg	kg	kg*m	kg*m	kg*m				
143	1	52623	19333	19333	1818	1818	1566	>100	24.6	>100	24.6

Asta : 1136 [495 , 290]

Sez. G: O 114.3x5.9 L=169.9 cm Crit.: Acciaio_Flessione $\gamma_M=1.05$ $f_{yk}/\gamma_M=2619$ kg/cm² $f_t=4300$ kg/cm²

:Verificato

X	cls	N	TY	TZ	MT	MY	MZ	My4	Mz4	Comb.
cm		kg	kg	kg	kg*m	kg*m	kg*m			
0	1	14	16	118	28	-162	19	--	--	2

X	cls	Nr	Vyr	Vzr	Mry	Mrz	MTrd	SF_V.	SF_M	SF_Mt	SF
cm		kg	kg	kg	kg*m	kg*m	kg*m				
0	1	52623	18997	18997	1818	1818	1566	>100	10.0	56.1	10.0

Asta : 1137 [290 , 494]

Sez. G: O 114.3x5.9 L=169.9 cm Crit.: Acciaio_Flessione $\gamma_M=1.05$ $f_{yk}/\gamma_M=2619$ kg/cm² $f_t=4300$ kg/cm²

:Verificato

X	cls	N	TY	TZ	MT	MY	MZ	My4	Mz4	Comb.
cm		kg	kg	kg	kg*m	kg*m	kg*m			
170	1	-469	-16	-120	-27	-163	19	--	--	2

X	cls	Nr	Vyr	Vzr	Mry	Mrz	MTrd	SF_V.	SF_M	SF_Mt	SF
cm		kg	kg	kg	kg*m	kg*m	kg*m				
170	1	52623	19011	19011	1818	1818	1566	>100	9.16	58.5	9.16

AUTOSTRADA VALDASTICO A31 NORD
1° LOTTO - PIOVENE ROCCHETTE – VALLE DELL'ASTICO

Asta : 1138 [271 , 493]

Sez. G: O 114.3x5.9 L=248.8 cm Crit.: Acciaio_Flessione $\gamma_M=1.05$ $f_{yk}/\gamma_M=2619$ kg/cmq $f_t=4300$ kg/cmq

:Verificato

X	cls	N	TY	TZ	MT	MY	MZ	My4	Mz4	Comb.
cm		kg	kg	kg	kg*m	kg*m	kg*m			
0	1	1621	3	-1187	-12	594	4	--	--	2

X	cls	Nr	Vyr	Vzr	Mry	Mrz	MTrd	SF_V.	SF_M	SF_Mt	SF
cm		kg	kg	kg	kg*m	kg*m	kg*m				
0	1	52623	19189	19189	1818	1818	1566	16.2	2.78	>100	2.78

Asta : 1139 [493 , 494]

Sez. G: O 114.3x5.9 L=286.0 cm Crit.: Acciaio_Flessione $\gamma_M=1.05$ $f_{yk}/\gamma_M=2619$ kg/cmq $f_t=4300$ kg/cmq

:Verificato

X	cls	N	TY	TZ	MT	MY	MZ	My4	Mz4	Comb.
cm		kg	kg	kg	kg*m	kg*m	kg*m			
0	1	432	-2	-46	9	33	-4	--	--	2

X	cls	Nr	Vyr	Vzr	Mry	Mrz	MTrd	SF_V.	SF_M	SF_Mt	SF
cm		kg	kg	kg	kg*m	kg*m	kg*m				
0	1	52623	19230	19230	1818	1818	1566	>100	35.0	>100	35.0

Asta : 1140 [494 , 273]

Sez. G: O 114.3x5.9 L=169.9 cm Crit.: Acciaio_Flessione $\gamma_M=1.05$ $f_{yk}/\gamma_M=2619$ kg/cmq $f_t=4300$ kg/cmq

:Verificato

X	cls	N	TY	TZ	MT	MY	MZ	My4	Mz4	Comb.
cm		kg	kg	kg	kg*m	kg*m	kg*m			
0	1	-2202	23	122	38	-168	28	--	--	2

X	cls	Nr	Vyr	Vzr	Mry	Mrz	MTrd	SF_V.	SF_M	SF_Mt	SF
cm		kg	kg	kg	kg*m	kg*m	kg*m				

AUTOSTRADA VALDASTICO A31 NORD
1° LOTTO - PIOVENE ROCCHETTE – VALLE DELL'ASTICO

X	cls	Nr	Vyr	Vzr	Mry	Mrz	MTrd	SF_V.	SF_M	SF_Mt	SF
0	1	52623	18876	18876	1818	1818	1566	>100	6.67	41.5	6.67

Asta : 1141 [273 , 493]

Sez. G: O 114.3x5.9 L=169.9 cm Crit.: Acciaio_Flessione $\gamma_M=1.05$ $f_{yk}/\gamma_M=2619$ kg/cm² $f_t=4300$ kg/cm²

:Verificato

X	cls	N	TY	TZ	MT	MY	MZ	My4	Mz4	Comb.
cm		kg	kg	kg	kg*m	kg*m	kg*m			
170	1	-1329	-8	-108	-38	-116	19	--	--	2

X	cls	Nr	Vyr	Vzr	Mry	Mrz	MTrd	SF_V.	SF_M	SF_Mt	SF
cm		kg	kg	kg	kg*m	kg*m	kg*m				
170	1	52623	18876	18876	1818	1818	1566	>100	10.0	41.5	10.0

Asta : 1142 [254 , 492]

Sez. G: O 114.3x5.9 L=248.8 cm Crit.: Acciaio_Flessione $\gamma_M=1.05$ $f_{yk}/\gamma_M=2619$ kg/cm² $f_t=4300$ kg/cm²

:Verificato

X	cls	N	TY	TZ	MT	MY	MZ	My4	Mz4	Comb.
cm		kg	kg	kg	kg*m	kg*m	kg*m			
0	1	1727	-9	-1195	16	600	-11	--	--	2

X	cls	Nr	Vyr	Vzr	Mry	Mrz	MTrd	SF_V.	SF_M	SF_Mt	SF
cm		kg	kg	kg	kg*m	kg*m	kg*m				
0	1	52623	19139	19139	1818	1818	1566	16.0	2.71	95.6	2.71

Asta : 1143 [492 , 493]

Sez. G: O 114.3x5.9 L=286.0 cm Crit.: Acciaio_Flessione $\gamma_M=1.05$ $f_{yk}/\gamma_M=2619$ kg/cm² $f_t=4300$ kg/cm²

:Verificato

X	cls	N	TY	TZ	MT	MY	MZ	My4	Mz4	Comb.
cm		kg	kg	kg	kg*m	kg*m	kg*m			
286	1	702	2	31	-3	31	-2	--	--	(12+13)-VIII-4

AUTOSTRADA VALDASTICO A31 NORD
1° LOTTO - PIOVENE ROCCHETTE – VALLE DELL'ASTICO

X	cls	Nr	Vyr	Vzr	Mry	Mrz	MTrd	SF_V.	SF_M	SF_Mt	SF
cm		kg	kg	kg	kg*m	kg*m	kg*m				
286	1	52623	19298	19298	1818	1818	1566	>100	31.3	>100	31.3

Asta : 1144 [493 , 256]

Sez. G: O 114.3x5.9 L=169.9 cm Crit.: Acciaio_Flessione $\gamma_M=1.05$ $f_{yk}/\gamma_M=2619$ kg/cm² $f_t=4300$ kg/cm²

:Verificato

X	cls	N	TY	TZ	MT	MY	MZ	My4	Mz4	Comb.
cm		kg	kg	kg	kg*m	kg*m	kg*m			
0	1	-1442	9	119	73	-128	28	--	--	2

X	cls	Nr	Vyr	Vzr	Mry	Mrz	MTrd	SF_V.	SF_M	SF_Mt	SF
cm		kg	kg	kg	kg*m	kg*m	kg*m				
0	1	52623	18440	18440	1818	1818	1566	>100	8.87	21.4	8.87

Asta : 1145 [256 , 492]

Sez. G: O 114.3x5.9 L=169.9 cm Crit.: Acciaio_Flessione $\gamma_M=1.05$ $f_{yk}/\gamma_M=2619$ kg/cm² $f_t=4300$ kg/cm²

:Verificato

X	cls	N	TY	TZ	MT	MY	MZ	My4	Mz4	Comb.
cm		kg	kg	kg	kg*m	kg*m	kg*m			
170	1	-1604	-36	-30	-64	-93	42	--	--	2

X	cls	Nr	Vyr	Vzr	Mry	Mrz	MTrd	SF_V.	SF_M	SF_Mt	SF
cm		kg	kg	kg	kg*m	kg*m	kg*m				
170	1	52623	18554	18554	1818	1818	1566	>100	9.53	24.6	9.53

Asta : 1146 [237 , 491]

Sez. G: O 114.3x5.9 L=248.8 cm Crit.: Acciaio_Flessione $\gamma_M=1.05$ $f_{yk}/\gamma_M=2619$ kg/cm² $f_t=4300$ kg/cm²

:Verificato

X	cls	N	TY	TZ	MT	MY	MZ	My4	Mz4	Comb.
cm		kg	kg	kg	kg*m	kg*m	kg*m			
0	1	1563	-4	-1167	7	570	-4	--	--	2

AUTOSTRADA VALDASTICO A31 NORD
1° LOTTO - PIOVENE ROCCHETTE – VALLE DELL'ASTICO

X	cls	Nr	Vyr	Vzr	Mry	Mrz	MTrd	SF_V.	SF_M	SF_Mt	SF
cm		kg	kg	kg	kg*m	kg*m	kg*m				
0	1	52623	19252	19252	1818	1818	1566	16.5	2.90	>100	2.90

Asta : 1147 [491 , 492]

Sez. G: O 114.3x5.9 L=286.0 cm Crit.: Acciaio_Flessione $\gamma_M=1.05$ $f_{yk}/\gamma_M=2619$ kg/cm² $f_t=4300$ kg/cm²

:Verificato

X	cls	N	TY	TZ	MT	MY	MZ	My4	Mz4	Comb.
cm		kg	kg	kg	kg*m	kg*m	kg*m			
286	1	344	4	42	-11	35	-8	--	--	2

X	cls	Nr	Vyr	Vzr	Mry	Mrz	MTrd	SF_V.	SF_M	SF_Mt	SF
cm		kg	kg	kg	kg*m	kg*m	kg*m				
286	1	52623	19209	19209	1818	1818	1566	>100	33.7	>100	33.7

Asta : 1148 [492 , 239]

Sez. G: O 114.3x5.9 L=169.9 cm Crit.: Acciaio_Flessione $\gamma_M=1.05$ $f_{yk}/\gamma_M=2619$ kg/cm² $f_t=4300$ kg/cm²

:Verificato

X	cls	N	TY	TZ	MT	MY	MZ	My4	Mz4	Comb.
cm		kg	kg	kg	kg*m	kg*m	kg*m			
0	1	-1417	23	103	40	-110	33	--	--	2

X	cls	Nr	Vyr	Vzr	Mry	Mrz	MTrd	SF_V.	SF_M	SF_Mt	SF
cm		kg	kg	kg	kg*m	kg*m	kg*m				
0	1	52623	18843	18843	1818	1818	1566	>100	9.49	38.8	9.49

Asta : 1149 [239 , 491]

Sez. G: O 114.3x5.9 L=169.9 cm Crit.: Acciaio_Flessione $\gamma_M=1.05$ $f_{yk}/\gamma_M=2619$ kg/cm² $f_t=4300$ kg/cm²

:Verificato

X	cls	N	TY	TZ	MT	MY	MZ	My4	Mz4	Comb.
cm		kg	kg	kg	kg*m	kg*m	kg*m			

AUTOSTRADA VALDASTICO A31 NORD
1° LOTTO - PIOVENE ROCCHETTE – VALLE DELL'ASTICO

X	cls	N	TY	TZ	MT	MY	MZ	My4	Mz4	Comb.
170	1	-2034	-29	-116	-44	-158	35	--	--	2

X	cls	Nr	Vyr	Vzr	Mry	Mrz	MTrd	SF_V.	SF_M	SF_Mt	SF
cm		kg	kg	kg	kg*m	kg*m	kg*m				
170	1	52623	18794	18794	1818	1818	1566	>100	6.89	35.3	6.89

Asta : 1150 [220 , 490]

Sez. G: O 114.3x5.9 L=248.8 cm Crit.: Acciaio_Flessione $\gamma_M=1.05$ $f_{yk}/\gamma_M=2619$ kg/cm² $f_t=4300$ kg/cm²

:Verificato

X	cls	N	TY	TZ	MT	MY	MZ	My4	Mz4	Comb.
cm		kg	kg	kg	kg*m	kg*m	kg*m			
0	1	1567	-6	-1168	-4	569	-7	--	--	2

X	cls	Nr	Vyr	Vzr	Mry	Mrz	MTrd	SF_V.	SF_M	SF_Mt	SF
cm		kg	kg	kg	kg*m	kg*m	kg*m				
0	1	52623	19291	19291	1818	1818	1566	16.5	2.88	>100	2.88

Asta : 1151 [490 , 491]

Sez. G: O 114.3x5.9 L=286.0 cm Crit.: Acciaio_Flessione $\gamma_M=1.05$ $f_{yk}/\gamma_M=2619$ kg/cm² $f_t=4300$ kg/cm²

:Verificato

X	cls	N	TY	TZ	MT	MY	MZ	My4	Mz4	Comb.
cm		kg	kg	kg	kg*m	kg*m	kg*m			
172	1	-796	0	-2	-3	-24	0	--	--	2

X	cls	Nr	Vyr	Vzr	Mry	Mrz	MTrd	SF_V.	SF_M	SF_Mt	SF
cm		kg	kg	kg	kg*m	kg*m	kg*m				
172	1	52623	19305	19305	1818	1818	1566	>100	35.4	>100	35.4

Asta : 1152 [491 , 222]

Sez. G: O 114.3x5.9 L=169.9 cm Crit.: Acciaio_Flessione $\gamma_M=1.05$ $f_{yk}/\gamma_M=2619$ kg/cm² $f_t=4300$ kg/cm²

:Verificato

AUTOSTRADA VALDASTICO A31 NORD
1° LOTTO - PIOVENE ROCCHETTE – VALLE DELL'ASTICO

X	cls	N	TY	TZ	MT	MY	MZ	My4	Mz4	Comb.
cm		kg	kg	kg	kg*m	kg*m	kg*m			
0	1	-683	27	113	31	-148	31	--	--	2

X	cls	Nr	Vyr	Vzr	Mry	Mrz	MTrd	SF_V.	SF_M	SF_Mt	SF
cm		kg	kg	kg	kg*m	kg*m	kg*m				
0	1	52623	18962	18962	1818	1818	1566	>100	9.01	51.0	9.01

Asta : 1153 [222 , 490]

Sez. G: O 114.3x5.9 L=169.9 cm Crit.: Acciaio_Flessione $\gamma_M=1.05$ $f_{yk}/\gamma_M=2619$ kg/cm² $f_t=4300$ kg/cm²

:Verificato

X	cls	N	TY	TZ	MT	MY	MZ	My4	Mz4	Comb.
cm		kg	kg	kg	kg*m	kg*m	kg*m			
170	1	55	-27	-101	-36	-137	32	--	--	2

X	cls	Nr	Vyr	Vzr	Mry	Mrz	MTrd	SF_V.	SF_M	SF_Mt	SF
cm		kg	kg	kg	kg*m	kg*m	kg*m				
170	1	52623	18893	18893	1818	1818	1566	>100	10.6	43.1	10.6

Asta : 1154 [203 , 489]

Sez. G: O 114.3x5.9 L=248.8 cm Crit.: Acciaio_Flessione $\gamma_M=1.05$ $f_{yk}/\gamma_M=2619$ kg/cm² $f_t=4300$ kg/cm²

:Verificato

X	cls	N	TY	TZ	MT	MY	MZ	My4	Mz4	Comb.
cm		kg	kg	kg	kg*m	kg*m	kg*m			
0	1	2489	4	-1627	-17	770	6	--	--	2

X	cls	Nr	Vyr	Vzr	Mry	Mrz	MTrd	SF_V.	SF_M	SF_Mt	SF
cm		kg	kg	kg	kg*m	kg*m	kg*m				
0	1	52623	19132	19132	1818	1818	1566	11.8	2.11	92.2	2.11

Asta : 1155 [489 , 490]

AUTOSTRADA VALDASTICO A31 NORD
1° LOTTO - PIOVENE ROCCHETTE – VALLE DELL'ASTICO

Sez. G: O 114.3x5.9 L=286.0 cm Crit.: Acciaio_Flessione $\gamma_M=1.05$ $f_{yk}/\gamma_M=2619$ kg/cm² $f_t=4300$ kg/cm²

:Verificato

X	cls	N	TY	TZ	MT	MY	MZ	My4	Mz4	Comb.
cm		kg	kg	kg	kg*m	kg*m	kg*m			
0	1	1598	-6	-50	-4	71	-11	--	--	2

X	cls	Nr	Vyr	Vzr	Mry	Mrz	MTrd	SF_V.	SF_M	SF_Mt	SF
cm		kg	kg	kg	kg*m	kg*m	kg*m				
0	1	52623	19297	19297	1818	1818	1566	>100	13.2	>100	13.2

Asta : 1156 [490 , 205]

Sez. G: O 114.3x5.9 L=169.9 cm Crit.: Acciaio_Flessione $\gamma_M=1.05$ $f_{yk}/\gamma_M=2619$ kg/cm² $f_t=4300$ kg/cm²

:Verificato

X	cls	N	TY	TZ	MT	MY	MZ	My4	Mz4	Comb.
cm		kg	kg	kg	kg*m	kg*m	kg*m			
0	1	-2794	41	129	54	-150	48	--	--	2

X	cls	Nr	Vyr	Vzr	Mry	Mrz	MTrd	SF_V.	SF_M	SF_Mt	SF
cm		kg	kg	kg	kg*m	kg*m	kg*m				
0	1	52623	18672	18672	1818	1818	1566	>100	6.17	28.9	6.17

Asta : 1157 [205 , 489]

Sez. G: O 114.3x5.9 L=169.9 cm Crit.: Acciaio_Flessione $\gamma_M=1.05$ $f_{yk}/\gamma_M=2619$ kg/cm² $f_t=4300$ kg/cm²

:Verificato

X	cls	N	TY	TZ	MT	MY	MZ	My4	Mz4	Comb.
cm		kg	kg	kg	kg*m	kg*m	kg*m			
170	1	-1450	-55	-118	-68	-124	70	--	--	2

X	cls	Nr	Vyr	Vzr	Mry	Mrz	MTrd	SF_V.	SF_M	SF_Mt	SF
cm		kg	kg	kg	kg*m	kg*m	kg*m				
170	1	52623	18504	18504	1818	1818	1566	>100	7.46	23.1	7.46

AUTOSTRADA VALDASTICO A31 NORD
1° LOTTO - PIOVENE ROCCHETTE – VALLE DELL'ASTICO

Asta : 1158 [444 , 488]

Sez. G: O 114.3x5.9 L=248.8 cm Crit.: Acciaio_Flessione $\gamma_M=1.05$ $f_{yk}/\gamma_M=2619$ kg/cm² $f_t=4300$ kg/cm²

:Verificato

X	cls	N	TY	TZ	MT	MY	MZ	My4	Mz4	Comb.
cm		kg	kg	kg	kg*m	kg*m	kg*m			
0	1	346	-5	-120	9	159	-6	--	--	2

X	cls	Nr	Vyr	Vzr	Mry	Mrz	MTrd	SF_V.	SF_M	SF_Mt	SF
cm		kg	kg	kg	kg*m	kg*m	kg*m				
0	1	52623	19225	19225	1818	1818	1566	>100	10.3	>100	10.3

Asta : 1159 [488 , 489]

Sez. G: O 114.3x5.9 L=266.5 cm Crit.: Acciaio_Flessione $\gamma_M=1.05$ $f_{yk}/\gamma_M=2619$ kg/cm² $f_t=4300$ kg/cm²

:Verificato

X	cls	N	TY	TZ	MT	MY	MZ	My4	Mz4	Comb.
cm		kg	kg	kg	kg*m	kg*m	kg*m			
0	1	2931	-5	-72	50	136	-7	--	--	2

X	cls	Nr	Vyr	Vzr	Mry	Mrz	MTrd	SF_V.	SF_M	SF_Mt	SF
cm		kg	kg	kg	kg*m	kg*m	kg*m				
0	1	52623	18729	18729	1818	1818	1566	>100	7.43	31.6	7.43

Asta : 1160 [489 , 196]

Sez. G: O 114.3x5.9 L=169.9 cm Crit.: Acciaio_Flessione $\gamma_M=1.05$ $f_{yk}/\gamma_M=2619$ kg/cm² $f_t=4300$ kg/cm²

:Verificato

X	cls	N	TY	TZ	MT	MY	MZ	My4	Mz4	Comb.
cm		kg	kg	kg	kg*m	kg*m	kg*m			
170	1	-2983	85	-21	84	-117	-55	--	--	2

X	cls	Nr	Vyr	Vzr	Mry	Mrz	MTrd	SF_V.	SF_M	SF_Mt	SF
cm		kg	kg	kg	kg*m	kg*m	kg*m				
170	1	52623	18300	18300	1818	1818	1566	>100	6.61	18.6	6.61

AUTOSTRADA VALDASTICO A31 NORD
1° LOTTO - PIOVENE ROCCHETTE – VALLE DELL'ASTICO

Asta : 1161 [196 , 488]

Sez. G: O 114.3x5.9 L=153.8 cm Crit.: Acciaio_Flessione $\gamma_M=1.05$ $f_{yk}/\gamma_M=2619$ kg/cmq $f_t=4300$ kg/cmq

:Verificato

X	cls	N	TY	TZ	MT	MY	MZ	My4	Mz4	Comb.
cm		kg	kg	kg	kg*m	kg*m	kg*m			
0	1	329	40	-111	-28	137	49	--	--	(12+13)-I-2

X	cls	Nr	Vyr	Vzr	Mry	Mrz	MTrd	SF_V.	SF_M	SF_Mt	SF
cm		kg	kg	kg	kg*m	kg*m	kg*m				
0	1	52623	18993	18993	1818	1818	1566	>100	9.19	55.5	9.19

Asta : 1162 [428 , 487]

Sez. G: O 114.3x5.9 L=248.8 cm Crit.: Acciaio_Flessione $\gamma_M=1.05$ $f_{yk}/\gamma_M=2619$ kg/cmq $f_t=4300$ kg/cmq

:Verificato

X	cls	N	TY	TZ	MT	MY	MZ	My4	Mz4	Comb.
cm		kg	kg	kg	kg*m	kg*m	kg*m			
0	1	2064	15	-1491	-8	676	16	--	--	2

X	cls	Nr	Vyr	Vzr	Mry	Mrz	MTrd	SF_V.	SF_M	SF_Mt	SF
cm		kg	kg	kg	kg*m	kg*m	kg*m				
0	1	52623	19241	19241	1818	1818	1566	12.9	2.38	>100	2.38

Asta : 1163 [487 , 488]

Sez. G: O 114.3x5.9 L=247.0 cm Crit.: Acciaio_Flessione $\gamma_M=1.05$ $f_{yk}/\gamma_M=2619$ kg/cmq $f_t=4300$ kg/cmq

:Verificato

X	cls	N	TY	TZ	MT	MY	MZ	My4	Mz4	Comb.
cm		kg	kg	kg	kg*m	kg*m	kg*m			
247	1	4407	-4	79	-37	135	0	--	--	2

X	cls	Nr	Vyr	Vzr	Mry	Mrz	MTrd	SF_V.	SF_M	SF_Mt	SF
cm		kg	kg	kg	kg*m	kg*m	kg*m				

AUTOSTRADA VALDASTICO A31 NORD
1° LOTTO - PIOVENE ROCCHETTE – VALLE DELL'ASTICO

X	cls	Nr	Vyr	Vzr	Mry	Mrz	MTrd	SF_V.	SF_M	SF_Mt	SF
247	1	52623	18885	18885	1818	1818	1566	>100	6.32	42.4	6.32

Asta : 1164 [488 , 427]

Sez. G: O 114.3x5.9 L=153.8 cm Crit.: Acciaio_Flessione $\gamma_M=1.05$ $f_{yk}/\gamma_M=2619$ kg/cm² $f_t=4300$ kg/cm²

:Verificato

X	cls	N	TY	TZ	MT	MY	MZ	My4	Mz4	Comb.
cm		kg	kg	kg	kg*m	kg*m	kg*m			
0	1	-1178	-16	-44	37	88	2	--	--	2

X	cls	Nr	Vyr	Vzr	Mry	Mrz	MTrd	SF_V.	SF_M	SF_Mt	SF
cm		kg	kg	kg	kg*m	kg*m	kg*m				
0	1	52623	18890	18890	1818	1818	1566	>100	13.9	42.8	13.9

Asta : 1165 [427 , 487]

Sez. G: O 114.3x5.9 L=153.8 cm Crit.: Acciaio_Flessione $\gamma_M=1.05$ $f_{yk}/\gamma_M=2619$ kg/cm² $f_t=4300$ kg/cm²

:Verificato

X	cls	N	TY	TZ	MT	MY	MZ	My4	Mz4	Comb.
cm		kg	kg	kg	kg*m	kg*m	kg*m			
154	1	-3840	-69	-140	-57	-151	72	--	--	2

X	cls	Nr	Vyr	Vzr	Mry	Mrz	MTrd	SF_V.	SF_M	SF_Mt	SF
cm		kg	kg	kg	kg*m	kg*m	kg*m				
154	1	52623	18643	18643	1818	1818	1566	>100	5.11	27.7	5.11

Asta : 1166 [416 , 486]

Sez. G: O 114.3x5.9 L=248.8 cm Crit.: Acciaio_Flessione $\gamma_M=1.05$ $f_{yk}/\gamma_M=2619$ kg/cm² $f_t=4300$ kg/cm²

:Verificato

X	cls	N	TY	TZ	MT	MY	MZ	My4	Mz4	Comb.
cm		kg	kg	kg	kg*m	kg*m	kg*m			
0	1	619	7	-521	-13	253	7	--	--	2

AUTOSTRADA VALDASTICO A31 NORD
1° LOTTO - PIOVENE ROCCHETTE – VALLE DELL'ASTICO

X	cls	Nr	Vyr	Vzr	Mry	Mrz	MTrd	SF_V.	SF_M	SF_Mt	SF
cm		kg	kg	kg	kg*m	kg*m	kg*m				
0	1	52623	19183	19183	1818	1818	1566	36.8	6.47	>100	6.47

Asta : 1167 [486 , 487]

Sez. G: O 114.3x5.9 L=247.0 cm Crit.: Acciaio_Flessione $\gamma_M=1.05$ $f_{yk}/\gamma_M=2619$ kg/cm² $f_t=4300$ kg/cm²

:Verificato

X	cls	N	TY	TZ	MT	MY	MZ	My4	Mz4	Comb.
cm		kg	kg	kg	kg*m	kg*m	kg*m			
247	1	926	-5	44	36	36	3	--	--	2

X	cls	Nr	Vyr	Vzr	Mry	Mrz	MTrd	SF_V.	SF_M	SF_Mt	SF
cm		kg	kg	kg	kg*m	kg*m	kg*m				
247	1	52623	18902	18902	1818	1818	1566	>100	25.6	44.0	25.6

Asta : 1168 [487 , 418]

Sez. G: O 114.3x5.9 L=153.8 cm Crit.: Acciaio_Flessione $\gamma_M=1.05$ $f_{yk}/\gamma_M=2619$ kg/cm² $f_t=4300$ kg/cm²

:Verificato

X	cls	N	TY	TZ	MT	MY	MZ	My4	Mz4	Comb.
cm		kg	kg	kg	kg*m	kg*m	kg*m			
0	1	506	57	141	55	-174	62	--	--	2

X	cls	Nr	Vyr	Vzr	Mry	Mrz	MTrd	SF_V.	SF_M	SF_Mt	SF
cm		kg	kg	kg	kg*m	kg*m	kg*m				
0	1	52623	18665	18665	1818	1818	1566	>100	7.15	28.6	7.15

Asta : 1169 [418 , 486]

Sez. G: O 114.3x5.9 L=153.8 cm Crit.: Acciaio_Flessione $\gamma_M=1.05$ $f_{yk}/\gamma_M=2619$ kg/cm² $f_t=4300$ kg/cm²

:Verificato

X	cls	N	TY	TZ	MT	MY	MZ	My4	Mz4	Comb.
cm		kg	kg	kg	kg*m	kg*m	kg*m			
154	1	-1121	-26	-104	-16	-91	26	--	--	2

AUTOSTRADA VALDASTICO A31 NORD
1° LOTTO - PIOVENE ROCCHETTE – VALLE DELL'ASTICO

X	cls	Nr	Vyr	Vzr	Mry	Mrz	MTrd	SF_V.	SF_M	SF_Mt	SF
cm		kg	kg	kg	kg*m	kg*m	kg*m				
154	1	52623	19146	19146	1818	1818	1566	>100	11.7	98.6	11.7

Asta : 1170 [417 , 517]

Sez. G: O 114.3x5.9 L=248.8 cm Crit.: Acciaio_Flessione $\gamma_M=1.05$ $f_{yk}/\gamma_M=2619$ kg/cm² $f_t=4300$ kg/cm²

:Verificato

X	cls	N	TY	TZ	MT	MY	MZ	My4	Mz4	Comb.
cm		kg	kg	kg	kg*m	kg*m	kg*m			
0	1	688	-7	-519	12	252	-6	--	--	2

X	cls	Nr	Vyr	Vzr	Mry	Mrz	MTrd	SF_V.	SF_M	SF_Mt	SF
cm		kg	kg	kg	kg*m	kg*m	kg*m				
0	1	52623	19196	19196	1818	1818	1566	37.0	6.46	>100	6.46

Asta : 1171 [517 , 503]

Sez. G: O 114.3x5.9 L=247.0 cm Crit.: Acciaio_Flessione $\gamma_M=1.05$ $f_{yk}/\gamma_M=2619$ kg/cm² $f_t=4300$ kg/cm²

:Verificato

X	cls	N	TY	TZ	MT	MY	MZ	My4	Mz4	Comb.
cm		kg	kg	kg	kg*m	kg*m	kg*m			
247	1	1208	5	52	-22	51	-3	--	--	2

X	cls	Nr	Vyr	Vzr	Mry	Mrz	MTrd	SF_V.	SF_M	SF_Mt	SF
cm		kg	kg	kg	kg*m	kg*m	kg*m				
247	1	52623	19072	19072	1818	1818	1566	>100	19.1	71.8	19.1

Asta : 1172 [503 , 442]

Sez. G: O 114.3x5.9 L=248.8 cm Crit.: Acciaio_Flessione $\gamma_M=1.05$ $f_{yk}/\gamma_M=2619$ kg/cm² $f_t=4300$ kg/cm²

:Verificato

X	cls	N	TY	TZ	MT	MY	MZ	My4	Mz4	Comb.
cm		kg	kg	kg	kg*m	kg*m	kg*m			

AUTOSTRADA VALDASTICO A31 NORD
1° LOTTO - PIOVENE ROCCHETTE – VALLE DELL'ASTICO

X	cls	N	TY	TZ	MT	MY	MZ	My4	Mz4	Comb.
249	1	1507	-12	1002	5	485	13	--	--	2

X	cls	Nr	Vyr	Vzr	Mry	Mrz	MTrd	SF_V.	SF_M	SF_Mt	SF
cm		kg	kg	kg	kg*m	kg*m	kg*m				
249	1	52623	19285	19285	1818	1818	1566	19.3	3.30	>100	3.30

Asta : 1173 [517 , 426]

Sez. G: O 114.3x5.9 L=153.8 cm Crit.: Acciaio_Flessione $\gamma_M=1.05$ $f_{yk}/\gamma_M=2619$ kg/cm² $f_t=4300$ kg/cm²

:Verificato

X	cls	N	TY	TZ	MT	MY	MZ	My4	Mz4	Comb.
cm		kg	kg	kg	kg*m	kg*m	kg*m			
0	1	-1286	27	88	14	-81	26	--	--	2

X	cls	Nr	Vyr	Vzr	Mry	Mrz	MTrd	SF_V.	SF_M	SF_Mt	SF
cm		kg	kg	kg	kg*m	kg*m	kg*m				
0	1	52623	19166	19166	1818	1818	1566	>100	12.0	>100	12.0

Asta : 1174 [426 , 503]

Sez. G: O 114.3x5.9 L=153.8 cm Crit.: Acciaio_Flessione $\gamma_M=1.05$ $f_{yk}/\gamma_M=2619$ kg/cm² $f_t=4300$ kg/cm²

:Verificato

X	cls	N	TY	TZ	MT	MY	MZ	My4	Mz4	Comb.
cm		kg	kg	kg	kg*m	kg*m	kg*m			
154	1	595	-35	-75	-42	-98	42	--	--	2

X	cls	Nr	Vyr	Vzr	Mry	Mrz	MTrd	SF_V.	SF_M	SF_Mt	SF
cm		kg	kg	kg	kg*m	kg*m	kg*m				
154	1	52623	18826	18826	1818	1818	1566	>100	11.3	37.5	11.3

Asta : 1175 [517 , 401]

Sez. G: O 114.3x5.9 L=153.8 cm Crit.: Acciaio_Flessione $\gamma_M=1.05$ $f_{yk}/\gamma_M=2619$ kg/cm² $f_t=4300$ kg/cm²

:Verificato

AUTOSTRADA VALDASTICO A31 NORD
1° LOTTO - PIOVENE ROCCHETTE – VALLE DELL'ASTICO

X	cls	N	TY	TZ	MT	MY	MZ	My4	Mz4	Comb.
cm		kg	kg	kg	kg*m	kg*m	kg*m			
0	1	237	-29	50	-15	-83	-27	--	--	2

X	cls	Nr	Vyr	Vzr	Mry	Mrz	MTrd	SF_V.	SF_M	SF_Mt	SF
cm		kg	kg	kg	kg*m	kg*m	kg*m				
0	1	52623	19160	19160	1818	1818	1566	>100	15.3	>100	15.3

Asta : 1176 [409 , 486]

Sez. G: O 114.3x5.9 L=153.8 cm Crit.: Acciaio_Flessione $\gamma_M=1.05$ $f_{yk}/\gamma_M=2619$ kg/cm² $f_t=4300$ kg/cm²

:Verificato

X	cls	N	TY	TZ	MT	MY	MZ	My4	Mz4	Comb.
cm		kg	kg	kg	kg*m	kg*m	kg*m			
154	1	54	29	-52	16	-86	-28	--	--	2

X	cls	Nr	Vyr	Vzr	Mry	Mrz	MTrd	SF_V.	SF_M	SF_Mt	SF
cm		kg	kg	kg	kg*m	kg*m	kg*m				
154	1	52623	19138	19138	1818	1818	1566	>100	15.8	95.0	15.8

Asta : 1177 [478 , 502]

Sez. G: O 114.3x5.9 L=160.6 cm Crit.: Acciaio_Flessione $\gamma_M=1.05$ $f_{yk}/\gamma_M=2619$ kg/cm² $f_t=4300$ kg/cm²

:Verificato

X	cls	N	TY	TZ	MT	MY	MZ	My4	Mz4	Comb.
cm		kg	kg	kg	kg*m	kg*m	kg*m			
161	1	627	-14	-39	-13	-57	17	--	--	2

X	cls	Nr	Vyr	Vzr	Mry	Mrz	MTrd	SF_V.	SF_M	SF_Mt	SF
cm		kg	kg	kg	kg*m	kg*m	kg*m				
161	1	52623	19177	19177	1818	1818	1566	>100	18.9	>100	18.9

Asta : 1178 [451 , 518]

AUTOSTRADA VALDASTICO A31 NORD
1° LOTTO - PIOVENE ROCCHETTE – VALLE DELL'ASTICO

Sez. G: O 114.3x5.9 L=248.8 cm Crit.: Acciaio_Flessione $\gamma M=1.05$ $f_{yk}/\gamma M=2619$ kg/cm² $f_t=4300$ kg/cm²

:Verificato

X	cls	N	TY	TZ	MT	MY	MZ	My4	Mz4	Comb.
cm		kg	kg	kg	kg*m	kg*m	kg*m			
0	1	1496	6	-1060	-10	529	7	--	--	2

X	cls	Nr	Vyr	Vzr	Mry	Mrz	MTrd	SF_V.	SF_M	SF_Mt	SF
cm		kg	kg	kg	kg*m	kg*m	kg*m				
0	1	52623	19214	19214	1818	1818	1566	18.1	3.09	>100	3.09

Asta : 1179 [518 , 503]

Sez. G: O 114.3x5.9 L=247.0 cm Crit.: Acciaio_Flessione $\gamma M=1.05$ $f_{yk}/\gamma M=2619$ kg/cm² $f_t=4300$ kg/cm²

:Verificato

X	cls	N	TY	TZ	MT	MY	MZ	My4	Mz4	Comb.
cm		kg	kg	kg	kg*m	kg*m	kg*m			
0	1	4023	2	-49	4	91	-1	--	--	2

X	cls	Nr	Vyr	Vzr	Mry	Mrz	MTrd	SF_V.	SF_M	SF_Mt	SF
cm		kg	kg	kg	kg*m	kg*m	kg*m				
0	1	52623	19288	19288	1818	1818	1566	>100	7.89	>100	7.89

Asta : 1180 [503 , 443]

Sez. G: O 114.3x5.9 L=153.8 cm Crit.: Acciaio_Flessione $\gamma M=1.05$ $f_{yk}/\gamma M=2619$ kg/cm² $f_t=4300$ kg/cm²

:Verificato

X	cls	N	TY	TZ	MT	MY	MZ	My4	Mz4	Comb.
cm		kg	kg	kg	kg*m	kg*m	kg*m			
0	1	-2921	47	88	47	-91	51	--	--	2

X	cls	Nr	Vyr	Vzr	Mry	Mrz	MTrd	SF_V.	SF_M	SF_Mt	SF
cm		kg	kg	kg	kg*m	kg*m	kg*m				
0	1	52623	18758	18758	1818	1818	1566	>100	7.48	33.1	7.48

AUTOSTRADA VALDASTICO A31 NORD
1° LOTTO - PIOVENE ROCCHETTE – VALLE DELL'ASTICO

Asta : 1181 [443 , 518]

Sez. G: O 114.3x5.9 L=153.8 cm Crit.: Acciaio_Flessione $\gamma_M=1.05$ $f_{yk}/\gamma_M=2619$ kg/cm² $f_t=4300$ kg/cm²

:Verificato

X	cls	N	TY	TZ	MT	MY	MZ	My4	Mz4	Comb.
cm		kg	kg	kg	kg*m	kg*m	kg*m			
0	1	-2219	-18	-115	-57	100	6	--	--	2

X	cls	Nr	Vyr	Vzr	Mry	Mrz	MTrd	SF_V.	SF_M	SF_Mt	SF
cm		kg	kg	kg	kg*m	kg*m	kg*m				
0	1	52623	18639	18639	1818	1818	1566	>100	9.95	27.5	9.95

Asta : 1182 [204 , 504]

Sez. G: O 114.3x5.9 L=248.8 cm Crit.: Acciaio_Flessione $\gamma_M=1.05$ $f_{yk}/\gamma_M=2619$ kg/cm² $f_t=4300$ kg/cm²

:Verificato

X	cls	N	TY	TZ	MT	MY	MZ	My4	Mz4	Comb.
cm		kg	kg	kg	kg*m	kg*m	kg*m			
0	1	1992	-8	-1173	20	594	-10	--	--	2

X	cls	Nr	Vyr	Vzr	Mry	Mrz	MTrd	SF_V.	SF_M	SF_Mt	SF
cm		kg	kg	kg	kg*m	kg*m	kg*m				
0	1	52623	19096	19096	1818	1818	1566	16.3	2.70	78.6	2.70

Asta : 1183 [504 , 518]

Sez. G: O 114.3x5.9 L=266.5 cm Crit.: Acciaio_Flessione $\gamma_M=1.05$ $f_{yk}/\gamma_M=2619$ kg/cm² $f_t=4300$ kg/cm²

:Verificato

X	cls	N	TY	TZ	MT	MY	MZ	My4	Mz4	Comb.
cm		kg	kg	kg	kg*m	kg*m	kg*m			
266	1	2219	6	52	-18	100	-9	--	--	2

X	cls	Nr	Vyr	Vzr	Mry	Mrz	MTrd	SF_V.	SF_M	SF_Mt	SF
cm		kg	kg	kg	kg*m	kg*m	kg*m				
266	1	52623	19117	19117	1818	1818	1566	>100	9.79	86.1	9.79

AUTOSTRADA VALDASTICO A31 NORD
1° LOTTO - PIOVENE ROCCHETTE – VALLE DELL'ASTICO

Asta : 1184 [518 , 188]

Sez. G: O 114.3x5.9 L=153.8 cm Crit.: Acciaio_Flessione $\gamma_M=1.05$ $f_{yk}/\gamma_M=2619$ kg/cmq $f_t=4300$ kg/cmq

:Verificato

X	cls	N	TY	TZ	MT	MY	MZ	My4	Mz4	Comb.
cm		kg	kg	kg	kg*m	kg*m	kg*m			
154	1	-1	-9	199	112	195	45	--	--	2

X	cls	Nr	Vyr	Vzr	Mry	Mrz	MTrd	SF_V.	SF_M	SF_Mt	SF
cm		kg	kg	kg	kg*m	kg*m	kg*m				
154	1	52623	17958	17958	1818	1818	1566	90.1	7.57	14.0	7.57

Asta : 1185 [188 , 504]

Sez. G: O 114.3x5.9 L=169.9 cm Crit.: Acciaio_Flessione $\gamma_M=1.05$ $f_{yk}/\gamma_M=2619$ kg/cmq $f_t=4300$ kg/cmq

:Verificato

X	cls	N	TY	TZ	MT	MY	MZ	My4	Mz4	Comb.
cm		kg	kg	kg	kg*m	kg*m	kg*m			
0	1	-1903	-72	98	-70	-180	-49	--	--	2

X	cls	Nr	Vyr	Vzr	Mry	Mrz	MTrd	SF_V.	SF_M	SF_Mt	SF
cm		kg	kg	kg	kg*m	kg*m	kg*m				
0	1	52623	18472	18472	1818	1818	1566	>100	6.16	22.3	6.16

Asta : 1186 [221 , 505]

Sez. G: O 114.3x5.9 L=248.8 cm Crit.: Acciaio_Flessione $\gamma_M=1.05$ $f_{yk}/\gamma_M=2619$ kg/cmq $f_t=4300$ kg/cmq

:Verificato

X	cls	N	TY	TZ	MT	MY	MZ	My4	Mz4	Comb.
cm		kg	kg	kg	kg*m	kg*m	kg*m			
0	1	1631	6	-1166	4	568	7	--	--	2

X	cls	Nr	Vyr	Vzr	Mry	Mrz	MTrd	SF_V.	SF_M	SF_Mt	SF
cm		kg	kg	kg	kg*m	kg*m	kg*m				

AUTOSTRADA VALDASTICO A31 NORD
1° LOTTO - PIOVENE ROCCHETTE – VALLE DELL'ASTICO

X	cls	Nr	Vyr	Vzr	Mry	Mrz	MTrd	SF_V.	SF_M	SF_Mt	SF
0	1	52623	19292	19292	1818	1818	1566	16.5	2.88	>100	2.88

Asta : 1187 [505 , 504]

Sez. G: O 114.3x5.9 L=286.0 cm Crit.: Acciaio_Flessione $\gamma_M=1.05$ $f_{yk}/\gamma_M=2619$ kg/cm² $f_t=4300$ kg/cm²

:Verificato

X	cls	N	TY	TZ	MT	MY	MZ	My4	Mz4	Comb.
cm		kg	kg	kg	kg*m	kg*m	kg*m			
286	1	1865	6	56	-7	85	-11	--	--	2

X	cls	Nr	Vyr	Vzr	Mry	Mrz	MTrd	SF_V.	SF_M	SF_Mt	SF
cm		kg	kg	kg	kg*m	kg*m	kg*m				
286	1	52623	19254	19254	1818	1818	1566	>100	11.3	>100	11.3

Asta : 1188 [504 , 213]

Sez. G: O 114.3x5.9 L=169.9 cm Crit.: Acciaio_Flessione $\gamma_M=1.05$ $f_{yk}/\gamma_M=2619$ kg/cm² $f_t=4300$ kg/cm²

:Verificato

X	cls	N	TY	TZ	MT	MY	MZ	My4	Mz4	Comb.
cm		kg	kg	kg	kg*m	kg*m	kg*m			
0	1	-1544	41	64	56	-57	55	--	--	2

X	cls	Nr	Vyr	Vzr	Mry	Mrz	MTrd	SF_V.	SF_M	SF_Mt	SF
cm		kg	kg	kg	kg*m	kg*m	kg*m				
0	1	52623	18652	18652	1818	1818	1566	>100	11.0	28.0	11.0

Asta : 1189 [213 , 505]

Sez. G: O 114.3x5.9 L=169.9 cm Crit.: Acciaio_Flessione $\gamma_M=1.05$ $f_{yk}/\gamma_M=2619$ kg/cm² $f_t=4300$ kg/cm²

:Verificato

X	cls	N	TY	TZ	MT	MY	MZ	My4	Mz4	Comb.
cm		kg	kg	kg	kg*m	kg*m	kg*m			
170	1	-2844	-40	-118	-53	-141	48	--	--	2

AUTOSTRADA VALDASTICO A31 NORD
1° LOTTO - PIOVENE ROCCHETTE – VALLE DELL'ASTICO

X	cls	Nr	Vyr	Vzr	Mry	Mrz	MTrd	SF_V.	SF_M	SF_Mt	SF
cm		kg	kg	kg	kg*m	kg*m	kg*m				
170	1	52623	18681	18681	1818	1818	1566	>100	6.34	29.3	6.34

Asta : 1190 [238 , 506]

Sez. G: O 114.3x5.9 L=248.8 cm Crit.: Acciaio_Flessione $\gamma_M=1.05$ $f_{yk}/\gamma_M=2619$ kg/cm² $f_t=4300$ kg/cm²

:Verificato

X	cls	N	TY	TZ	MT	MY	MZ	My4	Mz4	Comb.
cm		kg	kg	kg	kg*m	kg*m	kg*m			
0	1	1617	4	-1166	-8	570	4	--	--	2

X	cls	Nr	Vyr	Vzr	Mry	Mrz	MTrd	SF_V.	SF_M	SF_Mt	SF
cm		kg	kg	kg	kg*m	kg*m	kg*m				
0	1	52623	19243	19243	1818	1818	1566	16.5	2.89	>100	2.89

Asta : 1191 [506 , 505]

Sez. G: O 114.3x5.9 L=286.0 cm Crit.: Acciaio_Flessione $\gamma_M=1.05$ $f_{yk}/\gamma_M=2619$ kg/cm² $f_t=4300$ kg/cm²

:Verificato

X	cls	N	TY	TZ	MT	MY	MZ	My4	Mz4	Comb.
cm		kg	kg	kg	kg*m	kg*m	kg*m			
114	1	-640	-0	2	3	-23	0	--	--	2

X	cls	Nr	Vyr	Vzr	Mry	Mrz	MTrd	SF_V.	SF_M	SF_Mt	SF
cm		kg	kg	kg	kg*m	kg*m	kg*m				
114	1	52623	19307	19307	1818	1818	1566	>100	40.6	>100	40.6

Asta : 1192 [505 , 230]

Sez. G: O 114.3x5.9 L=169.9 cm Crit.: Acciaio_Flessione $\gamma_M=1.05$ $f_{yk}/\gamma_M=2619$ kg/cm² $f_t=4300$ kg/cm²

:Verificato

X	cls	N	TY	TZ	MT	MY	MZ	My4	Mz4	Comb.
cm		kg	kg	kg	kg*m	kg*m	kg*m			
0	1	135	26	98	36	-134	32	--	--	2

AUTOSTRADA VALDASTICO A31 NORD
1° LOTTO - PIOVENE ROCCHETTE – VALLE DELL'ASTICO

X	cls	Nr	Vyr	Vzr	Mry	Mrz	MTrd	SF_V.	SF_M	SF_Mt	SF
cm		kg	kg	kg	kg*m	kg*m	kg*m				
0	1	52623	18899	18899	1818	1818	1566	>100	10.7	43.7	10.7

Asta : 1193 [230 , 506]

Sez. G: O 114.3x5.9 L=169.9 cm Crit.: Acciaio_Flessione $\gamma_M=1.05$ $f_{yk}/\gamma_M=2619$ kg/cm² $f_t=4300$ kg/cm²

:Verificato

X	cls	N	TY	TZ	MT	MY	MZ	My4	Mz4	Comb.
cm		kg	kg	kg	kg*m	kg*m	kg*m			
170	1	-722	-27	-113	-31	-146	31	--	--	2

X	cls	Nr	Vyr	Vzr	Mry	Mrz	MTrd	SF_V.	SF_M	SF_Mt	SF
cm		kg	kg	kg	kg*m	kg*m	kg*m				
170	1	52623	18962	18962	1818	1818	1566	>100	9.02	51.0	9.02

Asta : 1194 [255 , 507]

Sez. G: O 114.3x5.9 L=248.8 cm Crit.: Acciaio_Flessione $\gamma_M=1.05$ $f_{yk}/\gamma_M=2619$ kg/cm² $f_t=4300$ kg/cm²

:Verificato

X	cls	N	TY	TZ	MT	MY	MZ	My4	Mz4	Comb.
cm		kg	kg	kg	kg*m	kg*m	kg*m			
0	1	1783	10	-1197	-18	602	12	--	--	2

X	cls	Nr	Vyr	Vzr	Mry	Mrz	MTrd	SF_V.	SF_M	SF_Mt	SF
cm		kg	kg	kg	kg*m	kg*m	kg*m				
0	1	52623	19125	19125	1818	1818	1566	16.0	2.69	89.3	2.69

Asta : 1195 [507 , 506]

Sez. G: O 114.3x5.9 L=286.0 cm Crit.: Acciaio_Flessione $\gamma_M=1.05$ $f_{yk}/\gamma_M=2619$ kg/cm² $f_t=4300$ kg/cm²

:Verificato

X	cls	N	TY	TZ	MT	MY	MZ	My4	Mz4	Comb.
cm		kg	kg	kg	kg*m	kg*m	kg*m			

AUTOSTRADA VALDASTICO A31 NORD
1° LOTTO - PIOVENE ROCCHETTE – VALLE DELL'ASTICO

X	cls	N	TY	TZ	MT	MY	MZ	My4	Mz4	Comb.
0	1	398	-4	-41	12	34	-8	--	--	2

X	cls	Nr	Vyr	Vzr	Mry	Mrz	MTrd	SF_V.	SF_M	SF_Mt	SF
cm		kg	kg	kg	kg*m	kg*m	kg*m				
0	1	52623	19197	19197	1818	1818	1566	>100	33.1	>100	33.1

Asta : 1196 [506 , 247]

Sez. G: O 114.3x5.9 L=169.9 cm Crit.: Acciaio_Flessione $\gamma_M=1.05$ $f_{yk}/\gamma_M=2619$ kg/cm² $f_t=4300$ kg/cm²

:Verificato

X	cls	N	TY	TZ	MT	MY	MZ	My4	Mz4	Comb.
cm		kg	kg	kg	kg*m	kg*m	kg*m			
0	1	-1950	29	114	45	-158	35	--	--	2

X	cls	Nr	Vyr	Vzr	Mry	Mrz	MTrd	SF_V.	SF_M	SF_Mt	SF
cm		kg	kg	kg	kg*m	kg*m	kg*m				
0	1	52623	18784	18784	1818	1818	1566	>100	6.99	34.7	6.99

Asta : 1197 [247 , 507]

Sez. G: O 114.3x5.9 L=169.9 cm Crit.: Acciaio_Flessione $\gamma_M=1.05$ $f_{yk}/\gamma_M=2619$ kg/cm² $f_t=4300$ kg/cm²

:Verificato

X	cls	N	TY	TZ	MT	MY	MZ	My4	Mz4	Comb.
cm		kg	kg	kg	kg*m	kg*m	kg*m			
170	1	-1657	-23	-104	-40	-110	32	--	--	2

X	cls	Nr	Vyr	Vzr	Mry	Mrz	MTrd	SF_V.	SF_M	SF_Mt	SF
cm		kg	kg	kg	kg*m	kg*m	kg*m				
170	1	52623	18848	18848	1818	1818	1566	>100	9.13	39.1	9.13

Asta : 1198 [272 , 508]

Sez. G: O 114.3x5.9 L=248.8 cm Crit.: Acciaio_Flessione $\gamma_M=1.05$ $f_{yk}/\gamma_M=2619$ kg/cm² $f_t=4300$ kg/cm²

:Verificato

AUTOSTRADA VALDASTICO A31 NORD
1° LOTTO - PIOVENE ROCCHETTE – VALLE DELL'ASTICO

X	cls	N	TY	TZ	MT	MY	MZ	My4	Mz4	Comb.
cm		kg	kg	kg	kg*m	kg*m	kg*m			
0	1	1680	-4	-1189	13	597	-6	--	--	2

X	cls	Nr	Vyr	Vzr	Mry	Mrz	MTrd	SF_V.	SF_M	SF_Mt	SF
cm		kg	kg	kg	kg*m	kg*m	kg*m				
0	1	52623	19176	19176	1818	1818	1566	16.1	2.75	>100	2.75

Asta : 1199 [508 , 507]

Sez. G: O 114.3x5.9 L=286.0 cm Crit.: Acciaio_Flessione $\gamma_M=1.05$ $f_{yk}/\gamma_M=2619$ kg/cm² $f_t=4300$ kg/cm²

:Verificato

X	cls	N	TY	TZ	MT	MY	MZ	My4	Mz4	Comb.
cm		kg	kg	kg	kg*m	kg*m	kg*m			
172	1	-1259	-1	4	1	-11	2	--	--	(12+13)-VIII-4

X	cls	Nr	Vyr	Vzr	Mry	Mrz	MTrd	SF_V.	SF_M	SF_Mt	SF
cm		kg	kg	kg	kg*m	kg*m	kg*m				
172	1	52623	19329	19329	1818	1818	1566	>100	31.8	>100	31.8

Asta : 1200 [507 , 264]

Sez. G: O 114.3x5.9 L=169.9 cm Crit.: Acciaio_Flessione $\gamma_M=1.05$ $f_{yk}/\gamma_M=2619$ kg/cm² $f_t=4300$ kg/cm²

:Verificato

X	cls	N	TY	TZ	MT	MY	MZ	My4	Mz4	Comb.
cm		kg	kg	kg	kg*m	kg*m	kg*m			
0	1	-1320	35	22	65	-90	42	--	--	2

X	cls	Nr	Vyr	Vzr	Mry	Mrz	MTrd	SF_V.	SF_M	SF_Mt	SF
cm		kg	kg	kg	kg*m	kg*m	kg*m				
0	1	52623	18535	18535	1818	1818	1566	>100	10.3	24.0	10.3

Asta : 1201 [264 , 508]

AUTOSTRADA VALDASTICO A31 NORD
1° LOTTO - PIOVENE ROCCHETTE – VALLE DELL'ASTICO

Sez. G: O 114.3x5.9 L=169.9 cm Crit.: Acciaio_Flessione $\gamma_M=1.05$ $f_{yk}/\gamma_M=2619$ kg/cmq $f_t=4300$ kg/cmq

:Verificato

X	cls	N	TY	TZ	MT	MY	MZ	My4	Mz4	Comb.
cm		kg	kg	kg	kg*m	kg*m	kg*m			
170	1	-1158	-8	-110	-74	-124	26	--	--	2

X	cls	Nr	Vyr	Vzr	Mry	Mrz	MTrd	SF_V.	SF_M	SF_Mt	SF
cm		kg	kg	kg	kg*m	kg*m	kg*m				
170	1	52623	18425	18425	1818	1818	1566	>100	9.55	21.1	9.55

Asta : 1202 [289 , 509]

Sez. G: O 114.3x5.9 L=248.8 cm Crit.: Acciaio_Flessione $\gamma_M=1.05$ $f_{yk}/\gamma_M=2619$ kg/cmq $f_t=4300$ kg/cmq

:Verificato

X	cls	N	TY	TZ	MT	MY	MZ	My4	Mz4	Comb.
cm		kg	kg	kg	kg*m	kg*m	kg*m			
0	1	1605	2	-1167	5	572	2	--	--	2

X	cls	Nr	Vyr	Vzr	Mry	Mrz	MTrd	SF_V.	SF_M	SF_Mt	SF
cm		kg	kg	kg	kg*m	kg*m	kg*m				
0	1	52623	19278	19278	1818	1818	1566	16.5	2.89	>100	2.89

Asta : 1203 [509 , 508]

Sez. G: O 114.3x5.9 L=286.0 cm Crit.: Acciaio_Flessione $\gamma_M=1.05$ $f_{yk}/\gamma_M=2619$ kg/cmq $f_t=4300$ kg/cmq

:Verificato

X	cls	N	TY	TZ	MT	MY	MZ	My4	Mz4	Comb.
cm		kg	kg	kg	kg*m	kg*m	kg*m			
286	1	488	2	45	-10	33	-4	--	--	2

X	cls	Nr	Vyr	Vzr	Mry	Mrz	MTrd	SF_V.	SF_M	SF_Mt	SF
cm		kg	kg	kg	kg*m	kg*m	kg*m				
286	1	52623	19220	19220	1818	1818	1566	>100	34.2	>100	34.2

AUTOSTRADA VALDASTICO A31 NORD
1° LOTTO - PIOVENE ROCCHETTE – VALLE DELL'ASTICO

Asta : 1204 [508 , 281]

Sez. G: O 114.3x5.9 L=169.9 cm Crit.: Acciaio_Flessione $\gamma_M=1.05$ $f_{yk}/\gamma_M=2619$ kg/cm² $f_t=4300$ kg/cm²

:Verificato

X	cls	N	TY	TZ	MT	MY	MZ	My4	Mz4	Comb.
cm		kg	kg	kg	kg*m	kg*m	kg*m			
0	1	-1572	8	109	38	-116	18	--	--	2

X	cls	Nr	Vyr	Vzr	Mry	Mrz	MTrd	SF_V.	SF_M	SF_Mt	SF
cm		kg	kg	kg	kg*m	kg*m	kg*m				
0	1	52623	18879	18879	1818	1818	1566	>100	9.63	41.8	9.63

Asta : 1205 [281 , 509]

Sez. G: O 114.3x5.9 L=169.9 cm Crit.: Acciaio_Flessione $\gamma_M=1.05$ $f_{yk}/\gamma_M=2619$ kg/cm² $f_t=4300$ kg/cm²

:Verificato

X	cls	N	TY	TZ	MT	MY	MZ	My4	Mz4	Comb.
cm		kg	kg	kg	kg*m	kg*m	kg*m			
170	1	-2136	-23	-121	-39	-167	28	--	--	2

X	cls	Nr	Vyr	Vzr	Mry	Mrz	MTrd	SF_V.	SF_M	SF_Mt	SF
cm		kg	kg	kg	kg*m	kg*m	kg*m				
170	1	52623	18866	18866	1818	1818	1566	>100	6.75	40.7	6.75

Asta : 1206 [306 , 510]

Sez. G: O 114.3x5.9 L=248.8 cm Crit.: Acciaio_Flessione $\gamma_M=1.05$ $f_{yk}/\gamma_M=2619$ kg/cm² $f_t=4300$ kg/cm²

:Verificato

X	cls	N	TY	TZ	MT	MY	MZ	My4	Mz4	Comb.
cm		kg	kg	kg	kg*m	kg*m	kg*m			
0	1	1602	-2	-1167	-4	572	-2	--	--	2

X	cls	Nr	Vyr	Vzr	Mry	Mrz	MTrd	SF_V.	SF_M	SF_Mt	SF
cm		kg	kg	kg	kg*m	kg*m	kg*m				
0	1	52623	19296	19296	1818	1818	1566	16.5	2.89	>100	2.89

AUTOSTRADA VALDASTICO A31 NORD
1° LOTTO - PIOVENE ROCCHETTE – VALLE DELL'ASTICO

Asta : 1207 [510 , 509]

Sez. G: O 114.3x5.9 L=286.0 cm Crit.: Acciaio_Flessione $\gamma_M=1.05$ $f_{yk}/\gamma_M=2619$ kg/cmq $f_t=4300$ kg/cmq

:Verificato

X	cls	N	TY	TZ	MT	MY	MZ	My4	Mz4	Comb.
cm		kg	kg	kg	kg*m	kg*m	kg*m			
143	1	-900	0	-1	-1	-36	1	--	--	2

X	cls	Nr	Vyr	Vzr	Mry	Mrz	MTrd	SF_V.	SF_M	SF_Mt	SF
cm		kg	kg	kg	kg*m	kg*m	kg*m				
143	1	52623	19332	19332	1818	1818	1566	>100	26.8	>100	26.8

Asta : 1208 [509 , 298]

Sez. G: O 114.3x5.9 L=169.9 cm Crit.: Acciaio_Flessione $\gamma_M=1.05$ $f_{yk}/\gamma_M=2619$ kg/cmq $f_t=4300$ kg/cmq

:Verificato

X	cls	N	TY	TZ	MT	MY	MZ	My4	Mz4	Comb.
cm		kg	kg	kg	kg*m	kg*m	kg*m			
0	1	-489	16	119	27	-161	20	--	--	2

X	cls	Nr	Vyr	Vzr	Mry	Mrz	MTrd	SF_V.	SF_M	SF_Mt	SF
cm		kg	kg	kg	kg*m	kg*m	kg*m				
0	1	52623	19009	19009	1818	1818	1566	>100	9.20	58.1	9.20

Asta : 1209 [298 , 510]

Sez. G: O 114.3x5.9 L=169.9 cm Crit.: Acciaio_Flessione $\gamma_M=1.05$ $f_{yk}/\gamma_M=2619$ kg/cmq $f_t=4300$ kg/cmq

:Verificato

X	cls	N	TY	TZ	MT	MY	MZ	My4	Mz4	Comb.
cm		kg	kg	kg	kg*m	kg*m	kg*m			
170	1	-2	-16	-117	-28	-160	20	--	--	2

X	cls	Nr	Vyr	Vzr	Mry	Mrz	MTrd	SF_V.	SF_M	SF_Mt	SF
cm		kg	kg	kg	kg*m	kg*m	kg*m				

AUTOSTRADA VALDASTICO A31 NORD
1° LOTTO - PIOVENE ROCCHETTE – VALLE DELL'ASTICO

X	cls	Nr	Vyr	Vzr	Mry	Mrz	MTrd	SF_V.	SF_M	SF_Mt	SF
170	1	52623	18994	18994	1818	1818	1566	>100	10.1	55.6	10.1

Asta : 1210 [349 , 511]

Sez. G: O 114.3x5.9 L=248.8 cm Crit.: Acciaio_Flessione $\gamma_M=1.05$ $f_{yk}/\gamma_M=2619$ kg/cm² $f_t=4300$ kg/cm²

:Verificato

X	cls	N	TY	TZ	MT	MY	MZ	My4	Mz4	Comb.
cm		kg	kg	kg	kg*m	kg*m	kg*m			
0	1	1746	6	-1193	-14	600	7	--	--	2

X	cls	Nr	Vyr	Vzr	Mry	Mrz	MTrd	SF_V.	SF_M	SF_Mt	SF
cm		kg	kg	kg	kg*m	kg*m	kg*m				
0	1	52623	19164	19164	1818	1818	1566	16.1	2.72	>100	2.72

Asta : 1211 [511 , 510]

Sez. G: O 114.3x5.9 L=286.0 cm Crit.: Acciaio_Flessione $\gamma_M=1.05$ $f_{yk}/\gamma_M=2619$ kg/cm² $f_t=4300$ kg/cm²

:Verificato

X	cls	N	TY	TZ	MT	MY	MZ	My4	Mz4	Comb.
cm		kg	kg	kg	kg*m	kg*m	kg*m			
0	1	1299	-3	-49	8	45	-6	--	--	2

X	cls	Nr	Vyr	Vzr	Mry	Mrz	MTrd	SF_V.	SF_M	SF_Mt	SF
cm		kg	kg	kg	kg*m	kg*m	kg*m				
0	1	52623	19237	19237	1818	1818	1566	>100	19.0	>100	19.0

Asta : 1212 [510 , 315]

Sez. G: O 114.3x5.9 L=169.9 cm Crit.: Acciaio_Flessione $\gamma_M=1.05$ $f_{yk}/\gamma_M=2619$ kg/cm² $f_t=4300$ kg/cm²

:Verificato

X	cls	N	TY	TZ	MT	MY	MZ	My4	Mz4	Comb.
cm		kg	kg	kg	kg*m	kg*m	kg*m			
0	1	-2614	22	125	40	-165	28	--	--	2

AUTOSTRADA VALDASTICO A31 NORD
1° LOTTO - PIOVENE ROCCHETTE – VALLE DELL'ASTICO

X	cls	Nr	Vyr	Vzr	Mry	Mrz	MTrd	SF_V.	SF_M	SF_Mt	SF
cm		kg	kg	kg	kg*m	kg*m	kg*m				
0	1	52623	18849	18849	1818	1818	1566	>100	6.40	39.2	6.40

Asta : 1213 [315 , 511]

Sez. G: O 114.3x5.9 L=169.9 cm Crit.: Acciaio_Flessione $\gamma_M=1.05$ $f_{yk}/\gamma_M=2619$ kg/cm² $f_t=4300$ kg/cm²

:Verificato

X	cls	N	TY	TZ	MT	MY	MZ	My4	Mz4	Comb.
cm		kg	kg	kg	kg*m	kg*m	kg*m			
170	1	-1202	-12	-103	-41	-107	23	--	--	2

X	cls	Nr	Vyr	Vzr	Mry	Mrz	MTrd	SF_V.	SF_M	SF_Mt	SF
cm		kg	kg	kg	kg*m	kg*m	kg*m				
170	1	52623	18835	18835	1818	1818	1566	>100	10.6	38.2	10.6

Asta : 1214 [332 , 512]

Sez. G: O 114.3x5.9 L=248.8 cm Crit.: Acciaio_Flessione $\gamma_M=1.05$ $f_{yk}/\gamma_M=2619$ kg/cm² $f_t=4300$ kg/cm²

:Verificato

X	cls	N	TY	TZ	MT	MY	MZ	My4	Mz4	Comb.
cm		kg	kg	kg	kg*m	kg*m	kg*m			
0	1	1749	-6	-1193	15	600	-7	--	--	2

X	cls	Nr	Vyr	Vzr	Mry	Mrz	MTrd	SF_V.	SF_M	SF_Mt	SF
cm		kg	kg	kg	kg*m	kg*m	kg*m				
0	1	52623	19161	19161	1818	1818	1566	16.1	2.72	>100	2.72

Asta : 1215 [512 , 511]

Sez. G: O 114.3x5.9 L=286.0 cm Crit.: Acciaio_Flessione $\gamma_M=1.05$ $f_{yk}/\gamma_M=2619$ kg/cm² $f_t=4300$ kg/cm²

:Verificato

X	cls	N	TY	TZ	MT	MY	MZ	My4	Mz4	Comb.
cm		kg	kg	kg	kg*m	kg*m	kg*m			
0	1	1708	-0	-30	-0	39	1	--	--	2

AUTOSTRADA VALDASTICO A31 NORD
1° LOTTO - PIOVENE ROCCHETTE – VALLE DELL'ASTICO

X	cls	Nr	Vyr	Vzr	Mry	Mrz	MTrd	SF_V.	SF_M	SF_Mt	SF
cm		kg	kg	kg	kg*m	kg*m	kg*m				
0	1	52623	19340	19340	1818	1818	1566	>100	18.3	>100	18.3

Asta : 1216 [511 , 316]

Sez. G: O 114.3x5.9 L=169.9 cm Crit.: Acciaio_Flessione $\gamma_M=1.05$ $f_{yk}/\gamma_M=2619$ kg/cm² $f_t=4300$ kg/cm²

:Verificato

X	cls	N	TY	TZ	MT	MY	MZ	My4	Mz4	Comb.
cm		kg	kg	kg	kg*m	kg*m	kg*m			
0	1	-1670	20	70	73	-102	34	--	--	2

X	cls	Nr	Vyr	Vzr	Mry	Mrz	MTrd	SF_V.	SF_M	SF_Mt	SF
cm		kg	kg	kg	kg*m	kg*m	kg*m				
0	1	52623	18436	18436	1818	1818	1566	>100	9.40	21.4	9.40

Asta : 1217 [316 , 512]

Sez. G: O 114.3x5.9 L=169.9 cm Crit.: Acciaio_Flessione $\gamma_M=1.05$ $f_{yk}/\gamma_M=2619$ kg/cm² $f_t=4300$ kg/cm²

:Verificato

X	cls	N	TY	TZ	MT	MY	MZ	My4	Mz4	Comb.
cm		kg	kg	kg	kg*m	kg*m	kg*m			
170	1	-1511	-18	-68	-73	-101	33	--	--	2

X	cls	Nr	Vyr	Vzr	Mry	Mrz	MTrd	SF_V.	SF_M	SF_Mt	SF
cm		kg	kg	kg	kg*m	kg*m	kg*m				
170	1	52623	18437	18437	1818	1818	1566	>100	9.76	21.4	9.76

Asta : 1218 [357 , 513]

Sez. G: O 114.3x5.9 L=248.8 cm Crit.: Acciaio_Flessione $\gamma_M=1.05$ $f_{yk}/\gamma_M=2619$ kg/cm² $f_t=4300$ kg/cm²

:Verificato

X	cls	N	TY	TZ	MT	MY	MZ	My4	Mz4	Comb.
cm		kg	kg	kg	kg*m	kg*m	kg*m			

AUTOSTRADA VALDASTICO A31 NORD
1° LOTTO - PIOVENE ROCCHETTE – VALLE DELL'ASTICO

X	cls	N	TY	TZ	MT	MY	MZ	My4	Mz4	Comb.
0	1	1600	3	-1166	4	572	3	--	--	2

X	cls	Nr	Vyr	Vzr	Mry	Mrz	MTrd	SF_V.	SF_M	SF_Mt	SF
cm		kg	kg	kg	kg*m	kg*m	kg*m				
0	1	52623	19297	19297	1818	1818	1566	16.5	2.88	>100	2.88

Asta : 1219 [513 , 512]

Sez. G: O 114.3x5.9 L=286.0 cm Crit.: Acciaio_Flessione $\gamma_M=1.05$ $f_{yk}/\gamma_M=2619$ kg/cm² $f_t=4300$ kg/cm²

:Verificato

X	cls	N	TY	TZ	MT	MY	MZ	My4	Mz4	Comb.
cm		kg	kg	kg	kg*m	kg*m	kg*m			
286	1	1567	3	49	-8	46	-6	--	--	2

X	cls	Nr	Vyr	Vzr	Mry	Mrz	MTrd	SF_V.	SF_M	SF_Mt	SF
cm		kg	kg	kg	kg*m	kg*m	kg*m				
286	1	52623	19240	19240	1818	1818	1566	>100	17.2	>100	17.2

Asta : 1220 [512 , 341]

Sez. G: O 114.3x5.9 L=169.9 cm Crit.: Acciaio_Flessione $\gamma_M=1.05$ $f_{yk}/\gamma_M=2619$ kg/cm² $f_t=4300$ kg/cm²

:Verificato

X	cls	N	TY	TZ	MT	MY	MZ	My4	Mz4	Comb.
cm		kg	kg	kg	kg*m	kg*m	kg*m			
0	1	-1362	11	103	41	-107	23	--	--	2

X	cls	Nr	Vyr	Vzr	Mry	Mrz	MTrd	SF_V.	SF_M	SF_Mt	SF
cm		kg	kg	kg	kg*m	kg*m	kg*m				
0	1	52623	18832	18832	1818	1818	1566	>100	10.3	37.9	10.3

Asta : 1221 [341 , 513]

Sez. G: O 114.3x5.9 L=169.9 cm Crit.: Acciaio_Flessione $\gamma_M=1.05$ $f_{yk}/\gamma_M=2619$ kg/cm² $f_t=4300$ kg/cm²

:Verificato

AUTOSTRADA VALDASTICO A31 NORD
1° LOTTO - PIOVENE ROCCHETTE – VALLE DELL'ASTICO

X	cls	N	TY	TZ	MT	MY	MZ	My4	Mz4	Comb.
cm		kg	kg	kg	kg*m	kg*m	kg*m			
170	1	-2472	-21	-126	-40	-165	28	--	--	2

X	cls	Nr	Vyr	Vzr	Mry	Mrz	MTrd	SF_V.	SF_M	SF_Mt	SF
cm		kg	kg	kg	kg*m	kg*m	kg*m				
170	1	52623	18846	18846	1818	1818	1566	>100	6.54	39.0	6.54

Asta : 1222 [374 , 519]

Sez. G: O 114.3x5.9 L=248.8 cm Crit.: Acciaio_Flessione $\gamma_M=1.05$ $f_{yk}/\gamma_M=2619$ kg/cm² $f_t=4300$ kg/cm²

:Verificato

X	cls	N	TY	TZ	MT	MY	MZ	My4	Mz4	Comb.
cm		kg	kg	kg	kg*m	kg*m	kg*m			
0	1	1591	-1	-1166	-5	572	-1	--	--	2

X	cls	Nr	Vyr	Vzr	Mry	Mrz	MTrd	SF_V.	SF_M	SF_Mt	SF
cm		kg	kg	kg	kg*m	kg*m	kg*m				
0	1	52623	19276	19276	1818	1818	1566	16.5	2.89	>100	2.89

Asta : 1223 [519 , 513]

Sez. G: O 114.3x5.9 L=286.0 cm Crit.: Acciaio_Flessione $\gamma_M=1.05$ $f_{yk}/\gamma_M=2619$ kg/cm² $f_t=4300$ kg/cm²

:Verificato

X	cls	N	TY	TZ	MT	MY	MZ	My4	Mz4	Comb.
cm		kg	kg	kg	kg*m	kg*m	kg*m			
143	1	-398	-0	2	1	-34	1	--	--	2

X	cls	Nr	Vyr	Vzr	Mry	Mrz	MTrd	SF_V.	SF_M	SF_Mt	SF
cm		kg	kg	kg	kg*m	kg*m	kg*m				
143	1	52623	19326	19326	1818	1818	1566	>100	37.4	>100	37.4

Asta : 1224 [513 , 366]

AUTOSTRADA VALDASTICO A31 NORD
1° LOTTO - PIOVENE ROCCHETTE – VALLE DELL'ASTICO

Sez. G: O 114.3x5.9 L=169.9 cm Crit.: Acciaio_Flessione $\gamma_M=1.05$ $f_{yk}/\gamma_M=2619$ kg/cmq $f_t=4300$ kg/cmq

:Verificato

X	cls	N	TY	TZ	MT	MY	MZ	My4	Mz4	Comb.
cm		kg	kg	kg	kg*m	kg*m	kg*m			
0	1	-137	14	119	29	-160	19	--	--	2

X	cls	Nr	Vyr	Vzr	Mry	Mrz	MTrd	SF_V.	SF_M	SF_Mt	SF
cm		kg	kg	kg	kg*m	kg*m	kg*m				
0	1	52623	18988	18988	1818	1818	1566	>100	9.88	54.7	9.88

Asta : 1225 [366 , 519]

Sez. G: O 114.3x5.9 L=169.9 cm Crit.: Acciaio_Flessione $\gamma_M=1.05$ $f_{yk}/\gamma_M=2619$ kg/cmq $f_t=4300$ kg/cmq

:Verificato

X	cls	N	TY	TZ	MT	MY	MZ	My4	Mz4	Comb.
cm		kg	kg	kg	kg*m	kg*m	kg*m			
170	1	-356	-14	-123	-27	-162	19	--	--	2

X	cls	Nr	Vyr	Vzr	Mry	Mrz	MTrd	SF_V.	SF_M	SF_Mt	SF
cm		kg	kg	kg	kg*m	kg*m	kg*m				
170	1	52623	19010	19010	1818	1818	1566	>100	9.42	58.3	9.42

Asta : 1226 [391 , 514]

Sez. G: O 114.3x5.9 L=248.8 cm Crit.: Acciaio_Flessione $\gamma_M=1.05$ $f_{yk}/\gamma_M=2619$ kg/cmq $f_t=4300$ kg/cmq

:Verificato

X	cls	N	TY	TZ	MT	MY	MZ	My4	Mz4	Comb.
cm		kg	kg	kg	kg*m	kg*m	kg*m			
0	1	1658	3	-1164	-14	583	4	--	--	2

X	cls	Nr	Vyr	Vzr	Mry	Mrz	MTrd	SF_V.	SF_M	SF_Mt	SF
cm		kg	kg	kg	kg*m	kg*m	kg*m				
0	1	52623	19174	19174	1818	1818	1566	16.5	2.82	>100	2.82

AUTOSTRADA VALDASTICO A31 NORD
1° LOTTO - PIOVENE ROCCHETTE – VALLE DELL'ASTICO

Asta : 1227 [514 , 519]

Sez. G: O 114.3x5.9 L=286.0 cm Crit.: Acciaio_Flessione $\gamma_M=1.05$ $f_{yk}/\gamma_M=2619$ kg/cm² $f_t=4300$ kg/cm²

:Verificato

X	cls	N	TY	TZ	MT	MY	MZ	My4	Mz4	Comb.
cm		kg	kg	kg	kg*m	kg*m	kg*m			
0	1	1188	-3	-46	10	35	-6	--	--	2

X	cls	Nr	Vyr	Vzr	Mry	Mrz	MTrd	SF_V.	SF_M	SF_Mt	SF
cm		kg	kg	kg	kg*m	kg*m	kg*m				
0	1	52623	19215	19215	1818	1818	1566	>100	22.1	>100	22.1

Asta : 1228 [519 , 383]

Sez. G: O 114.3x5.9 L=169.9 cm Crit.: Acciaio_Flessione $\gamma_M=1.05$ $f_{yk}/\gamma_M=2619$ kg/cm² $f_t=4300$ kg/cm²

:Verificato

X	cls	N	TY	TZ	MT	MY	MZ	My4	Mz4	Comb.
cm		kg	kg	kg	kg*m	kg*m	kg*m			
0	1	-2237	21	127	39	-170	27	--	--	2

X	cls	Nr	Vyr	Vzr	Mry	Mrz	MTrd	SF_V.	SF_M	SF_Mt	SF
cm		kg	kg	kg	kg*m	kg*m	kg*m				
0	1	52623	18861	18861	1818	1818	1566	>100	6.63	40.2	6.63

Asta : 1229 [383 , 514]

Sez. G: O 114.3x5.9 L=169.9 cm Crit.: Acciaio_Flessione $\gamma_M=1.05$ $f_{yk}/\gamma_M=2619$ kg/cm² $f_t=4300$ kg/cm²

:Verificato

X	cls	N	TY	TZ	MT	MY	MZ	My4	Mz4	Comb.
cm		kg	kg	kg	kg*m	kg*m	kg*m			
170	1	-1200	-9	-109	-37	-115	20	--	--	2

X	cls	Nr	Vyr	Vzr	Mry	Mrz	MTrd	SF_V.	SF_M	SF_Mt	SF
cm		kg	kg	kg	kg*m	kg*m	kg*m				
170	1	52623	18887	18887	1818	1818	1566	>100	10.3	42.5	10.3

AUTOSTRADA VALDASTICO A31 NORD
1° LOTTO - PIOVENE ROCCHETTE – VALLE DELL'ASTICO

Asta : 1230 [468 , 515]

Sez. G: O 114.3x5.9 L=248.8 cm Crit.: Acciaio_Flessione $\gamma_M=1.05$ $f_{yk}/\gamma_M=2619$ kg/cmq $f_t=4300$ kg/cmq

:Verificato

X	cls	N	TY	TZ	MT	MY	MZ	My4	Mz4	Comb.
cm		kg	kg	kg	kg*m	kg*m	kg*m			
0	1	1632	-10	-1118	13	559	-12	--	--	2

X	cls	Nr	Vyr	Vzr	Mry	Mrz	MTrd	SF_V.	SF_M	SF_Mt	SF
cm		kg	kg	kg	kg*m	kg*m	kg*m				
0	1	52623	19178	19178	1818	1818	1566	17.1	2.90	>100	2.90

Asta : 1231 [515 , 514]

Sez. G: O 114.3x5.9 L=274.8 cm Crit.: Acciaio_Flessione $\gamma_M=1.05$ $f_{yk}/\gamma_M=2619$ kg/cmq $f_t=4300$ kg/cmq

:Verificato

X	cls	N	TY	TZ	MT	MY	MZ	My4	Mz4	Comb.
cm		kg	kg	kg	kg*m	kg*m	kg*m			
0	1	1569	-1	-27	2	32	-3	--	--	(12+13)-VI-3

X	cls	Nr	Vyr	Vzr	Mry	Mrz	MTrd	SF_V.	SF_M	SF_Mt	SF
cm		kg	kg	kg	kg*m	kg*m	kg*m				
0	1	52623	19318	19318	1818	1818	1566	>100	20.4	>100	20.4

Asta : 1232 [514 , 400]

Sez. G: O 114.3x5.9 L=169.9 cm Crit.: Acciaio_Flessione $\gamma_M=1.05$ $f_{yk}/\gamma_M=2619$ kg/cmq $f_t=4300$ kg/cmq

:Verificato

X	cls	N	TY	TZ	MT	MY	MZ	My4	Mz4	Comb.
cm		kg	kg	kg	kg*m	kg*m	kg*m			
0	1	-1517	21	94	69	-115	34	--	--	2

X	cls	Nr	Vyr	Vzr	Mry	Mrz	MTrd	SF_V.	SF_M	SF_Mt	SF
cm		kg	kg	kg	kg*m	kg*m	kg*m				

AUTOSTRADA VALDASTICO A31 NORD
1° LOTTO - PIOVENE ROCCHETTE – VALLE DELL'ASTICO

X	cls	Nr	Vyr	Vzr	Mry	Mrz	MTrd	SF_V.	SF_M	SF_Mt	SF
0	1	52623	18491	18491	1818	1818	1566	>100	9.01	22.7	9.01

Asta : 1233 [400 , 515]

Sez. G: O 114.3x5.9 L=160.6 cm Crit.: Acciaio_Flessione $\gamma_M=1.05$ $f_{yk}/\gamma_M=2619$ kg/cm² $f_t=4300$ kg/cm²

:Verificato

X	cls	N	TY	TZ	MT	MY	MZ	My4	Mz4	Comb.
cm		kg	kg	kg	kg*m	kg*m	kg*m			
161	1	-868	-24	-54	-62	-93	36	--	--	2

X	cls	Nr	Vyr	Vzr	Mry	Mrz	MTrd	SF_V.	SF_M	SF_Mt	SF
cm		kg	kg	kg	kg*m	kg*m	kg*m				
161	1	52623	18579	18579	1818	1818	1566	>100	11.5	25.3	11.5

Asta : 1234 [485 , 516]

Sez. G: O 114.3x5.9 L=248.8 cm Crit.: Acciaio_Flessione $\gamma_M=1.05$ $f_{yk}/\gamma_M=2619$ kg/cm² $f_t=4300$ kg/cm²

:Verificato

X	cls	N	TY	TZ	MT	MY	MZ	My4	Mz4	Comb.
cm		kg	kg	kg	kg*m	kg*m	kg*m			
0	1	858	-3	-557	6	276	-4	--	--	2

X	cls	Nr	Vyr	Vzr	Mry	Mrz	MTrd	SF_V.	SF_M	SF_Mt	SF
cm		kg	kg	kg	kg*m	kg*m	kg*m				
0	1	52623	19263	19263	1818	1818	1566	34.6	5.87	>100	5.87

Asta : 1235 [516 , 515]

Sez. G: O 114.3x5.9 L=263.5 cm Crit.: Acciaio_Flessione $\gamma_M=1.05$ $f_{yk}/\gamma_M=2619$ kg/cm² $f_t=4300$ kg/cm²

:Verificato

X	cls	N	TY	TZ	MT	MY	MZ	My4	Mz4	Comb.
cm		kg	kg	kg	kg*m	kg*m	kg*m			
264	1	2128	4	34	2	39	-8	--	--	2

AUTOSTRADA VALDASTICO A31 NORD
1° LOTTO - PIOVENE ROCCHETTE – VALLE DELL'ASTICO

X	cls	Nr	Vyr	Vzr	Mry	Mrz	MTrd	SF_V.	SF_M	SF_Mt	SF
cm		kg	kg	kg	kg*m	kg*m	kg*m				
264	1	52623	19313	19313	1818	1818	1566	>100	15.1	>100	15.1

Asta : 1236 [515 , 452]

Sez. G: O 114.3x5.9 L=160.5 cm Crit.: Acciaio_Flessione $\gamma_M=1.05$ $f_{yk}/\gamma_M=2619$ kg/cm² $f_t=4300$ kg/cm²

:Verificato

X	cls	N	TY	TZ	MT	MY	MZ	My4	Mz4	Comb.
cm		kg	kg	kg	kg*m	kg*m	kg*m			
0	1	-1697	22	110	42	-102	33	--	--	2

X	cls	Nr	Vyr	Vzr	Mry	Mrz	MTrd	SF_V.	SF_M	SF_Mt	SF
cm		kg	kg	kg	kg*m	kg*m	kg*m				
0	1	52623	18827	18827	1818	1818	1566	>100	9.38	37.6	9.38

Asta : 1237 [452 , 516]

Sez. G: O 114.3x5.9 L=160.6 cm Crit.: Acciaio_Flessione $\gamma_M=1.05$ $f_{yk}/\gamma_M=2619$ kg/cm² $f_t=4300$ kg/cm²

:Verificato

X	cls	N	TY	TZ	MT	MY	MZ	My4	Mz4	Comb.
cm		kg	kg	kg	kg*m	kg*m	kg*m			
161	1	-1957	-16	-64	-30	-80	21	--	--	2

X	cls	Nr	Vyr	Vzr	Mry	Mrz	MTrd	SF_V.	SF_M	SF_Mt	SF
cm		kg	kg	kg	kg*m	kg*m	kg*m				
161	1	52623	18967	18967	1818	1818	1566	>100	10.7	51.7	10.7

Asta : 1238 [469 , 516]

Sez. G: O 108x5.9 L=160.5 cm Crit.: Acciaio_Flessione $\gamma_M=1.05$ $f_{yk}/\gamma_M=2619$ kg/cm² $f_t=4300$ kg/cm²

:Verificato

X	cls	N	TY	TZ	MT	MY	MZ	My4	Mz4	Comb.
cm		kg	kg	kg	kg*m	kg*m	kg*m			
160	1	632	12	-35	11	-51	-16	--	--	2

AUTOSTRADA VALDASTICO A31 NORD
1° LOTTO - PIOVENE ROCCHETTE – VALLE DELL'ASTICO

X	cls	Nr	Vyr	Vzr	Mry	Mrz	MTrd	SF_V.	SF_M	SF_Mt	SF
cm		kg	kg	kg	kg*m	kg*m	kg*m				
160	1	49565	18068	18068	1613	1613	1386	>100	18.5	>100	18.5

20 VERIFICHE STATO LIMITE DI ESERCIZIO

20.1 VERIFICA PLINTI

Plinto n°: 172 **Verificato**

Descrizione	Plinto Rettangolare su 4 pali
Terreno	Terreno1
Criterio di verifica	CLS_Plinti

Rp	Lp	H	HSup	Bx	By	BxSup	BySup	TR.X	TR.Y	Rot
cm	cm	cm	cm	cm	cm	cm	cm	cm	cm	°
30.0	1000.0	120.0	0.0	280.0	260.0	280.0	260.0	0.0	0.0	0

Geometria sezioni

Pos	B/R	H
	cm	cm
Pl(z=-0)	30.0	--
Arm. X	260.0	120.0

Verifica tensioni di esercizio

Pos	N	M	AfSup/ Af	Afinf	σ_c	σ_f	σ_{ca}	σ_{fa}	Comb	Ver	Cs
	kg	kg*m	cmq	cmq	kg/cmq	kg/cmq	kg/cmq	kg/cmq			
Pl(z=-0)	-4826	166	31.42	--	-2	-15	149	3600	14(Rara)	Si	67.6
Arm. X	0	-8858	4.71	4.71	-8	1659	149	3600	16(Rara)	Si	2.17
Pl(z=-0)	-5536	141	31.42	--	-2	-19	149	3600	16(Rara)	Si	63.9
Arm. X	0	-8610	4.71	4.71	-7	1612	112	3600	27(QP)	Si	2.23

AUTOSTRADA VALDASTICO A31 NORD
1° LOTTO - PIOVENE ROCCHETTE – VALLE DELL'ASTICO

Pos	N	M	AfSup/ Af	Afinf	σ_c	σ_f	σ_{ca}	σ_{fa}	Comb	Ver	Cs
Pl(z=-0)	-5285	54	31.42	--	-2	-23	112	3600	27(QP)	Si	58.6
Pl(z=-0)	-5381	54	31.42	--	-2	-23	112	3600	27(QP)	Si	57.7

Verifica apertura fessure

Pos	N	M	Act	Aft	pAft	$S_{r,max}$	σ_{fmed}	Wd	Wk	Wamm	Cb	Ver.	Cs
	kg	kg*m	m _q	cm _q	cm	cm	kg/cm _q	mm	mm	mm			
Pl(z=-0)	-5355	54	0.0	0.00	0.00	0.0	0	0.000	0.000	0.400	22(Freq.)	Si	>10 0
Arm. X	0	-8659	0.3	4.71	18.85	110.3	33	0.010	0.010	0.400	23(Freq.)	Si	38.6
Arm. X	0	-8610	0.3	4.71	18.85	110.3	33	0.010	0.010	0.300	27(QP)	Si	29.2
Pl(z=-0)	-5355	54	0.0	0.00	0.00	0.0	0	0.000	0.000	0.300	27(QP)	Si	>10 0

Plinto n°: 173 **Verificato**

Descrizione	Plinto Rettangolare su 4 pali
Terreno	Terreno1
Criterio di verifica	CLS_Plinti

Rp	Lp	H	HSup	Bx	By	BxSup	BySup	TR.X	TR.Y	Rot
cm	cm	cm	cm	cm	cm	cm	cm	cm	cm	°
30.0	1000.0	120.0	0.0	280.0	260.0	280.0	260.0	0.0	0.0	0

Geometria sezioni

Pos	B/R	H
	cm	cm
Pl(z=-0)	30.0	--
Arm. X	260.0	120.0

AUTOSTRADA VALDASTICO A31 NORD
1° LOTTO - PIOVENE ROCCHETTE – VALLE DELL'ASTICO

Verifica tensioni di esercizio

Pos	N	M	AfSup/ Af	Afinf	σ_c	σ_f	σ_{ca}	σ_{fa}	Comb	Ver	Cs
	kg	kg*m	cmq	cmq	kg/cmq	kg/cmq	kg/cmq	kg/cmq			
Pl(z=-0)	-5182	123	31.42	--	-2	-19	149	3600	14(Rara)	Si	69.4
Arm. X	0	-9037	4.71	4.71	-8	1692	149	3600	16(Rara)	Si	2.13
Pl(z=-0)	-5648	105	31.42	--	-2	-22	149	3600	16(Rara)	Si	67.0
Arm. X	0	-8825	4.71	4.71	-8	1652	112	3600	27(QP)	Si	2.18
Pl(z=-0)	-5438	42	31.42	--	-2	-24	112	3600	27(QP)	Si	58.6
Pl(z=-0)	-5516	42	31.42	--	-2	-24	112	3600	27(QP)	Si	57.8

Verifica apertura fessure

Pos	N	M	Act	Aft	pAft	$S_{r,max}$	σ_{fmed}	Wd	Wk	Wamm	Cb	Ve r.	Cs
	kg	kg*m	mq	cmq	cm	cm	kg/cmq	mm	mm	mm			
Pl(z=-0)	-5516	42	0.0	0.00	0.00	0.0	0	0.000	0.000	0.400	22(Freq.)	Si	>10 0
Arm. X	0	-8835	0.3	4.71	18.85	110.3	34	0.011	0.011	0.400	23(Freq.)	Si	37.9
Arm. X	0	-8825	0.3	4.71	18.85	110.3	33	0.011	0.011	0.300	27(QP)	Si	28.4
Pl(z=-0)	-5516	42	0.0	0.00	0.00	0.0	0	0.000	0.000	0.300	27(QP)	Si	>10 0

Plinto n°: 174 **Verificato**

Descrizione	Plinto Rettangolare su 4 pali
Terreno	Terreno1
Criterio di verifica	CLS_Plinti

Rp	Lp	H	HSup	Bx	By	BxSup	BySup	TR.X	TR.Y	Rot
cm	cm	cm	cm	cm	cm	cm	cm	cm	cm	°
30.0	1000.0	120.0	0.0	280.0	260.0	280.0	260.0	0.0	0.0	0

AUTOSTRADA VALDASTICO A31 NORD
1° LOTTO - PIOVENE ROCCHETTE – VALLE DELL'ASTICO

Geometria sezioni

Pos	B/R	H
	cm	cm
Pl(z=-0)	30.0	--
Arm. X	260.0	120.0

Verifica tensioni di esercizio

Pos	N	M	AfSup/ Af	Afinf	σ_c	σ_f	σ_{ca}	σ_{fa}	Comb	Ver	Cs
	kg	kg*m	cmq	cmq	kg/cmq	kg/cmq	kg/cmq	kg/cmq			
Pl(z=-0)	-5199	128	31.42	--	-2	-18	149	3600	14(Rara)	Si	68.5
Arm. X	0	-9074	4.71	4.71	-8	1699	149	3600	16(Rara)	Si	2.12
Pl(z=-0)	-5672	112	31.42	--	-2	-22	149	3600	16(Rara)	Si	65.9
Arm. X	0	-8835	4.71	4.71	-8	1654	112	3600	27(QP)	Si	2.18
Pl(z=-0)	-5457	41	31.42	--	-2	-24	112	3600	27(QP)	Si	58.6
Pl(z=-0)	-5522	41	31.42	--	-2	-24	112	3600	27(QP)	Si	57.9

Verifica apertura fessure

Pos	N	M	Act	Aft	pAft	$S_{r,max}$	σ_{fmed}	Wd	Wk	Wamm	Cb	Ver.	Cs
	kg	kg*m	mq	cmq	cm	cm	kg/cmq	mm	mm	mm			
Pl(z=-0)	-5522	41	0.0	0.00	0.00	0.0	0	0.000	0.000	0.400	22(Freq.)	Si	>10 0
Arm. X	0	-8870	0.3	4.71	18.85	110.3	34	0.011	0.011	0.400	23(Freq.)	Si	37.7
Arm. X	0	-8835	0.3	4.71	18.85	110.3	34	0.011	0.011	0.300	27(QP)	Si	28.4
Pl(z=-0)	-5522	41	0.0	0.00	0.00	0.0	0	0.000	0.000	0.300	27(QP)	Si	>10 0

Plinto n°: 175 **Verificato**

Descrizione	Plinto Rettangolare su 4 pali
Terreno	Terreno1

AUTOSTRADA VALDASTICO A31 NORD
1° LOTTO - PIOVENE ROCCHETTE – VALLE DELL'ASTICO

Criterio di verifica	CLS_Plinti
----------------------	------------

Rp	Lp	H	HSup	Bx	By	BxSup	BySup	TR.X	TR.Y	Rot
cm	cm	cm	cm	cm	cm	cm	cm	cm	cm	°
30.0	1000.0	120.0	0.0	280.0	260.0	280.0	260.0	0.0	0.0	0

Geometria sezioni

Pos	B/R	H
	cm	cm
Pl(z=-0)	30.0	--
Arm. X	260.0	120.0

Verifica tensioni di esercizio

Pos	N	M	AfSup/ Af	Afinf	σ_c	σ_f	σ_{ca}	σ_{fa}	Comb	Ver	Cs
	kg	kg*m	cmq	cmq	kg/cmq	kg/cmq	kg/cmq	kg/cmq			
Pl(z=-0)	-5189	118	31.42	--	-2	-19	149	3600	14(Rara)	Si	69.9
Arm. X	0	-9029	4.71	4.71	-8	1691	149	3600	16(Rara)	Si	2.13
Pl(z=-0)	-5643	110	31.42	--	-2	-21	149	3600	16(Rara)	Si	66.4
Arm. X	0	-8787	4.71	4.71	-8	1645	112	3600	27(QP)	Si	2.19
Pl(z=-0)	-5435	37	31.42	--	-2	-24	112	3600	27(QP)	Si	59.2
Pl(z=-0)	-5492	37	31.42	--	-2	-25	112	3600	27(QP)	Si	58.7

Verifica apertura fessure

Pos	N	M	Act	Aft	pAft	$S_{r,max}$	σ_{med}	Wd	Wk	Wamm	Cb	Ve r.	Cs
	kg	kg*m	mq	cmq	cm	cm	kg/cmq	mm	mm	mm			
Pl(z=-0)	-5492	37	0.0	0.00	0.00	0.0	0	0.000	0.000	0.400	22(Freq.)	Si	>10 0
Arm. X	0	-8826	0.3	4.71	18.85	110.3	33	0.011	0.011	0.400	23(Freq.)	Si	37.9
Arm. X	0	-8787	0.3	4.71	18.85	110.3	33	0.011	0.011	0.300	27(QP)	Si	28.6
Pl(z=-0)	-5492	37	0.0	0.00	0.00	0.0	0	0.000	0.000	0.300	27(QP)	Si	>10

AUTOSTRADA VALDASTICO A31 NORD
1° LOTTO - PIOVENE ROCCHETTE – VALLE DELL'ASTICO

Pos	N	M	Act	Aft	pAft	$S_{r,max}$	σ_{med}	Wd	Wk	Wamm	Cb	Ver.	Cs
													0

Plinto n°: 184 Verificato

Descrizione	Plinto Rettangolare su 4 pali
Terreno	Terreno1
Criterio di verifica	CLS_Plinti

Rp	Lp	H	HSup	Bx	By	BxSup	BySup	TR.X	TR.Y	Rot
cm	cm	cm	cm	cm	cm	cm	cm	cm	cm	°
30.0	1000.0	120.0	0.0	280.0	260.0	280.0	260.0	0.0	0.0	0

Geometria sezioni

Pos	B/R	H
	cm	cm
Pl(z=-0)	30.0	--
Arm. X	260.0	120.0

Verifica tensioni di esercizio

Pos	N	M	AfSup/ Af	Afinf	σ_c	σ_f	σ_{ca}	σ_{fa}	Comb	Ver	Cs
	kg	kg*m	cmq	cmq	kg/cmq	kg/cmq	kg/cmq	kg/cmq			
Pl(z=-0)	-4912	106	31.42	--	-2	-18	149	3600	14(Rara)	Si	74.7
Arm. X	0	-8908	4.71	4.71	-8	1668	149	3600	16(Rara)	Si	2.16
Pl(z=-0)	-5568	102	31.42	--	-2	-22	149	3600	16(Rara)	Si	68.1
Arm. X	0	-8600	4.71	4.71	-7	1610	112	3600	27(QP)	Si	2.24
Pl(z=-0)	-5295	45	31.42	--	-2	-23	112	3600	27(QP)	Si	59.6
Pl(z=-0)	-5375	45	31.42	--	-2	-24	112	3600	27(QP)	Si	58.8

Verifica apertura fessure

AUTOSTRADA VALDASTICO A31 NORD
1° LOTTO - PIOVENE ROCCHETTE – VALLE DELL'ASTICO

Pos	N	M	Act	Aft	pAft	$S_{r,max}$	σ_{med}	Wd	Wk	Wamm	Cb	Ver.	Cs
	kg	kg*m	mq	cmq	cm	cm	kg/cmq	mm	mm	mm			
Pl(z=-0)	-5295	45	0.0	0.00	0.00	0.0	0	0.000	0.000	0.400	22(Freq.)	Si	>10 0
Arm. X	0	-8662	0.3	4.71	18.85	110.3	33	0.010	0.010	0.400	23(Freq.)	Si	38.6
Arm. X	0	-8600	0.3	4.71	18.85	110.3	33	0.010	0.010	0.300	27(QP)	Si	29.2
Pl(z=-0)	-5295	45	0.0	0.00	0.00	0.0	0	0.000	0.000	0.300	27(QP)	Si	>10 0

Plinto n°: 185 Verificato

Descrizione	Plinto Rettangolare su 4 pali
Terreno	Terreno1
Criterio di verifica	CLS_Plinti

Rp	Lp	H	HSup	Bx	By	BxSup	BySup	TR.X	TR.Y	Rot
cm	cm	cm	cm	cm	cm	cm	cm	cm	cm	°
30.0	1000.0	120.0	0.0	280.0	260.0	280.0	260.0	0.0	0.0	0

Geometria sezioni

Pos	B/R	H
	cm	cm
Pl(z=-0)	30.0	--
Arm. X	260.0	120.0

Verifica tensioni di esercizio

Pos	N	M	AfSup/ Af	Afinf	σ_c	σ_f	σ_{ca}	σ_{fa}	Comb	Ver	Cs
	kg	kg*m	cmq	cmq	kg/cmq	kg/cmq	kg/cmq	kg/cmq			
Pl(z=-0)	-5294	66	31.42	--	-2	-22	149	3600	14(Rara)	Si	76.2
Arm. X	0	-9103	4.71	4.71	-8	1704	149	3600	16(Rara)	Si	2.11

AUTOSTRADA VALDASTICO A31 NORD
1° LOTTO - PIOVENE ROCCHETTE – VALLE DELL'ASTICO

Pos	N	M	AfSup/ Af	Afinf	σ_c	σ_f	σ_{ca}	σ_{fa}	Comb	Ver	Cs
Pl(z=-0)	-5689	70	31.42	--	-2	-24	149	3600	16(Rara)	Si	71.0
Arm. X	0	-8833	4.71	4.71	-8	1654	112	3600	27(QP)	Si	2.18
Pl(z=-0)	-5453	35	31.42	--	-2	-24	112	3600	27(QP)	Si	59.3
Pl(z=-0)	-5521	35	31.42	--	-2	-25	112	3600	27(QP)	Si	58.6

Verifica apertura fessure

Pos	N	M	Act	Aft	pAft	$S_{r,max}$	σ_{fmed}	Wd	Wk	Wamm	Cb	Ve r.	Cs
	kg	kg*m	mq	cmq	cm	cm	kg/cmq	mm	mm	mm			
Pl(z=-0)	-5479	35	0.0	0.00	0.00	0.0	0	0.000	0.000	0.400	22(Freq.)	Si	>10 0
Arm. X	0	-8851	0.3	4.71	18.85	110.3	34	0.011	0.011	0.400	23(Freq.)	Si	37.8
Arm. X	0	-8833	0.3	4.71	18.85	110.3	34	0.011	0.011	0.300	27(QP)	Si	28.4
Pl(z=-0)	-5479	35	0.0	0.00	0.00	0.0	0	0.000	0.000	0.300	27(QP)	Si	>10 0

Plinto n°: 186 **Verificato**

Descrizione	Plinto Rettangolare su 4 pali
Terreno	Terreno1
Criterio di verifica	CLS_Plinti

Rp	Lp	H	HSup	Bx	By	BxSup	BySup	TR.X	TR.Y	Rot
cm	cm	cm	cm	cm	cm	cm	cm	cm	cm	°
30.0	1000.0	120.0	0.0	280.0	260.0	280.0	260.0	0.0	0.0	0

Geometria sezioni

Pos	B/R	H
	cm	cm
Pl(z=-0)	30.0	--

AUTOSTRADA VALDASTICO A31 NORD
1° LOTTO - PIOVENE ROCCHETTE – VALLE DELL'ASTICO

Pos	B/R	H
Arm. X	260.0	120.0

Verifica tensioni di esercizio

Pos	N	M	AfSup/ Af	Afinf	σ_c	σ_f	σ_{ca}	σ_{fa}	Comb	Ver	Cs
	kg	kg*m	cmq	cmq	kg/cmq	kg/cmq	kg/cmq	kg/cmq			
Pl(z=-0)	-5301	77	31.42	--	-2	-22	149	3600	14(Rara)	Si	74.4
Arm. X	0	-9128	4.71	4.71	-8	1709	149	3600	16(Rara)	Si	2.11
Pl(z=-0)	-5705	80	31.42	--	-2	-23	149	3600	16(Rara)	Si	69.5
Arm. X	0	-8842	4.71	4.71	-8	1656	112	3600	27(QP)	Si	2.17
Pl(z=-0)	-5470	34	31.42	--	-2	-25	112	3600	27(QP)	Si	59.3
Pl(z=-0)	-5526	34	31.42	--	-2	-25	112	3600	27(QP)	Si	58.7

Verifica apertura fessure

Pos	N	M	Act	Aft	pAft	$S_{r,max}$	σ_{fmed}	Wd	Wk	Wamm	Cb	Ve r.	Cs
	kg	kg*m	mq	cmq	cm	cm	kg/cmq	mm	mm	mm			
Pl(z=-0)	-5481	34	0.0	0.00	0.00	0.0	0	0.000	0.000	0.400	22(Freq.)	Si	>10 0
Arm. X	0	-8884	0.3	4.71	18.85	110.3	34	0.011	0.011	0.400	23(Freq.)	Si	37.7
Arm. X	0	-8842	0.3	4.71	18.85	110.3	34	0.011	0.011	0.300	27(QP)	Si	28.4
Pl(z=-0)	-5481	34	0.0	0.00	0.00	0.0	0	0.000	0.000	0.300	27(QP)	Si	>10 0

Plinto n°: 187 **Verificato**

Descrizione	Plinto Rettangolare su 4 pali
Terreno	Terreno1
Criterio di verifica	CLS_Plinti

Rp	Lp	H	HSup	Bx	By	BxSup	BySup	TR.X	TR.Y	Rot
----	----	---	------	----	----	-------	-------	------	------	-----

AUTOSTRADA VALDASTICO A31 NORD
1° LOTTO - PIOVENE ROCCHETTE – VALLE DELL'ASTICO

Rp	Lp	H	HSup	Bx	By	BxSup	BySup	TR.X	TR.Y	Rot
cm	cm	cm	cm	cm	cm	cm	cm	cm	cm	°
30.0	1000.0	120.0	0.0	280.0	260.0	280.0	260.0	0.0	0.0	0

Geometria sezioni

Pos	B/R	H
	cm	cm
Pl(z=-0)	30.0	--
Arm. X	260.0	120.0

Verifica tensioni di esercizio

Pos	N	M	AfSup/ Af	Afinf	σ_c	σ_f	σ_{ca}	σ_{fa}	Comb	Ver	Cs
	kg	kg*m	cmq	cmq	kg/cmq	kg/cmq	kg/cmq	kg/cmq			
Pl(z=-0)	-5283	74	31.42	--	-2	-22	149	3600	14(Rara)	Si	75.0
Arm. X	0	-9083	4.71	4.71	-8	1701	149	3600	16(Rara)	Si	2.12
Pl(z=-0)	-5677	82	31.42	--	-2	-23	149	3600	16(Rara)	Si	69.5
Arm. X	0	-8795	4.71	4.71	-8	1647	112	3600	27(QP)	Si	2.19
Pl(z=-0)	-5447	31	31.42	--	-2	-25	112	3600	27(QP)	Si	59.9
Pl(z=-0)	-5497	31	31.42	--	-2	-25	112	3600	27(QP)	Si	59.4

Verifica apertura fessure

Pos	N	M	Act	Aft	pAft	$S_{r,max}$	σ_{med}	Wd	Wk	Wamm	Cb	Ver.	Cs
	kg	kg*m	mq	cmq	cm	cm	kg/cmq	mm	mm	mm			
Pl(z=-0)	-5455	31	0.0	0.00	0.00	0.0	0	0.000	0.000	0.400	22(Freq.)	Si	>10 0
Arm. X	0	-8840	0.3	4.71	18.85	110.3	34	0.011	0.011	0.400	23(Freq.)	Si	37.9
Arm. X	0	-8795	0.3	4.71	18.85	110.3	33	0.011	0.011	0.300	27(QP)	Si	28.5
Pl(z=-0)	-5455	31	0.0	0.00	0.00	0.0	0	0.000	0.000	0.300	27(QP)	Si	>10 0

20.1 VERIFICA SPOSTAMENTI VERTICALI DELLE ASTE IN ACCIAIO SECONDO NTC 2008

Travata: 1 [196 , 203]

$L = 229.9\text{cm}$

Crit.Prog: Acciaio_Flessione $\delta c = 0.0\text{cm}$ Verifica: **Verificata**

Verifica spostamento nello stato finale (§4.2.4.2.1 - NTC 2008)

x	Comb.	δ_{\max}	L/250.00	Cs
cm		mm	mm	
160.9	15	-0.22	9.19	41.0

Verifica spostamento elastico dovuto ai soli carichi variabili (§4.2.4.2.1 - NTC 2008)

x	Comb.	δ_2	L/300.00	Cs
cm		mm	mm	
137.9	15	-0.17	7.66	45.9

Travata: 2 [206 , 195]

$L = 286.0\text{cm}$

Crit.Prog: Acciaio_Flessione $\delta c = 0.0\text{cm}$ Verifica: **Verificata**

Verifica spostamento nello stato finale (§4.2.4.2.1 - NTC 2008)

x	Comb.	δ_{\max}	L/250.00	Cs
cm		mm	mm	
200.2	15	-0.38	11.44	30.1

Verifica spostamento elastico dovuto ai soli carichi variabili (§4.2.4.2.1 - NTC 2008)

x	Comb.	δ_2	L/300.00	Cs
cm		mm	mm	
200.2	15	-0.28	9.53	34.2

Travata: 3 [195 , 196]

$L = 314.0\text{cm}$

Crit.Prog: Acciaio_Flessione $\delta c = 0.0\text{cm}$ Verifica: **Verificata**

Verifica spostamento nello stato finale (§4.2.4.2.1 - NTC 2008)

x	Comb.	δ_{\max}	L/250.00	Cs
cm		mm	mm	
94.2	15	0.10	12.56	>100

Verifica spostamento elastico dovuto ai soli carichi variabili (§4.2.4.2.1 - NTC 2008)

x	Comb.	δ_2	L/300.00	Cs
cm		mm	mm	
62.8	15	0.06	10.47	>100

Travata: 4 [205 , 203]

$L = 229.9\text{cm}$

Crit.Prog: Acciaio_Flessione $\delta c = 0.0\text{cm}$ Verifica: **Verificata**

Verifica spostamento nello stato finale (§4.2.4.2.1 - NTC 2008)

x	Comb.	δ_{\max}	L/250.00	Cs
cm		mm	mm	
69.0	15	0.07	9.19	>100

Verifica spostamento elastico dovuto ai soli carichi variabili (§4.2.4.2.1 - NTC 2008)

x	Comb.	δ_2	L/300.00	Cs
cm		mm	mm	
69.0	15	0.03	7.66	>100

Travata: 5 [203 , 195]

$L = 229.9\text{cm}$

Crit.Prog: Acciaio_Flessione $\delta c = 0.0\text{cm}$ Verifica: **Verificata**

Verifica spostamento nello stato finale (§4.2.4.2.1 - NTC 2008)

x	Comb.	δ_{max}	L/250.00	Cs
cm		mm	mm	
137.9	15	0.16	9.19	56.8

Verifica spostamento elastico dovuto ai soli carichi variabili (§4.2.4.2.1 - NTC 2008)

x	Comb.	δ_2	L/300.00	Cs
cm		mm	mm	
137.9	15	0.09	7.66	85.0

Travata: 6 [203 , 206]

$L = 229.9\text{cm}$

Crit.Prog: Acciaio_Flessione $\delta c = 0.0\text{cm}$ Verifica: **Verificata**

Verifica spostamento nello stato finale (§4.2.4.2.1 - NTC 2008)

x	Comb.	δ_{max}	L/250.00	Cs
cm		mm	mm	
91.9	15	-0.29	9.19	31.3

Verifica spostamento elastico dovuto ai soli carichi variabili (§4.2.4.2.1 - NTC 2008)

x	Comb.	δ_2	L/300.00	Cs
cm		mm	mm	
91.9	15	-0.18	7.66	43.8

Travata: 7 [205 , 196]

$L = 286.0\text{cm}$

Crit.Prog: Acciaio_Flessione $\delta c = 0.0\text{cm}$ Verifica: **Verificata**

Verifica spostamento nello stato finale (§4.2.4.2.1 - NTC 2008)

x	Comb.	δ_{max}	L/250.00	Cs
cm		mm	mm	
57.2	15	-0.15	11.44	75.7

Verifica spostamento elastico dovuto ai soli carichi variabili (§4.2.4.2.1 - NTC 2008)

x	Comb.	δ_2	L/300.00	Cs
cm		mm	mm	
85.8	15	-0.11	9.53	88.2

Travata: 8 [207 , 194]

$L = 286.0\text{cm}$

Crit.Prog: Acciaio_Flessione $\delta c = 0.0\text{cm}$ Verifica: **Verificata**

Verifica spostamento nello stato finale (§4.2.4.2.1 - NTC 2008)

x	Comb.	δ_{max}	L/250.00	Cs
cm		mm	mm	
171.6	15	-0.28	11.44	40.8

Verifica spostamento elastico dovuto ai soli carichi variabili (§4.2.4.2.1 - NTC 2008)

x	Comb.	δ_2	L/300.00	Cs
cm		mm	mm	
171.6	15	-0.19	9.53	51.0

Travata: 9 [194 , 195]

AUTOSTRADA VALDASTICO A31 NORD
1° LOTTO - PIOVENE ROCCHETTE – VALLE DELL'ASTICO

$L = 314.0\text{cm}$

Crit.Prog: Acciaio_Flessione $\delta c = 0.0\text{cm}$ Verifica: **Verificata**

Verifica spostamento nello stato finale (§4.2.4.2.1 - NTC 2008)

x	Comb.	δ_{\max}	L/250.00	Cs
cm		mm	mm	
219.8	15	-1.39	12.56	9.05

Verifica spostamento elastico dovuto ai soli carichi variabili (§4.2.4.2.1 - NTC 2008)

x	Comb.	δ_2	L/300.00	Cs
cm		mm	mm	
219.8	15	-0.89	10.47	11.7

Travata: 10 [195 , 202]

$L = 254.4\text{cm}$

Crit.Prog: Acciaio_Flessione $\delta c = 0.0\text{cm}$ Verifica: **Verificata**

Verifica spostamento nello stato finale (§4.2.4.2.1 - NTC 2008)

x	Comb.	δ_{\max}	L/250.00	Cs
cm		mm	mm	
76.3	15	-0.68	10.17	14.9

Verifica spostamento elastico dovuto ai soli carichi variabili (§4.2.4.2.1 - NTC 2008)

x	Comb.	δ_2	L/300.00	Cs
cm		mm	mm	
76.3	15	-0.45	8.48	18.6

Travata: 11 [202 , 207]

$L = 254.4\text{cm}$

AUTOSTRADA VALDASTICO A31 NORD
1° LOTTO - PIOVENE ROCCHETTE – VALLE DELL'ASTICO

Crit.Prog: Acciaio_Flessione $\delta c = 0.0cm$ Verifica: **Verificata**

Verifica spostamento nello stato finale (§4.2.4.2.1 - NTC 2008)

x	Comb.	δ_{max}	L/250.00	Cs
cm		mm	mm	
127.2	15	0.20	10.17	51.5

Verifica spostamento elastico dovuto ai soli carichi variabili (§4.2.4.2.1 - NTC 2008)

x	Comb.	δ_2	L/300.00	Cs
cm		mm	mm	
127.2	15	0.11	8.48	74.2

Travata: 12 [206 , 202]

L = 254.4cm

Crit.Prog: Acciaio_Flessione $\delta c = 0.0cm$ Verifica: **Verificata**

Verifica spostamento nello stato finale (§4.2.4.2.1 - NTC 2008)

x	Comb.	δ_{max}	L/250.00	Cs
cm		mm	mm	
127.2	15	-0.29	10.17	35.5

Verifica spostamento elastico dovuto ai soli carichi variabili (§4.2.4.2.1 - NTC 2008)

x	Comb.	δ_2	L/300.00	Cs
cm		mm	mm	
127.2	15	-0.18	8.48	46.7

Travata: 13 [202 , 194]

L = 254.4cm

Crit.Prog: Acciaio_Flessione $\delta c = 0.0cm$ Verifica: **Verificata**

AUTOSTRADA VALDASTICO A31 NORD
1° LOTTO - PIOVENE ROCCHETTE – VALLE DELL'ASTICO

Verifica spostamento nello stato finale (§4.2.4.2.1 - NTC 2008)

x	Comb.	δ_{max}	L/250.00	Cs
cm		mm	mm	
127.2	15	-0.19	10.17	54.5

Verifica spostamento elastico dovuto ai soli carichi variabili (§4.2.4.2.1 - NTC 2008)

x	Comb.	δ_2	L/300.00	Cs
cm		mm	mm	
127.2	15	-0.12	8.48	69.4

Travata: 14 [208 , 193]

L = 286.0cm

Crit.Prog: Acciaio_Flessione $\delta_c = 0.0cm$ Verifica: **Verificata**

Verifica spostamento nello stato finale (§4.2.4.2.1 - NTC 2008)

x	Comb.	δ_{max}	L/250.00	Cs
cm		mm	mm	
143.0	15	-0.06	11.44	>100

Verifica spostamento elastico dovuto ai soli carichi variabili (§4.2.4.2.1 - NTC 2008)

x	Comb.	δ_2	L/300.00	Cs
cm		mm	mm	
143.0	15	-0.06	9.53	>100

Travata: 15 [193 , 194]

L = 314.0cm

Crit.Prog: Acciaio_Flessione $\delta_c = 0.0cm$ Verifica: **Verificata**

AUTOSTRADA VALDASTICO A31 NORD
1° LOTTO - PIOVENE ROCCHETTE – VALLE DELL'ASTICO

Verifica spostamento nello stato finale (§4.2.4.2.1 - NTC 2008)

x	Comb.	δ_{max}	L/250.00	Cs
cm		mm	mm	
157.0	15	0.65	12.56	19.3

Verifica spostamento elastico dovuto ai soli carichi variabili (§4.2.4.2.1 - NTC 2008)

x	Comb.	δ_2	L/300.00	Cs
cm		mm	mm	
157.0	15	0.36	10.47	29.0

Travata: 16 [207 , 201]

L = 273.9cm

Crit.Prog: Acciaio_Flessione $\delta_c = 0.0cm$ Verifica: **Verificata**

Verifica spostamento nello stato finale (§4.2.4.2.1 - NTC 2008)

x	Comb.	δ_{max}	L/250.00	Cs
cm		mm	mm	
82.2	15	-0.03	10.96	>100

Verifica spostamento elastico dovuto ai soli carichi variabili (§4.2.4.2.1 - NTC 2008)

x	Comb.	δ_2	L/300.00	Cs
cm		mm	mm	
82.2	15	-0.02	9.13	>100

Travata: 17 [201 , 193]

L = 273.9cm

Crit.Prog: Acciaio_Flessione $\delta_c = 0.0cm$ Verifica: **Verificata**

Verifica spostamento nello stato finale (§4.2.4.2.1 - NTC 2008)

AUTOSTRADA VALDASTICO A31 NORD
1° LOTTO - PIOVENE ROCCHETTE – VALLE DELL'ASTICO

x	Comb.	δ_{max}	L/250.00	Cs
cm		mm	mm	
164.3	15	0.09	10.96	>100

Verifica spostamento elastico dovuto ai soli carichi variabili (§4.2.4.2.1 - NTC 2008)

x	Comb.	δ_2	L/300.00	Cs
cm		mm	mm	
164.3	15	0.05	9.13	>100

Travata: 18 [194 , 201]

L = 273.9cm

Crit.Prog: Acciaio_Flessione $\delta_c = 0.0cm$ Verifica: **Verificata**

Verifica spostamento nello stato finale (§4.2.4.2.1 - NTC 2008)

x	Comb.	δ_{max}	L/250.00	Cs
cm		mm	mm	
109.6	15	0.14	10.96	79.1

Verifica spostamento elastico dovuto ai soli carichi variabili (§4.2.4.2.1 - NTC 2008)

x	Comb.	δ_2	L/300.00	Cs
cm		mm	mm	
109.6	15	0.07	9.13	>100

Travata: 19 [201 , 208]

L = 273.9cm

Crit.Prog: Acciaio_Flessione $\delta_c = 0.0cm$ Verifica: **Verificata**

Verifica spostamento nello stato finale (§4.2.4.2.1 - NTC 2008)

x	Comb.	δ_{max}	L/250.00	Cs
---	-------	----------------	----------	----

AUTOSTRADA VALDASTICO A31 NORD
1° LOTTO - PIOVENE ROCCHETTE – VALLE DELL'ASTICO

x	Comb.	δ_{max}	L/250.00	Cs
cm		mm	mm	
137.0	15	0.13	10.96	85.8

Verifica spostamento elastico dovuto ai soli carichi variabili (§4.2.4.2.1 - NTC 2008)

x	Comb.	δ_2	L/300.00	Cs
cm		mm	mm	
137.0	15	0.07	9.13	>100

Travata: 20 [209 , 192]

L = 286.0cm

Crit.Prog: Acciaio_Flessione $\delta_c = 0.0cm$ Verifica: **Verificata**

Verifica spostamento nello stato finale (§4.2.4.2.1 - NTC 2008)

x	Comb.	δ_{max}	L/250.00	Cs
cm		mm	mm	
57.2	15	-0.02	11.44	>100

Verifica spostamento elastico dovuto ai soli carichi variabili (§4.2.4.2.1 - NTC 2008)

x	Comb.	δ_2	L/300.00	Cs
cm		mm	mm	
114.4	15	-0.03	9.53	>100

Travata: 21 [192 , 193]

L = 314.0cm

Crit.Prog: Acciaio_Flessione $\delta_c = 0.0cm$ Verifica: **Verificata**

Verifica spostamento nello stato finale (§4.2.4.2.1 - NTC 2008)

x	Comb.	δ_{max}	L/250.00	Cs
---	-------	----------------	----------	----

AUTOSTRADA VALDASTICO A31 NORD
1° LOTTO - PIOVENE ROCCHETTE – VALLE DELL'ASTICO

x	Comb.	δ_{max}	L/250.00	Cs
cm		mm	mm	
157.0	15	0.52	12.56	24.0

Verifica spostamento elastico dovuto ai soli carichi variabili (§4.2.4.2.1 - NTC 2008)

x	Comb.	δ_2	L/300.00	Cs
cm		mm	mm	
157.0	15	0.28	10.47	37.4

Travata: 22 [208 , 200]

L = 281.6cm

Crit.Prog: Acciaio_Flessione $\delta_c = 0.0cm$ Verifica: **Verificata**

Verifica spostamento nello stato finale (§4.2.4.2.1 - NTC 2008)

x	Comb.	δ_{max}	L/250.00	Cs
cm		mm	mm	
140.8	15	0.09	11.27	>100

Verifica spostamento elastico dovuto ai soli carichi variabili (§4.2.4.2.1 - NTC 2008)

x	Comb.	δ_2	L/300.00	Cs
cm		mm	mm	
140.8	15	0.05	9.39	>100

Travata: 23 [200 , 209]

L = 281.6cm

Crit.Prog: Acciaio_Flessione $\delta_c = 0.0cm$ Verifica: **Verificata**

Verifica spostamento nello stato finale (§4.2.4.2.1 - NTC 2008)

x	Comb.	δ_{max}	L/250.00	Cs
---	-------	----------------	----------	----

AUTOSTRADA VALDASTICO A31 NORD
1° LOTTO - PIOVENE ROCCHETTE – VALLE DELL'ASTICO

x	Comb.	δ_{max}	L/250.00	Cs
cm		mm	mm	
140.8	15	0.12	11.27	90.2

Verifica spostamento elastico dovuto ai soli carichi variabili (§4.2.4.2.1 - NTC 2008)

x	Comb.	δ_2	L/300.00	Cs
cm		mm	mm	
140.8	15	0.06	9.39	>100

Travata: 24 [193 , 200]

L = 281.6cm

Crit.Prog: Acciaio_Flessione $\delta_c = 0.0cm$ Verifica: **Verificata**

Verifica spostamento nello stato finale (§4.2.4.2.1 - NTC 2008)

x	Comb.	δ_{max}	L/250.00	Cs
cm		mm	mm	
140.8	15	0.11	11.27	>100

Verifica spostamento elastico dovuto ai soli carichi variabili (§4.2.4.2.1 - NTC 2008)

x	Comb.	δ_2	L/300.00	Cs
cm		mm	mm	
140.8	15	0.05	9.39	>100

Travata: 25 [200 , 192]

L = 281.6cm

Crit.Prog: Acciaio_Flessione $\delta_c = 0.0cm$ Verifica: **Verificata**

Verifica spostamento nello stato finale (§4.2.4.2.1 - NTC 2008)

x	Comb.	δ_{max}	L/250.00	Cs
---	-------	----------------	----------	----

AUTOSTRADA VALDASTICO A31 NORD
1° LOTTO - PIOVENE ROCCHETTE – VALLE DELL'ASTICO

x	Comb.	δ_{max}	L/250.00	Cs
cm		mm	mm	
140.8	15	0.13	11.27	86.8

Verifica spostamento elastico dovuto ai soli carichi variabili (§4.2.4.2.1 - NTC 2008)

x	Comb.	δ_2	L/300.00	Cs
cm		mm	mm	
140.8	15	0.07	9.39	>100

Travata: 26 [192 , 199]

L = 281.6cm

Crit.Prog: Acciaio_Flessione $\delta_c = 0.0cm$ Verifica: **Verificata**

Verifica spostamento nello stato finale (§4.2.4.2.1 - NTC 2008)

x	Comb.	δ_{max}	L/250.00	Cs
cm		mm	mm	
140.8	15	0.13	11.27	88.4

Verifica spostamento elastico dovuto ai soli carichi variabili (§4.2.4.2.1 - NTC 2008)

x	Comb.	δ_2	L/300.00	Cs
cm		mm	mm	
140.8	15	0.06	9.39	>100

Travata: 27 [199 , 210]

L = 281.6cm

Crit.Prog: Acciaio_Flessione $\delta_c = 0.0cm$ Verifica: **Verificata**

Verifica spostamento nello stato finale (§4.2.4.2.1 - NTC 2008)

x	Comb.	δ_{max}	L/250.00	Cs
---	-------	----------------	----------	----

AUTOSTRADA VALDASTICO A31 NORD
1° LOTTO - PIOVENE ROCCHETTE – VALLE DELL'ASTICO

x	Comb.	δ_{max}	L/250.00	Cs
cm		mm	mm	
140.8	15	0.09	11.27	>100

Verifica spostamento elastico dovuto ai soli carichi variabili (§4.2.4.2.1 - NTC 2008)

x	Comb.	δ_2	L/300.00	Cs
cm		mm	mm	
140.8	15	0.05	9.39	>100

Travata: 28 [210 , 191]

L = 286.0cm

Crit.Prog: Acciaio_Flessione $\delta_c = 0.0cm$ Verifica: **Verificata**

Verifica spostamento nello stato finale (§4.2.4.2.1 - NTC 2008)

x	Comb.	δ_{max}	L/250.00	Cs
cm		mm	mm	
143.0	15	-0.06	11.44	>100

Verifica spostamento elastico dovuto ai soli carichi variabili (§4.2.4.2.1 - NTC 2008)

x	Comb.	δ_2	L/300.00	Cs
cm		mm	mm	
143.0	15	-0.06	9.53	>100

Travata: 29 [191 , 192]

L = 314.0cm

Crit.Prog: Acciaio_Flessione $\delta_c = 0.0cm$ Verifica: **Verificata**

Verifica spostamento nello stato finale (§4.2.4.2.1 - NTC 2008)

x	Comb.	δ_{max}	L/250.00	Cs
---	-------	----------------	----------	----

AUTOSTRADA VALDASTICO A31 NORD
1° LOTTO - PIOVENE ROCCHETTE – VALLE DELL'ASTICO

x	Comb.	δ_{max}	L/250.00	Cs
cm		mm	mm	
157.0	15	0.52	12.56	24.1

Verifica spostamento elastico dovuto ai soli carichi variabili (§4.2.4.2.1 - NTC 2008)

x	Comb.	δ_2	L/300.00	Cs
cm		mm	mm	
157.0	15	0.28	10.47	37.5

Travata: 30 [209 , 199]

L = 281.6cm

Crit.Prog: Acciaio_Flessione $\delta_c = 0.0cm$ Verifica: **Verificata**

Verifica spostamento nello stato finale (§4.2.4.2.1 - NTC 2008)

x	Comb.	δ_{max}	L/250.00	Cs
cm		mm	mm	
140.8	15	0.13	11.27	88.9

Verifica spostamento elastico dovuto ai soli carichi variabili (§4.2.4.2.1 - NTC 2008)

x	Comb.	δ_2	L/300.00	Cs
cm		mm	mm	
140.8	15	0.06	9.39	>100

Travata: 31 [199 , 191]

L = 281.6cm

Crit.Prog: Acciaio_Flessione $\delta_c = 0.0cm$ Verifica: **Verificata**

Verifica spostamento nello stato finale (§4.2.4.2.1 - NTC 2008)

x	Comb.	δ_{max}	L/250.00	Cs
---	-------	----------------	----------	----

AUTOSTRADA VALDASTICO A31 NORD
1° LOTTO - PIOVENE ROCCHETTE – VALLE DELL'ASTICO

x	Comb.	δ_{max}	L/250.00	Cs
cm		mm	mm	
140.8	15	0.11	11.27	>100

Verifica spostamento elastico dovuto ai soli carichi variabili (§4.2.4.2.1 - NTC 2008)

x	Comb.	δ_2	L/300.00	Cs
cm		mm	mm	
140.8	15	0.06	9.39	>100

Travata: 32 [211 , 190]

L = 286.0cm

Crit.Prog: Acciaio_Flessione $\delta_c = 0.0cm$ Verifica: **Verificata**

Verifica spostamento nello stato finale (§4.2.4.2.1 - NTC 2008)

x	Comb.	δ_{max}	L/250.00	Cs
cm		mm	mm	
171.6	15	-0.28	11.44	41.2

Verifica spostamento elastico dovuto ai soli carichi variabili (§4.2.4.2.1 - NTC 2008)

x	Comb.	δ_2	L/300.00	Cs
cm		mm	mm	
171.6	15	-0.18	9.53	51.9

Travata: 33 [190 , 191]

L = 314.0cm

Crit.Prog: Acciaio_Flessione $\delta_c = 0.0cm$ Verifica: **Verificata**

Verifica spostamento nello stato finale (§4.2.4.2.1 - NTC 2008)

AUTOSTRADA VALDASTICO A31 NORD
1° LOTTO - PIOVENE ROCCHETTE – VALLE DELL'ASTICO

x	Comb.	δ_{max}	L/250.00	Cs
cm		mm	mm	
157.0	15	0.65	12.56	19.4

Verifica spostamento elastico dovuto ai soli carichi variabili (§4.2.4.2.1 - NTC 2008)

x	Comb.	δ_2	L/300.00	Cs
cm		mm	mm	
157.0	15	0.36	10.47	29.2

Travata: 34 [191 , 198]

L = 273.9cm

Crit.Prog: Acciaio_Flessione $\delta_c = 0.0cm$ Verifica: **Verificata**

Verifica spostamento nello stato finale (§4.2.4.2.1 - NTC 2008)

x	Comb.	δ_{max}	L/250.00	Cs
cm		mm	mm	
109.6	15	0.09	10.96	>100

Verifica spostamento elastico dovuto ai soli carichi variabili (§4.2.4.2.1 - NTC 2008)

x	Comb.	δ_2	L/300.00	Cs
cm		mm	mm	
109.6	15	0.04	9.13	>100

Travata: 35 [198 , 211]

L = 273.9cm

Crit.Prog: Acciaio_Flessione $\delta_c = 0.0cm$ Verifica: **Verificata**

Verifica spostamento nello stato finale (§4.2.4.2.1 - NTC 2008)

x	Comb.	δ_{max}	L/250.00	Cs
---	-------	----------------	----------	----

AUTOSTRADA VALDASTICO A31 NORD
1° LOTTO - PIOVENE ROCCHETTE – VALLE DELL'ASTICO

x	Comb.	δ_{max}	L/250.00	Cs
cm		mm	mm	
191.7	15	-0.03	10.96	>100

Verifica spostamento elastico dovuto ai soli carichi variabili (§4.2.4.2.1 - NTC 2008)

x	Comb.	δ_2	L/300.00	Cs
cm		mm	mm	
164.3	15	-0.02	9.13	>100

Travata: 36 [210 , 198]

L = 273.9cm

Crit.Prog: Acciaio_Flessione $\delta_c = 0.0cm$ Verifica: **Verificata**

Verifica spostamento nello stato finale (§4.2.4.2.1 - NTC 2008)

x	Comb.	δ_{max}	L/250.00	Cs
cm		mm	mm	
137.0	15	0.13	10.96	84.8

Verifica spostamento elastico dovuto ai soli carichi variabili (§4.2.4.2.1 - NTC 2008)

x	Comb.	δ_2	L/300.00	Cs
cm		mm	mm	
137.0	15	0.07	9.13	>100

Travata: 37 [198 , 190]

L = 273.9cm

Crit.Prog: Acciaio_Flessione $\delta_c = 0.0cm$ Verifica: **Verificata**

Verifica spostamento nello stato finale (§4.2.4.2.1 - NTC 2008)

x	Comb.	δ_{max}	L/250.00	Cs
---	-------	----------------	----------	----

AUTOSTRADA VALDASTICO A31 NORD
1° LOTTO - PIOVENE ROCCHETTE – VALLE DELL'ASTICO

x	Comb.	δ_{max}	L/250.00	Cs
cm		mm	mm	
164.3	15	0.14	10.96	78.3

Verifica spostamento elastico dovuto ai soli carichi variabili (§4.2.4.2.1 - NTC 2008)

x	Comb.	δ_2	L/300.00	Cs
cm		mm	mm	
164.3	15	0.07	9.13	>100

Travata: 38 [190 , 189]

L = 314.0cm

Crit.Prog: Acciaio_Flessione $\delta_c = 0.0cm$ Verifica: **Verificata**

Verifica spostamento nello stato finale (§4.2.4.2.1 - NTC 2008)

x	Comb.	δ_{max}	L/250.00	Cs
cm		mm	mm	
219.8	15	-1.45	12.56	8.65

Verifica spostamento elastico dovuto ai soli carichi variabili (§4.2.4.2.1 - NTC 2008)

x	Comb.	δ_2	L/300.00	Cs
cm		mm	mm	
219.8	15	-0.91	10.47	11.5

Travata: 39 [189 , 212]

L = 286.0cm

Crit.Prog: Acciaio_Flessione $\delta_c = 0.0cm$ Verifica: **Verificata**

Verifica spostamento nello stato finale (§4.2.4.2.1 - NTC 2008)

x	Comb.	δ_{max}	L/250.00	Cs
---	-------	----------------	----------	----

AUTOSTRADA VALDASTICO A31 NORD
1° LOTTO - PIOVENE ROCCHETTE – VALLE DELL'ASTICO

x	Comb.	δ_{max}	L/250.00	Cs
cm		mm	mm	
85.8	15	-0.38	11.44	30.4

Verifica spostamento elastico dovuto ai soli carichi variabili (§4.2.4.2.1 - NTC 2008)

x	Comb.	δ_2	L/300.00	Cs
cm		mm	mm	
85.8	15	-0.27	9.53	34.7

Travata: 40 [211 , 197]

L = 254.4cm

Crit.Prog: Acciaio_Flessione $\delta_c = 0.0cm$ Verifica: **Verificata**

Verifica spostamento nello stato finale (§4.2.4.2.1 - NTC 2008)

x	Comb.	δ_{max}	L/250.00	Cs
cm		mm	mm	
127.2	15	0.20	10.17	52.0

Verifica spostamento elastico dovuto ai soli carichi variabili (§4.2.4.2.1 - NTC 2008)

x	Comb.	δ_2	L/300.00	Cs
cm		mm	mm	
127.2	15	0.11	8.48	75.9

Travata: 41 [197 , 212]

L = 254.4cm

Crit.Prog: Acciaio_Flessione $\delta_c = 0.0cm$ Verifica: **Verificata**

Verifica spostamento nello stato finale (§4.2.4.2.1 - NTC 2008)

x	Comb.	δ_{max}	L/250.00	Cs
---	-------	----------------	----------	----

AUTOSTRADA VALDASTICO A31 NORD
1° LOTTO - PIOVENE ROCCHETTE – VALLE DELL'ASTICO

x	Comb.	δ_{max}	L/250.00	Cs
cm		mm	mm	
127.2	15	-0.28	10.17	36.2

Verifica spostamento elastico dovuto ai soli carichi variabili (§4.2.4.2.1 - NTC 2008)

x	Comb.	δ_2	L/300.00	Cs
cm		mm	mm	
127.2	15	-0.18	8.48	48.4

Travata: 42 [190 , 197]

L = 254.4cm

Crit.Prog: Acciaio_Flessione $\delta_c = 0.0cm$ Verifica: **Verificata**

Verifica spostamento nello stato finale (§4.2.4.2.1 - NTC 2008)

x	Comb.	δ_{max}	L/250.00	Cs
cm		mm	mm	
127.2	15	-0.19	10.17	52.9

Verifica spostamento elastico dovuto ai soli carichi variabili (§4.2.4.2.1 - NTC 2008)

x	Comb.	δ_2	L/300.00	Cs
cm		mm	mm	
127.2	15	-0.12	8.48	68.5

Travata: 43 [197 , 189]

L = 254.4cm

Crit.Prog: Acciaio_Flessione $\delta_c = 0.0cm$ Verifica: **Verificata**

Verifica spostamento nello stato finale (§4.2.4.2.1 - NTC 2008)

x	Comb.	δ_{max}	L/250.00	Cs
---	-------	----------------	----------	----

AUTOSTRADA VALDASTICO A31 NORD
1° LOTTO - PIOVENE ROCCHETTE – VALLE DELL'ASTICO

x	Comb.	δ_{max}	L/250.00	Cs
cm		mm	mm	
178.1	15	-0.71	10.17	14.2

Verifica spostamento elastico dovuto ai soli carichi variabili (§4.2.4.2.1 - NTC 2008)

x	Comb.	δ_2	L/300.00	Cs
cm		mm	mm	
178.1	15	-0.46	8.48	18.3

Travata: 44 [213 , 188]

L = 286.0cm

Crit.Prog: Acciaio_Flessione $\delta_c = 0.0cm$ Verifica: **Verificata**

Verifica spostamento nello stato finale (§4.2.4.2.1 - NTC 2008)

x	Comb.	δ_{max}	L/250.00	Cs
cm		mm	mm	
57.2	15	-0.18	11.44	62.1

Verifica spostamento elastico dovuto ai soli carichi variabili (§4.2.4.2.1 - NTC 2008)

x	Comb.	δ_2	L/300.00	Cs
cm		mm	mm	
85.8	15	-0.14	9.53	70.4

Travata: 45 [188 , 189]

L = 314.0cm

Crit.Prog: Acciaio_Flessione $\delta_c = 0.0cm$ Verifica: **Verificata**

Verifica spostamento nello stato finale (§4.2.4.2.1 - NTC 2008)

x	Comb.	δ_{max}	L/250.00	Cs
---	-------	----------------	----------	----

AUTOSTRADA VALDASTICO A31 NORD
1° LOTTO - PIOVENE ROCCHETTE – VALLE DELL'ASTICO

x	Comb.	δ_{max}	L/250.00	Cs
cm		mm	mm	
219.8	15	0.11	12.56	>100

Verifica spostamento elastico dovuto ai soli carichi variabili (§4.2.4.2.1 - NTC 2008)

x	Comb.	δ_2	L/300.00	Cs
cm		mm	mm	
251.2	15	0.06	10.47	>100

Travata: 46 [212 , 204]

L = 229.9cm

Crit.Prog: Acciaio_Flessione $\delta_c = 0.0cm$ Verifica: **Verificata**

Verifica spostamento nello stato finale (§4.2.4.2.1 - NTC 2008)

x	Comb.	δ_{max}	L/250.00	Cs
cm		mm	mm	
137.9	15	-0.24	9.19	38.0

Verifica spostamento elastico dovuto ai soli carichi variabili (§4.2.4.2.1 - NTC 2008)

x	Comb.	δ_2	L/300.00	Cs
cm		mm	mm	
137.9	15	-0.13	7.66	57.8

Travata: 47 [204 , 188]

L = 229.9cm

Crit.Prog: Acciaio_Flessione $\delta_c = 0.0cm$ Verifica: **Verificata**

Verifica spostamento nello stato finale (§4.2.4.2.1 - NTC 2008)

x	Comb.	δ_{max}	L/250.00	Cs
---	-------	----------------	----------	----

AUTOSTRADA VALDASTICO A31 NORD
1° LOTTO - PIOVENE ROCCHETTE – VALLE DELL'ASTICO

x	Comb.	δ_{max}	L/250.00	Cs
cm		mm	mm	
69.0	15	-0.30	9.19	30.2

Verifica spostamento elastico dovuto ai soli carichi variabili (§4.2.4.2.1 - NTC 2008)

x	Comb.	δ_2	L/300.00	Cs
cm		mm	mm	
91.9	15	-0.22	7.66	34.8

Travata: 48 [204 , 213]

L = 229.9cm

Crit.Prog: Acciaio_Flessione $\delta_c = 0.0cm$ Verifica: **Verificata**

Verifica spostamento nello stato finale (§4.2.4.2.1 - NTC 2008)

x	Comb.	δ_{max}	L/250.00	Cs
cm		mm	mm	
46.0	15	-0.07	9.19	>100

Verifica spostamento elastico dovuto ai soli carichi variabili (§4.2.4.2.1 - NTC 2008)

x	Comb.	δ_2	L/300.00	Cs
cm		mm	mm	
69.0	15	-0.06	7.66	>100

Travata: 49 [203 , 202]

L = 318.3cm

Crit.Prog: Acciaio_Flessione $\delta_c = 0.0cm$ Verifica: **Verificata**

Verifica spostamento nello stato finale (§4.2.4.2.1 - NTC 2008)

x	Comb.	δ_{max}	L/250.00	Cs
---	-------	----------------	----------	----

AUTOSTRADA VALDASTICO A31 NORD
1° LOTTO - PIOVENE ROCCHETTE – VALLE DELL'ASTICO

x	Comb.	δ_{max}	L/250.00	Cs
cm		mm	mm	
159.1	15	1.66	12.73	7.66

Verifica spostamento elastico dovuto ai soli carichi variabili (§4.2.4.2.1 - NTC 2008)

x	Comb.	δ_2	L/300.00	Cs
cm		mm	mm	
159.1	15	1.33	10.61	7.99

Travata: 50 [202 , 201]

L = 315.7cm

Crit.Prog: Acciaio_Flessione $\delta_c = 0.0cm$ Verifica: **Verificata**

Verifica spostamento nello stato finale (§4.2.4.2.1 - NTC 2008)

x	Comb.	δ_{max}	L/250.00	Cs
cm		mm	mm	
157.9	15	2.73	12.63	4.63

Verifica spostamento elastico dovuto ai soli carichi variabili (§4.2.4.2.1 - NTC 2008)

x	Comb.	δ_2	L/300.00	Cs
cm		mm	mm	
157.9	15	1.96	10.52	5.36

Travata: 51 [201 , 200]

L = 314.2cm

Crit.Prog: Acciaio_Flessione $\delta_c = 0.0cm$ Verifica: **Verificata**

Verifica spostamento nello stato finale (§4.2.4.2.1 - NTC 2008)

x	Comb.	δ_{max}	L/250.00	Cs
---	-------	----------------	----------	----

AUTOSTRADA VALDASTICO A31 NORD
1° LOTTO - PIOVENE ROCCHETTE – VALLE DELL'ASTICO

x	Comb.	δ_{max}	L/250.00	Cs
cm		mm	mm	
157.1	15	2.78	12.57	4.52

Verifica spostamento elastico dovuto ai soli carichi variabili (§4.2.4.2.1 - NTC 2008)

x	Comb.	δ_2	L/300.00	Cs
cm		mm	mm	
157.1	15	1.99	10.47	5.26

Travata: 52 [200 , 199]

L = 314.0cm

Crit.Prog: Acciaio_Flessione $\delta_c = 0.0cm$ Verifica: **Verificata**

Verifica spostamento nello stato finale (§4.2.4.2.1 - NTC 2008)

x	Comb.	δ_{max}	L/250.00	Cs
cm		mm	mm	
157.0	15	2.81	12.56	4.47

Verifica spostamento elastico dovuto ai soli carichi variabili (§4.2.4.2.1 - NTC 2008)

x	Comb.	δ_2	L/300.00	Cs
cm		mm	mm	
157.0	15	2.00	10.47	5.22

Travata: 53 [199 , 198]

L = 314.2cm

Crit.Prog: Acciaio_Flessione $\delta_c = 0.0cm$ Verifica: **Verificata**

Verifica spostamento nello stato finale (§4.2.4.2.1 - NTC 2008)

x	Comb.	δ_{max}	L/250.00	Cs
---	-------	----------------	----------	----

AUTOSTRADA VALDASTICO A31 NORD
1° LOTTO - PIOVENE ROCCHETTE – VALLE DELL'ASTICO

x	Comb.	δ_{max}	L/250.00	Cs
cm		mm	mm	
157.1	15	2.78	12.57	4.52

Verifica spostamento elastico dovuto ai soli carichi variabili (§4.2.4.2.1 - NTC 2008)

x	Comb.	δ_2	L/300.00	Cs
cm		mm	mm	
157.1	15	1.99	10.47	5.27

Travata: 54 [198 , 197]

L = 315.7cm

Crit.Prog: Acciaio_Flessione $\delta_c = 0.0cm$ Verifica: **Verificata**

Verifica spostamento nello stato finale (§4.2.4.2.1 - NTC 2008)

x	Comb.	δ_{max}	L/250.00	Cs
cm		mm	mm	
157.9	15	2.72	12.63	4.65

Verifica spostamento elastico dovuto ai soli carichi variabili (§4.2.4.2.1 - NTC 2008)

x	Comb.	δ_2	L/300.00	Cs
cm		mm	mm	
157.9	15	1.96	10.52	5.37

Travata: 55 [197 , 204]

L = 318.3cm

Crit.Prog: Acciaio_Flessione $\delta_c = 0.0cm$ Verifica: **Verificata**

Verifica spostamento nello stato finale (§4.2.4.2.1 - NTC 2008)

x	Comb.	δ_{max}	L/250.00	Cs
---	-------	----------------	----------	----

AUTOSTRADA VALDASTICO A31 NORD
1° LOTTO - PIOVENE ROCCHETTE – VALLE DELL'ASTICO

x	Comb.	δ_{max}	L/250.00	Cs
cm		mm	mm	
159.1	15	1.77	12.73	7.20

Verifica spostamento elastico dovuto ai soli carichi variabili (§4.2.4.2.1 - NTC 2008)

x	Comb.	δ_2	L/300.00	Cs
cm		mm	mm	
159.1	15	1.42	10.61	7.49

Travata: 56 [205 , 220]

L = 229.9cm

Crit.Prog: Acciaio_Flessione $\delta_c = 0.0cm$ Verifica: **Verificata**

Verifica spostamento nello stato finale (§4.2.4.2.1 - NTC 2008)

x	Comb.	δ_{max}	L/250.00	Cs
cm		mm	mm	
114.9	15	-0.18	9.19	51.5

Verifica spostamento elastico dovuto ai soli carichi variabili (§4.2.4.2.1 - NTC 2008)

x	Comb.	δ_2	L/300.00	Cs
cm		mm	mm	
114.9	15	-0.13	7.66	60.2

Travata: 57 [223 , 206]

L = 286.0cm

Crit.Prog: Acciaio_Flessione $\delta_c = 0.0cm$ Verifica: **Verificata**

Verifica spostamento nello stato finale (§4.2.4.2.1 - NTC 2008)

x	Comb.	δ_{max}	L/250.00	Cs
---	-------	----------------	----------	----

AUTOSTRADA VALDASTICO A31 NORD
1° LOTTO - PIOVENE ROCCHETTE – VALLE DELL'ASTICO

x	Comb.	δ_{max}	L/250.00	Cs
cm		mm	mm	
143.0	15	0.31	11.44	37.3

Verifica spostamento elastico dovuto ai soli carichi variabili (§4.2.4.2.1 - NTC 2008)

x	Comb.	δ_2	L/300.00	Cs
cm		mm	mm	
143.0	15	0.18	9.53	53.2

Travata: 58 [206 , 205]

L = 314.0cm

Crit.Prog: Acciaio_Flessione $\delta_c = 0.0cm$ Verifica: **Verificata**

Verifica spostamento nello stato finale (§4.2.4.2.1 - NTC 2008)

x	Comb.	δ_{max}	L/250.00	Cs
cm		mm	mm	
125.6	15	-0.20	12.56	62.3

Verifica spostamento elastico dovuto ai soli carichi variabili (§4.2.4.2.1 - NTC 2008)

x	Comb.	δ_2	L/300.00	Cs
cm		mm	mm	
157.0	15	-0.16	10.47	64.0

Travata: 59 [222 , 220]

L = 229.9cm

Crit.Prog: Acciaio_Flessione $\delta_c = 0.0cm$ Verifica: **Verificata**

Verifica spostamento nello stato finale (§4.2.4.2.1 - NTC 2008)

AUTOSTRADA VALDASTICO A31 NORD
1° LOTTO - PIOVENE ROCCHETTE – VALLE DELL'ASTICO

x	Comb.	δ_{max}	L/250.00	Cs
cm		mm	mm	
91.9	21	0.02	9.19	>100

Verifica spostamento elastico dovuto ai soli carichi variabili (§4.2.4.2.1 - NTC 2008)

x	Comb.	δ_2	L/300.00	Cs
cm		mm	mm	
160.9	15	-0.02	7.66	>100

Travata: 60 [220 , 206]

L = 229.9cm

Crit.Prog: Acciaio_Flessione $\delta_c = 0.0cm$ Verifica: **Verificata**

Verifica spostamento nello stato finale (§4.2.4.2.1 - NTC 2008)

x	Comb.	δ_{max}	L/250.00	Cs
cm		mm	mm	
69.0	15	0.08	9.19	>100

Verifica spostamento elastico dovuto ai soli carichi variabili (§4.2.4.2.1 - NTC 2008)

x	Comb.	δ_2	L/300.00	Cs
cm		mm	mm	
69.0	15	0.06	7.66	>100

Travata: 61 [220 , 223]

L = 229.9cm

Crit.Prog: Acciaio_Flessione $\delta_c = 0.0cm$ Verifica: **Verificata**

Verifica spostamento nello stato finale (§4.2.4.2.1 - NTC 2008)

x	Comb.	δ_{max}	L/250.00	Cs
---	-------	----------------	----------	----

AUTOSTRADA VALDASTICO A31 NORD
1° LOTTO - PIOVENE ROCCHETTE – VALLE DELL'ASTICO

x	Comb.	δ_{max}	L/250.00	Cs
cm		mm	mm	
91.9	15	0.14	9.19	67.4

Verifica spostamento elastico dovuto ai soli carichi variabili (§4.2.4.2.1 - NTC 2008)

x	Comb.	δ_2	L/300.00	Cs
cm		mm	mm	
91.9	15	0.09	7.66	87.5

Travata: 62 [222 , 205]

L = 286.0cm

Crit.Prog: Acciaio_Flessione $\delta_c = 0.0cm$ Verifica: **Verificata**

Verifica spostamento nello stato finale (§4.2.4.2.1 - NTC 2008)

x	Comb.	δ_{max}	L/250.00	Cs
cm		mm	mm	
85.8	15	0.07	11.44	>100

Verifica spostamento elastico dovuto ai soli carichi variabili (§4.2.4.2.1 - NTC 2008)

x	Comb.	δ_2	L/300.00	Cs
cm		mm	mm	
85.8	15	0.05	9.53	>100

Travata: 63 [224 , 207]

L = 286.0cm

Crit.Prog: Acciaio_Flessione $\delta_c = 0.0cm$ Verifica: **Verificata**

Verifica spostamento nello stato finale (§4.2.4.2.1 - NTC 2008)

x	Comb.	δ_{max}	L/250.00	Cs
---	-------	----------------	----------	----

AUTOSTRADA VALDASTICO A31 NORD
1° LOTTO - PIOVENE ROCCHETTE – VALLE DELL'ASTICO

x	Comb.	δ_{max}	L/250.00	Cs
cm		mm	mm	
114.4	15	0.08	11.44	>100

Verifica spostamento elastico dovuto ai soli carichi variabili (§4.2.4.2.1 - NTC 2008)

x	Comb.	δ_2	L/300.00	Cs
cm		mm	mm	
85.8	15	0.04	9.53	>100

Travata: 64 [207 , 206]

L = 314.0cm

Crit.Prog: Acciaio_Flessione $\delta_c = 0.0cm$ Verifica: **Verificata**

Verifica spostamento nello stato finale (§4.2.4.2.1 - NTC 2008)

x	Comb.	δ_{max}	L/250.00	Cs
cm		mm	mm	
251.2	15	-0.13	12.56	94.1

Verifica spostamento elastico dovuto ai soli carichi variabili (§4.2.4.2.1 - NTC 2008)

x	Comb.	δ_2	L/300.00	Cs
cm		mm	mm	
219.8	15	-0.10	10.47	>100

Travata: 65 [206 , 219]

L = 254.4cm

Crit.Prog: Acciaio_Flessione $\delta_c = 0.0cm$ Verifica: **Verificata**

Verifica spostamento nello stato finale (§4.2.4.2.1 - NTC 2008)

x	Comb.	δ_{max}	L/250.00	Cs
---	-------	----------------	----------	----

AUTOSTRADA VALDASTICO A31 NORD
1° LOTTO - PIOVENE ROCCHETTE – VALLE DELL'ASTICO

x	Comb.	δ_{max}	L/250.00	Cs
cm		mm	mm	
152.6	15	0.10	10.17	97.8

Verifica spostamento elastico dovuto ai soli carichi variabili (§4.2.4.2.1 - NTC 2008)

x	Comb.	δ_2	L/300.00	Cs
cm		mm	mm	
152.6	15	0.06	8.48	>100

Travata: 66 [219 , 224]

L = 254.4cm

Crit.Prog: Acciaio_Flessione $\delta_c = 0.0cm$ Verifica: **Verificata**

Verifica spostamento nello stato finale (§4.2.4.2.1 - NTC 2008)

x	Comb.	δ_{max}	L/250.00	Cs
cm		mm	mm	
127.2	15	0.12	10.17	83.5

Verifica spostamento elastico dovuto ai soli carichi variabili (§4.2.4.2.1 - NTC 2008)

x	Comb.	δ_2	L/300.00	Cs
cm		mm	mm	
127.2	15	0.06	8.48	>100

Travata: 67 [223 , 219]

L = 254.4cm

Crit.Prog: Acciaio_Flessione $\delta_c = 0.0cm$ Verifica: **Verificata**

Verifica spostamento nello stato finale (§4.2.4.2.1 - NTC 2008)

x	Comb.	δ_{max}	L/250.00	Cs
---	-------	----------------	----------	----

AUTOSTRADA VALDASTICO A31 NORD
1° LOTTO - PIOVENE ROCCHETTE – VALLE DELL'ASTICO

x	Comb.	δ_{max}	L/250.00	Cs
cm		mm	mm	
50.9	15	-0.01	10.17	>100

Verifica spostamento elastico dovuto ai soli carichi variabili (§4.2.4.2.1 - NTC 2008)

x	Comb.	δ_2	L/300.00	Cs
cm		mm	mm	
50.9	15	-0.01	8.48	>100

Travata: 68 [219 , 207]

L = 254.4cm

Crit.Prog: Acciaio_Flessione $\delta_c = 0.0cm$ Verifica: **Verificata**

Verifica spostamento nello stato finale (§4.2.4.2.1 - NTC 2008)

x	Comb.	δ_{max}	L/250.00	Cs
cm		mm	mm	
152.6	15	-0.08	10.17	>100

Verifica spostamento elastico dovuto ai soli carichi variabili (§4.2.4.2.1 - NTC 2008)

x	Comb.	δ_2	L/300.00	Cs
cm		mm	mm	
152.6	15	-0.06	8.48	>100

Travata: 69 [225 , 208]

L = 286.0cm

Crit.Prog: Acciaio_Flessione $\delta_c = 0.0cm$ Verifica: **Verificata**

Verifica spostamento nello stato finale (§4.2.4.2.1 - NTC 2008)

x	Comb.	δ_{max}	L/250.00	Cs
---	-------	----------------	----------	----

AUTOSTRADA VALDASTICO A31 NORD
1° LOTTO - PIOVENE ROCCHETTE – VALLE DELL'ASTICO

x	Comb.	δ_{max}	L/250.00	Cs
cm		mm	mm	
200.2	15	-0.03	11.44	>100

Verifica spostamento elastico dovuto ai soli carichi variabili (§4.2.4.2.1 - NTC 2008)

x	Comb.	δ_2	L/300.00	Cs
cm		mm	mm	
143.0	15	-0.03	9.53	>100

Travata: 70 [208 , 207]

L = 314.0cm

Crit.Prog: Acciaio_Flessione $\delta_c = 0.0cm$ Verifica: **Verificata**

Verifica spostamento nello stato finale (§4.2.4.2.1 - NTC 2008)

x	Comb.	δ_{max}	L/250.00	Cs
cm		mm	mm	
157.0	15	0.40	12.56	31.5

Verifica spostamento elastico dovuto ai soli carichi variabili (§4.2.4.2.1 - NTC 2008)

x	Comb.	δ_2	L/300.00	Cs
cm		mm	mm	
157.0	15	0.21	10.47	50.9

Travata: 71 [224 , 218]

L = 273.9cm

Crit.Prog: Acciaio_Flessione $\delta_c = 0.0cm$ Verifica: **Verificata**

Verifica spostamento nello stato finale (§4.2.4.2.1 - NTC 2008)

x	Comb.	δ_{max}	L/250.00	Cs
---	-------	----------------	----------	----

AUTOSTRADA VALDASTICO A31 NORD
1° LOTTO - PIOVENE ROCCHETTE – VALLE DELL'ASTICO

x	Comb.	δ_{max}	L/250.00	Cs
cm		mm	mm	
137.0	15	0.03	10.96	>100

Verifica spostamento elastico dovuto ai soli carichi variabili (§4.2.4.2.1 - NTC 2008)

x	Comb.	δ_2	L/300.00	Cs
cm		mm	mm	
137.0	15	0.01	9.13	>100

Travata: 72 [218 , 208]

$L = 273.9\text{cm}$

Crit.Prog: Acciaio_Flessione $\delta_c = 0.0\text{cm}$ Verifica: **Verificata**

Verifica spostamento nello stato finale (§4.2.4.2.1 - NTC 2008)

x	Comb.	δ_{max}	L/250.00	Cs
cm		mm	mm	
137.0	15	0.03	10.96	>100

Verifica spostamento elastico dovuto ai soli carichi variabili (§4.2.4.2.1 - NTC 2008)

x	Comb.	δ_2	L/300.00	Cs
cm		mm	mm	
137.0	15	0.01	9.13	>100

Travata: 73 [207 , 218]

$L = 273.9\text{cm}$

Crit.Prog: Acciaio_Flessione $\delta_c = 0.0\text{cm}$ Verifica: **Verificata**

Verifica spostamento nello stato finale (§4.2.4.2.1 - NTC 2008)

x	Comb.	δ_{max}	L/250.00	Cs
---	-------	----------------	----------	----

AUTOSTRADA VALDASTICO A31 NORD
1° LOTTO - PIOVENE ROCCHETTE – VALLE DELL'ASTICO

x	Comb.	δ_{max}	L/250.00	Cs
cm		mm	mm	
137.0	15	0.17	10.96	65.8

Verifica spostamento elastico dovuto ai soli carichi variabili (§4.2.4.2.1 - NTC 2008)

x	Comb.	δ_2	L/300.00	Cs
cm		mm	mm	
137.0	15	0.09	9.13	>100

Travata: 74 [218 , 225]

L = 273.9cm

Crit.Prog: Acciaio_Flessione $\delta_c = 0.0cm$ Verifica: **Verificata**

Verifica spostamento nello stato finale (§4.2.4.2.1 - NTC 2008)

x	Comb.	δ_{max}	L/250.00	Cs
cm		mm	mm	
137.0	15	0.11	10.96	95.6

Verifica spostamento elastico dovuto ai soli carichi variabili (§4.2.4.2.1 - NTC 2008)

x	Comb.	δ_2	L/300.00	Cs
cm		mm	mm	
137.0	15	0.06	9.13	>100

Travata: 75 [226 , 209]

L = 286.0cm

Crit.Prog: Acciaio_Flessione $\delta_c = 0.0cm$ Verifica: **Verificata**

Verifica spostamento nello stato finale (§4.2.4.2.1 - NTC 2008)

x	Comb.	δ_{max}	L/250.00	Cs
---	-------	----------------	----------	----

AUTOSTRADA VALDASTICO A31 NORD
1° LOTTO - PIOVENE ROCCHETTE – VALLE DELL'ASTICO

x	Comb.	δ_{max}	L/250.00	Cs
cm		mm	mm	
85.8	15	-0.04	11.44	>100

Verifica spostamento elastico dovuto ai soli carichi variabili (§4.2.4.2.1 - NTC 2008)

x	Comb.	δ_2	L/300.00	Cs
cm		mm	mm	
143.0	15	-0.04	9.53	>100

Travata: 76 [209 , 208]

L = 314.0cm

Crit.Prog: Acciaio_Flessione $\delta_c = 0.0cm$ Verifica: **Verificata**

Verifica spostamento nello stato finale (§4.2.4.2.1 - NTC 2008)

x	Comb.	δ_{max}	L/250.00	Cs
cm		mm	mm	
157.0	15	0.49	12.56	25.4

Verifica spostamento elastico dovuto ai soli carichi variabili (§4.2.4.2.1 - NTC 2008)

x	Comb.	δ_2	L/300.00	Cs
cm		mm	mm	
157.0	15	0.26	10.47	39.6

Travata: 77 [225 , 217]

L = 281.6cm

Crit.Prog: Acciaio_Flessione $\delta_c = 0.0cm$ Verifica: **Verificata**

Verifica spostamento nello stato finale (§4.2.4.2.1 - NTC 2008)

x	Comb.	δ_{max}	L/250.00	Cs
---	-------	----------------	----------	----

AUTOSTRADA VALDASTICO A31 NORD
1° LOTTO - PIOVENE ROCCHETTE – VALLE DELL'ASTICO

x	Comb.	δ_{max}	L/250.00	Cs
cm		mm	mm	
140.8	15	0.08	11.27	>100

Verifica spostamento elastico dovuto ai soli carichi variabili (§4.2.4.2.1 - NTC 2008)

x	Comb.	δ_2	L/300.00	Cs
cm		mm	mm	
140.8	15	0.04	9.39	>100

Travata: 78 [217 , 226]

L = 281.6cm

Crit.Prog: Acciaio_Flessione $\delta_c = 0.0cm$ Verifica: **Verificata**

Verifica spostamento nello stato finale (§4.2.4.2.1 - NTC 2008)

x	Comb.	δ_{max}	L/250.00	Cs
cm		mm	mm	
140.8	15	0.11	11.27	>100

Verifica spostamento elastico dovuto ai soli carichi variabili (§4.2.4.2.1 - NTC 2008)

x	Comb.	δ_2	L/300.00	Cs
cm		mm	mm	
140.8	15	0.05	9.39	>100

Travata: 79 [208 , 217]

L = 281.6cm

Crit.Prog: Acciaio_Flessione $\delta_c = 0.0cm$ Verifica: **Verificata**

Verifica spostamento nello stato finale (§4.2.4.2.1 - NTC 2008)

x	Comb.	δ_{max}	L/250.00	Cs
---	-------	----------------	----------	----

AUTOSTRADA VALDASTICO A31 NORD
1° LOTTO - PIOVENE ROCCHETTE – VALLE DELL'ASTICO

x	Comb.	δ_{max}	L/250.00	Cs
cm		mm	mm	
140.8	15	0.13	11.27	87.5

Verifica spostamento elastico dovuto ai soli carichi variabili (§4.2.4.2.1 - NTC 2008)

x	Comb.	δ_2	L/300.00	Cs
cm		mm	mm	
140.8	15	0.07	9.39	>100

Travata: 80 [217 , 209]

L = 281.6cm

Crit.Prog: Acciaio_Flessione $\delta_c = 0.0cm$ Verifica: **Verificata**

Verifica spostamento nello stato finale (§4.2.4.2.1 - NTC 2008)

x	Comb.	δ_{max}	L/250.00	Cs
cm		mm	mm	
140.8	15	0.10	11.27	>100

Verifica spostamento elastico dovuto ai soli carichi variabili (§4.2.4.2.1 - NTC 2008)

x	Comb.	δ_2	L/300.00	Cs
cm		mm	mm	
140.8	15	0.05	9.39	>100

Travata: 81 [209 , 216]

L = 281.6cm

Crit.Prog: Acciaio_Flessione $\delta_c = 0.0cm$ Verifica: **Verificata**

Verifica spostamento nello stato finale (§4.2.4.2.1 - NTC 2008)

x	Comb.	δ_{max}	L/250.00	Cs
---	-------	----------------	----------	----

AUTOSTRADA VALDASTICO A31 NORD
1° LOTTO - PIOVENE ROCCHETTE – VALLE DELL'ASTICO

x	Comb.	δ_{max}	L/250.00	Cs
cm		mm	mm	
140.8	15	0.10	11.27	>100

Verifica spostamento elastico dovuto ai soli carichi variabili (§4.2.4.2.1 - NTC 2008)

x	Comb.	δ_2	L/300.00	Cs
cm		mm	mm	
140.8	15	0.05	9.39	>100

Travata: 82 [216 , 227]

L = 281.6cm

Crit.Prog: Acciaio_Flessione $\delta_c = 0.0cm$ Verifica: **Verificata**

Verifica spostamento nello stato finale (§4.2.4.2.1 - NTC 2008)

x	Comb.	δ_{max}	L/250.00	Cs
cm		mm	mm	
140.8	15	0.08	11.27	>100

Verifica spostamento elastico dovuto ai soli carichi variabili (§4.2.4.2.1 - NTC 2008)

x	Comb.	δ_2	L/300.00	Cs
cm		mm	mm	
140.8	15	0.04	9.39	>100

Travata: 83 [227 , 210]

L = 286.0cm

Crit.Prog: Acciaio_Flessione $\delta_c = 0.0cm$ Verifica: **Verificata**

Verifica spostamento nello stato finale (§4.2.4.2.1 - NTC 2008)

x	Comb.	δ_{max}	L/250.00	Cs
---	-------	----------------	----------	----

AUTOSTRADA VALDASTICO A31 NORD
1° LOTTO - PIOVENE ROCCHETTE – VALLE DELL'ASTICO

x	Comb.	δ_{max}	L/250.00	Cs
cm		mm	mm	
228.8	15	-0.03	11.44	>100

Verifica spostamento elastico dovuto ai soli carichi variabili (§4.2.4.2.1 - NTC 2008)

x	Comb.	δ_2	L/300.00	Cs
cm		mm	mm	
143.0	15	-0.03	9.53	>100

Travata: 84 [210 , 209]

L = 314.0cm

Crit.Prog: Acciaio_Flessione $\delta_c = 0.0cm$ Verifica: **Verificata**

Verifica spostamento nello stato finale (§4.2.4.2.1 - NTC 2008)

x	Comb.	δ_{max}	L/250.00	Cs
cm		mm	mm	
157.0	15	0.49	12.56	25.5

Verifica spostamento elastico dovuto ai soli carichi variabili (§4.2.4.2.1 - NTC 2008)

x	Comb.	δ_2	L/300.00	Cs
cm		mm	mm	
157.0	15	0.26	10.47	39.7

Travata: 85 [226 , 216]

L = 281.6cm

Crit.Prog: Acciaio_Flessione $\delta_c = 0.0cm$ Verifica: **Verificata**

Verifica spostamento nello stato finale (§4.2.4.2.1 - NTC 2008)

x	Comb.	δ_{max}	L/250.00	Cs
---	-------	----------------	----------	----

AUTOSTRADA VALDASTICO A31 NORD
1° LOTTO - PIOVENE ROCCHETTE – VALLE DELL'ASTICO

x	Comb.	δ_{max}	L/250.00	Cs
cm		mm	mm	
140.8	15	0.11	11.27	>100

Verifica spostamento elastico dovuto ai soli carichi variabili (§4.2.4.2.1 - NTC 2008)

x	Comb.	δ_2	L/300.00	Cs
cm		mm	mm	
140.8	15	0.05	9.39	>100

Travata: 86 [216 , 210]

L = 281.6cm

Crit.Prog: Acciaio_Flessione $\delta_c = 0.0cm$ Verifica: **Verificata**

Verifica spostamento nello stato finale (§4.2.4.2.1 - NTC 2008)

x	Comb.	δ_{max}	L/250.00	Cs
cm		mm	mm	
140.8	15	0.13	11.27	86.7

Verifica spostamento elastico dovuto ai soli carichi variabili (§4.2.4.2.1 - NTC 2008)

x	Comb.	δ_2	L/300.00	Cs
cm		mm	mm	
140.8	15	0.07	9.39	>100

Travata: 87 [228 , 211]

L = 286.0cm

Crit.Prog: Acciaio_Flessione $\delta_c = 0.0cm$ Verifica: **Verificata**

Verifica spostamento nello stato finale (§4.2.4.2.1 - NTC 2008)

x	Comb.	δ_{max}	L/250.00	Cs
---	-------	----------------	----------	----

AUTOSTRADA VALDASTICO A31 NORD
1° LOTTO - PIOVENE ROCCHETTE – VALLE DELL'ASTICO

x	Comb.	δ_{max}	L/250.00	Cs
cm		mm	mm	
114.4	15	0.08	11.44	>100

Verifica spostamento elastico dovuto ai soli carichi variabili (§4.2.4.2.1 - NTC 2008)

x	Comb.	δ_2	L/300.00	Cs
cm		mm	mm	
85.8	15	0.04	9.53	>100

Travata: 88 [211 , 210]

L = 314.0cm

Crit.Prog: Acciaio_Flessione $\delta_c = 0.0cm$ Verifica: **Verificata**

Verifica spostamento nello stato finale (§4.2.4.2.1 - NTC 2008)

x	Comb.	δ_{max}	L/250.00	Cs
cm		mm	mm	
157.0	15	0.40	12.56	31.7

Verifica spostamento elastico dovuto ai soli carichi variabili (§4.2.4.2.1 - NTC 2008)

x	Comb.	δ_2	L/300.00	Cs
cm		mm	mm	
157.0	15	0.21	10.47	50.8

Travata: 89 [210 , 215]

L = 273.9cm

Crit.Prog: Acciaio_Flessione $\delta_c = 0.0cm$ Verifica: **Verificata**

Verifica spostamento nello stato finale (§4.2.4.2.1 - NTC 2008)

x	Comb.	δ_{max}	L/250.00	Cs
---	-------	----------------	----------	----

AUTOSTRADA VALDASTICO A31 NORD
1° LOTTO - PIOVENE ROCCHETTE – VALLE DELL'ASTICO

x	Comb.	δ_{max}	L/250.00	Cs
cm		mm	mm	
137.0	15	0.03	10.96	>100

Verifica spostamento elastico dovuto ai soli carichi variabili (§4.2.4.2.1 - NTC 2008)

x	Comb.	δ_2	L/300.00	Cs
cm		mm	mm	
137.0	15	0.01	9.13	>100

Travata: 90 [215 , 228]

L = 273.9cm

Crit.Prog: Acciaio_Flessione $\delta_c = 0.0cm$ Verifica: **Verificata**

Verifica spostamento nello stato finale (§4.2.4.2.1 - NTC 2008)

x	Comb.	δ_{max}	L/250.00	Cs
cm		mm	mm	
137.0	15	0.03	10.96	>100

Verifica spostamento elastico dovuto ai soli carichi variabili (§4.2.4.2.1 - NTC 2008)

x	Comb.	δ_2	L/300.00	Cs
cm		mm	mm	
137.0	15	0.01	9.13	>100

Travata: 91 [227 , 215]

L = 273.9cm

Crit.Prog: Acciaio_Flessione $\delta_c = 0.0cm$ Verifica: **Verificata**

Verifica spostamento nello stato finale (§4.2.4.2.1 - NTC 2008)

x	Comb.	δ_{max}	L/250.00	Cs
---	-------	----------------	----------	----

AUTOSTRADA VALDASTICO A31 NORD
1° LOTTO - PIOVENE ROCCHETTE – VALLE DELL'ASTICO

x	Comb.	δ_{max}	L/250.00	Cs
cm		mm	mm	
137.0	15	0.12	10.96	95.1

Verifica spostamento elastico dovuto ai soli carichi variabili (§4.2.4.2.1 - NTC 2008)

x	Comb.	δ_2	L/300.00	Cs
cm		mm	mm	
137.0	15	0.06	9.13	>100

Travata: 92 [215 , 211]

L = 273.9cm

Crit.Prog: Acciaio_Flessione $\delta_c = 0.0cm$ Verifica: **Verificata**

Verifica spostamento nello stato finale (§4.2.4.2.1 - NTC 2008)

x	Comb.	δ_{max}	L/250.00	Cs
cm		mm	mm	
137.0	15	0.17	10.96	65.3

Verifica spostamento elastico dovuto ai soli carichi variabili (§4.2.4.2.1 - NTC 2008)

x	Comb.	δ_2	L/300.00	Cs
cm		mm	mm	
137.0	15	0.09	9.13	>100

Travata: 93 [211 , 212]

L = 314.0cm

Crit.Prog: Acciaio_Flessione $\delta_c = 0.0cm$ Verifica: **Verificata**

Verifica spostamento nello stato finale (§4.2.4.2.1 - NTC 2008)

x	Comb.	δ_{max}	L/250.00	Cs
---	-------	----------------	----------	----

AUTOSTRADA VALDASTICO A31 NORD
1° LOTTO - PIOVENE ROCCHETTE – VALLE DELL'ASTICO

x	Comb.	δ_{max}	L/250.00	Cs
cm		mm	mm	
251.2	15	-0.14	12.56	89.7

Verifica spostamento elastico dovuto ai soli carichi variabili (§4.2.4.2.1 - NTC 2008)

x	Comb.	δ_2	L/300.00	Cs
cm		mm	mm	
219.8	15	-0.10	10.47	99.9

Travata: 94 [212 , 229]

L = 286.0cm

Crit.Prog: Acciaio_Flessione $\delta_c = 0.0cm$ Verifica: **Verificata**

Verifica spostamento nello stato finale (§4.2.4.2.1 - NTC 2008)

x	Comb.	δ_{max}	L/250.00	Cs
cm		mm	mm	
143.0	15	0.30	11.44	37.9

Verifica spostamento elastico dovuto ai soli carichi variabili (§4.2.4.2.1 - NTC 2008)

x	Comb.	δ_2	L/300.00	Cs
cm		mm	mm	
171.6	15	0.18	9.53	54.4

Travata: 95 [228 , 214]

L = 254.4cm

Crit.Prog: Acciaio_Flessione $\delta_c = 0.0cm$ Verifica: **Verificata**

Verifica spostamento nello stato finale (§4.2.4.2.1 - NTC 2008)

x	Comb.	δ_{max}	L/250.00	Cs
---	-------	----------------	----------	----

AUTOSTRADA VALDASTICO A31 NORD
1° LOTTO - PIOVENE ROCCHETTE – VALLE DELL'ASTICO

x	Comb.	δ_{max}	L/250.00	Cs
cm		mm	mm	
127.2	15	0.12	10.17	82.9

Verifica spostamento elastico dovuto ai soli carichi variabili (§4.2.4.2.1 - NTC 2008)

x	Comb.	δ_2	L/300.00	Cs
cm		mm	mm	
127.2	15	0.06	8.48	>100

Travata: 96 [214 , 229]

L = 254.4cm

Crit.Prog: Acciaio_Flessione $\delta_c = 0.0cm$ Verifica: **Verificata**

Verifica spostamento nello stato finale (§4.2.4.2.1 - NTC 2008)

x	Comb.	δ_{max}	L/250.00	Cs
cm		mm	mm	
203.5	15	-0.01	10.17	>100

Verifica spostamento elastico dovuto ai soli carichi variabili (§4.2.4.2.1 - NTC 2008)

x	Comb.	δ_2	L/300.00	Cs
cm		mm	mm	
203.5	15	-0.01	8.48	>100

Travata: 97 [211 , 214]

L = 254.4cm

Crit.Prog: Acciaio_Flessione $\delta_c = 0.0cm$ Verifica: **Verificata**

Verifica spostamento nello stato finale (§4.2.4.2.1 - NTC 2008)

x	Comb.	δ_{max}	L/250.00	Cs
---	-------	----------------	----------	----

AUTOSTRADA VALDASTICO A31 NORD
1° LOTTO - PIOVENE ROCCHETTE – VALLE DELL'ASTICO

x	Comb.	δ_{max}	L/250.00	Cs
cm		mm	mm	
101.7	15	-0.08	10.17	>100

Verifica spostamento elastico dovuto ai soli carichi variabili (§4.2.4.2.1 - NTC 2008)

x	Comb.	δ_2	L/300.00	Cs
cm		mm	mm	
101.7	15	-0.05	8.48	>100

Travata: 98 [214 , 212]

L = 254.4cm

Crit.Prog: Acciaio_Flessione $\delta_c = 0.0cm$ Verifica: **Verificata**

Verifica spostamento nello stato finale (§4.2.4.2.1 - NTC 2008)

x	Comb.	δ_{max}	L/250.00	Cs
cm		mm	mm	
101.7	15	0.10	10.17	>100

Verifica spostamento elastico dovuto ai soli carichi variabili (§4.2.4.2.1 - NTC 2008)

x	Comb.	δ_2	L/300.00	Cs
cm		mm	mm	
101.7	15	0.06	8.48	>100

Travata: 99 [230 , 213]

L = 286.0cm

Crit.Prog: Acciaio_Flessione $\delta_c = 0.0cm$ Verifica: **Verificata**

Verifica spostamento nello stato finale (§4.2.4.2.1 - NTC 2008)

x	Comb.	δ_{max}	L/250.00	Cs
---	-------	----------------	----------	----

AUTOSTRADA VALDASTICO A31 NORD
1° LOTTO - PIOVENE ROCCHETTE – VALLE DELL'ASTICO

x	Comb.	δ_{max}	L/250.00	Cs
cm		mm	mm	
85.8	15	0.07	11.44	>100

Verifica spostamento elastico dovuto ai soli carichi variabili (§4.2.4.2.1 - NTC 2008)

x	Comb.	δ_2	L/300.00	Cs
cm		mm	mm	
85.8	15	0.05	9.53	>100

Travata: 100 [213 , 212]

L = 314.0cm

Crit.Prog: Acciaio_Flessione $\delta_c = 0.0cm$ Verifica: **Verificata**

Verifica spostamento nello stato finale (§4.2.4.2.1 - NTC 2008)

x	Comb.	δ_{max}	L/250.00	Cs
cm		mm	mm	
188.4	15	-0.20	12.56	63.5

Verifica spostamento elastico dovuto ai soli carichi variabili (§4.2.4.2.1 - NTC 2008)

x	Comb.	δ_2	L/300.00	Cs
cm		mm	mm	
157.0	15	-0.16	10.47	66.1

Travata: 101 [229 , 221]

L = 229.9cm

Crit.Prog: Acciaio_Flessione $\delta_c = 0.0cm$ Verifica: **Verificata**

Verifica spostamento nello stato finale (§4.2.4.2.1 - NTC 2008)

x	Comb.	δ_{max}	L/250.00	Cs
---	-------	----------------	----------	----

AUTOSTRADA VALDASTICO A31 NORD
1° LOTTO - PIOVENE ROCCHETTE – VALLE DELL'ASTICO

x	Comb.	δ_{max}	L/250.00	Cs
cm		mm	mm	
137.9	15	0.14	9.19	65.9

Verifica spostamento elastico dovuto ai soli carichi variabili (§4.2.4.2.1 - NTC 2008)

x	Comb.	δ_2	L/300.00	Cs
cm		mm	mm	
137.9	15	0.09	7.66	84.1

Travata: 102 [221 , 213]

L = 229.9cm

Crit.Prog: Acciaio_Flessione $\delta_c = 0.0cm$ Verifica: **Verificata**

Verifica spostamento nello stato finale (§4.2.4.2.1 - NTC 2008)

x	Comb.	δ_{max}	L/250.00	Cs
cm		mm	mm	
114.9	15	-0.18	9.19	51.2

Verifica spostamento elastico dovuto ai soli carichi variabili (§4.2.4.2.1 - NTC 2008)

x	Comb.	δ_2	L/300.00	Cs
cm		mm	mm	
114.9	15	-0.12	7.66	62.1

Travata: 103 [221 , 230]

L = 229.9cm

Crit.Prog: Acciaio_Flessione $\delta_c = 0.0cm$ Verifica: **Verificata**

Verifica spostamento nello stato finale (§4.2.4.2.1 - NTC 2008)

x	Comb.	δ_{max}	L/250.00	Cs
---	-------	----------------	----------	----

AUTOSTRADA VALDASTICO A31 NORD
1° LOTTO - PIOVENE ROCCHETTE – VALLE DELL'ASTICO

x	Comb.	δ_{max}	L/250.00	Cs
cm		mm	mm	
137.9	21	0.02	9.19	>100

Verifica spostamento elastico dovuto ai soli carichi variabili (§4.2.4.2.1 - NTC 2008)

x	Comb.	δ_2	L/300.00	Cs
cm		mm	mm	
91.9	15	-0.02	7.66	>100

Travata: 104 [220 , 219]

L = 318.3cm

Crit.Prog: Acciaio_Flessione $\delta_c = 0.0cm$ Verifica: **Verificata**

Verifica spostamento nello stato finale (§4.2.4.2.1 - NTC 2008)

x	Comb.	δ_{max}	L/250.00	Cs
cm		mm	mm	
159.1	15	2.46	12.73	5.18

Verifica spostamento elastico dovuto ai soli carichi variabili (§4.2.4.2.1 - NTC 2008)

x	Comb.	δ_2	L/300.00	Cs
cm		mm	mm	
159.1	15	1.83	10.61	5.79

Travata: 105 [219 , 218]

L = 315.7cm

Crit.Prog: Acciaio_Flessione $\delta_c = 0.0cm$ Verifica: **Verificata**

Verifica spostamento nello stato finale (§4.2.4.2.1 - NTC 2008)

x	Comb.	δ_{max}	L/250.00	Cs
---	-------	----------------	----------	----

AUTOSTRADA VALDASTICO A31 NORD
1° LOTTO - PIOVENE ROCCHETTE – VALLE DELL'ASTICO

x	Comb.	δ_{max}	L/250.00	Cs
cm		mm	mm	
157.9	15	2.58	12.63	4.89

Verifica spostamento elastico dovuto ai soli carichi variabili (§4.2.4.2.1 - NTC 2008)

x	Comb.	δ_2	L/300.00	Cs
cm		mm	mm	
157.9	15	1.88	10.52	5.59

Travata: 106 [218 , 217]

L = 314.2cm

Crit.Prog: Acciaio_Flessione $\delta_c = 0.0cm$ Verifica: **Verificata**

Verifica spostamento nello stato finale (§4.2.4.2.1 - NTC 2008)

x	Comb.	δ_{max}	L/250.00	Cs
cm		mm	mm	
157.1	15	2.76	12.57	4.55

Verifica spostamento elastico dovuto ai soli carichi variabili (§4.2.4.2.1 - NTC 2008)

x	Comb.	δ_2	L/300.00	Cs
cm		mm	mm	
157.1	15	1.99	10.47	5.26

Travata: 107 [217 , 216]

L = 314.0cm

Crit.Prog: Acciaio_Flessione $\delta_c = 0.0cm$ Verifica: **Verificata**

Verifica spostamento nello stato finale (§4.2.4.2.1 - NTC 2008)

x	Comb.	δ_{max}	L/250.00	Cs
---	-------	----------------	----------	----

AUTOSTRADA VALDASTICO A31 NORD
1° LOTTO - PIOVENE ROCCHETTE – VALLE DELL'ASTICO

x	Comb.	δ_{max}	L/250.00	Cs
cm		mm	mm	
157.0	15	2.82	12.56	4.45

Verifica spostamento elastico dovuto ai soli carichi variabili (§4.2.4.2.1 - NTC 2008)

x	Comb.	δ_2	L/300.00	Cs
cm		mm	mm	
157.0	15	2.03	10.47	5.16

Travata: 108 [216 , 215]

L = 314.2cm

Crit.Prog: Acciaio_Flessione $\delta_c = 0.0cm$ Verifica: **Verificata**

Verifica spostamento nello stato finale (§4.2.4.2.1 - NTC 2008)

x	Comb.	δ_{max}	L/250.00	Cs
cm		mm	mm	
157.1	15	2.76	12.57	4.56

Verifica spostamento elastico dovuto ai soli carichi variabili (§4.2.4.2.1 - NTC 2008)

x	Comb.	δ_2	L/300.00	Cs
cm		mm	mm	
157.1	15	1.99	10.47	5.26

Travata: 109 [215 , 214]

L = 315.7cm

Crit.Prog: Acciaio_Flessione $\delta_c = 0.0cm$ Verifica: **Verificata**

Verifica spostamento nello stato finale (§4.2.4.2.1 - NTC 2008)

x	Comb.	δ_{max}	L/250.00	Cs
---	-------	----------------	----------	----

AUTOSTRADA VALDASTICO A31 NORD
1° LOTTO - PIOVENE ROCCHETTE – VALLE DELL'ASTICO

x	Comb.	δ_{max}	L/250.00	Cs
cm		mm	mm	
157.9	15	2.58	12.63	4.90

Verifica spostamento elastico dovuto ai soli carichi variabili (§4.2.4.2.1 - NTC 2008)

x	Comb.	δ_2	L/300.00	Cs
cm		mm	mm	
157.9	15	1.88	10.52	5.59

Travata: 110 [214 , 221]

L = 318.3cm

Crit.Prog: Acciaio_Flessione $\delta_c = 0.0cm$ Verifica: **Verificata**

Verifica spostamento nello stato finale (§4.2.4.2.1 - NTC 2008)

x	Comb.	δ_{max}	L/250.00	Cs
cm		mm	mm	
159.1	15	2.46	12.73	5.17

Verifica spostamento elastico dovuto ai soli carichi variabili (§4.2.4.2.1 - NTC 2008)

x	Comb.	δ_2	L/300.00	Cs
cm		mm	mm	
159.1	15	1.84	10.61	5.77

Travata: 111 [222 , 237]

L = 229.9cm

Crit.Prog: Acciaio_Flessione $\delta_c = 0.0cm$ Verifica: **Verificata**

Verifica spostamento nello stato finale (§4.2.4.2.1 - NTC 2008)

x	Comb.	δ_{max}	L/250.00	Cs
---	-------	----------------	----------	----

AUTOSTRADA VALDASTICO A31 NORD
1° LOTTO - PIOVENE ROCCHETTE – VALLE DELL'ASTICO

x	Comb.	δ_{max}	L/250.00	Cs
cm		mm	mm	
91.9	15	0.05	9.19	>100

Verifica spostamento elastico dovuto ai soli carichi variabili (§4.2.4.2.1 - NTC 2008)

x	Comb.	δ_2	L/300.00	Cs
cm		mm	mm	
69.0	15	0.01	7.66	>100

Travata: 112 [240 , 223]

L = 286.0cm

Crit.Prog: Acciaio_Flessione $\delta_c = 0.0cm$ Verifica: **Verificata**

Verifica spostamento nello stato finale (§4.2.4.2.1 - NTC 2008)

x	Comb.	δ_{max}	L/250.00	Cs
cm		mm	mm	
143.0	15	0.41	11.44	28.0

Verifica spostamento elastico dovuto ai soli carichi variabili (§4.2.4.2.1 - NTC 2008)

x	Comb.	δ_2	L/300.00	Cs
cm		mm	mm	
143.0	15	0.23	9.53	40.6

Travata: 113 [223 , 222]

L = 314.0cm

Crit.Prog: Acciaio_Flessione $\delta_c = 0.0cm$ Verifica: **Verificata**

Verifica spostamento nello stato finale (§4.2.4.2.1 - NTC 2008)

x	Comb.	δ_{max}	L/250.00	Cs
---	-------	----------------	----------	----

AUTOSTRADA VALDASTICO A31 NORD
1° LOTTO - PIOVENE ROCCHETTE – VALLE DELL'ASTICO

x	Comb.	δ_{max}	L/250.00	Cs
cm		mm	mm	
157.0	21	0.04	12.56	>100

Verifica spostamento elastico dovuto ai soli carichi variabili (§4.2.4.2.1 - NTC 2008)

x	Comb.	δ_2	L/300.00	Cs
cm		mm	mm	
188.4	15	-0.06	10.47	>100

Travata: 114 [239 , 237]

L = 229.9cm

Crit.Prog: Acciaio_Flessione $\delta_c = 0.0cm$ Verifica: **Verificata**

Verifica spostamento nello stato finale (§4.2.4.2.1 - NTC 2008)

x	Comb.	δ_{max}	L/250.00	Cs
cm		mm	mm	
114.9	15	-0.12	9.19	74.1

Verifica spostamento elastico dovuto ai soli carichi variabili (§4.2.4.2.1 - NTC 2008)

x	Comb.	δ_2	L/300.00	Cs
cm		mm	mm	
114.9	15	-0.10	7.66	79.8

Travata: 115 [237 , 223]

L = 229.9cm

Crit.Prog: Acciaio_Flessione $\delta_c = 0.0cm$ Verifica: **Verificata**

Verifica spostamento nello stato finale (§4.2.4.2.1 - NTC 2008)

x	Comb.	δ_{max}	L/250.00	Cs
---	-------	----------------	----------	----

AUTOSTRADA VALDASTICO A31 NORD
1° LOTTO - PIOVENE ROCCHETTE – VALLE DELL'ASTICO

x	Comb.	δ_{max}	L/250.00	Cs
cm		mm	mm	
91.9	15	0.12	9.19	77.7

Verifica spostamento elastico dovuto ai soli carichi variabili (§4.2.4.2.1 - NTC 2008)

x	Comb.	δ_2	L/300.00	Cs
cm		mm	mm	
91.9	15	0.08	7.66	93.2

Travata: 116 [237 , 240]

L = 229.9cm

Crit.Prog: Acciaio_Flessione $\delta_c = 0.0cm$ Verifica: **Verificata**

Verifica spostamento nello stato finale (§4.2.4.2.1 - NTC 2008)

x	Comb.	δ_{max}	L/250.00	Cs
cm		mm	mm	
91.9	15	0.16	9.19	58.7

Verifica spostamento elastico dovuto ai soli carichi variabili (§4.2.4.2.1 - NTC 2008)

x	Comb.	δ_2	L/300.00	Cs
cm		mm	mm	
91.9	15	0.10	7.66	78.2

Travata: 117 [239 , 222]

L = 286.0cm

Crit.Prog: Acciaio_Flessione $\delta_c = 0.0cm$ Verifica: **Verificata**

Verifica spostamento nello stato finale (§4.2.4.2.1 - NTC 2008)

x	Comb.	δ_{max}	L/250.00	Cs
---	-------	----------------	----------	----

AUTOSTRADA VALDASTICO A31 NORD
1° LOTTO - PIOVENE ROCCHETTE – VALLE DELL'ASTICO

x	Comb.	δ_{max}	L/250.00	Cs
cm		mm	mm	
143.0	15	0.23	11.44	49.0

Verifica spostamento elastico dovuto ai soli carichi variabili (§4.2.4.2.1 - NTC 2008)

x	Comb.	δ_2	L/300.00	Cs
cm		mm	mm	
171.6	15	0.13	9.53	74.9

Travata: 118 [241 , 224]

L = 286.0cm

Crit.Prog: Acciaio_Flessione $\delta_c = 0.0cm$ Verifica: **Verificata**

Verifica spostamento nello stato finale (§4.2.4.2.1 - NTC 2008)

x	Comb.	δ_{max}	L/250.00	Cs
cm		mm	mm	
143.0	15	0.13	11.44	91.4

Verifica spostamento elastico dovuto ai soli carichi variabili (§4.2.4.2.1 - NTC 2008)

x	Comb.	δ_2	L/300.00	Cs
cm		mm	mm	
171.6	15	0.06	9.53	>100

Travata: 119 [224 , 223]

L = 314.0cm

Crit.Prog: Acciaio_Flessione $\delta_c = 0.0cm$ Verifica: **Verificata**

Verifica spostamento nello stato finale (§4.2.4.2.1 - NTC 2008)

x	Comb.	δ_{max}	L/250.00	Cs
---	-------	----------------	----------	----

AUTOSTRADA VALDASTICO A31 NORD
1° LOTTO - PIOVENE ROCCHETTE – VALLE DELL'ASTICO

x	Comb.	δ_{max}	L/250.00	Cs
cm		mm	mm	
125.6	15	0.05	12.56	>100

Verifica spostamento elastico dovuto ai soli carichi variabili (§4.2.4.2.1 - NTC 2008)

x	Comb.	δ_2	L/300.00	Cs
cm		mm	mm	
251.2	15	-0.02	10.47	>100

Travata: 120 [223 , 236]

L = 254.4cm

Crit.Prog: Acciaio_Flessione $\delta_c = 0.0cm$ Verifica: **Verificata**

Verifica spostamento nello stato finale (§4.2.4.2.1 - NTC 2008)

x	Comb.	δ_{max}	L/250.00	Cs
cm		mm	mm	
127.2	15	0.07	10.17	>100

Verifica spostamento elastico dovuto ai soli carichi variabili (§4.2.4.2.1 - NTC 2008)

x	Comb.	δ_2	L/300.00	Cs
cm		mm	mm	
152.6	15	0.03	8.48	>100

Travata: 121 [236 , 241]

L = 254.4cm

Crit.Prog: Acciaio_Flessione $\delta_c = 0.0cm$ Verifica: **Verificata**

Verifica spostamento nello stato finale (§4.2.4.2.1 - NTC 2008)

x	Comb.	δ_{max}	L/250.00	Cs
---	-------	----------------	----------	----

AUTOSTRADA VALDASTICO A31 NORD
1° LOTTO - PIOVENE ROCCHETTE – VALLE DELL'ASTICO

x	Comb.	δ_{max}	L/250.00	Cs
cm		mm	mm	
203.5	15	-0.01	10.17	>100

Verifica spostamento elastico dovuto ai soli carichi variabili (§4.2.4.2.1 - NTC 2008)

x	Comb.	δ_2	L/300.00	Cs
cm		mm	mm	
152.6	15	-0.02	8.48	>100

Travata: 122 [240 , 236]

L = 254.4cm

Crit.Prog: Acciaio_Flessione $\delta_c = 0.0cm$ Verifica: **Verificata**

Verifica spostamento nello stato finale (§4.2.4.2.1 - NTC 2008)

x	Comb.	δ_{max}	L/250.00	Cs
cm		mm	mm	
127.2	15	0.10	10.17	>100

Verifica spostamento elastico dovuto ai soli carichi variabili (§4.2.4.2.1 - NTC 2008)

x	Comb.	δ_2	L/300.00	Cs
cm		mm	mm	
152.6	15	0.06	8.48	>100

Travata: 123 [236 , 224]

L = 254.4cm

Crit.Prog: Acciaio_Flessione $\delta_c = 0.0cm$ Verifica: **Verificata**

Verifica spostamento nello stato finale (§4.2.4.2.1 - NTC 2008)

x	Comb.	δ_{max}	L/250.00	Cs
---	-------	----------------	----------	----

AUTOSTRADA VALDASTICO A31 NORD
1° LOTTO - PIOVENE ROCCHETTE – VALLE DELL'ASTICO

x	Comb.	δ_{max}	L/250.00	Cs
cm		mm	mm	
127.2	15	0.07	10.17	>100

Verifica spostamento elastico dovuto ai soli carichi variabili (§4.2.4.2.1 - NTC 2008)

x	Comb.	δ_2	L/300.00	Cs
cm		mm	mm	
101.7	15	0.04	8.48	>100

Travata: 124 [242 , 225]

L = 286.0cm

Crit.Prog: Acciaio_Flessione $\delta_c = 0.0cm$ Verifica: **Verificata**

Verifica spostamento nello stato finale (§4.2.4.2.1 - NTC 2008)

x	Comb.	δ_{max}	L/250.00	Cs
cm		mm	mm	
143.0	21	0.02	11.44	>100

Verifica spostamento elastico dovuto ai soli carichi variabili (§4.2.4.2.1 - NTC 2008)

x	Comb.	δ_2	L/300.00	Cs
cm		mm	mm	
171.6	15	-0.02	9.53	>100

Travata: 125 [225 , 224]

L = 314.0cm

Crit.Prog: Acciaio_Flessione $\delta_c = 0.0cm$ Verifica: **Verificata**

Verifica spostamento nello stato finale (§4.2.4.2.1 - NTC 2008)

x	Comb.	δ_{max}	L/250.00	Cs
---	-------	----------------	----------	----

AUTOSTRADA VALDASTICO A31 NORD
1° LOTTO - PIOVENE ROCCHETTE – VALLE DELL'ASTICO

x	Comb.	δ_{max}	L/250.00	Cs
cm		mm	mm	
157.0	15	0.29	12.56	43.0

Verifica spostamento elastico dovuto ai soli carichi variabili (§4.2.4.2.1 - NTC 2008)

x	Comb.	δ_2	L/300.00	Cs
cm		mm	mm	
125.6	15	0.15	10.47	71.8

Travata: 126 [241 , 235]

L = 273.9cm

Crit.Prog: Acciaio_Flessione $\delta_c = 0.0cm$ Verifica: **Verificata**

Verifica spostamento nello stato finale (§4.2.4.2.1 - NTC 2008)

x	Comb.	δ_{max}	L/250.00	Cs
cm		mm	mm	
137.0	15	0.13	10.96	85.1

Verifica spostamento elastico dovuto ai soli carichi variabili (§4.2.4.2.1 - NTC 2008)

x	Comb.	δ_2	L/300.00	Cs
cm		mm	mm	
137.0	15	0.07	9.13	>100

Travata: 127 [235 , 225]

L = 273.9cm

Crit.Prog: Acciaio_Flessione $\delta_c = 0.0cm$ Verifica: **Verificata**

Verifica spostamento nello stato finale (§4.2.4.2.1 - NTC 2008)

x	Comb.	δ_{max}	L/250.00	Cs
---	-------	----------------	----------	----

AUTOSTRADA VALDASTICO A31 NORD
1° LOTTO - PIOVENE ROCCHETTE – VALLE DELL'ASTICO

x	Comb.	δ_{max}	L/250.00	Cs
cm		mm	mm	
137.0	15	0.08	10.96	>100

Verifica spostamento elastico dovuto ai soli carichi variabili (§4.2.4.2.1 - NTC 2008)

x	Comb.	δ_2	L/300.00	Cs
cm		mm	mm	
137.0	15	0.04	9.13	>100

Travata: 128 [224 , 235]

L = 273.9cm

Crit.Prog: Acciaio_Flessione $\delta_c = 0.0cm$ Verifica: **Verificata**

Verifica spostamento nello stato finale (§4.2.4.2.1 - NTC 2008)

x	Comb.	δ_{max}	L/250.00	Cs
cm		mm	mm	
137.0	15	0.09	10.96	>100

Verifica spostamento elastico dovuto ai soli carichi variabili (§4.2.4.2.1 - NTC 2008)

x	Comb.	δ_2	L/300.00	Cs
cm		mm	mm	
137.0	15	0.04	9.13	>100

Travata: 129 [235 , 242]

L = 273.9cm

Crit.Prog: Acciaio_Flessione $\delta_c = 0.0cm$ Verifica: **Verificata**

Verifica spostamento nello stato finale (§4.2.4.2.1 - NTC 2008)

x	Comb.	δ_{max}	L/250.00	Cs
---	-------	----------------	----------	----

AUTOSTRADA VALDASTICO A31 NORD
1° LOTTO - PIOVENE ROCCHETTE – VALLE DELL'ASTICO

x	Comb.	δ_{max}	L/250.00	Cs
cm		mm	mm	
137.0	15	0.07	10.96	>100

Verifica spostamento elastico dovuto ai soli carichi variabili (§4.2.4.2.1 - NTC 2008)

x	Comb.	δ_2	L/300.00	Cs
cm		mm	mm	
137.0	15	0.03	9.13	>100

Travata: 130 [243 , 226]

L = 286.0cm

Crit.Prog: Acciaio_Flessione $\delta_c = 0.0cm$ Verifica: **Verificata**

Verifica spostamento nello stato finale (§4.2.4.2.1 - NTC 2008)

x	Comb.	δ_{max}	L/250.00	Cs
cm		mm	mm	
228.8	15	-0.03	11.44	>100

Verifica spostamento elastico dovuto ai soli carichi variabili (§4.2.4.2.1 - NTC 2008)

x	Comb.	δ_2	L/300.00	Cs
cm		mm	mm	
171.6	15	-0.03	9.53	>100

Travata: 131 [226 , 225]

L = 314.0cm

Crit.Prog: Acciaio_Flessione $\delta_c = 0.0cm$ Verifica: **Verificata**

Verifica spostamento nello stato finale (§4.2.4.2.1 - NTC 2008)

x	Comb.	δ_{max}	L/250.00	Cs
---	-------	----------------	----------	----

AUTOSTRADA VALDASTICO A31 NORD
1° LOTTO - PIOVENE ROCCHETTE – VALLE DELL'ASTICO

x	Comb.	δ_{max}	L/250.00	Cs
cm		mm	mm	
157.0	15	0.43	12.56	29.5

Verifica spostamento elastico dovuto ai soli carichi variabili (§4.2.4.2.1 - NTC 2008)

x	Comb.	δ_2	L/300.00	Cs
cm		mm	mm	
157.0	15	0.23	10.47	46.3

Travata: 132 [242 , 234]

L = 281.6cm

Crit.Prog: Acciaio_Flessione $\delta_c = 0.0cm$ Verifica: **Verificata**

Verifica spostamento nello stato finale (§4.2.4.2.1 - NTC 2008)

x	Comb.	δ_{max}	L/250.00	Cs
cm		mm	mm	
140.8	15	0.11	11.27	>100

Verifica spostamento elastico dovuto ai soli carichi variabili (§4.2.4.2.1 - NTC 2008)

x	Comb.	δ_2	L/300.00	Cs
cm		mm	mm	
140.8	15	0.06	9.39	>100

Travata: 133 [234 , 243]

L = 281.6cm

Crit.Prog: Acciaio_Flessione $\delta_c = 0.0cm$ Verifica: **Verificata**

Verifica spostamento nello stato finale (§4.2.4.2.1 - NTC 2008)

x	Comb.	δ_{max}	L/250.00	Cs
---	-------	----------------	----------	----

AUTOSTRADA VALDASTICO A31 NORD
1° LOTTO - PIOVENE ROCCHETTE – VALLE DELL'ASTICO

x	Comb.	δ_{max}	L/250.00	Cs
cm		mm	mm	
140.8	15	0.10	11.27	>100

Verifica spostamento elastico dovuto ai soli carichi variabili (§4.2.4.2.1 - NTC 2008)

x	Comb.	δ_2	L/300.00	Cs
cm		mm	mm	
140.8	15	0.05	9.39	>100

Travata: 134 [225 , 234]

L = 281.6cm

Crit.Prog: Acciaio_Flessione $\delta_c = 0.0cm$ Verifica: **Verificata**

Verifica spostamento nello stato finale (§4.2.4.2.1 - NTC 2008)

x	Comb.	δ_{max}	L/250.00	Cs
cm		mm	mm	
140.8	15	0.10	11.27	>100

Verifica spostamento elastico dovuto ai soli carichi variabili (§4.2.4.2.1 - NTC 2008)

x	Comb.	δ_2	L/300.00	Cs
cm		mm	mm	
140.8	15	0.05	9.39	>100

Travata: 135 [234 , 226]

L = 281.6cm

Crit.Prog: Acciaio_Flessione $\delta_c = 0.0cm$ Verifica: **Verificata**

Verifica spostamento nello stato finale (§4.2.4.2.1 - NTC 2008)

x	Comb.	δ_{max}	L/250.00	Cs
---	-------	----------------	----------	----

AUTOSTRADA VALDASTICO A31 NORD
1° LOTTO - PIOVENE ROCCHETTE – VALLE DELL'ASTICO

x	Comb.	δ_{max}	L/250.00	Cs
cm		mm	mm	
140.8	15	0.10	11.27	>100

Verifica spostamento elastico dovuto ai soli carichi variabili (§4.2.4.2.1 - NTC 2008)

x	Comb.	δ_2	L/300.00	Cs
cm		mm	mm	
140.8	15	0.05	9.39	>100

Travata: 136 [226 , 233]

L = 281.6cm

Crit.Prog: Acciaio_Flessione $\delta_c = 0.0cm$ Verifica: **Verificata**

Verifica spostamento nello stato finale (§4.2.4.2.1 - NTC 2008)

x	Comb.	δ_{max}	L/250.00	Cs
cm		mm	mm	
140.8	15	0.10	11.27	>100

Verifica spostamento elastico dovuto ai soli carichi variabili (§4.2.4.2.1 - NTC 2008)

x	Comb.	δ_2	L/300.00	Cs
cm		mm	mm	
140.8	15	0.05	9.39	>100

Travata: 137 [233 , 244]

L = 281.6cm

Crit.Prog: Acciaio_Flessione $\delta_c = 0.0cm$ Verifica: **Verificata**

Verifica spostamento nello stato finale (§4.2.4.2.1 - NTC 2008)

x	Comb.	δ_{max}	L/250.00	Cs
---	-------	----------------	----------	----

AUTOSTRADA VALDASTICO A31 NORD
1° LOTTO - PIOVENE ROCCHETTE – VALLE DELL'ASTICO

x	Comb.	δ_{max}	L/250.00	Cs
cm		mm	mm	
140.8	15	0.11	11.27	>100

Verifica spostamento elastico dovuto ai soli carichi variabili (§4.2.4.2.1 - NTC 2008)

x	Comb.	δ_2	L/300.00	Cs
cm		mm	mm	
140.8	15	0.06	9.39	>100

Travata: 138 [244 , 227]

L = 286.0cm

Crit.Prog: Acciaio_Flessione $\delta_c = 0.0cm$ Verifica: **Verificata**

Verifica spostamento nello stato finale (§4.2.4.2.1 - NTC 2008)

x	Comb.	δ_{max}	L/250.00	Cs
cm		mm	mm	
143.0	21	0.02	11.44	>100

Verifica spostamento elastico dovuto ai soli carichi variabili (§4.2.4.2.1 - NTC 2008)

x	Comb.	δ_2	L/300.00	Cs
cm		mm	mm	
171.6	15	-0.02	9.53	>100

Travata: 139 [227 , 226]

L = 314.0cm

Crit.Prog: Acciaio_Flessione $\delta_c = 0.0cm$ Verifica: **Verificata**

Verifica spostamento nello stato finale (§4.2.4.2.1 - NTC 2008)

x	Comb.	δ_{max}	L/250.00	Cs
---	-------	----------------	----------	----

AUTOSTRADA VALDASTICO A31 NORD
1° LOTTO - PIOVENE ROCCHETTE – VALLE DELL'ASTICO

x	Comb.	δ_{max}	L/250.00	Cs
cm		mm	mm	
157.0	15	0.42	12.56	29.6

Verifica spostamento elastico dovuto ai soli carichi variabili (§4.2.4.2.1 - NTC 2008)

x	Comb.	δ_2	L/300.00	Cs
cm		mm	mm	
157.0	15	0.23	10.47	46.2

Travata: 140 [243 , 233]

L = 281.6cm

Crit.Prog: Acciaio_Flessione $\delta_c = 0.0cm$ Verifica: **Verificata**

Verifica spostamento nello stato finale (§4.2.4.2.1 - NTC 2008)

x	Comb.	δ_{max}	L/250.00	Cs
cm		mm	mm	
140.8	15	0.10	11.27	>100

Verifica spostamento elastico dovuto ai soli carichi variabili (§4.2.4.2.1 - NTC 2008)

x	Comb.	δ_2	L/300.00	Cs
cm		mm	mm	
140.8	15	0.05	9.39	>100

Travata: 141 [233 , 227]

L = 281.6cm

Crit.Prog: Acciaio_Flessione $\delta_c = 0.0cm$ Verifica: **Verificata**

Verifica spostamento nello stato finale (§4.2.4.2.1 - NTC 2008)

x	Comb.	δ_{max}	L/250.00	Cs
---	-------	----------------	----------	----

AUTOSTRADA VALDASTICO A31 NORD
1° LOTTO - PIOVENE ROCCHETTE – VALLE DELL'ASTICO

x	Comb.	δ_{max}	L/250.00	Cs
cm		mm	mm	
140.8	15	0.10	11.27	>100

Verifica spostamento elastico dovuto ai soli carichi variabili (§4.2.4.2.1 - NTC 2008)

x	Comb.	δ_2	L/300.00	Cs
cm		mm	mm	
140.8	15	0.05	9.39	>100

Travata: 142 [245 , 228]

L = 286.0cm

Crit.Prog: Acciaio_Flessione $\delta_c = 0.0cm$ Verifica: **Verificata**

Verifica spostamento nello stato finale (§4.2.4.2.1 - NTC 2008)

x	Comb.	δ_{max}	L/250.00	Cs
cm		mm	mm	
143.0	15	0.13	11.44	90.1

Verifica spostamento elastico dovuto ai soli carichi variabili (§4.2.4.2.1 - NTC 2008)

x	Comb.	δ_2	L/300.00	Cs
cm		mm	mm	
171.6	15	0.06	9.53	>100

Travata: 143 [228 , 227]

L = 314.0cm

Crit.Prog: Acciaio_Flessione $\delta_c = 0.0cm$ Verifica: **Verificata**

Verifica spostamento nello stato finale (§4.2.4.2.1 - NTC 2008)

x	Comb.	δ_{max}	L/250.00	Cs
---	-------	----------------	----------	----

AUTOSTRADA VALDASTICO A31 NORD
1° LOTTO - PIOVENE ROCCHETTE – VALLE DELL'ASTICO

x	Comb.	δ_{max}	L/250.00	Cs
cm		mm	mm	
157.0	15	0.29	12.56	43.2

Verifica spostamento elastico dovuto ai soli carichi variabili (§4.2.4.2.1 - NTC 2008)

x	Comb.	δ_2	L/300.00	Cs
cm		mm	mm	
188.4	15	0.15	10.47	71.6

Travata: 144 [227 , 232]

L = 273.9cm

Crit.Prog: Acciaio_Flessione $\delta_c = 0.0cm$ Verifica: **Verificata**

Verifica spostamento nello stato finale (§4.2.4.2.1 - NTC 2008)

x	Comb.	δ_{max}	L/250.00	Cs
cm		mm	mm	
137.0	15	0.08	10.96	>100

Verifica spostamento elastico dovuto ai soli carichi variabili (§4.2.4.2.1 - NTC 2008)

x	Comb.	δ_2	L/300.00	Cs
cm		mm	mm	
137.0	15	0.04	9.13	>100

Travata: 145 [232 , 245]

L = 273.9cm

Crit.Prog: Acciaio_Flessione $\delta_c = 0.0cm$ Verifica: **Verificata**

Verifica spostamento nello stato finale (§4.2.4.2.1 - NTC 2008)

x	Comb.	δ_{max}	L/250.00	Cs
---	-------	----------------	----------	----

AUTOSTRADA VALDASTICO A31 NORD
1° LOTTO - PIOVENE ROCCHETTE – VALLE DELL'ASTICO

x	Comb.	δ_{max}	L/250.00	Cs
cm		mm	mm	
137.0	15	0.13	10.96	85.0

Verifica spostamento elastico dovuto ai soli carichi variabili (§4.2.4.2.1 - NTC 2008)

x	Comb.	δ_2	L/300.00	Cs
cm		mm	mm	
137.0	15	0.07	9.13	>100

Travata: 146 [244 , 232]

L = 273.9cm

Crit.Prog: Acciaio_Flessione $\delta_c = 0.0cm$ Verifica: **Verificata**

Verifica spostamento nello stato finale (§4.2.4.2.1 - NTC 2008)

x	Comb.	δ_{max}	L/250.00	Cs
cm		mm	mm	
137.0	15	0.07	10.96	>100

Verifica spostamento elastico dovuto ai soli carichi variabili (§4.2.4.2.1 - NTC 2008)

x	Comb.	δ_2	L/300.00	Cs
cm		mm	mm	
137.0	15	0.03	9.13	>100

Travata: 147 [232 , 228]

L = 273.9cm

Crit.Prog: Acciaio_Flessione $\delta_c = 0.0cm$ Verifica: **Verificata**

Verifica spostamento nello stato finale (§4.2.4.2.1 - NTC 2008)

x	Comb.	δ_{max}	L/250.00	Cs
---	-------	----------------	----------	----

AUTOSTRADA VALDASTICO A31 NORD
1° LOTTO - PIOVENE ROCCHETTE – VALLE DELL'ASTICO

x	Comb.	δ_{max}	L/250.00	Cs
cm		mm	mm	
137.0	15	0.09	10.96	>100

Verifica spostamento elastico dovuto ai soli carichi variabili (§4.2.4.2.1 - NTC 2008)

x	Comb.	δ_2	L/300.00	Cs
cm		mm	mm	
137.0	15	0.04	9.13	>100

Travata: 148 [228 , 229]

L = 314.0cm

Crit.Prog: Acciaio_Flessione $\delta_c = 0.0cm$ Verifica: **Verificata**

Verifica spostamento nello stato finale (§4.2.4.2.1 - NTC 2008)

x	Comb.	δ_{max}	L/250.00	Cs
cm		mm	mm	
125.6	15	0.05	12.56	>100

Verifica spostamento elastico dovuto ai soli carichi variabili (§4.2.4.2.1 - NTC 2008)

x	Comb.	δ_2	L/300.00	Cs
cm		mm	mm	
251.2	15	-0.02	10.47	>100

Travata: 149 [229 , 246]

L = 286.0cm

Crit.Prog: Acciaio_Flessione $\delta_c = 0.0cm$ Verifica: **Verificata**

Verifica spostamento nello stato finale (§4.2.4.2.1 - NTC 2008)

x	Comb.	δ_{max}	L/250.00	Cs
---	-------	----------------	----------	----

AUTOSTRADA VALDASTICO A31 NORD
1° LOTTO - PIOVENE ROCCHETTE – VALLE DELL'ASTICO

x	Comb.	δ_{max}	L/250.00	Cs
cm		mm	mm	
143.0	15	0.41	11.44	27.8

Verifica spostamento elastico dovuto ai soli carichi variabili (§4.2.4.2.1 - NTC 2008)

x	Comb.	δ_2	L/300.00	Cs
cm		mm	mm	
143.0	15	0.24	9.53	40.4

Travata: 150 [245 , 231]

L = 254.4cm

Crit.Prog: Acciaio_Flessione $\delta_c = 0.0cm$ Verifica: **Verificata**

Verifica spostamento nello stato finale (§4.2.4.2.1 - NTC 2008)

x	Comb.	δ_{max}	L/250.00	Cs
cm		mm	mm	
50.9	15	-0.02	10.17	>100

Verifica spostamento elastico dovuto ai soli carichi variabili (§4.2.4.2.1 - NTC 2008)

x	Comb.	δ_2	L/300.00	Cs
cm		mm	mm	
101.7	15	-0.02	8.48	>100

Travata: 151 [231 , 246]

L = 254.4cm

Crit.Prog: Acciaio_Flessione $\delta_c = 0.0cm$ Verifica: **Verificata**

Verifica spostamento nello stato finale (§4.2.4.2.1 - NTC 2008)

x	Comb.	δ_{max}	L/250.00	Cs
---	-------	----------------	----------	----

AUTOSTRADA VALDASTICO A31 NORD
1° LOTTO - PIOVENE ROCCHETTE – VALLE DELL'ASTICO

x	Comb.	δ_{max}	L/250.00	Cs
cm		mm	mm	
127.2	15	0.10	10.17	>100

Verifica spostamento elastico dovuto ai soli carichi variabili (§4.2.4.2.1 - NTC 2008)

x	Comb.	δ_2	L/300.00	Cs
cm		mm	mm	
101.7	15	0.06	8.48	>100

Travata: 152 [228 , 231]

L = 254.4cm

Crit.Prog: Acciaio_Flessione $\delta_c = 0.0cm$ Verifica: **Verificata**

Verifica spostamento nello stato finale (§4.2.4.2.1 - NTC 2008)

x	Comb.	δ_{max}	L/250.00	Cs
cm		mm	mm	
127.2	15	0.07	10.17	>100

Verifica spostamento elastico dovuto ai soli carichi variabili (§4.2.4.2.1 - NTC 2008)

x	Comb.	δ_2	L/300.00	Cs
cm		mm	mm	
152.6	15	0.04	8.48	>100

Travata: 153 [231 , 229]

L = 254.4cm

Crit.Prog: Acciaio_Flessione $\delta_c = 0.0cm$ Verifica: **Verificata**

Verifica spostamento nello stato finale (§4.2.4.2.1 - NTC 2008)

x	Comb.	δ_{max}	L/250.00	Cs
---	-------	----------------	----------	----

AUTOSTRADA VALDASTICO A31 NORD
1° LOTTO - PIOVENE ROCCHETTE – VALLE DELL'ASTICO

x	Comb.	δ_{max}	L/250.00	Cs
cm		mm	mm	
127.2	15	0.07	10.17	>100

Verifica spostamento elastico dovuto ai soli carichi variabili (§4.2.4.2.1 - NTC 2008)

x	Comb.	δ_2	L/300.00	Cs
cm		mm	mm	
101.7	15	0.03	8.48	>100

Travata: 154 [247 , 230]

L = 286.0cm

Crit.Prog: Acciaio_Flessione $\delta_c = 0.0cm$ Verifica: **Verificata**

Verifica spostamento nello stato finale (§4.2.4.2.1 - NTC 2008)

x	Comb.	δ_{max}	L/250.00	Cs
cm		mm	mm	
143.0	15	0.22	11.44	51.1

Verifica spostamento elastico dovuto ai soli carichi variabili (§4.2.4.2.1 - NTC 2008)

x	Comb.	δ_2	L/300.00	Cs
cm		mm	mm	
171.6	15	0.13	9.53	75.8

Travata: 155 [230 , 229]

L = 314.0cm

Crit.Prog: Acciaio_Flessione $\delta_c = 0.0cm$ Verifica: **Verificata**

Verifica spostamento nello stato finale (§4.2.4.2.1 - NTC 2008)

x	Comb.	δ_{max}	L/250.00	Cs
---	-------	----------------	----------	----

AUTOSTRADA VALDASTICO A31 NORD
1° LOTTO - PIOVENE ROCCHETTE – VALLE DELL'ASTICO

x	Comb.	δ_{max}	L/250.00	Cs
cm		mm	mm	
157.0	21	0.04	12.56	>100

Verifica spostamento elastico dovuto ai soli carichi variabili (§4.2.4.2.1 - NTC 2008)

x	Comb.	δ_2	L/300.00	Cs
cm		mm	mm	
125.6	15	-0.06	10.47	>100

Travata: 156 [246 , 238]

L = 229.9cm

Crit.Prog: Acciaio_Flessione $\delta_c = 0.0cm$ Verifica: **Verificata**

Verifica spostamento nello stato finale (§4.2.4.2.1 - NTC 2008)

x	Comb.	δ_{max}	L/250.00	Cs
cm		mm	mm	
137.9	15	0.16	9.19	57.1

Verifica spostamento elastico dovuto ai soli carichi variabili (§4.2.4.2.1 - NTC 2008)

x	Comb.	δ_2	L/300.00	Cs
cm		mm	mm	
137.9	15	0.10	7.66	76.4

Travata: 157 [238 , 230]

L = 229.9cm

Crit.Prog: Acciaio_Flessione $\delta_c = 0.0cm$ Verifica: **Verificata**

Verifica spostamento nello stato finale (§4.2.4.2.1 - NTC 2008)

x	Comb.	δ_{max}	L/250.00	Cs
---	-------	----------------	----------	----

AUTOSTRADA VALDASTICO A31 NORD
1° LOTTO - PIOVENE ROCCHETTE – VALLE DELL'ASTICO

x	Comb.	δ_{max}	L/250.00	Cs
cm		mm	mm	
137.9	15	0.06	9.19	>100

Verifica spostamento elastico dovuto ai soli carichi variabili (§4.2.4.2.1 - NTC 2008)

x	Comb.	δ_2	L/300.00	Cs
cm		mm	mm	
160.9	15	0.01	7.66	>100

Travata: 158 [238 , 247]

L = 229.9cm

Crit.Prog: Acciaio_Flessione $\delta_c = 0.0cm$ Verifica: **Verificata**

Verifica spostamento nello stato finale (§4.2.4.2.1 - NTC 2008)

x	Comb.	δ_{max}	L/250.00	Cs
cm		mm	mm	
114.9	15	-0.13	9.19	68.2

Verifica spostamento elastico dovuto ai soli carichi variabili (§4.2.4.2.1 - NTC 2008)

x	Comb.	δ_2	L/300.00	Cs
cm		mm	mm	
114.9	15	-0.10	7.66	76.9

Travata: 159 [237 , 236]

L = 318.3cm

Crit.Prog: Acciaio_Flessione $\delta_c = 0.0cm$ Verifica: **Verificata**

Verifica spostamento nello stato finale (§4.2.4.2.1 - NTC 2008)

x	Comb.	δ_{max}	L/250.00	Cs
---	-------	----------------	----------	----

AUTOSTRADA VALDASTICO A31 NORD
1° LOTTO - PIOVENE ROCCHETTE – VALLE DELL'ASTICO

x	Comb.	δ_{max}	L/250.00	Cs
cm		mm	mm	
159.1	15	2.49	12.73	5.12

Verifica spostamento elastico dovuto ai soli carichi variabili (§4.2.4.2.1 - NTC 2008)

x	Comb.	δ_2	L/300.00	Cs
cm		mm	mm	
159.1	15	1.85	10.61	5.73

Travata: 160 [236 , 235]

L = 315.7cm

Crit.Prog: Acciaio_Flessione $\delta_c = 0.0cm$ Verifica: **Verificata**

Verifica spostamento nello stato finale (§4.2.4.2.1 - NTC 2008)

x	Comb.	δ_{max}	L/250.00	Cs
cm		mm	mm	
157.9	15	2.57	12.63	4.92

Verifica spostamento elastico dovuto ai soli carichi variabili (§4.2.4.2.1 - NTC 2008)

x	Comb.	δ_2	L/300.00	Cs
cm		mm	mm	
157.9	15	1.88	10.52	5.61

Travata: 161 [235 , 234]

L = 314.2cm

Crit.Prog: Acciaio_Flessione $\delta_c = 0.0cm$ Verifica: **Verificata**

Verifica spostamento nello stato finale (§4.2.4.2.1 - NTC 2008)

x	Comb.	δ_{max}	L/250.00	Cs
---	-------	----------------	----------	----

AUTOSTRADA VALDASTICO A31 NORD
1° LOTTO - PIOVENE ROCCHETTE – VALLE DELL'ASTICO

x	Comb.	δ_{max}	L/250.00	Cs
cm		mm	mm	
157.1	15	2.73	12.57	4.61

Verifica spostamento elastico dovuto ai soli carichi variabili (§4.2.4.2.1 - NTC 2008)

x	Comb.	δ_2	L/300.00	Cs
cm		mm	mm	
157.1	15	1.97	10.47	5.30

Travata: 162 [234 , 233]

L = 314.0cm

Crit.Prog: Acciaio_Flessione $\delta_c = 0.0cm$ Verifica: **Verificata**

Verifica spostamento nello stato finale (§4.2.4.2.1 - NTC 2008)

x	Comb.	δ_{max}	L/250.00	Cs
cm		mm	mm	
157.0	15	2.79	12.56	4.50

Verifica spostamento elastico dovuto ai soli carichi variabili (§4.2.4.2.1 - NTC 2008)

x	Comb.	δ_2	L/300.00	Cs
cm		mm	mm	
157.0	15	2.01	10.47	5.20

Travata: 163 [233 , 232]

L = 314.2cm

Crit.Prog: Acciaio_Flessione $\delta_c = 0.0cm$ Verifica: **Verificata**

Verifica spostamento nello stato finale (§4.2.4.2.1 - NTC 2008)

x	Comb.	δ_{max}	L/250.00	Cs
---	-------	----------------	----------	----

AUTOSTRADA VALDASTICO A31 NORD
1° LOTTO - PIOVENE ROCCHETTE – VALLE DELL'ASTICO

x	Comb.	δ_{max}	L/250.00	Cs
cm		mm	mm	
157.1	15	2.73	12.57	4.61

Verifica spostamento elastico dovuto ai soli carichi variabili (§4.2.4.2.1 - NTC 2008)

x	Comb.	δ_2	L/300.00	Cs
cm		mm	mm	
157.1	15	1.98	10.47	5.30

Travata: 164 [232 , 231]

L = 315.7cm

Crit.Prog: Acciaio_Flessione $\delta_c = 0.0cm$ Verifica: **Verificata**

Verifica spostamento nello stato finale (§4.2.4.2.1 - NTC 2008)

x	Comb.	δ_{max}	L/250.00	Cs
cm		mm	mm	
157.9	15	2.57	12.63	4.92

Verifica spostamento elastico dovuto ai soli carichi variabili (§4.2.4.2.1 - NTC 2008)

x	Comb.	δ_2	L/300.00	Cs
cm		mm	mm	
157.9	15	1.88	10.52	5.61

Travata: 165 [231 , 238]

L = 318.3cm

Crit.Prog: Acciaio_Flessione $\delta_c = 0.0cm$ Verifica: **Verificata**

Verifica spostamento nello stato finale (§4.2.4.2.1 - NTC 2008)

x	Comb.	δ_{max}	L/250.00	Cs
---	-------	----------------	----------	----

AUTOSTRADA VALDASTICO A31 NORD
1° LOTTO - PIOVENE ROCCHETTE – VALLE DELL'ASTICO

x	Comb.	δ_{max}	L/250.00	Cs
cm		mm	mm	
159.1	15	2.49	12.73	5.12

Verifica spostamento elastico dovuto ai soli carichi variabili (§4.2.4.2.1 - NTC 2008)

x	Comb.	δ_2	L/300.00	Cs
cm		mm	mm	
159.1	15	1.85	10.61	5.73

Travata: 166 [239 , 254]

L = 229.9cm

Crit.Prog: Acciaio_Flessione $\delta_c = 0.0cm$ Verifica: **Verificata**

Verifica spostamento nello stato finale (§4.2.4.2.1 - NTC 2008)

x	Comb.	δ_{max}	L/250.00	Cs
cm		mm	mm	
69.0	15	0.07	9.19	>100

Verifica spostamento elastico dovuto ai soli carichi variabili (§4.2.4.2.1 - NTC 2008)

x	Comb.	δ_2	L/300.00	Cs
cm		mm	mm	
183.9	15	-0.03	7.66	>100

Travata: 167 [257 , 240]

L = 286.0cm

Crit.Prog: Acciaio_Flessione $\delta_c = 0.0cm$ Verifica: **Verificata**

Verifica spostamento nello stato finale (§4.2.4.2.1 - NTC 2008)

x	Comb.	δ_{max}	L/250.00	Cs
---	-------	----------------	----------	----

AUTOSTRADA VALDASTICO A31 NORD
1° LOTTO - PIOVENE ROCCHETTE – VALLE DELL'ASTICO

x	Comb.	δ_{max}	L/250.00	Cs
cm		mm	mm	
85.8	15	-0.39	11.44	29.0

Verifica spostamento elastico dovuto ai soli carichi variabili (§4.2.4.2.1 - NTC 2008)

x	Comb.	δ_2	L/300.00	Cs
cm		mm	mm	
85.8	15	-0.28	9.53	34.1

Travata: 168 [240 , 239]

L = 314.0cm

Crit.Prog: Acciaio_Flessione $\delta_c = 0.0cm$ Verifica: **Verificata**

Verifica spostamento nello stato finale (§4.2.4.2.1 - NTC 2008)

x	Comb.	δ_{max}	L/250.00	Cs
cm		mm	mm	
125.6	15	-0.16	12.56	79.5

Verifica spostamento elastico dovuto ai soli carichi variabili (§4.2.4.2.1 - NTC 2008)

x	Comb.	δ_2	L/300.00	Cs
cm		mm	mm	
157.0	15	-0.15	10.47	71.9

Travata: 169 [256 , 254]

L = 229.9cm

Crit.Prog: Acciaio_Flessione $\delta_c = 0.0cm$ Verifica: **Verificata**

Verifica spostamento nello stato finale (§4.2.4.2.1 - NTC 2008)

x	Comb.	δ_{max}	L/250.00	Cs
---	-------	----------------	----------	----

AUTOSTRADA VALDASTICO A31 NORD
1° LOTTO - PIOVENE ROCCHETTE – VALLE DELL'ASTICO

x	Comb.	δ_{max}	L/250.00	Cs
cm		mm	mm	
137.9	15	-0.27	9.19	33.5

Verifica spostamento elastico dovuto ai soli carichi variabili (§4.2.4.2.1 - NTC 2008)

x	Comb.	δ_2	L/300.00	Cs
cm		mm	mm	
137.9	15	-0.21	7.66	36.0

Travata: 170 [254 , 240]

L = 229.9cm

Crit.Prog: Acciaio_Flessione $\delta_c = 0.0cm$ Verifica: **Verificata**

Verifica spostamento nello stato finale (§4.2.4.2.1 - NTC 2008)

x	Comb.	δ_{max}	L/250.00	Cs
cm		mm	mm	
114.9	15	-0.14	9.19	66.2

Verifica spostamento elastico dovuto ai soli carichi variabili (§4.2.4.2.1 - NTC 2008)

x	Comb.	δ_2	L/300.00	Cs
cm		mm	mm	
114.9	15	-0.08	7.66	93.9

Travata: 171 [254 , 257]

L = 229.9cm

Crit.Prog: Acciaio_Flessione $\delta_c = 0.0cm$ Verifica: **Verificata**

Verifica spostamento nello stato finale (§4.2.4.2.1 - NTC 2008)

x	Comb.	δ_{max}	L/250.00	Cs
---	-------	----------------	----------	----

AUTOSTRADA VALDASTICO A31 NORD
1° LOTTO - PIOVENE ROCCHETTE – VALLE DELL'ASTICO

x	Comb.	δ_{max}	L/250.00	Cs
cm		mm	mm	
69.0	15	0.16	9.19	57.1

Verifica spostamento elastico dovuto ai soli carichi variabili (§4.2.4.2.1 - NTC 2008)

x	Comb.	δ_2	L/300.00	Cs
cm		mm	mm	
91.9	15	0.11	7.66	68.7

Travata: 172 [256 , 239]

L = 286.0cm

Crit.Prog: Acciaio_Flessione $\delta_c = 0.0cm$ Verifica: **Verificata**

Verifica spostamento nello stato finale (§4.2.4.2.1 - NTC 2008)

x	Comb.	δ_{max}	L/250.00	Cs
cm		mm	mm	
228.8	15	-0.05	11.44	>100

Verifica spostamento elastico dovuto ai soli carichi variabili (§4.2.4.2.1 - NTC 2008)

x	Comb.	δ_2	L/300.00	Cs
cm		mm	mm	
171.6	15	-0.07	9.53	>100

Travata: 173 [258 , 241]

L = 286.0cm

Crit.Prog: Acciaio_Flessione $\delta_c = 0.0cm$ Verifica: **Verificata**

Verifica spostamento nello stato finale (§4.2.4.2.1 - NTC 2008)

x	Comb.	δ_{max}	L/250.00	Cs
---	-------	----------------	----------	----

AUTOSTRADA VALDASTICO A31 NORD
1° LOTTO - PIOVENE ROCCHETTE – VALLE DELL'ASTICO

x	Comb.	δ_{max}	L/250.00	Cs
cm		mm	mm	
85.8	15	-0.11	11.44	>100

Verifica spostamento elastico dovuto ai soli carichi variabili (§4.2.4.2.1 - NTC 2008)

x	Comb.	δ_2	L/300.00	Cs
cm		mm	mm	
114.4	15	-0.09	9.53	>100

Travata: 174 [241 , 240]

L = 314.0cm

Crit.Prog: Acciaio_Flessione $\delta_c = 0.0cm$ Verifica: **Verificata**

Verifica spostamento nello stato finale (§4.2.4.2.1 - NTC 2008)

x	Comb.	δ_{max}	L/250.00	Cs
cm		mm	mm	
251.2	15	-0.10	12.56	>100

Verifica spostamento elastico dovuto ai soli carichi variabili (§4.2.4.2.1 - NTC 2008)

x	Comb.	δ_2	L/300.00	Cs
cm		mm	mm	
219.8	15	-0.09	10.47	>100

Travata: 175 [240 , 253]

L = 254.4cm

Crit.Prog: Acciaio_Flessione $\delta_c = 0.0cm$ Verifica: **Verificata**

Verifica spostamento nello stato finale (§4.2.4.2.1 - NTC 2008)

x	Comb.	δ_{max}	L/250.00	Cs
---	-------	----------------	----------	----

AUTOSTRADA VALDASTICO A31 NORD
1° LOTTO - PIOVENE ROCCHETTE – VALLE DELL'ASTICO

x	Comb.	δ_{max}	L/250.00	Cs
cm		mm	mm	
127.2	15	-0.18	10.17	56.1

Verifica spostamento elastico dovuto ai soli carichi variabili (§4.2.4.2.1 - NTC 2008)

x	Comb.	δ_2	L/300.00	Cs
cm		mm	mm	
127.2	15	-0.13	8.48	65.4

Travata: 176 [253 , 258]

L = 254.4cm

Crit.Prog: Acciaio_Flessione $\delta_c = 0.0cm$ Verifica: **Verificata**

Verifica spostamento nello stato finale (§4.2.4.2.1 - NTC 2008)

x	Comb.	δ_{max}	L/250.00	Cs
cm		mm	mm	
127.2	15	-0.12	10.17	83.0

Verifica spostamento elastico dovuto ai soli carichi variabili (§4.2.4.2.1 - NTC 2008)

x	Comb.	δ_2	L/300.00	Cs
cm		mm	mm	
127.2	15	-0.09	8.48	91.2

Travata: 177 [257 , 253]

L = 254.4cm

Crit.Prog: Acciaio_Flessione $\delta_c = 0.0cm$ Verifica: **Verificata**

Verifica spostamento nello stato finale (§4.2.4.2.1 - NTC 2008)

x	Comb.	δ_{max}	L/250.00	Cs
---	-------	----------------	----------	----

AUTOSTRADA VALDASTICO A31 NORD
1° LOTTO - PIOVENE ROCCHETTE – VALLE DELL'ASTICO

x	Comb.	δ_{max}	L/250.00	Cs
cm		mm	mm	
76.3	15	-0.65	10.17	15.6

Verifica spostamento elastico dovuto ai soli carichi variabili (§4.2.4.2.1 - NTC 2008)

x	Comb.	δ_2	L/300.00	Cs
cm		mm	mm	
76.3	15	-0.44	8.48	19.1

Travata: 178 [253 , 241]

L = 254.4cm

Crit.Prog: Acciaio_Flessione $\delta_c = 0.0cm$ Verifica: **Verificata**

Verifica spostamento nello stato finale (§4.2.4.2.1 - NTC 2008)

x	Comb.	δ_{max}	L/250.00	Cs
cm		mm	mm	
127.2	15	0.19	10.17	53.2

Verifica spostamento elastico dovuto ai soli carichi variabili (§4.2.4.2.1 - NTC 2008)

x	Comb.	δ_2	L/300.00	Cs
cm		mm	mm	
127.2	15	0.12	8.48	73.4

Travata: 179 [259 , 242]

L = 286.0cm

Crit.Prog: Acciaio_Flessione $\delta_c = 0.0cm$ Verifica: **Verificata**

Verifica spostamento nello stato finale (§4.2.4.2.1 - NTC 2008)

x	Comb.	δ_{max}	L/250.00	Cs
---	-------	----------------	----------	----

AUTOSTRADA VALDASTICO A31 NORD
1° LOTTO - PIOVENE ROCCHETTE – VALLE DELL'ASTICO

x	Comb.	δ_{max}	L/250.00	Cs
cm		mm	mm	
143.0	21	0.02	11.44	>100

Verifica spostamento elastico dovuto ai soli carichi variabili (§4.2.4.2.1 - NTC 2008)

x	Comb.	δ_2	L/300.00	Cs
cm		mm	mm	
143.0	15	-0.02	9.53	>100

Travata: 180 [242 , 241]

L = 314.0cm

Crit.Prog: Acciaio_Flessione $\delta_c = 0.0cm$ Verifica: **Verificata**

Verifica spostamento nello stato finale (§4.2.4.2.1 - NTC 2008)

x	Comb.	δ_{max}	L/250.00	Cs
cm		mm	mm	
157.0	15	0.35	12.56	36.2

Verifica spostamento elastico dovuto ai soli carichi variabili (§4.2.4.2.1 - NTC 2008)

x	Comb.	δ_2	L/300.00	Cs
cm		mm	mm	
157.0	15	0.18	10.47	57.4

Travata: 181 [258 , 252]

L = 273.9cm

Crit.Prog: Acciaio_Flessione $\delta_c = 0.0cm$ Verifica: **Verificata**

Verifica spostamento nello stato finale (§4.2.4.2.1 - NTC 2008)

x	Comb.	δ_{max}	L/250.00	Cs
---	-------	----------------	----------	----

AUTOSTRADA VALDASTICO A31 NORD
1° LOTTO - PIOVENE ROCCHETTE – VALLE DELL'ASTICO

x	Comb.	δ_{max}	L/250.00	Cs
cm		mm	mm	
109.6	15	0.16	10.96	68.7

Verifica spostamento elastico dovuto ai soli carichi variabili (§4.2.4.2.1 - NTC 2008)

x	Comb.	δ_2	L/300.00	Cs
cm		mm	mm	
109.6	15	0.09	9.13	98.0

Travata: 182 [252 , 242]

L = 273.9cm

Crit.Prog: Acciaio_Flessione $\delta_c = 0.0cm$ Verifica: **Verificata**

Verifica spostamento nello stato finale (§4.2.4.2.1 - NTC 2008)

x	Comb.	δ_{max}	L/250.00	Cs
cm		mm	mm	
137.0	15	0.11	10.96	97.9

Verifica spostamento elastico dovuto ai soli carichi variabili (§4.2.4.2.1 - NTC 2008)

x	Comb.	δ_2	L/300.00	Cs
cm		mm	mm	
137.0	15	0.06	9.13	>100

Travata: 183 [241 , 252]

L = 273.9cm

Crit.Prog: Acciaio_Flessione $\delta_c = 0.0cm$ Verifica: **Verificata**

Verifica spostamento nello stato finale (§4.2.4.2.1 - NTC 2008)

x	Comb.	δ_{max}	L/250.00	Cs
---	-------	----------------	----------	----

AUTOSTRADA VALDASTICO A31 NORD
1° LOTTO - PIOVENE ROCCHETTE – VALLE DELL'ASTICO

x	Comb.	δ_{max}	L/250.00	Cs
cm		mm	mm	
164.3	15	0.03	10.96	>100

Verifica spostamento elastico dovuto ai soli carichi variabili (§4.2.4.2.1 - NTC 2008)

x	Comb.	δ_2	L/300.00	Cs
cm		mm	mm	
191.7	15	0.01	9.13	>100

Travata: 184 [252 , 259]

L = 273.9cm

Crit.Prog: Acciaio_Flessione $\delta_c = 0.0cm$ Verifica: **Verificata**

Verifica spostamento nello stato finale (§4.2.4.2.1 - NTC 2008)

x	Comb.	δ_{max}	L/250.00	Cs
cm		mm	mm	
137.0	15	0.09	10.96	>100

Verifica spostamento elastico dovuto ai soli carichi variabili (§4.2.4.2.1 - NTC 2008)

x	Comb.	δ_2	L/300.00	Cs
cm		mm	mm	
164.3	15	0.04	9.13	>100

Travata: 185 [260 , 243]

L = 286.0cm

Crit.Prog: Acciaio_Flessione $\delta_c = 0.0cm$ Verifica: **Verificata**

Verifica spostamento nello stato finale (§4.2.4.2.1 - NTC 2008)

x	Comb.	δ_{max}	L/250.00	Cs
---	-------	----------------	----------	----

AUTOSTRADA VALDASTICO A31 NORD
1° LOTTO - PIOVENE ROCCHETTE – VALLE DELL'ASTICO

x	Comb.	δ_{max}	L/250.00	Cs
cm		mm	mm	
143.0	21	0.03	11.44	>100

Verifica spostamento elastico dovuto ai soli carichi variabili (§4.2.4.2.1 - NTC 2008)

x	Comb.	δ_2	L/300.00	Cs
cm		mm	mm	
200.2	15	-0.01	9.53	>100

Travata: 186 [243 , 242]

L = 314.0cm

Crit.Prog: Acciaio_Flessione $\delta_c = 0.0cm$ Verifica: **Verificata**

Verifica spostamento nello stato finale (§4.2.4.2.1 - NTC 2008)

x	Comb.	δ_{max}	L/250.00	Cs
cm		mm	mm	
157.0	15	0.43	12.56	29.1

Verifica spostamento elastico dovuto ai soli carichi variabili (§4.2.4.2.1 - NTC 2008)

x	Comb.	δ_2	L/300.00	Cs
cm		mm	mm	
157.0	15	0.23	10.47	44.6

Travata: 187 [259 , 251]

L = 281.6cm

Crit.Prog: Acciaio_Flessione $\delta_c = 0.0cm$ Verifica: **Verificata**

Verifica spostamento nello stato finale (§4.2.4.2.1 - NTC 2008)

x	Comb.	δ_{max}	L/250.00	Cs
---	-------	----------------	----------	----

AUTOSTRADA VALDASTICO A31 NORD
1° LOTTO - PIOVENE ROCCHETTE – VALLE DELL'ASTICO

x	Comb.	δ_{max}	L/250.00	Cs
cm		mm	mm	
140.8	15	0.11	11.27	>100

Verifica spostamento elastico dovuto ai soli carichi variabili (§4.2.4.2.1 - NTC 2008)

x	Comb.	δ_2	L/300.00	Cs
cm		mm	mm	
140.8	15	0.06	9.39	>100

Travata: 188 [251 , 260]

L = 281.6cm

Crit.Prog: Acciaio_Flessione $\delta_c = 0.0cm$ Verifica: **Verificata**

Verifica spostamento nello stato finale (§4.2.4.2.1 - NTC 2008)

x	Comb.	δ_{max}	L/250.00	Cs
cm		mm	mm	
140.8	15	0.12	11.27	97.0

Verifica spostamento elastico dovuto ai soli carichi variabili (§4.2.4.2.1 - NTC 2008)

x	Comb.	δ_2	L/300.00	Cs
cm		mm	mm	
140.8	15	0.06	9.39	>100

Travata: 189 [242 , 251]

L = 281.6cm

Crit.Prog: Acciaio_Flessione $\delta_c = 0.0cm$ Verifica: **Verificata**

Verifica spostamento nello stato finale (§4.2.4.2.1 - NTC 2008)

x	Comb.	δ_{max}	L/250.00	Cs
---	-------	----------------	----------	----

AUTOSTRADA VALDASTICO A31 NORD
1° LOTTO - PIOVENE ROCCHETTE – VALLE DELL'ASTICO

x	Comb.	δ_{max}	L/250.00	Cs
cm		mm	mm	
140.8	15	0.10	11.27	>100

Verifica spostamento elastico dovuto ai soli carichi variabili (§4.2.4.2.1 - NTC 2008)

x	Comb.	δ_2	L/300.00	Cs
cm		mm	mm	
140.8	15	0.05	9.39	>100

Travata: 190 [251 , 243]

L = 281.6cm

Crit.Prog: Acciaio_Flessione $\delta_c = 0.0cm$ Verifica: **Verificata**

Verifica spostamento nello stato finale (§4.2.4.2.1 - NTC 2008)

x	Comb.	δ_{max}	L/250.00	Cs
cm		mm	mm	
140.8	15	0.11	11.27	>100

Verifica spostamento elastico dovuto ai soli carichi variabili (§4.2.4.2.1 - NTC 2008)

x	Comb.	δ_2	L/300.00	Cs
cm		mm	mm	
140.8	15	0.06	9.39	>100

Travata: 191 [243 , 250]

L = 281.6cm

Crit.Prog: Acciaio_Flessione $\delta_c = 0.0cm$ Verifica: **Verificata**

Verifica spostamento nello stato finale (§4.2.4.2.1 - NTC 2008)

x	Comb.	δ_{max}	L/250.00	Cs
---	-------	----------------	----------	----

AUTOSTRADA VALDASTICO A31 NORD
1° LOTTO - PIOVENE ROCCHETTE – VALLE DELL'ASTICO

x	Comb.	δ_{max}	L/250.00	Cs
cm		mm	mm	
140.8	15	0.11	11.27	>100

Verifica spostamento elastico dovuto ai soli carichi variabili (§4.2.4.2.1 - NTC 2008)

x	Comb.	δ_2	L/300.00	Cs
cm		mm	mm	
140.8	15	0.06	9.39	>100

Travata: 192 [250 , 261]

L = 281.6cm

Crit.Prog: Acciaio_Flessione $\delta_c = 0.0cm$ Verifica: **Verificata**

Verifica spostamento nello stato finale (§4.2.4.2.1 - NTC 2008)

x	Comb.	δ_{max}	L/250.00	Cs
cm		mm	mm	
140.8	15	0.11	11.27	>100

Verifica spostamento elastico dovuto ai soli carichi variabili (§4.2.4.2.1 - NTC 2008)

x	Comb.	δ_2	L/300.00	Cs
cm		mm	mm	
140.8	15	0.06	9.39	>100

Travata: 193 [261 , 244]

L = 286.0cm

Crit.Prog: Acciaio_Flessione $\delta_c = 0.0cm$ Verifica: **Verificata**

Verifica spostamento nello stato finale (§4.2.4.2.1 - NTC 2008)

x	Comb.	δ_{max}	L/250.00	Cs
---	-------	----------------	----------	----

AUTOSTRADA VALDASTICO A31 NORD
1° LOTTO - PIOVENE ROCCHETTE – VALLE DELL'ASTICO

x	Comb.	δ_{max}	L/250.00	Cs
cm		mm	mm	
143.0	21	0.02	11.44	>100

Verifica spostamento elastico dovuto ai soli carichi variabili (§4.2.4.2.1 - NTC 2008)

x	Comb.	δ_2	L/300.00	Cs
cm		mm	mm	
143.0	15	-0.02	9.53	>100

Travata: 194 [244 , 243]

L = 314.0cm

Crit.Prog: Acciaio_Flessione $\delta_c = 0.0cm$ Verifica: **Verificata**

Verifica spostamento nello stato finale (§4.2.4.2.1 - NTC 2008)

x	Comb.	δ_{max}	L/250.00	Cs
cm		mm	mm	
157.0	15	0.43	12.56	29.1

Verifica spostamento elastico dovuto ai soli carichi variabili (§4.2.4.2.1 - NTC 2008)

x	Comb.	δ_2	L/300.00	Cs
cm		mm	mm	
157.0	15	0.23	10.47	44.6

Travata: 195 [260 , 250]

L = 281.6cm

Crit.Prog: Acciaio_Flessione $\delta_c = 0.0cm$ Verifica: **Verificata**

Verifica spostamento nello stato finale (§4.2.4.2.1 - NTC 2008)

x	Comb.	δ_{max}	L/250.00	Cs
---	-------	----------------	----------	----

AUTOSTRADA VALDASTICO A31 NORD
1° LOTTO - PIOVENE ROCCHETTE – VALLE DELL'ASTICO

x	Comb.	δ_{max}	L/250.00	Cs
cm		mm	mm	
140.8	15	0.12	11.27	97.2

Verifica spostamento elastico dovuto ai soli carichi variabili (§4.2.4.2.1 - NTC 2008)

x	Comb.	δ_2	L/300.00	Cs
cm		mm	mm	
140.8	15	0.06	9.39	>100

Travata: 196 [250 , 244]

L = 281.6cm

Crit.Prog: Acciaio_Flessione $\delta_c = 0.0cm$ Verifica: **Verificata**

Verifica spostamento nello stato finale (§4.2.4.2.1 - NTC 2008)

x	Comb.	δ_{max}	L/250.00	Cs
cm		mm	mm	
140.8	15	0.10	11.27	>100

Verifica spostamento elastico dovuto ai soli carichi variabili (§4.2.4.2.1 - NTC 2008)

x	Comb.	δ_2	L/300.00	Cs
cm		mm	mm	
140.8	15	0.05	9.39	>100

Travata: 197 [262 , 245]

L = 286.0cm

Crit.Prog: Acciaio_Flessione $\delta_c = 0.0cm$ Verifica: **Verificata**

Verifica spostamento nello stato finale (§4.2.4.2.1 - NTC 2008)

x	Comb.	δ_{max}	L/250.00	Cs
---	-------	----------------	----------	----

AUTOSTRADA VALDASTICO A31 NORD
1° LOTTO - PIOVENE ROCCHETTE – VALLE DELL'ASTICO

x	Comb.	δ_{max}	L/250.00	Cs
cm		mm	mm	
85.8	15	-0.11	11.44	>100

Verifica spostamento elastico dovuto ai soli carichi variabili (§4.2.4.2.1 - NTC 2008)

x	Comb.	δ_2	L/300.00	Cs
cm		mm	mm	
114.4	15	-0.09	9.53	>100

Travata: 198 [245 , 244]

L = 314.0cm

Crit.Prog: Acciaio_Flessione $\delta_c = 0.0cm$ Verifica: **Verificata**

Verifica spostamento nello stato finale (§4.2.4.2.1 - NTC 2008)

x	Comb.	δ_{max}	L/250.00	Cs
cm		mm	mm	
157.0	15	0.35	12.56	36.4

Verifica spostamento elastico dovuto ai soli carichi variabili (§4.2.4.2.1 - NTC 2008)

x	Comb.	δ_2	L/300.00	Cs
cm		mm	mm	
157.0	15	0.18	10.47	57.3

Travata: 199 [244 , 249]

L = 273.9cm

Crit.Prog: Acciaio_Flessione $\delta_c = 0.0cm$ Verifica: **Verificata**

Verifica spostamento nello stato finale (§4.2.4.2.1 - NTC 2008)

x	Comb.	δ_{max}	L/250.00	Cs
---	-------	----------------	----------	----

AUTOSTRADA VALDASTICO A31 NORD
1° LOTTO - PIOVENE ROCCHETTE – VALLE DELL'ASTICO

x	Comb.	δ_{max}	L/250.00	Cs
cm		mm	mm	
137.0	15	0.11	10.96	98.0

Verifica spostamento elastico dovuto ai soli carichi variabili (§4.2.4.2.1 - NTC 2008)

x	Comb.	δ_2	L/300.00	Cs
cm		mm	mm	
137.0	15	0.06	9.13	>100

Travata: 200 [249 , 262]

L = 273.9cm

Crit.Prog: Acciaio_Flessione $\delta_c = 0.0cm$ Verifica: **Verificata**

Verifica spostamento nello stato finale (§4.2.4.2.1 - NTC 2008)

x	Comb.	δ_{max}	L/250.00	Cs
cm		mm	mm	
164.3	15	0.16	10.96	68.0

Verifica spostamento elastico dovuto ai soli carichi variabili (§4.2.4.2.1 - NTC 2008)

x	Comb.	δ_2	L/300.00	Cs
cm		mm	mm	
164.3	15	0.09	9.13	97.5

Travata: 201 [261 , 249]

L = 273.9cm

Crit.Prog: Acciaio_Flessione $\delta_c = 0.0cm$ Verifica: **Verificata**

Verifica spostamento nello stato finale (§4.2.4.2.1 - NTC 2008)

x	Comb.	δ_{max}	L/250.00	Cs
---	-------	----------------	----------	----

AUTOSTRADA VALDASTICO A31 NORD
1° LOTTO - PIOVENE ROCCHETTE – VALLE DELL'ASTICO

x	Comb.	δ_{max}	L/250.00	Cs
cm		mm	mm	
137.0	15	0.09	10.96	>100

Verifica spostamento elastico dovuto ai soli carichi variabili (§4.2.4.2.1 - NTC 2008)

x	Comb.	δ_2	L/300.00	Cs
cm		mm	mm	
109.6	15	0.04	9.13	>100

Travata: 202 [249 , 245]

L = 273.9cm

Crit.Prog: Acciaio_Flessione $\delta_c = 0.0cm$ Verifica: **Verificata**

Verifica spostamento nello stato finale (§4.2.4.2.1 - NTC 2008)

x	Comb.	δ_{max}	L/250.00	Cs
cm		mm	mm	
109.6	15	0.03	10.96	>100

Verifica spostamento elastico dovuto ai soli carichi variabili (§4.2.4.2.1 - NTC 2008)

x	Comb.	δ_2	L/300.00	Cs
cm		mm	mm	
82.2	15	0.01	9.13	>100

Travata: 203 [245 , 246]

L = 314.0cm

Crit.Prog: Acciaio_Flessione $\delta_c = 0.0cm$ Verifica: **Verificata**

Verifica spostamento nello stato finale (§4.2.4.2.1 - NTC 2008)

x	Comb.	δ_{max}	L/250.00	Cs
---	-------	----------------	----------	----

AUTOSTRADA VALDASTICO A31 NORD
1° LOTTO - PIOVENE ROCCHETTE – VALLE DELL'ASTICO

x	Comb.	δ_{max}	L/250.00	Cs
cm		mm	mm	
251.2	15	-0.11	12.56	>100

Verifica spostamento elastico dovuto ai soli carichi variabili (§4.2.4.2.1 - NTC 2008)

x	Comb.	δ_2	L/300.00	Cs
cm		mm	mm	
219.8	15	-0.09	10.47	>100

Travata: 204 [246 , 263]

L = 286.0cm

Crit.Prog: Acciaio_Flessione $\delta_c = 0.0cm$ Verifica: **Verificata**

Verifica spostamento nello stato finale (§4.2.4.2.1 - NTC 2008)

x	Comb.	δ_{max}	L/250.00	Cs
cm		mm	mm	
200.2	15	-0.40	11.44	28.6

Verifica spostamento elastico dovuto ai soli carichi variabili (§4.2.4.2.1 - NTC 2008)

x	Comb.	δ_2	L/300.00	Cs
cm		mm	mm	
200.2	15	-0.28	9.53	33.9

Travata: 205 [262 , 248]

L = 254.4cm

Crit.Prog: Acciaio_Flessione $\delta_c = 0.0cm$ Verifica: **Verificata**

Verifica spostamento nello stato finale (§4.2.4.2.1 - NTC 2008)

x	Comb.	δ_{max}	L/250.00	Cs
---	-------	----------------	----------	----

AUTOSTRADA VALDASTICO A31 NORD
1° LOTTO - PIOVENE ROCCHETTE – VALLE DELL'ASTICO

x	Comb.	δ_{max}	L/250.00	Cs
cm		mm	mm	
127.2	15	-0.13	10.17	80.3

Verifica spostamento elastico dovuto ai soli carichi variabili (§4.2.4.2.1 - NTC 2008)

x	Comb.	δ_2	L/300.00	Cs
cm		mm	mm	
127.2	15	-0.09	8.48	90.4

Travata: 206 [248 , 263]

L = 254.4cm

Crit.Prog: Acciaio_Flessione $\delta_c = 0.0cm$ Verifica: **Verificata**

Verifica spostamento nello stato finale (§4.2.4.2.1 - NTC 2008)

x	Comb.	δ_{max}	L/250.00	Cs
cm		mm	mm	
178.1	15	-0.69	10.17	14.8

Verifica spostamento elastico dovuto ai soli carichi variabili (§4.2.4.2.1 - NTC 2008)

x	Comb.	δ_2	L/300.00	Cs
cm		mm	mm	
178.1	15	-0.45	8.48	18.7

Travata: 207 [245 , 248]

L = 254.4cm

Crit.Prog: Acciaio_Flessione $\delta_c = 0.0cm$ Verifica: **Verificata**

Verifica spostamento nello stato finale (§4.2.4.2.1 - NTC 2008)

x	Comb.	δ_{max}	L/250.00	Cs
---	-------	----------------	----------	----

AUTOSTRADA VALDASTICO A31 NORD
1° LOTTO - PIOVENE ROCCHETTE – VALLE DELL'ASTICO

x	Comb.	δ_{max}	L/250.00	Cs
cm		mm	mm	
127.2	15	0.19	10.17	52.7

Verifica spostamento elastico dovuto ai soli carichi variabili (§4.2.4.2.1 - NTC 2008)

x	Comb.	δ_2	L/300.00	Cs
cm		mm	mm	
127.2	15	0.12	8.48	73.1

Travata: 208 [248 , 246]

L = 254.4cm

Crit.Prog: Acciaio_Flessione $\delta_c = 0.0cm$ Verifica: **Verificata**

Verifica spostamento nello stato finale (§4.2.4.2.1 - NTC 2008)

x	Comb.	δ_{max}	L/250.00	Cs
cm		mm	mm	
127.2	15	-0.18	10.17	55.4

Verifica spostamento elastico dovuto ai soli carichi variabili (§4.2.4.2.1 - NTC 2008)

x	Comb.	δ_2	L/300.00	Cs
cm		mm	mm	
127.2	15	-0.13	8.48	65.3

Travata: 209 [264 , 247]

L = 286.0cm

Crit.Prog: Acciaio_Flessione $\delta_c = 0.0cm$ Verifica: **Verificata**

Verifica spostamento nello stato finale (§4.2.4.2.1 - NTC 2008)

x	Comb.	δ_{max}	L/250.00	Cs
---	-------	----------------	----------	----

AUTOSTRADA VALDASTICO A31 NORD
1° LOTTO - PIOVENE ROCCHETTE – VALLE DELL'ASTICO

x	Comb.	δ_{max}	L/250.00	Cs
cm		mm	mm	
114.4	21	0.05	11.44	>100

Verifica spostamento elastico dovuto ai soli carichi variabili (§4.2.4.2.1 - NTC 2008)

x	Comb.	δ_2	L/300.00	Cs
cm		mm	mm	
171.6	15	-0.06	9.53	>100

Travata: 210 [247 , 246]

L = 314.0cm

Crit.Prog: Acciaio_Flessione $\delta_c = 0.0cm$ Verifica: **Verificata**

Verifica spostamento nello stato finale (§4.2.4.2.1 - NTC 2008)

x	Comb.	δ_{max}	L/250.00	Cs
cm		mm	mm	
188.4	15	-0.16	12.56	76.3

Verifica spostamento elastico dovuto ai soli carichi variabili (§4.2.4.2.1 - NTC 2008)

x	Comb.	δ_2	L/300.00	Cs
cm		mm	mm	
157.0	15	-0.15	10.47	71.0

Travata: 211 [263 , 255]

L = 229.9cm

Crit.Prog: Acciaio_Flessione $\delta_c = 0.0cm$ Verifica: **Verificata**

Verifica spostamento nello stato finale (§4.2.4.2.1 - NTC 2008)

x	Comb.	δ_{max}	L/250.00	Cs
---	-------	----------------	----------	----

AUTOSTRADA VALDASTICO A31 NORD
1° LOTTO - PIOVENE ROCCHETTE – VALLE DELL'ASTICO

x	Comb.	δ_{max}	L/250.00	Cs
cm		mm	mm	
137.9	15	0.18	9.19	52.5

Verifica spostamento elastico dovuto ai soli carichi variabili (§4.2.4.2.1 - NTC 2008)

x	Comb.	δ_2	L/300.00	Cs
cm		mm	mm	
137.9	15	0.12	7.66	66.2

Travata: 212 [255 , 247]

L = 229.9cm

Crit.Prog: Acciaio_Flessione $\delta_c = 0.0cm$ Verifica: **Verificata**

Verifica spostamento nello stato finale (§4.2.4.2.1 - NTC 2008)

x	Comb.	δ_{max}	L/250.00	Cs
cm		mm	mm	
160.9	15	0.08	9.19	>100

Verifica spostamento elastico dovuto ai soli carichi variabili (§4.2.4.2.1 - NTC 2008)

x	Comb.	δ_2	L/300.00	Cs
cm		mm	mm	
46.0	15	-0.02	7.66	>100

Travata: 213 [255 , 264]

L = 229.9cm

Crit.Prog: Acciaio_Flessione $\delta_c = 0.0cm$ Verifica: **Verificata**

Verifica spostamento nello stato finale (§4.2.4.2.1 - NTC 2008)

x	Comb.	δ_{max}	L/250.00	Cs
---	-------	----------------	----------	----

AUTOSTRADA VALDASTICO A31 NORD
1° LOTTO - PIOVENE ROCCHETTE – VALLE DELL'ASTICO

x	Comb.	δ_{max}	L/250.00	Cs
cm		mm	mm	
91.9	15	-0.29	9.19	31.9

Verifica spostamento elastico dovuto ai soli carichi variabili (§4.2.4.2.1 - NTC 2008)

x	Comb.	δ_2	L/300.00	Cs
cm		mm	mm	
91.9	15	-0.22	7.66	35.4

Travata: 214 [254 , 253]

L = 318.3cm

Crit.Prog: Acciaio_Flessione $\delta_c = 0.0cm$ Verifica: **Verificata**

Verifica spostamento nello stato finale (§4.2.4.2.1 - NTC 2008)

x	Comb.	δ_{max}	L/250.00	Cs
cm		mm	mm	
159.1	15	1.99	12.73	6.39

Verifica spostamento elastico dovuto ai soli carichi variabili (§4.2.4.2.1 - NTC 2008)

x	Comb.	δ_2	L/300.00	Cs
cm		mm	mm	
159.1	15	1.54	10.61	6.89

Travata: 215 [253 , 252]

L = 315.7cm

Crit.Prog: Acciaio_Flessione $\delta_c = 0.0cm$ Verifica: **Verificata**

Verifica spostamento nello stato finale (§4.2.4.2.1 - NTC 2008)

x	Comb.	δ_{max}	L/250.00	Cs
---	-------	----------------	----------	----

AUTOSTRADA VALDASTICO A31 NORD
1° LOTTO - PIOVENE ROCCHETTE – VALLE DELL'ASTICO

x	Comb.	δ_{max}	L/250.00	Cs
cm		mm	mm	
157.9	15	2.76	12.63	4.58

Verifica spostamento elastico dovuto ai soli carichi variabili (§4.2.4.2.1 - NTC 2008)

x	Comb.	δ_2	L/300.00	Cs
cm		mm	mm	
157.9	15	2.00	10.52	5.26

Travata: 216 [252 , 251]

L = 314.2cm

Crit.Prog: Acciaio_Flessione $\delta_c = 0.0cm$ Verifica: **Verificata**

Verifica spostamento nello stato finale (§4.2.4.2.1 - NTC 2008)

x	Comb.	δ_{max}	L/250.00	Cs
cm		mm	mm	
157.1	15	2.78	12.57	4.51

Verifica spostamento elastico dovuto ai soli carichi variabili (§4.2.4.2.1 - NTC 2008)

x	Comb.	δ_2	L/300.00	Cs
cm		mm	mm	
157.1	15	2.01	10.47	5.20

Travata: 217 [251 , 250]

L = 314.0cm

Crit.Prog: Acciaio_Flessione $\delta_c = 0.0cm$ Verifica: **Verificata**

Verifica spostamento nello stato finale (§4.2.4.2.1 - NTC 2008)

x	Comb.	δ_{max}	L/250.00	Cs
---	-------	----------------	----------	----

AUTOSTRADA VALDASTICO A31 NORD
1° LOTTO - PIOVENE ROCCHETTE – VALLE DELL'ASTICO

x	Comb.	δ_{max}	L/250.00	Cs
cm		mm	mm	
157.0	15	2.81	12.56	4.47

Verifica spostamento elastico dovuto ai soli carichi variabili (§4.2.4.2.1 - NTC 2008)

x	Comb.	δ_2	L/300.00	Cs
cm		mm	mm	
157.0	15	2.03	10.47	5.16

Travata: 218 [250 , 249]

L = 314.2cm

Crit.Prog: Acciaio_Flessione $\delta_c = 0.0cm$ Verifica: **Verificata**

Verifica spostamento nello stato finale (§4.2.4.2.1 - NTC 2008)

x	Comb.	δ_{max}	L/250.00	Cs
cm		mm	mm	
157.1	15	2.78	12.57	4.52

Verifica spostamento elastico dovuto ai soli carichi variabili (§4.2.4.2.1 - NTC 2008)

x	Comb.	δ_2	L/300.00	Cs
cm		mm	mm	
157.1	15	2.01	10.47	5.20

Travata: 219 [249 , 248]

L = 315.7cm

Crit.Prog: Acciaio_Flessione $\delta_c = 0.0cm$ Verifica: **Verificata**

Verifica spostamento nello stato finale (§4.2.4.2.1 - NTC 2008)

x	Comb.	δ_{max}	L/250.00	Cs
---	-------	----------------	----------	----

AUTOSTRADA VALDASTICO A31 NORD
1° LOTTO - PIOVENE ROCCHETTE – VALLE DELL'ASTICO

x	Comb.	δ_{max}	L/250.00	Cs
cm		mm	mm	
157.9	15	2.76	12.63	4.58

Verifica spostamento elastico dovuto ai soli carichi variabili (§4.2.4.2.1 - NTC 2008)

x	Comb.	δ_2	L/300.00	Cs
cm		mm	mm	
157.9	15	2.00	10.52	5.26

Travata: 220 [248 , 255]

L = 318.3cm

Crit.Prog: Acciaio_Flessione $\delta_c = 0.0cm$ Verifica: **Verificata**

Verifica spostamento nello stato finale (§4.2.4.2.1 - NTC 2008)

x	Comb.	δ_{max}	L/250.00	Cs
cm		mm	mm	
159.1	15	1.97	12.73	6.45

Verifica spostamento elastico dovuto ai soli carichi variabili (§4.2.4.2.1 - NTC 2008)

x	Comb.	δ_2	L/300.00	Cs
cm		mm	mm	
159.1	15	1.53	10.61	6.91

Travata: 221 [256 , 271]

L = 229.9cm

Crit.Prog: Acciaio_Flessione $\delta_c = 0.0cm$ Verifica: **Verificata**

Verifica spostamento nello stato finale (§4.2.4.2.1 - NTC 2008)

x	Comb.	δ_{max}	L/250.00	Cs
---	-------	----------------	----------	----

AUTOSTRADA VALDASTICO A31 NORD
1° LOTTO - PIOVENE ROCCHETTE – VALLE DELL'ASTICO

x	Comb.	δ_{max}	L/250.00	Cs
cm		mm	mm	
114.9	15	-0.37	9.19	24.9

Verifica spostamento elastico dovuto ai soli carichi variabili (§4.2.4.2.1 - NTC 2008)

x	Comb.	δ_2	L/300.00	Cs
cm		mm	mm	
114.9	15	-0.27	7.66	28.0

Travata: 222 [274 , 257]

L = 286.0cm

Crit.Prog: Acciaio_Flessione $\delta_c = 0.0cm$ Verifica: **Verificata**

Verifica spostamento nello stato finale (§4.2.4.2.1 - NTC 2008)

x	Comb.	δ_{max}	L/250.00	Cs
cm		mm	mm	
200.2	15	-0.64	11.44	18.0

Verifica spostamento elastico dovuto ai soli carichi variabili (§4.2.4.2.1 - NTC 2008)

x	Comb.	δ_2	L/300.00	Cs
cm		mm	mm	
200.2	15	-0.42	9.53	22.8

Travata: 223 [257 , 256]

L = 314.0cm

Crit.Prog: Acciaio_Flessione $\delta_c = 0.0cm$ Verifica: **Verificata**

Verifica spostamento nello stato finale (§4.2.4.2.1 - NTC 2008)

x	Comb.	δ_{max}	L/250.00	Cs
---	-------	----------------	----------	----

AUTOSTRADA VALDASTICO A31 NORD
1° LOTTO - PIOVENE ROCCHETTE – VALLE DELL'ASTICO

x	Comb.	δ_{max}	L/250.00	Cs
cm		mm	mm	
188.4	17	0.08	12.56	>100

Verifica spostamento elastico dovuto ai soli carichi variabili (§4.2.4.2.1 - NTC 2008)

x	Comb.	δ_2	L/300.00	Cs
cm		mm	mm	
62.8	15	0.05	10.47	>100

Travata: 224 [273 , 271]

L = 229.9cm

Crit.Prog: Acciaio_Flessione $\delta_c = 0.0cm$ Verifica: **Verificata**

Verifica spostamento nello stato finale (§4.2.4.2.1 - NTC 2008)

x	Comb.	δ_{max}	L/250.00	Cs
cm		mm	mm	
46.0	15	0.04	9.19	>100

Verifica spostamento elastico dovuto ai soli carichi variabili (§4.2.4.2.1 - NTC 2008)

x	Comb.	δ_2	L/300.00	Cs
cm		mm	mm	
160.9	15	-0.03	7.66	>100

Travata: 225 [271 , 257]

L = 229.9cm

Crit.Prog: Acciaio_Flessione $\delta_c = 0.0cm$ Verifica: **Verificata**

Verifica spostamento nello stato finale (§4.2.4.2.1 - NTC 2008)

x	Comb.	δ_{max}	L/250.00	Cs
---	-------	----------------	----------	----

AUTOSTRADA VALDASTICO A31 NORD
1° LOTTO - PIOVENE ROCCHETTE – VALLE DELL'ASTICO

x	Comb.	δ_{max}	L/250.00	Cs
cm		mm	mm	
46.0	15	0.09	9.19	99.0

Verifica spostamento elastico dovuto ai soli carichi variabili (§4.2.4.2.1 - NTC 2008)

x	Comb.	δ_2	L/300.00	Cs
cm		mm	mm	
46.0	15	0.07	7.66	>100

Travata: 226 [271 , 274]

L = 229.9cm

Crit.Prog: Acciaio_Flessione $\delta_c = 0.0cm$ Verifica: **Verificata**

Verifica spostamento nello stato finale (§4.2.4.2.1 - NTC 2008)

x	Comb.	δ_{max}	L/250.00	Cs
cm		mm	mm	
114.9	15	-0.10	9.19	91.0

Verifica spostamento elastico dovuto ai soli carichi variabili (§4.2.4.2.1 - NTC 2008)

x	Comb.	δ_2	L/300.00	Cs
cm		mm	mm	
114.9	15	-0.06	7.66	>100

Travata: 227 [273 , 256]

L = 286.0cm

Crit.Prog: Acciaio_Flessione $\delta_c = 0.0cm$ Verifica: **Verificata**

Verifica spostamento nello stato finale (§4.2.4.2.1 - NTC 2008)

x	Comb.	δ_{max}	L/250.00	Cs
---	-------	----------------	----------	----

AUTOSTRADA VALDASTICO A31 NORD
1° LOTTO - PIOVENE ROCCHETTE – VALLE DELL'ASTICO

x	Comb.	δ_{max}	L/250.00	Cs
cm		mm	mm	
171.6	15	-0.31	11.44	37.5

Verifica spostamento elastico dovuto ai soli carichi variabili (§4.2.4.2.1 - NTC 2008)

x	Comb.	δ_2	L/300.00	Cs
cm		mm	mm	
171.6	15	-0.21	9.53	44.4

Travata: 228 [275 , 258]

L = 286.0cm

Crit.Prog: Acciaio_Flessione $\delta_c = 0.0cm$ Verifica: **Verificata**

Verifica spostamento nello stato finale (§4.2.4.2.1 - NTC 2008)

x	Comb.	δ_{max}	L/250.00	Cs
cm		mm	mm	
200.2	15	-0.10	11.44	>100

Verifica spostamento elastico dovuto ai soli carichi variabili (§4.2.4.2.1 - NTC 2008)

x	Comb.	δ_2	L/300.00	Cs
cm		mm	mm	
171.6	15	-0.08	9.53	>100

Travata: 229 [258 , 257]

L = 314.0cm

Crit.Prog: Acciaio_Flessione $\delta_c = 0.0cm$ Verifica: **Verificata**

Verifica spostamento nello stato finale (§4.2.4.2.1 - NTC 2008)

x	Comb.	δ_{max}	L/250.00	Cs
---	-------	----------------	----------	----

AUTOSTRADA VALDASTICO A31 NORD
1° LOTTO - PIOVENE ROCCHETTE – VALLE DELL'ASTICO

x	Comb.	δ_{max}	L/250.00	Cs
cm		mm	mm	
219.8	15	-1.17	12.56	10.7

Verifica spostamento elastico dovuto ai soli carichi variabili (§4.2.4.2.1 - NTC 2008)

x	Comb.	δ_2	L/300.00	Cs
cm		mm	mm	
219.8	15	-0.80	10.47	13.0

Travata: 230 [257 , 270]

L = 254.4cm

Crit.Prog: Acciaio_Flessione $\delta_c = 0.0cm$ Verifica: **Verificata**

Verifica spostamento nello stato finale (§4.2.4.2.1 - NTC 2008)

x	Comb.	δ_{max}	L/250.00	Cs
cm		mm	mm	
76.3	15	-0.75	10.17	13.5

Verifica spostamento elastico dovuto ai soli carichi variabili (§4.2.4.2.1 - NTC 2008)

x	Comb.	δ_2	L/300.00	Cs
cm		mm	mm	
76.3	15	-0.50	8.48	16.8

Travata: 231 [270 , 275]

L = 254.4cm

Crit.Prog: Acciaio_Flessione $\delta_c = 0.0cm$ Verifica: **Verificata**

Verifica spostamento nello stato finale (§4.2.4.2.1 - NTC 2008)

x	Comb.	δ_{max}	L/250.00	Cs
---	-------	----------------	----------	----

AUTOSTRADA VALDASTICO A31 NORD
1° LOTTO - PIOVENE ROCCHETTE – VALLE DELL'ASTICO

x	Comb.	δ_{max}	L/250.00	Cs
cm		mm	mm	
127.2	15	0.23	10.17	43.8

Verifica spostamento elastico dovuto ai soli carichi variabili (§4.2.4.2.1 - NTC 2008)

x	Comb.	δ_2	L/300.00	Cs
cm		mm	mm	
127.2	15	0.14	8.48	62.1

Travata: 232 [274 , 270]

L = 254.4cm

Crit.Prog: Acciaio_Flessione $\delta_c = 0.0cm$ Verifica: **Verificata**

Verifica spostamento nello stato finale (§4.2.4.2.1 - NTC 2008)

x	Comb.	δ_{max}	L/250.00	Cs
cm		mm	mm	
127.2	15	-0.21	10.17	47.6

Verifica spostamento elastico dovuto ai soli carichi variabili (§4.2.4.2.1 - NTC 2008)

x	Comb.	δ_2	L/300.00	Cs
cm		mm	mm	
127.2	15	-0.14	8.48	58.5

Travata: 233 [270 , 258]

L = 254.4cm

Crit.Prog: Acciaio_Flessione $\delta_c = 0.0cm$ Verifica: **Verificata**

Verifica spostamento nello stato finale (§4.2.4.2.1 - NTC 2008)

x	Comb.	δ_{max}	L/250.00	Cs
---	-------	----------------	----------	----

AUTOSTRADA VALDASTICO A31 NORD
1° LOTTO - PIOVENE ROCCHETTE – VALLE DELL'ASTICO

x	Comb.	δ_{max}	L/250.00	Cs
cm		mm	mm	
127.2	15	-0.15	10.17	69.1

Verifica spostamento elastico dovuto ai soli carichi variabili (§4.2.4.2.1 - NTC 2008)

x	Comb.	δ_2	L/300.00	Cs
cm		mm	mm	
127.2	15	-0.10	8.48	81.1

Travata: 234 [276 , 259]

L = 286.0cm

Crit.Prog: Acciaio_Flessione $\delta_c = 0.0cm$ Verifica: **Verificata**

Verifica spostamento nello stato finale (§4.2.4.2.1 - NTC 2008)

x	Comb.	δ_{max}	L/250.00	Cs
cm		mm	mm	
143.0	17	0.03	11.44	>100

Verifica spostamento elastico dovuto ai soli carichi variabili (§4.2.4.2.1 - NTC 2008)

x	Comb.	δ_2	L/300.00	Cs
cm		mm	mm	
171.6	15	-0.01	9.53	>100

Travata: 235 [259 , 258]

L = 314.0cm

Crit.Prog: Acciaio_Flessione $\delta_c = 0.0cm$ Verifica: **Verificata**

Verifica spostamento nello stato finale (§4.2.4.2.1 - NTC 2008)

x	Comb.	δ_{max}	L/250.00	Cs
---	-------	----------------	----------	----

AUTOSTRADA VALDASTICO A31 NORD
1° LOTTO - PIOVENE ROCCHETTE – VALLE DELL'ASTICO

x	Comb.	δ_{max}	L/250.00	Cs
cm		mm	mm	
157.0	15	0.56	12.56	22.3

Verifica spostamento elastico dovuto ai soli carichi variabili (§4.2.4.2.1 - NTC 2008)

x	Comb.	δ_2	L/300.00	Cs
cm		mm	mm	
157.0	15	0.32	10.47	32.2

Travata: 236 [275 , 269]

L = 273.9cm

Crit.Prog: Acciaio_Flessione $\delta_c = 0.0cm$ Verifica: **Verificata**

Verifica spostamento nello stato finale (§4.2.4.2.1 - NTC 2008)

x	Comb.	δ_{max}	L/250.00	Cs
cm		mm	mm	
137.0	21	0.02	10.96	>100

Verifica spostamento elastico dovuto ai soli carichi variabili (§4.2.4.2.1 - NTC 2008)

x	Comb.	δ_2	L/300.00	Cs
cm		mm	mm	
82.2	15	-0.01	9.13	>100

Travata: 237 [269 , 259]

L = 273.9cm

Crit.Prog: Acciaio_Flessione $\delta_c = 0.0cm$ Verifica: **Verificata**

Verifica spostamento nello stato finale (§4.2.4.2.1 - NTC 2008)

x	Comb.	δ_{max}	L/250.00	Cs
---	-------	----------------	----------	----

AUTOSTRADA VALDASTICO A31 NORD
1° LOTTO - PIOVENE ROCCHETTE – VALLE DELL'ASTICO

x	Comb.	δ_{max}	L/250.00	Cs
cm		mm	mm	
137.0	15	0.07	10.96	>100

Verifica spostamento elastico dovuto ai soli carichi variabili (§4.2.4.2.1 - NTC 2008)

x	Comb.	δ_2	L/300.00	Cs
cm		mm	mm	
164.3	15	0.04	9.13	>100

Travata: 238 [258 , 269]

L = 273.9cm

Crit.Prog: Acciaio_Flessione $\delta_c = 0.0cm$ Verifica: **Verificata**

Verifica spostamento nello stato finale (§4.2.4.2.1 - NTC 2008)

x	Comb.	δ_{max}	L/250.00	Cs
cm		mm	mm	
137.0	15	0.18	10.96	60.6

Verifica spostamento elastico dovuto ai soli carichi variabili (§4.2.4.2.1 - NTC 2008)

x	Comb.	δ_2	L/300.00	Cs
cm		mm	mm	
109.6	15	0.10	9.13	88.4

Travata: 239 [269 , 276]

L = 273.9cm

Crit.Prog: Acciaio_Flessione $\delta_c = 0.0cm$ Verifica: **Verificata**

Verifica spostamento nello stato finale (§4.2.4.2.1 - NTC 2008)

x	Comb.	δ_{max}	L/250.00	Cs
---	-------	----------------	----------	----

AUTOSTRADA VALDASTICO A31 NORD
1° LOTTO - PIOVENE ROCCHETTE – VALLE DELL'ASTICO

x	Comb.	δ_{max}	L/250.00	Cs
cm		mm	mm	
137.0	15	0.13	10.96	82.6

Verifica spostamento elastico dovuto ai soli carichi variabili (§4.2.4.2.1 - NTC 2008)

x	Comb.	δ_2	L/300.00	Cs
cm		mm	mm	
137.0	15	0.07	9.13	>100

Travata: 240 [277 , 260]

L = 286.0cm

Crit.Prog: Acciaio_Flessione $\delta_c = 0.0cm$ Verifica: **Verificata**

Verifica spostamento nello stato finale (§4.2.4.2.1 - NTC 2008)

x	Comb.	δ_{max}	L/250.00	Cs
cm		mm	mm	
143.0	21	0.04	11.44	>100

Verifica spostamento elastico dovuto ai soli carichi variabili (§4.2.4.2.1 - NTC 2008)

x	Comb.	δ_2	L/300.00	Cs
cm		mm	mm	
200.2	15	-0.00	9.53	>100

Travata: 241 [260 , 259]

L = 314.0cm

Crit.Prog: Acciaio_Flessione $\delta_c = 0.0cm$ Verifica: **Verificata**

Verifica spostamento nello stato finale (§4.2.4.2.1 - NTC 2008)

x	Comb.	δ_{max}	L/250.00	Cs
---	-------	----------------	----------	----

AUTOSTRADA VALDASTICO A31 NORD
1° LOTTO - PIOVENE ROCCHETTE – VALLE DELL'ASTICO

x	Comb.	δ_{max}	L/250.00	Cs
cm		mm	mm	
157.0	15	0.45	12.56	28.2

Verifica spostamento elastico dovuto ai soli carichi variabili (§4.2.4.2.1 - NTC 2008)

x	Comb.	δ_2	L/300.00	Cs
cm		mm	mm	
157.0	15	0.25	10.47	42.5

Travata: 242 [276 , 268]

L = 281.6cm

Crit.Prog: Acciaio_Flessione $\delta_c = 0.0cm$ Verifica: **Verificata**

Verifica spostamento nello stato finale (§4.2.4.2.1 - NTC 2008)

x	Comb.	δ_{max}	L/250.00	Cs
cm		mm	mm	
140.8	15	0.09	11.27	>100

Verifica spostamento elastico dovuto ai soli carichi variabili (§4.2.4.2.1 - NTC 2008)

x	Comb.	δ_2	L/300.00	Cs
cm		mm	mm	
140.8	15	0.04	9.39	>100

Travata: 243 [268 , 277]

L = 281.6cm

Crit.Prog: Acciaio_Flessione $\delta_c = 0.0cm$ Verifica: **Verificata**

Verifica spostamento nello stato finale (§4.2.4.2.1 - NTC 2008)

x	Comb.	δ_{max}	L/250.00	Cs
---	-------	----------------	----------	----

AUTOSTRADA VALDASTICO A31 NORD
1° LOTTO - PIOVENE ROCCHETTE – VALLE DELL'ASTICO

x	Comb.	δ_{max}	L/250.00	Cs
cm		mm	mm	
140.8	15	0.12	11.27	95.2

Verifica spostamento elastico dovuto ai soli carichi variabili (§4.2.4.2.1 - NTC 2008)

x	Comb.	δ_2	L/300.00	Cs
cm		mm	mm	
140.8	15	0.06	9.39	>100

Travata: 244 [259 , 268]

L = 281.6cm

Crit.Prog: Acciaio_Flessione $\delta_c = 0.0cm$ Verifica: **Verificata**

Verifica spostamento nello stato finale (§4.2.4.2.1 - NTC 2008)

x	Comb.	δ_{max}	L/250.00	Cs
cm		mm	mm	
140.8	15	0.12	11.27	93.1

Verifica spostamento elastico dovuto ai soli carichi variabili (§4.2.4.2.1 - NTC 2008)

x	Comb.	δ_2	L/300.00	Cs
cm		mm	mm	
140.8	15	0.06	9.39	>100

Travata: 245 [268 , 260]

L = 281.6cm

Crit.Prog: Acciaio_Flessione $\delta_c = 0.0cm$ Verifica: **Verificata**

Verifica spostamento nello stato finale (§4.2.4.2.1 - NTC 2008)

x	Comb.	δ_{max}	L/250.00	Cs
---	-------	----------------	----------	----

AUTOSTRADA VALDASTICO A31 NORD
1° LOTTO - PIOVENE ROCCHETTE – VALLE DELL'ASTICO

x	Comb.	δ_{max}	L/250.00	Cs
cm		mm	mm	
140.8	15	0.11	11.27	99.3

Verifica spostamento elastico dovuto ai soli carichi variabili (§4.2.4.2.1 - NTC 2008)

x	Comb.	δ_2	L/300.00	Cs
cm		mm	mm	
140.8	15	0.06	9.39	>100

Travata: 246 [260 , 267]

L = 281.6cm

Crit.Prog: Acciaio_Flessione $\delta_c = 0.0cm$ Verifica: **Verificata**

Verifica spostamento nello stato finale (§4.2.4.2.1 - NTC 2008)

x	Comb.	δ_{max}	L/250.00	Cs
cm		mm	mm	
140.8	15	0.11	11.27	99.3

Verifica spostamento elastico dovuto ai soli carichi variabili (§4.2.4.2.1 - NTC 2008)

x	Comb.	δ_2	L/300.00	Cs
cm		mm	mm	
140.8	15	0.06	9.39	>100

Travata: 247 [267 , 278]

L = 281.6cm

Crit.Prog: Acciaio_Flessione $\delta_c = 0.0cm$ Verifica: **Verificata**

Verifica spostamento nello stato finale (§4.2.4.2.1 - NTC 2008)

x	Comb.	δ_{max}	L/250.00	Cs
---	-------	----------------	----------	----

AUTOSTRADA VALDASTICO A31 NORD
1° LOTTO - PIOVENE ROCCHETTE – VALLE DELL'ASTICO

x	Comb.	δ_{max}	L/250.00	Cs
cm		mm	mm	
140.8	15	0.09	11.27	>100

Verifica spostamento elastico dovuto ai soli carichi variabili (§4.2.4.2.1 - NTC 2008)

x	Comb.	δ_2	L/300.00	Cs
cm		mm	mm	
140.8	15	0.04	9.39	>100

Travata: 248 [278 , 261]

L = 286.0cm

Crit.Prog: Acciaio_Flessione $\delta_c = 0.0cm$ Verifica: **Verificata**

Verifica spostamento nello stato finale (§4.2.4.2.1 - NTC 2008)

x	Comb.	δ_{max}	L/250.00	Cs
cm		mm	mm	
143.0	21	0.03	11.44	>100

Verifica spostamento elastico dovuto ai soli carichi variabili (§4.2.4.2.1 - NTC 2008)

x	Comb.	δ_2	L/300.00	Cs
cm		mm	mm	
171.6	15	-0.01	9.53	>100

Travata: 249 [261 , 260]

L = 314.0cm

Crit.Prog: Acciaio_Flessione $\delta_c = 0.0cm$ Verifica: **Verificata**

Verifica spostamento nello stato finale (§4.2.4.2.1 - NTC 2008)

x	Comb.	δ_{max}	L/250.00	Cs
---	-------	----------------	----------	----

AUTOSTRADA VALDASTICO A31 NORD
1° LOTTO - PIOVENE ROCCHETTE – VALLE DELL'ASTICO

x	Comb.	δ_{max}	L/250.00	Cs
cm		mm	mm	
157.0	15	0.44	12.56	28.2

Verifica spostamento elastico dovuto ai soli carichi variabili (§4.2.4.2.1 - NTC 2008)

x	Comb.	δ_2	L/300.00	Cs
cm		mm	mm	
157.0	15	0.25	10.47	42.5

Travata: 250 [277 , 267]

L = 281.6cm

Crit.Prog: Acciaio_Flessione $\delta_c = 0.0cm$ Verifica: **Verificata**

Verifica spostamento nello stato finale (§4.2.4.2.1 - NTC 2008)

x	Comb.	δ_{max}	L/250.00	Cs
cm		mm	mm	
140.8	15	0.12	11.27	95.1

Verifica spostamento elastico dovuto ai soli carichi variabili (§4.2.4.2.1 - NTC 2008)

x	Comb.	δ_2	L/300.00	Cs
cm		mm	mm	
140.8	15	0.06	9.39	>100

Travata: 251 [267 , 261]

L = 281.6cm

Crit.Prog: Acciaio_Flessione $\delta_c = 0.0cm$ Verifica: **Verificata**

Verifica spostamento nello stato finale (§4.2.4.2.1 - NTC 2008)

x	Comb.	δ_{max}	L/250.00	Cs
---	-------	----------------	----------	----

AUTOSTRADA VALDASTICO A31 NORD
1° LOTTO - PIOVENE ROCCHETTE – VALLE DELL'ASTICO

x	Comb.	δ_{max}	L/250.00	Cs
cm		mm	mm	
140.8	15	0.12	11.27	93.4

Verifica spostamento elastico dovuto ai soli carichi variabili (§4.2.4.2.1 - NTC 2008)

x	Comb.	δ_2	L/300.00	Cs
cm		mm	mm	
140.8	15	0.06	9.39	>100

Travata: 252 [279 , 262]

L = 286.0cm

Crit.Prog: Acciaio_Flessione $\delta_c = 0.0cm$ Verifica: **Verificata**

Verifica spostamento nello stato finale (§4.2.4.2.1 - NTC 2008)

x	Comb.	δ_{max}	L/250.00	Cs
cm		mm	mm	
200.2	15	-0.10	11.44	>100

Verifica spostamento elastico dovuto ai soli carichi variabili (§4.2.4.2.1 - NTC 2008)

x	Comb.	δ_2	L/300.00	Cs
cm		mm	mm	
171.6	15	-0.08	9.53	>100

Travata: 253 [262 , 261]

L = 314.0cm

Crit.Prog: Acciaio_Flessione $\delta_c = 0.0cm$ Verifica: **Verificata**

Verifica spostamento nello stato finale (§4.2.4.2.1 - NTC 2008)

x	Comb.	δ_{max}	L/250.00	Cs
---	-------	----------------	----------	----

AUTOSTRADA VALDASTICO A31 NORD
1° LOTTO - PIOVENE ROCCHETTE – VALLE DELL'ASTICO

x	Comb.	δ_{max}	L/250.00	Cs
cm		mm	mm	
157.0	15	0.57	12.56	22.2

Verifica spostamento elastico dovuto ai soli carichi variabili (§4.2.4.2.1 - NTC 2008)

x	Comb.	δ_2	L/300.00	Cs
cm		mm	mm	
157.0	15	0.33	10.47	32.1

Travata: 254 [261 , 266]

L = 273.9cm

Crit.Prog: Acciaio_Flessione $\delta_c = 0.0cm$ Verifica: **Verificata**

Verifica spostamento nello stato finale (§4.2.4.2.1 - NTC 2008)

x	Comb.	δ_{max}	L/250.00	Cs
cm		mm	mm	
137.0	15	0.07	10.96	>100

Verifica spostamento elastico dovuto ai soli carichi variabili (§4.2.4.2.1 - NTC 2008)

x	Comb.	δ_2	L/300.00	Cs
cm		mm	mm	
109.6	15	0.04	9.13	>100

Travata: 255 [266 , 279]

L = 273.9cm

Crit.Prog: Acciaio_Flessione $\delta_c = 0.0cm$ Verifica: **Verificata**

Verifica spostamento nello stato finale (§4.2.4.2.1 - NTC 2008)

x	Comb.	δ_{max}	L/250.00	Cs
---	-------	----------------	----------	----

AUTOSTRADA VALDASTICO A31 NORD
1° LOTTO - PIOVENE ROCCHETTE – VALLE DELL'ASTICO

x	Comb.	δ_{max}	L/250.00	Cs
cm		mm	mm	
137.0	21	0.02	10.96	>100

Verifica spostamento elastico dovuto ai soli carichi variabili (§4.2.4.2.1 - NTC 2008)

x	Comb.	δ_2	L/300.00	Cs
cm		mm	mm	
191.7	15	-0.01	9.13	>100

Travata: 256 [278 , 266]

L = 273.9cm

Crit.Prog: Acciaio_Flessione $\delta_c = 0.0cm$ Verifica: **Verificata**

Verifica spostamento nello stato finale (§4.2.4.2.1 - NTC 2008)

x	Comb.	δ_{max}	L/250.00	Cs
cm		mm	mm	
137.0	15	0.13	10.96	82.8

Verifica spostamento elastico dovuto ai soli carichi variabili (§4.2.4.2.1 - NTC 2008)

x	Comb.	δ_2	L/300.00	Cs
cm		mm	mm	
137.0	15	0.07	9.13	>100

Travata: 257 [266 , 262]

L = 273.9cm

Crit.Prog: Acciaio_Flessione $\delta_c = 0.0cm$ Verifica: **Verificata**

Verifica spostamento nello stato finale (§4.2.4.2.1 - NTC 2008)

x	Comb.	δ_{max}	L/250.00	Cs
---	-------	----------------	----------	----

AUTOSTRADA VALDASTICO A31 NORD
1° LOTTO - PIOVENE ROCCHETTE – VALLE DELL'ASTICO

x	Comb.	δ_{max}	L/250.00	Cs
cm		mm	mm	
164.3	15	0.18	10.96	60.0

Verifica spostamento elastico dovuto ai soli carichi variabili (§4.2.4.2.1 - NTC 2008)

x	Comb.	δ_2	L/300.00	Cs
cm		mm	mm	
164.3	15	0.10	9.13	87.9

Travata: 258 [262 , 263]

L = 314.0cm

Crit.Prog: Acciaio_Flessione $\delta_c = 0.0cm$ Verifica: **Verificata**

Verifica spostamento nello stato finale (§4.2.4.2.1 - NTC 2008)

x	Comb.	δ_{max}	L/250.00	Cs
cm		mm	mm	
219.8	15	-1.23	12.56	10.2

Verifica spostamento elastico dovuto ai soli carichi variabili (§4.2.4.2.1 - NTC 2008)

x	Comb.	δ_2	L/300.00	Cs
cm		mm	mm	
219.8	15	-0.82	10.47	12.8

Travata: 259 [263 , 280]

L = 286.0cm

Crit.Prog: Acciaio_Flessione $\delta_c = 0.0cm$ Verifica: **Verificata**

Verifica spostamento nello stato finale (§4.2.4.2.1 - NTC 2008)

x	Comb.	δ_{max}	L/250.00	Cs
---	-------	----------------	----------	----

AUTOSTRADA VALDASTICO A31 NORD
1° LOTTO - PIOVENE ROCCHETTE – VALLE DELL'ASTICO

x	Comb.	δ_{max}	L/250.00	Cs
cm		mm	mm	
85.8	15	-0.64	11.44	18.0

Verifica spostamento elastico dovuto ai soli carichi variabili (§4.2.4.2.1 - NTC 2008)

x	Comb.	δ_2	L/300.00	Cs
cm		mm	mm	
85.8	15	-0.42	9.53	22.8

Travata: 260 [279 , 265]

L = 254.4cm

Crit.Prog: Acciaio_Flessione $\delta_c = 0.0cm$ Verifica: **Verificata**

Verifica spostamento nello stato finale (§4.2.4.2.1 - NTC 2008)

x	Comb.	δ_{max}	L/250.00	Cs
cm		mm	mm	
127.2	15	0.23	10.17	43.5

Verifica spostamento elastico dovuto ai soli carichi variabili (§4.2.4.2.1 - NTC 2008)

x	Comb.	δ_2	L/300.00	Cs
cm		mm	mm	
127.2	15	0.14	8.48	61.8

Travata: 261 [265 , 280]

L = 254.4cm

Crit.Prog: Acciaio_Flessione $\delta_c = 0.0cm$ Verifica: **Verificata**

Verifica spostamento nello stato finale (§4.2.4.2.1 - NTC 2008)

x	Comb.	δ_{max}	L/250.00	Cs
---	-------	----------------	----------	----

AUTOSTRADA VALDASTICO A31 NORD
1° LOTTO - PIOVENE ROCCHETTE – VALLE DELL'ASTICO

x	Comb.	δ_{max}	L/250.00	Cs
cm		mm	mm	
127.2	15	-0.22	10.17	46.9

Verifica spostamento elastico dovuto ai soli carichi variabili (§4.2.4.2.1 - NTC 2008)

x	Comb.	δ_2	L/300.00	Cs
cm		mm	mm	
127.2	15	-0.15	8.48	58.1

Travata: 262 [262 , 265]

L = 254.4cm

Crit.Prog: Acciaio_Flessione $\delta_c = 0.0cm$ Verifica: **Verificata**

Verifica spostamento nello stato finale (§4.2.4.2.1 - NTC 2008)

x	Comb.	δ_{max}	L/250.00	Cs
cm		mm	mm	
127.2	15	-0.15	10.17	67.1

Verifica spostamento elastico dovuto ai soli carichi variabili (§4.2.4.2.1 - NTC 2008)

x	Comb.	δ_2	L/300.00	Cs
cm		mm	mm	
127.2	15	-0.11	8.48	80.2

Travata: 263 [265 , 263]

L = 254.4cm

Crit.Prog: Acciaio_Flessione $\delta_c = 0.0cm$ Verifica: **Verificata**

Verifica spostamento nello stato finale (§4.2.4.2.1 - NTC 2008)

x	Comb.	δ_{max}	L/250.00	Cs
---	-------	----------------	----------	----

AUTOSTRADA VALDASTICO A31 NORD
1° LOTTO - PIOVENE ROCCHETTE – VALLE DELL'ASTICO

x	Comb.	δ_{max}	L/250.00	Cs
cm		mm	mm	
178.1	15	-0.78	10.17	13.0

Verifica spostamento elastico dovuto ai soli carichi variabili (§4.2.4.2.1 - NTC 2008)

x	Comb.	δ_2	L/300.00	Cs
cm		mm	mm	
178.1	15	-0.51	8.48	16.6

Travata: 264 [281 , 264]

L = 286.0cm

Crit.Prog: Acciaio_Flessione $\delta_c = 0.0cm$ Verifica: **Verificata**

Verifica spostamento nello stato finale (§4.2.4.2.1 - NTC 2008)

x	Comb.	δ_{max}	L/250.00	Cs
cm		mm	mm	
171.6	15	-0.29	11.44	39.8

Verifica spostamento elastico dovuto ai soli carichi variabili (§4.2.4.2.1 - NTC 2008)

x	Comb.	δ_2	L/300.00	Cs
cm		mm	mm	
171.6	15	-0.21	9.53	45.4

Travata: 265 [264 , 263]

L = 314.0cm

Crit.Prog: Acciaio_Flessione $\delta_c = 0.0cm$ Verifica: **Verificata**

Verifica spostamento nello stato finale (§4.2.4.2.1 - NTC 2008)

x	Comb.	δ_{max}	L/250.00	Cs
---	-------	----------------	----------	----

AUTOSTRADA VALDASTICO A31 NORD
1° LOTTO - PIOVENE ROCCHETTE – VALLE DELL'ASTICO

x	Comb.	δ_{max}	L/250.00	Cs
cm		mm	mm	
188.4	15	0.09	12.56	>100

Verifica spostamento elastico dovuto ai soli carichi variabili (§4.2.4.2.1 - NTC 2008)

x	Comb.	δ_2	L/300.00	Cs
cm		mm	mm	
251.2	15	0.05	10.47	>100

Travata: 266 [280 , 272]

L = 229.9cm

Crit.Prog: Acciaio_Flessione $\delta_c = 0.0cm$ Verifica: **Verificata**

Verifica spostamento nello stato finale (§4.2.4.2.1 - NTC 2008)

x	Comb.	δ_{max}	L/250.00	Cs
cm		mm	mm	
114.9	15	-0.11	9.19	84.6

Verifica spostamento elastico dovuto ai soli carichi variabili (§4.2.4.2.1 - NTC 2008)

x	Comb.	δ_2	L/300.00	Cs
cm		mm	mm	
114.9	15	-0.07	7.66	>100

Travata: 267 [272 , 264]

L = 229.9cm

Crit.Prog: Acciaio_Flessione $\delta_c = 0.0cm$ Verifica: **Verificata**

Verifica spostamento nello stato finale (§4.2.4.2.1 - NTC 2008)

x	Comb.	δ_{max}	L/250.00	Cs
---	-------	----------------	----------	----

AUTOSTRADA VALDASTICO A31 NORD
1° LOTTO - PIOVENE ROCCHETTE – VALLE DELL'ASTICO

x	Comb.	δ_{max}	L/250.00	Cs
cm		mm	mm	
114.9	15	-0.38	9.19	24.2

Verifica spostamento elastico dovuto ai soli carichi variabili (§4.2.4.2.1 - NTC 2008)

x	Comb.	δ_2	L/300.00	Cs
cm		mm	mm	
114.9	15	-0.28	7.66	27.7

Travata: 268 [272 , 281]

L = 229.9cm

Crit.Prog: Acciaio_Flessione $\delta_c = 0.0cm$ Verifica: **Verificata**

Verifica spostamento nello stato finale (§4.2.4.2.1 - NTC 2008)

x	Comb.	δ_{max}	L/250.00	Cs
cm		mm	mm	
160.9	15	0.04	9.19	>100

Verifica spostamento elastico dovuto ai soli carichi variabili (§4.2.4.2.1 - NTC 2008)

x	Comb.	δ_2	L/300.00	Cs
cm		mm	mm	
69.0	15	-0.03	7.66	>100

Travata: 269 [271 , 270]

L = 318.3cm

Crit.Prog: Acciaio_Flessione $\delta_c = 0.0cm$ Verifica: **Verificata**

Verifica spostamento nello stato finale (§4.2.4.2.1 - NTC 2008)

x	Comb.	δ_{max}	L/250.00	Cs
---	-------	----------------	----------	----

AUTOSTRADA VALDASTICO A31 NORD
1° LOTTO - PIOVENE ROCCHETTE – VALLE DELL'ASTICO

x	Comb.	δ_{max}	L/250.00	Cs
cm		mm	mm	
159.1	15	1.99	12.73	6.40

Verifica spostamento elastico dovuto ai soli carichi variabili (§4.2.4.2.1 - NTC 2008)

x	Comb.	δ_2	L/300.00	Cs
cm		mm	mm	
159.1	15	1.54	10.61	6.90

Travata: 270 [270 , 269]

L = 315.7cm

Crit.Prog: Acciaio_Flessione $\delta_c = 0.0cm$ Verifica: **Verificata**

Verifica spostamento nello stato finale (§4.2.4.2.1 - NTC 2008)

x	Comb.	δ_{max}	L/250.00	Cs
cm		mm	mm	
157.9	15	2.76	12.63	4.57

Verifica spostamento elastico dovuto ai soli carichi variabili (§4.2.4.2.1 - NTC 2008)

x	Comb.	δ_2	L/300.00	Cs
cm		mm	mm	
157.9	15	2.00	10.52	5.25

Travata: 271 [269 , 268]

L = 314.2cm

Crit.Prog: Acciaio_Flessione $\delta_c = 0.0cm$ Verifica: **Verificata**

Verifica spostamento nello stato finale (§4.2.4.2.1 - NTC 2008)

x	Comb.	δ_{max}	L/250.00	Cs
---	-------	----------------	----------	----

AUTOSTRADA VALDASTICO A31 NORD
1° LOTTO - PIOVENE ROCCHETTE – VALLE DELL'ASTICO

x	Comb.	δ_{max}	L/250.00	Cs
cm		mm	mm	
157.1	15	2.77	12.57	4.53

Verifica spostamento elastico dovuto ai soli carichi variabili (§4.2.4.2.1 - NTC 2008)

x	Comb.	δ_2	L/300.00	Cs
cm		mm	mm	
157.1	15	2.01	10.47	5.22

Travata: 272 [268 , 267]

L = 314.0cm

Crit.Prog: Acciaio_Flessione $\delta_c = 0.0cm$ Verifica: **Verificata**

Verifica spostamento nello stato finale (§4.2.4.2.1 - NTC 2008)

x	Comb.	δ_{max}	L/250.00	Cs
cm		mm	mm	
157.0	15	2.80	12.56	4.49

Verifica spostamento elastico dovuto ai soli carichi variabili (§4.2.4.2.1 - NTC 2008)

x	Comb.	δ_2	L/300.00	Cs
cm		mm	mm	
157.0	15	2.02	10.47	5.17

Travata: 273 [267 , 266]

L = 314.2cm

Crit.Prog: Acciaio_Flessione $\delta_c = 0.0cm$ Verifica: **Verificata**

Verifica spostamento nello stato finale (§4.2.4.2.1 - NTC 2008)

x	Comb.	δ_{max}	L/250.00	Cs
---	-------	----------------	----------	----

AUTOSTRADA VALDASTICO A31 NORD
1° LOTTO - PIOVENE ROCCHETTE – VALLE DELL'ASTICO

x	Comb.	δ_{max}	L/250.00	Cs
cm		mm	mm	
157.1	15	2.77	12.57	4.54

Verifica spostamento elastico dovuto ai soli carichi variabili (§4.2.4.2.1 - NTC 2008)

x	Comb.	δ_2	L/300.00	Cs
cm		mm	mm	
157.1	15	2.01	10.47	5.22

Travata: 274 [266 , 265]

L = 315.7cm

Crit.Prog: Acciaio_Flessione $\delta_c = 0.0cm$ Verifica: **Verificata**

Verifica spostamento nello stato finale (§4.2.4.2.1 - NTC 2008)

x	Comb.	δ_{max}	L/250.00	Cs
cm		mm	mm	
157.9	15	2.76	12.63	4.57

Verifica spostamento elastico dovuto ai soli carichi variabili (§4.2.4.2.1 - NTC 2008)

x	Comb.	δ_2	L/300.00	Cs
cm		mm	mm	
157.9	15	2.00	10.52	5.25

Travata: 275 [265 , 272]

L = 318.3cm

Crit.Prog: Acciaio_Flessione $\delta_c = 0.0cm$ Verifica: **Verificata**

Verifica spostamento nello stato finale (§4.2.4.2.1 - NTC 2008)

x	Comb.	δ_{max}	L/250.00	Cs
---	-------	----------------	----------	----

AUTOSTRADA VALDASTICO A31 NORD
1° LOTTO - PIOVENE ROCCHETTE – VALLE DELL'ASTICO

x	Comb.	δ_{max}	L/250.00	Cs
cm		mm	mm	
159.1	15	1.97	12.73	6.47

Verifica spostamento elastico dovuto ai soli carichi variabili (§4.2.4.2.1 - NTC 2008)

x	Comb.	δ_2	L/300.00	Cs
cm		mm	mm	
159.1	15	1.53	10.61	6.92

Travata: 276 [273 , 288]

L = 229.9cm

Crit.Prog: Acciaio_Flessione $\delta_c = 0.0cm$ Verifica: **Verificata**

Verifica spostamento nello stato finale (§4.2.4.2.1 - NTC 2008)

x	Comb.	δ_{max}	L/250.00	Cs
cm		mm	mm	
137.9	15	-0.07	9.19	>100

Verifica spostamento elastico dovuto ai soli carichi variabili (§4.2.4.2.1 - NTC 2008)

x	Comb.	δ_2	L/300.00	Cs
cm		mm	mm	
114.9	15	-0.07	7.66	>100

Travata: 277 [291 , 274]

L = 286.0cm

Crit.Prog: Acciaio_Flessione $\delta_c = 0.0cm$ Verifica: **Verificata**

Verifica spostamento nello stato finale (§4.2.4.2.1 - NTC 2008)

x	Comb.	δ_{max}	L/250.00	Cs
---	-------	----------------	----------	----

AUTOSTRADA VALDASTICO A31 NORD
1° LOTTO - PIOVENE ROCCHETTE – VALLE DELL'ASTICO

x	Comb.	δ_{max}	L/250.00	Cs
cm		mm	mm	
143.0	15	0.50	11.44	22.7

Verifica spostamento elastico dovuto ai soli carichi variabili (§4.2.4.2.1 - NTC 2008)

x	Comb.	δ_2	L/300.00	Cs
cm		mm	mm	
143.0	15	0.29	9.53	33.1

Travata: 278 [274 , 273]

L = 314.0cm

Crit.Prog: Acciaio_Flessione $\delta_c = 0.0cm$ Verifica: **Verificata**

Verifica spostamento nello stato finale (§4.2.4.2.1 - NTC 2008)

x	Comb.	δ_{max}	L/250.00	Cs
cm		mm	mm	
125.6	15	-0.16	12.56	78.4

Verifica spostamento elastico dovuto ai soli carichi variabili (§4.2.4.2.1 - NTC 2008)

x	Comb.	δ_2	L/300.00	Cs
cm		mm	mm	
157.0	15	-0.15	10.47	71.2

Travata: 279 [290 , 288]

L = 229.9cm

Crit.Prog: Acciaio_Flessione $\delta_c = 0.0cm$ Verifica: **Verificata**

Verifica spostamento nello stato finale (§4.2.4.2.1 - NTC 2008)

x	Comb.	δ_{max}	L/250.00	Cs
---	-------	----------------	----------	----

AUTOSTRADA VALDASTICO A31 NORD
1° LOTTO - PIOVENE ROCCHETTE – VALLE DELL'ASTICO

x	Comb.	δ_{max}	L/250.00	Cs
cm		mm	mm	
91.9	15	0.06	9.19	>100

Verifica spostamento elastico dovuto ai soli carichi variabili (§4.2.4.2.1 - NTC 2008)

x	Comb.	δ_2	L/300.00	Cs
cm		mm	mm	
69.0	15	0.02	7.66	>100

Travata: 280 [288 , 274]

L = 229.9cm

Crit.Prog: Acciaio_Flessione $\delta_c = 0.0cm$ Verifica: **Verificata**

Verifica spostamento nello stato finale (§4.2.4.2.1 - NTC 2008)

x	Comb.	δ_{max}	L/250.00	Cs
cm		mm	mm	
91.9	15	0.16	9.19	57.5

Verifica spostamento elastico dovuto ai soli carichi variabili (§4.2.4.2.1 - NTC 2008)

x	Comb.	δ_2	L/300.00	Cs
cm		mm	mm	
91.9	15	0.10	7.66	74.5

Travata: 281 [288 , 291]

L = 229.9cm

Crit.Prog: Acciaio_Flessione $\delta_c = 0.0cm$ Verifica: **Verificata**

Verifica spostamento nello stato finale (§4.2.4.2.1 - NTC 2008)

x	Comb.	δ_{max}	L/250.00	Cs
---	-------	----------------	----------	----

AUTOSTRADA VALDASTICO A31 NORD
1° LOTTO - PIOVENE ROCCHETTE – VALLE DELL'ASTICO

x	Comb.	δ_{max}	L/250.00	Cs
cm		mm	mm	
91.9	15	0.16	9.19	58.1

Verifica spostamento elastico dovuto ai soli carichi variabili (§4.2.4.2.1 - NTC 2008)

x	Comb.	δ_2	L/300.00	Cs
cm		mm	mm	
91.9	15	0.10	7.66	75.1

Travata: 282 [290 , 273]

L = 286.0cm

Crit.Prog: Acciaio_Flessione $\delta_c = 0.0cm$ Verifica: **Verificata**

Verifica spostamento nello stato finale (§4.2.4.2.1 - NTC 2008)

x	Comb.	δ_{max}	L/250.00	Cs
cm		mm	mm	
143.0	15	0.36	11.44	31.4

Verifica spostamento elastico dovuto ai soli carichi variabili (§4.2.4.2.1 - NTC 2008)

x	Comb.	δ_2	L/300.00	Cs
cm		mm	mm	
143.0	15	0.20	9.53	48.2

Travata: 283 [292 , 275]

L = 286.0cm

Crit.Prog: Acciaio_Flessione $\delta_c = 0.0cm$ Verifica: **Verificata**

Verifica spostamento nello stato finale (§4.2.4.2.1 - NTC 2008)

x	Comb.	δ_{max}	L/250.00	Cs
---	-------	----------------	----------	----

AUTOSTRADA VALDASTICO A31 NORD
1° LOTTO - PIOVENE ROCCHETTE – VALLE DELL'ASTICO

x	Comb.	δ_{max}	L/250.00	Cs
cm		mm	mm	
143.0	15	0.19	11.44	59.3

Verifica spostamento elastico dovuto ai soli carichi variabili (§4.2.4.2.1 - NTC 2008)

x	Comb.	δ_2	L/300.00	Cs
cm		mm	mm	
114.4	15	0.09	9.53	>100

Travata: 284 [275 , 274]

L = 314.0cm

Crit.Prog: Acciaio_Flessione $\delta_c = 0.0cm$ Verifica: **Verificata**

Verifica spostamento nello stato finale (§4.2.4.2.1 - NTC 2008)

x	Comb.	δ_{max}	L/250.00	Cs
cm		mm	mm	
251.2	15	-0.11	12.56	>100

Verifica spostamento elastico dovuto ai soli carichi variabili (§4.2.4.2.1 - NTC 2008)

x	Comb.	δ_2	L/300.00	Cs
cm		mm	mm	
219.8	15	-0.09	10.47	>100

Travata: 285 [274 , 287]

L = 254.4cm

Crit.Prog: Acciaio_Flessione $\delta_c = 0.0cm$ Verifica: **Verificata**

Verifica spostamento nello stato finale (§4.2.4.2.1 - NTC 2008)

x	Comb.	δ_{max}	L/250.00	Cs
---	-------	----------------	----------	----

AUTOSTRADA VALDASTICO A31 NORD
1° LOTTO - PIOVENE ROCCHETTE – VALLE DELL'ASTICO

x	Comb.	δ_{max}	L/250.00	Cs
cm		mm	mm	
127.2	15	0.15	10.17	66.9

Verifica spostamento elastico dovuto ai soli carichi variabili (§4.2.4.2.1 - NTC 2008)

x	Comb.	δ_2	L/300.00	Cs
cm		mm	mm	
127.2	15	0.08	8.48	99.9

Travata: 286 [287 , 292]

L = 254.4cm

Crit.Prog: Acciaio_Flessione $\delta_c = 0.0cm$ Verifica: **Verificata**

Verifica spostamento nello stato finale (§4.2.4.2.1 - NTC 2008)

x	Comb.	δ_{max}	L/250.00	Cs
cm		mm	mm	
127.2	15	0.11	10.17	95.1

Verifica spostamento elastico dovuto ai soli carichi variabili (§4.2.4.2.1 - NTC 2008)

x	Comb.	δ_2	L/300.00	Cs
cm		mm	mm	
127.2	15	0.06	8.48	>100

Travata: 287 [291 , 287]

L = 254.4cm

Crit.Prog: Acciaio_Flessione $\delta_c = 0.0cm$ Verifica: **Verificata**

Verifica spostamento nello stato finale (§4.2.4.2.1 - NTC 2008)

x	Comb.	δ_{max}	L/250.00	Cs
---	-------	----------------	----------	----

AUTOSTRADA VALDASTICO A31 NORD
1° LOTTO - PIOVENE ROCCHETTE – VALLE DELL'ASTICO

x	Comb.	δ_{max}	L/250.00	Cs
cm		mm	mm	
127.2	15	0.07	10.17	>100

Verifica spostamento elastico dovuto ai soli carichi variabili (§4.2.4.2.1 - NTC 2008)

x	Comb.	δ_2	L/300.00	Cs
cm		mm	mm	
152.6	15	0.03	8.48	>100

Travata: 288 [287 , 275]

L = 254.4cm

Crit.Prog: Acciaio_Flessione $\delta_c = 0.0cm$ Verifica: **Verificata**

Verifica spostamento nello stato finale (§4.2.4.2.1 - NTC 2008)

x	Comb.	δ_{max}	L/250.00	Cs
cm		mm	mm	
178.1	15	-0.02	10.17	>100

Verifica spostamento elastico dovuto ai soli carichi variabili (§4.2.4.2.1 - NTC 2008)

x	Comb.	δ_2	L/300.00	Cs
cm		mm	mm	
152.6	15	-0.02	8.48	>100

Travata: 289 [293 , 276]

L = 286.0cm

Crit.Prog: Acciaio_Flessione $\delta_c = 0.0cm$ Verifica: **Verificata**

Verifica spostamento nello stato finale (§4.2.4.2.1 - NTC 2008)

x	Comb.	δ_{max}	L/250.00	Cs
---	-------	----------------	----------	----

AUTOSTRADA VALDASTICO A31 NORD
1° LOTTO - PIOVENE ROCCHETTE – VALLE DELL'ASTICO

x	Comb.	δ_{max}	L/250.00	Cs
cm		mm	mm	
143.0	15	0.07	11.44	>100

Verifica spostamento elastico dovuto ai soli carichi variabili (§4.2.4.2.1 - NTC 2008)

x	Comb.	δ_2	L/300.00	Cs
cm		mm	mm	
114.4	15	0.01	9.53	>100

Travata: 290 [276 , 275]

L = 314.0cm

Crit.Prog: Acciaio_Flessione $\delta_c = 0.0cm$ Verifica: **Verificata**

Verifica spostamento nello stato finale (§4.2.4.2.1 - NTC 2008)

x	Comb.	δ_{max}	L/250.00	Cs
cm		mm	mm	
157.0	15	0.33	12.56	38.4

Verifica spostamento elastico dovuto ai soli carichi variabili (§4.2.4.2.1 - NTC 2008)

x	Comb.	δ_2	L/300.00	Cs
cm		mm	mm	
157.0	15	0.17	10.47	60.4

Travata: 291 [292 , 286]

L = 273.9cm

Crit.Prog: Acciaio_Flessione $\delta_c = 0.0cm$ Verifica: **Verificata**

Verifica spostamento nello stato finale (§4.2.4.2.1 - NTC 2008)

x	Comb.	δ_{max}	L/250.00	Cs
---	-------	----------------	----------	----

AUTOSTRADA VALDASTICO A31 NORD
1° LOTTO - PIOVENE ROCCHETTE – VALLE DELL'ASTICO

x	Comb.	δ_{max}	L/250.00	Cs
cm		mm	mm	
137.0	15	0.08	10.96	>100

Verifica spostamento elastico dovuto ai soli carichi variabili (§4.2.4.2.1 - NTC 2008)

x	Comb.	δ_2	L/300.00	Cs
cm		mm	mm	
137.0	15	0.04	9.13	>100

Travata: 292 [286 , 276]

L = 273.9cm

Crit.Prog: Acciaio_Flessione $\delta_c = 0.0cm$ Verifica: **Verificata**

Verifica spostamento nello stato finale (§4.2.4.2.1 - NTC 2008)

x	Comb.	δ_{max}	L/250.00	Cs
cm		mm	mm	
137.0	15	0.06	10.96	>100

Verifica spostamento elastico dovuto ai soli carichi variabili (§4.2.4.2.1 - NTC 2008)

x	Comb.	δ_2	L/300.00	Cs
cm		mm	mm	
137.0	15	0.03	9.13	>100

Travata: 293 [275 , 286]

L = 273.9cm

Crit.Prog: Acciaio_Flessione $\delta_c = 0.0cm$ Verifica: **Verificata**

Verifica spostamento nello stato finale (§4.2.4.2.1 - NTC 2008)

x	Comb.	δ_{max}	L/250.00	Cs
---	-------	----------------	----------	----

AUTOSTRADA VALDASTICO A31 NORD
1° LOTTO - PIOVENE ROCCHETTE – VALLE DELL'ASTICO

x	Comb.	δ_{max}	L/250.00	Cs
cm		mm	mm	
137.0	15	0.16	10.96	68.3

Verifica spostamento elastico dovuto ai soli carichi variabili (§4.2.4.2.1 - NTC 2008)

x	Comb.	δ_2	L/300.00	Cs
cm		mm	mm	
137.0	15	0.09	9.13	>100

Travata: 294 [286 , 293]

L = 273.9cm

Crit.Prog: Acciaio_Flessione $\delta_c = 0.0cm$ Verifica: **Verificata**

Verifica spostamento nello stato finale (§4.2.4.2.1 - NTC 2008)

x	Comb.	δ_{max}	L/250.00	Cs
cm		mm	mm	
137.0	15	0.10	10.96	>100

Verifica spostamento elastico dovuto ai soli carichi variabili (§4.2.4.2.1 - NTC 2008)

x	Comb.	δ_2	L/300.00	Cs
cm		mm	mm	
137.0	15	0.05	9.13	>100

Travata: 295 [294 , 277]

L = 286.0cm

Crit.Prog: Acciaio_Flessione $\delta_c = 0.0cm$ Verifica: **Verificata**

Verifica spostamento nello stato finale (§4.2.4.2.1 - NTC 2008)

x	Comb.	δ_{max}	L/250.00	Cs
---	-------	----------------	----------	----

AUTOSTRADA VALDASTICO A31 NORD
1° LOTTO - PIOVENE ROCCHETTE – VALLE DELL'ASTICO

x	Comb.	δ_{max}	L/250.00	Cs
cm		mm	mm	
143.0	21	0.04	11.44	>100

Verifica spostamento elastico dovuto ai soli carichi variabili (§4.2.4.2.1 - NTC 2008)

x	Comb.	δ_2	L/300.00	Cs
cm		mm	mm	
143.0	15	-0.00	9.53	>100

Travata: 296 [277 , 276]

L = 314.0cm

Crit.Prog: Acciaio_Flessione $\delta_c = 0.0cm$ Verifica: **Verificata**

Verifica spostamento nello stato finale (§4.2.4.2.1 - NTC 2008)

x	Comb.	δ_{max}	L/250.00	Cs
cm		mm	mm	
157.0	15	0.40	12.56	31.2

Verifica spostamento elastico dovuto ai soli carichi variabili (§4.2.4.2.1 - NTC 2008)

x	Comb.	δ_2	L/300.00	Cs
cm		mm	mm	
157.0	15	0.22	10.47	47.3

Travata: 297 [293 , 285]

L = 281.6cm

Crit.Prog: Acciaio_Flessione $\delta_c = 0.0cm$ Verifica: **Verificata**

Verifica spostamento nello stato finale (§4.2.4.2.1 - NTC 2008)

x	Comb.	δ_{max}	L/250.00	Cs
---	-------	----------------	----------	----

AUTOSTRADA VALDASTICO A31 NORD
1° LOTTO - PIOVENE ROCCHETTE – VALLE DELL'ASTICO

x	Comb.	δ_{max}	L/250.00	Cs
cm		mm	mm	
140.8	15	0.10	11.27	>100

Verifica spostamento elastico dovuto ai soli carichi variabili (§4.2.4.2.1 - NTC 2008)

x	Comb.	δ_2	L/300.00	Cs
cm		mm	mm	
140.8	15	0.05	9.39	>100

Travata: 298 [285 , 294]

L = 281.6cm

Crit.Prog: Acciaio_Flessione $\delta_c = 0.0cm$ Verifica: **Verificata**

Verifica spostamento nello stato finale (§4.2.4.2.1 - NTC 2008)

x	Comb.	δ_{max}	L/250.00	Cs
cm		mm	mm	
140.8	15	0.10	11.27	>100

Verifica spostamento elastico dovuto ai soli carichi variabili (§4.2.4.2.1 - NTC 2008)

x	Comb.	δ_2	L/300.00	Cs
cm		mm	mm	
140.8	15	0.05	9.39	>100

Travata: 299 [276 , 285]

L = 281.6cm

Crit.Prog: Acciaio_Flessione $\delta_c = 0.0cm$ Verifica: **Verificata**

Verifica spostamento nello stato finale (§4.2.4.2.1 - NTC 2008)

x	Comb.	δ_{max}	L/250.00	Cs
---	-------	----------------	----------	----

AUTOSTRADA VALDASTICO A31 NORD
1° LOTTO - PIOVENE ROCCHETTE – VALLE DELL'ASTICO

x	Comb.	δ_{max}	L/250.00	Cs
cm		mm	mm	
140.8	15	0.12	11.27	92.3

Verifica spostamento elastico dovuto ai soli carichi variabili (§4.2.4.2.1 - NTC 2008)

x	Comb.	δ_2	L/300.00	Cs
cm		mm	mm	
140.8	15	0.06	9.39	>100

Travata: 300 [285 , 277]

L = 281.6cm

Crit.Prog: Acciaio_Flessione $\delta_c = 0.0cm$ Verifica: **Verificata**

Verifica spostamento nello stato finale (§4.2.4.2.1 - NTC 2008)

x	Comb.	δ_{max}	L/250.00	Cs
cm		mm	mm	
140.8	15	0.10	11.27	>100

Verifica spostamento elastico dovuto ai soli carichi variabili (§4.2.4.2.1 - NTC 2008)

x	Comb.	δ_2	L/300.00	Cs
cm		mm	mm	
140.8	15	0.05	9.39	>100

Travata: 301 [277 , 284]

L = 281.6cm

Crit.Prog: Acciaio_Flessione $\delta_c = 0.0cm$ Verifica: **Verificata**

Verifica spostamento nello stato finale (§4.2.4.2.1 - NTC 2008)

x	Comb.	δ_{max}	L/250.00	Cs
---	-------	----------------	----------	----

AUTOSTRADA VALDASTICO A31 NORD
1° LOTTO - PIOVENE ROCCHETTE – VALLE DELL'ASTICO

x	Comb.	δ_{max}	L/250.00	Cs
cm		mm	mm	
140.8	15	0.10	11.27	>100

Verifica spostamento elastico dovuto ai soli carichi variabili (§4.2.4.2.1 - NTC 2008)

x	Comb.	δ_2	L/300.00	Cs
cm		mm	mm	
140.8	15	0.05	9.39	>100

Travata: 302 [284 , 295]

L = 281.6cm

Crit.Prog: Acciaio_Flessione $\delta_c = 0.0cm$ Verifica: **Verificata**

Verifica spostamento nello stato finale (§4.2.4.2.1 - NTC 2008)

x	Comb.	δ_{max}	L/250.00	Cs
cm		mm	mm	
140.8	15	0.10	11.27	>100

Verifica spostamento elastico dovuto ai soli carichi variabili (§4.2.4.2.1 - NTC 2008)

x	Comb.	δ_2	L/300.00	Cs
cm		mm	mm	
140.8	15	0.05	9.39	>100

Travata: 303 [295 , 278]

L = 286.0cm

Crit.Prog: Acciaio_Flessione $\delta_c = 0.0cm$ Verifica: **Verificata**

Verifica spostamento nello stato finale (§4.2.4.2.1 - NTC 2008)

x	Comb.	δ_{max}	L/250.00	Cs
---	-------	----------------	----------	----

AUTOSTRADA VALDASTICO A31 NORD
1° LOTTO - PIOVENE ROCCHETTE – VALLE DELL'ASTICO

x	Comb.	δ_{max}	L/250.00	Cs
cm		mm	mm	
143.0	15	0.07	11.44	>100

Verifica spostamento elastico dovuto ai soli carichi variabili (§4.2.4.2.1 - NTC 2008)

x	Comb.	δ_2	L/300.00	Cs
cm		mm	mm	
114.4	15	0.01	9.53	>100

Travata: 304 [278 , 277]

L = 314.0cm

Crit.Prog: Acciaio_Flessione $\delta_c = 0.0cm$ Verifica: **Verificata**

Verifica spostamento nello stato finale (§4.2.4.2.1 - NTC 2008)

x	Comb.	δ_{max}	L/250.00	Cs
cm		mm	mm	
157.0	15	0.40	12.56	31.2

Verifica spostamento elastico dovuto ai soli carichi variabili (§4.2.4.2.1 - NTC 2008)

x	Comb.	δ_2	L/300.00	Cs
cm		mm	mm	
157.0	15	0.22	10.47	47.3

Travata: 305 [294 , 284]

L = 281.6cm

Crit.Prog: Acciaio_Flessione $\delta_c = 0.0cm$ Verifica: **Verificata**

Verifica spostamento nello stato finale (§4.2.4.2.1 - NTC 2008)

x	Comb.	δ_{max}	L/250.00	Cs
---	-------	----------------	----------	----

AUTOSTRADA VALDASTICO A31 NORD
1° LOTTO - PIOVENE ROCCHETTE – VALLE DELL'ASTICO

x	Comb.	δ_{max}	L/250.00	Cs
cm		mm	mm	
140.8	15	0.10	11.27	>100

Verifica spostamento elastico dovuto ai soli carichi variabili (§4.2.4.2.1 - NTC 2008)

x	Comb.	δ_2	L/300.00	Cs
cm		mm	mm	
140.8	15	0.05	9.39	>100

Travata: 306 [284 , 278]

L = 281.6cm

Crit.Prog: Acciaio_Flessione $\delta_c = 0.0cm$ Verifica: **Verificata**

Verifica spostamento nello stato finale (§4.2.4.2.1 - NTC 2008)

x	Comb.	δ_{max}	L/250.00	Cs
cm		mm	mm	
140.8	15	0.12	11.27	92.3

Verifica spostamento elastico dovuto ai soli carichi variabili (§4.2.4.2.1 - NTC 2008)

x	Comb.	δ_2	L/300.00	Cs
cm		mm	mm	
140.8	15	0.06	9.39	>100

Travata: 307 [296 , 279]

L = 286.0cm

Crit.Prog: Acciaio_Flessione $\delta_c = 0.0cm$ Verifica: **Verificata**

Verifica spostamento nello stato finale (§4.2.4.2.1 - NTC 2008)

x	Comb.	δ_{max}	L/250.00	Cs
---	-------	----------------	----------	----

AUTOSTRADA VALDASTICO A31 NORD
1° LOTTO - PIOVENE ROCCHETTE – VALLE DELL'ASTICO

x	Comb.	δ_{max}	L/250.00	Cs
cm		mm	mm	
143.0	15	0.19	11.44	59.0

Verifica spostamento elastico dovuto ai soli carichi variabili (§4.2.4.2.1 - NTC 2008)

x	Comb.	δ_2	L/300.00	Cs
cm		mm	mm	
114.4	15	0.09	9.53	>100

Travata: 308 [279 , 278]

L = 314.0cm

Crit.Prog: Acciaio_Flessione $\delta_c = 0.0cm$ Verifica: **Verificata**

Verifica spostamento nello stato finale (§4.2.4.2.1 - NTC 2008)

x	Comb.	δ_{max}	L/250.00	Cs
cm		mm	mm	
157.0	15	0.32	12.56	38.7

Verifica spostamento elastico dovuto ai soli carichi variabili (§4.2.4.2.1 - NTC 2008)

x	Comb.	δ_2	L/300.00	Cs
cm		mm	mm	
157.0	15	0.17	10.47	60.6

Travata: 309 [278 , 283]

L = 273.9cm

Crit.Prog: Acciaio_Flessione $\delta_c = 0.0cm$ Verifica: **Verificata**

Verifica spostamento nello stato finale (§4.2.4.2.1 - NTC 2008)

x	Comb.	δ_{max}	L/250.00	Cs
---	-------	----------------	----------	----

AUTOSTRADA VALDASTICO A31 NORD
1° LOTTO - PIOVENE ROCCHETTE – VALLE DELL'ASTICO

x	Comb.	δ_{max}	L/250.00	Cs
cm		mm	mm	
137.0	15	0.06	10.96	>100

Verifica spostamento elastico dovuto ai soli carichi variabili (§4.2.4.2.1 - NTC 2008)

x	Comb.	δ_2	L/300.00	Cs
cm		mm	mm	
137.0	15	0.03	9.13	>100

Travata: 310 [283 , 296]

L = 273.9cm

Crit.Prog: Acciaio_Flessione $\delta_c = 0.0cm$ Verifica: **Verificata**

Verifica spostamento nello stato finale (§4.2.4.2.1 - NTC 2008)

x	Comb.	δ_{max}	L/250.00	Cs
cm		mm	mm	
137.0	15	0.08	10.96	>100

Verifica spostamento elastico dovuto ai soli carichi variabili (§4.2.4.2.1 - NTC 2008)

x	Comb.	δ_2	L/300.00	Cs
cm		mm	mm	
137.0	15	0.04	9.13	>100

Travata: 311 [295 , 283]

L = 273.9cm

Crit.Prog: Acciaio_Flessione $\delta_c = 0.0cm$ Verifica: **Verificata**

Verifica spostamento nello stato finale (§4.2.4.2.1 - NTC 2008)

x	Comb.	δ_{max}	L/250.00	Cs
---	-------	----------------	----------	----

AUTOSTRADA VALDASTICO A31 NORD
1° LOTTO - PIOVENE ROCCHETTE – VALLE DELL'ASTICO

x	Comb.	δ_{max}	L/250.00	Cs
cm		mm	mm	
137.0	15	0.10	10.96	>100

Verifica spostamento elastico dovuto ai soli carichi variabili (§4.2.4.2.1 - NTC 2008)

x	Comb.	δ_2	L/300.00	Cs
cm		mm	mm	
137.0	15	0.05	9.13	>100

Travata: 312 [283 , 279]

L = 273.9cm

Crit.Prog: Acciaio_Flessione $\delta_c = 0.0cm$ Verifica: **Verificata**

Verifica spostamento nello stato finale (§4.2.4.2.1 - NTC 2008)

x	Comb.	δ_{max}	L/250.00	Cs
cm		mm	mm	
137.0	15	0.16	10.96	68.3

Verifica spostamento elastico dovuto ai soli carichi variabili (§4.2.4.2.1 - NTC 2008)

x	Comb.	δ_2	L/300.00	Cs
cm		mm	mm	
137.0	15	0.09	9.13	>100

Travata: 313 [279 , 280]

L = 314.0cm

Crit.Prog: Acciaio_Flessione $\delta_c = 0.0cm$ Verifica: **Verificata**

Verifica spostamento nello stato finale (§4.2.4.2.1 - NTC 2008)

x	Comb.	δ_{max}	L/250.00	Cs
---	-------	----------------	----------	----

AUTOSTRADA VALDASTICO A31 NORD
1° LOTTO - PIOVENE ROCCHETTE – VALLE DELL'ASTICO

x	Comb.	δ_{max}	L/250.00	Cs
cm		mm	mm	
251.2	15	-0.11	12.56	>100

Verifica spostamento elastico dovuto ai soli carichi variabili (§4.2.4.2.1 - NTC 2008)

x	Comb.	δ_2	L/300.00	Cs
cm		mm	mm	
219.8	15	-0.09	10.47	>100

Travata: 314 [280 , 297]

L = 286.0cm

Crit.Prog: Acciaio_Flessione $\delta_c = 0.0cm$ Verifica: **Verificata**

Verifica spostamento nello stato finale (§4.2.4.2.1 - NTC 2008)

x	Comb.	δ_{max}	L/250.00	Cs
cm		mm	mm	
143.0	15	0.51	11.44	22.6

Verifica spostamento elastico dovuto ai soli carichi variabili (§4.2.4.2.1 - NTC 2008)

x	Comb.	δ_2	L/300.00	Cs
cm		mm	mm	
143.0	15	0.29	9.53	33.0

Travata: 315 [296 , 282]

L = 254.4cm

Crit.Prog: Acciaio_Flessione $\delta_c = 0.0cm$ Verifica: **Verificata**

Verifica spostamento nello stato finale (§4.2.4.2.1 - NTC 2008)

x	Comb.	δ_{max}	L/250.00	Cs
---	-------	----------------	----------	----

AUTOSTRADA VALDASTICO A31 NORD
1° LOTTO - PIOVENE ROCCHETTE – VALLE DELL'ASTICO

x	Comb.	δ_{max}	L/250.00	Cs
cm		mm	mm	
127.2	15	0.11	10.17	95.6

Verifica spostamento elastico dovuto ai soli carichi variabili (§4.2.4.2.1 - NTC 2008)

x	Comb.	δ_2	L/300.00	Cs
cm		mm	mm	
127.2	15	0.06	8.48	>100

Travata: 316 [282 , 297]

L = 254.4cm

Crit.Prog: Acciaio_Flessione $\delta_c = 0.0cm$ Verifica: **Verificata**

Verifica spostamento nello stato finale (§4.2.4.2.1 - NTC 2008)

x	Comb.	δ_{max}	L/250.00	Cs
cm		mm	mm	
127.2	15	0.07	10.17	>100

Verifica spostamento elastico dovuto ai soli carichi variabili (§4.2.4.2.1 - NTC 2008)

x	Comb.	δ_2	L/300.00	Cs
cm		mm	mm	
101.7	15	0.03	8.48	>100

Travata: 317 [279 , 282]

L = 254.4cm

Crit.Prog: Acciaio_Flessione $\delta_c = 0.0cm$ Verifica: **Verificata**

Verifica spostamento nello stato finale (§4.2.4.2.1 - NTC 2008)

x	Comb.	δ_{max}	L/250.00	Cs
---	-------	----------------	----------	----

AUTOSTRADA VALDASTICO A31 NORD
1° LOTTO - PIOVENE ROCCHETTE – VALLE DELL'ASTICO

x	Comb.	δ_{max}	L/250.00	Cs
cm		mm	mm	
76.3	15	-0.02	10.17	>100

Verifica spostamento elastico dovuto ai soli carichi variabili (§4.2.4.2.1 - NTC 2008)

x	Comb.	δ_2	L/300.00	Cs
cm		mm	mm	
101.7	15	-0.02	8.48	>100

Travata: 318 [282 , 280]

L = 254.4cm

Crit.Prog: Acciaio_Flessione $\delta_c = 0.0cm$ Verifica: **Verificata**

Verifica spostamento nello stato finale (§4.2.4.2.1 - NTC 2008)

x	Comb.	δ_{max}	L/250.00	Cs
cm		mm	mm	
127.2	15	0.15	10.17	68.2

Verifica spostamento elastico dovuto ai soli carichi variabili (§4.2.4.2.1 - NTC 2008)

x	Comb.	δ_2	L/300.00	Cs
cm		mm	mm	
127.2	15	0.08	8.48	>100

Travata: 319 [298 , 281]

L = 286.0cm

Crit.Prog: Acciaio_Flessione $\delta_c = 0.0cm$ Verifica: **Verificata**

Verifica spostamento nello stato finale (§4.2.4.2.1 - NTC 2008)

x	Comb.	δ_{max}	L/250.00	Cs
---	-------	----------------	----------	----

AUTOSTRADA VALDASTICO A31 NORD
1° LOTTO - PIOVENE ROCCHETTE – VALLE DELL'ASTICO

x	Comb.	δ_{max}	L/250.00	Cs
cm		mm	mm	
143.0	15	0.35	11.44	32.4

Verifica spostamento elastico dovuto ai soli carichi variabili (§4.2.4.2.1 - NTC 2008)

x	Comb.	δ_2	L/300.00	Cs
cm		mm	mm	
143.0	15	0.20	9.53	48.7

Travata: 320 [281 , 280]

L = 314.0cm

Crit.Prog: Acciaio_Flessione $\delta_c = 0.0cm$ Verifica: **Verificata**

Verifica spostamento nello stato finale (§4.2.4.2.1 - NTC 2008)

x	Comb.	δ_{max}	L/250.00	Cs
cm		mm	mm	
188.4	15	-0.17	12.56	74.9

Verifica spostamento elastico dovuto ai soli carichi variabili (§4.2.4.2.1 - NTC 2008)

x	Comb.	δ_2	L/300.00	Cs
cm		mm	mm	
157.0	15	-0.15	10.47	70.1

Travata: 321 [297 , 289]

L = 229.9cm

Crit.Prog: Acciaio_Flessione $\delta_c = 0.0cm$ Verifica: **Verificata**

Verifica spostamento nello stato finale (§4.2.4.2.1 - NTC 2008)

x	Comb.	δ_{max}	L/250.00	Cs
---	-------	----------------	----------	----

AUTOSTRADA VALDASTICO A31 NORD
1° LOTTO - PIOVENE ROCCHETTE – VALLE DELL'ASTICO

x	Comb.	δ_{max}	L/250.00	Cs
cm		mm	mm	
137.9	15	0.16	9.19	58.9

Verifica spostamento elastico dovuto ai soli carichi variabili (§4.2.4.2.1 - NTC 2008)

x	Comb.	δ_2	L/300.00	Cs
cm		mm	mm	
137.9	15	0.10	7.66	75.6

Travata: 322 [289 , 281]

L = 229.9cm

Crit.Prog: Acciaio_Flessione $\delta_c = 0.0cm$ Verifica: **Verificata**

Verifica spostamento nello stato finale (§4.2.4.2.1 - NTC 2008)

x	Comb.	δ_{max}	L/250.00	Cs
cm		mm	mm	
91.9	15	-0.08	9.19	>100

Verifica spostamento elastico dovuto ai soli carichi variabili (§4.2.4.2.1 - NTC 2008)

x	Comb.	δ_2	L/300.00	Cs
cm		mm	mm	
114.9	15	-0.07	7.66	>100

Travata: 323 [289 , 298]

L = 229.9cm

Crit.Prog: Acciaio_Flessione $\delta_c = 0.0cm$ Verifica: **Verificata**

Verifica spostamento nello stato finale (§4.2.4.2.1 - NTC 2008)

x	Comb.	δ_{max}	L/250.00	Cs
---	-------	----------------	----------	----

AUTOSTRADA VALDASTICO A31 NORD
1° LOTTO - PIOVENE ROCCHETTE – VALLE DELL'ASTICO

x	Comb.	δ_{max}	L/250.00	Cs
cm		mm	mm	
137.9	15	0.06	9.19	>100

Verifica spostamento elastico dovuto ai soli carichi variabili (§4.2.4.2.1 - NTC 2008)

x	Comb.	δ_2	L/300.00	Cs
cm		mm	mm	
160.9	15	0.02	7.66	>100

Travata: 324 [288 , 287]

L = 318.3cm

Crit.Prog: Acciaio_Flessione $\delta_c = 0.0cm$ Verifica: **Verificata**

Verifica spostamento nello stato finale (§4.2.4.2.1 - NTC 2008)

x	Comb.	δ_{max}	L/250.00	Cs
cm		mm	mm	
159.1	15	2.49	12.73	5.12

Verifica spostamento elastico dovuto ai soli carichi variabili (§4.2.4.2.1 - NTC 2008)

x	Comb.	δ_2	L/300.00	Cs
cm		mm	mm	
159.1	15	1.85	10.61	5.73

Travata: 325 [287 , 286]

L = 315.7cm

Crit.Prog: Acciaio_Flessione $\delta_c = 0.0cm$ Verifica: **Verificata**

Verifica spostamento nello stato finale (§4.2.4.2.1 - NTC 2008)

x	Comb.	δ_{max}	L/250.00	Cs
---	-------	----------------	----------	----

AUTOSTRADA VALDASTICO A31 NORD
1° LOTTO - PIOVENE ROCCHETTE – VALLE DELL'ASTICO

x	Comb.	δ_{max}	L/250.00	Cs
cm		mm	mm	
157.9	15	2.55	12.63	4.95

Verifica spostamento elastico dovuto ai soli carichi variabili (§4.2.4.2.1 - NTC 2008)

x	Comb.	δ_2	L/300.00	Cs
cm		mm	mm	
157.9	15	1.87	10.52	5.63

Travata: 326 [286 , 285]

L = 314.2cm

Crit.Prog: Acciaio_Flessione $\delta_c = 0.0cm$ Verifica: **Verificata**

Verifica spostamento nello stato finale (§4.2.4.2.1 - NTC 2008)

x	Comb.	δ_{max}	L/250.00	Cs
cm		mm	mm	
157.1	15	2.69	12.57	4.67

Verifica spostamento elastico dovuto ai soli carichi variabili (§4.2.4.2.1 - NTC 2008)

x	Comb.	δ_2	L/300.00	Cs
cm		mm	mm	
157.1	15	1.96	10.47	5.35

Travata: 327 [285 , 284]

L = 314.0cm

Crit.Prog: Acciaio_Flessione $\delta_c = 0.0cm$ Verifica: **Verificata**

Verifica spostamento nello stato finale (§4.2.4.2.1 - NTC 2008)

x	Comb.	δ_{max}	L/250.00	Cs
---	-------	----------------	----------	----

AUTOSTRADA VALDASTICO A31 NORD
1° LOTTO - PIOVENE ROCCHETTE – VALLE DELL'ASTICO

x	Comb.	δ_{max}	L/250.00	Cs
cm		mm	mm	
157.0	15	2.74	12.56	4.58

Verifica spostamento elastico dovuto ai soli carichi variabili (§4.2.4.2.1 - NTC 2008)

x	Comb.	δ_2	L/300.00	Cs
cm		mm	mm	
157.0	15	1.99	10.47	5.26

Travata: 328 [284 , 283]

L = 314.2cm

Crit.Prog: Acciaio_Flessione $\delta_c = 0.0cm$ Verifica: **Verificata**

Verifica spostamento nello stato finale (§4.2.4.2.1 - NTC 2008)

x	Comb.	δ_{max}	L/250.00	Cs
cm		mm	mm	
157.1	15	2.69	12.57	4.67

Verifica spostamento elastico dovuto ai soli carichi variabili (§4.2.4.2.1 - NTC 2008)

x	Comb.	δ_2	L/300.00	Cs
cm		mm	mm	
157.1	15	1.96	10.47	5.35

Travata: 329 [283 , 282]

L = 315.7cm

Crit.Prog: Acciaio_Flessione $\delta_c = 0.0cm$ Verifica: **Verificata**

Verifica spostamento nello stato finale (§4.2.4.2.1 - NTC 2008)

x	Comb.	δ_{max}	L/250.00	Cs
---	-------	----------------	----------	----

AUTOSTRADA VALDASTICO A31 NORD
1° LOTTO - PIOVENE ROCCHETTE – VALLE DELL'ASTICO

x	Comb.	δ_{max}	L/250.00	Cs
cm		mm	mm	
157.9	15	2.55	12.63	4.96

Verifica spostamento elastico dovuto ai soli carichi variabili (§4.2.4.2.1 - NTC 2008)

x	Comb.	δ_2	L/300.00	Cs
cm		mm	mm	
157.9	15	1.87	10.52	5.64

Travata: 330 [282 , 289]

L = 318.3cm

Crit.Prog: Acciaio_Flessione $\delta_c = 0.0cm$ Verifica: **Verificata**

Verifica spostamento nello stato finale (§4.2.4.2.1 - NTC 2008)

x	Comb.	δ_{max}	L/250.00	Cs
cm		mm	mm	
159.1	15	2.48	12.73	5.13

Verifica spostamento elastico dovuto ai soli carichi variabili (§4.2.4.2.1 - NTC 2008)

x	Comb.	δ_2	L/300.00	Cs
cm		mm	mm	
159.1	15	1.85	10.61	5.73

Travata: 331 [290 , 305]

L = 229.9cm

Crit.Prog: Acciaio_Flessione $\delta_c = 0.0cm$ Verifica: **Verificata**

Verifica spostamento nello stato finale (§4.2.4.2.1 - NTC 2008)

x	Comb.	δ_{max}	L/250.00	Cs
---	-------	----------------	----------	----

AUTOSTRADA VALDASTICO A31 NORD
1° LOTTO - PIOVENE ROCCHETTE – VALLE DELL'ASTICO

x	Comb.	δ_{max}	L/250.00	Cs
cm		mm	mm	
91.9	15	0.05	9.19	>100

Verifica spostamento elastico dovuto ai soli carichi variabili (§4.2.4.2.1 - NTC 2008)

x	Comb.	δ_2	L/300.00	Cs
cm		mm	mm	
46.0	15	0.01	7.66	>100

Travata: 332 [308 , 291]

L = 286.0cm

Crit.Prog: Acciaio_Flessione $\delta_c = 0.0cm$ Verifica: **Verificata**

Verifica spostamento nello stato finale (§4.2.4.2.1 - NTC 2008)

x	Comb.	δ_{max}	L/250.00	Cs
cm		mm	mm	
143.0	15	0.49	11.44	23.3

Verifica spostamento elastico dovuto ai soli carichi variabili (§4.2.4.2.1 - NTC 2008)

x	Comb.	δ_2	L/300.00	Cs
cm		mm	mm	
143.0	15	0.28	9.53	34.1

Travata: 333 [291 , 290]

L = 314.0cm

Crit.Prog: Acciaio_Flessione $\delta_c = 0.0cm$ Verifica: **Verificata**

Verifica spostamento nello stato finale (§4.2.4.2.1 - NTC 2008)

x	Comb.	δ_{max}	L/250.00	Cs
---	-------	----------------	----------	----

AUTOSTRADA VALDASTICO A31 NORD
1° LOTTO - PIOVENE ROCCHETTE – VALLE DELL'ASTICO

x	Comb.	δ_{max}	L/250.00	Cs
cm		mm	mm	
157.0	21	0.04	12.56	>100

Verifica spostamento elastico dovuto ai soli carichi variabili (§4.2.4.2.1 - NTC 2008)

x	Comb.	δ_2	L/300.00	Cs
cm		mm	mm	
188.4	15	-0.07	10.47	>100

Travata: 334 [307 , 305]

L = 229.9cm

Crit.Prog: Acciaio_Flessione $\delta_c = 0.0cm$ Verifica: **Verificata**

Verifica spostamento nello stato finale (§4.2.4.2.1 - NTC 2008)

x	Comb.	δ_{max}	L/250.00	Cs
cm		mm	mm	
114.9	15	-0.08	9.19	>100

Verifica spostamento elastico dovuto ai soli carichi variabili (§4.2.4.2.1 - NTC 2008)

x	Comb.	δ_2	L/300.00	Cs
cm		mm	mm	
114.9	15	-0.07	7.66	>100

Travata: 335 [305 , 291]

L = 229.9cm

Crit.Prog: Acciaio_Flessione $\delta_c = 0.0cm$ Verifica: **Verificata**

Verifica spostamento nello stato finale (§4.2.4.2.1 - NTC 2008)

x	Comb.	δ_{max}	L/250.00	Cs
---	-------	----------------	----------	----

AUTOSTRADA VALDASTICO A31 NORD
1° LOTTO - PIOVENE ROCCHETTE – VALLE DELL'ASTICO

x	Comb.	δ_{max}	L/250.00	Cs
cm		mm	mm	
91.9	15	0.17	9.19	53.8

Verifica spostamento elastico dovuto ai soli carichi variabili (§4.2.4.2.1 - NTC 2008)

x	Comb.	δ_2	L/300.00	Cs
cm		mm	mm	
91.9	15	0.11	7.66	70.0

Travata: 336 [305 , 308]

L = 229.9cm

Crit.Prog: Acciaio_Flessione $\delta_c = 0.0cm$ Verifica: **Verificata**

Verifica spostamento nello stato finale (§4.2.4.2.1 - NTC 2008)

x	Comb.	δ_{max}	L/250.00	Cs
cm		mm	mm	
91.9	15	0.14	9.19	65.3

Verifica spostamento elastico dovuto ai soli carichi variabili (§4.2.4.2.1 - NTC 2008)

x	Comb.	δ_2	L/300.00	Cs
cm		mm	mm	
91.9	15	0.09	7.66	83.6

Travata: 337 [307 , 290]

L = 286.0cm

Crit.Prog: Acciaio_Flessione $\delta_c = 0.0cm$ Verifica: **Verificata**

Verifica spostamento nello stato finale (§4.2.4.2.1 - NTC 2008)

x	Comb.	δ_{max}	L/250.00	Cs
---	-------	----------------	----------	----

AUTOSTRADA VALDASTICO A31 NORD
1° LOTTO - PIOVENE ROCCHETTE – VALLE DELL'ASTICO

x	Comb.	δ_{max}	L/250.00	Cs
cm		mm	mm	
143.0	15	0.32	11.44	35.3

Verifica spostamento elastico dovuto ai soli carichi variabili (§4.2.4.2.1 - NTC 2008)

x	Comb.	δ_2	L/300.00	Cs
cm		mm	mm	
171.6	15	0.18	9.53	54.3

Travata: 338 [309 , 292]

L = 286.0cm

Crit.Prog: Acciaio_Flessione $\delta_c = 0.0cm$ Verifica: **Verificata**

Verifica spostamento nello stato finale (§4.2.4.2.1 - NTC 2008)

x	Comb.	δ_{max}	L/250.00	Cs
cm		mm	mm	
143.0	15	0.19	11.44	59.6

Verifica spostamento elastico dovuto ai soli carichi variabili (§4.2.4.2.1 - NTC 2008)

x	Comb.	δ_2	L/300.00	Cs
cm		mm	mm	
171.6	15	0.09	9.53	>100

Travata: 339 [292 , 291]

L = 314.0cm

Crit.Prog: Acciaio_Flessione $\delta_c = 0.0cm$ Verifica: **Verificata**

Verifica spostamento nello stato finale (§4.2.4.2.1 - NTC 2008)

x	Comb.	δ_{max}	L/250.00	Cs
---	-------	----------------	----------	----

AUTOSTRADA VALDASTICO A31 NORD
1° LOTTO - PIOVENE ROCCHETTE – VALLE DELL'ASTICO

x	Comb.	δ_{max}	L/250.00	Cs
cm		mm	mm	
157.0	21	0.05	12.56	>100

Verifica spostamento elastico dovuto ai soli carichi variabili (§4.2.4.2.1 - NTC 2008)

x	Comb.	δ_2	L/300.00	Cs
cm		mm	mm	
219.8	15	-0.02	10.47	>100

Travata: 340 [291 , 304]

L = 254.4cm

Crit.Prog: Acciaio_Flessione $\delta_c = 0.0cm$ Verifica: **Verificata**

Verifica spostamento nello stato finale (§4.2.4.2.1 - NTC 2008)

x	Comb.	δ_{max}	L/250.00	Cs
cm		mm	mm	
127.2	15	0.05	10.17	>100

Verifica spostamento elastico dovuto ai soli carichi variabili (§4.2.4.2.1 - NTC 2008)

x	Comb.	δ_2	L/300.00	Cs
cm		mm	mm	
152.6	15	0.02	8.48	>100

Travata: 341 [304 , 309]

L = 254.4cm

Crit.Prog: Acciaio_Flessione $\delta_c = 0.0cm$ Verifica: **Verificata**

Verifica spostamento nello stato finale (§4.2.4.2.1 - NTC 2008)

x	Comb.	δ_{max}	L/250.00	Cs
---	-------	----------------	----------	----

AUTOSTRADA VALDASTICO A31 NORD
1° LOTTO - PIOVENE ROCCHETTE – VALLE DELL'ASTICO

x	Comb.	δ_{max}	L/250.00	Cs
cm		mm	mm	
178.1	15	-0.03	10.17	>100

Verifica spostamento elastico dovuto ai soli carichi variabili (§4.2.4.2.1 - NTC 2008)

x	Comb.	δ_2	L/300.00	Cs
cm		mm	mm	
152.6	15	-0.03	8.48	>100

Travata: 342 [308 , 304]

L = 254.4cm

Crit.Prog: Acciaio_Flessione $\delta_c = 0.0cm$ Verifica: **Verificata**

Verifica spostamento nello stato finale (§4.2.4.2.1 - NTC 2008)

x	Comb.	δ_{max}	L/250.00	Cs
cm		mm	mm	
127.2	15	0.16	10.17	63.7

Verifica spostamento elastico dovuto ai soli carichi variabili (§4.2.4.2.1 - NTC 2008)

x	Comb.	δ_2	L/300.00	Cs
cm		mm	mm	
127.2	15	0.09	8.48	94.9

Travata: 343 [304 , 292]

L = 254.4cm

Crit.Prog: Acciaio_Flessione $\delta_c = 0.0cm$ Verifica: **Verificata**

Verifica spostamento nello stato finale (§4.2.4.2.1 - NTC 2008)

x	Comb.	δ_{max}	L/250.00	Cs
---	-------	----------------	----------	----

AUTOSTRADA VALDASTICO A31 NORD
1° LOTTO - PIOVENE ROCCHETTE – VALLE DELL'ASTICO

x	Comb.	δ_{max}	L/250.00	Cs
cm		mm	mm	
127.2	15	0.12	10.17	82.3

Verifica spostamento elastico dovuto ai soli carichi variabili (§4.2.4.2.1 - NTC 2008)

x	Comb.	δ_2	L/300.00	Cs
cm		mm	mm	
127.2	15	0.07	8.48	>100

Travata: 344 [310 , 293]

L = 286.0cm

Crit.Prog: Acciaio_Flessione $\delta_c = 0.0cm$ Verifica: **Verificata**

Verifica spostamento nello stato finale (§4.2.4.2.1 - NTC 2008)

x	Comb.	δ_{max}	L/250.00	Cs
cm		mm	mm	
143.0	15	0.07	11.44	>100

Verifica spostamento elastico dovuto ai soli carichi variabili (§4.2.4.2.1 - NTC 2008)

x	Comb.	δ_2	L/300.00	Cs
cm		mm	mm	
143.0	15	0.02	9.53	>100

Travata: 345 [293 , 292]

L = 314.0cm

Crit.Prog: Acciaio_Flessione $\delta_c = 0.0cm$ Verifica: **Verificata**

Verifica spostamento nello stato finale (§4.2.4.2.1 - NTC 2008)

x	Comb.	δ_{max}	L/250.00	Cs
---	-------	----------------	----------	----

AUTOSTRADA VALDASTICO A31 NORD
1° LOTTO - PIOVENE ROCCHETTE – VALLE DELL'ASTICO

x	Comb.	δ_{max}	L/250.00	Cs
cm		mm	mm	
157.0	15	0.26	12.56	49.1

Verifica spostamento elastico dovuto ai soli carichi variabili (§4.2.4.2.1 - NTC 2008)

x	Comb.	δ_2	L/300.00	Cs
cm		mm	mm	
125.6	15	0.13	10.47	81.0

Travata: 346 [309 , 303]

L = 273.9cm

Crit.Prog: Acciaio_Flessione $\delta_c = 0.0cm$ Verifica: **Verificata**

Verifica spostamento nello stato finale (§4.2.4.2.1 - NTC 2008)

x	Comb.	δ_{max}	L/250.00	Cs
cm		mm	mm	
137.0	15	0.18	10.96	62.5

Verifica spostamento elastico dovuto ai soli carichi variabili (§4.2.4.2.1 - NTC 2008)

x	Comb.	δ_2	L/300.00	Cs
cm		mm	mm	
137.0	15	0.10	9.13	93.9

Travata: 347 [303 , 293]

L = 273.9cm

Crit.Prog: Acciaio_Flessione $\delta_c = 0.0cm$ Verifica: **Verificata**

Verifica spostamento nello stato finale (§4.2.4.2.1 - NTC 2008)

x	Comb.	δ_{max}	L/250.00	Cs
---	-------	----------------	----------	----

AUTOSTRADA VALDASTICO A31 NORD
1° LOTTO - PIOVENE ROCCHETTE – VALLE DELL'ASTICO

x	Comb.	δ_{max}	L/250.00	Cs
cm		mm	mm	
137.0	15	0.11	10.96	97.2

Verifica spostamento elastico dovuto ai soli carichi variabili (§4.2.4.2.1 - NTC 2008)

x	Comb.	δ_2	L/300.00	Cs
cm		mm	mm	
137.0	15	0.06	9.13	>100

Travata: 348 [292 , 303]

L = 273.9cm

Crit.Prog: Acciaio_Flessione $\delta_c = 0.0cm$ Verifica: **Verificata**

Verifica spostamento nello stato finale (§4.2.4.2.1 - NTC 2008)

x	Comb.	δ_{max}	L/250.00	Cs
cm		mm	mm	
137.0	15	0.07	10.96	>100

Verifica spostamento elastico dovuto ai soli carichi variabili (§4.2.4.2.1 - NTC 2008)

x	Comb.	δ_2	L/300.00	Cs
cm		mm	mm	
137.0	15	0.03	9.13	>100

Travata: 349 [303 , 310]

L = 273.9cm

Crit.Prog: Acciaio_Flessione $\delta_c = 0.0cm$ Verifica: **Verificata**

Verifica spostamento nello stato finale (§4.2.4.2.1 - NTC 2008)

x	Comb.	δ_{max}	L/250.00	Cs
---	-------	----------------	----------	----

AUTOSTRADA VALDASTICO A31 NORD
1° LOTTO - PIOVENE ROCCHETTE – VALLE DELL'ASTICO

x	Comb.	δ_{max}	L/250.00	Cs
cm		mm	mm	
137.0	15	0.06	10.96	>100

Verifica spostamento elastico dovuto ai soli carichi variabili (§4.2.4.2.1 - NTC 2008)

x	Comb.	δ_2	L/300.00	Cs
cm		mm	mm	
137.0	15	0.02	9.13	>100

Travata: 350 [311 , 294]

L = 286.0cm

Crit.Prog: Acciaio_Flessione $\delta_c = 0.0cm$ Verifica: **Verificata**

Verifica spostamento nello stato finale (§4.2.4.2.1 - NTC 2008)

x	Comb.	δ_{max}	L/250.00	Cs
cm		mm	mm	
143.0	15	0.05	11.44	>100

Verifica spostamento elastico dovuto ai soli carichi variabili (§4.2.4.2.1 - NTC 2008)

x	Comb.	δ_2	L/300.00	Cs
cm		mm	mm	
85.8	15	0.01	9.53	>100

Travata: 351 [294 , 293]

L = 314.0cm

Crit.Prog: Acciaio_Flessione $\delta_c = 0.0cm$ Verifica: **Verificata**

Verifica spostamento nello stato finale (§4.2.4.2.1 - NTC 2008)

x	Comb.	δ_{max}	L/250.00	Cs
---	-------	----------------	----------	----

AUTOSTRADA VALDASTICO A31 NORD
1° LOTTO - PIOVENE ROCCHETTE – VALLE DELL'ASTICO

x	Comb.	δ_{max}	L/250.00	Cs
cm		mm	mm	
157.0	15	0.37	12.56	34.1

Verifica spostamento elastico dovuto ai soli carichi variabili (§4.2.4.2.1 - NTC 2008)

x	Comb.	δ_2	L/300.00	Cs
cm		mm	mm	
157.0	15	0.20	10.47	52.4

Travata: 352 [310 , 302]

L = 281.6cm

Crit.Prog: Acciaio_Flessione $\delta_c = 0.0cm$ Verifica: **Verificata**

Verifica spostamento nello stato finale (§4.2.4.2.1 - NTC 2008)

x	Comb.	δ_{max}	L/250.00	Cs
cm		mm	mm	
140.8	15	0.13	11.27	85.3

Verifica spostamento elastico dovuto ai soli carichi variabili (§4.2.4.2.1 - NTC 2008)

x	Comb.	δ_2	L/300.00	Cs
cm		mm	mm	
140.8	15	0.07	9.39	>100

Travata: 353 [302 , 311]

L = 281.6cm

Crit.Prog: Acciaio_Flessione $\delta_c = 0.0cm$ Verifica: **Verificata**

Verifica spostamento nello stato finale (§4.2.4.2.1 - NTC 2008)

x	Comb.	δ_{max}	L/250.00	Cs
---	-------	----------------	----------	----

AUTOSTRADA VALDASTICO A31 NORD
1° LOTTO - PIOVENE ROCCHETTE – VALLE DELL'ASTICO

x	Comb.	δ_{max}	L/250.00	Cs
cm		mm	mm	
140.8	15	0.11	11.27	>100

Verifica spostamento elastico dovuto ai soli carichi variabili (§4.2.4.2.1 - NTC 2008)

x	Comb.	δ_2	L/300.00	Cs
cm		mm	mm	
140.8	15	0.05	9.39	>100

Travata: 354 [293 , 302]

L = 281.6cm

Crit.Prog: Acciaio_Flessione $\delta_c = 0.0cm$ Verifica: **Verificata**

Verifica spostamento nello stato finale (§4.2.4.2.1 - NTC 2008)

x	Comb.	δ_{max}	L/250.00	Cs
cm		mm	mm	
140.8	15	0.09	11.27	>100

Verifica spostamento elastico dovuto ai soli carichi variabili (§4.2.4.2.1 - NTC 2008)

x	Comb.	δ_2	L/300.00	Cs
cm		mm	mm	
140.8	15	0.05	9.39	>100

Travata: 355 [302 , 294]

L = 281.6cm

Crit.Prog: Acciaio_Flessione $\delta_c = 0.0cm$ Verifica: **Verificata**

Verifica spostamento nello stato finale (§4.2.4.2.1 - NTC 2008)

x	Comb.	δ_{max}	L/250.00	Cs
---	-------	----------------	----------	----

AUTOSTRADA VALDASTICO A31 NORD
1° LOTTO - PIOVENE ROCCHETTE – VALLE DELL'ASTICO

x	Comb.	δ_{max}	L/250.00	Cs
cm		mm	mm	
140.8	15	0.11	11.27	>100

Verifica spostamento elastico dovuto ai soli carichi variabili (§4.2.4.2.1 - NTC 2008)

x	Comb.	δ_2	L/300.00	Cs
cm		mm	mm	
140.8	15	0.06	9.39	>100

Travata: 356 [294 , 301]

L = 281.6cm

Crit.Prog: Acciaio_Flessione $\delta_c = 0.0cm$ Verifica: **Verificata**

Verifica spostamento nello stato finale (§4.2.4.2.1 - NTC 2008)

x	Comb.	δ_{max}	L/250.00	Cs
cm		mm	mm	
140.8	15	0.11	11.27	>100

Verifica spostamento elastico dovuto ai soli carichi variabili (§4.2.4.2.1 - NTC 2008)

x	Comb.	δ_2	L/300.00	Cs
cm		mm	mm	
140.8	15	0.06	9.39	>100

Travata: 357 [301 , 312]

L = 281.6cm

Crit.Prog: Acciaio_Flessione $\delta_c = 0.0cm$ Verifica: **Verificata**

Verifica spostamento nello stato finale (§4.2.4.2.1 - NTC 2008)

x	Comb.	δ_{max}	L/250.00	Cs
---	-------	----------------	----------	----

AUTOSTRADA VALDASTICO A31 NORD
1° LOTTO - PIOVENE ROCCHETTE – VALLE DELL'ASTICO

x	Comb.	δ_{max}	L/250.00	Cs
cm		mm	mm	
140.8	15	0.13	11.27	85.3

Verifica spostamento elastico dovuto ai soli carichi variabili (§4.2.4.2.1 - NTC 2008)

x	Comb.	δ_2	L/300.00	Cs
cm		mm	mm	
140.8	15	0.07	9.39	>100

Travata: 358 [312 , 295]

L = 286.0cm

Crit.Prog: Acciaio_Flessione $\delta_c = 0.0cm$ Verifica: **Verificata**

Verifica spostamento nello stato finale (§4.2.4.2.1 - NTC 2008)

x	Comb.	δ_{max}	L/250.00	Cs
cm		mm	mm	
143.0	15	0.07	11.44	>100

Verifica spostamento elastico dovuto ai soli carichi variabili (§4.2.4.2.1 - NTC 2008)

x	Comb.	δ_2	L/300.00	Cs
cm		mm	mm	
143.0	15	0.02	9.53	>100

Travata: 359 [295 , 294]

L = 314.0cm

Crit.Prog: Acciaio_Flessione $\delta_c = 0.0cm$ Verifica: **Verificata**

Verifica spostamento nello stato finale (§4.2.4.2.1 - NTC 2008)

x	Comb.	δ_{max}	L/250.00	Cs
---	-------	----------------	----------	----

AUTOSTRADA VALDASTICO A31 NORD
1° LOTTO - PIOVENE ROCCHETTE – VALLE DELL'ASTICO

x	Comb.	δ_{max}	L/250.00	Cs
cm		mm	mm	
157.0	15	0.37	12.56	34.1

Verifica spostamento elastico dovuto ai soli carichi variabili (§4.2.4.2.1 - NTC 2008)

x	Comb.	δ_2	L/300.00	Cs
cm		mm	mm	
157.0	15	0.20	10.47	52.5

Travata: 360 [311 , 301]

L = 281.6cm

Crit.Prog: Acciaio_Flessione $\delta_c = 0.0cm$ Verifica: **Verificata**

Verifica spostamento nello stato finale (§4.2.4.2.1 - NTC 2008)

x	Comb.	δ_{max}	L/250.00	Cs
cm		mm	mm	
140.8	15	0.11	11.27	>100

Verifica spostamento elastico dovuto ai soli carichi variabili (§4.2.4.2.1 - NTC 2008)

x	Comb.	δ_2	L/300.00	Cs
cm		mm	mm	
140.8	15	0.05	9.39	>100

Travata: 361 [301 , 295]

L = 281.6cm

Crit.Prog: Acciaio_Flessione $\delta_c = 0.0cm$ Verifica: **Verificata**

Verifica spostamento nello stato finale (§4.2.4.2.1 - NTC 2008)

x	Comb.	δ_{max}	L/250.00	Cs
---	-------	----------------	----------	----

AUTOSTRADA VALDASTICO A31 NORD
1° LOTTO - PIOVENE ROCCHETTE – VALLE DELL'ASTICO

x	Comb.	δ_{max}	L/250.00	Cs
cm		mm	mm	
140.8	15	0.09	11.27	>100

Verifica spostamento elastico dovuto ai soli carichi variabili (§4.2.4.2.1 - NTC 2008)

x	Comb.	δ_2	L/300.00	Cs
cm		mm	mm	
140.8	15	0.05	9.39	>100

Travata: 362 [313 , 296]

L = 286.0cm

Crit.Prog: Acciaio_Flessione $\delta_c = 0.0cm$ Verifica: **Verificata**

Verifica spostamento nello stato finale (§4.2.4.2.1 - NTC 2008)

x	Comb.	δ_{max}	L/250.00	Cs
cm		mm	mm	
143.0	15	0.19	11.44	59.3

Verifica spostamento elastico dovuto ai soli carichi variabili (§4.2.4.2.1 - NTC 2008)

x	Comb.	δ_2	L/300.00	Cs
cm		mm	mm	
171.6	15	0.09	9.53	>100

Travata: 363 [296 , 295]

L = 314.0cm

Crit.Prog: Acciaio_Flessione $\delta_c = 0.0cm$ Verifica: **Verificata**

Verifica spostamento nello stato finale (§4.2.4.2.1 - NTC 2008)

x	Comb.	δ_{max}	L/250.00	Cs
---	-------	----------------	----------	----

AUTOSTRADA VALDASTICO A31 NORD
1° LOTTO - PIOVENE ROCCHETTE – VALLE DELL'ASTICO

x	Comb.	δ_{max}	L/250.00	Cs
cm		mm	mm	
157.0	15	0.25	12.56	49.6

Verifica spostamento elastico dovuto ai soli carichi variabili (§4.2.4.2.1 - NTC 2008)

x	Comb.	δ_2	L/300.00	Cs
cm		mm	mm	
188.4	15	0.13	10.47	81.3

Travata: 364 [295 , 300]

L = 273.9cm

Crit.Prog: Acciaio_Flessione $\delta_c = 0.0cm$ Verifica: **Verificata**

Verifica spostamento nello stato finale (§4.2.4.2.1 - NTC 2008)

x	Comb.	δ_{max}	L/250.00	Cs
cm		mm	mm	
137.0	15	0.11	10.96	97.4

Verifica spostamento elastico dovuto ai soli carichi variabili (§4.2.4.2.1 - NTC 2008)

x	Comb.	δ_2	L/300.00	Cs
cm		mm	mm	
137.0	15	0.06	9.13	>100

Travata: 365 [300 , 313]

L = 273.9cm

Crit.Prog: Acciaio_Flessione $\delta_c = 0.0cm$ Verifica: **Verificata**

Verifica spostamento nello stato finale (§4.2.4.2.1 - NTC 2008)

x	Comb.	δ_{max}	L/250.00	Cs
---	-------	----------------	----------	----

AUTOSTRADA VALDASTICO A31 NORD
1° LOTTO - PIOVENE ROCCHETTE – VALLE DELL'ASTICO

x	Comb.	δ_{max}	L/250.00	Cs
cm		mm	mm	
137.0	15	0.17	10.96	62.6

Verifica spostamento elastico dovuto ai soli carichi variabili (§4.2.4.2.1 - NTC 2008)

x	Comb.	δ_2	L/300.00	Cs
cm		mm	mm	
137.0	15	0.10	9.13	94.0

Travata: 366 [312 , 300]

L = 273.9cm

Crit.Prog: Acciaio_Flessione $\delta_c = 0.0cm$ Verifica: **Verificata**

Verifica spostamento nello stato finale (§4.2.4.2.1 - NTC 2008)

x	Comb.	δ_{max}	L/250.00	Cs
cm		mm	mm	
137.0	15	0.06	10.96	>100

Verifica spostamento elastico dovuto ai soli carichi variabili (§4.2.4.2.1 - NTC 2008)

x	Comb.	δ_2	L/300.00	Cs
cm		mm	mm	
137.0	15	0.02	9.13	>100

Travata: 367 [300 , 296]

L = 273.9cm

Crit.Prog: Acciaio_Flessione $\delta_c = 0.0cm$ Verifica: **Verificata**

Verifica spostamento nello stato finale (§4.2.4.2.1 - NTC 2008)

x	Comb.	δ_{max}	L/250.00	Cs
---	-------	----------------	----------	----

AUTOSTRADA VALDASTICO A31 NORD
1° LOTTO - PIOVENE ROCCHETTE – VALLE DELL'ASTICO

x	Comb.	δ_{max}	L/250.00	Cs
cm		mm	mm	
137.0	15	0.07	10.96	>100

Verifica spostamento elastico dovuto ai soli carichi variabili (§4.2.4.2.1 - NTC 2008)

x	Comb.	δ_2	L/300.00	Cs
cm		mm	mm	
137.0	15	0.03	9.13	>100

Travata: 368 [296 , 297]

L = 314.0cm

Crit.Prog: Acciaio_Flessione $\delta_c = 0.0cm$ Verifica: **Verificata**

Verifica spostamento nello stato finale (§4.2.4.2.1 - NTC 2008)

x	Comb.	δ_{max}	L/250.00	Cs
cm		mm	mm	
125.6	21	0.04	12.56	>100

Verifica spostamento elastico dovuto ai soli carichi variabili (§4.2.4.2.1 - NTC 2008)

x	Comb.	δ_2	L/300.00	Cs
cm		mm	mm	
219.8	15	-0.02	10.47	>100

Travata: 369 [297 , 314]

L = 286.0cm

Crit.Prog: Acciaio_Flessione $\delta_c = 0.0cm$ Verifica: **Verificata**

Verifica spostamento nello stato finale (§4.2.4.2.1 - NTC 2008)

x	Comb.	δ_{max}	L/250.00	Cs
---	-------	----------------	----------	----

AUTOSTRADA VALDASTICO A31 NORD
1° LOTTO - PIOVENE ROCCHETTE – VALLE DELL'ASTICO

x	Comb.	δ_{max}	L/250.00	Cs
cm		mm	mm	
143.0	15	0.49	11.44	23.3

Verifica spostamento elastico dovuto ai soli carichi variabili (§4.2.4.2.1 - NTC 2008)

x	Comb.	δ_2	L/300.00	Cs
cm		mm	mm	
143.0	15	0.28	9.53	34.0

Travata: 370 [313 , 299]

L = 254.4cm

Crit.Prog: Acciaio_Flessione $\delta_c = 0.0cm$ Verifica: **Verificata**

Verifica spostamento nello stato finale (§4.2.4.2.1 - NTC 2008)

x	Comb.	δ_{max}	L/250.00	Cs
cm		mm	mm	
76.3	15	-0.03	10.17	>100

Verifica spostamento elastico dovuto ai soli carichi variabili (§4.2.4.2.1 - NTC 2008)

x	Comb.	δ_2	L/300.00	Cs
cm		mm	mm	
101.7	15	-0.03	8.48	>100

Travata: 371 [299 , 314]

L = 254.4cm

Crit.Prog: Acciaio_Flessione $\delta_c = 0.0cm$ Verifica: **Verificata**

Verifica spostamento nello stato finale (§4.2.4.2.1 - NTC 2008)

x	Comb.	δ_{max}	L/250.00	Cs
---	-------	----------------	----------	----

AUTOSTRADA VALDASTICO A31 NORD
1° LOTTO - PIOVENE ROCCHETTE – VALLE DELL'ASTICO

x	Comb.	δ_{max}	L/250.00	Cs
cm		mm	mm	
127.2	15	0.16	10.17	64.6

Verifica spostamento elastico dovuto ai soli carichi variabili (§4.2.4.2.1 - NTC 2008)

x	Comb.	δ_2	L/300.00	Cs
cm		mm	mm	
127.2	15	0.09	8.48	95.4

Travata: 372 [296 , 299]

L = 254.4cm

Crit.Prog: Acciaio_Flessione $\delta_c = 0.0cm$ Verifica: **Verificata**

Verifica spostamento nello stato finale (§4.2.4.2.1 - NTC 2008)

x	Comb.	δ_{max}	L/250.00	Cs
cm		mm	mm	
127.2	15	0.12	10.17	82.6

Verifica spostamento elastico dovuto ai soli carichi variabili (§4.2.4.2.1 - NTC 2008)

x	Comb.	δ_2	L/300.00	Cs
cm		mm	mm	
127.2	15	0.07	8.48	>100

Travata: 373 [299 , 297]

L = 254.4cm

Crit.Prog: Acciaio_Flessione $\delta_c = 0.0cm$ Verifica: **Verificata**

Verifica spostamento nello stato finale (§4.2.4.2.1 - NTC 2008)

x	Comb.	δ_{max}	L/250.00	Cs
---	-------	----------------	----------	----

AUTOSTRADA VALDASTICO A31 NORD
1° LOTTO - PIOVENE ROCCHETTE – VALLE DELL'ASTICO

x	Comb.	δ_{max}	L/250.00	Cs
cm		mm	mm	
127.2	15	0.05	10.17	>100

Verifica spostamento elastico dovuto ai soli carichi variabili (§4.2.4.2.1 - NTC 2008)

x	Comb.	δ_2	L/300.00	Cs
cm		mm	mm	
101.7	15	0.02	8.48	>100

Travata: 374 [315 , 298]

L = 286.0cm

Crit.Prog: Acciaio_Flessione $\delta_c = 0.0cm$ Verifica: **Verificata**

Verifica spostamento nello stato finale (§4.2.4.2.1 - NTC 2008)

x	Comb.	δ_{max}	L/250.00	Cs
cm		mm	mm	
143.0	15	0.31	11.44	36.5

Verifica spostamento elastico dovuto ai soli carichi variabili (§4.2.4.2.1 - NTC 2008)

x	Comb.	δ_2	L/300.00	Cs
cm		mm	mm	
171.6	15	0.17	9.53	54.9

Travata: 375 [298 , 297]

L = 314.0cm

Crit.Prog: Acciaio_Flessione $\delta_c = 0.0cm$ Verifica: **Verificata**

Verifica spostamento nello stato finale (§4.2.4.2.1 - NTC 2008)

x	Comb.	δ_{max}	L/250.00	Cs
---	-------	----------------	----------	----

AUTOSTRADA VALDASTICO A31 NORD
1° LOTTO - PIOVENE ROCCHETTE – VALLE DELL'ASTICO

x	Comb.	δ_{max}	L/250.00	Cs
cm		mm	mm	
62.8	15	-0.04	12.56	>100

Verifica spostamento elastico dovuto ai soli carichi variabili (§4.2.4.2.1 - NTC 2008)

x	Comb.	δ_2	L/300.00	Cs
cm		mm	mm	
125.6	15	-0.07	10.47	>100

Travata: 376 [314 , 306]

L = 229.9cm

Crit.Prog: Acciaio_Flessione $\delta_c = 0.0cm$ Verifica: **Verificata**

Verifica spostamento nello stato finale (§4.2.4.2.1 - NTC 2008)

x	Comb.	δ_{max}	L/250.00	Cs
cm		mm	mm	
137.9	15	0.14	9.19	64.5

Verifica spostamento elastico dovuto ai soli carichi variabili (§4.2.4.2.1 - NTC 2008)

x	Comb.	δ_2	L/300.00	Cs
cm		mm	mm	
137.9	15	0.09	7.66	83.3

Travata: 377 [306 , 298]

L = 229.9cm

Crit.Prog: Acciaio_Flessione $\delta_c = 0.0cm$ Verifica: **Verificata**

Verifica spostamento nello stato finale (§4.2.4.2.1 - NTC 2008)

x	Comb.	δ_{max}	L/250.00	Cs
---	-------	----------------	----------	----

AUTOSTRADA VALDASTICO A31 NORD
1° LOTTO - PIOVENE ROCCHETTE – VALLE DELL'ASTICO

x	Comb.	δ_{max}	L/250.00	Cs
cm		mm	mm	
137.9	15	0.04	9.19	>100

Verifica spostamento elastico dovuto ai soli carichi variabili (§4.2.4.2.1 - NTC 2008)

x	Comb.	δ_2	L/300.00	Cs
cm		mm	mm	
183.9	15	0.01	7.66	>100

Travata: 378 [306 , 315]

L = 229.9cm

Crit.Prog: Acciaio_Flessione $\delta_c = 0.0cm$ Verifica: **Verificata**

Verifica spostamento nello stato finale (§4.2.4.2.1 - NTC 2008)

x	Comb.	δ_{max}	L/250.00	Cs
cm		mm	mm	
114.9	15	-0.08	9.19	>100

Verifica spostamento elastico dovuto ai soli carichi variabili (§4.2.4.2.1 - NTC 2008)

x	Comb.	δ_2	L/300.00	Cs
cm		mm	mm	
114.9	15	-0.07	7.66	>100

Travata: 379 [305 , 304]

L = 318.3cm

Crit.Prog: Acciaio_Flessione $\delta_c = 0.0cm$ Verifica: **Verificata**

Verifica spostamento nello stato finale (§4.2.4.2.1 - NTC 2008)

x	Comb.	δ_{max}	L/250.00	Cs
---	-------	----------------	----------	----

AUTOSTRADA VALDASTICO A31 NORD
1° LOTTO - PIOVENE ROCCHETTE – VALLE DELL'ASTICO

x	Comb.	δ_{max}	L/250.00	Cs
cm		mm	mm	
159.1	15	2.48	12.73	5.13

Verifica spostamento elastico dovuto ai soli carichi variabili (§4.2.4.2.1 - NTC 2008)

x	Comb.	δ_2	L/300.00	Cs
cm		mm	mm	
159.1	15	1.85	10.61	5.74

Travata: 380 [304 , 303]

L = 315.7cm

Crit.Prog: Acciaio_Flessione $\delta_c = 0.0cm$ Verifica: **Verificata**

Verifica spostamento nello stato finale (§4.2.4.2.1 - NTC 2008)

x	Comb.	δ_{max}	L/250.00	Cs
cm		mm	mm	
157.9	15	2.56	12.63	4.94

Verifica spostamento elastico dovuto ai soli carichi variabili (§4.2.4.2.1 - NTC 2008)

x	Comb.	δ_2	L/300.00	Cs
cm		mm	mm	
157.9	15	1.87	10.52	5.62

Travata: 381 [303 , 302]

L = 314.2cm

Crit.Prog: Acciaio_Flessione $\delta_c = 0.0cm$ Verifica: **Verificata**

Verifica spostamento nello stato finale (§4.2.4.2.1 - NTC 2008)

x	Comb.	δ_{max}	L/250.00	Cs
---	-------	----------------	----------	----

AUTOSTRADA VALDASTICO A31 NORD
1° LOTTO - PIOVENE ROCCHETTE – VALLE DELL'ASTICO

x	Comb.	δ_{max}	L/250.00	Cs
cm		mm	mm	
157.1	15	2.70	12.57	4.65

Verifica spostamento elastico dovuto ai soli carichi variabili (§4.2.4.2.1 - NTC 2008)

x	Comb.	δ_2	L/300.00	Cs
cm		mm	mm	
157.1	15	1.96	10.47	5.34

Travata: 382 [302 , 301]

L = 314.0cm

Crit.Prog: Acciaio_Flessione $\delta_c = 0.0cm$ Verifica: **Verificata**

Verifica spostamento nello stato finale (§4.2.4.2.1 - NTC 2008)

x	Comb.	δ_{max}	L/250.00	Cs
cm		mm	mm	
157.0	15	2.75	12.56	4.56

Verifica spostamento elastico dovuto ai soli carichi variabili (§4.2.4.2.1 - NTC 2008)

x	Comb.	δ_2	L/300.00	Cs
cm		mm	mm	
157.0	15	2.00	10.47	5.25

Travata: 383 [301 , 300]

L = 314.2cm

Crit.Prog: Acciaio_Flessione $\delta_c = 0.0cm$ Verifica: **Verificata**

Verifica spostamento nello stato finale (§4.2.4.2.1 - NTC 2008)

x	Comb.	δ_{max}	L/250.00	Cs
---	-------	----------------	----------	----

AUTOSTRADA VALDASTICO A31 NORD
1° LOTTO - PIOVENE ROCCHETTE – VALLE DELL'ASTICO

x	Comb.	δ_{max}	L/250.00	Cs
cm		mm	mm	
157.1	15	2.70	12.57	4.66

Verifica spostamento elastico dovuto ai soli carichi variabili (§4.2.4.2.1 - NTC 2008)

x	Comb.	δ_2	L/300.00	Cs
cm		mm	mm	
157.1	15	1.96	10.47	5.34

Travata: 384 [300 , 299]

L = 315.7cm

Crit.Prog: Acciaio_Flessione $\delta_c = 0.0cm$ Verifica: **Verificata**

Verifica spostamento nello stato finale (§4.2.4.2.1 - NTC 2008)

x	Comb.	δ_{max}	L/250.00	Cs
cm		mm	mm	
157.9	15	2.55	12.63	4.95

Verifica spostamento elastico dovuto ai soli carichi variabili (§4.2.4.2.1 - NTC 2008)

x	Comb.	δ_2	L/300.00	Cs
cm		mm	mm	
157.9	15	1.87	10.52	5.63

Travata: 385 [299 , 306]

L = 318.3cm

Crit.Prog: Acciaio_Flessione $\delta_c = 0.0cm$ Verifica: **Verificata**

Verifica spostamento nello stato finale (§4.2.4.2.1 - NTC 2008)

x	Comb.	δ_{max}	L/250.00	Cs
---	-------	----------------	----------	----

AUTOSTRADA VALDASTICO A31 NORD
1° LOTTO - PIOVENE ROCCHETTE – VALLE DELL'ASTICO

x	Comb.	δ_{max}	L/250.00	Cs
cm		mm	mm	
159.1	15	2.48	12.73	5.14

Verifica spostamento elastico dovuto ai soli carichi variabili (§4.2.4.2.1 - NTC 2008)

x	Comb.	δ_2	L/300.00	Cs
cm		mm	mm	
159.1	15	1.85	10.61	5.74

Travata: 386 [324 , 331]

L = 229.9cm

Crit.Prog: Acciaio_Flessione $\delta_c = 0.0cm$ Verifica: **Verificata**

Verifica spostamento nello stato finale (§4.2.4.2.1 - NTC 2008)

x	Comb.	δ_{max}	L/250.00	Cs
cm		mm	mm	
114.9	15	-0.35	9.19	26.4

Verifica spostamento elastico dovuto ai soli carichi variabili (§4.2.4.2.1 - NTC 2008)

x	Comb.	δ_2	L/300.00	Cs
cm		mm	mm	
114.9	15	-0.26	7.66	29.1

Travata: 387 [334 , 323]

L = 286.0cm

Crit.Prog: Acciaio_Flessione $\delta_c = 0.0cm$ Verifica: **Verificata**

Verifica spostamento nello stato finale (§4.2.4.2.1 - NTC 2008)

x	Comb.	δ_{max}	L/250.00	Cs
---	-------	----------------	----------	----

AUTOSTRADA VALDASTICO A31 NORD
1° LOTTO - PIOVENE ROCCHETTE – VALLE DELL'ASTICO

x	Comb.	δ_{max}	L/250.00	Cs
cm		mm	mm	
200.2	15	-0.58	11.44	19.6

Verifica spostamento elastico dovuto ai soli carichi variabili (§4.2.4.2.1 - NTC 2008)

x	Comb.	δ_2	L/300.00	Cs
cm		mm	mm	
200.2	15	-0.39	9.53	24.4

Travata: 388 [323 , 324]

L = 314.0cm

Crit.Prog: Acciaio_Flessione $\delta_c = 0.0cm$ Verifica: **Verificata**

Verifica spostamento nello stato finale (§4.2.4.2.1 - NTC 2008)

x	Comb.	δ_{max}	L/250.00	Cs
cm		mm	mm	
125.6	15	0.08	12.56	>100

Verifica spostamento elastico dovuto ai soli carichi variabili (§4.2.4.2.1 - NTC 2008)

x	Comb.	δ_2	L/300.00	Cs
cm		mm	mm	
62.8	15	0.05	10.47	>100

Travata: 389 [333 , 331]

L = 229.9cm

Crit.Prog: Acciaio_Flessione $\delta_c = 0.0cm$ Verifica: **Verificata**

Verifica spostamento nello stato finale (§4.2.4.2.1 - NTC 2008)

x	Comb.	δ_{max}	L/250.00	Cs
---	-------	----------------	----------	----

AUTOSTRADA VALDASTICO A31 NORD
1° LOTTO - PIOVENE ROCCHETTE – VALLE DELL'ASTICO

x	Comb.	δ_{max}	L/250.00	Cs
cm		mm	mm	
183.9	15	-0.04	9.19	>100

Verifica spostamento elastico dovuto ai soli carichi variabili (§4.2.4.2.1 - NTC 2008)

x	Comb.	δ_2	L/300.00	Cs
cm		mm	mm	
160.9	15	-0.04	7.66	>100

Travata: 390 [331 , 323]

L = 229.9cm

Crit.Prog: Acciaio_Flessione $\delta_c = 0.0cm$ Verifica: **Verificata**

Verifica spostamento nello stato finale (§4.2.4.2.1 - NTC 2008)

x	Comb.	δ_{max}	L/250.00	Cs
cm		mm	mm	
69.0	15	0.11	9.19	82.6

Verifica spostamento elastico dovuto ai soli carichi variabili (§4.2.4.2.1 - NTC 2008)

x	Comb.	δ_2	L/300.00	Cs
cm		mm	mm	
69.0	15	0.08	7.66	93.9

Travata: 391 [331 , 334]

L = 229.9cm

Crit.Prog: Acciaio_Flessione $\delta_c = 0.0cm$ Verifica: **Verificata**

Verifica spostamento nello stato finale (§4.2.4.2.1 - NTC 2008)

x	Comb.	δ_{max}	L/250.00	Cs
---	-------	----------------	----------	----

AUTOSTRADA VALDASTICO A31 NORD
1° LOTTO - PIOVENE ROCCHETTE – VALLE DELL'ASTICO

x	Comb.	δ_{max}	L/250.00	Cs
cm		mm	mm	
91.9	15	-0.12	9.19	75.1

Verifica spostamento elastico dovuto ai soli carichi variabili (§4.2.4.2.1 - NTC 2008)

x	Comb.	δ_2	L/300.00	Cs
cm		mm	mm	
114.9	15	-0.07	7.66	>100

Travata: 392 [333 , 324]

L = 286.0cm

Crit.Prog: Acciaio_Flessione $\delta_c = 0.0cm$ Verifica: **Verificata**

Verifica spostamento nello stato finale (§4.2.4.2.1 - NTC 2008)

x	Comb.	δ_{max}	L/250.00	Cs
cm		mm	mm	
171.6	15	-0.25	11.44	45.7

Verifica spostamento elastico dovuto ai soli carichi variabili (§4.2.4.2.1 - NTC 2008)

x	Comb.	δ_2	L/300.00	Cs
cm		mm	mm	
171.6	15	-0.20	9.53	48.8

Travata: 393 [335 , 322]

L = 286.0cm

Crit.Prog: Acciaio_Flessione $\delta_c = 0.0cm$ Verifica: **Verificata**

Verifica spostamento nello stato finale (§4.2.4.2.1 - NTC 2008)

x	Comb.	δ_{max}	L/250.00	Cs
---	-------	----------------	----------	----

AUTOSTRADA VALDASTICO A31 NORD
1° LOTTO - PIOVENE ROCCHETTE – VALLE DELL'ASTICO

x	Comb.	δ_{max}	L/250.00	Cs
cm		mm	mm	
200.2	15	-0.10	11.44	>100

Verifica spostamento elastico dovuto ai soli carichi variabili (§4.2.4.2.1 - NTC 2008)

x	Comb.	δ_2	L/300.00	Cs
cm		mm	mm	
171.6	15	-0.08	9.53	>100

Travata: 394 [322 , 323]

L = 314.0cm

Crit.Prog: Acciaio_Flessione $\delta_c = 0.0cm$ Verifica: **Verificata**

Verifica spostamento nello stato finale (§4.2.4.2.1 - NTC 2008)

x	Comb.	δ_{max}	L/250.00	Cs
cm		mm	mm	
219.8	15	-1.24	12.56	10.2

Verifica spostamento elastico dovuto ai soli carichi variabili (§4.2.4.2.1 - NTC 2008)

x	Comb.	δ_2	L/300.00	Cs
cm		mm	mm	
219.8	15	-0.84	10.47	12.4

Travata: 395 [323 , 330]

L = 254.4cm

Crit.Prog: Acciaio_Flessione $\delta_c = 0.0cm$ Verifica: **Verificata**

Verifica spostamento nello stato finale (§4.2.4.2.1 - NTC 2008)

x	Comb.	δ_{max}	L/250.00	Cs
---	-------	----------------	----------	----

AUTOSTRADA VALDASTICO A31 NORD
1° LOTTO - PIOVENE ROCCHETTE – VALLE DELL'ASTICO

x	Comb.	δ_{max}	L/250.00	Cs
cm		mm	mm	
76.3	15	-0.75	10.17	13.6

Verifica spostamento elastico dovuto ai soli carichi variabili (§4.2.4.2.1 - NTC 2008)

x	Comb.	δ_2	L/300.00	Cs
cm		mm	mm	
76.3	15	-0.50	8.48	17.0

Travata: 396 [330 , 335]

L = 254.4cm

Crit.Prog: Acciaio_Flessione $\delta_c = 0.0cm$ Verifica: **Verificata**

Verifica spostamento nello stato finale (§4.2.4.2.1 - NTC 2008)

x	Comb.	δ_{max}	L/250.00	Cs
cm		mm	mm	
127.2	15	0.24	10.17	42.5

Verifica spostamento elastico dovuto ai soli carichi variabili (§4.2.4.2.1 - NTC 2008)

x	Comb.	δ_2	L/300.00	Cs
cm		mm	mm	
127.2	15	0.14	8.48	58.8

Travata: 397 [334 , 330]

L = 254.4cm

Crit.Prog: Acciaio_Flessione $\delta_c = 0.0cm$ Verifica: **Verificata**

Verifica spostamento nello stato finale (§4.2.4.2.1 - NTC 2008)

x	Comb.	δ_{max}	L/250.00	Cs
---	-------	----------------	----------	----

AUTOSTRADA VALDASTICO A31 NORD
1° LOTTO - PIOVENE ROCCHETTE – VALLE DELL'ASTICO

x	Comb.	δ_{max}	L/250.00	Cs
cm		mm	mm	
127.2	15	-0.23	10.17	44.3

Verifica spostamento elastico dovuto ai soli carichi variabili (§4.2.4.2.1 - NTC 2008)

x	Comb.	δ_2	L/300.00	Cs
cm		mm	mm	
127.2	15	-0.16	8.48	53.6

Travata: 398 [330 , 322]

L = 254.4cm

Crit.Prog: Acciaio_Flessione $\delta_c = 0.0cm$ Verifica: **Verificata**

Verifica spostamento nello stato finale (§4.2.4.2.1 - NTC 2008)

x	Comb.	δ_{max}	L/250.00	Cs
cm		mm	mm	
127.2	15	-0.15	10.17	69.2

Verifica spostamento elastico dovuto ai soli carichi variabili (§4.2.4.2.1 - NTC 2008)

x	Comb.	δ_2	L/300.00	Cs
cm		mm	mm	
127.2	15	-0.11	8.48	78.9

Travata: 399 [336 , 321]

L = 286.0cm

Crit.Prog: Acciaio_Flessione $\delta_c = 0.0cm$ Verifica: **Verificata**

Verifica spostamento nello stato finale (§4.2.4.2.1 - NTC 2008)

x	Comb.	δ_{max}	L/250.00	Cs
---	-------	----------------	----------	----

AUTOSTRADA VALDASTICO A31 NORD
1° LOTTO - PIOVENE ROCCHETTE – VALLE DELL'ASTICO

x	Comb.	δ_{max}	L/250.00	Cs
cm		mm	mm	
143.0	15	0.05	11.44	>100

Verifica spostamento elastico dovuto ai soli carichi variabili (§4.2.4.2.1 - NTC 2008)

x	Comb.	δ_2	L/300.00	Cs
cm		mm	mm	
114.4	15	0.01	9.53	>100

Travata: 400 [321 , 322]

L = 314.0cm

Crit.Prog: Acciaio_Flessione $\delta_c = 0.0cm$ Verifica: **Verificata**

Verifica spostamento nello stato finale (§4.2.4.2.1 - NTC 2008)

x	Comb.	δ_{max}	L/250.00	Cs
cm		mm	mm	
157.0	15	0.59	12.56	21.2

Verifica spostamento elastico dovuto ai soli carichi variabili (§4.2.4.2.1 - NTC 2008)

x	Comb.	δ_2	L/300.00	Cs
cm		mm	mm	
157.0	15	0.34	10.47	30.6

Travata: 401 [335 , 329]

L = 273.9cm

Crit.Prog: Acciaio_Flessione $\delta_c = 0.0cm$ Verifica: **Verificata**

Verifica spostamento nello stato finale (§4.2.4.2.1 - NTC 2008)

x	Comb.	δ_{max}	L/250.00	Cs
---	-------	----------------	----------	----

AUTOSTRADA VALDASTICO A31 NORD
1° LOTTO - PIOVENE ROCCHETTE – VALLE DELL'ASTICO

x	Comb.	δ_{max}	L/250.00	Cs
cm		mm	mm	
137.0	21	0.02	10.96	>100

Verifica spostamento elastico dovuto ai soli carichi variabili (§4.2.4.2.1 - NTC 2008)

x	Comb.	δ_2	L/300.00	Cs
cm		mm	mm	
82.2	15	-0.01	9.13	>100

Travata: 402 [329 , 321]

L = 273.9cm

Crit.Prog: Acciaio_Flessione $\delta_c = 0.0cm$ Verifica: **Verificata**

Verifica spostamento nello stato finale (§4.2.4.2.1 - NTC 2008)

x	Comb.	δ_{max}	L/250.00	Cs
cm		mm	mm	
137.0	15	0.09	10.96	>100

Verifica spostamento elastico dovuto ai soli carichi variabili (§4.2.4.2.1 - NTC 2008)

x	Comb.	δ_2	L/300.00	Cs
cm		mm	mm	
164.3	15	0.04	9.13	>100

Travata: 403 [322 , 329]

L = 273.9cm

Crit.Prog: Acciaio_Flessione $\delta_c = 0.0cm$ Verifica: **Verificata**

Verifica spostamento nello stato finale (§4.2.4.2.1 - NTC 2008)

x	Comb.	δ_{max}	L/250.00	Cs
---	-------	----------------	----------	----

AUTOSTRADA VALDASTICO A31 NORD
1° LOTTO - PIOVENE ROCCHETTE – VALLE DELL'ASTICO

x	Comb.	δ_{max}	L/250.00	Cs
cm		mm	mm	
109.6	15	0.19	10.96	58.4

Verifica spostamento elastico dovuto ai soli carichi variabili (§4.2.4.2.1 - NTC 2008)

x	Comb.	δ_2	L/300.00	Cs
cm		mm	mm	
109.6	15	0.11	9.13	83.2

Travata: 404 [329 , 336]

L = 273.9cm

Crit.Prog: Acciaio_Flessione $\delta_c = 0.0cm$ Verifica: **Verificata**

Verifica spostamento nello stato finale (§4.2.4.2.1 - NTC 2008)

x	Comb.	δ_{max}	L/250.00	Cs
cm		mm	mm	
137.0	15	0.14	10.96	76.0

Verifica spostamento elastico dovuto ai soli carichi variabili (§4.2.4.2.1 - NTC 2008)

x	Comb.	δ_2	L/300.00	Cs
cm		mm	mm	
137.0	15	0.08	9.13	>100

Travata: 405 [337 , 320]

L = 286.0cm

Crit.Prog: Acciaio_Flessione $\delta_c = 0.0cm$ Verifica: **Verificata**

Verifica spostamento nello stato finale (§4.2.4.2.1 - NTC 2008)

x	Comb.	δ_{max}	L/250.00	Cs
---	-------	----------------	----------	----

AUTOSTRADA VALDASTICO A31 NORD
1° LOTTO - PIOVENE ROCCHETTE – VALLE DELL'ASTICO

x	Comb.	δ_{max}	L/250.00	Cs
cm		mm	mm	
143.0	15	0.08	11.44	>100

Verifica spostamento elastico dovuto ai soli carichi variabili (§4.2.4.2.1 - NTC 2008)

x	Comb.	δ_2	L/300.00	Cs
cm		mm	mm	
143.0	15	0.03	9.53	>100

Travata: 406 [320 , 321]

L = 314.0cm

Crit.Prog: Acciaio_Flessione $\delta_c = 0.0cm$ Verifica: **Verificata**

Verifica spostamento nello stato finale (§4.2.4.2.1 - NTC 2008)

x	Comb.	δ_{max}	L/250.00	Cs
cm		mm	mm	
157.0	15	0.46	12.56	27.4

Verifica spostamento elastico dovuto ai soli carichi variabili (§4.2.4.2.1 - NTC 2008)

x	Comb.	δ_2	L/300.00	Cs
cm		mm	mm	
157.0	15	0.25	10.47	41.2

Travata: 407 [336 , 328]

L = 281.6cm

Crit.Prog: Acciaio_Flessione $\delta_c = 0.0cm$ Verifica: **Verificata**

Verifica spostamento nello stato finale (§4.2.4.2.1 - NTC 2008)

x	Comb.	δ_{max}	L/250.00	Cs
---	-------	----------------	----------	----

AUTOSTRADA VALDASTICO A31 NORD
1° LOTTO - PIOVENE ROCCHETTE – VALLE DELL'ASTICO

x	Comb.	δ_{max}	L/250.00	Cs
cm		mm	mm	
140.8	15	0.10	11.27	>100

Verifica spostamento elastico dovuto ai soli carichi variabili (§4.2.4.2.1 - NTC 2008)

x	Comb.	δ_2	L/300.00	Cs
cm		mm	mm	
140.8	15	0.05	9.39	>100

Travata: 408 [328 , 337]

L = 281.6cm

Crit.Prog: Acciaio_Flessione $\delta_c = 0.0cm$ Verifica: **Verificata**

Verifica spostamento nello stato finale (§4.2.4.2.1 - NTC 2008)

x	Comb.	δ_{max}	L/250.00	Cs
cm		mm	mm	
140.8	15	0.13	11.27	85.5

Verifica spostamento elastico dovuto ai soli carichi variabili (§4.2.4.2.1 - NTC 2008)

x	Comb.	δ_2	L/300.00	Cs
cm		mm	mm	
140.8	15	0.07	9.39	>100

Travata: 409 [321 , 328]

L = 281.6cm

Crit.Prog: Acciaio_Flessione $\delta_c = 0.0cm$ Verifica: **Verificata**

Verifica spostamento nello stato finale (§4.2.4.2.1 - NTC 2008)

x	Comb.	δ_{max}	L/250.00	Cs
---	-------	----------------	----------	----

AUTOSTRADA VALDASTICO A31 NORD
1° LOTTO - PIOVENE ROCCHETTE – VALLE DELL'ASTICO

x	Comb.	δ_{max}	L/250.00	Cs
cm		mm	mm	
140.8	15	0.13	11.27	86.2

Verifica spostamento elastico dovuto ai soli carichi variabili (§4.2.4.2.1 - NTC 2008)

x	Comb.	δ_2	L/300.00	Cs
cm		mm	mm	
140.8	15	0.07	9.39	>100

Travata: 410 [328 , 320]

L = 281.6cm

Crit.Prog: Acciaio_Flessione $\delta_c = 0.0cm$ Verifica: **Verificata**

Verifica spostamento nello stato finale (§4.2.4.2.1 - NTC 2008)

x	Comb.	δ_{max}	L/250.00	Cs
cm		mm	mm	
140.8	15	0.13	11.27	86.9

Verifica spostamento elastico dovuto ai soli carichi variabili (§4.2.4.2.1 - NTC 2008)

x	Comb.	δ_2	L/300.00	Cs
cm		mm	mm	
140.8	15	0.07	9.39	>100

Travata: 411 [320 , 327]

L = 281.6cm

Crit.Prog: Acciaio_Flessione $\delta_c = 0.0cm$ Verifica: **Verificata**

Verifica spostamento nello stato finale (§4.2.4.2.1 - NTC 2008)

x	Comb.	δ_{max}	L/250.00	Cs
---	-------	----------------	----------	----

AUTOSTRADA VALDASTICO A31 NORD
1° LOTTO - PIOVENE ROCCHETTE – VALLE DELL'ASTICO

x	Comb.	δ_{max}	L/250.00	Cs
cm		mm	mm	
140.8	15	0.13	11.27	87.0

Verifica spostamento elastico dovuto ai soli carichi variabili (§4.2.4.2.1 - NTC 2008)

x	Comb.	δ_2	L/300.00	Cs
cm		mm	mm	
140.8	15	0.07	9.39	>100

Travata: 412 [327 , 338]

L = 281.6cm

Crit.Prog: Acciaio_Flessione $\delta_c = 0.0cm$ Verifica: **Verificata**

Verifica spostamento nello stato finale (§4.2.4.2.1 - NTC 2008)

x	Comb.	δ_{max}	L/250.00	Cs
cm		mm	mm	
140.8	15	0.10	11.27	>100

Verifica spostamento elastico dovuto ai soli carichi variabili (§4.2.4.2.1 - NTC 2008)

x	Comb.	δ_2	L/300.00	Cs
cm		mm	mm	
140.8	15	0.05	9.39	>100

Travata: 413 [338 , 319]

L = 286.0cm

Crit.Prog: Acciaio_Flessione $\delta_c = 0.0cm$ Verifica: **Verificata**

Verifica spostamento nello stato finale (§4.2.4.2.1 - NTC 2008)

x	Comb.	δ_{max}	L/250.00	Cs
---	-------	----------------	----------	----

AUTOSTRADA VALDASTICO A31 NORD
1° LOTTO - PIOVENE ROCCHETTE – VALLE DELL'ASTICO

x	Comb.	δ_{max}	L/250.00	Cs
cm		mm	mm	
143.0	15	0.05	11.44	>100

Verifica spostamento elastico dovuto ai soli carichi variabili (§4.2.4.2.1 - NTC 2008)

x	Comb.	δ_2	L/300.00	Cs
cm		mm	mm	
114.4	15	0.01	9.53	>100

Travata: 414 [319 , 320]

L = 314.0cm

Crit.Prog: Acciaio_Flessione $\delta_c = 0.0cm$ Verifica: **Verificata**

Verifica spostamento nello stato finale (§4.2.4.2.1 - NTC 2008)

x	Comb.	δ_{max}	L/250.00	Cs
cm		mm	mm	
157.0	15	0.46	12.56	27.4

Verifica spostamento elastico dovuto ai soli carichi variabili (§4.2.4.2.1 - NTC 2008)

x	Comb.	δ_2	L/300.00	Cs
cm		mm	mm	
157.0	15	0.25	10.47	41.2

Travata: 415 [337 , 327]

L = 281.6cm

Crit.Prog: Acciaio_Flessione $\delta_c = 0.0cm$ Verifica: **Verificata**

Verifica spostamento nello stato finale (§4.2.4.2.1 - NTC 2008)

x	Comb.	δ_{max}	L/250.00	Cs
---	-------	----------------	----------	----

AUTOSTRADA VALDASTICO A31 NORD
1° LOTTO - PIOVENE ROCCHETTE – VALLE DELL'ASTICO

x	Comb.	δ_{max}	L/250.00	Cs
cm		mm	mm	
140.8	15	0.13	11.27	85.4

Verifica spostamento elastico dovuto ai soli carichi variabili (§4.2.4.2.1 - NTC 2008)

x	Comb.	δ_2	L/300.00	Cs
cm		mm	mm	
140.8	15	0.07	9.39	>100

Travata: 416 [327 , 319]

L = 281.6cm

Crit.Prog: Acciaio_Flessione $\delta_c = 0.0cm$ Verifica: **Verificata**

Verifica spostamento nello stato finale (§4.2.4.2.1 - NTC 2008)

x	Comb.	δ_{max}	L/250.00	Cs
cm		mm	mm	
140.8	15	0.13	11.27	86.4

Verifica spostamento elastico dovuto ai soli carichi variabili (§4.2.4.2.1 - NTC 2008)

x	Comb.	δ_2	L/300.00	Cs
cm		mm	mm	
140.8	15	0.07	9.39	>100

Travata: 417 [339 , 318]

L = 286.0cm

Crit.Prog: Acciaio_Flessione $\delta_c = 0.0cm$ Verifica: **Verificata**

Verifica spostamento nello stato finale (§4.2.4.2.1 - NTC 2008)

x	Comb.	δ_{max}	L/250.00	Cs
---	-------	----------------	----------	----

AUTOSTRADA VALDASTICO A31 NORD
1° LOTTO - PIOVENE ROCCHETTE – VALLE DELL'ASTICO

x	Comb.	δ_{max}	L/250.00	Cs
cm		mm	mm	
200.2	15	-0.10	11.44	>100

Verifica spostamento elastico dovuto ai soli carichi variabili (§4.2.4.2.1 - NTC 2008)

x	Comb.	δ_2	L/300.00	Cs
cm		mm	mm	
171.6	15	-0.08	9.53	>100

Travata: 418 [318 , 319]

L = 314.0cm

Crit.Prog: Acciaio_Flessione $\delta_c = 0.0cm$ Verifica: **Verificata**

Verifica spostamento nello stato finale (§4.2.4.2.1 - NTC 2008)

x	Comb.	δ_{max}	L/250.00	Cs
cm		mm	mm	
157.0	15	0.59	12.56	21.1

Verifica spostamento elastico dovuto ai soli carichi variabili (§4.2.4.2.1 - NTC 2008)

x	Comb.	δ_2	L/300.00	Cs
cm		mm	mm	
157.0	15	0.34	10.47	30.6

Travata: 419 [319 , 326]

L = 273.9cm

Crit.Prog: Acciaio_Flessione $\delta_c = 0.0cm$ Verifica: **Verificata**

Verifica spostamento nello stato finale (§4.2.4.2.1 - NTC 2008)

x	Comb.	δ_{max}	L/250.00	Cs
---	-------	----------------	----------	----

AUTOSTRADA VALDASTICO A31 NORD
1° LOTTO - PIOVENE ROCCHETTE – VALLE DELL'ASTICO

x	Comb.	δ_{max}	L/250.00	Cs
cm		mm	mm	
137.0	15	0.09	10.96	>100

Verifica spostamento elastico dovuto ai soli carichi variabili (§4.2.4.2.1 - NTC 2008)

x	Comb.	δ_2	L/300.00	Cs
cm		mm	mm	
109.6	15	0.04	9.13	>100

Travata: 420 [326 , 339]

L = 273.9cm

Crit.Prog: Acciaio_Flessione $\delta_c = 0.0cm$ Verifica: **Verificata**

Verifica spostamento nello stato finale (§4.2.4.2.1 - NTC 2008)

x	Comb.	δ_{max}	L/250.00	Cs
cm		mm	mm	
137.0	21	0.02	10.96	>100

Verifica spostamento elastico dovuto ai soli carichi variabili (§4.2.4.2.1 - NTC 2008)

x	Comb.	δ_2	L/300.00	Cs
cm		mm	mm	
191.7	15	-0.01	9.13	>100

Travata: 421 [338 , 326]

L = 273.9cm

Crit.Prog: Acciaio_Flessione $\delta_c = 0.0cm$ Verifica: **Verificata**

Verifica spostamento nello stato finale (§4.2.4.2.1 - NTC 2008)

x	Comb.	δ_{max}	L/250.00	Cs
---	-------	----------------	----------	----

AUTOSTRADA VALDASTICO A31 NORD
1° LOTTO - PIOVENE ROCCHETTE – VALLE DELL'ASTICO

x	Comb.	δ_{max}	L/250.00	Cs
cm		mm	mm	
137.0	15	0.14	10.96	76.2

Verifica spostamento elastico dovuto ai soli carichi variabili (§4.2.4.2.1 - NTC 2008)

x	Comb.	δ_2	L/300.00	Cs
cm		mm	mm	
137.0	15	0.08	9.13	>100

Travata: 422 [326 , 318]

L = 273.9cm

Crit.Prog: Acciaio_Flessione $\delta_c = 0.0cm$ Verifica: **Verificata**

Verifica spostamento nello stato finale (§4.2.4.2.1 - NTC 2008)

x	Comb.	δ_{max}	L/250.00	Cs
cm		mm	mm	
164.3	15	0.19	10.96	58.0

Verifica spostamento elastico dovuto ai soli carichi variabili (§4.2.4.2.1 - NTC 2008)

x	Comb.	δ_2	L/300.00	Cs
cm		mm	mm	
164.3	15	0.11	9.13	82.9

Travata: 423 [318 , 317]

L = 314.0cm

Crit.Prog: Acciaio_Flessione $\delta_c = 0.0cm$ Verifica: **Verificata**

Verifica spostamento nello stato finale (§4.2.4.2.1 - NTC 2008)

x	Comb.	δ_{max}	L/250.00	Cs
---	-------	----------------	----------	----

AUTOSTRADA VALDASTICO A31 NORD
1° LOTTO - PIOVENE ROCCHETTE – VALLE DELL'ASTICO

x	Comb.	δ_{max}	L/250.00	Cs
cm		mm	mm	
219.8	15	-1.29	12.56	9.71

Verifica spostamento elastico dovuto ai soli carichi variabili (§4.2.4.2.1 - NTC 2008)

x	Comb.	δ_2	L/300.00	Cs
cm		mm	mm	
219.8	15	-0.86	10.47	12.2

Travata: 424 [317 , 340]

L = 286.0cm

Crit.Prog: Acciaio_Flessione $\delta_c = 0.0cm$ Verifica: **Verificata**

Verifica spostamento nello stato finale (§4.2.4.2.1 - NTC 2008)

x	Comb.	δ_{max}	L/250.00	Cs
cm		mm	mm	
85.8	15	-0.58	11.44	19.6

Verifica spostamento elastico dovuto ai soli carichi variabili (§4.2.4.2.1 - NTC 2008)

x	Comb.	δ_2	L/300.00	Cs
cm		mm	mm	
85.8	15	-0.39	9.53	24.5

Travata: 425 [339 , 325]

L = 254.4cm

Crit.Prog: Acciaio_Flessione $\delta_c = 0.0cm$ Verifica: **Verificata**

Verifica spostamento nello stato finale (§4.2.4.2.1 - NTC 2008)

x	Comb.	δ_{max}	L/250.00	Cs
---	-------	----------------	----------	----

AUTOSTRADA VALDASTICO A31 NORD
1° LOTTO - PIOVENE ROCCHETTE – VALLE DELL'ASTICO

x	Comb.	δ_{max}	L/250.00	Cs
cm		mm	mm	
127.2	15	0.24	10.17	42.2

Verifica spostamento elastico dovuto ai soli carichi variabili (§4.2.4.2.1 - NTC 2008)

x	Comb.	δ_2	L/300.00	Cs
cm		mm	mm	
127.2	15	0.14	8.48	58.7

Travata: 426 [325 , 340]

L = 254.4cm

Crit.Prog: Acciaio_Flessione $\delta_c = 0.0cm$ Verifica: **Verificata**

Verifica spostamento nello stato finale (§4.2.4.2.1 - NTC 2008)

x	Comb.	δ_{max}	L/250.00	Cs
cm		mm	mm	
127.2	15	-0.23	10.17	43.7

Verifica spostamento elastico dovuto ai soli carichi variabili (§4.2.4.2.1 - NTC 2008)

x	Comb.	δ_2	L/300.00	Cs
cm		mm	mm	
127.2	15	-0.16	8.48	53.3

Travata: 427 [318 , 325]

L = 254.4cm

Crit.Prog: Acciaio_Flessione $\delta_c = 0.0cm$ Verifica: **Verificata**

Verifica spostamento nello stato finale (§4.2.4.2.1 - NTC 2008)

x	Comb.	δ_{max}	L/250.00	Cs
---	-------	----------------	----------	----

AUTOSTRADA VALDASTICO A31 NORD
1° LOTTO - PIOVENE ROCCHETTE – VALLE DELL'ASTICO

x	Comb.	δ_{max}	L/250.00	Cs
cm		mm	mm	
127.2	15	-0.15	10.17	67.3

Verifica spostamento elastico dovuto ai soli carichi variabili (§4.2.4.2.1 - NTC 2008)

x	Comb.	δ_2	L/300.00	Cs
cm		mm	mm	
127.2	15	-0.11	8.48	78.2

Travata: 428 [325 , 317]

L = 254.4cm

Crit.Prog: Acciaio_Flessione $\delta_c = 0.0cm$ Verifica: **Verificata**

Verifica spostamento nello stato finale (§4.2.4.2.1 - NTC 2008)

x	Comb.	δ_{max}	L/250.00	Cs
cm		mm	mm	
178.1	15	-0.78	10.17	13.1

Verifica spostamento elastico dovuto ai soli carichi variabili (§4.2.4.2.1 - NTC 2008)

x	Comb.	δ_2	L/300.00	Cs
cm		mm	mm	
178.1	15	-0.51	8.48	16.8

Travata: 429 [341 , 316]

L = 286.0cm

Crit.Prog: Acciaio_Flessione $\delta_c = 0.0cm$ Verifica: **Verificata**

Verifica spostamento nello stato finale (§4.2.4.2.1 - NTC 2008)

x	Comb.	δ_{max}	L/250.00	Cs
---	-------	----------------	----------	----

AUTOSTRADA VALDASTICO A31 NORD
1° LOTTO - PIOVENE ROCCHETTE – VALLE DELL'ASTICO

x	Comb.	δ_{max}	L/250.00	Cs
cm		mm	mm	
171.6	15	-0.23	11.44	48.9

Verifica spostamento elastico dovuto ai soli carichi variabili (§4.2.4.2.1 - NTC 2008)

x	Comb.	δ_2	L/300.00	Cs
cm		mm	mm	
171.6	15	-0.19	9.53	50.1

Travata: 430 [316 , 317]

L = 314.0cm

Crit.Prog: Acciaio_Flessione $\delta_c = 0.0cm$ Verifica: **Verificata**

Verifica spostamento nello stato finale (§4.2.4.2.1 - NTC 2008)

x	Comb.	δ_{max}	L/250.00	Cs
cm		mm	mm	
188.4	15	0.09	12.56	>100

Verifica spostamento elastico dovuto ai soli carichi variabili (§4.2.4.2.1 - NTC 2008)

x	Comb.	δ_2	L/300.00	Cs
cm		mm	mm	
251.2	15	0.05	10.47	>100

Travata: 431 [340 , 332]

L = 229.9cm

Crit.Prog: Acciaio_Flessione $\delta_c = 0.0cm$ Verifica: **Verificata**

Verifica spostamento nello stato finale (§4.2.4.2.1 - NTC 2008)

x	Comb.	δ_{max}	L/250.00	Cs
---	-------	----------------	----------	----

AUTOSTRADA VALDASTICO A31 NORD
1° LOTTO - PIOVENE ROCCHETTE – VALLE DELL'ASTICO

x	Comb.	δ_{max}	L/250.00	Cs
cm		mm	mm	
137.9	15	-0.13	9.19	70.9

Verifica spostamento elastico dovuto ai soli carichi variabili (§4.2.4.2.1 - NTC 2008)

x	Comb.	δ_2	L/300.00	Cs
cm		mm	mm	
114.9	15	-0.07	7.66	>100

Travata: 432 [332 , 316]

L = 229.9cm

Crit.Prog: Acciaio_Flessione $\delta_c = 0.0cm$ Verifica: **Verificata**

Verifica spostamento nello stato finale (§4.2.4.2.1 - NTC 2008)

x	Comb.	δ_{max}	L/250.00	Cs
cm		mm	mm	
114.9	15	-0.36	9.19	25.7

Verifica spostamento elastico dovuto ai soli carichi variabili (§4.2.4.2.1 - NTC 2008)

x	Comb.	δ_2	L/300.00	Cs
cm		mm	mm	
114.9	15	-0.26	7.66	28.9

Travata: 433 [332 , 341]

L = 229.9cm

Crit.Prog: Acciaio_Flessione $\delta_c = 0.0cm$ Verifica: **Verificata**

Verifica spostamento nello stato finale (§4.2.4.2.1 - NTC 2008)

x	Comb.	δ_{max}	L/250.00	Cs
---	-------	----------------	----------	----

AUTOSTRADA VALDASTICO A31 NORD
1° LOTTO - PIOVENE ROCCHETTE – VALLE DELL'ASTICO

x	Comb.	δ_{max}	L/250.00	Cs
cm		mm	mm	
160.9	21	0.04	9.19	>100

Verifica spostamento elastico dovuto ai soli carichi variabili (§4.2.4.2.1 - NTC 2008)

x	Comb.	δ_2	L/300.00	Cs
cm		mm	mm	
69.0	15	-0.04	7.66	>100

Travata: 434 [331 , 330]

L = 318.3cm

Crit.Prog: Acciaio_Flessione $\delta_c = 0.0cm$ Verifica: **Verificata**

Verifica spostamento nello stato finale (§4.2.4.2.1 - NTC 2008)

x	Comb.	δ_{max}	L/250.00	Cs
cm		mm	mm	
159.1	15	1.96	12.73	6.50

Verifica spostamento elastico dovuto ai soli carichi variabili (§4.2.4.2.1 - NTC 2008)

x	Comb.	δ_2	L/300.00	Cs
cm		mm	mm	
159.1	15	1.52	10.61	6.97

Travata: 435 [330 , 329]

L = 315.7cm

Crit.Prog: Acciaio_Flessione $\delta_c = 0.0cm$ Verifica: **Verificata**

Verifica spostamento nello stato finale (§4.2.4.2.1 - NTC 2008)

x	Comb.	δ_{max}	L/250.00	Cs
---	-------	----------------	----------	----

AUTOSTRADA VALDASTICO A31 NORD
1° LOTTO - PIOVENE ROCCHETTE – VALLE DELL'ASTICO

x	Comb.	δ_{max}	L/250.00	Cs
cm		mm	mm	
157.9	15	2.78	12.63	4.54

Verifica spostamento elastico dovuto ai soli carichi variabili (§4.2.4.2.1 - NTC 2008)

x	Comb.	δ_2	L/300.00	Cs
cm		mm	mm	
157.9	15	2.01	10.52	5.22

Travata: 436 [329 , 328]

L = 314.2cm

Crit.Prog: Acciaio_Flessione $\delta_c = 0.0cm$ Verifica: **Verificata**

Verifica spostamento nello stato finale (§4.2.4.2.1 - NTC 2008)

x	Comb.	δ_{max}	L/250.00	Cs
cm		mm	mm	
157.1	15	2.79	12.57	4.50

Verifica spostamento elastico dovuto ai soli carichi variabili (§4.2.4.2.1 - NTC 2008)

x	Comb.	δ_2	L/300.00	Cs
cm		mm	mm	
157.1	15	2.02	10.47	5.19

Travata: 437 [328 , 327]

L = 314.0cm

Crit.Prog: Acciaio_Flessione $\delta_c = 0.0cm$ Verifica: **Verificata**

Verifica spostamento nello stato finale (§4.2.4.2.1 - NTC 2008)

x	Comb.	δ_{max}	L/250.00	Cs
---	-------	----------------	----------	----

AUTOSTRADA VALDASTICO A31 NORD
1° LOTTO - PIOVENE ROCCHETTE – VALLE DELL'ASTICO

x	Comb.	δ_{max}	L/250.00	Cs
cm		mm	mm	
157.0	15	2.81	12.56	4.46

Verifica spostamento elastico dovuto ai soli carichi variabili (§4.2.4.2.1 - NTC 2008)

x	Comb.	δ_2	L/300.00	Cs
cm		mm	mm	
157.0	15	2.03	10.47	5.15

Travata: 438 [327 , 326]

L = 314.2cm

Crit.Prog: Acciaio_Flessione $\delta_c = 0.0cm$ Verifica: **Verificata**

Verifica spostamento nello stato finale (§4.2.4.2.1 - NTC 2008)

x	Comb.	δ_{max}	L/250.00	Cs
cm		mm	mm	
157.1	15	2.79	12.57	4.50

Verifica spostamento elastico dovuto ai soli carichi variabili (§4.2.4.2.1 - NTC 2008)

x	Comb.	δ_2	L/300.00	Cs
cm		mm	mm	
157.1	15	2.02	10.47	5.19

Travata: 439 [326 , 325]

L = 315.7cm

Crit.Prog: Acciaio_Flessione $\delta_c = 0.0cm$ Verifica: **Verificata**

Verifica spostamento nello stato finale (§4.2.4.2.1 - NTC 2008)

x	Comb.	δ_{max}	L/250.00	Cs
---	-------	----------------	----------	----

AUTOSTRADA VALDASTICO A31 NORD
1° LOTTO - PIOVENE ROCCHETTE – VALLE DELL'ASTICO

x	Comb.	δ_{max}	L/250.00	Cs
cm		mm	mm	
157.9	15	2.78	12.63	4.54

Verifica spostamento elastico dovuto ai soli carichi variabili (§4.2.4.2.1 - NTC 2008)

x	Comb.	δ_2	L/300.00	Cs
cm		mm	mm	
157.9	15	2.01	10.52	5.22

Travata: 440 [325 , 332]

L = 318.3cm

Crit.Prog: Acciaio_Flessione $\delta_c = 0.0cm$ Verifica: **Verificata**

Verifica spostamento nello stato finale (§4.2.4.2.1 - NTC 2008)

x	Comb.	δ_{max}	L/250.00	Cs
cm		mm	mm	
159.1	15	1.94	12.73	6.56

Verifica spostamento elastico dovuto ai soli carichi variabili (§4.2.4.2.1 - NTC 2008)

x	Comb.	δ_2	L/300.00	Cs
cm		mm	mm	
159.1	15	1.52	10.61	6.99

Travata: 441 [307 , 348]

L = 229.9cm

Crit.Prog: Acciaio_Flessione $\delta_c = 0.0cm$ Verifica: **Verificata**

Verifica spostamento nello stato finale (§4.2.4.2.1 - NTC 2008)

x	Comb.	δ_{max}	L/250.00	Cs
---	-------	----------------	----------	----

AUTOSTRADA VALDASTICO A31 NORD
1° LOTTO - PIOVENE ROCCHETTE – VALLE DELL'ASTICO

x	Comb.	δ_{max}	L/250.00	Cs
cm		mm	mm	
183.9	15	-0.04	9.19	>100

Verifica spostamento elastico dovuto ai soli carichi variabili (§4.2.4.2.1 - NTC 2008)

x	Comb.	δ_2	L/300.00	Cs
cm		mm	mm	
160.9	15	-0.04	7.66	>100

Travata: 442 [323 , 308]

L = 286.0cm

Crit.Prog: Acciaio_Flessione $\delta_c = 0.0cm$ Verifica: **Verificata**

Verifica spostamento nello stato finale (§4.2.4.2.1 - NTC 2008)

x	Comb.	δ_{max}	L/250.00	Cs
cm		mm	mm	
85.8	15	-0.57	11.44	20.1

Verifica spostamento elastico dovuto ai soli carichi variabili (§4.2.4.2.1 - NTC 2008)

x	Comb.	δ_2	L/300.00	Cs
cm		mm	mm	
85.8	15	-0.38	9.53	25.2

Travata: 443 [308 , 307]

L = 314.0cm

Crit.Prog: Acciaio_Flessione $\delta_c = 0.0cm$ Verifica: **Verificata**

Verifica spostamento nello stato finale (§4.2.4.2.1 - NTC 2008)

x	Comb.	δ_{max}	L/250.00	Cs
---	-------	----------------	----------	----

AUTOSTRADA VALDASTICO A31 NORD
1° LOTTO - PIOVENE ROCCHETTE – VALLE DELL'ASTICO

x	Comb.	δ_{max}	L/250.00	Cs
cm		mm	mm	
125.6	15	-0.17	12.56	73.6

Verifica spostamento elastico dovuto ai soli carichi variabili (§4.2.4.2.1 - NTC 2008)

x	Comb.	δ_2	L/300.00	Cs
cm		mm	mm	
157.0	15	-0.15	10.47	68.3

Travata: 444 [324 , 348]

L = 229.9cm

Crit.Prog: Acciaio_Flessione $\delta_c = 0.0cm$ Verifica: **Verificata**

Verifica spostamento nello stato finale (§4.2.4.2.1 - NTC 2008)

x	Comb.	δ_{max}	L/250.00	Cs
cm		mm	mm	
114.9	15	-0.34	9.19	26.7

Verifica spostamento elastico dovuto ai soli carichi variabili (§4.2.4.2.1 - NTC 2008)

x	Comb.	δ_2	L/300.00	Cs
cm		mm	mm	
114.9	15	-0.26	7.66	29.6

Travata: 445 [348 , 308]

L = 229.9cm

Crit.Prog: Acciaio_Flessione $\delta_c = 0.0cm$ Verifica: **Verificata**

Verifica spostamento nello stato finale (§4.2.4.2.1 - NTC 2008)

x	Comb.	δ_{max}	L/250.00	Cs
---	-------	----------------	----------	----

AUTOSTRADA VALDASTICO A31 NORD
1° LOTTO - PIOVENE ROCCHETTE – VALLE DELL'ASTICO

x	Comb.	δ_{max}	L/250.00	Cs
cm		mm	mm	
91.9	15	-0.12	9.19	77.8

Verifica spostamento elastico dovuto ai soli carichi variabili (§4.2.4.2.1 - NTC 2008)

x	Comb.	δ_2	L/300.00	Cs
cm		mm	mm	
114.9	15	-0.07	7.66	>100

Travata: 446 [348 , 323]

L = 229.9cm

Crit.Prog: Acciaio_Flessione $\delta_c = 0.0cm$ Verifica: **Verificata**

Verifica spostamento nello stato finale (§4.2.4.2.1 - NTC 2008)

x	Comb.	δ_{max}	L/250.00	Cs
cm		mm	mm	
69.0	15	0.11	9.19	82.6

Verifica spostamento elastico dovuto ai soli carichi variabili (§4.2.4.2.1 - NTC 2008)

x	Comb.	δ_2	L/300.00	Cs
cm		mm	mm	
69.0	15	0.09	7.66	89.4

Travata: 447 [324 , 307]

L = 286.0cm

Crit.Prog: Acciaio_Flessione $\delta_c = 0.0cm$ Verifica: **Verificata**

Verifica spostamento nello stato finale (§4.2.4.2.1 - NTC 2008)

x	Comb.	δ_{max}	L/250.00	Cs
---	-------	----------------	----------	----

AUTOSTRADA VALDASTICO A31 NORD
1° LOTTO - PIOVENE ROCCHETTE – VALLE DELL'ASTICO

x	Comb.	δ_{max}	L/250.00	Cs
cm		mm	mm	
114.4	15	-0.24	11.44	47.2

Verifica spostamento elastico dovuto ai soli carichi variabili (§4.2.4.2.1 - NTC 2008)

x	Comb.	δ_2	L/300.00	Cs
cm		mm	mm	
114.4	15	-0.18	9.53	53.6

Travata: 448 [322 , 309]

L = 286.0cm

Crit.Prog: Acciaio_Flessione $\delta_c = 0.0cm$ Verifica: **Verificata**

Verifica spostamento nello stato finale (§4.2.4.2.1 - NTC 2008)

x	Comb.	δ_{max}	L/250.00	Cs
cm		mm	mm	
85.8	15	-0.10	11.44	>100

Verifica spostamento elastico dovuto ai soli carichi variabili (§4.2.4.2.1 - NTC 2008)

x	Comb.	δ_2	L/300.00	Cs
cm		mm	mm	
114.4	15	-0.08	9.53	>100

Travata: 449 [309 , 308]

L = 314.0cm

Crit.Prog: Acciaio_Flessione $\delta_c = 0.0cm$ Verifica: **Verificata**

Verifica spostamento nello stato finale (§4.2.4.2.1 - NTC 2008)

x	Comb.	δ_{max}	L/250.00	Cs
---	-------	----------------	----------	----

AUTOSTRADA VALDASTICO A31 NORD
1° LOTTO - PIOVENE ROCCHETTE – VALLE DELL'ASTICO

x	Comb.	δ_{max}	L/250.00	Cs
cm		mm	mm	
251.2	15	-0.11	12.56	>100

Verifica spostamento elastico dovuto ai soli carichi variabili (§4.2.4.2.1 - NTC 2008)

x	Comb.	δ_2	L/300.00	Cs
cm		mm	mm	
219.8	15	-0.09	10.47	>100

Travata: 450 [308 , 347]

L = 254.4cm

Crit.Prog: Acciaio_Flessione $\delta_c = 0.0cm$ Verifica: **Verificata**

Verifica spostamento nello stato finale (§4.2.4.2.1 - NTC 2008)

x	Comb.	δ_{max}	L/250.00	Cs
cm		mm	mm	
127.2	15	-0.23	10.17	44.2

Verifica spostamento elastico dovuto ai soli carichi variabili (§4.2.4.2.1 - NTC 2008)

x	Comb.	δ_2	L/300.00	Cs
cm		mm	mm	
127.2	15	-0.15	8.48	54.8

Travata: 451 [347 , 322]

L = 254.4cm

Crit.Prog: Acciaio_Flessione $\delta_c = 0.0cm$ Verifica: **Verificata**

Verifica spostamento nello stato finale (§4.2.4.2.1 - NTC 2008)

x	Comb.	δ_{max}	L/250.00	Cs
---	-------	----------------	----------	----

AUTOSTRADA VALDASTICO A31 NORD
1° LOTTO - PIOVENE ROCCHETTE – VALLE DELL'ASTICO

x	Comb.	δ_{max}	L/250.00	Cs
cm		mm	mm	
127.2	15	-0.15	10.17	68.0

Verifica spostamento elastico dovuto ai soli carichi variabili (§4.2.4.2.1 - NTC 2008)

x	Comb.	δ_2	L/300.00	Cs
cm		mm	mm	
127.2	15	-0.11	8.48	80.2

Travata: 452 [323 , 347]

L = 254.4cm

Crit.Prog: Acciaio_Flessione $\delta_c = 0.0cm$ Verifica: **Verificata**

Verifica spostamento nello stato finale (§4.2.4.2.1 - NTC 2008)

x	Comb.	δ_{max}	L/250.00	Cs
cm		mm	mm	
76.3	15	-0.74	10.17	13.7

Verifica spostamento elastico dovuto ai soli carichi variabili (§4.2.4.2.1 - NTC 2008)

x	Comb.	δ_2	L/300.00	Cs
cm		mm	mm	
76.3	15	-0.50	8.48	17.1

Travata: 453 [347 , 309]

L = 254.4cm

Crit.Prog: Acciaio_Flessione $\delta_c = 0.0cm$ Verifica: **Verificata**

Verifica spostamento nello stato finale (§4.2.4.2.1 - NTC 2008)

x	Comb.	δ_{max}	L/250.00	Cs
---	-------	----------------	----------	----

AUTOSTRADA VALDASTICO A31 NORD
1° LOTTO - PIOVENE ROCCHETTE – VALLE DELL'ASTICO

x	Comb.	δ_{max}	L/250.00	Cs
cm		mm	mm	
127.2	15	0.24	10.17	42.2

Verifica spostamento elastico dovuto ai soli carichi variabili (§4.2.4.2.1 - NTC 2008)

x	Comb.	δ_2	L/300.00	Cs
cm		mm	mm	
127.2	15	0.14	8.48	60.0

Travata: 454 [321 , 310]

L = 286.0cm

Crit.Prog: Acciaio_Flessione $\delta_c = 0.0cm$ Verifica: **Verificata**

Verifica spostamento nello stato finale (§4.2.4.2.1 - NTC 2008)

x	Comb.	δ_{max}	L/250.00	Cs
cm		mm	mm	
143.0	15	0.05	11.44	>100

Verifica spostamento elastico dovuto ai soli carichi variabili (§4.2.4.2.1 - NTC 2008)

x	Comb.	δ_2	L/300.00	Cs
cm		mm	mm	
143.0	15	0.00	9.53	>100

Travata: 455 [310 , 309]

L = 314.0cm

Crit.Prog: Acciaio_Flessione $\delta_c = 0.0cm$ Verifica: **Verificata**

Verifica spostamento nello stato finale (§4.2.4.2.1 - NTC 2008)

x	Comb.	δ_{max}	L/250.00	Cs
---	-------	----------------	----------	----

AUTOSTRADA VALDASTICO A31 NORD
1° LOTTO - PIOVENE ROCCHETTE – VALLE DELL'ASTICO

x	Comb.	δ_{max}	L/250.00	Cs
cm		mm	mm	
157.0	15	0.34	12.56	36.7

Verifica spostamento elastico dovuto ai soli carichi variabili (§4.2.4.2.1 - NTC 2008)

x	Comb.	δ_2	L/300.00	Cs
cm		mm	mm	
157.0	15	0.18	10.47	57.4

Travata: 456 [322 , 346]

L = 273.9cm

Crit.Prog: Acciaio_Flessione $\delta_c = 0.0cm$ Verifica: **Verificata**

Verifica spostamento nello stato finale (§4.2.4.2.1 - NTC 2008)

x	Comb.	δ_{max}	L/250.00	Cs
cm		mm	mm	
137.0	15	0.19	10.96	57.9

Verifica spostamento elastico dovuto ai soli carichi variabili (§4.2.4.2.1 - NTC 2008)

x	Comb.	δ_2	L/300.00	Cs
cm		mm	mm	
109.6	15	0.11	9.13	84.6

Travata: 457 [346 , 310]

L = 273.9cm

Crit.Prog: Acciaio_Flessione $\delta_c = 0.0cm$ Verifica: **Verificata**

Verifica spostamento nello stato finale (§4.2.4.2.1 - NTC 2008)

x	Comb.	δ_{max}	L/250.00	Cs
---	-------	----------------	----------	----

AUTOSTRADA VALDASTICO A31 NORD
1° LOTTO - PIOVENE ROCCHETTE – VALLE DELL'ASTICO

x	Comb.	δ_{max}	L/250.00	Cs
cm		mm	mm	
137.0	15	0.14	10.96	76.1

Verifica spostamento elastico dovuto ai soli carichi variabili (§4.2.4.2.1 - NTC 2008)

x	Comb.	δ_2	L/300.00	Cs
cm		mm	mm	
137.0	15	0.08	9.13	>100

Travata: 458 [309 , 346]

L = 273.9cm

Crit.Prog: Acciaio_Flessione $\delta_c = 0.0cm$ Verifica: **Verificata**

Verifica spostamento nello stato finale (§4.2.4.2.1 - NTC 2008)

x	Comb.	δ_{max}	L/250.00	Cs
cm		mm	mm	
137.0	21	0.02	10.96	>100

Verifica spostamento elastico dovuto ai soli carichi variabili (§4.2.4.2.1 - NTC 2008)

x	Comb.	δ_2	L/300.00	Cs
cm		mm	mm	
82.2	15	-0.01	9.13	>100

Travata: 459 [346 , 321]

L = 273.9cm

Crit.Prog: Acciaio_Flessione $\delta_c = 0.0cm$ Verifica: **Verificata**

Verifica spostamento nello stato finale (§4.2.4.2.1 - NTC 2008)

x	Comb.	δ_{max}	L/250.00	Cs
---	-------	----------------	----------	----

AUTOSTRADA VALDASTICO A31 NORD
1° LOTTO - PIOVENE ROCCHETTE – VALLE DELL'ASTICO

x	Comb.	δ_{max}	L/250.00	Cs
cm		mm	mm	
164.3	15	0.09	10.96	>100

Verifica spostamento elastico dovuto ai soli carichi variabili (§4.2.4.2.1 - NTC 2008)

x	Comb.	δ_2	L/300.00	Cs
cm		mm	mm	
164.3	15	0.05	9.13	>100

Travata: 460 [320 , 311]

L = 286.0cm

Crit.Prog: Acciaio_Flessione $\delta_c = 0.0cm$ Verifica: **Verificata**

Verifica spostamento nello stato finale (§4.2.4.2.1 - NTC 2008)

x	Comb.	δ_{max}	L/250.00	Cs
cm		mm	mm	
143.0	15	0.08	11.44	>100

Verifica spostamento elastico dovuto ai soli carichi variabili (§4.2.4.2.1 - NTC 2008)

x	Comb.	δ_2	L/300.00	Cs
cm		mm	mm	
114.4	15	0.02	9.53	>100

Travata: 461 [311 , 310]

L = 314.0cm

Crit.Prog: Acciaio_Flessione $\delta_c = 0.0cm$ Verifica: **Verificata**

Verifica spostamento nello stato finale (§4.2.4.2.1 - NTC 2008)

x	Comb.	δ_{max}	L/250.00	Cs
---	-------	----------------	----------	----

AUTOSTRADA VALDASTICO A31 NORD
1° LOTTO - PIOVENE ROCCHETTE – VALLE DELL'ASTICO

x	Comb.	δ_{max}	L/250.00	Cs
cm		mm	mm	
157.0	15	0.42	12.56	30.1

Verifica spostamento elastico dovuto ai soli carichi variabili (§4.2.4.2.1 - NTC 2008)

x	Comb.	δ_2	L/300.00	Cs
cm		mm	mm	
157.0	15	0.23	10.47	45.6

Travata: 462 [321 , 345]

L = 281.6cm

Crit.Prog: Acciaio_Flessione $\delta_c = 0.0cm$ Verifica: **Verificata**

Verifica spostamento nello stato finale (§4.2.4.2.1 - NTC 2008)

x	Comb.	δ_{max}	L/250.00	Cs
cm		mm	mm	
140.8	15	0.13	11.27	86.1

Verifica spostamento elastico dovuto ai soli carichi variabili (§4.2.4.2.1 - NTC 2008)

x	Comb.	δ_2	L/300.00	Cs
cm		mm	mm	
140.8	15	0.07	9.39	>100

Travata: 463 [345 , 320]

L = 281.6cm

Crit.Prog: Acciaio_Flessione $\delta_c = 0.0cm$ Verifica: **Verificata**

Verifica spostamento nello stato finale (§4.2.4.2.1 - NTC 2008)

x	Comb.	δ_{max}	L/250.00	Cs
---	-------	----------------	----------	----

AUTOSTRADA VALDASTICO A31 NORD
1° LOTTO - PIOVENE ROCCHETTE – VALLE DELL'ASTICO

x	Comb.	δ_{max}	L/250.00	Cs
cm		mm	mm	
140.8	15	0.13	11.27	88.0

Verifica spostamento elastico dovuto ai soli carichi variabili (§4.2.4.2.1 - NTC 2008)

x	Comb.	δ_2	L/300.00	Cs
cm		mm	mm	
140.8	15	0.07	9.39	>100

Travata: 464 [310 , 345]

L = 281.6cm

Crit.Prog: Acciaio_Flessione $\delta_c = 0.0cm$ Verifica: **Verificata**

Verifica spostamento nello stato finale (§4.2.4.2.1 - NTC 2008)

x	Comb.	δ_{max}	L/250.00	Cs
cm		mm	mm	
140.8	15	0.10	11.27	>100

Verifica spostamento elastico dovuto ai soli carichi variabili (§4.2.4.2.1 - NTC 2008)

x	Comb.	δ_2	L/300.00	Cs
cm		mm	mm	
140.8	15	0.05	9.39	>100

Travata: 465 [345 , 311]

L = 281.6cm

Crit.Prog: Acciaio_Flessione $\delta_c = 0.0cm$ Verifica: **Verificata**

Verifica spostamento nello stato finale (§4.2.4.2.1 - NTC 2008)

x	Comb.	δ_{max}	L/250.00	Cs
---	-------	----------------	----------	----

AUTOSTRADA VALDASTICO A31 NORD
1° LOTTO - PIOVENE ROCCHETTE – VALLE DELL'ASTICO

x	Comb.	δ_{max}	L/250.00	Cs
cm		mm	mm	
140.8	15	0.13	11.27	86.6

Verifica spostamento elastico dovuto ai soli carichi variabili (§4.2.4.2.1 - NTC 2008)

x	Comb.	δ_2	L/300.00	Cs
cm		mm	mm	
140.8	15	0.07	9.39	>100

Travata: 466 [311 , 344]

L = 281.6cm

Crit.Prog: Acciaio_Flessione $\delta_c = 0.0cm$ Verifica: **Verificata**

Verifica spostamento nello stato finale (§4.2.4.2.1 - NTC 2008)

x	Comb.	δ_{max}	L/250.00	Cs
cm		mm	mm	
140.8	15	0.13	11.27	86.6

Verifica spostamento elastico dovuto ai soli carichi variabili (§4.2.4.2.1 - NTC 2008)

x	Comb.	δ_2	L/300.00	Cs
cm		mm	mm	
140.8	15	0.07	9.39	>100

Travata: 467 [344 , 319]

L = 281.6cm

Crit.Prog: Acciaio_Flessione $\delta_c = 0.0cm$ Verifica: **Verificata**

Verifica spostamento nello stato finale (§4.2.4.2.1 - NTC 2008)

x	Comb.	δ_{max}	L/250.00	Cs
---	-------	----------------	----------	----

AUTOSTRADA VALDASTICO A31 NORD
1° LOTTO - PIOVENE ROCCHETTE – VALLE DELL'ASTICO

x	Comb.	δ_{max}	L/250.00	Cs
cm		mm	mm	
140.8	15	0.13	11.27	86.4

Verifica spostamento elastico dovuto ai soli carichi variabili (§4.2.4.2.1 - NTC 2008)

x	Comb.	δ_2	L/300.00	Cs
cm		mm	mm	
140.8	15	0.07	9.39	>100

Travata: 468 [319 , 312]

L = 286.0cm

Crit.Prog: Acciaio_Flessione $\delta_c = 0.0cm$ Verifica: **Verificata**

Verifica spostamento nello stato finale (§4.2.4.2.1 - NTC 2008)

x	Comb.	δ_{max}	L/250.00	Cs
cm		mm	mm	
143.0	15	0.05	11.44	>100

Verifica spostamento elastico dovuto ai soli carichi variabili (§4.2.4.2.1 - NTC 2008)

x	Comb.	δ_2	L/300.00	Cs
cm		mm	mm	
143.0	15	0.00	9.53	>100

Travata: 469 [312 , 311]

L = 314.0cm

Crit.Prog: Acciaio_Flessione $\delta_c = 0.0cm$ Verifica: **Verificata**

Verifica spostamento nello stato finale (§4.2.4.2.1 - NTC 2008)

x	Comb.	δ_{max}	L/250.00	Cs
---	-------	----------------	----------	----

AUTOSTRADA VALDASTICO A31 NORD
1° LOTTO - PIOVENE ROCCHETTE – VALLE DELL'ASTICO

x	Comb.	δ_{max}	L/250.00	Cs
cm		mm	mm	
157.0	15	0.42	12.56	30.1

Verifica spostamento elastico dovuto ai soli carichi variabili (§4.2.4.2.1 - NTC 2008)

x	Comb.	δ_2	L/300.00	Cs
cm		mm	mm	
157.0	15	0.23	10.47	45.6

Travata: 470 [320 , 344]

L = 281.6cm

Crit.Prog: Acciaio_Flessione $\delta_c = 0.0cm$ Verifica: **Verificata**

Verifica spostamento nello stato finale (§4.2.4.2.1 - NTC 2008)

x	Comb.	δ_{max}	L/250.00	Cs
cm		mm	mm	
140.8	15	0.13	11.27	88.1

Verifica spostamento elastico dovuto ai soli carichi variabili (§4.2.4.2.1 - NTC 2008)

x	Comb.	δ_2	L/300.00	Cs
cm		mm	mm	
140.8	15	0.07	9.39	>100

Travata: 471 [344 , 312]

L = 281.6cm

Crit.Prog: Acciaio_Flessione $\delta_c = 0.0cm$ Verifica: **Verificata**

Verifica spostamento nello stato finale (§4.2.4.2.1 - NTC 2008)

x	Comb.	δ_{max}	L/250.00	Cs
---	-------	----------------	----------	----

AUTOSTRADA VALDASTICO A31 NORD
1° LOTTO - PIOVENE ROCCHETTE – VALLE DELL'ASTICO

x	Comb.	δ_{max}	L/250.00	Cs
cm		mm	mm	
140.8	15	0.10	11.27	>100

Verifica spostamento elastico dovuto ai soli carichi variabili (§4.2.4.2.1 - NTC 2008)

x	Comb.	δ_2	L/300.00	Cs
cm		mm	mm	
140.8	15	0.05	9.39	>100

Travata: 472 [318 , 313]

L = 286.0cm

Crit.Prog: Acciaio_Flessione $\delta_c = 0.0cm$ Verifica: **Verificata**

Verifica spostamento nello stato finale (§4.2.4.2.1 - NTC 2008)

x	Comb.	δ_{max}	L/250.00	Cs
cm		mm	mm	
85.8	15	-0.10	11.44	>100

Verifica spostamento elastico dovuto ai soli carichi variabili (§4.2.4.2.1 - NTC 2008)

x	Comb.	δ_2	L/300.00	Cs
cm		mm	mm	
114.4	15	-0.09	9.53	>100

Travata: 473 [313 , 312]

L = 314.0cm

Crit.Prog: Acciaio_Flessione $\delta_c = 0.0cm$ Verifica: **Verificata**

Verifica spostamento nello stato finale (§4.2.4.2.1 - NTC 2008)

x	Comb.	δ_{max}	L/250.00	Cs
---	-------	----------------	----------	----

AUTOSTRADA VALDASTICO A31 NORD
1° LOTTO - PIOVENE ROCCHETTE – VALLE DELL'ASTICO

x	Comb.	δ_{max}	L/250.00	Cs
cm		mm	mm	
157.0	15	0.34	12.56	36.9

Verifica spostamento elastico dovuto ai soli carichi variabili (§4.2.4.2.1 - NTC 2008)

x	Comb.	δ_2	L/300.00	Cs
cm		mm	mm	
157.0	15	0.18	10.47	57.6

Travata: 474 [312 , 343]

L = 273.9cm

Crit.Prog: Acciaio_Flessione $\delta_c = 0.0cm$ Verifica: **Verificata**

Verifica spostamento nello stato finale (§4.2.4.2.1 - NTC 2008)

x	Comb.	δ_{max}	L/250.00	Cs
cm		mm	mm	
137.0	15	0.14	10.96	76.3

Verifica spostamento elastico dovuto ai soli carichi variabili (§4.2.4.2.1 - NTC 2008)

x	Comb.	δ_2	L/300.00	Cs
cm		mm	mm	
137.0	15	0.08	9.13	>100

Travata: 475 [343 , 318]

L = 273.9cm

Crit.Prog: Acciaio_Flessione $\delta_c = 0.0cm$ Verifica: **Verificata**

Verifica spostamento nello stato finale (§4.2.4.2.1 - NTC 2008)

x	Comb.	δ_{max}	L/250.00	Cs
---	-------	----------------	----------	----

AUTOSTRADA VALDASTICO A31 NORD
1° LOTTO - PIOVENE ROCCHETTE – VALLE DELL'ASTICO

x	Comb.	δ_{max}	L/250.00	Cs
cm		mm	mm	
137.0	15	0.19	10.96	57.5

Verifica spostamento elastico dovuto ai soli carichi variabili (§4.2.4.2.1 - NTC 2008)

x	Comb.	δ_2	L/300.00	Cs
cm		mm	mm	
164.3	15	0.11	9.13	84.4

Travata: 476 [319 , 343]

L = 273.9cm

Crit.Prog: Acciaio_Flessione $\delta_c = 0.0cm$ Verifica: **Verificata**

Verifica spostamento nello stato finale (§4.2.4.2.1 - NTC 2008)

x	Comb.	δ_{max}	L/250.00	Cs
cm		mm	mm	
109.6	15	0.09	10.96	>100

Verifica spostamento elastico dovuto ai soli carichi variabili (§4.2.4.2.1 - NTC 2008)

x	Comb.	δ_2	L/300.00	Cs
cm		mm	mm	
109.6	15	0.05	9.13	>100

Travata: 477 [343 , 313]

L = 273.9cm

Crit.Prog: Acciaio_Flessione $\delta_c = 0.0cm$ Verifica: **Verificata**

Verifica spostamento nello stato finale (§4.2.4.2.1 - NTC 2008)

x	Comb.	δ_{max}	L/250.00	Cs
---	-------	----------------	----------	----

AUTOSTRADA VALDASTICO A31 NORD
1° LOTTO - PIOVENE ROCCHETTE – VALLE DELL'ASTICO

x	Comb.	δ_{max}	L/250.00	Cs
cm		mm	mm	
137.0	21	0.02	10.96	>100

Verifica spostamento elastico dovuto ai soli carichi variabili (§4.2.4.2.1 - NTC 2008)

x	Comb.	δ_2	L/300.00	Cs
cm		mm	mm	
191.7	15	-0.01	9.13	>100

Travata: 478 [313 , 314]

L = 314.0cm

Crit.Prog: Acciaio_Flessione $\delta_c = 0.0cm$ Verifica: **Verificata**

Verifica spostamento nello stato finale (§4.2.4.2.1 - NTC 2008)

x	Comb.	δ_{max}	L/250.00	Cs
cm		mm	mm	
251.2	15	-0.12	12.56	>100

Verifica spostamento elastico dovuto ai soli carichi variabili (§4.2.4.2.1 - NTC 2008)

x	Comb.	δ_2	L/300.00	Cs
cm		mm	mm	
219.8	15	-0.09	10.47	>100

Travata: 479 [314 , 317]

L = 286.0cm

Crit.Prog: Acciaio_Flessione $\delta_c = 0.0cm$ Verifica: **Verificata**

Verifica spostamento nello stato finale (§4.2.4.2.1 - NTC 2008)

x	Comb.	δ_{max}	L/250.00	Cs
---	-------	----------------	----------	----

AUTOSTRADA VALDASTICO A31 NORD
1° LOTTO - PIOVENE ROCCHETTE – VALLE DELL'ASTICO

x	Comb.	δ_{max}	L/250.00	Cs
cm		mm	mm	
200.2	15	-0.58	11.44	19.8

Verifica spostamento elastico dovuto ai soli carichi variabili (§4.2.4.2.1 - NTC 2008)

x	Comb.	δ_2	L/300.00	Cs
cm		mm	mm	
200.2	15	-0.38	9.53	25.0

Travata: 480 [318 , 342]

L = 254.4cm

Crit.Prog: Acciaio_Flessione $\delta_c = 0.0cm$ Verifica: **Verificata**

Verifica spostamento nello stato finale (§4.2.4.2.1 - NTC 2008)

x	Comb.	δ_{max}	L/250.00	Cs
cm		mm	mm	
127.2	15	-0.15	10.17	66.2

Verifica spostamento elastico dovuto ai soli carichi variabili (§4.2.4.2.1 - NTC 2008)

x	Comb.	δ_2	L/300.00	Cs
cm		mm	mm	
127.2	15	-0.11	8.48	79.5

Travata: 481 [342 , 317]

L = 254.4cm

Crit.Prog: Acciaio_Flessione $\delta_c = 0.0cm$ Verifica: **Verificata**

Verifica spostamento nello stato finale (§4.2.4.2.1 - NTC 2008)

x	Comb.	δ_{max}	L/250.00	Cs
---	-------	----------------	----------	----

AUTOSTRADA VALDASTICO A31 NORD
1° LOTTO - PIOVENE ROCCHETTE – VALLE DELL'ASTICO

x	Comb.	δ_{max}	L/250.00	Cs
cm		mm	mm	
178.1	15	-0.77	10.17	13.2

Verifica spostamento elastico dovuto ai soli carichi variabili (§4.2.4.2.1 - NTC 2008)

x	Comb.	δ_2	L/300.00	Cs
cm		mm	mm	
178.1	15	-0.50	8.48	16.8

Travata: 482 [313 , 342]

L = 254.4cm

Crit.Prog: Acciaio_Flessione $\delta_c = 0.0cm$ Verifica: **Verificata**

Verifica spostamento nello stato finale (§4.2.4.2.1 - NTC 2008)

x	Comb.	δ_{max}	L/250.00	Cs
cm		mm	mm	
127.2	15	0.24	10.17	41.9

Verifica spostamento elastico dovuto ai soli carichi variabili (§4.2.4.2.1 - NTC 2008)

x	Comb.	δ_2	L/300.00	Cs
cm		mm	mm	
127.2	15	0.14	8.48	59.8

Travata: 483 [342 , 314]

L = 254.4cm

Crit.Prog: Acciaio_Flessione $\delta_c = 0.0cm$ Verifica: **Verificata**

Verifica spostamento nello stato finale (§4.2.4.2.1 - NTC 2008)

x	Comb.	δ_{max}	L/250.00	Cs
---	-------	----------------	----------	----

AUTOSTRADA VALDASTICO A31 NORD
1° LOTTO - PIOVENE ROCCHETTE – VALLE DELL'ASTICO

x	Comb.	δ_{max}	L/250.00	Cs
cm		mm	mm	
127.2	15	-0.23	10.17	43.6

Verifica spostamento elastico dovuto ai soli carichi variabili (§4.2.4.2.1 - NTC 2008)

x	Comb.	δ_2	L/300.00	Cs
cm		mm	mm	
127.2	15	-0.16	8.48	54.6

Travata: 484 [316 , 315]

L = 286.0cm

Crit.Prog: Acciaio_Flessione $\delta_c = 0.0cm$ Verifica: **Verificata**

Verifica spostamento nello stato finale (§4.2.4.2.1 - NTC 2008)

x	Comb.	δ_{max}	L/250.00	Cs
cm		mm	mm	
114.4	15	-0.23	11.44	48.7

Verifica spostamento elastico dovuto ai soli carichi variabili (§4.2.4.2.1 - NTC 2008)

x	Comb.	δ_2	L/300.00	Cs
cm		mm	mm	
114.4	15	-0.18	9.53	53.7

Travata: 485 [315 , 314]

L = 314.0cm

Crit.Prog: Acciaio_Flessione $\delta_c = 0.0cm$ Verifica: **Verificata**

Verifica spostamento nello stato finale (§4.2.4.2.1 - NTC 2008)

x	Comb.	δ_{max}	L/250.00	Cs
---	-------	----------------	----------	----

AUTOSTRADA VALDASTICO A31 NORD
1° LOTTO - PIOVENE ROCCHETTE – VALLE DELL'ASTICO

x	Comb.	δ_{max}	L/250.00	Cs
cm		mm	mm	
188.4	15	-0.18	12.56	71.0

Verifica spostamento elastico dovuto ai soli carichi variabili (§4.2.4.2.1 - NTC 2008)

x	Comb.	δ_2	L/300.00	Cs
cm		mm	mm	
157.0	15	-0.15	10.47	67.6

Travata: 486 [317 , 349]

L = 229.9cm

Crit.Prog: Acciaio_Flessione $\delta_c = 0.0cm$ Verifica: **Verificata**

Verifica spostamento nello stato finale (§4.2.4.2.1 - NTC 2008)

x	Comb.	δ_{max}	L/250.00	Cs
cm		mm	mm	
160.9	15	0.12	9.19	76.3

Verifica spostamento elastico dovuto ai soli carichi variabili (§4.2.4.2.1 - NTC 2008)

x	Comb.	δ_2	L/300.00	Cs
cm		mm	mm	
160.9	15	0.09	7.66	87.5

Travata: 487 [349 , 315]

L = 229.9cm

Crit.Prog: Acciaio_Flessione $\delta_c = 0.0cm$ Verifica: **Verificata**

Verifica spostamento nello stato finale (§4.2.4.2.1 - NTC 2008)

x	Comb.	δ_{max}	L/250.00	Cs
---	-------	----------------	----------	----

AUTOSTRADA VALDASTICO A31 NORD
1° LOTTO - PIOVENE ROCCHETTE – VALLE DELL'ASTICO

x	Comb.	δ_{max}	L/250.00	Cs
cm		mm	mm	
46.0	15	-0.04	9.19	>100

Verifica spostamento elastico dovuto ai soli carichi variabili (§4.2.4.2.1 - NTC 2008)

x	Comb.	δ_2	L/300.00	Cs
cm		mm	mm	
69.0	15	-0.04	7.66	>100

Travata: 488 [349 , 316]

L = 229.9cm

Crit.Prog: Acciaio_Flessione $\delta_c = 0.0cm$ Verifica: **Verificata**

Verifica spostamento nello stato finale (§4.2.4.2.1 - NTC 2008)

x	Comb.	δ_{max}	L/250.00	Cs
cm		mm	mm	
114.9	15	-0.36	9.19	25.7

Verifica spostamento elastico dovuto ai soli carichi variabili (§4.2.4.2.1 - NTC 2008)

x	Comb.	δ_2	L/300.00	Cs
cm		mm	mm	
114.9	15	-0.26	7.66	29.2

Travata: 489 [348 , 347]

L = 318.3cm

Crit.Prog: Acciaio_Flessione $\delta_c = 0.0cm$ Verifica: **Verificata**

Verifica spostamento nello stato finale (§4.2.4.2.1 - NTC 2008)

x	Comb.	δ_{max}	L/250.00	Cs
---	-------	----------------	----------	----

AUTOSTRADA VALDASTICO A31 NORD
1° LOTTO - PIOVENE ROCCHETTE – VALLE DELL'ASTICO

x	Comb.	δ_{max}	L/250.00	Cs
cm		mm	mm	
159.1	15	1.96	12.73	6.50

Verifica spostamento elastico dovuto ai soli carichi variabili (§4.2.4.2.1 - NTC 2008)

x	Comb.	δ_2	L/300.00	Cs
cm		mm	mm	
159.1	15	1.52	10.61	6.97

Travata: 490 [347 , 346]

$L = 315.7\text{cm}$

Crit.Prog: Acciaio_Flessione $\delta_c = 0.0\text{cm}$ Verifica: **Verificata**

Verifica spostamento nello stato finale (§4.2.4.2.1 - NTC 2008)

x	Comb.	δ_{max}	L/250.00	Cs
cm		mm	mm	
157.9	15	2.78	12.63	4.54

Verifica spostamento elastico dovuto ai soli carichi variabili (§4.2.4.2.1 - NTC 2008)

x	Comb.	δ_2	L/300.00	Cs
cm		mm	mm	
157.9	15	2.02	10.52	5.22

Travata: 491 [346 , 345]

$L = 314.2\text{cm}$

Crit.Prog: Acciaio_Flessione $\delta_c = 0.0\text{cm}$ Verifica: **Verificata**

Verifica spostamento nello stato finale (§4.2.4.2.1 - NTC 2008)

x	Comb.	δ_{max}	L/250.00	Cs
---	-------	----------------	----------	----

AUTOSTRADA VALDASTICO A31 NORD
1° LOTTO - PIOVENE ROCCHETTE – VALLE DELL'ASTICO

x	Comb.	δ_{max}	L/250.00	Cs
cm		mm	mm	
157.1	15	2.79	12.57	4.50

Verifica spostamento elastico dovuto ai soli carichi variabili (§4.2.4.2.1 - NTC 2008)

x	Comb.	δ_2	L/300.00	Cs
cm		mm	mm	
157.1	15	2.02	10.47	5.19

Travata: 492 [345 , 344]

L = 314.0cm

Crit.Prog: Acciaio_Flessione $\delta_c = 0.0cm$ Verifica: **Verificata**

Verifica spostamento nello stato finale (§4.2.4.2.1 - NTC 2008)

x	Comb.	δ_{max}	L/250.00	Cs
cm		mm	mm	
157.0	15	2.81	12.56	4.47

Verifica spostamento elastico dovuto ai soli carichi variabili (§4.2.4.2.1 - NTC 2008)

x	Comb.	δ_2	L/300.00	Cs
cm		mm	mm	
157.0	15	2.03	10.47	5.15

Travata: 493 [344 , 343]

L = 314.2cm

Crit.Prog: Acciaio_Flessione $\delta_c = 0.0cm$ Verifica: **Verificata**

Verifica spostamento nello stato finale (§4.2.4.2.1 - NTC 2008)

x	Comb.	δ_{max}	L/250.00	Cs
---	-------	----------------	----------	----

AUTOSTRADA VALDASTICO A31 NORD
1° LOTTO - PIOVENE ROCCHETTE – VALLE DELL'ASTICO

x	Comb.	δ_{max}	L/250.00	Cs
cm		mm	mm	
157.1	15	2.79	12.57	4.51

Verifica spostamento elastico dovuto ai soli carichi variabili (§4.2.4.2.1 - NTC 2008)

x	Comb.	δ_2	L/300.00	Cs
cm		mm	mm	
157.1	15	2.02	10.47	5.19

Travata: 494 [343 , 342]

L = 315.7cm

Crit.Prog: Acciaio_Flessione $\delta_c = 0.0cm$ Verifica: **Verificata**

Verifica spostamento nello stato finale (§4.2.4.2.1 - NTC 2008)

x	Comb.	δ_{max}	L/250.00	Cs
cm		mm	mm	
157.9	15	2.78	12.63	4.54

Verifica spostamento elastico dovuto ai soli carichi variabili (§4.2.4.2.1 - NTC 2008)

x	Comb.	δ_2	L/300.00	Cs
cm		mm	mm	
157.9	15	2.02	10.52	5.22

Travata: 495 [342 , 349]

L = 318.3cm

Crit.Prog: Acciaio_Flessione $\delta_c = 0.0cm$ Verifica: **Verificata**

Verifica spostamento nello stato finale (§4.2.4.2.1 - NTC 2008)

x	Comb.	δ_{max}	L/250.00	Cs
---	-------	----------------	----------	----

AUTOSTRADA VALDASTICO A31 NORD
1° LOTTO - PIOVENE ROCCHETTE – VALLE DELL'ASTICO

x	Comb.	δ_{max}	L/250.00	Cs
cm		mm	mm	
159.1	15	1.94	12.73	6.55

Verifica spostamento elastico dovuto ai soli carichi variabili (§4.2.4.2.1 - NTC 2008)

x	Comb.	δ_2	L/300.00	Cs
cm		mm	mm	
159.1	15	1.52	10.61	6.99

Travata: 496 [333 , 356]

L = 229.9cm

Crit.Prog: Acciaio_Flessione $\delta_c = 0.0cm$ Verifica: **Verificata**

Verifica spostamento nello stato finale (§4.2.4.2.1 - NTC 2008)

x	Comb.	δ_{max}	L/250.00	Cs
cm		mm	mm	
114.9	15	-0.08	9.19	>100

Verifica spostamento elastico dovuto ai soli carichi variabili (§4.2.4.2.1 - NTC 2008)

x	Comb.	δ_2	L/300.00	Cs
cm		mm	mm	
114.9	15	-0.07	7.66	>100

Travata: 497 [359 , 334]

L = 286.0cm

Crit.Prog: Acciaio_Flessione $\delta_c = 0.0cm$ Verifica: **Verificata**

Verifica spostamento nello stato finale (§4.2.4.2.1 - NTC 2008)

x	Comb.	δ_{max}	L/250.00	Cs
---	-------	----------------	----------	----

AUTOSTRADA VALDASTICO A31 NORD
1° LOTTO - PIOVENE ROCCHETTE – VALLE DELL'ASTICO

x	Comb.	δ_{max}	L/250.00	Cs
cm		mm	mm	
143.0	15	0.48	11.44	23.8

Verifica spostamento elastico dovuto ai soli carichi variabili (§4.2.4.2.1 - NTC 2008)

x	Comb.	δ_2	L/300.00	Cs
cm		mm	mm	
143.0	15	0.28	9.53	34.4

Travata: 498 [334 , 333]

L = 314.0cm

Crit.Prog: Acciaio_Flessione $\delta_c = 0.0cm$ Verifica: **Verificata**

Verifica spostamento nello stato finale (§4.2.4.2.1 - NTC 2008)

x	Comb.	δ_{max}	L/250.00	Cs
cm		mm	mm	
125.6	15	-0.17	12.56	73.2

Verifica spostamento elastico dovuto ai soli carichi variabili (§4.2.4.2.1 - NTC 2008)

x	Comb.	δ_2	L/300.00	Cs
cm		mm	mm	
157.0	15	-0.15	10.47	67.7

Travata: 499 [358 , 356]

L = 229.9cm

Crit.Prog: Acciaio_Flessione $\delta_c = 0.0cm$ Verifica: **Verificata**

Verifica spostamento nello stato finale (§4.2.4.2.1 - NTC 2008)

x	Comb.	δ_{max}	L/250.00	Cs
---	-------	----------------	----------	----

AUTOSTRADA VALDASTICO A31 NORD
1° LOTTO - PIOVENE ROCCHETTE – VALLE DELL'ASTICO

x	Comb.	δ_{max}	L/250.00	Cs
cm		mm	mm	
91.9	21	0.04	9.19	>100

Verifica spostamento elastico dovuto ai soli carichi variabili (§4.2.4.2.1 - NTC 2008)

x	Comb.	δ_2	L/300.00	Cs
cm		mm	mm	
160.9	15	-0.01	7.66	>100

Travata: 500 [356 , 334]

L = 229.9cm

Crit.Prog: Acciaio_Flessione $\delta_c = 0.0cm$ Verifica: **Verificata**

Verifica spostamento nello stato finale (§4.2.4.2.1 - NTC 2008)

x	Comb.	δ_{max}	L/250.00	Cs
cm		mm	mm	
91.9	15	0.14	9.19	66.3

Verifica spostamento elastico dovuto ai soli carichi variabili (§4.2.4.2.1 - NTC 2008)

x	Comb.	δ_2	L/300.00	Cs
cm		mm	mm	
91.9	15	0.09	7.66	87.8

Travata: 501 [356 , 359]

L = 229.9cm

Crit.Prog: Acciaio_Flessione $\delta_c = 0.0cm$ Verifica: **Verificata**

Verifica spostamento nello stato finale (§4.2.4.2.1 - NTC 2008)

x	Comb.	δ_{max}	L/250.00	Cs
---	-------	----------------	----------	----

AUTOSTRADA VALDASTICO A31 NORD
1° LOTTO - PIOVENE ROCCHETTE – VALLE DELL'ASTICO

x	Comb.	δ_{max}	L/250.00	Cs
cm		mm	mm	
91.9	15	0.17	9.19	54.1

Verifica spostamento elastico dovuto ai soli carichi variabili (§4.2.4.2.1 - NTC 2008)

x	Comb.	δ_2	L/300.00	Cs
cm		mm	mm	
91.9	15	0.11	7.66	67.9

Travata: 502 [358 , 333]

L = 286.0cm

Crit.Prog: Acciaio_Flessione $\delta_c = 0.0cm$ Verifica: **Verificata**

Verifica spostamento nello stato finale (§4.2.4.2.1 - NTC 2008)

x	Comb.	δ_{max}	L/250.00	Cs
cm		mm	mm	
143.0	15	0.30	11.44	37.5

Verifica spostamento elastico dovuto ai soli carichi variabili (§4.2.4.2.1 - NTC 2008)

x	Comb.	δ_2	L/300.00	Cs
cm		mm	mm	
114.4	15	0.17	9.53	56.0

Travata: 503 [360 , 335]

L = 286.0cm

Crit.Prog: Acciaio_Flessione $\delta_c = 0.0cm$ Verifica: **Verificata**

Verifica spostamento nello stato finale (§4.2.4.2.1 - NTC 2008)

x	Comb.	δ_{max}	L/250.00	Cs
---	-------	----------------	----------	----

AUTOSTRADA VALDASTICO A31 NORD
1° LOTTO - PIOVENE ROCCHETTE – VALLE DELL'ASTICO

x	Comb.	δ_{max}	L/250.00	Cs
cm		mm	mm	
143.0	15	0.19	11.44	58.9

Verifica spostamento elastico dovuto ai soli carichi variabili (§4.2.4.2.1 - NTC 2008)

x	Comb.	δ_2	L/300.00	Cs
cm		mm	mm	
114.4	15	0.10	9.53	96.8

Travata: 504 [335 , 334]

L = 314.0cm

Crit.Prog: Acciaio_Flessione $\delta_c = 0.0cm$ Verifica: **Verificata**

Verifica spostamento nello stato finale (§4.2.4.2.1 - NTC 2008)

x	Comb.	δ_{max}	L/250.00	Cs
cm		mm	mm	
251.2	15	-0.11	12.56	>100

Verifica spostamento elastico dovuto ai soli carichi variabili (§4.2.4.2.1 - NTC 2008)

x	Comb.	δ_2	L/300.00	Cs
cm		mm	mm	
219.8	15	-0.09	10.47	>100

Travata: 505 [334 , 355]

L = 254.4cm

Crit.Prog: Acciaio_Flessione $\delta_c = 0.0cm$ Verifica: **Verificata**

Verifica spostamento nello stato finale (§4.2.4.2.1 - NTC 2008)

x	Comb.	δ_{max}	L/250.00	Cs
---	-------	----------------	----------	----

AUTOSTRADA VALDASTICO A31 NORD
1° LOTTO - PIOVENE ROCCHETTE – VALLE DELL'ASTICO

x	Comb.	δ_{max}	L/250.00	Cs
cm		mm	mm	
127.2	15	0.16	10.17	64.1

Verifica spostamento elastico dovuto ai soli carichi variabili (§4.2.4.2.1 - NTC 2008)

x	Comb.	δ_2	L/300.00	Cs
cm		mm	mm	
127.2	15	0.09	8.48	91.1

Travata: 506 [355 , 360]

L = 254.4cm

Crit.Prog: Acciaio_Flessione $\delta_c = 0.0cm$ Verifica: **Verificata**

Verifica spostamento nello stato finale (§4.2.4.2.1 - NTC 2008)

x	Comb.	δ_{max}	L/250.00	Cs
cm		mm	mm	
127.2	15	0.13	10.17	80.4

Verifica spostamento elastico dovuto ai soli carichi variabili (§4.2.4.2.1 - NTC 2008)

x	Comb.	δ_2	L/300.00	Cs
cm		mm	mm	
127.2	15	0.07	8.48	>100

Travata: 507 [359 , 355]

L = 254.4cm

Crit.Prog: Acciaio_Flessione $\delta_c = 0.0cm$ Verifica: **Verificata**

Verifica spostamento nello stato finale (§4.2.4.2.1 - NTC 2008)

x	Comb.	δ_{max}	L/250.00	Cs
---	-------	----------------	----------	----

AUTOSTRADA VALDASTICO A31 NORD
1° LOTTO - PIOVENE ROCCHETTE – VALLE DELL'ASTICO

x	Comb.	δ_{max}	L/250.00	Cs
cm		mm	mm	
127.2	15	0.05	10.17	>100

Verifica spostamento elastico dovuto ai soli carichi variabili (§4.2.4.2.1 - NTC 2008)

x	Comb.	δ_2	L/300.00	Cs
cm		mm	mm	
152.6	15	0.02	8.48	>100

Travata: 508 [355 , 335]

L = 254.4cm

Crit.Prog: Acciaio_Flessione $\delta_c = 0.0cm$ Verifica: **Verificata**

Verifica spostamento nello stato finale (§4.2.4.2.1 - NTC 2008)

x	Comb.	δ_{max}	L/250.00	Cs
cm		mm	mm	
178.1	15	-0.04	10.17	>100

Verifica spostamento elastico dovuto ai soli carichi variabili (§4.2.4.2.1 - NTC 2008)

x	Comb.	δ_2	L/300.00	Cs
cm		mm	mm	
152.6	15	-0.03	8.48	>100

Travata: 509 [361 , 336]

L = 286.0cm

Crit.Prog: Acciaio_Flessione $\delta_c = 0.0cm$ Verifica: **Verificata**

Verifica spostamento nello stato finale (§4.2.4.2.1 - NTC 2008)

x	Comb.	δ_{max}	L/250.00	Cs
---	-------	----------------	----------	----

AUTOSTRADA VALDASTICO A31 NORD
1° LOTTO - PIOVENE ROCCHETTE – VALLE DELL'ASTICO

x	Comb.	δ_{max}	L/250.00	Cs
cm		mm	mm	
143.0	15	0.09	11.44	>100

Verifica spostamento elastico dovuto ai soli carichi variabili (§4.2.4.2.1 - NTC 2008)

x	Comb.	δ_2	L/300.00	Cs
cm		mm	mm	
143.0	15	0.03	9.53	>100

Travata: 510 [336 , 335]

L = 314.0cm

Crit.Prog: Acciaio_Flessione $\delta_c = 0.0cm$ Verifica: **Verificata**

Verifica spostamento nello stato finale (§4.2.4.2.1 - NTC 2008)

x	Comb.	δ_{max}	L/250.00	Cs
cm		mm	mm	
157.0	15	0.34	12.56	36.5

Verifica spostamento elastico dovuto ai soli carichi variabili (§4.2.4.2.1 - NTC 2008)

x	Comb.	δ_2	L/300.00	Cs
cm		mm	mm	
157.0	15	0.18	10.47	57.9

Travata: 511 [360 , 354]

L = 273.9cm

Crit.Prog: Acciaio_Flessione $\delta_c = 0.0cm$ Verifica: **Verificata**

Verifica spostamento nello stato finale (§4.2.4.2.1 - NTC 2008)

x	Comb.	δ_{max}	L/250.00	Cs
---	-------	----------------	----------	----

AUTOSTRADA VALDASTICO A31 NORD
1° LOTTO - PIOVENE ROCCHETTE – VALLE DELL'ASTICO

x	Comb.	δ_{max}	L/250.00	Cs
cm		mm	mm	
137.0	15	0.07	10.96	>100

Verifica spostamento elastico dovuto ai soli carichi variabili (§4.2.4.2.1 - NTC 2008)

x	Comb.	δ_2	L/300.00	Cs
cm		mm	mm	
137.0	15	0.03	9.13	>100

Travata: 512 [354 , 336]

L = 273.9cm

Crit.Prog: Acciaio_Flessione $\delta_c = 0.0cm$ Verifica: **Verificata**

Verifica spostamento nello stato finale (§4.2.4.2.1 - NTC 2008)

x	Comb.	δ_{max}	L/250.00	Cs
cm		mm	mm	
137.0	15	0.06	10.96	>100

Verifica spostamento elastico dovuto ai soli carichi variabili (§4.2.4.2.1 - NTC 2008)

x	Comb.	δ_2	L/300.00	Cs
cm		mm	mm	
137.0	15	0.02	9.13	>100

Travata: 513 [335 , 354]

L = 273.9cm

Crit.Prog: Acciaio_Flessione $\delta_c = 0.0cm$ Verifica: **Verificata**

Verifica spostamento nello stato finale (§4.2.4.2.1 - NTC 2008)

x	Comb.	δ_{max}	L/250.00	Cs
---	-------	----------------	----------	----

AUTOSTRADA VALDASTICO A31 NORD
1° LOTTO - PIOVENE ROCCHETTE – VALLE DELL'ASTICO

x	Comb.	δ_{max}	L/250.00	Cs
cm		mm	mm	
137.0	15	0.18	10.96	61.9

Verifica spostamento elastico dovuto ai soli carichi variabili (§4.2.4.2.1 - NTC 2008)

x	Comb.	δ_2	L/300.00	Cs
cm		mm	mm	
137.0	15	0.10	9.13	90.0

Travata: 514 [354 , 361]

L = 273.9cm

Crit.Prog: Acciaio_Flessione $\delta_c = 0.0cm$ Verifica: **Verificata**

Verifica spostamento nello stato finale (§4.2.4.2.1 - NTC 2008)

x	Comb.	δ_{max}	L/250.00	Cs
cm		mm	mm	
137.0	15	0.12	10.96	92.9

Verifica spostamento elastico dovuto ai soli carichi variabili (§4.2.4.2.1 - NTC 2008)

x	Comb.	δ_2	L/300.00	Cs
cm		mm	mm	
137.0	15	0.06	9.13	>100

Travata: 515 [362 , 337]

L = 286.0cm

Crit.Prog: Acciaio_Flessione $\delta_c = 0.0cm$ Verifica: **Verificata**

Verifica spostamento nello stato finale (§4.2.4.2.1 - NTC 2008)

x	Comb.	δ_{max}	L/250.00	Cs
---	-------	----------------	----------	----

AUTOSTRADA VALDASTICO A31 NORD
1° LOTTO - PIOVENE ROCCHETTE – VALLE DELL'ASTICO

x	Comb.	δ_{max}	L/250.00	Cs
cm		mm	mm	
143.0	15	0.07	11.44	>100

Verifica spostamento elastico dovuto ai soli carichi variabili (§4.2.4.2.1 - NTC 2008)

x	Comb.	δ_2	L/300.00	Cs
cm		mm	mm	
143.0	15	0.02	9.53	>100

Travata: 516 [337 , 336]

L = 314.0cm

Crit.Prog: Acciaio_Flessione $\delta_c = 0.0cm$ Verifica: **Verificata**

Verifica spostamento nello stato finale (§4.2.4.2.1 - NTC 2008)

x	Comb.	δ_{max}	L/250.00	Cs
cm		mm	mm	
157.0	15	0.42	12.56	29.9

Verifica spostamento elastico dovuto ai soli carichi variabili (§4.2.4.2.1 - NTC 2008)

x	Comb.	δ_2	L/300.00	Cs
cm		mm	mm	
157.0	15	0.23	10.47	46.0

Travata: 517 [361 , 353]

L = 281.6cm

Crit.Prog: Acciaio_Flessione $\delta_c = 0.0cm$ Verifica: **Verificata**

Verifica spostamento nello stato finale (§4.2.4.2.1 - NTC 2008)

x	Comb.	δ_{max}	L/250.00	Cs
---	-------	----------------	----------	----

AUTOSTRADA VALDASTICO A31 NORD
1° LOTTO - PIOVENE ROCCHETTE – VALLE DELL'ASTICO

x	Comb.	δ_{max}	L/250.00	Cs
cm		mm	mm	
140.8	15	0.10	11.27	>100

Verifica spostamento elastico dovuto ai soli carichi variabili (§4.2.4.2.1 - NTC 2008)

x	Comb.	δ_2	L/300.00	Cs
cm		mm	mm	
140.8	15	0.05	9.39	>100

Travata: 518 [353 , 362]

L = 281.6cm

Crit.Prog: Acciaio_Flessione $\delta_c = 0.0cm$ Verifica: **Verificata**

Verifica spostamento nello stato finale (§4.2.4.2.1 - NTC 2008)

x	Comb.	δ_{max}	L/250.00	Cs
cm		mm	mm	
140.8	15	0.11	11.27	99.0

Verifica spostamento elastico dovuto ai soli carichi variabili (§4.2.4.2.1 - NTC 2008)

x	Comb.	δ_2	L/300.00	Cs
cm		mm	mm	
140.8	15	0.06	9.39	>100

Travata: 519 [336 , 353]

L = 281.6cm

Crit.Prog: Acciaio_Flessione $\delta_c = 0.0cm$ Verifica: **Verificata**

Verifica spostamento nello stato finale (§4.2.4.2.1 - NTC 2008)

x	Comb.	δ_{max}	L/250.00	Cs
---	-------	----------------	----------	----

AUTOSTRADA VALDASTICO A31 NORD
1° LOTTO - PIOVENE ROCCHETTE – VALLE DELL'ASTICO

x	Comb.	δ_{max}	L/250.00	Cs
cm		mm	mm	
140.8	15	0.14	11.27	82.8

Verifica spostamento elastico dovuto ai soli carichi variabili (§4.2.4.2.1 - NTC 2008)

x	Comb.	δ_2	L/300.00	Cs
cm		mm	mm	
140.8	15	0.07	9.39	>100

Travata: 520 [353 , 337]

L = 281.6cm

Crit.Prog: Acciaio_Flessione $\delta_c = 0.0cm$ Verifica: **Verificata**

Verifica spostamento nello stato finale (§4.2.4.2.1 - NTC 2008)

x	Comb.	δ_{max}	L/250.00	Cs
cm		mm	mm	
140.8	15	0.11	11.27	>100

Verifica spostamento elastico dovuto ai soli carichi variabili (§4.2.4.2.1 - NTC 2008)

x	Comb.	δ_2	L/300.00	Cs
cm		mm	mm	
140.8	15	0.06	9.39	>100

Travata: 521 [337 , 352]

L = 281.6cm

Crit.Prog: Acciaio_Flessione $\delta_c = 0.0cm$ Verifica: **Verificata**

Verifica spostamento nello stato finale (§4.2.4.2.1 - NTC 2008)

x	Comb.	δ_{max}	L/250.00	Cs
---	-------	----------------	----------	----

AUTOSTRADA VALDASTICO A31 NORD
1° LOTTO - PIOVENE ROCCHETTE – VALLE DELL'ASTICO

x	Comb.	δ_{max}	L/250.00	Cs
cm		mm	mm	
140.8	15	0.11	11.27	>100

Verifica spostamento elastico dovuto ai soli carichi variabili (§4.2.4.2.1 - NTC 2008)

x	Comb.	δ_2	L/300.00	Cs
cm		mm	mm	
140.8	15	0.06	9.39	>100

Travata: 522 [352 , 363]

L = 281.6cm

Crit.Prog: Acciaio_Flessione $\delta_c = 0.0cm$ Verifica: **Verificata**

Verifica spostamento nello stato finale (§4.2.4.2.1 - NTC 2008)

x	Comb.	δ_{max}	L/250.00	Cs
cm		mm	mm	
140.8	15	0.10	11.27	>100

Verifica spostamento elastico dovuto ai soli carichi variabili (§4.2.4.2.1 - NTC 2008)

x	Comb.	δ_2	L/300.00	Cs
cm		mm	mm	
140.8	15	0.05	9.39	>100

Travata: 523 [363 , 338]

L = 286.0cm

Crit.Prog: Acciaio_Flessione $\delta_c = 0.0cm$ Verifica: **Verificata**

Verifica spostamento nello stato finale (§4.2.4.2.1 - NTC 2008)

x	Comb.	δ_{max}	L/250.00	Cs
---	-------	----------------	----------	----

AUTOSTRADA VALDASTICO A31 NORD
1° LOTTO - PIOVENE ROCCHETTE – VALLE DELL'ASTICO

x	Comb.	δ_{max}	L/250.00	Cs
cm		mm	mm	
143.0	15	0.09	11.44	>100

Verifica spostamento elastico dovuto ai soli carichi variabili (§4.2.4.2.1 - NTC 2008)

x	Comb.	δ_2	L/300.00	Cs
cm		mm	mm	
143.0	15	0.03	9.53	>100

Travata: 524 [338 , 337]

L = 314.0cm

Crit.Prog: Acciaio_Flessione $\delta_c = 0.0cm$ Verifica: **Verificata**

Verifica spostamento nello stato finale (§4.2.4.2.1 - NTC 2008)

x	Comb.	δ_{max}	L/250.00	Cs
cm		mm	mm	
157.0	15	0.42	12.56	29.9

Verifica spostamento elastico dovuto ai soli carichi variabili (§4.2.4.2.1 - NTC 2008)

x	Comb.	δ_2	L/300.00	Cs
cm		mm	mm	
157.0	15	0.23	10.47	46.0

Travata: 525 [362 , 352]

L = 281.6cm

Crit.Prog: Acciaio_Flessione $\delta_c = 0.0cm$ Verifica: **Verificata**

Verifica spostamento nello stato finale (§4.2.4.2.1 - NTC 2008)

x	Comb.	δ_{max}	L/250.00	Cs
---	-------	----------------	----------	----

AUTOSTRADA VALDASTICO A31 NORD
1° LOTTO - PIOVENE ROCCHETTE – VALLE DELL'ASTICO

x	Comb.	δ_{max}	L/250.00	Cs
cm		mm	mm	
140.8	15	0.11	11.27	99.0

Verifica spostamento elastico dovuto ai soli carichi variabili (§4.2.4.2.1 - NTC 2008)

x	Comb.	δ_2	L/300.00	Cs
cm		mm	mm	
140.8	15	0.06	9.39	>100

Travata: 526 [352 , 338]

L = 281.6cm

Crit.Prog: Acciaio_Flessione $\delta_c = 0.0cm$ Verifica: **Verificata**

Verifica spostamento nello stato finale (§4.2.4.2.1 - NTC 2008)

x	Comb.	δ_{max}	L/250.00	Cs
cm		mm	mm	
140.8	15	0.14	11.27	82.8

Verifica spostamento elastico dovuto ai soli carichi variabili (§4.2.4.2.1 - NTC 2008)

x	Comb.	δ_2	L/300.00	Cs
cm		mm	mm	
140.8	15	0.07	9.39	>100

Travata: 527 [364 , 339]

L = 286.0cm

Crit.Prog: Acciaio_Flessione $\delta_c = 0.0cm$ Verifica: **Verificata**

Verifica spostamento nello stato finale (§4.2.4.2.1 - NTC 2008)

x	Comb.	δ_{max}	L/250.00	Cs
---	-------	----------------	----------	----

AUTOSTRADA VALDASTICO A31 NORD
1° LOTTO - PIOVENE ROCCHETTE – VALLE DELL'ASTICO

x	Comb.	δ_{max}	L/250.00	Cs
cm		mm	mm	
143.0	15	0.20	11.44	58.6

Verifica spostamento elastico dovuto ai soli carichi variabili (§4.2.4.2.1 - NTC 2008)

x	Comb.	δ_2	L/300.00	Cs
cm		mm	mm	
114.4	15	0.10	9.53	96.7

Travata: 528 [339 , 338]

L = 314.0cm

Crit.Prog: Acciaio_Flessione $\delta_c = 0.0cm$ Verifica: **Verificata**

Verifica spostamento nello stato finale (§4.2.4.2.1 - NTC 2008)

x	Comb.	δ_{max}	L/250.00	Cs
cm		mm	mm	
157.0	15	0.34	12.56	36.7

Verifica spostamento elastico dovuto ai soli carichi variabili (§4.2.4.2.1 - NTC 2008)

x	Comb.	δ_2	L/300.00	Cs
cm		mm	mm	
157.0	15	0.18	10.47	58.0

Travata: 529 [338 , 351]

L = 273.9cm

Crit.Prog: Acciaio_Flessione $\delta_c = 0.0cm$ Verifica: **Verificata**

Verifica spostamento nello stato finale (§4.2.4.2.1 - NTC 2008)

x	Comb.	δ_{max}	L/250.00	Cs
---	-------	----------------	----------	----

AUTOSTRADA VALDASTICO A31 NORD
1° LOTTO - PIOVENE ROCCHETTE – VALLE DELL'ASTICO

x	Comb.	δ_{max}	L/250.00	Cs
cm		mm	mm	
137.0	15	0.06	10.96	>100

Verifica spostamento elastico dovuto ai soli carichi variabili (§4.2.4.2.1 - NTC 2008)

x	Comb.	δ_2	L/300.00	Cs
cm		mm	mm	
137.0	15	0.02	9.13	>100

Travata: 530 [351 , 364]

L = 273.9cm

Crit.Prog: Acciaio_Flessione $\delta_c = 0.0cm$ Verifica: **Verificata**

Verifica spostamento nello stato finale (§4.2.4.2.1 - NTC 2008)

x	Comb.	δ_{max}	L/250.00	Cs
cm		mm	mm	
137.0	15	0.07	10.96	>100

Verifica spostamento elastico dovuto ai soli carichi variabili (§4.2.4.2.1 - NTC 2008)

x	Comb.	δ_2	L/300.00	Cs
cm		mm	mm	
137.0	15	0.03	9.13	>100

Travata: 531 [363 , 351]

L = 273.9cm

Crit.Prog: Acciaio_Flessione $\delta_c = 0.0cm$ Verifica: **Verificata**

Verifica spostamento nello stato finale (§4.2.4.2.1 - NTC 2008)

x	Comb.	δ_{max}	L/250.00	Cs
---	-------	----------------	----------	----

AUTOSTRADA VALDASTICO A31 NORD
1° LOTTO - PIOVENE ROCCHETTE – VALLE DELL'ASTICO

x	Comb.	δ_{max}	L/250.00	Cs
cm		mm	mm	
137.0	15	0.12	10.96	93.1

Verifica spostamento elastico dovuto ai soli carichi variabili (§4.2.4.2.1 - NTC 2008)

x	Comb.	δ_2	L/300.00	Cs
cm		mm	mm	
137.0	15	0.06	9.13	>100

Travata: 532 [351 , 339]

L = 273.9cm

Crit.Prog: Acciaio_Flessione $\delta_c = 0.0cm$ Verifica: **Verificata**

Verifica spostamento nello stato finale (§4.2.4.2.1 - NTC 2008)

x	Comb.	δ_{max}	L/250.00	Cs
cm		mm	mm	
137.0	15	0.18	10.96	62.0

Verifica spostamento elastico dovuto ai soli carichi variabili (§4.2.4.2.1 - NTC 2008)

x	Comb.	δ_2	L/300.00	Cs
cm		mm	mm	
137.0	15	0.10	9.13	90.0

Travata: 533 [339 , 340]

L = 314.0cm

Crit.Prog: Acciaio_Flessione $\delta_c = 0.0cm$ Verifica: **Verificata**

Verifica spostamento nello stato finale (§4.2.4.2.1 - NTC 2008)

x	Comb.	δ_{max}	L/250.00	Cs
---	-------	----------------	----------	----

AUTOSTRADA VALDASTICO A31 NORD
1° LOTTO - PIOVENE ROCCHETTE – VALLE DELL'ASTICO

x	Comb.	δ_{max}	L/250.00	Cs
cm		mm	mm	
251.2	15	-0.12	12.56	>100

Verifica spostamento elastico dovuto ai soli carichi variabili (§4.2.4.2.1 - NTC 2008)

x	Comb.	δ_2	L/300.00	Cs
cm		mm	mm	
219.8	15	-0.09	10.47	>100

Travata: 534 [340 , 365]

L = 286.0cm

Crit.Prog: Acciaio_Flessione $\delta_c = 0.0cm$ Verifica: **Verificata**

Verifica spostamento nello stato finale (§4.2.4.2.1 - NTC 2008)

x	Comb.	δ_{max}	L/250.00	Cs
cm		mm	mm	
143.0	15	0.48	11.44	23.7

Verifica spostamento elastico dovuto ai soli carichi variabili (§4.2.4.2.1 - NTC 2008)

x	Comb.	δ_2	L/300.00	Cs
cm		mm	mm	
143.0	15	0.28	9.53	34.4

Travata: 535 [364 , 350]

L = 254.4cm

Crit.Prog: Acciaio_Flessione $\delta_c = 0.0cm$ Verifica: **Verificata**

Verifica spostamento nello stato finale (§4.2.4.2.1 - NTC 2008)

x	Comb.	δ_{max}	L/250.00	Cs
---	-------	----------------	----------	----

AUTOSTRADA VALDASTICO A31 NORD
1° LOTTO - PIOVENE ROCCHETTE – VALLE DELL'ASTICO

x	Comb.	δ_{max}	L/250.00	Cs
cm		mm	mm	
127.2	15	0.13	10.17	80.6

Verifica spostamento elastico dovuto ai soli carichi variabili (§4.2.4.2.1 - NTC 2008)

x	Comb.	δ_2	L/300.00	Cs
cm		mm	mm	
127.2	15	0.07	8.48	>100

Travata: 536 [350 , 365]

L = 254.4cm

Crit.Prog: Acciaio_Flessione $\delta_c = 0.0cm$ Verifica: **Verificata**

Verifica spostamento nello stato finale (§4.2.4.2.1 - NTC 2008)

x	Comb.	δ_{max}	L/250.00	Cs
cm		mm	mm	
127.2	15	0.05	10.17	>100

Verifica spostamento elastico dovuto ai soli carichi variabili (§4.2.4.2.1 - NTC 2008)

x	Comb.	δ_2	L/300.00	Cs
cm		mm	mm	
101.7	15	0.02	8.48	>100

Travata: 537 [339 , 350]

L = 254.4cm

Crit.Prog: Acciaio_Flessione $\delta_c = 0.0cm$ Verifica: **Verificata**

Verifica spostamento nello stato finale (§4.2.4.2.1 - NTC 2008)

x	Comb.	δ_{max}	L/250.00	Cs
---	-------	----------------	----------	----

AUTOSTRADA VALDASTICO A31 NORD
1° LOTTO - PIOVENE ROCCHETTE – VALLE DELL'ASTICO

x	Comb.	δ_{max}	L/250.00	Cs
cm		mm	mm	
76.3	15	-0.04	10.17	>100

Verifica spostamento elastico dovuto ai soli carichi variabili (§4.2.4.2.1 - NTC 2008)

x	Comb.	δ_2	L/300.00	Cs
cm		mm	mm	
101.7	15	-0.03	8.48	>100

Travata: 538 [350 , 340]

L = 254.4cm

Crit.Prog: Acciaio_Flessione $\delta_c = 0.0cm$ Verifica: **Verificata**

Verifica spostamento nello stato finale (§4.2.4.2.1 - NTC 2008)

x	Comb.	δ_{max}	L/250.00	Cs
cm		mm	mm	
127.2	15	0.16	10.17	65.2

Verifica spostamento elastico dovuto ai soli carichi variabili (§4.2.4.2.1 - NTC 2008)

x	Comb.	δ_2	L/300.00	Cs
cm		mm	mm	
127.2	15	0.09	8.48	91.7

Travata: 539 [366 , 341]

L = 286.0cm

Crit.Prog: Acciaio_Flessione $\delta_c = 0.0cm$ Verifica: **Verificata**

Verifica spostamento nello stato finale (§4.2.4.2.1 - NTC 2008)

x	Comb.	δ_{max}	L/250.00	Cs
---	-------	----------------	----------	----

AUTOSTRADA VALDASTICO A31 NORD
1° LOTTO - PIOVENE ROCCHETTE – VALLE DELL'ASTICO

x	Comb.	δ_{max}	L/250.00	Cs
cm		mm	mm	
143.0	15	0.29	11.44	38.8

Verifica spostamento elastico dovuto ai soli carichi variabili (§4.2.4.2.1 - NTC 2008)

x	Comb.	δ_2	L/300.00	Cs
cm		mm	mm	
114.4	15	0.17	9.53	56.7

Travata: 540 [341 , 340]

L = 314.0cm

Crit.Prog: Acciaio_Flessione $\delta_c = 0.0cm$ Verifica: **Verificata**

Verifica spostamento nello stato finale (§4.2.4.2.1 - NTC 2008)

x	Comb.	δ_{max}	L/250.00	Cs
cm		mm	mm	
188.4	15	-0.18	12.56	70.5

Verifica spostamento elastico dovuto ai soli carichi variabili (§4.2.4.2.1 - NTC 2008)

x	Comb.	δ_2	L/300.00	Cs
cm		mm	mm	
157.0	15	-0.16	10.47	66.9

Travata: 541 [365 , 357]

L = 229.9cm

Crit.Prog: Acciaio_Flessione $\delta_c = 0.0cm$ Verifica: **Verificata**

Verifica spostamento nello stato finale (§4.2.4.2.1 - NTC 2008)

x	Comb.	δ_{max}	L/250.00	Cs
---	-------	----------------	----------	----

AUTOSTRADA VALDASTICO A31 NORD
1° LOTTO - PIOVENE ROCCHETTE – VALLE DELL'ASTICO

x	Comb.	δ_{max}	L/250.00	Cs
cm		mm	mm	
137.9	15	0.17	9.19	54.7

Verifica spostamento elastico dovuto ai soli carichi variabili (§4.2.4.2.1 - NTC 2008)

x	Comb.	δ_2	L/300.00	Cs
cm		mm	mm	
137.9	15	0.11	7.66	68.2

Travata: 542 [357 , 341]

L = 229.9cm

Crit.Prog: Acciaio_Flessione $\delta_c = 0.0cm$ Verifica: **Verificata**

Verifica spostamento nello stato finale (§4.2.4.2.1 - NTC 2008)

x	Comb.	δ_{max}	L/250.00	Cs
cm		mm	mm	
114.9	15	-0.09	9.19	>100

Verifica spostamento elastico dovuto ai soli carichi variabili (§4.2.4.2.1 - NTC 2008)

x	Comb.	δ_2	L/300.00	Cs
cm		mm	mm	
114.9	15	-0.07	7.66	>100

Travata: 543 [357 , 366]

L = 229.9cm

Crit.Prog: Acciaio_Flessione $\delta_c = 0.0cm$ Verifica: **Verificata**

Verifica spostamento nello stato finale (§4.2.4.2.1 - NTC 2008)

x	Comb.	δ_{max}	L/250.00	Cs
---	-------	----------------	----------	----

AUTOSTRADA VALDASTICO A31 NORD
1° LOTTO - PIOVENE ROCCHETTE – VALLE DELL'ASTICO

x	Comb.	δ_{max}	L/250.00	Cs
cm		mm	mm	
137.9	21	0.04	9.19	>100

Verifica spostamento elastico dovuto ai soli carichi variabili (§4.2.4.2.1 - NTC 2008)

x	Comb.	δ_2	L/300.00	Cs
cm		mm	mm	
69.0	15	-0.01	7.66	>100

Travata: 544 [356 , 355]

L = 318.3cm

Crit.Prog: Acciaio_Flessione $\delta_c = 0.0cm$ Verifica: **Verificata**

Verifica spostamento nello stato finale (§4.2.4.2.1 - NTC 2008)

x	Comb.	δ_{max}	L/250.00	Cs
cm		mm	mm	
159.1	15	2.48	12.73	5.13

Verifica spostamento elastico dovuto ai soli carichi variabili (§4.2.4.2.1 - NTC 2008)

x	Comb.	δ_2	L/300.00	Cs
cm		mm	mm	
159.1	15	1.85	10.61	5.74

Travata: 545 [355 , 354]

L = 315.7cm

Crit.Prog: Acciaio_Flessione $\delta_c = 0.0cm$ Verifica: **Verificata**

Verifica spostamento nello stato finale (§4.2.4.2.1 - NTC 2008)

x	Comb.	δ_{max}	L/250.00	Cs
---	-------	----------------	----------	----

AUTOSTRADA VALDASTICO A31 NORD
1° LOTTO - PIOVENE ROCCHETTE – VALLE DELL'ASTICO

x	Comb.	δ_{max}	L/250.00	Cs
cm		mm	mm	
157.9	15	2.56	12.63	4.94

Verifica spostamento elastico dovuto ai soli carichi variabili (§4.2.4.2.1 - NTC 2008)

x	Comb.	δ_2	L/300.00	Cs
cm		mm	mm	
157.9	15	1.87	10.52	5.63

Travata: 546 [354 , 353]

L = 314.2cm

Crit.Prog: Acciaio_Flessione $\delta_c = 0.0cm$ Verifica: **Verificata**

Verifica spostamento nello stato finale (§4.2.4.2.1 - NTC 2008)

x	Comb.	δ_{max}	L/250.00	Cs
cm		mm	mm	
157.1	15	2.70	12.57	4.65

Verifica spostamento elastico dovuto ai soli carichi variabili (§4.2.4.2.1 - NTC 2008)

x	Comb.	δ_2	L/300.00	Cs
cm		mm	mm	
157.1	15	1.96	10.47	5.35

Travata: 547 [353 , 352]

L = 314.0cm

Crit.Prog: Acciaio_Flessione $\delta_c = 0.0cm$ Verifica: **Verificata**

Verifica spostamento nello stato finale (§4.2.4.2.1 - NTC 2008)

x	Comb.	δ_{max}	L/250.00	Cs
---	-------	----------------	----------	----

AUTOSTRADA VALDASTICO A31 NORD
1° LOTTO - PIOVENE ROCCHETTE – VALLE DELL'ASTICO

x	Comb.	δ_{max}	L/250.00	Cs
cm		mm	mm	
157.0	15	2.76	12.56	4.56

Verifica spostamento elastico dovuto ai soli carichi variabili (§4.2.4.2.1 - NTC 2008)

x	Comb.	δ_2	L/300.00	Cs
cm		mm	mm	
157.0	15	1.99	10.47	5.26

Travata: 548 [352 , 351]

L = 314.2cm

Crit.Prog: Acciaio_Flessione $\delta_c = 0.0cm$ Verifica: **Verificata**

Verifica spostamento nello stato finale (§4.2.4.2.1 - NTC 2008)

x	Comb.	δ_{max}	L/250.00	Cs
cm		mm	mm	
157.1	15	2.70	12.57	4.65

Verifica spostamento elastico dovuto ai soli carichi variabili (§4.2.4.2.1 - NTC 2008)

x	Comb.	δ_2	L/300.00	Cs
cm		mm	mm	
157.1	15	1.96	10.47	5.35

Travata: 549 [351 , 350]

L = 315.7cm

Crit.Prog: Acciaio_Flessione $\delta_c = 0.0cm$ Verifica: **Verificata**

Verifica spostamento nello stato finale (§4.2.4.2.1 - NTC 2008)

x	Comb.	δ_{max}	L/250.00	Cs
---	-------	----------------	----------	----

AUTOSTRADA VALDASTICO A31 NORD
1° LOTTO - PIOVENE ROCCHETTE – VALLE DELL'ASTICO

x	Comb.	δ_{max}	L/250.00	Cs
cm		mm	mm	
157.9	15	2.55	12.63	4.95

Verifica spostamento elastico dovuto ai soli carichi variabili (§4.2.4.2.1 - NTC 2008)

x	Comb.	δ_2	L/300.00	Cs
cm		mm	mm	
157.9	15	1.87	10.52	5.63

Travata: 550 [350 , 357]

L = 318.3cm

Crit.Prog: Acciaio_Flessione $\delta_c = 0.0cm$ Verifica: **Verificata**

Verifica spostamento nello stato finale (§4.2.4.2.1 - NTC 2008)

x	Comb.	δ_{max}	L/250.00	Cs
cm		mm	mm	
159.1	15	2.48	12.73	5.14

Verifica spostamento elastico dovuto ai soli carichi variabili (§4.2.4.2.1 - NTC 2008)

x	Comb.	δ_2	L/300.00	Cs
cm		mm	mm	
159.1	15	1.85	10.61	5.74

Travata: 551 [358 , 373]

L = 229.9cm

Crit.Prog: Acciaio_Flessione $\delta_c = 0.0cm$ Verifica: **Verificata**

Verifica spostamento nello stato finale (§4.2.4.2.1 - NTC 2008)

x	Comb.	δ_{max}	L/250.00	Cs
---	-------	----------------	----------	----

AUTOSTRADA VALDASTICO A31 NORD
1° LOTTO - PIOVENE ROCCHETTE – VALLE DELL'ASTICO

x	Comb.	δ_{max}	L/250.00	Cs
cm		mm	mm	
91.9	15	0.06	9.19	>100

Verifica spostamento elastico dovuto ai soli carichi variabili (§4.2.4.2.1 - NTC 2008)

x	Comb.	δ_2	L/300.00	Cs
cm		mm	mm	
69.0	15	0.02	7.66	>100

Travata: 552 [376 , 359]

L = 286.0cm

Crit.Prog: Acciaio_Flessione $\delta_c = 0.0cm$ Verifica: **Verificata**

Verifica spostamento nello stato finale (§4.2.4.2.1 - NTC 2008)

x	Comb.	δ_{max}	L/250.00	Cs
cm		mm	mm	
143.0	15	0.47	11.44	24.3

Verifica spostamento elastico dovuto ai soli carichi variabili (§4.2.4.2.1 - NTC 2008)

x	Comb.	δ_2	L/300.00	Cs
cm		mm	mm	
143.0	15	0.27	9.53	34.7

Travata: 553 [359 , 358]

L = 314.0cm

Crit.Prog: Acciaio_Flessione $\delta_c = 0.0cm$ Verifica: **Verificata**

Verifica spostamento nello stato finale (§4.2.4.2.1 - NTC 2008)

x	Comb.	δ_{max}	L/250.00	Cs
---	-------	----------------	----------	----

AUTOSTRADA VALDASTICO A31 NORD
1° LOTTO - PIOVENE ROCCHETTE – VALLE DELL'ASTICO

x	Comb.	δ_{max}	L/250.00	Cs
cm		mm	mm	
251.2	15	-0.04	12.56	>100

Verifica spostamento elastico dovuto ai soli carichi variabili (§4.2.4.2.1 - NTC 2008)

x	Comb.	δ_2	L/300.00	Cs
cm		mm	mm	
188.4	15	-0.07	10.47	>100

Travata: 554 [375 , 373]

L = 229.9cm

Crit.Prog: Acciaio_Flessione $\delta_c = 0.0cm$ Verifica: **Verificata**

Verifica spostamento nello stato finale (§4.2.4.2.1 - NTC 2008)

x	Comb.	δ_{max}	L/250.00	Cs
cm		mm	mm	
114.9	15	-0.08	9.19	>100

Verifica spostamento elastico dovuto ai soli carichi variabili (§4.2.4.2.1 - NTC 2008)

x	Comb.	δ_2	L/300.00	Cs
cm		mm	mm	
114.9	15	-0.07	7.66	>100

Travata: 555 [373 , 359]

L = 229.9cm

Crit.Prog: Acciaio_Flessione $\delta_c = 0.0cm$ Verifica: **Verificata**

Verifica spostamento nello stato finale (§4.2.4.2.1 - NTC 2008)

x	Comb.	δ_{max}	L/250.00	Cs
---	-------	----------------	----------	----

AUTOSTRADA VALDASTICO A31 NORD
1° LOTTO - PIOVENE ROCCHETTE – VALLE DELL'ASTICO

x	Comb.	δ_{max}	L/250.00	Cs
cm		mm	mm	
91.9	15	0.15	9.19	61.7

Verifica spostamento elastico dovuto ai soli carichi variabili (§4.2.4.2.1 - NTC 2008)

x	Comb.	δ_2	L/300.00	Cs
cm		mm	mm	
91.9	15	0.10	7.66	80.0

Travata: 556 [373 , 376]

L = 229.9cm

Crit.Prog: Acciaio_Flessione $\delta_c = 0.0cm$ Verifica: **Verificata**

Verifica spostamento nello stato finale (§4.2.4.2.1 - NTC 2008)

x	Comb.	δ_{max}	L/250.00	Cs
cm		mm	mm	
91.9	15	0.16	9.19	58.2

Verifica spostamento elastico dovuto ai soli carichi variabili (§4.2.4.2.1 - NTC 2008)

x	Comb.	δ_2	L/300.00	Cs
cm		mm	mm	
91.9	15	0.11	7.66	72.1

Travata: 557 [375 , 358]

L = 286.0cm

Crit.Prog: Acciaio_Flessione $\delta_c = 0.0cm$ Verifica: **Verificata**

Verifica spostamento nello stato finale (§4.2.4.2.1 - NTC 2008)

x	Comb.	δ_{max}	L/250.00	Cs
---	-------	----------------	----------	----

AUTOSTRADA VALDASTICO A31 NORD
1° LOTTO - PIOVENE ROCCHETTE – VALLE DELL'ASTICO

x	Comb.	δ_{max}	L/250.00	Cs
cm		mm	mm	
143.0	15	0.33	11.44	34.6

Verifica spostamento elastico dovuto ai soli carichi variabili (§4.2.4.2.1 - NTC 2008)

x	Comb.	δ_2	L/300.00	Cs
cm		mm	mm	
143.0	15	0.20	9.53	48.3

Travata: 558 [377 , 360]

L = 286.0cm

Crit.Prog: Acciaio_Flessione $\delta_c = 0.0cm$ Verifica: **Verificata**

Verifica spostamento nello stato finale (§4.2.4.2.1 - NTC 2008)

x	Comb.	δ_{max}	L/250.00	Cs
cm		mm	mm	
143.0	15	0.20	11.44	58.4

Verifica spostamento elastico dovuto ai soli carichi variabili (§4.2.4.2.1 - NTC 2008)

x	Comb.	δ_2	L/300.00	Cs
cm		mm	mm	
171.6	15	0.10	9.53	93.0

Travata: 559 [360 , 359]

L = 314.0cm

Crit.Prog: Acciaio_Flessione $\delta_c = 0.0cm$ Verifica: **Verificata**

Verifica spostamento nello stato finale (§4.2.4.2.1 - NTC 2008)

x	Comb.	δ_{max}	L/250.00	Cs
---	-------	----------------	----------	----

AUTOSTRADA VALDASTICO A31 NORD
1° LOTTO - PIOVENE ROCCHETTE – VALLE DELL'ASTICO

x	Comb.	δ_{max}	L/250.00	Cs
cm		mm	mm	
125.6	21	0.05	12.56	>100

Verifica spostamento elastico dovuto ai soli carichi variabili (§4.2.4.2.1 - NTC 2008)

x	Comb.	δ_2	L/300.00	Cs
cm		mm	mm	
219.8	15	-0.02	10.47	>100

Travata: 560 [359 , 372]

L = 254.4cm

Crit.Prog: Acciaio_Flessione $\delta_c = 0.0cm$ Verifica: **Verificata**

Verifica spostamento nello stato finale (§4.2.4.2.1 - NTC 2008)

x	Comb.	δ_{max}	L/250.00	Cs
cm		mm	mm	
127.2	15	0.08	10.17	>100

Verifica spostamento elastico dovuto ai soli carichi variabili (§4.2.4.2.1 - NTC 2008)

x	Comb.	δ_2	L/300.00	Cs
cm		mm	mm	
127.2	15	0.04	8.48	>100

Travata: 561 [372 , 377]

L = 254.4cm

Crit.Prog: Acciaio_Flessione $\delta_c = 0.0cm$ Verifica: **Verificata**

Verifica spostamento nello stato finale (§4.2.4.2.1 - NTC 2008)

x	Comb.	δ_{max}	L/250.00	Cs
---	-------	----------------	----------	----

AUTOSTRADA VALDASTICO A31 NORD
1° LOTTO - PIOVENE ROCCHETTE – VALLE DELL'ASTICO

x	Comb.	δ_{max}	L/250.00	Cs
cm		mm	mm	
203.5	15	-0.01	10.17	>100

Verifica spostamento elastico dovuto ai soli carichi variabili (§4.2.4.2.1 - NTC 2008)

x	Comb.	δ_2	L/300.00	Cs
cm		mm	mm	
178.1	15	-0.01	8.48	>100

Travata: 562 [376 , 372]

L = 254.4cm

Crit.Prog: Acciaio_Flessione $\delta_c = 0.0cm$ Verifica: **Verificata**

Verifica spostamento nello stato finale (§4.2.4.2.1 - NTC 2008)

x	Comb.	δ_{max}	L/250.00	Cs
cm		mm	mm	
127.2	15	0.13	10.17	77.9

Verifica spostamento elastico dovuto ai soli carichi variabili (§4.2.4.2.1 - NTC 2008)

x	Comb.	δ_2	L/300.00	Cs
cm		mm	mm	
127.2	15	0.07	8.48	>100

Travata: 563 [372 , 360]

L = 254.4cm

Crit.Prog: Acciaio_Flessione $\delta_c = 0.0cm$ Verifica: **Verificata**

Verifica spostamento nello stato finale (§4.2.4.2.1 - NTC 2008)

x	Comb.	δ_{max}	L/250.00	Cs
---	-------	----------------	----------	----

AUTOSTRADA VALDASTICO A31 NORD
1° LOTTO - PIOVENE ROCCHETTE – VALLE DELL'ASTICO

x	Comb.	δ_{max}	L/250.00	Cs
cm		mm	mm	
127.2	15	0.10	10.17	>100

Verifica spostamento elastico dovuto ai soli carichi variabili (§4.2.4.2.1 - NTC 2008)

x	Comb.	δ_2	L/300.00	Cs
cm		mm	mm	
127.2	15	0.05	8.48	>100

Travata: 564 [378 , 361]

L = 286.0cm

Crit.Prog: Acciaio_Flessione $\delta_c = 0.0cm$ Verifica: **Verificata**

Verifica spostamento nello stato finale (§4.2.4.2.1 - NTC 2008)

x	Comb.	δ_{max}	L/250.00	Cs
cm		mm	mm	
143.0	15	0.09	11.44	>100

Verifica spostamento elastico dovuto ai soli carichi variabili (§4.2.4.2.1 - NTC 2008)

x	Comb.	δ_2	L/300.00	Cs
cm		mm	mm	
143.0	15	0.03	9.53	>100

Travata: 565 [361 , 360]

L = 314.0cm

Crit.Prog: Acciaio_Flessione $\delta_c = 0.0cm$ Verifica: **Verificata**

Verifica spostamento nello stato finale (§4.2.4.2.1 - NTC 2008)

x	Comb.	δ_{max}	L/250.00	Cs
---	-------	----------------	----------	----

AUTOSTRADA VALDASTICO A31 NORD
1° LOTTO - PIOVENE ROCCHETTE – VALLE DELL'ASTICO

x	Comb.	δ_{max}	L/250.00	Cs
cm		mm	mm	
157.0	15	0.26	12.56	49.0

Verifica spostamento elastico dovuto ai soli carichi variabili (§4.2.4.2.1 - NTC 2008)

x	Comb.	δ_2	L/300.00	Cs
cm		mm	mm	
125.6	15	0.12	10.47	84.4

Travata: 566 [377 , 371]

L = 273.9cm

Crit.Prog: Acciaio_Flessione $\delta_c = 0.0cm$ Verifica: **Verificata**

Verifica spostamento nello stato finale (§4.2.4.2.1 - NTC 2008)

x	Comb.	δ_{max}	L/250.00	Cs
cm		mm	mm	
137.0	15	0.15	10.96	73.9

Verifica spostamento elastico dovuto ai soli carichi variabili (§4.2.4.2.1 - NTC 2008)

x	Comb.	δ_2	L/300.00	Cs
cm		mm	mm	
137.0	15	0.08	9.13	>100

Travata: 567 [371 , 361]

L = 273.9cm

Crit.Prog: Acciaio_Flessione $\delta_c = 0.0cm$ Verifica: **Verificata**

Verifica spostamento nello stato finale (§4.2.4.2.1 - NTC 2008)

x	Comb.	δ_{max}	L/250.00	Cs
---	-------	----------------	----------	----

AUTOSTRADA VALDASTICO A31 NORD
1° LOTTO - PIOVENE ROCCHETTE – VALLE DELL'ASTICO

x	Comb.	δ_{max}	L/250.00	Cs
cm		mm	mm	
137.0	15	0.10	10.96	>100

Verifica spostamento elastico dovuto ai soli carichi variabili (§4.2.4.2.1 - NTC 2008)

x	Comb.	δ_2	L/300.00	Cs
cm		mm	mm	
137.0	15	0.05	9.13	>100

Travata: 568 [360 , 371]

L = 273.9cm

Crit.Prog: Acciaio_Flessione $\delta_c = 0.0cm$ Verifica: **Verificata**

Verifica spostamento nello stato finale (§4.2.4.2.1 - NTC 2008)

x	Comb.	δ_{max}	L/250.00	Cs
cm		mm	mm	
137.0	15	0.09	10.96	>100

Verifica spostamento elastico dovuto ai soli carichi variabili (§4.2.4.2.1 - NTC 2008)

x	Comb.	δ_2	L/300.00	Cs
cm		mm	mm	
137.0	15	0.05	9.13	>100

Travata: 569 [371 , 378]

L = 273.9cm

Crit.Prog: Acciaio_Flessione $\delta_c = 0.0cm$ Verifica: **Verificata**

Verifica spostamento nello stato finale (§4.2.4.2.1 - NTC 2008)

x	Comb.	δ_{max}	L/250.00	Cs
---	-------	----------------	----------	----

AUTOSTRADA VALDASTICO A31 NORD
1° LOTTO - PIOVENE ROCCHETTE – VALLE DELL'ASTICO

x	Comb.	δ_{max}	L/250.00	Cs
cm		mm	mm	
137.0	15	0.07	10.96	>100

Verifica spostamento elastico dovuto ai soli carichi variabili (§4.2.4.2.1 - NTC 2008)

x	Comb.	δ_2	L/300.00	Cs
cm		mm	mm	
137.0	15	0.03	9.13	>100

Travata: 570 [379 , 362]

L = 286.0cm

Crit.Prog: Acciaio_Flessione $\delta_c = 0.0cm$ Verifica: **Verificata**

Verifica spostamento nello stato finale (§4.2.4.2.1 - NTC 2008)

x	Comb.	δ_{max}	L/250.00	Cs
cm		mm	mm	
143.0	15	0.07	11.44	>100

Verifica spostamento elastico dovuto ai soli carichi variabili (§4.2.4.2.1 - NTC 2008)

x	Comb.	δ_2	L/300.00	Cs
cm		mm	mm	
143.0	15	0.02	9.53	>100

Travata: 571 [362 , 361]

L = 314.0cm

Crit.Prog: Acciaio_Flessione $\delta_c = 0.0cm$ Verifica: **Verificata**

Verifica spostamento nello stato finale (§4.2.4.2.1 - NTC 2008)

x	Comb.	δ_{max}	L/250.00	Cs
---	-------	----------------	----------	----

AUTOSTRADA VALDASTICO A31 NORD
1° LOTTO - PIOVENE ROCCHETTE – VALLE DELL'ASTICO

x	Comb.	δ_{max}	L/250.00	Cs
cm		mm	mm	
157.0	15	0.37	12.56	33.9

Verifica spostamento elastico dovuto ai soli carichi variabili (§4.2.4.2.1 - NTC 2008)

x	Comb.	δ_2	L/300.00	Cs
cm		mm	mm	
157.0	15	0.19	10.47	54.2

Travata: 572 [378 , 370]

L = 281.6cm

Crit.Prog: Acciaio_Flessione $\delta_c = 0.0cm$ Verifica: **Verificata**

Verifica spostamento nello stato finale (§4.2.4.2.1 - NTC 2008)

x	Comb.	δ_{max}	L/250.00	Cs
cm		mm	mm	
140.8	15	0.12	11.27	92.7

Verifica spostamento elastico dovuto ai soli carichi variabili (§4.2.4.2.1 - NTC 2008)

x	Comb.	δ_2	L/300.00	Cs
cm		mm	mm	
140.8	15	0.06	9.39	>100

Travata: 573 [370 , 379]

L = 281.6cm

Crit.Prog: Acciaio_Flessione $\delta_c = 0.0cm$ Verifica: **Verificata**

Verifica spostamento nello stato finale (§4.2.4.2.1 - NTC 2008)

x	Comb.	δ_{max}	L/250.00	Cs
---	-------	----------------	----------	----

AUTOSTRADA VALDASTICO A31 NORD
1° LOTTO - PIOVENE ROCCHETTE – VALLE DELL'ASTICO

x	Comb.	δ_{max}	L/250.00	Cs
cm		mm	mm	
140.8	15	0.11	11.27	>100

Verifica spostamento elastico dovuto ai soli carichi variabili (§4.2.4.2.1 - NTC 2008)

x	Comb.	δ_2	L/300.00	Cs
cm		mm	mm	
140.8	15	0.06	9.39	>100

Travata: 574 [361 , 370]

L = 281.6cm

Crit.Prog: Acciaio_Flessione $\delta_c = 0.0cm$ Verifica: **Verificata**

Verifica spostamento nello stato finale (§4.2.4.2.1 - NTC 2008)

x	Comb.	δ_{max}	L/250.00	Cs
cm		mm	mm	
140.8	15	0.11	11.27	>100

Verifica spostamento elastico dovuto ai soli carichi variabili (§4.2.4.2.1 - NTC 2008)

x	Comb.	δ_2	L/300.00	Cs
cm		mm	mm	
140.8	15	0.05	9.39	>100

Travata: 575 [370 , 362]

L = 281.6cm

Crit.Prog: Acciaio_Flessione $\delta_c = 0.0cm$ Verifica: **Verificata**

Verifica spostamento nello stato finale (§4.2.4.2.1 - NTC 2008)

x	Comb.	δ_{max}	L/250.00	Cs
---	-------	----------------	----------	----

AUTOSTRADA VALDASTICO A31 NORD
1° LOTTO - PIOVENE ROCCHETTE – VALLE DELL'ASTICO

x	Comb.	δ_{max}	L/250.00	Cs
cm		mm	mm	
140.8	15	0.11	11.27	>100

Verifica spostamento elastico dovuto ai soli carichi variabili (§4.2.4.2.1 - NTC 2008)

x	Comb.	δ_2	L/300.00	Cs
cm		mm	mm	
140.8	15	0.05	9.39	>100

Travata: 576 [362 , 369]

L = 281.6cm

Crit.Prog: Acciaio_Flessione $\delta_c = 0.0cm$ Verifica: **Verificata**

Verifica spostamento nello stato finale (§4.2.4.2.1 - NTC 2008)

x	Comb.	δ_{max}	L/250.00	Cs
cm		mm	mm	
140.8	15	0.11	11.27	>100

Verifica spostamento elastico dovuto ai soli carichi variabili (§4.2.4.2.1 - NTC 2008)

x	Comb.	δ_2	L/300.00	Cs
cm		mm	mm	
140.8	15	0.05	9.39	>100

Travata: 577 [369 , 380]

L = 281.6cm

Crit.Prog: Acciaio_Flessione $\delta_c = 0.0cm$ Verifica: **Verificata**

Verifica spostamento nello stato finale (§4.2.4.2.1 - NTC 2008)

x	Comb.	δ_{max}	L/250.00	Cs
---	-------	----------------	----------	----

AUTOSTRADA VALDASTICO A31 NORD
1° LOTTO - PIOVENE ROCCHETTE – VALLE DELL'ASTICO

x	Comb.	δ_{max}	L/250.00	Cs
cm		mm	mm	
140.8	15	0.12	11.27	92.7

Verifica spostamento elastico dovuto ai soli carichi variabili (§4.2.4.2.1 - NTC 2008)

x	Comb.	δ_2	L/300.00	Cs
cm		mm	mm	
140.8	15	0.06	9.39	>100

Travata: 578 [380 , 363]

L = 286.0cm

Crit.Prog: Acciaio_Flessione $\delta_c = 0.0cm$ Verifica: **Verificata**

Verifica spostamento nello stato finale (§4.2.4.2.1 - NTC 2008)

x	Comb.	δ_{max}	L/250.00	Cs
cm		mm	mm	
143.0	15	0.09	11.44	>100

Verifica spostamento elastico dovuto ai soli carichi variabili (§4.2.4.2.1 - NTC 2008)

x	Comb.	δ_2	L/300.00	Cs
cm		mm	mm	
143.0	15	0.03	9.53	>100

Travata: 579 [363 , 362]

L = 314.0cm

Crit.Prog: Acciaio_Flessione $\delta_c = 0.0cm$ Verifica: **Verificata**

Verifica spostamento nello stato finale (§4.2.4.2.1 - NTC 2008)

x	Comb.	δ_{max}	L/250.00	Cs
---	-------	----------------	----------	----

AUTOSTRADA VALDASTICO A31 NORD
1° LOTTO - PIOVENE ROCCHETTE – VALLE DELL'ASTICO

x	Comb.	δ_{max}	L/250.00	Cs
cm		mm	mm	
157.0	15	0.37	12.56	34.0

Verifica spostamento elastico dovuto ai soli carichi variabili (§4.2.4.2.1 - NTC 2008)

x	Comb.	δ_2	L/300.00	Cs
cm		mm	mm	
157.0	15	0.19	10.47	54.3

Travata: 580 [379 , 369]

L = 281.6cm

Crit.Prog: Acciaio_Flessione $\delta_c = 0.0cm$ Verifica: **Verificata**

Verifica spostamento nello stato finale (§4.2.4.2.1 - NTC 2008)

x	Comb.	δ_{max}	L/250.00	Cs
cm		mm	mm	
140.8	15	0.11	11.27	>100

Verifica spostamento elastico dovuto ai soli carichi variabili (§4.2.4.2.1 - NTC 2008)

x	Comb.	δ_2	L/300.00	Cs
cm		mm	mm	
140.8	15	0.06	9.39	>100

Travata: 581 [369 , 363]

L = 281.6cm

Crit.Prog: Acciaio_Flessione $\delta_c = 0.0cm$ Verifica: **Verificata**

Verifica spostamento nello stato finale (§4.2.4.2.1 - NTC 2008)

x	Comb.	δ_{max}	L/250.00	Cs
---	-------	----------------	----------	----

AUTOSTRADA VALDASTICO A31 NORD
1° LOTTO - PIOVENE ROCCHETTE – VALLE DELL'ASTICO

x	Comb.	δ_{max}	L/250.00	Cs
cm		mm	mm	
140.8	15	0.11	11.27	>100

Verifica spostamento elastico dovuto ai soli carichi variabili (§4.2.4.2.1 - NTC 2008)

x	Comb.	δ_2	L/300.00	Cs
cm		mm	mm	
140.8	15	0.05	9.39	>100

Travata: 582 [381 , 364]

L = 286.0cm

Crit.Prog: Acciaio_Flessione $\delta_c = 0.0cm$ Verifica: **Verificata**

Verifica spostamento nello stato finale (§4.2.4.2.1 - NTC 2008)

x	Comb.	δ_{max}	L/250.00	Cs
cm		mm	mm	
143.0	15	0.20	11.44	58.0

Verifica spostamento elastico dovuto ai soli carichi variabili (§4.2.4.2.1 - NTC 2008)

x	Comb.	δ_2	L/300.00	Cs
cm		mm	mm	
171.6	15	0.10	9.53	92.9

Travata: 583 [364 , 363]

L = 314.0cm

Crit.Prog: Acciaio_Flessione $\delta_c = 0.0cm$ Verifica: **Verificata**

Verifica spostamento nello stato finale (§4.2.4.2.1 - NTC 2008)

x	Comb.	δ_{max}	L/250.00	Cs
---	-------	----------------	----------	----

AUTOSTRADA VALDASTICO A31 NORD
1° LOTTO - PIOVENE ROCCHETTE – VALLE DELL'ASTICO

x	Comb.	δ_{max}	L/250.00	Cs
cm		mm	mm	
157.0	15	0.25	12.56	49.5

Verifica spostamento elastico dovuto ai soli carichi variabili (§4.2.4.2.1 - NTC 2008)

x	Comb.	δ_2	L/300.00	Cs
cm		mm	mm	
188.4	15	0.12	10.47	84.7

Travata: 584 [363 , 368]

L = 273.9cm

Crit.Prog: Acciaio_Flessione $\delta_c = 0.0cm$ Verifica: **Verificata**

Verifica spostamento nello stato finale (§4.2.4.2.1 - NTC 2008)

x	Comb.	δ_{max}	L/250.00	Cs
cm		mm	mm	
137.0	15	0.10	10.96	>100

Verifica spostamento elastico dovuto ai soli carichi variabili (§4.2.4.2.1 - NTC 2008)

x	Comb.	δ_2	L/300.00	Cs
cm		mm	mm	
137.0	15	0.05	9.13	>100

Travata: 585 [368 , 381]

L = 273.9cm

Crit.Prog: Acciaio_Flessione $\delta_c = 0.0cm$ Verifica: **Verificata**

Verifica spostamento nello stato finale (§4.2.4.2.1 - NTC 2008)

x	Comb.	δ_{max}	L/250.00	Cs
---	-------	----------------	----------	----

AUTOSTRADA VALDASTICO A31 NORD
1° LOTTO - PIOVENE ROCCHETTE – VALLE DELL'ASTICO

x	Comb.	δ_{max}	L/250.00	Cs
cm		mm	mm	
137.0	15	0.15	10.96	74.0

Verifica spostamento elastico dovuto ai soli carichi variabili (§4.2.4.2.1 - NTC 2008)

x	Comb.	δ_2	L/300.00	Cs
cm		mm	mm	
137.0	15	0.08	9.13	>100

Travata: 586 [380 , 368]

L = 273.9cm

Crit.Prog: Acciaio_Flessione $\delta_c = 0.0cm$ Verifica: **Verificata**

Verifica spostamento nello stato finale (§4.2.4.2.1 - NTC 2008)

x	Comb.	δ_{max}	L/250.00	Cs
cm		mm	mm	
137.0	15	0.07	10.96	>100

Verifica spostamento elastico dovuto ai soli carichi variabili (§4.2.4.2.1 - NTC 2008)

x	Comb.	δ_2	L/300.00	Cs
cm		mm	mm	
137.0	15	0.03	9.13	>100

Travata: 587 [368 , 364]

L = 273.9cm

Crit.Prog: Acciaio_Flessione $\delta_c = 0.0cm$ Verifica: **Verificata**

Verifica spostamento nello stato finale (§4.2.4.2.1 - NTC 2008)

x	Comb.	δ_{max}	L/250.00	Cs
---	-------	----------------	----------	----

AUTOSTRADA VALDASTICO A31 NORD
1° LOTTO - PIOVENE ROCCHETTE – VALLE DELL'ASTICO

x	Comb.	δ_{max}	L/250.00	Cs
cm		mm	mm	
137.0	15	0.09	10.96	>100

Verifica spostamento elastico dovuto ai soli carichi variabili (§4.2.4.2.1 - NTC 2008)

x	Comb.	δ_2	L/300.00	Cs
cm		mm	mm	
137.0	15	0.05	9.13	>100

Travata: 588 [364 , 365]

L = 314.0cm

Crit.Prog: Acciaio_Flessione $\delta_c = 0.0cm$ Verifica: **Verificata**

Verifica spostamento nello stato finale (§4.2.4.2.1 - NTC 2008)

x	Comb.	δ_{max}	L/250.00	Cs
cm		mm	mm	
125.6	21	0.05	12.56	>100

Verifica spostamento elastico dovuto ai soli carichi variabili (§4.2.4.2.1 - NTC 2008)

x	Comb.	δ_2	L/300.00	Cs
cm		mm	mm	
219.8	15	-0.03	10.47	>100

Travata: 589 [365 , 382]

L = 286.0cm

Crit.Prog: Acciaio_Flessione $\delta_c = 0.0cm$ Verifica: **Verificata**

Verifica spostamento nello stato finale (§4.2.4.2.1 - NTC 2008)

x	Comb.	δ_{max}	L/250.00	Cs
---	-------	----------------	----------	----

AUTOSTRADA VALDASTICO A31 NORD
1° LOTTO - PIOVENE ROCCHETTE – VALLE DELL'ASTICO

x	Comb.	δ_{max}	L/250.00	Cs
cm		mm	mm	
143.0	15	0.47	11.44	24.2

Verifica spostamento elastico dovuto ai soli carichi variabili (§4.2.4.2.1 - NTC 2008)

x	Comb.	δ_2	L/300.00	Cs
cm		mm	mm	
143.0	15	0.28	9.53	34.6

Travata: 590 [381 , 367]

L = 254.4cm

Crit.Prog: Acciaio_Flessione $\delta_c = 0.0cm$ Verifica: **Verificata**

Verifica spostamento nello stato finale (§4.2.4.2.1 - NTC 2008)

x	Comb.	δ_{max}	L/250.00	Cs
cm		mm	mm	
50.9	15	-0.01	10.17	>100

Verifica spostamento elastico dovuto ai soli carichi variabili (§4.2.4.2.1 - NTC 2008)

x	Comb.	δ_2	L/300.00	Cs
cm		mm	mm	
76.3	15	-0.01	8.48	>100

Travata: 591 [367 , 382]

L = 254.4cm

Crit.Prog: Acciaio_Flessione $\delta_c = 0.0cm$ Verifica: **Verificata**

Verifica spostamento nello stato finale (§4.2.4.2.1 - NTC 2008)

x	Comb.	δ_{max}	L/250.00	Cs
---	-------	----------------	----------	----

AUTOSTRADA VALDASTICO A31 NORD
1° LOTTO - PIOVENE ROCCHETTE – VALLE DELL'ASTICO

x	Comb.	δ_{max}	L/250.00	Cs
cm		mm	mm	
127.2	15	0.13	10.17	79.2

Verifica spostamento elastico dovuto ai soli carichi variabili (§4.2.4.2.1 - NTC 2008)

x	Comb.	δ_2	L/300.00	Cs
cm		mm	mm	
127.2	15	0.07	8.48	>100

Travata: 592 [364 , 367]

L = 254.4cm

Crit.Prog: Acciaio_Flessione $\delta_c = 0.0cm$ Verifica: **Verificata**

Verifica spostamento nello stato finale (§4.2.4.2.1 - NTC 2008)

x	Comb.	δ_{max}	L/250.00	Cs
cm		mm	mm	
127.2	15	0.10	10.17	>100

Verifica spostamento elastico dovuto ai soli carichi variabili (§4.2.4.2.1 - NTC 2008)

x	Comb.	δ_2	L/300.00	Cs
cm		mm	mm	
127.2	15	0.05	8.48	>100

Travata: 593 [367 , 365]

L = 254.4cm

Crit.Prog: Acciaio_Flessione $\delta_c = 0.0cm$ Verifica: **Verificata**

Verifica spostamento nello stato finale (§4.2.4.2.1 - NTC 2008)

x	Comb.	δ_{max}	L/250.00	Cs
---	-------	----------------	----------	----

AUTOSTRADA VALDASTICO A31 NORD
1° LOTTO - PIOVENE ROCCHETTE – VALLE DELL'ASTICO

x	Comb.	δ_{max}	L/250.00	Cs
cm		mm	mm	
127.2	15	0.07	10.17	>100

Verifica spostamento elastico dovuto ai soli carichi variabili (§4.2.4.2.1 - NTC 2008)

x	Comb.	δ_2	L/300.00	Cs
cm		mm	mm	
127.2	15	0.04	8.48	>100

Travata: 594 [383 , 366]

L = 286.0cm

Crit.Prog: Acciaio_Flessione $\delta_c = 0.0cm$ Verifica: **Verificata**

Verifica spostamento nello stato finale (§4.2.4.2.1 - NTC 2008)

x	Comb.	δ_{max}	L/250.00	Cs
cm		mm	mm	
143.0	15	0.32	11.44	35.6

Verifica spostamento elastico dovuto ai soli carichi variabili (§4.2.4.2.1 - NTC 2008)

x	Comb.	δ_2	L/300.00	Cs
cm		mm	mm	
143.0	15	0.20	9.53	48.8

Travata: 595 [366 , 365]

L = 314.0cm

Crit.Prog: Acciaio_Flessione $\delta_c = 0.0cm$ Verifica: **Verificata**

Verifica spostamento nello stato finale (§4.2.4.2.1 - NTC 2008)

x	Comb.	δ_{max}	L/250.00	Cs
---	-------	----------------	----------	----

AUTOSTRADA VALDASTICO A31 NORD
1° LOTTO - PIOVENE ROCCHETTE – VALLE DELL'ASTICO

x	Comb.	δ_{max}	L/250.00	Cs
cm		mm	mm	
62.8	15	-0.04	12.56	>100

Verifica spostamento elastico dovuto ai soli carichi variabili (§4.2.4.2.1 - NTC 2008)

x	Comb.	δ_2	L/300.00	Cs
cm		mm	mm	
125.6	15	-0.07	10.47	>100

Travata: 596 [382 , 374]

L = 229.9cm

Crit.Prog: Acciaio_Flessione $\delta_c = 0.0cm$ Verifica: **Verificata**

Verifica spostamento nello stato finale (§4.2.4.2.1 - NTC 2008)

x	Comb.	δ_{max}	L/250.00	Cs
cm		mm	mm	
137.9	15	0.16	9.19	57.6

Verifica spostamento elastico dovuto ai soli carichi variabili (§4.2.4.2.1 - NTC 2008)

x	Comb.	δ_2	L/300.00	Cs
cm		mm	mm	
137.9	15	0.11	7.66	71.9

Travata: 597 [374 , 366]

L = 229.9cm

Crit.Prog: Acciaio_Flessione $\delta_c = 0.0cm$ Verifica: **Verificata**

Verifica spostamento nello stato finale (§4.2.4.2.1 - NTC 2008)

x	Comb.	δ_{max}	L/250.00	Cs
---	-------	----------------	----------	----

AUTOSTRADA VALDASTICO A31 NORD
1° LOTTO - PIOVENE ROCCHETTE – VALLE DELL'ASTICO

x	Comb.	δ_{max}	L/250.00	Cs
cm		mm	mm	
137.9	15	0.06	9.19	>100

Verifica spostamento elastico dovuto ai soli carichi variabili (§4.2.4.2.1 - NTC 2008)

x	Comb.	δ_2	L/300.00	Cs
cm		mm	mm	
160.9	15	0.02	7.66	>100

Travata: 598 [374 , 383]

L = 229.9cm

Crit.Prog: Acciaio_Flessione $\delta_c = 0.0cm$ Verifica: **Verificata**

Verifica spostamento nello stato finale (§4.2.4.2.1 - NTC 2008)

x	Comb.	δ_{max}	L/250.00	Cs
cm		mm	mm	
114.9	15	-0.09	9.19	>100

Verifica spostamento elastico dovuto ai soli carichi variabili (§4.2.4.2.1 - NTC 2008)

x	Comb.	δ_2	L/300.00	Cs
cm		mm	mm	
114.9	15	-0.07	7.66	>100

Travata: 599 [373 , 372]

L = 318.3cm

Crit.Prog: Acciaio_Flessione $\delta_c = 0.0cm$ Verifica: **Verificata**

Verifica spostamento nello stato finale (§4.2.4.2.1 - NTC 2008)

x	Comb.	δ_{max}	L/250.00	Cs
---	-------	----------------	----------	----

AUTOSTRADA VALDASTICO A31 NORD
1° LOTTO - PIOVENE ROCCHETTE – VALLE DELL'ASTICO

x	Comb.	δ_{max}	L/250.00	Cs
cm		mm	mm	
159.1	15	2.49	12.73	5.11

Verifica spostamento elastico dovuto ai soli carichi variabili (§4.2.4.2.1 - NTC 2008)

x	Comb.	δ_2	L/300.00	Cs
cm		mm	mm	
159.1	15	1.86	10.61	5.72

Travata: 600 [372 , 371]

L = 315.7cm

Crit.Prog: Acciaio_Flessione $\delta_c = 0.0cm$ Verifica: **Verificata**

Verifica spostamento nello stato finale (§4.2.4.2.1 - NTC 2008)

x	Comb.	δ_{max}	L/250.00	Cs
cm		mm	mm	
157.9	15	2.55	12.63	4.96

Verifica spostamento elastico dovuto ai soli carichi variabili (§4.2.4.2.1 - NTC 2008)

x	Comb.	δ_2	L/300.00	Cs
cm		mm	mm	
157.9	15	1.86	10.52	5.65

Travata: 601 [371 , 370]

L = 314.2cm

Crit.Prog: Acciaio_Flessione $\delta_c = 0.0cm$ Verifica: **Verificata**

Verifica spostamento nello stato finale (§4.2.4.2.1 - NTC 2008)

x	Comb.	δ_{max}	L/250.00	Cs
---	-------	----------------	----------	----

AUTOSTRADA VALDASTICO A31 NORD
1° LOTTO - PIOVENE ROCCHETTE – VALLE DELL'ASTICO

x	Comb.	δ_{max}	L/250.00	Cs
cm		mm	mm	
157.1	15	2.69	12.57	4.67

Verifica spostamento elastico dovuto ai soli carichi variabili (§4.2.4.2.1 - NTC 2008)

x	Comb.	δ_2	L/300.00	Cs
cm		mm	mm	
157.1	15	1.95	10.47	5.38

Travata: 602 [370 , 369]

L = 314.0cm

Crit.Prog: Acciaio_Flessione $\delta_c = 0.0cm$ Verifica: **Verificata**

Verifica spostamento nello stato finale (§4.2.4.2.1 - NTC 2008)

x	Comb.	δ_{max}	L/250.00	Cs
cm		mm	mm	
157.0	15	2.74	12.56	4.58

Verifica spostamento elastico dovuto ai soli carichi variabili (§4.2.4.2.1 - NTC 2008)

x	Comb.	δ_2	L/300.00	Cs
cm		mm	mm	
157.0	15	1.98	10.47	5.29

Travata: 603 [369 , 368]

L = 314.2cm

Crit.Prog: Acciaio_Flessione $\delta_c = 0.0cm$ Verifica: **Verificata**

Verifica spostamento nello stato finale (§4.2.4.2.1 - NTC 2008)

x	Comb.	δ_{max}	L/250.00	Cs
---	-------	----------------	----------	----

AUTOSTRADA VALDASTICO A31 NORD
1° LOTTO - PIOVENE ROCCHETTE – VALLE DELL'ASTICO

x	Comb.	δ_{max}	L/250.00	Cs
cm		mm	mm	
157.1	15	2.69	12.57	4.67

Verifica spostamento elastico dovuto ai soli carichi variabili (§4.2.4.2.1 - NTC 2008)

x	Comb.	δ_2	L/300.00	Cs
cm		mm	mm	
157.1	15	1.95	10.47	5.38

Travata: 604 [368 , 367]

L = 315.7cm

Crit.Prog: Acciaio_Flessione $\delta_c = 0.0cm$ Verifica: **Verificata**

Verifica spostamento nello stato finale (§4.2.4.2.1 - NTC 2008)

x	Comb.	δ_{max}	L/250.00	Cs
cm		mm	mm	
157.9	15	2.54	12.63	4.97

Verifica spostamento elastico dovuto ai soli carichi variabili (§4.2.4.2.1 - NTC 2008)

x	Comb.	δ_2	L/300.00	Cs
cm		mm	mm	
157.9	15	1.86	10.52	5.66

Travata: 605 [367 , 374]

L = 318.3cm

Crit.Prog: Acciaio_Flessione $\delta_c = 0.0cm$ Verifica: **Verificata**

Verifica spostamento nello stato finale (§4.2.4.2.1 - NTC 2008)

x	Comb.	δ_{max}	L/250.00	Cs
---	-------	----------------	----------	----

AUTOSTRADA VALDASTICO A31 NORD
1° LOTTO - PIOVENE ROCCHETTE – VALLE DELL'ASTICO

x	Comb.	δ_{max}	L/250.00	Cs
cm		mm	mm	
159.1	15	2.49	12.73	5.12

Verifica spostamento elastico dovuto ai soli carichi variabili (§4.2.4.2.1 - NTC 2008)

x	Comb.	δ_2	L/300.00	Cs
cm		mm	mm	
159.1	15	1.86	10.61	5.72

Travata: 606 [375 , 390]

L = 229.9cm

Crit.Prog: Acciaio_Flessione $\delta_c = 0.0cm$ Verifica: **Verificata**

Verifica spostamento nello stato finale (§4.2.4.2.1 - NTC 2008)

x	Comb.	δ_{max}	L/250.00	Cs
cm		mm	mm	
69.0	15	0.04	9.19	>100

Verifica spostamento elastico dovuto ai soli carichi variabili (§4.2.4.2.1 - NTC 2008)

x	Comb.	δ_2	L/300.00	Cs
cm		mm	mm	
160.9	15	-0.03	7.66	>100

Travata: 607 [393 , 376]

L = 286.0cm

Crit.Prog: Acciaio_Flessione $\delta_c = 0.0cm$ Verifica: **Verificata**

Verifica spostamento nello stato finale (§4.2.4.2.1 - NTC 2008)

x	Comb.	δ_{max}	L/250.00	Cs
---	-------	----------------	----------	----

AUTOSTRADA VALDASTICO A31 NORD
1° LOTTO - PIOVENE ROCCHETTE – VALLE DELL'ASTICO

x	Comb.	δ_{max}	L/250.00	Cs
cm		mm	mm	
85.8	15	-0.56	11.44	20.6

Verifica spostamento elastico dovuto ai soli carichi variabili (§4.2.4.2.1 - NTC 2008)

x	Comb.	δ_2	L/300.00	Cs
cm		mm	mm	
85.8	15	-0.38	9.53	25.0

Travata: 608 [376 , 375]

L = 314.0cm

Crit.Prog: Acciaio_Flessione $\delta_c = 0.0cm$ Verifica: **Verificata**

Verifica spostamento nello stato finale (§4.2.4.2.1 - NTC 2008)

x	Comb.	δ_{max}	L/250.00	Cs
cm		mm	mm	
125.6	15	-0.15	12.56	84.1

Verifica spostamento elastico dovuto ai soli carichi variabili (§4.2.4.2.1 - NTC 2008)

x	Comb.	δ_2	L/300.00	Cs
cm		mm	mm	
157.0	15	-0.13	10.47	77.8

Travata: 609 [392 , 390]

L = 229.9cm

Crit.Prog: Acciaio_Flessione $\delta_c = 0.0cm$ Verifica: **Verificata**

Verifica spostamento nello stato finale (§4.2.4.2.1 - NTC 2008)

x	Comb.	δ_{max}	L/250.00	Cs
---	-------	----------------	----------	----

AUTOSTRADA VALDASTICO A31 NORD
1° LOTTO - PIOVENE ROCCHETTE – VALLE DELL'ASTICO

x	Comb.	δ_{max}	L/250.00	Cs
cm		mm	mm	
114.9	15	-0.33	9.19	28.1

Verifica spostamento elastico dovuto ai soli carichi variabili (§4.2.4.2.1 - NTC 2008)

x	Comb.	δ_2	L/300.00	Cs
cm		mm	mm	
114.9	15	-0.25	7.66	30.4

Travata: 610 [390 , 376]

L = 229.9cm

Crit.Prog: Acciaio_Flessione $\delta_c = 0.0cm$ Verifica: **Verificata**

Verifica spostamento nello stato finale (§4.2.4.2.1 - NTC 2008)

x	Comb.	δ_{max}	L/250.00	Cs
cm		mm	mm	
114.9	15	-0.11	9.19	85.9

Verifica spostamento elastico dovuto ai soli carichi variabili (§4.2.4.2.1 - NTC 2008)

x	Comb.	δ_2	L/300.00	Cs
cm		mm	mm	
114.9	15	-0.06	7.66	>100

Travata: 611 [390 , 393]

L = 229.9cm

Crit.Prog: Acciaio_Flessione $\delta_c = 0.0cm$ Verifica: **Verificata**

Verifica spostamento nello stato finale (§4.2.4.2.1 - NTC 2008)

x	Comb.	δ_{max}	L/250.00	Cs
---	-------	----------------	----------	----

AUTOSTRADA VALDASTICO A31 NORD
1° LOTTO - PIOVENE ROCCHETTE – VALLE DELL'ASTICO

x	Comb.	δ_{max}	L/250.00	Cs
cm		mm	mm	
46.0	15	0.10	9.19	96.3

Verifica spostamento elastico dovuto ai soli carichi variabili (§4.2.4.2.1 - NTC 2008)

x	Comb.	δ_2	L/300.00	Cs
cm		mm	mm	
46.0	15	0.07	7.66	>100

Travata: 612 [392 , 375]

L = 286.0cm

Crit.Prog: Acciaio_Flessione $\delta_c = 0.0cm$ Verifica: **Verificata**

Verifica spostamento nello stato finale (§4.2.4.2.1 - NTC 2008)

x	Comb.	δ_{max}	L/250.00	Cs
cm		mm	mm	
114.4	15	-0.23	11.44	48.8

Verifica spostamento elastico dovuto ai soli carichi variabili (§4.2.4.2.1 - NTC 2008)

x	Comb.	δ_2	L/300.00	Cs
cm		mm	mm	
114.4	15	-0.19	9.53	49.3

Travata: 613 [394 , 377]

L = 286.0cm

Crit.Prog: Acciaio_Flessione $\delta_c = 0.0cm$ Verifica: **Verificata**

Verifica spostamento nello stato finale (§4.2.4.2.1 - NTC 2008)

x	Comb.	δ_{max}	L/250.00	Cs
---	-------	----------------	----------	----

AUTOSTRADA VALDASTICO A31 NORD
1° LOTTO - PIOVENE ROCCHETTE – VALLE DELL'ASTICO

x	Comb.	δ_{max}	L/250.00	Cs
cm		mm	mm	
85.8	15	-0.09	11.44	>100

Verifica spostamento elastico dovuto ai soli carichi variabili (§4.2.4.2.1 - NTC 2008)

x	Comb.	δ_2	L/300.00	Cs
cm		mm	mm	
85.8	15	-0.07	9.53	>100

Travata: 614 [377 , 376]

L = 314.0cm

Crit.Prog: Acciaio_Flessione $\delta_c = 0.0cm$ Verifica: **Verificata**

Verifica spostamento nello stato finale (§4.2.4.2.1 - NTC 2008)

x	Comb.	δ_{max}	L/250.00	Cs
cm		mm	mm	
251.2	15	-0.10	12.56	>100

Verifica spostamento elastico dovuto ai soli carichi variabili (§4.2.4.2.1 - NTC 2008)

x	Comb.	δ_2	L/300.00	Cs
cm		mm	mm	
219.8	15	-0.08	10.47	>100

Travata: 615 [376 , 389]

L = 254.4cm

Crit.Prog: Acciaio_Flessione $\delta_c = 0.0cm$ Verifica: **Verificata**

Verifica spostamento nello stato finale (§4.2.4.2.1 - NTC 2008)

x	Comb.	δ_{max}	L/250.00	Cs
---	-------	----------------	----------	----

AUTOSTRADA VALDASTICO A31 NORD
1° LOTTO - PIOVENE ROCCHETTE – VALLE DELL'ASTICO

x	Comb.	δ_{max}	L/250.00	Cs
cm		mm	mm	
127.2	15	-0.18	10.17	55.4

Verifica spostamento elastico dovuto ai soli carichi variabili (§4.2.4.2.1 - NTC 2008)

x	Comb.	δ_2	L/300.00	Cs
cm		mm	mm	
101.7	15	-0.12	8.48	71.5

Travata: 616 [389 , 394]

L = 254.4cm

Crit.Prog: Acciaio_Flessione $\delta_c = 0.0cm$ Verifica: **Verificata**

Verifica spostamento nello stato finale (§4.2.4.2.1 - NTC 2008)

x	Comb.	δ_{max}	L/250.00	Cs
cm		mm	mm	
127.2	15	-0.12	10.17	87.0

Verifica spostamento elastico dovuto ai soli carichi variabili (§4.2.4.2.1 - NTC 2008)

x	Comb.	δ_2	L/300.00	Cs
cm		mm	mm	
127.2	15	-0.08	8.48	>100

Travata: 617 [393 , 389]

L = 254.4cm

Crit.Prog: Acciaio_Flessione $\delta_c = 0.0cm$ Verifica: **Verificata**

Verifica spostamento nello stato finale (§4.2.4.2.1 - NTC 2008)

x	Comb.	δ_{max}	L/250.00	Cs
---	-------	----------------	----------	----

AUTOSTRADA VALDASTICO A31 NORD
1° LOTTO - PIOVENE ROCCHETTE – VALLE DELL'ASTICO

x	Comb.	δ_{max}	L/250.00	Cs
cm		mm	mm	
76.3	15	-0.69	10.17	14.8

Verifica spostamento elastico dovuto ai soli carichi variabili (§4.2.4.2.1 - NTC 2008)

x	Comb.	δ_2	L/300.00	Cs
cm		mm	mm	
76.3	15	-0.45	8.48	18.7

Travata: 618 [389 , 377]

L = 254.4cm

Crit.Prog: Acciaio_Flessione $\delta_c = 0.0cm$ Verifica: **Verificata**

Verifica spostamento nello stato finale (§4.2.4.2.1 - NTC 2008)

x	Comb.	δ_{max}	L/250.00	Cs
cm		mm	mm	
127.2	15	0.20	10.17	50.9

Verifica spostamento elastico dovuto ai soli carichi variabili (§4.2.4.2.1 - NTC 2008)

x	Comb.	δ_2	L/300.00	Cs
cm		mm	mm	
127.2	15	0.11	8.48	74.6

Travata: 619 [395 , 378]

L = 286.0cm

Crit.Prog: Acciaio_Flessione $\delta_c = 0.0cm$ Verifica: **Verificata**

Verifica spostamento nello stato finale (§4.2.4.2.1 - NTC 2008)

x	Comb.	δ_{max}	L/250.00	Cs
---	-------	----------------	----------	----

AUTOSTRADA VALDASTICO A31 NORD
1° LOTTO - PIOVENE ROCCHETTE – VALLE DELL'ASTICO

x	Comb.	δ_{max}	L/250.00	Cs
cm		mm	mm	
143.0	15	0.06	11.44	>100

Verifica spostamento elastico dovuto ai soli carichi variabili (§4.2.4.2.1 - NTC 2008)

x	Comb.	δ_2	L/300.00	Cs
cm		mm	mm	
171.6	15	0.01	9.53	>100

Travata: 620 [378 , 377]

L = 314.0cm

Crit.Prog: Acciaio_Flessione $\delta_c = 0.0cm$ Verifica: **Verificata**

Verifica spostamento nello stato finale (§4.2.4.2.1 - NTC 2008)

x	Comb.	δ_{max}	L/250.00	Cs
cm		mm	mm	
157.0	15	0.32	12.56	39.7

Verifica spostamento elastico dovuto ai soli carichi variabili (§4.2.4.2.1 - NTC 2008)

x	Comb.	δ_2	L/300.00	Cs
cm		mm	mm	
157.0	15	0.16	10.47	66.8

Travata: 621 [394 , 388]

L = 273.9cm

Crit.Prog: Acciaio_Flessione $\delta_c = 0.0cm$ Verifica: **Verificata**

Verifica spostamento nello stato finale (§4.2.4.2.1 - NTC 2008)

x	Comb.	δ_{max}	L/250.00	Cs
---	-------	----------------	----------	----

AUTOSTRADA VALDASTICO A31 NORD
1° LOTTO - PIOVENE ROCCHETTE – VALLE DELL'ASTICO

x	Comb.	δ_{max}	L/250.00	Cs
cm		mm	mm	
137.0	15	0.15	10.96	73.0

Verifica spostamento elastico dovuto ai soli carichi variabili (§4.2.4.2.1 - NTC 2008)

x	Comb.	δ_2	L/300.00	Cs
cm		mm	mm	
109.6	15	0.08	9.13	>100

Travata: 622 [388 , 378]

L = 273.9cm

Crit.Prog: Acciaio_Flessione $\delta_c = 0.0cm$ Verifica: **Verificata**

Verifica spostamento nello stato finale (§4.2.4.2.1 - NTC 2008)

x	Comb.	δ_{max}	L/250.00	Cs
cm		mm	mm	
137.0	15	0.12	10.96	88.4

Verifica spostamento elastico dovuto ai soli carichi variabili (§4.2.4.2.1 - NTC 2008)

x	Comb.	δ_2	L/300.00	Cs
cm		mm	mm	
137.0	15	0.06	9.13	>100

Travata: 623 [377 , 388]

L = 273.9cm

Crit.Prog: Acciaio_Flessione $\delta_c = 0.0cm$ Verifica: **Verificata**

Verifica spostamento nello stato finale (§4.2.4.2.1 - NTC 2008)

x	Comb.	δ_{max}	L/250.00	Cs
---	-------	----------------	----------	----

AUTOSTRADA VALDASTICO A31 NORD
1° LOTTO - PIOVENE ROCCHETTE – VALLE DELL'ASTICO

x	Comb.	δ_{max}	L/250.00	Cs
cm		mm	mm	
164.3	15	0.03	10.96	>100

Verifica spostamento elastico dovuto ai soli carichi variabili (§4.2.4.2.1 - NTC 2008)

x	Comb.	δ_2	L/300.00	Cs
cm		mm	mm	
191.7	15	0.01	9.13	>100

Travata: 624 [388 , 395]

L = 273.9cm

Crit.Prog: Acciaio_Flessione $\delta_c = 0.0cm$ Verifica: **Verificata**

Verifica spostamento nello stato finale (§4.2.4.2.1 - NTC 2008)

x	Comb.	δ_{max}	L/250.00	Cs
cm		mm	mm	
137.0	15	0.09	10.96	>100

Verifica spostamento elastico dovuto ai soli carichi variabili (§4.2.4.2.1 - NTC 2008)

x	Comb.	δ_2	L/300.00	Cs
cm		mm	mm	
164.3	15	0.05	9.13	>100

Travata: 625 [396 , 379]

L = 286.0cm

Crit.Prog: Acciaio_Flessione $\delta_c = 0.0cm$ Verifica: **Verificata**

Verifica spostamento nello stato finale (§4.2.4.2.1 - NTC 2008)

x	Comb.	δ_{max}	L/250.00	Cs
---	-------	----------------	----------	----

AUTOSTRADA VALDASTICO A31 NORD
1° LOTTO - PIOVENE ROCCHETTE – VALLE DELL'ASTICO

x	Comb.	δ_{max}	L/250.00	Cs
cm		mm	mm	
143.0	15	0.08	11.44	>100

Verifica spostamento elastico dovuto ai soli carichi variabili (§4.2.4.2.1 - NTC 2008)

x	Comb.	δ_2	L/300.00	Cs
cm		mm	mm	
143.0	15	0.03	9.53	>100

Travata: 626 [379 , 378]

L = 314.0cm

Crit.Prog: Acciaio_Flessione $\delta_c = 0.0cm$ Verifica: **Verificata**

Verifica spostamento nello stato finale (§4.2.4.2.1 - NTC 2008)

x	Comb.	δ_{max}	L/250.00	Cs
cm		mm	mm	
157.0	15	0.39	12.56	31.8

Verifica spostamento elastico dovuto ai soli carichi variabili (§4.2.4.2.1 - NTC 2008)

x	Comb.	δ_2	L/300.00	Cs
cm		mm	mm	
157.0	15	0.20	10.47	51.2

Travata: 627 [395 , 387]

L = 281.6cm

Crit.Prog: Acciaio_Flessione $\delta_c = 0.0cm$ Verifica: **Verificata**

Verifica spostamento nello stato finale (§4.2.4.2.1 - NTC 2008)

x	Comb.	δ_{max}	L/250.00	Cs
---	-------	----------------	----------	----

AUTOSTRADA VALDASTICO A31 NORD
1° LOTTO - PIOVENE ROCCHETTE – VALLE DELL'ASTICO

x	Comb.	δ_{max}	L/250.00	Cs
cm		mm	mm	
140.8	15	0.11	11.27	98.7

Verifica spostamento elastico dovuto ai soli carichi variabili (§4.2.4.2.1 - NTC 2008)

x	Comb.	δ_2	L/300.00	Cs
cm		mm	mm	
140.8	15	0.06	9.39	>100

Travata: 628 [387 , 396]

L = 281.6cm

Crit.Prog: Acciaio_Flessione $\delta_c = 0.0cm$ Verifica: **Verificata**

Verifica spostamento nello stato finale (§4.2.4.2.1 - NTC 2008)

x	Comb.	δ_{max}	L/250.00	Cs
cm		mm	mm	
140.8	15	0.12	11.27	92.1

Verifica spostamento elastico dovuto ai soli carichi variabili (§4.2.4.2.1 - NTC 2008)

x	Comb.	δ_2	L/300.00	Cs
cm		mm	mm	
140.8	15	0.06	9.39	>100

Travata: 629 [378 , 387]

L = 281.6cm

Crit.Prog: Acciaio_Flessione $\delta_c = 0.0cm$ Verifica: **Verificata**

Verifica spostamento nello stato finale (§4.2.4.2.1 - NTC 2008)

x	Comb.	δ_{max}	L/250.00	Cs
---	-------	----------------	----------	----

AUTOSTRADA VALDASTICO A31 NORD
1° LOTTO - PIOVENE ROCCHETTE – VALLE DELL'ASTICO

x	Comb.	δ_{max}	L/250.00	Cs
cm		mm	mm	
140.8	15	0.10	11.27	>100

Verifica spostamento elastico dovuto ai soli carichi variabili (§4.2.4.2.1 - NTC 2008)

x	Comb.	δ_2	L/300.00	Cs
cm		mm	mm	
140.8	15	0.05	9.39	>100

Travata: 630 [387 , 379]

L = 281.6cm

Crit.Prog: Acciaio_Flessione $\delta_c = 0.0cm$ Verifica: **Verificata**

Verifica spostamento nello stato finale (§4.2.4.2.1 - NTC 2008)

x	Comb.	δ_{max}	L/250.00	Cs
cm		mm	mm	
140.8	15	0.12	11.27	92.1

Verifica spostamento elastico dovuto ai soli carichi variabili (§4.2.4.2.1 - NTC 2008)

x	Comb.	δ_2	L/300.00	Cs
cm		mm	mm	
140.8	15	0.06	9.39	>100

Travata: 631 [379 , 386]

L = 281.6cm

Crit.Prog: Acciaio_Flessione $\delta_c = 0.0cm$ Verifica: **Verificata**

Verifica spostamento nello stato finale (§4.2.4.2.1 - NTC 2008)

x	Comb.	δ_{max}	L/250.00	Cs
---	-------	----------------	----------	----

AUTOSTRADA VALDASTICO A31 NORD
1° LOTTO - PIOVENE ROCCHETTE – VALLE DELL'ASTICO

x	Comb.	δ_{max}	L/250.00	Cs
cm		mm	mm	
140.8	15	0.12	11.27	92.0

Verifica spostamento elastico dovuto ai soli carichi variabili (§4.2.4.2.1 - NTC 2008)

x	Comb.	δ_2	L/300.00	Cs
cm		mm	mm	
140.8	15	0.06	9.39	>100

Travata: 632 [386 , 397]

L = 281.6cm

Crit.Prog: Acciaio_Flessione $\delta_c = 0.0cm$ Verifica: **Verificata**

Verifica spostamento nello stato finale (§4.2.4.2.1 - NTC 2008)

x	Comb.	δ_{max}	L/250.00	Cs
cm		mm	mm	
140.8	15	0.11	11.27	99.0

Verifica spostamento elastico dovuto ai soli carichi variabili (§4.2.4.2.1 - NTC 2008)

x	Comb.	δ_2	L/300.00	Cs
cm		mm	mm	
140.8	15	0.06	9.39	>100

Travata: 633 [397 , 380]

L = 286.0cm

Crit.Prog: Acciaio_Flessione $\delta_c = 0.0cm$ Verifica: **Verificata**

Verifica spostamento nello stato finale (§4.2.4.2.1 - NTC 2008)

x	Comb.	δ_{max}	L/250.00	Cs
---	-------	----------------	----------	----

AUTOSTRADA VALDASTICO A31 NORD
1° LOTTO - PIOVENE ROCCHETTE – VALLE DELL'ASTICO

x	Comb.	δ_{max}	L/250.00	Cs
cm		mm	mm	
143.0	15	0.06	11.44	>100

Verifica spostamento elastico dovuto ai soli carichi variabili (§4.2.4.2.1 - NTC 2008)

x	Comb.	δ_2	L/300.00	Cs
cm		mm	mm	
171.6	15	0.01	9.53	>100

Travata: 634 [380 , 379]

L = 314.0cm

Crit.Prog: Acciaio_Flessione $\delta_c = 0.0cm$ Verifica: **Verificata**

Verifica spostamento nello stato finale (§4.2.4.2.1 - NTC 2008)

x	Comb.	δ_{max}	L/250.00	Cs
cm		mm	mm	
157.0	15	0.39	12.56	31.9

Verifica spostamento elastico dovuto ai soli carichi variabili (§4.2.4.2.1 - NTC 2008)

x	Comb.	δ_2	L/300.00	Cs
cm		mm	mm	
157.0	15	0.20	10.47	51.2

Travata: 635 [396 , 386]

L = 281.6cm

Crit.Prog: Acciaio_Flessione $\delta_c = 0.0cm$ Verifica: **Verificata**

Verifica spostamento nello stato finale (§4.2.4.2.1 - NTC 2008)

x	Comb.	δ_{max}	L/250.00	Cs
---	-------	----------------	----------	----

AUTOSTRADA VALDASTICO A31 NORD
1° LOTTO - PIOVENE ROCCHETTE – VALLE DELL'ASTICO

x	Comb.	δ_{max}	L/250.00	Cs
cm		mm	mm	
140.8	15	0.12	11.27	92.2

Verifica spostamento elastico dovuto ai soli carichi variabili (§4.2.4.2.1 - NTC 2008)

x	Comb.	δ_2	L/300.00	Cs
cm		mm	mm	
140.8	15	0.06	9.39	>100

Travata: 636 [386 , 380]

L = 281.6cm

Crit.Prog: Acciaio_Flessione $\delta_c = 0.0cm$ Verifica: **Verificata**

Verifica spostamento nello stato finale (§4.2.4.2.1 - NTC 2008)

x	Comb.	δ_{max}	L/250.00	Cs
cm		mm	mm	
140.8	15	0.10	11.27	>100

Verifica spostamento elastico dovuto ai soli carichi variabili (§4.2.4.2.1 - NTC 2008)

x	Comb.	δ_2	L/300.00	Cs
cm		mm	mm	
140.8	15	0.05	9.39	>100

Travata: 637 [398 , 381]

L = 286.0cm

Crit.Prog: Acciaio_Flessione $\delta_c = 0.0cm$ Verifica: **Verificata**

Verifica spostamento nello stato finale (§4.2.4.2.1 - NTC 2008)

x	Comb.	δ_{max}	L/250.00	Cs
---	-------	----------------	----------	----

AUTOSTRADA VALDASTICO A31 NORD
1° LOTTO - PIOVENE ROCCHETTE – VALLE DELL'ASTICO

x	Comb.	δ_{max}	L/250.00	Cs
cm		mm	mm	
85.8	15	-0.09	11.44	>100

Verifica spostamento elastico dovuto ai soli carichi variabili (§4.2.4.2.1 - NTC 2008)

x	Comb.	δ_2	L/300.00	Cs
cm		mm	mm	
85.8	15	-0.07	9.53	>100

Travata: 638 [381 , 380]

L = 314.0cm

Crit.Prog: Acciaio_Flessione $\delta_c = 0.0cm$ Verifica: **Verificata**

Verifica spostamento nello stato finale (§4.2.4.2.1 - NTC 2008)

x	Comb.	δ_{max}	L/250.00	Cs
cm		mm	mm	
157.0	15	0.31	12.56	40.0

Verifica spostamento elastico dovuto ai soli carichi variabili (§4.2.4.2.1 - NTC 2008)

x	Comb.	δ_2	L/300.00	Cs
cm		mm	mm	
157.0	15	0.16	10.47	67.0

Travata: 639 [380 , 385]

L = 273.9cm

Crit.Prog: Acciaio_Flessione $\delta_c = 0.0cm$ Verifica: **Verificata**

Verifica spostamento nello stato finale (§4.2.4.2.1 - NTC 2008)

x	Comb.	δ_{max}	L/250.00	Cs
---	-------	----------------	----------	----

AUTOSTRADA VALDASTICO A31 NORD
1° LOTTO - PIOVENE ROCCHETTE – VALLE DELL'ASTICO

x	Comb.	δ_{max}	L/250.00	Cs
cm		mm	mm	
137.0	15	0.12	10.96	88.6

Verifica spostamento elastico dovuto ai soli carichi variabili (§4.2.4.2.1 - NTC 2008)

x	Comb.	δ_2	L/300.00	Cs
cm		mm	mm	
137.0	15	0.06	9.13	>100

Travata: 640 [385 , 398]

L = 273.9cm

Crit.Prog: Acciaio_Flessione $\delta_c = 0.0cm$ Verifica: **Verificata**

Verifica spostamento nello stato finale (§4.2.4.2.1 - NTC 2008)

x	Comb.	δ_{max}	L/250.00	Cs
cm		mm	mm	
137.0	15	0.15	10.96	72.5

Verifica spostamento elastico dovuto ai soli carichi variabili (§4.2.4.2.1 - NTC 2008)

x	Comb.	δ_2	L/300.00	Cs
cm		mm	mm	
164.3	15	0.08	9.13	>100

Travata: 641 [397 , 385]

L = 273.9cm

Crit.Prog: Acciaio_Flessione $\delta_c = 0.0cm$ Verifica: **Verificata**

Verifica spostamento nello stato finale (§4.2.4.2.1 - NTC 2008)

x	Comb.	δ_{max}	L/250.00	Cs
---	-------	----------------	----------	----

AUTOSTRADA VALDASTICO A31 NORD
1° LOTTO - PIOVENE ROCCHETTE – VALLE DELL'ASTICO

x	Comb.	δ_{max}	L/250.00	Cs
cm		mm	mm	
137.0	15	0.09	10.96	>100

Verifica spostamento elastico dovuto ai soli carichi variabili (§4.2.4.2.1 - NTC 2008)

x	Comb.	δ_2	L/300.00	Cs
cm		mm	mm	
109.6	15	0.05	9.13	>100

Travata: 642 [385 , 381]

L = 273.9cm

Crit.Prog: Acciaio_Flessione $\delta_c = 0.0cm$ Verifica: **Verificata**

Verifica spostamento nello stato finale (§4.2.4.2.1 - NTC 2008)

x	Comb.	δ_{max}	L/250.00	Cs
cm		mm	mm	
109.6	15	0.03	10.96	>100

Verifica spostamento elastico dovuto ai soli carichi variabili (§4.2.4.2.1 - NTC 2008)

x	Comb.	δ_2	L/300.00	Cs
cm		mm	mm	
82.2	15	0.01	9.13	>100

Travata: 643 [381 , 382]

L = 314.0cm

Crit.Prog: Acciaio_Flessione $\delta_c = 0.0cm$ Verifica: **Verificata**

Verifica spostamento nello stato finale (§4.2.4.2.1 - NTC 2008)

x	Comb.	δ_{max}	L/250.00	Cs
---	-------	----------------	----------	----

AUTOSTRADA VALDASTICO A31 NORD
1° LOTTO - PIOVENE ROCCHETTE – VALLE DELL'ASTICO

x	Comb.	δ_{max}	L/250.00	Cs
cm		mm	mm	
251.2	15	-0.11	12.56	>100

Verifica spostamento elastico dovuto ai soli carichi variabili (§4.2.4.2.1 - NTC 2008)

x	Comb.	δ_2	L/300.00	Cs
cm		mm	mm	
219.8	15	-0.08	10.47	>100

Travata: 644 [382 , 399]

L = 286.0cm

Crit.Prog: Acciaio_Flessione $\delta_c = 0.0cm$ Verifica: **Verificata**

Verifica spostamento nello stato finale (§4.2.4.2.1 - NTC 2008)

x	Comb.	δ_{max}	L/250.00	Cs
cm		mm	mm	
200.2	15	-0.56	11.44	20.4

Verifica spostamento elastico dovuto ai soli carichi variabili (§4.2.4.2.1 - NTC 2008)

x	Comb.	δ_2	L/300.00	Cs
cm		mm	mm	
200.2	15	-0.38	9.53	24.9

Travata: 645 [398 , 384]

L = 254.4cm

Crit.Prog: Acciaio_Flessione $\delta_c = 0.0cm$ Verifica: **Verificata**

Verifica spostamento nello stato finale (§4.2.4.2.1 - NTC 2008)

x	Comb.	δ_{max}	L/250.00	Cs
---	-------	----------------	----------	----

AUTOSTRADA VALDASTICO A31 NORD
1° LOTTO - PIOVENE ROCCHETTE – VALLE DELL'ASTICO

x	Comb.	δ_{max}	L/250.00	Cs
cm		mm	mm	
127.2	15	-0.12	10.17	84.2

Verifica spostamento elastico dovuto ai soli carichi variabili (§4.2.4.2.1 - NTC 2008)

x	Comb.	δ_2	L/300.00	Cs
cm		mm	mm	
127.2	15	-0.08	8.48	>100

Travata: 646 [384 , 399]

L = 254.4cm

Crit.Prog: Acciaio_Flessione $\delta_c = 0.0cm$ Verifica: **Verificata**

Verifica spostamento nello stato finale (§4.2.4.2.1 - NTC 2008)

x	Comb.	δ_{max}	L/250.00	Cs
cm		mm	mm	
178.1	15	-0.71	10.17	14.3

Verifica spostamento elastico dovuto ai soli carichi variabili (§4.2.4.2.1 - NTC 2008)

x	Comb.	δ_2	L/300.00	Cs
cm		mm	mm	
178.1	15	-0.46	8.48	18.4

Travata: 647 [381 , 384]

L = 254.4cm

Crit.Prog: Acciaio_Flessione $\delta_c = 0.0cm$ Verifica: **Verificata**

Verifica spostamento nello stato finale (§4.2.4.2.1 - NTC 2008)

x	Comb.	δ_{max}	L/250.00	Cs
---	-------	----------------	----------	----

AUTOSTRADA VALDASTICO A31 NORD
1° LOTTO - PIOVENE ROCCHETTE – VALLE DELL'ASTICO

x	Comb.	δ_{max}	L/250.00	Cs
cm		mm	mm	
127.2	15	0.20	10.17	50.6

Verifica spostamento elastico dovuto ai soli carichi variabili (§4.2.4.2.1 - NTC 2008)

x	Comb.	δ_2	L/300.00	Cs
cm		mm	mm	
127.2	15	0.11	8.48	74.4

Travata: 648 [384 , 382]

L = 254.4cm

Crit.Prog: Acciaio_Flessione $\delta_c = 0.0cm$ Verifica: **Verificata**

Verifica spostamento nello stato finale (§4.2.4.2.1 - NTC 2008)

x	Comb.	δ_{max}	L/250.00	Cs
cm		mm	mm	
127.2	15	-0.19	10.17	54.6

Verifica spostamento elastico dovuto ai soli carichi variabili (§4.2.4.2.1 - NTC 2008)

x	Comb.	δ_2	L/300.00	Cs
cm		mm	mm	
152.6	15	-0.12	8.48	71.1

Travata: 649 [400 , 383]

L = 286.0cm

Crit.Prog: Acciaio_Flessione $\delta_c = 0.0cm$ Verifica: **Verificata**

Verifica spostamento nello stato finale (§4.2.4.2.1 - NTC 2008)

x	Comb.	δ_{max}	L/250.00	Cs
---	-------	----------------	----------	----

AUTOSTRADA VALDASTICO A31 NORD
1° LOTTO - PIOVENE ROCCHETTE – VALLE DELL'ASTICO

x	Comb.	δ_{max}	L/250.00	Cs
cm		mm	mm	
114.4	15	-0.23	11.44	50.1

Verifica spostamento elastico dovuto ai soli carichi variabili (§4.2.4.2.1 - NTC 2008)

x	Comb.	δ_2	L/300.00	Cs
cm		mm	mm	
114.4	15	-0.19	9.53	49.3

Travata: 650 [383 , 382]

L = 314.0cm

Crit.Prog: Acciaio_Flessione $\delta_c = 0.0cm$ Verifica: **Verificata**

Verifica spostamento nello stato finale (§4.2.4.2.1 - NTC 2008)

x	Comb.	δ_{max}	L/250.00	Cs
cm		mm	mm	
188.4	15	-0.16	12.56	80.9

Verifica spostamento elastico dovuto ai soli carichi variabili (§4.2.4.2.1 - NTC 2008)

x	Comb.	δ_2	L/300.00	Cs
cm		mm	mm	
157.0	15	-0.14	10.47	76.9

Travata: 651 [399 , 391]

L = 229.9cm

Crit.Prog: Acciaio_Flessione $\delta_c = 0.0cm$ Verifica: **Verificata**

Verifica spostamento nello stato finale (§4.2.4.2.1 - NTC 2008)

x	Comb.	δ_{max}	L/250.00	Cs
---	-------	----------------	----------	----

AUTOSTRADA VALDASTICO A31 NORD
1° LOTTO - PIOVENE ROCCHETTE – VALLE DELL'ASTICO

x	Comb.	δ_{max}	L/250.00	Cs
cm		mm	mm	
160.9	15	0.10	9.19	89.6

Verifica spostamento elastico dovuto ai soli carichi variabili (§4.2.4.2.1 - NTC 2008)

x	Comb.	δ_2	L/300.00	Cs
cm		mm	mm	
183.9	15	0.07	7.66	>100

Travata: 652 [391 , 383]

L = 229.9cm

Crit.Prog: Acciaio_Flessione $\delta_c = 0.0cm$ Verifica: **Verificata**

Verifica spostamento nello stato finale (§4.2.4.2.1 - NTC 2008)

x	Comb.	δ_{max}	L/250.00	Cs
cm		mm	mm	
160.9	15	0.04	9.19	>100

Verifica spostamento elastico dovuto ai soli carichi variabili (§4.2.4.2.1 - NTC 2008)

x	Comb.	δ_2	L/300.00	Cs
cm		mm	mm	
69.0	15	-0.03	7.66	>100

Travata: 653 [391 , 400]

L = 229.9cm

Crit.Prog: Acciaio_Flessione $\delta_c = 0.0cm$ Verifica: **Verificata**

Verifica spostamento nello stato finale (§4.2.4.2.1 - NTC 2008)

x	Comb.	δ_{max}	L/250.00	Cs
---	-------	----------------	----------	----

AUTOSTRADA VALDASTICO A31 NORD
1° LOTTO - PIOVENE ROCCHETTE – VALLE DELL'ASTICO

x	Comb.	δ_{max}	L/250.00	Cs
cm		mm	mm	
114.9	15	-0.34	9.19	27.0

Verifica spostamento elastico dovuto ai soli carichi variabili (§4.2.4.2.1 - NTC 2008)

x	Comb.	δ_2	L/300.00	Cs
cm		mm	mm	
114.9	15	-0.25	7.66	30.1

Travata: 654 [390 , 389]

L = 318.3cm

Crit.Prog: Acciaio_Flessione $\delta_c = 0.0cm$ Verifica: **Verificata**

Verifica spostamento nello stato finale (§4.2.4.2.1 - NTC 2008)

x	Comb.	δ_{max}	L/250.00	Cs
cm		mm	mm	
159.1	15	1.98	12.73	6.43

Verifica spostamento elastico dovuto ai soli carichi variabili (§4.2.4.2.1 - NTC 2008)

x	Comb.	δ_2	L/300.00	Cs
cm		mm	mm	
159.1	15	1.55	10.61	6.87

Travata: 655 [389 , 388]

L = 315.7cm

Crit.Prog: Acciaio_Flessione $\delta_c = 0.0cm$ Verifica: **Verificata**

Verifica spostamento nello stato finale (§4.2.4.2.1 - NTC 2008)

x	Comb.	δ_{max}	L/250.00	Cs
---	-------	----------------	----------	----

AUTOSTRADA VALDASTICO A31 NORD
1° LOTTO - PIOVENE ROCCHETTE – VALLE DELL'ASTICO

x	Comb.	δ_{max}	L/250.00	Cs
cm		mm	mm	
157.9	15	2.69	12.63	4.70

Verifica spostamento elastico dovuto ai soli carichi variabili (§4.2.4.2.1 - NTC 2008)

x	Comb.	δ_2	L/300.00	Cs
cm		mm	mm	
157.9	15	1.94	10.52	5.42

Travata: 656 [388 , 387]

L = 314.2cm

Crit.Prog: Acciaio_Flessione $\delta_c = 0.0cm$ Verifica: **Verificata**

Verifica spostamento nello stato finale (§4.2.4.2.1 - NTC 2008)

x	Comb.	δ_{max}	L/250.00	Cs
cm		mm	mm	
157.1	15	2.71	12.57	4.64

Verifica spostamento elastico dovuto ai soli carichi variabili (§4.2.4.2.1 - NTC 2008)

x	Comb.	δ_2	L/300.00	Cs
cm		mm	mm	
157.1	15	1.95	10.47	5.37

Travata: 657 [387 , 386]

L = 314.0cm

Crit.Prog: Acciaio_Flessione $\delta_c = 0.0cm$ Verifica: **Verificata**

Verifica spostamento nello stato finale (§4.2.4.2.1 - NTC 2008)

x	Comb.	δ_{max}	L/250.00	Cs
---	-------	----------------	----------	----

AUTOSTRADA VALDASTICO A31 NORD
1° LOTTO - PIOVENE ROCCHETTE – VALLE DELL'ASTICO

x	Comb.	δ_{max}	L/250.00	Cs
cm		mm	mm	
157.0	15	2.73	12.56	4.60

Verifica spostamento elastico dovuto ai soli carichi variabili (§4.2.4.2.1 - NTC 2008)

x	Comb.	δ_2	L/300.00	Cs
cm		mm	mm	
157.0	15	1.96	10.47	5.33

Travata: 658 [386 , 385]

L = 314.2cm

Crit.Prog: Acciaio_Flessione $\delta_c = 0.0cm$ Verifica: **Verificata**

Verifica spostamento nello stato finale (§4.2.4.2.1 - NTC 2008)

x	Comb.	δ_{max}	L/250.00	Cs
cm		mm	mm	
157.1	15	2.71	12.57	4.64

Verifica spostamento elastico dovuto ai soli carichi variabili (§4.2.4.2.1 - NTC 2008)

x	Comb.	δ_2	L/300.00	Cs
cm		mm	mm	
157.1	15	1.95	10.47	5.37

Travata: 659 [385 , 384]

L = 315.7cm

Crit.Prog: Acciaio_Flessione $\delta_c = 0.0cm$ Verifica: **Verificata**

Verifica spostamento nello stato finale (§4.2.4.2.1 - NTC 2008)

x	Comb.	δ_{max}	L/250.00	Cs
---	-------	----------------	----------	----

AUTOSTRADA VALDASTICO A31 NORD
1° LOTTO - PIOVENE ROCCHETTE – VALLE DELL'ASTICO

x	Comb.	δ_{max}	L/250.00	Cs
cm		mm	mm	
157.9	15	2.69	12.63	4.70

Verifica spostamento elastico dovuto ai soli carichi variabili (§4.2.4.2.1 - NTC 2008)

x	Comb.	δ_2	L/300.00	Cs
cm		mm	mm	
157.9	15	1.94	10.52	5.42

Travata: 660 [384 , 391]

L = 318.3cm

Crit.Prog: Acciaio_Flessione $\delta_c = 0.0cm$ Verifica: **Verificata**

Verifica spostamento nello stato finale (§4.2.4.2.1 - NTC 2008)

x	Comb.	δ_{max}	L/250.00	Cs
cm		mm	mm	
159.1	15	1.97	12.73	6.48

Verifica spostamento elastico dovuto ai soli carichi variabili (§4.2.4.2.1 - NTC 2008)

x	Comb.	δ_2	L/300.00	Cs
cm		mm	mm	
159.1	15	1.54	10.61	6.88

Travata: 661 [409 , 416]

L = 218.3cm

Crit.Prog: Acciaio_Flessione $\delta_c = 0.0cm$ Verifica: **Verificata**

Verifica spostamento nello stato finale (§4.2.4.2.1 - NTC 2008)

x	Comb.	δ_{max}	L/250.00	Cs
---	-------	----------------	----------	----

AUTOSTRADA VALDASTICO A31 NORD
1° LOTTO - PIOVENE ROCCHETTE – VALLE DELL'ASTICO

x	Comb.	δ_{max}	L/250.00	Cs
cm		mm	mm	
152.8	15	-0.07	8.73	>100

Verifica spostamento elastico dovuto ai soli carichi variabili (§4.2.4.2.1 - NTC 2008)

x	Comb.	δ_2	L/300.00	Cs
cm		mm	mm	
131.0	15	-0.06	7.28	>100

Travata: 662 [419 , 408]

L = 247.0cm

Crit.Prog: Acciaio_Flessione $\delta_c = 0.0cm$ Verifica: **Verificata**

Verifica spostamento nello stato finale (§4.2.4.2.1 - NTC 2008)

x	Comb.	δ_{max}	L/250.00	Cs
cm		mm	mm	
148.2	15	0.08	9.88	>100

Verifica spostamento elastico dovuto ai soli carichi variabili (§4.2.4.2.1 - NTC 2008)

x	Comb.	δ_2	L/300.00	Cs
cm		mm	mm	
123.5	15	0.02	8.23	>100

Travata: 663 [408 , 409]

L = 314.0cm

Crit.Prog: Acciaio_Flessione $\delta_c = 0.0cm$ Verifica: **Verificata**

Verifica spostamento nello stato finale (§4.2.4.2.1 - NTC 2008)

x	Comb.	δ_{max}	L/250.00	Cs
---	-------	----------------	----------	----

AUTOSTRADA VALDASTICO A31 NORD
1° LOTTO - PIOVENE ROCCHETTE – VALLE DELL'ASTICO

x	Comb.	δ_{max}	L/250.00	Cs
cm		mm	mm	
188.4	15	0.13	12.56	93.3

Verifica spostamento elastico dovuto ai soli carichi variabili (§4.2.4.2.1 - NTC 2008)

x	Comb.	δ_2	L/300.00	Cs
cm		mm	mm	
219.8	15	0.03	10.47	>100

Travata: 664 [418 , 416]

L = 218.3cm

Crit.Prog: Acciaio_Flessione $\delta_c = 0.0cm$ Verifica: **Verificata**

Verifica spostamento nello stato finale (§4.2.4.2.1 - NTC 2008)

x	Comb.	δ_{max}	L/250.00	Cs
cm		mm	mm	
109.1	15	0.08	8.73	>100

Verifica spostamento elastico dovuto ai soli carichi variabili (§4.2.4.2.1 - NTC 2008)

x	Comb.	δ_2	L/300.00	Cs
cm		mm	mm	
131.0	15	0.03	7.28	>100

Travata: 665 [416 , 408]

L = 218.3cm

Crit.Prog: Acciaio_Flessione $\delta_c = 0.0cm$ Verifica: **Verificata**

Verifica spostamento nello stato finale (§4.2.4.2.1 - NTC 2008)

x	Comb.	δ_{max}	L/250.00	Cs
---	-------	----------------	----------	----

AUTOSTRADA VALDASTICO A31 NORD
1° LOTTO - PIOVENE ROCCHETTE – VALLE DELL'ASTICO

x	Comb.	δ_{max}	L/250.00	Cs
cm		mm	mm	
109.1	15	0.18	8.73	48.9

Verifica spostamento elastico dovuto ai soli carichi variabili (§4.2.4.2.1 - NTC 2008)

x	Comb.	δ_2	L/300.00	Cs
cm		mm	mm	
109.1	15	0.10	7.28	72.3

Travata: 666 [416 , 419]

L = 218.3cm

Crit.Prog: Acciaio_Flessione $\delta_c = 0.0cm$ Verifica: **Verificata**

Verifica spostamento nello stato finale (§4.2.4.2.1 - NTC 2008)

x	Comb.	δ_{max}	L/250.00	Cs
cm		mm	mm	
131.0	15	-0.11	8.73	82.5

Verifica spostamento elastico dovuto ai soli carichi variabili (§4.2.4.2.1 - NTC 2008)

x	Comb.	δ_2	L/300.00	Cs
cm		mm	mm	
131.0	15	-0.07	7.28	>100

Travata: 667 [418 , 409]

L = 247.0cm

Crit.Prog: Acciaio_Flessione $\delta_c = 0.0cm$ Verifica: **Verificata**

Verifica spostamento nello stato finale (§4.2.4.2.1 - NTC 2008)

x	Comb.	δ_{max}	L/250.00	Cs
---	-------	----------------	----------	----

AUTOSTRADA VALDASTICO A31 NORD
1° LOTTO - PIOVENE ROCCHETTE – VALLE DELL'ASTICO

x	Comb.	δ_{max}	L/250.00	Cs
cm		mm	mm	
172.9	15	0.09	9.88	>100

Verifica spostamento elastico dovuto ai soli carichi variabili (§4.2.4.2.1 - NTC 2008)

x	Comb.	δ_2	L/300.00	Cs
cm		mm	mm	
172.9	15	0.03	8.23	>100

Travata: 668 [420 , 407]

L = 247.0cm

Crit.Prog: Acciaio_Flessione $\delta_c = 0.0cm$ Verifica: **Verificata**

Verifica spostamento nello stato finale (§4.2.4.2.1 - NTC 2008)

x	Comb.	δ_{max}	L/250.00	Cs
cm		mm	mm	
148.2	15	0.06	9.88	>100

Verifica spostamento elastico dovuto ai soli carichi variabili (§4.2.4.2.1 - NTC 2008)

x	Comb.	δ_2	L/300.00	Cs
cm		mm	mm	
123.5	15	0.01	8.23	>100

Travata: 669 [407 , 408]

L = 314.0cm

Crit.Prog: Acciaio_Flessione $\delta_c = 0.0cm$ Verifica: **Verificata**

Verifica spostamento nello stato finale (§4.2.4.2.1 - NTC 2008)

x	Comb.	δ_{max}	L/250.00	Cs
---	-------	----------------	----------	----

AUTOSTRADA VALDASTICO A31 NORD
1° LOTTO - PIOVENE ROCCHETTE – VALLE DELL'ASTICO

x	Comb.	δ_{max}	L/250.00	Cs
cm		mm	mm	
219.8	15	0.07	12.56	>100

Verifica spostamento elastico dovuto ai soli carichi variabili (§4.2.4.2.1 - NTC 2008)

x	Comb.	δ_2	L/300.00	Cs
cm		mm	mm	
62.8	15	-0.02	10.47	>100

Travata: 670 [408 , 415]

L = 243.9cm

Crit.Prog: Acciaio_Flessione $\delta_c = 0.0cm$ Verifica: **Verificata**

Verifica spostamento nello stato finale (§4.2.4.2.1 - NTC 2008)

x	Comb.	δ_{max}	L/250.00	Cs
cm		mm	mm	
146.4	15	-0.13	9.76	75.3

Verifica spostamento elastico dovuto ai soli carichi variabili (§4.2.4.2.1 - NTC 2008)

x	Comb.	δ_2	L/300.00	Cs
cm		mm	mm	
122.0	15	-0.09	8.13	92.4

Travata: 671 [415 , 420]

L = 243.9cm

Crit.Prog: Acciaio_Flessione $\delta_c = 0.0cm$ Verifica: **Verificata**

Verifica spostamento nello stato finale (§4.2.4.2.1 - NTC 2008)

x	Comb.	δ_{max}	L/250.00	Cs
---	-------	----------------	----------	----

AUTOSTRADA VALDASTICO A31 NORD
1° LOTTO - PIOVENE ROCCHETTE – VALLE DELL'ASTICO

x	Comb.	δ_{max}	L/250.00	Cs
cm		mm	mm	
122.0	15	-0.16	9.76	62.8

Verifica spostamento elastico dovuto ai soli carichi variabili (§4.2.4.2.1 - NTC 2008)

x	Comb.	δ_2	L/300.00	Cs
cm		mm	mm	
122.0	15	-0.10	8.13	78.1

Travata: 672 [419 , 415]

L = 243.9cm

Crit.Prog: Acciaio_Flessione $\delta_c = 0.0cm$ Verifica: **Verificata**

Verifica spostamento nello stato finale (§4.2.4.2.1 - NTC 2008)

x	Comb.	δ_{max}	L/250.00	Cs
cm		mm	mm	
122.0	15	0.19	9.76	51.5

Verifica spostamento elastico dovuto ai soli carichi variabili (§4.2.4.2.1 - NTC 2008)

x	Comb.	δ_2	L/300.00	Cs
cm		mm	mm	
122.0	15	0.10	8.13	77.7

Travata: 673 [415 , 407]

L = 243.9cm

Crit.Prog: Acciaio_Flessione $\delta_c = 0.0cm$ Verifica: **Verificata**

Verifica spostamento nello stato finale (§4.2.4.2.1 - NTC 2008)

x	Comb.	δ_{max}	L/250.00	Cs
---	-------	----------------	----------	----

AUTOSTRADA VALDASTICO A31 NORD
1° LOTTO - PIOVENE ROCCHETTE – VALLE DELL'ASTICO

x	Comb.	δ_{max}	L/250.00	Cs
cm		mm	mm	
122.0	15	0.18	9.76	54.6

Verifica spostamento elastico dovuto ai soli carichi variabili (§4.2.4.2.1 - NTC 2008)

x	Comb.	δ_2	L/300.00	Cs
cm		mm	mm	
122.0	15	0.09	8.13	86.5

Travata: 674 [421 , 406]

L = 247.0cm

Crit.Prog: Acciaio_Flessione $\delta_c = 0.0cm$ Verifica: **Verificata**

Verifica spostamento nello stato finale (§4.2.4.2.1 - NTC 2008)

x	Comb.	δ_{max}	L/250.00	Cs
cm		mm	mm	
148.2	21	0.05	9.88	>100

Verifica spostamento elastico dovuto ai soli carichi variabili (§4.2.4.2.1 - NTC 2008)

x	Comb.	δ_2	L/300.00	Cs
cm		mm	mm	
123.5	15	-0.00	8.23	>100

Travata: 675 [406 , 407]

L = 314.0cm

Crit.Prog: Acciaio_Flessione $\delta_c = 0.0cm$ Verifica: **Verificata**

Verifica spostamento nello stato finale (§4.2.4.2.1 - NTC 2008)

x	Comb.	δ_{max}	L/250.00	Cs
---	-------	----------------	----------	----

AUTOSTRADA VALDASTICO A31 NORD
1° LOTTO - PIOVENE ROCCHETTE – VALLE DELL'ASTICO

x	Comb.	δ_{max}	L/250.00	Cs
cm		mm	mm	
188.4	21	0.05	12.56	>100

Verifica spostamento elastico dovuto ai soli carichi variabili (§4.2.4.2.1 - NTC 2008)

x	Comb.	δ_2	L/300.00	Cs
cm		mm	mm	
94.2	15	-0.02	10.47	>100

Travata: 676 [420 , 414]

L = 264.3cm

Crit.Prog: Acciaio_Flessione $\delta_c = 0.0cm$ Verifica: **Verificata**

Verifica spostamento nello stato finale (§4.2.4.2.1 - NTC 2008)

x	Comb.	δ_{max}	L/250.00	Cs
cm		mm	mm	
132.1	15	0.19	10.57	54.2

Verifica spostamento elastico dovuto ai soli carichi variabili (§4.2.4.2.1 - NTC 2008)

x	Comb.	δ_2	L/300.00	Cs
cm		mm	mm	
132.1	15	0.10	8.81	83.9

Travata: 677 [414 , 406]

L = 264.3cm

Crit.Prog: Acciaio_Flessione $\delta_c = 0.0cm$ Verifica: **Verificata**

Verifica spostamento nello stato finale (§4.2.4.2.1 - NTC 2008)

x	Comb.	δ_{max}	L/250.00	Cs
---	-------	----------------	----------	----

AUTOSTRADA VALDASTICO A31 NORD
1° LOTTO - PIOVENE ROCCHETTE – VALLE DELL'ASTICO

x	Comb.	δ_{max}	L/250.00	Cs
cm		mm	mm	
132.1	15	0.13	10.57	81.3

Verifica spostamento elastico dovuto ai soli carichi variabili (§4.2.4.2.1 - NTC 2008)

x	Comb.	δ_2	L/300.00	Cs
cm		mm	mm	
105.7	15	0.06	8.81	>100

Travata: 678 [407 , 414]

L = 264.3cm

Crit.Prog: Acciaio_Flessione $\delta_c = 0.0cm$ Verifica: **Verificata**

Verifica spostamento nello stato finale (§4.2.4.2.1 - NTC 2008)

x	Comb.	δ_{max}	L/250.00	Cs
cm		mm	mm	
132.1	15	-0.12	10.57	89.6

Verifica spostamento elastico dovuto ai soli carichi variabili (§4.2.4.2.1 - NTC 2008)

x	Comb.	δ_2	L/300.00	Cs
cm		mm	mm	
132.1	15	-0.09	8.81	>100

Travata: 679 [414 , 421]

L = 264.3cm

Crit.Prog: Acciaio_Flessione $\delta_c = 0.0cm$ Verifica: **Verificata**

Verifica spostamento nello stato finale (§4.2.4.2.1 - NTC 2008)

x	Comb.	δ_{max}	L/250.00	Cs
---	-------	----------------	----------	----

AUTOSTRADA VALDASTICO A31 NORD
1° LOTTO - PIOVENE ROCCHETTE – VALLE DELL'ASTICO

x	Comb.	δ_{max}	L/250.00	Cs
cm		mm	mm	
132.1	15	-0.07	10.57	>100

Verifica spostamento elastico dovuto ai soli carichi variabili (§4.2.4.2.1 - NTC 2008)

x	Comb.	δ_2	L/300.00	Cs
cm		mm	mm	
132.1	15	-0.06	8.81	>100

Travata: 680 [422 , 405]

L = 247.0cm

Crit.Prog: Acciaio_Flessione $\delta_c = 0.0cm$ Verifica: **Verificata**

Verifica spostamento nello stato finale (§4.2.4.2.1 - NTC 2008)

x	Comb.	δ_{max}	L/250.00	Cs
cm		mm	mm	
148.2	21	0.05	9.88	>100

Verifica spostamento elastico dovuto ai soli carichi variabili (§4.2.4.2.1 - NTC 2008)

x	Comb.	δ_2	L/300.00	Cs
cm		mm	mm	
148.2	15	-0.01	8.23	>100

Travata: 681 [405 , 406]

L = 314.0cm

Crit.Prog: Acciaio_Flessione $\delta_c = 0.0cm$ Verifica: **Verificata**

Verifica spostamento nello stato finale (§4.2.4.2.1 - NTC 2008)

x	Comb.	δ_{max}	L/250.00	Cs
---	-------	----------------	----------	----

AUTOSTRADA VALDASTICO A31 NORD
1° LOTTO - PIOVENE ROCCHETTE – VALLE DELL'ASTICO

x	Comb.	δ_{max}	L/250.00	Cs
cm		mm	mm	
157.0	15	0.06	12.56	>100

Verifica spostamento elastico dovuto ai soli carichi variabili (§4.2.4.2.1 - NTC 2008)

x	Comb.	δ_2	L/300.00	Cs
cm		mm	mm	
251.2	15	0.00	10.47	>100

Travata: 682 [421 , 413]

L = 272.3cm

Crit.Prog: Acciaio_Flessione $\delta_c = 0.0cm$ Verifica: **Verificata**

Verifica spostamento nello stato finale (§4.2.4.2.1 - NTC 2008)

x	Comb.	δ_{max}	L/250.00	Cs
cm		mm	mm	
136.1	15	0.12	10.89	88.5

Verifica spostamento elastico dovuto ai soli carichi variabili (§4.2.4.2.1 - NTC 2008)

x	Comb.	δ_2	L/300.00	Cs
cm		mm	mm	
136.1	15	0.06	9.08	>100

Travata: 683 [413 , 422]

L = 272.3cm

Crit.Prog: Acciaio_Flessione $\delta_c = 0.0cm$ Verifica: **Verificata**

Verifica spostamento nello stato finale (§4.2.4.2.1 - NTC 2008)

x	Comb.	δ_{max}	L/250.00	Cs
---	-------	----------------	----------	----

AUTOSTRADA VALDASTICO A31 NORD
1° LOTTO - PIOVENE ROCCHETTE – VALLE DELL'ASTICO

x	Comb.	δ_{max}	L/250.00	Cs
cm		mm	mm	
163.4	15	0.03	10.89	>100

Verifica spostamento elastico dovuto ai soli carichi variabili (§4.2.4.2.1 - NTC 2008)

x	Comb.	δ_2	L/300.00	Cs
cm		mm	mm	
190.6	15	0.01	9.08	>100

Travata: 684 [406 , 413]

L = 272.3cm

Crit.Prog: Acciaio_Flessione $\delta_c = 0.0cm$ Verifica: **Verificata**

Verifica spostamento nello stato finale (§4.2.4.2.1 - NTC 2008)

x	Comb.	δ_{max}	L/250.00	Cs
cm		mm	mm	
163.4	15	-0.03	10.89	>100

Verifica spostamento elastico dovuto ai soli carichi variabili (§4.2.4.2.1 - NTC 2008)

x	Comb.	δ_2	L/300.00	Cs
cm		mm	mm	
136.1	15	-0.04	9.08	>100

Travata: 685 [413 , 405]

L = 272.3cm

Crit.Prog: Acciaio_Flessione $\delta_c = 0.0cm$ Verifica: **Verificata**

Verifica spostamento nello stato finale (§4.2.4.2.1 - NTC 2008)

x	Comb.	δ_{max}	L/250.00	Cs
---	-------	----------------	----------	----

AUTOSTRADA VALDASTICO A31 NORD
1° LOTTO - PIOVENE ROCCHETTE – VALLE DELL'ASTICO

x	Comb.	δ_{max}	L/250.00	Cs
cm		mm	mm	
136.1	15	0.06	10.89	>100

Verifica spostamento elastico dovuto ai soli carichi variabili (§4.2.4.2.1 - NTC 2008)

x	Comb.	δ_2	L/300.00	Cs
cm		mm	mm	
108.9	15	0.02	9.08	>100

Travata: 686 [405 , 412]

L = 272.3cm

Crit.Prog: Acciaio_Flessione $\delta_c = 0.0cm$ Verifica: **Verificata**

Verifica spostamento nello stato finale (§4.2.4.2.1 - NTC 2008)

x	Comb.	δ_{max}	L/250.00	Cs
cm		mm	mm	
136.1	15	0.05	10.89	>100

Verifica spostamento elastico dovuto ai soli carichi variabili (§4.2.4.2.1 - NTC 2008)

x	Comb.	δ_2	L/300.00	Cs
cm		mm	mm	
163.4	15	0.02	9.08	>100

Travata: 687 [412 , 423]

L = 272.3cm

Crit.Prog: Acciaio_Flessione $\delta_c = 0.0cm$ Verifica: **Verificata**

Verifica spostamento nello stato finale (§4.2.4.2.1 - NTC 2008)

x	Comb.	δ_{max}	L/250.00	Cs
---	-------	----------------	----------	----

AUTOSTRADA VALDASTICO A31 NORD
1° LOTTO - PIOVENE ROCCHETTE – VALLE DELL'ASTICO

x	Comb.	δ_{max}	L/250.00	Cs
cm		mm	mm	
136.1	15	0.12	10.89	90.6

Verifica spostamento elastico dovuto ai soli carichi variabili (§4.2.4.2.1 - NTC 2008)

x	Comb.	δ_2	L/300.00	Cs
cm		mm	mm	
136.1	15	0.06	9.08	>100

Travata: 688 [423 , 404]

L = 247.0cm

Crit.Prog: Acciaio_Flessione $\delta_c = 0.0cm$ Verifica: **Verificata**

Verifica spostamento nello stato finale (§4.2.4.2.1 - NTC 2008)

x	Comb.	δ_{max}	L/250.00	Cs
cm		mm	mm	
148.2	17	0.05	9.88	>100

Verifica spostamento elastico dovuto ai soli carichi variabili (§4.2.4.2.1 - NTC 2008)

x	Comb.	δ_2	L/300.00	Cs
cm		mm	mm	
123.5	15	-0.00	8.23	>100

Travata: 689 [404 , 405]

L = 314.0cm

Crit.Prog: Acciaio_Flessione $\delta_c = 0.0cm$ Verifica: **Verificata**

Verifica spostamento nello stato finale (§4.2.4.2.1 - NTC 2008)

x	Comb.	δ_{max}	L/250.00	Cs
---	-------	----------------	----------	----

AUTOSTRADA VALDASTICO A31 NORD
1° LOTTO - PIOVENE ROCCHETTE – VALLE DELL'ASTICO

x	Comb.	δ_{max}	L/250.00	Cs
cm		mm	mm	
157.0	15	0.06	12.56	>100

Verifica spostamento elastico dovuto ai soli carichi variabili (§4.2.4.2.1 - NTC 2008)

x	Comb.	δ_2	L/300.00	Cs
cm		mm	mm	
94.2	15	0.00	10.47	>100

Travata: 690 [422 , 412]

L = 272.3cm

Crit.Prog: Acciaio_Flessione $\delta_c = 0.0cm$ Verifica: **Verificata**

Verifica spostamento nello stato finale (§4.2.4.2.1 - NTC 2008)

x	Comb.	δ_{max}	L/250.00	Cs
cm		mm	mm	
108.9	15	0.03	10.89	>100

Verifica spostamento elastico dovuto ai soli carichi variabili (§4.2.4.2.1 - NTC 2008)

x	Comb.	δ_2	L/300.00	Cs
cm		mm	mm	
81.7	15	0.01	9.08	>100

Travata: 691 [412 , 404]

L = 272.3cm

Crit.Prog: Acciaio_Flessione $\delta_c = 0.0cm$ Verifica: **Verificata**

Verifica spostamento nello stato finale (§4.2.4.2.1 - NTC 2008)

x	Comb.	δ_{max}	L/250.00	Cs
---	-------	----------------	----------	----

AUTOSTRADA VALDASTICO A31 NORD
1° LOTTO - PIOVENE ROCCHETTE – VALLE DELL'ASTICO

x	Comb.	δ_{max}	L/250.00	Cs
cm		mm	mm	
108.9	15	-0.03	10.89	>100

Verifica spostamento elastico dovuto ai soli carichi variabili (§4.2.4.2.1 - NTC 2008)

x	Comb.	δ_2	L/300.00	Cs
cm		mm	mm	
136.1	15	-0.03	9.08	>100

Travata: 692 [424 , 403]

L = 247.0cm

Crit.Prog: Acciaio_Flessione $\delta_c = 0.0cm$ Verifica: **Verificata**

Verifica spostamento nello stato finale (§4.2.4.2.1 - NTC 2008)

x	Comb.	δ_{max}	L/250.00	Cs
cm		mm	mm	
148.2	15	0.06	9.88	>100

Verifica spostamento elastico dovuto ai soli carichi variabili (§4.2.4.2.1 - NTC 2008)

x	Comb.	δ_2	L/300.00	Cs
cm		mm	mm	
123.5	15	0.01	8.23	>100

Travata: 693 [403 , 404]

L = 314.0cm

Crit.Prog: Acciaio_Flessione $\delta_c = 0.0cm$ Verifica: **Verificata**

Verifica spostamento nello stato finale (§4.2.4.2.1 - NTC 2008)

x	Comb.	δ_{max}	L/250.00	Cs
---	-------	----------------	----------	----

AUTOSTRADA VALDASTICO A31 NORD
1° LOTTO - PIOVENE ROCCHETTE – VALLE DELL'ASTICO

x	Comb.	δ_{max}	L/250.00	Cs
cm		mm	mm	
125.6	21	0.05	12.56	>100

Verifica spostamento elastico dovuto ai soli carichi variabili (§4.2.4.2.1 - NTC 2008)

x	Comb.	δ_2	L/300.00	Cs
cm		mm	mm	
219.8	15	-0.02	10.47	>100

Travata: 694 [404 , 411]

L = 264.3cm

Crit.Prog: Acciaio_Flessione $\delta_c = 0.0cm$ Verifica: **Verificata**

Verifica spostamento nello stato finale (§4.2.4.2.1 - NTC 2008)

x	Comb.	δ_{max}	L/250.00	Cs
cm		mm	mm	
132.1	15	0.13	10.57	83.1

Verifica spostamento elastico dovuto ai soli carichi variabili (§4.2.4.2.1 - NTC 2008)

x	Comb.	δ_2	L/300.00	Cs
cm		mm	mm	
158.6	15	0.06	8.81	>100

Travata: 695 [411 , 424]

L = 264.3cm

Crit.Prog: Acciaio_Flessione $\delta_c = 0.0cm$ Verifica: **Verificata**

Verifica spostamento nello stato finale (§4.2.4.2.1 - NTC 2008)

x	Comb.	δ_{max}	L/250.00	Cs
---	-------	----------------	----------	----

AUTOSTRADA VALDASTICO A31 NORD
1° LOTTO - PIOVENE ROCCHETTE – VALLE DELL'ASTICO

x	Comb.	δ_{max}	L/250.00	Cs
cm		mm	mm	
132.1	15	0.19	10.57	55.3

Verifica spostamento elastico dovuto ai soli carichi variabili (§4.2.4.2.1 - NTC 2008)

x	Comb.	δ_2	L/300.00	Cs
cm		mm	mm	
132.1	15	0.10	8.81	86.0

Travata: 696 [423 , 411]

L = 264.3cm

Crit.Prog: Acciaio_Flessione $\delta_c = 0.0cm$ Verifica: **Verificata**

Verifica spostamento nello stato finale (§4.2.4.2.1 - NTC 2008)

x	Comb.	δ_{max}	L/250.00	Cs
cm		mm	mm	
132.1	15	-0.07	10.57	>100

Verifica spostamento elastico dovuto ai soli carichi variabili (§4.2.4.2.1 - NTC 2008)

x	Comb.	δ_2	L/300.00	Cs
cm		mm	mm	
132.1	15	-0.05	8.81	>100

Travata: 697 [411 , 403]

L = 264.3cm

Crit.Prog: Acciaio_Flessione $\delta_c = 0.0cm$ Verifica: **Verificata**

Verifica spostamento nello stato finale (§4.2.4.2.1 - NTC 2008)

x	Comb.	δ_{max}	L/250.00	Cs
---	-------	----------------	----------	----

AUTOSTRADA VALDASTICO A31 NORD
1° LOTTO - PIOVENE ROCCHETTE – VALLE DELL'ASTICO

x	Comb.	δ_{max}	L/250.00	Cs
cm		mm	mm	
132.1	15	-0.11	10.57	94.8

Verifica spostamento elastico dovuto ai soli carichi variabili (§4.2.4.2.1 - NTC 2008)

x	Comb.	δ_2	L/300.00	Cs
cm		mm	mm	
132.1	15	-0.08	8.81	>100

Travata: 698 [403 , 402]

L = 314.0cm

Crit.Prog: Acciaio_Flessione $\delta_c = 0.0cm$ Verifica: **Verificata**

Verifica spostamento nello stato finale (§4.2.4.2.1 - NTC 2008)

x	Comb.	δ_{max}	L/250.00	Cs
cm		mm	mm	
219.8	15	0.08	12.56	>100

Verifica spostamento elastico dovuto ai soli carichi variabili (§4.2.4.2.1 - NTC 2008)

x	Comb.	δ_2	L/300.00	Cs
cm		mm	mm	
251.2	15	0.03	10.47	>100

Travata: 699 [402 , 425]

L = 247.0cm

Crit.Prog: Acciaio_Flessione $\delta_c = 0.0cm$ Verifica: **Verificata**

Verifica spostamento nello stato finale (§4.2.4.2.1 - NTC 2008)

x	Comb.	δ_{max}	L/250.00	Cs
---	-------	----------------	----------	----

AUTOSTRADA VALDASTICO A31 NORD
1° LOTTO - PIOVENE ROCCHETTE – VALLE DELL'ASTICO

x	Comb.	δ_{max}	L/250.00	Cs
cm		mm	mm	
98.8	15	0.07	9.88	>100

Verifica spostamento elastico dovuto ai soli carichi variabili (§4.2.4.2.1 - NTC 2008)

x	Comb.	δ_2	L/300.00	Cs
cm		mm	mm	
98.8	15	0.02	8.23	>100

Travata: 700 [424 , 410]

L = 243.9cm

Crit.Prog: Acciaio_Flessione $\delta_c = 0.0cm$ Verifica: **Verificata**

Verifica spostamento nello stato finale (§4.2.4.2.1 - NTC 2008)

x	Comb.	δ_{max}	L/250.00	Cs
cm		mm	mm	
122.0	15	-0.15	9.76	65.9

Verifica spostamento elastico dovuto ai soli carichi variabili (§4.2.4.2.1 - NTC 2008)

x	Comb.	δ_2	L/300.00	Cs
cm		mm	mm	
122.0	15	-0.10	8.13	82.1

Travata: 701 [410 , 425]

L = 243.9cm

Crit.Prog: Acciaio_Flessione $\delta_c = 0.0cm$ Verifica: **Verificata**

Verifica spostamento nello stato finale (§4.2.4.2.1 - NTC 2008)

x	Comb.	δ_{max}	L/250.00	Cs
---	-------	----------------	----------	----

AUTOSTRADA VALDASTICO A31 NORD
1° LOTTO - PIOVENE ROCCHETTE – VALLE DELL'ASTICO

x	Comb.	δ_{max}	L/250.00	Cs
cm		mm	mm	
122.0	15	0.18	9.76	55.5

Verifica spostamento elastico dovuto ai soli carichi variabili (§4.2.4.2.1 - NTC 2008)

x	Comb.	δ_2	L/300.00	Cs
cm		mm	mm	
122.0	15	0.10	8.13	85.0

Travata: 702 [403 , 410]

L = 243.9cm

Crit.Prog: Acciaio_Flessione $\delta_c = 0.0cm$ Verifica: **Verificata**

Verifica spostamento nello stato finale (§4.2.4.2.1 - NTC 2008)

x	Comb.	δ_{max}	L/250.00	Cs
cm		mm	mm	
122.0	15	0.17	9.76	55.9

Verifica spostamento elastico dovuto ai soli carichi variabili (§4.2.4.2.1 - NTC 2008)

x	Comb.	δ_2	L/300.00	Cs
cm		mm	mm	
122.0	15	0.09	8.13	88.9

Travata: 703 [410 , 402]

L = 243.9cm

Crit.Prog: Acciaio_Flessione $\delta_c = 0.0cm$ Verifica: **Verificata**

Verifica spostamento nello stato finale (§4.2.4.2.1 - NTC 2008)

x	Comb.	δ_{max}	L/250.00	Cs
---	-------	----------------	----------	----

AUTOSTRADA VALDASTICO A31 NORD
1° LOTTO - PIOVENE ROCCHETTE – VALLE DELL'ASTICO

x	Comb.	δ_{max}	L/250.00	Cs
cm		mm	mm	
97.6	15	-0.12	9.76	81.8

Verifica spostamento elastico dovuto ai soli carichi variabili (§4.2.4.2.1 - NTC 2008)

x	Comb.	δ_2	L/300.00	Cs
cm		mm	mm	
122.0	15	-0.08	8.13	>100

Travata: 704 [426 , 401]

L = 247.0cm

Crit.Prog: Acciaio_Flessione $\delta_c = 0.0cm$ Verifica: **Verificata**

Verifica spostamento nello stato finale (§4.2.4.2.1 - NTC 2008)

x	Comb.	δ_{max}	L/250.00	Cs
cm		mm	mm	
148.2	15	0.10	9.88	96.7

Verifica spostamento elastico dovuto ai soli carichi variabili (§4.2.4.2.1 - NTC 2008)

x	Comb.	δ_2	L/300.00	Cs
cm		mm	mm	
172.9	15	0.04	8.23	>100

Travata: 705 [401 , 402]

L = 314.0cm

Crit.Prog: Acciaio_Flessione $\delta_c = 0.0cm$ Verifica: **Verificata**

Verifica spostamento nello stato finale (§4.2.4.2.1 - NTC 2008)

x	Comb.	δ_{max}	L/250.00	Cs
---	-------	----------------	----------	----

AUTOSTRADA VALDASTICO A31 NORD
1° LOTTO - PIOVENE ROCCHETTE – VALLE DELL'ASTICO

x	Comb.	δ_{max}	L/250.00	Cs
cm		mm	mm	
125.6	15	0.14	12.56	92.6

Verifica spostamento elastico dovuto ai soli carichi variabili (§4.2.4.2.1 - NTC 2008)

x	Comb.	δ_2	L/300.00	Cs
cm		mm	mm	
125.6	15	0.03	10.47	>100

Travata: 706 [425 , 417]

L = 218.3cm

Crit.Prog: Acciaio_Flessione $\delta_c = 0.0cm$ Verifica: **Verificata**

Verifica spostamento nello stato finale (§4.2.4.2.1 - NTC 2008)

x	Comb.	δ_{max}	L/250.00	Cs
cm		mm	mm	
87.3	15	-0.09	8.73	92.8

Verifica spostamento elastico dovuto ai soli carichi variabili (§4.2.4.2.1 - NTC 2008)

x	Comb.	δ_2	L/300.00	Cs
cm		mm	mm	
87.3	15	-0.06	7.28	>100

Travata: 707 [417 , 401]

L = 218.3cm

Crit.Prog: Acciaio_Flessione $\delta_c = 0.0cm$ Verifica: **Verificata**

Verifica spostamento nello stato finale (§4.2.4.2.1 - NTC 2008)

x	Comb.	δ_{max}	L/250.00	Cs
---	-------	----------------	----------	----

AUTOSTRADA VALDASTICO A31 NORD
1° LOTTO - PIOVENE ROCCHETTE – VALLE DELL'ASTICO

x	Comb.	δ_{max}	L/250.00	Cs
cm		mm	mm	
65.5	15	-0.07	8.73	>100

Verifica spostamento elastico dovuto ai soli carichi variabili (§4.2.4.2.1 - NTC 2008)

x	Comb.	δ_2	L/300.00	Cs
cm		mm	mm	
87.3	15	-0.06	7.28	>100

Travata: 708 [417 , 426]

L = 218.3cm

Crit.Prog: Acciaio_Flessione $\delta_c = 0.0cm$ Verifica: **Verificata**

Verifica spostamento nello stato finale (§4.2.4.2.1 - NTC 2008)

x	Comb.	δ_{max}	L/250.00	Cs
cm		mm	mm	
109.1	15	0.08	8.73	>100

Verifica spostamento elastico dovuto ai soli carichi variabili (§4.2.4.2.1 - NTC 2008)

x	Comb.	δ_2	L/300.00	Cs
cm		mm	mm	
109.1	15	0.03	7.28	>100

Travata: 709 [416 , 415]

L = 318.3cm

Crit.Prog: Acciaio_Flessione $\delta_c = 0.0cm$ Verifica: **Verificata**

Verifica spostamento nello stato finale (§4.2.4.2.1 - NTC 2008)

x	Comb.	δ_{max}	L/250.00	Cs
---	-------	----------------	----------	----

AUTOSTRADA VALDASTICO A31 NORD
1° LOTTO - PIOVENE ROCCHETTE – VALLE DELL'ASTICO

x	Comb.	δ_{max}	L/250.00	Cs
cm		mm	mm	
159.1	15	1.14	12.73	11.2

Verifica spostamento elastico dovuto ai soli carichi variabili (§4.2.4.2.1 - NTC 2008)

x	Comb.	δ_2	L/300.00	Cs
cm		mm	mm	
159.1	15	0.82	10.61	12.9

Travata: 710 [415 , 414]

L = 315.7cm

Crit.Prog: Acciaio_Flessione $\delta_c = 0.0cm$ Verifica: **Verificata**

Verifica spostamento nello stato finale (§4.2.4.2.1 - NTC 2008)

x	Comb.	δ_{max}	L/250.00	Cs
cm		mm	mm	
157.9	15	1.09	12.63	11.6

Verifica spostamento elastico dovuto ai soli carichi variabili (§4.2.4.2.1 - NTC 2008)

x	Comb.	δ_2	L/300.00	Cs
cm		mm	mm	
157.9	15	0.78	10.52	13.5

Travata: 711 [414 , 413]

L = 314.2cm

Crit.Prog: Acciaio_Flessione $\delta_c = 0.0cm$ Verifica: **Verificata**

Verifica spostamento nello stato finale (§4.2.4.2.1 - NTC 2008)

x	Comb.	δ_{max}	L/250.00	Cs
---	-------	----------------	----------	----

AUTOSTRADA VALDASTICO A31 NORD
1° LOTTO - PIOVENE ROCCHETTE – VALLE DELL'ASTICO

x	Comb.	δ_{max}	L/250.00	Cs
cm		mm	mm	
157.1	15	1.13	12.57	11.1

Verifica spostamento elastico dovuto ai soli carichi variabili (§4.2.4.2.1 - NTC 2008)

x	Comb.	δ_2	L/300.00	Cs
cm		mm	mm	
157.1	15	0.80	10.47	13.0

Travata: 712 [413 , 412]

L = 314.0cm

Crit.Prog: Acciaio_Flessione $\delta_c = 0.0cm$ Verifica: **Verificata**

Verifica spostamento nello stato finale (§4.2.4.2.1 - NTC 2008)

x	Comb.	δ_{max}	L/250.00	Cs
cm		mm	mm	
157.0	15	1.16	12.56	10.8

Verifica spostamento elastico dovuto ai soli carichi variabili (§4.2.4.2.1 - NTC 2008)

x	Comb.	δ_2	L/300.00	Cs
cm		mm	mm	
157.0	15	0.82	10.47	12.8

Travata: 713 [412 , 411]

L = 314.2cm

Crit.Prog: Acciaio_Flessione $\delta_c = 0.0cm$ Verifica: **Verificata**

Verifica spostamento nello stato finale (§4.2.4.2.1 - NTC 2008)

x	Comb.	δ_{max}	L/250.00	Cs
---	-------	----------------	----------	----

AUTOSTRADA VALDASTICO A31 NORD
1° LOTTO - PIOVENE ROCCHETTE – VALLE DELL'ASTICO

x	Comb.	δ_{max}	L/250.00	Cs
cm		mm	mm	
157.1	15	1.14	12.57	11.1

Verifica spostamento elastico dovuto ai soli carichi variabili (§4.2.4.2.1 - NTC 2008)

x	Comb.	δ_2	L/300.00	Cs
cm		mm	mm	
157.1	15	0.81	10.47	13.0

Travata: 714 [411 , 410]

L = 315.7cm

Crit.Prog: Acciaio_Flessione $\delta_c = 0.0cm$ Verifica: **Verificata**

Verifica spostamento nello stato finale (§4.2.4.2.1 - NTC 2008)

x	Comb.	δ_{max}	L/250.00	Cs
cm		mm	mm	
157.9	15	1.10	12.63	11.5

Verifica spostamento elastico dovuto ai soli carichi variabili (§4.2.4.2.1 - NTC 2008)

x	Comb.	δ_2	L/300.00	Cs
cm		mm	mm	
157.9	15	0.78	10.52	13.4

Travata: 715 [410 , 417]

L = 318.3cm

Crit.Prog: Acciaio_Flessione $\delta_c = 0.0cm$ Verifica: **Verificata**

Verifica spostamento nello stato finale (§4.2.4.2.1 - NTC 2008)

x	Comb.	δ_{max}	L/250.00	Cs
---	-------	----------------	----------	----

AUTOSTRADA VALDASTICO A31 NORD
1° LOTTO - PIOVENE ROCCHETTE – VALLE DELL'ASTICO

x	Comb.	δ_{max}	L/250.00	Cs
cm		mm	mm	
159.1	15	1.15	12.73	11.1

Verifica spostamento elastico dovuto ai soli carichi variabili (§4.2.4.2.1 - NTC 2008)

x	Comb.	δ_2	L/300.00	Cs
cm		mm	mm	
159.1	15	0.83	10.61	12.8

Travata: 716 [427 , 418]

L = 247.0cm

Crit.Prog: Acciaio_Flessione $\delta_c = 0.0cm$ Verifica: **Verificata**

Verifica spostamento nello stato finale (§4.2.4.2.1 - NTC 2008)

x	Comb.	δ_{max}	L/250.00	Cs
cm		mm	mm	
74.1	15	-0.04	9.88	>100

Verifica spostamento elastico dovuto ai soli carichi variabili (§4.2.4.2.1 - NTC 2008)

x	Comb.	δ_2	L/300.00	Cs
cm		mm	mm	
49.4	15	-0.01	8.23	>100

Travata: 717 [428 , 419]

L = 218.3cm

Crit.Prog: Acciaio_Flessione $\delta_c = 0.0cm$ Verifica: **Verificata**

Verifica spostamento nello stato finale (§4.2.4.2.1 - NTC 2008)

x	Comb.	δ_{max}	L/250.00	Cs
---	-------	----------------	----------	----

AUTOSTRADA VALDASTICO A31 NORD
1° LOTTO - PIOVENE ROCCHETTE – VALLE DELL'ASTICO

x	Comb.	δ_{max}	L/250.00	Cs
cm		mm	mm	
109.1	15	0.10	8.73	84.1

Verifica spostamento elastico dovuto ai soli carichi variabili (§4.2.4.2.1 - NTC 2008)

x	Comb.	δ_2	L/300.00	Cs
cm		mm	mm	
109.1	15	0.06	7.28	>100

Travata: 718 [419 , 418]

L = 314.0cm

Crit.Prog: Acciaio_Flessione $\delta_c = 0.0cm$ Verifica: **Verificata**

Verifica spostamento nello stato finale (§4.2.4.2.1 - NTC 2008)

x	Comb.	δ_{max}	L/250.00	Cs
cm		mm	mm	
157.0	21	0.04	12.56	>100

Verifica spostamento elastico dovuto ai soli carichi variabili (§4.2.4.2.1 - NTC 2008)

x	Comb.	δ_2	L/300.00	Cs
cm		mm	mm	
188.4	15	-0.05	10.47	>100

Travata: 719 [419 , 429]

L = 243.9cm

Crit.Prog: Acciaio_Flessione $\delta_c = 0.0cm$ Verifica: **Verificata**

Verifica spostamento nello stato finale (§4.2.4.2.1 - NTC 2008)

x	Comb.	δ_{max}	L/250.00	Cs
---	-------	----------------	----------	----

AUTOSTRADA VALDASTICO A31 NORD
1° LOTTO - PIOVENE ROCCHETTE – VALLE DELL'ASTICO

x	Comb.	δ_{max}	L/250.00	Cs
cm		mm	mm	
122.0	15	-0.19	9.76	51.3

Verifica spostamento elastico dovuto ai soli carichi variabili (§4.2.4.2.1 - NTC 2008)

x	Comb.	δ_2	L/300.00	Cs
cm		mm	mm	
122.0	15	-0.12	8.13	66.7

Travata: 720 [428 , 430]

L = 218.3cm

Crit.Prog: Acciaio_Flessione $\delta_c = 0.0cm$ Verifica: **Verificata**

Verifica spostamento nello stato finale (§4.2.4.2.1 - NTC 2008)

x	Comb.	δ_{max}	L/250.00	Cs
cm		mm	mm	
109.1	15	-0.12	8.73	72.5

Verifica spostamento elastico dovuto ai soli carichi variabili (§4.2.4.2.1 - NTC 2008)

x	Comb.	δ_2	L/300.00	Cs
cm		mm	mm	
109.1	15	-0.08	7.28	90.1

Travata: 721 [428 , 429]

L = 318.3cm

Crit.Prog: Acciaio_Flessione $\delta_c = 0.0cm$ Verifica: **Verificata**

Verifica spostamento nello stato finale (§4.2.4.2.1 - NTC 2008)

x	Comb.	δ_{max}	L/250.00	Cs
---	-------	----------------	----------	----

AUTOSTRADA VALDASTICO A31 NORD
1° LOTTO - PIOVENE ROCCHETTE – VALLE DELL'ASTICO

x	Comb.	δ_{max}	L/250.00	Cs
cm		mm	mm	
159.1	15	1.96	12.73	6.48

Verifica spostamento elastico dovuto ai soli carichi variabili (§4.2.4.2.1 - NTC 2008)

x	Comb.	δ_2	L/300.00	Cs
cm		mm	mm	
159.1	15	1.47	10.61	7.23

Travata: 722 [418 , 428]

L = 218.3cm

Crit.Prog: Acciaio_Flessione $\delta_c = 0.0cm$ Verifica: **Verificata**

Verifica spostamento nello stato finale (§4.2.4.2.1 - NTC 2008)

x	Comb.	δ_{max}	L/250.00	Cs
cm		mm	mm	
109.1	15	-0.08	8.73	>100

Verifica spostamento elastico dovuto ai soli carichi variabili (§4.2.4.2.1 - NTC 2008)

x	Comb.	δ_2	L/300.00	Cs
cm		mm	mm	
87.3	15	-0.06	7.28	>100

Travata: 723 [427 , 428]

L = 218.3cm

Crit.Prog: Acciaio_Flessione $\delta_c = 0.0cm$ Verifica: **Verificata**

Verifica spostamento nello stato finale (§4.2.4.2.1 - NTC 2008)

x	Comb.	δ_{max}	L/250.00	Cs
---	-------	----------------	----------	----

AUTOSTRADA VALDASTICO A31 NORD
1° LOTTO - PIOVENE ROCCHETTE – VALLE DELL'ASTICO

x	Comb.	δ_{max}	L/250.00	Cs
cm		mm	mm	
43.7	15	-0.01	8.73	>100

Verifica spostamento elastico dovuto ai soli carichi variabili (§4.2.4.2.1 - NTC 2008)

x	Comb.	δ_2	L/300.00	Cs
cm		mm	mm	
43.7	15	-0.01	7.28	>100

Travata: 724 [430 , 419]

L = 247.0cm

Crit.Prog: Acciaio_Flessione $\delta_c = 0.0cm$ Verifica: **Verificata**

Verifica spostamento nello stato finale (§4.2.4.2.1 - NTC 2008)

x	Comb.	δ_{max}	L/250.00	Cs
cm		mm	mm	
123.5	15	0.12	9.88	81.5

Verifica spostamento elastico dovuto ai soli carichi variabili (§4.2.4.2.1 - NTC 2008)

x	Comb.	δ_2	L/300.00	Cs
cm		mm	mm	
123.5	15	0.06	8.23	>100

Travata: 725 [430 , 429]

L = 243.9cm

Crit.Prog: Acciaio_Flessione $\delta_c = 0.0cm$ Verifica: **Verificata**

Verifica spostamento nello stato finale (§4.2.4.2.1 - NTC 2008)

x	Comb.	δ_{max}	L/250.00	Cs
---	-------	----------------	----------	----

AUTOSTRADA VALDASTICO A31 NORD
1° LOTTO - PIOVENE ROCCHETTE – VALLE DELL'ASTICO

x	Comb.	δ_{max}	L/250.00	Cs
cm		mm	mm	
122.0	15	0.17	9.76	58.2

Verifica spostamento elastico dovuto ai soli carichi variabili (§4.2.4.2.1 - NTC 2008)

x	Comb.	δ_2	L/300.00	Cs
cm		mm	mm	
122.0	15	0.09	8.13	88.6

Travata: 726 [429 , 431]

L = 315.7cm

Crit.Prog: Acciaio_Flessione $\delta_c = 0.0cm$ Verifica: **Verificata**

Verifica spostamento nello stato finale (§4.2.4.2.1 - NTC 2008)

x	Comb.	δ_{max}	L/250.00	Cs
cm		mm	mm	
157.9	15	2.22	12.63	5.69

Verifica spostamento elastico dovuto ai soli carichi variabili (§4.2.4.2.1 - NTC 2008)

x	Comb.	δ_2	L/300.00	Cs
cm		mm	mm	
157.9	15	1.62	10.52	6.51

Travata: 727 [429 , 432]

L = 243.9cm

Crit.Prog: Acciaio_Flessione $\delta_c = 0.0cm$ Verifica: **Verificata**

Verifica spostamento nello stato finale (§4.2.4.2.1 - NTC 2008)

x	Comb.	δ_{max}	L/250.00	Cs
---	-------	----------------	----------	----

AUTOSTRADA VALDASTICO A31 NORD
1° LOTTO - PIOVENE ROCCHETTE – VALLE DELL'ASTICO

x	Comb.	δ_{max}	L/250.00	Cs
cm		mm	mm	
122.0	15	-0.20	9.76	49.2

Verifica spostamento elastico dovuto ai soli carichi variabili (§4.2.4.2.1 - NTC 2008)

x	Comb.	δ_2	L/300.00	Cs
cm		mm	mm	
122.0	15	-0.13	8.13	64.0

Travata: 728 [429 , 420]

L = 243.9cm

Crit.Prog: Acciaio_Flessione $\delta_c = 0.0cm$ Verifica: **Verificata**

Verifica spostamento nello stato finale (§4.2.4.2.1 - NTC 2008)

x	Comb.	δ_{max}	L/250.00	Cs
cm		mm	mm	
122.0	15	0.21	9.76	45.9

Verifica spostamento elastico dovuto ai soli carichi variabili (§4.2.4.2.1 - NTC 2008)

x	Comb.	δ_2	L/300.00	Cs
cm		mm	mm	
122.0	15	0.12	8.13	66.9

Travata: 729 [420 , 419]

L = 314.0cm

Crit.Prog: Acciaio_Flessione $\delta_c = 0.0cm$ Verifica: **Verificata**

Verifica spostamento nello stato finale (§4.2.4.2.1 - NTC 2008)

x	Comb.	δ_{max}	L/250.00	Cs
---	-------	----------------	----------	----

AUTOSTRADA VALDASTICO A31 NORD
1° LOTTO - PIOVENE ROCCHETTE – VALLE DELL'ASTICO

x	Comb.	δ_{max}	L/250.00	Cs
cm		mm	mm	
157.0	21	0.05	12.56	>100

Verifica spostamento elastico dovuto ai soli carichi variabili (§4.2.4.2.1 - NTC 2008)

x	Comb.	δ_2	L/300.00	Cs
cm		mm	mm	
219.8	15	-0.02	10.47	>100

Travata: 730 [432 , 420]

L = 247.0cm

Crit.Prog: Acciaio_Flessione $\delta_c = 0.0cm$ Verifica: **Verificata**

Verifica spostamento nello stato finale (§4.2.4.2.1 - NTC 2008)

x	Comb.	δ_{max}	L/250.00	Cs
cm		mm	mm	
49.4	15	-0.04	9.88	>100

Verifica spostamento elastico dovuto ai soli carichi variabili (§4.2.4.2.1 - NTC 2008)

x	Comb.	δ_2	L/300.00	Cs
cm		mm	mm	
74.1	15	-0.03	8.23	>100

Travata: 731 [420 , 431]

L = 264.3cm

Crit.Prog: Acciaio_Flessione $\delta_c = 0.0cm$ Verifica: **Verificata**

Verifica spostamento nello stato finale (§4.2.4.2.1 - NTC 2008)

x	Comb.	δ_{max}	L/250.00	Cs
---	-------	----------------	----------	----

AUTOSTRADA VALDASTICO A31 NORD
1° LOTTO - PIOVENE ROCCHETTE – VALLE DELL'ASTICO

x	Comb.	δ_{max}	L/250.00	Cs
cm		mm	mm	
105.7	15	-0.13	10.57	83.6

Verifica spostamento elastico dovuto ai soli carichi variabili (§4.2.4.2.1 - NTC 2008)

x	Comb.	δ_2	L/300.00	Cs
cm		mm	mm	
132.1	15	-0.08	8.81	>100

Travata: 732 [432 , 431]

L = 264.3cm

Crit.Prog: Acciaio_Flessione $\delta_c = 0.0cm$ Verifica: **Verificata**

Verifica spostamento nello stato finale (§4.2.4.2.1 - NTC 2008)

x	Comb.	δ_{max}	L/250.00	Cs
cm		mm	mm	
132.1	15	0.23	10.57	45.9

Verifica spostamento elastico dovuto ai soli carichi variabili (§4.2.4.2.1 - NTC 2008)

x	Comb.	δ_2	L/300.00	Cs
cm		mm	mm	
132.1	15	0.13	8.81	67.7

Travata: 733 [421 , 420]

L = 314.0cm

Crit.Prog: Acciaio_Flessione $\delta_c = 0.0cm$ Verifica: **Verificata**

Verifica spostamento nello stato finale (§4.2.4.2.1 - NTC 2008)

x	Comb.	δ_{max}	L/250.00	Cs
---	-------	----------------	----------	----

AUTOSTRADA VALDASTICO A31 NORD
1° LOTTO - PIOVENE ROCCHETTE – VALLE DELL'ASTICO

x	Comb.	δ_{max}	L/250.00	Cs
cm		mm	mm	
157.0	15	0.16	12.56	77.4

Verifica spostamento elastico dovuto ai soli carichi variabili (§4.2.4.2.1 - NTC 2008)

x	Comb.	δ_2	L/300.00	Cs
cm		mm	mm	
125.6	15	0.06	10.47	>100

Travata: 734 [431 , 421]

L = 264.3cm

Crit.Prog: Acciaio_Flessione $\delta_c = 0.0cm$ Verifica: **Verificata**

Verifica spostamento nello stato finale (§4.2.4.2.1 - NTC 2008)

x	Comb.	δ_{max}	L/250.00	Cs
cm		mm	mm	
132.1	15	0.17	10.57	61.9

Verifica spostamento elastico dovuto ai soli carichi variabili (§4.2.4.2.1 - NTC 2008)

x	Comb.	δ_2	L/300.00	Cs
cm		mm	mm	
132.1	15	0.09	8.81	93.7

Travata: 735 [431 , 433]

L = 264.3cm

Crit.Prog: Acciaio_Flessione $\delta_c = 0.0cm$ Verifica: **Verificata**

Verifica spostamento nello stato finale (§4.2.4.2.1 - NTC 2008)

x	Comb.	δ_{max}	L/250.00	Cs
---	-------	----------------	----------	----

AUTOSTRADA VALDASTICO A31 NORD
1° LOTTO - PIOVENE ROCCHETTE – VALLE DELL'ASTICO

x	Comb.	δ_{max}	L/250.00	Cs
cm		mm	mm	
105.7	15	-0.05	10.57	>100

Verifica spostamento elastico dovuto ai soli carichi variabili (§4.2.4.2.1 - NTC 2008)

x	Comb.	δ_2	L/300.00	Cs
cm		mm	mm	
132.1	15	-0.04	8.81	>100

Travata: 736 [431 , 434]

L = 314.2cm

Crit.Prog: Acciaio_Flessione $\delta_c = 0.0cm$ Verifica: **Verificata**

Verifica spostamento nello stato finale (§4.2.4.2.1 - NTC 2008)

x	Comb.	δ_{max}	L/250.00	Cs
cm		mm	mm	
157.1	15	2.33	12.57	5.39

Verifica spostamento elastico dovuto ai soli carichi variabili (§4.2.4.2.1 - NTC 2008)

x	Comb.	δ_2	L/300.00	Cs
cm		mm	mm	
157.1	15	1.68	10.47	6.23

Travata: 737 [433 , 421]

L = 247.0cm

Crit.Prog: Acciaio_Flessione $\delta_c = 0.0cm$ Verifica: **Verificata**

Verifica spostamento nello stato finale (§4.2.4.2.1 - NTC 2008)

x	Comb.	δ_{max}	L/250.00	Cs
---	-------	----------------	----------	----

AUTOSTRADA VALDASTICO A31 NORD
1° LOTTO - PIOVENE ROCCHETTE – VALLE DELL'ASTICO

x	Comb.	δ_{max}	L/250.00	Cs
cm		mm	mm	
49.4	15	-0.02	9.88	>100

Verifica spostamento elastico dovuto ai soli carichi variabili (§4.2.4.2.1 - NTC 2008)

x	Comb.	δ_2	L/300.00	Cs
cm		mm	mm	
98.8	15	-0.02	8.23	>100

Travata: 738 [421 , 434]

L = 272.3cm

Crit.Prog: Acciaio_Flessione $\delta_c = 0.0cm$ Verifica: **Verificata**

Verifica spostamento nello stato finale (§4.2.4.2.1 - NTC 2008)

x	Comb.	δ_{max}	L/250.00	Cs
cm		mm	mm	
54.5	15	-0.02	10.89	>100

Verifica spostamento elastico dovuto ai soli carichi variabili (§4.2.4.2.1 - NTC 2008)

x	Comb.	δ_2	L/300.00	Cs
cm		mm	mm	
108.9	15	-0.02	9.08	>100

Travata: 739 [433 , 434]

L = 272.3cm

Crit.Prog: Acciaio_Flessione $\delta_c = 0.0cm$ Verifica: **Verificata**

Verifica spostamento nello stato finale (§4.2.4.2.1 - NTC 2008)

x	Comb.	δ_{max}	L/250.00	Cs
---	-------	----------------	----------	----

AUTOSTRADA VALDASTICO A31 NORD
1° LOTTO - PIOVENE ROCCHETTE – VALLE DELL'ASTICO

x	Comb.	δ_{max}	L/250.00	Cs
cm		mm	mm	
136.1	15	0.16	10.89	69.6

Verifica spostamento elastico dovuto ai soli carichi variabili (§4.2.4.2.1 - NTC 2008)

x	Comb.	δ_2	L/300.00	Cs
cm		mm	mm	
136.1	15	0.08	9.08	>100

Travata: 740 [434 , 422]

L = 272.3cm

Crit.Prog: Acciaio_Flessione $\delta_c = 0.0cm$ Verifica: **Verificata**

Verifica spostamento nello stato finale (§4.2.4.2.1 - NTC 2008)

x	Comb.	δ_{max}	L/250.00	Cs
cm		mm	mm	
136.1	15	0.09	10.89	>100

Verifica spostamento elastico dovuto ai soli carichi variabili (§4.2.4.2.1 - NTC 2008)

x	Comb.	δ_2	L/300.00	Cs
cm		mm	mm	
136.1	15	0.05	9.08	>100

Travata: 741 [434 , 436]

L = 272.3cm

Crit.Prog: Acciaio_Flessione $\delta_c = 0.0cm$ Verifica: **Verificata**

Verifica spostamento nello stato finale (§4.2.4.2.1 - NTC 2008)

x	Comb.	δ_{max}	L/250.00	Cs
---	-------	----------------	----------	----

AUTOSTRADA VALDASTICO A31 NORD
1° LOTTO - PIOVENE ROCCHETTE – VALLE DELL'ASTICO

x	Comb.	δ_{max}	L/250.00	Cs
cm		mm	mm	
136.1	15	0.07	10.89	>100

Verifica spostamento elastico dovuto ai soli carichi variabili (§4.2.4.2.1 - NTC 2008)

x	Comb.	δ_2	L/300.00	Cs
cm		mm	mm	
163.4	15	0.03	9.08	>100

Travata: 742 [422 , 435]

L = 272.3cm

Crit.Prog: Acciaio_Flessione $\delta_c = 0.0cm$ Verifica: **Verificata**

Verifica spostamento nello stato finale (§4.2.4.2.1 - NTC 2008)

x	Comb.	δ_{max}	L/250.00	Cs
cm		mm	mm	
136.1	15	0.09	10.89	>100

Verifica spostamento elastico dovuto ai soli carichi variabili (§4.2.4.2.1 - NTC 2008)

x	Comb.	δ_2	L/300.00	Cs
cm		mm	mm	
136.1	15	0.05	9.08	>100

Travata: 743 [435 , 437]

L = 272.3cm

Crit.Prog: Acciaio_Flessione $\delta_c = 0.0cm$ Verifica: **Verificata**

Verifica spostamento nello stato finale (§4.2.4.2.1 - NTC 2008)

x	Comb.	δ_{max}	L/250.00	Cs
---	-------	----------------	----------	----

AUTOSTRADA VALDASTICO A31 NORD
1° LOTTO - PIOVENE ROCCHETTE – VALLE DELL'ASTICO

x	Comb.	δ_{max}	L/250.00	Cs
cm		mm	mm	
136.1	15	0.15	10.89	71.0

Verifica spostamento elastico dovuto ai soli carichi variabili (§4.2.4.2.1 - NTC 2008)

x	Comb.	δ_2	L/300.00	Cs
cm		mm	mm	
136.1	15	0.08	9.08	>100

Travata: 744 [436 , 435]

L = 272.3cm

Crit.Prog: Acciaio_Flessione $\delta_c = 0.0cm$ Verifica: **Verificata**

Verifica spostamento nello stato finale (§4.2.4.2.1 - NTC 2008)

x	Comb.	δ_{max}	L/250.00	Cs
cm		mm	mm	
136.1	15	0.07	10.89	>100

Verifica spostamento elastico dovuto ai soli carichi variabili (§4.2.4.2.1 - NTC 2008)

x	Comb.	δ_2	L/300.00	Cs
cm		mm	mm	
136.1	15	0.03	9.08	>100

Travata: 745 [435 , 423]

L = 272.3cm

Crit.Prog: Acciaio_Flessione $\delta_c = 0.0cm$ Verifica: **Verificata**

Verifica spostamento nello stato finale (§4.2.4.2.1 - NTC 2008)

x	Comb.	δ_{max}	L/250.00	Cs
---	-------	----------------	----------	----

AUTOSTRADA VALDASTICO A31 NORD
1° LOTTO - PIOVENE ROCCHETTE – VALLE DELL'ASTICO

x	Comb.	δ_{max}	L/250.00	Cs
cm		mm	mm	
217.8	15	-0.01	10.89	>100

Verifica spostamento elastico dovuto ai soli carichi variabili (§4.2.4.2.1 - NTC 2008)

x	Comb.	δ_2	L/300.00	Cs
cm		mm	mm	
190.6	15	-0.01	9.08	>100

Travata: 746 [434 , 435]

L = 314.0cm

Crit.Prog: Acciaio_Flessione $\delta_c = 0.0cm$ Verifica: **Verificata**

Verifica spostamento nello stato finale (§4.2.4.2.1 - NTC 2008)

x	Comb.	δ_{max}	L/250.00	Cs
cm		mm	mm	
157.0	15	2.37	12.56	5.31

Verifica spostamento elastico dovuto ai soli carichi variabili (§4.2.4.2.1 - NTC 2008)

x	Comb.	δ_2	L/300.00	Cs
cm		mm	mm	
157.0	15	1.70	10.47	6.15

Travata: 747 [435 , 438]

L = 314.2cm

Crit.Prog: Acciaio_Flessione $\delta_c = 0.0cm$ Verifica: **Verificata**

Verifica spostamento nello stato finale (§4.2.4.2.1 - NTC 2008)

x	Comb.	δ_{max}	L/250.00	Cs
---	-------	----------------	----------	----

AUTOSTRADA VALDASTICO A31 NORD
1° LOTTO - PIOVENE ROCCHETTE – VALLE DELL'ASTICO

x	Comb.	δ_{max}	L/250.00	Cs
cm		mm	mm	
157.1	15	2.33	12.57	5.39

Verifica spostamento elastico dovuto ai soli carichi variabili (§4.2.4.2.1 - NTC 2008)

x	Comb.	δ_2	L/300.00	Cs
cm		mm	mm	
157.1	15	1.68	10.47	6.23

Travata: 748 [436 , 422]

L = 247.0cm

Crit.Prog: Acciaio_Flessione $\delta_c = 0.0cm$ Verifica: **Verificata**

Verifica spostamento nello stato finale (§4.2.4.2.1 - NTC 2008)

x	Comb.	δ_{max}	L/250.00	Cs
cm		mm	mm	
123.5	21	0.01	9.88	>100

Verifica spostamento elastico dovuto ai soli carichi variabili (§4.2.4.2.1 - NTC 2008)

x	Comb.	δ_2	L/300.00	Cs
cm		mm	mm	
123.5	15	-0.00	8.23	>100

Travata: 749 [422 , 421]

L = 314.0cm

Crit.Prog: Acciaio_Flessione $\delta_c = 0.0cm$ Verifica: **Verificata**

Verifica spostamento nello stato finale (§4.2.4.2.1 - NTC 2008)

x	Comb.	δ_{max}	L/250.00	Cs
---	-------	----------------	----------	----

AUTOSTRADA VALDASTICO A31 NORD
1° LOTTO - PIOVENE ROCCHETTE – VALLE DELL'ASTICO

x	Comb.	δ_{max}	L/250.00	Cs
cm		mm	mm	
157.0	15	0.23	12.56	55.3

Verifica spostamento elastico dovuto ai soli carichi variabili (§4.2.4.2.1 - NTC 2008)

x	Comb.	δ_2	L/300.00	Cs
cm		mm	mm	
157.0	15	0.10	10.47	>100

Travata: 750 [423 , 422]

L = 314.0cm

Crit.Prog: Acciaio_Flessione $\delta_c = 0.0cm$ Verifica: **Verificata**

Verifica spostamento nello stato finale (§4.2.4.2.1 - NTC 2008)

x	Comb.	δ_{max}	L/250.00	Cs
cm		mm	mm	
157.0	15	0.23	12.56	55.3

Verifica spostamento elastico dovuto ai soli carichi variabili (§4.2.4.2.1 - NTC 2008)

x	Comb.	δ_2	L/300.00	Cs
cm		mm	mm	
157.0	15	0.10	10.47	>100

Travata: 751 [423 , 438]

L = 264.3cm

Crit.Prog: Acciaio_Flessione $\delta_c = 0.0cm$ Verifica: **Verificata**

Verifica spostamento nello stato finale (§4.2.4.2.1 - NTC 2008)

x	Comb.	δ_{max}	L/250.00	Cs
---	-------	----------------	----------	----

AUTOSTRADA VALDASTICO A31 NORD
1° LOTTO - PIOVENE ROCCHETTE – VALLE DELL'ASTICO

x	Comb.	δ_{max}	L/250.00	Cs
cm		mm	mm	
132.1	15	0.17	10.57	63.1

Verifica spostamento elastico dovuto ai soli carichi variabili (§4.2.4.2.1 - NTC 2008)

x	Comb.	δ_2	L/300.00	Cs
cm		mm	mm	
132.1	15	0.09	8.81	96.1

Travata: 752 [437 , 423]

L = 247.0cm

Crit.Prog: Acciaio_Flessione $\delta_c = 0.0cm$ Verifica: **Verificata**

Verifica spostamento nello stato finale (§4.2.4.2.1 - NTC 2008)

x	Comb.	δ_{max}	L/250.00	Cs
cm		mm	mm	
49.4	15	-0.02	9.88	>100

Verifica spostamento elastico dovuto ai soli carichi variabili (§4.2.4.2.1 - NTC 2008)

x	Comb.	δ_2	L/300.00	Cs
cm		mm	mm	
98.8	15	-0.02	8.23	>100

Travata: 753 [437 , 438]

L = 264.3cm

Crit.Prog: Acciaio_Flessione $\delta_c = 0.0cm$ Verifica: **Verificata**

Verifica spostamento nello stato finale (§4.2.4.2.1 - NTC 2008)

x	Comb.	δ_{max}	L/250.00	Cs
---	-------	----------------	----------	----

AUTOSTRADA VALDASTICO A31 NORD
1° LOTTO - PIOVENE ROCCHETTE – VALLE DELL'ASTICO

x	Comb.	δ_{max}	L/250.00	Cs
cm		mm	mm	
158.6	15	-0.04	10.57	>100

Verifica spostamento elastico dovuto ai soli carichi variabili (§4.2.4.2.1 - NTC 2008)

x	Comb.	δ_2	L/300.00	Cs
cm		mm	mm	
132.1	15	-0.03	8.81	>100

Travata: 754 [438 , 424]

L = 264.3cm

Crit.Prog: Acciaio_Flessione $\delta_c = 0.0cm$ Verifica: **Verificata**

Verifica spostamento nello stato finale (§4.2.4.2.1 - NTC 2008)

x	Comb.	δ_{max}	L/250.00	Cs
cm		mm	mm	
158.6	15	-0.12	10.57	87.7

Verifica spostamento elastico dovuto ai soli carichi variabili (§4.2.4.2.1 - NTC 2008)

x	Comb.	δ_2	L/300.00	Cs
cm		mm	mm	
132.1	15	-0.08	8.81	>100

Travata: 755 [424 , 423]

L = 314.0cm

Crit.Prog: Acciaio_Flessione $\delta_c = 0.0cm$ Verifica: **Verificata**

Verifica spostamento nello stato finale (§4.2.4.2.1 - NTC 2008)

x	Comb.	δ_{max}	L/250.00	Cs
---	-------	----------------	----------	----

AUTOSTRADA VALDASTICO A31 NORD
1° LOTTO - PIOVENE ROCCHETTE – VALLE DELL'ASTICO

x	Comb.	δ_{max}	L/250.00	Cs
cm		mm	mm	
157.0	15	0.16	12.56	76.2

Verifica spostamento elastico dovuto ai soli carichi variabili (§4.2.4.2.1 - NTC 2008)

x	Comb.	δ_2	L/300.00	Cs
cm		mm	mm	
188.4	15	0.07	10.47	>100

Travata: 756 [439 , 424]

L = 247.0cm

Crit.Prog: Acciaio_Flessione $\delta_c = 0.0cm$ Verifica: **Verificata**

Verifica spostamento nello stato finale (§4.2.4.2.1 - NTC 2008)

x	Comb.	δ_{max}	L/250.00	Cs
cm		mm	mm	
49.4	15	-0.04	9.88	>100

Verifica spostamento elastico dovuto ai soli carichi variabili (§4.2.4.2.1 - NTC 2008)

x	Comb.	δ_2	L/300.00	Cs
cm		mm	mm	
74.1	15	-0.03	8.23	>100

Travata: 757 [440 , 441]

L = 243.9cm

Crit.Prog: Acciaio_Flessione $\delta_c = 0.0cm$ Verifica: **Verificata**

Verifica spostamento nello stato finale (§4.2.4.2.1 - NTC 2008)

x	Comb.	δ_{max}	L/250.00	Cs
---	-------	----------------	----------	----

AUTOSTRADA VALDASTICO A31 NORD
1° LOTTO - PIOVENE ROCCHETTE – VALLE DELL'ASTICO

x	Comb.	δ_{max}	L/250.00	Cs
cm		mm	mm	
122.0	15	0.17	9.76	58.1

Verifica spostamento elastico dovuto ai soli carichi variabili (§4.2.4.2.1 - NTC 2008)

x	Comb.	δ_2	L/300.00	Cs
cm		mm	mm	
122.0	15	0.09	8.13	86.3

Travata: 758 [440 , 425]

L = 243.9cm

Crit.Prog: Acciaio_Flessione $\delta_c = 0.0cm$ Verifica: **Verificata**

Verifica spostamento nello stato finale (§4.2.4.2.1 - NTC 2008)

x	Comb.	δ_{max}	L/250.00	Cs
cm		mm	mm	
122.0	15	-0.17	9.76	55.8

Verifica spostamento elastico dovuto ai soli carichi variabili (§4.2.4.2.1 - NTC 2008)

x	Comb.	δ_2	L/300.00	Cs
cm		mm	mm	
122.0	15	-0.11	8.13	73.3

Travata: 759 [438 , 440]

L = 315.7cm

Crit.Prog: Acciaio_Flessione $\delta_c = 0.0cm$ Verifica: **Verificata**

Verifica spostamento nello stato finale (§4.2.4.2.1 - NTC 2008)

x	Comb.	δ_{max}	L/250.00	Cs
---	-------	----------------	----------	----

AUTOSTRADA VALDASTICO A31 NORD
1° LOTTO - PIOVENE ROCCHETTE – VALLE DELL'ASTICO

x	Comb.	δ_{max}	L/250.00	Cs
cm		mm	mm	
157.9	15	2.21	12.63	5.72

Verifica spostamento elastico dovuto ai soli carichi variabili (§4.2.4.2.1 - NTC 2008)

x	Comb.	δ_2	L/300.00	Cs
cm		mm	mm	
157.9	15	1.61	10.52	6.53

Travata: 760 [440 , 442]

L = 318.3cm

Crit.Prog: Acciaio_Flessione $\delta_c = 0.0cm$ Verifica: **Verificata**

Verifica spostamento nello stato finale (§4.2.4.2.1 - NTC 2008)

x	Comb.	δ_{max}	L/250.00	Cs
cm		mm	mm	
159.1	15	2.09	12.73	6.10

Verifica spostamento elastico dovuto ai soli carichi variabili (§4.2.4.2.1 - NTC 2008)

x	Comb.	δ_2	L/300.00	Cs
cm		mm	mm	
159.1	15	1.56	10.61	6.80

Travata: 761 [424 , 440]

L = 243.9cm

Crit.Prog: Acciaio_Flessione $\delta_c = 0.0cm$ Verifica: **Verificata**

Verifica spostamento nello stato finale (§4.2.4.2.1 - NTC 2008)

x	Comb.	δ_{max}	L/250.00	Cs
---	-------	----------------	----------	----

AUTOSTRADA VALDASTICO A31 NORD
1° LOTTO - PIOVENE ROCCHETTE – VALLE DELL'ASTICO

x	Comb.	δ_{max}	L/250.00	Cs
cm		mm	mm	
122.0	15	0.20	9.76	48.6

Verifica spostamento elastico dovuto ai soli carichi variabili (§4.2.4.2.1 - NTC 2008)

x	Comb.	δ_2	L/300.00	Cs
cm		mm	mm	
122.0	15	0.11	8.13	71.8

Travata: 762 [438 , 439]

L = 264.3cm

Crit.Prog: Acciaio_Flessione $\delta_c = 0.0cm$ Verifica: **Verificata**

Verifica spostamento nello stato finale (§4.2.4.2.1 - NTC 2008)

x	Comb.	δ_{max}	L/250.00	Cs
cm		mm	mm	
132.1	15	0.22	10.57	47.1

Verifica spostamento elastico dovuto ai soli carichi variabili (§4.2.4.2.1 - NTC 2008)

x	Comb.	δ_2	L/300.00	Cs
cm		mm	mm	
132.1	15	0.13	8.81	70.0

Travata: 763 [439 , 440]

L = 243.9cm

Crit.Prog: Acciaio_Flessione $\delta_c = 0.0cm$ Verifica: **Verificata**

Verifica spostamento nello stato finale (§4.2.4.2.1 - NTC 2008)

x	Comb.	δ_{max}	L/250.00	Cs
---	-------	----------------	----------	----

AUTOSTRADA VALDASTICO A31 NORD
1° LOTTO - PIOVENE ROCCHETTE – VALLE DELL'ASTICO

x	Comb.	δ_{max}	L/250.00	Cs
cm		mm	mm	
122.0	15	-0.19	9.76	50.1

Verifica spostamento elastico dovuto ai soli carichi variabili (§4.2.4.2.1 - NTC 2008)

x	Comb.	δ_2	L/300.00	Cs
cm		mm	mm	
122.0	15	-0.12	8.13	65.4

Travata: 764 [424 , 425]

L = 314.0cm

Crit.Prog: Acciaio_Flessione $\delta_c = 0.0cm$ Verifica: **Verificata**

Verifica spostamento nello stato finale (§4.2.4.2.1 - NTC 2008)

x	Comb.	δ_{max}	L/250.00	Cs
cm		mm	mm	
157.0	21	0.04	12.56	>100

Verifica spostamento elastico dovuto ai soli carichi variabili (§4.2.4.2.1 - NTC 2008)

x	Comb.	δ_2	L/300.00	Cs
cm		mm	mm	
219.8	15	-0.02	10.47	>100

Travata: 765 [425 , 441]

L = 247.0cm

Crit.Prog: Acciaio_Flessione $\delta_c = 0.0cm$ Verifica: **Verificata**

Verifica spostamento nello stato finale (§4.2.4.2.1 - NTC 2008)

x	Comb.	δ_{max}	L/250.00	Cs
---	-------	----------------	----------	----

AUTOSTRADA VALDASTICO A31 NORD
1° LOTTO - PIOVENE ROCCHETTE – VALLE DELL'ASTICO

x	Comb.	δ_{max}	L/250.00	Cs
cm		mm	mm	
123.5	15	0.14	9.88	68.4

Verifica spostamento elastico dovuto ai soli carichi variabili (§4.2.4.2.1 - NTC 2008)

x	Comb.	δ_2	L/300.00	Cs
cm		mm	mm	
123.5	15	0.08	8.23	>100

Travata: 766 [441 , 442]

L = 218.3cm

Crit.Prog: Acciaio_Flessione $\delta_c = 0.0cm$ Verifica: **Verificata**

Verifica spostamento nello stato finale (§4.2.4.2.1 - NTC 2008)

x	Comb.	δ_{max}	L/250.00	Cs
cm		mm	mm	
65.5	15	-0.05	8.73	>100

Verifica spostamento elastico dovuto ai soli carichi variabili (§4.2.4.2.1 - NTC 2008)

x	Comb.	δ_2	L/300.00	Cs
cm		mm	mm	
65.5	15	-0.03	7.28	>100

Travata: 767 [442 , 426]

L = 218.3cm

Crit.Prog: Acciaio_Flessione $\delta_c = 0.0cm$ Verifica: **Verificata**

Verifica spostamento nello stato finale (§4.2.4.2.1 - NTC 2008)

x	Comb.	δ_{max}	L/250.00	Cs
---	-------	----------------	----------	----

AUTOSTRADA VALDASTICO A31 NORD
1° LOTTO - PIOVENE ROCCHETTE – VALLE DELL'ASTICO

x	Comb.	δ_{max}	L/250.00	Cs
cm		mm	mm	
87.3	15	-0.14	8.73	62.8

Verifica spostamento elastico dovuto ai soli carichi variabili (§4.2.4.2.1 - NTC 2008)

x	Comb.	δ_2	L/300.00	Cs
cm		mm	mm	
109.1	15	-0.10	7.28	71.8

Travata: 768 [442 , 443]

L = 218.3cm

Crit.Prog: Acciaio_Flessione $\delta_c = 0.0cm$ Verifica: **Verificata**

Verifica spostamento nello stato finale (§4.2.4.2.1 - NTC 2008)

x	Comb.	δ_{max}	L/250.00	Cs
cm		mm	mm	
109.1	15	-0.12	8.73	74.3

Verifica spostamento elastico dovuto ai soli carichi variabili (§4.2.4.2.1 - NTC 2008)

x	Comb.	δ_2	L/300.00	Cs
cm		mm	mm	
109.1	15	-0.09	7.28	83.8

Travata: 769 [426 , 425]

L = 314.0cm

Crit.Prog: Acciaio_Flessione $\delta_c = 0.0cm$ Verifica: **Verificata**

Verifica spostamento nello stato finale (§4.2.4.2.1 - NTC 2008)

x	Comb.	δ_{max}	L/250.00	Cs
---	-------	----------------	----------	----

AUTOSTRADA VALDASTICO A31 NORD
1° LOTTO - PIOVENE ROCCHETTE – VALLE DELL'ASTICO

x	Comb.	δ_{max}	L/250.00	Cs
cm		mm	mm	
157.0	21	0.04	12.56	>100

Verifica spostamento elastico dovuto ai soli carichi variabili (§4.2.4.2.1 - NTC 2008)

x	Comb.	δ_2	L/300.00	Cs
cm		mm	mm	
125.6	15	-0.05	10.47	>100

Travata: 770 [443 , 426]

L = 247.0cm

Crit.Prog: Acciaio_Flessione $\delta_c = 0.0cm$ Verifica: **Verificata**

Verifica spostamento nello stato finale (§4.2.4.2.1 - NTC 2008)

x	Comb.	δ_{max}	L/250.00	Cs
cm		mm	mm	
98.8	15	-0.14	9.88	73.0

Verifica spostamento elastico dovuto ai soli carichi variabili (§4.2.4.2.1 - NTC 2008)

x	Comb.	δ_2	L/300.00	Cs
cm		mm	mm	
98.8	15	-0.09	8.23	96.7

Travata: 771 [196 , 427]

L = 247.0cm

Crit.Prog: Acciaio_Flessione $\delta_c = 0.0cm$ Verifica: **Verificata**

Verifica spostamento nello stato finale (§4.2.4.2.1 - NTC 2008)

x	Comb.	δ_{max}	L/250.00	Cs
---	-------	----------------	----------	----

AUTOSTRADA VALDASTICO A31 NORD
1° LOTTO - PIOVENE ROCCHETTE – VALLE DELL'ASTICO

x	Comb.	δ_{max}	L/250.00	Cs
cm		mm	mm	
98.8	15	-1.11	9.88	8.90

Verifica spostamento elastico dovuto ai soli carichi variabili (§4.2.4.2.1 - NTC 2008)

x	Comb.	δ_2	L/300.00	Cs
cm		mm	mm	
123.5	15	-0.66	8.23	12.5

Travata: 772 [444 , 430]

L = 218.3cm

Crit.Prog: Acciaio_Flessione $\delta_c = 0.0cm$ Verifica: **Verificata**

Verifica spostamento nello stato finale (§4.2.4.2.1 - NTC 2008)

x	Comb.	δ_{max}	L/250.00	Cs
cm		mm	mm	
152.8	15	-0.09	8.73	>100

Verifica spostamento elastico dovuto ai soli carichi variabili (§4.2.4.2.1 - NTC 2008)

x	Comb.	δ_2	L/300.00	Cs
cm		mm	mm	
152.8	15	-0.03	7.28	>100

Travata: 773 [430 , 427]

L = 314.0cm

Crit.Prog: Acciaio_Flessione $\delta_c = 0.0cm$ Verifica: **Verificata**

Verifica spostamento nello stato finale (§4.2.4.2.1 - NTC 2008)

x	Comb.	δ_{max}	L/250.00	Cs
---	-------	----------------	----------	----

AUTOSTRADA VALDASTICO A31 NORD
1° LOTTO - PIOVENE ROCCHETTE – VALLE DELL'ASTICO

x	Comb.	δ_{max}	L/250.00	Cs
cm		mm	mm	
125.6	15	-0.20	12.56	61.3

Verifica spostamento elastico dovuto ai soli carichi variabili (§4.2.4.2.1 - NTC 2008)

x	Comb.	δ_2	L/300.00	Cs
cm		mm	mm	
157.0	15	-0.17	10.47	62.9

Travata: 774 [430 , 445]

L = 243.9cm

Crit.Prog: Acciaio_Flessione $\delta_c = 0.0cm$ Verifica: **Verificata**

Verifica spostamento nello stato finale (§4.2.4.2.1 - NTC 2008)

x	Comb.	δ_{max}	L/250.00	Cs
cm		mm	mm	
122.0	15	-0.43	9.76	22.6

Verifica spostamento elastico dovuto ai soli carichi variabili (§4.2.4.2.1 - NTC 2008)

x	Comb.	δ_2	L/300.00	Cs
cm		mm	mm	
122.0	15	-0.26	8.13	30.8

Travata: 775 [444 , 195]

L = 218.3cm

Crit.Prog: Acciaio_Flessione $\delta_c = 0.0cm$ Verifica: **Verificata**

Verifica spostamento nello stato finale (§4.2.4.2.1 - NTC 2008)

x	Comb.	δ_{max}	L/250.00	Cs
---	-------	----------------	----------	----

AUTOSTRADA VALDASTICO A31 NORD
1° LOTTO - PIOVENE ROCCHETTE – VALLE DELL'ASTICO

x	Comb.	δ_{max}	L/250.00	Cs
cm		mm	mm	
174.6	15	-0.20	8.73	43.7

Verifica spostamento elastico dovuto ai soli carichi variabili (§4.2.4.2.1 - NTC 2008)

x	Comb.	δ_2	L/300.00	Cs
cm		mm	mm	
43.7	15	0.09	7.28	83.6

Travata: 776 [444 , 445]

L = 318.3cm

Crit.Prog: Acciaio_Flessione $\delta_c = 0.0cm$ Verifica: **Verificata**

Verifica spostamento nello stato finale (§4.2.4.2.1 - NTC 2008)

x	Comb.	δ_{max}	L/250.00	Cs
cm		mm	mm	
159.1	15	1.79	12.73	7.11

Verifica spostamento elastico dovuto ai soli carichi variabili (§4.2.4.2.1 - NTC 2008)

x	Comb.	δ_2	L/300.00	Cs
cm		mm	mm	
159.1	15	1.44	10.61	7.39

Travata: 777 [427 , 444]

L = 218.3cm

Crit.Prog: Acciaio_Flessione $\delta_c = 0.0cm$ Verifica: **Verificata**

Verifica spostamento nello stato finale (§4.2.4.2.1 - NTC 2008)

x	Comb.	δ_{max}	L/250.00	Cs
---	-------	----------------	----------	----

AUTOSTRADA VALDASTICO A31 NORD
1° LOTTO - PIOVENE ROCCHETTE – VALLE DELL'ASTICO

x	Comb.	δ_{max}	L/250.00	Cs
cm		mm	mm	
131.0	15	-0.34	8.73	25.8

Verifica spostamento elastico dovuto ai soli carichi variabili (§4.2.4.2.1 - NTC 2008)

x	Comb.	δ_2	L/300.00	Cs
cm		mm	mm	
131.0	15	-0.25	7.28	29.0

Travata: 778 [196 , 444]

L = 218.3cm

Crit.Prog: Acciaio_Flessione $\delta_c = 0.0cm$ Verifica: **Verificata**

Verifica spostamento nello stato finale (§4.2.4.2.1 - NTC 2008)

x	Comb.	δ_{max}	L/250.00	Cs
cm		mm	mm	
109.1	15	-0.70	8.73	12.5

Verifica spostamento elastico dovuto ai soli carichi variabili (§4.2.4.2.1 - NTC 2008)

x	Comb.	δ_2	L/300.00	Cs
cm		mm	mm	
109.1	15	-0.46	7.28	15.8

Travata: 779 [195 , 430]

L = 247.0cm

Crit.Prog: Acciaio_Flessione $\delta_c = 0.0cm$ Verifica: **Verificata**

Verifica spostamento nello stato finale (§4.2.4.2.1 - NTC 2008)

x	Comb.	δ_{max}	L/250.00	Cs
---	-------	----------------	----------	----

AUTOSTRADA VALDASTICO A31 NORD
1° LOTTO - PIOVENE ROCCHETTE – VALLE DELL'ASTICO

x	Comb.	δ_{max}	L/250.00	Cs
cm		mm	mm	
74.1	15	-1.21	9.88	8.19

Verifica spostamento elastico dovuto ai soli carichi variabili (§4.2.4.2.1 - NTC 2008)

x	Comb.	δ_2	L/300.00	Cs
cm		mm	mm	
74.1	15	-0.70	8.23	11.8

Travata: 780 [195 , 445]

L = 243.9cm

Crit.Prog: Acciaio_Flessione $\delta_c = 0.0cm$ Verifica: **Verificata**

Verifica spostamento nello stato finale (§4.2.4.2.1 - NTC 2008)

x	Comb.	δ_{max}	L/250.00	Cs
cm		mm	mm	
73.2	15	-1.03	9.76	9.48

Verifica spostamento elastico dovuto ai soli carichi variabili (§4.2.4.2.1 - NTC 2008)

x	Comb.	δ_2	L/300.00	Cs
cm		mm	mm	
73.2	15	-0.62	8.13	13.0

Travata: 781 [445 , 446]

L = 315.7cm

Crit.Prog: Acciaio_Flessione $\delta_c = 0.0cm$ Verifica: **Verificata**

Verifica spostamento nello stato finale (§4.2.4.2.1 - NTC 2008)

x	Comb.	δ_{max}	L/250.00	Cs
---	-------	----------------	----------	----

AUTOSTRADA VALDASTICO A31 NORD
1° LOTTO - PIOVENE ROCCHETTE – VALLE DELL'ASTICO

x	Comb.	δ_{max}	L/250.00	Cs
cm		mm	mm	
157.9	15	2.60	12.63	4.86

Verifica spostamento elastico dovuto ai soli carichi variabili (§4.2.4.2.1 - NTC 2008)

x	Comb.	δ_2	L/300.00	Cs
cm		mm	mm	
157.9	15	1.86	10.52	5.67

Travata: 782 [445 , 194]

L = 243.9cm

Crit.Prog: Acciaio_Flessione $\delta_c = 0.0cm$ Verifica: **Verificata**

Verifica spostamento nello stato finale (§4.2.4.2.1 - NTC 2008)

x	Comb.	δ_{max}	L/250.00	Cs
cm		mm	mm	
122.0	15	-0.23	9.76	43.4

Verifica spostamento elastico dovuto ai soli carichi variabili (§4.2.4.2.1 - NTC 2008)

x	Comb.	δ_2	L/300.00	Cs
cm		mm	mm	
122.0	15	-0.14	8.13	56.3

Travata: 783 [445 , 432]

L = 243.9cm

Crit.Prog: Acciaio_Flessione $\delta_c = 0.0cm$ Verifica: **Verificata**

Verifica spostamento nello stato finale (§4.2.4.2.1 - NTC 2008)

x	Comb.	δ_{max}	L/250.00	Cs
---	-------	----------------	----------	----

AUTOSTRADA VALDASTICO A31 NORD
1° LOTTO - PIOVENE ROCCHETTE – VALLE DELL'ASTICO

x	Comb.	δ_{max}	L/250.00	Cs
cm		mm	mm	
122.0	15	0.28	9.76	35.2

Verifica spostamento elastico dovuto ai soli carichi variabili (§4.2.4.2.1 - NTC 2008)

x	Comb.	δ_2	L/300.00	Cs
cm		mm	mm	
122.0	15	0.16	8.13	50.8

Travata: 784 [432 , 430]

L = 314.0cm

Crit.Prog: Acciaio_Flessione $\delta_c = 0.0cm$ Verifica: **Verificata**

Verifica spostamento nello stato finale (§4.2.4.2.1 - NTC 2008)

x	Comb.	δ_{max}	L/250.00	Cs
cm		mm	mm	
219.8	15	-0.16	12.56	77.3

Verifica spostamento elastico dovuto ai soli carichi variabili (§4.2.4.2.1 - NTC 2008)

x	Comb.	δ_2	L/300.00	Cs
cm		mm	mm	
219.8	15	-0.12	10.47	85.2

Travata: 785 [194 , 432]

L = 247.0cm

Crit.Prog: Acciaio_Flessione $\delta_c = 0.0cm$ Verifica: **Verificata**

Verifica spostamento nello stato finale (§4.2.4.2.1 - NTC 2008)

x	Comb.	δ_{max}	L/250.00	Cs
---	-------	----------------	----------	----

AUTOSTRADA VALDASTICO A31 NORD
1° LOTTO - PIOVENE ROCCHETTE – VALLE DELL'ASTICO

x	Comb.	δ_{max}	L/250.00	Cs
cm		mm	mm	
98.8	15	-0.28	9.88	34.7

Verifica spostamento elastico dovuto ai soli carichi variabili (§4.2.4.2.1 - NTC 2008)

x	Comb.	δ_2	L/300.00	Cs
cm		mm	mm	
98.8	15	-0.18	8.23	46.7

Travata: 786 [432 , 446]

L = 264.3cm

Crit.Prog: Acciaio_Flessione $\delta_c = 0.0cm$ Verifica: **Verificata**

Verifica spostamento nello stato finale (§4.2.4.2.1 - NTC 2008)

x	Comb.	δ_{max}	L/250.00	Cs
cm		mm	mm	
105.7	15	-0.09	10.57	>100

Verifica spostamento elastico dovuto ai soli carichi variabili (§4.2.4.2.1 - NTC 2008)

x	Comb.	δ_2	L/300.00	Cs
cm		mm	mm	
105.7	15	-0.06	8.81	>100

Travata: 787 [194 , 446]

L = 264.3cm

Crit.Prog: Acciaio_Flessione $\delta_c = 0.0cm$ Verifica: **Verificata**

Verifica spostamento nello stato finale (§4.2.4.2.1 - NTC 2008)

x	Comb.	δ_{max}	L/250.00	Cs
---	-------	----------------	----------	----

AUTOSTRADA VALDASTICO A31 NORD
1° LOTTO - PIOVENE ROCCHETTE – VALLE DELL'ASTICO

x	Comb.	δ_{max}	L/250.00	Cs
cm		mm	mm	
132.1	15	0.20	10.57	53.0

Verifica spostamento elastico dovuto ai soli carichi variabili (§4.2.4.2.1 - NTC 2008)

x	Comb.	δ_2	L/300.00	Cs
cm		mm	mm	
105.7	15	0.11	8.81	76.9

Travata: 788 [433 , 432]

L = 314.0cm

Crit.Prog: Acciaio_Flessione $\delta_c = 0.0cm$ Verifica: **Verificata**

Verifica spostamento nello stato finale (§4.2.4.2.1 - NTC 2008)

x	Comb.	δ_{max}	L/250.00	Cs
cm		mm	mm	
157.0	15	0.36	12.56	35.1

Verifica spostamento elastico dovuto ai soli carichi variabili (§4.2.4.2.1 - NTC 2008)

x	Comb.	δ_2	L/300.00	Cs
cm		mm	mm	
157.0	15	0.18	10.47	57.6

Travata: 789 [446 , 433]

L = 264.3cm

Crit.Prog: Acciaio_Flessione $\delta_c = 0.0cm$ Verifica: **Verificata**

Verifica spostamento nello stato finale (§4.2.4.2.1 - NTC 2008)

x	Comb.	δ_{max}	L/250.00	Cs
---	-------	----------------	----------	----

AUTOSTRADA VALDASTICO A31 NORD
1° LOTTO - PIOVENE ROCCHETTE – VALLE DELL'ASTICO

x	Comb.	δ_{max}	L/250.00	Cs
cm		mm	mm	
132.1	15	0.17	10.57	62.1

Verifica spostamento elastico dovuto ai soli carichi variabili (§4.2.4.2.1 - NTC 2008)

x	Comb.	δ_2	L/300.00	Cs
cm		mm	mm	
132.1	15	0.09	8.81	93.6

Travata: 790 [446 , 193]

L = 264.3cm

Crit.Prog: Acciaio_Flessione $\delta_c = 0.0cm$ Verifica: **Verificata**

Verifica spostamento nello stato finale (§4.2.4.2.1 - NTC 2008)

x	Comb.	δ_{max}	L/250.00	Cs
cm		mm	mm	
158.6	15	0.04	10.57	>100

Verifica spostamento elastico dovuto ai soli carichi variabili (§4.2.4.2.1 - NTC 2008)

x	Comb.	δ_2	L/300.00	Cs
cm		mm	mm	
185.0	15	0.02	8.81	>100

Travata: 791 [446 , 447]

L = 314.2cm

Crit.Prog: Acciaio_Flessione $\delta_c = 0.0cm$ Verifica: **Verificata**

Verifica spostamento nello stato finale (§4.2.4.2.1 - NTC 2008)

x	Comb.	δ_{max}	L/250.00	Cs
---	-------	----------------	----------	----

AUTOSTRADA VALDASTICO A31 NORD
1° LOTTO - PIOVENE ROCCHETTE – VALLE DELL'ASTICO

x	Comb.	δ_{max}	L/250.00	Cs
cm		mm	mm	
157.1	15	2.59	12.57	4.85

Verifica spostamento elastico dovuto ai soli carichi variabili (§4.2.4.2.1 - NTC 2008)

x	Comb.	δ_2	L/300.00	Cs
cm		mm	mm	
157.1	15	1.85	10.47	5.66

Travata: 792 [193 , 433]

L = 247.0cm

Crit.Prog: Acciaio_Flessione $\delta_c = 0.0cm$ Verifica: **Verificata**

Verifica spostamento nello stato finale (§4.2.4.2.1 - NTC 2008)

x	Comb.	δ_{max}	L/250.00	Cs
cm		mm	mm	
98.8	15	-0.06	9.88	>100

Verifica spostamento elastico dovuto ai soli carichi variabili (§4.2.4.2.1 - NTC 2008)

x	Comb.	δ_2	L/300.00	Cs
cm		mm	mm	
123.5	15	-0.04	8.23	>100

Travata: 793 [433 , 447]

L = 272.3cm

Crit.Prog: Acciaio_Flessione $\delta_c = 0.0cm$ Verifica: **Verificata**

Verifica spostamento nello stato finale (§4.2.4.2.1 - NTC 2008)

x	Comb.	δ_{max}	L/250.00	Cs
---	-------	----------------	----------	----

AUTOSTRADA VALDASTICO A31 NORD
1° LOTTO - PIOVENE ROCCHETTE – VALLE DELL'ASTICO

x	Comb.	δ_{max}	L/250.00	Cs
cm		mm	mm	
163.4	15	0.05	10.89	>100

Verifica spostamento elastico dovuto ai soli carichi variabili (§4.2.4.2.1 - NTC 2008)

x	Comb.	δ_2	L/300.00	Cs
cm		mm	mm	
163.4	15	0.02	9.08	>100

Travata: 794 [193 , 447]

L = 272.3cm

Crit.Prog: Acciaio_Flessione $\delta_c = 0.0cm$ Verifica: **Verificata**

Verifica spostamento nello stato finale (§4.2.4.2.1 - NTC 2008)

x	Comb.	δ_{max}	L/250.00	Cs
cm		mm	mm	
136.1	15	0.14	10.89	77.6

Verifica spostamento elastico dovuto ai soli carichi variabili (§4.2.4.2.1 - NTC 2008)

x	Comb.	δ_2	L/300.00	Cs
cm		mm	mm	
136.1	15	0.08	9.08	>100

Travata: 795 [447 , 436]

L = 272.3cm

Crit.Prog: Acciaio_Flessione $\delta_c = 0.0cm$ Verifica: **Verificata**

Verifica spostamento nello stato finale (§4.2.4.2.1 - NTC 2008)

x	Comb.	δ_{max}	L/250.00	Cs
---	-------	----------------	----------	----

AUTOSTRADA VALDASTICO A31 NORD
1° LOTTO - PIOVENE ROCCHETTE – VALLE DELL'ASTICO

x	Comb.	δ_{max}	L/250.00	Cs
cm		mm	mm	
136.1	15	0.13	10.89	85.1

Verifica spostamento elastico dovuto ai soli carichi variabili (§4.2.4.2.1 - NTC 2008)

x	Comb.	δ_2	L/300.00	Cs
cm		mm	mm	
136.1	15	0.07	9.08	>100

Travata: 796 [447 , 192]

L = 272.3cm

Crit.Prog: Acciaio_Flessione $\delta_c = 0.0cm$ Verifica: **Verificata**

Verifica spostamento nello stato finale (§4.2.4.2.1 - NTC 2008)

x	Comb.	δ_{max}	L/250.00	Cs
cm		mm	mm	
136.1	15	0.11	10.89	97.7

Verifica spostamento elastico dovuto ai soli carichi variabili (§4.2.4.2.1 - NTC 2008)

x	Comb.	δ_2	L/300.00	Cs
cm		mm	mm	
136.1	15	0.06	9.08	>100

Travata: 797 [436 , 448]

L = 272.3cm

Crit.Prog: Acciaio_Flessione $\delta_c = 0.0cm$ Verifica: **Verificata**

Verifica spostamento nello stato finale (§4.2.4.2.1 - NTC 2008)

x	Comb.	δ_{max}	L/250.00	Cs
---	-------	----------------	----------	----

AUTOSTRADA VALDASTICO A31 NORD
1° LOTTO - PIOVENE ROCCHETTE – VALLE DELL'ASTICO

x	Comb.	δ_{max}	L/250.00	Cs
cm		mm	mm	
136.1	15	0.13	10.89	86.8

Verifica spostamento elastico dovuto ai soli carichi variabili (§4.2.4.2.1 - NTC 2008)

x	Comb.	δ_2	L/300.00	Cs
cm		mm	mm	
136.1	15	0.07	9.08	>100

Travata: 798 [448 , 191]

L = 272.3cm

Crit.Prog: Acciaio_Flessione $\delta_c = 0.0cm$ Verifica: **Verificata**

Verifica spostamento nello stato finale (§4.2.4.2.1 - NTC 2008)

x	Comb.	δ_{max}	L/250.00	Cs
cm		mm	mm	
136.1	15	0.14	10.89	79.1

Verifica spostamento elastico dovuto ai soli carichi variabili (§4.2.4.2.1 - NTC 2008)

x	Comb.	δ_2	L/300.00	Cs
cm		mm	mm	
136.1	15	0.07	9.08	>100

Travata: 799 [192 , 448]

L = 272.3cm

Crit.Prog: Acciaio_Flessione $\delta_c = 0.0cm$ Verifica: **Verificata**

Verifica spostamento nello stato finale (§4.2.4.2.1 - NTC 2008)

x	Comb.	δ_{max}	L/250.00	Cs
---	-------	----------------	----------	----

AUTOSTRADA VALDASTICO A31 NORD
1° LOTTO - PIOVENE ROCCHETTE – VALLE DELL'ASTICO

x	Comb.	δ_{max}	L/250.00	Cs
cm		mm	mm	
136.1	15	0.11	10.89	95.9

Verifica spostamento elastico dovuto ai soli carichi variabili (§4.2.4.2.1 - NTC 2008)

x	Comb.	δ_2	L/300.00	Cs
cm		mm	mm	
136.1	15	0.06	9.08	>100

Travata: 800 [448 , 437]

L = 272.3cm

Crit.Prog: Acciaio_Flessione $\delta_c = 0.0cm$ Verifica: **Verificata**

Verifica spostamento nello stato finale (§4.2.4.2.1 - NTC 2008)

x	Comb.	δ_{max}	L/250.00	Cs
cm		mm	mm	
136.1	15	0.05	10.89	>100

Verifica spostamento elastico dovuto ai soli carichi variabili (§4.2.4.2.1 - NTC 2008)

x	Comb.	δ_2	L/300.00	Cs
cm		mm	mm	
108.9	15	0.02	9.08	>100

Travata: 801 [447 , 448]

L = 314.0cm

Crit.Prog: Acciaio_Flessione $\delta_c = 0.0cm$ Verifica: **Verificata**

Verifica spostamento nello stato finale (§4.2.4.2.1 - NTC 2008)

x	Comb.	δ_{max}	L/250.00	Cs
---	-------	----------------	----------	----

AUTOSTRADA VALDASTICO A31 NORD
1° LOTTO - PIOVENE ROCCHETTE – VALLE DELL'ASTICO

x	Comb.	δ_{max}	L/250.00	Cs
cm		mm	mm	
157.0	15	2.61	12.56	4.82

Verifica spostamento elastico dovuto ai soli carichi variabili (§4.2.4.2.1 - NTC 2008)

x	Comb.	δ_2	L/300.00	Cs
cm		mm	mm	
157.0	15	1.86	10.47	5.63

Travata: 802 [448 , 449]

L = 314.2cm

Crit.Prog: Acciaio_Flessione $\delta_c = 0.0cm$ Verifica: **Verificata**

Verifica spostamento nello stato finale (§4.2.4.2.1 - NTC 2008)

x	Comb.	δ_{max}	L/250.00	Cs
cm		mm	mm	
157.1	15	2.59	12.57	4.86

Verifica spostamento elastico dovuto ai soli carichi variabili (§4.2.4.2.1 - NTC 2008)

x	Comb.	δ_2	L/300.00	Cs
cm		mm	mm	
157.1	15	1.85	10.47	5.67

Travata: 803 [192 , 436]

L = 247.0cm

Crit.Prog: Acciaio_Flessione $\delta_c = 0.0cm$ Verifica: **Verificata**

Verifica spostamento nello stato finale (§4.2.4.2.1 - NTC 2008)

x	Comb.	δ_{max}	L/250.00	Cs
---	-------	----------------	----------	----

AUTOSTRADA VALDASTICO A31 NORD
1° LOTTO - PIOVENE ROCCHETTE – VALLE DELL'ASTICO

x	Comb.	δ_{max}	L/250.00	Cs
cm		mm	mm	
49.4	15	-0.01	9.88	>100

Verifica spostamento elastico dovuto ai soli carichi variabili (§4.2.4.2.1 - NTC 2008)

x	Comb.	δ_2	L/300.00	Cs
cm		mm	mm	
123.5	15	-0.01	8.23	>100

Travata: 804 [436 , 433]

L = 314.0cm

Crit.Prog: Acciaio_Flessione $\delta_c = 0.0cm$ Verifica: **Verificata**

Verifica spostamento nello stato finale (§4.2.4.2.1 - NTC 2008)

x	Comb.	δ_{max}	L/250.00	Cs
cm		mm	mm	
157.0	15	0.42	12.56	30.0

Verifica spostamento elastico dovuto ai soli carichi variabili (§4.2.4.2.1 - NTC 2008)

x	Comb.	δ_2	L/300.00	Cs
cm		mm	mm	
157.0	15	0.22	10.47	48.3

Travata: 805 [437 , 436]

L = 314.0cm

Crit.Prog: Acciaio_Flessione $\delta_c = 0.0cm$ Verifica: **Verificata**

Verifica spostamento nello stato finale (§4.2.4.2.1 - NTC 2008)

x	Comb.	δ_{max}	L/250.00	Cs
---	-------	----------------	----------	----

AUTOSTRADA VALDASTICO A31 NORD
1° LOTTO - PIOVENE ROCCHETTE – VALLE DELL'ASTICO

x	Comb.	δ_{max}	L/250.00	Cs
cm		mm	mm	
157.0	15	0.42	12.56	30.1

Verifica spostamento elastico dovuto ai soli carichi variabili (§4.2.4.2.1 - NTC 2008)

x	Comb.	δ_2	L/300.00	Cs
cm		mm	mm	
157.0	15	0.22	10.47	48.4

Travata: 806 [437 , 449]

L = 264.3cm

Crit.Prog: Acciaio_Flessione $\delta_c = 0.0cm$ Verifica: **Verificata**

Verifica spostamento nello stato finale (§4.2.4.2.1 - NTC 2008)

x	Comb.	δ_{max}	L/250.00	Cs
cm		mm	mm	
132.1	15	0.17	10.57	63.7

Verifica spostamento elastico dovuto ai soli carichi variabili (§4.2.4.2.1 - NTC 2008)

x	Comb.	δ_2	L/300.00	Cs
cm		mm	mm	
132.1	15	0.09	8.81	96.6

Travata: 807 [191 , 437]

L = 247.0cm

Crit.Prog: Acciaio_Flessione $\delta_c = 0.0cm$ Verifica: **Verificata**

Verifica spostamento nello stato finale (§4.2.4.2.1 - NTC 2008)

x	Comb.	δ_{max}	L/250.00	Cs
---	-------	----------------	----------	----

AUTOSTRADA VALDASTICO A31 NORD
1° LOTTO - PIOVENE ROCCHETTE – VALLE DELL'ASTICO

x	Comb.	δ_{max}	L/250.00	Cs
cm		mm	mm	
98.8	15	-0.06	9.88	>100

Verifica spostamento elastico dovuto ai soli carichi variabili (§4.2.4.2.1 - NTC 2008)

x	Comb.	δ_2	L/300.00	Cs
cm		mm	mm	
123.5	15	-0.04	8.23	>100

Travata: 808 [191 , 449]

L = 264.3cm

Crit.Prog: Acciaio_Flessione $\delta_c = 0.0cm$ Verifica: **Verificata**

Verifica spostamento nello stato finale (§4.2.4.2.1 - NTC 2008)

x	Comb.	δ_{max}	L/250.00	Cs
cm		mm	mm	
105.7	15	0.04	10.57	>100

Verifica spostamento elastico dovuto ai soli carichi variabili (§4.2.4.2.1 - NTC 2008)

x	Comb.	δ_2	L/300.00	Cs
cm		mm	mm	
79.3	15	0.02	8.81	>100

Travata: 809 [449 , 439]

L = 264.3cm

Crit.Prog: Acciaio_Flessione $\delta_c = 0.0cm$ Verifica: **Verificata**

Verifica spostamento nello stato finale (§4.2.4.2.1 - NTC 2008)

x	Comb.	δ_{max}	L/250.00	Cs
---	-------	----------------	----------	----

AUTOSTRADA VALDASTICO A31 NORD
1° LOTTO - PIOVENE ROCCHETTE – VALLE DELL'ASTICO

x	Comb.	δ_{max}	L/250.00	Cs
cm		mm	mm	
158.6	15	-0.09	10.57	>100

Verifica spostamento elastico dovuto ai soli carichi variabili (§4.2.4.2.1 - NTC 2008)

x	Comb.	δ_2	L/300.00	Cs
cm		mm	mm	
158.6	15	-0.06	8.81	>100

Travata: 810 [439 , 437]

L = 314.0cm

Crit.Prog: Acciaio_Flessione $\delta_c = 0.0cm$ Verifica: **Verificata**

Verifica spostamento nello stato finale (§4.2.4.2.1 - NTC 2008)

x	Comb.	δ_{max}	L/250.00	Cs
cm		mm	mm	
157.0	15	0.35	12.56	35.6

Verifica spostamento elastico dovuto ai soli carichi variabili (§4.2.4.2.1 - NTC 2008)

x	Comb.	δ_2	L/300.00	Cs
cm		mm	mm	
157.0	15	0.18	10.47	58.5

Travata: 811 [190 , 439]

L = 247.0cm

Crit.Prog: Acciaio_Flessione $\delta_c = 0.0cm$ Verifica: **Verificata**

Verifica spostamento nello stato finale (§4.2.4.2.1 - NTC 2008)

x	Comb.	δ_{max}	L/250.00	Cs
---	-------	----------------	----------	----

AUTOSTRADA VALDASTICO A31 NORD
1° LOTTO - PIOVENE ROCCHETTE – VALLE DELL'ASTICO

x	Comb.	δ_{max}	L/250.00	Cs
cm		mm	mm	
98.8	15	-0.28	9.88	35.4

Verifica spostamento elastico dovuto ai soli carichi variabili (§4.2.4.2.1 - NTC 2008)

x	Comb.	δ_2	L/300.00	Cs
cm		mm	mm	
98.8	15	-0.17	8.23	48.1

Travata: 812 [450 , 189]

L = 243.9cm

Crit.Prog: Acciaio_Flessione $\delta_c = 0.0cm$ Verifica: **Verificata**

Verifica spostamento nello stato finale (§4.2.4.2.1 - NTC 2008)

x	Comb.	δ_{max}	L/250.00	Cs
cm		mm	mm	
170.8	15	-1.06	9.76	9.22

Verifica spostamento elastico dovuto ai soli carichi variabili (§4.2.4.2.1 - NTC 2008)

x	Comb.	δ_2	L/300.00	Cs
cm		mm	mm	
170.8	15	-0.63	8.13	12.9

Travata: 813 [450 , 441]

L = 243.9cm

Crit.Prog: Acciaio_Flessione $\delta_c = 0.0cm$ Verifica: **Verificata**

Verifica spostamento nello stato finale (§4.2.4.2.1 - NTC 2008)

x	Comb.	δ_{max}	L/250.00	Cs
---	-------	----------------	----------	----

AUTOSTRADA VALDASTICO A31 NORD
1° LOTTO - PIOVENE ROCCHETTE – VALLE DELL'ASTICO

x	Comb.	δ_{max}	L/250.00	Cs
cm		mm	mm	
122.0	15	-0.44	9.76	22.3

Verifica spostamento elastico dovuto ai soli carichi variabili (§4.2.4.2.1 - NTC 2008)

x	Comb.	δ_2	L/300.00	Cs
cm		mm	mm	
122.0	15	-0.27	8.13	30.5

Travata: 814 [449 , 450]

L = 315.7cm

Crit.Prog: Acciaio_Flessione $\delta_c = 0.0cm$ Verifica: **Verificata**

Verifica spostamento nello stato finale (§4.2.4.2.1 - NTC 2008)

x	Comb.	δ_{max}	L/250.00	Cs
cm		mm	mm	
157.9	15	2.61	12.63	4.84

Verifica spostamento elastico dovuto ai soli carichi variabili (§4.2.4.2.1 - NTC 2008)

x	Comb.	δ_2	L/300.00	Cs
cm		mm	mm	
157.9	15	1.86	10.52	5.65

Travata: 815 [450 , 451]

L = 318.3cm

Crit.Prog: Acciaio_Flessione $\delta_c = 0.0cm$ Verifica: **Verificata**

Verifica spostamento nello stato finale (§4.2.4.2.1 - NTC 2008)

x	Comb.	δ_{max}	L/250.00	Cs
---	-------	----------------	----------	----

AUTOSTRADA VALDASTICO A31 NORD
1° LOTTO - PIOVENE ROCCHETTE – VALLE DELL'ASTICO

x	Comb.	δ_{max}	L/250.00	Cs
cm		mm	mm	
159.1	15	1.53	12.73	8.31

Verifica spostamento elastico dovuto ai soli carichi variabili (§4.2.4.2.1 - NTC 2008)

x	Comb.	δ_2	L/300.00	Cs
cm		mm	mm	
159.1	15	1.25	10.61	8.47

Travata: 816 [439 , 450]

L = 243.9cm

Crit.Prog: Acciaio_Flessione $\delta_c = 0.0cm$ Verifica: **Verificata**

Verifica spostamento nello stato finale (§4.2.4.2.1 - NTC 2008)

x	Comb.	δ_{max}	L/250.00	Cs
cm		mm	mm	
122.0	15	0.28	9.76	34.7

Verifica spostamento elastico dovuto ai soli carichi variabili (§4.2.4.2.1 - NTC 2008)

x	Comb.	δ_2	L/300.00	Cs
cm		mm	mm	
122.0	15	0.16	8.13	50.1

Travata: 817 [449 , 190]

L = 264.3cm

Crit.Prog: Acciaio_Flessione $\delta_c = 0.0cm$ Verifica: **Verificata**

Verifica spostamento nello stato finale (§4.2.4.2.1 - NTC 2008)

x	Comb.	δ_{max}	L/250.00	Cs
---	-------	----------------	----------	----

AUTOSTRADA VALDASTICO A31 NORD
1° LOTTO - PIOVENE ROCCHETTE – VALLE DELL'ASTICO

x	Comb.	δ_{max}	L/250.00	Cs
cm		mm	mm	
132.1	15	0.20	10.57	53.2

Verifica spostamento elastico dovuto ai soli carichi variabili (§4.2.4.2.1 - NTC 2008)

x	Comb.	δ_2	L/300.00	Cs
cm		mm	mm	
158.6	15	0.11	8.81	77.4

Travata: 818 [190 , 450]

L = 243.9cm

Crit.Prog: Acciaio_Flessione $\delta_c = 0.0cm$ Verifica: **Verificata**

Verifica spostamento nello stato finale (§4.2.4.2.1 - NTC 2008)

x	Comb.	δ_{max}	L/250.00	Cs
cm		mm	mm	
122.0	15	-0.22	9.76	44.7

Verifica spostamento elastico dovuto ai soli carichi variabili (§4.2.4.2.1 - NTC 2008)

x	Comb.	δ_2	L/300.00	Cs
cm		mm	mm	
122.0	15	-0.14	8.13	59.2

Travata: 819 [439 , 441]

L = 314.0cm

Crit.Prog: Acciaio_Flessione $\delta_c = 0.0cm$ Verifica: **Verificata**

Verifica spostamento nello stato finale (§4.2.4.2.1 - NTC 2008)

x	Comb.	δ_{max}	L/250.00	Cs
---	-------	----------------	----------	----

AUTOSTRADA VALDASTICO A31 NORD
1° LOTTO - PIOVENE ROCCHETTE – VALLE DELL'ASTICO

x	Comb.	δ_{max}	L/250.00	Cs
cm		mm	mm	
219.8	15	-0.17	12.56	74.0

Verifica spostamento elastico dovuto ai soli carichi variabili (§4.2.4.2.1 - NTC 2008)

x	Comb.	δ_2	L/300.00	Cs
cm		mm	mm	
219.8	15	-0.12	10.47	84.8

Travata: 820 [441 , 189]

L = 247.0cm

Crit.Prog: Acciaio_Flessione $\delta_c = 0.0cm$ Verifica: **Verificata**

Verifica spostamento nello stato finale (§4.2.4.2.1 - NTC 2008)

x	Comb.	δ_{max}	L/250.00	Cs
cm		mm	mm	
172.9	15	-1.19	9.88	8.29

Verifica spostamento elastico dovuto ai soli carichi variabili (§4.2.4.2.1 - NTC 2008)

x	Comb.	δ_2	L/300.00	Cs
cm		mm	mm	
172.9	15	-0.68	8.23	12.0

Travata: 821 [189 , 451]

L = 218.3cm

Crit.Prog: Acciaio_Flessione $\delta_c = 0.0cm$ Verifica: **Verificata**

Verifica spostamento nello stato finale (§4.2.4.2.1 - NTC 2008)

x	Comb.	δ_{max}	L/250.00	Cs
---	-------	----------------	----------	----

AUTOSTRADA VALDASTICO A31 NORD
1° LOTTO - PIOVENE ROCCHETTE – VALLE DELL'ASTICO

x	Comb.	δ_{max}	L/250.00	Cs
cm		mm	mm	
65.5	15	-0.23	8.73	37.8

Verifica spostamento elastico dovuto ai soli carichi variabili (§4.2.4.2.1 - NTC 2008)

x	Comb.	δ_2	L/300.00	Cs
cm		mm	mm	
65.5	15	-0.11	7.28	66.2

Travata: 822 [451 , 443]

L = 218.3cm

Crit.Prog: Acciaio_Flessione $\delta_c = 0.0cm$ Verifica: **Verificata**

Verifica spostamento nello stato finale (§4.2.4.2.1 - NTC 2008)

x	Comb.	δ_{max}	L/250.00	Cs
cm		mm	mm	
87.3	15	-0.16	8.73	54.6

Verifica spostamento elastico dovuto ai soli carichi variabili (§4.2.4.2.1 - NTC 2008)

x	Comb.	δ_2	L/300.00	Cs
cm		mm	mm	
87.3	15	-0.12	7.28	61.3

Travata: 823 [451 , 188]

L = 218.3cm

Crit.Prog: Acciaio_Flessione $\delta_c = 0.0cm$ Verifica: **Verificata**

Verifica spostamento nello stato finale (§4.2.4.2.1 - NTC 2008)

x	Comb.	δ_{max}	L/250.00	Cs
---	-------	----------------	----------	----

AUTOSTRADA VALDASTICO A31 NORD
1° LOTTO - PIOVENE ROCCHETTE – VALLE DELL'ASTICO

x	Comb.	δ_{max}	L/250.00	Cs
cm		mm	mm	
109.1	15	-0.59	8.73	14.8

Verifica spostamento elastico dovuto ai soli carichi variabili (§4.2.4.2.1 - NTC 2008)

x	Comb.	δ_2	L/300.00	Cs
cm		mm	mm	
109.1	15	-0.37	7.28	19.6

Travata: 824 [443 , 441]

L = 314.0cm

Crit.Prog: Acciaio_Flessione $\delta_c = 0.0cm$ Verifica: **Verificata**

Verifica spostamento nello stato finale (§4.2.4.2.1 - NTC 2008)

x	Comb.	δ_{max}	L/250.00	Cs
cm		mm	mm	
188.4	15	-0.22	12.56	56.4

Verifica spostamento elastico dovuto ai soli carichi variabili (§4.2.4.2.1 - NTC 2008)

x	Comb.	δ_2	L/300.00	Cs
cm		mm	mm	
157.0	15	-0.17	10.47	59.8

Travata: 825 [188 , 443]

L = 247.0cm

Crit.Prog: Acciaio_Flessione $\delta_c = 0.0cm$ Verifica: **Verificata**

Verifica spostamento nello stato finale (§4.2.4.2.1 - NTC 2008)

x	Comb.	δ_{max}	L/250.00	Cs
---	-------	----------------	----------	----

AUTOSTRADA VALDASTICO A31 NORD
1° LOTTO - PIOVENE ROCCHETTE – VALLE DELL'ASTICO

x	Comb.	δ_{max}	L/250.00	Cs
cm		mm	mm	
98.8	15	-0.99	9.88	9.98

Verifica spostamento elastico dovuto ai soli carichi variabili (§4.2.4.2.1 - NTC 2008)

x	Comb.	δ_2	L/300.00	Cs
cm		mm	mm	
98.8	15	-0.58	8.23	14.3

Travata: 826 [402 , 417]

L = 218.3cm

Crit.Prog: Acciaio_Flessione $\delta_c = 0.0cm$ Verifica: **Verificata**

Verifica spostamento nello stato finale (§4.2.4.2.1 - NTC 2008)

x	Comb.	δ_{max}	L/250.00	Cs
cm		mm	mm	
109.1	15	0.17	8.73	50.4

Verifica spostamento elastico dovuto ai soli carichi variabili (§4.2.4.2.1 - NTC 2008)

x	Comb.	δ_2	L/300.00	Cs
cm		mm	mm	
131.0	15	0.10	7.28	74.0

Travata: 827 [425 , 442]

L = 218.3cm

Crit.Prog: Acciaio_Flessione $\delta_c = 0.0cm$ Verifica: **Verificata**

Verifica spostamento nello stato finale (§4.2.4.2.1 - NTC 2008)

x	Comb.	δ_{max}	L/250.00	Cs
---	-------	----------------	----------	----

AUTOSTRADA VALDASTICO A31 NORD
1° LOTTO - PIOVENE ROCCHETTE – VALLE DELL'ASTICO

x	Comb.	δ_{max}	L/250.00	Cs
cm		mm	mm	
109.1	15	0.15	8.73	57.9

Verifica spostamento elastico dovuto ai soli carichi variabili (§4.2.4.2.1 - NTC 2008)

x	Comb.	δ_2	L/300.00	Cs
cm		mm	mm	
131.0	15	0.10	7.28	75.4

Travata: 828 [441 , 451]

L = 218.3cm

Crit.Prog: Acciaio_Flessione $\delta_c = 0.0cm$ Verifica: **Verificata**

Verifica spostamento nello stato finale (§4.2.4.2.1 - NTC 2008)

x	Comb.	δ_{max}	L/250.00	Cs
cm		mm	mm	
109.1	15	-0.20	8.73	43.7

Verifica spostamento elastico dovuto ai soli carichi variabili (§4.2.4.2.1 - NTC 2008)

x	Comb.	δ_2	L/300.00	Cs
cm		mm	mm	
109.1	15	-0.11	7.28	67.6

Travata: 829 [189 , 204]

L = 229.9cm

Crit.Prog: Acciaio_Flessione $\delta_c = 0.0cm$ Verifica: **Verificata**

Verifica spostamento nello stato finale (§4.2.4.2.1 - NTC 2008)

x	Comb.	δ_{max}	L/250.00	Cs
---	-------	----------------	----------	----

AUTOSTRADA VALDASTICO A31 NORD
1° LOTTO - PIOVENE ROCCHETTE – VALLE DELL'ASTICO

x	Comb.	δ_{max}	L/250.00	Cs
cm		mm	mm	
114.9	15	0.24	9.19	38.2

Verifica spostamento elastico dovuto ai soli carichi variabili (§4.2.4.2.1 - NTC 2008)

x	Comb.	δ_2	L/300.00	Cs
cm		mm	mm	
114.9	15	0.14	7.66	54.0

Travata: 830 [212 , 221]

L = 229.9cm

Crit.Prog: Acciaio_Flessione $\delta_c = 0.0cm$ Verifica: **Verificata**

Verifica spostamento nello stato finale (§4.2.4.2.1 - NTC 2008)

x	Comb.	δ_{max}	L/250.00	Cs
cm		mm	mm	
160.9	15	0.09	9.19	>100

Verifica spostamento elastico dovuto ai soli carichi variabili (§4.2.4.2.1 - NTC 2008)

x	Comb.	δ_2	L/300.00	Cs
cm		mm	mm	
160.9	15	0.06	7.66	>100

Travata: 831 [229 , 238]

L = 229.9cm

Crit.Prog: Acciaio_Flessione $\delta_c = 0.0cm$ Verifica: **Verificata**

Verifica spostamento nello stato finale (§4.2.4.2.1 - NTC 2008)

x	Comb.	δ_{max}	L/250.00	Cs
---	-------	----------------	----------	----

AUTOSTRADA VALDASTICO A31 NORD
1° LOTTO - PIOVENE ROCCHETTE – VALLE DELL'ASTICO

x	Comb.	δ_{max}	L/250.00	Cs
cm		mm	mm	
137.9	15	0.12	9.19	79.5

Verifica spostamento elastico dovuto ai soli carichi variabili (§4.2.4.2.1 - NTC 2008)

x	Comb.	δ_2	L/300.00	Cs
cm		mm	mm	
137.9	15	0.08	7.66	94.5

Travata: 832 [246 , 255]

L = 229.9cm

Crit.Prog: Acciaio_Flessione $\delta_c = 0.0cm$ Verifica: **Verificata**

Verifica spostamento nello stato finale (§4.2.4.2.1 - NTC 2008)

x	Comb.	δ_{max}	L/250.00	Cs
cm		mm	mm	
114.9	15	-0.15	9.19	62.2

Verifica spostamento elastico dovuto ai soli carichi variabili (§4.2.4.2.1 - NTC 2008)

x	Comb.	δ_2	L/300.00	Cs
cm		mm	mm	
114.9	15	-0.08	7.66	90.8

Travata: 833 [263 , 272]

L = 229.9cm

Crit.Prog: Acciaio_Flessione $\delta_c = 0.0cm$ Verifica: **Verificata**

Verifica spostamento nello stato finale (§4.2.4.2.1 - NTC 2008)

x	Comb.	δ_{max}	L/250.00	Cs
---	-------	----------------	----------	----

AUTOSTRADA VALDASTICO A31 NORD
1° LOTTO - PIOVENE ROCCHETTE – VALLE DELL'ASTICO

x	Comb.	δ_{max}	L/250.00	Cs
cm		mm	mm	
183.9	15	0.10	9.19	92.0

Verifica spostamento elastico dovuto ai soli carichi variabili (§4.2.4.2.1 - NTC 2008)

x	Comb.	δ_2	L/300.00	Cs
cm		mm	mm	
183.9	15	0.07	7.66	>100

Travata: 834 [280 , 289]

L = 229.9cm

Crit.Prog: Acciaio_Flessione $\delta_c = 0.0cm$ Verifica: **Verificata**

Verifica spostamento nello stato finale (§4.2.4.2.1 - NTC 2008)

x	Comb.	δ_{max}	L/250.00	Cs
cm		mm	mm	
137.9	15	0.16	9.19	56.8

Verifica spostamento elastico dovuto ai soli carichi variabili (§4.2.4.2.1 - NTC 2008)

x	Comb.	δ_2	L/300.00	Cs
cm		mm	mm	
137.9	15	0.10	7.66	74.1

Travata: 835 [297 , 306]

L = 229.9cm

Crit.Prog: Acciaio_Flessione $\delta_c = 0.0cm$ Verifica: **Verificata**

Verifica spostamento nello stato finale (§4.2.4.2.1 - NTC 2008)

x	Comb.	δ_{max}	L/250.00	Cs
---	-------	----------------	----------	----

AUTOSTRADA VALDASTICO A31 NORD
1° LOTTO - PIOVENE ROCCHETTE – VALLE DELL'ASTICO

x	Comb.	δ_{max}	L/250.00	Cs
cm		mm	mm	
137.9	15	0.17	9.19	54.4

Verifica spostamento elastico dovuto ai soli carichi variabili (§4.2.4.2.1 - NTC 2008)

x	Comb.	δ_2	L/300.00	Cs
cm		mm	mm	
137.9	15	0.11	7.66	70.3

Travata: 836 [314 , 349]

L = 229.9cm

Crit.Prog: Acciaio_Flessione $\delta_c = 0.0cm$ Verifica: **Verificata**

Verifica spostamento nello stato finale (§4.2.4.2.1 - NTC 2008)

x	Comb.	δ_{max}	L/250.00	Cs
cm		mm	mm	
137.9	15	-0.13	9.19	73.3

Verifica spostamento elastico dovuto ai soli carichi variabili (§4.2.4.2.1 - NTC 2008)

x	Comb.	δ_2	L/300.00	Cs
cm		mm	mm	
114.9	15	-0.07	7.66	>100

Travata: 837 [317 , 332]

L = 229.9cm

Crit.Prog: Acciaio_Flessione $\delta_c = 0.0cm$ Verifica: **Verificata**

Verifica spostamento nello stato finale (§4.2.4.2.1 - NTC 2008)

x	Comb.	δ_{max}	L/250.00	Cs
---	-------	----------------	----------	----

AUTOSTRADA VALDASTICO A31 NORD
1° LOTTO - PIOVENE ROCCHETTE – VALLE DELL'ASTICO

x	Comb.	δ_{max}	L/250.00	Cs
cm		mm	mm	
160.9	15	0.12	9.19	75.4

Verifica spostamento elastico dovuto ai soli carichi variabili (§4.2.4.2.1 - NTC 2008)

x	Comb.	δ_2	L/300.00	Cs
cm		mm	mm	
160.9	15	0.08	7.66	91.0

Travata: 838 [340 , 357]

L = 229.9cm

Crit.Prog: Acciaio_Flessione $\delta_c = 0.0cm$ Verifica: **Verificata**

Verifica spostamento nello stato finale (§4.2.4.2.1 - NTC 2008)

x	Comb.	δ_{max}	L/250.00	Cs
cm		mm	mm	
137.9	15	0.14	9.19	65.5

Verifica spostamento elastico dovuto ai soli carichi variabili (§4.2.4.2.1 - NTC 2008)

x	Comb.	δ_2	L/300.00	Cs
cm		mm	mm	
137.9	15	0.09	7.66	87.5

Travata: 839 [365 , 374]

L = 229.9cm

Crit.Prog: Acciaio_Flessione $\delta_c = 0.0cm$ Verifica: **Verificata**

Verifica spostamento nello stato finale (§4.2.4.2.1 - NTC 2008)

x	Comb.	δ_{max}	L/250.00	Cs
---	-------	----------------	----------	----

AUTOSTRADA VALDASTICO A31 NORD
1° LOTTO - PIOVENE ROCCHETTE – VALLE DELL'ASTICO

x	Comb.	δ_{max}	L/250.00	Cs
cm		mm	mm	
137.9	15	0.15	9.19	62.4

Verifica spostamento elastico dovuto ai soli carichi variabili (§4.2.4.2.1 - NTC 2008)

x	Comb.	δ_2	L/300.00	Cs
cm		mm	mm	
137.9	15	0.10	7.66	80.3

Travata: 840 [382 , 391]

L = 229.9cm

Crit.Prog: Acciaio_Flessione $\delta_c = 0.0cm$ Verifica: **Verificata**

Verifica spostamento nello stato finale (§4.2.4.2.1 - NTC 2008)

x	Comb.	δ_{max}	L/250.00	Cs
cm		mm	mm	
114.9	15	-0.11	9.19	81.1

Verifica spostamento elastico dovuto ai soli carichi variabili (§4.2.4.2.1 - NTC 2008)

x	Comb.	δ_2	L/300.00	Cs
cm		mm	mm	
114.9	15	-0.06	7.66	>100

Travata: 841 [392 , 461]

L = 263.5cm

Crit.Prog: Acciaio_Flessione $\delta_c = 0.0cm$ Verifica: **Verificata**

Verifica spostamento nello stato finale (§4.2.4.2.1 - NTC 2008)

x	Comb.	δ_{max}	L/250.00	Cs
---	-------	----------------	----------	----

AUTOSTRADA VALDASTICO A31 NORD
1° LOTTO - PIOVENE ROCCHETTE – VALLE DELL'ASTICO

x	Comb.	δ_{max}	L/250.00	Cs
cm		mm	mm	
131.7	15	-0.21	10.54	51.0

Verifica spostamento elastico dovuto ai soli carichi variabili (§4.2.4.2.1 - NTC 2008)

x	Comb.	δ_2	L/300.00	Cs
cm		mm	mm	
158.1	15	-0.10	8.78	83.7

Travata: 842 [461 , 478]

L = 263.5cm

Crit.Prog: Acciaio_Flessione $\delta_c = 0.0cm$ Verifica: **Verificata**

Verifica spostamento nello stato finale (§4.2.4.2.1 - NTC 2008)

x	Comb.	δ_{max}	L/250.00	Cs
cm		mm	mm	
158.1	17	0.06	10.54	>100

Verifica spostamento elastico dovuto ai soli carichi variabili (§4.2.4.2.1 - NTC 2008)

x	Comb.	δ_2	L/300.00	Cs
cm		mm	mm	
79.1	15	-0.03	8.78	>100

Travata: 843 [393 , 460]

L = 263.5cm

Crit.Prog: Acciaio_Flessione $\delta_c = 0.0cm$ Verifica: **Verificata**

Verifica spostamento nello stato finale (§4.2.4.2.1 - NTC 2008)

x	Comb.	δ_{max}	L/250.00	Cs
---	-------	----------------	----------	----

AUTOSTRADA VALDASTICO A31 NORD
1° LOTTO - PIOVENE ROCCHETTE – VALLE DELL'ASTICO

x	Comb.	δ_{max}	L/250.00	Cs
cm		mm	mm	
79.0	15	-0.47	10.54	22.2

Verifica spostamento elastico dovuto ai soli carichi variabili (§4.2.4.2.1 - NTC 2008)

x	Comb.	δ_2	L/300.00	Cs
cm		mm	mm	
79.0	15	-0.26	8.78	34.0

Travata: 844 [460 , 477]

L = 263.5cm

Crit.Prog: Acciaio_Flessione $\delta_c = 0.0cm$ Verifica: **Verificata**

Verifica spostamento nello stato finale (§4.2.4.2.1 - NTC 2008)

x	Comb.	δ_{max}	L/250.00	Cs
cm		mm	mm	
131.8	15	0.18	10.54	59.8

Verifica spostamento elastico dovuto ai soli carichi variabili (§4.2.4.2.1 - NTC 2008)

x	Comb.	δ_2	L/300.00	Cs
cm		mm	mm	
131.8	15	0.07	8.78	>100

Travata: 845 [460 , 461]

L = 314.0cm

Crit.Prog: Acciaio_Flessione $\delta_c = 0.0cm$ Verifica: **Verificata**

Verifica spostamento nello stato finale (§4.2.4.2.1 - NTC 2008)

x	Comb.	δ_{max}	L/250.00	Cs
---	-------	----------------	----------	----

AUTOSTRADA VALDASTICO A31 NORD
1° LOTTO - PIOVENE ROCCHETTE – VALLE DELL'ASTICO

x	Comb.	δ_{max}	L/250.00	Cs
cm		mm	mm	
125.6	15	-0.15	12.56	86.3

Verifica spostamento elastico dovuto ai soli carichi variabili (§4.2.4.2.1 - NTC 2008)

x	Comb.	δ_2	L/300.00	Cs
cm		mm	mm	
157.0	15	-0.13	10.47	79.9

Travata: 846 [477 , 478]

L = 314.0cm

Crit.Prog: Acciaio_Flessione $\delta_c = 0.0cm$ Verifica: **Verificata**

Verifica spostamento nello stato finale (§4.2.4.2.1 - NTC 2008)

x	Comb.	δ_{max}	L/250.00	Cs
cm		mm	mm	
157.0	21	0.08	12.56	>100

Verifica spostamento elastico dovuto ai soli carichi variabili (§4.2.4.2.1 - NTC 2008)

x	Comb.	δ_2	L/300.00	Cs
cm		mm	mm	
219.8	15	-0.02	10.47	>100

Travata: 847 [393 , 392]

L = 314.0cm

Crit.Prog: Acciaio_Flessione $\delta_c = 0.0cm$ Verifica: **Verificata**

Verifica spostamento nello stato finale (§4.2.4.2.1 - NTC 2008)

x	Comb.	δ_{max}	L/250.00	Cs
---	-------	----------------	----------	----

AUTOSTRADA VALDASTICO A31 NORD
1° LOTTO - PIOVENE ROCCHETTE – VALLE DELL'ASTICO

x	Comb.	δ_{max}	L/250.00	Cs
cm		mm	mm	
188.4	17	0.08	12.56	>100

Verifica spostamento elastico dovuto ai soli carichi variabili (§4.2.4.2.1 - NTC 2008)

x	Comb.	δ_2	L/300.00	Cs
cm		mm	mm	
62.8	15	0.04	10.47	>100

Travata: 848 [392 , 462]

L = 223.0cm

Crit.Prog: Acciaio_Flessione $\delta_c = 0.0cm$ Verifica: **Verificata**

Verifica spostamento nello stato finale (§4.2.4.2.1 - NTC 2008)

x	Comb.	δ_{max}	L/250.00	Cs
cm		mm	mm	
133.8	15	-0.27	8.92	33.0

Verifica spostamento elastico dovuto ai soli carichi variabili (§4.2.4.2.1 - NTC 2008)

x	Comb.	δ_2	L/300.00	Cs
cm		mm	mm	
133.8	15	-0.18	7.43	40.7

Travata: 849 [462 , 461]

L = 223.0cm

Crit.Prog: Acciaio_Flessione $\delta_c = 0.0cm$ Verifica: **Verificata**

Verifica spostamento nello stato finale (§4.2.4.2.1 - NTC 2008)

x	Comb.	δ_{max}	L/250.00	Cs
---	-------	----------------	----------	----

AUTOSTRADA VALDASTICO A31 NORD
1° LOTTO - PIOVENE ROCCHETTE – VALLE DELL'ASTICO

x	Comb.	δ_{max}	L/250.00	Cs
cm		mm	mm	
44.6	15	-0.06	8.92	>100

Verifica spostamento elastico dovuto ai soli carichi variabili (§4.2.4.2.1 - NTC 2008)

x	Comb.	δ_2	L/300.00	Cs
cm		mm	mm	
66.9	15	-0.05	7.43	>100

Travata: 850 [393 , 462]

L = 223.0cm

Crit.Prog: Acciaio_Flessione $\delta_c = 0.0cm$ Verifica: **Verificata**

Verifica spostamento nello stato finale (§4.2.4.2.1 - NTC 2008)

x	Comb.	δ_{max}	L/250.00	Cs
cm		mm	mm	
156.1	15	0.10	8.92	89.0

Verifica spostamento elastico dovuto ai soli carichi variabili (§4.2.4.2.1 - NTC 2008)

x	Comb.	δ_2	L/300.00	Cs
cm		mm	mm	
156.1	15	0.09	7.43	87.0

Travata: 851 [462 , 460]

L = 223.0cm

Crit.Prog: Acciaio_Flessione $\delta_c = 0.0cm$ Verifica: **Verificata**

Verifica spostamento nello stato finale (§4.2.4.2.1 - NTC 2008)

x	Comb.	δ_{max}	L/250.00	Cs
---	-------	----------------	----------	----

AUTOSTRADA VALDASTICO A31 NORD
1° LOTTO - PIOVENE ROCCHETTE – VALLE DELL'ASTICO

x	Comb.	δ_{max}	L/250.00	Cs
cm		mm	mm	
111.5	15	-0.13	8.92	66.2

Verifica spostamento elastico dovuto ai soli carichi variabili (§4.2.4.2.1 - NTC 2008)

x	Comb.	δ_2	L/300.00	Cs
cm		mm	mm	
111.5	15	-0.07	7.43	>100

Travata: 852 [461 , 479]

L = 223.6cm

Crit.Prog: Acciaio_Flessione $\delta_c = 0.0cm$ Verifica: **Verificata**

Verifica spostamento nello stato finale (§4.2.4.2.1 - NTC 2008)

x	Comb.	δ_{max}	L/250.00	Cs
cm		mm	mm	
111.8	15	-0.12	8.95	74.4

Verifica spostamento elastico dovuto ai soli carichi variabili (§4.2.4.2.1 - NTC 2008)

x	Comb.	δ_2	L/300.00	Cs
cm		mm	mm	
111.8	15	-0.10	7.45	78.3

Travata: 853 [479 , 478]

L = 222.5cm

Crit.Prog: Acciaio_Flessione $\delta_c = 0.0cm$ Verifica: **Verificata**

Verifica spostamento nello stato finale (§4.2.4.2.1 - NTC 2008)

x	Comb.	δ_{max}	L/250.00	Cs
---	-------	----------------	----------	----

AUTOSTRADA VALDASTICO A31 NORD
1° LOTTO - PIOVENE ROCCHETTE – VALLE DELL'ASTICO

x	Comb.	δ_{max}	L/250.00	Cs
cm		mm	mm	
155.7	15	0.05	8.90	>100

Verifica spostamento elastico dovuto ai soli carichi variabili (§4.2.4.2.1 - NTC 2008)

x	Comb.	δ_2	L/300.00	Cs
cm		mm	mm	
44.5	15	-0.01	7.42	>100

Travata: 854 [460 , 479]

L = 223.6cm

Crit.Prog: Acciaio_Flessione $\delta_c = 0.0cm$ Verifica: **Verificata**

Verifica spostamento nello stato finale (§4.2.4.2.1 - NTC 2008)

x	Comb.	δ_{max}	L/250.00	Cs
cm		mm	mm	
134.2	15	0.03	8.95	>100

Verifica spostamento elastico dovuto ai soli carichi variabili (§4.2.4.2.1 - NTC 2008)

x	Comb.	δ_2	L/300.00	Cs
cm		mm	mm	
156.5	15	0.02	7.45	>100

Travata: 855 [479 , 477]

L = 222.5cm

Crit.Prog: Acciaio_Flessione $\delta_c = 0.0cm$ Verifica: **Verificata**

Verifica spostamento nello stato finale (§4.2.4.2.1 - NTC 2008)

x	Comb.	δ_{max}	L/250.00	Cs
---	-------	----------------	----------	----

AUTOSTRADA VALDASTICO A31 NORD
1° LOTTO - PIOVENE ROCCHETTE – VALLE DELL'ASTICO

x	Comb.	δ_{max}	L/250.00	Cs
cm		mm	mm	
111.2	15	0.08	8.90	>100

Verifica spostamento elastico dovuto ai soli carichi variabili (§4.2.4.2.1 - NTC 2008)

x	Comb.	δ_2	L/300.00	Cs
cm		mm	mm	
89.0	15	0.04	7.42	>100

Travata: 856 [393 , 394]

L = 314.0cm

Crit.Prog: Acciaio_Flessione $\delta_c = 0.0cm$ Verifica: **Verificata**

Verifica spostamento nello stato finale (§4.2.4.2.1 - NTC 2008)

x	Comb.	δ_{max}	L/250.00	Cs
cm		mm	mm	
94.2	15	-1.07	12.56	11.8

Verifica spostamento elastico dovuto ai soli carichi variabili (§4.2.4.2.1 - NTC 2008)

x	Comb.	δ_2	L/300.00	Cs
cm		mm	mm	
94.2	15	-0.70	10.47	15.0

Travata: 857 [394 , 459]

L = 263.5cm

Crit.Prog: Acciaio_Flessione $\delta_c = 0.0cm$ Verifica: **Verificata**

Verifica spostamento nello stato finale (§4.2.4.2.1 - NTC 2008)

x	Comb.	δ_{max}	L/250.00	Cs
---	-------	----------------	----------	----

AUTOSTRADA VALDASTICO A31 NORD
1° LOTTO - PIOVENE ROCCHETTE – VALLE DELL'ASTICO

x	Comb.	δ_{max}	L/250.00	Cs
cm		mm	mm	
105.4	15	-0.12	10.54	88.8

Verifica spostamento elastico dovuto ai soli carichi variabili (§4.2.4.2.1 - NTC 2008)

x	Comb.	δ_2	L/300.00	Cs
cm		mm	mm	
105.4	15	-0.08	8.78	>100

Travata: 858 [459 , 476]

L = 263.5cm

Crit.Prog: Acciaio_Flessione $\delta_c = 0.0cm$ Verifica: **Verificata**

Verifica spostamento nello stato finale (§4.2.4.2.1 - NTC 2008)

x	Comb.	δ_{max}	L/250.00	Cs
cm		mm	mm	
158.1	15	0.06	10.54	>100

Verifica spostamento elastico dovuto ai soli carichi variabili (§4.2.4.2.1 - NTC 2008)

x	Comb.	δ_2	L/300.00	Cs
cm		mm	mm	
52.7	15	-0.00	8.78	>100

Travata: 859 [476 , 477]

L = 314.0cm

Crit.Prog: Acciaio_Flessione $\delta_c = 0.0cm$ Verifica: **Verificata**

Verifica spostamento nello stato finale (§4.2.4.2.1 - NTC 2008)

x	Comb.	δ_{max}	L/250.00	Cs
---	-------	----------------	----------	----

AUTOSTRADA VALDASTICO A31 NORD
1° LOTTO - PIOVENE ROCCHETTE – VALLE DELL'ASTICO

x	Comb.	δ_{max}	L/250.00	Cs
cm		mm	mm	
188.4	15	0.10	12.56	>100

Verifica spostamento elastico dovuto ai soli carichi variabili (§4.2.4.2.1 - NTC 2008)

x	Comb.	δ_2	L/300.00	Cs
cm		mm	mm	
188.4	15	0.03	10.47	>100

Travata: 860 [460 , 459]

L = 314.0cm

Crit.Prog: Acciaio_Flessione $\delta_c = 0.0cm$ Verifica: **Verificata**

Verifica spostamento nello stato finale (§4.2.4.2.1 - NTC 2008)

x	Comb.	δ_{max}	L/250.00	Cs
cm		mm	mm	
62.8	15	-0.09	12.56	>100

Verifica spostamento elastico dovuto ai soli carichi variabili (§4.2.4.2.1 - NTC 2008)

x	Comb.	δ_2	L/300.00	Cs
cm		mm	mm	
94.2	15	-0.07	10.47	>100

Travata: 861 [394 , 463]

L = 248.2cm

Crit.Prog: Acciaio_Flessione $\delta_c = 0.0cm$ Verifica: **Verificata**

Verifica spostamento nello stato finale (§4.2.4.2.1 - NTC 2008)

x	Comb.	δ_{max}	L/250.00	Cs
---	-------	----------------	----------	----

AUTOSTRADA VALDASTICO A31 NORD
1° LOTTO - PIOVENE ROCCHETTE – VALLE DELL'ASTICO

x	Comb.	δ_{max}	L/250.00	Cs
cm		mm	mm	
124.1	15	-0.13	9.93	74.7

Verifica spostamento elastico dovuto ai soli carichi variabili (§4.2.4.2.1 - NTC 2008)

x	Comb.	δ_2	L/300.00	Cs
cm		mm	mm	
124.1	15	-0.09	8.27	93.9

Travata: 862 [463 , 393]

L = 248.2cm

Crit.Prog: Acciaio_Flessione $\delta_c = 0.0cm$ Verifica: **Verificata**

Verifica spostamento nello stato finale (§4.2.4.2.1 - NTC 2008)

x	Comb.	δ_{max}	L/250.00	Cs
cm		mm	mm	
173.7	15	-0.61	9.93	16.4

Verifica spostamento elastico dovuto ai soli carichi variabili (§4.2.4.2.1 - NTC 2008)

x	Comb.	δ_2	L/300.00	Cs
cm		mm	mm	
173.7	15	-0.37	8.27	22.4

Travata: 863 [459 , 463]

L = 248.2cm

Crit.Prog: Acciaio_Flessione $\delta_c = 0.0cm$ Verifica: **Verificata**

Verifica spostamento nello stato finale (§4.2.4.2.1 - NTC 2008)

x	Comb.	δ_{max}	L/250.00	Cs
---	-------	----------------	----------	----

AUTOSTRADA VALDASTICO A31 NORD
1° LOTTO - PIOVENE ROCCHETTE – VALLE DELL'ASTICO

x	Comb.	δ_{max}	L/250.00	Cs
cm		mm	mm	
124.1	15	0.20	9.93	49.7

Verifica spostamento elastico dovuto ai soli carichi variabili (§4.2.4.2.1 - NTC 2008)

x	Comb.	δ_2	L/300.00	Cs
cm		mm	mm	
124.1	15	0.11	8.27	73.7

Travata: 864 [463 , 460]

L = 248.2cm

Crit.Prog: Acciaio_Flessione $\delta_c = 0.0cm$ Verifica: **Verificata**

Verifica spostamento nello stato finale (§4.2.4.2.1 - NTC 2008)

x	Comb.	δ_{max}	L/250.00	Cs
cm		mm	mm	
124.1	15	-0.24	9.93	40.5

Verifica spostamento elastico dovuto ai soli carichi variabili (§4.2.4.2.1 - NTC 2008)

x	Comb.	δ_2	L/300.00	Cs
cm		mm	mm	
124.1	15	-0.15	8.27	54.6

Travata: 865 [459 , 480]

L = 248.7cm

Crit.Prog: Acciaio_Flessione $\delta_c = 0.0cm$ Verifica: **Verificata**

Verifica spostamento nello stato finale (§4.2.4.2.1 - NTC 2008)

x	Comb.	δ_{max}	L/250.00	Cs
---	-------	----------------	----------	----

AUTOSTRADA VALDASTICO A31 NORD
1° LOTTO - PIOVENE ROCCHETTE – VALLE DELL'ASTICO

x	Comb.	δ_{max}	L/250.00	Cs
cm		mm	mm	
124.4	15	-0.10	9.95	>100

Verifica spostamento elastico dovuto ai soli carichi variabili (§4.2.4.2.1 - NTC 2008)

x	Comb.	δ_2	L/300.00	Cs
cm		mm	mm	
124.4	15	-0.07	8.29	>100

Travata: 866 [480 , 460]

L = 248.7cm

Crit.Prog: Acciaio_Flessione $\delta_c = 0.0cm$ Verifica: **Verificata**

Verifica spostamento nello stato finale (§4.2.4.2.1 - NTC 2008)

x	Comb.	δ_{max}	L/250.00	Cs
cm		mm	mm	
124.4	15	0.12	9.95	83.7

Verifica spostamento elastico dovuto ai soli carichi variabili (§4.2.4.2.1 - NTC 2008)

x	Comb.	δ_2	L/300.00	Cs
cm		mm	mm	
99.5	15	0.06	8.29	>100

Travata: 867 [476 , 480]

L = 247.7cm

Crit.Prog: Acciaio_Flessione $\delta_c = 0.0cm$ Verifica: **Verificata**

Verifica spostamento nello stato finale (§4.2.4.2.1 - NTC 2008)

x	Comb.	δ_{max}	L/250.00	Cs
---	-------	----------------	----------	----

AUTOSTRADA VALDASTICO A31 NORD
1° LOTTO - PIOVENE ROCCHETTE – VALLE DELL'ASTICO

x	Comb.	δ_{max}	L/250.00	Cs
cm		mm	mm	
123.8	15	0.15	9.91	67.6

Verifica spostamento elastico dovuto ai soli carichi variabili (§4.2.4.2.1 - NTC 2008)

x	Comb.	δ_2	L/300.00	Cs
cm		mm	mm	
123.8	15	0.07	8.26	>100

Travata: 868 [480 , 477]

L = 247.7cm

Crit.Prog: Acciaio_Flessione $\delta_c = 0.0cm$ Verifica: **Verificata**

Verifica spostamento nello stato finale (§4.2.4.2.1 - NTC 2008)

x	Comb.	δ_{max}	L/250.00	Cs
cm		mm	mm	
74.3	15	-0.05	9.91	>100

Verifica spostamento elastico dovuto ai soli carichi variabili (§4.2.4.2.1 - NTC 2008)

x	Comb.	δ_2	L/300.00	Cs
cm		mm	mm	
99.1	15	-0.04	8.26	>100

Travata: 869 [394 , 395]

L = 314.0cm

Crit.Prog: Acciaio_Flessione $\delta_c = 0.0cm$ Verifica: **Verificata**

Verifica spostamento nello stato finale (§4.2.4.2.1 - NTC 2008)

x	Comb.	δ_{max}	L/250.00	Cs
---	-------	----------------	----------	----

AUTOSTRADA VALDASTICO A31 NORD
1° LOTTO - PIOVENE ROCCHETTE – VALLE DELL'ASTICO

x	Comb.	δ_{max}	L/250.00	Cs
cm		mm	mm	
157.0	15	0.52	12.56	24.2

Verifica spostamento elastico dovuto ai soli carichi variabili (§4.2.4.2.1 - NTC 2008)

x	Comb.	δ_2	L/300.00	Cs
cm		mm	mm	
157.0	15	0.28	10.47	37.2

Travata: 870 [395 , 458]

L = 263.5cm

Crit.Prog: Acciaio_Flessione $\delta_c = 0.0cm$ Verifica: **Verificata**

Verifica spostamento nello stato finale (§4.2.4.2.1 - NTC 2008)

x	Comb.	δ_{max}	L/250.00	Cs
cm		mm	mm	
131.7	15	0.02	10.54	>100

Verifica spostamento elastico dovuto ai soli carichi variabili (§4.2.4.2.1 - NTC 2008)

x	Comb.	δ_2	L/300.00	Cs
cm		mm	mm	
52.7	15	0.00	8.78	>100

Travata: 871 [458 , 459]

L = 314.0cm

Crit.Prog: Acciaio_Flessione $\delta_c = 0.0cm$ Verifica: **Verificata**

Verifica spostamento nello stato finale (§4.2.4.2.1 - NTC 2008)

x	Comb.	δ_{max}	L/250.00	Cs
---	-------	----------------	----------	----

AUTOSTRADA VALDASTICO A31 NORD
1° LOTTO - PIOVENE ROCCHETTE – VALLE DELL'ASTICO

x	Comb.	δ_{max}	L/250.00	Cs
cm		mm	mm	
157.0	15	0.30	12.56	41.2

Verifica spostamento elastico dovuto ai soli carichi variabili (§4.2.4.2.1 - NTC 2008)

x	Comb.	δ_2	L/300.00	Cs
cm		mm	mm	
157.0	15	0.15	10.47	69.6

Travata: 872 [394 , 464]

L = 268.2cm

Crit.Prog: Acciaio_Flessione $\delta_c = 0.0cm$ Verifica: **Verificata**

Verifica spostamento nello stato finale (§4.2.4.2.1 - NTC 2008)

x	Comb.	δ_{max}	L/250.00	Cs
cm		mm	mm	
134.1	15	0.17	10.73	62.4

Verifica spostamento elastico dovuto ai soli carichi variabili (§4.2.4.2.1 - NTC 2008)

x	Comb.	δ_2	L/300.00	Cs
cm		mm	mm	
107.3	15	0.10	8.94	92.0

Travata: 873 [464 , 458]

L = 268.2cm

Crit.Prog: Acciaio_Flessione $\delta_c = 0.0cm$ Verifica: **Verificata**

Verifica spostamento nello stato finale (§4.2.4.2.1 - NTC 2008)

x	Comb.	δ_{max}	L/250.00	Cs
---	-------	----------------	----------	----

AUTOSTRADA VALDASTICO A31 NORD
1° LOTTO - PIOVENE ROCCHETTE – VALLE DELL'ASTICO

x	Comb.	δ_{max}	L/250.00	Cs
cm		mm	mm	
134.1	15	0.13	10.73	80.3

Verifica spostamento elastico dovuto ai soli carichi variabili (§4.2.4.2.1 - NTC 2008)

x	Comb.	δ_2	L/300.00	Cs
cm		mm	mm	
134.1	15	0.07	8.94	>100

Travata: 874 [395 , 464]

L = 268.2cm

Crit.Prog: Acciaio_Flessione $\delta_c = 0.0cm$ Verifica: **Verificata**

Verifica spostamento nello stato finale (§4.2.4.2.1 - NTC 2008)

x	Comb.	δ_{max}	L/250.00	Cs
cm		mm	mm	
107.3	15	0.07	10.73	>100

Verifica spostamento elastico dovuto ai soli carichi variabili (§4.2.4.2.1 - NTC 2008)

x	Comb.	δ_2	L/300.00	Cs
cm		mm	mm	
107.3	15	0.03	8.94	>100

Travata: 875 [464 , 459]

L = 268.2cm

Crit.Prog: Acciaio_Flessione $\delta_c = 0.0cm$ Verifica: **Verificata**

Verifica spostamento nello stato finale (§4.2.4.2.1 - NTC 2008)

x	Comb.	δ_{max}	L/250.00	Cs
---	-------	----------------	----------	----

AUTOSTRADA VALDASTICO A31 NORD
1° LOTTO - PIOVENE ROCCHETTE – VALLE DELL'ASTICO

x	Comb.	δ_{max}	L/250.00	Cs
cm		mm	mm	
187.7	15	-0.03	10.73	>100

Verifica spostamento elastico dovuto ai soli carichi variabili (§4.2.4.2.1 - NTC 2008)

x	Comb.	δ_2	L/300.00	Cs
cm		mm	mm	
160.9	15	-0.02	8.94	>100

Travata: 876 [458 , 475]

L = 263.5cm

Crit.Prog: Acciaio_Flessione $\delta_c = 0.0cm$ Verifica: **Verificata**

Verifica spostamento nello stato finale (§4.2.4.2.1 - NTC 2008)

x	Comb.	δ_{max}	L/250.00	Cs
cm		mm	mm	
158.1	21	0.06	10.54	>100

Verifica spostamento elastico dovuto ai soli carichi variabili (§4.2.4.2.1 - NTC 2008)

x	Comb.	δ_2	L/300.00	Cs
cm		mm	mm	
184.5	15	-0.01	8.78	>100

Travata: 877 [475 , 476]

L = 314.0cm

Crit.Prog: Acciaio_Flessione $\delta_c = 0.0cm$ Verifica: **Verificata**

Verifica spostamento nello stato finale (§4.2.4.2.1 - NTC 2008)

x	Comb.	δ_{max}	L/250.00	Cs
---	-------	----------------	----------	----

AUTOSTRADA VALDASTICO A31 NORD
1° LOTTO - PIOVENE ROCCHETTE – VALLE DELL'ASTICO

x	Comb.	δ_{max}	L/250.00	Cs
cm		mm	mm	
157.0	15	0.18	12.56	69.4

Verifica spostamento elastico dovuto ai soli carichi variabili (§4.2.4.2.1 - NTC 2008)

x	Comb.	δ_2	L/300.00	Cs
cm		mm	mm	
157.0	15	0.08	10.47	>100

Travata: 878 [459 , 481]

L = 268.7cm

Crit.Prog: Acciaio_Flessione $\delta_c = 0.0cm$ Verifica: **Verificata**

Verifica spostamento nello stato finale (§4.2.4.2.1 - NTC 2008)

x	Comb.	δ_{max}	L/250.00	Cs
cm		mm	mm	
134.4	15	0.17	10.75	61.8

Verifica spostamento elastico dovuto ai soli carichi variabili (§4.2.4.2.1 - NTC 2008)

x	Comb.	δ_2	L/300.00	Cs
cm		mm	mm	
134.4	15	0.09	8.96	98.9

Travata: 879 [481 , 458]

L = 268.7cm

Crit.Prog: Acciaio_Flessione $\delta_c = 0.0cm$ Verifica: **Verificata**

Verifica spostamento nello stato finale (§4.2.4.2.1 - NTC 2008)

x	Comb.	δ_{max}	L/250.00	Cs
---	-------	----------------	----------	----

AUTOSTRADA VALDASTICO A31 NORD
1° LOTTO - PIOVENE ROCCHETTE – VALLE DELL'ASTICO

x	Comb.	δ_{max}	L/250.00	Cs
cm		mm	mm	
134.4	21	0.02	10.75	>100

Verifica spostamento elastico dovuto ai soli carichi variabili (§4.2.4.2.1 - NTC 2008)

x	Comb.	δ_2	L/300.00	Cs
cm		mm	mm	
80.6	15	-0.01	8.96	>100

Travata: 880 [476 , 481]

L = 267.7cm

Crit.Prog: Acciaio_Flessione $\delta_c = 0.0cm$ Verifica: **Verificata**

Verifica spostamento nello stato finale (§4.2.4.2.1 - NTC 2008)

x	Comb.	δ_{max}	L/250.00	Cs
cm		mm	mm	
187.4	15	-0.03	10.71	>100

Verifica spostamento elastico dovuto ai soli carichi variabili (§4.2.4.2.1 - NTC 2008)

x	Comb.	δ_2	L/300.00	Cs
cm		mm	mm	
133.9	15	-0.03	8.92	>100

Travata: 881 [481 , 475]

L = 267.7cm

Crit.Prog: Acciaio_Flessione $\delta_c = 0.0cm$ Verifica: **Verificata**

Verifica spostamento nello stato finale (§4.2.4.2.1 - NTC 2008)

x	Comb.	δ_{max}	L/250.00	Cs
---	-------	----------------	----------	----

AUTOSTRADA VALDASTICO A31 NORD
1° LOTTO - PIOVENE ROCCHETTE – VALLE DELL'ASTICO

x	Comb.	δ_{max}	L/250.00	Cs
cm		mm	mm	
133.9	15	0.12	10.71	88.0

Verifica spostamento elastico dovuto ai soli carichi variabili (§4.2.4.2.1 - NTC 2008)

x	Comb.	δ_2	L/300.00	Cs
cm		mm	mm	
133.9	15	0.06	8.92	>100

Travata: 882 [395 , 396]

L = 314.0cm

Crit.Prog: Acciaio_Flessione $\delta_c = 0.0cm$ Verifica: **Verificata**

Verifica spostamento nello stato finale (§4.2.4.2.1 - NTC 2008)

x	Comb.	δ_{max}	L/250.00	Cs
cm		mm	mm	
157.0	15	0.42	12.56	30.3

Verifica spostamento elastico dovuto ai soli carichi variabili (§4.2.4.2.1 - NTC 2008)

x	Comb.	δ_2	L/300.00	Cs
cm		mm	mm	
157.0	15	0.22	10.47	48.5

Travata: 883 [396 , 457]

L = 263.5cm

Crit.Prog: Acciaio_Flessione $\delta_c = 0.0cm$ Verifica: **Verificata**

Verifica spostamento nello stato finale (§4.2.4.2.1 - NTC 2008)

x	Comb.	δ_{max}	L/250.00	Cs
---	-------	----------------	----------	----

AUTOSTRADA VALDASTICO A31 NORD
1° LOTTO - PIOVENE ROCCHETTE – VALLE DELL'ASTICO

x	Comb.	δ_{max}	L/250.00	Cs
cm		mm	mm	
131.7	15	0.05	10.54	>100

Verifica spostamento elastico dovuto ai soli carichi variabili (§4.2.4.2.1 - NTC 2008)

x	Comb.	δ_2	L/300.00	Cs
cm		mm	mm	
105.4	15	0.02	8.78	>100

Travata: 884 [457 , 458]

L = 314.0cm

Crit.Prog: Acciaio_Flessione $\delta_c = 0.0cm$ Verifica: **Verificata**

Verifica spostamento nello stato finale (§4.2.4.2.1 - NTC 2008)

x	Comb.	δ_{max}	L/250.00	Cs
cm		mm	mm	
157.0	15	0.36	12.56	35.2

Verifica spostamento elastico dovuto ai soli carichi variabili (§4.2.4.2.1 - NTC 2008)

x	Comb.	δ_2	L/300.00	Cs
cm		mm	mm	
157.0	15	0.18	10.47	57.8

Travata: 885 [395 , 465]

L = 276.1cm

Crit.Prog: Acciaio_Flessione $\delta_c = 0.0cm$ Verifica: **Verificata**

Verifica spostamento nello stato finale (§4.2.4.2.1 - NTC 2008)

x	Comb.	δ_{max}	L/250.00	Cs
---	-------	----------------	----------	----

AUTOSTRADA VALDASTICO A31 NORD
1° LOTTO - PIOVENE ROCCHETTE – VALLE DELL'ASTICO

x	Comb.	δ_{max}	L/250.00	Cs
cm		mm	mm	
138.1	15	0.12	11.04	90.6

Verifica spostamento elastico dovuto ai soli carichi variabili (§4.2.4.2.1 - NTC 2008)

x	Comb.	δ_2	L/300.00	Cs
cm		mm	mm	
138.1	15	0.06	9.20	>100

Travata: 886 [465 , 457]

L = 276.1cm

Crit.Prog: Acciaio_Flessione $\delta_c = 0.0cm$ Verifica: **Verificata**

Verifica spostamento nello stato finale (§4.2.4.2.1 - NTC 2008)

x	Comb.	δ_{max}	L/250.00	Cs
cm		mm	mm	
138.1	15	0.11	11.04	98.6

Verifica spostamento elastico dovuto ai soli carichi variabili (§4.2.4.2.1 - NTC 2008)

x	Comb.	δ_2	L/300.00	Cs
cm		mm	mm	
138.1	15	0.06	9.20	>100

Travata: 887 [396 , 465]

L = 276.1cm

Crit.Prog: Acciaio_Flessione $\delta_c = 0.0cm$ Verifica: **Verificata**

Verifica spostamento nello stato finale (§4.2.4.2.1 - NTC 2008)

x	Comb.	δ_{max}	L/250.00	Cs
---	-------	----------------	----------	----

AUTOSTRADA VALDASTICO A31 NORD
1° LOTTO - PIOVENE ROCCHETTE – VALLE DELL'ASTICO

x	Comb.	δ_{max}	L/250.00	Cs
cm		mm	mm	
138.1	15	0.11	11.04	>100

Verifica spostamento elastico dovuto ai soli carichi variabili (§4.2.4.2.1 - NTC 2008)

x	Comb.	δ_2	L/300.00	Cs
cm		mm	mm	
138.1	15	0.06	9.20	>100

Travata: 888 [465 , 458]

L = 276.1cm

Crit.Prog: Acciaio_Flessione $\delta_c = 0.0cm$ Verifica: **Verificata**

Verifica spostamento nello stato finale (§4.2.4.2.1 - NTC 2008)

x	Comb.	δ_{max}	L/250.00	Cs
cm		mm	mm	
138.1	15	0.07	11.04	>100

Verifica spostamento elastico dovuto ai soli carichi variabili (§4.2.4.2.1 - NTC 2008)

x	Comb.	δ_2	L/300.00	Cs
cm		mm	mm	
138.1	15	0.03	9.20	>100

Travata: 889 [457 , 474]

L = 263.5cm

Crit.Prog: Acciaio_Flessione $\delta_c = 0.0cm$ Verifica: **Verificata**

Verifica spostamento nello stato finale (§4.2.4.2.1 - NTC 2008)

x	Comb.	δ_{max}	L/250.00	Cs
---	-------	----------------	----------	----

AUTOSTRADA VALDASTICO A31 NORD
1° LOTTO - PIOVENE ROCCHETTE – VALLE DELL'ASTICO

x	Comb.	δ_{max}	L/250.00	Cs
cm		mm	mm	
131.8	17	0.06	10.54	>100

Verifica spostamento elastico dovuto ai soli carichi variabili (§4.2.4.2.1 - NTC 2008)

x	Comb.	δ_2	L/300.00	Cs
cm		mm	mm	
184.5	15	-0.01	8.78	>100

Travata: 890 [474 , 475]

L = 314.0cm

Crit.Prog: Acciaio_Flessione $\delta_c = 0.0cm$ Verifica: **Verificata**

Verifica spostamento nello stato finale (§4.2.4.2.1 - NTC 2008)

x	Comb.	δ_{max}	L/250.00	Cs
cm		mm	mm	
157.0	15	0.27	12.56	46.8

Verifica spostamento elastico dovuto ai soli carichi variabili (§4.2.4.2.1 - NTC 2008)

x	Comb.	δ_2	L/300.00	Cs
cm		mm	mm	
157.0	15	0.13	10.47	81.7

Travata: 891 [457 , 482]

L = 276.6cm

Crit.Prog: Acciaio_Flessione $\delta_c = 0.0cm$ Verifica: **Verificata**

Verifica spostamento nello stato finale (§4.2.4.2.1 - NTC 2008)

x	Comb.	δ_{max}	L/250.00	Cs
---	-------	----------------	----------	----

AUTOSTRADA VALDASTICO A31 NORD
1° LOTTO - PIOVENE ROCCHETTE – VALLE DELL'ASTICO

x	Comb.	δ_{max}	L/250.00	Cs
cm		mm	mm	
138.3	15	0.08	11.06	>100

Verifica spostamento elastico dovuto ai soli carichi variabili (§4.2.4.2.1 - NTC 2008)

x	Comb.	δ_2	L/300.00	Cs
cm		mm	mm	
110.6	15	0.04	9.22	>100

Travata: 892 [482 , 458]

L = 276.6cm

Crit.Prog: Acciaio_Flessione $\delta_c = 0.0cm$ Verifica: **Verificata**

Verifica spostamento nello stato finale (§4.2.4.2.1 - NTC 2008)

x	Comb.	δ_{max}	L/250.00	Cs
cm		mm	mm	
138.3	15	0.13	11.06	86.8

Verifica spostamento elastico dovuto ai soli carichi variabili (§4.2.4.2.1 - NTC 2008)

x	Comb.	δ_2	L/300.00	Cs
cm		mm	mm	
138.3	15	0.06	9.22	>100

Travata: 893 [474 , 482]

L = 275.6cm

Crit.Prog: Acciaio_Flessione $\delta_c = 0.0cm$ Verifica: **Verificata**

Verifica spostamento nello stato finale (§4.2.4.2.1 - NTC 2008)

x	Comb.	δ_{max}	L/250.00	Cs
---	-------	----------------	----------	----

AUTOSTRADA VALDASTICO A31 NORD
1° LOTTO - PIOVENE ROCCHETTE – VALLE DELL'ASTICO

x	Comb.	δ_{max}	L/250.00	Cs
cm		mm	mm	
137.8	15	0.09	11.03	>100

Verifica spostamento elastico dovuto ai soli carichi variabili (§4.2.4.2.1 - NTC 2008)

x	Comb.	δ_2	L/300.00	Cs
cm		mm	mm	
137.8	15	0.04	9.19	>100

Travata: 894 [482 , 475]

L = 275.6cm

Crit.Prog: Acciaio_Flessione $\delta_c = 0.0cm$ Verifica: **Verificata**

Verifica spostamento nello stato finale (§4.2.4.2.1 - NTC 2008)

x	Comb.	δ_{max}	L/250.00	Cs
cm		mm	mm	
165.4	15	0.05	11.03	>100

Verifica spostamento elastico dovuto ai soli carichi variabili (§4.2.4.2.1 - NTC 2008)

x	Comb.	δ_2	L/300.00	Cs
cm		mm	mm	
165.4	15	0.01	9.19	>100

Travata: 895 [396 , 397]

L = 314.0cm

Crit.Prog: Acciaio_Flessione $\delta_c = 0.0cm$ Verifica: **Verificata**

Verifica spostamento nello stato finale (§4.2.4.2.1 - NTC 2008)

x	Comb.	δ_{max}	L/250.00	Cs
---	-------	----------------	----------	----

AUTOSTRADA VALDASTICO A31 NORD
1° LOTTO - PIOVENE ROCCHETTE – VALLE DELL'ASTICO

x	Comb.	δ_{max}	L/250.00	Cs
cm		mm	mm	
157.0	15	0.41	12.56	30.3

Verifica spostamento elastico dovuto ai soli carichi variabili (§4.2.4.2.1 - NTC 2008)

x	Comb.	δ_2	L/300.00	Cs
cm		mm	mm	
157.0	15	0.22	10.47	48.6

Travata: 896 [397 , 456]

L = 263.5cm

Crit.Prog: Acciaio_Flessione $\delta_c = 0.0cm$ Verifica: **Verificata**

Verifica spostamento nello stato finale (§4.2.4.2.1 - NTC 2008)

x	Comb.	δ_{max}	L/250.00	Cs
cm		mm	mm	
131.7	15	0.02	10.54	>100

Verifica spostamento elastico dovuto ai soli carichi variabili (§4.2.4.2.1 - NTC 2008)

x	Comb.	δ_2	L/300.00	Cs
cm		mm	mm	
52.7	15	0.00	8.78	>100

Travata: 897 [456 , 457]

L = 314.0cm

Crit.Prog: Acciaio_Flessione $\delta_c = 0.0cm$ Verifica: **Verificata**

Verifica spostamento nello stato finale (§4.2.4.2.1 - NTC 2008)

x	Comb.	δ_{max}	L/250.00	Cs
---	-------	----------------	----------	----

AUTOSTRADA VALDASTICO A31 NORD
1° LOTTO - PIOVENE ROCCHETTE – VALLE DELL'ASTICO

x	Comb.	δ_{max}	L/250.00	Cs
cm		mm	mm	
157.0	15	0.36	12.56	35.2

Verifica spostamento elastico dovuto ai soli carichi variabili (§4.2.4.2.1 - NTC 2008)

x	Comb.	δ_2	L/300.00	Cs
cm		mm	mm	
157.0	15	0.18	10.47	57.8

Travata: 898 [397 , 466]

L = 276.1cm

Crit.Prog: Acciaio_Flessione $\delta_c = 0.0cm$ Verifica: **Verificata**

Verifica spostamento nello stato finale (§4.2.4.2.1 - NTC 2008)

x	Comb.	δ_{max}	L/250.00	Cs
cm		mm	mm	
138.1	15	0.12	11.04	90.9

Verifica spostamento elastico dovuto ai soli carichi variabili (§4.2.4.2.1 - NTC 2008)

x	Comb.	δ_2	L/300.00	Cs
cm		mm	mm	
138.1	15	0.06	9.20	>100

Travata: 899 [466 , 396]

L = 276.1cm

Crit.Prog: Acciaio_Flessione $\delta_c = 0.0cm$ Verifica: **Verificata**

Verifica spostamento nello stato finale (§4.2.4.2.1 - NTC 2008)

x	Comb.	δ_{max}	L/250.00	Cs
---	-------	----------------	----------	----

AUTOSTRADA VALDASTICO A31 NORD
1° LOTTO - PIOVENE ROCCHETTE – VALLE DELL'ASTICO

x	Comb.	δ_{max}	L/250.00	Cs
cm		mm	mm	
138.1	15	0.11	11.04	>100

Verifica spostamento elastico dovuto ai soli carichi variabili (§4.2.4.2.1 - NTC 2008)

x	Comb.	δ_2	L/300.00	Cs
cm		mm	mm	
138.1	15	0.06	9.20	>100

Travata: 900 [457 , 466]

L = 276.1cm

Crit.Prog: Acciaio_Flessione $\delta_c = 0.0cm$ Verifica: **Verificata**

Verifica spostamento nello stato finale (§4.2.4.2.1 - NTC 2008)

x	Comb.	δ_{max}	L/250.00	Cs
cm		mm	mm	
138.1	15	0.11	11.04	98.5

Verifica spostamento elastico dovuto ai soli carichi variabili (§4.2.4.2.1 - NTC 2008)

x	Comb.	δ_2	L/300.00	Cs
cm		mm	mm	
138.1	15	0.06	9.20	>100

Travata: 901 [466 , 456]

L = 276.1cm

Crit.Prog: Acciaio_Flessione $\delta_c = 0.0cm$ Verifica: **Verificata**

Verifica spostamento nello stato finale (§4.2.4.2.1 - NTC 2008)

x	Comb.	δ_{max}	L/250.00	Cs
---	-------	----------------	----------	----

AUTOSTRADA VALDASTICO A31 NORD
1° LOTTO - PIOVENE ROCCHETTE – VALLE DELL'ASTICO

x	Comb.	δ_{max}	L/250.00	Cs
cm		mm	mm	
138.1	15	0.07	11.04	>100

Verifica spostamento elastico dovuto ai soli carichi variabili (§4.2.4.2.1 - NTC 2008)

x	Comb.	δ_2	L/300.00	Cs
cm		mm	mm	
138.1	15	0.03	9.20	>100

Travata: 902 [456 , 473]

L = 263.5cm

Crit.Prog: Acciaio_Flessione $\delta_c = 0.0cm$ Verifica: **Verificata**

Verifica spostamento nello stato finale (§4.2.4.2.1 - NTC 2008)

x	Comb.	δ_{max}	L/250.00	Cs
cm		mm	mm	
158.1	17	0.06	10.54	>100

Verifica spostamento elastico dovuto ai soli carichi variabili (§4.2.4.2.1 - NTC 2008)

x	Comb.	δ_2	L/300.00	Cs
cm		mm	mm	
184.5	15	-0.01	8.78	>100

Travata: 903 [473 , 474]

L = 314.0cm

Crit.Prog: Acciaio_Flessione $\delta_c = 0.0cm$ Verifica: **Verificata**

Verifica spostamento nello stato finale (§4.2.4.2.1 - NTC 2008)

x	Comb.	δ_{max}	L/250.00	Cs
---	-------	----------------	----------	----

AUTOSTRADA VALDASTICO A31 NORD
1° LOTTO - PIOVENE ROCCHETTE – VALLE DELL'ASTICO

x	Comb.	δ_{max}	L/250.00	Cs
cm		mm	mm	
157.0	15	0.27	12.56	47.0

Verifica spostamento elastico dovuto ai soli carichi variabili (§4.2.4.2.1 - NTC 2008)

x	Comb.	δ_2	L/300.00	Cs
cm		mm	mm	
157.0	15	0.13	10.47	81.9

Travata: 904 [456 , 483]

L = 276.6cm

Crit.Prog: Acciaio_Flessione $\delta_c = 0.0cm$ Verifica: **Verificata**

Verifica spostamento nello stato finale (§4.2.4.2.1 - NTC 2008)

x	Comb.	δ_{max}	L/250.00	Cs
cm		mm	mm	
138.3	15	0.13	11.06	86.7

Verifica spostamento elastico dovuto ai soli carichi variabili (§4.2.4.2.1 - NTC 2008)

x	Comb.	δ_2	L/300.00	Cs
cm		mm	mm	
138.3	15	0.06	9.22	>100

Travata: 905 [483 , 457]

L = 276.6cm

Crit.Prog: Acciaio_Flessione $\delta_c = 0.0cm$ Verifica: **Verificata**

Verifica spostamento nello stato finale (§4.2.4.2.1 - NTC 2008)

x	Comb.	δ_{max}	L/250.00	Cs
---	-------	----------------	----------	----

AUTOSTRADA VALDASTICO A31 NORD
1° LOTTO - PIOVENE ROCCHETTE – VALLE DELL'ASTICO

x	Comb.	δ_{max}	L/250.00	Cs
cm		mm	mm	
138.3	15	0.08	11.06	>100

Verifica spostamento elastico dovuto ai soli carichi variabili (§4.2.4.2.1 - NTC 2008)

x	Comb.	δ_2	L/300.00	Cs
cm		mm	mm	
165.9	15	0.04	9.22	>100

Travata: 906 [473 , 483]

L = 275.6cm

Crit.Prog: Acciaio_Flessione $\delta_c = 0.0cm$ Verifica: **Verificata**

Verifica spostamento nello stato finale (§4.2.4.2.1 - NTC 2008)

x	Comb.	δ_{max}	L/250.00	Cs
cm		mm	mm	
110.3	15	0.05	11.03	>100

Verifica spostamento elastico dovuto ai soli carichi variabili (§4.2.4.2.1 - NTC 2008)

x	Comb.	δ_2	L/300.00	Cs
cm		mm	mm	
110.3	15	0.01	9.19	>100

Travata: 907 [483 , 474]

L = 275.6cm

Crit.Prog: Acciaio_Flessione $\delta_c = 0.0cm$ Verifica: **Verificata**

Verifica spostamento nello stato finale (§4.2.4.2.1 - NTC 2008)

x	Comb.	δ_{max}	L/250.00	Cs
---	-------	----------------	----------	----

AUTOSTRADA VALDASTICO A31 NORD
1° LOTTO - PIOVENE ROCCHETTE – VALLE DELL'ASTICO

x	Comb.	δ_{max}	L/250.00	Cs
cm		mm	mm	
137.8	15	0.09	11.03	>100

Verifica spostamento elastico dovuto ai soli carichi variabili (§4.2.4.2.1 - NTC 2008)

x	Comb.	δ_2	L/300.00	Cs
cm		mm	mm	
137.8	15	0.04	9.19	>100

Travata: 908 [397 , 398]

L = 314.0cm

Crit.Prog: Acciaio_Flessione $\delta_c = 0.0cm$ Verifica: **Verificata**

Verifica spostamento nello stato finale (§4.2.4.2.1 - NTC 2008)

x	Comb.	δ_{max}	L/250.00	Cs
cm		mm	mm	
157.0	15	0.52	12.56	24.1

Verifica spostamento elastico dovuto ai soli carichi variabili (§4.2.4.2.1 - NTC 2008)

x	Comb.	δ_2	L/300.00	Cs
cm		mm	mm	
157.0	15	0.28	10.47	37.1

Travata: 909 [398 , 455]

L = 263.5cm

Crit.Prog: Acciaio_Flessione $\delta_c = 0.0cm$ Verifica: **Verificata**

Verifica spostamento nello stato finale (§4.2.4.2.1 - NTC 2008)

x	Comb.	δ_{max}	L/250.00	Cs
---	-------	----------------	----------	----

AUTOSTRADA VALDASTICO A31 NORD
1° LOTTO - PIOVENE ROCCHETTE – VALLE DELL'ASTICO

x	Comb.	δ_{max}	L/250.00	Cs
cm		mm	mm	
105.4	15	-0.12	10.54	87.9

Verifica spostamento elastico dovuto ai soli carichi variabili (§4.2.4.2.1 - NTC 2008)

x	Comb.	δ_2	L/300.00	Cs
cm		mm	mm	
105.4	15	-0.08	8.78	>100

Travata: 910 [455 , 456]

L = 314.0cm

Crit.Prog: Acciaio_Flessione $\delta_c = 0.0cm$ Verifica: **Verificata**

Verifica spostamento nello stato finale (§4.2.4.2.1 - NTC 2008)

x	Comb.	δ_{max}	L/250.00	Cs
cm		mm	mm	
157.0	15	0.30	12.56	41.4

Verifica spostamento elastico dovuto ai soli carichi variabili (§4.2.4.2.1 - NTC 2008)

x	Comb.	δ_2	L/300.00	Cs
cm		mm	mm	
157.0	15	0.15	10.47	69.8

Travata: 911 [397 , 454]

L = 268.2cm

Crit.Prog: Acciaio_Flessione $\delta_c = 0.0cm$ Verifica: **Verificata**

Verifica spostamento nello stato finale (§4.2.4.2.1 - NTC 2008)

x	Comb.	δ_{max}	L/250.00	Cs
---	-------	----------------	----------	----

AUTOSTRADA VALDASTICO A31 NORD
1° LOTTO - PIOVENE ROCCHETTE – VALLE DELL'ASTICO

x	Comb.	δ_{max}	L/250.00	Cs
cm		mm	mm	
107.3	15	0.07	10.73	>100

Verifica spostamento elastico dovuto ai soli carichi variabili (§4.2.4.2.1 - NTC 2008)

x	Comb.	δ_2	L/300.00	Cs
cm		mm	mm	
107.3	15	0.03	8.94	>100

Travata: 912 [454 , 398]

L = 268.2cm

Crit.Prog: Acciaio_Flessione $\delta_c = 0.0cm$ Verifica: **Verificata**

Verifica spostamento nello stato finale (§4.2.4.2.1 - NTC 2008)

x	Comb.	δ_{max}	L/250.00	Cs
cm		mm	mm	
160.9	15	0.17	10.73	62.1

Verifica spostamento elastico dovuto ai soli carichi variabili (§4.2.4.2.1 - NTC 2008)

x	Comb.	δ_2	L/300.00	Cs
cm		mm	mm	
160.9	15	0.10	8.94	91.7

Travata: 913 [456 , 454]

L = 268.2cm

Crit.Prog: Acciaio_Flessione $\delta_c = 0.0cm$ Verifica: **Verificata**

Verifica spostamento nello stato finale (§4.2.4.2.1 - NTC 2008)

x	Comb.	δ_{max}	L/250.00	Cs
---	-------	----------------	----------	----

AUTOSTRADA VALDASTICO A31 NORD
1° LOTTO - PIOVENE ROCCHETTE – VALLE DELL'ASTICO

x	Comb.	δ_{max}	L/250.00	Cs
cm		mm	mm	
134.1	15	0.13	10.73	80.6

Verifica spostamento elastico dovuto ai soli carichi variabili (§4.2.4.2.1 - NTC 2008)

x	Comb.	δ_2	L/300.00	Cs
cm		mm	mm	
134.1	15	0.07	8.94	>100

Travata: 914 [454 , 455]

L = 268.2cm

Crit.Prog: Acciaio_Flessione $\delta_c = 0.0cm$ Verifica: **Verificata**

Verifica spostamento nello stato finale (§4.2.4.2.1 - NTC 2008)

x	Comb.	δ_{max}	L/250.00	Cs
cm		mm	mm	
187.7	15	-0.03	10.73	>100

Verifica spostamento elastico dovuto ai soli carichi variabili (§4.2.4.2.1 - NTC 2008)

x	Comb.	δ_2	L/300.00	Cs
cm		mm	mm	
160.9	15	-0.02	8.94	>100

Travata: 915 [455 , 472]

L = 263.5cm

Crit.Prog: Acciaio_Flessione $\delta_c = 0.0cm$ Verifica: **Verificata**

Verifica spostamento nello stato finale (§4.2.4.2.1 - NTC 2008)

x	Comb.	δ_{max}	L/250.00	Cs
---	-------	----------------	----------	----

AUTOSTRADA VALDASTICO A31 NORD
1° LOTTO - PIOVENE ROCCHETTE – VALLE DELL'ASTICO

x	Comb.	δ_{max}	L/250.00	Cs
cm		mm	mm	
158.1	15	0.06	10.54	>100

Verifica spostamento elastico dovuto ai soli carichi variabili (§4.2.4.2.1 - NTC 2008)

x	Comb.	δ_2	L/300.00	Cs
cm		mm	mm	
210.8	15	0.00	8.78	>100

Travata: 916 [472 , 473]

L = 314.0cm

Crit.Prog: Acciaio_Flessione $\delta_c = 0.0cm$ Verifica: **Verificata**

Verifica spostamento nello stato finale (§4.2.4.2.1 - NTC 2008)

x	Comb.	δ_{max}	L/250.00	Cs
cm		mm	mm	
157.0	15	0.18	12.56	68.9

Verifica spostamento elastico dovuto ai soli carichi variabili (§4.2.4.2.1 - NTC 2008)

x	Comb.	δ_2	L/300.00	Cs
cm		mm	mm	
157.0	15	0.08	10.47	>100

Travata: 917 [456 , 471]

L = 268.7cm

Crit.Prog: Acciaio_Flessione $\delta_c = 0.0cm$ Verifica: **Verificata**

Verifica spostamento nello stato finale (§4.2.4.2.1 - NTC 2008)

x	Comb.	δ_{max}	L/250.00	Cs
---	-------	----------------	----------	----

AUTOSTRADA VALDASTICO A31 NORD
1° LOTTO - PIOVENE ROCCHETTE – VALLE DELL'ASTICO

x	Comb.	δ_{max}	L/250.00	Cs
cm		mm	mm	
134.4	21	0.02	10.75	>100

Verifica spostamento elastico dovuto ai soli carichi variabili (§4.2.4.2.1 - NTC 2008)

x	Comb.	δ_2	L/300.00	Cs
cm		mm	mm	
188.1	15	-0.01	8.96	>100

Travata: 918 [471 , 455]

L = 268.7cm

Crit.Prog: Acciaio_Flessione $\delta_c = 0.0cm$ Verifica: **Verificata**

Verifica spostamento nello stato finale (§4.2.4.2.1 - NTC 2008)

x	Comb.	δ_{max}	L/250.00	Cs
cm		mm	mm	
134.4	15	0.17	10.75	61.9

Verifica spostamento elastico dovuto ai soli carichi variabili (§4.2.4.2.1 - NTC 2008)

x	Comb.	δ_2	L/300.00	Cs
cm		mm	mm	
134.4	15	0.09	8.96	98.8

Travata: 919 [472 , 471]

L = 267.7cm

Crit.Prog: Acciaio_Flessione $\delta_c = 0.0cm$ Verifica: **Verificata**

Verifica spostamento nello stato finale (§4.2.4.2.1 - NTC 2008)

x	Comb.	δ_{max}	L/250.00	Cs
---	-------	----------------	----------	----

AUTOSTRADA VALDASTICO A31 NORD
1° LOTTO - PIOVENE ROCCHETTE – VALLE DELL'ASTICO

x	Comb.	δ_{max}	L/250.00	Cs
cm		mm	mm	
187.4	15	-0.03	10.71	>100

Verifica spostamento elastico dovuto ai soli carichi variabili (§4.2.4.2.1 - NTC 2008)

x	Comb.	δ_2	L/300.00	Cs
cm		mm	mm	
133.9	15	-0.03	8.92	>100

Travata: 920 [471 , 473]

L = 267.7cm

Crit.Prog: Acciaio_Flessione $\delta_c = 0.0cm$ Verifica: **Verificata**

Verifica spostamento nello stato finale (§4.2.4.2.1 - NTC 2008)

x	Comb.	δ_{max}	L/250.00	Cs
cm		mm	mm	
133.9	15	0.12	10.71	87.7

Verifica spostamento elastico dovuto ai soli carichi variabili (§4.2.4.2.1 - NTC 2008)

x	Comb.	δ_2	L/300.00	Cs
cm		mm	mm	
133.9	15	0.06	8.92	>100

Travata: 921 [398 , 399]

L = 314.0cm

Crit.Prog: Acciaio_Flessione $\delta_c = 0.0cm$ Verifica: **Verificata**

Verifica spostamento nello stato finale (§4.2.4.2.1 - NTC 2008)

x	Comb.	δ_{max}	L/250.00	Cs
---	-------	----------------	----------	----

AUTOSTRADA VALDASTICO A31 NORD
1° LOTTO - PIOVENE ROCCHETTE – VALLE DELL'ASTICO

x	Comb.	δ_{max}	L/250.00	Cs
cm		mm	mm	
219.8	15	-1.12	12.56	11.2

Verifica spostamento elastico dovuto ai soli carichi variabili (§4.2.4.2.1 - NTC 2008)

x	Comb.	δ_2	L/300.00	Cs
cm		mm	mm	
219.8	15	-0.71	10.47	14.8

Travata: 922 [399 , 453]

L = 263.5cm

Crit.Prog: Acciaio_Flessione $\delta_c = 0.0cm$ Verifica: **Verificata**

Verifica spostamento nello stato finale (§4.2.4.2.1 - NTC 2008)

x	Comb.	δ_{max}	L/250.00	Cs
cm		mm	mm	
79.0	15	-0.47	10.54	22.3

Verifica spostamento elastico dovuto ai soli carichi variabili (§4.2.4.2.1 - NTC 2008)

x	Comb.	δ_2	L/300.00	Cs
cm		mm	mm	
79.0	15	-0.26	8.78	34.1

Travata: 923 [453 , 455]

L = 314.0cm

Crit.Prog: Acciaio_Flessione $\delta_c = 0.0cm$ Verifica: **Verificata**

Verifica spostamento nello stato finale (§4.2.4.2.1 - NTC 2008)

x	Comb.	δ_{max}	L/250.00	Cs
---	-------	----------------	----------	----

AUTOSTRADA VALDASTICO A31 NORD
1° LOTTO - PIOVENE ROCCHETTE – VALLE DELL'ASTICO

x	Comb.	δ_{max}	L/250.00	Cs
cm		mm	mm	
62.8	15	-0.10	12.56	>100

Verifica spostamento elastico dovuto ai soli carichi variabili (§4.2.4.2.1 - NTC 2008)

x	Comb.	δ_2	L/300.00	Cs
cm		mm	mm	
94.2	15	-0.08	10.47	>100

Travata: 924 [398 , 467]

L = 248.2cm

Crit.Prog: Acciaio_Flessione $\delta_c = 0.0cm$ Verifica: **Verificata**

Verifica spostamento nello stato finale (§4.2.4.2.1 - NTC 2008)

x	Comb.	δ_{max}	L/250.00	Cs
cm		mm	mm	
124.1	15	-0.14	9.93	73.0

Verifica spostamento elastico dovuto ai soli carichi variabili (§4.2.4.2.1 - NTC 2008)

x	Comb.	δ_2	L/300.00	Cs
cm		mm	mm	
124.1	15	-0.09	8.27	93.1

Travata: 925 [467 , 399]

L = 248.2cm

Crit.Prog: Acciaio_Flessione $\delta_c = 0.0cm$ Verifica: **Verificata**

Verifica spostamento nello stato finale (§4.2.4.2.1 - NTC 2008)

x	Comb.	δ_{max}	L/250.00	Cs
---	-------	----------------	----------	----

AUTOSTRADA VALDASTICO A31 NORD
1° LOTTO - PIOVENE ROCCHETTE – VALLE DELL'ASTICO

x	Comb.	δ_{max}	L/250.00	Cs
cm		mm	mm	
173.7	15	-0.63	9.93	15.8

Verifica spostamento elastico dovuto ai soli carichi variabili (§4.2.4.2.1 - NTC 2008)

x	Comb.	δ_2	L/300.00	Cs
cm		mm	mm	
173.7	15	-0.37	8.27	22.1

Travata: 926 [453 , 467]

L = 248.2cm

Crit.Prog: Acciaio_Flessione $\delta_c = 0.0cm$ Verifica: **Verificata**

Verifica spostamento nello stato finale (§4.2.4.2.1 - NTC 2008)

x	Comb.	δ_{max}	L/250.00	Cs
cm		mm	mm	
124.1	15	-0.25	9.93	40.2

Verifica spostamento elastico dovuto ai soli carichi variabili (§4.2.4.2.1 - NTC 2008)

x	Comb.	δ_2	L/300.00	Cs
cm		mm	mm	
124.1	15	-0.15	8.27	54.5

Travata: 927 [467 , 455]

L = 248.2cm

Crit.Prog: Acciaio_Flessione $\delta_c = 0.0cm$ Verifica: **Verificata**

Verifica spostamento nello stato finale (§4.2.4.2.1 - NTC 2008)

x	Comb.	δ_{max}	L/250.00	Cs
---	-------	----------------	----------	----

AUTOSTRADA VALDASTICO A31 NORD
1° LOTTO - PIOVENE ROCCHETTE – VALLE DELL'ASTICO

x	Comb.	δ_{max}	L/250.00	Cs
cm		mm	mm	
124.1	15	0.20	9.93	49.6

Verifica spostamento elastico dovuto ai soli carichi variabili (§4.2.4.2.1 - NTC 2008)

x	Comb.	δ_2	L/300.00	Cs
cm		mm	mm	
124.1	15	0.11	8.27	73.5

Travata: 928 [453 , 470]

L = 263.5cm

Crit.Prog: Acciaio_Flessione $\delta_c = 0.0cm$ Verifica: **Verificata**

Verifica spostamento nello stato finale (§4.2.4.2.1 - NTC 2008)

x	Comb.	δ_{max}	L/250.00	Cs
cm		mm	mm	
131.8	15	0.18	10.54	60.1

Verifica spostamento elastico dovuto ai soli carichi variabili (§4.2.4.2.1 - NTC 2008)

x	Comb.	δ_2	L/300.00	Cs
cm		mm	mm	
131.8	15	0.07	8.78	>100

Travata: 929 [470 , 472]

L = 314.0cm

Crit.Prog: Acciaio_Flessione $\delta_c = 0.0cm$ Verifica: **Verificata**

Verifica spostamento nello stato finale (§4.2.4.2.1 - NTC 2008)

x	Comb.	δ_{max}	L/250.00	Cs
---	-------	----------------	----------	----

AUTOSTRADA VALDASTICO A31 NORD
1° LOTTO - PIOVENE ROCCHETTE – VALLE DELL'ASTICO

x	Comb.	δ_{max}	L/250.00	Cs
cm		mm	mm	
125.6	15	0.11	12.56	>100

Verifica spostamento elastico dovuto ai soli carichi variabili (§4.2.4.2.1 - NTC 2008)

x	Comb.	δ_2	L/300.00	Cs
cm		mm	mm	
94.2	15	0.03	10.47	>100

Travata: 930 [453 , 484]

L = 248.7cm

Crit.Prog: Acciaio_Flessione $\delta_c = 0.0cm$ Verifica: **Verificata**

Verifica spostamento nello stato finale (§4.2.4.2.1 - NTC 2008)

x	Comb.	δ_{max}	L/250.00	Cs
cm		mm	mm	
124.4	15	0.12	9.95	86.4

Verifica spostamento elastico dovuto ai soli carichi variabili (§4.2.4.2.1 - NTC 2008)

x	Comb.	δ_2	L/300.00	Cs
cm		mm	mm	
149.2	15	0.06	8.29	>100

Travata: 931 [484 , 455]

L = 248.7cm

Crit.Prog: Acciaio_Flessione $\delta_c = 0.0cm$ Verifica: **Verificata**

Verifica spostamento nello stato finale (§4.2.4.2.1 - NTC 2008)

x	Comb.	δ_{max}	L/250.00	Cs
---	-------	----------------	----------	----

AUTOSTRADA VALDASTICO A31 NORD
1° LOTTO - PIOVENE ROCCHETTE – VALLE DELL'ASTICO

x	Comb.	δ_{max}	L/250.00	Cs
cm		mm	mm	
124.4	15	-0.10	9.95	>100

Verifica spostamento elastico dovuto ai soli carichi variabili (§4.2.4.2.1 - NTC 2008)

x	Comb.	δ_2	L/300.00	Cs
cm		mm	mm	
124.4	15	-0.07	8.29	>100

Travata: 932 [470 , 484]

L = 247.7cm

Crit.Prog: Acciaio_Flessione $\delta_c = 0.0cm$ Verifica: **Verificata**

Verifica spostamento nello stato finale (§4.2.4.2.1 - NTC 2008)

x	Comb.	δ_{max}	L/250.00	Cs
cm		mm	mm	
173.4	15	-0.05	9.91	>100

Verifica spostamento elastico dovuto ai soli carichi variabili (§4.2.4.2.1 - NTC 2008)

x	Comb.	δ_2	L/300.00	Cs
cm		mm	mm	
148.6	15	-0.04	8.26	>100

Travata: 933 [484 , 472]

L = 247.7cm

Crit.Prog: Acciaio_Flessione $\delta_c = 0.0cm$ Verifica: **Verificata**

Verifica spostamento nello stato finale (§4.2.4.2.1 - NTC 2008)

x	Comb.	δ_{max}	L/250.00	Cs
---	-------	----------------	----------	----

AUTOSTRADA VALDASTICO A31 NORD
1° LOTTO - PIOVENE ROCCHETTE – VALLE DELL'ASTICO

x	Comb.	δ_{max}	L/250.00	Cs
cm		mm	mm	
123.8	15	0.15	9.91	67.8

Verifica spostamento elastico dovuto ai soli carichi variabili (§4.2.4.2.1 - NTC 2008)

x	Comb.	δ_2	L/300.00	Cs
cm		mm	mm	
123.8	15	0.07	8.26	>100

Travata: 934 [399 , 400]

L = 314.0cm

Crit.Prog: Acciaio_Flessione $\delta_c = 0.0cm$ Verifica: **Verificata**

Verifica spostamento nello stato finale (§4.2.4.2.1 - NTC 2008)

x	Comb.	δ_{max}	L/250.00	Cs
cm		mm	mm	
125.6	15	0.09	12.56	>100

Verifica spostamento elastico dovuto ai soli carichi variabili (§4.2.4.2.1 - NTC 2008)

x	Comb.	δ_2	L/300.00	Cs
cm		mm	mm	
62.8	15	0.04	10.47	>100

Travata: 935 [400 , 452]

L = 263.5cm

Crit.Prog: Acciaio_Flessione $\delta_c = 0.0cm$ Verifica: **Verificata**

Verifica spostamento nello stato finale (§4.2.4.2.1 - NTC 2008)

x	Comb.	δ_{max}	L/250.00	Cs
---	-------	----------------	----------	----

AUTOSTRADA VALDASTICO A31 NORD
1° LOTTO - PIOVENE ROCCHETTE – VALLE DELL'ASTICO

x	Comb.	δ_{max}	L/250.00	Cs
cm		mm	mm	
131.7	15	-0.19	10.54	55.7

Verifica spostamento elastico dovuto ai soli carichi variabili (§4.2.4.2.1 - NTC 2008)

x	Comb.	δ_2	L/300.00	Cs
cm		mm	mm	
158.1	15	-0.10	8.78	86.3

Travata: 936 [452 , 453]

L = 314.0cm

Crit.Prog: Acciaio_Flessione $\delta_c = 0.0cm$ Verifica: **Verificata**

Verifica spostamento nello stato finale (§4.2.4.2.1 - NTC 2008)

x	Comb.	δ_{max}	L/250.00	Cs
cm		mm	mm	
188.4	15	-0.15	12.56	83.1

Verifica spostamento elastico dovuto ai soli carichi variabili (§4.2.4.2.1 - NTC 2008)

x	Comb.	δ_2	L/300.00	Cs
cm		mm	mm	
157.0	15	-0.13	10.47	79.4

Travata: 937 [400 , 468]

L = 223.0cm

Crit.Prog: Acciaio_Flessione $\delta_c = 0.0cm$ Verifica: **Verificata**

Verifica spostamento nello stato finale (§4.2.4.2.1 - NTC 2008)

x	Comb.	δ_{max}	L/250.00	Cs
---	-------	----------------	----------	----

AUTOSTRADA VALDASTICO A31 NORD
1° LOTTO - PIOVENE ROCCHETTE – VALLE DELL'ASTICO

x	Comb.	δ_{max}	L/250.00	Cs
cm		mm	mm	
133.8	15	-0.28	8.92	32.0

Verifica spostamento elastico dovuto ai soli carichi variabili (§4.2.4.2.1 - NTC 2008)

x	Comb.	δ_2	L/300.00	Cs
cm		mm	mm	
133.8	15	-0.18	7.43	40.4

Travata: 938 [468 , 399]

L = 223.0cm

Crit.Prog: Acciaio_Flessione $\delta_c = 0.0cm$ Verifica: **Verificata**

Verifica spostamento nello stato finale (§4.2.4.2.1 - NTC 2008)

x	Comb.	δ_{max}	L/250.00	Cs
cm		mm	mm	
66.9	15	0.11	8.92	80.8

Verifica spostamento elastico dovuto ai soli carichi variabili (§4.2.4.2.1 - NTC 2008)

x	Comb.	δ_2	L/300.00	Cs
cm		mm	mm	
89.2	15	0.09	7.43	84.2

Travata: 939 [452 , 468]

L = 223.0cm

Crit.Prog: Acciaio_Flessione $\delta_c = 0.0cm$ Verifica: **Verificata**

Verifica spostamento nello stato finale (§4.2.4.2.1 - NTC 2008)

x	Comb.	δ_{max}	L/250.00	Cs
---	-------	----------------	----------	----

AUTOSTRADA VALDASTICO A31 NORD
1° LOTTO - PIOVENE ROCCHETTE – VALLE DELL'ASTICO

x	Comb.	δ_{max}	L/250.00	Cs
cm		mm	mm	
178.4	15	-0.05	8.92	>100

Verifica spostamento elastico dovuto ai soli carichi variabili (§4.2.4.2.1 - NTC 2008)

x	Comb.	δ_2	L/300.00	Cs
cm		mm	mm	
156.1	15	-0.05	7.43	>100

Travata: 940 [468 , 453]

L = 223.0cm

Crit.Prog: Acciaio_Flessione $\delta_c = 0.0cm$ Verifica: **Verificata**

Verifica spostamento nello stato finale (§4.2.4.2.1 - NTC 2008)

x	Comb.	δ_{max}	L/250.00	Cs
cm		mm	mm	
111.5	15	-0.14	8.92	63.1

Verifica spostamento elastico dovuto ai soli carichi variabili (§4.2.4.2.1 - NTC 2008)

x	Comb.	δ_2	L/300.00	Cs
cm		mm	mm	
111.5	15	-0.07	7.43	99.9

Travata: 941 [452 , 469]

L = 263.5cm

Crit.Prog: Acciaio_Flessione $\delta_c = 0.0cm$ Verifica: **Verificata**

Verifica spostamento nello stato finale (§4.2.4.2.1 - NTC 2008)

x	Comb.	δ_{max}	L/250.00	Cs
---	-------	----------------	----------	----

AUTOSTRADA VALDASTICO A31 NORD
1° LOTTO - PIOVENE ROCCHETTE – VALLE DELL'ASTICO

x	Comb.	δ_{max}	L/250.00	Cs
cm		mm	mm	
158.1	17	0.06	10.54	>100

Verifica spostamento elastico dovuto ai soli carichi variabili (§4.2.4.2.1 - NTC 2008)

x	Comb.	δ_2	L/300.00	Cs
cm		mm	mm	
79.1	15	-0.03	8.78	>100

Travata: 942 [469 , 470]

L = 314.0cm

Crit.Prog: Acciaio_Flessione $\delta_c = 0.0cm$ Verifica: **Verificata**

Verifica spostamento nello stato finale (§4.2.4.2.1 - NTC 2008)

x	Comb.	δ_{max}	L/250.00	Cs
cm		mm	mm	
157.0	21	0.09	12.56	>100

Verifica spostamento elastico dovuto ai soli carichi variabili (§4.2.4.2.1 - NTC 2008)

x	Comb.	δ_2	L/300.00	Cs
cm		mm	mm	
94.2	15	-0.02	10.47	>100

Travata: 943 [452 , 485]

L = 223.6cm

Crit.Prog: Acciaio_Flessione $\delta_c = 0.0cm$ Verifica: **Verificata**

Verifica spostamento nello stato finale (§4.2.4.2.1 - NTC 2008)

x	Comb.	δ_{max}	L/250.00	Cs
---	-------	----------------	----------	----

AUTOSTRADA VALDASTICO A31 NORD
1° LOTTO - PIOVENE ROCCHETTE – VALLE DELL'ASTICO

x	Comb.	δ_{max}	L/250.00	Cs
cm		mm	mm	
111.8	15	-0.13	8.95	69.4

Verifica spostamento elastico dovuto ai soli carichi variabili (§4.2.4.2.1 - NTC 2008)

x	Comb.	δ_2	L/300.00	Cs
cm		mm	mm	
111.8	15	-0.10	7.45	76.8

Travata: 944 [485 , 453]

L = 223.6cm

Crit.Prog: Acciaio_Flessione $\delta_c = 0.0cm$ Verifica: **Verificata**

Verifica spostamento nello stato finale (§4.2.4.2.1 - NTC 2008)

x	Comb.	δ_{max}	L/250.00	Cs
cm		mm	mm	
89.5	15	0.04	8.95	>100

Verifica spostamento elastico dovuto ai soli carichi variabili (§4.2.4.2.1 - NTC 2008)

x	Comb.	δ_2	L/300.00	Cs
cm		mm	mm	
67.1	15	0.02	7.45	>100

Travata: 945 [469 , 485]

L = 222.5cm

Crit.Prog: Acciaio_Flessione $\delta_c = 0.0cm$ Verifica: **Verificata**

Verifica spostamento nello stato finale (§4.2.4.2.1 - NTC 2008)

x	Comb.	δ_{max}	L/250.00	Cs
---	-------	----------------	----------	----

AUTOSTRADA VALDASTICO A31 NORD
1° LOTTO - PIOVENE ROCCHETTE – VALLE DELL'ASTICO

x	Comb.	δ_{max}	L/250.00	Cs
cm		mm	mm	
89.0	15	0.05	8.90	>100

Verifica spostamento elastico dovuto ai soli carichi variabili (§4.2.4.2.1 - NTC 2008)

x	Comb.	δ_2	L/300.00	Cs
cm		mm	mm	
178.0	15	-0.01	7.42	>100

Travata: 946 [485 , 470]

L = 222.5cm

Crit.Prog: Acciaio_Flessione $\delta_c = 0.0cm$ Verifica: **Verificata**

Verifica spostamento nello stato finale (§4.2.4.2.1 - NTC 2008)

x	Comb.	δ_{max}	L/250.00	Cs
cm		mm	mm	
111.2	15	0.08	8.90	>100

Verifica spostamento elastico dovuto ai soli carichi variabili (§4.2.4.2.1 - NTC 2008)

x	Comb.	δ_2	L/300.00	Cs
cm		mm	mm	
89.0	15	0.04	7.42	>100

Travata: 947 [462 , 463]

L = 318.3cm

Crit.Prog: Acciaio_Flessione $\delta_c = 0.0cm$ Verifica: **Verificata**

Verifica spostamento nello stato finale (§4.2.4.2.1 - NTC 2008)

x	Comb.	δ_{max}	L/250.00	Cs
---	-------	----------------	----------	----

AUTOSTRADA VALDASTICO A31 NORD
1° LOTTO - PIOVENE ROCCHETTE – VALLE DELL'ASTICO

x	Comb.	δ_{max}	L/250.00	Cs
cm		mm	mm	
159.1	15	1.88	12.73	6.78

Verifica spostamento elastico dovuto ai soli carichi variabili (§4.2.4.2.1 - NTC 2008)

x	Comb.	δ_2	L/300.00	Cs
cm		mm	mm	
159.1	15	1.47	10.61	7.22

Travata: 948 [463 , 464]

L = 315.7cm

Crit.Prog: Acciaio_Flessione $\delta_c = 0.0cm$ Verifica: **Verificata**

Verifica spostamento nello stato finale (§4.2.4.2.1 - NTC 2008)

x	Comb.	δ_{max}	L/250.00	Cs
cm		mm	mm	
157.9	15	2.60	12.63	4.86

Verifica spostamento elastico dovuto ai soli carichi variabili (§4.2.4.2.1 - NTC 2008)

x	Comb.	δ_2	L/300.00	Cs
cm		mm	mm	
157.9	15	1.87	10.52	5.61

Travata: 949 [464 , 465]

L = 314.2cm

Crit.Prog: Acciaio_Flessione $\delta_c = 0.0cm$ Verifica: **Verificata**

Verifica spostamento nello stato finale (§4.2.4.2.1 - NTC 2008)

x	Comb.	δ_{max}	L/250.00	Cs
---	-------	----------------	----------	----

AUTOSTRADA VALDASTICO A31 NORD
1° LOTTO - PIOVENE ROCCHETTE – VALLE DELL'ASTICO

x	Comb.	δ_{max}	L/250.00	Cs
cm		mm	mm	
157.1	15	2.61	12.57	4.82

Verifica spostamento elastico dovuto ai soli carichi variabili (§4.2.4.2.1 - NTC 2008)

x	Comb.	δ_2	L/300.00	Cs
cm		mm	mm	
157.1	15	1.88	10.47	5.58

Travata: 950 [465 , 466]

L = 314.0cm

Crit.Prog: Acciaio_Flessione $\delta_c = 0.0cm$ Verifica: **Verificata**

Verifica spostamento nello stato finale (§4.2.4.2.1 - NTC 2008)

x	Comb.	δ_{max}	L/250.00	Cs
cm		mm	mm	
157.0	15	2.62	12.56	4.79

Verifica spostamento elastico dovuto ai soli carichi variabili (§4.2.4.2.1 - NTC 2008)

x	Comb.	δ_2	L/300.00	Cs
cm		mm	mm	
157.0	15	1.89	10.47	5.55

Travata: 951 [466 , 454]

L = 314.2cm

Crit.Prog: Acciaio_Flessione $\delta_c = 0.0cm$ Verifica: **Verificata**

Verifica spostamento nello stato finale (§4.2.4.2.1 - NTC 2008)

x	Comb.	δ_{max}	L/250.00	Cs
---	-------	----------------	----------	----

AUTOSTRADA VALDASTICO A31 NORD
1° LOTTO - PIOVENE ROCCHETTE – VALLE DELL'ASTICO

x	Comb.	δ_{max}	L/250.00	Cs
cm		mm	mm	
157.1	15	2.61	12.57	4.82

Verifica spostamento elastico dovuto ai soli carichi variabili (§4.2.4.2.1 - NTC 2008)

x	Comb.	δ_2	L/300.00	Cs
cm		mm	mm	
157.1	15	1.88	10.47	5.58

Travata: 952 [454 , 467]

L = 315.7cm

Crit.Prog: Acciaio_Flessione $\delta_c = 0.0cm$ Verifica: **Verificata**

Verifica spostamento nello stato finale (§4.2.4.2.1 - NTC 2008)

x	Comb.	δ_{max}	L/250.00	Cs
cm		mm	mm	
157.9	15	2.60	12.63	4.86

Verifica spostamento elastico dovuto ai soli carichi variabili (§4.2.4.2.1 - NTC 2008)

x	Comb.	δ_2	L/300.00	Cs
cm		mm	mm	
157.9	15	1.87	10.52	5.62

Travata: 953 [467 , 468]

L = 318.3cm

Crit.Prog: Acciaio_Flessione $\delta_c = 0.0cm$ Verifica: **Verificata**

Verifica spostamento nello stato finale (§4.2.4.2.1 - NTC 2008)

x	Comb.	δ_{max}	L/250.00	Cs
---	-------	----------------	----------	----

AUTOSTRADA VALDASTICO A31 NORD
1° LOTTO - PIOVENE ROCCHETTE – VALLE DELL'ASTICO

x	Comb.	δ_{max}	L/250.00	Cs
cm		mm	mm	
159.1	15	1.86	12.73	6.84

Verifica spostamento elastico dovuto ai soli carichi variabili (§4.2.4.2.1 - NTC 2008)

x	Comb.	δ_2	L/300.00	Cs
cm		mm	mm	
159.1	15	1.47	10.61	7.23

Travata: 954 [479 , 480]

L = 318.3cm

Crit.Prog: Acciaio_Flessione $\delta_c = 0.0cm$ Verifica: **Verificata**

Verifica spostamento nello stato finale (§4.2.4.2.1 - NTC 2008)

x	Comb.	δ_{max}	L/250.00	Cs
cm		mm	mm	
159.1	15	1.17	12.73	10.9

Verifica spostamento elastico dovuto ai soli carichi variabili (§4.2.4.2.1 - NTC 2008)

x	Comb.	δ_2	L/300.00	Cs
cm		mm	mm	
159.1	15	0.85	10.61	12.5

Travata: 955 [480 , 481]

L = 315.7cm

Crit.Prog: Acciaio_Flessione $\delta_c = 0.0cm$ Verifica: **Verificata**

Verifica spostamento nello stato finale (§4.2.4.2.1 - NTC 2008)

x	Comb.	δ_{max}	L/250.00	Cs
---	-------	----------------	----------	----

AUTOSTRADA VALDASTICO A31 NORD
1° LOTTO - PIOVENE ROCCHETTE – VALLE DELL'ASTICO

x	Comb.	δ_{max}	L/250.00	Cs
cm		mm	mm	
157.9	15	1.26	12.63	10.0

Verifica spostamento elastico dovuto ai soli carichi variabili (§4.2.4.2.1 - NTC 2008)

x	Comb.	δ_2	L/300.00	Cs
cm		mm	mm	
157.9	15	0.89	10.52	11.8

Travata: 956 [481 , 482]

L = 314.2cm

Crit.Prog: Acciaio_Flessione $\delta_c = 0.0cm$ Verifica: **Verificata**

Verifica spostamento nello stato finale (§4.2.4.2.1 - NTC 2008)

x	Comb.	δ_{max}	L/250.00	Cs
cm		mm	mm	
157.1	15	1.37	12.57	9.20

Verifica spostamento elastico dovuto ai soli carichi variabili (§4.2.4.2.1 - NTC 2008)

x	Comb.	δ_2	L/300.00	Cs
cm		mm	mm	
157.1	15	0.96	10.47	11.0

Travata: 957 [482 , 483]

L = 314.0cm

Crit.Prog: Acciaio_Flessione $\delta_c = 0.0cm$ Verifica: **Verificata**

Verifica spostamento nello stato finale (§4.2.4.2.1 - NTC 2008)

x	Comb.	δ_{max}	L/250.00	Cs
---	-------	----------------	----------	----

AUTOSTRADA VALDASTICO A31 NORD
1° LOTTO - PIOVENE ROCCHETTE – VALLE DELL'ASTICO

x	Comb.	δ_{max}	L/250.00	Cs
cm		mm	mm	
157.0	15	1.40	12.56	8.95

Verifica spostamento elastico dovuto ai soli carichi variabili (§4.2.4.2.1 - NTC 2008)

x	Comb.	δ_2	L/300.00	Cs
cm		mm	mm	
157.0	15	0.98	10.47	10.7

Travata: 958 [483 , 471]

L = 314.2cm

Crit.Prog: Acciaio_Flessione $\delta_c = 0.0cm$ Verifica: **Verificata**

Verifica spostamento nello stato finale (§4.2.4.2.1 - NTC 2008)

x	Comb.	δ_{max}	L/250.00	Cs
cm		mm	mm	
157.1	15	1.37	12.57	9.21

Verifica spostamento elastico dovuto ai soli carichi variabili (§4.2.4.2.1 - NTC 2008)

x	Comb.	δ_2	L/300.00	Cs
cm		mm	mm	
157.1	15	0.96	10.47	11.0

Travata: 959 [471 , 484]

L = 315.7cm

Crit.Prog: Acciaio_Flessione $\delta_c = 0.0cm$ Verifica: **Verificata**

Verifica spostamento nello stato finale (§4.2.4.2.1 - NTC 2008)

x	Comb.	δ_{max}	L/250.00	Cs
---	-------	----------------	----------	----

AUTOSTRADA VALDASTICO A31 NORD
1° LOTTO - PIOVENE ROCCHETTE – VALLE DELL'ASTICO

x	Comb.	δ_{max}	L/250.00	Cs
cm		mm	mm	
157.9	15	1.26	12.63	10.0

Verifica spostamento elastico dovuto ai soli carichi variabili (§4.2.4.2.1 - NTC 2008)

x	Comb.	δ_2	L/300.00	Cs
cm		mm	mm	
157.9	15	0.89	10.52	11.8

Travata: 960 [484 , 485]

$L = 318.3\text{cm}$

Crit.Prog: Acciaio_Flessione $\delta_c = 0.0\text{cm}$ Verifica: **Verificata**

Verifica spostamento nello stato finale (§4.2.4.2.1 - NTC 2008)

x	Comb.	δ_{max}	L/250.00	Cs
cm		mm	mm	
159.1	15	1.16	12.73	10.9

Verifica spostamento elastico dovuto ai soli carichi variabili (§4.2.4.2.1 - NTC 2008)

x	Comb.	δ_2	L/300.00	Cs
cm		mm	mm	
159.1	15	0.85	10.61	12.5

Travata: 961 [416 , 428]

$L = 247.0\text{cm}$

Crit.Prog: Acciaio_Flessione $\delta_c = 0.0\text{cm}$ Verifica: **Verificata**

Verifica spostamento nello stato finale (§4.2.4.2.1 - NTC 2008)

x	Comb.	δ_{max}	L/250.00	Cs
---	-------	----------------	----------	----

AUTOSTRADA VALDASTICO A31 NORD
1° LOTTO - PIOVENE ROCCHETTE – VALLE DELL'ASTICO

x	Comb.	δ_{max}	L/250.00	Cs
cm		mm	mm	
98.8	15	0.05	9.88	>100

Verifica spostamento elastico dovuto ai soli carichi variabili (§4.2.4.2.1 - NTC 2008)

x	Comb.	δ_2	L/300.00	Cs
cm		mm	mm	
123.5	15	0.02	8.23	>100

Travata: 962 [428 , 444]

L = 247.0cm

Crit.Prog: Acciaio_Flessione $\delta_c = 0.0cm$ Verifica: **Verificata**

Verifica spostamento nello stato finale (§4.2.4.2.1 - NTC 2008)

x	Comb.	δ_{max}	L/250.00	Cs
cm		mm	mm	
172.9	15	-0.31	9.88	31.5

Verifica spostamento elastico dovuto ai soli carichi variabili (§4.2.4.2.1 - NTC 2008)

x	Comb.	δ_2	L/300.00	Cs
cm		mm	mm	
172.9	15	-0.20	8.23	41.7

Travata: 963 [444 , 203]

L = 266.5cm

Crit.Prog: Acciaio_Flessione $\delta_c = 0.0cm$ Verifica: **Verificata**

Verifica spostamento nello stato finale (§4.2.4.2.1 - NTC 2008)

x	Comb.	δ_{max}	L/250.00	Cs
---	-------	----------------	----------	----

AUTOSTRADA VALDASTICO A31 NORD
1° LOTTO - PIOVENE ROCCHETTE – VALLE DELL'ASTICO

x	Comb.	δ_{max}	L/250.00	Cs
cm		mm	mm	
133.2	15	-0.91	10.66	11.7

Verifica spostamento elastico dovuto ai soli carichi variabili (§4.2.4.2.1 - NTC 2008)

x	Comb.	δ_2	L/300.00	Cs
cm		mm	mm	
133.2	15	-0.57	8.88	15.7

Travata: 964 [203 , 220]

L = 286.0cm

Crit.Prog: Acciaio_Flessione $\delta_c = 0.0cm$ Verifica: **Verificata**

Verifica spostamento nello stato finale (§4.2.4.2.1 - NTC 2008)

x	Comb.	δ_{max}	L/250.00	Cs
cm		mm	mm	
85.8	15	-0.19	11.44	60.6

Verifica spostamento elastico dovuto ai soli carichi variabili (§4.2.4.2.1 - NTC 2008)

x	Comb.	δ_2	L/300.00	Cs
cm		mm	mm	
85.8	15	-0.11	9.53	84.4

Travata: 965 [220 , 237]

L = 286.0cm

Crit.Prog: Acciaio_Flessione $\delta_c = 0.0cm$ Verifica: **Verificata**

Verifica spostamento nello stato finale (§4.2.4.2.1 - NTC 2008)

x	Comb.	δ_{max}	L/250.00	Cs
---	-------	----------------	----------	----

AUTOSTRADA VALDASTICO A31 NORD
1° LOTTO - PIOVENE ROCCHETTE – VALLE DELL'ASTICO

x	Comb.	δ_{max}	L/250.00	Cs
cm		mm	mm	
143.0	15	0.36	11.44	31.6

Verifica spostamento elastico dovuto ai soli carichi variabili (§4.2.4.2.1 - NTC 2008)

x	Comb.	δ_2	L/300.00	Cs
cm		mm	mm	
143.0	15	0.21	9.53	45.7

Travata: 966 [237 , 254]

L = 286.0cm

Crit.Prog: Acciaio_Flessione $\delta_c = 0.0cm$ Verifica: **Verificata**

Verifica spostamento nello stato finale (§4.2.4.2.1 - NTC 2008)

x	Comb.	δ_{max}	L/250.00	Cs
cm		mm	mm	
85.8	15	0.17	11.44	67.9

Verifica spostamento elastico dovuto ai soli carichi variabili (§4.2.4.2.1 - NTC 2008)

x	Comb.	δ_2	L/300.00	Cs
cm		mm	mm	
85.8	15	0.09	9.53	>100

Travata: 967 [254 , 271]

L = 286.0cm

Crit.Prog: Acciaio_Flessione $\delta_c = 0.0cm$ Verifica: **Verificata**

Verifica spostamento nello stato finale (§4.2.4.2.1 - NTC 2008)

x	Comb.	δ_{max}	L/250.00	Cs
---	-------	----------------	----------	----

AUTOSTRADA VALDASTICO A31 NORD
1° LOTTO - PIOVENE ROCCHETTE – VALLE DELL'ASTICO

x	Comb.	δ_{max}	L/250.00	Cs
cm		mm	mm	
143.0	15	-0.51	11.44	22.3

Verifica spostamento elastico dovuto ai soli carichi variabili (§4.2.4.2.1 - NTC 2008)

x	Comb.	δ_2	L/300.00	Cs
cm		mm	mm	
143.0	15	-0.36	9.53	26.4

Travata: 968 [271 , 288]

L = 286.0cm

Crit.Prog: Acciaio_Flessione $\delta_c = 0.0cm$ Verifica: **Verificata**

Verifica spostamento nello stato finale (§4.2.4.2.1 - NTC 2008)

x	Comb.	δ_{max}	L/250.00	Cs
cm		mm	mm	
200.2	15	0.23	11.44	49.5

Verifica spostamento elastico dovuto ai soli carichi variabili (§4.2.4.2.1 - NTC 2008)

x	Comb.	δ_2	L/300.00	Cs
cm		mm	mm	
200.2	15	0.12	9.53	77.4

Travata: 969 [288 , 305]

L = 286.0cm

Crit.Prog: Acciaio_Flessione $\delta_c = 0.0cm$ Verifica: **Verificata**

Verifica spostamento nello stato finale (§4.2.4.2.1 - NTC 2008)

x	Comb.	δ_{max}	L/250.00	Cs
---	-------	----------------	----------	----

AUTOSTRADA VALDASTICO A31 NORD
1° LOTTO - PIOVENE ROCCHETTE – VALLE DELL'ASTICO

x	Comb.	δ_{max}	L/250.00	Cs
cm		mm	mm	
143.0	15	0.49	11.44	23.4

Verifica spostamento elastico dovuto ai soli carichi variabili (§4.2.4.2.1 - NTC 2008)

x	Comb.	δ_2	L/300.00	Cs
cm		mm	mm	
143.0	15	0.28	9.53	34.2

Travata: 970 [305 , 348]

L = 286.0cm

Crit.Prog: Acciaio_Flessione $\delta_c = 0.0cm$ Verifica: **Verificata**

Verifica spostamento nello stato finale (§4.2.4.2.1 - NTC 2008)

x	Comb.	δ_{max}	L/250.00	Cs
cm		mm	mm	
85.8	15	0.20	11.44	57.5

Verifica spostamento elastico dovuto ai soli carichi variabili (§4.2.4.2.1 - NTC 2008)

x	Comb.	δ_2	L/300.00	Cs
cm		mm	mm	
85.8	15	0.10	9.53	91.7

Travata: 971 [348 , 331]

L = 286.0cm

Crit.Prog: Acciaio_Flessione $\delta_c = 0.0cm$ Verifica: **Verificata**

Verifica spostamento nello stato finale (§4.2.4.2.1 - NTC 2008)

x	Comb.	δ_{max}	L/250.00	Cs
---	-------	----------------	----------	----

AUTOSTRADA VALDASTICO A31 NORD
1° LOTTO - PIOVENE ROCCHETTE – VALLE DELL'ASTICO

x	Comb.	δ_{max}	L/250.00	Cs
cm		mm	mm	
143.0	15	-0.61	11.44	18.7

Verifica spostamento elastico dovuto ai soli carichi variabili (§4.2.4.2.1 - NTC 2008)

x	Comb.	δ_2	L/300.00	Cs
cm		mm	mm	
143.0	15	-0.42	9.53	22.8

Travata: 972 [331 , 356]

L = 286.0cm

Crit.Prog: Acciaio_Flessione $\delta_c = 0.0cm$ Verifica: **Verificata**

Verifica spostamento nello stato finale (§4.2.4.2.1 - NTC 2008)

x	Comb.	δ_{max}	L/250.00	Cs
cm		mm	mm	
200.2	15	0.19	11.44	60.5

Verifica spostamento elastico dovuto ai soli carichi variabili (§4.2.4.2.1 - NTC 2008)

x	Comb.	δ_2	L/300.00	Cs
cm		mm	mm	
200.2	15	0.10	9.53	94.8

Travata: 973 [356 , 373]

L = 286.0cm

Crit.Prog: Acciaio_Flessione $\delta_c = 0.0cm$ Verifica: **Verificata**

Verifica spostamento nello stato finale (§4.2.4.2.1 - NTC 2008)

x	Comb.	δ_{max}	L/250.00	Cs
---	-------	----------------	----------	----

AUTOSTRADA VALDASTICO A31 NORD
1° LOTTO - PIOVENE ROCCHETTE – VALLE DELL'ASTICO

x	Comb.	δ_{max}	L/250.00	Cs
cm		mm	mm	
143.0	15	0.47	11.44	24.5

Verifica spostamento elastico dovuto ai soli carichi variabili (§4.2.4.2.1 - NTC 2008)

x	Comb.	δ_2	L/300.00	Cs
cm		mm	mm	
143.0	15	0.27	9.53	35.1

Travata: 974 [373 , 390]

$L = 286.0\text{cm}$

Crit.Prog: Acciaio_Flessione $\delta_c = 0.0\text{cm}$ Verifica: **Verificata**

Verifica spostamento nello stato finale (§4.2.4.2.1 - NTC 2008)

x	Comb.	δ_{max}	L/250.00	Cs
cm		mm	mm	
85.8	15	0.21	11.44	55.8

Verifica spostamento elastico dovuto ai soli carichi variabili (§4.2.4.2.1 - NTC 2008)

x	Comb.	δ_2	L/300.00	Cs
cm		mm	mm	
85.8	15	0.12	9.53	79.0

Travata: 975 [390 , 462]

$L = 274.8\text{cm}$

Crit.Prog: Acciaio_Flessione $\delta_c = 0.0\text{cm}$ Verifica: **Verificata**

Verifica spostamento nello stato finale (§4.2.4.2.1 - NTC 2008)

x	Comb.	δ_{max}	L/250.00	Cs
---	-------	----------------	----------	----

AUTOSTRADA VALDASTICO A31 NORD
1° LOTTO - PIOVENE ROCCHETTE – VALLE DELL'ASTICO

x	Comb.	δ_{max}	L/250.00	Cs
cm		mm	mm	
137.4	15	-0.52	10.99	21.1

Verifica spostamento elastico dovuto ai soli carichi variabili (§4.2.4.2.1 - NTC 2008)

x	Comb.	δ_2	L/300.00	Cs
cm		mm	mm	
137.4	15	-0.33	9.16	27.9

Travata: 976 [462 , 479]

L = 264.5cm

Crit.Prog: Acciaio_Flessione $\delta_c = 0.0cm$ Verifica: **Verificata**

Verifica spostamento nello stato finale (§4.2.4.2.1 - NTC 2008)

x	Comb.	δ_{max}	L/250.00	Cs
cm		mm	mm	
79.4	15	-0.11	10.58	99.7

Verifica spostamento elastico dovuto ai soli carichi variabili (§4.2.4.2.1 - NTC 2008)

x	Comb.	δ_2	L/300.00	Cs
cm		mm	mm	
79.4	15	-0.08	8.82	>100

Travata: 977 [415 , 429]

L = 247.0cm

Crit.Prog: Acciaio_Flessione $\delta_c = 0.0cm$ Verifica: **Verificata**

Verifica spostamento nello stato finale (§4.2.4.2.1 - NTC 2008)

x	Comb.	δ_{max}	L/250.00	Cs
---	-------	----------------	----------	----

AUTOSTRADA VALDASTICO A31 NORD
1° LOTTO - PIOVENE ROCCHETTE – VALLE DELL'ASTICO

x	Comb.	δ_{max}	L/250.00	Cs
cm		mm	mm	
98.8	15	0.05	9.88	>100

Verifica spostamento elastico dovuto ai soli carichi variabili (§4.2.4.2.1 - NTC 2008)

x	Comb.	δ_2	L/300.00	Cs
cm		mm	mm	
98.8	15	0.02	8.23	>100

Travata: 978 [429 , 445]

L = 247.0cm

Crit.Prog: Acciaio_Flessione $\delta_c = 0.0cm$ Verifica: **Verificata**

Verifica spostamento nello stato finale (§4.2.4.2.1 - NTC 2008)

x	Comb.	δ_{max}	L/250.00	Cs
cm		mm	mm	
172.9	15	-0.10	9.88	97.7

Verifica spostamento elastico dovuto ai soli carichi variabili (§4.2.4.2.1 - NTC 2008)

x	Comb.	δ_2	L/300.00	Cs
cm		mm	mm	
172.9	15	-0.07	8.23	>100

Travata: 979 [445 , 202]

L = 266.5cm

Crit.Prog: Acciaio_Flessione $\delta_c = 0.0cm$ Verifica: **Verificata**

Verifica spostamento nello stato finale (§4.2.4.2.1 - NTC 2008)

x	Comb.	δ_{max}	L/250.00	Cs
---	-------	----------------	----------	----

AUTOSTRADA VALDASTICO A31 NORD
1° LOTTO - PIOVENE ROCCHETTE – VALLE DELL'ASTICO

x	Comb.	δ_{max}	L/250.00	Cs
cm		mm	mm	
133.2	15	-0.83	10.66	12.9

Verifica spostamento elastico dovuto ai soli carichi variabili (§4.2.4.2.1 - NTC 2008)

x	Comb.	δ_2	L/300.00	Cs
cm		mm	mm	
133.2	15	-0.52	8.88	17.2

Travata: 980 [202 , 219]

L = 286.0cm

Crit.Prog: Acciaio_Flessione $\delta_c = 0.0cm$ Verifica: **Verificata**

Verifica spostamento nello stato finale (§4.2.4.2.1 - NTC 2008)

x	Comb.	δ_{max}	L/250.00	Cs
cm		mm	mm	
200.2	15	0.07	11.44	>100

Verifica spostamento elastico dovuto ai soli carichi variabili (§4.2.4.2.1 - NTC 2008)

x	Comb.	δ_2	L/300.00	Cs
cm		mm	mm	
228.8	15	0.04	9.53	>100

Travata: 981 [219 , 236]

L = 286.0cm

Crit.Prog: Acciaio_Flessione $\delta_c = 0.0cm$ Verifica: **Verificata**

Verifica spostamento nello stato finale (§4.2.4.2.1 - NTC 2008)

x	Comb.	δ_{max}	L/250.00	Cs
---	-------	----------------	----------	----

AUTOSTRADA VALDASTICO A31 NORD
1° LOTTO - PIOVENE ROCCHETTE – VALLE DELL'ASTICO

x	Comb.	δ_{max}	L/250.00	Cs
cm		mm	mm	
143.0	15	0.26	11.44	44.8

Verifica spostamento elastico dovuto ai soli carichi variabili (§4.2.4.2.1 - NTC 2008)

x	Comb.	δ_2	L/300.00	Cs
cm		mm	mm	
143.0	15	0.14	9.53	68.3

Travata: 982 [236 , 253]

L = 286.0cm

Crit.Prog: Acciaio_Flessione $\delta_c = 0.0cm$ Verifica: **Verificata**

Verifica spostamento nello stato finale (§4.2.4.2.1 - NTC 2008)

x	Comb.	δ_{max}	L/250.00	Cs
cm		mm	mm	
114.4	15	0.18	11.44	62.2

Verifica spostamento elastico dovuto ai soli carichi variabili (§4.2.4.2.1 - NTC 2008)

x	Comb.	δ_2	L/300.00	Cs
cm		mm	mm	
114.4	15	0.09	9.53	>100

Travata: 983 [253 , 270]

L = 286.0cm

Crit.Prog: Acciaio_Flessione $\delta_c = 0.0cm$ Verifica: **Verificata**

Verifica spostamento nello stato finale (§4.2.4.2.1 - NTC 2008)

x	Comb.	δ_{max}	L/250.00	Cs
---	-------	----------------	----------	----

AUTOSTRADA VALDASTICO A31 NORD
1° LOTTO - PIOVENE ROCCHETTE – VALLE DELL'ASTICO

x	Comb.	δ_{max}	L/250.00	Cs
cm		mm	mm	
143.0	15	-0.52	11.44	21.9

Verifica spostamento elastico dovuto ai soli carichi variabili (§4.2.4.2.1 - NTC 2008)

x	Comb.	δ_2	L/300.00	Cs
cm		mm	mm	
143.0	15	-0.36	9.53	26.2

Travata: 984 [270 , 287]

L = 286.0cm

Crit.Prog: Acciaio_Flessione $\delta_c = 0.0cm$ Verifica: **Verificata**

Verifica spostamento nello stato finale (§4.2.4.2.1 - NTC 2008)

x	Comb.	δ_{max}	L/250.00	Cs
cm		mm	mm	
171.6	15	0.24	11.44	47.7

Verifica spostamento elastico dovuto ai soli carichi variabili (§4.2.4.2.1 - NTC 2008)

x	Comb.	δ_2	L/300.00	Cs
cm		mm	mm	
171.6	15	0.13	9.53	75.9

Travata: 985 [287 , 304]

L = 286.0cm

Crit.Prog: Acciaio_Flessione $\delta_c = 0.0cm$ Verifica: **Verificata**

Verifica spostamento nello stato finale (§4.2.4.2.1 - NTC 2008)

x	Comb.	δ_{max}	L/250.00	Cs
---	-------	----------------	----------	----

AUTOSTRADA VALDASTICO A31 NORD
1° LOTTO - PIOVENE ROCCHETTE – VALLE DELL'ASTICO

x	Comb.	δ_{max}	L/250.00	Cs
cm		mm	mm	
143.0	15	0.35	11.44	32.8

Verifica spostamento elastico dovuto ai soli carichi variabili (§4.2.4.2.1 - NTC 2008)

x	Comb.	δ_2	L/300.00	Cs
cm		mm	mm	
143.0	15	0.19	9.53	49.9

Travata: 986 [304 , 347]

L = 286.0cm

Crit.Prog: Acciaio_Flessione $\delta_c = 0.0cm$ Verifica: **Verificata**

Verifica spostamento nello stato finale (§4.2.4.2.1 - NTC 2008)

x	Comb.	δ_{max}	L/250.00	Cs
cm		mm	mm	
114.4	15	0.23	11.44	50.1

Verifica spostamento elastico dovuto ai soli carichi variabili (§4.2.4.2.1 - NTC 2008)

x	Comb.	δ_2	L/300.00	Cs
cm		mm	mm	
114.4	15	0.12	9.53	80.2

Travata: 987 [347 , 330]

L = 286.0cm

Crit.Prog: Acciaio_Flessione $\delta_c = 0.0cm$ Verifica: **Verificata**

Verifica spostamento nello stato finale (§4.2.4.2.1 - NTC 2008)

x	Comb.	δ_{max}	L/250.00	Cs
---	-------	----------------	----------	----

AUTOSTRADA VALDASTICO A31 NORD
1° LOTTO - PIOVENE ROCCHETTE – VALLE DELL'ASTICO

x	Comb.	δ_{max}	L/250.00	Cs
cm		mm	mm	
143.0	15	-0.57	11.44	20.2

Verifica spostamento elastico dovuto ai soli carichi variabili (§4.2.4.2.1 - NTC 2008)

x	Comb.	δ_2	L/300.00	Cs
cm		mm	mm	
143.0	15	-0.39	9.53	24.5

Travata: 988 [330 , 355]

L = 286.0cm

Crit.Prog: Acciaio_Flessione $\delta_c = 0.0cm$ Verifica: **Verificata**

Verifica spostamento nello stato finale (§4.2.4.2.1 - NTC 2008)

x	Comb.	δ_{max}	L/250.00	Cs
cm		mm	mm	
171.6	15	0.23	11.44	50.6

Verifica spostamento elastico dovuto ai soli carichi variabili (§4.2.4.2.1 - NTC 2008)

x	Comb.	δ_2	L/300.00	Cs
cm		mm	mm	
171.6	15	0.12	9.53	79.7

Travata: 989 [355 , 372]

L = 286.0cm

Crit.Prog: Acciaio_Flessione $\delta_c = 0.0cm$ Verifica: **Verificata**

Verifica spostamento nello stato finale (§4.2.4.2.1 - NTC 2008)

x	Comb.	δ_{max}	L/250.00	Cs
---	-------	----------------	----------	----

AUTOSTRADA VALDASTICO A31 NORD
1° LOTTO - PIOVENE ROCCHETTE – VALLE DELL'ASTICO

x	Comb.	δ_{max}	L/250.00	Cs
cm		mm	mm	
143.0	15	0.34	11.44	33.5

Verifica spostamento elastico dovuto ai soli carichi variabili (§4.2.4.2.1 - NTC 2008)

x	Comb.	δ_2	L/300.00	Cs
cm		mm	mm	
143.0	15	0.19	9.53	50.0

Travata: 990 [372 , 389]

L = 286.0cm

Crit.Prog: Acciaio_Flessione $\delta_c = 0.0cm$ Verifica: **Verificata**

Verifica spostamento nello stato finale (§4.2.4.2.1 - NTC 2008)

x	Comb.	δ_{max}	L/250.00	Cs
cm		mm	mm	
114.4	15	0.22	11.44	50.9

Verifica spostamento elastico dovuto ai soli carichi variabili (§4.2.4.2.1 - NTC 2008)

x	Comb.	δ_2	L/300.00	Cs
cm		mm	mm	
114.4	15	0.12	9.53	76.3

Travata: 991 [389 , 463]

L = 274.8cm

Crit.Prog: Acciaio_Flessione $\delta_c = 0.0cm$ Verifica: **Verificata**

Verifica spostamento nello stato finale (§4.2.4.2.1 - NTC 2008)

x	Comb.	δ_{max}	L/250.00	Cs
---	-------	----------------	----------	----

AUTOSTRADA VALDASTICO A31 NORD
1° LOTTO - PIOVENE ROCCHETTE – VALLE DELL'ASTICO

x	Comb.	δ_{max}	L/250.00	Cs
cm		mm	mm	
137.4	15	-0.49	10.99	22.4

Verifica spostamento elastico dovuto ai soli carichi variabili (§4.2.4.2.1 - NTC 2008)

x	Comb.	δ_2	L/300.00	Cs
cm		mm	mm	
137.4	15	-0.31	9.16	29.3

Travata: 992 [463 , 480]

L = 264.5cm

Crit.Prog: Acciaio_Flessione $\delta_c = 0.0cm$ Verifica: **Verificata**

Verifica spostamento nello stato finale (§4.2.4.2.1 - NTC 2008)

x	Comb.	δ_{max}	L/250.00	Cs
cm		mm	mm	
185.2	15	0.05	10.58	>100

Verifica spostamento elastico dovuto ai soli carichi variabili (§4.2.4.2.1 - NTC 2008)

x	Comb.	δ_2	L/300.00	Cs
cm		mm	mm	
52.9	15	-0.01	8.82	>100

Travata: 993 [414 , 431]

L = 247.0cm

Crit.Prog: Acciaio_Flessione $\delta_c = 0.0cm$ Verifica: **Verificata**

Verifica spostamento nello stato finale (§4.2.4.2.1 - NTC 2008)

x	Comb.	δ_{max}	L/250.00	Cs
---	-------	----------------	----------	----

AUTOSTRADA VALDASTICO A31 NORD
1° LOTTO - PIOVENE ROCCHETTE – VALLE DELL'ASTICO

x	Comb.	δ_{max}	L/250.00	Cs
cm		mm	mm	
98.8	21	0.03	9.88	>100

Verifica spostamento elastico dovuto ai soli carichi variabili (§4.2.4.2.1 - NTC 2008)

x	Comb.	δ_2	L/300.00	Cs
cm		mm	mm	
172.9	15	-0.01	8.23	>100

Travata: 994 [431 , 446]

L = 247.0cm

Crit.Prog: Acciaio_Flessione $\delta_c = 0.0cm$ Verifica: **Verificata**

Verifica spostamento nello stato finale (§4.2.4.2.1 - NTC 2008)

x	Comb.	δ_{max}	L/250.00	Cs
cm		mm	mm	
172.9	15	-0.09	9.88	>100

Verifica spostamento elastico dovuto ai soli carichi variabili (§4.2.4.2.1 - NTC 2008)

x	Comb.	δ_2	L/300.00	Cs
cm		mm	mm	
148.2	15	-0.06	8.23	>100

Travata: 995 [446 , 201]

L = 266.5cm

Crit.Prog: Acciaio_Flessione $\delta_c = 0.0cm$ Verifica: **Verificata**

Verifica spostamento nello stato finale (§4.2.4.2.1 - NTC 2008)

x	Comb.	δ_{max}	L/250.00	Cs
---	-------	----------------	----------	----

AUTOSTRADA VALDASTICO A31 NORD
1° LOTTO - PIOVENE ROCCHETTE – VALLE DELL'ASTICO

x	Comb.	δ_{max}	L/250.00	Cs
cm		mm	mm	
133.2	15	-0.17	10.66	63.9

Verifica spostamento elastico dovuto ai soli carichi variabili (§4.2.4.2.1 - NTC 2008)

x	Comb.	δ_2	L/300.00	Cs
cm		mm	mm	
133.2	15	-0.11	8.88	78.7

Travata: 996 [201 , 218]

L = 286.0cm

Crit.Prog: Acciaio_Flessione $\delta_c = 0.0cm$ Verifica: **Verificata**

Verifica spostamento nello stato finale (§4.2.4.2.1 - NTC 2008)

x	Comb.	δ_{max}	L/250.00	Cs
cm		mm	mm	
85.8	15	-0.08	11.44	>100

Verifica spostamento elastico dovuto ai soli carichi variabili (§4.2.4.2.1 - NTC 2008)

x	Comb.	δ_2	L/300.00	Cs
cm		mm	mm	
114.4	15	-0.06	9.53	>100

Travata: 997 [218 , 235]

L = 286.0cm

Crit.Prog: Acciaio_Flessione $\delta_c = 0.0cm$ Verifica: **Verificata**

Verifica spostamento nello stato finale (§4.2.4.2.1 - NTC 2008)

x	Comb.	δ_{max}	L/250.00	Cs
---	-------	----------------	----------	----

AUTOSTRADA VALDASTICO A31 NORD
1° LOTTO - PIOVENE ROCCHETTE – VALLE DELL'ASTICO

x	Comb.	δ_{max}	L/250.00	Cs
cm		mm	mm	
171.6	15	0.04	11.44	>100

Verifica spostamento elastico dovuto ai soli carichi variabili (§4.2.4.2.1 - NTC 2008)

x	Comb.	δ_2	L/300.00	Cs
cm		mm	mm	
200.2	15	0.01	9.53	>100

Travata: 998 [235 , 252]

L = 286.0cm

Crit.Prog: Acciaio_Flessione $\delta_c = 0.0cm$ Verifica: **Verificata**

Verifica spostamento nello stato finale (§4.2.4.2.1 - NTC 2008)

x	Comb.	δ_{max}	L/250.00	Cs
cm		mm	mm	
143.0	21	0.03	11.44	>100

Verifica spostamento elastico dovuto ai soli carichi variabili (§4.2.4.2.1 - NTC 2008)

x	Comb.	δ_2	L/300.00	Cs
cm		mm	mm	
200.2	15	-0.02	9.53	>100

Travata: 999 [252 , 269]

L = 286.0cm

Crit.Prog: Acciaio_Flessione $\delta_c = 0.0cm$ Verifica: **Verificata**

Verifica spostamento nello stato finale (§4.2.4.2.1 - NTC 2008)

x	Comb.	δ_{max}	L/250.00	Cs
---	-------	----------------	----------	----

AUTOSTRADA VALDASTICO A31 NORD
1° LOTTO - PIOVENE ROCCHETTE – VALLE DELL'ASTICO

x	Comb.	δ_{max}	L/250.00	Cs
cm		mm	mm	
85.8	15	-0.04	11.44	>100

Verifica spostamento elastico dovuto ai soli carichi variabili (§4.2.4.2.1 - NTC 2008)

x	Comb.	δ_2	L/300.00	Cs
cm		mm	mm	
143.0	15	-0.05	9.53	>100

Travata: 1000 [269 , 286]

L = 286.0cm

Crit.Prog: Acciaio_Flessione $\delta_c = 0.0cm$ Verifica: **Verificata**

Verifica spostamento nello stato finale (§4.2.4.2.1 - NTC 2008)

x	Comb.	δ_{max}	L/250.00	Cs
cm		mm	mm	
171.6	15	0.06	11.44	>100

Verifica spostamento elastico dovuto ai soli carichi variabili (§4.2.4.2.1 - NTC 2008)

x	Comb.	δ_2	L/300.00	Cs
cm		mm	mm	
200.2	15	0.02	9.53	>100

Travata: 1001 [286 , 303]

L = 286.0cm

Crit.Prog: Acciaio_Flessione $\delta_c = 0.0cm$ Verifica: **Verificata**

Verifica spostamento nello stato finale (§4.2.4.2.1 - NTC 2008)

x	Comb.	δ_{max}	L/250.00	Cs
---	-------	----------------	----------	----

AUTOSTRADA VALDASTICO A31 NORD
1° LOTTO - PIOVENE ROCCHETTE – VALLE DELL'ASTICO

x	Comb.	δ_{max}	L/250.00	Cs
cm		mm	mm	
143.0	15	0.13	11.44	91.1

Verifica spostamento elastico dovuto ai soli carichi variabili (§4.2.4.2.1 - NTC 2008)

x	Comb.	δ_2	L/300.00	Cs
cm		mm	mm	
143.0	15	0.05	9.53	>100

Travata: 1002 [303 , 346]

L = 286.0cm

Crit.Prog: Acciaio_Flessione $\delta_c = 0.0cm$ Verifica: **Verificata**

Verifica spostamento nello stato finale (§4.2.4.2.1 - NTC 2008)

x	Comb.	δ_{max}	L/250.00	Cs
cm		mm	mm	
114.4	15	0.07	11.44	>100

Verifica spostamento elastico dovuto ai soli carichi variabili (§4.2.4.2.1 - NTC 2008)

x	Comb.	δ_2	L/300.00	Cs
cm		mm	mm	
85.8	15	0.02	9.53	>100

Travata: 1003 [346 , 329]

L = 286.0cm

Crit.Prog: Acciaio_Flessione $\delta_c = 0.0cm$ Verifica: **Verificata**

Verifica spostamento nello stato finale (§4.2.4.2.1 - NTC 2008)

x	Comb.	δ_{max}	L/250.00	Cs
---	-------	----------------	----------	----

AUTOSTRADA VALDASTICO A31 NORD
1° LOTTO - PIOVENE ROCCHETTE – VALLE DELL'ASTICO

x	Comb.	δ_{max}	L/250.00	Cs
cm		mm	mm	
57.2	15	-0.02	11.44	>100

Verifica spostamento elastico dovuto ai soli carichi variabili (§4.2.4.2.1 - NTC 2008)

x	Comb.	δ_2	L/300.00	Cs
cm		mm	mm	
143.0	15	-0.04	9.53	>100

Travata: 1004 [329 , 354]

L = 286.0cm

Crit.Prog: Acciaio_Flessione $\delta_c = 0.0cm$ Verifica: **Verificata**

Verifica spostamento nello stato finale (§4.2.4.2.1 - NTC 2008)

x	Comb.	δ_{max}	L/250.00	Cs
cm		mm	mm	
171.6	15	0.07	11.44	>100

Verifica spostamento elastico dovuto ai soli carichi variabili (§4.2.4.2.1 - NTC 2008)

x	Comb.	δ_2	L/300.00	Cs
cm		mm	mm	
200.2	15	0.03	9.53	>100

Travata: 1005 [354 , 371]

L = 286.0cm

Crit.Prog: Acciaio_Flessione $\delta_c = 0.0cm$ Verifica: **Verificata**

Verifica spostamento nello stato finale (§4.2.4.2.1 - NTC 2008)

x	Comb.	δ_{max}	L/250.00	Cs
---	-------	----------------	----------	----

AUTOSTRADA VALDASTICO A31 NORD
1° LOTTO - PIOVENE ROCCHETTE – VALLE DELL'ASTICO

x	Comb.	δ_{max}	L/250.00	Cs
cm		mm	mm	
143.0	15	0.14	11.44	83.7

Verifica spostamento elastico dovuto ai soli carichi variabili (§4.2.4.2.1 - NTC 2008)

x	Comb.	δ_2	L/300.00	Cs
cm		mm	mm	
143.0	15	0.06	9.53	>100

Travata: 1006 [371 , 388]

L = 286.0cm

Crit.Prog: Acciaio_Flessione $\delta_c = 0.0cm$ Verifica: **Verificata**

Verifica spostamento nello stato finale (§4.2.4.2.1 - NTC 2008)

x	Comb.	δ_{max}	L/250.00	Cs
cm		mm	mm	
114.4	15	0.08	11.44	>100

Verifica spostamento elastico dovuto ai soli carichi variabili (§4.2.4.2.1 - NTC 2008)

x	Comb.	δ_2	L/300.00	Cs
cm		mm	mm	
85.8	15	0.03	9.53	>100

Travata: 1007 [388 , 464]

L = 274.8cm

Crit.Prog: Acciaio_Flessione $\delta_c = 0.0cm$ Verifica: **Verificata**

Verifica spostamento nello stato finale (§4.2.4.2.1 - NTC 2008)

x	Comb.	δ_{max}	L/250.00	Cs
---	-------	----------------	----------	----

AUTOSTRADA VALDASTICO A31 NORD
1° LOTTO - PIOVENE ROCCHETTE – VALLE DELL'ASTICO

x	Comb.	δ_{max}	L/250.00	Cs
cm		mm	mm	
192.3	15	-0.03	10.99	>100

Verifica spostamento elastico dovuto ai soli carichi variabili (§4.2.4.2.1 - NTC 2008)

x	Comb.	δ_2	L/300.00	Cs
cm		mm	mm	
164.9	15	-0.03	9.16	>100

Travata: 1008 [464 , 481]

L = 264.5cm

Crit.Prog: Acciaio_Flessione $\delta_c = 0.0cm$ Verifica: **Verificata**

Verifica spostamento nello stato finale (§4.2.4.2.1 - NTC 2008)

x	Comb.	δ_{max}	L/250.00	Cs
cm		mm	mm	
158.7	17	0.03	10.58	>100

Verifica spostamento elastico dovuto ai soli carichi variabili (§4.2.4.2.1 - NTC 2008)

x	Comb.	δ_2	L/300.00	Cs
cm		mm	mm	
105.8	15	-0.02	8.82	>100

Travata: 1009 [413 , 434]

L = 247.0cm

Crit.Prog: Acciaio_Flessione $\delta_c = 0.0cm$ Verifica: **Verificata**

Verifica spostamento nello stato finale (§4.2.4.2.1 - NTC 2008)

x	Comb.	δ_{max}	L/250.00	Cs
---	-------	----------------	----------	----

AUTOSTRADA VALDASTICO A31 NORD
1° LOTTO - PIOVENE ROCCHETTE – VALLE DELL'ASTICO

x	Comb.	δ_{max}	L/250.00	Cs
cm		mm	mm	
123.5	21	0.03	9.88	>100

Verifica spostamento elastico dovuto ai soli carichi variabili (§4.2.4.2.1 - NTC 2008)

x	Comb.	δ_2	L/300.00	Cs
cm		mm	mm	
148.2	15	-0.00	8.23	>100

Travata: 1010 [434 , 447]

L = 247.0cm

Crit.Prog: Acciaio_Flessione $\delta_c = 0.0cm$ Verifica: **Verificata**

Verifica spostamento nello stato finale (§4.2.4.2.1 - NTC 2008)

x	Comb.	δ_{max}	L/250.00	Cs
cm		mm	mm	
197.6	15	-0.01	9.88	>100

Verifica spostamento elastico dovuto ai soli carichi variabili (§4.2.4.2.1 - NTC 2008)

x	Comb.	δ_2	L/300.00	Cs
cm		mm	mm	
148.2	15	-0.01	8.23	>100

Travata: 1011 [447 , 200]

L = 266.5cm

Crit.Prog: Acciaio_Flessione $\delta_c = 0.0cm$ Verifica: **Verificata**

Verifica spostamento nello stato finale (§4.2.4.2.1 - NTC 2008)

x	Comb.	δ_{max}	L/250.00	Cs
---	-------	----------------	----------	----

AUTOSTRADA VALDASTICO A31 NORD
1° LOTTO - PIOVENE ROCCHETTE – VALLE DELL'ASTICO

x	Comb.	δ_{max}	L/250.00	Cs
cm		mm	mm	
186.5	15	-0.02	10.66	>100

Verifica spostamento elastico dovuto ai soli carichi variabili (§4.2.4.2.1 - NTC 2008)

x	Comb.	δ_2	L/300.00	Cs
cm		mm	mm	
133.2	15	-0.02	8.88	>100

Travata: 1012 [200 , 217]

L = 286.0cm

Crit.Prog: Acciaio_Flessione $\delta_c = 0.0cm$ Verifica: **Verificata**

Verifica spostamento nello stato finale (§4.2.4.2.1 - NTC 2008)

x	Comb.	δ_{max}	L/250.00	Cs
cm		mm	mm	
200.2	15	-0.03	11.44	>100

Verifica spostamento elastico dovuto ai soli carichi variabili (§4.2.4.2.1 - NTC 2008)

x	Comb.	δ_2	L/300.00	Cs
cm		mm	mm	
143.0	15	-0.04	9.53	>100

Travata: 1013 [217 , 234]

L = 286.0cm

Crit.Prog: Acciaio_Flessione $\delta_c = 0.0cm$ Verifica: **Verificata**

Verifica spostamento nello stato finale (§4.2.4.2.1 - NTC 2008)

x	Comb.	δ_{max}	L/250.00	Cs
---	-------	----------------	----------	----

AUTOSTRADA VALDASTICO A31 NORD
1° LOTTO - PIOVENE ROCCHETTE – VALLE DELL'ASTICO

x	Comb.	δ_{max}	L/250.00	Cs
cm		mm	mm	
85.8	15	-0.03	11.44	>100

Verifica spostamento elastico dovuto ai soli carichi variabili (§4.2.4.2.1 - NTC 2008)

x	Comb.	δ_2	L/300.00	Cs
cm		mm	mm	
143.0	15	-0.04	9.53	>100

Travata: 1014 [234 , 251]

L = 286.0cm

Crit.Prog: Acciaio_Flessione $\delta_c = 0.0cm$ Verifica: **Verificata**

Verifica spostamento nello stato finale (§4.2.4.2.1 - NTC 2008)

x	Comb.	δ_{max}	L/250.00	Cs
cm		mm	mm	
143.0	21	0.02	11.44	>100

Verifica spostamento elastico dovuto ai soli carichi variabili (§4.2.4.2.1 - NTC 2008)

x	Comb.	δ_2	L/300.00	Cs
cm		mm	mm	
114.4	15	-0.02	9.53	>100

Travata: 1015 [251 , 268]

L = 286.0cm

Crit.Prog: Acciaio_Flessione $\delta_c = 0.0cm$ Verifica: **Verificata**

Verifica spostamento nello stato finale (§4.2.4.2.1 - NTC 2008)

x	Comb.	δ_{max}	L/250.00	Cs
---	-------	----------------	----------	----

AUTOSTRADA VALDASTICO A31 NORD
1° LOTTO - PIOVENE ROCCHETTE – VALLE DELL'ASTICO

x	Comb.	δ_{max}	L/250.00	Cs
cm		mm	mm	
143.0	21	0.03	11.44	>100

Verifica spostamento elastico dovuto ai soli carichi variabili (§4.2.4.2.1 - NTC 2008)

x	Comb.	δ_2	L/300.00	Cs
cm		mm	mm	
114.4	15	-0.01	9.53	>100

Travata: 1016 [268 , 285]

L = 286.0cm

Crit.Prog: Acciaio_Flessione $\delta_c = 0.0cm$ Verifica: **Verificata**

Verifica spostamento nello stato finale (§4.2.4.2.1 - NTC 2008)

x	Comb.	δ_{max}	L/250.00	Cs
cm		mm	mm	
143.0	21	0.04	11.44	>100

Verifica spostamento elastico dovuto ai soli carichi variabili (§4.2.4.2.1 - NTC 2008)

x	Comb.	δ_2	L/300.00	Cs
cm		mm	mm	
57.2	15	-0.00	9.53	>100

Travata: 1017 [285 , 302]

L = 286.0cm

Crit.Prog: Acciaio_Flessione $\delta_c = 0.0cm$ Verifica: **Verificata**

Verifica spostamento nello stato finale (§4.2.4.2.1 - NTC 2008)

x	Comb.	δ_{max}	L/250.00	Cs
---	-------	----------------	----------	----

AUTOSTRADA VALDASTICO A31 NORD
1° LOTTO - PIOVENE ROCCHETTE – VALLE DELL'ASTICO

x	Comb.	δ_{max}	L/250.00	Cs
cm		mm	mm	
143.0	15	0.05	11.44	>100

Verifica spostamento elastico dovuto ai soli carichi variabili (§4.2.4.2.1 - NTC 2008)

x	Comb.	δ_2	L/300.00	Cs
cm		mm	mm	
200.2	15	0.00	9.53	>100

Travata: 1018 [302 , 345]

L = 286.0cm

Crit.Prog: Acciaio_Flessione $\delta_c = 0.0cm$ Verifica: **Verificata**

Verifica spostamento nello stato finale (§4.2.4.2.1 - NTC 2008)

x	Comb.	δ_{max}	L/250.00	Cs
cm		mm	mm	
143.0	15	0.06	11.44	>100

Verifica spostamento elastico dovuto ai soli carichi variabili (§4.2.4.2.1 - NTC 2008)

x	Comb.	δ_2	L/300.00	Cs
cm		mm	mm	
171.6	15	0.01	9.53	>100

Travata: 1019 [345 , 328]

L = 286.0cm

Crit.Prog: Acciaio_Flessione $\delta_c = 0.0cm$ Verifica: **Verificata**

Verifica spostamento nello stato finale (§4.2.4.2.1 - NTC 2008)

x	Comb.	δ_{max}	L/250.00	Cs
---	-------	----------------	----------	----

AUTOSTRADA VALDASTICO A31 NORD
1° LOTTO - PIOVENE ROCCHETTE – VALLE DELL'ASTICO

x	Comb.	δ_{max}	L/250.00	Cs
cm		mm	mm	
143.0	15	0.07	11.44	>100

Verifica spostamento elastico dovuto ai soli carichi variabili (§4.2.4.2.1 - NTC 2008)

x	Comb.	δ_2	L/300.00	Cs
cm		mm	mm	
143.0	15	0.02	9.53	>100

Travata: 1020 [328 , 353]

L = 286.0cm

Crit.Prog: Acciaio_Flessione $\delta_c = 0.0cm$ Verifica: **Verificata**

Verifica spostamento nello stato finale (§4.2.4.2.1 - NTC 2008)

x	Comb.	δ_{max}	L/250.00	Cs
cm		mm	mm	
143.0	15	0.07	11.44	>100

Verifica spostamento elastico dovuto ai soli carichi variabili (§4.2.4.2.1 - NTC 2008)

x	Comb.	δ_2	L/300.00	Cs
cm		mm	mm	
143.0	15	0.02	9.53	>100

Travata: 1021 [353 , 370]

L = 286.0cm

Crit.Prog: Acciaio_Flessione $\delta_c = 0.0cm$ Verifica: **Verificata**

Verifica spostamento nello stato finale (§4.2.4.2.1 - NTC 2008)

x	Comb.	δ_{max}	L/250.00	Cs
---	-------	----------------	----------	----

AUTOSTRADA VALDASTICO A31 NORD
1° LOTTO - PIOVENE ROCCHETTE – VALLE DELL'ASTICO

x	Comb.	δ_{max}	L/250.00	Cs
cm		mm	mm	
143.0	15	0.07	11.44	>100

Verifica spostamento elastico dovuto ai soli carichi variabili (§4.2.4.2.1 - NTC 2008)

x	Comb.	δ_2	L/300.00	Cs
cm		mm	mm	
143.0	15	0.02	9.53	>100

Travata: 1022 [370 , 387]

L = 286.0cm

Crit.Prog: Acciaio_Flessione $\delta_c = 0.0cm$ Verifica: **Verificata**

Verifica spostamento nello stato finale (§4.2.4.2.1 - NTC 2008)

x	Comb.	δ_{max}	L/250.00	Cs
cm		mm	mm	
143.0	15	0.07	11.44	>100

Verifica spostamento elastico dovuto ai soli carichi variabili (§4.2.4.2.1 - NTC 2008)

x	Comb.	δ_2	L/300.00	Cs
cm		mm	mm	
143.0	15	0.02	9.53	>100

Travata: 1023 [387 , 465]

L = 274.8cm

Crit.Prog: Acciaio_Flessione $\delta_c = 0.0cm$ Verifica: **Verificata**

Verifica spostamento nello stato finale (§4.2.4.2.1 - NTC 2008)

x	Comb.	δ_{max}	L/250.00	Cs
---	-------	----------------	----------	----

AUTOSTRADA VALDASTICO A31 NORD
1° LOTTO - PIOVENE ROCCHETTE – VALLE DELL'ASTICO

x	Comb.	δ_{max}	L/250.00	Cs
cm		mm	mm	
137.4	15	0.06	10.99	>100

Verifica spostamento elastico dovuto ai soli carichi variabili (§4.2.4.2.1 - NTC 2008)

x	Comb.	δ_2	L/300.00	Cs
cm		mm	mm	
137.4	15	0.02	9.16	>100

Travata: 1024 [465 , 482]

L = 264.5cm

Crit.Prog: Acciaio_Flessione $\delta_c = 0.0cm$ Verifica: **Verificata**

Verifica spostamento nello stato finale (§4.2.4.2.1 - NTC 2008)

x	Comb.	δ_{max}	L/250.00	Cs
cm		mm	mm	
132.3	15	0.05	10.58	>100

Verifica spostamento elastico dovuto ai soli carichi variabili (§4.2.4.2.1 - NTC 2008)

x	Comb.	δ_2	L/300.00	Cs
cm		mm	mm	
79.4	15	0.01	8.82	>100

Travata: 1025 [412 , 435]

L = 247.0cm

Crit.Prog: Acciaio_Flessione $\delta_c = 0.0cm$ Verifica: **Verificata**

Verifica spostamento nello stato finale (§4.2.4.2.1 - NTC 2008)

x	Comb.	δ_{max}	L/250.00	Cs
---	-------	----------------	----------	----

AUTOSTRADA VALDASTICO A31 NORD
1° LOTTO - PIOVENE ROCCHETTE – VALLE DELL'ASTICO

x	Comb.	δ_{max}	L/250.00	Cs
cm		mm	mm	
123.5	21	0.03	9.88	>100

Verifica spostamento elastico dovuto ai soli carichi variabili (§4.2.4.2.1 - NTC 2008)

x	Comb.	δ_2	L/300.00	Cs
cm		mm	mm	
148.2	15	-0.00	8.23	>100

Travata: 1026 [435 , 448]

L = 247.0cm

Crit.Prog: Acciaio_Flessione $\delta_c = 0.0cm$ Verifica: **Verificata**

Verifica spostamento nello stato finale (§4.2.4.2.1 - NTC 2008)

x	Comb.	δ_{max}	L/250.00	Cs
cm		mm	mm	
197.6	15	-0.01	9.88	>100

Verifica spostamento elastico dovuto ai soli carichi variabili (§4.2.4.2.1 - NTC 2008)

x	Comb.	δ_2	L/300.00	Cs
cm		mm	mm	
148.2	15	-0.01	8.23	>100

Travata: 1027 [448 , 199]

L = 266.5cm

Crit.Prog: Acciaio_Flessione $\delta_c = 0.0cm$ Verifica: **Verificata**

Verifica spostamento nello stato finale (§4.2.4.2.1 - NTC 2008)

x	Comb.	δ_{max}	L/250.00	Cs
---	-------	----------------	----------	----

AUTOSTRADA VALDASTICO A31 NORD
1° LOTTO - PIOVENE ROCCHETTE – VALLE DELL'ASTICO

x	Comb.	δ_{max}	L/250.00	Cs
cm		mm	mm	
186.5	15	-0.02	10.66	>100

Verifica spostamento elastico dovuto ai soli carichi variabili (§4.2.4.2.1 - NTC 2008)

x	Comb.	δ_2	L/300.00	Cs
cm		mm	mm	
133.2	15	-0.02	8.88	>100

Travata: 1028 [199 , 216]

L = 286.0cm

Crit.Prog: Acciaio_Flessione $\delta_c = 0.0cm$ Verifica: **Verificata**

Verifica spostamento nello stato finale (§4.2.4.2.1 - NTC 2008)

x	Comb.	δ_{max}	L/250.00	Cs
cm		mm	mm	
200.2	15	-0.03	11.44	>100

Verifica spostamento elastico dovuto ai soli carichi variabili (§4.2.4.2.1 - NTC 2008)

x	Comb.	δ_2	L/300.00	Cs
cm		mm	mm	
143.0	15	-0.04	9.53	>100

Travata: 1029 [216 , 233]

L = 286.0cm

Crit.Prog: Acciaio_Flessione $\delta_c = 0.0cm$ Verifica: **Verificata**

Verifica spostamento nello stato finale (§4.2.4.2.1 - NTC 2008)

x	Comb.	δ_{max}	L/250.00	Cs
---	-------	----------------	----------	----

AUTOSTRADA VALDASTICO A31 NORD
1° LOTTO - PIOVENE ROCCHETTE – VALLE DELL'ASTICO

x	Comb.	δ_{max}	L/250.00	Cs
cm		mm	mm	
85.8	15	-0.03	11.44	>100

Verifica spostamento elastico dovuto ai soli carichi variabili (§4.2.4.2.1 - NTC 2008)

x	Comb.	δ_2	L/300.00	Cs
cm		mm	mm	
143.0	15	-0.04	9.53	>100

Travata: 1030 [233 , 250]

L = 286.0cm

Crit.Prog: Acciaio_Flessione $\delta_c = 0.0cm$ Verifica: **Verificata**

Verifica spostamento nello stato finale (§4.2.4.2.1 - NTC 2008)

x	Comb.	δ_{max}	L/250.00	Cs
cm		mm	mm	
143.0	21	0.02	11.44	>100

Verifica spostamento elastico dovuto ai soli carichi variabili (§4.2.4.2.1 - NTC 2008)

x	Comb.	δ_2	L/300.00	Cs
cm		mm	mm	
114.4	15	-0.02	9.53	>100

Travata: 1031 [250 , 267]

L = 286.0cm

Crit.Prog: Acciaio_Flessione $\delta_c = 0.0cm$ Verifica: **Verificata**

Verifica spostamento nello stato finale (§4.2.4.2.1 - NTC 2008)

x	Comb.	δ_{max}	L/250.00	Cs
---	-------	----------------	----------	----

AUTOSTRADA VALDASTICO A31 NORD
1° LOTTO - PIOVENE ROCCHETTE – VALLE DELL'ASTICO

x	Comb.	δ_{max}	L/250.00	Cs
cm		mm	mm	
143.0	21	0.03	11.44	>100

Verifica spostamento elastico dovuto ai soli carichi variabili (§4.2.4.2.1 - NTC 2008)

x	Comb.	δ_2	L/300.00	Cs
cm		mm	mm	
114.4	15	-0.01	9.53	>100

Travata: 1032 [267 , 284]

L = 286.0cm

Crit.Prog: Acciaio_Flessione $\delta_c = 0.0cm$ Verifica: **Verificata**

Verifica spostamento nello stato finale (§4.2.4.2.1 - NTC 2008)

x	Comb.	δ_{max}	L/250.00	Cs
cm		mm	mm	
143.0	21	0.04	11.44	>100

Verifica spostamento elastico dovuto ai soli carichi variabili (§4.2.4.2.1 - NTC 2008)

x	Comb.	δ_2	L/300.00	Cs
cm		mm	mm	
57.2	15	-0.00	9.53	>100

Travata: 1033 [284 , 301]

L = 286.0cm

Crit.Prog: Acciaio_Flessione $\delta_c = 0.0cm$ Verifica: **Verificata**

Verifica spostamento nello stato finale (§4.2.4.2.1 - NTC 2008)

x	Comb.	δ_{max}	L/250.00	Cs
---	-------	----------------	----------	----

AUTOSTRADA VALDASTICO A31 NORD
1° LOTTO - PIOVENE ROCCHETTE – VALLE DELL'ASTICO

x	Comb.	δ_{max}	L/250.00	Cs
cm		mm	mm	
143.0	15	0.05	11.44	>100

Verifica spostamento elastico dovuto ai soli carichi variabili (§4.2.4.2.1 - NTC 2008)

x	Comb.	δ_2	L/300.00	Cs
cm		mm	mm	
200.2	15	0.00	9.53	>100

Travata: 1034 [301 , 344]

L = 286.0cm

Crit.Prog: Acciaio_Flessione $\delta_c = 0.0cm$ Verifica: **Verificata**

Verifica spostamento nello stato finale (§4.2.4.2.1 - NTC 2008)

x	Comb.	δ_{max}	L/250.00	Cs
cm		mm	mm	
143.0	15	0.06	11.44	>100

Verifica spostamento elastico dovuto ai soli carichi variabili (§4.2.4.2.1 - NTC 2008)

x	Comb.	δ_2	L/300.00	Cs
cm		mm	mm	
171.6	15	0.01	9.53	>100

Travata: 1035 [344 , 327]

L = 286.0cm

Crit.Prog: Acciaio_Flessione $\delta_c = 0.0cm$ Verifica: **Verificata**

Verifica spostamento nello stato finale (§4.2.4.2.1 - NTC 2008)

x	Comb.	δ_{max}	L/250.00	Cs
---	-------	----------------	----------	----

AUTOSTRADA VALDASTICO A31 NORD
1° LOTTO - PIOVENE ROCCHETTE – VALLE DELL'ASTICO

x	Comb.	δ_{max}	L/250.00	Cs
cm		mm	mm	
143.0	15	0.07	11.44	>100

Verifica spostamento elastico dovuto ai soli carichi variabili (§4.2.4.2.1 - NTC 2008)

x	Comb.	δ_2	L/300.00	Cs
cm		mm	mm	
143.0	15	0.02	9.53	>100

Travata: 1036 [327 , 352]

L = 286.0cm

Crit.Prog: Acciaio_Flessione $\delta_c = 0.0cm$ Verifica: **Verificata**

Verifica spostamento nello stato finale (§4.2.4.2.1 - NTC 2008)

x	Comb.	δ_{max}	L/250.00	Cs
cm		mm	mm	
143.0	15	0.07	11.44	>100

Verifica spostamento elastico dovuto ai soli carichi variabili (§4.2.4.2.1 - NTC 2008)

x	Comb.	δ_2	L/300.00	Cs
cm		mm	mm	
143.0	15	0.02	9.53	>100

Travata: 1037 [352 , 369]

L = 286.0cm

Crit.Prog: Acciaio_Flessione $\delta_c = 0.0cm$ Verifica: **Verificata**

Verifica spostamento nello stato finale (§4.2.4.2.1 - NTC 2008)

x	Comb.	δ_{max}	L/250.00	Cs
---	-------	----------------	----------	----

AUTOSTRADA VALDASTICO A31 NORD
1° LOTTO - PIOVENE ROCCHETTE – VALLE DELL'ASTICO

x	Comb.	δ_{max}	L/250.00	Cs
cm		mm	mm	
143.0	15	0.07	11.44	>100

Verifica spostamento elastico dovuto ai soli carichi variabili (§4.2.4.2.1 - NTC 2008)

x	Comb.	δ_2	L/300.00	Cs
cm		mm	mm	
143.0	15	0.02	9.53	>100

Travata: 1038 [369 , 386]

L = 286.0cm

Crit.Prog: Acciaio_Flessione $\delta_c = 0.0cm$ Verifica: **Verificata**

Verifica spostamento nello stato finale (§4.2.4.2.1 - NTC 2008)

x	Comb.	δ_{max}	L/250.00	Cs
cm		mm	mm	
143.0	15	0.07	11.44	>100

Verifica spostamento elastico dovuto ai soli carichi variabili (§4.2.4.2.1 - NTC 2008)

x	Comb.	δ_2	L/300.00	Cs
cm		mm	mm	
143.0	15	0.02	9.53	>100

Travata: 1039 [386 , 466]

L = 274.8cm

Crit.Prog: Acciaio_Flessione $\delta_c = 0.0cm$ Verifica: **Verificata**

Verifica spostamento nello stato finale (§4.2.4.2.1 - NTC 2008)

x	Comb.	δ_{max}	L/250.00	Cs
---	-------	----------------	----------	----

AUTOSTRADA VALDASTICO A31 NORD
1° LOTTO - PIOVENE ROCCHETTE – VALLE DELL'ASTICO

x	Comb.	δ_{max}	L/250.00	Cs
cm		mm	mm	
137.4	15	0.06	10.99	>100

Verifica spostamento elastico dovuto ai soli carichi variabili (§4.2.4.2.1 - NTC 2008)

x	Comb.	δ_2	L/300.00	Cs
cm		mm	mm	
137.4	15	0.02	9.16	>100

Travata: 1040 [466 , 483]

L = 264.5cm

Crit.Prog: Acciaio_Flessione $\delta_c = 0.0cm$ Verifica: **Verificata**

Verifica spostamento nello stato finale (§4.2.4.2.1 - NTC 2008)

x	Comb.	δ_{max}	L/250.00	Cs
cm		mm	mm	
132.3	15	0.05	10.58	>100

Verifica spostamento elastico dovuto ai soli carichi variabili (§4.2.4.2.1 - NTC 2008)

x	Comb.	δ_2	L/300.00	Cs
cm		mm	mm	
79.4	15	0.01	8.82	>100

Travata: 1041 [411 , 438]

L = 247.0cm

Crit.Prog: Acciaio_Flessione $\delta_c = 0.0cm$ Verifica: **Verificata**

Verifica spostamento nello stato finale (§4.2.4.2.1 - NTC 2008)

x	Comb.	δ_{max}	L/250.00	Cs
---	-------	----------------	----------	----

AUTOSTRADA VALDASTICO A31 NORD
1° LOTTO - PIOVENE ROCCHETTE – VALLE DELL'ASTICO

x	Comb.	δ_{max}	L/250.00	Cs
cm		mm	mm	
98.8	21	0.03	9.88	>100

Verifica spostamento elastico dovuto ai soli carichi variabili (§4.2.4.2.1 - NTC 2008)

x	Comb.	δ_2	L/300.00	Cs
cm		mm	mm	
172.9	15	-0.01	8.23	>100

Travata: 1042 [438 , 449]

L = 247.0cm

Crit.Prog: Acciaio_Flessione $\delta_c = 0.0cm$ Verifica: **Verificata**

Verifica spostamento nello stato finale (§4.2.4.2.1 - NTC 2008)

x	Comb.	δ_{max}	L/250.00	Cs
cm		mm	mm	
172.9	15	-0.08	9.88	>100

Verifica spostamento elastico dovuto ai soli carichi variabili (§4.2.4.2.1 - NTC 2008)

x	Comb.	δ_2	L/300.00	Cs
cm		mm	mm	
148.2	15	-0.06	8.23	>100

Travata: 1043 [449 , 198]

L = 266.5cm

Crit.Prog: Acciaio_Flessione $\delta_c = 0.0cm$ Verifica: **Verificata**

Verifica spostamento nello stato finale (§4.2.4.2.1 - NTC 2008)

x	Comb.	δ_{max}	L/250.00	Cs
---	-------	----------------	----------	----

AUTOSTRADA VALDASTICO A31 NORD
1° LOTTO - PIOVENE ROCCHETTE – VALLE DELL'ASTICO

x	Comb.	δ_{max}	L/250.00	Cs
cm		mm	mm	
133.2	15	-0.16	10.66	64.8

Verifica spostamento elastico dovuto ai soli carichi variabili (§4.2.4.2.1 - NTC 2008)

x	Comb.	δ_2	L/300.00	Cs
cm		mm	mm	
133.2	15	-0.11	8.88	80.4

Travata: 1044 [198 , 215]

L = 286.0cm

Crit.Prog: Acciaio_Flessione $\delta_c = 0.0cm$ Verifica: **Verificata**

Verifica spostamento nello stato finale (§4.2.4.2.1 - NTC 2008)

x	Comb.	δ_{max}	L/250.00	Cs
cm		mm	mm	
85.8	15	-0.08	11.44	>100

Verifica spostamento elastico dovuto ai soli carichi variabili (§4.2.4.2.1 - NTC 2008)

x	Comb.	δ_2	L/300.00	Cs
cm		mm	mm	
114.4	15	-0.06	9.53	>100

Travata: 1045 [215 , 232]

L = 286.0cm

Crit.Prog: Acciaio_Flessione $\delta_c = 0.0cm$ Verifica: **Verificata**

Verifica spostamento nello stato finale (§4.2.4.2.1 - NTC 2008)

x	Comb.	δ_{max}	L/250.00	Cs
---	-------	----------------	----------	----

AUTOSTRADA VALDASTICO A31 NORD
1° LOTTO - PIOVENE ROCCHETTE – VALLE DELL'ASTICO

x	Comb.	δ_{max}	L/250.00	Cs
cm		mm	mm	
171.6	15	0.04	11.44	>100

Verifica spostamento elastico dovuto ai soli carichi variabili (§4.2.4.2.1 - NTC 2008)

x	Comb.	δ_2	L/300.00	Cs
cm		mm	mm	
200.2	15	0.01	9.53	>100

Travata: 1046 [232 , 249]

L = 286.0cm

Crit.Prog: Acciaio_Flessione $\delta_c = 0.0cm$ Verifica: **Verificata**

Verifica spostamento nello stato finale (§4.2.4.2.1 - NTC 2008)

x	Comb.	δ_{max}	L/250.00	Cs
cm		mm	mm	
143.0	21	0.03	11.44	>100

Verifica spostamento elastico dovuto ai soli carichi variabili (§4.2.4.2.1 - NTC 2008)

x	Comb.	δ_2	L/300.00	Cs
cm		mm	mm	
200.2	15	-0.02	9.53	>100

Travata: 1047 [249 , 266]

L = 286.0cm

Crit.Prog: Acciaio_Flessione $\delta_c = 0.0cm$ Verifica: **Verificata**

Verifica spostamento nello stato finale (§4.2.4.2.1 - NTC 2008)

x	Comb.	δ_{max}	L/250.00	Cs
---	-------	----------------	----------	----

AUTOSTRADA VALDASTICO A31 NORD
1° LOTTO - PIOVENE ROCCHETTE – VALLE DELL'ASTICO

x	Comb.	δ_{max}	L/250.00	Cs
cm		mm	mm	
85.8	15	-0.04	11.44	>100

Verifica spostamento elastico dovuto ai soli carichi variabili (§4.2.4.2.1 - NTC 2008)

x	Comb.	δ_2	L/300.00	Cs
cm		mm	mm	
143.0	15	-0.05	9.53	>100

Travata: 1048 [266 , 283]

L = 286.0cm

Crit.Prog: Acciaio_Flessione $\delta_c = 0.0cm$ Verifica: **Verificata**

Verifica spostamento nello stato finale (§4.2.4.2.1 - NTC 2008)

x	Comb.	δ_{max}	L/250.00	Cs
cm		mm	mm	
171.6	15	0.06	11.44	>100

Verifica spostamento elastico dovuto ai soli carichi variabili (§4.2.4.2.1 - NTC 2008)

x	Comb.	δ_2	L/300.00	Cs
cm		mm	mm	
200.2	15	0.02	9.53	>100

Travata: 1049 [283 , 300]

L = 286.0cm

Crit.Prog: Acciaio_Flessione $\delta_c = 0.0cm$ Verifica: **Verificata**

Verifica spostamento nello stato finale (§4.2.4.2.1 - NTC 2008)

x	Comb.	δ_{max}	L/250.00	Cs
---	-------	----------------	----------	----

AUTOSTRADA VALDASTICO A31 NORD
1° LOTTO - PIOVENE ROCCHETTE – VALLE DELL'ASTICO

x	Comb.	δ_{max}	L/250.00	Cs
cm		mm	mm	
143.0	15	0.13	11.44	90.5

Verifica spostamento elastico dovuto ai soli carichi variabili (§4.2.4.2.1 - NTC 2008)

x	Comb.	δ_2	L/300.00	Cs
cm		mm	mm	
143.0	15	0.05	9.53	>100

Travata: 1050 [300 , 343]

L = 286.0cm

Crit.Prog: Acciaio_Flessione $\delta_c = 0.0cm$ Verifica: **Verificata**

Verifica spostamento nello stato finale (§4.2.4.2.1 - NTC 2008)

x	Comb.	δ_{max}	L/250.00	Cs
cm		mm	mm	
114.4	15	0.07	11.44	>100

Verifica spostamento elastico dovuto ai soli carichi variabili (§4.2.4.2.1 - NTC 2008)

x	Comb.	δ_2	L/300.00	Cs
cm		mm	mm	
85.8	15	0.02	9.53	>100

Travata: 1051 [343 , 326]

L = 286.0cm

Crit.Prog: Acciaio_Flessione $\delta_c = 0.0cm$ Verifica: **Verificata**

Verifica spostamento nello stato finale (§4.2.4.2.1 - NTC 2008)

x	Comb.	δ_{max}	L/250.00	Cs
---	-------	----------------	----------	----

AUTOSTRADA VALDASTICO A31 NORD
1° LOTTO - PIOVENE ROCCHETTE – VALLE DELL'ASTICO

x	Comb.	δ_{max}	L/250.00	Cs
cm		mm	mm	
57.2	15	-0.02	11.44	>100

Verifica spostamento elastico dovuto ai soli carichi variabili (§4.2.4.2.1 - NTC 2008)

x	Comb.	δ_2	L/300.00	Cs
cm		mm	mm	
143.0	15	-0.04	9.53	>100

Travata: 1052 [326 , 351]

L = 286.0cm

Crit.Prog: Acciaio_Flessione $\delta_c = 0.0cm$ Verifica: **Verificata**

Verifica spostamento nello stato finale (§4.2.4.2.1 - NTC 2008)

x	Comb.	δ_{max}	L/250.00	Cs
cm		mm	mm	
171.6	15	0.07	11.44	>100

Verifica spostamento elastico dovuto ai soli carichi variabili (§4.2.4.2.1 - NTC 2008)

x	Comb.	δ_2	L/300.00	Cs
cm		mm	mm	
200.2	15	0.03	9.53	>100

Travata: 1053 [351 , 368]

L = 286.0cm

Crit.Prog: Acciaio_Flessione $\delta_c = 0.0cm$ Verifica: **Verificata**

Verifica spostamento nello stato finale (§4.2.4.2.1 - NTC 2008)

x	Comb.	δ_{max}	L/250.00	Cs
---	-------	----------------	----------	----

AUTOSTRADA VALDASTICO A31 NORD
1° LOTTO - PIOVENE ROCCHETTE – VALLE DELL'ASTICO

x	Comb.	δ_{max}	L/250.00	Cs
cm		mm	mm	
143.0	15	0.14	11.44	83.1

Verifica spostamento elastico dovuto ai soli carichi variabili (§4.2.4.2.1 - NTC 2008)

x	Comb.	δ_2	L/300.00	Cs
cm		mm	mm	
143.0	15	0.06	9.53	>100

Travata: 1054 [368 , 385]

L = 286.0cm

Crit.Prog: Acciaio_Flessione $\delta_c = 0.0cm$ Verifica: **Verificata**

Verifica spostamento nello stato finale (§4.2.4.2.1 - NTC 2008)

x	Comb.	δ_{max}	L/250.00	Cs
cm		mm	mm	
114.4	15	0.08	11.44	>100

Verifica spostamento elastico dovuto ai soli carichi variabili (§4.2.4.2.1 - NTC 2008)

x	Comb.	δ_2	L/300.00	Cs
cm		mm	mm	
85.8	15	0.03	9.53	>100

Travata: 1055 [385 , 454]

L = 274.8cm

Crit.Prog: Acciaio_Flessione $\delta_c = 0.0cm$ Verifica: **Verificata**

Verifica spostamento nello stato finale (§4.2.4.2.1 - NTC 2008)

x	Comb.	δ_{max}	L/250.00	Cs
---	-------	----------------	----------	----

AUTOSTRADA VALDASTICO A31 NORD
1° LOTTO - PIOVENE ROCCHETTE – VALLE DELL'ASTICO

x	Comb.	δ_{max}	L/250.00	Cs
cm		mm	mm	
192.3	15	-0.03	10.99	>100

Verifica spostamento elastico dovuto ai soli carichi variabili (§4.2.4.2.1 - NTC 2008)

x	Comb.	δ_2	L/300.00	Cs
cm		mm	mm	
164.9	15	-0.03	9.16	>100

Travata: 1056 [454 , 471]

L = 264.5cm

Crit.Prog: Acciaio_Flessione $\delta_c = 0.0cm$ Verifica: **Verificata**

Verifica spostamento nello stato finale (§4.2.4.2.1 - NTC 2008)

x	Comb.	δ_{max}	L/250.00	Cs
cm		mm	mm	
158.7	21	0.03	10.58	>100

Verifica spostamento elastico dovuto ai soli carichi variabili (§4.2.4.2.1 - NTC 2008)

x	Comb.	δ_2	L/300.00	Cs
cm		mm	mm	
105.8	15	-0.02	8.82	>100

Travata: 1057 [410 , 440]

L = 247.0cm

Crit.Prog: Acciaio_Flessione $\delta_c = 0.0cm$ Verifica: **Verificata**

Verifica spostamento nello stato finale (§4.2.4.2.1 - NTC 2008)

x	Comb.	δ_{max}	L/250.00	Cs
---	-------	----------------	----------	----

AUTOSTRADA VALDASTICO A31 NORD
1° LOTTO - PIOVENE ROCCHETTE – VALLE DELL'ASTICO

x	Comb.	δ_{max}	L/250.00	Cs
cm		mm	mm	
98.8	15	0.05	9.88	>100

Verifica spostamento elastico dovuto ai soli carichi variabili (§4.2.4.2.1 - NTC 2008)

x	Comb.	δ_2	L/300.00	Cs
cm		mm	mm	
98.8	15	0.02	8.23	>100

Travata: 1058 [440 , 450]

L = 247.0cm

Crit.Prog: Acciaio_Flessione $\delta_c = 0.0cm$ Verifica: **Verificata**

Verifica spostamento nello stato finale (§4.2.4.2.1 - NTC 2008)

x	Comb.	δ_{max}	L/250.00	Cs
cm		mm	mm	
172.9	15	-0.09	9.88	>100

Verifica spostamento elastico dovuto ai soli carichi variabili (§4.2.4.2.1 - NTC 2008)

x	Comb.	δ_2	L/300.00	Cs
cm		mm	mm	
172.9	15	-0.06	8.23	>100

Travata: 1059 [450 , 197]

L = 266.5cm

Crit.Prog: Acciaio_Flessione $\delta_c = 0.0cm$ Verifica: **Verificata**

Verifica spostamento nello stato finale (§4.2.4.2.1 - NTC 2008)

x	Comb.	δ_{max}	L/250.00	Cs
---	-------	----------------	----------	----

AUTOSTRADA VALDASTICO A31 NORD
1° LOTTO - PIOVENE ROCCHETTE – VALLE DELL'ASTICO

x	Comb.	δ_{max}	L/250.00	Cs
cm		mm	mm	
133.2	15	-0.82	10.66	12.9

Verifica spostamento elastico dovuto ai soli carichi variabili (§4.2.4.2.1 - NTC 2008)

x	Comb.	δ_2	L/300.00	Cs
cm		mm	mm	
133.2	15	-0.51	8.88	17.5

Travata: 1060 [197 , 214]

L = 286.0cm

Crit.Prog: Acciaio_Flessione $\delta_c = 0.0cm$ Verifica: **Verificata**

Verifica spostamento nello stato finale (§4.2.4.2.1 - NTC 2008)

x	Comb.	δ_{max}	L/250.00	Cs
cm		mm	mm	
200.2	15	0.08	11.44	>100

Verifica spostamento elastico dovuto ai soli carichi variabili (§4.2.4.2.1 - NTC 2008)

x	Comb.	δ_2	L/300.00	Cs
cm		mm	mm	
228.8	15	0.04	9.53	>100

Travata: 1061 [214 , 231]

L = 286.0cm

Crit.Prog: Acciaio_Flessione $\delta_c = 0.0cm$ Verifica: **Verificata**

Verifica spostamento nello stato finale (§4.2.4.2.1 - NTC 2008)

x	Comb.	δ_{max}	L/250.00	Cs
---	-------	----------------	----------	----

AUTOSTRADA VALDASTICO A31 NORD
1° LOTTO - PIOVENE ROCCHETTE – VALLE DELL'ASTICO

x	Comb.	δ_{max}	L/250.00	Cs
cm		mm	mm	
143.0	15	0.26	11.44	44.2

Verifica spostamento elastico dovuto ai soli carichi variabili (§4.2.4.2.1 - NTC 2008)

x	Comb.	δ_2	L/300.00	Cs
cm		mm	mm	
143.0	15	0.14	9.53	67.6

Travata: 1062 [231 , 248]

L = 286.0cm

Crit.Prog: Acciaio_Flessione $\delta_c = 0.0cm$ Verifica: **Verificata**

Verifica spostamento nello stato finale (§4.2.4.2.1 - NTC 2008)

x	Comb.	δ_{max}	L/250.00	Cs
cm		mm	mm	
114.4	15	0.19	11.44	61.0

Verifica spostamento elastico dovuto ai soli carichi variabili (§4.2.4.2.1 - NTC 2008)

x	Comb.	δ_2	L/300.00	Cs
cm		mm	mm	
114.4	15	0.10	9.53	99.7

Travata: 1063 [248 , 265]

L = 286.0cm

Crit.Prog: Acciaio_Flessione $\delta_c = 0.0cm$ Verifica: **Verificata**

Verifica spostamento nello stato finale (§4.2.4.2.1 - NTC 2008)

x	Comb.	δ_{max}	L/250.00	Cs
---	-------	----------------	----------	----

AUTOSTRADA VALDASTICO A31 NORD
1° LOTTO - PIOVENE ROCCHETTE – VALLE DELL'ASTICO

x	Comb.	δ_{max}	L/250.00	Cs
cm		mm	mm	
143.0	15	-0.53	11.44	21.6

Verifica spostamento elastico dovuto ai soli carichi variabili (§4.2.4.2.1 - NTC 2008)

x	Comb.	δ_2	L/300.00	Cs
cm		mm	mm	
143.0	15	-0.37	9.53	26.1

Travata: 1064 [265 , 282]

L = 286.0cm

Crit.Prog: Acciaio_Flessione $\delta_c = 0.0cm$ Verifica: **Verificata**

Verifica spostamento nello stato finale (§4.2.4.2.1 - NTC 2008)

x	Comb.	δ_{max}	L/250.00	Cs
cm		mm	mm	
171.6	15	0.24	11.44	47.1

Verifica spostamento elastico dovuto ai soli carichi variabili (§4.2.4.2.1 - NTC 2008)

x	Comb.	δ_2	L/300.00	Cs
cm		mm	mm	
171.6	15	0.13	9.53	75.3

Travata: 1065 [282 , 299]

L = 286.0cm

Crit.Prog: Acciaio_Flessione $\delta_c = 0.0cm$ Verifica: **Verificata**

Verifica spostamento nello stato finale (§4.2.4.2.1 - NTC 2008)

x	Comb.	δ_{max}	L/250.00	Cs
---	-------	----------------	----------	----

AUTOSTRADA VALDASTICO A31 NORD
1° LOTTO - PIOVENE ROCCHETTE – VALLE DELL'ASTICO

x	Comb.	δ_{max}	L/250.00	Cs
cm		mm	mm	
143.0	15	0.35	11.44	32.6

Verifica spostamento elastico dovuto ai soli carichi variabili (§4.2.4.2.1 - NTC 2008)

x	Comb.	δ_2	L/300.00	Cs
cm		mm	mm	
143.0	15	0.19	9.53	49.8

Travata: 1066 [299 , 342]

L = 286.0cm

Crit.Prog: Acciaio_Flessione $\delta_c = 0.0cm$ Verifica: **Verificata**

Verifica spostamento nello stato finale (§4.2.4.2.1 - NTC 2008)

x	Comb.	δ_{max}	L/250.00	Cs
cm		mm	mm	
114.4	15	0.23	11.44	49.4

Verifica spostamento elastico dovuto ai soli carichi variabili (§4.2.4.2.1 - NTC 2008)

x	Comb.	δ_2	L/300.00	Cs
cm		mm	mm	
114.4	15	0.12	9.53	79.7

Travata: 1067 [342 , 325]

L = 286.0cm

Crit.Prog: Acciaio_Flessione $\delta_c = 0.0cm$ Verifica: **Verificata**

Verifica spostamento nello stato finale (§4.2.4.2.1 - NTC 2008)

x	Comb.	δ_{max}	L/250.00	Cs
---	-------	----------------	----------	----

AUTOSTRADA VALDASTICO A31 NORD
1° LOTTO - PIOVENE ROCCHETTE – VALLE DELL'ASTICO

x	Comb.	δ_{max}	L/250.00	Cs
cm		mm	mm	
143.0	15	-0.57	11.44	19.9

Verifica spostamento elastico dovuto ai soli carichi variabili (§4.2.4.2.1 - NTC 2008)

x	Comb.	δ_2	L/300.00	Cs
cm		mm	mm	
143.0	15	-0.39	9.53	24.4

Travata: 1068 [325 , 350]

L = 286.0cm

Crit.Prog: Acciaio_Flessione $\delta_c = 0.0cm$ Verifica: **Verificata**

Verifica spostamento nello stato finale (§4.2.4.2.1 - NTC 2008)

x	Comb.	δ_{max}	L/250.00	Cs
cm		mm	mm	
171.6	15	0.23	11.44	50.0

Verifica spostamento elastico dovuto ai soli carichi variabili (§4.2.4.2.1 - NTC 2008)

x	Comb.	δ_2	L/300.00	Cs
cm		mm	mm	
171.6	15	0.12	9.53	79.4

Travata: 1069 [350 , 367]

L = 286.0cm

Crit.Prog: Acciaio_Flessione $\delta_c = 0.0cm$ Verifica: **Verificata**

Verifica spostamento nello stato finale (§4.2.4.2.1 - NTC 2008)

x	Comb.	δ_{max}	L/250.00	Cs
---	-------	----------------	----------	----

AUTOSTRADA VALDASTICO A31 NORD
1° LOTTO - PIOVENE ROCCHETTE – VALLE DELL'ASTICO

x	Comb.	δ_{max}	L/250.00	Cs
cm		mm	mm	
143.0	15	0.34	11.44	33.3

Verifica spostamento elastico dovuto ai soli carichi variabili (§4.2.4.2.1 - NTC 2008)

x	Comb.	δ_2	L/300.00	Cs
cm		mm	mm	
143.0	15	0.19	9.53	49.9

Travata: 1070 [367 , 384]

L = 286.0cm

Crit.Prog: Acciaio_Flessione $\delta_c = 0.0cm$ Verifica: **Verificata**

Verifica spostamento nello stato finale (§4.2.4.2.1 - NTC 2008)

x	Comb.	δ_{max}	L/250.00	Cs
cm		mm	mm	
114.4	15	0.23	11.44	50.2

Verifica spostamento elastico dovuto ai soli carichi variabili (§4.2.4.2.1 - NTC 2008)

x	Comb.	δ_2	L/300.00	Cs
cm		mm	mm	
114.4	15	0.13	9.53	76.0

Travata: 1071 [384 , 467]

L = 274.8cm

Crit.Prog: Acciaio_Flessione $\delta_c = 0.0cm$ Verifica: **Verificata**

Verifica spostamento nello stato finale (§4.2.4.2.1 - NTC 2008)

x	Comb.	δ_{max}	L/250.00	Cs
---	-------	----------------	----------	----

AUTOSTRADA VALDASTICO A31 NORD
1° LOTTO - PIOVENE ROCCHETTE – VALLE DELL'ASTICO

x	Comb.	δ_{max}	L/250.00	Cs
cm		mm	mm	
137.4	15	-0.50	10.99	22.1

Verifica spostamento elastico dovuto ai soli carichi variabili (§4.2.4.2.1 - NTC 2008)

x	Comb.	δ_2	L/300.00	Cs
cm		mm	mm	
137.4	15	-0.31	9.16	29.2

Travata: 1072 [467 , 484]

L = 264.5cm

Crit.Prog: Acciaio_Flessione $\delta_c = 0.0cm$ Verifica: **Verificata**

Verifica spostamento nello stato finale (§4.2.4.2.1 - NTC 2008)

x	Comb.	δ_{max}	L/250.00	Cs
cm		mm	mm	
185.2	15	0.05	10.58	>100

Verifica spostamento elastico dovuto ai soli carichi variabili (§4.2.4.2.1 - NTC 2008)

x	Comb.	δ_2	L/300.00	Cs
cm		mm	mm	
52.9	15	-0.01	8.82	>100

Travata: 1073 [417 , 442]

L = 247.0cm

Crit.Prog: Acciaio_Flessione $\delta_c = 0.0cm$ Verifica: **Verificata**

Verifica spostamento nello stato finale (§4.2.4.2.1 - NTC 2008)

x	Comb.	δ_{max}	L/250.00	Cs
---	-------	----------------	----------	----

AUTOSTRADA VALDASTICO A31 NORD
1° LOTTO - PIOVENE ROCCHETTE – VALLE DELL'ASTICO

x	Comb.	δ_{max}	L/250.00	Cs
cm		mm	mm	
98.8	15	0.04	9.88	>100

Verifica spostamento elastico dovuto ai soli carichi variabili (§4.2.4.2.1 - NTC 2008)

x	Comb.	δ_2	L/300.00	Cs
cm		mm	mm	
74.1	15	0.01	8.23	>100

Travata: 1074 [442 , 451]

L = 247.0cm

Crit.Prog: Acciaio_Flessione $\delta_c = 0.0cm$ Verifica: **Verificata**

Verifica spostamento nello stato finale (§4.2.4.2.1 - NTC 2008)

x	Comb.	δ_{max}	L/250.00	Cs
cm		mm	mm	
172.9	15	-0.28	9.88	35.3

Verifica spostamento elastico dovuto ai soli carichi variabili (§4.2.4.2.1 - NTC 2008)

x	Comb.	δ_2	L/300.00	Cs
cm		mm	mm	
148.2	15	-0.17	8.23	47.8

Travata: 1075 [451 , 204]

L = 266.5cm

Crit.Prog: Acciaio_Flessione $\delta_c = 0.0cm$ Verifica: **Verificata**

Verifica spostamento nello stato finale (§4.2.4.2.1 - NTC 2008)

x	Comb.	δ_{max}	L/250.00	Cs
---	-------	----------------	----------	----

AUTOSTRADA VALDASTICO A31 NORD
1° LOTTO - PIOVENE ROCCHETTE – VALLE DELL'ASTICO

x	Comb.	δ_{max}	L/250.00	Cs
cm		mm	mm	
133.2	15	-0.87	10.66	12.2

Verifica spostamento elastico dovuto ai soli carichi variabili (§4.2.4.2.1 - NTC 2008)

x	Comb.	δ_2	L/300.00	Cs
cm		mm	mm	
133.2	15	-0.54	8.88	16.4

Travata: 1076 [204 , 221]

L = 286.0cm

Crit.Prog: Acciaio_Flessione $\delta_c = 0.0cm$ Verifica: **Verificata**

Verifica spostamento nello stato finale (§4.2.4.2.1 - NTC 2008)

x	Comb.	δ_{max}	L/250.00	Cs
cm		mm	mm	
85.8	15	-0.21	11.44	55.1

Verifica spostamento elastico dovuto ai soli carichi variabili (§4.2.4.2.1 - NTC 2008)

x	Comb.	δ_2	L/300.00	Cs
cm		mm	mm	
85.8	15	-0.13	9.53	75.4

Travata: 1077 [221 , 238]

L = 286.0cm

Crit.Prog: Acciaio_Flessione $\delta_c = 0.0cm$ Verifica: **Verificata**

Verifica spostamento nello stato finale (§4.2.4.2.1 - NTC 2008)

x	Comb.	δ_{max}	L/250.00	Cs
---	-------	----------------	----------	----

AUTOSTRADA VALDASTICO A31 NORD
1° LOTTO - PIOVENE ROCCHETTE – VALLE DELL'ASTICO

x	Comb.	δ_{max}	L/250.00	Cs
cm		mm	mm	
143.0	15	0.36	11.44	31.9

Verifica spostamento elastico dovuto ai soli carichi variabili (§4.2.4.2.1 - NTC 2008)

x	Comb.	δ_2	L/300.00	Cs
cm		mm	mm	
143.0	15	0.21	9.53	45.8

Travata: 1078 [238 , 255]

L = 286.0cm

Crit.Prog: Acciaio_Flessione $\delta_c = 0.0cm$ Verifica: **Verificata**

Verifica spostamento nello stato finale (§4.2.4.2.1 - NTC 2008)

x	Comb.	δ_{max}	L/250.00	Cs
cm		mm	mm	
85.8	15	0.17	11.44	68.2

Verifica spostamento elastico dovuto ai soli carichi variabili (§4.2.4.2.1 - NTC 2008)

x	Comb.	δ_2	L/300.00	Cs
cm		mm	mm	
85.8	15	0.09	9.53	>100

Travata: 1079 [255 , 272]

L = 286.0cm

Crit.Prog: Acciaio_Flessione $\delta_c = 0.0cm$ Verifica: **Verificata**

Verifica spostamento nello stato finale (§4.2.4.2.1 - NTC 2008)

x	Comb.	δ_{max}	L/250.00	Cs
---	-------	----------------	----------	----

AUTOSTRADA VALDASTICO A31 NORD
1° LOTTO - PIOVENE ROCCHETTE – VALLE DELL'ASTICO

x	Comb.	δ_{max}	L/250.00	Cs
cm		mm	mm	
143.0	15	-0.50	11.44	22.7

Verifica spostamento elastico dovuto ai soli carichi variabili (§4.2.4.2.1 - NTC 2008)

x	Comb.	δ_2	L/300.00	Cs
cm		mm	mm	
143.0	15	-0.36	9.53	26.6

Travata: 1080 [272 , 289]

L = 286.0cm

Crit.Prog: Acciaio_Flessione $\delta_c = 0.0cm$ Verifica: **Verificata**

Verifica spostamento nello stato finale (§4.2.4.2.1 - NTC 2008)

x	Comb.	δ_{max}	L/250.00	Cs
cm		mm	mm	
200.2	15	0.23	11.44	49.7

Verifica spostamento elastico dovuto ai soli carichi variabili (§4.2.4.2.1 - NTC 2008)

x	Comb.	δ_2	L/300.00	Cs
cm		mm	mm	
200.2	15	0.12	9.53	77.4

Travata: 1081 [289 , 306]

L = 286.0cm

Crit.Prog: Acciaio_Flessione $\delta_c = 0.0cm$ Verifica: **Verificata**

Verifica spostamento nello stato finale (§4.2.4.2.1 - NTC 2008)

x	Comb.	δ_{max}	L/250.00	Cs
---	-------	----------------	----------	----

AUTOSTRADA VALDASTICO A31 NORD
1° LOTTO - PIOVENE ROCCHETTE – VALLE DELL'ASTICO

x	Comb.	δ_{max}	L/250.00	Cs
cm		mm	mm	
143.0	15	0.49	11.44	23.5

Verifica spostamento elastico dovuto ai soli carichi variabili (§4.2.4.2.1 - NTC 2008)

x	Comb.	δ_2	L/300.00	Cs
cm		mm	mm	
143.0	15	0.28	9.53	34.2

Travata: 1082 [306 , 349]

L = 286.0cm

Crit.Prog: Acciaio_Flessione $\delta_c = 0.0cm$ Verifica: **Verificata**

Verifica spostamento nello stato finale (§4.2.4.2.1 - NTC 2008)

x	Comb.	δ_{max}	L/250.00	Cs
cm		mm	mm	
85.8	15	0.20	11.44	58.1

Verifica spostamento elastico dovuto ai soli carichi variabili (§4.2.4.2.1 - NTC 2008)

x	Comb.	δ_2	L/300.00	Cs
cm		mm	mm	
85.8	15	0.10	9.53	92.0

Travata: 1083 [349 , 332]

L = 286.0cm

Crit.Prog: Acciaio_Flessione $\delta_c = 0.0cm$ Verifica: **Verificata**

Verifica spostamento nello stato finale (§4.2.4.2.1 - NTC 2008)

x	Comb.	δ_{max}	L/250.00	Cs
---	-------	----------------	----------	----

AUTOSTRADA VALDASTICO A31 NORD
1° LOTTO - PIOVENE ROCCHETTE – VALLE DELL'ASTICO

x	Comb.	δ_{max}	L/250.00	Cs
cm		mm	mm	
143.0	15	-0.60	11.44	19.0

Verifica spostamento elastico dovuto ai soli carichi variabili (§4.2.4.2.1 - NTC 2008)

x	Comb.	δ_2	L/300.00	Cs
cm		mm	mm	
143.0	15	-0.42	9.53	22.9

Travata: 1084 [332 , 357]

L = 286.0cm

Crit.Prog: Acciaio_Flessione $\delta_c = 0.0cm$ Verifica: **Verificata**

Verifica spostamento nello stato finale (§4.2.4.2.1 - NTC 2008)

x	Comb.	δ_{max}	L/250.00	Cs
cm		mm	mm	
200.2	15	0.19	11.44	61.0

Verifica spostamento elastico dovuto ai soli carichi variabili (§4.2.4.2.1 - NTC 2008)

x	Comb.	δ_2	L/300.00	Cs
cm		mm	mm	
200.2	15	0.10	9.53	95.2

Travata: 1085 [357 , 374]

L = 286.0cm

Crit.Prog: Acciaio_Flessione $\delta_c = 0.0cm$ Verifica: **Verificata**

Verifica spostamento nello stato finale (§4.2.4.2.1 - NTC 2008)

x	Comb.	δ_{max}	L/250.00	Cs
---	-------	----------------	----------	----

AUTOSTRADA VALDASTICO A31 NORD
1° LOTTO - PIOVENE ROCCHETTE – VALLE DELL'ASTICO

x	Comb.	δ_{max}	L/250.00	Cs
cm		mm	mm	
143.0	15	0.47	11.44	24.6

Verifica spostamento elastico dovuto ai soli carichi variabili (§4.2.4.2.1 - NTC 2008)

x	Comb.	δ_2	L/300.00	Cs
cm		mm	mm	
143.0	15	0.27	9.53	35.2

Travata: 1086 [374 , 391]

L = 286.0cm

Crit.Prog: Acciaio_Flessione $\delta_c = 0.0cm$ Verifica: **Verificata**

Verifica spostamento nello stato finale (§4.2.4.2.1 - NTC 2008)

x	Comb.	δ_{max}	L/250.00	Cs
cm		mm	mm	
85.8	15	0.20	11.44	56.0

Verifica spostamento elastico dovuto ai soli carichi variabili (§4.2.4.2.1 - NTC 2008)

x	Comb.	δ_2	L/300.00	Cs
cm		mm	mm	
85.8	15	0.12	9.53	79.2

Travata: 1087 [391 , 468]

L = 274.8cm

Crit.Prog: Acciaio_Flessione $\delta_c = 0.0cm$ Verifica: **Verificata**

Verifica spostamento nello stato finale (§4.2.4.2.1 - NTC 2008)

x	Comb.	δ_{max}	L/250.00	Cs
---	-------	----------------	----------	----

AUTOSTRADA VALDASTICO A31 NORD
1° LOTTO - PIOVENE ROCCHETTE – VALLE DELL'ASTICO

x	Comb.	δ_{max}	L/250.00	Cs
cm		mm	mm	
137.4	15	-0.51	10.99	21.4

Verifica spostamento elastico dovuto ai soli carichi variabili (§4.2.4.2.1 - NTC 2008)

x	Comb.	δ_2	L/300.00	Cs
cm		mm	mm	
137.4	15	-0.33	9.16	28.0

Travata: 1088 [468 , 485]

L = 264.5cm

Crit.Prog: Acciaio_Flessione $\delta_c = 0.0cm$ Verifica: **Verificata**

Verifica spostamento nello stato finale (§4.2.4.2.1 - NTC 2008)

x	Comb.	δ_{max}	L/250.00	Cs
cm		mm	mm	
79.4	15	-0.11	10.58	>100

Verifica spostamento elastico dovuto ai soli carichi variabili (§4.2.4.2.1 - NTC 2008)

x	Comb.	δ_2	L/300.00	Cs
cm		mm	mm	
79.4	15	-0.08	8.82	>100

Travata: 1089 [185 , 256]

L = 654.3cm

Crit.Prog: Acciaio_Flessione $\delta_c = 0.0cm$ Verifica: **Verificata**

Verifica spostamento nello stato finale (§4.2.4.2.1 - NTC 2008)

x	Comb.	δ_{max}	L/250.00	Cs
---	-------	----------------	----------	----

AUTOSTRADA VALDASTICO A31 NORD
1° LOTTO - PIOVENE ROCCHETTE – VALLE DELL'ASTICO

x	Comb.	δ_{max}	L/250.00	Cs
cm		mm	mm	
196.3	15	-0.01	26.17	>100

Verifica spostamento elastico dovuto ai soli carichi variabili (§4.2.4.2.1 - NTC 2008)

x	Comb.	δ_2	L/300.00	Cs
cm		mm	mm	
261.7	15	-0.02	21.81	>100

Travata: 1090 [181 , 257]

L = 655.1cm

Crit.Prog: Acciaio_Flessione $\delta_c = 0.0cm$ Verifica: **Verificata**

Verifica spostamento nello stato finale (§4.2.4.2.1 - NTC 2008)

x	Comb.	δ_{max}	L/250.00	Cs
cm		mm	mm	
262.1	15	0.03	26.21	>100

Verifica spostamento elastico dovuto ai soli carichi variabili (§4.2.4.2.1 - NTC 2008)

x	Comb.	δ_2	L/300.00	Cs
cm		mm	mm	
196.5	15	0.02	21.84	>100

Travata: 1091 [186 , 324]

L = 654.3cm

Crit.Prog: Acciaio_Flessione $\delta_c = 0.0cm$ Verifica: **Verificata**

Verifica spostamento nello stato finale (§4.2.4.2.1 - NTC 2008)

x	Comb.	δ_{max}	L/250.00	Cs
---	-------	----------------	----------	----

AUTOSTRADA VALDASTICO A31 NORD
1° LOTTO - PIOVENE ROCCHETTE – VALLE DELL'ASTICO

x	Comb.	δ_{max}	L/250.00	Cs
cm		mm	mm	
196.3	15	-0.01	26.17	>100

Verifica spostamento elastico dovuto ai soli carichi variabili (§4.2.4.2.1 - NTC 2008)

x	Comb.	δ_2	L/300.00	Cs
cm		mm	mm	
261.7	15	-0.02	21.81	>100

Travata: 1092 [182 , 323]

L = 655.1cm

Crit.Prog: Acciaio_Flessione $\delta_c = 0.0cm$ Verifica: **Verificata**

Verifica spostamento nello stato finale (§4.2.4.2.1 - NTC 2008)

x	Comb.	δ_{max}	L/250.00	Cs
cm		mm	mm	
262.1	15	0.03	26.21	>100

Verifica spostamento elastico dovuto ai soli carichi variabili (§4.2.4.2.1 - NTC 2008)

x	Comb.	δ_2	L/300.00	Cs
cm		mm	mm	
196.5	15	0.02	21.84	>100

Travata: 1093 [184 , 196]

L = 654.3cm

Crit.Prog: Acciaio_Flessione $\delta_c = 0.0cm$ Verifica: **Verificata**

Verifica spostamento nello stato finale (§4.2.4.2.1 - NTC 2008)

x	Comb.	δ_{max}	L/250.00	Cs
---	-------	----------------	----------	----

AUTOSTRADA VALDASTICO A31 NORD
1° LOTTO - PIOVENE ROCCHETTE – VALLE DELL'ASTICO

x	Comb.	δ_{max}	L/250.00	Cs
cm		mm	mm	
196.3	15	-0.02	26.17	>100

Verifica spostamento elastico dovuto ai soli carichi variabili (§4.2.4.2.1 - NTC 2008)

x	Comb.	δ_2	L/300.00	Cs
cm		mm	mm	
261.7	15	-0.02	21.81	>100

Travata: 1094 [180 , 195]

L = 655.1cm

Crit.Prog: Acciaio_Flessione $\delta_c = 0.0cm$ Verifica: **Verificata**

Verifica spostamento nello stato finale (§4.2.4.2.1 - NTC 2008)

x	Comb.	δ_{max}	L/250.00	Cs
cm		mm	mm	
262.1	15	0.04	26.21	>100

Verifica spostamento elastico dovuto ai soli carichi variabili (§4.2.4.2.1 - NTC 2008)

x	Comb.	δ_2	L/300.00	Cs
cm		mm	mm	
196.5	15	0.03	21.84	>100

Travata: 1095 [187 , 392]

L = 654.3cm

Crit.Prog: Acciaio_Flessione $\delta_c = 0.0cm$ Verifica: **Verificata**

Verifica spostamento nello stato finale (§4.2.4.2.1 - NTC 2008)

x	Comb.	δ_{max}	L/250.00	Cs
---	-------	----------------	----------	----

AUTOSTRADA VALDASTICO A31 NORD
1° LOTTO - PIOVENE ROCCHETTE – VALLE DELL'ASTICO

x	Comb.	δ_{max}	L/250.00	Cs
cm		mm	mm	
196.3	15	-0.01	26.17	>100

Verifica spostamento elastico dovuto ai soli carichi variabili (§4.2.4.2.1 - NTC 2008)

x	Comb.	δ_2	L/300.00	Cs
cm		mm	mm	
261.7	15	-0.01	21.81	>100

Travata: 1096 [183 , 393]

L = 655.1cm

Crit.Prog: Acciaio_Flessione $\delta_c = 0.0cm$ Verifica: **Verificata**

Verifica spostamento nello stato finale (§4.2.4.2.1 - NTC 2008)

x	Comb.	δ_{max}	L/250.00	Cs
cm		mm	mm	
262.1	15	0.03	26.21	>100

Verifica spostamento elastico dovuto ai soli carichi variabili (§4.2.4.2.1 - NTC 2008)

x	Comb.	δ_2	L/300.00	Cs
cm		mm	mm	
196.5	15	0.02	21.84	>100

Travata: 1097 [176 , 189]

L = 654.7cm

Crit.Prog: Acciaio_Flessione $\delta_c = 0.0cm$ Verifica: **Verificata**

Verifica spostamento nello stato finale (§4.2.4.2.1 - NTC 2008)

x	Comb.	δ_{max}	L/250.00	Cs
---	-------	----------------	----------	----

AUTOSTRADA VALDASTICO A31 NORD
1° LOTTO - PIOVENE ROCCHETTE – VALLE DELL'ASTICO

x	Comb.	δ_{max}	L/250.00	Cs
cm		mm	mm	
261.9	15	0.06	26.19	>100

Verifica spostamento elastico dovuto ai soli carichi variabili (§4.2.4.2.1 - NTC 2008)

x	Comb.	δ_2	L/300.00	Cs
cm		mm	mm	
261.9	15	0.03	21.82	>100

Travata: 1098 [172 , 188]

L = 654.7cm

Crit.Prog: Acciaio_Flessione $\delta_c = 0.0cm$ Verifica: **Verificata**

Verifica spostamento nello stato finale (§4.2.4.2.1 - NTC 2008)

x	Comb.	δ_{max}	L/250.00	Cs
cm		mm	mm	
261.9	15	-0.04	26.19	>100

Verifica spostamento elastico dovuto ai soli carichi variabili (§4.2.4.2.1 - NTC 2008)

x	Comb.	δ_2	L/300.00	Cs
cm		mm	mm	
261.9	15	-0.03	21.82	>100

Travata: 1099 [177 , 263]

L = 654.7cm

Crit.Prog: Acciaio_Flessione $\delta_c = 0.0cm$ Verifica: **Verificata**

Verifica spostamento nello stato finale (§4.2.4.2.1 - NTC 2008)

x	Comb.	δ_{max}	L/250.00	Cs
---	-------	----------------	----------	----

AUTOSTRADA VALDASTICO A31 NORD
1° LOTTO - PIOVENE ROCCHETTE – VALLE DELL'ASTICO

x	Comb.	δ_{max}	L/250.00	Cs
cm		mm	mm	
261.9	15	0.05	26.19	>100

Verifica spostamento elastico dovuto ai soli carichi variabili (§4.2.4.2.1 - NTC 2008)

x	Comb.	δ_2	L/300.00	Cs
cm		mm	mm	
261.9	15	0.03	21.82	>100

Travata: 1100 [173 , 264]

L = 654.7cm

Crit.Prog: Acciaio_Flessione $\delta_c = 0.0cm$ Verifica: **Verificata**

Verifica spostamento nello stato finale (§4.2.4.2.1 - NTC 2008)

x	Comb.	δ_{max}	L/250.00	Cs
cm		mm	mm	
261.9	15	-0.03	26.19	>100

Verifica spostamento elastico dovuto ai soli carichi variabili (§4.2.4.2.1 - NTC 2008)

x	Comb.	δ_2	L/300.00	Cs
cm		mm	mm	
261.9	15	-0.02	21.82	>100

Travata: 1101 [178 , 317]

L = 654.7cm

Crit.Prog: Acciaio_Flessione $\delta_c = 0.0cm$ Verifica: **Verificata**

Verifica spostamento nello stato finale (§4.2.4.2.1 - NTC 2008)

x	Comb.	δ_{max}	L/250.00	Cs
---	-------	----------------	----------	----

AUTOSTRADA VALDASTICO A31 NORD
1° LOTTO - PIOVENE ROCCHETTE – VALLE DELL'ASTICO

x	Comb.	δ_{max}	L/250.00	Cs
cm		mm	mm	
261.9	15	0.05	26.19	>100

Verifica spostamento elastico dovuto ai soli carichi variabili (§4.2.4.2.1 - NTC 2008)

x	Comb.	δ_2	L/300.00	Cs
cm		mm	mm	
261.9	15	0.03	21.82	>100

Travata: 1102 [174 , 316]

L = 654.7cm

Crit.Prog: Acciaio_Flessione $\delta_c = 0.0cm$ Verifica: **Verificata**

Verifica spostamento nello stato finale (§4.2.4.2.1 - NTC 2008)

x	Comb.	δ_{max}	L/250.00	Cs
cm		mm	mm	
261.9	15	-0.03	26.19	>100

Verifica spostamento elastico dovuto ai soli carichi variabili (§4.2.4.2.1 - NTC 2008)

x	Comb.	δ_2	L/300.00	Cs
cm		mm	mm	
261.9	15	-0.02	21.82	>100

Travata: 1103 [179 , 399]

L = 654.7cm

Crit.Prog: Acciaio_Flessione $\delta_c = 0.0cm$ Verifica: **Verificata**

Verifica spostamento nello stato finale (§4.2.4.2.1 - NTC 2008)

x	Comb.	δ_{max}	L/250.00	Cs
---	-------	----------------	----------	----

AUTOSTRADA VALDASTICO A31 NORD
1° LOTTO - PIOVENE ROCCHETTE – VALLE DELL'ASTICO

x	Comb.	δ_{max}	L/250.00	Cs
cm		mm	mm	
261.9	15	0.04	26.19	>100

Verifica spostamento elastico dovuto ai soli carichi variabili (§4.2.4.2.1 - NTC 2008)

x	Comb.	δ_2	L/300.00	Cs
cm		mm	mm	
261.9	15	0.02	21.82	>100

Travata: 1104 [175 , 400]

L = 654.7cm

Crit.Prog: Acciaio_Flessione $\delta_c = 0.0cm$ Verifica: **Verificata**

Verifica spostamento nello stato finale (§4.2.4.2.1 - NTC 2008)

x	Comb.	δ_{max}	L/250.00	Cs
cm		mm	mm	
261.9	15	-0.03	26.19	>100

Verifica spostamento elastico dovuto ai soli carichi variabili (§4.2.4.2.1 - NTC 2008)

x	Comb.	δ_2	L/300.00	Cs
cm		mm	mm	
261.9	15	-0.02	21.82	>100

Travata: 1105 [479 , 502]

L = 248.8cm

Crit.Prog: Acciaio_Flessione $\delta_c = 0.0cm$ Verifica: **Verificata**

Verifica spostamento nello stato finale (§4.2.4.2.1 - NTC 2008)

x	Comb.	δ_{max}	L/250.00	Cs
---	-------	----------------	----------	----

AUTOSTRADA VALDASTICO A31 NORD
1° LOTTO - PIOVENE ROCCHETTE – VALLE DELL'ASTICO

x	Comb.	δ_{max}	L/250.00	Cs
cm		mm	mm	
149.3	15	0.54	9.95	18.6

Verifica spostamento elastico dovuto ai soli carichi variabili (§4.2.4.2.1 - NTC 2008)

x	Comb.	δ_2	L/300.00	Cs
cm		mm	mm	
149.3	15	0.38	8.29	21.7

Travata: 1106 [502 , 501]

L = 263.5cm

Crit.Prog: Acciaio_Flessione $\delta_c = 0.0cm$ Verifica: **Verificata**

Verifica spostamento nello stato finale (§4.2.4.2.1 - NTC 2008)

x	Comb.	δ_{max}	L/250.00	Cs
cm		mm	mm	
158.1	15	-0.14	10.54	73.6

Verifica spostamento elastico dovuto ai soli carichi variabili (§4.2.4.2.1 - NTC 2008)

x	Comb.	δ_2	L/300.00	Cs
cm		mm	mm	
131.7	15	-0.11	8.78	79.4

Travata: 1107 [501 , 462]

L = 248.8cm

Crit.Prog: Acciaio_Flessione $\delta_c = 0.0cm$ Verifica: **Verificata**

Verifica spostamento nello stato finale (§4.2.4.2.1 - NTC 2008)

x	Comb.	δ_{max}	L/250.00	Cs
---	-------	----------------	----------	----

AUTOSTRADA VALDASTICO A31 NORD
1° LOTTO - PIOVENE ROCCHETTE – VALLE DELL'ASTICO

x	Comb.	δ_{max}	L/250.00	Cs
cm		mm	mm	
99.5	15	1.10	9.95	9.06

Verifica spostamento elastico dovuto ai soli carichi variabili (§4.2.4.2.1 - NTC 2008)

x	Comb.	δ_2	L/300.00	Cs
cm		mm	mm	
99.5	15	0.80	8.29	10.3

Travata: 1108 [501 , 461]

L = 160.6cm

Crit.Prog: Acciaio_Flessione $\delta_c = 0.0cm$ Verifica: **Verificata**

Verifica spostamento nello stato finale (§4.2.4.2.1 - NTC 2008)

x	Comb.	δ_{max}	L/250.00	Cs
cm		mm	mm	
32.1	15	0.06	6.42	>100

Verifica spostamento elastico dovuto ai soli carichi variabili (§4.2.4.2.1 - NTC 2008)

x	Comb.	δ_2	L/300.00	Cs
cm		mm	mm	
48.2	15	0.05	5.35	>100

Travata: 1109 [461 , 502]

L = 160.5cm

Crit.Prog: Acciaio_Flessione $\delta_c = 0.0cm$ Verifica: **Verificata**

Verifica spostamento nello stato finale (§4.2.4.2.1 - NTC 2008)

x	Comb.	δ_{max}	L/250.00	Cs
---	-------	----------------	----------	----

AUTOSTRADA VALDASTICO A31 NORD
1° LOTTO - PIOVENE ROCCHETTE – VALLE DELL'ASTICO

x	Comb.	δ_{max}	L/250.00	Cs
cm		mm	mm	
112.3	15	0.09	6.42	72.7

Verifica spostamento elastico dovuto ai soli carichi variabili (§4.2.4.2.1 - NTC 2008)

x	Comb.	δ_2	L/300.00	Cs
cm		mm	mm	
112.3	15	0.06	5.35	96.4

Travata: 1110 [501 , 500]

L = 274.7cm

Crit.Prog: Acciaio_Flessione $\delta_c = 0.0cm$ Verifica: **Verificata**

Verifica spostamento nello stato finale (§4.2.4.2.1 - NTC 2008)

x	Comb.	δ_{max}	L/250.00	Cs
cm		mm	mm	
137.3	15	-0.21	10.99	51.2

Verifica spostamento elastico dovuto ai soli carichi variabili (§4.2.4.2.1 - NTC 2008)

x	Comb.	δ_2	L/300.00	Cs
cm		mm	mm	
137.3	15	-0.14	9.16	64.8

Travata: 1111 [500 , 390]

L = 248.8cm

Crit.Prog: Acciaio_Flessione $\delta_c = 0.0cm$ Verifica: **Verificata**

Verifica spostamento nello stato finale (§4.2.4.2.1 - NTC 2008)

x	Comb.	δ_{max}	L/250.00	Cs
---	-------	----------------	----------	----

AUTOSTRADA VALDASTICO A31 NORD
1° LOTTO - PIOVENE ROCCHETTE – VALLE DELL'ASTICO

x	Comb.	δ_{max}	L/250.00	Cs
cm		mm	mm	
99.5	15	1.15	9.95	8.67

Verifica spostamento elastico dovuto ai soli carichi variabili (§4.2.4.2.1 - NTC 2008)

x	Comb.	δ_2	L/300.00	Cs
cm		mm	mm	
99.5	15	0.83	8.29	9.95

Travata: 1112 [500 , 392]

L = 169.9cm

Crit.Prog: Acciaio_Flessione $\delta_c = 0.0cm$ Verifica: **Verificata**

Verifica spostamento nello stato finale (§4.2.4.2.1 - NTC 2008)

x	Comb.	δ_{max}	L/250.00	Cs
cm		mm	mm	
51.0	15	0.12	6.80	54.8

Verifica spostamento elastico dovuto ai soli carichi variabili (§4.2.4.2.1 - NTC 2008)

x	Comb.	δ_2	L/300.00	Cs
cm		mm	mm	
51.0	15	0.09	5.66	63.1

Travata: 1113 [392 , 501]

L = 160.5cm

Crit.Prog: Acciaio_Flessione $\delta_c = 0.0cm$ Verifica: **Verificata**

Verifica spostamento nello stato finale (§4.2.4.2.1 - NTC 2008)

x	Comb.	δ_{max}	L/250.00	Cs
---	-------	----------------	----------	----

AUTOSTRADA VALDASTICO A31 NORD
1° LOTTO - PIOVENE ROCCHETTE – VALLE DELL'ASTICO

x	Comb.	δ_{max}	L/250.00	Cs
cm		mm	mm	
96.3	15	0.14	6.42	47.5

Verifica spostamento elastico dovuto ai soli carichi variabili (§4.2.4.2.1 - NTC 2008)

x	Comb.	δ_2	L/300.00	Cs
cm		mm	mm	
96.3	15	0.12	5.35	44.3

Travata: 1114 [500 , 499]

L = 286.0cm

Crit.Prog: Acciaio_Flessione $\delta_c = 0.0cm$ Verifica: **Verificata**

Verifica spostamento nello stato finale (§4.2.4.2.1 - NTC 2008)

x	Comb.	δ_{max}	L/250.00	Cs
cm		mm	mm	
200.2	15	0.09	11.44	>100

Verifica spostamento elastico dovuto ai soli carichi variabili (§4.2.4.2.1 - NTC 2008)

x	Comb.	δ_2	L/300.00	Cs
cm		mm	mm	
200.2	15	0.05	9.53	>100

Travata: 1115 [499 , 373]

L = 248.8cm

Crit.Prog: Acciaio_Flessione $\delta_c = 0.0cm$ Verifica: **Verificata**

Verifica spostamento nello stato finale (§4.2.4.2.1 - NTC 2008)

x	Comb.	δ_{max}	L/250.00	Cs
---	-------	----------------	----------	----

AUTOSTRADA VALDASTICO A31 NORD
1° LOTTO - PIOVENE ROCCHETTE – VALLE DELL'ASTICO

x	Comb.	δ_{max}	L/250.00	Cs
cm		mm	mm	
99.5	15	1.13	9.95	8.84

Verifica spostamento elastico dovuto ai soli carichi variabili (§4.2.4.2.1 - NTC 2008)

x	Comb.	δ_2	L/300.00	Cs
cm		mm	mm	
99.5	15	0.83	8.29	9.97

Travata: 1116 [499 , 375]

$L = 169.9cm$

Crit.Prog: Acciaio_Flessione $\delta_c = 0.0cm$ Verifica: **Verificata**

Verifica spostamento nello stato finale (§4.2.4.2.1 - NTC 2008)

x	Comb.	δ_{max}	L/250.00	Cs
cm		mm	mm	
68.0	15	0.23	6.80	29.5

Verifica spostamento elastico dovuto ai soli carichi variabili (§4.2.4.2.1 - NTC 2008)

x	Comb.	δ_2	L/300.00	Cs
cm		mm	mm	
68.0	15	0.17	5.66	34.3

Travata: 1117 [375 , 500]

$L = 169.9cm$

Crit.Prog: Acciaio_Flessione $\delta_c = 0.0cm$ Verifica: **Verificata**

Verifica spostamento nello stato finale (§4.2.4.2.1 - NTC 2008)

x	Comb.	δ_{max}	L/250.00	Cs
---	-------	----------------	----------	----

AUTOSTRADA VALDASTICO A31 NORD
1° LOTTO - PIOVENE ROCCHETTE – VALLE DELL'ASTICO

x	Comb.	δ_{max}	L/250.00	Cs
cm		mm	mm	
118.9	15	0.09	6.80	74.3

Verifica spostamento elastico dovuto ai soli carichi variabili (§4.2.4.2.1 - NTC 2008)

x	Comb.	δ_2	L/300.00	Cs
cm		mm	mm	
118.9	15	0.07	5.66	76.2

Travata: 1118 [499 , 498]

L = 286.0cm

Crit.Prog: Acciaio_Flessione $\delta_c = 0.0cm$ Verifica: **Verificata**

Verifica spostamento nello stato finale (§4.2.4.2.1 - NTC 2008)

x	Comb.	δ_{max}	L/250.00	Cs
cm		mm	mm	
143.0	15	0.37	11.44	31.3

Verifica spostamento elastico dovuto ai soli carichi variabili (§4.2.4.2.1 - NTC 2008)

x	Comb.	δ_2	L/300.00	Cs
cm		mm	mm	
143.0	15	0.21	9.53	44.9

Travata: 1119 [498 , 356]

L = 248.8cm

Crit.Prog: Acciaio_Flessione $\delta_c = 0.0cm$ Verifica: **Verificata**

Verifica spostamento nello stato finale (§4.2.4.2.1 - NTC 2008)

x	Comb.	δ_{max}	L/250.00	Cs
---	-------	----------------	----------	----

AUTOSTRADA VALDASTICO A31 NORD
1° LOTTO - PIOVENE ROCCHETTE – VALLE DELL'ASTICO

x	Comb.	δ_{max}	L/250.00	Cs
cm		mm	mm	
99.5	15	1.13	9.95	8.84

Verifica spostamento elastico dovuto ai soli carichi variabili (§4.2.4.2.1 - NTC 2008)

x	Comb.	δ_2	L/300.00	Cs
cm		mm	mm	
99.5	15	0.83	8.29	9.97

Travata: 1120 [498 , 358]

L = 169.9cm

Crit.Prog: Acciaio_Flessione $\delta_c = 0.0cm$ Verifica: **Verificata**

Verifica spostamento nello stato finale (§4.2.4.2.1 - NTC 2008)

x	Comb.	δ_{max}	L/250.00	Cs
cm		mm	mm	
68.0	15	0.22	6.80	30.6

Verifica spostamento elastico dovuto ai soli carichi variabili (§4.2.4.2.1 - NTC 2008)

x	Comb.	δ_2	L/300.00	Cs
cm		mm	mm	
68.0	15	0.16	5.66	36.0

Travata: 1121 [358 , 499]

L = 169.9cm

Crit.Prog: Acciaio_Flessione $\delta_c = 0.0cm$ Verifica: **Verificata**

Verifica spostamento nello stato finale (§4.2.4.2.1 - NTC 2008)

x	Comb.	δ_{max}	L/250.00	Cs
---	-------	----------------	----------	----

AUTOSTRADA VALDASTICO A31 NORD
1° LOTTO - PIOVENE ROCCHETTE – VALLE DELL'ASTICO

x	Comb.	δ_{max}	L/250.00	Cs
cm		mm	mm	
101.9	15	0.22	6.80	31.3

Verifica spostamento elastico dovuto ai soli carichi variabili (§4.2.4.2.1 - NTC 2008)

x	Comb.	δ_2	L/300.00	Cs
cm		mm	mm	
101.9	15	0.15	5.66	36.8

Travata: 1122 [331 , 497]

L = 248.8cm

Crit.Prog: Acciaio_Flessione $\delta_c = 0.0cm$ Verifica: **Verificata**

Verifica spostamento nello stato finale (§4.2.4.2.1 - NTC 2008)

x	Comb.	δ_{max}	L/250.00	Cs
cm		mm	mm	
149.3	15	1.18	9.95	8.41

Verifica spostamento elastico dovuto ai soli carichi variabili (§4.2.4.2.1 - NTC 2008)

x	Comb.	δ_2	L/300.00	Cs
cm		mm	mm	
149.3	15	0.86	8.29	9.61

Travata: 1123 [497 , 498]

L = 286.0cm

Crit.Prog: Acciaio_Flessione $\delta_c = 0.0cm$ Verifica: **Verificata**

Verifica spostamento nello stato finale (§4.2.4.2.1 - NTC 2008)

x	Comb.	δ_{max}	L/250.00	Cs
---	-------	----------------	----------	----

AUTOSTRADA VALDASTICO A31 NORD
1° LOTTO - PIOVENE ROCCHETTE – VALLE DELL'ASTICO

x	Comb.	δ_{max}	L/250.00	Cs
cm		mm	mm	
171.6	17	0.05	11.44	>100

Verifica spostamento elastico dovuto ai soli carichi variabili (§4.2.4.2.1 - NTC 2008)

x	Comb.	δ_2	L/300.00	Cs
cm		mm	mm	
85.8	15	-0.04	9.53	>100

Travata: 1124 [498 , 333]

L = 169.9cm

Crit.Prog: Acciaio_Flessione $\delta_c = 0.0cm$ Verifica: **Verificata**

Verifica spostamento nello stato finale (§4.2.4.2.1 - NTC 2008)

x	Comb.	δ_{max}	L/250.00	Cs
cm		mm	mm	
68.0	15	0.22	6.80	31.4

Verifica spostamento elastico dovuto ai soli carichi variabili (§4.2.4.2.1 - NTC 2008)

x	Comb.	δ_2	L/300.00	Cs
cm		mm	mm	
68.0	15	0.15	5.66	37.5

Travata: 1125 [333 , 497]

L = 169.9cm

Crit.Prog: Acciaio_Flessione $\delta_c = 0.0cm$ Verifica: **Verificata**

Verifica spostamento nello stato finale (§4.2.4.2.1 - NTC 2008)

x	Comb.	δ_{max}	L/250.00	Cs
---	-------	----------------	----------	----

AUTOSTRADA VALDASTICO A31 NORD
1° LOTTO - PIOVENE ROCCHETTE – VALLE DELL'ASTICO

x	Comb.	δ_{max}	L/250.00	Cs
cm		mm	mm	
118.9	15	0.08	6.80	84.1

Verifica spostamento elastico dovuto ai soli carichi variabili (§4.2.4.2.1 - NTC 2008)

x	Comb.	δ_2	L/300.00	Cs
cm		mm	mm	
118.9	15	0.06	5.66	88.2

Travata: 1126 [497 , 496]

L = 286.0cm

Crit.Prog: Acciaio_Flessione $\delta_c = 0.0cm$ Verifica: **Verificata**

Verifica spostamento nello stato finale (§4.2.4.2.1 - NTC 2008)

x	Comb.	δ_{max}	L/250.00	Cs
cm		mm	mm	
143.0	15	-0.27	11.44	42.9

Verifica spostamento elastico dovuto ai soli carichi variabili (§4.2.4.2.1 - NTC 2008)

x	Comb.	δ_2	L/300.00	Cs
cm		mm	mm	
143.0	15	-0.20	9.53	48.2

Travata: 1127 [496 , 348]

L = 248.8cm

Crit.Prog: Acciaio_Flessione $\delta_c = 0.0cm$ Verifica: **Verificata**

Verifica spostamento nello stato finale (§4.2.4.2.1 - NTC 2008)

x	Comb.	δ_{max}	L/250.00	Cs
---	-------	----------------	----------	----

AUTOSTRADA VALDASTICO A31 NORD
1° LOTTO - PIOVENE ROCCHETTE – VALLE DELL'ASTICO

x	Comb.	δ_{max}	L/250.00	Cs
cm		mm	mm	
99.5	15	1.18	9.95	8.41

Verifica spostamento elastico dovuto ai soli carichi variabili (§4.2.4.2.1 - NTC 2008)

x	Comb.	δ_2	L/300.00	Cs
cm		mm	mm	
99.5	15	0.87	8.29	9.58

Travata: 1128 [497 , 324]

L = 169.9cm

Crit.Prog: Acciaio_Flessione $\delta_c = 0.0cm$ Verifica: **Verificata**

Verifica spostamento nello stato finale (§4.2.4.2.1 - NTC 2008)

x	Comb.	δ_{max}	L/250.00	Cs
cm		mm	mm	
68.0	15	0.14	6.80	50.1

Verifica spostamento elastico dovuto ai soli carichi variabili (§4.2.4.2.1 - NTC 2008)

x	Comb.	δ_2	L/300.00	Cs
cm		mm	mm	
68.0	15	0.10	5.66	54.9

Travata: 1129 [324 , 496]

L = 169.9cm

Crit.Prog: Acciaio_Flessione $\delta_c = 0.0cm$ Verifica: **Verificata**

Verifica spostamento nello stato finale (§4.2.4.2.1 - NTC 2008)

x	Comb.	δ_{max}	L/250.00	Cs
---	-------	----------------	----------	----

AUTOSTRADA VALDASTICO A31 NORD
1° LOTTO - PIOVENE ROCCHETTE – VALLE DELL'ASTICO

x	Comb.	δ_{max}	L/250.00	Cs
cm		mm	mm	
101.9	15	0.14	6.80	49.9

Verifica spostamento elastico dovuto ai soli carichi variabili (§4.2.4.2.1 - NTC 2008)

x	Comb.	δ_2	L/300.00	Cs
cm		mm	mm	
101.9	15	0.11	5.66	51.2

Travata: 1130 [305 , 495]

L = 248.8cm

Crit.Prog: Acciaio_Flessione $\delta_c = 0.0cm$ Verifica: **Verificata**

Verifica spostamento nello stato finale (§4.2.4.2.1 - NTC 2008)

x	Comb.	δ_{max}	L/250.00	Cs
cm		mm	mm	
149.3	15	1.13	9.95	8.82

Verifica spostamento elastico dovuto ai soli carichi variabili (§4.2.4.2.1 - NTC 2008)

x	Comb.	δ_2	L/300.00	Cs
cm		mm	mm	
149.3	15	0.83	8.29	9.95

Travata: 1131 [495 , 496]

L = 286.0cm

Crit.Prog: Acciaio_Flessione $\delta_c = 0.0cm$ Verifica: **Verificata**

Verifica spostamento nello stato finale (§4.2.4.2.1 - NTC 2008)

x	Comb.	δ_{max}	L/250.00	Cs
---	-------	----------------	----------	----

AUTOSTRADA VALDASTICO A31 NORD
1° LOTTO - PIOVENE ROCCHETTE – VALLE DELL'ASTICO

x	Comb.	δ_{max}	L/250.00	Cs
cm		mm	mm	
114.4	17	0.06	11.44	>100

Verifica spostamento elastico dovuto ai soli carichi variabili (§4.2.4.2.1 - NTC 2008)

x	Comb.	δ_2	L/300.00	Cs
cm		mm	mm	
228.8	15	-0.04	9.53	>100

Travata: 1132 [496 , 307]

L = 169.9cm

Crit.Prog: Acciaio_Flessione $\delta_c = 0.0cm$ Verifica: **Verificata**

Verifica spostamento nello stato finale (§4.2.4.2.1 - NTC 2008)

x	Comb.	δ_{max}	L/250.00	Cs
cm		mm	mm	
51.0	15	0.08	6.80	81.3

Verifica spostamento elastico dovuto ai soli carichi variabili (§4.2.4.2.1 - NTC 2008)

x	Comb.	δ_2	L/300.00	Cs
cm		mm	mm	
51.0	15	0.06	5.66	88.1

Travata: 1133 [307 , 495]

L = 169.9cm

Crit.Prog: Acciaio_Flessione $\delta_c = 0.0cm$ Verifica: **Verificata**

Verifica spostamento nello stato finale (§4.2.4.2.1 - NTC 2008)

x	Comb.	δ_{max}	L/250.00	Cs
---	-------	----------------	----------	----

AUTOSTRADA VALDASTICO A31 NORD
1° LOTTO - PIOVENE ROCCHETTE – VALLE DELL'ASTICO

x	Comb.	δ_{max}	L/250.00	Cs
cm		mm	mm	
101.9	15	0.22	6.80	30.7

Verifica spostamento elastico dovuto ai soli carichi variabili (§4.2.4.2.1 - NTC 2008)

x	Comb.	δ_2	L/300.00	Cs
cm		mm	mm	
101.9	15	0.15	5.66	36.7

Travata: 1134 [288 , 494]

L = 248.8cm

Crit.Prog: Acciaio_Flessione $\delta_c = 0.0cm$ Verifica: **Verificata**

Verifica spostamento nello stato finale (§4.2.4.2.1 - NTC 2008)

x	Comb.	δ_{max}	L/250.00	Cs
cm		mm	mm	
149.3	15	1.13	9.95	8.80

Verifica spostamento elastico dovuto ai soli carichi variabili (§4.2.4.2.1 - NTC 2008)

x	Comb.	δ_2	L/300.00	Cs
cm		mm	mm	
149.3	15	0.84	8.29	9.93

Travata: 1135 [494 , 495]

L = 286.0cm

Crit.Prog: Acciaio_Flessione $\delta_c = 0.0cm$ Verifica: **Verificata**

Verifica spostamento nello stato finale (§4.2.4.2.1 - NTC 2008)

x	Comb.	δ_{max}	L/250.00	Cs
---	-------	----------------	----------	----

AUTOSTRADA VALDASTICO A31 NORD
1° LOTTO - PIOVENE ROCCHETTE – VALLE DELL'ASTICO

x	Comb.	δ_{max}	L/250.00	Cs
cm		mm	mm	
143.0	15	0.39	11.44	29.4

Verifica spostamento elastico dovuto ai soli carichi variabili (§4.2.4.2.1 - NTC 2008)

x	Comb.	δ_2	L/300.00	Cs
cm		mm	mm	
143.0	15	0.22	9.53	44.3

Travata: 1136 [495 , 290]

L = 169.9cm

Crit.Prog: Acciaio_Flessione $\delta_c = 0.0cm$ Verifica: **Verificata**

Verifica spostamento nello stato finale (§4.2.4.2.1 - NTC 2008)

x	Comb.	δ_{max}	L/250.00	Cs
cm		mm	mm	
68.0	15	0.23	6.80	30.0

Verifica spostamento elastico dovuto ai soli carichi variabili (§4.2.4.2.1 - NTC 2008)

x	Comb.	δ_2	L/300.00	Cs
cm		mm	mm	
68.0	15	0.16	5.66	36.1

Travata: 1137 [290 , 494]

L = 169.9cm

Crit.Prog: Acciaio_Flessione $\delta_c = 0.0cm$ Verifica: **Verificata**

Verifica spostamento nello stato finale (§4.2.4.2.1 - NTC 2008)

x	Comb.	δ_{max}	L/250.00	Cs
---	-------	----------------	----------	----

AUTOSTRADA VALDASTICO A31 NORD
1° LOTTO - PIOVENE ROCCHETTE – VALLE DELL'ASTICO

x	Comb.	δ_{max}	L/250.00	Cs
cm		mm	mm	
101.9	15	0.22	6.80	30.2

Verifica spostamento elastico dovuto ai soli carichi variabili (§4.2.4.2.1 - NTC 2008)

x	Comb.	δ_2	L/300.00	Cs
cm		mm	mm	
101.9	15	0.16	5.66	36.3

Travata: 1138 [271 , 493]

L = 248.8cm

Crit.Prog: Acciaio_Flessione $\delta_c = 0.0cm$ Verifica: **Verificata**

Verifica spostamento nello stato finale (§4.2.4.2.1 - NTC 2008)

x	Comb.	δ_{max}	L/250.00	Cs
cm		mm	mm	
149.3	15	1.17	9.95	8.52

Verifica spostamento elastico dovuto ai soli carichi variabili (§4.2.4.2.1 - NTC 2008)

x	Comb.	δ_2	L/300.00	Cs
cm		mm	mm	
149.3	15	0.86	8.29	9.68

Travata: 1139 [493 , 494]

L = 286.0cm

Crit.Prog: Acciaio_Flessione $\delta_c = 0.0cm$ Verifica: **Verificata**

Verifica spostamento nello stato finale (§4.2.4.2.1 - NTC 2008)

x	Comb.	δ_{max}	L/250.00	Cs
---	-------	----------------	----------	----

AUTOSTRADA VALDASTICO A31 NORD
1° LOTTO - PIOVENE ROCCHETTE – VALLE DELL'ASTICO

x	Comb.	δ_{max}	L/250.00	Cs
cm		mm	mm	
171.6	15	0.12	11.44	98.2

Verifica spostamento elastico dovuto ai soli carichi variabili (§4.2.4.2.1 - NTC 2008)

x	Comb.	δ_2	L/300.00	Cs
cm		mm	mm	
200.2	15	0.04	9.53	>100

Travata: 1140 [494 , 273]

L = 169.9cm

Crit.Prog: Acciaio_Flessione $\delta_c = 0.0cm$ Verifica: **Verificata**

Verifica spostamento nello stato finale (§4.2.4.2.1 - NTC 2008)

x	Comb.	δ_{max}	L/250.00	Cs
cm		mm	mm	
68.0	15	0.24	6.80	28.3

Verifica spostamento elastico dovuto ai soli carichi variabili (§4.2.4.2.1 - NTC 2008)

x	Comb.	δ_2	L/300.00	Cs
cm		mm	mm	
68.0	15	0.17	5.66	34.3

Travata: 1141 [273 , 493]

L = 169.9cm

Crit.Prog: Acciaio_Flessione $\delta_c = 0.0cm$ Verifica: **Verificata**

Verifica spostamento nello stato finale (§4.2.4.2.1 - NTC 2008)

x	Comb.	δ_{max}	L/250.00	Cs
---	-------	----------------	----------	----

AUTOSTRADA VALDASTICO A31 NORD
1° LOTTO - PIOVENE ROCCHETTE – VALLE DELL'ASTICO

x	Comb.	δ_{max}	L/250.00	Cs
cm		mm	mm	
118.9	15	0.10	6.80	68.7

Verifica spostamento elastico dovuto ai soli carichi variabili (§4.2.4.2.1 - NTC 2008)

x	Comb.	δ_2	L/300.00	Cs
cm		mm	mm	
118.9	15	0.07	5.66	77.1

Travata: 1142 [254 , 492]

L = 248.8cm

Crit.Prog: Acciaio_Flessione $\delta_c = 0.0cm$ Verifica: **Verificata**

Verifica spostamento nello stato finale (§4.2.4.2.1 - NTC 2008)

x	Comb.	δ_{max}	L/250.00	Cs
cm		mm	mm	
149.3	15	1.21	9.95	8.21

Verifica spostamento elastico dovuto ai soli carichi variabili (§4.2.4.2.1 - NTC 2008)

x	Comb.	δ_2	L/300.00	Cs
cm		mm	mm	
149.3	15	0.88	8.29	9.42

Travata: 1143 [492 , 493]

L = 286.0cm

Crit.Prog: Acciaio_Flessione $\delta_c = 0.0cm$ Verifica: **Verificata**

Verifica spostamento nello stato finale (§4.2.4.2.1 - NTC 2008)

x	Comb.	δ_{max}	L/250.00	Cs
---	-------	----------------	----------	----

AUTOSTRADA VALDASTICO A31 NORD
1° LOTTO - PIOVENE ROCCHETTE – VALLE DELL'ASTICO

x	Comb.	δ_{max}	L/250.00	Cs
cm		mm	mm	
143.0	15	-0.15	11.44	76.3

Verifica spostamento elastico dovuto ai soli carichi variabili (§4.2.4.2.1 - NTC 2008)

x	Comb.	δ_2	L/300.00	Cs
cm		mm	mm	
143.0	15	-0.13	9.53	74.6

Travata: 1144 [493 , 256]

L = 169.9cm

Crit.Prog: Acciaio_Flessione $\delta_c = 0.0cm$ Verifica: **Verificata**

Verifica spostamento nello stato finale (§4.2.4.2.1 - NTC 2008)

x	Comb.	δ_{max}	L/250.00	Cs
cm		mm	mm	
51.0	15	0.11	6.80	63.6

Verifica spostamento elastico dovuto ai soli carichi variabili (§4.2.4.2.1 - NTC 2008)

x	Comb.	δ_2	L/300.00	Cs
cm		mm	mm	
51.0	15	0.09	5.66	62.2

Travata: 1145 [256 , 492]

L = 169.9cm

Crit.Prog: Acciaio_Flessione $\delta_c = 0.0cm$ Verifica: **Verificata**

Verifica spostamento nello stato finale (§4.2.4.2.1 - NTC 2008)

x	Comb.	δ_{max}	L/250.00	Cs
---	-------	----------------	----------	----

AUTOSTRADA VALDASTICO A31 NORD
1° LOTTO - PIOVENE ROCCHETTE – VALLE DELL'ASTICO

x	Comb.	δ_{max}	L/250.00	Cs
cm		mm	mm	
101.9	15	0.23	6.80	29.4

Verifica spostamento elastico dovuto ai soli carichi variabili (§4.2.4.2.1 - NTC 2008)

x	Comb.	δ_2	L/300.00	Cs
cm		mm	mm	
101.9	15	0.16	5.66	35.4

Travata: 1146 [237 , 491]

L = 248.8cm

Crit.Prog: Acciaio_Flessione $\delta_c = 0.0cm$ Verifica: **Verificata**

Verifica spostamento nello stato finale (§4.2.4.2.1 - NTC 2008)

x	Comb.	δ_{max}	L/250.00	Cs
cm		mm	mm	
149.3	15	1.15	9.95	8.68

Verifica spostamento elastico dovuto ai soli carichi variabili (§4.2.4.2.1 - NTC 2008)

x	Comb.	δ_2	L/300.00	Cs
cm		mm	mm	
149.3	15	0.84	8.29	9.83

Travata: 1147 [491 , 492]

L = 286.0cm

Crit.Prog: Acciaio_Flessione $\delta_c = 0.0cm$ Verifica: **Verificata**

Verifica spostamento nello stato finale (§4.2.4.2.1 - NTC 2008)

x	Comb.	δ_{max}	L/250.00	Cs
---	-------	----------------	----------	----

AUTOSTRADA VALDASTICO A31 NORD
1° LOTTO - PIOVENE ROCCHETTE – VALLE DELL'ASTICO

x	Comb.	δ_{max}	L/250.00	Cs
cm		mm	mm	
114.4	17	0.05	11.44	>100

Verifica spostamento elastico dovuto ai soli carichi variabili (§4.2.4.2.1 - NTC 2008)

x	Comb.	δ_2	L/300.00	Cs
cm		mm	mm	
200.2	15	-0.03	9.53	>100

Travata: 1148 [492 , 239]

L = 169.9cm

Crit.Prog: Acciaio_Flessione $\delta_c = 0.0cm$ Verifica: **Verificata**

Verifica spostamento nello stato finale (§4.2.4.2.1 - NTC 2008)

x	Comb.	δ_{max}	L/250.00	Cs
cm		mm	mm	
51.0	15	0.09	6.80	77.3

Verifica spostamento elastico dovuto ai soli carichi variabili (§4.2.4.2.1 - NTC 2008)

x	Comb.	δ_2	L/300.00	Cs
cm		mm	mm	
51.0	15	0.07	5.66	83.0

Travata: 1149 [239 , 491]

L = 169.9cm

Crit.Prog: Acciaio_Flessione $\delta_c = 0.0cm$ Verifica: **Verificata**

Verifica spostamento nello stato finale (§4.2.4.2.1 - NTC 2008)

x	Comb.	δ_{max}	L/250.00	Cs
---	-------	----------------	----------	----

AUTOSTRADA VALDASTICO A31 NORD
1° LOTTO - PIOVENE ROCCHETTE – VALLE DELL'ASTICO

x	Comb.	δ_{max}	L/250.00	Cs
cm		mm	mm	
101.9	15	0.22	6.80	30.5

Verifica spostamento elastico dovuto ai soli carichi variabili (§4.2.4.2.1 - NTC 2008)

x	Comb.	δ_2	L/300.00	Cs
cm		mm	mm	
101.9	15	0.15	5.66	36.7

Travata: 1150 [220 , 490]

L = 248.8cm

Crit.Prog: Acciaio_Flessione $\delta_c = 0.0cm$ Verifica: **Verificata**

Verifica spostamento nello stato finale (§4.2.4.2.1 - NTC 2008)

x	Comb.	δ_{max}	L/250.00	Cs
cm		mm	mm	
149.3	15	1.16	9.95	8.57

Verifica spostamento elastico dovuto ai soli carichi variabili (§4.2.4.2.1 - NTC 2008)

x	Comb.	δ_2	L/300.00	Cs
cm		mm	mm	
149.3	15	0.85	8.29	9.71

Travata: 1151 [490 , 491]

L = 286.0cm

Crit.Prog: Acciaio_Flessione $\delta_c = 0.0cm$ Verifica: **Verificata**

Verifica spostamento nello stato finale (§4.2.4.2.1 - NTC 2008)

x	Comb.	δ_{max}	L/250.00	Cs
---	-------	----------------	----------	----

AUTOSTRADA VALDASTICO A31 NORD
1° LOTTO - PIOVENE ROCCHETTE – VALLE DELL'ASTICO

x	Comb.	δ_{max}	L/250.00	Cs
cm		mm	mm	
143.0	15	0.22	11.44	53.0

Verifica spostamento elastico dovuto ai soli carichi variabili (§4.2.4.2.1 - NTC 2008)

x	Comb.	δ_2	L/300.00	Cs
cm		mm	mm	
143.0	15	0.12	9.53	78.3

Travata: 1152 [491 , 222]

L = 169.9cm

Crit.Prog: Acciaio_Flessione $\delta_c = 0.0cm$ Verifica: **Verificata**

Verifica spostamento nello stato finale (§4.2.4.2.1 - NTC 2008)

x	Comb.	δ_{max}	L/250.00	Cs
cm		mm	mm	
51.0	15	0.19	6.80	36.3

Verifica spostamento elastico dovuto ai soli carichi variabili (§4.2.4.2.1 - NTC 2008)

x	Comb.	δ_2	L/300.00	Cs
cm		mm	mm	
68.0	15	0.14	5.66	41.5

Travata: 1153 [222 , 490]

L = 169.9cm

Crit.Prog: Acciaio_Flessione $\delta_c = 0.0cm$ Verifica: **Verificata**

Verifica spostamento nello stato finale (§4.2.4.2.1 - NTC 2008)

x	Comb.	δ_{max}	L/250.00	Cs
---	-------	----------------	----------	----

AUTOSTRADA VALDASTICO A31 NORD
1° LOTTO - PIOVENE ROCCHETTE – VALLE DELL'ASTICO

x	Comb.	δ_{max}	L/250.00	Cs
cm		mm	mm	
101.9	15	0.18	6.80	36.9

Verifica spostamento elastico dovuto ai soli carichi variabili (§4.2.4.2.1 - NTC 2008)

x	Comb.	δ_2	L/300.00	Cs
cm		mm	mm	
101.9	15	0.13	5.66	42.2

Travata: 1154 [203 , 489]

L = 248.8cm

Crit.Prog: Acciaio_Flessione $\delta_c = 0.0cm$ Verifica: **Verificata**

Verifica spostamento nello stato finale (§4.2.4.2.1 - NTC 2008)

x	Comb.	δ_{max}	L/250.00	Cs
cm		mm	mm	
149.3	15	1.83	9.95	5.45

Verifica spostamento elastico dovuto ai soli carichi variabili (§4.2.4.2.1 - NTC 2008)

x	Comb.	δ_2	L/300.00	Cs
cm		mm	mm	
124.4	15	1.33	8.29	6.26

Travata: 1155 [489 , 490]

L = 286.0cm

Crit.Prog: Acciaio_Flessione $\delta_c = 0.0cm$ Verifica: **Verificata**

Verifica spostamento nello stato finale (§4.2.4.2.1 - NTC 2008)

x	Comb.	δ_{max}	L/250.00	Cs
---	-------	----------------	----------	----

AUTOSTRADA VALDASTICO A31 NORD
1° LOTTO - PIOVENE ROCCHETTE – VALLE DELL'ASTICO

x	Comb.	δ_{max}	L/250.00	Cs
cm		mm	mm	
114.4	15	-0.29	11.44	40.0

Verifica spostamento elastico dovuto ai soli carichi variabili (§4.2.4.2.1 - NTC 2008)

x	Comb.	δ_2	L/300.00	Cs
cm		mm	mm	
114.4	15	-0.17	9.53	56.3

Travata: 1156 [490 , 205]

L = 169.9cm

Crit.Prog: Acciaio_Flessione $\delta_c = 0.0cm$ Verifica: **Verificata**

Verifica spostamento nello stato finale (§4.2.4.2.1 - NTC 2008)

x	Comb.	δ_{max}	L/250.00	Cs
cm		mm	mm	
51.0	15	0.15	6.80	43.9

Verifica spostamento elastico dovuto ai soli carichi variabili (§4.2.4.2.1 - NTC 2008)

x	Comb.	δ_2	L/300.00	Cs
cm		mm	mm	
51.0	15	0.12	5.66	47.3

Travata: 1157 [205 , 489]

L = 169.9cm

Crit.Prog: Acciaio_Flessione $\delta_c = 0.0cm$ Verifica: **Verificata**

Verifica spostamento nello stato finale (§4.2.4.2.1 - NTC 2008)

x	Comb.	δ_{max}	L/250.00	Cs
---	-------	----------------	----------	----

AUTOSTRADA VALDASTICO A31 NORD
1° LOTTO - PIOVENE ROCCHETTE – VALLE DELL'ASTICO

x	Comb.	δ_{max}	L/250.00	Cs
cm		mm	mm	
118.9	15	0.09	6.80	71.8

Verifica spostamento elastico dovuto ai soli carichi variabili (§4.2.4.2.1 - NTC 2008)

x	Comb.	δ_2	L/300.00	Cs
cm		mm	mm	
118.9	15	0.09	5.66	64.3

Travata: 1158 [444 , 488]

L = 248.8cm

Crit.Prog: Acciaio_Flessione $\delta_c = 0.0cm$ Verifica: **Verificata**

Verifica spostamento nello stato finale (§4.2.4.2.1 - NTC 2008)

x	Comb.	δ_{max}	L/250.00	Cs
cm		mm	mm	
74.7	15	-0.30	9.95	33.3

Verifica spostamento elastico dovuto ai soli carichi variabili (§4.2.4.2.1 - NTC 2008)

x	Comb.	δ_2	L/300.00	Cs
cm		mm	mm	
74.7	15	-0.23	8.29	35.6

Travata: 1159 [488 , 489]

L = 266.5cm

Crit.Prog: Acciaio_Flessione $\delta_c = 0.0cm$ Verifica: **Verificata**

Verifica spostamento nello stato finale (§4.2.4.2.1 - NTC 2008)

x	Comb.	δ_{max}	L/250.00	Cs
---	-------	----------------	----------	----

AUTOSTRADA VALDASTICO A31 NORD
1° LOTTO - PIOVENE ROCCHETTE – VALLE DELL'ASTICO

x	Comb.	δ_{max}	L/250.00	Cs
cm		mm	mm	
106.6	15	-0.62	10.66	17.3

Verifica spostamento elastico dovuto ai soli carichi variabili (§4.2.4.2.1 - NTC 2008)

x	Comb.	δ_2	L/300.00	Cs
cm		mm	mm	
106.6	15	-0.39	8.88	22.9

Travata: 1160 [489 , 196]

L = 169.9cm

Crit.Prog: Acciaio_Flessione $\delta_c = 0.0cm$ Verifica: **Verificata**

Verifica spostamento nello stato finale (§4.2.4.2.1 - NTC 2008)

x	Comb.	δ_{max}	L/250.00	Cs
cm		mm	mm	
84.9	15	0.36	6.80	19.0

Verifica spostamento elastico dovuto ai soli carichi variabili (§4.2.4.2.1 - NTC 2008)

x	Comb.	δ_2	L/300.00	Cs
cm		mm	mm	
84.9	15	0.23	5.66	24.9

Travata: 1161 [196 , 488]

L = 153.8cm

Crit.Prog: Acciaio_Flessione $\delta_c = 0.0cm$ Verifica: **Verificata**

Verifica spostamento nello stato finale (§4.2.4.2.1 - NTC 2008)

x	Comb.	δ_{max}	L/250.00	Cs
---	-------	----------------	----------	----

AUTOSTRADA VALDASTICO A31 NORD
1° LOTTO - PIOVENE ROCCHETTE – VALLE DELL'ASTICO

x	Comb.	δ_{max}	L/250.00	Cs
cm		mm	mm	
76.9	15	-0.27	6.15	22.7

Verifica spostamento elastico dovuto ai soli carichi variabili (§4.2.4.2.1 - NTC 2008)

x	Comb.	δ_2	L/300.00	Cs
cm		mm	mm	
76.9	15	-0.14	5.13	37.2

Travata: 1162 [428 , 487]

L = 248.8cm

Crit.Prog: Acciaio_Flessione $\delta_c = 0.0cm$ Verifica: **Verificata**

Verifica spostamento nello stato finale (§4.2.4.2.1 - NTC 2008)

x	Comb.	δ_{max}	L/250.00	Cs
cm		mm	mm	
124.4	15	1.60	9.95	6.21

Verifica spostamento elastico dovuto ai soli carichi variabili (§4.2.4.2.1 - NTC 2008)

x	Comb.	δ_2	L/300.00	Cs
cm		mm	mm	
124.4	15	1.19	8.29	6.99

Travata: 1163 [487 , 488]

L = 247.0cm

Crit.Prog: Acciaio_Flessione $\delta_c = 0.0cm$ Verifica: **Verificata**

Verifica spostamento nello stato finale (§4.2.4.2.1 - NTC 2008)

x	Comb.	δ_{max}	L/250.00	Cs
---	-------	----------------	----------	----

AUTOSTRADA VALDASTICO A31 NORD
1° LOTTO - PIOVENE ROCCHETTE – VALLE DELL'ASTICO

x	Comb.	δ_{max}	L/250.00	Cs
cm		mm	mm	
148.2	15	-0.49	9.88	20.3

Verifica spostamento elastico dovuto ai soli carichi variabili (§4.2.4.2.1 - NTC 2008)

x	Comb.	δ_2	L/300.00	Cs
cm		mm	mm	
148.2	15	-0.31	8.23	26.4

Travata: 1164 [488 , 427]

L = 153.8cm

Crit.Prog: Acciaio_Flessione $\delta_c = 0.0cm$ Verifica: **Verificata**

Verifica spostamento nello stato finale (§4.2.4.2.1 - NTC 2008)

x	Comb.	δ_{max}	L/250.00	Cs
cm		mm	mm	
76.9	15	-0.20	6.15	31.3

Verifica spostamento elastico dovuto ai soli carichi variabili (§4.2.4.2.1 - NTC 2008)

x	Comb.	δ_2	L/300.00	Cs
cm		mm	mm	
76.9	15	-0.12	5.13	42.2

Travata: 1165 [427 , 487]

L = 153.8cm

Crit.Prog: Acciaio_Flessione $\delta_c = 0.0cm$ Verifica: **Verificata**

Verifica spostamento nello stato finale (§4.2.4.2.1 - NTC 2008)

x	Comb.	δ_{max}	L/250.00	Cs
---	-------	----------------	----------	----

AUTOSTRADA VALDASTICO A31 NORD
1° LOTTO - PIOVENE ROCCHETTE – VALLE DELL'ASTICO

x	Comb.	δ_{max}	L/250.00	Cs
cm		mm	mm	
107.7	15	0.14	6.15	44.5

Verifica spostamento elastico dovuto ai soli carichi variabili (§4.2.4.2.1 - NTC 2008)

x	Comb.	δ_2	L/300.00	Cs
cm		mm	mm	
107.7	15	0.11	5.13	46.4

Travata: 1166 [416 , 486]

L = 248.8cm

Crit.Prog: Acciaio_Flessione $\delta_c = 0.0cm$ Verifica: **Verificata**

Verifica spostamento nello stato finale (§4.2.4.2.1 - NTC 2008)

x	Comb.	δ_{max}	L/250.00	Cs
cm		mm	mm	
149.3	15	0.54	9.95	18.4

Verifica spostamento elastico dovuto ai soli carichi variabili (§4.2.4.2.1 - NTC 2008)

x	Comb.	δ_2	L/300.00	Cs
cm		mm	mm	
149.3	15	0.38	8.29	21.7

Travata: 1167 [486 , 487]

L = 247.0cm

Crit.Prog: Acciaio_Flessione $\delta_c = 0.0cm$ Verifica: **Verificata**

Verifica spostamento nello stato finale (§4.2.4.2.1 - NTC 2008)

x	Comb.	δ_{max}	L/250.00	Cs
---	-------	----------------	----------	----

AUTOSTRADA VALDASTICO A31 NORD
1° LOTTO - PIOVENE ROCCHETTE – VALLE DELL'ASTICO

x	Comb.	δ_{max}	L/250.00	Cs
cm		mm	mm	
197.6	15	-0.03	9.88	>100

Verifica spostamento elastico dovuto ai soli carichi variabili (§4.2.4.2.1 - NTC 2008)

x	Comb.	δ_2	L/300.00	Cs
cm		mm	mm	
172.9	15	-0.02	8.23	>100

Travata: 1168 [487 , 418]

L = 153.8cm

Crit.Prog: Acciaio_Flessione $\delta_c = 0.0cm$ Verifica: **Verificata**

Verifica spostamento nello stato finale (§4.2.4.2.1 - NTC 2008)

x	Comb.	δ_{max}	L/250.00	Cs
cm		mm	mm	
61.5	15	0.20	6.15	30.3

Verifica spostamento elastico dovuto ai soli carichi variabili (§4.2.4.2.1 - NTC 2008)

x	Comb.	δ_2	L/300.00	Cs
cm		mm	mm	
61.5	15	0.15	5.13	33.8

Travata: 1169 [418 , 486]

L = 153.8cm

Crit.Prog: Acciaio_Flessione $\delta_c = 0.0cm$ Verifica: **Verificata**

Verifica spostamento nello stato finale (§4.2.4.2.1 - NTC 2008)

x	Comb.	δ_{max}	L/250.00	Cs
---	-------	----------------	----------	----

AUTOSTRADA VALDASTICO A31 NORD
1° LOTTO - PIOVENE ROCCHETTE – VALLE DELL'ASTICO

x	Comb.	δ_{max}	L/250.00	Cs
cm		mm	mm	
123.1	15	0.05	6.15	>100

Verifica spostamento elastico dovuto ai soli carichi variabili (§4.2.4.2.1 - NTC 2008)

x	Comb.	δ_2	L/300.00	Cs
cm		mm	mm	
123.1	15	0.03	5.13	>100

Travata: 1170 [417 , 517]

L = 248.8cm

Crit.Prog: Acciaio_Flessione $\delta_c = 0.0cm$ Verifica: **Verificata**

Verifica spostamento nello stato finale (§4.2.4.2.1 - NTC 2008)

x	Comb.	δ_{max}	L/250.00	Cs
cm		mm	mm	
149.3	15	0.53	9.95	18.8

Verifica spostamento elastico dovuto ai soli carichi variabili (§4.2.4.2.1 - NTC 2008)

x	Comb.	δ_2	L/300.00	Cs
cm		mm	mm	
149.3	15	0.37	8.29	22.2

Travata: 1171 [517 , 503]

L = 247.0cm

Crit.Prog: Acciaio_Flessione $\delta_c = 0.0cm$ Verifica: **Verificata**

Verifica spostamento nello stato finale (§4.2.4.2.1 - NTC 2008)

x	Comb.	δ_{max}	L/250.00	Cs
---	-------	----------------	----------	----

AUTOSTRADA VALDASTICO A31 NORD
1° LOTTO - PIOVENE ROCCHETTE – VALLE DELL'ASTICO

x	Comb.	δ_{max}	L/250.00	Cs
cm		mm	mm	
172.9	15	-0.07	9.88	>100

Verifica spostamento elastico dovuto ai soli carichi variabili (§4.2.4.2.1 - NTC 2008)

x	Comb.	δ_2	L/300.00	Cs
cm		mm	mm	
172.9	15	-0.05	8.23	>100

Travata: 1172 [503 , 442]

L = 248.8cm

Crit.Prog: Acciaio_Flessione $\delta_c = 0.0cm$ Verifica: **Verificata**

Verifica spostamento nello stato finale (§4.2.4.2.1 - NTC 2008)

x	Comb.	δ_{max}	L/250.00	Cs
cm		mm	mm	
99.5	15	0.96	9.95	10.3

Verifica spostamento elastico dovuto ai soli carichi variabili (§4.2.4.2.1 - NTC 2008)

x	Comb.	δ_2	L/300.00	Cs
cm		mm	mm	
99.5	15	0.71	8.29	11.7

Travata: 1173 [517 , 426]

L = 153.8cm

Crit.Prog: Acciaio_Flessione $\delta_c = 0.0cm$ Verifica: **Verificata**

Verifica spostamento nello stato finale (§4.2.4.2.1 - NTC 2008)

x	Comb.	δ_{max}	L/250.00	Cs
---	-------	----------------	----------	----

AUTOSTRADA VALDASTICO A31 NORD
1° LOTTO - PIOVENE ROCCHETTE – VALLE DELL'ASTICO

x	Comb.	δ_{max}	L/250.00	Cs
cm		mm	mm	
46.1	15	0.05	6.15	>100

Verifica spostamento elastico dovuto ai soli carichi variabili (§4.2.4.2.1 - NTC 2008)

x	Comb.	δ_2	L/300.00	Cs
cm		mm	mm	
46.1	15	0.03	5.13	>100

Travata: 1174 [426 , 503]

L = 153.8cm

Crit.Prog: Acciaio_Flessione $\delta_c = 0.0cm$ Verifica: **Verificata**

Verifica spostamento nello stato finale (§4.2.4.2.1 - NTC 2008)

x	Comb.	δ_{max}	L/250.00	Cs
cm		mm	mm	
92.3	15	0.11	6.15	53.5

Verifica spostamento elastico dovuto ai soli carichi variabili (§4.2.4.2.1 - NTC 2008)

x	Comb.	δ_2	L/300.00	Cs
cm		mm	mm	
92.3	15	0.09	5.13	58.4

Travata: 1175 [517 , 401]

L = 153.8cm

Crit.Prog: Acciaio_Flessione $\delta_c = 0.0cm$ Verifica: **Verificata**

Verifica spostamento nello stato finale (§4.2.4.2.1 - NTC 2008)

x	Comb.	δ_{max}	L/250.00	Cs
---	-------	----------------	----------	----

AUTOSTRADA VALDASTICO A31 NORD
1° LOTTO - PIOVENE ROCCHETTE – VALLE DELL'ASTICO

x	Comb.	δ_{max}	L/250.00	Cs
cm		mm	mm	
61.5	15	0.13	6.15	48.5

Verifica spostamento elastico dovuto ai soli carichi variabili (§4.2.4.2.1 - NTC 2008)

x	Comb.	δ_2	L/300.00	Cs
cm		mm	mm	
61.5	15	0.08	5.13	61.9

Travata: 1176 [409 , 486]

L = 153.8cm

Crit.Prog: Acciaio_Flessione $\delta_c = 0.0cm$ Verifica: **Verificata**

Verifica spostamento nello stato finale (§4.2.4.2.1 - NTC 2008)

x	Comb.	δ_{max}	L/250.00	Cs
cm		mm	mm	
92.3	15	0.13	6.15	47.0

Verifica spostamento elastico dovuto ai soli carichi variabili (§4.2.4.2.1 - NTC 2008)

x	Comb.	δ_2	L/300.00	Cs
cm		mm	mm	
92.3	15	0.08	5.13	60.3

Travata: 1177 [478 , 502]

L = 160.6cm

Crit.Prog: Acciaio_Flessione $\delta_c = 0.0cm$ Verifica: **Verificata**

Verifica spostamento nello stato finale (§4.2.4.2.1 - NTC 2008)

x	Comb.	δ_{max}	L/250.00	Cs
---	-------	----------------	----------	----

AUTOSTRADA VALDASTICO A31 NORD
1° LOTTO - PIOVENE ROCCHETTE – VALLE DELL'ASTICO

x	Comb.	δ_{max}	L/250.00	Cs
cm		mm	mm	
96.3	15	0.07	6.42	91.6

Verifica spostamento elastico dovuto ai soli carichi variabili (§4.2.4.2.1 - NTC 2008)

x	Comb.	δ_2	L/300.00	Cs
cm		mm	mm	
112.4	15	0.05	5.35	>100

Travata: 1178 [451 , 518]

L = 248.8cm

Crit.Prog: Acciaio_Flessione $\delta_c = 0.0cm$ Verifica: **Verificata**

Verifica spostamento nello stato finale (§4.2.4.2.1 - NTC 2008)

x	Comb.	δ_{max}	L/250.00	Cs
cm		mm	mm	
149.3	15	1.01	9.95	9.85

Verifica spostamento elastico dovuto ai soli carichi variabili (§4.2.4.2.1 - NTC 2008)

x	Comb.	δ_2	L/300.00	Cs
cm		mm	mm	
149.3	15	0.74	8.29	11.2

Travata: 1179 [518 , 503]

L = 247.0cm

Crit.Prog: Acciaio_Flessione $\delta_c = 0.0cm$ Verifica: **Verificata**

Verifica spostamento nello stato finale (§4.2.4.2.1 - NTC 2008)

x	Comb.	δ_{max}	L/250.00	Cs
---	-------	----------------	----------	----

AUTOSTRADA VALDASTICO A31 NORD
1° LOTTO - PIOVENE ROCCHETTE – VALLE DELL'ASTICO

x	Comb.	δ_{max}	L/250.00	Cs
cm		mm	mm	
98.8	15	-0.41	9.88	23.9

Verifica spostamento elastico dovuto ai soli carichi variabili (§4.2.4.2.1 - NTC 2008)

x	Comb.	δ_2	L/300.00	Cs
cm		mm	mm	
98.8	15	-0.26	8.23	32.2

Travata: 1180 [503 , 443]

L = 153.8cm

Crit.Prog: Acciaio_Flessione $\delta_c = 0.0cm$ Verifica: **Verificata**

Verifica spostamento nello stato finale (§4.2.4.2.1 - NTC 2008)

x	Comb.	δ_{max}	L/250.00	Cs
cm		mm	mm	
46.1	15	0.07	6.15	86.2

Verifica spostamento elastico dovuto ai soli carichi variabili (§4.2.4.2.1 - NTC 2008)

x	Comb.	δ_2	L/300.00	Cs
cm		mm	mm	
46.1	15	0.06	5.13	86.5

Travata: 1181 [443 , 518]

L = 153.8cm

Crit.Prog: Acciaio_Flessione $\delta_c = 0.0cm$ Verifica: **Verificata**

Verifica spostamento nello stato finale (§4.2.4.2.1 - NTC 2008)

x	Comb.	δ_{max}	L/250.00	Cs
---	-------	----------------	----------	----

AUTOSTRADA VALDASTICO A31 NORD
1° LOTTO - PIOVENE ROCCHETTE – VALLE DELL'ASTICO

x	Comb.	δ_{max}	L/250.00	Cs
cm		mm	mm	
46.1	15	-0.08	6.15	77.7

Verifica spostamento elastico dovuto ai soli carichi variabili (§4.2.4.2.1 - NTC 2008)

x	Comb.	δ_2	L/300.00	Cs
cm		mm	mm	
46.1	15	-0.03	5.13	>100

Travata: 1182 [204 , 504]

L = 248.8cm

Crit.Prog: Acciaio_Flessione $\delta_c = 0.0cm$ Verifica: **Verificata**

Verifica spostamento nello stato finale (§4.2.4.2.1 - NTC 2008)

x	Comb.	δ_{max}	L/250.00	Cs
cm		mm	mm	
149.3	15	1.25	9.95	7.94

Verifica spostamento elastico dovuto ai soli carichi variabili (§4.2.4.2.1 - NTC 2008)

x	Comb.	δ_2	L/300.00	Cs
cm		mm	mm	
149.3	15	0.89	8.29	9.27

Travata: 1183 [504 , 518]

L = 266.5cm

Crit.Prog: Acciaio_Flessione $\delta_c = 0.0cm$ Verifica: **Verificata**

Verifica spostamento nello stato finale (§4.2.4.2.1 - NTC 2008)

x	Comb.	δ_{max}	L/250.00	Cs
---	-------	----------------	----------	----

AUTOSTRADA VALDASTICO A31 NORD
1° LOTTO - PIOVENE ROCCHETTE – VALLE DELL'ASTICO

x	Comb.	δ_{max}	L/250.00	Cs
cm		mm	mm	
159.9	15	-0.52	10.66	20.7

Verifica spostamento elastico dovuto ai soli carichi variabili (§4.2.4.2.1 - NTC 2008)

x	Comb.	δ_2	L/300.00	Cs
cm		mm	mm	
133.2	15	-0.33	8.88	26.7

Travata: 1184 [518 , 188]

L = 153.8cm

Crit.Prog: Acciaio_Flessione $\delta_c = 0.0cm$ Verifica: **Verificata**

Verifica spostamento nello stato finale (§4.2.4.2.1 - NTC 2008)

x	Comb.	δ_{max}	L/250.00	Cs
cm		mm	mm	
107.7	15	-0.19	6.15	33.1

Verifica spostamento elastico dovuto ai soli carichi variabili (§4.2.4.2.1 - NTC 2008)

x	Comb.	δ_2	L/300.00	Cs
cm		mm	mm	
107.7	15	-0.08	5.13	61.5

Travata: 1185 [188 , 504]

L = 169.9cm

Crit.Prog: Acciaio_Flessione $\delta_c = 0.0cm$ Verifica: **Verificata**

Verifica spostamento nello stato finale (§4.2.4.2.1 - NTC 2008)

x	Comb.	δ_{max}	L/250.00	Cs
---	-------	----------------	----------	----

AUTOSTRADA VALDASTICO A31 NORD
1° LOTTO - PIOVENE ROCCHETTE – VALLE DELL'ASTICO

x	Comb.	δ_{max}	L/250.00	Cs
cm		mm	mm	
68.0	15	0.36	6.80	18.8

Verifica spostamento elastico dovuto ai soli carichi variabili (§4.2.4.2.1 - NTC 2008)

x	Comb.	δ_2	L/300.00	Cs
cm		mm	mm	
68.0	15	0.21	5.66	26.3

Travata: 1186 [221 , 505]

L = 248.8cm

Crit.Prog: Acciaio_Flessione $\delta_c = 0.0cm$ Verifica: **Verificata**

Verifica spostamento nello stato finale (§4.2.4.2.1 - NTC 2008)

x	Comb.	δ_{max}	L/250.00	Cs
cm		mm	mm	
149.3	15	1.15	9.95	8.65

Verifica spostamento elastico dovuto ai soli carichi variabili (§4.2.4.2.1 - NTC 2008)

x	Comb.	δ_2	L/300.00	Cs
cm		mm	mm	
149.3	15	0.85	8.29	9.79

Travata: 1187 [505 , 504]

L = 286.0cm

Crit.Prog: Acciaio_Flessione $\delta_c = 0.0cm$ Verifica: **Verificata**

Verifica spostamento nello stato finale (§4.2.4.2.1 - NTC 2008)

x	Comb.	δ_{max}	L/250.00	Cs
---	-------	----------------	----------	----

AUTOSTRADA VALDASTICO A31 NORD
1° LOTTO - PIOVENE ROCCHETTE – VALLE DELL'ASTICO

x	Comb.	δ_{max}	L/250.00	Cs
cm		mm	mm	
171.6	15	-0.35	11.44	33.1

Verifica spostamento elastico dovuto ai soli carichi variabili (§4.2.4.2.1 - NTC 2008)

x	Comb.	δ_2	L/300.00	Cs
cm		mm	mm	
171.6	15	-0.21	9.53	45.1

Travata: 1188 [504 , 213]

L = 169.9cm

Crit.Prog: Acciaio_Flessione $\delta_c = 0.0cm$ Verifica: **Verificata**

Verifica spostamento nello stato finale (§4.2.4.2.1 - NTC 2008)

x	Comb.	δ_{max}	L/250.00	Cs
cm		mm	mm	
118.9	15	-0.05	6.80	>100

Verifica spostamento elastico dovuto ai soli carichi variabili (§4.2.4.2.1 - NTC 2008)

x	Comb.	δ_2	L/300.00	Cs
cm		mm	mm	
34.0	15	0.03	5.66	>100

Travata: 1189 [213 , 505]

L = 169.9cm

Crit.Prog: Acciaio_Flessione $\delta_c = 0.0cm$ Verifica: **Verificata**

Verifica spostamento nello stato finale (§4.2.4.2.1 - NTC 2008)

x	Comb.	δ_{max}	L/250.00	Cs
---	-------	----------------	----------	----

AUTOSTRADA VALDASTICO A31 NORD
1° LOTTO - PIOVENE ROCCHETTE – VALLE DELL'ASTICO

x	Comb.	δ_{max}	L/250.00	Cs
cm		mm	mm	
118.9	15	0.15	6.80	44.6

Verifica spostamento elastico dovuto ai soli carichi variabili (§4.2.4.2.1 - NTC 2008)

x	Comb.	δ_2	L/300.00	Cs
cm		mm	mm	
118.9	15	0.12	5.66	48.1

Travata: 1190 [238 , 506]

L = 248.8cm

Crit.Prog: Acciaio_Flessione $\delta_c = 0.0cm$ Verifica: **Verificata**

Verifica spostamento nello stato finale (§4.2.4.2.1 - NTC 2008)

x	Comb.	δ_{max}	L/250.00	Cs
cm		mm	mm	
149.3	15	1.14	9.95	8.70

Verifica spostamento elastico dovuto ai soli carichi variabili (§4.2.4.2.1 - NTC 2008)

x	Comb.	δ_2	L/300.00	Cs
cm		mm	mm	
149.3	15	0.84	8.29	9.84

Travata: 1191 [506 , 505]

L = 286.0cm

Crit.Prog: Acciaio_Flessione $\delta_c = 0.0cm$ Verifica: **Verificata**

Verifica spostamento nello stato finale (§4.2.4.2.1 - NTC 2008)

x	Comb.	δ_{max}	L/250.00	Cs
---	-------	----------------	----------	----

AUTOSTRADA VALDASTICO A31 NORD
1° LOTTO - PIOVENE ROCCHETTE – VALLE DELL'ASTICO

x	Comb.	δ_{max}	L/250.00	Cs
cm		mm	mm	
143.0	15	0.21	11.44	55.6

Verifica spostamento elastico dovuto ai soli carichi variabili (§4.2.4.2.1 - NTC 2008)

x	Comb.	δ_2	L/300.00	Cs
cm		mm	mm	
143.0	15	0.12	9.53	78.3

Travata: 1192 [505 , 230]

L = 169.9cm

Crit.Prog: Acciaio_Flessione $\delta_c = 0.0cm$ Verifica: **Verificata**

Verifica spostamento nello stato finale (§4.2.4.2.1 - NTC 2008)

x	Comb.	δ_{max}	L/250.00	Cs
cm		mm	mm	
68.0	15	0.18	6.80	37.6

Verifica spostamento elastico dovuto ai soli carichi variabili (§4.2.4.2.1 - NTC 2008)

x	Comb.	δ_2	L/300.00	Cs
cm		mm	mm	
68.0	15	0.13	5.66	42.3

Travata: 1193 [230 , 506]

L = 169.9cm

Crit.Prog: Acciaio_Flessione $\delta_c = 0.0cm$ Verifica: **Verificata**

Verifica spostamento nello stato finale (§4.2.4.2.1 - NTC 2008)

x	Comb.	δ_{max}	L/250.00	Cs
---	-------	----------------	----------	----

AUTOSTRADA VALDASTICO A31 NORD
1° LOTTO - PIOVENE ROCCHETTE – VALLE DELL'ASTICO

x	Comb.	δ_{max}	L/250.00	Cs
cm		mm	mm	
118.9	15	0.18	6.80	37.2

Verifica spostamento elastico dovuto ai soli carichi variabili (§4.2.4.2.1 - NTC 2008)

x	Comb.	δ_2	L/300.00	Cs
cm		mm	mm	
118.9	15	0.13	5.66	42.0

Travata: 1194 [255 , 507]

L = 248.8cm

Crit.Prog: Acciaio_Flessione $\delta_c = 0.0cm$ Verifica: **Verificata**

Verifica spostamento nello stato finale (§4.2.4.2.1 - NTC 2008)

x	Comb.	δ_{max}	L/250.00	Cs
cm		mm	mm	
149.3	15	1.21	9.95	8.22

Verifica spostamento elastico dovuto ai soli carichi variabili (§4.2.4.2.1 - NTC 2008)

x	Comb.	δ_2	L/300.00	Cs
cm		mm	mm	
149.3	15	0.88	8.29	9.42

Travata: 1195 [507 , 506]

L = 286.0cm

Crit.Prog: Acciaio_Flessione $\delta_c = 0.0cm$ Verifica: **Verificata**

Verifica spostamento nello stato finale (§4.2.4.2.1 - NTC 2008)

x	Comb.	δ_{max}	L/250.00	Cs
---	-------	----------------	----------	----

AUTOSTRADA VALDASTICO A31 NORD
1° LOTTO - PIOVENE ROCCHETTE – VALLE DELL'ASTICO

x	Comb.	δ_{max}	L/250.00	Cs
cm		mm	mm	
171.6	17	0.03	11.44	>100

Verifica spostamento elastico dovuto ai soli carichi variabili (§4.2.4.2.1 - NTC 2008)

x	Comb.	δ_2	L/300.00	Cs
cm		mm	mm	
85.8	15	-0.03	9.53	>100

Travata: 1196 [506 , 247]

L = 169.9cm

Crit.Prog: Acciaio_Flessione $\delta_c = 0.0cm$ Verifica: **Verificata**

Verifica spostamento nello stato finale (§4.2.4.2.1 - NTC 2008)

x	Comb.	δ_{max}	L/250.00	Cs
cm		mm	mm	
68.0	15	0.22	6.80	30.4

Verifica spostamento elastico dovuto ai soli carichi variabili (§4.2.4.2.1 - NTC 2008)

x	Comb.	δ_2	L/300.00	Cs
cm		mm	mm	
68.0	15	0.16	5.66	36.4

Travata: 1197 [247 , 507]

L = 169.9cm

Crit.Prog: Acciaio_Flessione $\delta_c = 0.0cm$ Verifica: **Verificata**

Verifica spostamento nello stato finale (§4.2.4.2.1 - NTC 2008)

x	Comb.	δ_{max}	L/250.00	Cs
---	-------	----------------	----------	----

AUTOSTRADA VALDASTICO A31 NORD
1° LOTTO - PIOVENE ROCCHETTE – VALLE DELL'ASTICO

x	Comb.	δ_{max}	L/250.00	Cs
cm		mm	mm	
118.9	15	0.08	6.80	80.4

Verifica spostamento elastico dovuto ai soli carichi variabili (§4.2.4.2.1 - NTC 2008)

x	Comb.	δ_2	L/300.00	Cs
cm		mm	mm	
118.9	15	0.07	5.66	84.0

Travata: 1198 [272 , 508]

L = 248.8cm

Crit.Prog: Acciaio_Flessione $\delta_c = 0.0cm$ Verifica: **Verificata**

Verifica spostamento nello stato finale (§4.2.4.2.1 - NTC 2008)

x	Comb.	δ_{max}	L/250.00	Cs
cm		mm	mm	
149.3	15	1.17	9.95	8.53

Verifica spostamento elastico dovuto ai soli carichi variabili (§4.2.4.2.1 - NTC 2008)

x	Comb.	δ_2	L/300.00	Cs
cm		mm	mm	
149.3	15	0.86	8.29	9.69

Travata: 1199 [508 , 507]

L = 286.0cm

Crit.Prog: Acciaio_Flessione $\delta_c = 0.0cm$ Verifica: **Verificata**

Verifica spostamento nello stato finale (§4.2.4.2.1 - NTC 2008)

x	Comb.	δ_{max}	L/250.00	Cs
---	-------	----------------	----------	----

AUTOSTRADA VALDASTICO A31 NORD
1° LOTTO - PIOVENE ROCCHETTE – VALLE DELL'ASTICO

x	Comb.	δ_{max}	L/250.00	Cs
cm		mm	mm	
114.4	15	-0.12	11.44	99.3

Verifica spostamento elastico dovuto ai soli carichi variabili (§4.2.4.2.1 - NTC 2008)

x	Comb.	δ_2	L/300.00	Cs
cm		mm	mm	
143.0	15	-0.12	9.53	81.1

Travata: 1200 [507 , 264]

L = 169.9cm

Crit.Prog: Acciaio_Flessione $\delta_c = 0.0cm$ Verifica: **Verificata**

Verifica spostamento nello stato finale (§4.2.4.2.1 - NTC 2008)

x	Comb.	δ_{max}	L/250.00	Cs
cm		mm	mm	
84.9	15	0.25	6.80	27.6

Verifica spostamento elastico dovuto ai soli carichi variabili (§4.2.4.2.1 - NTC 2008)

x	Comb.	δ_2	L/300.00	Cs
cm		mm	mm	
68.0	15	0.16	5.66	34.6

Travata: 1201 [264 , 508]

L = 169.9cm

Crit.Prog: Acciaio_Flessione $\delta_c = 0.0cm$ Verifica: **Verificata**

Verifica spostamento nello stato finale (§4.2.4.2.1 - NTC 2008)

x	Comb.	δ_{max}	L/250.00	Cs
---	-------	----------------	----------	----

AUTOSTRADA VALDASTICO A31 NORD
1° LOTTO - PIOVENE ROCCHETTE – VALLE DELL'ASTICO

x	Comb.	δ_{max}	L/250.00	Cs
cm		mm	mm	
118.9	15	0.12	6.80	57.7

Verifica spostamento elastico dovuto ai soli carichi variabili (§4.2.4.2.1 - NTC 2008)

x	Comb.	δ_2	L/300.00	Cs
cm		mm	mm	
118.9	15	0.09	5.66	60.4

Travata: 1202 [289 , 509]

L = 248.8cm

Crit.Prog: Acciaio_Flessione $\delta_c = 0.0cm$ Verifica: **Verificata**

Verifica spostamento nello stato finale (§4.2.4.2.1 - NTC 2008)

x	Comb.	δ_{max}	L/250.00	Cs
cm		mm	mm	
149.3	15	1.13	9.95	8.81

Verifica spostamento elastico dovuto ai soli carichi variabili (§4.2.4.2.1 - NTC 2008)

x	Comb.	δ_2	L/300.00	Cs
cm		mm	mm	
149.3	15	0.83	8.29	9.93

Travata: 1203 [509 , 508]

L = 286.0cm

Crit.Prog: Acciaio_Flessione $\delta_c = 0.0cm$ Verifica: **Verificata**

Verifica spostamento nello stato finale (§4.2.4.2.1 - NTC 2008)

x	Comb.	δ_{max}	L/250.00	Cs
---	-------	----------------	----------	----

AUTOSTRADA VALDASTICO A31 NORD
1° LOTTO - PIOVENE ROCCHETTE – VALLE DELL'ASTICO

x	Comb.	δ_{max}	L/250.00	Cs
cm		mm	mm	
114.4	15	0.11	11.44	>100

Verifica spostamento elastico dovuto ai soli carichi variabili (§4.2.4.2.1 - NTC 2008)

x	Comb.	δ_2	L/300.00	Cs
cm		mm	mm	
85.8	15	0.04	9.53	>100

Travata: 1204 [508 , 281]

L = 169.9cm

Crit.Prog: Acciaio_Flessione $\delta_c = 0.0cm$ Verifica: **Verificata**

Verifica spostamento nello stato finale (§4.2.4.2.1 - NTC 2008)

x	Comb.	δ_{max}	L/250.00	Cs
cm		mm	mm	
51.0	15	0.10	6.80	70.7

Verifica spostamento elastico dovuto ai soli carichi variabili (§4.2.4.2.1 - NTC 2008)

x	Comb.	δ_2	L/300.00	Cs
cm		mm	mm	
51.0	15	0.07	5.66	77.7

Travata: 1205 [281 , 509]

L = 169.9cm

Crit.Prog: Acciaio_Flessione $\delta_c = 0.0cm$ Verifica: **Verificata**

Verifica spostamento nello stato finale (§4.2.4.2.1 - NTC 2008)

x	Comb.	δ_{max}	L/250.00	Cs
---	-------	----------------	----------	----

AUTOSTRADA VALDASTICO A31 NORD
1° LOTTO - PIOVENE ROCCHETTE – VALLE DELL'ASTICO

x	Comb.	δ_{max}	L/250.00	Cs
cm		mm	mm	
101.9	15	0.24	6.80	28.3

Verifica spostamento elastico dovuto ai soli carichi variabili (§4.2.4.2.1 - NTC 2008)

x	Comb.	δ_2	L/300.00	Cs
cm		mm	mm	
101.9	15	0.17	5.66	34.2

Travata: 1206 [306 , 510]

L = 248.8cm

Crit.Prog: Acciaio_Flessione $\delta_c = 0.0cm$ Verifica: **Verificata**

Verifica spostamento nello stato finale (§4.2.4.2.1 - NTC 2008)

x	Comb.	δ_{max}	L/250.00	Cs
cm		mm	mm	
149.3	15	1.13	9.95	8.82

Verifica spostamento elastico dovuto ai soli carichi variabili (§4.2.4.2.1 - NTC 2008)

x	Comb.	δ_2	L/300.00	Cs
cm		mm	mm	
149.3	15	0.83	8.29	9.95

Travata: 1207 [510 , 509]

L = 286.0cm

Crit.Prog: Acciaio_Flessione $\delta_c = 0.0cm$ Verifica: **Verificata**

Verifica spostamento nello stato finale (§4.2.4.2.1 - NTC 2008)

x	Comb.	δ_{max}	L/250.00	Cs
---	-------	----------------	----------	----

AUTOSTRADA VALDASTICO A31 NORD
1° LOTTO - PIOVENE ROCCHETTE – VALLE DELL'ASTICO

x	Comb.	δ_{max}	L/250.00	Cs
cm		mm	mm	
143.0	15	0.37	11.44	30.5

Verifica spostamento elastico dovuto ai soli carichi variabili (§4.2.4.2.1 - NTC 2008)

x	Comb.	δ_2	L/300.00	Cs
cm		mm	mm	
143.0	15	0.21	9.53	45.0

Travata: 1208 [509 , 298]

L = 169.9cm

Crit.Prog: Acciaio_Flessione $\delta_c = 0.0cm$ Verifica: **Verificata**

Verifica spostamento nello stato finale (§4.2.4.2.1 - NTC 2008)

x	Comb.	δ_{max}	L/250.00	Cs
cm		mm	mm	
68.0	15	0.22	6.80	30.8

Verifica spostamento elastico dovuto ai soli carichi variabili (§4.2.4.2.1 - NTC 2008)

x	Comb.	δ_2	L/300.00	Cs
cm		mm	mm	
68.0	15	0.16	5.66	36.5

Travata: 1209 [298 , 510]

L = 169.9cm

Crit.Prog: Acciaio_Flessione $\delta_c = 0.0cm$ Verifica: **Verificata**

Verifica spostamento nello stato finale (§4.2.4.2.1 - NTC 2008)

x	Comb.	δ_{max}	L/250.00	Cs
---	-------	----------------	----------	----

AUTOSTRADA VALDASTICO A31 NORD
1° LOTTO - PIOVENE ROCCHETTE – VALLE DELL'ASTICO

x	Comb.	δ_{max}	L/250.00	Cs
cm		mm	mm	
101.9	15	0.22	6.80	30.5

Verifica spostamento elastico dovuto ai soli carichi variabili (§4.2.4.2.1 - NTC 2008)

x	Comb.	δ_2	L/300.00	Cs
cm		mm	mm	
101.9	15	0.16	5.66	36.3

Travata: 1210 [349 , 511]

L = 248.8cm

Crit.Prog: Acciaio_Flessione $\delta_c = 0.0cm$ Verifica: **Verificata**

Verifica spostamento nello stato finale (§4.2.4.2.1 - NTC 2008)

x	Comb.	δ_{max}	L/250.00	Cs
cm		mm	mm	
149.3	15	1.18	9.95	8.42

Verifica spostamento elastico dovuto ai soli carichi variabili (§4.2.4.2.1 - NTC 2008)

x	Comb.	δ_2	L/300.00	Cs
cm		mm	mm	
149.3	15	0.87	8.29	9.59

Travata: 1211 [511 , 510]

L = 286.0cm

Crit.Prog: Acciaio_Flessione $\delta_c = 0.0cm$ Verifica: **Verificata**

Verifica spostamento nello stato finale (§4.2.4.2.1 - NTC 2008)

x	Comb.	δ_{max}	L/250.00	Cs
---	-------	----------------	----------	----

AUTOSTRADA VALDASTICO A31 NORD
1° LOTTO - PIOVENE ROCCHETTE – VALLE DELL'ASTICO

x	Comb.	δ_{max}	L/250.00	Cs
cm		mm	mm	
200.2	15	0.05	11.44	>100

Verifica spostamento elastico dovuto ai soli carichi variabili (§4.2.4.2.1 - NTC 2008)

x	Comb.	δ_2	L/300.00	Cs
cm		mm	mm	
85.8	15	-0.04	9.53	>100

Travata: 1212 [510 , 315]

L = 169.9cm

Crit.Prog: Acciaio_Flessione $\delta_c = 0.0cm$ Verifica: **Verificata**

Verifica spostamento nello stato finale (§4.2.4.2.1 - NTC 2008)

x	Comb.	δ_{max}	L/250.00	Cs
cm		mm	mm	
68.0	15	0.22	6.80	30.7

Verifica spostamento elastico dovuto ai soli carichi variabili (§4.2.4.2.1 - NTC 2008)

x	Comb.	δ_2	L/300.00	Cs
cm		mm	mm	
68.0	15	0.15	5.66	36.7

Travata: 1213 [315 , 511]

L = 169.9cm

Crit.Prog: Acciaio_Flessione $\delta_c = 0.0cm$ Verifica: **Verificata**

Verifica spostamento nello stato finale (§4.2.4.2.1 - NTC 2008)

x	Comb.	δ_{max}	L/250.00	Cs
---	-------	----------------	----------	----

AUTOSTRADA VALDASTICO A31 NORD
1° LOTTO - PIOVENE ROCCHETTE – VALLE DELL'ASTICO

x	Comb.	δ_{max}	L/250.00	Cs
cm		mm	mm	
118.9	15	0.08	6.80	84.6

Verifica spostamento elastico dovuto ai soli carichi variabili (§4.2.4.2.1 - NTC 2008)

x	Comb.	δ_2	L/300.00	Cs
cm		mm	mm	
118.9	15	0.06	5.66	89.2

Travata: 1214 [332 , 512]

L = 248.8cm

Crit.Prog: Acciaio_Flessione $\delta_c = 0.0cm$ Verifica: **Verificata**

Verifica spostamento nello stato finale (§4.2.4.2.1 - NTC 2008)

x	Comb.	δ_{max}	L/250.00	Cs
cm		mm	mm	
149.3	15	1.18	9.95	8.42

Verifica spostamento elastico dovuto ai soli carichi variabili (§4.2.4.2.1 - NTC 2008)

x	Comb.	δ_2	L/300.00	Cs
cm		mm	mm	
149.3	15	0.86	8.29	9.61

Travata: 1215 [512 , 511]

L = 286.0cm

Crit.Prog: Acciaio_Flessione $\delta_c = 0.0cm$ Verifica: **Verificata**

Verifica spostamento nello stato finale (§4.2.4.2.1 - NTC 2008)

x	Comb.	δ_{max}	L/250.00	Cs
---	-------	----------------	----------	----

AUTOSTRADA VALDASTICO A31 NORD
1° LOTTO - PIOVENE ROCCHETTE – VALLE DELL'ASTICO

x	Comb.	δ_{max}	L/250.00	Cs
cm		mm	mm	
143.0	15	-0.24	11.44	48.3

Verifica spostamento elastico dovuto ai soli carichi variabili (§4.2.4.2.1 - NTC 2008)

x	Comb.	δ_2	L/300.00	Cs
cm		mm	mm	
143.0	15	-0.19	9.53	49.9

Travata: 1216 [511 , 316]

L = 169.9cm

Crit.Prog: Acciaio_Flessione $\delta_c = 0.0cm$ Verifica: **Verificata**

Verifica spostamento nello stato finale (§4.2.4.2.1 - NTC 2008)

x	Comb.	δ_{max}	L/250.00	Cs
cm		mm	mm	
68.0	15	0.15	6.80	46.5

Verifica spostamento elastico dovuto ai soli carichi variabili (§4.2.4.2.1 - NTC 2008)

x	Comb.	δ_2	L/300.00	Cs
cm		mm	mm	
68.0	15	0.11	5.66	50.4

Travata: 1217 [316 , 512]

L = 169.9cm

Crit.Prog: Acciaio_Flessione $\delta_c = 0.0cm$ Verifica: **Verificata**

Verifica spostamento nello stato finale (§4.2.4.2.1 - NTC 2008)

x	Comb.	δ_{max}	L/250.00	Cs
---	-------	----------------	----------	----

AUTOSTRADA VALDASTICO A31 NORD
1° LOTTO - PIOVENE ROCCHETTE – VALLE DELL'ASTICO

x	Comb.	δ_{max}	L/250.00	Cs
cm		mm	mm	
101.9	15	0.15	6.80	45.6

Verifica spostamento elastico dovuto ai soli carichi variabili (§4.2.4.2.1 - NTC 2008)

x	Comb.	δ_2	L/300.00	Cs
cm		mm	mm	
101.9	15	0.11	5.66	53.1

Travata: 1218 [357 , 513]

L = 248.8cm

Crit.Prog: Acciaio_Flessione $\delta_c = 0.0cm$ Verifica: **Verificata**

Verifica spostamento nello stato finale (§4.2.4.2.1 - NTC 2008)

x	Comb.	δ_{max}	L/250.00	Cs
cm		mm	mm	
149.3	15	1.12	9.95	8.85

Verifica spostamento elastico dovuto ai soli carichi variabili (§4.2.4.2.1 - NTC 2008)

x	Comb.	δ_2	L/300.00	Cs
cm		mm	mm	
149.3	15	0.83	8.29	9.98

Travata: 1219 [513 , 512]

L = 286.0cm

Crit.Prog: Acciaio_Flessione $\delta_c = 0.0cm$ Verifica: **Verificata**

Verifica spostamento nello stato finale (§4.2.4.2.1 - NTC 2008)

x	Comb.	δ_{max}	L/250.00	Cs
---	-------	----------------	----------	----

AUTOSTRADA VALDASTICO A31 NORD
1° LOTTO - PIOVENE ROCCHETTE – VALLE DELL'ASTICO

x	Comb.	δ_{max}	L/250.00	Cs
cm		mm	mm	
228.8	15	-0.05	11.44	>100

Verifica spostamento elastico dovuto ai soli carichi variabili (§4.2.4.2.1 - NTC 2008)

x	Comb.	δ_2	L/300.00	Cs
cm		mm	mm	
200.2	15	-0.05	9.53	>100

Travata: 1220 [512 , 341]

L = 169.9cm

Crit.Prog: Acciaio_Flessione $\delta_c = 0.0cm$ Verifica: **Verificata**

Verifica spostamento nello stato finale (§4.2.4.2.1 - NTC 2008)

x	Comb.	δ_{max}	L/250.00	Cs
cm		mm	mm	
51.0	15	0.08	6.80	87.1

Verifica spostamento elastico dovuto ai soli carichi variabili (§4.2.4.2.1 - NTC 2008)

x	Comb.	δ_2	L/300.00	Cs
cm		mm	mm	
51.0	15	0.06	5.66	89.1

Travata: 1221 [341 , 513]

L = 169.9cm

Crit.Prog: Acciaio_Flessione $\delta_c = 0.0cm$ Verifica: **Verificata**

Verifica spostamento nello stato finale (§4.2.4.2.1 - NTC 2008)

x	Comb.	δ_{max}	L/250.00	Cs
---	-------	----------------	----------	----

AUTOSTRADA VALDASTICO A31 NORD
1° LOTTO - PIOVENE ROCCHETTE – VALLE DELL'ASTICO

x	Comb.	δ_{max}	L/250.00	Cs
cm		mm	mm	
101.9	15	0.22	6.80	31.5

Verifica spostamento elastico dovuto ai soli carichi variabili (§4.2.4.2.1 - NTC 2008)

x	Comb.	δ_2	L/300.00	Cs
cm		mm	mm	
101.9	15	0.15	5.66	37.6

Travata: 1222 [374 , 519]

L = 248.8cm

Crit.Prog: Acciaio_Flessione $\delta_c = 0.0cm$ Verifica: **Verificata**

Verifica spostamento nello stato finale (§4.2.4.2.1 - NTC 2008)

x	Comb.	δ_{max}	L/250.00	Cs
cm		mm	mm	
149.3	15	1.13	9.95	8.85

Verifica spostamento elastico dovuto ai soli carichi variabili (§4.2.4.2.1 - NTC 2008)

x	Comb.	δ_2	L/300.00	Cs
cm		mm	mm	
149.3	15	0.83	8.29	9.97

Travata: 1223 [519 , 513]

L = 286.0cm

Crit.Prog: Acciaio_Flessione $\delta_c = 0.0cm$ Verifica: **Verificata**

Verifica spostamento nello stato finale (§4.2.4.2.1 - NTC 2008)

x	Comb.	δ_{max}	L/250.00	Cs
---	-------	----------------	----------	----

AUTOSTRADA VALDASTICO A31 NORD
1° LOTTO - PIOVENE ROCCHETTE – VALLE DELL'ASTICO

x	Comb.	δ_{max}	L/250.00	Cs
cm		mm	mm	
143.0	15	0.35	11.44	32.4

Verifica spostamento elastico dovuto ai soli carichi variabili (§4.2.4.2.1 - NTC 2008)

x	Comb.	δ_2	L/300.00	Cs
cm		mm	mm	
143.0	15	0.21	9.53	45.6

Travata: 1224 [513 , 366]

L = 169.9cm

Crit.Prog: Acciaio_Flessione $\delta_c = 0.0cm$ Verifica: **Verificata**

Verifica spostamento nello stato finale (§4.2.4.2.1 - NTC 2008)

x	Comb.	δ_{max}	L/250.00	Cs
cm		mm	mm	
68.0	15	0.22	6.80	31.1

Verifica spostamento elastico dovuto ai soli carichi variabili (§4.2.4.2.1 - NTC 2008)

x	Comb.	δ_2	L/300.00	Cs
cm		mm	mm	
68.0	15	0.16	5.66	36.2

Travata: 1225 [366 , 519]

L = 169.9cm

Crit.Prog: Acciaio_Flessione $\delta_c = 0.0cm$ Verifica: **Verificata**

Verifica spostamento nello stato finale (§4.2.4.2.1 - NTC 2008)

x	Comb.	δ_{max}	L/250.00	Cs
---	-------	----------------	----------	----

AUTOSTRADA VALDASTICO A31 NORD
1° LOTTO - PIOVENE ROCCHETTE – VALLE DELL'ASTICO

x	Comb.	δ_{max}	L/250.00	Cs
cm		mm	mm	
101.9	15	0.21	6.80	31.8

Verifica spostamento elastico dovuto ai soli carichi variabili (§4.2.4.2.1 - NTC 2008)

x	Comb.	δ_2	L/300.00	Cs
cm		mm	mm	
101.9	15	0.15	5.66	37.0

Travata: 1226 [391 , 514]

L = 248.8cm

Crit.Prog: Acciaio_Flessione $\delta_c = 0.0cm$ Verifica: **Verificata**

Verifica spostamento nello stato finale (§4.2.4.2.1 - NTC 2008)

x	Comb.	δ_{max}	L/250.00	Cs
cm		mm	mm	
149.3	15	1.15	9.95	8.68

Verifica spostamento elastico dovuto ai soli carichi variabili (§4.2.4.2.1 - NTC 2008)

x	Comb.	δ_2	L/300.00	Cs
cm		mm	mm	
149.3	15	0.83	8.29	9.96

Travata: 1227 [514 , 519]

L = 286.0cm

Crit.Prog: Acciaio_Flessione $\delta_c = 0.0cm$ Verifica: **Verificata**

Verifica spostamento nello stato finale (§4.2.4.2.1 - NTC 2008)

x	Comb.	δ_{max}	L/250.00	Cs
---	-------	----------------	----------	----

AUTOSTRADA VALDASTICO A31 NORD
1° LOTTO - PIOVENE ROCCHETTE – VALLE DELL'ASTICO

x	Comb.	δ_{max}	L/250.00	Cs
cm		mm	mm	
200.2	15	0.08	11.44	>100

Verifica spostamento elastico dovuto ai soli carichi variabili (§4.2.4.2.1 - NTC 2008)

x	Comb.	δ_2	L/300.00	Cs
cm		mm	mm	
200.2	15	0.05	9.53	>100

Travata: 1228 [519 , 383]

L = 169.9cm

Crit.Prog: Acciaio_Flessione $\delta_c = 0.0cm$ Verifica: **Verificata**

Verifica spostamento nello stato finale (§4.2.4.2.1 - NTC 2008)

x	Comb.	δ_{max}	L/250.00	Cs
cm		mm	mm	
68.0	15	0.23	6.80	29.4

Verifica spostamento elastico dovuto ai soli carichi variabili (§4.2.4.2.1 - NTC 2008)

x	Comb.	δ_2	L/300.00	Cs
cm		mm	mm	
68.0	15	0.17	5.66	34.3

Travata: 1229 [383 , 514]

L = 169.9cm

Crit.Prog: Acciaio_Flessione $\delta_c = 0.0cm$ Verifica: **Verificata**

Verifica spostamento nello stato finale (§4.2.4.2.1 - NTC 2008)

x	Comb.	δ_{max}	L/250.00	Cs
---	-------	----------------	----------	----

AUTOSTRADA VALDASTICO A31 NORD
1° LOTTO - PIOVENE ROCCHETTE – VALLE DELL'ASTICO

x	Comb.	δ_{max}	L/250.00	Cs
cm		mm	mm	
118.9	15	0.09	6.80	76.6

Verifica spostamento elastico dovuto ai soli carichi variabili (§4.2.4.2.1 - NTC 2008)

x	Comb.	δ_2	L/300.00	Cs
cm		mm	mm	
118.9	15	0.07	5.66	77.0

Travata: 1230 [468 , 515]

L = 248.8cm

Crit.Prog: Acciaio_Flessione $\delta_c = 0.0cm$ Verifica: **Verificata**

Verifica spostamento nello stato finale (§4.2.4.2.1 - NTC 2008)

x	Comb.	δ_{max}	L/250.00	Cs
cm		mm	mm	
149.3	15	1.10	9.95	9.06

Verifica spostamento elastico dovuto ai soli carichi variabili (§4.2.4.2.1 - NTC 2008)

x	Comb.	δ_2	L/300.00	Cs
cm		mm	mm	
149.3	15	0.80	8.29	10.3

Travata: 1231 [515 , 514]

L = 274.8cm

Crit.Prog: Acciaio_Flessione $\delta_c = 0.0cm$ Verifica: **Verificata**

Verifica spostamento nello stato finale (§4.2.4.2.1 - NTC 2008)

x	Comb.	δ_{max}	L/250.00	Cs
---	-------	----------------	----------	----

AUTOSTRADA VALDASTICO A31 NORD
1° LOTTO - PIOVENE ROCCHETTE – VALLE DELL'ASTICO

x	Comb.	δ_{max}	L/250.00	Cs
cm		mm	mm	
137.4	15	-0.18	10.99	59.5

Verifica spostamento elastico dovuto ai soli carichi variabili (§4.2.4.2.1 - NTC 2008)

x	Comb.	δ_2	L/300.00	Cs
cm		mm	mm	
137.4	15	-0.14	9.16	67.8

Travata: 1232 [514 , 400]

L = 169.9cm

Crit.Prog: Acciaio_Flessione $\delta_c = 0.0cm$ Verifica: **Verificata**

Verifica spostamento nello stato finale (§4.2.4.2.1 - NTC 2008)

x	Comb.	δ_{max}	L/250.00	Cs
cm		mm	mm	
51.0	15	0.13	6.80	52.0

Verifica spostamento elastico dovuto ai soli carichi variabili (§4.2.4.2.1 - NTC 2008)

x	Comb.	δ_2	L/300.00	Cs
cm		mm	mm	
51.0	15	0.09	5.66	62.3

Travata: 1233 [400 , 515]

L = 160.6cm

Crit.Prog: Acciaio_Flessione $\delta_c = 0.0cm$ Verifica: **Verificata**

Verifica spostamento nello stato finale (§4.2.4.2.1 - NTC 2008)

x	Comb.	δ_{max}	L/250.00	Cs
---	-------	----------------	----------	----

AUTOSTRADA VALDASTICO A31 NORD
1° LOTTO - PIOVENE ROCCHETTE – VALLE DELL'ASTICO

x	Comb.	δ_{max}	L/250.00	Cs
cm		mm	mm	
96.3	15	0.15	6.42	43.1

Verifica spostamento elastico dovuto ai soli carichi variabili (§4.2.4.2.1 - NTC 2008)

x	Comb.	δ_2	L/300.00	Cs
cm		mm	mm	
96.3	15	0.12	5.35	43.1

Travata: 1234 [485 , 516]

L = 248.8cm

Crit.Prog: Acciaio_Flessione $\delta_c = 0.0cm$ Verifica: **Verificata**

Verifica spostamento nello stato finale (§4.2.4.2.1 - NTC 2008)

x	Comb.	δ_{max}	L/250.00	Cs
cm		mm	mm	
149.3	15	0.54	9.95	18.4

Verifica spostamento elastico dovuto ai soli carichi variabili (§4.2.4.2.1 - NTC 2008)

x	Comb.	δ_2	L/300.00	Cs
cm		mm	mm	
149.3	15	0.39	8.29	21.4

Travata: 1235 [516 , 515]

L = 263.5cm

Crit.Prog: Acciaio_Flessione $\delta_c = 0.0cm$ Verifica: **Verificata**

Verifica spostamento nello stato finale (§4.2.4.2.1 - NTC 2008)

x	Comb.	δ_{max}	L/250.00	Cs
---	-------	----------------	----------	----

AUTOSTRADA VALDASTICO A31 NORD
1° LOTTO - PIOVENE ROCCHETTE – VALLE DELL'ASTICO

x	Comb.	δ_{max}	L/250.00	Cs
cm		mm	mm	
158.1	15	-0.15	10.54	71.2

Verifica spostamento elastico dovuto ai soli carichi variabili (§4.2.4.2.1 - NTC 2008)

x	Comb.	δ_2	L/300.00	Cs
cm		mm	mm	
131.8	15	-0.11	8.78	76.4

Travata: 1236 [515 , 452]

L = 160.5cm

Crit.Prog: Acciaio_Flessione $\delta_c = 0.0cm$ Verifica: **Verificata**

Verifica spostamento nello stato finale (§4.2.4.2.1 - NTC 2008)

x	Comb.	δ_{max}	L/250.00	Cs
cm		mm	mm	
32.1	15	0.06	6.42	>100

Verifica spostamento elastico dovuto ai soli carichi variabili (§4.2.4.2.1 - NTC 2008)

x	Comb.	δ_2	L/300.00	Cs
cm		mm	mm	
48.1	15	0.05	5.35	>100

Travata: 1237 [452 , 516]

L = 160.6cm

Crit.Prog: Acciaio_Flessione $\delta_c = 0.0cm$ Verifica: **Verificata**

Verifica spostamento nello stato finale (§4.2.4.2.1 - NTC 2008)

x	Comb.	δ_{max}	L/250.00	Cs
---	-------	----------------	----------	----

AUTOSTRADA VALDASTICO A31 NORD
1° LOTTO - PIOVENE ROCCHETTE – VALLE DELL'ASTICO

x	Comb.	δ_{max}	L/250.00	Cs
cm		mm	mm	
112.4	15	0.09	6.42	71.5

Verifica spostamento elastico dovuto ai soli carichi variabili (§4.2.4.2.1 - NTC 2008)

x	Comb.	δ_2	L/300.00	Cs
cm		mm	mm	
112.4	15	0.06	5.35	96.0

Travata: 1238 [469 , 516]

L = 160.5cm

Crit.Prog: Acciaio_Flessione $\delta_c = 0.0cm$ Verifica: **Verificata**

Verifica spostamento nello stato finale (§4.2.4.2.1 - NTC 2008)

x	Comb.	δ_{max}	L/250.00	Cs
cm		mm	mm	
96.3	15	0.07	6.42	87.8

Verifica spostamento elastico dovuto ai soli carichi variabili (§4.2.4.2.1 - NTC 2008)

x	Comb.	δ_2	L/300.00	Cs
cm		mm	mm	
112.3	15	0.05	5.35	>100

21 PIASTRA COLONNA PENSILINA

Ove non diversamente specificato le dimensioni usate sono DaN e cm

Simbologia sezione I	
Sezione	Nome della sezione
B	Base delle ali
H	Altezza della sezione
tbi,tbs,th	Spessore ala inferiore, superiore, spessore anima
Geometria costole	
N°	Indice della costola
X_i, Y_i	coordinate estremo iniziale
X_i, Y_i	coordinate estremo finale
l, h, t	lunghezza, altezza, spessore della costola
Geometria Tirafondi	
N°	Indice del tirafondo
X, Y	coordinate centro bullone
$\Phi(\text{mm})$	Diametro nominale del bullone
classe	classe di resistenza
Ares	Area resistente
L	Lunghezza del tirafondo
R	Eventuale raggio dell'uncino del tirafondo
Φ_m	Min(diametro del dado, diametro medio della testa) (NTC 4.2.64)
Forze applicate	
Comb.	Nome della combinazione cui corrispondono le forze
N, T_y, T_z	Sforzo normale, taglio in direzione Y, taglio in direzione Z, nel riferimento locale della colonna
M_t, M_y, M_z	Momento torcente, flettente secondo Y, flettente secondo Z, nel riferimento locale della colonna
Verifica piastra di base	
Comb., Pann.	combinazione, indice del pannello della mesh con minimo SF
N°	indice del pannello della mesh
X, Y	coordinate del centro del pannello della mesh

AUTOSTRADA VALDASTICO A31 NORD
1° LOTTO - PIOVENE ROCCHETTE – VALLE DELL'ASTICO

$\sigma_{xx}, \sigma_{yy}, \tau_{xy}$	tensioni del pannello nel riferimento della piastra
σ_{id}	tensione ideale di Von Mises= $(\sigma_{xx}^2 + \sigma_{yy}^2 - \sigma_{xx} \cdot \sigma_{yy} + 3 \cdot \tau_{xy}^2)^{1/2}$
SF	Fattore di sicurezza= $\sigma_{id}/(f_{yk}/\gamma_{M0})$ (cfr. NTC. 4.2.4.1.2)
Verifica a punzonamento piastra di base	
N°bull	indice del tirafondo
X,Y	coordinate del tirafondo
Fd	azione assiale nel tirafondo
Bp,Rd	resistenza al punzonamento della piastra (cfr. formula NTC. 4.2.64)
SF	Fattore di sicurezza al punzonamento = $Bp,Rd/Azione$
Verifica calcestruzzo	
Comb.	combinazione delle azioni
N°Vert	indice vertice area compressa
X,Y	coordinate del vertice
σ	tensione (di compressione) nel vertice
SF	Fattore di sicurezza = f_{cd}/σ
Verifica costole	
N°	indice elemento di costola, parte di costola compresa tra due costole o tra costola e sezione
N° cost	Indice della costola cui appartiene l'elemento
Xi,Yi	coordinate estremo iniziale dell'elemento
Xf,Yf	coordinate estremo finale dell'elemento
σ, τ	tensione normale e tangenziale agente sulla sezione verticale dell'elemento di costola
σ_{id}	tensione ideale di Von Mises= $(\sigma^2 + 3 \cdot \tau^2)^{1/2}$
SF	Fattore di sicurezza= $\sigma_{id}/(f_{yk}/\gamma_{M0})$ (cfr. NTC. 4.2.4.1.2)
Verifica saldature orizzontali costole	
Comb	nome della combinazione delle azioni
N°	indice elemento di costola, parte di costola compresa tra due costole o tra costola e sezione
N° cost	Indice della costola cui appartiene l'elemento
Xi,Yi	coordinate estremo iniziale dell'elemento
Xf,Yf	coordinate estremo finale dell'elemento
L	lunghezza dell'elemento
a/2	semidimensione del cordone di saldatura

AUTOSTRADA VALDASTICO A31 NORD
1° LOTTO - PIOVENE ROCCHETTE – VALLE DELL'ASTICO

σ_n, τ_p, τ_n	tensione normale, tangenziale parallela ed ortogonale sul cordone
⁽¹⁾ SF	Fattore di sicurezza
Verifica saldature verticali costole	
Comb	nome della combinazione delle azioni
N° cost	Indice della costola
X,Y	punto nel piano ove è posto il cordone
H	altezza della costola
a	dimensione del cordone di saldatura
σ_n, τ_p, τ_n	tensione normale, tangenziale parallela ed ortogonale sul cordone
⁽¹⁾ SF	Fattore di sicurezza
Verifica tirafondi uncino	
Comb	nome della combinazione delle azioni
N°	indice tirafondo
X,Y	coordinate tirafondo
Dbordo	distanza dal bordo del tirafondo
Ft,Fv	azione assiale e tangenziale del tirafondo
⁽²⁾ Ftrd,Fvrd	resistenza assiale e tangenziale
⁽³⁾ SF	fattore di sicurezza
⁽⁴⁾ Lid,Lrich	lunghezza ideale effettiva e lunghezza ideale richiesta del tirafondo

⁽¹⁾SF=valore minimo tra: $\beta_1 \cdot f_{yk} / (\sigma_n^2 + \tau_p^2 + \tau_n^2)^{1/2}$ e $\beta_2 \cdot f_{yk} / (|\sigma_n| + |\tau_n|)$ (cfr. formule NTC 4.2.78, 4.2.79)

⁽²⁾(cfr. formule NTC 4.2.57-4.2.59 e 4.2.62)

⁽³⁾nel caso di sola trazione SF=Ftrd/Ft, solo taglio SF=Fvrd/Fv, nel caso di taglio e trazione SF=1/(Fv/Fvrd+Ft/Ftrd/1.4) con la condizione Ft/Ftrd<1(cfr. formula NTC 4.2.65)

⁽⁴⁾Lid=L+6.4*R la resistenza a sfilamento è Fmax= $\pi \cdot \Phi \cdot Lid / (1 + \Phi / Dbordo)^{0.5}$, la lunghezza richiesta è Lrich=F/Fmax*Lid, il fattore di sicurezza è il minimo tra quello in⁽³⁾ e Lid/Lrich

Dimensioni piastra :140 x 110 x 8

21.1 SEZIONE DELLA COLONNA

Centro (70,55), Rotazione 0 (°)

Baricentro (70,55)

Sezione					
Tubo 609 x 10					

21.2 GEOMETRIA COSTOLE

N°	Xi	Yi	Xf	Yf	l	h1	h2	t
1	16.5	55	39.5	55	23	50	50	4
2	100.5	55	123.5	55	23	50	50	4
3	70	1.5	70	24.5	23	50	50	4
4	70	85.5	70	108.5	23	50	50	4

21.3 GEOMETRIA TIRAFONDI

N°	X	Y	Φ(mm)	classe	Ares	L	R	Φm(mm)
1	6	6	30	8.8	7.06	50	15	30
2	26	6	30	8.8	7.06	50	15	30
3	46	6	30	8.8	7.06	50	15	30
4	94	6	30	8.8	7.06	50	15	30
5	114	6	30	8.8	7.06	50	15	30
6	134	6	30	8.8	7.06	50	15	30
7	134	104	30	8.8	7.06	50	15	30
8	114	104	30	8.8	7.06	50	15	30
9	94	104	30	8.8	7.06	50	15	30
10	46	104	30	8.8	7.06	50	15	30
11	26	104	30	8.8	7.06	50	15	30
12	6	104	30	8.8	7.06	50	15	30

AUTOSTRADA VALDASTICO A31 NORD
1° LOTTO - PIOVENE ROCCHETTE – VALLE DELL'ASTICO

N°	X	Y	Φ(mm)	classe	Ares	L	R	Φm(mm)
13	6	26	30	8.8	7.06	50	15	30
14	6	46	30	8.8	7.06	50	15	30
15	6	84	30	8.8	7.06	50	15	30
16	6	64	30	8.8	7.06	50	15	30
17	134	26	30	8.8	7.06	50	15	30
18	134	46	30	8.8	7.06	50	15	30
19	134	84	30	8.8	7.06	50	15	30
20	134	64	30	8.8	7.06	50	15	30

21.4 PROPRIETA' MATERIALI

Calcestruzzo Rck=300, fcd=141.10

Coefficiente Omog. 15

Aderenza tirafondi-clc τ_{ad} =26.86

Acciaio piastra classe S275: $f_{yd}=f_{yk}/\gamma_M=2550/1.05=2428.57$

Acciaio costole:

(t<40 mm) classe S275: $f_{yd}=f_{yk}/\gamma_M=2750/1.05=2619.05$

(t>=40 mm) classe S275: $f_{yd}=f_{yk}/\gamma_M=2550/1.05=2428.57$

21.5 PROPRIETA' SALDATURE

Verifiche condotte secondo le formule:

$$(\sigma_n^2 + \tau_p^2 + \tau_n^2)^{0.5} \leq f_{yk} * \beta_1$$

$$|\sigma_n| + |\tau_n| \leq f_{yk} * \beta_2$$

Elemento	f _{yk} <40mm	f _{yk} >40mm	β ₁	β ₂
Piastra	2750	2550	0.7	0.85
Costole	2750	2550	0.7	0.85

21.6 CARATTERISTICHE APPLICATE ALLA COLONNA

Le caratteristiche sono intese positive se dirette secondo gli assi locali della colonna e sono applicate nel baricentro della sezione

Riferimento locale della colonna

	X	Y	Z
Origine	70.0000	55.0000	0.0000
Asse x	0.0000	0.0000	1.0000
Asse y	0.0000	1.0000	0.0000
Asse z	-1.0000	0.0000	0.0000

Comb.	N	Ty	Tz	Mt(DaN*m)	My(DaN*m)	Mz(DaN*m)
Cond_1	26005	101	54	54	768	333

Verifiche piastra

Comb.	Pann.	X	Y	σ_{xx}	σ_{yy}	τ_{xy}	σ_{id}	SF
Cond_1	2099	43.04	54.68	1376.12	593.18	-296.27	1301.01	1.87

Tensione massima ideale = 1301.01 SF=1.87 (Cond_1)**Verificato**

Verifica a punzonamento piastra

Comb.	N°bull	X	Y	Fd	Bp,Rd	SF
Cond_1	12	6.00	104.00	1331	148384	>100

Forza di punz. massima = 1330.55 SF=>100 (Cond_1) (bull 12)**Verificato**

Verifica calcestruzzo

Comb.	N°Vert	X	Y	σ	SF
Cond_1		Calcestruzzo interamente teso			>100

Tensione cls max = 0.00 SF=>100 (Cond_1)**Verificato**

Verifiche Costole

Cond	N°Cost.	σ	τ	σ_{id}	SF
		DaN/cmq	DaN/cmq	DaN/cmq	
Cond_1	122	164	24	169	15.5

Calcolo saldature orizzontali

Comb	N°cost	Xi	Yi	Xf	Yf	L	a/2	σ_n	τ_p	SF
Cond_1	1	16.50	55.00	39.50	55.00	23.00	1.00	0.00	0.00	>100
Cond_1	2	100.50	55.00	123.50	55.00	23.00	1.00	0.00	0.00	>100
Cond_1	3	70.00	1.50	70.00	24.50	23.00	1.00	713.80	28.04	2.50
Cond_1	4	70.00	85.50	70.00	108.50	23.00	1.00	514.38	20.80	3.47

Calcolo saldature verticali

Comb	N°cost	X	Y	H	a	σ_n	τ_p	SF
Cond_1	1	39.50	55.00	50.00	2.00	36.05	12.90	50.3
Cond_1	2	100.50	55.00	50.00	2.00	26.10	9.57	69.2
Cond_1	3	70.00	24.50	50.00	2.00	27.29	9.65	66.5
Cond_1	4	70.00	85.50	50.00	2.00	29.11	10.31	62.3

Verifica Tirafondi Uncino

Comb	N°	X	Y	Dbordo	Ft	Fv	FtRd	FvRd	Lid	Lrich	SF
Cond_1	12	6.00	104.00	6.00	1331	6	40666	27110	146	12	12.3

Coefficiente di sicurezza minimo 12.345840 (Cond_1): **Verificato**

Verifica complessiva

Coefficiente di sicurezza minimo 1.866678 (Piastra di base): **Verificato**

Verifica nodo

Verifica funzioni cerniera

Piatto collegamento cerniera asta

$$Nsd \leq Nrd = Ares * fyd$$

$$Ned \leq Ares * fyd = (79 * 24) * 275 = 521,14 \text{ Kn} - \text{Verificato}$$

Verifica unione bullonata

$$Ned = 411.700 \text{ N}$$

$$Fved = Ned/4 = 412/4 \text{ kN} = 103 \text{ kN}$$

$$ftb = 800 \text{ N/mm}^2$$

$$Ares = \pi d^2/4 = \pi 20^2 = 314,16 \text{ mm}^2$$

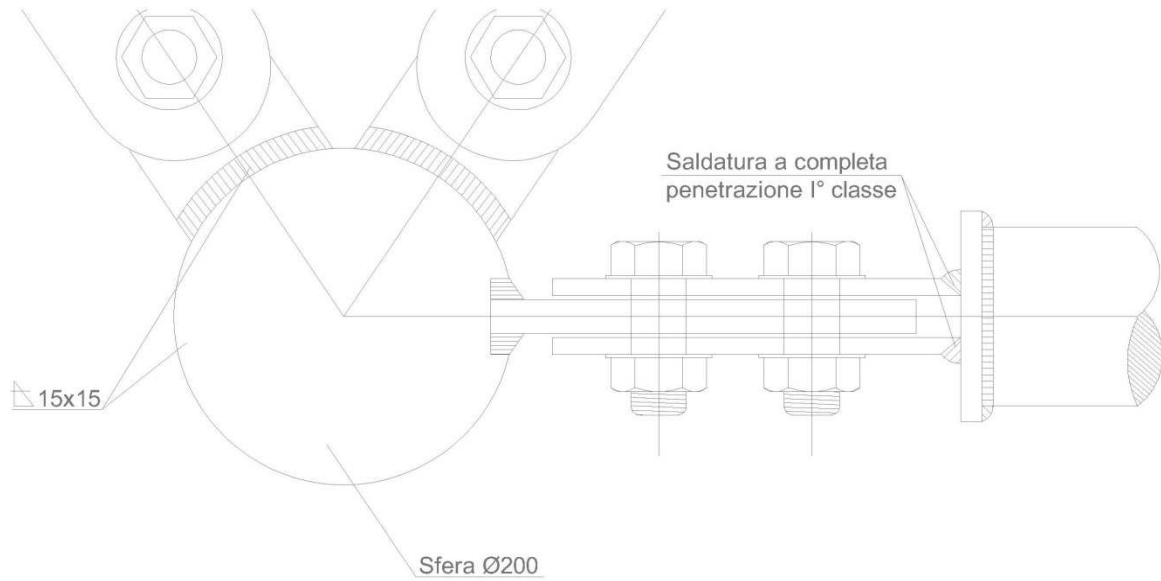

Resistenza a taglio del Bullone

$$F_{vrd} = 0,6 * f_{tb} * A_{res} / \gamma_{m2} = 0,6 * 800 * 314,16 = 120,63 \text{ kN} > F_{ved} - \text{Verificato}$$

Resistenza a rifollamento

$$F_{bed} = 206 \text{ kN}$$

$$C1 = 60 \quad e_r = 90 \quad P1 = 90$$

$$A_{min} 60/3.19 = 1.05; \quad f_{tb}/f_{tn} = 800/430; \quad 1;$$

$$F_{brd} = K\alpha * f_{tk} * d * t / \gamma_{m2}$$

$$K_{min} 2,8 * e^2/d_o - 1,7 = 4,5; \quad 2,5$$

$$\alpha = 1,05 \quad K = 2,5$$

$$F_{brd} = 2,5 * 1,05 * 430 * 20 * 24 / 1,25 = 433,44 \text{ kN} > F_{bed} - \text{Verificato}$$

22 CAPACITA' PORTANTE FONDAZIONE

GD = Palo di **Grande** diametro per $D > D_g = 0.60$ [m]

Tipologie Palo: PR=Prefabbricato, G=Gettato, TR=Trivellato, TRP=Trivellato Pressato

Palo	Tipo	Testa	GD	D [m]	e [m]	L [m]	Mu [kg*m]	V [kg]	H [kg]
0 (Nodo 174)	TR	Vinc	No	0.60	--	10.00	20382	7400	89

Coefficienti di sicurezza:

Palo	γ_b	γ_s	γ_{st}	γ_T	ξ	effV	effH
0 (Nodo 174)	1.35	1.15	1.25	1.30	1.50	1.00	1.00

Stratigrafie:

H [m]	ϕ [°]	OCR	c [kg/cm ²]	c _u [kg/cm ²]	γ [t/mc]	γ_{sat} [t/mc]	Addens.	Descrizione
Palo n° 0 (Nodo 174), Falda assente								
20.00	38.00	--	0.00	--	2.00	--	No	Strato 1

Verifica Carico Verticale

Palo	N [kg]	P [kg]	S [kg]	Peso Palo [kg]	(*)Nd [kg]	N _q	N _c	Verifica
0 (Nodo 174)[4]	14469	366131	88361	7069	232029	58.86	82.63	VERIFICATO
0 (Nodo 174)[(12+13)-III-3]	12269	366131	88361	7069	232029	58.86	82.63	VERIFICATO

Verifica Carico Orizzontale

Palo	H [kg]	H _l [kg]	H _d [kg]	Meccanismo di rottura	Z ₀ [m]	Z _{max} [m]	M _{max} [kg*m]	Verifica
0 (Nodo 174)[4]	89	44040	22585	Lungo	--	1.61	20382	VERIFICATO
0 (Nodo 174)[(12+13)-III-3]	316	43598	22358	Lungo	--	1.60	20028	VERIFICATO

$N_d = (P/\gamma_b + S/\gamma_s) * \text{effV} / \xi$ (per pali in trazione $\gamma_s = \gamma_{st}$ e $P=0$)

$H_d = (H / (\xi * \gamma_T)) * \text{effH}$

23 CALCOLI COMPARATIVI

CASI PROVA

L'affidabilità dei codici utilizzati è stata testata attraverso la risoluzione di alcuni casi prova, che il Produttore fornisce all'Utente, e vengono di seguito documentati.

CASO PROVA 1 - Influenza della posizione dei nodi rispetto agli assi delle aste

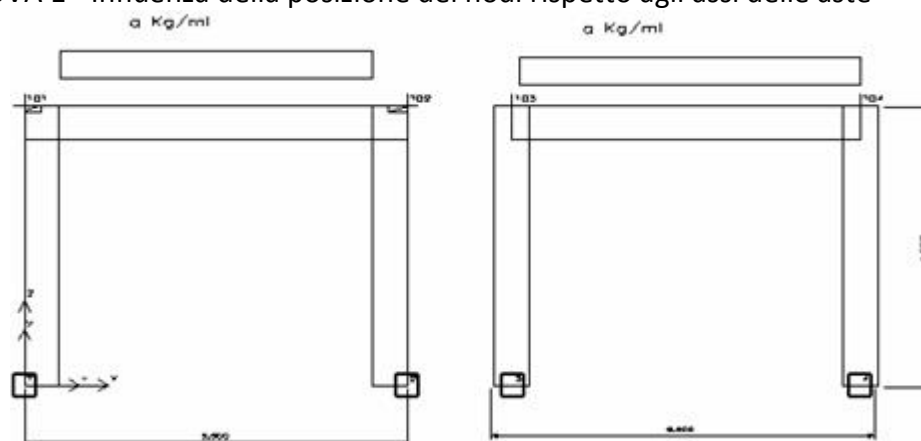

I due portali sono due strutture identiche, ma il primo ha la luce teorica (da nodo a nodo) del traverso di lunghezza maggiore ($5.50 > 5.00$) e i risultati di calcolo sono diversi; se però si introducono nel traverso del primo telaio dei conci rigidi pari a 25 cm, cioè mezzo pilastro, allora la luce flessibile dei due telai coincide praticamente e i risultati sono perfettamente coincidenti.

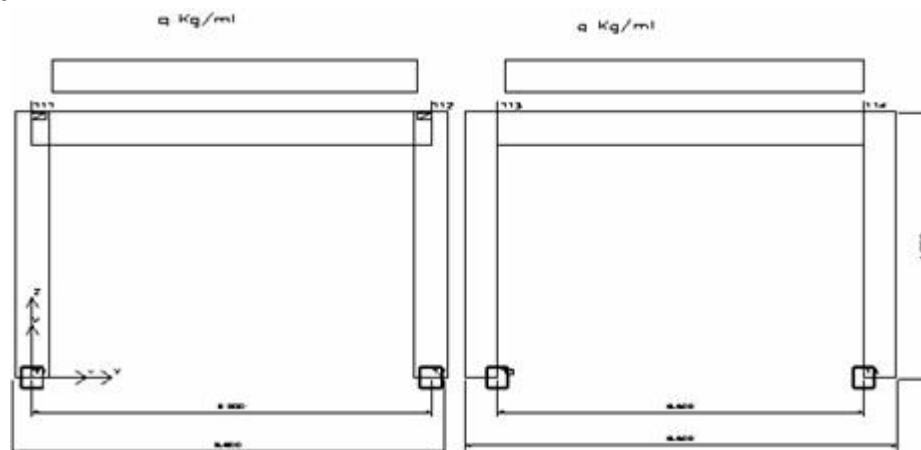

Anche in questo esempio i portali sono due strutture identiche, però il traverso del primo è più lungo e quindi i risultati saranno gli stessi se vengono introdotti sul traverso del primo portale dei conci rigidi pari a metà pilastro.

In entrambi gli esempi (anziché introdurre i conci rigidi) si potevano avere gli stessi risultati modificando il filo fisso del traverso del primo portale rispettivamente 8585 per l'esempio I e 8684 per l'esempio II.

Concludendo qualunque sia la posizione dei nodi rispetto agli assi delle travi e dei pilastri, le sollecitazioni (vengono prese sugli assi delle aste) sono sempre le stesse se la geometria 3D è la stessa e si scelgono oculatamente i fili fissi o si introducono i conci rigidi. Al riguardo si ribadisce che lo schema di calcolo è quello 3D e NON lo schema unifilare. Infine si fa notare

che l'equilibrio nel nodo (ad esempio N° 101) non sussiste in quanto le sollecitazioni nel traverso vengono prese sull'asse dello stesso, mentre le sollecitazioni del pilastro vengono prese nel nodo e quindi in punti diversi. Per l'equilibrio quindi non bisogna prendere in considerazione solo i momenti, ma anche gli effetti delle altre sollecitazioni sul nodo rigido.

CASO PROVA 2 - Piastra rettangolare

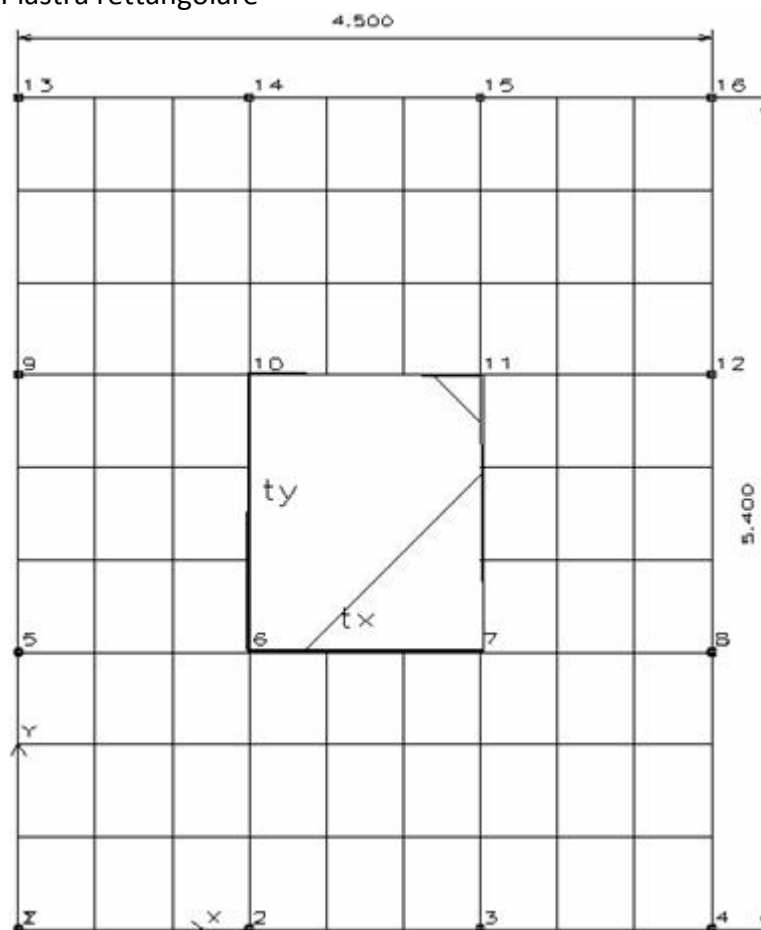

Siano L_x ed L_y i lati della piastra ($L_y \geq L_x$) e t_x t_y i corrispondenti lati del rettangolo caricato, si ha:

p carico uniforme;

$P = p \cdot t_x \cdot t_y$ carico totale;

$M_{xm} = a_{xm} \cdot P$ momento al centro, agente parallelamente al lato L_x (cioè nella sezione di mezzeria parallela al lato L_y);

$M_{ym} = a_{ym} \cdot P$ momento al centro, agente parallelamente al lato L_y (cioè nella sezione di mezzeria parallela al lato L_x).

Nel caso in esame essendo:

$L_x = 4.5$ [m]; $L_y = 5.4$ [m]; $t_x = 1.5$ [m]; $t_y = 1.8$ [m]; $p = 5000$ [dN/mq]; si ha:

$P = 13500$ [dN]

e per $n = 0$ sarà: $a_{xm} = 0.1377$; $a_{ym} = 0.1050$ e pertanto si ha:

$M_{xm} = 1860$ [dNm]; $M_{ym} = 1418$ [dNm].

Se consideriamo la piastra discretizzata come in figura (9 x 9) con IperSpace si hanno i seguenti valori:

$M_{xx} = 1731$ [dNm]; $M_{yy} = 1314$ [dNm] con un errore $< 8\%$

Se la discretizzazione è di 15 x 15 elementi i valori sono:

$M_{xx} = 1810$ [dNm]; $M_{yy} = 1382$ [dNm] con un errore < 3 %

Se la discretizzazione è di 21 x 21 elementi i valori sono:

$M_{xx} = 1832$ [dNm]; $M_{yy} = 1400$ [dNm] con un errore < 1.5 %.

CASO PROVA 3 - Mensola inflessa

Prendiamo in considerazione la mensola di acciaio ($E = 20.000$ kN/cm². e $n = 0.25$) delle dimensioni 48x4x1 cm, sollecitata all'estremità da un taglio di 40 kN, riportata a pag. 121 del testo di C.A. BREBBIA e J.J. CONNOR.

Il limite superiore dello spostamento all'estremo caricato, ottenuto con la Teoria delle travi è : cm 0.53374.

Nella tabella che segue vengono riportati i valori dello spostamento per vari tipi di elementi finiti e varie discretizzazioni.

Risultati estratti dal Testo di Trebbia e Connor

Tipo di elemento	Numero elementi	Freccia di estremità	Errore %
Elemento triangolare a deformazione costante	160	0.45834	14.59
	576	0.51282	3.92
Elemento triangolare a deformazione lineare	160	0.53259	0.22
	576	0.53353	0.04
Elemento triangolare a deformazione quadratica	68	0.53059	0.17
	214	0.53259	0.22
Elemento rettangolare di primo ordine	160	0.51679	3.18
Elemento rettangolare del terzo ordine	52	0.52807	1.25

Risultati del solutore di IperSpace

Tipo di elemento	Numero elementi	Freccia di estremità	Errore %
Elemento rettangolare	16	0.5198	2.60
"	36	0.5298	0.74
"	64	0.5311	0.49
"	100	0.5322	0.29
"	144	0.5328	0.18

L'elemento piastra consente, con una discretizzazione molto piccola ($12 \times 3 = 36$ elementi), di avere un errore inferiore all'1%. Per ottenere risultati simili occorre eseguire non solo discretizzazioni più spinte, ma scegliere anche elementi a deformazione quadratica o di

ordine superiore. L'impiego di tale elemento risulta particolarmente indicato per seguire le prescrizioni delle Norme Tecniche (D.M. 2005), che impongono la sostituzione ai pilastri snelli delle pareti. La risoluzione di questo problema di modellazione consente di evitare errori grossolani sulla stima di sforzi e deformazioni degli elementi bidimensionali.

CASO PROVA 4 - Analisi Dinamica

Si consideri la struttura a telaio riportata nelle successive figure, costituita da un materiale con modulo elastico $E=250.000 \text{ dN/mq}$, nella quale le dimensioni delle sezioni trasversali dei pilastri sono:

50x50 al primo piano

40x40 al secondo piano

35x35 al terzo piano

e le dimensioni delle sezioni trasversali delle travi sono tutte 25x60.

I carichi gravitazionali sono tutti nulli a meno di un carico uniformemente distribuito, dato attraverso le aree di carico costituite dai solai, sulla struttura è di 850 dN/mq .

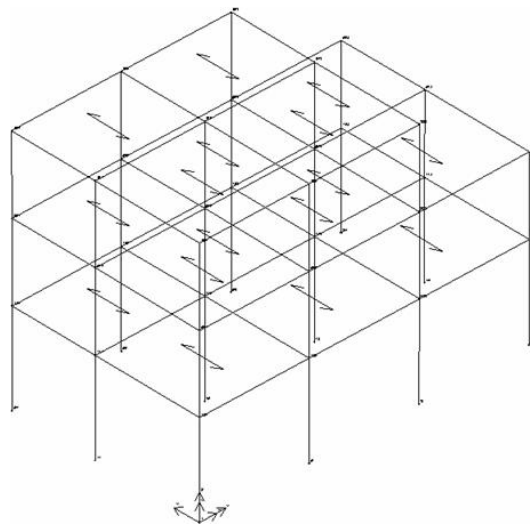

AUTOSTRADA VALDASTICO A31 NORD
1° LOTTO - PIOVENE ROCCHETTE – VALLE DELL'ASTICO

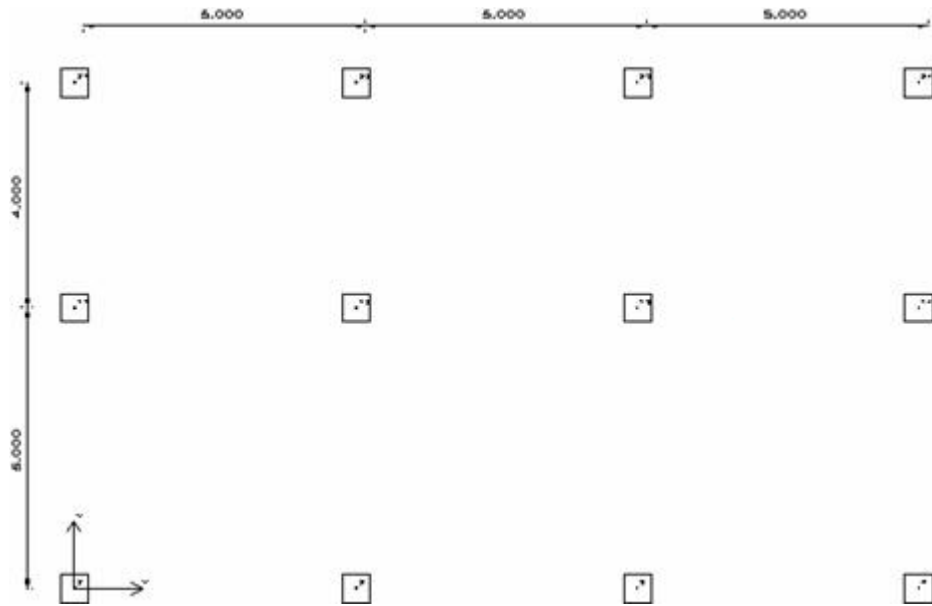

Pianta

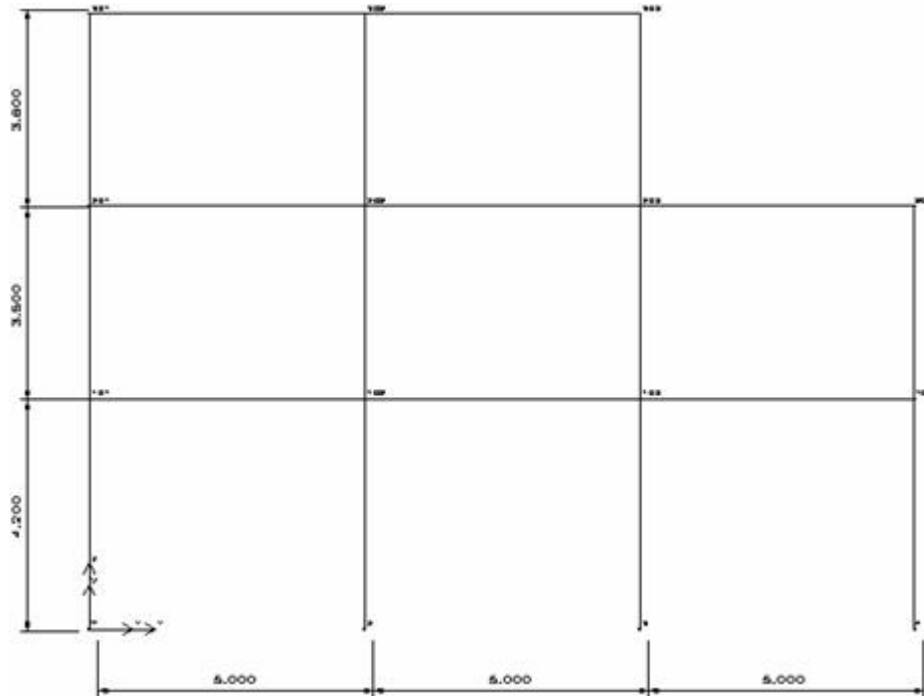

Telaio 1

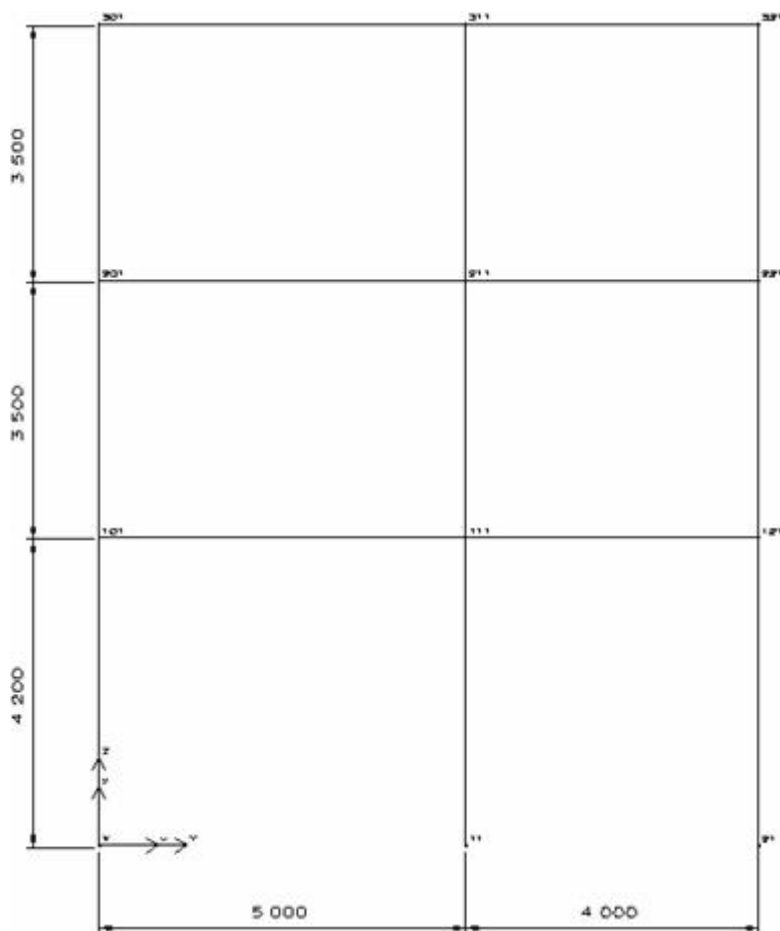

Telaio 4

Nell'ipotesi di telai shear-type, cioè con traversi infinitamente rigidi, il calcolo eseguito a mano dai *proff. Carlo Greco e Roberto Ramasco* dell' Università di Napoli (esempio riportato nella pubblicazione *PROGETTAZIONE E PARTICOLARI ESECUTIVI IN ZONA SISMICA* – ed. ANCE), fornisce, per $S=12$, i seguenti risultati:

Modo	Periodo in sec.	Spostamenti dir y dei nodi del telaio 4 in mm	
1	0.3227	piano primo	1.204
2	0.3160	piano secondo	2.667
3	0.2175	piano terzo	4.332
4	0.1466		
5	0.1450		

I momenti nei pilastri del telaio 4, dovuti solo al primo modo di vibrare, (uguali al piede ed in testa di ogni pilastro, essendo i traversi infinitamente rigidi) sono:

$M_1=5309$ dNm; $M_2=3840$ dNm; $M_3=2622$ dNm.

Risultati di IperSpace:

a) traversi deformabili, cioè travi di sezione effettiva (25x60)

Modo	Periodo in sec	Spostamenti in mm dei nodi del pilastro N° 1	
1	0.431	piano primo	2.157

2	0.416	piano secondo	5.000
3	0.326	piano terzo	7.300
4	0.173		
5	0.170		

I momenti nel pilastro N° 1 (telai N° 4), dovuti al primo modo (non più uguali in testa e piede come nel modello shear-type) sono :

M1 max=6633 dNm; M2max=3210 dNm; M3max=2045 dNm.

Dai risultati si evince che ci sono le seguenti variazioni:

- 25 % circa sul periodo del primo modo di vibrare;
- 40 % sullo spostamento del terzo piano;
- 20 % sul momento d'incastro al piede del piano primo.

b) traversi rigidi (travi di sezione 200x200 e modulo 21000000 dN/mq)

Modo	Periodo in sec.	Spostamenti in mm dei nodi del pilastro N° 1	
1	0.326	piano primo	1.244
2	0.317	piano secondo	2.728
3	0.251	piano terzo	4.203
4	0.151		
5	0.148		

I momenti nel pilastro N° 1, dovuti al primo modo (uguali in testa e piede) sono:

M1=5509 dNm; M2=3878 dNm; M3=2258 dNm.

In questo caso le variazioni sono contenute entro il 3 %. E' da presupporre che esse siano dovute essenzialmente al differente tipo di arrotondamento praticato tra il calcolo manuale ed il calcolo numerico, nonchè al fatto che il calcolo eseguito da IperSpace è di tipo spaziale. Si può concludere che il test su IperSpace è nettamente positivo. Inoltre la e che la qualità della soluzione il modello shear-type fornisce risultati tanto più piuttosto grossolani quanto più ci si allontana dall'ipotesi di traversi infinitamente rigidi.

23.1 CARATTERISTICHE DELLE SOLLECITAZIONI DELLE ASTE

Per l'ottemperanza a quanto previsto al par. 10.2 del D.M. Infrastrutture 14.01.2008 relativamente al "giudizio motivato di accettabilità dei risultati" si sono confrontati i risultati ottenuti con l'utilizzo dei codici di calcolo automatici con le soluzioni di semplici calcoli di larga massima.

In particolare il sistema reticolare spaziale costituente la copertura della pensilina è stato semplificato con una serie parallela di diaframmi piani reticolari come schematizzato nella figura sottostante.

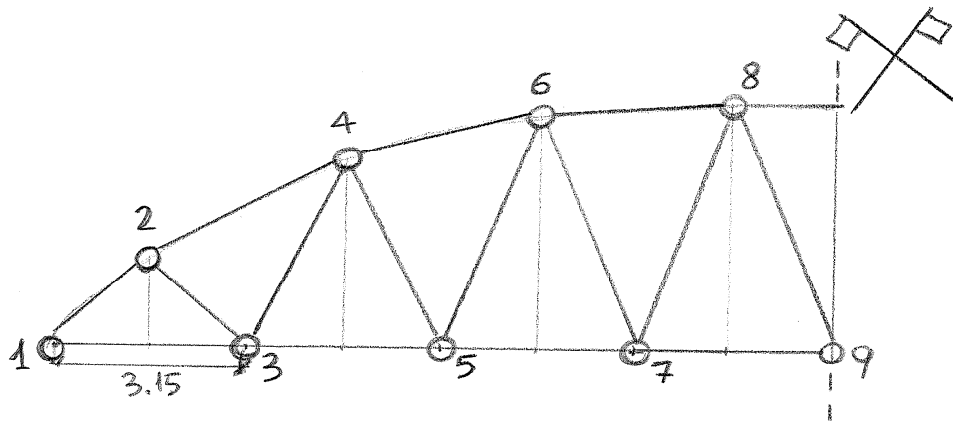

Per determinare le reazioni vincolari trasmesse sulle colonne del suddetto diaframma reticolare, si è adottato lo schema di trave continua su 4 appoggi e stabilito con l'equazione dei 3 momenti avendo imposto un carico uniforme ripartito. Per i calcoli di massima si sono utilizzati i metodi tipici della scienza delle costruzioni ricorrendo alle formulazioni semplificate di prontuari di calcolo (Ing. L. Santarella XXXVII edizione Edizioni Hoepli), come di seguito calcolato:



$$\frac{1}{24}(q_{n-1}L_{n-1}^3 + q_n L_n^3) = \frac{1}{6}(L_{n-1}M_{n-1} + L_n M_{n+1}) + \frac{1}{3}(L_{n-1} + L_n)M_n$$

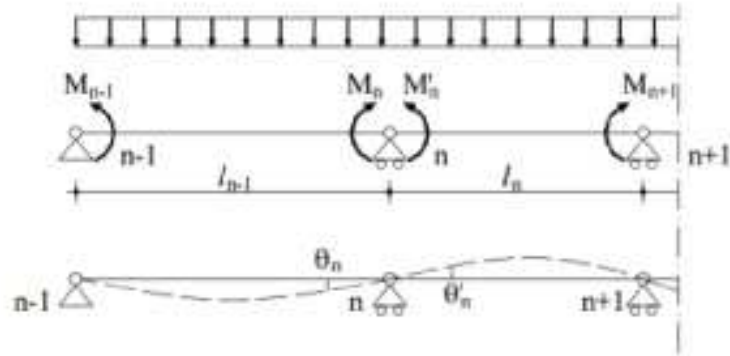

ANALISI DEI CARICHI

Peso totale diaframma piano (profilati tubolari \varnothing 114.3 x 5.9): 82.16 ml x 16 kg/ml = 1315 kg

Peso proprio struttura: $\frac{1315}{25.15} = 52.30$ Kg/ml

Carico accidentale: 445.9 Kg/ml

Peso rivestimento : 15 Kg/ml

Peso struttura + carico accidentale + peso pannelli di copertura e accessori = **513.2 Km/ml**

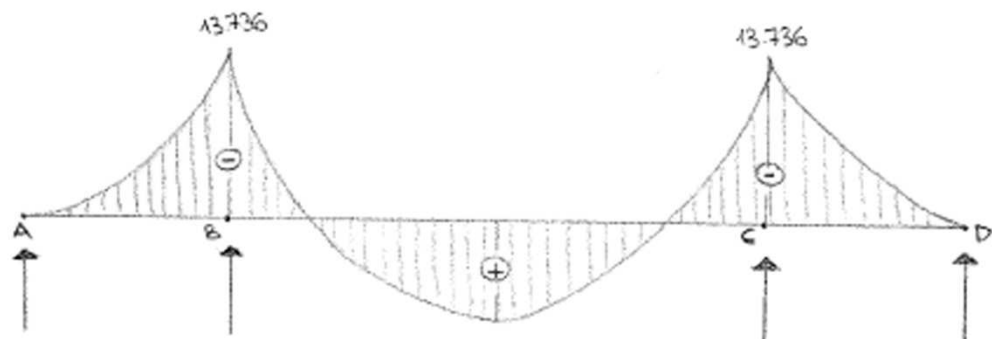

Ricaviamo le reazioni vincolari:

Equilibrio al nodo B

$$R_A = - \frac{13736.54}{3.15} + (256.6 \times 3.15) = - 3552.52 \text{ Kg}$$

$$R_{B_1} = R_A + (513.2 \times 3.15) = 5169.1 \text{ Kg}$$

Equilibrio al nodo C dell'elemento BC

$$R_{B_2} = \frac{513.2 \times 18.06}{2} = 4836.91 \text{ Kg}$$

$$R_{C_2} = 4836.91 \text{ Kg}$$

$$R_B = R_C = 5169.1 + 4836.91 = 10006.01 \text{ Kg}$$

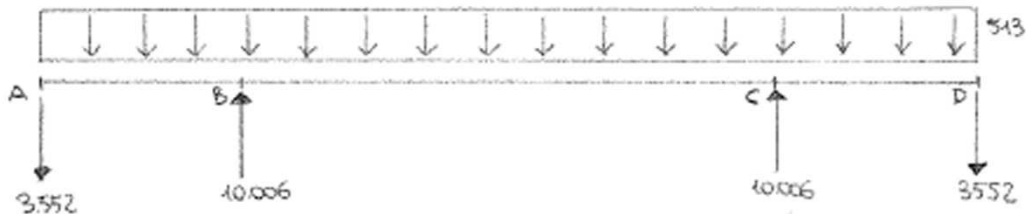

Il carico viene applicato ai nodi della struttura

$$P_{\text{Nodi}} = \frac{q \times l_{\text{tot}}}{n^{\circ} \text{ nodi}} = \frac{513.2 \times 25.15}{8} = 1613.37 \text{ Kg}$$

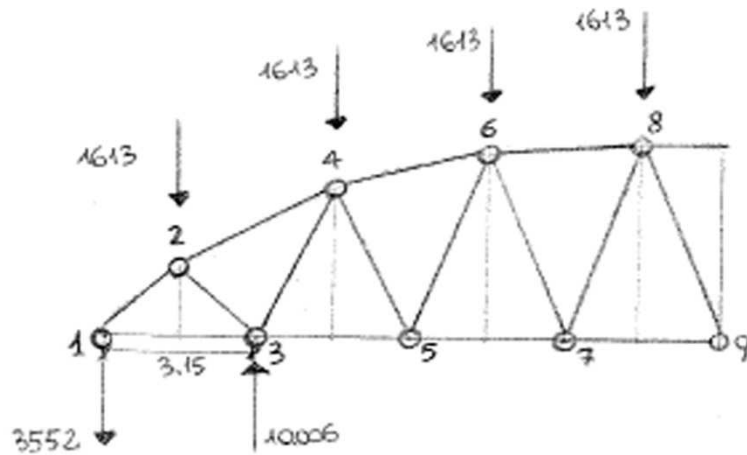

Calcoliamo la sollecitazione sull'asta con il metodo dell'equilibrio ai nodi:

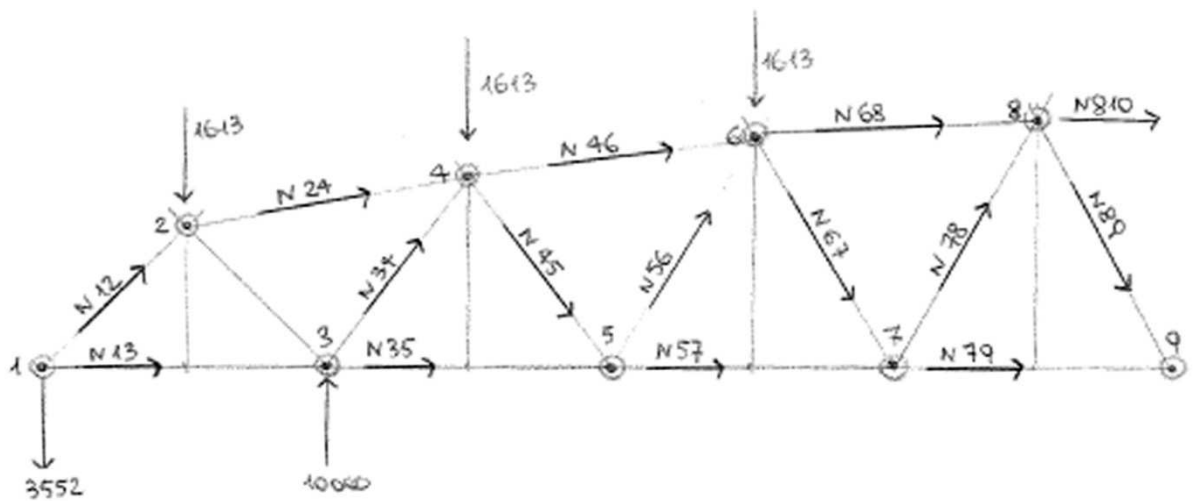

Equilibrio al nodo 3

$$(3552 \times 3.15) - (N_{12} \times 1.52) = 0$$

$$N_{1-2} = 7362.13 \text{ Kg}$$

Equilibrio al nodo 2

$$(3552 \times 1.58) + (N_{13} \times 0.88) = 0$$

$$N_{1-3} = 6378.39 \text{ Kg}$$

Equilibrio al nodo 4

$$(N_{3-5} \times 1.42) - (10000 \times 1.58) + (3552 \times 4.73) + (1613.37 \times 3.15) = 0$$

$$N_{3-5} = -4285.6 \text{ Kg}$$

Equilibrio al nodo 3

$$(N_{2-4} \times 1.13) - (1613.37 \times 1.56) - (3552 \times 3.14) = 0$$

$$N_{2-4} = 12085 \text{ Kg}$$

Equilibrio al nodo 5

$$(N_{3-4} \times 2.1) + (12085 \times 1.66) + (10000 \times 3.14) + - (3552 \times 6.28) - (1613.37 \times 4.70) = 0$$

$$N_{3-4} = -10270.7 \text{ Kg}$$

Equilibrio al nodo 5

$$(N_{4-6} \times 1.57) - (1613.37 \times 1.57) - (1613.37 \times 4.71) + - (10000 \times 3.14) - (3552.52 \times 1.57) = 0$$

$$= 663.56 \text{ Kg} \geq N_{4-6}$$

Equilibrio al nodo 6

$$(3552 \times 7.86) - (10000 \times 4.73) + (1613 \times 6.28) + (1613 \times 3.14) + (N_{4-5} \times 2.35) - (4285 \times 1.75) = 0$$

$$N_{4-5} = 4973 \text{ Kg}$$

Equilibrio al nodo 6

$$(N_{5-7} \times 1.75) + (1613.37 \times 3.14) + (1613.37 \times 6.28) - (10000 \times 4.73) + (3552.52 \times 7.86) = 0$$

$$N_{5-7} = 2393 \text{ Kg}$$

Equilibrio al nodo 7

$$(-N_{5-6} \times 2.33) - (664 \times 1.9) - (10000 \times 6.29) + (3552 \times 9.43) + (1613 \times 7.85) + (1613 \times 4.71) = 0$$

$$N_{5-6} = -4467$$

Equilibrio al nodo 7

$$-(N_{6-8} \times 1.82) - (10000 \times 6.29) + (1613.37 \times 1.57) + (1613 \times 4.71) + (1613 \times 7.85) + (3552 \times 9.43) = 0$$

$$N_{6-8} = -3633 \text{ Kg}$$

Equilibrio al nodo 8

$$(N_{6-7} \times 2.43) + (2393 \times 1.89) + (1613.37 \times 3.14) + (1613 \times 6.28) + (1613 \times 9.42) + (3552 \times 11) - (10000 \times 7.87) = 0$$

$$N_{6-7} = 1941 \text{ Kg}$$

Equilibrio al nodo 8

$$(N_{7-9} \times 1.89) + (1613 \times 3.14) + (1613.37 \times 6.28) + (1613 \times 9.42) + (3552 \times 11) - (10000 \times 7.87) = 0$$

$$N_{7-9} = 4888 \text{ Kg}$$

Equilibrio al nodo 9

$$(N_{7-8} \times 2.41) + (3633 \times 1.82) + (1613.37 \times 4.71) + (1613 \times 7.85) + (1613 \times 11) + (3552 \times 12.57) - (10000 \times 9.43) = 0$$

$$N_{7-8} = -2090 \text{ Kg}$$

Equilibrio al nodo 9

$$-(N_{8-10} \times 1.82) + (1613.37 \times 1.57) + (1613 \times 4.71) + (1613 \times 7.85) + (1613 \times 11) + (3552 \times 12.57) - (10000 \times 9.43) = 0$$

$$N_{8-10} = - 5009 \text{ Kg}$$

Equilibrio al nodo 10

$$(N_{8-9} \times 2.40) + (4888 \times 1.87) + (1613 \times 3.14) + (1613 \times 6.28) + (1613 \times 9.42) + (1613 \times 12.56) + (3552 \times 14.14) + - (10000 \times 11) = 0$$

$$N_{8-9} = - 5.85 \text{ Kg} \approx 0 \text{ Asta scarica}$$

I risultati conseguiti hanno ordine di grandezza compatibile con quanto ottenuto dalle verifiche condotte con l'ausilio di codici di calcolo automatici.

23.2 VERIFICA DELLE ASTE (Profili tubolari)

Per la verifica dei profili tubolari utilizzati $\varnothing 114.3 \times 5.9$ sezioni utilizzate sono stati confrontati i risultati ottenuti utilizzando il codice di calcolo con quelli ricavati utilizzando dei semplici fogli di calcolo.

RESISTENZA E STABILITA' DEI PROFILI TUBOLARI - Metodo B - EN 1993 - 1 - 1:2010		
Materiali utilizzati	© Dott. Ing. Simone Caffè - 25/02/2013	
Valore di snervamento dell'acciaio del profilo	f_{yk}	275 [N/mm ²]
Valore di rottura dell'acciaio del profilo	f_{uk}	390 [N/mm ²]
Modulo di elasticità dell'acciaio del profilo	E	210000 [N/mm ²]
Modulo di elasticità tangenziale dell'acciaio del profilo	G	80769 [N/mm ²]
Coefficiente parziale di sicurezza per le verifiche di resistenza	γ_{M0}	1,05 [-]
Coefficiente parziale di sicurezza per le verifiche di stabilità	γ_{M1}	1,05 [-]
Coefficiente parziale di sicurezza per le verifiche di rottura	γ_{M2}	1,25 [-]
Caratteristiche meccaniche del profilo		
Diametro esterno del profilo tubolare	d_{ext}	114,30 [mm]
Spessore del profilo tubolare	t	6,00 [mm]
Diametro interno	d_{int}	102,30 [mm]
Raggio esterno	r_{ext}	57,15 [mm]
Raggio interno	r_{int}	51,15 [mm]
Area della sezione trasversale	A	2041 [mm ²]
Momento d'inerzia della sezione trasversale attorno all'asse forte	I_y	3,0021E+06 [mm ⁴]
Modulo di resistenza elastico attorno all'asse forte	$W_{el,y}$	5,2530E+04 [mm ³]
Modulo di resistenza plastico attorno all'asse forte	$W_{pl,y}$	7,0445E+04 [mm ³]
Area resistente a taglio nel piano dell'anima	$A_{v,z}$	1300 [mm ²]
Raggio d'inerzia attorno all'asse forte	i_y	38,35 [mm]
Momento d'inerzia della sezione trasversale attorno all'asse debole	I_z	3,0021E+06 [mm ⁴]
Modulo di resistenza elastico attorno all'asse debole	$W_{el,z}$	5,2530E+04 [mm ³]
Modulo di resistenza plastico attorno all'asse debole	$W_{pl,z}$	7,0445E+04 [mm ³]
Area resistente a taglio nel piano delle ali	$A_{v,y}$	1300 [mm ²]
Raggio d'inerzia attorno all'asse debole	i_z	38,35 [mm]
Momento d'inerzia torsionale	I_t	6,004E+06 [mm ⁴]
Caratteristiche di sollecitazione nella sezione di verifica		
Forza normale (positiva se di compressione)	N_{Ed}	170,00 [kN]
Forza di taglio agente in direzione parallela all'anima	$V_{z,Ed}$	193,00 [kN]
Forza di taglio agente in direzione parallela alle ali	$V_{y,Ed}$	193,00 [kN]
Momento flettente attorno all'asse maggiore di inerzia	$M_{y,Ed}$	6,86 [kNm]
Momento flettente attorno all'asse minore di inerzia	$M_{z,Ed}$	0,06 [kNm]
Momento torcente primario (alla Saint Venant)	T_{Ed}	0,00 [kNm]
Classificazione della sezione trasversale di verifica		
Coefficiente ϵ	ϵ	0,924 [-]
Rapporto tra diametro esterno e spessore	ρ	19,050 [-]
Rapporto limite per la classe 1	ρ_1	42,727 [-]
Rapporto limite per la classe 2	ρ_2	59,818 [-]
Rapporto limite per la classe 3	ρ_3	76,909 [-]
Classificazione della sezione trasversale	CL	1

AUTOSTRADA VALDASTICO A31 NORD
1° LOTTO - PIOVENE ROCCHETTE – VALLE DELL'ASTICO

Verifiche di resistenza della sezione trasversale		
Resistenza a trazione pura		
Resistenza plastica a trazione	$N_{t,Rd}$	534,65 [kN]
Verifica a trazione pura	ρ_{Nt}	0,000 [-]
Resistenza a compressione pura		
Resistenza a compressione pura	$N_{c,Rd}$	534,65 [kN]
Verifica a compressione pura	ρ_{Nc}	0,318 [-]
Resistenza a torsione e taglio		
Diametro medio della sezione trasversale	d_{med}	108,30 [mm]
Area della sezione compresa nel diametro medio	Ω	9211,85 [mm ²]
Tensioni tangenziali dovute al momento torcente	$\tau_{t,Ed}$	0,00 [N/mm ²]
Verifica tensionale per pura torsione	ρ_T	0,000 [-]
Resistenza plastica a taglio	$V_{pl,Rd}$	196,51 [kN]
Resistenza plastica a taglio ridotta per effetto della torsione	$V_{pl,T,Rd}$	196,51 [kN]
Verifica a taglio in direzione z - z	ρ_{Vz}	0,982 [-]
Verifica a taglio in direzione y - y	ρ_{Vy}	0,982 [-]
Resistenza a flessione		
Modulo di resistenza di calcolo per flessione attorno all'asse y - y	W_y	7,04E+04 [mm ³]
Resistenza a flessione attorno all'asse y - y	$M_{cy,Rd}$	18,45 [kNm]
Verifica flessionale attorno all'asse y - y	ρ_{My}	0,372 [-]
Modulo di resistenza di calcolo per flessione attorno all'asse z - z	W_z	7,04E+04 [mm ³]
Resistenza a flessione attorno all'asse z - z	$M_{cz,Rd}$	18,45 [kNm]
Verifica flessionale attorno all'asse z - z	ρ_{Mz}	0,003 [-]
Resistenza a flessione e taglio (per sezioni in classe 1 o 2)		
Fattore di riduzione per la presenza della forza di taglio in direzione z - z	$\rho_{Vz,red}$	0,93 [-]
Fattore di riduzione per la presenza della forza di taglio in direzione y - y	$\rho_{Vy,red}$	0,93 [-]
Resistenza a flessione ridotta, per flessione attorno all'asse y - y	$M_{Vy,Rd}$	17,15 [kNm]
Verifica flessionale attorno all'asse y - y	$\rho_{My - Vz}$	0,400 [-]
Resistenza a flessione ridotta, per flessione attorno all'asse z - z	$M_{Vz,Rd}$	17,15 [kNm]
Verifica flessionale attorno all'asse z - z	$\rho_{Mz - Vy}$	0,003 [-]
Resistenza a flessione, forza assiale e taglio		
<u>Calcolo plastico per sezioni in classe 1 o 2</u>		
Coefficiente n	n	0,318 [-]
Resistenza a flessione ridotta, per flessione attorno all'asse y - y	$M_{Ny,Rd}$	14,71 [kNm]
Resistenza a flessione ridotta, per flessione attorno all'asse z - z	$M_{Nz,Rd}$	14,71 [kNm]
Verifica di presso/tenso flessione biassiale (metodo EN1993 - 1 - 1:2010)	$\rho_{N - My - Mz - pl}$	0,218 [-]
Verifica di presso/tenso flessione biassiale (metodo cautelativo)	$\rho_{N - My - Mz - pl}$	0,721 [-]
<u>Calcolo elastico per sezioni in classe 3</u>		
Momento globale agente nella sezione	$M_{tot,Ed}$	6,86 [kNm]
Taglio globale agente nella sezione	$V_{tot,Ed}$	272,94 [kN]
Tensione normale massima	$\sigma_{x,Ed,fs}$	213,87 [N/mm ²]
Verifica relativa alle sole tensioni normali	ρ_{el}	ver. plastica [-]
Tensione tangenziale dovuta al taglio	$\tau_{V,Ed}$	210,02 [N/mm ²]
Tensione tangenziale dovuta al momento torcente	$\tau_{t,Ed}$	0,00 [N/mm ²]
Verifica relativa alle tensioni totali	$\rho_{el - tot}$	ver. plastica [-]

AUTOSTRADA VALDASTICO A31 NORD
1° LOTTO - PIOVENE ROCCHETTE – VALLE DELL'ASTICO

Verifiche di stabilità flessionale		
Lunghezza geometrica della membratura	L	3,14 [m]
Coefficiente di lunghezza di libera inflessione attorno all'asse y - y	β_y	1,00 [-]
Coefficiente di lunghezza di libera inflessione attorno all'asse z - z	β_z	1,00 [-]
Lunghezza di libera inflessione attorno all'asse y - y	$L_{\sigma,y}$	3140,00 [mm]
Lunghezza di libera inflessione attorno all'asse z - z	$L_{\sigma,z}$	3140,00 [mm]

Resistenza nei confronti dell'instabilità flessionale		
Area della sezione trasversale da considerare nel calcolo	A	2041 [mm ²]
Forza normale critica euleriana attorno all'asse y - y	$N_{\sigma,y}$	631 [kN]
Forza normale critica euleriana attorno all'asse z - z	$N_{\sigma,z}$	631 [kN]
Snellezza adimensionale attorno all'asse y - y	$\lambda_{ad,y}$	0,9432 [-]
Snellezza adimensionale attorno all'asse z - z	$\lambda_{ad,z}$	0,9432 [-]
Rapporto dimensionale per la determinazione delle curve di instabilità	h/b	19,05 [-]
Spessore massimo della sezione trasversale	t_{max}	102,3 [mm]
Curva di instabilità attorno all'asse y - y	Curva _{y-y}	a [-]
Curva di instabilità attorno all'asse z - z	Curva _{z-z}	a [-]
Coefficiente di imperfezione attorno all'asse y - y	α_y	0,21 [-]
Coefficiente di instabilità attorno all'asse y - y	ϕ_y	1,0228 [-]
Coefficiente di imperfezione attorno all'asse z - z	α_z	0,21 [-]
Coefficiente di instabilità attorno all'asse z - z	ϕ_z	1,0228 [-]
Coefficiente di riduzione di resistenza attorno all'asse y - y	χ_y	0,705 [-]
Coefficiente di riduzione di resistenza attorno all'asse z - z	χ_z	0,705 [-]
Resistenza all'instabilità flessionale attorno all'asse y - y	$N_{by,Rd}$	376,91 [kN]
Resistenza all'instabilità flessionale attorno all'asse z - z	$N_{bz,Rd}$	376,91 [kN]
Verifica nei confronti dell'instabilità flessionale	$\rho_{buck,N}$	0,451 [-]

Verifiche di stabilità nel caso di presso - flessione biassiale - ANNEX B, EN 1993 - 1 - 1:2010

Nota: l'utente deve inserire i valori C_{my} , C_{mz} con riferimento al prospetto B.3 - EN 1993 - 1 - 1: 2010, tenendo presente che utilizzando $C_{my} = C_{mz} = 1.00$ la verifica sarà sempre "cautelativa".

Coefficienti di momento equivalente

Coefficiente di momento equivalente per flessione attorno all'asse y - y	C_{my}	1,000 [-]
Coefficiente di momento equivalente per flessione attorno all'asse z - z	C_{mz}	1,000 [-]

Coefficienti di interazione

Coefficiente di interazione k_{yy} per sezioni in classe 1 o 2	$k_{yy,1-2}$	1,335 [-]
Coefficiente di interazione k_{yy} per sezioni in classe 3	$k_{yy,3}$	1,255 [-]
	k_{yy}	1,335 [-]
Coefficiente di interazione k_{zz} per sezioni in classe 1 o 2	$k_{zz,1-2}$	1,335 [-]
Coefficiente di interazione k_{zz} per sezioni in classe 3	$k_{zz,3}$	1,255 [-]
	k_{zz}	1,335 [-]
Coefficiente di interazione k_{yz} per sezioni in classe 1 o 2	$k_{yz,1-2}$	0,801 [-]
Coefficiente di interazione k_{yz} per sezioni in classe 3	$k_{yz,3}$	1,335 [-]
	k_{yz}	0,801 [-]
Coefficiente di interazione k_{zy} per sezioni in classe 1 o 2	$k_{zy,1-2}$	0,801 [-]
Coefficiente di interazione k_{zy} per sezioni in classe 3	$k_{zy,3}$	1,068 [-]
	k_{zy}	0,801 [-]

Verifiche di presso flessione biassiale

Verifica di presso flessione biassiale per sezioni di classe 1 o 2	$\rho_{buck,N-M-M}$	0,950 [-]
	$\rho_{buck,N-M-M}$	0,753 [-]
Verifica di presso flessione biassiale per sezioni di classe 3	$\rho_{buck,N-M-M}$	ver. plastica [-]
	$\rho_{buck,N-M-M}$	ver. plastica [-]
Tasso di lavoro massimo del profilo tubolare (resistenza e stabilità)	ρ_{max}	0,982 [-]

Tubi \varnothing 609.6 x 10

RESISTENZA E STABILITA' DEI PROFILI TUBOLARI - Metodo B - EN 1993 - 1 - 1:2010		
Materiali utilizzati	© Dott. Ing. Simone Caffè - 25/02/2013	
Valore di snervamento dell'acciaio del profilo	f_{yk}	275 [N/mm ²]
Valore di rottura dell'acciaio del profilo	f_{uk}	390 [N/mm ²]
Modulo di elasticità dell'acciaio del profilo	E	210000 [N/mm ²]
Modulo di elasticità tangenziale dell'acciaio del profilo	G	80769 [N/mm ²]
Coefficiente parziale di sicurezza per le verifiche di resistenza	γ_{M0}	1,05 [-]
Coefficiente parziale di sicurezza per le verifiche di stabilità	γ_{M1}	1,05 [-]
Coefficiente parziale di sicurezza per le verifiche di rottura	γ_{M2}	1,25 [-]
Caratteristiche meccaniche del profilo		
Diametro esterno del profilo tubolare	d_{ext}	610,00 [mm]
Spessore del profilo tubolare	t	10,00 [mm]
Diametro interno	d_{int}	590,00 [mm]
Raggio esterno	r_{ext}	305,00 [mm]
Raggio interno	r_{int}	295,00 [mm]
Area della sezione trasversale	A	18850 [mm ²]
Momento d'inerzia della sezione trasversale attorno all'asse forte	I_y	8,4847E+08 [mm ⁴]
Modulo di resistenza elastico attorno all'asse forte	$W_{el,y}$	2,7819E+06 [mm ³]
Modulo di resistenza plastico attorno all'asse forte	$W_{pl,y}$	3,6003E+06 [mm ³]
Area resistente a taglio nel piano dell'anima	$A_{v,z}$	12000 [mm ²]
Raggio d'inerzia attorno all'asse forte	i_y	212,16 [mm]
Momento d'inerzia della sezione trasversale attorno all'asse debole	I_z	8,4847E+08 [mm ⁴]
Modulo di resistenza elastico attorno all'asse debole	$W_{el,z}$	2,7819E+06 [mm ³]
Modulo di resistenza plastico attorno all'asse debole	$W_{pl,z}$	3,6003E+06 [mm ³]
Area resistente a taglio nel piano delle ali	$A_{v,y}$	12000 [mm ²]
Raggio d'inerzia attorno all'asse debole	i_z	212,16 [mm]
Momento d'inerzia torsionale	I_t	1,697E+09 [mm ⁴]
Caratteristiche di sollecitazione nella sezione di verifica		
Forza normale (positiva se di compressione)	N_{Ed}	170,00 [kN]
Forza di taglio agente in direzione parallela all'anima	$V_{z,Ed}$	193,00 [kN]
Forza di taglio agente in direzione parallela alle ali	$V_{y,Ed}$	193,00 [kN]
Momento flettente attorno all'asse maggiore di inerzia	$M_{y,Ed}$	6,86 [kNm]
Momento flettente attorno all'asse minore di inerzia	$M_{z,Ed}$	0,06 [kNm]
Momento torcente primario (alla Saint Venant)	T_{Ed}	0,00 [kNm]
Classificazione della sezione trasversale di verifica		
Coefficiente ϵ	ϵ	0,924 [-]
Rapporto tra diametro esterno e spessore	ρ	61,000 [-]
Rapporto limite per la classe 1	ρ_1	42,727 [-]
Rapporto limite per la classe 2	ρ_2	59,818 [-]
Rapporto limite per la classe 3	ρ_3	76,909 [-]
Classificazione della sezione trasversale	CL	3

AUTOSTRADA VALDASTICO A31 NORD
1° LOTTO - PIOVENE ROCCHETTE – VALLE DELL'ASTICO

Verifiche di resistenza della sezione trasversale		
Resistenza a trazione pura		
Resistenza plastica a trazione	$N_{t,Rd}$	4936,79 [kN]
Verifica a trazione pura	ρ_{Nt}	0,000 [-]
Resistenza a compressione pura		
Resistenza a compressione pura	$N_{c,Rd}$	4936,79 [kN]
Verifica a compressione pura	ρ_{Nc}	0,034 [-]
Resistenza a torsione e taglio		
Diametro medio della sezione trasversale	d_{med}	600,00 [mm]
Area della sezione compresa nel diametro medio	Ω	282743,34 [mm ²]
Tensioni tangenziali dovute al momento torcente	$\tau_{t,Ed}$	0,00 [N/mm ²]
Verifica tensionale per pura torsione	ρ_T	0,000 [-]
Resistenza plastica a taglio	$V_{pl,Rd}$	1814,53 [kN]
Resistenza plastica a taglio ridotta per effetto della torsione	$V_{pl,T,Rd}$	1814,53 [kN]
Verifica a taglio in direzione z - z	ρ_{Vz}	0,106 [-]
Verifica a taglio in direzione y - y	ρ_{Vy}	0,106 [-]
Resistenza a flessione		
Modulo di resistenza di calcolo per flessione attorno all'asse y - y	W_y	2,78E+06 [mm ³]
Resistenza a flessione attorno all'asse y - y	$M_{cy,Rd}$	728,58 [kNm]
Verifica flessionale attorno all'asse y - y	ρ_{My}	0,009 [-]
Modulo di resistenza di calcolo per flessione attorno all'asse z - z	W_z	2,78E+06 [mm ³]
Resistenza a flessione attorno all'asse z - z	$M_{cz,Rd}$	728,58 [kNm]
Verifica flessionale attorno all'asse z - z	ρ_{Mz}	0,000 [-]
Resistenza a flessione e taglio (per sezioni in classe 1 o 2)		
Fattore di riduzione per la presenza della forza di taglio in direzione z - z	$\rho_{Vz,red}$	1,00 [-]
Fattore di riduzione per la presenza della forza di taglio in direzione y - y	$\rho_{Vy,red}$	1,00 [-]
Resistenza a flessione ridotta, per flessione attorno all'asse y - y	$M_{Vy,Rd}$	942,94 [kNm]
Verifica flessionale attorno all'asse y - y	$\rho_{My - Vz}$	ver. elastica [-]
Resistenza a flessione ridotta, per flessione attorno all'asse z - z	$M_{Vz,Rd}$	942,94 [kNm]
Verifica flessionale attorno all'asse z - z	$\rho_{Mz - Vy}$	ver. elastica [-]
Resistenza a flessione, forza assiale e taglio		
<u>Calcolo plastico per sezioni in classe 1 o 2</u>		
Coefficiente n	n	0,034 [-]
Resistenza a flessione ridotta, per flessione attorno all'asse y - y	$M_{Ny,Rd}$	939,87 [kNm]
Resistenza a flessione ridotta, per flessione attorno all'asse z - z	$M_{Nz,Rd}$	939,87 [kNm]
Verifica di presso/tenso flessione biassiale (metodo EN1993 - 1 - 1:2010)	$\rho_{N - My - Mz - pl}$	ver. elastica [-]
Verifica di presso/tenso flessione biassiale (metodo cautelativo)	$\rho_{N - My - Mz - pl}$	ver. elastica [-]
<u>Calcolo elastico per sezioni in classe 3</u>		
Momento globale agente nella sezione	$M_{tot,Ed}$	6,86 [kNm]
Taglio globale agente nella sezione	$V_{tot,Ed}$	272,94 [kN]
Tensione normale massima	$\sigma_{x,Ed,fs}$	11,48 [N/mm ²]
Verifica relativa alle sole tensioni normali	ρ_{el}	0,044 [-]
Tensione tangenziale dovuta al taglio	$\tau_{V,Ed}$	22,75 [N/mm ²]
Tensione tangenziale dovuta al momento torcente	$\tau_{t,Ed}$	0,00 [N/mm ²]
Verifica relativa alle tensioni totali	$\rho_{el - tot}$	0,025 [-]

AUTOSTRADA VALDASTICO A31 NORD
1° LOTTO - PIOVENE ROCCHETTE – VALLE DELL'ASTICO

Verifiche di stabilità flessionale		
Lunghezza geometrica della membratura	L	5,80 [m]
Coefficiente di lunghezza di libera inflessione attorno all'asse y - y	β_y	1,00 [-]
Coefficiente di lunghezza di libera inflessione attorno all'asse z - z	β_z	1,00 [-]
Lunghezza di libera inflessione attorno all'asse y - y	$L_{cr,y}$	5800,00 [mm]
Lunghezza di libera inflessione attorno all'asse z - z	$L_{cr,z}$	5800,00 [mm]
Resistenza nei confronti dell'instabilità flessionale		
Area della sezione trasversale da considerare nel calcolo	A	18850 [mm ²]
Forza normale critica euleriana attorno all'asse y - y	$N_{cr,y}$	52275 [kN]
Forza normale critica euleriana attorno all'asse z - z	$N_{cr,z}$	52275 [kN]
Snellezza adimensionale attorno all'asse y - y	$\lambda_{ad,y}$	0,3149 [-]
Snellezza adimensionale attorno all'asse z - z	$\lambda_{ad,z}$	0,3149 [-]
Rapporto dimensionale per la determinazione delle curve di instabilità	h/b	61,00 [-]
Spessore massimo della sezione trasversale	t_{max}	590 [mm]
Curva di instabilità attorno all'asse y - y	Curva _{y-y}	a [-]
Curva di instabilità attorno all'asse z - z	Curva _{z-z}	a [-]
Coefficiente di imperfezione attorno all'asse y - y	α_y	0,21 [-]
Coefficiente di instabilità attorno all'asse y - y	ϕ_y	0,5616 [-]
Coefficiente di imperfezione attorno all'asse z - z	α_z	0,21 [-]
Coefficiente di instabilità attorno all'asse z - z	ϕ_z	0,5616 [-]
Coefficiente di riduzione di resistenza attorno all'asse y - y	χ_y	0,974 [-]
Coefficiente di riduzione di resistenza attorno all'asse z - z	χ_z	0,974 [-]
Resistenza all'instabilità flessionale attorno all'asse y - y	$N_{by,Rd}$	4808,37 [kN]
Resistenza all'instabilità flessionale attorno all'asse z - z	$N_{bz,Rd}$	4808,37 [kN]
Verifica nei confronti dell'instabilità flessionale	$\rho_{buck, N}$	0,035 [-]

Verifiche di stabilità nel caso di presso - flessione biassiale - ANNEX B, EN 1993 - 1 - 1:2010

Nota: l'utente deve inserire i valori C_{my} , C_{mz} con riferimento al prospetto B.3 - EN 1993 - 1 - 1:2010, tenendo presente che utilizzando $C_{my} = C_{mz} = 1.00$ la verifica sarà sempre "cautelativa".

Coefficienti di momento equivalente

Coefficiente di momento equivalente per flessione attorno all'asse y - y	C_{my}	1,000 [-]
Coefficiente di momento equivalente per flessione attorno all'asse z - z	C_{mz}	1,000 [-]

Coefficienti di interazione

Coefficiente di interazione k_{yy} per sezioni in classe 1 o 2	$k_{yy,1-2}$	1,004 [-]
Coefficiente di interazione k_{yy} per sezioni in classe 3	$k_{yy,3}$	1,007 [-]
	k_{yy}	1,007 [-]
Coefficiente di interazione k_{zz} per sezioni in classe 1 o 2	$k_{zz,1-2}$	1,004 [-]
Coefficiente di interazione k_{zz} per sezioni in classe 3	$k_{zz,3}$	1,007 [-]
	k_{zz}	1,007 [-]
Coefficiente di interazione k_{yz} per sezioni in classe 1 o 2	$k_{yz,1-2}$	0,604 [-]
Coefficiente di interazione k_{yz} per sezioni in classe 3	$k_{yz,3}$	1,007 [-]
	k_{yz}	1,007 [-]
Coefficiente di interazione k_{zy} per sezioni in classe 1 o 2	$k_{zy,1-2}$	0,604 [-]
Coefficiente di interazione k_{zy} per sezioni in classe 3	$k_{zy,3}$	0,805 [-]
	k_{zy}	0,805 [-]

Verifiche di presso flessione biassiale

Verifica di presso flessione biassiale per sezioni di classe 1 o 2	$\rho_{buck, N - M - M}$	ver. elastica [-]
	$\rho_{buck, N - M - M}$	ver. elastica [-]
Verifica di presso flessione biassiale per sezioni di classe 3	$\rho_{buck, N - M - M}$	0,045 [-]
	$\rho_{buck, N - M - M}$	0,043 [-]
Tasso di lavoro massimo del profilo tubolare (resistenza e stabilità)	ρ_{max}	0,106 [-]

I risultati conseguiti hanno ordine di grandezza compatibile con quanto ottenuto dalle verifiche condotte con l'ausilio di codici di calcolo automatici.

24 TABULATI DI INPUT- TETTOIA PARCHEGGIO



Figura 7 Vista 1

24.1 DATI GENERALI

Nome struttura	
Fattore rigidità assiale pilastri	1
Numero di frequenze	15
% Filtro masse libere	0.1
% Coefficiente di smorzamento viscoso	5
Spostamenti modali con segno	Si
Deformabilità a taglio delle aste	Si
Spostamento ammissibile impalcati	0.0050*h

24.2 IMPALCATI

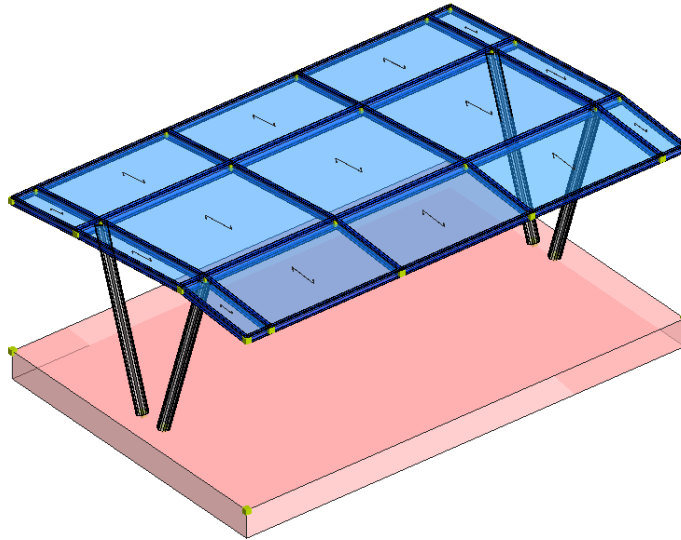
N°	Quota	Rigido	Incr.Soll.Pil	Inc.Soll.Par.
	mm			
0	0	No	1.000	1.000

24.3 PERCENTUALI SPOSTAMENTO MASSE IMPALCATI

Posizione	% Spostamento direzione X	% Spostamento direzione Y
1	0	-5
2	5	0
3	0	5
4	-5	0

24.4 ANALISI DEI CARICHI

La valutazione dei carichi e dei sovraccarichi è stata effettuata in accordo con le disposizioni contenute nel **D.M. 14.01.2008 (nuove norme tecniche per le costruzioni)**

I carichi adottati sono i seguenti:

○ *SOVRACCARICO NEVE*

Provincia : VICENZA
Zona : 1 - Alpina
Altitudine a_s : 305 m s.l.m.
Esposizione : Normale
Periodo di ritorno : 50 anni

Il carico neve sulle coperture viene valutato con la seguente espressione:

$$q_s = m_i \cdot q_{sk} \cdot C_E \cdot C_t \text{ KN/m}^2$$

dove:

μ_i	Coefficiente di forma della copertura
$C_E = 1.0$	Coefficiente di esposizione
$C_t = 1.0$	Coefficiente termico
$q_{sk} = 1.82 \text{ KN/m}^2$	Carico neve al suolo

Nel caso in esame (copertura ad una falda), con

$$\alpha = 0.00^\circ$$

il coefficiente di forma vale:

$$\mu_i(\alpha) = 0.80 \Rightarrow q_s = 1.46 \text{ KN/m}^2$$

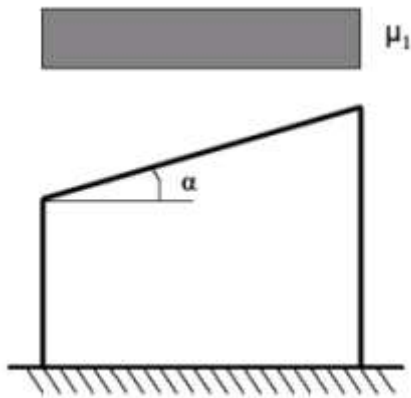

○ SOVRACCARICO VENTO

Zona Vento	$V_{b,0}$ (m/s)	a_0 (m)	K_a (1/s)
1	25	1000	0.010

Categoria di esposizione	K	z_0 (m)	z_{min} (m)
2	0.19	0.05	4

Altitudine: $a_s = 305 \text{ m s.l.m.}$

Distanza dalla costa: terra - oltre 40 Km

Classe di rugosità terreno: D

Altezza manufatto: $h = 5.00 \text{ m}$

Periodo di ritorno: $T_R = 50.0 \text{ anni} \Rightarrow$
 $a_R = 0.75 \{1 - 0.2 \ln[-\ln(1 - 1/T_R)]\}^{0.5} = 1.00$

Velocità di riferimento del vento: $V_b = V_{b,0}$ per $a_s \leq a_0$
 $V_b = V_{b,0} + K_a (a_s - a_0)$ per $a_s > a_0$

$$V_b = 25.000 \text{ m/s}$$

$$V_b(T_R) = a_R V_b = 25.018 \text{ m/s}$$

Coefficiente dinamico: $C_d = 1.00$

Coefficiente di forma: $C_p = 1.20$

Coefficiente di attrito: $C_f = 0.02$

Coefficiente di topografia: $C_t = 1.00$

Coefficiente di esposizione: $C_e(z) = K^2 C_t \ln(z/z_0) [7 + C_t \ln(z/z_0)]$ per $z \geq z_{\min}$
 $C_e(z) = C_e(z_{\min})$ per $z < z_{\min}$
 $C_e(z) = 1.93$

Le azioni del vento si traducono in pressioni (positive) e depressioni (negative) agenti normalmente alla superficie degli elementi che compongono la costruzione. La pressione agente su un singolo elemento è data dall'espressione:

$$p = q_b C_e C_p C_d = 905.70 \text{ Pa}$$

dove,

$$q_b = 1/2 \rho v_b^2 \quad \text{è la pressione cinetica di riferimento;}$$

$$\rho = 1,25 \text{ Kg/m}^3 \quad \text{è la densità dell'aria.}$$

L'azione tangente per unità di superficie parallela alla direzione del vento è:

$$p_f = q_b C_e C_f = 15.09 \text{ Pa}$$

I carichi relativi ai pesi propri vengono valutati in automatico in funzione della geometria degli elementi ed al loro peso specifico i tamponamenti vengono valutati per metro lineare di trave su cui insistono maggiori dettagli ad essi relativi sono riportati nel tabulato di calcolo alla sezione dei carichi relativi alle aste, nodi ed shell.

Analisi carichi

SOLAIO copertura tipo Riverclack

PESO PROPRIO

Totale Pesi Propri: = 10 Kg/mq

SOVRACCARICHI FISSI

Accessori elementi

Copertura, etc : = 5 Kg/mq

Totale carichi permanenti = 15 Kg/mq

Carichi variabili = 146 Kg/mq

24.5 COMBINAZIONI DEL SISMA IN X E Y E VERTICALE

Comb	Pos. SismaX	Pos. SismaY	Fx	Fy	Fz
1	1	2	1	0.3	0
2	1	2	0.3	1	0
3	1	4	1	0.3	0
4	1	4	0.3	1	0
5	3	2	1	0.3	0

AUTOSTRADA VALDASTICO A31 NORD
1° LOTTO - PIOVENE ROCCHETTE – VALLE DELL'ASTICO

Comb	Pos. SismaX	Pos. SismaY	Fx	Fy	Fz
6	3	2	0.3	1	0
7	3	4	1	0.3	0
8	3	4	0.3	1	0

Comb. = Numero di combinazione dei sismi

Pos. SismaX = Posizione in cui viene scelto il sisma in direzione X

Pos. SismaY = Posizione in cui viene scelto il sisma in direzione Y

Fx = Fattore con cui il sisma X partecipa

Fy = Fattore con cui il sisma Y partecipa

Fz = Fattore con cui il sisma Verticale partecipa (quando richiesto)

Ogni combinazione genera al massimo 8 sotto-combinazioni in base a tutte le combinazioni possibili dei segni di Fx ed Fy ed Fz



Figura 8 Diagramma Deformata tettoia parcheggio



Figura 9 Diagramma Sollecitazioni tettoia parcheggio

24.6 SPETTRI DI RISPOSTA

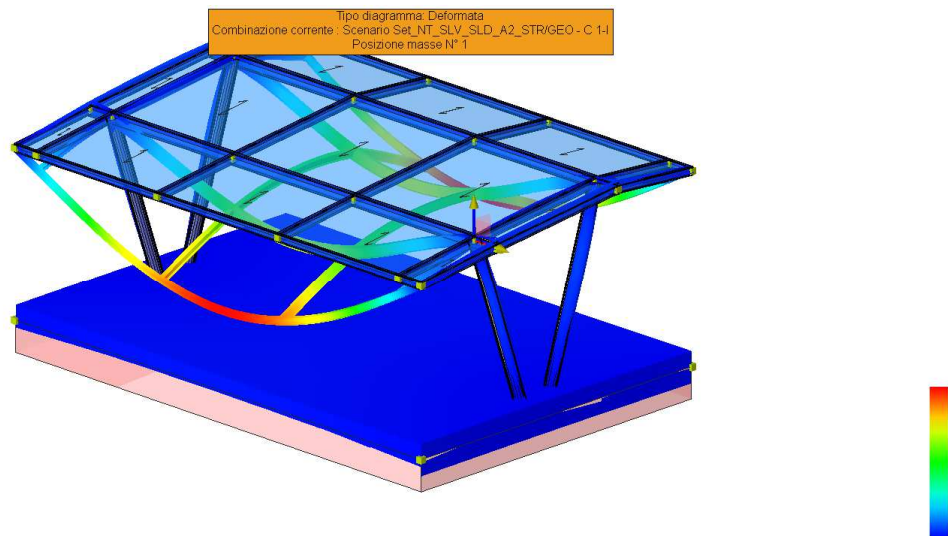
Spettro :SpettroNT

Il calcolo degli spettri e del fattore di struttura sono stati calcolati per la seguente tipologia di terreno e struttura

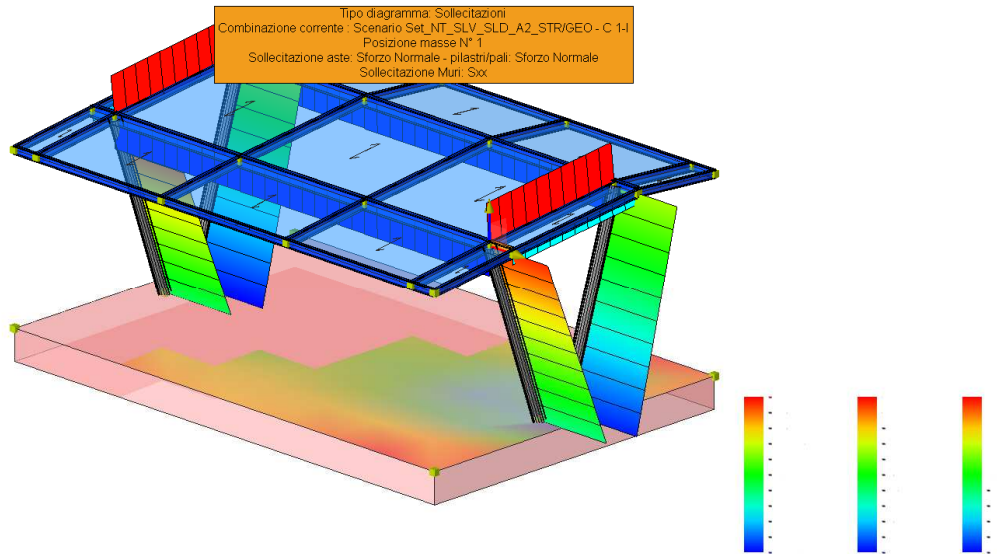
Vita della struttura	
Tipo	Opere ordinarie (50-100) 50 - 100 anni
Vita nominale(anni)	50.0
Classe d'uso	Classe II
Coefficiente d'uso	1.000
Periodo di riferimento(anni)	50.000
Stato limite di esercizio - SLD	PVR=63.0%
Stato limite ultimo - SLV	PVR=10.0%
Periodo di ritorno SLD(anni)	TR=50.3
Periodo di ritorno SLV(anni)	TR=474.6

AUTOSTRADA VALDASTICO A31 NORD
1° LOTTO - PIOVENE ROCCHETTE – VALLE DELL'ASTICO

Parametri del sito	
Comune	Cogollo del Cengio - (VI)
Longitudine	11.421
Latitudine	45.789
Id reticolo del sito	10961-10960-11182-11183
Valori di riferimento del sito	
Ag/g(TR=50.3) SLD	0.0559
F0(TR=50.3) SLD	2.4956
T[*]C(TR=50.3) SLD	0.250
Ag/g(TR=474.6) SLV	0.1533
F0(TR=474.6) SLV	2.4174
T[*]C(TR=474.6) SLV	0.290
Coefficiente Amplificazione Topografica	St=1.000
Categoria terreno B	
stato limite SLV	
	S=1.20
	TB=0.14
	TC=0.41
	TD=2.21
stato limite SLD	
	S=1.20
	TB=0.12
	TC=0.36
	TD=1.82
Fattore di struttura (SLV)	
Classe duttilità	B

AUTOSTRADA VALDASTICO A31 NORD
1° LOTTO - PIOVENE ROCCHETTE – VALLE DELL'ASTICO

Tipo struttura	Acciaio
Struttura non regolare in altezza	Kr=0.800000
	Kw=1.000
Regolare in pianta	SI
Tipologia : Strutture a telaio	Ce=4.000
Fattore di struttura $q=Kw*Kr*Ce$	3.200

TSLV [s]	SLV[a/g]	TSLD [s]	SLD[a/g]
0.00000	0.18391	0.00000	0.06707
0.13620	0.13893	0.12101	0.16737
0.40860	0.13893	0.36304	0.16737
0.60909	0.09320	0.57169	0.10629
0.80958	0.07012	0.78033	0.07787
1.01007	0.05620	0.98898	0.06144
1.21057	0.04689	1.19762	0.05074
1.41106	0.04023	1.40626	0.04321
1.61155	0.03523	1.61491	0.03763
1.81204	0.03133	1.82355	0.03332
2.01253	0.03065	2.04120	0.02659
2.21302	0.03065	2.25884	0.02172
2.43639	0.03065	2.47649	0.01807
2.65977	0.03065	2.69413	0.01527
2.88314	0.03065	2.91178	0.01307
3.10651	0.03065	3.12942	0.01131
3.32988	0.03065	3.34707	0.00989
3.55326	0.03065	3.56471	0.00872
3.77663	0.03065	3.78236	0.00775
4.00000	0.03065	4.00000	0.00693

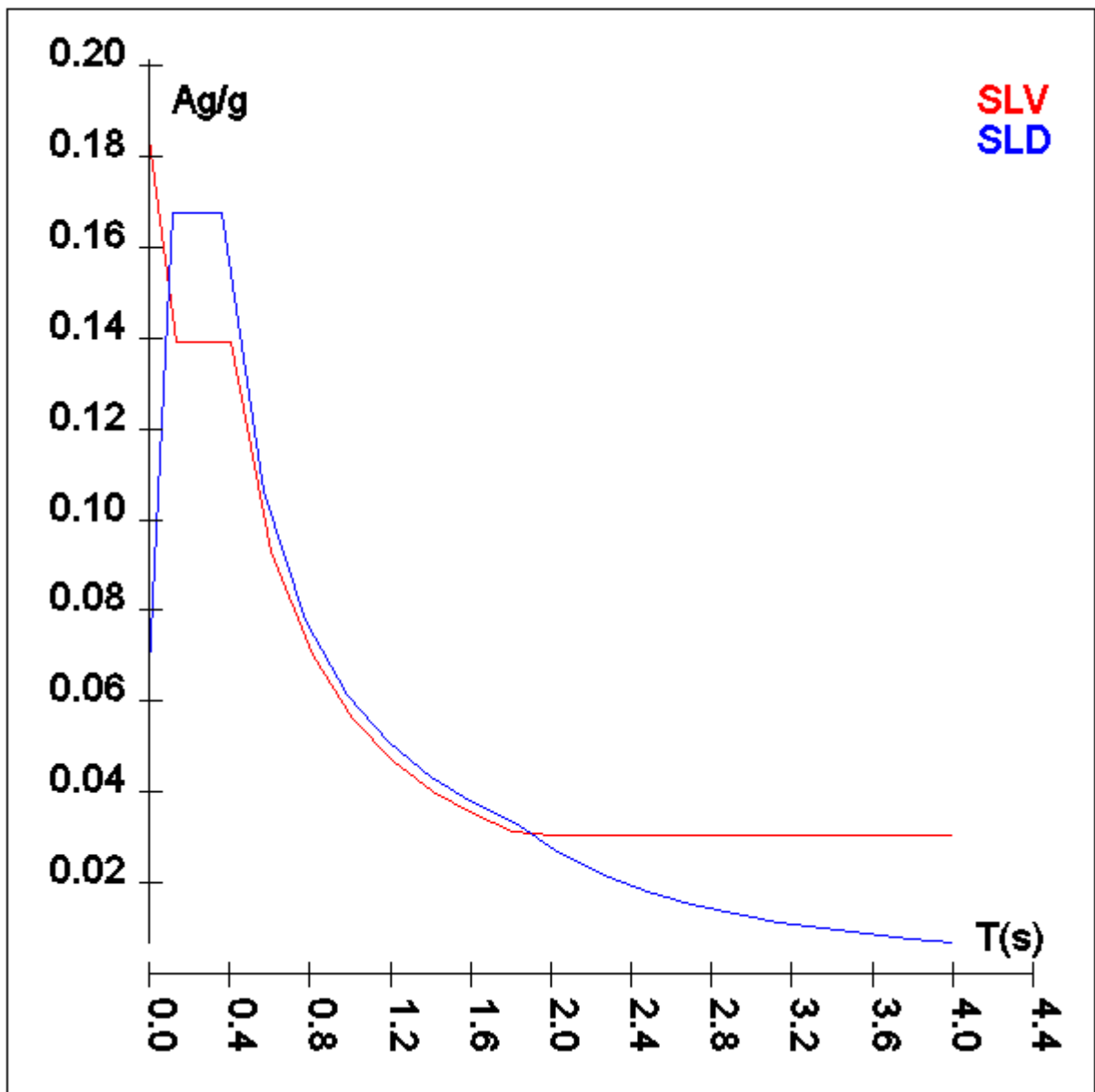

AUTOSTRADA VALDASTICO A31 NORD
1° LOTTO - PIOVENE ROCCHETTE – VALLE DELL'ASTICO

24.7 NODI- GEOMETRIA E VINCOLI

Nodo	X	Y	Z	Tx	Ty	Tz	Rx	Ry	Rz	Impalcato
	Coordinate [mm]			Vincoli						
1	2550	450	0	1	1	1	1	1	1	-1
2	3050	450	0	1	1	1	1	1	1	-1
3	2550	7950	0	1	1	1	1	1	1	-1
4	3050	7950	0	1	1	1	1	1	1	-1
5	0	0	2700	0	0	0	0	0	0	-1
6	1550	0	2900	0	0	0	0	0	0	-1
7	4050	0	3170	0	0	0	0	0	0	-1
8	5600	0	3060	0	0	0	0	0	0	-1
9	0	450	2700	0	0	0	0	0	0	-1
10	1550	450	2900	0	0	0	0	0	0	-1
11	4050	450	3170	0	0	0	0	0	0	-1
12	5600	450	3060	0	0	0	0	0	0	-1
13	0	7950	2700	0	0	0	0	0	0	-1
14	1550	7950	2900	0	0	0	0	0	0	-1
15	4050	7950	3170	0	0	0	0	0	0	-1
16	5600	7950	3060	0	0	0	0	0	0	-1
17	0	8400	2700	0	0	0	0	0	0	-1
18	1550	8400	2900	0	0	0	0	0	0	-1
19	4050	8400	3170	0	0	0	0	0	0	-1
20	5600	8400	3060	0	0	0	0	0	0	-1
21	0	0	0	0	0	0	0	0	0	-1
22	5600	0	0	0	0	0	0	0	0	-1
23	0	8400	0	0	0	0	0	0	0	-1
109	0	2950	2700	0	0	0	0	0	0	-1
110	1550	2950	2900	0	0	0	0	0	0	-1
111	4050	2950	3170	0	0	0	0	0	0	-1
112	5600	2950	3060	0	0	0	0	0	0	-1

AUTOSTRADA VALDASTICO A31 NORD
1° LOTTO - PIOVENE ROCCHETTE – VALLE DELL'ASTICO

Nodo	X	Y	Z	Tx	Ty	Tz	Rx	Ry	Rz	Impalcato
122	5600	8400	0	0	0	0	0	0	0	-1
209	0	5450	2700	0	0	0	0	0	0	-1
210	1550	5450	2900	0	0	0	0	0	0	-1
211	4050	5450	3170	0	0	0	0	0	0	-1
212	5600	5450	3060	0	0	0	0	0	0	-1

24.8 IMPUT ASTE TABELLA SEZIONI TIPO

Tipo	Nome	Area	Ix	Iy	It	Fx	Fy	Lx	Lx
G		mq	m ⁴	m ⁴	m ⁴			cm	cm
	O 200x10	0.0	2.701E-05	2.701E-05	5.402E-05	1.000	1.000	10	10
	IPE 140	0.0	5.412E-06	4.492E-07	2.450E-08	1.000	1.000	7	14
	IPE 120	0.0	3.178E-06	2.767E-07	1.740E-08	1.000	1.000	6	12
	IPE 180	0.0	1.317E-05	1.009E-06	4.790E-08	1.000	1.000	9	18

24.9 ASTE CARICHI

Descrizione carichi aste

UnifG	Uniforme globale
UnifL	Uniforme locale
VarG	Variabile lineare globale
VarL	Variabile lineare locale
PolG	Poligonale globale
Termico	Distorsione termica
Torcente	Carico torcente
Precomp.	Carico da precompressione
PolL	Poligonale locale

AUTOSTRADA VALDASTICO A31 NORD
1° LOTTO - PIOVENE ROCCHETTE – VALLE DELL'ASTICO

Sezione	Ni	Nf	Cond.	Tipo c.	Xi	QXi	QYi	QZi	Xf	QXf	QYf	QZf
					cm	car. dist. kg/m coppie torc. kg*m/m			cm	car. dist. kg/m coppie torc. kg*m/m		
Pilastro 1												
O 200x10	1	10	Peso Proprio	UnifG	0	0	0	47	307	0	0	47
Pilastro 2												
O 200x10	2	11	Peso Proprio	UnifG	0	0	0	47	332	0	0	47
Pilastro 3												
O 200x10	3	14	Peso Proprio	UnifG	0	0	0	47	307	0	0	47
Pilastro 4												
O 200x10	4	15	Peso Proprio	UnifG	0	0	0	47	332	0	0	47
Trave 8000												
IPE 120	17	18	Peso Proprio	UnifG	0	0	0	10	156	0	0	10
IPE 120	18	19	Peso Proprio	UnifG	0	0	0	10	251	0	0	10
IPE 120	19	20	Peso Proprio	UnifG	0	0	0	10	155	0	0	10
Trave 8001												
IPE 140	13	14	Peso Proprio	UnifG	0	0	0	13	156	0	0	13
IPE 140	14	15	Peso Proprio	UnifG	0	0	0	13	242	0	0	13
IPE 140	15	16	Peso Proprio	UnifG	0	0	0	13	164	0	0	13
Trave 8002												
IPE 140	209	210	Peso Proprio	UnifG	0	0	0	13	156	0	0	13
IPE 140	210	211	Peso Proprio	UnifG	0	0	0	13	251	0	0	13
IPE 140	211	212	Peso Proprio	UnifG	0	0	0	13	155	0	0	13
Trave 8003												
IPE 140	109	110	Peso Proprio	UnifG	0	0	0	13	156	0	0	13
IPE 140	110	111	Peso Proprio	UnifG	0	0	0	13	251	0	0	13
IPE 140	111	112	Peso Proprio	UnifG	0	0	0	13	155	0	0	13
Trave 8004												
IPE 120	5	6	Peso Proprio	UnifG	0	0	0	10	156	0	0	10
IPE 120	6	7	Peso Proprio	UnifG	0	0	0	10	251	0	0	10
IPE 120	7	8	Peso Proprio	UnifG	0	0	0	10	155	0	0	10

AUTOSTRADA VALDASTICO A31 NORD
1° LOTTO - PIOVENE ROCCHETTE – VALLE DELL'ASTICO

Sezione	Ni	Nf	Cond.	Tipo c.	Xi	QXi	QYi	QZi	Xf	QXf	QYf	QZf
Trave 8005												
IPE 140	9	10	Peso Proprio	UnifG	0	0	0	13	156	0	0	13
IPE 140	10	11	Peso Proprio	UnifG	0	0	0	13	251	0	0	13
IPE 140	11	12	Peso Proprio	UnifG	0	0	0	13	155	0	0	13
Trave 8006												
IPE 120	12	8	Peso Proprio	UnifG	0	0	0	10	45	0	0	10
IPE 120	12	8	QP Solai	PolG	0	0	0	23	45	0	0	23
IPE 120	12	8	QFissi Solai	PolG	0	0	0	16	45	0	0	16
IPE 120	12	8	QV Solai	PolG	0	0	0	117	45	0	0	117
IPE 120	16	212	Peso Proprio	UnifG	0	0	0	10	250	0	0	10
IPE 120	16	212	QP Solai	PolG	0	0	0	23	250	0	0	23
IPE 120	16	212	QFissi Solai	PolG	0	0	0	16	250	0	0	16
IPE 120	16	212	QV Solai	PolG	0	0	0	117	250	0	0	117
IPE 120	20	16	Peso Proprio	UnifG	0	0	0	10	45	0	0	10
IPE 120	20	16	QP Solai	PolG	0	0	0	23	45	0	0	23
IPE 120	20	16	QFissi Solai	PolG	0	0	0	16	45	0	0	16
IPE 120	20	16	QV Solai	PolG	0	0	0	117	45	0	0	117
IPE 120	112	12	Peso Proprio	UnifG	0	0	0	10	250	0	0	10
IPE 120	112	12	QP Solai	PolG	0	0	0	23	250	0	0	23
IPE 120	112	12	QFissi Solai	PolG	0	0	0	16	250	0	0	16
IPE 120	112	12	QV Solai	PolG	0	0	0	117	250	0	0	117
IPE 120	212	112	Peso Proprio	UnifG	0	0	0	10	250	0	0	10
IPE 120	212	112	QP Solai	PolG	0	0	0	23	250	0	0	23
IPE 120	212	112	QFissi Solai	PolG	0	0	0	16	250	0	0	16
IPE 120	212	112	QV Solai	PolG	0	0	0	117	250	0	0	117
Trave 8007												
IPE 180	11	7	Peso Proprio	UnifG	0	0	0	19	45	0	0	19
IPE 180	11	7	QP Solai	PolG	0	0	0	61	45	0	0	61
IPE 180	11	7	QFissi Solai	PolG	0	0	0	41	45	0	0	41
IPE 180	11	7	QV Solai	PolG	0	0	0	305	45	0	0	305

AUTOSTRADA VALDASTICO A31 NORD
1° LOTTO - PIOVENE ROCCHETTE – VALLE DELL'ASTICO

Sezione	Ni	Nf	Cond.	Tipo c.	Xi	QXi	QYi	QZi	Xf	QXf	QYf	QZf
IPE 180	15	211	Peso Proprio	UnifG	0	0	0	19	250	0	0	19
IPE 180	15	211	QP Solai	PolG	0	0	0	61	250	0	0	61
IPE 180	15	211	QFissi Solai	PolG	0	0	0	41	250	0	0	41
IPE 180	15	211	QV Solai	PolG	0	0	0	305	250	0	0	305
IPE 180	19	15	Peso Proprio	UnifG	0	0	0	19	45	0	0	19
IPE 180	19	15	QP Solai	PolG	0	0	0	61	45	0	0	61
IPE 180	19	15	QFissi Solai	PolG	0	0	0	41	45	0	0	41
IPE 180	19	15	QV Solai	PolG	0	0	0	305	45	0	0	305
IPE 180	111	11	Peso Proprio	UnifG	0	0	0	19	250	0	0	19
IPE 180	111	11	QP Solai	PolG	0	0	0	61	250	0	0	61
IPE 180	111	11	QFissi Solai	PolG	0	0	0	41	250	0	0	41
IPE 180	111	11	QV Solai	PolG	0	0	0	305	250	0	0	305
IPE 180	211	111	Peso Proprio	UnifG	0	0	0	19	250	0	0	19
IPE 180	211	111	QP Solai	PolG	0	0	0	61	250	0	0	61
IPE 180	211	111	QFissi Solai	PolG	0	0	0	41	250	0	0	41
IPE 180	211	111	QV Solai	PolG	0	0	0	305	250	0	0	305
Trave 8008												
IPE 180	10	6	Peso Proprio	UnifG	0	0	0	19	45	0	0	19
IPE 180	10	6	QP Solai	PolG	0	0	0	61	45	0	0	61
IPE 180	10	6	QFissi Solai	PolG	0	0	0	41	45	0	0	41
IPE 180	10	6	QV Solai	PolG	0	0	0	306	45	0	0	306
IPE 180	14	210	Peso Proprio	UnifG	0	0	0	19	250	0	0	19
IPE 180	14	210	QP Solai	PolG	0	0	0	61	250	0	0	61
IPE 180	14	210	QFissi Solai	PolG	0	0	0	41	250	0	0	41
IPE 180	14	210	QV Solai	PolG	0	0	0	306	250	0	0	306
IPE 180	18	14	Peso Proprio	UnifG	0	0	0	19	45	0	0	19
IPE 180	18	14	QP Solai	PolG	0	0	0	61	45	0	0	61
IPE 180	18	14	QFissi Solai	PolG	0	0	0	41	45	0	0	41
IPE 180	18	14	QV Solai	PolG	0	0	0	306	45	0	0	306
IPE 180	110	10	Peso Proprio	UnifG	0	0	0	19	250	0	0	19

AUTOSTRADA VALDASTICO A31 NORD
1° LOTTO - PIOVENE ROCCHETTE – VALLE DELL'ASTICO

Sezione	Ni	Nf	Cond.	Tipo c.	Xi	QXi	QYi	QZi	Xf	QXf	QYf	QZf
IPE 180	110	10	QP Solai	PolG	0	0	0	61	250	0	0	61
IPE 180	110	10	QFissi Solai	PolG	0	0	0	41	250	0	0	41
IPE 180	110	10	QV Solai	PolG	0	0	0	306	250	0	0	306
IPE 180	210	110	Peso Proprio	UnifG	0	0	0	19	250	0	0	19
IPE 180	210	110	QP Solai	PolG	0	0	0	61	250	0	0	61
IPE 180	210	110	QFissi Solai	PolG	0	0	0	41	250	0	0	41
IPE 180	210	110	QV Solai	PolG	0	0	0	306	250	0	0	306
Trave 8009												
IPE 120	9	5	Peso Proprio	UnifG	0	0	0	10	45	0	0	10
IPE 120	9	5	QP Solai	PolG	0	0	0	23	45	0	0	23
IPE 120	9	5	QFissi Solai	PolG	0	0	0	16	45	0	0	16
IPE 120	9	5	QV Solai	PolG	0	0	0	117	45	0	0	117
IPE 120	13	209	Peso Proprio	UnifG	0	0	0	10	250	0	0	10
IPE 120	13	209	QP Solai	PolG	0	0	0	23	250	0	0	23
IPE 120	13	209	QFissi Solai	PolG	0	0	0	16	250	0	0	16
IPE 120	13	209	QV Solai	PolG	0	0	0	117	250	0	0	117
IPE 120	17	13	Peso Proprio	UnifG	0	0	0	10	45	0	0	10
IPE 120	17	13	QP Solai	PolG	0	0	0	23	45	0	0	23
IPE 120	17	13	QFissi Solai	PolG	0	0	0	16	45	0	0	16
IPE 120	17	13	QV Solai	PolG	0	0	0	117	45	0	0	117
IPE 120	109	9	Peso Proprio	UnifG	0	0	0	10	250	0	0	10
IPE 120	109	9	QP Solai	PolG	0	0	0	23	250	0	0	23
IPE 120	109	9	QFissi Solai	PolG	0	0	0	16	250	0	0	16
IPE 120	109	9	QV Solai	PolG	0	0	0	117	250	0	0	117
IPE 120	209	109	Peso Proprio	UnifG	0	0	0	10	250	0	0	10
IPE 120	209	109	QP Solai	PolG	0	0	0	23	250	0	0	23
IPE 120	209	109	QFissi Solai	PolG	0	0	0	16	250	0	0	16
IPE 120	209	109	QV Solai	PolG	0	0	0	117	250	0	0	117

TABULATI DI VERIFICA

L'esito di ogni elaborazione viene sintetizzato nei disegni e schemi grafici allegati, che evidenziano i valori numerici nei punti e/o nelle sezioni significative, ai fini della valutazione del comportamento complessivo della struttura, e quelli necessari ai fini delle verifiche di misura della sicurezza.

Di seguito si riportano le tabelle relative a:

- Massime sollecitazioni pilastri

Risultati Analisi Dinamica - Sollecitazioni massime - Involuppi - Pilastri

Asta	N.in.	N	Ty	Tz	Mt	My	Mz
	N.fin.	kg	kg	kg	kg*m	kg*m	kg*m
1	1	-4120(2)	302(2)	-1575(2)	588(2)	1599(2)	340(12-l-1)
	10	-3943(2)	363(2)	-1575(2)	588(2)	-3232(2)	-748(2)
2	2	-4428(2)	-313(2)	-1445(2)	-550(2)	1571(2)	-380(2)
	11	-4235(2)	-374(2)	-1445(2)	-550(2)	-3234(2)	762(2)
3	3	-4078(2)	296(2)	1549(2)	-582(2)	-1537(2)	338(12-l-1)
	14	-3901(2)	357(2)	1549(2)	-582(2)	3214(2)	-741(2)
4	4	-4459(2)	-279(2)	1472(2)	513(2)	-1613(2)	-359(2)
	15	-4266(2)	-340(2)	1472(2)	513(2)	3279(2)	670(2)

VERIFICHE STATO LIMITE ULTIMO

VERIFICA MURI IN CALCESTRUZZO

Muro [Platea]:0 - Nodi : [23 - 122 - 22 - 21]:**Verificato**

Pann=48 Spess.= 50 cm Terreno:**Terreno1** Criterio CLS_Platee Materiale: C25/30

AUTOSTRADA VALDASTICO A31 NORD
1° LOTTO - PIOVENE ROCCHETTE – VALLE DELL'ASTICO

Armatura a maglia doppia

Pannello	Nx	Ny	Nxy	Mx	My	Mxy	Ax	Ay	C	Cs
	kg	kg	kg	kg*m	kg*m	kg*m	cmq	cmq		
1	51	5772	1683	-256	511	153	10.26	12.32	1	14.0
2	116	8943	723	-176	912	51	10.26	12.32	1	8.95
3	111	8931	-734	-177	912	-52	10.26	12.32	1	8.93
4	60	5743	-1680	-260	510	-157	10.26	12.32	1	13.9
5	92	2057	-1629	-361	-29	-212	10.26	12.32	1	15.4
6	50	361	-118	-168	-256	55	10.26	12.32	1	33.6
7	-6625	-340	4742	-781	-193	195	10.26	12.32	1	10.4
8	-6486	196	518	-687	288	127	10.26	12.32	1	12.5
9	-12926	-1320	-6419	-1715	-7	-345	10.26	12.32	1	5.58
10	-3324	-694	-1719	-332	-310	-122	10.26	12.32	1	20.9
11	-509	297	-220	-84	-118	53	10.26	12.32	1	61.2
12	42	1572	1646	-259	-5	173	10.26	12.32	1	20.4
13	64	5846	1743	-182	531	132	10.26	12.32	1	14.0
14	126	8985	676	-158	902	44	10.26	12.32	1	9.10
15	113	8955	-717	-162	901	-49	10.26	12.32	1	9.06
16	52	5810	-1778	-191	529	-136	10.26	12.32	1	14.0
17	62	1588	-1671	-266	-7	-174	10.26	12.32	1	20.0
18	-494	313	223	-88	-120	-50	10.26	12.32	1	61.2
19	-3325	-690	1733	-337	-315	124	10.26	12.32	1	20.6
20	-12942	-1336	6478	-1719	-9	352	10.26	12.32	1	5.55
21	-6493	200	-531	-686	288	-128	10.26	12.32	1	12.5
22	-6631	-333	-4732	-780	-193	-196	10.26	12.32	1	10.5
23	36	362	114	-165	-255	-54	10.26	12.32	1	33.8
24	93	2049	1611	-356	-29	212	10.26	12.32	1	15.5
25	-3236	11088	-746	-272	924	-75	10.26	12.32	1	8.15
26	-5326	11920	-393	-445	995	-46	10.26	12.32	1	7.65
27	-4491	-1288	-1345	-448	-109	-303	10.26	12.32	1	13.0
28	-13347	-12343	3679	-1031	-1052	255	10.26	12.32	1	9.01

AUTOSTRADA VALDASTICO A31 NORD
1° LOTTO - PIOVENE ROCCHETTE – VALLE DELL'ASTICO

Pannello	Nx	Ny	Nxy	Mx	My	Mxy	Ax	Ay	C	Cs
29	-3654	6256	-1917	-322	528	-231	10.26	12.32	1	12.1
30	-7129	6320	-1452	-624	555	-234	10.26	12.32	1	11.6
31	-5304	12010	279	-442	1005	33	10.26	12.32	1	7.65
32	-3416	11230	646	-290	930	74	10.26	12.32	1	8.08
33	-9096	-18682	393	-782	-1746	25	10.26	12.32	1	8.09
34	-8597	-8438	-1845	-678	-645	-116	10.26	12.32	1	13.4
35	-8676	6361	494	-721	558	102	10.26	12.32	1	12.9
36	-4378	6223	1871	-422	450	289	10.26	12.32	1	12.5
37	-3411	11225	-658	-290	928	-76	10.26	12.32	1	8.08
38	-5313	12011	-285	-443	1005	-32	10.26	12.32	1	7.66
39	-8649	-8516	1867	-682	-648	116	10.26	12.32	1	13.3
40	-9098	-18637	-376	-782	-1745	-24	10.26	12.32	1	8.10
41	-4409	6231	-1878	-424	453	-289	10.26	12.32	1	12.4
42	-8683	6383	-490	-720	561	-98	10.26	12.32	1	13.0
43	-3209	11107	710	-270	926	73	10.26	12.32	1	8.16
44	-5308	11934	383	-444	996	47	10.26	12.32	1	7.63
45	-13269	-12200	-3624	-1025	-1037	-251	10.26	12.32	1	9.07
46	-4389	-1186	1375	-438	-100	303	10.26	12.32	1	13.1
47	-7082	6372	1467	-621	559	236	10.26	12.32	1	11.5
48	-3584	6303	1903	-316	532	230	10.26	12.32	1	12.1
Massimi/minimi										
1							10.26			
1								12.32		
20										5.55

AUTOSTRADA VALDASTICO A31 NORD
1° LOTTO - PIOVENE ROCCHETTE – VALLE DELL'ASTICO

Nessuna asta da verificare ad instabilità

VERIFICHE RESISTENZA ASTE METALLICHE

Asta : 1 [1 , 10]

Sez. G: O 200x10 L=306.8 cm Crit.: Acciaio_Flessione $\gamma_M=1.05$ $f_{yk}/\gamma_M=2619$ kg/cm² $f_t=4300$ kg/cm²

:Verificato

X	cls	N	TY	TZ	MT	MY	MZ	My4	Mz4	Comb.
cm		kg	kg	kg	kg*m	kg*m	kg*m			
307	1	-3943	363	-1575	588	-3232	-748	--	--	2

X	cls	Nr	Vyr	Vzr	Mry	Mrz	MTrd	SF_V.	SF_M	SF_Mt	SF
cm		kg	kg	kg	kg*m	kg*m	kg*m				
307	1	156332	53327	53327	9463	9463	8168	33.9	2.24	13.9	2.24

Asta : 2 [2 , 11]

Sez. G: O 200x10 L=332.4 cm Crit.: Acciaio_Flessione $\gamma_M=1.05$ $f_{yk}/\gamma_M=2619$ kg/cm² $f_t=4300$ kg/cm²

:Verificato

X	cls	N	TY	TZ	MT	MY	MZ	My4	Mz4	Comb.
cm		kg	kg	kg	kg*m	kg*m	kg*m			
332	1	-4235	-374	-1445	-550	-3234	762	--	--	2

X	cls	Nr	Vyr	Vzr	Mry	Mrz	MTrd	SF_V.	SF_M	SF_Mt	SF
cm		kg	kg	kg	kg*m	kg*m	kg*m				
332	1	156332	53589	53589	9463	9463	8168	37.1	2.23	14.8	2.23

Asta : 3 [3 , 14]

Sez. G: O 200x10 L=306.8 cm Crit.: Acciaio_Flessione $\gamma_M=1.05$ $f_{yk}/\gamma_M=2619$ kg/cm² $f_t=4300$ kg/cm²

:Verificato

X	cls	N	TY	TZ	MT	MY	MZ	My4	Mz4	Comb.
cm		kg	kg	kg	kg*m	kg*m	kg*m			
307	1	-3901	357	1549	-582	3214	-741	--	--	2

AUTOSTRADA VALDASTICO A31 NORD
1° LOTTO - PIOVENE ROCCHETTE – VALLE DELL'ASTICO

X	cls	Nr	Vyr	Vzr	Mry	Mrz	MTrd	SF_V.	SF_M	SF_Mt	SF
cm		kg	kg	kg	kg*m	kg*m	kg*m				
307	1	156332	53363	53363	9463	9463	8168	34.5	2.26	14.0	2.26

Asta : 4 [4 , 15]

Sez. G: O 200x10 L=332.4 cm Crit.: Acciaio_Flessione $\gamma_M=1.05$ fyk/ $\gamma_M=2619$ kg/cmq ft=4300 kg/cmq

:Verificato

X	cls	N	TY	TZ	MT	MY	MZ	My4	Mz4	Comb.
cm		kg	kg	kg	kg*m	kg*m	kg*m			
332	1	-4266	-340	1472	513	3279	670	--	--	2

X	cls	Nr	Vyr	Vzr	Mry	Mrz	MTrd	SF_V.	SF_M	SF_Mt	SF
cm		kg	kg	kg	kg*m	kg*m	kg*m				
332	1	156332	53850	53850	9463	9463	8168	36.6	2.25	15.9	2.25

Asta : 8000 [17 , 18]

Sez. G: IPE 120 L=156.3 cm Crit.: Acciaio_Flessione $\gamma_M=1.05$ fyk/ $\gamma_M=2619$ kg/cmq ft=4300 kg/cmq

:Verificato

X	cls	N	TY	TZ	MT	MY	MZ	My4	Mz4	Comb.
cm		kg	kg	kg	kg*m	kg*m	kg*m			
156	1	64	17	23	-0	24	-13	--	--	(12+13)-II-4

X	cls	Nr	Vyr	Vzr	Mry	Mrz	MTrd	SF_V.	SF_M	SF_Mt	SF
cm		kg	kg	kg	kg*m	kg*m	kg*m				
156	1	34598	12163	9511	1591	356	35	>100	19.1	>100	19.1

Asta : 8000 [18 , 19]

Sez. G: IPE 120 L=251.5 cm Crit.: Acciaio_Flessione $\gamma_M=1.05$ fyk/ $\gamma_M=2619$ kg/cmq ft=4300 kg/cmq

:Verificato

X	cls	N	TY	TZ	MT	MY	MZ	My4	Mz4	Comb.
cm		kg	kg	kg	kg*m	kg*m	kg*m			

AUTOSTRADA VALDASTICO A31 NORD
1° LOTTO - PIOVENE ROCCHETTE – VALLE DELL'ASTICO

X	cls	N	TY	TZ	MT	MY	MZ	My4	Mz4	Comb.
251	1	-617	6	28	0	66	-12	--	--	2

X	cls	Nr	Vyr	Vzr	Mry	Mrz	MTrd	SF_V.	SF_M	SF_Mt	SF
cm		kg	kg	kg	kg*m	kg*m	kg*m				
251	1	34598	12193	9534	1591	356	35	>100	10.8	>100	10.8

Asta : 8000 [19 , 20]

Sez. G: IPE 120 L=155.4 cm Crit.: Acciaio_Flessione $\gamma_M=1.05$ $f_yk/\gamma_M=2619$ kg/cm² $f_t=4300$ kg/cm²

:Verificato

X	cls	N	TY	TZ	MT	MY	MZ	My4	Mz4	Comb.
cm		kg	kg	kg	kg*m	kg*m	kg*m			
0	1	53	-15	-26	0	28	-11	--	--	(12+13)-II-2

X	cls	Nr	Vyr	Vzr	Mry	Mrz	MTrd	SF_V.	SF_M	SF_Mt	SF
cm		kg	kg	kg	kg*m	kg*m	kg*m				
0	1	34598	12162	9510	1591	356	35	>100	19.8	>100	19.8

Asta : 8001 [13 , 14]

Sez. G: IPE 140 L=156.3 cm Crit.: Acciaio_Flessione $\gamma_M=1.05$ $f_yk/\gamma_M=2619$ kg/cm² $f_t=4300$ kg/cm²

:Verificato

X	cls	N	TY	TZ	MT	MY	MZ	My4	Mz4	Comb.
cm		kg	kg	kg	kg*m	kg*m	kg*m			
156	1	4	74	572	-2	872	-75	--	--	2

X	cls	Nr	Vyr	Vzr	Mry	Mrz	MTrd	SF_V.	SF_M	SF_Mt	SF
cm		kg	kg	kg	kg*m	kg*m	kg*m				
156	1	43021	14988	11370	2315	504	46	19.9	1.90	25.1	1.90

Asta : 8001 [14 , 15]

Sez. G: IPE 140 L=251.5 cm Crit.: Acciaio_Flessione $\gamma_M=1.05$ $f_yk/\gamma_M=2619$ kg/cm² $f_t=4300$ kg/cm²

:Verificato

AUTOSTRADA VALDASTICO A31 NORD
1° LOTTO - PIOVENE ROCCHETTE – VALLE DELL'ASTICO

X	cls	N	TY	TZ	MT	MY	MZ	My4	Mz4	Comb.
cm		kg	kg	kg	kg*m	kg*m	kg*m			
0	1	2214	14	-39	0	126	34	--	--	2

X	cls	Nr	Vyr	Vzr	Mry	Mrz	MTrd	SF_V.	SF_M	SF_Mt	SF
cm		kg	kg	kg	kg*m	kg*m	kg*m				
0	1	43021	15225	11550	2315	504	46	>100	5.75	>100	5.75

Asta : 8001 [15 , 16]

Sez. G: IPE 140 L=155.4 cm Crit.: Acciaio_Flessione $\gamma_M=1.05$ $f_yk/\gamma_M=2619$ kg/cmq $f_t=4300$ kg/cmq

:Verificato

X	cls	N	TY	TZ	MT	MY	MZ	My4	Mz4	Comb.
cm		kg	kg	kg	kg*m	kg*m	kg*m			
0	1	-9	-57	-555	2	889	-60	--	--	2

X	cls	Nr	Vyr	Vzr	Mry	Mrz	MTrd	SF_V.	SF_M	SF_Mt	SF
cm		kg	kg	kg	kg*m	kg*m	kg*m				
0	1	43021	15001	11380	2315	504	46	20.5	1.99	26.4	1.99

Asta : 8002 [209 , 210]

Sez. G: IPE 140 L=156.3 cm Crit.: Acciaio_Flessione $\gamma_M=1.05$ $f_yk/\gamma_M=2619$ kg/cmq $f_t=4300$ kg/cmq

:Verificato

X	cls	N	TY	TZ	MT	MY	MZ	My4	Mz4	Comb.
cm		kg	kg	kg	kg*m	kg*m	kg*m			
156	1	53	8	482	0	732	-3	--	--	2

X	cls	Nr	Vyr	Vzr	Mry	Mrz	MTrd	SF_V.	SF_M	SF_Mt	SF
cm		kg	kg	kg	kg*m	kg*m	kg*m				
156	1	43021	15218	11545	2315	504	46	24.0	3.09	>100	3.09

AUTOSTRADA VALDASTICO A31 NORD
1° LOTTO - PIOVENE ROCCHETTE – VALLE DELL'ASTICO

Asta : 8002 [210 , 211]

Sez. G: IPE 140 L=251.5 cm Crit.: Acciaio_Flessione $\gamma_M=1.05$ $f_{yk}/\gamma_M=2619$ kg/cmq $f_t=4300$ kg/cmq

:Verificato

X	cls	N	TY	TZ	MT	MY	MZ	My4	Mz4	Comb.
cm		kg	kg	kg	kg*m	kg*m	kg*m			
251	1	25	12	22	-0	734	-21	--	--	2

X	cls	Nr	Vyr	Vzr	Mry	Mrz	MTrd	SF_V.	SF_M	SF_Mt	SF
cm		kg	kg	kg	kg*m	kg*m	kg*m				
251	1	43021	15232	11555	2315	504	46	>100	2.78	>100	2.78

Asta : 8002 [211 , 212]

Sez. G: IPE 140 L=155.4 cm Crit.: Acciaio_Flessione $\gamma_M=1.05$ $f_{yk}/\gamma_M=2619$ kg/cmq $f_t=4300$ kg/cmq

:Verificato

X	cls	N	TY	TZ	MT	MY	MZ	My4	Mz4	Comb.
cm		kg	kg	kg	kg*m	kg*m	kg*m			
0	1	27	-15	-486	-0	734	-12	--	--	2

X	cls	Nr	Vyr	Vzr	Mry	Mrz	MTrd	SF_V.	SF_M	SF_Mt	SF
cm		kg	kg	kg	kg*m	kg*m	kg*m				
0	1	43021	15219	11545	2315	504	46	23.8	2.92	>100	2.92

Asta : 8003 [109 , 110]

Sez. G: IPE 140 L=156.3 cm Crit.: Acciaio_Flessione $\gamma_M=1.05$ $f_{yk}/\gamma_M=2619$ kg/cmq $f_t=4300$ kg/cmq

:Verificato

X	cls	N	TY	TZ	MT	MY	MZ	My4	Mz4	Comb.
cm		kg	kg	kg	kg*m	kg*m	kg*m			
156	1	55	-9	485	-0	737	4	--	--	2

X	cls	Nr	Vyr	Vzr	Mry	Mrz	MTrd	SF_V.	SF_M	SF_Mt	SF
cm		kg	kg	kg	kg*m	kg*m	kg*m				
156	1	43021	15218	11545	2315	504	46	23.8	3.05	>100	3.05

AUTOSTRADA VALDASTICO A31 NORD
1° LOTTO - PIOVENE ROCCHETTE – VALLE DELL'ASTICO

Asta : 8003 [110 , 111]

Sez. G: IPE 140 L=251.5 cm Crit.: Acciaio_Flessione $\gamma_M=1.05$ $f_{yk}/\gamma_M=2619$ kg/cmq $f_t=4300$ kg/cmq

:Verificato

X	cls	N	TY	TZ	MT	MY	MZ	My4	Mz4	Comb.
cm		kg	kg	kg	kg*m	kg*m	kg*m			
251	1	29	-10	14	0	720	19	--	--	2

X	cls	Nr	Vyr	Vzr	Mry	Mrz	MTrd	SF_V.	SF_M	SF_Mt	SF
cm		kg	kg	kg	kg*m	kg*m	kg*m				
251	1	43021	15231	11555	2315	504	46	>100	2.87	>100	2.87

Asta : 8003 [111 , 112]

Sez. G: IPE 140 L=155.4 cm Crit.: Acciaio_Flessione $\gamma_M=1.05$ $f_{yk}/\gamma_M=2619$ kg/cmq $f_t=4300$ kg/cmq

:Verificato

X	cls	N	TY	TZ	MT	MY	MZ	My4	Mz4	Comb.
cm		kg	kg	kg	kg*m	kg*m	kg*m			
0	1	26	8	-477	0	721	6	--	--	2

X	cls	Nr	Vyr	Vzr	Mry	Mrz	MTrd	SF_V.	SF_M	SF_Mt	SF
cm		kg	kg	kg	kg*m	kg*m	kg*m				
0	1	43021	15222	11548	2315	504	46	24.2	3.09	>100	3.09

Asta : 8004 [5 , 6]

Sez. G: IPE 120 L=156.3 cm Crit.: Acciaio_Flessione $\gamma_M=1.05$ $f_{yk}/\gamma_M=2619$ kg/cmq $f_t=4300$ kg/cmq

:Verificato

X	cls	N	TY	TZ	MT	MY	MZ	My4	Mz4	Comb.
cm		kg	kg	kg	kg*m	kg*m	kg*m			
156	1	64	-16	24	0	25	13	--	--	(12+13)-II-3

X	cls	Nr	Vyr	Vzr	Mry	Mrz	MTrd	SF_V.	SF_M	SF_Mt	SF
cm		kg	kg	kg	kg*m	kg*m	kg*m				

AUTOSTRADA VALDASTICO A31 NORD
1° LOTTO - PIOVENE ROCCHETTE – VALLE DELL'ASTICO

X	cls	Nr	Vyr	Vzr	Mry	Mrz	MTrd	SF_V.	SF_M	SF_Mt	SF
156	1	34598	12163	9510	1591	356	35	>100	19.0	>100	19.0

Asta : 8004 [6 , 7]

Sez. G: IPE 120 L=251.5 cm Crit.: Acciaio_Flessione $\gamma_M=1.05$ fyk/ $\gamma_M=2619$ kg/cm² ft=4300 kg/cm²

:Verificato

X	cls	N	TY	TZ	MT	MY	MZ	My4	Mz4	Comb.
cm		kg	kg	kg	kg*m	kg*m	kg*m			
251	1	-628	-4	19	-0	45	9	--	--	2

X	cls	Nr	Vyr	Vzr	Mry	Mrz	MTrd	SF_V.	SF_M	SF_Mt	SF
cm		kg	kg	kg	kg*m	kg*m	kg*m				
251	1	34598	12192	9533	1591	356	35	>100	14.1	>100	14.1

Asta : 8004 [7 , 8]

Sez. G: IPE 120 L=155.4 cm Crit.: Acciaio_Flessione $\gamma_M=1.05$ fyk/ $\gamma_M=2619$ kg/cm² ft=4300 kg/cm²

:Verificato

X	cls	N	TY	TZ	MT	MY	MZ	My4	Mz4	Comb.
cm		kg	kg	kg	kg*m	kg*m	kg*m			
0	1	53	14	-23	-0	24	11	--	--	(12+13)-II-1

X	cls	Nr	Vyr	Vzr	Mry	Mrz	MTrd	SF_V.	SF_M	SF_Mt	SF
cm		kg	kg	kg	kg*m	kg*m	kg*m				
0	1	34598	12162	9510	1591	356	35	>100	21.5	>100	21.5

Asta : 8005 [9 , 10]

Sez. G: IPE 140 L=156.3 cm Crit.: Acciaio_Flessione $\gamma_M=1.05$ fyk/ $\gamma_M=2619$ kg/cm² ft=4300 kg/cm²

:Verificato

X	cls	N	TY	TZ	MT	MY	MZ	My4	Mz4	Comb.
cm		kg	kg	kg	kg*m	kg*m	kg*m			
156	1	2	-74	567	2	865	75	--	--	2

AUTOSTRADA VALDASTICO A31 NORD
1° LOTTO - PIOVENE ROCCHETTE – VALLE DELL'ASTICO

X	cls	Nr	Vyr	Vzr	Mry	Mrz	MTrd	SF_V.	SF_M	SF_Mt	SF
cm		kg	kg	kg	kg*m	kg*m	kg*m				
156	1	43021	14986	11369	2315	504	46	20.0	1.91	24.9	1.91

Asta : 8005 [10 , 11]

Sez. G: IPE 140 L=251.5 cm Crit.: Acciaio_Flessione $\gamma_M=1.05$ $f_{yk}/\gamma_M=2619$ kg/cm² $f_t=4300$ kg/cm²

:Verificato

X	cls	N	TY	TZ	MT	MY	MZ	My4	Mz4	Comb.
cm		kg	kg	kg	kg*m	kg*m	kg*m			
0	1	2239	-9	-27	-0	117	-30	--	--	2

X	cls	Nr	Vyr	Vzr	Mry	Mrz	MTrd	SF_V.	SF_M	SF_Mt	SF
cm		kg	kg	kg	kg*m	kg*m	kg*m				
0	1	43021	15223	11549	2315	504	46	>100	6.19	>100	6.19

Asta : 8005 [11 , 12]

Sez. G: IPE 140 L=155.4 cm Crit.: Acciaio_Flessione $\gamma_M=1.05$ $f_{yk}/\gamma_M=2619$ kg/cm² $f_t=4300$ kg/cm²

:Verificato

X	cls	N	TY	TZ	MT	MY	MZ	My4	Mz4	Comb.
cm		kg	kg	kg	kg*m	kg*m	kg*m			
0	1	-22	66	-569	-2	862	67	--	--	2

X	cls	Nr	Vyr	Vzr	Mry	Mrz	MTrd	SF_V.	SF_M	SF_Mt	SF
cm		kg	kg	kg	kg*m	kg*m	kg*m				
0	1	43021	14989	11371	2315	504	46	20.0	1.97	25.1	1.97

Asta : 8006 [20 , 16]

Sez. G: IPE 120 L=45.0 cm Crit.: Acciaio_Flessione $\gamma_M=1.05$ $f_{yk}/\gamma_M=2619$ kg/cm² $f_t=4300$ kg/cm² **:Verificato**

X	cls	N	TY	TZ	MT	MY	MZ	My4	Mz4	Comb.
cm		kg	kg	kg	kg*m	kg*m	kg*m			
45	1	5	62	76	-2	12	-21	--	--	2

AUTOSTRADA VALDASTICO A31 NORD
1° LOTTO - PIOVENE ROCCHETTE – VALLE DELL'ASTICO

X	cls	Nr	Vyr	Vzr	Mry	Mrz	MTrd	SF_V.	SF_M	SF_Mt	SF
cm		kg	kg	kg	kg*m	kg*m	kg*m				
45	1	34598	11933	9330	1591	356	35	>100	15.3	18.9	15.3

Asta : 8006 [16 , 212]

Sez. G: IPE 120 L=250.0 cm Crit.: Acciaio_Flessione $\gamma_M=1.05$ $f_{yk}/\gamma_M=2619$ kg/cmq ft=4300 kg/cmq

:Verificato

X	cls	N	TY	TZ	MT	MY	MZ	My4	Mz4	Comb.
cm		kg	kg	kg	kg*m	kg*m	kg*m			
200	1	63	9	35	-0	-398	-4	--	--	2

X	cls	Nr	Vyr	Vzr	Mry	Mrz	MTrd	SF_V.	SF_M	SF_Mt	SF
cm		kg	kg	kg	kg*m	kg*m	kg*m				
200	1	34598	12151	9501	1591	356	35	>100	3.79	>100	3.79

Asta : 8006 [212 , 112]

Sez. G: IPE 120 L=250.0 cm Crit.: Acciaio_Flessione $\gamma_M=1.05$ $f_{yk}/\gamma_M=2619$ kg/cmq ft=4300 kg/cmq

:Verificato

X	cls	N	TY	TZ	MT	MY	MZ	My4	Mz4	Comb.
cm		kg	kg	kg	kg*m	kg*m	kg*m			
125	1	79	1	-2	0	-541	2	--	--	2

X	cls	Nr	Vyr	Vzr	Mry	Mrz	MTrd	SF_V.	SF_M	SF_Mt	SF
cm		kg	kg	kg	kg*m	kg*m	kg*m				
125	1	34598	12193	9534	1591	356	35	>100	2.88	>100	2.88

Asta : 8006 [112 , 12]

Sez. G: IPE 120 L=250.0 cm Crit.: Acciaio_Flessione $\gamma_M=1.05$ $f_{yk}/\gamma_M=2619$ kg/cmq ft=4300 kg/cmq

:Verificato

X	cls	N	TY	TZ	MT	MY	MZ	My4	Mz4	Comb.
cm		kg	kg	kg	kg*m	kg*m	kg*m			
50	1	70	-7	-31	0	-401	-3	--	--	2

AUTOSTRADA VALDASTICO A31 NORD
1° LOTTO - PIOVENE ROCCHETTE – VALLE DELL'ASTICO

X	cls	Nr	Vyr	Vzr	Mry	Mrz	MTrd	SF_V.	SF_M	SF_Mt	SF
cm		kg	kg	kg	kg*m	kg*m	kg*m				
50	1	34598	12147	9498	1591	356	35	>100	3.80	>100	3.80

Asta : 8006 [12 , 8]

Sez. G: IPE 120 L=45.0 cm Crit.: Acciaio_Flessione $\gamma_M=1.05$ $f_{yk}/\gamma_M=2619$ kg/cm² $f_t=4300$ kg/cm² :**Verificato**

X	cls	N	TY	TZ	MT	MY	MZ	My4	Mz4	Comb.
cm		kg	kg	kg	kg*m	kg*m	kg*m			
0	1	4	-69	-87	2	16	-24	--	--	2

X	cls	Nr	Vyr	Vzr	Mry	Mrz	MTrd	SF_V.	SF_M	SF_Mt	SF
cm		kg	kg	kg	kg*m	kg*m	kg*m				
0	1	34598	11940	9336	1591	356	35	>100	13.0	19.5	13.0

Asta : 8007 [19 , 15]

Sez. G: IPE 180 L=45.0 cm Crit.: Acciaio_Flessione $\gamma_M=1.05$ $f_{yk}/\gamma_M=2619$ kg/cm² $f_t=4300$ kg/cm² :**Verificato**

X	cls	N	TY	TZ	MT	MY	MZ	My4	Mz4	Comb.
cm		kg	kg	kg	kg*m	kg*m	kg*m			
45	1	-6	-678	295	0	70	294	--	--	2

X	cls	Nr	Vyr	Vzr	Mry	Mrz	MTrd	SF_V.	SF_M	SF_Mt	SF
cm		kg	kg	kg	kg*m	kg*m	kg*m				
45	1	62719	22012	17010	4361	906	79	32.4	2.94	>100	2.94

Asta : 8007 [15 , 211]

Sez. G: IPE 180 L=250.0 cm Crit.: Acciaio_Flessione $\gamma_M=1.05$ $f_{yk}/\gamma_M=2619$ kg/cm² $f_t=4300$ kg/cm²

:**Verificato**

X	cls	N	TY	TZ	MT	MY	MZ	My4	Mz4	Comb.
cm		kg	kg	kg	kg*m	kg*m	kg*m			
0	1	-1527	-30	-2840	-1	3333	-60	--	--	2

AUTOSTRADA VALDASTICO A31 NORD
1° LOTTO - PIOVENE ROCCHETTE – VALLE DELL'ASTICO

cm		kg	kg	kg	kg*m	kg*m	kg*m				
X	cls	Nr	Vyr	Vzr	Mry	Mrz	MTrd	SF_V.	SF_M	SF_Mt	SF
0	1	62719	21890	16916	4361	906	79	5.96	1.17	69.9	1.17

Asta : 8007 [211 , 111]

Sez. G: IPE 180 L=250.0 cm Crit.: Acciaio_Flessione $\gamma_M=1.05$ $f_{yk}/\gamma_M=2619$ kg/cm² $f_t=4300$ kg/cm²

:Verificato

X	cls	N	TY	TZ	MT	MY	MZ	My4	Mz4	Comb.
cm		kg	kg	kg	kg*m	kg*m	kg*m			
125	1	-1547	-0	5	0	-2309	7	--	--	2

X	cls	Nr	Vyr	Vzr	Mry	Mrz	MTrd	SF_V.	SF_M	SF_Mt	SF
cm		kg	kg	kg	kg*m	kg*m	kg*m				
125	1	62719	22015	17012	4361	906	79	>100	1.78	>100	1.78

Asta : 8007 [111 , 11]

Sez. G: IPE 180 L=250.0 cm Crit.: Acciaio_Flessione $\gamma_M=1.05$ $f_{yk}/\gamma_M=2619$ kg/cm² $f_t=4300$ kg/cm²

:Verificato

X	cls	N	TY	TZ	MT	MY	MZ	My4	Mz4	Comb.
cm		kg	kg	kg	kg*m	kg*m	kg*m			
250	1	-1521	35	2835	1	3312	-69	--	--	2

X	cls	Nr	Vyr	Vzr	Mry	Mrz	MTrd	SF_V.	SF_M	SF_Mt	SF
cm		kg	kg	kg	kg*m	kg*m	kg*m				
250	1	62719	21895	16919	4361	906	79	5.97	1.16	72.6	1.16

Asta : 8007 [11 , 7]

Sez. G: IPE 180 L=45.0 cm Crit.: Acciaio_Flessione $\gamma_M=1.05$ $f_{yk}/\gamma_M=2619$ kg/cm² $f_t=4300$ kg/cm² **:Verificato**

X	cls	N	TY	TZ	MT	MY	MZ	My4	Mz4	Comb.
cm		kg	kg	kg	kg*m	kg*m	kg*m			

AUTOSTRADA VALDASTICO A31 NORD
1° LOTTO - PIOVENE ROCCHETTE – VALLE DELL'ASTICO

X	cls	N	TY	TZ	MT	MY	MZ	My4	Mz4	Comb.
0	1	-13	695	-275	0	60	304	--	--	2

X	cls	Nr	Vyr	Vzr	Mry	Mrz	MTrd	SF_V.	SF_M	SF_Mt	SF
cm		kg	kg	kg	kg*m	kg*m	kg*m				
0	1	62719	21965	16974	4361	906	79	31.6	2.86	>100	2.86

Asta : 8008 [18 , 14]

Sez. G: IPE 180 L=45.0 cm Crit.: Acciaio_Flessione $\gamma_M=1.05$ $f_{yk}/\gamma_M=2619$ kg/cm² $f_t=4300$ kg/cm² :**Verificato**

X	cls	N	TY	TZ	MT	MY	MZ	My4	Mz4	Comb.
cm		kg	kg	kg	kg*m	kg*m	kg*m			
45	1	5	694	395	0	114	-317	--	--	2

X	cls	Nr	Vyr	Vzr	Mry	Mrz	MTrd	SF_V.	SF_M	SF_Mt	SF
cm		kg	kg	kg	kg*m	kg*m	kg*m				
45	1	62719	21992	16995	4361	906	79	31.7	2.66	>100	2.66

Asta : 8008 [14 , 210]

Sez. G: IPE 180 L=250.0 cm Crit.: Acciaio_Flessione $\gamma_M=1.05$ $f_{yk}/\gamma_M=2619$ kg/cm² $f_t=4300$ kg/cm²

:**Verificato**

X	cls	N	TY	TZ	MT	MY	MZ	My4	Mz4	Comb.
cm		kg	kg	kg	kg*m	kg*m	kg*m			
0	1	-1652	32	-2838	1	3341	71	--	--	2

X	cls	Nr	Vyr	Vzr	Mry	Mrz	MTrd	SF_V.	SF_M	SF_Mt	SF
cm		kg	kg	kg	kg*m	kg*m	kg*m				
0	1	62719	21899	16923	4361	906	79	5.96	1.15	75.6	1.15

Asta : 8008 [210 , 110]

Sez. G: IPE 180 L=250.0 cm Crit.: Acciaio_Flessione $\gamma_M=1.05$ $f_{yk}/\gamma_M=2619$ kg/cm² $f_t=4300$ kg/cm²

:**Verificato**

AUTOSTRADA VALDASTICO A31 NORD
1° LOTTO - PIOVENE ROCCHETTE – VALLE DELL'ASTICO

X	cls	N	TY	TZ	MT	MY	MZ	My4	Mz4	Comb.
cm		kg	kg	kg	kg*m	kg*m	kg*m			
125	1	-1641	0	4	-0	-2295	-21	--	--	2

X	cls	Nr	Vyr	Vzr	Mry	Mrz	MTrd	SF_V.	SF_M	SF_Mt	SF
cm		kg	kg	kg	kg*m	kg*m	kg*m				
125	1	62719	22016	17013	4361	906	79	>100	1.74	>100	1.74

Asta : 8008 [110 , 10]

Sez. G: IPE 180 L=250.0 cm Crit.: Acciaio_Flessione $\gamma_M=1.05$ $f_yk/\gamma_M=2619$ kg/cm² $f_t=4300$ kg/cm²

:Verificato

X	cls	N	TY	TZ	MT	MY	MZ	My4	Mz4	Comb.
cm		kg	kg	kg	kg*m	kg*m	kg*m			
250	1	-1634	-35	2856	-1	3377	75	--	--	2

X	cls	Nr	Vyr	Vzr	Mry	Mrz	MTrd	SF_V.	SF_M	SF_Mt	SF
cm		kg	kg	kg	kg*m	kg*m	kg*m				
250	1	62719	21900	16924	4361	906	79	5.92	1.13	76.1	1.13

Asta : 8008 [10 , 6]

Sez. G: IPE 180 L=45.0 cm Crit.: Acciaio_Flessione $\gamma_M=1.05$ $f_yk/\gamma_M=2619$ kg/cm² $f_t=4300$ kg/cm² **:Verificato**

X	cls	N	TY	TZ	MT	MY	MZ	My4	Mz4	Comb.
cm		kg	kg	kg	kg*m	kg*m	kg*m			
0	1	-8	-704	-408	-0	119	-319	--	--	2

X	cls	Nr	Vyr	Vzr	Mry	Mrz	MTrd	SF_V.	SF_M	SF_Mt	SF
cm		kg	kg	kg	kg*m	kg*m	kg*m				
0	1	62719	21973	16979	4361	906	79	31.2	2.64	>100	2.64

Asta : 8009 [17 , 13]

Sez. G: IPE 120 L=45.0 cm Crit.: Acciaio_Flessione $\gamma_M=1.05$ $f_yk/\gamma_M=2619$ kg/cm² $f_t=4300$ kg/cm² **:Verificato**

AUTOSTRADA VALDASTICO A31 NORD
1° LOTTO - PIOVENE ROCCHETTE – VALLE DELL'ASTICO

X	cls	N	TY	TZ	MT	MY	MZ	My4	Mz4	Comb.
cm		kg	kg	kg	kg*m	kg*m	kg*m			
45	1	6	-78	89	2	18	26	--	--	2

X	cls	Nr	Vyr	Vzr	Mry	Mrz	MTrd	SF_V.	SF_M	SF_Mt	SF
cm		kg	kg	kg	kg*m	kg*m	kg*m				
45	1	34598	11939	9335	1591	356	35	>100	11.9	19.3	11.9

Asta : 8009 [13 , 209]

Sez. G: IPE 120 L=250.0 cm Crit.: Acciaio_Flessione $\gamma_M=1.05$ $f_{yk}/\gamma_M=2619$ kg/cmq $f_t=4300$ kg/cmq

:Verificato

X	cls	N	TY	TZ	MT	MY	MZ	My4	Mz4	Comb.
cm		kg	kg	kg	kg*m	kg*m	kg*m			
200	1	81	-8	34	0	-394	3	--	--	2

X	cls	Nr	Vyr	Vzr	Mry	Mrz	MTrd	SF_V.	SF_M	SF_Mt	SF
cm		kg	kg	kg	kg*m	kg*m	kg*m				
200	1	34598	12149	9500	1591	356	35	>100	3.89	>100	3.89

Asta : 8009 [209 , 109]

Sez. G: IPE 120 L=250.0 cm Crit.: Acciaio_Flessione $\gamma_M=1.05$ $f_{yk}/\gamma_M=2619$ kg/cmq $f_t=4300$ kg/cmq

:Verificato

X	cls	N	TY	TZ	MT	MY	MZ	My4	Mz4	Comb.
cm		kg	kg	kg	kg*m	kg*m	kg*m			
125	1	89	0	1	-0	-534	-3	--	--	2

X	cls	Nr	Vyr	Vzr	Mry	Mrz	MTrd	SF_V.	SF_M	SF_Mt	SF
cm		kg	kg	kg	kg*m	kg*m	kg*m				
125	1	34598	12194	9534	1591	356	35	>100	2.88	>100	2.88

Asta : 8009 [109 , 9]

AUTOSTRADA VALDASTICO A31 NORD
1° LOTTO - PIOVENE ROCCHETTE – VALLE DELL'ASTICO

Sez. G: IPE 120 L=250.0 cm Crit.: Acciaio_Flessione $\gamma_M=1.05$ $f_{yk}/\gamma_M=2619$ kg/cmq $f_t=4300$ kg/cmq

:Verificato

X	cls	N	TY	TZ	MT	MY	MZ	My4	Mz4	Comb.
cm		kg	kg	kg	kg*m	kg*m	kg*m			
50	1	80	8	-35	-0	-392	2	--	--	2

X	cls	Nr	Vyr	Vzr	Mry	Mrz	MTrd	SF_V.	SF_M	SF_Mt	SF
cm		kg	kg	kg	kg*m	kg*m	kg*m				
50	1	34598	12149	9499	1591	356	35	>100	3.91	>100	3.91

Asta : 8009 [9 , 5]

Sez. G: IPE 120 L=45.0 cm Crit.: Acciaio_Flessione $\gamma_M=1.05$ $f_{yk}/\gamma_M=2619$ kg/cmq $f_t=4300$ kg/cmq **:Verificato**

X	cls	N	TY	TZ	MT	MY	MZ	My4	Mz4	Comb.
cm		kg	kg	kg	kg*m	kg*m	kg*m			
0	1	6	78	-86	-2	16	26	--	--	2

X	cls	Nr	Vyr	Vzr	Mry	Mrz	MTrd	SF_V.	SF_M	SF_Mt	SF
cm		kg	kg	kg	kg*m	kg*m	kg*m				
0	1	34598	11939	9335	1591	356	35	>100	11.9	19.3	11.9

VERIFICHE STATO LIMITE DI ESERCIZIO

VERIFICA SPOSTAMENTI VERTICALI DELLE ASTE IN ACCIAIO SECONDO NTC 2008

Travata: 8000 [17 , 20]

$L = 563.1$ cm

Crit.Prog: Acciaio_Flessione $\delta_c = 0.0$ cm Verifica: **Verificata**

Verifica spostamento nello stato finale (§4.2.4.2.1 - NTC 2008)

x	Comb.	δ_{max}	L/250.00	Cs
cm		mm	mm	

AUTOSTRADA VALDASTICO A31 NORD
1° LOTTO - PIOVENE ROCCHETTE – VALLE DELL'ASTICO

x	Comb.	δ_{max}	L/250.00	Cs
307.2	15	-1.67	22.53	13.5

Verifica spostamento elastico dovuto ai soli carichi variabili (§4.2.4.2.1 - NTC 2008)

x	Comb.	δ_2	L/300.00	Cs
cm		mm	mm	
307.2	15	-1.08	18.77	17.4

Travata: 8001 [13 , 16]

L = 563.1cm

Crit.Prog: Acciaio_Flessione $\delta_c = 0.0cm$ Verifica: **Verificata**

Verifica spostamento nello stato finale (§4.2.4.2.1 - NTC 2008)

x	Comb.	δ_{max}	L/250.00	Cs
cm		mm	mm	
277.5	15	-5.99	22.52	3.76

Verifica spostamento elastico dovuto ai soli carichi variabili (§4.2.4.2.1 - NTC 2008)

x	Comb.	δ_2	L/300.00	Cs
cm		mm	mm	
277.5	15	-4.11	18.77	4.57

Travata: 8002 [209 , 212]

L = 563.1cm

Crit.Prog: Acciaio_Flessione $\delta_c = 0.0cm$ Verifica: **Verificata**

Verifica spostamento nello stato finale (§4.2.4.2.1 - NTC 2008)

AUTOSTRADA VALDASTICO A31 NORD
1° LOTTO - PIOVENE ROCCHETTE – VALLE DELL'ASTICO

x	Comb.	δ_{max}	L/250.00	Cs
cm		mm	mm	
282.0	15	-15.51	22.53	1.45

Verifica spostamento elastico dovuto ai soli carichi variabili (§4.2.4.2.1 - NTC 2008)

x	Comb.	δ_2	L/300.00	Cs
cm		mm	mm	
282.0	15	-10.76	18.77	1.74

Travata: 8003 [109 , 112]

L = 563.1cm

Crit.Prog: Acciaio_Flessione $\delta_c = 0.0cm$ Verifica: **Verificata**

Verifica spostamento nello stato finale (§4.2.4.2.1 - NTC 2008)

x	Comb.	δ_{max}	L/250.00	Cs
cm		mm	mm	
282.0	15	-15.42	22.53	1.46

Verifica spostamento elastico dovuto ai soli carichi variabili (§4.2.4.2.1 - NTC 2008)

x	Comb.	δ_2	L/300.00	Cs
cm		mm	mm	
282.0	15	-10.70	18.77	1.75

Travata: 8004 [5 , 8]

L = 563.1cm

Crit.Prog: Acciaio_Flessione $\delta_c = 0.0cm$ Verifica: **Verificata**

Verifica spostamento nello stato finale (§4.2.4.2.1 - NTC 2008)

AUTOSTRADA VALDASTICO A31 NORD
1° LOTTO - PIOVENE ROCCHETTE – VALLE DELL'ASTICO

x	Comb.	δ_{max}	L/250.00	Cs
cm		mm	mm	
282.0	15	-1.32	22.53	17.1

Verifica spostamento elastico dovuto ai soli carichi variabili (§4.2.4.2.1 - NTC 2008)

x	Comb.	δ_2	L/300.00	Cs
cm		mm	mm	
282.0	15	-0.84	18.77	22.4

Travata: 8005 [9 , 12]

L = 563.1cm

Crit.Prog: Acciaio_Flessione $\delta_c = 0.0cm$ Verifica: **Verificata**

Verifica spostamento nello stato finale (§4.2.4.2.1 - NTC 2008)

x	Comb.	δ_{max}	L/250.00	Cs
cm		mm	mm	
282.0	15	-5.87	22.53	3.84

Verifica spostamento elastico dovuto ai soli carichi variabili (§4.2.4.2.1 - NTC 2008)

x	Comb.	δ_2	L/300.00	Cs
cm		mm	mm	
282.0	15	-4.03	18.77	4.66

Travata: 8006 [20 , 8]

L = 840.0cm

Crit.Prog: Acciaio_Flessione $\delta_c = 0.0cm$ Verifica: **Verificata**

AUTOSTRADA VALDASTICO A31 NORD
1° LOTTO - PIOVENE ROCCHETTE – VALLE DELL'ASTICO

Verifica spostamento nello stato finale (§4.2.4.2.1 - NTC 2008)

x	Comb.	δ_{max}	L/250.00	Cs
cm		mm	mm	
420.0	15	25.88	28.00	1.08

Verifica spostamento elastico dovuto ai soli carichi variabili (§4.2.4.2.1 - NTC 2008)

x	Comb.	δ_2	L/300.00	Cs
cm		mm	mm	
420.0	15	25.88	28.00	1.08

Travata: 8007 [19 , 7]

L = 840.0cm

Crit.Prog: Acciaio_Flessione $\delta_c = 0.0cm$ Verifica: **Verificata**

Verifica spostamento nello stato finale (§4.2.4.2.1 - NTC 2008)

x	Comb.	δ_{max}	L/250.00	Cs
cm		mm	mm	
420.0	15	26.32	33.60	1.28

Verifica spostamento elastico dovuto ai soli carichi variabili (§4.2.4.2.1 - NTC 2008)

x	Comb.	δ_2	L/300.00	Cs
cm		mm	mm	
420.0	15	18.37	28.00	1.52

Travata: 8008 [18 , 6]

L = 840.0cm

Crit.Prog: Acciaio_Flessione $\delta_c = 0.0cm$ Verifica: **Verificata**

AUTOSTRADA VALDASTICO A31 NORD
1° LOTTO - PIOVENE ROCCHETTE – VALLE DELL'ASTICO

Verifica spostamento nello stato finale (§4.2.4.2.1 - NTC 2008)

x	Comb.	δ_{max}	L/250.00	Cs
cm		mm	mm	
420.0	15	25.90	33.60	1.30

Verifica spostamento elastico dovuto ai soli carichi variabili (§4.2.4.2.1 - NTC 2008)

x	Comb.	δ_2	L/300.00	Cs
cm		mm	mm	
420.0	15	18.08	28.00	1.55

Travata: 8009 [17 , 5]

L = 840.0cm

Crit.Prog: Acciaio_Flessione $\delta_c = 0.0cm$ Verifica: **Verificata**

Verifica spostamento nello stato finale (§4.2.4.2.1 - NTC 2008)

x	Comb.	δ_{max}	L/250.00	Cs
cm		mm	mm	
420.0	15	25.88	28.00	1.08

Verifica spostamento elastico dovuto ai soli carichi variabili (§4.2.4.2.1 - NTC 2008)

x	Comb.	δ_2	L/300.00	Cs
cm		mm	mm	
420.0	15	25.47	28.00	1.10

24.10 VERIFICA PORTANZA FONDAZIONE

Elm.	Cmb	V [kg]	Vd [kg]	CsV (>2.30)	H [kg]	Hd [kg]	CsH (>1.10)	Qd [kg/cmq]	qe [kg/cmq]	w [mm]
0	2	92348	1758492	43.80	0	48470	>100	3.74	0.00	0
	3	92348	1758492	43.80	0	48470	>100	3.74	0.00	0
	4	81705	1757977	49.49	0	42884	>100	3.74	0.00	0
	5	81705	1757977	49.49	0	42884	>100	3.74	0.00	0
	6	81705	1757977	49.49	0	42884	>100	3.74	0.00	0
	7	81705	1757977	49.49	0	42884	>100	3.74	0.00	0
	8	81705	1757977	49.49	0	42884	>100	3.74	0.00	0
	9	81705	1757977	49.49	0	42884	>100	3.74	0.00	0
	10	61758	1757898	65.47	0	32415	>100	3.74	0.00	0
	11	61758	1757898	65.47	0	32415	>100	3.74	0.00	0
	(12+13)-I-1	62706	1674770	61.43	377	32912	95.97	3.59	0.00	0
	(12+13)-I-2	62705	1674709	61.43	378	32912	95.76	3.59	0.00	0
	(12+13)-I-3	62704	1678139	61.56	378	32911	95.76	3.59	0.00	0
	(12+13)-I-4	62703	1678189	61.56	377	32911	95.97	3.59	0.00	0
	(12+13)-II-1	62705	1675373	61.45	463	32912	78.15	3.59	0.00	0
	(12+13)-II-2	62704	1675423	61.45	464	32911	78.03	3.59	0.00	0
	(12+13)-II-3	62705	1678839	61.58	464	32911	78.03	3.59	0.00	0
	(12+13)-II-4	62704	1678777	61.58	463	32911	78.14	3.59	0.00	0
	(12+13)-III-1	62706	1674770	61.43	377	32912	95.97	3.59	0.00	0
	(12+13)-III-2	62705	1674709	61.43	378	32912	95.76	3.59	0.00	0
	(12+13)-III-3	62704	1678139	61.56	378	32911	95.76	3.59	0.00	0
	(12+13)-III-4	62703	1678189	61.56	377	32911	95.97	3.59	0.00	0
	(12+13)-IV-1	62705	1675373	61.45	463	32912	78.15	3.59	0.00	0
	(12+13)-IV-2	62704	1675423	61.45	464	32911	78.03	3.59	0.00	0
	(12+13)-IV-3	62705	1678839	61.58	464	32911	78.03	3.59	0.00	0
	(12+13)-IV-4	62704	1678777	61.58	463	32911	78.14	3.59	0.00	0
	(12+13)-V-1	62706	1674770	61.43	377	32912	95.97	3.59	0.00	0
	(12+13)-V-2	62705	1674709	61.43	378	32912	95.76	3.59	0.00	0
	(12+13)-V-3	62704	1678139	61.56	378	32911	95.76	3.59	0.00	0
	(12+13)-V-4	62703	1678189	61.56	377	32911	95.97	3.59	0.00	0
	(12+13)-VI-1	62705	1675373	61.45	463	32912	78.15	3.59	0.00	0
	(12+13)-VI-2	62704	1675423	61.45	464	32911	78.03	3.59	0.00	0
	(12+13)-VI-3	62705	1678839	61.58	464	32911	78.03	3.59	0.00	0
	(12+13)-VI-4	62704	1678777	61.58	463	32911	78.14	3.59	0.00	0
	(12+13)-VII-1	62706	1674770	61.43	377	32912	95.97	3.59	0.00	0
	(12+13)-VII-2	62705	1674709	61.43	378	32912	95.76	3.59	0.00	0
	(12+13)-VII-3	62704	1678139	61.56	378	32911	95.76	3.59	0.00	0
	(12+13)-VII-4	62703	1678189	61.56	377	32911	95.97	3.59	0.00	0
	(12+13)-VIII-1	62705	1675373	61.45	463	32912	78.15	3.59	0.00	0
	(12+13)-VIII-2	62704	1675423	61.45	464	32911	78.03	3.59	0.00	0
	(12+13)-VIII-3	62705	1678839	61.58	464	32911	78.03	3.59	0.00	0
	(12+13)-VIII-4	62704	1678777	61.58	463	32911	78.14	3.59	0.00	0
	Minimi coeff. sic.									
0	3			43.80						
0	(12+13)-IV-2						78.03			

Wmax=0, Wmin=0

Verifica a scorrimento globale delle fondazione

AUTOSTRADA VALDASTICO A31 NORD
1° LOTTO - PIOVENE ROCCHETTE – VALLE DELL'ASTICO

Comb. = Combinazione di verifica

N[kg] = Sforzo normale

Hd[kg] = Azione orizzontale depurata dalle azioni assorbite da pali e plinti su pali

R[kg] = Resistenza allo scorrimento $R=Area \cdot c + N \cdot \tan(\phi)$

CS = R/Hd

CSd = Coefficiente di sicurezza di progetto

Area delle strutture di fondazione a contatto con il terreno **A=47.0400 m²**

Comb.	N	Hd	R	CS.	CSd	ver
	kg	kg	kg			
2	12427	0	7175	--	1.10	Si
3	12427	0	7175	--	1.10	Si
4	12427	0	7175	--	1.10	Si
5	12427	0	7175	--	1.10	Si
6	12427	0	7175	--	1.10	Si
7	12427	0	7175	--	1.10	Si
8	12427	0	7175	--	1.10	Si
9	12427	0	7175	--	1.10	Si
10	9559	0	5519	--	1.10	Si
11	9559	0	5519	--	1.10	Si
(12+13)-I-1	9559	377	5519	14.63	1.10	Si
(12+13)-I-2	9559	378	5519	14.60	1.10	Si
(12+13)-I-3	9559	378	5519	14.60	1.10	Si
(12+13)-I-4	9559	377	5519	14.63	1.10	Si
(12+13)-II-1	9559	463	5519	11.91	1.10	Si
(12+13)-II-2	9559	464	5519	11.90	1.10	Si
(12+13)-II-3	9559	464	5519	11.90	1.10	Si
(12+13)-II-4	9559	463	5519	11.91	1.10	Si
(12+13)-III-1	9559	377	5519	14.63	1.10	Si
(12+13)-III-2	9559	378	5519	14.60	1.10	Si
(12+13)-III-3	9559	378	5519	14.60	1.10	Si
(12+13)-III-4	9559	377	5519	14.63	1.10	Si
(12+13)-IV-1	9559	463	5519	11.91	1.10	Si
(12+13)-IV-2	9559	464	5519	11.90	1.10	Si
(12+13)-IV-3	9559	464	5519	11.90	1.10	Si
(12+13)-IV-4	9559	463	5519	11.91	1.10	Si
(12+13)-V-1	9559	377	5519	14.63	1.10	Si
(12+13)-V-2	9559	378	5519	14.60	1.10	Si
(12+13)-V-3	9559	378	5519	14.60	1.10	Si
(12+13)-V-4	9559	377	5519	14.63	1.10	Si
(12+13)-VI-1	9559	463	5519	11.91	1.10	Si
(12+13)-VI-2	9559	464	5519	11.90	1.10	Si
(12+13)-VI-3	9559	464	5519	11.90	1.10	Si
(12+13)-VI-4	9559	463	5519	11.91	1.10	Si
(12+13)-VII-1	9559	377	5519	14.63	1.10	Si
(12+13)-VII-2	9559	378	5519	14.60	1.10	Si
(12+13)-VII-3	9559	378	5519	14.60	1.10	Si
(12+13)-VII-4	9559	377	5519	14.63	1.10	Si
(12+13)-VIII-1	9559	463	5519	11.91	1.10	Si
(12+13)-VIII-2	9559	464	5519	11.90	1.10	Si
(12+13)-VIII-3	9559	464	5519	11.90	1.10	Si
(12+13)-VIII-4	9559	463	5519	11.91	1.10	Si

24.11 VERIFICA DELLA SEZIONE

DATI DI INPUT

© Dott. Ing. Simone Caffè - 25/02/2013 (macro Excel sviluppata dall'Ing. Marco Panzano)

Tipo di acciaio utilizzato S 275

Coefficiente parziale di sicurezza per le verifiche di resistenza	γ_{M0}	1,05 [-]
Coefficiente parziale di sicurezza per le verifiche di stabilità	γ_{M1}	1,05 [-]
Coefficiente parziale di sicurezza per le verifiche di rottura	γ_{M2}	1,25 [-]

Caratteristiche del profilo

Sezione trasversale del tubolare Ø193,7/10

Diametro esterno del profilo tubolare (UTENTE)	d_{ext}	1000,00 [mm]
Spessore del profilo tubolare (UTENTE)	t	50,00 [mm]
Diametro esterno del profilo tubolare utilizzato nelle verifiche		193,7 [mm]
Spessore del profilo tubolare utilizzato nelle verifiche		10 [mm]

Geometria della membratura

Lunghezza geometrica della membratura	L	2,50 [m]
Coefficiente di lunghezza di libera inflessione attorno all'asse y - y	β_y	1,00 [-]
Coefficiente di lunghezza di libera inflessione attorno all'asse z - z	β_z	1,00 [-]
Lunghezza di libera inflessione attorno all'asse y - y	$L_{cr,y}$	2500,00 [mm]
Lunghezza di libera inflessione attorno all'asse z - z	$L_{cr,z}$	2500,00 [mm]

Coefficienti di momento equivalente

Nota: l'utente deve inserire i valori C_{my} , C_{mz} con riferimento al prospetto B.3 - EN 1993 - 1 - 1: 2010, tenendo presente che utilizzando $C_{my} = C_{mz} = 1,00$ la verifica sarà sempre "cautelativa".

Coefficienti di momento equivalente

Coefficiente di momento equivalente per flessione attorno all'asse y - y C_{my}		1,000 [-]
Coefficiente di momento equivalente per flessione attorno all'asse z - z C_{mz}		1,000 [-]

Caratteristiche di sollecitazione

Nota: la forza assiale è POSITIVA se di compressione

Calcola

Svuota

Comb.	N_{Ed}	$V_{z,Ed}$	$V_{y,Ed}$	$M_{y,Ed}$	$M_{z,Ed}$	T_{Ed}	Verifica
[n°]	[kN]	[kN]	[kN]	[kNm]	[kNm]	[kNm]	[-]
1	145,00			44,00	10,00		✔ 0,71

RESISTENZA E STABILITA' DEI PROFILI TUBOLARI - Metodo B - EN 1993 - 1 - 1:2010		
Materiali utilizzati	© Dott. Ing. Simone Caffè - 25/02/2013	
Valore di snervamento dell'acciaio del profilo	f_{yk}	275 [N/mm ²]
Valore di rottura dell'acciaio del profilo	f_{uk}	430 [N/mm ²]
Modulo di elasticità dell'acciaio del profilo	E	210000 [N/mm ²]
Modulo di elasticità tangenziale dell'acciaio del profilo	G	80769 [N/mm ²]
Coefficiente parziale di sicurezza per le verifiche di resistenza	γ_{M0}	1,05 [-]
Coefficiente parziale di sicurezza per le verifiche di stabilità	γ_{M1}	1,05 [-]
Coefficiente parziale di sicurezza per le verifiche di rottura	γ_{M2}	1,25 [-]
Caratteristiche meccaniche del profilo		
Diametro esterno del profilo tubolare	d_{ext}	193,70 [mm]
Spessore del profilo tubolare	t	10,00 [mm]
Diametro interno	d_{int}	173,70 [mm]
Raggio esterno	r_{ext}	96,85 [mm]
Raggio interno	r_{int}	86,85 [mm]
Area della sezione trasversale	A	5771 [mm ²]
Momento d'inerzia della sezione trasversale attorno all'asse forte	I_y	2,4416E+07 [mm ⁴]
Modulo di resistenza elastico attorno all'asse forte	$W_{el,y}$	2,5210E+05 [mm ³]
Modulo di resistenza plastico attorno all'asse forte	$W_{pl,y}$	3,3779E+05 [mm ³]
Area resistente a taglio nel piano dell'anima	$A_{v,z}$	3674 [mm ²]
Raggio d'inerzia attorno all'asse forte	i_y	65,04 [mm]
Momento d'inerzia della sezione trasversale attorno all'asse debole	I_z	2,4416E+07 [mm ⁴]
Modulo di resistenza elastico attorno all'asse debole	$W_{el,z}$	2,5210E+05 [mm ³]
Modulo di resistenza plastico attorno all'asse debole	$W_{pl,z}$	3,3779E+05 [mm ³]
Area resistente a taglio nel piano delle ali	$A_{v,y}$	3674 [mm ²]
Raggio d'inerzia attorno all'asse debole	i_z	65,04 [mm]
Momento d'inerzia torsionale	I_t	4,883E+07 [mm ⁴]
Caratteristiche di sollecitazione nella sezione di verifica		
Forza normale (positiva se di compressione)	N_{Ed}	145,00 [kN]
Forza di taglio agente in direzione parallela all'anima	$V_{z,Ed}$	[kN]
Forza di taglio agente in direzione parallela alle ali	$V_{y,Ed}$	[kN]
Momento flettente attorno all'asse maggiore di inerzia	$M_{y,Ed}$	44,00 [kNm]
Momento flettente attorno all'asse minore di inerzia	$M_{z,Ed}$	10,00 [kNm]
Momento torcente primario (alla Saint Venant)	T_{Ed}	[kNm]

Classificazione della sezione trasversale di verifica		
Coefficiente ϵ	ϵ	0,924 [-]
Rapporto tra diametro esterno e spessore	ρ	19,370 [-]
Rapporto limite per la classe 1	ρ_1	42,727 [-]
Rapporto limite per la classe 2	ρ_2	59,818 [-]
Rapporto limite per la classe 3	ρ_3	76,909 [-]
Classificazione della sezione trasversale	CL	1

Verifiche di resistenza della sezione trasversale		
Resistenza a trazione pura		
Resistenza plastica a trazione	$N_{t,Rd}$	1511,48 [kN]
Verifica a trazione pura	ρ_{Nt}	0,000 [-]
Resistenza a compressione pura		
Resistenza a compressione pura	$N_{c,Rd}$	1511,48 [kN]
Verifica a compressione pura	ρ_{Nc}	0,096 [-]
Resistenza a torsione e taglio		
Diametro medio della sezione trasversale	d_{med}	183,70 [mm]
Area della sezione compresa nel diametro medio	Ω	26503,80 [mm ²]
Tensioni tangenziali dovute al momento torcente	$\tau_{t,Ed}$	0,00 [N/mm ²]
Verifica tensionale per pura torsione	ρ_T	0,000 [-]
Resistenza plastica a taglio	$V_{pl,Rd}$	555,55 [kN]
Resistenza plastica a taglio ridotta per effetto della torsione	$V_{pl,T,Rd}$	555,55 [kN]
Verifica a taglio in direzione z - z	ρ_{Vz}	0,000 [-]
Verifica a taglio in direzione y - y	ρ_{Vy}	0,000 [-]
Resistenza a flessione		
Modulo di resistenza di calcolo per flessione attorno all'asse y - y	W_y	3,38E+05 [mm ³]
Resistenza a flessione attorno all'asse y - y	$M_{cy,Rd}$	88,47 [kNm]
Verifica flessionale attorno all'asse y - y	ρ_{My}	0,497 [-]
Modulo di resistenza di calcolo per flessione attorno all'asse z - z	W_z	3,38E+05 [mm ³]
Resistenza a flessione attorno all'asse z - z	$M_{cz,Rd}$	88,47 [kNm]
Verifica flessionale attorno all'asse z - z	ρ_{Mz}	0,113 [-]
Resistenza a flessione e taglio (per sezioni in classe 1 o 2)		
Fattore di riduzione per la presenza della forza di taglio in direzione z - z	$\rho_{Vz,red}$	1,00 [-]
Fattore di riduzione per la presenza della forza di taglio in direzione y - y	$\rho_{Vy,red}$	1,00 [-]
Resistenza a flessione ridotta, per flessione attorno all'asse y - y	$M_{Vy,Rd}$	88,47 [kNm]
Verifica flessionale attorno all'asse y - y	$\rho_{My - Vz}$	0,497 [-]
Resistenza a flessione ridotta, per flessione attorno all'asse z - z	$M_{Vz,Rd}$	88,47 [kNm]
Verifica flessionale attorno all'asse z - z	$\rho_{Mz - Vy}$	0,113 [-]

Resistenza a flessione, forza assiale e taglio

Calcolo plastico per sezioni in classe 1 o 2

Coefficiente n	n	0,096 [-]
Resistenza a flessione ridotta, per flessione attorno all'asse y - y	$M_{Ny,Rd}$	86,82 [kNm]
Resistenza a flessione ridotta, per flessione attorno all'asse z - z	$M_{Nz,Rd}$	86,82 [kNm]
Verifica di presso/tenso flessione biassiale (metodo EN1993 - 1 - 1:2010)	$\rho_{N - My - Mz - pl}$	0,270 [-]
Verifica di presso/tenso flessione biassiale (metodo cautelativo)	$\rho_{N - My - Mz - pl}$	0,706 [-]

Calcolo elastico per sezioni in classe 3

Momento globale agente nella sezione	$M_{tot,Ed}$	45,12 [kNm]
Taglio globale agente nella sezione	$V_{tot,Ed}$	0,00 [kN]
Tensione normale massima	$\sigma_{x,Ed,fs}$	204,11 [N/mm ²]
Verifica relativa alle sole tensioni normali	ρ_{el}	ver. plastica [-]
Tensione tangenziale dovuta al taglio	$\tau_{V,Ed}$	0,00 [N/mm ²]
Tensione tangenziale dovuta al momento torcente	$\tau_{t,Ed}$	0,00 [N/mm ²]
Verifica relativa alle tensioni totali	$\rho_{el - tot}$	ver. plastica [-]

Verifiche di stabilità flessionale

Lunghezza geometrica della membratura	L	2,50 [m]
Coefficiente di lunghezza di libera inflessione attorno all'asse y - y	β_y	1,00 [-]
Coefficiente di lunghezza di libera inflessione attorno all'asse z - z	β_z	1,00 [-]
Lunghezza di libera inflessione attorno all'asse y - y	$L_{cr,y}$	2500,00 [mm]
Lunghezza di libera inflessione attorno all'asse z - z	$L_{cr,z}$	2500,00 [mm]

Resistenza nei confronti dell'instabilità flessionale

Area della sezione trasversale da considerare nel calcolo	A	5771 [mm ²]
Forza normale critica euleriana attorno all'asse y - y	$N_{cr,y}$	8097 [kN]
Forza normale critica euleriana attorno all'asse z - z	$N_{cr,z}$	8097 [kN]
Snellezza adimensionale attorno all'asse y - y	$\lambda_{ad,y}$	0,4427 [-]
Snellezza adimensionale attorno all'asse z - z	$\lambda_{ad,z}$	0,4427 [-]
Rapporto dimensionale per la determinazione delle curve di instabilità	h/b	19,37 [-]
Spessore massimo della sezione trasversale	t_{max}	173,7 [mm]
Curva di instabilità attorno all'asse y - y	Curva _{y - y}	a [-]
Curva di instabilità attorno all'asse z - z	Curva _{z - z}	a [-]
Coefficiente di imperfezione attorno all'asse y - y	α_y	0,21 [-]
Coefficiente di instabilità attorno all'asse y - y	ϕ_y	0,6235 [-]
Coefficiente di imperfezione attorno all'asse z - z	α_z	0,21 [-]
Coefficiente di instabilità attorno all'asse z - z	ϕ_z	0,6235 [-]
Coefficiente di riduzione di resistenza attorno all'asse y - y	χ_y	0,941 [-]
Coefficiente di riduzione di resistenza attorno all'asse z - z	χ_z	0,941 [-]
Resistenza all'instabilità flessionale attorno all'asse y - y	$N_{by,Rd}$	1422,56 [kN]
Resistenza all'instabilità flessionale attorno all'asse z - z	$N_{bz,Rd}$	1422,56 [kN]
Verifica nei confronti dell'instabilità flessionale	$\rho_{buck, N}$	0,102 [-]

Verifiche di stabilità nel caso di presso - flessione biassiale - ANNEX B, EN 1993 - 1 - 1:2010

Nota: l'utente deve inserire i valori C_{my} , C_{mz} con riferimento al prospetto B.3 - EN 1993 - 1 - 1: 2010, tenendo presente che utilizzando $C_{my} = C_{mz} = 1.00$ la verifica sarà sempre "cautelativa".

Coefficienti di momento equivalente

Coefficiente di momento equivalente per flessione attorno all'asse y - y	C_{my}	1,000 [-]
Coefficiente di momento equivalente per flessione attorno all'asse z - z	C_{mz}	1,000 [-]

Coefficienti di interazione

Coefficiente di interazione k_{yy} per sezioni in classe 1 o 2	$k_{yy,1-2}$	1,025 [-]
Coefficiente di interazione k_{yy} per sezioni in classe 3	$k_{yy,3}$	1,027 [-]
	k_{yy}	1,025 [-]
Coefficiente di interazione k_{zz} per sezioni in classe 1 o 2	$k_{zz,1-2}$	1,025 [-]
Coefficiente di interazione k_{zz} per sezioni in classe 3	$k_{zz,3}$	1,027 [-]
	k_{zz}	1,025 [-]
Coefficiente di interazione k_{yz} per sezioni in classe 1 o 2	$k_{yz,1-2}$	0,615 [-]
Coefficiente di interazione k_{yz} per sezioni in classe 3	$k_{yz,3}$	1,025 [-]
	k_{yz}	0,615 [-]
Coefficiente di interazione k_{zy} per sezioni in classe 1 o 2	$k_{zy,1-2}$	0,615 [-]
Coefficiente di interazione k_{zy} per sezioni in classe 3	$k_{zy,3}$	0,820 [-]
	k_{zy}	0,615 [-]

Verifiche di presso flessione biassiale

Verifica di presso flessione biassiale per sezioni di classe 1 o 2	$\rho_{buck, N - M - M}$	0,681 [-]
	$\rho_{buck, N - M - M}$	0,524 [-]
Verifica di presso flessione biassiale per sezioni di classe 3	$\rho_{buck, N - M - M}$	ver. plastica [-]
	$\rho_{buck, N - M - M}$	ver. plastica [-]
Tasso di lavoro massimo del profilo tubolare (resistenza e stabilità)	ρ_{max}	0,706 [-]

RESISTENZA E STABILITA' DELLE MEMBRATURE - Metodo B - EN 1993 - 1 - 1:2010

Materiali utilizzati

© Dott. Ing. Simone Caffè - 14/02/2013

		S 275
Valore di snervamento dell'acciaio del profilo	f_{yk}	275 [N/mm ²]
Valore di rottura dell'acciaio del profilo	f_{uk}	430 [N/mm ²]
Modulo di elasticità dell'acciaio del profilo	E	210000 [N/mm ²]
Modulo di elasticità tangenziale dell'acciaio del profilo	G	80769 [N/mm ²]
Coefficiente parziale di sicurezza per le verifiche di resistenza	γ_{M0}	1,05 [-]
Coefficiente parziale di sicurezza per le verifiche di stabilità	γ_{M1}	1,05 [-]
Coefficiente parziale di sicurezza per le verifiche di rottura	γ_{M2}	1,25 [-]

Caratteristiche meccaniche del profilo

		IPE 180
Altezza della sezione trasversale	h	180 [mm]
Larghezza della sezione trasversale	b_f	91 [mm]
Spessore dell'anima	t_w	5,3 [mm]
Spessore dell'ala	t_f	8 [mm]
Raggio di raccordo	r	9 [mm]
Area della sezione trasversale	A	2390 [mm ²]
Altezza della sezione trasversale al netto delle ali	h_w	164 [mm]
Altezza del pannello d'anima	c_w	146 [mm]
Diametro massimo consentito dei bulloni d'ala	$d_{bf,max}$	10 [mm]
Passo minimo trasversale tra i bulloni d'ala	$p_{b,min}$	48 [mm]
Passo massimo trasversale tra i bulloni d'ala	$p_{b,max}$	48 [mm]
Momento d'inerzia della sezione trasversale attorno all'asse forte	I_y	1,317E+07 [mm ⁴]
Modulo di resistenza elastico attorno all'asse forte	$W_{el,y}$	1,463E+05 [mm ³]
Modulo di resistenza plastico attorno all'asse forte	$W_{pl,y}$	1,664E+05 [mm ³]
Area resistente a taglio nel piano dell'anima	$A_{v,z}$	1125 [mm ²]
Raggio d'inerzia attorno all'asse forte	i_y	74,2 [mm]
Momento d'inerzia della sezione trasversale attorno all'asse debole	I_z	1,009E+06 [mm ⁴]
Modulo di resistenza elastico attorno all'asse debole	$W_{el,z}$	2,216E+04 [mm ³]
Modulo di resistenza plastico attorno all'asse debole	$W_{pl,z}$	3,460E+04 [mm ³]
Area resistente a taglio nel piano delle ali	$A_{v,y}$	1521 [mm ²]
Raggio d'inerzia attorno all'asse debole	i_z	20,5 [mm]
Momento d'inerzia torsionale	I_t	4,790E+04 [mm ⁴]
Costante di Warping	I_w	7,430E+09 [mm ⁶]

Caratteristiche di sollecitazione nella sezione di verifica

Forza normale (positiva se di compressione)	N_{Ed}	67,00 [kN]
Forza di taglio agente in direzione parallela all'anima	$V_{z,Ed}$	0,00 [kN]
Forza di taglio agente in direzione parallela alle ali	$V_{y,Ed}$	0,00 [kN]
Momento flettente attorno all'asse maggiore di inerzia	$M_{y,Ed}$	35,00 [kNm]
Momento flettente attorno all'asse minore di inerzia	$M_{z,Ed}$	2,00 [kNm]
Momento torcente primario (alla Saint Venant)	T_{Ed}	0,00 [kNm]

Classificazione della sezione trasversale di verifica

Determinazione dello stato tensionale dovuto a $N - M_y - M_z$

Distribuzione delle tensioni normali nei punti salienti della sezione trasversale

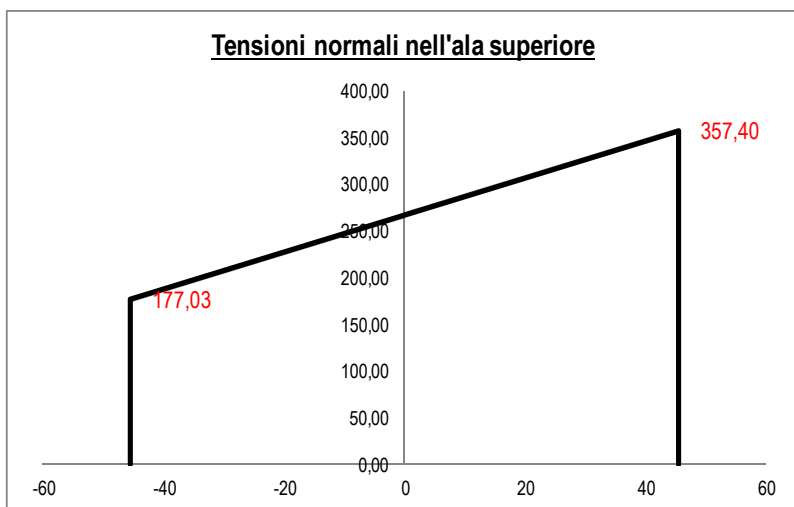

Tensioni elastiche per CL < 4

σ_A	357,40 [N/mm ²]
σ_B	267,21 [N/mm ²]
σ_C	177,03 [N/mm ²]
σ_D	336,14 [N/mm ²]
σ_E	155,76 [N/mm ²]

Tensioni efficaci per CL = 4

$\sigma_{A,eff}$	357,40 [N/mm ²]
$\sigma_{B,eff}$	267,21 [N/mm ²]
$\sigma_{C,eff}$	177,03 [N/mm ²]
$\sigma_{D,eff}$	336,14 [N/mm ²]
$\sigma_{E,eff}$	155,76 [N/mm ²]

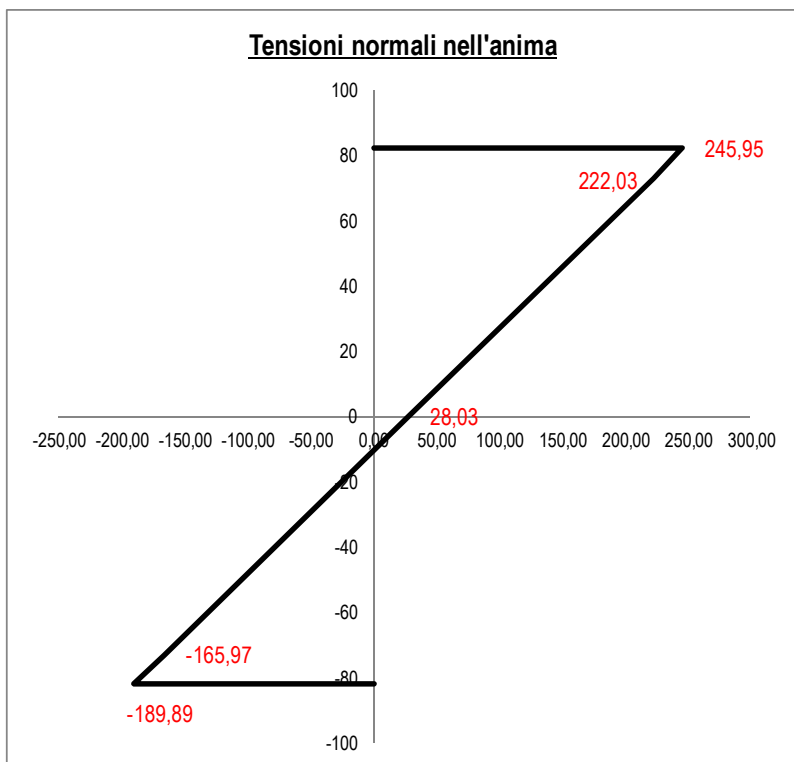

Tensioni elastiche per CL < 4

σ_F	245,95 [N/mm ²]
σ'_F	222,03 [N/mm ²]
σ_G	28,03 [N/mm ²]
σ'_H	-165,97 [N/mm ²]
σ_H	-189,89 [N/mm ²]

Tensioni efficaci per CL = 4

$\sigma_{F,eff}$	245,95 [N/mm ²]
$\sigma'_{F,eff}$	222,03 [N/mm ²]
$\sigma_{G,eff}$	28,03 [N/mm ²]
$\sigma'_{H,eff}$	-165,97 [N/mm ²]
$\sigma_{H,eff}$	-189,89 [N/mm ²]

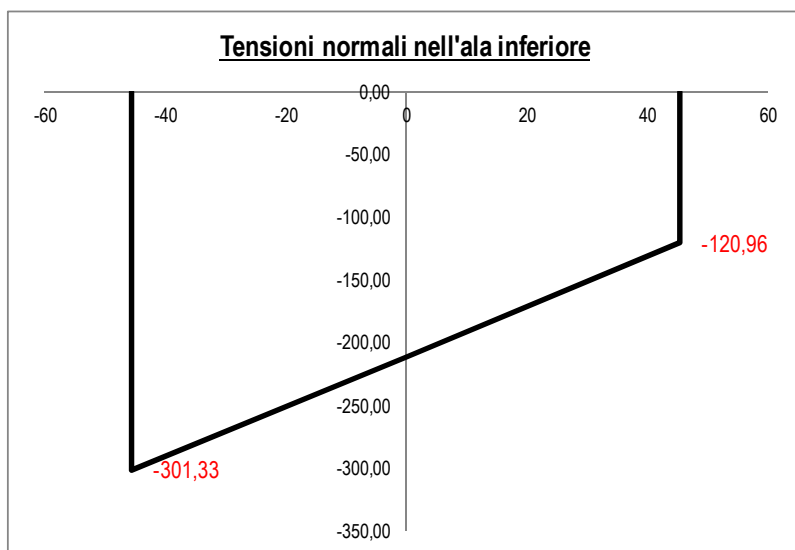

Tensioni elastiche per CL < 4

σ_I	-99,70	[N/mm ²]
σ_L	-280,07	[N/mm ²]
σ_M	-120,96	[N/mm ²]
σ_N	-211,15	[N/mm ²]
σ_O	-301,33	[N/mm ²]

Tensioni efficaci per CL = 4

$\sigma_{I,eff}$	-99,70	[N/mm ²]
$\sigma_{L,eff}$	-280,07	[N/mm ²]
$\sigma_{M,eff}$	-120,96	[N/mm ²]
$\sigma_{N,eff}$	-211,15	[N/mm ²]
$\sigma_{O,eff}$	-301,33	[N/mm ²]

Classificazione della sezione nel caso di pura compressione

Coefficiente dipendente dal tipo di acciaio	ϵ	0,924 [-]
Rapporto tra la dimensione del pannello d'anima ed il suo spessore	ρ_{web}	27,55 [-]
Larghezza del pannello d'ala	c_f	33,85 [mm]
Spessore del pannello d'ala	t_f	8,00 [mm]
Rapporto tra la dimensione del pannello d'ala ed il suo spessore	ρ_{flange}	4,23 [-]
Classificazione del pannello d'anima	$CL_{N,web}$	1
Classificazione del pannello d'ala	$CL_{N,flange}$	1
Classificazione della sezione per compressione pura	CL_N	1

Classificazione della sezione nel caso di pura flessione

Classificazione del pannello d'anima	$CL_{My,web}$	1
Classificazione del pannello d'ala	$CL_{My,flange}$	1
Classificazione della sezione per pura flessione attorno a y - y	CL_{My}	1
Classificazione della sezione per pura flessione attorno a z - z	CL_{Mz}	1

Classificazione del pannello d'anima nel caso di presso/tenso flessione

Nota: il presente metodo di classificazione si basa sull'effettiva distribuzione delle tensioni normali all'interno della sezione trasversale dovuta alla presenza contemporanea di forza assiale e momento flettente, secondo la EN1993 - 1 - 5:2006

Coefficiente dipendente dal tipo di acciaio	ϵ	0,924 [-]
Altezza del pannello d'anima	c_w	146,00 [mm]
Spessore del pannello d'anima	t_w	5,30 [mm]
Tensione normale al lembo superiore del pannello d'anima	$\sigma_{web,1}$	222,03 [N/mm ²]
Tensione normale al lembo inferiore del pannello d'anima	$\sigma_{web,2}$	-165,97 [N/mm ²]
Rapporto tra le tensioni presenti nel pannello d'anima	ψ_{web}	-0,747 [-]
Rapporto tra la dimensione del pannello d'anima ed il suo spessore	ρ_{web}	27,55 [-]
Limite del rapporto che divide la classe 3 dalla classe 4	$\rho_{web_34_A}$	91,71 [-]
	$\rho_{web_34_B}$	0,00 [-]
	ρ_{web_34}	91,71 [-]

AUTOSTRADA VALDASTICO A31 NORD
1° LOTTO - PIOVENE ROCCHETTE – VALLE DELL'ASTICO

Classificazione dell'anima soggetta a presso/tenso flessione	$CL_{NM,web}$	< 4
Dimensioni efficaci del pannello d'anima		
Fattore di imbozzamento del pannello d'anima	k_{G,web_A}	0,00 [-]
	k_{G,web_B}	0,00 [-]
	k_{G,web_C}	0,00 [-]
	k_{G,web_D}	17,98 [-]
	k_{G,web_E}	0,00 [-]
	k_{G,web_F}	0,00 [-]
	$k_{G,web}$	17,98 [-]
Snellezza adimensionale del pannello d'anima	$\lambda_{p,web}$	0,247 [-]
Snellezza adimensionale limite del pannello d'anima	$\lambda_{p,web,lim}$	0,855 [-]
Fattore di riduzione di altezza del pannello d'anima	$\rho_{p,web}$	1,000 [-]
Altezza efficace del pannello d'anima	$c_{w,eff}$	146,00 [mm]
Dimensioni efficaci del pannello d'anima	c_{w1}	58,40 [mm]
	c_{w2}	87,60 [mm]
Porzione dell'anima non efficace	s_w	0,00 [mm]
Baricentro della porzione non efficace	z_{sw}	75,40 [mm]
Caratteristiche meccaniche efficaci della sezione trasversale		
Area efficace della sezione trasversale	A_{eff}	2390,00 [mm ²]
Eccentricità tra il baricentro della sez. integra e quello della sez. efficace	e_{Nz}	0,000 [mm]
Momento d'inerzia attorno all'asse maggiore della sez. efficace	$I_{eff,y}$	1,317E+07 [mm ⁴]
Momento d'inerzia attorno all'asse minore della sez. efficace	$I_{eff,z}$	1,009E+06 [mm ⁴]
Moduli di resistenza efficaci attorno all'asse maggiore	$W_{eff,y,1}$	1,463E+05 [mm ³]
	$W_{eff,y,2}$	1,463E+05 [mm ³]
	$W_{eff,y,min}$	1,463E+05 [mm ³]
Modulo di resistenza efficace attorno all'asse minore	$W_{eff,z}$	2,218E+04 [mm ³]
Costruzione del dominio di transizione di classe		
<u>Punto 1:</u>		
Forza assiale	N_1	0,00 [kN]
Momento flettente attorno all'asse maggiore	M_{y1}	45,76 [kNm]
Angolo	θ_1	1,571 [rad]
<u>Punto 2:</u>		
Profondità adimensionale dell'asse neutro	α_2	1,099 [-]
Forza assiale	N_2	254,99 [kN]
Momento flettente attorno all'asse maggiore	M_2	34,61 [kNm]
Angolo	θ_2	0,135 [rad]
<u>Punto 3:</u>		
Profondità adimensionale dell'asse neutro	α_3	1,254 [-]
Forza assiale	N_3	320,90 [kN]
Momento flettente attorno all'asse maggiore	M_3	28,10 [kNm]
Angolo	θ_3	0,087 [rad]
<u>Punto 4:</u>		
Profondità adimensionale dell'asse neutro	ψ_4	2,241 [-]
Forza assiale	N_4	1064,96 [kN]
Momento flettente attorno all'asse maggiore	M_4	-24,96 [kNm]
Angolo	θ_4	0,000 [rad]
<u>Punto 5:</u>		
Snellezza adimensionale del pannello d'anima per compressione pura	λ_5	0,525 [-]
Snellezza limite del pannello d'anima per compressione pura	$\lambda_{5,lim}$	0,673 [-]
Fattore di riduzione di altezza del pannello d'anima	ρ_5	1,000 [-]
Area efficace della sezione nel caso di pura compressione	A_5	2390,00 [mm ²]
Forza assiale	N_5	657,25 [kN]
Momento flettente attorno all'asse maggiore	M_5	0,00 [kNm]
Angolo	θ_5	0,000 [rad]

AUTOSTRADA VALDASTICO A31 NORD
1° LOTTO - PIOVENE ROCCHETTE – VALLE DELL'ASTICO

Classificazione della sezione trasversale nel caso di presso/tenso flessione biassiale		
<i>Nota: nel caso di presenza di forza assiale di compressione e momento flettente attorno all'asse minore si adotta, in favore di sicurezza, la classificazione della sezione per pura compressione.</i>		
Forza assiale di progetto	N_{Ed}	67,00 [kN]
Momento flettente di progetto attorno all'asse maggiore	$M_{y,Ed}$	35,00 [kNm]
Momento flettente di progetto attorno all'asse minore	$M_{z,Ed}$	2,00 [kNm]
Angolo	θ_{Ed}	0,481 [rad]
Classificazione nel caso di assenza di forza normale	$CL_{N=0}$	1
Classificazione nel caso di tenso flessione biassiale	$CL_{N<0}$	1
Classificazione nel caso di presso flessione biassiale	$CL_{N>0}$	1
Classificazione della sezione trasversale	CL	1

Verifiche di resistenza della sezione trasversale

Resistenza a trazione pura

Resistenza plastica a trazione $N_{t,Rd}$ 625,95 [kN]

Verifica a trazione pura ρ_{Nt} **0,000 [-]**

Resistenza a compressione pura

Resistenza a compressione pura $N_{c,Rd}$ 625,95 [kN]

Verifica a compressione pura ρ_{Nc} **0,107 [-]**

Resistenza a taglio

Tensioni tangenziali nell'ala dovute al momento torcente $\tau_{tf,Ed}$ 0,00 [N/mm²]

Tensioni tangenziali nell'anima dovute al momento torcente $\tau_{tw,Ed}$ 0,00 [N/mm²]

Verifica tensionale per pura torsione ρ_T **0,000 [-]**

Area resistente a taglio in direzione parallela all'anima $A_{vz,eff}$ 1125,00 [mm²]

Resistenza plastica a taglio in direzione parallela all'anima $V_{pl,z,Rd}$ 170,11 [kN]

Area resistente a taglio in direzione parallela alle ali $A_{vy,eff}$ 1456,00 [mm²]

Resistenza plastica a taglio in direzione parallela alle ali $V_{pl,y,Rd}$ 220,16 [kN]

Resistenza plastica a taglio in direzione parallela all'anima, ridotta per T_{Ed} $V_{pl,T,z,Rd}$ 170,11 [kN]

Resistenza plastica a taglio in direzione parallela alle ali, ridotta per T_{Ed} $V_{pl,T,y,Rd}$ 220,16 [kN]

Verifica a taglio - torsione in direzione parallela all'anima ρ_{Vz} **0,000 [-]**

Verifica a taglio - torsione in direzione parallela alle ali ρ_{Vy} **0,000 [-]**

Resistenza a flessione

Modulo di resistenza di calcolo attorno all'asse maggiore W_y 1,66E+05 [mm³]

Resistenza a flessione attorno all'asse maggiore $M_{cy,Rd}$ 43,58 [kNm]

Verifica flessionale attorno all'asse maggiore ρ_{My} **0,803 [-]**

Modulo di resistenza di calcolo attorno all'asse minore W_z 3,46E+04 [mm³]

Resistenza a flessione attorno all'asse minore $M_{cz,Rd}$ 9,06 [kNm]

Verifica flessionale attorno all'asse minore ρ_{Mz} **0,221 [-]**

Resistenza a flessione e taglio (per sezioni di classe 1 o 2)

Fattore di riduzione per la presenza della forza di taglio parallela all'anima $\rho_{Vz,red}$ 0,00 [-]

Fattore di riduzione per la presenza della forza di taglio parallela alle ali $\rho_{Vy,red}$ 0,00 [-]

Resistenza a flessione ridotta, attorno all'asse maggiore $M_{Vy,Rd}$ 43,58 [kNm]

Verifica flessionale attorno all'asse maggiore $\rho_{My - Vz}$ **0,803 [-]**

Resistenza a flessione ridotta, attorno all'asse minore $M_{Vz,Rd}$ 9,06 [kNm]

Verifica flessionale attorno all'asse minore $\rho_{Mz - Vy}$ **0,221 [-]**

Resistenza a flessione, forza assiale e taglio

Calcolo plastico per sezioni in classe 1 o 2

Parametri limite che valutano l'intensità della forza assiale $N_{lim,1}$ 156,49 [kN]

$N_{lim,2}$ 113,82 [kN]

$N_{lim,3}$ 227,65 [kN]

n 0,107 [-]

a 0,391 [-]

Resistenza a flessione attorno all'asse maggiore ridotta per effetto di N_{Ed} $M_{Ny,Rd}$ 43,58 [kNm]

Verifica flessionale attorno all'asse maggiore $\rho_{N - My - pl}$ **0,803 [-]**

Resistenza a flessione attorno all'asse minore ridotta per effetto di N_{Ed} $M_{Nz,Rd}$ 9,06 [kNm]

Verifica flessionale attorno all'asse minore $\rho_{N - Mz - pl}$ **0,221 [-]**

Verifica di presso/tenso flessione biassiale (metodo normale) $\rho_{N - My - Mz - pl}$ **0,866 [-]**

AUTOSTRADA VALDASTICO A31 NORD
1° LOTTO - PIOVENE ROCCHETTE – VALLE DELL'ASTICO

Verifiche di stabilità flessionale, torsionale e flesso - torsionale		
Lunghezza geometrica della membratura	L	2,50 [m]
Coefficiente di lunghezza di libera inflessione attorno all'asse maggiore	β_y	1,00 [-]
Coefficiente di lunghezza di libera inflessione attorno all'asse minore	β_z	0,33 [-]
Lunghezza di libera inflessione attorno all'asse maggiore	$L_{cr,y}$	2500,00 [mm]
Lunghezza di libera inflessione attorno all'asse minore	$L_{cr,z}$	833,33 [mm]

Resistenza nei confronti dell'instabilità flessionale

Area della sezione trasversale da considerare nel calcolo	A o A_{eff}	2390 [mm ²]
Forza normale critica euleriana attorno all'asse maggiore	$N_{cr,y}$	4367 [kN]
Forza normale critica euleriana attorno all'asse minore	$N_{cr,z}$	3011 [kN]
Snellezza adimensionale attorno all'asse maggiore	$\lambda_{ad,y}$	0,3879 [-]
Snellezza adimensionale attorno all'asse minore	$\lambda_{ad,z}$	0,4672 [-]
Rapporto dimensionale per la determinazione delle curve di instabilità	h/b	1,98 [-]
Spessore massimo della sezione trasversale	t_{max}	8 [mm]
Curva di instabilità attorno all'asse maggiore	Curva $y-y$	a [-]
Curva di instabilità attorno all'asse minore	Curva $z-z$	b [-]
Coefficiente di imperfezione attorno all'asse maggiore	α_y	0,21 [-]
Coefficiente di instabilità attorno all'asse maggiore	ϕ_y	0,5950 [-]
Coefficiente di imperfezione attorno all'asse minore	α_z	0,34 [-]
Coefficiente di instabilità attorno all'asse minore	ϕ_z	0,6545 [-]
Coefficiente di riduzione di resistenza attorno all'asse maggiore	χ_y	0,9559 [-]
Coefficiente di riduzione di resistenza attorno all'asse minore	χ_z	0,8985 [-]
Resistenza all'instabilità flessionale attorno all'asse maggiore	$N_{by,Rd}$	598,37 [kN]
Resistenza all'instabilità flessionale attorno all'asse minore	$N_{bz,Rd}$	562,40 [kN]
Verifica nei confronti dell'instabilità flessionale	$\rho_{buck,N}$	<input checked="" type="checkbox"/> 0,119 [-]

Resistenza nei confronti dell'instabilità torsionale

Forza normale critica per instabilità torsionale	$N_{cr,T}$	4395 [kN]
Snellezza adimensionale per instabilità torsionale	$\lambda_{ad,T}$	0,3867 [-]
Coefficiente di imperfezione attorno all'asse minore	α_T	0,34 [-]
Coefficiente di instabilità	ϕ_T	0,6065 [-]
Coefficiente di riduzione di resistenza	χ_T	0,9313 [-]
Resistenza all'instabilità torsionale	$N_{bT,Rd}$	582,96 [kN]
Verifica nei confronti dell'instabilità torsionale	$\rho_{buck,T}$	<input checked="" type="checkbox"/> 0,115 [-]

Resistenza nei confronti dell'instabilità laterale o svergolamento o flesso - torsione

Nota: al fine di determinare in modo corretto il valore del momento critico elastico in funzione delle condizioni al contorno, delle condizioni di vincolo e degli effettivi ritegni laterali, si consiglia l'utilizzo del software LT - Beam.

Diversamente si potranno compilare le celle relative alle condizioni al contorno ed ottenere un valore di massima di M_{cr} .

Link per effettuare il download del software LT - Beam <http://www.cesdb.com/structural/ltbody.html>

Momento critico con LT - Beam

Valore del momento critico elastico ottenuto dal software LT - Beam	$M_{cr,LTbeam}$	2470,00 [kNm]
---	-----------------	---------------

Momento critico con calcolo tradizionale

Lunghezza critica per instabilità laterale (distanza tra i ritegni laterali)	$L_{cr,LT}$	3,30 [m]
Distanza tra il baricentro della sezione ed il punto di applicazione del carico	z_g	300,00 [mm]

AUTOSTRADA VALDASTICO A31 NORD
1° LOTTO - PIOVENE ROCCHETTE – VALLE DELL'ASTICO

Nota: $z_g > 0$ se il carico è posizionato al di sopra del centro di taglio, $z_g = 0$ se il carico è posizionato nel centro di taglio, $z_g < 0$ se il carico è posizionato al di sotto del centro di taglio.

Coefficiente di vincolo relativo alla capacità di rotazione attorno a z - z	k_z	1,00 [-]
Coefficiente di vincolo relativo alla capacità di ingobbamento	k_w	1,00 [-]

Selezionare la tipologia di condizione al contorno, mutuamente esclusiva:

- Membratura soggetta unicamente a momenti di estremità selezionare per momenti di estremità
 Membratura soggetta unicamente a carichi trasversali selezionare per carichi trasversali

Membratura (o parte di essa) soggetta unicamente a momenti di estremità

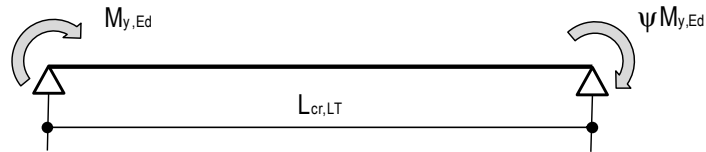

Momento di estremità avente valore maggiore	$M_{y,Ed}$	35,00 [kNm]
Rapporto tra i momenti di estremità	ψ	0,50
Momento di estremità avente valore minore	$\psi M_{y,Ed}$	17,50 [kNm]
Coefficiente C_1	C_1	1,310 [-]

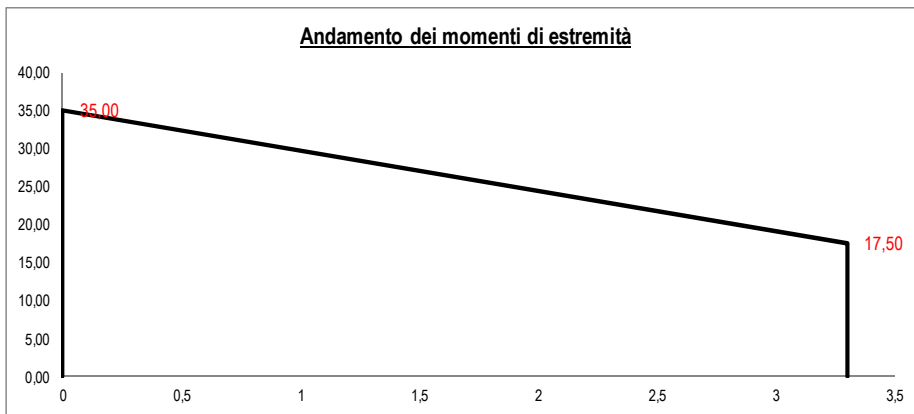

Membratura soggetta unicamente a carichi trasversali

Nota: i valori dei coefficienti C_1 e C_2 di seguito forniti, valgono unicamente nel caso in cui $k_z = 1$

Selezionare la tipologia di carico e di condizione di vincolo	Doppio appoggio - carico distribuito	
Coefficiente C_1	C_1	0,000 [-]
Coefficiente C_2	C_2	0,000 [-]
Momento critico elastico valutato secondo i metodi tradizionali	$M_{cr,trad.}$	41,73 [kNm]

Verifica di stabilità

Momento critico elastico utilizzato nella verifica di stabilità	M_{cr}	2470,00 [kNm]
Snellezza adimensionale per instabilità laterale	$\lambda_{ad,LT}$	0,1361 [-]
Parametri limite per sezioni laminate	$\lambda_{LT,0}$	0,40 [-]
	β_{LT}	0,75 [-]
Curva di instabilità per fenomeni di flessione - torsione	Curva $_{LT}$	b [-]
Coefficiente di imperfezione per fenomeni di flessione - torsione	α_{LT}	0,34 [-]
Coefficiente di instabilità per fenomeni di flessione - torsione	ϕ_{LT}	0,4621 [-]
Coefficienti di correzione, funzione del diagramma del momento	k_c	0,858 [-]
	f_{mod}	0,992 [-]
Coefficiente di riduzione per fenomeni di flessione - torsione	χ_{LT}	1,0000 [-]
Coefficiente di riduzione modificato	$\chi_{LT,mod}$	1,0000 [-]
Modulo di resistenza da utilizzare nelle verifiche di flessione - torsione	W_y	1,664E+05 [mm ³]
Resistenza all'instabilità flessione - torsionale	$M_{by,Rd}$	43,58 [kN]
Verifica nei confronti dell'instabilità flessione - torsionale	$\rho_{buck, M}$	0,803 [-]

Verifiche di stabilità nel caso di presso - flessione biassiale - ANNEX B, EN 1993 - 1 - 1:2010

Nota: l'utente deve inserire i valori C_{my} , C_{mz} , C_{mLT} con riferimento al prospetto B.3 - EN 1993 - 1 - 1: 2010, tenendo presente che utilizzando $C_{my} = C_{mz} = C_{mLT} = 1.00$ la verifica sarà sempre "cautelativa".

Coefficienti di momento equivalente

Coefficiente di momento equivalente per flessione attorno all'asse y - y	C_{my}	0,800 [-]
Coefficiente di momento equivalente per flessione attorno all'asse z - z	C_{mz}	0,714 [-]
Coefficiente di momento equivalente per instabilità flesso - torsionale	C_{mLT}	0,900 [-]

Coefficienti di interazione

Coefficiente di interazione k_{yy} per sezioni in classe 1 o 2	$k_{yy,1-2}$	0,817 [-]
Coefficiente di interazione k_{yy} per sezioni in classe 3 o 4	$k_{yy,3-4}$	0,821 [-]
	k_{yy}	0,817 [-]
Coefficiente di interazione k_{zz} per sezioni in classe 1 o 2	$k_{zz,1-2}$	0,742 [-]
Coefficiente di interazione k_{zz} per sezioni in classe 3 o 4	$k_{zz,3-4}$	0,738 [-]
	k_{zz}	0,742 [-]
Coefficiente di interazione k_{yz} per sezioni in classe 1 o 2	$k_{yz,1-2}$	0,445 [-]
Coefficiente di interazione k_{yz} per sezioni in classe 3 o 4	$k_{yz,3-4}$	0,742 [-]
	k_{yz}	0,445 [-]
Coefficiente di interazione k_{zy} per sezioni in classe 1 o 2	$k_{zy,1-2}$	0,991 [-]
Coefficiente di interazione k_{zy} per sezioni in classe 3 o 4	$k_{zy,3-4}$	0,996 [-]
	k_{zy}	0,991 [-]

I risultati conseguiti hanno ordine di grandezza compatibile con quanto ottenuto dalle verifiche condotte con l'ausilio di codici di calcolo automatici.