





ASSE VIARIO MARCHE – UMBRIA E QUADRILATERO DI PENETRAZIONE INTERNA MAXI LOTTO 2

LAVORI DI COMPLETAMENTO DELLA DIRETTRICE PERUGIA ANCONA:
SS. 318 DI “VALFABBRICA”. TRATTO PIANELLO – VALFABBRICA
SS. 76 “VAL D’ESINO”. TRATTI FOSSATO VICO – CANCELLI E ALBACINA – SERRA SAN QUIRICO
“PEDEMONTANA DELLE MARCHE”, TRATTO FABRIANO – MUCCIA – SFERCIA

PROGETTO ESECUTIVO

CONTRAENTE GENERALE: 	Il responsabile del Contraente Generale: Ing. Federico Montanari	Il responsabile Integrazioni delle Prestazioni Specialistiche: Ing. Salvatore Lieto
--	---	--

PROGETTAZIONE: Associazione Temporanea di Imprese Mandataria:			
			

RESPONSABILE DELLA PROGETTAZIONE PER L'ATI Ing. Antonio Grimaldi GEOLOGO Dott. Geol. Fabrizio Pontoni COORDINATORE DELLA SICUREZZA IN FASE DI PROGETTAZIONE Ing. Michele Curiale			
--	---	--	---

IL RESPONSABILE DEL PROCEDIMENTO Ing. Giulio Petrizzelli		
--	--	--

2.1.2 PEDEMONTANA DELLE MARCHE Secondo stralcio funzionale: Matelica Nord – Matelica Sud/Castelraimondo Nord EDIFICI E MANUFATTI TECNOLOGICI Relazione di calcolo cabina elettrica MT	SCALA: DATA: Agosto 2016
--	--

Codice Unico di Progetto (CUP) F12C03000050021 (Assegnato CIPE 23-12-2015)

Codice Elaborato:	Opera	Tratto	Settore	CEE	WBS	Id. doc.	N. prog.	Rev.
	L 0 7 0 3	2 1 2	E	1 6	I M 0 0 0 0	R E L	0 1	A

REV.	DATA	DESCRIZIONE	Redatto	Controllato	Approvato
A	Ago.2016	Emissione esecutiva	PROGIN	A.Falace	S.Lieto

I N D I C E

1. INTRODUZIONE.....	3
2. NORMATIVA DI RIFERIMENTO.....	4
3. CARATTERISTICHE DEI MATERIALI IMPIEGATI	5
4. SCHEMATIZZAZIONE DELLE STRUTTURE E DEI VINCOLI	6
4.1 MODELLAZIONE DELLE AZIONI.....	7
4.2 TIPO DI ANALISI.....	8
5. ANALISI E VERIFICHE PARETI E FONDAZIONE	8
5.1 DATI ANALISI SISMICA.....	8
5.2 VERIFICA SPOSTAMENTI SISMICI.....	9
5.3 PRESSIONI SUL TERRENO	9
5.4 INVILUPPO ARMATURE TEORICHE GUSCI DELLA PLATEA	10
5.5 INVILUPPO ARMATURE TEORICHE GUSCI DEL PANNELLO TIPO.....	17
6. ANALISI E VERIFICHE SOLAIO DI COPERTURA	19
6.1 ANALISI DEI CARICHI.....	19
6.2 COMBINAZIONI DELLE AZIONI	20
6.3 SOLLECITAZIONI DI CALCOLO	22
6.4 VERIFICHE IN FASE DI TIRO	24
6.4.1 SEZIONE DI APPOGGIO	24
6.4.2 SEZIONE DI MEZZERIA	25
6.5 VERIFICHE IN FASE FINALE	26
6.5.1 SEZIONE DI MEZZERIA	26
6.5.2 SEZIONE DI APPOGGIO	28
7. ORIGINE E CARATTERISTICHE DEI CODICI DI CALCOLO	29

Opera L073	Tratto 212	Settore E	CEE 16	WBS IM0000	Id. doc. REL	N. prog. 01	Rev. A	Pag. di Pag. 3 di 3
---------------	---------------	--------------	-----------	---------------	-----------------	----------------	-----------	------------------------

1. INTRODUZIONE

Nella presente relazione si riportano le analisi di dimensionamento delle cabine elettriche di alimentazione degli impianti elettromeccanici delle gallerie Croce di Calle e Mistranello. Gli edifici sono ubicati nei piazzali previsti in prossimità degli imbocchi delle gallerie. Le opere in oggetto rientrano nei lavori del Secondo stralcio funzionale Matelica Nord- Matelica sud/ Castelraimondo Nord della Pedemontana delle Marche,

Gli edifici in oggetto sono costituiti da strutture monopiano di forma regolare; per la parte fuori terra sono completamente prefabbricate, mentre la fondazione è realizzata con getto in opera.

Le fondazioni sono del tipo dirette e sono costituite da platee in c.a. su cui vengono impostati i pannelli prefabbricati perimetrali dello spessore di 16 cm, nei quali sono ricavate o meno porte e finestre.

I solai di copertura sono costituiti da lastre prefabbricate, alleggerite con polistirolo. I pannelli perimetrali sul lato lungo sono collegati ai solai di copertura mediante barre metalliche.

All'insieme dei pannelli perimetrali è affidato l'assorbimento delle azioni orizzontali (vento e/o sisma) e di quelle verticali indotte dal solaio di copertura.

Opera L073	Tratto 212	Settore E	CEE 16	WBS IM0000	Id. doc. REL	N. prog. 01	Rev. A	Pag. di Pag. 4 di 4
---------------	---------------	--------------	-----------	---------------	-----------------	----------------	-----------	------------------------

2. NORMATIVA DI RIFERIMENTO

D.M. 14/01/2008.

Norme tecniche per le costruzioni.

Circolare del 02/02/2009.

Istruzioni per l'applicazione delle "Norme tecniche per le costruzioni" di cui al D.M. del 14/01/2008.

UNI EN 206-1-2001: Calcestruzzo. "Specificazione, prestazione, produzione e conformità".

UNI 11104-2004: Specificazione, prestazione, produzione e conformità: Istruzioni complementari per l'applicazione della EN 206-1

Opera L073	Tratto 212	Settore E	CEE 16	WBS IM0000	Id. doc. REL	N. prog. 01	Rev. A	Pag. di Pag. 5 di 5
---------------	---------------	--------------	-----------	---------------	-----------------	----------------	-----------	------------------------

3. CARATTERISTICHE DEI MATERIALI IMPIEGATI

CALCESTRUZZO:Rck scassero ≥ 30 N/mm²R'ck a 28 gg ≥ 50 N/mm²**CALCESTRUZZO GETTO INTEGRATIVO:**Rck a 28 gg ≥ 25 N/mm²**ACCIAIO FeB44k controllato:**fyk ≥ 430 N/mm²ftk ≥ 540 N/mm² A5>12%**ACCIAIO [GANCI] FeB32k controllato:**fyk ≥ 315 N/mm²ftk ≥ 490 N/mm² A5>23%**TREFOLO C.A.P.**f_{ptk} > 1860 N/mm²f_{p(1)k} > 1770 N/mm²**RETE ELETTROSALDATA:**fyk ≥ 390 N/mm²ftk ≥ 440 N/mm² A10>8%

Opera L073	Tratto 212	Settore E	CEE 16	WBS M0000	Id. doc. REL	N. prog. 01	Rev. A	Pag. di Pag. 6 di 6
---------------	---------------	--------------	-----------	--------------	-----------------	----------------	-----------	------------------------

4. SCHEMATIZZAZIONE DELLE STRUTTURE E DEI VINCOLI

Le strutture sono modellate con il metodo degli elementi finiti, applicato a sistemi tridimensionali. Gli elementi utilizzati sono bidimensionali (piastre e membrane triangolari e quadrangolari). I vincoli sono considerati puntuali ed inseriti tramite le sei costanti di rigidezza elastica.

Per considerare la presenza del terreno si è utilizzato il vincolo esterno “blocco orizzontale” che non permette gli spostamenti lungo l’asse X e l’asse Y, lasciando libere le rotazioni e lo spostamento lungo l’asse Z.



Figura 1. – Modello tridimensionale cabina elettrica

4.1 MODELLAZIONE DELLE AZIONI

In accordo con le sopraccitate normative, sono state considerate nei calcoli le seguenti azioni:

- pesi propri strutturali
- carichi permanenti portati dalla struttura
- carichi variabili sui solai, neve.
- forze di piano simulanti il sisma, ricavate tramite analisi dinamica

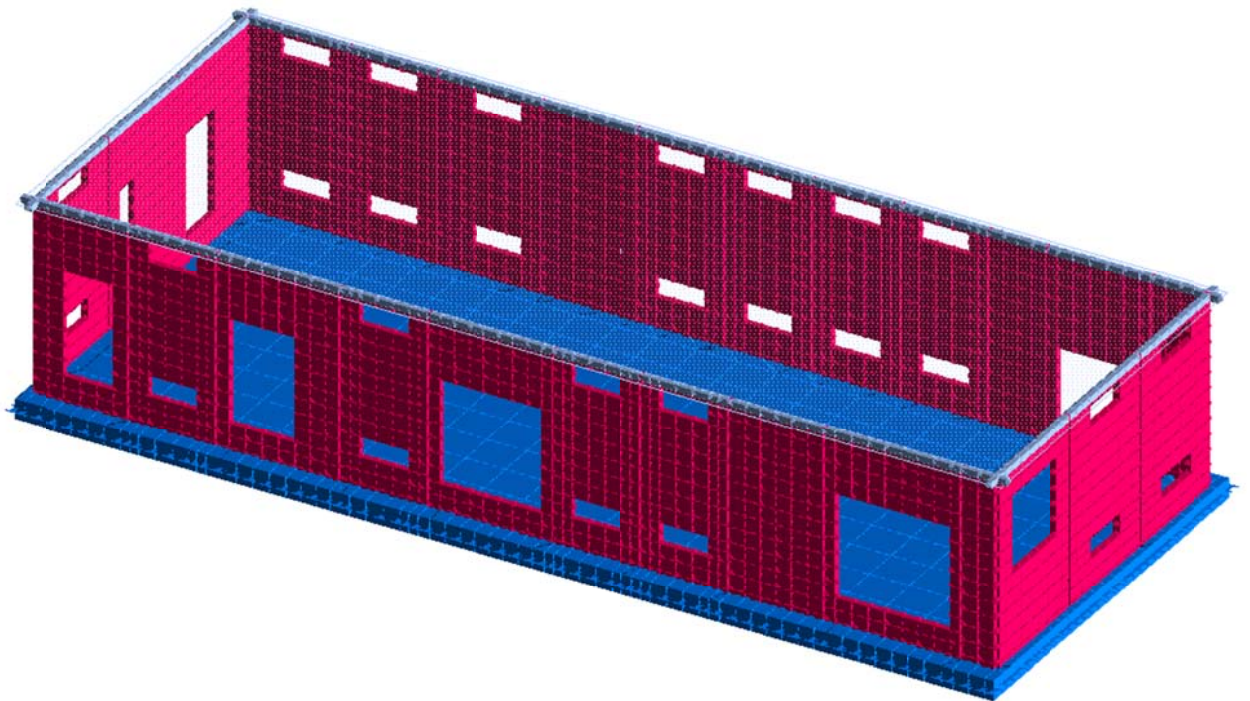
Sono stati adottati i seguenti valori di carico:

- peso proprio solette (H=5+18+5 cm): 400 Kg/m²
- getto integrativo (5 cm): 125 Kg/m²
- carico permanente: 50 Kg/m²
- neve: 250 Kg/m²

Le azioni sono state modellate tramite opportuni carichi concentrati e distribuiti su nodi ed aste.

Per quanto riguarda i coefficienti da utilizzare per il passaggio dalle masse alle forze di piano, essi sono stati assunti pari a:

Accelerazione orizzontale massima su suolo $a_g = 0.275 \cdot g$

Categoria di suolo di fondazione C

Fattore di struttura $q = 3.08$

Classe di duttilità B

Fattori di partecipazione per il calcolo delle masse:

Condizione di carico permanente 1

Condizione di carico variabile (Neve) allo SLU $\varphi \cdot \psi_{2i} = 1.0 \times 0.2 = 0.2$

Condizione di carico variabile (Neve) allo SLD $\varphi \cdot \psi_{0i} = 1.0 \times 0.7 = 0.7$

I materiali costituenti la struttura sono considerati elastici e con comportamento lineare. Le loro caratteristiche sono specificate nella stampa dei dati di input.

5.2 VERIFICA SPOSTAMENTI SISMICI

Spostamento limite interpiano = 0.5% dell'altezza

CASO n. 8 - SISMA X

Zi nf [cm]	Zsup [cm]	h [cm]	spost. max [cm]	%h	nodo	sest.	ver.
0.00	490.00	490.00	0.057972	0.012	3469	5	SI

CASO n. 9 - SISMA Y

Zi nf [cm]	Zsup [cm]	h [cm]	spost. max [cm]	%h	nodo	sest.	ver.
0.00	490.00	490.00	0.112954	0.023	3469	1	SI

5.3 PRESSIONI SUL TERRENO



Figura 2. – Pressioni [Kg/cm²]

Opera L073	Tratto 212	Settore E	CEE 16	WBS IM0000	Id.doc. REL	N. prog. 01	Rev. A	Pag. di Pag. 10 di 10
---------------	---------------	--------------	-----------	---------------	----------------	----------------	-----------	--------------------------

5.4 INVILUPPO ARMATURE TEORICHE GUSCI DELLA PLATEA

unità di misura:

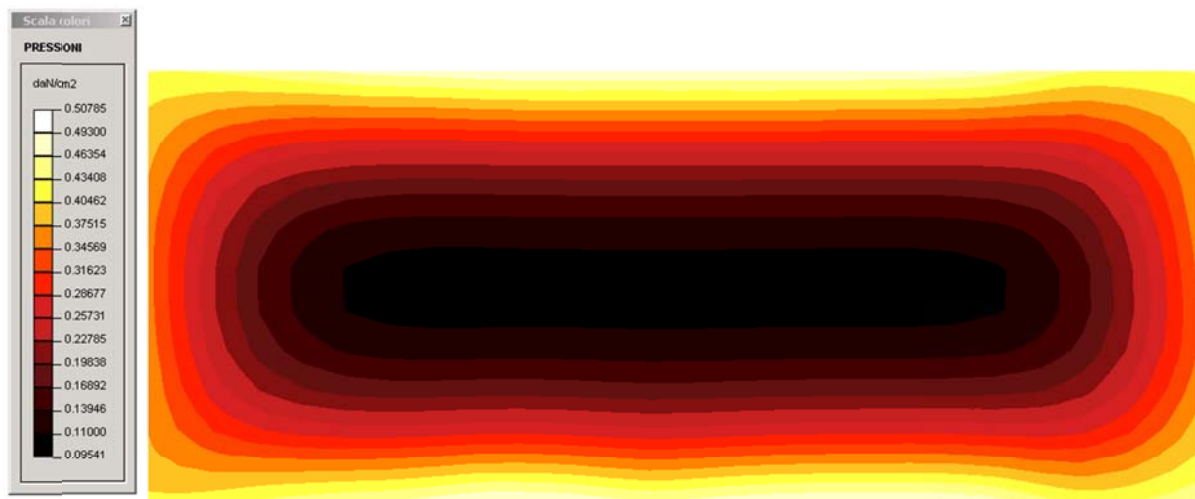
lunghezze : [cm] - forze : [daN]
 momenti : [daNcm/cm] - tensioni : [daN/cm²]
 pesi specifici : [daN/cm³] - angoli : [gradi]
 armature : [cm²]

CASI DI CARICO:

Nome Descrizione
 4 VERT SLU
 8 SI SMA X
 9 SI SMA Y

DATI:

tensione di calcolo acciai (fyd): 3826.09 daN/cm²
 tensione di calcolo cls (fcd): 129.69 daN/cm²
 copri ferro inferiore (asse armatura): 4 cm
 copri ferro superiore (asse armatura): 4 cm
 moltiplicatore sollecitazioni : 1

GUSCI	AREE ARMATURA (cm ² al metro)									tauX	tauY	tauT			
	INF. ORIZZ.			INF. VERTIC.			SUP. ORIZZ.						SUP. VERTIC.		
	area	EpsC	EpsF	area	EpsC	EpsF	area	EpsC	EpsF	area	EpsC	EpsF			
1	4.56	0.04	10.00	4.55	0.04	10.00	4.56	0.07	10.00	4.55	0.08	10.00	1.8	1.7	2.1
2	4.56	0.04	10.00	4.55	0.04	10.00	4.56	0.07	10.00	4.55	0.07	10.00	0.4	1.1	0.8
3	4.56	0.03	10.00	4.55	0.05	10.00	4.56	0.08	10.00	4.55	0.07	10.00	0.9	0.1	0.8
4	4.56	0.04	10.00	4.55	0.06	10.00	4.56	0.08	10.00	4.55	0.07	10.00	0.6	0.3	0.6
5	4.56	0.04	10.00	4.55	0.07	10.00	4.56	0.08	10.00	4.55	0.06	10.00	0.7	0.2	0.6
6	4.56	0.05	10.00	4.55	0.07	10.00	4.56	0.07	10.00	4.55	0.05	10.00	0.4	0.5	0.5
7	4.56	0.09	10.00	4.55	0.07	10.00	4.56	0.08	10.00	4.55	0.05	10.00	3.2	0.4	1.6
8	4.56	0.08	10.00	4.55	0.07	10.00	4.56	0.07	10.00	4.55	0.04	10.00	0.9	0.5	0.8
9	4.56	0.07	10.00	4.55	0.07	10.00	4.56	0.06	10.00	4.55	0.04	10.00	0.8	0.3	0.8
10	4.56	0.06	10.00	4.55	0.07	10.00	4.56	0.06	10.00	4.55	0.03	10.00	0.5	0.5	0.6
11	4.56	0.04	10.00	4.55	0.06	10.00	4.56	0.04	10.00	4.55	0.03	10.00	0.6	0.3	0.6
12	4.56	0.03	10.00	4.55	0.05	10.00	4.56	0.03	10.00	4.55	0.03	10.00	0.3	0.4	0.4
13	4.56	0.04	10.00	4.55	0.04	10.00	4.56	0.04	10.00	4.55	0.02	10.00	0.1	0.5	0.4
14	4.56	0.04	10.00	4.55	0.04	10.00	4.56	0.04	10.00	4.55	0.02	10.00	0.3	0.7	0.7
15	4.56	0.02	10.00	4.55	0.04	10.00	4.56	0.03	10.00	4.55	0.02	10.00	1.6	1.9	1.4
16	4.56	0.01	10.00	4.55	0.03	10.00	4.56	0.03	10.00	4.55	0.02	10.00	0.3	0.4	0.5
17	4.56	0.01	10.00	4.55	0.03	10.00	4.56	0.03	10.00	4.55	0.02	10.00	0.3	0.2	0.3
18	4.56	0.01	10.00	4.55	0.03	10.00	4.56	0.04	10.00	4.55	0.02	10.00	0.2	0.2	0.2
19	4.56	0.02	10.00	4.55	0.03	10.00	4.56	0.04	10.00	4.55	0.01	10.00	0.2	0.2	0.2
20	4.56	0.02	10.00	4.55	0.03	10.00	4.56	0.02	10.00	4.55	0.01	10.00	0.4	0.4	0.5
21	4.56	0.03	10.00	4.55	0.03	10.00	4.56	0.00	0.00	4.55	0.01	10.00	0.2	0.4	0.4
22	4.56	0.03	10.00	4.55	0.02	10.00	4.56	0.00	0.00	4.55	0.01	10.00	0.2	0.6	0.5
23	4.56	0.04	10.00	4.55	0.02	10.00	4.56	0.00	0.00	4.55	0.00	10.00	3.5	1.2	2.0
24	4.56	0.03	10.00	4.55	0.02	10.00	4.56	0.00	10.00	4.55	0.00	10.00	0.9	0.7	0.7
25	4.56	0.02	10.00	4.55	0.02	10.00	4.56	0.01	10.00	4.55	0.00	10.00	0.3	0.2	0.3
26	4.56	0.03	10.00	4.55	0.03	10.00	4.56	0.02	10.00	4.55	0.00	10.00	0.4	0.3	0.4
27	4.56	0.05	10.00	4.55	0.03	10.00	4.56	0.03	10.00	4.55	0.00	10.00	0.5	0.6	0.6
28	4.56	0.07	10.00	4.55	0.03	10.00	4.56	0.05	10.00	4.55	0.01	10.00	1.1	0.9	1.1
29	4.56	0.08	10.00	4.55	0.03	10.00	4.56	0.05	10.00	4.55	0.01	10.00	0.2	1.1	1.0
30	4.56	0.07	10.00	4.55	0.03	10.00	4.56	0.05	10.00	4.55	0.01	10.00	2.2	1.4	1.7
31	4.56	0.06	10.00	4.55	0.03	10.00	4.56	0.04	10.00	4.55	0.01	10.00	0.6	0.4	0.5
32	4.56	0.01	10.00	4.55	0.02	10.00	4.56	0.04	10.00	4.55	0.01	10.00	0.2	0.1	0.2
33	4.56	0.00	10.00	4.55	0.01	10.00	4.56	0.05	10.00	4.55	0.01	10.00	0.1	0.1	0.1
34	4.56	0.00	0.00	4.55	0.01	10.00	4.56	0.06	10.00	4.55	0.01	10.00	0.1	0.1	0.1
35	4.56	0.00	10.00	4.55	0.01	10.00	4.56	0.05	10.00	4.55	0.01	10.00	0.3	0.1	0.2
36	4.56	0.01	10.00	4.55	0.01	10.00	4.56	0.04	10.00	4.55	0.01	10.00	0.2	0.3	0.3
37	4.56	0.04	10.00	4.55	0.02	10.00	4.56	0.05	10.00	4.55	0.01	10.00	0.3	0.2	0.2
38	4.56	0.07	10.00	4.55	0.03	10.00	4.56	0.05	10.00	4.55	0.01	10.00	2.3	0.6	1.3
39	4.56	0.08	10.00	4.55	0.03	10.00	4.56	0.06	10.00	4.55	0.01	10.00	0.7	0.4	0.5
40	4.56	0.07	10.00	4.55	0.03	10.00	4.56	0.05	10.00	4.55	0.01	10.00	0.1	0.4	0.4
41	4.56	0.04	10.00	4.55	0.02	10.00	4.56	0.04	10.00	4.55	0.00	10.00	0.4	0.4	0.4
42	4.56	0.02	10.00	4.55	0.02	10.00	4.56	0.03	10.00	4.55	0.00	10.00	0.2	0.2	0.2
43	4.56	0.01	10.00	4.55	0.02	10.00	4.56	0.01	10.00	4.55	0.00	10.00	0.3	0.4	0.4
44	4.56	0.02	10.00	4.55	0.01	10.00	4.56	0.00	10.00	4.55	0.00	10.00	0.4	0.3	0.4
45	4.56	0.02	10.00	4.55	0.01	10.00	4.56	0.01	10.00	4.55	0.00	10.00	1.8	1.8	1.4
46	4.56	0.02	10.00	4.55	0.01	10.00	4.56	0.01	10.00	4.55	0.00	10.00	0.6	0.2	0.5
47	4.56	0.02	10.00	4.55	0.01	10.00	4.56	0.03	10.00	4.55	0.00	10.00	0.2	0.2	0.2
48	4.56	0.01	10.00	4.55	0.01	10.00	4.56	0.02	10.00	4.55	0.00	10.00	0.1	0.2	0.2
49	4.56	0.00	10.00	4.55	0.01	10.00	4.56	0.02	10.00	4.55	0.00	10.00	0.1	0.3	0.3
50	4.56	0.01	10.00	4.55	0.02	10.00	4.56	0.02	10.00	4.55	0.00	10.00	0.1	0.3	0.2
51	4.56	0.02	10.00	4.55	0.02	10.00	4.56	0.01	10.00	4.55	0.00	10.00	0.7	0.4	0.5
52	4.56	0.01	10.00	4.55	0.02	10.00	4.56	0.00	10.00	4.55	0.00	10.00	1.8	0.9	1.1
53	4.56	0.02	10.00	4.55	0.02	10.00	4.56	0.01	10.00	4.55	0.00	10.00	0.3	0.3	0.3
54	4.56	0.02	10.00	4.55	0.03	10.00	4.56	0.01	10.00	4.55	0.01	10.00	0.2	0.2	0.3
55	4.56	0.02	10.00	4.55	0.04	10.00	4.56	0.01	10.00	4.55	0.01	10.00	0.5	0.5	0.6
56	4.56	0.05	10.00	4.55	0.04	10.00	4.56	0.03	10.00	4.55	0.01	10.00	0.5	0.5	0.5
57	4.56	0.09	10.00	4.55	0.05	10.00	4.56	0.05	10.00	4.55	0.02	10.00	0.9	0.6	1.0
58	4.56	0.12	10.00	4.55	0.05	10.00	4.56	0.08	10.00	4.55	0.03	10.00	1.3	1.4	1.4

2.1.2 PEDEMONTANA DELLE MARCHE

Secondo stralcio funzionale: Matelica Nord – Matelica Sud/Castelraimondo Nord

Opera L073	Tratto 212	Settore E	CEE 16	WBS IM0000	Id. doc. REL	N. prog. 01	Rev. A	Pag. di Pag. 11 di 11
---------------	---------------	--------------	-----------	---------------	-----------------	----------------	-----------	--------------------------

59	4.56	0.11	10.00	4.55	0.05	10.00	4.56	0.09	10.00	4.55	0.03	10.00	3.1	6.8	4.2
60	4.56	0.08	10.00	4.55	0.05	10.00	4.56	0.08	10.00	4.55	0.03	10.00	0.1	0.3	0.3
61	4.56	0.06	10.00	4.55	0.05	10.00	4.56	0.08	10.00	4.55	0.04	10.00	0.1	0.4	0.3
62	4.56	0.03	10.00	4.55	0.05	10.00	4.56	0.10	10.00	4.55	0.04	10.00	0.3	0.3	0.3
63	4.56	0.03	10.00	4.55	0.05	10.00	4.56	0.12	10.00	4.55	0.05	10.00	0.2	0.0	0.1
64	4.56	0.01	10.00	4.55	0.05	10.00	4.56	0.11	10.00	4.55	0.05	10.00	0.8	0.3	0.7
65	4.56	0.01	10.00	4.55	0.05	10.00	4.56	0.09	10.00	4.55	0.05	10.00	0.7	0.2	0.6
66	4.56	0.02	10.00	4.55	0.05	10.00	4.56	0.08	10.00	4.55	0.05	10.00	0.6	0.4	0.5
67	4.56	0.03	10.00	4.55	0.04	10.00	4.56	0.07	10.00	4.55	0.05	10.00	0.8	2.7	1.5
68	4.56	0.04	10.00	4.55	0.04	10.00	4.56	0.07	10.00	4.55	0.05	10.00	0.2	0.2	0.2
69	4.56	0.02	10.00	4.55	0.04	10.00	4.56	0.05	10.00	4.55	0.05	10.00	0.5	0.4	0.4
70	4.56	0.02	10.00	4.55	0.03	10.00	4.56	0.04	10.00	4.55	0.05	10.00	1.4	0.6	1.4
71	4.56	0.06	10.00	4.55	0.07	10.00	4.56	0.07	10.00	4.55	0.04	10.00	0.5	0.0	0.5
72	4.56	0.00	10.00	4.55	0.03	10.00	4.56	0.02	10.00	4.55	0.01	10.00	1.0	0.1	1.1
73	4.56	0.03	10.00	4.55	0.02	10.00	4.56	0.00	0.00	4.55	0.00	0.00	0.5	0.6	0.7
74	4.56	0.05	10.00	4.55	0.03	10.00	4.56	0.04	10.00	4.55	0.01	10.00	0.0	0.4	0.4
75	4.56	0.04	10.00	4.55	0.02	10.00	4.56	0.05	10.00	4.55	0.00	10.00	1.0	0.3	1.1
76	4.56	0.01	10.00	4.55	0.01	10.00	4.56	0.01	10.00	4.55	0.00	10.00	0.5	0.3	0.6
77	4.56	0.01	10.00	4.55	0.02	10.00	4.56	0.00	10.00	4.55	0.00	10.00	0.3	0.3	0.4
78	4.56	0.08	10.00	4.55	0.05	10.00	4.56	0.08	10.00	4.55	0.03	10.00	2.2	0.6	2.3
79	4.56	0.02	10.00	4.55	0.04	10.00	4.56	0.07	10.00	4.55	0.05	10.00	1.5	0.5	1.6
80	4.56	0.04	10.00	4.55	0.06	10.00	4.56	0.09	10.00	4.55	0.07	10.00	1.5	0.9	1.1
81	4.56	0.08	10.00	4.55	0.06	10.00	4.56	0.07	10.00	4.55	0.04	10.00	3.5	1.1	2.0
82	4.56	0.05	10.00	4.55	0.05	10.00	4.56	0.05	10.00	4.55	0.02	10.00	1.0	1.2	1.1
83	4.56	0.03	10.00	4.55	0.04	10.00	4.56	0.04	10.00	4.55	0.02	10.00	2.8	4.6	2.9
84	4.56	0.00	10.00	4.55	0.03	10.00	4.56	0.03	10.00	4.55	0.01	10.00	0.7	0.9	0.8
85	4.56	0.03	10.00	4.55	0.02	10.00	4.56	0.00	10.00	4.55	0.00	10.00	3.7	1.8	2.3
86	4.56	0.07	10.00	4.55	0.04	10.00	4.56	0.05	10.00	4.55	0.02	10.00	1.2	2.2	1.8
87	4.56	0.05	10.00	4.55	0.04	10.00	4.56	0.04	10.00	4.55	0.02	10.00	0.6	1.3	1.0
88	4.56	0.00	10.00	4.55	0.01	10.00	4.56	0.05	10.00	4.55	0.02	10.00	0.3	0.4	0.4
89	4.56	0.03	10.00	4.55	0.03	10.00	4.56	0.05	10.00	4.55	0.02	10.00	0.2	1.1	0.9
90	4.56	0.06	10.00	4.55	0.03	10.00	4.56	0.05	10.00	4.55	0.02	10.00	3.7	0.8	2.0
91	4.56	0.06	10.00	4.55	0.03	10.00	4.56	0.05	10.00	4.55	0.02	10.00	0.4	1.2	0.9
92	4.56	0.01	10.00	4.55	0.02	10.00	4.56	0.01	10.00	4.55	0.01	10.00	0.3	1.5	1.1
93	4.56	0.02	10.00	4.55	0.02	10.00	4.56	0.01	10.00	4.55	0.00	10.00	4.1	3.4	2.8
94	4.56	0.00	10.00	4.55	0.02	10.00	4.56	0.01	10.00	4.55	0.00	10.00	0.1	1.1	0.9
95	4.56	0.02	10.00	4.55	0.03	10.00	4.56	0.01	10.00	4.55	0.00	10.00	2.6	2.3	1.9
96	4.56	0.04	10.00	4.55	0.06	10.00	4.56	0.03	10.00	4.55	0.02	10.00	0.6	1.5	1.2
97	4.56	0.11	10.00	4.55	0.07	10.00	4.56	0.08	10.00	4.55	0.04	10.00	10.3	4.4	5.8
98	4.56	0.08	10.00	4.55	0.06	10.00	4.56	0.09	10.00	4.55	0.04	10.00	1.1	1.1	1.0
99	4.56	0.02	10.00	4.55	0.02	10.00	4.56	0.09	10.00	4.55	0.04	10.00	1.2	1.3	1.1
100	4.56	0.04	10.00	4.55	0.02	10.00	4.56	0.08	10.00	4.55	0.05	10.00	7.7	1.5	4.1
101	4.56	0.03	10.00	4.55	0.01	10.00	4.56	0.04	10.00	4.55	0.05	10.00	6.2	4.9	4.3
102	4.56	0.05	10.00	4.55	0.04	10.00	4.56	0.07	10.00	4.55	0.10	10.00	5.0	4.9	4.3
103	4.56	0.05	10.00	4.55	0.04	10.00	4.56	0.08	10.00	4.55	0.10	10.00	6.7	1.6	3.6
104	4.56	0.01	10.00	4.55	0.02	10.00	4.56	0.03	10.00	4.55	0.05	10.00	6.5	1.4	3.4
105	4.56	0.07	10.00	4.55	0.06	10.00	4.56	0.08	10.00	4.55	0.04	10.00	0.3	0.7	0.8
106	4.56	0.04	10.00	4.55	0.04	10.00	4.56	0.04	10.00	4.55	0.02	10.00	0.2	1.0	1.0
107	4.56	0.01	10.00	4.55	0.02	10.00	4.56	0.04	10.00	4.55	0.01	10.00	0.2	0.8	0.8
108	4.56	0.03	10.00	4.55	0.02	10.00	4.56	0.00	0.00	4.55	0.00	10.00	0.2	1.2	1.2
109	4.56	0.03	10.00	4.55	0.02	10.00	4.56	0.00	0.00	4.55	0.00	10.00	0.4	1.7	1.8
110	4.56	0.01	10.00	4.55	0.02	10.00	4.56	0.00	10.00	4.55	0.01	10.00	0.2	0.8	0.8
111	4.56	0.04	10.00	4.55	0.03	10.00	4.56	0.03	10.00	4.55	0.02	10.00	0.5	1.2	1.3
112	4.56	0.02	10.00	4.55	0.01	10.00	4.56	0.02	10.00	4.55	0.00	10.00	0.0	0.6	0.6
113	4.56	0.01	10.00	4.55	0.01	10.00	4.56	0.00	10.00	4.55	0.00	10.00	0.3	1.0	1.0
114	4.56	0.03	10.00	4.55	0.04	10.00	4.56	0.12	10.00	4.55	0.04	10.00	0.1	0.5	0.5
115	4.56	0.04	10.00	4.55	0.05	10.00	4.56	0.09	10.00	4.55	0.10	10.00	0.9	0.5	0.9
116	4.56	0.06	10.00	4.55	0.06	10.00	4.56	0.08	10.00	4.55	0.07	10.00	0.5	0.4	0.4
117	4.56	0.07	10.00	4.55	0.06	10.00	4.56	0.07	10.00	4.55	0.04	10.00	0.3	0.6	0.6
118	4.56	0.03	10.00	4.55	0.05	10.00	4.56	0.04	10.00	4.55	0.03	10.00	0.3	0.5	0.4
119	4.56	0.01	10.00	4.55	0.03	10.00	4.56	0.03	10.00	4.55	0.02	10.00	0.8	0.9	0.7
120	4.56	0.00	10.00	4.55	0.02	10.00	4.56	0.04	10.00	4.55	0.02	10.00	0.2	0.5	0.4
121	4.56	0.02	10.00	4.55	0.02	10.00	4.56	0.02	10.00	4.55	0.02	10.00	0.3	0.8	0.8
122	4.56	0.03	10.00	4.55	0.02	10.00	4.56	0.00	10.00	4.55	0.01	10.00	0.7	1.1	1.0
123	4.56	0.04	10.00	4.55	0.03	10.00	4.56	0.03	10.00	4.55	0.03	10.00	0.3	0.8	0.7
124	4.56	0.06	10.00	4.55	0.03	10.00	4.56	0.05	10.00	4.55	0.04	10.00	3.1	1.1	1.8
125	4.56	0.00	10.00	4.55	0.02	10.00	4.56	0.04	10.00	4.55	0.03	10.00	0.4	0.6	0.6
126	4.56	0.00	10.00	4.55	0.01	10.00	4.56	0.05	10.00	4.55	0.02	10.00	0.3	0.5	0.5
127	4.56	0.06	10.00	4.55	0.03	10.00	4.56	0.05	10.00	4.55	0.02	10.00	1.1	0.7	0.8
128	4.56	0.03	10.00	4.55	0.03	10.00	4.56	0.03	10.00	4.55	0.02	10.00	0.1	0.5	0.5
129	4.56	0.01	10.00	4.55	0.02	10.00	4.56	0.01	10.00	4.55	0.01	10.00	0.3	0.7	0.7
130	4.56	0.01	10.00	4.55	0.02	10.00	4.56	0.02	10.00	4.55	0.01	10.00	0.1	0.6	0.5
131	4.56	0.01	10.00	4.55	0.01	10.00	4.56	0.01	10.00	4.55	0.02	10.00	0.6	0.8	0.7
132	4.56	0.02	10.00	4.55	0.03	10.00	4.56	0.01	10.00	4.55	0.02	10.00	0.1	0.6	0.5
133	4.56	0.08	10.00	4.55	0.06	10.00	4.56	0.05	10.00	4.55	0.04	10.00	0.8	1.0	0.9
134	4.56	0.10	10.00	4.55	0.07	10.00	4.56	0.09	10.00	4.55	0.05	10.00	2.8	1.9	2.0
135	4.56	0.04	10.00	4.55	0.05	10.00	4.56	0.10	10.00	4.55	0.06	10.00	0.2	0.7	0.7
136	4.56	0.01	10.00	4.55	0.04	10.00	4.56	0.11	10.00	4.55	0.06	10.00	0.5	0.4	0.5
137	4.56	0.03	10.00	4.55	0.03	10.00	4.56	0.08	10.00	4.55	0.07	10.00	1.5	1.2	1.3
138	4.56	0.03	10.00	4.55	0.02	10.00	4.56	0.04	10.00	4.55	0.07	10.00	1.2	0.8	1.4
139	4.56	0.04	10.00	4.55	0.04	10.00	4.56	0.							

2.1.2 PEDEMONTANA DELLE MARCHE

Secondo stralcio funzionale: Matelica Nord – Matelica Sud/Castelraimondo Nord

Opera L073	Tratto 212	Settore E	CEE 16	WBS IM0000	Id. doc. REL	N. prog. 01	Rev. A	Pag. di Pag. 12 di 12
---------------	---------------	--------------	-----------	---------------	-----------------	----------------	-----------	--------------------------

146	4.56	0.02	10.00	4.55	0.00	10.00	4.56	0.05	10.00	4.55	0.09	10.00	0.4	0.3	0.4
147	4.56	0.06	10.00	4.55	0.01	10.00	4.56	0.08	10.00	4.55	0.11	10.00	0.4	0.4	0.4
148	4.56	0.04	10.00	4.55	0.02	10.00	4.56	0.10	10.00	4.55	0.11	10.00	0.4	0.5	0.5
149	4.56	0.06	10.00	4.55	0.04	10.00	4.56	0.09	10.00	4.55	0.14	10.00	0.6	0.5	0.6
150	4.56	0.06	10.00	4.55	0.03	10.00	4.56	0.08	10.00	4.55	0.12	10.00	0.4	0.6	0.6
151	4.56	0.02	10.00	4.55	0.01	10.00	4.56	0.05	10.00	4.55	0.11	10.00	0.3	0.5	0.5
152	4.56	0.00	10.00	4.55	0.00	10.00	4.56	0.04	10.00	4.55	0.10	10.00	0.1	0.5	0.5
153	4.56	0.00	10.00	4.55	0.00	10.00	4.56	0.04	10.00	4.55	0.10	10.00	0.2	0.4	0.4
154	4.56	0.02	10.00	4.55	0.00	10.00	4.56	0.02	10.00	4.55	0.10	10.00	0.2	0.5	0.5
155	4.56	0.02	10.00	4.55	0.00	0.00	4.56	0.00	10.00	4.55	0.10	10.00	0.1	0.5	0.5
156	4.56	0.03	10.00	4.55	0.00	0.00	4.56	0.03	10.00	4.55	0.10	10.00	0.0	0.5	0.5
157	4.56	0.05	10.00	4.55	0.00	10.00	4.56	0.04	10.00	4.55	0.10	10.00	0.3	0.5	0.5
158	4.56	0.00	10.00	4.55	0.00	0.00	4.56	0.05	10.00	4.55	0.10	10.00	0.3	0.4	0.4
159	4.56	0.00	10.00	4.55	0.00	0.00	4.56	0.04	10.00	4.55	0.09	10.00	0.2	0.4	0.4
160	4.56	0.05	10.00	4.55	0.00	10.00	4.56	0.05	10.00	4.55	0.10	10.00	0.3	0.5	0.5
161	4.56	0.03	10.00	4.55	0.00	0.00	4.56	0.03	10.00	4.55	0.10	10.00	0.1	0.5	0.5
162	4.56	0.01	10.00	4.55	0.00	0.00	4.56	0.01	10.00	4.55	0.10	10.00	0.0	0.5	0.5
163	4.56	0.00	10.00	4.55	0.00	0.00	4.56	0.02	10.00	4.55	0.09	10.00	0.0	0.5	0.5
164	4.56	0.00	10.00	4.55	0.00	0.00	4.56	0.01	10.00	4.55	0.09	10.00	0.1	0.5	0.5
165	4.56	0.01	10.00	4.55	0.00	10.00	4.56	0.02	10.00	4.55	0.10	10.00	0.1	0.6	0.5
166	4.56	0.07	10.00	4.55	0.00	10.00	4.56	0.06	10.00	4.55	0.11	10.00	0.2	0.6	0.6
167	4.56	0.09	10.00	4.55	0.02	10.00	4.56	0.08	10.00	4.55	0.12	10.00	0.6	0.6	0.8
168	4.56	0.04	10.00	4.55	0.04	10.00	4.56	0.11	10.00	4.55	0.12	10.00	0.5	0.4	0.6
169	4.56	0.02	10.00	4.55	0.03	10.00	4.56	0.11	10.00	4.55	0.12	10.00	0.3	0.3	0.3
170	4.56	0.04	10.00	4.55	0.01	10.00	4.56	0.09	10.00	4.55	0.11	10.00	0.3	0.2	0.3
171	4.56	0.07	10.00	4.55	0.01	10.00	4.56	0.07	10.00	4.55	0.10	10.00	0.6	1.9	1.6
172	4.56	0.04	10.00	4.55	0.03	10.00	4.56	0.04	10.00	4.55	0.11	10.00	0.7	0.6	0.6
173	4.56	0.08	10.00	4.55	0.03	10.00	4.56	0.08	10.00	4.55	0.10	10.00	0.8	1.6	1.1
174	4.56	0.01	10.00	4.55	0.03	10.00	4.56	0.03	10.00	4.55	0.11	10.00	0.9	1.6	1.1
175	4.56	0.08	10.00	4.55	0.03	10.00	4.56	0.07	10.00	4.55	0.08	10.00	0.2	1.8	1.5
176	4.56	0.05	10.00	4.55	0.03	10.00	4.56	0.04	10.00	4.55	0.09	10.00	0.3	0.7	0.5
177	4.56	0.06	10.00	4.55	0.03	10.00	4.56	0.12	10.00	4.55	0.11	10.00	0.3	0.6	0.6
178	4.56	0.04	10.00	4.55	0.03	10.00	4.56	0.12	10.00	4.55	0.15	10.00	0.1	0.1	0.1
179	4.56	0.03	10.00	4.55	0.00	10.00	4.56	0.09	10.00	4.55	0.15	10.00	0.0	0.2	0.2
180	4.56	0.00	10.00	4.55	0.00	0.00	4.56	0.07	10.00	4.55	0.14	10.00	0.0	0.2	0.1
181	4.56	0.00	0.00	4.55	0.00	0.00	4.56	0.05	10.00	4.55	0.13	10.00	0.0	0.1	0.1
182	4.56	0.00	0.00	4.55	0.00	0.00	4.56	0.04	10.00	4.55	0.13	10.00	0.0	0.1	0.1
183	4.56	0.00	10.00	4.55	0.00	0.00	4.56	0.03	10.00	4.55	0.13	10.00	0.1	0.1	0.1
184	4.56	0.00	10.00	4.55	0.00	0.00	4.56	0.01	10.00	4.55	0.13	10.00	0.0	0.1	0.1
185	4.56	0.01	10.00	4.55	0.00	0.00	4.56	0.03	10.00	4.55	0.13	10.00	0.1	0.1	0.1
186	4.56	0.02	10.00	4.55	0.00	0.00	4.56	0.03	10.00	4.55	0.14	10.00	0.1	0.1	0.1
187	4.56	0.00	10.00	4.55	0.00	0.00	4.56	0.04	10.00	4.55	0.13	10.00	0.1	0.0	0.1
188	4.56	0.00	10.00	4.55	0.00	0.00	4.56	0.03	10.00	4.55	0.13	10.00	0.1	0.0	0.0
189	4.56	0.02	10.00	4.55	0.00	0.00	4.56	0.04	10.00	4.55	0.13	10.00	0.1	0.1	0.1
190	4.56	0.01	10.00	4.55	0.00	0.00	4.56	0.03	10.00	4.55	0.13	10.00	0.1	0.1	0.1
191	4.56	0.00	10.00	4.55	0.00	0.00	4.56	0.02	10.00	4.55	0.13	10.00	0.0	0.1	0.1
192	4.56	0.00	0.00	4.55	0.00	0.00	4.56	0.02	10.00	4.55	0.13	10.00	0.0	0.1	0.1
193	4.56	0.00	0.00	4.55	0.00	0.00	4.56	0.02	10.00	4.55	0.13	10.00	0.0	0.1	0.1
194	4.56	0.00	10.00	4.55	0.00	0.00	4.56	0.03	10.00	4.55	0.14	10.00	0.0	0.1	0.1
195	4.56	0.03	10.00	4.55	0.00	0.00	4.56	0.06	10.00	4.55	0.15	10.00	0.1	0.2	0.2
196	4.56	0.05	10.00	4.55	0.00	0.00	4.56	0.08	10.00	4.55	0.15	10.00	0.1	0.2	0.2
197	4.56	0.03	10.00	4.55	0.00	10.00	4.56	0.11	10.00	4.55	0.15	10.00	0.1	0.1	0.1
198	4.56	0.03	10.00	4.55	0.01	10.00	4.56	0.12	10.00	4.55	0.14	10.00	0.1	0.1	0.1
199	4.56	0.03	10.00	4.55	0.02	10.00	4.56	0.11	10.00	4.55	0.10	10.00	0.4	0.2	0.3
200	4.56	0.02	10.00	4.55	0.02	10.00	4.56	0.05	10.00	4.55	0.08	10.00	0.6	0.1	0.5
201	4.56	0.08	10.00	4.55	0.04	10.00	4.56	0.09	10.00	4.55	0.09	10.00	0.6	0.2	0.5
202	4.56	0.05	10.00	4.55	0.01	10.00	4.56	0.03	10.00	4.55	0.07	10.00	0.5	0.7	0.8
203	4.56	0.08	10.00	4.55	0.03	10.00	4.56	0.06	10.00	4.55	0.08	10.00	0.5	1.6	1.6
204	4.56	0.07	10.00	4.55	0.07	10.00	4.56	0.05	10.00	4.55	0.07	10.00	1.0	1.0	1.1
205	4.56	0.04	10.00	4.55	0.03	10.00	4.56	0.03	10.00	4.55	0.08	10.00	0.2	1.0	0.7
206	4.56	0.07	10.00	4.55	0.06	10.00	4.56	0.05	10.00	4.55	0.08	10.00	1.2	1.3	1.0
207	4.56	0.03	10.00	4.55	0.01	10.00	4.56	0.04	10.00	4.55	0.09	10.00	0.7	0.2	0.5
208	4.56	0.06	10.00	4.55	0.07	10.00	4.56	0.05	10.00	4.55	0.07	10.00	0.9	1.2	1.2
209	4.56	0.03	10.00	4.55	0.00	10.00	4.56	0.04	10.00	4.55	0.08	10.00	1.8	0.7	1.3
210	4.56	0.02	10.00	4.55	0.05	10.00	4.56	0.11	10.00	4.55	0.10	10.00	0.4	0.4	0.4
211	4.56	0.00	10.00	4.55	0.00	10.00	4.56	0.12	10.00	4.55	0.13	10.00	0.1	0.1	0.1
212	4.56	0.00	10.00	4.55	0.00	0.00	4.56	0.10	10.00	4.55	0.13	10.00	0.0	0.1	0.1
213	4.56	0.00	0.00	4.55	0.00	0.00	4.56	0.07	10.00	4.55	0.13	10.00	0.0	0.0	0.0
214	4.56	0.00	0.00	4.55	0.00	0.00	4.56	0.05	10.00	4.55	0.13	10.00	0.0	0.0	0.0
215	4.56	0.00	0.00	4.55	0.00	0.00	4.56	0.04	10.00	4.55	0.13	10.00	0.0	0.1	0.1
216	4.56	0.00	0.00	4.55	0.00	0.00	4.56	0.03	10.00	4.55	0.13	10.00	0.0	0.1	0.1
217	4.56	0.00	10.00	4.55	0.00	0.00	4.56	0.02	10.00	4.55	0.13	10.00	0.0	0.1	0.0
218	4.56	0.00	10.00	4.55	0.00	0.00	4.56	0.02	10.00	4.55	0.13	10.00	0.0	0.1	0.1
219	4.56	0.00	10.00	4.55	0.00	0.00	4.56	0.03	10.00	4.55	0.13	10.00	0.0	0.1	0.1
220	4.56	0.00	0.00	4.55	0.00	0.00	4.56	0.03	10.00	4.55	0.13	10.00	0.0	0.1	0.1
221	4.56	0.00	0.00	4.55	0.00	0.00	4.56	0.03	10.00	4.55	0.13	10.00	0.0	0.1	0.1
222	4.56	0.00	10.00	4.55	0.00	0.00	4.56	0.03	10.00	4.55	0.13	10.00	0.0	0.1	0.1
223	4.56	0.00	10.00	4.55	0.00	0.00	4.56	0.03	10.00	4.55	0.13	10.00	0.0	0.1	0.1
224	4.56	0.00	10.00	4.55	0.00	0.00	4.56	0.02	10.00	4.55	0.13	10.00	0.0	0.1	0.1
225	4.56	0.00	0.00	4.55	0.00	0.00	4.56	0.02	10.00	4.55	0.13	10.00	0.0	0.1	0.1
226	4.56	0.00	0.00	4.55	0.00	0.00	4.56	0.02	10.00	4.55					

2.1.2 PEDEMONTANA DELLE MARCHE
Secondo stralcio funzionale: Matelica Nord – Matelica Sud/Castelraimondo Nord

Opera L073	Tratto 212	Settore E	CEE 16	WBS IM0000	Id. doc. REL	N. prog. 01	Rev. A	Pag. di Pag. 13 di 13
---------------	---------------	--------------	-----------	---------------	-----------------	----------------	-----------	--------------------------

233	4.56	0.05	10.00	4.55	0.06	10.00	4.56	0.06	10.00	4.55	0.08	10.00	0.7	0.6	0.7
234	4.56	0.03	10.00	4.55	0.00	0.00	4.56	0.04	10.00	4.55	0.07	10.00	1.2	2.1	2.4
235	4.56	0.02	10.00	4.55	0.00	10.00	4.56	0.02	10.00	4.55	0.08	10.00	1.3	1.3	1.4
236	4.56	0.05	10.00	4.55	0.05	10.00	4.56	0.04	10.00	4.55	0.07	10.00	1.0	1.7	1.8
237	4.56	0.02	10.00	4.55	0.00	10.00	4.56	0.04	10.00	4.55	0.08	10.00	2.1	9.5	5.5
238	4.56	0.04	10.00	4.55	0.03	10.00	4.56	0.04	10.00	4.55	0.06	10.00	1.6	4.5	2.9
239	4.56	0.04	10.00	4.55	0.03	10.00	4.56	0.04	10.00	4.55	0.06	10.00	1.6	1.8	1.7
240	4.56	0.02	10.00	4.55	0.03	10.00	4.56	0.02	10.00	4.55	0.15	10.00	6.6	9.9	6.2
241	4.56	0.03	10.00	4.55	0.00	10.00	4.56	0.03	10.00	4.55	0.04	10.00	0.3	1.3	1.4
242	4.56	0.02	10.00	4.55	0.04	10.00	4.56	0.04	10.00	4.55	0.15	10.00	2.0	0.8	1.7
243	4.56	0.03	10.00	4.55	0.00	10.00	4.56	0.04	10.00	4.55	0.06	10.00	0.0	0.3	0.3
244	4.56	0.03	10.00	4.55	0.00	10.00	4.56	0.03	10.00	4.55	0.05	10.00	0.5	0.6	0.6
245	4.56	0.02	10.00	4.55	0.04	10.00	4.56	0.04	10.00	4.55	0.13	10.00	1.5	0.3	1.0
246	4.56	0.03	10.00	4.55	0.03	10.00	4.56	0.03	10.00	4.55	0.13	10.00	1.1	1.0	0.9
247	4.56	0.00	0.00	4.55	0.00	10.00	4.56	0.08	10.00	4.55	0.08	10.00	0.4	0.2	0.4
248	4.56	0.00	0.00	4.55	0.00	0.00	4.56	0.11	10.00	4.55	0.10	10.00	0.1	0.1	0.1
249	4.56	0.00	0.00	4.55	0.00	0.00	4.56	0.10	10.00	4.55	0.11	10.00	0.0	0.1	0.1
250	4.56	0.00	0.00	4.55	0.00	0.00	4.56	0.07	10.00	4.55	0.12	10.00	0.1	0.0	0.1
251	4.56	0.00	0.00	4.55	0.00	0.00	4.56	0.05	10.00	4.55	0.12	10.00	0.1	0.1	0.1
252	4.56	0.00	0.00	4.55	0.00	0.00	4.56	0.04	10.00	4.55	0.12	10.00	0.0	0.1	0.1
253	4.56	0.00	0.00	4.55	0.00	0.00	4.56	0.03	10.00	4.55	0.12	10.00	0.0	0.1	0.1
254	4.56	0.00	0.00	4.55	0.00	0.00	4.56	0.02	10.00	4.55	0.12	10.00	0.0	0.1	0.1
255	4.56	0.00	0.00	4.55	0.00	0.00	4.56	0.02	10.00	4.55	0.12	10.00	0.0	0.1	0.1
256	4.56	0.00	0.00	4.55	0.00	0.00	4.56	0.02	10.00	4.55	0.12	10.00	0.0	0.1	0.1
257	4.56	0.00	0.00	4.55	0.00	0.00	4.56	0.02	10.00	4.55	0.12	10.00	0.0	0.1	0.1
258	4.56	0.00	0.00	4.55	0.00	0.00	4.56	0.02	10.00	4.55	0.11	10.00	0.0	0.1	0.1
259	4.56	0.00	0.00	4.55	0.00	0.00	4.56	0.02	10.00	4.55	0.12	10.00	0.0	0.1	0.1
260	4.56	0.00	0.00	4.55	0.00	0.00	4.56	0.02	10.00	4.55	0.12	10.00	0.0	0.1	0.1
261	4.56	0.00	0.00	4.55	0.00	0.00	4.56	0.02	10.00	4.55	0.12	10.00	0.0	0.1	0.1
262	4.56	0.00	0.00	4.55	0.00	0.00	4.56	0.02	10.00	4.55	0.12	10.00	0.0	0.1	0.1
263	4.56	0.00	0.00	4.55	0.00	0.00	4.56	0.02	10.00	4.55	0.12	10.00	0.0	0.1	0.1
264	4.56	0.00	0.00	4.55	0.00	0.00	4.56	0.03	10.00	4.55	0.12	10.00	0.0	0.1	0.1
265	4.56	0.00	0.00	4.55	0.00	0.00	4.56	0.05	10.00	4.55	0.12	10.00	0.1	0.1	0.1
266	4.56	0.00	0.00	4.55	0.00	0.00	4.56	0.07	10.00	4.55	0.12	10.00	0.1	0.1	0.1
267	4.56	0.00	0.00	4.55	0.00	0.00	4.56	0.10	10.00	4.55	0.12	10.00	0.0	0.1	0.1
268	4.56	0.00	10.00	4.55	0.00	0.00	4.56	0.09	10.00	4.55	0.12	10.00	0.1	0.1	0.1
269	4.56	0.02	10.00	4.55	0.02	10.00	4.56	0.08	10.00	4.55	0.12	10.00	0.5	0.1	0.4
270	4.56	0.02	10.00	4.55	0.00	10.00	4.56	0.05	10.00	4.55	0.07	10.00	0.5	0.3	0.4
271	4.56	0.02	10.00	4.55	0.00	10.00	4.56	0.03	10.00	4.55	0.06	10.00	0.4	0.9	0.8
272	4.56	0.03	10.00	4.55	0.06	10.00	4.56	0.03	10.00	4.55	0.13	10.00	0.5	0.5	0.4
273	4.56	0.03	10.00	4.55	0.02	10.00	4.56	0.02	10.00	4.55	0.07	10.00	0.1	0.7	0.6
274	4.56	0.04	10.00	4.55	0.05	10.00	4.56	0.03	10.00	4.55	0.13	10.00	0.7	1.5	1.0
275	4.56	0.03	10.00	4.55	0.01	10.00	4.56	0.02	10.00	4.55	0.07	10.00	0.6	0.6	0.5
276	4.56	0.03	10.00	4.55	0.06	10.00	4.56	0.03	10.00	4.55	0.13	10.00	0.4	0.4	0.4
277	4.56	0.03	10.00	4.55	0.02	10.00	4.56	0.01	10.00	4.55	0.06	10.00	0.4	0.6	0.5
278	4.56	0.00	10.00	4.55	0.00	10.00	4.56	0.08	10.00	4.55	0.07	10.00	0.4	0.3	0.4
279	4.56	0.00	0.00	4.55	0.00	0.00	4.56	0.10	10.00	4.55	0.09	10.00	0.1	0.0	0.1
280	4.56	0.00	0.00	4.55	0.00	0.00	4.56	0.09	10.00	4.55	0.10	10.00	0.0	0.1	0.1
281	4.56	0.00	0.00	4.55	0.00	0.00	4.56	0.07	10.00	4.55	0.10	10.00	0.0	0.1	0.1
282	4.56	0.00	0.00	4.55	0.00	0.00	4.56	0.05	10.00	4.55	0.11	10.00	0.0	0.0	0.0
283	4.56	0.00	0.00	4.55	0.00	0.00	4.56	0.03	10.00	4.55	0.11	10.00	0.0	0.0	0.0
284	4.56	0.00	0.00	4.55	0.00	0.00	4.56	0.02	10.00	4.55	0.11	10.00	0.0	0.0	0.0
285	4.56	0.00	0.00	4.55	0.00	0.00	4.56	0.02	10.00	4.55	0.11	10.00	0.0	0.0	0.0
286	4.56	0.00	0.00	4.55	0.00	0.00	4.56	0.02	10.00	4.55	0.11	10.00	0.0	0.0	0.0
287	4.56	0.00	0.00	4.55	0.00	0.00	4.56	0.02	10.00	4.55	0.11	10.00	0.0	0.0	0.0
288	4.56	0.00	0.00	4.55	0.00	0.00	4.56	0.02	10.00	4.55	0.11	10.00	0.0	0.0	0.0
289	4.56	0.00	0.00	4.55	0.00	0.00	4.56	0.02	10.00	4.55	0.11	10.00	0.0	0.0	0.0
290	4.56	0.00	0.00	4.55	0.00	0.00	4.56	0.02	10.00	4.55	0.11	10.00	0.0	0.0	0.0
291	4.56	0.00	0.00	4.55	0.00	0.00	4.56	0.02	10.00	4.55	0.11	10.00	0.0	0.0	0.0
292	4.56	0.00	0.00	4.55	0.00	0.00	4.56	0.02	10.00	4.55	0.11	10.00	0.0	0.0	0.0
293	4.56	0.00	0.00	4.55	0.00	0.00	4.56	0.02	10.00	4.55	0.11	10.00	0.0	0.0	0.0
294	4.56	0.00	0.00	4.55	0.00	0.00	4.56	0.02	10.00	4.55	0.11	10.00	0.0	0.0	0.0
295	4.56	0.00	0.00	4.55	0.00	0.00	4.56	0.03	10.00	4.55	0.11	10.00	0.0	0.0	0.0
296	4.56	0.00	0.00	4.55	0.00	0.00	4.56	0.04	10.00	4.55	0.11	10.00	0.1	0.1	0.1
297	4.56	0.00	0.00	4.55	0.00	0.00	4.56	0.07	10.00	4.55	0.11	10.00	0.0	0.1	0.1
298	4.56	0.00	0.00	4.55	0.00	0.00	4.56	0.09	10.00	4.55	0.10	10.00	0.0	0.1	0.1
299	4.56	0.00	10.00	4.55	0.00	0.00	4.56	0.11	10.00	4.55	0.10	10.00	0.1	0.0	0.1
300	4.56	0.02	10.00	4.55	0.01	10.00	4.56	0.09	10.00	4.55	0.09	10.00	0.4	0.5	0.6
301	4.56	0.03	10.00	4.55	0.01	10.00	4.56	0.04	10.00	4.55	0.08	10.00	0.5	0.0	0.5
302	4.56	0.04	10.00	4.55	0.01	10.00	4.56	0.02	10.00	4.55	0.06	10.00	0.2	1.1	0.8
303	4.56	0.03	10.00	4.55	0.00	10.00	4.56	0.04	10.00	4.55	0.06	10.00	0.6	0.1	0.5
304	4.56	0.03	10.00	4.55	0.01	10.00	4.56	0.01	10.00	4.55	0.04	10.00	0.5	0.4	0.4
305	4.56	0.04	10.00	4.55	0.03	10.00	4.56	0.01	10.00	4.55	0.07	10.00	0.6	0.9	0.9
306	4.56	0.03	10.00	4.55	0.03	10.00	4.56	0.04	10.00	4.55	0.07	10.00	0.4	0.3	0.5
307	4.56	0.02	10.00	4.55	0.02	10.00	4.56	0.02	10.00	4.55	0.09	10.00	0.6	0.1	0.6
308	4.56	0.04	10.00	4.55	0.03	10.00	4.56	0.02	10.00	4.55	0.08	10.00	0.7	0.3	0.6
309	4.56	0.04	10.00	4.55	0.02	10.00	4.56	0.02	10.00	4.55	0.07	10.00	0.7	1.0	1.0
310	4.56	0.02	10.00	4.55	0.01	10.00	4.56	0.04	10.00	4.55	0.07	10.00	0.6	0.2	0.5
311	4.56	0.01	10.00	4.55	0.00	10.00	4.56	0.09	10.00	4.55	0.10	10.00	0.4	0.1	0.4
312	4.56	0.00	0.00	4.55	0.00	0.00	4.56	0.11	10.00	4.55	0.10	10.00	0.1	0.1	0.1
313	4.56	0.00	0.00	4.55	0.00	0.00	4.56	0.09	10.00	4.55	0.11	10.00	0.0	0.1	

2.1.2 PEDEMONTANA DELLE MARCHE
Secondo stralcio funzionale: Matelica Nord – Matelica Sud/Castelraimondo Nord

Opera	Tratto	Settore	CEE	WBS	Id. doc.	N. prog.	Rev.	Pag. di Pag.
L073	212	E	16	IM0000	REL	01	A	14 di 14

320	4.56	0.00	0.00	4.55	0.00	0.00	4.56	0.02	10.00	4.55	0.11	10.00	0.0	0.1	0.1
321	4.56	0.00	0.00	4.55	0.00	0.00	4.56	0.02	10.00	4.55	0.11	10.00	0.0	0.1	0.1
322	4.56	0.00	0.00	4.55	0.00	0.00	4.56	0.02	10.00	4.55	0.11	10.00	0.0	0.1	0.1
323	4.56	0.00	0.00	4.55	0.00	0.00	4.56	0.02	10.00	4.55	0.11	10.00	0.0	0.1	0.1
324	4.56	0.00	0.00	4.55	0.00	0.00	4.56	0.02	10.00	4.55	0.11	10.00	0.0	0.1	0.1
325	4.56	0.00	0.00	4.55	0.00	0.00	4.56	0.02	10.00	4.55	0.11	10.00	0.0	0.1	0.1
326	4.56	0.00	0.00	4.55	0.00	0.00	4.56	0.02	10.00	4.55	0.11	10.00	0.0	0.1	0.1
327	4.56	0.00	0.00	4.55	0.00	0.00	4.56	0.02	10.00	4.55	0.12	10.00	0.0	0.1	0.1
328	4.56	0.00	0.00	4.55	0.00	0.00	4.56	0.03	10.00	4.55	0.12	10.00	0.0	0.1	0.1
329	4.56	0.00	0.00	4.55	0.00	0.00	4.56	0.05	10.00	4.55	0.12	10.00	0.1	0.1	0.1
330	4.56	0.00	0.00	4.55	0.00	0.00	4.56	0.07	10.00	4.55	0.11	10.00	0.1	0.1	0.1
331	4.56	0.00	0.00	4.55	0.00	0.00	4.56	0.10	10.00	4.55	0.11	10.00	0.0	0.1	0.1
332	4.56	0.00	0.00	4.55	0.00	10.00	4.56	0.11	10.00	4.55	0.09	10.00	0.1	0.1	0.1
333	4.56	0.00	10.00	4.55	0.02	10.00	4.56	0.10	10.00	4.55	0.07	10.00	0.4	0.3	0.4
334	4.56	0.04	10.00	4.55	0.01	10.00	4.56	0.03	10.00	4.55	0.09	10.00	0.8	0.2	0.7
335	4.56	0.04	10.00	4.55	0.02	10.00	4.56	0.03	10.00	4.55	0.09	10.00	0.9	0.2	0.8
336	4.56	0.03	10.00	4.55	0.02	10.00	4.56	0.03	10.00	4.55	0.07	10.00	1.3	0.7	1.2
337	4.56	0.01	10.00	4.55	0.02	10.00	4.56	0.04	10.00	4.55	0.07	10.00	0.5	0.2	0.6
338	4.56	0.04	10.00	4.55	0.02	10.00	4.56	0.04	10.00	4.55	0.11	10.00	1.0	0.4	1.0
339	4.56	0.02	10.00	4.55	0.02	10.00	4.56	0.04	10.00	4.55	0.06	10.00	0.9	1.2	1.2
340	4.56	0.03	10.00	4.55	0.01	10.00	4.56	0.03	10.00	4.55	0.11	10.00	3.3	4.9	3.1
341	4.56	0.03	10.00	4.55	0.03	10.00	4.56	0.05	10.00	4.55	0.06	10.00	3.4	5.8	3.6
342	4.56	0.02	10.00	4.55	0.00	10.00	4.56	0.03	10.00	4.55	0.08	10.00	1.1	0.8	1.4
343	4.56	0.04	10.00	4.55	0.00	10.00	4.56	0.04	10.00	4.55	0.08	10.00	1.0	4.4	2.6
344	4.56	0.03	10.00	4.55	0.02	10.00	4.56	0.04	10.00	4.55	0.04	10.00	1.6	5.9	3.3
345	4.56	0.04	10.00	4.55	0.00	10.00	4.56	0.04	10.00	4.55	0.07	10.00	0.3	0.8	0.9
346	4.56	0.03	10.00	4.55	0.02	10.00	4.56	0.04	10.00	4.55	0.05	10.00	0.4	0.9	1.0
347	4.56	0.05	10.00	4.55	0.06	10.00	4.56	0.06	10.00	4.55	0.07	10.00	0.7	1.1	0.7
348	4.56	0.02	10.00	4.55	0.00	10.00	4.56	0.10	10.00	4.55	0.10	10.00	0.4	0.4	0.4
349	4.56	0.00	0.00	4.55	0.00	0.00	4.56	0.12	10.00	4.55	0.13	10.00	0.1	0.1	0.1
350	4.56	0.00	0.00	4.55	0.00	0.00	4.56	0.10	10.00	4.55	0.13	10.00	0.0	0.1	0.0
351	4.56	0.00	0.00	4.55	0.00	0.00	4.56	0.07	10.00	4.55	0.13	10.00	0.0	0.1	0.1
352	4.56	0.00	0.00	4.55	0.00	0.00	4.56	0.05	10.00	4.55	0.13	10.00	0.1	0.1	0.1
353	4.56	0.00	0.00	4.55	0.00	0.00	4.56	0.03	10.00	4.55	0.13	10.00	0.0	0.1	0.1
354	4.56	0.00	0.00	4.55	0.00	0.00	4.56	0.03	10.00	4.55	0.13	10.00	0.0	0.1	0.1
355	4.56	0.00	0.00	4.55	0.00	0.00	4.56	0.02	10.00	4.55	0.13	10.00	0.0	0.1	0.1
356	4.56	0.00	0.00	4.55	0.00	0.00	4.56	0.02	10.00	4.55	0.13	10.00	0.0	0.1	0.1
357	4.56	0.00	0.00	4.55	0.00	0.00	4.56	0.02	10.00	4.55	0.13	10.00	0.0	0.1	0.1
358	4.56	0.00	0.00	4.55	0.00	0.00	4.56	0.02	10.00	4.55	0.13	10.00	0.0	0.1	0.1
359	4.56	0.00	0.00	4.55	0.00	0.00	4.56	0.02	10.00	4.55	0.13	10.00	0.0	0.1	0.1
360	4.56	0.00	0.00	4.55	0.00	0.00	4.56	0.02	10.00	4.55	0.13	10.00	0.0	0.1	0.1
361	4.56	0.00	0.00	4.55	0.00	0.00	4.56	0.02	10.00	4.55	0.13	10.00	0.0	0.1	0.1
362	4.56	0.00	0.00	4.55	0.00	0.00	4.56	0.02	10.00	4.55	0.13	10.00	0.0	0.1	0.1
363	4.56	0.00	0.00	4.55	0.00	0.00	4.56	0.02	10.00	4.55	0.13	10.00	0.0	0.1	0.1
364	4.56	0.00	0.00	4.55	0.00	0.00	4.56	0.02	10.00	4.55	0.13	10.00	0.0	0.1	0.1
365	4.56	0.00	0.00	4.55	0.00	0.00	4.56	0.03	10.00	4.55	0.13	10.00	0.0	0.1	0.1
366	4.56	0.00	0.00	4.55	0.00	0.00	4.56	0.05	10.00	4.55	0.13	10.00	0.1	0.1	0.1
367	4.56	0.00	10.00	4.55	0.00	0.00	4.56	0.07	10.00	4.55	0.13	10.00	0.1	0.1	0.1
368	4.56	0.01	10.00	4.55	0.01	10.00	4.56	0.10	10.00	4.55	0.13	10.00	0.0	0.1	0.1
369	4.56	0.01	10.00	4.55	0.04	10.00	4.56	0.12	10.00	4.55	0.12	10.00	0.1	0.1	0.1
370	4.56	0.03	10.00	4.55	0.06	10.00	4.56	0.11	10.00	4.55	0.09	10.00	0.4	0.3	0.4
371	4.56	0.04	10.00	4.55	0.01	10.00	4.56	0.04	10.00	4.55	0.08	10.00	0.3	0.5	0.4
372	4.56	0.04	10.00	4.55	0.07	10.00	4.56	0.04	10.00	4.55	0.07	10.00	0.6	0.9	0.7
373	4.56	0.05	10.00	4.55	0.01	10.00	4.56	0.05	10.00	4.55	0.07	10.00	0.5	1.4	1.1
374	4.56	0.06	10.00	4.55	0.06	10.00	4.56	0.06	10.00	4.55	0.07	10.00	1.2	1.4	1.1
375	4.56	0.05	10.00	4.55	0.07	10.00	4.56	0.05	10.00	4.55	0.07	10.00	0.9	1.0	1.0
376	4.56	0.05	10.00	4.55	0.04	10.00	4.56	0.04	10.00	4.55	0.08	10.00	0.4	0.1	0.4
377	4.56	0.06	10.00	4.55	0.04	10.00	4.56	0.05	10.00	4.55	0.08	10.00	0.5	1.3	1.3
378	4.56	0.06	10.00	4.55	0.04	10.00	4.56	0.05	10.00	4.55	0.07	10.00	0.4	1.4	1.4
379	4.56	0.08	10.00	4.55	0.04	10.00	4.56	0.08	10.00	4.55	0.09	10.00	0.5	0.1	0.4
380	4.56	0.04	10.00	4.55	0.04	10.00	4.56	0.12	10.00	4.55	0.11	10.00	0.4	0.5	0.5
381	4.56	0.01	10.00	4.55	0.02	10.00	4.56	0.12	10.00	4.55	0.14	10.00	0.1	0.1	0.1
382	4.56	0.01	10.00	4.55	0.00	10.00	4.56	0.10	10.00	4.55	0.14	10.00	0.0	0.1	0.1
383	4.56	0.00	0.00	4.55	0.00	0.00	4.56	0.07	10.00	4.55	0.14	10.00	0.0	0.1	0.1
384	4.56	0.00	0.00	4.55	0.00	0.00	4.56	0.04	10.00	4.55	0.13	10.00	0.0	0.1	0.1
385	4.56	0.00	0.00	4.55	0.00	0.00	4.56	0.03	10.00	4.55	0.13	10.00	0.0	0.1	0.1
386	4.56	0.00	0.00	4.55	0.00	0.00	4.56	0.03	10.00	4.55	0.13	10.00	0.0	0.1	0.1
387	4.56	0.00	0.00	4.55	0.00	0.00	4.56	0.02	10.00	4.55	0.13	10.00	0.0	0.1	0.1
388	4.56	0.00	0.00	4.55	0.00	0.00	4.56	0.02	10.00	4.55	0.13	10.00	0.0	0.1	0.1
389	4.56	0.00	0.00	4.55	0.00	0.00	4.56	0.02	10.00	4.55	0.13	10.00	0.0	0.0	0.0
390	4.56	0.00	0.00	4.55	0.00	0.00	4.56	0.02	10.00	4.55	0.13	10.00	0.0	0.0	0.0
391	4.56	0.00	0.00	4.55	0.00	0.00	4.56	0.02	10.00	4.55	0.13	10.00	0.0	0.0	0.0
392	4.56	0.00	0.00	4.55	0.00	0.00	4.56	0.02	10.00	4.55	0.13	10.00	0.0	0.0	0.0
393	4.56	0.00	0.00	4.55	0.00	0.00	4.56	0.02	10.00	4.55	0.13	10.00	0.0	0.1	0.1
394	4.56	0.00	0.00	4.55	0.00	0.00	4.56	0.02	10.00	4.55	0.13	10.00	0.0	0.0	0.0
395	4.56	0.00	0.00	4.55	0.00	0.00	4.56	0.02	10.00	4.55	0.13	10.00	0.0	0.1	0.1
396	4.56	0.00	0.00	4.55	0.00	0.00	4.56	0.02	10.00	4.55	0.13	10.00	0.0	0.1	0.1
397	4.56	0.00	10.00	4.55	0.00	0.00	4.56	0.03	10.00	4.55	0.13	10.00	0.0	0.1	0.1
398	4.56	0.02	10.00	4.55	0.00	0.00	4.56	0.04	10.00	4.55	0.14	10.00	0.1	0.1	0.1
399	4.56	0.04	10.00	4.55	0.00	10.00	4.56	0.07	10.00	4.55	0.14	10.00	0.1	0.1	0.1
400	4.56	0.03	10.00	4.55	0.03	10.00	4.56	0.11	10.00	4.55</					

2.1.2 PEDEMONTANA DELLE MARCHE
Secondo stralcio funzionale: Matelica Nord – Matelica Sud/Castelraimondo Nord

Opera L073	Tratto 212	Settore E	CEE 16	WBS IM0000	Id. doc. REL	N. prog. 01	Rev. A	Pag. di Pag. 15 di 15
---------------	---------------	--------------	-----------	---------------	-----------------	----------------	-----------	--------------------------

407	4.56	0.07	10.00	4.55	0.05	10.00	4.56	0.08	10.00	4.55	0.06	10.00	0.5	0.2	0.5
408	4.56	0.06	10.00	4.55	0.04	10.00	4.56	0.06	10.00	4.55	0.10	10.00	0.8	1.4	1.0
409	4.56	0.07	10.00	4.55	0.01	10.00	4.56	0.07	10.00	4.55	0.09	10.00	0.6	1.7	1.4
410	4.56	0.07	10.00	4.55	0.02	10.00	4.56	0.06	10.00	4.55	0.08	10.00	0.4	1.8	1.7
411	4.56	0.06	10.00	4.55	0.03	10.00	4.56	0.08	10.00	4.55	0.09	10.00	0.5	0.5	0.5
412	4.56	0.05	10.00	4.55	0.03	10.00	4.56	0.12	10.00	4.55	0.10	10.00	0.3	0.6	0.5
413	4.56	0.03	10.00	4.55	0.04	10.00	4.56	0.11	10.00	4.55	0.13	10.00	0.1	0.5	0.4
414	4.56	0.03	10.00	4.55	0.02	10.00	4.56	0.08	10.00	4.55	0.12	10.00	0.0	0.6	0.5
415	4.56	0.02	10.00	4.55	0.01	10.00	4.56	0.06	10.00	4.55	0.11	10.00	0.1	0.5	0.5
416	4.56	0.02	10.00	4.55	0.00	10.00	4.56	0.03	10.00	4.55	0.10	10.00	0.1	0.5	0.5
417	4.56	0.00	10.00	4.55	0.00	0.00	4.56	0.02	10.00	4.55	0.10	10.00	0.1	0.5	0.4
418	4.56	0.00	10.00	4.55	0.00	0.00	4.56	0.02	10.00	4.55	0.10	10.00	0.1	0.5	0.5
419	4.56	0.01	10.00	4.55	0.00	0.00	4.56	0.02	10.00	4.55	0.10	10.00	0.0	0.5	0.5
420	4.56	0.01	10.00	4.55	0.00	0.00	4.56	0.02	10.00	4.55	0.10	10.00	0.0	0.5	0.5
421	4.56	0.01	10.00	4.55	0.00	0.00	4.56	0.01	10.00	4.55	0.10	10.00	0.0	0.4	0.4
422	4.56	0.00	0.00	4.55	0.00	0.00	4.56	0.02	10.00	4.55	0.10	10.00	0.0	0.5	0.4
423	4.56	0.00	10.00	4.55	0.00	0.00	4.56	0.01	10.00	4.55	0.10	10.00	0.0	0.5	0.4
424	4.56	0.00	0.00	4.55	0.00	0.00	4.56	0.02	10.00	4.55	0.10	10.00	0.0	0.4	0.4
425	4.56	0.00	10.00	4.55	0.00	0.00	4.56	0.01	10.00	4.55	0.10	10.00	0.0	0.5	0.5
426	4.56	0.00	10.00	4.55	0.00	0.00	4.56	0.02	10.00	4.55	0.10	10.00	0.1	0.5	0.5
427	4.56	0.00	10.00	4.55	0.00	0.00	4.56	0.02	10.00	4.55	0.10	10.00	0.0	0.5	0.5
428	4.56	0.01	10.00	4.55	0.00	0.00	4.56	0.02	10.00	4.55	0.10	10.00	0.0	0.5	0.5
429	4.56	0.02	10.00	4.55	0.00	0.00	4.56	0.02	10.00	4.55	0.10	10.00	0.1	0.5	0.5
430	4.56	0.05	10.00	4.55	0.01	10.00	4.56	0.03	10.00	4.55	0.11	10.00	0.0	0.5	0.5
431	4.56	0.07	10.00	4.55	0.03	10.00	4.56	0.07	10.00	4.55	0.12	10.00	0.2	0.5	0.5
432	4.56	0.05	10.00	4.55	0.05	10.00	4.56	0.11	10.00	4.55	0.12	10.00	0.1	0.4	0.4
433	4.56	0.04	10.00	4.55	0.05	10.00	4.56	0.11	10.00	4.55	0.13	10.00	0.2	0.4	0.4
434	4.56	0.06	10.00	4.55	0.02	10.00	4.56	0.12	10.00	4.55	0.11	10.00	0.5	0.4	0.5
435	4.56	0.05	10.00	4.55	0.01	10.00	4.56	0.06	10.00	4.55	0.10	10.00	0.7	0.3	0.6
436	4.56	0.06	10.00	4.55	0.00	10.00	4.56	0.07	10.00	4.55	0.09	10.00	0.8	1.6	1.3
437	4.56	0.06	10.00	4.55	0.00	10.00	4.56	0.07	10.00	4.55	0.08	10.00	0.9	1.5	1.1
438	4.56	0.06	10.00	4.55	0.04	10.00	4.56	0.07	10.00	4.55	0.12	10.00	1.2	1.4	1.2
439	4.56	0.05	10.00	4.55	0.02	10.00	4.56	0.07	10.00	4.55	0.09	10.00	2.2	1.9	1.6
440	4.56	0.01	10.00	4.55	0.04	10.00	4.56	0.05	10.00	4.55	0.13	10.00	2.7	2.5	2.0
441	4.56	0.05	10.00	4.55	0.01	10.00	4.56	0.07	10.00	4.55	0.08	10.00	0.9	0.3	0.9
442	4.56	0.05	10.00	4.55	0.03	10.00	4.56	0.07	10.00	4.55	0.09	10.00	1.3	0.7	1.5
443	4.56	0.05	10.00	4.55	0.04	10.00	4.56	0.11	10.00	4.55	0.08	10.00	0.8	0.6	0.7
444	4.56	0.04	10.00	4.55	0.07	10.00	4.56	0.10	10.00	4.55	0.07	10.00	0.5	0.9	0.8
445	4.56	0.04	10.00	4.55	0.06	10.00	4.56	0.07	10.00	4.55	0.05	10.00	0.7	0.6	0.6
446	4.56	0.02	10.00	4.55	0.05	10.00	4.56	0.05	10.00	4.55	0.03	10.00	0.0	0.5	0.5
447	4.56	0.03	10.00	4.55	0.03	10.00	4.56	0.02	10.00	4.55	0.02	10.00	0.4	0.7	0.6
448	4.56	0.01	10.00	4.55	0.02	10.00	4.56	0.02	10.00	4.55	0.02	10.00	0.2	0.6	0.5
449	4.56	0.01	10.00	4.55	0.02	10.00	4.56	0.02	10.00	4.55	0.01	10.00	0.1	0.5	0.5
450	4.56	0.01	10.00	4.55	0.02	10.00	4.56	0.02	10.00	4.55	0.02	10.00	0.3	0.6	0.6
451	4.56	0.01	10.00	4.55	0.02	10.00	4.56	0.02	10.00	4.55	0.02	10.00	0.1	0.7	0.6
452	4.56	0.01	10.00	4.55	0.01	10.00	4.56	0.01	10.00	4.55	0.02	10.00	1.0	0.6	0.7
453	4.56	0.00	10.00	4.55	0.01	10.00	4.56	0.02	10.00	4.55	0.02	10.00	0.1	0.5	0.5
454	4.56	0.01	10.00	4.55	0.01	10.00	4.56	0.01	10.00	4.55	0.02	10.00	2.8	0.5	1.4
455	4.56	0.00	10.00	4.55	0.01	10.00	4.56	0.02	10.00	4.55	0.02	10.00	0.0	0.6	0.5
456	4.56	0.01	10.00	4.55	0.01	10.00	4.56	0.01	10.00	4.55	0.02	10.00	0.5	0.7	0.7
457	4.56	0.01	10.00	4.55	0.01	10.00	4.56	0.02	10.00	4.55	0.02	10.00	0.1	0.5	0.5
458	4.56	0.01	10.00	4.55	0.01	10.00	4.56	0.01	10.00	4.55	0.02	10.00	0.3	0.6	0.6
459	4.56	0.01	10.00	4.55	0.02	10.00	4.56	0.02	10.00	4.55	0.02	10.00	0.1	0.5	0.4
460	4.56	0.02	10.00	4.55	0.03	10.00	4.56	0.02	10.00	4.55	0.02	10.00	0.3	0.7	0.6
461	4.56	0.06	10.00	4.55	0.05	10.00	4.56	0.03	10.00	4.55	0.03	10.00	0.1	0.7	0.7
462	4.56	0.09	10.00	4.55	0.07	10.00	4.56	0.06	10.00	4.55	0.05	10.00	2.0	0.7	1.2
463	4.56	0.06	10.00	4.55	0.07	10.00	4.56	0.10	10.00	4.55	0.07	10.00	0.3	0.6	0.5
464	4.56	0.04	10.00	4.55	0.06	10.00	4.56	0.11	10.00	4.55	0.08	10.00	0.3	0.5	0.5
465	4.56	0.06	10.00	4.55	0.05	10.00	4.56	0.11	10.00	4.55	0.10	10.00	1.0	1.1	1.0
466	4.56	0.04	10.00	4.55	0.05	10.00	4.56	0.10	10.00	4.55	0.06	10.00	0.5	0.7	0.8
467	4.56	0.01	10.00	4.55	0.06	10.00	4.56	0.06	10.00	4.55	0.05	10.00	0.8	0.6	1.0
468	4.56	0.01	10.00	4.55	0.01	10.00	4.56	0.02	10.00	4.55	0.01	10.00	0.3	0.5	0.6
469	4.56	0.00	10.00	4.55	0.00	10.00	4.56	0.01	10.00	4.55	0.01	10.00	0.4	0.6	0.8
470	4.56	0.04	10.00	4.55	0.04	10.00	4.56	0.01	10.00	4.55	0.01	10.00	0.1	1.0	1.0
471	4.56	0.05	10.00	4.55	0.01	10.00	4.56	0.07	10.00	4.55	0.07	10.00	1.7	1.7	1.4
472	4.56	0.05	10.00	4.55	0.03	10.00	4.56	0.08	10.00	4.55	0.07	10.00	3.9	5.4	3.5
473	4.56	0.03	10.00	4.55	0.03	10.00	4.56	0.05	10.00	4.55	0.09	10.00	1.7	4.6	2.5
474	4.56	0.06	10.00	4.55	0.03	10.00	4.56	0.10	10.00	4.55	0.07	10.00	0.9	0.6	0.8
475	4.56	0.02	10.00	4.55	0.07	10.00	4.56	0.05	10.00	4.55	0.05	10.00	3.3	1.1	2.0
476	4.56	0.04	10.00	4.55	0.06	10.00	4.56	0.06	10.00	4.55	0.03	10.00	0.3	1.2	0.8
477	4.56	0.02	10.00	4.55	0.05	10.00	4.56	0.04	10.00	4.55	0.02	10.00	0.5	1.1	0.9
478	4.56	0.02	10.00	4.55	0.04	10.00	4.56	0.02	10.00	4.55	0.02	10.00	2.3	1.5	1.6
479	4.56	0.03	10.00	4.55	0.03	10.00	4.56	0.02	10.00	4.55	0.01	10.00	0.6	1.3	1.1
480	4.56	0.01	10.00	4.55	0.03	10.00	4.56	0.02	10.00	4.55	0.01	10.00	0.0	0.9	0.7
481	4.56	0.01	10.00	4.55	0.02	10.00	4.56	0.01	10.00	4.55	0.01	10.00	2.4	1.0	1.5
482	4.56	0.01	10.00	4.55	0.02	10.00	4.56	0.01	10.00	4.55	0.01	10.00	0.2	1.2	1.0
483	4.56	0.01	10.00	4.55	0.02	10.00	4.56	0.02	10.00	4.55	0.01	10.00	1.1	2.7	1.6
484	4.56	0.01	10.00	4.55	0.02	10.00	4.56	0.01	10.00	4.55	0.01	10.00	0.2	1.2	0.9
485	4.56	0.01	10.00	4.55	0.01	10.00	4.56	0.02	10.00	4.55	0.01	10.00	0.3	1.1	0.8
486	4.56	0.01	10.00	4.55	0.01	10.00	4.56	0.01	10.00	4.55	0.01	10.00	0.3	1.4	1.0
487	4.56	0.00	10.00	4.55	0.01	10.00									

2.1.2 PEDEMONTANA DELLE MARCHE
Secondo stralcio funzionale: Matelica Nord – Matelica Sud/Castelraimondo Nord

Opera L073	Tratto 212	Settore E	CEE 16	WBS IM0000	Id. doc. REL	N. prog. 01	Rev. A	Pag. di Pag. 16 di 16
---------------	---------------	--------------	-----------	---------------	-----------------	----------------	-----------	--------------------------

494	4.56	0.03	10.00	4.55	0.04	10.00	4.56	0.02	10.00	4.55	0.01	10.00	2.8	2.0	2.0
495	4.56	0.09	10.00	4.55	0.07	10.00	4.56	0.05	10.00	4.55	0.02	10.00	0.8	1.6	1.3
496	4.56	0.08	10.00	4.55	0.07	10.00	4.56	0.07	10.00	4.55	0.04	10.00	1.1	1.9	1.4
497	4.56	0.05	10.00	4.55	0.07	10.00	4.56	0.11	10.00	4.55	0.07	10.00	0.1	0.7	0.6
498	4.56	0.04	10.00	4.55	0.06	10.00	4.56	0.09	10.00	4.55	0.07	10.00	5.1	3.7	3.4
499	4.56	0.06	10.00	4.55	0.04	10.00	4.56	0.09	10.00	4.55	0.08	10.00	0.7	0.8	0.7
500	4.56	0.05	10.00	4.55	0.03	10.00	4.56	0.07	10.00	4.55	0.08	10.00	1.5	4.0	2.3
501	4.56	0.03	10.00	4.55	0.05	10.00	4.56	0.06	10.00	4.55	0.02	10.00	0.7	0.2	0.7
502	4.56	0.02	10.00	4.55	0.03	10.00	4.56	0.01	10.00	4.55	0.01	10.00	0.9	0.1	0.9
503	4.56	0.01	10.00	4.55	0.02	10.00	4.56	0.01	10.00	4.55	0.00	10.00	0.4	0.1	0.4
504	4.56	0.00	10.00	4.55	0.01	10.00	4.56	0.01	10.00	4.55	0.00	10.00	1.0	0.1	1.0
505	4.56	0.01	10.00	4.55	0.01	10.00	4.56	0.01	10.00	4.55	0.00	0.00	0.3	0.1	0.3
506	4.56	0.01	10.00	4.55	0.01	10.00	4.56	0.00	0.00	4.55	0.00	0.00	0.2	0.1	0.3
507	4.56	0.01	10.00	4.55	0.01	10.00	4.56	0.00	10.00	4.55	0.00	0.00	0.1	0.2	0.3
508	4.56	0.03	10.00	4.55	0.03	10.00	4.56	0.01	10.00	4.55	0.00	10.00	0.7	0.2	0.7
509	4.56	0.08	10.00	4.55	0.05	10.00	4.56	0.05	10.00	4.55	0.03	10.00	0.3	0.4	0.5
510	4.56	0.04	10.00	4.55	0.05	10.00	4.56	0.09	10.00	4.55	0.06	10.00	1.2	0.1	1.2
511	4.56	0.05	10.00	4.55	0.04	10.00	4.56	0.07	10.00	4.55	0.07	10.00	2.4	1.4	2.2
512	4.56	0.04	10.00	4.55	0.04	10.00	4.56	0.08	10.00	4.55	0.07	10.00	0.7	0.7	0.6
513	4.56	0.06	10.00	4.55	0.05	10.00	4.56	0.10	10.00	4.55	0.07	10.00	0.1	0.6	0.4
514	4.56	0.06	10.00	4.55	0.05	10.00	4.56	0.10	10.00	4.55	0.06	10.00	0.2	0.3	0.3
515	4.56	0.05	10.00	4.55	0.05	10.00	4.56	0.11	10.00	4.55	0.05	10.00	0.4	0.2	0.3
516	4.56	0.04	10.00	4.55	0.05	10.00	4.56	0.10	10.00	4.55	0.04	10.00	0.4	0.2	0.3
517	4.56	0.04	10.00	4.55	0.06	10.00	4.56	0.09	10.00	4.55	0.03	10.00	0.2	0.6	0.5
518	4.56	0.02	10.00	4.55	0.06	10.00	4.56	0.06	10.00	4.55	0.03	10.00	0.7	0.3	0.7
519	4.56	0.02	10.00	4.55	0.06	10.00	4.56	0.04	10.00	4.55	0.02	10.00	1.2	1.7	1.2
520	4.56	0.05	10.00	4.55	0.05	10.00	4.56	0.06	10.00	4.55	0.02	10.00	0.2	1.5	1.2
521	4.56	0.05	10.00	4.55	0.05	10.00	4.56	0.06	10.00	4.55	0.02	10.00	0.1	0.3	0.3
522	4.56	0.04	10.00	4.55	0.04	10.00	4.56	0.05	10.00	4.55	0.01	10.00	0.3	0.3	0.3
523	4.56	0.03	10.00	4.55	0.04	10.00	4.56	0.05	10.00	4.55	0.01	10.00	0.3	0.1	0.2
524	4.56	0.03	10.00	4.55	0.04	10.00	4.56	0.04	10.00	4.55	0.01	10.00	0.3	0.1	0.2
525	4.56	0.01	10.00	4.55	0.04	10.00	4.56	0.03	10.00	4.55	0.01	10.00	0.1	0.3	0.3
526	4.56	0.02	10.00	4.55	0.03	10.00	4.56	0.01	10.00	4.55	0.01	10.00	0.6	1.0	0.8
527	4.56	0.04	10.00	4.55	0.03	10.00	4.56	0.02	10.00	4.55	0.01	10.00	0.3	0.7	0.7
528	4.56	0.04	10.00	4.55	0.03	10.00	4.56	0.02	10.00	4.55	0.01	10.00	0.2	0.4	0.4
529	4.56	0.03	10.00	4.55	0.02	10.00	4.56	0.02	10.00	4.55	0.00	10.00	0.5	0.4	0.5
530	4.56	0.01	10.00	4.55	0.03	10.00	4.56	0.02	10.00	4.55	0.01	10.00	0.2	0.2	0.2
531	4.56	0.01	10.00	4.55	0.02	10.00	4.56	0.02	10.00	4.55	0.01	10.00	0.2	0.2	0.2
532	4.56	0.01	10.00	4.55	0.02	10.00	4.56	0.02	10.00	4.55	0.01	10.00	0.1	0.3	0.2
533	4.56	0.02	10.00	4.55	0.02	10.00	4.56	0.02	10.00	4.55	0.01	10.00	0.2	0.2	0.2
534	4.56	0.01	10.00	4.55	0.02	10.00	4.56	0.01	10.00	4.55	0.00	10.00	2.5	0.5	1.3
535	4.56	0.02	10.00	4.55	0.02	10.00	4.56	0.02	10.00	4.55	0.00	10.00	0.2	0.4	0.4
536	4.56	0.02	10.00	4.55	0.02	10.00	4.56	0.02	10.00	4.55	0.00	10.00	0.2	0.3	0.3
537	4.56	0.01	10.00	4.55	0.02	10.00	4.56	0.02	10.00	4.55	0.00	10.00	0.2	0.4	0.3
538	4.56	0.02	10.00	4.55	0.02	10.00	4.56	0.02	10.00	4.55	0.00	10.00	0.1	0.4	0.3
539	4.56	0.02	10.00	4.55	0.02	10.00	4.56	0.02	10.00	4.55	0.00	10.00	0.1	0.4	0.3
540	4.56	0.02	10.00	4.55	0.01	10.00	4.56	0.02	10.00	4.55	0.00	10.00	0.2	0.3	0.3
541	4.56	0.01	10.00	4.55	0.01	10.00	4.56	0.01	10.00	4.55	0.00	10.00	0.5	0.8	0.6
542	4.56	0.01	10.00	4.55	0.01	10.00	4.56	0.01	10.00	4.55	0.00	10.00	0.2	0.3	0.3
543	4.56	0.01	10.00	4.55	0.01	10.00	4.56	0.01	10.00	4.55	0.00	10.00	0.3	0.3	0.3
544	4.56	0.00	10.00	4.55	0.01	10.00	4.56	0.02	10.00	4.55	0.00	10.00	0.2	0.1	0.2
545	4.56	0.01	10.00	4.55	0.01	10.00	4.56	0.02	10.00	4.55	0.00	10.00	0.2	0.3	0.3
546	4.56	0.01	10.00	4.55	0.01	10.00	4.56	0.01	10.00	4.55	0.00	10.00	0.2	0.4	0.3
547	4.56	0.01	10.00	4.55	0.01	10.00	4.56	0.01	10.00	4.55	0.00	10.00	2.8	0.3	1.4
548	4.56	0.01	10.00	4.55	0.01	10.00	4.56	0.01	10.00	4.55	0.00	10.00	0.3	0.4	0.3
549	4.56	0.01	10.00	4.55	0.01	10.00	4.56	0.01	10.00	4.55	0.00	10.00	0.4	0.3	0.4
550	4.56	0.01	10.00	4.55	0.01	10.00	4.56	0.02	10.00	4.55	0.00	10.00	0.2	0.2	0.2
551	4.56	0.00	10.00	4.55	0.01	10.00	4.56	0.01	10.00	4.55	0.00	10.00	0.0	0.3	0.3
552	4.56	0.01	10.00	4.55	0.01	10.00	4.56	0.01	10.00	4.55	0.00	10.00	0.1	0.3	0.3
553	4.56	0.01	10.00	4.55	0.01	10.00	4.56	0.01	10.00	4.55	0.00	10.00	0.5	0.2	0.3
554	4.56	0.01	10.00	4.55	0.01	10.00	4.56	0.00	10.00	4.55	0.00	10.00	3.2	1.1	1.8
555	4.56	0.01	10.00	4.55	0.01	10.00	4.56	0.01	10.00	4.55	0.00	10.00	0.4	0.1	0.4
556	4.56	0.02	10.00	4.55	0.01	10.00	4.56	0.02	10.00	4.55	0.00	10.00	0.3	0.4	0.4
557	4.56	0.01	10.00	4.55	0.01	10.00	4.56	0.02	10.00	4.55	0.00	10.00	0.1	0.3	0.2
558	4.56	0.00	10.00	4.55	0.01	10.00	4.56	0.01	10.00	4.55	0.00	10.00	0.2	0.3	0.2
559	4.56	0.00	10.00	4.55	0.01	10.00	4.56	0.01	10.00	4.55	0.00	10.00	0.1	0.3	0.3
560	4.56	0.01	10.00	4.55	0.01	10.00	4.56	0.01	10.00	4.55	0.00	10.00	0.3	0.2	0.3
561	4.56	0.01	10.00	4.55	0.01	10.00	4.56	0.00	10.00	4.55	0.00	10.00	3.0	0.7	1.6
562	4.56	0.01	10.00	4.55	0.01	10.00	4.56	0.01	10.00	4.55	0.00	10.00	0.3	0.2	0.3
563	4.56	0.02	10.00	4.55	0.02	10.00	4.56	0.02	10.00	4.55	0.00	10.00	0.2	0.3	0.3
564	4.56	0.01	10.00	4.55	0.02	10.00	4.56	0.02	10.00	4.55	0.00	10.00	0.2	0.2	0.2
565	4.56	0.01	10.00	4.55	0.02	10.00	4.56	0.02	10.00	4.55	0.00	10.00	0.2	0.3	0.2
566	4.56	0.02	10.00	4.55	0.02	10.00	4.56	0.02	10.00	4.55	0.00	10.00	0.1	0.4	0.3
567	4.56	0.03	10.00	4.55	0.03	10.00	4.56	0.02	10.00	4.55	0.00	10.00	0.3	0.5	0.4
568	4.56	0.03	10.00	4.55	0.03	10.00	4.56	0.01	10.00	4.55	0.00	10.00	2.6	0.4	1.4
569	4.56	0.04	10.00	4.55	0.04	10.00	4.56	0.01	10.00	4.55	0.00	10.00	0.2	0.3	0.3
570	4.56	0.06	10.00	4.55	0.04	10.00	4.56	0.02	10.00	4.55	0.00	10.00	0.4	0.3	0.4
571	4.56	0.08	10.00	4.55	0.05	10.00	4.56	0.04	10.00	4.55	0.01	10.00	0.6	0.5	0.5
572	4.56	0.10	10.00	4.55	0.06	10.00	4.56	0.06	10.00	4.55	0.02	10.00	0.8	1.1	1.0
573	4.56	0.08	10.00	4.55	0.06	10.00	4.56	0.06	10.00	4.55	0.02	10.00	1.8	0.4	1.1
574	4.56	0.09	10.00	4.55	0.06										

Opera L073	Tratto 212	Settore E	CEE 16	WBS IM0000	Id. doc. REL	N. prog. 01	Rev. A	Pag. di Pag. 17 di 17
---------------	---------------	--------------	-----------	---------------	-----------------	----------------	-----------	--------------------------

581	4.56	0.06	10.00	4.55	0.04	10.00	4.56	0.09	10.00	4.55	0.06	10.00	0.4	0.5	0.5
582	4.56	0.06	10.00	4.55	0.04	10.00	4.56	0.08	10.00	4.55	0.06	10.00	0.8	0.4	0.6
583	4.56	0.01	10.00	4.55	0.04	10.00	4.56	0.04	10.00	4.55	0.06	10.00	0.6	0.5	0.5
584	4.56	0.04	10.00	4.55	0.03	10.00	4.56	0.07	10.00	4.55	0.07	10.00	2.4	1.1	2.1

5.5 INVILUPPO ARMATURE TEORICHE GUSCI DEL PANNELLO TIPO

unità di misura:
 lunghezze : [cm] - forze : [daN]
 momenti : [daNcm/cm] - tensioni : [daN/cm²]
 pesi specifici : [daN/cm³] - angoli : [gradi]
 armature : [cm²]

CASI DI CARICO:
 Nome Descrizione
 4 VERT SLU
 8 SI SMA X
 9 SI SMA Y

DATI:
 tensione di calcolo acciai (fyd): 3826.09 daN/cm²
 tensione di calcolo cls (fcd): 155.62 daN/cm²
 copri ferro inferiore (asse armatura): 3 cm
 copri ferro superiore (asse armatura): 3 cm
 moltiplicatore sollecitazioni : 1

GUSCI	AREE ARMATURA (cm² al metro)									tauX	tauY	tauT			
	INF. ORIZZ.			INF. VERTIC.			SUP. ORIZZ.						SUP. VERTIC.		
	area	EpsC	EpsF	area	EpsC	EpsF	area	EpsC	EpsF	area	EpsC	EpsF			
641	1.43	0.00	10.00	5.03	2.00	10.00	1.43	0.00	10.00	5.03	0.12	10.00	0.1	0.1	0.1
642	1.43	0.00	10.00	5.03	2.00	10.00	1.43	0.00	10.00	5.03	0.10	10.00	0.0	0.1	0.0
643	1.43	0.00	10.00	0.94	2.00	10.00	1.43	0.00	10.00	0.94	0.13	10.00	0.0	0.1	0.1
644	1.43	2.00	10.00	0.94	2.00	10.00	1.43	0.01	10.00	0.94	0.15	10.00	0.0	0.1	0.1
645	1.43	0.00	10.00	0.94	2.00	-2.00	1.43	0.00	10.00	0.94	0.15	10.00	0.0	0.1	0.1
646	1.43	0.00	10.00	5.03	0.00	10.00	1.43	0.00	10.00	5.03	0.05	10.00	0.0	0.1	0.1
647	1.43	0.00	10.00	5.03	0.00	10.00	1.43	0.00	10.00	5.03	0.01	10.00	0.1	0.1	0.1
834	1.43	0.00	10.00	5.03	2.00	10.00	1.43	0.00	10.00	5.03	3.31	10.00	0.0	0.0	0.0
835	1.43	0.00	10.00	5.03	2.00	-2.00	1.43	0.00	10.00	5.03	3.16	10.00	0.0	0.0	0.0
836	1.43	0.00	10.00	0.94	2.00	10.00	1.43	0.00	10.00	0.94	3.14	10.00	0.0	0.1	0.1
837	1.43	0.00	10.00	0.94	2.00	10.00	1.43	0.00	10.00	0.94	0.12	10.00	0.1	0.1	0.1
838	1.43	0.00	10.00	0.94	2.00	10.00	1.43	0.00	10.00	0.94	0.12	10.00	0.0	0.1	0.1
839	1.43	0.00	10.00	5.03	2.00	10.00	1.43	0.00	10.00	5.03	0.09	10.00	0.0	0.0	0.0
840	1.43	0.00	10.00	5.03	2.00	10.00	1.43	0.00	10.00	5.03	0.11	10.00	0.0	0.0	0.0
1027	1.43	0.00	10.00	5.03	2.00	10.00	1.43	0.00	10.00	5.03	3.25	10.00	0.1	0.1	0.1
1028	1.43	0.00	10.00	5.03	2.00	-2.00	1.43	0.00	10.00	5.03	3.40	10.00	0.0	0.2	0.1
1029	1.43	0.00	10.00	0.94	2.00	10.00	1.43	0.00	10.00	0.94	3.40	10.00	0.1	0.2	0.1
1030	1.43	0.00	10.00	0.94	2.00	10.00	1.43	0.00	10.00	0.94	0.06	10.00	0.1	0.1	0.1
1031	1.43	0.00	10.00	0.94	2.00	10.00	1.43	0.00	10.00	0.94	3.28	10.00	0.1	0.2	0.1
1032	1.43	0.00	10.00	5.03	2.00	-2.00	1.43	0.00	10.00	5.03	3.44	10.00	0.0	0.2	0.1
1033	1.43	0.00	10.00	5.03	2.00	10.00	1.43	0.00	10.00	5.03	3.15	10.00	0.1	0.1	0.1
1186	1.43	0.00	10.00	5.03	2.00	10.00	1.43	0.00	10.00	5.03	2.96	10.00	0.1	0.1	0.1
1187	1.43	0.00	10.00	5.03	2.00	-2.00	1.43	0.00	10.00	5.03	2.94	10.00	0.2	0.1	0.2
1188	1.43	0.00	10.00	5.03	2.00	-2.00	1.43	0.00	10.00	5.03	3.10	10.00	0.2	0.1	0.2
1189	1.43	0.00	10.00	5.03	2.00	10.00	1.43	0.00	10.00	5.03	3.10	10.00	0.1	0.1	0.1
1283	1.43	0.00	10.00	5.03	2.00	10.00	1.43	0.00	10.00	5.03	2.82	10.00	0.0	0.1	0.1
1284	1.43	0.00	10.00	5.03	2.00	-2.00	1.43	0.00	10.00	5.03	2.79	10.00	0.2	0.1	0.2
1285	1.43	0.00	10.00	5.03	2.00	-2.00	1.43	0.00	10.00	5.03	2.55	-1.76	0.2	0.1	0.2
1286	1.43	0.00	10.00	5.03	2.00	-2.00	1.43	0.00	10.00	5.03	2.55	10.00	0.0	0.1	0.1
1395	1.43	0.00	10.00	5.03	2.00	-2.00	1.43	0.00	10.00	5.03	2.28	-1.84	0.0	0.2	0.1
1396	1.43	0.00	10.00	5.03	2.00	-2.00	1.43	0.00	10.00	5.03	2.62	-1.85	0.1	0.2	0.2
1397	1.43	0.00	10.00	0.94	2.00	10.00	1.43	0.00	10.00	0.94	3.12	10.00	0.1	0.2	0.1
1398	1.43	0.00	10.00	0.94	2.00	10.00	1.43	0.00	10.00	0.94	0.05	10.00	0.0	0.1	0.1
1399	1.43	0.00	10.00	0.94	2.00	10.00	1.43	0.00	10.00	0.94	3.34	10.00	0.1	0.2	0.1
1400	1.43	0.00	10.00	5.03	2.00	-2.00	1.43	0.00	10.00	5.03	2.61	-1.76	0.0	0.2	0.2
1401	1.43	0.00	10.00	5.03	2.00	-2.00	1.43	0.00	10.00	5.03	2.32	-1.81	0.0	0.2	0.1
1559	1.43	0.00	10.00	5.03	2.00	-2.00	1.43	0.00	10.00	5.03	2.17	-1.84	0.0	0.1	0.1
1560	1.43	0.00	10.00	5.03	2.00	-2.00	1.43	0.00	10.00	5.03	2.31	-1.78	0.0	0.0	0.0
1561	1.43	0.00	10.00	0.94	2.00	10.00	1.43	0.00	10.00	0.94	3.14	10.00	0.0	0.0	0.0
1562	1.43	0.00	10.00	0.94	2.00	10.00	1.43	0.00	10.00	0.94	3.31	10.00	0.0	0.0	0.0
1563	1.43	0.00	10.00	0.94	2.00	-2.00	1.43	0.00	10.00	0.94	2.86	10.00	0.0	0.0	0.0
1564	1.43	0.00	10.00	5.03	2.00	-2.00	1.43	0.00	10.00	5.03	2.30	-1.80	0.0	0.0	0.0
1565	1.43	2.41	10.00	5.03	2.00	-2.00	1.43	0.00	10.00	5.03	2.17	-1.86	0.0	0.1	0.0
1721	1.43	2.19	10.00	5.03	2.00	-2.00	1.43	0.00	10.00	5.03	2.19	-1.80	0.0	0.0	0.0
1722	1.43	2.00	10.00	5.03	2.00	-2.00	1.43	0.01	10.00	5.03	2.21	-1.76	0.0	0.0	0.0
1723	1.43	2.00	10.00	0.94	2.00	-2.00	1.43	0.01	10.00	0.94	2.30	-1.68	0.0	0.0	0.0
1724	1.43	2.16	10.00	0.94	2.00	-2.00	1.43	2.31	10.00	0.94	2.30	-1.60	0.0	0.0	0.0
1725	1.43	2.04	10.00	0.94	2.00	-2.00	1.43	2.70	10.00	0.94	2.21	-1.80	0.0	0.0	0.0
1726	1.43	2.01	10.00	5.03	2.00	-2.00	1.43	2.50	10.00	5.03	2.14	-1.84	0.0	0.0	0.0
1727	1.43	2.03	10.00	5.03	2.00	-2.00	1.43	2.74	10.00	5.03	2.13	-1.87	0.0	0.0	0.0

2.1.2 PEDEMONTANA DELLE MARCHE
Secondo stralcio funzionale: Matelica Nord – Matelica Sud/Castelraimondo Nord

Opera L073	Tratto 212	Settore E	CEE 16	WBS IM0000	Id. doc. REL	N. prog. 01	Rev. A	Pag. di Pag. 18 di 18
---------------	---------------	--------------	-----------	---------------	-----------------	----------------	-----------	--------------------------

1887	1.43	2.34	10.00	5.03	2.00	-2.00	1.43	0.01	10.00	5.03	2.18	-1.79	0.0	0.0	0.0
1888	1.43	3.07	-1.35	5.03	2.00	-2.00	1.43	2.98	10.00	5.03	2.19	-1.78	0.0	0.0	0.0
1889	1.43	2.06	-1.60	0.94	2.00	-2.00	1.43	2.36	10.00	0.94	2.23	-1.73	0.0	0.0	0.0
1890	1.43	2.10	10.00	0.94	2.00	-2.00	1.43	2.23	10.00	0.94	2.24	-1.70	0.0	0.0	0.0
1891	1.43	2.49	-1.75	0.94	2.00	-2.00	1.43	2.70	10.00	0.94	2.18	-1.82	0.0	0.0	0.0
1892	1.43	2.37	10.00	5.03	2.00	-2.00	1.43	2.61	10.00	5.03	2.12	-1.86	0.0	0.0	0.0
1893	1.43	2.00	10.00	5.03	2.00	-2.00	1.43	2.63	10.00	5.03	2.11	-1.88	0.0	0.0	0.0
2056	1.43	0.00	10.00	5.03	2.00	-2.00	1.43	0.00	10.00	5.03	2.18	-1.80	0.0	0.0	0.0
2057	1.43	2.00	10.00	5.03	2.00	-2.00	1.43	2.81	10.00	5.03	2.18	-1.78	0.0	0.0	0.0
2058	1.43	2.00	10.00	0.94	2.00	-2.00	1.43	2.17	10.00	0.94	2.32	-1.76	0.0	0.0	0.0
2059	1.43	2.86	10.00	0.94	2.00	-2.00	1.43	2.38	10.00	0.94	2.35	10.00	0.0	0.0	0.0
2060	1.43	2.13	10.00	0.94	2.00	-2.00	1.43	2.23	10.00	0.94	2.25	-1.83	0.0	0.0	0.0
2061	1.43	2.22	10.00	5.03	2.00	-2.00	1.43	3.39	10.00	5.03	2.11	-1.88	0.0	0.0	0.0
2062	1.43	2.05	10.00	5.03	2.00	-2.00	1.43	2.68	10.00	5.03	2.09	-1.91	0.0	0.0	0.0
2260	1.43	0.00	10.00	5.03	2.01	-2.00	1.43	0.00	10.00	5.03	2.19	-1.82	0.0	0.0	0.0
2261	1.43	0.00	10.00	5.03	2.01	-2.00	1.43	0.00	10.00	5.03	2.27	-1.77	0.0	0.0	0.0
2262	1.43	0.00	10.00	0.94	2.00	10.00	1.43	0.00	10.00	0.94	2.64	10.00	0.0	0.0	0.0
2263	1.43	0.00	10.00	0.94	2.00	10.00	1.43	0.00	10.00	0.94	2.73	10.00	0.0	0.0	0.0
2264	1.43	0.00	10.00	0.94	2.00	10.00	1.43	0.00	10.00	0.94	2.41	10.00	0.0	0.0	0.0
2265	1.43	0.00	10.00	5.03	2.00	-2.00	1.43	0.00	10.00	5.03	2.12	-1.91	0.0	0.0	0.0
2266	1.43	0.00	10.00	5.03	2.01	-2.00	1.43	0.00	10.00	5.03	2.07	-1.94	0.0	0.0	0.0
2448	1.43	0.00	10.00	5.03	2.02	-2.00	1.43	0.00	10.00	5.03	2.21	-1.74	0.0	0.0	0.0
2449	1.43	0.00	10.00	5.03	2.01	-1.99	1.43	0.00	10.00	5.03	2.31	-1.79	0.0	0.0	0.0
2450	1.43	0.00	10.00	0.94	2.00	10.00	1.43	0.00	10.00	0.94	2.85	10.00	0.0	0.0	0.0
2451	1.43	0.00	10.00	0.94	2.00	10.00	1.43	0.00	10.00	0.94	3.36	10.00	0.0	0.0	0.0
2452	1.43	0.00	10.00	0.94	2.00	10.00	1.43	0.00	10.00	0.94	2.32	10.00	0.0	0.0	0.0
2453	1.43	0.00	10.00	5.03	2.02	-1.99	1.43	0.00	10.00	5.03	2.07	-1.93	0.0	0.0	0.0
2454	1.43	0.00	10.00	5.03	2.02	-1.98	1.43	0.00	10.00	5.03	2.05	-1.94	0.0	0.0	0.0
2629	1.43	0.00	10.00	5.03	2.00	10.00	1.43	0.00	10.00	5.03	2.61	10.00	0.0	0.0	0.0
2630	1.43	0.00	10.00	5.03	2.00	-2.00	1.43	0.00	10.00	5.03	2.61	10.00	0.1	0.0	0.1
2631	1.43	2.36	10.00	5.03	2.02	-1.99	1.43	2.00	10.00	5.03	2.04	-1.97	0.1	0.0	0.1
2632	1.43	3.39	10.00	5.03	2.02	-1.97	1.43	2.00	10.00	5.03	2.04	-1.93	0.0	0.0	0.0
2702	1.43	2.71	10.00	5.03	2.00	10.00	1.43	3.11	10.00	5.03	2.24	10.00	0.1	0.1	0.1
2703	1.43	2.01	10.00	5.03	2.00	10.00	1.43	2.73	10.00	5.03	3.44	10.00	0.1	0.1	0.1
2704	1.43	2.56	-1.74	5.03	2.04	-2.00	1.43	2.00	10.00	5.03	2.04	-1.99	0.1	0.1	0.1
2705	1.43	2.34	10.00	5.03	2.04	-1.91	1.43	3.07	10.00	5.03	2.04	-1.89	0.0	0.0	0.0
2856	10.47	3.29	10.00	5.03	2.00	10.00	10.47	3.07	10.00	5.03	2.59	10.00	0.5	0.3	0.4
2857	10.47	2.00	-2.00	5.03	2.00	-2.00	10.47	3.03	10.00	5.03	2.80	-1.86	0.2	0.2	0.2
2858	10.47	0.00	10.00	0.94	2.13	10.00	10.47	0.00	10.00	0.94	2.32	10.00	0.3	0.2	0.3
2859	10.47	0.00	10.00	0.94	2.23	10.00	10.47	0.00	10.00	0.94	2.21	10.00	0.1	0.1	0.2
2860	10.47	0.00	10.00	0.94	2.00	10.00	10.47	0.00	10.00	0.94	2.14	10.00	0.2	0.1	0.2
2861	10.47	2.33	-2.00	5.03	2.07	-1.96	10.47	2.00	-2.00	5.03	2.34	-2.00	0.1	0.1	0.1
2862	10.47	3.30	10.00	5.03	2.10	10.00	10.47	2.45	10.00	5.03	2.11	10.00	0.4	0.4	0.4

6. ANALISI E VERIFICHE SOLAIO DI COPERTURA

Nell'ambito del presente paragrafo, si riportano i risultati dell'analisi delle sollecitazioni e relative verifiche del solaio di copertura, da realizzarsi mediante una serie di moduli in c.a.p. prefabbricati.

Il generico modulo è caratterizzato da uno spessore strutturale complessivo di 28cm, opportunamente alleggerito mediante moduli in polistirolo di dimensioni 50x18cm, disposti col fondo a 5cm dall'intradosso del modulo.

Per ulteriori dettagli in merito si rimanda agli elaborati specifici.

6.1 ANALISI DEI CARICHI

Carichi Permanenti			
Peso Proprio Solette e travetti in c.a.		4.00	KN/m ² (strutturale)
Getto integrativo e carico permanente		1.75	KN/m ² (permanenti portati)

Carichi Variabili			
Carico da Neve	2.50	KN/m ²	(Azione Variabile Principale)

Carichi di precompressione

I carichi di precompressione sono valutati con riferimento alla fascia tipo di dimensione B=0.60m, rispetto a cui nel seguito si procede con le relative verifiche.

Trefolo 7 fili Pr EN 10138

Diametro nominale	Sezione
mm	mm ²
9.3	52.0
9.6	55.0
11.3	75.0

N°trefoli :	4			
Tiro iniziale per trefolo(Ti):	97.65	KN	(≅0.7 f_{ptk})	
Tiro finale per trefolo(Tf):	83	KN	(0.85Ti / cadute di tensione al 15%)	
Sforzo di precompressione iniziale	391	KN		
Sforzo di precompressione finale	332	KN		
e _{pG} =	-0.11	m	(eccentricità rispetto al baricentro della sezione)	

6.2 COMBINAZIONI DELLE AZIONI

Per la valutazione dei carichi complessivi di progetto nei riguardi delle verifiche agli SLU e SLE, si fa riferimento a quanto specificato in merito nell'EC2, di cui nel seguito

5.1.2.1. Verifiche agli stati limite ultimi

5.1.2.1.1. GENERALITÀ

Definite le opportune combinazioni delle azioni (azioni di calcolo, F_d), si valutano le azioni interne (sollecitazioni di calcolo, E_d) nei vari elementi strutturali.

Per ogni elemento strutturale sono valutate le resistenze (resistenze di calcolo, R_d).

La verifica della sicurezza agli stati limite ultimi si ritiene soddisfatta controllando che, per ogni elemento strutturale e per ciascuna delle combinazioni delle azioni prese in esame, risulti:

$$R_d \geq E_d$$

5.1.2.1.2. LE AZIONI E LE LORO COMBINAZIONI

Le azioni caratteristiche (carichi, distorsioni, variazioni termiche, ecc.) devono essere definite in accordo con quanto indicato nei capitoli 3, 4 e 6 delle presenti norme.

Per costruzioni civili o industriali di tipo corrente e per le quali non esistano regolamentazioni specifiche, le azioni di calcolo F_d si ottengono (nello spirito di quanto indicato nel capitolo 2) combinando le azioni caratteristiche secondo la seguente formula di correlazione:

$$F_d = \sum_{j=1}^m (\gamma_{Gj} \cdot \gamma_{EGj} \cdot G_{Kj}) + \gamma_{Q1} \cdot \gamma_{EQ1} \cdot Q_{K1} + \sum_{i=2}^n (\psi_{0i} \cdot \gamma_{Qi} \cdot \gamma_{EQi} \cdot Q_{Ki}) + \sum_{h=1}^l (\gamma_{Ph} \cdot \gamma_{EPH} \cdot P_{Kh})$$

dove:

SLU

5.1.2.2.2. LE AZIONI E LE LORO COMBINAZIONI

Le azioni caratteristiche (carichi, distorsioni, variazioni termiche, ecc.) devono essere definite in accordo con quanto indicato nei capitoli 3, 4 e 6 delle presenti norme.

Per costruzioni civili o industriali di tipo corrente e per le quali non esistano regolamentazioni specifiche, le azioni di calcolo F_d si ottengono (nello spirito di quanto indicato nel capitolo 2) combinando le azioni caratteristiche secondo le seguenti formule di correlazione:

combinazioni frequenti:

$$F_d = \sum_{j=1}^m (\gamma_{Gj} \cdot \gamma_{EGj} \cdot G_{Kj}) + \psi_{11} \cdot \gamma_{Q1} \cdot \gamma_{EQ1} \cdot Q_{K1} + \sum_{i=2}^n (\psi_{2i} \cdot \gamma_{Qi} \cdot \gamma_{EQi} \cdot Q_{Ki}) + \sum_{h=1}^l (\gamma_{Ph} \cdot \gamma_{EPH} \cdot P_{Kh})$$

combinazioni quasi permanenti:

$$F_d = \sum_{j=1}^m (\gamma_{Gj} \cdot \gamma_{EGj} \cdot G_{Kj}) + \psi_{21} \cdot \gamma_{Q1} \cdot \gamma_{EQ1} \cdot Q_{K1} + \sum_{i=2}^n (\psi_{2i} \cdot \gamma_{Qi} \cdot \gamma_{EQi} \cdot Q_{Ki}) + \sum_{h=1}^l (\gamma_{Ph} \cdot \gamma_{EPH} \cdot P_{Kh})$$

dove:

SLE

Combinazione	Azione di progetto	Azione permanente	Azione di pretensione	1° Azione variabile	2° Azione variabile	Commento
	E_d	G_k	P_k	Q_{1k}	Q_{2k}	
Stati limite ultimi	$n.1$	γ_g	γ_p	$\gamma_q \cdot 1$	$\gamma_q \cdot \psi_{0,2}$	2 combinazioni, prendendo a turno una delle 2 azioni variabili come dominante
	$n.2$	γ_g	γ_p	$\gamma_q \cdot \psi_{0,1}$	$\gamma_q \cdot 1$	
Stati limite di esercizio						
	<i>Rara</i>	$n.1$	1	1	$\psi_{0,1}$	$\psi_{0,2}$
<i>Frequente</i>	$n.1$	1	1	$\psi_{1,2}$	$\psi_{2,2}$	2 combinazioni, prendendo a turno una delle 2 azioni variabili come dominante
	$n.2$	1	1	$\psi_{2,1}$	$\psi_{1,2}$	
<i>Quasi permanente</i>	$n.1$	1	1	$\psi_{2,1}$	$\psi_{2,2}$	1 unica combinazione

Tabella 5.1-III

Azione	ψ_{0i}
carichi variabili nei fabbricati per abitazione ed uffici	0,7
negozi, uffici aperti al pubblico ed autorimesse	0,7
magazzini, depositi	1,0
variazioni termiche	0,6
vento	0,6
neve	0,6

Tabella 5.1-VII

Azione	ψ_{1i}	ψ_{2i}
carichi variabili nei fabbricati per abitazione ed uffici	0,5	0,3
negozi, uffici aperti al pubblico ed autorimesse	0,7	0,6
magazzini, depositi	0,9	0,8
vento	0,2	0
neve	0,3	0,1

Per tutte le azioni variabili non contemplate nella Tabella 5.1-VII, si deve assumere $\psi = 1,0$.

Per il cao di calcolo in esame si è assunto quindi:

Carichi Permanenti

Coefficienti di combinazione agli SLU

$$\gamma_{G1} = 1.4 \qquad \gamma_{EG1} = 1$$

Coefficienti di combinazione agli SLE

$$\gamma_{G1} = 1 \qquad \gamma_{EG1} = 1$$

Carichi Variabili

Coefficienti di combinazione agli SLU

$$\gamma_{G1} = 1.4 \qquad \gamma_{EG1} = 1$$

Coefficienti di combinazione agli SLE

$$\gamma_{G1} = 1 \qquad \gamma_{EG1} = 1$$

Carichi di precompressione / (B=0.60m)

Coefficienti di combinazione agli SLU

$$\gamma_{P\text{ fav}} = 0.9 \qquad \gamma_{EP} = 1$$

Coefficienti di combinazione agli SLE

$$\gamma_{P} = 1 \qquad \gamma_{EP} = 1$$

6.3 SOLLECITAZIONI DI CALCOLO

Per la valutazione delle sollecitazioni di progetto, si è fatto riferimento allo schema di trave appoggiata di cui nel seguito:

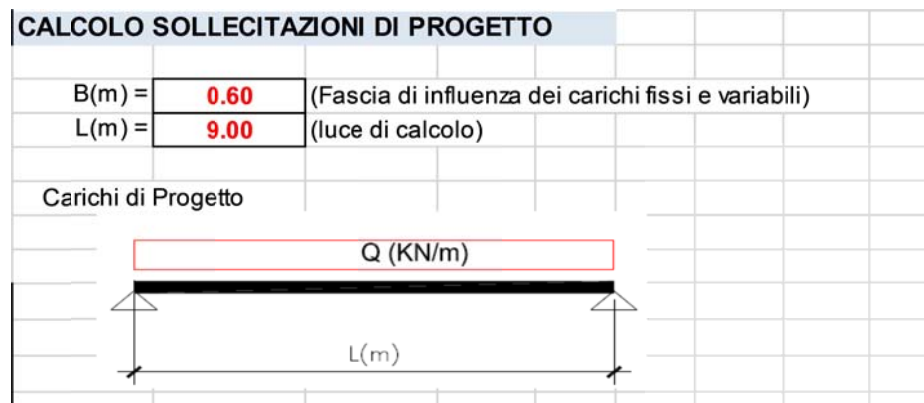

Sulla scorta dei valori dei coefficienti parziali e di combinazione indicati al paragrafo precedente, sono stati valutati i seguenti carichi di progetto:

FASE DI TIRO (Precompressione al 100% e solo pesi propri)

$Q_{SLE} =$	2.40	KN/m	(Carico combinato risultante allo SLE)
-------------	-------------	------	--

FASE FINALE (Precompressione all 85% e carichi tutti presenti)

$Q_{SLU} =$	6.93	KN/m	(Carico combinato risultante allo SLU)
$Q_{SLE} =$	4.95	KN/m	(Carico combinato risultante allo SLE)

Stimando in circa 70cm la lunghezza di trasferimento dello sforzo di precompressione in corrispondenza della sezione di appoggio di calcolo posta a circa 35cm dal terminale del modulo, le sollecitazioni di precompressione saranno ridotte del fattore 0.5(35/70) per cui risulta:

crid P **0.50**

FASE DI TIRO (Solo precompressione e peso propri)

SLE			
Appoggio		Mezzeria	
N (KN)=	195.3	N (KN)=	390.6
V (KN)=	10.8	V (KN)=	0
M (KNm)=	-21.5	M (KNm)=	-18.7

FASE FINALE

SLU			
Appoggio		Mezzeria	
N (KN)=	149.4045	N (KN)=	298.81
V (KN)=	31.2	V (KN)=	0
M (KNm)=	-16.4	M (KNm)=	37.3

SLE			
Appoggio		Mezzeria	
N (KN)=	166.005	N (KN)=	332.01
V (KN)=	22.3	V (KN)=	0
M (KNm)=	-18.3	M (KNm)=	13.6

6.4 VERIFICHE IN FASE DI TIRO

Di seguito si riporta uno schema della sezione resistente considerata nelle verifiche:

CLS : $R_{ck} = R_{ckj} = 50 \text{ MPa}$

$B_{max} = 60 \text{ cm}$

$B_{min} = 10 \text{ cm}$

$H = 28 \text{ cm}$

$A'f = 1 \phi 5/20$

$Af = 1 \phi 5/20$

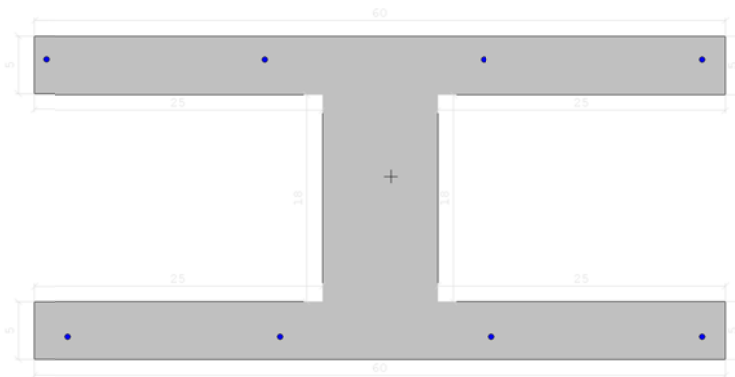

6.4.1 SEZIONE DI APPOGGIO

Verifica alle tensioni :

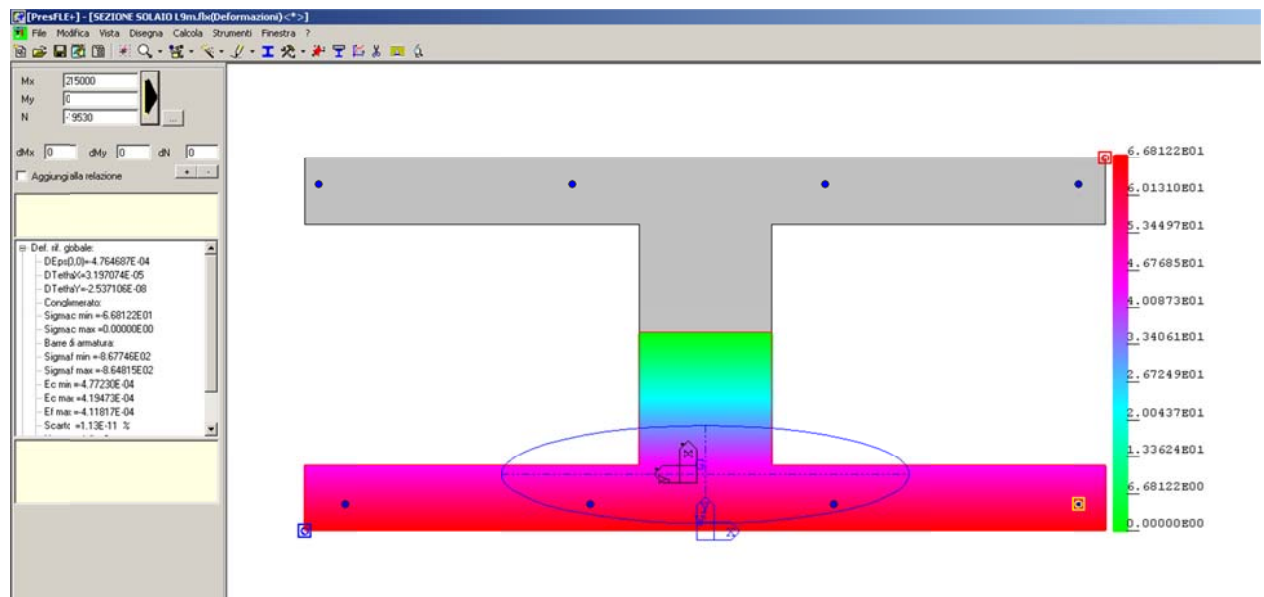

La sezione risulta parzializzata; le tensioni di compressione maggiormente elevate si registrano al lembo inferiore della sezione, come atteso, risultando tuttavia nell'ordine dei 67 daN/cm² e pertanto ampiamente inferiori alle tensioni ammissibili per un calcestruzzo C40/50 nella fase iniziale di precompressione

Verifica a fessurazione :

I risultati della Verifica a Fessurazione forniscono per $N=195$ KN un valore del momento di prima fessurazione della sezione pari a circa 31.3 KNm; la sezione risulta pertanto non fessurata in fase di tiro.

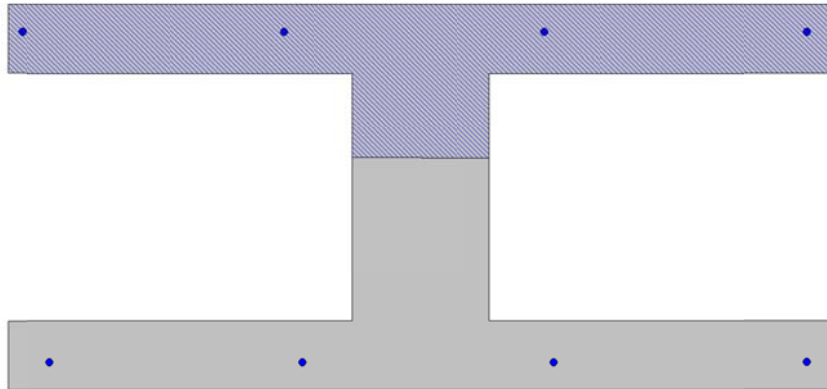
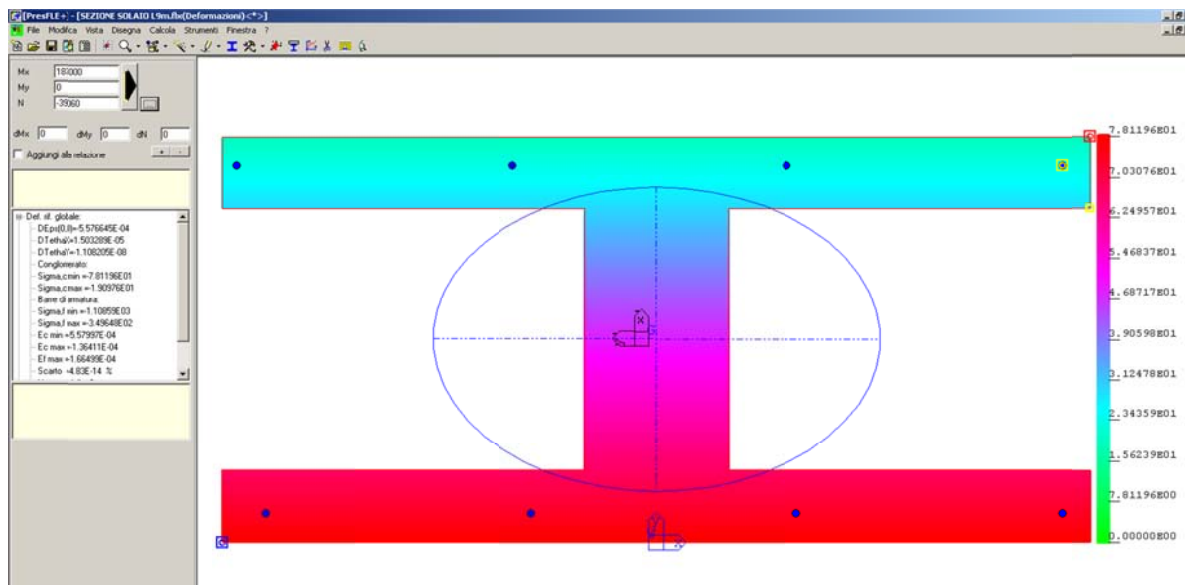
6.4.2 SEZIONE DI MEZZERIA
Verifica alle tensioni :

La sezione risulta interamente compressa, con valori massimi registrati al lembo inferiore della sezione, come atteso, nell'ordine dei 78 daN/cm² e pertanto ampiamente inferiori alle tensioni ammissibili per un calcestruzzo Rck 50

Verifica a fessurazione :

Non significativa, risultando la sezione interamente compressa.

6.5 VERIFICHE IN FASE FINALE

Di seguito si riporta uno schema della sezione resistente considerata nelle verifiche:

CLS : $R_{ck} = 50 \text{ MPa}$

$B_{max} = 60 \text{ cm}$

$B_{min} = 10 \text{ cm}$

$H = 28 \text{ cm}$

$A'f = 1 \phi 5/20$

$Af = 1 \phi 5/20$

Di seguito si riporta uno schema della sezione resistente considerata nelle verifiche:

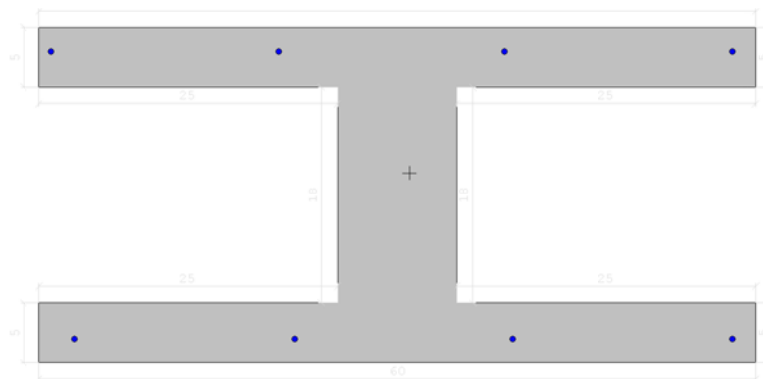

6.5.1 SEZIONE DI MEZZERIA

Verifica a Pressoflessione SLU :

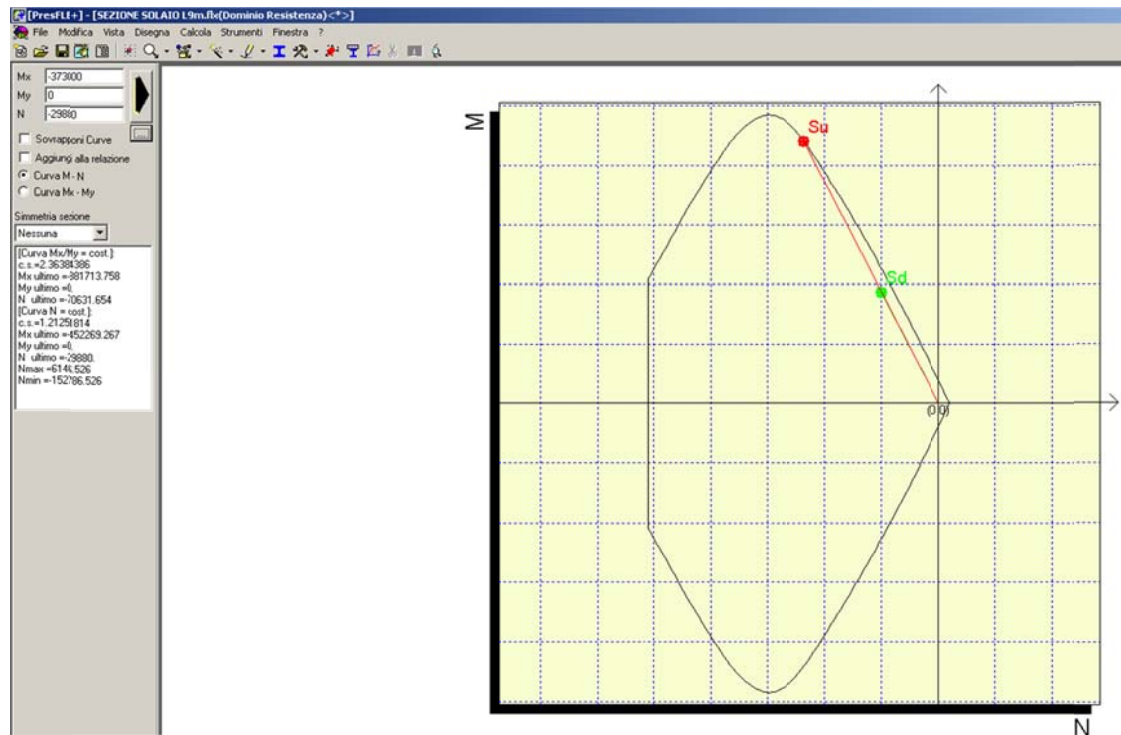

Opera L073	Tratto 212	Settore E	CEE 16	WBS M0000	Id. doc. REL	N. prog. 01	Rev. A	Pag. di Pag. 27 di 27
---------------	---------------	--------------	-----------	--------------	-----------------	----------------	-----------	--------------------------

La verifica a pressoflessione allo SLU, fornisce un coefficiente di sicurezza minimo $M_{rd}/M_d=1.21$ (ipotesi $N=costante$) ovvero $M_{rd} \geq 45.2 \text{ kNm}$; la verifica è da intendersi pertanto soddisfatta.

Verifica a alle tensioni SLE :

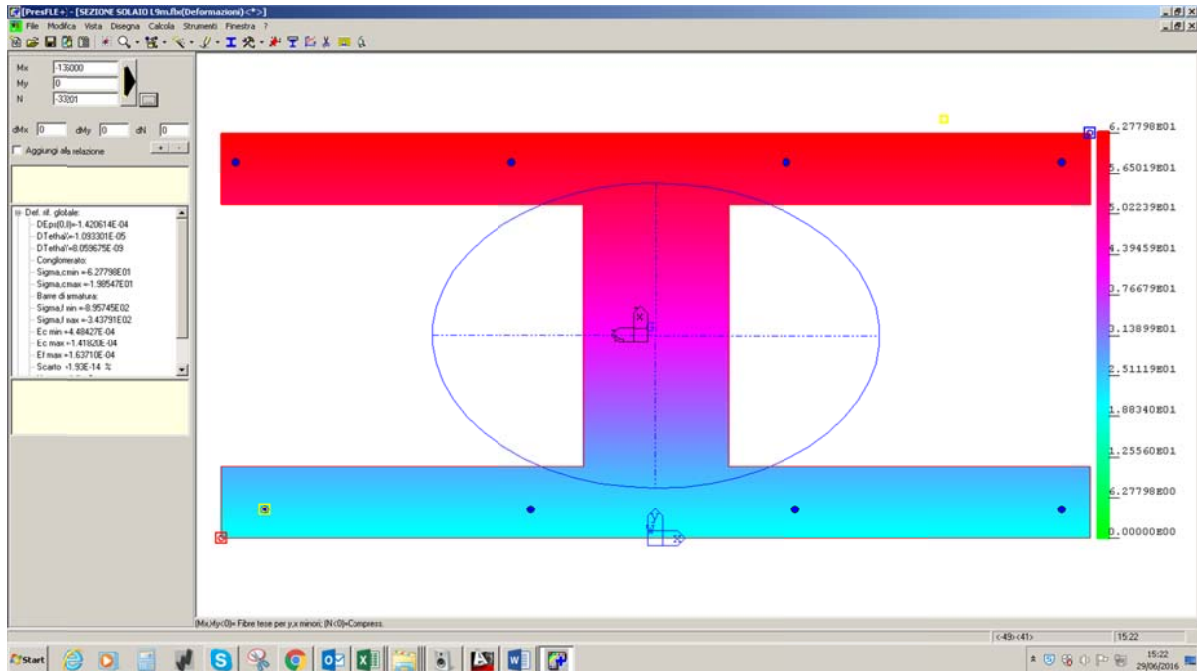

La sezione risulta interamente compressa, con valori massimi registrati al lembo inferiore della sezione, come atteso, nell'ordine dei 63 daN/cm^2 e pertanto ampiamente inferiori alle tensioni ammissibili per un calcestruzzo $R_{ck} 50$

Verifica a fessurazione SLE :

I risultati della Verifica a Fessurazione forniscono per $N=332 \text{ KN}$ un valore del momento di prima fessurazione della sezione pari a circa 43.0 kNm ; la sezione risulta pertanto non fessurata in fase finale.

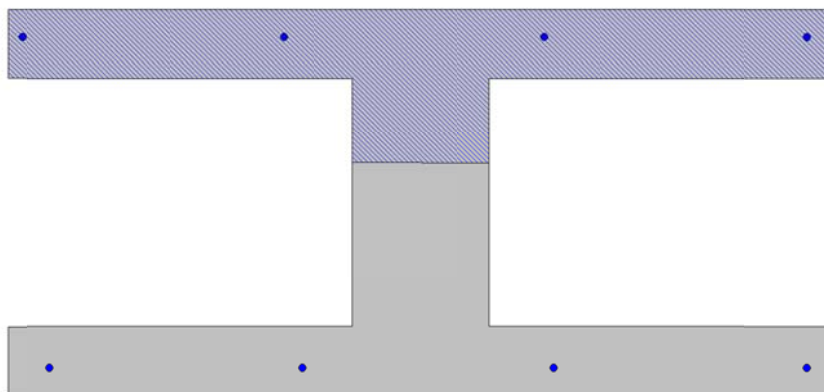

6.5.2 SEZIONE DI APPOGGIO

Verifica a taglio SLU :

Le verifiche a taglio all'appoggio sono condotte considerando cautelativamente la sola sezione resistente del travetto

SEZIONE	Geometrie					Caratteristiche Materiali								
	b _w (cm)	H (cm)	c (cm)	d (cm)	A _c (mm ²)	Calcestruzzo					Acciaio			
						R _{ck} (Mpa)	f _{ck} (Mpa)	F _c	γ _c	α _{cc}	f _{cd} (Mpa)	γ _s	f _{yk} (Mpa)	f _{yd} (Mpa)
SEZIONE APPOGGIO	10	28	3	25.0	28000	50.0	41.5	1.00	1.50	0.85	23.52	1.15	450.00	391

Armature									
Armature trasversali							Armature longitudinali .		
n _b	∅	p(cm)	A _{sw} (mm ²)	α°	α ^{rad}	ω ^{sw}	n	∅	mm ²
2.00	6.0	25	56.55	90	1.57	0.04	3.5	5	68.7

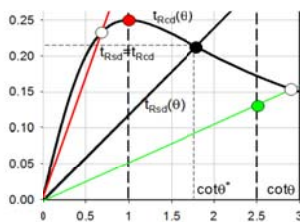

Inclinazione Bielle Compresse					Taglio Compressione				Taglio Trazione		Risultati Verifica a Taglio		
cotgθ*	θ* °	θ° cal	θ ^{rad}	ctgθ	σ _{cp} (Mpa)	α _c	f _{cd} (Mpa)	V _{Rcd} (KN)	V _{Rct} (KN)	V _{Rsd} (KN)	V _{rd}	c (V _{rd} /V _{sd})	Esito
3.913	14.336	21.80	0.380	2.50	5.36	1.23	11.76	112.01	0.00	49.79	49.79	1.60	Soddisfatta

Come evidente dai risultati appena espoti, le verifica è soddisfatta.

7. ORIGINE E CARATTERISTICHE DEI CODICI DI CALCOLO

Nell'ambito del presente paragrafo si riporta una descrizione delle caratteristiche dei Software utilizzati per l'effettuazione delle Analisi 3D e delle Verifiche delle struttura oggetto del presente documento

Nello specifico, il software utilizzato per l'analisi del modello globale della struttura è individuato commercialmente dalla sigla **Midas Civil**, prodotto e distribuito dalla **CSP FEA** (Padova), di cui si possiede regolare licenza, identificata nello specifico da key NUMBER n° 34219EF86526F342, intestata a PROGIN SPA - CENTRO DIREZIONALE DI NAPOLI ISOLA F4 - 80143 NAPOLI.

Per l'esecuzione invece di verifiche aggiuntive di sezioni in cemento armato, si è invece utilizzato il software **PresFle+**, prodotto e distribuito dalla **Concrete srl**, (Padova) di cui si possiede regolare licenza, identificata nello specifico da chiave USB n° **4552054**, intestata a PROGIN SPA - CENTRO DIREZIONALE DI NAPOLI ISOLA F4 - 80143 NAPOLI.

Infine si è ricorso a fogli di calcolo elettronici auto-prodotti, per l'analisi e verifica dei solai di copertura.

Affidabilità dei codici di calcolo

Un attento esame preliminare della documentazione a corredo dei software impiegati ha consentito di valutarne l'affidabilità. La documentazione fornita dal produttore contiene un'esauriente descrizione delle basi teoriche, degli algoritmi impiegati e l'individuazione dei campi d'impiego. Le stesse società produttrici hanno verificato l'affidabilità e la robustezza dei codice di calcolo attraverso un numero significativo di casi prova in cui i risultati sono contenuti in apposita documentazione fornita a corredo dell'acquisto dei prodotti, che per brevità espositiva si omette di allegare al presente documento.

Giudizio motivato di accettabilità dei risultati

I risultati delle elaborazioni esposte nel documento sono state inoltre sottoposte a controlli dal sottoscritto utente del software.

Tale valutazione ha compreso il confronto con i risultati di semplici calcoli, eseguiti con metodi tradizionali, che per brevità espositiva si omette dall'allegare al presente documento.

Inoltre sulla base di considerazioni riguardanti gli stati tensionali e deformativi determinati, si è valutata la validità delle scelte operate in sede di schematizzazione e di modellazione della struttura e delle azioni.

In base a quanto sopra, Il Progettista dichiara pertanto che l'elaborazione è corretta ed idonea al caso specifico, validando conseguentemente i risultati dei calcoli esposti nella presente relazione.