

Autorizzazione Integrata Ambientale

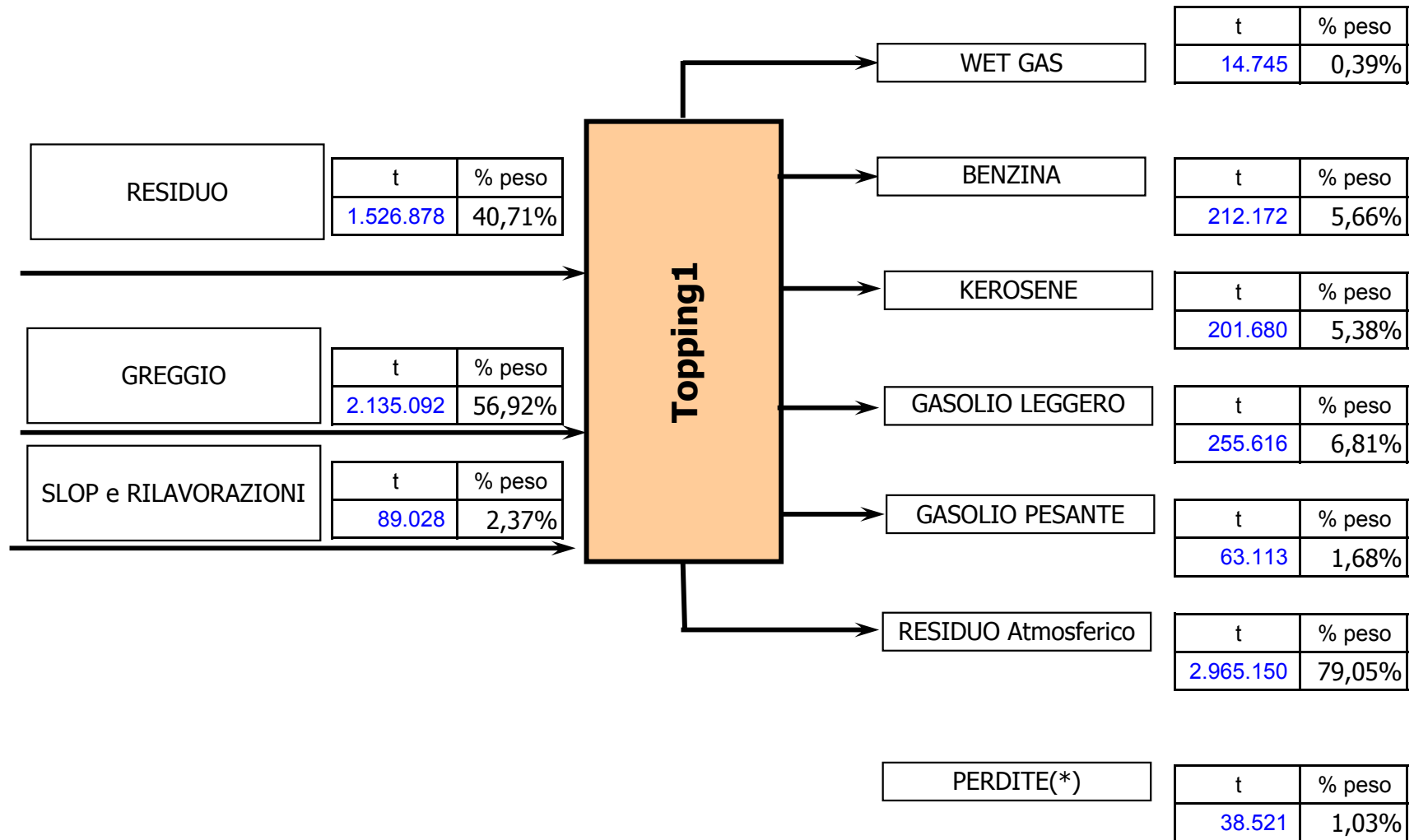

(*) Le perdite sono comprensive dell'acqua contenuta nei grezzi, pari a 16.639,160 t.

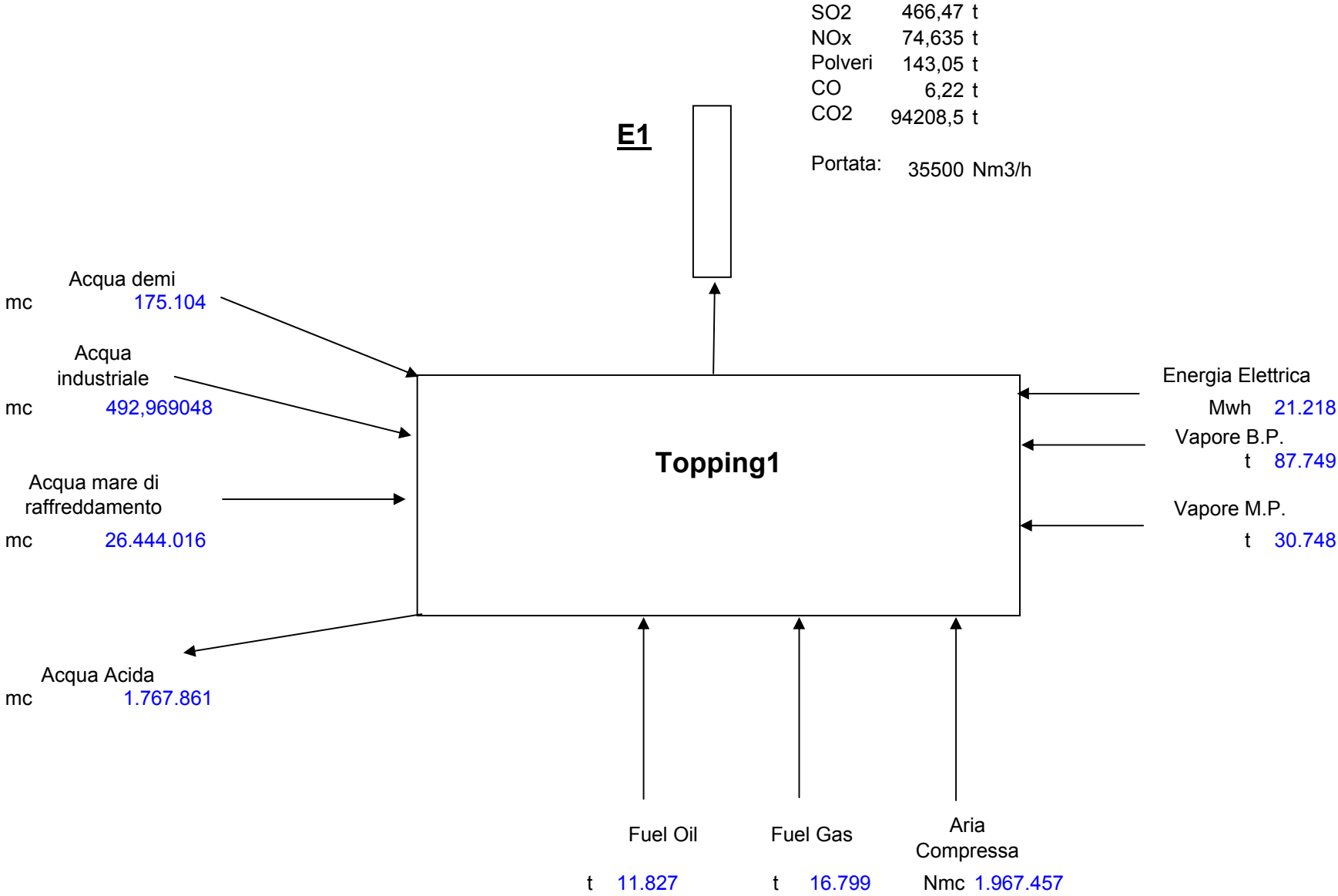

Autorizzazione Integrata Ambientale

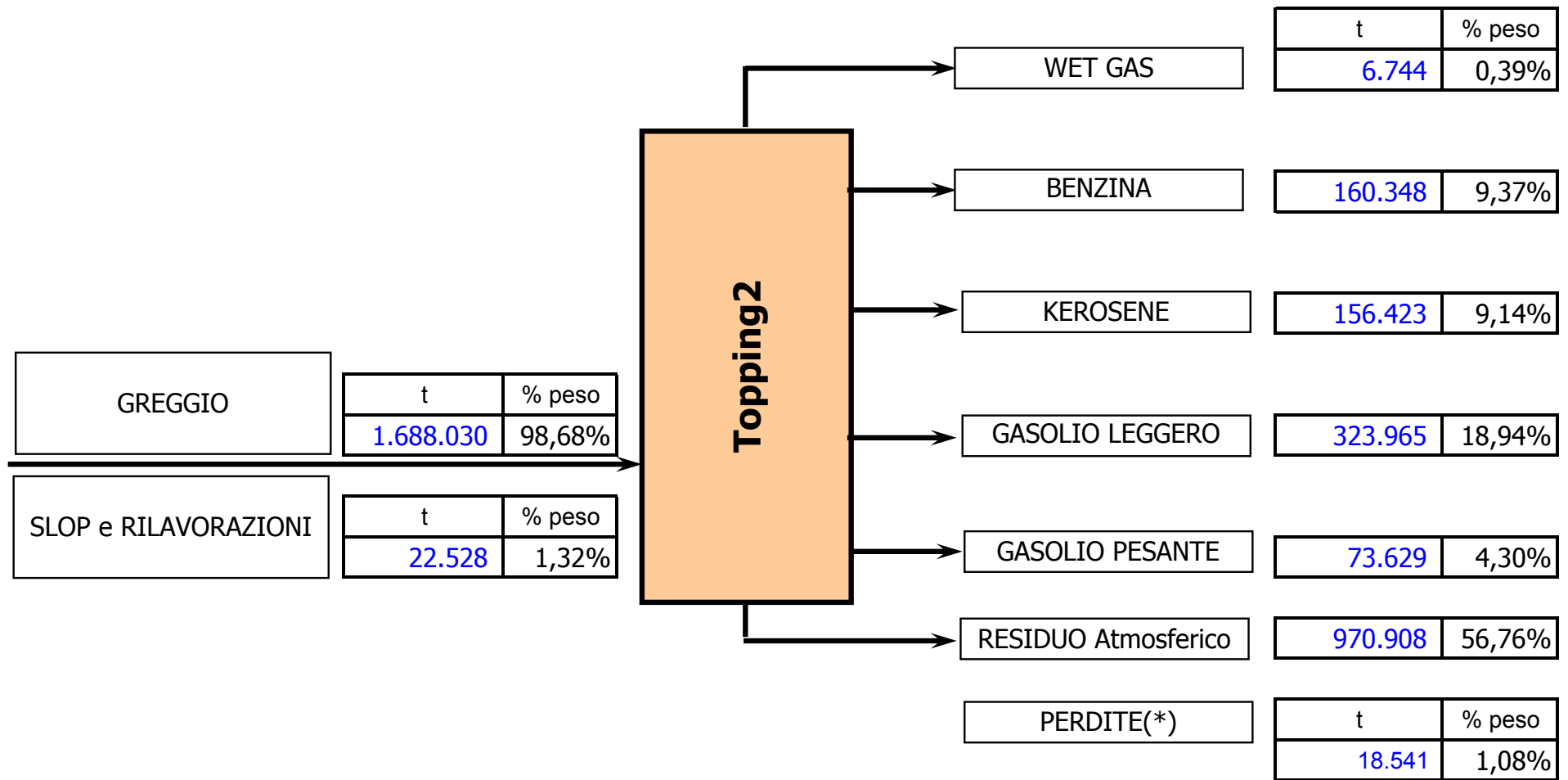

(*) Le perdite sono comprensive dell'acqua contenuta nei grezzi, pari a 8.622,207 t.

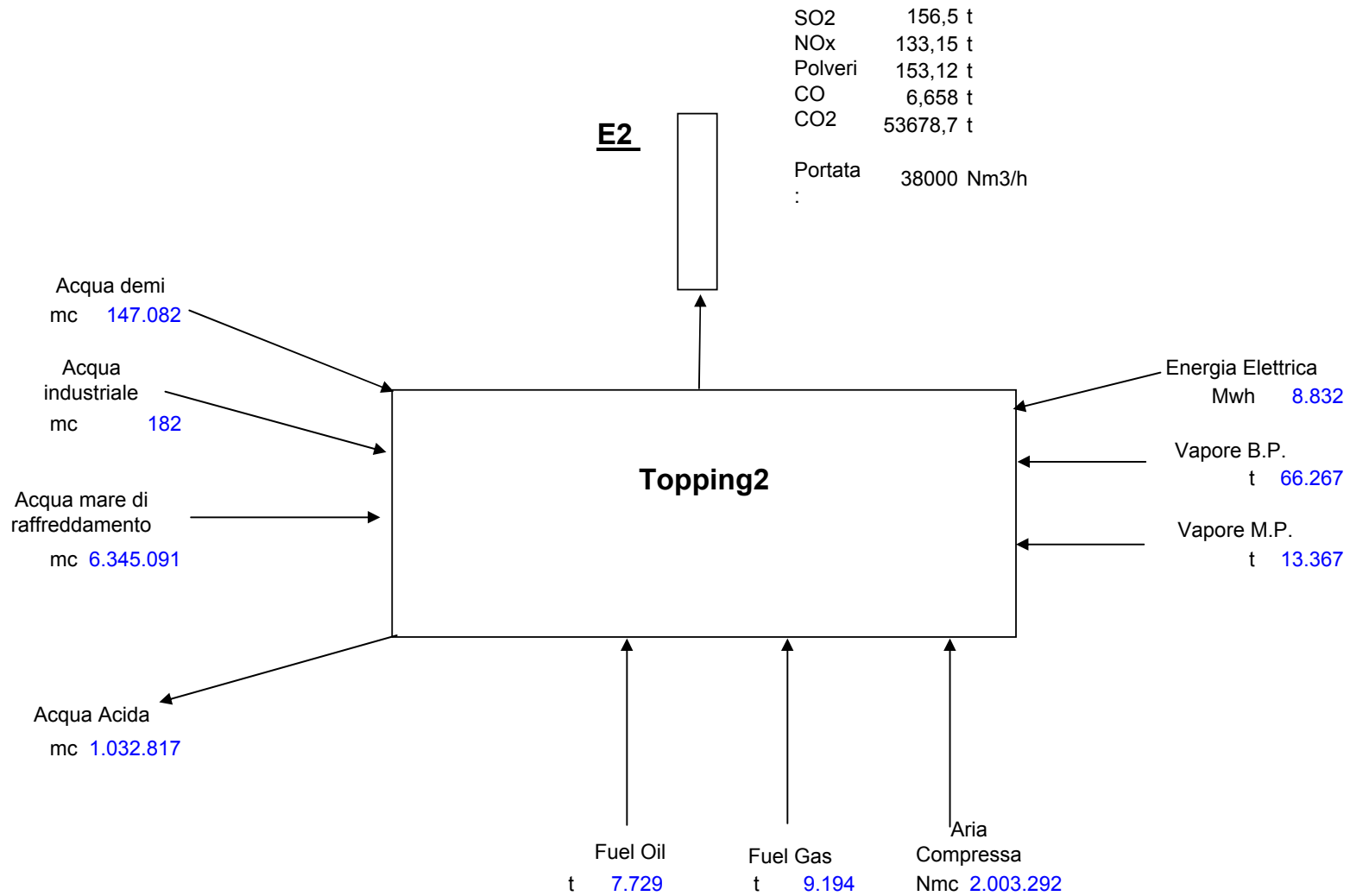

Autorizzazione Integrata Ambientale

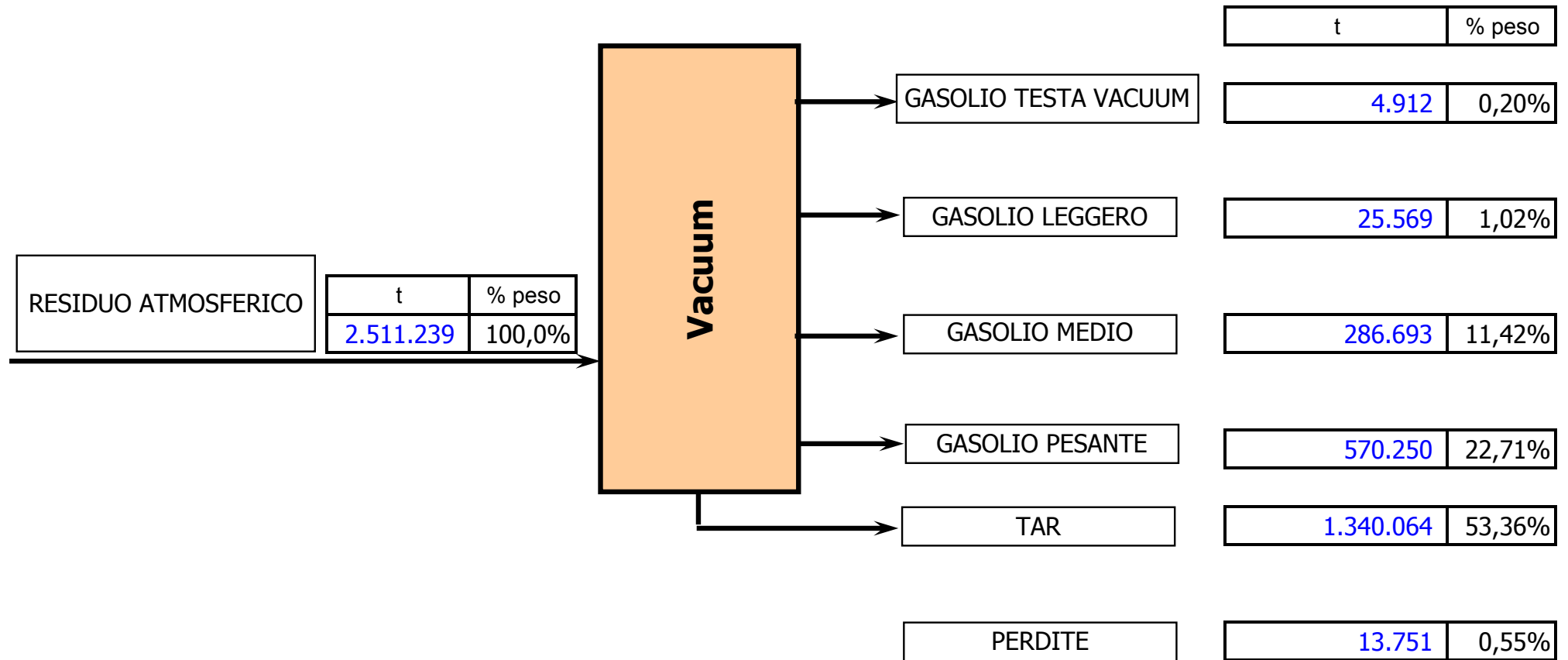

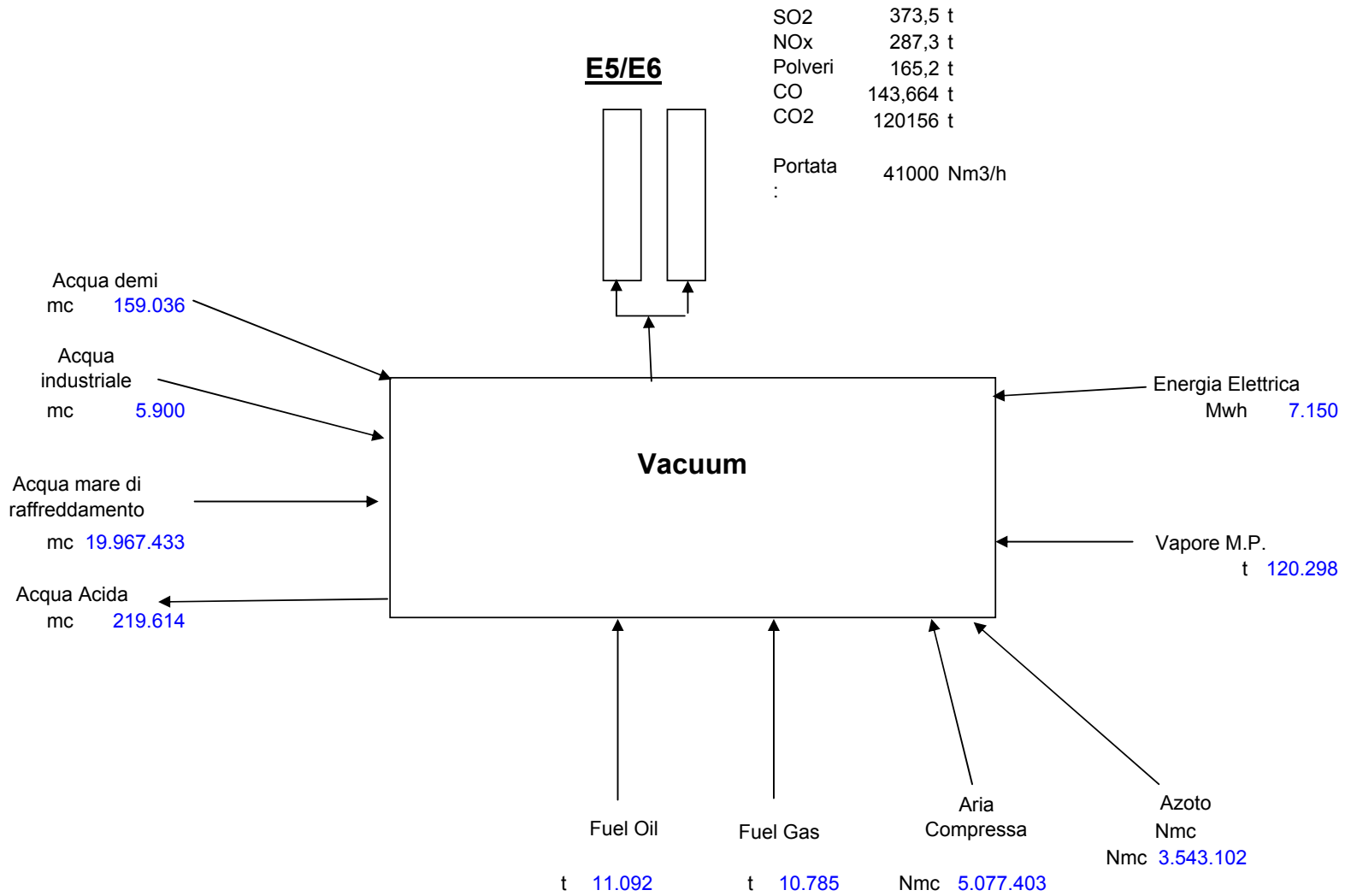

Autorizzazione Integrata Ambientale

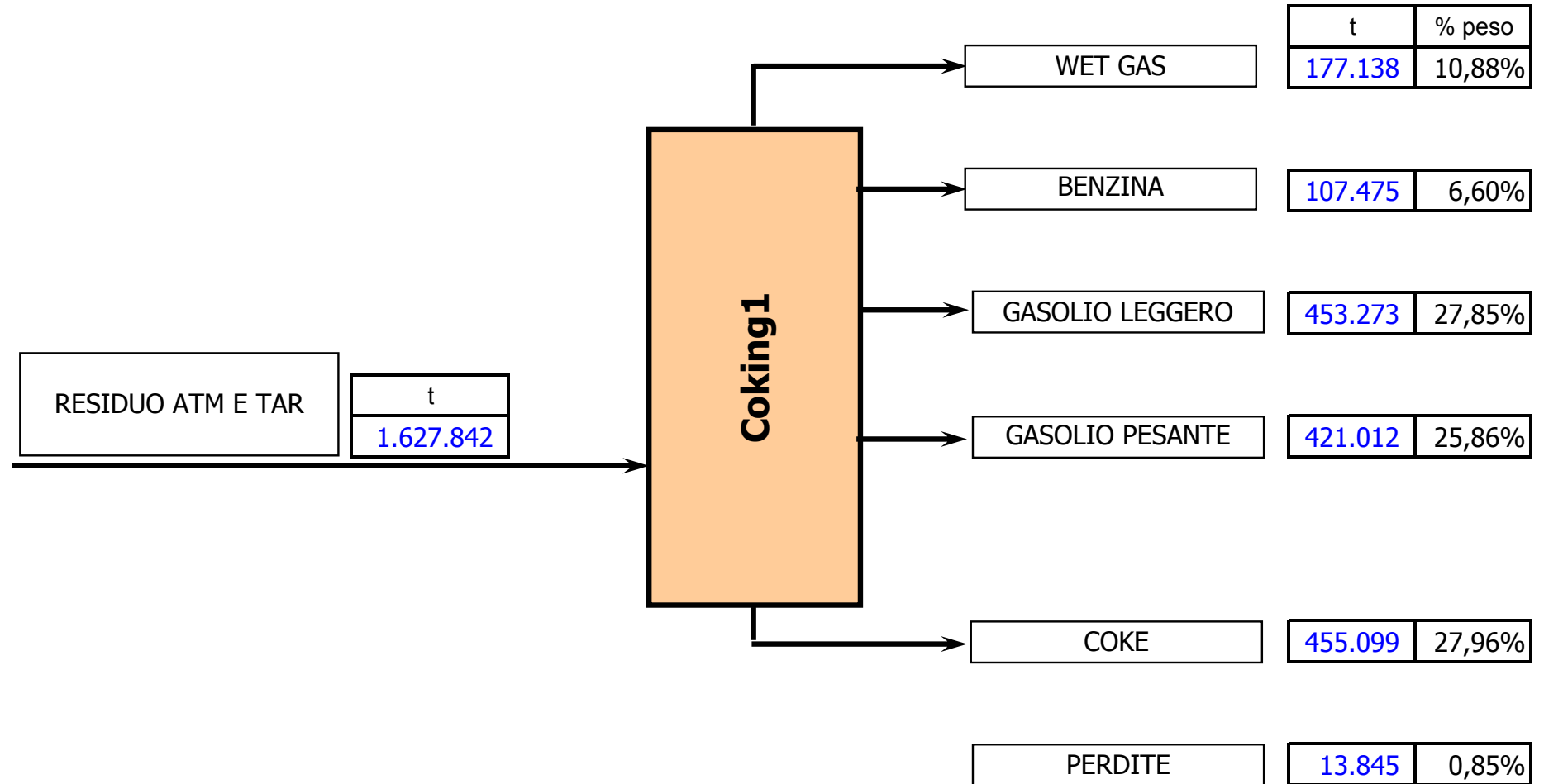

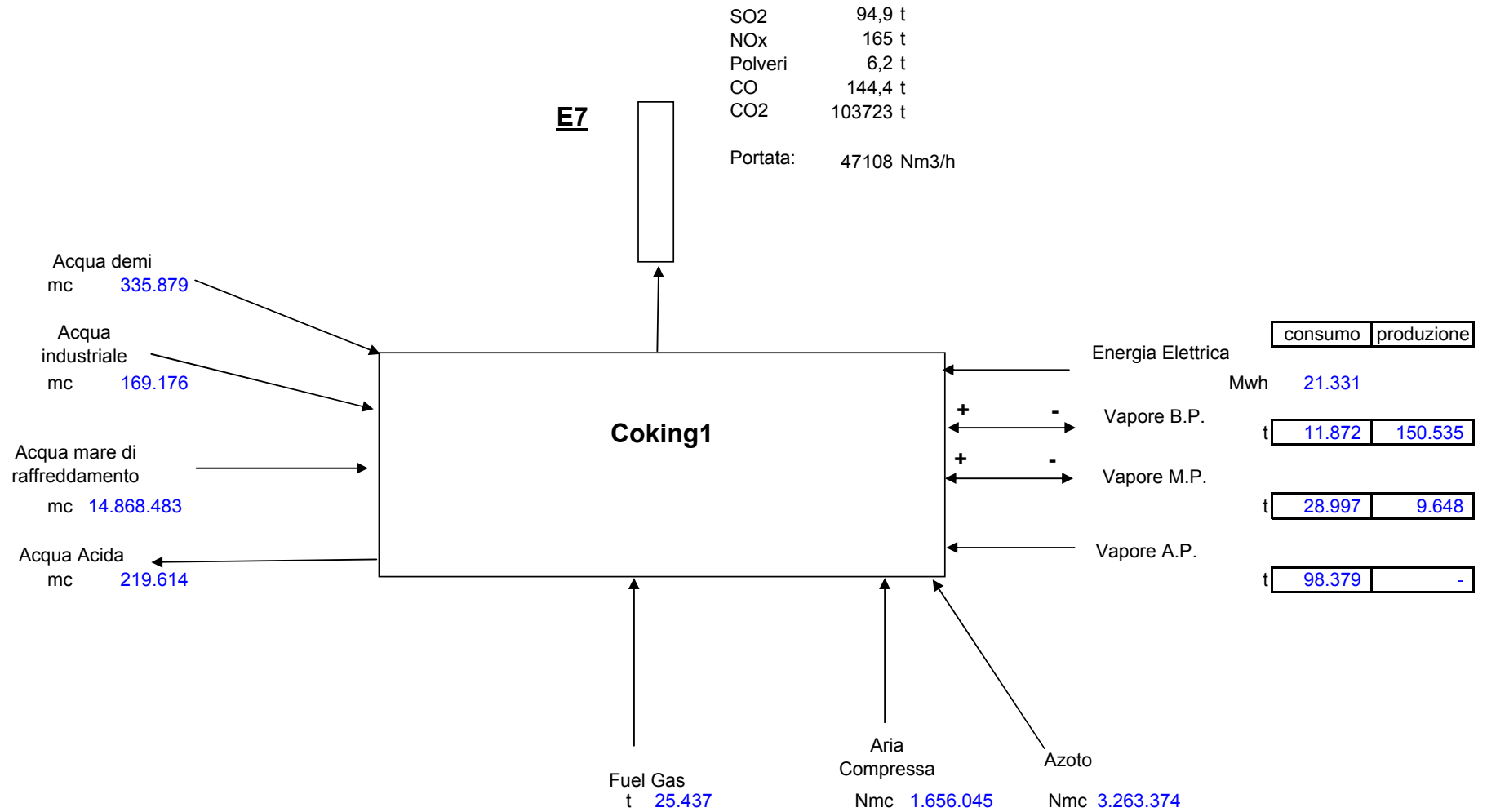

Autorizzazione Integrata Ambientale

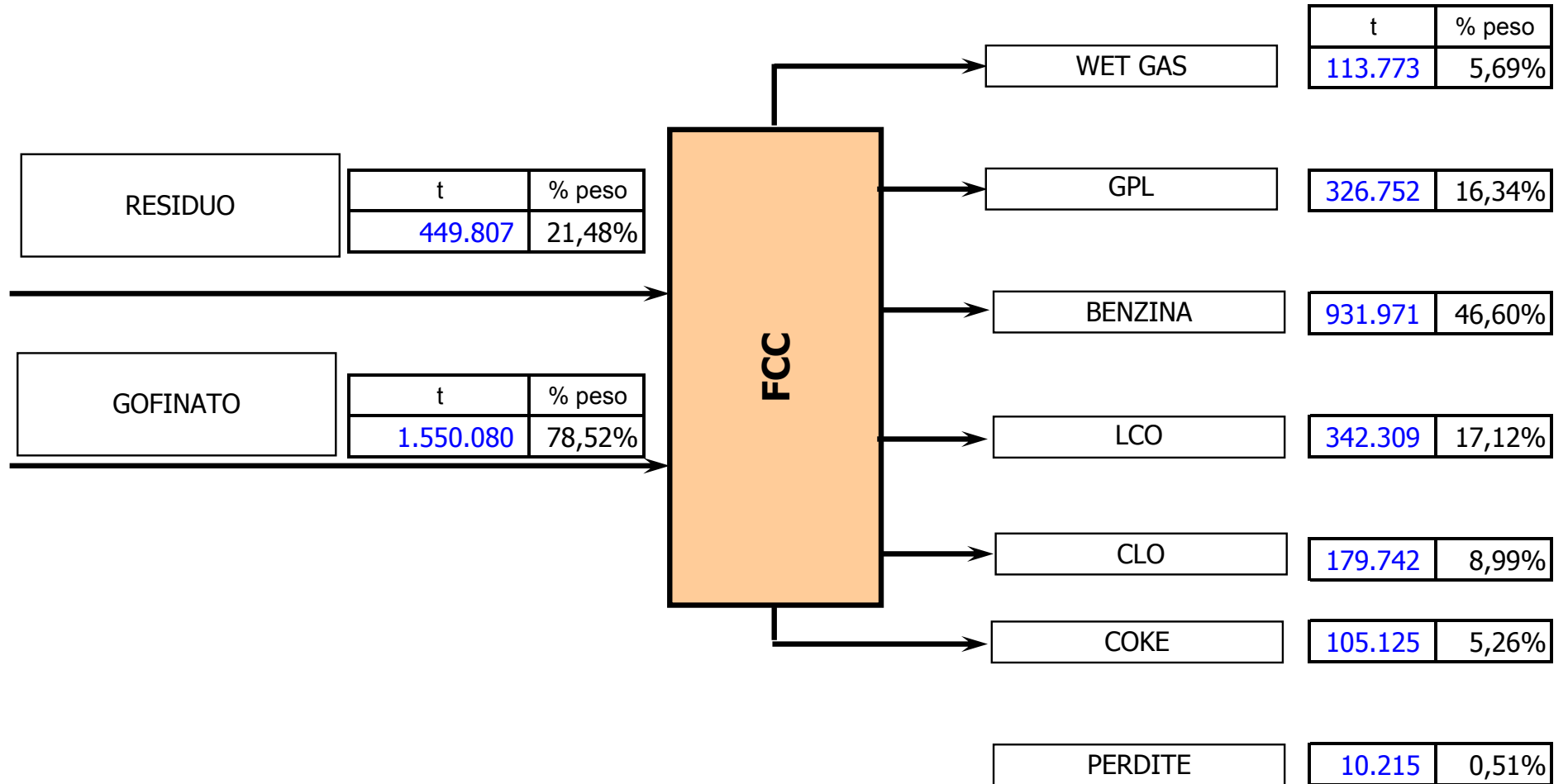

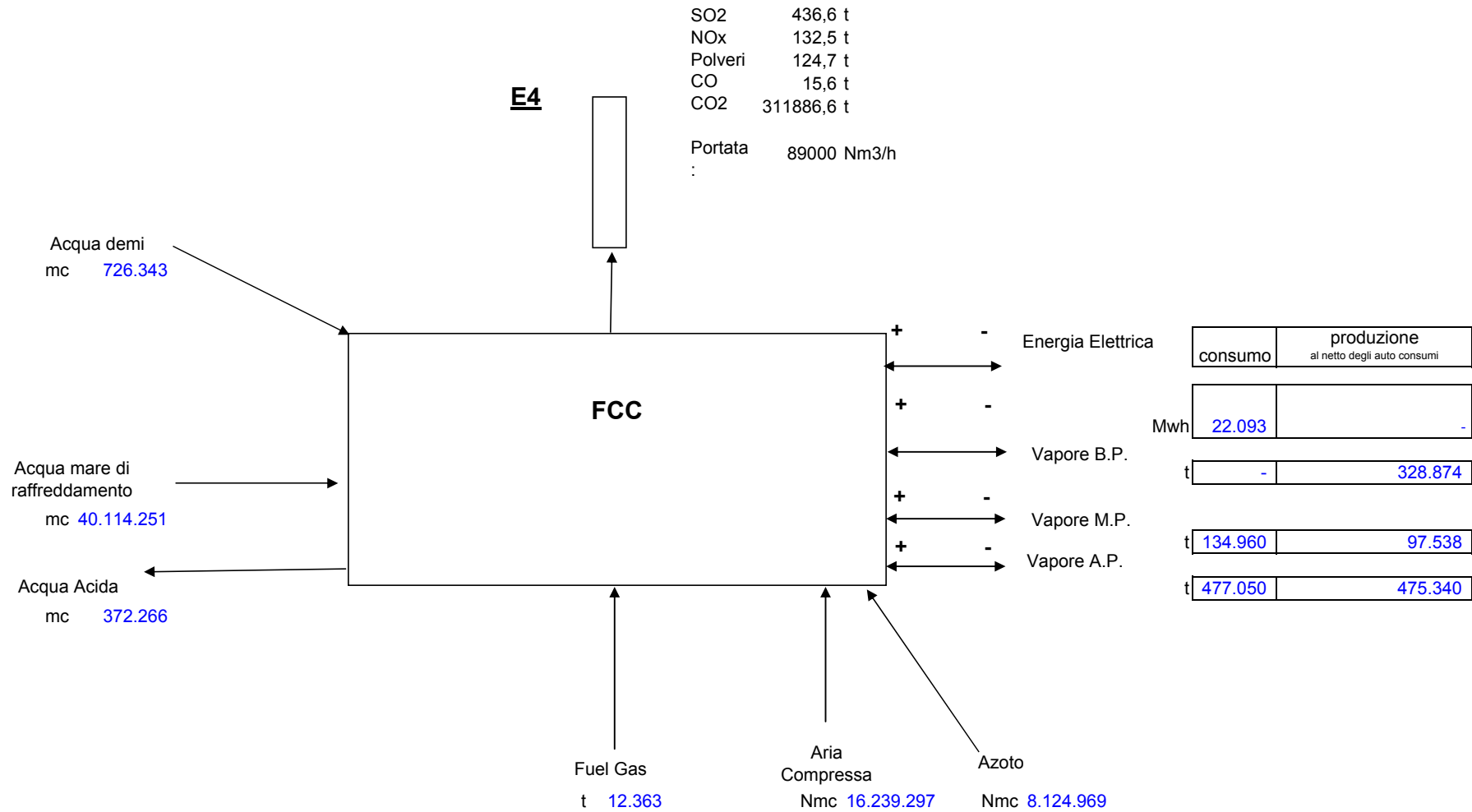

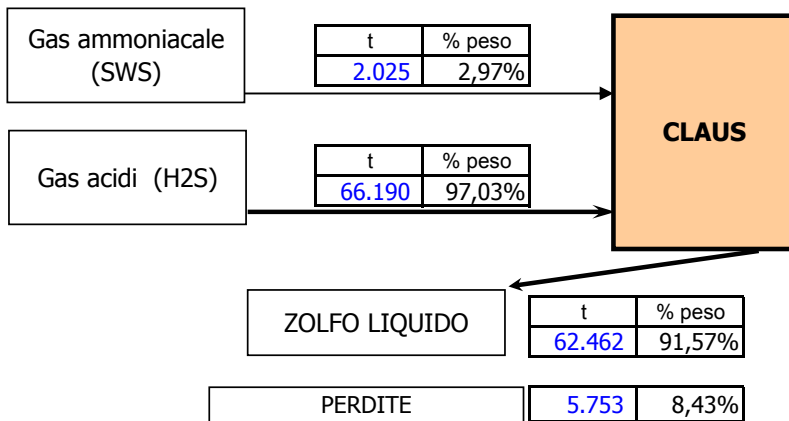

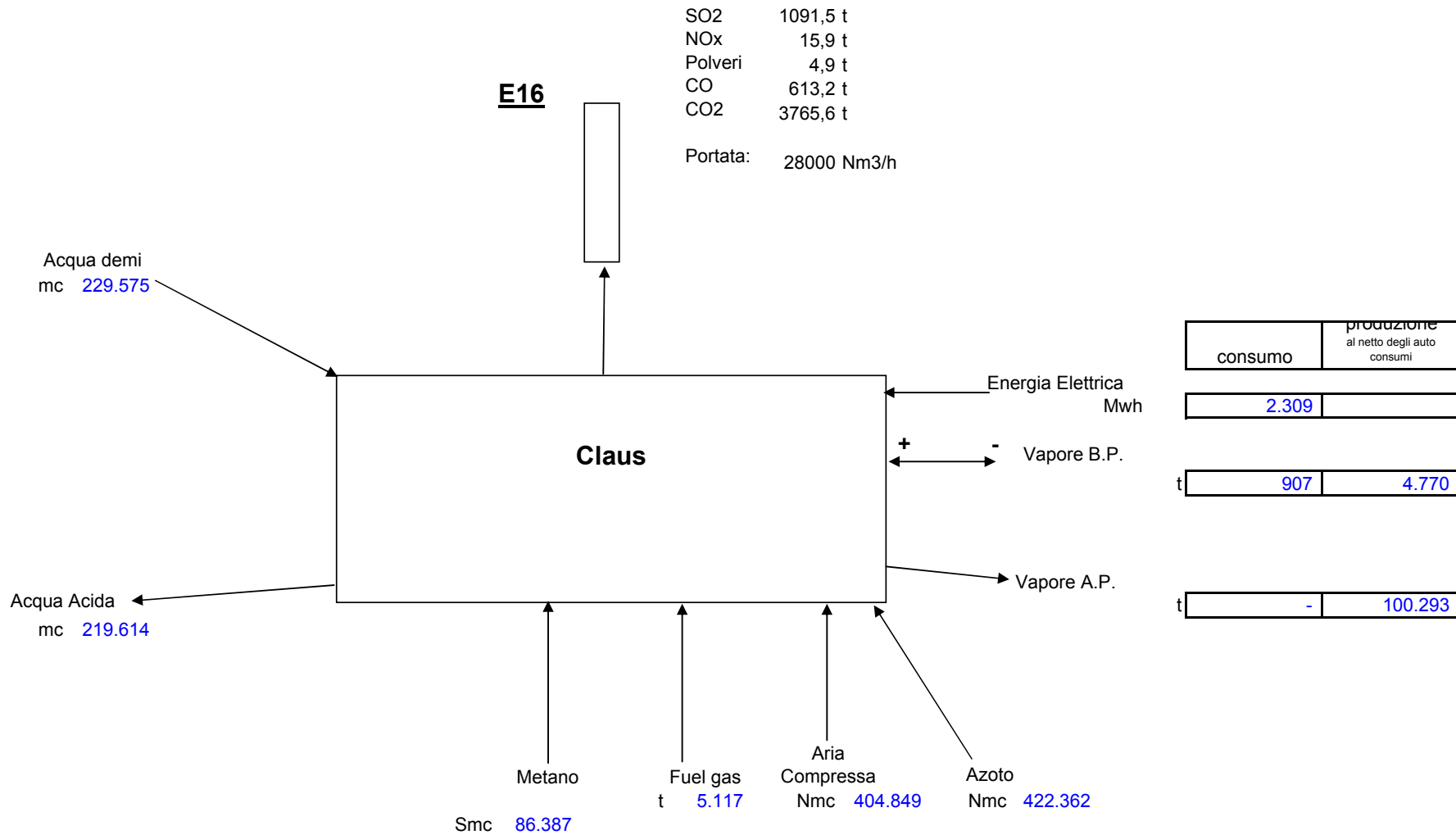

Autorizzazione Integrata Ambientale

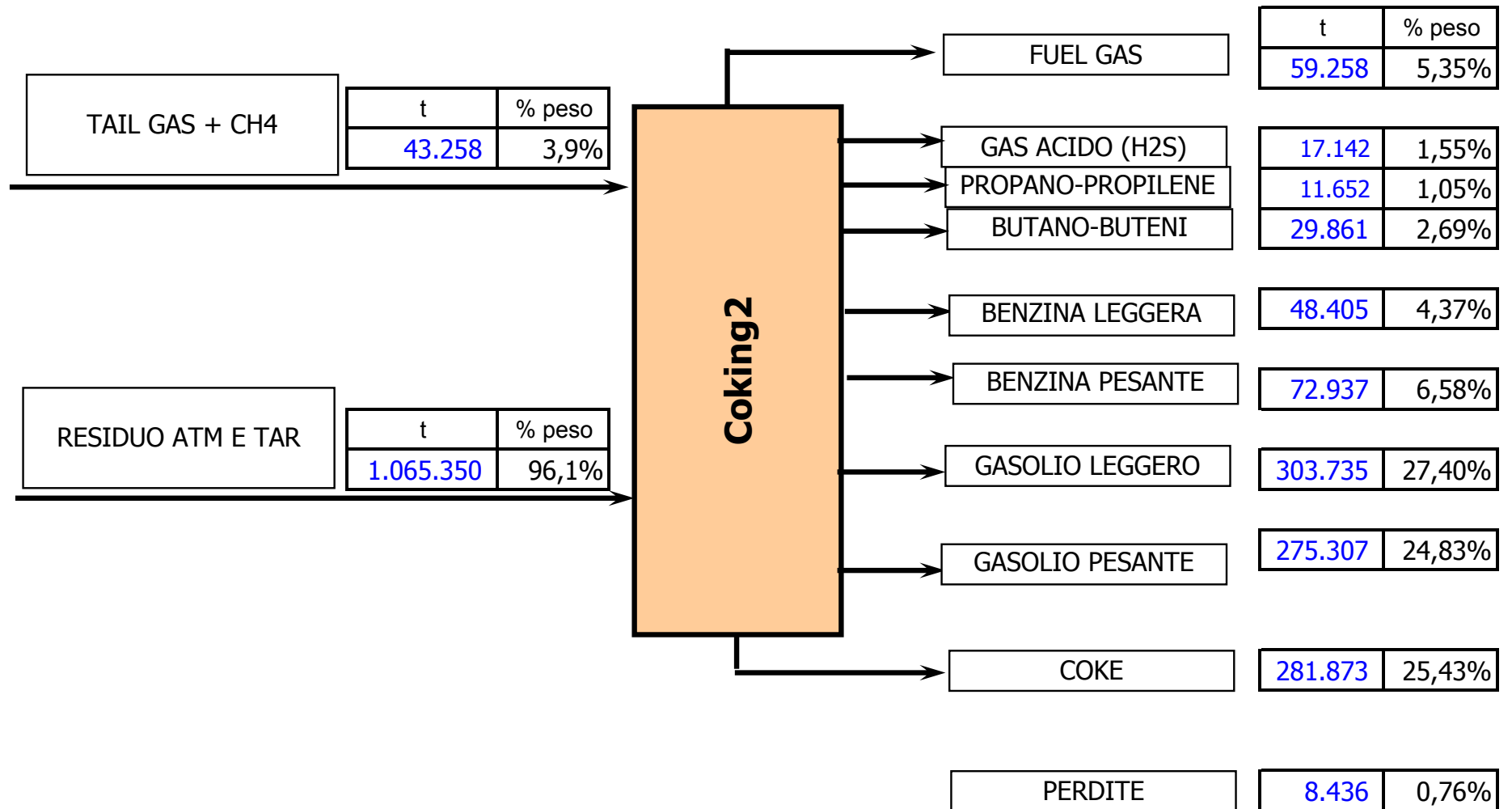

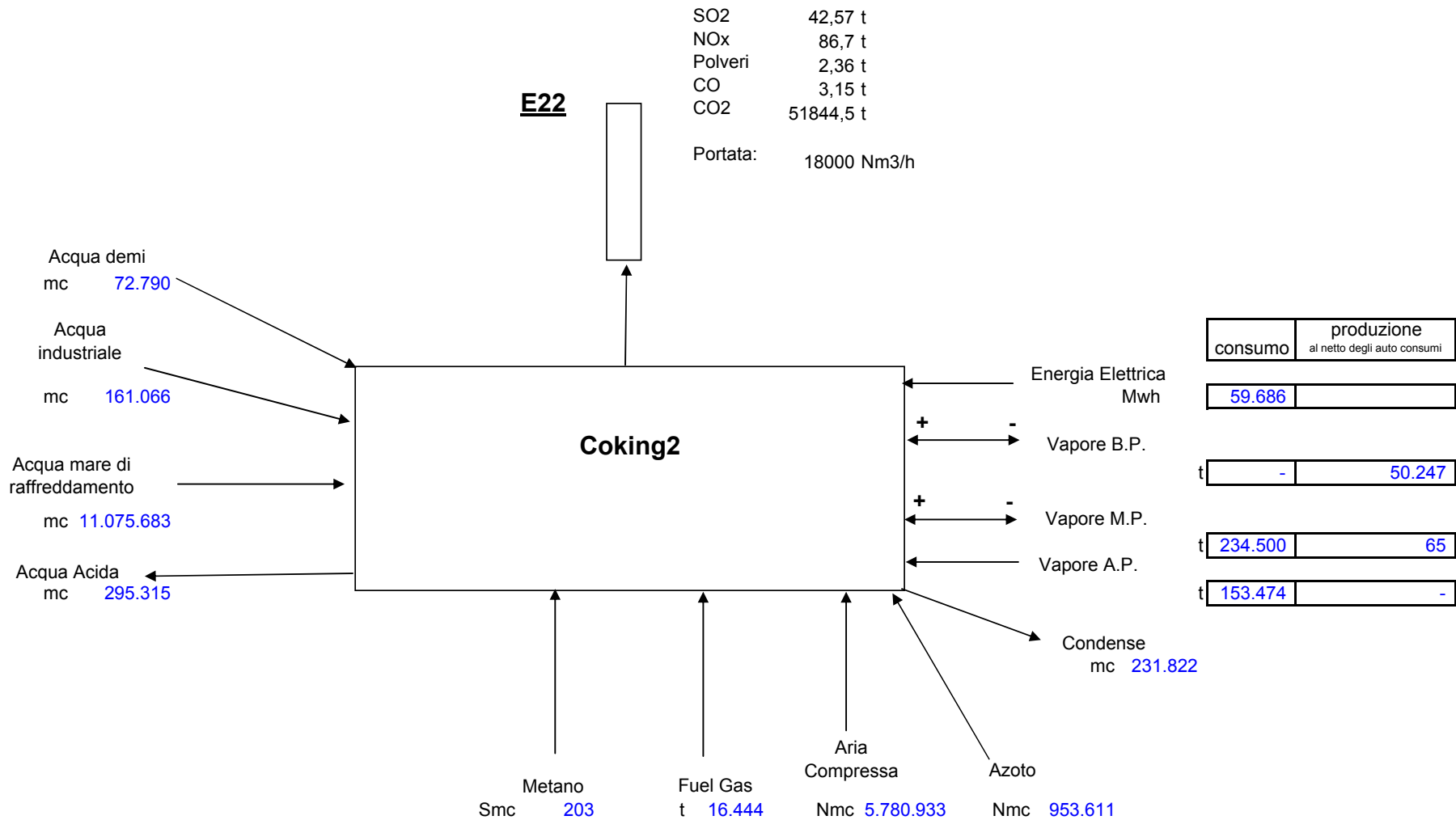

Autorizzazione Integrata Ambientale

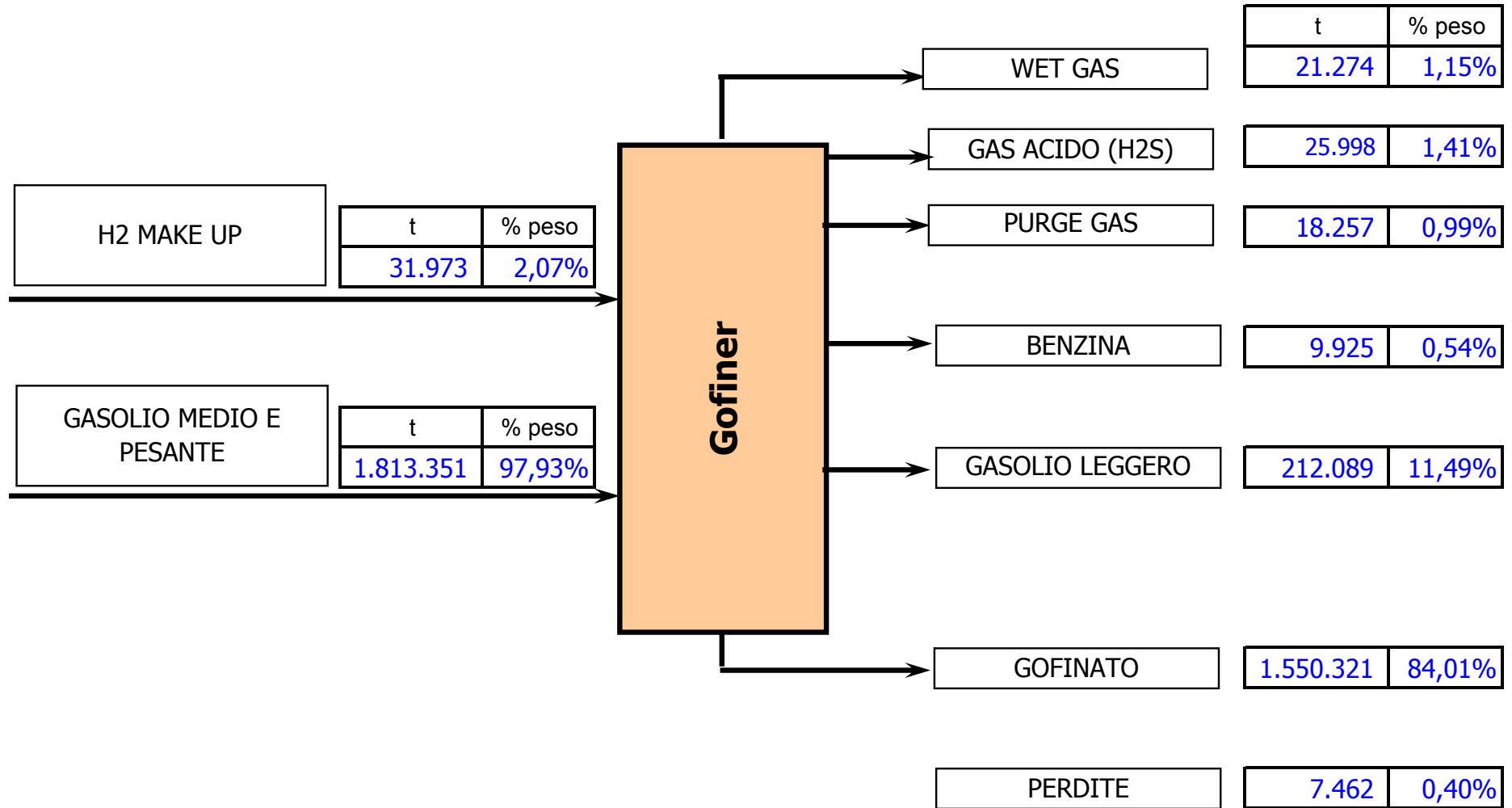

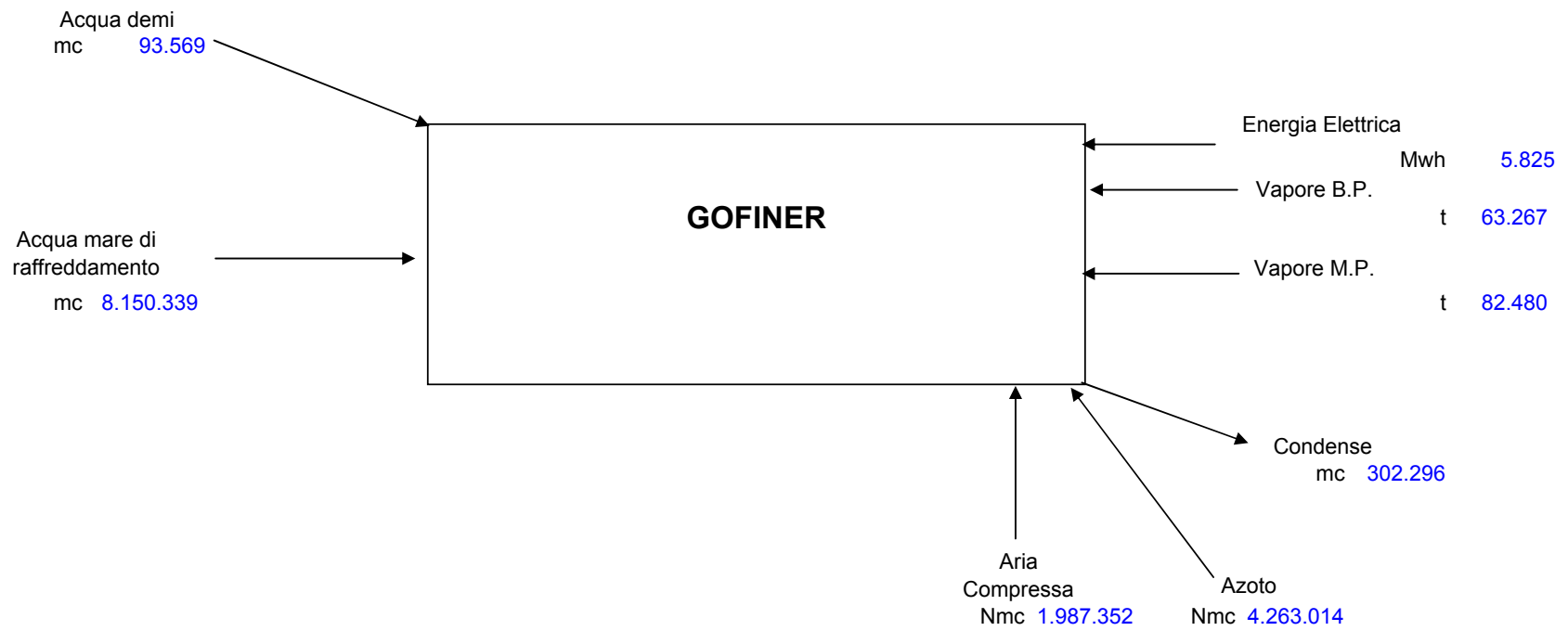

Autorizzazione Integrata Ambientale

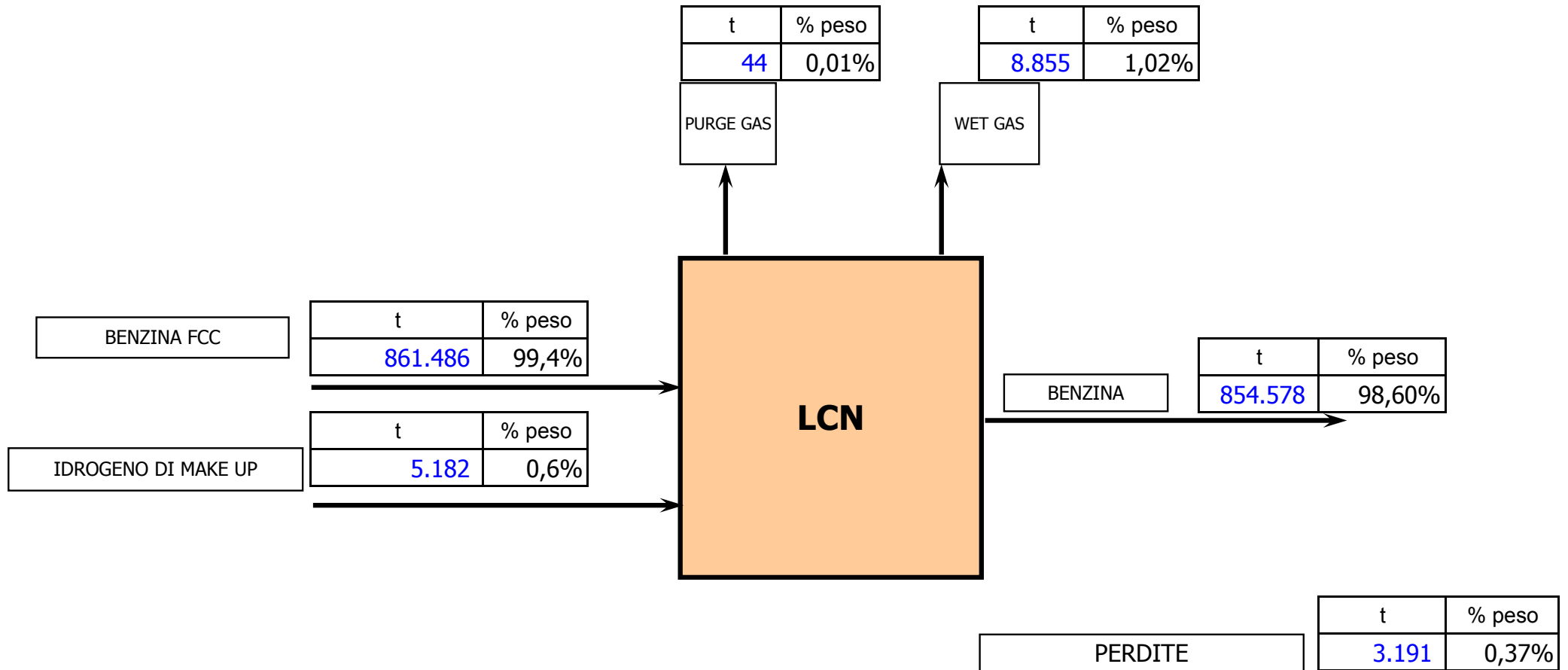

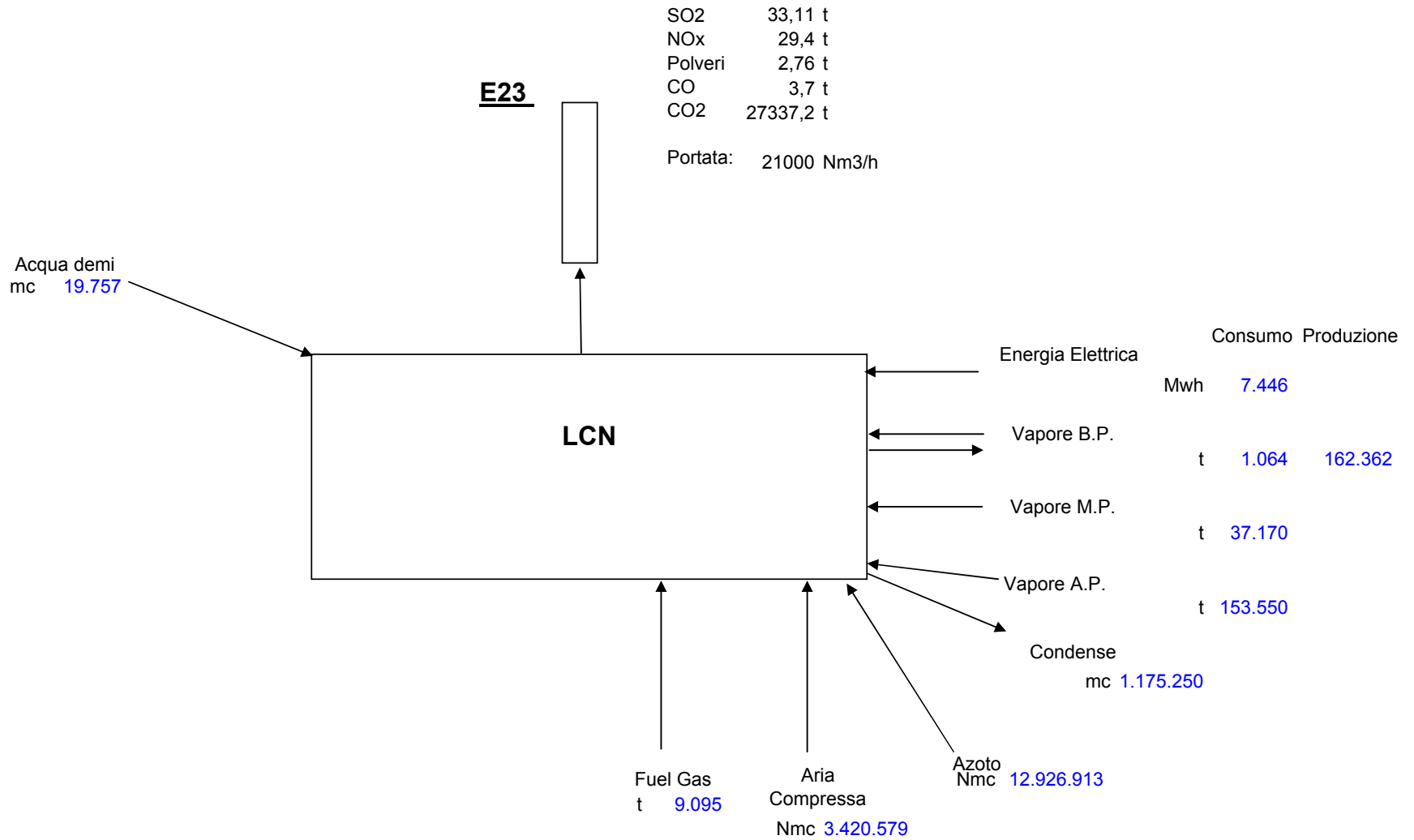

Autorizzazione Integrata Ambientale

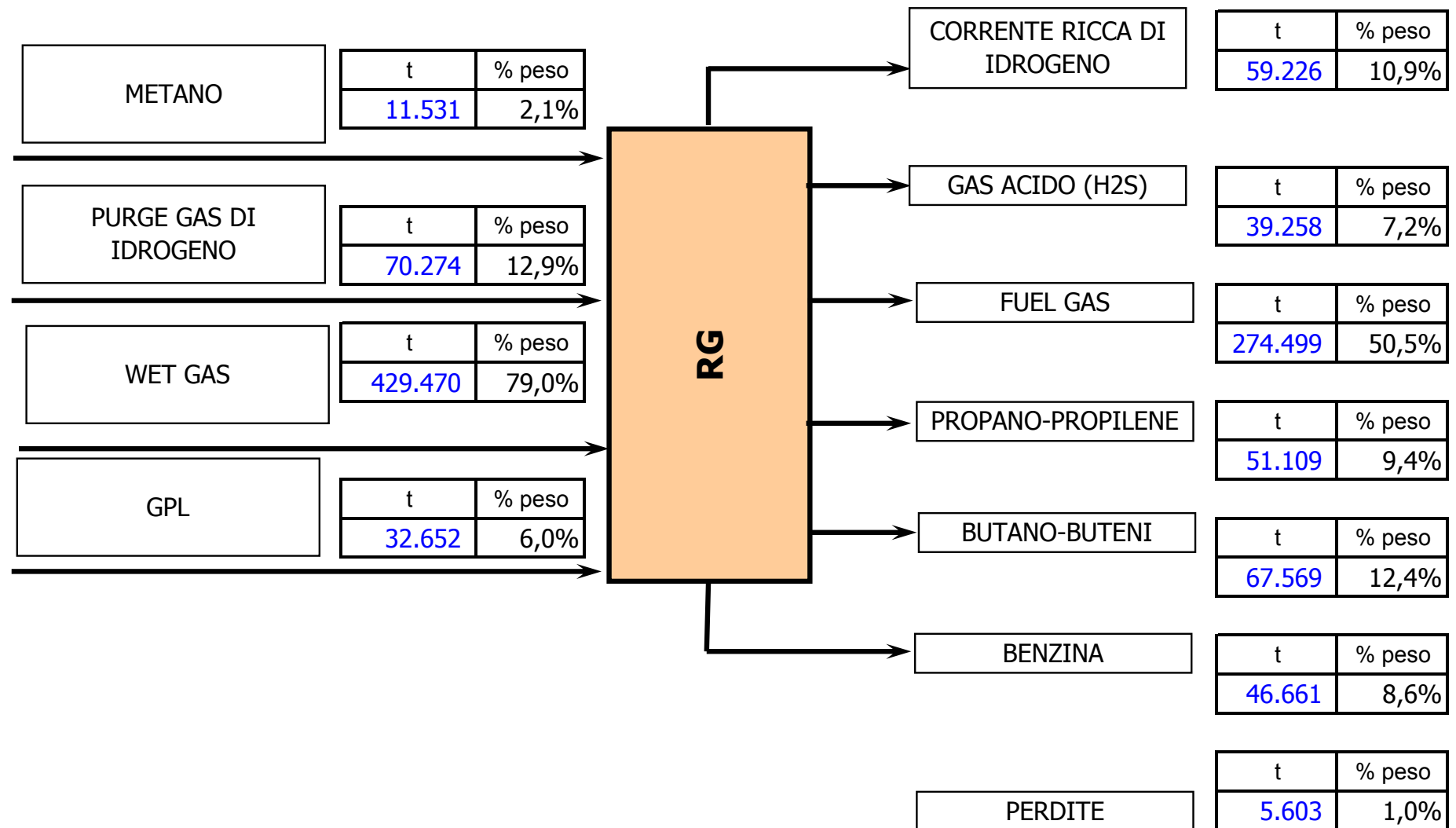

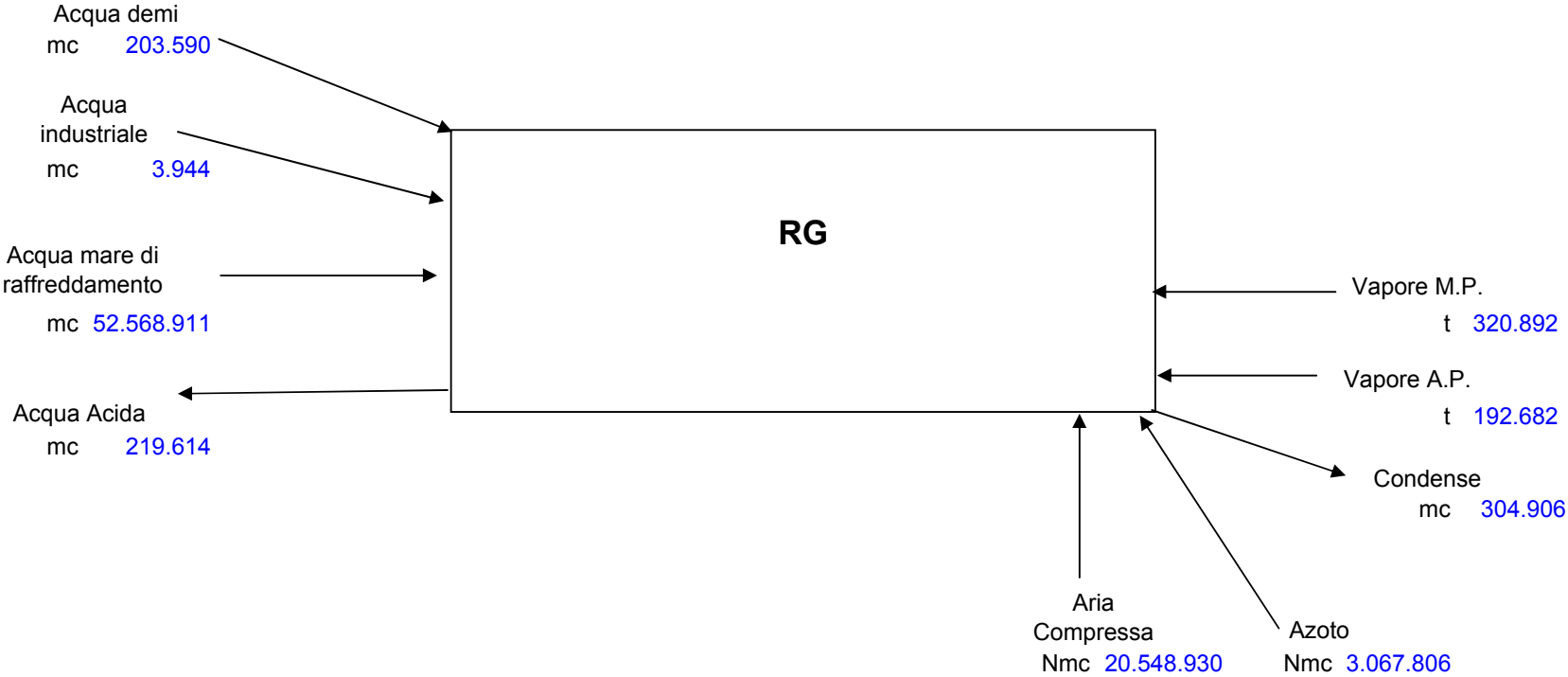

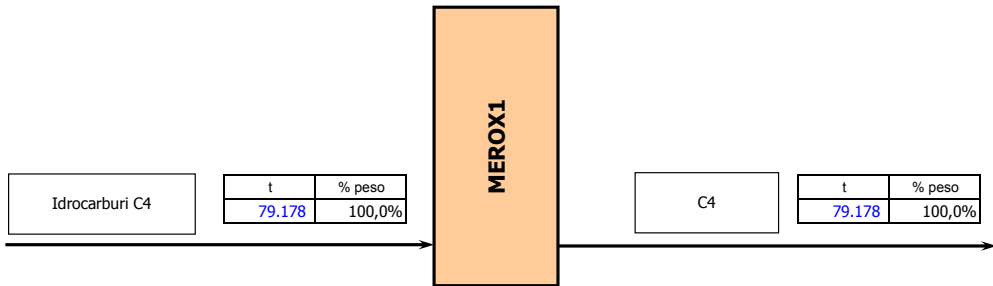

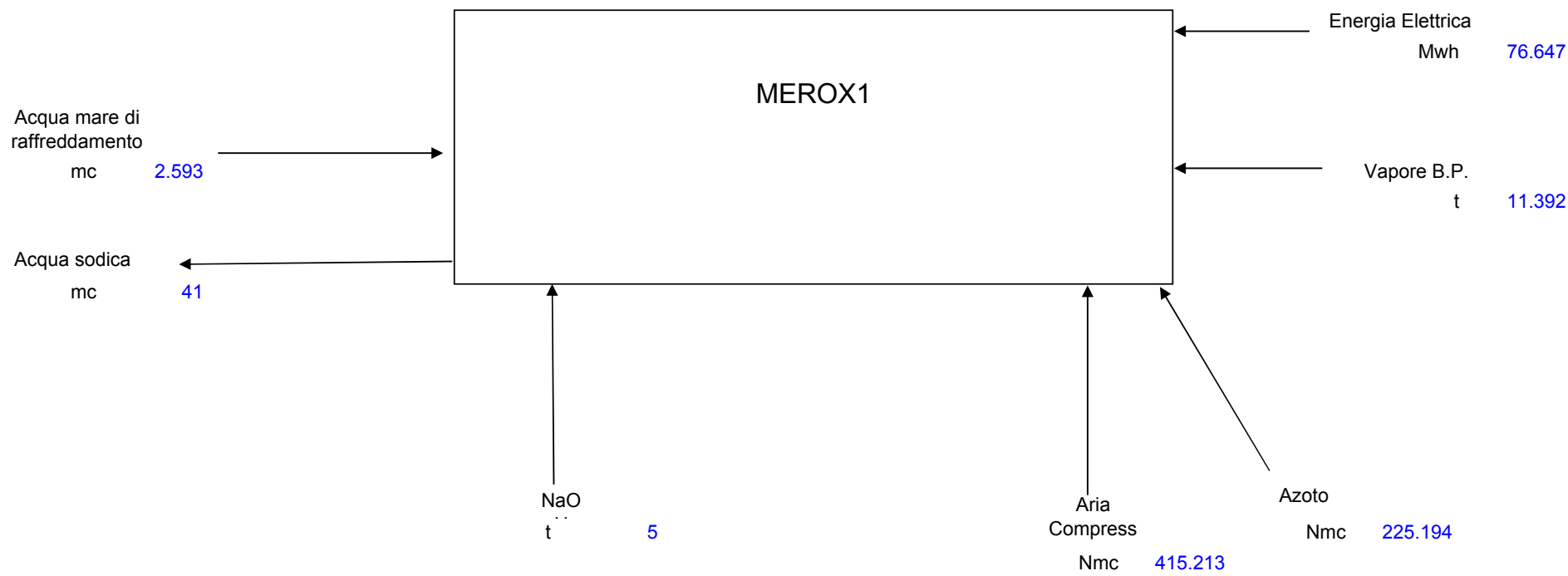

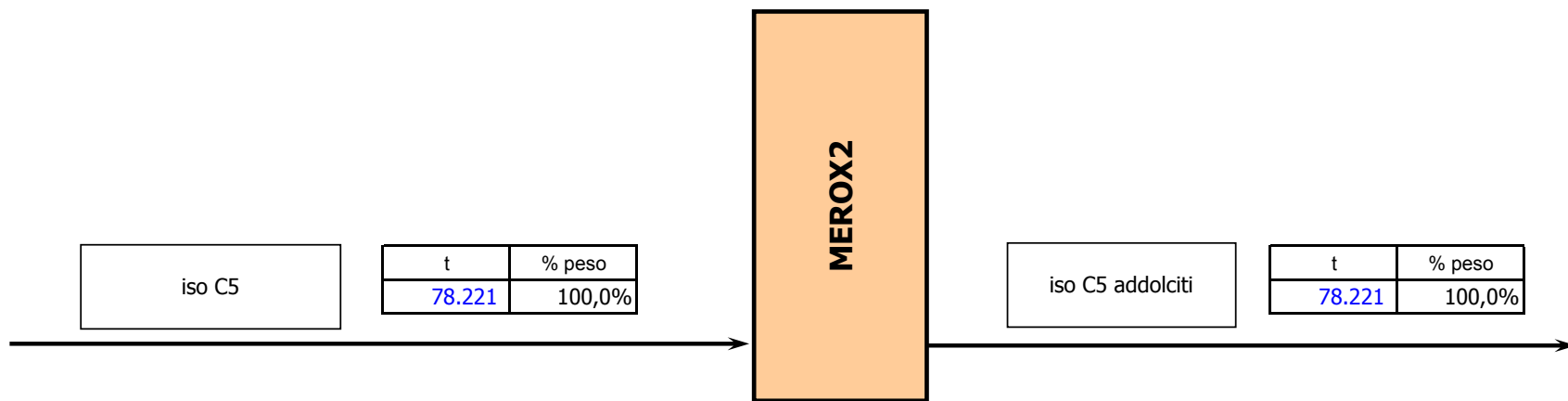

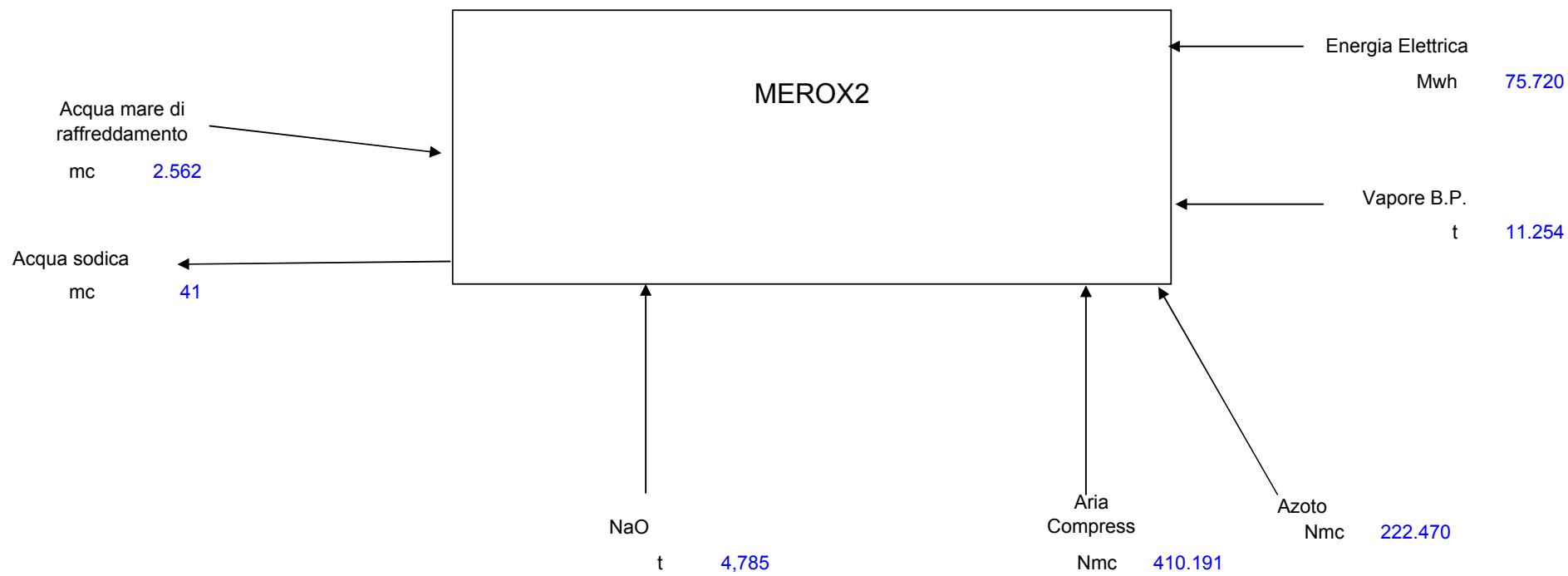

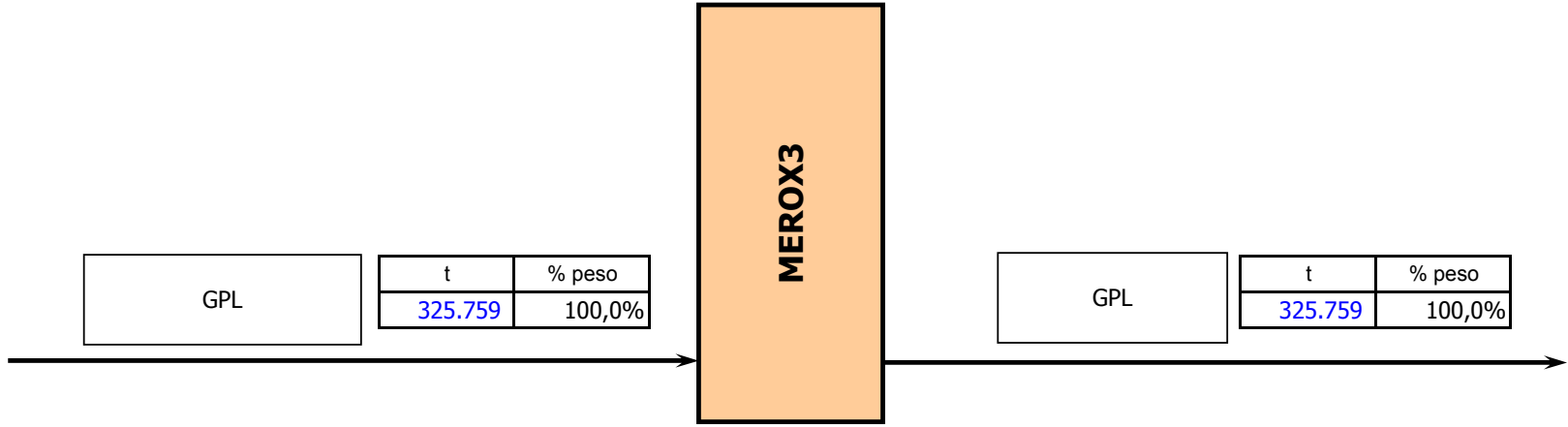

GPL

t	% peso
325.759	100,0%

MEROX3

GPL

t	% peso
325.759	100,0%

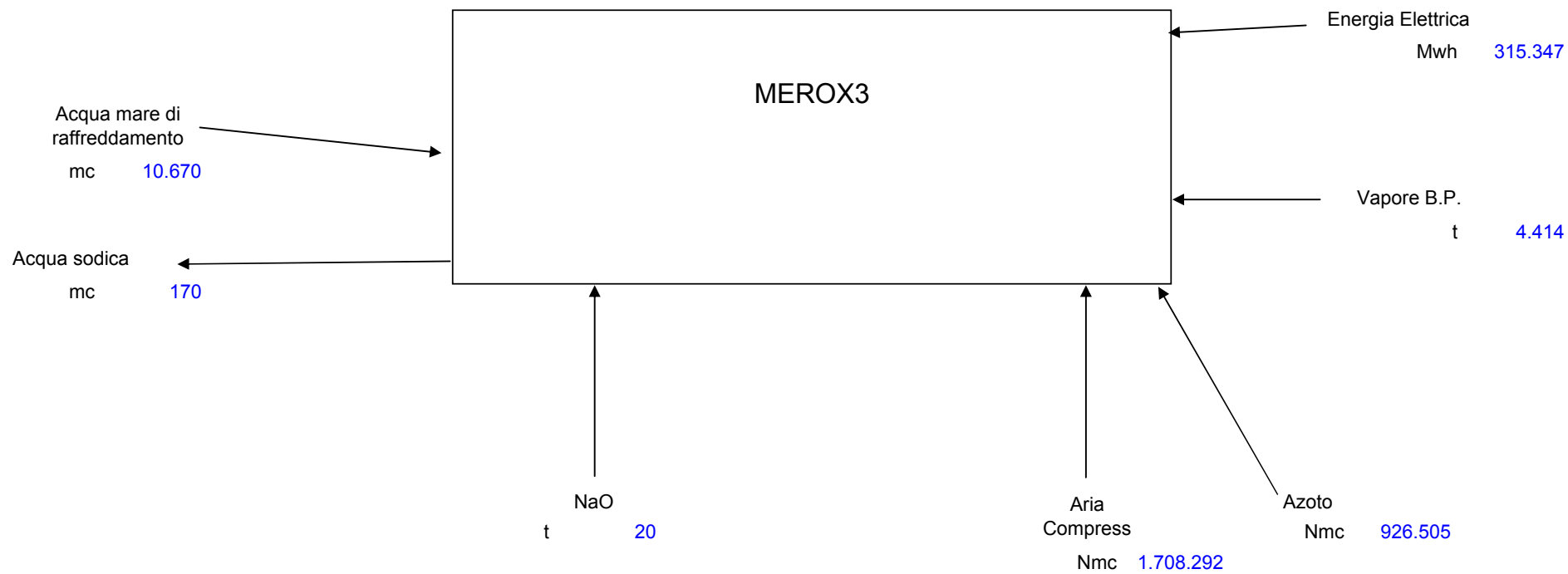

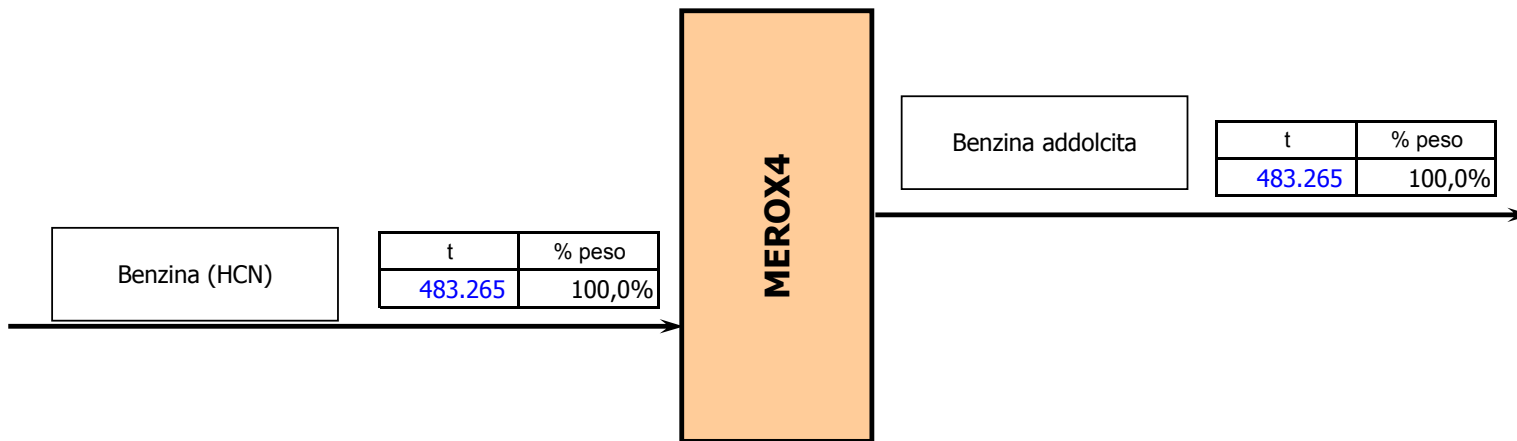

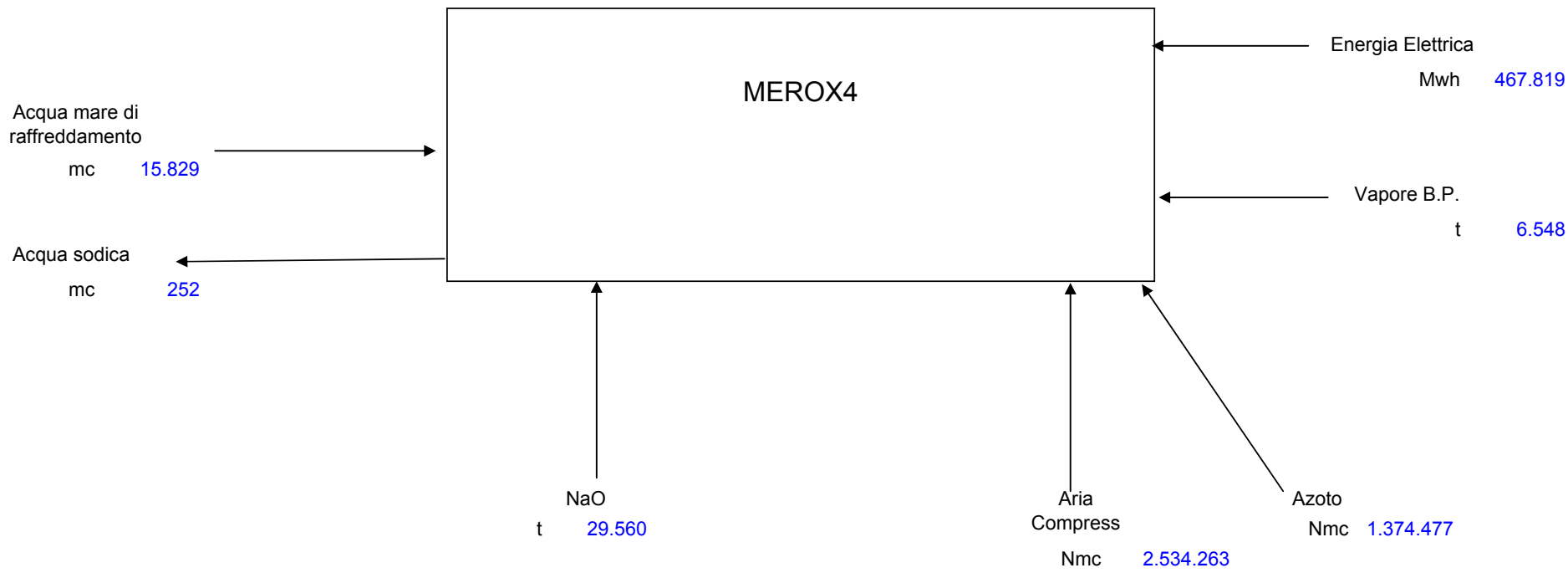

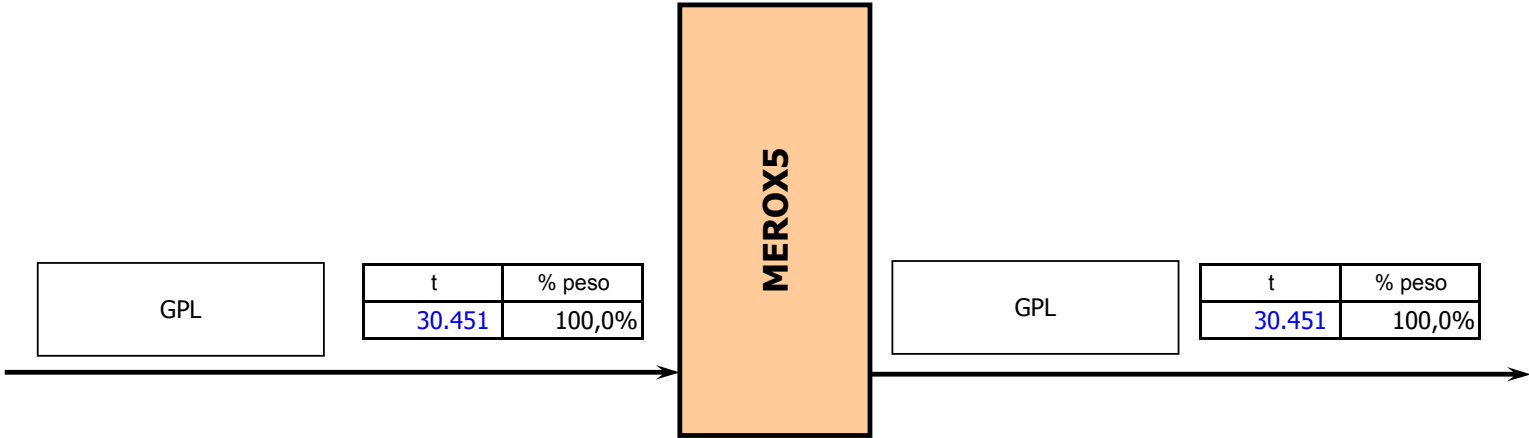

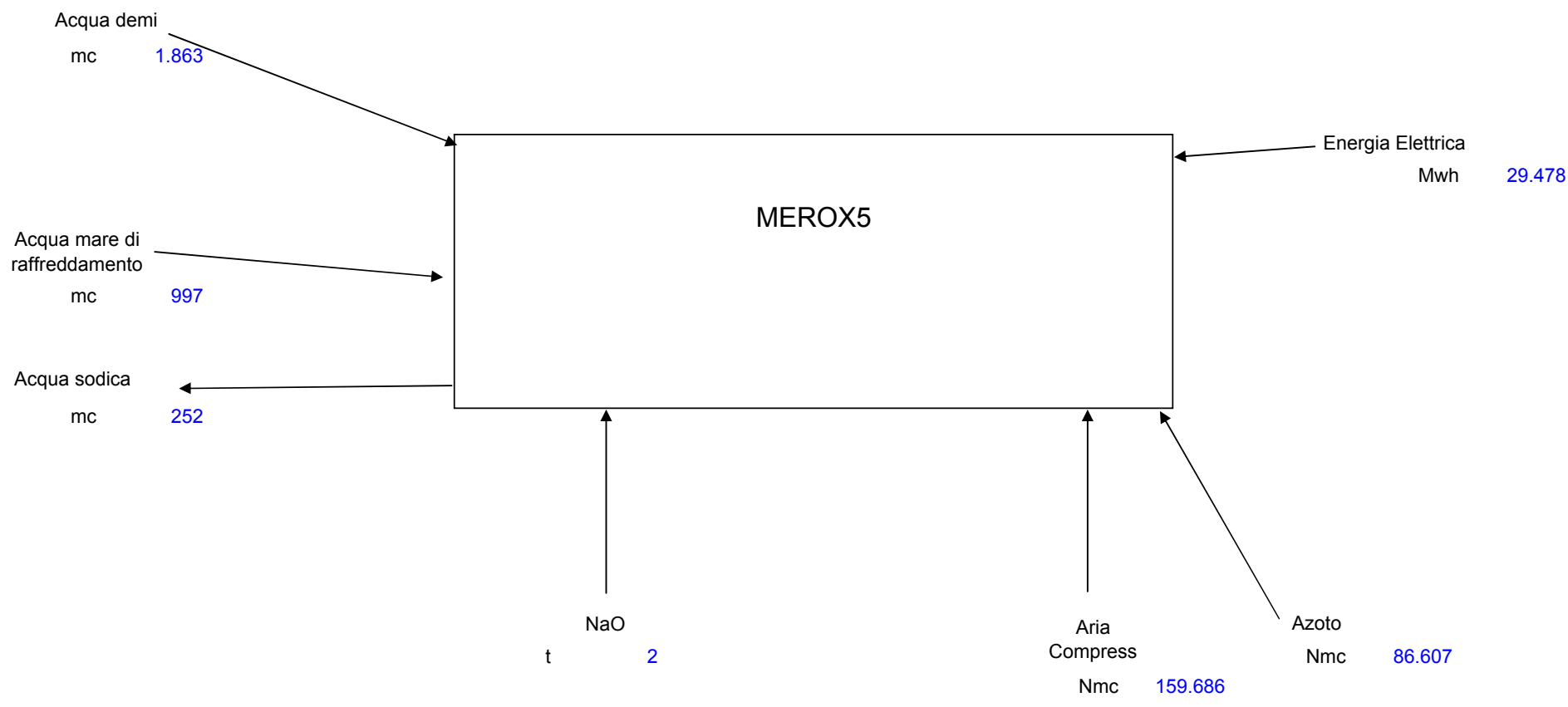

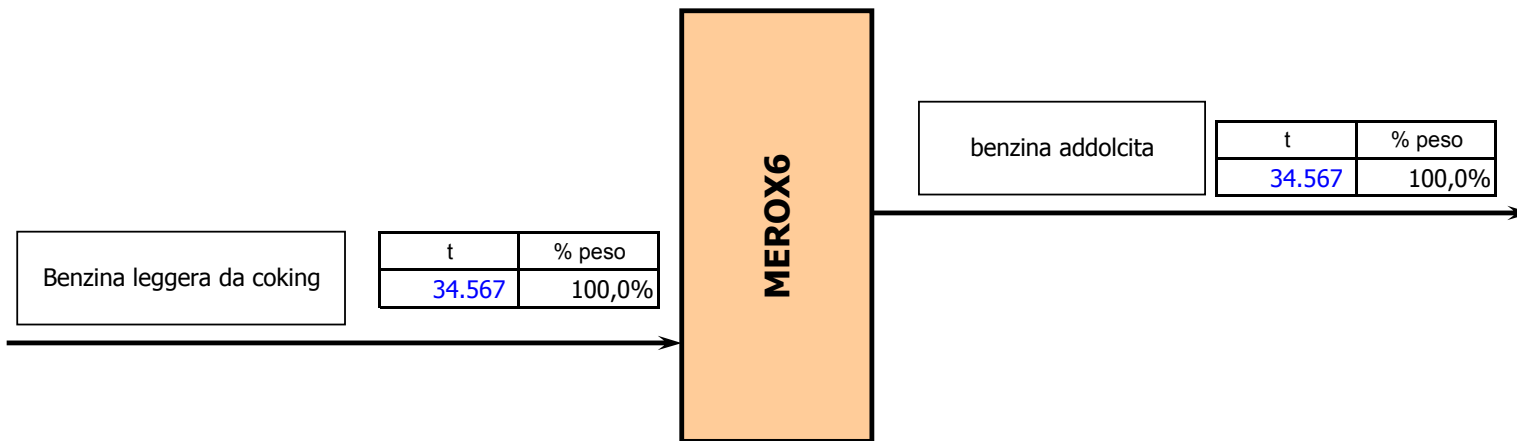

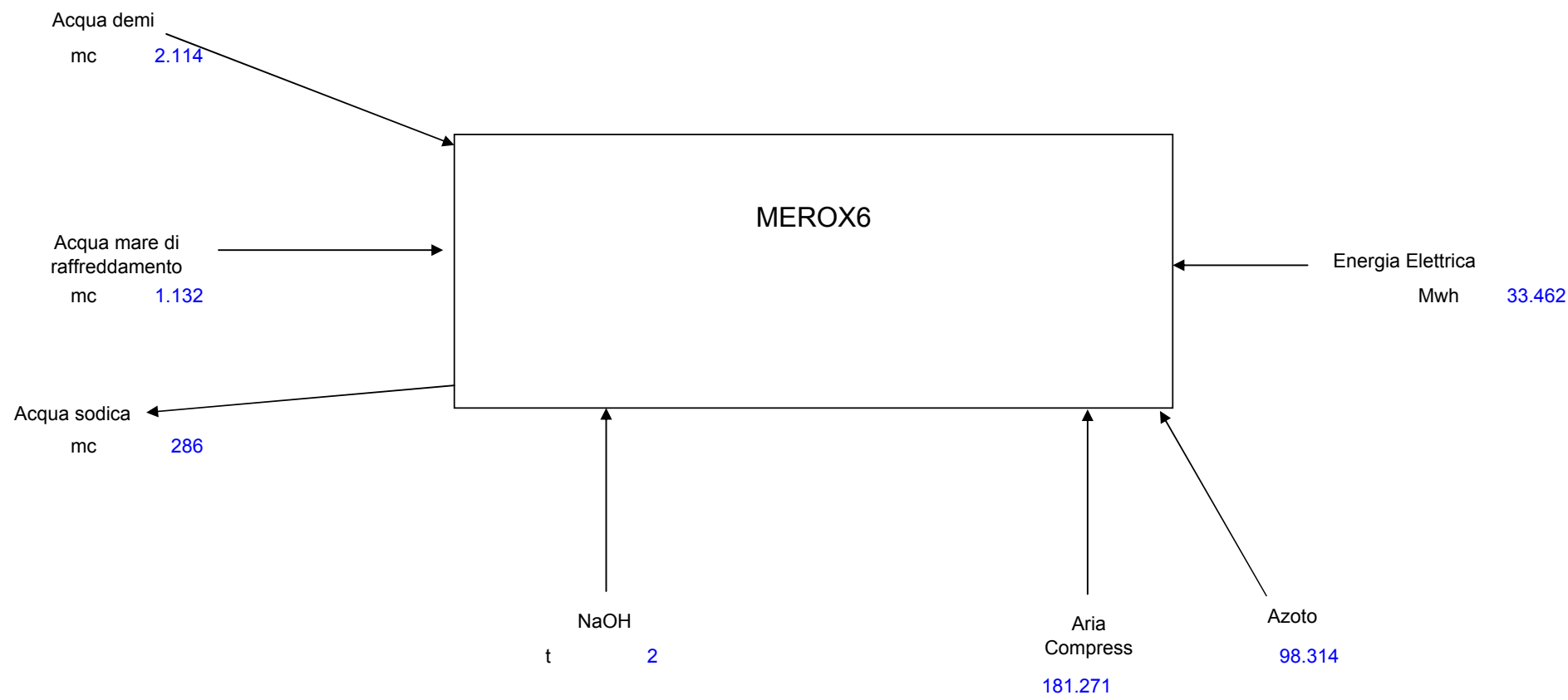

GPL da C3BTX, C4 da
PLF, GPL da Fraz. benzine

t	% peso
113.542	100,0%

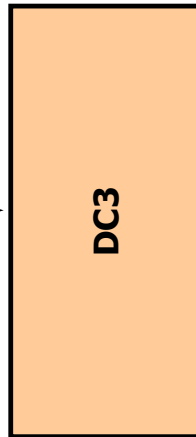

Gas + C3

t	% peso
34.043	30,0%

C4

t	% peso
79.178	69,7%

Perdite

t	% peso
321	0,3%

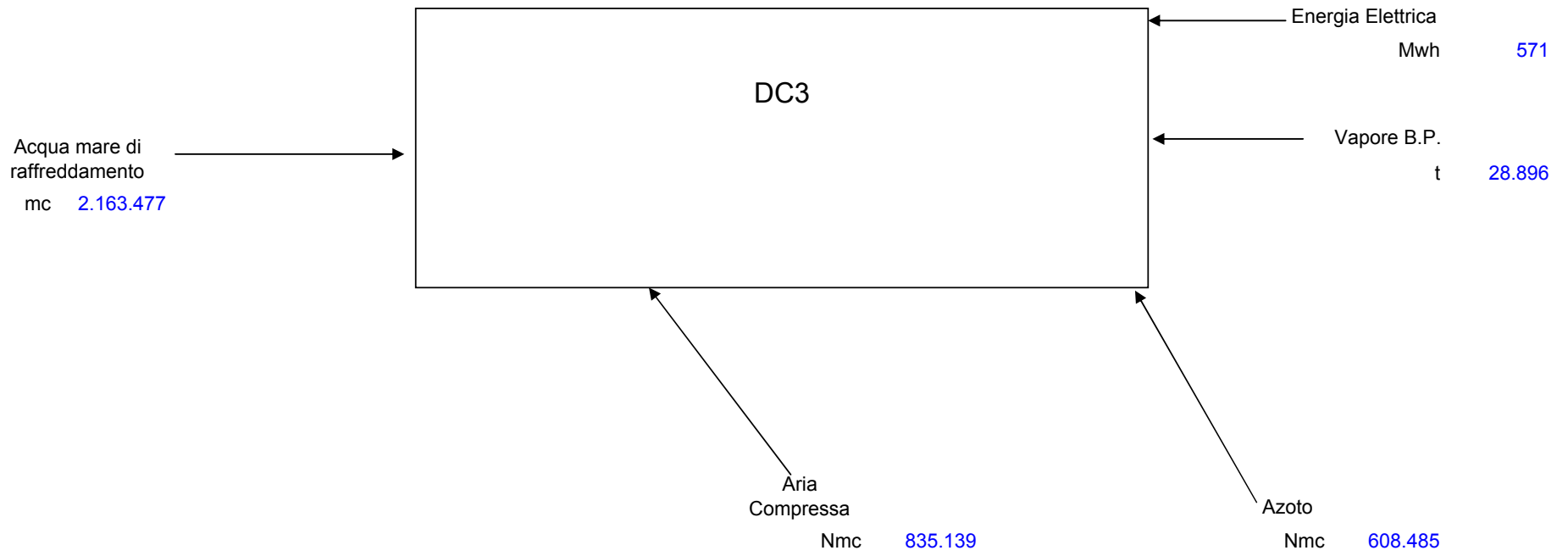

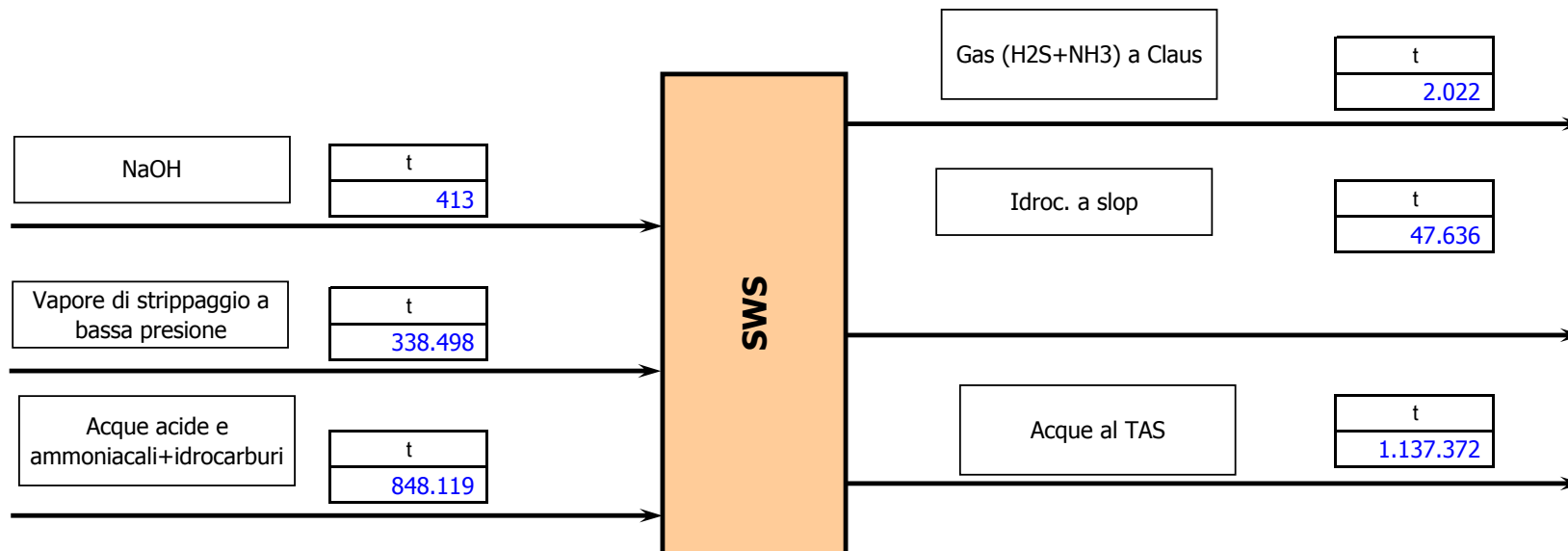

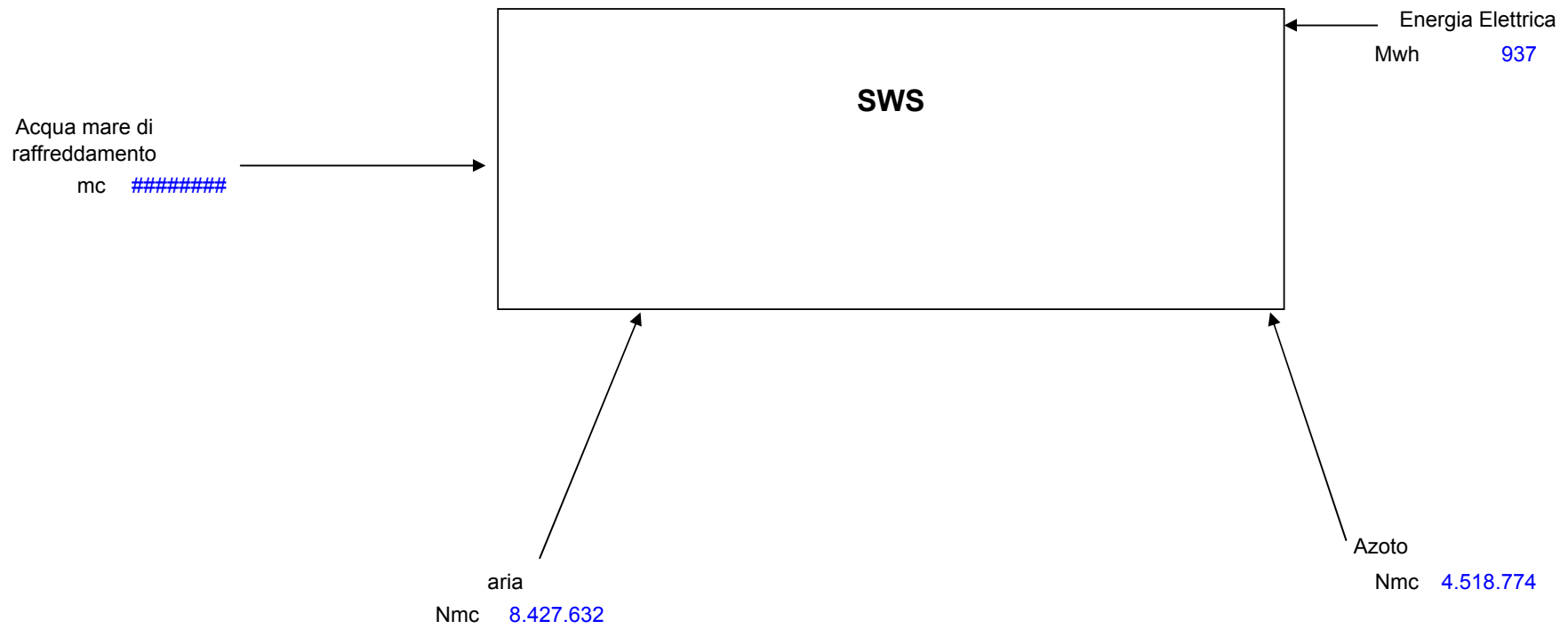

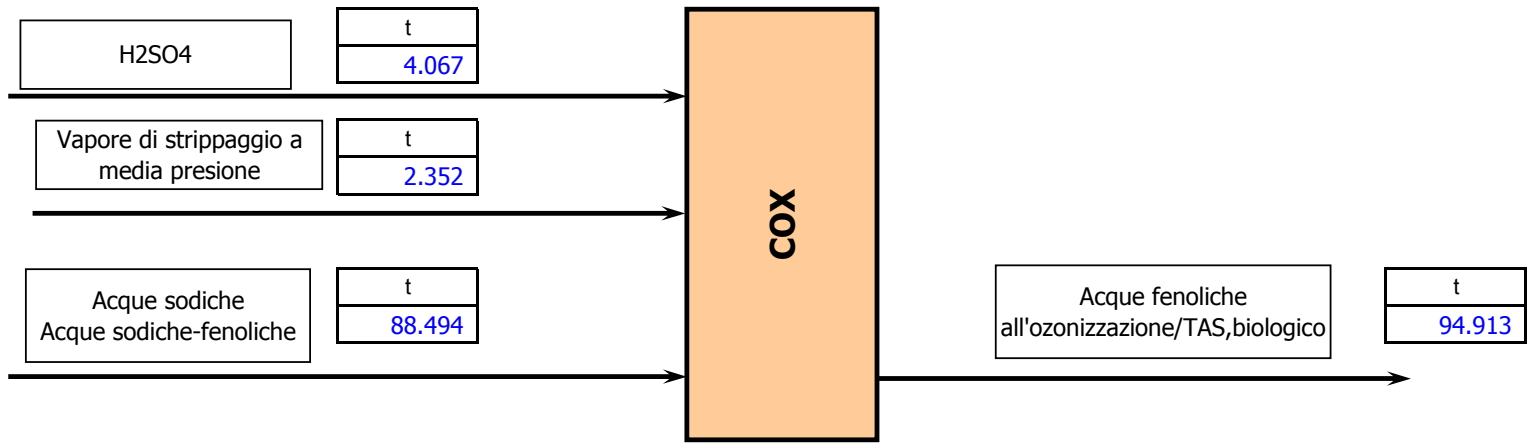

Nmc Azoto
118.805

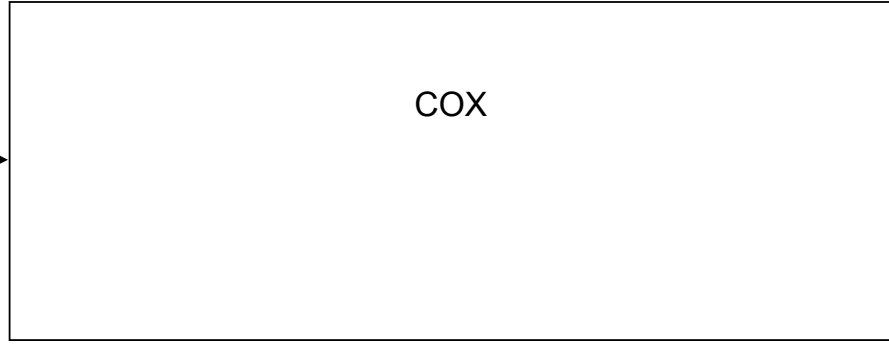

Energia Elettrica
Mwh 2.490

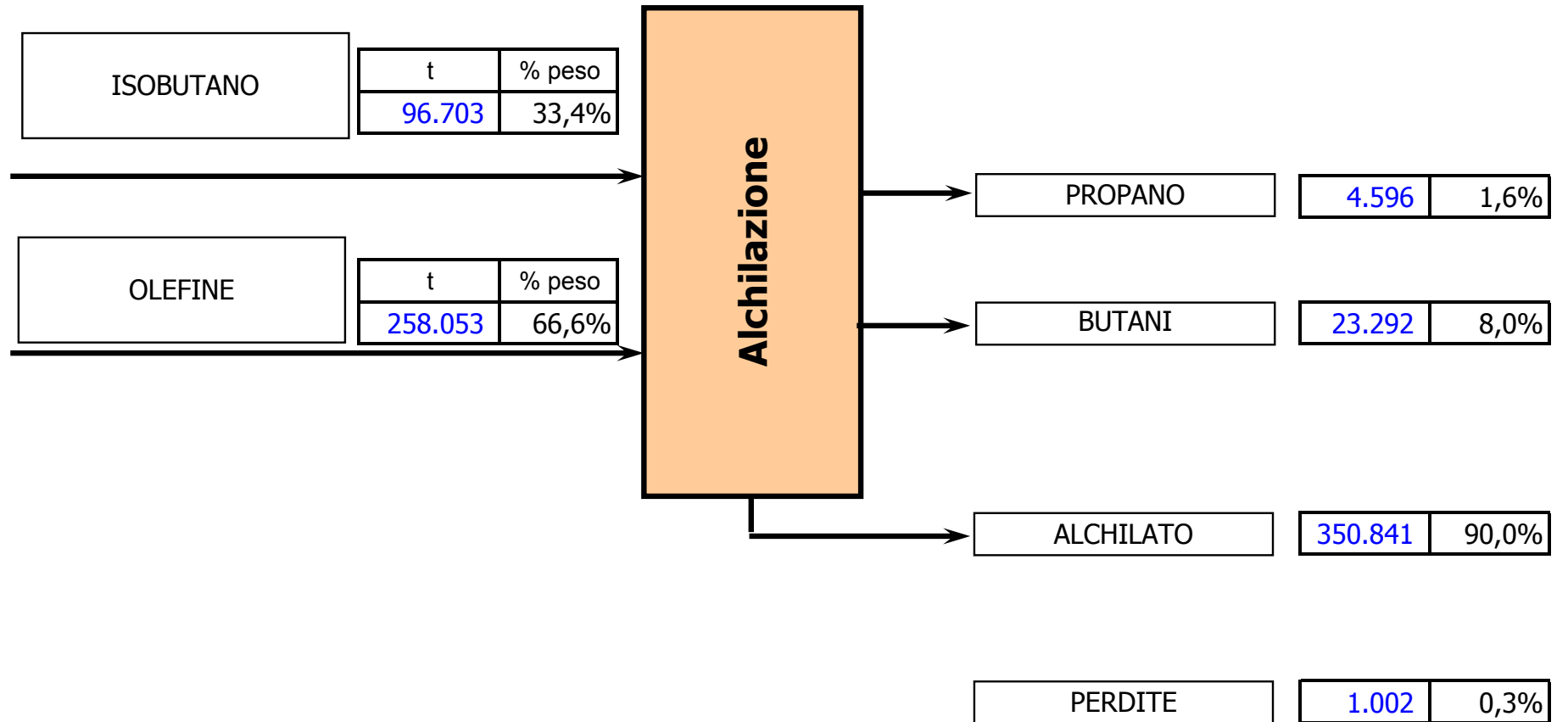

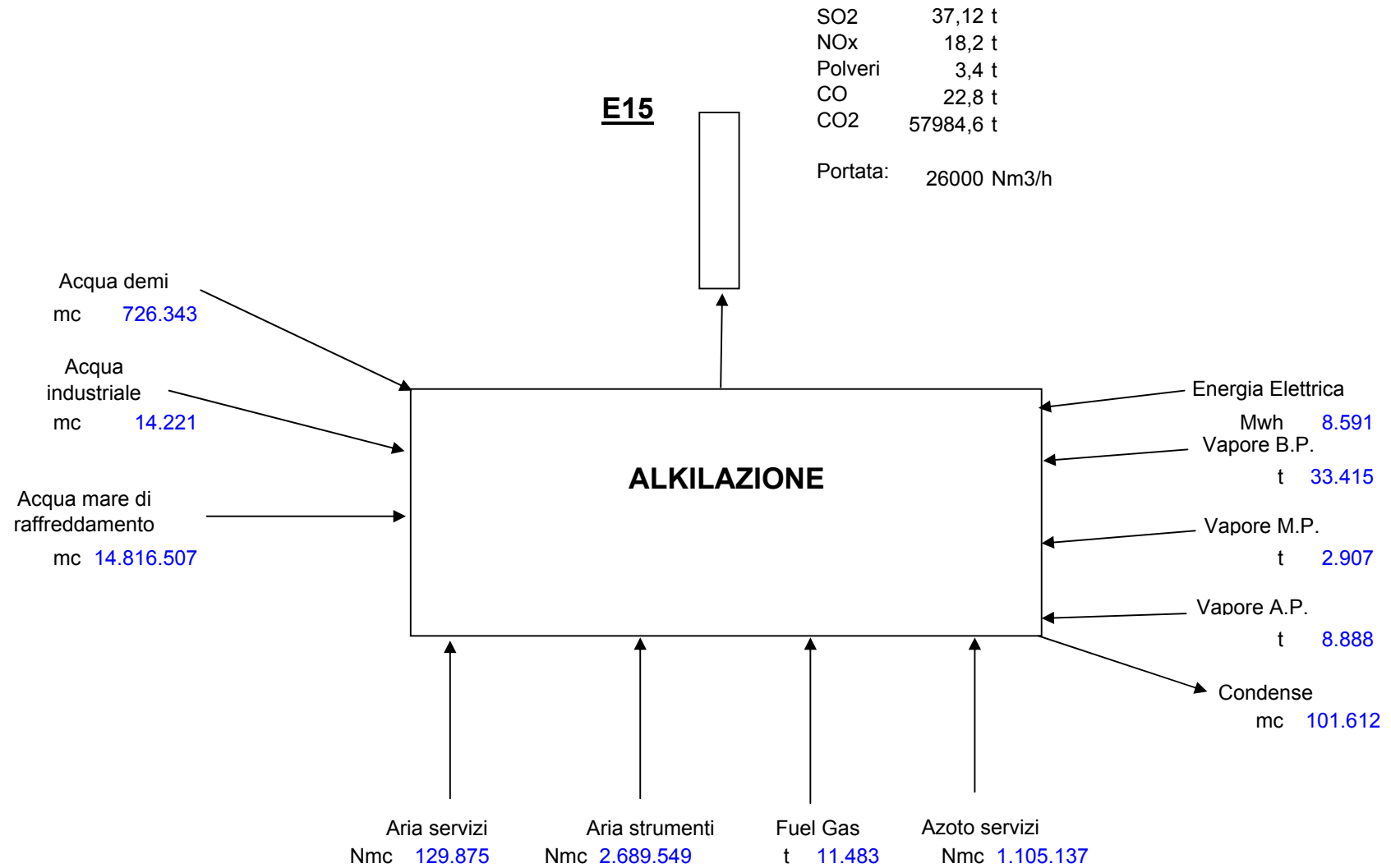

Autorizzazione Integrata Ambientale

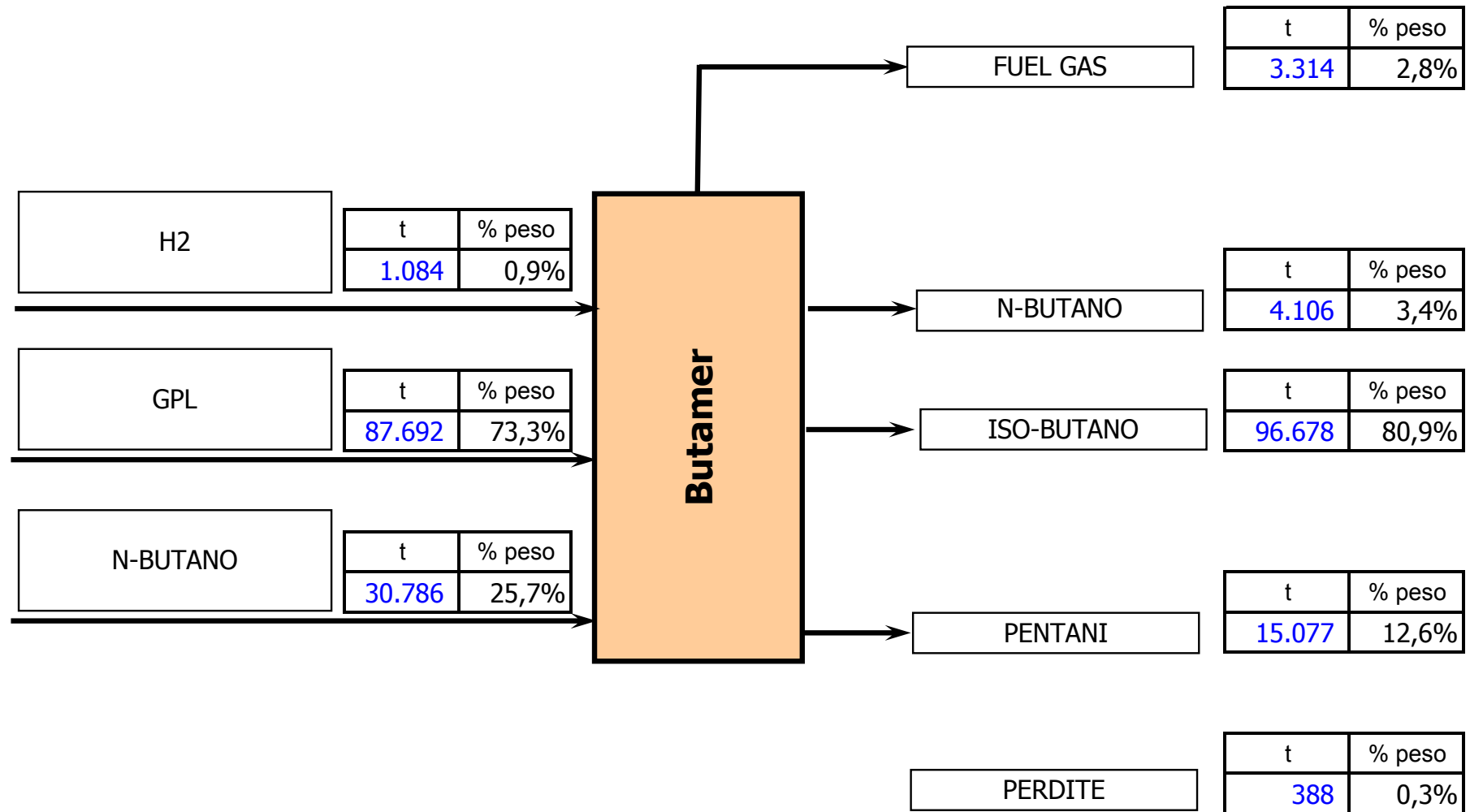

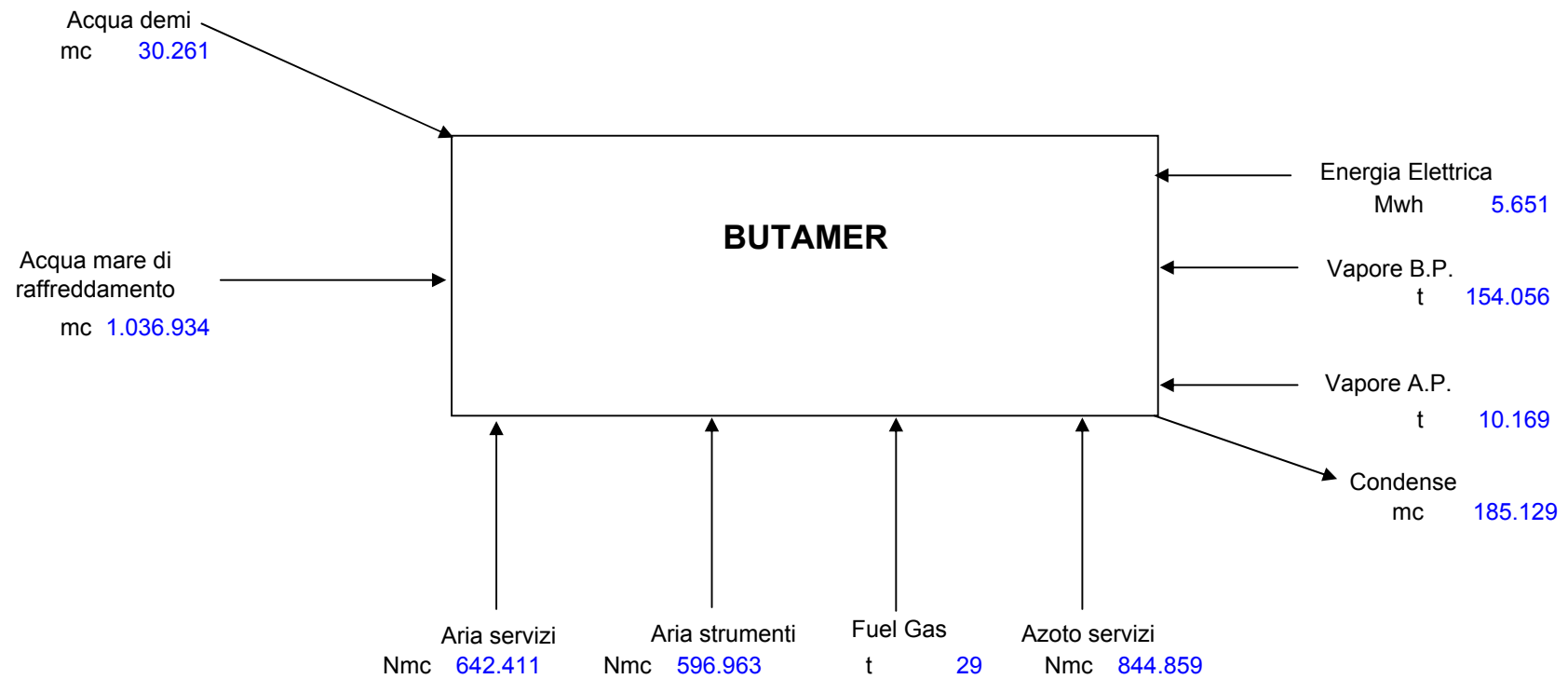

Autorizzazione Integrata Ambientale

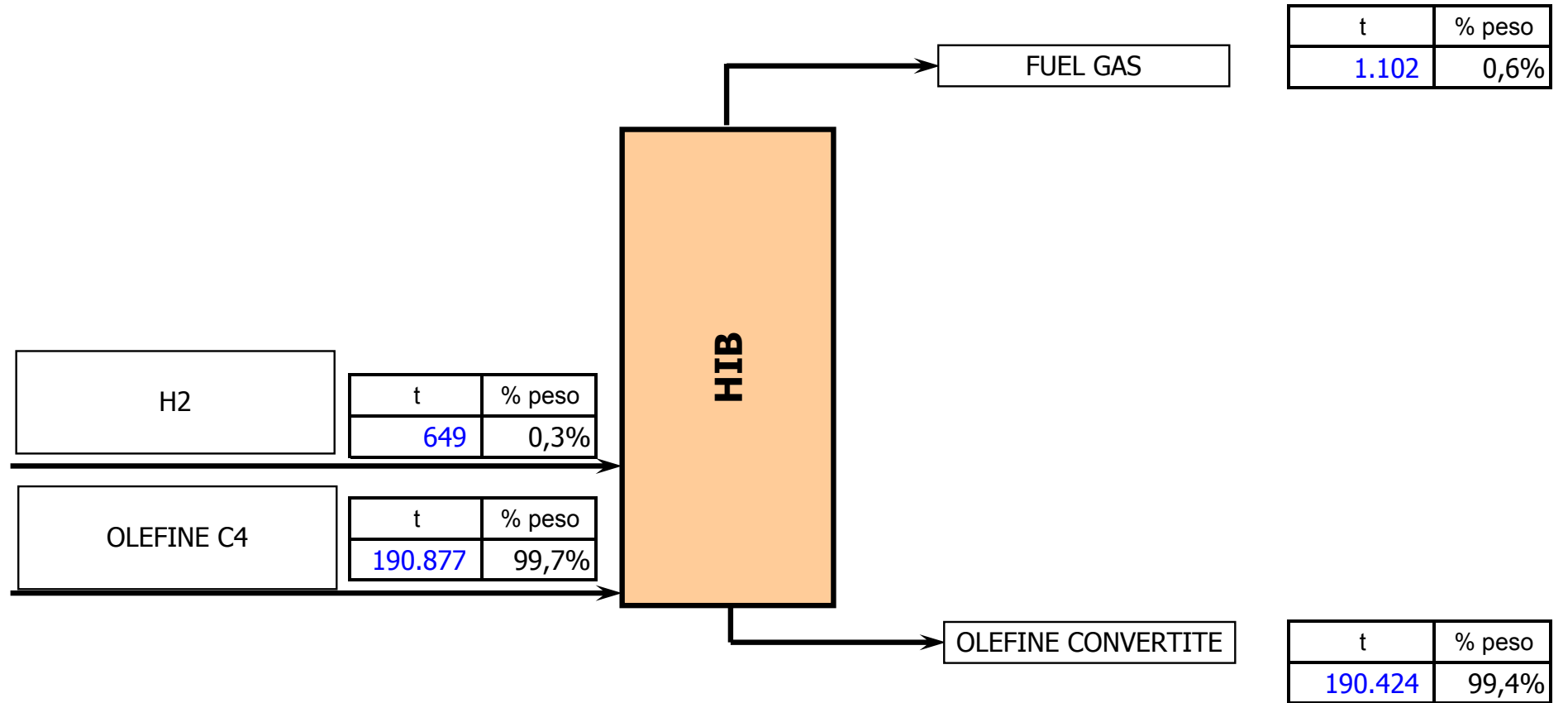

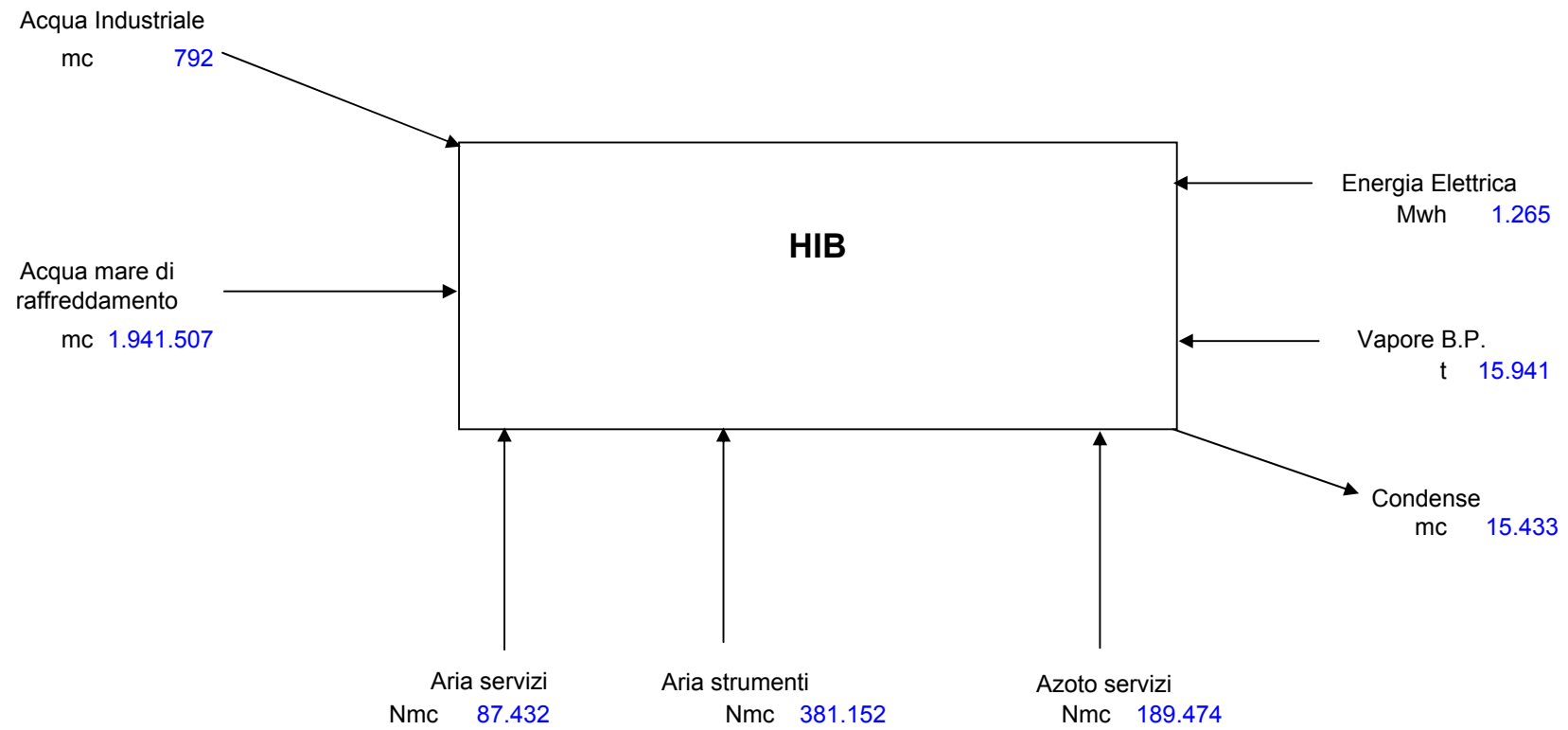

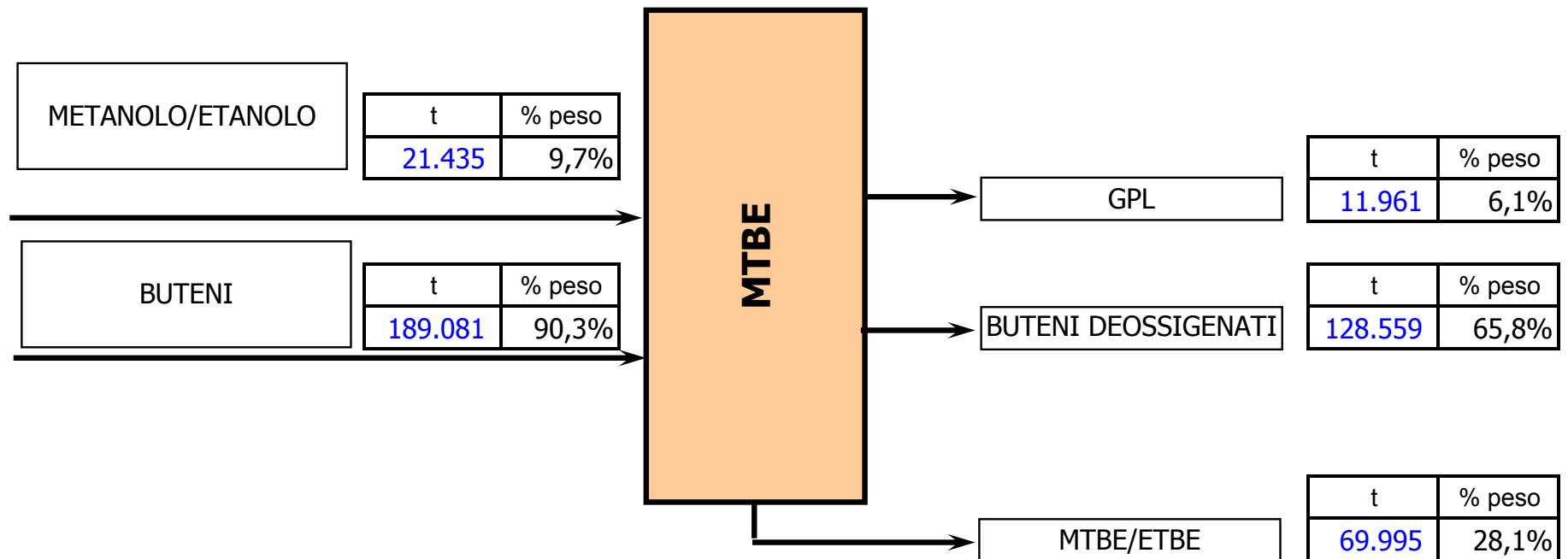

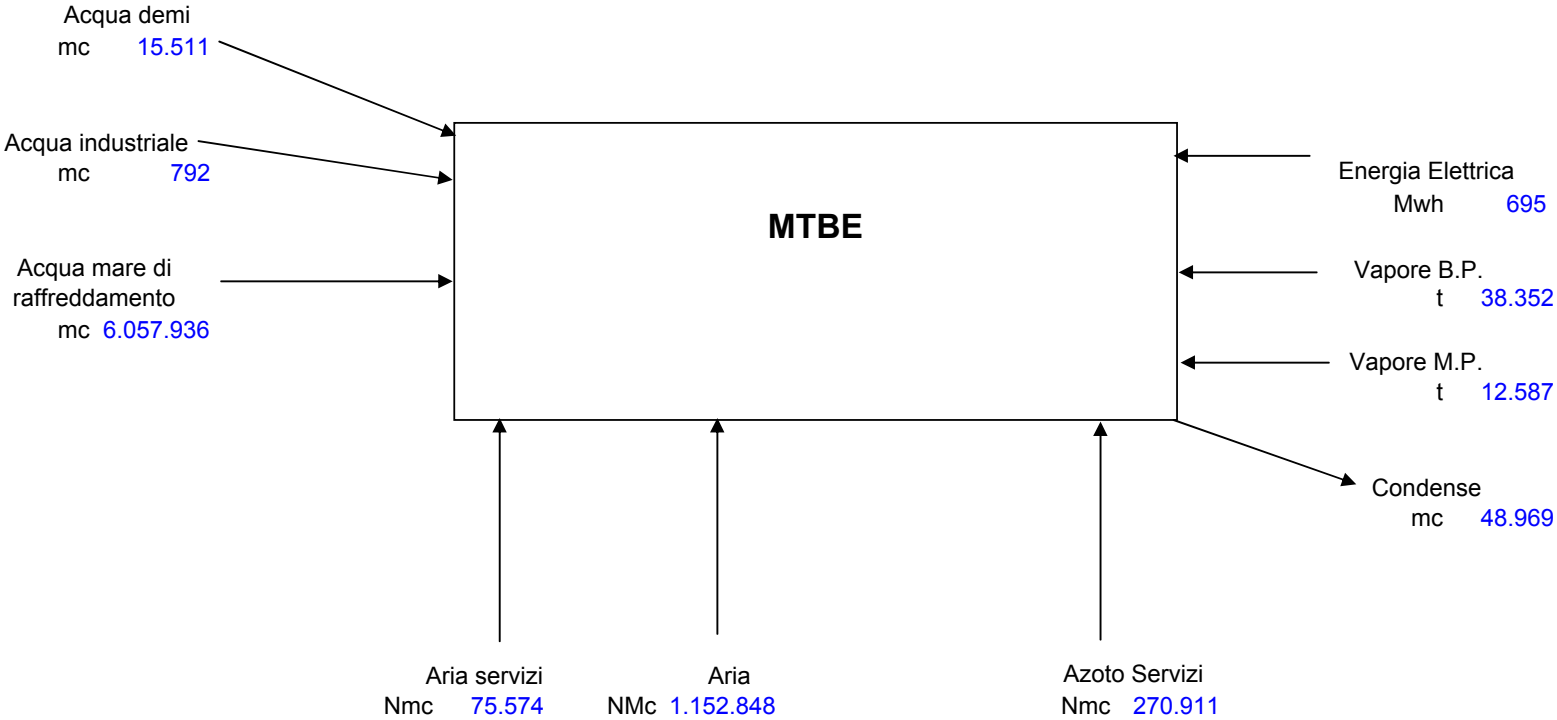

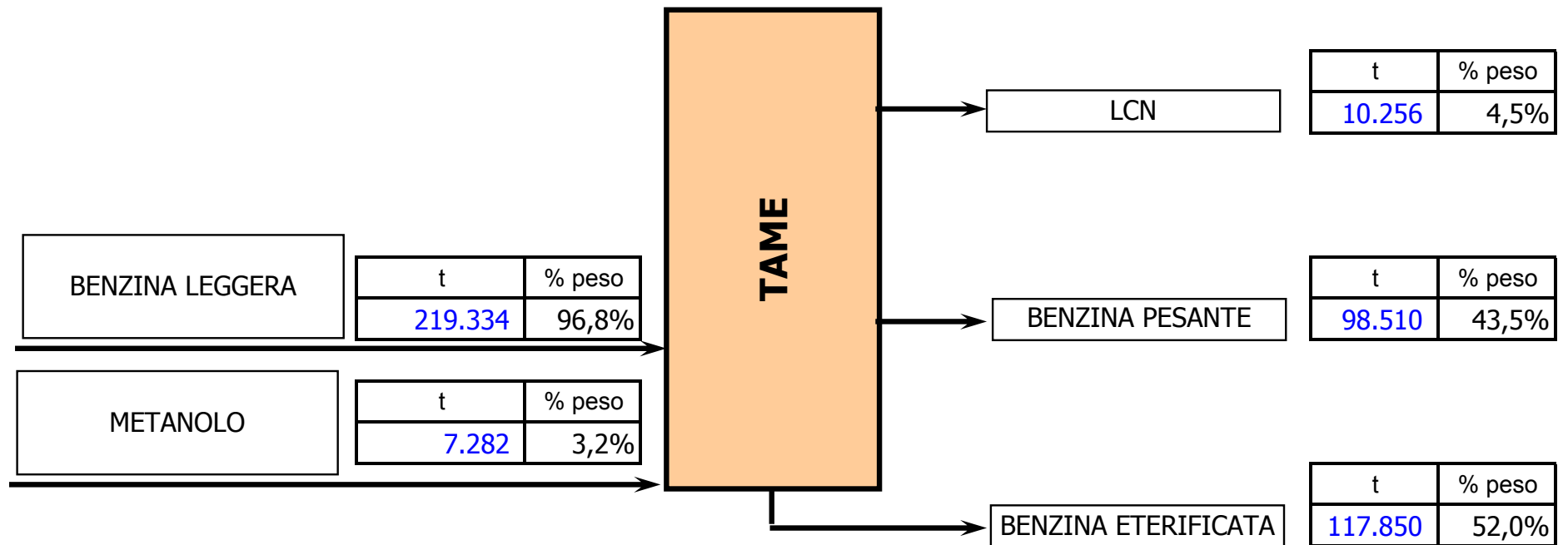

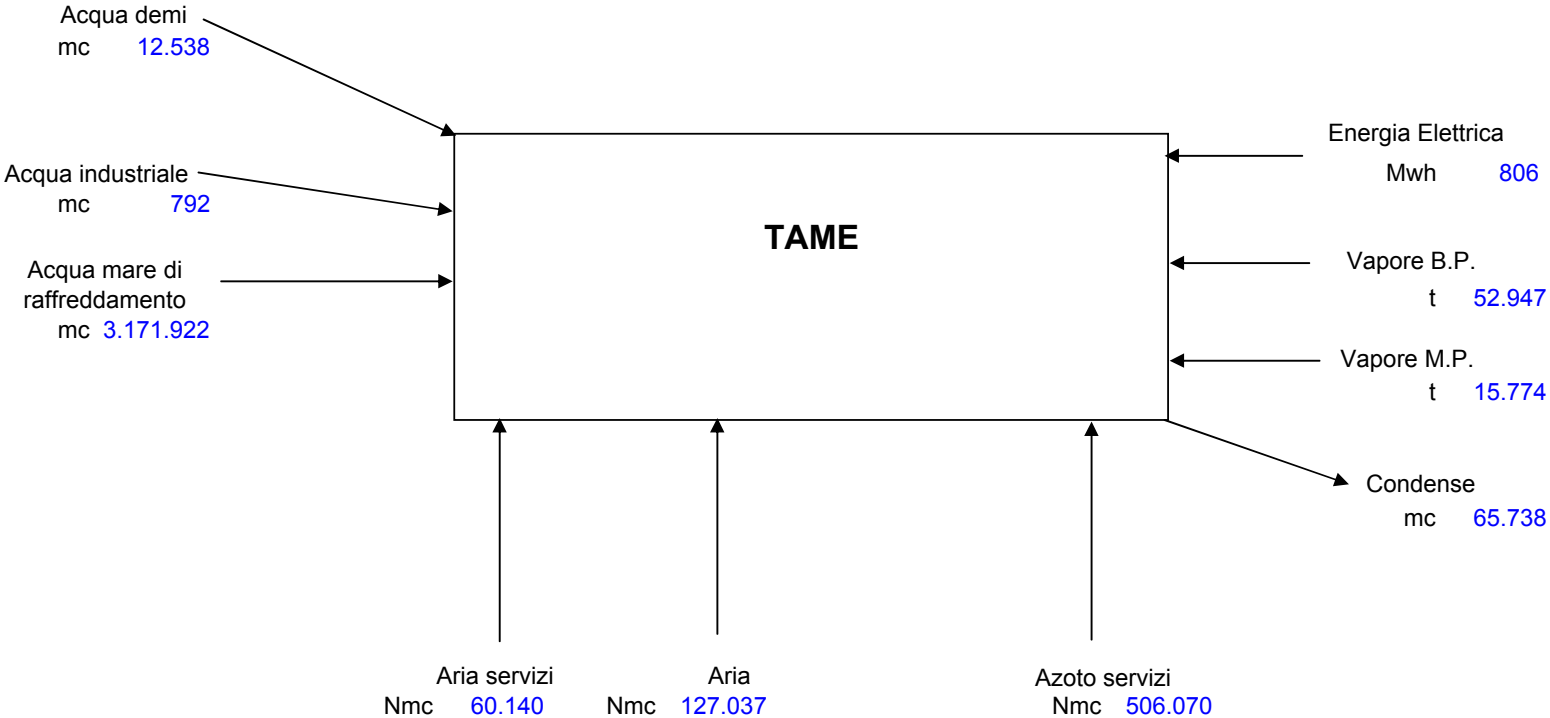

Autorizzazione Integrata Ambientale

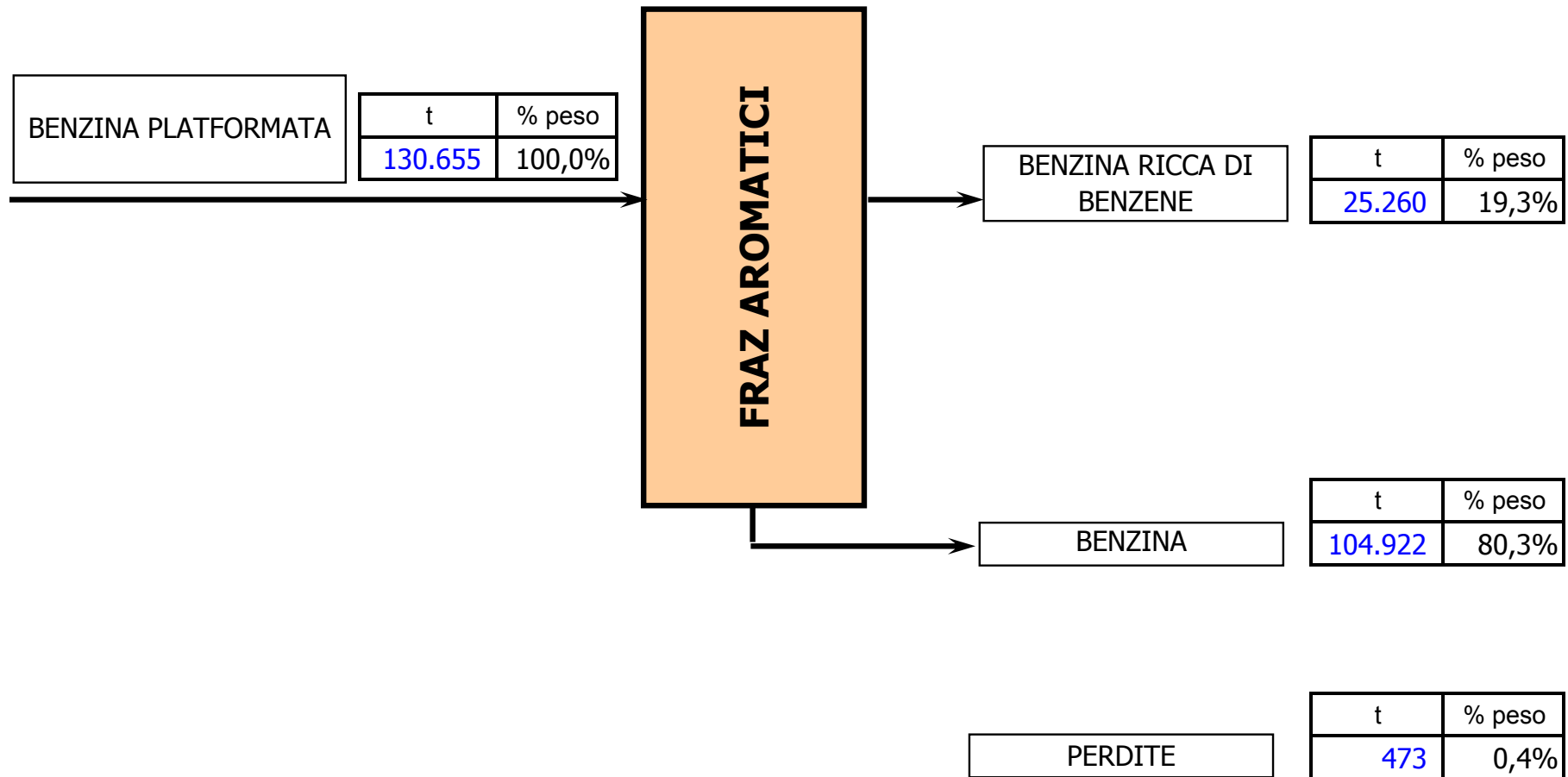

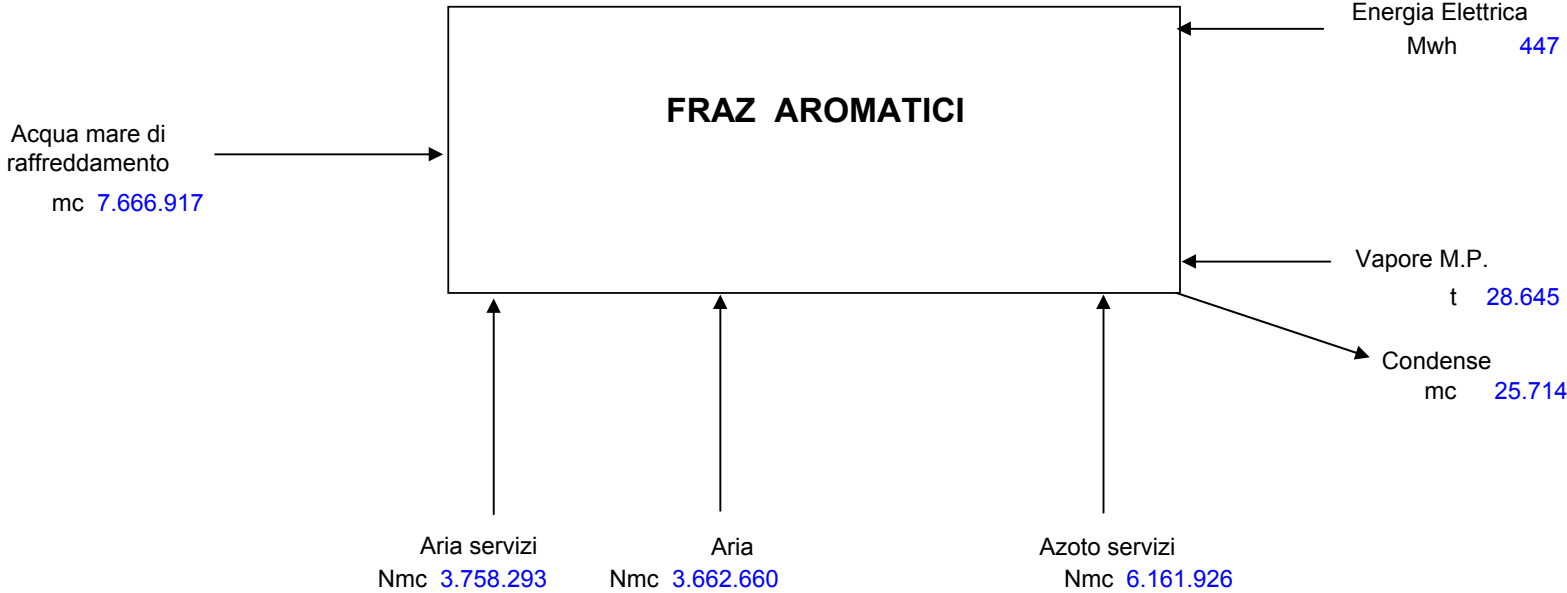

Autorizzazione Integrata Ambientale

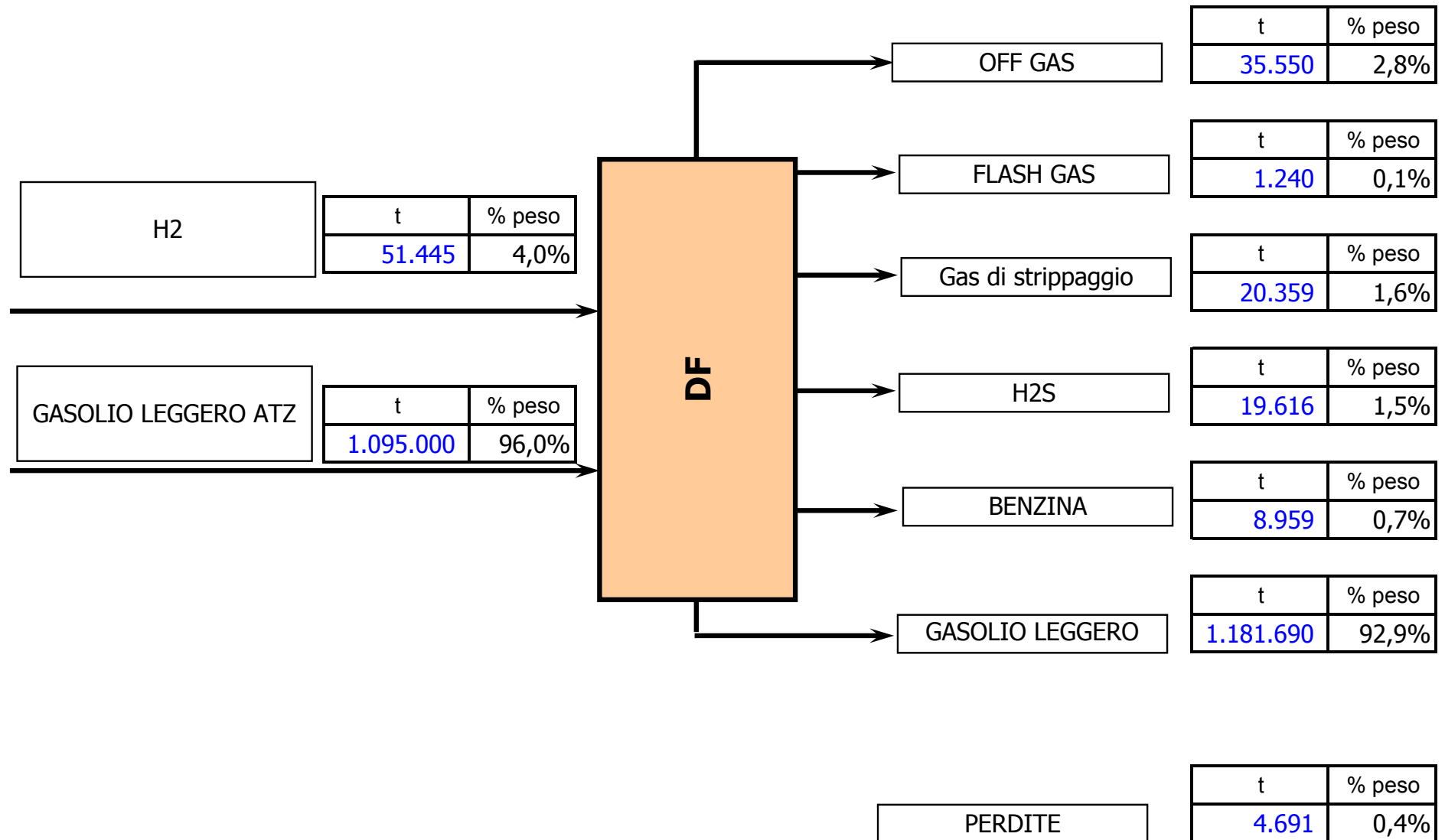

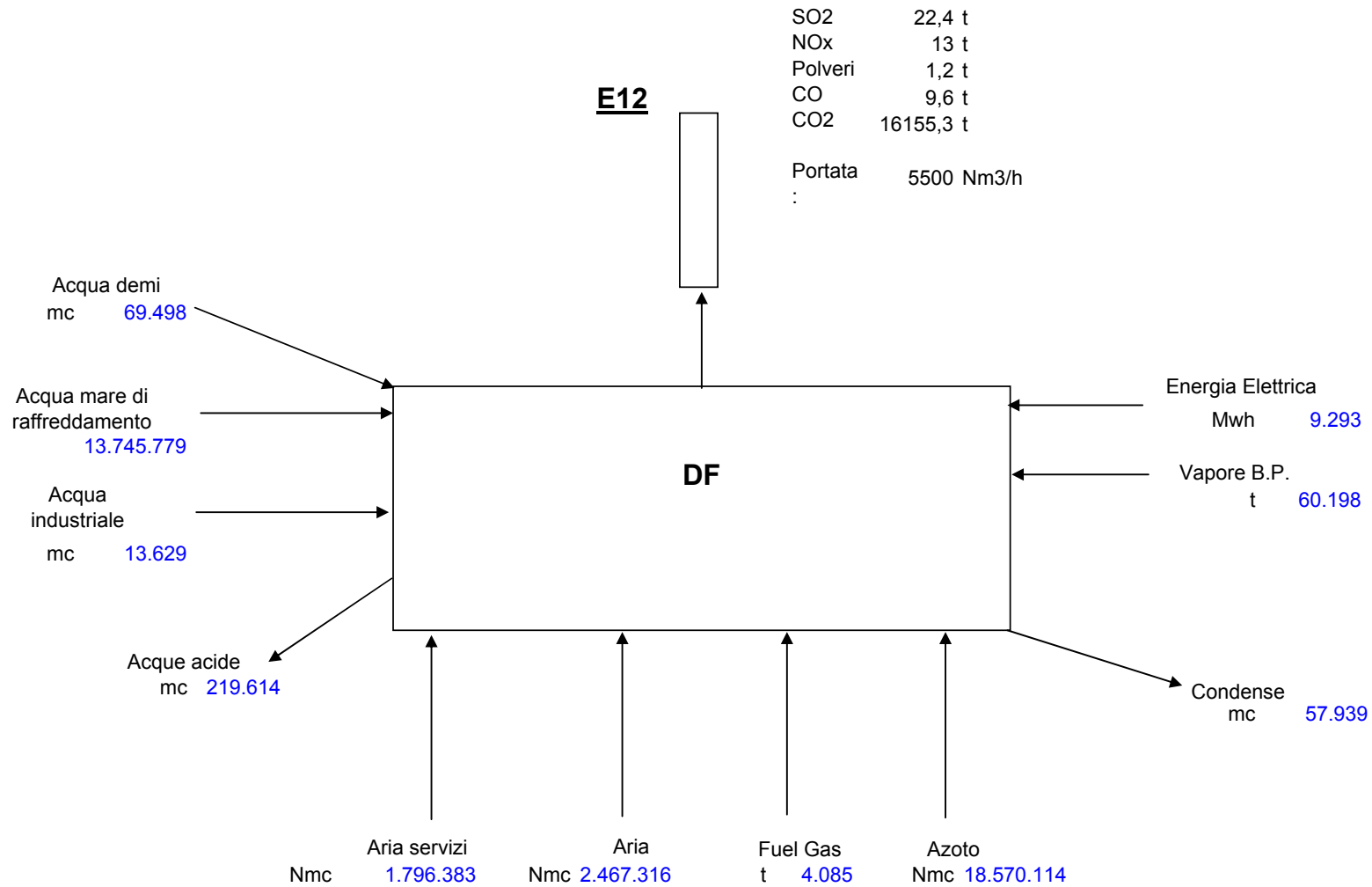

Autorizzazione Integrata Ambientale

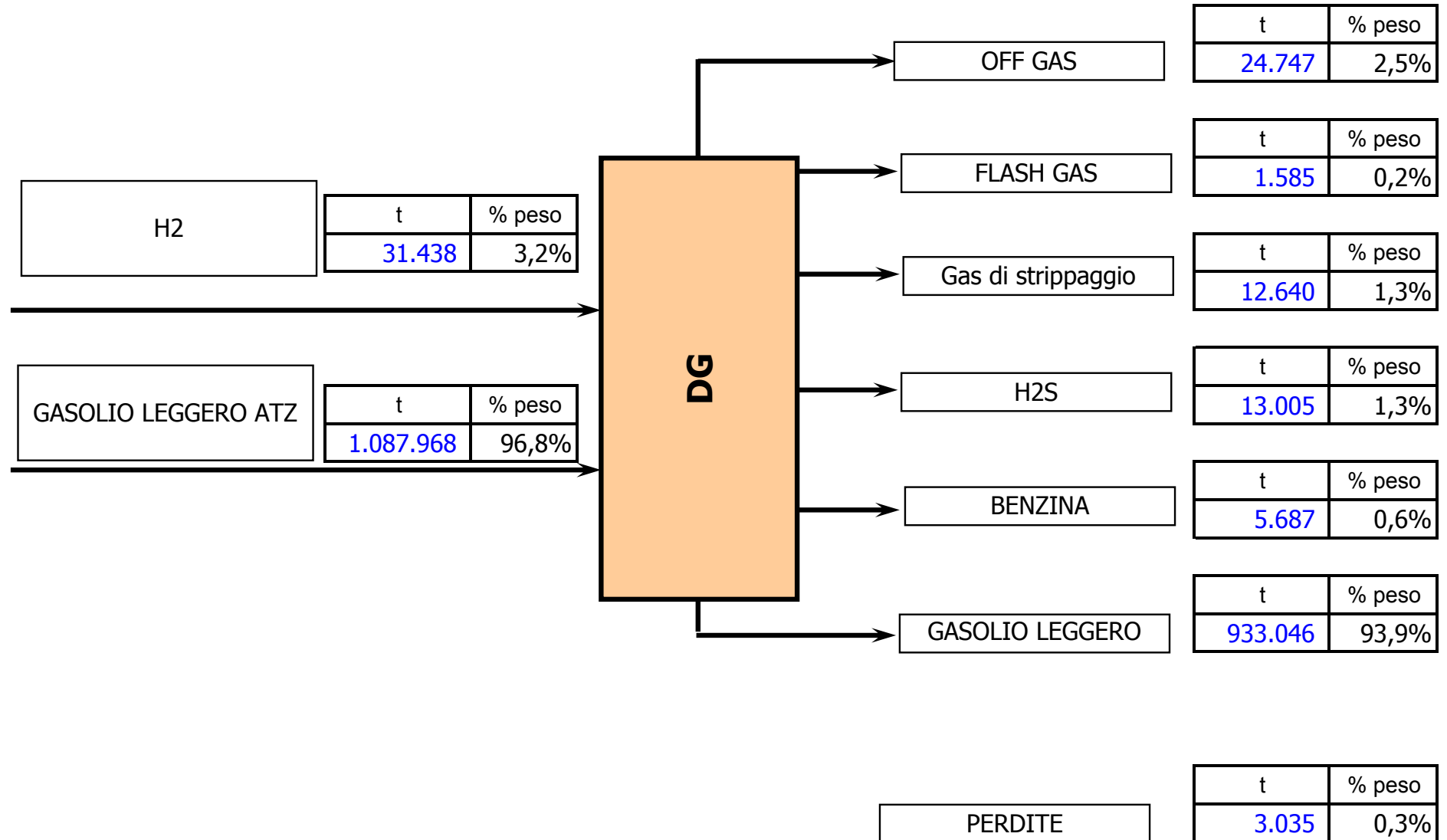

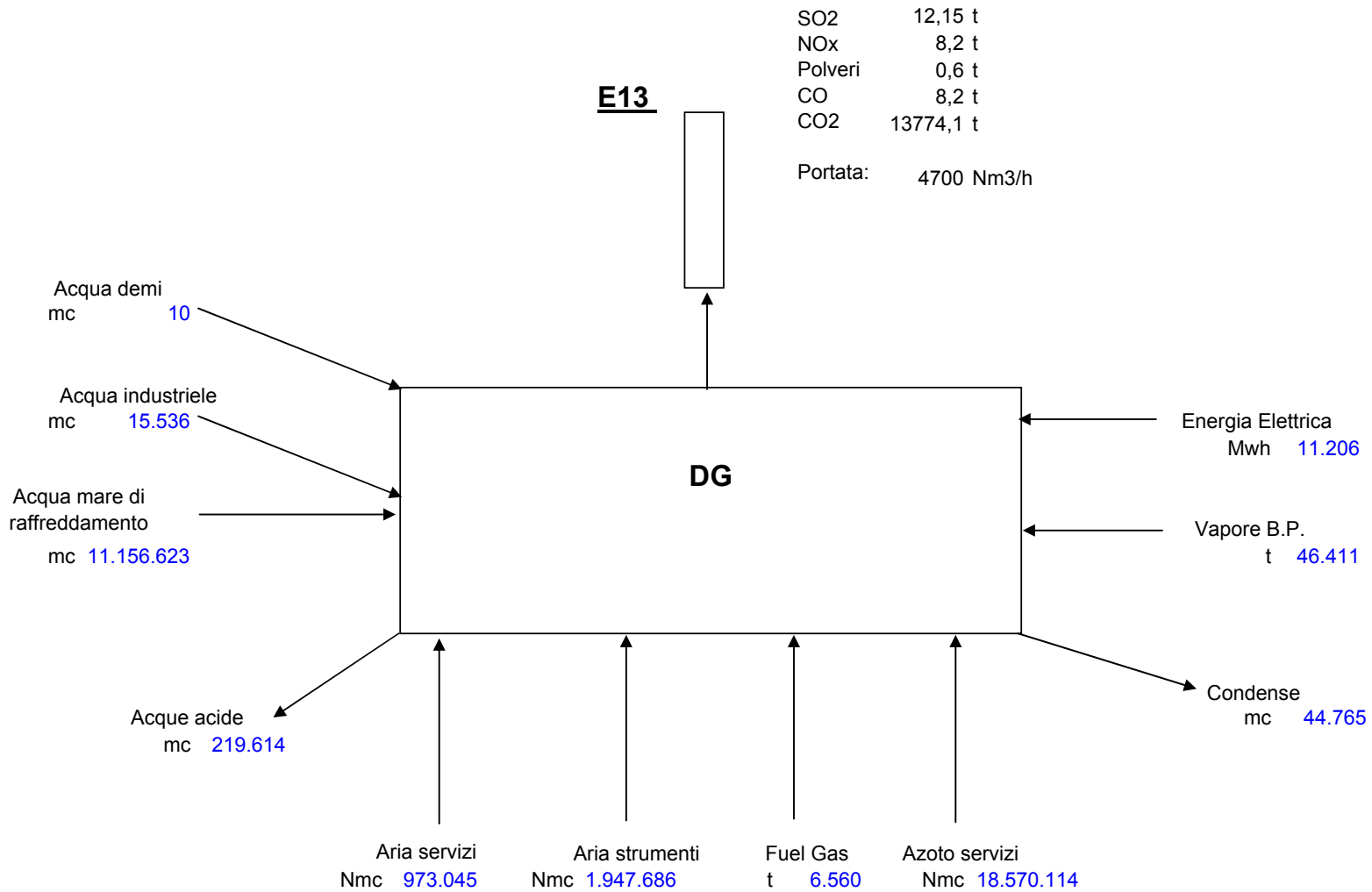

Autorizzazione Integrata Ambientale

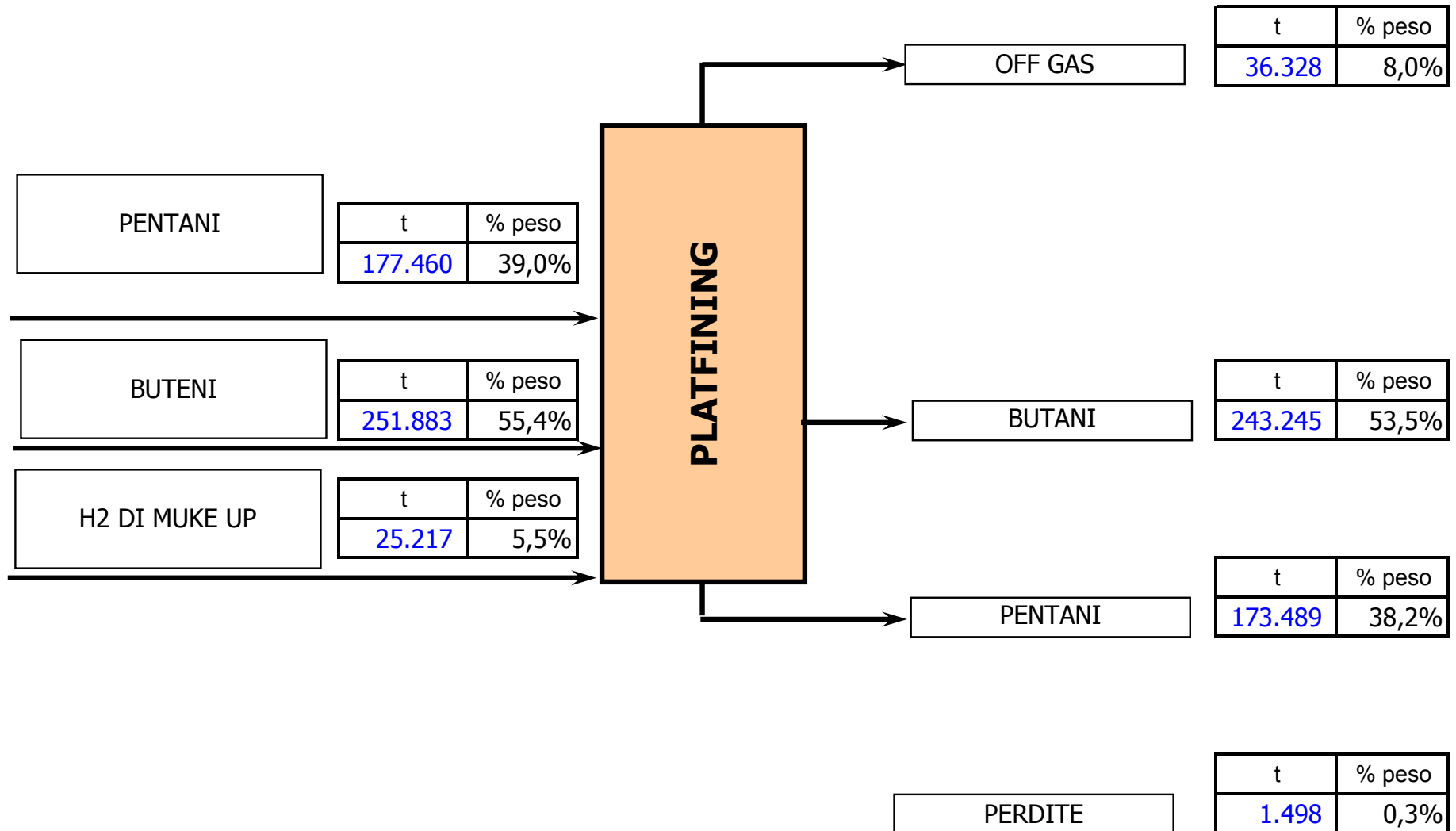

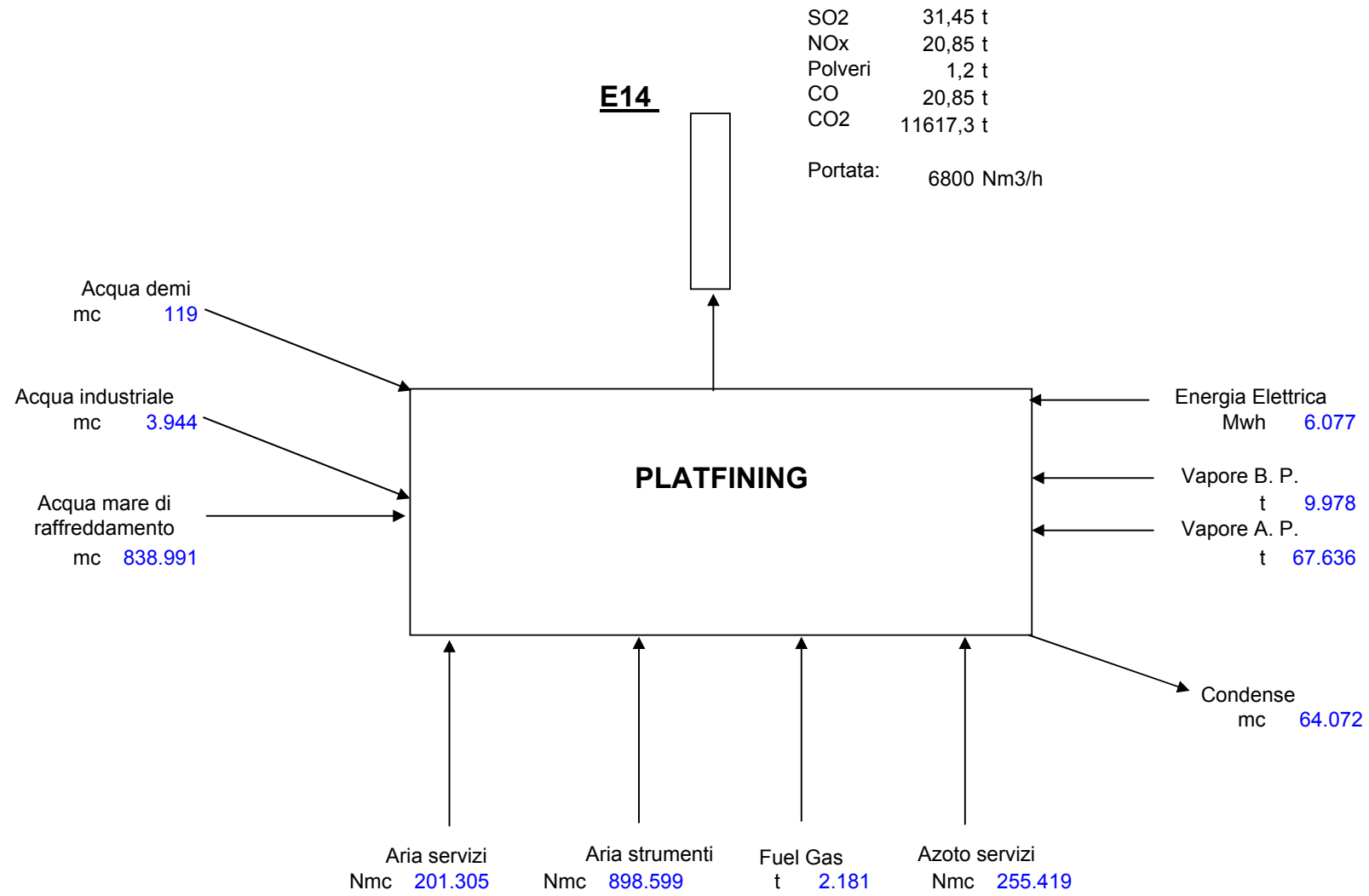

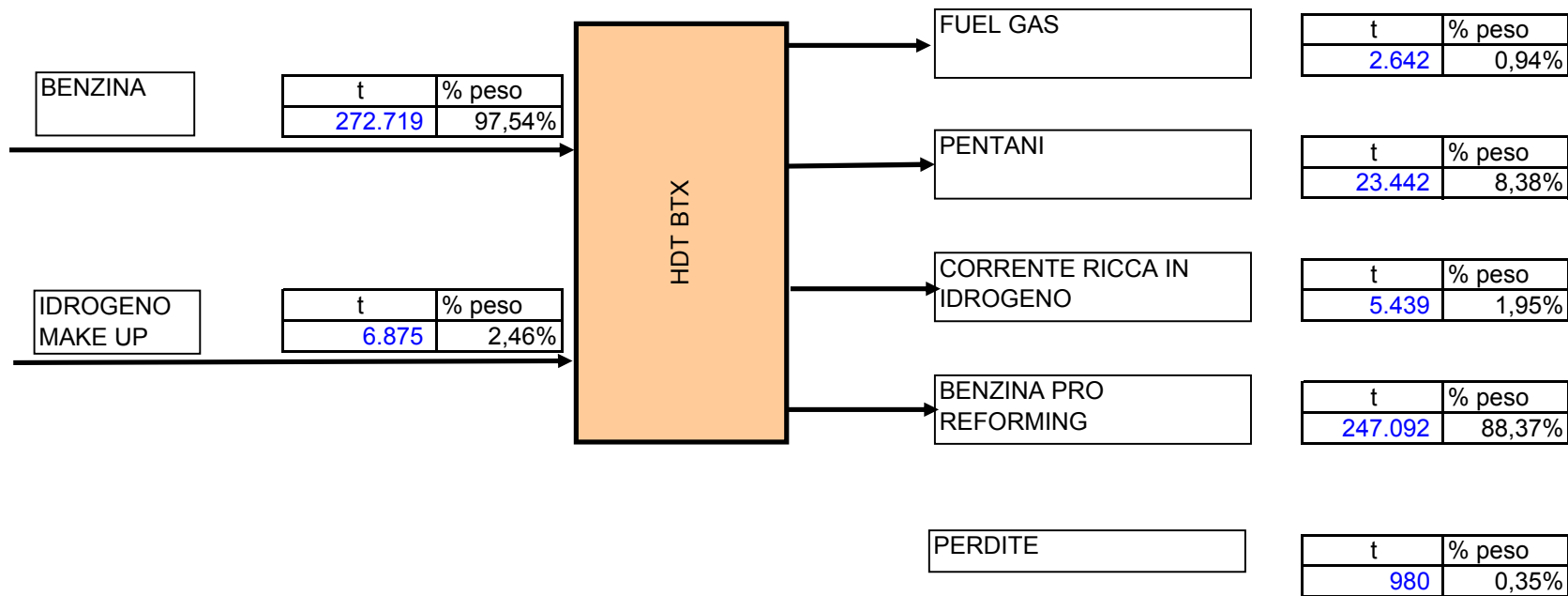

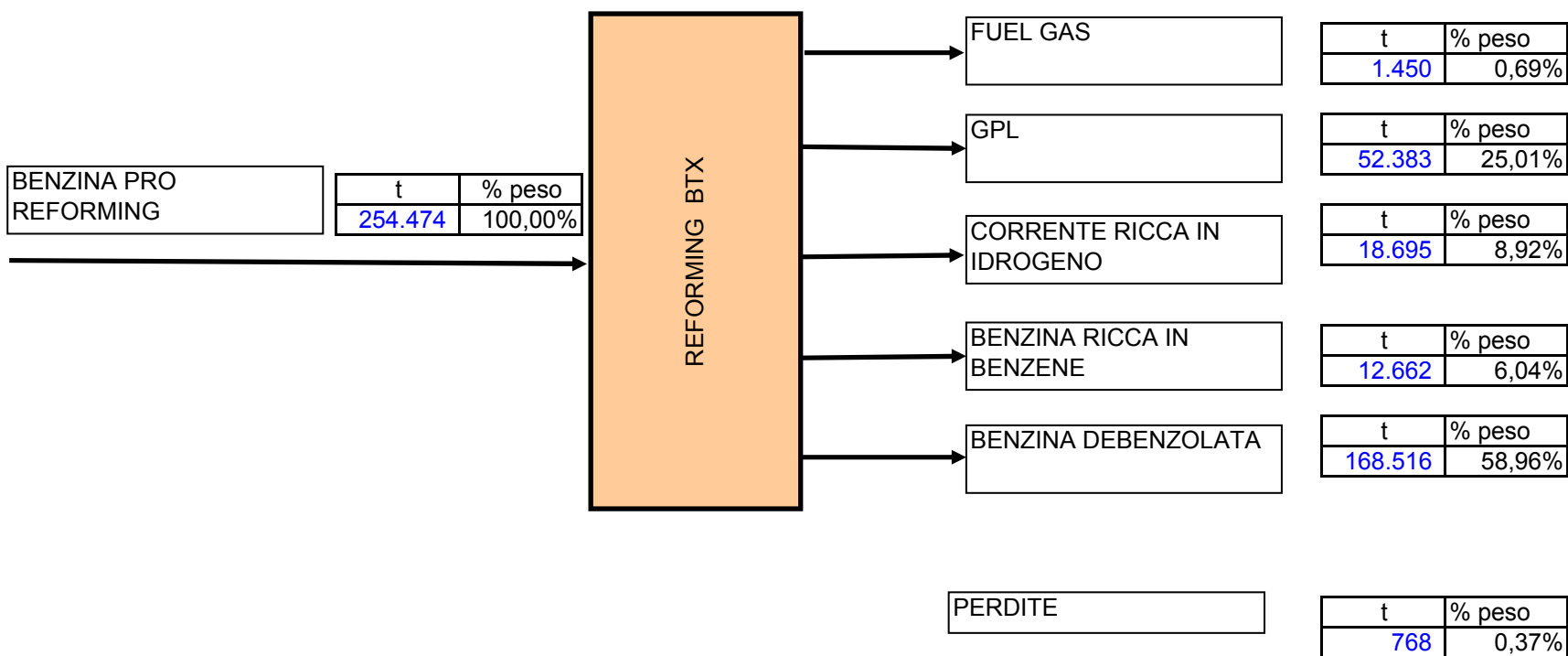

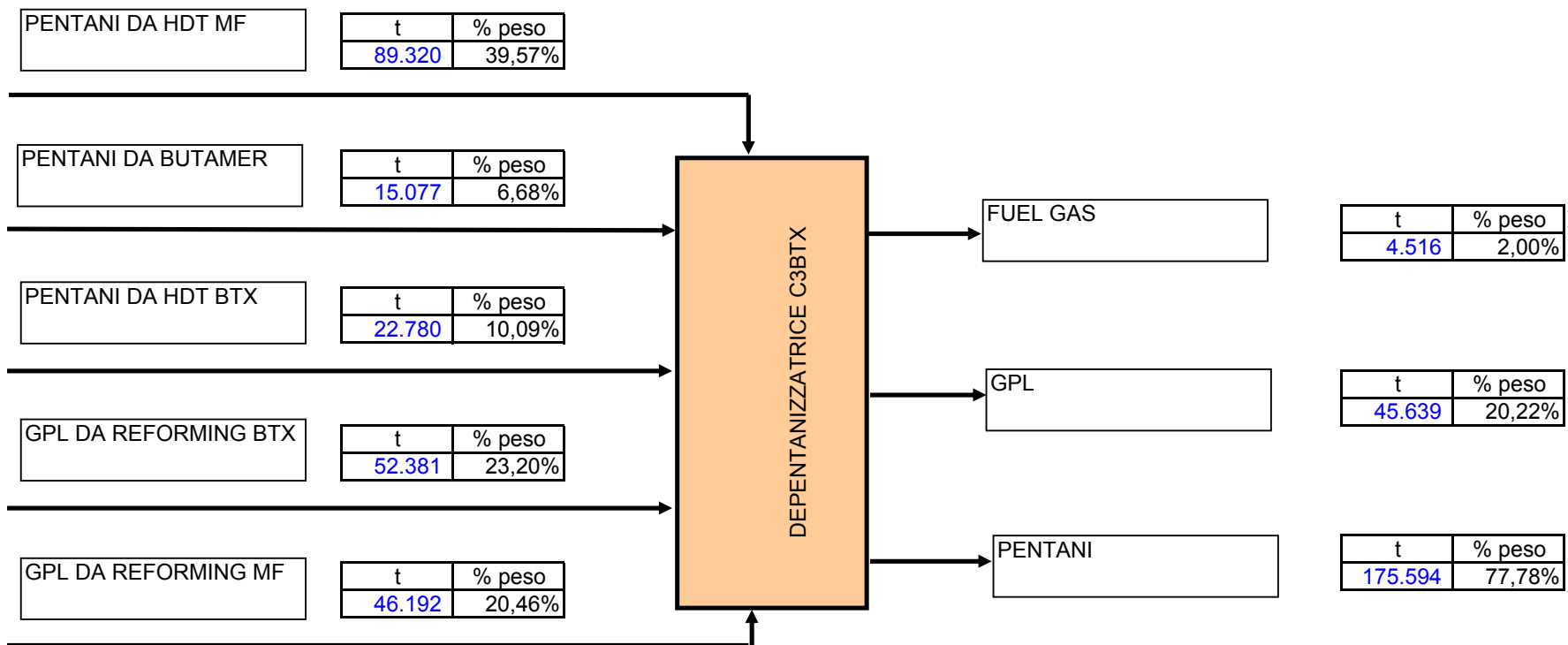

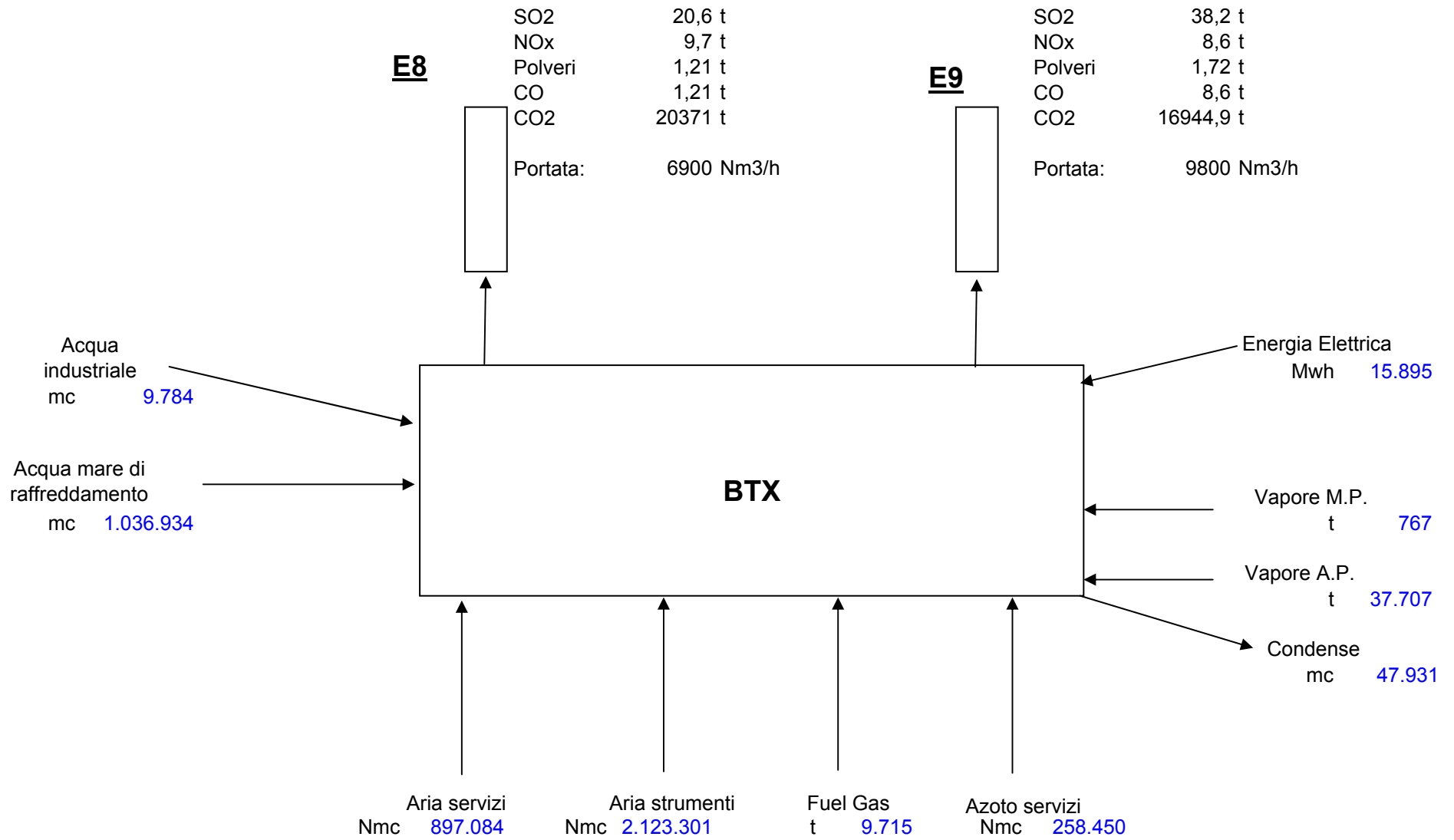

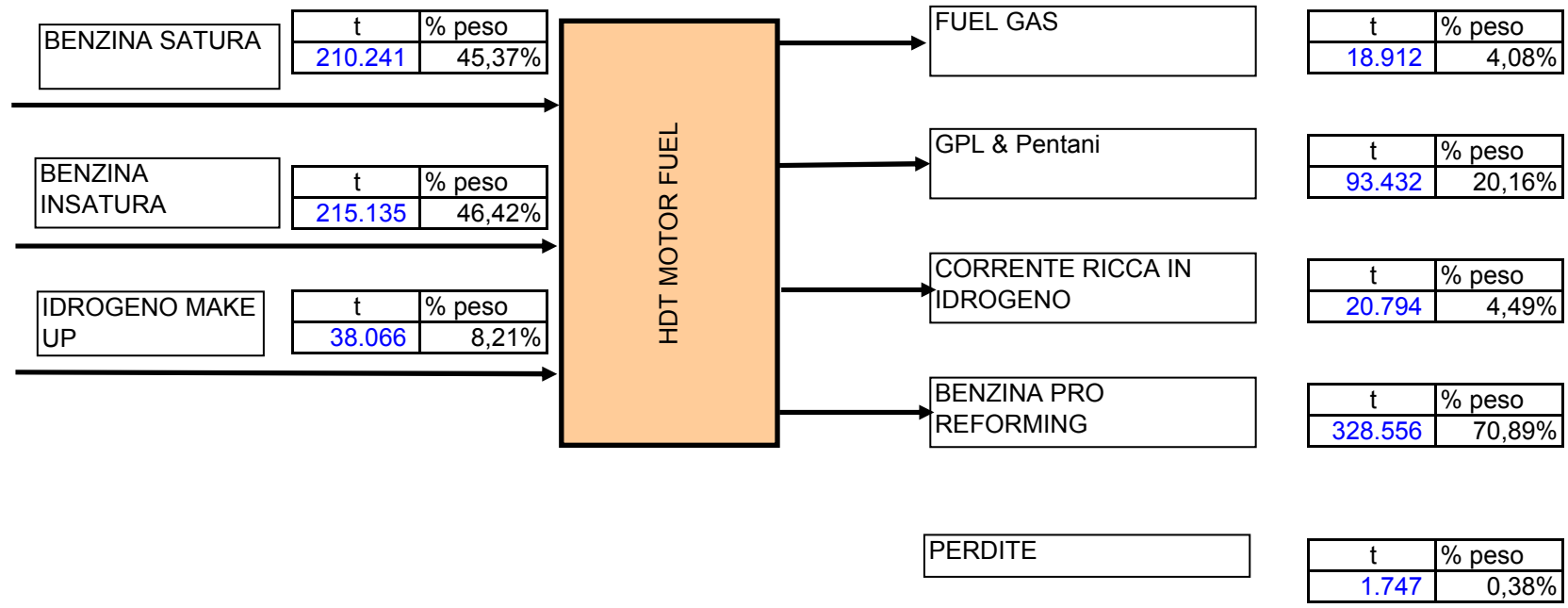

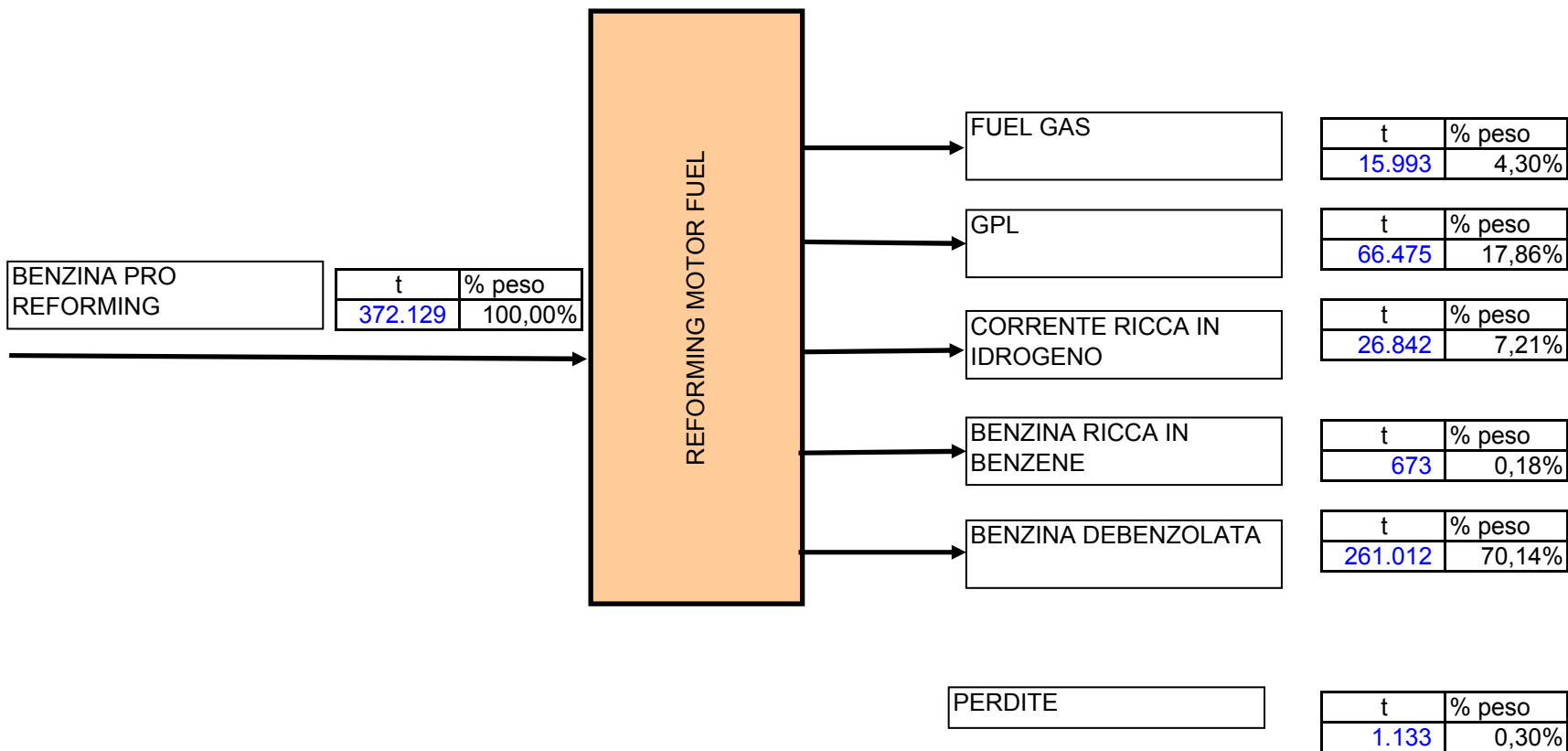

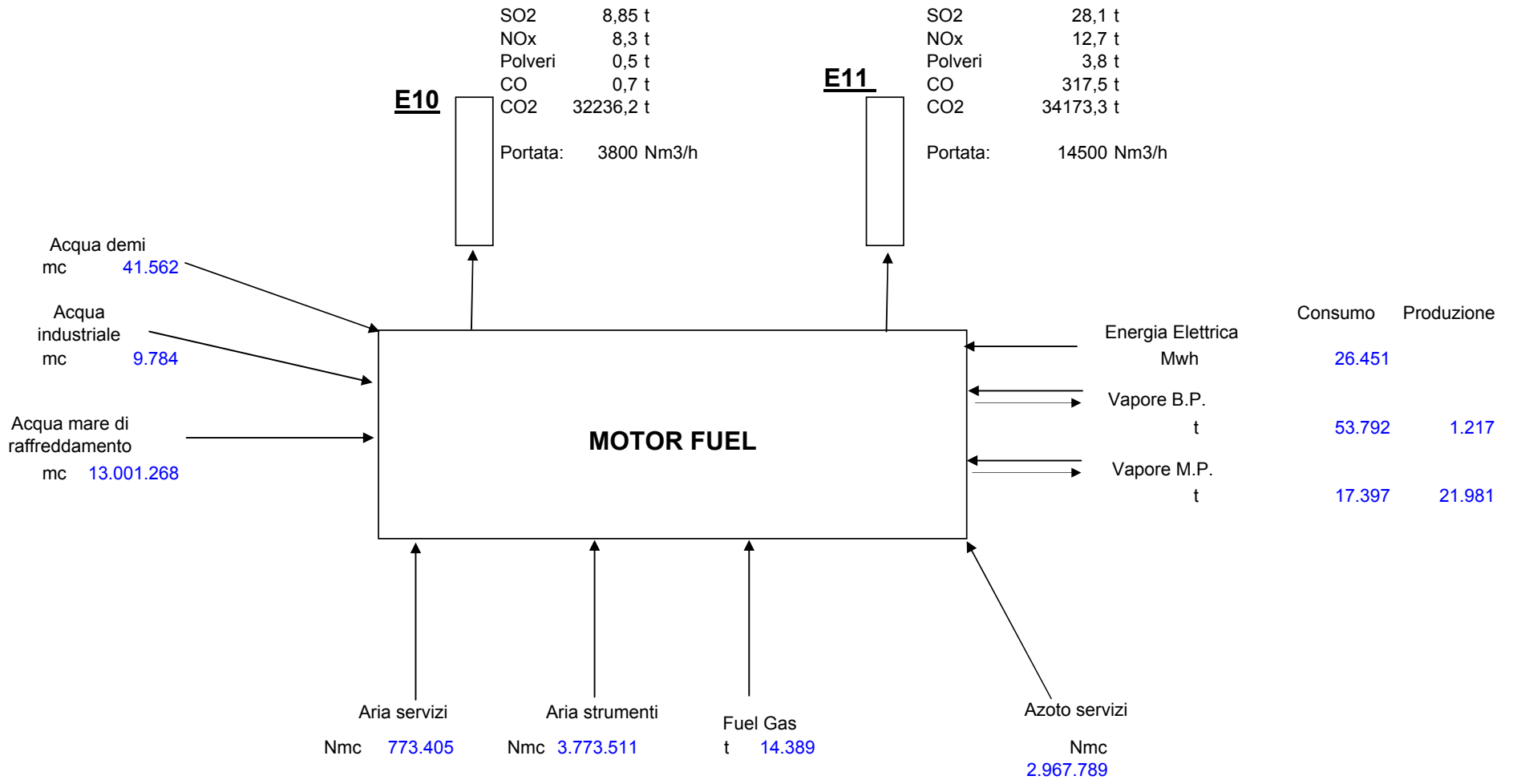

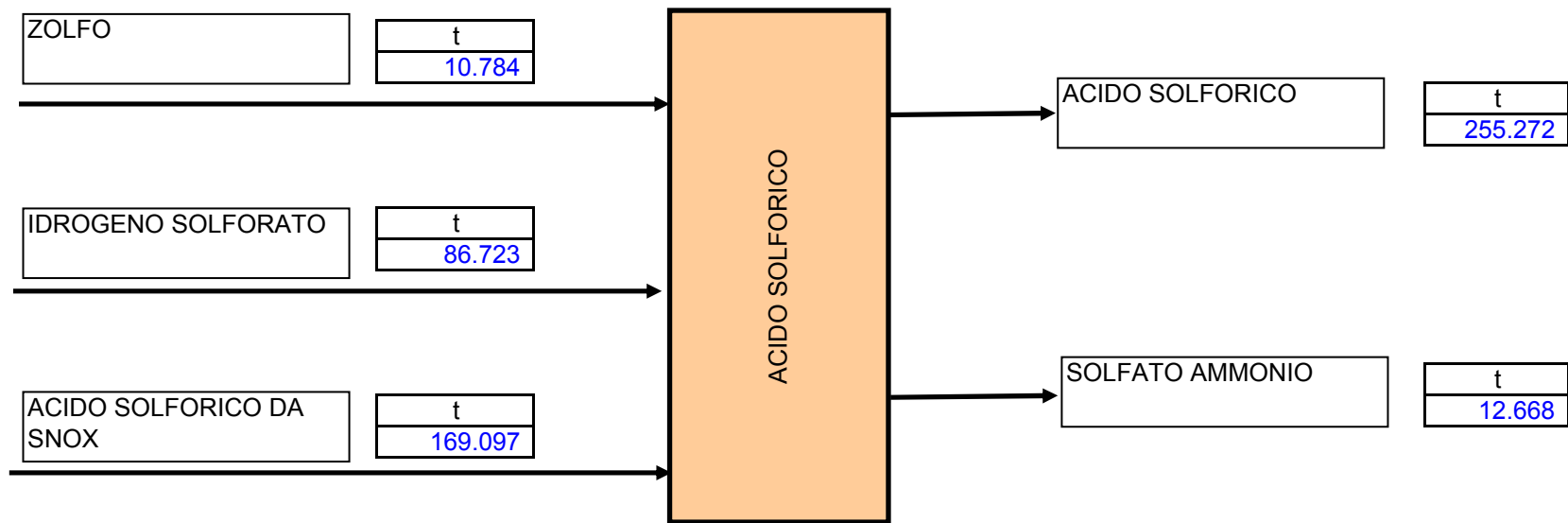

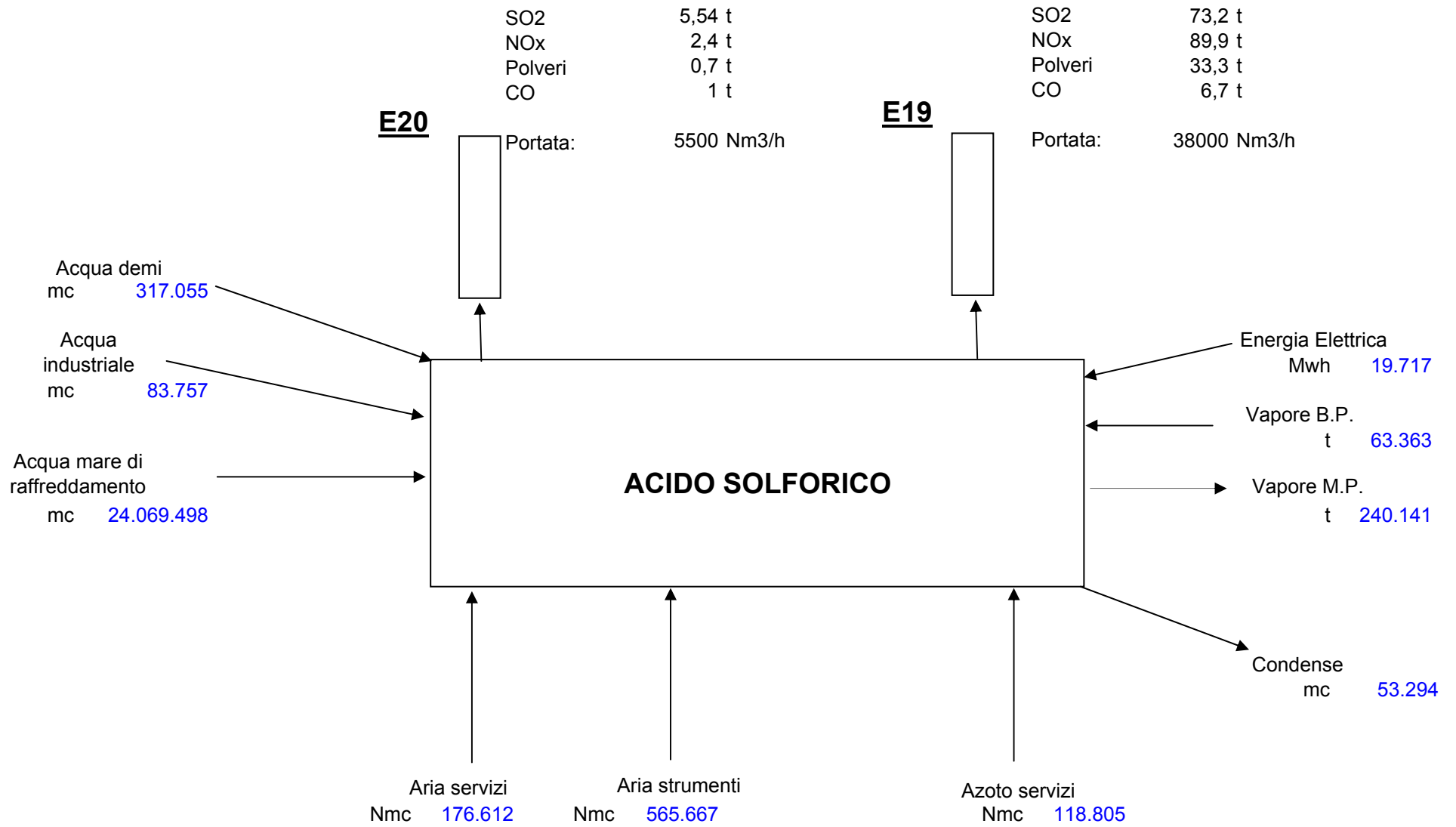

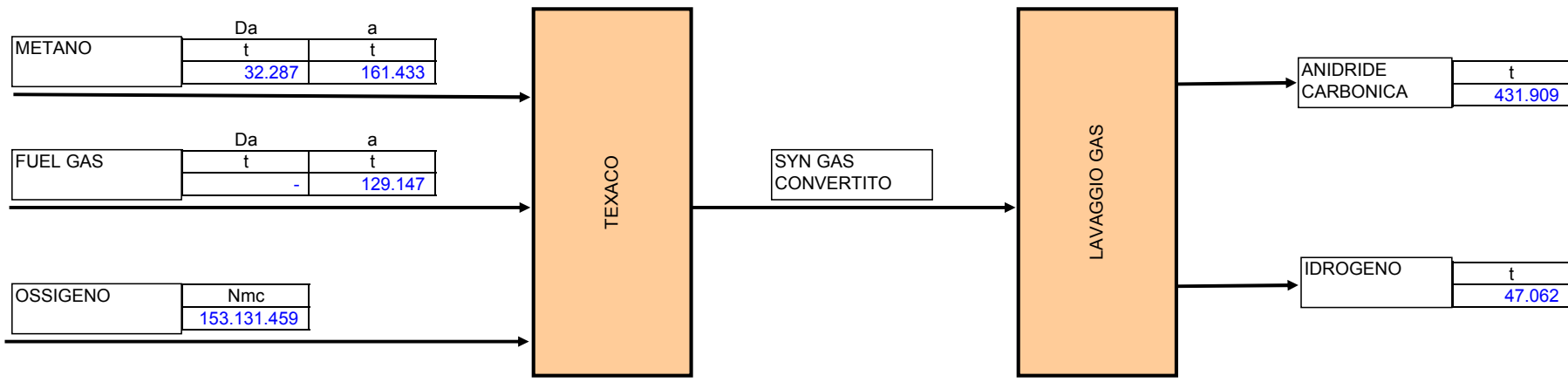

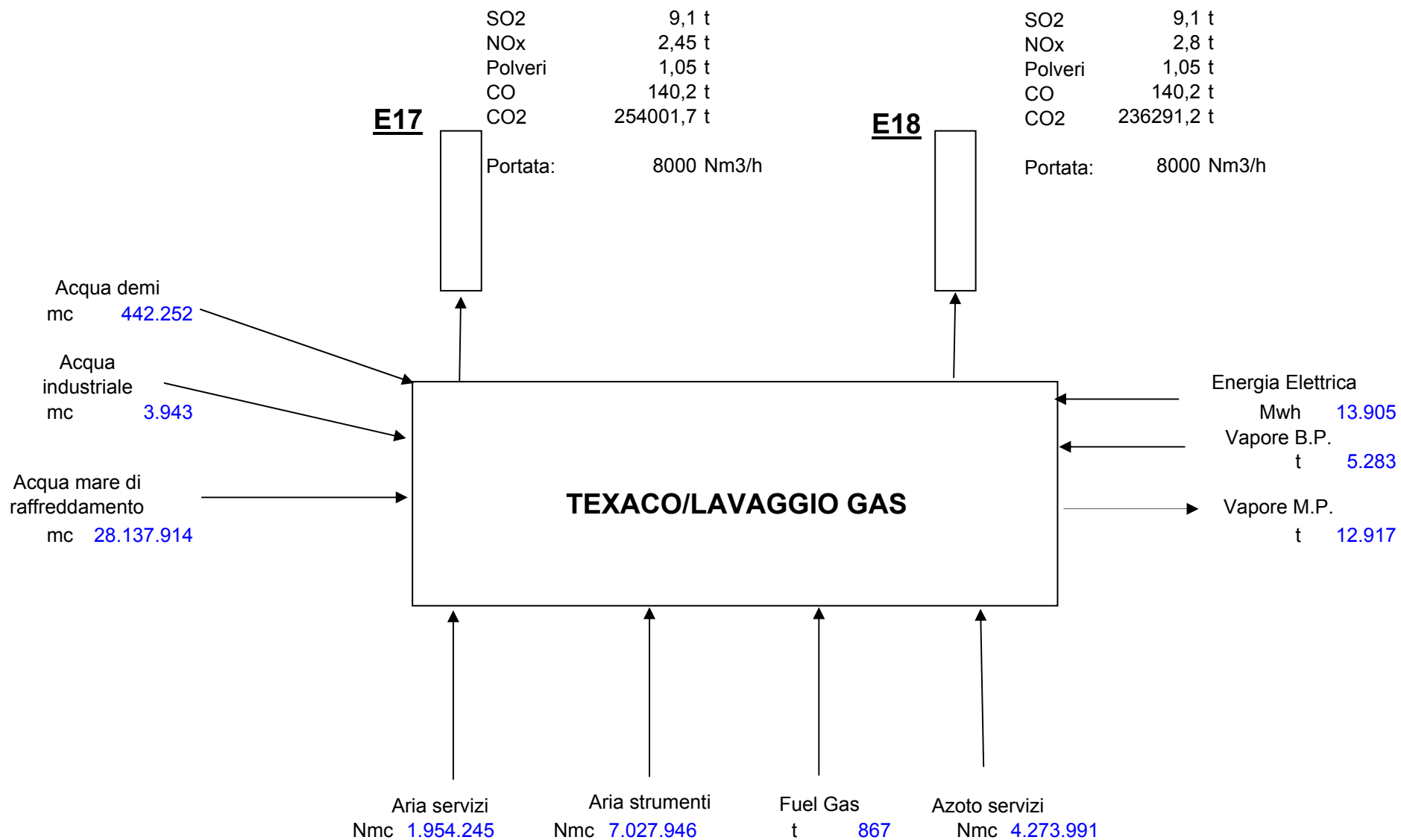

E27

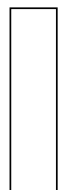

SO2	0,56 t
NOx	0,56 t
Polveri	0,011 t
CO	0,375 t
CO2	0,002 t
COV	30 t

Portata: 1500 Nm3/h



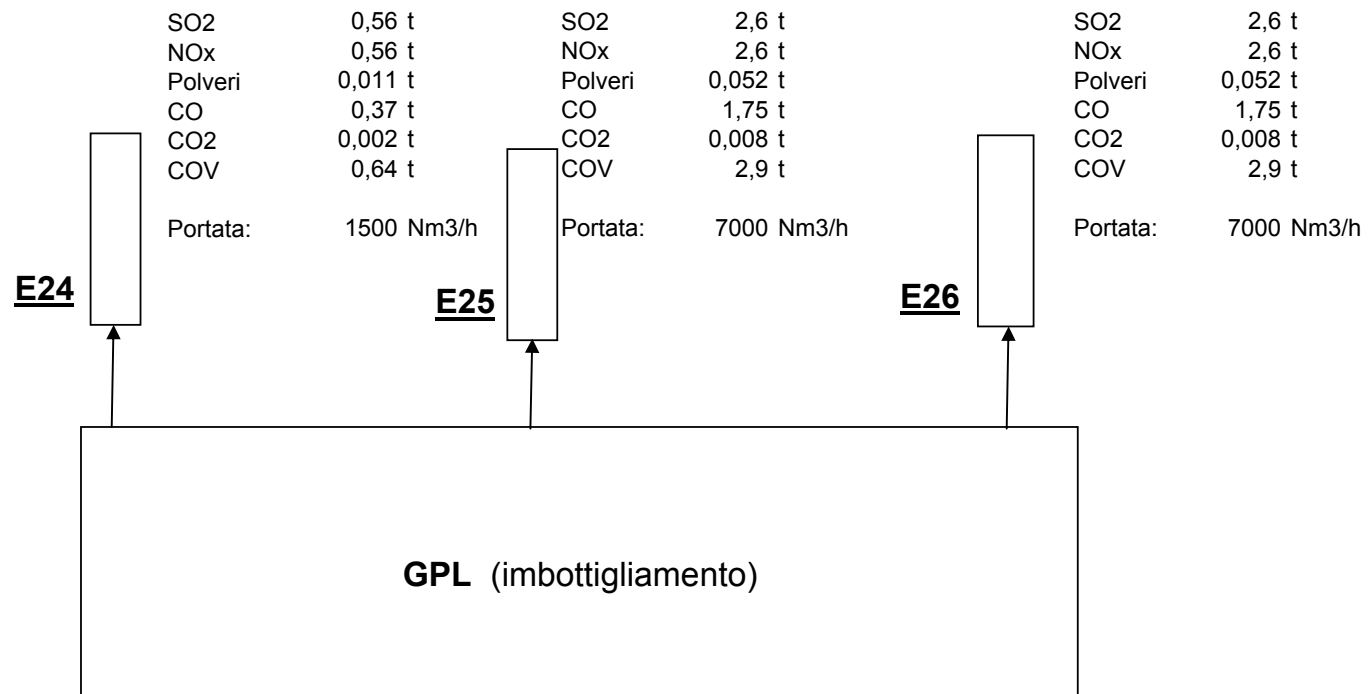

SO2 12579,2 t
 NOx 2152,3 t
 Polveri 526,12 t
 CO 1363,14 t
 CO2 3252412,8 t

Portata: 1365000 Nm3/h

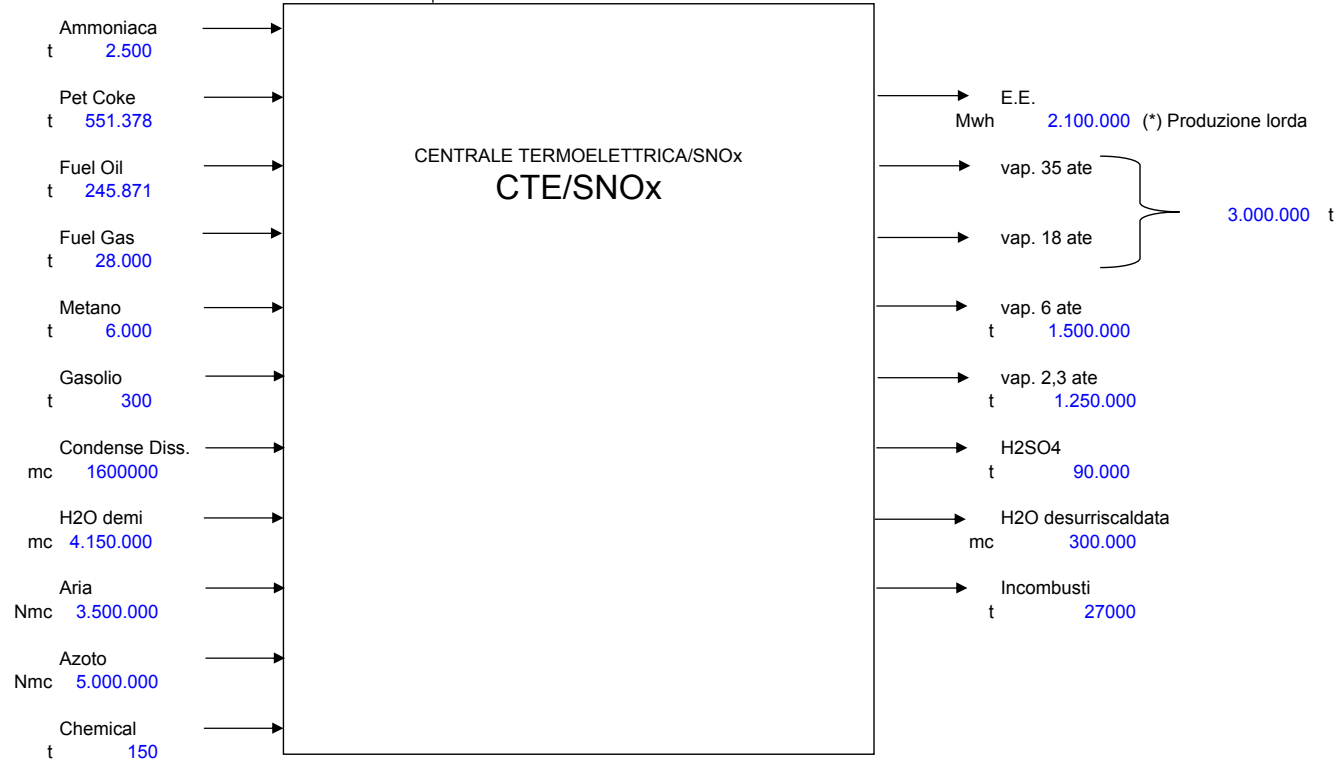
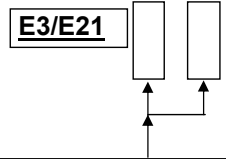

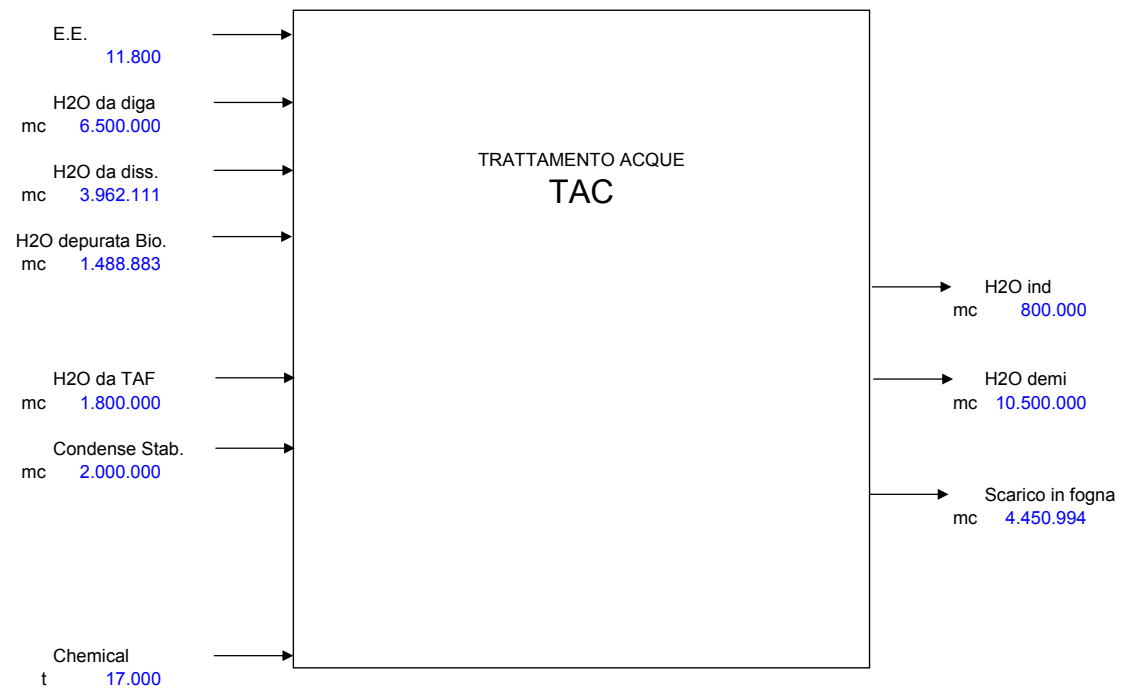



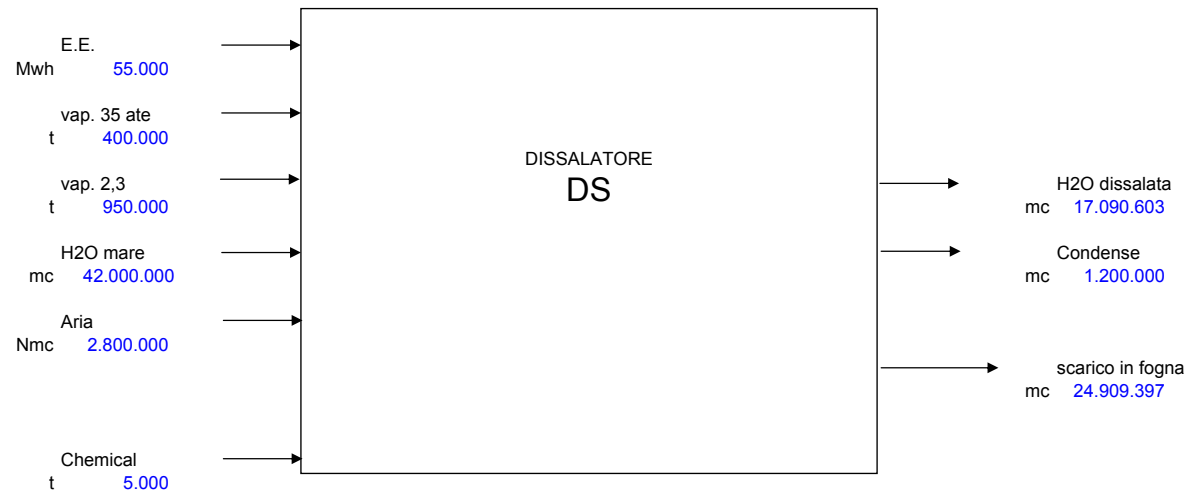





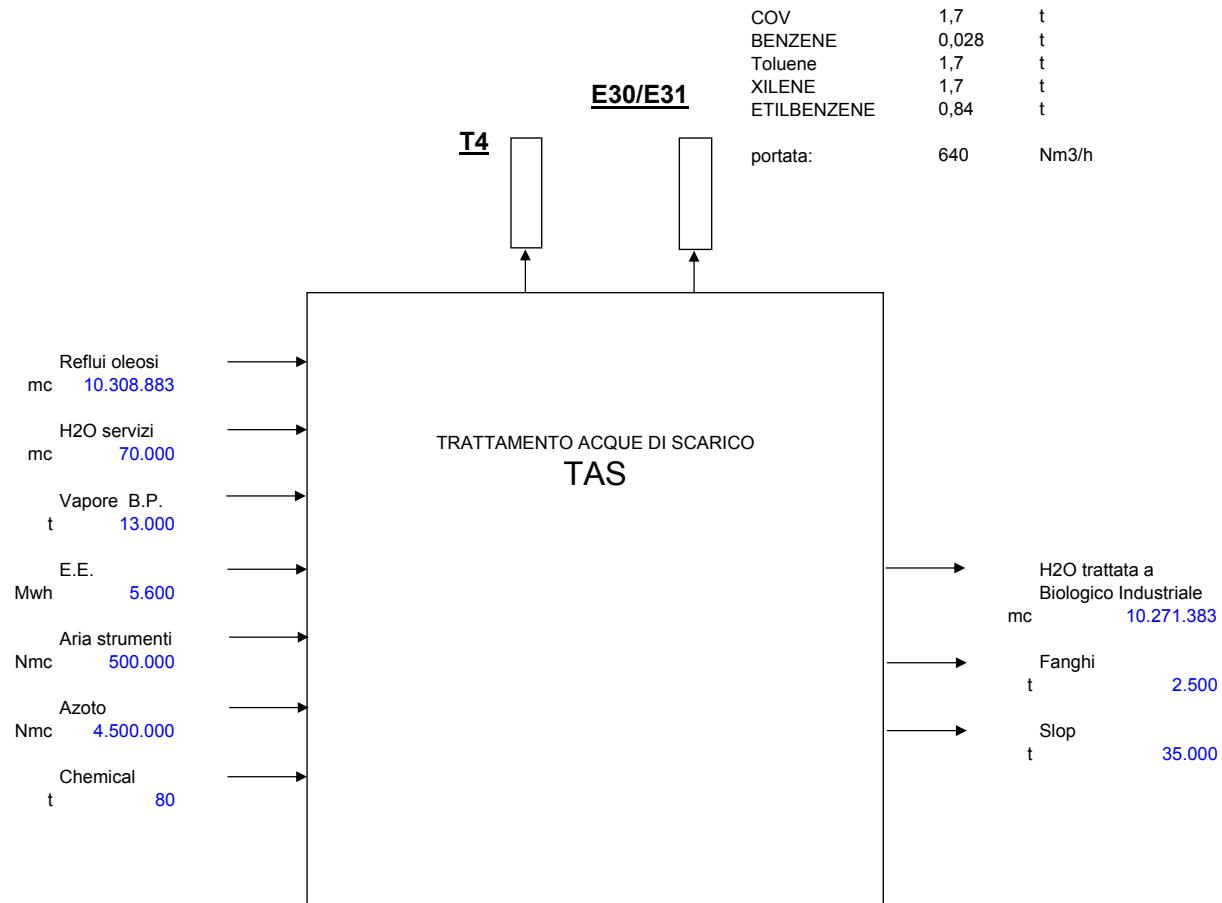

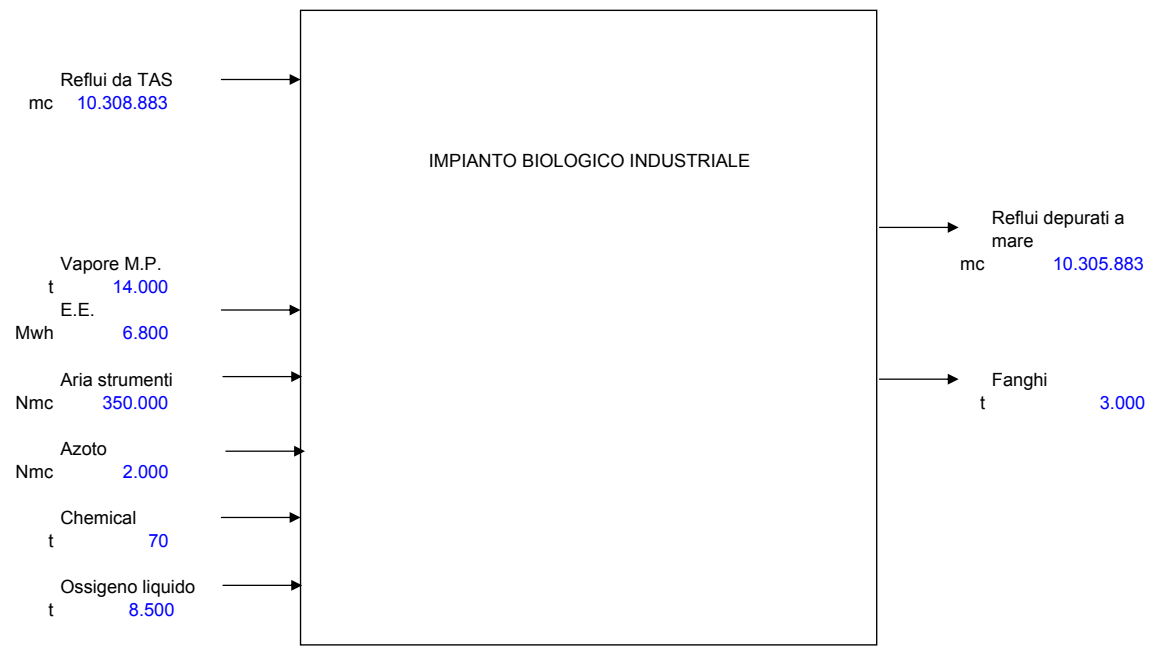

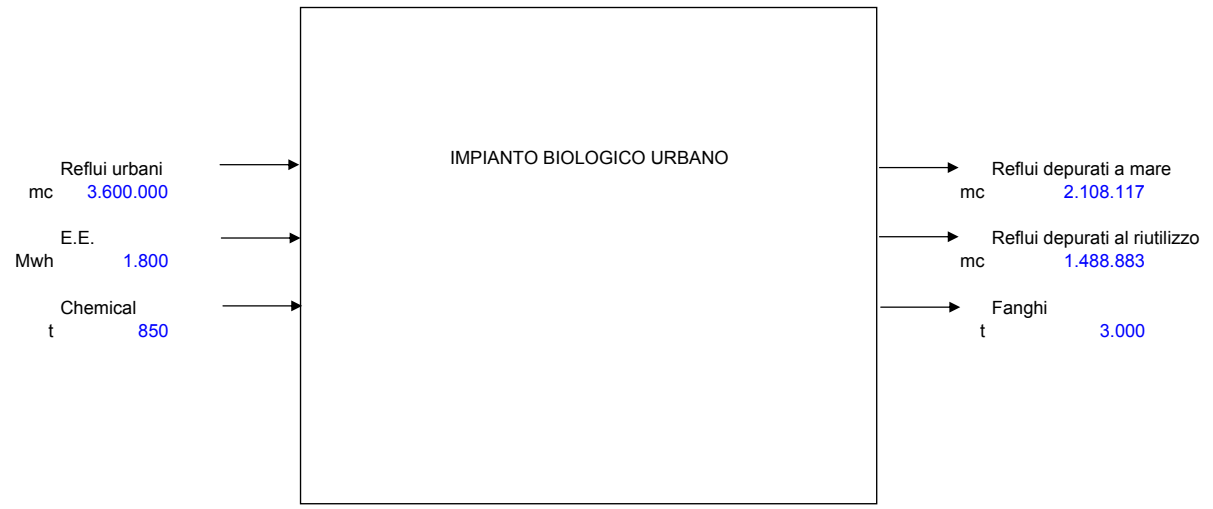

BENZENE	1,3 t		
ETILBENZENE	39,42 t		
STIRENE	39,42 t		
TOLUENE	78,84 t	CO	4,38 t
p-XILENE	78,84 t	COV	6,57 t
1,1 DICLOROEt	5,25 t	NOx	8,76 t
1,1 DICLOROPropano	39,42 t		
TETRACLOROEt	5,25 t		
MTBE	1,3 t	Portata:	2500 Nm3/h

Portata:

30000 Nm3/h

E29

E28

