

Allegato A25

Schema a Blocchi

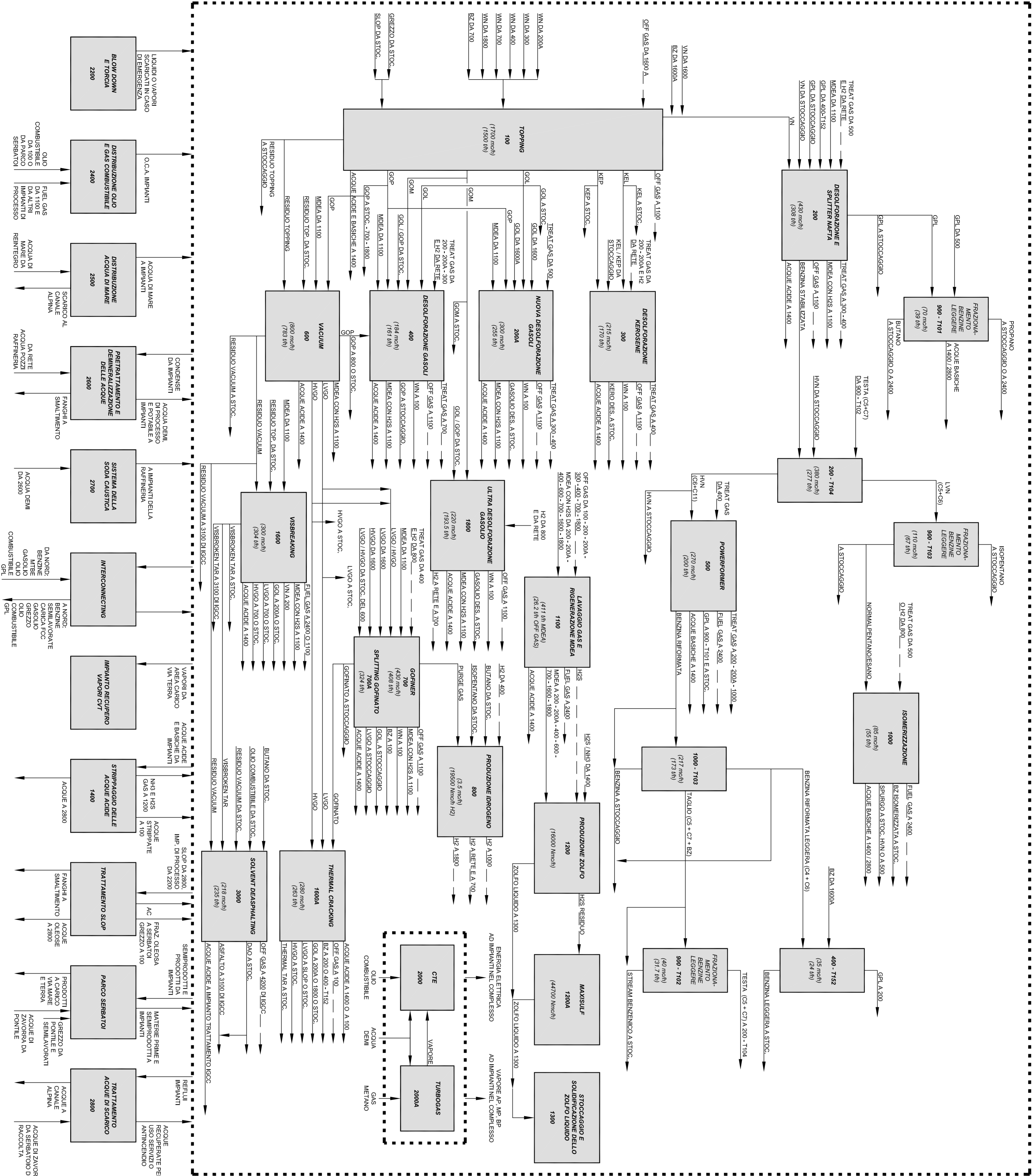

ERG Raffinerie Mediterranee S.p.A.
 Raffineria ISAB SUD
 P.leo Garibaldi (SR)

IMPIANTO ISAB SUD
 SCHEMA A BLOCCHI GENERALE

Allegato
A25.00

IMPIANTO 100
TOPPING

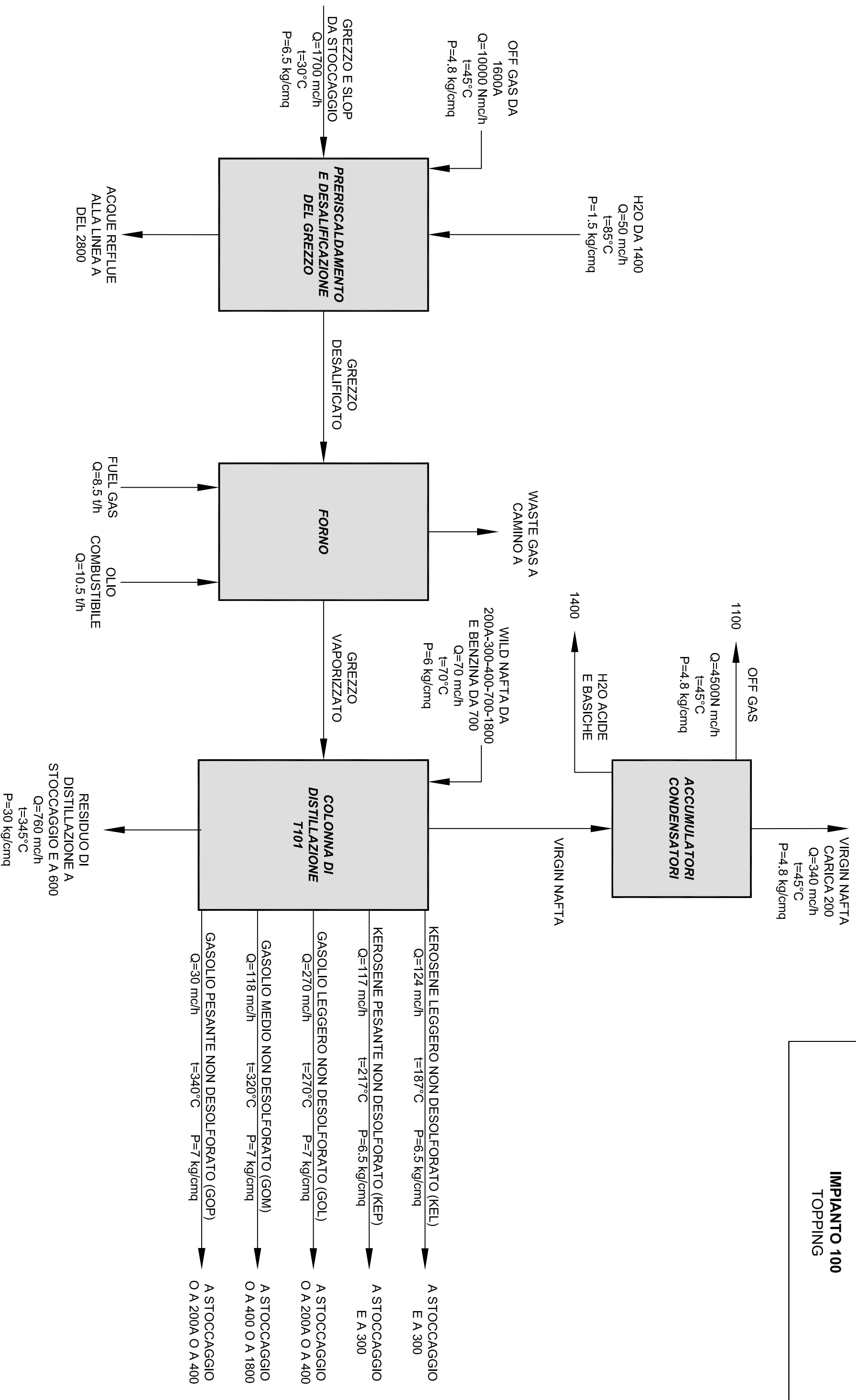

IMPIANTO 200
DESOLFORAZIONE E SPLITTER NAFTA

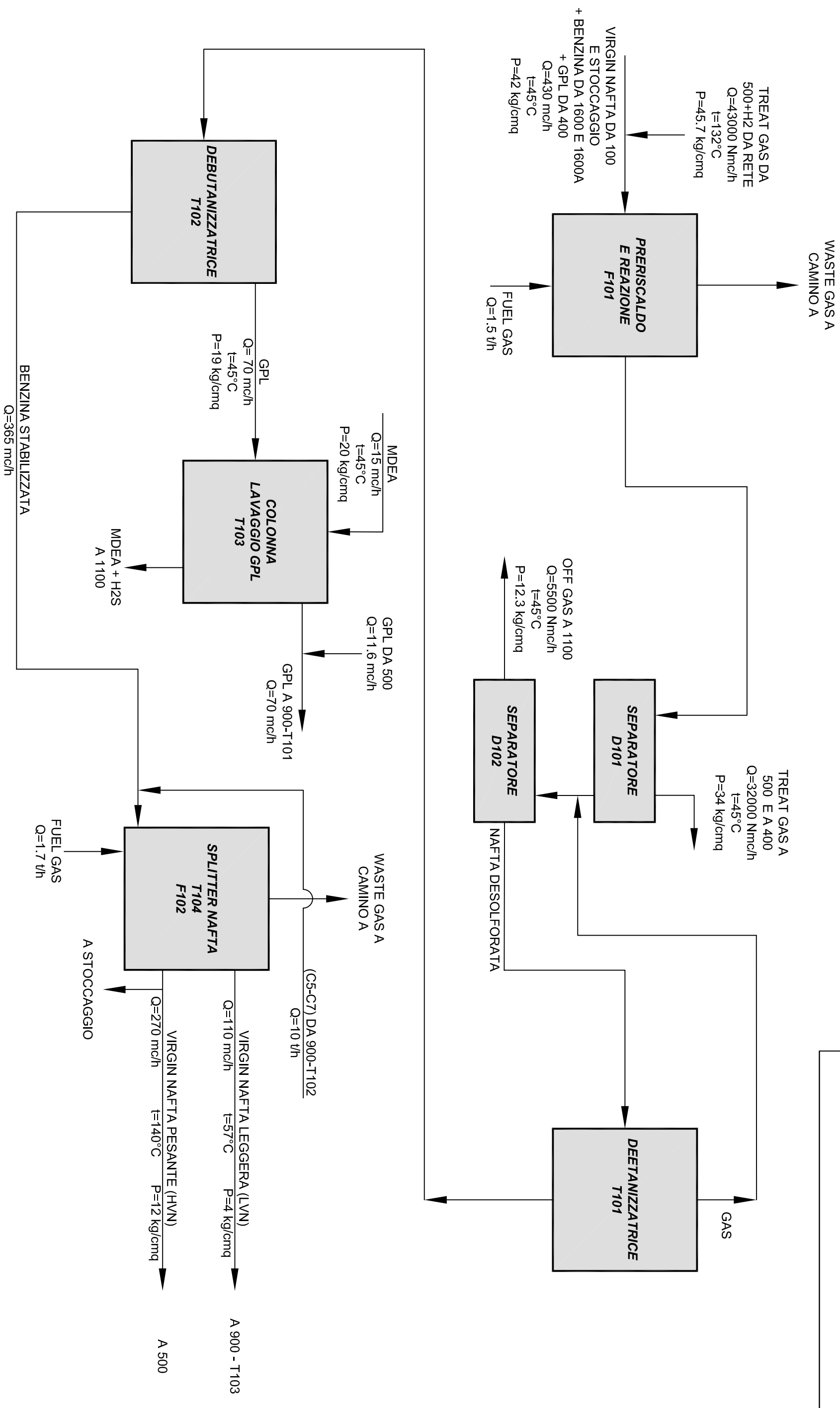

IMPIANTO 200A
 NUOVA DESOLFORAZIONE GASOLI

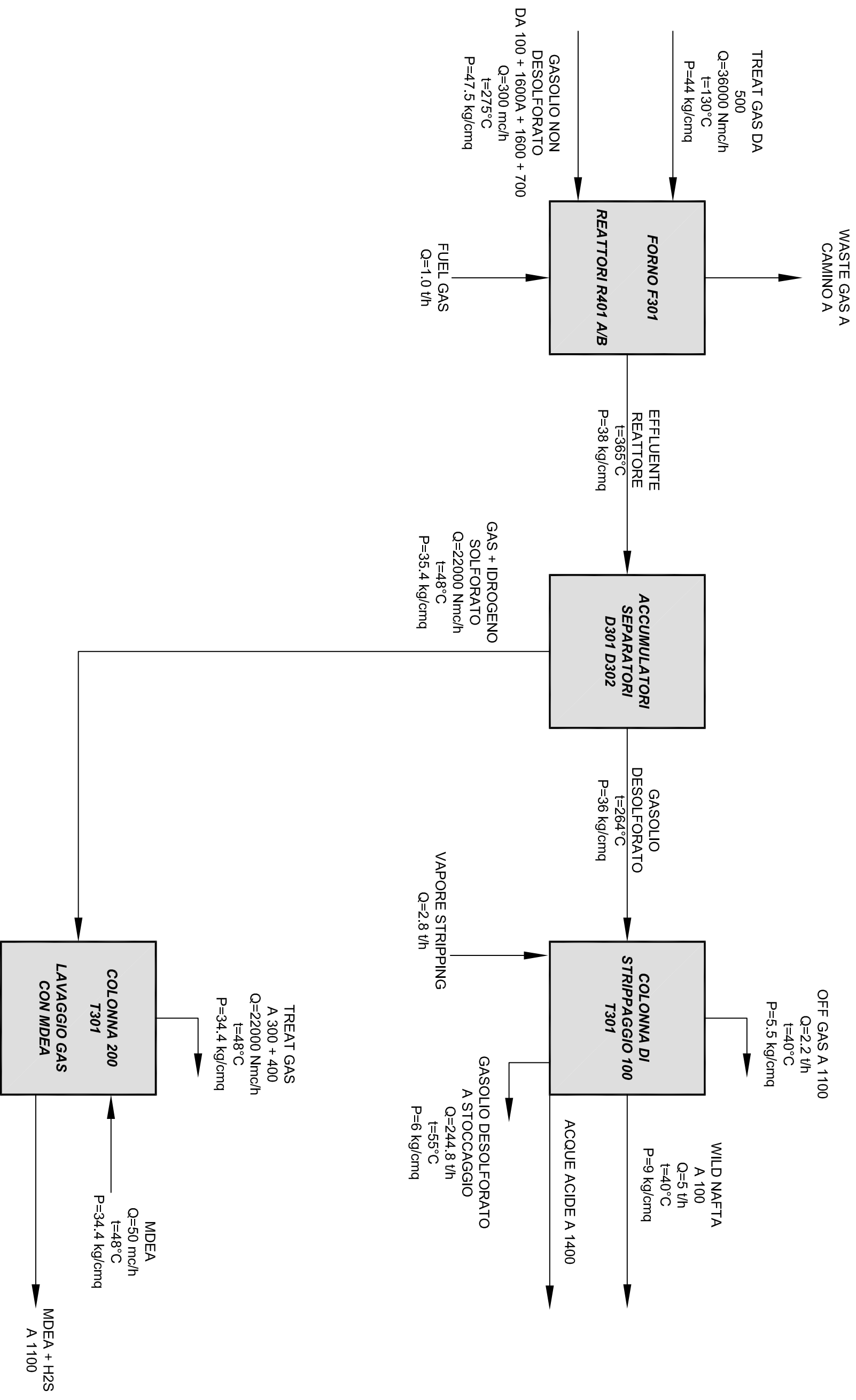

STEAM S.r.l.

IMPIANTO 300
DESOLFORAZIONE KEROSENE

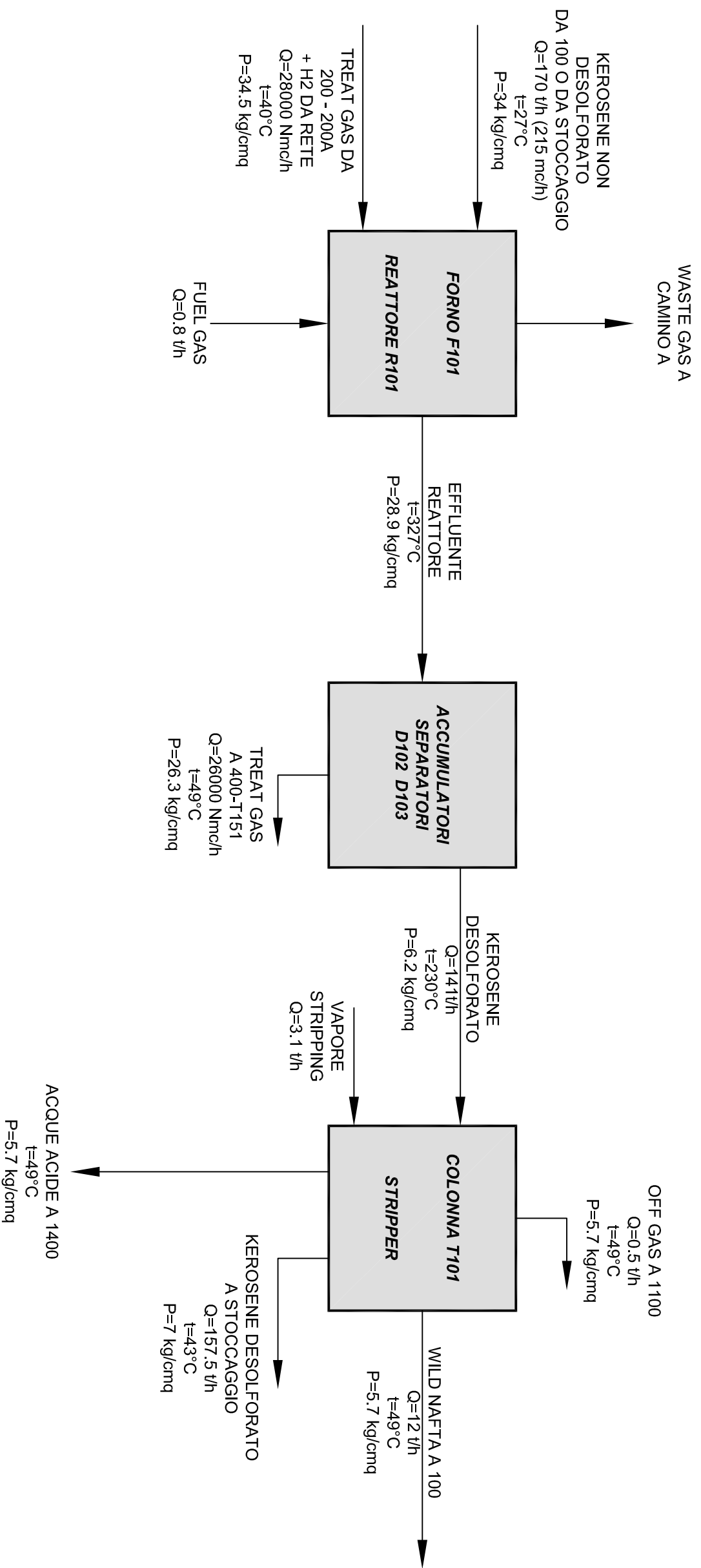

IMPIANTO 400
 DESOLFORAZIONE GASOLI

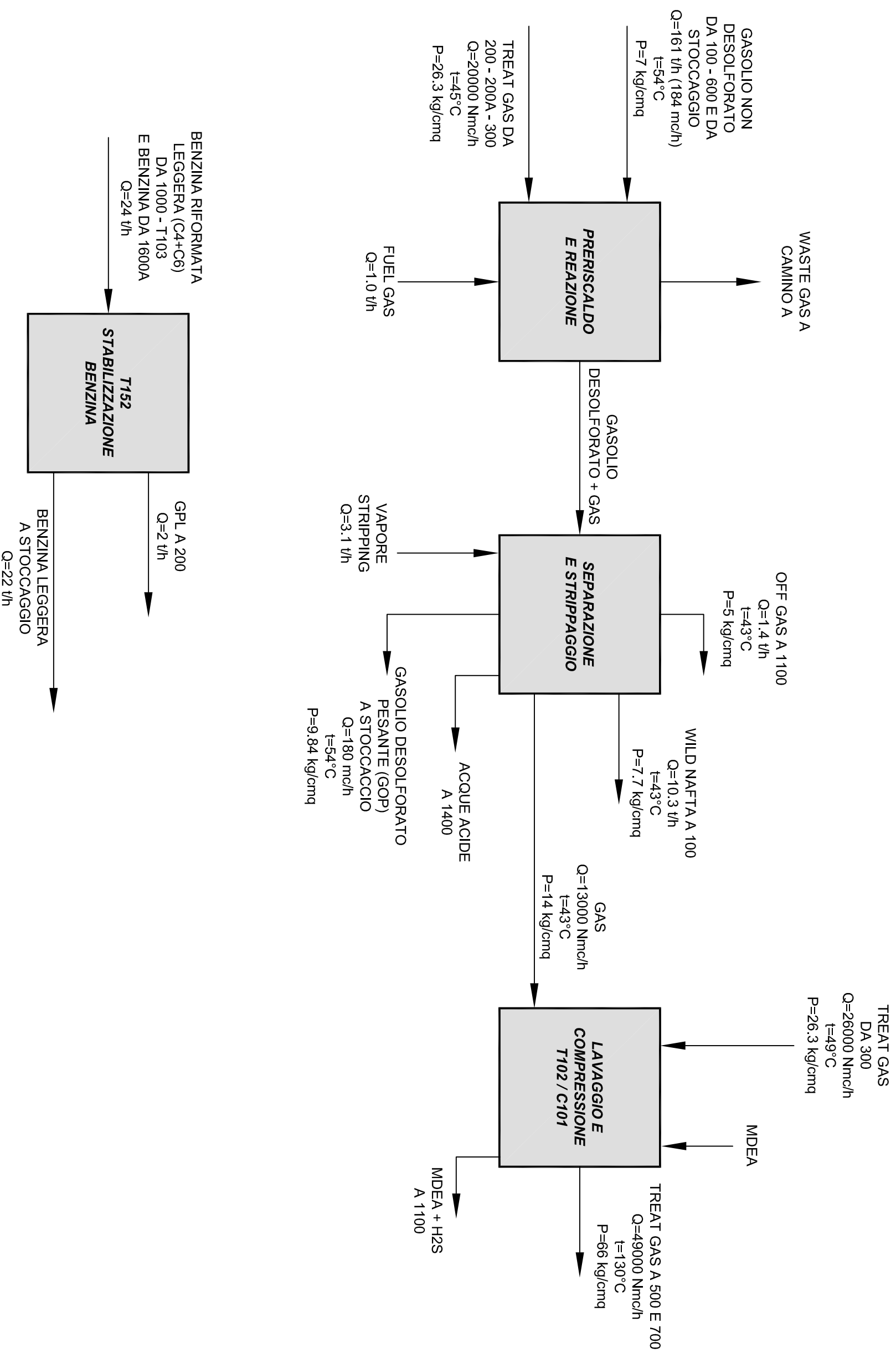

**IMPIANTO 500
POWERFORMER**

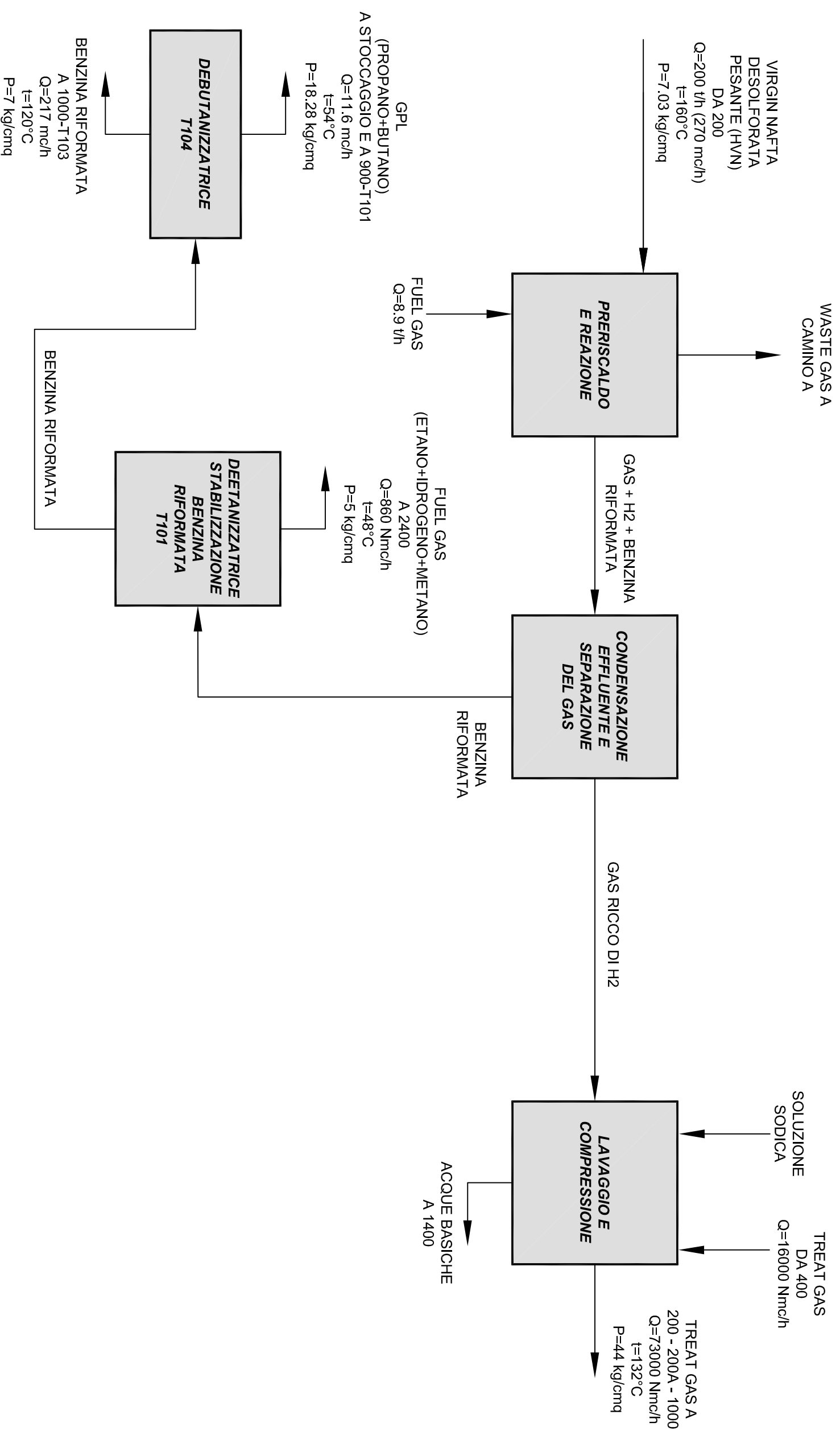

IMPIANTO 600
VACUUM

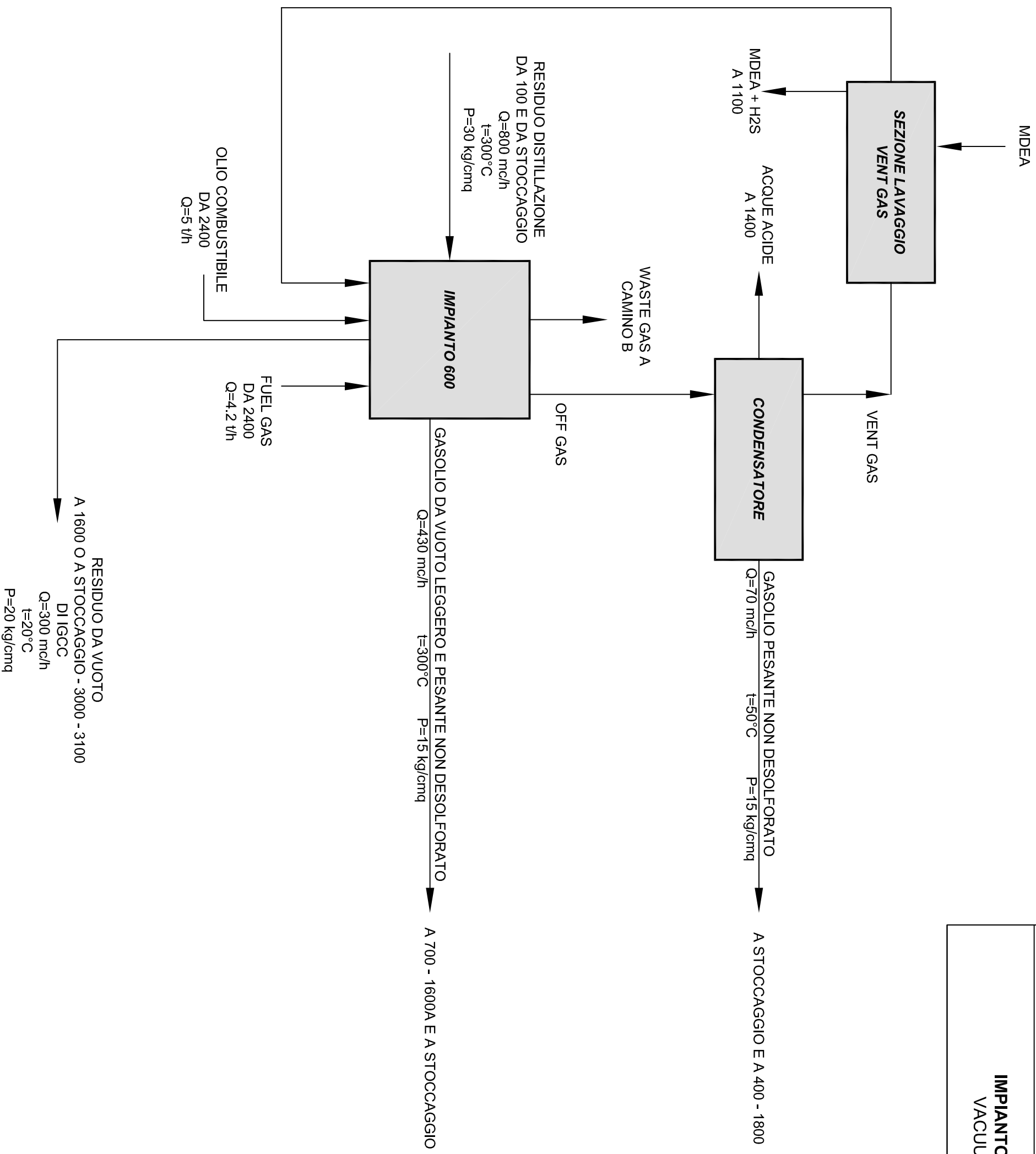

IMPIANTO 700 E 700A
GOFINER E SPLITTING GOFINATO

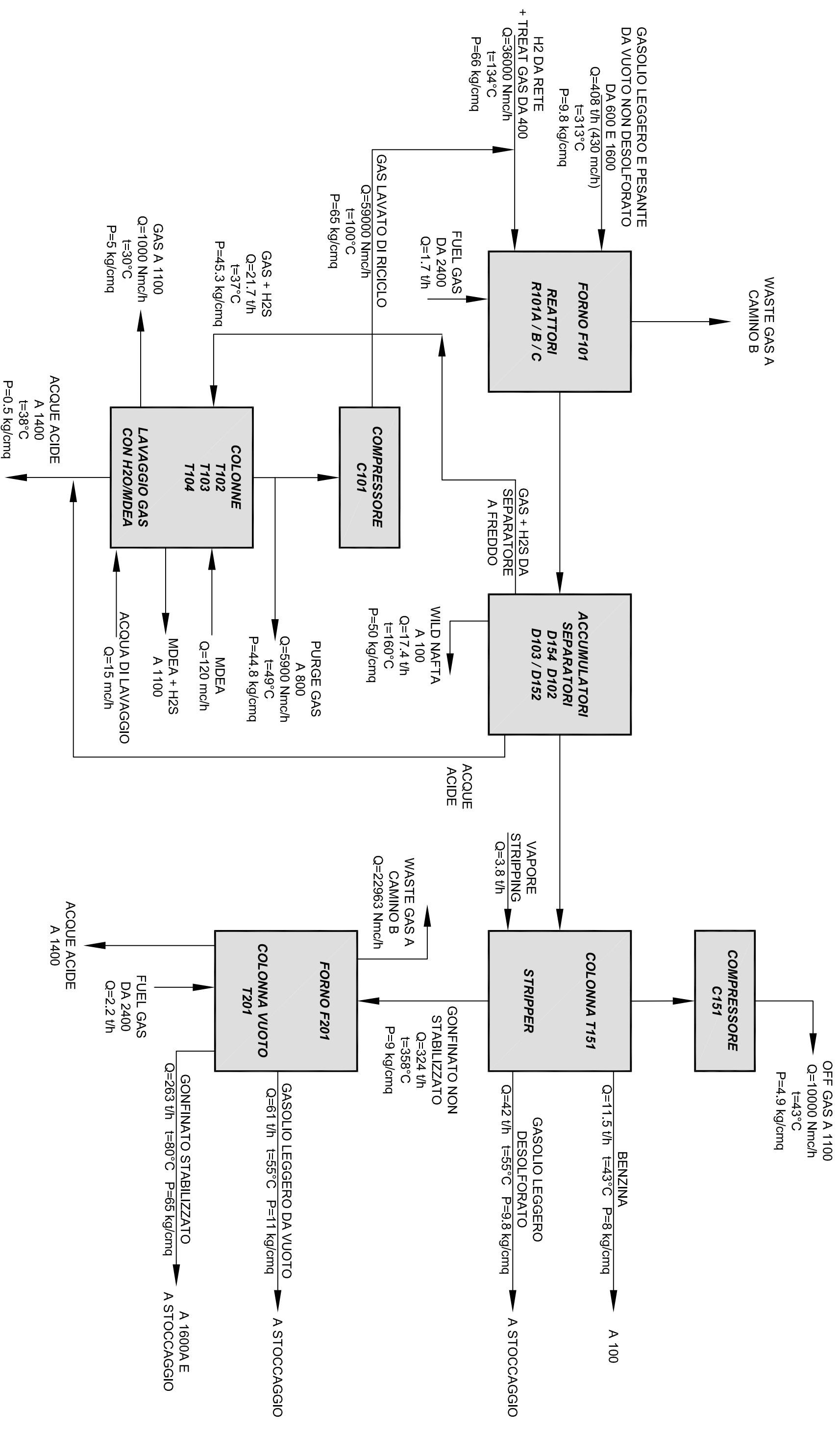

IMPIANTO 800
 PRODUZIONE IDROGENO

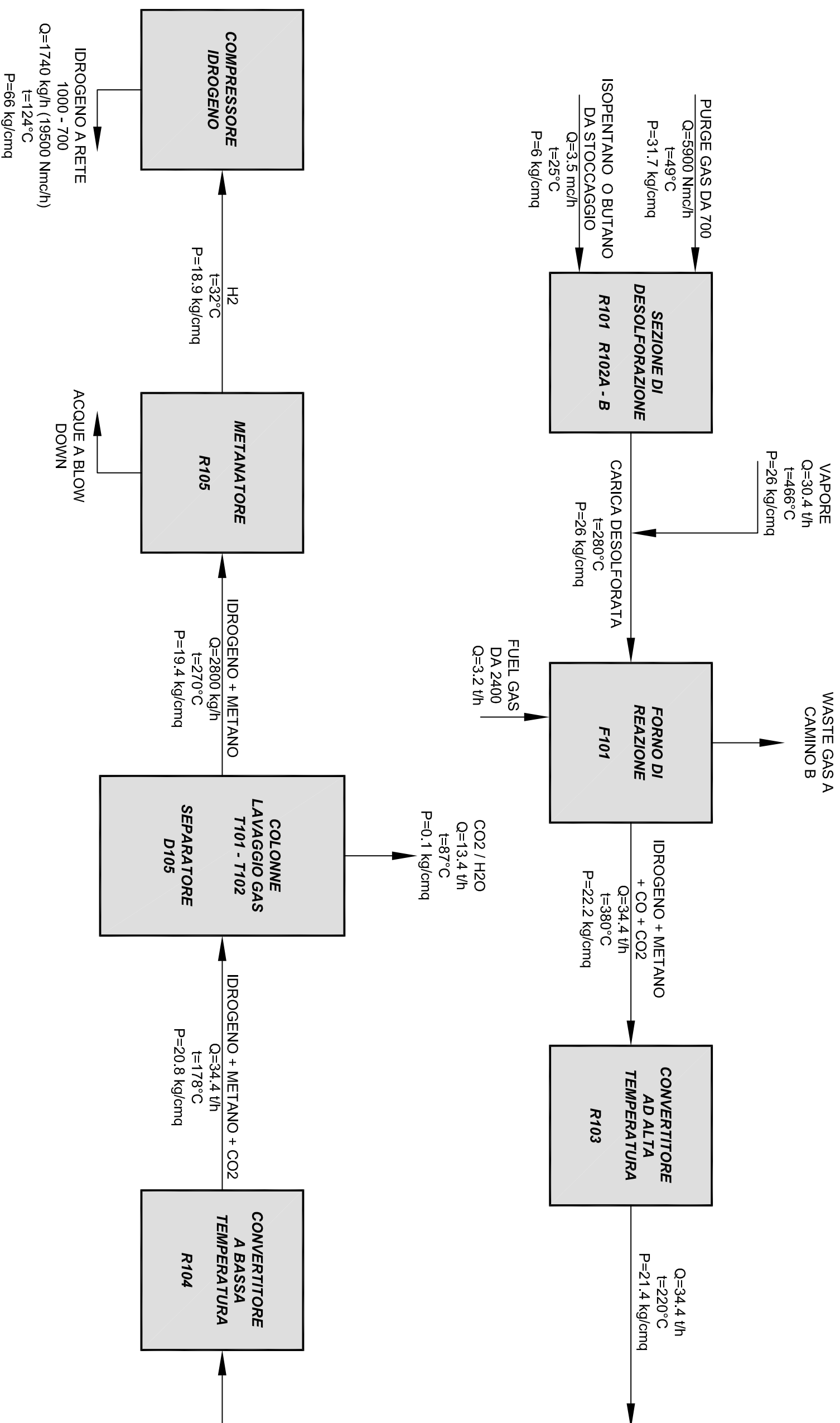

IMPIANTO 900
FRAZIONAMENTO BENZINE LEGGERE

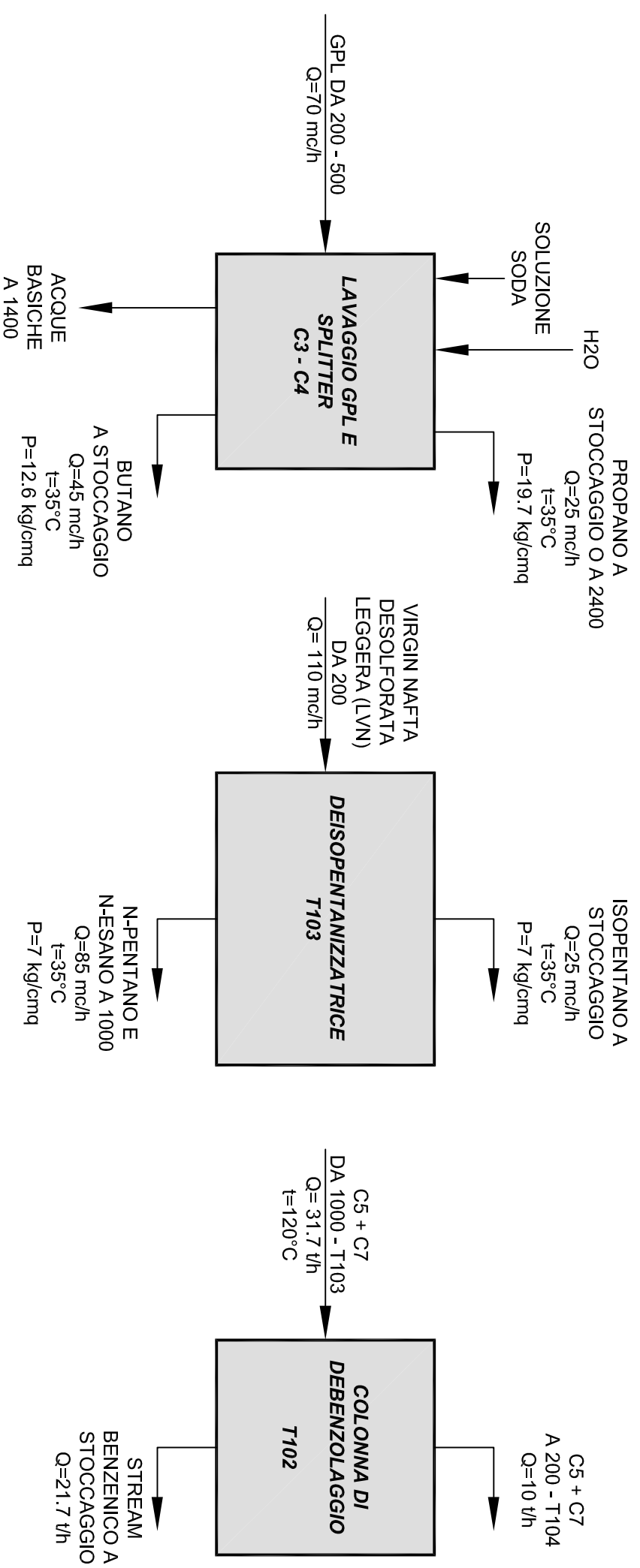

IMPIANTO 1000
ISOMERIZZAZIONE

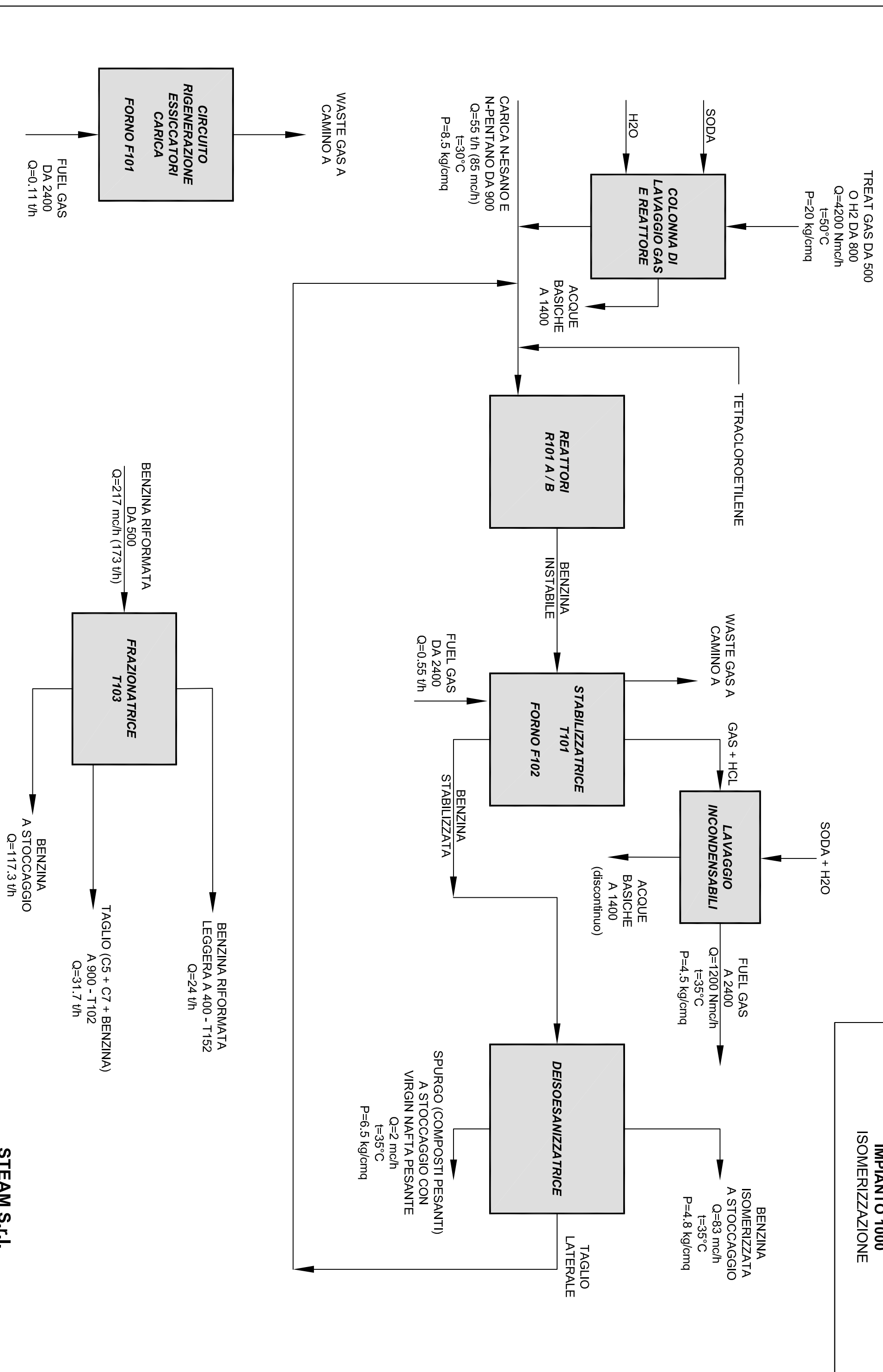

STEAM S.r.l.

IMPIANTO 1100
LAVAGGIO FUEL GAS
E RIGENERAZIONE MDEA

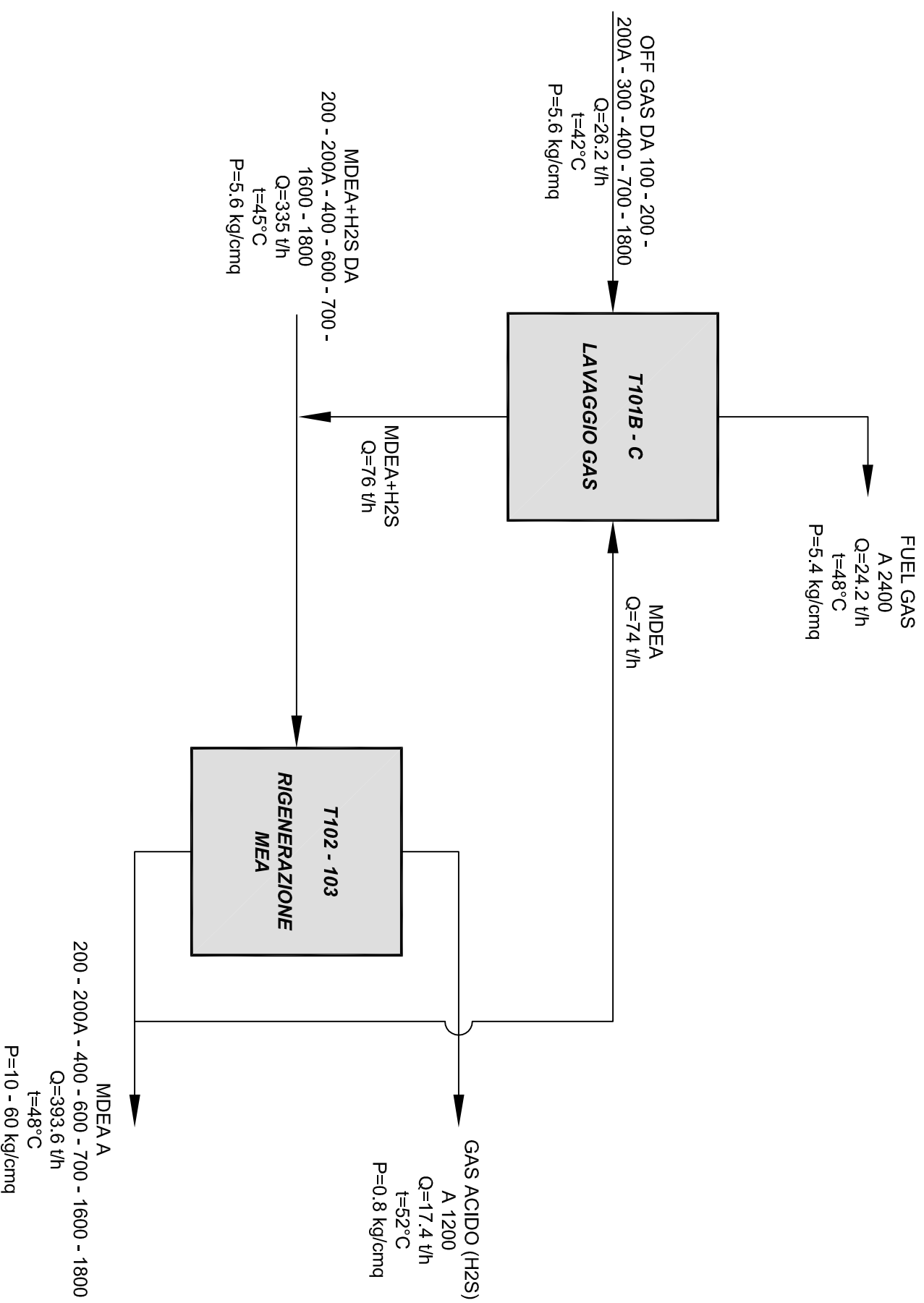

IMPIANTO 1200
PRODUZIONE ZOLFO
(TIPICO PER UNA LINEA ZOLFO)

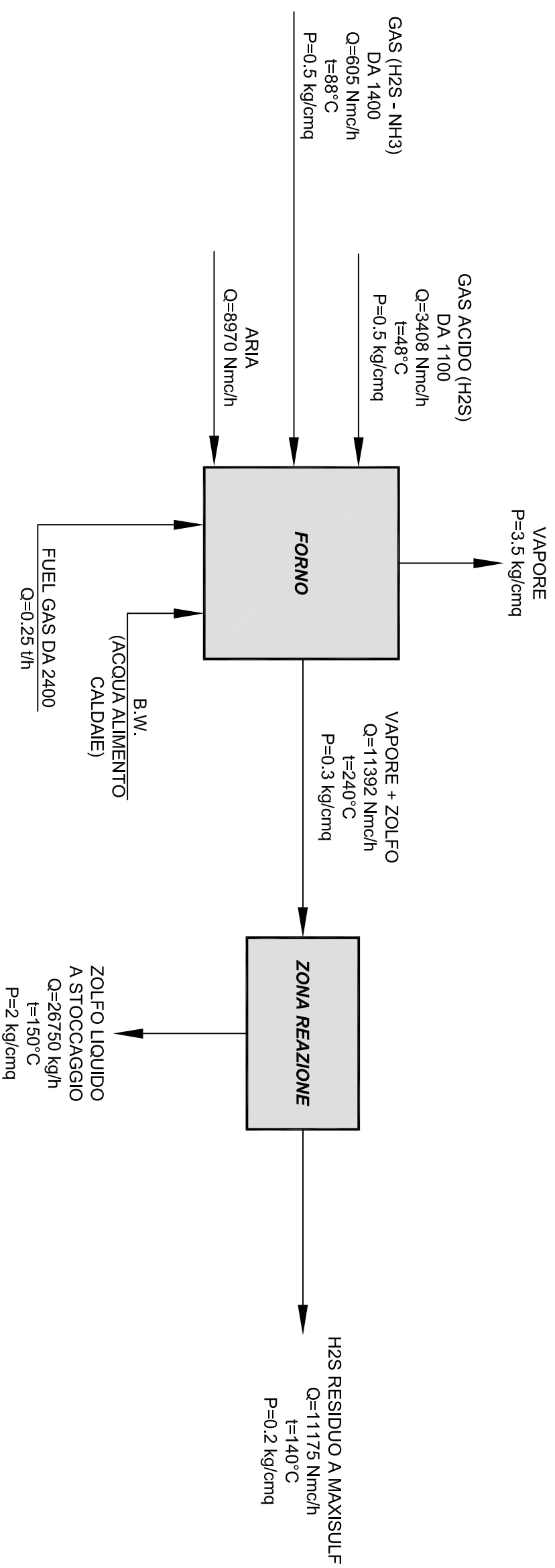

**IMPIANTO 1200A
MAXISULF**

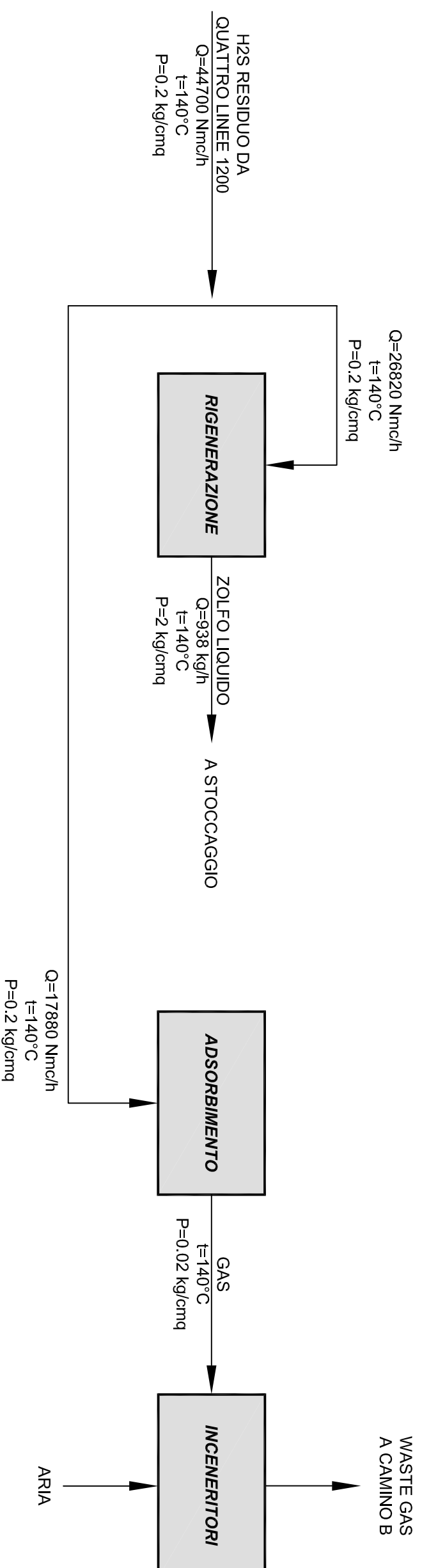

IMPIANTO 1400
STRIPPAGGIO DELLE ACQUE ACIDE (SWS)

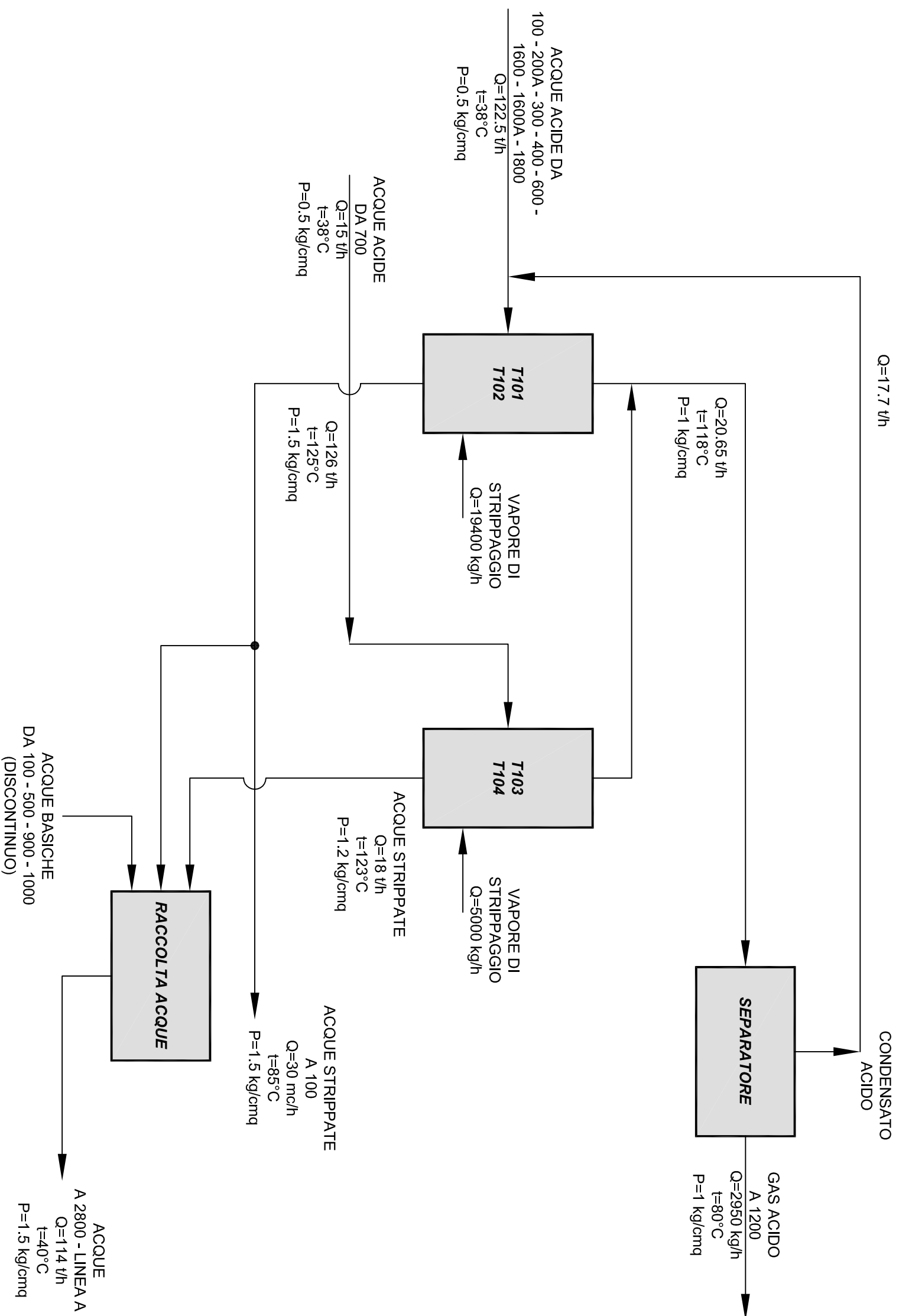

IMPIANTO 1600
VISBREAKING

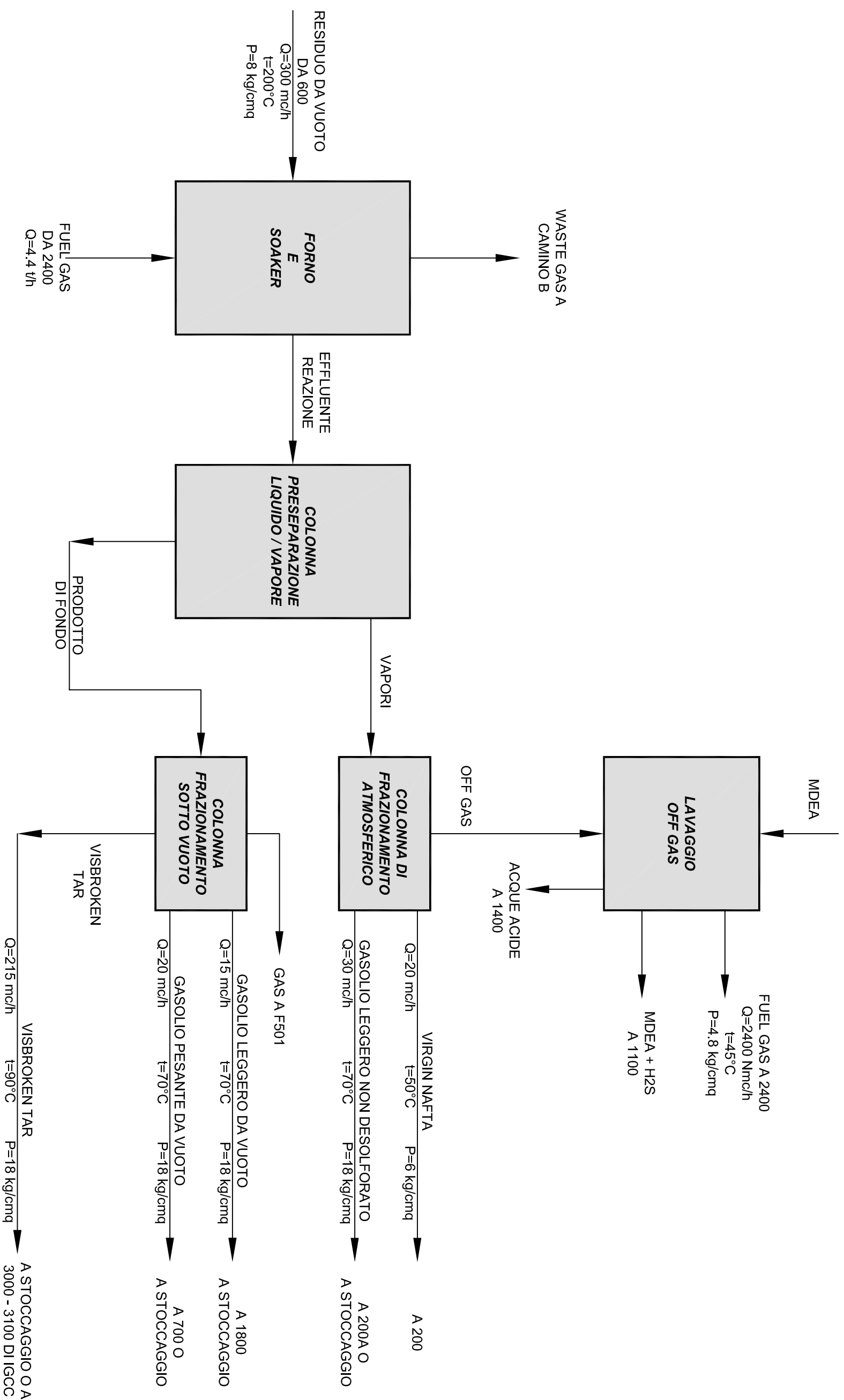

IMPIANTO 1600A
THERMAL CRACKING

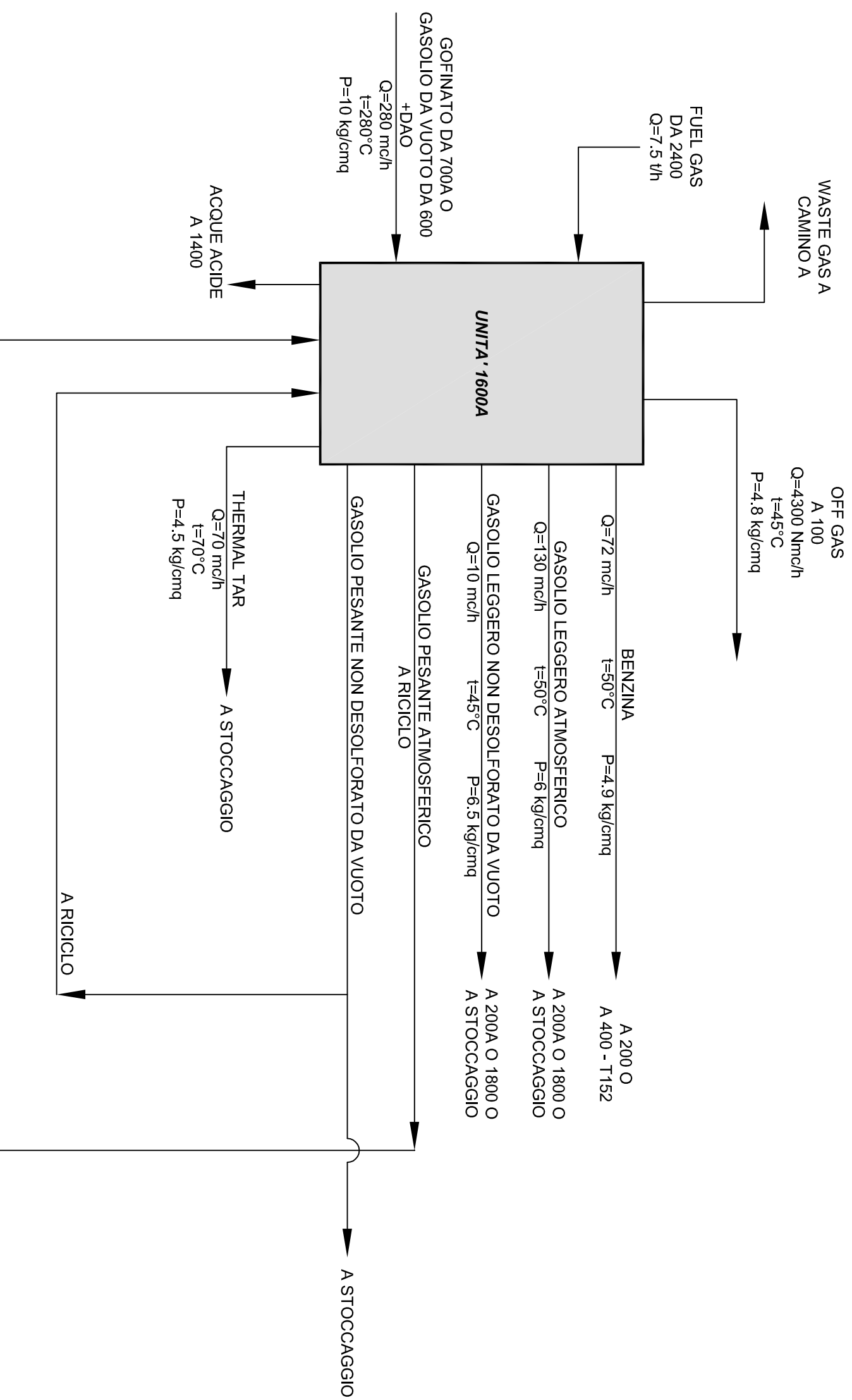

IMPIANTO 1800
 ULTRA DESOLFORAZIONE GASOLIO

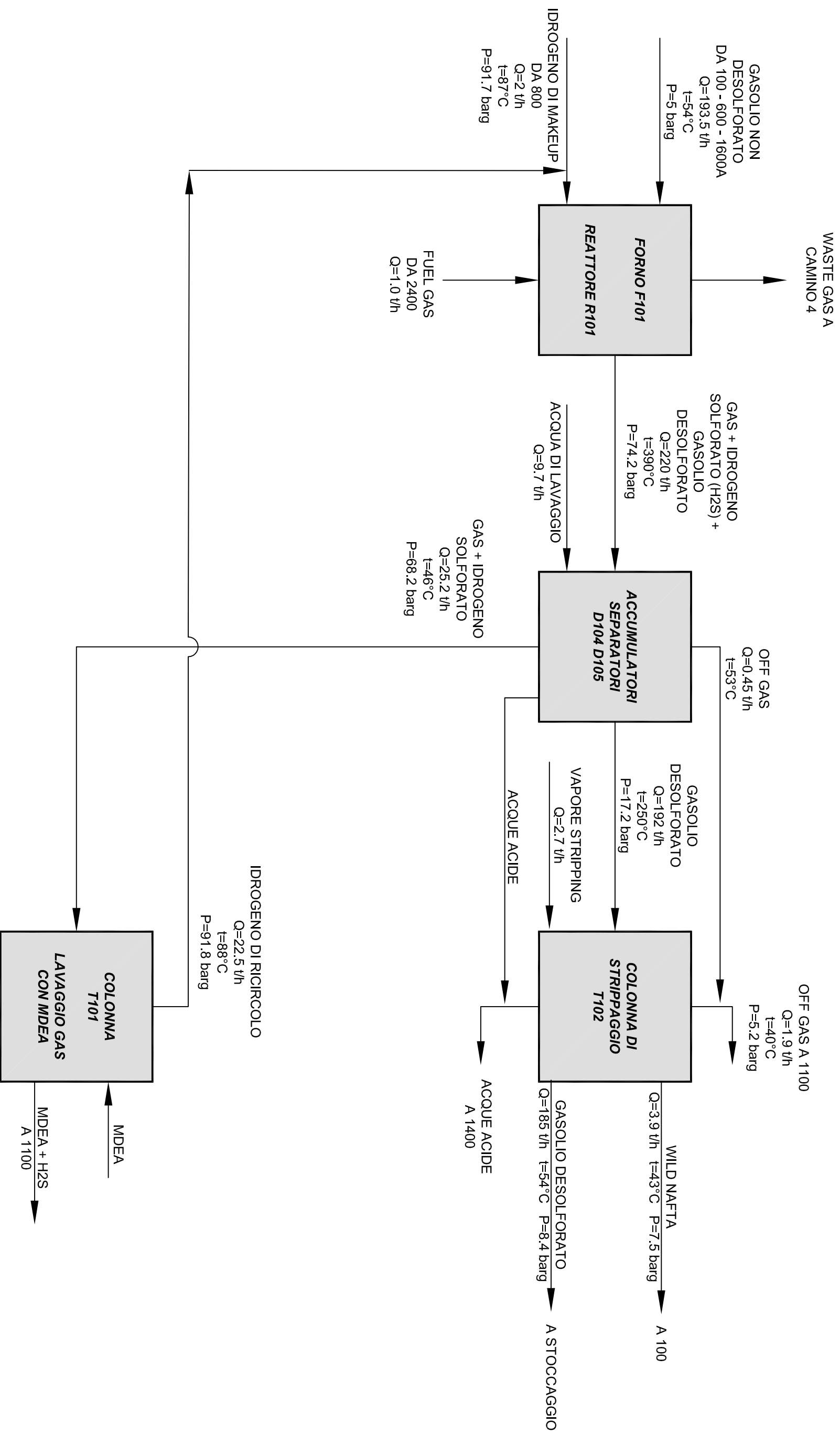

IMPIANTO 2000
 CENTRALE TERMoeLETRICA (CTE)
 SCHEMA DI UN GRUPPO

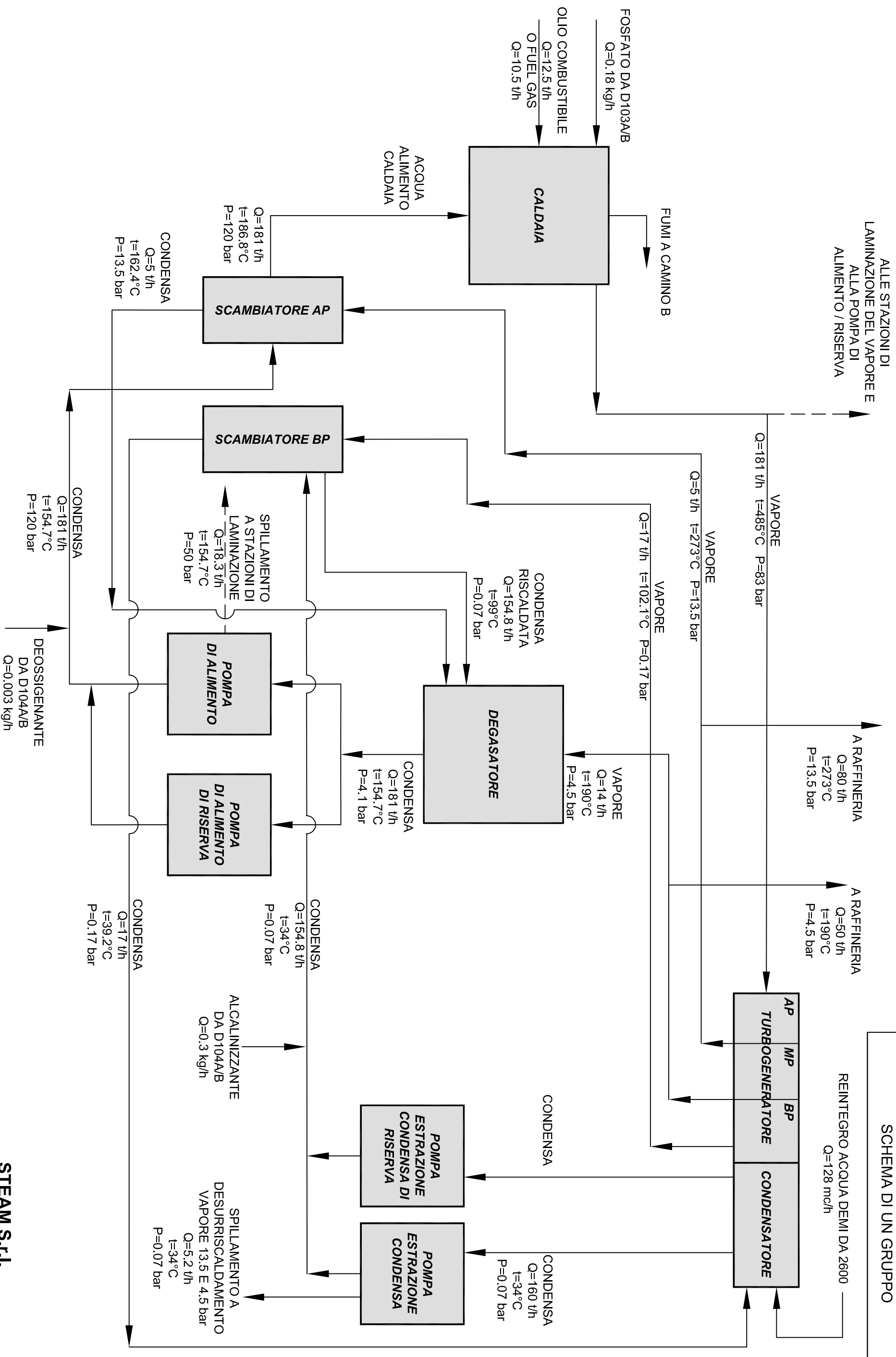

STEAM S.r.l.

IMPIANTO 2000/A
TURBOGAS

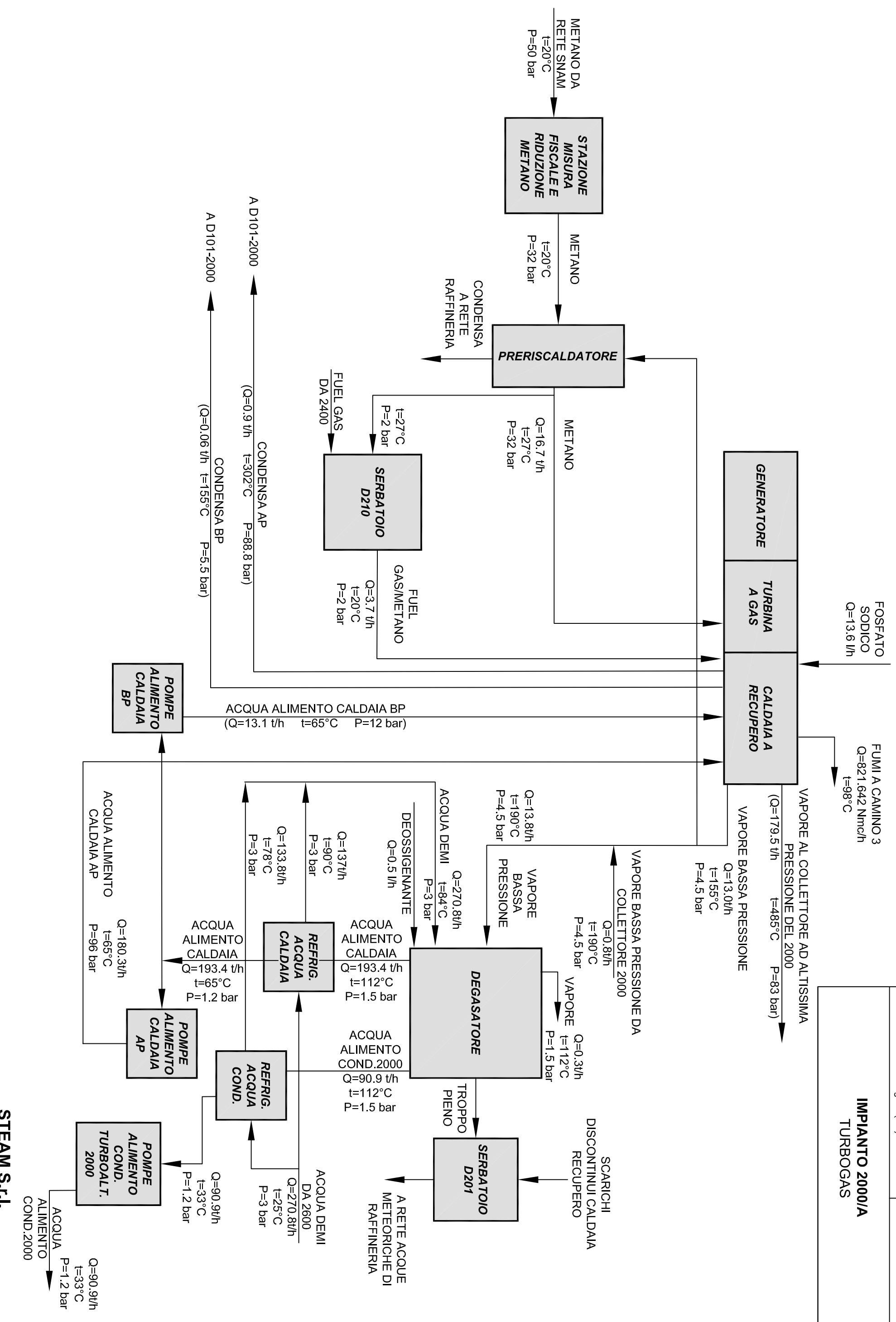

IMPIANTO 2500
DISTRIBUZIONE ACQUA DI MARE

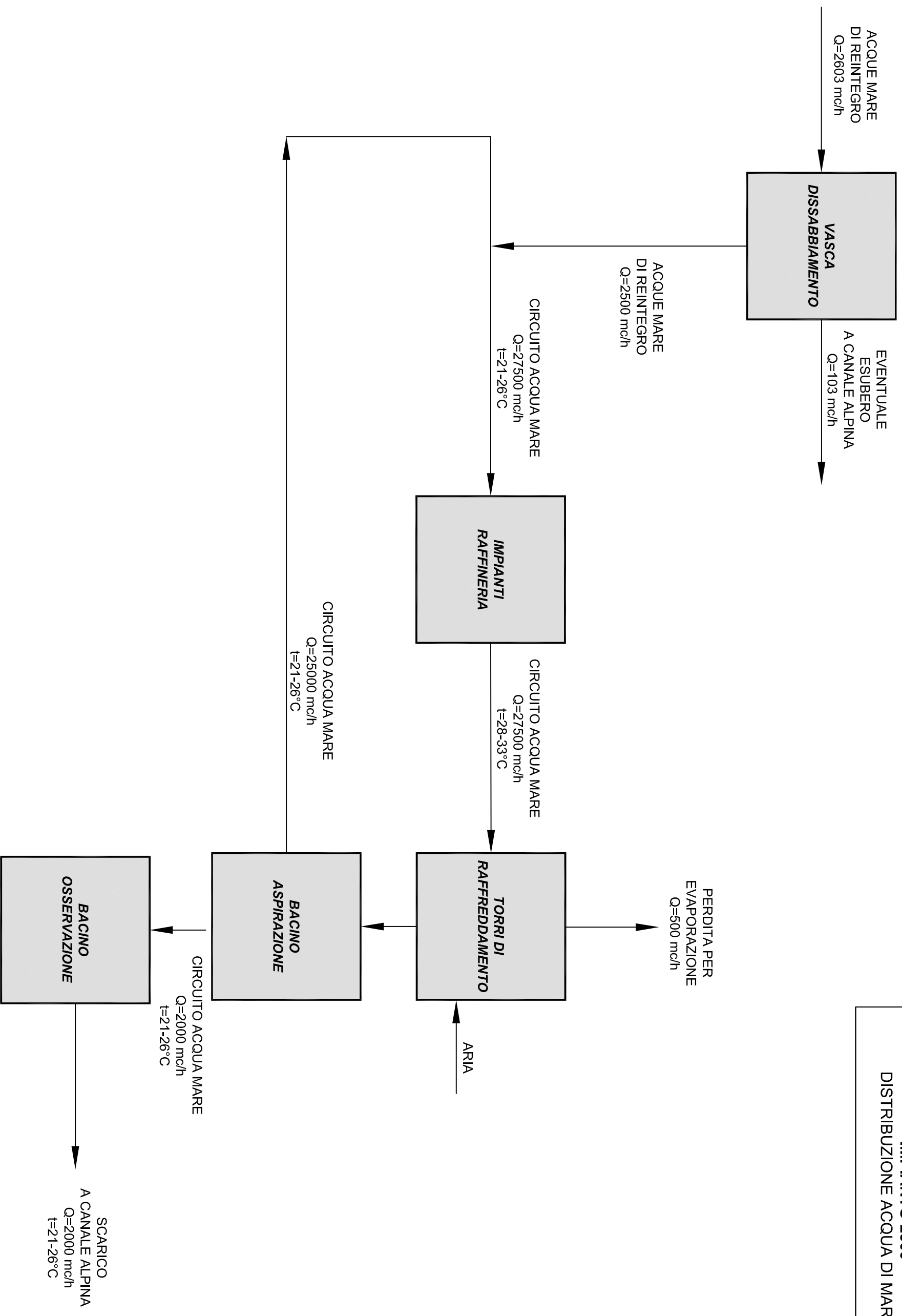

IMPIANTO 2600
PRETRATTAMENTO E DEMINERALIZZAZIONE
DELLE ACQUE

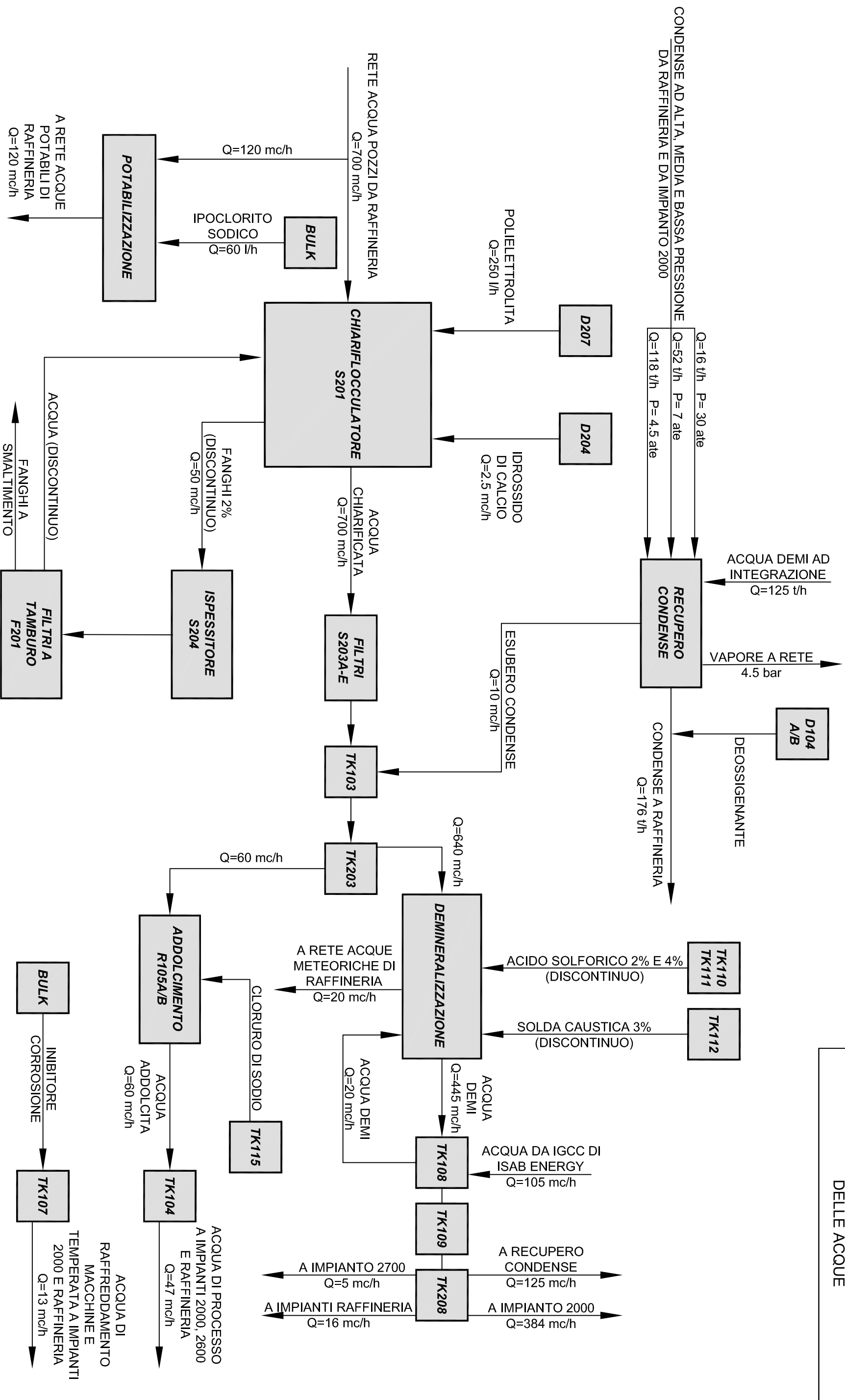

IMPIANTO 2700
SISTEMA DELLA SODA CAUSTICA

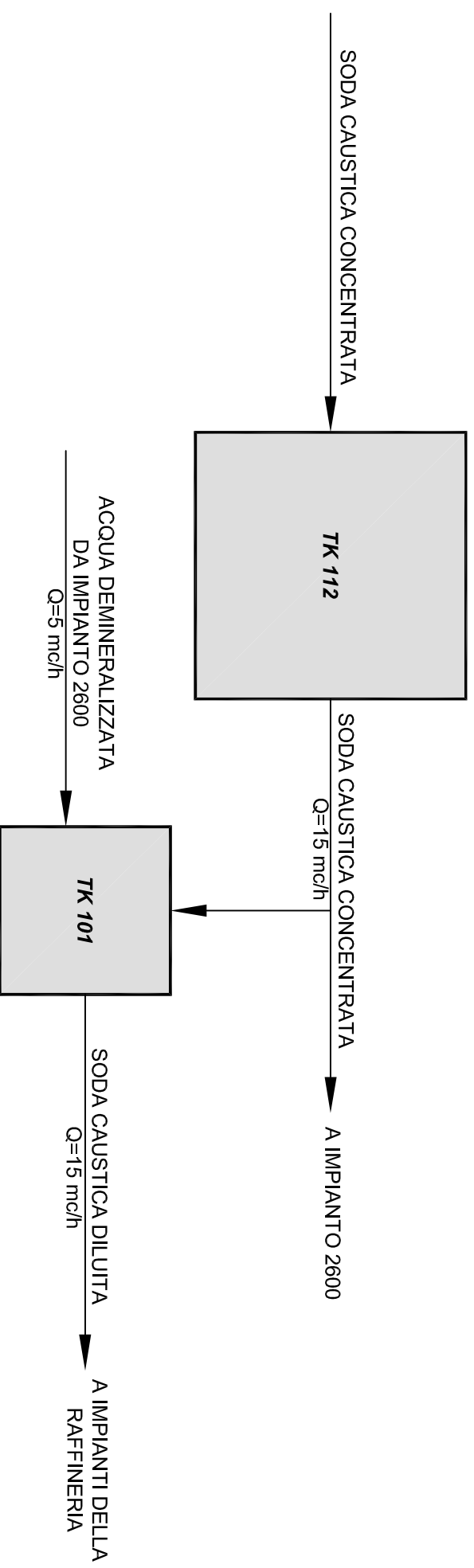

IMPIANTO 2800
 TRATTAMENTO ACQUE DI SCARICO

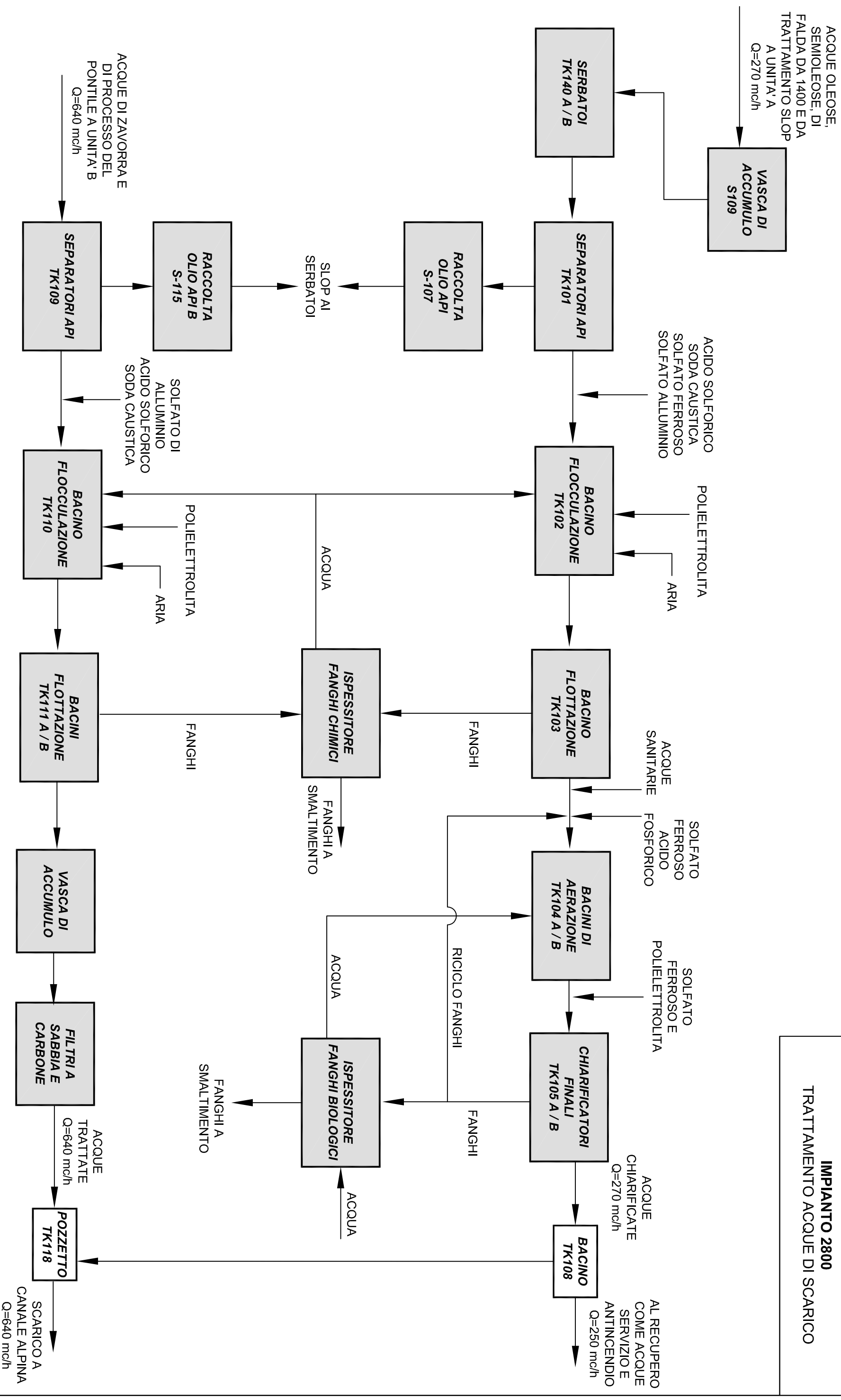

IMPIANTO 3000
SOLVENT DEASPHALTING (SDA)

