



ALLEGATO AL PUNTO 16



A world of
capabilities
delivered locally

Sasol Italy

Stabilimento di Sarroch

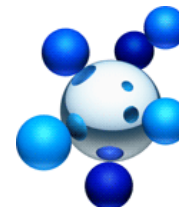

AUTORIZZAZIONE
INTEGRATA
AMBIENTALE

**Allegato alla “Scheda A”
della Domanda di Autorizzazione**

A 25

SCHEMI A BLOCCHI

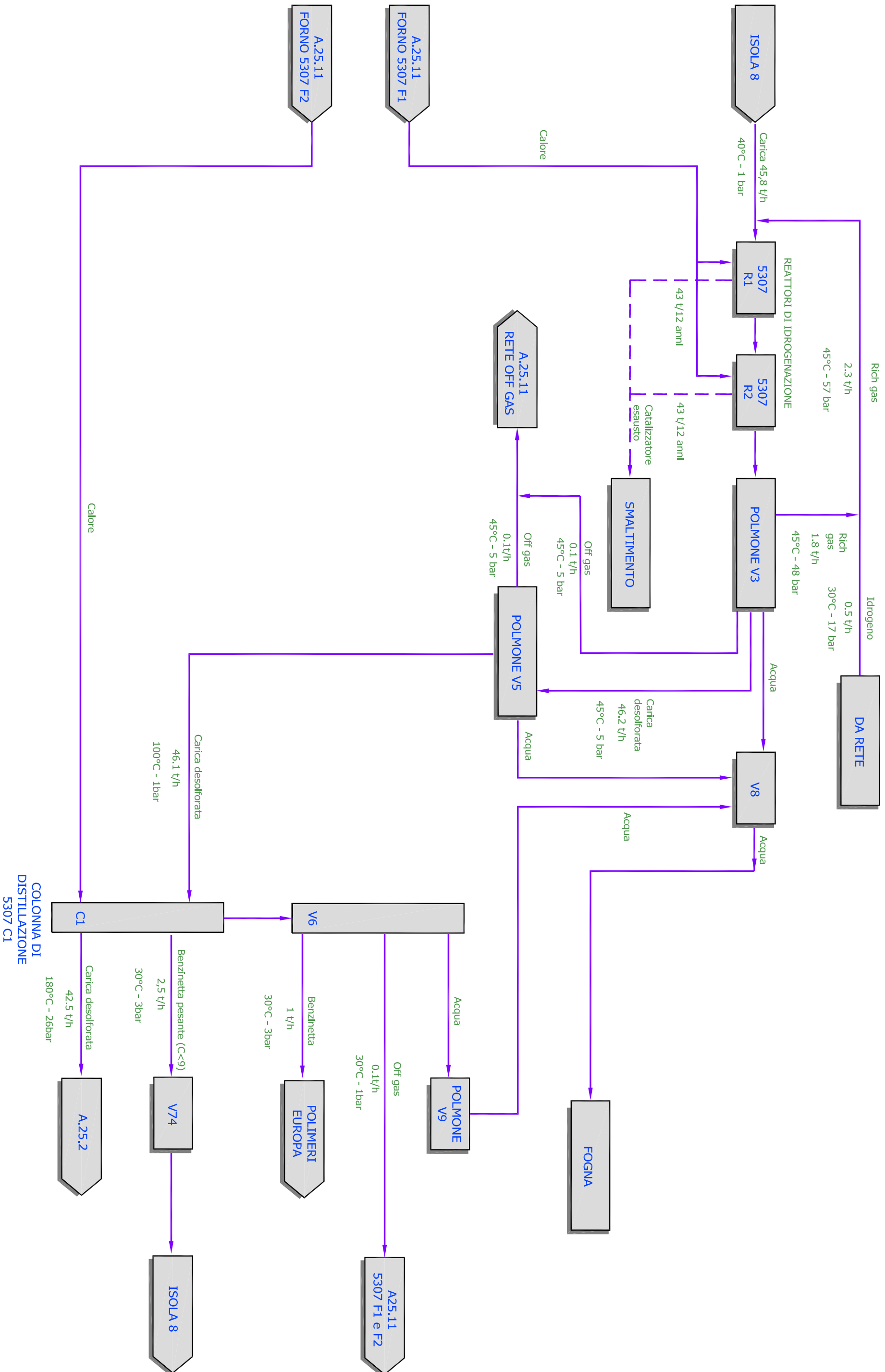

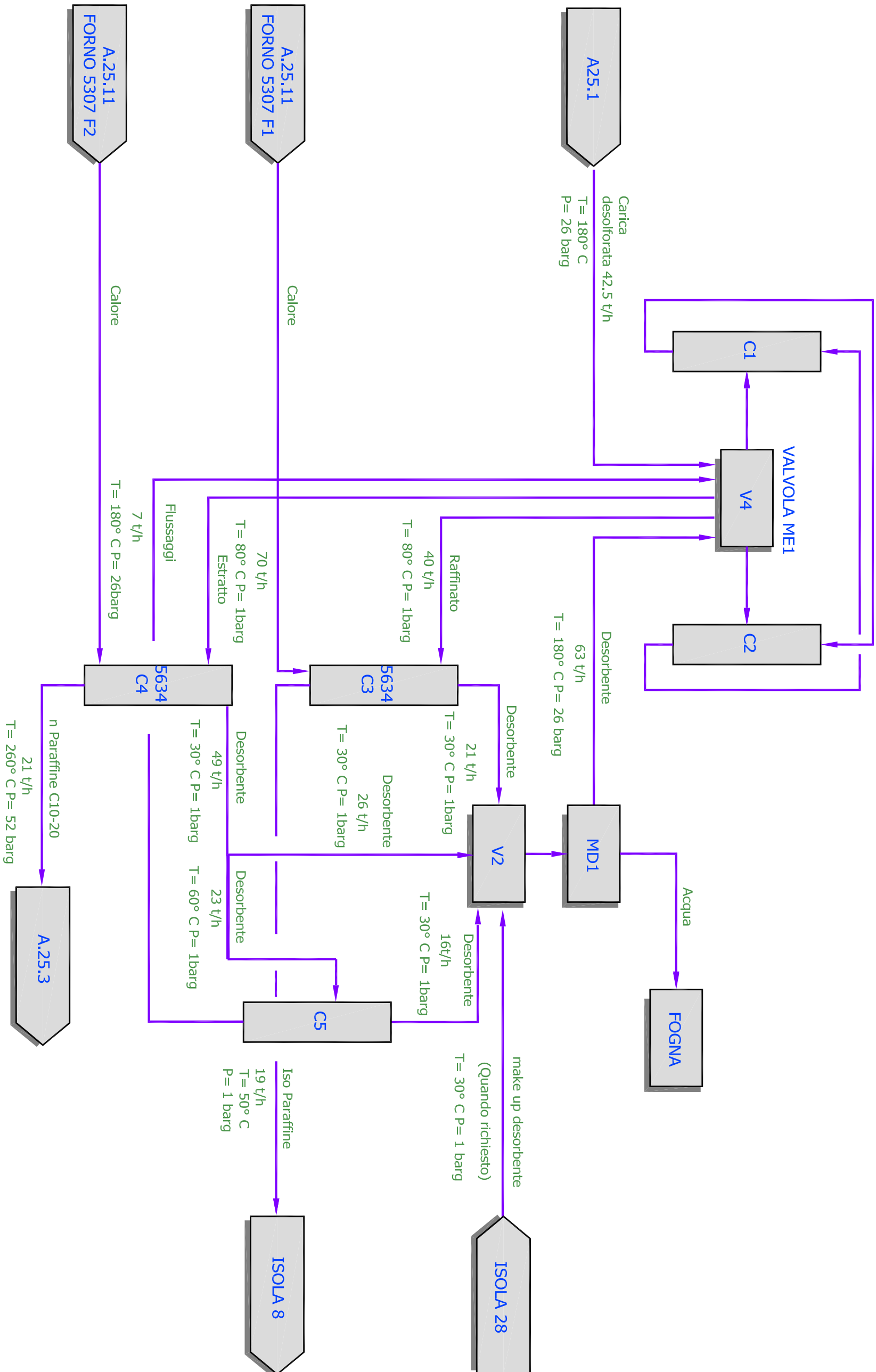

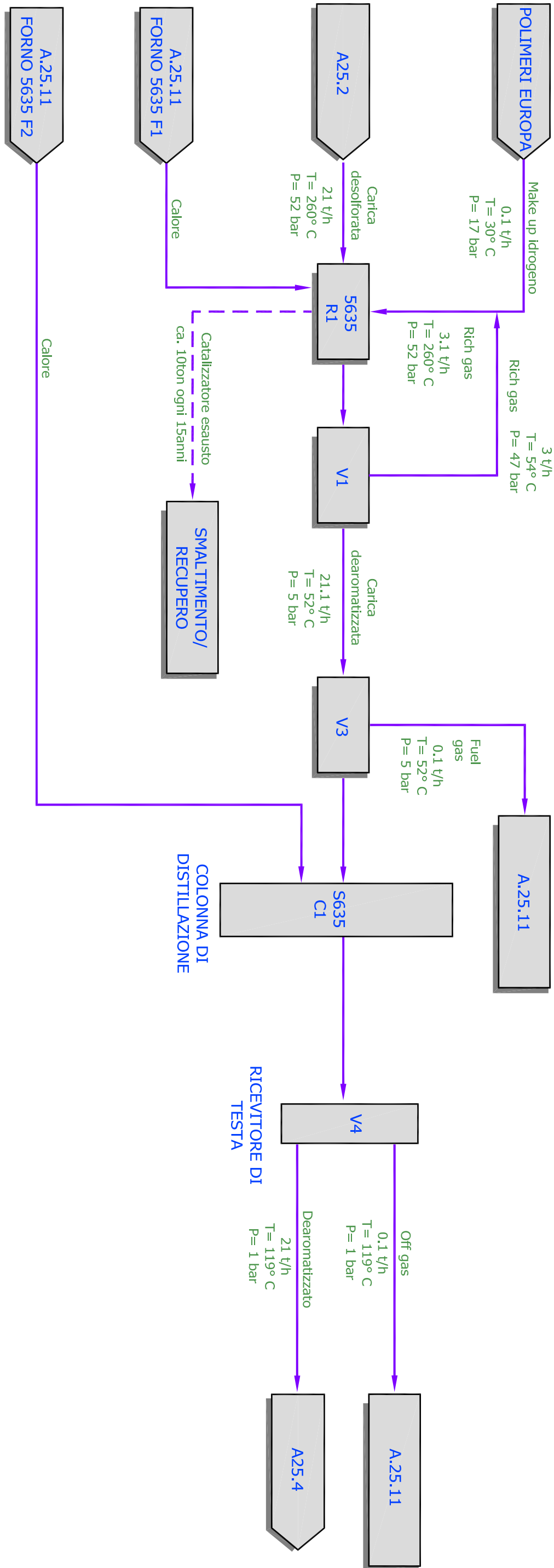

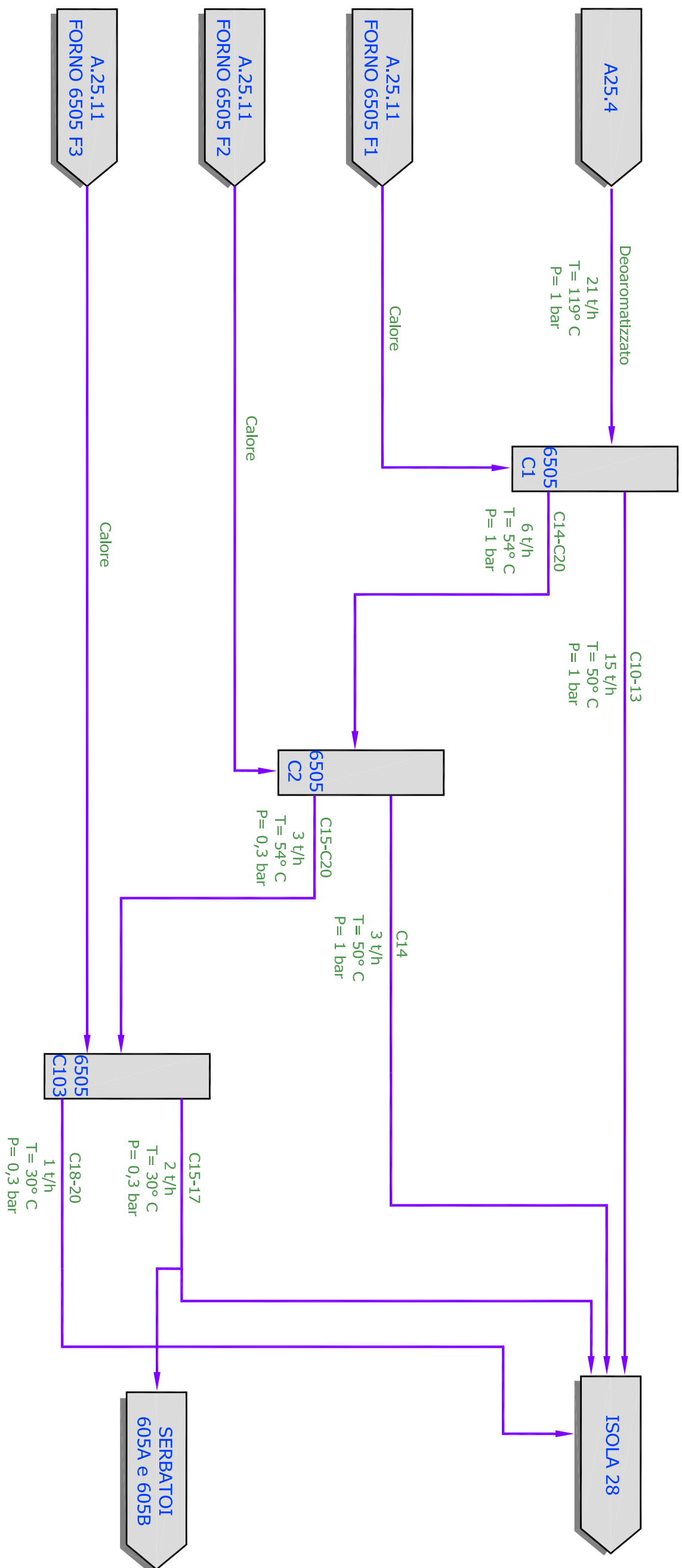

SASOL ITALY S.p.A.

SCHEMA A BLOCCHI DELLA SEZIONE FRAZIONAMENTO

SARROCH (CA)

10508441090/8396

FIG. A25.4

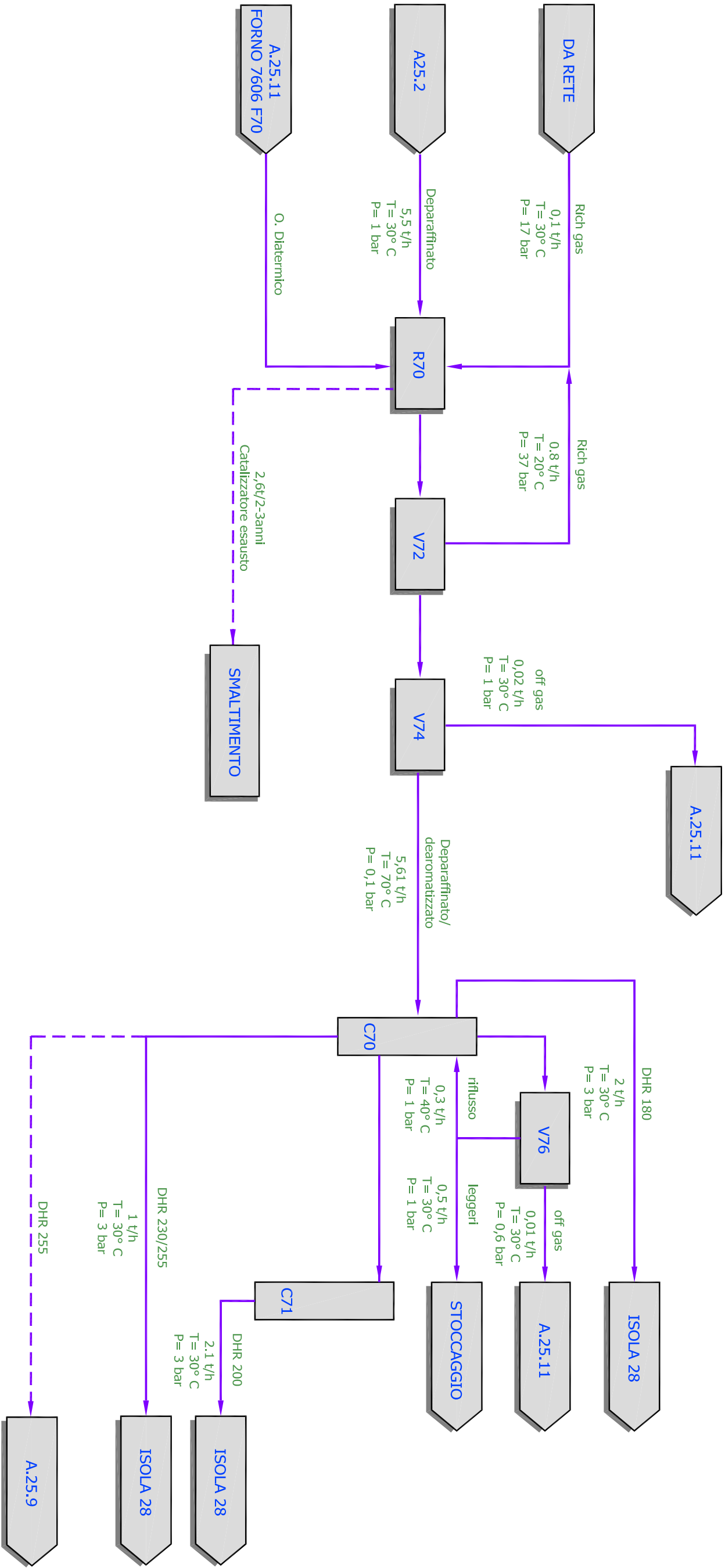

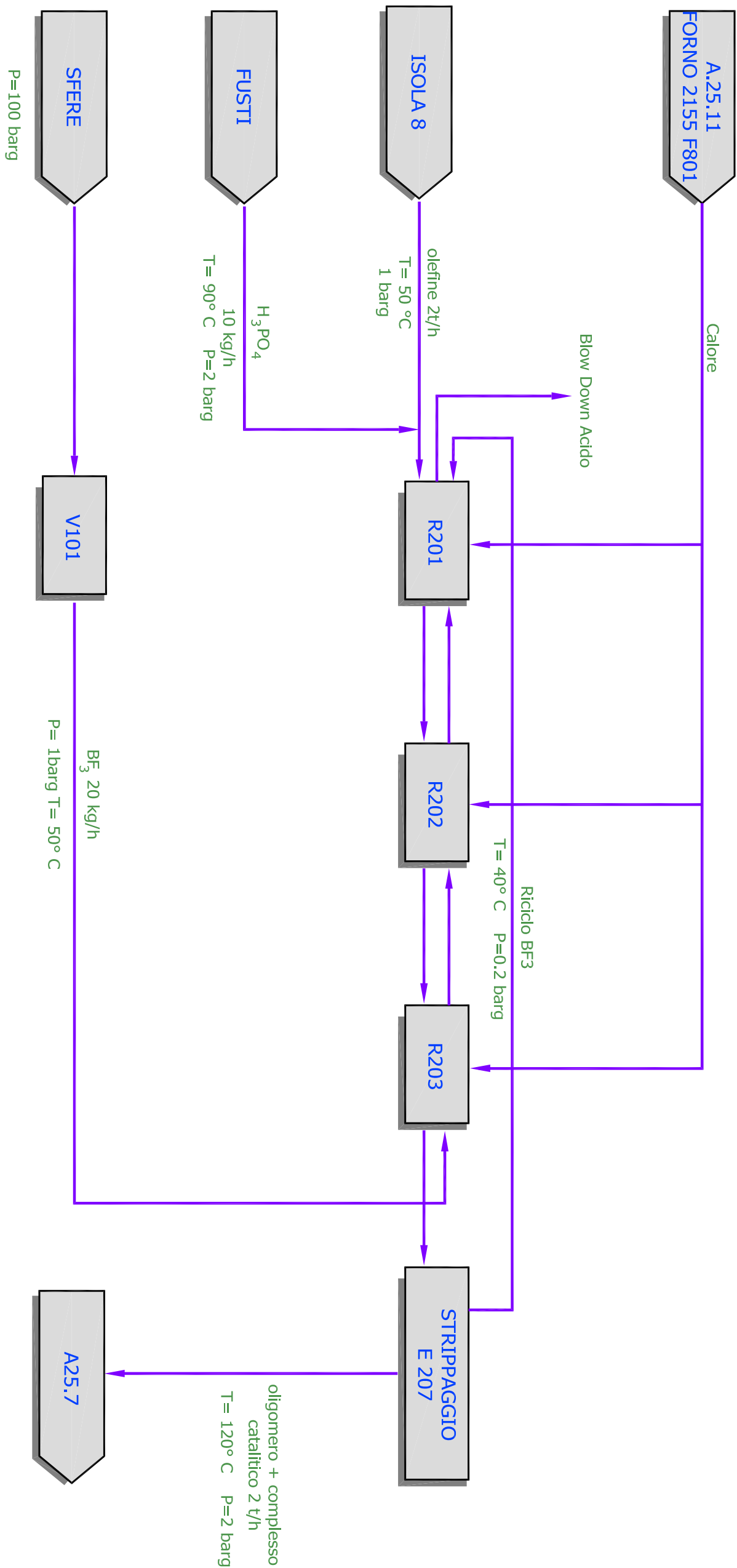

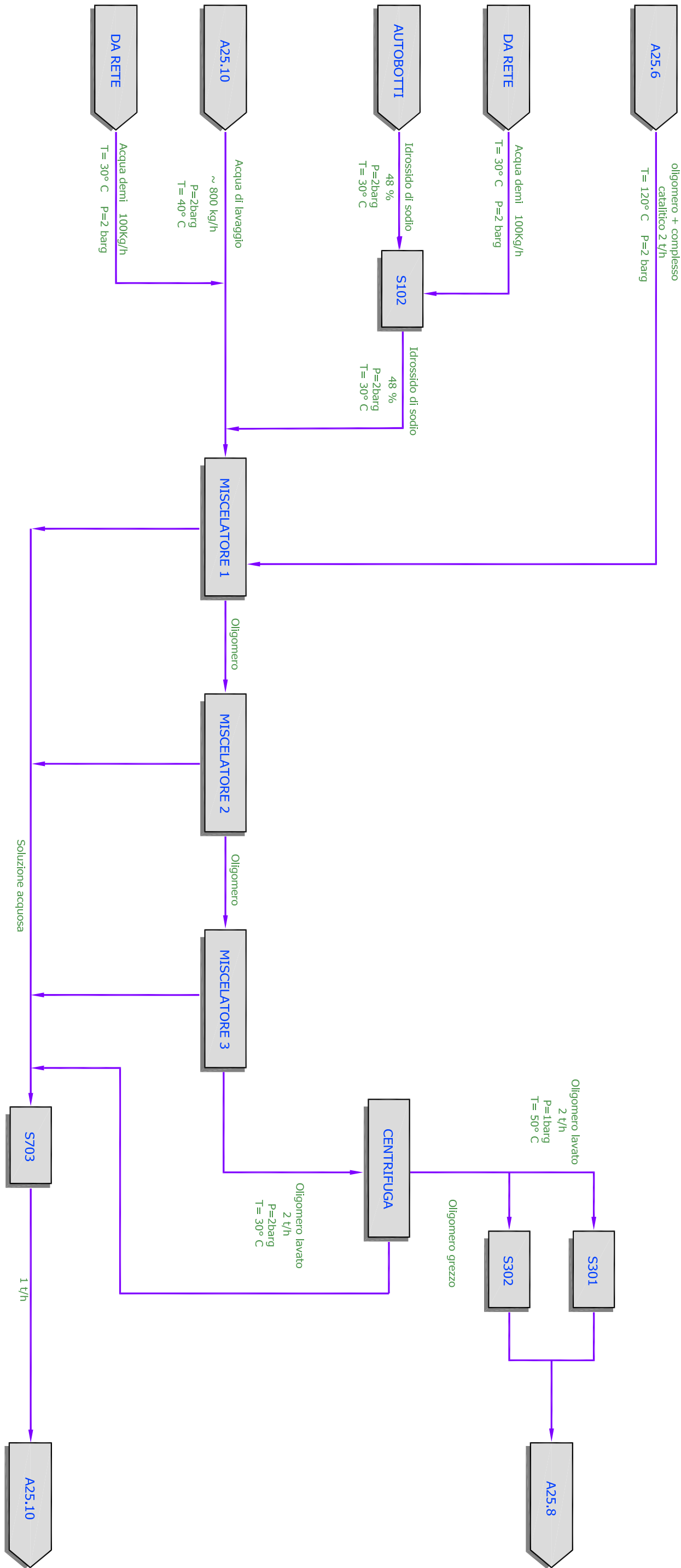

SASOL ITALY S.p.A.
**SCHEMA A BLOCCHI DELLA SEZIONE
 NEUTRALIZZAZIONE - LAVAGGIO**

SARROCH (CA)

10508441090/8396

FIG. A25.7

