

**ALLEGATO C7**  
**ATTIVITA' 4: PRODUZIONE DI**  
**CORO E SODA CAUSTICA**  
**SCHEMA A BLOCCHI NUOVO**  
**IMPIANTO A MEMBRANE**

FASI:

**4.1 PREPARAZIONE**  
**SALAMOIA**

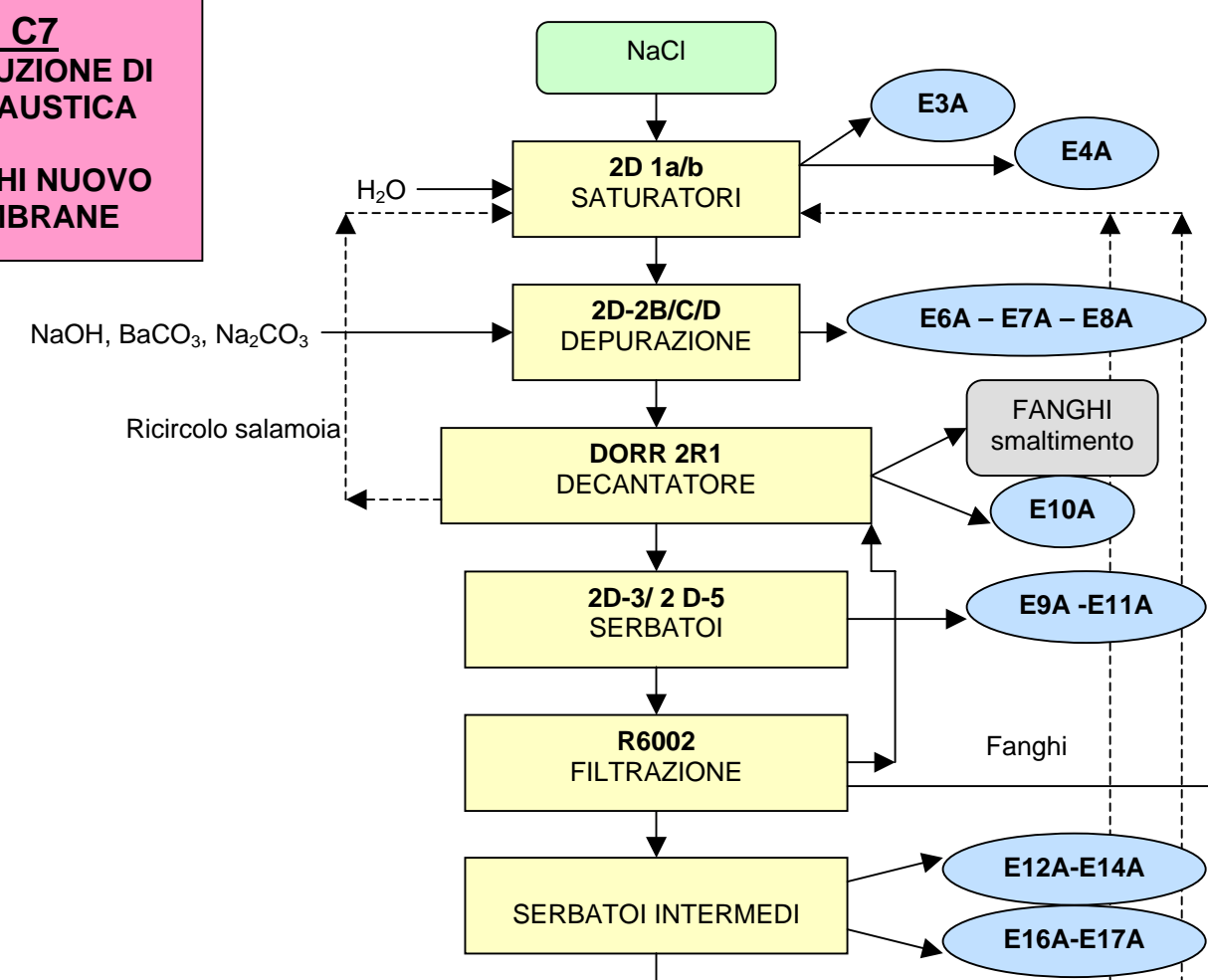

**4.2 DEPURAZIONE**  
**PRIMARIA**

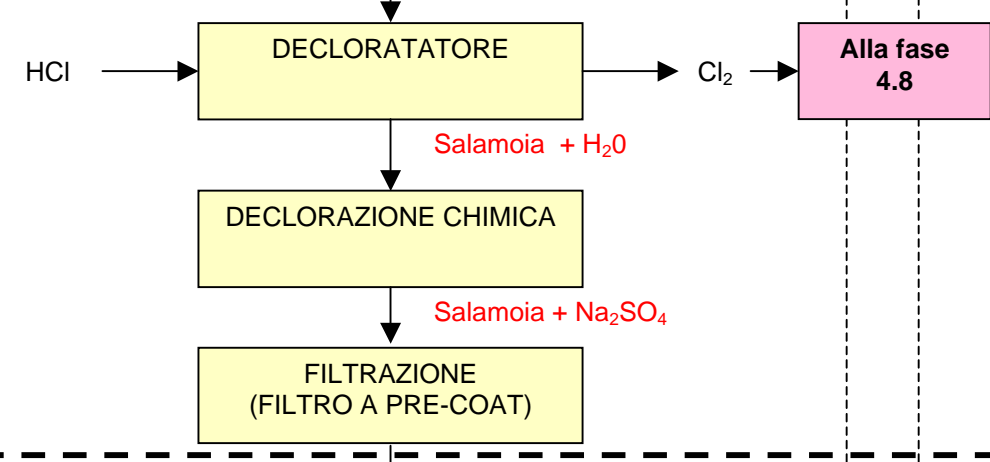

**4.3 DEPURAZIONE**  
**SECONDARIA**

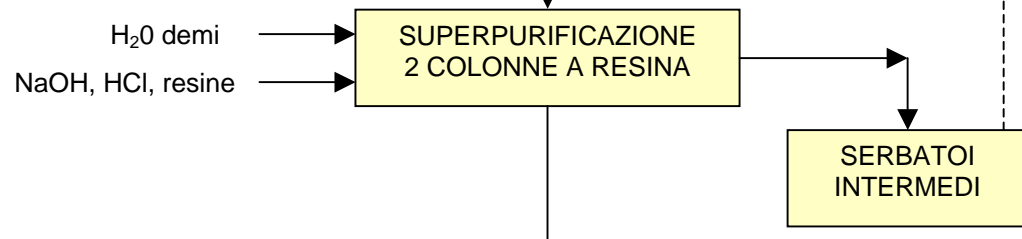

**4.4 ELETTROLISI**

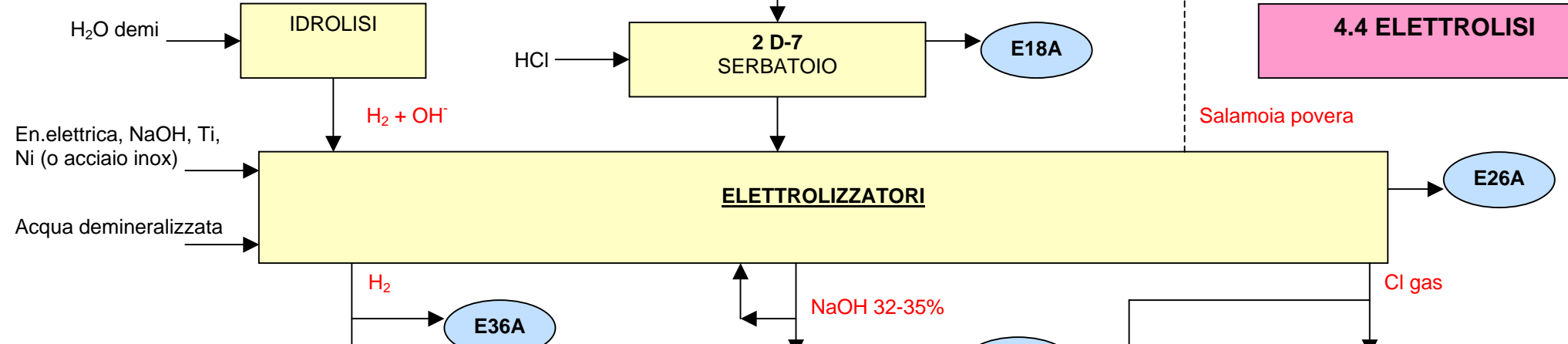

**4.8 PRODUZIONE Cl**

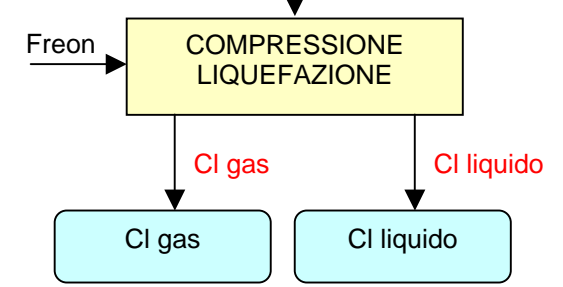

**4.6 PRODUZIONE NaOH**

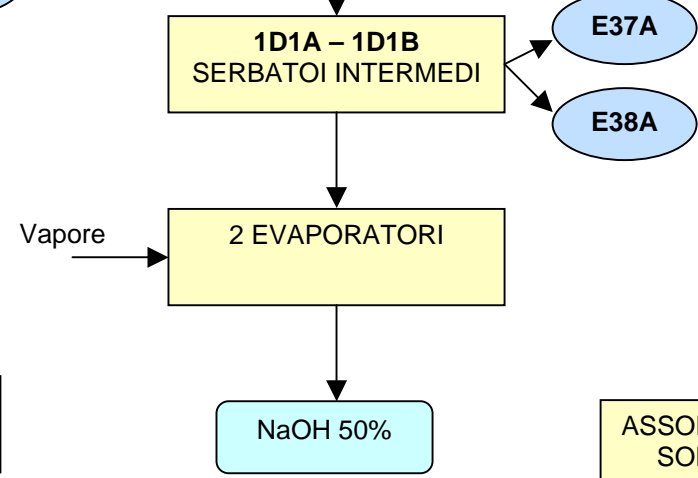

**4.7 PRODUZIONE IPOCLORITO**

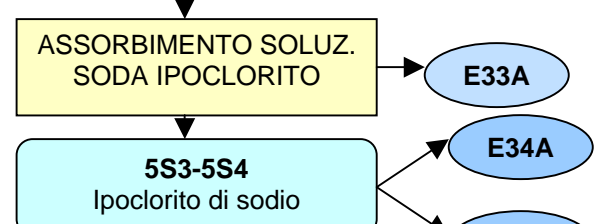

**4.5 PRODUZIONE H**

