

ITINERARIO INTERNAZIONALE E78 S.G.C. GROSSETO – FANO  
 Tratto Selci Lama (E45) – S. Stefano di Gaifa  
 Adeguamento a 2 corsie della Galleria della Guinza (lotto 2)  
 e del tratto Guinza – Mercatello Ovest (lotto 3)  
 1° stralcio

**PROGETTO DEFINITIVO**

COD. AN58

**PROGETTAZIONE: ANAS - DIREZIONE PROGETTAZIONE E REALIZZAZIONE LAVORI**

PROGETTISTI:

Ing. VINCENZO MARZI  
 Ordine Ingegneri di Bari n. 3594

IL GEOLOGO

Geol. FRANCESCO MATALONI  
 Ordine Geologici del Lazio n. 725

IL RESPONSABILE DEL S.I.A.

Arch. GIOVANNI MAGARO'  
 Ordine Architetti di Roma n. 16183

COORDINATORE PER LA SICUREZZA IN FASE DI PROGETTAZIONE

Geom. FABIO QUONDAM

VISTO: IL RESP. DEL PROCEDIMENTO

Dott. ing. ANTONIO SCALAMANDRÈ

PROTOCOLLO

DATA:

**OPERE D'ARTE MAGGIORI**

**Galleria artificiale imbocco lato Umbria - Relazione di calcolo**

CODICE PROGETTO		NOME FILE			REVISIONE		
PROGETTO	LIV. PROG.	N. PROG.	T00GA02OSTRE01.dwg				
<b>L0702M</b>	<b>D</b>	<b>1801</b>	CODICE ELAB.	<b>T00GA02OSTRE01</b>	<b>A</b>	VARIE	
D							
C							
B							
A				22-06-2018			
REV.	DESCRIZIONE		DATA	REDATTO	VERIFICATO	APPROVATO	

INDICE

1	DESCRIZIONE DELL'OPERA	3
2	DOCUMENTAZIONE E NORMATIVA DI RIFERIMENTO	4
2.1	NORMATIVA DI RIFERIMENTO .....	4
2.2	NORME UNI .....	4
2.3	BIBLIOGRAFIA.....	4
3	CARATTERISTICHE DEI MATERIALI	6
3.1	CALCESTRUZZO PER GETTI IN OPERA C28/35.....	6
3.2	ACCIAIO PER CALCESTRUZZO ARMATO B450C.....	6
4	CARATTERIZZAZIONE GEOTECNICA	7
4.1	CARATTERISTICHE MECCANICHE TERRENO DI FONDAZIONE DELLA GALLERIA ARTIFICIALE .....	7
4.2	CARATTERISTICHE MECCANICHE TERRENO DI RIEMPIMENTO.....	7
5	DIMENSIONAMENTO GALLERIA ARTIFICIALE	8
5.1	IPOTESI DI CALCOLO.....	8
5.2	MODELLO DI CALCOLO.....	9
6	VERIFICA DELLA GALLERIA ARTIFICIALE DI IMBOCCO	10
6.1	GEOMETRIA DELLA SEZIONE E PARAMETRI DI CALCOLO ED ANALISI DEI CARICHI .....	10
6.2	COMBINAZIONI DI CARICO .....	18
6.3	VERIFICA DELLA STRUTTURA IN CALCESTRUZZO ARMATO .....	18
6.4	VERIFICA GALLERIA ARTIFICIALE DI IMBOCCO.....	21
6.4.1	Sollecitazioni nelle combinazioni di carico .....	21
6.4.2	Verifiche .....	28
7	ALLEGATO A - VERIFICHE SEZIONI IN C.A.	50
7.1	VERIFICA SEZIONE S1 .....	50
7.2	VERIFICA SEZIONE S2.....	57
7.3	VERIFICA SEZIONE S4.....	65
7.4	VERIFICA SEZIONE S5.....	74
7.5	VERIFICA SEZIONE S6.....	82

7.6 VERIFICA SEZIONE S7.....	90
8 ALLEGATO B - TABULATI DI CALCOLO	98
8.1 TABULATI SAP2000 GALLERIA ARTIFICIALE .....	98

## 1. DESCRIZIONE DELL'OPERA

La presente relazione fa parte della documentazione allegata al Progetto Definitivo della galleria artificiale di imbocco lato Umbria della galleria della Guinza facente parte dell' Itinerario Internazionale E78 S.G.C. Grosseto – Fano – Tratto Selci Lama (E45) – S. Stefano di Gaifa - Adeguamento a 2 corsie della Galleria della Guinza (lotto 2) e del tratto Guinza – Mercatello Ovest (lotto 3).

La galleria della Guinza è un traforo stradale a canna unica di lunghezza pari a 5960 m, non ancora aperto al traffico, situato nell'Appennino umbro-marchigiano.

Il presente progetto ha lo scopo di garantire la messa in sicurezza dell'opera finalizzata all'apertura al traffico del fornice.

In particolare nel seguito verranno illustrate le soluzioni progettuali e le verifiche di dimensionamento della galleria artificiale di imbocco.

Nella figura sottostante è rappresentata la sagoma della sezione di galleria artificiale oggetto dei dimensionamenti e delle verifiche.

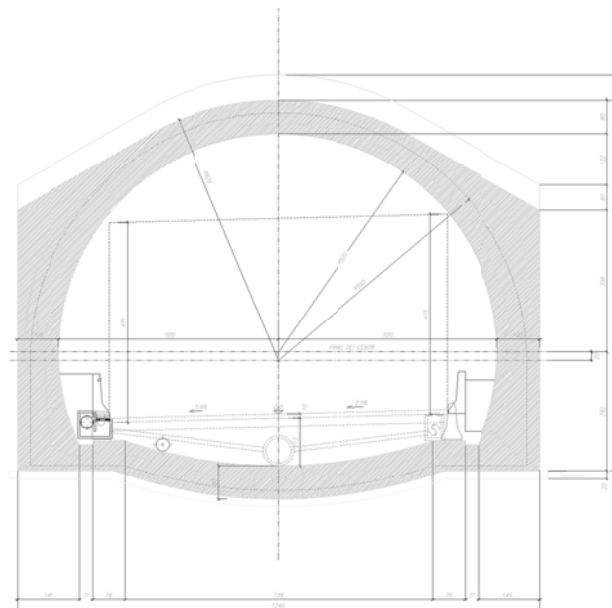

*Galleria della Guinza - Sagoma galleria artificiale di imbocco*

I piedritti hanno spessore minimo di 1.00 m, e le calotte spessore variabile, con un minimo di 0,80 m in chiave. L'arco rovescio è di spessore costante pari a 0,80 m.

## 2. DOCUMENTAZIONE E NORMATIVA DI RIFERIMENTO

### 2.1 NORMATIVA DI RIFERIMENTO

- Ministero delle Infrastrutture - D.M. 14/01/2008: "Nuove norme tecniche per le costruzioni"
- Circ.Min. n°617 del 02/02/2009: "Istruzioni per l'applicazione delle Norme tecniche per le costruzioni di cui al D.M. 14 gennaio 2008";
- Consiglio Superiore dei Lavori Pubblici STC, "Linee guida per la messa in opera del calcestruzzo strutturale e per la valutazione delle caratteristiche meccaniche del calcestruzzo indurito mediante prove non distruttive", febbraio 2008.
- Legge 5.11.1971, n.1086, "Norme per la disciplina delle opere di conglomerato cementizio armato, normale e precompresso ed a struttura metallica".
- CNR 10012: "Istruzioni per la valutazione delle azioni sulle costruzioni".
- CNR 10024: "Analisi di strutture mediante elaboratore. Impostazione e redazione delle relazioni di calcolo".

### 2.2 NORME UNI

- UNI EN 197-1: "Cemento - Composizione, specificazioni e criteri di conformità per cementi comuni.
- UNI EN 206-1: "Calcestruzzo - Specificazioni, prestazioni, produzione e conformità".
- UNI 11104/2004: "Calcestruzzo - Specificazione, prestazione, produzione e conformità – Istruzioni complementari per l'applicazione della EN 206-1".

### 2.3 BIBLIOGRAFIA

- Migliacci – F. Mola: Progetto agli stati limite delle strutture in c.a. Masson Italia Editori 1985
- C. Cestelli Guidi: Geotecnica e tecnica delle fondazioni – Ulrico Hoepli Editore 1987
- R. Lancellotta: Geotecnica – Edizioni Zanichelli 1987
- Bowles J.E.: Foundation Analysis and Design 4th edition – McGraw-Hill – New York, 1988



ITINERARIO INTERNAZIONALE E78 S.G.C. GROSSETO – FANO  
Tratto Selci lama (E45) – Santo Stefano di Gaifa - Adeguamento a 2 corsie della  
Galleria della Guinza (lotto 2) e del tratto Guinza – Mercatello Ovest (lotto 3)

**PROGETTO DEFINITIVO**

---

**RELAZIONE DI CALCOLO GALLERIA ARTIFICIALE**

---

### 3. CARATTERISTICHE DEI MATERIALI

#### 3.1 CALCESTRUZZO PER GETTI IN OPERA C28/35

D.M. 14/01/2008 e UNI EN 1992-1-1		
CLASSE	<b>C 28/35</b>	classe identificativa del calcestruzzo
acc	<b>0.85</b>	coefficiente riduttivo per le resistenze di lunga durata
$\gamma_c$	<b>1.5</b>	coefficiente parziale di sicurezza del calcestruzzo
Rck	<b>35</b> MPa	resistenza cubica caratteristica
<i>in esercizio</i>		
fck	29.05 MPa	resistenza cilindrica caratteristica
fc <sub>m</sub>	37.05 MPa	resistenza cilindrica media
<b>fcd</b>	<b>16.46</b> MPa	resistenza a compressione di calcolo
fct <sub>m</sub>	-2.83 MPa	resistenza media a trazione semplice (assiale)
fctk0.05	-1.98 MPa	frattile 5% della resistenza a trazione semplice
fctk0.95	-3.69 MPa	frattile 95% della resistenza a trazione semplice
fctd	-1.32 MPa	resistenza a trazione semplice di calcolo
fc <sub>fm</sub>	-3.40 MPa	resistenza media a trazione per flessione
fcfk0.05	-2.38 MPa	frattile 5% della resistenza a trazione per flessione
fcfk0.95	-4.42 MPa	frattile 95% della resistenza a trazione per flessione
E <sub>cm</sub>	32588 MPa	modulo elastico secante tra la tensione nulla e 0.40f <sub>cm</sub>
E <sub>c</sub>	34218 MPa	modulo elastico tangente
$\nu$	<b>0.2</b>	coefficiente di Poisson
G	13578 MPa	modulo di rigidezza al taglio
<i>tensioni massime in esercizio</i>		
<b>0.60fck</b>	<b>17.43</b> MPa	combinazione caratteristica (rara)
<b>0.45fck</b>	<b>13.07</b> MPa	combinazione quasi permanente
fc <sub>fd</sub>	-1.59 MPa	resistenza a trazione per flessione di calcolo
<b>fctm / 1.2</b>	<b>-2.36</b> MPa	trazione limite per la formazione di fessure

#### 3.2 ACCIAIO PER CALCESTRUZZO ARMATO B450C

D.M. 14/01/2008 e UNI EN 1992-1-1		
<b>B450C</b>		
fy.nom	<b>450</b> MPa	valore nominale della tensione caratteristica di snervamento
ft.nom	<b>540</b> MPa	valore nominale della tensione caratteristica di rottura
fyk	450 MPa	valore caratteristico della tensione di snervamento
ftk	540 MPa	valore caratteristico della tensione di rottura
$\gamma_s$	1.15	coefficiente parziale di sicurezza relativo all'acciaio
<b>fyd</b>	<b>391.30</b> MPa	resistenza di calcolo
E <sub>s</sub>	<b>2.06E+05</b> MPa	modulo elastico dell'acciaio

## 4. CARATTERIZZAZIONE GEOTECNICA

La trattazione completa della situazione geotecnica in prossimità delle opere in oggetto è riportata nella Relazione Geotecnica allegata al progetto. Nel seguito si riportano i parametri geotecnici caratteristici delle varie unità assunti nei calcoli.

### 4.1 CARATTERISTICHE MECCANICHE TERRENO DI FONDAZIONE DELLA GALLERIA ARTIFICIALE

Formazione	$\gamma$ kN/m <sup>3</sup>	$c'$ kPa	$\phi$ °	E MPa
Marnoso- Arenacea	21	200	35	100 0

### 4.2 CARATTERISTICHE MECCANICHE TERRENO DI RIEMPIMENTO

Tipo di terreno	$\gamma$ kN/m <sup>3</sup>	$c'$ kPa	$\phi$ °	E MPa
Terreno di riempimento	19	0	30	40



## 5. DIMENSIONAMENTO GALLERIA ARTIFICIALE

### 5.1 IPOTESI DI CALCOLO

Per il dimensionamento della galleria artificiale di imbocco è stata considerata la sezione in corrispondenza della progressiva in cui si ha la massima altezza di ritombamento. In particolare sono state effettuate le verifiche considerando un ritombamento orizzontale pari a circa 3m al di sopra della chiave calotta.

I carichi agenti sulle gallerie artificiali sono i seguenti:

- Peso proprio della struttura valutato automaticamente dal programma di calcolo attribuendo al c.a. un peso specifico di 25 kN/m<sup>3</sup>;
- Carico verticale del terreno di ricoprimento  $P_v$ , considerato nella parte sovrastante la calotta, pari a  $\gamma H$ , con  $H$  costante quando il piano campagna è assunto orizzontale; nel modello è stata tenuta in conto l'aliquota variabile di carico litostatico da imputare al riempimento tra la quota massima della calotta e la quota di imposta del piedritto;
- Spinte orizzontali  $P_h$  presenti a lungo termine variabili con la profondità calcolate secondo la formula:

$$P_h = \gamma H K_o$$

con

$K_o = 1 - \sin \phi$ , coefficiente di spinta a riposo.

Le spinte orizzontali, sono state anche considerate, in maniera alternativa, ipotizzando condizioni di spinta attiva e quindi calcolate adottando un coefficiente di spinta attiva come da teoria di Coulomb.

I due approcci faranno parte di combinazioni di carico distinte; ciò al fine di valutare la combinazione di carico più gravosa per la struttura con lo scopo di effettuare i dimensionamenti e le verifiche dell'opera nella condizione peggiore.

- Carico relativo al ricoprimento al di sopra dell'arco rovescio e al pacchetto di pavimentazione
- Carico accidentale sulla copertura della galleria artificiale posto pari a 10 kN/m<sup>2</sup>
- Carico accidentale relativo al traffico gravante sull'arco rovescio pari a 20 kN/m<sup>2</sup>
- Azioni sismiche ricavate secondo l'approccio consigliato dal DM 14/01/2008.

Si riportano nella tabella seguente i valori delle principali grandezze sismiche per l'opera in progetto ricavate dalla caratterizzazione di pericolosità sismica del sito relativamente al periodo di ritorno associato allo stato limite di salvaguardia della vita SLV. In particolare è stata considerata una Classe d'uso III e una vita utile di 50 anni.

Opera	Stato limite	TR anni	ag g	Ss	St	S	amax g
Galleria artificiale Guinza	SLV	712	0.30	1.19	1.0	1.19	0.36

L'azione sismica è applicata sia come incremento / decremento della spinta del terreno, sia come forza di inerzia della struttura stessa.

## 5.2 MODELLO DI CALCOLO

Per il calcolo delle azioni interne si adotta il metodo delle reazioni iperstatiche attraverso una modellazione numerica ad elementi finiti monodimensionali. Il programma di calcolo utilizzato è SAP2000 ver. 19.

Si considera una sezione di galleria di lunghezza unitaria (1m) definendo per la struttura un modello costituito da conci monodimensionali (elementi frame). Gli spessori delle diverse aste sono variabili secondo l'elemento strutturale considerato (calotta, piedritto, arco rovescio).

In corrispondenza dei frame vengono considerate delle molle distribuite che hanno lo scopo di simulare l'interazione tra il terreno e la struttura e che inducono su quest'ultima, solo se compresse, una reazione pari alla pressione di contatto terreno-struttura.

La rigidezza di tali supporti è stata posta pari a 30000 kN/mc per le molle che simulano l'interazione tra l'opera e il terreno di ricoprimento (costante di reazione orizzontale) e pari a 300000kN/mc per le molle che simulano l'interazione tra l'arco rovescio ed il terreno di fondazione (costante di sottofondo fondazione).

Nei punti di estremità del modello i valori delle rigidezze sono stati raddoppiati.

## 6. VERIFICA DELLA GALLERIA ARTIFICIALE DI IMBOCCO

### 6.1 GEOMETRIA DELLA SEZIONE E PARAMETRI DI CALCOLO ED ANALISI DEI CARICHI

Le verifiche delle galleria artificiale di imbocco sono state condotte analizzando la sezione riportata in precedenza e considerando un ritombamento orizzontale pari a circa 3m in chiave calotta.

La figura seguente illustra il modello di calcolo base adottato per le analisi.

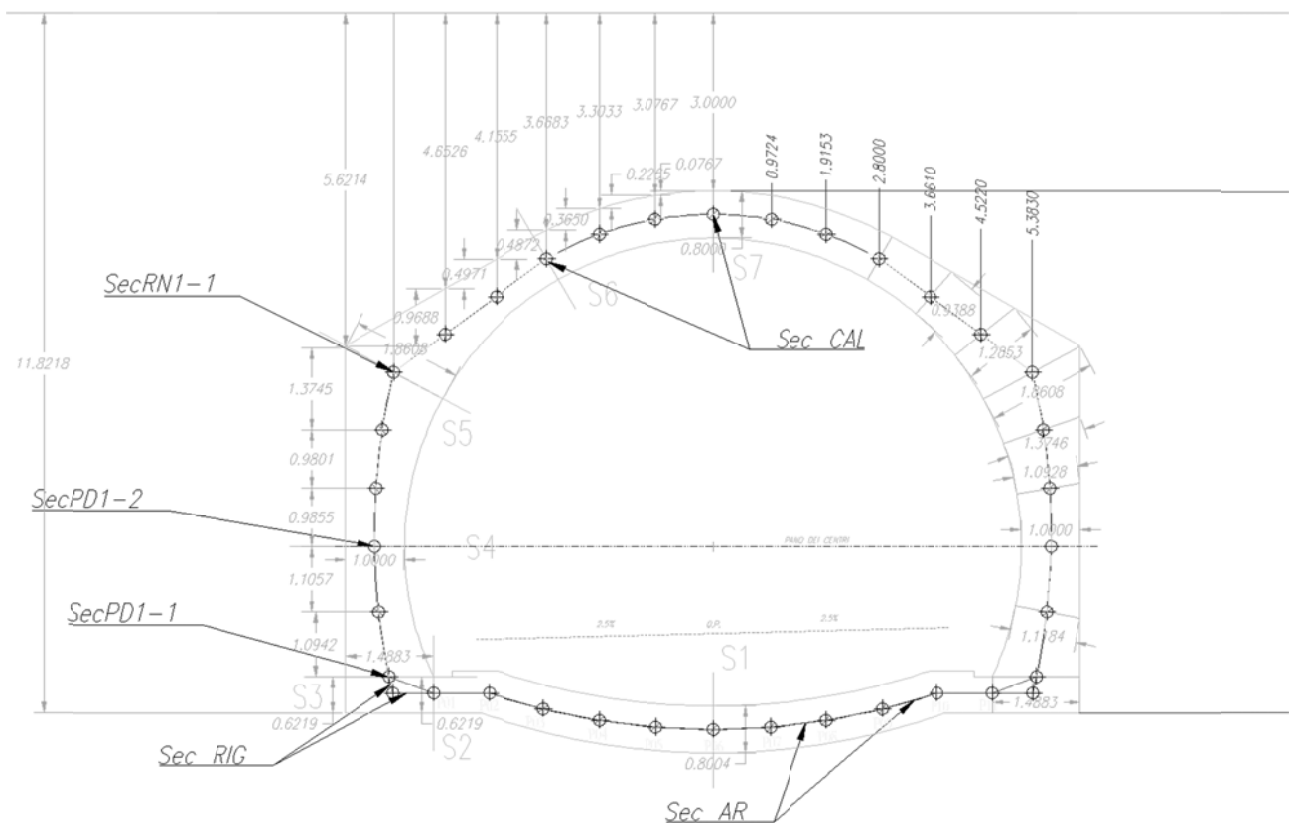

Modello di calcolo adottato per le analisi

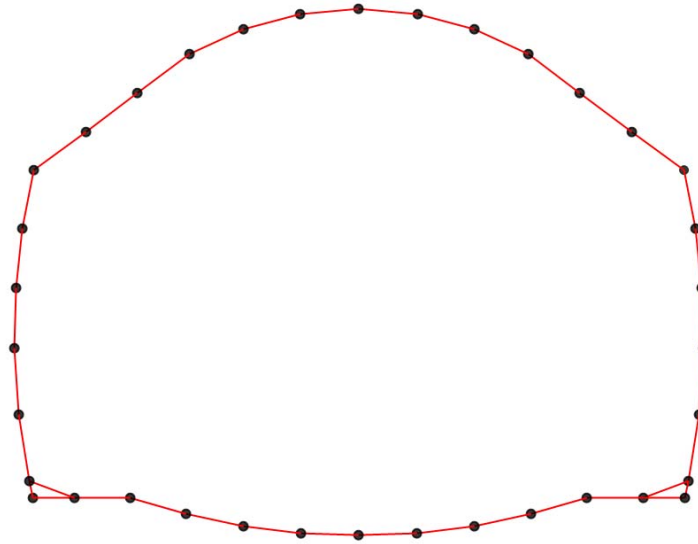

*Modello agli elementi finiti*

**SOVRASTRUTTURA STRADALE SU ARCO ROVESCIO (g2)**

**Ricoprimento arco rovescio**

(g2)

$\gamma_{pav}$	=	<b>24</b>	kN/m <sup>3</sup>	peso dell'unità di volume pavimentazione
$H_{pav}$	=	<b>0.50</b>	m	altezza pavimentazione
$\gamma_{ric}$	=	<b>20.00</b>	kN/m <sup>3</sup>	peso specifico ricoprimento
$H_{ric}$	=	<b>0.7</b>	m	altezza ricoprimento
$g_{2.2}$	=	<b>26</b>	kPa	carico esercitato dal terreno sulla soletta

**CARICHI GENERATI DALLA PRESENZA DEL TERRENO (g3)**

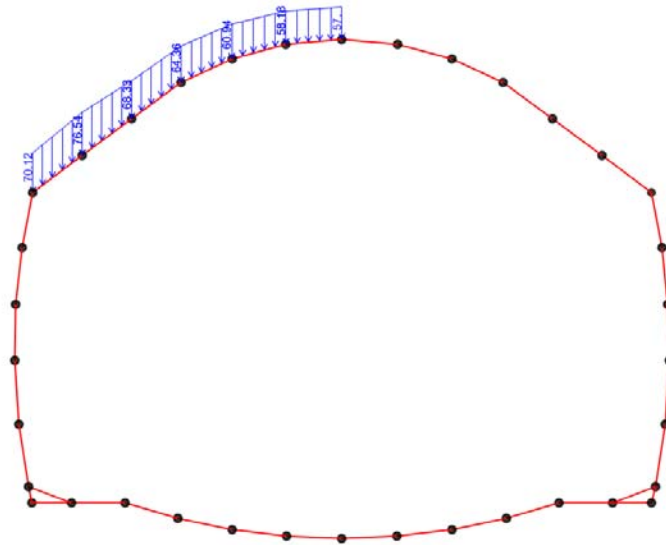

*Carico verticale terreno in sinistra*

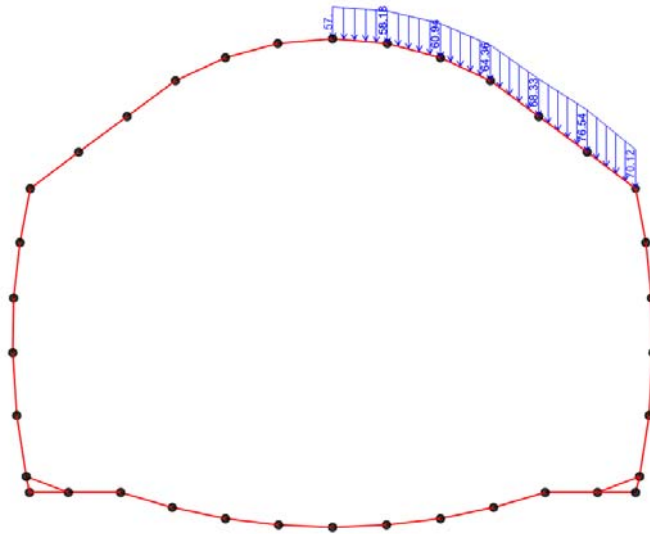

*Carico verticale terreno in destra*

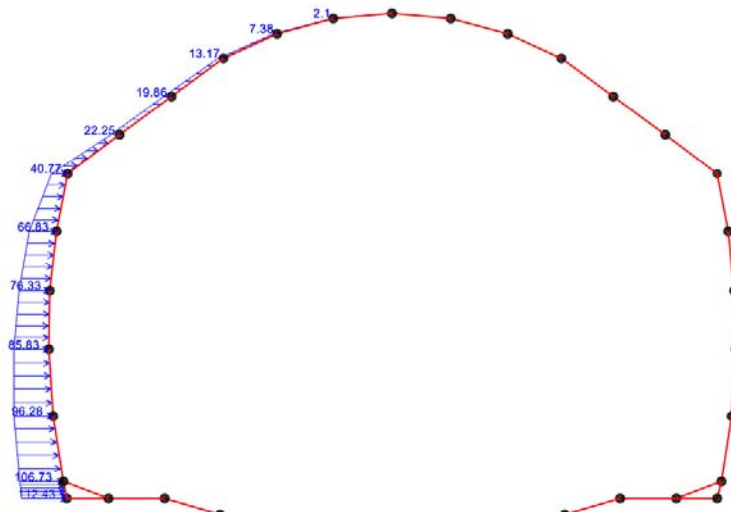

*Spinta a riposo in sinistra*

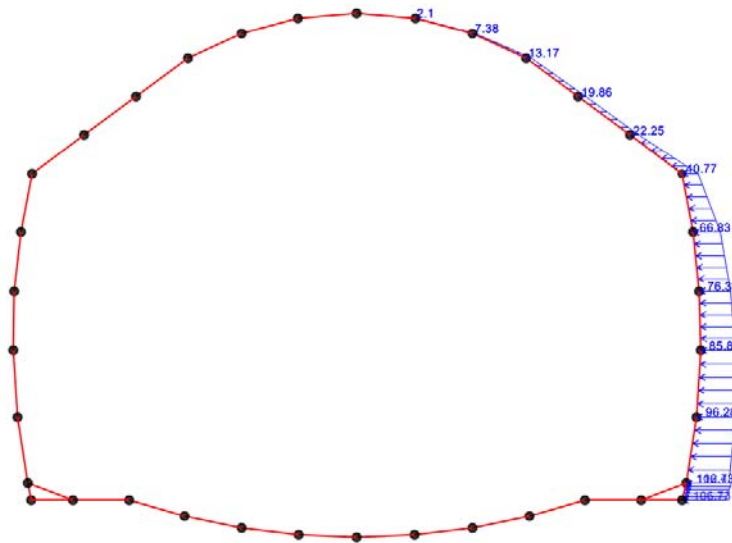

*Spinta a riposo in destra*

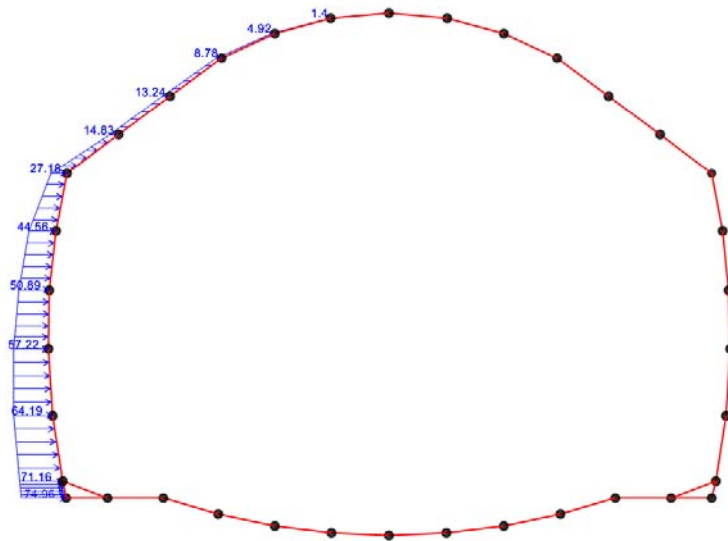

*Spinta attiva in sinistra*

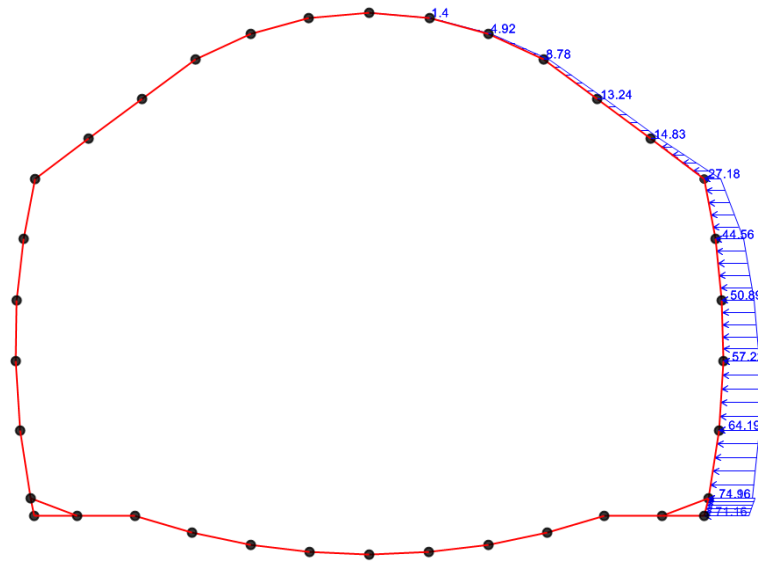

*Spinta attiva in destra*

**CARICHI MOBILI SULL'ARCO ROVESCIO (q1)**

Si considera sull'arco rovescio, per tenere in conto dell'azione esercitata dai veicoli in transito, un carico variabile uniformemente distribuito di intensità pari a 20 kPa.

**Carico stradale su arco rovescio (q1)**

**PROGETTO DEFINITIVO**

**RELAZIONE DI CALCOLO GALLERIA ARTIFICIALE**

q1 = 20.00 kPa intensità carico verticale  
 variabile

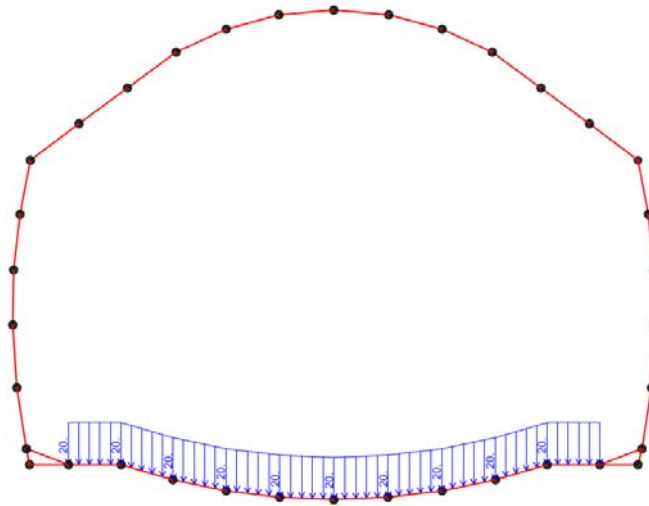

*Carichi mobili su arco rovescio*

**INCREMENTO DI SPINTA DEL TERRENO IN FASE SISMICA (q6.1)**

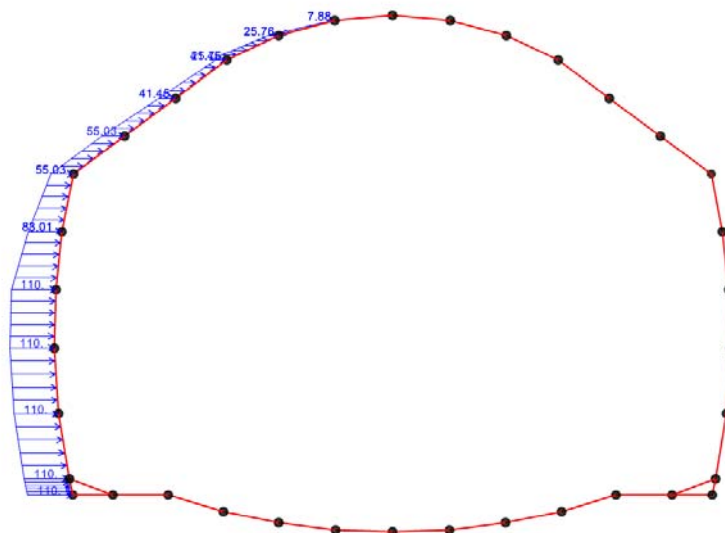

*Incremento sismico di spinta orizzontale in sinistra*



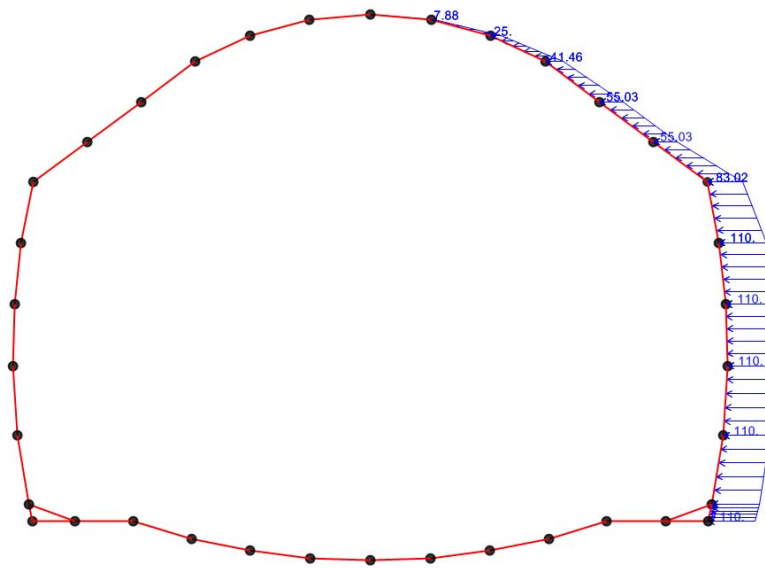

*Incremento sismico di spinta orizzontale in destra*

**FORZE D'INERZIA IN FASE SISMICA (q6.2)**

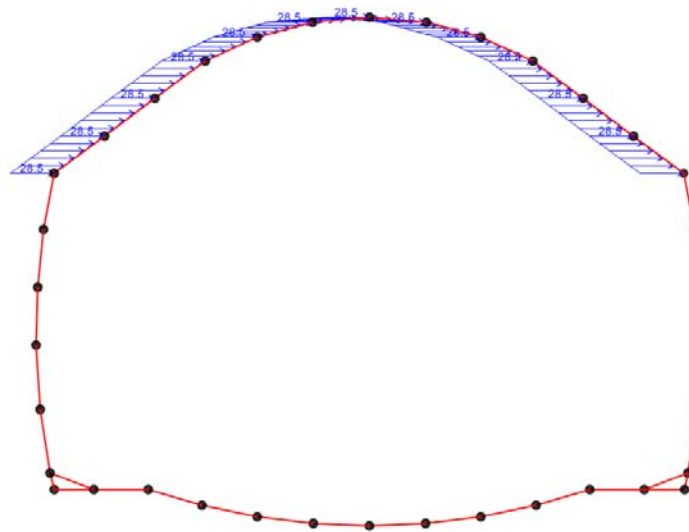

Forze d'inerzia orizzontali  $q_{6.2}$  h

**VARIAZIONE TERMICA (q7)**

$\Delta T_U = 15^\circ$

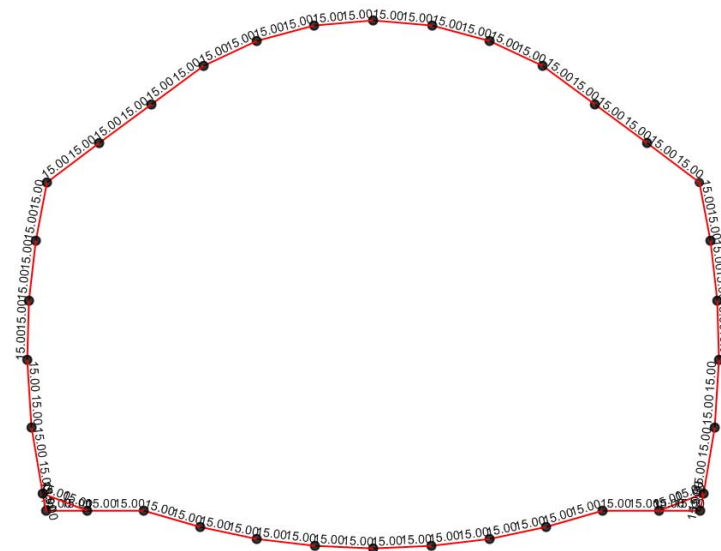

Variazione termica

## 6.2 COMBINAZIONI DI CARICO

La struttura della galleria è stata verificata per le condizioni di carico riportate nel DM 2008 sia nei riguardi degli stati limite ultimi che nei riguardi degli stati limite di esercizio, mediante il metodo dei coefficienti parziali di sicurezza sulle azioni e sulle resistenze (§ 6.2.3).

Le combinazioni di calcolo adottate sono schematizzate nella seguente tabella:

MATRICE COEFFICIENTI DI COMBINAZIONE DEI CARICHI																							
	1	2	3	4	5	6	7	8	9	10	11	12	13	14	15	16	17	18	19	20	21	22	23
	SLU q1.1	SLU q1.2	SLU q1.3	SLU q1.4	SLU q1.5	SLU q1.6	SLU q1.7	SLU q1.8	SLU q1.9	SLU q1.10	SLU q1.11	SLU q1.12	SLU q1.13	SLU q1.14	SLU q1.15	SLU q1.16	SLU q1.17	SLU q1.18	SLU q1.19	SLU q1.20	SLU q1.21	SLU q1.22	SLU q1.23
g1	1.3	1.3	1.3	1.3	1.3	1.3	1.3	1.3	1.3	1.3	1.3	1.3	1.3	1.3	1.3	1.3	1.3	1.3	1.3	1.3	1.3	1.3	1.3
g2	1.5	1.5	1.5	1.5	1.5	1.5	1.5	1.5	1.5	1.5	1.5	1.5	1.5	1.5	1.5	1.5	1.5	1.5	1.5	1.5	1.5	1.5	1.5
g3h_sx_k0	1.3	0	0	1.3	0	0	1.3	0	0	1.3	0	0	1.3	0	0	1.3	0	0	1.3	0	0	1.3	0
g3h_sx_ka	0	0	1.3	0	0	1.3	0	0	1.3	0	0	1.3	0	0	1.3	0	0	1.3	0	0	1.3	0	0
g3h_dx_k0	1.3	0	0	1.3	0	0	1.3	0	0	1.3	0	0	1.3	0	0	1.3	0	0	1.3	0	0	1.3	0
g3h_dx_ka	0	1.3	0	0	1.3	0	0	1.3	0	0	1.3	0	0	1.3	0	0	1.3	0	0	1.3	0	0	1.3
g3v_sx	1.3	0	1.3	1.3	0	1.3	1.3	0	1.3	1.3	0	1.3	1.3	0	1.3	1.3	0	1.3	1.3	0	1.3	1.3	0
g3v_dx	1.3	1.3	0	1.3	1.3	0	1.3	1.3	0	1.3	1.3	0	1.3	1.3	0	1.3	1.3	0	1.3	1.3	0	1.3	1.3
q1_1sx_k0	0	0	0	1.5	1.5	1.5	0	0	0	1.5	1.5	1.5	0	0	1.5	1.5	1.5	0	0	0	1.5	1.5	1.5
q1_1dx_k0	0	0	0	1.5	1.5	1.5	0	0	0	1.5	1.5	1.5	0	0	1.5	1.5	1.5	0	0	0	1.5	1.5	1.5
q1_2	1.5	1.5	1.5	0	0	0	0	0	0	1.5	1.5	1.5	0	0	1.5	1.5	1.5	0	0	0	1.5	1.5	1.5
q6.1_sx	0	0	0	0	0	0	0	0	0	0	0	0	0	0	0	0	0	0	0	0	0	0	0
q6.1_dx	0	0	0	0	0	0	0	0	0	0	0	0	0	0	0	0	0	0	0	0	0	0	0
q6.1v	0	0	0	0	0	0	0	0	0	0	0	0	0	0	0	0	0	0	0	0	0	0	0
q6.2h	0	0	0	0	0	0	0	0	0	0	0	0	0	0	0	0	0	0	0	0	0	0	0
q6.2v	0	0	0	0	0	0	0	0	0	0	0	0	0	0	0	0	0	0	0	0	0	0	0
q7	1.3	1.3	1.3	1.3	1.3	1.3	1.3	1.3	1.3	1.3	1.3	1.3	1.3	1.3	1.3	1.3	1.3	1.3	1.3	1.3	1.3	1.3	1.3

favorevoli																										
	24	25	26	27	28	29	30	31	32	33	34	35	36	37	38	39	40	41	42	43	44	45	46	47	48	49
	SLU q1.24	SLU q1.25	SLU q1.26	SLU q1.27	SLU q1.28	SLU q1.29	SLU q1.30	SLU q1.31	SLU q1.32	SLU q1.33	SLU q1.34	SLU q1.35	SLU q1.36	SL Ex.1	SL Ex.2	SL Ey.1	SL Ey.2	SL Ez.1	SL Ez.2	SLE f1	SLE f2	SLE qp1	SLE qp2	SLE c1	SLE c2	SLE c3
1.3	1.3	1.3	1.3	1.3	1.3	1.3	1.3	1	1	1	1	1	1	1	1	1	1	1	1	1	1	1	1	1	1	1
1.5	1.5	1.5	1.5	1.5	1.5	1.5	1.5	0.8	0.8	0.8	0.8	0.8	0.8	0	0	0	0	0	0	0	0	0	0	0	0	0
0	1.3	0	0	1.3	0	0	1.3	0	0	0	1	0	0	0	0	0	0	0	0	0	0	0	0	0	0	0
1.3	0	0	1.3	0	0	0	1.3	0	0	1	0	0	0	1	0	0	0	0	0	0	0	0	0	0	0	0
0	1.3	0	0	1.3	0	0	1.3	0	1	0	0	1	0	0	0	0	0	0	0	0	0	0	0	0	0	0
0	0	1.3	0	0	1.3	0	0	0	1	0	0	0	1	0	0	0	0	0	0	0	0	0	0	0	0	0
1.3	1.3	0	1.3	1.3	0	1.3	1.3	1	0	1	1	0	0	1	1	1	1	1	1	1	1	1	1	1	1	1
0	1.3	1.3	0	1.3	1.3	0	0	1	1	1	0	1	1	0	1	1	1	1	1	1	1	1	1	1	1	1
1.5	1.5	1.5	1.5	0	0	0	0	0	0	0	0	0	0	0	0.2	0	0.2	0	0.2	0.75	0.75	0	0	1	0	1
1.5	0	0	0	1.5	1.5	1.5	1.5	0	0	0	0	0	0	0	0.2	0	0.2	0	0.2	0.75	0.75	0	0	1	0	1
1.5	1.5	1.5	1.5	1.5	1.5	1.5	0	0	0	0	0	0	0	0	0.2	0	0.2	0	0.2	0.75	0.75	0	0	0	0	1
0	0	0	0	0	0	0	0	0	0	0	0	0	0	0	1	1	0.3	0.3	0.3	0.3	0	0	0	0	0	0
0	0	0	0	0	0	0	0	0	0	0	0	0	0	0	0.3	0.3	1	1	0.3	0.3	0	0	0	0	0	0
0	0	0	0	0	0	0	0	0	0	0	0	0	0	0	0.3	0.3	0.3	0.3	1	1	0	0	0	0	0	0
0	0	0	0	0	0	0	0	0	0	0	0	0	0	0	1	1	1	1	0.3	0.3	0	0	0	0	0	0
0	0	0	0	0	0	0	0	0	0	0	0	0	0	0	0.3	0.3	0.3	0.3	1	1	0	0	0	0	0	0
1.3	1.3	1.3	1.3	1.3	1.3	1.3	1.3	0	0	0	0	0	0	0	0	0	0	0	0	0.6	0.6	0	0	0	0	0

Matrice dei coefficienti e delle combinazioni di carico

## 6.3 VERIFICA DELLA STRUTTURA IN CALCESTRUZZO ARMATO

Per la sezione della galleria artificiale in c.a. soggetta a forza normale e flessione retta, la verifica si effettua operando nel piano N-M: basta accertare che il punto avente le coordinate Md, Nd rappresentative degli effetti delle azioni di calcolo (cioè delle azioni di servizio moltiplicate per i correlativi coefficienti parziali di sicurezza ye), appartenga al dominio

resistente, delimitato dalla curva di interazione M-N. Sono state verificate le sezioni in cemento armato della galleria artificiale ritenute più significative.

In questo caso viene adottato un procedimento rigoroso, basato sulle ipotesi seguenti (DM 2008 4.1.2.1.2):

- diagramma  $\sigma$ - $\varepsilon$  del calcestruzzo compresso a forma di parabola-rettangolo;
- diagramma  $\sigma$ - $\varepsilon$  dell'acciaio, sia teso che compresso, elastico-perfettamente plastico:
  - o conservazione delle sezioni piane;
  - o perfetta aderenza fra acciaio e calcestruzzo;
  - o calcestruzzo teso non reagente.

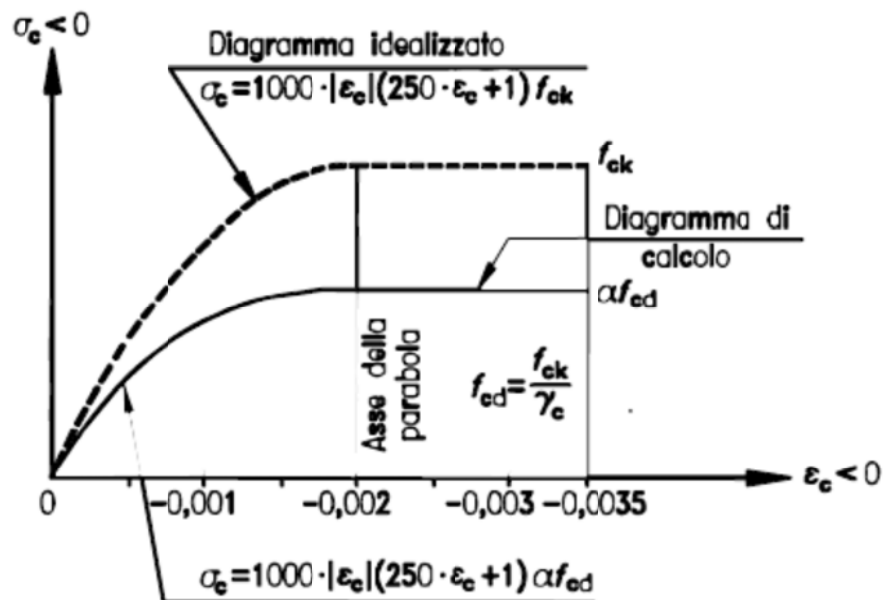

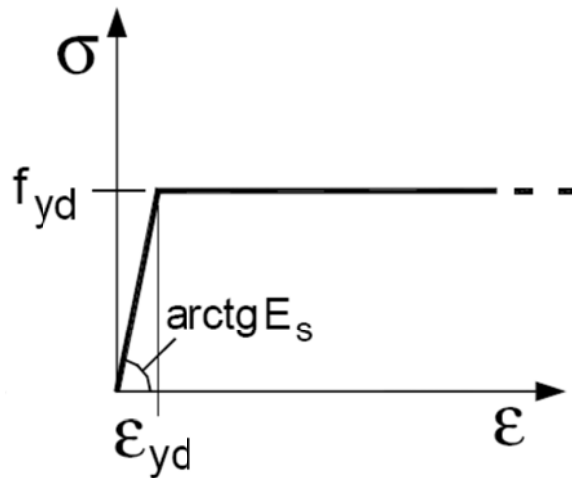

Sono stati calcolati i momenti resistenti di progetto (momenti ultimi) corrispondenti al valore assegnato dell'azione assiale sollecitante di progetto  $N_{sd}$ . È stato verificato che il valore di  $N_{sd}$  non risulti maggiore del valore ultimo per compressione o trazione semplice. I momenti sono calcolati rispetto al baricentro della sezione.

Il momento resistente viene determinato dopo aver calcolato la curvatura che, in condizioni di deformazione limite del calcestruzzo o dell'acciaio, soddisfa l'equilibrio alla traslazione.

Sono stati ricavati i punti di dominio M-N della sezione, evidenziando la posizione del punto  $N_{sd}-M_{sd}$  rappresentativo dello stato di sollecitazione. Si assumono come positive le compressioni.

Successivamente sono state effettuate delle verifiche agli Stati Limite di Esercizio, che consistono in una limitazione delle tensioni di esercizio, e verifiche agli Stati Limite di Fessurazione (limitazione delle ampiezze massime delle aperture) DM 2008 4.1.2.2.

In particolare:

$\sigma_{cls} < 0.45 f_{ck}$	tensione nel calcestruzzo
$\sigma_s < 0.80 f_{yk}$	tensione nell'acciaio di armatura
$w_k < 0.30 \text{ mm}$	apertura delle fessure nel cls.

Per il calcolo dell'apertura delle fessure si procede in questo modo:

$$w_k = 1.7 s_{rm} \varepsilon_{sm} \quad \text{ampiezza delle fessure}$$

dove:

$w_k$  è l'ampiezza di calcolo delle fessure;

$s_{rm}$  è la distanza media finale tra le fessure;

esm è la deformazione media che tiene conto, nella combinazione di carico considerata, degli effetti di "tension stiffening", del ritiro ecc.;

## 6.4 VERIFICA GALLERIA ARTIFICIALE DI IMBOCCO

### 6.4.1 Sollecitazioni nelle combinazioni di carico

In questa sezione, per motivi di compattezza, si riportano i diagrammi delle sollecitazioni per la combinazione involuppo (ENV) delle combinazioni analizzate.

#### SLU (SLU\_ENVE)

Diagramma dello sforzo normale per la combinazione involuppo



Diagramma dello sforzo di taglio per la combinazione involuppo

PROGETTO DEFINITIVO

RELAZIONE DI CALCOLO GALLERIA ARTIFICIALE

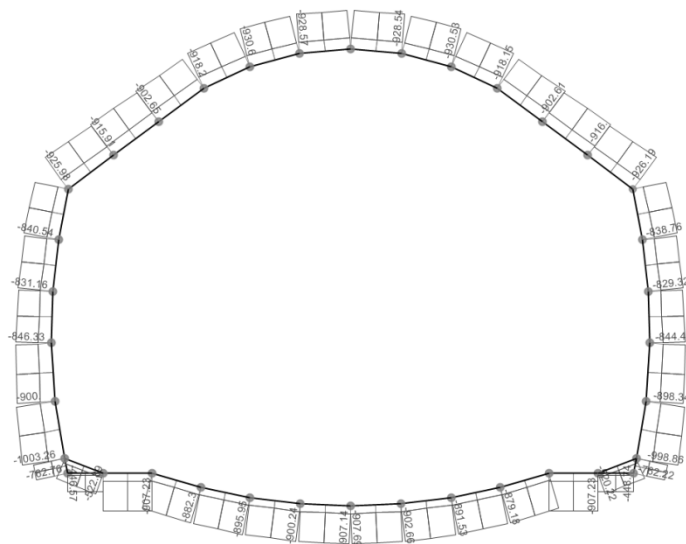

Diagramma dello sforzo flettente per la combinazione involuppo



SLV (SLV\_ENVE)

Diagramma dello sforzo normale per la combinazione involuppo

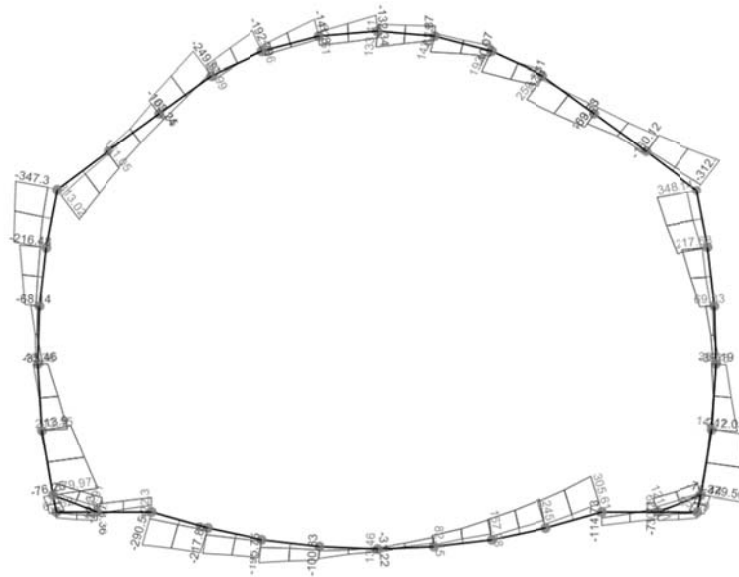
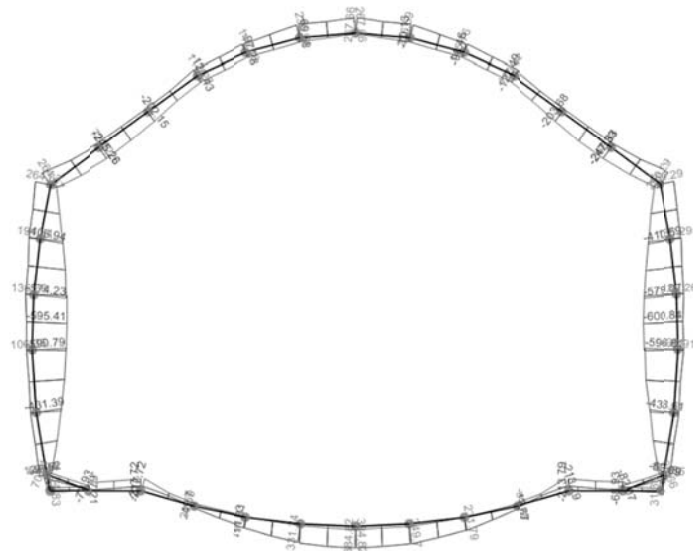
PROGETTO DEFINITIVO

RELAZIONE DI CALCOLO GALLERIA ARTIFICIALE



Diagramma dello sforzo di taglio per la combinazione involuppo



Diagramma dello sforzo flettente per la combinazione involuppo

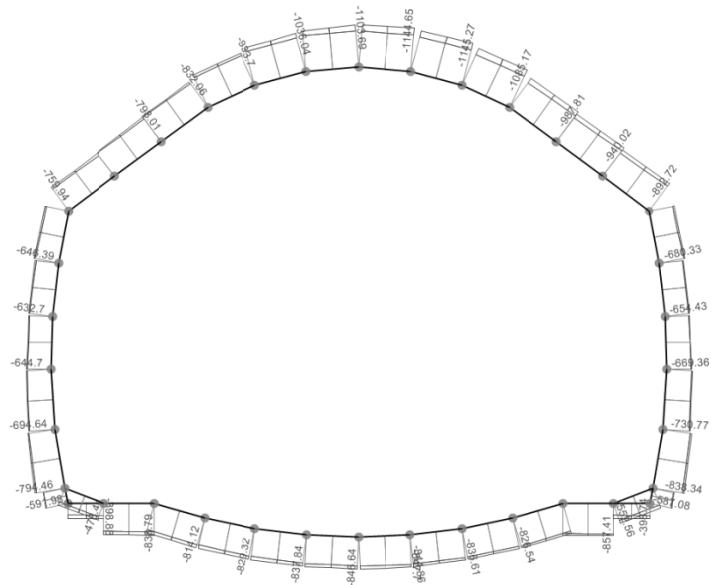

PROGETTO DEFINITIVO

RELAZIONE DI CALCOLO GALLERIA ARTIFICIALE

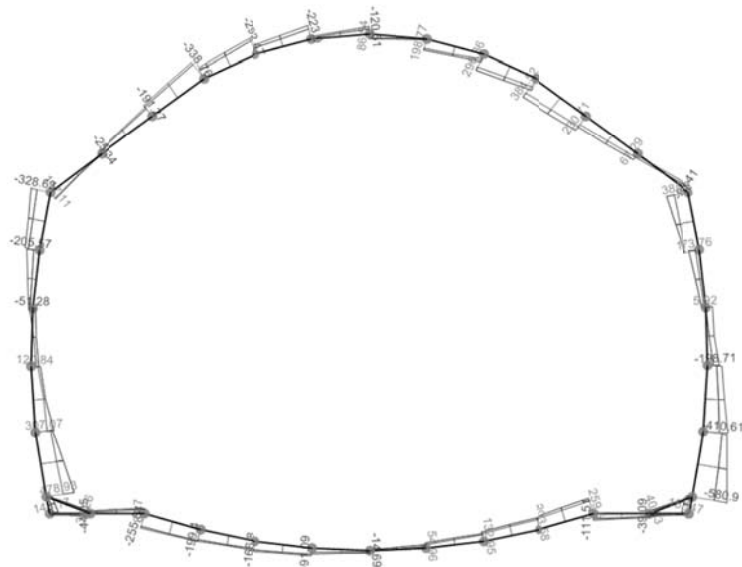
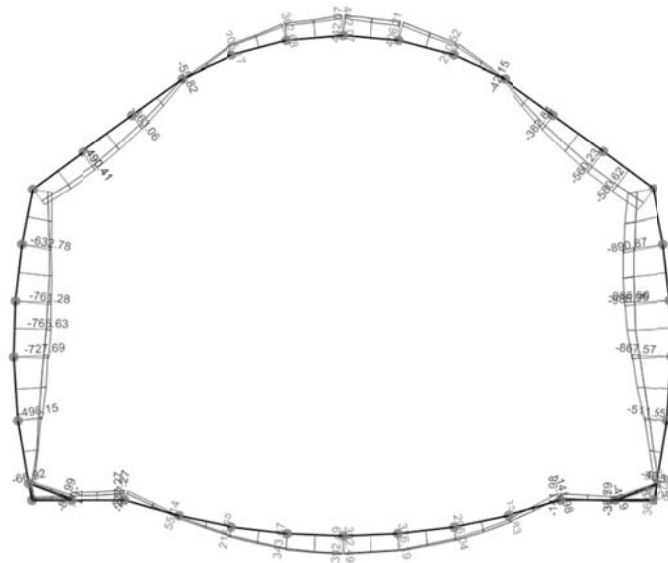

SLE –Rara (SLE\_C\_ENVE)

Diagramma dello sforzo normale per la combinazione involuppo



Diagramma dello sforzo di taglio per la combinazione involuppo



Diagramma dello sforzo flettente per la combinazione inviluppo

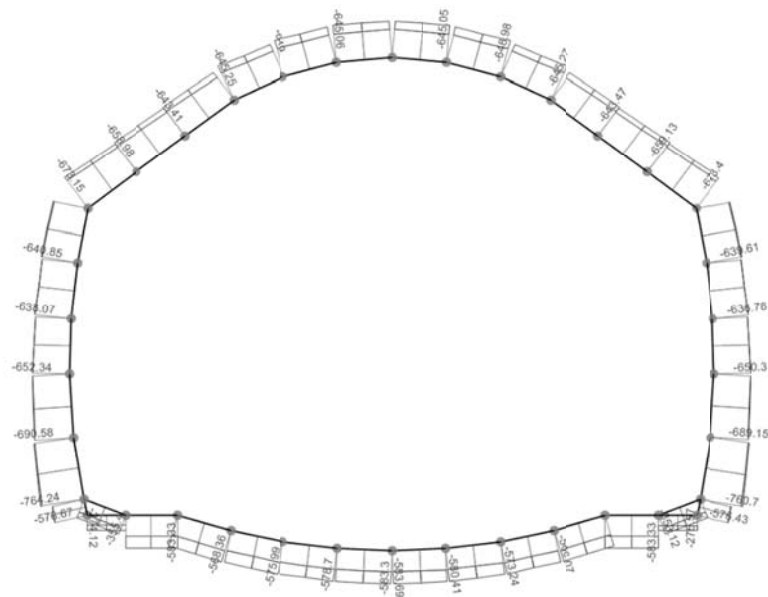

SLE –Frequente (SLE\_FR\_ENVE)

Diagramma dello sforzo normale per la combinazione inviluppo

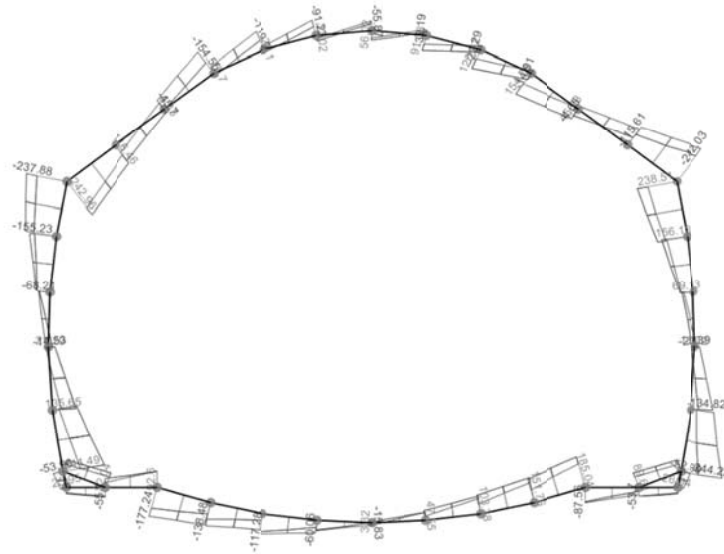
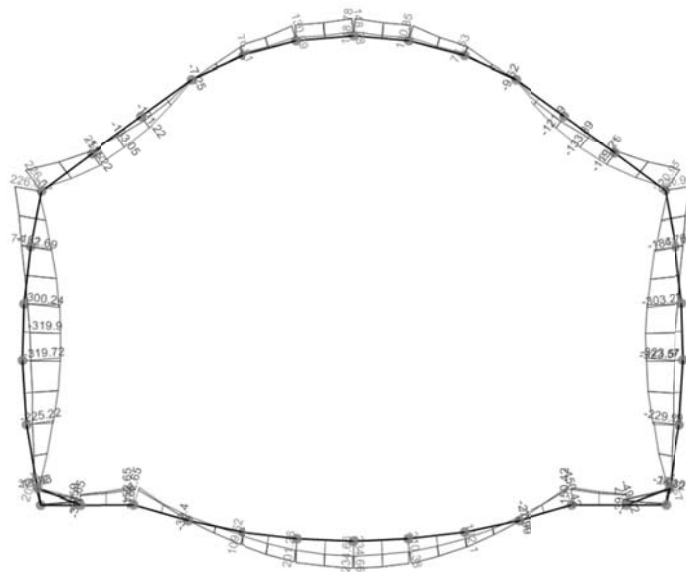
PROGETTO DEFINITIVO

RELAZIONE DI CALCOLO GALLERIA ARTIFICIALE



Diagramma dello sforzo di taglio per la combinazione involuppo



Diagramma dello sforzo flettente per la combinazione involuppo

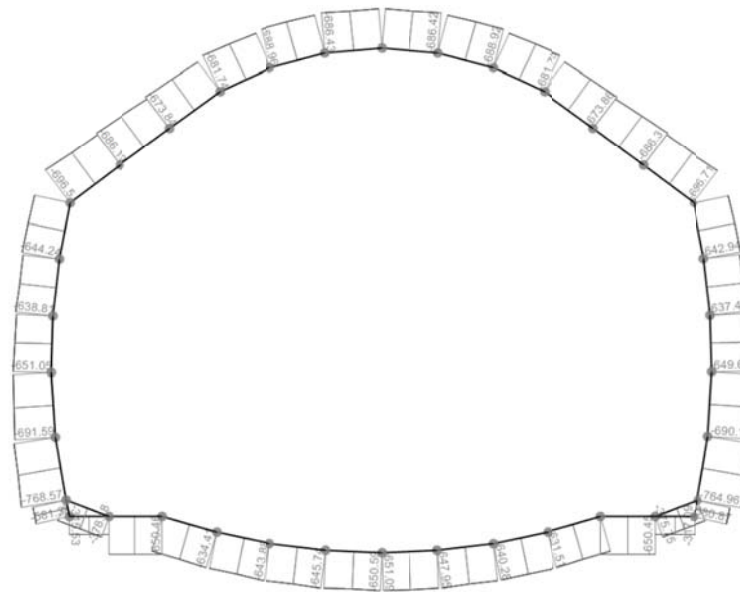

SLE –Quasi permanente (SLE\_QP\_ENVE)

Diagramma dello sforzo normale per la combinazione involuppo

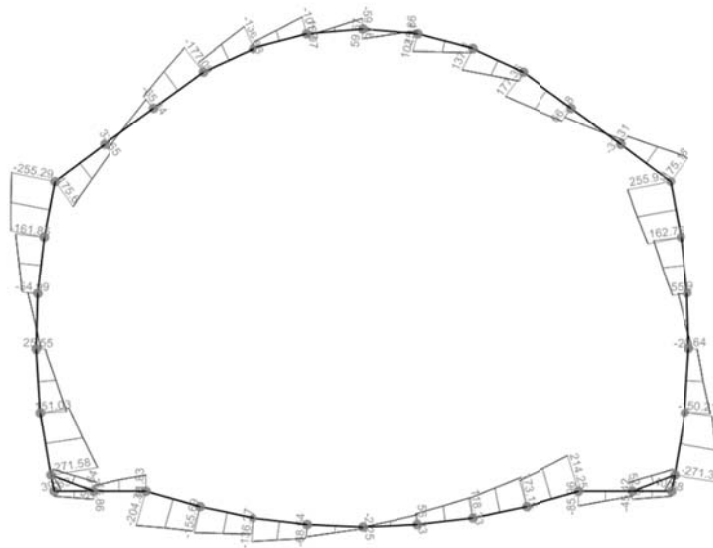
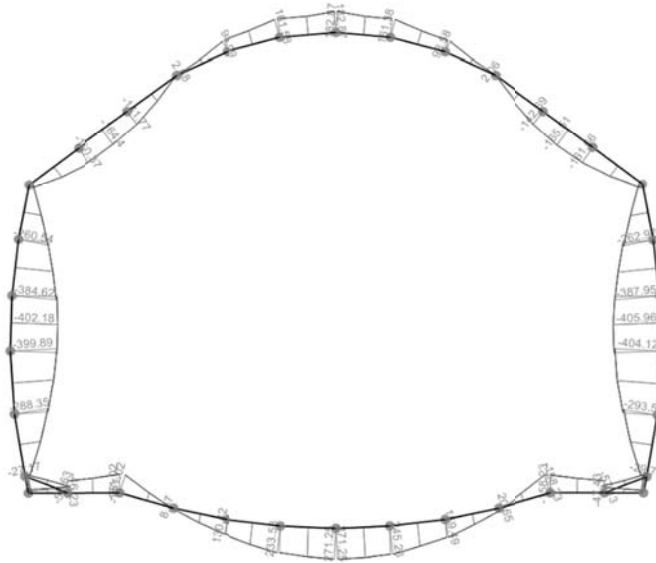

Diagramma dello sforzo di taglio per la combinazione involuppo



Diagramma dello sforzo flettente per la combinazione involuppo

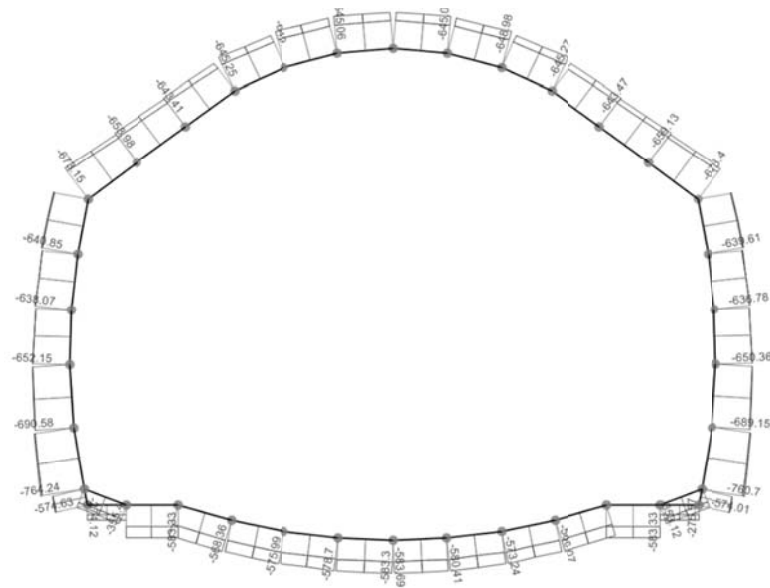

#### 6.4.2 Verifiche

Le verifiche di resistenza sulla galleria sono condotte nelle sezioni significative indicate in figura

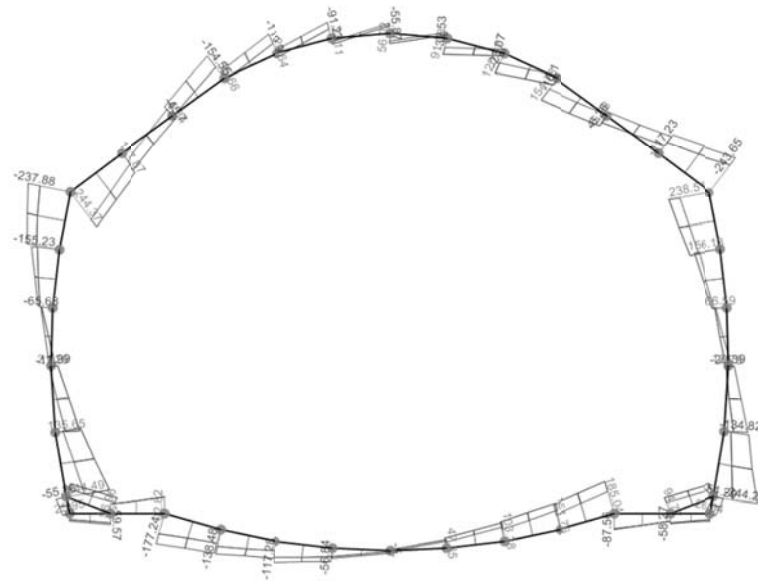
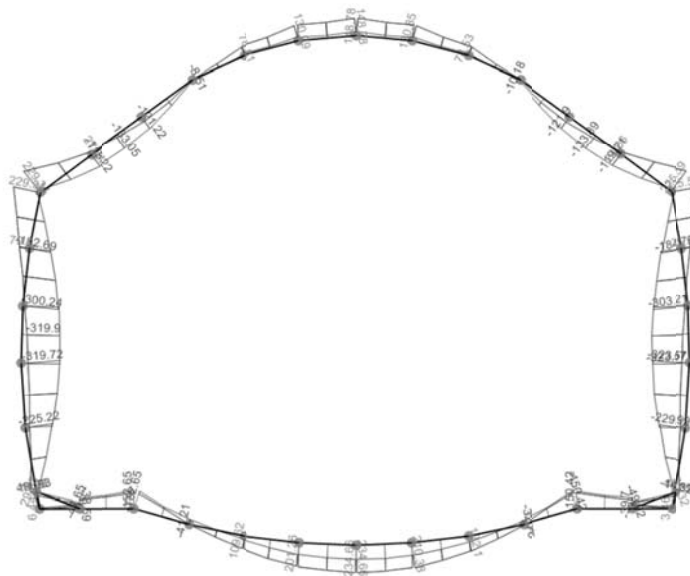
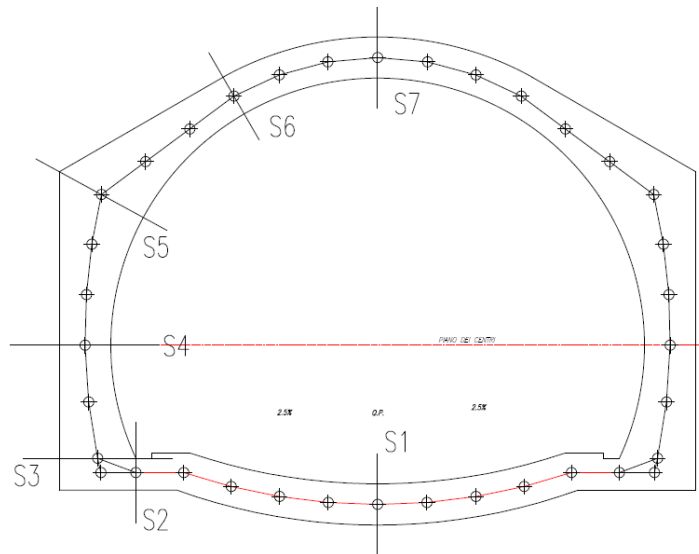

Sezioni di verifica per la galleria artificiale

Nelle tabelle seguenti, per ogni sezione tipo, sono riportate le sollecitazioni associate alla generica condizione di carico.

Sezione S1

TABLE: Element Forces - Frames									
Frame	Station	OutputCase	CaseType	P	V2	V3	T	M2	M3
Text	m	Text	Text	KN	KN	KN	KN-m	KN-m	KN-m
5	0	SLU_ENV E	Combina tion	- 187.998	- 36.024	5.082E -13	- 1.622E- 14	2.479E -13	331.7 447
5	0.48 057	SLU_ENV E	Combina tion	- 188.796	- 16.436	5.082E -13	- 1.622E- 14	9.688E -15	369.2 406
5	0.96 115	SLU_ENV E	Combina tion	- 189.595	13. 457	5.082E -13	- 1.622E- 14	3.682E -14	384.8 162
5	0	SLU_ENV E	Combina tion	- 904.597	- 100.83	6.445E -14	- 1.301E- 13	- 2.513E- 14	33.24 11
5	0.48 057	SLU_ENV E	Combina tion	- 905.869	- 55.217	6.445E -14	- 1.301E- 13	1.207E -15	47.12 59

PROGETTO DEFINITIVO

RELAZIONE DI CALCOLO GALLERIA ARTIFICIALE

5	0.96 115	SLU_ENV E	Combina tion	- 907.141	- 20.664	- 6.445E- 14	- 1.301E- 13	- 2.405E- 13	51.59 71
5	0	SLV_ENV E	Combina tion	- 760.518	- 71.058	- 8.321E- 14	- 1.255E- 13	- 3.108E- 14	343.6 711
5	0.48 057	SLV_ENV E	Combina tion	- 764.953	- 49.114	- 8.465E- 14	- 1.255E- 13	- 9.821E- 15	373.8 378
5	0.96 115	SLV_ENV E	Combina tion	- 769.388	- 25.695	- 8.609E- 14	- 1.255E- 13	- 5.478E- 14	392.4 883
5	0	SLV_ENV E	Combina tion	- 842.769	- 91.092	- 9.296E- 14	- 1.324E- 13	- 3.498E- 14	320.3 807
5	0.48 057	SLV_ENV E	Combina tion	- 844.706	- 67.227	- 9.339E- 14	- 1.324E- 13	- 9.227E- 15	354.3 033
5	0.96 115	SLV_ENV E	Combina tion	- 846.642	- 44.836	- 9.382E- 14	- 1.324E- 13	- 5.027E- 14	372.6 332
5	0	SLE_FR_E NVE	Combina tion	- 648.201	- 68.535	- 1.827E- 13	- 9.151E- 14	- 9.461E- 14	233.5 29
5	0.48 057	SLE_FR_E NVE	Combina tion	- 649.395	- 39.247	- 1.827E- 13	- 9.151E- 14	- 6.813E- 15	259.4 278
5	0.96 115	SLE_FR_E NVE	Combina tion	- 650.588	- 9.96	- 1.827E- 13	- 9.151E- 14	- 8.099E- 14	271.2 516
5	0	SLE_FR_E NVE	Combina tion	- 648.201	- 68.535	- 1.827E- 13	- 9.151E- 14	- 9.461E- 14	233.5 29
5	0.48 057	SLE_FR_E NVE	Combina tion	- 649.395	- 39.247	- 1.827E- 13	- 9.151E- 14	- 6.813E- 15	259.4 278
5	0.96 115	SLE_FR_E NVE	Combina tion	- 650.588	- 9.96	- 1.827E- 13	- 9.151E- 14	- 8.099E- 14	271.2 516
5	0	SLE_QP_E NVE	Combina tion	- 375.306	- 48.228	- 4.166E- 14	- 4.062E- 14	- -1.7E- 14	201.2 579
5	0.48 057	SLE_QP_E NVE	Combina tion	- 376.207	- 26.142	- 4.166E- 14	- 4.062E- 14	- 5.87E- 15	223.2 667
5	0.96 115	SLE_QP_E NVE	Combina tion	- 377.107	- 4.057	- 4.166E- 14	- 4.062E- 14	- 3.681E- 14	234.6 618
5	0	SLE_QP_E	Combina	-	-	-	-	-	98.02

PROGETTO DEFINITIVO

RELAZIONE DI CALCOLO GALLERIA ARTIFICIALE

		NVE	tion	581.502	56.839	6.439E-14	7.885E-14	2.507E-14	23
5	0.48057	SLE_QP_E NVE	Combina tion	- 582.402	- 34.754	6.439E-14	7.885E-14	3.024E-15	115.8924
5	0.96115	SLE_QP_E NVE	Combina tion	- 583.302	- 12.669	6.439E-14	7.885E-14	2.305E-14	123.149
5	0	SLE_C_EN VE	Combina tion	- 372.281	- 56.839	4.142E-14	4.205E-14	1.677E-14	201.2579
5	0.48057	SLE_C_EN VE	Combina tion	- 373.573	- 28.372	4.142E-14	4.205E-14	5.87E-15	223.2667
5	0.96115	SLE_C_EN VE	Combina tion	- 374.864	3.316	4.142E-14	4.205E-14	3.681E-14	234.6618
5	0	SLE_C_EN VE	Combina tion	- 581.502	- 60.061	6.439E-14	7.885E-14	2.507E-14	99.4196
5	0.48057	SLE_C_EN VE	Combina tion	- 582.402	- 34.754	6.439E-14	7.885E-14	3.13E-15	120.669
5	0.96115	SLE_C_EN VE	Combina tion	- 583.302	- 12.669	6.439E-14	7.885E-14	2.304E-14	126.6895
6	0	SLU_ENV E	Combina tion	- 190.002	7.16	5.084E-13	1.764E-14	2.404E-13	384.8162
6	0.48059	SLU_ENV E	Combina tion	- 189.204	38.369	5.084E-13	1.764E-14	1.313E-15	378.2208
6	0.96119	SLU_ENV E	Combina tion	- 188.406	82.146	5.084E-13	1.764E-14	2.496E-14	349.7032
6	0	SLU_ENV E	Combina tion	- 907.691	- 31.22	6.432E-14	1.333E-13	3.686E-14	51.5971
6	0.48059	SLU_ENV E	Combina tion	- 906.419	8.555	6.432E-14	1.333E-13	9.926E-15	51.1196
6	0.96119	SLU_ENV E	Combina tion	- 905.147	28.144	6.432E-14	1.333E-13	2.483E-13	41.0103
6	0	SLV_ENV E	Combina tion	- 770.362	9.025	8.361E-14	1.294E-13	5.031E-14	392.4883
6	0.48059	SLV_ENV E	Combina tion	- 772.84	31.154	8.505E-14	1.294E-13	9.751E-14	386.5337



PROGETTO DEFINITIVO

RELAZIONE DI CALCOLO GALLERIA ARTIFICIALE

						14	13	15	
6	0.96 119	SLV_ENV E	Combina tion	- 775.318	54. 958	8.649E- 14	1.294E- 13	3.484E -14	376.1 871
6	0	SLV_ENV E	Combina tion	- 847.428	- 14.693	9.289E- 14	1.369E- 13	5.486E- 14	372.6 332
6	0.48 059	SLV_ENV E	Combina tion	- 847.565	9.4 55	9.333E- 14	1.369E- 13	1.031E- 14	365.3 908
6	0.96 119	SLV_ENV E	Combina tion	- 847.702	31. 927	9.376E- 14	1.369E- 13	3.144E -14	347.4 663
6	0	SLE_FR_E NVE	Combina tion	- 651.086	- 2.247	1.829E -13	-9.36E- 14	8.092E -14	271.2 516
6	0.48 059	SLE_FR_E NVE	Combina tion	- 649.892	27. 042	1.829E -13	-9.36E- 14	6.968E- 15	265.2 934
6	0.96 119	SLE_FR_E NVE	Combina tion	- 648.698	56. 331	1.829E -13	-9.36E- 14	9.485E- 14	245.2 591
6	0	SLE_FR_E NVE	Combina tion	- 651.086	- 2.247	1.829E -13	-9.36E- 14	8.092E -14	271.2 516
6	0.48 059	SLE_FR_E NVE	Combina tion	- 649.892	27. 042	1.829E -13	-9.36E- 14	6.968E- 15	265.2 934
6	0.96 119	SLE_FR_E NVE	Combina tion	- 648.698	56. 331	1.829E -13	-9.36E- 14	9.485E- 14	245.2 591
6	0	SLE_QP_E NVE	Combina tion	- 377.476	3.1 77	4.153E- 14	4.217E- 14	-2.31E- 14	234.6 618
6	0.48 059	SLE_QP_E NVE	Combina tion	- 376.575	25. 263	4.153E- 14	4.217E- 14	-3.14E- 15	227.8 276
6	0.96 119	SLE_QP_E NVE	Combina tion	- 375.675	47. 35	4.153E- 14	4.217E- 14	2.489E -14	210.3 789
6	0	SLE_QP_E NVE	Combina tion	- 583.689	- 4.996	6.425E- 14	8.047E- 14	3.687E- 14	123.1 49
6	0.48 059	SLE_QP_E NVE	Combina tion	- 582.789	17. 09	6.425E- 14	8.047E- 14	5.991E- 15	120.2 427
6	0.96 119	SLE_QP_E NVE	Combina tion	- 581.888	39. 177	6.425E- 14	8.047E- 14	1.682E -14	106.7 219
6	0	SLE_C_EN VE	Combina tion	- 375.374	3.1 77	4.123E- 14	4.419E- 14	2.311E- 14	234.6 618

PROGETTO DEFINITIVO

RELAZIONE DI CALCOLO GALLERIA ARTIFICIALE

						14	14	14	
6	0.48 059	SLE_C_EN VE	Combina tion	- 374.082	25. 263	4.123E- 14	4.419E- 14	-3.29E- 15	227.8 276
6	0.96 119	SLE_C_EN VE	Combina tion	- 372.791	47. 555	4.123E- 14	4.419E- 14	2.489E -14	210.3 789
6	0	SLE_C_EN VE	Combina tion	- 583.689	- 15.825	6.425E- 14	8.047E- 14	3.687E- 14	126.6 895
6	0.48 059	SLE_C_EN VE	Combina tion	- 582.789	15. 865	6.425E- 14	8.047E- 14	5.991E- 15	126.6 801
6	0.96 119	SLE_C_EN VE	Combina tion	- 581.888	47. 35	6.425E- 14	8.047E- 14	1.653E -14	111.4 406

Sezione S2

TABLE: Element Forces - Frames									
Frame	Station	OutputCase	CaseType	P	V2	V3	T	M2	M3
Text	m	Text	Text	KN	KN	KN	KN-m	KN-m	KN-m
1	0	SLU_ENV E	Combina tion	- 189.41 7	61.6 13	5.309E -13	6.409 E-14	2.479E -13	- 12.8611
1	0.46 685	SLU_ENV E	Combina tion	- 189.41 8	91.9 54	5.309E -13	6.409 E-14	2.765E- 19	- 43.6799
1	0.93 369	SLU_ENV E	Combina tion	- 189.41 8	122. 296	5.309E -13	6.409 E-14	3.113E -14	- 83.3896
1	0	SLU_ENV E	Combina tion	- 907.23	- 22.305	6.668E- 14	1.655 E-14	3.113E- 14	- 147.146 3
1	0.46 685	SLU_ENV E	Combina tion	- 907.23 1	22.0 42	6.668E- 14	1.655 E-14	1.071E- 18	- 171.452 2
1	0.93 369	SLU_ENV E	Combina tion	- 907.23 1	52.7 06	6.668E- 14	1.655 E-14	2.479E- 13	- 217.719 2
1	0	SLV_ENV E	Combina tion	- 735.40 2	44.7 57	8.292E- 14	6.684 E-14	3.916E- 14	- 85.5411
1	0.46 685	SLV_ENV E	Combina tion	- 738.76 3	66.2 29	8.436E- 14	6.684 E-14	3.446E- 17	- 110.526 2

PROGETTO DEFINITIVO

RELAZIONE DI CALCOLO GALLERIA ARTIFICIALE

1	0.93 369	SLV_ENV E	Combina tion	- 742.12 3	87.7 01	-8.58E- 14	6.684 E-14	4.473E -14	145.367 7
1	0	SLV_ENV E	Combina tion	- 836.77 5	21.7 68	9.523E- 14	4.111 E-14	4.459E- 14	164.986 4
1	0.46 685	SLV_ENV E	Combina tion	- 837.78 3	45.1 08	9.566E- 14	4.111 E-14	1.131E- 16	180.596 8
1	0.93 369	SLV_ENV E	Combina tion	- 838.79 1	68.4 47	-9.61E- 14	4.111 E-14	3.961E -14	207.270 9
1	0	SLE_FR_E NVE	Combina tion	- 650.45 5	34.8 83	1.913E -13	4.654 E-14	8.933E -14	101.860 1
1	0.46 685	SLE_FR_E NVE	Combina tion	- 650.45 5	63.3 58	1.913E -13	4.654 E-14	7.777E- 19	124.791 9
1	0.93 369	SLE_FR_E NVE	Combina tion	- 650.45 5	91.8 33	1.913E -13	4.654 E-14	8.933E- 14	- 161.017
1	0	SLE_FR_E NVE	Combina tion	- 650.45 5	34.8 83	1.913E -13	4.654 E-14	8.933E -14	101.860 1
1	0.46 685	SLE_FR_E NVE	Combina tion	- 650.45 5	63.3 58	1.913E -13	4.654 E-14	7.777E- 19	124.791 9
1	0.93 369	SLE_FR_E NVE	Combina tion	- 650.45 5	91.8 33	1.913E -13	4.654 E-14	8.933E- 14	- 161.017
1	0	SLE_QP_E NVE	Combina tion	- 376.95 9	49.8 78	4.304E- 14	4.254 E-14	-2.01E- 14	- 68.5656
1	0.46 685	SLE_QP_E NVE	Combina tion	- 376.96	71.3 5	4.304E- 14	4.254 E-14	6.033E- 19	- 96.8631
1	0.93 369	SLE_QP_E NVE	Combina tion	- 376.96	92.8 22	4.304E- 14	4.254 E-14	3.11E- 14	135.184 8
1	0	SLE_QP_E NVE	Combina tion	- 583.33 4	49.6 57	6.661E- 14	3.611 E-14	-3.11E- 14	- 86.2358
1	0.46 685	SLE_QP_E NVE	Combina tion	- 583.33 5	71.1 3	6.661E- 14	3.611 E-14	7.109E- 19	114.430 3
1	0.93 369	SLE_QP_E NVE	Combina tion	- 583.33 5	92.6 02	6.661E- 14	3.611 E-14	2.009E -14	- 152.649
1	0	SLE_C_EN	Combina tion	-	49.6	-	4.254	-	-

PROGETTO DEFINITIVO

RELAZIONE DI CALCOLO GALLERIA ARTIFICIALE

		VE	ation	374.418	57	4.275E-14	E-14	1.996E-14	77.3588
1	0.46685	SLE_C_ENVE	Combination	374.419	71.13	4.275E-14	4.254E-14	6.188E-19	-98.6609
1	0.93369	SLE_C_ENVE	Combination	374.419	92.602	4.275E-14	4.254E-14	3.11E-14	-134.3461
1	0	SLE_C_ENVE	Combination	583.334	30.225	6.661E-14	3.703E-14	-3.11E-14	-86.2358
1	0.46685	SLE_C_ENVE	Combination	583.335	61.034	6.661E-14	3.703E-14	7.109E-19	-114.4303
1	0.93369	SLE_C_ENVE	Combination	583.335	91.843	6.661E-14	3.703E-14	1.996E-14	-152.649
2	0	SLU_ENV E	Combination	177.592	-61.981	3.721E-13	2.538E-14	1.687E-13	-83.3896
2	0.48058	SLU_ENV E	Combination	183.106	-43.168	3.721E-13	2.538E-14	8.524E-15	-58.123
2	0.96117	SLU_ENV E	Combination	188.62	24.354	3.721E-13	2.538E-14	1.926E-14	20.693
2	0	SLU_ENV E	Combination	864.733	290.544	6.239E-14	1.592E-14	-4.07E-14	217.7192
2	0.48058	SLU_ENV E	Combination	873.518	246.735	6.239E-14	1.592E-14	1.359E-14	-92.6621
2	0.96117	SLU_ENV E	Combination	882.304	215.259	6.239E-14	1.592E-14	1.912E-13	-49.6985
2	0	SLV_ENV E	Combination	705.727	228.645	-7.93E-14	2.51E-14	4.441E-14	145.3677
2	0.48058	SLV_ENV E	Combination	715.805	208.407	8.043E-14	2.51E-14	6.033E-15	-39.8079
2	0.96117	SLV_ENV E	Combination	725.882	186.524	8.155E-14	2.51E-14	3.512E-14	55.1389
2	0	SLV_ENV E	Combination	799.69	255.842	9.009E-14	1.11E-14	5.331E-14	207.2709
2	0.48058	SLV_ENV E	Combination	806.903	233.077	9.042E-14	1.11E-14	1.353E-14	-92.3826

PROGETTO DEFINITIVO

RELAZIONE DI CALCOLO GALLERIA ARTIFICIALE

2	0.96 117	SLV_ENV E	Combina tion	- 814.11 6	- 211.95 7	- 9.076E- 14	1.11E- 14	2.68E- 14	12.77 94
2	0	SLE_FR_E NVE	Combina tion	- 617.92 1	- 204.35 8	- 1.212E- 13	1.917 E-14	4.797E- 14	- 161.017
2	0.48 058	SLE_FR_E NVE	Combina tion	- 626.16 6	- 176.22 8	- 1.212E- 13	1.917 E-14	1.027E- 14	- 69.5651
2	0.96 117	SLE_FR_E NVE	Combina tion	- 634.41	- 148.09 9	- 1.212E- 13	1.917 E-14	-6.85E- 14	8.368 2
2	0	SLE_FR_E NVE	Combina tion	- 617.92 1	- 204.35 8	- 1.212E- 13	1.917 E-14	4.797E- 14	- 161.017
2	0.48 058	SLE_FR_E NVE	Combina tion	- 626.16 6	- 176.22 8	- 1.212E- 13	1.917 E-14	1.027E- 14	- 69.5651
2	0.96 117	SLE_FR_E NVE	Combina tion	- 634.41	- 148.09 9	- 1.212E- 13	1.917 E-14	-6.85E- 14	8.368 2
2	0	SLE_QP_E NVE	Combina tion	- 357.94 2	- 118.98 7	- 4.005E- 14	2.264 E-14	3.137E- 14	- 135.184 8
2	0.48 058	SLE_QP_E NVE	Combina tion	- 364.15 9	- 97.776	- 4.005E- 14	2.264 E-14	1.062E- 14	- 72.5652
2	0.96 117	SLE_QP_E NVE	Combina tion	- 370.37 6	- 76.564	- 4.005E- 14	2.264 E-14	1.935E- 14	- 2.6753
2	0	SLE_QP_E NVE	Combina tion	- 555.92 4	- 177.24 4	- 6.235E- 14	1.983 E-14	4.058E- 14	- 152.649
2	0.48 058	SLE_QP_E NVE	Combina tion	- 562.14 1	- 156.03 3	- 6.235E- 14	1.983 E-14	1.212E- 14	- 83.0983
2	0.96 117	SLE_QP_E NVE	Combina tion	- 568.35 8	- 134.82 1	- 6.235E- 14	1.983 E-14	7.125E- 15	- 41.2058
2	0	SLE_C_EN VE	Combina tion	- 352.29 7	- 129.21 3	- 3.991E- 14	2.189 E-14	-3.09E- 14	134.346 1
2	0.48 058	SLE_C_EN VE	Combina tion	- 361.21 8	- 98.778	- 3.991E- 14	2.189 E-14	1.062E- 14	- 72.5652
2	0.96 117	SLE_C_EN VE	Combina tion	- 370.13 8	- 68.343	- 3.991E- 14	2.189 E-14	1.935E- 14	- 2.6753
2	0	SLE_C_EN	Combina	-	-	-	1.983	-	-

PROGETTO DEFINITIVO

RELAZIONE DI CALCOLO GALLERIA ARTIFICIALE

		VE	ation	555.92 4	177.24 4	6.235E- 14	E-14	4.058E- 14	152.649
2	0.48 058	SLE_C_EN VE	Combinat ation	562.14 1	156.03 3	6.235E- 14	1.983 E-14	1.172E- 14	- 79.5617
2	0.96 117	SLE_C_EN VE	Combinat ation	568.35 8	134.82 1	6.235E- 14	1.983 E-14	7.459E -15	- 39.404

Sezione S4

TABLE: Element Forces - Frames									
Frame	Station	OutputCase	CaseType	P	V2	V3	T	M2	M3
Text	m	Text	Text	KN	KN	KN	KN-m	KN-m	KN-m
12	0	SLU_ENVE	Combinat ion	- 351.581	213.1 51	1.119E- 12	2.963E- 14	6.795E- 13	102.52 33
12	0.55 396	SLU_ENVE	Combinat ion	- 336.728	147.0 68	7.516E- 13	2.963E- 14	6.088E- 13	95.398 3
12	1.10 792	SLU_ENVE	Combinat ion	- 322.566	84.68 2	4.048E- 13	2.963E- 14	6.7E-13	106.35 05
12	0	SLU_ENVE	Combinat ion	- 900.003	- 1.987	- 4.121E-13	- 1.584E-13	- 2.989E-12	- 431.3922
12	0.55 396	SLU_ENVE	Combinat ion	- 876.393	- 3.768	- 4.442E-13	- 1.584E-13	- -3.41E- 12	- 528.8817
12	1.10 792	SLU_ENVE	Combinat ion	- 853.921	- 35.46	- 7.448E-13	- 1.584E-13	- 3.575E-12	- 590.7879
12	0	SLV_ENVE	Combinat ion	- 670.656	307.0 66	2.417E- 12	- 1.623E-13	- 2.599E-12	- 432.5903
12	0.55 396	SLV_ENVE	Combinat ion	- 654.296	207.3 34	1.703E- 12	- 1.623E-13	- 3.456E-12	- 536.9054
12	1.10 792	SLV_ENVE	Combinat ion	- 638.643	154.5 68	1.298E- 12	- 1.623E-13	- 4.221E-12	- 628.7346
12	0	SLV_ENVE	Combinat ion	- 694.643	199.1 38	1.628E- 12	- 1.915E-13	- 2.986E-12	- 498.148
12	0.55 396	SLV_ENVE	Combinat ion	- 674.162	176.4 96	1.461E- 12	- 1.915E-13	- 4.126E-12	- 640.2461
12	1.10 792	SLV_ENVE	Combinat ion	- 655.613	109.2 24	1.002E- 12	- 1.915E-13	- 4.873E-12	- 727.6868
12	0	SLE_FR_ENV E	Combinat ion	- 691.594	151.0 35	9.096E- 13	-1.07E- 13	- 1.905E-12	- 288.3525
12	0.55 396	SLE_FR_ENV E	Combinat ion	- 673.433	100.2 02	5.423E- 13	-1.07E- 13	- 2.307E-12	- 357.8085
12	1.10 792	SLE_FR_ENV E	Combinat ion	- 656.147	52.21 3	1.955E- 13	-1.07E- 13	-2.51E- 12	- 399.8928
12	0	SLE_FR_ENV E	Combinat ion	- 691.594	151.0 35	9.096E- 13	-1.07E- 13	- 1.905E-12	- 288.3525
12	0.55 396	SLE_FR_ENV E	Combinat ion	- 673.433	100.2 02	5.423E- 13	-1.07E- 13	- 2.307E-12	- 357.8085
12	1.10 792	SLE_FR_ENV E	Combinat ion	- 656.147	52.21 3	1.955E- 13	-1.07E- 13	-2.51E- 12	- 399.8928
12	0	SLE_QP_EN	Combinat	-	135.6	1.115E-	-	-1.53E-	-

PROGETTO DEFINITIVO

RELAZIONE DI CALCOLO GALLERIA ARTIFICIALE

		VE	ion	685.535	49	12	1.525E-14	13	33.0748
12	0.55 396	SLE_QP_EN VE	Combinat ion	- 668.477	84.81 5	7.481E- 13	- 1.525E-14	- 3.446E-13	- 53.2001
12	1.10 792	SLE_QP_EN VE	Combinat ion	- 652.232	36.82 6	4.013E- 13	- 1.525E-14	- 4.043E-13	- 55.2482
12	0	SLE_QP_EN VE	Combinat ion	- 690.579	53.27 4	4.694E- 13	- 8.537E-14	- 1.328E-12	- 225.224
12	0.55 396	SLE_QP_EN VE	Combinat ion	- 672.418	- 19.7	2.246E- 13	- 8.537E-14	- 1.843E-12	- 286.1567
12	1.10 792	SLE_QP_EN VE	Combinat ion	- 655.132	- 11.992	- 6.627E-15	- 8.537E-14	- 2.161E-12	- 319.7177
12	0	SLE_C_ENV E	Combinat ion	- 685.499	135.6 49	1.115E- 12	- 1.887E-14	- 2.376E-13	- 46.5757
12	0.55 396	SLE_C_ENV E	Combinat ion	- 668.44	84.81 5	7.481E- 13	- 1.887E-14	- 4.217E-13	- 65.2924
12	1.10 792	SLE_C_ENV E	Combinat ion	- 652.196	36.82 6	4.013E- 13	- 1.887E-14	- 4.739E-13	- 65.9319
12	0	SLE_C_ENV E	Combinat ion	- 690.579	50.73 1	4.559E- 13	- 8.537E-14	- 1.328E-12	- 225.224
12	0.55 396	SLE_C_ENV E	Combinat ion	- 672.418	17.15 7	2.111E- 13	- 8.537E-14	- 1.843E-12	- 286.1567
12	1.10 792	SLE_C_ENV E	Combinat ion	- 655.132	- 14.534	- 2.013E-14	- 8.537E-14	- 2.161E-12	- 319.7177
13	0	SLU_ENVE	Combinat ion	- 322.463	40.36 3	4.097E- 13	3.934E- 14	1.091E- 11	106.35 05
13	0.49 289	SLU_ENVE	Combinat ion	- 309.841	- 12.394	7.591E- 13	3.934E- 14	1.112E- 11	114.87 54
13	0.98 577	SLU_ENVE	Combinat ion	- 296.602	- 12.816	1.558E- 12	3.934E- 14	1.08E- 11	136.68 46
13	0	SLU_ENVE	Combinat ion	- 846.331	- 18.327	- 1.069E-12	- -2E-13	- 1.977E-12	- 590.7879
13	0.49 289	SLU_ENVE	Combinat ion	- 831.232	- 32.309	- 4.228E-13	- -2E-13	- -2.13E- 12	- 595.41
13	0.98 577	SLU_ENVE	Combinat ion	- 815.257	- 68.138	- 4.228E-13	- -2E-13	- 2.554E-12	- 574.2301
13	0	SLV_ENVE	Combinat ion	- 625.598	120.8 39	9.814E-13	2.239E-13	1.388E- 11	- 628.7346
13	0.49 289	SLV_ENVE	Combinat ion	- 613.485	64.00 9	2.283E- 13	2.239E-13	1.428E- 11	- 665.4971
13	0.98 577	SLV_ENVE	Combinat ion	- 600.762	42.65 9	1.833E- 12	2.239E-13	1.38E- 11	- 691.7944
13	0	SLV_ENVE	Combinat ion	- 644.7	84.52 2	-1.7E- 12	2.562E-13	1.199E- 11	- 727.6868
13	0.49 289	SLV_ENVE	Combinat ion	- 633.516	25.46 7	- 6.048E-13	2.562E-13	1.239E- 11	- 765.6324
13	0.98 577	SLV_ENVE	Combinat ion	- 621.662	- 51.285	- 1.719E-13	2.562E-13	1.258E- 11	- 761.2843
13	0	SLE_FR_ENV E	Combinat ion	- 651.053	25.54 6	4.848E-13	-1.35E- 13	7.483E- 12	- 399.8928
13	0.49 289	SLE_FR_ENV E	Combinat ion	- 639.437	- 15.884	3.619E- 13	-1.35E- 13	7.511E- 12	- 402.1784
13	0.98 577	SLE_FR_ENV E	Combinat ion	- 627.149	- 54.99	1.16E- 12	-1.35E- 13	7.134E- 12	- 384.6164
13	0	SLE_FR_ENV	Combinat	-	25.54	-	-1.35E-	7.483E-	-

PROGETTO DEFINITIVO

RELAZIONE DI CALCOLO GALLERIA ARTIFICIALE

		E	ion	651.053	6	4.848E-13	13	12	399.8928
13	0.49 289	SLE_FR_ENV E	Combinat ion	- 639.437	- 15.884	3.619E- 13	-1.35E- 13	7.511E- 12	- 402.1784
13	0.98 577	SLE_FR_ENV E	Combinat ion	- 627.149	- 54.99	1.16E- 12	-1.35E- 13	7.134E- 12	- 384.6164
13	0	SLE_QP_EN VE	Combinat ion	- 651.125	21.28 7	3.492E- 13	- 1.394E-14	6.15E- 12	- 55.2482
13	0.49 289	SLE_QP_EN VE	Combinat ion	- 639.509	- 20.144	9.137E- 13	- 1.394E-14	5.975E- 12	- 42.5488
13	0.98 577	SLE_QP_EN VE	Combinat ion	- 627.221	- 59.249	1.573E- 12	- 1.394E-14	5.394E- 12	- 16.5652
13	0	SLE_QP_EN VE	Combinat ion	- 652.154	- 11.775	- 7.212E-14	- 1.072E-13	1.12E- 12	- 319.7177
13	0.49 289	SLE_QP_EN VE	Combinat ion	- 640.203	- 39.499	7.746E- 13	- 1.072E-13	8.073E- 13	- 319.904
13	0.98 577	SLE_QP_EN VE	Combinat ion	- 627.598	- 65.678	1.446E- 12	- 1.072E-13	2.244E- 13	- 300.2426
13	0	SLE_C_ENV E	Combinat ion	- 651.125	21.28 7	4.088E- 13	- 1.715E-14	6.15E- 12	- 65.9319
13	0.49 289	SLE_C_ENV E	Combinat ion	- 639.509	- 20.144	9.733E- 13	- 1.715E-14	5.975E- 12	- 51.9828
13	0.98 577	SLE_C_ENV E	Combinat ion	- 627.221	- 59.249	1.573E- 12	- 1.715E-14	5.394E- 12	- 24.7494
13	0	SLE_C_ENV E	Combinat ion	- 652.341	- 14.31	- 7.212E-14	- 1.072E-13	1.326E- 12	- 319.7177
13	0.49 289	SLE_C_ENV E	Combinat ion	- 640.39	- 42.034	7.746E- 13	- 1.072E-13	9.839E- 13	- 319.904
13	0.98 577	SLE_C_ENV E	Combinat ion	- 627.785	- 68.214	1.506E- 12	- 1.072E-13	3.716E- 13	- 300.2426
14	0	SLU_ENVE	Combinat ion	- 302.382	- 30.28	4.913E- 13	4.439E- 14	1.486E- 12	136.68 46
14	0.49 289	SLU_ENVE	Combinat ion	- 288.144	- 44.198	6.588E- 13	4.439E- 14	1.557E- 12	158.00 01
14	0.98 577	SLU_ENVE	Combinat ion	- 272.376	- 45.902	8.154E- 13	4.439E- 14	1.523E- 12	191.64 18
14	0	SLU_ENVE	Combinat ion	- 831.16	- 121.065	- 7.223E-13	-1.43E- 13	- 4.058E-13	- 574.2301
14	0.49 289	SLU_ENVE	Combinat ion	- 817.743	- 170.178	- 6.352E-13	-1.43E- 13	- 4.729E-13	- 502.3398
14	0.98 577	SLU_ENVE	Combinat ion	- 802.008	- 216.479	- 6.355E-13	-1.43E- 13	- 6.252E-13	- 406.9351
14	0	SLV_ENVE	Combinat ion	- 609.845	- 43.648	6.034E- 13	-1.88E- 13	2.522E- 12	- 691.7944
14	0.49 289	SLV_ENVE	Combinat ion	- 597.802	- 65.491	8.571E- 13	-1.88E- 13	2.189E- 12	- 664.8455
14	0.98 577	SLV_ENVE	Combinat ion	- 584.073	- 86.067	1.191E- 12	-1.88E- 13	1.725E- 12	- 599.4518
14	0	SLV_ENVE	Combinat ion	- 632.703	- 77.561	4.686E- 13	- 2.021E-13	2.275E- 12	- 761.2843
14	0.49 289	SLV_ENVE	Combinat ion	- 624.188	- 132.057	5.623E- 13	- 2.021E-13	2.021E- 12	- 716.1821
14	0.98 577	SLV_ENVE	Combinat ion	- 614.193	- 205.574	6.494E- 13	- 2.021E-13	1.593E- 12	- 632.7825
14	0	SLE_FR_ENV	Combinat	-	-	8.057E-	-9.45E-	1.107E-	-



PROGETTO DEFINITIVO

RELAZIONE DI CALCOLO GALLERIA ARTIFICIALE

		E	ion	638.814	88.453	14	14	12	384.6164
14	0.49 289	SLE_FR_ENV E	Combinat ion	- 628.493	- 126.232	2.48E- 13	-9.45E- 14	1.026E- 12	- 331.62
14	0.98 577	SLE_FR_ENV E	Combinat ion	- 616.389	- 161.848	4.047E- 13	-9.45E- 14	8.644E- 13	- 260.5356
14	0	SLE_FR_ENV E	Combinat ion	- 638.814	- 88.453	8.057E- 14	-9.45E- 14	1.107E- 12	- 384.6164
14	0.49 289	SLE_FR_ENV E	Combinat ion	- 628.493	- 126.232	2.48E- 13	-9.45E- 14	1.026E- 12	- 331.62
14	0.98 577	SLE_FR_ENV E	Combinat ion	- 616.389	- 161.848	4.047E- 13	-9.45E- 14	8.644E- 13	- 260.5356
14	0	SLE_QP_EN VE	Combinat ion	- 637.268	- 72.41	4.946E- 13	6.408E- 15	1.057E- 12	- 16.5652
14	0.49 289	SLE_QP_EN VE	Combinat ion	- 625.642	- 98.111	6.621E- 13	6.408E- 15	7.715E- 13	25.515 4
14	0.98 577	SLE_QP_EN VE	Combinat ion	- 612.317	- 122.426	8.188E- 13	6.408E- 15	4.061E- 13	79.922 1
14	0	SLE_QP_EN VE	Combinat ion	- 638.066	- 81.832	3.734E- 13	- 7.151E-14	1.437E- 13	- 300.2426
14	0.49 289	SLE_QP_EN VE	Combinat ion	- 627.745	- 119.611	4.85E- 13	- 7.151E-14	- 6.818E-14	- 250.5092
14	0.98 577	SLE_QP_EN VE	Combinat ion	- 615.641	- 155.228	5.894E- 13	- 7.151E-14	- 3.332E-13	- 182.6878
14	0	SLE_C_ENV E	Combinat ion	- 637.666	- 74.921	4.946E- 13	4.412E- 15	1.057E- 12	- 24.7494
14	0.49 289	SLE_C_ENV E	Combinat ion	- 626.039	- 100.621	6.621E- 13	4.412E- 15	7.715E- 13	18.568 7
14	0.98 577	SLE_C_ENV E	Combinat ion	- 612.714	- 124.937	8.188E- 13	4.412E- 15	4.061E- 13	74.213
14	0	SLE_C_ENV E	Combinat ion	- 638.066	- 81.832	3.862E- 13	- 7.151E-14	1.712E- 13	- 300.2426
14	0.49 289	SLE_C_ENV E	Combinat ion	- 627.745	- 119.611	4.978E- 13	- 7.151E-14	- 4.692E-14	- 250.5092
14	0.98 577	SLE_C_ENV E	Combinat ion	- 615.641	- 155.228	6.022E- 13	- 7.151E-14	- 3.183E-13	- 182.6878

Sezione S5

TABLE: Element Forces - Frames									
Frame	Station	OutputCase	CaseType	P	V2	V3	T	M2	M3
Text	m	Text	Text	KN	KN	KN	KN-m	KN-m	KN-m
15	0	SLU_ENVE	Combinat ion	- 284.835	- 51.783	4.672E- 13	4.339E- 14	3.37E- 13	191.64 18
15	0.49 289	SLU_ENVE	Combinat ion	- 266.995	- 74.69	5.428E- 13	4.339E- 14	2.955E- 13	222.95 89
15	0.98 577	SLU_ENVE	Combinat ion	- 246.131	- 80.241	6.018E- 13	4.339E- 14	5.414E- 13	264.67 44
15	0	SLU_ENVE	Combinat ion	- 840.538	- 269.883	- 1.032E-12	- 5.617E-14	- 5.949E-13	- 406.9351
15	0.49 289	SLU_ENVE	Combinat ion	- 824.674	- 312.308	- 9.821E-13	- 5.617E-14	- 2.138E-13	- 263.1522

PROGETTO DEFINITIVO

RELAZIONE DI CALCOLO GALLERIA ARTIFICIALE

15	0.98 577	SLU_ENVE	Combinat ion	- 803.297	- 347.295	- 9.828E-13	- 5.617E-14	- 3.196E-13	- 100.2915
15	0	SLV_ENVE	Combinat ion	- 617.819	- 185.429	- 6.388E-13	- 9.724E-14	- 8.332E-13	- 599.4518
15	0.49 289	SLV_ENVE	Combinat ion	- 603.351	- 206.333	- 7.48E-13	- 9.724E-14	- 5.176E-13	- 473.4312
15	0.98 577	SLV_ENVE	Combinat ion	- 585.677	- 226.879	- 8.766E-13	- 9.724E-14	- 2.112E-13	- 326.7664
15	0	SLV_ENVE	Combinat ion	- 646.394	- 232.754	- 5.541E-13	- 1.081E-13	- 8.01E-13	- 632.7825
15	0.49 289	SLV_ENVE	Combinat ion	- 636.695	- 278.352	- 5.991E-13	- 1.081E-13	- 4.653E-13	- 531.779
15	0.98 577	SLV_ENVE	Combinat ion	- 622.752	- 328.63	- 6.416E-13	- 1.081E-13	- 7.454E-14	- 424.7584
15	0	SLE_FR_ENV E	Combinat ion	- 644.241	- 195.74	- 9.099E-14	- 3.379E-14	- 1.46E-13	- 260.5356
15	0.49 289	SLE_FR_ENV E	Combinat ion	- 632.039	- 228.374	- 1.547E-14	- 3.379E-14	- 1.715E-13	- 155.7804
15	0.98 577	SLE_FR_ENV E	Combinat ion	- 615.594	- 255.287	- 4.357E-14	- 3.379E-14	- 1.639E-13	- -36.35
15	0	SLE_FR_ENV E	Combinat ion	- 644.241	- 195.74	- 9.099E-14	- 3.379E-14	- 1.46E-13	- 260.5356
15	0.49 289	SLE_FR_ENV E	Combinat ion	- 632.039	- 228.374	- 1.547E-14	- 3.379E-14	- 1.715E-13	- 155.7804
15	0.98 577	SLE_FR_ENV E	Combinat ion	- 615.594	- 255.287	- 4.357E-14	- 3.379E-14	- 1.639E-13	- -36.35
15	0	SLE_QP_EN VE	Combinat ion	- 631.594	- 129.273	- 4.688E-13	- 2.766E-14	- 3.389E-13	- 79.9221
15	0.49 289	SLE_QP_EN VE	Combinat ion	- 617.513	- 152.181	- 5.443E-13	- 2.766E-14	- 8.858E-14	- 149.4334
15	0.98 577	SLE_QP_EN VE	Combinat ion	- 599.595	- 171.467	- 6.034E-13	- 2.766E-14	- 1.949E-13	- 229.343
15	0	SLE_QP_EN VE	Combinat ion	- 640.846	- 178.33	- 3.315E-13	- 1.981E-14	- 3.462E-14	- 182.6878
15	0.49 289	SLE_QP_EN VE	Combinat ion	- 628.643	- 210.965	- 3.817E-13	- 1.981E-14	- 1.416E-13	- 86.5136
15	0.98 577	SLE_QP_EN VE	Combinat ion	- 612.199	- 237.878	- 4.209E-13	- 1.981E-14	- 3.399E-13	- 24.3358
15	0	SLE_C_ENV E	Combinat ion	- 632.199	- 131.742	- 4.688E-13	- 2.673E-14	- 3.389E-13	- 74.213
15	0.49 289	SLE_C_ENV E	Combinat ion	- 618.118	- 154.649	- 5.443E-13	- 2.673E-14	- 8.858E-14	- 144.9411
15	0.98 577	SLE_C_ENV E	Combinat ion	- 600.2	- 173.935	- 6.034E-13	- 2.673E-14	- 1.949E-13	- 226.0675
15	0	SLE_C_ENV E	Combinat ion	- 640.846	- 178.33	- 3.376E-13	- 1.981E-14	- 4.197E-14	- 182.6878
15	0.49 289	SLE_C_ENV E	Combinat ion	- 628.643	- 210.965	- 3.878E-13	- 1.981E-14	- 1.372E-13	- 86.5136
15	0.98 577	SLE_C_ENV E	Combinat ion	- 612.199	- 237.878	- 4.27E-13	- 1.981E-14	- 3.385E-13	- 24.3358
16	0	SLU_ENVE	Combinat ion	- 277.602	- 313.019	- 5.624E-14	- 3.156E-14	- 4.577E-14	- 264.6744
16	0.53 604	SLU_ENVE	Combinat ion	- 264.033	- 239.096	- 6.455E-14	- 3.156E-14	- 1.324E-14	- 136.1698

PROGETTO DEFINITIVO

RELAZIONE DI CALCOLO GALLERIA ARTIFICIALE

16	1.07 208	SLU_ENVE	Combinat ion	- 252.857	170.1 37	6.942E- 14	3.156E- 14	7.618E- 13	72.020 9
16	0	SLU_ENVE	Combinat ion	- 925.978	60.69 4	-1.54E- 12	5.261E-14	8.853E-13	- 100.2915
16	0.53 604	SLU_ENVE	Combinat ion	- 898.783	36.91 6	- 1.536E-12	5.261E-14	-6.09E- 14	- 193.09
16	1.07 208	SLU_ENVE	Combinat ion	- 868.186	17.33 4	- 1.534E-12	5.261E-14	- 2.799E-14	- 245.2555
16	0	SLV_ENVE	Combinat ion	- 718.378	147.1 14	7.544E- 14	9.816E-14	1.147E- 13	- 326.7664
16	0.53 604	SLV_ENVE	Combinat ion	- 707.861	61.06 9	9.552E- 14	9.816E-14	7.518E- 14	- 373.504
16	1.07 208	SLV_ENVE	Combinat ion	- 697.553	- 4.652	1.292E- 13	9.816E-14	2.63E- 14	- 383.9791
16	0	SLV_ENVE	Combinat ion	- 759.944	122.4 2	4.688E- 14	1.253E-13	1.058E- 13	- 424.7584
16	0.53 604	SLV_ENVE	Combinat ion	- 751.788	52.24	8.246E- 14	1.253E-13	6.037E- 14	- 475.5615
16	1.07 208	SLV_ENVE	Combinat ion	- 754.152	- 25.341	9.952E- 14	1.253E-13	4.702E- 15	- 490.4099
16	0	SLE_FR_ENV E	Combinat ion	- 696.501	175.5 96	- 6.577E-13	3.168E-14	- 3.544E-13	- -36.35
16	0.53 604	SLE_FR_ENV E	Combinat ion	- 675.582	114.8 84	- 6.494E-13	3.168E-14	- 4.224E-15	- 113.9896
16	1.07 208	SLE_FR_ENV E	Combinat ion	- 652.046	58.97 7	- 6.446E-13	3.168E-14	3.424E- 13	- 160.3732
16	0	SLE_FR_ENV E	Combinat ion	- 696.501	175.5 96	- 6.577E-13	3.168E-14	3.544E-13	- -36.35
16	0.53 604	SLE_FR_ENV E	Combinat ion	- 675.582	114.8 84	- 6.494E-13	3.168E-14	4.224E-15	- 113.9896
16	1.07 208	SLE_FR_ENV E	Combinat ion	- 652.046	58.97 7	- 6.446E-13	3.168E-14	3.424E- 13	- 160.3732
16	0	SLE_QP_EN VE	Combinat ion	- 604.109	244.3 72	5.642E- 14	2.631E- 14	4.596E- 14	229.34 3
16	0.53 604	SLE_QP_EN VE	Combinat ion	- 578.004	187.5 09	6.473E- 14	2.631E- 14	1.334E- 14	113.76 13
16	1.07 208	SLE_QP_EN VE	Combinat ion	- 550.609	134.4 63	6.96E- 14	2.631E- 14	- 2.282E-14	27.637 2
16	0	SLE_QP_EN VE	Combinat ion	- 673.146	192.8 82	3.767E- 14	1.859E-14	8.039E- 15	24.335 8
16	0.53 604	SLE_QP_EN VE	Combinat ion	- 652.226	132.1 71	4.12E- 14	1.859E-14	-1.32E- 14	- 62.5703
16	1.07 208	SLE_QP_EN VE	Combinat ion	- 628.69	76.26 4	4.251E- 14	1.859E-14	- 3.574E-14	- 118.2203
16	0	SLE_C_ENV E	Combinat ion	- 606.223	242.9 6	5.642E- 14	2.568E- 14	4.596E- 14	226.06 75
16	0.53 604	SLE_C_ENV E	Combinat ion	- 580.117	186.0 97	6.473E- 14	2.568E- 14	1.334E- 14	111.24 24
16	1.07 208	SLE_C_ENV E	Combinat ion	- 552.723	133.0 52	6.96E- 14	2.568E- 14	- 2.282E-14	25.875
16	0	SLE_C_ENV E	Combinat ion	- 673.146	192.8 82	3.836E- 14	1.859E-14	8.789E- 15	24.335 8
16	0.53 604	SLE_C_ENV E	Combinat ion	- 652.226	132.1 71	4.19E- 14	1.859E-14	- 1.282E-14	- 62.5703

**PROGETTO DEFINITIVO**

**RELAZIONE DI CALCOLO GALLERIA ARTIFICIALE**

16	1.07 208	SLE_C_ENV E	Combinat ion	- 628.69	76.26 4	4.321E- 14	- 1.859E-14	- 3.573E-14	- 118.2203
----	-------------	----------------	-----------------	-------------	------------	---------------	----------------	----------------	---------------

**Sezione S6**

TABLE: Element Forces - Frames									
Frame	Station	OutputCase	CaseType	P	V2	V3	T	M2	M3
Text	m	Text	Text	KN	KN	KN	KN-m	KN-m	KN-m
17	0	SLU_ENVE	Combinat ion	- 274.173	161.0 47	9.38E- 14	2.494E- 14	9.193E- 14	72.020 9
17	0.53 604	SLU_ENVE	Combinat ion	- 264.794	107.0 22	9.691E- 14	2.494E- 14	4.564E- 14	61.091 2
17	1.07 208	SLU_ENVE	Combinat ion	- 256.612	61.33 8	9.996E- 14	2.494E- 14	5.786E- 13	56.505 7
17	0	SLU_ENVE	Combinat ion	- 915.909	9.414	1.067E-12	9.465E-14	5.886E-13	245.2555
17	0.53 604	SLU_ENVE	Combinat ion	- 884.907	41.02	1.066E-12	9.465E-14	3.035E-14	241.0363
17	1.07 208	SLU_ENVE	Combinat ion	- 856.497	103.24	1.066E-12	9.465E-14	-3.88E- 14	202.1535
17	0	SLV_ENVE	Combinat ion	- 768.271	40.648	1.341E- 13	1.346E-13	2.063E- 13	383.9791
17	0.53 604	SLV_ENVE	Combinat ion	- 758.591	106.146	1.527E- 13	1.346E-13	1.324E- 13	343.0438
17	1.07 208	SLV_ENVE	Combinat ion	- 749.961	161.919	1.858E- 13	1.346E-13	5.005E- 14	270.9944
17	0	SLV_ENVE	Combinat ion	- 785.464	-57.4	1.163E- 13	1.748E-13	1.785E- 13	490.4099
17	0.53 604	SLV_ENVE	Combinat ion	- 787.258	119.535	1.458E- 13	1.748E-13	1.029E- 13	442.7886
17	1.07 208	SLV_ENVE	Combinat ion	- 798.013	191.273	1.607E- 13	1.748E-13	2.012E- 14	363.0565
17	0	SLE_FR_ENV E	Combinat ion	- 686.188	33.64 7	4.112E-13	6.464E-14	1.822E-13	160.3732
17	0.53 604	SLE_FR_ENV E	Combinat ion	- 662.34	17.978	4.081E-13	6.464E-14	3.74E- 14	164.4048
17	1.07 208	SLE_FR_ENV E	Combinat ion	- 640.486	65.839	4.051E-13	6.464E-14	2.553E- 13	141.7722
17	0	SLE_FR_ENV E	Combinat ion	- 686.188	33.64 7	4.112E-13	6.464E-14	1.822E-13	160.3732
17	0.53 604	SLE_FR_ENV E	Combinat ion	- 662.34	17.978	4.081E-13	6.464E-14	3.74E- 14	164.4048
17	1.07 208	SLE_FR_ENV E	Combinat ion	- 640.486	65.839	4.051E-13	6.464E-14	2.553E- 13	141.7722
17	0	SLE_QP_EN VE	Combinat ion	- 572.972	117.8 73	9.4E-14	9.279E-15	9.211E- 14	27.637 2
17	0.53 604	SLE_QP_EN VE	Combinat ion	- 546.016	68.55 4	9.712E- 14	9.279E-15	4.088E- 14	22.1663
17	1.07 208	SLE_QP_EN VE	Combinat ion	- 521.226	22.87	1.002E- 13	9.279E-15	1.199E-14	46.5074
17	0	SLE_QP_EN VE	Combinat ion	- 658.981	53.79 1	6.423E- 14	5.245E-14	4.286E- 14	118.2203
17	0.53 604	SLE_QP_EN VE	Combinat ion	- 635.133	2.166	6.448E- 14	5.245E-14	8.369E- 15	133.0499

PROGETTO DEFINITIVO

RELAZIONE DI CALCOLO GALLERIA ARTIFICIALE

17	1.07 208	SLE_QP_EN VE	Combinat ion	- 613.28	- 45.695	6.483E- 14	- 5.245E-14	- 2.628E-14	- 121.2152
17	0	SLE_C_ENV E	Combinat ion	- 575.085	116.4 61	9.4E-14	9.647E-15	9.211E- 14	25.875
17	0.53 604	SLE_C_ENV E	Combinat ion	- 548.129	67.14 2	9.712E- 14	9.647E-15	4.088E- 14	- 23.172
17	1.07 208	SLE_C_ENV E	Combinat ion	- 523.34	21.45 9	1.002E- 13	9.647E-15	- 1.199E-14	- 46.7564
17	0	SLE_C_ENV E	Combinat ion	- 658.981	53.79 1	6.501E- 14	5.245E-14	4.357E- 14	- 118.2203
17	0.53 604	SLE_C_ENV E	Combinat ion	- 635.133	2.166	6.526E- 14	5.245E-14	8.657E- 15	- 133.0499
17	1.07 208	SLE_C_ENV E	Combinat ion	- 613.28	45.695	6.561E- 14	5.245E-14	- 2.642E-14	- 121.2152
18	0	SLU_ENVE	Combinat ion	- 278.213	60.35 6	1.401E- 13	3.737E- 14	1.082E- 13	56.505 7
18	0.53 604	SLU_ENVE	Combinat ion	- 270.93	17.67 7	1.425E- 13	3.737E- 14	5.437E- 14	67.750 2
18	1.07 208	SLU_ENVE	Combinat ion	- 264.245	- 22.629	1.439E- 13	3.737E- 14	4.88E- 13	113.26 12
18	0	SLU_ENVE	Combinat ion	- 902.647	- 137.478	- 8.086E-13	- 7.304E-14	- 4.694E-13	- 202.1535
18	0.53 604	SLU_ENVE	Combinat ion	- 875.398	- 195.478	- 8.086E-13	- 7.304E-14	- 4.642E-14	- 147.683
18	1.07 208	SLU_ENVE	Combinat ion	- 847.88	- 249.93	- 8.094E-13	- 7.304E-14	-6.09E- 14	- 120.4268
18	0	SLV_ENVE	Combinat ion	- 807.986	- 196.244	2.225E- 13	6.999E-14	2.249E- 13	- 270.9944
18	0.53 604	SLV_ENVE	Combinat ion	- 796.614	- 247.973	2.368E- 13	6.999E-14	1.018E- 13	- 151.6759
18	1.07 208	SLV_ENVE	Combinat ion	- 783.933	- 296.155	2.604E- 13	6.999E-14	- 2.859E-14	- 5.5296
18	0	SLV_ENVE	Combinat ion	- 825.765	- 233.132	2.052E- 13	-1.06E- 13	1.839E- 13	- 363.0565
18	0.53 604	SLV_ENVE	Combinat ion	- 827.071	- 287.259	2.21E- 13	-1.06E- 13	6.833E- 14	- 223.566
18	1.07 208	SLV_ENVE	Combinat ion	- 832.065	- 338.757	2.302E- 13	-1.06E- 13	- 5.328E-14	- 55.8157
18	0	SLE_FR_ENV E	Combinat ion	- 673.84	- 90.584	- 2.576E-13	- 3.661E-14	- 1.076E-13	- 141.7722
18	0.53 604	SLE_FR_ENV E	Combinat ion	- 652.879	- 135.2	- 2.551E-13	- 3.661E-14	2.974E- 14	- 81.1359
18	1.07 208	SLE_FR_ENV E	Combinat ion	- 631.711	- 177.085	- 2.538E-13	- 3.661E-14	1.661E- 13	- 2.6844
18	0	SLE_FR_ENV E	Combinat ion	- 673.84	- 90.584	- 2.576E-13	- 3.661E-14	- 1.076E-13	- 141.7722
18	0.53 604	SLE_FR_ENV E	Combinat ion	- 652.879	- 135.2	- 2.551E-13	- 3.661E-14	2.974E- 14	- 81.1359
18	1.07 208	SLE_FR_ENV E	Combinat ion	- 631.711	- 177.085	- 2.538E-13	- 3.661E-14	1.661E- 13	- 2.6844
18	0	SLE_QP_EN VE	Combinat ion	- 542.827	- 6.845	1.403E- 13	1.713E-14	1.083E- 13	- 46.5074
18	0.53 604	SLE_QP_EN VE	Combinat ion	- 519.257	- 35.835	1.428E- 13	1.713E-14	3.234E- 14	- 38.6314

PROGETTO DEFINITIVO

RELAZIONE DI CALCOLO GALLERIA ARTIFICIALE

18	1.07 208	SLE_QP_EN VE	Combinat ion	- 495.959	- 76.14	1.441E- 13	- 1.713E-14	- 3.482E-14	- 0.9154
18	0	SLE_QP_EN VE	Combinat ion	- 643.413	- 68.051	9.711E- 14	- 3.277E-14	6.924E- 14	- 121.2152
18	0.53 604	SLE_QP_EN VE	Combinat ion	- 622.453	- 112.667	9.717E- 14	- 3.277E-14	1.713E- 14	- 72.6573
18	1.07 208	SLE_QP_EN VE	Combinat ion	- 601.285	- 154.553	9.655E- 14	- 3.277E-14	- 4.461E-14	- 8.5139
18	0	SLE_C_ENV E	Combinat ion	- 544.941	- 5.433	1.403E- 13	- 1.684E-14	1.083E- 13	- 46.7564
18	0.53 604	SLE_C_ENV E	Combinat ion	- 521.37	- 37.246	1.428E- 13	- 1.684E-14	3.234E- 14	- 38.1239
18	1.07 208	SLE_C_ENV E	Combinat ion	- 498.073	- 77.552	1.441E- 13	- 1.684E-14	3.557E-14	- 0.9154
18	0	SLE_C_ENV E	Combinat ion	- 643.413	- 68.051	9.804E- 14	- 3.277E-14	6.948E- 14	- 121.2152
18	0.53 604	SLE_C_ENV E	Combinat ion	- 622.453	- 112.667	9.809E- 14	- 3.277E-14	1.688E- 14	- 72.6573
18	1.07 208	SLE_C_ENV E	Combinat ion	- 601.285	- 154.553	9.747E- 14	- 3.277E-14	- 4.461E-14	- 7.2498

Sezione S7

TABLE: Element Forces - Frames									
Frame	Station	OutputCase	CaseType	P	V2	V3	T	M2	M3
Text	m	Text	Text	KN	KN	KN	KN-m	KN-m	KN-m
24	0	SLU_ENVE	Combina tion	-265	82.50 6	8.844E- 14	1.07E- 13	5.792E- 14	236.9 385
24	0.48 807	SLU_ENVE	Combina tion	-262.197	69.86 8	8.419E- 14	1.07E- 13	2.918E- 14	240.3 164
24	0.97 615	SLU_ENVE	Combina tion	-259.08	57.23	7.971E- 14	1.07E- 13	3.079E- 13	267.6 575
24	0	SLU_ENVE	Combina tion	-928.568	-34.186	-6.18E- 13	-2.074E-14	-3.028E-13	-69.5809
24	0.48 807	SLU_ENVE	Combina tion	-925.257	-83.47	-6.237E-13	-2.074E-14	-6.106E-15	-50.4172
24	0.97 615	SLU_ENVE	Combina tion	-921.315	-132.342	-6.296E-13	-2.074E-14	-2.422E-14	-12.8274
24	0	SLV_ENVE	Combina tion	-940.85	-11.135	-1.338E-13	-1.735E-13	-1.149E-13	-362.6 79
24	0.48 807	SLV_ENVE	Combina tion	-944.372	-49.599	-1.384E-13	-1.735E-13	-4.841E-14	-392.7 858
24	0.97 615	SLV_ENVE	Combina tion	-946.834	-87.681	-1.427E-13	-1.735E-13	-1.892E-14	-442.0 697
24	0	SLV_ENVE	Combina tion	-1074.431	-41.927	-1.231E-13	-1.454E-13	-9.993E-14	-313.8 11
24	0.48 807	SLV_ENVE	Combina tion	-1089.337	-81.387	-1.219E-13	-1.454E-13	-4.014E-14	-328.6 476
24	0.97 615	SLV_ENVE	Combina tion	-1103.693	-120.51	-1.202E-13	-1.454E-13	-2.064E-14	-362.1 644
24	0	SLE_FR_EN VE	Combina tion	-686.434	-16.07 2	-2.171E-13	-7.276E-14	-8.721E-14	-161.5 844
24	0.48	SLE_FR_EN	Combina	-	-	-	-7.276E-	-1.98E-	-163.0

PROGETTO DEFINITIVO

RELAZIONE DI CALCOLO GALLERIA ARTIFICIALE

	807	VE	tion	683.887	21.861	2.214E-13	14	14	106
24	0.97 615	SLE_FR_EN VE	Combina tion	- 680.855	- 59.463	- 2.259E-13	7.276E- 14	1.289E- 13	182.8 7
24	0	SLE_FR_EN VE	Combina tion	- 686.434	16.07 2	- 2.171E-13	7.276E- 14	- 8.721E-14	161.5 844
24	0.48 807	SLE_FR_EN VE	Combina tion	- 683.887	- 21.861	- 2.214E-13	7.276E- 14	1.98E- 14	163.0 106
24	0.97 615	SLE_FR_EN VE	Combina tion	- 680.855	- 59.463	- 2.259E-13	7.276E- 14	1.289E- 13	182.8 7
24	0	SLE_QP_EN VE	Combina tion	- 493.798	33.11 3	8.852E- 14	5.86E- 14	5.805E- 14	130.9 947
24	0.48 807	SLE_QP_EN VE	Combina tion	- 490.996	- 4.798	8.427E- 14	5.86E- 14	1.587E- 14	130.6 699
24	0.97 615	SLE_QP_EN VE	Combina tion	- 487.878	- 42.392	7.98E- 14	5.86E- 14	- 2.418E-14	148.7 783
24	0	SLE_QP_EN VE	Combina tion	- 645.058	- 19.66	6.959E- 14	1.01E- 14	3.534E- 14	26.87 6
24	0.48 807	SLE_QP_EN VE	Combina tion	- 642.51	- 18.273	6.521E- 14	1.01E- 14	2.435E- 15	19.97 9
24	0.97 615	SLE_QP_EN VE	Combina tion	- 639.478	- 55.875	6.069E- 14	1.01E- 14	-2.83E- 14	31.50 79
24	0	SLE_C_ENV E	Combina tion	- 496.342	33.01 6	8.852E- 14	5.86E- 14	5.805E- 14	130.9 947
24	0.48 807	SLE_C_ENV E	Combina tion	- 493.54	- 4.894	8.427E- 14	5.86E- 14	1.587E- 14	130.6 699
24	0.97 615	SLE_C_ENV E	Combina tion	- 490.422	- 42.488	7.98E- 14	5.86E- 14	- 2.418E-14	148.7 783
24	0	SLE_C_ENV E	Combina tion	- 645.058	- 19.66	6.992E- 14	1.131E- 14	3.583E- 14	29.59 93
24	0.48 807	SLE_C_ENV E	Combina tion	- 642.51	- 18.273	6.554E- 14	1.131E- 14	2.771E- 15	22.74 93
24	0.97 615	SLE_C_ENV E	Combina tion	- 639.478	- 55.875	6.102E- 14	1.131E- 14	- 2.812E-14	34.32 53
25	0	SLU_ENVE	Combina tion	- 259.26	133.4 12	7.666E- 14	8.557E- 14	6.878E- 14	267.6 575
25	0.48 807	SLU_ENVE	Combina tion	- 262.378	84.53 9	7.195E- 14	8.557E- 14	5.988E- 14	240.1 407
25	0.97 615	SLU_ENVE	Combina tion	- 265.18	35.25 5	6.699E- 14	8.557E- 14	2.733E- 13	236.5 871
25	0	SLU_ENVE	Combina tion	- 921.283	- 56.59	- 5.026E-13	- 1.668E-14	- 2.309E-13	- 12.8274
25	0.48 807	SLU_ENVE	Combina tion	- 925.226	- 69.227	- 5.041E-13	- 1.668E-14	- 1.216E-14	- 50.6566
25	0.97 615	SLU_ENVE	Combina tion	- 928.537	- 81.865	- 5.057E-13	- 1.668E-14	- 2.986E-14	- 70.125
25	0	SLV_ENVE	Combina tion	- 947.675	86.53 9	1.25E- 13	1.466E- 13	1.652E- 13	442.0 697
25	0.48 807	SLV_ENVE	Combina tion	- 955.627	50.45 3	1.273E- 13	1.466E- 13	1.036E- 13	415.2 565
25	0.97 615	SLV_ENVE	Combina tion	- 962.519	14.03	1.285E- 13	1.466E- 13	4.113E- 14	406.2 1
25	0	SLV_ENVE	Combina tion	- 1107.852	72.90 7	1.122E- 13	1.178E- 13	1.371E- 13	362.1 644
25	0.48	SLV_ENVE	Combina	-	36.74	1.096E-	1.178E-	8.292E-	333.1

PROGETTO DEFINITIVO

RELAZIONE DI CALCOLO GALLERIA ARTIFICIALE

	807		tion	1127.369	7	13	13	14	171
25	0.97 615	SLV_ENVE	Combina tion	- 1144.654	- 0.104	1.065E- 13	1.178E- 13	3.017E- 14	322.3 053
25	0	SLE_FR_EN VE	Combina tion	- 680.837	- 59.67	- 1.669E-13	5.818E- 14	- 4.192E-14	182.8 7
25	0.48 807	SLE_FR_EN VE	Combina tion	- 683.869	- 22.06 9	- 1.716E-13	5.818E- 14	4.067E- 14	162.9 091
25	0.97 615	SLE_FR_EN VE	Combina tion	- 686.416	- 15.864	- 1.765E-13	5.818E- 14	1.256E- 13	161.3 815
25	0	SLE_FR_EN VE	Combina tion	- 680.837	- 59.67	- 1.669E-13	5.818E- 14	- 4.192E-14	182.8 7
25	0.48 807	SLE_FR_EN VE	Combina tion	- 683.869	- 22.06 9	- 1.716E-13	5.818E- 14	4.067E- 14	162.9 091
25	0.97 615	SLE_FR_EN VE	Combina tion	- 686.416	- 15.864	- 1.765E-13	5.818E- 14	1.256E- 13	161.3 815
25	0	SLE_QP_EN VE	Combina tion	- 487.827	56.01 8	7.674E- 14	4.685E- 14	6.899E- 14	148.7 783
25	0.48 807	SLE_QP_EN VE	Combina tion	- 490.945	18.41 7	7.203E- 14	4.685E- 14	3.267E- 14	130.5 999
25	0.97 615	SLE_QP_EN VE	Combina tion	- 493.747	- 19.516	- 6.707E- 14	4.685E- 14	- 1.284E-15	130.8 546
25	0	SLE_QP_EN VE	Combina tion	- 639.465	42.97 1	5.814E- 14	7.98E- 15	3.249E- 14	31.50 79
25	0.48 807	SLE_QP_EN VE	Combina tion	- 642.498	- 5.377	- 5.347E- 14	7.98E- 15	5.244E- 15	19.69 62
25	0.97 615	SLE_QP_EN VE	Combina tion	- 645.045	- 32.533	- 4.862E- 14	7.98E- 15	- 1.968E-14	26.31 04
25	0	SLE_C_ENV E	Combina tion	- 490.35	56.01 8	7.674E- 14	4.685E- 14	6.899E- 14	148.7 783
25	0.48 807	SLE_C_ENV E	Combina tion	- 493.467	18.41 7	7.203E- 14	4.685E- 14	3.267E- 14	130.5 999
25	0.97 615	SLE_C_ENV E	Combina tion	- 496.269	- 19.516	- 6.707E- 14	4.685E- 14	- 1.284E-15	130.8 546
25	0	SLE_C_ENV E	Combina tion	- 639.465	43.31 8	5.848E- 14	8.908E- 15	3.331E- 14	34.32 53
25	0.48 807	SLE_C_ENV E	Combina tion	- 642.498	- 5.724	- 5.38E- 14	8.908E- 15	5.899E- 15	22.34 43
25	0.97 615	SLE_C_ENV E	Combina tion	- 645.045	- 32.187	- 4.895E- 14	8.908E- 15	- 1.918E-14	28.78 92

In allegato A sono riportate le verifiche effettuate.

Le armature calcolate sono di seguito riportate:

Sezione	H				A <sub>res,</sub> TOT
S1	[ cm]				[cm <sup>2</sup> ]
Arm. lato terra	8 0			2 4	22. 62
Arm. lato interno	8 0			2 4	22. 62



PROGETTO DEFINITIVO

RELAZIONE DI CALCOLO GALLERIA ARTIFICIALE

Sezione	H				A <sub>res,</sub> TOT
<b>S2</b>	[ cm]				[cm <sup>2</sup> ]
Arm. lato terra	<b>8</b> <b>0</b>		<b>2</b> <b>4</b>	<b>2</b> <b>4</b>	22. 62
Arm. lato interno	8 0			<b>2</b> <b>4</b>	22. 62

Sezione	H				A <sub>res,</sub> TOT
<b>S4</b>	[ cm]				[cm <sup>2</sup> ]
Arm. lato terra	<b>1</b> <b>00</b>		<b>2</b> <b>4</b>	<b>2</b> <b>4</b>	22. 62
Arm. lato interno	1 00			<b>2</b> <b>4</b>	22. 62

Sezione	H				A <sub>res,</sub> TOT
<b>S5</b>	[ cm]				[cm <sup>2</sup> ]
Arm. lato terra	<b>1</b> <b>60</b>		<b>2</b> <b>4</b>	<b>2</b> <b>4</b>	22. 62
Arm. lato interno	1 60			<b>2</b> <b>4</b>	22. 62

Sezione	H				A <sub>res,</sub> TOT
<b>S6</b>	[ cm]				[cm <sup>2</sup> ]
Arm. lato terra	<b>8</b> <b>0</b>		<b>2</b> <b>4</b>	<b>2</b> <b>4</b>	22. 62
Arm. lato interno	8 0			<b>2</b> <b>4</b>	22. 62

Sezione	H				A <sub>res,</sub> TOT
<b>S7</b>	[ cm]				[cm <sup>2</sup> ]
Arm. lato terra	<b>8</b> <b>0</b>		<b>2</b> <b>4</b>	<b>2</b> <b>4</b>	22. 62
Arm. lato interno	8 0			<b>2</b> <b>4</b>	22. 62



ITINERARIO INTERNAZIONALE E78 S.G.C. GROSSETO – FANO  
Tratto Selci lama (E45) – Santo Stefano di Gaifa - Adeguamento a 2 corsie della  
Galleria della Guinza (lotto 2) e del tratto Guinza – Mercatello Ovest (lotto 3)

**PROGETTO DEFINITIVO**

---

**RELAZIONE DI CALCOLO GALLERIA ARTIFICIALE**

---

## 7. ALLEGATO A - VERIFICHE SEZIONI IN C.A.

### 7.1 VERIFICA SEZIONE S1

#### DATI GENERALI SEZIONE IN C.A.

NOME SEZIONE: Sezione 1

(Percorso File: C:\Users\id-209\Desktop\Galleria Artificiale\Verifica Sezioni\Sezione 1.sez)

Descrizione Sezione:	
Metodo di calcolo resistenza:	Stati Limite Ultimi
Tipologia sezione:	Sezione generica
Normativa di riferimento:	N.T.C.
Percorso sollecitazione:	A Sforzo Norm. costante
Condizioni Ambientali:	Moderat. aggressive
Tipo di sollecitazione:	Retta (asse neutro sempre parallelo all'asse X)
Riferimento Sforzi assegnati:	Assi x,y principali d'inerzia
Riferimento alla sismicità:	Zona non sismica

#### CARATTERISTICHE DI RESISTENZA DEI MATERIALI IMPIEGATI

CALCESTRUZZO -	Classe:	C28/35
	Resis. compr. di calcolo fcd:	15.860 MPa
	Resis. compr. ridotta fcd':	0.000 MPa
	Def.unit. max resistenza ec2:	0.0020
	Def.unit. ultima ecu:	0.0035
	Diagramma tensione-deformaz.:	Parabola-Rettangolo
	Modulo Elastico Normale Ec:	32308.0 MPa
	Resis. media a trazione fctm:	2.760 MPa
	Coeff. Omogen. S.L.E.:	15.00
	Coeff. Omogen. S.L.E.:	15.00
	Sc limite S.L.E. comb. Frequenti:	168.00 daN/cm <sup>2</sup>
	Ap.Fessure limite S.L.E. comb. Frequenti:	0.300 mm
	Sc limite S.L.E. comb. Q.Permanenti:	0.00 Mpa
	Ap.Fessure limite S.L.E. comb. Q.Permanenti:	0.200 mm
ACCIAIO -	Tipo:	B450C
	Resist. caratt. snervam. fyk:	450.00 MPa
	Resist. caratt. rottura ftk:	450.00 MPa
	Resist. snerv. di calcolo fyd:	391.30 MPa
	Resist. ultima di calcolo ftd:	391.30 MPa
	Deform. ultima di calcolo Epu:	0.068
	Modulo Elastico Ef	2000000 daN/cm <sup>2</sup>
	Diagramma tensione-deformaz.:	Bilineare finito
	Coeff. Aderenza istantaneo $\beta_1 \cdot \beta_2$ :	1.00
	Coeff. Aderenza differito $\beta_1 \cdot \beta_2$ :	0.50
Sf limite S.L.E. Comb. Rare:	360.00 MPa	

#### CARATTERISTICHE DOMINIO CONGLOMERATO

Forma del Dominio:	Poligonale	
Classe Conglomerato:	C28/35	
N°vertice:	X [cm]	Y [cm]

PROGETTO DEFINITIVO

RELAZIONE DI CALCOLO GALLERIA ARTIFICIALE

1	-50.0	0.0
2	-50.0	80.0
3	50.0	80.0
4	50.0	0.0

DATI BARRE ISOLATE

N°Barra	X [cm]	Y [cm]	DiamØ[mm]
1	-39.7	10.3	24
2	-39.7	69.7	24
3	39.7	69.7	24
4	39.7	10.3	24

DATI GENERAZIONI LINEARI DI BARRE

N°Gen.	Numero assegnato alla singola generazione lineare di barre			
N°Barra Ini.	Numero della barra iniziale cui si riferisce la generazione			
N°Barra Fin.	Numero della barra finale cui si riferisce la generazione			
N°Barre	Numero di barre generate equidistanti cui si riferisce la generazione			
Ø	Diametro in mm delle barre della generazione			

N°Gen.	N°Barra Ini.	N°Barra Fin.	N°Barre	Ø
1	2	3	3	24
2	1	4	3	24

ARMATURE A TAGLIO

Diametro staffe:	12	mm
Passo staffe:	1000.0	cm
Staffe:	Una sola staffa chiusa perimetrale	

ST.LIM.ULTIMI - SFORZI PER OGNI COMBINAZIONE ASSEGNATA

N	Sforzo normale [kN] applicato nel Baric. (+ se di compressione)		
Mx	Momento flettente [daNm] intorno all'asse X di riferimento delle coordinate con verso positivo se tale da comprimere il lembo sup. della sez.		
Vy	Componente del Taglio [kN] parallela all'asse Y di riferimento delle coordinate		

N°Comb.	N	Mx	Vy
1	188.00	331.74	-36.02
2	188.80	369.24	-16.44
3	189.60	384.82	13.46
4	904.60	33.24	-100.83
5	905.87	47.13	-55.22
6	907.14	51.60	-20.66
7	190.00	384.82	7.16
8	189.20	378.22	38.37
9	188.41	349.70	82.15
10	907.69	51.60	-31.22
11	906.42	51.12	8.56
12	905.15	41.01	28.14
13	760.52	343.67	-71.06
14	764.95	373.84	-49.11
15	769.39	392.49	-25.70

**PROGETTO DEFINITIVO**

**RELAZIONE DI CALCOLO GALLERIA ARTIFICIALE**

16	842.77	320.38	-91.09
17	844.71	354.30	-67.23
18	846.64	372.63	-44.84
19	770.36	392.49	9.03
20	772.84	386.53	31.15
21	775.32	376.19	54.96
22	847.43	372.63	-14.69
23	847.57	365.39	9.46
24	847.70	347.47	31.93

**COMB. RARE (S.L.E.) - SFORZI PER OGNI COMBINAZIONE ASSEGNATA**

N Sforzo normale [kN] applicato nel Baricentro (+ se di compressione)  
 Mx Momento flettente [kNm] intorno all'asse X di riferimento (tra parentesi Mom.Fessurazione)  
 con verso positivo se tale da comprimere il lembo superiore della sezione

N°Comb.	N	Mx	My
1	372.28	201.26	0.00
2	373.57	223.27	0.00
3	374.86	234.66	0.00
4	581.50	99.42	0.00
5	582.40	120.67	0.00
6	583.30	126.69	0.00
7	375.37	234.66	0.00
8	374.08	227.83	0.00
9	372.79	210.38	0.00
10	583.69	126.69	0.00
11	582.79	126.68	0.00
12	581.89	111.44	0.00

**COMB. FREQUENTI (S.L.E.) - SFORZI PER OGNI COMBINAZIONE ASSEGNATA**

N Sforzo normale [kN] applicato nel Baricentro (+ se di compressione)  
 Mx Momento flettente [kNm] intorno all'asse X di riferimento (tra parentesi Mom.Fessurazione)  
 con verso positivo se tale da comprimere il lembo superiore della sezione

N°Comb.	N	Mx	My
1	648.20	233.53 (549.44)	0.00 (0.00)
2	649.40	259.43 (517.12)	0.00 (0.00)
3	650.59	271.25 (505.69)	0.00 (0.00)
4	648.20	233.53 (549.44)	0.00 (0.00)
5	649.40	259.43 (517.12)	0.00 (0.00)
6	650.59	271.25 (505.69)	0.00 (0.00)
7	651.09	271.25 (505.88)	0.00 (0.00)
8	649.89	265.29 (511.22)	0.00 (0.00)
9	648.70	245.26 (533.45)	0.00 (0.00)
10	651.09	271.25 (505.88)	0.00 (0.00)
11	649.89	265.29 (511.22)	0.00 (0.00)
12	648.70	245.26 (533.45)	0.00 (0.00)

**COMB. QUASI PERMANENTI (S.L.E.) - SFORZI PER OGNI COMBINAZIONE ASSEGNATA**

N Sforzo normale [kN] applicato nel Baricentro (+ se di compressione)  
 Mx Momento flettente [kNm] intorno all'asse X di riferimento (tra parentesi Mom.Fessurazione)  
 con verso positivo se tale da comprimere il lembo superiore della sezione

PROGETTO DEFINITIVO

RELAZIONE DI CALCOLO GALLERIA ARTIFICIALE

N°Comb.	N	Mx	My
1	375.31	201.26 (454.48)	0.00 (0.00)
2	376.21	223.27 (439.49)	0.00 (0.00)
3	377.11	234.66 (433.29)	0.00 (0.00)
4	581.50	98.02 (1991.37)	0.00 (0.00)
5	582.40	115.89 (1135.31)	0.00 (0.00)
6	583.30	123.15 (998.61)	0.00 (0.00)
7	377.48	234.66 (433.41)	0.00 (0.00)
8	376.58	227.83 (436.91)	0.00 (0.00)
9	375.68	210.38 (447.76)	0.00 (0.00)
10	583.69	123.15 (999.92)	0.00 (0.00)
11	582.79	120.24 (1046.71)	0.00 (0.00)
12	581.89	106.72 (1423.40)	0.00 (0.00)

RISULTATI DEL CALCOLO

Sezione verificata per tutte le combinazioni assegnate

Copriferro netto minimo barre longitudinali:	9.1 cm
Interferro netto minimo barre longitudinali:	17.5 cm

METODO AGLI STATI LIMITE ULTIMI - RISULTATI PRESSO-TENSO FLESSIONE

Ver	S = combinazione verificata / N = combin. non verificata
N	Sforzo normale assegnato [kN] nel baricentro B sezione cls.(positivo se di compressione)
Mx	Momento flettente assegnato [kNm] riferito all'asse x princ. d'inerzia
N ult	Sforzo normale ultimo [kN] nel baricentro B sezione cls.(positivo se di compress.)
Mx ult	Momento flettente ultimo [kNm] riferito all'asse x princ. d'inerzia
Mis.Sic.	Misura sicurezza = rapporto vettoriale tra (N ult,Mx ult,My ult) e (N,Mx,My) Verifica positiva se tale rapporto risulta >=1.000
As Tesa	Area armature [cm <sup>2</sup> ] in zona tesa (solo travi). Tra parentesi l'area minima di normativa

N°Comb	Ver	N	Mx	N ult	Mx ult	Mis.Sic.	As Tesa
1	S	188.00	331.74	187.81	658.81	1.986	-----
2	S	188.80	369.24	188.76	659.10	1.785	-----
3	S	189.60	384.82	189.71	659.39	1.714	-----
4	S	904.60	33.24	904.76	876.26	26.361	-----
5	S	905.87	47.13	905.93	876.61	18.602	-----
6	S	907.14	51.60	907.10	876.96	16.996	-----
7	S	190.00	384.82	189.71	659.39	1.714	-----
8	S	189.20	378.22	189.23	659.24	1.743	-----
9	S	188.41	349.70	188.28	658.95	1.884	-----
10	S	907.69	51.60	907.68	877.14	17.000	-----
11	S	906.42	51.12	906.51	876.79	17.152	-----
12	S	905.15	41.01	905.34	876.44	21.371	-----
13	S	760.52	343.67	760.25	832.98	2.424	-----
14	S	764.95	373.84	764.77	834.34	2.232	-----
15	S	769.39	392.49	769.27	835.70	2.129	-----
16	S	842.77	320.38	842.50	857.67	2.677	-----
17	S	844.71	354.30	844.90	858.38	2.423	-----
18	S	846.64	372.63	846.70	858.92	2.305	-----
19	S	770.36	392.49	770.40	836.03	2.130	-----
20	S	772.84	386.53	772.65	836.71	2.165	-----
21	S	775.32	376.19	775.46	837.55	2.226	-----
22	S	847.43	372.63	847.30	859.10	2.305	-----
23	S	847.57	365.39	847.30	859.10	2.351	-----
24	S	847.70	347.47	847.90	859.28	2.473	-----

**METODO AGLI STATI LIMITE ULTIMI - DEFORMAZIONI UNITARIE ALLO STATO ULTIMO**

ec max	Deform. unit. massima del conglomerato a compressione
ec 3/7	Deform. unit. del conglomerato nella fibra a 3/7 dell'altezza efficace
Xc max	Ascissa in cm della fibra corrisp. a ec max (sistema rif. X,Y,O sez.)
Yc max	Ordinata in cm della fibra corrisp. a ec max (sistema rif. X,Y,O sez.)
es min	Deform. unit. minima nell'acciaio (negativa se di trazione)
Xs min	Ascissa in cm della barra corrisp. a es min (sistema rif. X,Y,O sez.)
Ys min	Ordinata in cm della barra corrisp. a es min (sistema rif. X,Y,O sez.)
es max	Deform. unit. massima nell'acciaio (positiva se di compress.)
Xs max	Ascissa in cm della barra corrisp. a es max (sistema rif. X,Y,O sez.)
Ys max	Ordinata in cm della barra corrisp. a es max (sistema rif. X,Y,O sez.)

N°Comb	ec max	ec 3/7	Xc max	Yc max	es min	Xs min	Ys min	es max	Xs max	Ys max
1	0.00350	-0.00919	-50.0	80.0	-0.00031	-39.7	69.7	-0.02230	-39.7	10.3
2	0.00350	-0.00919	-50.0	80.0	-0.00031	-39.7	69.7	-0.02229	-39.7	10.3
3	0.00350	-0.00918	-50.0	80.0	-0.00031	-39.7	69.7	-0.02229	-39.7	10.3
4	0.00350	-0.00642	-50.0	80.0	0.00052	-39.7	69.7	-0.01666	-39.7	10.3
5	0.00350	-0.00641	-50.0	80.0	0.00052	-39.7	69.7	-0.01665	-39.7	10.3
6	0.00350	-0.00641	-50.0	80.0	0.00052	-39.7	69.7	-0.01664	-39.7	10.3
7	0.00350	-0.00918	-50.0	80.0	-0.00031	-39.7	69.7	-0.02229	-39.7	10.3
8	0.00350	-0.00919	-50.0	80.0	-0.00031	-39.7	69.7	-0.02229	-39.7	10.3
9	0.00350	-0.00919	-50.0	80.0	-0.00031	-39.7	69.7	-0.02230	-39.7	10.3
10	0.00350	-0.00641	-50.0	80.0	0.00052	-39.7	69.7	-0.01664	-39.7	10.3
11	0.00350	-0.00641	-50.0	80.0	0.00052	-39.7	69.7	-0.01664	-39.7	10.3
12	0.00350	-0.00641	-50.0	80.0	0.00052	-39.7	69.7	-0.01665	-39.7	10.3
13	0.00350	-0.00692	-50.0	80.0	0.00037	-39.7	69.7	-0.01769	-39.7	10.3
14	0.00350	-0.00691	-50.0	80.0	0.00037	-39.7	69.7	-0.01766	-39.7	10.3
15	0.00350	-0.00689	-50.0	80.0	0.00038	-39.7	69.7	-0.01762	-39.7	10.3
16	0.00350	-0.00663	-50.0	80.0	0.00046	-39.7	69.7	-0.01709	-39.7	10.3
17	0.00350	-0.00662	-50.0	80.0	0.00046	-39.7	69.7	-0.01708	-39.7	10.3
18	0.00350	-0.00662	-50.0	80.0	0.00046	-39.7	69.7	-0.01706	-39.7	10.3
19	0.00350	-0.00689	-50.0	80.0	0.00038	-39.7	69.7	-0.01762	-39.7	10.3
20	0.00350	-0.00688	-50.0	80.0	0.00038	-39.7	69.7	-0.01760	-39.7	10.3
21	0.00350	-0.00687	-50.0	80.0	0.00039	-39.7	69.7	-0.01758	-39.7	10.3
22	0.00350	-0.00661	-50.0	80.0	0.00046	-39.7	69.7	-0.01706	-39.7	10.3
23	0.00350	-0.00661	-50.0	80.0	0.00046	-39.7	69.7	-0.01706	-39.7	10.3
24	0.00350	-0.00661	-50.0	80.0	0.00046	-39.7	69.7	-0.01706	-39.7	10.3

**POSIZIONE ASSE NEUTRO PER OGNI COMB. DI RESISTENZA**

a, b, c	Coeff. a, b, c nell'eq. dell'asse neutro $aX+bY+c=0$ nel rif. X,Y,O gen.
x/d	Rapp. di duttilità a rottura in presenza di sola fless.(travi)
C.Rid.	Coeff. di riduz. momenti per sola flessione in travi continue

N°Comb	a	b	c	x/d	C.Rid.
1	0.00000000	0.000370185	-0.026114789	----	----
2	0.00000000	0.000370066	-0.026105269	----	----
3	0.00000000	0.000369947	-0.026095748	----	----
4	0.00000000	0.000289201	-0.019636075	----	----
5	0.00000000	0.000289082	-0.019626554	----	----
6	0.00000000	0.000288963	-0.019617034	----	----
7	0.00000000	0.000369947	-0.026095748	----	----
8	0.00000000	0.000370006	-0.026100509	----	----
9	0.00000000	0.000370125	-0.026110029	----	----
10	0.00000000	0.000288903	-0.019612274	----	----
11	0.00000000	0.000289022	-0.019621794	----	----
12	0.00000000	0.000289141	-0.019631315	----	----

PROGETTO DEFINITIVO

RELAZIONE DI CALCOLO GALLERIA ARTIFICIALE

13	0.000000000	0.000304017	-0.020821380	----	----
14	0.000000000	0.000303541	-0.020783298	----	----
15	0.000000000	0.000303065	-0.020745216	----	----
16	0.000000000	0.000295449	-0.020135902	----	----
17	0.000000000	0.000295211	-0.020116861	----	----
18	0.000000000	0.000295032	-0.020102580	----	----
19	0.000000000	0.000302946	-0.020735695	----	----
20	0.000000000	0.000302708	-0.020716654	----	----
21	0.000000000	0.000302411	-0.020692853	----	----
22	0.000000000	0.000294973	-0.020097820	----	----
23	0.000000000	0.000294973	-0.020097820	----	----
24	0.000000000	0.000294913	-0.020093060	----	----

METODO SLU - VERIFICHE A TAGLIO SENZA ARMATURE TRASVERSALI (§ 4.1.2.1.3.1 NTC)

Ver	S = comb.verificata a taglio/ N = comb. non verificata
Vsdu	Taglio agente [daN] uguale al taglio Vy di comb. (sollecit. retta)
Vwct	Taglio trazione resistente [kN] in assenza di staffe [formula (4.1.14)NTC]
d	Altezza utile sezione [cm]
bw	Larghezza minima sezione [cm]
Ro	Rapporto geometrico di armatura longitudinale [ $<0.02$ ]
Scp	Tensione media di compressione nella sezione [Mpa]

N°Comb	Ver	Vsdu	Vwct	d	bw	Ro	Scp
1	S	36.02	292.60	69.7	100.0	0.0032	0.23
2	S	16.44	292.70	69.7	100.0	0.0032	0.24
3	S	13.46	292.81	69.7	100.0	0.0032	0.24
4	S	100.83	386.25	69.7	100.0	0.0032	1.13
5	S	55.22	386.41	69.7	100.0	0.0032	1.13
6	S	20.66	386.58	69.7	100.0	0.0032	1.13
7	S	7.16	292.86	69.7	100.0	0.0032	0.24
8	S	38.37	292.76	69.7	100.0	0.0032	0.24
9	S	82.15	292.65	69.7	100.0	0.0032	0.24
10	S	31.22	386.65	69.7	100.0	0.0032	1.13
11	S	8.56	386.49	69.7	100.0	0.0032	1.13
12	S	28.14	386.32	69.7	100.0	0.0032	1.13
13	S	71.06	367.42	69.7	100.0	0.0032	0.95
14	S	49.11	368.00	69.7	100.0	0.0032	0.96
15	S	25.70	368.58	69.7	100.0	0.0032	0.96
16	S	91.09	378.17	69.7	100.0	0.0032	1.05
17	S	67.23	378.42	69.7	100.0	0.0032	1.06
18	S	44.84	378.67	69.7	100.0	0.0032	1.06
19	S	9.03	368.71	69.7	100.0	0.0032	0.96
20	S	31.15	369.03	69.7	100.0	0.0032	0.97
21	S	54.96	369.35	69.7	100.0	0.0032	0.97
22	S	14.69	378.78	69.7	100.0	0.0032	1.06
23	S	9.46	378.80	69.7	100.0	0.0032	1.06
24	S	31.93	378.81	69.7	100.0	0.0032	1.06

COMBINAZIONI RARE IN ESERCIZIO - MASSIME TENSIONI NORMALI ED APERTURA FESSURE

Ver	S = comb. verificata/ N = comb. non verificata
Sc max	Massima tensione (positiva se di compressione) nel conglomerato [Mpa]
Xc max, Yc max	Ascissa, Ordinata [cm] del punto corrisp. a Sc max (sistema rif. X,Y,O)
Sf min	Minima tensione (negativa se di trazione) nell'acciaio [Mpa]
Xs min, Ys min	Ascissa, Ordinata [cm] della barra corrisp. a Sf min (sistema rif. X,Y,O)
Ac eff.	Area di calcestruzzo [cm <sup>2</sup> ] in zona tesa considerata aderente alle barre
As eff.	Area barre [cm <sup>2</sup> ] in zona tesa considerate efficaci per l'apertura delle fessure
D barre	Distanza tra le barre tese [cm] ai fini del calcolo dell'apertura fessure
Beta12	Prodotto dei coeff. di aderenza delle barre Beta1*Beta2



PROGETTO DEFINITIVO

RELAZIONE DI CALCOLO GALLERIA ARTIFICIALE

N°Comb	Ver	Sc max	Xc max	Yc max	Sf min	Xs min	Ys min	Ac eff.	As eff.	D barre	Beta12
1	S	3.11	-50.0	80.0	-65.4	19.9	10.3	2528	22.6	19.9	1.00
2	S	3.48	-50.0	80.0	-79.6	19.9	10.3	2561	22.6	19.9	1.00
3	S	3.67	-50.0	80.0	-87.0	19.9	10.3	2588	22.6	19.9	1.00
4	S	1.50	-50.0	80.0	0.6	19.9	10.3	----	----	----	----
5	S	1.74	-50.0	80.0	-3.1	19.9	10.3	----	----	----	----
6	S	1.81	-50.0	80.0	-4.4	19.9	10.3	----	----	----	----
7	S	3.67	-50.0	80.0	-86.9	19.9	10.3	2588	22.6	19.9	1.00
8	S	3.55	-50.0	80.0	-82.6	19.9	10.3	2588	22.6	19.9	1.00
9	S	3.27	-50.0	80.0	-71.3	19.9	10.3	2561	22.6	19.9	1.00
10	S	1.81	-50.0	80.0	-4.4	19.9	10.3	----	----	----	----
11	S	1.81	-50.0	80.0	-4.4	19.9	10.3	----	----	----	----
12	S	1.63	-50.0	80.0	-1.3	19.9	10.3	----	----	----	----

COMBINAZIONI FREQUENTI IN ESERCIZIO - MASSIME TENSIONI NORMALI ED APERTURA FESSURE

N°Comb	Ver	Sc max	Xc max	Yc max	Sf min	Xs min	Ys min	Ac eff.	As eff.	D barre	Beta12
1	S	3.45	-50.0	80.0	-42.5	19.9	10.3	2100	22.6	19.9	0.50
2	S	3.89	-50.0	80.0	-56.9	19.9	10.3	2250	22.6	19.9	0.50
3	S	4.09	-50.0	80.0	-63.7	19.9	10.3	2300	22.6	19.9	0.50
4	S	3.45	-50.0	80.0	-42.5	19.9	10.3	2100	22.6	19.9	0.50
5	S	3.89	-50.0	80.0	-56.9	19.9	10.3	2250	22.6	19.9	0.50
6	S	4.09	-50.0	80.0	-63.7	19.9	10.3	2300	22.6	19.9	0.50
7	S	4.08	-50.0	80.0	-63.7	19.9	10.3	2300	22.6	19.9	0.50
8	S	3.98	-50.0	80.0	-60.3	19.9	10.3	2250	22.6	19.9	0.50
9	S	3.64	-50.0	80.0	-48.9	19.9	10.3	2150	22.6	19.9	0.50
10	S	4.08	-50.0	80.0	-63.7	19.9	10.3	2300	22.6	19.9	0.50
11	S	3.98	-50.0	80.0	-60.3	19.9	10.3	2250	22.6	19.9	0.50
12	S	3.64	-50.0	80.0	-48.9	19.9	10.3	2150	22.6	19.9	0.50

COMBINAZIONI FREQUENTI IN ESERCIZIO - APERTURA FESSURE [§B.6.6 DM96]

La sezione viene assunta sempre fessurata anche nel caso in cui la trazione minima del calcestruzzo sia inferiore a  $f_{ctm}$

Ver.	Esito della verifica
S1	Massima tensione [Mpa] di trazione nel calcestruzzo valutata in sezione non fessurata
S2	Minima tensione [Mpa] di trazione nel calcestruzzo valutata in sezione fessurata
k2	= 0.4 per barre ad aderenza migliorata
k3	= 0.125 per flessione e presso-flessione; $=(e1 + e2)/(2 \cdot e1)$ per trazione eccentrica
Ø	Diametro [mm] medio delle barre tese comprese nell'area efficace Ac eff
Cf	Copriferro [mm] netto calcolato con riferimento alla barra più tesa
Psi	$= 1 - \text{Beta}12 \cdot (Ssr/Ss)^2 = 1 - \text{Beta}12 \cdot (f_{ctm}/S2)^2 = 1 - \text{Beta}12 \cdot (M_{fess}/M)^2$ [B.6.6 DM96]
e sm	Deformazione unitaria media tra le fessure [4.3.1.7.1.3 DM96]. Il valore limite = $0.4 \cdot Ss/Es$ è tra parentesi
srm	Distanza media tra le fessure [mm]
wk	Valore caratteristico [mm] dell'apertura fessure = $1.7 \cdot e \cdot sm \cdot srm$ . Valore limite tra parentesi
MX fess.	Componente momento di prima fessurazione intorno all'asse X [kNm]
MY fess.	Componente momento di prima fessurazione intorno all'asse Y [kNm]

Comb.	Ver	S1	S2	k3	Ø	Cf	Psi	e sm	srm	wk	Mx fess	My fess
1	S	-1.2	0	0.125	24	91.0	-1.768	0.00009 (0.00009)	333	0.048 (0.30)	549.44	0.00
2	S	-1.4	0	0.125	24	91.0	-0.987	0.00011 (0.00011)	341	0.066 (0.30)	517.12	0.00
3	S	-1.5	0	0.125	24	91.0	-0.738	0.00013 (0.00013)	344	0.074 (0.30)	505.69	0.00
4	S	-1.2	0	0.125	24	91.0	-1.768	0.00009 (0.00009)	333	0.048 (0.30)	549.44	0.00
5	S	-1.4	0	0.125	24	91.0	-0.987	0.00011 (0.00011)	341	0.066 (0.30)	517.12	0.00
6	S	-1.5	0	0.125	24	91.0	-0.738	0.00013 (0.00013)	344	0.074 (0.30)	505.69	0.00
7	S	-1.5	0	0.125	24	91.0	-0.739	0.00013 (0.00013)	344	0.074 (0.30)	505.88	0.00
8	S	-1.4	0	0.125	24	91.0	-0.857	0.00012 (0.00012)	341	0.070 (0.30)	511.22	0.00
9	S	-1.3	0	0.125	24	91.0	-1.365	0.00010 (0.00010)	336	0.056 (0.30)	533.45	0.00

PROGETTO DEFINITIVO

RELAZIONE DI CALCOLO GALLERIA ARTIFICIALE

10	S	-1.5	0	0.125	24	91.0	-0.739	0.00013 (0.00013)	344	0.074 (0.30)	505.88	0.00
11	S	-1.4	0	0.125	24	91.0	-0.857	0.00012 (0.00012)	341	0.070 (0.30)	511.22	0.00
12	S	-1.3	0	0.125	24	91.0	-1.365	0.00010 (0.00010)	336	0.056 (0.30)	533.45	0.00

COMBINAZIONI QUASI PERMANENTI IN ESERCIZIO - MASSIME TENSIONI NORMALI ED APERTURA FESSURE

N°Comb	Ver	Sc max	Xc max	Yc max	Sf min	Xs min	Ys min	Ac eff.	As eff.	D barre	Beta12
1	S	3.11	-50.0	80.0	-64.9	19.9	10.3	2528	22.6	19.9	0.50
2	S	3.48	-50.0	80.0	-79.2	19.9	10.3	2561	22.6	19.9	0.50
3	S	3.66	-50.0	80.0	-86.6	19.9	10.3	2588	22.6	19.9	0.50
4	S	1.49	-50.0	80.0	0.7	19.9	10.3	----	----	----	----
5	S	1.68	-50.0	80.0	-2.1	19.9	10.3	----	----	----	----
6	S	1.77	-50.0	80.0	-3.6	19.9	10.3	----	----	----	----
7	S	3.66	-50.0	80.0	-86.5	19.9	10.3	2588	22.6	19.9	0.50
8	S	3.55	-50.0	80.0	-82.1	19.9	10.3	2588	22.6	19.9	0.50
9	S	3.26	-50.0	80.0	-70.8	19.9	10.3	2561	22.6	19.9	0.50
10	S	1.77	-50.0	80.0	-3.6	19.9	10.3	----	----	----	----
11	S	1.73	-50.0	80.0	-3.0	19.9	10.3	----	----	----	----
12	S	1.58	-50.0	80.0	-0.5	19.9	10.3	----	----	----	----

COMBINAZIONI QUASI PERMANENTI IN ESERCIZIO - APERTURA FESSURE [§B.6.6 DM96]

Comb.	Ver	S1	S2	k3	Ø	Cf	Psi	e sm	srm	wk	Mx fess	My fess
1	S	-1.2	0	0.125	24	91.0	-1.550	0.00013 (0.00013)	356	0.078 (0.20)	454.48	0.00
2	S	-1.4	0	0.125	24	91.0	-0.937	0.00016 (0.00016)	358	0.096 (0.20)	439.49	0.00
3	S	-1.5	0	0.125	24	91.0	-0.705	0.00017 (0.00017)	359	0.106 (0.20)	433.29	0.00
4	S	-0.1	0	----	----	----	----	----	----	----	1991.37	0.00
5	S	-0.3	0	----	----	----	----	----	----	----	1135.31	0.00
6	S	-0.3	0	----	----	----	----	----	----	----	998.61	0.00
7	S	-1.5	0	0.125	24	91.0	-0.706	0.00017 (0.00017)	359	0.106 (0.20)	433.41	0.00
8	S	-1.4	0	0.125	24	91.0	-0.839	0.00016 (0.00016)	359	0.100 (0.20)	436.91	0.00
9	S	-1.3	0	0.125	24	91.0	-1.265	0.00014 (0.00014)	358	0.086 (0.20)	447.76	0.00
10	S	-0.3	0	----	----	----	----	----	----	----	999.92	0.00
11	S	-0.3	0	----	----	----	----	----	----	----	1046.71	0.00
12	S	-0.2	0	----	----	----	----	----	----	----	1423.40	0.00

7.2 VERIFICA SEZIONE S2

DATI GENERALI SEZIONE IN C.A.

NOME SEZIONE: Sezione 2

(Percorso File: C:\Users\ld-209\Desktop\Galleria Artificiale\Verifica Sezioni\Sezione 2.sez)

Descrizione Sezione:	
Metodo di calcolo resistenza:	Stati Limite Ultimi
Tipologia sezione:	Sezione generica
Normativa di riferimento:	N.T.C.
Percorso sollecitazione:	A Sforzo Norm. costante
Condizioni Ambientali:	Moderat. aggressive
Tipo di sollecitazione:	Retta (asse neutro sempre parallelo all'asse X)
Riferimento Sforzi assegnati:	Assi x,y principali d'inerzia
Riferimento alla sismicità:	Zona non sismica

**PROGETTO DEFINITIVO**

**RELAZIONE DI CALCOLO GALLERIA ARTIFICIALE**

**CARATTERISTICHE DI RESISTENZA DEI MATERIALI IMPIEGATI**

CALCESTRUZZO -	Classe:	C28/35	
	Resis. compr. di calcolo fcd:	15.860	MPa
	Resis. compr. ridotta fcd':	0.000	MPa
	Def.unit. max resistenza ec2:	0.0020	
	Def.unit. ultima ecu:	0.0035	
	Diagramma tensione-deformaz.:	Parabola-Rettangolo	
	Modulo Elastico Normale Ec:	32308.0	MPa
	Resis. media a trazione fctm:	2.760	MPa
	Coeff. Omogen. S.L.E.:	15.00	
	Coeff. Omogen. S.L.E.:	15.00	
	Sc limite S.L.E. comb. Frequenti:	168.00	daN/cm <sup>2</sup>
	Ap.Fessure limite S.L.E. comb. Frequenti:	0.300	mm
	Sc limite S.L.E. comb. Q.Permanenti:	0.00	Mpa
	Ap.Fessure limite S.L.E. comb. Q.Permanenti:	0.200	mm
	ACCIAIO -	Tipo:	B450C
Resist. caratt. snervam. fyk:		450.00	MPa
Resist. caratt. rottura ftk:		450.00	MPa
Resist. snerv. di calcolo fyd:		391.30	MPa
Resist. ultima di calcolo ftd:		391.30	MPa
Deform. ultima di calcolo Epu:		0.068	
Modulo Elastico Ef		2000000	daN/cm <sup>2</sup>
Diagramma tensione-deformaz.:		Bilineare finito	
Coeff. Aderenza istantaneo $\beta_1 \cdot \beta_2$ :		1.00	
Coeff. Aderenza differito $\beta_1 \cdot \beta_2$ :		0.50	
Sf limite S.L.E. Comb. Rare:	360.00	MPa	

**CARATTERISTICHE DOMINIO CONGLOMERATO**

Forma del Dominio:	Poligonale
Classe Conglomerato:	C28/35

N°vertice:	X [cm]	Y [cm]
1	-50.0	0.0
2	-50.0	80.0
3	50.0	80.0
4	50.0	0.0

**DATI BARRE ISOLATE**

N°Barra	X [cm]	Y [cm]	DiamØ[mm]
1	-39.7	10.3	24
2	-39.7	69.7	24
3	39.7	69.7	24
4	39.7	10.3	24

**DATI GENERAZIONI LINEARI DI BARRE**

N°Gen.	Numero assegnato alla singola generazione lineare di barre
N°Barra Ini.	Numero della barra iniziale cui si riferisce la generazione
N°Barra Fin.	Numero della barra finale cui si riferisce la generazione
N°Barre	Numero di barre generate equidistanti cui si riferisce la generazione
Ø	Diametro in mm delle barre della generazione

PROGETTO DEFINITIVO

RELAZIONE DI CALCOLO GALLERIA ARTIFICIALE

N°Gen.	N°Barra Ini.	N°Barra Fin.	N°Barre	Ø
1	2	3	3	24
2	1	4	3	24

ARMATURE A TAGLIO

Diametro staffe:	12	mm
Passo staffe:	1000.0	cm
Staffe:	Una sola staffa chiusa perimetrale	

ST.LIM.ULTIMI - SFORZI PER OGNI COMBINAZIONE ASSEGNATA

N°Comb.	N	Mx	Vy
1	189.42	-12.86	61.61
2	189.42	-43.68	91.95
3	189.42	-83.39	122.30
4	907.23	-147.15	-22.31
5	907.23	-171.45	22.04
6	907.23	-217.72	52.71
7	177.59	-83.39	-61.98
8	183.11	-58.12	-43.17
9	188.62	20.69	-24.35
10	864.73	-217.72	-290.54
11	873.52	-92.66	-246.74
12	882.30	-49.70	-215.26
13	735.40	-85.54	44.76
14	738.76	-110.53	66.23
15	742.12	-145.37	87.70
16	836.78	-164.99	21.77
17	837.78	-180.60	45.11
18	838.79	-207.27	68.45
19	705.73	-145.37	-228.65
20	715.81	-39.81	-208.41
21	725.88	55.14	-186.52
22	799.69	-207.27	-255.84
23	806.90	-92.38	-233.08
24	814.12	12.78	-211.96

COMB. RARE (S.L.E.) - SFORZI PER OGNI COMBINAZIONE ASSEGNATA

N	Sforzo normale [kN] applicato nel Baricentro (+ se di compressione)		
Mx	Momento flettente [kNm] intorno all'asse X di riferimento (tra parentesi Mom.Fessurazione) con verso positivo se tale da comprimere il lembo superiore della sezione		

N°Comb.	N	Mx	My
1	374.42	-77.36	0.00
2	374.42	-98.66	0.00
3	374.42	-134.35	0.00
4	583.33	-86.24	0.00
5	583.34	-114.43	0.00

PROGETTO DEFINITIVO

RELAZIONE DI CALCOLO GALLERIA ARTIFICIALE

6	583.34	-152.65	0.00
7	352.30	-134.35	0.00
8	361.22	-72.57	0.00
9	370.14	-2.68	0.00
10	555.92	-152.65	0.00
11	562.14	-79.56	0.00
12	568.36	-39.40	0.00

COMB. FREQUENTI (S.L.E.) - SFORZI PER OGNI COMBINAZIONE ASSEGNATA

N Sforzo normale [kN] applicato nel Baricentro (+ se di compressione)  
Mx Momento flettente [kNm] intorno all'asse X di riferimento (tra parentesi Mom.Fessurazione)  
con verso positivo se tale da comprimere il lembo superiore della sezione

N°Comb.	N	Mx	My
1	650.46	-101.86 (-3196.24)	0.00 (0.00)
2	650.46	-124.79 (-1245.69)	0.00 (0.00)
3	650.46	-161.02 (-773.79)	0.00 (0.00)
4	650.46	-101.86 (-3196.24)	0.00 (0.00)
5	650.46	-124.79 (-1245.69)	0.00 (0.00)
6	650.46	-161.02 (-773.79)	0.00 (0.00)
7	617.92	-161.02 (-726.38)	0.00 (0.00)
8	626.17	-69.57 (0.00)	0.00 (0.00)
9	634.41	8.37 (0.00)	0.00 (0.00)
10	617.92	-161.02 (-726.38)	0.00 (0.00)
11	626.17	-69.57 (0.00)	0.00 (0.00)
12	634.41	8.37 (0.00)	0.00 (0.00)

COMB. QUASI PERMANENTI (S.L.E.) - SFORZI PER OGNI COMBINAZIONE ASSEGNATA

N Sforzo normale [kN] applicato nel Baricentro (+ se di compressione)  
Mx Momento flettente [kNm] intorno all'asse X di riferimento (tra parentesi Mom.Fessurazione)  
con verso positivo se tale da comprimere il lembo superiore della sezione

N°Comb.	N	Mx	My
1	376.96	-68.57 (-1462.87)	0.00 (0.00)
2	376.96	-96.86 (-738.49)	0.00 (0.00)
3	376.96	-135.18 (-551.06)	0.00 (0.00)
4	583.33	-86.24 (-6460.32)	0.00 (0.00)
5	583.34	-114.43 (-1175.63)	0.00 (0.00)
6	583.34	-152.65 (-722.83)	0.00 (0.00)
7	357.94	-135.18 (-533.78)	0.00 (0.00)
8	364.16	-72.57 (-1131.56)	0.00 (0.00)
9	370.38	-2.68 (0.00)	0.00 (0.00)
10	555.92	-152.65 (-685.67)	0.00 (0.00)
11	562.14	-83.10 (-6466.68)	0.00 (0.00)
12	568.36	-41.21 (0.00)	0.00 (0.00)

RISULTATI DEL CALCOLO

Sezione verificata per tutte le combinazioni assegnate

Copriferro netto minimo barre longitudinali: 9.1 cm  
Interferro netto minimo barre longitudinali: 17.5 cm

METODO AGLI STATI LIMITE ULTIMI - RISULTATI PRESSO-TENSO FLESSIONE

Ver	S = combinazione verificata / N = combin. non verificata
N	Sforzo normale assegnato [kN] nel baricentro B sezione cls.(positivo se di compressione)
Mx	Momento flettente assegnato [kNm] riferito all'asse x princ. d'inerzia
N ult	Sforzo normale ultimo [kN] nel baricentro B sezione cls.(positivo se di compress.)
Mx ult	Momento flettente ultimo [kNm] riferito all'asse x princ. d'inerzia
Mis.Sic.	Misura sicurezza = rapporto vettoriale tra (N ult,Mx ult,My ult) e (N,Mx,My) Verifica positiva se tale rapporto risulta >=1.000
As Tesa	Area armature [cm <sup>2</sup> ] in zona tesa (solo travi). Tra parentesi l'area minima di normativa

N°Comb	Ver	N	Mx	N ult	Mx ult	Mis.Sic.	As Tesa
1	S	189.42	-12.86	189.71	-659.39	51.270	-----
2	S	189.42	-43.68	189.71	-659.39	15.096	-----
3	S	189.42	-83.39	189.71	-659.39	7.907	-----
4	S	907.23	-147.15	907.10	-876.96	5.960	-----
5	S	907.23	-171.45	907.10	-876.96	5.115	-----
6	S	907.23	-217.72	907.10	-876.96	4.028	-----
7	S	177.59	-83.39	177.31	-655.58	7.862	-----
8	S	183.11	-58.12	183.04	-657.34	11.310	-----
9	S	188.62	20.69	188.76	659.10	31.851	-----
10	S	864.73	-217.72	864.63	-864.28	3.970	-----
11	S	873.52	-92.66	873.54	-866.94	9.356	-----
12	S	882.30	-49.70	882.42	-869.59	17.497	-----
13	S	735.40	-85.54	735.26	-825.47	9.650	-----
14	S	738.76	-110.53	738.69	-826.49	7.478	-----
15	S	742.12	-145.37	742.10	-827.52	5.693	-----
16	S	836.78	-164.99	836.48	-855.87	5.188	-----
17	S	837.78	-180.60	837.69	-856.23	4.741	-----
18	S	838.79	-207.27	838.89	-856.59	4.133	-----
19	S	705.73	-145.37	705.99	-816.66	5.618	-----
20	S	715.81	-39.81	715.78	-819.60	20.589	-----
21	S	725.88	55.14	726.12	822.71	14.921	-----
22	S	799.69	-207.27	799.48	-844.78	4.076	-----
23	S	806.90	-92.38	806.69	-846.95	9.168	-----
24	S	814.12	12.78	813.89	849.11	66.444	-----

**METODO AGLI STATI LIMITE ULTIMI - DEFORMAZIONI UNITARIE ALLO STATO ULTIMO**

ec max	Deform. unit. massima del conglomerato a compressione
ec 3/7	Deform. unit. del conglomerato nella fibra a 3/7 dell'altezza efficace
Xc max	Ascissa in cm della fibra corrisp. a ec max (sistema rif. X,Y,O sez.)
Yc max	Ordinata in cm della fibra corrisp. a ec max (sistema rif. X,Y,O sez.)
es min	Deform. unit. minima nell'acciaio (negativa se di trazione)
Xs min	Ascissa in cm della barra corrisp. a es min (sistema rif. X,Y,O sez.)
Ys min	Ordinata in cm della barra corrisp. a es min (sistema rif. X,Y,O sez.)
es max	Deform. unit. massima nell'acciaio (positiva se di compress.)
Xs max	Ascissa in cm della barra corrisp. a es max (sistema rif. X,Y,O sez.)
Ys max	Ordinata in cm della barra corrisp. a es max (sistema rif. X,Y,O sez.)

N°Comb	ec max	ec 3/7	Xc max	Yc max	es min	Xs min	Ys min	es max	Xs max	Ys max
1	0.00350	-0.00918	-50.0	0.0	-0.00031	-39.7	10.3	-0.02229	-39.7	69.7
2	0.00350	-0.00918	-50.0	0.0	-0.00031	-39.7	10.3	-0.02229	-39.7	69.7
3	0.00350	-0.00918	-50.0	0.0	-0.00031	-39.7	10.3	-0.02229	-39.7	69.7
4	0.00350	-0.00641	-50.0	0.0	0.00052	-39.7	10.3	-0.01664	-39.7	69.7
5	0.00350	-0.00641	-50.0	0.0	0.00052	-39.7	10.3	-0.01664	-39.7	69.7
6	0.00350	-0.00641	-50.0	0.0	0.00052	-39.7	10.3	-0.01664	-39.7	69.7
7	0.00350	-0.00924	-50.0	0.0	-0.00033	-39.7	10.3	-0.02239	-39.7	69.7
8	0.00350	-0.00921	-50.0	0.0	-0.00032	-39.7	10.3	-0.02234	-39.7	69.7
9	0.00350	-0.00919	-50.0	80.0	-0.00031	-39.7	69.7	-0.02229	-39.7	10.3

PROGETTO DEFINITIVO

RELAZIONE DI CALCOLO GALLERIA ARTIFICIALE

10	0.00350	-0.00655	-50.0	0.0	0.00048	-39.7	10.3	-0.01694	-39.7	69.7
11	0.00350	-0.00652	-50.0	0.0	0.00049	-39.7	10.3	-0.01688	-39.7	69.7
12	0.00350	-0.00649	-50.0	0.0	0.00050	-39.7	10.3	-0.01681	-39.7	69.7
13	0.00350	-0.00701	-50.0	0.0	0.00034	-39.7	10.3	-0.01787	-39.7	69.7
14	0.00350	-0.00700	-50.0	0.0	0.00035	-39.7	10.3	-0.01785	-39.7	69.7
15	0.00350	-0.00699	-50.0	0.0	0.00035	-39.7	10.3	-0.01782	-39.7	69.7
16	0.00350	-0.00665	-50.0	0.0	0.00045	-39.7	10.3	-0.01713	-39.7	69.7
17	0.00350	-0.00665	-50.0	0.0	0.00045	-39.7	10.3	-0.01713	-39.7	69.7
18	0.00350	-0.00664	-50.0	0.0	0.00045	-39.7	10.3	-0.01712	-39.7	69.7
19	0.00350	-0.00712	-50.0	0.0	0.00031	-39.7	10.3	-0.01808	-39.7	69.7
20	0.00350	-0.00708	-50.0	0.0	0.00032	-39.7	10.3	-0.01801	-39.7	69.7
21	0.00350	-0.00705	-50.0	80.0	0.00033	-39.7	69.7	-0.01794	-39.7	10.3
22	0.00350	-0.00678	-50.0	0.0	0.00041	-39.7	10.3	-0.01740	-39.7	69.7
23	0.00350	-0.00675	-50.0	0.0	0.00042	-39.7	10.3	-0.01735	-39.7	69.7
24	0.00350	-0.00673	-50.0	80.0	0.00043	-39.7	69.7	-0.01729	-39.7	10.3

POSIZIONE ASSE NEUTRO PER OGNI COMB. DI RESISTENZA

a, b, c      Coeff. a, b, c nell'eq. dell'asse neutro  $aX+bY+c=0$  nel rif. X,Y,O gen.  
 x/d          Rapp. di duttilità a rottura in presenza di sola fless. (travi)  
 C.Rid.        Coeff. di riduz. momenti per sola flessione in travi continue

N°Comb	a	b	c	x/d	C.Rid.
1	0.000000000	-0.000369947	0.003500000	----	----
2	0.000000000	-0.000369947	0.003500000	----	----
3	0.000000000	-0.000369947	0.003500000	----	----
4	0.000000000	-0.000288963	0.003500000	----	----
5	0.000000000	-0.000288963	0.003500000	----	----
6	0.000000000	-0.000288963	0.003500000	----	----
7	0.000000000	-0.000371494	0.003500000	----	----
8	0.000000000	-0.000370780	0.003500000	----	----
9	0.000000000	0.000370066	-0.026105269	----	----
10	0.000000000	-0.000293247	0.003500000	----	----
11	0.000000000	-0.000292355	0.003500000	----	----
12	0.000000000	-0.000291462	0.003500000	----	----
13	0.000000000	-0.000306635	0.003500000	----	----
14	0.000000000	-0.000306278	0.003500000	----	----
15	0.000000000	-0.000305921	0.003500000	----	----
16	0.000000000	-0.000296044	0.003500000	----	----
17	0.000000000	-0.000295925	0.003500000	----	----
18	0.000000000	-0.000295806	0.003500000	----	----
19	0.000000000	-0.000309670	0.003500000	----	----
20	0.000000000	-0.000308659	0.003500000	----	----
21	0.000000000	0.000307587	-0.021106995	----	----
22	0.000000000	-0.000299852	0.003500000	----	----
23	0.000000000	-0.000299078	0.003500000	----	----
24	0.000000000	0.000298305	-0.020364395	----	----

METODO SLU - VERIFICHE A TAGLIO SENZA ARMATURE TRASVERSALI (§ 4.1.2.1.3.1 NTC)

Ver            S = comb.verificata a taglio/ N = comb. non verificata  
 Vsdu        Taglio agente [daN] uguale al taglio Vy di comb. (sollecit. retta)  
 Vwct        Taglio trazione resistente [kN] in assenza di staffe [formula (4.1.14)NTC]  
 d            Altezza utile sezione [cm]  
 bw          Larghezza minima sezione [cm]  
 Ro          Rapporto geometrico di armatura longitudinale [ $<0.02$ ]  
 Scp         Tensione media di compressione nella sezione [Mpa]

N°Comb	Ver	Vsdu	Vwct	d	bw	Ro	Scp
--------	-----	------	------	---	----	----	-----

PROGETTO DEFINITIVO

RELAZIONE DI CALCOLO GALLERIA ARTIFICIALE

1	S	61.61	292.78	69.7	100.0	0.0032	0.24
2	S	91.95	292.78	69.7	100.0	0.0032	0.24
3	S	122.30	292.78	69.7	100.0	0.0032	0.24
4	S	22.31	386.59	69.7	100.0	0.0032	1.13
5	S	22.04	386.59	69.7	100.0	0.0032	1.13
6	S	52.71	386.59	69.7	100.0	0.0032	1.13
7	S	61.98	291.24	69.7	100.0	0.0032	0.22
8	S	43.17	291.96	69.7	100.0	0.0032	0.23
9	S	24.35	292.68	69.7	100.0	0.0032	0.24
10	S	290.54	381.04	69.7	100.0	0.0032	1.08
11	S	246.74	382.19	69.7	100.0	0.0032	1.09
12	S	215.26	383.33	69.7	100.0	0.0032	1.10
13	S	44.76	364.14	69.7	100.0	0.0032	0.92
14	S	66.23	364.58	69.7	100.0	0.0032	0.92
15	S	87.70	365.02	69.7	100.0	0.0032	0.93
16	S	21.77	377.38	69.7	100.0	0.0032	1.05
17	S	45.11	377.52	69.7	100.0	0.0032	1.05
18	S	68.45	377.65	69.7	100.0	0.0032	1.05
19	S	228.65	360.26	69.7	100.0	0.0032	0.88
20	S	208.41	361.58	69.7	100.0	0.0032	0.89
21	S	186.52	362.89	69.7	100.0	0.0032	0.91
22	S	255.84	372.54	69.7	100.0	0.0032	1.00
23	S	233.08	373.48	69.7	100.0	0.0032	1.01
24	S	211.96	374.42	69.7	100.0	0.0032	1.02

COMBINAZIONI RARE IN ESERCIZIO - MASSIME TENSIONI NORMALI ED APERTURA FESSURE

Ver	S = comb. verificata/ N = comb. non verificata
Sc max	Massima tensione (positiva se di compressione) nel conglomerato [Mpa]
Xc max, Yc max	Ascissa, Ordinata [cm] del punto corrisp. a Sc max (sistema rif. X,Y,O)
Sf min	Minima tensione (negativa se di trazione) nell'acciaio [Mpa]
Xs min, Ys min	Ascissa, Ordinata [cm] della barra corrisp. a Sf min (sistema rif. X,Y,O)
Ac eff.	Area di calcestruzzo [cm <sup>2</sup> ] in zona tesa considerata aderente alle barre
As eff.	Area barre [cm <sup>2</sup> ] in zona tesa considerate efficaci per l'apertura delle fessure
D barre	Distanza tra le barre tese [cm] ai fini del calcolo dell'apertura fessure
Beta12	Prodotto dei coeff. di aderenza delle barre Beta1*Beta2

N°Comb	Ver	Sc max	Xc max	Yc max	Sf min	Xs min	Ys min	Ac eff.	As eff.	D barre	Beta12
1	S	1.11	-50.0	0.0	-2.0	19.9	69.7	----	----	----	----
2	S	1.40	-50.0	0.0	-8.0	19.9	69.7	1450	22.6	19.9	1.00
3	S	1.98	-50.0	0.0	-24.3	19.9	69.7	2100	22.6	19.9	1.00
4	S	1.38	-50.0	0.0	2.2	19.9	69.7	----	----	----	----
5	S	1.66	-50.0	0.0	-1.8	19.9	69.7	----	----	----	----
6	S	2.17	-50.0	0.0	-12.0	19.9	69.7	1450	22.6	19.9	1.00
7	S	2.00	-50.0	0.0	-27.2	19.9	69.7	2150	22.6	19.9	1.00
8	S	1.05	-50.0	0.0	-1.5	19.9	69.7	----	----	----	----
9	S	0.45	-50.0	0.0	6.2	19.9	69.7	----	----	----	----
10	S	2.18	-50.0	0.0	-14.1	19.9	69.7	1550	22.6	19.9	1.00
11	S	1.30	-50.0	0.0	2.4	19.9	69.7	----	----	----	----
12	S	0.98	-50.0	0.0	6.2	19.9	69.7	----	----	----	----

COMBINAZIONI FREQUENTI IN ESERCIZIO - MASSIME TENSIONI NORMALI ED APERTURA FESSURE

N°Comb	Ver	Sc max	Xc max	Yc max	Sf min	Xs min	Ys min	Ac eff.	As eff.	D barre	Beta12
1	S	1.59	-50.0	0.0	1.8	19.9	69.7	----	----	----	----
2	S	1.82	-50.0	0.0	-1.5	19.9	69.7	----	----	----	----
3	S	2.28	-50.0	0.0	-10.4	19.9	69.7	1300	22.6	19.9	0.50



PROGETTO DEFINITIVO

RELAZIONE DI CALCOLO GALLERIA ARTIFICIALE

4	S	1.59	-50.0	0.0	1.8	19.9	69.7	----	----	----	----
5	S	1.82	-50.0	0.0	-1.5	19.9	69.7	----	----	----	----
6	S	2.28	-50.0	0.0	-10.4	19.9	69.7	1300	22.6	19.9	0.50
7	S	2.29	-50.0	0.0	-12.5	19.9	69.7	1450	22.6	19.9	0.50
8	S	1.29	-50.0	0.0	4.5	19.9	69.7	----	----	----	----
9	S	0.80	-50.0	80.0	10.2	19.9	10.3	----	----	----	----
10	S	2.29	-50.0	0.0	-12.5	19.9	69.7	1450	22.6	19.9	0.50
11	S	1.29	-50.0	0.0	4.5	19.9	69.7	----	----	----	----
12	S	0.80	-50.0	80.0	10.2	19.9	10.3	----	----	----	----

COMBINAZIONI FREQUENTI IN ESERCIZIO - APERTURA FESSURE [§B.6.6 DM96]

Ver.	La sezione viene assunta sempre fessurata anche nel caso in cui la trazione minima del calcestruzzo sia inferiore a $f_{ctm}$
S1	Esito della verifica
S2	Massima tensione [Mpa] di trazione nel calcestruzzo valutata in sezione non fessurata
k2	Minima tensione [Mpa] di trazione nel calcestruzzo valutata in sezione fessurata
k3	= 0.4 per barre ad aderenza migliorata
Ø	= 0.125 per flessione e presso-flessione; $= (e1 + e2)/(2 \cdot e1)$ per trazione eccentrica
Cf	Diametro [mm] medio delle barre tese comprese nell'area efficace $A_c$ eff
Psi	Copriferro [mm] netto calcolato con riferimento alla barra più tesa
e sm	$= 1 - \text{Beta}12 \cdot (Ssr/Ss)^2 = 1 - \text{Beta}12 \cdot (f_{ctm}/S2)^2 = 1 - \text{Beta}12 \cdot (M_{fess}/M)^2$ [B.6.6 DM96]
srm	Deformazione unitaria media tra le fessure [4.3.1.7.1.3 DM96]. Il valore limite = $0.4 \cdot Ss/Es$ è tra parentesi
wk	Distanza media tra le fessure [mm]
MX fess.	Valore caratteristico [mm] dell'apertura fessure = $1.7 \cdot e$ sm * srm . Valore limite tra parentesi
MY fess.	Componente momento di prima fessurazione intorno all'asse X [kNm]
	Componente momento di prima fessurazione intorno all'asse Y [kNm]

Comb.	Ver	S1	S2	k3	Ø	Cf	Psi	e sm	srm	wk	Mx fess	My fess
1	S	-0.1	0	----	----	----	----	----	----	----	-3196.24	0.00
2	S	-0.3	0	----	----	----	----	----	----	----	-1245.69	0.00
3	S	-0.6	0	0.125	24	91.0	-10.547	0.00002 (0.00002)	291	0.010 (0.30)	-773.79	0.00
4	S	-0.1	0	----	----	----	----	----	----	----	-3196.24	0.00
5	S	-0.3	0	----	----	----	----	----	----	----	-1245.69	0.00
6	S	-0.6	0	0.125	24	91.0	-10.547	0.00002 (0.00002)	291	0.010 (0.30)	-773.79	0.00
7	S	-0.6	0	0.125	24	91.0	-9.176	0.00003 (0.00003)	299	0.013 (0.30)	-726.38	0.00
8	S	0.1	0	----	----	----	----	----	----	----	0.00	0.00
9	S	0.7	0	----	----	----	----	----	----	----	0.00	0.00
10	S	-0.6	0	0.125	24	91.0	-9.176	0.00003 (0.00003)	299	0.013 (0.30)	-726.38	0.00
11	S	0.1	0	----	----	----	----	----	----	----	0.00	0.00
12	S	0.7	0	----	----	----	----	----	----	----	0.00	0.00

COMBINAZIONI QUASI PERMANENTI IN ESERCIZIO - MASSIME TENSIONI NORMALI ED APERTURA FESSURE

N°Comb	Ver	Sc max	Xc max	Yc max	Sf min	Xs min	Ys min	Ac eff.	As eff.	D barre	Beta12
1	S	1.02	-50.0	0.0	-0.3	19.9	69.7	----	----	----	----
2	S	1.38	-50.0	0.0	-7.2	19.9	69.7	1400	22.6	19.9	0.50
3	S	1.99	-50.0	0.0	-24.4	19.9	69.7	2100	22.6	19.9	0.50
4	S	1.38	-50.0	0.0	2.2	19.9	69.7	----	----	----	----
5	S	1.66	-50.0	0.0	-1.8	19.9	69.7	----	----	----	----
6	S	2.17	-50.0	0.0	-12.0	19.9	69.7	1450	22.6	19.9	0.50
7	S	2.01	-50.0	0.0	-26.9	19.9	69.7	2150	22.6	19.9	0.50
8	S	1.05	-50.0	0.0	-1.4	19.9	69.7	----	----	----	----
9	S	0.45	-50.0	0.0	6.2	19.9	69.7	----	----	----	----
10	S	2.18	-50.0	0.0	-14.1	19.9	69.7	1550	22.6	19.9	0.50
11	S	1.33	-50.0	0.0	2.1	19.9	69.7	----	----	----	----
12	S	0.99	-50.0	0.0	6.1	19.9	69.7	----	----	----	----

COMBINAZIONI QUASI PERMANENTI IN ESERCIZIO - APERTURA FESSURE [§B.6.6 DM96]

PROGETTO DEFINITIVO

RELAZIONE DI CALCOLO GALLERIA ARTIFICIALE

Comb.	Ver	S1	S2	k3	Ø	Cf	Psi	e sm	srm	wk	Mx fess	My fess
1	S	-0.1	0	----	----	----	----	----	----	----	-1462.87	0.00
2	S	-0.4	0	0.125	24	91.0	-28.063	0.00001 (0.00001)	296	0.007 (0.20)	-738.49	0.00
3	S	-0.7	0	0.125	24	91.0	-7.308	0.00005 (0.00005)	333	0.028 (0.20)	-551.06	0.00
4	S	0.0	0	----	----	----	----	----	----	----	-6460.32	0.00
5	S	-0.3	0	----	----	----	----	----	----	----	-1175.63	0.00
6	S	-0.6	0	0.125	24	91.0	-10.211	0.00002 (0.00002)	299	0.012 (0.20)	-722.83	0.00
7	S	-0.7	0	0.125	24	91.0	-6.796	0.00005 (0.00005)	336	0.031 (0.20)	-533.78	0.00
8	S	-0.2	0	----	----	----	----	----	----	----	-1131.56	0.00
9	S	0.4	0	----	----	----	----	----	----	----	0.00	0.00
10	S	-0.6	0	0.125	24	91.0	-9.088	0.00003 (0.00003)	304	0.015 (0.20)	-685.67	0.00
11	S	0.0	0	----	----	----	----	----	----	----	-6466.68	0.00
12	S	0.3	0	----	----	----	----	----	----	----	0.00	0.00

### 7.3 VERIFICA SEZIONE S4

#### DATI GENERALI SEZIONE IN C.A.

NOME SEZIONE: Sezione 4

(Percorso File: C:\Users\id-209\Desktop\Galleria Artificiale\Verifica Sezioni\Sezione 4.sez)

Descrizione Sezione:

Metodo di calcolo resistenza:	Stati Limite Ultimi
Tipologia sezione:	Sezione generica
Normativa di riferimento:	N.T.C.
Percorso sollecitazione:	A Sforzo Norm. costante
Condizioni Ambientali:	Moderat. aggressive
Tipo di sollecitazione:	Retta (asse neutro sempre parallelo all'asse X)
Riferimento Sforzi assegnati:	Assi x,y principali d'inerzia
Riferimento alla sismicità:	Zona non sismica

#### CARATTERISTICHE DI RESISTENZA DEI MATERIALI IMPIEGATI

CALCESTRUZZO -	Classe:	C28/35
	Resis. compr. di calcolo fcd:	15.860 MPa
	Resis. compr. ridotta fcd':	0.000 MPa
	Def.unit. max resistenza ec2:	0.0020
	Def.unit. ultima ecu:	0.0035
	Diagramma tensione-deformaz.:	Parabola-Rettangolo
	Modulo Elastico Normale Ec:	32308.0 MPa
	Resis. media a trazione fctm:	2.760 MPa
	Coeff. Omogen. S.L.E.:	15.00
	Coeff. Omogen. S.L.E.:	15.00
	Sc limite S.L.E. comb. Frequenti:	168.00 daN/cm <sup>2</sup>
	Ap.Fessure limite S.L.E. comb. Frequenti:	0.300 mm
	Sc limite S.L.E. comb. Q.Permanenti:	0.00 Mpa
	Ap.Fessure limite S.L.E. comb. Q.Permanenti:	0.200 mm
ACCIAIO -	Tipo:	B450C
	Resist. caratt. snervam. fyk:	450.00 MPa

**PROGETTO DEFINITIVO**

**RELAZIONE DI CALCOLO GALLERIA ARTIFICIALE**

Resist. caratt. rottura ftk:	450.00	MPa
Resist. snerv. di calcolo fyd:	391.30	MPa
Resist. ultima di calcolo ftd:	391.30	MPa
Deform. ultima di calcolo Epu:	0.068	
Modulo Elastico Ef	2000000	daN/cm <sup>2</sup>
Diagramma tensione-deformaz.:	Bilineare finito	
Coeff. Aderenza istantaneo $\beta_1 \cdot \beta_2$ :	1.00	
Coeff. Aderenza differito $\beta_1 \cdot \beta_2$ :	0.50	
Sf limite S.L.E. Comb. Rare:	360.00	MPa

**CARATTERISTICHE DOMINIO CONGLOMERATO**

Forma del Dominio:	Poligonale	
Classe Conglomerato:	C28/35	
N° vertice:	X [cm]	Y [cm]
1	-50.0	0.0
2	-50.0	100.0
3	50.0	100.0
4	50.0	0.0

**DATI BARRE ISOLATE**

N° Barra	X [cm]	Y [cm]	DiamØ[mm]
1	-39.7	10.3	24
2	-39.7	89.7	24
3	39.7	89.7	24
4	39.7	10.3	24

**DATI GENERAZIONI LINEARI DI BARRE**

N° Gen.	Numero assegnato alla singola generazione lineare di barre			
N° Barra Ini.	Numero della barra iniziale cui si riferisce la generazione			
N° Barra Fin.	Numero della barra finale cui si riferisce la generazione			
N° Barre	Numero di barre generate equidistanti cui si riferisce la generazione			
Ø	Diametro in mm delle barre della generazione			
N° Gen.	N° Barra Ini.	N° Barra Fin.	N° Barre	Ø
1	2	3	3	24
2	1	4	3	24

**ARMATURE A TAGLIO**

Diametro staffe:	12	mm
Passo staffe:	1000.0	cm
Staffe:	Una sola staffa chiusa perimetrale	

**ST.LIM.ULTIMI - SFORZI PER OGNI COMBINAZIONE ASSEGNATA**

N	Sforzo normale [kN] applicato nel Baric. (+ se di compressione)		
Mx	Momento flettente [daNm] intorno all'asse X di riferimento delle coordinate con verso positivo se tale da comprimere il lembo sup. della sez.		
Vy	Componente del Taglio [kN] parallela all'asse Y di riferimento delle coordinate		
N° Comb.	N	Mx	Vy

PROGETTO DEFINITIVO

RELAZIONE DI CALCOLO GALLERIA ARTIFICIALE

1	351.58	102.52	213.15
2	336.73	95.40	147.07
3	322.57	106.35	84.68
4	900.00	-431.39	-1.99
5	876.39	-528.88	-3.77
6	853.92	-590.79	-35.46
7	322.46	106.35	40.36
8	309.84	114.88	-12.39
9	296.60	136.68	-12.82
10	846.33	-590.79	-18.33
11	831.23	-595.41	-32.31
12	815.26	-574.23	-68.14
13	302.38	136.68	-30.28
14	288.14	158.00	-44.20
15	272.38	191.64	-45.90
16	831.16	-574.23	-121.07
17	817.74	-502.34	-170.18
18	802.01	-406.94	-216.48
19	670.66	-432.59	307.07
20	654.30	-536.91	207.33
21	638.64	-628.73	154.57
22	694.64	-498.15	199.14
23	674.16	-640.25	176.50
24	655.61	-727.69	109.22
25	625.60	-628.73	120.84
26	613.49	-665.50	64.01
27	600.76	-691.79	42.66
28	644.70	-727.69	84.52
29	633.52	-765.63	25.47
30	621.66	-761.28	-51.29
31	609.85	-691.79	-43.65
32	597.80	-664.85	-65.49
33	584.07	-599.45	-86.07
34	632.70	-761.28	-77.56
35	624.19	-716.18	-132.06
36	614.19	-632.78	-205.57

COMB. RARE (S.L.E.) - SFORZI PER OGNI COMBINAZIONE ASSEGNATA

N Sforzo normale [kN] applicato nel Baricentro (+ se di compressione)  
 Mx Momento flettente [kNm] intorno all'asse X di riferimento (tra parentesi Mom.Fessurazione)  
 con verso positivo se tale da comprimere il lembo superiore della sezione

N°Comb.	N	Mx	My
1	685.50	-46.58	0.00
2	668.44	-65.29	0.00
3	652.20	-65.93	0.00
4	690.58	-225.22	0.00
5	672.42	-286.16	0.00
6	655.13	-319.72	0.00
7	651.13	-65.93	0.00
8	639.51	-51.98	0.00
9	627.22	-24.75	0.00
10	652.34	-319.72	0.00
11	640.39	-319.90	0.00
12	627.79	-300.24	0.00
13	637.67	-24.75	0.00

PROGETTO DEFINITIVO

RELAZIONE DI CALCOLO GALLERIA ARTIFICIALE

14	626.04	18.57	0.00
15	612.71	74.21	0.00
16	638.07	-300.24	0.00
17	627.75	-250.51	0.00
18	615.64	-182.69	0.00

COMB. FREQUENTI (S.L.E.) - SFORZI PER OGNI COMBINAZIONE ASSEGNATA

N Sforzo normale [kN] applicato nel Baricentro (+ se di compressione)  
Mx Momento flettente [kNm] intorno all'asse X di riferimento (tra parentesi Mom.Fessurazione)  
con verso positivo se tale da comprimere il lembo superiore della sezione

N°Comb.	N	Mx	My
1	691.59	-288.35 (-898.58)	0.00 (0.00)
2	673.43	-357.81 (-776.36)	0.00 (0.00)
3	656.15	-399.89 (-729.97)	0.00 (0.00)
4	691.59	-288.35 (-898.58)	0.00 (0.00)
5	673.43	-357.81 (-776.36)	0.00 (0.00)
6	656.15	-399.89 (-729.97)	0.00 (0.00)
7	651.05	-399.89 (-727.67)	0.00 (0.00)
8	639.44	-402.18 (-720.88)	0.00 (0.00)
9	627.15	-384.62 (-728.12)	0.00 (0.00)
10	651.05	-399.89 (-727.67)	0.00 (0.00)
11	639.44	-402.18 (-720.88)	0.00 (0.00)
12	627.15	-384.62 (-728.12)	0.00 (0.00)
13	638.81	-384.62 (-733.62)	0.00 (0.00)
14	628.49	-331.62 (-779.05)	0.00 (0.00)
15	616.39	-260.54 (-889.74)	0.00 (0.00)
16	638.81	-384.62 (-733.62)	0.00 (0.00)
17	628.49	-331.62 (-779.05)	0.00 (0.00)
18	616.39	-260.54 (-889.74)	0.00 (0.00)

COMB. QUASI PERMANENTI (S.L.E.) - SFORZI PER OGNI COMBINAZIONE ASSEGNATA

N Sforzo normale [kN] applicato nel Baricentro (+ se di compressione)  
Mx Momento flettente [kNm] intorno all'asse X di riferimento (tra parentesi Mom.Fessurazione)  
con verso positivo se tale da comprimere il lembo superiore della sezione

N°Comb.	N	Mx	My
1	685.54	-33.07 (0.00)	0.00 (0.00)
2	668.48	-53.20 (0.00)	0.00 (0.00)
3	652.23	-55.25 (0.00)	0.00 (0.00)
4	690.58	-225.22 (-1128.28)	0.00 (0.00)
5	672.42	-286.16 (-885.46)	0.00 (0.00)
6	655.13	-319.72 (-812.09)	0.00 (0.00)
7	651.13	-55.25 (0.00)	0.00 (0.00)
8	639.51	-42.55 (0.00)	0.00 (0.00)
9	627.22	-16.57 (0.00)	0.00 (0.00)
10	652.15	-319.72 (-810.01)	0.00 (0.00)
11	640.20	-319.90 (-801.52)	0.00 (0.00)
12	627.60	-300.24 (-821.41)	0.00 (0.00)
13	637.27	-16.57 (0.00)	0.00 (0.00)
14	625.64	25.52 (0.00)	0.00 (0.00)
15	612.32	79.92 (0.00)	0.00 (0.00)
16	638.07	-300.24 (-829.47)	0.00 (0.00)
17	627.75	-250.51 (-929.01)	0.00 (0.00)

PROGETTO DEFINITIVO

RELAZIONE DI CALCOLO GALLERIA ARTIFICIALE

18                      615.64                      -182.69 (-1276.73)                      0.00 (0.00)

RISULTATI DEL CALCOLO

Sezione verificata per tutte le combinazioni assegnate

Copriferro netto minimo barre longitudinali: 9.1 cm  
Interferro netto minimo barre longitudinali: 17.5 cm

METODO AGLI STATI LIMITE ULTIMI - RISULTATI PRESSO-TENSO FLESSIONE

Ver                      S = combinazione verificata / N = combin. non verificata  
N                      Sforzo normale assegnato [kN] nel baricentro B sezione cls.(positivo se di compressione)  
Mx                      Momento flettente assegnato [kNm] riferito all'asse x princ. d'inerzia  
N ult                      Sforzo normale ultimo [kN] nel baricentro B sezione cls.(positivo se di compress.)  
Mx ult                      Momento flettente ultimo [kNm] riferito all'asse x princ. d'inerzia  
Mis.Sic.                      Misura sicurezza = rapporto vettoriale tra (N ult,Mx ult,My ult) e (N,Mx,My)  
Verifica positiva se tale rapporto risulta >=1.000  
As Tesa                      Area armature [cm<sup>2</sup>] in zona tesa (solo travi). Tra parentesi l'area minima di normativa

N°Comb	Ver	N	Mx	N ult	Mx ult	Mis.Sic.	As Tesa
1	S	351.58	102.52	351.84	921.27	8.986	-----
2	S	336.73	95.40	336.43	915.02	9.592	-----
3	S	322.57	106.35	322.49	909.36	8.551	-----
4	S	900.00	-431.39	899.85	-1141.80	2.647	-----
5	S	876.39	-528.88	876.52	-1132.50	2.141	-----
6	S	853.92	-590.79	853.89	-1123.48	1.902	-----
7	S	322.46	106.35	322.49	909.36	8.551	-----
8	S	309.84	114.88	310.04	904.31	7.872	-----
9	S	296.60	136.68	296.75	898.91	6.577	-----
10	S	846.33	-590.79	846.46	-1120.51	1.897	-----
11	S	831.23	-595.41	831.52	-1114.55	1.872	-----
12	S	815.26	-574.23	815.33	-1108.09	1.930	-----
13	S	302.38	136.68	302.23	901.14	6.593	-----
14	S	288.14	158.00	288.13	895.41	5.667	-----
15	S	272.38	191.64	272.36	889.00	4.639	-----
16	S	831.16	-574.23	831.05	-1114.37	1.941	-----
17	S	817.74	-502.34	817.47	-1108.95	2.208	-----
18	S	802.01	-406.94	802.01	-1102.76	2.710	-----
19	S	670.66	-432.59	670.46	-1050.00	2.427	-----
20	S	654.30	-536.91	654.31	-1043.50	1.944	-----
21	S	638.64	-628.73	638.89	-1037.29	1.650	-----
22	S	694.64	-498.15	694.53	-1059.68	2.127	-----
23	S	674.16	-640.25	674.18	-1051.49	1.642	-----
24	S	655.61	-727.69	655.55	-1044.00	1.435	-----
25	S	625.60	-628.73	625.47	-1031.89	1.641	-----
26	S	613.49	-665.50	613.68	-1027.14	1.543	-----
27	S	600.76	-691.79	600.98	-1022.03	1.477	-----
28	S	644.70	-727.69	644.73	-1039.64	1.429	-----
29	S	633.52	-765.63	633.45	-1035.10	1.352	-----
30	S	621.66	-761.28	621.69	-1030.37	1.353	-----
31	S	609.85	-691.79	609.87	-1025.61	1.483	-----
32	S	597.80	-664.85	597.58	-1020.66	1.535	-----
33	S	584.07	-599.45	583.94	-1015.17	1.693	-----
34	S	632.70	-761.28	632.61	-1034.76	1.359	-----
35	S	624.19	-716.18	624.21	-1031.38	1.440	-----
36	S	614.19	-632.78	614.10	-1027.31	1.623	-----

METODO AGLI STATI LIMITE ULTIMI - DEFORMAZIONI UNITARIE ALLO STATO ULTIMO

**PROGETTO DEFINITIVO**

**RELAZIONE DI CALCOLO GALLERIA ARTIFICIALE**

ec max	Deform. unit. massima del conglomerato a compressione
ec 3/7	Deform. unit. del conglomerato nella fibra a 3/7 dell'altezza efficace
Xc max	Ascissa in cm della fibra corrisp. a ec max (sistema rif. X,Y,O sez.)
Yc max	Ordinata in cm della fibra corrisp. a ec max (sistema rif. X,Y,O sez.)
es min	Deform. unit. minima nell'acciaio (negativa se di trazione)
Xs min	Ascissa in cm della barra corrisp. a es min (sistema rif. X,Y,O sez.)
Ys min	Ordinata in cm della barra corrisp. a es min (sistema rif. X,Y,O sez.)
es max	Deform. unit. massima nell'acciaio (positiva se di compress.)
Xs max	Ascissa in cm della barra corrisp. a es max (sistema rif. X,Y,O sez.)
Ys max	Ordinata in cm della barra corrisp. a es max (sistema rif. X,Y,O sez.)

N°Comb	ec max	ec 3/7	Xc max	Yc max	es min	Xs min	Ys min	es max	Xs max	Ys max
1	0.00350	-0.01150	-50.0	100.0	-0.00011	-39.7	89.7	-0.02790	-39.7	10.3
2	0.00350	-0.01158	-50.0	100.0	-0.00012	-39.7	89.7	-0.02806	-39.7	10.3
3	0.00350	-0.01165	-50.0	100.0	-0.00014	-39.7	89.7	-0.02821	-39.7	10.3
4	0.00350	-0.00892	-50.0	0.0	0.00052	-39.7	10.3	-0.02249	-39.7	89.7
5	0.00350	-0.00902	-50.0	0.0	0.00049	-39.7	10.3	-0.02270	-39.7	89.7
6	0.00350	-0.00911	-50.0	0.0	0.00047	-39.7	10.3	-0.02290	-39.7	89.7
7	0.00350	-0.01165	-50.0	100.0	-0.00014	-39.7	89.7	-0.02821	-39.7	10.3
8	0.00350	-0.01171	-50.0	100.0	-0.00016	-39.7	89.7	-0.02834	-39.7	10.3
9	0.00350	-0.01178	-50.0	100.0	-0.00017	-39.7	89.7	-0.02848	-39.7	10.3
10	0.00350	-0.00915	-50.0	0.0	0.00046	-39.7	10.3	-0.02297	-39.7	89.7
11	0.00350	-0.00921	-50.0	0.0	0.00045	-39.7	10.3	-0.02310	-39.7	89.7
12	0.00350	-0.00928	-50.0	0.0	0.00043	-39.7	10.3	-0.02324	-39.7	89.7
13	0.00350	-0.01175	-50.0	100.0	-0.00017	-39.7	89.7	-0.02843	-39.7	10.3
14	0.00350	-0.01182	-50.0	100.0	-0.00018	-39.7	89.7	-0.02857	-39.7	10.3
15	0.00350	-0.01191	-50.0	100.0	-0.00020	-39.7	89.7	-0.02874	-39.7	10.3
16	0.00350	-0.00921	-50.0	0.0	0.00045	-39.7	10.3	-0.02310	-39.7	89.7
17	0.00350	-0.00927	-50.0	0.0	0.00043	-39.7	10.3	-0.02322	-39.7	89.7
18	0.00350	-0.00934	-50.0	0.0	0.00041	-39.7	10.3	-0.02337	-39.7	89.7
19	0.00350	-0.00994	-50.0	0.0	0.00027	-39.7	10.3	-0.02462	-39.7	89.7
20	0.00350	-0.01001	-50.0	0.0	0.00025	-39.7	10.3	-0.02478	-39.7	89.7
21	0.00350	-0.01009	-50.0	0.0	0.00023	-39.7	10.3	-0.02494	-39.7	89.7
22	0.00350	-0.00982	-50.0	0.0	0.00030	-39.7	10.3	-0.02438	-39.7	89.7
23	0.00350	-0.00992	-50.0	0.0	0.00027	-39.7	10.3	-0.02459	-39.7	89.7
24	0.00350	-0.01001	-50.0	0.0	0.00025	-39.7	10.3	-0.02477	-39.7	89.7
25	0.00350	-0.01015	-50.0	0.0	0.00022	-39.7	10.3	-0.02507	-39.7	89.7
26	0.00350	-0.01021	-50.0	0.0	0.00021	-39.7	10.3	-0.02519	-39.7	89.7
27	0.00350	-0.01027	-50.0	0.0	0.00019	-39.7	10.3	-0.02531	-39.7	89.7
28	0.00350	-0.01006	-50.0	0.0	0.00024	-39.7	10.3	-0.02488	-39.7	89.7
29	0.00350	-0.01011	-50.0	0.0	0.00023	-39.7	10.3	-0.02499	-39.7	89.7
30	0.00350	-0.01017	-50.0	0.0	0.00022	-39.7	10.3	-0.02511	-39.7	89.7
31	0.00350	-0.01022	-50.0	0.0	0.00020	-39.7	10.3	-0.02522	-39.7	89.7
32	0.00350	-0.01028	-50.0	0.0	0.00019	-39.7	10.3	-0.02534	-39.7	89.7
33	0.00350	-0.01034	-50.0	0.0	0.00017	-39.7	10.3	-0.02548	-39.7	89.7
34	0.00350	-0.01012	-50.0	0.0	0.00023	-39.7	10.3	-0.02500	-39.7	89.7
35	0.00350	-0.01016	-50.0	0.0	0.00022	-39.7	10.3	-0.02508	-39.7	89.7
36	0.00350	-0.01020	-50.0	0.0	0.00021	-39.7	10.3	-0.02518	-39.7	89.7

**POSIZIONE ASSE NEUTRO PER OGNI COMB. DI RESISTENZA**

a, b, c	Coeff. a, b, c nell'eq. dell'asse neutro $aX+bY+c=0$ nel rif. X,Y,O gen.
x/d	Rapp. di duttilità a rottura in presenza di sola fless. (travi)
C.Rid.	Coeff. di riduz. momenti per sola flessione in travi continue

N°Comb	a	b	c	x/d	C.Rid.
1	0.000000000	0.000350004	-0.031500423	----	----

PROGETTO DEFINITIVO

RELAZIONE DI CALCOLO GALLERIA ARTIFICIALE

2	0.000000000	0.000351851	-0.031685122	----	----
3	0.000000000	0.000353514	-0.031851351	----	----
4	0.000000000	-0.000289700	0.003500000	----	----
5	0.000000000	-0.000292055	0.003500000	----	----
6	0.000000000	-0.000294317	0.003500000	----	----
7	0.000000000	0.000353514	-0.031851351	----	----
8	0.000000000	0.000354991	-0.031999111	----	----
9	0.000000000	0.000356561	-0.032156105	----	----
10	0.000000000	-0.000295056	0.003500000	----	----
11	0.000000000	-0.000296534	0.003500000	----	----
12	0.000000000	-0.000298150	0.003500000	----	----
13	0.000000000	0.000355915	-0.032091460	----	----
14	0.000000000	0.000357577	-0.032257689	----	----
15	0.000000000	0.000359470	-0.032447006	----	----
16	0.000000000	-0.000296580	0.003500000	----	----
17	0.000000000	-0.000297919	0.003500000	----	----
18	0.000000000	-0.000299581	0.003500000	----	----
19	0.000000000	-0.000313526	0.003500000	----	----
20	0.000000000	-0.000315327	0.003500000	----	----
21	0.000000000	-0.000317035	0.003500000	----	----
22	0.000000000	-0.000310848	0.003500000	----	----
23	0.000000000	-0.000313111	0.003500000	----	----
24	0.000000000	-0.000315188	0.003500000	----	----
25	0.000000000	-0.000318513	0.003500000	----	----
26	0.000000000	-0.000319806	0.003500000	----	----
27	0.000000000	-0.000321191	0.003500000	----	----
28	0.000000000	-0.000316389	0.003500000	----	----
29	0.000000000	-0.000317636	0.003500000	----	----
30	0.000000000	-0.000318929	0.003500000	----	----
31	0.000000000	-0.000320222	0.003500000	----	----
32	0.000000000	-0.000321561	0.003500000	----	----
33	0.000000000	-0.000323038	0.003500000	----	----
34	0.000000000	-0.000317728	0.003500000	----	----
35	0.000000000	-0.000318652	0.003500000	----	----
36	0.000000000	-0.000319760	0.003500000	----	----

METODO SLU - VERIFICHE A TAGLIO SENZA ARMATURE TRASVERSALI (§ 4.1.2.1.3.1 NTC)

Ver	S = comb.verificata a taglio/ N = comb. non verificata
Vsdu	Taglio agente [daN] uguale al taglio Vy di comb. (sollecit. retta)
Vwct	Taglio trazione resistente [kN] in assenza di staffe [formula (4.1.14)NTC]
d	Altezza utile sezione [cm]
bw	Larghezza minima sezione [cm]
Ro	Rapporto geometrico di armatura longitudinale [<0.02]
Scp	Tensione media di compressione nella sezione [Mpa]

N°Comb	Ver	Vsdu	Vwct	d	bw	Ro	Scp
1	S	213.15	351.31	89.7	100.0	0.0025	0.35
2	S	147.07	349.32	89.7	100.0	0.0025	0.34
3	S	84.68	347.41	89.7	100.0	0.0025	0.32
4	S	1.99	425.11	89.7	100.0	0.0025	0.90
5	S	3.77	421.93	89.7	100.0	0.0025	0.88
6	S	35.46	418.90	89.7	100.0	0.0025	0.85
7	S	40.36	347.40	89.7	100.0	0.0025	0.32
8	S	12.39	345.70	89.7	100.0	0.0025	0.31
9	S	12.82	343.92	89.7	100.0	0.0025	0.30
10	S	18.33	417.88	89.7	100.0	0.0025	0.85
11	S	32.31	415.85	89.7	100.0	0.0025	0.83
12	S	68.14	413.70	89.7	100.0	0.0025	0.82



PROGETTO DEFINITIVO

RELAZIONE DI CALCOLO GALLERIA ARTIFICIALE

13	S	30.28	344.70	89.7	100.0	0.0025	0.30
14	S	44.20	342.78	89.7	100.0	0.0025	0.29
15	S	45.90	340.66	89.7	100.0	0.0025	0.27
16	S	121.07	415.84	89.7	100.0	0.0025	0.83
17	S	170.18	414.04	89.7	100.0	0.0025	0.82
18	S	216.48	411.92	89.7	100.0	0.0025	0.80
19	S	307.07	394.25	89.7	100.0	0.0025	0.67
20	S	207.33	392.05	89.7	100.0	0.0025	0.65
21	S	154.57	389.94	89.7	100.0	0.0025	0.64
22	S	199.14	397.47	89.7	100.0	0.0025	0.69
23	S	176.50	394.72	89.7	100.0	0.0025	0.67
24	S	109.22	392.22	89.7	100.0	0.0025	0.66
25	S	120.84	388.18	89.7	100.0	0.0025	0.63
26	S	64.01	386.55	89.7	100.0	0.0025	0.61
27	S	42.66	384.84	89.7	100.0	0.0025	0.60
28	S	84.52	390.75	89.7	100.0	0.0025	0.64
29	S	25.47	389.25	89.7	100.0	0.0025	0.63
30	S	51.29	387.65	89.7	100.0	0.0025	0.62
31	S	43.65	386.06	89.7	100.0	0.0025	0.61
32	S	65.49	384.44	89.7	100.0	0.0025	0.60
33	S	86.07	382.60	89.7	100.0	0.0025	0.58
34	S	77.56	389.14	89.7	100.0	0.0025	0.63
35	S	132.06	387.99	89.7	100.0	0.0025	0.62
36	S	205.57	386.65	89.7	100.0	0.0025	0.61

COMBINAZIONI RARE IN ESERCIZIO - MASSIME TENSIONI NORMALI ED APERTURA FESSURE

Ver	S = comb. verificata/ N = comb. non verificata
Sc max	Massima tensione (positiva se di compressione) nel conglomerato [Mpa]
Xc max, Yc max	Ascissa, Ordinata [cm] del punto corrisp. a Sc max (sistema rif. X,Y,O)
Sf min	Minima tensione (negativa se di trazione) nell'acciaio [Mpa]
Xs min, Ys min	Ascissa, Ordinata [cm] della barra corrisp. a Sf min (sistema rif. X,Y,O)
Ac eff.	Area di calcestruzzo [cm <sup>2</sup> ] in zona tesa considerata aderente alle barre
As eff.	Area barre [cm <sup>2</sup> ] in zona tesa considerate efficaci per l'apertura delle fessure
D barre	Distanza tra le barre tese [cm] ai fini del calcolo dell'apertura fessure
Beta12	Prodotto dei coeff. di aderenza delle barre Beta1*Beta2

N°Comb	Ver	Sc max	Xc max	Yc max	Sf min	Xs min	Ys min	Ac eff.	As eff.	D barre	Beta12
1	S	0.89	-50.0	0.0	6.7	19.9	89.7	----	----	----	----
2	S	0.97	-50.0	0.0	5.3	19.9	89.7	----	----	----	----
3	S	0.96	-50.0	0.0	5.0	19.9	89.7	----	----	----	----
4	S	2.08	-50.0	0.0	-12.8	19.9	89.7	1800	22.6	19.9	1.00
5	S	2.74	-50.0	0.0	-33.7	19.9	89.7	2528	22.6	19.9	1.00
6	S	3.14	-50.0	0.0	-49.5	19.9	89.7	2605	22.6	19.9	1.00
7	S	0.96	-50.0	0.0	5.0	19.9	89.7	----	----	----	----
8	S	0.88	-50.0	0.0	5.7	19.9	89.7	----	----	----	----
9	S	0.72	-50.0	0.0	7.2	19.9	89.7	----	----	----	----
10	S	3.14	-50.0	0.0	-49.9	19.9	89.7	2605	22.6	19.9	1.00
11	S	3.15	-50.0	0.0	-51.6	19.9	89.7	2605	22.6	19.9	1.00
12	S	2.94	-50.0	0.0	-44.8	19.9	89.7	2605	22.6	19.9	1.00
13	S	0.73	-50.0	0.0	7.4	19.9	89.7	----	----	----	----
14	S	0.68	-50.0	100.0	7.6	19.9	10.3	----	----	----	----
15	S	0.97	-50.0	100.0	3.9	19.9	10.3	----	----	----	----
16	S	2.93	-50.0	0.0	-43.5	19.9	89.7	2605	22.6	19.9	1.00
17	S	2.37	-50.0	0.0	-25.4	19.9	89.7	2400	22.6	19.9	1.00
18	S	1.68	-50.0	0.0	-7.4	19.9	89.7	1550	22.6	19.9	1.00

COMBINAZIONI FREQUENTI IN ESERCIZIO - MASSIME TENSIONI NORMALI ED APERTURA FESSURE

PROGETTO DEFINITIVO

RELAZIONE DI CALCOLO GALLERIA ARTIFICIALE

N°Comb	Ver	Sc max	Xc max	Yc max	Sf min	Xs min	Ys min	Ac eff.	As eff.	D barre	Beta12
1	S	2.75	-50.0	0.0	-32.4	19.9	89.7	2490	22.6	19.9	0.50
2	S	3.56	-50.0	0.0	-63.8	19.9	89.7	2605	22.6	19.9	0.50
3	S	4.05	-50.0	0.0	-86.3	19.9	89.7	2605	22.6	19.9	0.50
4	S	2.75	-50.0	0.0	-32.4	19.9	89.7	2490	22.6	19.9	0.50
5	S	3.56	-50.0	0.0	-63.8	19.9	89.7	2605	22.6	19.9	0.50
6	S	4.05	-50.0	0.0	-86.3	19.9	89.7	2605	22.6	19.9	0.50
7	S	4.06	-50.0	0.0	-87.1	19.9	89.7	2605	22.6	19.9	0.50
8	S	4.09	-50.0	0.0	-90.1	19.9	89.7	2605	22.6	19.9	0.50
9	S	3.90	-50.0	0.0	-83.6	19.9	89.7	2605	22.6	19.9	0.50
10	S	4.06	-50.0	0.0	-87.1	19.9	89.7	2605	22.6	19.9	0.50
11	S	4.09	-50.0	0.0	-90.1	19.9	89.7	2605	22.6	19.9	0.50
12	S	3.90	-50.0	0.0	-83.6	19.9	89.7	2605	22.6	19.9	0.50
13	S	3.89	-50.0	0.0	-81.7	19.9	89.7	2605	22.6	19.9	0.50
14	S	3.30	-50.0	0.0	-58.5	19.9	89.7	2605	22.6	19.9	0.50
15	S	2.49	-50.0	0.0	-30.2	19.9	89.7	2490	22.6	19.9	0.50
16	S	3.89	-50.0	0.0	-81.7	19.9	89.7	2605	22.6	19.9	0.50
17	S	3.30	-50.0	0.0	-58.5	19.9	89.7	2605	22.6	19.9	0.50
18	S	2.49	-50.0	0.0	-30.2	19.9	89.7	2490	22.6	19.9	0.50

COMBINAZIONI FREQUENTI IN ESERCIZIO - APERTURA FESSURE [§B.6.6 DM96]

Ver.	La sezione viene assunta sempre fessurata anche nel caso in cui la trazione minima del calcestruzzo sia inferiore a $f_{ctm}$
S1	Esito della verifica
S2	Massima tensione [Mpa] di trazione nel calcestruzzo valutata in sezione non fessurata
k2	Minima tensione [Mpa] di trazione nel calcestruzzo valutata in sezione fessurata
k3	= 0.4 per barre ad aderenza migliorata
Ø	= 0.125 per flessione e presso-flessione; $= (e1 + e2)/(2 \cdot e1)$ per trazione eccentrica
Cf	Diametro [mm] medio delle barre tese comprese nell'area efficace Ac eff
Psi	Copriferro [mm] netto calcolato con riferimento alla barra più tesa
e sm	= $1 - \text{Beta}12 \cdot (Ssr/Ss)^2 = 1 - \text{Beta}12 \cdot (f_{ctm}/S2)^2 = 1 - \text{Beta}12 \cdot (M_{fess}/M)^2$ [B.6.6 DM96]
srm	Deformazione unitaria media tra le fessure [4.3.1.7.1.3 DM96]. Il valore limite = $0.4 \cdot Ss/Es$ è tra parentesi
wk	Distanza media tra le fessure [mm]
MX fess.	Valore caratteristico [mm] dell'apertura fessure = $1.7 \cdot e \cdot sm \cdot srm$ . Valore limite tra parentesi
MY fess.	Componente momento di prima fessurazione intorno all'asse X [kNm]
	Componente momento di prima fessurazione intorno all'asse Y [kNm]

Comb.	Ver	S1	S2	k3	Ø	Cf	Psi	e sm	srm	wk	Mx fess	My fess
1	S	-0.9	0	0.125	24	91.0	-3.856	0.00006 (0.00006)	354	0.039 (0.30)	-898.58	0.00
2	S	-1.3	0	0.125	24	91.0	-1.354	0.00013 (0.00013)	360	0.078 (0.30)	-776.36	0.00
3	S	-1.5	0	0.125	24	91.0	-0.666	0.00017 (0.00017)	360	0.106 (0.30)	-729.97	0.00
4	S	-0.9	0	0.125	24	91.0	-3.856	0.00006 (0.00006)	354	0.039 (0.30)	-898.58	0.00
5	S	-1.3	0	0.125	24	91.0	-1.354	0.00013 (0.00013)	360	0.078 (0.30)	-776.36	0.00
6	S	-1.5	0	0.125	24	91.0	-0.666	0.00017 (0.00017)	360	0.106 (0.30)	-729.97	0.00
7	S	-1.5	0	0.125	24	91.0	-0.656	0.00017 (0.00017)	360	0.107 (0.30)	-727.67	0.00
8	S	-1.5	0	0.125	24	91.0	-0.606	0.00018 (0.00018)	360	0.110 (0.30)	-720.88	0.00
9	S	-1.5	0	0.125	24	91.0	-0.792	0.00017 (0.00017)	360	0.102 (0.30)	-728.12	0.00
10	S	-1.5	0	0.125	24	91.0	-0.656	0.00017 (0.00017)	360	0.107 (0.30)	-727.67	0.00
11	S	-1.5	0	0.125	24	91.0	-0.606	0.00018 (0.00018)	360	0.110 (0.30)	-720.88	0.00
12	S	-1.5	0	0.125	24	91.0	-0.792	0.00017 (0.00017)	360	0.102 (0.30)	-728.12	0.00
13	S	-1.4	0	0.125	24	91.0	-0.819	0.00016 (0.00016)	360	0.100 (0.30)	-733.62	0.00
14	S	-1.2	0	0.125	24	91.0	-1.759	0.00012 (0.00012)	360	0.072 (0.30)	-779.05	0.00
15	S	-0.8	0	0.125	24	91.0	-4.831	0.00006 (0.00006)	354	0.036 (0.30)	-889.74	0.00
16	S	-1.4	0	0.125	24	91.0	-0.819	0.00016 (0.00016)	360	0.100 (0.30)	-733.62	0.00
17	S	-1.2	0	0.125	24	91.0	-1.759	0.00012 (0.00012)	360	0.072 (0.30)	-779.05	0.00
18	S	-0.8	0	0.125	24	91.0	-4.831	0.00006 (0.00006)	354	0.036 (0.30)	-889.74	0.00

COMBINAZIONI QUASI PERMANENTI IN ESERCIZIO - MASSIME TENSIONI NORMALI ED APERTURA FESSURE

PROGETTO DEFINITIVO

RELAZIONE DI CALCOLO GALLERIA ARTIFICIALE

N°Comb	Ver	Sc max	Xc max	Yc max	Sf min	Xs min	Ys min	Ac eff.	As eff.	D barre	Beta12
1	S	0.82	-50.0	0.0	7.5	19.9	89.7	----	----	----	----
2	S	0.91	-50.0	0.0	6.0	19.9	89.7	----	----	----	----
3	S	0.90	-50.0	0.0	5.7	19.9	89.7	----	----	----	----
4	S	2.08	-50.0	0.0	-12.8	19.9	89.7	1800	22.6	19.9	0.50
5	S	2.74	-50.0	0.0	-33.7	19.9	89.7	2528	22.6	19.9	0.50
6	S	3.14	-50.0	0.0	-49.5	19.9	89.7	2605	22.6	19.9	0.50
7	S	0.90	-50.0	0.0	5.6	19.9	89.7	----	----	----	----
8	S	0.83	-50.0	0.0	6.3	19.9	89.7	----	----	----	----
9	S	0.68	-50.0	0.0	7.8	19.9	89.7	----	----	----	----
10	S	3.14	-50.0	0.0	-49.9	19.9	89.7	2605	22.6	19.9	0.50
11	S	3.15	-50.0	0.0	-51.6	19.9	89.7	2605	22.6	19.9	0.50
12	S	2.94	-50.0	0.0	-44.8	19.9	89.7	2605	22.6	19.9	0.50
13	S	0.68	-50.0	0.0	7.9	19.9	89.7	----	----	----	----
14	S	0.72	-50.0	100.0	7.2	19.9	10.3	----	----	----	----
15	S	1.00	-50.0	100.0	3.5	19.9	10.3	----	----	----	----
16	S	2.93	-50.0	0.0	-43.5	19.9	89.7	2605	22.6	19.9	0.50
17	S	2.37	-50.0	0.0	-25.4	19.9	89.7	2400	22.6	19.9	0.50
18	S	1.68	-50.0	0.0	-7.4	19.9	89.7	1550	22.6	19.9	0.50

COMBINAZIONI QUASI PERMANENTI IN ESERCIZIO - APERTURA FESSURE [SB.6.6 DM96]

Comb.	Ver	S1	S2	k3	Ø	Cf	Psi	e sm	srm	wk	Mx fess	My fess
1	S	0.5	0	----	----	----	----	----	----	----	0.00	0.00
2	S	0.3	0	----	----	----	----	----	----	----	0.00	0.00
3	S	0.3	0	----	----	----	----	----	----	----	0.00	0.00
4	S	-0.6	0	0.125	24	91.0	-11.548	0.00003 (0.00003)	317	0.014 (0.20)	-1128.28	0.00
5	S	-0.9	0	0.125	24	91.0	-3.787	0.00007 (0.00007)	356	0.041 (0.20)	-885.46	0.00
6	S	-1.1	0	0.125	24	91.0	-2.226	0.00010 (0.00010)	360	0.061 (0.20)	-812.09	0.00
7	S	0.3	0	----	----	----	----	----	----	----	0.00	0.00
8	S	0.4	0	----	----	----	----	----	----	----	0.00	0.00
9	S	0.5	0	----	----	----	----	----	----	----	0.00	0.00
10	S	-1.1	0	0.125	24	91.0	-2.209	0.00010 (0.00010)	360	0.061 (0.20)	-810.01	0.00
11	S	-1.1	0	0.125	24	91.0	-2.139	0.00010 (0.00010)	360	0.063 (0.20)	-801.52	0.00
12	S	-1.0	0	0.125	24	91.0	-2.742	0.00009 (0.00009)	360	0.055 (0.20)	-821.41	0.00
13	S	0.5	0	----	----	----	----	----	----	----	0.00	0.00
14	S	0.5	0	----	----	----	----	----	----	----	0.00	0.00
15	S	0.1	0	----	----	----	----	----	----	----	0.00	0.00
16	S	-1.0	0	0.125	24	91.0	-2.816	0.00009 (0.00009)	360	0.053 (0.20)	-829.47	0.00
17	S	-0.7	0	0.125	24	91.0	-5.876	0.00005 (0.00005)	349	0.030 (0.20)	-929.01	0.00
18	S	-0.4	0	0.125	24	91.0	-23.420	0.00001 (0.00001)	304	0.008 (0.20)	-1276.73	0.00

7.4 VERIFICA SEZIONE S5

DATI GENERALI SEZIONE IN C.A.

NOME SEZIONE: Sezione 5

(Percorso File: C:\Users\lid-209\Desktop\Galleria Artificiale\Verifica Sezioni\Sezione 5.sez)

Descrizione Sezione: Sezione S5  
Metodo di calcolo resistenza: Stati Limite Ultimi

**PROGETTO DEFINITIVO**

**RELAZIONE DI CALCOLO GALLERIA ARTIFICIALE**

Tipologia sezione:	Sezione generica
Normativa di riferimento:	N.T.C.
Percorso sollecitazione:	A Sforzo Norm. costante
Condizioni Ambientali:	Moderat. aggressive
Tipo di sollecitazione:	Retta (asse neutro sempre parallelo all'asse X)
Riferimento Sforzi assegnati:	Assi x,y principali d'inerzia
Riferimento alla sismicità:	Zona non sismica

**CARATTERISTICHE DI RESISTENZA DEI MATERIALI IMPIEGATI**

CALCESTRUZZO -	Classe:	C28/35
	Resis. compr. di calcolo fcd:	15.860 MPa
	Resis. compr. ridotta fcd':	0.000 MPa
	Def.unit. max resistenza ec2:	0.0020
	Def.unit. ultima ecu:	0.0035
	Diagramma tensione-deformaz.:	Parabola-Rettangolo
	Modulo Elastico Normale Ec:	32308.0 MPa
	Resis. media a trazione fctm:	2.760 MPa
	Coeff. Omogen. S.L.E.:	15.00
	Coeff. Omogen. S.L.E.:	15.00
	Sc limite S.L.E. comb. Frequenti:	168.00 daN/cm <sup>2</sup>
	Ap.Fessure limite S.L.E. comb. Frequenti:	0.300 mm
	Sc limite S.L.E. comb. Q.Permanenti:	0.00 Mpa
Ap.Fessure limite S.L.E. comb. Q.Permanenti:	0.200 mm	
ACCIAIO -	Tipo:	B450C
	Resist. caratt. snervam. fyk:	450.00 MPa
	Resist. caratt. rottura ftk:	450.00 MPa
	Resist. snerv. di calcolo fyd:	391.30 MPa
	Resist. ultima di calcolo ftd:	391.30 MPa
	Deform. ultima di calcolo Epu:	0.068
	Modulo Elastico Ef	2000000 daN/cm <sup>2</sup>
	Diagramma tensione-deformaz.:	Bilineare finito
	Coeff. Aderenza istantaneo $\beta_1 \cdot \beta_2$ :	1.00
	Coeff. Aderenza differito $\beta_1 \cdot \beta_2$ :	0.50
Sf limite S.L.E. Comb. Rare:	360.00 MPa	

**CARATTERISTICHE DOMINIO CONGLOMERATO**

Forma del Dominio:	Poligonale
Classe Conglomerato:	C28/35

N° vertice:	X [cm]	Y [cm]
1	-50.0	0.0
2	-50.0	150.0
3	50.0	150.0
4	50.0	0.0

**DATI BARRE ISOLATE**

N° Barra	X [cm]	Y [cm]	DiamØ[mm]
1	-39.7	10.3	24
2	-39.7	139.7	24
3	39.7	139.7	24
4	39.7	10.3	24

**DATI GENERAZIONI LINEARI DI BARRE**

**PROGETTO DEFINITIVO**

**RELAZIONE DI CALCOLO GALLERIA ARTIFICIALE**

N°Gen. Numero assegnato alla singola generazione lineare di barre  
 N°Barra Ini. Numero della barra iniziale cui si riferisce la generazione  
 N°Barra Fin. Numero della barra finale cui si riferisce la generazione  
 N°Barre Numero di barre generate equidistanti cui si riferisce la generazione  
 Ø Diametro in mm delle barre della generazione

N°Gen.	N°Barra Ini.	N°Barra Fin.	N°Barre	Ø
1	2	3	3	24
2	1	4	3	24

**ARMATURE A TAGLIO**

Diametro staffe: 12 mm  
 Passo staffe: 1000.0 cm  
 Staffe: Una sola staffa chiusa perimetrale

**ST.LIM.ULTIMI - SFORZI PER OGNI COMBINAZIONE ASSEGNATA**

N Sforzo normale [kN] applicato nel Baric. (+ se di compressione)  
 Mx Momento flettente [daNm] intorno all'asse X di riferimento delle coordinate  
 con verso positivo se tale da comprimere il lembo sup. della sez.  
 Vy Componente del Taglio [kN] parallela all'asse Y di riferimento delle coordinate

N°Comb.	N	Mx	Vy
1	284.84	191.64	-51.78
2	267.00	222.96	-74.69
3	246.13	264.67	-80.24
4	840.54	-406.94	-269.88
5	824.67	-263.15	-312.31
6	803.30	-100.29	-347.30
7	277.60	264.67	313.02
8	264.03	136.17	239.10
9	252.86	72.02	170.14
10	925.98	-100.29	60.69
11	898.78	-193.09	36.92
12	868.19	-245.26	17.33
13	617.82	-599.45	-185.43
14	603.35	-473.43	-206.33
15	585.68	-326.77	-226.88
16	646.39	-632.78	-232.75
17	636.70	-531.78	-278.35
18	622.75	-424.76	-328.63
19	718.38	-326.77	147.11
20	707.86	-373.50	61.07
21	697.55	-383.98	-4.65
22	759.94	-424.76	122.42
23	751.79	-475.56	52.24
24	754.15	-490.41	-25.34

**COMB. RARE (S.L.E.) - SFORZI PER OGNI COMBINAZIONE ASSEGNATA**

N Sforzo normale [kN] applicato nel Baricentro (+ se di compressione)  
 Mx Momento flettente [kNm] intorno all'asse X di riferimento (tra parentesi Mom.Fessurazione)  
 con verso positivo se tale da comprimere il lembo superiore della sezione

PROGETTO DEFINITIVO

RELAZIONE DI CALCOLO GALLERIA ARTIFICIALE

N°Comb.	N	Mx	My
1	632.20	74.21	0.00
2	618.12	144.94	0.00
3	600.20	226.07	0.00
4	640.85	-182.69	0.00
5	628.64	-86.51	0.00
6	612.20	24.34	0.00
7	606.22	226.07	0.00
8	580.12	111.24	0.00
9	552.72	25.88	0.00
10	673.15	24.34	0.00
11	652.23	-62.57	0.00
12	628.69	-118.22	0.00

COMB. FREQUENTI (S.L.E.) - SFORZI PER OGNI COMBINAZIONE ASSEGNATA

N Sforzo normale [kN] applicato nel Baricentro (+ se di compressione)  
 Mx Momento flettente [kNm] intorno all'asse X di riferimento (tra parentesi Mom.Fessurazione)  
 con verso positivo se tale da comprimere il lembo superiore della sezione

N°Comb.	N	Mx	My
1	644.24	-260.54 (-3266.71)	0.00 (0.00)
2	632.04	-155.78 (0.00)	0.00 (0.00)
3	615.59	-36.35 (0.00)	0.00 (0.00)
4	644.24	-260.54 (-3266.71)	0.00 (0.00)
5	632.04	-155.78 (0.00)	0.00 (0.00)
6	615.59	-36.35 (0.00)	0.00 (0.00)
7	696.50	-36.35 (0.00)	0.00 (0.00)
8	675.58	-113.99 (0.00)	0.00 (0.00)
9	652.05	-160.37 (0.00)	0.00 (0.00)
10	696.50	-36.35 (0.00)	0.00 (0.00)
11	675.58	-113.99 (0.00)	0.00 (0.00)
12	652.05	-160.37 (0.00)	0.00 (0.00)

COMB. QUASI PERMANENTI (S.L.E.) - SFORZI PER OGNI COMBINAZIONE ASSEGNATA

N Sforzo normale [kN] applicato nel Baricentro (+ se di compressione)  
 Mx Momento flettente [kNm] intorno all'asse X di riferimento (tra parentesi Mom.Fessurazione)  
 con verso positivo se tale da comprimere il lembo superiore della sezione

N°Comb.	N	Mx	My
1	631.59	79.92 (0.00)	0.00 (0.00)
2	617.51	149.43 (0.00)	0.00 (0.00)
3	599.60	229.34 (3657.85)	0.00 (0.00)
4	640.85	-182.69 (-14945.25)	0.00 (0.00)
5	628.64	-86.51 (0.00)	0.00 (0.00)
6	612.20	24.34 (0.00)	0.00 (0.00)
7	604.11	229.34 (3719.73)	0.00 (0.00)
8	578.00	113.76 (0.00)	0.00 (0.00)
9	550.61	27.64 (0.00)	0.00 (0.00)
10	673.15	24.34 (0.00)	0.00 (0.00)
11	652.23	-62.57 (0.00)	0.00 (0.00)
12	628.69	-118.22 (0.00)	0.00 (0.00)

RISULTATI DEL CALCOLO

Sezione verificata per tutte le combinazioni assegnate

Copriferro netto minimo barre longitudinali: 9.1 cm  
Interferro netto minimo barre longitudinali: 17.5 cm

METODO AGLI STATI LIMITE ULTIMI - RISULTATI PRESSO-TENSO FLESSIONE

Ver S = combinazione verificata / N = combin. non verificata  
N Sforzo normale assegnato [kN] nel baricentro B sezione cls.(positivo se di compressione)  
Mx Momento flettente assegnato [kNm] riferito all'asse x princ. d'inerzia  
N ult Sforzo normale ultimo [kN] nel baricentro B sezione cls.(positivo se di compress.)  
Mx ult Momento flettente ultimo [kNm] riferito all'asse x princ. d'inerzia  
Mis.Sic. Misura sicurezza = rapporto vettoriale tra (N ult,Mx ult,My ult) e (N,Mx,My)  
Verifica positiva se tale rapporto risulta >=1.000  
As Tesa Area armature [cm²] in zona tesa (solo travi). Tra parentesi l'area minima di normativa

N°Comb	Ver	N	Mx	N ult	Mx ult	Mis.Sic.	As Tesa
1	S	284.84	191.64	285.00	1407.94	7.347	-----
2	S	267.00	222.96	267.19	1396.25	6.262	-----
3	S	246.13	264.67	245.89	1382.26	5.223	-----
4	S	840.54	-406.94	840.82	-1771.02	4.352	-----
5	S	824.67	-263.15	824.61	-1760.50	6.690	-----
6	S	803.30	-100.29	803.11	-1746.53	17.415	-----
7	S	277.60	264.67	277.43	1402.97	5.301	-----
8	S	264.03	136.17	263.96	1394.13	10.238	-----
9	S	252.86	72.02	252.85	1386.84	19.256	-----
10	S	925.98	-100.29	925.98	-1826.27	18.210	-----
11	S	898.78	-193.09	898.72	-1808.58	9.367	-----
12	S	868.19	-245.26	868.17	-1788.77	7.293	-----
13	S	617.82	-599.45	617.83	-1625.82	2.712	-----
14	S	603.35	-473.43	603.20	-1616.27	3.414	-----
15	S	585.68	-326.77	585.74	-1604.88	4.911	-----
16	S	646.39	-632.78	646.31	-1644.41	2.599	-----
17	S	636.70	-531.78	636.68	-1638.12	3.080	-----
18	S	622.75	-424.76	622.69	-1628.99	3.835	-----
19	S	718.38	-326.77	718.27	-1691.32	5.176	-----
20	S	707.86	-373.50	707.96	-1684.61	4.510	-----
21	S	697.55	-383.98	697.61	-1677.87	4.370	-----
22	S	759.94	-424.76	760.22	-1718.62	4.046	-----
23	S	751.79	-475.56	751.77	-1713.12	3.602	-----
24	S	754.15	-490.41	754.03	-1714.59	3.496	-----

METODO AGLI STATI LIMITE ULTIMI - DEFORMAZIONI UNITARIE ALLO STATO ULTIMO

ec max Deform. unit. massima del conglomerato a compressione  
ec 3/7 Deform. unit. del conglomerato nella fibra a 3/7 dell'altezza efficace  
Xc max Ascissa in cm della fibra corrisp. a ec max (sistema rif. X,Y,O sez.)  
Yc max Ordinata in cm della fibra corrisp. a ec max (sistema rif. X,Y,O sez.)  
es min Deform. unit. minima nell'acciaio (negativa se di trazione)  
Xs min Ascissa in cm della barra corrisp. a es min (sistema rif. X,Y,O sez.)  
Ys min Ordinata in cm della barra corrisp. a es min (sistema rif. X,Y,O sez.)  
es max Deform. unit. massima nell'acciaio (positiva se di compress.)  
Xs max Ascissa in cm della barra corrisp. a es max (sistema rif. X,Y,O sez.)  
Ys max Ordinata in cm della barra corrisp. a es max (sistema rif. X,Y,O sez.)

N°Comb	ec max	ec 3/7	Xc max	Yc max	es min	Xs min	Ys min	es max	Xs max	Ys max
1	0.00350	-0.01951	-50.0	150.0	-0.00019	-39.7	139.7	-0.04650	-39.7	10.3
2	0.00350	-0.01965	-50.0	150.0	-0.00021	-39.7	139.7	-0.04681	-39.7	10.3

PROGETTO DEFINITIVO

RELAZIONE DI CALCOLO GALLERIA ARTIFICIALE

3	0.00350	-0.01983	-50.0	150.0	-0.00024	-39.7	139.7	-0.04719	-39.7	10.3
4	0.00350	-0.01550	-50.0	0.0	0.00046	-39.7	10.3	-0.03780	-39.7	139.7
5	0.00350	-0.01561	-50.0	0.0	0.00044	-39.7	10.3	-0.03802	-39.7	139.7
6	0.00350	-0.01575	-50.0	0.0	0.00042	-39.7	10.3	-0.03833	-39.7	139.7
7	0.00350	-0.01957	-50.0	150.0	-0.00020	-39.7	139.7	-0.04663	-39.7	10.3
8	0.00350	-0.01968	-50.0	150.0	-0.00021	-39.7	139.7	-0.04687	-39.7	10.3
9	0.00350	-0.01977	-50.0	150.0	-0.00023	-39.7	139.7	-0.04707	-39.7	10.3
10	0.00350	-0.01495	-50.0	0.0	0.00054	-39.7	10.3	-0.03660	-39.7	139.7
11	0.00350	-0.01513	-50.0	0.0	0.00051	-39.7	10.3	-0.03699	-39.7	139.7
12	0.00350	-0.01533	-50.0	0.0	0.00048	-39.7	10.3	-0.03742	-39.7	139.7
13	0.00350	-0.01703	-50.0	0.0	0.00021	-39.7	10.3	-0.04111	-39.7	139.7
14	0.00350	-0.01713	-50.0	0.0	0.00019	-39.7	10.3	-0.04134	-39.7	139.7
15	0.00350	-0.01725	-50.0	0.0	0.00017	-39.7	10.3	-0.04160	-39.7	139.7
16	0.00350	-0.01683	-50.0	0.0	0.00024	-39.7	10.3	-0.04068	-39.7	139.7
17	0.00350	-0.01690	-50.0	0.0	0.00023	-39.7	10.3	-0.04082	-39.7	139.7
18	0.00350	-0.01700	-50.0	0.0	0.00022	-39.7	10.3	-0.04104	-39.7	139.7
19	0.00350	-0.01633	-50.0	0.0	0.00032	-39.7	10.3	-0.03958	-39.7	139.7
20	0.00350	-0.01639	-50.0	0.0	0.00031	-39.7	10.3	-0.03973	-39.7	139.7
21	0.00350	-0.01646	-50.0	0.0	0.00030	-39.7	10.3	-0.03988	-39.7	139.7
22	0.00350	-0.01604	-50.0	0.0	0.00037	-39.7	10.3	-0.03897	-39.7	139.7
23	0.00350	-0.01610	-50.0	0.0	0.00036	-39.7	10.3	-0.03910	-39.7	139.7
24	0.00350	-0.01609	-50.0	0.0	0.00036	-39.7	10.3	-0.03906	-39.7	139.7

POSIZIONE ASSE NEUTRO PER OGNI COMB. DI RESISTENZA

a, b, c            Coeff. a, b, c nell'eq. dell'asse neutro  $aX+bY+c=0$  nel rif. X,Y,O gen.  
 x/d                Rapp. di duttilità a rottura in presenza di sola fless. (travi)  
 C.Rid.             Coeff. di riduz. momenti per sola flessione in travi continue

N° Comb	a	b	c	x/d	C.Rid.
1	0.000000000	0.000357944	-0.050191621	----	----
2	0.000000000	0.000360134	-0.050520135	----	----
3	0.000000000	0.000362857	-0.050928558	----	----
4	0.000000000	-0.000295615	0.003500000	----	----
5	0.000000000	-0.000297213	0.003500000	----	----
6	0.000000000	-0.000299463	0.003500000	----	----
7	0.000000000	0.000358832	-0.050324803	----	----
8	0.000000000	0.000360549	-0.050582287	----	----
9	0.000000000	0.000361969	-0.050795377	----	----
10	0.000000000	-0.000287032	0.003500000	----	----
11	0.000000000	-0.000289814	0.003500000	----	----
12	0.000000000	-0.000292892	0.003500000	----	----
13	0.000000000	-0.000319351	0.003500000	----	----
14	0.000000000	-0.000320949	0.003500000	----	----
15	0.000000000	-0.000322843	0.003500000	----	----
16	0.000000000	-0.000316214	0.003500000	----	----
17	0.000000000	-0.000317279	0.003500000	----	----
18	0.000000000	-0.000318818	0.003500000	----	----
19	0.000000000	-0.000308401	0.003500000	----	----
20	0.000000000	-0.000309466	0.003500000	----	----
21	0.000000000	-0.000310532	0.003500000	----	----
22	0.000000000	-0.000304020	0.003500000	----	----
23	0.000000000	-0.000304908	0.003500000	----	----
24	0.000000000	-0.000304672	0.003500000	----	----

METODO SLU - VERIFICHE A TAGLIO SENZA ARMATURE TRASVERSALI (§ 4.1.2.1.3.1 NTC)

Ver                S = comb.verificata a taglio/ N = comb. non verificata



PROGETTO DEFINITIVO

RELAZIONE DI CALCOLO GALLERIA ARTIFICIALE

Vsdu	Taglio agente [daN] uguale al taglio Vy di comb. (sollecit. retta)
Vwct	Taglio trazione resistente [kN] in assenza di staffe [formula (4.1.14)NTC]
d	Altezza utile sezione [cm]
bw	Larghezza minima sezione [cm]
Ro	Rapporto geometrico di armatura longitudinale [ $<0.02$ ]
Scp	Tensione media di compressione nella sezione [Mpa]

N°Comb	Ver	Vsdu	Vwct	d	bw	Ro	Scp
1	S	51.78	422.67	139.7	100.0	0.0016	0.19
2	S	74.69	422.42	139.7	100.0	0.0016	0.18
3	S	80.24	422.13	139.7	100.0	0.0016	0.16
4	S	269.88	499.86	139.7	100.0	0.0016	0.56
5	S	312.31	497.64	139.7	100.0	0.0016	0.55
6	S	347.30	494.66	139.7	100.0	0.0016	0.54
7	S	313.02	422.57	139.7	100.0	0.0016	0.19
8	S	239.10	422.38	139.7	100.0	0.0016	0.18
9	S	170.14	422.22	139.7	100.0	0.0016	0.17
10	S	60.69	511.79	139.7	100.0	0.0016	0.62
11	S	36.92	508.00	139.7	100.0	0.0016	0.60
12	S	17.33	503.72	139.7	100.0	0.0016	0.58
13	S	185.43	468.74	139.7	100.0	0.0016	0.41
14	S	206.33	466.72	139.7	100.0	0.0016	0.40
15	S	226.88	464.25	139.7	100.0	0.0016	0.39
16	S	232.75	472.74	139.7	100.0	0.0016	0.43
17	S	278.35	471.38	139.7	100.0	0.0016	0.42
18	S	328.63	469.43	139.7	100.0	0.0016	0.42
19	S	147.11	482.79	139.7	100.0	0.0016	0.48
20	S	61.07	481.32	139.7	100.0	0.0016	0.47
21	S	4.65	479.88	139.7	100.0	0.0016	0.47
22	S	122.42	488.60	139.7	100.0	0.0016	0.51
23	S	52.24	487.46	139.7	100.0	0.0016	0.50
24	S	25.34	487.79	139.7	100.0	0.0016	0.50

COMBINAZIONI RARE IN ESERCIZIO - MASSIME TENSIONI NORMALI ED APERTURA FESSURE

Ver	S = comb. verificata/ N = comb. non verificata
Sc max	Massima tensione (positiva se di compressione) nel conglomerato [Mpa]
Xc max, Yc max	Ascissa, Ordinata [cm] del punto corrisp. a Sc max (sistema rif. X,Y,O)
Sf min	Minima tensione (negativa se di trazione) nell'acciaio [Mpa]
Xs min, Ys min	Ascissa, Ordinata [cm] della barra corrisp. a Sf min (sistema rif. X,Y,O)
Ac eff.	Area di calcestruzzo [cm <sup>2</sup> ] in zona tesa considerata aderente alle barre
As eff.	Area barre [cm <sup>2</sup> ] in zona tesa considerate efficaci per l'apertura delle fessure
D barre	Distanza tra le barre tese [cm] ai fini del calcolo dell'apertura fessure
Beta12	Prodotto dei coeff. di aderenza delle barre Beta1*Beta2

N°Comb	Ver	Sc max	Xc max	Yc max	Sf min	Xs min	Ys min	Ac eff.	As eff.	D barre	Beta12
1	S	0.58	-50.0	150.0	3.7	19.9	10.3	----	----	----	----
2	S	0.75	-50.0	150.0	1.4	19.9	10.3	----	----	----	----
3	S	0.97	-50.0	150.0	-2.5	19.9	10.3	1550	22.6	19.9	1.00
4	S	0.85	-50.0	0.0	0.4	19.9	139.7	----	----	----	----
5	S	0.61	-50.0	0.0	3.3	19.9	139.7	----	----	----	----
6	S	0.45	-50.0	150.0	5.1	19.9	10.3	----	----	----	----
7	S	0.97	-50.0	150.0	-2.4	19.9	10.3	1500	22.6	19.9	1.00
8	S	0.64	-50.0	150.0	2.1	19.9	10.3	----	----	----	----
9	S	0.42	-50.0	150.0	4.5	19.9	10.3	----	----	----	----
10	S	0.49	-50.0	150.0	5.7	19.9	10.3	----	----	----	----
11	S	0.57	-50.0	0.0	4.3	19.9	139.7	----	----	----	----
12	S	0.69	-50.0	0.0	2.3	19.9	139.7	----	----	----	----

PROGETTO DEFINITIVO

RELAZIONE DI CALCOLO GALLERIA ARTIFICIALE

COMBINAZIONI FREQUENTI IN ESERCIZIO - MASSIME TENSIONI NORMALI ED APERTURA FESSURE

N°Comb	Ver	Sc max	Xc max	Yc max	Sf min	Xs min	Ys min	Ac eff.	As eff.	D barre	Beta12
1	S	1.10	-50.0	0.0	-4.0	19.9	139.7	1900	22.6	19.9	0.50
2	S	0.78	-50.0	0.0	1.2	19.9	139.7	----	----	----	----
3	S	0.48	-50.0	0.0	4.8	19.9	139.7	----	----	----	----
4	S	1.10	-50.0	0.0	-4.0	19.9	139.7	1900	22.6	19.9	0.50
5	S	0.78	-50.0	0.0	1.2	19.9	139.7	----	----	----	----
6	S	0.48	-50.0	0.0	4.8	19.9	139.7	----	----	----	----
7	S	0.53	-50.0	0.0	5.5	19.9	139.7	----	----	----	----
8	S	0.71	-50.0	0.0	2.9	19.9	139.7	----	----	----	----
9	S	0.80	-50.0	0.0	1.2	19.9	139.7	----	----	----	----
10	S	0.53	-50.0	0.0	5.5	19.9	139.7	----	----	----	----
11	S	0.71	-50.0	0.0	2.9	19.9	139.7	----	----	----	----
12	S	0.80	-50.0	0.0	1.2	19.9	139.7	----	----	----	----

COMBINAZIONI FREQUENTI IN ESERCIZIO - APERTURA FESSURE [§B.6.6 DM96]

Ver.	Esito della verifica
S1	Massima tensione [Mpa] di trazione nel calcestruzzo valutata in sezione non fessurata
S2	Minima tensione [Mpa] di trazione nel calcestruzzo valutata in sezione fessurata
k2	= 0.4 per barre ad aderenza migliorata
k3	= 0.125 per flessione e presso-flessione; $= (e1 + e2) / (2 * e1)$ per trazione eccentrica
Ø	Diametro [mm] medio delle barre tese comprese nell'area efficace Ac eff
Cf	Copriferro [mm] netto calcolato con riferimento alla barra più tesa
Psi	$= 1 - \text{Beta}12 * (Ssr/Ss)^2 = 1 - \text{Beta}12 * (fctm/S2)^2 = 1 - \text{Beta}12 * (Mfess/M)^2$ [B.6.6 DM96]
e sm	Deformazione unitaria media tra le fessure [4.3.1.7.1.3 DM96]. Il valore limite = $0.4 * Ss/Es$ è tra parentesi
srm	Distanza media tra le fessure [mm]
wk	Valore caratteristico [mm] dell'apertura fessure = $1.7 * e * sm * srm$ . Valore limite tra parentesi
MX fess.	Componente momento di prima fessurazione intorno all'asse X [kNm]
MY fess.	Componente momento di prima fessurazione intorno all'asse Y [kNm]

Comb.	Ver	S1	S2	k3	Ø	Cf	Psi	e sm	srm	wk	Mx fess	My fess
1	S	-0.2	0	0.125	24	91.0	-77.606	0.00001 (0.00001)	322	0.004 (0.30)	-3266.71	0.00
2	S	0.0	0	----	----	----	----	----	----	----	0.00	0.00
3	S	0.3	0	----	----	----	----	----	----	----	0.00	0.00
4	S	-0.2	0	0.125	24	91.0	-77.606	0.00001 (0.00001)	322	0.004 (0.30)	-3266.71	0.00
5	S	0.0	0	----	----	----	----	----	----	----	0.00	0.00
6	S	0.3	0	----	----	----	----	----	----	----	0.00	0.00
7	S	0.4	0	----	----	----	----	----	----	----	0.00	0.00
8	S	0.2	0	----	----	----	----	----	----	----	0.00	0.00
9	S	0.0	0	----	----	----	----	----	----	----	0.00	0.00
10	S	0.4	0	----	----	----	----	----	----	----	0.00	0.00
11	S	0.2	0	----	----	----	----	----	----	----	0.00	0.00
12	S	0.0	0	----	----	----	----	----	----	----	0.00	0.00

COMBINAZIONI QUASI PERMANENTI IN ESERCIZIO - MASSIME TENSIONI NORMALI ED APERTURA FESSURE

N°Comb	Ver	Sc max	Xc max	Yc max	Sf min	Xs min	Ys min	Ac eff.	As eff.	D barre	Beta12
1	S	0.60	-50.0	150.0	3.5	19.9	10.3	----	----	----	----
2	S	0.76	-50.0	150.0	1.2	19.9	10.3	----	----	----	----
3	S	0.98	-50.0	150.0	-2.7	19.9	10.3	1600	22.6	19.9	0.50
4	S	0.85	-50.0	0.0	0.4	19.9	139.7	----	----	----	----
5	S	0.61	-50.0	0.0	3.3	19.9	139.7	----	----	----	----
6	S	0.45	-50.0	150.0	5.1	19.9	10.3	----	----	----	----
7	S	0.98	-50.0	150.0	-2.6	19.9	10.3	1600	22.6	19.9	0.50
8	S	0.64	-50.0	150.0	2.0	19.9	10.3	----	----	----	----

PROGETTO DEFINITIVO

RELAZIONE DI CALCOLO GALLERIA ARTIFICIALE

9	S	0.42	-50.0	150.0	4.4	19.9	10.3	----	----	----	----
10	S	0.49	-50.0	150.0	5.7	19.9	10.3	----	----	----	----
11	S	0.57	-50.0	0.0	4.3	19.9	139.7	----	----	----	----
12	S	0.69	-50.0	0.0	2.3	19.9	139.7	----	----	----	----

COMBINAZIONI QUASI PERMANENTI IN ESERCIZIO - APERTURA FESSURE [§B.6.6 DM96]

Comb.	Ver	S1	S2	k3	Ø	Cf	Psi	e sm	srm	wk	Mx fess	My fess
1	S	0.2	0	----	----	----	----	----	----	----	0.00	0.00
2	S	0.0	0	----	----	----	----	----	----	----	0.00	0.00
3	S	-0.2	0	0.125	24	91.0-126.189	0.00001 (0.00001)	307	0.003 (0.20)	----	3657.85	0.00
4	S	0.0	0	----	----	----	----	----	----	----	-14945.25	0.00
5	S	0.2	0	----	----	----	----	----	----	----	0.00	0.00
6	S	0.3	0	----	----	----	----	----	----	----	0.00	0.00
7	S	-0.2	0	0.125	24	91.0-130.529	0.00001 (0.00001)	307	0.003 (0.20)	----	3719.73	0.00
8	S	0.1	0	----	----	----	----	----	----	----	0.00	0.00
9	S	0.3	0	----	----	----	----	----	----	----	0.00	0.00
10	S	0.4	0	----	----	----	----	----	----	----	0.00	0.00
11	S	0.3	0	----	----	----	----	----	----	----	0.00	0.00
12	S	0.1	0	----	----	----	----	----	----	----	0.00	0.00

7.5 VERIFICA SEZIONE S6

DATI GENERALI SEZIONE IN C.A.

NOME SEZIONE: Sezione 6

(Percorso File: C:\Users\id-209\Desktop\Galleria Artificiale\Verifica Sezioni\Sezione 6.sez)

Descrizione Sezione:	Sezione S6
Metodo di calcolo resistenza:	Stati Limite Ultimi
Tipologia sezione:	Sezione generica
Normativa di riferimento:	N.T.C.
Percorso sollecitazione:	A Sforzo Norm. costante
Condizioni Ambientali:	Moderat. aggressive
Tipo di sollecitazione:	Retta (asse neutro sempre parallelo all'asse X)
Riferimento Sforzi assegnati:	Assi x,y principali d'inerzia
Riferimento alla sismicità:	Zona non sismica

CARATTERISTICHE DI RESISTENZA DEI MATERIALI IMPIEGATI

CALCESTRUZZO -	Classe:	C28/35
	Resis. compr. di calcolo fcd:	15.860 MPa
	Resis. compr. ridotta fcd':	0.000 MPa
	Def.unit. max resistenza ec2:	0.0020
	Def.unit. ultima ecu:	0.0035
	Diagramma tensione-deformaz.:	Parabola-Rettangolo
	Modulo Elastico Normale Ec:	32308.0 MPa
	Resis. media a trazione fctm:	2.760 MPa
	Coeff. Omogen. S.L.E.:	15.00
	Coeff. Omogen. S.L.E.:	15.00
	Sc limite S.L.E. comb. Frequenti:	168.00 daN/cm <sup>2</sup>
	Ap.Fessure limite S.L.E. comb. Frequenti:	0.300 mm

**PROGETTO DEFINITIVO**

**RELAZIONE DI CALCOLO GALLERIA ARTIFICIALE**

	Sc limite S.L.E. comb. Q.Permanenti:	0.00	Mpa
	Ap.Fessure limite S.L.E. comb. Q.Permanenti:	0.200	mm
ACCIAIO -	Tipo:	B450C	
	Resist. caratt. snervam. fyk:	450.00	MPa
	Resist. caratt. rottura ftk:	450.00	MPa
	Resist. snerv. di calcolo fyd:	391.30	MPa
	Resist. ultima di calcolo ftd:	391.30	MPa
	Deform. ultima di calcolo Epu:	0.068	
	Modulo Elastico Ef	2000000	daN/cm <sup>2</sup>
	Diagramma tensione-deformaz.:	Bilineare finito	
	Coeff. Aderenza istantaneo $\beta_1 \cdot \beta_2$ :	1.00	
	Coeff. Aderenza differito $\beta_1 \cdot \beta_2$ :	0.50	
	Sf limite S.L.E. Comb. Rare:	360.00	MPa

**CARATTERISTICHE DOMINIO CONGLOMERATO**

Forma del Dominio:	Poligonale	
Classe Conglomerato:	C28/35	
N°vertice:	X [cm]	Y [cm]
1	-50.0	0.0
2	-50.0	80.0
3	50.0	80.0
4	50.0	0.0

**DATI BARRE ISOLATE**

N°Barra	X [cm]	Y [cm]	DiamØ[mm]
1	-39.7	10.3	24
2	-39.7	69.7	24
3	39.7	69.7	24
4	39.7	10.3	24

**DATI GENERAZIONI LINEARI DI BARRE**

N°Gen.	Numero assegnato alla singola generazione lineare di barre			
N°Barra Ini.	Numero della barra iniziale cui si riferisce la generazione			
N°Barra Fin.	Numero della barra finale cui si riferisce la generazione			
N°Barre	Numero di barre generate equidistanti cui si riferisce la generazione			
Ø	Diametro in mm delle barre della generazione			
N°Gen.	N°Barra Ini.	N°Barra Fin.	N°Barre	Ø
1	2	3	3	24
2	1	4	3	24

**ARMATURE A TAGLIO**

Diametro staffe:	12	mm
Passo staffe:	1000.0	cm
Staffe:	Una sola staffa chiusa perimetrale	

**ST.LIM.ULTIMI - SFORZI PER OGNI COMBINAZIONE ASSEGNATA**

N	Sforzo normale [kN] applicato nel Baric. (+ se di compressione)
---	---

PROGETTO DEFINITIVO

RELAZIONE DI CALCOLO GALLERIA ARTIFICIALE

N°Comb.	N	Mx	Vy
		Momento flettente [daNm] intorno all'asse X di riferimento delle coordinate con verso positivo se tale da comprimere il lembo sup. della sez.	
		Componente del Taglio [kN] parallela all'asse Y di riferimento delle coordinate	
1	274.17	72.02	161.05
2	264.79	61.09	107.02
3	256.61	56.51	61.34
4	915.91	-245.26	-9.41
5	884.91	-241.04	-41.02
6	856.50	-202.15	-103.24
7	278.21	56.51	60.36
8	270.93	67.75	17.68
9	264.25	113.26	-22.63
10	902.65	-202.15	-137.48
11	875.40	-147.68	-195.48
12	847.88	-120.43	-249.93
13	768.27	-383.98	-40.65
14	758.59	-343.04	-106.15
15	749.96	-270.99	-161.92
16	785.46	-490.41	-57.40
17	787.26	-442.79	-119.54
18	798.01	-363.06	-191.27
19	807.99	-270.99	-196.24
20	796.61	-151.68	-247.97
21	783.93	-5.53	-296.16
22	825.77	-363.06	-233.13
23	827.07	-223.57	-287.26
24	832.07	-55.82	-338.76

COMB. RARE (S.L.E.) - SFORZI PER OGNI COMBINAZIONE ASSEGNATA

N°Comb.	N	Mx	My
		Sforzo normale [kN] applicato nel Baricentro (+ se di compressione)	
		Momento flettente [kNm] intorno all'asse X di riferimento (tra parentesi Mom.Fessurazione) con verso positivo se tale da comprimere il lembo superiore della sezione	
1	575.09	25.88	0.00
2	548.13	-23.17	0.00
3	523.34	-46.76	0.00
4	658.98	-118.22	0.00
5	635.13	-133.05	0.00
6	613.28	-121.22	0.00
7	544.94	-46.76	0.00
8	521.37	-38.12	0.00
9	498.07	-0.92	0.00
10	643.41	-121.22	0.00
11	622.45	-72.66	0.00
12	601.29	-7.25	0.00

COMB. FREQUENTI (S.L.E.) - SFORZI PER OGNI COMBINAZIONE ASSEGNATA

N°Comb.	N	Mx	My
		Sforzo normale [kN] applicato nel Baricentro (+ se di compressione)	
		Momento flettente [kNm] intorno all'asse X di riferimento (tra parentesi Mom.Fessurazione) con verso positivo se tale da comprimere il lembo superiore della sezione	

PROGETTO DEFINITIVO

RELAZIONE DI CALCOLO GALLERIA ARTIFICIALE

1	686.19	-160.37 (-838.55)	0.00 (0.00)
2	662.34	-164.40 (-771.07)	0.00 (0.00)
3	640.49	-141.77 (-915.12)	0.00 (0.00)
4	686.19	-160.37 (-838.55)	0.00 (0.00)
5	662.34	-164.40 (-771.07)	0.00 (0.00)
6	640.49	-141.77 (-915.12)	0.00 (0.00)
7	673.84	-141.77 (-1005.49)	0.00 (0.00)
8	652.88	-81.14 (0.00)	0.00 (0.00)
9	631.71	2.68 (0.00)	0.00 (0.00)
10	673.84	-141.77 (-1005.49)	0.00 (0.00)
11	652.88	-81.14 (0.00)	0.00 (0.00)
12	631.71	2.68 (0.00)	0.00 (0.00)

COMB. QUASI PERMANENTI (S.L.E.) - SFORZI PER OGNI COMBINAZIONE ASSEGNATA

N Sforzo normale [kN] applicato nel Baricentro (+ se di compressione)  
Mx Momento flettente [kNm] intorno all'asse X di riferimento (tra parentesi Mom.Fessurazione)  
con verso positivo se tale da comprimere il lembo superiore della sezione

N°Comb.	N	Mx	My
1	572.97	27.64 (0.00)	0.00 (0.00)
2	546.02	-22.17 (0.00)	0.00 (0.00)
3	521.23	-46.51 (0.00)	0.00 (0.00)
4	658.98	-118.22 (-1534.46)	0.00 (0.00)
5	635.13	-133.05 (-1014.30)	0.00 (0.00)
6	613.28	-121.22 (-1153.94)	0.00 (0.00)
7	542.83	-46.51 (0.00)	0.00 (0.00)
8	519.26	-38.63 (0.00)	0.00 (0.00)
9	495.96	-0.92 (0.00)	0.00 (0.00)
10	643.41	-121.22 (-1310.94)	0.00 (0.00)
11	622.45	-72.66 (0.00)	0.00 (0.00)
12	601.29	-8.51 (0.00)	0.00 (0.00)

RISULTATI DEL CALCOLO

Sezione verificata per tutte le combinazioni assegnate

Copriferro netto minimo barre longitudinali: 9.1 cm  
Interferro netto minimo barre longitudinali: 17.5 cm

METODO AGLI STATI LIMITE ULTIMI - RISULTATI PRESSO-TENSO FLESSIONE

Ver S = combinazione verificata / N = combin. non verificata  
N Sforzo normale assegnato [kN] nel baricentro B sezione cls.(positivo se di compressione)  
Mx Momento flettente assegnato [kNm] riferito all'asse x princ. d'inerzia  
N ult Sforzo normale ultimo [kN] nel baricentro B sezione cls.(positivo se di compress.)  
Mx ult Momento flettente ultimo [kNm] riferito all'asse x princ. d'inerzia  
Mis.Sic. Misura sicurezza = rapporto vettoriale tra (N ult,Mx ult,My ult) e (N,Mx,My)  
Verifica positiva se tale rapporto risulta >=1.000  
As Tesa Area armature [cm²] in zona tesa (solo travi). Tra parentesi l'area minima di normativa

N°Comb	Ver	N	Mx	N ult	Mx ult	Mis.Sic.	As Tesa
1	S	274.17	72.02	274.18	685.30	9.515	-----
2	S	264.79	61.09	264.91	682.46	11.171	-----
3	S	256.61	56.51	256.55	679.90	12.032	-----
4	S	915.91	-245.26	915.85	-879.58	3.586	-----
5	S	884.91	-241.04	884.78	-870.30	3.611	-----

PROGETTO DEFINITIVO

RELAZIONE DI CALCOLO GALLERIA ARTIFICIALE

6	S	856.50	-202.15	856.28	-861.78	4.263	-----
7	S	278.21	56.51	278.04	686.49	12.149	-----
8	S	270.93	67.75	270.94	684.31	10.101	-----
9	S	264.25	113.26	263.98	682.18	6.023	-----
10	S	902.65	-202.15	902.42	-875.57	4.331	-----
11	S	875.40	-147.68	875.32	-867.47	5.874	-----
12	S	847.88	-120.43	847.90	-859.28	7.135	-----
13	S	768.27	-383.98	768.15	-835.36	2.176	-----
14	S	758.59	-343.04	758.55	-832.47	2.427	-----
15	S	749.96	-270.99	750.06	-829.92	3.062	-----
16	S	785.46	-490.41	785.54	-840.59	1.714	-----
17	S	787.26	-442.79	787.22	-841.09	1.900	-----
18	S	798.01	-363.06	797.81	-844.28	2.325	-----
19	S	807.99	-270.99	807.80	-847.28	3.127	-----
20	S	796.61	-151.68	796.70	-843.94	5.564	-----
21	S	783.93	-5.53	783.86	-840.08	151.925	-----
22	S	825.77	-363.06	825.61	-852.62	2.348	-----
23	S	827.07	-223.57	826.82	-852.98	3.815	-----
24	S	832.07	-55.82	832.26	-854.61	15.311	-----

METODO AGLI STATI LIMITE ULTIMI - DEFORMAZIONI UNITARIE ALLO STATO ULTIMO

ec max	Deform. unit. massima del conglomerato a compressione
ec 3/7	Deform. unit. del conglomerato nella fibra a 3/7 dell'altezza efficace
Xc max	Ascissa in cm della fibra corrisp. a ec max (sistema rif. X,Y,O sez.)
Yc max	Ordinata in cm della fibra corrisp. a ec max (sistema rif. X,Y,O sez.)
es min	Deform. unit. minima nell'acciaio (negativa se di trazione)
Xs min	Ascissa in cm della barra corrisp. a es min (sistema rif. X,Y,O sez.)
Ys min	Ordinata in cm della barra corrisp. a es min (sistema rif. X,Y,O sez.)
es max	Deform. unit. massima nell'acciaio (positiva se di compress.)
Xs max	Ascissa in cm della barra corrisp. a es max (sistema rif. X,Y,O sez.)
Ys max	Ordinata in cm della barra corrisp. a es max (sistema rif. X,Y,O sez.)

N°Comb	ec max	ec 3/7	Xc max	Yc max	es min	Xs min	Ys min	es max	Xs max	Ys max
1	0.00350	-0.00882	-50.0	80.0	-0.00020	-39.7	69.7	-0.02154	-39.7	10.3
2	0.00350	-0.00886	-50.0	80.0	-0.00021	-39.7	69.7	-0.02162	-39.7	10.3
3	0.00350	-0.00889	-50.0	80.0	-0.00022	-39.7	69.7	-0.02170	-39.7	10.3
4	0.00350	-0.00638	-50.0	0.0	0.00053	-39.7	10.3	-0.01658	-39.7	69.7
5	0.00350	-0.00648	-50.0	0.0	0.00050	-39.7	10.3	-0.01680	-39.7	69.7
6	0.00350	-0.00658	-50.0	0.0	0.00047	-39.7	10.3	-0.01700	-39.7	69.7
7	0.00350	-0.00880	-50.0	80.0	-0.00020	-39.7	69.7	-0.02151	-39.7	10.3
8	0.00350	-0.00883	-50.0	80.0	-0.00020	-39.7	69.7	-0.02157	-39.7	10.3
9	0.00350	-0.00886	-50.0	80.0	-0.00021	-39.7	69.7	-0.02163	-39.7	10.3
10	0.00350	-0.00642	-50.0	0.0	0.00052	-39.7	10.3	-0.01667	-39.7	69.7
11	0.00350	-0.00652	-50.0	0.0	0.00049	-39.7	10.3	-0.01686	-39.7	69.7
12	0.00350	-0.00661	-50.0	0.0	0.00046	-39.7	10.3	-0.01706	-39.7	69.7
13	0.00350	-0.00689	-50.0	0.0	0.00038	-39.7	10.3	-0.01763	-39.7	69.7
14	0.00350	-0.00693	-50.0	0.0	0.00037	-39.7	10.3	-0.01770	-39.7	69.7
15	0.00350	-0.00696	-50.0	0.0	0.00036	-39.7	10.3	-0.01776	-39.7	69.7
16	0.00350	-0.00683	-50.0	0.0	0.00040	-39.7	10.3	-0.01750	-39.7	69.7
17	0.00350	-0.00683	-50.0	0.0	0.00040	-39.7	10.3	-0.01749	-39.7	69.7
18	0.00350	-0.00679	-50.0	0.0	0.00041	-39.7	10.3	-0.01741	-39.7	69.7
19	0.00350	-0.00675	-50.0	0.0	0.00042	-39.7	10.3	-0.01734	-39.7	69.7
20	0.00350	-0.00679	-50.0	0.0	0.00041	-39.7	10.3	-0.01742	-39.7	69.7
21	0.00350	-0.00684	-50.0	0.0	0.00039	-39.7	10.3	-0.01752	-39.7	69.7
22	0.00350	-0.00669	-50.0	0.0	0.00044	-39.7	10.3	-0.01721	-39.7	69.7
23	0.00350	-0.00668	-50.0	0.0	0.00044	-39.7	10.3	-0.01720	-39.7	69.7
24	0.00350	-0.00666	-50.0	0.0	0.00045	-39.7	10.3	-0.01716	-39.7	69.7

PROGETTO DEFINITIVO

RELAZIONE DI CALCOLO GALLERIA ARTIFICIALE

POSIZIONE ASSE NEUTRO PER OGNI COMB. DI RESISTENZA

	a, b, c	Coeff. a, b, c nell'eq. dell'asse neutro $aX+bY+c=0$ nel rif. X,Y,O gen.				
	x/d	Rapp. di duttilità a rottura in presenza di sola fless.(travi)				
	C.Rid.	Coeff. di riduz. momenti per sola flessione in travi continue				
N°Comb		a	b	c	x/d	C.Rid.
1		0.00000000	0.000359236	-0.025238901	----	----
2		0.00000000	0.000360426	-0.025334107	----	----
3		0.00000000	0.000361497	-0.025419791	----	----
4		0.00000000	-0.000288070	0.003500000	----	----
5		0.00000000	-0.000291224	0.003500000	----	----
6		0.00000000	-0.000294080	0.003500000	----	----
7		0.00000000	0.000358760	-0.025200819	----	----
8		0.00000000	0.000359653	-0.025272223	----	----
9		0.00000000	0.000360545	-0.025343627	----	----
10		0.00000000	-0.000289439	0.003500000	----	----
11		0.00000000	-0.000292176	0.003500000	----	----
12		0.00000000	-0.000294913	0.003500000	----	----
13		0.00000000	-0.000303184	0.003500000	----	----
14		0.00000000	-0.000304196	0.003500000	----	----
15		0.00000000	-0.000305088	0.003500000	----	----
16		0.00000000	-0.000301340	0.003500000	----	----
17		0.00000000	-0.000301161	0.003500000	----	----
18		0.00000000	-0.000300031	0.003500000	----	----
19		0.00000000	-0.000298959	0.003500000	----	----
20		0.00000000	-0.000300150	0.003500000	----	----
21		0.00000000	-0.000301518	0.003500000	----	----
22		0.00000000	-0.000297115	0.003500000	----	----
23		0.00000000	-0.000296996	0.003500000	----	----
24		0.00000000	-0.000296460	0.003500000	----	----

METODO SLU - VERIFICHE A TAGLIO SENZA ARMATURE TRASVERSALI (§ 4.1.2.1.3.1 NTC)

Ver	S = comb.verificata a taglio/ N = comb. non verificata
Vsdu	Taglio agente [daN] uguale al taglio $V_y$ di comb. (sollecit. retta)
Vwct	Taglio trazione resistente [kN] in assenza di staffe [formula (4.1.14)NTC]
d	Altezza utile sezione [cm]
bw	Larghezza minima sezione [cm]
Ro	Rapporto geometrico di armatura longitudinale [ $<0.02$ ]
Scp	Tensione media di compressione nella sezione [Mpa]

N°Comb	Ver	Vsdu	Vwct	d	bw	Ro	Scp
1	S	161.05	303.86	69.7	100.0	0.0032	0.34
2	S	107.02	302.63	69.7	100.0	0.0032	0.33
3	S	61.34	301.56	69.7	100.0	0.0032	0.32
4	S	9.41	387.73	69.7	100.0	0.0032	1.14
5	S	41.02	383.68	69.7	100.0	0.0032	1.11
6	S	103.24	379.96	69.7	100.0	0.0032	1.07
7	S	60.36	304.39	69.7	100.0	0.0032	0.35
8	S	17.68	303.44	69.7	100.0	0.0032	0.34
9	S	22.63	302.56	69.7	100.0	0.0032	0.33
10	S	137.48	385.99	69.7	100.0	0.0032	1.13
11	S	195.48	382.43	69.7	100.0	0.0032	1.09
12	S	249.93	378.84	69.7	100.0	0.0032	1.06
13	S	40.65	368.43	69.7	100.0	0.0032	0.96
14	S	106.15	367.17	69.7	100.0	0.0032	0.95
15	S	161.92	366.04	69.7	100.0	0.0032	0.94



PROGETTO DEFINITIVO

RELAZIONE DI CALCOLO GALLERIA ARTIFICIALE

16	S	57.40	370.68	69.7	100.0	0.0032	0.98
17	S	119.54	370.91	69.7	100.0	0.0032	0.98
18	S	191.27	372.32	69.7	100.0	0.0032	1.00
19	S	196.24	373.62	69.7	100.0	0.0032	1.01
20	S	247.97	372.14	69.7	100.0	0.0032	1.00
21	S	296.16	370.48	69.7	100.0	0.0032	0.98
22	S	233.13	375.95	69.7	100.0	0.0032	1.03
23	S	287.26	376.12	69.7	100.0	0.0032	1.03
24	S	338.76	376.77	69.7	100.0	0.0032	1.04

COMBINAZIONI RARE IN ESERCIZIO - MASSIME TENSIONI NORMALI ED APERTURA FESSURE

Ver	S = comb. verificata/ N = comb. non verificata
Sc max	Massima tensione (positiva se di compressione) nel conglomerato [Mpa]
Xc max, Yc max	Ascissa, Ordinata [cm] del punto corrisp. a Sc max (sistema rif. X,Y,O)
Sf min	Minima tensione (negativa se di trazione) nell'acciaio [Mpa]
Xs min, Ys min	Ascissa, Ordinata [cm] della barra corrisp. a Sf min (sistema rif. X,Y,O)
Ac eff.	Area di calcestruzzo [cm <sup>2</sup> ] in zona tesa considerata aderente alle barre
As eff.	Area barre [cm <sup>2</sup> ] in zona tesa considerate efficaci per l'apertura delle fessure
D barre	Distanza tra le barre tese [cm] ai fini del calcolo dell'apertura fessure
Beta12	Prodotto dei coeff. di aderenza delle barre Beta1*Beta2

N°Comb	Ver	Sc max	Xc max	Yc max	Sf min	Xs min	Ys min	Ac eff.	As eff.	D barre	Beta12
1	S	0.88	-50.0	80.0	7.6	19.9	10.3	----	----	----	----
2	S	0.82	-50.0	0.0	7.4	19.9	69.7	----	----	----	----
3	S	0.99	-50.0	0.0	4.8	19.9	69.7	----	----	----	----
4	S	1.76	-50.0	0.0	-0.2	19.9	69.7	----	----	----	----
5	S	1.91	-50.0	0.0	-3.7	19.9	69.7	----	----	----	----
6	S	1.76	-50.0	0.0	-2.1	19.9	69.7	----	----	----	----
7	S	1.01	-50.0	0.0	5.1	19.9	69.7	----	----	----	----
8	S	0.91	-50.0	0.0	5.5	19.9	69.7	----	----	----	----
9	S	0.58	-50.0	0.0	8.5	19.9	69.7	----	----	----	----
10	S	1.78	-50.0	0.0	-1.1	19.9	69.7	----	----	----	----
11	S	1.31	-50.0	0.0	4.1	19.9	69.7	----	----	----	----
12	S	0.75	-50.0	0.0	9.7	19.9	69.7	----	----	----	----

COMBINAZIONI FREQUENTI IN ESERCIZIO - MASSIME TENSIONI NORMALI ED APERTURA FESSURE

N°Comb	Ver	Sc max	Xc max	Yc max	Sf min	Xs min	Ys min	Ac eff.	As eff.	D barre	Beta12
1	S	2.28	-50.0	0.0	-8.1	19.9	69.7	1200	22.6	19.9	0.50
2	S	2.33	-50.0	0.0	-10.7	19.9	69.7	1350	22.6	19.9	0.50
3	S	2.02	-50.0	0.0	-5.5	19.9	69.7	1050	22.6	19.9	0.50
4	S	2.28	-50.0	0.0	-8.1	19.9	69.7	1200	22.6	19.9	0.50
5	S	2.33	-50.0	0.0	-10.7	19.9	69.7	1350	22.6	19.9	0.50
6	S	2.02	-50.0	0.0	-5.5	19.9	69.7	1050	22.6	19.9	0.50
7	S	2.03	-50.0	0.0	-4.1	19.9	69.7	----	----	----	----
8	S	1.42	-50.0	0.0	3.9	19.9	69.7	----	----	----	----
9	S	0.75	-50.0	80.0	10.7	19.9	10.3	----	----	----	----
10	S	2.03	-50.0	0.0	-4.1	19.9	69.7	----	----	----	----
11	S	1.42	-50.0	0.0	3.9	19.9	69.7	----	----	----	----
12	S	0.75	-50.0	80.0	10.7	19.9	10.3	----	----	----	----

COMBINAZIONI FREQUENTI IN ESERCIZIO - APERTURA FESSURE [§B.6.6 DM96]

Ver.	La sezione viene assunta sempre fessurata anche nel caso in cui la trazione minima del calcestruzzo sia inferiore a $f_{ctm}$
S1	Esito della verifica
S2	Massima tensione [Mpa] di trazione nel calcestruzzo valutata in sezione non fessurata
k2	Minima tensione [Mpa] di trazione nel calcestruzzo valutata in sezione fessurata = 0.4 per barre ad aderenza migliorata

PROGETTO DEFINITIVO

RELAZIONE DI CALCOLO GALLERIA ARTIFICIALE

k3	= 0.125 per flessione e presso-flessione; $= (e1 + e2) / (2 * e1)$ per trazione eccentrica
Ø	Diametro [mm] medio delle barre tese comprese nell'area efficace Ac eff
Cf	Copriferro [mm] netto calcolato con riferimento alla barra più tesa
Psi	$= 1 - \text{Beta}12 * (Ssr/Ss)^2 = 1 - \text{Beta}12 * (fctm/S2)^2 = 1 - \text{Beta}12 * (Mfess/M)^2$ [B.6.6 DM96]
e sm	Deformazione unitaria media tra le fessure [4.3.1.7.1.3 DM96]. Il valore limite = $0.4 * Ss/Es$ è tra parentesi
srm	Distanza media tra le fessure [mm]
wk	Valore caratteristico [mm] dell'apertura fessure = $1.7 * e \text{ sm} * srm$ . Valore limite tra parentesi
MX fess.	Componente momento di prima fessurazione intorno all'asse X [kNm]
MY fess.	Componente momento di prima fessurazione intorno all'asse Y [kNm]

Comb.	Ver	S1	S2	k3	Ø	Cf	Psi	e sm	srm	wk	Mx fess	My fess
1	S	-0.5	0	0.125	24	91.0	-12.670	0.00002 (0.00002)	285	0.008 (0.30)	-838.55	0.00
2	S	-0.6	0	0.125	24	91.0	-9.998	0.00002 (0.00002)	293	0.011 (0.30)	-771.07	0.00
3	S	-0.4	0	0.125	24	91.0	-19.833	0.00001 (0.00001)	277	0.005 (0.30)	-915.12	0.00
4	S	-0.5	0	0.125	24	91.0	-12.670	0.00002 (0.00002)	285	0.008 (0.30)	-838.55	0.00
5	S	-0.6	0	0.125	24	91.0	-9.998	0.00002 (0.00002)	293	0.011 (0.30)	-771.07	0.00
6	S	-0.4	0	0.125	24	91.0	-19.833	0.00001 (0.00001)	277	0.005 (0.30)	-915.12	0.00
7	S	-0.4	0	----	----	----	----	----	----	----	-1005.49	0.00
8	S	0.1	0	----	----	----	----	----	----	----	0.00	0.00
9	S	0.7	0	----	----	----	----	----	----	----	0.00	0.00
10	S	-0.4	0	----	----	----	----	----	----	----	-1005.49	0.00
11	S	0.1	0	----	----	----	----	----	----	----	0.00	0.00
12	S	0.7	0	----	----	----	----	----	----	----	0.00	0.00

COMBINAZIONI QUASI PERMANENTI IN ESERCIZIO - MASSIME TENSIONI NORMALI ED APERTURA FESSURE

N°Comb	Ver	Sc max	Xc max	Yc max	Sf min	Xs min	Ys min	Ac eff.	As eff.	D barre	Beta12
1	S	0.89	-50.0	80.0	7.4	19.9	10.3	----	----	----	----
2	S	0.81	-50.0	0.0	7.4	19.9	69.7	----	----	----	----
3	S	0.98	-50.0	0.0	4.8	19.9	69.7	----	----	----	----
4	S	1.76	-50.0	0.0	-0.2	19.9	69.7	----	----	----	----
5	S	1.91	-50.0	0.0	-3.7	19.9	69.7	----	----	----	----
6	S	1.76	-50.0	0.0	-2.1	19.9	69.7	----	----	----	----
7	S	1.01	-50.0	0.0	5.1	19.9	69.7	----	----	----	----
8	S	0.92	-50.0	0.0	5.4	19.9	69.7	----	----	----	----
9	S	0.58	-50.0	0.0	8.5	19.9	69.7	----	----	----	----
10	S	1.78	-50.0	0.0	-1.1	19.9	69.7	----	----	----	----
11	S	1.31	-50.0	0.0	4.1	19.9	69.7	----	----	----	----
12	S	0.76	-50.0	0.0	9.6	19.9	69.7	----	----	----	----

COMBINAZIONI QUASI PERMANENTI IN ESERCIZIO - APERTURA FESSURE [§B.6.6 DM96]

Comb.	Ver	S1	S2	k3	Ø	Cf	Psi	e sm	srm	wk	Mx fess	My fess
1	S	0.4	0	----	----	----	----	----	----	----	0.00	0.00
2	S	0.4	0	----	----	----	----	----	----	----	0.00	0.00
3	S	0.2	0	----	----	----	----	----	----	----	0.00	0.00
4	S	-0.2	0	----	----	----	----	----	----	----	-1534.46	0.00
5	S	-0.4	0	----	----	----	----	----	----	----	-1014.30	0.00
6	S	-0.3	0	----	----	----	----	----	----	----	-1153.94	0.00
7	S	0.2	0	----	----	----	----	----	----	----	0.00	0.00
8	S	0.3	0	----	----	----	----	----	----	----	0.00	0.00
9	S	0.6	0	----	----	----	----	----	----	----	0.00	0.00
10	S	-0.3	0	----	----	----	----	----	----	----	-1310.94	0.00
11	S	0.1	0	----	----	----	----	----	----	----	0.00	0.00
12	S	0.6	0	----	----	----	----	----	----	----	0.00	0.00

## 7.6 VERIFICA SEZIONE S7

### DATI GENERALI SEZIONE IN C.A.

NOME SEZIONE: Sezione 7

(Percorso File: C:\Users\id-209\Desktop\Galleria Artificiale\Verifica Sezioni\Sezione 7.sez)

Descrizione Sezione:	
Metodo di calcolo resistenza:	Stati Limite Ultimi
Tipologia sezione:	Sezione generica
Normativa di riferimento:	N.T.C.
Percorso sollecitazione:	A Sforzo Norm. costante
Condizioni Ambientali:	Moderat. aggressive
Tipo di sollecitazione:	Retta (asse neutro sempre parallelo all'asse X)
Riferimento Sforzi assegnati:	Assi x,y principali d'inerzia
Riferimento alla sismicità:	Zona non sismica

### CARATTERISTICHE DI RESISTENZA DEI MATERIALI IMPIEGATI

CALCESTRUZZO -	Classe:	C28/35
	Resis. compr. di calcolo fcd:	15.860 MPa
	Resis. compr. ridotta fcd':	0.000 MPa
	Def.unit. max resistenza ec2:	0.0020
	Def.unit. ultima ecu:	0.0035
	Diagramma tensione-deformaz.:	Parabola-Rettangolo
	Modulo Elastico Normale Ec:	32308.0 MPa
	Resis. media a trazione fctm:	2.760 MPa
	Coeff. Omogen. S.L.E.:	15.00
	Coeff. Omogen. S.L.E.:	15.00
	Sc limite S.L.E. comb. Frequenti:	168.00 daN/cm <sup>2</sup>
	Ap.Fessure limite S.L.E. comb. Frequenti:	0.300 mm
	Sc limite S.L.E. comb. Q.Permanenti:	0.00 Mpa
	Ap.Fessure limite S.L.E. comb. Q.Permanenti:	0.200 mm
ACCIAIO -	Tipo:	B450C
	Resist. caratt. snervam. fyk:	450.00 MPa
	Resist. caratt. rottura ftk:	450.00 MPa
	Resist. snerv. di calcolo fyd:	391.30 MPa
	Resist. ultima di calcolo ftd:	391.30 MPa
	Deform. ultima di calcolo Epu:	0.068
	Modulo Elastico Ef	2000000 daN/cm <sup>2</sup>
	Diagramma tensione-deformaz.:	Bilineare finito
	Coeff. Aderenza istantaneo $\beta_1 \cdot \beta_2$ :	1.00
	Coeff. Aderenza differito $\beta_1 \cdot \beta_2$ :	0.50
Sf limite S.L.E. Comb. Rare:	360.00 MPa	

### CARATTERISTICHE DOMINIO CONGLOMERATO

Forma del Dominio:	Poligonale	
Classe Conglomerato:	C28/35	
N°vertice:	X [cm]	Y [cm]
1	-50.0	0.0

**PROGETTO DEFINITIVO**

**RELAZIONE DI CALCOLO GALLERIA ARTIFICIALE**

2	-50.0	80.0
3	50.0	80.0
4	50.0	0.0

**DATI BARRE ISOLATE**

N°Barra	X [cm]	Y [cm]	DiamØ[mm]
1	-39.7	10.3	24
2	-39.7	69.7	24
3	39.7	69.7	24
4	39.7	10.3	24

**DATI GENERAZIONI LINEARI DI BARRE**

N°Gen.	Numero assegnato alla singola generazione lineare di barre
N°Barra Ini.	Numero della barra iniziale cui si riferisce la generazione
N°Barra Fin.	Numero della barra finale cui si riferisce la generazione
N°Barre	Numero di barre generate equidistanti cui si riferisce la generazione
Ø	Diametro in mm delle barre della generazione

N°Gen.	N°Barra Ini.	N°Barra Fin.	N°Barre	Ø
1	2	3	3	24
2	1	4	3	24

**ARMATURE A TAGLIO**

Diametro staffe:	12	mm
Passo staffe:	1000.0	cm
Staffe:	Una sola staffa chiusa perimetrale	

**ST.LIM.ULTIMI - SFORZI PER OGNI COMBINAZIONE ASSEGNATA**

N	Sforzo normale [kN] applicato nel Baric. (+ se di compressione)
Mx	Momento flettente [daNm] intorno all'asse X di riferimento delle coordinate con verso positivo se tale da comprimere il lembo sup. della sez.
Vy	Componente del Taglio [kN] parallela all'asse Y di riferimento delle coordinate

N°Comb.	N	Mx	Vy
1	265.00	236.94	82.51
2	262.20	240.32	69.87
3	259.08	267.66	57.23
4	928.57	-69.58	-34.19
5	925.26	-50.42	-83.47
6	921.32	-12.83	-132.34
7	259.26	267.66	133.41
8	262.38	240.14	84.54
9	265.18	236.59	35.26
10	921.28	-12.83	-56.59
11	925.23	-50.66	-69.23
12	928.54	-70.13	-81.87
13	940.85	362.68	-11.14
14	944.37	392.79	-49.60
15	946.83	442.07	-87.68
16	1074.43	313.81	-41.93
17	1089.34	328.65	-81.39

PROGETTO DEFINITIVO

RELAZIONE DI CALCOLO GALLERIA ARTIFICIALE

18	1103.69	362.16	-120.51
19	947.68	442.07	86.54
20	955.63	415.26	50.45
21	962.52	406.21	14.03
22	1107.85	362.16	72.91
23	1127.37	333.12	36.75
24	1144.65	322.31	0.10

COMB. RARE (S.L.E.) - SFORZI PER OGNI COMBINAZIONE ASSEGNATA

N Sforzo normale [kN] applicato nel Baricentro (+ se di compressione)  
 Mx Momento flettente [kNm] intorno all'asse X di riferimento (tra parentesi Mom.Fessurazione)  
 con verso positivo se tale da comprimere il lembo superiore della sezione

N°Comb.	N	Mx	My
1	496.34	130.99	0.00
2	493.54	130.67	0.00
3	490.42	148.78	0.00
4	645.06	29.60	0.00
5	642.51	22.75	0.00
6	639.48	34.33	0.00
7	490.35	148.78	0.00
8	493.47	130.60	0.00
9	496.27	130.85	0.00
10	639.47	34.33	0.00
11	642.50	22.34	0.00
12	645.05	28.79	0.00

COMB. FREQUENTI (S.L.E.) - SFORZI PER OGNI COMBINAZIONE ASSEGNATA

N Sforzo normale [kN] applicato nel Baricentro (+ se di compressione)  
 Mx Momento flettente [kNm] intorno all'asse X di riferimento (tra parentesi Mom.Fessurazione)  
 con verso positivo se tale da comprimere il lembo superiore della sezione

N°Comb.	N	Mx	My
1	686.43	161.58 (829.67)	0.00 (0.00)
2	683.89	163.01 (814.77)	0.00 (0.00)
3	680.86	182.87 (702.02)	0.00 (0.00)
4	686.43	161.58 (829.67)	0.00 (0.00)
5	683.89	163.01 (814.77)	0.00 (0.00)
6	680.86	182.87 (702.02)	0.00 (0.00)
7	680.84	182.87 (702.00)	0.00 (0.00)
8	683.87	162.91 (815.47)	0.00 (0.00)
9	686.42	161.38 (831.18)	0.00 (0.00)
10	680.84	182.87 (702.00)	0.00 (0.00)
11	683.87	162.91 (815.47)	0.00 (0.00)
12	686.42	161.38 (831.18)	0.00 (0.00)

COMB. QUASI PERMANENTI (S.L.E.) - SFORZI PER OGNI COMBINAZIONE ASSEGNATA

N Sforzo normale [kN] applicato nel Baricentro (+ se di compressione)  
 Mx Momento flettente [kNm] intorno all'asse X di riferimento (tra parentesi Mom.Fessurazione)  
 con verso positivo se tale da comprimere il lembo superiore della sezione

N°Comb.	N	Mx	My
---------	---	----	----

PROGETTO DEFINITIVO

RELAZIONE DI CALCOLO GALLERIA ARTIFICIALE

1	493.80	130.99 (711.70)	0.00 (0.00)
2	491.00	130.67 (709.16)	0.00 (0.00)
3	487.88	148.78 (621.19)	0.00 (0.00)
4	645.06	26.88 (0.00)	0.00 (0.00)
5	642.51	19.98 (0.00)	0.00 (0.00)
6	639.48	31.51 (0.00)	0.00 (0.00)
7	487.83	148.78 (621.14)	0.00 (0.00)
8	490.95	130.60 (709.50)	0.00 (0.00)
9	493.75	130.85 (712.48)	0.00 (0.00)
10	639.47	31.51 (0.00)	0.00 (0.00)
11	642.50	19.70 (0.00)	0.00 (0.00)
12	645.05	26.31 (0.00)	0.00 (0.00)

RISULTATI DEL CALCOLO

Sezione verificata per tutte le combinazioni assegnate

Copriferro netto minimo barre longitudinali:	9.1 cm
Interferro netto minimo barre longitudinali:	17.5 cm

METODO AGLI STATI LIMITE ULTIMI - RISULTATI PRESSO-TENSO FLESSIONE

Ver	S = combinazione verificata / N = combin. non verificata
N	Sforzo normale assegnato [kN] nel baricentro B sezione cls.(positivo se di compressione)
Mx	Momento flettente assegnato [kNm] riferito all'asse x princ. d'inerzia
N ult	Sforzo normale ultimo [kN] nel baricentro B sezione cls.(positivo se di compress.)
Mx ult	Momento flettente ultimo [kNm] riferito all'asse x princ. d'inerzia
Mis.Sic.	Misura sicurezza = rapporto vettoriale tra (N ult,Mx ult,My ult) e (N,Mx,My) Verifica positiva se tale rapporto risulta >=1.000
As Tesa	Area armature [cm²] in zona tesa (solo travi). Tra parentesi l'area minima di normativa

N°Comb	Ver	N	Mx	N ult	Mx ult	Mis.Sic.	As Tesa
1	S	265.00	236.94	264.91	682.46	2.880	-----
2	S	262.20	240.32	262.13	681.61	2.836	-----
3	S	259.08	267.66	259.34	680.76	2.543	-----
4	S	928.57	-69.58	928.62	-883.39	12.696	-----
5	S	925.26	-50.42	925.14	-882.35	17.501	-----
6	S	921.32	-12.83	921.08	-881.14	68.692	-----
7	S	259.26	267.66	259.34	680.76	2.543	-----
8	S	262.38	240.14	262.13	681.61	2.838	-----
9	S	265.18	236.59	264.91	682.46	2.885	-----
10	S	921.28	-12.83	921.08	-881.14	68.692	-----
11	S	925.23	-50.66	925.14	-882.35	17.418	-----
12	S	928.54	-70.13	928.62	-883.39	12.597	-----
13	S	940.85	362.68	940.94	887.06	2.446	-----
14	S	944.37	392.79	944.11	888.00	2.261	-----
15	S	946.83	442.07	946.64	888.75	2.010	-----
16	S	1074.43	313.81	1074.43	926.60	2.953	-----
17	S	1089.34	328.65	1089.50	931.03	2.833	-----
18	S	1103.69	362.16	1103.82	935.24	2.582	-----
19	S	947.68	442.07	947.90	889.13	2.011	-----
20	S	955.63	415.26	955.47	891.37	2.147	-----
21	S	962.52	406.21	962.39	893.42	2.199	-----
22	S	1107.85	362.16	1107.71	936.38	2.586	-----
23	S	1127.37	333.12	1127.37	942.17	2.828	-----
24	S	1144.65	322.31	1144.95	947.34	2.939	-----

METODO AGLI STATI LIMITE ULTIMI - DEFORMAZIONI UNITARIE ALLO STATO ULTIMO

PROGETTO DEFINITIVO

RELAZIONE DI CALCOLO GALLERIA ARTIFICIALE

ec max	Deform. unit. massima del conglomerato a compressione
ec 3/7	Deform. unit. del conglomerato nella fibra a 3/7 dell'altezza efficace
Xc max	Ascissa in cm della fibra corrisp. a ec max (sistema rif. X,Y,O sez.)
Yc max	Ordinata in cm della fibra corrisp. a ec max (sistema rif. X,Y,O sez.)
es min	Deform. unit. minima nell'acciaio (negativa se di trazione)
Xs min	Ascissa in cm della barra corrisp. a es min (sistema rif. X,Y,O sez.)
Ys min	Ordinata in cm della barra corrisp. a es min (sistema rif. X,Y,O sez.)
es max	Deform. unit. massima nell'acciaio (positiva se di compress.)
Xs max	Ascissa in cm della barra corrisp. a es max (sistema rif. X,Y,O sez.)
Ys max	Ordinata in cm della barra corrisp. a es max (sistema rif. X,Y,O sez.)

N°Comb	ec max	ec 3/7	Xc max	Yc max	es min	Xs min	Ys min	es max	Xs max	Ys max
1	0.00350	-0.00886	-50.0	80.0	-0.00021	-39.7	69.7	-0.02162	-39.7	10.3
2	0.00350	-0.00887	-50.0	80.0	-0.00022	-39.7	69.7	-0.02165	-39.7	10.3
3	0.00350	-0.00888	-50.0	80.0	-0.00022	-39.7	69.7	-0.02167	-39.7	10.3
4	0.00350	-0.00633	-50.0	0.0	0.00055	-39.7	10.3	-0.01649	-39.7	69.7
5	0.00350	-0.00634	-50.0	0.0	0.00054	-39.7	10.3	-0.01651	-39.7	69.7
6	0.00350	-0.00636	-50.0	0.0	0.00054	-39.7	10.3	-0.01654	-39.7	69.7
7	0.00350	-0.00888	-50.0	80.0	-0.00022	-39.7	69.7	-0.02167	-39.7	10.3
8	0.00350	-0.00887	-50.0	80.0	-0.00022	-39.7	69.7	-0.02165	-39.7	10.3
9	0.00350	-0.00886	-50.0	80.0	-0.00021	-39.7	69.7	-0.02162	-39.7	10.3
10	0.00350	-0.00636	-50.0	0.0	0.00054	-39.7	10.3	-0.01654	-39.7	69.7
11	0.00350	-0.00634	-50.0	0.0	0.00054	-39.7	10.3	-0.01651	-39.7	69.7
12	0.00350	-0.00633	-50.0	0.0	0.00055	-39.7	10.3	-0.01649	-39.7	69.7
13	0.00350	-0.00629	-50.0	80.0	0.00056	-39.7	69.7	-0.01640	-39.7	10.3
14	0.00350	-0.00628	-50.0	80.0	0.00056	-39.7	69.7	-0.01638	-39.7	10.3
15	0.00350	-0.00627	-50.0	80.0	0.00056	-39.7	69.7	-0.01636	-39.7	10.3
16	0.00350	-0.00585	-50.0	80.0	0.00069	-39.7	69.7	-0.01551	-39.7	10.3
17	0.00350	-0.00581	-50.0	80.0	0.00070	-39.7	69.7	-0.01542	-39.7	10.3
18	0.00350	-0.00576	-50.0	80.0	0.00072	-39.7	69.7	-0.01533	-39.7	10.3
19	0.00350	-0.00627	-50.0	80.0	0.00057	-39.7	69.7	-0.01635	-39.7	10.3
20	0.00350	-0.00624	-50.0	80.0	0.00057	-39.7	69.7	-0.01630	-39.7	10.3
21	0.00350	-0.00622	-50.0	80.0	0.00058	-39.7	69.7	-0.01626	-39.7	10.3
22	0.00350	-0.00575	-50.0	80.0	0.00072	-39.7	69.7	-0.01530	-39.7	10.3
23	0.00350	-0.00569	-50.0	80.0	0.00074	-39.7	69.7	-0.01517	-39.7	10.3
24	0.00350	-0.00563	-50.0	80.0	0.00076	-39.7	69.7	-0.01506	-39.7	10.3

POSIZIONE ASSE NEUTRO PER OGNI COMB. DI RESISTENZA

a, b, c	Coeff. a, b, c nell'eq. dell'asse neutro $aX+bY+c=0$ nel rif. X,Y,O gen.
x/d	Rapp. di duttilità a rottura in presenza di sola fless. (travi)
C.Rid.	Coeff. di riduz. momenti per sola flessione in travi continue

N°Comb	a	b	c	x/d	C.Rid.
1	0.000000000	0.000360426	-0.025334107	----	----
2	0.000000000	0.000360783	-0.025362668	----	----
3	0.000000000	0.000361140	-0.025391230	----	----
4	0.000000000	-0.000286761	0.003500000	----	----
5	0.000000000	-0.000287118	0.003500000	----	----
6	0.000000000	-0.000287535	0.003500000	----	----
7	0.000000000	0.000361140	-0.025391230	----	----
8	0.000000000	0.000360783	-0.025362668	----	----
9	0.000000000	0.000360426	-0.025334107	----	----
10	0.000000000	-0.000287535	0.003500000	----	----
11	0.000000000	-0.000287118	0.003500000	----	----
12	0.000000000	-0.000286761	0.003500000	----	----
13	0.000000000	0.000285512	-0.019340939	----	----
14	0.000000000	0.000285214	-0.019317137	----	----

PROGETTO DEFINITIVO

RELAZIONE DI CALCOLO GALLERIA ARTIFICIALE

15	0.000000000	0.000284976	-0.019298096	----	----
16	0.000000000	0.000272778	-0.018322243	----	----
17	0.000000000	0.000271409	-0.018212757	----	----
18	0.000000000	0.000270100	-0.018108031	----	----
19	0.000000000	0.000284857	-0.019288576	----	----
20	0.000000000	0.000284143	-0.019231453	----	----
21	0.000000000	0.000283489	-0.019179090	----	----
22	0.000000000	0.000269743	-0.018079470	----	----
23	0.000000000	0.000267929	-0.017934282	----	----
24	0.000000000	0.000266292	-0.017803374	----	----

METODO SLU - VERIFICHE A TAGLIO SENZA ARMATURE TRASVERSALI (§ 4.1.2.1.3.1 NTC)

Ver	S = comb.verificata a taglio/ N = comb. non verificata
Vsdu	Taglio agente [daN] uguale al taglio Vy di comb. (sollecit. retta)
Vwct	Taglio trazione resistente [kN] in assenza di staffe [formula (4.1.14)NTC]
d	Altezza utile sezione [cm]
bw	Larghezza minima sezione [cm]
Ro	Rapporto geometrico di armatura longitudinale [<0.02]
Scp	Tensione media di compressione nella sezione [Mpa]

N°Comb	Ver	Vsdu	Vwct	d	bw	Ro	Scp
1	S	82.51	302.66	69.7	100.0	0.0032	0.33
2	S	69.87	302.29	69.7	100.0	0.0032	0.33
3	S	57.23	301.89	69.7	100.0	0.0032	0.32
4	S	34.19	389.38	69.7	100.0	0.0032	1.16
5	S	83.47	388.95	69.7	100.0	0.0032	1.16
6	S	132.34	388.43	69.7	100.0	0.0032	1.15
7	S	133.41	301.91	69.7	100.0	0.0032	0.32
8	S	84.54	302.32	69.7	100.0	0.0032	0.33
9	S	35.26	302.68	69.7	100.0	0.0032	0.33
10	S	56.59	388.43	69.7	100.0	0.0032	1.15
11	S	69.23	388.94	69.7	100.0	0.0032	1.16
12	S	81.87	389.38	69.7	100.0	0.0032	1.16
13	S	11.14	390.99	69.7	100.0	0.0032	1.18
14	S	49.60	391.45	69.7	100.0	0.0032	1.18
15	S	87.68	391.77	69.7	100.0	0.0032	1.18
16	S	41.93	408.44	69.7	100.0	0.0032	1.34
17	S	81.39	410.39	69.7	100.0	0.0032	1.36
18	S	120.51	412.27	69.7	100.0	0.0032	1.38
19	S	86.54	391.88	69.7	100.0	0.0032	1.18
20	S	50.45	392.92	69.7	100.0	0.0032	1.19
21	S	14.03	393.82	69.7	100.0	0.0032	1.20
22	S	72.91	412.81	69.7	100.0	0.0032	1.38
23	S	36.75	415.36	69.7	100.0	0.0032	1.41
24	S	0.10	417.62	69.7	100.0	0.0032	1.43

COMBINAZIONI RARE IN ESERCIZIO - MASSIME TENSIONI NORMALI ED APERTURA FESSURE

Ver	S = comb. verificata/ N = comb. non verificata
Sc max	Massima tensione (positiva se di compressione) nel conglomerato [Mpa]
Xc max, Yc max	Ascissa, Ordinata [cm] del punto corrisp. a Sc max (sistema rif. X,Y,O)
Sf min	Minima tensione (negativa se di trazione) nell'acciaio [Mpa]
Xs min, Ys min	Ascissa, Ordinata [cm] della barra corrisp. a Sf min (sistema rif. X,Y,O)
Ac eff.	Area di calcestruzzo [cm²] in zona tesa considerata aderente alle barre
As eff.	Area barre [cm²] in zona tesa considerate efficaci per l'apertura delle fessure
D barre	Distanza tra le barre tese [cm] ai fini del calcolo dell'apertura fessure
Beta12	Prodotto dei coeff. di aderenza delle barre Beta1*Beta2

N°Comb	Ver	Sc max	Xc max	Yc max	Sf min	Xs min	Ys min	Ac eff.	As eff.	D barre	Beta12
--------	-----	--------	--------	--------	--------	--------	--------	---------	---------	---------	--------



PROGETTO DEFINITIVO

RELAZIONE DI CALCOLO GALLERIA ARTIFICIALE

1	S	1.86	-50.0	80.0	-10.6	19.9	10.3	1500	22.6	19.9	1.00
2	S	1.86	-50.0	80.0	-10.7	19.9	10.3	1500	22.6	19.9	1.00
3	S	2.14	-50.0	80.0	-18.3	19.9	10.3	1800	22.6	19.9	1.00
4	S	0.99	-50.0	80.0	8.4	19.9	10.3	----	----	----	----
5	S	0.93	-50.0	80.0	9.0	19.9	10.3	----	----	----	----
6	S	1.02	-50.0	80.0	7.9	19.9	10.3	----	----	----	----
7	S	2.14	-50.0	80.0	-18.3	19.9	10.3	1800	22.6	19.9	1.00
8	S	1.86	-50.0	80.0	-10.7	19.9	10.3	1500	22.6	19.9	1.00
9	S	1.86	-50.0	80.0	-10.6	19.9	10.3	1450	22.6	19.9	1.00
10	S	1.02	-50.0	80.0	7.9	19.9	10.3	----	----	----	----
11	S	0.92	-50.0	80.0	9.1	19.9	10.3	----	----	----	----
12	S	0.98	-50.0	80.0	8.5	19.9	10.3	----	----	----	----

COMBINAZIONI FREQUENTI IN ESERCIZIO - MASSIME TENSIONI NORMALI ED APERTURA FESSURE

N°Comb	Ver	Sc max	Xc max	Yc max	Sf min	Xs min	Ys min	Ac eff.	As eff.	D barre	Beta12
1	S	2.29	-50.0	80.0	-8.4	19.9	10.3	1200	22.6	19.9	0.50
2	S	2.31	-50.0	80.0	-9.0	19.9	10.3	1250	22.6	19.9	0.50
3	S	2.60	-50.0	80.0	-15.7	19.9	10.3	1500	22.6	19.9	0.50
4	S	2.29	-50.0	80.0	-8.4	19.9	10.3	1200	22.6	19.9	0.50
5	S	2.31	-50.0	80.0	-9.0	19.9	10.3	1250	22.6	19.9	0.50
6	S	2.60	-50.0	80.0	-15.7	19.9	10.3	1500	22.6	19.9	0.50
7	S	2.60	-50.0	80.0	-15.7	19.9	10.3	1500	22.6	19.9	0.50
8	S	2.31	-50.0	80.0	-9.0	19.9	10.3	1250	22.6	19.9	0.50
9	S	2.29	-50.0	80.0	-8.4	19.9	10.3	1200	22.6	19.9	0.50
10	S	2.60	-50.0	80.0	-15.7	19.9	10.3	1500	22.6	19.9	0.50
11	S	2.31	-50.0	80.0	-9.0	19.9	10.3	1250	22.6	19.9	0.50
12	S	2.29	-50.0	80.0	-8.4	19.9	10.3	1200	22.6	19.9	0.50

COMBINAZIONI FREQUENTI IN ESERCIZIO - APERTURA FESSURE [§B.6.6 DM96]

La sezione viene assunta sempre fessurata anche nel caso in cui la trazione minima del calcestruzzo sia inferiore a  $f_{ctm}$

Ver. Esito della verifica

S1 Massima tensione [Mpa] di trazione nel calcestruzzo valutata in sezione non fessurata

S2 Minima tensione [Mpa] di trazione nel calcestruzzo valutata in sezione fessurata

k2 = 0.4 per barre ad aderenza migliorata

k3 = 0.125 per flessione e presso-flessione;  $= (e1 + e2) / (2 * e1)$  per trazione eccentrica

Ø Diametro [mm] medio delle barre tese comprese nell'area efficace Ac eff

Cf Copriferro [mm] netto calcolato con riferimento alla barra più tesa

Psi =  $1 - \text{Beta}12 * (Ssr/Ss)^2 = 1 - \text{Beta}12 * (f_{ctm}/S2)^2 = 1 - \text{Beta}12 * (M_{fess}/M)^2$  [B.6.6 DM96]

e sm Deformazione unitaria media tra le fessure [4.3.1.7.1.3 DM96]. Il valore limite =  $0.4 * Ss/Es$  è tra parentesi

srm Distanza media tra le fessure [mm]

wk Valore caratteristico [mm] dell'apertura fessure =  $1.7 * e * sm * srm$ . Valore limite tra parentesi

MX fess. Componente momento di prima fessurazione intorno all'asse X [kNm]

MY fess. Componente momento di prima fessurazione intorno all'asse Y [kNm]

Comb.	Ver	S1	S2	k3	Ø	Cf	Psi	e sm	srm	wk	Mx fess	My fess
1	S	-0.5	0	0.125	24	91.0	-12.182	0.00002 (0.00002)	285	0.008 (0.30)	829.67	0.00
2	S	-0.6	0	0.125	24	91.0	-11.491	0.00002 (0.00002)	288	0.009 (0.30)	814.77	0.00
3	S	-0.7	0	0.125	24	91.0	-6.369	0.00003 (0.00003)	301	0.016 (0.30)	702.02	0.00
4	S	-0.5	0	0.125	24	91.0	-12.182	0.00002 (0.00002)	285	0.008 (0.30)	829.67	0.00
5	S	-0.6	0	0.125	24	91.0	-11.491	0.00002 (0.00002)	288	0.009 (0.30)	814.77	0.00
6	S	-0.7	0	0.125	24	91.0	-6.369	0.00003 (0.00003)	301	0.016 (0.30)	702.02	0.00
7	S	-0.7	0	0.125	24	91.0	-6.368	0.00003 (0.00003)	301	0.016 (0.30)	702.00	0.00
8	S	-0.6	0	0.125	24	91.0	-11.528	0.00002 (0.00002)	288	0.009 (0.30)	815.47	0.00
9	S	-0.5	0	0.125	24	91.0	-12.263	0.00002 (0.00002)	285	0.008 (0.30)	831.18	0.00
10	S	-0.7	0	0.125	24	91.0	-6.368	0.00003 (0.00003)	301	0.016 (0.30)	702.00	0.00
11	S	-0.6	0	0.125	24	91.0	-11.528	0.00002 (0.00002)	288	0.009 (0.30)	815.47	0.00

PROGETTO DEFINITIVO

RELAZIONE DI CALCOLO GALLERIA ARTIFICIALE

12 S -0.5 0 0.125 24 91.0 -12.263 0.00002 (0.00002) 285 0.008 (0.30) 831.18 0.00

COMBINAZIONI QUASI PERMANENTI IN ESERCIZIO - MASSIME TENSIONI NORMALI ED APERTURA FESSURE

N°Comb	Ver	Sc max	Xc max	Yc max	Sf min	Xs min	Ys min	Ac eff.	As eff.	D barre	Beta12
1	S	1.86	-50.0	80.0	-10.8	19.9	10.3	1500	22.6	19.9	0.50
2	S	1.86	-50.0	80.0	-10.9	19.9	10.3	1500	22.6	19.9	0.50
3	S	2.14	-50.0	80.0	-18.5	19.9	10.3	1800	22.6	19.9	0.50
4	S	0.96	-50.0	80.0	8.7	19.9	10.3	----	----	----	----
5	S	0.90	-50.0	80.0	9.3	19.9	10.3	----	----	----	----
6	S	1.00	-50.0	80.0	8.2	19.9	10.3	----	----	----	----
7	S	2.14	-50.0	80.0	-18.5	19.9	10.3	1800	22.6	19.9	0.50
8	S	1.86	-50.0	80.0	-10.9	19.9	10.3	1500	22.6	19.9	0.50
9	S	1.86	-50.0	80.0	-10.8	19.9	10.3	1500	22.6	19.9	0.50
10	S	1.00	-50.0	80.0	8.2	19.9	10.3	----	----	----	----
11	S	0.90	-50.0	80.0	9.3	19.9	10.3	----	----	----	----
12	S	0.96	-50.0	80.0	8.7	19.9	10.3	----	----	----	----

COMBINAZIONI QUASI PERMANENTI IN ESERCIZIO - APERTURA FESSURE [§B.6.6 DM96]

Comb.	Ver	S1	S2	k3	Ø	Cf	Psi	e sm	srm	wk	Mx fess	My fess
1	S	-0.5	0	0.125	24	91.0	-13.759	0.00002 (0.00002)	301	0.011 (0.20)	711.70	0.00
2	S	-0.5	0	0.125	24	91.0	-13.727	0.00002 (0.00002)	301	0.011 (0.20)	709.16	0.00
3	S	-0.7	0	0.125	24	91.0	-7.717	0.00004 (0.00004)	317	0.020 (0.20)	621.19	0.00
4	S	0.5	0	----	----	----	----	----	----	----	0.00	0.00
5	S	0.6	0	----	----	----	----	----	----	----	0.00	0.00
6	S	0.5	0	----	----	----	----	----	----	----	0.00	0.00
7	S	-0.7	0	0.125	24	91.0	-7.715	0.00004 (0.00004)	317	0.020 (0.20)	621.14	0.00
8	S	-0.5	0	0.125	24	91.0	-13.757	0.00002 (0.00002)	301	0.011 (0.20)	709.50	0.00
9	S	-0.5	0	0.125	24	91.0	-13.823	0.00002 (0.00002)	301	0.011 (0.20)	712.48	0.00
10	S	0.5	0	----	----	----	----	----	----	----	0.00	0.00
11	S	0.6	0	----	----	----	----	----	----	----	0.00	0.00
12	S	0.5	0	----	----	----	----	----	----	----	0.00	0.00

## 8. ALLEGATO B - TABULATI DI CALCOLO

### 8.1 TABULATI SAP2000 GALLERIA ARTIFICIALE

#### MATERIAL PROPERTIES

This section provides material property information for materials used in the model.

Table 1: Material Properties 02 - Basic Mechanical Properties

Table 1: Material Properties 02 - Basic Mechanical Properties						
Material	UnitWeight	UnitMass	E1	G12	U12	A1
	KN/m3	KN-s2/m4	KN/m2	KN/m2		1/C
B450C	7.6973E+01	7.8490E+00	210000000			1.1700E-05
C28/35	2.4993E+01	2.5485E+00	32308000.	13461666. 67	0.2	1.0000E-05

#### SECTION PROPERTIES

This section provides section property information for objects used in the model.

#### Frames

Table 2: Frame Section Properties 01 - General, Part 1 of 4

Table 2: Frame Section Properties 01 - General, Part 1 of 4									
SectionName	Material	Shape	t3	t2	tf	tw	t2b	tfb	
			m	m	m	m	m	m	m
AR80X100	C28/35	Rectangular	0.8	1.					
CL80X100	C28/35	Rectangular	0.8	1.					
PD100X100	C28/35	Rectangular	1.	1.					
PD110X100	C28/35	Rectangular	1.1	1.					
PD135X100	C28/35	Rectangular	1.35	1.					
PD150X100	C28/35	Rectangular	1.5	1.					
PD185X100	C28/35	Rectangular	1.85	1.					
RIGID	C28/35	Rectangular	1.	1.					
RN125X100	C28/35	Rectangular	1.25	1.					
RN95X100	C28/35	Rectangular	0.95	1.					
VAR_CL80-95		Nonprismatic							
VAR_CL95-80		Nonprismatic							
VAR_PD100-110		Nonprismatic							
VAR_PD110-100		Nonprismatic							
VAR_PD110-135		Nonprismatic							
VAR_PD135-110		Nonprismatic							
VAR_PD135-185		Nonprismatic							
VAR_PD150-110		Nonprismatic							
VAR_PD185-135		Nonprismatic							

PROGETTO DEFINITIVO

RELAZIONE DI CALCOLO GALLERIA ARTIFICIALE

Table 2: Frame Section Properties 01 - General, Part 1 of 4

SectionName	Material	Shape	t3 m	t2 m	tf m	tw m	t2b m	tfb m
VAR_RN125-185		Nonprismatic						
VAR_RN125-95		Nonprismatic						
VAR_RN185-125		Nonprismatic						
VAR_RN95-125		Nonprismatic						
VAR1		Nonprismatic						
W18X35	A992Fy50	I/Wide Flange	0.44958	0.1524	0.010795	0.00762	0.1524	0.010795

Table 2: Frame Section Properties 01 - General, Part 2 of 4

Table 2: Frame Section Properties 01 - General, Part 2 of 4

SectionName	Area m2	TorsConst m4	I33 m4	I22 m4	I23 m4	AS2 m2	AS3 m2
AR80X100	0.8	0.087587	0.042667	0.066667	0.	0.666667	0.666667
CL80X100	0.8	0.087587	0.042667	0.066667	0.	0.666667	0.666667
PD100X100	1.	0.140833	0.083333	0.083333	0.	0.833333	0.833333
PD110X100	1.1	0.168619	0.110917	0.091667	0.	0.916667	0.916667
PD135X100	1.35	0.245269	0.205031	0.1125	0.	1.125	1.125
PD150X100	1.5	0.293457	0.28125	0.125	0.	1.25	1.25
PD185X100	1.85	0.408161	0.527635	0.154167	0.	1.541667	1.541667
RIGID	1.	0.140833	0.083333	0.083333	0.	0.833333	0.833333
RN125X100	1.25	0.213835	0.16276	0.104167	0.	1.041667	1.041667
RN95X100	0.95	0.126355	0.071448	0.079167	0.	0.791667	0.791667
VAR_CL80-95							
VAR_CL95-80							
VAR_PD100-110							
VAR_PD110-100							
VAR_PD110-135							
VAR_PD135-110							
VAR_PD135-185							
VAR_PD150-110							
VAR_PD185-135							
VAR_RN125-185							
VAR_RN125-95							
VAR_RN185-125							
VAR_RN95-125							
VAR1							
W18X35	0.006645	2.106E-07	0.000212	6.368E-06	0.	0.003426	0.002742

Table 2: Frame Section Properties 01 - General, Part 3 of 4

Table 2: Frame Section Properties 01 - General, Part 3 of 4

SectionName	S33 m3	S22 m3	Z33 m3	Z22 m3	R33 m	R22 m
AR80X100	0.106667	0.133333	0.16	0.2	0.23094	0.288675
CL80X100	0.106667	0.133333	0.16	0.2	0.23094	0.288675
PD100X100	0.166667	0.166667	0.25	0.25	0.288675	0.288675
PD110X100	0.201667	0.183333	0.3025	0.275	0.317543	0.288675
PD135X100	0.30375	0.225	0.455625	0.3375	0.389711	0.288675
PD150X100	0.375	0.25	0.5625	0.375	0.433013	0.288675
PD185X100	0.570417	0.308333	0.855625	0.4625	0.534049	0.288675

PROGETTO DEFINITIVO

RELAZIONE DI CALCOLO GALLERIA ARTIFICIALE

Table 2: Frame Section Properties 01 - General, Part 3 of 4

SectionName	S33 m3	S22 m3	Z33 m3	Z22 m3	R33 m	R22 m
RIGID	0.166667	0.166667	0.25	0.25	0.288675	0.288675
RN125X100	0.260417	0.208333	0.390625	0.3125	0.360844	0.288675
RN95X100	0.150417	0.158333	0.225625	0.2375	0.274241	0.288675
VAR_CL80-95						
VAR_CL95-80						
VAR_PD100-110						
VAR_PD110-100						
VAR_PD110-135						
VAR_PD135-110						
VAR_PD135-185						
VAR_PD150-110						
VAR_PD185-135						
VAR_RN125-185						
VAR_RN125-95						
VAR_RN185-125						
VAR_RN95-125						
VAR1						
W18X35	0.000944	0.000084	0.00109	0.000132	0.178731	0.030957

Table 2: Frame Section Properties 01 - General, Part 4 of 4

Table 2: Frame Section Properties 01 - General, Part 4 of 4

SectionName	AMod	A2Mod	A3Mod	JMod	I2Mod	I3Mod	MMod	WMod
AR80X100	1.	1.	1.	1.	1.	1.	1.	1.
CL80X100	1.	1.	1.	1.	1.	1.	1.	1.
PD100X100	1.	1.	1.	1.	1.	1.	1.	1.
PD110X100	1.	1.	1.	1.	1.	1.	1.	1.
PD135X100	1.	1.	1.	1.	1.	1.	1.	1.
PD150X100	1.	1.	1.	1.	1.	1.	1.	1.
PD185X100	1.	1.	1.	1.	1.	1.	1.	1.
RIGID	10000.	10000.	10000.	10000.	10000.	10000.	1.	1.
RN125X100	1.	1.	1.	1.	1.	1.	1.	1.
RN95X100	1.	1.	1.	1.	1.	1.	1.	1.
VAR_CL80-95								
VAR_CL95-80								
VAR_PD100-110								
VAR_PD110-100								
VAR_PD110-135								
VAR_PD135-110								
VAR_PD135-185								
VAR_PD150-110								
VAR_PD185-135								
VAR_RN125-185								
VAR_RN125-95								
VAR_RN185-125								
VAR_RN95-125								
VAR1								
W18X35	1.	1.	1.	1.	1.	1.	1.	1.

PROGETTO DEFINITIVO

RELAZIONE DI CALCOLO GALLERIA ARTIFICIALE

Table 3: Frame Section Properties 02 - Concrete Column, Part 1 of 2

Table 3: Frame Section Properties 02 - Concrete Column, Part 1 of 2

SectionName	RebarMatL	RebarMatC	ReinfConfig	LatReinf	Cover m	NumBars3D ir	NumBars2D ir
AR80X100	B450C	B450C	Rectangular	Ties	0.05	10	5
CL80X100	B450C	B450C	Rectangular	Ties	0.05	10	5
PD100X100	B450C	B450C	Rectangular	Ties	0.05	10	5
PD110X100	B450C	B450C	Rectangular	Ties	0.05	10	5
PD135X100	B450C	B450C	Rectangular	Ties	0.05	10	5
PD150X100	B450C	B450C	Rectangular	Ties	0.05	10	5
PD185X100	B450C	B450C	Rectangular	Ties	0.05	10	5
RIGID	B450C	B450C	Rectangular	Ties	0.05	10	5
RN125X100	B450C	B450C	Rectangular	Ties	0.05	10	5
RN95X100	B450C	B450C	Rectangular	Ties	0.05	10	5

Table 3: Frame Section Properties 02 - Concrete Column, Part 2 of 2

Table 3: Frame Section Properties 02 - Concrete Column, Part 2 of 2

SectionName	BarSizeL	BarSizeC	SpacingC m	NumCBars2	NumCBars3
AR80X100	20d	#2	0.15	3	3
CL80X100	20d	#2	0.15	3	3
PD100X100	20d	#4	0.15	3	3
PD110X100	20d	#4	0.15	3	3
PD135X100	20d	#4	0.15	3	3
PD150X100	20d	#4	0.15	3	3
PD185X100	20d	#4	0.15	3	3
RIGID	20d	#4	0.15	3	3
RN125X100	20d	#4	0.15	3	3
RN95X100	20d	#4	0.15	3	3

Table 4: Frame Section Properties 05 - Nonprismatic

Table 4: Frame Section Properties 05 - Nonprismatic

SectionName	SegmentNum m	StartSect	EndSect	AbsLength m	VarLength	EI33Var	EI22Var
VAR_CL80-95	1	CL80X100	RN95X100		1.	Linear	Linear
VAR_CL95-80	1	RN95X100	CL80X100		1.	Linear	Linear
VAR_PD100-110	1	PD100X100	PD110X100		1.	Linear	Linear
VAR_PD110-100	1	PD110X100	PD100X100		1.	Linear	Linear
VAR_PD110-135	1	PD110X100	PD135X100		1.	Linear	Linear
VAR_PD135-110	1	PD135X100	PD110X100		1.	Linear	Linear
VAR_PD135-185	1	PD135X100	PD185X100		1.	Linear	Linear
VAR_PD150-110	1	PD150X100	PD110X100		1.	Linear	Linear
VAR_PD185-135	1	PD185X100	PD135X100		1.	Linear	Linear
VAR_RN125-185	1	RN125X100	PD185X100		1.	Linear	Linear
VAR_RN125-95	1	RN125X100	RN95X100		1.	Linear	Linear

PROGETTO DEFINITIVO

RELAZIONE DI CALCOLO GALLERIA ARTIFICIALE

Table 4: Frame Section Properties 05 - Nonprismatic

SectionName	SegmentNum	StartSect	EndSect	AbsLength	VarLength	EI33Var	EI22Var
				m			
VAR_RN185-125	1	PD185X100	RN125X100		1.	Linear	Linear
VAR_RN95-125	1	RN95X100	RN125X100		1.	Linear	Linear
VAR1	1	RN125X100	PD185X100		1.	Linear	Linear

LOAD PATTERNS

This section provides loading information as applied to the model.

Definitions

Table 5: Load Pattern Definitions

Table 5: Load Pattern Definitions

LoadPat	DesignType	SelfWtMult	AutoLoad
g1	Dead	1.	
g2	Live	0.	
g3h_sx_k0	Other	0.	
g3h_sx_ka	Other	0.	
g3h_dx_k0	Other	0.	
g3h_dx_ka	Other	0.	
q1_1sx_k0	Live	0.	
q6.1_sx	Quake	0.	None
q6.1_dx	Quake	0.	None
q6.1v	Quake	0.	None
q6.2h	Quake	0.	None
q6.2v	Quake	0.	None
q7	Live	0.	
q1_2	Live	0.	
g3v_sx	Live	0.	
g3v_dx	Live	0.	
q1_1dx_k0	Live	0.	

LOAD CASES

This section provides load case information.

Definitions

Table 6: Load Case Definitions, Part 1 of 2

Table 6: Load Case Definitions, Part 1 of 2

Case	Type	InitialCond	ModalCase	BaseCase	MassSource	DesActOpt
g1	NonStatic	Zero				Prog Det
MODAL	LinModal	Zero				Prog Det
g2	NonStatic	Zero				Prog Det

Table 6: Load Case Definitions, Part 1 of 2

Case	Type	InitialCond	ModalCase	BaseCase	MassSource	DesActOpt
g3h_sx_k0	NonStatic	Zero				Prog Det
g3h_sx_ka	NonStatic	Zero				Prog Det
g3h_dx_k0	NonStatic	Zero				Prog Det
g3h_dx_ka	NonStatic	Zero				Prog Det
q1_1	NonStatic	Zero				Prog Det
q6.1_sx	NonStatic	Zero				Prog Det
q6.1_dx	NonStatic	Zero				Prog Det
q6.1v	NonStatic	Zero				Prog Det
q6.2h	NonStatic	Zero				Prog Det
q6.2v	NonStatic	Zero				Prog Det
q7	NonStatic	Zero				Prog Det
q1_2	NonStatic	Zero				Prog Det
g3v_sx	NonStatic	Zero				Prog Det
g3v_dx	NonStatic	Zero				Prog Det
q1_1dx_k0	NonStatic	Zero				Prog Det

Table 7: Load Case Definitions, Part 2 of 2

Table 7: Load Case  
 Definitions, Part 2 of 2

Case	DesignAct
g1	Non-Composite
MODAL	Other
g2	Short-Term Composite
g3h_sx_k0	Other
g3h_sx_ka	Other
g3h_dx_k0	Other
g3h_dx_ka	Other
q1_1	Short-Term Composite
q6.1_sx	Short-Term Composite
q6.1_dx	Short-Term Composite
q6.1v	Short-Term Composite
q6.2h	Short-Term Composite
q6.2v	Short-Term Composite
q7	Short-Term Composite
q1_2	Short-Term Composite
g3v_sx	Short-Term Composite
g3v_dx	Short-Term Composite
q1_1dx_k0	Short-Term Composite



### Static case load assignments

Table 8: Case - Static 1 - Load Assignments

**Table 8: Case - Static 1 - Load Assignments**

Case	LoadType	LoadName	LoadSF
g1	Load pattern	g1	1.
g2	Load pattern	g2	1.
g3h_sx_k0	Load pattern	g3h_sx_k0	1.
g3h_sx_ka	Load pattern	g3h_sx_ka	1.
g3h_dx_k0	Load pattern	g3h_dx_k0	1.
g3h_dx_ka	Load pattern	g3h_dx_ka	1.
q1_1	Load pattern	q1_1sx_k0	1.
q6.1_sx	Load pattern	q6.1_sx	1.
q6.1_dx	Load pattern	q6.1_dx	1.
q6.1v	Load pattern	q6.1v	1.
q6.2h	Load pattern	q6.2h	1.
q6.2v	Load pattern	q6.2v	1.
q7	Load pattern	q7	1.
q1_2	Load pattern	q1_2	1.
g3v_sx	Load pattern	g3v_sx	1.
g3v_dx	Load pattern	g3v_dx	1.
q1_1dx_k0	Load pattern	q1_1dx_k0	1.

### Response spectrum case load assignments

Table 9: Function - Response Spectrum - User

**Table 9: Function - Response Spectrum - User**

Name	Period Sec	Accel	FuncDamp
UNIFRS	0.	1.	0.05
UNIFRS	1.	1.	

### LOAD COMBINATIONS

This section provides load combination information.

Table 10: Combination Definitions

**Table 10: Combination Definitions**

ComboName	ComboType	CaseName	ScaleFactor
SLU q1.1	Linear Add	g1	1.3
SLU q1.1		g2	1.5
SLU q1.1		g3h_sx_k0	1.3
SLU q1.1		g3h_sx_ka	0.

Table 10: Combination Definitions

ComboName	ComboType	CaseName	ScaleFactor
SLU q1.1		g3h_dx_k0	1.3
SLU q1.1		g3h_dx_ka	0.
SLU q1.1		g3v_sx	1.3
SLU q1.1		g3v_dx	1.3
SLU q1.1		q1_2	1.5
SLU q1.1		q6.1_sx	0.
SLU q1.1		q6.1_dx	0.
SLU q1.1		q6.1v	0.
SLU q1.1		q6.2h	0.
SLU q1.1		q6.2v	0.
SLU q1.1		q7	1.3
SLU q1.2	Linear Add	g1	1.3
SLU q1.2		g2	1.5
SLU q1.2		g3h_sx_k0	0.
SLU q1.2		g3h_sx_ka	0.
SLU q1.2		g3h_dx_k0	0.
SLU q1.2		g3h_dx_ka	1.3
SLU q1.2		g3v_sx	0.
SLU q1.2		g3v_dx	1.3
SLU q1.2		q1_2	1.5
SLU q1.2		q6.1_sx	0.
SLU q1.2		q6.1_dx	0.
SLU q1.2		q6.1v	0.
SLU q1.2		q6.2h	0.
SLU q1.2		q6.2v	0.
SLU q1.2		q7	1.3
SLU q1.3	Linear Add	g1	1.3
SLU q1.3		g2	1.5
SLU q1.3		g3h_sx_k0	0.
SLU q1.3		g3h_sx_ka	1.3
SLU q1.3		g3h_dx_k0	0.
SLU q1.3		g3h_dx_ka	0.
SLU q1.3		g3v_sx	1.3
SLU q1.3		g3v_dx	0.
SLU q1.3		q1_2	1.5
SLU q1.3		q6.1_sx	0.
SLU q1.3		q6.1_dx	0.
SLU q1.3		q6.1v	0.
SLU q1.3		q6.2h	0.
SLU q1.3		q6.2v	0.
SLU q1.3		q7	1.3
SLU q1.4	Linear Add	g1	1.3
SLU q1.4		g2	1.5
SLU q1.4		g3h_sx_k0	1.3
SLU q1.4		g3h_sx_ka	0.
SLU q1.4		g3h_dx_k0	1.3
SLU q1.4		g3h_dx_ka	0.
SLU q1.4		g3v_sx	1.3
SLU q1.4		g3v_dx	1.3
SLU q1.4		q1_2	0.
SLU q1.4		q6.1_sx	0.
SLU q1.4		q6.1_dx	0.

Table 10: Combination Definitions

ComboName	ComboType	CaseName	ScaleFactor
SLU q1.4		q6.1v	0.
SLU q1.4		q6.2h	0.
SLU q1.4		q6.2v	0.
SLU q1.4		q7	1.3
SLU q1.5	Linear Add	g1	1.3
SLU q1.5		g2	1.5
SLU q1.5		g3h_sx_k0	0.
SLU q1.5		g3h_sx_ka	0.
SLU q1.5		g3h_dx_k0	0.
SLU q1.5		g3h_dx_ka	1.3
SLU q1.5		g3v_sx	0.
SLU q1.5		g3v_dx	1.3
SLU q1.5		q1_2	0.
SLU q1.5		q6.1_sx	0.
SLU q1.5		q6.1_dx	0.
SLU q1.5		q6.1v	0.
SLU q1.5		q6.2h	0.
SLU q1.5		q6.2v	0.
SLU q1.5		q7	1.3
SLU q1.6	Linear Add	g1	1.3
SLU q1.6		g2	1.5
SLU q1.6		g3h_sx_k0	0.
SLU q1.6		g3h_sx_ka	1.3
SLU q1.6		g3h_dx_k0	0.
SLU q1.6		g3h_dx_ka	0.
SLU q1.6		g3v_sx	1.3
SLU q1.6		g3v_dx	0.
SLU q1.6		q1_2	0.
SLU q1.6		q6.1_sx	0.
SLU q1.6		q6.1_dx	0.
SLU q1.6		q6.1v	0.
SLU q1.6		q6.2h	0.
SLU q1.6		q6.2v	0.
SLU q1.6		q7	1.3
SLU q1.7	Linear Add	g1	1.3
SLU q1.7		g2	1.5
SLU q1.7		g3h_sx_k0	1.3
SLU q1.7		g3h_sx_ka	0.
SLU q1.7		g3h_dx_k0	1.3
SLU q1.7		g3h_dx_ka	0.
SLU q1.7		g3v_sx	1.3
SLU q1.7		g3v_dx	1.3
SLU q1.7		q1_2	0.
SLU q1.7		q6.1_sx	0.
SLU q1.7		q6.1_dx	0.
SLU q1.7		q6.1v	0.
SLU q1.7		q6.2h	0.
SLU q1.7		q6.2v	0.
SLU q1.7		q7	1.3
SLU q1.8	Linear Add	g1	1.3
SLU q1.8		g2	1.5
SLU q1.8		g3h_sx_k0	0.

Table 10: Combination Definitions

ComboName	ComboType	CaseName	ScaleFactor
SLU q1.8		g3h_sx_ka	0.
SLU q1.8		g3h_dx_k0	0.
SLU q1.8		g3h_dx_ka	1.3
SLU q1.8		g3v_sx	0.
SLU q1.8		g3v_dx	1.3
SLU q1.8		q1_2	0.
SLU q1.8		q6.1_sx	0.
SLU q1.8		q6.1_dx	0.
SLU q1.8		q6.1v	0.
SLU q1.8		q6.2h	0.
SLU q1.8		q6.2v	0.
SLU q1.8		q7	1.3
SLU q1.9	Linear Add	g1	1.3
SLU q1.9		g2	1.5
SLU q1.9		g3h_sx_k0	0.
SLU q1.9		g3h_sx_ka	1.3
SLU q1.9		g3h_dx_k0	0.
SLU q1.9		g3h_dx_ka	0.
SLU q1.9		g3v_sx	1.3
SLU q1.9		g3v_dx	0.
SLU q1.9		q1_2	0.
SLU q1.9		q6.1_sx	0.
SLU q1.9		q6.1_dx	0.
SLU q1.9		q6.1v	0.
SLU q1.9		q6.2h	0.
SLU q1.9		q6.2v	0.
SLU q1.9		q7	1.3
SLU q1.10	Linear Add	g1	1.3
SLU q1.10		g2	1.5
SLU q1.10		g3h_sx_k0	1.3
SLU q1.10		g3h_sx_ka	0.
SLU q1.10		g3h_dx_k0	1.3
SLU q1.10		g3h_dx_ka	0.
SLU q1.10		g3v_sx	1.3
SLU q1.10		g3v_dx	1.3
SLU q1.10		q1_2	1.5
SLU q1.10		q6.1_sx	0.
SLU q1.10		q6.1_dx	0.
SLU q1.10		q6.1v	0.
SLU q1.10		q6.2h	0.
SLU q1.10		q6.2v	0.
SLU q1.10		q7	1.3
SLU q1.11	Linear Add	g1	1.3
SLU q1.11		g2	1.5
SLU q1.11		g3h_sx_k0	0.
SLU q1.11		g3h_sx_ka	0.
SLU q1.11		g3h_dx_k0	0.
SLU q1.11		g3h_dx_ka	1.3
SLU q1.11		g3v_sx	0.
SLU q1.11		g3v_dx	1.3
SLU q1.11		q1_2	1.5
SLU q1.11		q6.1_sx	0.

Table 10: Combination Definitions

ComboName	ComboType	CaseName	ScaleFactor
SLU q1.11		q6.1_dx	0.
SLU q1.11		q6.1v	0.
SLU q1.11		q6.2h	0.
SLU q1.11		q6.2v	0.
SLU q1.11		q7	1.3
SLU q1.12	Linear Add	g1	1.3
SLU q1.12		g2	1.5
SLU q1.12		g3h_sx_k0	0.
SLU q1.12		g3h_sx_ka	1.3
SLU q1.12		g3h_dx_k0	0.
SLU q1.12		g3h_dx_ka	0.
SLU q1.12		g3v_sx	1.3
SLU q1.12		g3v_dx	0.
SLU q1.12		q1_2	1.5
SLU q1.12		q6.1_sx	0.
SLU q1.12		q6.1_dx	0.
SLU q1.12		q6.1v	0.
SLU q1.12		q6.2h	0.
SLU q1.12		q6.2v	0.
SLU q1.12		q7	1.3
SLU q1.13	Linear Add	g1	1.3
SLU q1.13		g2	1.5
SLU q1.13		g3h_sx_k0	1.3
SLU q1.13		g3h_sx_ka	0.
SLU q1.13		g3h_dx_k0	1.3
SLU q1.13		g3h_dx_ka	0.
SLU q1.13		g3v_sx	1.3
SLU q1.13		g3v_dx	1.3
SLU q1.13		q1_2	1.5
SLU q1.13		q6.1_sx	0.
SLU q1.13		q6.1_dx	0.
SLU q1.13		q6.1v	0.
SLU q1.13		q6.2h	0.
SLU q1.13		q6.2v	0.
SLU q1.13		q7	1.3
SLU q1.14	Linear Add	g1	1.3
SLU q1.14		g2	1.5
SLU q1.14		g3h_sx_k0	0.
SLU q1.14		g3h_sx_ka	0.
SLU q1.14		g3h_dx_k0	0.
SLU q1.14		g3h_dx_ka	1.3
SLU q1.14		g3v_sx	0.
SLU q1.14		g3v_dx	1.3
SLU q1.14		q1_2	1.5
SLU q1.14		q6.1_sx	0.
SLU q1.14		q6.1_dx	0.
SLU q1.14		q6.1v	0.
SLU q1.14		q6.2h	0.
SLU q1.14		q6.2v	0.
SLU q1.14		q7	1.3
SLU q1.15	Linear Add	g1	1.3
SLU q1.15		g2	1.5

Table 10: Combination Definitions

ComboName	ComboType	CaseName	ScaleFactor
SLU q1.15		g3h_sx_k0	0.
SLU q1.15		g3h_sx_ka	1.3
SLU q1.15		g3h_dx_k0	0.
SLU q1.15		g3h_dx_ka	0.
SLU q1.15		g3v_sx	1.3
SLU q1.15		g3v_dx	0.
SLU q1.15		q1_2	1.5
SLU q1.15		q6.1_sx	0.
SLU q1.15		q6.1_dx	0.
SLU q1.15		q6.1v	0.
SLU q1.15		q6.2h	0.
SLU q1.15		q6.2v	0.
SLU q1.15		q7	1.3
SLU q1.16	Linear Add	g1	1.3
SLU q1.16		g2	1.5
SLU q1.16		g3h_sx_k0	1.3
SLU q1.16		g3h_sx_ka	0.
SLU q1.16		g3h_dx_k0	1.3
SLU q1.16		g3h_dx_ka	0.
SLU q1.16		g3v_sx	1.3
SLU q1.16		g3v_dx	1.3
SLU q1.16		q1_2	1.5
SLU q1.16		q6.1_sx	0.
SLU q1.16		q6.1_dx	0.
SLU q1.16		q6.1v	0.
SLU q1.16		q6.2h	0.
SLU q1.16		q6.2v	0.
SLU q1.16		q7	1.3
SLU q1.17	Linear Add	g1	1.3
SLU q1.17		g2	1.5
SLU q1.17		g3h_sx_k0	0.
SLU q1.17		g3h_sx_ka	0.
SLU q1.17		g3h_dx_k0	0.
SLU q1.17		g3h_dx_ka	1.3
SLU q1.17		g3v_sx	0.
SLU q1.17		g3v_dx	1.3
SLU q1.17		q1_2	1.5
SLU q1.17		q6.1_sx	0.
SLU q1.17		q6.1_dx	0.
SLU q1.17		q6.1v	0.
SLU q1.17		q6.2h	0.
SLU q1.17		q6.2v	0.
SLU q1.17		q7	1.3
SLU q1.18	Linear Add	g1	1.3
SLU q1.18		g2	1.5
SLU q1.18		g3h_sx_k0	0.
SLU q1.18		g3h_sx_ka	1.3
SLU q1.18		g3h_dx_k0	0.
SLU q1.18		g3h_dx_ka	0.
SLU q1.18		g3v_sx	1.3
SLU q1.18		g3v_dx	0.
SLU q1.18		q1_2	1.5

Table 10: Combination Definitions

ComboName	ComboType	CaseName	ScaleFactor
SLU q1.18		q6.1_sx	0.
SLU q1.18		q6.1_dx	0.
SLU q1.18		q6.1v	0.
SLU q1.18		q6.2h	0.
SLU q1.18		q6.2v	0.
SLU q1.18		q7	1.3
SLU q1.19	Linear Add	g1	1.3
SLU q1.19		g2	1.5
SLU q1.19		g3h_sx_k0	1.3
SLU q1.19		g3h_sx_ka	0.
SLU q1.19		g3h_dx_k0	1.3
SLU q1.19		g3h_dx_ka	0.
SLU q1.19		g3v_sx	1.3
SLU q1.19		g3v_dx	1.3
SLU q1.19		q1_2	0.
SLU q1.19		q6.1_sx	0.
SLU q1.19		q6.1_dx	0.
SLU q1.19		q6.1v	0.
SLU q1.19		q6.2h	0.
SLU q1.19		q6.2v	0.
SLU q1.19		q7	1.3
SLU q1.20	Linear Add	g1	1.3
SLU q1.20		g2	1.5
SLU q1.20		g3h_sx_k0	0.
SLU q1.20		g3h_sx_ka	0.
SLU q1.20		g3h_dx_k0	0.
SLU q1.20		g3h_dx_ka	1.3
SLU q1.20		g3v_sx	0.
SLU q1.20		g3v_dx	1.3
SLU q1.20		q1_2	0.
SLU q1.20		q6.1_sx	0.
SLU q1.20		q6.1_dx	0.
SLU q1.20		q6.1v	0.
SLU q1.20		q6.2h	0.
SLU q1.20		q6.2v	0.
SLU q1.20		q7	1.3
SLU q1.21	Linear Add	g1	1.3
SLU q1.21		g2	1.5
SLU q1.21		g3h_sx_k0	0.
SLU q1.21		g3h_sx_ka	1.3
SLU q1.21		g3h_dx_k0	0.
SLU q1.21		g3h_dx_ka	0.
SLU q1.21		g3v_sx	1.3
SLU q1.21		g3v_dx	0.
SLU q1.21		q1_2	0.
SLU q1.21		q6.1_sx	0.
SLU q1.21		q6.1_dx	0.
SLU q1.21		q6.1v	0.
SLU q1.21		q6.2h	0.
SLU q1.21		q6.2v	0.
SLU q1.21		q7	1.3
SLU q1.22	Linear Add	g1	1.3

Table 10: Combination Definitions

ComboName	ComboType	CaseName	ScaleFactor
SLU q1.22		g2	1.5
SLU q1.22		g3h_sx_k0	1.3
SLU q1.22		g3h_sx_ka	0.
SLU q1.22		g3h_dx_k0	1.3
SLU q1.22		g3h_dx_ka	0.
SLU q1.22		g3v_sx	1.3
SLU q1.22		g3v_dx	1.3
SLU q1.22		q1_2	1.5
SLU q1.22		q6.1_sx	0.
SLU q1.22		q6.1_dx	0.
SLU q1.22		q6.1v	0.
SLU q1.22		q6.2h	0.
SLU q1.22		q6.2v	0.
SLU q1.22		q7	1.3
SLU q1.23	Linear Add	g1	1.3
SLU q1.23		g2	1.5
SLU q1.23		g3h_sx_k0	0.
SLU q1.23		g3h_sx_ka	0.
SLU q1.23		g3h_dx_k0	0.
SLU q1.23		g3h_dx_ka	1.3
SLU q1.23		g3v_sx	0.
SLU q1.23		g3v_dx	1.3
SLU q1.23		q1_2	1.5
SLU q1.23		q6.1_sx	0.
SLU q1.23		q6.1_dx	0.
SLU q1.23		q6.1v	0.
SLU q1.23		q6.2h	0.
SLU q1.23		q6.2v	0.
SLU q1.23		q7	1.3
SLU q1.24	Linear Add	g1	1.3
SLU q1.24		g2	1.5
SLU q1.24		g3h_sx_k0	0.
SLU q1.24		g3h_sx_ka	1.3
SLU q1.24		g3h_dx_k0	0.
SLU q1.24		g3h_dx_ka	0.
SLU q1.24		g3v_sx	1.3
SLU q1.24		g3v_dx	0.
SLU q1.24		q1_2	1.5
SLU q1.24		q6.1_sx	0.
SLU q1.24		q6.1_dx	0.
SLU q1.24		q6.1v	0.
SLU q1.24		q6.2h	0.
SLU q1.24		q6.2v	0.
SLU q1.24		q7	1.3
SL Ex.1	Linear Add	g1	1.
SL Ex.1		g2	1.
SL Ex.1		g3h_sx_k0	0.
SL Ex.1		g3h_sx_ka	1.
SL Ex.1		g3h_dx_k0	0.
SL Ex.1		g3h_dx_ka	0.
SL Ex.1		g3v_sx	1.
SL Ex.1		g3v_dx	1.



Table 10: Combination Definitions

ComboName	ComboType	CaseName	ScaleFactor
SL Ex.1		q1_2	0.
SL Ex.1		q6.1_sx	1.
SL Ex.1		q6.1_dx	0.3
SL Ex.1		q6.1v	0.3
SL Ex.1		q6.2h	1.
SL Ex.1		q6.2v	0.3
SL Ex.1		q7	0.
SL Ex.2	Linear Add	g1	1.
SL Ex.2		g2	1.
SL Ex.2		g3h_sx_k0	0.
SL Ex.2		g3h_sx_ka	1.
SL Ex.2		g3h_dx_k0	0.
SL Ex.2		g3h_dx_ka	0.
SL Ex.2		g3v_sx	1.
SL Ex.2		g3v_dx	1.
SL Ex.2		q1_2	0.2
SL Ex.2		q6.1_sx	1.
SL Ex.2		q6.1_dx	0.3
SL Ex.2		q6.1v	0.3
SL Ex.2		q6.2h	1.
SL Ex.2		q6.2v	0.3
SL Ex.2		q7	0.
SL Ey.1	Linear Add	g1	1.
SL Ey.1		g2	1.
SL Ey.1		g3h_sx_k0	0.
SL Ey.1		g3h_sx_ka	0.
SL Ey.1		g3h_dx_k0	0.
SL Ey.1		g3h_dx_ka	1.
SL Ey.1		g3v_sx	1.
SL Ey.1		g3v_dx	1.
SL Ey.1		q1_2	0.
SL Ey.1		q6.1_sx	0.3
SL Ey.1		q6.1_dx	1.
SL Ey.1		q6.1v	0.3
SL Ey.1		q6.2h	1.
SL Ey.1		q6.2v	0.3
SL Ey.1		q7	0.
SL Ey.2	Linear Add	g1	1.
SL Ey.2		g2	1.
SL Ey.2		g3h_sx_k0	0.
SL Ey.2		g3h_sx_ka	0.
SL Ey.2		g3h_dx_k0	0.
SL Ey.2		g3h_dx_ka	1.
SL Ey.2		g3v_sx	1.
SL Ey.2		g3v_dx	1.
SL Ey.2		q1_2	0.2
SL Ey.2		q6.1_sx	0.3
SL Ey.2		q6.1_dx	1.
SL Ey.2		q6.1v	0.3
SL Ey.2		q6.2h	1.
SL Ey.2		q6.2v	0.3
SL Ey.2		q7	0.

Table 10: Combination Definitions

ComboName	ComboType	CaseName	ScaleFactor	
SL Ez.1	Linear Add	g1	1.	
SL Ez.1		g2	1.	
SL Ez.1		g3h_sx_k0	1.	
SL Ez.1		g3h_sx_ka	0.	
SL Ez.1		g3h_dx_k0	1.	
SL Ez.1		g3h_dx_ka	0.	
SL Ez.1		g3v_sx	1.	
SL Ez.1		g3v_dx	1.	
SL Ez.1		q1_2	0.	
SL Ez.1		q6.1_sx	0.3	
SL Ez.1		q6.1_dx	0.3	
SL Ez.1		q6.1v	1.	
SL Ez.1		q6.2h	0.3	
SL Ez.1		q6.2v	1.	
SL Ez.1		q7	0.	
SL Ez.2		Linear Add	g1	1.
SL Ez.2			g2	1.
SL Ez.2	g3h_sx_k0		1.	
SL Ez.2	g3h_sx_ka		0.	
SL Ez.2	g3h_dx_k0		1.	
SL Ez.2	g3h_dx_ka		0.	
SL Ez.2	g3v_sx		1.	
SL Ez.2	g3v_dx		1.	
SL Ez.2	q1_2		0.2	
SL Ez.2	q6.1_sx		0.3	
SL Ez.2	q6.1_dx		0.3	
SL Ez.2	q6.1v		1.	
SL Ez.2	q6.2h		0.3	
SL Ez.2	q6.2v		1.	
SL Ez.2	q7		0.	
SLE fr1	Linear Add		g1	1.
SLE fr1			g2	1.
SLE fr1		g3h_sx_k0	1.	
SLE fr1		g3h_sx_ka	0.	
SLE fr1		g3h_dx_k0	1.	
SLE fr1		g3h_dx_ka	0.	
SLE fr1		g3v_sx	1.	
SLE fr1		g3v_dx	1.	
SLE fr1		q1_2	0.75	
SLE fr1		q6.1_sx	0.	
SLE fr1		q6.1_dx	0.	
SLE fr1		q6.1v	0.	
SLE fr1		q6.2h	0.	
SLE fr1		q6.2v	0.	
SLE fr1		q7	0.6	
SLE fr2		Linear Add	g1	1.
SLE fr2			g2	1.
SLE fr2	g3h_sx_k0		1.	
SLE fr2	g3h_sx_ka		0.	
SLE fr2	g3h_dx_k0		1.	
SLE fr2	g3h_dx_ka		0.	
SLE fr2	g3v_sx		1.	

Table 10: Combination Definitions

ComboName	ComboType	CaseName	ScaleFactor
SLE fr2		g3v_dx	1.
SLE fr2		q1_2	0.75
SLE fr2		q6.1_sx	0.
SLE fr2		q6.1_dx	0.
SLE fr2		q6.1v	0.
SLE fr2		q6.2h	0.
SLE fr2		q6.2v	0.
SLE fr2		q7	0.6
SLE qp1	Linear Add	g1	1.
SLE qp1		g2	1.
SLE qp1		g3h_sx_k0	1.
SLE qp1		g3h_sx_ka	0.
SLE qp1		g3h_dx_k0	1.
SLE qp1		g3h_dx_ka	0.
SLE qp1		g3v_sx	1.
SLE qp1		g3v_dx	1.
SLE qp1		q1_2	0.
SLE qp1		q6.1_sx	0.
SLE qp1		q6.1_dx	0.
SLE qp1		q6.1v	0.
SLE qp1		q6.2h	0.
SLE qp1		q6.2v	0.
SLE qp1		q7	0.
SLE qp2	Linear Add	g1	1.
SLE qp2		g2	1.
SLE qp2		g3h_sx_k0	0.
SLE qp2		g3h_sx_ka	1.
SLE qp2		g3h_dx_k0	0.
SLE qp2		g3h_dx_ka	1.
SLE qp2		g3v_sx	1.
SLE qp2		g3v_dx	1.
SLE qp2		q1_2	0.
SLE qp2		q6.1_sx	0.
SLE qp2		q6.1_dx	0.
SLE qp2		q6.1v	0.
SLE qp2		q6.2h	0.
SLE qp2		q6.2v	0.
SLE qp2		q7	0.
SLE c1	Linear Add	g1	1.
SLE c1		g2	1.
SLE c1		g3h_sx_k0	1.
SLE c1		g3h_sx_ka	0.
SLE c1		g3h_dx_k0	1.
SLE c1		g3h_dx_ka	0.
SLE c1		g3v_sx	1.
SLE c1		g3v_dx	1.
SLE c1		q1_2	0.
SLE c1		q6.1_sx	0.
SLE c1		q6.1_dx	0.
SLE c1		q6.1v	0.
SLE c1		q6.2h	0.
SLE c1		q6.2v	0.

Table 10: Combination Definitions

ComboName	ComboType	CaseName	ScaleFactor
SLE c1		q7	0.
SLE c2	Linear Add	g1	1.
SLE c2		g2	1.
SLE c2		g3h_sx_k0	0.
SLE c2		g3h_sx_ka	1.
SLE c2		g3h_dx_k0	0.
SLE c2		g3h_dx_ka	1.
SLE c2		g3v_sx	1.
SLE c2		g3v_dx	1.
SLE c2		q1_2	1.
SLE c2		q6.1_sx	0.
SLE c2		q6.1_dx	0.
SLE c2		q6.1v	0.
SLE c2		q6.2h	0.
SLE c2		q6.2v	0.
SLE c2		q7	0.
SLE c3	Linear Add	g1	1.
SLE c3		g2	1.
SLE c3		g3h_sx_k0	0.
SLE c3		g3h_sx_ka	1.
SLE c3		g3h_dx_k0	0.
SLE c3		g3h_dx_ka	1.
SLE c3		g3v_sx	1.
SLE c3		g3v_dx	1.
SLE c3		q1_2	1.
SLE c3		q6.1_sx	0.
SLE c3		q6.1_dx	0.
SLE c3		q6.1v	0.
SLE c3		q6.2h	0.
SLE c3		q6.2v	0.
SLE c3		q7	0.
SLU q1.25	Linear Add	g1	1.3
SLU q1.25		g2	1.5
SLU q1.25		g3h_sx_k0	1.3
SLU q1.25		g3h_sx_ka	0.
SLU q1.25		g3h_dx_k0	1.3
SLU q1.25		g3h_dx_ka	0.
SLU q1.25		g3v_sx	1.3
SLU q1.25		g3v_dx	1.3
SLU q1.25		q1_2	1.5
SLU q1.25		q6.1_sx	0.
SLU q1.25		q6.1_dx	0.
SLU q1.25		q6.1v	0.
SLU q1.25		q6.2h	0.
SLU q1.25		q6.2v	0.
SLU q1.25		q7	1.3
SLU q1.26	Linear Add	g1	1.3
SLU q1.26		g2	1.5
SLU q1.26		g3h_sx_k0	0.
SLU q1.26		g3h_sx_ka	0.
SLU q1.26		g3h_dx_k0	0.
SLU q1.26		g3h_dx_ka	1.3

Table 10: Combination Definitions

ComboName	ComboType	CaseName	ScaleFactor
SLU q1.26		g3v_sx	0.
SLU q1.26		g3v_dx	1.3
SLU q1.26		q1_2	1.5
SLU q1.26		q6.1_sx	0.
SLU q1.26		q6.1_dx	0.
SLU q1.26		q6.1v	0.
SLU q1.26		q6.2h	0.
SLU q1.26		q6.2v	0.
SLU q1.26		q7	1.3
SLU q1.27	Linear Add	g1	1.3
SLU q1.27		g2	1.5
SLU q1.27		g3h_sx_k0	0.
SLU q1.27		g3h_sx_ka	1.3
SLU q1.27		g3h_dx_k0	0.
SLU q1.27		g3h_dx_ka	0.
SLU q1.27		g3v_sx	1.3
SLU q1.27		g3v_dx	0.
SLU q1.27		q1_2	1.5
SLU q1.27		q6.1_sx	0.
SLU q1.27		q6.1_dx	0.
SLU q1.27		q6.1v	0.
SLU q1.27		q6.2h	0.
SLU q1.27		q6.2v	0.
SLU q1.27		q7	1.3
SLU q1.28	Linear Add	g1	1.3
SLU q1.28		g2	1.5
SLU q1.28		g3h_sx_k0	1.3
SLU q1.28		g3h_sx_ka	0.
SLU q1.28		g3h_dx_k0	1.3
SLU q1.28		g3h_dx_ka	0.
SLU q1.28		g3v_sx	1.3
SLU q1.28		g3v_dx	1.3
SLU q1.28		q1_2	1.5
SLU q1.28		q6.1_sx	0.
SLU q1.28		q6.1_dx	0.
SLU q1.28		q6.1v	0.
SLU q1.28		q6.2h	0.
SLU q1.28		q6.2v	0.
SLU q1.28		q7	1.3
SLU q1.29	Linear Add	g1	1.3
SLU q1.29		g2	1.5
SLU q1.29		g3h_sx_k0	0.
SLU q1.29		g3h_sx_ka	0.
SLU q1.29		g3h_dx_k0	0.
SLU q1.29		g3h_dx_ka	1.3
SLU q1.29		g3v_sx	0.
SLU q1.29		g3v_dx	1.3
SLU q1.29		q1_2	1.5
SLU q1.29		q6.1_sx	0.
SLU q1.29		q6.1_dx	0.
SLU q1.29		q6.1v	0.
SLU q1.29		q6.2h	0.

Table 10: Combination Definitions

ComboName	ComboType	CaseName	ScaleFactor
SLU q1.29		q6.2v	0.
SLU q1.29		q7	1.3
SLU q1.30	Linear Add	g1	1.3
SLU q1.30		g2	1.5
SLU q1.30		g3h_sx_k0	0.
SLU q1.30		g3h_sx_ka	1.3
SLU q1.30		g3h_dx_k0	0.
SLU q1.30		g3h_dx_ka	0.
SLU q1.30		g3v_sx	1.3
SLU q1.30		g3v_dx	0.
SLU q1.30		q1_2	1.5
SLU q1.30		q6.1_sx	0.
SLU q1.30		q6.1_dx	0.
SLU q1.30		q6.1v	0.
SLU q1.30		q6.2h	0.
SLU q1.30		q6.2v	0.
SLU q1.30		q7	1.3
SLU q1.31	Linear Add	g1	1.
SLU q1.31		g2	0.8
SLU q1.31		g3h_sx_k0	1.
SLU q1.31		g3h_sx_ka	0.
SLU q1.31		g3h_dx_k0	1.
SLU q1.31		g3h_dx_ka	0.
SLU q1.31		g3v_sx	1.
SLU q1.31		g3v_dx	1.
SLU q1.31		q1_2	0.
SLU q1.31		q6.1_sx	0.
SLU q1.31		q6.1_dx	0.
SLU q1.31		q6.1v	0.
SLU q1.31		q6.2h	0.
SLU q1.31		q6.2v	0.
SLU q1.31		q7	0.
SLU q1.32	Linear Add	g1	1.
SLU q1.32		g2	0.8
SLU q1.32		g3h_sx_k0	0.
SLU q1.32		g3h_sx_ka	0.
SLU q1.32		g3h_dx_k0	0.
SLU q1.32		g3h_dx_ka	1.
SLU q1.32		g3v_sx	0.
SLU q1.32		g3v_dx	1.
SLU q1.32		q1_2	0.
SLU q1.32		q6.1_sx	0.
SLU q1.32		q6.1_dx	0.
SLU q1.32		q6.1v	0.
SLU q1.32		q6.2h	0.
SLU q1.32		q6.2v	0.
SLU q1.32		q7	0.
SLU q1.33	Linear Add	g1	1.
SLU q1.33		g2	0.8
SLU q1.33		g3h_sx_k0	0.
SLU q1.33		g3h_sx_ka	1.
SLU q1.33		g3h_dx_k0	0.

Table 10: Combination Definitions

ComboName	ComboType	CaseName	ScaleFactor
SLU q1.33		g3h_dx_ka	0.
SLU q1.33		g3v_sx	1.
SLU q1.33		g3v_dx	0.
SLU q1.33		q1_2	0.
SLU q1.33		q6.1_sx	0.
SLU q1.33		q6.1_dx	0.
SLU q1.33		q6.1v	0.
SLU q1.33		q6.2h	0.
SLU q1.33		q6.2v	0.
SLU q1.33		q7	0.
SLU q1.34	Linear Add	g1	1.
SLU q1.34		g2	0.8
SLU q1.34		g3h_sx_k0	1.
SLU q1.34		g3h_sx_ka	0.
SLU q1.34		g3h_dx_k0	1.
SLU q1.34		g3h_dx_ka	0.
SLU q1.34		g3v_sx	1.
SLU q1.34		g3v_dx	1.
SLU q1.34		q1_2	0.
SLU q1.34		q6.1_sx	0.
SLU q1.34		q6.1_dx	0.
SLU q1.34		q6.1v	0.
SLU q1.34		q6.2h	0.
SLU q1.34		q6.2v	0.
SLU q1.34		q7	0.
SLU q1.35	Linear Add	g1	1.
SLU q1.35		g2	0.8
SLU q1.35		g3h_sx_k0	0.
SLU q1.35		g3h_sx_ka	0.
SLU q1.35		g3h_dx_k0	0.
SLU q1.35		g3h_dx_ka	1.
SLU q1.35		g3v_sx	0.
SLU q1.35		g3v_dx	1.
SLU q1.35		q1_2	0.
SLU q1.35		q6.1_sx	0.
SLU q1.35		q6.1_dx	0.
SLU q1.35		q6.1v	0.
SLU q1.35		q6.2h	0.
SLU q1.35		q6.2v	0.
SLU q1.35		q7	0.
SLU q1.36	Linear Add	g1	1.
SLU q1.36		g2	0.8
SLU q1.36		g3h_sx_k0	0.
SLU q1.36		g3h_sx_ka	1.
SLU q1.36		g3h_dx_k0	0.
SLU q1.36		g3h_dx_ka	0.
SLU q1.36		g3v_sx	1.
SLU q1.36		g3v_dx	0.
SLU q1.36		q1_2	0.
SLU q1.36		q6.1_sx	0.
SLU q1.36		q6.1_dx	0.
SLU q1.36		q6.1v	0.

Table 10: Combination Definitions

ComboName	ComboType	CaseName	ScaleFactor
SLU q1.36		q6.2h	0.
SLU q1.36		q6.2v	0.
SLU q1.36		q7	0.
SLU_ENVE	Envelope	SLU q1.1	1.
SLU_ENVE		SLU q1.2	1.
SLU_ENVE		SLU q1.3	1.
SLU_ENVE		SLU q1.4	1.
SLU_ENVE		SLU q1.5	1.
SLU_ENVE		SLU q1.6	1.
SLU_ENVE		SLU q1.7	1.
SLU_ENVE		SLU q1.8	1.
SLU_ENVE		SLU q1.9	1.
SLU_ENVE		SLU q1.10	1.
SLU_ENVE		SLU q1.11	1.
SLU_ENVE		SLU q1.12	1.
SLU_ENVE		SLU q1.13	1.
SLU_ENVE		SLU q1.14	1.
SLU_ENVE		SLU q1.15	1.
SLU_ENVE		SLU q1.16	1.
SLU_ENVE		SLU q1.17	1.
SLU_ENVE		SLU q1.18	1.
SLU_ENVE		SLU q1.19	1.
SLU_ENVE		SLU q1.20	1.
SLU_ENVE		SLU q1.21	1.
SLU_ENVE		SLU q1.22	1.
SLU_ENVE		SLU q1.23	1.
SLU_ENVE		SLU q1.24	1.
SLU_ENVE		SLU q1.25	1.
SLU_ENVE		SLU q1.26	1.
SLU_ENVE		SLU q1.27	1.
SLU_ENVE		SLU q1.28	1.
SLU_ENVE		SLU q1.29	1.
SLU_ENVE		SLU q1.30	1.
SLU_ENVE		SLU q1.31	1.
SLU_ENVE		SLU q1.32	1.
SLU_ENVE		SLU q1.33	1.
SLU_ENVE		SLU q1.34	1.
SLU_ENVE		SLU q1.35	1.
SLU_ENVE		SLU q1.36	1.
SLV_ENVE	Envelope	SL Ex.1	1.
SLV_ENVE		SL Ex.2	1.
SLV_ENVE		SL Ey.1	1.
SLV_ENVE		SL Ey.2	1.
SLV_ENVE		SL Ez.1	1.
SLV_ENVE		SL Ez.2	1.
SLE_FR_ENVE	Envelope	SLE fr1	1.
SLE_FR_ENVE		SLE fr2	1.
SLE_QP_ENVE	Envelope	SLE qp1	1.
SLE_QP_ENVE		SLE qp2	1.
SLE_C_ENVE	Envelope	SLE c1	1.
SLE_C_ENVE		SLE c2	1.



**Table 10: Combination Definitions**

ComboName	ComboType	CaseName	ScaleFactor
SLE_C_ENVE		SLE c3	1.

## FRAME RESULTS

This section provides frame force results.

Table 11: Element Forces - Frames, Part 1 of 2

Table 11: Element Forces - Frames, Part 1 of 2

Frame	Station m	OutputCase	StepType	P KN	V2 KN	V3 KN
1	0.	SLU_ENVE	Max	-189.417	61.613	5.309E-13
1	0.46685	SLU_ENVE	Max	-189.418	91.954	5.309E-13
1	0.93369	SLU_ENVE	Max	-189.418	122.296	5.309E-13
1	0.	SLU_ENVE	Min	-907.23	-22.305	-6.668E-14
1	0.46685	SLU_ENVE	Min	-907.231	22.042	-6.668E-14
1	0.93369	SLU_ENVE	Min	-907.231	52.706	-6.668E-14
1	0.	SLV_ENVE	Max	-735.402	44.757	-8.292E-14
1	0.46685	SLV_ENVE	Max	-738.763	66.229	-8.436E-14
1	0.93369	SLV_ENVE	Max	-742.123	87.701	-8.580E-14
1	0.	SLV_ENVE	Min	-836.775	21.768	-9.523E-14
1	0.46685	SLV_ENVE	Min	-837.783	45.108	-9.566E-14
1	0.93369	SLV_ENVE	Min	-838.791	68.447	-9.610E-14
1	0.	SLE_FR_ENVE	Max	-650.455	34.883	1.913E-13
1	0.46685	SLE_FR_ENVE	Max	-650.455	63.358	1.913E-13
1	0.93369	SLE_FR_ENVE	Max	-650.455	91.833	1.913E-13
1	0.	SLE_FR_ENVE	Min	-650.455	34.883	1.913E-13
1	0.46685	SLE_FR_ENVE	Min	-650.455	63.358	1.913E-13
1	0.93369	SLE_FR_ENVE	Min	-650.455	91.833	1.913E-13
1	0.	SLE_QP_ENVE	Max	-376.959	49.878	-4.304E-14
1	0.46685	SLE_QP_ENVE	Max	-376.96	71.35	-4.304E-14
1	0.93369	SLE_QP_ENVE	Max	-376.96	92.822	-4.304E-14
1	0.	SLE_QP_ENVE	Min	-583.334	49.657	-6.661E-14
1	0.46685	SLE_QP_ENVE	Min	-583.335	71.13	-6.661E-14
1	0.93369	SLE_QP_ENVE	Min	-583.335	92.602	-6.661E-14
1	0.	SLE_C_ENVE	Max	-374.418	49.657	-4.275E-14
1	0.46685	SLE_C_ENVE	Max	-374.419	71.13	-4.275E-14
1	0.93369	SLE_C_ENVE	Max	-374.419	92.602	-4.275E-14
1	0.	SLE_C_ENVE	Min	-583.334	30.225	-6.661E-14
1	0.46685	SLE_C_ENVE	Min	-583.335	61.034	-6.661E-14
1	0.93369	SLE_C_ENVE	Min	-583.335	91.843	-6.661E-14
2	0.	SLU_ENVE	Max	-177.592	-61.981	3.721E-13
2	0.48058	SLU_ENVE	Max	-183.106	-43.168	3.721E-13
2	0.96117	SLU_ENVE	Max	-188.62	-24.354	3.721E-13
2	0.	SLU_ENVE	Min	-864.733	-290.544	-6.239E-14
2	0.48058	SLU_ENVE	Min	-873.518	-246.735	-6.239E-14
2	0.96117	SLU_ENVE	Min	-882.304	-215.259	-6.239E-14
2	0.	SLV_ENVE	Max	-705.727	-228.645	-7.930E-14
2	0.48058	SLV_ENVE	Max	-715.805	-208.407	-8.043E-14
2	0.96117	SLV_ENVE	Max	-725.882	-186.524	-8.155E-14
2	0.	SLV_ENVE	Min	-799.69	-255.842	-9.009E-14
2	0.48058	SLV_ENVE	Min	-806.903	-233.077	-9.042E-14
2	0.96117	SLV_ENVE	Min	-814.116	-211.957	-9.076E-14
2	0.	SLE_FR_ENVE	Max	-617.921	-204.358	1.212E-13
2	0.48058	SLE_FR_ENVE	Max	-626.166	-176.228	1.212E-13
2	0.96117	SLE_FR_ENVE	Max	-634.41	-148.099	1.212E-13
2	0.	SLE_FR_ENVE	Min	-617.921	-204.358	1.212E-13

RELAZIONE DI CALCOLO GALLERIA ARTIFICIALE

Table 11: Element Forces - Frames, Part 1 of 2

Frame	Station m	OutputCase	StepType	P KN	V2 KN	V3 KN
2	0.48058	SLE_FR_ENVE	Min	-626.166	-176.228	1.212E-13
2	0.96117	SLE_FR_ENVE	Min	-634.41	-148.099	1.212E-13
2	0.	SLE_QP_ENVE	Max	-357.942	-118.987	-4.005E-14
2	0.48058	SLE_QP_ENVE	Max	-364.159	-97.776	-4.005E-14
2	0.96117	SLE_QP_ENVE	Max	-370.376	-76.564	-4.005E-14
2	0.	SLE_QP_ENVE	Min	-555.924	-177.244	-6.235E-14
2	0.48058	SLE_QP_ENVE	Min	-562.141	-156.033	-6.235E-14
2	0.96117	SLE_QP_ENVE	Min	-568.358	-134.821	-6.235E-14
2	0.	SLE_C_ENVE	Max	-352.297	-129.213	-3.991E-14
2	0.48058	SLE_C_ENVE	Max	-361.218	-98.778	-3.991E-14
2	0.96117	SLE_C_ENVE	Max	-370.138	-68.343	-3.991E-14
2	0.	SLE_C_ENVE	Min	-555.924	-177.244	-6.235E-14
2	0.48058	SLE_C_ENVE	Min	-562.141	-156.033	-6.235E-14
2	0.96117	SLE_C_ENVE	Min	-568.358	-134.821	-6.235E-14
3	0.	SLU_ENVE	Max	-181.334	-55.901	3.770E-13
3	0.48058	SLU_ENVE	Max	-185.299	-36.701	3.770E-13
3	0.96117	SLU_ENVE	Max	-189.264	-17.501	3.770E-13
3	0.	SLU_ENVE	Min	-882.711	-217.892	-5.558E-14
3	0.48058	SLU_ENVE	Min	-889.028	-180.838	-5.558E-14
3	0.96117	SLU_ENVE	Min	-895.95	-150.249	-5.558E-14
3	0.	SLV_ENVE	Max	-727.737	-178.832	-7.078E-14
3	0.48058	SLV_ENVE	Max	-735.984	-156.863	-7.188E-14
3	0.96117	SLV_ENVE	Max	-744.151	-134.033	-7.299E-14
3	0.	SLV_ENVE	Min	-818.265	-199.398	-8.000E-14
3	0.48058	SLV_ENVE	Min	-823.752	-177.588	-8.033E-14
3	0.96117	SLV_ENVE	Min	-829.319	-156.64	-8.067E-14
3	0.	SLE_FR_ENVE	Max	-632.028	-155.689	1.292E-13
3	0.48058	SLE_FR_ENVE	Max	-637.956	-126.982	1.292E-13
3	0.96117	SLE_FR_ENVE	Max	-643.885	-98.275	1.292E-13
3	0.	SLE_FR_ENVE	Min	-632.028	-155.689	1.292E-13
3	0.48058	SLE_FR_ENVE	Min	-637.956	-126.982	1.292E-13
3	0.96117	SLE_FR_ENVE	Min	-643.885	-98.275	1.292E-13
3	0.	SLE_QP_ENVE	Max	-364.979	-96.527	-3.580E-14
3	0.48058	SLE_QP_ENVE	Max	-369.45	-74.88	-3.580E-14
3	0.96117	SLE_QP_ENVE	Max	-373.92	-53.233	-3.580E-14
3	0.	SLE_QP_ENVE	Min	-567.045	-138.479	-5.545E-14
3	0.48058	SLE_QP_ENVE	Min	-571.516	-116.832	-5.545E-14
3	0.96117	SLE_QP_ENVE	Min	-575.986	-95.184	-5.545E-14
3	0.	SLE_C_ENVE	Max	-361.494	-100.837	-3.530E-14
3	0.48058	SLE_C_ENVE	Max	-367.909	-69.777	-3.530E-14
3	0.96117	SLE_C_ENVE	Max	-374.323	-38.717	-3.530E-14
3	0.	SLE_C_ENVE	Min	-567.045	-138.479	-5.545E-14
3	0.48058	SLE_C_ENVE	Min	-571.516	-116.832	-5.545E-14
3	0.96117	SLE_C_ENVE	Min	-575.986	-95.184	-5.545E-14
4	0.	SLU_ENVE	Max	-182.68	-63.821	5.045E-13
4	0.48058	SLU_ENVE	Max	-185.069	-44.362	5.045E-13
4	0.96117	SLU_ENVE	Max	-187.459	-24.903	5.045E-13
4	0.	SLU_ENVE	Min	-892.626	-195.746	-6.857E-14
4	0.48058	SLU_ENVE	Min	-896.433	-150.435	-6.857E-14
4	0.96117	SLU_ENVE	Min	-900.241	-112.41	-6.857E-14
4	0.	SLV_ENVE	Max	-743.456	-145.217	-8.782E-14
4	0.48058	SLV_ENVE	Max	-749.817	-123.699	-8.927E-14

RELAZIONE DI CALCOLO GALLERIA ARTIFICIALE

Table 11: Element Forces - Frames, Part 1 of 2

Frame	Station m	OutputCase	StepType	P KN	V2 KN	V3 KN
4	0.96117	SLV_ENVE	Max	-756.179	-101.21	-9.072E-14
4	0.	SLV_ENVE	Min	-830.389	-166.803	-9.849E-14
4	0.48058	SLV_ENVE	Min	-834.113	-143.377	-9.892E-14
4	0.96117	SLV_ENVE	Min	-837.837	-120.923	-9.936E-14
4	0.	SLE_FR_ENVE	Max	-638.594	-136.37	1.780E-13
4	0.48058	SLE_FR_ENVE	Max	-642.167	-107.276	1.780E-13
4	0.96117	SLE_FR_ENVE	Max	-645.74	-78.182	1.780E-13
4	0.	SLE_FR_ENVE	Min	-638.594	-136.37	1.780E-13
4	0.48058	SLE_FR_ENVE	Min	-642.167	-107.276	1.780E-13
4	0.96117	SLE_FR_ENVE	Min	-645.74	-78.182	1.780E-13
4	0.	SLE_QP_ENVE	Max	-368.504	-91.912	-4.468E-14
4	0.48058	SLE_QP_ENVE	Max	-371.198	-69.973	-4.468E-14
4	0.96117	SLE_QP_ENVE	Max	-373.892	-48.034	-4.468E-14
4	0.	SLE_QP_ENVE	Min	-573.314	-117.28	-6.856E-14
4	0.48058	SLE_QP_ENVE	Min	-576.008	-95.341	-6.856E-14
4	0.96117	SLE_QP_ENVE	Min	-578.702	-73.401	-6.856E-14
4	0.	SLE_C_ENVE	Max	-364.197	-106.134	-4.460E-14
4	0.48058	SLE_C_ENVE	Max	-368.063	-74.655	-4.460E-14
4	0.96117	SLE_C_ENVE	Max	-371.929	-43.176	-4.460E-14
4	0.	SLE_C_ENVE	Min	-573.314	-117.28	-6.856E-14
4	0.48058	SLE_C_ENVE	Min	-576.008	-95.341	-6.856E-14
4	0.96117	SLE_C_ENVE	Min	-578.702	-73.401	-6.856E-14
5	0.	SLU_ENVE	Max	-187.998	-36.024	5.082E-13
5	0.48057	SLU_ENVE	Max	-188.796	-16.436	5.082E-13
5	0.96115	SLU_ENVE	Max	-189.595	13.457	5.082E-13
5	0.	SLU_ENVE	Min	-904.597	-100.83	-6.445E-14
5	0.48057	SLU_ENVE	Min	-905.869	-55.217	-6.445E-14
5	0.96115	SLU_ENVE	Min	-907.141	-20.664	-6.445E-14
5	0.	SLV_ENVE	Max	-760.518	-71.058	-8.321E-14
5	0.48057	SLV_ENVE	Max	-764.953	-49.114	-8.465E-14
5	0.96115	SLV_ENVE	Max	-769.388	-25.695	-8.609E-14
5	0.	SLV_ENVE	Min	-842.769	-91.092	-9.296E-14
5	0.48057	SLV_ENVE	Min	-844.706	-67.227	-9.339E-14
5	0.96115	SLV_ENVE	Min	-846.642	-44.836	-9.382E-14
5	0.	SLE_FR_ENVE	Max	-648.201	-68.535	1.827E-13
5	0.48057	SLE_FR_ENVE	Max	-649.395	-39.247	1.827E-13
5	0.96115	SLE_FR_ENVE	Max	-650.588	-9.96	1.827E-13
5	0.	SLE_FR_ENVE	Min	-648.201	-68.535	1.827E-13
5	0.48057	SLE_FR_ENVE	Min	-649.395	-39.247	1.827E-13
5	0.96115	SLE_FR_ENVE	Min	-650.588	-9.96	1.827E-13
5	0.	SLE_QP_ENVE	Max	-375.306	-48.228	-4.166E-14
5	0.48057	SLE_QP_ENVE	Max	-376.207	-26.142	-4.166E-14
5	0.96115	SLE_QP_ENVE	Max	-377.107	-4.057	-4.166E-14
5	0.	SLE_QP_ENVE	Min	-581.502	-56.839	-6.439E-14
5	0.48057	SLE_QP_ENVE	Min	-582.402	-34.754	-6.439E-14
5	0.96115	SLE_QP_ENVE	Min	-583.302	-12.669	-6.439E-14
5	0.	SLE_C_ENVE	Max	-372.281	-56.839	-4.142E-14
5	0.48057	SLE_C_ENVE	Max	-373.573	-28.372	-4.142E-14
5	0.96115	SLE_C_ENVE	Max	-374.864	3.316	-4.142E-14
5	0.	SLE_C_ENVE	Min	-581.502	-60.061	-6.439E-14
5	0.48057	SLE_C_ENVE	Min	-582.402	-34.754	-6.439E-14
5	0.96115	SLE_C_ENVE	Min	-583.302	-12.669	-6.439E-14

PROGETTO DEFINITIVO

RELAZIONE DI CALCOLO GALLERIA ARTIFICIALE

Table 11: Element Forces - Frames, Part 1 of 2

Frame	Station m	OutputCase	StepType	P KN	V2 KN	V3 KN
6	0.	SLU_ENVE	Max	-190.002	7.16	5.084E-13
6	0.48059	SLU_ENVE	Max	-189.204	38.369	5.084E-13
6	0.96119	SLU_ENVE	Max	-188.406	82.146	5.084E-13
6	0.	SLU_ENVE	Min	-907.691	-31.22	-6.432E-14
6	0.48059	SLU_ENVE	Min	-906.419	8.555	-6.432E-14
6	0.96119	SLU_ENVE	Min	-905.147	28.144	-6.432E-14
6	0.	SLV_ENVE	Max	-770.362	9.025	-8.361E-14
6	0.48059	SLV_ENVE	Max	-772.84	31.154	-8.505E-14
6	0.96119	SLV_ENVE	Max	-775.318	54.958	-8.649E-14
6	0.	SLV_ENVE	Min	-847.428	-14.693	-9.289E-14
6	0.48059	SLV_ENVE	Min	-847.565	9.455	-9.333E-14
6	0.96119	SLV_ENVE	Min	-847.702	31.927	-9.376E-14
6	0.	SLE_FR_ENVE	Max	-651.086	-2.247	1.829E-13
6	0.48059	SLE_FR_ENVE	Max	-649.892	27.042	1.829E-13
6	0.96119	SLE_FR_ENVE	Max	-648.698	56.331	1.829E-13
6	0.	SLE_FR_ENVE	Min	-651.086	-2.247	1.829E-13
6	0.48059	SLE_FR_ENVE	Min	-649.892	27.042	1.829E-13
6	0.96119	SLE_FR_ENVE	Min	-648.698	56.331	1.829E-13
6	0.	SLE_QP_ENVE	Max	-377.476	3.177	-4.153E-14
6	0.48059	SLE_QP_ENVE	Max	-376.575	25.263	-4.153E-14
6	0.96119	SLE_QP_ENVE	Max	-375.675	47.35	-4.153E-14
6	0.	SLE_QP_ENVE	Min	-583.689	-4.996	-6.425E-14
6	0.48059	SLE_QP_ENVE	Min	-582.789	17.09	-6.425E-14
6	0.96119	SLE_QP_ENVE	Min	-581.888	39.177	-6.425E-14
6	0.	SLE_C_ENVE	Max	-375.374	3.177	-4.123E-14
6	0.48059	SLE_C_ENVE	Max	-374.082	25.263	-4.123E-14
6	0.96119	SLE_C_ENVE	Max	-372.791	47.555	-4.123E-14
6	0.	SLE_C_ENVE	Min	-583.689	-15.825	-6.425E-14
6	0.48059	SLE_C_ENVE	Min	-582.789	15.865	-6.425E-14
6	0.96119	SLE_C_ENVE	Min	-581.888	47.35	-6.425E-14
7	0.	SLU_ENVE	Max	-188.991	92.688	6.322E-13
7	0.48058	SLU_ENVE	Max	-186.601	123.689	6.322E-13
7	0.96117	SLU_ENVE	Max	-184.212	167.984	6.322E-13
7	0.	SLU_ENVE	Min	-902.663	13.095	-8.502E-14
7	0.48058	SLU_ENVE	Min	-898.855	32.553	-8.502E-14
7	0.96117	SLU_ENVE	Min	-895.048	52.012	-8.502E-14
7	0.	SLV_ENVE	Max	-773.425	87.047	-1.112E-13
7	0.48058	SLV_ENVE	Max	-773.93	109.113	-1.130E-13
7	0.96117	SLV_ENVE	Max	-774.434	132.951	-1.148E-13
7	0.	SLV_ENVE	Min	-844.858	59.12	-1.227E-13
7	0.48058	SLV_ENVE	Min	-843.193	83.389	-1.232E-13
7	0.96117	SLV_ENVE	Min	-841.529	105.886	-1.238E-13
7	0.	SLE_FR_ENVE	Max	-647.955	60.143	2.235E-13
7	0.48058	SLE_FR_ENVE	Max	-644.382	89.237	2.235E-13
7	0.96117	SLE_FR_ENVE	Max	-640.809	118.332	2.235E-13
7	0.	SLE_FR_ENVE	Min	-647.955	60.143	2.235E-13
7	0.48058	SLE_FR_ENVE	Min	-644.382	89.237	2.235E-13
7	0.96117	SLE_FR_ENVE	Min	-640.809	118.332	2.235E-13
7	0.	SLE_QP_ENVE	Max	-375.545	59.503	-5.509E-14
7	0.48058	SLE_QP_ENVE	Max	-372.851	81.442	-5.509E-14
7	0.96117	SLE_QP_ENVE	Max	-370.156	103.382	-5.509E-14
7	0.	SLE_QP_ENVE	Min	-580.409	34.574	-8.492E-14

Table 11: Element Forces - Frames, Part 1 of 2

Frame	Station m	OutputCase	StepType	P KN	V2 KN	V3 KN
7	0.48058	SLE_QP_ENVE	Min	-577.715	56.513	-8.492E-14
7	0.96117	SLE_QP_ENVE	Min	-575.02	78.452	-8.492E-14
7	0.	SLE_C_ENVE	Max	-374.24	59.503	-5.471E-14
7	0.48058	SLE_C_ENVE	Max	-370.374	81.442	-5.471E-14
7	0.96117	SLE_C_ENVE	Max	-366.508	103.382	-5.471E-14
7	0.	SLE_C_ENVE	Min	-580.409	24.356	-8.492E-14
7	0.48058	SLE_C_ENVE	Min	-577.715	55.835	-8.492E-14
7	0.96117	SLE_C_ENVE	Min	-575.02	87.314	-8.492E-14
8	0.	SLU_ENVE	Max	-186.766	168.745	6.258E-13
8	0.48058	SLU_ENVE	Max	-182.801	200.289	6.258E-13
8	0.96117	SLU_ENVE	Max	-178.836	244.998	6.258E-13
8	0.	SLU_ENVE	Min	-891.525	29.974	-9.375E-14
8	0.48058	SLU_ENVE	Min	-885.208	49.173	-9.375E-14
8	0.96117	SLU_ENVE	Min	-878.891	68.373	-9.375E-14
8	0.	SLV_ENVE	Max	-771.131	157.852	-1.235E-13
8	0.48058	SLV_ENVE	Max	-769.659	179.836	-1.254E-13
8	0.96117	SLV_ENVE	Max	-768.187	203.576	-1.272E-13
8	0.	SLV_ENVE	Min	-836.608	126.844	-1.353E-13
8	0.48058	SLV_ENVE	Min	-833.153	150.946	-1.359E-13
8	0.96117	SLV_ENVE	Min	-829.699	173.293	-1.364E-13
8	0.	SLE_FR_ENVE	Max	-640.278	115.738	2.137E-13
8	0.48058	SLE_FR_ENVE	Max	-634.35	144.445	2.137E-13
8	0.96117	SLE_FR_ENVE	Max	-628.421	173.152	2.137E-13
8	0.	SLE_FR_ENVE	Min	-640.278	115.738	2.137E-13
8	0.48058	SLE_FR_ENVE	Min	-634.35	144.445	2.137E-13
8	0.96117	SLE_FR_ENVE	Min	-628.421	173.152	2.137E-13
8	0.	SLE_QP_ENVE	Max	-371.089	108.461	-6.095E-14
8	0.48058	SLE_QP_ENVE	Max	-366.618	130.108	-6.095E-14
8	0.96117	SLE_QP_ENVE	Max	-362.148	151.755	-6.095E-14
8	0.	SLE_QP_ENVE	Min	-573.244	66.942	-9.367E-14
8	0.48058	SLE_QP_ENVE	Min	-568.774	88.589	-9.367E-14
8	0.96117	SLE_QP_ENVE	Min	-564.303	110.236	-9.367E-14
8	0.	SLE_C_ENVE	Max	-370.307	108.461	-6.066E-14
8	0.48058	SLE_C_ENVE	Max	-363.892	130.108	-6.066E-14
8	0.96117	SLE_C_ENVE	Max	-357.478	151.755	-6.066E-14
8	0.	SLE_C_ENVE	Min	-573.244	58.166	-9.367E-14
8	0.48058	SLE_C_ENVE	Min	-568.774	89.226	-9.367E-14
8	0.96117	SLE_C_ENVE	Min	-564.303	120.286	-9.367E-14
9	0.	SLU_ENVE	Max	-186.624	225.907	7.421E-13
9	0.48057	SLU_ENVE	Max	-181.11	261.806	7.421E-13
9	0.96114	SLU_ENVE	Max	-175.596	305.614	7.421E-13
9	0.	SLU_ENVE	Min	-879.183	32.054	-1.259E-13
9	0.48057	SLU_ENVE	Min	-870.398	50.867	-1.259E-13
9	0.96114	SLU_ENVE	Min	-861.613	69.68	-1.259E-13
9	0.	SLV_ENVE	Max	-767.121	213.857	-1.683E-13
9	0.48057	SLV_ENVE	Max	-763.683	236.151	-1.705E-13
9	0.96114	SLV_ENVE	Max	-760.245	259.498	-1.728E-13
9	0.	SLV_ENVE	Min	-826.536	181.146	-1.831E-13
9	0.48057	SLV_ENVE	Min	-821.315	204.384	-1.838E-13
9	0.96114	SLV_ENVE	Min	-816.094	226.568	-1.845E-13
9	0.	SLE_FR_ENVE	Max	-631.511	157.99	2.408E-13
9	0.48057	SLE_FR_ENVE	Max	-623.267	186.119	2.408E-13

RELAZIONE DI CALCOLO GALLERIA ARTIFICIALE

Table 11: Element Forces - Frames, Part 1 of 2

Frame	Station m	OutputCase	StepType	P KN	V2 KN	V3 KN
9	0.96114	SLE_FR_ENVE	Max	-615.022	214.247	2.408E-13
9	0.	SLE_FR_ENVE	Min	-631.511	157.99	2.408E-13
9	0.48057	SLE_FR_ENVE	Min	-623.267	186.119	2.408E-13
9	0.96114	SLE_FR_ENVE	Min	-615.022	214.247	2.408E-13
9	0.	SLE_QP_ENVE	Max	-367.967	142.617	-8.141E-14
9	0.48057	SLE_QP_ENVE	Max	-361.75	163.828	-8.141E-14
9	0.96114	SLE_QP_ENVE	Max	-355.533	185.039	-8.141E-14
9	0.	SLE_QP_ENVE	Min	-566.073	84.784	-1.260E-13
9	0.48057	SLE_QP_ENVE	Min	-559.856	105.995	-1.260E-13
9	0.96114	SLE_QP_ENVE	Min	-553.639	127.206	-1.260E-13
9	0.	SLE_C_ENVE	Max	-366.864	142.617	-8.161E-14
9	0.48057	SLE_C_ENVE	Max	-357.944	163.828	-8.161E-14
9	0.96114	SLE_C_ENVE	Max	-349.024	185.039	-8.161E-14
9	0.	SLE_C_ENVE	Min	-566.073	79.512	-1.260E-13
9	0.48057	SLE_C_ENVE	Min	-559.856	109.947	-1.260E-13
9	0.96114	SLE_C_ENVE	Min	-553.639	140.381	-1.260E-13
10	0.	SLU_ENVE	Max	-189.417	-48.406	5.309E-13
10	0.46683	SLU_ENVE	Max	-189.417	-14.058	5.309E-13
10	0.93367	SLU_ENVE	Max	-189.417	30.287	5.309E-13
10	0.	SLU_ENVE	Min	-907.229	-114.732	-6.669E-14
10	0.46683	SLU_ENVE	Min	-907.23	-84.391	-6.669E-14
10	0.93367	SLU_ENVE	Min	-907.23	-54.051	-6.669E-14
10	0.	SLV_ENVE	Max	-797.469	-92.001	-9.001E-14
10	0.46683	SLV_ENVE	Max	-800.829	-68.662	-9.145E-14
10	0.93367	SLV_ENVE	Max	-804.189	-45.324	-9.289E-14
10	0.	SLV_ENVE	Min	-855.395	-111.509	-9.736E-14
10	0.46683	SLV_ENVE	Min	-856.403	-90.037	-9.779E-14
10	0.93367	SLV_ENVE	Min	-857.411	-68.566	-9.823E-14
10	0.	SLE_FR_ENVE	Max	-650.454	-85.958	1.914E-13
10	0.46683	SLE_FR_ENVE	Max	-650.454	-57.484	1.914E-13
10	0.93367	SLE_FR_ENVE	Max	-650.454	-29.01	1.914E-13
10	0.	SLE_FR_ENVE	Min	-650.454	-85.958	1.914E-13
10	0.46683	SLE_FR_ENVE	Min	-650.454	-57.484	1.914E-13
10	0.93367	SLE_FR_ENVE	Min	-650.454	-29.01	1.914E-13
10	0.	SLE_QP_ENVE	Max	-376.959	-87.336	-4.305E-14
10	0.46683	SLE_QP_ENVE	Max	-376.959	-65.864	-4.305E-14
10	0.93367	SLE_QP_ENVE	Max	-376.959	-44.393	-4.305E-14
10	0.	SLE_QP_ENVE	Min	-583.334	-87.555	-6.661E-14
10	0.46683	SLE_QP_ENVE	Min	-583.334	-66.084	-6.661E-14
10	0.93367	SLE_QP_ENVE	Min	-583.334	-44.612	-6.661E-14
10	0.	SLE_C_ENVE	Max	-374.418	-85.088	-4.276E-14
10	0.46683	SLE_C_ENVE	Max	-374.418	-54.279	-4.276E-14
10	0.93367	SLE_C_ENVE	Max	-374.418	-23.471	-4.276E-14
10	0.	SLE_C_ENVE	Min	-583.334	-87.555	-6.661E-14
10	0.46683	SLE_C_ENVE	Min	-583.334	-66.084	-6.661E-14
10	0.93367	SLE_C_ENVE	Min	-583.334	-44.612	-6.661E-14
11	0.	SLU_ENVE	Max	-392.356	379.973	6.090E-13
11	0.55396	SLU_ENVE	Max	-373.212	309.865	4.760E-13
11	1.10792	SLU_ENVE	Max	-356.804	242.909	3.497E-13
11	0.	SLU_ENVE	Min	-1003.264	3.359	-5.143E-13
11	0.55396	SLU_ENVE	Min	-966.634	6.395	-5.143E-13
11	1.10792	SLU_ENVE	Min	-934.15	-13.899	-5.904E-13

PROGETTO DEFINITIVO

RELAZIONE DI CALCOLO GALLERIA ARTIFICIALE

Table 11: Element Forces - Frames, Part 1 of 2

Frame	Station m	OutputCase	StepType	P KN	V2 KN	V3 KN
11	0.	SLV_ENVE	Max	-747.702	478.929	1.135E-12
11	0.55396	SLV_ENVE	Max	-724.603	376.909	8.902E-13
11	1.10792	SLV_ENVE	Max	-704.394	280.978	6.695E-13
11	0.	SLV_ENVE	Min	-794.456	292.988	7.300E-13
11	0.55396	SLV_ENVE	Min	-758.654	271.076	6.718E-13
11	1.10792	SLV_ENVE	Min	-728.62	249.716	6.158E-13
11	0.	SLE_FR_ENVE	Max	-768.569	271.575	3.441E-13
11	0.55396	SLE_FR_ENVE	Max	-740.392	217.646	2.111E-13
11	1.10792	SLE_FR_ENVE	Max	-715.404	166.141	8.484E-14
11	0.	SLE_FR_ENVE	Min	-768.569	271.575	3.441E-13
11	0.55396	SLE_FR_ENVE	Min	-740.392	217.646	2.111E-13
11	1.10792	SLE_FR_ENVE	Min	-715.404	166.141	8.484E-14
11	0.	SLE_QP_ENVE	Max	-742.981	244.49	6.085E-13
11	0.55396	SLE_QP_ENVE	Max	-717.815	190.561	4.755E-13
11	1.10792	SLE_QP_ENVE	Max	-695.686	139.056	3.493E-13
11	0.	SLE_QP_ENVE	Min	-764.241	109.012	3.000E-13
11	0.55396	SLE_QP_ENVE	Min	-736.065	74.068	2.113E-13
11	1.10792	SLE_QP_ENVE	Min	-711.077	40.596	1.271E-13
11	0.	SLE_C_ENVE	Max	-742.707	244.49	6.085E-13
11	0.55396	SLE_C_ENVE	Max	-717.541	190.561	4.755E-13
11	1.10792	SLE_C_ENVE	Max	-695.412	139.056	3.493E-13
11	0.	SLE_C_ENVE	Min	-764.241	106.484	2.981E-13
11	0.55396	SLE_C_ENVE	Min	-736.065	71.539	2.095E-13
11	1.10792	SLE_C_ENVE	Min	-711.077	38.068	1.253E-13
12	0.	SLU_ENVE	Max	-351.581	213.151	1.119E-12
12	0.55396	SLU_ENVE	Max	-336.728	147.068	7.516E-13
12	1.10792	SLU_ENVE	Max	-322.566	84.682	4.048E-13
12	0.	SLU_ENVE	Min	-900.003	-1.987	-4.121E-13
12	0.55396	SLU_ENVE	Min	-876.393	-3.768	-4.442E-13
12	1.10792	SLU_ENVE	Min	-853.921	-35.46	-7.448E-13
12	0.	SLV_ENVE	Max	-670.656	307.066	2.417E-12
12	0.55396	SLV_ENVE	Max	-654.296	207.334	1.703E-12
12	1.10792	SLV_ENVE	Max	-638.643	154.568	1.298E-12
12	0.	SLV_ENVE	Min	-694.643	199.138	1.628E-12
12	0.55396	SLV_ENVE	Min	-674.162	176.496	1.461E-12
12	1.10792	SLV_ENVE	Min	-655.613	109.224	1.002E-12
12	0.	SLE_FR_ENVE	Max	-691.594	151.035	9.096E-13
12	0.55396	SLE_FR_ENVE	Max	-673.433	100.202	5.423E-13
12	1.10792	SLE_FR_ENVE	Max	-656.147	52.213	1.955E-13
12	0.	SLE_FR_ENVE	Min	-691.594	151.035	9.096E-13
12	0.55396	SLE_FR_ENVE	Min	-673.433	100.202	5.423E-13
12	1.10792	SLE_FR_ENVE	Min	-656.147	52.213	1.955E-13
12	0.	SLE_QP_ENVE	Max	-685.535	135.649	1.115E-12
12	0.55396	SLE_QP_ENVE	Max	-668.477	84.815	7.481E-13
12	1.10792	SLE_QP_ENVE	Max	-652.232	36.826	4.013E-13
12	0.	SLE_QP_ENVE	Min	-690.579	53.274	4.694E-13
12	0.55396	SLE_QP_ENVE	Min	-672.418	19.7	2.246E-13
12	1.10792	SLE_QP_ENVE	Min	-655.132	-11.992	-6.627E-13
12	0.	SLE_C_ENVE	Max	-685.499	135.649	1.115E-12
12	0.55396	SLE_C_ENVE	Max	-668.44	84.815	7.481E-13
12	1.10792	SLE_C_ENVE	Max	-652.196	36.826	4.013E-13
12	0.	SLE_C_ENVE	Min	-690.579	50.731	4.559E-13



PROGETTO DEFINITIVO

RELAZIONE DI CALCOLO GALLERIA ARTIFICIALE

Table 11: Element Forces - Frames, Part 1 of 2

Frame	Station m	OutputCase	StepType	P KN	V2 KN	V3 KN
12	0.55396	SLE_C_ENVE	Min	-672.418	17.157	2.111E-13
12	1.10792	SLE_C_ENVE	Min	-655.132	-14.534	-2.013E-14
13	0.	SLU_ENVE	Max	-322.463	40.363	4.097E-13
13	0.49289	SLU_ENVE	Max	-309.841	-12.394	7.591E-13
13	0.98577	SLU_ENVE	Max	-296.602	-12.816	1.558E-12
13	0.	SLU_ENVE	Min	-846.331	-18.327	-1.069E-12
13	0.49289	SLU_ENVE	Min	-831.232	-32.309	-4.228E-13
13	0.98577	SLU_ENVE	Min	-815.257	-68.138	-4.228E-13
13	0.	SLV_ENVE	Max	-625.598	120.839	-9.814E-13
13	0.49289	SLV_ENVE	Max	-613.485	64.009	2.283E-13
13	0.98577	SLV_ENVE	Max	-600.762	42.659	1.833E-12
13	0.	SLV_ENVE	Min	-644.7	84.522	-1.700E-12
13	0.49289	SLV_ENVE	Min	-633.516	25.467	-6.048E-13
13	0.98577	SLV_ENVE	Min	-621.662	-51.285	-1.719E-13
13	0.	SLE_FR_ENVE	Max	-651.053	25.546	-4.848E-13
13	0.49289	SLE_FR_ENVE	Max	-639.437	-15.884	3.619E-13
13	0.98577	SLE_FR_ENVE	Max	-627.149	-54.99	1.160E-12
13	0.	SLE_FR_ENVE	Min	-651.053	25.546	-4.848E-13
13	0.49289	SLE_FR_ENVE	Min	-639.437	-15.884	3.619E-13
13	0.98577	SLE_FR_ENVE	Min	-627.149	-54.99	1.160E-12
13	0.	SLE_QP_ENVE	Max	-651.125	21.287	3.492E-13
13	0.49289	SLE_QP_ENVE	Max	-639.509	-20.144	9.137E-13
13	0.98577	SLE_QP_ENVE	Max	-627.221	-59.249	1.573E-12
13	0.	SLE_QP_ENVE	Min	-652.154	-11.775	-7.212E-14
13	0.49289	SLE_QP_ENVE	Min	-640.203	-39.499	7.746E-13
13	0.98577	SLE_QP_ENVE	Min	-627.598	-65.678	1.446E-12
13	0.	SLE_C_ENVE	Max	-651.125	21.287	4.088E-13
13	0.49289	SLE_C_ENVE	Max	-639.509	-20.144	9.733E-13
13	0.98577	SLE_C_ENVE	Max	-627.221	-59.249	1.573E-12
13	0.	SLE_C_ENVE	Min	-652.341	-14.31	-7.212E-14
13	0.49289	SLE_C_ENVE	Min	-640.39	-42.034	7.746E-13
13	0.98577	SLE_C_ENVE	Min	-627.785	-68.214	1.506E-12
14	0.	SLU_ENVE	Max	-302.382	-30.28	4.913E-13
14	0.49289	SLU_ENVE	Max	-288.144	-44.198	6.588E-13
14	0.98577	SLU_ENVE	Max	-272.376	-45.902	8.154E-13
14	0.	SLU_ENVE	Min	-831.16	-121.065	-7.223E-13
14	0.49289	SLU_ENVE	Min	-817.743	-170.178	-6.352E-13
14	0.98577	SLU_ENVE	Min	-802.008	-216.479	-6.355E-13
14	0.	SLV_ENVE	Max	-609.845	-43.648	6.034E-13
14	0.49289	SLV_ENVE	Max	-597.802	-65.491	8.571E-13
14	0.98577	SLV_ENVE	Max	-584.073	-86.067	1.191E-12
14	0.	SLV_ENVE	Min	-632.703	-77.561	4.686E-13
14	0.49289	SLV_ENVE	Min	-624.188	-132.057	5.623E-13
14	0.98577	SLV_ENVE	Min	-614.193	-205.574	6.494E-13
14	0.	SLE_FR_ENVE	Max	-638.814	-88.453	8.057E-14
14	0.49289	SLE_FR_ENVE	Max	-628.493	-126.232	2.480E-13
14	0.98577	SLE_FR_ENVE	Max	-616.389	-161.848	4.047E-13
14	0.	SLE_FR_ENVE	Min	-638.814	-88.453	8.057E-14
14	0.49289	SLE_FR_ENVE	Min	-628.493	-126.232	2.480E-13
14	0.98577	SLE_FR_ENVE	Min	-616.389	-161.848	4.047E-13
14	0.	SLE_QP_ENVE	Max	-637.268	-72.41	4.946E-13
14	0.49289	SLE_QP_ENVE	Max	-625.642	-98.111	6.621E-13

RELAZIONE DI CALCOLO GALLERIA ARTIFICIALE

Table 11: Element Forces - Frames, Part 1 of 2

Frame	Station m	OutputCase	StepType	P KN	V2 KN	V3 KN
14	0.98577	SLE_QP_ENVE	Max	-612.317	-122.426	8.188E-13
14	0.	SLE_QP_ENVE	Min	-638.066	-81.832	3.734E-13
14	0.49289	SLE_QP_ENVE	Min	-627.745	-119.611	4.850E-13
14	0.98577	SLE_QP_ENVE	Min	-615.641	-155.228	5.894E-13
14	0.	SLE_C_ENVE	Max	-637.666	-74.921	4.946E-13
14	0.49289	SLE_C_ENVE	Max	-626.039	-100.621	6.621E-13
14	0.98577	SLE_C_ENVE	Max	-612.714	-124.937	8.188E-13
14	0.	SLE_C_ENVE	Min	-638.066	-81.832	3.862E-13
14	0.49289	SLE_C_ENVE	Min	-627.745	-119.611	4.978E-13
14	0.98577	SLE_C_ENVE	Min	-615.641	-155.228	6.022E-13
15	0.	SLU_ENVE	Max	-284.835	-51.783	4.672E-13
15	0.49289	SLU_ENVE	Max	-266.995	-74.69	5.428E-13
15	0.98577	SLU_ENVE	Max	-246.131	-80.241	6.018E-13
15	0.	SLU_ENVE	Min	-840.538	-269.883	-1.032E-12
15	0.49289	SLU_ENVE	Min	-824.674	-312.308	-9.821E-13
15	0.98577	SLU_ENVE	Min	-803.297	-347.295	-9.828E-13
15	0.	SLV_ENVE	Max	-617.819	-185.429	6.388E-13
15	0.49289	SLV_ENVE	Max	-603.351	-206.333	7.480E-13
15	0.98577	SLV_ENVE	Max	-585.677	-226.879	8.766E-13
15	0.	SLV_ENVE	Min	-646.394	-232.754	5.541E-13
15	0.49289	SLV_ENVE	Min	-636.695	-278.352	5.991E-13
15	0.98577	SLV_ENVE	Min	-622.752	-328.63	6.416E-13
15	0.	SLE_FR_ENVE	Max	-644.241	-195.74	-9.099E-14
15	0.49289	SLE_FR_ENVE	Max	-632.039	-228.374	-1.547E-14
15	0.98577	SLE_FR_ENVE	Max	-615.594	-255.287	4.357E-14
15	0.	SLE_FR_ENVE	Min	-644.241	-195.74	-9.099E-14
15	0.49289	SLE_FR_ENVE	Min	-632.039	-228.374	-1.547E-14
15	0.98577	SLE_FR_ENVE	Min	-615.594	-255.287	4.357E-14
15	0.	SLE_QP_ENVE	Max	-631.594	-129.273	4.688E-13
15	0.49289	SLE_QP_ENVE	Max	-617.513	-152.181	5.443E-13
15	0.98577	SLE_QP_ENVE	Max	-599.595	-171.467	6.034E-13
15	0.	SLE_QP_ENVE	Min	-640.846	-178.33	3.315E-13
15	0.49289	SLE_QP_ENVE	Min	-628.643	-210.965	3.817E-13
15	0.98577	SLE_QP_ENVE	Min	-612.199	-237.878	4.209E-13
15	0.	SLE_C_ENVE	Max	-632.199	-131.742	4.688E-13
15	0.49289	SLE_C_ENVE	Max	-618.118	-154.649	5.443E-13
15	0.98577	SLE_C_ENVE	Max	-600.2	-173.935	6.034E-13
15	0.	SLE_C_ENVE	Min	-640.846	-178.33	3.376E-13
15	0.49289	SLE_C_ENVE	Min	-628.643	-210.965	3.878E-13
15	0.98577	SLE_C_ENVE	Min	-612.199	-237.878	4.270E-13
16	0.	SLU_ENVE	Max	-277.602	313.019	5.624E-14
16	0.53604	SLU_ENVE	Max	-264.033	239.096	6.455E-14
16	1.07208	SLU_ENVE	Max	-252.857	170.137	6.942E-14
16	0.	SLU_ENVE	Min	-925.978	60.694	-1.540E-12
16	0.53604	SLU_ENVE	Min	-898.783	36.916	-1.536E-12
16	1.07208	SLU_ENVE	Min	-868.186	17.334	-1.534E-12
16	0.	SLV_ENVE	Max	-718.378	147.114	7.544E-14
16	0.53604	SLV_ENVE	Max	-707.861	61.069	9.552E-14
16	1.07208	SLV_ENVE	Max	-697.553	-4.652	1.292E-13
16	0.	SLV_ENVE	Min	-759.944	122.42	4.688E-14
16	0.53604	SLV_ENVE	Min	-751.788	52.24	8.246E-14
16	1.07208	SLV_ENVE	Min	-754.152	-25.341	9.952E-14

RELAZIONE DI CALCOLO GALLERIA ARTIFICIALE

Table 11: Element Forces - Frames, Part 1 of 2

Frame	Station m	OutputCase	StepType	P KN	V2 KN	V3 KN
16	0.	SLE_FR_ENVE	Max	-696.501	175.596	-6.577E-13
16	0.53604	SLE_FR_ENVE	Max	-675.582	114.884	-6.494E-13
16	1.07208	SLE_FR_ENVE	Max	-652.046	58.977	-6.446E-13
16	0.	SLE_FR_ENVE	Min	-696.501	175.596	-6.577E-13
16	0.53604	SLE_FR_ENVE	Min	-675.582	114.884	-6.494E-13
16	1.07208	SLE_FR_ENVE	Min	-652.046	58.977	-6.446E-13
16	0.	SLE_QP_ENVE	Max	-604.109	244.372	5.642E-14
16	0.53604	SLE_QP_ENVE	Max	-578.004	187.509	6.473E-14
16	1.07208	SLE_QP_ENVE	Max	-550.609	134.463	6.960E-14
16	0.	SLE_QP_ENVE	Min	-673.146	192.882	3.767E-14
16	0.53604	SLE_QP_ENVE	Min	-652.226	132.171	4.120E-14
16	1.07208	SLE_QP_ENVE	Min	-628.69	76.264	4.251E-14
16	0.	SLE_C_ENVE	Max	-606.223	242.96	5.642E-14
16	0.53604	SLE_C_ENVE	Max	-580.117	186.097	6.473E-14
16	1.07208	SLE_C_ENVE	Max	-552.723	133.052	6.960E-14
16	0.	SLE_C_ENVE	Min	-673.146	192.882	3.836E-14
16	0.53604	SLE_C_ENVE	Min	-652.226	132.171	4.190E-14
16	1.07208	SLE_C_ENVE	Min	-628.69	76.264	4.321E-14
17	0.	SLU_ENVE	Max	-274.173	161.047	9.380E-14
17	0.53604	SLU_ENVE	Max	-264.794	107.022	9.691E-14
17	1.07208	SLU_ENVE	Max	-256.612	61.338	9.996E-14
17	0.	SLU_ENVE	Min	-915.909	-9.414	-1.067E-12
17	0.53604	SLU_ENVE	Min	-884.907	-41.02	-1.066E-12
17	1.07208	SLU_ENVE	Min	-856.497	-103.24	-1.066E-12
17	0.	SLV_ENVE	Max	-768.271	-40.648	1.341E-13
17	0.53604	SLV_ENVE	Max	-758.591	-106.146	1.527E-13
17	1.07208	SLV_ENVE	Max	-749.961	-161.919	1.858E-13
17	0.	SLV_ENVE	Min	-785.464	-57.4	1.163E-13
17	0.53604	SLV_ENVE	Min	-787.258	-119.535	1.458E-13
17	1.07208	SLV_ENVE	Min	-798.013	-191.273	1.607E-13
17	0.	SLE_FR_ENVE	Max	-686.188	33.647	-4.112E-13
17	0.53604	SLE_FR_ENVE	Max	-662.34	-17.978	-4.081E-13
17	1.07208	SLE_FR_ENVE	Max	-640.486	-65.839	-4.051E-13
17	0.	SLE_FR_ENVE	Min	-686.188	33.647	-4.112E-13
17	0.53604	SLE_FR_ENVE	Min	-662.34	-17.978	-4.081E-13
17	1.07208	SLE_FR_ENVE	Min	-640.486	-65.839	-4.051E-13
17	0.	SLE_QP_ENVE	Max	-572.972	117.873	9.400E-14
17	0.53604	SLE_QP_ENVE	Max	-546.016	68.554	9.712E-14
17	1.07208	SLE_QP_ENVE	Max	-521.226	22.87	1.002E-13
17	0.	SLE_QP_ENVE	Min	-658.981	53.791	6.423E-14
17	0.53604	SLE_QP_ENVE	Min	-635.133	2.166	6.448E-14
17	1.07208	SLE_QP_ENVE	Min	-613.28	-45.695	6.483E-14
17	0.	SLE_C_ENVE	Max	-575.085	116.461	9.400E-14
17	0.53604	SLE_C_ENVE	Max	-548.129	67.142	9.712E-14
17	1.07208	SLE_C_ENVE	Max	-523.34	21.459	1.002E-13
17	0.	SLE_C_ENVE	Min	-658.981	53.791	6.501E-14
17	0.53604	SLE_C_ENVE	Min	-635.133	2.166	6.526E-14
17	1.07208	SLE_C_ENVE	Min	-613.28	-45.695	6.561E-14
18	0.	SLU_ENVE	Max	-278.213	60.356	1.401E-13
18	0.53604	SLU_ENVE	Max	-270.93	17.677	1.425E-13
18	1.07208	SLU_ENVE	Max	-264.245	-22.629	1.439E-13
18	0.	SLU_ENVE	Min	-902.647	-137.478	-8.086E-13

RELAZIONE DI CALCOLO GALLERIA ARTIFICIALE

Table 11: Element Forces - Frames, Part 1 of 2

Frame	Station m	OutputCase	StepType	P KN	V2 KN	V3 KN
18	0.53604	SLU_ENVE	Min	-875.398	-195.478	-8.086E-13
18	1.07208	SLU_ENVE	Min	-847.88	-249.93	-8.094E-13
18	0.	SLV_ENVE	Max	-807.986	-196.244	2.225E-13
18	0.53604	SLV_ENVE	Max	-796.614	-247.973	2.368E-13
18	1.07208	SLV_ENVE	Max	-783.933	-296.155	2.604E-13
18	0.	SLV_ENVE	Min	-825.765	-233.132	2.052E-13
18	0.53604	SLV_ENVE	Min	-827.071	-287.259	2.210E-13
18	1.07208	SLV_ENVE	Min	-832.065	-338.757	2.302E-13
18	0.	SLE_FR_ENVE	Max	-673.84	-90.584	-2.576E-13
18	0.53604	SLE_FR_ENVE	Max	-652.879	-135.2	-2.551E-13
18	1.07208	SLE_FR_ENVE	Max	-631.711	-177.085	-2.538E-13
18	0.	SLE_FR_ENVE	Min	-673.84	-90.584	-2.576E-13
18	0.53604	SLE_FR_ENVE	Min	-652.879	-135.2	-2.551E-13
18	1.07208	SLE_FR_ENVE	Min	-631.711	-177.085	-2.538E-13
18	0.	SLE_QP_ENVE	Max	-542.827	6.845	1.403E-13
18	0.53604	SLE_QP_ENVE	Max	-519.257	-35.835	1.428E-13
18	1.07208	SLE_QP_ENVE	Max	-495.959	-76.14	1.441E-13
18	0.	SLE_QP_ENVE	Min	-643.413	-68.051	9.711E-14
18	0.53604	SLE_QP_ENVE	Min	-622.453	-112.667	9.717E-14
18	1.07208	SLE_QP_ENVE	Min	-601.285	-154.553	9.655E-14
18	0.	SLE_C_ENVE	Max	-544.941	5.433	1.403E-13
18	0.53604	SLE_C_ENVE	Max	-521.37	-37.246	1.428E-13
18	1.07208	SLE_C_ENVE	Max	-498.073	-77.552	1.441E-13
18	0.	SLE_C_ENVE	Min	-643.413	-68.051	9.804E-14
18	0.53604	SLE_C_ENVE	Min	-622.453	-112.667	9.809E-14
18	1.07208	SLE_C_ENVE	Min	-601.285	-154.553	9.747E-14
19	0.	SLU_ENVE	Max	-263.838	250.365	3.131E-14
19	0.53603	SLU_ENVE	Max	-270.523	195.915	2.464E-14
19	1.07206	SLU_ENVE	Max	-277.807	137.916	1.754E-14
19	0.	SLU_ENVE	Min	-847.847	23.354	1.303E-15
19	0.53603	SLU_ENVE	Min	-875.365	-16.951	-3.633E-15
19	1.07206	SLU_ENVE	Min	-902.614	-59.629	-8.859E-15
19	0.	SLV_ENVE	Max	-813.206	384.518	4.810E-14
19	0.53603	SLV_ENVE	Max	-833.235	341.397	4.282E-14
19	1.07206	SLV_ENVE	Max	-852.268	293.951	3.701E-14
19	0.	SLV_ENVE	Min	-951.162	305.867	3.824E-14
19	0.53603	SLV_ENVE	Min	-970.664	263.137	3.300E-14
19	1.07206	SLV_ENVE	Min	-987.809	217.092	2.737E-14
19	0.	SLE_FR_ENVE	Max	-631.727	177.364	2.214E-14
19	0.53603	SLE_FR_ENVE	Max	-652.895	135.479	1.701E-14
19	1.07206	SLE_FR_ENVE	Max	-673.855	90.864	1.154E-14
19	0.	SLE_FR_ENVE	Min	-631.727	177.364	2.214E-14
19	0.53603	SLE_FR_ENVE	Min	-652.895	135.479	1.701E-14
19	1.07206	SLE_FR_ENVE	Min	-673.855	90.864	1.154E-14
19	0.	SLE_QP_ENVE	Max	-495.755	154.779	1.925E-14
19	0.53603	SLE_QP_ENVE	Max	-519.053	112.894	1.412E-14
19	1.07206	SLE_QP_ENVE	Max	-542.624	68.279	8.653E-15
19	0.	SLE_QP_ENVE	Min	-601.338	76.719	9.309E-15
19	0.53603	SLE_QP_ENVE	Min	-622.506	36.414	4.373E-15
19	1.07206	SLE_QP_ENVE	Min	-643.467	-6.265	-8.534E-16
19	0.	SLE_C_ENVE	Max	-497.723	154.779	1.925E-14
19	0.53603	SLE_C_ENVE	Max	-521.021	112.894	1.412E-14

RELAZIONE DI CALCOLO GALLERIA ARTIFICIALE

Table 11: Element Forces - Frames, Part 1 of 2

Frame	Station m	OutputCase	StepType	P KN	V2 KN	V3 KN
19	1.07206	SLE_C_ENVE	Max	-544.591	68.279	8.653E-15
19	0.	SLE_C_ENVE	Min	-601.338	78.335	9.520E-15
19	0.53603	SLE_C_ENVE	Min	-622.506	38.03	4.585E-15
19	1.07206	SLE_C_ENVE	Min	-643.467	-4.649	-6.421E-16
20	0.	SLU_ENVE	Max	-256.309	103.752	1.861E-14
20	0.53603	SLU_ENVE	Max	-264.49	41.531	1.148E-14
20	1.07207	SLU_ENVE	Max	-273.869	10.305	3.806E-15
20	0.	SLU_ENVE	Min	-856.589	-60.548	-1.585E-13
20	0.53603	SLU_ENVE	Min	-884.998	-106.231	-1.669E-13
20	1.07207	SLU_ENVE	Min	-916.	-160.12	-1.759E-13
20	0.	SLV_ENVE	Max	-788.434	230.713	5.175E-14
20	0.53603	SLV_ENVE	Max	-808.051	179.502	4.355E-14
20	1.07207	SLV_ENVE	Max	-829.837	125.087	3.500E-14
20	0.	SLV_ENVE	Min	-902.6	169.716	3.997E-14
20	0.53603	SLV_ENVE	Min	-919.938	120.196	3.277E-14
20	1.07207	SLV_ENVE	Min	-940.024	67.043	2.461E-14
20	0.	SLE_FR_ENVE	Max	-640.6	66.178	-5.131E-14
20	0.53603	SLE_FR_ENVE	Max	-662.453	18.317	-5.844E-14
20	1.07207	SLE_FR_ENVE	Max	-686.3	-33.308	-6.611E-14
20	0.	SLE_FR_ENVE	Min	-640.6	66.178	-5.131E-14
20	0.53603	SLE_FR_ENVE	Min	-662.453	18.317	-5.844E-14
20	1.07207	SLE_FR_ENVE	Min	-686.3	-33.308	-6.611E-14
20	0.	SLE_QP_ENVE	Max	-521.125	45.984	1.869E-14
20	0.53603	SLE_QP_ENVE	Max	-545.914	-1.878	1.155E-14
20	1.07207	SLE_QP_ENVE	Max	-572.87	-53.502	3.883E-15
20	0.	SLE_QP_ENVE	Min	-613.433	-22.224	6.303E-15
20	0.53603	SLE_QP_ENVE	Min	-635.286	-67.908	-1.410E-16
20	1.07207	SLE_QP_ENVE	Min	-659.133	-117.226	-7.079E-15
20	0.	SLE_C_ENVE	Max	-523.093	45.984	1.869E-14
20	0.53603	SLE_C_ENVE	Max	-547.882	-1.878	1.155E-14
20	1.07207	SLE_C_ENVE	Max	-574.837	-53.502	3.883E-15
20	0.	SLE_C_ENVE	Min	-613.433	-20.608	6.598E-15
20	0.53603	SLE_C_ENVE	Min	-635.286	-66.292	1.543E-16
20	1.07207	SLE_C_ENVE	Min	-659.133	-115.61	-6.784E-15
21	0.	SLU_ENVE	Max	-252.646	-16.353	1.597E-15
21	0.53605	SLU_ENVE	Max	-263.821	-35.935	-1.485E-15
21	1.0721	SLU_ENVE	Max	-277.391	-59.714	-3.725E-15
21	0.	SLU_ENVE	Min	-868.401	-169.12	-2.366E-13
21	0.53605	SLU_ENVE	Min	-898.999	-238.08	-2.465E-13
21	1.0721	SLU_ENVE	Min	-926.194	-312.004	-2.575E-13
21	0.	SLV_ENVE	Max	-769.533	67.285	2.235E-14
21	0.53605	SLV_ENVE	Max	-790.366	7.554	1.262E-14
21	1.0721	SLV_ENVE	Max	-807.123	-58.978	3.953E-15
21	0.	SLV_ENVE	Min	-862.103	22.309	1.131E-14
21	0.53605	SLV_ENVE	Min	-880.486	-35.605	6.325E-15
21	1.0721	SLV_ENVE	Min	-892.718	-99.405	-4.340E-15
21	0.	SLE_FR_ENVE	Max	-652.254	-58.562	-9.893E-14
21	0.53605	SLE_FR_ENVE	Max	-675.791	-114.47	-1.074E-13
21	1.0721	SLE_FR_ENVE	Max	-696.71	-175.183	-1.171E-13
21	0.	SLE_FR_ENVE	Min	-652.254	-58.562	-9.893E-14
21	0.53605	SLE_FR_ENVE	Min	-675.791	-114.47	-1.074E-13
21	1.0721	SLE_FR_ENVE	Min	-696.71	-175.183	-1.171E-13

RELAZIONE DI CALCOLO GALLERIA ARTIFICIALE

Table 11: Element Forces - Frames, Part 1 of 2

Frame	Station m	OutputCase	StepType	P KN	V2 KN	V3 KN
21	0.	SLE_QP_ENVE	Max	-550.608	-75.898	1.661E-15
21	0.53605	SLE_QP_ENVE	Max	-578.003	-131.807	-6.859E-15
21	1.0721	SLE_QP_ENVE	Max	-604.109	-192.519	-1.654E-14
21	0.	SLE_QP_ENVE	Min	-628.94	-133.739	-7.042E-15
21	0.53605	SLE_QP_ENVE	Min	-652.477	-186.785	-1.465E-14
21	1.0721	SLE_QP_ENVE	Min	-673.396	-243.65	-2.312E-14
21	0.	SLE_C_ENVE	Max	-552.575	-75.898	1.661E-15
21	0.53605	SLE_C_ENVE	Max	-579.97	-131.807	-6.859E-15
21	1.0721	SLE_C_ENVE	Max	-606.076	-192.519	-1.654E-14
21	0.	SLE_C_ENVE	Min	-628.94	-132.123	-6.797E-15
21	0.53605	SLE_C_ENVE	Min	-652.477	-185.169	-1.441E-14
21	1.0721	SLE_C_ENVE	Min	-673.396	-242.034	-2.287E-14
22	0.	SLU_ENVE	Max	-282.88	37.988	1.177E-13
22	0.48807	SLU_ENVE	Max	-278.756	4.892	1.168E-13
22	0.97615	SLU_ENVE	Max	-271.981	-3.952	1.151E-13
22	0.	SLU_ENVE	Min	-918.2	-92.228	-7.309E-13
22	0.48807	SLU_ENVE	Min	-902.551	-143.387	-7.323E-13
22	0.97615	SLU_ENVE	Min	-885.695	-192.787	-7.337E-13
22	0.	SLV_ENVE	Max	-867.212	-151.453	1.857E-13
22	0.48807	SLV_ENVE	Max	-864.891	-195.338	1.956E-13
22	0.97615	SLV_ENVE	Max	-860.602	-237.383	2.064E-13
22	0.	SLV_ENVE	Min	-927.293	-200.47	1.687E-13
22	0.48807	SLV_ENVE	Min	-930.841	-247.091	1.754E-13
22	0.97615	SLV_ENVE	Min	-933.7	-292.47	1.796E-13
22	0.	SLE_FR_ENVE	Max	-681.74	-59.526	-2.461E-13
22	0.48807	SLE_FR_ENVE	Max	-669.702	-98.88	-2.471E-13
22	0.97615	SLE_FR_ENVE	Max	-656.736	-136.88	-2.488E-13
22	0.	SLE_FR_ENVE	Min	-681.74	-59.526	-2.461E-13
22	0.48807	SLE_FR_ENVE	Min	-669.702	-98.88	-2.471E-13
22	0.97615	SLE_FR_ENVE	Min	-656.736	-136.88	-2.488E-13
22	0.	SLE_QP_ENVE	Max	-518.804	16.658	1.179E-13
22	0.48807	SLE_QP_ENVE	Max	-505.037	-21.89	1.169E-13
22	0.97615	SLE_QP_ENVE	Max	-490.77	-59.282	1.152E-13
22	0.	SLE_QP_ENVE	Min	-645.254	-42.549	8.725E-14
22	0.48807	SLE_QP_ENVE	Min	-633.216	-81.902	8.512E-14
22	0.97615	SLE_QP_ENVE	Min	-620.25	-119.902	8.249E-14
22	0.	SLE_C_ENVE	Max	-521.157	15.699	1.179E-13
22	0.48807	SLE_C_ENVE	Max	-507.391	-22.848	1.169E-13
22	0.97615	SLE_C_ENVE	Max	-493.124	-60.241	1.152E-13
22	0.	SLE_C_ENVE	Min	-645.254	-42.549	8.781E-14
22	0.48807	SLE_C_ENVE	Min	-633.216	-81.902	8.567E-14
22	0.97615	SLE_C_ENVE	Min	-620.25	-119.902	8.304E-14
23	0.	SLU_ENVE	Max	-274.56	40.596	8.979E-14
23	0.48807	SLU_ENVE	Max	-266.328	31.169	8.663E-14
23	0.97615	SLU_ENVE	Max	-257.441	21.743	8.291E-14
23	0.	SLU_ENVE	Min	-930.602	-42.726	-6.124E-13
23	0.48807	SLU_ENVE	Min	-921.138	-92.901	-6.150E-13
23	0.97615	SLU_ENVE	Min	-910.283	-141.797	-6.202E-13
23	0.	SLV_ENVE	Max	-916.745	-91.836	1.348E-13
23	0.48807	SLV_ENVE	Max	-917.525	-132.592	1.404E-13
23	0.97615	SLV_ENVE	Max	-915.971	-172.025	1.455E-13
23	0.	SLV_ENVE	Min	-1017.718	-138.596	1.240E-13

RELAZIONE DI CALCOLO GALLERIA ARTIFICIALE

Table 11: Element Forces - Frames, Part 1 of 2

Frame	Station m	OutputCase	StepType	P KN	V2 KN	V3 KN
23	0.48807	SLV_ENVE	Min	-1027.422	-181.743	1.250E-13
23	0.97615	SLV_ENVE	Min	-1036.036	-223.9	1.248E-13
23	0.	SLE_FR_ENVE	Max	-688.956	-25.697	-2.155E-13
23	0.48807	SLE_FR_ENVE	Max	-681.676	-64.293	-2.186E-13
23	0.97615	SLE_FR_ENVE	Max	-673.326	-101.905	-2.223E-13
23	0.	SLE_FR_ENVE	Min	-688.956	-25.697	-2.155E-13
23	0.48807	SLE_FR_ENVE	Min	-681.676	-64.293	-2.186E-13
23	0.97615	SLE_FR_ENVE	Min	-673.326	-101.905	-2.223E-13
23	0.	SLE_QP_ENVE	Max	-505.558	23.638	8.988E-14
23	0.48807	SLE_QP_ENVE	Max	-497.326	-14.703	8.672E-14
23	0.97615	SLE_QP_ENVE	Max	-488.438	-52.171	8.300E-14
23	0.	SLE_QP_ENVE	Min	-649.004	-15.025	7.039E-14
23	0.48807	SLE_QP_ENVE	Min	-641.725	-53.621	6.675E-14
23	0.97615	SLE_QP_ENVE	Min	-633.375	-91.233	6.275E-14
23	0.	SLE_C_ENVE	Max	-508.044	23.102	8.988E-14
23	0.48807	SLE_C_ENVE	Max	-499.812	-15.239	8.672E-14
23	0.97615	SLE_C_ENVE	Max	-490.925	-52.707	8.300E-14
23	0.	SLE_C_ENVE	Min	-649.004	-15.025	7.074E-14
23	0.48807	SLE_C_ENVE	Min	-641.725	-53.621	6.709E-14
23	0.97615	SLE_C_ENVE	Min	-633.375	-91.233	6.309E-14
24	0.	SLU_ENVE	Max	-265.	82.506	8.844E-14
24	0.48807	SLU_ENVE	Max	-262.197	69.868	8.419E-14
24	0.97615	SLU_ENVE	Max	-259.08	57.23	7.971E-14
24	0.	SLU_ENVE	Min	-928.568	-34.186	-6.180E-13
24	0.48807	SLU_ENVE	Min	-925.257	-83.47	-6.237E-13
24	0.97615	SLU_ENVE	Min	-921.315	-132.342	-6.296E-13
24	0.	SLV_ENVE	Max	-940.85	-11.135	1.338E-13
24	0.48807	SLV_ENVE	Max	-944.372	-49.599	1.384E-13
24	0.97615	SLV_ENVE	Max	-946.834	-87.681	1.427E-13
24	0.	SLV_ENVE	Min	-1074.431	-41.927	1.231E-13
24	0.48807	SLV_ENVE	Min	-1089.337	-81.387	1.219E-13
24	0.97615	SLV_ENVE	Min	-1103.693	-120.51	1.202E-13
24	0.	SLE_FR_ENVE	Max	-686.434	16.072	-2.171E-13
24	0.48807	SLE_FR_ENVE	Max	-683.887	-21.861	-2.214E-13
24	0.97615	SLE_FR_ENVE	Max	-680.855	-59.463	-2.259E-13
24	0.	SLE_FR_ENVE	Min	-686.434	16.072	-2.171E-13
24	0.48807	SLE_FR_ENVE	Min	-683.887	-21.861	-2.214E-13
24	0.97615	SLE_FR_ENVE	Min	-680.855	-59.463	-2.259E-13
24	0.	SLE_QP_ENVE	Max	-493.798	33.113	8.852E-14
24	0.48807	SLE_QP_ENVE	Max	-490.996	-4.798	8.427E-14
24	0.97615	SLE_QP_ENVE	Max	-487.878	-42.392	7.980E-14
24	0.	SLE_QP_ENVE	Min	-645.058	19.66	6.959E-14
24	0.48807	SLE_QP_ENVE	Min	-642.51	-18.273	6.521E-14
24	0.97615	SLE_QP_ENVE	Min	-639.478	-55.875	6.069E-14
24	0.	SLE_C_ENVE	Max	-496.342	33.016	8.852E-14
24	0.48807	SLE_C_ENVE	Max	-493.54	-4.894	8.427E-14
24	0.97615	SLE_C_ENVE	Max	-490.422	-42.488	7.980E-14
24	0.	SLE_C_ENVE	Min	-645.058	19.66	6.992E-14
24	0.48807	SLE_C_ENVE	Min	-642.51	-18.273	6.554E-14
24	0.97615	SLE_C_ENVE	Min	-639.478	-55.875	6.102E-14
25	0.	SLU_ENVE	Max	-259.26	133.412	7.666E-14
25	0.48807	SLU_ENVE	Max	-262.378	84.539	7.195E-14

RELAZIONE DI CALCOLO GALLERIA ARTIFICIALE

Table 11: Element Forces - Frames, Part 1 of 2

Frame	Station m	OutputCase	StepType	P KN	V2 KN	V3 KN
25	0.97615	SLU_ENVE	Max	-265.18	35.255	6.699E-14
25	0.	SLU_ENVE	Min	-921.283	-56.59	-5.026E-13
25	0.48807	SLU_ENVE	Min	-925.226	-69.227	-5.041E-13
25	0.97615	SLU_ENVE	Min	-928.537	-81.865	-5.057E-13
25	0.	SLV_ENVE	Max	-947.675	86.539	1.250E-13
25	0.48807	SLV_ENVE	Max	-955.627	50.453	1.273E-13
25	0.97615	SLV_ENVE	Max	-962.519	14.03	1.285E-13
25	0.	SLV_ENVE	Min	-1107.852	72.907	1.122E-13
25	0.48807	SLV_ENVE	Min	-1127.369	36.747	1.096E-13
25	0.97615	SLV_ENVE	Min	-1144.654	0.104	1.065E-13
25	0.	SLE_FR_ENVE	Max	-680.837	59.67	-1.669E-13
25	0.48807	SLE_FR_ENVE	Max	-683.869	22.069	-1.716E-13
25	0.97615	SLE_FR_ENVE	Max	-686.416	-15.864	-1.765E-13
25	0.	SLE_FR_ENVE	Min	-680.837	59.67	-1.669E-13
25	0.48807	SLE_FR_ENVE	Min	-683.869	22.069	-1.716E-13
25	0.97615	SLE_FR_ENVE	Min	-686.416	-15.864	-1.765E-13
25	0.	SLE_QP_ENVE	Max	-487.827	56.018	7.674E-14
25	0.48807	SLE_QP_ENVE	Max	-490.945	18.417	7.203E-14
25	0.97615	SLE_QP_ENVE	Max	-493.747	-19.516	6.707E-14
25	0.	SLE_QP_ENVE	Min	-639.465	42.971	5.814E-14
25	0.48807	SLE_QP_ENVE	Min	-642.498	5.377	5.347E-14
25	0.97615	SLE_QP_ENVE	Min	-645.045	-32.533	4.862E-14
25	0.	SLE_C_ENVE	Max	-490.35	56.018	7.674E-14
25	0.48807	SLE_C_ENVE	Max	-493.467	18.417	7.203E-14
25	0.97615	SLE_C_ENVE	Max	-496.269	-19.516	6.707E-14
25	0.	SLE_C_ENVE	Min	-639.465	43.318	5.848E-14
25	0.48807	SLE_C_ENVE	Min	-642.498	5.724	5.380E-14
25	0.97615	SLE_C_ENVE	Min	-645.045	-32.187	4.895E-14
26	0.	SLU_ENVE	Max	-257.521	142.152	6.908E-14
26	0.48807	SLU_ENVE	Max	-266.408	93.256	6.394E-14
26	0.97615	SLU_ENVE	Max	-274.64	43.081	5.827E-14
26	0.	SLU_ENVE	Min	-910.212	-21.215	-3.707E-13
26	0.48807	SLU_ENVE	Min	-921.067	-30.641	-3.722E-13
26	0.97615	SLU_ENVE	Min	-930.531	-40.067	-3.737E-13
26	0.	SLV_ENVE	Max	-934.956	198.77	1.290E-13
26	0.48807	SLV_ENVE	Max	-946.635	165.639	1.281E-13
26	0.97615	SLV_ENVE	Max	-956.033	131.533	1.262E-13
26	0.	SLV_ENVE	Min	-1109.997	167.122	1.103E-13
26	0.48807	SLV_ENVE	Min	-1129.982	130.402	1.064E-13
26	0.97615	SLV_ENVE	Min	-1145.275	92.373	1.015E-13
26	0.	SLE_FR_ENVE	Max	-673.287	102.11	-1.116E-13
26	0.48807	SLE_FR_ENVE	Max	-681.637	64.498	-1.168E-13
26	0.97615	SLE_FR_ENVE	Max	-688.917	25.902	-1.224E-13
26	0.	SLE_FR_ENVE	Min	-673.287	102.11	-1.116E-13
26	0.48807	SLE_FR_ENVE	Min	-681.637	64.498	-1.168E-13
26	0.97615	SLE_FR_ENVE	Min	-688.917	25.902	-1.224E-13
26	0.	SLE_QP_ENVE	Max	-488.301	91.376	6.917E-14
26	0.48807	SLE_QP_ENVE	Max	-497.189	53.764	6.404E-14
26	0.97615	SLE_QP_ENVE	Max	-505.421	15.168	5.837E-14
26	0.	SLE_QP_ENVE	Min	-633.351	52.736	4.839E-14
26	0.48807	SLE_QP_ENVE	Min	-641.701	15.268	4.345E-14
26	0.97615	SLE_QP_ENVE	Min	-648.981	-23.072	3.813E-14



RELAZIONE DI CALCOLO GALLERIA ARTIFICIALE

Table 11: Element Forces - Frames, Part 1 of 2

Frame	Station m	OutputCase	StepType	P KN	V2 KN	V3 KN
26	0.	SLE_C_ENVE	Max	-490.725	91.376	6.917E-14
26	0.48807	SLE_C_ENVE	Max	-499.612	53.764	6.404E-14
26	0.97615	SLE_C_ENVE	Max	-507.844	15.168	5.837E-14
26	0.	SLE_C_ENVE	Min	-633.351	53.516	4.877E-14
26	0.48807	SLE_C_ENVE	Min	-641.701	16.048	4.383E-14
26	0.97615	SLE_C_ENVE	Min	-648.981	-22.293	3.850E-14
27	0.	SLU_ENVE	Max	-272.	193.162	5.978E-14
27	0.48807	SLU_ENVE	Max	-278.36	143.762	5.415E-14
27	0.97615	SLU_ENVE	Max	-282.484	92.602	4.804E-14
27	0.	SLU_ENVE	Min	-885.643	4.436	-2.371E-13
27	0.48807	SLU_ENVE	Min	-902.499	-4.408	-2.385E-13
27	0.97615	SLU_ENVE	Min	-918.148	-37.31	-2.434E-13
27	0.	SLV_ENVE	Max	-888.22	296.363	1.264E-13
27	0.48807	SLV_ENVE	Max	-902.059	260.328	1.221E-13
27	0.97615	SLV_ENVE	Max	-913.878	221.858	1.163E-13
27	0.	SLV_ENVE	Min	-1054.953	239.615	1.038E-13
27	0.48807	SLV_ENVE	Min	-1072.132	202.022	9.846E-14
27	0.97615	SLV_ENVE	Min	-1085.17	162.567	9.228E-14
27	0.	SLE_FR_ENVE	Max	-656.723	137.104	-5.828E-14
27	0.48807	SLE_FR_ENVE	Max	-669.689	99.104	-6.391E-14
27	0.97615	SLE_FR_ENVE	Max	-681.727	59.751	-7.002E-14
27	0.	SLE_FR_ENVE	Min	-656.723	137.104	-5.828E-14
27	0.48807	SLE_FR_ENVE	Min	-669.689	99.104	-6.391E-14
27	0.97615	SLE_FR_ENVE	Min	-681.727	59.751	-7.002E-14
27	0.	SLE_QP_ENVE	Max	-490.597	120.066	5.989E-14
27	0.48807	SLE_QP_ENVE	Max	-504.865	82.066	5.426E-14
27	0.97615	SLE_QP_ENVE	Max	-518.631	42.713	4.815E-14
27	0.	SLE_QP_ENVE	Min	-620.262	59.844	3.780E-14
27	0.48807	SLE_QP_ENVE	Min	-633.228	22.451	3.257E-14
27	0.97615	SLE_QP_ENVE	Min	-645.266	-16.097	2.699E-14
27	0.	SLE_C_ENVE	Max	-492.849	120.066	5.989E-14
27	0.48807	SLE_C_ENVE	Max	-507.116	82.066	5.426E-14
27	0.97615	SLE_C_ENVE	Max	-520.882	42.713	4.815E-14
27	0.	SLE_C_ENVE	Min	-620.262	61.032	3.822E-14
27	0.48807	SLE_C_ENVE	Min	-633.228	23.639	3.299E-14
27	0.97615	SLE_C_ENVE	Min	-645.266	-14.908	2.741E-14
28	0.	SLU_ENVE	Max	-245.609	348.144	7.474E-13
28	0.49288	SLU_ENVE	Max	-266.171	313.234	7.467E-13
28	0.98576	SLU_ENVE	Max	-283.103	271.037	7.909E-13
28	0.	SLU_ENVE	Min	-803.093	80.736	-4.840E-13
28	0.49288	SLU_ENVE	Min	-824.077	75.648	-4.375E-13
28	0.98576	SLU_ENVE	Min	-838.761	52.916	-3.778E-13
28	0.	SLV_ENVE	Max	-624.572	385.703	-6.180E-13
28	0.49288	SLV_ENVE	Max	-644.046	330.437	-6.069E-13
28	0.98576	SLV_ENVE	Max	-658.069	263.832	-5.642E-13
28	0.	SLV_ENVE	Min	-664.974	266.46	-8.537E-13
28	0.49288	SLV_ENVE	Min	-675.629	256.858	-7.487E-13
28	0.98576	SLV_ENVE	Min	-680.329	244.693	-6.188E-13
28	0.	SLE_FR_ENVE	Max	-615.506	255.928	-5.717E-14
28	0.49288	SLE_FR_ENVE	Max	-631.647	229.074	-1.059E-14
28	0.98576	SLE_FR_ENVE	Max	-642.943	196.615	4.905E-14
28	0.	SLE_FR_ENVE	Min	-615.506	255.928	-5.717E-14

Table 11: Element Forces - Frames, Part 1 of 2

Frame	Station m	OutputCase	StepType	P KN	V2 KN	V3 KN
28	0.49288	SLE_FR_ENVE	Min	-631.647	229.074	-1.059E-14
28	0.98576	SLE_FR_ENVE	Min	-642.943	196.615	4.905E-14
28	0.	SLE_QP_ENVE	Max	-599.143	238.509	-3.321E-13
28	0.49288	SLE_QP_ENVE	Max	-616.758	211.655	-3.012E-13
28	0.98576	SLE_QP_ENVE	Max	-629.932	179.196	-2.616E-13
28	0.	SLE_QP_ENVE	Min	-612.174	172.191	-4.854E-13
28	0.49288	SLE_QP_ENVE	Min	-628.316	152.963	-4.388E-13
28	0.98576	SLE_QP_ENVE	Min	-639.612	130.232	-3.792E-13
28	0.	SLE_C_ENVE	Max	-599.502	238.509	-3.373E-13
28	0.49288	SLE_C_ENVE	Max	-617.117	211.655	-3.064E-13
28	0.98576	SLE_C_ENVE	Max	-630.291	179.196	-2.668E-13
28	0.	SLE_C_ENVE	Min	-612.174	174.712	-4.854E-13
28	0.49288	SLE_C_ENVE	Min	-628.316	155.484	-4.388E-13
28	0.98576	SLE_C_ENVE	Min	-639.612	132.753	-3.792E-13
29	0.	SLU_ENVE	Max	-270.607	217.679	5.060E-13
29	0.49289	SLU_ENVE	Max	-286.376	171.378	5.057E-13
29	0.98578	SLU_ENVE	Max	-300.613	122.265	5.727E-13
29	0.	SLU_ENVE	Min	-800.163	46.643	-6.518E-13
29	0.49289	SLU_ENVE	Min	-815.898	44.939	-5.273E-13
29	0.98578	SLU_ENVE	Min	-829.315	31.368	-3.943E-13
29	0.	SLV_ENVE	Max	-610.894	173.762	-4.656E-13
29	0.49289	SLV_ENVE	Max	-625.528	123.677	-4.273E-13
29	0.98578	SLV_ENVE	Max	-638.572	71.264	-3.618E-13
29	0.	SLV_ENVE	Min	-639.959	60.139	-8.921E-13
29	0.49289	SLV_ENVE	Min	-648.072	47.941	-6.618E-13
29	0.98578	SLV_ENVE	Min	-654.427	22.811	-4.749E-13
29	0.	SLE_FR_ENVE	Max	-615.038	162.76	-3.231E-13
29	0.49289	SLE_FR_ENVE	Max	-627.142	127.144	-1.987E-13
29	0.98578	SLE_FR_ENVE	Max	-637.463	89.365	-6.561E-14
29	0.	SLE_FR_ENVE	Min	-615.038	162.76	-3.231E-13
29	0.49289	SLE_FR_ENVE	Min	-627.142	127.144	-1.987E-13
29	0.98578	SLE_FR_ENVE	Min	-637.463	89.365	-6.561E-14
29	0.	SLE_QP_ENVE	Max	-610.594	156.129	-4.730E-13
29	0.49289	SLE_QP_ENVE	Max	-623.919	120.512	-3.900E-13
29	0.98578	SLE_QP_ENVE	Max	-635.546	82.733	-3.014E-13
29	0.	SLE_QP_ENVE	Min	-614.354	123.37	-6.545E-13
29	0.49289	SLE_QP_ENVE	Min	-626.458	99.055	-5.301E-13
29	0.98578	SLE_QP_ENVE	Min	-636.779	73.354	-3.970E-13
29	0.	SLE_C_ENVE	Max	-610.743	156.129	-4.836E-13
29	0.49289	SLE_C_ENVE	Max	-624.068	120.512	-4.006E-13
29	0.98578	SLE_C_ENVE	Max	-635.694	82.733	-3.120E-13
29	0.	SLE_C_ENVE	Min	-614.354	125.913	-6.545E-13
29	0.49289	SLE_C_ENVE	Min	-626.458	101.598	-5.301E-13
29	0.98578	SLE_C_ENVE	Min	-636.779	75.897	-3.970E-13
30	0.	SLU_ENVE	Max	-294.781	69.33	3.199E-13
30	0.4929	SLU_ENVE	Max	-308.019	33.67	3.198E-13
30	0.98579	SLU_ENVE	Max	-320.642	19.037	8.339E-13
30	0.	SLU_ENVE	Min	-813.417	13.746	-1.261E-12
30	0.4929	SLU_ENVE	Min	-829.392	13.324	-6.230E-13
30	0.98579	SLU_ENVE	Min	-844.492	-39.189	-3.421E-13
30	0.	SLV_ENVE	Max	-628.443	5.92	1.221E-12
30	0.4929	SLV_ENVE	Max	-641.334	-48.017	1.410E-12

Table 11: Element Forces - Frames, Part 1 of 2

Frame	Station m	OutputCase	StepType	P KN	V2 KN	V3 KN
30	0.98579	SLV_ENVE	Max	-652.584	-104.347	2.470E-12
30	0.	SLV_ENVE	Min	-647.234	-114.72	-7.338E-13
30	0.4929	SLV_ENVE	Min	-658.628	-126.539	1.480E-13
30	0.98579	SLV_ENVE	Min	-669.362	-198.715	1.069E-12
30	0.	SLE_FR_ENVE	Max	-625.73	55.901	-9.437E-13
30	0.4929	SLE_FR_ENVE	Max	-638.018	16.795	-3.059E-13
30	0.98579	SLE_FR_ENVE	Max	-649.634	-24.637	3.704E-13
30	0.	SLE_FR_ENVE	Min	-625.73	55.901	-9.437E-13
30	0.4929	SLE_FR_ENVE	Min	-638.018	16.795	-3.059E-13
30	0.98579	SLE_FR_ENVE	Min	-649.634	-24.637	3.704E-13
30	0.	SLE_QP_ENVE	Max	-625.805	66.588	-1.174E-12
30	0.4929	SLE_QP_ENVE	Max	-638.155	40.407	-6.357E-13
30	0.98579	SLE_QP_ENVE	Max	-649.77	12.683	4.069E-14
30	0.	SLE_QP_ENVE	Min	-625.867	60.152	-1.273E-12
30	0.4929	SLE_QP_ENVE	Min	-638.411	21.046	-7.486E-13
30	0.98579	SLE_QP_ENVE	Min	-650.362	-20.386	-2.978E-13
30	0.	SLE_C_ENVE	Max	-625.742	69.134	-1.223E-12
30	0.4929	SLE_C_ENVE	Max	-638.155	42.954	-6.357E-13
30	0.98579	SLE_C_ENVE	Max	-649.77	15.229	4.069E-14
30	0.	SLE_C_ENVE	Min	-625.867	60.152	-1.273E-12
30	0.4929	SLE_C_ENVE	Min	-638.347	21.046	-7.974E-13
30	0.98579	SLE_C_ENVE	Min	-650.298	-20.386	-3.466E-13
31	0.	SLU_ENVE	Max	-320.685	36.35	8.990E-13
31	0.55395	SLU_ENVE	Max	-334.847	4.659	5.383E-13
31	1.1079	SLU_ENVE	Max	-349.7	2.587	4.979E-13
31	0.	SLU_ENVE	Min	-852.262	-83.587	-4.804E-13
31	0.55395	SLU_ENVE	Min	-874.734	-145.972	-8.965E-13
31	1.1079	SLU_ENVE	Min	-898.343	-212.055	-1.337E-12
31	0.	SLV_ENVE	Max	-666.079	-153.39	-1.576E-12
31	0.55395	SLV_ENVE	Max	-684.433	-218.092	-2.134E-12
31	1.1079	SLV_ENVE	Max	-703.657	-274.598	-2.588E-12
31	0.	SLV_ENVE	Min	-690.364	-250.917	-2.369E-12
31	0.55395	SLV_ENVE	Min	-710.168	-321.575	-3.020E-12
31	1.1079	SLV_ENVE	Min	-730.77	-410.612	-3.786E-12
31	0.	SLE_FR_ENVE	Max	-654.651	-51.385	-2.294E-13
31	0.55395	SLE_FR_ENVE	Max	-671.936	-99.373	-6.456E-13
31	1.1079	SLE_FR_ENVE	Max	-690.097	-150.206	-1.086E-12
31	0.	SLE_FR_ENVE	Min	-654.651	-51.385	-2.294E-13
31	0.55395	SLE_FR_ENVE	Min	-671.936	-99.373	-6.456E-13
31	1.1079	SLE_FR_ENVE	Min	-690.097	-150.206	-1.086E-12
31	0.	SLE_QP_ENVE	Max	-650.364	12.784	1.205E-14
31	0.55395	SLE_QP_ENVE	Max	-666.609	-18.907	-2.654E-13
31	1.1079	SLE_QP_ENVE	Max	-683.667	-52.481	-5.592E-13
31	0.	SLE_QP_ENVE	Min	-653.7	-36.002	-4.763E-13
31	0.55395	SLE_QP_ENVE	Min	-670.986	-83.99	-8.925E-13
31	1.1079	SLE_QP_ENVE	Min	-689.147	-134.823	-1.333E-12
31	0.	SLE_C_ENVE	Max	-650.076	15.315	2.762E-14
31	0.55395	SLE_C_ENVE	Max	-666.321	-16.376	-2.498E-13
31	1.1079	SLE_C_ENVE	Max	-683.379	-49.949	-5.436E-13
31	0.	SLE_C_ENVE	Min	-653.7	-36.002	-4.763E-13
31	0.55395	SLE_C_ENVE	Min	-670.986	-83.99	-8.925E-13
31	1.1079	SLE_C_ENVE	Min	-689.147	-134.823	-1.333E-12

PROGETTO DEFINITIVO

RELAZIONE DI CALCOLO GALLERIA ARTIFICIALE

Table 11: Element Forces - Frames, Part 1 of 2

Frame	Station m	OutputCase	StepType	P KN	V2 KN	V3 KN
32	0.	SLU_ENVE	Max	-354.885	14.465	8.193E-13
32	0.55397	SLU_ENVE	Max	-370.782	-6.117	7.176E-13
32	1.10793	SLU_ENVE	Max	-388.387	-3.325	7.176E-13
32	0.	SLU_ENVE	Min	-932.411	-242.076	-5.269E-13
32	0.55397	SLU_ENVE	Min	-964.23	-309.138	-7.163E-13
32	1.10793	SLU_ENVE	Min	-998.86	-379.565	-9.158E-13
32	0.	SLV_ENVE	Max	-742.256	-313.389	-1.103E-12
32	0.55397	SLV_ENVE	Max	-767.373	-356.393	-1.254E-12
32	1.10793	SLV_ENVE	Max	-786.837	-365.319	-1.295E-12
32	0.	SLV_ENVE	Min	-775.924	-403.851	-1.367E-12
32	0.55397	SLV_ENVE	Min	-806.176	-491.866	-1.684E-12
32	1.10793	SLV_ENVE	Min	-838.342	-580.901	-2.006E-12
32	0.	SLE_FR_ENVE	Max	-713.85	-165.541	-1.539E-13
32	0.55397	SLE_FR_ENVE	Max	-738.326	-217.127	-3.434E-13
32	1.10793	SLE_FR_ENVE	Max	-764.964	-271.302	-5.428E-13
32	0.	SLE_FR_ENVE	Min	-713.85	-165.541	-1.539E-13
32	0.55397	SLE_FR_ENVE	Min	-738.326	-217.127	-3.434E-13
32	1.10793	SLE_FR_ENVE	Min	-764.964	-271.302	-5.428E-13
32	0.	SLE_QP_ENVE	Max	-693.769	-40.09	-1.961E-13
32	0.55397	SLE_QP_ENVE	Max	-715.385	-73.643	-3.224E-13
32	1.10793	SLE_QP_ENVE	Max	-739.013	-108.832	-4.554E-13
32	0.	SLE_QP_ENVE	Min	-709.589	-138.462	-5.259E-13
32	0.55397	SLE_QP_ENVE	Min	-734.065	-190.048	-7.154E-13
32	1.10793	SLE_QP_ENVE	Min	-760.703	-244.223	-9.148E-13
32	0.	SLE_C_ENVE	Max	-693.246	-37.596	-1.924E-13
32	0.55397	SLE_C_ENVE	Max	-714.862	-71.149	-3.187E-13
32	1.10793	SLE_C_ENVE	Max	-738.49	-106.338	-4.517E-13
32	0.	SLE_C_ENVE	Min	-709.589	-138.462	-5.259E-13
32	0.55397	SLE_C_ENVE	Min	-734.065	-190.048	-7.154E-13
32	1.10793	SLE_C_ENVE	Min	-760.703	-244.223	-9.148E-13
51	0.	SLU_ENVE	Max	-56.568	-30.382	2.150E-13
51	0.34164	SLU_ENVE	Max	-56.569	-19.282	2.150E-13
51	0.68329	SLU_ENVE	Max	-56.569	-8.182	2.150E-13
51	0.	SLU_ENVE	Min	-446.573	-73.357	-4.959E-08
51	0.34164	SLU_ENVE	Min	-446.574	-62.257	-4.959E-08
51	0.68329	SLU_ENVE	Min	-446.574	-51.157	-4.959E-08
51	0.	SLV_ENVE	Max	-316.242	-41.121	3.157E-13
51	0.34164	SLV_ENVE	Max	-313.169	-32.582	3.132E-13
51	0.68329	SLV_ENVE	Max	-310.095	-24.044	3.108E-13
51	0.	SLV_ENVE	Min	-398.882	-44.052	2.546E-13
51	0.34164	SLV_ENVE	Min	-397.96	-35.514	2.465E-13
51	0.68329	SLV_ENVE	Min	-397.039	-26.975	2.384E-13
51	0.	SLE_FR_ENVE	Max	-315.533	-46.861	-2.289E-08
51	0.34164	SLE_FR_ENVE	Max	-315.533	-38.322	-2.289E-08
51	0.68329	SLE_FR_ENVE	Max	-315.534	-29.784	-2.289E-08
51	0.	SLE_FR_ENVE	Min	-315.533	-46.861	-2.289E-08
51	0.34164	SLE_FR_ENVE	Min	-315.533	-38.322	-2.289E-08
51	0.68329	SLE_FR_ENVE	Min	-315.534	-29.784	-2.289E-08
51	0.	SLE_QP_ENVE	Max	-171.721	-52.276	2.158E-13
51	0.34164	SLE_QP_ENVE	Max	-171.722	-43.737	2.158E-13
51	0.68329	SLE_QP_ENVE	Max	-171.722	-35.199	2.158E-13
51	0.	SLE_QP_ENVE	Min	-274.12	-59.572	1.352E-13

RELAZIONE DI CALCOLO GALLERIA ARTIFICIALE

Table 11: Element Forces - Frames, Part 1 of 2

Frame	Station m	OutputCase	StepType	P KN	V2 KN	V3 KN
51	0.34164	SLE_QP_ENVE	Min	-274.12	-51.033	1.352E-13
51	0.68329	SLE_QP_ENVE	Min	-274.121	-42.495	1.352E-13
51	0.	SLE_C_ENVE	Max	-175.341	-52.276	2.158E-13
51	0.34164	SLE_C_ENVE	Max	-175.342	-43.737	2.158E-13
51	0.68329	SLE_C_ENVE	Max	-175.342	-35.199	2.158E-13
51	0.	SLE_C_ENVE	Min	-274.12	-55.096	1.380E-13
51	0.34164	SLE_C_ENVE	Min	-274.12	-46.558	1.380E-13
51	0.68329	SLE_C_ENVE	Min	-274.121	-38.019	1.380E-13
52	0.	SLU_ENVE	Max	-319.266	63.621	1.489E-07
52	0.14282	SLU_ENVE	Max	-315.778	44.472	1.489E-07
52	0.28564	SLU_ENVE	Max	-312.291	25.84	1.489E-07
52	0.	SLU_ENVE	Min	-762.764	-57.379	-2.203E-12
52	0.14282	SLU_ENVE	Min	-753.84	-66.946	-1.682E-12
52	0.28564	SLU_ENVE	Min	-745.03	-76.249	-1.174E-12
52	0.	SLV_ENVE	Max	-571.94	143.167	-3.053E-12
52	0.14282	SLV_ENVE	Max	-567.175	116.994	-2.855E-12
52	0.28564	SLV_ENVE	Max	-562.41	91.086	-2.658E-12
52	0.	SLV_ENVE	Min	-591.978	52.251	-6.042E-12
52	0.14282	SLV_ENVE	Min	-582.62	47.151	-5.135E-12
52	0.28564	SLV_ENVE	Min	-573.319	42.051	-4.238E-12
52	0.	SLE_FR_ENVE	Max	-581.381	39.627	6.874E-08
52	0.14282	SLE_FR_ENVE	Max	-574.517	24.897	6.874E-08
52	0.28564	SLE_FR_ENVE	Max	-567.739	10.565	6.874E-08
52	0.	SLE_FR_ENVE	Min	-581.381	39.627	6.874E-08
52	0.14282	SLE_FR_ENVE	Min	-574.517	24.897	6.874E-08
52	0.28564	SLE_FR_ENVE	Min	-567.739	10.565	6.874E-08
52	0.	SLE_QP_ENVE	Max	-568.385	25.954	-1.823E-13
52	0.14282	SLE_QP_ENVE	Max	-562.646	11.224	1.652E-13
52	0.28564	SLE_QP_ENVE	Max	-556.965	-3.108	5.038E-13
52	0.	SLE_QP_ENVE	Min	-574.63	-36.986	-2.224E-12
52	0.14282	SLE_QP_ENVE	Min	-567.766	-46.554	-1.703E-12
52	0.28564	SLE_QP_ENVE	Min	-560.989	-55.856	-1.195E-12
52	0.	SLE_C_ENVE	Max	-574.63	25.954	-2.629E-13
52	0.14282	SLE_C_ENVE	Max	-567.766	11.224	8.464E-14
52	0.28564	SLE_C_ENVE	Max	-560.989	-3.108	4.232E-13
52	0.	SLE_C_ENVE	Min	-576.668	-35.087	-2.224E-12
52	0.14282	SLE_C_ENVE	Min	-570.93	-44.654	-1.703E-12
52	0.28564	SLE_C_ENVE	Min	-565.249	-53.957	-1.195E-12
53	0.	SLU_ENVE	Max	-103.829	99.736	4.515E-09
53	0.39736	SLU_ENVE	Max	-107.316	111.824	4.515E-09
53	0.79472	SLU_ENVE	Max	-110.803	123.912	4.515E-09
53	0.	SLU_ENVE	Min	-513.822	20.578	-1.980E-14
53	0.39736	SLU_ENVE	Min	-518.355	32.666	-1.980E-14
53	0.79472	SLU_ENVE	Min	-522.888	44.755	-1.980E-14
53	0.	SLV_ENVE	Max	-382.799	18.17	-2.458E-14
53	0.39736	SLV_ENVE	Max	-389.633	26.213	-2.554E-14
53	0.79472	SLV_ENVE	Max	-396.468	34.257	-2.650E-14
53	0.	SLV_ENVE	Min	-469.462	7.849	-3.200E-14
53	0.39736	SLV_ENVE	Min	-473.953	16.771	-3.229E-14
53	0.79472	SLV_ENVE	Min	-478.445	25.693	-3.258E-14
53	0.	SLE_FR_ENVE	Max	-371.21	36.044	2.084E-09
53	0.39736	SLE_FR_ENVE	Max	-374.697	45.342	2.084E-09

RELAZIONE DI CALCOLO GALLERIA ARTIFICIALE

Table 11: Element Forces - Frames, Part 1 of 2

Frame	Station m	OutputCase	StepType	P KN	V2 KN	V3 KN
53	0.79472	SLE_FR_ENVE	Max	-378.184	54.641	2.084E-09
53	0.	SLE_FR_ENVE	Min	-371.21	36.044	2.084E-09
53	0.39736	SLE_FR_ENVE	Min	-374.697	45.342	2.084E-09
53	0.79472	SLE_FR_ENVE	Min	-378.184	54.641	2.084E-09
53	0.	SLE_QP_ENVE	Max	-248.577	78.365	-9.791E-15
53	0.39736	SLE_QP_ENVE	Max	-252.065	87.664	-9.791E-15
53	0.79472	SLE_QP_ENVE	Max	-255.552	96.963	-9.791E-15
53	0.	SLE_QP_ENVE	Min	-348.421	48.489	-1.977E-14
53	0.39736	SLE_QP_ENVE	Min	-351.908	57.788	-1.977E-14
53	0.79472	SLE_QP_ENVE	Min	-355.395	67.087	-1.977E-14
53	0.	SLE_C_ENVE	Max	-240.153	73.447	-9.652E-15
53	0.39736	SLE_C_ENVE	Max	-243.64	82.746	-9.652E-15
53	0.79472	SLE_C_ENVE	Max	-247.127	92.044	-9.652E-15
53	0.	SLE_C_ENVE	Min	-348.421	48.489	-1.977E-14
53	0.39736	SLE_C_ENVE	Min	-351.908	57.788	-1.977E-14
53	0.79472	SLE_C_ENVE	Min	-355.395	67.087	-1.977E-14
54	0.	SLU_ENVE	Max	-58.854	-28.964	2.881E-13
54	0.34165	SLU_ENVE	Max	-58.855	-17.864	2.881E-13
54	0.6833	SLU_ENVE	Max	-58.855	-6.763	2.881E-13
54	0.	SLU_ENVE	Min	-448.741	-71.709	-6.612E-08
54	0.34165	SLU_ENVE	Min	-448.741	-60.609	-6.612E-08
54	0.6833	SLU_ENVE	Min	-448.742	-49.508	-6.612E-08
54	0.	SLV_ENVE	Max	-313.459	-34.471	4.143E-13
54	0.34165	SLV_ENVE	Max	-316.533	-25.932	4.175E-13
54	0.6833	SLV_ENVE	Max	-319.607	-17.393	4.207E-13
54	0.	SLV_ENVE	Min	-396.898	-39.089	3.214E-13
54	0.34165	SLV_ENVE	Min	-397.82	-30.551	3.322E-13
54	0.6833	SLV_ENVE	Min	-398.743	-22.012	3.430E-13
54	0.	SLE_FR_ENVE	Max	-317.093	-45.42	-3.051E-08
54	0.34165	SLE_FR_ENVE	Max	-317.094	-36.882	-3.051E-08
54	0.6833	SLE_FR_ENVE	Max	-317.094	-28.343	-3.051E-08
54	0.	SLE_FR_ENVE	Min	-317.093	-45.42	-3.051E-08
54	0.34165	SLE_FR_ENVE	Min	-317.094	-36.882	-3.051E-08
54	0.6833	SLE_FR_ENVE	Min	-317.094	-28.343	-3.051E-08
54	0.	SLE_QP_ENVE	Max	-173.759	-50.918	2.892E-13
54	0.34165	SLE_QP_ENVE	Max	-173.76	-42.379	2.892E-13
54	0.6833	SLE_QP_ENVE	Max	-173.76	-33.84	2.892E-13
54	0.	SLE_QP_ENVE	Min	-275.573	-58.269	1.824E-13
54	0.34165	SLE_QP_ENVE	Min	-275.574	-49.73	1.824E-13
54	0.6833	SLE_QP_ENVE	Min	-275.574	-41.191	1.824E-13
54	0.	SLE_C_ENVE	Max	-177.725	-50.918	2.892E-13
54	0.34165	SLE_C_ENVE	Max	-177.726	-42.379	2.892E-13
54	0.6833	SLE_C_ENVE	Max	-177.726	-33.84	2.892E-13
54	0.	SLE_C_ENVE	Min	-275.573	-53.703	1.865E-13
54	0.34165	SLE_C_ENVE	Min	-275.574	-45.165	1.865E-13
54	0.6833	SLE_C_ENVE	Min	-275.574	-36.626	1.865E-13
55	0.	SLU_ENVE	Max	-318.116	65.089	2.085E-07
55	0.14283	SLU_ENVE	Max	-314.628	46.458	2.085E-07
55	0.28565	SLU_ENVE	Max	-311.141	27.309	2.085E-07
55	0.	SLU_ENVE	Min	-762.22	-55.572	-3.122E-12
55	0.14283	SLU_ENVE	Min	-753.408	-64.874	-2.411E-12
55	0.28565	SLU_ENVE	Min	-744.482	-74.441	-1.682E-12

PROGETTO DEFINITIVO

RELAZIONE DI CALCOLO GALLERIA ARTIFICIALE

Table 11: Element Forces - Frames, Part 1 of 2

Frame	Station m	OutputCase	StepType	P KN	V2 KN	V3 KN
55	0.	SLV_ENVE	Max	-566.552	152.468	-4.161E-12
55	0.14283	SLV_ENVE	Max	-562.334	129.072	-4.003E-12
55	0.28565	SLV_ENVE	Max	-558.116	105.41	-3.846E-12
55	0.	SLV_ENVE	Min	-587.085	50.248	-8.853E-12
55	0.14283	SLV_ENVE	Min	-578.329	47.66	-7.716E-12
55	0.28565	SLV_ENVE	Min	-569.515	45.071	-6.566E-12
55	0.	SLE_FR_ENVE	Max	-580.867	40.679	9.624E-08
55	0.14283	SLE_FR_ENVE	Max	-574.088	26.347	9.624E-08
55	0.28565	SLE_FR_ENVE	Max	-567.222	11.618	9.624E-08
55	0.	SLE_FR_ENVE	Min	-580.867	40.679	9.624E-08
55	0.14283	SLE_FR_ENVE	Min	-574.088	26.347	9.624E-08
55	0.28565	SLE_FR_ENVE	Min	-567.222	11.618	9.624E-08
55	0.	SLE_QP_ENVE	Max	-567.934	26.938	-3.245E-13
55	0.14283	SLE_QP_ENVE	Max	-562.252	12.606	1.493E-13
55	0.28565	SLE_QP_ENVE	Max	-556.512	-2.124	6.356E-13
55	0.	SLE_QP_ENVE	Min	-574.005	-35.424	-3.155E-12
55	0.14283	SLE_QP_ENVE	Min	-567.226	-44.726	-2.444E-12
55	0.28565	SLE_QP_ENVE	Min	-560.361	-54.293	-1.715E-12
55	0.	SLE_C_ENVE	Max	-574.005	26.938	-4.516E-13
55	0.14283	SLE_C_ENVE	Max	-567.226	12.606	2.222E-14
55	0.28565	SLE_C_ENVE	Max	-560.361	-2.124	5.085E-13
55	0.	SLE_C_ENVE	Min	-576.429	-33.222	-3.155E-12
55	0.14283	SLE_C_ENVE	Min	-570.747	-42.524	-2.444E-12
55	0.28565	SLE_C_ENVE	Min	-565.007	-52.091	-1.715E-12
56	0.	SLU_ENVE	Max	-101.423	96.829	9.029E-09
56	0.39738	SLU_ENVE	Max	-104.91	108.918	9.029E-09
56	0.79477	SLU_ENVE	Max	-108.397	121.007	9.029E-09
56	0.	SLU_ENVE	Min	-511.152	17.956	-3.965E-14
56	0.39738	SLU_ENVE	Min	-515.685	30.045	-3.965E-14
56	0.79477	SLU_ENVE	Min	-520.218	42.134	-3.965E-14
56	0.	SLV_ENVE	Max	-470.361	19.725	-6.383E-14
56	0.39738	SLV_ENVE	Max	-470.501	30.28	-6.191E-14
56	0.79477	SLV_ENVE	Max	-470.64	40.834	-5.999E-14
56	0.	SLV_ENVE	Min	-552.28	6.516	-7.695E-14
56	0.39738	SLV_ENVE	Min	-552.42	16.192	-7.503E-14
56	0.79477	SLV_ENVE	Min	-552.559	25.868	-7.310E-14
56	0.	SLE_FR_ENVE	Max	-368.775	33.997	4.167E-09
56	0.39738	SLE_FR_ENVE	Max	-372.262	43.296	4.167E-09
56	0.79477	SLE_FR_ENVE	Max	-375.749	52.595	4.167E-09
56	0.	SLE_FR_ENVE	Min	-368.775	33.997	4.167E-09
56	0.39738	SLE_FR_ENVE	Min	-372.262	43.296	4.167E-09
56	0.79477	SLE_FR_ENVE	Min	-375.749	52.595	4.167E-09
56	0.	SLE_QP_ENVE	Max	-245.578	76.172	-1.957E-14
56	0.39738	SLE_QP_ENVE	Max	-249.065	85.471	-1.957E-14
56	0.79477	SLE_QP_ENVE	Max	-252.552	94.771	-1.957E-14
56	0.	SLE_QP_ENVE	Min	-346.142	46.551	-3.957E-14
56	0.39738	SLE_QP_ENVE	Min	-349.629	55.851	-3.957E-14
56	0.79477	SLE_QP_ENVE	Min	-353.116	65.15	-3.957E-14
56	0.	SLE_C_ENVE	Max	-236.692	71.007	-1.927E-14
56	0.39738	SLE_C_ENVE	Max	-240.179	80.307	-1.927E-14
56	0.79477	SLE_C_ENVE	Max	-243.667	89.606	-1.927E-14
56	0.	SLE_C_ENVE	Min	-346.142	46.551	-3.957E-14

PROGETTO DEFINITIVO

RELAZIONE DI CALCOLO GALLERIA ARTIFICIALE

Table 11: Element Forces - Frames, Part 1 of 2

Frame	Station m	OutputCase	StepType	P KN	V2 KN	V3 KN
56	0.39738	SLE_C_ENVE	Min	-349.629	55.851	-3.957E-14
56	0.79477	SLE_C_ENVE	Min	-353.116	65.15	-3.957E-14

Table 12: Element Forces - Frames, Part 2 of 2

Table 12: Element Forces - Frames, Part 2 of 2

Frame	Station m	OutputCase	StepType	T KN-m	M2 KN-m	M3 KN-m
1	0.	SLU_ENVE	Max	6.409E-14	2.479E-13	-12.8611
1	0.46685	SLU_ENVE	Max	6.409E-14	-2.765E-19	-43.6799
1	0.93369	SLU_ENVE	Max	6.409E-14	3.113E-14	-83.3896
1	0.	SLU_ENVE	Min	1.655E-14	-3.113E-14	-147.1463
1	0.46685	SLU_ENVE	Min	1.655E-14	-1.071E-18	-171.4522
1	0.93369	SLU_ENVE	Min	1.655E-14	-2.479E-13	-217.7192
1	0.	SLV_ENVE	Max	6.684E-14	-3.916E-14	-85.5411
1	0.46685	SLV_ENVE	Max	6.684E-14	-3.446E-17	-110.5262
1	0.93369	SLV_ENVE	Max	6.684E-14	4.473E-14	-145.3677
1	0.	SLV_ENVE	Min	4.111E-14	-4.459E-14	-164.9864
1	0.46685	SLV_ENVE	Min	4.111E-14	-1.131E-16	-180.5968
1	0.93369	SLV_ENVE	Min	4.111E-14	3.961E-14	-207.2709
1	0.	SLE_FR_ENVE	Max	4.654E-14	8.933E-14	-101.8601
1	0.46685	SLE_FR_ENVE	Max	4.654E-14	-7.777E-19	-124.7919
1	0.93369	SLE_FR_ENVE	Max	4.654E-14	-8.933E-14	-161.017
1	0.	SLE_FR_ENVE	Min	4.654E-14	8.933E-14	-101.8601
1	0.46685	SLE_FR_ENVE	Min	4.654E-14	-7.777E-19	-124.7919
1	0.93369	SLE_FR_ENVE	Min	4.654E-14	-8.933E-14	-161.017
1	0.	SLE_QP_ENVE	Max	4.254E-14	-2.010E-14	-68.5656
1	0.46685	SLE_QP_ENVE	Max	4.254E-14	-6.033E-19	-96.8631
1	0.93369	SLE_QP_ENVE	Max	4.254E-14	3.110E-14	-135.1848
1	0.	SLE_QP_ENVE	Min	3.611E-14	-3.110E-14	-86.2358
1	0.46685	SLE_QP_ENVE	Min	3.611E-14	-7.109E-19	-114.4303
1	0.93369	SLE_QP_ENVE	Min	3.611E-14	2.009E-14	-152.649
1	0.	SLE_C_ENVE	Max	4.254E-14	-1.996E-14	-77.3588
1	0.46685	SLE_C_ENVE	Max	4.254E-14	-6.188E-19	-98.6609
1	0.93369	SLE_C_ENVE	Max	4.254E-14	3.110E-14	-134.3461
1	0.	SLE_C_ENVE	Min	3.703E-14	-3.110E-14	-86.2358
1	0.46685	SLE_C_ENVE	Min	3.703E-14	-7.109E-19	-114.4303
1	0.93369	SLE_C_ENVE	Min	3.703E-14	1.996E-14	-152.649
2	0.	SLU_ENVE	Max	2.538E-14	1.687E-13	-83.3896
2	0.48058	SLU_ENVE	Max	2.538E-14	-8.524E-15	-58.123
2	0.96117	SLU_ENVE	Max	2.538E-14	1.926E-14	20.693
2	0.	SLU_ENVE	Min	1.592E-14	-4.070E-14	-217.7192
2	0.48058	SLU_ENVE	Min	1.592E-14	-1.359E-14	-92.6621
2	0.96117	SLU_ENVE	Min	1.592E-14	-1.912E-13	-49.6985
2	0.	SLV_ENVE	Max	2.510E-14	-4.441E-14	-145.3677
2	0.48058	SLV_ENVE	Max	2.510E-14	-6.033E-15	-39.8079
2	0.96117	SLV_ENVE	Max	2.510E-14	3.512E-14	55.1389
2	0.	SLV_ENVE	Min	1.110E-14	-5.331E-14	-207.2709
2	0.48058	SLV_ENVE	Min	1.110E-14	-1.353E-14	-92.3826
2	0.96117	SLV_ENVE	Min	1.110E-14	2.680E-14	12.7794
2	0.	SLE_FR_ENVE	Max	1.917E-14	4.797E-14	-161.017



RELAZIONE DI CALCOLO GALLERIA ARTIFICIALE

Table 12: Element Forces - Frames, Part 2 of 2

Frame	Station m	OutputCase	StepType	T KN-m	M2 KN-m	M3 KN-m
2	0.48058	SLE_FR_ENVE	Max	1.917E-14	-1.027E-14	-69.5651
2	0.96117	SLE_FR_ENVE	Max	1.917E-14	-6.850E-14	8.3682
2	0.	SLE_FR_ENVE	Min	1.917E-14	4.797E-14	-161.017
2	0.48058	SLE_FR_ENVE	Min	1.917E-14	-1.027E-14	-69.5651
2	0.96117	SLE_FR_ENVE	Min	1.917E-14	-6.850E-14	8.3682
2	0.	SLE_QP_ENVE	Max	2.264E-14	-3.137E-14	-135.1848
2	0.48058	SLE_QP_ENVE	Max	2.264E-14	-1.062E-14	-72.5652
2	0.96117	SLE_QP_ENVE	Max	2.264E-14	1.935E-14	-2.6753
2	0.	SLE_QP_ENVE	Min	1.983E-14	-4.058E-14	-152.649
2	0.48058	SLE_QP_ENVE	Min	1.983E-14	-1.212E-14	-83.0983
2	0.96117	SLE_QP_ENVE	Min	1.983E-14	7.125E-15	-41.2058
2	0.	SLE_C_ENVE	Max	2.189E-14	-3.090E-14	-134.3461
2	0.48058	SLE_C_ENVE	Max	2.189E-14	-1.062E-14	-72.5652
2	0.96117	SLE_C_ENVE	Max	2.189E-14	1.935E-14	-2.6753
2	0.	SLE_C_ENVE	Min	1.983E-14	-4.058E-14	-152.649
2	0.48058	SLE_C_ENVE	Min	1.983E-14	-1.172E-14	-79.5617
2	0.96117	SLE_C_ENVE	Min	1.983E-14	7.459E-15	-39.404
3	0.	SLU_ENVE	Max	7.405E-15	1.822E-13	20.693
3	0.48058	SLU_ENVE	Max	7.405E-15	1.119E-14	114.6654
3	0.96117	SLU_ENVE	Max	7.405E-15	3.243E-14	191.806
3	0.	SLU_ENVE	Min	-2.966E-14	-2.100E-14	-49.6985
3	0.48058	SLU_ENVE	Min	-2.966E-14	-2.794E-15	-26.199
3	0.96117	SLU_ENVE	Min	-2.966E-14	-1.810E-13	-11.9267
3	0.	SLV_ENVE	Max	-2.709E-14	-2.085E-14	55.1389
3	0.48058	SLV_ENVE	Max	-2.709E-14	1.373E-14	138.4339
3	0.96117	SLV_ENVE	Max	-2.709E-14	5.240E-14	216.5454
3	0.	SLV_ENVE	Min	-3.646E-14	-2.532E-14	12.7794
3	0.48058	SLV_ENVE	Min	-3.646E-14	1.013E-14	103.1589
3	0.96117	SLV_ENVE	Min	-3.646E-14	4.609E-14	182.8508
3	0.	SLE_FR_ENVE	Max	-1.975E-14	6.955E-14	8.3682
3	0.48058	SLE_FR_ENVE	Max	-1.975E-14	7.452E-15	76.2916
3	0.96117	SLE_FR_ENVE	Max	-1.975E-14	-5.465E-14	130.4189
3	0.	SLE_FR_ENVE	Min	-1.975E-14	6.955E-14	8.3682
3	0.48058	SLE_FR_ENVE	Min	-1.975E-14	7.452E-15	76.2916
3	0.96117	SLE_FR_ENVE	Min	-1.975E-14	-5.465E-14	130.4189
3	0.	SLE_QP_ENVE	Max	4.677E-16	-1.738E-14	-2.6753
3	0.48058	SLE_QP_ENVE	Max	4.677E-16	5.735E-15	58.6738
3	0.96117	SLE_QP_ENVE	Max	4.677E-16	3.239E-14	109.6196
3	0.	SLE_QP_ENVE	Min	-1.520E-14	-2.092E-14	-41.2058
3	0.48058	SLE_QP_ENVE	Min	-1.520E-14	-1.764E-16	-0.0181
3	0.96117	SLE_QP_ENVE	Min	-1.520E-14	1.703E-14	30.7664
3	0.	SLE_C_ENVE	Max	2.388E-16	-1.705E-14	-2.6753
3	0.48058	SLE_C_ENVE	Max	2.388E-16	5.735E-15	58.6738
3	0.96117	SLE_C_ENVE	Max	2.388E-16	3.239E-14	109.6196
3	0.	SLE_C_ENVE	Min	-1.520E-14	-2.092E-14	-39.404
3	0.48058	SLE_C_ENVE	Min	-1.520E-14	-9.009E-17	1.5933
3	0.96117	SLE_C_ENVE	Min	-1.520E-14	1.687E-14	27.6635
4	0.	SLU_ENVE	Max	-4.903E-15	2.491E-13	191.806
4	0.48058	SLU_ENVE	Max	-4.903E-15	2.130E-14	270.3362
4	0.96117	SLU_ENVE	Max	-4.903E-15	4.563E-14	331.7447
4	0.	SLU_ENVE	Min	-9.494E-14	-2.028E-14	-11.9267
4	0.48058	SLU_ENVE	Min	-9.494E-14	1.100E-15	15.333

Table 12: Element Forces - Frames, Part 2 of 2

Frame	Station m	OutputCase	StepType	T KN-m	M2 KN-m	M3 KN-m
4	0.96117	SLU_ENVE	Min	-9.494E-14	-2.362E-13	33.2411
4	0.	SLV_ENVE	Max	-9.090E-14	-2.115E-14	216.5454
4	0.48058	SLV_ENVE	Max	-9.090E-14	2.261E-14	285.4979
4	0.96117	SLV_ENVE	Max	-9.090E-14	7.025E-14	343.6711
4	0.	SLV_ENVE	Min	-1.009E-13	-2.484E-14	182.8508
4	0.48058	SLV_ENVE	Min	-1.009E-13	2.028E-14	257.0965
4	0.96117	SLV_ENVE	Min	-1.009E-13	6.466E-14	320.3807
4	0.	SLE_FR_ENVE	Max	-6.643E-14	1.005E-13	130.4189
4	0.48058	SLE_FR_ENVE	Max	-6.643E-14	1.490E-14	188.9651
4	0.96117	SLE_FR_ENVE	Max	-6.643E-14	-7.064E-14	233.529
4	0.	SLE_FR_ENVE	Min	-6.643E-14	1.005E-13	130.4189
4	0.48058	SLE_FR_ENVE	Min	-6.643E-14	1.490E-14	188.9651
4	0.96117	SLE_FR_ENVE	Min	-6.643E-14	-7.064E-14	233.529
4	0.	SLE_QP_ENVE	Max	-2.417E-14	-1.605E-14	109.6196
4	0.48058	SLE_QP_ENVE	Max	-2.417E-14	1.269E-14	160.7106
4	0.96117	SLE_QP_ENVE	Max	-2.417E-14	4.564E-14	201.2579
4	0.	SLE_QP_ENVE	Min	-5.658E-14	-2.025E-14	30.7664
4	0.48058	SLE_QP_ENVE	Min	-5.658E-14	5.423E-15	69.6662
4	0.96117	SLE_QP_ENVE	Min	-5.658E-14	2.689E-14	98.0223
4	0.	SLE_C_ENVE	Max	-2.441E-14	-1.596E-14	109.6196
4	0.48058	SLE_C_ENVE	Max	-2.441E-14	1.269E-14	160.7106
4	0.96117	SLE_C_ENVE	Max	-2.441E-14	4.564E-14	201.2579
4	0.	SLE_C_ENVE	Min	-5.658E-14	-2.025E-14	27.6635
4	0.48058	SLE_C_ENVE	Min	-5.658E-14	5.477E-15	71.1058
4	0.96117	SLE_C_ENVE	Min	-5.658E-14	2.691E-14	99.4196
5	0.	SLU_ENVE	Max	-1.622E-14	2.479E-13	331.7447
5	0.48057	SLU_ENVE	Max	-1.622E-14	9.688E-15	369.2406
5	0.96115	SLU_ENVE	Max	-1.622E-14	3.682E-14	384.8162
5	0.	SLU_ENVE	Min	-1.301E-13	-2.513E-14	33.2411
5	0.48057	SLU_ENVE	Min	-1.301E-13	1.207E-15	47.1259
5	0.96115	SLU_ENVE	Min	-1.301E-13	-2.405E-13	51.5971
5	0.	SLV_ENVE	Max	-1.255E-13	-3.108E-14	343.6711
5	0.48057	SLV_ENVE	Max	-1.255E-13	9.821E-15	373.8378
5	0.96115	SLV_ENVE	Max	-1.255E-13	5.478E-14	392.4883
5	0.	SLV_ENVE	Min	-1.324E-13	-3.498E-14	320.3807
5	0.48057	SLV_ENVE	Min	-1.324E-13	9.227E-15	354.3033
5	0.96115	SLV_ENVE	Min	-1.324E-13	5.027E-14	372.6332
5	0.	SLE_FR_ENVE	Max	-9.151E-14	9.461E-14	233.529
5	0.48057	SLE_FR_ENVE	Max	-9.151E-14	6.813E-15	259.4278
5	0.96115	SLE_FR_ENVE	Max	-9.151E-14	-8.099E-14	271.2516
5	0.	SLE_FR_ENVE	Min	-9.151E-14	9.461E-14	233.529
5	0.48057	SLE_FR_ENVE	Min	-9.151E-14	6.813E-15	259.4278
5	0.96115	SLE_FR_ENVE	Min	-9.151E-14	-8.099E-14	271.2516
5	0.	SLE_QP_ENVE	Max	-4.062E-14	-1.700E-14	201.2579
5	0.48057	SLE_QP_ENVE	Max	-4.062E-14	5.870E-15	223.2667
5	0.96115	SLE_QP_ENVE	Max	-4.062E-14	3.681E-14	234.6618
5	0.	SLE_QP_ENVE	Min	-7.885E-14	-2.507E-14	98.0223
5	0.48057	SLE_QP_ENVE	Min	-7.885E-14	3.024E-15	115.8924
5	0.96115	SLE_QP_ENVE	Min	-7.885E-14	2.305E-14	123.149
5	0.	SLE_C_ENVE	Max	-4.205E-14	-1.677E-14	201.2579
5	0.48057	SLE_C_ENVE	Max	-4.205E-14	5.870E-15	223.2667
5	0.96115	SLE_C_ENVE	Max	-4.205E-14	3.681E-14	234.6618

PROGETTO DEFINITIVO

RELAZIONE DI CALCOLO GALLERIA ARTIFICIALE

Table 12: Element Forces - Frames, Part 2 of 2

Frame	Station m	OutputCase	StepType	T KN-m	M2 KN-m	M3 KN-m
5	0.	SLE_C_ENVE	Min	-7.885E-14	-2.507E-14	99.4196
5	0.48057	SLE_C_ENVE	Min	-7.885E-14	3.130E-15	120.669
5	0.96115	SLE_C_ENVE	Min	-7.885E-14	2.304E-14	126.6895
6	0.	SLU_ENVE	Max	-1.764E-14	2.404E-13	384.8162
6	0.48059	SLU_ENVE	Max	-1.764E-14	-1.313E-15	378.2208
6	0.96119	SLU_ENVE	Max	-1.764E-14	2.496E-14	349.7032
6	0.	SLU_ENVE	Min	-1.333E-13	-3.686E-14	51.5971
6	0.48059	SLU_ENVE	Min	-1.333E-13	-9.926E-15	51.1196
6	0.96119	SLU_ENVE	Min	-1.333E-13	-2.483E-13	41.0103
6	0.	SLV_ENVE	Max	-1.294E-13	-5.031E-14	392.4883
6	0.48059	SLV_ENVE	Max	-1.294E-13	-9.751E-15	386.5337
6	0.96119	SLV_ENVE	Max	-1.294E-13	3.484E-14	376.1871
6	0.	SLV_ENVE	Min	-1.369E-13	-5.486E-14	372.6332
6	0.48059	SLV_ENVE	Min	-1.369E-13	-1.031E-14	365.3908
6	0.96119	SLV_ENVE	Min	-1.369E-13	3.144E-14	347.4663
6	0.	SLE_FR_ENVE	Max	-9.360E-14	8.092E-14	271.2516
6	0.48059	SLE_FR_ENVE	Max	-9.360E-14	-6.968E-15	265.2934
6	0.96119	SLE_FR_ENVE	Max	-9.360E-14	-9.485E-14	245.2591
6	0.	SLE_FR_ENVE	Min	-9.360E-14	8.092E-14	271.2516
6	0.48059	SLE_FR_ENVE	Min	-9.360E-14	-6.968E-15	265.2934
6	0.96119	SLE_FR_ENVE	Min	-9.360E-14	-9.485E-14	245.2591
6	0.	SLE_QP_ENVE	Max	-4.217E-14	-2.310E-14	234.6618
6	0.48059	SLE_QP_ENVE	Max	-4.217E-14	-3.140E-15	227.8276
6	0.96119	SLE_QP_ENVE	Max	-4.217E-14	2.489E-14	210.3789
6	0.	SLE_QP_ENVE	Min	-8.047E-14	-3.687E-14	123.149
6	0.48059	SLE_QP_ENVE	Min	-8.047E-14	-5.991E-15	120.2427
6	0.96119	SLE_QP_ENVE	Min	-8.047E-14	1.682E-14	106.7219
6	0.	SLE_C_ENVE	Max	-4.419E-14	-2.311E-14	234.6618
6	0.48059	SLE_C_ENVE	Max	-4.419E-14	-3.290E-15	227.8276
6	0.96119	SLE_C_ENVE	Max	-4.419E-14	2.489E-14	210.3789
6	0.	SLE_C_ENVE	Min	-8.047E-14	-3.687E-14	126.6895
6	0.48059	SLE_C_ENVE	Min	-8.047E-14	-5.991E-15	126.6801
6	0.96119	SLE_C_ENVE	Min	-8.047E-14	1.653E-14	111.4406
7	0.	SLU_ENVE	Max	-1.210E-14	2.936E-13	349.7032
7	0.48058	SLU_ENVE	Max	-1.210E-14	-2.714E-15	301.6367
7	0.96117	SLU_ENVE	Max	-1.210E-14	2.359E-14	231.7942
7	0.	SLU_ENVE	Min	-1.326E-13	-5.813E-14	41.0103
7	0.48058	SLU_ENVE	Min	-1.326E-13	-2.975E-14	28.7527
7	0.96117	SLU_ENVE	Min	-1.326E-13	-3.151E-13	7.1435
7	0.	SLV_ENVE	Max	-1.351E-13	-8.436E-14	376.1871
7	0.48058	SLV_ENVE	Max	-1.351E-13	-3.045E-14	341.9431
7	0.96117	SLV_ENVE	Max	-1.351E-13	2.808E-14	296.0359
7	0.	SLV_ENVE	Min	-1.513E-13	-9.047E-14	347.4663
7	0.48058	SLV_ENVE	Min	-1.513E-13	-3.408E-14	305.404
7	0.96117	SLV_ENVE	Min	-1.513E-13	2.122E-14	252.5954
7	0.	SLE_FR_ENVE	Max	-9.212E-14	8.675E-14	245.2591
7	0.48058	SLE_FR_ENVE	Max	-9.212E-14	-2.067E-14	209.3641
7	0.96117	SLE_FR_ENVE	Max	-9.212E-14	-1.281E-13	159.487
7	0.	SLE_FR_ENVE	Min	-9.212E-14	8.675E-14	245.2591
7	0.48058	SLE_FR_ENVE	Min	-9.212E-14	-2.067E-14	209.3641
7	0.96117	SLE_FR_ENVE	Min	-9.212E-14	-1.281E-13	159.487
7	0.	SLE_QP_ENVE	Max	-3.697E-14	-3.477E-14	210.3789

Table 12: Element Forces - Frames, Part 2 of 2

Frame	Station m	OutputCase	StepType	T KN-m	M2 KN-m	M3 KN-m
7	0.48058	SLE_QP_ENVE	Max	-3.697E-14	-8.293E-15	176.5108
7	0.96117	SLE_QP_ENVE	Max	-3.697E-14	2.337E-14	132.099
7	0.	SLE_QP_ENVE	Min	-7.776E-14	-5.825E-14	106.7219
7	0.48058	SLE_QP_ENVE	Min	-7.776E-14	-1.744E-14	84.8346
7	0.96117	SLE_QP_ENVE	Min	-7.776E-14	1.818E-14	52.4036
7	0.	SLE_C_ENVE	Max	-3.989E-14	-3.524E-14	210.3789
7	0.48058	SLE_C_ENVE	Max	-3.989E-14	-8.949E-15	176.5108
7	0.96117	SLE_C_ENVE	Max	-3.989E-14	2.337E-14	132.099
7	0.	SLE_C_ENVE	Min	-7.776E-14	-5.825E-14	111.4406
7	0.48058	SLE_C_ENVE	Min	-7.776E-14	-1.744E-14	92.1713
7	0.96117	SLE_C_ENVE	Min	-7.776E-14	1.734E-14	57.7736
8	0.	SLU_ENVE	Max	6.535E-15	2.968E-13	231.7942
8	0.48058	SLU_ENVE	Max	6.535E-15	2.465E-15	146.2814
8	0.96117	SLU_ENVE	Max	6.535E-15	3.308E-14	39.2825
8	0.	SLU_ENVE	Min	-6.349E-14	-5.703E-14	7.1435
8	0.48058	SLU_ENVE	Min	-6.349E-14	-2.395E-14	-13.1494
8	0.96117	SLU_ENVE	Min	-6.349E-14	-3.073E-13	-42.6694
8	0.	SLV_ENVE	Max	-7.746E-14	-8.971E-14	296.0359
8	0.48058	SLV_ENVE	Max	-7.746E-14	-2.927E-14	229.2546
8	0.96117	SLV_ENVE	Max	-7.746E-14	3.617E-14	150.8289
8	0.	SLV_ENVE	Min	-1.011E-13	-9.849E-14	252.5954
8	0.48058	SLV_ENVE	Min	-1.011E-13	-3.830E-14	175.8469
8	0.96117	SLV_ENVE	Min	-1.011E-13	2.276E-14	84.2297
8	0.	SLE_FR_ENVE	Max	-4.212E-14	8.682E-14	159.487
8	0.48058	SLE_FR_ENVE	Max	-4.212E-14	-1.589E-14	96.9671
8	0.96117	SLE_FR_ENVE	Max	-4.212E-14	-1.186E-13	20.6512
8	0.	SLE_FR_ENVE	Min	-4.212E-14	8.682E-14	159.487
8	0.48058	SLE_FR_ENVE	Min	-4.212E-14	-1.589E-14	96.9671
8	0.96117	SLE_FR_ENVE	Min	-4.212E-14	-1.186E-13	20.6512
8	0.	SLE_QP_ENVE	Max	-5.916E-15	-3.153E-14	132.099
8	0.48058	SLE_QP_ENVE	Max	-5.916E-15	-2.232E-15	74.7727
8	0.96117	SLE_QP_ENVE	Max	-5.916E-15	3.276E-14	7.0432
8	0.	SLE_QP_ENVE	Min	-3.250E-14	-5.728E-14	52.4036
8	0.48058	SLE_QP_ENVE	Min	-3.250E-14	-1.226E-14	15.0308
8	0.96117	SLE_QP_ENVE	Min	-3.250E-14	2.706E-14	-32.7452
8	0.	SLE_C_ENVE	Max	-8.841E-15	-3.249E-14	132.099
8	0.48058	SLE_C_ENVE	Max	-8.841E-15	-3.335E-15	74.7727
8	0.96117	SLE_C_ENVE	Max	-8.841E-15	3.276E-14	7.0432
8	0.	SLE_C_ENVE	Min	-3.250E-14	-5.728E-14	57.7736
8	0.48058	SLE_C_ENVE	Min	-3.250E-14	-1.226E-14	22.3566
8	0.96117	SLE_C_ENVE	Min	-3.250E-14	2.582E-14	-27.9874
9	0.	SLU_ENVE	Max	4.593E-14	3.796E-13	39.2825
9	0.48057	SLU_ENVE	Max	4.593E-14	2.459E-14	-55.1036
9	0.96114	SLU_ENVE	Max	4.593E-14	8.035E-14	-84.0693
9	0.	SLU_ENVE	Min	3.023E-14	-4.066E-14	-42.6694
9	0.48057	SLU_ENVE	Min	3.023E-14	1.618E-14	-83.6201
9	0.96114	SLU_ENVE	Min	3.023E-14	-3.385E-13	-213.7897
9	0.	SLV_ENVE	Max	1.358E-14	-7.979E-14	150.8289
9	0.48057	SLV_ENVE	Max	1.358E-14	7.217E-15	58.0019
9	0.96114	SLV_ENVE	Max	1.358E-14	9.568E-14	-46.3725
9	0.	SLV_ENVE	Min	-2.994E-14	-9.790E-14	84.2297
9	0.48057	SLV_ENVE	Min	-2.994E-14	-1.621E-14	-23.7106

RELAZIONE DI CALCOLO GALLERIA ARTIFICIALE

Table 12: Element Forces - Frames, Part 2 of 2

Frame	Station m	OutputCase	StepType	T KN-m	M2 KN-m	M3 KN-m
9	0.96114	SLV_ENVE	Min	-2.994E-14	6.656E-14	-141.9844
9	0.	SLE_FR_ENVE	Max	3.433E-14	1.341E-13	20.6512
9	0.48057	SLE_FR_ENVE	Max	3.433E-14	1.838E-14	-62.033
9	0.96114	SLE_FR_ENVE	Max	3.433E-14	-9.733E-14	-158.235
9	0.	SLE_FR_ENVE	Min	3.433E-14	1.341E-13	20.6512
9	0.48057	SLE_FR_ENVE	Min	3.433E-14	1.838E-14	-62.033
9	0.96114	SLE_FR_ENVE	Min	3.433E-14	-9.733E-14	-158.235
9	0.	SLE_QP_ENVE	Max	4.287E-14	-1.617E-14	7.0432
9	0.48057	SLE_QP_ENVE	Max	4.287E-14	2.295E-14	-66.5911
9	0.96114	SLE_QP_ENVE	Max	4.287E-14	8.005E-14	-134.6214
9	0.	SLE_QP_ENVE	Min	3.646E-14	-4.100E-14	-32.7452
9	0.48057	SLE_QP_ENVE	Min	3.646E-14	1.952E-14	-78.5866
9	0.96114	SLE_QP_ENVE	Min	3.646E-14	6.208E-14	-150.4188
9	0.	SLE_C_ENVE	Max	4.055E-14	-1.751E-14	7.0432
9	0.48057	SLE_C_ENVE	Max	4.055E-14	2.171E-14	-66.5911
9	0.96114	SLE_C_ENVE	Max	4.055E-14	8.005E-14	-133.6615
9	0.	SLE_C_ENVE	Min	3.646E-14	-4.100E-14	-27.9874
9	0.48057	SLE_C_ENVE	Min	3.646E-14	1.952E-14	-73.5115
9	0.96114	SLE_C_ENVE	Min	3.646E-14	6.093E-14	-150.4188
10	0.	SLU_ENVE	Max	6.404E-14	2.479E-13	-84.0693
10	0.46683	SLU_ENVE	Max	6.404E-14	-5.653E-20	-46.9006
10	0.93367	SLU_ENVE	Max	6.404E-14	3.113E-14	-18.6223
10	0.	SLU_ENVE	Min	1.773E-14	-3.113E-14	-213.7897
10	0.46683	SLU_ENVE	Min	1.773E-14	-2.042E-19	-171.3223
10	0.93367	SLU_ENVE	Min	1.773E-14	-2.479E-13	-150.9967
10	0.	SLV_ENVE	Max	3.888E-14	-4.247E-14	-46.3725
10	0.46683	SLV_ENVE	Max	3.888E-14	-3.373E-17	0.4797
10	0.93367	SLV_ENVE	Max	3.888E-14	4.572E-14	37.5002
10	0.	SLV_ENVE	Min	4.364E-16	-4.559E-14	-141.9844
10	0.46683	SLV_ENVE	Min	4.364E-16	-1.121E-16	-104.291
10	0.93367	SLV_ENVE	Min	4.364E-16	4.292E-14	-77.6848
10	0.	SLE_FR_ENVE	Max	4.653E-14	8.933E-14	-158.235
10	0.46683	SLE_FR_ENVE	Max	4.653E-14	-1.483E-19	-124.7533
10	0.93367	SLE_FR_ENVE	Max	4.653E-14	-8.933E-14	-104.5642
10	0.	SLE_FR_ENVE	Min	4.653E-14	8.933E-14	-158.235
10	0.46683	SLE_FR_ENVE	Min	4.653E-14	-1.483E-19	-124.7533
10	0.93367	SLE_FR_ENVE	Min	4.653E-14	-8.933E-14	-104.5642
10	0.	SLE_QP_ENVE	Max	4.259E-14	-2.010E-14	-134.6214
10	0.46683	SLE_QP_ENVE	Max	4.259E-14	-1.175E-19	-98.8619
10	0.93367	SLE_QP_ENVE	Max	4.259E-14	3.110E-14	-73.1261
10	0.	SLE_QP_ENVE	Min	3.684E-14	-3.110E-14	-150.4188
10	0.46683	SLE_QP_ENVE	Min	3.684E-14	-1.358E-19	-114.557
10	0.93367	SLE_QP_ENVE	Min	3.684E-14	2.010E-14	-88.7189
10	0.	SLE_C_ENVE	Max	4.259E-14	-1.996E-14	-133.6615
10	0.46683	SLE_C_ENVE	Max	4.259E-14	-1.210E-19	-101.1309
10	0.93367	SLE_C_ENVE	Max	4.259E-14	3.110E-14	-82.9826
10	0.	SLE_C_ENVE	Min	3.794E-14	-3.110E-14	-150.4188
10	0.46683	SLE_C_ENVE	Min	3.794E-14	-1.358E-19	-114.557
10	0.93367	SLE_C_ENVE	Min	3.794E-14	1.996E-14	-88.7189
11	0.	SLU_ENVE	Max	1.957E-14	1.992E-13	124.4798
11	0.55396	SLU_ENVE	Max	1.957E-14	1.353E-13	104.0267
11	1.10792	SLU_ENVE	Max	1.957E-14	3.292E-13	102.5233

Table 12: Element Forces - Frames, Part 2 of 2

Frame	Station m	OutputCase	StepType	T KN-m	M2 KN-m	M3 KN-m
11	0.	SLU_ENVE	Min	-5.551E-14	-4.556E-13	-91.7078
11	0.55396	SLU_ENVE	Min	-5.551E-14	-4.151E-13	-280.532
11	1.10792	SLU_ENVE	Min	-5.551E-14	-4.156E-13	-431.3922
11	0.	SLV_ENVE	Max	-5.721E-14	1.140E-13	-77.4098
11	0.55396	SLV_ENVE	Max	-5.721E-14	-3.991E-13	-288.0867
11	1.10792	SLV_ENVE	Max	-5.721E-14	-7.558E-13	-432.5903
11	0.	SLV_ENVE	Min	-6.351E-14	-1.489E-14	-134.8584
11	0.55396	SLV_ENVE	Min	-6.351E-14	-4.508E-13	-320.3117
11	1.10792	SLV_ENVE	Min	-6.351E-14	-8.772E-13	-498.148
11	0.	SLE_FR_ENVE	Max	-3.619E-14	-1.138E-13	-46.7712
11	0.55396	SLE_FR_ENVE	Max	-3.619E-14	-2.673E-13	-182.1633
11	1.10792	SLE_FR_ENVE	Max	-3.619E-14	-3.490E-13	-288.3525
11	0.	SLE_FR_ENVE	Min	-3.619E-14	-1.138E-13	-46.7712
11	0.55396	SLE_FR_ENVE	Min	-3.619E-14	-2.673E-13	-182.1633
11	1.10792	SLE_FR_ENVE	Min	-3.619E-14	-3.490E-13	-288.3525
11	0.	SLE_QP_ENVE	Max	-8.024E-16	1.336E-13	49.2582
11	0.55396	SLE_QP_ENVE	Max	-8.024E-16	-7.769E-15	-1.3832
11	1.10792	SLE_QP_ENVE	Max	-8.024E-16	-1.013E-13	-33.0748
11	0.	SLE_QP_ENVE	Min	-2.686E-14	1.076E-13	-13.6506
11	0.55396	SLE_QP_ENVE	Min	-2.686E-14	-1.923E-13	-134.0388
11	1.10792	SLE_QP_ENVE	Min	-2.686E-14	-4.205E-13	-225.224
11	0.	SLE_C_ENVE	Max	-3.522E-15	1.129E-13	32.9558
11	0.55396	SLE_C_ENVE	Max	-3.522E-15	-2.746E-14	-16.2848
11	1.10792	SLE_C_ENVE	Max	-3.522E-15	-1.200E-13	-46.5757
11	0.	SLE_C_ENVE	Min	-2.686E-14	1.076E-13	-13.6506
11	0.55396	SLE_C_ENVE	Min	-2.686E-14	-1.923E-13	-134.0388
11	1.10792	SLE_C_ENVE	Min	-2.686E-14	-4.205E-13	-225.224
12	0.	SLU_ENVE	Max	2.963E-14	6.795E-13	102.5233
12	0.55396	SLU_ENVE	Max	2.963E-14	6.088E-13	95.3983
12	1.10792	SLU_ENVE	Max	2.963E-14	6.700E-13	106.3505
12	0.	SLU_ENVE	Min	-1.584E-13	-2.989E-12	-431.3922
12	0.55396	SLU_ENVE	Min	-1.584E-13	-3.410E-12	-528.8817
12	1.10792	SLU_ENVE	Min	-1.584E-13	-3.575E-12	-590.7879
12	0.	SLV_ENVE	Max	-1.623E-13	-2.599E-12	-432.5903
12	0.55396	SLV_ENVE	Max	-1.623E-13	-3.456E-12	-536.9054
12	1.10792	SLV_ENVE	Max	-1.623E-13	-4.221E-12	-628.7346
12	0.	SLV_ENVE	Min	-1.915E-13	-2.986E-12	-498.148
12	0.55396	SLV_ENVE	Min	-1.915E-13	-4.126E-12	-640.2461
12	1.10792	SLV_ENVE	Min	-1.915E-13	-4.873E-12	-727.6868
12	0.	SLE_FR_ENVE	Max	-1.070E-13	-1.905E-12	-288.3525
12	0.55396	SLE_FR_ENVE	Max	-1.070E-13	-2.307E-12	-357.8085
12	1.10792	SLE_FR_ENVE	Max	-1.070E-13	-2.510E-12	-399.8928
12	0.	SLE_FR_ENVE	Min	-1.070E-13	-1.905E-12	-288.3525
12	0.55396	SLE_FR_ENVE	Min	-1.070E-13	-2.307E-12	-357.8085
12	1.10792	SLE_FR_ENVE	Min	-1.070E-13	-2.510E-12	-399.8928
12	0.	SLE_QP_ENVE	Max	-1.525E-14	-1.530E-13	-33.0748
12	0.55396	SLE_QP_ENVE	Max	-1.525E-14	-3.446E-13	-53.2001
12	1.10792	SLE_QP_ENVE	Max	-1.525E-14	-4.043E-13	-55.2482
12	0.	SLE_QP_ENVE	Min	-8.537E-14	-1.328E-12	-225.224
12	0.55396	SLE_QP_ENVE	Min	-8.537E-14	-1.843E-12	-286.1567
12	1.10792	SLE_QP_ENVE	Min	-8.537E-14	-2.161E-12	-319.7177
12	0.	SLE_C_ENVE	Max	-1.887E-14	-2.376E-13	-46.5757

RELAZIONE DI CALCOLO GALLERIA ARTIFICIALE

Table 12: Element Forces - Frames, Part 2 of 2

Frame	Station m	OutputCase	StepType	T KN-m	M2 KN-m	M3 KN-m
12	0.55396	SLE_C_ENVE	Max	-1.887E-14	-4.217E-13	-65.2924
12	1.10792	SLE_C_ENVE	Max	-1.887E-14	-4.739E-13	-65.9319
12	0.	SLE_C_ENVE	Min	-8.537E-14	-1.328E-12	-225.224
12	0.55396	SLE_C_ENVE	Min	-8.537E-14	-1.843E-12	-286.1567
12	1.10792	SLE_C_ENVE	Min	-8.537E-14	-2.161E-12	-319.7177
13	0.	SLU_ENVE	Max	3.934E-14	1.091E-11	106.3505
13	0.49289	SLU_ENVE	Max	3.934E-14	1.112E-11	114.8754
13	0.98577	SLU_ENVE	Max	3.934E-14	1.080E-11	136.6846
13	0.	SLU_ENVE	Min	-2.000E-13	-1.977E-12	-590.7879
13	0.49289	SLU_ENVE	Min	-2.000E-13	-2.130E-12	-595.41
13	0.98577	SLU_ENVE	Min	-2.000E-13	-2.554E-12	-574.2301
13	0.	SLV_ENVE	Max	-2.239E-13	1.388E-11	-628.7346
13	0.49289	SLV_ENVE	Max	-2.239E-13	1.428E-11	-665.4971
13	0.98577	SLV_ENVE	Max	-2.239E-13	1.380E-11	-691.7944
13	0.	SLV_ENVE	Min	-2.562E-13	1.199E-11	-727.6868
13	0.49289	SLV_ENVE	Min	-2.562E-13	1.239E-11	-765.6324
13	0.98577	SLV_ENVE	Min	-2.562E-13	1.258E-11	-761.2843
13	0.	SLE_FR_ENVE	Max	-1.350E-13	7.483E-12	-399.8928
13	0.49289	SLE_FR_ENVE	Max	-1.350E-13	7.511E-12	-402.1784
13	0.98577	SLE_FR_ENVE	Max	-1.350E-13	7.134E-12	-384.6164
13	0.	SLE_FR_ENVE	Min	-1.350E-13	7.483E-12	-399.8928
13	0.49289	SLE_FR_ENVE	Min	-1.350E-13	7.511E-12	-402.1784
13	0.98577	SLE_FR_ENVE	Min	-1.350E-13	7.134E-12	-384.6164
13	0.	SLE_QP_ENVE	Max	-1.394E-14	6.150E-12	-55.2482
13	0.49289	SLE_QP_ENVE	Max	-1.394E-14	5.975E-12	-42.5488
13	0.98577	SLE_QP_ENVE	Max	-1.394E-14	5.394E-12	-16.5652
13	0.	SLE_QP_ENVE	Min	-1.072E-13	1.120E-12	-319.7177
13	0.49289	SLE_QP_ENVE	Min	-1.072E-13	8.073E-13	-319.904
13	0.98577	SLE_QP_ENVE	Min	-1.072E-13	2.244E-13	-300.2426
13	0.	SLE_C_ENVE	Max	-1.715E-14	6.150E-12	-65.9319
13	0.49289	SLE_C_ENVE	Max	-1.715E-14	5.975E-12	-51.9828
13	0.98577	SLE_C_ENVE	Max	-1.715E-14	5.394E-12	-24.7494
13	0.	SLE_C_ENVE	Min	-1.072E-13	1.326E-12	-319.7177
13	0.49289	SLE_C_ENVE	Min	-1.072E-13	9.839E-13	-319.904
13	0.98577	SLE_C_ENVE	Min	-1.072E-13	3.716E-13	-300.2426
14	0.	SLU_ENVE	Max	4.439E-14	1.486E-12	136.6846
14	0.49289	SLU_ENVE	Max	4.439E-14	1.557E-12	158.0001
14	0.98577	SLU_ENVE	Max	4.439E-14	1.523E-12	191.6418
14	0.	SLU_ENVE	Min	-1.430E-13	-4.058E-13	-574.2301
14	0.49289	SLU_ENVE	Min	-1.430E-13	-4.729E-13	-502.3398
14	0.98577	SLU_ENVE	Min	-1.430E-13	-6.252E-13	-406.9351
14	0.	SLV_ENVE	Max	-1.880E-13	2.522E-12	-691.7944
14	0.49289	SLV_ENVE	Max	-1.880E-13	2.189E-12	-664.8455
14	0.98577	SLV_ENVE	Max	-1.880E-13	1.725E-12	-599.4518
14	0.	SLV_ENVE	Min	-2.021E-13	2.275E-12	-761.2843
14	0.49289	SLV_ENVE	Min	-2.021E-13	2.021E-12	-716.1821
14	0.98577	SLV_ENVE	Min	-2.021E-13	1.593E-12	-632.7825
14	0.	SLE_FR_ENVE	Max	-9.450E-14	1.107E-12	-384.6164
14	0.49289	SLE_FR_ENVE	Max	-9.450E-14	1.026E-12	-331.62
14	0.98577	SLE_FR_ENVE	Max	-9.450E-14	8.644E-13	-260.5356
14	0.	SLE_FR_ENVE	Min	-9.450E-14	1.107E-12	-384.6164
14	0.49289	SLE_FR_ENVE	Min	-9.450E-14	1.026E-12	-331.62

RELAZIONE DI CALCOLO GALLERIA ARTIFICIALE

Table 12: Element Forces - Frames, Part 2 of 2

Frame	Station m	OutputCase	StepType	T KN-m	M2 KN-m	M3 KN-m
14	0.98577	SLE_FR_ENVE	Min	-9.450E-14	8.644E-13	-260.5356
14	0.	SLE_QP_ENVE	Max	6.408E-15	1.057E-12	-16.5652
14	0.49289	SLE_QP_ENVE	Max	6.408E-15	7.715E-13	25.5154
14	0.98577	SLE_QP_ENVE	Max	6.408E-15	4.061E-13	79.9221
14	0.	SLE_QP_ENVE	Min	-7.151E-14	1.437E-13	-300.2426
14	0.49289	SLE_QP_ENVE	Min	-7.151E-14	-6.818E-14	-250.5092
14	0.98577	SLE_QP_ENVE	Min	-7.151E-14	-3.332E-13	-182.6878
14	0.	SLE_C_ENVE	Max	4.412E-15	1.057E-12	-24.7494
14	0.49289	SLE_C_ENVE	Max	4.412E-15	7.715E-13	18.5687
14	0.98577	SLE_C_ENVE	Max	4.412E-15	4.061E-13	74.213
14	0.	SLE_C_ENVE	Min	-7.151E-14	1.712E-13	-300.2426
14	0.49289	SLE_C_ENVE	Min	-7.151E-14	-4.692E-14	-250.5092
14	0.98577	SLE_C_ENVE	Min	-7.151E-14	-3.183E-13	-182.6878
15	0.	SLU_ENVE	Max	4.339E-14	3.370E-13	191.6418
15	0.49289	SLU_ENVE	Max	4.339E-14	2.955E-13	222.9589
15	0.98577	SLU_ENVE	Max	4.339E-14	5.414E-13	264.6744
15	0.	SLU_ENVE	Min	-5.617E-14	-5.949E-13	-406.9351
15	0.49289	SLU_ENVE	Min	-5.617E-14	-2.138E-13	-263.1522
15	0.98577	SLU_ENVE	Min	-5.617E-14	-3.196E-13	-100.2915
15	0.	SLV_ENVE	Max	-9.724E-14	8.332E-13	-599.4518
15	0.49289	SLV_ENVE	Max	-9.724E-14	5.176E-13	-473.4312
15	0.98577	SLV_ENVE	Max	-9.724E-14	2.112E-13	-326.7664
15	0.	SLV_ENVE	Min	-1.081E-13	8.010E-13	-632.7825
15	0.49289	SLV_ENVE	Min	-1.081E-13	4.653E-13	-531.779
15	0.98577	SLV_ENVE	Min	-1.081E-13	7.454E-14	-424.7584
15	0.	SLE_FR_ENVE	Max	-3.379E-14	1.460E-13	-260.5356
15	0.49289	SLE_FR_ENVE	Max	-3.379E-14	1.715E-13	-155.7804
15	0.98577	SLE_FR_ENVE	Max	-3.379E-14	1.639E-13	-36.35
15	0.	SLE_FR_ENVE	Min	-3.379E-14	1.460E-13	-260.5356
15	0.49289	SLE_FR_ENVE	Min	-3.379E-14	1.715E-13	-155.7804
15	0.98577	SLE_FR_ENVE	Min	-3.379E-14	1.639E-13	-36.35
15	0.	SLE_QP_ENVE	Max	2.766E-14	3.389E-13	79.9221
15	0.49289	SLE_QP_ENVE	Max	2.766E-14	8.858E-14	149.4334
15	0.98577	SLE_QP_ENVE	Max	2.766E-14	-1.949E-13	229.343
15	0.	SLE_QP_ENVE	Min	-1.981E-14	3.462E-14	-182.6878
15	0.49289	SLE_QP_ENVE	Min	-1.981E-14	-1.416E-13	-86.5136
15	0.98577	SLE_QP_ENVE	Min	-1.981E-14	-3.399E-13	24.3358
15	0.	SLE_C_ENVE	Max	2.673E-14	3.389E-13	74.213
15	0.49289	SLE_C_ENVE	Max	2.673E-14	8.858E-14	144.9411
15	0.98577	SLE_C_ENVE	Max	2.673E-14	-1.949E-13	226.0675
15	0.	SLE_C_ENVE	Min	-1.981E-14	4.197E-14	-182.6878
15	0.49289	SLE_C_ENVE	Min	-1.981E-14	-1.372E-13	-86.5136
15	0.98577	SLE_C_ENVE	Min	-1.981E-14	-3.385E-13	24.3358
16	0.	SLU_ENVE	Max	3.156E-14	4.577E-14	264.6744
16	0.53604	SLU_ENVE	Max	3.156E-14	1.324E-14	136.1698
16	1.07208	SLU_ENVE	Max	3.156E-14	7.618E-13	72.0209
16	0.	SLU_ENVE	Min	-5.261E-14	-8.853E-13	-100.2915
16	0.53604	SLU_ENVE	Min	-5.261E-14	-6.090E-14	-193.09
16	1.07208	SLU_ENVE	Min	-5.261E-14	-2.799E-14	-245.2555
16	0.	SLV_ENVE	Max	-9.816E-14	1.147E-13	-326.7664
16	0.53604	SLV_ENVE	Max	-9.816E-14	7.518E-14	-373.504
16	1.07208	SLV_ENVE	Max	-9.816E-14	2.630E-14	-383.9791



Table 12: Element Forces - Frames, Part 2 of 2

Frame	Station m	OutputCase	StepType	T KN-m	M2 KN-m	M3 KN-m
16	0.	SLV_ENVE	Min	-1.253E-13	1.058E-13	-424.7584
16	0.53604	SLV_ENVE	Min	-1.253E-13	6.037E-14	-475.5615
16	1.07208	SLV_ENVE	Min	-1.253E-13	4.702E-15	-490.4099
16	0.	SLE_FR_ENVE	Max	-3.168E-14	-3.544E-13	-36.35
16	0.53604	SLE_FR_ENVE	Max	-3.168E-14	-4.224E-15	-113.9896
16	1.07208	SLE_FR_ENVE	Max	-3.168E-14	3.424E-13	-160.3732
16	0.	SLE_FR_ENVE	Min	-3.168E-14	-3.544E-13	-36.35
16	0.53604	SLE_FR_ENVE	Min	-3.168E-14	-4.224E-15	-113.9896
16	1.07208	SLE_FR_ENVE	Min	-3.168E-14	3.424E-13	-160.3732
16	0.	SLE_QP_ENVE	Max	2.631E-14	4.596E-14	229.343
16	0.53604	SLE_QP_ENVE	Max	2.631E-14	1.334E-14	113.7613
16	1.07208	SLE_QP_ENVE	Max	2.631E-14	-2.282E-14	27.6372
16	0.	SLE_QP_ENVE	Min	-1.859E-14	8.039E-15	24.3358
16	0.53604	SLE_QP_ENVE	Min	-1.859E-14	-1.320E-14	-62.5703
16	1.07208	SLE_QP_ENVE	Min	-1.859E-14	-3.574E-14	-118.2203
16	0.	SLE_C_ENVE	Max	2.568E-14	4.596E-14	226.0675
16	0.53604	SLE_C_ENVE	Max	2.568E-14	1.334E-14	111.2424
16	1.07208	SLE_C_ENVE	Max	2.568E-14	-2.282E-14	25.875
16	0.	SLE_C_ENVE	Min	-1.859E-14	8.789E-15	24.3358
16	0.53604	SLE_C_ENVE	Min	-1.859E-14	-1.282E-14	-62.5703
16	1.07208	SLE_C_ENVE	Min	-1.859E-14	-3.573E-14	-118.2203
17	0.	SLU_ENVE	Max	2.494E-14	9.193E-14	72.0209
17	0.53604	SLU_ENVE	Max	2.494E-14	4.564E-14	61.0912
17	1.07208	SLU_ENVE	Max	2.494E-14	5.786E-13	56.5057
17	0.	SLU_ENVE	Min	-9.465E-14	-5.886E-13	-245.2555
17	0.53604	SLU_ENVE	Min	-9.465E-14	-3.035E-14	-241.0363
17	1.07208	SLU_ENVE	Min	-9.465E-14	-3.880E-14	-202.1535
17	0.	SLV_ENVE	Max	-1.346E-13	2.063E-13	-383.9791
17	0.53604	SLV_ENVE	Max	-1.346E-13	1.324E-13	-343.0438
17	1.07208	SLV_ENVE	Max	-1.346E-13	5.005E-14	-270.9944
17	0.	SLV_ENVE	Min	-1.748E-13	1.785E-13	-490.4099
17	0.53604	SLV_ENVE	Min	-1.748E-13	1.029E-13	-442.7886
17	1.07208	SLV_ENVE	Min	-1.748E-13	2.012E-14	-363.0565
17	0.	SLE_FR_ENVE	Max	-6.464E-14	-1.822E-13	-160.3732
17	0.53604	SLE_FR_ENVE	Max	-6.464E-14	3.740E-14	-164.4048
17	1.07208	SLE_FR_ENVE	Max	-6.464E-14	2.553E-13	-141.7722
17	0.	SLE_FR_ENVE	Min	-6.464E-14	-1.822E-13	-160.3732
17	0.53604	SLE_FR_ENVE	Min	-6.464E-14	3.740E-14	-164.4048
17	1.07208	SLE_FR_ENVE	Min	-6.464E-14	2.553E-13	-141.7722
17	0.	SLE_QP_ENVE	Max	-9.279E-15	9.211E-14	27.6372
17	0.53604	SLE_QP_ENVE	Max	-9.279E-15	4.088E-14	-22.1663
17	1.07208	SLE_QP_ENVE	Max	-9.279E-15	-1.199E-14	-46.5074
17	0.	SLE_QP_ENVE	Min	-5.245E-14	4.286E-14	-118.2203
17	0.53604	SLE_QP_ENVE	Min	-5.245E-14	8.369E-15	-133.0499
17	1.07208	SLE_QP_ENVE	Min	-5.245E-14	-2.628E-14	-121.2152
17	0.	SLE_C_ENVE	Max	-9.647E-15	9.211E-14	25.875
17	0.53604	SLE_C_ENVE	Max	-9.647E-15	4.088E-14	-23.172
17	1.07208	SLE_C_ENVE	Max	-9.647E-15	-1.199E-14	-46.7564
17	0.	SLE_C_ENVE	Min	-5.245E-14	4.357E-14	-118.2203
17	0.53604	SLE_C_ENVE	Min	-5.245E-14	8.657E-15	-133.0499
17	1.07208	SLE_C_ENVE	Min	-5.245E-14	-2.642E-14	-121.2152
18	0.	SLU_ENVE	Max	3.737E-14	1.082E-13	56.5057

RELAZIONE DI CALCOLO GALLERIA ARTIFICIALE

Table 12: Element Forces - Frames, Part 2 of 2

Frame	Station m	OutputCase	StepType	T KN-m	M2 KN-m	M3 KN-m
18	0.53604	SLU_ENVE	Max	3.737E-14	5.437E-14	67.7502
18	1.07208	SLU_ENVE	Max	3.737E-14	4.880E-13	113.2612
18	0.	SLU_ENVE	Min	-7.304E-14	-4.694E-13	-202.1535
18	0.53604	SLU_ENVE	Min	-7.304E-14	-4.642E-14	-147.683
18	1.07208	SLU_ENVE	Min	-7.304E-14	-6.090E-14	-120.4268
18	0.	SLV_ENVE	Max	-6.999E-14	2.249E-13	-270.9944
18	0.53604	SLV_ENVE	Max	-6.999E-14	1.018E-13	-151.6759
18	1.07208	SLV_ENVE	Max	-6.999E-14	-2.859E-14	-5.5296
18	0.	SLV_ENVE	Min	-1.060E-13	1.839E-13	-363.0565
18	0.53604	SLV_ENVE	Min	-1.060E-13	6.833E-14	-223.566
18	1.07208	SLV_ENVE	Min	-1.060E-13	-5.328E-14	-55.8157
18	0.	SLE_FR_ENVE	Max	-3.661E-14	-1.076E-13	-141.7722
18	0.53604	SLE_FR_ENVE	Max	-3.661E-14	2.974E-14	-81.1359
18	1.07208	SLE_FR_ENVE	Max	-3.661E-14	1.661E-13	2.6844
18	0.	SLE_FR_ENVE	Min	-3.661E-14	-1.076E-13	-141.7722
18	0.53604	SLE_FR_ENVE	Min	-3.661E-14	2.974E-14	-81.1359
18	1.07208	SLE_FR_ENVE	Min	-3.661E-14	1.661E-13	2.6844
18	0.	SLE_QP_ENVE	Max	-1.713E-14	1.083E-13	-46.5074
18	0.53604	SLE_QP_ENVE	Max	-1.713E-14	3.234E-14	-38.6314
18	1.07208	SLE_QP_ENVE	Max	-1.713E-14	-3.482E-14	-0.9154
18	0.	SLE_QP_ENVE	Min	-3.277E-14	6.924E-14	-121.2152
18	0.53604	SLE_QP_ENVE	Min	-3.277E-14	1.713E-14	-72.6573
18	1.07208	SLE_QP_ENVE	Min	-3.277E-14	-4.461E-14	-8.5139
18	0.	SLE_C_ENVE	Max	-1.684E-14	1.083E-13	-46.7564
18	0.53604	SLE_C_ENVE	Max	-1.684E-14	3.234E-14	-38.1239
18	1.07208	SLE_C_ENVE	Max	-1.684E-14	-3.557E-14	-0.9154
18	0.	SLE_C_ENVE	Min	-3.277E-14	6.948E-14	-121.2152
18	0.53604	SLE_C_ENVE	Min	-3.277E-14	1.688E-14	-72.6573
18	1.07208	SLE_C_ENVE	Min	-3.277E-14	-4.461E-14	-7.2498
19	0.	SLU_ENVE	Max	0.	1.735E-14	110.421
19	0.53603	SLU_ENVE	Max	0.	1.080E-14	64.9426
19	1.07206	SLU_ENVE	Max	0.	8.535E-15	54.3938
19	0.	SLU_ENVE	Min	0.	-2.117E-14	-122.4886
19	0.53603	SLU_ENVE	Min	0.	-2.367E-14	-150.6614
19	1.07206	SLU_ENVE	Min	0.	-2.827E-14	-203.6822
19	0.	SLV_ENVE	Max	0.	-3.923E-15	-1.5622
19	0.53603	SLV_ENVE	Max	0.	-2.305E-14	-154.3239
19	1.07206	SLV_ENVE	Max	0.	-3.925E-14	-283.1812
19	0.	SLV_ENVE	Min	0.	-1.131E-14	-42.1477
19	0.53603	SLV_ENVE	Min	0.	-3.339E-14	-220.7426
19	1.07206	SLV_ENVE	Min	0.	-5.345E-14	-382.8422
19	0.	SLE_FR_ENVE	Max	0.	-1.682E-15	2.0616
19	0.53603	SLE_FR_ENVE	Max	0.	-1.219E-14	-81.9072
19	1.07206	SLE_FR_ENVE	Max	0.	-1.985E-14	-142.6927
19	0.	SLE_FR_ENVE	Min	0.	-1.682E-15	2.0616
19	0.53603	SLE_FR_ENVE	Min	0.	-1.219E-14	-81.9072
19	1.07206	SLE_FR_ENVE	Min	0.	-1.985E-14	-142.6927
19	0.	SLE_QP_ENVE	Max	0.	-1.965E-15	-1.3556
19	0.53603	SLE_QP_ENVE	Max	0.	-6.134E-15	-40.6065
19	1.07206	SLE_QP_ENVE	Max	0.	-7.091E-15	-48.793
19	0.	SLE_QP_ENVE	Min	0.	-2.454E-15	-10.1792
19	0.53603	SLE_QP_ENVE	Min	0.	-1.092E-14	-73.2179

RELAZIONE DI CALCOLO GALLERIA ARTIFICIALE

Table 12: Element Forces - Frames, Part 2 of 2

Frame	Station m	OutputCase	StepType	T KN-m	M2 KN-m	M3 KN-m
19	1.07206	SLE_QP_ENVE	Min	0.	-1.704E-14	-121.897
19	0.	SLE_C_ENVE	Max	0.	-1.965E-15	-1.3556
19	0.53603	SLE_C_ENVE	Max	0.	-6.175E-15	-40.9152
19	1.07206	SLE_C_ENVE	Max	0.	-7.245E-15	-49.9679
19	0.	SLE_C_ENVE	Min	0.	-2.382E-15	-9.6216
19	0.53603	SLE_C_ENVE	Min	0.	-1.092E-14	-73.2179
19	1.07206	SLE_C_ENVE	Min	0.	-1.704E-14	-121.897
20	0.	SLU_ENVE	Max	3.426E-15	1.206E-14	54.3938
20	0.53603	SLU_ENVE	Max	3.426E-15	9.003E-15	58.6965
20	1.07207	SLU_ENVE	Max	3.426E-15	8.395E-14	69.3432
20	0.	SLU_ENVE	Min	-1.362E-14	-1.050E-13	-203.6822
20	0.53603	SLU_ENVE	Min	-1.362E-14	-3.433E-14	-242.839
20	1.07207	SLU_ENVE	Min	-1.362E-14	-2.536E-14	-247.3327
20	0.	SLV_ENVE	Max	-2.025E-14	-3.658E-14	-283.1812
20	0.53603	SLV_ENVE	Max	-2.025E-14	-5.622E-14	-361.0445
20	1.07207	SLV_ENVE	Max	-2.025E-14	-7.162E-14	-411.3898
20	0.	SLV_ENVE	Min	-2.683E-14	-5.281E-14	-382.8422
20	0.53603	SLV_ENVE	Min	-2.683E-14	-7.431E-14	-478.4533
20	1.07207	SLV_ENVE	Min	-2.683E-14	-9.538E-14	-560.2314
20	0.	SLE_FR_ENVE	Max	-9.297E-15	-5.374E-14	-142.6927
20	0.53603	SLE_FR_ENVE	Max	-9.297E-15	-2.435E-14	-165.5069
20	1.07207	SLE_FR_ENVE	Max	-9.297E-15	9.009E-15	-161.6571
20	0.	SLE_FR_ENVE	Min	-9.297E-15	-5.374E-14	-142.6927
20	0.53603	SLE_FR_ENVE	Min	-9.297E-15	-2.435E-14	-165.5069
20	1.07207	SLE_FR_ENVE	Min	-9.297E-15	9.009E-15	-161.6571
20	0.	SLE_QP_ENVE	Max	-1.476E-15	-2.911E-15	-48.793
20	0.53603	SLE_QP_ENVE	Max	-1.476E-15	-4.584E-15	-24.7985
20	1.07207	SLE_QP_ENVE	Max	-1.476E-15	-2.671E-15	24.6581
20	0.	SLE_QP_ENVE	Min	-7.541E-15	-1.319E-14	-121.897
20	0.53603	SLE_QP_ENVE	Min	-7.541E-15	-2.132E-14	-133.8863
20	1.07207	SLE_QP_ENVE	Min	-7.541E-15	-2.548E-14	-119.2117
20	0.	SLE_C_ENVE	Max	-1.588E-15	-3.063E-15	-49.9679
20	0.53603	SLE_C_ENVE	Max	-1.588E-15	-4.894E-15	-26.8397
20	1.07207	SLE_C_ENVE	Max	-1.588E-15	-3.140E-15	21.7506
20	0.	SLE_C_ENVE	Min	-7.541E-15	-1.319E-14	-121.897
20	0.53603	SLE_C_ENVE	Min	-7.541E-15	-2.132E-14	-133.8863
20	1.07207	SLE_C_ENVE	Min	-7.541E-15	-2.548E-14	-119.2117
21	0.	SLU_ENVE	Max	4.364E-15	6.795E-15	69.3432
21	0.53605	SLU_ENVE	Max	4.364E-15	1.131E-14	132.243
21	1.0721	SLU_ENVE	Max	4.364E-15	1.463E-13	260.2888
21	0.	SLU_ENVE	Min	-7.604E-15	-1.276E-13	-247.3327
21	0.53605	SLU_ENVE	Min	-7.604E-15	-9.048E-15	-195.4928
21	1.0721	SLU_ENVE	Min	-7.604E-15	1.051E-16	-103.0184
21	0.	SLV_ENVE	Max	-1.529E-14	-2.718E-14	-411.3898
21	0.53605	SLV_ENVE	Max	-1.529E-14	-3.309E-14	-408.0892
21	1.0721	SLV_ENVE	Max	-1.529E-14	-3.369E-14	-372.1662
21	0.	SLV_ENVE	Min	-2.161E-14	-3.839E-14	-560.2314
21	0.53605	SLV_ENVE	Min	-2.161E-14	-4.661E-14	-580.6218
21	1.0721	SLV_ENVE	Min	-2.161E-14	-5.032E-14	-567.003
21	0.	SLE_FR_ENVE	Max	-4.581E-15	-6.191E-14	-161.6571
21	0.53605	SLE_FR_ENVE	Max	-4.581E-15	-6.648E-15	-115.4949
21	1.0721	SLE_FR_ENVE	Max	-4.581E-15	5.349E-14	-38.0754

PROGETTO DEFINITIVO

RELAZIONE DI CALCOLO GALLERIA ARTIFICIALE

Table 12: Element Forces - Frames, Part 2 of 2

Frame	Station m	OutputCase	StepType	T KN-m	M2 KN-m	M3 KN-m
21	0.	SLE_FR_ENVE	Min	-4.581E-15	-6.191E-14	-161.6571
21	0.53605	SLE_FR_ENVE	Min	-4.581E-15	-6.648E-15	-115.4949
21	1.0721	SLE_FR_ENVE	Min	-4.581E-15	5.349E-14	-38.0754
21	0.	SLE_QP_ENVE	Max	3.634E-15	1.617E-15	24.6581
21	0.53605	SLE_QP_ENVE	Max	3.634E-15	7.394E-15	110.3958
21	1.0721	SLE_QP_ENVE	Max	3.634E-15	1.748E-14	225.5923
21	0.	SLE_QP_ENVE	Min	-2.699E-15	-7.567E-15	-119.2117
21	0.53605	SLE_QP_ENVE	Min	-2.699E-15	-6.226E-15	-63.7565
21	1.0721	SLE_QP_ENVE	Min	-2.699E-15	-5.172E-18	22.9561
21	0.	SLE_C_ENVE	Max	3.498E-15	1.455E-15	21.7506
21	0.53605	SLE_C_ENVE	Max	3.498E-15	7.101E-15	106.622
21	1.0721	SLE_C_ENVE	Max	3.498E-15	1.706E-14	220.9522
21	0.	SLE_C_ENVE	Min	-2.699E-15	-7.567E-15	-119.2117
21	0.53605	SLE_C_ENVE	Min	-2.699E-15	-6.226E-15	-63.7565
21	1.0721	SLE_C_ENVE	Min	-2.699E-15	-5.172E-18	22.9561
22	0.	SLU_ENVE	Max	6.649E-14	4.940E-14	113.2612
22	0.48807	SLU_ENVE	Max	6.649E-14	2.816E-14	125.5268
22	0.97615	SLU_ENVE	Max	6.649E-14	3.850E-13	146.4612
22	0.	SLU_ENVE	Min	-5.823E-14	-3.892E-13	-120.4268
22	0.48807	SLU_ENVE	Min	-5.823E-14	-3.255E-14	-114.7663
22	0.97615	SLU_ENVE	Min	-5.823E-14	-6.498E-14	-97.2787
22	0.	SLV_ENVE	Max	4.648E-14	7.914E-14	-5.5296
22	0.48807	SLV_ENVE	Max	4.648E-14	-1.387E-14	84.1529
22	0.97615	SLV_ENVE	Max	4.648E-14	-1.074E-13	205.1654
22	0.	SLV_ENVE	Min	3.002E-14	6.348E-14	-55.8157
22	0.48807	SLV_ENVE	Min	3.002E-14	-2.115E-14	53.3625
22	0.97615	SLV_ENVE	Min	3.002E-14	-1.178E-13	184.597
22	0.	SLE_FR_ENVE	Max	2.342E-14	-1.319E-13	2.6844
22	0.48807	SLE_FR_ENVE	Max	2.342E-14	-1.153E-14	41.3964
22	0.97615	SLE_FR_ENVE	Max	2.342E-14	1.095E-13	98.9855
22	0.	SLE_FR_ENVE	Min	2.342E-14	-1.319E-13	2.6844
22	0.48807	SLE_FR_ENVE	Min	2.342E-14	-1.153E-14	41.3964
22	0.97615	SLE_FR_ENVE	Min	2.342E-14	1.095E-13	98.9855
22	0.	SLE_QP_ENVE	Max	1.717E-14	4.885E-14	-0.9154
22	0.48807	SLE_QP_ENVE	Max	1.717E-14	8.582E-16	29.5101
22	0.97615	SLE_QP_ENVE	Max	1.717E-14	-4.006E-14	78.8127
22	0.	SLE_QP_ENVE	Min	-2.156E-15	4.294E-14	-8.5139
22	0.48807	SLE_QP_ENVE	Min	-2.156E-15	-8.485E-15	-7.1902
22	0.97615	SLE_QP_ENVE	Min	-2.156E-15	-6.516E-14	12.6657
22	0.	SLE_C_ENVE	Max	1.717E-14	4.885E-14	-0.9154
22	0.48807	SLE_C_ENVE	Max	1.717E-14	4.139E-16	29.5101
22	0.97615	SLE_C_ENVE	Max	1.717E-14	-4.078E-14	78.8127
22	0.	SLE_C_ENVE	Min	-1.246E-15	4.277E-14	-7.2498
22	0.48807	SLE_C_ENVE	Min	-1.246E-15	-8.485E-15	-5.4582
22	0.97615	SLE_C_ENVE	Min	-1.246E-15	-6.516E-14	14.8657
23	0.	SLU_ENVE	Max	8.046E-14	4.053E-14	146.4612
23	0.48807	SLU_ENVE	Max	8.046E-14	1.759E-15	179.6114
23	0.97615	SLU_ENVE	Max	8.046E-14	3.025E-13	236.9385
23	0.	SLU_ENVE	Min	-3.925E-14	-3.024E-13	-97.2787
23	0.48807	SLU_ENVE	Min	-3.925E-14	-4.606E-15	-92.6799
23	0.97615	SLU_ENVE	Min	-3.925E-14	-4.394E-14	-69.5809
23	0.	SLV_ENVE	Max	1.199E-13	6.145E-14	205.1654

RELAZIONE DI CALCOLO GALLERIA ARTIFICIALE

Table 12: Element Forces - Frames, Part 2 of 2

Frame	Station m	OutputCase	StepType	T KN-m	M2 KN-m	M3 KN-m
23	0.48807	SLV_ENVE	Max	1.199E-13	-5.574E-15	270.1428
23	0.97615	SLV_ENVE	Max	1.199E-13	-6.657E-14	362.679
23	0.	SLV_ENVE	Min	1.063E-13	5.523E-14	184.597
23	0.48807	SLV_ENVE	Min	1.063E-13	-5.738E-15	239.4195
23	0.97615	SLV_ENVE	Min	1.063E-13	-7.553E-14	313.811
23	0.	SLE_FR_ENVE	Max	5.436E-14	-1.091E-13	98.9855
23	0.48807	SLE_FR_ENVE	Max	5.436E-14	-3.146E-15	120.9862
23	0.97615	SLE_FR_ENVE	Max	5.436E-14	1.044E-13	161.5844
23	0.	SLE_FR_ENVE	Min	5.436E-14	-1.091E-13	98.9855
23	0.48807	SLE_FR_ENVE	Min	5.436E-14	-3.146E-15	120.9862
23	0.97615	SLE_FR_ENVE	Min	5.436E-14	1.044E-13	161.5844
23	0.	SLE_QP_ENVE	Max	4.324E-14	4.056E-14	78.8127
23	0.48807	SLE_QP_ENVE	Max	4.324E-14	-6.253E-16	95.6049
23	0.97615	SLE_QP_ENVE	Max	4.324E-14	-3.224E-14	130.9947
23	0.	SLE_QP_ENVE	Min	5.960E-15	3.286E-14	12.6657
23	0.48807	SLE_QP_ENVE	Min	5.960E-15	-2.560E-15	10.5208
23	0.97615	SLE_QP_ENVE	Min	5.960E-15	-4.400E-14	26.876
23	0.	SLE_C_ENVE	Max	4.324E-14	4.056E-14	78.8127
23	0.48807	SLE_C_ENVE	Max	4.324E-14	-6.822E-16	95.6049
23	0.97615	SLE_C_ENVE	Max	4.324E-14	-3.246E-14	130.9947
23	0.	SLE_C_ENVE	Min	7.039E-15	3.297E-14	14.8657
23	0.48807	SLE_C_ENVE	Min	7.039E-15	-2.560E-15	12.9824
23	0.97615	SLE_C_ENVE	Min	7.039E-15	-4.400E-14	29.5993
24	0.	SLU_ENVE	Max	1.070E-13	5.792E-14	236.9385
24	0.48807	SLU_ENVE	Max	1.070E-13	2.918E-14	240.3164
24	0.97615	SLU_ENVE	Max	1.070E-13	3.079E-13	267.6575
24	0.	SLU_ENVE	Min	-2.074E-14	-3.028E-13	-69.5809
24	0.48807	SLU_ENVE	Min	-2.074E-14	-6.106E-15	-50.4172
24	0.97615	SLU_ENVE	Min	-2.074E-14	-2.422E-14	-12.8274
24	0.	SLV_ENVE	Max	1.735E-13	1.149E-13	362.679
24	0.48807	SLV_ENVE	Max	1.735E-13	4.841E-14	392.7858
24	0.97615	SLV_ENVE	Max	1.735E-13	-1.892E-14	442.0697
24	0.	SLV_ENVE	Min	1.454E-13	9.993E-14	313.811
24	0.48807	SLV_ENVE	Min	1.454E-13	4.014E-14	328.6476
24	0.97615	SLV_ENVE	Min	1.454E-13	-2.064E-14	362.1644
24	0.	SLE_FR_ENVE	Max	7.276E-14	-8.721E-14	161.5844
24	0.48807	SLE_FR_ENVE	Max	7.276E-14	1.980E-14	163.0106
24	0.97615	SLE_FR_ENVE	Max	7.276E-14	1.289E-13	182.87
24	0.	SLE_FR_ENVE	Min	7.276E-14	-8.721E-14	161.5844
24	0.48807	SLE_FR_ENVE	Min	7.276E-14	1.980E-14	163.0106
24	0.97615	SLE_FR_ENVE	Min	7.276E-14	1.289E-13	182.87
24	0.	SLE_QP_ENVE	Max	5.860E-14	5.805E-14	130.9947
24	0.48807	SLE_QP_ENVE	Max	5.860E-14	1.587E-14	130.6699
24	0.97615	SLE_QP_ENVE	Max	5.860E-14	-2.418E-14	148.7783
24	0.	SLE_QP_ENVE	Min	1.010E-14	3.534E-14	26.876
24	0.48807	SLE_QP_ENVE	Min	1.010E-14	2.435E-15	19.979
24	0.97615	SLE_QP_ENVE	Min	1.010E-14	-2.830E-14	31.5079
24	0.	SLE_C_ENVE	Max	5.860E-14	5.805E-14	130.9947
24	0.48807	SLE_C_ENVE	Max	5.860E-14	1.587E-14	130.6699
24	0.97615	SLE_C_ENVE	Max	5.860E-14	-2.418E-14	148.7783
24	0.	SLE_C_ENVE	Min	1.131E-14	3.583E-14	29.5993
24	0.48807	SLE_C_ENVE	Min	1.131E-14	2.771E-15	22.7493

RELAZIONE DI CALCOLO GALLERIA ARTIFICIALE

Table 12: Element Forces - Frames, Part 2 of 2

Frame	Station m	OutputCase	StepType	T KN-m	M2 KN-m	M3 KN-m
24	0.97615	SLE_C_ENVE	Min	1.131E-14	-2.812E-14	34.3253
25	0.	SLU_ENVE	Max	8.557E-14	6.878E-14	267.6575
25	0.48807	SLU_ENVE	Max	8.557E-14	5.988E-14	240.1407
25	0.97615	SLU_ENVE	Max	8.557E-14	2.733E-13	236.5871
25	0.	SLU_ENVE	Min	-1.668E-14	-2.309E-13	-12.8274
25	0.48807	SLU_ENVE	Min	-1.668E-14	-1.216E-14	-50.6566
25	0.97615	SLU_ENVE	Min	-1.668E-14	-2.986E-14	-70.125
25	0.	SLV_ENVE	Max	1.466E-13	1.652E-13	442.0697
25	0.48807	SLV_ENVE	Max	1.466E-13	1.036E-13	415.2565
25	0.97615	SLV_ENVE	Max	1.466E-13	4.113E-14	406.21
25	0.	SLV_ENVE	Min	1.178E-13	1.371E-13	362.1644
25	0.48807	SLV_ENVE	Min	1.178E-13	8.292E-14	333.1171
25	0.97615	SLV_ENVE	Min	1.178E-13	3.017E-14	322.3053
25	0.	SLE_FR_ENVE	Max	5.818E-14	-4.192E-14	182.87
25	0.48807	SLE_FR_ENVE	Max	5.818E-14	4.067E-14	162.9091
25	0.97615	SLE_FR_ENVE	Max	5.818E-14	1.256E-13	161.3815
25	0.	SLE_FR_ENVE	Min	5.818E-14	-4.192E-14	182.87
25	0.48807	SLE_FR_ENVE	Min	5.818E-14	4.067E-14	162.9091
25	0.97615	SLE_FR_ENVE	Min	5.818E-14	1.256E-13	161.3815
25	0.	SLE_QP_ENVE	Max	4.685E-14	6.899E-14	148.7783
25	0.48807	SLE_QP_ENVE	Max	4.685E-14	3.267E-14	130.5999
25	0.97615	SLE_QP_ENVE	Max	4.685E-14	-1.284E-15	130.8546
25	0.	SLE_QP_ENVE	Min	7.980E-15	3.249E-14	31.5079
25	0.48807	SLE_QP_ENVE	Min	7.980E-15	5.244E-15	19.6962
25	0.97615	SLE_QP_ENVE	Min	7.980E-15	-1.968E-14	26.3104
25	0.	SLE_C_ENVE	Max	4.685E-14	6.899E-14	148.7783
25	0.48807	SLE_C_ENVE	Max	4.685E-14	3.267E-14	130.5999
25	0.97615	SLE_C_ENVE	Max	4.685E-14	-1.284E-15	130.8546
25	0.	SLE_C_ENVE	Min	8.908E-15	3.331E-14	34.3253
25	0.48807	SLE_C_ENVE	Min	8.908E-15	5.899E-15	22.3443
25	0.97615	SLE_C_ENVE	Min	8.908E-15	-1.918E-14	28.7892
26	0.	SLU_ENVE	Max	4.814E-14	6.339E-14	236.5871
26	0.48807	SLU_ENVE	Max	4.814E-14	5.803E-14	179.0869
26	0.97615	SLU_ENVE	Max	4.814E-14	2.237E-13	145.7634
26	0.	SLU_ENVE	Min	-2.378E-14	-1.933E-13	-70.125
26	0.48807	SLU_ENVE	Min	-2.378E-14	-2.937E-14	-93.5408
26	0.97615	SLU_ENVE	Min	-2.378E-14	-4.184E-14	-98.4564
26	0.	SLV_ENVE	Max	8.480E-14	1.659E-13	406.21
26	0.48807	SLV_ENVE	Max	8.480E-14	1.031E-13	319.7062
26	0.97615	SLV_ENVE	Max	8.480E-14	4.118E-14	250.5151
26	0.	SLV_ENVE	Min	6.642E-14	1.334E-13	322.3053
26	0.48807	SLV_ENVE	Min	6.642E-14	8.051E-14	249.6454
26	0.97615	SLV_ENVE	Min	6.642E-14	2.830E-14	195.2268
26	0.	SLE_FR_ENVE	Max	3.254E-14	-1.655E-14	161.3815
26	0.48807	SLE_FR_ENVE	Max	3.254E-14	3.917E-14	120.6828
26	0.97615	SLE_FR_ENVE	Max	3.254E-14	9.753E-14	98.5816
26	0.	SLE_FR_ENVE	Min	3.254E-14	-1.655E-14	161.3815
26	0.48807	SLE_FR_ENVE	Min	3.254E-14	3.917E-14	120.6828
26	0.97615	SLE_FR_ENVE	Min	3.254E-14	9.753E-14	98.5816
26	0.	SLE_QP_ENVE	Max	2.589E-14	6.361E-14	130.8546
26	0.48807	SLE_QP_ENVE	Max	2.589E-14	3.108E-14	95.3951
26	0.97615	SLE_QP_ENVE	Max	2.589E-14	1.188E-15	78.5331

Table 12: Element Forces - Frames, Part 2 of 2

Frame	Station m	OutputCase	StepType	T KN-m	M2 KN-m	M3 KN-m
26	0.	SLE_QP_ENVE	Min	3.355E-15	2.610E-14	26.3104
26	0.48807	SLE_QP_ENVE	Min	3.355E-15	3.667E-15	9.6792
26	0.97615	SLE_QP_ENVE	Min	3.355E-15	-1.626E-14	11.5482
26	0.	SLE_C_ENVE	Max	2.589E-14	6.361E-14	130.8546
26	0.48807	SLE_C_ENVE	Max	2.589E-14	3.108E-14	95.3951
26	0.97615	SLE_C_ENVE	Max	2.589E-14	1.188E-15	78.5331
26	0.	SLE_C_ENVE	Min	3.907E-15	2.695E-14	28.7892
26	0.48807	SLE_C_ENVE	Min	3.907E-15	4.338E-15	11.7776
26	0.97615	SLE_C_ENVE	Min	3.907E-15	-1.577E-14	13.266
27	0.	SLU_ENVE	Max	2.174E-14	3.825E-14	145.7634
27	0.48807	SLU_ENVE	Max	2.174E-14	4.214E-14	123.11
27	0.97615	SLU_ENVE	Max	2.174E-14	1.586E-13	110.421
27	0.	SLU_ENVE	Min	-1.970E-14	-1.524E-13	-98.4564
27	0.48807	SLU_ENVE	Min	-1.970E-14	-3.887E-14	-116.4498
27	0.97615	SLU_ENVE	Min	-1.970E-14	-4.253E-14	-122.4886
27	0.	SLV_ENVE	Max	2.061E-14	1.003E-13	250.5151
27	0.48807	SLV_ENVE	Max	2.061E-14	3.964E-14	114.5458
27	0.97615	SLV_ENVE	Max	2.061E-14	-1.618E-14	-1.5622
27	0.	SLV_ENVE	Min	1.339E-14	7.976E-14	195.2268
27	0.48807	SLV_ENVE	Min	1.339E-14	2.594E-14	73.8513
27	0.97615	SLV_ENVE	Min	1.339E-14	-3.107E-14	-42.1477
27	0.	SLE_FR_ENVE	Max	7.716E-15	-1.528E-14	98.5816
27	0.48807	SLE_FR_ENVE	Max	7.716E-15	1.452E-14	40.8831
27	0.97615	SLE_FR_ENVE	Max	7.716E-15	4.718E-14	2.0616
27	0.	SLE_FR_ENVE	Min	7.716E-15	-1.528E-14	98.5816
27	0.48807	SLE_FR_ENVE	Min	7.716E-15	1.452E-14	40.8831
27	0.97615	SLE_FR_ENVE	Min	7.716E-15	4.718E-14	2.0616
27	0.	SLE_QP_ENVE	Max	5.660E-15	3.840E-14	78.5331
27	0.48807	SLE_QP_ENVE	Max	5.660E-15	1.052E-14	29.1502
27	0.97615	SLE_QP_ENVE	Max	5.660E-15	-1.449E-14	-1.3556
27	0.	SLE_QP_ENVE	Min	-9.626E-16	1.488E-14	11.5482
27	0.48807	SLE_QP_ENVE	Min	-9.626E-16	-2.311E-15	-8.5816
27	0.97615	SLE_QP_ENVE	Min	-9.626E-16	-1.686E-14	-10.1792
27	0.	SLE_C_ENVE	Max	5.660E-15	3.840E-14	78.5331
27	0.48807	SLE_C_ENVE	Max	5.660E-15	1.052E-14	29.1502
27	0.97615	SLE_C_ENVE	Max	5.660E-15	-1.449E-14	-1.3556
27	0.	SLE_C_ENVE	Min	-7.632E-16	1.547E-14	13.266
27	0.48807	SLE_C_ENVE	Min	-7.632E-16	-1.923E-15	-7.4439
27	0.97615	SLE_C_ENVE	Min	-7.632E-16	-1.668E-14	-9.6216
28	0.	SLU_ENVE	Max	4.790E-14	4.256E-13	260.2888
28	0.49288	SLU_ENVE	Max	4.790E-14	2.551E-13	218.1211
28	0.98576	SLU_ENVE	Max	4.790E-14	2.764E-13	186.2938
28	0.	SLU_ENVE	Min	-3.488E-14	-2.565E-13	-103.0184
28	0.49288	SLU_ENVE	Min	-3.488E-14	-1.750E-13	-266.3077
28	0.98576	SLU_ENVE	Min	-3.488E-14	-4.537E-13	-410.5948
28	0.	SLV_ENVE	Max	1.261E-13	2.320E-13	-372.1662
28	0.49288	SLV_ENVE	Max	1.261E-13	6.118E-13	-526.9629
28	0.98576	SLV_ENVE	Max	1.261E-13	9.498E-13	-661.2346
28	0.	SLV_ENVE	Min	9.027E-14	9.524E-14	-567.003
28	0.49288	SLV_ENVE	Min	9.027E-14	4.338E-13	-743.9545
28	0.98576	SLV_ENVE	Min	9.027E-14	7.340E-13	-890.8723
28	0.	SLE_FR_ENVE	Max	2.896E-14	1.306E-13	-38.0754

Table 12: Element Forces - Frames, Part 2 of 2

Frame	Station m	OutputCase	StepType	T KN-m	M2 KN-m	M3 KN-m
28	0.49288	SLE_FR_ENVE	Max	2.896E-14	1.479E-13	-157.8298
28	0.98576	SLE_FR_ENVE	Max	2.896E-14	1.389E-13	-262.9671
28	0.	SLE_FR_ENVE	Min	2.896E-14	1.306E-13	-38.0754
28	0.49288	SLE_FR_ENVE	Min	2.896E-14	1.479E-13	-157.8298
28	0.98576	SLE_FR_ENVE	Min	2.896E-14	1.389E-13	-262.9671
28	0.	SLE_QP_ENVE	Max	1.728E-14	-1.521E-13	225.5923
28	0.49288	SLE_QP_ENVE	Max	1.728E-14	7.616E-14	145.3174
28	0.98576	SLE_QP_ENVE	Max	1.728E-14	2.783E-13	75.3828
28	0.	SLE_QP_ENVE	Min	-2.175E-14	-2.711E-13	22.9561
28	0.49288	SLE_QP_ENVE	Min	-2.175E-14	-1.147E-13	-88.2128
28	0.98576	SLE_QP_ENVE	Min	-2.175E-14	2.432E-14	-184.7645
28	0.	SLE_C_ENVE	Max	1.728E-14	-1.521E-13	220.9522
28	0.49288	SLE_C_ENVE	Max	1.728E-14	7.616E-14	139.4347
28	0.98576	SLE_C_ENVE	Max	1.728E-14	2.783E-13	68.2575
28	0.	SLE_C_ENVE	Min	-2.075E-14	-2.689E-13	22.9561
28	0.49288	SLE_C_ENVE	Min	-2.075E-14	-1.099E-13	-88.2128
28	0.98576	SLE_C_ENVE	Min	-2.075E-14	3.171E-14	-184.7645
29	0.	SLU_ENVE	Max	1.154E-13	1.221E-12	186.2938
29	0.49289	SLU_ENVE	Max	1.154E-13	1.247E-12	152.1158
29	0.98578	SLU_ENVE	Max	1.154E-13	1.192E-12	130.264
29	0.	SLU_ENVE	Min	-3.417E-14	-4.852E-13	-410.5948
29	0.49289	SLU_ENVE	Min	-3.417E-14	-3.616E-13	-506.591
29	0.98578	SLU_ENVE	Min	-3.417E-14	-3.049E-13	-579.0729
29	0.	SLV_ENVE	Max	2.158E-13	1.941E-12	-661.2346
29	0.49289	SLV_ENVE	Max	2.158E-13	2.317E-12	-734.3814
29	0.98578	SLV_ENVE	Max	2.158E-13	2.562E-12	-782.2684
29	0.	SLV_ENVE	Min	1.662E-13	1.411E-12	-890.8723
29	0.49289	SLV_ENVE	Min	1.662E-13	1.780E-12	-957.0335
29	0.98578	SLV_ENVE	Min	1.662E-13	2.059E-12	-986.962
29	0.	SLE_FR_ENVE	Max	7.626E-14	6.932E-13	-262.9671
29	0.49289	SLE_FR_ENVE	Max	7.626E-14	8.221E-13	-334.5011
29	0.98578	SLE_FR_ENVE	Max	7.626E-14	8.876E-13	-387.947
29	0.	SLE_FR_ENVE	Min	7.626E-14	6.932E-13	-262.9671
29	0.49289	SLE_FR_ENVE	Min	7.626E-14	8.221E-13	-334.5011
29	0.98578	SLE_FR_ENVE	Min	7.626E-14	8.876E-13	-387.947
29	0.	SLE_QP_ENVE	Max	5.779E-14	3.269E-13	75.3828
29	0.49289	SLE_QP_ENVE	Max	5.779E-14	6.192E-13	20.5105
29	0.98578	SLE_QP_ENVE	Max	5.779E-14	8.480E-13	-22.0357
29	0.	SLE_QP_ENVE	Min	-3.986E-15	-2.550E-13	-184.7645
29	0.49289	SLE_QP_ENVE	Min	-3.986E-15	-4.207E-14	-253.0296
29	0.98578	SLE_QP_ENVE	Min	-3.986E-15	1.286E-13	-303.2068
29	0.	SLE_C_ENVE	Max	5.779E-14	3.269E-13	68.2575
29	0.49289	SLE_C_ENVE	Max	5.779E-14	6.192E-13	12.132
29	0.98578	SLE_C_ENVE	Max	5.779E-14	8.480E-13	-31.6673
29	0.	SLE_C_ENVE	Min	-2.065E-15	-2.399E-13	-184.7645
29	0.49289	SLE_C_ENVE	Min	-2.065E-15	-2.173E-14	-253.0296
29	0.98578	SLE_C_ENVE	Min	-2.065E-15	1.541E-13	-303.2068
30	0.	SLU_ENVE	Max	1.614E-13	8.698E-12	130.264
30	0.4929	SLU_ENVE	Max	1.614E-13	8.963E-12	107.9466
30	0.98579	SLU_ENVE	Max	1.614E-13	8.807E-12	98.914
30	0.	SLU_ENVE	Min	-2.959E-14	-1.947E-12	-579.0729
30	0.4929	SLU_ENVE	Min	-2.959E-14	-1.598E-12	-600.8408



Table 12: Element Forces - Frames, Part 2 of 2

Frame	Station m	OutputCase	StepType	T KN-m	M2 KN-m	M3 KN-m
30	0.98579	SLU_ENVE	Min	-2.959E-14	-1.465E-12	-596.8057
30	0.	SLV_ENVE	Max	2.534E-13	1.435E-11	-782.2684
30	0.4929	SLV_ENVE	Max	2.534E-13	1.407E-11	-766.8608
30	0.98579	SLV_ENVE	Max	2.534E-13	1.317E-11	-701.535
30	0.	SLV_ENVE	Min	2.063E-13	1.135E-11	-986.962
30	0.4929	SLV_ENVE	Min	2.063E-13	1.139E-11	-946.117
30	0.98579	SLV_ENVE	Min	2.063E-13	1.065E-11	-867.5655
30	0.	SLE_FR_ENVE	Max	1.090E-13	5.746E-12	-387.947
30	0.4929	SLE_FR_ENVE	Max	1.090E-13	6.056E-12	-405.9582
30	0.98579	SLE_FR_ENVE	Max	1.090E-13	6.042E-12	-404.1209
30	0.	SLE_FR_ENVE	Min	1.090E-13	5.746E-12	-387.947
30	0.4929	SLE_FR_ENVE	Min	1.090E-13	6.056E-12	-405.9582
30	0.98579	SLE_FR_ENVE	Min	1.090E-13	6.042E-12	-404.1209
30	0.	SLE_QP_ENVE	Max	8.667E-14	4.352E-12	-22.0357
30	0.4929	SLE_QP_ENVE	Max	8.667E-14	4.824E-12	-48.4679
30	0.98579	SLE_QP_ENVE	Max	8.667E-14	4.972E-12	-61.6153
30	0.	SLE_QP_ENVE	Min	1.276E-14	2.583E-13	-303.2068
30	0.4929	SLE_QP_ENVE	Min	1.276E-14	7.332E-13	-323.3135
30	0.98579	SLE_QP_ENVE	Min	1.276E-14	9.921E-13	-323.5717
30	0.	SLE_C_ENVE	Max	8.667E-14	4.352E-12	-31.6673
30	0.4929	SLE_C_ENVE	Max	8.667E-14	4.824E-12	-59.3547
30	0.98579	SLE_C_ENVE	Max	8.667E-14	4.972E-12	-73.7574
30	0.	SLE_C_ENVE	Min	1.572E-14	3.970E-13	-303.2068
30	0.4929	SLE_C_ENVE	Min	1.572E-14	8.959E-13	-323.3135
30	0.98579	SLE_C_ENVE	Min	1.572E-14	1.179E-12	-323.5717
31	0.	SLU_ENVE	Max	1.925E-13	7.458E-13	98.914
31	0.55395	SLU_ENVE	Max	1.925E-13	6.698E-13	87.4684
31	1.1079	SLU_ENVE	Max	1.925E-13	7.521E-13	94.0996
31	0.	SLU_ENVE	Min	-3.271E-14	-4.337E-12	-596.8057
31	0.55395	SLU_ENVE	Min	-3.271E-14	-4.143E-12	-535.4976
31	1.1079	SLU_ENVE	Min	-3.271E-14	-3.641E-12	-438.6072
31	0.	SLV_ENVE	Max	2.578E-13	-5.672E-12	-701.535
31	0.55395	SLV_ENVE	Max	2.578E-13	-4.329E-12	-559.1355
31	1.1079	SLV_ENVE	Max	2.578E-13	-2.924E-12	-410.0368
31	0.	SLV_ENVE	Min	2.039E-13	-6.994E-12	-867.5655
31	0.55395	SLV_ENVE	Min	2.039E-13	-5.531E-12	-713.9934
31	1.1079	SLV_ENVE	Min	2.039E-13	-3.648E-12	-511.5516
31	0.	SLE_FR_ENVE	Max	1.301E-13	-3.045E-12	-404.1209
31	0.55395	SLE_FR_ENVE	Max	1.301E-13	-2.804E-12	-362.4961
31	1.1079	SLE_FR_ENVE	Max	1.301E-13	-2.325E-12	-293.5002
31	0.	SLE_FR_ENVE	Min	1.301E-13	-3.045E-12	-404.1209
31	0.55395	SLE_FR_ENVE	Min	1.301E-13	-2.804E-12	-362.4961
31	1.1079	SLE_FR_ENVE	Min	1.301E-13	-2.325E-12	-293.5002
31	0.	SLE_QP_ENVE	Max	1.040E-13	-5.351E-13	-61.6153
31	0.55395	SLE_QP_ENVE	Max	1.040E-13	-4.656E-13	-60.0062
31	1.1079	SLE_QP_ENVE	Max	1.040E-13	-2.380E-13	-40.3204
31	0.	SLE_QP_ENVE	Min	2.075E-14	-2.623E-12	-323.5717
31	0.55395	SLE_QP_ENVE	Min	2.075E-14	-2.245E-12	-290.4682
31	1.1079	SLE_QP_ENVE	Min	2.075E-14	-1.630E-12	-229.9936
31	0.	SLE_C_ENVE	Max	1.040E-13	-6.301E-13	-73.7574
31	0.55395	SLE_C_ENVE	Max	1.040E-13	-5.693E-13	-73.5506
31	1.1079	SLE_C_ENVE	Max	1.040E-13	-3.503E-13	-55.2671

Table 12: Element Forces - Frames, Part 2 of 2

Frame	Station m	OutputCase	StepType	T KN-m	M2 KN-m	M3 KN-m
31	0.	SLE_C_ENVE	Min	2.561E-14	-2.623E-12	-323.5717
31	0.55395	SLE_C_ENVE	Min	2.561E-14	-2.245E-12	-290.4682
31	1.1079	SLE_C_ENVE	Min	2.561E-14	-1.630E-12	-229.9936
32	0.	SLU_ENVE	Max	9.006E-14	4.571E-13	94.0996
32	0.55397	SLU_ENVE	Max	9.006E-14	2.113E-13	95.3045
32	1.10793	SLU_ENVE	Max	9.006E-14	3.129E-13	115.5498
32	0.	SLU_ENVE	Min	-2.937E-14	-6.985E-13	-438.6072
32	0.55397	SLU_ENVE	Min	-2.937E-14	-6.989E-13	-288.1578
32	1.10793	SLU_ENVE	Min	-2.937E-14	-6.930E-13	-99.6263
32	0.	SLV_ENVE	Max	9.551E-14	-1.195E-12	-410.0368
32	0.55397	SLV_ENVE	Max	9.551E-14	-5.115E-13	-215.0074
32	1.10793	SLV_ENVE	Max	9.551E-14	3.894E-13	36.5808
32	0.	SLV_ENVE	Min	7.058E-14	-1.484E-12	-511.5516
32	0.55397	SLV_ENVE	Min	7.058E-14	-7.167E-13	-302.0203
32	1.10793	SLV_ENVE	Min	7.058E-14	1.014E-13	-71.4163
32	0.	SLE_FR_ENVE	Max	5.872E-14	-5.908E-13	-293.5002
32	0.55397	SLE_FR_ENVE	Max	5.872E-14	-4.535E-13	-187.627
32	1.10793	SLE_FR_ENVE	Max	5.872E-14	-2.085E-13	-52.4599
32	0.	SLE_FR_ENVE	Min	5.872E-14	-5.908E-13	-293.5002
32	0.55397	SLE_FR_ENVE	Min	5.872E-14	-4.535E-13	-187.627
32	1.10793	SLE_FR_ENVE	Min	5.872E-14	-2.085E-13	-52.4599
32	0.	SLE_QP_ENVE	Max	4.364E-14	-1.714E-13	-40.3204
32	0.55397	SLE_QP_ENVE	Max	4.364E-14	-2.813E-14	-8.8939
32	1.10793	SLE_QP_ENVE	Max	4.364E-14	1.870E-13	41.5729
32	0.	SLE_QP_ENVE	Min	2.954E-15	-6.763E-13	-229.9936
32	0.55397	SLE_QP_ENVE	Min	2.954E-15	-3.330E-13	-139.1212
32	1.10793	SLE_QP_ENVE	Min	2.954E-15	1.181E-13	-18.9549
32	0.	SLE_C_ENVE	Max	4.364E-14	-2.062E-13	-55.2671
32	0.55397	SLE_C_ENVE	Max	4.364E-14	-6.492E-14	-25.2223
32	1.10793	SLE_C_ENVE	Max	4.364E-14	1.481E-13	23.8629
32	0.	SLE_C_ENVE	Min	7.831E-15	-6.763E-13	-229.9936
32	0.55397	SLE_C_ENVE	Min	7.831E-15	-3.330E-13	-139.1212
32	1.10793	SLE_C_ENVE	Min	7.831E-15	1.181E-13	-18.9549
51	0.	SLU_ENVE	Max	3.258E-14	7.347E-14	-1.6443
51	0.34164	SLU_ENVE	Max	3.258E-14	8.609E-18	18.0511
51	0.68329	SLU_ENVE	Max	3.258E-14	1.694E-08	34.8293
51	0.	SLU_ENVE	Min	-9.412E-14	-1.694E-08	-67.2134
51	0.34164	SLU_ENVE	Min	-9.412E-14	-2.980E-18	-50.1068
51	0.68329	SLU_ENVE	Min	-9.412E-14	-7.346E-14	-41.3567
51	0.	SLV_ENVE	Max	-5.031E-14	1.073E-13	-39.7755
51	0.34164	SLV_ENVE	Max	-5.031E-14	-1.312E-16	-26.6365
51	0.68329	SLV_ENVE	Max	-5.031E-14	-8.329E-14	-16.4147
51	0.	SLV_ENVE	Min	-1.191E-13	8.514E-14	-76.9984
51	0.34164	SLV_ENVE	Min	-1.191E-13	-4.565E-16	-63.7126
51	0.68329	SLV_ENVE	Min	-1.191E-13	-1.067E-13	-53.344
51	0.	SLE_FR_ENVE	Max	-5.966E-14	-7.819E-09	-46.2261
51	0.34164	SLE_FR_ENVE	Max	-5.966E-14	5.457E-18	-31.6751
51	0.68329	SLE_FR_ENVE	Max	-5.966E-14	7.819E-09	-20.0412
51	0.	SLE_FR_ENVE	Min	-5.966E-14	-7.819E-09	-46.2261
51	0.34164	SLE_FR_ENVE	Min	-5.966E-14	5.457E-18	-31.6751
51	0.68329	SLE_FR_ENVE	Min	-5.966E-14	7.819E-09	-20.0412
51	0.	SLE_QP_ENVE	Max	-1.859E-14	7.372E-14	-28.427

Table 12: Element Forces - Frames, Part 2 of 2

Frame	Station m	OutputCase	StepType	T KN-m	M2 KN-m	M3 KN-m
51	0.34164	SLE_QP_ENVE	Max	-1.859E-14	3.847E-18	-9.5334
51	0.68329	SLE_QP_ENVE	Max	-1.859E-14	-4.618E-14	6.4431
51	0.	SLE_QP_ENVE	Min	-4.206E-14	4.618E-14	-38.5895
51	0.34164	SLE_QP_ENVE	Min	-4.206E-14	1.700E-18	-22.1884
51	0.68329	SLE_QP_ENVE	Min	-4.206E-14	-7.371E-14	-8.7045
51	0.	SLE_C_ENVE	Max	-2.831E-14	7.372E-14	-32.1385
51	0.34164	SLE_C_ENVE	Max	-2.831E-14	3.847E-18	-14.7737
51	0.68329	SLE_C_ENVE	Max	-2.831E-14	-4.715E-14	-0.3261
51	0.	SLE_C_ENVE	Min	-4.206E-14	4.716E-14	-38.5895
51	0.34164	SLE_C_ENVE	Min	-4.206E-14	2.589E-18	-22.1884
51	0.68329	SLE_C_ENVE	Min	-4.206E-14	-7.371E-14	-8.7045
52	0.	SLU_ENVE	Max	2.172E-13	2.127E-08	34.8293
52	0.14282	SLU_ENVE	Max	2.172E-13	1.431E-12	43.7106
52	0.28564	SLU_ENVE	Max	2.172E-13	5.108E-13	53.9395
52	0.	SLU_ENVE	Min	-2.166E-13	-1.288E-12	-41.3567
52	0.14282	SLU_ENVE	Min	-2.166E-13	-1.403E-12	-44.5054
52	0.28564	SLU_ENVE	Min	-2.166E-13	-2.127E-08	-49.5203
52	0.	SLV_ENVE	Max	2.977E-13	1.520E-12	-16.4147
52	0.14282	SLV_ENVE	Max	2.977E-13	1.944E-12	-34.9356
52	0.28564	SLV_ENVE	Max	2.977E-13	2.340E-12	-49.7374
52	0.	SLV_ENVE	Min	1.692E-13	3.280E-13	-53.344
52	0.14282	SLV_ENVE	Min	1.692E-13	1.124E-12	-60.4967
52	0.28564	SLV_ENVE	Min	1.692E-13	1.791E-12	-66.9209
52	0.	SLE_FR_ENVE	Max	1.198E-13	9.819E-09	-20.0412
52	0.14282	SLE_FR_ENVE	Max	1.198E-13	7.928E-13	-24.6441
52	0.28564	SLE_FR_ENVE	Max	1.198E-13	-9.817E-09	-27.1717
52	0.	SLE_FR_ENVE	Min	1.198E-13	9.819E-09	-20.0412
52	0.14282	SLE_FR_ENVE	Min	1.198E-13	7.928E-13	-24.6441
52	0.28564	SLE_FR_ENVE	Min	1.198E-13	-9.817E-09	-27.1717
52	0.	SLE_QP_ENVE	Max	5.428E-14	8.562E-14	6.4431
52	0.14282	SLE_QP_ENVE	Max	5.428E-14	3.659E-13	12.412
52	0.28564	SLE_QP_ENVE	Max	5.428E-14	5.726E-13	19.7284
52	0.	SLE_QP_ENVE	Min	-6.230E-14	-3.989E-13	-8.7045
52	0.14282	SLE_QP_ENVE	Min	-6.230E-14	-3.977E-13	-11.3547
52	0.28564	SLE_QP_ENVE	Min	-6.230E-14	-4.456E-13	-11.9295
52	0.	SLE_C_ENVE	Max	5.428E-14	8.562E-14	-0.3261
52	0.14282	SLE_C_ENVE	Max	5.428E-14	3.659E-13	5.3714
52	0.28564	SLE_C_ENVE	Max	5.428E-14	5.726E-13	12.4164
52	0.	SLE_C_ENVE	Min	-2.759E-14	-1.842E-13	-8.7045
52	0.14282	SLE_C_ENVE	Min	-2.759E-14	-1.716E-13	-11.3547
52	0.28564	SLE_C_ENVE	Min	-2.759E-14	-2.080E-13	-11.9295
53	0.	SLU_ENVE	Max	1.054E-14	1.794E-09	70.5403
53	0.39736	SLU_ENVE	Max	1.054E-14	2.916E-15	31.5092
53	0.79472	SLU_ENVE	Max	1.054E-14	5.828E-15	-11.2168
53	0.	SLU_ENVE	Min	-5.475E-15	-9.909E-15	-42.1875
53	0.39736	SLU_ENVE	Min	-5.475E-15	-5.611E-15	-58.6585
53	0.79472	SLU_ENVE	Min	-5.475E-15	-1.794E-09	-79.9329
53	0.	SLV_ENVE	Max	1.363E-14	-1.528E-14	-27.6724
53	0.39736	SLV_ENVE	Max	1.363E-14	-3.428E-15	-35.1209
53	0.79472	SLV_ENVE	Max	1.363E-14	8.807E-15	-45.7656
53	0.	SLV_ENVE	Min	6.318E-15	-1.774E-14	-67.9374
53	0.39736	SLV_ENVE	Min	6.318E-15	-7.321E-15	-76.3646

Table 12: Element Forces - Frames, Part 2 of 2

Frame	Station m	OutputCase	StepType	T KN-m	M2 KN-m	M3 KN-m
53	0.79472	SLV_ENVE	Min	6.318E-15	3.020E-15	-87.988
53	0.	SLE_FR_ENVE	Max	6.448E-15	8.280E-10	-19.5994
53	0.39736	SLE_FR_ENVE	Max	6.448E-15	-3.434E-15	-35.7692
53	0.79472	SLE_FR_ENVE	Max	6.448E-15	-8.280E-10	-55.634
53	0.	SLE_FR_ENVE	Min	6.448E-15	8.280E-10	-19.5994
53	0.39736	SLE_FR_ENVE	Min	6.448E-15	-3.434E-15	-35.7692
53	0.79472	SLE_FR_ENVE	Min	6.448E-15	-8.280E-10	-55.634
53	0.	SLE_QP_ENVE	Max	4.156E-15	-4.275E-15	29.5299
53	0.39736	SLE_QP_ENVE	Max	4.156E-15	-3.844E-16	-3.4569
53	0.79472	SLE_QP_ENVE	Max	4.156E-15	5.641E-15	-40.1386
53	0.	SLE_QP_ENVE	Min	7.217E-16	-1.007E-14	-1.7211
53	0.39736	SLE_QP_ENVE	Min	7.217E-16	-2.213E-15	-22.8362
53	0.79472	SLE_QP_ENVE	Min	7.217E-16	3.506E-15	-47.6463
53	0.	SLE_C_ENVE	Max	4.156E-15	-4.884E-15	20.5394
53	0.39736	SLE_C_ENVE	Max	4.156E-15	-1.048E-15	-10.493
53	0.79472	SLE_C_ENVE	Max	4.156E-15	5.641E-15	-45.2203
53	0.	SLE_C_ENVE	Min	1.969E-15	-1.007E-14	-1.7211
53	0.39736	SLE_C_ENVE	Min	1.969E-15	-2.213E-15	-22.8362
53	0.79472	SLE_C_ENVE	Min	1.969E-15	2.787E-15	-47.6463
54	0.	SLU_ENVE	Max	3.585E-14	9.844E-14	-4.3036
54	0.34165	SLU_ENVE	Max	3.585E-14	9.240E-18	14.9815
54	0.6833	SLU_ENVE	Max	3.585E-14	2.259E-08	31.3494
54	0.	SLU_ENVE	Min	-1.314E-13	-2.259E-08	-68.931
54	0.34165	SLU_ENVE	Min	-1.314E-13	-2.521E-18	-52.4924
54	0.6833	SLU_ENVE	Min	-1.314E-13	-9.843E-14	-45.0858
54	0.	SLV_ENVE	Max	6.891E-14	1.423E-13	17.7191
54	0.34165	SLV_ENVE	Max	6.891E-14	6.167E-16	28.3494
54	0.6833	SLV_ENVE	Max	6.891E-14	-1.147E-13	36.0624
54	0.	SLV_ENVE	Min	-6.354E-14	1.123E-13	-36.7898
54	0.34165	SLV_ENVE	Min	-6.354E-14	1.887E-16	-25.2055
54	0.6833	SLV_ENVE	Min	-6.354E-14	-1.430E-13	-16.5384
54	0.	SLE_FR_ENVE	Max	-8.374E-14	-1.043E-08	-47.4308
54	0.34165	SLE_FR_ENVE	Max	-8.374E-14	5.889E-18	-33.3715
54	0.6833	SLE_FR_ENVE	Max	-8.374E-14	1.043E-08	-22.2296
54	0.	SLE_FR_ENVE	Min	-8.374E-14	-1.043E-08	-47.4308
54	0.34165	SLE_FR_ENVE	Min	-8.374E-14	5.889E-18	-33.3715
54	0.6833	SLE_FR_ENVE	Min	-8.374E-14	1.043E-08	-22.2296
54	0.	SLE_QP_ENVE	Max	-3.105E-14	9.881E-14	-30.5172
54	0.34165	SLE_QP_ENVE	Max	-3.105E-14	4.217E-18	-12.0683
54	0.6833	SLE_QP_ENVE	Max	-3.105E-14	-6.230E-14	3.4634
54	0.	SLE_QP_ENVE	Min	-5.997E-14	6.231E-14	-39.6963
54	0.34165	SLE_QP_ENVE	Min	-5.997E-14	2.184E-18	-23.7589
54	0.6833	SLE_QP_ENVE	Min	-5.997E-14	-9.880E-14	-10.7387
54	0.	SLE_C_ENVE	Max	-4.531E-14	9.881E-14	-34.7231
54	0.34165	SLE_C_ENVE	Max	-4.531E-14	4.217E-18	-17.834
54	0.6833	SLE_C_ENVE	Max	-4.531E-14	-6.372E-14	-3.8622
54	0.	SLE_C_ENVE	Min	-5.997E-14	6.373E-14	-39.6963
54	0.34165	SLE_C_ENVE	Min	-5.997E-14	3.187E-18	-23.7589
54	0.6833	SLE_C_ENVE	Min	-5.997E-14	-9.880E-14	-10.7387
55	0.	SLU_ENVE	Max	3.270E-13	2.978E-08	31.3494
55	0.14283	SLU_ENVE	Max	3.270E-13	2.151E-12	39.9476
55	0.28565	SLU_ENVE	Max	3.270E-13	8.146E-13	49.8933

Table 12: Element Forces - Frames, Part 2 of 2

Frame	Station m	OutputCase	StepType	T KN-m	M2 KN-m	M3 KN-m
55	0.	SLU_ENVE	Min	-2.773E-13	-1.645E-12	-45.0858
55	0.14283	SLU_ENVE	Min	-2.773E-13	-1.794E-12	-47.8182
55	0.28565	SLU_ENVE	Min	-2.773E-13	-2.978E-08	-53.0922
55	0.	SLV_ENVE	Max	2.130E-13	4.682E-13	36.0625
55	0.14283	SLV_ENVE	Max	2.130E-13	1.409E-12	16.0167
55	0.28565	SLV_ENVE	Max	2.130E-13	2.218E-12	-0.6685
55	0.	SLV_ENVE	Min	-1.144E-13	-1.898E-12	-16.5383
55	0.14283	SLV_ENVE	Min	-1.144E-13	-7.179E-13	-31.3038
55	0.28565	SLV_ENVE	Min	-1.144E-13	2.985E-13	-43.3901
55	0.	SLE_FR_ENVE	Max	1.841E-13	1.375E-08	-22.2296
55	0.14283	SLE_FR_ENVE	Max	1.841E-13	1.216E-12	-27.0208
55	0.28565	SLE_FR_ENVE	Max	1.841E-13	-1.374E-08	-29.7367
55	0.	SLE_FR_ENVE	Min	1.841E-13	1.375E-08	-22.2296
55	0.14283	SLE_FR_ENVE	Min	1.841E-13	1.216E-12	-27.0208
55	0.28565	SLE_FR_ENVE	Min	1.841E-13	-1.374E-08	-29.7367
55	0.	SLE_QP_ENVE	Max	9.126E-14	2.114E-13	3.4634
55	0.14283	SLE_QP_ENVE	Max	9.126E-14	6.114E-13	9.1839
55	0.28565	SLE_QP_ENVE	Max	9.126E-14	9.086E-13	16.2519
55	0.	SLE_QP_ENVE	Min	-6.494E-14	-4.241E-13	-10.7387
55	0.14283	SLE_QP_ENVE	Min	-6.494E-14	-4.115E-13	-13.5673
55	0.28565	SLE_QP_ENVE	Min	-6.494E-14	-4.674E-13	-14.3206
55	0.	SLE_C_ENVE	Max	9.126E-14	2.114E-13	-3.8622
55	0.14283	SLE_C_ENVE	Max	9.126E-14	6.114E-13	1.5438
55	0.28565	SLE_C_ENVE	Max	9.126E-14	9.086E-13	8.2973
55	0.	SLE_C_ENVE	Min	-1.221E-14	-9.887E-14	-10.7387
55	0.14283	SLE_C_ENVE	Min	-1.221E-14	-6.806E-14	-13.5673
55	0.28565	SLE_C_ENVE	Min	-1.221E-14	-1.058E-13	-14.3206
56	0.	SLU_ENVE	Max	2.222E-14	3.588E-09	65.6566
56	0.39738	SLU_ENVE	Max	2.222E-14	5.077E-15	27.5166
56	0.79477	SLU_ENVE	Max	2.222E-14	1.130E-14	-14.3187
56	0.	SLU_ENVE	Min	-9.534E-15	-2.021E-14	-47.4274
56	0.39738	SLU_ENVE	Min	-9.534E-15	-1.183E-14	-61.8979
56	0.79477	SLU_ENVE	Min	-9.534E-15	-3.588E-09	-82.0657
56	0.	SLV_ENVE	Max	1.176E-14	-2.442E-14	37.2493
56	0.39738	SLV_ENVE	Max	1.176E-14	5.773E-15	30.6123
56	0.79477	SLV_ENVE	Max	1.176E-14	3.520E-14	19.7811
56	0.	SLV_ENVE	Min	-1.060E-14	-3.352E-14	-28.0262
56	0.39738	SLV_ENVE	Min	-1.060E-14	-6.224E-15	-32.5381
56	0.79477	SLV_ENVE	Min	-1.060E-14	2.084E-14	-40.8951
56	0.	SLE_FR_ENVE	Max	1.371E-14	1.656E-09	-22.7232
56	0.39738	SLE_FR_ENVE	Max	1.371E-14	-7.303E-15	-38.0806
56	0.79477	SLE_FR_ENVE	Max	1.371E-14	-1.656E-09	-57.1334
56	0.	SLE_FR_ENVE	Min	1.371E-14	1.656E-09	-22.7232
56	0.39738	SLE_FR_ENVE	Min	1.371E-14	-7.303E-15	-38.0806
56	0.79477	SLE_FR_ENVE	Min	1.371E-14	-1.656E-09	-57.1334
56	0.	SLE_QP_ENVE	Max	9.072E-15	-9.174E-15	25.321
56	0.39738	SLE_QP_ENVE	Max	9.072E-15	-1.399E-15	-6.7962
56	0.79477	SLE_QP_ENVE	Max	9.072E-15	1.089E-14	-42.6089
56	0.	SLE_QP_ENVE	Min	2.627E-15	-2.055E-14	-4.6343
56	0.39738	SLE_QP_ENVE	Min	2.627E-15	-4.831E-15	-24.9807
56	0.79477	SLE_QP_ENVE	Min	2.627E-15	6.376E-15	-49.0226
56	0.	SLE_C_ENVE	Max	9.072E-15	-1.051E-14	15.5656

PROGETTO DEFINITIVO

RELAZIONE DI CALCOLO GALLERIA ARTIFICIALE

Table 12: Element Forces - Frames, Part 2 of 2

Frame	Station m	OutputCase	StepType	T KN-m	M2 KN-m	M3 KN-m
56	0.39738	SLE_C_ENVE	Max	9.072E-15	-2.853E-15	-14.4993
56	0.79477	SLE_C_ENVE	Max	9.072E-15	1.089E-14	-48.2595
56	0.	SLE_C_ENVE	Min	5.357E-15	-2.055E-14	-4.6343
56	0.39738	SLE_C_ENVE	Min	5.357E-15	-4.831E-15	-24.9807
56	0.79477	SLE_C_ENVE	Min	5.357E-15	4.803E-15	-49.0226