



Società Autostrada Tirrenica p.A.
GRUPPO AUTOSTRADALE PER L'ITALIA S.p.A.

AUTOSTRADA (A12) : ROSIGNANO – CIVITAVECCHIA
LOTTO 3

TRATTO: SCARLINO – GROSSETO SUD

PROGETTO DEFINITIVO

INFRASTRUTTURA STRATEGICA DI PREMINENTE INTERESSE
NAZIONALE LE CUI PROCEDURE DI APPROVAZIONE SONO REGOLATE
DALL' ART. 161 DEL D.LGS. 163/2006

AU – CORPO AUTOSTRADALE

OPERE D'ARTE MINORI
OPERE DI SOSTEGNO
TIPOLOGIE NUOVE OPERE DI SOSTEGNO
RELAZIONE DESCRITTIVA GENERALE

IL RESPONSABILE PROGETTAZIONE SPECIALISTICA Ing. Tiziano Collotta Ord. Ingg. Lecco N. 122 RESPONSABILE UFFICIO GEI-APE	IL RESPONSABILE INTEGRAZIONE PRESTAZIONI SPECIALISTICHE Ing. Alessandro Alfì Ord. Ingg. Milano N. 20015 COORDINATORE GENERALE APS	IL DIRETTORE TECNICO Ing. Maurizio Torresi Ord. Ingg. Milano N. 16492 RESPONSABILE DIREZIONE SVILUPPO INFRASTRUTTURE
---	--	---

RIFERIMENTO ELABORATO	DIRETTORIO		FILE		DATA:	REVISIONE		
	codice	commessa	N.Prog.	unita'	n. progressivo	FEBBRAIO 2011	n.	data
	1	2	1	2	1	2	0	2
	APE				600	--		
	SCALA:							

 ingegneria europea	ELABORAZIONE GRAFICA A CURA DI :	
	ELABORAZIONE PROGETTUALE A CURA DI :	Ing. Antonio Sibilìa Ord. Ingg. Avellino N. 1713
CONSULENZA A CURA DI :	IL RESPONSABILE UFFICIO/UNITA'	Ing. Tiziano Collotta Ord. Ingg. Lecco N. 122

RESPONSABILE DI COMMESSA Ing. Michele Parrella Ord. Ingg. Avellino N. 933 COORDINATORE OPERATIVO DI PROGETTO	VISTO DEL COMMITTENTE 	VISTO DEL CONCEDENTE 
---	---	--

1. GENERALITA'	3
1.1 Oggetto e scopo del lavoro	3
1.2 Criteri di verifica	3
2. RIFERIMENTI	4
2.1 Normative di riferimento	4
2.2 Software di calcolo	4
3. MATERIALI	5
4. CARATTERIZZAZIONE GEOTECNICA E STRATIGRAFICA	6
4.1 Generalità	6
4.2 Caratterizzazione geotecnica adottata	6
4.2.1 Rilevato autostradale esistente	6
4.2.2 Terreno di fondazione	6
4.3 Azione sismica di riferimento	7
5. ANALISI DELLA PARATIA – METODO DI CALCOLO	9
5.1 Codice di calcolo	9
5.2 Spinta della terra – Effetto dell'attrito terreno/struttura	9
5.3 Spinta della terra - Coefficienti di spinta in condizioni statiche	10
5.3.1 Spinta a riposo	10
5.3.2 Spinta attiva	10
5.3.3 Spinta passiva	10
5.4 Coefficienti di spinta in condizioni sismiche	11
5.4.1 Coefficienti sismici	11
5.4.2 Spinta attiva	11
5.4.3 Spinta passiva	12
6. ANALISI DELLA PARATIA – CRITERI DI VERIFICA	13
6.1 Verifica dei micropali (paratie provvisorie)	13
6.1.1 Flessione e Taglio	13
6.1.2 Taglio	13
6.1.3 Flessione	14
6.2 Verifica delle travi di ripartizione	14
6.2.1 Calcolo delle sollecitazioni agenti sulla trave metallica di riscontro dei tiranti	14
6.2.2 Taglio	15
6.2.3 Flessione e taglio	16
7. TIRANTI DI ANCORAGGIO – CRITERI DI VERIFICA	17
7.1 Verifiche di sicurezza	17

7.1.1	Resistenza limite allo sfilamento del bulbo	17
7.1.2	Resistenza strutturale dei tiranti	19
8.	ANALISI DELLA PARATIA	20
8.1	Sezioni di verifica (tipo)	20
8.2	Stratigrafia di calcolo	25
8.2.1	Geometria dello scavo	26
8.2.2	Caratteristiche geometriche della paratia	26
8.2.3	Caratteristiche del sistema di ripartizione/collegamento	26
8.2.4	Quota della falda	27
8.2.5	Sovraccarichi accidentali e permanenti	27
8.2.6	Parametri di spinta	27
8.3	Fasi del calcolo	28
8.4	Analisi della struttura - Risultati	29
9.	VERIFICHE STRUTTURALI E GEOTECNICHE	57
9.1	Verifica dei micropali	57
9.2	Verifica dei tiranti	58
9.2.1	Verifica strutturale	58
9.2.2	Verifica allo sfilamento	58
9.2.3	Gerarchia resistenze	59
9.3	Verifica delle travi di ripartizione	59
10.	APPENDICE 1 – ANALISI DELLA PARATIA – TABULATI DI CALCOLO	64

1. GENERALITA'

1.1 Oggetto e scopo del lavoro

Oggetto della presente relazione sono le verifiche geotecniche e strutturali delle opere di sostegno tirantate provvisionali, necessarie al fine di consentire i lavori di adeguamento dell'autostrada A12 Rosignano-Civitavecchia.

1.2 Criteri di verifica

Le verifiche agli stati limite sono eseguite mediante analisi d'interazione terreno-struttura rispettando le condizioni di equilibrio e congruenza e la compatibilità con i criteri di resistenza del terreno.

Le azioni considerate sull'opera di sostegno sono quelle dovute al peso proprio del terreno, ai sovraccarichi all'acqua e ad eventuali ancoraggi presollecitati.

Gli stati limiti ultimi delle opere di sostegno si riferiscono allo sviluppo di meccanismi di collasso determinati dalla mobilitazione della resistenza del terreno interagente con le opere (GEO) e al raggiungimento della resistenza degli elementi che strutturali che compongono le opere stesse (STR).

Per ogni stato limite considerato si verifica il rispetto della condizione

$$Ed \leq Rd \quad [6.2.1]$$

In cui Ed è il valore di progetto dell'azione e dove Rd è il valore di progetto della resistenza del sistema geotecnica. Tale verifica viene condotta impiegando diverse combinazioni di gruppi di coefficienti parziali, rispettivamente definiti per le azioni ($A1$ e $A2$, per i parametri geotecnica ($M1$ e $M2$) e per le resistenze ($R1$, $R2$, $R3$).

Gli stati limite ultimi risultati significativi per l'opera in esame sono di seguito elencati insieme alle corrispondenti combinazioni di coefficienti utilizzati nelle verifiche:

Paratie

- SLU di tipo geotecnico GEO e strutturale STR:

combinazione 1	A1+M1+R1;	combinazione 2	A2+M2+R1
----------------	-----------	----------------	----------

- Verifica di stabilità globale terreno-opera

combinazione 2	A2+M2+R2
----------------	----------

Tiranti ancoraggio

- SLU di tipo strutturale STR:

combinazione 1	A1+M1+R1;	combinazione 2	A2+M2+R1
----------------	-----------	----------------	----------

- SLU di tipo geotecnico GEO (sfilamento)

combinazione 1	A1+M1+R3
----------------	----------

2. RIFERIMENTI

2.1 Normative di riferimento

- [1] Legge 5/11/71 n.1086 “Norme per la disciplina delle opere in conglomerato cementizio armato, normale, precompresso e per le strutture metalliche”.
- [2] Lg. 2 febbraio 1974, n.64 “Provvedimenti per le costruzioni con particolari prescrizioni per le zone sismiche”. G.U. n.76 del 21 Marzo, 1974
- [3] Circ. LL.PP. del 2 febbraio 2009, n. 617 Istruzioni per l'applicazione delle “Nuove norme tecniche per le costruzioni” di cui al D.M. 14 gennaio 2008.
- [4] D.M. LL.PP. 14 Gennaio 2008, Suppl.Ord. n.30 alla G.U. 4-2-2008 n. 29 “ Nuove norme tecniche per le costruzioni”
- [5] prEN 1998-1:2003 “Eurocode 8: design of structures for earthquake resistance – Part 1: General rules, seismic actions and rules for buildings”.
- [6] AICAP (1991) "*Ancoraggi nei terreni e nelle rocce-Raccomandazioni*" Maggio 1993.

2.2 Software di calcolo

Le analisi sono state svolte ricorrendo ai seguenti codici di calcolo:

- *Paratie 8.1.1 (HARPACEAS)*

3. MATERIALI

- Calcestruzzo per cordolo paratie
caratteristica di resistenza minima C25 / C30
- Acciaio per armatura ordinaria in barre nervate tipo B450C
 $f_{yk} \geq 450$ MPa, $f_{tk} \geq 540$ MPa
- Acciaio armonico per tiranti in trefoli da 0.6”
 - Tensione caratteristica di rottura: $f_{ptk} = 1860$ MPa
 - Tensione caratteristica all'1% di deformazione totale: $f_{p(1)k} = 1670$ MPa
- Acciaio in profili a sezione aperta laminati a caldo saldati
 - Tipo EN 10025-2 S355 J2+N – per spessori nominali $t \leq 40$ mm
 - Tipo EN 10025-2 S355 K2+N – per spessori nominali $t > 40$ mm
- Acciaio in profili a sezione cava
 - Tipo EN 10210-1 S355 J0H+N
- Miscela cementizia di iniezione dei tiranti
Classe di esposizione XC2
Eventuali additivi secondo NTA
Caratteristica di resistenza minima C25 / C30
- Miscela cementizia per micropali
Secondo NTA - soggetto ad approvazione della Direzione Lavori
Caratteristica di resistenza minima C25 / C30
Eventuali additivi secondo NTA

4. CARATTERIZZAZIONE GEOTECNICA E STRATIGRAFICA

4.1 Generalità

I dati stratigrafici e geotecnici utili per il progetto delle opere oggetto della presente relazione sono descritti nei successivi paragrafi, e si riferiscono sostanzialmente al rilevato stradale esistente da sostenere ed al terreno di fondazione.

4.2 Caratterizzazione geotecnica adottata

Ai fini delle verifiche geotecniche, i parametri riportati di seguito vengono considerati come “*parametri caratteristici*” per le verifiche agli stati limite (SLU), ai sensi delle NTC 08. .

4.2.1 Rilevato autostradale esistente

Nell’area in esame i rilevati sono costituiti da ghiaia-sabbiosa, per essi si assumono le caratteristiche meccaniche di seguito riportate:

Peso specifico	$\gamma_t = 18 \text{ kN/m}^3$
Angolo di attrito operativo	$\phi' = 32^\circ$
Coesione efficace	$c' = 0 \text{ kPa}$
Modulo elastico operativo	$E'_{op} = 30 \text{ MPa}$

4.2.2 Terreno di fondazione

Per i terreni posti al di sotto del piano di posa dei rilevati esistenti sono state assunte, cautelativamente, le caratteristiche di resistenza meccanica e deformabilità riportate nella tabella seguente.

Tabella 4.1 – Caratteristiche geotecniche del terreno di fondazione

		Materiale in situ
Peso naturale di volume	$\gamma \text{ (kN/m}^3\text{)}$	18
Angolo di attrito efficace di picco	$\phi' \text{ (}^\circ\text{)}$	25
Coesione efficace	$c' \text{ (kPa)}$	0
Coefficiente di Poisson	$\nu \text{ (-)}$	0.3
Modulo elastico drenato operativo di scarico-ricarico	$E'_{op} \text{ (MPa)}$	25

4.3 Azione sismica di riferimento

Pericolosità sismica del sito

Sito: Lotto 3 parte 2 sez. 4

Latitudine: 42.8838 [°];

Longitudine: 11.07664 [°];

Strategia di progettazione

Classe d'uso: IV; Coefficiente d'uso: $cu = 2$

Vita nominale costruzione: 50 anni

Periodo di riferimento per la costruzione: $V_R = 100$ anni

Valori dei parametri a_g , F_0 , T_C^* per i periodi di ritorno T_R associati a ciascuno a stato limite

	T_R	a_g	F_0	T_C^*
STATO LIMITE	[anni]	[g]	[-]	[sec]
SLO	60	0.043	2.586	0.236
SLD	101	0.052	2.597	0.255
SLV	949	0.106	2.645	0.286
SLC	1950	0.129	2.668	0.293

Azione sismica di progetto

Stato limite considerato: SLV

Categoria sottosuolo: D; $S_S = 1.8$

Categoria topografica: T1; $S_T = 1.0$

Acceler. orizzontale massima attesa su sito di riferimento rigido (cat. A): $a_g = 0.106$ g

Poiché le opere oggetto delle presenti verifiche sono di tipo provvisoria, si ritiene possibile impiegare accelerazioni sismiche di progetto opportunamente ridotte. A tale scopo, sono state seguite le considerazioni riportate nell'Appendice A dell'Eurocodice 8 Parte 2 ("Evento sismico di progetto per ponti e raccomandazioni per la scelta di un evento per la fase di costruzione").

Ipotizzando che t_c sia la durata della fase di costruzione dell'opera e p la probabilità di superamento ritenuta accettabile in questa fase, il periodo di ritorno col quale si verifica il sisma t_{rc} è individuato dalla relazione:

$$t_{rc} = 1 / [1 - (1 - p)^{1/t_c}]$$

Per valori relativamente piccoli solitamente associati a t_c (≤ 5 anni), la formula proposta può essere approssimata con la relazione seguente:

$$t_{rc} \cong \frac{t_c}{p}$$

Il sopraccitato riferimento normativo raccomanda di assumere valori della probabilità di superamento p non superiori a 0,05.

Il valore dell'accelerazione sismica di riferimento, corrispondente ad un periodo di ritorno t_{rc} , è individuato dalla relazione:

$$a_{gc} = a_{g,475} (t_{rc} / t_{ro})^k$$

dove:

$a_{g,475}$ è l'accelerazione convenzionale massima su suolo di categoria A corrispondente ad un periodo di ritorno di riferimento t_{ro} pari a 475 anni (probabilità di superamento pari al 10% in 50anni);

k parametro che dipende dalla sismicità del luogo ($\cong 0,3 \div 0,45$).

Assunto:

$$p = 0,05$$

$$t_c = 6 \text{ mesi} = 0,5 \text{ anni}$$

$$k = 0,3$$

ponendo cautelativamente

$$a_{g,475} = a_g (\text{SLV}) = 0.106g$$

risulta un'accelerazione sismica di riferimento pari a

$$a_{gc} = 0.314 a_{g,475} = 0.033 g$$

L'accelerazione massima al suolo per le opere provvisionali in esame risulta dunque pari a

$$a_{max} = S_S S_T a_{gc} = 0.06g$$

5. ANALISI DELLA PARATIA – METODO DI CALCOLO

5.1 Codice di calcolo

Lo studio del comportamento di una paratia tirantata è condotto mediante l'ausilio di un codice di calcolo (PARATIE versione Paratie Plus 2010) che permetta di simulare in maniera verosimile, anche se semplificata, l'interazione tra terreno e struttura di sostegno; basato sulle seguenti ipotesi di carattere generale:

1. stato piano nelle deformazioni (paratia di lunghezza infinita);
2. la paratia venga discretizzata con elementi monodimensionali a due gradi di libertà (spostamento orizzontale e rotazione);
3. gli elementi di ancoraggio siano schematizzati mediante elementi finiti (definiti da una rigidezza assiale) che divengono attivi a partire dal momento del loro inserimento;
4. il terreno venga schematizzato mediante una legge costitutiva di tipo elasto-plastico, identificata da parametri di spinta/reazione e di deformabilità del terreno, che preveda cicli di scarico e ricarico;
5. i parametri di spinta/reazione del terreno siano identificabili con:
 - il coefficiente di spinta riposo K_0 , (corrispondente alla condizione iniziale indeformata);
 - i coefficienti di spinta attiva (K_A) e passiva (K_P) (corrispondenti alle condizioni di equilibrio limite inferiore e superiore);
6. l'interazione terreno-struttura venga simulata, in accordo ai metodi della reazione di sottofondo, con "molle" elasto-plastiche che reagiscono elasticamente sino ad un valore limite dello spostamento, raggiunto il quale la reazione corrisponde, a seconda del segno dello spostamento, ai valori limite di pressione attiva o passiva;
7. tiranti modellati per mezzo di molle di opportuna rigidezza;
8. sovraccarichi a monte ed a valle della paratia trasformati in spinte sul paramento in accordo a quanto previsto dalla teoria elastica.

Tale codice di calcolo, che permette di seguire analiticamente la successione delle fasi di costruzione, di carico e di contrasto, consente di ottenere informazioni attendibili sull'entità delle deformazioni e sugli effetti che esse inducono sul diagramma delle pressioni esercitate dal terreno sulla paratia.

5.2 Spinta della terra – Effetto dell'attrito terreno/struttura

Nella valutazione dei coefficienti di spinta (attiva e passiva) è necessario tenere in conto dell'angolo di attrito tra manufatto e terreno (δ) che risulta inferiore all'angolo di attrito interno del terreno. Nel caso in studio si assume quanto segue:

$$\delta/\phi = 0.50 \quad \text{Spinta attiva - Analisi statiche e sismiche}$$

$\delta/\phi = 0.50$ Spinta passiva - Analisi statiche

$\delta/\phi = 0$ Spinta passiva - Analisi sismiche

5.3 Spinta della terra - Coefficienti di spinta in condizioni statiche

5.3.1 Spinta a riposo

Per piano campagna orizzontale si fa riferimento alla seguente correlazione (Jaky, 1944 e Schmidt, 1966):

$$k_o = 1 - \sin(\phi') \text{OCR}^\alpha$$

con :

$$\alpha = 0.5$$

OCR = grado di sovraconsolidazione

5.3.2 Spinta attiva

Il coefficiente di spinta attiva (K_a) viene valutato ricorrendo alla correlazione generale di Muller-Breslau basata sulla teoria di Coulomb e riferita a superfici di rottura piane. In questo caso l'approssimazione (rispetto a quanto si sarebbe ottenuto considerando superfici di rottura di geometria complessa) risulta molto contenuta e a favore di sicurezza.

$$K_a = \frac{\sin^2(\alpha + \varphi)}{\sin^2 \alpha \cdot \sin(\alpha - \delta) \left[1 + \frac{\sqrt{\sin(\varphi + \delta) \sin(\varphi - \beta)}}{\sqrt{\sin(\alpha - \delta) \sin(\alpha + \beta)}} \right]^2}$$

dove:

φ = angolo d'attrito del terreno;

α = angolo che la parete forma con l'orizzontale ($\alpha = 90^\circ$ per parete verticale);

δ = angolo d'attrito terreno-parete;

β = inclinazione del terreno a monte rispetto all'orizzontale.

5.3.3 Spinta passiva

Per il calcolo del coefficiente di spinta passiva si fa riferimento a superfici di rottura di tipo complesso (spirale logaritmica) come suggerito da Caquot & Kerisel (1948).

5.4 Coefficienti di spinta in condizioni sismiche

5.4.1 Coefficienti sismici

In accordo a quanto contenuto nel paragrafo 7.11.6.3 delle NTC08 l'azione sismica è definita come un'accelerazione equivalente costante avente componenti orizzontali a_h e verticali a_v legate all'accelerazione di picco a_{max} attesa nel volume di terreno significativo mediante la relazione:

$$a_h = k_h g = \alpha \beta a_{max} \geq 0.2 a_{max} / g \quad [7.11.9]$$

$$a_v = 0$$

in cui

g : accelerazione di gravità

k_h : coefficiente sismico in direzione orizzontale

$\alpha \leq 1$ coefficiente che tiene conto della deformabilità dei terreni interagenti con l'opera. Il valore viene ricavato a partire dall'altezza della paratia e dalla categoria di sottosuolo mediante il diagramma di fig. 7.11.2 (NTC08)

$\beta \leq 1$: coefficiente funzione della capacità dell'opera di subire spostamenti senza cadute di resistenza; viene ricavato dal diagramma di fig. 7.11.3 delle NTC08, in funzione del massimo spostamento u_s che può tollerare l'opera senza riduzioni di resistenza. Nelle analisi si pone $u_s = 0.005h$ con h pari all'altezza di scavo della paratia.

L'accelerazione di picco a_{max} è valutata come

$$a_{max} = S_S S_T a_g = 0.06 g$$

Con

$S_S = 1.8$ effetto amplificazione stratigrafica (suolo tipo D)

$S_T = 1.0$ effetto amplificazione topografica

$a_g = 0.033g$ accelerazione orizzontale massima su sito di riferimento rigido (suolo A; $T_R = 10$ anni, opera provvisoriale)

5.4.2 Spinta attiva

La spinta attiva in condizioni dinamiche in termini di tensioni totali di progetto è stata determinata, in accordo a quanto descritto nella O.P.C.M. 3274/2003 e successive modifiche e/o nell'Eurocodice 8 (2003) secondo la teoria di Mononobe-Okabe:

$$K_{as} = \frac{\sin^2(\alpha + \varphi - \vartheta)}{\cos \vartheta \cdot \sin^2 \alpha \cdot \sin(\alpha - \vartheta - \delta) \left[1 + \frac{\sqrt{\sin(\varphi + \delta) \sin(\varphi - \beta - \vartheta)}}{\sqrt{\sin(\alpha - \vartheta - \delta) \sin(\alpha + \beta)}} \right]^2}$$

dove:

$$\vartheta = \arctan k_h / (1 \pm k_v) = \arctan k_h$$

Come altezza di spinta si considera l'altezza dello scavo della paratia.

5.4.3 Spinta passiva

Il coefficiente di spinta passiva in condizioni dinamiche, in termini di tensioni totali di progetto, è stato determinato, in accordo a quanto descritto nella O.P.C.M. 3274/2003 e successive modifiche e/o nell'Eurocodice 8 (2003) secondo la teoria di Mononobe-Okabe:

$$K_{ps} = \frac{\sin^2(\alpha + \varphi - \vartheta)}{\cos \vartheta \cdot \sin^2 \alpha \cdot \sin(\alpha + \vartheta) \left[1 - \frac{\sqrt{\sin(\varphi) \sin(\varphi + \beta - \vartheta)}}{\sqrt{\sin(\alpha + \beta) \sin(\alpha + \vartheta)}} \right]^2}$$

dove,

nel caso in esame, di terreno impermeabile in condizioni dinamiche al di sotto del livello di falda:

$$\vartheta = \arctan \left(\frac{\gamma_{sat}}{\gamma'} \cdot \frac{k_h}{1 \pm k_v} \right) = \arctan \left(\frac{\gamma_{sat}}{\gamma'} \cdot k_h \right)$$

6. ANALISI DELLA PARATIA – CRITERI DI VERIFICA

Per le verifiche strutturali degli elementi in carpenteria metallica si fa riferimento a quanto prescritto in NTC08 e successiva Istruzione Tecnica (Circ. 02.02.2009 n° 617/C.S.LL:PP.).

La resistenza di calcolo della membratura si assume pari a :

$$R_d = R_k / \gamma_M$$

in cui

R_k : valore caratteristico della resistenza dipendente dalla resistenza f_{yk} del materiale, dalla geometria dell'elemento strutturale e dalla classe della sezione

$\gamma_M = 1.05$: coefficiente di sicurezza parziale per la resistenza delle membrature

6.1 Verifica dei micropali (paratie provvisorie)

Le tipologie di tubi commerciali impiegati per l'armatura dei micropali in esame hanno una sezione di tipo compatto (classe 1); la capacità resistente della sezione si determina pertanto con il metodo plastico assumendo una la completa plasticizzazione del materiale.

Classificazione sezione

classe 1: $D/t \leq 50 \times \varepsilon^2$

dove:

$$\varepsilon = \sqrt{(235\text{MPa}/f_y)}$$

f_y = tensione di snervamento (355MPa per Fe510)

D = diametro del tubo

t = spessore del tubo

6.1.1 Flessione e Taglio

Si rammenta, ai sensi del cap. 4.2.3.2 delle NTC, che “la capacità resistente delle sezioni deve essere valutata (...) determinando anche gli effetti indotti sulla resistenza dalla presenza combinata di più sollecitazioni”; tuttavia, se si verifica che il taglio di calcolo allo stato limite ultimo (V_{Ed}) è inferiore alla metà della resistenza di calcolo a taglio ($V_{c,Rd}$):

$$V_{Ed} \leq 0.5 \cdot V_{c,Rd} \quad (4.2.31 \text{ NTC})$$

la Normativa (cap. 4.2.4.1.2) afferma che si può trascurare l'influenza del taglio sulla resistenza a flessione, pertanto le due verifiche a taglio e a flessione possono essere condotte in maniera separata.

6.1.2 Taglio

Il valore di calcolo dell'azione tagliante V_{Ed} deve rispettare la seguente condizione:

$$V_{Ed} / V_{c,Rd} \leq 1 \quad (4.2.17 \text{ NTC})$$

$$V_{c,Rd} = \frac{A_v \cdot f_{yk}}{\sqrt{3} \cdot \gamma_{M0}} \quad \text{in assenza di torsione} \quad (4.2.18 \text{ NTC})$$

dove A_v è l'area di taglio, che, nel caso specifico di sezioni tubolari vale

$$A_v = 2A / \pi \quad A = \text{area lorda} \quad (4.2.24 \text{ NTC})$$

6.1.3 Flessione

Il momento flettente di calcolo M_{Ed} deve rispettare la seguente condizione:

$$M_{Ed} / M_{c,Rd} \leq 1 \quad (4.2.12 \text{ NTC})$$

$$M_{c,Rd} = M_{pl,Rd} = \frac{W_{pl} \cdot f_{yk}}{\gamma_{M0}} \quad \text{per le sezioni di classe 1 e 2} \quad (4.2.13 \text{ NTC})$$

In cui

$f_{yk} = 355 \text{ N/mm}^2$ tensione snervamento (acciaio S355 - ex Fe510)

D : diametro esterno tubo

t : spessore della parete

$W_{pl} = 4/3 (R^3 - r^3) =$ modulo di resistenza plastico

$R = D/2$ raggio esterno

$r = D/2 - t$ raggio interno

6.2 Verifica delle travi di ripartizione

La verifica a flessione+taglio (essendo in questo caso l'azione assiale nulla) delle travi metalliche viene svolta in accordo a NTC08. Il profilo HEA180 ha una sezione compatta di classe 2 si assume pertanto come stato limite ultimo della sezione la completa plasticizzazione.

6.2.1 Calcolo delle sollecitazioni agenti sulla trave metallica di riscontro dei tiranti

Nel seguito si riporta il calcolo del momento e del taglio di calcolo risultanti nella trave metallica di riscontro dei tiranti posti ad interasse i , con angolo di inclinazione α .

Il comportamento globale della trave è schematizzabile come quello di una trave pluriappoggiata in corrispondenza delle teste dei tiranti (Figura 6.1). Si considera quindi un carico uniformemente distribuito sulla trave che equilibra le reazioni (tiro massimo dei tiranti). L'entità di tale carico sarà:

$$p = \frac{T_{\max} \cdot \cos \alpha}{i} \quad [\text{kN/m}]$$

dove:

T_{max} = tiro massimo nei tiranti;

α = angolo d'inclinazione del tirante;

i = interasse tiranti.



Figura 6.1 - Schema statico di calcolo travi di contrasto e cordoli

Il valore di calcolo del momento flettente sarà quindi:

$$M_{Ed} = \frac{p \cdot i^2}{10} \quad [\text{kN} \cdot \text{m}/\text{trave}]$$

Il valore di calcolo del taglio sarà invece:

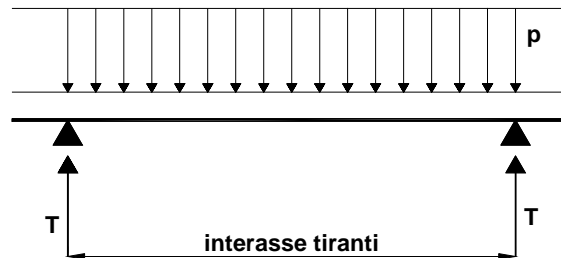
$$V_{Ed} = \frac{p \cdot i}{2} \quad [\text{kN}/\text{trave}]$$

6.2.2 Taglio

Il valore di calcolo dell'azione tagliante V_{Ed} deve rispettare la seguente condizione:

$$V_{Ed}/V_{c,Rd} \leq 1 \quad (4.2.17 \text{ NTC})$$

$$V_{c,Rd} = \frac{A_v \cdot f_{yk}}{\sqrt{3} \cdot \gamma_{M0}} \quad \text{in assenza di torsione} \quad (4.2.18 \text{ NTC})$$

dove A_v è l'area di taglio, che, nel caso specifico di profili HEA 180, può essere calcolata con la seguente espressione:

$$A_v = A - 2bt_f + (t_w + 2r)t_f \quad (4.2.19 \text{ NTC})$$

dove:

A è l'area lorda della sezione del profilo;

b è la larghezza delle ali;

t_f è lo spessore delle ali;

t_w è lo spessore dell'anima;

r è il raggio di raccordo tra ala e anima.

6.2.3 Flessione e taglio

Se il taglio di calcolo V_{Ed} è inferiore a metà della resistenza di calcolo a taglio $V_{c,Rd}$ si può trascurare l'influenza del taglio sulla resistenza a flessione. Nel caso contrario per le sezioni ad H di classe 1 e 2 doppiamente simmetriche soggette a flessione e taglio nel piano dell'anima, la resistenza convenzionale di calcolo può essere valutata secondo la [4.2.33]

$$\begin{aligned} \text{Per } V_{Ed} \leq 0.5 \times V_{pl,Rd} & \rightarrow M_{pl,Rd} = W_{pl} \times (f_y / \gamma_{m0}) \\ \text{Per } V_{Ed} > 0.5 \times V_{pl,Rd} & \rightarrow M_{pl,Rd} = \frac{\left[W_{pl} - \frac{\rho A_w^2}{4t_w} \right] f_y}{\gamma_{M0}} \end{aligned} \quad [4.2.33 \text{ NTC}]$$

dove:

V_{Ed} = taglio di progetto

$A_w = h_w \cdot t_w$

h_w = altezza anima

$\rho = [2 \times (V_{sd} / V_{pl,Rd}) - 1]^2$

7. TIRANTI DI ANCORAGGIO – CRITERI DI VERIFICA

7.1 Verifiche di sicurezza

L'ancoraggio delle paratie provvisionali viene realizzato a mezzo di tiranti a trefoli con bulbo iniettato a pressione valvola per valvola (iniezioni multiple e ripetute).

Gli stati limite ultimi dei tiranti di ancoraggio si riferiscono allo sviluppo di meccanismi di collasso determinati dalla mobilitazione della resistenza del terreno a al raggiungimento della resistenza degli elementi strutturali che li compongono.

7.1.1 Resistenza limite allo sfilamento del bulbo

In accordo con gli orientamenti normativi (Paragrafo 6.6.1 Criteri di Progetto delle NORME TECNICHE DELLE COSTRUZIONI) per la valutazione del carico limite della fondazione dell'ancoraggio (sfilamento bulbo-terreno) si può procedere in prima approssimazione con formule teoriche o con correlazioni empiriche. *Tuttavia, la conferma sperimentale con prove di trazione in sito nelle fasi di progetto e di collaudo risulta sempre necessaria.*

La progettazione dei tiranti di ancoraggio è avvenuta nel rispetto della condizione:

$$P_{d\ TIR} \leq R_{ad\ TIR}$$

dove:

- $P_{d\ TIR}$ è il valore della massima azione di Progetto tra tutti i possibili stati limite ultimi (SLU) e di esercizio (SLE).
- $R_{ad\ TIR}$ è la resistenza di progetto con specifico riferimento ad uno stato limite di sfilamento della fondazione dell'ancoraggio.

La verifica di tale condizione viene effettuata con riferimento alla combinazione A1+M1+R3, tenendo conto dei coefficienti parziali riportati nelle Tab. 6.2.I, 6.2.II e 6.6.I delle NTC.

La resistenza di progetto $R_{ad\ TIR}$ è determinata applicando alla resistenza caratteristica $R_{ak\ TIR}$ i fattori parziali riportati in Tabella 6.6.I delle NTC e di seguito riportata.

$$R_{ad\ TIR} = \frac{R_{ak\ TIR}}{\gamma_{R\ TIR}}$$

Tabella 7-1 – Coefficienti parziali per la resistenza di ancoraggi

	Simbolo	COEFFICIENTE PARZIALE
Temporanei	$\gamma_{R\ TIR, t}$	1.1
Permanenti	$\gamma_{R\ TIR, p}$	1.2

Il valore caratteristico della resistenza allo sfilamento dell'ancoraggio $R_{ak\ TIR}$, nel caso specifico, è stato dedotto con metodi analitici, a partire dai valori caratteristici dei parametri geotecnici (risultati di prove in sito e/o di laboratorio).

Quindi, il valore della resistenza caratteristica $R_{ak\ TIR}$ è il minore dei valori derivanti dall'applicazione dei fattori di correlazione ξ_{a3} e ξ_{a4} rispettivamente al valor medio e al valor minimo delle resistenze $R_{a,c}$ ottenute dal calcolo. Per la valutazione dei fattori ξ_{a3} e ξ_{a4} si deve tenere conto che i profili di indagine sono solo quelli che consentono la completa identificazione del modello geotecnico di sottosuolo per il terreno di fondazione dell'ancoraggio.

$$R_{ak\ TIR} = MIN \left(\frac{(R_{a,c})_{medio}}{\xi_{a3}}, \frac{(R_{a,c})_{min}}{\xi_{a4}} \right)$$

Tabella 7-2 – Fattori di correlazione per derivare la resistenza caratteristica dalle prove geotecniche, in funzione del numero n di profili di indagine.

Numero di profili di indagine	1	2	3	4	≥ 5
ξ_{a3}	1.80	1.75	1.70	1.65	1.60
ξ_{a4}	1.80	1.70	1.65	1.60	1.55

Nel caso specifico si sono adottati i valori seguenti dei fattori di correzione:

$$\xi_{a3} = 1.75$$

$$\xi_{a4} = 1.70$$

Per ancoraggi con bulbo realizzato nel terreno naturale e/o nel rilevato dell'autostrada esistente ad iniezioni multiple e ripetute si fa riferimento a valori di resistenza allo sfilamento cautelativi come di seguito indicato:

		ordine	I	II	III	IV
Aderenza unitaria media	$\alpha_{\tau_{ad},kmed}$	[kN/m ²]	160	160	210	210
Aderenza unitaria min	$\alpha_{\tau_{ad},kmin}$	[kN/m ²]	150	150	200	200

Si precisa che nella valutazione analitica della resistenza allo sfilamento degli ancoraggi non si applicano coefficienti parziali di sicurezza sui valori caratteristici della resistenza del terreno; si fa quindi riferimento ai coefficienti parziali di sicurezza M1.

Il valore della resistenza è svolto secondo la seguente relazione:

$$\begin{aligned} (R_{a,c})_{med} &= \pi \cdot \alpha \cdot D_{perf} \cdot L_{bulbo} \cdot \tau_{ad\ k\ med} \\ (R_{a,c})_{min} &= \pi \cdot \alpha \cdot D_{perf} \cdot L_{bulbo} \cdot \tau_{ad\ k\ min} \end{aligned}$$

in cui:

- $(R_{a,c})_{med}$ = resistenza caratteristica media
- $(R_{a,c})_{mi}$ = resistenza caratteristica minima
- \varnothing_{perf} = diametro medio del bulbo per tiranti a trefoli
- L_{bulbo} = lunghezza del bulbo di ancoraggio
- α = coefficiente empirico correlato con la metodologia di esecuzione delle iniezioni del tratto di fondazione.
- $\tau_{ad\ medio}$ = aderenza media caratteristica bulbo-terreno
- $\tau_{ad\ min}$ = aderenza minima caratteristica bulbo-terreno

7.1.2 Resistenza strutturale dei tiranti

La resistenza di calcolo del tirante risulta pari a

$$R_{p(1)k} = n_{pi} \cdot A_{pi} \cdot f_{p(1)k} / \gamma_s$$

dove

- n_{pi} numero dei trefoli per tirante
- $A_{pi} = 139 \text{ mm}^2$ area del singolo trefolo
- $f_{p(1)k} \geq 1670 \text{ N/mm}^2$ tensione caratteristica all'1% di deformazione totale
- γ_s : coefficiente parziale di sicurezza dell'acciaio

la resistenza dei tiranti utilizzati nelle paratie in esame risulta dunque pari a

n_{pi}	$R_{p(1)k}$
	kN
3	605.5
4	807.4
5	1009.3

Nei tiranti realizzati con trefoli in acciaio armonico per il rispetto della gerarchia delle resistenze (par. 6.6.2 NTC) si controlla che la resistenza caratteristica al limite di snervamento del tratto libero sia sempre maggiore della resistenza (caratteristica, N_{dR}) a sfilamento della fondazione dell'ancoraggio

$$R_{p(1)k} > R_{ak}$$

8. ANALISI DELLA PARATIA

8.1 Sezioni di verifica (tipo)

Sono state analizzate cinque sezioni tipo le cui caratteristiche geometriche sono riassunte in Tabella 9.1.

Tabella 9.1 - Caratteristiche di progetto dei tiranti

Sezione tipo	Altezza paratia (m)	Altezza di scavo massima (m)	Ordine tiranti	Distanza da estradosso cordolo (m)	n° trefoli (-)	Interasse orizzontale massimo i (m)	Inclinazione α (°)	Lunghezza libera L_L (m)	Lunghezza bulbo di ancoraggio L_B (m)	Pretiro T_0 (kN)
0	6	2,5	-	-	-	-	-	-	-	-
1	9	4,5	I	1,25	3	2,4	15	6	10	240
2	12	6	I	1,25	3	2,4	15	7	10	240
			II	3,75	5	2,4	20	6	13	340
3	15	7,5	I	1,25	3	2,4	15	9	10	240
			II	3,75	4	2,4	20	8	12	340
			III	6,25	4	2,4	25	6	12	340
4	18	10	I	1,5	3	2,4	15	11	10	145
			II	4	3	2,4	20	11	10	240
			III	6,5	5	2	25	12	15	570
			IV	8,5	5	2	30	12	15	510

Nelle figure 9.1, 9.2, 9.3, 9.4 e 9.5 sono illustrate le sezioni trasversali delle sezioni tipologiche analizzate.



Figura 9.1 – Sezione trasversale paratia tipo 0 – $H_{scavo} = 2,5m$



Figura 9.2 – Sezione trasversale paratia tipo 1 – $H_{scavo} = 4,5m$

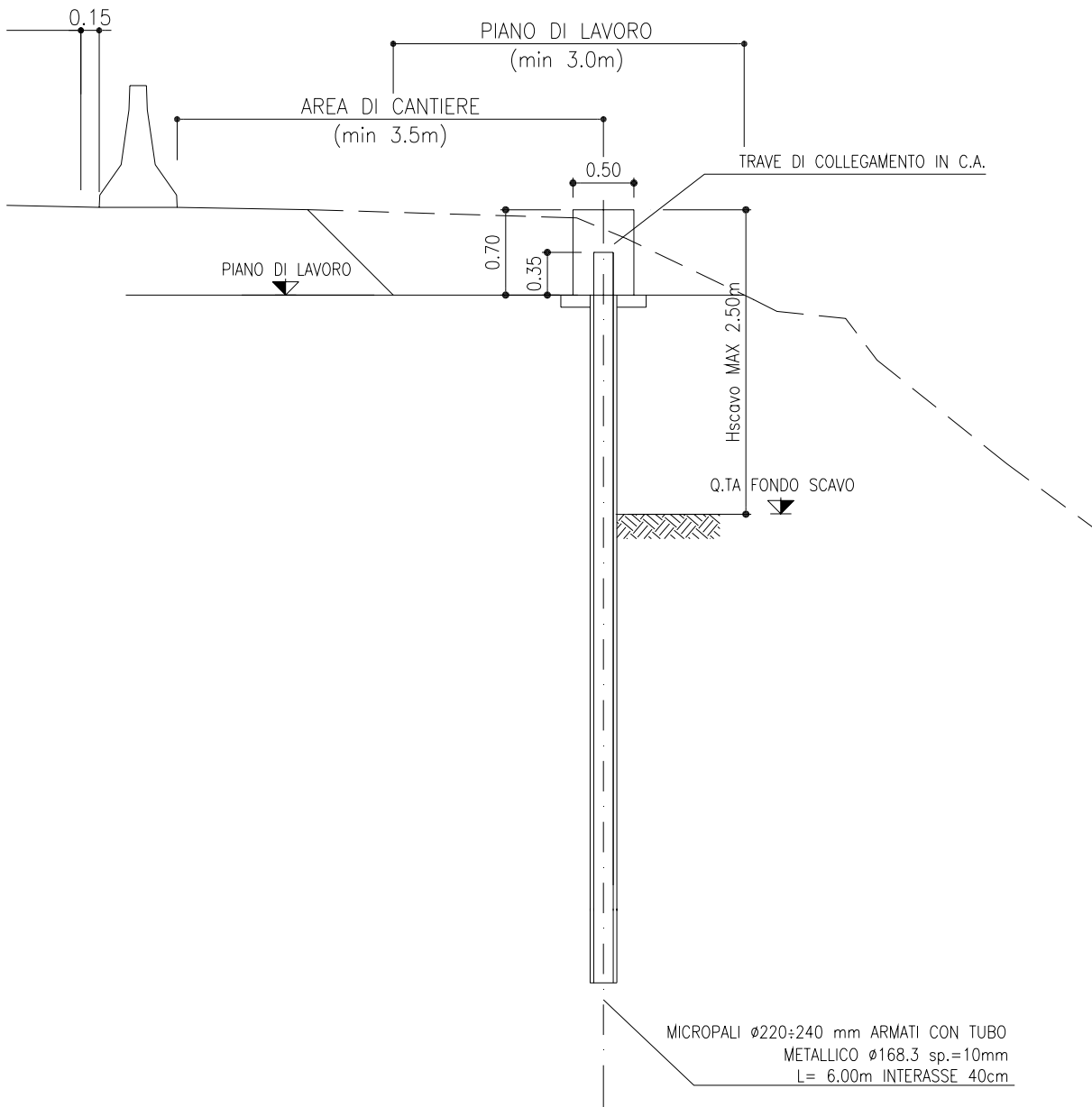

Figura 9.3 – Sezione trasversale paratia tipo 2 – $H_{scavo} = 6m$

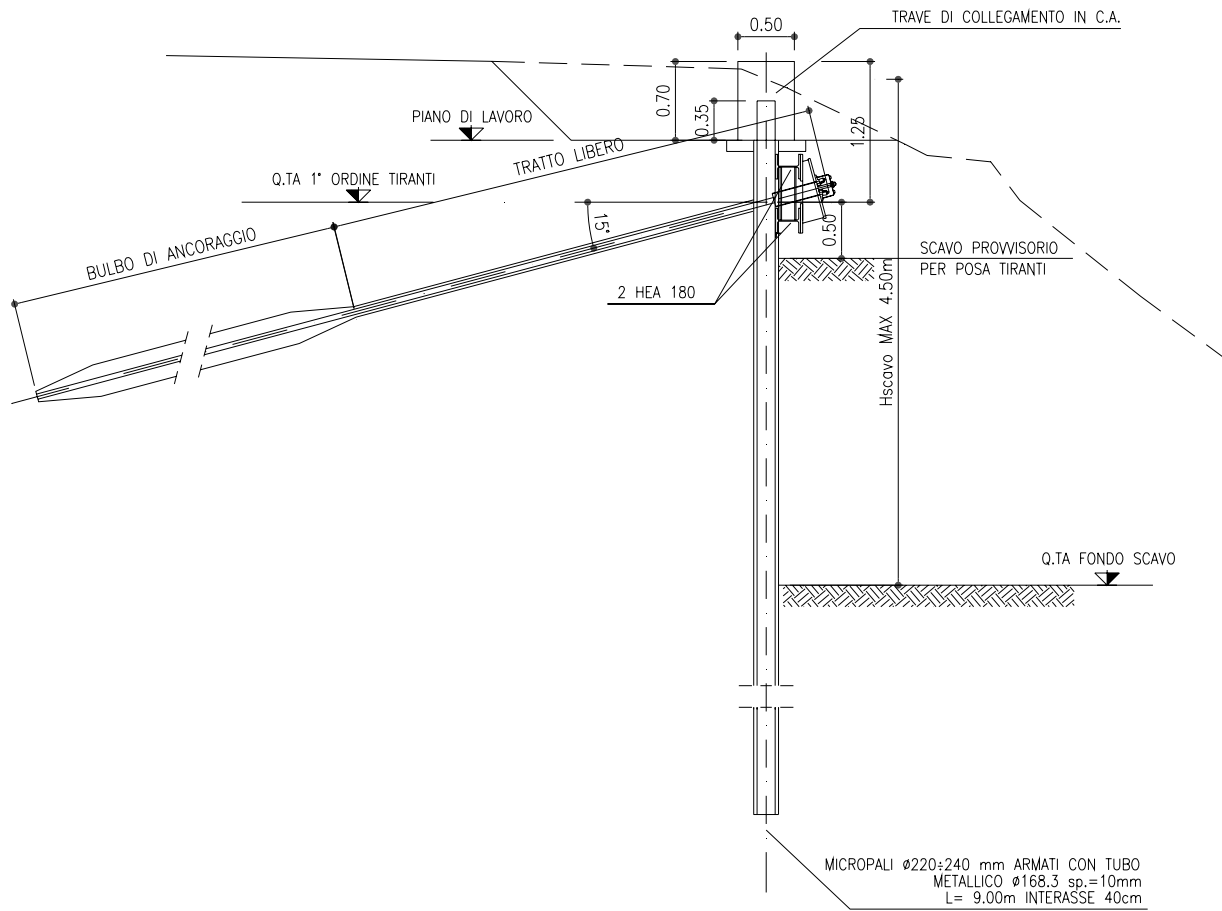

Figura 9.4 – Sezione trasversale paratia tipo 3 – $H_{scavo} = 7,5m$

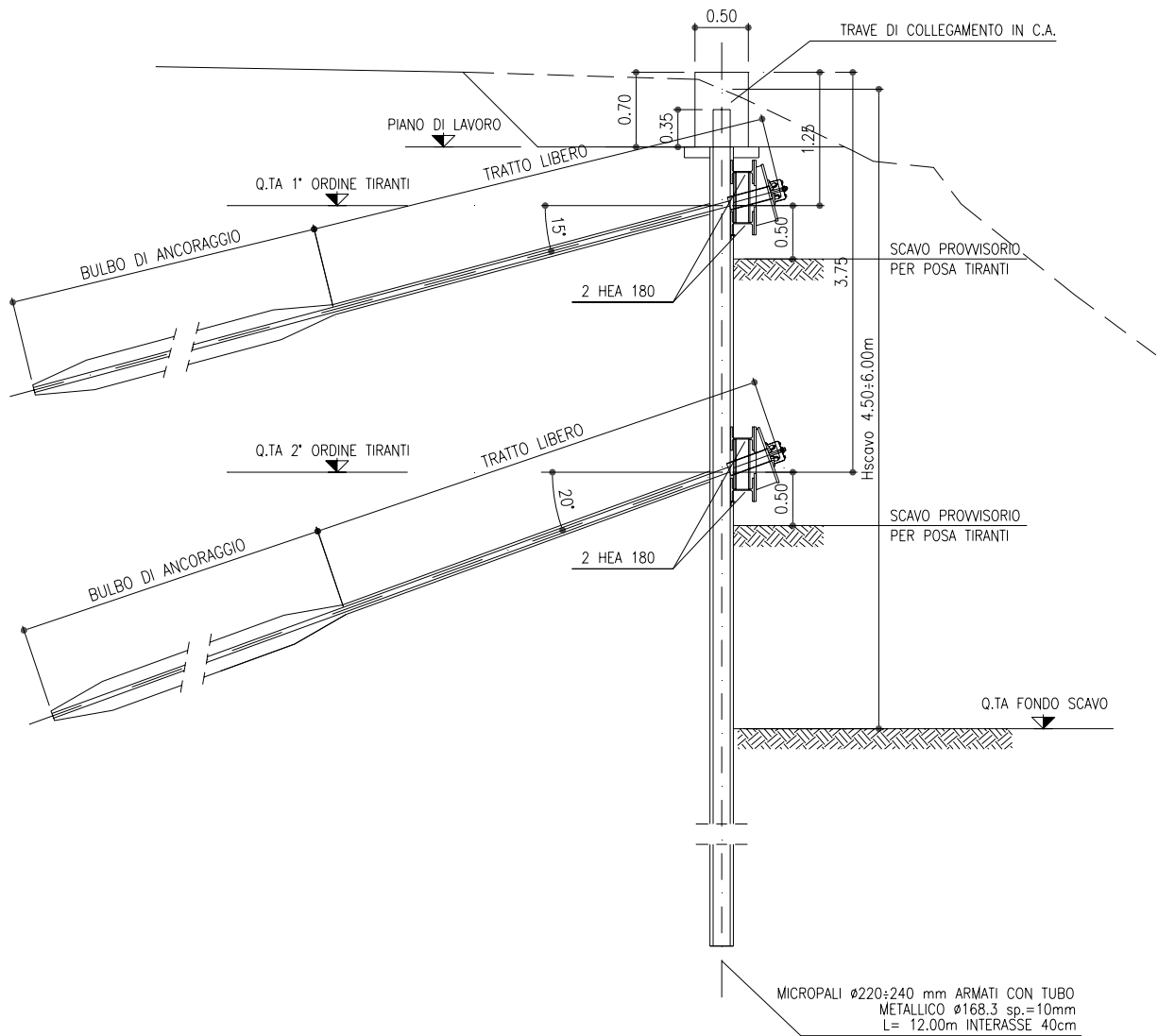

Figura 9.5 – Sezione trasversale paratia tipo 4 – $H_{scavo} = 10m$

8.2 Stratigrafia di calcolo

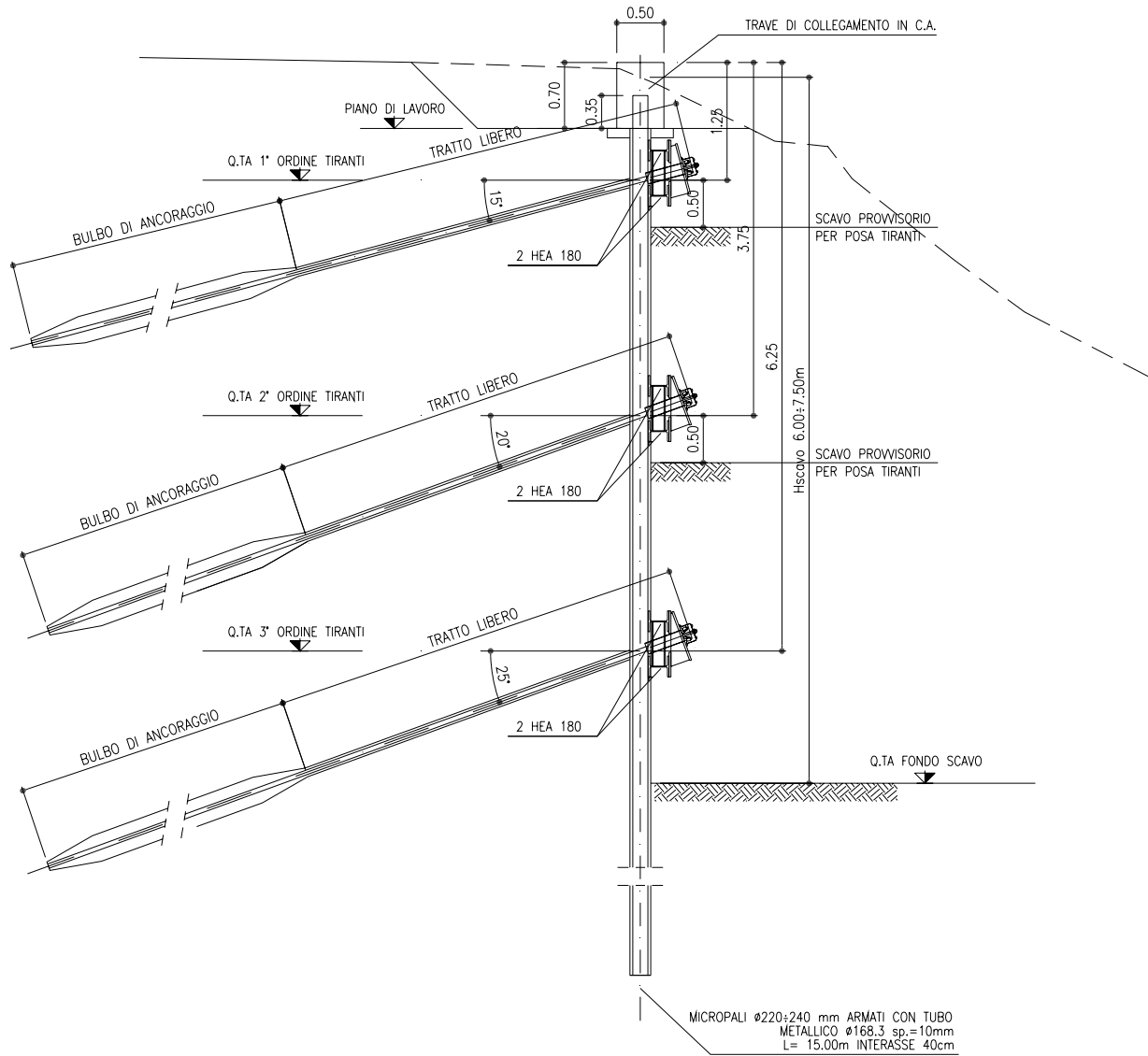
Nei calcoli si è ipotizzato (cautelativamente) che il terreno di fondazione sia presente a partire dalla quota del fondo scavo.

Per i parametri geotecnici caratteristici si rimanda al paragrafo 4.2.

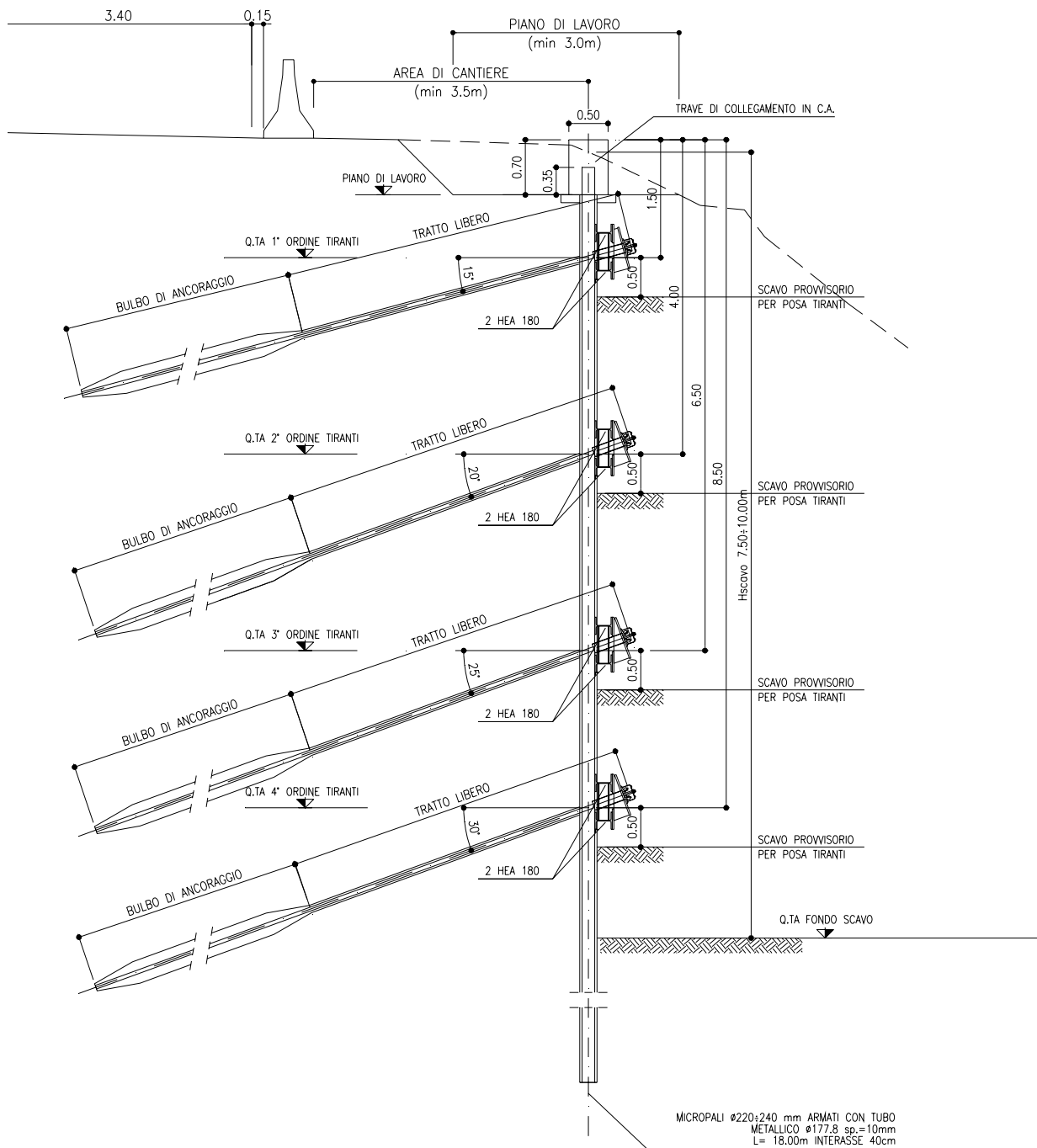
8.2.1 Geometria dello scavo

Inclinazione media terreno a monte della paratia: 0°

Inclinazione terreno a valle della paratia: 0°

8.2.2 Caratteristiche geometriche della paratia

Diametro di perforazione: 220 ÷ 240mm

Sezione tipo	Caratteristiche armatura tubolare (m)
0	L=6m φ=168,3mm sp=10mm i=0,4m
1	L=9m φ=168,3mm sp=10mm i=0,4m
2	L=12m φ=168,3mm sp=10mm i=0,4m
3	L=15m φ=168,3mm sp=10mm i=0,4m
4	L=18m φ=177,8mm sp=10,0mm i=0,4m
L = lunghezza φ = diametro sp = spessore i = interasse	

8.2.3 Caratteristiche del sistema di ripartizione/collegamento

collegamento: cordolo in c.a.

1°, 2°, 3° e 4° livello di tiranti: travi metalliche accoppiate HEA 180

8.2.4 Quota della falda

Sulla base delle informazioni riguardo all'andamento dei livelli di falda nella tratta in oggetto, il livello piezometrico è stato ipotizzato ad 1m al di sotto del fondo scavo.

8.2.5 Sovraccarichi accidentali e permanenti

Nelle verifiche statiche si considera un sovraccarico accidentale uniforme di 20kPa, dovuto al traffico stradale, posto cautelativamente in corrispondenza della testa della paratia.

Per la sezione di tipo 0 tale sovraccarico non è stato tenuto in conto, in quanto ricadente al di fuori del cuneo di spinta attiva.

8.2.6 Parametri di spinta

Nella Tabella 9.2 e Tabella 9.3 sono riportati i valori dei parametri geotecnici utilizzati nelle fasi di statiche ed in condizioni sismiche.

dell'incremento di spinta dovuto al solo sisma calcolati con il metodo di Mononobe-Okabe per i vari casi analizzati

Condizioni statiche

Tabella 9.2 – Coefficienti di spinta

TERRENO	γ kN/m ³	ϕ °	c' kPa	Evc MPa	Eur	Ko	δ/ϕ	Ka	Kp
Rilevato	18	32	0	30	30	0.470	0.5	0.2674	5.056
Base	18	25	0	25	25	0.577	0.5	0.3587	3.324

CASO	$\tan\phi'$	c'	cu
Caso M1	1	1	1
Caso M2	1.25	1.25	1.4

Caso M1									
TERRENO	ϕ °	c' kPa	Evc MPa	Eur 0	Ko -	δ/ϕ -	Ka -	Kp -	
Rilevato	32	0	30	30	0.470	0.5	0.267	5.056	
Base	25	0	25	25	0.577	0.5	0.359	3.324	

Caso M2									
TERRENO	ϕ °	c' kPa	Evc MPa	Eur 0	Ko -	δ/ϕ -	Ka -	Kp -	
Rilevato	26.56	0	30	30	0.5529	0.5	0.336	3.626	
Base	20.46	0	25	25	0.6504	0.5	0.432	2.575	

Condizioni sismiche

Tabella 9.3 – Coefficienti di spinta

Sez.	H	h	$u_{s,max}$	α	β	$\alpha*\beta$	a_g/g	$a_{max}/g = S a_g/g$	$\tan\theta = k_h$	$\tan\theta = k_h * \gamma/(\gamma-\gamma_w)$
[-]	[m]	[m]	m	[-]	[-]	[-]	[-]	[-]	[-]	
0	6	2.5	0.0125	1.000	0.661	0.661	0.033	0.06	0.040	0.089
1	9	4.5	0.0225	0.978	0.583	0.570	0.033	0.06	0.034	0.077
2	12	6	0.03	0.912	0.544	0.496	0.033	0.06	0.030	0.067
3	15	7.5	0.0375	0.847	0.515	0.436	0.033	0.06	0.026	0.059
4	18	10	0.05	0.738	0.476	0.351	0.033	0.06	0.021	0.047

Metodo di Monobe - Okabe									
		monte					valle		
	H	h	ϕ_k	ϕ_d	δ/ϕ	$k_A [\beta < \phi - \theta]$	ϕ_k	ϕ_d	kP
[-]	[m]	[m]	°	°	-	[-]	°	-	[-]
0	6	2.5	32	26.56	0.5	0.372	25	20.46	1.94
1	9	4.5	32	26.56	0.5	0.368	25	20.46	1.96
2	12	6	32	26.56	0.5	0.365	25	20.46	1.97
3	15	7.5	32	26.56	0.5	0.363	25	20.46	1.99
4	18	10	32	26.56	0.5	0.359	25	20.46	2.00

In cui

H: altezza paratia

h : altezza massima di scavo

$u_{s,max}$, α , β , a_g , a_{max} , k_h : parametri sismici definiti al punto 5.4.1

θ ; angolo rispetto la verticale tra le azioni esterne orizzontali e quelle verticali agenti sul cune di spinta

ϕ_k : valore caratteristico angolo d'attrito

$\phi_d = \arctan(\tan(\phi_k)/\gamma_{M2})$: valore di calcolo angolo d'attrito

8.3 Fasi del calcolo

Sono state modellate le seguenti fasi di calcolo:

1. Inizializzazione dello stato di sforzo geostatico.
2. Realizzazione dei micropali e della trave di testa.
3. Applicazione del sovraccarico stradale.
4. Scavo fino a 50cm sotto il primo livello di tiranti (fase non presente per la sezione di tipo 0).
5. Realizzazione del primo ordine di tiranti (fase non presente per la sezione di tipo 0).

6. Eventuale scavo sino alla quota relativa al piano di lavoro per l'esecuzione del secondo ordine di tiranti o al fondo scavo (fase non presente per la sezione di tipo 0).
7. Ripetizione delle fasi 5 e 6 sino al raggiungimento del piano relativo al fondo scavo.
8. Analisi in condizioni sismiche.

8.4 Analisi della struttura - Risultati

Nella Tabella 9.4÷Tabella 9.8 sono riassunti i principali risultati del calcolo. I valori indicati sono da intendersi come "caratteristici" per metro lineare di paratia.

Tabella 9.4 – Risultati dell'analisi tenso-deformativa (azioni "caratteristiche") – sezione tipo 0 – $H_{scavo} = 2,5m$

	STATICO	SISMICO
s_{max} (mm)	12	-
M_{max} (kNm/m)	32.69	36.8
V_{max} (kN/m)	21.09	23.85

Legenda

s_{max} = spostamento laterale massimo

M_{max} = momento flettente massimo

V_{max} = azione di taglio massima

M_{Vmax} = momento flettente nella sezione di taglio massimo

Tabella 9.5 – Risultati dell'analisi tenso-deformativa (azioni "caratteristiche") – sezione tipo 1 – $H_{scavo} = 4,5m$

	STATICO	SISMICO
s_{max} (mm)	8.9	-
M_{max} (kNm/m)	88.44	80.0
V_{max} (kN/m)	75.5	67.2

Tabella 9.6 – Risultati dell'analisi tenso-deformativa (azioni "caratteristiche") – sezione tipo 2 – $H_{scavo} = 6m$

	STATICO	SISMICO
s_{max} (mm)	4.5	-
M_{max} (kNm/m)	73.7	78.3
V_{max} (kN/m)	103.8	89.8

Tabella 9.7 – Risultati dell’analisi tenso-deformativa (azioni “caratteristiche”) – sezione tipo 3 – $H_{scavo} = 7,5m$

	STATICO	SISMICO
S_{max} (mm)	9.9	-
M_{max} (kNm/m)	87.3	85.4
V_{max} (kN/m)	107.2	100.5

Tabella 9.8 – Risultati dell’analisi tenso-deformativa (azioni “caratteristiche”) – sezione tipo 4 – $H_{scavo} = 10m$

	STATICO	SISMICO
S_{max} (mm)	12.2	-
M_{max} (kNm/m)	156.3	183.2
V_{max} (kN/m)	184.6	194.6

Nella Figura 9.6÷Figura 9.8 sono illustrati rispettivamente l’andamento degli spostamenti orizzontali, il diagramma del momento flettente, del taglio e dell’azione assiale nei tiranti (**valori “caratteristici” per metro lineare di paratia**) per le paratie non tirantate. Seguono il caso delle berlinesi con un solo ordine di tiranti (Figura 9.9÷Figura 9.12), con due ordini di tiranti (Figura 9.13÷Figura 9.17), con tre livelli di tiranti (Figura 9.18÷Figura 9.23) e con quattro livelli di tiranti (Figura 9.24÷Figura 9.30).



Figura 9.6 – Spostamento orizzontale - sezione tipo 0 – $H_{scavo} = 2,5m$



Figura 9.7 – Momento flettente - sezione tipo 0 – $H_{scavo} = 2,5m$

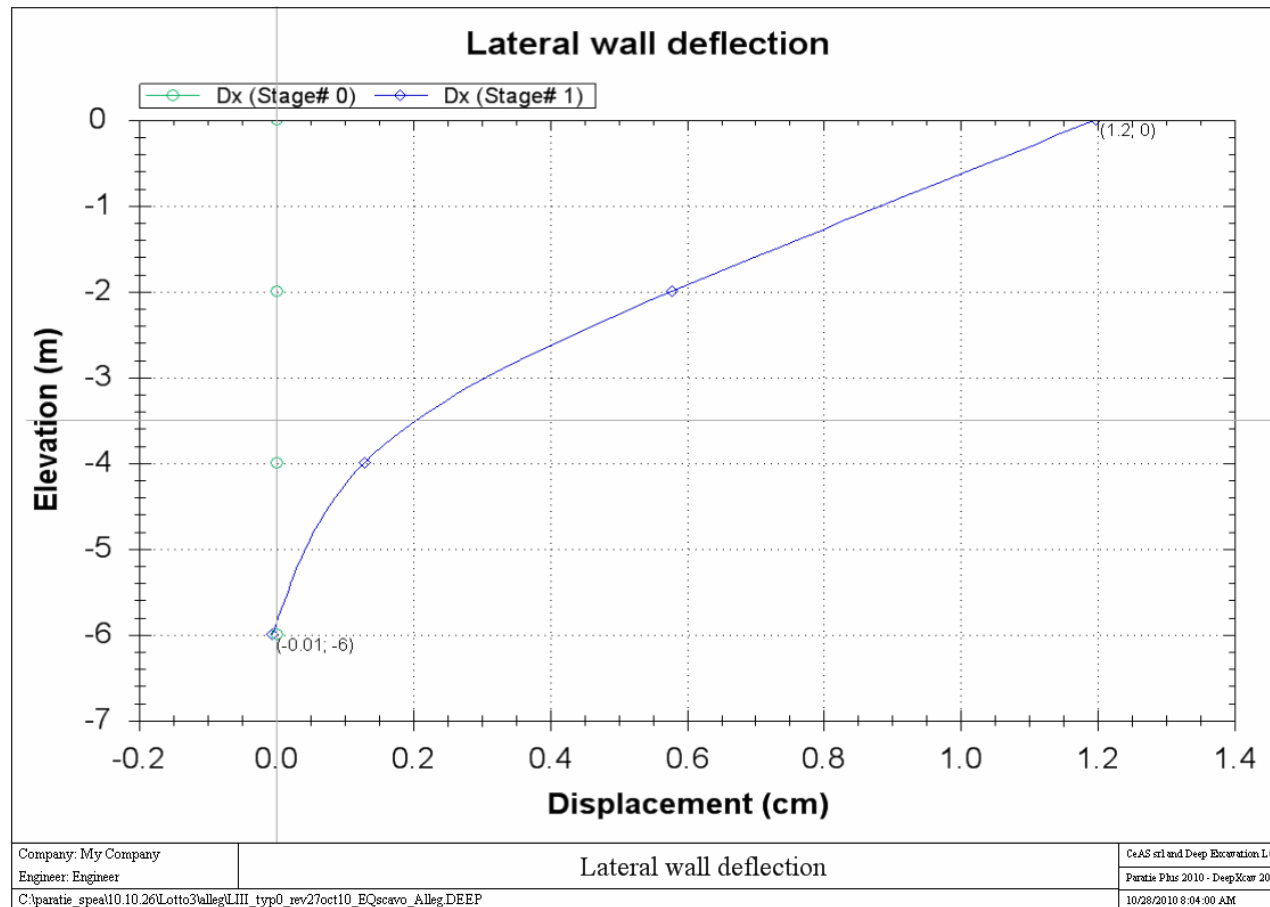

Figura 9.8 – Taglio - sezione tipo 0 – $H_{scavo} = 2,5m$

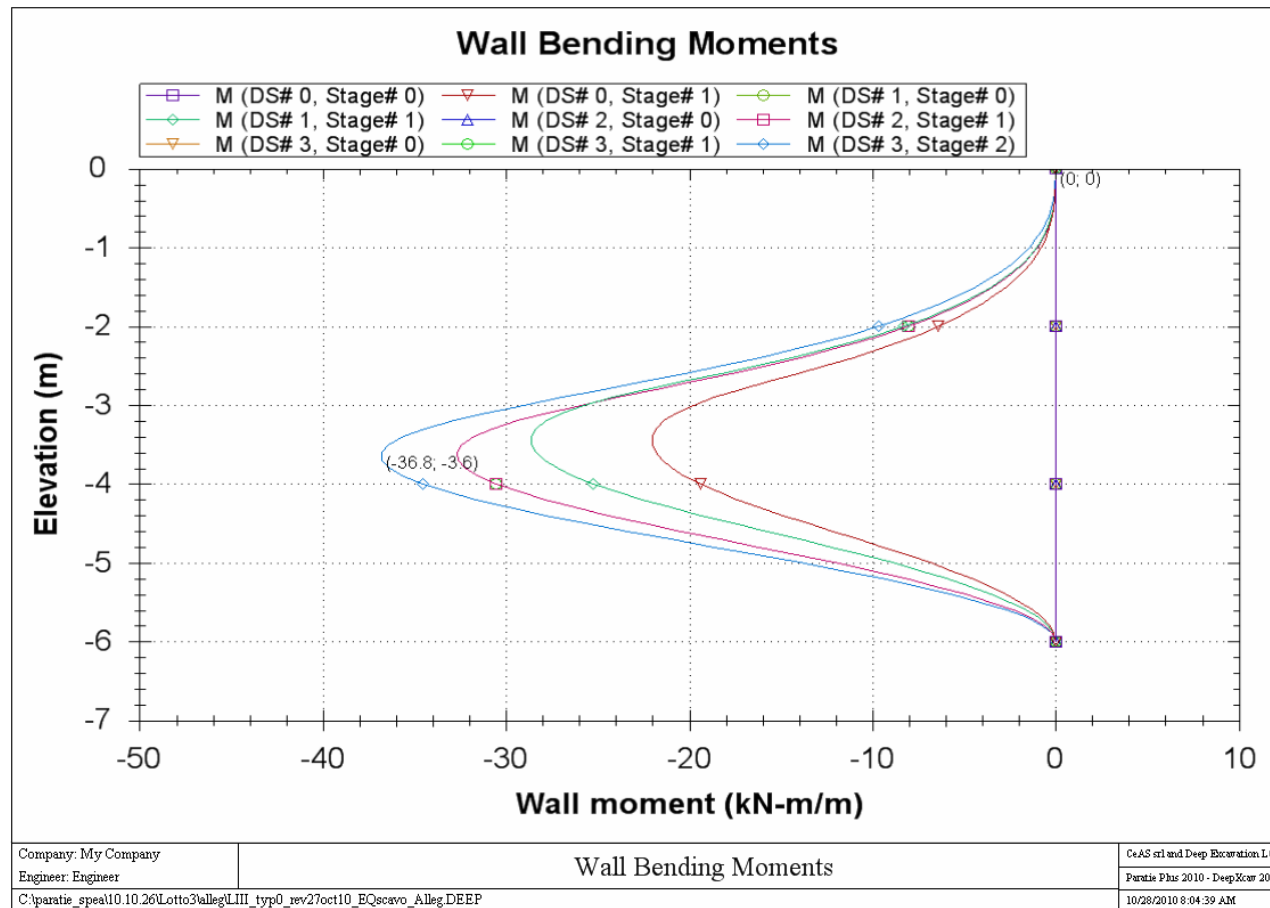

Figura 9.9 – Spostamento orizzontale - sezione tipo 1 – $H_{scavo} = 4,5m$

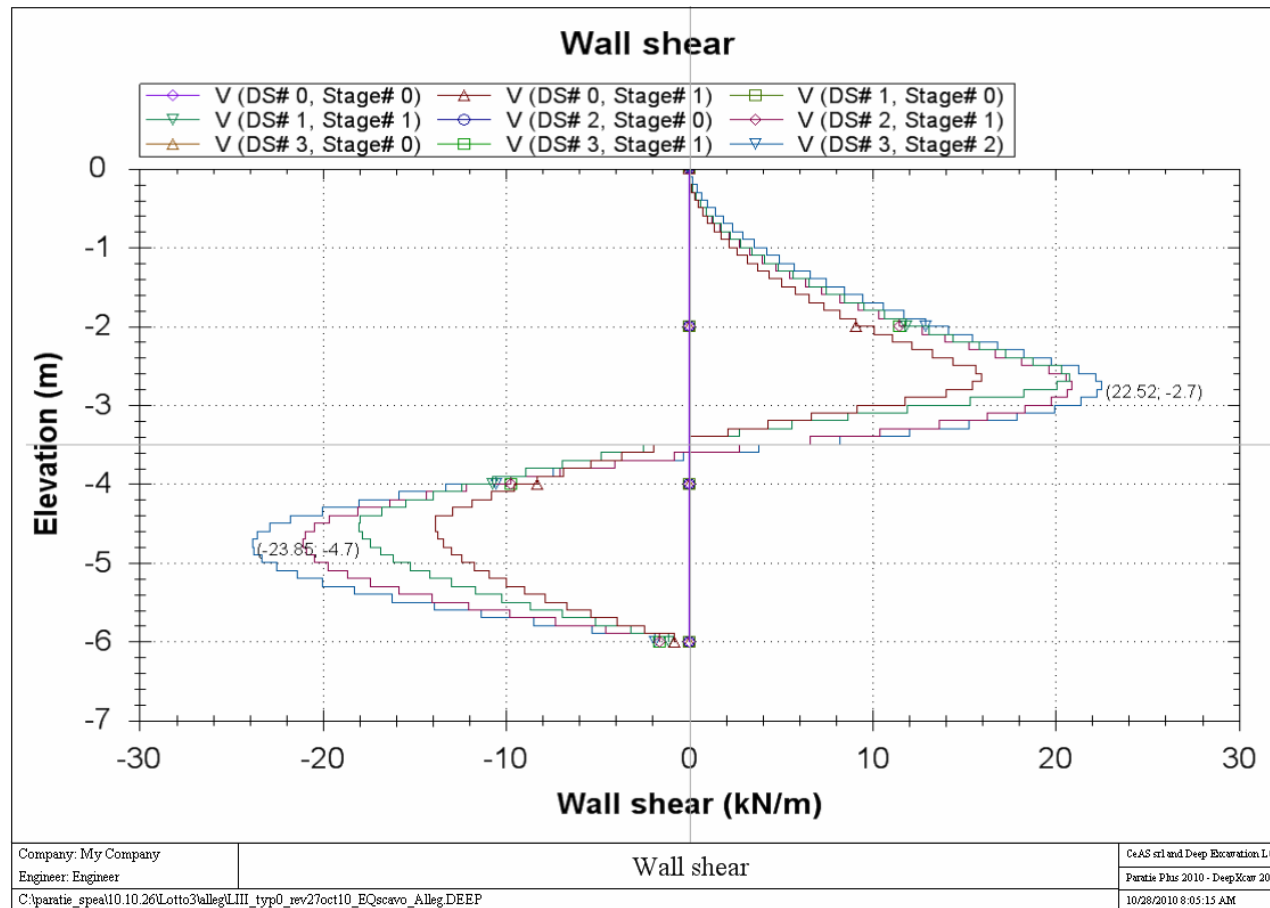

Figura 9.10 – Momento flettente - sezione tipo 1 – $H_{scavo} = 4,5m$

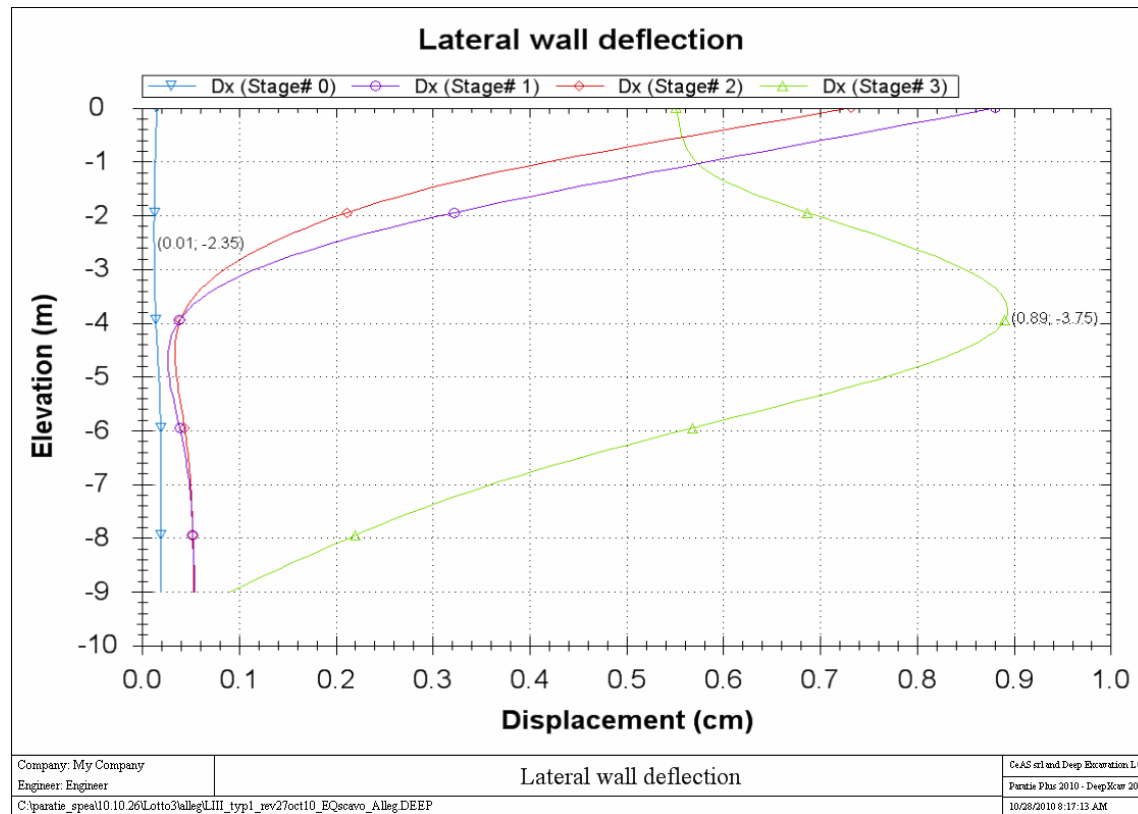

Figura 9.11 – Taglio - sezione tipo 1 – $H_{scavo} = 4,5m$

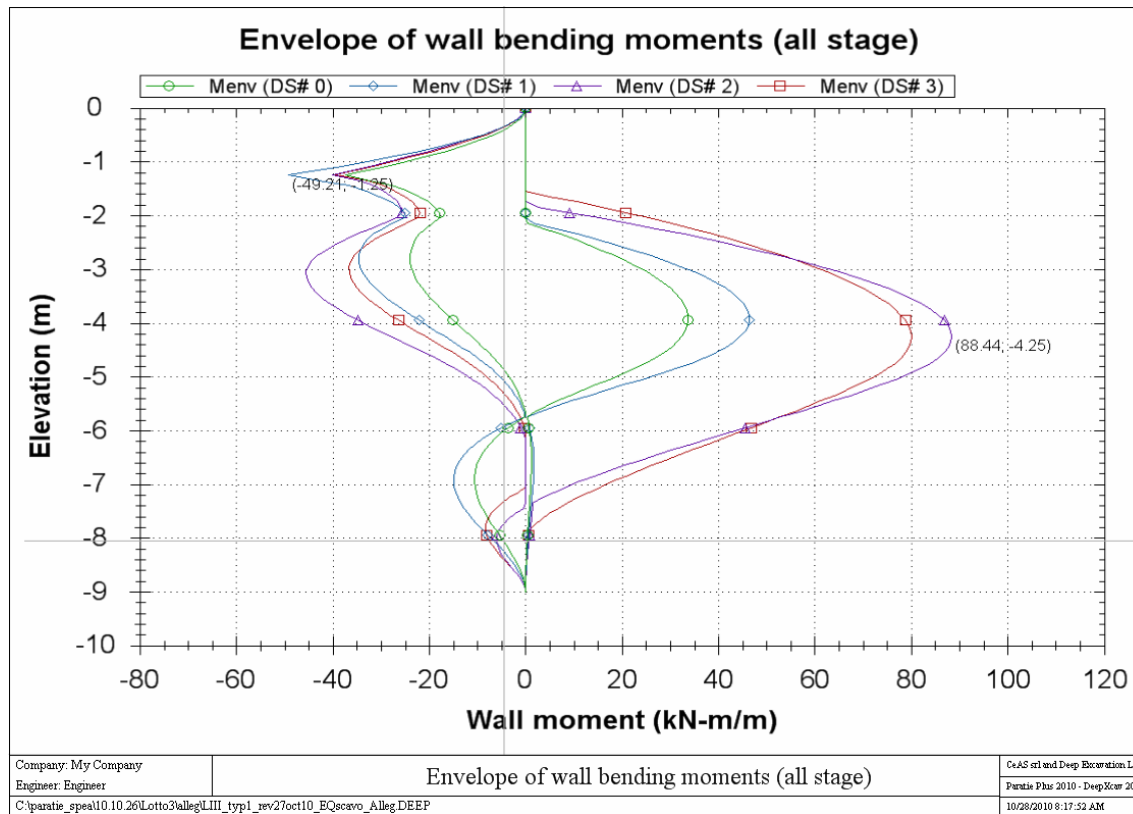

Figura 9.12 – Storia di carico nei tiranti - sezione tipo 1 – $H_{\text{scavo}} = 4,5\text{m}$

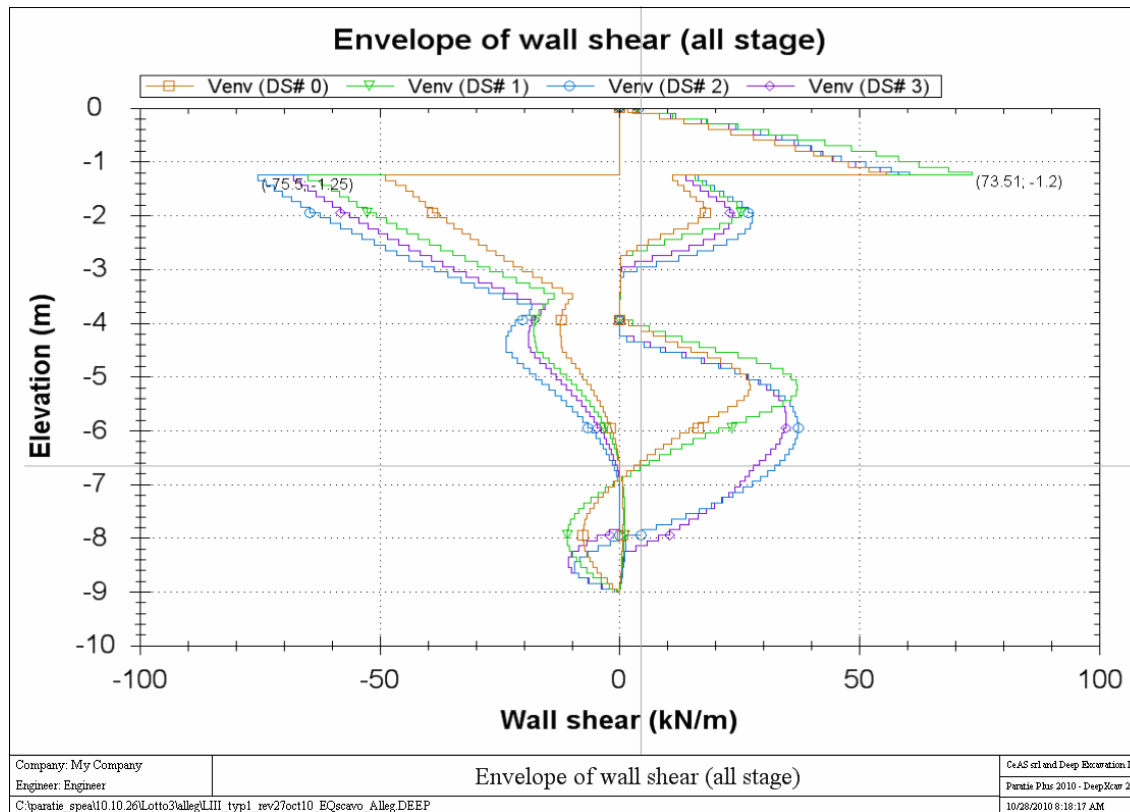

Figura 9.13 – Spostamento orizzontale - sezione tipo 2 – $H_{scavo} = 6m$

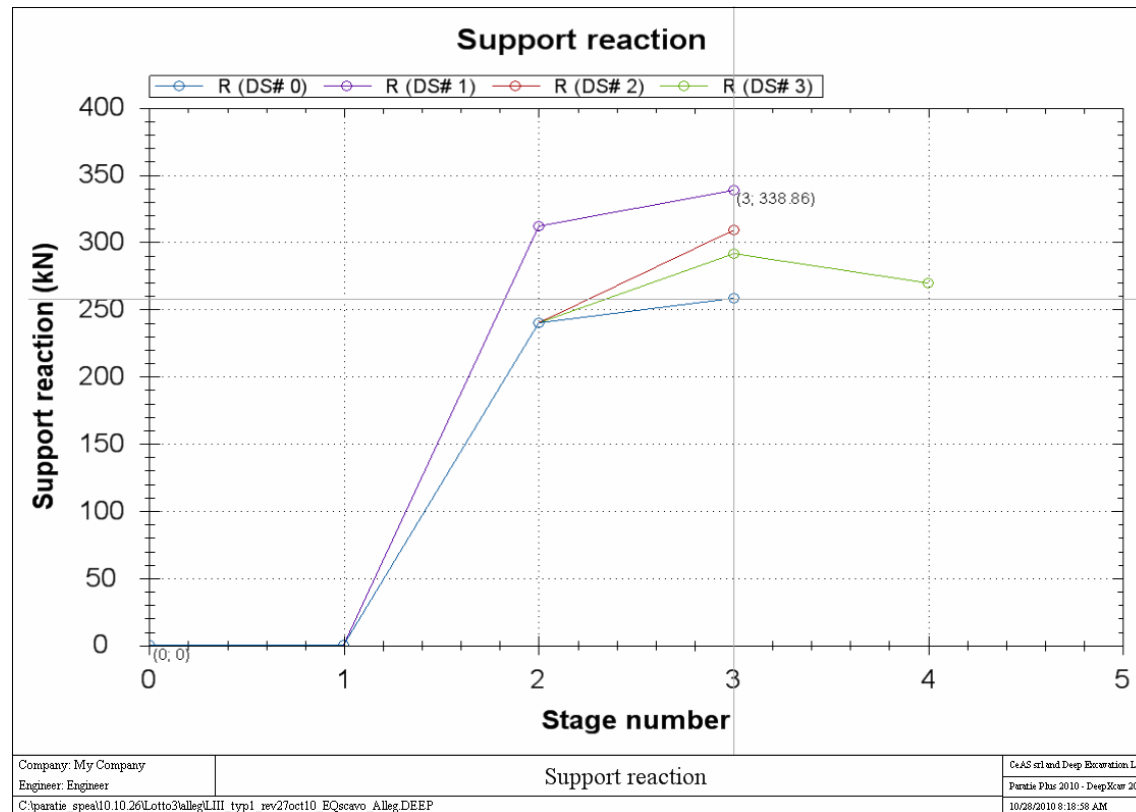

Figura 9.14 – Momento flettente - sezione tipo 2 – $H_{scavo} = 6m$

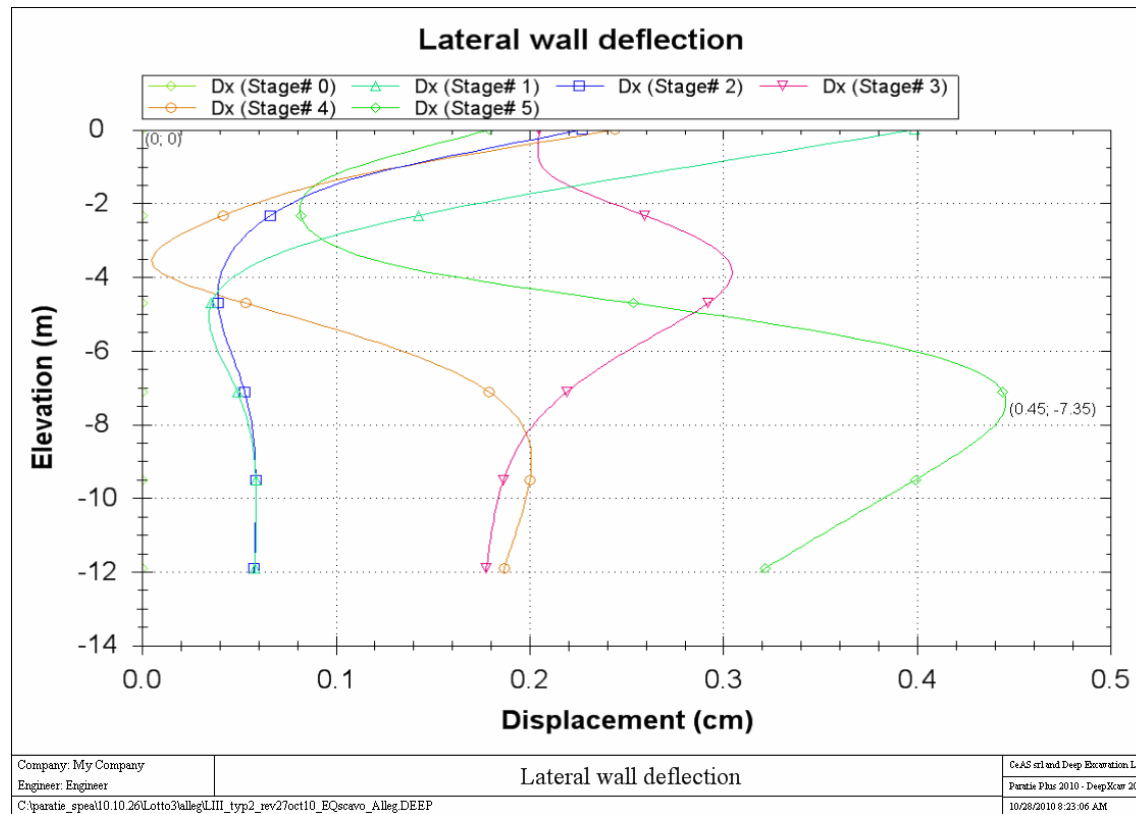

Figura 9.15 – Taglio - sezione tipo 2 – $H_{scavo} = 6m$

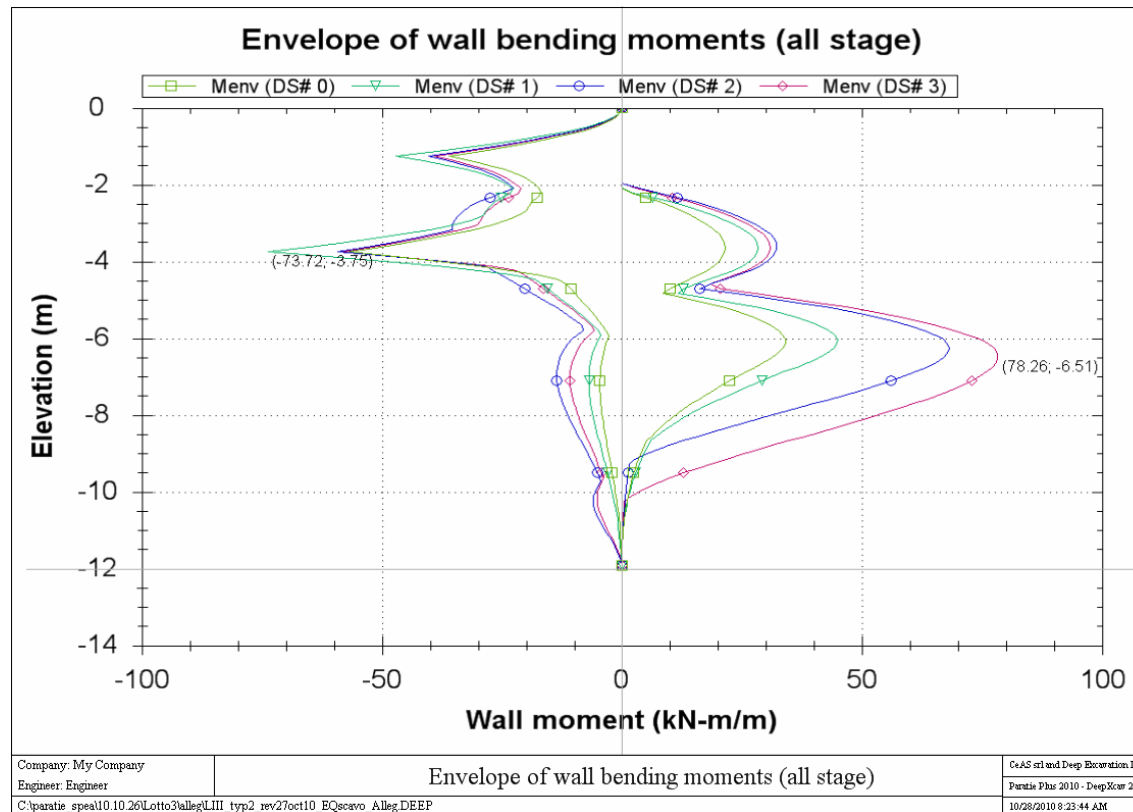

Figura 9.16 – Storia di carico nei tiranti - sezione tipo 2 – $H_{scavo} = 6m$ - I ordine di tiranti

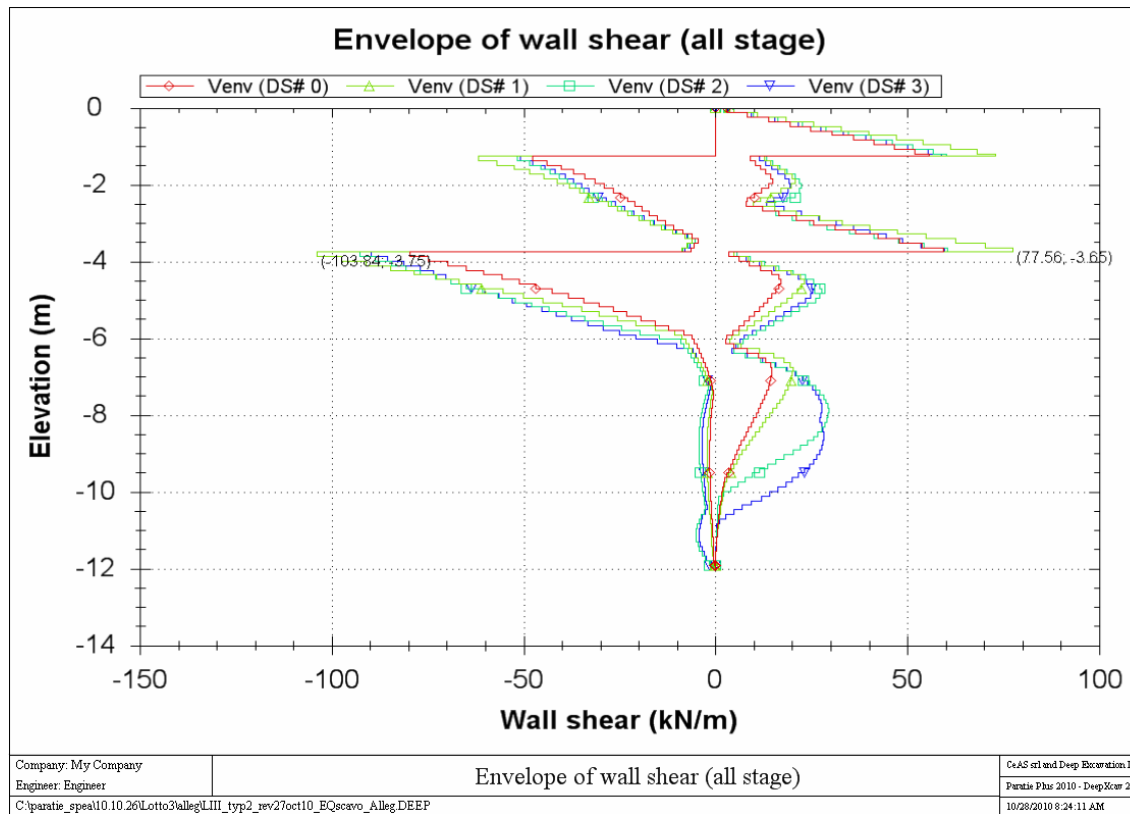

Figura 9.17 – Storia di carico nei tiranti - sezione tipo 2 – $H_{scavo} = 6m$ - Il ordine di tiranti

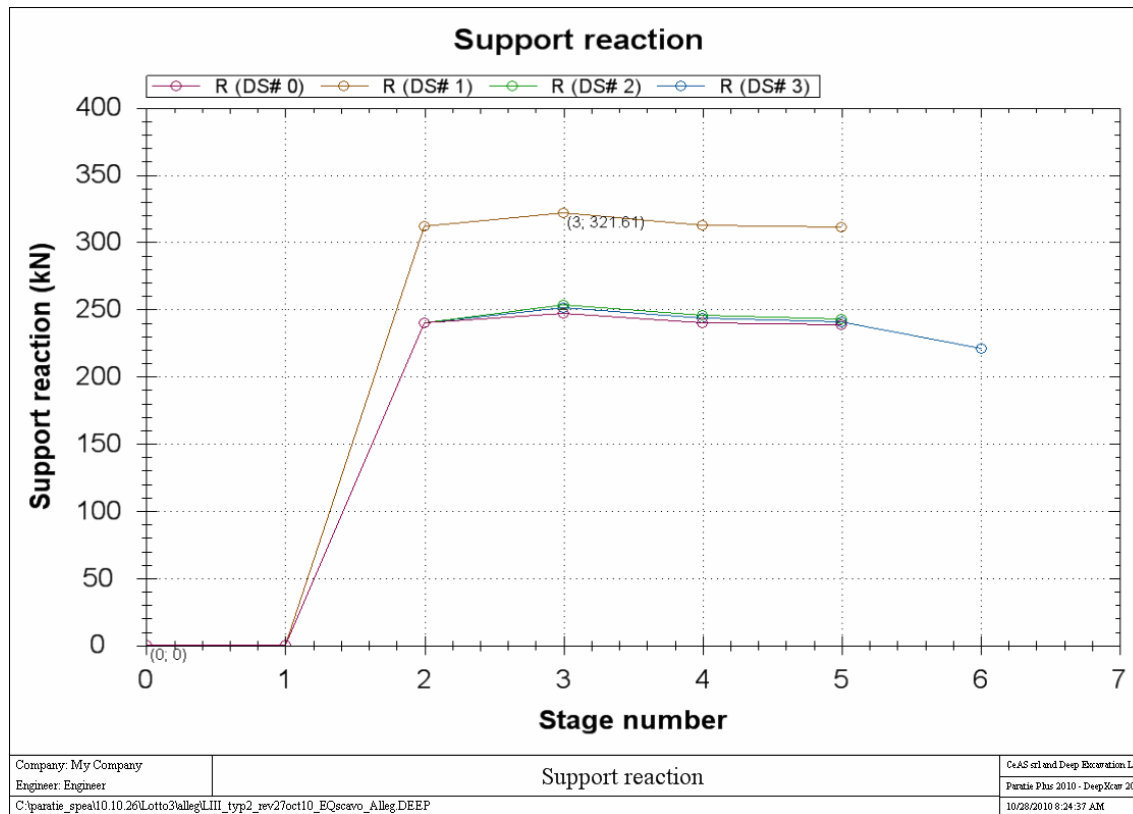

Figura 9.18 – Spostamento orizzontale - sezione tipo 3 – $H_{scavo} = 7,5m$

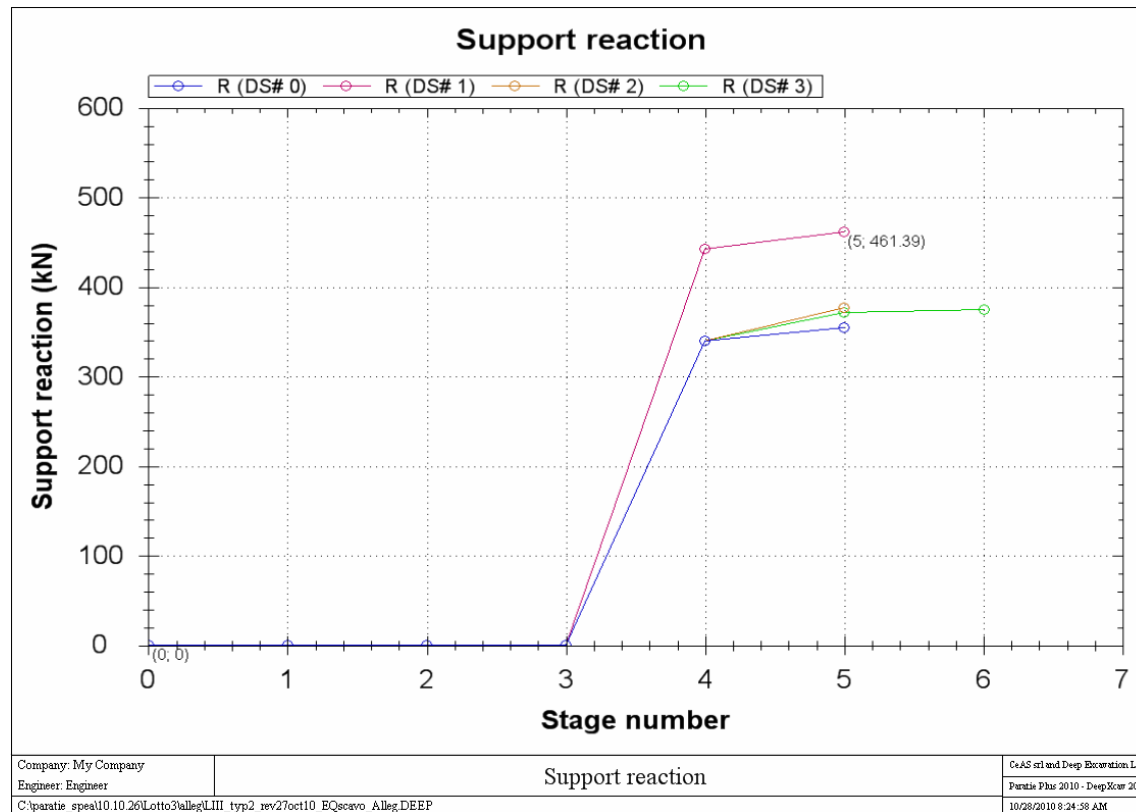

Figura 9.19 – Momento flettente - sezione tipo 3 – $H_{scavo} = 7,5m$

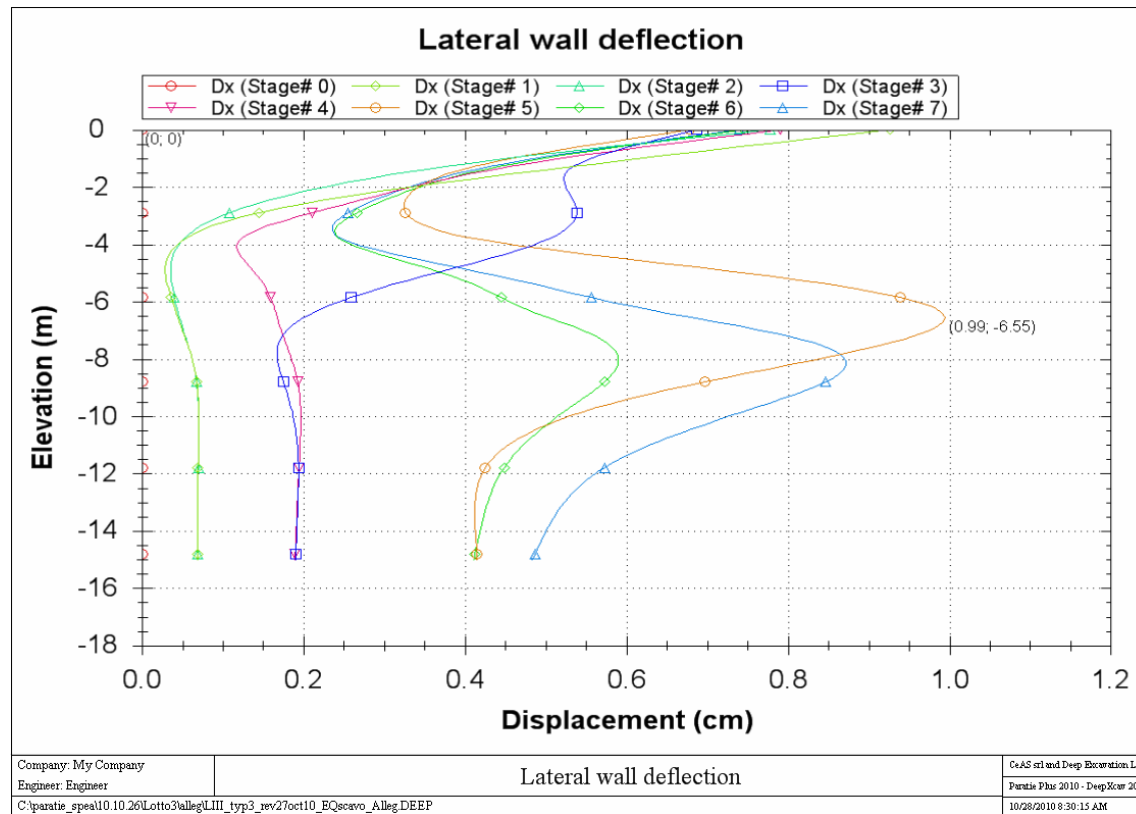

Figura 9.20 – Taglio - sezione tipo 3 – $H_{scavo} = 7,5m$

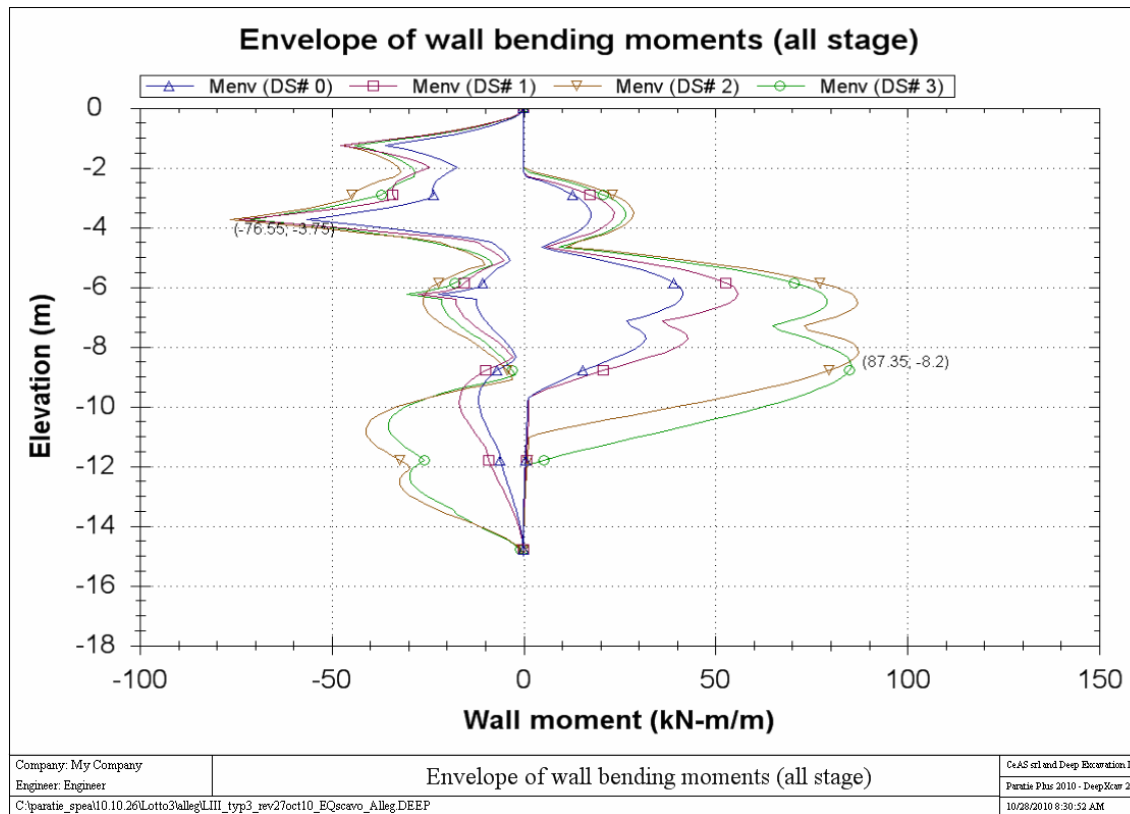

Figura 9.21 – Storia di carico nei tiranti - sezione tipo 3 – $H_{scavo} = 7,5m$ – I ordine di tiranti

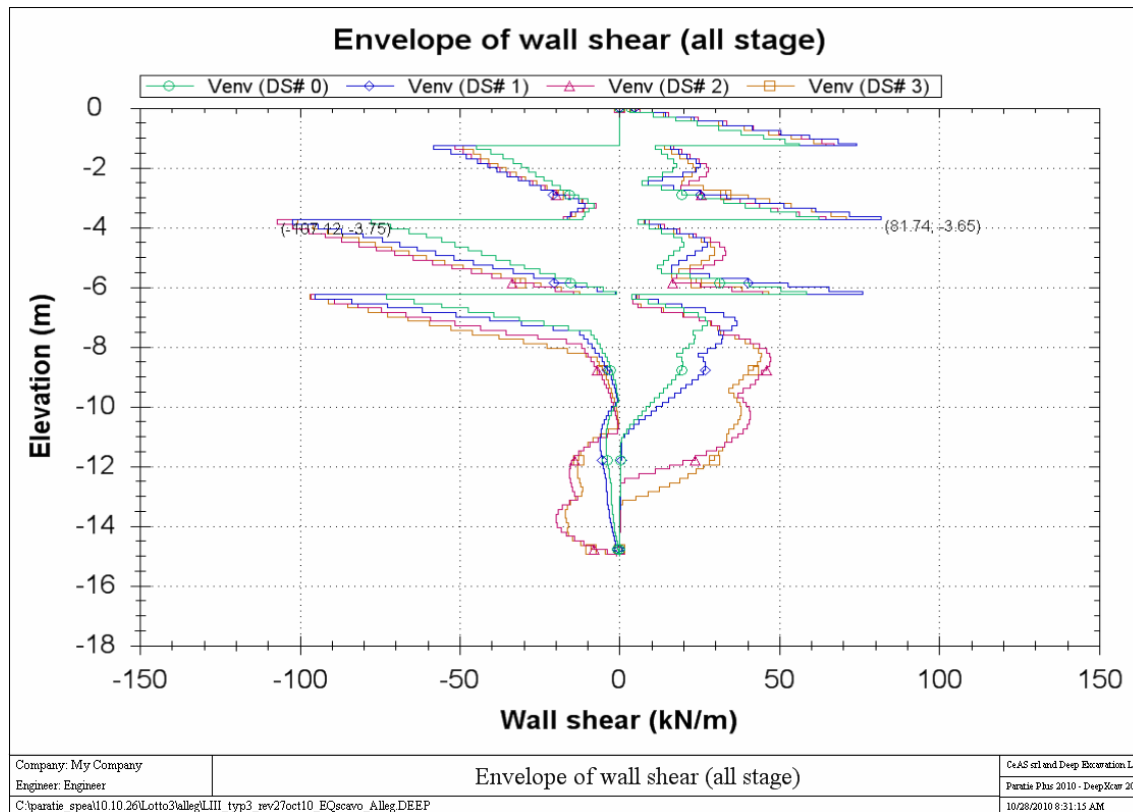

Figura 9.22 – Storia di carico nei tiranti - sezione tipo 3 – $H_{scavo} = 7,5m$ – II ordine di tiranti

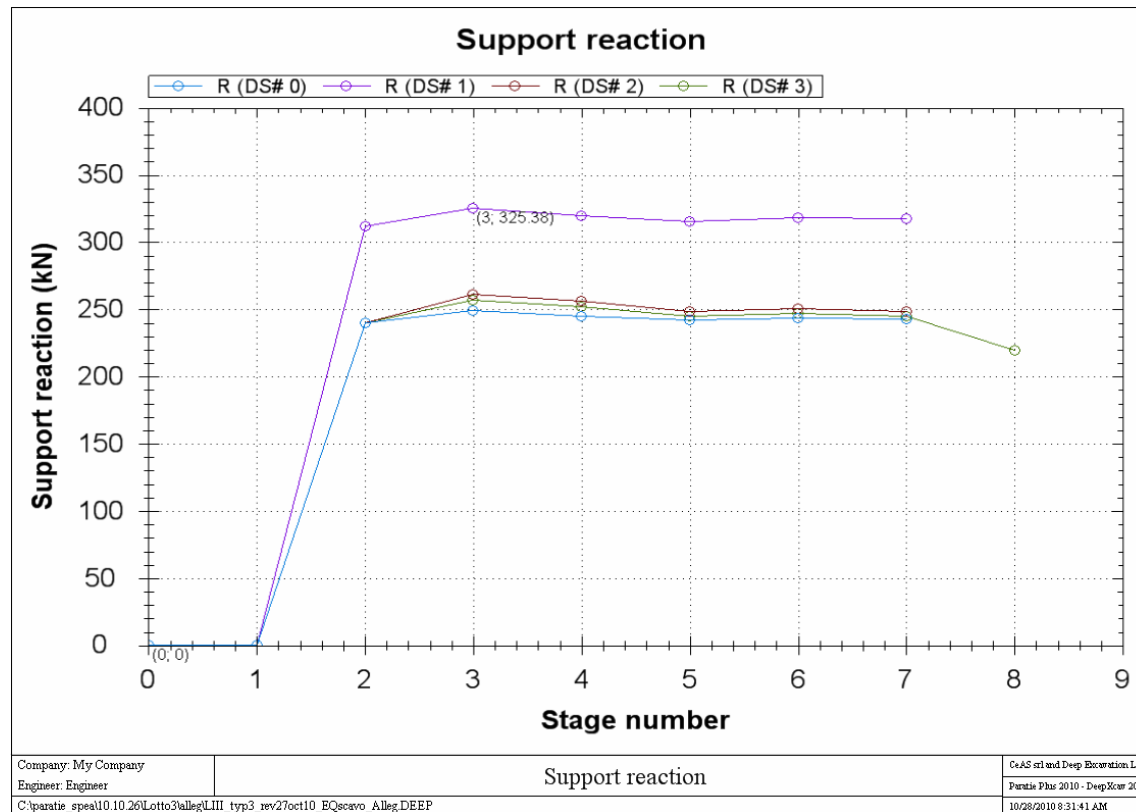

Figura 9.23 – Storia di carico nei tiranti - sezione tipo 3 – $H_{scavo} = 7,5m$ – III ordine di tiranti

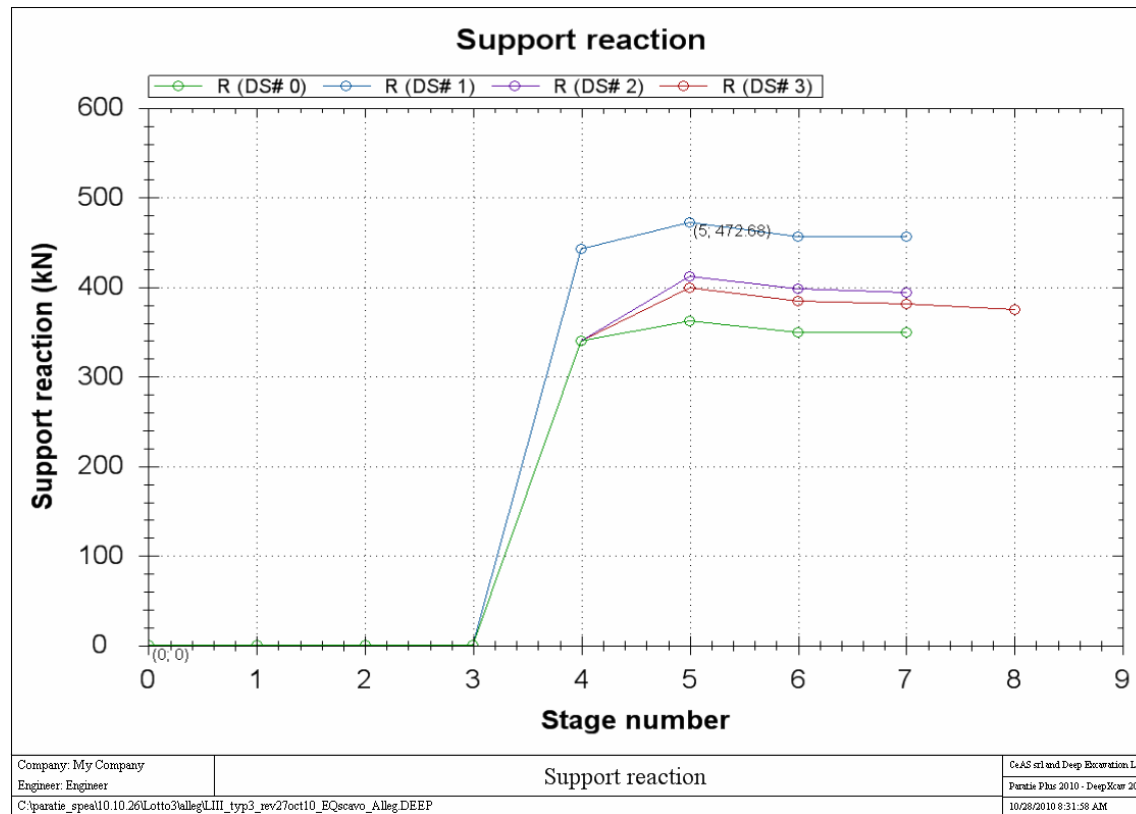

Figura 9.24 – Spostamento orizzontale - sezione tipo 4 – $H_{scavo} = 10m$

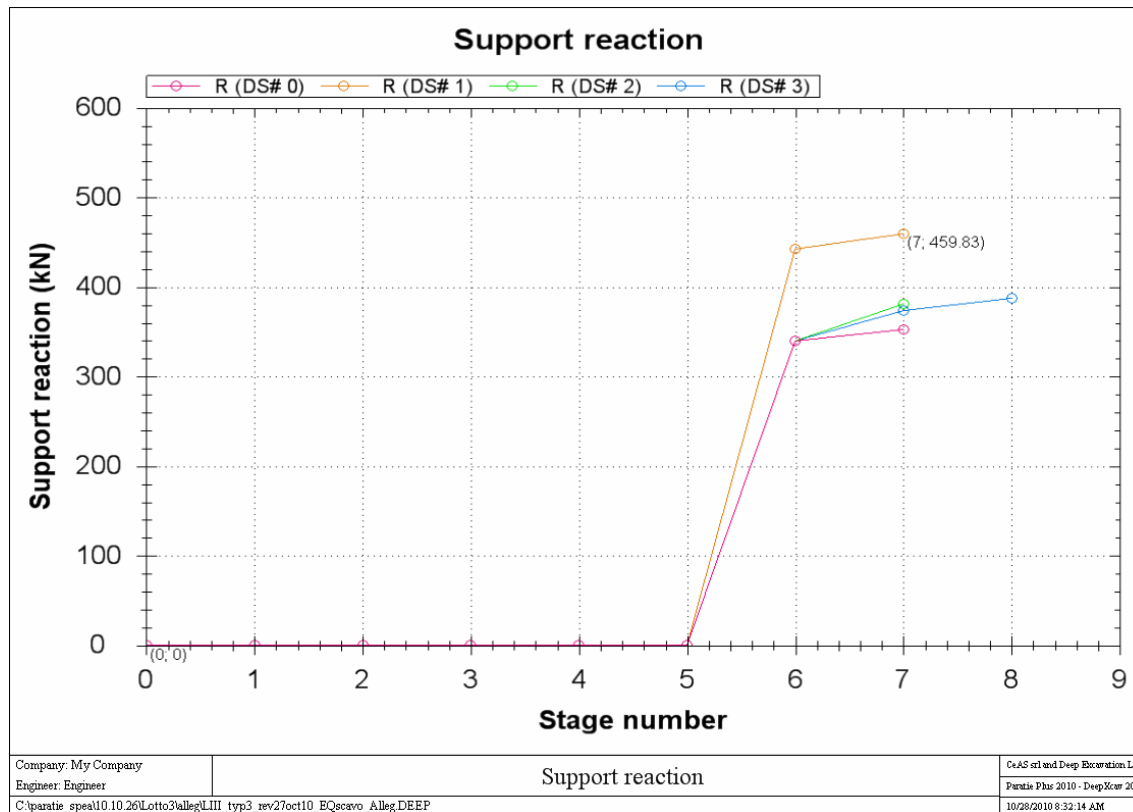

Figura 9.25 – Momento flettente - sezione tipo 4 – $H_{scavo} = 10m$

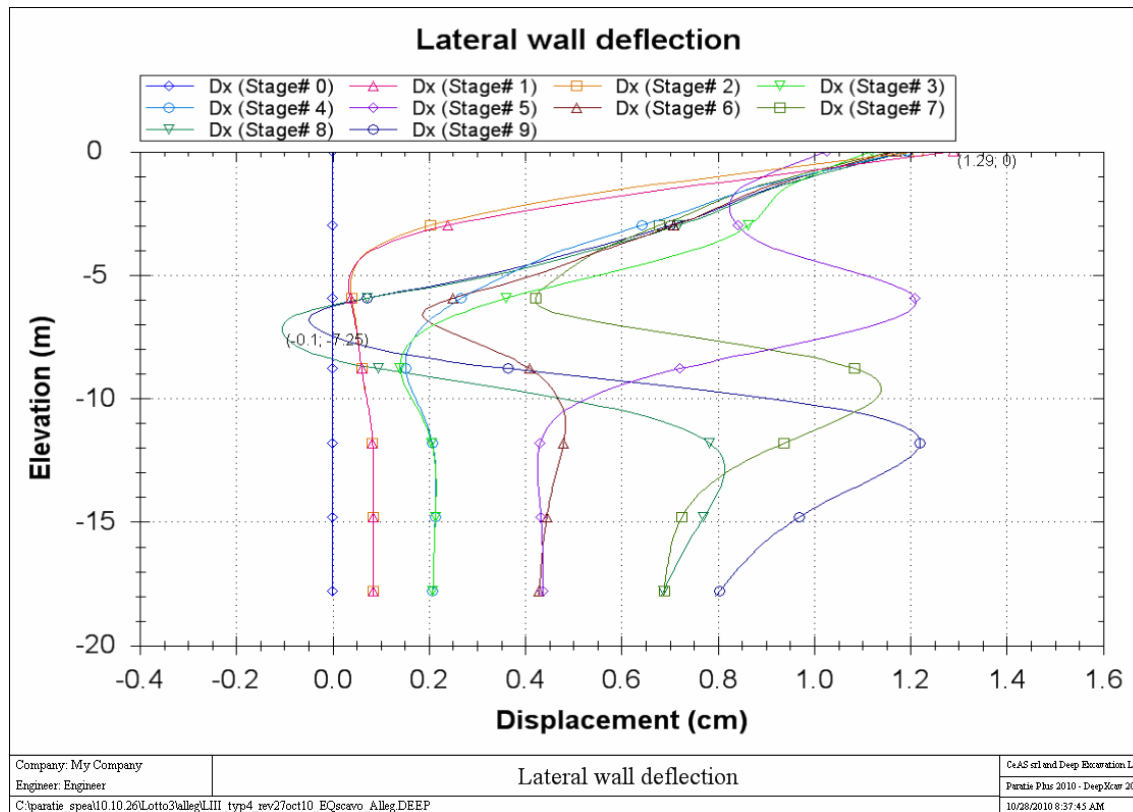

Figura 9.26 – Taglio - sezione tipo 4 – $H_{scavo} = 10m$

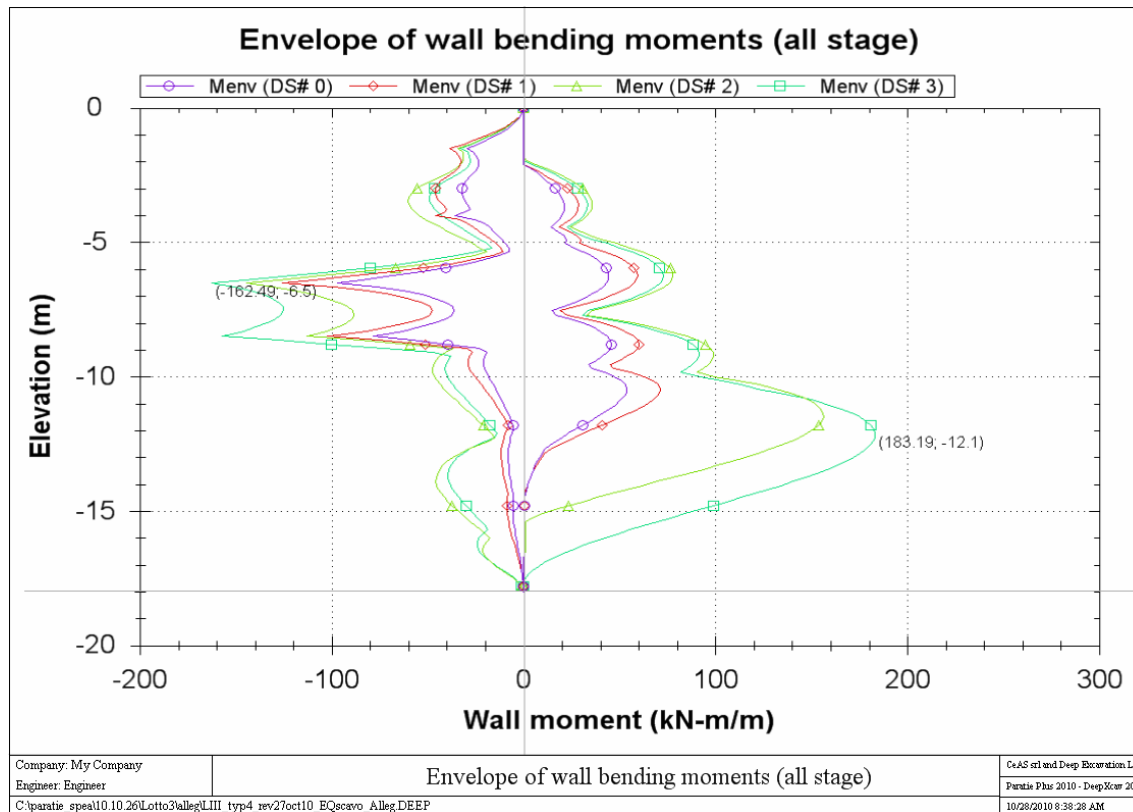

Figura 9.27 – Storia di carico nei tiranti - sezione tipo 4 – $H_{scavo} = 10m$ – I ordine di tiranti -

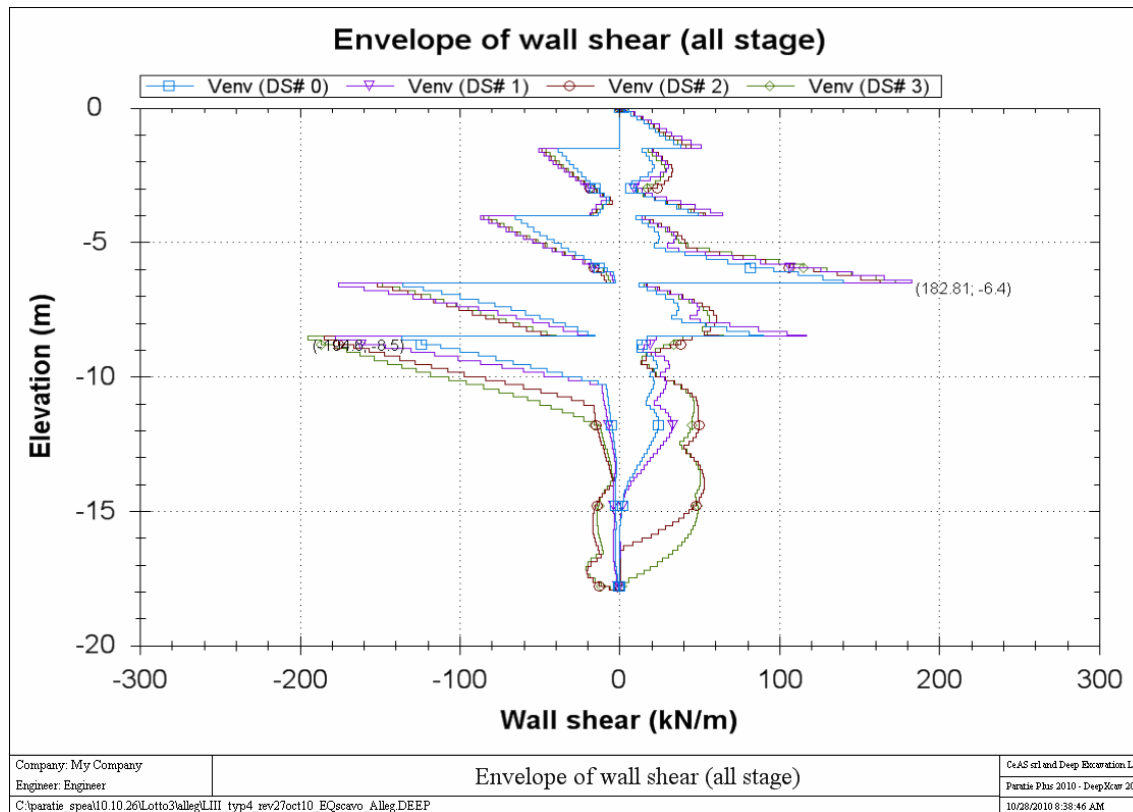

Figura 9.28 – Storia di carico nei tiranti - sezione tipo 4 – $H_{scavo} = 10m$ – II ordine di tiranti

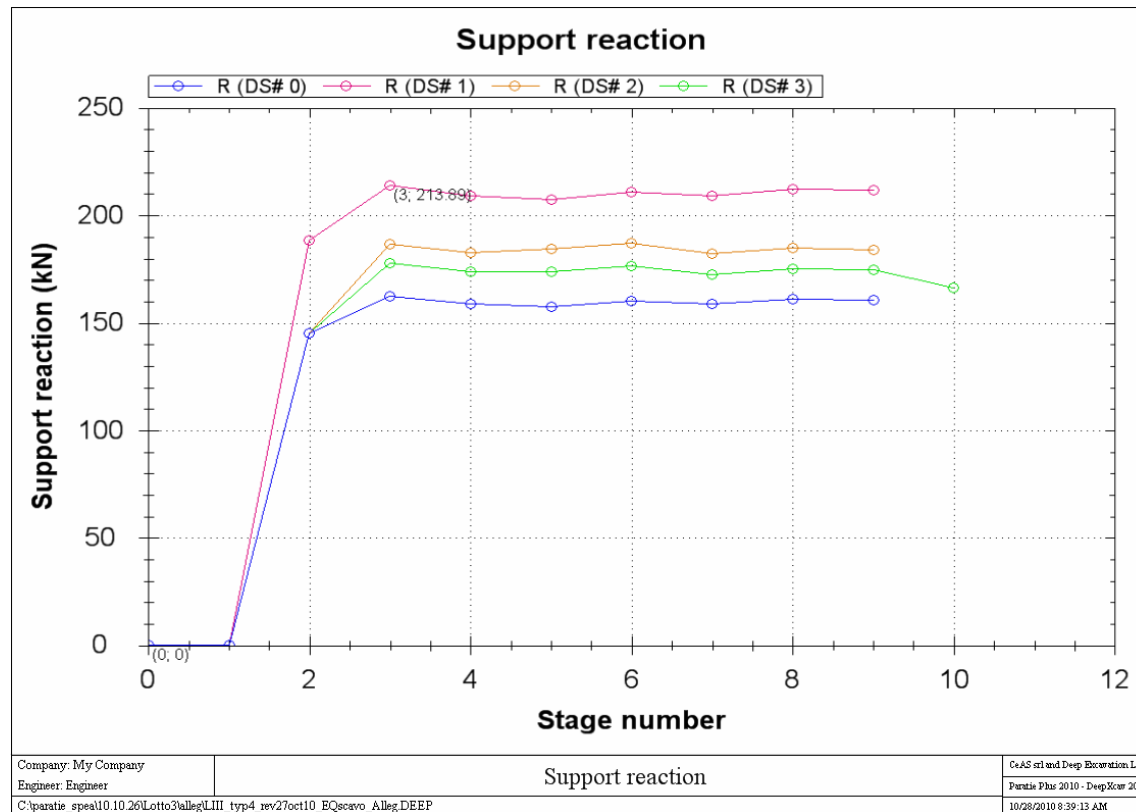

Figura 9.29 – Storia di carico nei tiranti - sezione tipo 4 – $H_{scavo} = 10m$ – III ordine di tiranti -

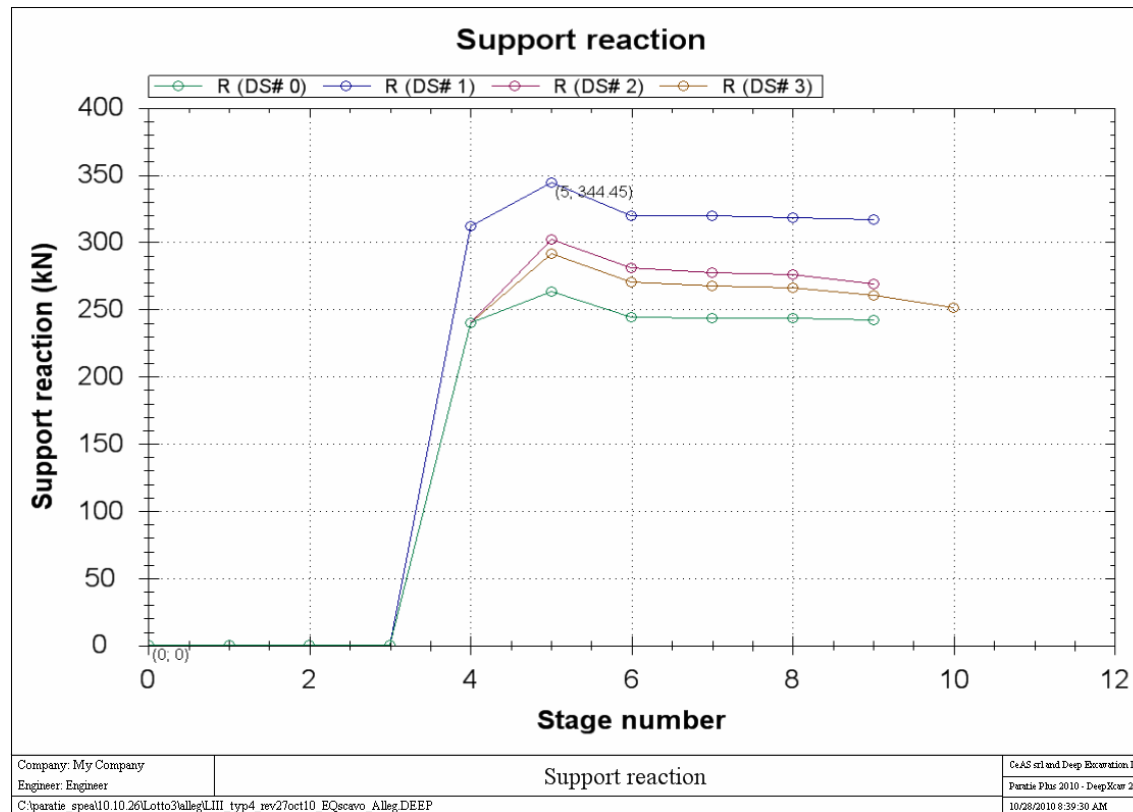

Figura 9.30 – Storia di carico nei tiranti - sezione tipo 4 – $H_{scavo} = 10m$ – IV ordine di tiranti

In Tabella 9.9 sono riassunti i valori della forza “**caratteristica**” calcolata in corrispondenza dei tiranti, i valori riportati tengono conto dell’interasse tra i tiranti.

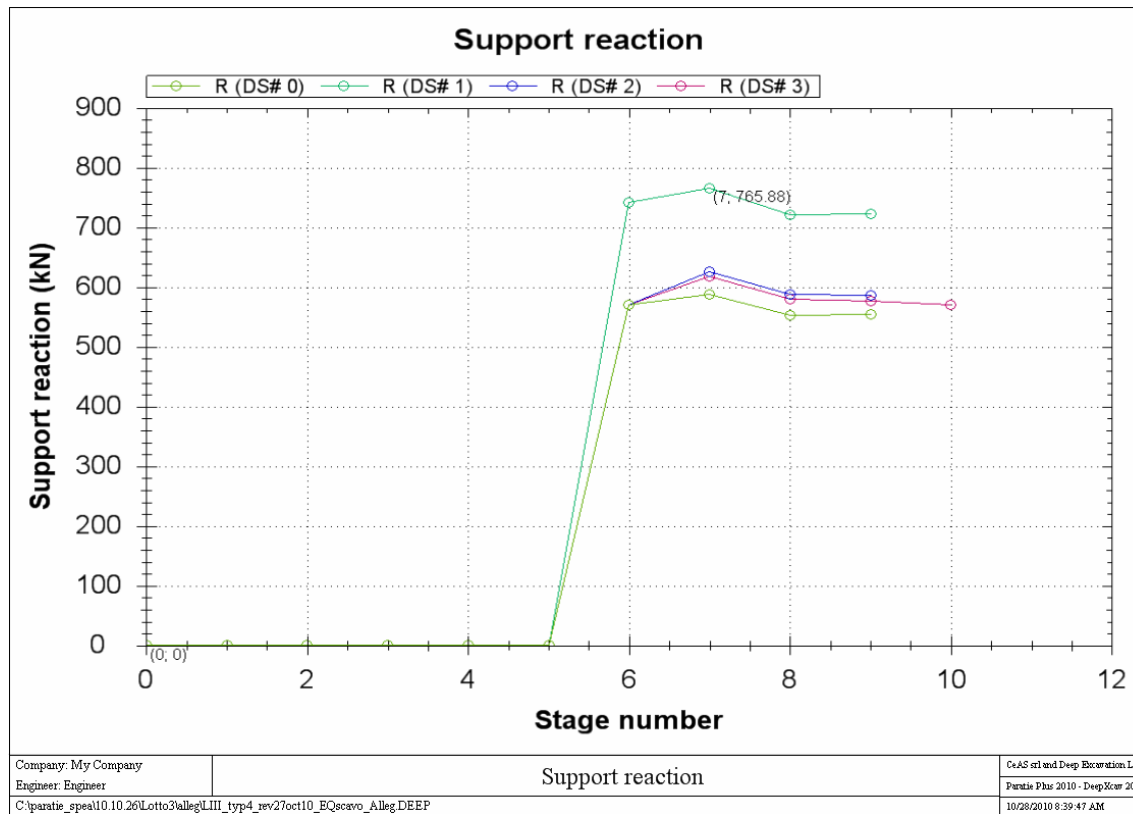
Tabella 9.9 – Azioni nei tiranti – Valori caratteristici

Sezione tipo	Altezza scavo (m)	Ordine di tiranti	n° trefoli	Tensione pretiro (kN)	TENSIONE IN ESERCIZIO (kN)	
					Statico	Sismico
1	4,5	1°	3	240	338.9	291.5
2	6	1°	3	240	321.6	251.5
		2°	5	340	461.4	375.5
3	7,5	1°	3	240	325.4	256.8
		2°	4	340	472.7	398.7
		3°	4	340	459.8	387.1
4	10	1°	3	145	213.9	177.8
		2°	3	240	344.4	291.6
		3°	5	570	765.9	617.4
		4°	5	510	682.7	596.9

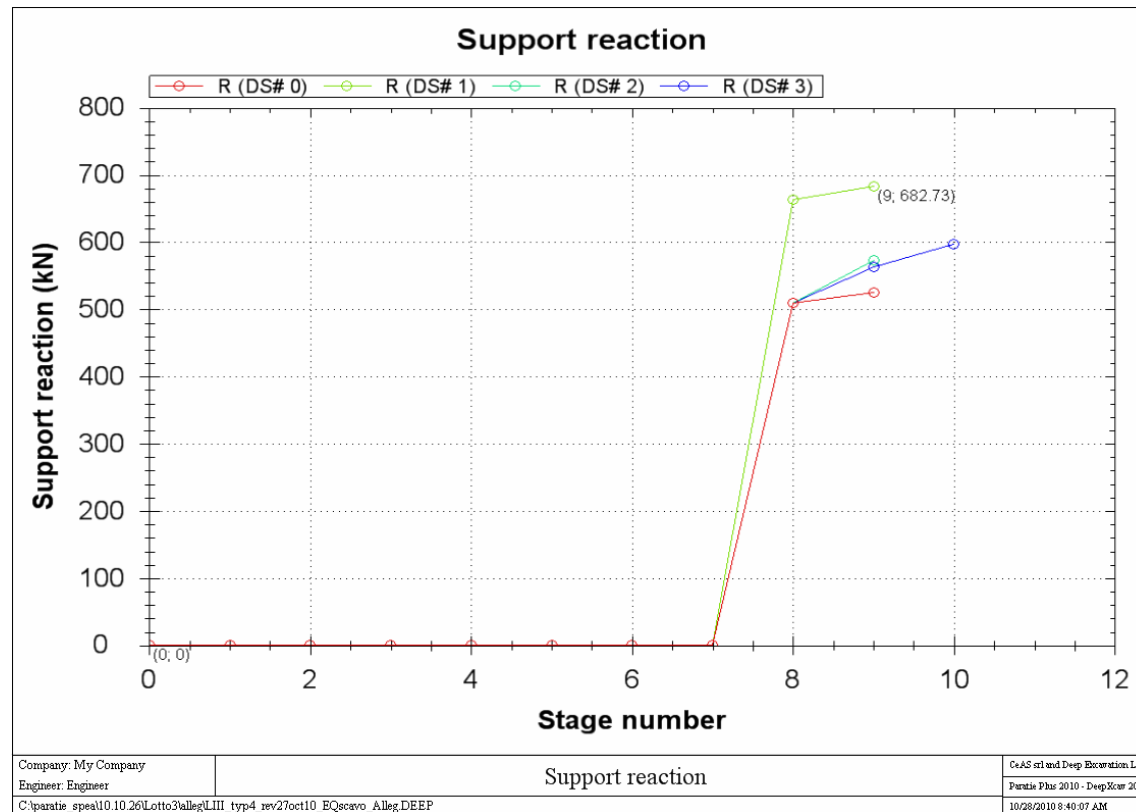
9. VERIFICHE STRUTTURALI E GEOTECNICHE

9.1 Verifica dei micropali

Nel seguito sono riportate le verifiche delle armature dei micropali per le quattro sezioni tipologiche analizzate in accordo a quanto prescritto in NTC08 e successive Istruzioni Tecniche

		sezione tipo				
		0	1	2	3	4
Materiale						
	Acciaio	S355	S355	S355	S355	S355
Tensione di snervamento	f_{yk} [N/mm ²]	355	355	355	355	355
Coefficiente sicurezza resisten	$\gamma_{M,0}$ [-]	1.05	1.05	1.05	1.05	1.05
Caratteristiche geometriche sezione						
Diametro esterno	d [mm]	168.3	168.3	168.3	168.3	177.8
Spessore	t [mm]	10	10	10	10	10
Diametro interno	di [mm]	148.3	148.3	148.3	148.3	157.8
Area lorda	A [cm ²]	49.7	49.7	49.7	49.7	52.7
Momento d'inerzia	J [cm ⁴]	1564.0	1564.0	1564.0	1564.0	1862.0
Modulo di resistenza elastico	W _{el} [cm ³]	185.9	185.9	185.9	185.9	209.4
Modulo di resistenza plastico	W _{pl} [cm ³]	250.9	250.9	250.9	250.9	281.9
Raggio d'inerzia	i [cm]	5.6	5.6	5.6	5.6	5.9
Area di taglio	A _v [cm ²]	31.7	31.7	31.7	31.7	33.6
Peso	p [daN/m]	39.0	39.0	39.0	39.0	41.4
Interasse pali	i [m]	0.4	0.4	0.4	0.4	0.4
	ε	0.8	0.8	0.8	0.8	0.8
	d/t	16.8	16.8	16.8	16.8	17.8
	d/t / ε^2	25.4	25.4	25.4	25.4	26.9
Classificazione della sezione	Classe	1	1	1	1	1
Sollecitazioni						
Esercizio	V _{Ed} [kN/m]	21.1	75.5	103.8	107.1	184.6
	M _{Ed} [kNm/m]	32.7	88.4	80.2	87.4	156.3
Sismica	V _{Ed} [kN/m]	23.9	67.3	89.8	100.5	194.6
	M _{Ed} [kNm/m]	36.8	80.1	78.3	85.4	183.2
Verifica di resistenza condizioni statiche						
Taglio di calcolo	V _{Ed} [kN]	8.436	30.2	41.536	42.848	73.836
Taglio resistente in assenza di	V _{c,Rd} [kN]	618.00	618.00	618.00	618.00	655.09
tasso lavoro	V _{Ed} / V _{c,Rd}	0.01	0.05	0.07	0.07	0.11
stato verifica		ok	ok	ok	ok	ok
	ρ	0.0	0.0	0.0	0.0	0.0
Momento di calcolo	M _{Ed} [kNm]	13.076	35.376	32.06	34.94	62.524
	f _{y,red} =(1- ρ)f _{yk}	355	355	355	355	355
Resistenza a flessione	M _{c,Rd} [kNm]	84.84	84.84	84.84	84.84	95.31
tasso lavoro	M _{Ed} / M _{c,Rd}	0.15	0.42	0.38	0.41	0.66
stato verifica		ok	ok	ok	ok	ok
Verifica di resistenza condizioni sismiche						
Taglio di calcolo	V _{Ed} [kN]	9.54	26.9	35.92	40.2	77.84
Taglio resistente in assenza di	V _{c,Rd} [kN]	618.00	618.00	618.00	618.00	655.09
tasso lavoro	V _{Ed} / V _{c,Rd}	0.02	0.04	0.06	0.07	0.12
stato verifica		ok	ok	ok	ok	ok
	ρ	0.0	0.0	0.0	0.0	0.0
Momento di calcolo	M _{Ed} [kNm]	14.72	32.02	31.304	34.148	73.28
	f _{y,red} =(1- ρ)f _{yk}	355	355	355	355	355
Resistenza a flessione	M _{c,Rd} [kNm]	84.84	84.84	84.84	84.84	95.31
tasso lavoro	M _{Ed} / M _{c,Rd}	0.17	0.38	0.37	0.40	0.77
stato verifica		ok	ok	ok	ok	ok

Tutte le verifiche risultano soddisfatte.

9.2 Verifica dei tiranti

Si fa riferimento a quanto esposto nei paragrafi 7.1 nonché alle azioni caratteristiche di cui alla Tabella 9.9.

9.2.1 Verifica strutturale

Vale quanto segue:

Verifica strutturale

Sezione tipo	Altezza paratia	Altezza di scavo massima	Ordine tiranti	Distanza da estradosso cordolo	n° trefoli	Area acciaio	Interasse orizzontale max	Inclinazione	Sollec. Esercizio	Sollec. Sisma	Resistenza strutturale tirante	c.s. Esercizio	c.s. Sisma	c.s. Tot STR	stato verifica
	H	h		d	n	Aa	i	α	N_{Ed}	N_{Ed}	$R_{d,s}$	$R_{d,s} / N_{Ed}$	$R_{d,s} / N_{Ed}$	$R_{d,s} / N_{Ed}$	STR
[-]	[m]	[m]	[-]	[m]	[-]	[mm ²]	[m]	[°]	[kN]	[kN]	[kN]	[-]	[-]	[-]	
0	6	2.5	-	-	-	-	-	-	-	-	-	-	-	-	-
1	9	4.5	I	1.25	3	417	2.4	15	338.9	291.5	605.6	1.79	2.08	1.79	ok
2	12	6	I	1.25	3	417	2.4	15	321.6	251.5	605.6	1.88	2.41	1.88	ok
			II	3.75	5	695	2.4	20	461.4	374.9	1009.3	2.19	2.69	2.19	ok
3	15	7.5	I	1.25	3	417	2.4	15	325.4	256.8	605.6	1.86	2.36	1.86	ok
			II	3.75	4	556	2.4	20	472.7	398.7	807.4	1.71	2.02	1.71	ok
			III	6.25	4	556	2.4	25	459.8	387.1	807.4	1.76	2.09	1.76	ok
4	18	10	I	1.5	3	417	2.4	15	213.9	177.8	605.6	2.83	3.41	2.83	ok
			II	4	3	417	2.4	20	344.4	291.6	605.6	1.76	2.08	1.76	ok
			III	6.5	5	695	2.0	25	765.9	617.4	1009.3	1.32	1.63	1.32	ok
			IV	8.5	5	695	2.0	30	682.7	596.9	1009.3	1.48	1.69	1.48	ok

9.2.2 Verifica allo sfilamento

Vale quanto segue:

Verifica geotecnica

Sezione tipo	Ordine tiranti	Interasse orizzontale max	Inclinazione	Lungh. Libera	Lungh. Bulbo ancoraggio	Pretiro	Diametro perforazione	Aderenza unitaria media	Aderenza unitaria min				Resistenza geotecnica allo sfilamento	c.s. Esercizio	c.s. Sisma	c.s. Tot GEO	stato verifica
		i	α	L_L	L_B	T_0	D_{perf}	α_{tad}^{k/m^2}	α_{tad}^{k/m^2}	$R_{ac,med}/\zeta_3$	$R_{ac,min}/\zeta_4$	R_{ak}	$R_{ad}=R_{ak}/\gamma_R$			R_{ad} / N_{Ed}	GEO
[-]	[-]	[m]	[°]	[m]	[m]	[kN]	[mm]	[kN/m ²]	[kN/m ²]	[kN]	[kN]	[kN]	[kN]	[-]	[-]	[-]	
0	-	-	-	-	-	-	-	-	-	-	-	-	-	-	-	-	-
1	I	2.4	15	6.0	10.0	240.0	160	160	150	459.6	443.5	443.5	403.2	1.2	1.4	1.19	ok
2	I	2.4	15	7.0	10.0	240.0	160	160	150	459.6	443.5	443.5	403.2	1.3	1.6	1.25	ok
	II	2.4	20	6.0	13.0	340.0	160	160	150	597.4	576.6	576.6	524.2	1.1	1.4	1.14	ok
3	I	2.4	15	9.0	10.0	240.0	160	160	150	459.6	443.5	443.5	403.2	1.2	1.6	1.24	ok
	II	2.4	20	8.0	12.0	340.0	160	160	150	551.5	532.2	532.2	483.8	1.0	1.2	1.02	ok
	III	2.4	25	6.0	12.0	340.0	160	210	200	723.8	709.6	709.6	645.1	1.4	1.7	1.40	ok
4	I	2.4	15	11.0	10.0	145.0	160	160	150	459.6	443.5	443.5	403.2	1.9	2.3	1.88	ok
	II	2.4	20	11.0	10.0	240.0	160	160	150	459.6	443.5	443.5	403.2	1.2	1.4	1.17	ok
	III	2.0	25	12.0	15.0	570.0	160	210	200	904.8	887.0	887.0	806.4	1.1	1.3	1.05	ok
	IV	2.0	30	12.0	15.0	510.0	160	210	200	904.8	887.0	887.0	806.4	1.2	1.4	1.18	ok

9.2.3 Gerarchia resistenze

Sezione tipo	Ordine tiranti	$R_{p(1)k}$	R_{ak}	$R_{p(1)k}/R_{ak}$	
[-]	[-]	[kN]	[kN]	[-]	
0	-				
1	I	696.39	443.52	1.57	ok
2	I	696.39	443.52	1.57	ok
	II	1160.65	576.57	2.01	ok
3	I	696.39	443.52	1.57	ok
	II	928.52	532.22	1.74	ok
	III	928.52	709.63	1.31	ok
4	I	696.39	443.52	1.57	ok
	II	696.39	443.52	1.57	ok
	III	1160.65	887.04	1.31	ok
	IV	1160.65	887.04	1.31	ok

9.3 Verifica delle travi di ripartizione

Nel seguito sono riportate le verifiche delle travi di ripartizione per le quattro sezioni tipologiche analizzate in accordo a quanto prescritto nelle norme NTC08. Per maggiori dettagli si rimanda al §6.2.

Sezione tipo 1 – altezza di scavo = 4,5m

Ordine tiranti
Configurazione Tiranti

Interasse	i [m]	2.4
Inclinazione tirante	α [°]	15

Materiale

	Acciaio	S 355
Tensione di snervamento	f_{yk} [N/mm ²]	355
Coefficiente sicurezza resistenza	$\gamma_{M,0}$ [-]	1.05

Caratteristiche geometriche profilo

Profilo		HE 180
Larghezza	b [mm]	180
Altezza	h [mm]	171
Spessore anima	t_w [mm]	6
Spessore flangia	t_f [mm]	9.5
Raggio di raccordo	r [mm]	15
Altezza utile	d [mm]	122
Area lorda	A [mm ²]	45.3

Asse forte y-y

Momento d'inerzia asse y	I_y [cm ⁴]	2510
Modulo di resistenza elastico	$W_{el,y}$ [cm ³]	293.6
Modulo di resistenza plastico	$W_{pl,y}$ [cm ³]	324.9
Raggio d'inerzia	i_y [cm]	7.44
Area di taglio in direzione z	$A_{v,zz}$ [cm ²]	14.52

Classificazione della sezione a flessione Classe [-]

2

Forza di trazione nel tirante

Esercizio	p [kN/m]	141.2
Sismica	p [kN/m]	121.5

Sollecitazioni trave di ripartizione

Numero travi	n	2
Esercizio	V_E [kN]	81.83
	M_E [kNm]	39.28
Sisma	V_E [kN]	70.39
	M_{Ed} [kNm]	33.79

Verifica di resistenza trave di ripartizione condizioni statiche

Coefficiente amplificazione carichi	γ_E	1.0
	V_{Ed} [kN]	81.83
Taglio resistente in assenza di torsione	$V_{c,Rd}$ [kN]	283.43
	tasso lavoro $V_{Ed} / V_{c,Rd}$	0.29
[4.2.17] stato verifica		ok
	ρ	0.0
Momento di calcolo	M_{Ed} [kNm]	39.28
Resistenza a flessione	$M_{c,Rd} = M_{y,V,Rd}$	109.85
	tasso lavoro $M_{Ed} / M_{c,Rd}$	0.36
stato verifica		ok

Verifica di resistenza trave di ripartizione condizioni sismiche

Coefficiente amplificazione carichi	γ_E	1.0
	V_{Ed} [kN]	70.39
Taglio resistente in assenza di torsione	$V_{c,Rd}$ [kN]	283.43
	tasso lavoro $V_{Ed} / V_{c,Rd}$	0.25
[4.2.17] stato verifica		ok
	ρ	0.0
Momento di calcolo	M_{Ed} [kNm]	33.79
Resistenza a flessione	$M_{c,Rd} = M_{y,V,Rd}$	109.85
	tasso lavoro $M_{Ed} / M_{c,Rd}$	0.31
stato verifica		ok

Sezione tipo 2 – altezza di scavo = 6m

Ordine tiranti		I	II
Configurazione Tiranti			
Interasse	i [m]	2.4	2.4
Inclinazione tirante	α [°]	15	20
Materiale			
	Acciaio	S 355	S 355
Tensione di snervamento	f_{yk} [N/mm ²]	355	355
Coefficiente sicurezza resistenza	$\gamma_{M,0}$ [-]	1.05	1.05
Caratteristiche geometriche profilo			
Profilo		HE 180	HE180A
Larghezza	b [mm]	180	180
Altezza	h [mm]	171	171
Spessore anima	t_w [mm]	6	6
Spessore flangia	t_f [mm]	9.5	9.5
Raggio di raccordo	r [mm]	15	15
Altezza utile	d [mm]	122	122
Area lorda	A [mm ²]	45.3	45.3
Asse forte y-y			
Momento d'inerzia asse y	I_y [cm ⁴]	2510	2510
Modulo di resistenza elastico	$W_{el,y}$ [cm ³]	293.6	293.6
Modulo di resistenza plastico	$W_{pl,y}$ [cm ³]	324.9	324.9
Raggio d'inerzia	i_y [cm]	7.44	7.44
Area di taglio in direzione z	$A_{v,zz}$ [cm ²]	14.52	14.52
Classificazione della sezione a flessione			
	Classe [-]	2	2
Forza di trazione nel tirante			
Esercizio	p [kN/m]	134.0	104.8
Sismica	p [kN/m]	104.8	156.2
Sollecitazioni trave di ripartizione			
Numero travi	n	2	2
Esercizio	V_E [kN]	77.66	59.08
	M_E [kNm]	37.28	28.36
Sisma	V_E [kN]	60.73	88.07
	M_{Ed} [kNm]	29.15	42.27
Verifica di resistenza trave di ripartizione condizioni statiche			
Coefficiente amplificazione carichi	γ_E	1.0	1.0
	V_{Ed} [kN]	77.66	59.08
Taglio resistente in assenza di torsione	$V_{c,Rd}$ [kN]	283.43	283.43
tasso lavoro	$V_{Ed} / V_{c,Rd}$	0.27	0.21
[4.2.17] stato verifica		ok	ok
	ρ	0.0	0.0
Momento di calcolo	M_{Ed} [kNm]	37.28	28.36
Resistenza a flessione	$M_{c,Rd} = M_{y,V,Rd}$	109.85	109.85
tasso lavoro	$M_{Ed} / M_{c,Rd}$	0.34	0.26
stato verifica		ok	ok
Verifica di resistenza trave di ripartizione condizioni sismiche			
Coefficiente amplificazione carichi	γ_E	1.0	1.0
	V_{Ed} [kN]	60.73	88.07
Taglio resistente in assenza di torsione	$V_{c,Rd}$ [kN]	283.43	283.43
tasso lavoro	$V_{Ed} / V_{c,Rd}$	0.21	0.31
[4.2.17] stato verifica		ok	ok
	ρ	0.0	0.0
Momento di calcolo	M_{Ed} [kNm]	29.15	42.27
Resistenza a flessione	$M_{c,Rd} = M_{y,V,Rd}$	109.85	109.85
tasso lavoro	$M_{Ed} / M_{c,Rd}$	0.27	0.38
stato verifica		ok	ok

Sezione tipo 3 – altezza di scavo = 7,5m

Ordine tiranti		I	II	III
Configurazione Tiranti				
Interasse	i [m]	2.4	2.4	2.4
Inclinazione tirante	α [°]	15	20	25
Materiale				
	Acciaio	S 355	S 355	S 355
Tensione di snervamento	f_{yk} [N/mm ²]	355	355	355
Coefficiente sicurezza resistenza	$\gamma_{M,0}$ [-]	1.05	1.05	1.05
Caratteristiche geometriche profilo				
		HE180	HE180A	HE180A
Profilo		180	180	180
Larghezza	b [mm]	171	171	171
Altezza	h [mm]	6	6	6
Spessore anima	t_w [mm]	9.5	9.5	9.5
Spessore flangia	t_f [mm]	15	15	15
Raggio di raccordo	r [mm]	122	122	122
Altezza utile	d [mm]	45.3	45.3	45.3
Area lorda	A [mm ²]			
Asse forte y-y				
Momento d'inerzia asse y	I_y [cm ⁴]	2510	2510	2510
Modulo di resistenza elastico	$W_{el,y}$ [cm ³]	293.6	293.6	293.6
Modulo di resistenza plastico	$W_{pl,y}$ [cm ³]	324.9	324.9	324.9
Raggio d'inerzia	i_y [cm]	7.44	7.44	7.44
Area di taglio in direzione z	$A_{v,zz}$ [cm ²]	14.52	14.52	14.52
Classificazione della sezione a flessione				
	Classe [-]	2	2	2
Forza di trazione nel tirante				
Esercizio	p [kN/m]	135.6	197.0	191.6
Sismica	p [kN/m]	107.0	166.1	161.3
Sollecitazioni trave di ripartizione				
Numero travi	n	2	2	2
Esercizio	V_E [kN]	78.58	111.05	104.18
	M_E [kNm]	37.72	53.30	50.01
Sisma	V_E [kN]	62.01	93.66	87.70
	M_{Ed} [kNm]	29.77	44.96	42.10
Verifica di resistenza trave di ripartizione condizioni statiche				
Coefficiente amplificazione carichi	γ_E	1.0	1.0	1.0
	V_{Ed} [kN]	78.58	111.05	104.18
Taglio resistente in assenza di torsione	$V_{c,Rd}$ [kN]	283.43	283.43	283.43
tasso lavoro	$V_{Ed} / V_{c,Rd}$	0.28	0.39	0.37
[4.2.17] stato verifica		ok	ok	ok
	ρ	0.0	0.0	0.0
Momento di calcolo	M_{Ed} [kNm]	37.72	53.30	50.01
Resistenza a flessione	$M_{c,Rd} = M_{y,V,Rd}$	109.85	109.85	109.85
tasso lavoro	$M_{Ed} / M_{c,Rd}$	0.34	0.49	0.46
stato verifica		ok	ok	ok
Verifica di resistenza trave di ripartizione condizioni sismiche				
Coefficiente amplificazione carichi	γ_E	1.0	1.0	1.0
	V_{Ed} [kN]	62.01	93.66	87.70
Taglio resistente in assenza di torsione	$V_{c,Rd}$ [kN]	283.43	283.43	283.43
tasso lavoro	$V_{Ed} / V_{c,Rd}$	0.22	0.33	0.31
[4.2.17] stato verifica		ok	ok	ok
	ρ	0.0	0.0	0.0
Momento di calcolo	M_{Ed} [kNm]	29.77	44.96	42.10
Resistenza a flessione	$M_{c,Rd} = M_{y,V,Rd}$	109.85	109.85	109.85
tasso lavoro	$M_{Ed} / M_{c,Rd}$	0.27	0.41	0.38
stato verifica		ok	ok	ok

Sezione tipo 4 – altezza di scavo = 10m

Ordine tiranti		I	II	III	IV
Configurazione Tiranti					
Interasse	i [m]	2.4	2.4	2.0	2.0
Inclinazione tirante	α [°]	15	20	25	30
Materiale					
	Acciaio	S 355	S 355	S 355	S 355
Tensione di snervamento	f_{yk} [N/mm ²]	355	355	355	355
Coefficiente sicurezza resistenza	$\gamma_{M,0}$ [-]	1.05	1.05	1.05	1.05
Caratteristiche geometriche profilo					
Profilo		HE 180	HE180A	HE180A	HE180A
Larghezza	b [mm]	180	180	180	180
Altezza	h [mm]	171	171	171	171
Spessore anima	t_w [mm]	6	6	6	6
Spessore flangia	t_f [mm]	9.5	9.5	9.5	9.5
Raggio di raccordo	r [mm]	15	15	15	15
Altezza utile	d [mm]	122	122	122	122
Area lorda	A [mm ²]	45.3	45.3	45.3	45.3
Asse forte y-y					
Momento d'inerzia asse y	I_y [cm ⁴]	2510	2510	2510	2510
Modulo di resistenza elastico	$W_{el,y}$ [cm ³]	293.6	293.6	293.6	293.6
Modulo di resistenza plastico	$W_{pl,y}$ [cm ³]	324.9	324.9	324.9	324.9
Raggio d'inerzia	i_y [cm]	7.44	7.44	7.44	7.44
Area di taglio in direzione z	$A_{v,zz}$ [cm ²]	14.52	14.52	14.52	14.52
Classificazione della sezione a flessione	Classe [-]	2	2	2	2
Forza di trazione nel tirante					
Esercizio	p [kN/m]	89.1	143.5	383.0	341.4
Sismica	p [kN/m]	74.1	121.5	308.7	298.5
Sollecitazioni trave di ripartizione					
Numero travi	n	2	2	2	2
Esercizio	V_E [kN]	51.65	80.91	173.54	147.81
	M_E [kNm]	24.79	38.84	69.41	59.12
Sisma	V_E [kN]	42.94	68.50	139.89	129.23
	M_{Ed} [kNm]	20.61	32.88	55.96	51.69
Verifica di resistenza trave di ripartizione condizioni statiche					
Coefficiente amplificazione carichi	γ_E	1.0	1.0	1.0	1.0
Taglio resistente in assenza di torsione	V_{Ed} [kN]	51.65	80.91	173.54	147.81
	$V_{c,Rd}$ [kN]	283.43	283.43	283.43	283.43
	tasso lavoro $V_{Ed} / V_{c,Rd}$	0.18	0.29	0.61	0.52
[4.2.17] stato verifica		ok	ok	ok	ok
	ρ	0.0	0.0	0.1	0.0
Momento di calcolo	M_{Ed} [kNm]	24.79	38.84	69.41	59.12
Resistenza a flessione	$M_{c,Rd} = M_{y,V,Rd}$	109.85	109.85	108.35	109.79
	tasso lavoro $M_{Ed} / M_{c,Rd}$	0.23	0.35	0.64	0.54
	stato verifica	ok	ok	ok	ok
Verifica di resistenza trave di ripartizione condizioni sismiche					
Coefficiente amplificazione carichi	γ_E	1.0	1.0	1.0	1.0
Taglio resistente in assenza di torsione	V_{Ed} [kN]	42.94	68.50	139.89	129.23
	$V_{c,Rd}$ [kN]	283.43	283.43	283.43	283.43
	tasso lavoro $V_{Ed} / V_{c,Rd}$	0.15	0.24	0.49	0.46
[4.2.17] stato verifica		ok	ok	ok	ok
	ρ	0.0	0.0	0.0	0.0
Momento di calcolo	M_{Ed} [kNm]	20.61	32.88	55.96	51.69
Resistenza a flessione	$M_{c,Rd} = M_{y,V,Rd}$	109.85	109.85	109.85	109.85
	tasso lavoro $M_{Ed} / M_{c,Rd}$	0.19	0.30	0.51	0.47
	stato verifica	ok	ok	ok	ok

10. APPENDICE 1 – ANALISI DELLA PARATIA – TABULATI DI CALCOLO

Sezione tipo 0 – $H_{scavo} = 2,5m$

Sezione tipo 3 – $H_{scavo} = 7,5m$

Sezione tipo 1 – $H_{scavo} = 4,5m$

Sezione tipo 2 – $H_{scavo} = 6,0m$

Sezione tipo 3 – $H_{scavo} = 7,5m$

Sezione tipo 4 – $H_{scavo} = 10,0m$

DeepXcav 2010: Report Output

Copyright©2009 - 2010 Deep Excavation LLC: www.deepexcavation.com
A program for the evaluation of deep excavations

Project: My Project

Company: My Company
Prepared by engineer: Engineer
File number: 1
Time: 10/28/2010 9:17:33 PM

THIS PROGRAM IS PROTECTED BY U.S. COPYRIGHT LAWS AS DESCRIBED IN THE EULA. UNAUTHORIZED COPYING IS PROHIBITED. LICENSED TO: Deep Excavation LLC BY DEEP EXCAVATION LLC UNDER SPECIFIC LICENCE. This report has printed because the user has accepted responsibility as described in the disclaimer and EULA
File: C:\nda\paratie\10.10.28_sera\Lotto3\alleg\LIH_typ0_rev27oct10_EQscavo_Alleg.DEEP

DeepXcav 2010: Report Output

Copyright©2009 - 2010 Deep Excavation LLC: www.deepexcavation.com
A program for the evaluation of deep excavations

Project: My Project

Company: My Company
Prepared by engineer: Engineer
File number: 1
Time: 10/28/2010 9:17:33 PM

THIS PROGRAM IS PROTECTED BY U.S. COPYRIGHT LAWS AS DESCRIBED IN THE EULA. UNAUTHORIZED COPYING IS PROHIBITED. LICENSED TO: Deep Excavation LLC BY DEEP EXCAVATION LLC UNDER SPECIFIC LICENCE. This report has printed because the user has accepted responsibility as described in the disclaimer and EULA
File: C:\nda\paratie\10.10.28_sera\Lotto3\alleg\LIII_typ0_rev27oct10_EQscavo_Alleg.DEEP

OBJECTIVES

The objective of this document is to report the most important results of the calculations

BIBLIOGRAPHIC REFERENCES

BECCI,B.,NOVA,R. (1987) "Un metodo di calcolo automatico per il progetto di paratie", Rivista Italiana di

GENERAL CALCULATION ASSUMPTIONS

DEEP EXC is a program to simulate the behavior of flexible diaphragms. It is possible to simulate all the different stages of excavation.

The program is able to perform both classic and non linear analysis.

For the non linear analysis a FEM model is used. The FEM model follows the well known beam on elasto plastic foundation approach. The wall is modeled using BEAM elements, the soil is simulated using a double system (for each part of the wall) of elasto plastic springs.

An elasto plastic spring is connected on each node of the beam elements.

The excavation procedure is performed through 2 types of analysis:

1) Classic analysis

2) Non linear analysis : every step represents an excavation phase with a defined configuration of excavations, loads, etc.

The non linear analysis has been performed using a full Newton Raphson approach.

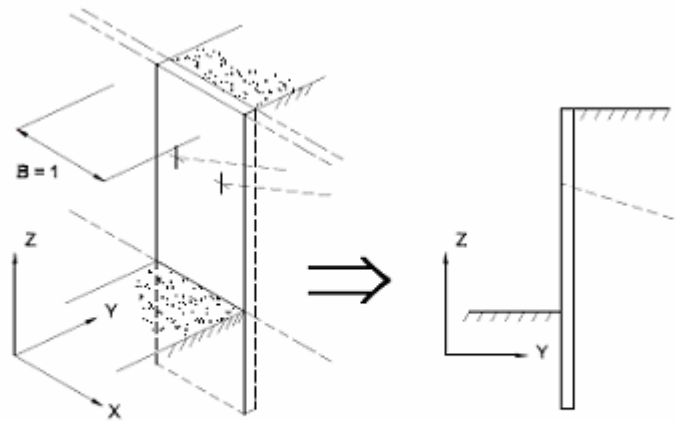

CONVENTIONS AND REFERENCE COORDINATE SYSTEMS

Loads, anelastic displacements, support reactions and displacements, are all referred to a righthand coordinate system

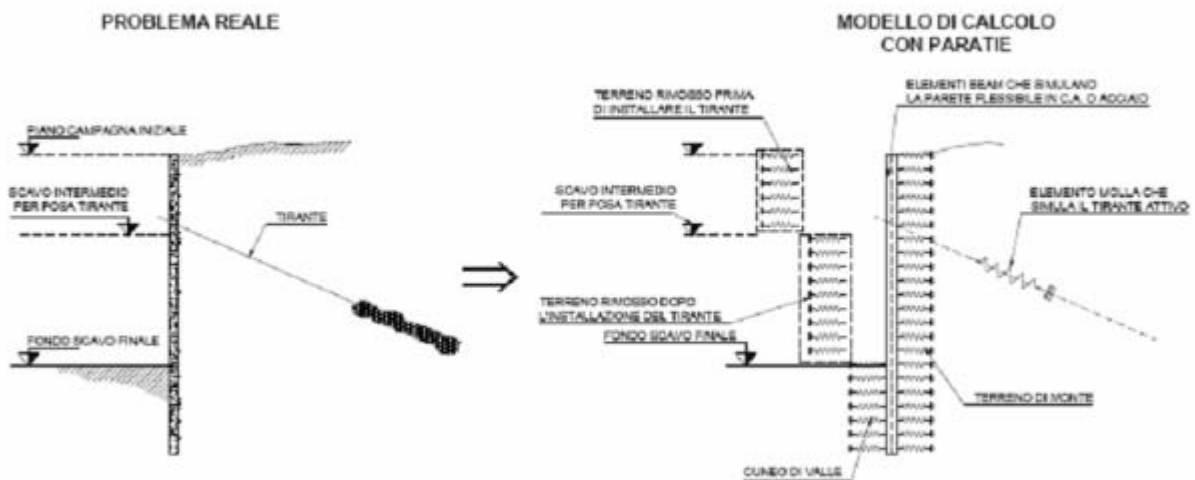

ELEMENTO TRUSS

1. FORCE : FORZA NELL'ELEMENTO PER UNITÀ DI PROFONDITÀ
2. STRESS : SPORZO

ELEMENTO BEAM (vedi figura 11-1)

1. VA : TAGLIO AL PRIMO ESTREMO
2. VB : TAGLIO AL SECONDO ESTREMO
3. MA : MOMENTO AL PRIMO ESTREMO
4. MB : MOMENTO AL SECONDO ESTREMO
(tutti per unità di profondità)

ELEMENTO ELPL (MOLLA ELASTOPLASTICA)

1. FORCE : FORZA NELL'ELEMENTO PER UNITÀ DI PROFONDITÀ
2. PLASTIC: DEFORMAZIONE PLASTICA

ELEMENTO WIRE (TIRANTE)

1. FORCE : FORZA NELL'ELEMENTO PER UNITÀ DI PROFONDITÀ

ELEMENTO CELAS (MOLLA ELASTICA)

1. FORCE : FORZA NELL'ELEMENTO PER UNITÀ DI PROFONDITÀ
2. MOMENT : MOMENTO NELL'ELEMENTO PER UNITÀ DI PROFONDITÀ

ELEMENTO SLAB (SOLETTA FRA DUE PARETI)

1. VA : TAGLIO AL PRIMO ESTREMO
2. VB : TAGLIO AL SECONDO ESTREMO
3. MA : MOMENTO AL PRIMO ESTREMO
4. MB : MOMENTO AL SECONDO ESTREMO
5. AXIAL : AZIONE ASSIALE
(tutti per unità di profondità)



Figura 11-1: convenzioni di segno per l'elemento BEAM

Checking of cross sections is performed according to the coordinate systems showed in the next figure

- X axis follow the 2 nodes direction of the beam elements , positive going from the first to the secondo node

ELEMENTO TRUSS

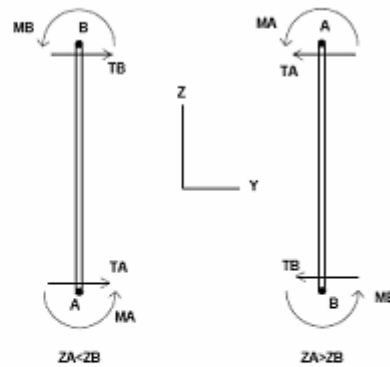
1. FORCE : FORZA NELL'ELEMENTO PER UNITÀ DI PROFONDITÀ
2. STRESS : SPORZO

ELEMENTO BEAM (vedi figura 11-1)

1. VA : TAGLIO AL PRIMO ESTREMO
2. VB : TAGLIO AL SECONDO ESTREMO
3. MA : MOMENTO AL PRIMO ESTREMO
4. MB : MOMENTO AL SECONDO ESTREMO
(tutti per unità di profondità)

ELEMENTO ELPL (MOLLA ELASTOPLASTICA)

1. FORCE : FORZA NELL'ELEMENTO PER UNITÀ DI PROFONDITÀ
2. PLASTIC: DEFORMAZIONE PLASTICA

ELEMENTO WIRE (TIRANTE)

1. FORCE : FORZA NELL'ELEMENTO PER UNITÀ DI PROFONDITÀ

ELEMENTO CELAS (MOLLA ELASTICA)

1. FORCE : FORZA NELL'ELEMENTO PER UNITÀ DI PROFONDITÀ
2. MOMENT : MOMENTO NELL'ELEMENTO PER UNITÀ DI PROFONDITÀ

ELEMENTO SLAB (SOLETTA FRA DUE PARETI)

1. VA : TAGLIO AL PRIMO ESTREMO
2. VB : TAGLIO AL SECONDO ESTREMO
3. MA : MOMENTO AL PRIMO ESTREMO
4. MB : MOMENTO AL SECONDO ESTREMO
5. AXIAL : AZIONE ASSIALE
(tutti per unità di profondità)



Figura 11-1: convenzioni di segno per l'elemento BEAM

DESIGN CODES

Reference codes are:

- DM 2008 - "Norme tecniche per le costruzioni"
- CSLP, "Istruzioni per l'applicazione delle Norme tecniche per le costruzioni di cui al DM 14/1/2008"
- EC2 1-1 :2004, Eurocode 2 - Design of concrete structures
- Ec3 1-1:2005, Eurocodice 3 - Design of steel structures
- Ec3 5:2002, Eurocodice 3 - Design of steel sheet piles walls
- Ec8:2004 - Seismic design of structures
- AISC ASD 9th Edition, 1989
- AISC LRFD 2nd Edition, 2003
- ACI 318-2002
- AASHTO 2000 ADS / LRFD

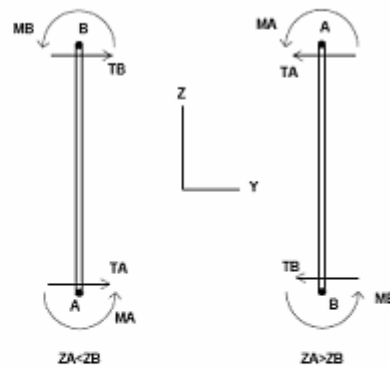
DESIGN PARAMETERS

Project: My Project

Results for Design Section 0: Base Section - Service

DESIGN APPROACHES AND COMBINATION FACTORS

The Design Approaches (from Codes or Customized by the user) and related safety factors are the following:

Ftan fr=mult factor for friction angle

F C'=mult factor for effective cohesion

F Su'=mult factof for undrained cohesion

F EQ=mult factor for seismic action

F perm load=mult factor for perm loads

F temp load=mult factor for live loads

F perm supp=reduct factor for resistance for pull out checking

F temp supp=fattore di riduzione resistenza per verifica pull out tirante

F earth Dstab=mult factor for active press coeff , unfavorable

F earth stab=mult factor for passive pressure , favorable

F GWT Dstab (ground water)=mult factor for hydrostatic pressure , unfavorable

F GWT stab (ground water)=mult factor for hydrostatic pressure, favorable

F HYD Dstab=mult factor for hydrodynamic pressure, unfavorable

F HYD stab=mult factor for hydrodynamic pressure, favorable

F UPL Dstab=mult factor for hydraulic heave, unfavorable

Stage	Design Name	Design Case	F(tan fr)	F (c')	F (Su)	F (EQ)	F(perm load)	F(temp load)	F(perm sup)	F(temp sup)	F Earth (Dstab)	F Earth (stab)	F GWT (Dstab)	F GWT (stab)	F HYD (Dstab)	F HYD (stab)	F UPL (Dstab)	F UPL (stab)
0	Default	Service	1	1	1	1	1	1	1	1	1	1	1	1	1	1	1	1
1	Default	Service	1	1	1	1	1	1	1	1	1	1	1	1	1	1	1	1

SOIL DATA

Name	g tot (kN/m3)	g dry (kN/m3)	Frict (deg)	C' (kPa)	Su (kPa)	FRp (deg)	FRcv (deg)	Eload (kPa)	Eur (kPa)	kAp Springs	kPp Springs	kAcv Springs	kPcv Springs	Vary	Spring Model	Color
F	20	19	30	0	N/A	N/A	N/A	15000	45000	0.33	3	N/A	N/A	True	Linear	
O1	16.5	14	22	2	20	22	22	2874	8622	0.46	2.2	0.46	2.2	True	Linear	
O2	19	16.5	28	2	N/A	N/A	N/A	7185	21555	0.36	2.77	N/A	N/A	True	Linear	
S1	21	19	34	0	N/A	N/A	N/A	25000	75000	0.28	3.54	N/A	N/A	True	Linear	
Clay	20	19	28	0	150	28	28	20000	60000	0.36	2.77	0.36	2.77	True	Linear	
GT	22	20	36	10	N/A	N/A	N/A	30000	90000	0.26	3.85	N/A	N/A	True	Linear	
Rock	27	25	30	100	N/A	N/A	N/A	479000	143700	0.33	3	N/A	N/A	True	Linear	
Rileva	18	18	32	0	N/A	N/A	N/A	30000	30000	0.31	3.26	N/A	N/A	True	Linear	
Base	18	18	25	0	N/A	N/A	N/A	25000	25000	0.41	2.46	N/A	N/A	True	Linear	

gtot=total soil specific weight

gdry=dry weight of the soil

Frict=friction angle

C'=effective cohesion

Su = Undrained cohesiona (only for CLAY soils in undrained conditions)

Dilat=SOil Dilatancy (only for non linear analysis)

Evc=Virgin compression elastic module

Eur=unloading/reloading elastic module

Kap= Peak active thrust coeff

Kpp= Peak passive thrust coeff

Kacv= Constant volume active thrust coeff

Kpcv= Constant volume passive thrust coeff

Spring models= spring model (LIN=constant over the soil layer height , EXP=exponential ,

SIMC=simplified winkler)

LIN= Linear-Elastic-Perfectly Plastic,

EXP: Exponential, SUB: Modulus of Subgrade Reaction

SOIL BORINGS

Top Elev= superior SOil level

Soil type=type of the soil (sand , clay , etc)

OCR=overconsolidation ratio

K0=at rest coefficient

Name: Boring 1, pos: (-20, 0)

Top elev.	Soil type	OCR	Ko
0	Rilevato	1	0.47
-4.5	Base	1	0.58

STRUCTURAL MATERIALS DATA

Steel

Name	Strength Fy (MPa)	Fu (MPa)	Elastic E (MPa)	Density g (kN/m3)
Fe360	235	360	206000	77
Fe510	355	510	210000	77
A36	248.3	400	206000	77
A50	355	500	206000	77
New steel 4	241.4	413.8	206000	77

Concrete

Name	Strength Fc' (MPa)	Elastic E (MPa)	Density g (kN/m3)	Tension Strength (MPa)
C20/25	20	29962	25	10
C25/30	25	31476	25	10
Fc 3ksi	20.7	21541.8	23.573	10

Steel rebar

Name	Strength Fy (MPa)	Elastic E (MPa)
S1860 (Strands)	1670	210000
Grade 75	517.2	200100
Grade 80	551.7	200100
Grade 150	1034.5	200100
Strands 270 ksi	1862.1	200100
S410	410	210000
S500	500	210000
B450C	450	210000

Wood

Name	Ultimate Bending (MPa)	Ultimate Tensile Strength (MPa)	Ultimate Shear Strength (MPa)	Density g (kN/m3)	Elastic E (MPa)
Construction	11	9.7	5.5	7.8576	6900
Regular grade	6.9	6.9	4.1	7.8576	5520

STEEL

Name=material name
 fy=fyk=characteristic resistance for steel (for all the codes)
 Fu=fuk=ultimate resistance for steel (for all the codes)
 Elastic E=Elastic modulus
 Density g=specific weight

CONCRETE

Name=material name
 f'c=fck=cylindrical resistance for concrete (for all the codes)
 Elastic E=Elastic modulus
 Density g=specific weight
 Tension strength=ft=fctk=characteristic tension resistance for concrete

STEEL REBARS

Name=material name
 fy=fyk=characteristic resistance for steel (for all the codes)
 Fu=fuk=ultimate resistance for steel (for all the codes)
 Elastic E=Elastic modulus
 Density g=specific weight

WOOD

Name=material name
 Fb=fbk=Ultimate bending strength
 Ftu=ftuk=Ultimate tensile strength
 Fvu=fvuk=Ultimate shear strength
 Density g=specific weight
 Elastic E=Elastic modulus

WALL DATA

Wall section 0: P168.3x10/40

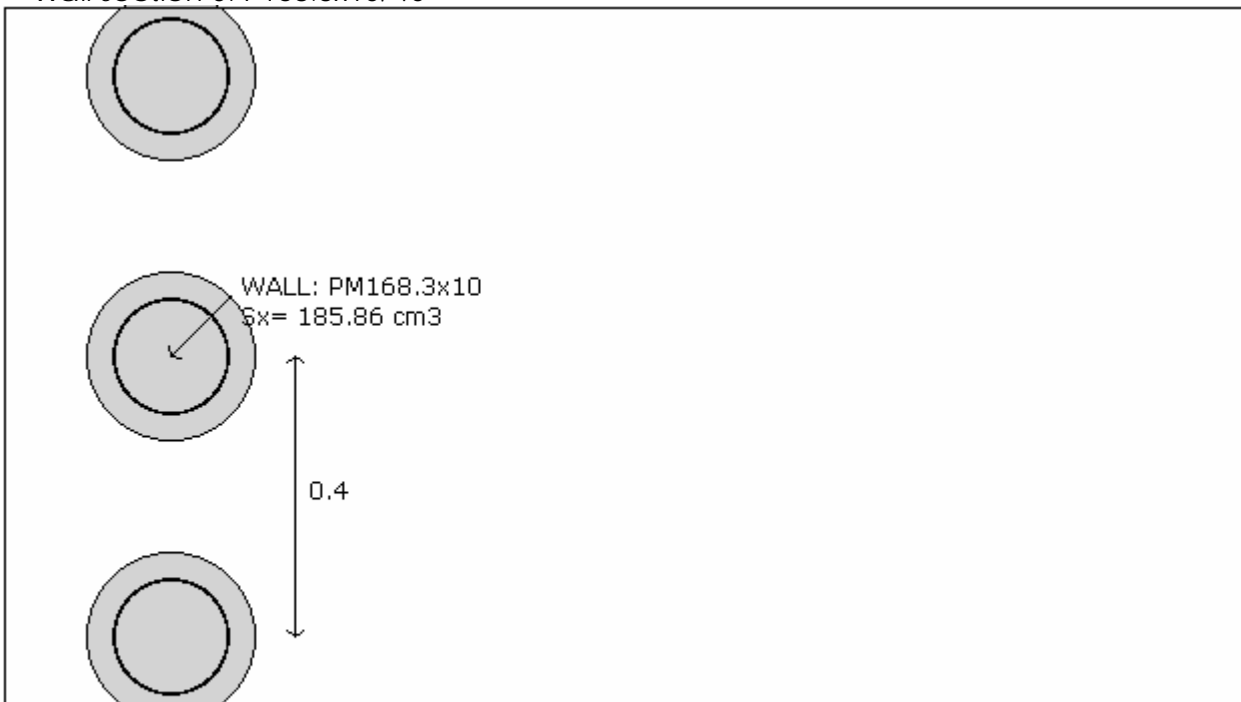

Company: My Company	Wall sketch	CeAS srl and Deep Excavation LCC
Engineer: Engineer		Paratie Plus 2010 - DeepXcar 2010
C:\nd.28_seraLotto3\alleg\LIII_typ0_rev27oct10_EQscavo_Alleg.DEEP		10/28/2010

Wall uses wall section 0: P168.3x10/40
 Wall type: Tangent pile wall
 Top wall El: 0 m Bottom wall El: -6 m
 Hor. wall spacing: 0.4 Wall thickness = 0.24
 Passive width below exc: 0.4 Active width below exc: 0.4
 Concrete f'c = 25 Rebar Fy = 410 Econc = 31476 Concrete tension FcT = 10% of Fc'

Steel members $f_y = 355$ Esteel = 210000
 Wall friction: Percentage of Soil Friction = 50%
 Steel wall capacities are calculated with NTC 2008
 Concrete capacities are calculated with ACI 318-2002.
 Note: With ultimate capacities you may have to use a structural safety factor.
 Tangent pile wall soldier pile properties

Table: Soldier Pile Properties

Name	Section	W	A	D	tw or	bf	tf	k	Ixx	Sxx	rX	Iyy	Syy	rY	rT	Cw	fy
		(kN/m)	(cm ²)	(cm)	(cm)	(cm)	(cm)	(cm)	(cm ⁴)	(cm ³)	(cm)	(cm ⁴)	(cm ³)	(cm)	(cm)	(cm ⁶)	(MPa)
	PM16	257.3	75.62	16.8	1	16.83	1	1	3771	185.9	7.06	3771	185.9	7.06	7.06	1	355

GENERAL WALL DATA

Hor wall spacing=wall horizontal spacing
 Passive width below exc=spacing for passive thrust pressure for classic analysis
 $f'_c=f_{ck}$ =cylindrical concrete resistance
 $f_y=f_{yk}$ =steel rebar characteristic resistance
 E_{conc} =Concrete Elastic modulus
 f_{ctk} =characteristic Concrete tension
 E_{steel} =steel elastic modulus
 TABULAR DATA (principal parameters)

1) Diaphragm wall (rectangular cross section section)
 N/A= data not available

$F_y=f_{yk}$
 $F'_c=f_{ck}$
 D=wall height
 B=wall width
 2) Steel sheet pile
 DES=shape (Z or U)
 W=weight per unit of length
 A=area
 h=height
 t=horiz part thickness
 b=width of the single sheet pile part
 s=inclined part thickness
 Ixx=strong axis inertia (per unit of length)
 Sxx=strong axis section modulus (per unit of length)

3) Secant piles wall, Tangent piles wall, soldier piles, soldier piles and timber lagging
 W=weight per unit of length
 A=area
 D=diameter
 tw=web thickness
 tp= pipe thickness
 bf=flange width
 tf=flange thickness
 k=flange thickness+stem thickness
 Ixx=strong axis inertia modulus (per unit of length)
 Sxx=strong axis section modulus (per unit of length)
 rx=radius of gyration about X axis
 ry=radius of gyration about Y axis
 Iyy=weak axis inertia modulus (per unit of length)
 Syy=weak axis section modulus (per unit of length)
 rT=radius of gyration for torsion
 Cw=warping constant

TIEBACK DATA

Name	Fy	Fc'	Dfix	Afix	Efix	Afree	Efree	Pa STR	Pu STR	PresGr	FSgeo	UserGca	Pa	Pu	WireMod
	(MPa)	(MPa)	(cm)	(cm ²)	(MPa)	(cm ²)	(MPa)	(kN)	(kN)	(kPa)			(kN)	(kN)	Yes/No
4-Strands	1862.1	25	15	176.7	31476	2.8	200100	453.4	453.4	N/A	1.4	False	N/A	N/A	Yes
5-Strands	1862.1	25	15	176.7	31476	0	200100	0	0	N/A	1.4	False	N/A	N/A	Yes
6-Strands	1862.1	25	15	176.7	31476	8.39	200100	1357.9	1357.9	N/A	1.4	False	N/A	N/A	Yes

Tieback_	1670	25	16	201.0	31476	4.17	210000	605.2	605.2	N/A	1	False	N/A	N/A	Yes
----------	------	----	----	-------	-------	------	--------	-------	-------	-----	---	-------	-----	-----	-----

EXCAVATION STAGES SKETCHES

A sequence of figures for each excavation stage is reported

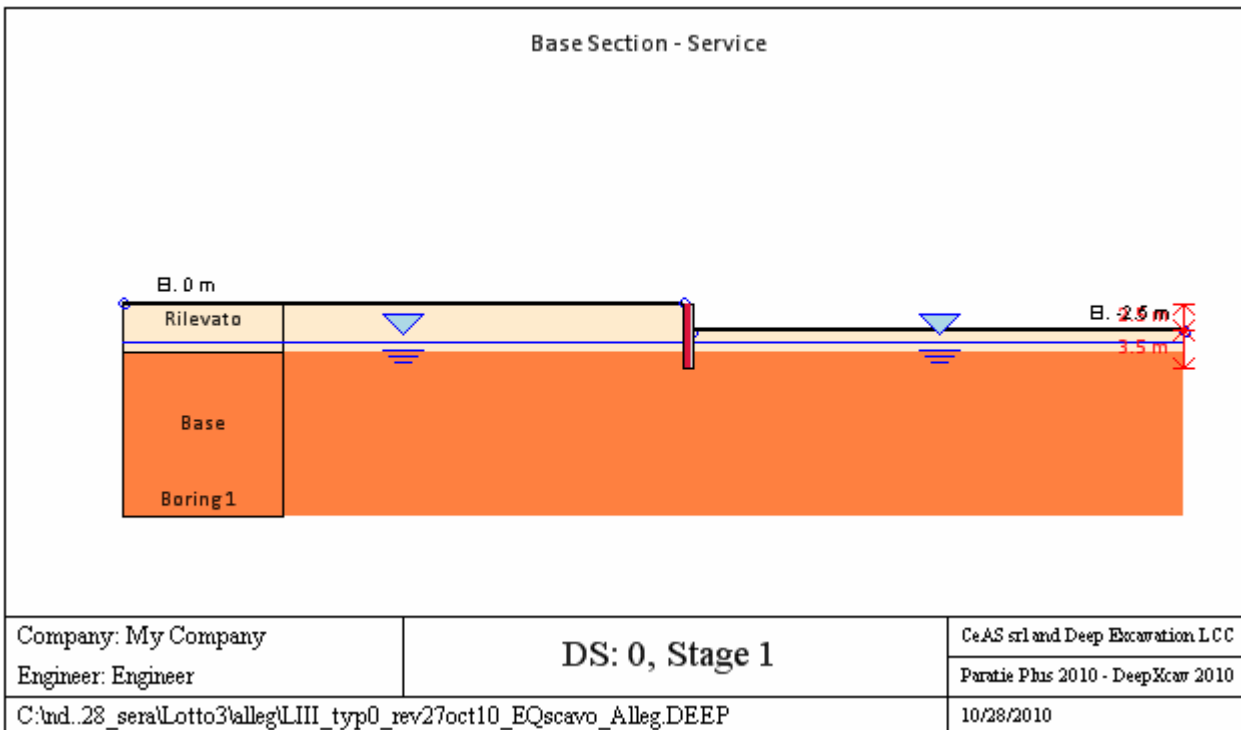
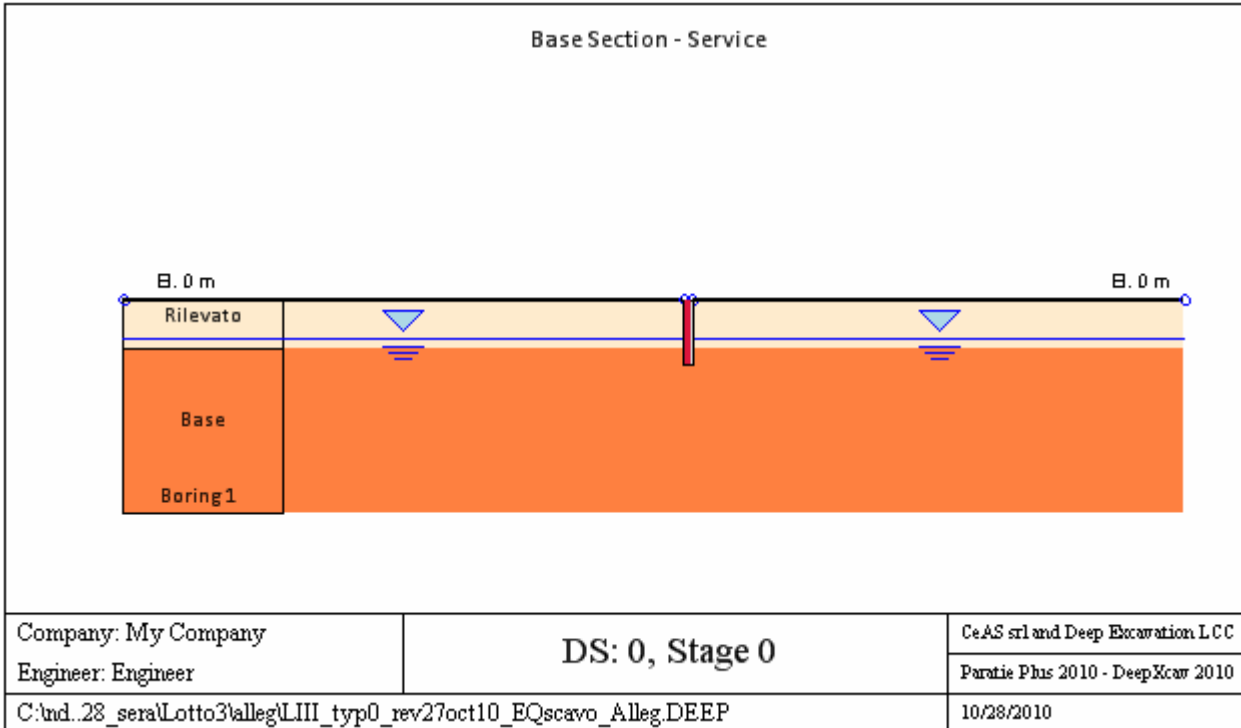

GENERAL ANALYSIS CRITERIA

Summary of stage assumptions

Name	Analysis	Drive	ka-Mult	Htr	Resist	Res	Contl	Supp	Axial	Used	Min	Toe	Toe
	Method	Press		(%)	Press	Mult	Meth	Mode	Incl	FSwall	FDtoe	FSrot	FSpas

Stage 0	Springs-Up	Ka+ d	N/A	N/A	Kp+ d	N/A		Fixed	N/A	1	14.51	17.25	14.51
Stage 1	Springs-Up	Ka+ d	N/A	N/A	Kp+ d	N/A		Fixed	N/A	1	2.188	2.648	3.551

Name=excavation phase name

Analysis method

- springs=elasto plastic springs are used
- DR=Drained condition for CLAY model
- U=Undrained condition for CLAY model for all the soils
- Up=Undrained condition just for selected soil

Drive press=Ka

ka mult=multiply factor for Ka

Htr T/B (%)=trapezoidal pressure scheme

Resit press=Kp

Res Mult=Multiply factor for Kp

COntle Method=cantilver method

Support Model=Fix support type

Axial Incl=Axial action is included for design

Used FS wall=Reduction factor for axial+bending resistance dominium

Min FD TOe=embedded minimum safety factor (for classic analysis)

Toe FS rot=rotation safety factor (classic for classic analysis)

Toe FSpas=driving/resistent pressure safety factor (for classic analysis)

SEISMIC DATA

Seismic action is modeled through a pseudo static approach

Summary of stage assumptions

Stage Number	Seismic g Used	Method Used	aX (g)	aY (g)	Beta	Building Code (Name)
0	No		0.04	0	1	N/A
1	No		0.04	0	1	N/A

N/A= data non available

Stage number=number of stage input

Seismic ag =value of design acceleration according to a code or input by the user

Method=the method used to evaluated the seismic thrustover the wall

ahd or khd otr axd=design horizontal acceleration

avd or kvd or ayd=design vertical acceleration

Beta=multip coeff for the semirigd approach

Buildind code=code used for design acceleration calculation

WALL RESULTS TABLE

P168.3x10/40 Stage: 0

Wall Nod	EL (m)	Sht L (kPa)	Sht R (kPa)	Shs L (kPa)	Shs R (kPa)	q (kPa)	U L (kPa)	U R (kPa)	M (kN-	V (kN/m)	dx (cm)
0	0	0	0	0	0	0	0	0	0	0	0
2	-0.2	1.692	1.692	1.692	1.692	0	0	0	0	0	0
4	-0.4	3.384	3.384	3.384	3.384	0	0	0	0	0	0
6	-0.6	5.076	5.076	5.076	5.076	0	0	0	0	0	0
8	-0.8	6.768	6.768	6.768	6.768	0	0	0	0	0	0
10	-1	8.46	8.46	8.46	8.46	0	0	0	0	0	0
12	-1.2	10.152	10.152	10.152	10.152	0	0	0	0	0	0
14	-1.4	11.844	11.844	11.844	11.844	0	0	0	0	0	0
16	-1.6	13.536	13.536	13.536	13.536	0	0	0	0	0	0
18	-1.8	15.228	15.228	15.228	15.228	0	0	0	0	0	0
20	-2	16.92	16.92	16.92	16.92	0	0	0	0	0	0
22	-2.2	18.612	18.612	18.612	18.612	0	0	0	0	0	0
24	-2.4	20.304	20.304	20.304	20.304	0	0	0	0	0	0
26	-2.6	21.996	21.996	21.996	21.996	0	0	0	0	0	0

28	-2.8	23.688	23.688	23.688	23.688	0	0	0	0	0	0
30	-3	25.38	25.38	25.38	25.38	0	0	0	0	0	0
32	-3.2	27.072	27.072	27.072	27.072	0	0	0	0	0	0
34	-3.4	28.764	28.764	28.764	28.764	0	0	0	0	0	0
36	-3.6	30.986	30.986	29.986	29.986	0	1	1	0	0	0
38	-3.8	33.738	33.738	30.738	30.738	0	3	3	0	0	0
40	-4	36.49	36.49	31.49	31.49	0	5	5	0	0	0
42	-4.2	39.242	39.242	32.242	32.242	0	7	7	0	0	0
44	-4.4	41.994	41.994	32.994	32.994	0	9	9	0	0	0
46	-4.6	52.429	52.429	41.429	41.429	0	11	11	0	0	0
48	-4.8	55.352	55.352	42.352	42.352	0	13	13	0	0	0
50	-5	58.275	58.275	43.275	43.275	0	15	15	0	0	0
52	-5.2	61.198	61.198	44.198	44.198	0	17	17	0	0	0
54	-5.4	64.121	64.121	45.121	45.121	0	19	19	0	0	0
56	-5.6	67.045	67.045	46.045	46.045	0	21	21	0	0	0
58	-5.8	69.968	69.968	46.968	46.968	0	23	23	0	0	0
60	-6	72.891	72.891	47.891	47.891	0	25	25	0	0	0

P168.3x10/40 Stage: 1

Wall	EL	Sht L	Sht R	Shs L	Shs R	q	U L	U R	M	V	dx
Nod	(m)	(kPa)	(kPa)	(kPa)	(kPa)	(kPa)	(kPa)	(kPa)	(kN-	(kN/m)	(cm)
0	0	0	0	0	0	0	0	0	0	0	1.2
2	-0.2	0.961	0	0.961	0	0	0	0	0	0.05	1.13
4	-0.4	1.922	0	1.922	0	0	0	0	0.05	0.29	1.07
6	-0.6	2.884	0	2.884	0	0	0	0	0.17	0.72	1.01
8	-0.8	3.845	0	3.845	0	0	0	0	0.4	1.35	0.95
10	-1	4.806	0	4.806	0	0	0	0	0.79	2.16	0.88
12	-1.2	5.767	0	5.767	0	0	0	0	1.37	3.17	0.82
14	-1.4	6.728	0	6.728	0	0	0	0	2.19	4.37	0.76
16	-1.6	7.69	0	7.69	0	0	0	0	3.27	5.77	0.7
18	-1.8	8.651	0	8.651	0	0	0	0	4.66	7.35	0.64
20	-2	9.612	0	9.612	0	0	0	0	6.39	9.13	0.58
22	-2.2	10.573	0	10.573	0	0	0	0	8.51	11.1	0.52
24	-2.4	11.534	0	11.534	0	0	0	0	11.05	13.26	0.46
26	-2.6	12.496	9.101	12.496	9.101	0	0	0	14.06	15.62	0.41
28	-2.8	13.457	27.302	13.457	27.302	0	0	0	17.2	15.44	0.36
30	-3	14.418	40.999	14.418	40.999	0	0	0	19.78	11.8	0.31
32	-3.2	15.379	38.867	15.379	38.867	0	0	0	21.36	6.65	0.26
34	-3.4	16.34	37	16.34	37	0	0	0	22	2.09	0.22
36	-3.6	18.035	35.916	17.035	34.916	0	1	1	21.81	-1.91	0.19
38	-3.8	20.462	35.682	17.462	32.682	0	3	3	20.91	-5.35	0.16
40	-4	22.889	35.856	17.889	30.856	0	5	5	19.4	-8.27	0.13
42	-4.2	25.316	36.409	18.316	29.409	0	7	7	17.36	-10.77	0.11
44	-4.4	28.108	37.301	19.108	28.301	0	9	9	14.88	-12.91	0.09
46	-4.6	44.325	42.889	33.325	31.889	0	11	11	12.12	-13.85	0.07
48	-4.8	48.924	44.561	35.924	31.561	0	13	13	9.4	-13.41	0.05
50	-5	53.299	46.408	38.299	31.408	0	15	15	6.87	-12.4	0.04
52	-5.2	57.511	48.381	40.511	31.381	0	17	17	4.6	-10.91	0.03
54	-5.4	61.611	50.437	42.611	31.437	0	19	19	2.71	-8.98	0.02
56	-5.6	65.647	52.541	44.647	31.541	0	21	21	1.25	-6.65	0.01
58	-5.8	69.651	54.665	46.651	31.665	0	23	23	0.33	-3.93	0
60	-6	73.646	56.792	48.646	31.792	0	25	25	0	-0.84	-0.01

LEGENDA

Wall node=number of the node

EL=elevation

Sht L=Total horizontal soil pressure (on the left side of the wall)

Sht R=Total horizontal soil pressure (on the right side of the wall)

Shs L=Effective horizontal soil pressure (on the left side of the wall)

Shs R=Effective horizontal soil pressure (on the right side of the wall)

q=pressure given by the surcharge

U L=Water pressure (on the left side of the wall)

U R=pressione acqua (on the right side of the wall)

M=bending moment (per meter)

V=shear (per metro)

dx=wall deflection

McapL=Ultimate bending moment (on the left side of the wall)

McapR=Ultimate bending moment (on the right side of the wall)

VcapL=Ultimate resistance shear (on the left side of the wall)

VcapR=Ultimate resistance shear (on the right side of the wall)

Project: My Project

Results for Design Section 1: DM08_ITA: Comb. 1:

A1+M1+R1

DESIGN APPROACHES AND COMBINATION FACTORS

The Design Approaches (from Codes or Customized by the user) and related safety factors are the following:

Ftan fr=mult factor for friction angle

F C'=mult factor for effective cohesion

F Su'=mult factof for undrained cohesion

F EQ=mult factor for seismic action

F perm load=mult factor for perm loads

F temp load=mult factor for live loads

F perm supp=reduct factor for resistance for pull out checking

F temp supp=fattore di riduzione resistenza per verifica pull out tirante

F earth Dstab=mult factor for active press coeff , unfavorable

F earth stab=mult factor for passive pressure , favorable

F GWT Dstab (ground water)=mult factor for hydrostatic pressure , unfavorable

F GWT stab (ground water)=mult factor for hydrostatic pressure, favorable

F HYD Dstab=mult factor for hydrodynamic pressure, unfavorable

F HYD stab=mult factor for hydrodynamic pressure, favorable

F UPL Dstab=mult factor for hydraulic heave, unfavorable

Stage	Design Name	Design Case	F(tan fr)	F (c')	F (Su)	F (EQ)	F(perm load)	F(temp load)	F(perm sup)	F(temp sup)	F Earth (Dstab)	F Earth (stab)	F GWT (Dstab)	F GWT (stab)	F HYD (Dstab)	F HYD (stab)	F UPL (Dstab)	F UPL (stab)
0	DM08_ITA	1: A1+M1+R1	1	1	1	0	1.3	1.5	1.2	1.1	1.3	1	1.3	1	1.35	0.9	1	1
1	DM08_ITA	1: A1+M1+R1	1	1	1	0	1.3	1.5	1.2	1.1	1.3	1	1.3	1	1.35	0.9	1	1

SOIL DATA

Name	g tot (kN/m3)	g dry (kN/m3)	Frict (deg)	C' (kPa)	Su (kPa)	FRp (deg)	FRcv (deg)	Eload (kPa)	Eur (kPa)	kAp Springs	kPp Springs	kAcv Springs	kPcv Springs	Vary	Spring Model	Color
F	20	19	30	0	N/A	N/A	N/A	15000	45000	0.33	3	N/A	N/A	True	Linear	
O1	16.5	14	22	2	20	22	22	2874	8622	0.46	2.2	0.46	2.2	True	Linear	
O2	19	16.5	28	2	N/A	N/A	N/A	7185	21555	0.36	2.77	N/A	N/A	True	Linear	
S1	21	19	34	0	N/A	N/A	N/A	25000	75000	0.28	3.54	N/A	N/A	True	Linear	
Clay	20	19	28	0	150	28	28	20000	60000	0.36	2.77	0.36	2.77	True	Linear	
GT	22	20	36	10	N/A	N/A	N/A	30000	90000	0.26	3.85	N/A	N/A	True	Linear	
Rock	27	25	30	100	N/A	N/A	N/A	479000	143700	0.33	3	N/A	N/A	True	Linear	
Rileva	18	18	32	0	N/A	N/A	N/A	30000	30000	0.31	3.26	N/A	N/A	True	Linear	
Base	18	18	25	0	N/A	N/A	N/A	25000	25000	0.41	2.46	N/A	N/A	True	Linear	

gtot=total soil specific weight

gdry=dry weight of the soil

Frict=friction angle

C'=effective cohesion

Su = Undrained cohesiona (only for CLAY soils in undrained conditions)

Dilat=SOil Dilatancy (only for non linear analysis)

Evc=Virgin compression elastic module

Eur=unloading/reloading elastic module

Kap= Peak active thrust coeff

Kpp= Peak passive thrust coeff

Kacv= Constant volume active thrust coeff

Kpcv= Constant volume passive thrust coeff

Spring models= spring model (LIN=constant over the soil layer heigth , EXP=exponential ,

SIMC=simplified winkler)

LIN= Linear-Elastic-Perfectly Plastic,

EXP: Exponential, SUB: Modulus of Subgrade Reaction

SOIL BORINGS

Top Elev= superior SOil level

Soil type=type of the soil (sand , clay , etc)

OCR=overconsolidation ratio

K0=at rest coefficient

Name: Boring 1, pos: (-20, 0)

Top elev.	Soil type	OCR	Ko
0	Rilevato	1	0.47
-4.5	Base	1	0.58

STRUCTURAL MATERIALS DATA

Steel

Name	Strength Fy (MPa)	Fu (MPa)	Elastic E (MPa)	Density g (kN/m3)
Fe360	235	360	206000	77
Fe510	355	510	210000	77
A36	248.3	400	206000	77
A50	355	500	206000	77
New steel 4	241.4	413.8	206000	77

Concrete

Name	Strength Fc' (MPa)	Elastic E (MPa)	Density g (kN/m3)	Tension Strength (MPa)
C20/25	20	29962	25	10
C25/30	25	31476	25	10
Fc 3ksi	20.7	21541.8	23.573	10

Steel rebar

Name	Strength Fy (MPa)	Elastic E (MPa)
S1860 (Strands)	1670	210000
Grade 75	517.2	200100
Grade 80	551.7	200100
Grade 150	1034.5	200100
Strands 270 ksi	1862.1	200100
S410	410	210000
S500	500	210000
B450C	450	210000

Wood

Name	Ultimate Bending (MPa)	Ultimate Tensile Strength (MPa)	Ultimate Shear Strength (MPa)	Density g (kN/m3)	Elastic E (MPa)
Construction	11	9.7	5.5	7.8576	6900
Regular grade	6.9	6.9	4.1	7.8576	5520

STEEL

Name=material name
 fy=fyk=characteristic resistance for steel (for all the codes)
 Fu=fuk=ultimate resistance for steel (for all the codes)
 Elastic E=Elastic modulus
 Density g=specific weight

CONCRETE

Name=material name
 f'c=fck=cylindrical resistance for concrete (for all the codes)
 Elastic E=Elastic modulus
 Density g=specific weight
 Tension strength=ft=fctk=characteristic tension resistance for concrete

STEEL REBARS

Name=material name
 fy=fyk=characteristic resistance for steel (for all the codes)
 Fu=fuk=ultimate resistance for steel (for all the codes)
 Elastic E=Elastic modulus
 Density g=specific weight

WOOD

Name=material name
 Fb=fbk=Ultimate bending strength
 Ftu=ftuk=Ultimate tensile strength
 Fvu=fvuk=Ultimate shear strength
 Density g=specific weight
 Elastic E=Elastic modulus

WALL DATA

Wall section 0: P168.3x10/40

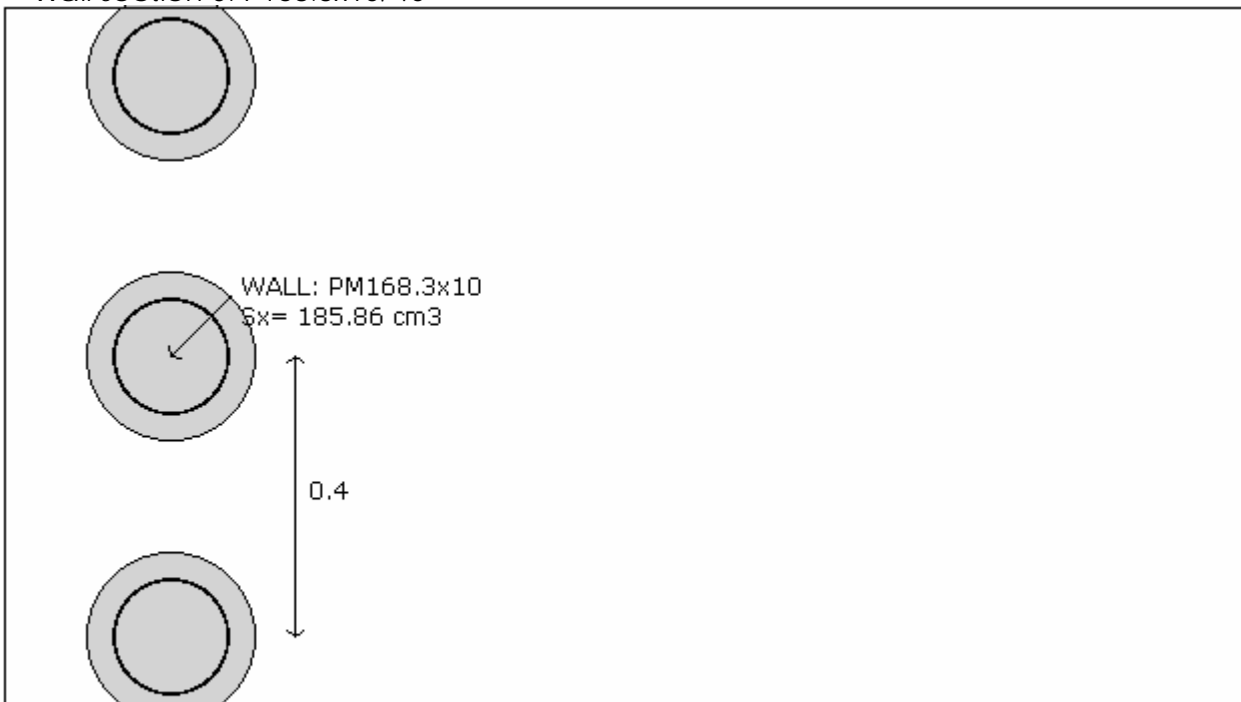

Company: My Company	Wall sketch	CeAS srl and Deep Excavation LCC
Engineer: Engineer		Paratie Plus 2010 - DeepXcar 2010
C:\nd.28_seraLotto3\alleg\LIII_typ0_rev27oct10_EQscavo_Alleg.DEEP		10/28/2010

Wall uses wall section 0: P168.3x10/40
 Wall type: Tangent pile wall
 Top wall El: 0 m Bottom wall El: -6 m
 Hor. wall spacing: 0.4 Wall thickness = 0.24
 Passive width below exc: 0.4 Active width below exc: 0.4
 Concrete f'c = 25 Rebar Fy = 410 Econc = 31476 Concrete tension FcT = 10% of Fc'

Steel members $f_y = 355$ Esteel = 210000

Wall friction: Percentage of Soil Friction = 50%

Steel wall capacities are calculated with NTC 2008

Concrete capacities are calculated with ACI 318-2002.

Note: With ultimate capacities you may have to use a structural safety factor.

Tangent pile wall soldier pile properties

Table: Soldier Pile Properties

Name	Section	W	A	D	tw or	bf	tf	k	Ixx	Sxx	rX	Iyy	Syy	rY	rT	Cw	fy
		(kN/m)	(cm ²)	(cm)	(cm)	(cm)	(cm)	(cm)	(cm ⁴)	(cm ³)	(cm)	(cm ⁴)	(cm ³)	(cm)	(cm)	(cm ⁶)	(MPa)
	PM16	257.3	75.62	16.8	1	16.83	1	1	3771	185.9	7.06	3771	185.9	7.06	7.06	1	355

GENERAL WALL DATA

Hor wall spacing=wall horizontal spacing

Passive width below exc=spacing for passive thrust pressure for classic analysis

$f'_c=f_{ck}$ =cylindrical concrete resistance

$f_y=f_{yk}$ =steel rebar characteristic resistance

E_{conc} =Concrete Elastic modulus

f_{ctk} =characteristic Concrete tension

E_{steel} =steel elastic modulus

TABULAR DATA (principal parameters)

1) Diaphragm wall (rectangular cross section section)

N/A= data not available

$F_y=f_{yk}$

$F'_c=f_{ck}$

D=wall height

B=wall width

2) Steel sheet pile

DES=shape (Z or U)

W=weight per unit of length

A=area

h=height

t=horiz part thickness

b=width of the single sheet pile part

s=inclined part thickness

I_{xx} =strong axis inertia (per unit of length)

S_{xx} =strong axis section modulus (per unit of length)

3) Secant piles wall, Tangent piles wall, soldier piles, soldier piles and timber lagging

W=weight per unit of length

A=area

D=diameter

tw=web thickness

tp= pipe thickness

bf=flange width

tf=flange thickness

k=flange thickness+stem thickness

I_{xx} =strong axis inertia modulus (per unit of length)

S_{xx} =strong axis section modulus (per unit of length)

r_x =radius of gyration about X axis

r_y =radius of gyration about Y axis

I_{yy} =weak axis inertia modulus (per unit of length)

S_{yy} =weak axis section modulus (per unit of length)

r_T =radius of gyration for torsion

Cw=warping constant

TIEBACK DATA

Name	F_y	F'_c	D_{fix}	A_{fix}	E_{fix}	A_{free}	E_{free}	Pa STR	Pu STR	PresGr	FSgeo	UserGca	Pa	Pu	WireMod
	(MPa)	(MPa)	(cm)	(cm ²)	(MPa)	(cm ²)	(MPa)	(kN)	(kN)	(kPa)			(kN)	(kN)	Yes/No
4-Strands	1862.1	25	15	176.7	31476	2.8	200100	453.4	453.4	N/A	1.4	False	N/A	N/A	Yes
5-Strands	1862.1	25	15	176.7	31476	0	200100	0	0	N/A	1.4	False	N/A	N/A	Yes
6-Strands	1862.1	25	15	176.7	31476	8.39	200100	1357.9	1357.9	N/A	1.4	False	N/A	N/A	Yes

Tieback_	1670	25	16	201.0	31476	4.17	210000	605.2	605.2	N/A	1	False	N/A	N/A	Yes
----------	------	----	----	-------	-------	------	--------	-------	-------	-----	---	-------	-----	-----	-----

EXCAVATION STAGES SKETCHES

A sequence of figures for each excavation stage is reported

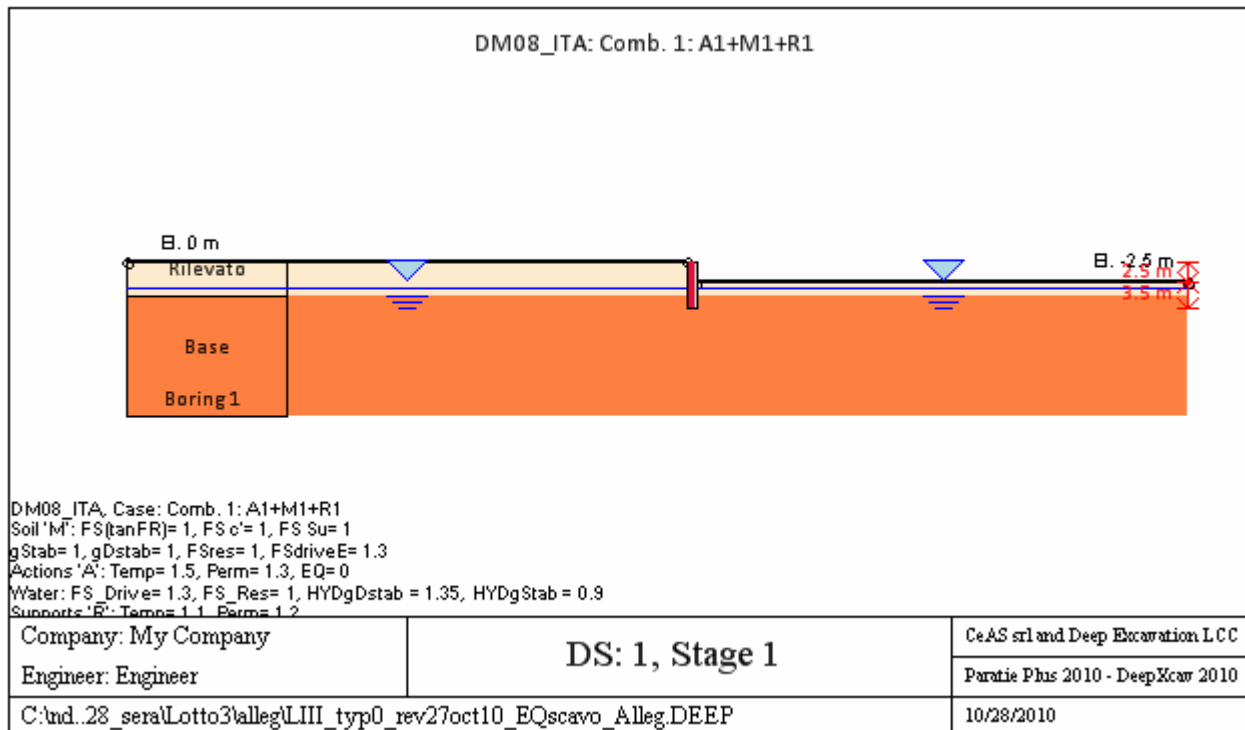
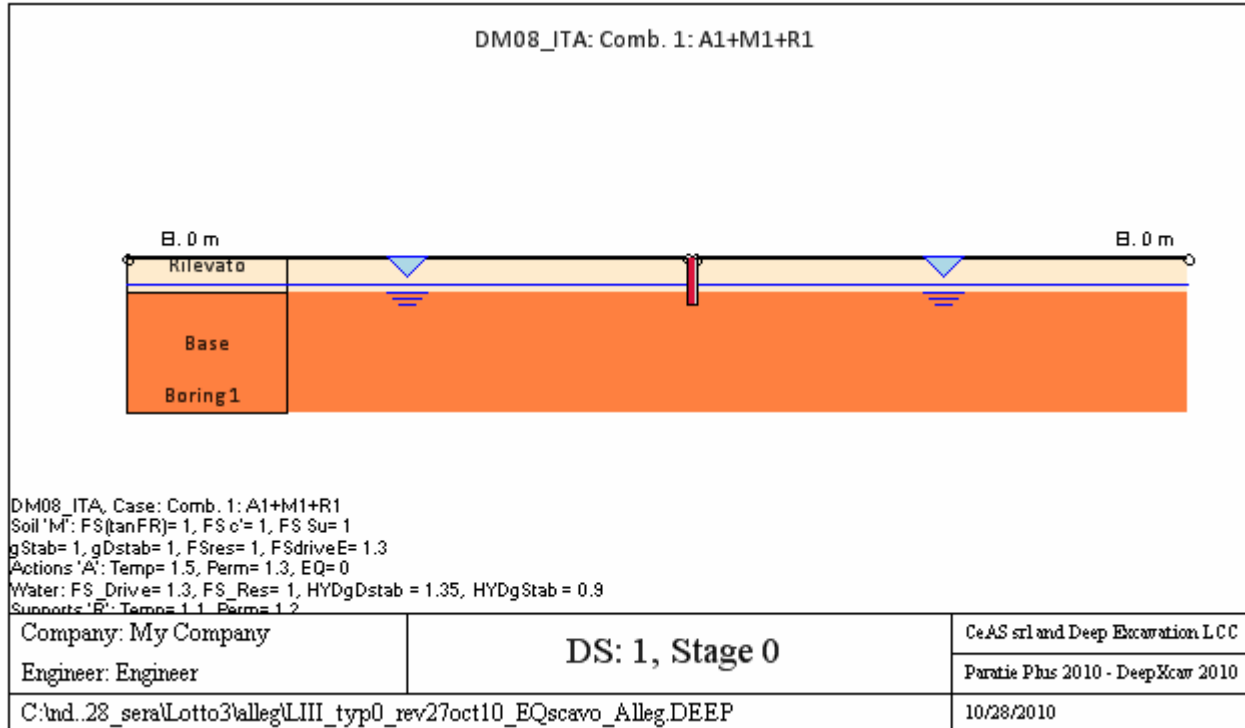

GENERAL ANALYSIS CRITERIA

Summary of stage assumptions

Name	Analysis	Drive	ka-Mult	Htr	Resist	Res	Contl	Supp	Axial	Used	Min	Toe	Toe
	Method	Press		(%)	Press	Mult	Meth	Mode	Incl	FWall	FDtoe	FSrot	FSpas

Stage 0	Springs-Up	Ka+ d	N/A	N/A	Kp+ d	N/A		Fixed	N/A	1	11.16	13.27	11.16
Stage 1	Springs-Up	Ka+ d	N/A	N/A	Kp+ d	N/A		Fixed	N/A	1	1.944	2.037	2.732

Name=excavation phase name

Analysis method

springs=elasto plastic springs are used

DR=Drained condition for CLAY model

U=Undrained condition for CLAY model for all the soils

Up=Undrained condition just for selected soil

Drive press=Ka

ka mult=multiply factor for Ka

Htr T/B (%)=trapezoidal pressure scheme

Resit press=Kp

Res Mult=Multiply factor for Kp

COntle Method=cantilver method

Support Model=Fix support type

Axial Incl=Axial action is included for design

Used FS wall=Reduction factor for axial+bending resistance dominium

Min FD TOe=embedded minimum safety factor (for classic analysis)

Toe FS rot=rotation safety factor (classic for classic analysis)

Toe FSpas=driving/resistent pressure safety factor (for classic analysis)

SEISMIC DATA

Seismic action is modeled through a pseudo static approach

Summary of stage assumptions

Stage Number	Seismic g Used	Method Used	aX (g)	aY (g)	Beta	Building Code (Name)
0	No		0.04	0	1	N/A
1	No		0.04	0	1	N/A

N/A= data non available

Stage number=number of stage input

Seismic ag =value of design acceleration according to a code or input by the user

Method=the method used to evaluated the seismic thrustover the wall

ahd or khd otr axd=design horizontal acceleration

avd or kvd or ayd=design vertical acceleration

Beta=multip coeff for the semirigd approach

Buildind code=code used for design acceleration calculation

WALL RESULTS TABLE

P168.3x10/40 Stage: 0

Wall Nod	EL (m)	Sht L (kPa)	Sht R (kPa)	Shs L (kPa)	Shs R (kPa)	q (kPa)	U L (kPa)	U R (kPa)	M (kN-	V (kN/m)	dx (cm)
0	0	0	0	0	0	0	0	0	0	0	0
2	-0.2	1.692	1.692	1.692	1.692	0	0	0	0	0	0
4	-0.4	3.384	3.384	3.384	3.384	0	0	0	0	0	0
6	-0.6	5.076	5.076	5.076	5.076	0	0	0	0	0	0
8	-0.8	6.768	6.768	6.768	6.768	0	0	0	0	0	0
10	-1	8.46	8.46	8.46	8.46	0	0	0	0	0	0
12	-1.2	10.152	10.152	10.152	10.152	0	0	0	0	0	0
14	-1.4	11.844	11.844	11.844	11.844	0	0	0	0	0	0
16	-1.6	13.536	13.536	13.536	13.536	0	0	0	0	0	0
18	-1.8	15.228	15.228	15.228	15.228	0	0	0	0	0	0
20	-2	16.92	16.92	16.92	16.92	0	0	0	0	0	0
22	-2.2	18.612	18.612	18.612	18.612	0	0	0	0	0	0
24	-2.4	20.304	20.304	20.304	20.304	0	0	0	0	0	0
26	-2.6	21.996	21.996	21.996	21.996	0	0	0	0	0	0

28	-2.8	23.688	23.688	23.688	23.688	0	0	0	0	0	0
30	-3	25.38	25.38	25.38	25.38	0	0	0	0	0	0
32	-3.2	27.072	27.072	27.072	27.072	0	0	0	0	0	0
34	-3.4	28.764	28.764	28.764	28.764	0	0	0	0	0	0
36	-3.6	30.986	30.986	29.986	29.986	0	1	1	0	0	0
38	-3.8	33.738	33.738	30.738	30.738	0	3	3	0	0	0
40	-4	36.49	36.49	31.49	31.49	0	5	5	0	0	0
42	-4.2	39.242	39.242	32.242	32.242	0	7	7	0	0	0
44	-4.4	41.994	41.994	32.994	32.994	0	9	9	0	0	0
46	-4.6	52.429	52.429	41.429	41.429	0	11	11	0	0	0
48	-4.8	55.352	55.352	42.352	42.352	0	13	13	0	0	0
50	-5	58.275	58.275	43.275	43.275	0	15	15	0	0	0
52	-5.2	61.198	61.198	44.198	44.198	0	17	17	0	0	0
54	-5.4	64.121	64.121	45.121	45.121	0	19	19	0	0	0
56	-5.6	67.045	67.045	46.045	46.045	0	21	21	0	0	0
58	-5.8	69.968	69.968	46.968	46.968	0	23	23	0	0	0
60	-6	72.891	72.891	47.891	47.891	0	25	25	0	0	0

P168.3x10/40 Stage: 1

Wall	EL	Sht L	Sht R	Shs L	Shs R	q	U L	U R	M	V	dx
Nod	(m)	(kPa)	(kPa)	(kPa)	(kPa)	(kPa)	(kPa)	(kPa)	(kN-	(kN/m)	(cm)
0	0	0	0	0	0	0	0	0	0	0	1.2
2	-0.2	0.961	0	0.961	0	0	0	0	0.01	0.06	1.13
4	-0.4	1.922	0	1.922	0	0	0	0	0.06	0.37	1.07
6	-0.6	2.884	0	2.884	0	0	0	0	0.22	0.94	1.01
8	-0.8	3.845	0	3.845	0	0	0	0	0.52	1.75	0.95
10	-1	4.806	0	4.806	0	0	0	0	1.03	2.81	0.88
12	-1.2	5.767	0	5.767	0	0	0	0	1.79	4.12	0.82
14	-1.4	6.728	0	6.728	0	0	0	0	2.84	5.69	0.76
16	-1.6	7.69	0	7.69	0	0	0	0	4.25	7.5	0.7
18	-1.8	8.651	0	8.651	0	0	0	0	6.05	9.56	0.64
20	-2	9.612	0	9.612	0	0	0	0	8.31	11.87	0.58
22	-2.2	10.573	0	10.573	0	0	0	0	11.06	14.43	0.52
24	-2.4	11.534	0	11.534	0	0	0	0	14.37	17.24	0.46
26	-2.6	12.496	9.101	12.496	9.101	0	0	0	18.28	20.31	0.41
28	-2.8	13.457	27.302	13.457	27.302	0	0	0	22.36	20.07	0.36
30	-3	14.418	40.999	14.418	40.999	0	0	0	25.72	15.35	0.31
32	-3.2	15.379	38.867	15.379	38.867	0	0	0	27.77	8.64	0.26
34	-3.4	16.34	37	16.34	37	0	0	0	28.6	2.72	0.22
36	-3.6	18.035	35.916	17.035	34.916	0	1	1	28.36	-2.48	0.19
38	-3.8	20.462	35.682	17.462	32.682	0	3	3	27.18	-6.95	0.16
40	-4	22.889	35.856	17.889	30.856	0	5	5	25.21	-10.76	0.13
42	-4.2	25.316	36.409	18.316	29.409	0	7	7	22.57	-14	0.11
44	-4.4	28.108	37.301	19.108	28.301	0	9	9	19.35	-16.78	0.09
46	-4.6	44.325	42.889	33.325	31.889	0	11	11	15.75	-18	0.07
48	-4.8	48.924	44.561	35.924	31.561	0	13	13	12.23	-17.43	0.05
50	-5	53.299	46.408	38.299	31.408	0	15	15	8.93	-16.13	0.04
52	-5.2	57.511	48.381	40.511	31.381	0	17	17	5.99	-14.18	0.03
54	-5.4	61.611	50.437	42.611	31.437	0	19	19	3.52	-11.68	0.02
56	-5.6	65.647	52.541	44.647	31.541	0	21	21	1.63	-8.64	0.01
58	-5.8	69.651	54.665	46.651	31.665	0	23	23	0.43	-5.11	0
60	-6	73.646	56.792	48.646	31.792	0	25	25	0	-1.1	-0.01

LEGENDA

Wall node=number of the node

EL=elevation

Sht L=Total horizontal soil pressure (on the left side of the wall)

Sht R=Total horizontal soil pressure (on the right side of the wall)

Shs L=Effective horizontal soil pressure (on the left side of the wall)

Shs R=Effective horizontal soil pressure (on the right side of the wall)

q=pressure given by the surcharge

U L=Water pressure (on the left side of the wall)

U R=pressione acqua (on the right side of the wall)

M=bending moment (per meter)

V=shear (per metro)

dx=wall deflection

McapL=Ultimate bending moment (on the left side of the wall)

McapR=Ultimate bending moment (on the right side of the wall)

VcapL=Ultimate resistance shear (on the left side of the wall)

VcapR=Ultimate resistance shear (on the right side of the wall)

Project: My Project

Results for Design Section 2: DM08_ITA: Comb. 2:

A2+M2+R1

DESIGN APPROACHES AND COMBINATION FACTORS

The Design Approaches (from Codes or Customized by the user) and related safety factors are the following:

Ftan fr=mult factor for friction angle

F C'=mult factor for effective cohesion

F Su'=mult factof for undrained cohesion

F EQ=mult factor for seismic action

F perm load=mult factor for perm loads

F temp load=mult factor for live loads

F perm supp=reduct factor for resistance for pull out checking

F temp supp=fattore di riduzione resistance per verifica pull out tirante

F earth Dstab=mult factor for active press coeff , unfavorable

F earth stab=mult factor for passive pressure , favorable

F GWT Dstab (ground water)=mult factor for hydrostatic pressure , unfavorable

F GWT stab (ground water)=mult factor for hydrostatic pressure, favorable

F HYD Dstab=mult factor for hydrodynamic pressure, unfavorable

F HYD stab=mult factor for hydrodynamic pressure, favorable

F UPL Dstab=mult factor for hydraulic heave, unfavorable

Stage	Design Name	Design Case	F(tan fr)	F (c')	F (Su)	F (EQ)	F(perm load)	F(temp load)	F(perm sup)	F(temp sup)	F Earth (Dstab)	F Earth (stab)	F GWT (Dstab)	F GWT (stab)	F HYD (Dstab)	F HYD (stab)	F UPL (Dstab)	F UPL (stab)
0	DM08_ITA	2: A2+M2+R1	1.25	1.25	1.4	0	1	1.3	1.2	1.1	1	1	1	1	1.35	0.9	1	1
1	DM08_ITA	2: A2+M2+R1	1.25	1.25	1.4	0	1	1.3	1.2	1.1	1	1	1	1	1.35	0.9	1	1

SOIL DATA

Name	g tot (kN/m3)	g dry (kN/m3)	Frict (deg)	C' (kPa)	Su (kPa)	FRp (deg)	FRcv (deg)	Eload (kPa)	Eur (kPa)	kAp Springs	kPp Springs	kAcv Springs	kPcv Springs	Vary	Spring Model	Color
F	20	19	30	0	N/A	N/A	N/A	15000	45000	0.33	3	N/A	N/A	True	Linear	
O1	16.5	14	22	2	20	22	22	2874	8622	0.46	2.2	0.46	2.2	True	Linear	
O2	19	16.5	28	2	N/A	N/A	N/A	7185	21555	0.36	2.77	N/A	N/A	True	Linear	
S1	21	19	34	0	N/A	N/A	N/A	25000	75000	0.28	3.54	N/A	N/A	True	Linear	
Clay	20	19	28	0	150	28	28	20000	60000	0.36	2.77	0.36	2.77	True	Linear	
GT	22	20	36	10	N/A	N/A	N/A	30000	90000	0.26	3.85	N/A	N/A	True	Linear	
Rock	27	25	30	100	N/A	N/A	N/A	479000	143700	0.33	3	N/A	N/A	True	Linear	
Rileva	18	18	32	0	N/A	N/A	N/A	30000	30000	0.31	3.26	N/A	N/A	True	Linear	
Base	18	18	25	0	N/A	N/A	N/A	25000	25000	0.41	2.46	N/A	N/A	True	Linear	

gtot=total soil specific weight

gdry=dry weight of the soil

Frict=friction angle

C'=effective cohesion

Su = Undrained cohesiona (only for CLAY soils in undrained conditions)

Dilat=SOil Dilatancy (only for non linear analysis)

Evc=Virgin compression elastic module

Eur=unloading/reloading elastic module

Kap= Peak active thrust coeff

Kpp= Peak passive thrust coeff

Kacv= Constant volume active thrust coeff

Kpcv= Constant volume passive thrust coeff

Spring models= spring model (LIN=constant over the soil layer heigth , EXP=exponential ,

SIMC=simplified winkler)

LIN= Linear-Elastic-Perfectly Plastic,

EXP: Exponential, SUB: Modulus of Subgrade Reaction

SOIL BORINGS

Top Elev= superior SOil level

Soil type=type of the soil (sand , clay , etc)

OCR=overconsolidation ratio

K0=at rest coefficient

Name: Boring 1, pos: (-20, 0)

Top elev.	Soil type	OCR	Ko
0	Rilevato	1	0.47
-4.5	Base	1	0.58

STRUCTURAL MATERIALS DATA

Steel

Name	Strength Fy (MPa)	Fu (MPa)	Elastic E (MPa)	Density g (kN/m3)
Fe360	235	360	206000	77
Fe510	355	510	210000	77
A36	248.3	400	206000	77
A50	355	500	206000	77
New steel 4	241.4	413.8	206000	77

Concrete

Name	Strength Fc' (MPa)	Elastic E (MPa)	Density g (kN/m3)	Tension Strength (MPa)
C20/25	20	29962	25	10
C25/30	25	31476	25	10
Fc 3ksi	20.7	21541.8	23.573	10

Steel rebar

Name	Strength Fy (MPa)	Elastic E (MPa)
S1860 (Strands)	1670	210000
Grade 75	517.2	200100
Grade 80	551.7	200100
Grade 150	1034.5	200100
Strands 270 ksi	1862.1	200100
S410	410	210000
S500	500	210000
B450C	450	210000

Wood

Name	Ultimate Bending (MPa)	Ultimate Tensile Strength (MPa)	Ultimate Shear Strength (MPa)	Density g (kN/m3)	Elastic E (MPa)
Construction	11	9.7	5.5	7.8576	6900
Regular grade	6.9	6.9	4.1	7.8576	5520

STEEL

Name=material name
 fy=fyk=characteristic resistance for steel (for all the codes)
 Fu=fuk=ultimate resistance for steel (for all the codes)
 Elastic E=Elastic modulus
 Density g=specific weight

CONCRETE

Name=material name
 f'c=fck=cylindrical resistance for concrete (for all the codes)
 Elastic E=Elastic modulus
 Density g=specific weight
 Tension strength=ft=fctk=characteristic tension resistance for concrete

STEEL REBARS

Name=material name
 fy=fyk=characteristic resistance for steel (for all the codes)
 Fu=fuk=ultimate resistance for steel (for all the codes)
 Elastic E=Elastic modulus
 Density g=specific weight

WOOD

Name=material name
 Fb=fbk=Ultimate bending strength
 Ftu=ftuk=Ultimate tensile strength
 Fvu=fvuk=Ultimate shear strength
 Density g=specific weight
 Elastic E=Elastic modulus

WALL DATA

Wall section 0: P168.3x10/40

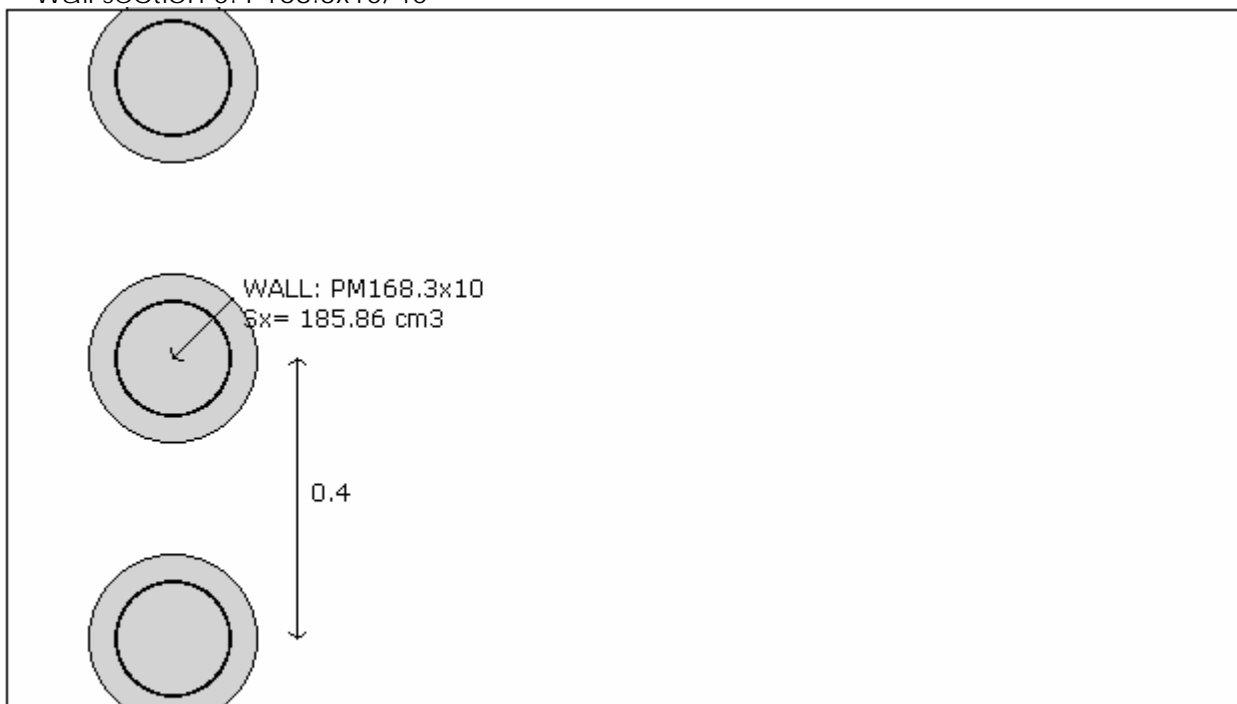

Company: My Company	Wall sketch	CeAS srl and Deep Excavation LCC
Engineer: Engineer		Paratie Plus 2010 - DeepXcar 2010
C:\nd.28_seraLotto3\alleg\LIII_typ0_rev27oct10_EQscavo_Alleg.DEEP		10/28/2010

Wall uses wall section 0: P168.3x10/40
 Wall type: Tangent pile wall
 Top wall El: 0 m Bottom wall El: -6 m
 Hor. wall spacing: 0.4 Wall thickness = 0.24
 Passive width below exc: 0.4 Active width below exc: 0.4
 Concrete f'c = 25 Rebar Fy = 410 Econc = 31476 Concrete tension FcT = 10% of Fc'

Steel members $f_y = 355$ Esteel = 210000

Wall friction: Percentage of Soil Friction = 50%

Steel wall capacities are calculated with NTC 2008

Concrete capacities are calculated with ACI 318-2002.

Note: With ultimate capacities you may have to use a structural safety factor.

Tangent pile wall soldier pile properties

Table: Soldier Pile Properties

Name	Section	W	A	D	tw or	bf	tf	k	Ixx	Sxx	rX	Iyy	Syy	rY	rT	Cw	fy
		(kN/m)	(cm ²)	(cm)	(cm)	(cm)	(cm)	(cm)	(cm ⁴)	(cm ³)	(cm)	(cm ⁴)	(cm ³)	(cm)	(cm)	(cm ⁶)	(MPa)
	PM16	257.3	75.62	16.8	1	16.83	1	1	3771	185.9	7.06	3771	185.9	7.06	7.06	1	355

GENERAL WALL DATA

Hor wall spacing=wall horizontal spacing

Passive width below exc=spacing for passive thrust pressure for classic analysis

$f'_c=f_{ck}$ =cylindrical concrete resistance

$f_y=f_{yk}$ =steel rebar characteristic resistance

E_{conc} =Concrete Elastic modulus

f_{ctk} =characteristic Concrete tension

E_{steel} =steel elastic modulus

TABULAR DATA (principal parameters)

1) Diaphragm wall (rectangular cross section section)

N/A= data not available

$F_y=f_{yk}$

$F'_c=f_{ck}$

D=wall height

B=wall width

2) Steel sheet pile

DES=shape (Z or U)

W=weight per unit of length

A=area

h=height

t=horiz part thickness

b=width of the single sheet pile part

s=inclined part thickness

I_{xx} =strong axis inertia (per unit of length)

S_{xx} =strong axis section modulus (per unit of length)

3) Secant piles wall, Tangent piles wall, soldier piles, soldier piles and timber lagging

W=weight per unit of length

A=area

D=diameter

tw=web thickness

tp= pipe thickness

bf=flange width

tf=flange thickness

k=flange thickness+stem thickness

I_{xx} =strong axis inertia modulus (per unit of length)

S_{xx} =strong axis section modulus (per unit of length)

r_x =radius of gyration about X axis

r_y =radius of gyration about Y axis

I_{yy} =weak axis inertia modulus (per unit of length)

S_{yy} =weak axis section modulus (per unit of length)

r_T =radius of gyration for torsion

Cw=warping constant

TIEBACK DATA

Name	F_y	F'_c	Dfix	Afix	Efix	Afree	Efree	Pa STR	Pu STR	PresGr	FSgeo	UserGca	Pa	Pu	WireMod
	(MPa)	(MPa)	(cm)	(cm ²)	(MPa)	(cm ²)	(MPa)	(kN)	(kN)	(kPa)			(kN)	(kN)	Yes/No
4-Strands	1862.1	25	15	176.7	31476	2.8	200100	453.4	453.4	N/A	1.4	False	N/A	N/A	Yes
5-Strands	1862.1	25	15	176.7	31476	0	200100	0	0	N/A	1.4	False	N/A	N/A	Yes
6-Strands	1862.1	25	15	176.7	31476	8.39	200100	1357.9	1357.9	N/A	1.4	False	N/A	N/A	Yes

Tieback_	1670	25	16	201.0	31476	4.17	210000	605.2	605.2	N/A	1	False	N/A	N/A	Yes
----------	------	----	----	-------	-------	------	--------	-------	-------	-----	---	-------	-----	-----	-----

EXCAVATION STAGES SKETCHES

A sequence of figures for each excavation stage is reported

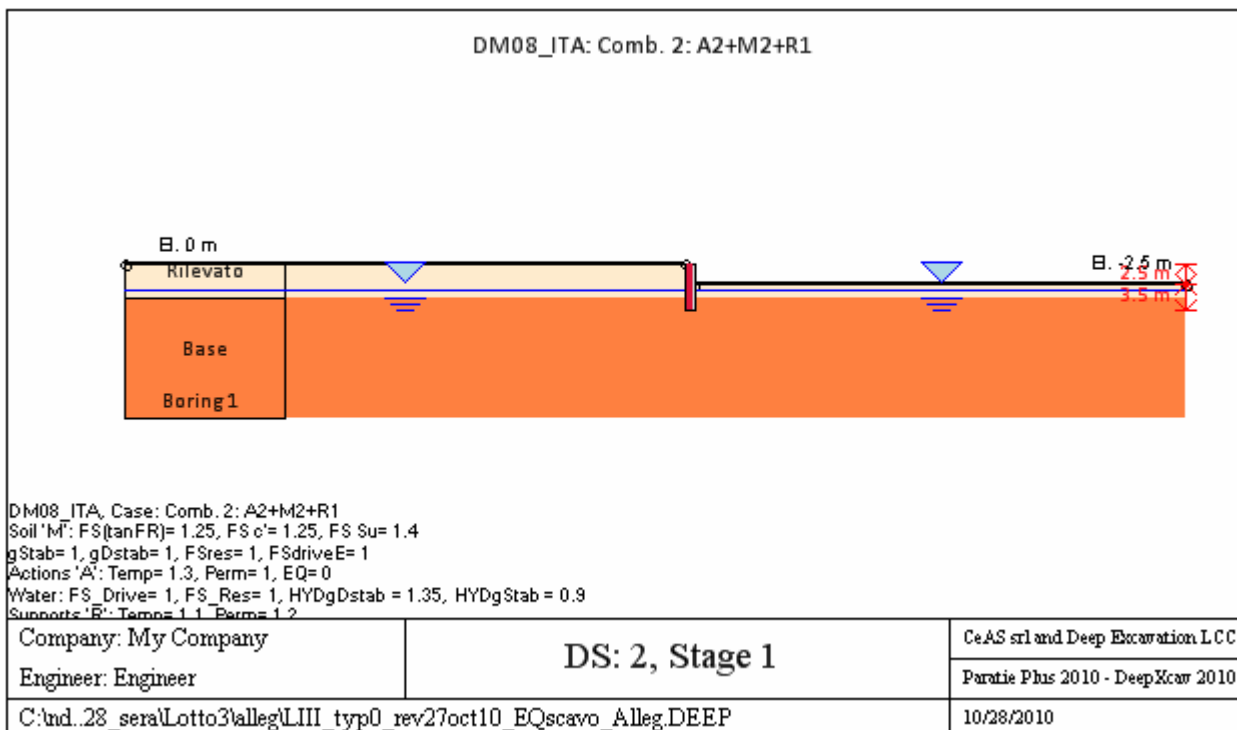
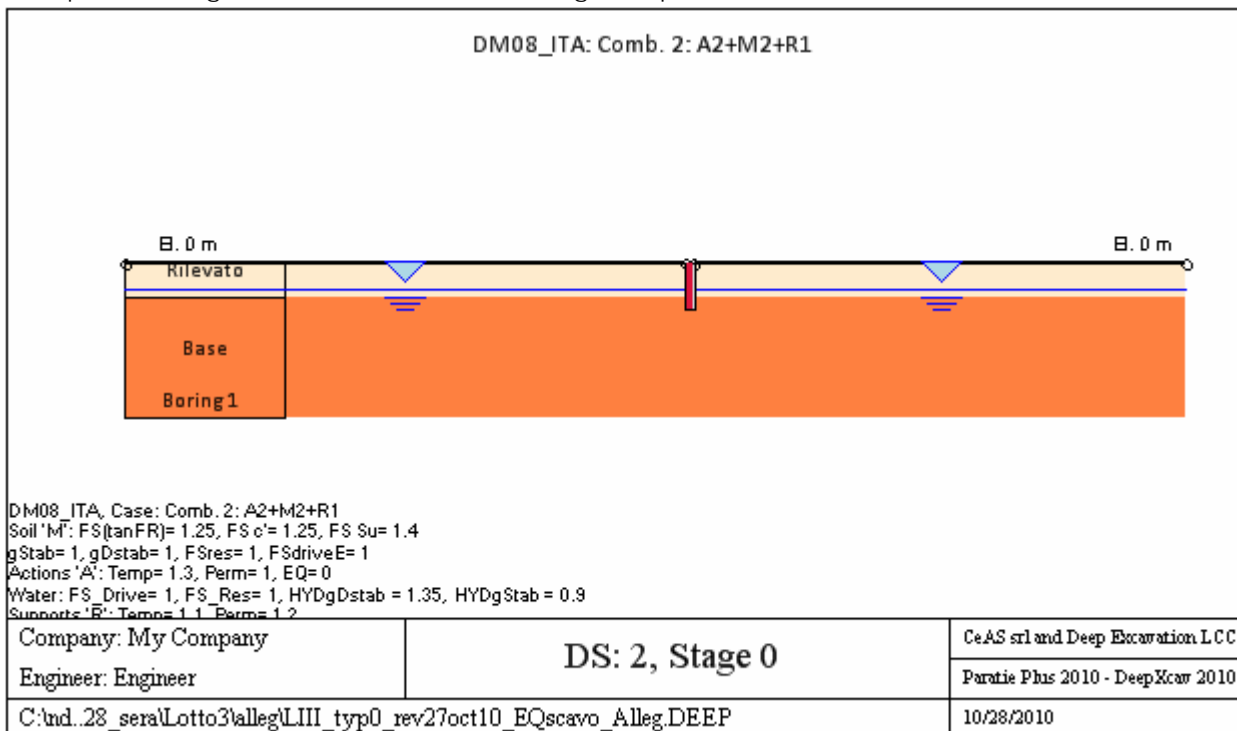

GENERAL ANALYSIS CRITERIA

Summary of stage assumptions

Name	Analysis	Drive	ka-Mult	Htr	Resist	Res	Contl	Supp	Axial	Used	Min	Toe	Toe
	Method	Press		(%)	Press	Mult	Meth	Mode	Incl	FSwall	FDtoe	FSrot	FSpas

Stage 0	Springs-Up	Ka+ d	N/A	N/A	Kp+ d	N/A		Fixed	N/A	1	8.626	9.97	8.626
Stage 1	Springs-Up	Ka+ d	N/A	N/A	Kp+ d	N/A		Fixed	N/A	1	1.548	1.548	2.145

Name=excavation phase name

Analysis method

springs=elasto plastic springs are used

DR=Drained condition for CLAY model

U=Undrained condition for CLAY model for all the soils

Up=Undrained condition just for selected soil

Drive press=Ka

ka mult=multiply factor for Ka

Htr T/B (%)=trapezoidal pressure scheme

Resit press=Kp

Res Mult=Multiply factor for Kp

COntle Method=cantilver method

Support Model=Fix support type

Axial Incl=Axial action is included for design

Used FS wall=Reduction factor for axial+bending resistance dominium

Min FD TOe=embedded minimum safety factor (for classic analysis)

Toe FS rot=rotation safety factor (classic for classic analysis)

Toe FSpas=driving/resistent pressure safety factor (for classic analysis)

SEISMIC DATA

Seismic action is modeled through a pseudo static approach

Summary of stage assumptions

Stage Number	Seismic g Used	Method Used	aX (g)	aY (g)	Beta	Building Code (Name)
0	No		0.04	0	1	N/A
1	No		0.04	0	1	N/A

N/A= data non available

Stage number=number of stage input

Seismic ag =value of design acceleration according to a code or input by the user

Method=the method used to evaluated the seismic thrustover the wall

ahd or khd otr axd=design horizontal acceleration

avd or kvd or ayd=design vertical acceleration

Beta=multip coeff for the semirigd approach

Buildind code=code used for design acceleration calculation

WALL RESULTS TABLE

P168.3x10/40 Stage: 0

Wall Nod	EL (m)	Sht L (kPa)	Sht R (kPa)	Shs L (kPa)	Shs R (kPa)	q (kPa)	U L (kPa)	U R (kPa)	M (kN-	V (kN/m)	dx (cm)
0	0	0	0	0	0	0	0	0	0	0	0
2	-0.2	1.99	1.99	1.99	1.99	0	0	0	0	0	0
4	-0.4	3.981	3.981	3.981	3.981	0	0	0	0	0	0
6	-0.6	5.971	5.971	5.971	5.971	0	0	0	0	0	0
8	-0.8	7.962	7.962	7.962	7.962	0	0	0	0	0	0
10	-1	9.952	9.952	9.952	9.952	0	0	0	0	0	0
12	-1.2	11.943	11.943	11.943	11.943	0	0	0	0	0	0
14	-1.4	13.933	13.933	13.933	13.933	0	0	0	0	0	0
16	-1.6	15.924	15.924	15.924	15.924	0	0	0	0	0	0
18	-1.8	17.914	17.914	17.914	17.914	0	0	0	0	0	0
20	-2	19.904	19.904	19.904	19.904	0	0	0	0	0	0
22	-2.2	21.895	21.895	21.895	21.895	0	0	0	0	0	0
24	-2.4	23.885	23.885	23.885	23.885	0	0	0	0	0	0
26	-2.6	25.876	25.876	25.876	25.876	0	0	0	0	0	0

28	-2.8	27.866	27.866	27.866	27.866	0	0	0	0	0	0
30	-3	29.857	29.857	29.857	29.857	0	0	0	0	0	0
32	-3.2	31.847	31.847	31.847	31.847	0	0	0	0	0	0
34	-3.4	33.837	33.837	33.837	33.837	0	0	0	0	0	0
36	-3.6	36.275	36.275	35.275	35.275	0	1	1	0	0	0
38	-3.8	39.16	39.16	36.16	36.16	0	3	3	0	0	0
40	-4	42.044	42.044	37.044	37.044	0	5	5	0	0	0
42	-4.2	44.929	44.929	37.929	37.929	0	7	7	0	0	0
44	-4.4	47.814	47.814	38.814	38.814	0	9	9	0	0	0
46	-4.6	57.706	57.706	46.706	46.706	0	11	11	0	0	0
48	-4.8	60.747	60.747	47.747	47.747	0	13	13	0	0	0
50	-5	63.787	63.787	48.787	48.787	0	15	15	0	0	0
52	-5.2	66.828	66.828	49.828	49.828	0	17	17	0	0	0
54	-5.4	69.869	69.869	50.869	50.869	0	19	19	0	0	0
56	-5.6	72.91	72.91	51.91	51.91	0	21	21	0	0	0
58	-5.8	75.951	75.951	52.951	52.951	0	23	23	0	0	0
60	-6	78.992	78.992	53.992	53.992	0	25	25	0	0	0

P168.3x10/40 Stage: 1

Wall	EL	Sht L	Sht R	Shs L	Shs R	q	U L	U R	M	V	dx
Nod	(m)	(kPa)	(kPa)	(kPa)	(kPa)	(kPa)	(kPa)	(kPa)	(kN-	(kN/m)	(cm)
0	0	0	0	0	0	0	0	0	0	0	2
2	-0.2	1.21	0	1.21	0	0	0	0	0.01	0.06	1.9
4	-0.4	2.419	0	2.419	0	0	0	0	0.06	0.36	1.8
6	-0.6	3.629	0	3.629	0	0	0	0	0.21	0.91	1.7
8	-0.8	4.838	0	4.838	0	0	0	0	0.51	1.69	1.6
10	-1	6.048	0	6.048	0	0	0	0	1	2.72	1.5
12	-1.2	7.258	0	7.258	0	0	0	0	1.73	3.99	1.4
14	-1.4	8.467	0	8.467	0	0	0	0	2.75	5.5	1.3
16	-1.6	9.677	0	9.677	0	0	0	0	4.11	7.26	1.2
18	-1.8	10.886	0	10.886	0	0	0	0	5.86	9.25	1.1
20	-2	12.096	0	12.096	0	0	0	0	8.04	11.49	1
22	-2.2	13.306	0	13.306	0	0	0	0	10.71	13.97	0.91
24	-2.4	14.515	0	14.515	0	0	0	0	13.91	16.69	0.81
26	-2.6	15.725	6.527	15.725	6.527	0	0	0	17.69	19.66	0.72
28	-2.8	16.934	19.58	16.934	19.58	0	0	0	21.84	20.9	0.64
30	-3	18.144	32.634	18.144	32.634	0	0	0	25.88	19.78	0.55
32	-3.2	19.354	45.688	19.354	45.688	0	0	0	29.34	16.29	0.48
34	-3.4	20.563	58.741	20.563	58.741	0	0	0	31.75	10.43	0.41
36	-3.6	22.437	58.032	21.437	57.032	0	1	1	32.69	2.73	0.34
38	-3.8	24.974	54.563	21.974	51.563	0	3	3	32.2	-4.08	0.28
40	-4	27.512	51.8	22.512	46.8	0	5	5	30.52	-9.73	0.23
42	-4.2	30.05	49.708	23.05	42.708	0	7	7	27.87	-14.34	0.18
44	-4.4	32.587	48.229	23.587	39.229	0	9	9	24.43	-18.07	0.14
46	-4.6	46.019	50.801	35.019	39.801	0	11	11	20.42	-20.47	0.11
48	-4.8	52.439	50.708	39.439	37.708	0	13	13	16.22	-21.09	0.08
50	-5	58.505	50.949	43.505	35.949	0	15	15	12.08	-20.44	0.05
52	-5.2	64.306	51.436	47.306	34.436	0	17	17	8.25	-18.66	0.02
54	-5.4	69.925	52.091	50.925	33.091	0	19	19	4.93	-15.84	0
56	-5.6	75.436	52.845	54.436	31.845	0	21	21	2.32	-12.03	-0.02
58	-5.8	80.894	53.643	57.894	30.643	0	23	23	0.61	-7.28	-0.05
60	-6	86.336	54.452	61.336	29.452	0	25	25	0	-1.59	-0.07

LEGENDA

Wall node=number of the node

EL=elevation

Sht L=Total horizontal soil pressure (on the left side of the wall)

Sht R=Total horizontal soil pressure (on the right side of the wall)

Shs L=Effective horizontal soil pressure (on the left side of the wall)

Shs R=Effective horizontal soil pressure (on the right side of the wall)

q=pressure given by the surcharge

U L=Water pressure (on the left side of the wall)

U R=pressione acqua (on the right side of the wall)

M=bending moment (per meter)

V=shear (per metro)

dx=wall deflection

McapL=Ultimate bending moment (on the left side of the wall)

McapR=Ultimate bending moment (on the right side of the wall)

VcapL=Ultimate resistance shear (on the left side of the wall)

VcapR=Ultimate resistance shear (on the right side of the wall)

Project: My Project

Results for Design Section 3: DM08_ITA: EQK - Seismic

DESIGN APPROACHES AND COMBINATION FACTORS

The Design Approaches (from Codes or Customized by the user) and related safety factors are the following:

Ftan fr=mult factor for friction angle

F C'=mult factor for effective cohesion

F Su'=mult factof for undrained cohesion

F EQ=mult factor for seismic action

F perm load=mult factor for perm loads

F temp load=mult factor for live loads

F perm supp=reduct factor for resistance for pull out checking

F temp supp=fattore di riduzione resistenza per verifica pull out tirante

F earth Dstab=mult factor for active press coeff , unfavorable

F earth stab=mult factor for passive pressure , favorable

F GWT Dstab (ground water)=mult factor for hydrostatic pressure , unfavorable

F GWT stab (ground water)=mult factor for hydrostatic pressure, favorable

F HYD Dstab=mult factor for hydrodynamic pressure, unfavorable

F HYD stab=mult factor for hydrodynamic pressure, favorable

F UPL Dstab=mult factor for hydraulic heave, unfavorable

Stage	Design Name	Design Case	F(tan fr)	F (c')	F (Su)	F (EQ)	F(perm load)	F(temp load)	F(perm sup)	F(temp sup)	F Earth (Dstab)	F Earth (stab)	F GWT (Dstab)	F GWT (stab)	F HYD (Dstab)	F HYD (stab)	F UPL (Dstab)	F UPL (stab)
0	DM08_ITA	EQK - Seismic	1.25	1.25	1.4	1	1	1	1.2	1.1	1	1	1	1	1.35	0.9	1	1
1	DM08_ITA	EQK - Seismic	1.25	1.25	1.4	1	1	1	1.2	1.1	1	1	1	1	1.35	0.9	1	1
2	DM08_ITA	EQK - Seismic	1.25	1.25	1.4	1	1	1	1.2	1.1	1	1	1	1	1.35	0.9	1	1

SOIL DATA

Name	g tot (kN/m3)	g dry (kN/m3)	Frict (deg)	C' (kPa)	Su (kPa)	FRp (deg)	FRcv (deg)	Eload (kPa)	Eur (kPa)	kAp Springs	kPp Springs	kAcv Springs	kPcv Springs	Vary	Spring Model	Color
F	20	19	30	0	N/A	N/A	N/A	15000	45000	0.33	3	N/A	N/A	True	Linear	
O1	16.5	14	22	2	20	22	22	2874	8622	0.46	2.2	0.46	2.2	True	Linear	
O2	19	16.5	28	2	N/A	N/A	N/A	7185	21555	0.36	2.77	N/A	N/A	True	Linear	
S1	21	19	34	0	N/A	N/A	N/A	25000	75000	0.28	3.54	N/A	N/A	True	Linear	
Clay	20	19	28	0	150	28	28	20000	60000	0.36	2.77	0.36	2.77	True	Linear	
GT	22	20	36	10	N/A	N/A	N/A	30000	90000	0.26	3.85	N/A	N/A	True	Linear	
Rock	27	25	30	100	N/A	N/A	N/A	479000	143700	0.33	3	N/A	N/A	True	Linear	
Rileva	18	18	32	0	N/A	N/A	N/A	30000	30000	0.31	3.26	N/A	N/A	True	Linear	
Base	18	18	25	0	N/A	N/A	N/A	25000	25000	0.41	2.46	N/A	N/A	True	Linear	

gtot=total soil specific weighth

gdry=dry weighth of the soil

Frict=friction angle

C'=effective cohesion

Su = Undrained cohesiona (only for CLAY soils in undrained conditions)

Dilat=SOil Dilatancy (only for non linear analysis)

Evc=Virgin compression elastic module

Eur=unloading/reloading elastic module

Kap= Peak active thrust coeff

Kpp= Peak passive thrust coeff

Kacv= Constant volume active thrust coeff

Kpcv= Constant volume passive thrust coeff

Spring models= spring model (LIN=constant over the soil layer heighth , EXP=exponential ,

SIMC=simplified winkler)

LIN= Linear-Elastic-Perfectly Plastic,

EXP: Exponential, SUB: Modulus of Subgrade Reaction

SOIL BORINGS

Top Elev= superior SOil level

Soil type=type of the soil (sand , clay , etc)

OCR=overconsolidation ratio

K0=at rest coefficient

Name: Boring 1, pos: (-20, 0)

Top elev.	Soil type	OCR	Ko
0	Rilevato	1	0.47
-4.5	Base	1	0.58

STRUCTURAL MATERIALS DATA

Steel

Name	Strength Fy (MPa)	Fu (MPa)	Elastic E (MPa)	Density g (kN/m3)
Fe360	235	360	206000	77
Fe510	355	510	210000	77
A36	248.3	400	206000	77
A50	355	500	206000	77
New steel 4	241.4	413.8	206000	77

Concrete

Name	Strength Fc' (MPa)	Elastic E (MPa)	Density g (kN/m3)	Tension Strength (MPa)
C20/25	20	29962	25	10
C25/30	25	31476	25	10
Fc 3ksi	20.7	21541.8	23.573	10

Steel rebar

Name	Strength Fy (MPa)	Elastic E (MPa)
S1860 (Strands)	1670	210000
Grade 75	517.2	200100
Grade 80	551.7	200100
Grade 150	1034.5	200100
Strands 270 ksi	1862.1	200100
S410	410	210000
S500	500	210000
B450C	450	210000

Wood

Name	Ultimate Bending (MPa)	Ultimate Tensile Strength (MPa)	Ultimate Shear Strength (MPa)	Density g (kN/m3)	Elastic E (MPa)
Construction	11	9.7	5.5	7.8576	6900
Regular grade	6.9	6.9	4.1	7.8576	5520

STEEL

Name=material name
 fy=fyk=characteristic resistance for steel (for all the codes)
 Fu=fuk=ultimate resistance for steel (for all the codes)
 Elastic E=Elastic modulus
 Density g=specific weight

CONCRETE

Name=material name
 f'c=fck=cylindrical resistance for concrete (for all the codes)
 Elastic E=Elastic modulus
 Density g=specific weight
 Tension strength=ft=fctk=characteristic tension resistance for concrete

STEEL REBARS

Name=material name
 fy=fyk=characteristic resistance for steel (for all the codes)
 Fu=fuk=ultimate resistance for steel (for all the codes)
 Elastic E=Elastic modulus
 Density g=specific weight

WOOD

Name=material name
 Fb=fbk=Ultimate bending strength
 Ftu=ftuk=Ultimate tensile strength
 Fvu=fvuk=Ultimate shear strength
 Density g=specific weight
 Elastic E=Elastic modulus

WALL DATA

Wall section 0: P168.3x10/40

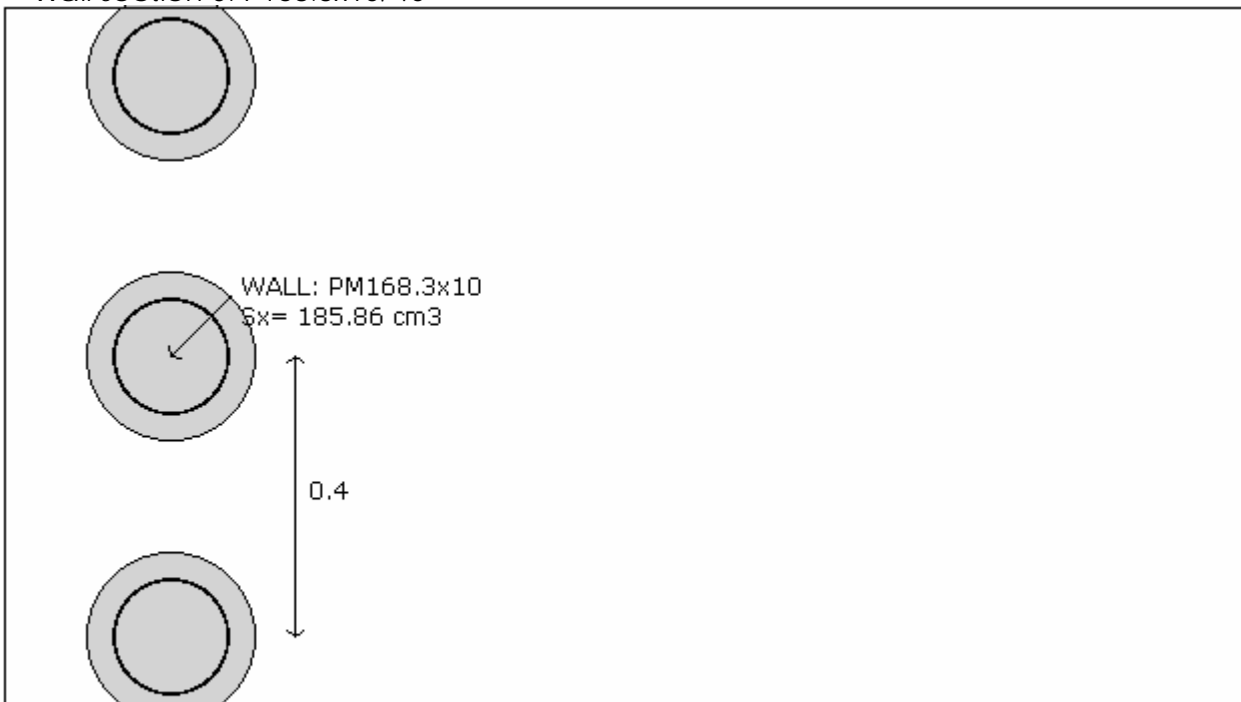

Company: My Company	Wall sketch	CeAS srl and Deep Excavation LCC
Engineer: Engineer		Paratie Plus 2010 - DeepXcar 2010
C:\nd.28_seraLotto3\alleg\LIII_typ0_rev27oct10_EQscavo_Alleg.DEEP		10/28/2010

Wall uses wall section 0: P168.3x10/40
 Wall type: Tangent pile wall
 Top wall El: 0 m Bottom wall El: -6 m
 Hor. wall spacing: 0.4 Wall thickness = 0.24
 Passive width below exc: 0.4 Active width below exc: 0.4
 Concrete f'c = 25 Rebar Fy = 410 Econc = 31476 Concrete tension FcT = 10% of Fc'

Steel members $f_y = 355$ Esteel = 210000

Wall friction: Percentage of Soil Friction = 50%

Steel wall capacities are calculated with NTC 2008

Concrete capacities are calculated with ACI 318-2002.

Note: With ultimate capacities you may have to use a structural safety factor.

Tangent pile wall soldier pile properties

Table: Soldier Pile Properties

Name	Section	W	A	D	tw or	bf	tf	k	Ixx	Sxx	rX	Iyy	Syy	rY	rT	Cw	fy
		(kN/m)	(cm ²)	(cm)	(cm)	(cm)	(cm)	(cm)	(cm ⁴)	(cm ³)	(cm)	(cm ⁴)	(cm ³)	(cm)	(cm)	(cm ⁶)	(MPa)
	PM16	257.3	75.62	16.8	1	16.83	1	1	3771	185.9	7.06	3771	185.9	7.06	7.06	1	355

GENERAL WALL DATA

Hor wall spacing=wall horizontal spacing

Passive width below exc=spacing for passive thrust pressure for classic analysis

$f'_c=f_{ck}$ =cylindrical concrete resistance

$f_y=f_{yk}$ =steel rebar characteristic resistance

Econc=Concrete Elastic modulus

f_{ctk} =characteristic Concrete tension

Esteel=steel elastic modulus

TABULAR DATA (principal parameters)

1) Diaphragm wall (rectangular cross section section)

N/A= data not available

$F_y=f_{yk}$

$F'_c=f_{ck}$

D=wall height

B=wall width

2) Steel sheet pile

DES=shape (Z or U)

W=weight per unit of length

A=area

h=height

t=horiz part thickness

b=width of the single sheet pile part

s=inclined part thickness

Ixx=strong axis inertia (per unit of length)

Sxx=strong axis section modulus (per unit of length)

3) Secant piles wall, Tangent piles wall, soldier piles, soldier piles and timber lagging

W=weight per unit of length

A=area

D=diameter

tw=web thickness

tp= pipe thickness

bf=flange width

tf=flange thickness

k=flange thickness+stem thickness

Ixx=strong axis inertia modulus (per unit of length)

Sxx=strong axis section modulus (per unit of length)

rx=radius of gyration about X axis

ry=radius of gyration about Y axis

Iyy=weak axis inertia modulus (per unit of length)

Syy=weak axis section modulus (per unit of length)

rT=radius of gyration for torsion

Cw=warping constant

TIEBACK DATA

Name	Fy	Fc'	Dfix	Afix	Efix	Afree	Efree	Pa STR	Pu STR	PresGr	FSgeo	UserGca	Pa	Pu	WireMod
	(MPa)	(MPa)	(cm)	(cm ²)	(MPa)	(cm ²)	(MPa)	(kN)	(kN)	(kPa)			(kN)	(kN)	Yes/No
4-Strands	1862.1	25	15	176.7	31476	2.8	200100	453.4	453.4	N/A	1.4	False	N/A	N/A	Yes
5-Strands	1862.1	25	15	176.7	31476	0	200100	0	0	N/A	1.4	False	N/A	N/A	Yes
6-Strands	1862.1	25	15	176.7	31476	8.39	200100	1357.9	1357.9	N/A	1.4	False	N/A	N/A	Yes

Tieback_	1670	25	16	201.0	31476	4.17	210000	605.2	605.2	N/A	1	False	N/A	N/A	Yes
----------	------	----	----	-------	-------	------	--------	-------	-------	-----	---	-------	-----	-----	-----

EXCAVATION STAGES SKETCHES

A sequence of figures for each excavation stage is reported

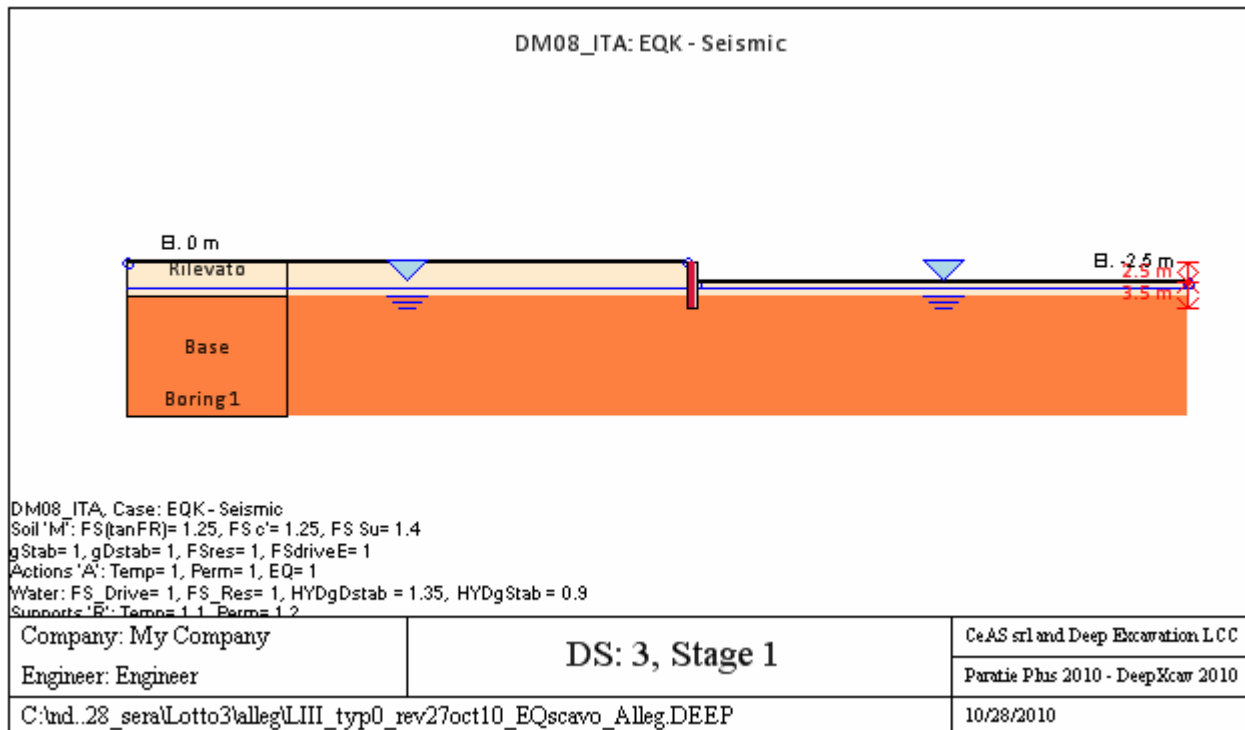
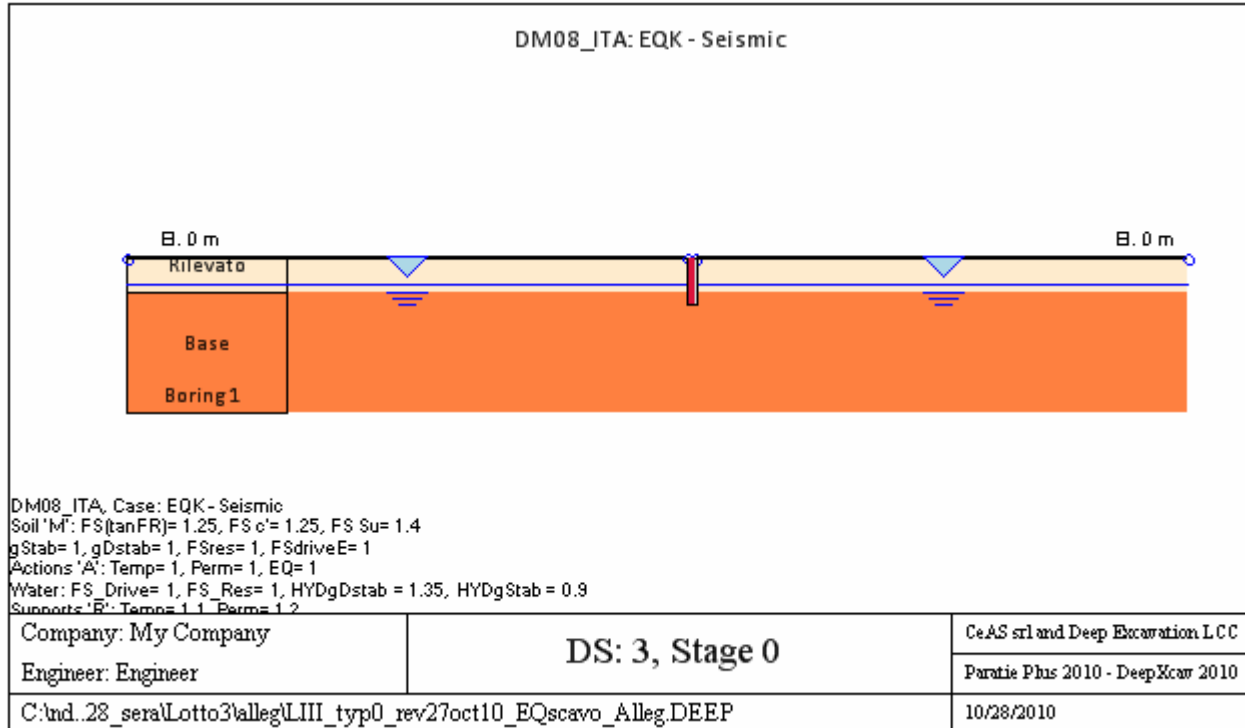

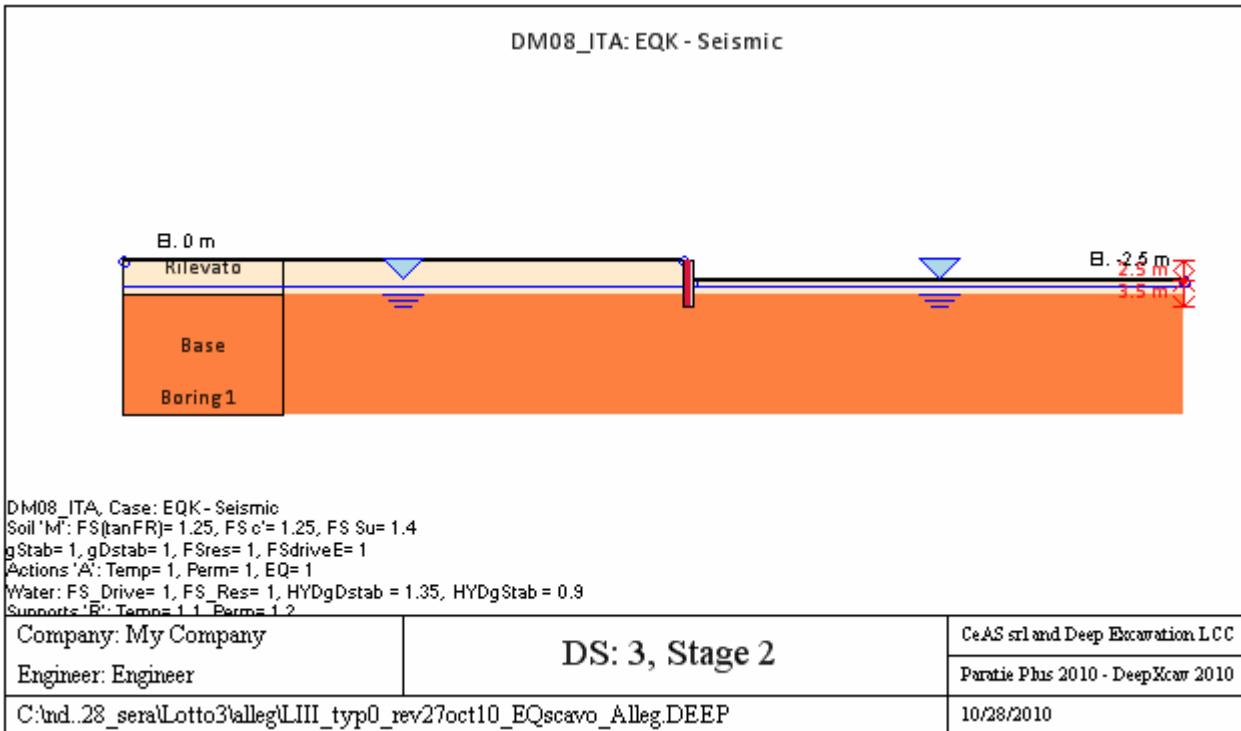

GENERAL ANALYSIS CRITERIA

Summary of stage assumptions

Name	Analysis	Drive	ka-Mult	Htr	Resist	Res	Contl	Supp	Axial	Used	Min	Toe	Toe
	Method	Press		(%)	Press	Mult	Meth	Mode	Incl	FSwall	FDtoe	FSrot	FSpas
Stage 0	Springs-Up	Ka+ d	N/A	N/A	Kp+ d	N/A		Fixed	N/A	1	8.626	9.97	8.626
Stage 1	Springs-Up	Ka+ d	N/A	N/A	Kp+ d	N/A		Fixed	N/A	1	1.548	1.548	2.145
Stage 2	Springs-Up	FHWA	1.3	m=	Kp+ d	N/A		Fixed	N/A	1	1.494	1.494	N/A

Name=excavation phase name

Analysis method

- springs=elasto plastic springs are used
- DR=Drained condition for CLAY model
- U=Undrained condition for CLAY model for all the soils
- Up=Undrained condition just for selected soil

Drive press=Ka

ka mult=multiply factor for Ka

Htr T/B (%)=trapezoidal pressure scheme

Resit press=Kp

Res Mult=Multiply factor for Kp

COntle Method=cantilver method

Support Model=Fix support type

Axial Incl=Axial action is included for design

Used FS wall=Reduction factor for axial+bending resistance dominium

Min FD TOe=embedded minimum safety factor (for classic analysis)

Toe FS rot=rotation safety factor (classic for classic analysis)

Toe FSpas=driving/resistent pressure safety factor (for classic analysis)

SEISMIC DATA

Seismic action is modeled through a pseudo static approach

Summary of stage assumptions

Stage	Seismic g	Method	aX	aY	Beta	Building Code
Number	Used	Used	(g)	(g)		(Name)
0	No		0.04	0	1	N/A

1	No		0.04	0	1	N/A
2	Yes		0.04	0	1	N/A

N/A= data non available

Stage number=number of stage input

Seismic ag =value of design acceleration according to a code or input by the user

Method=the method used to evaluated the seismic thrustover the wall

ahd or khd otr axd=design horizontal acceleration

avd or kvd or ayd=design vertical acceleration

Beta=multip coeff for the semirigd approach

Buildind code=code used for design acceleration calculation

WALL RESULTS TABLE

P168.3x10/40 Stage: 0

Wall Nod	EL (m)	Sht L (kPa)	Sht R (kPa)	Shs L (kPa)	Shs R (kPa)	q (kPa)	U L (kPa)	U R (kPa)	M (kN-)	V (kN/m)	dx (cm)
0	0	0	0	0	0	0	0	0	0	0	0
2	-0.2	1.99	1.99	1.99	1.99	0	0	0	0	0	0
4	-0.4	3.981	3.981	3.981	3.981	0	0	0	0	0	0
6	-0.6	5.971	5.971	5.971	5.971	0	0	0	0	0	0
8	-0.8	7.962	7.962	7.962	7.962	0	0	0	0	0	0
10	-1	9.952	9.952	9.952	9.952	0	0	0	0	0	0
12	-1.2	11.943	11.943	11.943	11.943	0	0	0	0	0	0
14	-1.4	13.933	13.933	13.933	13.933	0	0	0	0	0	0
16	-1.6	15.924	15.924	15.924	15.924	0	0	0	0	0	0
18	-1.8	17.914	17.914	17.914	17.914	0	0	0	0	0	0
20	-2	19.904	19.904	19.904	19.904	0	0	0	0	0	0
22	-2.2	21.895	21.895	21.895	21.895	0	0	0	0	0	0
24	-2.4	23.885	23.885	23.885	23.885	0	0	0	0	0	0
26	-2.6	25.876	25.876	25.876	25.876	0	0	0	0	0	0
28	-2.8	27.866	27.866	27.866	27.866	0	0	0	0	0	0
30	-3	29.857	29.857	29.857	29.857	0	0	0	0	0	0
32	-3.2	31.847	31.847	31.847	31.847	0	0	0	0	0	0
34	-3.4	33.837	33.837	33.837	33.837	0	0	0	0	0	0
36	-3.6	36.275	36.275	35.275	35.275	0	1	1	0	0	0
38	-3.8	39.16	39.16	36.16	36.16	0	3	3	0	0	0
40	-4	42.044	42.044	37.044	37.044	0	5	5	0	0	0
42	-4.2	44.929	44.929	37.929	37.929	0	7	7	0	0	0
44	-4.4	47.814	47.814	38.814	38.814	0	9	9	0	0	0
46	-4.6	57.706	57.706	46.706	46.706	0	11	11	0	0	0
48	-4.8	60.747	60.747	47.747	47.747	0	13	13	0	0	0
50	-5	63.787	63.787	48.787	48.787	0	15	15	0	0	0
52	-5.2	66.828	66.828	49.828	49.828	0	17	17	0	0	0
54	-5.4	69.869	69.869	50.869	50.869	0	19	19	0	0	0
56	-5.6	72.91	72.91	51.91	51.91	0	21	21	0	0	0
58	-5.8	75.951	75.951	52.951	52.951	0	23	23	0	0	0
60	-6	78.992	78.992	53.992	53.992	0	25	25	0	0	0

P168.3x10/40 Stage: 1

Wall Nod	EL (m)	Sht L (kPa)	Sht R (kPa)	Shs L (kPa)	Shs R (kPa)	q (kPa)	U L (kPa)	U R (kPa)	M (kN-)	V (kN/m)	dx (cm)
0	0	0	0	0	0	0	0	0	0	0	2
2	-0.2	1.21	0	1.21	0	0	0	0	0.01	0.06	1.9
4	-0.4	2.419	0	2.419	0	0	0	0	0.06	0.36	1.8
6	-0.6	3.629	0	3.629	0	0	0	0	0.21	0.91	1.7
8	-0.8	4.838	0	4.838	0	0	0	0	0.51	1.69	1.6
10	-1	6.048	0	6.048	0	0	0	0	1	2.72	1.5
12	-1.2	7.258	0	7.258	0	0	0	0	1.73	3.99	1.4

14	-1.4	8.467	0	8.467	0	0	0	0	2.75	5.5	1.3
16	-1.6	9.677	0	9.677	0	0	0	0	4.11	7.26	1.2
18	-1.8	10.886	0	10.886	0	0	0	0	5.86	9.25	1.1
20	-2	12.096	0	12.096	0	0	0	0	8.04	11.49	1
22	-2.2	13.306	0	13.306	0	0	0	0	10.71	13.97	0.91
24	-2.4	14.515	0	14.515	0	0	0	0	13.91	16.69	0.81
26	-2.6	15.725	6.527	15.725	6.527	0	0	0	17.69	19.66	0.72
28	-2.8	16.934	19.58	16.934	19.58	0	0	0	21.84	20.9	0.64
30	-3	18.144	32.634	18.144	32.634	0	0	0	25.88	19.78	0.55
32	-3.2	19.354	45.688	19.354	45.688	0	0	0	29.34	16.29	0.48
34	-3.4	20.563	58.741	20.563	58.741	0	0	0	31.75	10.43	0.41
36	-3.6	22.437	58.032	21.437	57.032	0	1	1	32.69	2.73	0.34
38	-3.8	24.974	54.563	21.974	51.563	0	3	3	32.2	-4.08	0.28
40	-4	27.512	51.8	22.512	46.8	0	5	5	30.52	-9.73	0.23
42	-4.2	30.05	49.708	23.05	42.708	0	7	7	27.87	-14.34	0.18
44	-4.4	32.587	48.229	23.587	39.229	0	9	9	24.43	-18.07	0.14
46	-4.6	46.019	50.801	35.019	39.801	0	11	11	20.42	-20.47	0.11
48	-4.8	52.439	50.708	39.439	37.708	0	13	13	16.22	-21.09	0.08
50	-5	58.505	50.949	43.505	35.949	0	15	15	12.08	-20.44	0.05
52	-5.2	64.306	51.436	47.306	34.436	0	17	17	8.25	-18.66	0.02
54	-5.4	69.925	52.091	50.925	33.091	0	19	19	4.93	-15.84	0
56	-5.6	75.436	52.845	54.436	31.845	0	21	21	2.32	-12.03	-0.02
58	-5.8	80.894	53.643	57.894	30.643	0	23	23	0.61	-7.28	-0.05
60	-6	86.336	54.452	61.336	29.452	0	25	25	0	-1.59	-0.07

P168.3x10/40 Stage: 2

Wall	EL	Sht L	Sht R	Shs L	Shs R	q	U L	U R	M	V	dx
Nod	(m)	(kPa)	(kPa)	(kPa)	(kPa)	(kPa)	(kPa)	(kPa)	(kN-	(kN/m)	(cm)
0	0	0	0	0	0	0	0	0	0	0.05	2.31
2	-0.2	1.21	0	1.21	0	0	0	0	0.03	0.21	2.19
4	-0.4	2.419	0	2.419	0	0	0	0	0.14	0.7	2.08
6	-0.6	3.629	0	3.629	0	0	0	0	0.38	1.41	1.96
8	-0.8	4.838	0	4.838	0	0	0	0	0.8	2.36	1.84
10	-1	6.048	0	6.048	0	0	0	0	1.45	3.54	1.73
12	-1.2	7.258	0	7.258	0	0	0	0	2.37	4.95	1.61
14	-1.4	8.467	0	8.467	0	0	0	0	3.6	6.59	1.5
16	-1.6	9.677	0	9.677	0	0	0	0	5.2	8.47	1.38
18	-1.8	10.886	0	10.886	0	0	0	0	7.2	10.57	1.27
20	-2	12.096	0	12.096	0	0	0	0	9.66	12.9	1.16
22	-2.2	13.306	0	13.306	0	0	0	0	12.63	15.46	1.05
24	-2.4	14.515	0	14.515	0	0	0	0	16.14	18.26	0.94
26	-2.6	15.725	6.527	15.725	6.527	0	0	0	20.24	21.27	0.83
28	-2.8	16.934	19.58	16.934	19.58	0	0	0	24.71	22.52	0.73
30	-3	18.144	32.634	18.144	32.634	0	0	0	29.07	21.4	0.64
32	-3.2	19.354	45.688	19.354	45.688	0	0	0	32.86	17.91	0.55
34	-3.4	20.563	58.741	20.563	58.741	0	0	0	35.59	12.05	0.47
36	-3.6	22.437	63.581	21.437	62.581	0	1	1	36.79	3.82	0.39
38	-3.8	24.974	59.043	21.974	56.043	0	3	3	36.36	-4.05	0.32
40	-4	27.512	55.305	22.512	50.305	0	5	5	34.56	-10.54	0.26
42	-4.2	30.05	52.328	23.05	45.328	0	7	7	31.65	-15.81	0.21
44	-4.4	32.587	50.05	23.587	41.05	0	9	9	27.84	-20.02	0.16
46	-4.6	44.954	51.828	33.954	40.828	0	11	11	23.38	-22.87	0.12
48	-4.8	52.011	51.121	39.011	38.121	0	13	13	18.64	-23.85	0.08
50	-5	58.661	50.798	43.661	35.798	0	15	15	13.93	-23.32	0.05
52	-5.2	65.007	50.76	48.007	33.76	0	17	17	9.54	-21.42	0.02
54	-5.4	71.143	50.917	52.143	31.917	0	19	19	5.71	-18.26	-0.01
56	-5.6	77.153	51.19	56.153	30.19	0	21	21	2.69	-13.93	-0.04
58	-5.8	83.101	51.516	60.101	28.516	0	23	23	0.72	-8.46	-0.07

60	-6	89.031	51.854	64.031	26.854	0	25	25	0	-1.86	-0.09
----	----	--------	--------	--------	--------	---	----	----	---	-------	-------

LEGENDA

Wall node=number of the node

EL=elevation

Sht L=Total horizontal soil pressure (on the left side of the wall)

Sht R=Total horizontal soil pressure (on the right side of the wall)

Shs L=Effective horizontal soil pressure (on the left side of the wall)

Shs R=Effective horizontal soil pressure (on the right side of the wall)

q=pressure given by the surcharge

U L=Water pressure (on the left side of the wall)

U R=pressione acqua (on the right side of the wall)

M=bending moment (per meter)

V=shear (per metro)

dx=wall deflection

McapL=Ultimate bending moment (on the left side of the wall)

McapR=Ultimate bending moment (on the right side of the wall)

VcapL=Ultimate resistance shear (on the left side of the wall)

VcapR=Ultimate resistance shear (on the right side of the wall)

DeepXcav 2010: Report Output

Copyright©2009 - 2010 Deep Excavation LLC: www.deepexcavation.com
A program for the evaluation of deep excavations

Project: My Project

Company: My Company
Prepared by engineer: Engineer
File number: 1
Time: 10/28/2010 8:58:01 PM

THIS PROGRAM IS PROTECTED BY U.S. COPYRIGHT LAWS AS DESCRIBED IN THE EULA. UNAUTHORIZED COPYING IS PROHIBITED. LICENSED TO: Deep Excavation LLC BY DEEP EXCAVATION LLC UNDER SPECIFIC LICENCE. This report has printed because the user has accepted responsibility as described in the disclaimer and EULA
File: C:\nda\paratie\10.10.28_sera\Lotto3\alleg\LIH_typ1_rev27oct10_EQscavo_Alleg.DEEP

DeepXcav 2010: Report Output

Copyright©2009 - 2010 Deep Excavation LLC: www.deepexcavation.com
A program for the evaluation of deep excavations

Project: My Project

Company: My Company
Prepared by engineer: Engineer
File number: 1
Time: 10/28/2010 8:58:01 PM

THIS PROGRAM IS PROTECTED BY U.S. COPYRIGHT LAWS AS DESCRIBED IN THE EULA. UNAUTHORIZED COPYING IS PROHIBITED. LICENSED TO: Deep Excavation LLC BY DEEP EXCAVATION LLC UNDER SPECIFIC LICENCE. This report has printed because the user has accepted responsibility as described in the disclaimer and EULA
File: C:\nda\paratie\10.10.28_sera\Lotto3\alleg\LIII_typ1_rev27oct10_EQscavo_Alleg.DEEP

OBJECTIVES

The objective of this document is to report the most important results of the calculations

BIBLIOGRAPHIC REFERENCES

BECCI,B.,NOVA,R. (1987) "Un metodo di calcolo automatico per il progetto di paratie", Rivista Italiana di

GENERAL CALCULATION ASSUMPTIONS

DEEP EXC is a program to simulate the behavior of flexible diaphragms. It is possible to simulate all the different stages of excavation.

The program is able to perform both classic and non linear analysis.

For the non linear analysis a FEM model is used. The FEM model follows the well known beam on elasto plastic foundation approach. The wall is modeled using BEAM elements, the soil is simulated using a double system (for each part of the wall) of elasto plastic springs,

An elasto plastic spring is connected on each node of the beam elements.

The excavation procedure is performed through 2 types of analysis:

- 1) Classic analysis
- 2) Non linear analysis : every step represents an excavation phase with a defined configuration of excavations, loads, etc.

The non linear analysis has been performed using a full Newton Raphson approach.

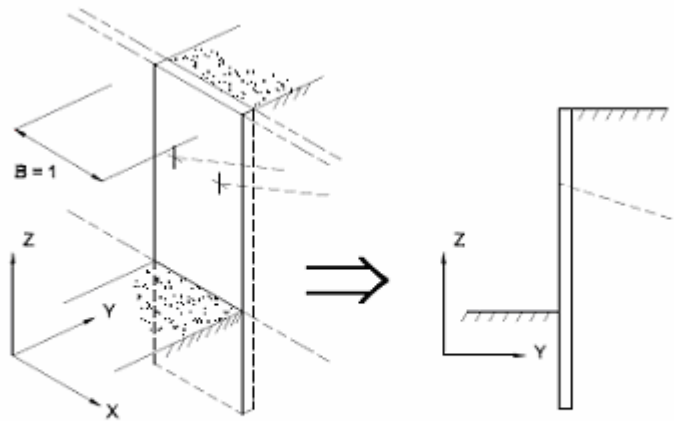

CONVENTIONS AND REFERENCE COORDINATE SYSTEMS

Loads, anelastic displacements, support reactions and displacements, are all referred to a righthand coordinate system

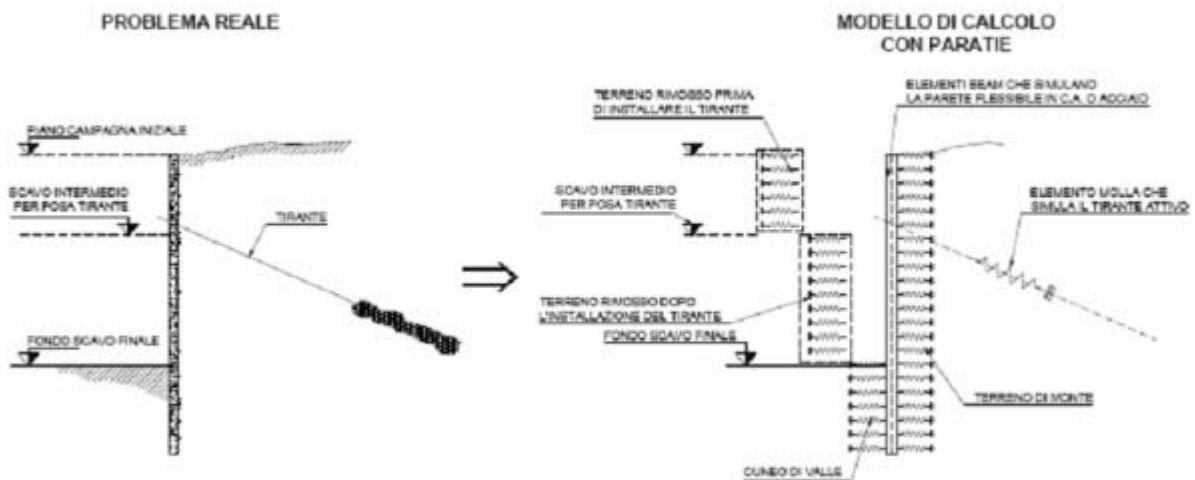

ELEMENTO TRUSS

1. FORCE : FORZA NELL'ELEMENTO PER UNITÀ DI PROFONDITÀ
2. STRESS : SPORZO

ELEMENTO BEAM (vedi figura 11-1)

1. VA : TAGLIO AL PRIMO ESTREMO
2. VB : TAGLIO AL SECONDO ESTREMO
3. MA : MOMENTO AL PRIMO ESTREMO
4. MB : MOMENTO AL SECONDO ESTREMO
(tutti per unità di profondità)

ELEMENTO ELPL (MOLLA ELASTOPLASTICA)

1. FORCE : FORZA NELL'ELEMENTO PER UNITÀ DI PROFONDITÀ
2. PLASTIC: DEFORMAZIONE PLASTICA

ELEMENTO WIRE (TIRANTE)

1. FORCE : FORZA NELL'ELEMENTO PER UNITÀ DI PROFONDITÀ

ELEMENTO CELAS (MOLLA ELASTICA)

1. FORCE : FORZA NELL'ELEMENTO PER UNITÀ DI PROFONDITÀ
2. MOMENT : MOMENTO NELL'ELEMENTO PER UNITÀ DI PROFONDITÀ

ELEMENTO SLAB (SOLETTA FRA DUE PARETI)

1. VA : TAGLIO AL PRIMO ESTREMO
2. VB : TAGLIO AL SECONDO ESTREMO
3. MA : MOMENTO AL PRIMO ESTREMO
4. MB : MOMENTO AL SECONDO ESTREMO
5. AXIAL : AZIONE ASSIALE
(tutti per unità di profondità)



Figura 11-1: convenzioni di segno per l'elemento BEAM

Checking of cross sections is performed according to the coordinate systems showed in the next figure

- X axis follow the 2 nodes direction of the beam elements , positive going from the first to the secondo node

ELEMENTO TRUSS

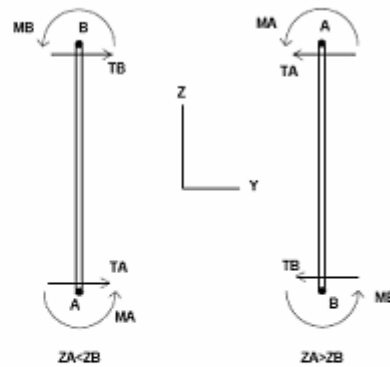
1. FORCE : FORZA NELL'ELEMENTO PER UNITÀ DI PROFONDITÀ
2. STRESS : SPORZO

ELEMENTO BEAM (vedi figura 11-1)

1. VA : TAGLIO AL PRIMO ESTREMO
2. VB : TAGLIO AL SECONDO ESTREMO
3. MA : MOMENTO AL PRIMO ESTREMO
4. MB : MOMENTO AL SECONDO ESTREMO
(tutti per unità di profondità)

ELEMENTO ELPL (MOLLA ELASTOPLASTICA)

1. FORCE : FORZA NELL'ELEMENTO PER UNITÀ DI PROFONDITÀ
2. PLASTIC: DEFORMAZIONE PLASTICA

ELEMENTO WIRE (TIRANTE)

1. FORCE : FORZA NELL'ELEMENTO PER UNITÀ DI PROFONDITÀ

ELEMENTO CELAS (MOLLA ELASTICA)

1. FORCE : FORZA NELL'ELEMENTO PER UNITÀ DI PROFONDITÀ
2. MOMENT : MOMENTO NELL'ELEMENTO PER UNITÀ DI PROFONDITÀ

ELEMENTO SLAB (SOLETTA FRA DUE PARETI)

1. VA : TAGLIO AL PRIMO ESTREMO
2. VB : TAGLIO AL SECONDO ESTREMO
3. MA : MOMENTO AL PRIMO ESTREMO
4. MB : MOMENTO AL SECONDO ESTREMO
5. AXIAL : AZIONE ASSIALE
(tutti per unità di profondità)



Figura 11-1: convenzioni di segno per l'elemento BEAM

DESIGN CODES

Reference codes are:

- DM 2008 - "Norme tecniche per le costruzioni"
- CSLP, "Istruzioni per l'applicazione delle Norme tecniche per le costruzioni di cui al DM 14/1/2008"
- EC2 1-1 :2004, Eurocode 2 - Design of concrete structures
- Ec3 1-1:2005, Eurocodice 3 - Design of steel structures
- Ec3 5:2002, Eurocodice 3 - Design of steel sheet piles walls
- Ec8:2004 - Seismic design of structures
- AISC ASD 9th Edition, 1989
- AISC LRFD 2nd Edition, 2003
- ACI 318-2002
- AASHTO 2000 ADS / LRFD

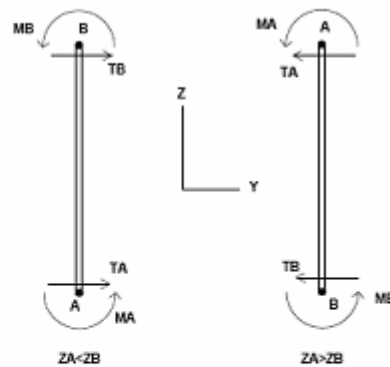
DESIGN PARAMETERS

Project: My Project

Results for Design Section 0: Base Section - Service

DESIGN APPROACHES AND COMBINATION FACTORS

The Design Approaches (from Codes or Customized by the user) and related safety factors are the following:

Ftan fr=mult factor for friction angle

F C'=mult factor for effective cohesion

F Su'=mult factof for undrained cohesion

F EQ=mult factor for seismic action

F perm load=mult factor for perm loads

F temp load=mult factor for live loads

F perm supp=reduct factor for resistance for pull out checking

F temp supp=fattore di riduzione resistenza per verifica pull out tirante

F earth Dstab=mult factor for active press coeff , unfavorable

F earth stab=mult factor for passive pressure , favorable

F GW Dstab (ground water)=mult factor for hydrostatic pressure , unfavorable

F GW stab (ground water)=mult factor for hydrostatic pressure, favorable

F HYD Dstab=mult factor for hydrodynamic pressure, unfavorable

F HYD stab=mult factor for hydrodynamic pressure, favorable

F UPL Dstab=mult factor for hydraulic heave, unfavorable

Stage	Design Name	Design Case	F(tan fr)	F (c')	F (Su)	F (EQ)	F(perm load)	F(temp load)	F(perm sup)	F(temp sup)	F Earth (Dstab)	F Earth (stab)	F GW Dstab (Dstab)	F GW Dstab (stab)	F HYD Dstab (Dstab)	F HYD Dstab (stab)	F UPL Dstab (Dstab)	F UPL Dstab (stab)
0	Default	Service	1	1	1	1	1	1	1	1	1	1	1	1	1	1	1	1
1	Default	Service	1	1	1	1	1	1	1	1	1	1	1	1	1	1	1	1
2	Default	Service	1	1	1	1	1	1	1	1	1	1	1	1	1	1	1	1
3	Default	Service	1	1	1	1	1	1	1	1	1	1	1	1	1	1	1	1

SOIL DATA

Name	g tot (kN/m3)	g dry (kN/m3)	Frict (deg)	C' (kPa)	Su (kPa)	FRp (deg)	FRcv (deg)	Eload (kPa)	Eur (kPa)	kAp Springs	kPp Springs	kAcv Springs	kPcv Springs	Vary	Spring Model	Color
F	20	19	30	0	N/A	N/A	N/A	15000	45000	0.33	3	N/A	N/A	True	Linear	
O1	16.5	14	22	2	20	22	22	2874	8622	0.46	2.2	0.46	2.2	True	Linear	
O2	19	16.5	28	2	N/A	N/A	N/A	7185	21555	0.36	2.77	N/A	N/A	True	Linear	
S1	21	19	34	0	N/A	N/A	N/A	25000	75000	0.28	3.54	N/A	N/A	True	Linear	
Clay	20	19	28	0	150	28	28	20000	60000	0.36	2.77	0.36	2.77	True	Linear	
GT	22	20	36	10	N/A	N/A	N/A	30000	90000	0.26	3.85	N/A	N/A	True	Linear	
Rock	27	25	30	100	N/A	N/A	N/A	479000	143700	0.33	3	N/A	N/A	True	Linear	
Rileva	18	18	32	0	N/A	N/A	N/A	30000	30000	0.31	3.26	N/A	N/A	True	Linear	
Base	18	18	25	0	N/A	N/A	N/A	25000	25000	0.41	2.46	N/A	N/A	True	Linear	

gtot=total soil specific weight

gdry=dry weight of the soil

Frict=friction angle

C'=effective cohesion

Su = Undrained cohesiona (only for CLAY soils in undrained conditions)

Dilat=SOil Dilatancy (only for non linear analysis)

Evc=Virgin compression elastic module

Eur=unloading/reloading elastic module

Kap= Peak active thrust coeff

Kpp= Peak passive thrust coeff

Kacv= Constant volume active thrust coeff

Kpcv= Constant volume passive thrust coeff

Spring models= spring model (LIN=constant over the soil layer height , EXP=exponential ,

SIMC=simplified winkler)

LIN= Linear-Elastic-Perfectly Plastic,

EXP: Exponential, SUB: Modulus of Subgrade Reaction

SOIL BORINGS

Top Elev= superior SOil level

Soil type=type of the soil (sand , clay , etc)

OCR=overconsolidation ratio

K0=at rest coefficient

Name: Boring 1, pos: (-20, 0)

Top elev.	Soil type	OCR	Ko
0	Rilevato	1	0.47
-4.5	Base	1	0.58

STRUCTURAL MATERIALS DATA

Steel

Name	Strength Fy (MPa)	Fu (MPa)	Elastic E (MPa)	Density g (kN/m3)
Fe360	235	360	206000	77
Fe510	355	510	210000	77
A36	248.3	400	206000	77
A50	355	500	206000	77
New steel 4	241.4	413.8	206000	77

Concrete

Name	Strength Fc' (MPa)	Elastic E (MPa)	Density g (kN/m3)	Tension Strength (MPa)
C20/25	20	29962	25	10
C25/30	25	31476	25	10
Fc 3ksi	20.7	21541.8	23.573	10

Steel rebar

Name	Strength Fy (MPa)	Elastic E (MPa)
S1860 (Strands)	1670	210000
Grade 75	517.2	200100
Grade 80	551.7	200100
Grade 150	1034.5	200100
Strands 270 ksi	1862.1	200100
S410	410	210000
S500	500	210000
B450C	450	210000

Wood

Name	Ultimate Bending (MPa)	Ultimate Tensile Strength (MPa)	Ultimate Shear Strength (MPa)	Density g (kN/m3)	Elastic E (MPa)
Construction	11	9.7	5.5	7.8576	6900
Regular grade	6.9	6.9	4.1	7.8576	5520

STEEL

Name=material name
 fy=fyk=characteristic resistance for steel (for all the codes)
 Fu=fuk=ultimate resistance for steel (for all the codes)
 Elastic E=Elastic modulus
 Density g=specific weight

CONCRETE

Name=material name
 f'c=fck=cylindrical resistance for concrete (for all the codes)
 Elastic E=Elastic modulus
 Density g=specific weight
 Tension strength=ft=fctk=characteristic tension resistance for concrete

STEEL REBARS

Name=material name
 fy=fyk=characteristic resistance for steel (for all the codes)
 Fu=fuk=ultimate resistance for steel (for all the codes)
 Elastic E=Elastic modulus
 Density g=specific weight

WOOD

Name=material name
 Fb=fbk=Ultimate bending strength
 Ftu=ftuk=Ultimate tensile strength
 Fvu=fvuk=Ultimate shear strength
 Density g=specific weight
 Elastic E=Elastic modulus

WALL DATA

Wall section 0: P168.3x10/40

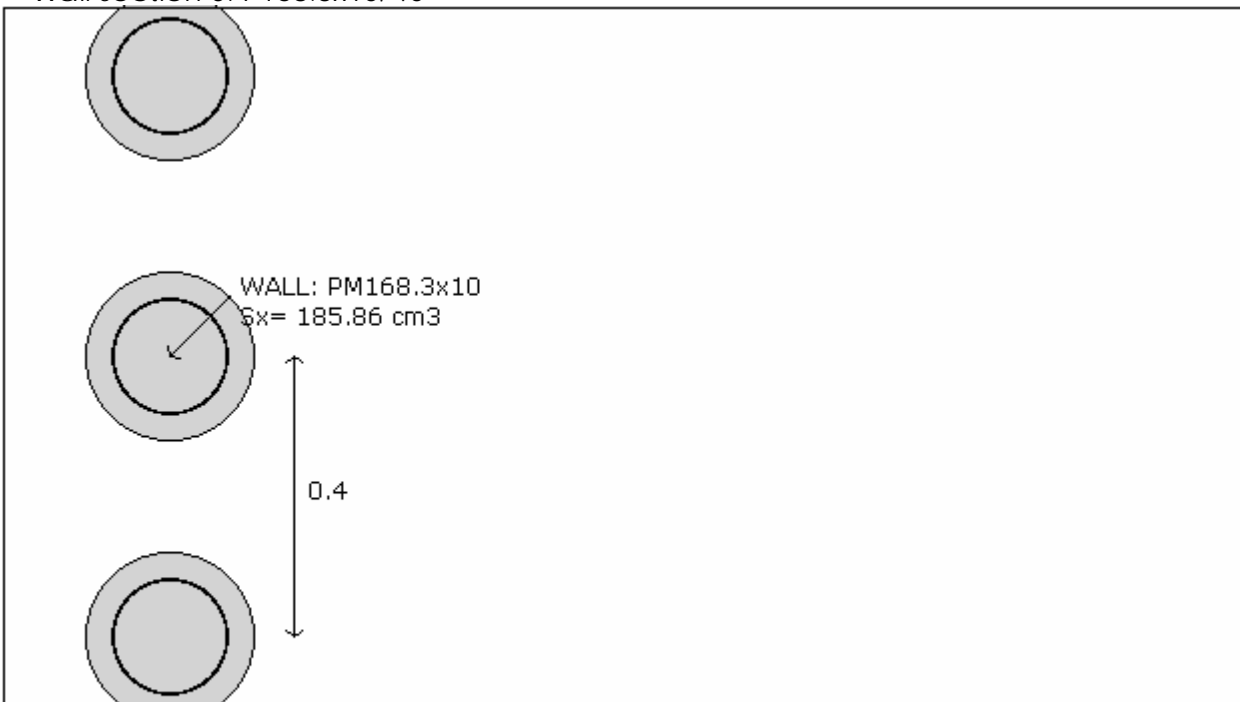

Company: My Company	Wall sketch	CeAS srl and Deep Excavation LCC
Engineer: Engineer		Paratie Plus 2010 - DeepXcar 2010
C:\nd.28_seraLotto3\alleg\LIII_typ1_rev27oct10_EQscavo_Alleg.DEEP		10/28/2010

Wall uses wall section 0: P168.3x10/40
 Wall type: Tangent pile wall
 Top wall El: 0 m Bottom wall El: -9 m
 Hor. wall spacing: 0.4 Wall thickness = 0.24
 Passive width below exc: 0.4 Active width below exc: 0.4
 Concrete f'c = 25 Rebar Fy = 410 Econc = 31476 Concrete tension FcT = 10% of Fc'

Steel members $f_y = 355$ Esteel = 210000

Wall friction: Percentage of Soil Friction = 50%

Steel wall capacities are calculated with NTC 2008

Concrete capacities are calculated with ACI 318-2002.

Note: With ultimate capacities you may have to use a structural safety factor.

Tangent pile wall soldier pile properties

Table: Soldier Pile Properties

Name	Section	W	A	D	tw or	bf	tf	k	Ixx	Sxx	rX	Iyy	Syy	rY	rT	Cw	fy
		(kN/m)	(cm ²)	(cm)	(cm)	(cm)	(cm)	(cm)	(cm ⁴)	(cm ³)	(cm)	(cm ⁴)	(cm ³)	(cm)	(cm)	(cm ⁶)	(MPa)
	PM16	257.3	75.62	16.8	1	16.83	1	1	3771	185.9	7.06	3771	185.9	7.06	7.06	1	355

GENERAL WALL DATA

Hor wall spacing=wall horizontal spacing

Passive width below exc=spacing for passive thrust pressure for classic analysis

$f'_c=f_{ck}$ =cylindrical concrete resistance

$f_y=f_{yk}$ =steel rebar characteristic resistance

E_{conc} =Concrete Elastic modulus

f_{ctk} =characteristic Concrete tension

E_{steel} =steel elastic modulus

TABULAR DATA (principal parameters)

1) Diaphragm wall (rectangular cross section section)

N/A= data not available

$F_y=f_{yk}$

$F'_c=f_{ck}$

D=wall height

B=wall width

2) Steel sheet pile

DES=shape (Z or U)

W=weight per unit of length

A=area

h=height

t=horiz part thickness

b=width of the single sheet pile part

s=inclined part thickness

I_{xx} =strong axis inertia (per unit of length)

S_{xx} =strong axis section modulus (per unit of length)

3) Secant piles wall, Tangent piles wall, soldier piles, soldier piles and timber lagging

W=weight per unit of length

A=area

D=diameter

tw=web thickness

tp= pipe thickness

bf=flange width

tf=flange thickness

k=flange thickness+stem thickness

I_{xx} =strong axis inertia modulus (per unit of length)

S_{xx} =strong axis section modulus (per unit of length)

r_x =radius of gyration about X axis

r_y =radius of gyration about Y axis

I_{yy} =weak axis inertia modulus (per unit of length)

S_{yy} =weak axis section modulus (per unit of length)

r_T =radius of gyration for torsion

Cw=warping constant

TIEBACK DATA

Name	F_y	F'_c	D_{fix}	A_{fix}	E_{fix}	A_{free}	E_{free}	Pa STR	Pu STR	PresGr	FSgeo	UserGca	Pa	Pu	WireMod
	(MPa)	(MPa)	(cm)	(cm ²)	(MPa)	(cm ²)	(MPa)	(kN)	(kN)	(kPa)			(kN)	(kN)	Yes/No
4-Strands	1862.1	25	15	176.7	31476	2.8	200100	453.4	453.4	N/A	1.4	False	N/A	N/A	Yes
5-Strands	1862.1	25	15	176.7	31476	0	200100	0	0	N/A	1.4	False	N/A	N/A	Yes
6-Strands	1862.1	25	15	176.7	31476	8.39	200100	1357.9	1357.9	N/A	1.4	False	N/A	N/A	Yes

Tieback_	1670	25	16	201.0	31476	4.17	210000	605.2	605.2	N/A	1	False	N/A	N/A	Yes
----------	------	----	----	-------	-------	------	--------	-------	-------	-----	---	-------	-----	-----	-----

EXCAVATION STAGES SKETCHES

A sequence of figures for each excavation stage is reported

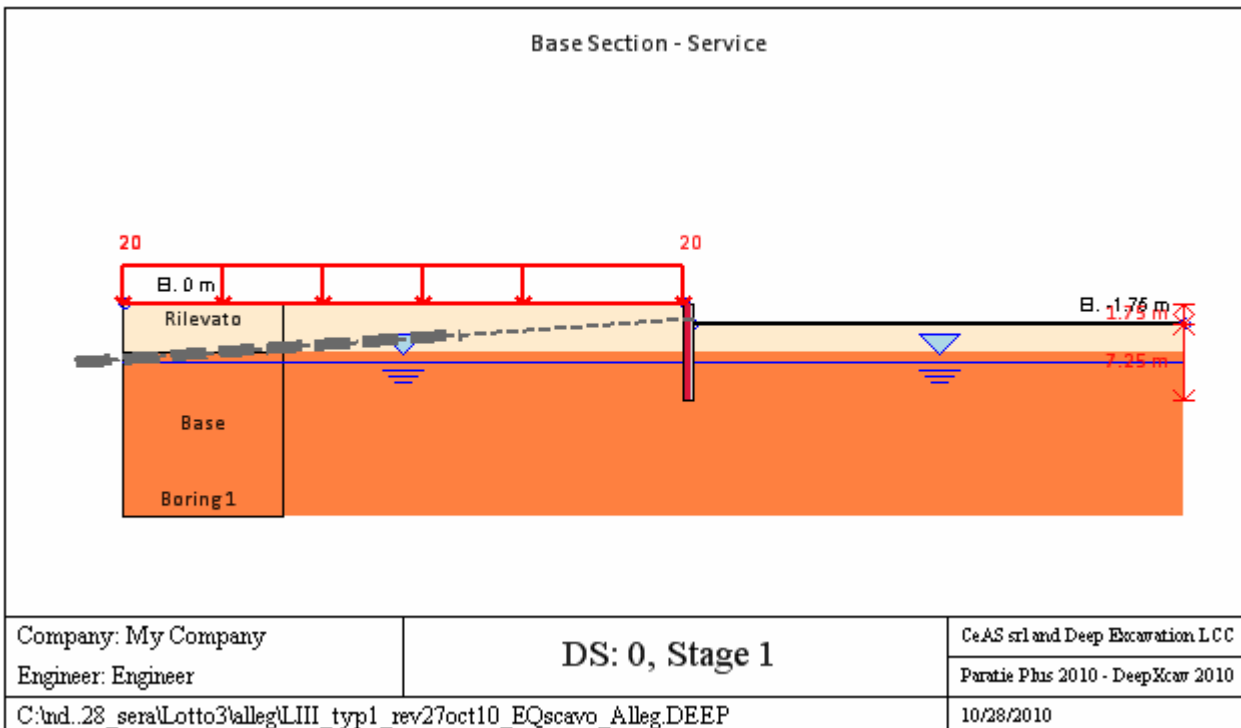
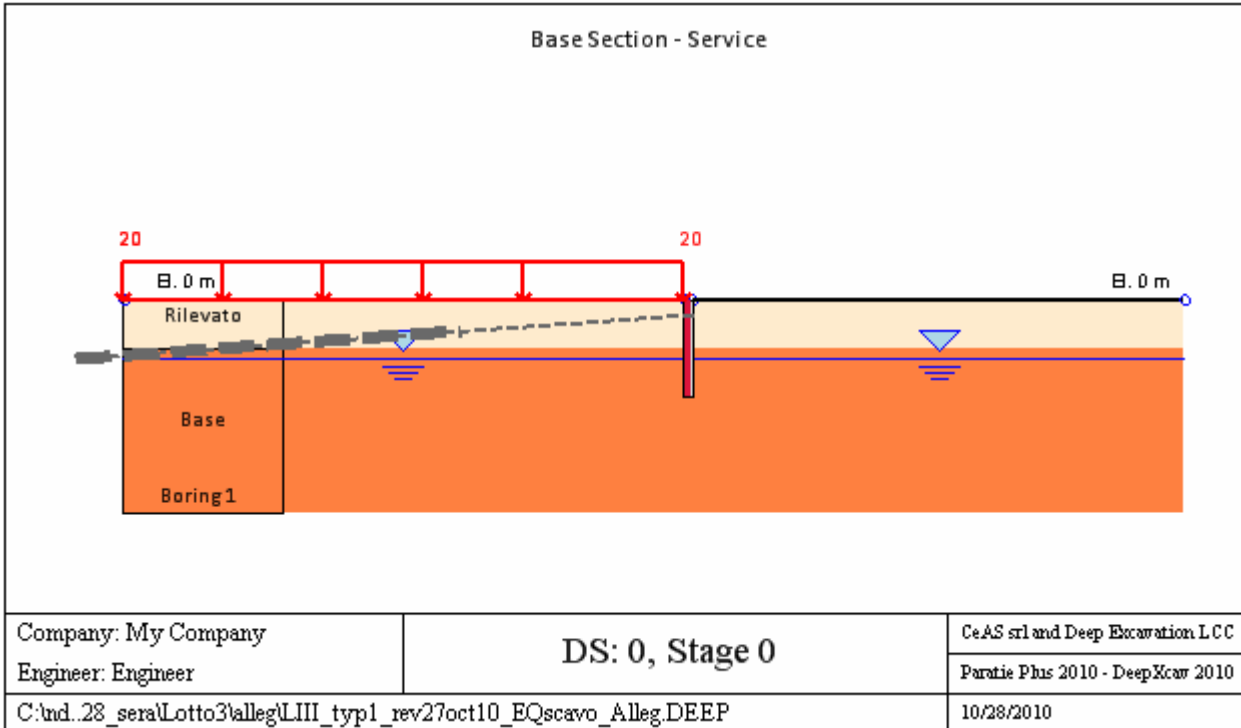

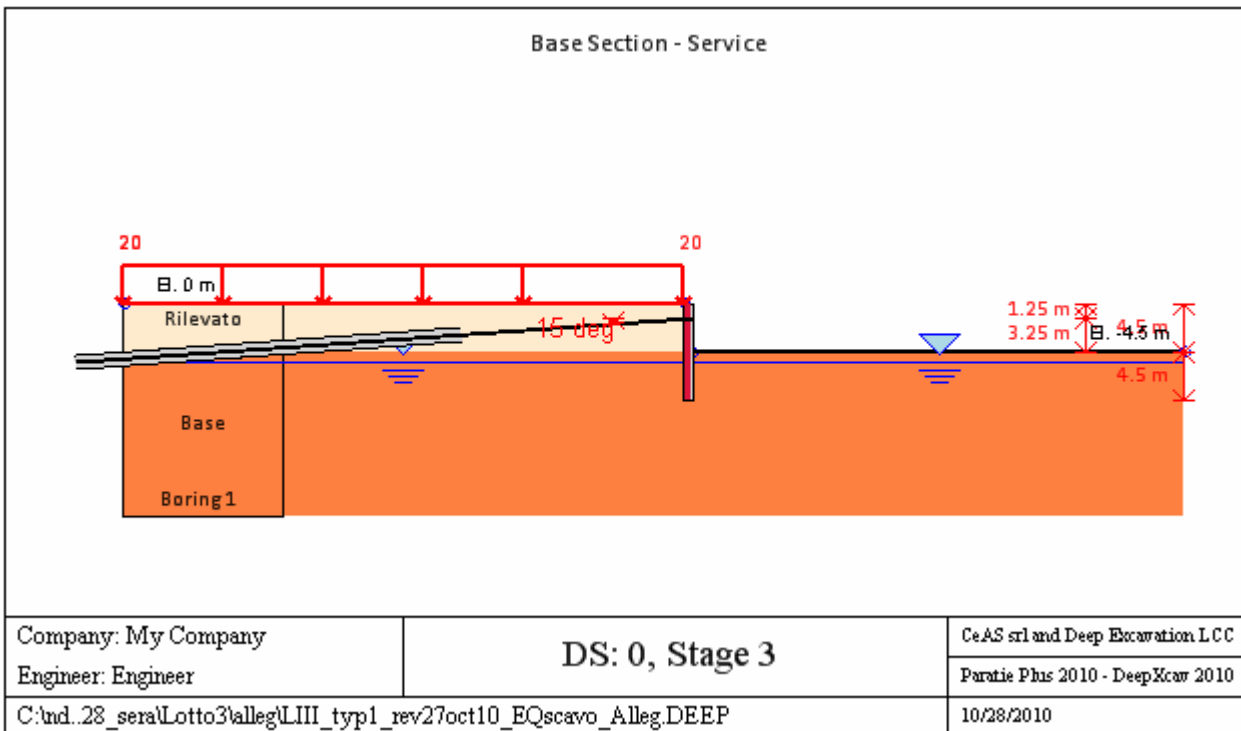
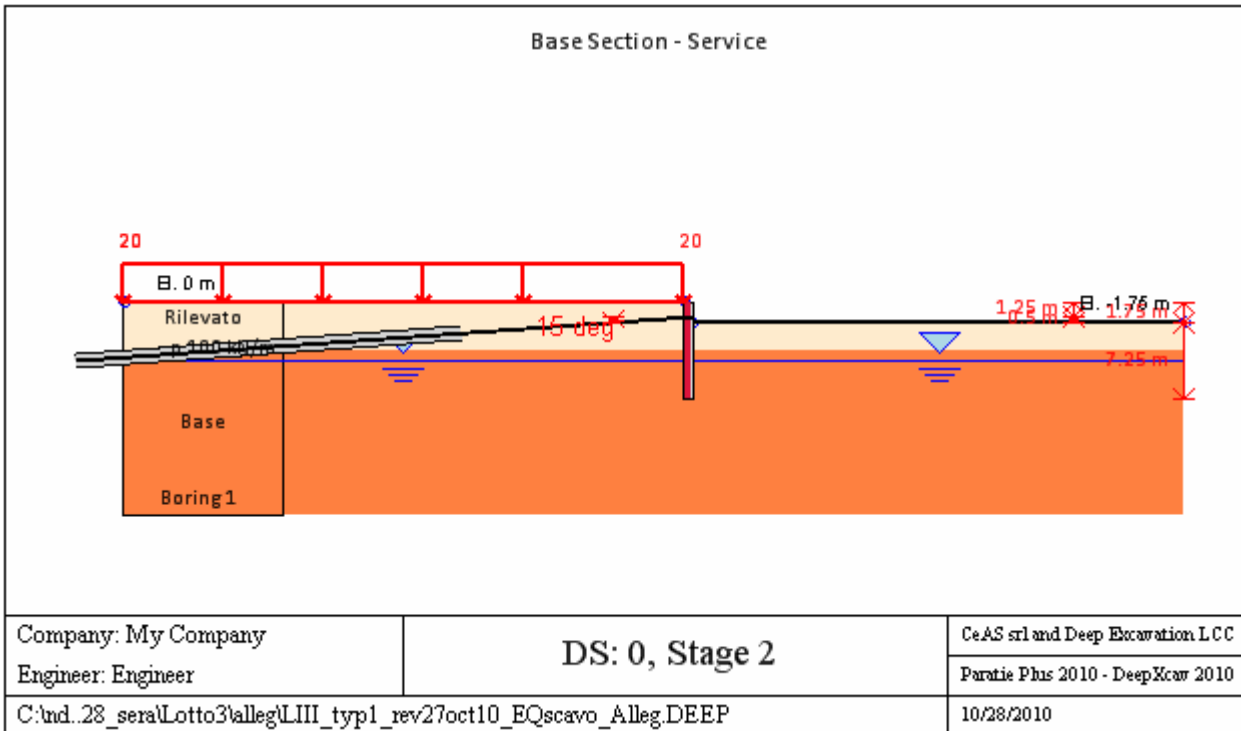

GENERAL ANALYSIS CRITERIA

Summary of stage assumptions

Name	Analysis	Drive	ka-Mult	Htr	Resist	Res	Contl	Supp	Axial	Used	Min	Toe	Toe
	Method	Press		(%)	Press	Mult	Meth	Mode	Incl	FWall	FDtoe	FSrot	FSpas
Stage 0	Springs-Up	Ka+ d	N/A	N/A	Kp+ d	N/A		Fixed	N/A	1	0	0	0
Stage 1	Springs-Up	Ka+ d	N/A	N/A	Kp+ d	N/A		Fixed	N/A	1	0	0	0
Stage 2	Springs-Up	FHWA	1.3	m=	Kp+ d	N/A		Fixed	N/A	1	0	0	N/A
Stage 3	Springs-Up	FHWA	1.3	m=	Kp+ d	N/A		Fixed	N/A	1	0	0	N/A

Name=excavation phase name

Analysis method

springs=elasto plastic springs are used

DR=Drained condition for CLAY model

U=Undrained condition for CLAY model for all the soils

Up=Undrained condition just for selected soil

Drive press=Ka

ka mult=multiply factor for Ka

Htr T/B (%)=trapezoidal pressure scheme

Resit press=Kp

Res Mult=Multiply factor for Kp

COntle Method=cantilver method

Support Model=Fix support type

Axial Incl=Axial action is included for design

Used FS wall=Reduction factor for axial+bending resistance dominium

Min FD TOe=embedded minimum safety factor (for classic analysis)

Toe FS rot=rotation safety factor (classic for classic analysis)

Toe FSpas=driving/resistent pressure safety factor (for classic analysis)

SEISMIC DATA

Seismic action is modeled through a pseudo static approach

Summary of stage assumptions

Stage	Seismic g	Method	aX	aY	Beta	Building Code
Number	Used	Used	(g)	(g)		(Name)
0	No		0.034	0	1	N/A
1	No		0.034	0	1	N/A
2	No		0.034	0	1	N/A
3	No		0.034	0	1	N/A

N/A= data non available

Stage number=number of stage input

Seismic ag =value of design acceleration according to a code or input by the user

Method=the method used to evaluated the seismic thrustover the wall

ahd or khd otr axd=design horizontal acceleration

avd or kvd or ayd=design vertical acceleration

Beta=multip coeff for the semirigd approach

Buildind code=code used for design acceleration calculation

SUPPORTS PROPERTIES

Support 0: type = tieback

X = 0.24 m, Z = -1.25 m, S = 2.4 m

Lfree = 6 m, Lfix = 10 m, Rfix = 50 %

Walls: P168.3x10/40

Stage No	Active	Prestress	Slab live load	User add. strain
	Yes/No	(kN)	(kPa)	+expansion
0	No	-	-	-
1	No	-	-	-
2	Yes	240	-	-
3	Yes	-	-	-

Support type

LEGENDA for TIEBACKS

General data

Z=support level

S=horizontal distance between each tieback

Lfree=free length

Lfix=rigid body length

Rfix=% effective part of the rigid body length

Stage No=excavation steps number

Active=tieback status (YES=active)

Post stress= tieback preload (Load considering the horiz distance bewteen the tiebacks)

SURFACE LOADS

Surcharge 0: X1 = -14, X2 = 0

Variable surcharge

Stage No	Active	X1	Z1	qX1	qZ1	X2	Z2	qX2	qZ2
	Yes/No	(m)	(m)	(kPa)	(kPa)	(m)	(m)	(kPa)	(kPa)
0	Yes	-14	0	0	20	0	0	0	20
1	Yes	-14	0	0	20	0	0	0	20
2	Yes	-14	0	0	20	0	0	0	20
3	Yes	-14	0	0	20	0	0	0	20

LEGENDA

Stage No=Excavation step number

Active=load status (Yes=active)

X1=first X coordinate position of the load

Z1=first Z coordinate position of the load

qX1=first horizontal point load value

qZ1=first vertical point load value

X2=second X coordinate position of the load

Z2=second Z coordinate position of the load

qX2=second horizontal point load value

qZ2=second vertical point load value

WALL RESULTS TABLE

P168.3x10/40 Stage: 0

Wall	EL	Sht L	Sht R	Shs L	Shs R	q	U L	U R	M	V	dx
Nod	(m)	(kPa)	(kPa)	(kPa)	(kPa)	(kPa)	(kPa)	(kPa)	(kN-	(kN/m)	(cm)
0	0	5.34	0	5.34	0	0	0	0	0	0.27	0.02
2	-0.2	6.301	5.878	6.301	5.878	0	0	0	0.06	0.34	0.02
4	-0.4	7.262	7.445	7.262	7.445	0	0	0	0.14	0.39	0.01
6	-0.6	8.224	9.02	8.224	9.02	0	0	0	0.21	0.33	0.01
8	-0.8	9.922	10.607	9.922	10.607	0	0	0	0.25	0.17	0.01
10	-1	11.763	12.207	11.763	12.207	0	0	0	0.26	0.04	0.01
12	-1.2	13.581	13.822	13.581	13.822	0	0	0	0.26	-0.04	0.01
14	-1.35	14.928	15.042	14.928	15.042	0	0	0	0.25	-0.07	0.01
16	-1.55	16.705	16.682	16.705	16.682	0	0	0	0.23	-0.09	0.01
18	-1.75	18.461	18.335	18.461	18.335	0	0	0	0.22	-0.08	0.01
20	-1.95	20.198	19.999	20.198	19.999	0	0	0	0.21	-0.05	0.01
22	-2.15	21.915	21.676	21.915	21.676	0	0	0	0.2	0	0.01
24	-2.35	23.614	23.364	23.614	23.364	0	0	0	0.21	0.04	0.01
26	-2.55	25.293	25.063	25.293	25.063	0	0	0	0.23	0.09	0.01
28	-2.75	26.952	26.776	26.952	26.776	0	0	0	0.25	0.14	0.01
30	-2.95	28.588	28.502	28.588	28.502	0	0	0	0.28	0.17	0.01
32	-3.15	30.198	30.244	30.198	30.244	0	0	0	0.32	0.18	0.01

34	-3.35	31.779	32.005	31.779	32.005	0	0	0	0.35	0.16	0.01
36	-3.55	33.328	33.785	33.328	33.785	0	0	0	0.38	0.11	0.01
38	-3.75	34.843	35.586	34.843	35.586	0	0	0	0.38	0	0.01
40	-3.95	36.323	37.408	36.323	37.408	0	0	0	0.36	-0.16	0.01
42	-4.15	37.77	39.25	37.77	39.25	0	0	0	0.29	-0.4	0.01
44	-4.35	39.191	41.109	39.191	41.109	0	0	0	0.17	-0.72	0.02
46	-4.55	53.546	51.581	53.546	51.581	0	0	0	-0.04	-1.12	0.02
48	-4.75	55.419	53.826	55.419	53.826	0	0	0	-0.2	-0.75	0.02
50	-4.95	57.306	56.06	57.306	56.06	0	0	0	-0.31	-0.45	0.02
52	-5.15	59.213	58.278	59.213	58.278	0	0	0	-0.36	-0.21	0.02
54	-5.35	61.143	60.477	61.143	60.477	0	0	0	-0.38	-0.04	0.02
56	-5.55	63.31	62.867	62.81	62.367	0	0.5	0.5	-0.37	0.08	0.02
58	-5.75	66.134	65.871	63.634	63.371	0	2.5	2.5	-0.34	0.16	0.02
60	-5.95	68.981	68.858	64.481	64.358	0	4.5	4.5	-0.3	0.2	0.02
62	-6.15	71.848	71.828	65.348	65.328	0	6.5	6.5	-0.26	0.22	0.02
64	-6.35	74.731	74.784	66.231	66.284	0	8.5	8.5	-0.21	0.22	0.02
66	-6.55	77.629	77.73	67.129	67.23	0	10.5	10.5	-0.17	0.21	0.02
68	-6.75	80.537	80.666	68.037	68.166	0	12.5	12.5	-0.13	0.19	0.02
70	-6.95	83.455	83.595	68.955	69.095	0	14.5	14.5	-0.1	0.16	0.02
72	-7.15	86.378	86.519	69.878	70.019	0	16.5	16.5	-0.07	0.13	0.02
74	-7.35	89.306	89.439	70.806	70.939	0	18.5	18.5	-0.05	0.11	0.02
76	-7.55	92.238	92.357	71.738	71.857	0	20.5	20.5	-0.03	0.08	0.02
78	-7.75	95.171	95.273	72.671	72.773	0	22.5	22.5	-0.02	0.06	0.02
80	-7.95	98.105	98.188	73.605	73.688	0	24.5	24.5	-0.01	0.04	0.02
82	-8.15	101.04	101.10	74.54	74.603	0	26.5	26.5	0	0.02	0.02
84	-8.35	103.97	104.01	75.474	75.518	0	28.5	28.5	0	0.01	0.02
86	-8.55	106.90	106.93	76.409	76.433	0	30.5	30.5	0	0	0.02
88	-8.75	109.84	109.84	77.344	77.348	0	32.5	32.5	0	0	0.02
90	-8.95	112.77	112.76	78.279	78.263	0	34.5	34.5	0	0	0.02

P168.3x10/40 Stage: 1

Wall	EL	Sht L	Sht R	Shs L	Shs R	q	U L	U R	M	V	dx
Nod	(m)	(kPa)	(kPa)	(kPa)	(kPa)	(kPa)	(kPa)	(kPa)	(kN-	(kN/m)	(cm)
0	0	5.34	0	5.34	0	0	0	0	0	0.27	0.88
2	-0.2	6.301	0	6.301	0	0	0	0	0.11	0.85	0.82
4	-0.4	7.262	0	7.262	0	0	0	0	0.48	2.16	0.76
6	-0.6	8.224	0	8.224	0	0	0	0	1.13	3.66	0.7
8	-0.8	9.185	0	9.185	0	0	0	0	2.11	5.35	0.64
10	-1	10.146	0	10.146	0	0	0	0	3.46	7.24	0.58
12	-1.2	11.107	0	11.107	0	0	0	0	5.22	9.31	0.53
14	-1.35	11.828	0	11.828	0	0	0	0	6.83	11	0.48
16	-1.55	12.789	0	12.789	0	0	0	0	9.39	13.41	0.43
18	-1.75	13.75	0	13.75	0	0	0	0	12.46	16.02	0.37
20	-1.95	14.712	18.202	14.712	18.202	0	0	0	15.99	17.9	0.32
22	-2.15	15.673	36.403	15.673	36.403	0	0	0	19.38	16.34	0.27
24	-2.35	16.634	44.467	16.634	44.467	0	0	0	21.94	11.34	0.23
26	-2.55	17.595	40.816	17.595	40.816	0	0	0	23.39	6.01	0.19
28	-2.75	18.556	37.75	18.556	37.75	0	0	0	23.92	1.57	0.15
30	-2.95	19.518	35.32	19.518	35.32	0	0	0	23.68	-2.09	0.12
32	-3.15	20.479	33.538	20.479	33.538	0	0	0	22.8	-5.1	0.1
34	-3.35	21.44	32.391	21.44	32.391	0	0	0	21.4	-7.6	0.08
36	-3.55	22.407	31.848	22.407	31.848	0	0	0	19.56	-9.71	0.06
38	-3.75	26.979	31.862	26.979	31.862	0	0	0	17.36	-11.35	0.05
40	-3.95	30.721	32.372	30.721	32.372	0	0	0	14.96	-12.15	0.04
42	-4.15	33.747	33.313	33.747	33.313	0	0	0	12.49	-12.36	0.03
44	-4.35	36.175	34.612	36.175	34.612	0	0	0	10.04	-12.21	0.03
46	-4.55	51.753	42.844	51.753	42.844	0	0	0	7.64	-11.87	0.03

48	-4.75	53.758	45.04	53.758	45.04	0	0	0	5.53	-10.1	0.03
50	-4.95	55.581	47.379	55.581	47.379	0	0	0	3.77	-8.37	0.03
52	-5.15	57.284	49.809	57.284	49.809	0	0	0	2.34	-6.77	0.03
54	-5.35	58.918	52.292	58.918	52.292	0	0	0	1.21	-5.31	0.03
56	-5.55	60.733	55.001	60.233	54.501	0	0.5	0.5	0.34	-4.03	0.03
58	-5.75	63.181	58.327	60.681	55.827	0	2.5	2.5	-0.3	-2.93	0.04
60	-5.95	65.65	61.636	61.15	57.136	0	4.5	4.5	-0.74	-2	0.04
62	-6.15	68.153	64.917	61.653	58.417	0	6.5	6.5	-1.03	-1.24	0.04
64	-6.35	70.698	68.163	62.198	59.663	0	8.5	8.5	-1.18	-0.63	0.04
66	-6.55	73.291	71.37	62.791	60.87	0	10.5	10.5	-1.23	-0.15	0.05
68	-6.75	75.93	74.538	63.43	62.038	0	12.5	12.5	-1.21	0.2	0.05
70	-6.95	78.614	77.67	64.114	63.17	0	14.5	14.5	-1.13	0.46	0.05
72	-7.15	81.34	80.767	64.84	64.267	0	16.5	16.5	-1.01	0.63	0.05
74	-7.35	84.103	83.834	65.603	65.334	0	18.5	18.5	-0.87	0.73	0.05
76	-7.55	86.896	86.876	66.396	66.376	0	20.5	20.5	-0.72	0.77	0.05
78	-7.75	89.715	89.896	67.215	67.396	0	22.5	22.5	-0.57	0.76	0.05
80	-7.95	92.554	92.9	68.054	68.4	0	24.5	24.5	-0.42	0.72	0.05
82	-8.15	95.407	95.892	68.907	69.392	0	26.5	26.5	-0.29	0.64	0.05
84	-8.35	98.27	98.876	69.77	70.376	0	28.5	28.5	-0.18	0.54	0.05
86	-8.55	101.14	101.85	70.64	71.354	0	30.5	30.5	-0.09	0.41	0.05
88	-8.75	104.01	104.82	71.512	72.329	0	32.5	32.5	-0.03	0.26	0.05
90	-8.95	106.88	107.80	72.386	73.304	0	34.5	34.5	0	0.09	0.05

P168.3x10/40 Stage: 2

Wall	EL	Sht L	Sht R	Shs L	Shs R	q	U L	U R	M	V	dx
Nod	(m)	(kPa)	(kPa)	(kPa)	(kPa)	(kPa)	(kPa)	(kPa)	(kN-	(kN/m)	(cm)
0	0	40.011	0	40.011	0	0	0	0	0	2	0.73
2	-0.2	42.009	0	42.009	0	0	0	0	0.81	6.1	0.67
4	-0.4	43.966	0	43.966	0	0	0	0	3.3	14.6	0.6
6	-0.6	45.785	0	45.785	0	0	0	0	7.55	23.49	0.54
8	-0.8	47.295	0	47.295	0	0	0	0	13.63	32.73	0.48
10	-1	48.257	0	48.257	0	0	0	0	21.6	42.24	0.42
12	-1.2	48.363	0	48.363	0	0	0	0	31.5	51.91	0.37
14	-1.35	47.671	0	47.671	0	0	0	0	30.53	-37.44	0.33
16	-1.55	45.806	0	45.806	0	0	0	0	24.46	-27.98	0.29
18	-1.75	43.228	0	43.228	0	0	0	0	20.23	-18.95	0.25
20	-1.95	40.28	2.489	40.28	2.489	0	0	0	17.72	-10.49	0.21
22	-2.15	37.243	23.148	37.243	23.148	0	0	0	16.63	-4.12	0.18
24	-2.35	34.328	33.594	34.328	33.594	0	0	0	16.11	-2.48	0.15
26	-2.55	31.679	32.161	31.679	32.161	0	0	0	15.63	-2.39	0.13
28	-2.75	29.39	31.092	29.39	31.092	0	0	0	15.14	-2.55	0.11
30	-2.95	27.509	30.408	27.509	30.408	0	0	0	14.57	-2.95	0.09
32	-3.15	26.053	30.112	26.053	30.112	0	0	0	13.88	-3.59	0.07
34	-3.35	25.013	30.196	25.013	30.196	0	0	0	13.04	-4.46	0.06
36	-3.55	24.368	30.643	24.368	30.643	0	0	0	11.99	-5.55	0.05
38	-3.75	27.683	31.429	27.683	31.429	0	0	0	10.7	-6.67	0.04
40	-3.95	30.481	32.52	30.481	32.52	0	0	0	9.27	-7.32	0.04
42	-4.15	32.828	33.877	32.828	33.877	0	0	0	7.75	-7.67	0.04
44	-4.35	34.8	35.457	34.8	35.457	0	0	0	6.18	-7.86	0.03
46	-4.55	50.557	43.815	50.557	43.815	0	0	0	4.59	-7.99	0.03
48	-4.75	52.467	46.088	52.467	46.088	0	0	0	3.19	-6.65	0.03
50	-4.95	54.274	48.439	54.274	48.439	0	0	0	2.05	-5.4	0.04
52	-5.15	56.021	50.835	56.021	50.835	0	0	0	1.14	-4.27	0.04
54	-5.35	57.739	53.249	57.739	53.249	0	0	0	0.44	-3.26	0.04
56	-5.55	59.665	55.868	59.165	55.368	0	0.5	0.5	-0.08	-2.4	0.04
58	-5.75	62.239	59.092	59.739	56.592	0	2.5	2.5	-0.45	-1.68	0.04
60	-5.95	64.838	62.295	60.338	57.795	0	4.5	4.5	-0.69	-1.08	0.04

62	-6.15	67.471	65.471	60.971	58.971	0	6.5	6.5	-0.83	-0.6	0.05
64	-6.35	70.139	68.617	61.639	60.117	0	8.5	8.5	-0.9	-0.22	0.05
66	-6.55	72.845	71.732	62.345	61.232	0	10.5	10.5	-0.9	0.06	0.05
68	-6.75	75.586	74.817	63.086	62.317	0	12.5	12.5	-0.85	0.27	0.05
70	-6.95	78.36	77.876	63.86	63.376	0	14.5	14.5	-0.78	0.41	0.05
72	-7.15	81.164	80.91	64.664	64.41	0	16.5	16.5	-0.68	0.49	0.05
74	-7.35	83.994	83.923	65.494	65.423	0	18.5	18.5	-0.58	0.53	0.05
76	-7.55	86.844	86.918	66.344	66.418	0	20.5	20.5	-0.47	0.54	0.05
78	-7.75	89.711	89.899	67.211	67.399	0	22.5	22.5	-0.37	0.52	0.05
80	-7.95	92.592	92.87	68.092	68.37	0	24.5	24.5	-0.27	0.47	0.05
82	-8.15	95.481	95.832	68.981	69.332	0	26.5	26.5	-0.18	0.42	0.05
84	-8.35	98.377	98.789	69.877	70.289	0	28.5	28.5	-0.11	0.34	0.05
86	-8.55	101.27	101.74	70.777	71.242	0	30.5	30.5	-0.05	0.26	0.05
88	-8.75	104.17	104.69	71.679	72.194	0	32.5	32.5	-0.02	0.16	0.05
90	-8.95	107.08	107.64	72.582	73.144	0	34.5	34.5	0	0.06	0.05

P168.3x10/40 Stage: 3

Wall	EL	Sht L	Sht R	Shs L	Shs R	q	U L	U R	M	V	dx
Nod	(m)	(kPa)	(kPa)	(kPa)	(kPa)	(kPa)	(kPa)	(kPa)	(kN-)	(kN/m)	(cm)
0	0	56.248	0	56.248	0	0	0	0	0	2.81	0.55
2	-0.2	52.299	0	52.299	0	0	0	0	1.11	8.24	0.55
4	-0.4	48.304	0	48.304	0	0	0	0	4.3	18.5	0.56
6	-0.6	44.151	0	44.151	0	0	0	0	9.43	27.96	0.56
8	-0.8	39.655	0	39.655	0	0	0	0	16.32	36.57	0.56
10	-1	34.563	0	34.563	0	0	0	0	24.8	44.25	0.57
12	-1.2	28.557	0	28.557	0	0	0	0	34.66	50.88	0.59
14	-1.35	23.245	0	23.245	0	0	0	0	32.43	-48.87	0.6
16	-1.55	15.194	0	15.194	0	0	0	0	23.31	-44.62	0.62
18	-1.75	13.75	0	13.75	0	0	0	0	14.82	-41.77	0.65
20	-1.95	14.712	0	14.712	0	0	0	0	6.89	-38.97	0.69
22	-2.15	15.673	0	15.673	0	0	0	0	-0.46	-35.98	0.72
24	-2.35	16.634	0	16.634	0	0	0	0	-7.18	-32.8	0.75
26	-2.55	17.595	0	17.595	0	0	0	0	-13.24	-29.42	0.79
28	-2.75	18.556	0	18.556	0	0	0	0	-18.59	-25.86	0.82
30	-2.95	19.518	0	19.518	0	0	0	0	-23.2	-22.1	0.84
32	-3.15	20.479	0	20.479	0	0	0	0	-27.03	-18.15	0.86
34	-3.35	21.44	0	21.44	0	0	0	0	-30.04	-14	0.88
36	-3.55	22.401	0	22.401	0	0	0	0	-32.19	-9.67	0.89
38	-3.75	23.362	0	23.362	0	0	0	0	-33.45	-5.14	0.89
40	-3.95	24.324	0	24.324	0	0	0	0	-33.77	-0.42	0.89
42	-4.15	25.285	0	25.285	0	0	0	0	-33.12	4.5	0.88
44	-4.35	26.246	0	26.246	0	0	0	0	-31.46	9.6	0.86
46	-4.55	36.582	2.992	36.582	2.992	0	0	0	-28.74	14.9	0.84
48	-4.75	37.875	14.958	37.875	14.958	0	0	0	-24.81	21.08	0.81
50	-4.95	39.167	26.924	39.167	26.924	0	0	0	-19.96	25.13	0.78
52	-5.15	40.459	38.891	40.459	38.891	0	0	0	-14.62	27.05	0.74
54	-5.35	41.752	50.857	41.752	50.857	0	0	0	-9.22	26.83	0.7
56	-5.55	43.365	61.662	42.865	61.162	0	0.5	0.5	-4.18	24.47	0.66
58	-5.75	45.939	66.936	43.439	64.436	0	2.5	2.5	0.14	20.58	0.61
60	-5.95	48.513	68.024	44.013	63.524	0	4.5	4.5	3.64	16.45	0.57
62	-6.15	51.088	69.107	44.588	62.607	0	6.5	6.5	6.35	12.62	0.53
64	-6.35	53.662	70.217	45.162	61.717	0	8.5	8.5	8.34	9.09	0.48
66	-6.55	56.237	71.378	45.737	60.878	0	10.5	10.5	9.67	5.85	0.44
68	-6.75	58.811	72.605	46.311	60.105	0	12.5	12.5	10.39	2.89	0.41
70	-6.95	61.385	73.912	46.885	59.412	0	14.5	14.5	10.56	0.2	0.37
72	-7.15	63.96	75.302	47.46	58.802	0	16.5	16.5	10.23	-2.25	0.34
74	-7.35	67.416	76.777	48.916	58.277	0	18.5	18.5	9.45	-4.46	0.3

76	-7.55	72.248	78.331	51.748	57.831	0	20.5	20.5	8.29	-6.17	0.27
78	-7.75	76.982	79.956	54.482	57.456	0	22.5	22.5	6.89	-7.22	0.25
80	-7.95	81.632	81.639	57.132	57.139	0	24.5	24.5	5.37	-7.67	0.22
82	-8.15	86.218	83.366	59.718	56.866	0	26.5	26.5	3.85	-7.53	0.19
84	-8.35	90.756	85.125	62.256	56.625	0	28.5	28.5	2.45	-6.82	0.17
86	-8.55	95.264	86.901	64.764	56.401	0	30.5	30.5	1.27	-5.55	0.14
88	-8.75	99.756	88.683	67.256	56.183	0	32.5	32.5	0.42	-3.74	0.12
90	-8.95	104.24	90.465	69.743	55.965	0	34.5	34.5	0.02	-1.39	0.1

LEGENDA

Wall node=number of the node

EL=elevation

Sht L=Total horizontal soil pressure (on the left side of the wall)

Sht R=Total horizontal soil pressure (on the right side of the wall)

Shs L=Effective horizontal soil pressure (on the left side of the wall)

Shs R=Effective horizontal soil pressure (on the right side of the wall)

q=pressure given by the surcharge

U L=Water pressure (on the left side of the wall)

U R=pressione acqua (on the right side of the wall)

M=bending moment (per meter)

V=shear (per metro)

dx=wall deflection

McapL=Ultimate bending moment (on the left side of the wall)

McapR=Ultimate bending moment (on the right side of the wall)

VcapL=Ultimate resistance shear (on the left side of the wall)

VcapR=Ultimate resistance shear (on the right side of the wall)

SUPPORTS REACTIONS (TIEBACKS, STRUTS, SLABS, RAKERS)

Support 0

Stage No	R
	(kN)
0	0
1	0
2	240
3	258.192

Project: My Project
Results for Design Section 1: DM08_ITA: Comb. 1:
A1+M1+R1

DESIGN APPROACHES AND COMBINATION FACTORS

The Design Approaches (from Codes or Customized by the user) and related safety factors are the following:

Ftan fr=mult factor for friction angle

F C'=mult factor for effective cohesion

F Su'=mult factof for undrained cohesion

F EQ=mult factor for seismic action

F perm load=mult factor for perm loads

F temp load=mult factor for live loads

F perm supp=reduct factor for resistance for pull out checking

F temp supp=fattore di riduzione resistance per verifica pull out tirante

F earth Dstab=mult factor for active press coeff , unfavorable

F earth stab=mult factor for passive pressure , favorable

F GW Dstab (ground water)=mult factor for hydrostatic pressure , unfavorable

F GW stab (ground water)=mult factor for hydrostatic pressure, favorable

F HYD Dstab=mult factor for hydrodynamic pressure, unfavorable

F HYD stab=mult factor for hydrodynamic pressure, favorable

F UPL Dstab=mult factor for hydraulic heave, unfavorable

Stage	Design Name	Design Case	F(tan fr)	F (c')	F (Su)	F (EO)	F(perm load)	F(temp load)	F(perm sup)	F(temp sup)	F Earth (Dstab)	F Earth (stab)	F GW Dstab (stab)	F GW Dstab (stab)	F HYD Dstab (stab)	F HYD Dstab (stab)	F UPL Dstab (stab)	F UPL Dstab (stab)
0	DM08_ITA	1: A1+M1+R1	1	1	1	0	1.3	1.5	1.2	1.1	1.3	1	1.3	1	1.35	0.9	1	1
1	DM08_ITA	1: A1+M1+R1	1	1	1	0	1.3	1.5	1.2	1.1	1.3	1	1.3	1	1.35	0.9	1	1
2	DM08_ITA	1: A1+M1+R1	1	1	1	0	1.3	1.5	1.2	1.1	1.3	1	1.3	1	1.35	0.9	1	1
3	DM08_ITA	1: A1+M1+R1	1	1	1	0	1.3	1.5	1.2	1.1	1.3	1	1.3	1	1.35	0.9	1	1

SOIL DATA

Name	g tot	g dry	Frict	C'	Su	FRp	FRcv	Eload	Eur	kAp	kPp	kAcv	kPcv	Vary	Spring	Color
------	-------	-------	-------	----	----	-----	------	-------	-----	-----	-----	------	------	------	--------	-------

	(kN/m3)	(kN/m3)	(deg)	(kPa)	(kPa)	(deg)	(deg)	(kPa)	(kPa)	Springs	Springs	Springs	Springs		Model	
F	20	19	30	0	N/A	N/A	N/A	15000	45000	0.33	3	N/A	N/A	True	Linear	
O1	16.5	14	22	2	20	22	22	2874	8622	0.46	2.2	0.46	2.2	True	Linear	
O2	19	16.5	28	2	N/A	N/A	N/A	7185	21555	0.36	2.77	N/A	N/A	True	Linear	
S1	21	19	34	0	N/A	N/A	N/A	25000	75000	0.28	3.54	N/A	N/A	True	Linear	
Clay	20	19	28	0	150	28	28	20000	60000	0.36	2.77	0.36	2.77	True	Linear	
GT	22	20	36	10	N/A	N/A	N/A	30000	90000	0.26	3.85	N/A	N/A	True	Linear	
Rock	27	25	30	100	N/A	N/A	N/A	479000	143700	0.33	3	N/A	N/A	True	Linear	
Rileva	18	18	32	0	N/A	N/A	N/A	30000	30000	0.31	3.26	N/A	N/A	True	Linear	
Base	18	18	25	0	N/A	N/A	N/A	25000	25000	0.41	2.46	N/A	N/A	True	Linear	

gtot=total soil specific weight

gdry=dry weight of the soil

Frict=friction angle

C'=effective cohesion

Su = Undrained cohesion (only for CLAY soils in undrained conditions)

Dilat=SOil Dilatancy (only for non linear analysis)

Evc=Virgin compression elastic module

Eur=unloading/reloading elastic module

Kap= Peak active thrust coeff

Kpp= Peak passive thrust coeff

Kacv= Constant volume active thrust coeff

Kpcv= Constant volume passive thrust coeff

Spring models= spring model (LIN=constant over the soil layer height , EXP=exponential ,

SIMC=simplified winkler)

LIN= Linear-Elastic-Perfectly Plastic,

EXP: Exponential, SUB: Modulus of Subgrade Reaction

SOIL BORINGS

Top Elev= superior SOil level

Soil type=type of the soil (sand , clay , etc)

OCR=overconsolidation ratio

K0=at rest coefficient

Name: Boring 1, pos: (-20, 0)

Top elev.	Soil type	OCR	Ko
0	Rilevato	1	0.47
-4.5	Base	1	0.58

STRUCTURAL MATERIALS DATA

Steel

Name	Strength Fy (MPa)	Fu (MPa)	Elastic E (MPa)	Density g (kN/m3)
Fe360	235	360	206000	77
Fe510	355	510	210000	77
A36	248.3	400	206000	77
A50	355	500	206000	77
New steel 4	241.4	413.8	206000	77

Concrete

Name	Strength Fc' (MPa)	Elastic E (MPa)	Density g (kN/m3)	Tension Strength (MPa)
C20/25	20	29962	25	10
C25/30	25	31476	25	10
Fc 3ksi	20.7	21541.8	23.573	10

Steel rebar

Name	Strength Fy (MPa)	Elastic E (MPa)

S1860 (Strands)	1670	210000
Grade 75	517.2	200100
Grade 80	551.7	200100
Grade 150	1034.5	200100
Strands 270 ksi	1862.1	200100
S410	410	210000
S500	500	210000
B450C	450	210000

Wood

Name	Ultimate Bending (MPa)	Ultimate Tensile Strength (MPa)	Ultimate Shear Strength (MPa)	Density g (kN/m ³)	Elastic E (MPa)
Construction	11	9.7	5.5	7.8576	6900
Regular grade	6.9	6.9	4.1	7.8576	5520

STEEL

Name=material name

$f_y=f_{yk}$ =characteristic resistance for steel (for all the codes)

$F_u=f_{uk}$ =ultimate resistance for steel (for all the codes)

Elastic E=Elastic modulus

Density g=specific weight

CONCRETE

Name=material name

$f'_c=f_{ck}$ =cylindrical resistance for concrete (for all the codes)

Elastic E=Elastic modulus

Density g=specific weight

Tension strength= $f_t=f_{ctk}$ =characteristic tension resistance for concrete

STEEL REBARS

Name=material name

$f_y=f_{yk}$ =characteristic resistance for steel (for all the codes)

$F_u=f_{uk}$ =ultimate resistance for steel (for all the codes)

Elastic E=Elastic modulus

Density g=specific weight

WOOD

Name=material name

$F_b=f_{bk}$ =Ultimate bending strength

$F_{tu}=f_{tuk}$ =Ultimate tensile strength

$F_{vu}=f_{vuk}$ =Ultimate shear strength

Density g=specific weight

Elastic E=Elastic modulus

WALL DATA

Wall section 0: P168.3x10/40

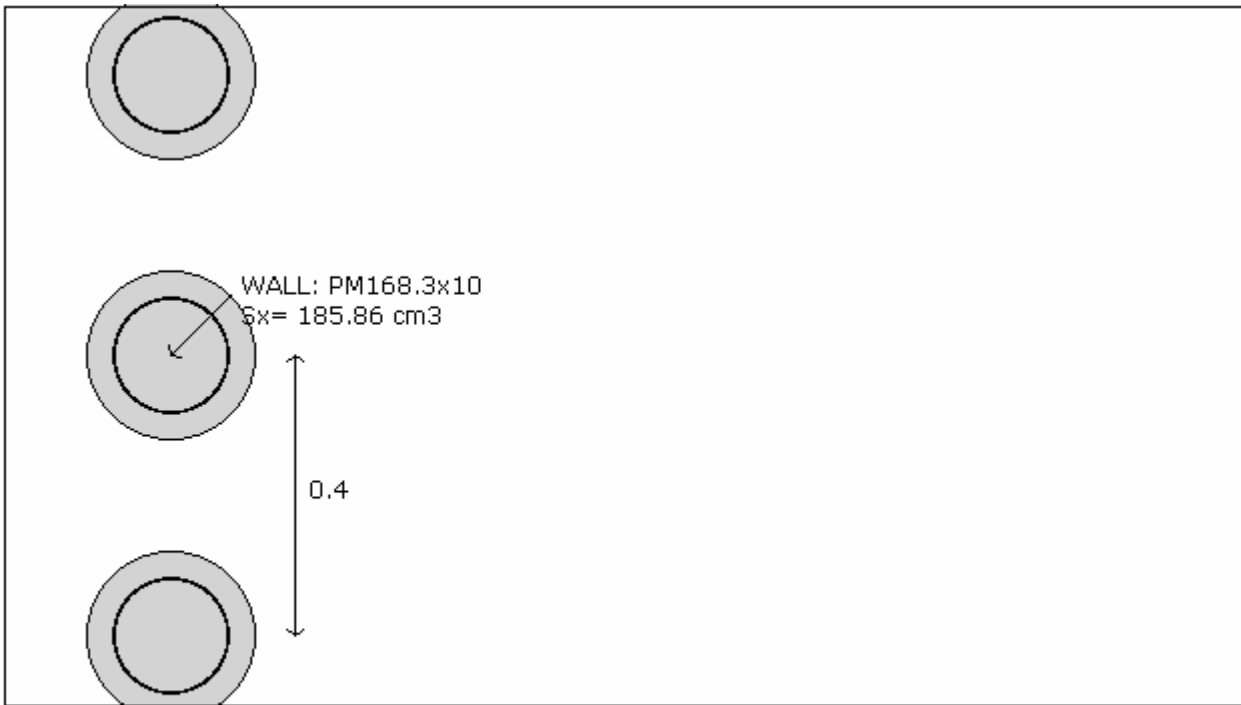

Company: My Company	Wall sketch	CeAS srl and Deep Excavation LCC
Engineer: Engineer		Paratie Plus 2010 - DeepXcar 2010
C:\nd.28_sera\otto3\alleg\LIII_typ1_rev27oct10_EQscavo_Alleg.DEEP		10/28/2010

Wall uses wall section 0: P168.3x10/40

Wall type: Tangent pile wall

Top wall El: 0 m Bottom wall El: -9 m

Hor. wall spacing: 0.4 Wall thickness = 0.24

Passive width below exc: 0.4 Active width below exc: 0.4

Concrete $f_c' = 25$ Rebar $F_y = 410$ $E_{conc} = 31476$ Concrete tension $F_{cT} = 10\%$ of F_c'

Steel members $f_y = 355$ $E_{steel} = 210000$

Wall friction: Percentage of Soil Friction = 50%

Steel wall capacities are calculated with NTC 2008

Concrete capacities are calculated with ACI 318-2002.

Note: With ultimate capacities you may have to use a structural safety factor.

Tangent pile wall soldier pile properties

Table: Soldier Pile Properties

Name	Section	W	A	D	tw or	bf	tf	k	Ixx	Sxx	rX	Iyy	Syy	rY	rT	Cw	fy
		(kN/m)	(cm ²)	(cm)	(cm)	(cm)	(cm)	(cm)	(cm ⁴)	(cm ³)	(cm)	(cm ⁴)	(cm ³)	(cm)	(cm)	(cm ⁶)	(MPa)
	PM16	257.3	75.62	16.8	1	16.83	1	1	3771	185.9	7.06	3771	185.9	7.06	7.06	1	355

GENERAL WALL DATA

Hor wall spacing=wall horizontal spacing

Passive width below exc=spacing for passive thrust pressure for classic analysis

$f'c=fck$ =cylindrical concrete resistance

$fyk=fy$ =steel rebar characteristic resistance

E_{conc} =Concrete Elastic modulus

f_{ctk} =characteristic Concrete tension

E_{steel} =steel elastic modulus

TABULAR DATA (principal parameters)

1) Diaphragm wall (rectangular cross section section)

N/A= data not available

$Fy=fyk$

$F'c=fck$

D=wall height

B=wall width

2)Steel sheet pile

DES=shape (Z or U)

W=width per unit of length

A=area

h=height

t=horiz part thickness

b=width of the single sheet pile part

s=inclined part thickness

I_{xx} =strong axis inertia (per unit of length)

S_{xx} =strong axis section modulus (per unit of length)

3)Secant piles wall, Tangent piles wall, soldier piles, soldier piles and timber lagging

W=weight per unit of length

A=area

D=diameter

tw=web thickness

tp= pipe thickness

bf=flange width

tf=flange thickness

k=flange thickness+stem thickness

I_{xx} =strong axis inertia modulus (per unit of length)

S_{xx} =strong axis section modulus (per unit of length)

r_x =radius of gyration about X axis

r_y =radius of gyration about Y axis

I_{yy} =weak axis inertia modulus (per unit of length)

S_{yy} =weak axis section modulus (per unit of length)

r_T =radius of gyration for torsion

C_w =warping constant

TIEBACK DATA

Name	Fy	Fc'	Dfix	Afix	Efix	Afree	Efree	Pa STR	Pu STR	PresGr	FSgeo	UserGca	Pa	Pu	WireMod
	(MPa)	(MPa)	(cm)	(cm ²)	(MPa)	(cm ²)	(MPa)	(kN)	(kN)	(kPa)			(kN)	(kN)	Yes/No
4-Strands	1862.1	25	15	176.7	31476	2.8	200100	453.4	453.4	N/A	1.4	False	N/A	N/A	Yes
5-Strands	1862.1	25	15	176.7	31476	0	200100	0	0	N/A	1.4	False	N/A	N/A	Yes
6-Strands	1862.1	25	15	176.7	31476	8.39	200100	1357.9	1357.9	N/A	1.4	False	N/A	N/A	Yes
Tieback	1670	25	16	201.0	31476	4.17	210000	605.2	605.2	N/A	1	False	N/A	N/A	Yes

EXCAVATION STAGES SKETCHES

A sequence of figures for each excavation stage is reported

GENERAL ANALYSIS CRITERIA

Summary of stage assumptions

Name	Analysis	Drive	ka-Mult	Htr	Resist	Res	Contl	Supp	Axial	Used	Min	Toe	Toe
------	----------	-------	---------	-----	--------	-----	-------	------	-------	------	-----	-----	-----

	Method	Press		(%)	Press	Mult	Meth	Mode	Incl	FSwall	FDtoe	FSrot	FSpas
Stage 0	Springs-Up	Ka+ d	N/A	N/A	Kp+ d	N/A		Fixed	N/A	1	0	0	0
Stage 1	Springs-Up	Ka+ d	N/A	N/A	Kp+ d	N/A		Fixed	N/A	1	0	0	0
Stage 2	Springs-Up	FHWA	1.3	m=	Kp+ d	N/A		Fixed	N/A	1	0	0	N/A
Stage 3	Springs-Up	FHWA	1.3	m=	Kp+ d	N/A		Fixed	N/A	1	0	0	N/A

Name=excavation phase name

Analysis method

springs=elasto plastic springs are used

DR=Drained condition for CLAY model

U=Undrained condition for CLAY model for all the soils

Up=Undrained condition just for selected soil

Drive press=Ka

ka mult=multiply factor for Ka

Htr T/B (%)=trapezoidal pressure scheme

Resit press=Kp

Res Mult=Multiply factor for Kp

COntle Method=cantilver method

Support Model=Fix support type

Axial Incl=Axial action is included for design

Used FS wall=Reduction factor for axial+bending resistance dominium

Min FD TOe=embedded minimum safety factor (for classic analysis)

Toe FS rot=rotation safety factor (classic for classic analysis)

Toe FSpas=driving/resistent pressure safety factor (for classic analysis)

SEISMIC DATA

Seismic action is modeled through a pseudo static approach

Summary of stage assumptions

Stage	Seismic g	Method	aX	aY	Beta	Building Code
Number	Used	Used	(g)	(g)		(Name)
0	No		0.034	0	1	N/A
1	No		0.034	0	1	N/A
2	No		0.034	0	1	N/A
3	No		0.034	0	1	N/A

N/A= data non available

Stage number=number of stage input

Seismic ag =value of design acceleration according to a code or input by the user

Method=the method used to evaluated the seismic thrustover the wall

ahd or khd otr axd=design horizontal acceleration

avd or kvd or ayd=design vertical acceleration

Beta=multipl coeff for the semirigd approach

Buildind code=code used for design acceleration calculation

SUPPORTS PROPERTIES

Support 0: type = tieback

X = 0.24 m, Z = -1.25 m, S = 2.4 m

Lfree = 6 m, Lfix = 10 m, Rfix = 50 %

Walls: P168.3x10/40

Stage No	Active	Prestress	Slab live load	User add. strain
	Yes/No	(kN)	(kPa)	+expansion
0	No	-	-	-
1	No	-	-	-
2	Yes	240	-	-
3	Yes	-	-	-

Support type

LEGENDA for TIEBACKS

General data

Z=support level

S=horizontal distance between each tieback

Lfree=free length

Lfix=rigid body length

Rfix=% effective part of the rigid body length

Stage No=excavation steps number

Active=tieback status (YES=active)

Post stress= tieback preload (Load considering the horiz distance bewteen the tiebacks)

SURFACE LOADS

Surcharge 0: X1 = -14, X2 = 0

Variable surcharge

Stage No	Active	X1	Z1	qX1	qZ1	X2	Z2	qX2	qZ2
	Yes/No	(m)	(m)	(kPa)	(kPa)	(m)	(m)	(kPa)	(kPa)
0	Yes	-14	0	0	20	0	0	0	20
1	Yes	-14	0	0	20	0	0	0	20
2	Yes	-14	0	0	20	0	0	0	20
3	Yes	-14	0	0	20	0	0	0	20

LEGENDA

Stage No=Excavation step number

Active=load status (Yes=active)

X1=first X coordinate position of the load

Z1=first Z coordinate position of the load

qX1=first horizontal point load value

qZ1=first vertical point load value

X2=second X coordinate position of the load

Z2=second Z coordinate position of the load

qX2=second horizontal point load value

qZ2=second vertical point load value

WALL RESULTS TABLE

LEGENDA

Wall node=number of the node

EL=elevation

Sht L=Total horizontal soil pressure (on the left side of the wall)

Sht R=Total horizontal soil pressure (on the right side of the wall)

Shs L=Effective horizontal soil pressure (on the left side of the wall)

Shs R=Effective horizontal soil pressure (on the right side of the wall)

q=pressure given by the surcharge

U L=Water pressure (on the left side of the wall)

U R=pressione acqua (on the right side of the wall)

M=bending moment (per meter)

V=shear (per metro)

dx=wall deflection

McapL=Ultimate bending moment (on the left side of the wall)

McapR=Ultimate bending moment (on the right side of the wall)

VcapL=Ultimate resistance shear (on the left side of the wall)

VcapR=Ultimate resistance shear (on the right side of the wall)

SUPPORTS REACTIONS (TIEBACKS, STRUTS, SLABS, RAKERS)

Support 0

Stage No	R
	(kN)
0	0
1	0
2	312
3	338.863

Project: My Project
Results for Design Section 2: DM08_ITA: Comb. 2:
A2+M2+R1

DESIGN APPROACHES AND COMBINATION FACTORS

The Design Approaches (from Codes or Customized by the user) and related safety factors are the following:

F_{tan fr}=mult factor for friction angle

F_{C'}=mult factor for effective cohesion

F_{Su'}=mult factor for undrained cohesion

F_{EQ}=mult factor for seismic action

F_{perm load}=mult factor for perm loads

F_{temp load}=mult factor for live loads

F_{perm supp}=reduct factor for resistance for pull out checking

F_{temp supp}=fattore di riduzione resistenza per verifica pull out tirante

F_{earth Dstab}=mult factor for active press coeff , unfavorable

F_{earth stab}=mult factor for passive pressure , favorable

F_{GWT Dstab} (ground water)=mult factor for hydrostatic pressure , unfavorable

F_{GWT stab} (ground water)=mult factor for hydrostatic pressure, favorable

F_{HYD Dstab}=mult factor for hydrodynamic pressure, unfavorable

F_{HYD stab}=mult factor for hydrodynamic pressure, favorable

F_{UPL Dstab}=mult factor for hydraulic heave, unfavorable

Stage	Design	Design Case	F(tan fr)	F (c')	F (Su)	F (EQ)	F(perm load)	F(temp load)	F(perm sup)	F(temp sup)	F Earth (Dstab)	F Earth (stab)	F GWI (Dstab)	F GWI (stab)	F HYD (Dstab)	F HYD (stab)	F UPL (Dstab)	F UPL (stab)
0	DM08_ITA	2: A2+M2+R1	1.25	1.25	1.4	0	1	1.3	1.2	1.1	1	1	1	1	1.35	0.9	1	1
1	DM08_ITA	2: A2+M2+R1	1.25	1.25	1.4	0	1	1.3	1.2	1.1	1	1	1	1	1.35	0.9	1	1
2	DM08_ITA	2: A2+M2+R1	1.25	1.25	1.4	0	1	1.3	1.2	1.1	1	1	1	1	1.35	0.9	1	1
3	DM08_ITA	2: A2+M2+R1	1.25	1.25	1.4	0	1	1.3	1.2	1.1	1	1	1	1	1.35	0.9	1	1

SOIL DATA

Name	g tot (kN/m3)	g dry (kN/m3)	Frict (deg)	C' (kPa)	Su (kPa)	FRp (deg)	FRcv (deg)	Eload (kPa)	Eur (kPa)	kAp Springs	kPp Springs	kAcv Springs	kPcv Springs	Vary	Spring Model	Color
F	20	19	30	0	N/A	N/A	N/A	15000	45000	0.33	3	N/A	N/A	True	Linear	
O1	16.5	14	22	2	20	22	22	2874	8622	0.46	2.2	0.46	2.2	True	Linear	
O2	19	16.5	28	2	N/A	N/A	N/A	7185	21555	0.36	2.77	N/A	N/A	True	Linear	
S1	21	19	34	0	N/A	N/A	N/A	25000	75000	0.28	3.54	N/A	N/A	True	Linear	
Clay	20	19	28	0	150	28	28	20000	60000	0.36	2.77	0.36	2.77	True	Linear	
GT	22	20	36	10	N/A	N/A	N/A	30000	90000	0.26	3.85	N/A	N/A	True	Linear	
Rock	27	25	30	100	N/A	N/A	N/A	479000	143700	0.33	3	N/A	N/A	True	Linear	
Rileva	18	18	32	0	N/A	N/A	N/A	30000	30000	0.31	3.26	N/A	N/A	True	Linear	
Base	18	18	25	0	N/A	N/A	N/A	25000	25000	0.41	2.46	N/A	N/A	True	Linear	

gtot=total soil specific weight

gdry=dry weight of the soil

Frict=friction angle

C'=effective cohesion

Su = Undrained cohesiona (only for CLAY soils in undrained conditions)

Dilat=SOil Dilatancy (only for non linear analysis)

Evc=Virgin compression elastic module

Eur=unloading/reloading elastic module

Kap= Peak active thrust coeff

Kpp= Peak passive thrust coeff

Kacv= Constant volume active thrust coeff

Kpcv= Constant volume passive thrust coeff

Spring models= spring model (LIN=constant over the soil layer height , EXP=exponential ,

SIMC=simplified winkler)

LIN= Linear-Elastic-Perfectly Plastic,

EXP: Exponential, SUB: Modulus of Subgrade Reaction

SOIL BORINGS

Top Elev= superior SOil level

Soil type=type of the soil (sand , clay , etc)

OCR=overconsolidation ratio

K0=at rest coefficient

Name: Boring 1, pos: (-20, 0)

Top elev.	Soil type	OCR	Ko
0	Rilevato	1	0.47
-4.5	Base	1	0.58

STRUCTURAL MATERIALS DATA

Steel

Name	Strength Fy (MPa)	Fu (MPa)	Elastic E (MPa)	Density g (kN/m3)
Fe360	235	360	206000	77
Fe510	355	510	210000	77
A36	248.3	400	206000	77
A50	355	500	206000	77
New steel 4	241.4	413.8	206000	77

Concrete

Name	Strength Fc'	Elastic E	Density g	Tension Strength
	(MPa)	(MPa)	(kN/m3)	(MPa)
C20/25	20	29962	25	10
C25/30	25	31476	25	10
Fc 3ksi	20.7	21541.8	23.573	10

Steel rebar

Name	Strength Fy	Elastic E
	(MPa)	(MPa)
S1860 (Strands)	1670	210000
Grade 75	517.2	200100
Grade 80	551.7	200100
Grade 150	1034.5	200100
Strands 270 ksi	1862.1	200100
S410	410	210000
S500	500	210000
B450C	450	210000

Wood

Name	Ultimate Bending	Ultimate Tensile Strength	Ultimate Shear Strength	Density g	Elastic E
	(MPa)	(MPa)	(MPa)	(kN/m3)	(MPa)
Construction	11	9.7	5.5	7.8576	6900
Regular grade	6.9	6.9	4.1	7.8576	5520

STEEL

Name=material name

fy=fyk=characteristic resistance for steel (for all the codes)

Fu=fuk=ultimate resistance for steel (for all the codes)

Elastic E=Elastic modulus

Density g=specific weight

CONCRETE

Name=material name

f'c=fck=cylindrical resistance for concrete (for all the codes)

Elastic E=Elastic modulus

Density g=specific weight

Tension strength=ft=fctk=characteristic tension resistance for concrete

STEEL REBARS

Name=material name

fy=fyk=characteristic resistance for steel (for all the codes)

Fu=fuk=ultimate resistance for steel (for all the codes)

Elastic E=Elastic modulus

Density g=specific weight

WOOD

Name=material name

Fb=fbk=Ultimate bending strength

Ftu=ftuk=Ultimate tensile strength

Fvu=fvuk=Ultimate shear strength

Density g=specific weight

Elastic E=Elastic modulus

WALL DATA

Wall section 0: P168.3x10/40

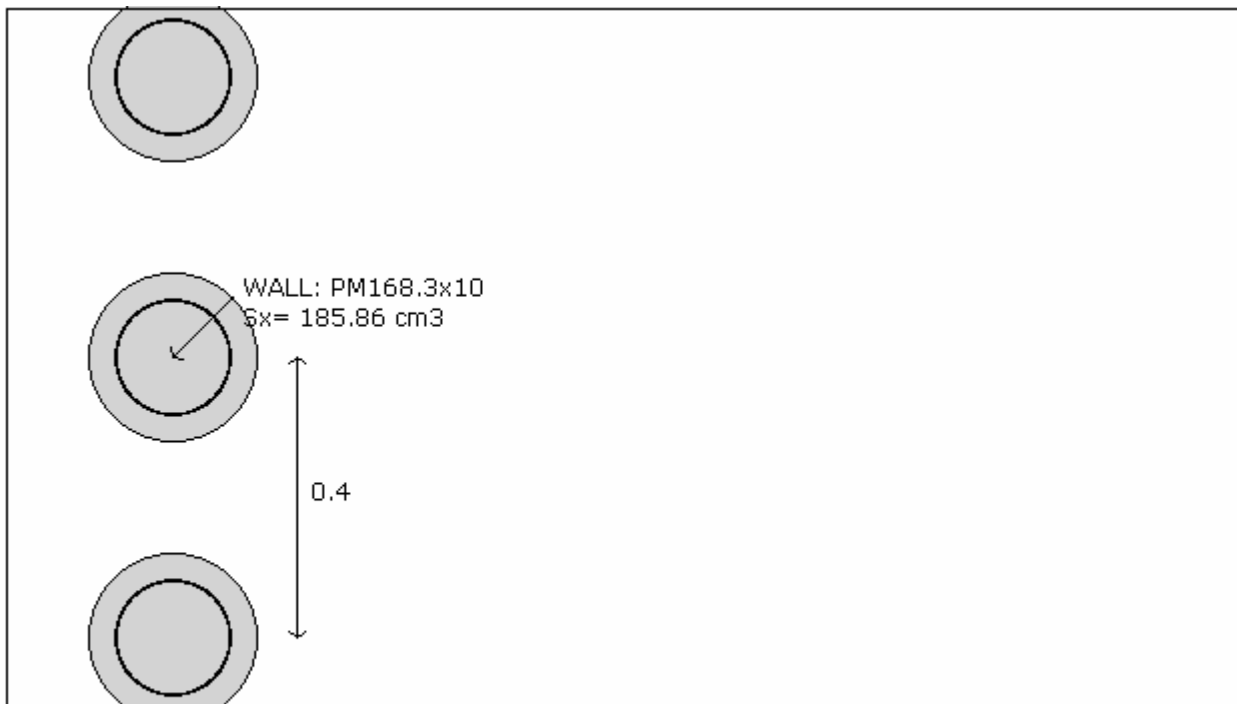

Company: My Company	Wall sketch	CeAS srl and Deep Excavation LCC
Engineer: Engineer		Paratie Plus 2010 - DeepXcar 2010
C:\nd.28_sera\otto3\alleg\LIII_typ1_rev27oct10_EQscavo_Alleg.DEEP		10/28/2010

Wall uses wall section 0: P168.3x10/40

Wall type: Tangent pile wall

Top wall El: 0 m Bottom wall El: -9 m

Hor. wall spacing: 0.4 Wall thickness = 0.24

Passive width below exc: 0.4 Active width below exc: 0.4

Concrete $f_c' = 25$ Rebar $F_y = 410$ $E_{conc} = 31476$ Concrete tension $F_{cT} = 10\%$ of F_c'

Steel members $f_y = 355$ $E_{steel} = 210000$

Wall friction: Percentage of Soil Friction = 50%

Steel wall capacities are calculated with NTC 2008

Concrete capacities are calculated with ACI 318-2002.

Note: With ultimate capacities you may have to use a structural safety factor.

Tangent pile wall soldier pile properties

Table: Soldier Pile Properties

Name	Section	W	A	D	tw or	bf	tf	k	Ixx	Sxx	rX	Iyy	Syy	rY	rT	Cw	fy
		(kN/m)	(cm ²)	(cm)	(cm)	(cm)	(cm)	(cm)	(cm ⁴)	(cm ³)	(cm)	(cm ⁴)	(cm ³)	(cm)	(cm)	(cm ⁶)	(MPa)
	PM16	257.3	75.62	16.8	1	16.83	1	1	3771	185.9	7.06	3771	185.9	7.06	7.06	1	355

GENERAL WALL DATA

Hor wall spacing=wall horizontal spacing

Passive width below exc=spacing for passive thrust pressure for classic analysis

$f'c=fck$ =cylindrical concrete resistance

$fyk=fy$ =steel rebar characteristic resistance

E_{conc} =Concrete Elastic modulus

f_{ctk} =characteristic Concrete tension

E_{steel} =steel elastic modulus

TABULAR DATA (principal parameters)

1) Diaphragm wall (rectangular cross section section)

N/A= data not available

$Fy=fyk$

$F'c=fck$

D=wall height

B=wall width

2)Steel sheet pile

DES=shape (Z or U)

W=width per unit of length

A=area

h=height

t=horiz part thickness

b=width of the single sheet pile part

s=inclined part thickness

I_{xx} =strong axis inertia (per unit of length)

S_{xx} =strong axis section modulus (per unit of length)

3)Secant piles wall, Tangent piles wall, soldier piles, soldier piles and timber lagging

W=weight per unit of length

A=area

D=diameter

tw=web thickness

tp= pipe thickness

bf=flange width

tf=flange thickness

k=flange thickness+stem thickness

I_{xx} =strong axis inertia modulus (per unit of length)

S_{xx} =strong axis section modulus (per unit of length)

r_x =radius of gyration about X axis

r_y =radius of gyration about Y axis

I_{yy} =weak axis inertia modulus (per unit of length)

S_{yy} =weak axis section modulus (per unit of length)

r_T =radius of gyration for torsion

C_w =warping constant

TIEBACK DATA

Name	Fy	Fc'	Dfix	Afix	Efix	Afree	Efree	Pa STR	Pu STR	PresGr	FSgeo	UserGca	Pa	Pu	WireMod
	(MPa)	(MPa)	(cm)	(cm ²)	(MPa)	(cm ²)	(MPa)	(kN)	(kN)	(kPa)			(kN)	(kN)	Yes/No
4-Strands	1862.1	25	15	176.7	31476	2.8	200100	453.4	453.4	N/A	1.4	False	N/A	N/A	Yes
5-Strands	1862.1	25	15	176.7	31476	0	200100	0	0	N/A	1.4	False	N/A	N/A	Yes
6-Strands	1862.1	25	15	176.7	31476	8.39	200100	1357.9	1357.9	N/A	1.4	False	N/A	N/A	Yes
Tieback	1670	25	16	201.0	31476	4.17	210000	605.2	605.2	N/A	1	False	N/A	N/A	Yes

EXCAVATION STAGES SKETCHES

A sequence of figures for each excavation stage is reported

GENERAL ANALYSIS CRITERIA

Summary of stage assumptions

Name	Analysis	Drive	ka-Mult	Htr	Resist	Res	Contl	Supp	Axial	Used	Min	Toe	Toe
------	----------	-------	---------	-----	--------	-----	-------	------	-------	------	-----	-----	-----

	Method	Press		(%)	Press	Mult	Meth	Mode	Incl	FSwall	FDtoe	FSrot	FSpas
Stage 0	Springs-Up	Ka+ d	N/A	N/A	Kp+ d	N/A		Fixed	N/A	1	0	0	0
Stage 1	Springs-Up	Ka+ d	N/A	N/A	Kp+ d	N/A		Fixed	N/A	1	0	0	0
Stage 2	Springs-Up	FHWA	1.3	m=	Kp+ d	N/A		Fixed	N/A	1	0	0	N/A
Stage 3	Springs-Up	FHWA	1.3	m=	Kp+ d	N/A		Fixed	N/A	1	0	0	N/A

Name=excavation phase name

Analysis method

springs=elasto plastic springs are used

DR=Drained condition for CLAY model

U=Undrained condition for CLAY model for all the soils

Up=Undrained condition just for selected soil

Drive press=Ka

ka mult=multiply factor for Ka

Htr T/B (%)=trapezoidal pressure scheme

Resit press=Kp

Res Mult=Multiply factor for Kp

COntle Method=cantilver method

Support Model=Fix support type

Axial Incl=Axial action is included for design

Used FS wall=Reduction factor for axial+bending resistance dominium

Min FD TOe=embedded minimum safety factor (for classic analysis)

Toe FS rot=rotation safety factor (classic for classic analysis)

Toe FSpas=driving/resistent pressure safety factor (for classic analysis)

SEISMIC DATA

Seismic action is modeled through a pseudo static approach

Summary of stage assumptions

Stage	Seismic g	Method	aX	aY	Beta	Building Code
Number	Used	Used	(g)	(g)		(Name)
0	No		0.034	0	1	N/A
1	No		0.034	0	1	N/A
2	No		0.034	0	1	N/A
3	No		0.034	0	1	N/A

N/A= data non available

Stage number=number of stage input

Seismic ag =value of design acceleration according to a code or input by the user

Method=the method used to evaluated the seismic thrustover the wall

ahd or khd otr axd=design horizontal acceleration

avd or kvd or ayd=design vertical acceleration

Beta=multipl coeff for the semirigd approach

Buildind code=code used for design acceleration calculation

SUPPORTS PROPERTIES

Support 0: type = tieback

X = 0.24 m, Z = -1.25 m, S = 2.4 m

Lfree = 6 m, Lfix = 10 m, Rfix = 50 %

Walls: P168.3x10/40

Stage No	Active	Prestress	Slab live load	User add. strain
	Yes/No	(kN)	(kPa)	+expansion
0	No	-	-	-
1	No	-	-	-
2	Yes	240	-	-
3	Yes	-	-	-

Support type

LEGENDA for TIEBACKS

General data

Z=support level

S=horizontal distance between each tieback

Lfree=free length

Lfix=rigid body length

Rfix=% effective part of the rigid body length

Stage No=excavation steps number

Active=tieback status (YES=active)

Post stress= tieback preload (Load considering the horiz distance bewteen the tiebacks)

SURFACE LOADS

Surcharge 0: X1 = -14, X2 = 0

Variable surcharge

Stage No	Active	X1	Z1	qX1	qZ1	X2	Z2	qX2	qZ2
	Yes/No	(m)	(m)	(kPa)	(kPa)	(m)	(m)	(kPa)	(kPa)
0	Yes	-14	0	0	20	0	0	0	20
1	Yes	-14	0	0	20	0	0	0	20
2	Yes	-14	0	0	20	0	0	0	20
3	Yes	-14	0	0	20	0	0	0	20

LEGENDA

Stage No=Excavation step number

Active=load status (Yes=active)

X1=first X coordinate position of the load

Z1=first Z coordinate position of the load

qX1=first horizontal point load value

qZ1=first vertical point load value

X2=second X coordinate position of the load

Z2=second Z coordinate position of the load

qX2=second horizontal point load value

qZ2=second vertical point load value

WALL RESULTS TABLE

LEGENDA

Wall node=number of the node

EL=elevation

Sht L=Total horizontal soil pressure (on the left side of the wall)

Sht R=Total horizontal soil pressure (on the right side of the wall)

Shs L=Effective horizontal soil pressure (on the left side of the wall)

Shs R=Effective horizontal soil pressure (on the right side of the wall)

q=pressure given by the surcharge

U L=Water pressure (on the left side of the wall)

U R=pressione acqua (on the right side of the wall)

M=bending moment (per meter)

V=shear (per metro)

dx=wall deflection

McapL=Ultimate bending moment (on the left side of the wall)

McapR=Ultimate bending moment (on the right side of the wall)

VcapL=Ultimate resistance shear (on the left side of the wall)

VcapR=Ultimate resistance shear (on the right side of the wall)

SUPPORTS REACTIONS (TIEBACKS, STRUTS, SLABS, RAKERS)

Support 0

Stage No	R
	(kN)
0	0
1	0
2	240
3	308.952

Project: My Project***Results for Design Section 3: DM08_ITA: EQK - Seismic*****DESIGN APPROACHES AND COMBINATION FACTORS**

The Design Approaches (from Codes or Customized by the user) and related safety factors are the following:

Ftan fr=mult factor for friction angle

F C'=mult factor for effective cohesion

F Su'=mult factof for undrained cohesion

F EQ=mult factor for seismic action

F perm load=mult factor for perm loads

F temp load=mult factor for live loads

F perm supp=reduct factor for resistance for pull out checking

F temp supp=fattore di riduzione resistenza per verifica pull out tirante

F earth Dstab=mult factor for active press coeff , unfavorable

F earth stab=mult factor for passive pressure , favorable

F GWT Dstab (ground water)=mult factor for hydrostatic pressure , unfavorable

F GWT stab (ground water)=mult factor for hydrostatic pressure, favorable

F HYD Dstab=mult factor for hydrodynamic pressure, unfavorable

F HYD stab=mult factor for hydrodynamic pressure, favorable

F UPL Dstab=mult factor for hydraulic heave, unfavorable

Stage	Design	Design Case	F(tan	F	F	F	F(perm	F(temp	F(perm	F(temp	F Earth	F Earth	F GWT	F GWT	F HYD	F HYD	F UPL	F UPL
	Name		fr)	(c')	(Su)	(EQ)	load)	load)	sup)	sup)	(Dstab)	(stab)	(Dstab)	(stab)	(Dstab)	(stab)	(Dstab)	(stab)

0	DM08_ITA	EQK - Seismic	1.25	1.25	1.4	1	1	1	1.2	1.1	1	1	1	1.35	0.9	1	1
1	DM08_ITA	EQK - Seismic	1.25	1.25	1.4	1	1	1	1.2	1.1	1	1	1	1.35	0.9	1	1
2	DM08_ITA	EQK - Seismic	1.25	1.25	1.4	1	1	1	1.2	1.1	1	1	1	1.35	0.9	1	1
3	DM08_ITA	EQK - Seismic	1.25	1.25	1.4	1	1	1	1.2	1.1	1	1	1	1.35	0.9	1	1
4	DM08_ITA	EQK - Seismic	1.25	1.25	1.4	1	1	1	1.2	1.1	1	1	1	1.35	0.9	1	1

SOIL DATA

Name	g tot	g dry	Frict	C'	Su	FRp	FRcv	Eload	Eur	kAp	kPp	kAcv	kPcv	Vary	Spring	Color
	(kN/m3)	(kN/m3)	(deg)	(kPa)	(kPa)	(deg)	(deg)	(kPa)	(kPa)	Springs	Springs	Springs	Springs		Model	
F	20	19	30	0	N/A	N/A	N/A	15000	45000	0.33	3	N/A	N/A	True	Linear	
O1	16.5	14	22	2	20	22	22	2874	8622	0.46	2.2	0.46	2.2	True	Linear	
O2	19	16.5	28	2	N/A	N/A	N/A	7185	21555	0.36	2.77	N/A	N/A	True	Linear	
S1	21	19	34	0	N/A	N/A	N/A	25000	75000	0.28	3.54	N/A	N/A	True	Linear	
Clay	20	19	28	0	150	28	28	20000	60000	0.36	2.77	0.36	2.77	True	Linear	
GT	22	20	36	10	N/A	N/A	N/A	30000	90000	0.26	3.85	N/A	N/A	True	Linear	
Rock	27	25	30	100	N/A	N/A	N/A	479000	143700	0.33	3	N/A	N/A	True	Linear	
Rileva	18	18	32	0	N/A	N/A	N/A	30000	30000	0.31	3.26	N/A	N/A	True	Linear	
Base	18	18	25	0	N/A	N/A	N/A	25000	25000	0.41	2.46	N/A	N/A	True	Linear	

gtot=total soil specific weight

gdry=dry weight of the soil

Frict=friction angle

C'=effective cohesion

Su = Undrained cohesiona (only for CLAY soils in undrained conditions)

Dilat=SOil Dilatancy (only for non linear analysis)

Evc=Virgin compression elastic module

Eur=unloading/reloading elastic module

Kap= Peak active thrust coeff

Kpp= Peak passive thrust coeff

Kacv= Constant volume active thrust coeff

Kpcv= Constant volume passive thrust coeff

Spring models= spring model (LIN=constant over the soil layer height , EXP=exponential ,

SIMC=simplified winkler)

LIN= Linear-Elastic-Perfectly Plastic,

EXP: Exponential, SUB: Modulus of Subgrade Reaction

SOIL BORINGS

Top Elev= superior SOil level

Soil type=type of the soil (sand , clay , etc)

OCR=overconsolidation ratio

K0=at rest coefficient

Name: Boring 1, pos: (-20, 0)

Top elev.	Soil type	OCR	Ko
0	Rilevato	1	0.47
-4.5	Base	1	0.58

STRUCTURAL MATERIALS DATA

Steel

Name	Strength Fy	Fu	Elastic E	Density g
	(MPa)	(MPa)	(MPa)	(kN/m3)
Fe360	235	360	206000	77
Fe510	355	510	210000	77
A36	248.3	400	206000	77
A50	355	500	206000	77
New steel 4	241.4	413.8	206000	77

Concrete

Name	Strength Fc'	Elastic E	Density g	Tension Strength
------	--------------	-----------	-----------	------------------

	(MPa)	(MPa)	(kN/m ³)	(MPa)
C20/25	20	29962	25	10
C25/30	25	31476	25	10
Fc 3ksi	20.7	21541.8	23.573	10

Steel rebar

Name	Strength Fy (MPa)	Elastic E (MPa)
S1860 (Strands)	1670	210000
Grade 75	517.2	200100
Grade 80	551.7	200100
Grade 150	1034.5	200100
Strands 270 ksi	1862.1	200100
S410	410	210000
S500	500	210000
B450C	450	210000

Wood

Name	Ultimate Bending (MPa)	Ultimate Tensile Strength (MPa)	Ultimate Shear Strength (MPa)	Density g (kN/m ³)	Elastic E (MPa)
Construction	11	9.7	5.5	7.8576	6900
Regular grade	6.9	6.9	4.1	7.8576	5520

STEEL

Name=material name

fy=fyk=characteristic resistance for steel (for all the codes)

Fu=fuk=ultimate resistance for steel (for all the codes)

Elastic E=Elastic modulus

Density g=specific weight

CONCRETE

Name=material name

f'c=fck=cylindrical resistance for concrete (for all the codes)

Elastic E=Elastic modulus

Density g=specific weight

Tension strength=ft=fctk=characteristic tension resistance for concrete

STEEL REBARS

Name=material name

fy=fyk=characteristic resistance for steel (for all the codes)

Fu=fuk=ultimate resistance for steel (for all the codes)

Elastic E=Elastic modulus

Density g=specific weight

WOOD

Name=material name

Fb=fbk=Ultimate bending strength

Ftu=ftuk=Ultimate tensile strength

Fvu=fvuk=Ultimate shear strength

Density g=specific weight

Elastic E=Elastic modulus

WALL DATA

Wall section 0: P168.3x10/40

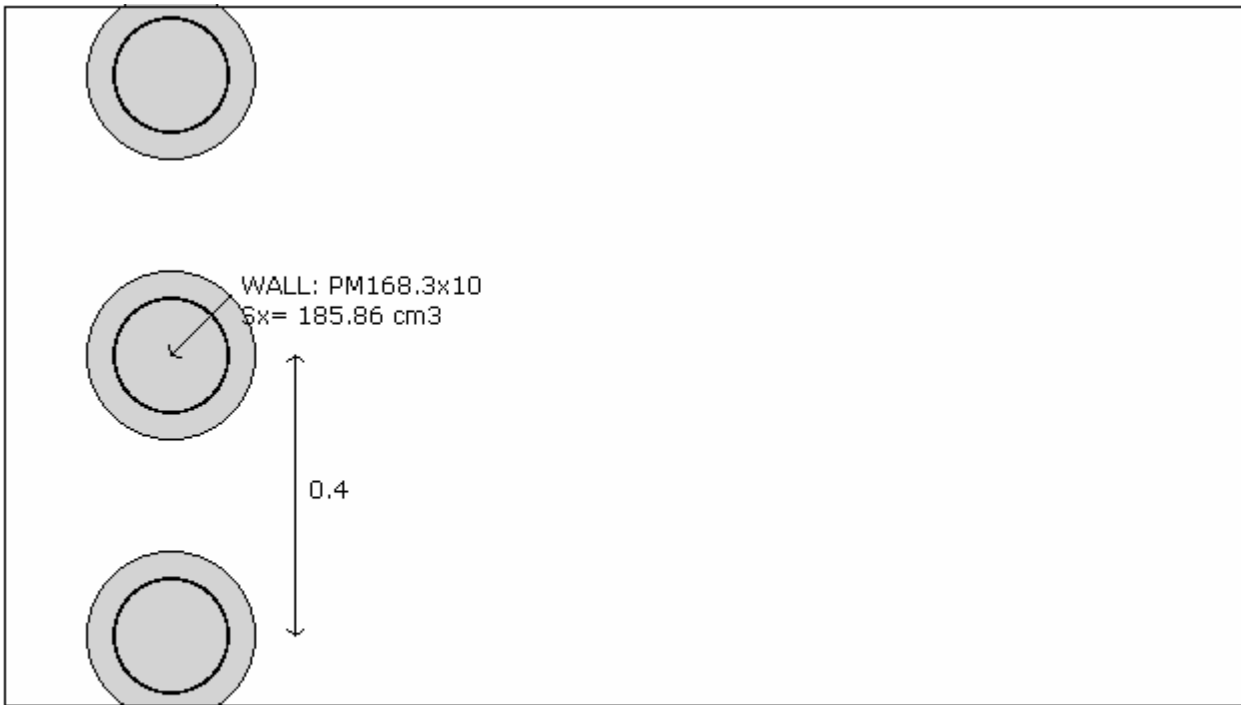

Company: My Company	Wall sketch	CeAS srl and Deep Excavation LCC
Engineer: Engineer		Paratie Plus 2010 - DeepXcar 2010
C:\nd.28_sera\otto3\alleg\LIII_typ1_rev27oct10_EQscavo_Alleg.DEEP		10/28/2010

Wall uses wall section 0: P168.3x10/40

Wall type: Tangent pile wall

Top wall El: 0 m Bottom wall El: -9 m

Hor. wall spacing: 0.4 Wall thickness = 0.24

Passive width below exc: 0.4 Active width below exc: 0.4

Concrete $f_c' = 25$ Rebar $F_y = 410$ $E_{conc} = 31476$ Concrete tension $F_{cT} = 10\%$ of F_c'

Steel members $f_y = 355$ $E_{steel} = 210000$

Wall friction: Percentage of Soil Friction = 50%

Steel wall capacities are calculated with NTC 2008

Concrete capacities are calculated with ACI 318-2002.

Note: With ultimate capacities you may have to use a structural safety factor.

Tangent pile wall soldier pile properties

Table: Soldier Pile Properties

Name	Section	W	A	D	tw or	bf	tf	k	Ixx	Sxx	rX	Iyy	Syy	rY	rT	Cw	fy
		(kN/m)	(cm ²)	(cm)	(cm)	(cm)	(cm)	(cm)	(cm ⁴)	(cm ³)	(cm)	(cm ⁴)	(cm ³)	(cm)	(cm)	(cm ⁶)	(MPa)
	PM16	257.3	75.62	16.8	1	16.83	1	1	3771	185.9	7.06	3771	185.9	7.06	7.06	1	355

GENERAL WALL DATA

Hor wall spacing=wall horizontal spacing

Passive width below exc=spacing for passive thrust pressure for classic analysis

$f'c=fck$ =cylindrical concrete resistance

$fyk=fy$ =steel rebar characteristic resistance

E_{conc} =Concrete Elastic modulus

f_{ctk} =characteristic Concrete tension

E_{steel} =steel elastic modulus

TABULAR DATA (principal parameters)

1) Diaphragm wall (rectangular cross section section)

N/A= data not available

$Fy=fyk$

$F'c=fck$

D=wall height

B=wall width

2)Steel sheet pile

DES=shape (Z or U)

W=width per unit of length

A=area

h=height

t=horiz part thickness

b=width of the single sheet pile part

s=inclined part thickness

I_{xx} =strong axis inertia (per unit of length)

S_{xx} =strong axis section modulus (per unit of length)

3)Secant piles wall, Tangent piles wall, soldier piles, soldier piles and timber lagging

W=weight per unit of length

A=area

D=diameter

tw=web thickness

tp= pipe thickness

bf=flange width

tf=flange thickness

k=flange thickness+stem thickness

I_{xx} =strong axis inertia modulus (per unit of length)

S_{xx} =strong axis section modulus (per unit of length)

r_x =radius of gyration about X axis

r_y =radius of gyration about Y axis

I_{yy} =weak axis inertia modulus (per unit of length)

S_{yy} =weak axis section modulus (per unit of length)

r_T =radius of gyration for torsion

C_w =warping constant

TIEBACK DATA

Name	Fy	Fc'	Dfix	Afix	Efix	Afree	Efree	Pa STR	Pu STR	PresGr	FSgeo	UserGca	Pa	Pu	WireMod
	(MPa)	(MPa)	(cm)	(cm ²)	(MPa)	(cm ²)	(MPa)	(kN)	(kN)	(kPa)			(kN)	(kN)	Yes/No
4-Strands	1862.1	25	15	176.7	31476	2.8	200100	453.4	453.4	N/A	1.4	False	N/A	N/A	Yes
5-Strands	1862.1	25	15	176.7	31476	0	200100	0	0	N/A	1.4	False	N/A	N/A	Yes
6-Strands	1862.1	25	15	176.7	31476	8.39	200100	1357.9	1357.9	N/A	1.4	False	N/A	N/A	Yes
Tieback	1670	25	16	201.0	31476	4.17	210000	605.2	605.2	N/A	1	False	N/A	N/A	Yes

EXCAVATION STAGES SKETCHES

A sequence of figures for each excavation stage is reported

GENERAL ANALYSIS CRITERIA

Summary of stage assumptions

Name	Analysis	Drive	ka-Mult	Htr	Resist	Res	Contl	Supp	Axial	Used	Min	Toe	Toe
------	----------	-------	---------	-----	--------	-----	-------	------	-------	------	-----	-----	-----

	Method	Press		(%)	Press	Mult	Meth	Mode	Incl	FSwall	FDtoe	FSrot	FSpas
Stage 0	Springs-Up	Ka+ d	N/A	N/A	Kp+ d	N/A		Fixed	N/A	1	0	0	0
Stage 1	Springs-Up	Ka+ d	N/A	N/A	Kp+ d	N/A		Fixed	N/A	1	0	0	0
Stage 2	Springs-Up	FHWA	1.3	m=	Kp+ d	N/A		Fixed	N/A	1	0	0	N/A
Stage 3	Springs-Up	FHWA	1.3	m=	Kp+ d	N/A		Fixed	N/A	1	0	0	N/A
Stage 4	Springs-Up	FHWA	1.3	m=	Kp+ d	N/A		Fixed	N/A	1	0	0	N/A

Name=excavation phase name

Analysis method

springs=elasto plastic springs are used

DR=Drained condition for CLAY model

U=Undrained condition for CLAY model for all the soils

Up=Undrained condition just for selected soil

Drive press=Ka

ka mult=multiply factor for Ka

Htr T/B (%)=trapezoidal pressure scheme

Resit press=Kp

Res Mult=Multiply factor for Kp

COntle Method=cantilver method

Support Model=Fix support type

Axial Incl=Axial action is included for design

Used FS wall=Reduction factor for axial+bending resistance dominium

Min FD TOe=embedded minimum safety factor (for classic analysis)

Toe FS rot=rotation safety factor (classic for classic analysis)

Toe FSpas=driving/resistent pressure safety factor (for classic analysis)

SEISMIC DATA

Seismic action is modeled through a pseudo static approach

Summary of stage assumptions

Stage Number	Seismic g Used	Method Used	aX (g)	aY (g)	Beta	Building Code (Name)
0	No		0.034	0	1	N/A
1	No		0.034	0	1	N/A
2	No		0.034	0	1	N/A
3	No		0.034	0	1	N/A
4	Yes		0.034	0	1	N/A

N/A= data non available

Stage number=number of stage input

Seismic ag =value of design acceleration according to a code or input by the user

Method=the method used to evaluated the seismic thrustover the wall

ahd or khd otr axd=design horizontal acceleration

avd or kvd or ayd=design vertical acceleration

Beta=multip coeff for the semirigd approach

Buildind code=code used for design acceleration calculation

SUPPORTS PROPERTIES

Support 0: type = tieback

X = 0.24 m, Z = -1.25 m, S = 2.4 m

Lfree = 6 m, Lfix = 10 m, Rfix = 50 %

Walls: P168.3x10/40

Stage No	Active	Prestress	Slab live load	User add. strain
	Yes/No	(kN)	(kPa)	+expansion
0	No	-	-	-
1	No	-	-	-
2	Yes	240	-	-

3	Yes	-	-	-
4	Yes	-	-	-

Support type

LEGENDA for TIEBACKS

General data

Z=support level

S=horizontal distance between each tieback

Lfree=free length

Lfix=rigid body length

Rfix=% effective part of the rigid body length

Stage No=excavation steps number

Active=tieback status (YES=active)

Post stress= tieback preload (Load considering the horiz distance bewteen the tiebacks)

SURFACE LOADS

Surcharge 0: X1 = -14, X2 = 0

Variable surcharge

Stage No	Active	X1	Z1	qX1	qZ1	X2	Z2	qX2	qZ2
	Yes/No	(m)	(m)	(kPa)	(kPa)	(m)	(m)	(kPa)	(kPa)
0	Yes	-14	0	0	20	0	0	0	20
1	Yes	-14	0	0	20	0	0	0	20
2	Yes	-14	0	0	20	0	0	0	20
3	Yes	-14	0	0	20	0	0	0	20
4	No	-14	0	0	20	0	0	0	20

LEGENDA

Stage No=Excavation step number

Active=load status (Yes=active)

X1=first X coordinate position of the load

Z1=first Z coordinate position of the load

qX1=first horizontal point load value

qZ1=first vertical point load value

X2=second X coordinate position of the load

Z2=second Z coordinate position of the load

qX2=second horizontal point load value

qZ2=second vertical point load value

WALL RESULTS TABLE

LEGENDA

Wall node=number of the node

EL=elevation

Sht L=Total horizontal soil pressure (on the left side of the wall)

Sht R=Total horizontal soil pressure (on the right side of the wall)

Shs L=Effective horizontal soil pressure (on the left side of the wall)

Shs R=Effective horizontal soil pressure (on the right side of the wall)

q=pressure given by the surcharge

U L=Water pressure (on the left side of the wall)

U R=pressione acqua (on the right side of the wall)

M=bending moment (per meter)

V=shear (per metro)

dx=wall deflection

McapL=Ultimate bending moment (on the left side of the wall)

McapR=Ultimate bending moment (on the right side of the wall)

VcapL=Ultimate resistance shear (on the left side of the wall)

VcapR=Ultimate resistance shear (on the right side of the wall)

SUPPORTS REACTIONS (TIEBACKS, STRUTS, SLABS, RAKERS)

Support 0

Stage No	R (kN)
0	0
1	0
2	240
3	291.528
4	269.52

DeepXcav 2010: Report Output

Copyright©2009 - 2010 Deep Excavation LLC: www.deepexcavation.com
A program for the evaluation of deep excavations

Project: My Project

Company: My Company
Prepared by engineer: Engineer
File number: 1
Time: 10/28/2010 9:03:31 PM

THIS PROGRAM IS PROTECTED BY U.S. COPYRIGHT LAWS AS DESCRIBED IN THE EULA. UNAUTHORIZED COPYING IS PROHIBITED. LICENSED TO: Deep Excavation LLC BY DEEP EXCAVATION LLC UNDER SPECIFIC LICENCE. This report has printed because the user has accepted responsibility as described in the disclaimer and EULA
File: C:\nda\paratie\10.10.28_sera\Lotto3\alleg\LIH_typ2_rev27oct10_EQscavo_Alleg.DEEP

DeepXcav 2010: Report Output

Copyright©2009 - 2010 Deep Excavation LLC: www.deepexcavation.com
A program for the evaluation of deep excavations

Project: My Project

Company: My Company
Prepared by engineer: Engineer
File number: 1
Time: 10/28/2010 9:03:31 PM

THIS PROGRAM IS PROTECTED BY U.S. COPYRIGHT LAWS AS DESCRIBED IN THE EULA. UNAUTHORIZED COPYING IS PROHIBITED. LICENSED TO: Deep Excavation LLC BY DEEP EXCAVATION LLC UNDER SPECIFIC LICENCE. This report has printed because the user has accepted responsibility as described in the disclaimer and EULA
File: C:\nda\paratie\10.10.28_sera\Lotto3\alleg\LIII_typ2_rev27oct10_EQscavo_Alleg.DEEP

OBJECTIVES

The objective of this document is to report the most important results of the calculations

BIBLIOGRAPHIC REFERENCES

BECCI,B.,NOVA,R. (1987) "Un metodo di calcolo automatico per il progetto di paratie", Rivista Italiana di

GENERAL CALCULATION ASSUMPTIONS

DEEP EXC is a program to simulate the behavior of flexible diaphragms. It is possible to simulate all the different stages of excavation.

The program is able to perform both classic and non linear analysis.

For the non linear analysis a FEM model is used. The FEM model follows the well known beam on elasto plastic foundation approach. The wall is modeled using BEAM elements, the soil is simulated using a double system (for each part of the wall) of elasto plastic springs,

An elasto plastic spring is connected on each node of the beam elements.

The excavation procedure is performed through 2 types of analysis:

1) Classic analysis

2) Non linear analysis : every step represents an excavation phase with a defined configuration of excavations, loads, etc.

The non linear analysis has been performed using a full Newton Raphson approach.

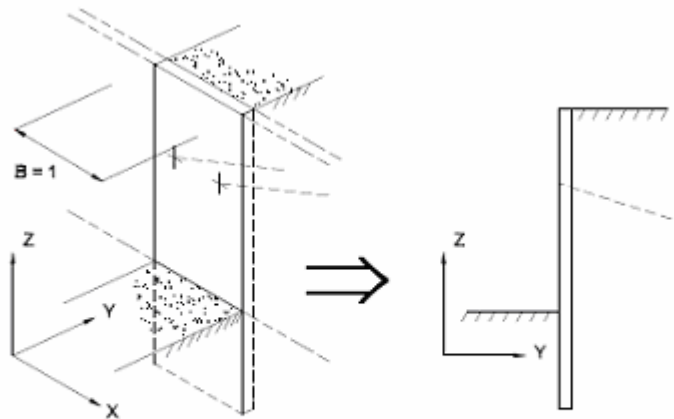

CONVENTIONS AND REFERENCE COORDINATE SYSTEMS

Loads, anelastic displacements, support reactions and displacements, are all referred to a righthand coordinate system

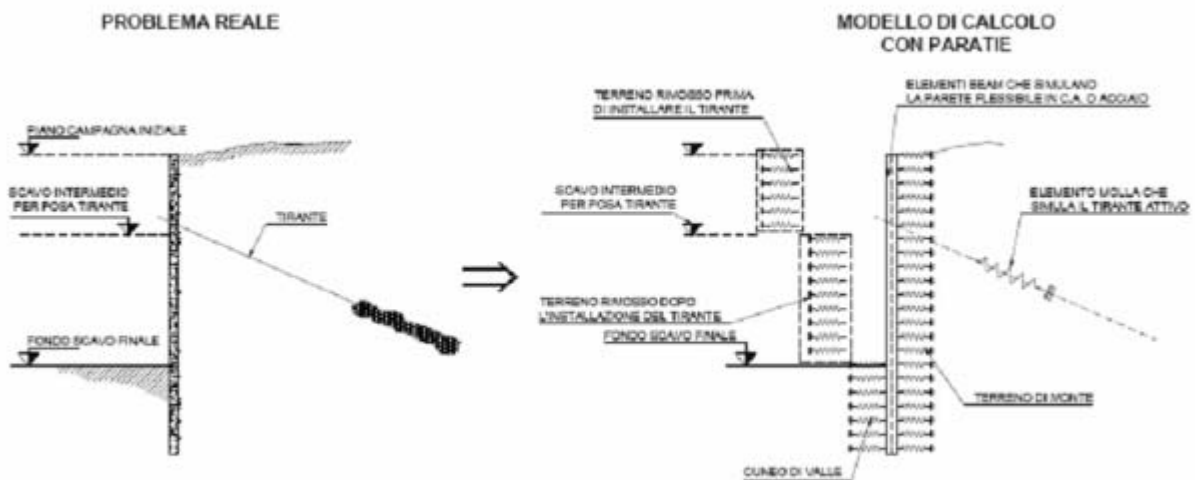

ELEMENTO TRUSS

1. FORCE : FORZA NELL'ELEMENTO PER UNITÀ DI PROFONDITÀ
2. STRESS : SPORZO

ELEMENTO BEAM (vedi figura 11-1)

1. VA : TAGLIO AL PRIMO ESTREMO
2. VB : TAGLIO AL SECONDO ESTREMO
3. MA : MOMENTO AL PRIMO ESTREMO
4. MB : MOMENTO AL SECONDO ESTREMO
(tutti per unità di profondità)

ELEMENTO ELPL (MOLLA ELASTOPLASTICA)

1. FORCE : FORZA NELL'ELEMENTO PER UNITÀ DI PROFONDITÀ
2. PLASTIC: DEFORMAZIONE PLASTICA

ELEMENTO WIRE (TIRANTE)

1. FORCE : FORZA NELL'ELEMENTO PER UNITÀ DI PROFONDITÀ

ELEMENTO CELAS (MOLLA ELASTICA)

1. FORCE : FORZA NELL'ELEMENTO PER UNITÀ DI PROFONDITÀ
2. MOMENT : MOMENTO NELL'ELEMENTO PER UNITÀ DI PROFONDITÀ

ELEMENTO SLAB (SOLETTA FRA DUE PARETI)

1. VA : TAGLIO AL PRIMO ESTREMO
2. VB : TAGLIO AL SECONDO ESTREMO
3. MA : MOMENTO AL PRIMO ESTREMO
4. MB : MOMENTO AL SECONDO ESTREMO
5. AXIAL : AZIONE ASSIALE
(tutti per unità di profondità)



Figura 11-1: convenzioni di segno per l'elemento BEAM

Checking of cross sections is performed according to the coordinate systems showed in the next figure

- X axis follow the 2 nodes direction of the beam elements , positive going from the first to the secondo node

ELEMENTO TRUSS

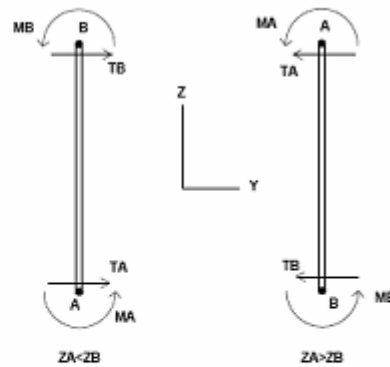
1. FORCE : FORZA NELL'ELEMENTO PER UNITÀ DI PROFONDITÀ
2. STRESS : SPORZO

ELEMENTO BEAM (vedi figura 11-1)

1. VA : TAGLIO AL PRIMO ESTREMO
2. VB : TAGLIO AL SECONDO ESTREMO
3. MA : MOMENTO AL PRIMO ESTREMO
4. MB : MOMENTO AL SECONDO ESTREMO
(tutti per unità di profondità)

ELEMENTO ELPL (MOLLA ELASTOPLASTICA)

1. FORCE : FORZA NELL'ELEMENTO PER UNITÀ DI PROFONDITÀ
2. PLASTIC: DEFORMAZIONE PLASTICA

ELEMENTO WIRE (TIRANTE)

1. FORCE : FORZA NELL'ELEMENTO PER UNITÀ DI PROFONDITÀ

ELEMENTO CELAS (MOLLA ELASTICA)

1. FORCE : FORZA NELL'ELEMENTO PER UNITÀ DI PROFONDITÀ
2. MOMENT : MOMENTO NELL'ELEMENTO PER UNITÀ DI PROFONDITÀ

ELEMENTO SLAB (SOLETTA FRA DUE PARETI)

1. VA : TAGLIO AL PRIMO ESTREMO
2. VB : TAGLIO AL SECONDO ESTREMO
3. MA : MOMENTO AL PRIMO ESTREMO
4. MB : MOMENTO AL SECONDO ESTREMO
5. AXIAL : AZIONE ASSIALE
(tutti per unità di profondità)



Figura 11-1: convenzioni di segno per l'elemento BEAM

DESIGN CODES

Reference codes are:

- DM 2008 - "Norme tecniche per le costruzioni"
- CSLP, "Istruzioni per l'applicazione delle Norme tecniche per le costruzioni di cui al DM 14/1/2008"
- EC2 1-1 :2004, Eurocode 2 - Design of concrete structures
- Ec3 1-1:2005, Eurocodice 3 - Design of steel structures
- Ec3 5:2002, Eurocodice 3 - Design of steel sheet piles walls
- Ec8:2004 - Seismic design of structures
- AISC ASD 9th Edition, 1989
- AISC LRFD 2nd Edition, 2003
- ACI 318-2002
- AASHTO 2000 ADS / LRFD

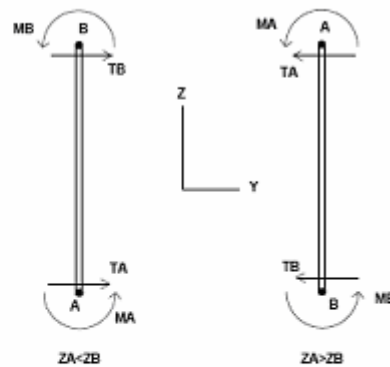
DESIGN PARAMETERS

Project: My Project

Results for Design Section 0: Base Section - Service

DESIGN APPROACHES AND COMBINATION FACTORS

The Design Approaches (from Codes or Customized by the user) and related safety factors are the following:

Ftan fr=mult factor for friction angle

F C'=mult factor for effective cohesion

F Su'=mult factof for undrained cohesion

F EQ=mult factor for seismic action

F perm load=mult factor for perm loads

F temp load=mult factor for live loads

F perm supp=reduct factor for resistance for pull out checking

F temp supp=fattore di riduzione resistance per verifica pull out tirante

F earth Dstab=mult factor for active press coeff , unfavorable

F earth stab=mult factor for passive pressure , favorable

F GWT Dstab (ground water)=mult factor for hydrostatic pressure , unfavorable

F GWT stab (ground water)=mult factor for hydrostatic pressure, favorable

F HYD Dstab=mult factor for hydrodynamic pressure, unfavorable

F HYD stab=mult factor for hydrodynamic pressure, favorable

F UPL Dstab=mult factor for hydraulic heave, unfavorable

Stage	Design Name	Design Case	F(tan fr)	F (c')	F (Su)	F (EQ)	F(perm load)	F(temp load)	F(perm sup)	F(temp sup)	F Earth (Dstab)	F Earth (stab)	F GWT (Dstab)	F GWT (stab)	F HYD (Dstab)	F HYD (stab)	F UPL (Dstab)	F UPL (stab)
0	Default	Service	1	1	1	1	1	1	1	1	1	1	1	1	1	1	1	1
1	Default	Service	1	1	1	1	1	1	1	1	1	1	1	1	1	1	1	1
2	Default	Service	1	1	1	1	1	1	1	1	1	1	1	1	1	1	1	1
3	Default	Service	1	1	1	1	1	1	1	1	1	1	1	1	1	1	1	1
4	Default	Service	1	1	1	1	1	1	1	1	1	1	1	1	1	1	1	1
5	Default	Service	1	1	1	1	1	1	1	1	1	1	1	1	1	1	1	1

SOIL DATA

Name	g tot (kN/m3)	g dry (kN/m3)	Frict (deg)	C' (kPa)	Su (kPa)	FRp (deg)	FRcv (deg)	Eload (kPa)	Eur (kPa)	kAp Springs	kPp Springs	kAcv Springs	kPcv Springs	Vary	Spring Model	Color
F	20	19	30	0	N/A	N/A	N/A	15000	45000	0.33	3	N/A	N/A	True	Linear	
O1	16.5	14	22	2	20	22	22	2874	8622	0.46	2.2	0.46	2.2	True	Linear	
O2	19	16.5	28	2	N/A	N/A	N/A	7185	21555	0.36	2.77	N/A	N/A	True	Linear	
S1	21	19	34	0	N/A	N/A	N/A	25000	75000	0.28	3.54	N/A	N/A	True	Linear	
Clay	20	19	28	0	150	28	28	20000	60000	0.36	2.77	0.36	2.77	True	Linear	
GT	22	20	36	10	N/A	N/A	N/A	30000	90000	0.26	3.85	N/A	N/A	True	Linear	
Rock	27	25	30	100	N/A	N/A	N/A	479000	143700	0.33	3	N/A	N/A	True	Linear	
Rileva	18	18	32	0	N/A	N/A	N/A	30000	30000	0.31	3.26	N/A	N/A	True	Linear	
Base	18	18	25	0	N/A	N/A	N/A	25000	25000	0.41	2.46	N/A	N/A	True	Linear	

gtot=total soil specific weigth

gdry=dry weigth of the soil

Frict=friction angle

C'=effective cohesion

Su = Undrained cohesiona (only for CLAY soils in undrained conditions)

Dilat=SOil Dilatancy (only for non linear analysis)

Evc=Virgin compression elastic module

Eur=unloading/reloading elastic module

Kap= Peak active thrust coeff

Kpp= Peak passive thrust coeff

Kacv= Constant volume active thrust coeff

Kpcv= Constant volume passive thrust coeff

Spring models= spring model (LIN=constant over the soil layer heigth , EXP=exponential ,

SIMC=simplified winkler)

LIN= Linear-Elastic-Perfectly Plastic,

EXP: Exponential, SUB: Modulus of Subgrade Reaction

SOIL BORINGS

Top Elev= superior Soil level

Soil type=type of the soil (sand , clay , etc)

OCR=overconsolidation ratio

K0=at rest coefficient

Name: Boring 1, pos: (-20, 0)

Top elev.	Soil type	OCR	Ko
0	Rilevato	1	0.47
-6	Base	1	0.58

STRUCTURAL MATERIALS DATA

Steel

Name	Strength Fy (MPa)	Fu (MPa)	Elastic E (MPa)	Density g (kN/m3)
Fe360	235	360	210000	77
Fe510	355	510	210000	77
A36	248.3	400	206000	77
A50	355	500	206000	77
New steel 4	241.4	413.8	206000	77

Concrete

Name	Strength Fc' (MPa)	Elastic E (MPa)	Density g (kN/m3)	Tension Strength (MPa)
C20/25	20	29962	25	10
C25/30	25	31476	25	10
Fc 3ksi	20.7	21541.8	23.573	10

Steel rebar

Name	Strength Fy (MPa)	Elastic E (MPa)
S1860 (Strands)	1670	210000
Grade 75	517.2	200100
Grade 80	551.7	200100
Grade 150	1034.5	200100
Strands 270 ksi	1862.1	200100
S410	410	210000
S500	500	210000
B450C	450	210000

Wood

Name	Ultimate Bending (MPa)	Ultimate Tensile Strength (MPa)	Ultimate Shear Strength (MPa)	Density g (kN/m3)	Elastic E (MPa)
Construction	11	9.7	5.5	7.8576	6900
Regular grade	6.9	6.9	4.1	7.8576	5520

STEEL

Name=material name
 fy=fyk=characteristic resistance for steel (for all the codes)
 Fu=fuk=ultimate resistance for steel (for all the codes)
 Elastic E=Elastic modulus
 Density g=specific weight

CONCRETE

Name=material name
 f'c=fck=cylindrical resistance for concrete (for all the codes)
 Elastic E=Elastic modulus
 Density g=specific weight
 Tension strength=ft=fctk=characteristic tension resistance for concrete

STEEL REBARS

Name=material name
 fy=fyk=characteristic resistance for steel (for all the codes)
 Fu=fuk=ultimate resistance for steel (for all the codes)
 Elastic E=Elastic modulus
 Density g=specific weight

WOOD

Name=material name
 Fb=fbk=Ultimate bending strength
 Ftu=ftuk=Ultimate tensile strength
 Fvu=fvuk=Ultimate shear strength
 Density g=specific weight
 Elastic E=Elastic modulus

WALL DATA

Wall section 0: P168.3x10/40

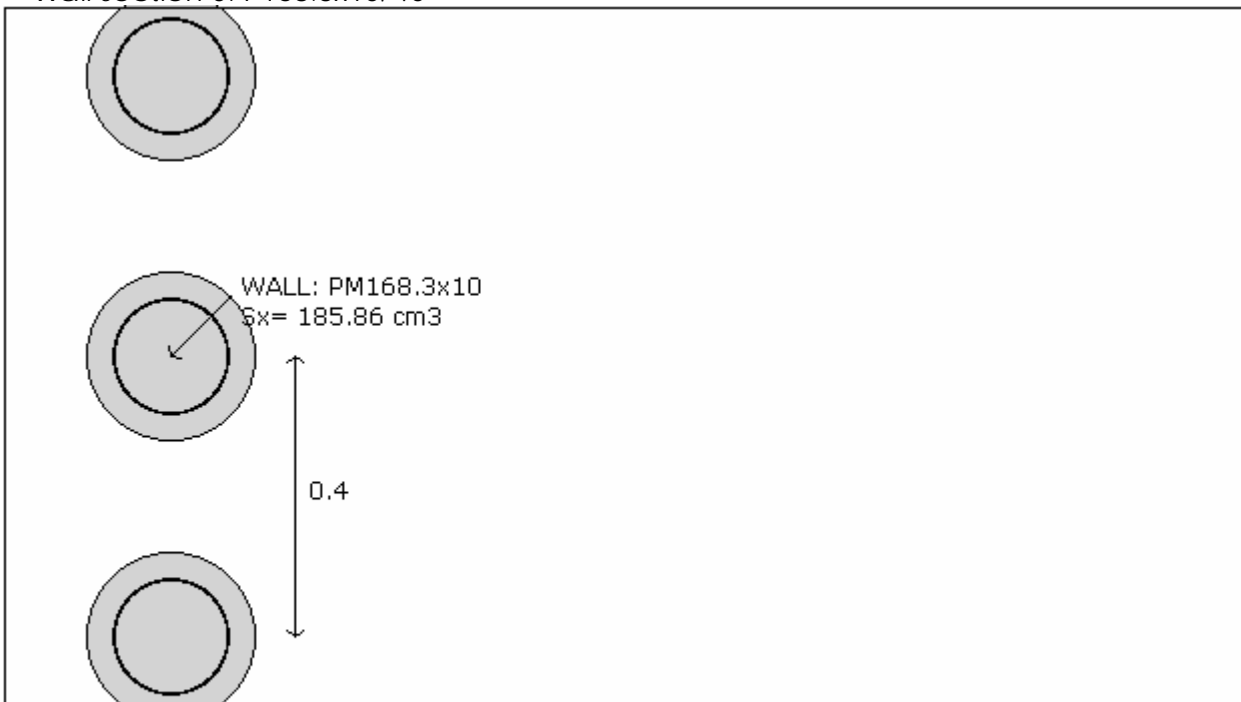

Company: My Company	Wall sketch	CeAS srl and Deep Excavation LCC
Engineer: Engineer		Paratie Plus 2010 - DeepXcar 2010
C:\nd.28_seraLotto3\alleg\LIII_typ2_rev27oct10_EQscavo_Alleg.DEEP		10/28/2010

Wall uses wall section 0: P168.3x10/40
 Wall type: Tangent pile wall
 Top wall El: 0 m Bottom wall El: -12 m
 Hor. wall spacing: 0.4 Wall thickness = 0.24
 Passive width below exc: 0.4 Active width below exc: 0.4
 Concrete f'c = 25 Rebar Fy = 410 Econc = 31476 Concrete tension FcT = 10% of Fc'

Steel members $f_y = 355$ Esteel = 210000

Wall friction: Percentage of Soil Friction = 50%

Steel wall capacities are calculated with NTC 2008

Concrete capacities are calculated with ACI 318-2002.

Note: With ultimate capacities you may have to use a structural safety factor.

Tangent pile wall soldier pile properties

Table: Soldier Pile Properties

Name	Section	W	A	D	tw or	bf	tf	k	Ixx	Sxx	rX	Iyy	Syy	rY	rT	Cw	fy
		(kN/m)	(cm ²)	(cm)	(cm)	(cm)	(cm)	(cm)	(cm ⁴)	(cm ³)	(cm)	(cm ⁴)	(cm ³)	(cm)	(cm)	(cm ⁶)	(MPa)
	PM16	257.3	75.62	16.8	1	16.83	1	1	3771	185.9	7.06	3771	185.9	7.06	7.06	1	355

GENERAL WALL DATA

Hor wall spacing=wall horizontal spacing

Passive width below exc=spacing for passive thrust pressure for classic analysis

$f'_c=f_{ck}$ =cylindrical concrete resistance

$f_y=f_{yk}$ =steel rebar characteristic resistance

Econc=Concrete Elastic modulus

f_{ctk} =characteristic Concrete tension

Esteel=steel elastic modulus

TABULAR DATA (principal parameters)

1) Diaphragm wall (rectangular cross section section)

N/A= data not available

$F_y=f_{yk}$

$F'_c=f_{ck}$

D=wall height

B=wall width

2) Steel sheet pile

DES=shape (Z or U)

W=weight per unit of length

A=area

h=height

t=horiz part thickness

b=width of the single sheet pile part

s=inclined part thickness

Ixx=strong axis inertia (per unit of length)

Sxx=strong axis section modulus (per unit of length)

3) Secant piles wall, Tangent piles wall, soldier piles, soldier piles and timber lagging

W=weight per unit of length

A=area

D=diameter

tw=web thickness

tp= pipe thickness

bf=flange width

tf=flange thickness

k=flange thickness+stem thickness

Ixx=strong axis inertia modulus (per unit of length)

Sxx=strong axis section modulus (per unit of length)

rx=radius of gyration about X axis

ry=radius of gyration about Y axis

Iyy=weak axis inertia modulus (per unit of length)

Syy=weak axis section modulus (per unit of length)

rT=radius of gyration for torsion

Cw=warping constant

TIEBACK DATA

Name	Fy	Fc'	Dfix	Afix	Efix	Afree	Efree	Pa STR	Pu STR	PresGr	FSgeo	UserGca	Pa	Pu	WireMod
	(MPa)	(MPa)	(cm)	(cm ²)	(MPa)	(cm ²)	(MPa)	(kN)	(kN)	(kPa)			(kN)	(kN)	Yes/No
4-Strands	1862.1	25	15	176.7	31476	2.8	200100	453.4	453.4	N/A	1.4	False	N/A	N/A	Yes
5-Strands	1862.1	25	15	176.7	31476	0	200100	0	0	N/A	1.4	False	N/A	N/A	Yes
6-Strands	1862.1	25	15	176.7	31476	8.39	200100	1357.9	1357.9	N/A	1.4	False	N/A	N/A	Yes

Tieback_	1670	25	16	201.0	31476	4.17	210000	605.2	605.2	N/A	1	False	N/A	N/A	Yes
Tieback_	1670	25	16	201.0	31476	6.95	210000	1008.7	1008.7	N/A	1	False	N/A	N/A	Yes

EXCAVATION STAGES SKETCHES

A sequence of figures for each excavation stage is reported

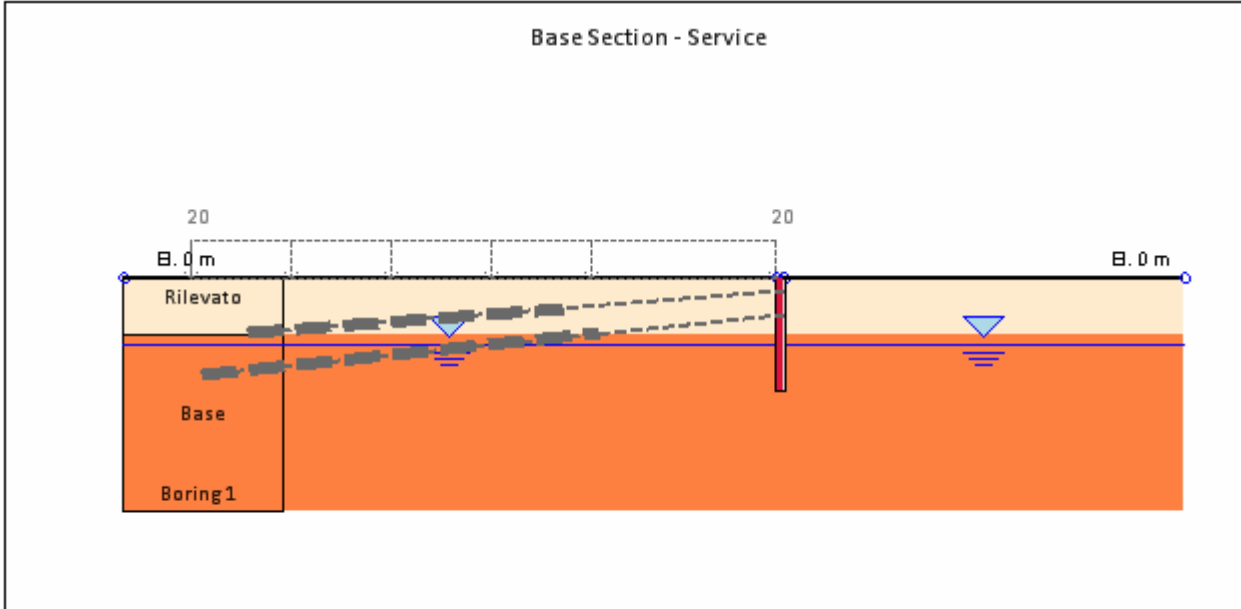

Company: My Company	DS: 0, Stage 0	CeAS srl and Deep Excavation LCC
Engineer: Engineer		Paratie Plus 2010 - DeepXcar 2010
C:\nd..28_sera\Lotto3\alleg\LIII_typ2_rev27oct10_EQscavo_Alleg.DEEP		10/28/2010

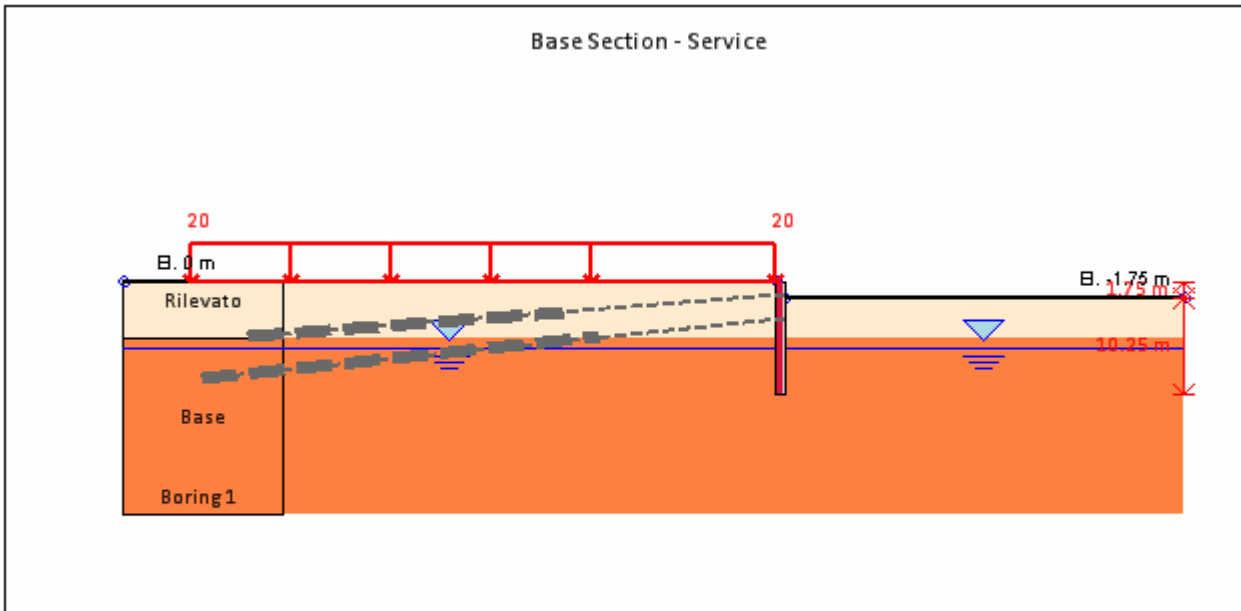

Company: My Company	DS: 0, Stage 1	CeAS srl and Deep Excavation LCC
Engineer: Engineer		Paratie Plus 2010 - DeepXcar 2010
C:\nd..28_sera\Lotto3\alleg\LIII_typ2_rev27oct10_EQscavo_Alleg.DEEP		10/28/2010

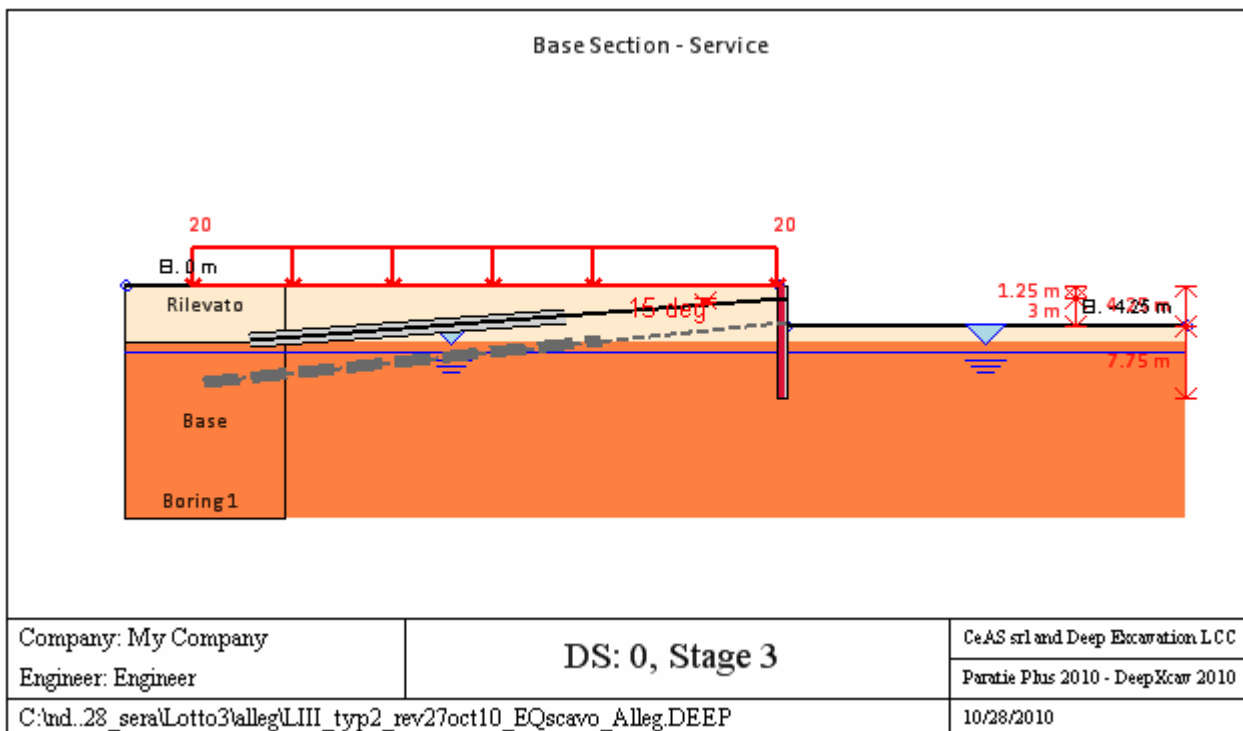
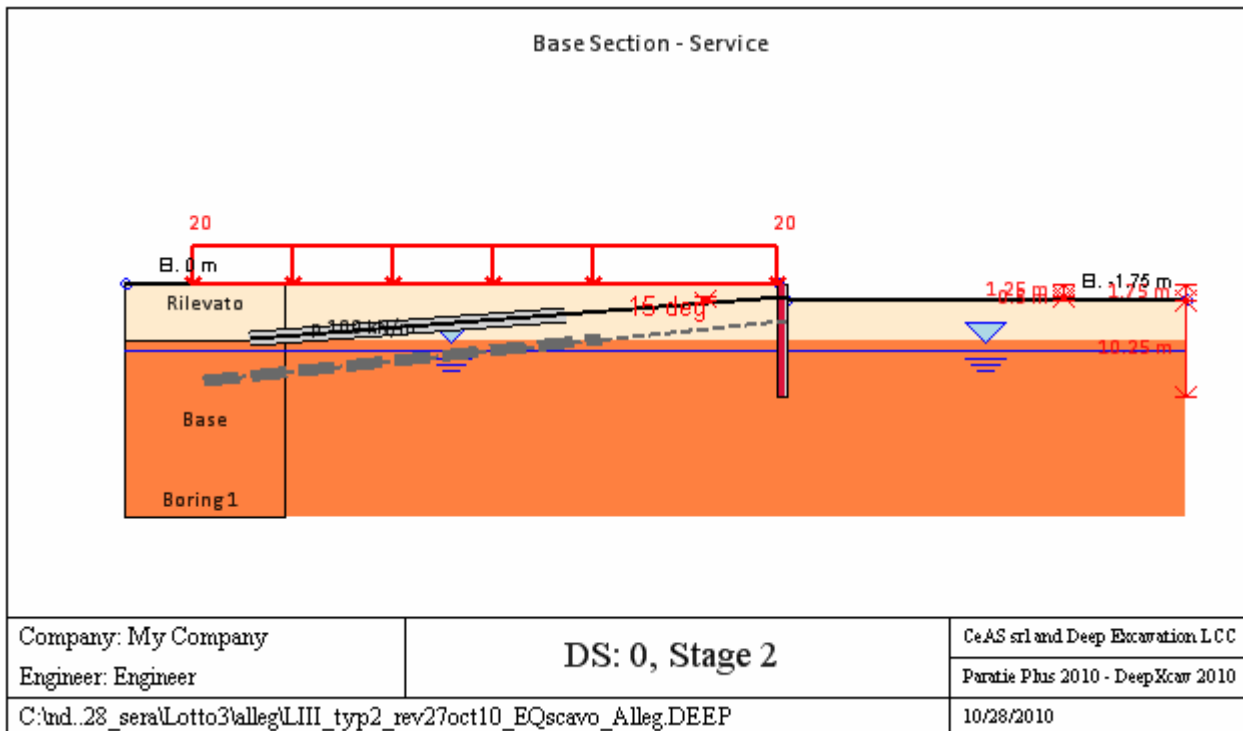

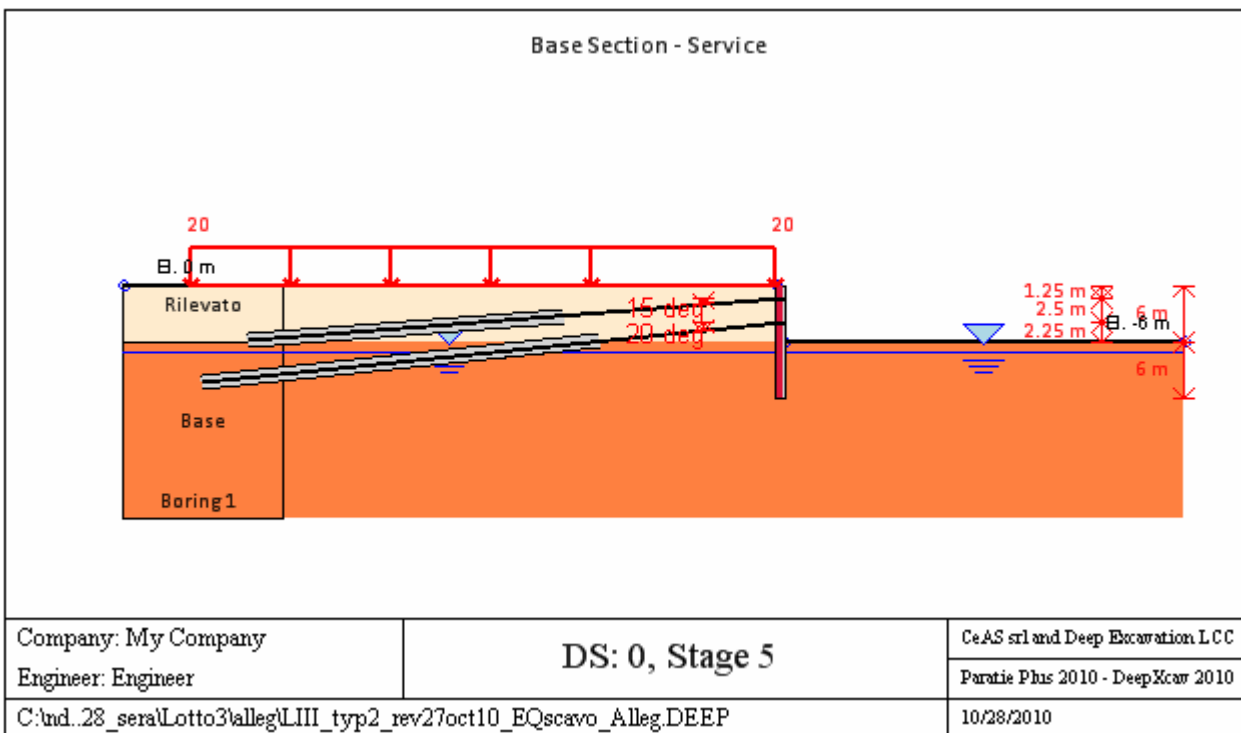
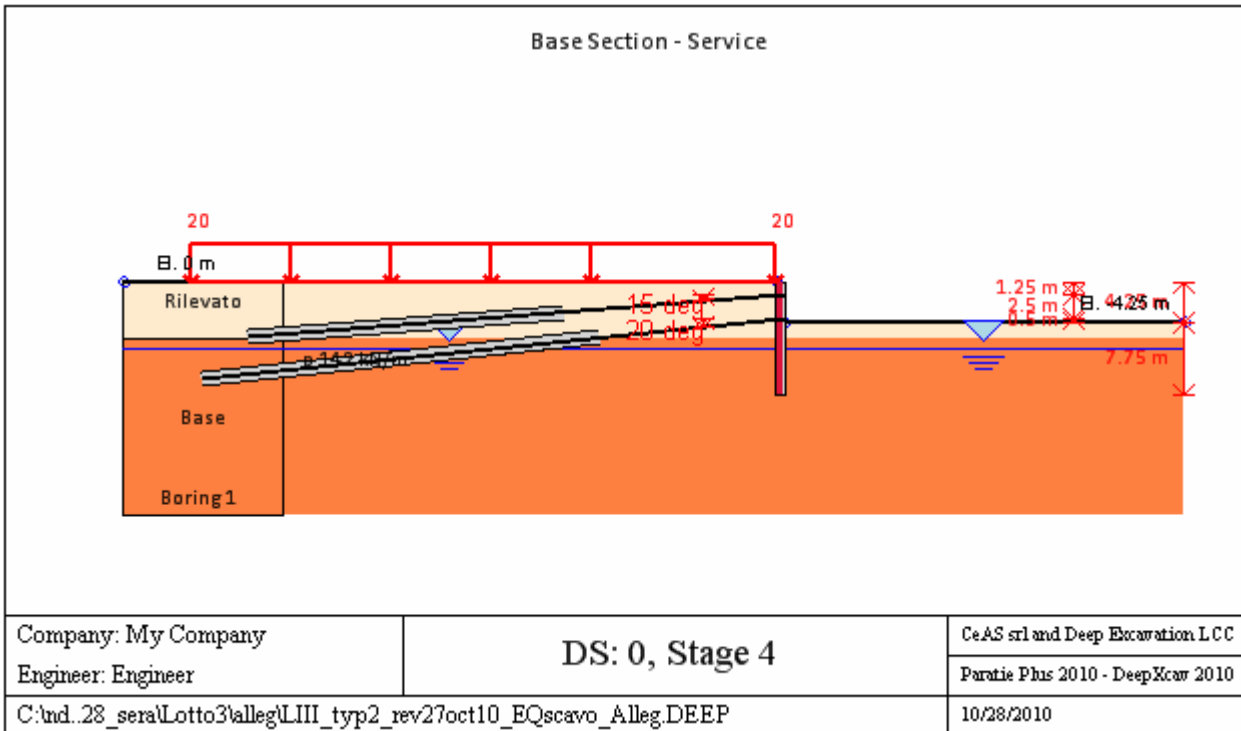

GENERAL ANALYSIS CRITERIA

Summary of stage assumptions

Name	Analysis	Drive	ka-Mult	Htr	Resist	Res	Contl	Supp	Axial	Used	Min	Toe	Toe
	Method	Press		(%)	Press	Mult	Meth	Mode	Incl	FWall	FDtoe	FSrot	FSpas
Stage 0	Springs-Up	Ka+ d	N/A	N/A	Kp+ d	N/A		Fixed	N/A	1	0	0	0
Stage 1	Springs-Up	Ka+ d	N/A	N/A	Kp+ d	N/A		Fixed	N/A	1	0	0	0
Stage 2	Springs-Up	FHWA	1.3	m=	Kp+ d	N/A		Fixed	N/A	1	0	0	N/A
Stage 3	Springs-Up	FHWA	1.3	m=	Kp+ d	N/A		Fixed	N/A	1	0	0	N/A
Stage 4	Springs-Up	FHWA	1.3	m=	Kp+ d	N/A		Fixed	N/A	1	0	0	0

Stage 5	Springs-Up	FHWA	1.3	m=	Kp+ d	N/A		Fixed	N/A	1	0	0	0
---------	------------	------	-----	----	-------	-----	--	-------	-----	---	---	---	---

Name=excavation phase name

Analysis method

springs=elasto plastic springs are used

DR=Drained condition for CLAY model

U=Undrained condition for CLAY model for all the soils

Up=Undrained condition just for selected soil

Drive press=Ka

ka mult=multiply factor for Ka

Htr T/B (%)=trapezoidal pressure scheme

Resit press=Kp

Res Mult=Multiply factor for Kp

COntle Method=cantilver method

Support Model=Fix support type

Axial Incl=Axial action is included for design

Used FS wall=Reduction factor for axial+bending resistance dominium

Min FD TOe=embedded minimum safety factor (for classic analysis)

Toe FS rot=rotation safety factor (classic for classic analysis)

Toe FSpas=driving/resistent pressure safety factor (for classic analysis)

SEISMIC DATA

Seismic action is modeled through a pseudo static approach

Summary of stage assumptions

Stage Number	Seismic g Used	Method Used	aX (g)	aY (g)	Beta	Building Code (Name)
0	No		0.03	0	1	N/A
1	No		0.03	0	1	N/A
2	No		0.03	0	1	N/A
3	No		0.03	0	1	N/A
4	No		0.03	0	1	N/A
5	No		0.03	0	1	N/A

N/A= data non available

Stage number=number of stage input

Seismic ag =value of design acceleration according to a code or input by the user

Method=the method used to evaluated the seismic thrustover the wall

ahd or khd otr axd=design horizontal acceleration

avd or kvd or ayd=design vertical acceleration

Beta=multip coeff for the semirigd approach

Buildind code=code used for design acceleration calculation

SUPPORTS PROPERTIES

Support 0: type = tieback

X = 0.24 m, Z = -1.25 m, S = 2.4 m

Lfree = 7 m, Lfix = 10 m, Rfix = 50 %

Walls: P168.3x10/40

Stage No	Active	Prestress	Slab live load	User add. strain
	Yes/No	(kN)	(kPa)	+expansion
0	No	-	-	-
1	No	-	-	-
2	Yes	240	-	-
3	Yes	-	-	-
4	Yes	-	-	-
5	Yes	-	-	-

Support 1: type = tieback

2	-0.24	2.03	2.03	2.03	2.03	0	0	0	0	0	0
4	-0.48	4.061	4.061	4.061	4.061	0	0	0	0	0	0
6	-0.72	6.091	6.091	6.091	6.091	0	0	0	0	0	0
8	-0.96	8.122	8.122	8.122	8.122	0	0	0	0	0	0
10	-1.2	10.152	10.152	10.152	10.152	0	0	0	0	0	0
12	-1.37	11.59	11.59	11.59	11.59	0	0	0	0	0	0
14	-1.61	13.621	13.621	13.621	13.621	0	0	0	0	0	0
16	-1.85	15.651	15.651	15.651	15.651	0	0	0	0	0	0
18	-2.09	17.681	17.681	17.681	17.681	0	0	0	0	0	0
20	-2.33	19.712	19.712	19.712	19.712	0	0	0	0	0	0
22	-2.57	21.742	21.742	21.742	21.742	0	0	0	0	0	0
24	-2.81	23.773	23.773	23.773	23.773	0	0	0	0	0	0
26	-3.05	25.803	25.803	25.803	25.803	0	0	0	0	0	0
28	-3.29	27.833	27.833	27.833	27.833	0	0	0	0	0	0
30	-3.53	29.864	29.864	29.864	29.864	0	0	0	0	0	0
32	-3.75	31.725	31.725	31.725	31.725	0	0	0	0	0	0
34	-3.99	33.755	33.755	33.755	33.755	0	0	0	0	0	0
36	-4.23	35.786	35.786	35.786	35.786	0	0	0	0	0	0
38	-4.47	37.816	37.816	37.816	37.816	0	0	0	0	0	0
40	-4.71	39.847	39.847	39.847	39.847	0	0	0	0	0	0
42	-4.95	41.877	41.877	41.877	41.877	0	0	0	0	0	0
44	-5.19	43.907	43.907	43.907	43.907	0	0	0	0	0	0
46	-5.43	45.938	45.938	45.938	45.938	0	0	0	0	0	0
48	-5.67	47.968	47.968	47.968	47.968	0	0	0	0	0	0
50	-5.91	49.999	49.999	49.999	49.999	0	0	0	0	0	0
52	-6.15	63.916	63.916	63.916	63.916	0	0	0	0	0	0
54	-6.39	66.41	66.41	66.41	66.41	0	0	0	0	0	0
56	-6.63	68.905	68.905	68.905	68.905	0	0	0	0	0	0
58	-6.87	71.399	71.399	71.399	71.399	0	0	0	0	0	0
60	-7.11	74.358	74.358	73.258	73.258	0	1.1	1.1	0	0	0
62	-7.35	77.867	77.867	74.367	74.367	0	3.5	3.5	0	0	0
64	-7.59	81.375	81.375	75.475	75.475	0	5.9	5.9	0	0	0
66	-7.83	84.884	84.884	76.584	76.584	0	8.3	8.3	0	0	0
68	-8.07	88.392	88.392	77.692	77.692	0	10.7	10.7	0	0	0
70	-8.31	91.901	91.901	78.801	78.801	0	13.1	13.1	0	0	0
72	-8.55	95.409	95.409	79.909	79.909	0	15.5	15.5	0	0	0
74	-8.79	98.918	98.918	81.018	81.018	0	17.9	17.9	0	0	0
76	-9.03	102.42	102.42	82.127	82.127	0	20.3	20.3	0	0	0
78	-9.27	105.93	105.93	83.235	83.235	0	22.7	22.7	0	0	0
80	-9.51	109.44	109.44	84.344	84.344	0	25.1	25.1	0	0	0
82	-9.75	112.95	112.95	85.452	85.452	0	27.5	27.5	0	0	0
84	-9.99	116.46	116.46	86.561	86.561	0	29.9	29.9	0	0	0
86	-10.23	119.96	119.96	87.669	87.669	0	32.3	32.3	0	0	0
88	-10.47	123.47	123.47	88.778	88.778	0	34.7	34.7	0	0	0
90	-10.71	126.98	126.98	89.887	89.887	0	37.1	37.1	0	0	0
92	-10.95	130.49	130.49	90.995	90.995	0	39.5	39.5	0	0	0
94	-11.19	134.00	134.00	92.104	92.104	0	41.9	41.9	0	0	0
96	-11.43	137.51	137.51	93.212	93.212	0	44.3	44.3	0	0	0
98	-11.67	141.02	141.02	94.321	94.321	0	46.7	46.7	0	0	0
100	-11.91	144.52	144.52	95.429	95.429	0	49.1	49.1	0	0	0

P168.3x10/40 Stage: 1

Wall	EL	Sht L	Sht R	Shs L	Shs R	q	U L	U R	M	V	dx
Nod	(m)	(kPa)	(kPa)	(kPa)	(kPa)	(kPa)	(kPa)	(kPa)	(kN-	(kN/m)	(cm)
0	0	5.34	0	5.34	0	0	0	0	0	0.32	0.4
2	-0.24	5.038	0	5.038	0	0	0	0	0.13	0.77	0.37
4	-0.48	5.843	0	5.843	0	0	0	0	0.55	2.09	0.34
6	-0.72	7.434	0	7.434	0	0	0	0	1.31	3.59	0.32

8	-0.96	8.378	0	8.378	0	0	0	0	2.5	5.4	0.29
10	-1.2	9.395	0	9.395	0	0	0	0	4.17	7.49	0.26
12	-1.37	10.238	0	10.238	0	0	0	0	5.67	9.1	0.24
14	-1.61	11.302	0	11.302	0	0	0	0	8.31	11.64	0.21
16	-1.85	12.637	9.101	12.637	9.101	0	0	0	11.6	14.43	0.19
18	-2.09	13.712	30.659	13.712	30.659	0	0	0	15.07	14.02	0.17
20	-2.33	14.801	30.164	14.801	30.164	0	0	0	17.71	10.06	0.14
22	-2.57	16.083	29.696	16.083	29.696	0	0	0	19.48	6.48	0.12
24	-2.81	17.179	29.414	17.179	29.414	0	0	0	20.45	3.29	0.1
26	-3.05	18.435	29.385	18.435	29.385	0	0	0	20.72	0.43	0.09
28	-3.29	19.535	29.642	19.535	29.642	0	0	0	20.36	-2.15	0.07
30	-3.53	21.715	30.192	21.715	30.192	0	0	0	19.41	-4.53	0.06
32	-3.75	25.489	30.95	25.489	30.95	0	0	0	18.12	-6.28	0.05
34	-3.99	29.347	32.037	29.347	32.037	0	0	0	16.41	-7.35	0.05
36	-4.23	32.563	33.376	32.563	33.376	0	0	0	14.55	-7.89	0.04
38	-4.47	35.405	34.937	35.405	34.937	0	0	0	12.63	-7.99	0.04
40	-4.71	38.098	36.693	38.098	36.693	0	0	0	10.74	-7.81	0.04
42	-4.95	40.331	38.615	40.331	38.615	0	0	0	8.93	-7.46	0.03
44	-5.19	42.334	40.675	42.334	40.675	0	0	0	7.21	-7.04	0.03
46	-5.43	44.305	42.846	44.305	42.846	0	0	0	5.59	-6.65	0.04
48	-5.67	45.975	45.104	45.975	45.104	0	0	0	4.06	-6.34	0.04
50	-5.91	47.542	47.423	47.542	47.423	0	0	0	2.57	-6.16	0.04
52	-6.15	65.145	59.592	65.145	59.592	0	0	0	1.18	-5.45	0.04
54	-6.39	67.21	62.423	67.21	62.423	0	0	0	0.1	-4.17	0.04
56	-6.63	69.276	65.254	69.276	65.254	0	0	0	-0.69	-3.06	0.04
58	-6.87	71.507	68.071	71.507	68.071	0	0	0	-1.26	-2.13	0.05
60	-7.11	74.077	71.326	72.977	70.226	0	1.1	1.1	-1.63	-1.36	0.05
62	-7.35	77.229	75.097	73.729	71.597	0	3.5	3.5	-1.84	-0.72	0.05
64	-7.59	80.554	78.84	74.654	72.94	0	5.9	5.9	-1.92	-0.24	0.05
66	-7.83	83.779	82.552	75.479	74.252	0	8.3	8.3	-1.91	0.13	0.05
68	-8.07	87.043	86.235	76.343	75.535	0	10.7	10.7	-1.83	0.41	0.06
70	-8.31	90.467	89.89	77.367	76.79	0	13.1	13.1	-1.7	0.59	0.06
72	-8.55	93.799	93.518	78.299	78.018	0	15.5	15.5	-1.53	0.7	0.06
74	-8.79	97.163	97.122	79.263	79.222	0	17.9	17.9	-1.35	0.76	0.06
76	-9.03	100.66	100.70	80.367	80.405	0	20.3	20.3	-1.17	0.77	0.06
78	-9.27	104.08	104.26	81.38	81.569	0	22.7	22.7	-0.99	0.75	0.06
80	-9.51	107.62	107.81	82.52	82.718	0	25.1	25.1	-0.82	0.71	0.06
82	-9.75	111.06	111.35	83.568	83.854	0	27.5	27.5	-0.66	0.65	0.06
84	-9.99	114.53	114.88	84.63	84.98	0	29.9	29.9	-0.51	0.58	0.06
86	-10.23	118.10	118.39	85.804	86.098	0	32.3	32.3	-0.39	0.5	0.06
88	-10.47	121.58	121.90	86.884	87.209	0	34.7	34.7	-0.28	0.42	0.06
90	-10.71	125.07	125.41	87.971	88.316	0	37.1	37.1	-0.19	0.35	0.06
92	-10.95	128.65	128.92	89.156	89.42	0	39.5	39.5	-0.12	0.27	0.06
94	-11.19	132.15	132.42	90.25	90.521	0	41.9	41.9	-0.07	0.2	0.06
96	-11.43	135.64	135.92	91.347	91.621	0	44.3	44.3	-0.03	0.14	0.06
98	-11.67	139.23	139.42	92.533	92.721	0	46.7	46.7	-0.01	0.08	0.06
100	-11.91	142.73	142.92	93.631	93.82	0	49.1	49.1	0	0.03	0.06

P168.3x10/40 Stage: 2

Wall	EL	Sht L	Sht R	Shs L	Shs R	q	U L	U R	M	V	dx
Nod	(m)	(kPa)	(kPa)	(kPa)	(kPa)	(kPa)	(kPa)	(kPa)	(kN-	(kN/m)	(cm)
0	0	45.122	0	45.122	0	0	0	0	0	2.71	0.23
2	-0.24	43.752	0	43.752	0	0	0	0	1.27	7.87	0.2
4	-0.48	43.454	0	43.454	0	0	0	0	5.05	18.41	0.18
6	-0.72	43.817	0	43.817	0	0	0	0	11.35	28.87	0.16
8	-0.96	43.265	0	43.265	0	0	0	0	20.17	39.32	0.14
10	-1.2	42.317	0	42.317	0	0	0	0	31.47	49.68	0.12
12	-1.37	41.361	0	41.361	0	0	0	0	29.36	-39.74	0.11

14	-1.61	39.377	0	39.377	0	0	0	0	21.6	-29.91	0.09
16	-1.85	37.312	0.481	37.312	0.481	0	0	0	16.11	-20.58	0.08
18	-2.09	34.862	17.662	34.862	17.662	0	0	0	12.66	-12.56	0.07
20	-2.33	32.485	19.297	32.485	19.297	0	0	0	10.36	-8.66	0.07
22	-2.57	30.489	20.844	30.489	20.844	0	0	0	8.83	-5.71	0.06
24	-2.81	28.582	22.407	28.582	22.407	0	0	0	7.85	-3.62	0.05
26	-3.05	27.163	24.022	27.163	24.022	0	0	0	7.22	-2.33	0.05
28	-3.29	25.94	25.706	25.94	25.706	0	0	0	6.78	-1.76	0.05
30	-3.53	26.151	27.466	26.151	27.466	0	0	0	6.35	-1.86	0.04
32	-3.75	28.421	29.148	28.421	29.148	0	0	0	5.89	-2.11	0.04
34	-3.99	30.943	31.057	30.943	31.057	0	0	0	5.36	-2.24	0.04
36	-4.23	33.114	33.037	33.114	33.037	0	0	0	4.82	-2.26	0.04
38	-4.47	35.165	35.085	35.165	35.085	0	0	0	4.28	-2.23	0.04
40	-4.71	37.286	37.192	37.286	37.192	0	0	0	3.75	-2.21	0.04
42	-4.95	39.129	39.353	39.129	39.353	0	0	0	3.22	-2.21	0.04
44	-5.19	40.894	41.56	40.894	41.56	0	0	0	2.68	-2.28	0.04
46	-5.43	42.745	43.805	42.745	43.805	0	0	0	2.1	-2.46	0.04
48	-5.67	44.387	46.08	44.387	46.08	0	0	0	1.46	-2.76	0.04
50	-5.91	45.994	48.374	45.994	48.374	0	0	0	0.72	-3.2	0.05
52	-6.15	64.088	60.45	64.088	60.45	0	0	0	-0.06	-3.02	0.05
54	-6.39	66.241	63.209	66.241	63.209	0	0	0	-0.63	-2.2	0.05
56	-6.63	68.41	65.956	68.41	65.956	0	0	0	-1.03	-1.49	0.05
58	-6.87	70.751	68.685	70.751	68.685	0	0	0	-1.29	-0.93	0.05
60	-7.11	73.431	71.851	72.331	70.751	0	1.1	1.1	-1.43	-0.47	0.05
62	-7.35	76.689	75.536	73.189	72.036	0	3.5	3.5	-1.47	-0.11	0.05
64	-7.59	80.114	79.197	74.214	73.297	0	5.9	5.9	-1.45	0.15	0.06
66	-7.83	83.43	82.836	75.13	74.536	0	8.3	8.3	-1.38	0.34	0.06
68	-8.07	86.774	86.454	76.074	75.754	0	10.7	10.7	-1.27	0.48	0.06
70	-8.31	90.269	90.051	77.169	76.951	0	13.1	13.1	-1.15	0.55	0.06
72	-8.55	93.66	93.631	78.16	78.131	0	15.5	15.5	-1.01	0.58	0.06
74	-8.79	97.073	97.194	79.173	79.294	0	17.9	17.9	-0.87	0.58	0.06
76	-9.03	100.61	100.74	80.319	80.444	0	20.3	20.3	-0.73	0.55	0.06
78	-9.27	104.06	104.28	81.363	81.583	0	22.7	22.7	-0.6	0.52	0.06
80	-9.51	107.62	107.81	82.529	82.712	0	25.1	25.1	-0.49	0.47	0.06
82	-9.75	111.09	111.33	83.595	83.833	0	27.5	27.5	-0.38	0.42	0.06
84	-9.99	114.57	114.84	84.67	84.947	0	29.9	29.9	-0.29	0.37	0.06
86	-10.23	118.15	118.35	85.853	86.058	0	32.3	32.3	-0.22	0.3	0.06
88	-10.47	121.63	121.86	86.939	87.164	0	34.7	34.7	-0.15	0.25	0.06
90	-10.71	125.13	125.36	88.03	88.268	0	37.1	37.1	-0.1	0.2	0.06
92	-10.95	128.71	128.87	89.217	89.37	0	39.5	39.5	-0.06	0.15	0.06
94	-11.19	132.21	132.37	90.312	90.471	0	41.9	41.9	-0.04	0.1	0.06
96	-11.43	135.70	135.87	91.408	91.572	0	44.3	44.3	-0.02	0.07	0.06
98	-11.67	139.29	139.37	92.594	92.672	0	46.7	46.7	-0.01	0.04	0.06
100	-11.91	142.79	142.87	93.691	93.771	0	49.1	49.1	0	0.01	0.06

P168.3x10/40 Stage: 3

Wall	EL	Sht L	Sht R	Shs L	Shs R	q	U L	U R	M	V	dx
Nod	(m)	(kPa)	(kPa)	(kPa)	(kPa)	(kPa)	(kPa)	(kPa)	(kN-	(kN/m)	(cm)
0	0	47.22	0	47.22	0	0	0	0	0	2.83	0.21
2	-0.24	43.675	0	43.675	0	0	0	0	1.31	8.12	0.2
4	-0.48	41.202	0	41.202	0	0	0	0	5.14	18.51	0.2
6	-0.72	39.39	0	39.39	0	0	0	0	11.35	28.3	0.2
8	-0.96	36.662	0	36.662	0	0	0	0	19.82	37.56	0.21
10	-1.2	33.542	0	33.542	0	0	0	0	30.4	46.2	0.21
12	-1.37	31.056	0	31.056	0	0	0	0	27.15	-47.5	0.21
14	-1.61	26.933	0	26.933	0	0	0	0	17.07	-40.26	0.22
16	-1.85	22.779	0	22.779	0	0	0	0	8.54	-34.05	0.23
18	-2.09	18.323	0	18.323	0	0	0	0	1.32	-28.86	0.25

20	-2.33	14.801	0	14.801	0	0	0	0	-4.85	-24.71	0.26
22	-2.57	16.083	0	16.083	0	0	0	0	-10.13	-21.08	0.27
24	-2.81	17.179	0	17.179	0	0	0	0	-14.49	-17.17	0.28
26	-3.05	18.435	0	18.435	0	0	0	0	-17.86	-12.97	0.29
28	-3.29	19.535	0	19.535	0	0	0	0	-20.17	-8.49	0.3
30	-3.53	20.643	0	20.643	0	0	0	0	-21.35	-3.72	0.3
32	-3.75	21.673	0	21.673	0	0	0	0	-21.39	1.09	0.3
34	-3.99	22.907	0	22.907	0	0	0	0	-20.24	6.15	0.3
36	-4.23	24.022	0	24.022	0	0	0	0	-17.76	11.71	0.3
38	-4.47	25.14	20.022	25.14	20.022	0	0	0	-14.04	16.45	0.3
40	-4.71	26.362	32.891	26.362	32.891	0	0	0	-10.02	16.45	0.29
42	-4.95	27.482	35.826	27.482	35.826	0	0	0	-6.37	14.76	0.29
44	-5.19	28.605	38.392	28.605	38.392	0	0	0	-3.2	12.67	0.28
46	-5.43	29.818	40.752	29.818	40.752	0	0	0	-0.59	10.25	0.27
48	-5.67	30.942	42.99	30.942	42.99	0	0	0	1.39	7.55	0.26
50	-5.91	32.069	45.153	32.069	45.153	0	0	0	2.68	4.6	0.25
52	-6.15	50.307	53.099	50.307	53.099	0	0	0	3.36	2.68	0.25
54	-6.39	53.082	55.732	53.082	55.732	0	0	0	3.89	2.01	0.24
56	-6.63	55.837	58.331	55.837	58.331	0	0	0	4.25	1.39	0.23
58	-6.87	58.723	60.903	58.723	60.903	0	0	0	4.48	0.81	0.23
60	-7.11	61.902	63.854	60.802	62.754	0	1.1	1.1	4.58	0.29	0.22
62	-7.35	65.614	67.278	62.114	63.778	0	3.5	3.5	4.57	-0.15	0.21
64	-7.59	69.444	70.711	63.544	64.811	0	5.9	5.9	4.47	-0.53	0.21
66	-7.83	73.12	74.154	64.82	65.854	0	8.3	8.3	4.29	-0.83	0.2
68	-8.07	76.78	77.607	66.08	66.907	0	10.7	10.7	4.04	-1.05	0.2
70	-8.31	80.548	81.07	67.448	67.97	0	13.1	13.1	3.76	-1.23	0.2
72	-8.55	84.175	84.542	68.675	69.042	0	15.5	15.5	3.44	-1.36	0.19
74	-8.79	87.788	88.023	69.888	70.123	0	17.9	17.9	3.1	-1.43	0.19
76	-9.03	91.503	91.511	71.203	71.211	0	20.3	20.3	2.75	-1.47	0.19
78	-9.27	95.09	95.008	72.39	72.308	0	22.7	22.7	2.4	-1.46	0.19
80	-9.51	98.775	98.51	73.675	73.41	0	25.1	25.1	2.05	-1.43	0.19
82	-9.75	102.34	102.01	74.84	74.519	0	27.5	27.5	1.72	-1.37	0.19
84	-9.99	105.89	105.53	75.998	75.632	0	29.9	29.9	1.41	-1.28	0.18
86	-10.23	109.55	109.04	77.25	76.748	0	32.3	32.3	1.11	-1.19	0.18
88	-10.47	113.09	112.56	78.394	77.867	0	34.7	34.7	0.85	-1.07	0.18
90	-10.71	116.63	116.08	79.536	78.988	0	37.1	37.1	0.62	-0.94	0.18
92	-10.95	120.26	119.60	80.768	80.109	0	39.5	39.5	0.42	-0.8	0.18
94	-11.19	123.80	123.13	81.904	81.23	0	41.9	41.9	0.25	-0.65	0.18
96	-11.43	127.33	126.65	83.039	82.351	0	44.3	44.3	0.13	-0.48	0.18
98	-11.67	130.96	130.17	84.263	83.47	0	46.7	46.7	0.04	-0.31	0.18
100	-11.91	134.49	133.68	85.398	84.588	0	49.1	49.1	0	-0.12	0.18

P168.3x10/40 Stage: 4

Wall	EL	Sht L	Sht R	Shs L	Shs R	q	U L	U R	M	V	dx
Nod	(m)	(kPa)	(kPa)	(kPa)	(kPa)	(kPa)	(kPa)	(kPa)	(kN-	(kN/m)	(cm)
0	0	43.484	0	43.484	0	0	0	0	0	2.61	0.24
2	-0.24	42.505	0	42.505	0	0	0	0	1.22	7.6	0.22
4	-0.48	42.599	0	42.599	0	0	0	0	4.89	17.86	0.19
6	-0.72	43.357	0	43.357	0	0	0	0	11.03	28.14	0.16
8	-0.96	43.202	0	43.202	0	0	0	0	19.65	38.51	0.14
10	-1.2	42.657	0	42.657	0	0	0	0	30.76	48.88	0.11
12	-1.37	41.991	0	41.991	0	0	0	0	28.54	-40.36	0.1
14	-1.61	40.425	0	40.425	0	0	0	0	20.66	-30.35	0.08
16	-1.85	38.787	0	38.787	0	0	0	0	15.11	-20.74	0.07
18	-2.09	36.775	0	36.775	0	0	0	0	11.79	-11.57	0.05
20	-2.33	35.584	0	35.584	0	0	0	0	10.59	-2.85	0.04
22	-2.57	39.028	0	39.028	0	0	0	0	11.47	5.9	0.03
24	-2.81	42.051	0	42.051	0	0	0	0	14.59	15.44	0.02

26	-3.05	44.919	0	44.919	0	0	0	0	20.14	25.71	0.01
28	-3.29	47.22	0	47.22	0	0	0	0	28.26	36.63	0.01
30	-3.53	49.002	0	49.002	0	0	0	0	39.11	48.09	0.01
32	-3.75	50.08	0	50.08	0	0	0	0	51.53	59.44	0.01
34	-3.99	50.663	0	50.663	0	0	0	0	35.88	-62.15	0.01
36	-4.23	50.519	0	50.519	0	0	0	0	23.16	-50	0.02
38	-4.47	49.935	4.785	49.935	4.785	0	0	0	13.33	-37.96	0.04
40	-4.71	49.156	18.883	49.156	18.883	0	0	0	6	-28.55	0.05
42	-4.95	48.101	23.155	48.101	23.155	0	0	0	0.41	-21.61	0.07
44	-5.19	46.973	27.105	46.973	27.105	0	0	0	-3.73	-15.93	0.09
46	-5.43	45.939	30.846	45.939	30.846	0	0	0	-6.73	-11.45	0.1
48	-5.67	44.881	34.425	44.881	34.425	0	0	0	-8.86	-8.11	0.12
50	-5.91	43.934	37.861	43.934	37.861	0	0	0	-10.39	-5.87	0.13
52	-6.15	57.508	47.254	57.508	47.254	0	0	0	-11.46	-3.78	0.14
54	-6.39	58.997	50.931	58.997	50.931	0	0	0	-11.94	-1.46	0.15
56	-6.63	60.589	54.474	60.589	54.474	0	0	0	-11.95	0.37	0.16
58	-6.87	62.438	57.888	62.438	57.888	0	0	0	-11.61	1.74	0.17
60	-7.11	64.706	61.578	63.606	60.478	0	1.1	1.1	-11.01	2.73	0.18
62	-7.35	67.629	65.642	64.129	62.142	0	3.5	3.5	-10.23	3.41	0.19
64	-7.59	70.786	69.622	64.886	63.722	0	5.9	5.9	-9.33	3.84	0.19
66	-7.83	73.896	73.524	65.596	65.224	0	8.3	8.3	-8.37	4.06	0.19
68	-8.07	77.09	77.355	66.39	66.655	0	10.7	10.7	-7.38	4.12	0.2
70	-8.31	80.481	81.124	67.381	68.024	0	13.1	13.1	-6.41	4.03	0.2
72	-8.55	83.811	84.837	68.311	69.337	0	15.5	15.5	-5.47	3.84	0.2
74	-8.79	87.197	88.503	69.297	70.603	0	17.9	17.9	-4.6	3.59	0.2
76	-9.03	90.744	92.127	70.444	71.827	0	20.3	20.3	-3.79	3.27	0.2
78	-9.27	94.215	95.718	71.515	73.018	0	22.7	22.7	-3.07	2.93	0.2
80	-9.51	97.826	99.28	72.726	74.18	0	25.1	25.1	-2.43	2.57	0.2
82	-9.75	101.35	102.81	73.854	75.319	0	27.5	27.5	-1.87	2.22	0.2
84	-9.99	104.90	106.34	75.002	76.44	0	29.9	29.9	-1.4	1.87	0.2
86	-10.23	108.56	109.84	76.266	77.546	0	32.3	32.3	-1.02	1.54	0.2
88	-10.47	112.14	113.34	77.44	78.642	0	34.7	34.7	-0.7	1.23	0.2
90	-10.71	115.72	116.82	78.622	79.729	0	37.1	37.1	-0.46	0.95	0.19
92	-10.95	119.40	120.31	79.905	80.81	0	39.5	39.5	-0.28	0.7	0.19
94	-11.19	122.99	123.78	81.096	81.887	0	41.9	41.9	-0.15	0.48	0.19
96	-11.43	126.58	127.26	82.289	82.96	0	44.3	44.3	-0.06	0.3	0.19
98	-11.67	130.27	130.73	83.573	84.03	0	46.7	46.7	-0.02	0.16	0.19
100	-11.91	133.86	134.19	84.769	85.099	0	49.1	49.1	0	0.05	0.19

P168.3x10/40 Stage: 5

Wall	EL	Sht L	Sht R	Shs L	Shs R	q	U L	U R	M	V	dx
Nod	(m)	(kPa)	(kPa)	(kPa)	(kPa)	(kPa)	(kPa)	(kPa)	(kN-	(kN/m)	(cm)
0	0	47.874	0	47.874	0	0	0	0	0	2.87	0.18
2	-0.24	46.217	0	46.217	0	0	0	0	1.35	8.35	0.16
4	-0.48	45.63	0	45.63	0	0	0	0	5.35	19.46	0.14
6	-0.72	45.703	0	45.703	0	0	0	0	11.99	30.43	0.13
8	-0.96	44.857	0	44.857	0	0	0	0	21.26	41.32	0.11
10	-1.2	43.608	0	43.608	0	0	0	0	33.11	52.04	0.1
12	-1.37	42.433	0	42.433	0	0	0	0	31.49	-36.71	0.09
14	-1.61	40.128	0	40.128	0	0	0	0	24.5	-26.64	0.09
16	-1.85	37.722	0	37.722	0	0	0	0	19.82	-17.15	0.08
18	-2.09	34.906	0	34.906	0	0	0	0	17.31	-8.28	0.08
20	-2.33	32.868	0	32.868	0	0	0	0	16.82	-0.06	0.08
22	-2.57	35.419	0	35.419	0	0	0	0	18.24	7.99	0.08
24	-2.81	37.496	0	37.496	0	0	0	0	21.7	16.61	0.09
26	-3.05	39.365	0	39.365	0	0	0	0	27.32	25.72	0.1
28	-3.29	40.611	0	40.611	0	0	0	0	35.21	35.25	0.11
30	-3.53	41.286	0	41.286	0	0	0	0	45.43	45.05	0.12

32	-3.75	41.307	0	41.307	0	0	0	0	56.88	54.56	0.14
34	-3.99	40.7	0	40.7	0	0	0	0	38.37	-74.68	0.16
36	-4.23	39.347	0	39.347	0	0	0	0	22.19	-65	0.19
38	-4.47	37.562	0	37.562	0	0	0	0	8.28	-55.65	0.22
40	-4.71	35.622	0	35.622	0	0	0	0	-3.46	-46.75	0.25
42	-4.95	33.476	0	33.476	0	0	0	0	-13.16	-38.33	0.29
44	-5.19	31.362	0	31.362	0	0	0	0	-20.93	-30.42	0.32
46	-5.43	29.818	0	29.818	0	0	0	0	-26.89	-23.01	0.34
48	-5.67	30.942	0	30.942	0	0	0	0	-31.12	-15.79	0.37
50	-5.91	32.069	0	32.069	0	0	0	0	-33.56	-8.29	0.39
52	-6.15	44.74	8.975	44.74	8.975	0	0	0	-34.02	0.61	0.41
54	-6.39	46.257	23.334	46.257	23.334	0	0	0	-32.42	8.42	0.42
56	-6.63	47.776	37.694	47.776	37.694	0	0	0	-29.5	13.16	0.43
58	-6.87	49.39	49.897	49.39	49.897	0	0	0	-26	14.81	0.44
60	-7.11	51.689	54.242	50.589	53.142	0	1.1	1.1	-22.49	14.52	0.44
62	-7.35	54.831	58.527	51.331	55.027	0	3.5	3.5	-19.12	13.85	0.45
64	-7.59	58.258	62.649	52.358	56.749	0	5.9	5.9	-15.96	12.91	0.45
66	-7.83	61.674	66.63	53.374	58.33	0	8.3	8.3	-13.06	11.81	0.44
68	-8.07	65.199	70.49	54.499	59.79	0	10.7	10.7	-10.44	10.61	0.44
70	-8.31	68.94	74.25	55.84	61.15	0	13.1	13.1	-8.12	9.33	0.43
72	-8.55	72.628	77.925	57.128	62.425	0	15.5	15.5	-6.11	8.05	0.43
74	-8.79	76.377	81.53	58.477	63.63	0	17.9	17.9	-4.41	6.79	0.42
76	-9.03	80.286	85.078	59.986	64.778	0	20.3	20.3	-2.99	5.58	0.41
78	-9.27	84.114	88.581	61.414	65.881	0	22.7	22.7	-1.86	4.45	0.41
80	-9.51	88.076	92.047	62.976	66.947	0	25.1	25.1	-0.98	3.41	0.4
82	-9.75	91.946	95.485	64.446	67.985	0	27.5	27.5	-0.33	2.48	0.39
84	-9.99	95.829	98.901	65.929	69.001	0	29.9	29.9	0.11	1.66	0.38
86	-10.23	99.819	102.3	67.519	70	0	32.3	32.3	0.38	0.96	0.38
88	-10.47	103.71	105.68	69.011	70.985	0	34.7	34.7	0.51	0.39	0.37
90	-10.71	107.60	109.05	70.505	71.959	0	37.1	37.1	0.52	-0.05	0.36
92	-10.95	111.59	112.42	72.094	72.923	0	39.5	39.5	0.45	-0.36	0.35
94	-11.19	115.48	115.78	73.587	73.88	0	41.9	41.9	0.33	-0.53	0.34
96	-11.43	119.38	119.12	75.08	74.829	0	44.3	44.3	0.2	-0.57	0.34
98	-11.67	123.36	122.47	76.662	75.771	0	46.7	46.7	0.08	-0.47	0.33
100	-11.91	127.25	125.80	78.154	76.706	0	49.1	49.1	0.01	-0.23	0.32

LEGENDA

Wall node=number of the node

EL=elevation

Sht L=Total horizontal soil pressure (on the left side of the wall)

Sht R=Total horizontal soil pressure (on the right side of the wall)

Shs L=Effective horizontal soil pressure (on the left side of the wall)

Shs R=Effective horizontal soil pressure (on the right side of the wall)

q=pressure given by the surcharge

U L=Water pressure (on the left side of the wall)

U R=pressione acqua (on the right side of the wall)

M=bending moment (per meter)

V=shear (per metro)

dx=wall deflection

McapL=Ultimate bending moment (on the left side of the wall)

McapR=Ultimate bending moment (on the right side of the wall)

VcapL=Ultimate resistance shear (on the left side of the wall)

VcapR=Ultimate resistance shear (on the right side of the wall)

SUPPORTS REACTIONS (TIEBACKS, STRUTS, SLABS, RAKERS)

Support 0

Stage No	R
	(kN)

0	0
1	0
2	240
3	246.816
4	239.686
5	238.85

Support 1

Stage No	R
	(kN)
0	0
1	0
2	0
3	0
4	340.08
5	354.288
6	0

Project: My Project

Results for Design Section 1: DM08_ITA: Comb. 1:

A1+M1+R1

DESIGN APPROACHES AND COMBINATION FACTORS

The Design Approaches (from Codes or Customized by the user) and related safety factors are the following:

Ftan fr=mult factor for friction angle

F C'=mult factor for effective cohesion

F Su'=mult factof for undrained cohesion

F EQ=mult factor for seismic action

F perm load=mult factor for perm loads

F temp load=mult factor for live loads

F perm supp=reduct factor for resistance for pull out checking

F temp supp=fattore di riduzione resistance per verifica pull out tirante

F earth Dstab=mult factor for active press coeff , unfavorable

F earth stab=mult factor for passive pressure , favorable

F GWT Dstab (ground water)=mult factor for hydrostatic pressure , unfavorable

F GWT stab (ground water)=mult factor for hydrostatic pressure, favorable

F HYD Dstab=mult factor for hydrodynamic pressure, unfavorable

F HYD stab=mult factor for hydrodynamic pressure, favorable

F UPL Dstab=mult factor for hydraulic heave, unfavorable

Stage	Design Name	Design Case	F(tan fr)	F (c')	F (Su)	F (EQ)	F(perm load)	F(temp load)	F(perm sup)	F(temp sup)	F Earth (Dstab)	F Earth (stab)	F GWT (Dstab)	F GWT (stab)	F HYD (Dstab)	F HYD (stab)	F UPL (Dstab)	F UPL (stab)
0	DM08_ITA	1: A1+M1+R1	1	1	1	0	1.3	1.5	1.2	1.1	1.3	1	1.3	1	1.35	0.9	1	1
1	DM08_ITA	1: A1+M1+R1	1	1	1	0	1.3	1.5	1.2	1.1	1.3	1	1.3	1	1.35	0.9	1	1
2	DM08_ITA	1: A1+M1+R1	1	1	1	0	1.3	1.5	1.2	1.1	1.3	1	1.3	1	1.35	0.9	1	1
3	DM08_ITA	1: A1+M1+R1	1	1	1	0	1.3	1.5	1.2	1.1	1.3	1	1.3	1	1.35	0.9	1	1
4	DM08_ITA	1: A1+M1+R1	1	1	1	0	1.3	1.5	1.2	1.1	1.3	1	1.3	1	1.35	0.9	1	1
5	DM08_ITA	1: A1+M1+R1	1	1	1	0	1.3	1.5	1.2	1.1	1.3	1	1.3	1	1.35	0.9	1	1

SOIL DATA

Name	g tot (kN/m3)	g dry (kN/m3)	Frict (deg)	C' (kPa)	Su (kPa)	FRp (deg)	FRcv (deg)	Eload (kPa)	Eur (kPa)	kAp Springs	kPp Springs	kAcv Springs	kPcv Springs	Vary	Spring Model	Color
F	20	19	30	0	N/A	N/A	N/A	15000	45000	0.33	3	N/A	N/A	True	Linear	
O1	16.5	14	22	2	20	22	22	2874	8622	0.46	2.2	0.46	2.2	True	Linear	
O2	19	16.5	28	2	N/A	N/A	N/A	7185	21555	0.36	2.77	N/A	N/A	True	Linear	
S1	21	19	34	0	N/A	N/A	N/A	25000	75000	0.28	3.54	N/A	N/A	True	Linear	
Clay	20	19	28	0	150	28	28	20000	60000	0.36	2.77	0.36	2.77	True	Linear	
GT	22	20	36	10	N/A	N/A	N/A	30000	90000	0.26	3.85	N/A	N/A	True	Linear	
Rock	27	25	30	100	N/A	N/A	N/A	479000	143700	0.33	3	N/A	N/A	True	Linear	
Rileva	18	18	32	0	N/A	N/A	N/A	30000	30000	0.31	3.26	N/A	N/A	True	Linear	
Base	18	18	25	0	N/A	N/A	N/A	25000	25000	0.41	2.46	N/A	N/A	True	Linear	

gtot=total soil specific weight

gdry=dry weight of the soil

Frict=friction angle

C'=effective cohesion

Su = Undrained cohesiona (only for CLAY soils in undrained conditions)

Dilat=SOil Dilatancy (only for non linear analysis)

Evc=Virgin compression elastic module

Eur=unloading/reloading elastic module

Kap= Peak active thrust coeff

Kpp= Peak passive thrust coeff

Kacv= Constant volume active thrust coeff

Kpcv= Constant volume passive thrust coeff

Spring models= spring model (LIN=constant over the soil layer height , EXP=exponential ,

SIMC=simplified winkler)

LIN= Linear-Elastic-Perfectly Plastic,

EXP: Exponential, SUB: Modulus of Subgrade Reaction

SOIL BORINGS

Top Elev= superior Soil level

Soil type=type of the soil (sand , clay , etc)

OCR=overconsolidation ratio

K0=at rest coefficient

Name: Boring 1, pos: (-20, 0)

Top elev.	Soil type	OCR	Ko
0	Rilevato	1	0.47
-6	Base	1	0.58

STRUCTURAL MATERIALS DATA

Steel

Name	Strength Fy (MPa)	Fu (MPa)	Elastic E (MPa)	Density g (kN/m3)
Fe360	235	360	210000	77
Fe510	355	510	210000	77
A36	248.3	400	206000	77
A50	355	500	206000	77
New steel 4	241.4	413.8	206000	77

Concrete

Name	Strength Fc' (MPa)	Elastic E (MPa)	Density g (kN/m3)	Tension Strength (MPa)
C20/25	20	29962	25	10
C25/30	25	31476	25	10
Fc 3ksi	20.7	21541.8	23.573	10

Steel rebar

Name	Strength Fy (MPa)	Elastic E (MPa)
S1860 (Strands)	1670	210000
Grade 75	517.2	200100
Grade 80	551.7	200100
Grade 150	1034.5	200100
Strands 270 ksi	1862.1	200100
S410	410	210000
S500	500	210000
B450C	450	210000

Wood

Name	Ultimate Bending (MPa)	Ultimate Tensile Strength (MPa)	Ultimate Shear Strength (MPa)	Density g (kN/m3)	Elastic E (MPa)
Construction	11	9.7	5.5	7.8576	6900
Regular grade	6.9	6.9	4.1	7.8576	5520

STEEL

Name=material name
 fy=fyk=characteristic resistance for steel (for all the codes)
 Fu=fuk=ultimate resistance for steel (for all the codes)
 Elastic E=Elastic modulus
 Density g=specific weight

CONCRETE

Name=material name
 f'c=fck=cylindrical resistance for concrete (for all the codes)
 Elastic E=Elastic modulus
 Density g=specific weight
 Tension strength=ft=fctk=characteristic tension resistance for concrete

STEEL REBARS

Name=material name
 fy=fyk=characteristic resistance for steel (for all the codes)
 Fu=fuk=ultimate resistance for steel (for all the codes)
 Elastic E=Elastic modulus
 Density g=specific weight

WOOD

Name=material name
 Fb=fbk=Ultimate bending strength
 Ftu=ftuk=Ultimate tensile strength
 Fvu=fvuk=Ultimate shear strength
 Density g=specific weight
 Elastic E=Elastic modulus

WALL DATA

Wall section 0: P168.3x10/40

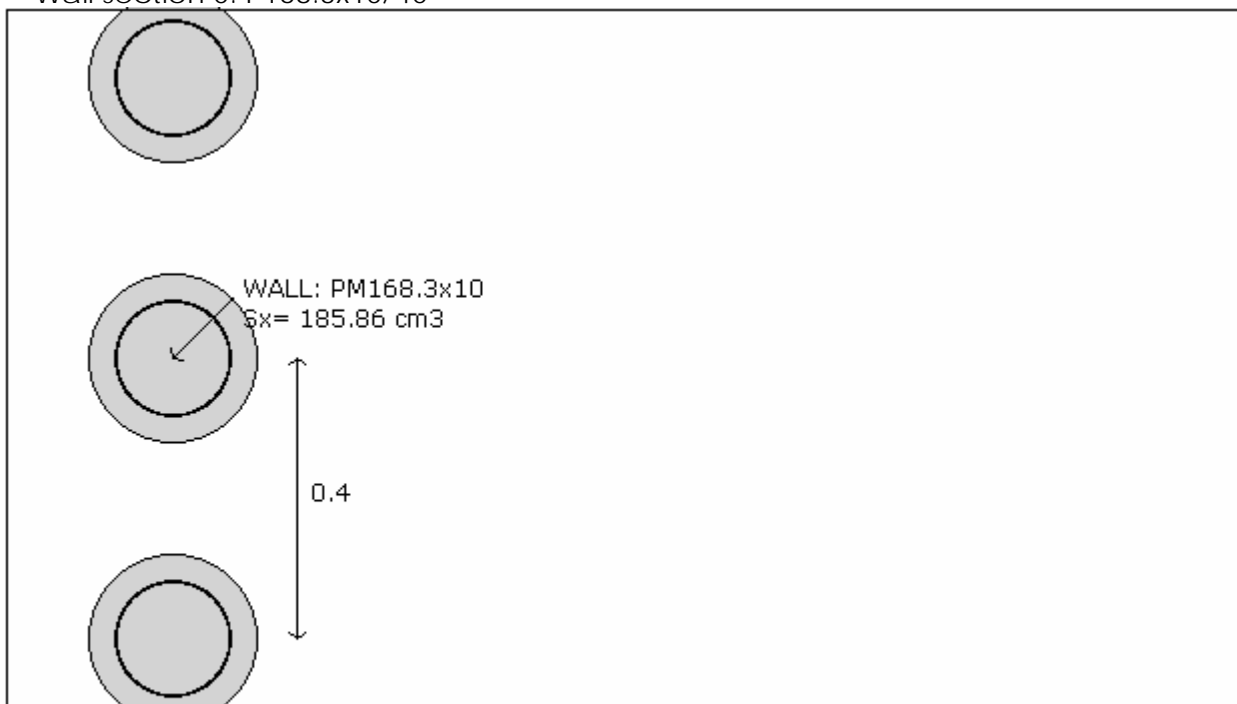

Company: My Company	Wall sketch	CeAS srl and Deep Excavation LCC
Engineer: Engineer		Paratie Plus 2010 - DeepXcar 2010
C:\nd.28_seraLotto3\alleg\LIII_typ2_rev27oct10_EQscavo_Alleg.DEEP		10/28/2010

Wall uses wall section 0: P168.3x10/40
 Wall type: Tangent pile wall
 Top wall El: 0 m Bottom wall El: -12 m
 Hor. wall spacing: 0.4 Wall thickness = 0.24
 Passive width below exc: 0.4 Active width below exc: 0.4
 Concrete f'c = 25 Rebar Fy = 410 Econc = 31476 Concrete tension FcT = 10% of Fc'

Steel members $f_y = 355$ Esteel = 210000

Wall friction: Percentage of Soil Friction = 50%

Steel wall capacities are calculated with NTC 2008

Concrete capacities are calculated with ACI 318-2002.

Note: With ultimate capacities you may have to use a structural safety factor.

Tangent pile wall soldier pile properties

Table: Soldier Pile Properties

Name	Section	W	A	D	tw or	bf	tf	k	Ixx	Sxx	rX	Iyy	Syy	rY	rT	Cw	fy
		(kN/m)	(cm ²)	(cm)	(cm)	(cm)	(cm)	(cm)	(cm ⁴)	(cm ³)	(cm)	(cm ⁴)	(cm ³)	(cm)	(cm)	(cm ⁶)	(MPa)
	PM16	257.3	75.62	16.8	1	16.83	1	1	3771	185.9	7.06	3771	185.9	7.06	7.06	1	355

GENERAL WALL DATA

Hor wall spacing=wall horizontal spacing

Passive width below exc=spacing for passive thrust pressure for classic analysis

$f'_c=f_{ck}$ =cylindrical concrete resistance

$f_y=f_{yk}$ =steel rebar characteristic resistance

E_{conc} =Concrete Elastic modulus

f_{ctk} =characteristic Concrete tension

E_{steel} =steel elastic modulus

TABULAR DATA (principal parameters)

1) Diaphragm wall (rectangular cross section section)

N/A= data not available

$F_y=f_{yk}$

$F'_c=f_{ck}$

D=wall height

B=wall width

2) Steel sheet pile

DES=shape (Z or U)

W=weight per unit of length

A=area

h=height

t=horiz part thickness

b=width of the single sheet pile part

s=inclined part thickness

I_{xx} =strong axis inertia (per unit of length)

S_{xx} =strong axis section modulus (per unit of length)

3) Secant piles wall, Tangent piles wall, soldier piles, soldier piles and timber lagging

W=weight per unit of length

A=area

D=diameter

tw=web thickness

tp= pipe thickness

bf=flange width

tf=flange thickness

k=flange thickness+stem thickness

I_{xx} =strong axis inertia modulus (per unit of length)

S_{xx} =strong axis section modulus (per unit of length)

r_x =radius of gyration about X axis

r_y =radius of gyration about Y axis

I_{yy} =weak axis inertia modulus (per unit of length)

S_{yy} =weak axis section modulus (per unit of length)

r_T =radius of gyration for torsion

Cw=warping constant

TIEBACK DATA

Name	F_y	F'_c	D_{fix}	A_{fix}	E_{fix}	A_{free}	E_{free}	Pa STR	Pu STR	PresGr	FSgeo	UserGca	Pa	Pu	WireMod
	(MPa)	(MPa)	(cm)	(cm ²)	(MPa)	(cm ²)	(MPa)	(kN)	(kN)	(kPa)			(kN)	(kN)	Yes/No
4-Strands	1862.1	25	15	176.7	31476	2.8	200100	453.4	453.4	N/A	1.4	False	N/A	N/A	Yes
5-Strands	1862.1	25	15	176.7	31476	0	200100	0	0	N/A	1.4	False	N/A	N/A	Yes
6-Strands	1862.1	25	15	176.7	31476	8.39	200100	1357.9	1357.9	N/A	1.4	False	N/A	N/A	Yes

Tieback_	1670	25	16	201.0	31476	4.17	210000	605.2	605.2	N/A	1	False	N/A	N/A	Yes
Tieback_	1670	25	16	201.0	31476	6.95	210000	1008.7	1008.7	N/A	1	False	N/A	N/A	Yes

EXCAVATION STAGES SKETCHES

A sequence of figures for each excavation stage is reported

GENERAL ANALYSIS CRITERIA

Summary of stage assumptions

Name	Analysis	Drive	ka-Mult	Htr	Resist	Res	Contl	Supp	Axial	Used	Min	Toe	Toe
	Method	Press		(%)	Press	Mult	Meth	Mode	Incl	FSwall	FDtoe	FSrot	FSpas
Stage 0	Springs-Up	Ka+ d	N/A	N/A	Kp+ d	N/A		Fixed	N/A	1	0	0	0
Stage 1	Springs-Up	Ka+ d	N/A	N/A	Kp+ d	N/A		Fixed	N/A	1	0	0	0
Stage 2	Springs-Up	FHWA	1.3	m=	Kp+ d	N/A		Fixed	N/A	1	0	0	N/A
Stage 3	Springs-Up	FHWA	1.3	m=	Kp+ d	N/A		Fixed	N/A	1	0	0	N/A
Stage 4	Springs-Up	FHWA	1.3	m=	Kp+ d	N/A		Fixed	N/A	1	0	0	0
Stage 5	Springs-Up	FHWA	1.3	m=	Kp+ d	N/A		Fixed	N/A	1	0	0	0

Name=excavation phase name

Analysis method

springs=elasto plastic springs are used

DR=Drained condition for CLAY model

U=Undrained condition for CLAY model for all the soils

Up=Undrained condition just for selected soil

Drive press=Ka

ka mult=multiply factor for Ka

Htr T/B (%)=trapezioidal pressure scheme

Resit press=Kp

Res Mult=Multiply factor for Kp

COntle Method=cantilver method

Support Model=Fix support type

Axial Incl=Axial action is included for design

Used FS wall=Reduction factor for axial+bending resistance dominium

Min FD TOe=embedded minimum safety factor (for classic analysis)

Toe FS rot=rotation safety factor (classic for classic analysis)

Toe FSpas=driving/resistent pressure safety factor (for classic analysis)

SEISMIC DATA

Seismic action is modeled through a pseudo static approach

Summary of stage assumptions

Stage	Seismic g	Method	aX	aY	Beta	Building Code
Number	Used	Used	(g)	(g)		(Name)
0	No		0.03	0	1	N/A
1	No		0.03	0	1	N/A
2	No		0.03	0	1	N/A
3	No		0.03	0	1	N/A
4	No		0.03	0	1	N/A
5	No		0.03	0	1	N/A

N/A= data non available

Stage number=number of stage input

Seismic ag =value of design acceleration according to a code or input by the user

Method=the method used to evaluated the seismic thrustover the wall

ahd or khd otr axd=design horizontal acceleration

avd or kvd or ayd=design vertical acceleration

Beta=multip coeff for the semirigd approach

Buildind code=code used for design acceleration calculation

SUPPORTS PROPERTIES

Support 0: type = tieback

X = 0.24 m, Z = -1.25 m, S = 2.4 m

Lfree = 7 m, Lfix = 10 m, Rfix = 50 %

Walls: P168.3x10/40

Stage No	Active	Prestress	Slab live load	User add. strain
	Yes/No	(kN)	(kPa)	+expansion
0	No	-	-	-
1	No	-	-	-
2	Yes	240	-	-
3	Yes	-	-	-
4	Yes	-	-	-
5	Yes	-	-	-

Support 1: type = tieback

X = 0.24 m, Z = -3.75 m, S = 2.4 m

Lfree = 6 m, Lfix = 13 m, Rfix = 50 %

Walls: P168.3x10/40

Stage No	Active	Prestress	Slab live load	User add. strain
	Yes/No	(kN)	(kPa)	+expansion
0	No	-	-	-
1	No	-	-	-
2	No	-	-	-
3	No	-	-	-
4	Yes	340	-	-
5	Yes	-	-	-
6	Yes	-	-	-

Support type

LEGENDA for TIEBACKS

General data

Z=support level

S=horizontal distance between each tieback

Lfree=free length

Lfix=rigid body length

Rfix=% effective part of the rigid body length

Stage No=excavation steps number

Active=tieback status (YES=active)

Post stress= tieback preload (Load considering the horiz distance bewteen the tiebacks)

SURFACE LOADS

Surcharge 0: X1 = -17.9427272727273, X2 = 0

Variable surcharge

Stage No	Active	X1	Z1	qX1	qZ1	X2	Z2	qX2	qZ2
	Yes/No	(m)	(m)	(kPa)	(kPa)	(m)	(m)	(kPa)	(kPa)
0	No	-	0	0	20	0	0	0	20

1	Yes	-	0	0	20	0	0	0	20
2	Yes	-	0	0	20	0	0	0	20
3	Yes	-	0	0	20	0	0	0	20
4	Yes	-	0	0	20	0	0	0	20
5	Yes	-	0	0	20	0	0	0	20

LEGENDA

Stage No=Excavation step number

Active=load status (Yes=active)

X1=first X coordinate position of the load

Z1=first Z coordinate position of the load

qX1=first horizontal point load value

qZ1=first vertical point load value

X2=second X coordinate position of the load

Z2=second Z coordinate position of the load

qX2=second horizontal point load value

qZ2=second vertical point load value

WALL RESULTS TABLE**LEGENDA**

Wall node=number of the node

EL=elevation

Sht L=Total horizontal soil pressure (on the left side of the wall)

Sht R=Total horizontal soil pressure (on the right side of the wall)

Shs L=Effective horizontal soil pressure (on the left side of the wall)

Shs R=Effective horizontal soil pressure (on the right side of the wall)

q=pressure given by the surcharge

U L=Water pressure (on the left side of the wall)

U R=pressione acqua (on the right side of the wall)

M=bending moment (per meter)

V=shear (per metro)

dx=wall deflection

McapL=Ultimate bending moment (on the left side of the wall)

McapR=Ultimate bending moment (on the right side of the wall)

VcapL=Ultimate resistance shear (on the left side of the wall)

VcapR=Ultimate resistance shear (on the right side of the wall)

SUPPORTS REACTIONS (TIEBACKS, STRUTS, SLABS, RAKERS)**Support 0**

Stage No	R
	(kN)
0	0
1	0
2	312
3	321.61
4	312.374
5	311.257

Support 1

Stage No	R
	(kN)
0	0
1	0
2	0
3	0

4	442.104
5	461.386
6	0

Project: My Project
Results for Design Section 2: DM08_ITA: Comb. 2:
A2+M2+R1

DESIGN APPROACHES AND COMBINATION FACTORS

The Design Approaches (from Codes or Customized by the user) and related safety factors are the following:

Ftan fr=mult factor for friction angle

F C'=mult factor for effective cohesion

F Su'=mult factof for undrained cohesion

F EQ=mult factor for seismic action

F perm load=mult factor for perm loads

F temp load=mult factor for live loads

F perm supp=reduct factor for resistance for pull out checking

F temp supp=fattore di riduzione resistenza per verifica pull out tirante

F earth Dstab=mult factor for active press coeff , unfavorable

F earth stab=mult factor for passive pressure , favorable

F GWT Dstab (ground water)=mult factor for hydrostatic pressure , unfavorable

F GWT stab (ground water)=mult factor for hydrostatic pressure, favorable

F HYD Dstab=mult factor for hydrodynamic pressure, unfavorable

F HYD stab=mult factor for hydrodynamic pressure, favorable

F UPL Dstab=mult factor for hydraulic heave, unfavorable

Stage	Design	Design Case	F(tan fr)	F (c')	F (Su)	F (EQ)	F(perm load)	F(temp load)	F(perm sup)	F(temp sup)	F Earth (Dstab)	F Earth (stab)	F GWT (Dstab)	F GWT (stab)	F HYD (Dstab)	F HYD (stab)	F UPL (Dstab)	F UPL (stab)
0	DM08_ITA	2: A2+M2+R1	1.25	1.25	1.4	0	1	1.3	1.2	1.1	1	1	1	1	1.35	0.9	1	1
1	DM08_ITA	2: A2+M2+R1	1.25	1.25	1.4	0	1	1.3	1.2	1.1	1	1	1	1	1.35	0.9	1	1
2	DM08_ITA	2: A2+M2+R1	1.25	1.25	1.4	0	1	1.3	1.2	1.1	1	1	1	1	1.35	0.9	1	1
3	DM08_ITA	2: A2+M2+R1	1.25	1.25	1.4	0	1	1.3	1.2	1.1	1	1	1	1	1.35	0.9	1	1

4	DM08_ITA	2: A2+M2+R1	1.25	1.25	1.4	0	1	1.3	1.2	1.1	1	1	1	1	1.35	0.9	1	1
5	DM08_ITA	2: A2+M2+R1	1.25	1.25	1.4	0	1	1.3	1.2	1.1	1	1	1	1	1.35	0.9	1	1

SOIL DATA

Name	g tot	g dry	Frict	C'	Su	FRp	FRcv	Eload	Eur	kAp	kPp	kAcv	kPcv	Vary	Spring	Color
	(kN/m3)	(kN/m3)	(deg)	(kPa)	(kPa)	(deg)	(deg)	(kPa)	(kPa)	Springs	Springs	Springs	Springs		Model	
F	20	19	30	0	N/A	N/A	N/A	15000	45000	0.33	3	N/A	N/A	True	Linear	
O1	16.5	14	22	2	20	22	22	2874	8622	0.46	2.2	0.46	2.2	True	Linear	
O2	19	16.5	28	2	N/A	N/A	N/A	7185	21555	0.36	2.77	N/A	N/A	True	Linear	
S1	21	19	34	0	N/A	N/A	N/A	25000	75000	0.28	3.54	N/A	N/A	True	Linear	
Clay	20	19	28	0	150	28	28	20000	60000	0.36	2.77	0.36	2.77	True	Linear	
GT	22	20	36	10	N/A	N/A	N/A	30000	90000	0.26	3.85	N/A	N/A	True	Linear	
Rock	27	25	30	100	N/A	N/A	N/A	479000	143700	0.33	3	N/A	N/A	True	Linear	
Rileva	18	18	32	0	N/A	N/A	N/A	30000	30000	0.31	3.26	N/A	N/A	True	Linear	
Base	18	18	25	0	N/A	N/A	N/A	25000	25000	0.41	2.46	N/A	N/A	True	Linear	

gtot=total soil specific weight

gdry=dry weight of the soil

Frict=friction angle

C'=effective cohesion

Su = Undrained cohesion (only for CLAY soils in undrained conditions)

Dilat=SOil Dilatancy (only for non linear analysis)

Evc=Virgin compression elastic module

Eur=unloading/reloading elastic module

Kap= Peak active thrust coeff

Kpp= Peak passive thrust coeff

Kacv= Constant volume active thrust coeff

Kpcv= Constant volume passive thrust coeff

Spring models= spring model (LIN=constant over the soil layer height , EXP=exponential ,

SIMC=simplified winkler)

LIN= Linear-Elastic-Perfectly Plastic,

EXP: Exponential, SUB: Modulus of Subgrade Reaction

SOIL BORINGS

Top Elev= superior SOil level

Soil type=type of the soil (sand , clay , etc)

OCR=overconsolidation ratio

K0=at rest coefficient

Name: Boring 1, pos: (-20, 0)

Top elev.	Soil type	OCR	Ko
0	Rilevato	1	0.47
-6	Base	1	0.58

STRUCTURAL MATERIALS DATA

Steel

Name	Strength Fy	Fu	Elastic E	Density g
	(MPa)	(MPa)	(MPa)	(kN/m3)
Fe360	235	360	210000	77
Fe510	355	510	210000	77
A36	248.3	400	206000	77
A50	355	500	206000	77
New steel 4	241.4	413.8	206000	77

Concrete

Name	Strength Fc'	Elastic E	Density g	Tension Strength
	(MPa)	(MPa)	(kN/m3)	(MPa)
C20/25	20	29962	25	10

C25/30	25	31476	25	10
Fc 3ksi	20.7	21541.8	23.573	10

Steel rebar

Name	Strength Fy (MPa)	Elastic E (MPa)
S1860 (Strands)	1670	210000
Grade 75	517.2	200100
Grade 80	551.7	200100
Grade 150	1034.5	200100
Strands 270 ksi	1862.1	200100
S410	410	210000
S500	500	210000
B450C	450	210000

Wood

Name	Ultimate Bending (MPa)	Ultimate Tensile Strength (MPa)	Ultimate Shear Strength (MPa)	Density g (kN/m ³)	Elastic E (MPa)
Construction	11	9.7	5.5	7.8576	6900
Regular grade	6.9	6.9	4.1	7.8576	5520

STEEL

Name=material name

fy=fyk=characteristic resistance for steel (for all the codes)

Fu=fuk=ultimate resistance for steel (for all the codes)

Elastic E=Elastic modulus

Density g=specific weight

CONCRETE

Name=material name

f'c=fck=cylindrical resistance for concrete (for all the codes)

Elastic E=Elastic modulus

Density g=specific weight

Tension strength=ft=fctk=characteristic tension resistance for concrete

STEEL REBARS

Name=material name

fy=fyk=characteristic resistance for steel (for all the codes)

Fu=fuk=ultimate resistance for steel (for all the codes)

Elastic E=Elastic modulus

Density g=specific weight

WOOD

Name=material name

Fb=fbk=Ultimate bending strength

Ftu=ftuk=Ultimate tensile strength

Fvu=fvuk=Ultimate shear strength

Density g=specific weight

Elastic E=Elastic modulus

WALL DATA

Wall section 0: P168.3x10/40

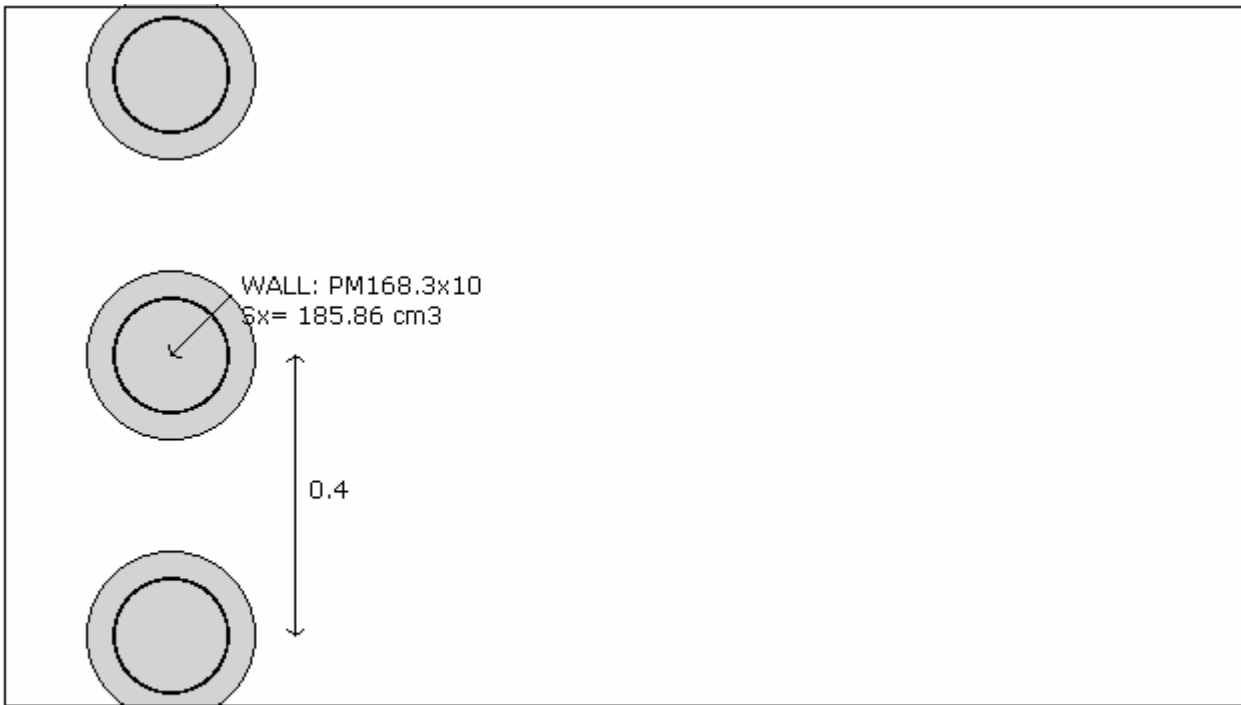

Company: My Company	Wall sketch	CeAS srl and Deep Excavation LCC
Engineer: Engineer		Paratie Plus 2010 - DeepXcar 2010
C:\nd.28_sera\otto3\alleg\LIII_typ2_rev27oct10_EQscavo_Alleg.DEEP		10/28/2010

Wall uses wall section 0: P168.3x10/40

Wall type: Tangent pile wall

Top wall El: 0 m Bottom wall El: -12 m

Hor. wall spacing: 0.4 Wall thickness = 0.24

Passive width below exc: 0.4 Active width below exc: 0.4

Concrete $f_c' = 25$ Rebar $F_y = 410$ $E_{conc} = 31476$ Concrete tension $F_{cT} = 10\%$ of F_c'

Steel members $f_y = 355$ $E_{steel} = 210000$

Wall friction: Percentage of Soil Friction = 50%

Steel wall capacities are calculated with NTC 2008

Concrete capacities are calculated with ACI 318-2002.

Note: With ultimate capacities you may have to use a structural safety factor.

Tangent pile wall soldier pile properties

Table: Soldier Pile Properties

Name	Section	W	A	D	tw or	bf	tf	k	Ixx	Sxx	rX	Iyy	Syy	rY	rT	Cw	fy
		(kN/m)	(cm ²)	(cm)	(cm)	(cm)	(cm)	(cm)	(cm ⁴)	(cm ³)	(cm)	(cm ⁴)	(cm ³)	(cm)	(cm)	(cm ⁶)	(MPa)
	PM16	257.3	75.62	16.8	1	16.83	1	1	3771	185.9	7.06	3771	185.9	7.06	7.06	1	355

GENERAL WALL DATA

Hor wall spacing=wall horizontal spacing

Passive width below exc=spacing for passive thrust pressure for classic analysis

$f'c=fck$ =cylindrical concrete resistance

$fyk=fyk$ =steel rebar characteristic resistance

Econc=Concrete Elastic modulus

$fctk$ =characteristic Concrete tension

Esteel=steel elastic modulus

TABULAR DATA (principal parameters)

1) Diaphragm wall (rectangular cross section section)

N/A= data not available

$Fy=fyk$

$F'c=fck$

D=wall height

B=wall width

2)Steel sheet pile

DES=shape (Z or U)

W=width per unit of length

A=area

h=height

t=horiz part thickness

b=width of the single sheet pile part

s=inclined part thickness

I_{xx} =strong axis inertia (per unit of length)

S_{xx} =strong axis section modulus (per unit of length)

3)Secant piles wall, Tangent piles wall, soldier piles, soldier piles and timber lagging

W=weight per unit of length

A=area

D=diameter

tw=web thickness

tp= pipe thickness

bf=flange width

tf=flange thickness

k=flange thickness+stem thickness

I_{xx} =strong axis inertia modulus (per unit of length)

S_{xx} =strong axis section modulus (per unit of length)

r_x =radius of gyration about X axis

r_y =radius of gyration about Y axis

I_{yy} =weak axis inertia modulus (per unit of length)

S_{yy} =weak axis section modulus (per unit of length)

r_T =radius of gyration for torsion

Cw=warpage constant

TIEBACK DATA

Name	Fy	Fc'	Dfix	Afix	Efix	Afree	Efree	Pa STR	Pu STR	PresGr	FSgeo	UserGca	Pa	Pu	WireMod
	(MPa)	(MPa)	(cm)	(cm ²)	(MPa)	(cm ²)	(MPa)	(kN)	(kN)	(kPa)			(kN)	(kN)	Yes/No
4-Strands	1862.1	25	15	176.7	31476	2.8	200100	453.4	453.4	N/A	1.4	False	N/A	N/A	Yes
5-Strands	1862.1	25	15	176.7	31476	0	200100	0	0	N/A	1.4	False	N/A	N/A	Yes
6-Strands	1862.1	25	15	176.7	31476	8.39	200100	1357.9	1357.9	N/A	1.4	False	N/A	N/A	Yes
Tieback_	1670	25	16	201.0	31476	4.17	210000	605.2	605.2	N/A	1	False	N/A	N/A	Yes
Tieback_	1670	25	16	201.0	31476	6.95	210000	1008.7	1008.7	N/A	1	False	N/A	N/A	Yes

EXCAVATION STAGES SKETCHES

A sequence of figures for each excavation stage is reported

GENERAL ANALYSIS CRITERIA

Summary of stage assumptions

Name	Analysis	Drive	ka-Mult	Htr	Resist	Res	Contl	Supp	Axial	Used	Min	Toe	Toe
	Method	Press		(%)	Press	Mult	Meth	Mode	Incl	FSwall	FDtoe	FSrot	FSpas
Stage 0	Springs-Up	Ka+ d	N/A	N/A	Kp+ d	N/A		Fixed	N/A	1	0	0	0
Stage 1	Springs-Up	Ka+ d	N/A	N/A	Kp+ d	N/A		Fixed	N/A	1	0	0	0
Stage 2	Springs-Up	FHWA	1.3	m=	Kp+ d	N/A		Fixed	N/A	1	0	0	N/A
Stage 3	Springs-Up	FHWA	1.3	m=	Kp+ d	N/A		Fixed	N/A	1	0	0	N/A
Stage 4	Springs-Up	FHWA	1.3	m=	Kp+ d	N/A		Fixed	N/A	1	0	0	0
Stage 5	Springs-Up	FHWA	1.3	m=	Kp+ d	N/A		Fixed	N/A	1	0	0	0

Name=excavation phase name

Analysis method

springs=elasto plastic springs are used

DR=Drained condition for CLAY model

U=Undrained condition for CLAY model for all the soils

Up=Undrained condition just for selected soil

Drive press=Ka

ka mult=multiply factor for Ka

Htr T/B (%)=trapezoidal pressure scheme

Resit press=Kp

Res Mult=Multiply factor for Kp

COntle Method=cantilver method

Support Model=Fix support type

Axial Incl=Axial action is included for design

Used FS wall=Reduction factor for axial+bending resistance dominium

Min FD TOe=embedded minimum safety factor (for classic analysis)

Toe FS rot=rotation safety factor (classic for classic analysis)

Toe FSpas=driving/resistent pressure safety factor (for classic analysis)

SEISMIC DATA

Seismic action is modeled through a pseudo static approach

Summary of stage assumptions

Stage	Seismic g	Method	aX	aY	Beta	Building Code
Number	Used	Used	(g)	(g)		(Name)
0	No		0.03	0	1	N/A
1	No		0.03	0	1	N/A
2	No		0.03	0	1	N/A
3	No		0.03	0	1	N/A
4	No		0.03	0	1	N/A
5	No		0.03	0	1	N/A

N/A= data non available

Stage number=number of stage input

Seismic ag =value of design acceleration according to a code or input by the user

Method=the method used to evaluated the seismic thrustover the wall

ahd or khd otr axd=design horizontal acceleration

avd or kvd or ayd=design vertical acceleration

Beta=multip coeff for the semirigd approach

Buildind code=code used for design acceleration calculation

SUPPORTS PROPERTIES

Support 0: type = tieback

X = 0.24 m, Z = -1.25 m, S = 2.4 m

Lfree = 7 m, Lfix = 10 m, Rfix = 50 %

Walls: P168.3x10/40

Stage No	Active	Prestress	Slab live load	User add. strain
	Yes/No	(kN)	(kPa)	+expansion

0	No	-	-	-
1	No	-	-	-
2	Yes	240	-	-
3	Yes	-	-	-
4	Yes	-	-	-
5	Yes	-	-	-

Support 1: type = tieback

X = 0.24 m, Z = -3.75 m, S = 2.4 m

Lfree = 6 m, Lfix = 13 m, Rfix = 50 %

Walls: P168.3x10/40

Stage No	Active	Prestress	Slab live load	User add. strain
	Yes/No	(kN)	(kPa)	+expansion
0	No	-	-	-
1	No	-	-	-
2	No	-	-	-
3	No	-	-	-
4	Yes	340	-	-
5	Yes	-	-	-
6	Yes	-	-	-

Support type

LEGENDA for TIEBACKS

General data

Z=support level

S=horizontal distance between each tieback

Lfree=free length

Lfix=rigid body length

Rfix=% effective part of the rigid body length

Stage No=excavation steps number

Active=tieback status (YES=active)

Post stress= tieback preload (Load considering the horiz distance bewteen the tiebacks)

SURFACE LOADS

Surcharge 0: X1 = -17.9427272727273, X2 = 0

Variable surcharge

Stage No	Active	X1	Z1	qX1	qZ1	X2	Z2	qX2	qZ2
	Yes/No	(m)	(m)	(kPa)	(kPa)	(m)	(m)	(kPa)	(kPa)
0	No	-	0	0	20	0	0	0	20
1	Yes	-	0	0	20	0	0	0	20
2	Yes	-	0	0	20	0	0	0	20
3	Yes	-	0	0	20	0	0	0	20
4	Yes	-	0	0	20	0	0	0	20
5	Yes	-	0	0	20	0	0	0	20

LEGENDA

Stage No=Excavation step number

Active=load status (Yes=active)

X1=first X coordinate position of the load

Z1=first Z coordinate position of the load

qX1=first horizontal point load value

qZ1=first vertical point load value

X2=second X coordinate position of the load

Z2=second Z coordinate position of the load

qX2=second horizontal point load value

qZ2=second vertical point load value

WALL RESULTS TABLE**LEGENDA**

Wall node=number of the node

EL=elevation

Sht L=Total horizontal soil pressure (on the left side of the wall)

Sht R=Total horizontal soil pressure (on the right side of the wall)

Shs L=Effective horizontal soil pressure (on the left side of the wall)

Shs R=Effective horizontal soil pressure (on the right side of the wall)

q=pressure given by the surcharge

U L=Water pressure (on the left side of the wall)

U R=pressione acqua (on the right side of the wall)

M=bending moment (per meter)

V=shear (per metro)

dx=wall deflection

McapL=Ultimate bending moment (on the left side of the wall)

McapR=Ultimate bending moment (on the right side of the wall)

VcapL=Ultimate resistance shear (on the left side of the wall)

VcapR=Ultimate resistance shear (on the right side of the wall)

SUPPORTS REACTIONS (TIEBACKS, STRUTS, SLABS, RAKERS)

Support 0

Stage No	R
	(kN)
0	0
1	0
2	240
3	253.512
4	245.448
5	242.76

Support 1

Stage No	R
	(kN)
0	0
1	0
2	0
3	0
4	340.08
5	376.56
6	0

Project: My Project

Results for Design Section 3: DM08_ITA: EQK - Seismic

DESIGN APPROACHES AND COMBINATION FACTORS

The Design Approaches (from Codes or Customized by the user) and related safety factors are the following:

Ftan fr=mult factor for friction angle

F C'=mult factor for effective cohesion

F Su'=mult factof for undrained cohesion

F EQ=mult factor for seismic action

F perm load=mult factor for perm loads

F temp load=mult factor for live loads

F perm supp=reduct factor for resistance for pull out checking

F temp supp=fattore di riduzione resistance per verifica pull out tirante

F earth Dstab=mult factor for active press coeff , unfavorable

F earth stab=mult factor for passive pressure , favorable

F GWT Dstab (ground water)=mult factor for hydrostatic pressure , unfavorable

F GWT stab (ground water)=mult factor for hydrostatic pressure, favorable

F HYD Dstab=mult factor for hydrodynamic pressure, unfavorable

F HYD stab=mult factor for hydrodynamic pressure, favorable

F UPL Dstab=mult factor for hydraulic heave, unfavorable

Stage	Design Name	Design Case	F(tan fr)	F (c')	F (Su)	F (EQ)	F(perm load)	F(temp load)	F(perm sup)	F(temp sup)	F Earth (Dstab)	F Earth (stab)	F GWT (Dstab)	F GWT (stab)	F HYD (Dstab)	F HYD (stab)	F UPL (Dstab)	F UPL (stab)
0	DM08_ITA	EQK - Seismic	1.25	1.25	1.4	1	1	1	1.2	1.1	1	1	1	1	1.35	0.9	1	1
1	DM08_ITA	EQK - Seismic	1.25	1.25	1.4	1	1	1	1.2	1.1	1	1	1	1	1.35	0.9	1	1
2	DM08_ITA	EQK - Seismic	1.25	1.25	1.4	1	1	1	1.2	1.1	1	1	1	1	1.35	0.9	1	1
3	DM08_ITA	EQK - Seismic	1.25	1.25	1.4	1	1	1	1.2	1.1	1	1	1	1	1.35	0.9	1	1
4	DM08_ITA	EQK - Seismic	1.25	1.25	1.4	1	1	1	1.2	1.1	1	1	1	1	1.35	0.9	1	1
5	DM08_ITA	EQK - Seismic	1.25	1.25	1.4	1	1	1	1.2	1.1	1	1	1	1	1.35	0.9	1	1
6	DM08_ITA	EQK - Seismic	1.25	1.25	1.4	1	1	1	1.2	1.1	1	1	1	1	1.35	0.9	1	1

SOIL DATA

Name	g tot	g dry	Frict	C'	Su	FRp	FRcv	Eload	Eur	kAp	kPp	kAcv	kPcv	Vary	Spring	Color
------	-------	-------	-------	----	----	-----	------	-------	-----	-----	-----	------	------	------	--------	-------

	(kN/m3)	(kN/m3)	(deg)	(kPa)	(kPa)	(deg)	(deg)	(kPa)	(kPa)	Springs	Springs	Springs	Springs		Model	
F	20	19	30	0	N/A	N/A	N/A	15000	45000	0.33	3	N/A	N/A	True	Linear	
O1	16.5	14	22	2	20	22	22	2874	8622	0.46	2.2	0.46	2.2	True	Linear	
O2	19	16.5	28	2	N/A	N/A	N/A	7185	21555	0.36	2.77	N/A	N/A	True	Linear	
S1	21	19	34	0	N/A	N/A	N/A	25000	75000	0.28	3.54	N/A	N/A	True	Linear	
Clay	20	19	28	0	150	28	28	20000	60000	0.36	2.77	0.36	2.77	True	Linear	
GT	22	20	36	10	N/A	N/A	N/A	30000	90000	0.26	3.85	N/A	N/A	True	Linear	
Rock	27	25	30	100	N/A	N/A	N/A	479000	143700	0.33	3	N/A	N/A	True	Linear	
Rileva	18	18	32	0	N/A	N/A	N/A	30000	30000	0.31	3.26	N/A	N/A	True	Linear	
Base	18	18	25	0	N/A	N/A	N/A	25000	25000	0.41	2.46	N/A	N/A	True	Linear	

gtot=total soil specific weight

gdry=dry weight of the soil

Frict=friction angle

C'=effective cohesion

Su = Undrained cohesion (only for CLAY soils in undrained conditions)

Dilat=Soil Dilatancy (only for non linear analysis)

Evc=Virgin compression elastic module

Eur=unloading/reloading elastic module

Kap= Peak active thrust coeff

Kpp= Peak passive thrust coeff

Kacv= Constant volume active thrust coeff

Kpcv= Constant volume passive thrust coeff

Spring models= spring model (LIN=constant over the soil layer height , EXP=exponential ,

SIMC=simplified winkler)

LIN= Linear-Elastic-Perfectly Plastic,

EXP: Exponential, SUB: Modulus of Subgrade Reaction

SOIL BORINGS

Top Elev= superior SOil level

Soil type=type of the soil (sand , clay , etc)

OCR=overconsolidation ratio

K0=at rest coefficient

Name: Boring 1, pos: (-20, 0)

Top elev.	Soil type	OCR	Ko
0	Rilevato	1	0.47
-6	Base	1	0.58

STRUCTURAL MATERIALS DATA

Steel

Name	Strength Fy (MPa)	Fu (MPa)	Elastic E (MPa)	Density g (kN/m3)
Fe360	235	360	210000	77
Fe510	355	510	210000	77
A36	248.3	400	206000	77
A50	355	500	206000	77
New steel 4	241.4	413.8	206000	77

Concrete

Name	Strength Fc' (MPa)	Elastic E (MPa)	Density g (kN/m3)	Tension Strength (MPa)
C20/25	20	29962	25	10
C25/30	25	31476	25	10
Fc 3ksi	20.7	21541.8	23.573	10

Steel rebar

Name	Strength Fy (MPa)	Elastic E (MPa)

S1860 (Strands)	1670	210000
Grade 75	517.2	200100
Grade 80	551.7	200100
Grade 150	1034.5	200100
Strands 270 ksi	1862.1	200100
S410	410	210000
S500	500	210000
B450C	450	210000

Wood

Name	Ultimate Bending (MPa)	Ultimate Tensile Strength (MPa)	Ultimate Shear Strength (MPa)	Density g (kN/m ³)	Elastic E (MPa)
Construction	11	9.7	5.5	7.8576	6900
Regular grade	6.9	6.9	4.1	7.8576	5520

STEEL

Name=material name

$f_y=f_{yk}$ =characteristic resistance for steel (for all the codes)

$F_u=f_{uk}$ =ultimate resistance for steel (for all the codes)

Elastic E=Elastic modulus

Density g=specific weight

CONCRETE

Name=material name

$f'_c=f_{ck}$ =cylindrical resistance for concrete (for all the codes)

Elastic E=Elastic modulus

Density g=specific weight

Tension strength= $f_t=f_{ctk}$ =characteristic tension resistance for concrete

STEEL REBARS

Name=material name

$f_y=f_{yk}$ =characteristic resistance for steel (for all the codes)

$F_u=f_{uk}$ =ultimate resistance for steel (for all the codes)

Elastic E=Elastic modulus

Density g=specific weight

WOOD

Name=material name

$F_b=f_{bk}$ =Ultimate bending strength

$F_t=f_{tk}$ =Ultimate tensile strength

$F_v=f_{vk}$ =Ultimate shear strength

Density g=specific weight

Elastic E=Elastic modulus

WALL DATA

Wall section 0: P168.3x10/40

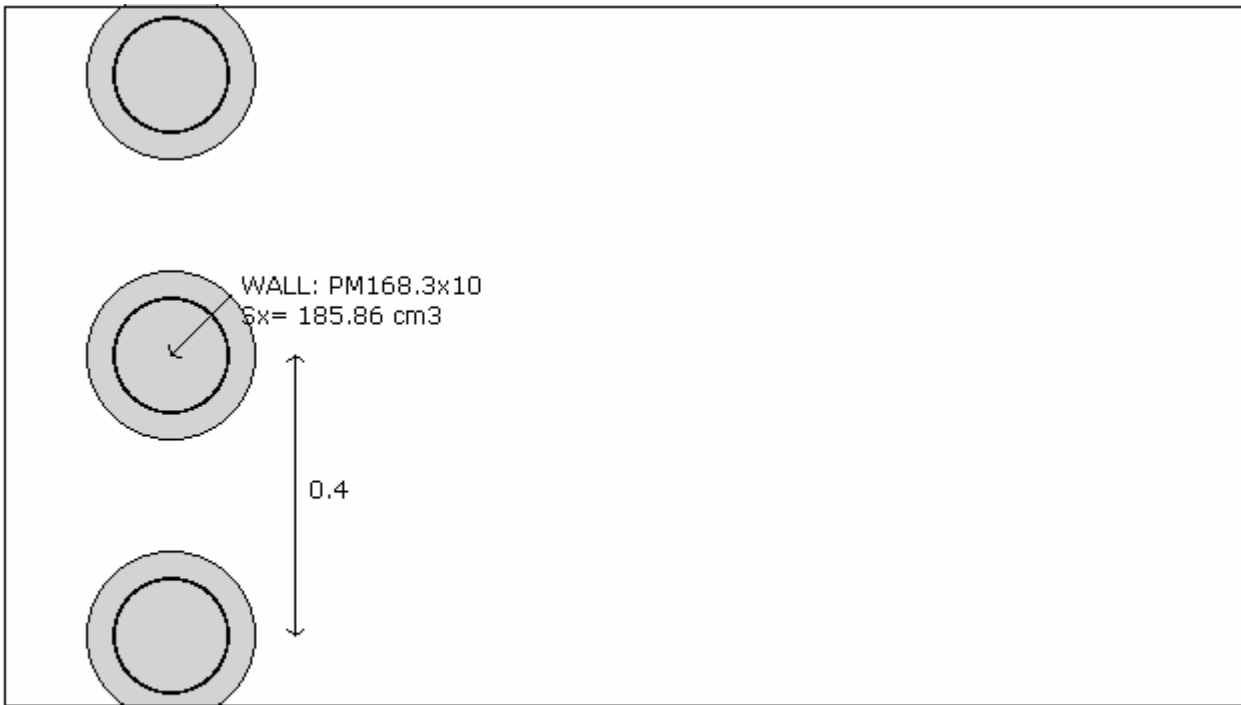

Company: My Company Engineer: Engineer	Wall sketch	CeAS srl and Deep Excavation LCC Paratie Plus 2010 - DeepXcar 2010
C:\nd.28_sera\otto3\alleg\LIII_typ2_rev27oct10_EQscavo_Alleg.DEEP		10/28/2010

Wall uses wall section 0: P168.3x10/40
 Wall type: Tangent pile wall
 Top wall El: 0 m Bottom wall El: -12 m
 Hor. wall spacing: 0.4 Wall thickness = 0.24
 Passive width below exc: 0.4 Active width below exc: 0.4
 Concrete $f_c' = 25$ Rebar $F_y = 410$ $E_{conc} = 31476$ Concrete tension $F_{cT} = 10\%$ of F_c'
 Steel members $f_y = 355$ $E_{steel} = 210000$
 Wall friction: Percentage of Soil Friction = 50%
 Steel wall capacities are calculated with NTC 2008
 Concrete capacities are calculated with ACI 318-2002.
 Note: With ultimate capacities you may have to use a structural safety factor.
 Tangent pile wall soldier pile properties

Table: Soldier Pile Properties

Name	Section	W	A	D	tw or	bf	tf	k	Ixx	Sxx	rX	Iyy	Syy	rY	rT	Cw	fy
		(kN/m)	(cm ²)	(cm)	(cm)	(cm)	(cm)	(cm)	(cm ⁴)	(cm ³)	(cm)	(cm ⁴)	(cm ³)	(cm)	(cm)	(cm ⁶)	(MPa)
	PM16	257.3	75.62	16.8	1	16.83	1	1	3771	185.9	7.06	3771	185.9	7.06	7.06	1	355

GENERAL WALL DATA

Hor wall spacing=wall horizontal spacing

Passive width below exc=spacing for passive thrust pressure for classic analysis

$f'c=fck$ =cylindrical concrete resistance

$fyk=fyk$ =steel rebar characteristic resistance

E_{conc} =Concrete Elastic modulus

f_{ctk} =characteristic Concrete tension

E_{steel} =steel elastic modulus

TABULAR DATA (principal parameters)

1) Diaphragm wall (rectangular cross section section)

N/A= data not available

$Fy=fyk$

$F'c=fck$

D=wall height

B=wall width

2)Steel sheet pile

DES=shape (Z or U)

W=width per unit of length

A=area

h=height

t=horiz part thickness

b=width of the single sheet pile part

s=inclined part thickness

I_{xx} =strong axis inertia (per unit of length)

S_{xx} =strong axis section modulus (per unit of length)

3)Secant piles wall, Tangent piles wall, soldier piles, soldier piles and timber lagging

W=weight per unit of length

A=area

D=diameter

tw=web thickness

tp= pipe thickness

bf=flange width

tf=flange thickness

k=flange thickness+stem thickness

I_{xx} =strong axis inertia modulus (per unit of length)

S_{xx} =strong axis section modulus (per unit of length)

r_x =radius of gyration about X axis

r_y =radius of gyration about Y axis

I_{yy} =weak axis inertia modulus (per unit of length)

S_{yy} =weak axis section modulus (per unit of length)

r_T =radius of gyration for torsion

C_w =warping constant

TIEBACK DATA

Name	Fy	Fc'	Dfix	Afix	Efix	Afree	Efree	Pa STR	Pu STR	PresGr	FSgeo	UserGca	Pa	Pu	WireMod
	(MPa)	(MPa)	(cm)	(cm ²)	(MPa)	(cm ²)	(MPa)	(kN)	(kN)	(kPa)			(kN)	(kN)	Yes/No
4-Strands	1862.1	25	15	176.7	31476	2.8	200100	453.4	453.4	N/A	1.4	False	N/A	N/A	Yes
5-Strands	1862.1	25	15	176.7	31476	0	200100	0	0	N/A	1.4	False	N/A	N/A	Yes
6-Strands	1862.1	25	15	176.7	31476	8.39	200100	1357.9	1357.9	N/A	1.4	False	N/A	N/A	Yes
Tieback_	1670	25	16	201.0	31476	4.17	210000	605.2	605.2	N/A	1	False	N/A	N/A	Yes
Tieback_	1670	25	16	201.0	31476	6.95	210000	1008.7	1008.7	N/A	1	False	N/A	N/A	Yes

EXCAVATION STAGES SKETCHES

A sequence of figures for each excavation stage is reported

GENERAL ANALYSIS CRITERIA

Summary of stage assumptions

Name	Analysis	Drive	ka-Mult	Htr	Resist	Res	Contl	Supp	Axial	Used	Min	Toe	Toe
	Method	Press		(%)	Press	Mult	Meth	Mode	Incl	FSwall	FDtoe	FSrot	FSpas
Stage 0	Springs-Up	Ka+ d	N/A	N/A	Kp+ d	N/A		Fixed	N/A	1	0	0	0
Stage 1	Springs-Up	Ka+ d	N/A	N/A	Kp+ d	N/A		Fixed	N/A	1	0	0	0
Stage 2	Springs-Up	FHWA	1.3	m=	Kp+ d	N/A		Fixed	N/A	1	0	0	N/A
Stage 3	Springs-Up	FHWA	1.3	m=	Kp+ d	N/A		Fixed	N/A	1	0	0	N/A
Stage 4	Springs-Up	FHWA	1.3	m=	Kp+ d	N/A		Fixed	N/A	1	0	0	0
Stage 5	Springs-Up	FHWA	1.3	m=	Kp+ d	N/A		Fixed	N/A	1	0	0	0
Stage 6	Springs-Up	FHWA	1.3	m=	Kp+ d	N/A		Fixed	N/A	1	0	0	0

Name=excavation phase name

Analysis method

springs=elasto plastic springs are used

DR=Drained condition for CLAY model

U=Undrained condition for CLAY model for all the soils

Up=Undrained condition just for selected soil

Drive press=Ka

ka mult=multiply factor for Ka

Htr T/B (%)=trapezioidal pressure scheme

Resit press=Kp

Res Mult=Multiply factor for Kp

COntle Method=cantilver method

Support Model=Fix support type

Axial Incl=Axial action is included for design

Used FS wall=Reduction factor for axial+bending resistance dominium

Min FD TOe=embedded minimum safety factor (for classic analysis)

Toe FS rot=rotation safety factor (classic for classic analysis)

Toe FSpas=driving/resistent pressure safety factor (for classic analysis)

SEISMIC DATA

Seismic action is modeled through a pseudo static approach

Summary of stage assumptions

Stage	Seismic g	Method	aX	aY	Beta	Building Code
Number	Used	Used	(g)	(g)		(Name)
0	No		0.03	0	1	N/A
1	No		0.03	0	1	N/A
2	No		0.03	0	1	N/A
3	No		0.03	0	1	N/A
4	No		0.03	0	1	N/A
5	No		0.03	0	1	N/A
6	Yes		0.03	0	1	N/A

N/A= data non available

Stage number=number of stage input

Seismic ag =value of design acceleration according to a code or input by the user

Method=the method used to evaluated the seismic thrustover the wall

ahd or khd otr axd=design horizontal acceleration

avd or kvd or ayd=design vertical acceleration

Beta=multip coeff for the semirigd approach

Buildind code=code used for design acceleration calculation

SUPPORTS PROPERTIES

Support 0: type = tieback

X = 0.24 m, Z = -1.25 m, S = 2.4 m

Lfree = 7 m, Lfix = 10 m, Rfix = 50 %

Walls: P168.3x10/40

Stage No	Active	Prestress	Slab live load	User add. strain
	Yes/No	(kN)	(kPa)	+expansion
0	No	-	-	-
1	No	-	-	-
2	Yes	240	-	-
3	Yes	-	-	-
4	Yes	-	-	-
5	Yes	-	-	-
6	Yes	-	-	-

Support 1: type = tieback

X = 0.24 m, Z = -3.75 m, S = 2.4 m

Lfree = 6 m, Lfix = 13 m, Rfix = 50 %

Walls: P168.3x10/40

Stage No	Active	Prestress	Slab live load	User add. strain
	Yes/No	(kN)	(kPa)	+expansion
0	No	-	-	-
1	No	-	-	-
2	No	-	-	-
3	No	-	-	-
4	Yes	340	-	-
5	Yes	-	-	-
6	Yes	-	-	-

Support type

LEGENDA for TIEBACKS

General data

Z=support level

S=horizontal distance between each tieback

Lfree=free length

Lfix=rigid body length

Rfix=% effective part of the rigid body length

Stage No=excavation steps number

Active=tieback status (YES=active)

Post stress= tieback preload (Load considering the horiz distance bewteen the tiebacks)

SURFACE LOADS

Surcharge 0: X1 = -17.9427272727273, X2 = 0

Variable surcharge

Stage No	Active	X1	Z1	qX1	qZ1	X2	Z2	qX2	qZ2
	Yes/No	(m)	(m)	(kPa)	(kPa)	(m)	(m)	(kPa)	(kPa)
0	No	-	0	0	20	0	0	0	20
1	Yes	-	0	0	20	0	0	0	20
2	Yes	-	0	0	20	0	0	0	20
3	Yes	-	0	0	20	0	0	0	20
4	Yes	-	0	0	20	0	0	0	20
5	Yes	-	0	0	20	0	0	0	20
6	No	-	0	0	20	0	0	0	20
7	Yes	-	0	0	20	0	0	0	20

LEGENDA

Stage No=Excavation step number

Active=load status (Yes=active)

X1=first X coordinate position of the load

Z1=first Z coordinate position of the load

qX1=first horizontal point load value

qZ1=first vertical point load value

X2=second X coordinate position of the load

Z2=second Z coordinate position of the load

qX2=second horizontal point load value

qZ2=second vertical point load value

WALL RESULTS TABLE**LEGENDA**

Wall node=number of the node

EL=elevation

Sht L=Total horizontal soil pressure (on the left side of the wall)

Sht R=Total horizontal soil pressure (on the right side of the wall)

Shs L=Effective horizontal soil pressure (on the left side of the wall)

Shs R=Effective horizontal soil pressure (on the right side of the wall)

q=pressure given by the surcharge

U L=Water pressure (on the left side of the wall)

U R=pressione acqua (on the right side of the wall)

M=bending moment (per meter)

V=shear (per metro)

dx=wall deflection

McapL=Ultimate bending moment (on the left side of the wall)

McapR=Ultimate bending moment (on the right side of the wall)

VcapL=Ultimate resistance shear (on the left side of the wall)

VcapR=Ultimate resistance shear (on the right side of the wall)

SUPPORTS REACTIONS (TIEBACKS, STRUTS, SLABS, RAKERS)**Support 0**

Stage No	R
	(kN)
0	0
1	0
2	240
3	251.472
4	243.384
5	241.08
6	221.95

Support 1

Stage No	R
	(kN)
0	0
1	0
2	0
3	0
4	340.08
5	371.304
6	375.456

DeepXcav 2010: Report Output

Copyright©2009 - 2010 Deep Excavation LLC: www.deepexcavation.com
A program for the evaluation of deep excavations

Project: My Project

Company: My Company
Prepared by engineer: Engineer
File number: 1
Time: 10/28/2010 9:09:50 PM

THIS PROGRAM IS PROTECTED BY U.S. COPYRIGHT LAWS AS DESCRIBED IN THE EULA. UNAUTHORIZED COPYING IS PROHIBITED. LICENSED TO: Deep Excavation LLC BY DEEP EXCAVATION LLC UNDER SPECIFIC LICENCE. This report has printed because the user has accepted responsibility as described in the disclaimer and EULA
File: C:\nda\paratie\10.10.28_sera\Lotto3\alleg\LIH_typ3_rev27oct10_EQscavo_Alleg.DEEP

DeepXcav 2010: Report Output

Copyright©2009 - 2010 Deep Excavation LLC: www.deepexcavation.com
A program for the evaluation of deep excavations

Project: My Project

Company: My Company
Prepared by engineer: Engineer
File number: 1
Time: 10/28/2010 9:09:50 PM

THIS PROGRAM IS PROTECTED BY U.S. COPYRIGHT LAWS AS DESCRIBED IN THE EULA. UNAUTHORIZED COPYING IS PROHIBITED. LICENSED TO: Deep Excavation LLC BY DEEP EXCAVATION LLC UNDER SPECIFIC LICENCE. This report has printed because the user has accepted responsibility as described in the disclaimer and EULA
File: C:\nda\paratie\10.10.28_sera\Lotto3\alleg\LIII_typ3_rev27oct10_EQscavo_Alleg.DEEP

OBJECTIVES

The objective of this document is to report the most important results of the calculations

BIBLIOGRAPHIC REFERENCES

BECCI,B.,NOVA,R. (1987) "Un metodo di calcolo automatico per il progetto di paratie", Rivista Italiana di

GENERAL CALCULATION ASSUMPTIONS

DEEP EXC is a program to simulate the behavior of flexible diaphragms. It is possible to simulate all the different stages of excavation.

The program is able to perform both classic and non linear analysis.

For the non linear analysis a FEM model is used. The FEM model follows the well known beam on elasto plastic foundation approach. The wall is modeled using BEAM elements, the soil is simulated using a double system (for each part of the wall) of elasto plastic springs,

An elasto plastic spring is connected on each node of the beam elements.

The excavation procedure is performed through 2 types of analysis:

- 1) Classic analysis
- 2) Non linear analysis : every step represents an excavation phase with a defined configuration of excavations, loads, etc.

The non linear analysis has been performed using a full Newton Raphson approach.

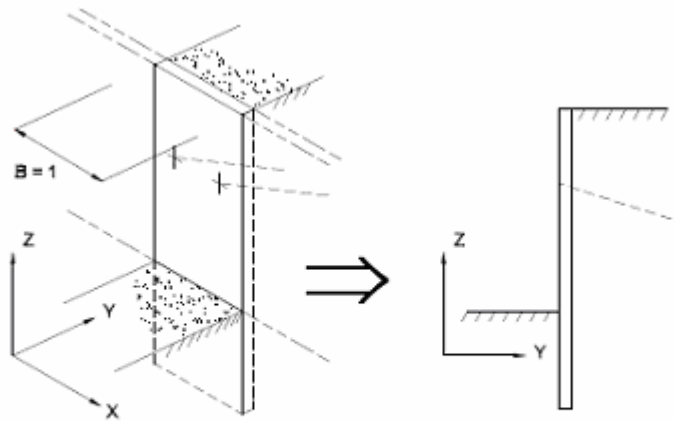

CONVENTIONS AND REFERENCE COORDINATE SYSTEMS

Loads, anelastic displacements, support reactions and displacements, are all referred to a righthand coordinate system

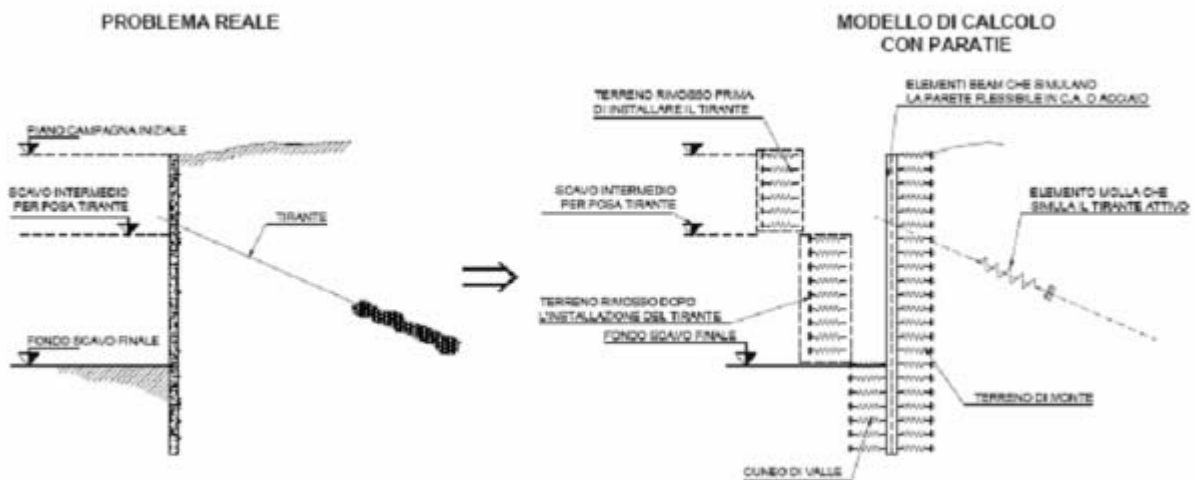

ELEMENTO TRUSS

1. FORCE : FORZA NELL'ELEMENTO PER UNITÀ DI PROFONDITÀ
2. STRESS : SPORZO

ELEMENTO BEAM (vedi figura 11-1)

1. VA : TAGLIO AL PRIMO ESTREMO
2. VB : TAGLIO AL SECONDO ESTREMO
3. MA : MOMENTO AL PRIMO ESTREMO
4. MB : MOMENTO AL SECONDO ESTREMO
(tutti per unità di profondità)

ELEMENTO ELPL (MOLLA ELASTOPLASTICA)

1. FORCE : FORZA NELL'ELEMENTO PER UNITÀ DI PROFONDITÀ
2. PLASTIC : DEFORMAZIONE PLASTICA

ELEMENTO WIRE (TIRANTE)

1. FORCE : FORZA NELL'ELEMENTO PER UNITÀ DI PROFONDITÀ

ELEMENTO CELAS (MOLLA ELASTICA)

1. FORCE : FORZA NELL'ELEMENTO PER UNITÀ DI PROFONDITÀ
2. MOMENT : MOMENTO NELL'ELEMENTO PER UNITÀ DI PROFONDITÀ

ELEMENTO SLAB (SOLETTA FRA DUE PARETI)

1. VA : TAGLIO AL PRIMO ESTREMO
2. VB : TAGLIO AL SECONDO ESTREMO
3. MA : MOMENTO AL PRIMO ESTREMO
4. MB : MOMENTO AL SECONDO ESTREMO
5. AXIAL : AZIONE ASSIALE
(tutti per unità di profondità)



Figura 11-1: convenzioni di segno per l'elemento BEAM

Checking of cross sections is performed according to the coordinate systems showed in the next figure

- X axis follow the 2 nodes direction of the beam elements , positive going from the first to the secondo node

ELEMENTO TRUSS

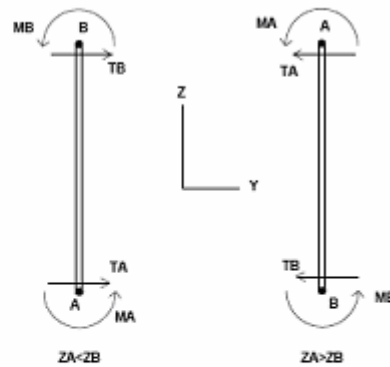
1. FORCE : FORZA NELL'ELEMENTO PER UNITÀ DI PROFONDITÀ
2. STRESS : SPORZO

ELEMENTO BEAM (vedi figura 11-1)

1. VA : TAGLIO AL PRIMO ESTREMO
2. VB : TAGLIO AL SECONDO ESTREMO
3. MA : MOMENTO AL PRIMO ESTREMO
4. MB : MOMENTO AL SECONDO ESTREMO
(tutti per unità di profondità)

ELEMENTO ELPL (MOLLA ELASTOPLASTICA)

1. FORCE : FORZA NELL'ELEMENTO PER UNITÀ DI PROFONDITÀ
2. PLASTIC : DEFORMAZIONE PLASTICA

ELEMENTO WIRE (TIRANTE)

1. FORCE : FORZA NELL'ELEMENTO PER UNITÀ DI PROFONDITÀ

ELEMENTO CELAS (MOLLA ELASTICA)

1. FORCE : FORZA NELL'ELEMENTO PER UNITÀ DI PROFONDITÀ
2. MOMENT : MOMENTO NELL'ELEMENTO PER UNITÀ DI PROFONDITÀ

ELEMENTO SLAB (SOLETTA FRA DUE PARETI)

1. VA : TAGLIO AL PRIMO ESTREMO
2. VB : TAGLIO AL SECONDO ESTREMO
3. MA : MOMENTO AL PRIMO ESTREMO
4. MB : MOMENTO AL SECONDO ESTREMO
5. AXIAL : AZIONE ASSIALE
(tutti per unità di profondità)



Figura 11-1: convenzioni di segno per l'elemento BEAM

DESIGN CODES

Reference codes are:

- DM 2008 - "Norme tecniche per le costruzioni"
- CSLP, "Istruzioni per l'applicazione delle Norme tecniche per le costruzioni di cui al DM 14/1/2008"
- EC2 1-1 :2004, Eurocode 2 - Design of concrete structures
- Ec3 1-1:2005, Eurocodice 3 - Design of steel structures
- Ec3 5:2002, Eurocodice 3 - Design of steel sheet piles walls
- Ec8:2004 - Seismic design of structures
- AISC ASD 9th Edition, 1989
- AISC LRFD 2nd Edition, 2003
- ACI 318-2002
- AASHTO 2000 ADS / LRFD

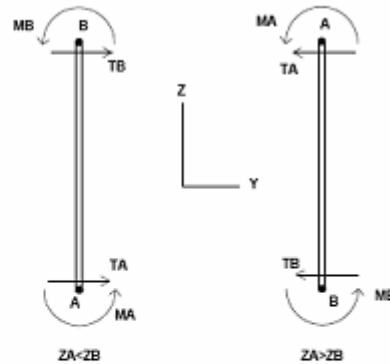
DESIGN PARAMETERS

Project: My Project

Results for Design Section 0: Base Section - Service

DESIGN APPROACHES AND COMBINATION FACTORS

The Design Approaches (from Codes or Customized by the user) and related safety factors are the following:

Ftan fr=mult factor for friction angle

F C'=mult factor for effective cohesion

F Su'=mult factof for undrained cohesion

F EQ=mult factor for seismic action

F perm load=mult factor for perm loads

F temp load=mult factor for live loads

F perm supp=reduct factor for resistance for pull out checking

F temp supp=fattore di riduzione resistance per verifica pull out tirante

F earth Dstab=mult factor for active press coeff , unfavorable

F earth stab=mult factor for passive pressure , favorable

F GWT Dstab (ground water)=mult factor for hydrostatic pressure , unfavorable

F GWT stab (ground water)=mult factor for hydrostatic pressure, favorable

F HYD Dstab=mult factor for hydrodynamic pressure, unfavorable

F HYD stab=mult factor for hydrodynamic pressure, favorable

F UPL Dstab=mult factor for hydraulic heave, unfavorable

Stage	Design Name	Design Case	F(tan fr)	F (c')	F (Su)	F (EQ)	F(perm load)	F(temp load)	F(perm sup)	F(temp sup)	F Earth (Dstab)	F Earth (stab)	F GWT (Dstab)	F GWT (stab)	F HYD (Dstab)	F HYD (stab)	F UPL (Dstab)	F UPL (stab)
0	Default	Service	1	1	1	1	1	1	1	1	1	1	1	1	1	1	1	1
1	Default	Service	1	1	1	1	1	1	1	1	1	1	1	1	1	1	1	1
2	Default	Service	1	1	1	1	1	1	1	1	1	1	1	1	1	1	1	1
3	Default	Service	1	1	1	1	1	1	1	1	1	1	1	1	1	1	1	1
4	Default	Service	1	1	1	1	1	1	1	1	1	1	1	1	1	1	1	1
5	Default	Service	1	1	1	1	1	1	1	1	1	1	1	1	1	1	1	1
6	Default	Service	1	1	1	1	1	1	1	1	1	1	1	1	1	1	1	1
7	Default	Service	1	1	1	1	1	1	1	1	1	1	1	1	1	1	1	1

SOIL DATA

Name	g tot (kN/m3)	g dry (kN/m3)	Frict (deg)	C' (kPa)	Su (kPa)	FRp (deg)	FRcv (deg)	Eload (kPa)	Eur (kPa)	kAp Springs	kPp Springs	kAcv Springs	kPcv Springs	Vary	Spring Model	Color
F	20	19	30	0	N/A	N/A	N/A	15000	45000	0.33	3	N/A	N/A	True	Linear	
O1	16.5	14	22	2	20	22	22	2874	8622	0.46	2.2	0.46	2.2	True	Linear	
O2	19	16.5	28	2	N/A	N/A	N/A	7185	21555	0.36	2.77	N/A	N/A	True	Linear	
S1	21	19	34	0	N/A	N/A	N/A	25000	75000	0.28	3.54	N/A	N/A	True	Linear	
Clay	20	19	28	0	150	28	28	20000	60000	0.36	2.77	0.36	2.77	True	Linear	
GT	22	20	36	10	N/A	N/A	N/A	30000	90000	0.26	3.85	N/A	N/A	True	Linear	
Rock	27	25	30	100	N/A	N/A	N/A	479000	143700	0.33	3	N/A	N/A	True	Linear	
Rileva	18	18	32	0	N/A	N/A	N/A	30000	30000	0.31	3.26	N/A	N/A	True	Linear	
Base	18	18	25	0	N/A	N/A	N/A	25000	25000	0.41	2.46	N/A	N/A	True	Linear	

gtot=total soil specific weight

gdry=dry weight of the soil

Frict=friction angle

C'=effective cohesion

Su = Undrained cohesiona (only for CLAY soils in undrained conditions)

Dilat=SOil Dilatancy (only for non linear analysis)

Evc=Virgin compression elastic module

Eur=unloading/reloading elastic module

Kap= Peak active thrust coeff

Kpp= Peak passive thrust coeff

Kacv= Constant volume active thrust coeff

Kpcv= Constant volume passive thrust coeff

Spring models= spring model (LIN=constant over the soil layer heigth , EXP=exponential ,

SIMC=simplified winkler)

LIN= Linear-Elastic-Perfectly Plastic,

EXP: Exponential, SUB: Modulus of Subgrade Reaction

SOIL BORINGS

Top Elev= superior Soil level

Soil type=type of the soil (sand , clay , etc)

OCR=overconsolidation ratio

K0=at rest coefficient

Name: Boring 1, pos: (-20, 0)

Top elev.	Soil type	OCR	Ko
0	Rilevato	1	0.47
-7.5	Base	1	0.58

STRUCTURAL MATERIALS DATA

Steel

Name	Strength Fy (MPa)	Fu (MPa)	Elastic E (MPa)	Density g (kN/m3)
Fe360	235	360	206000	77
Fe510	355	510	206000	77
A36	248.3	400	206000	77
A50	355	500	206000	77
New steel 4	241.4	413.8	206000	77

Concrete

Name	Strength Fc' (MPa)	Elastic E (MPa)	Density g (kN/m3)	Tension Strength (MPa)
C20/25	20	29962	25	10
C25/30	25	31476	25	10
Fc 3ksi	20.7	21541.8	23.573	10

Steel rebar

Name	Strength Fy (MPa)	Elastic E (MPa)
S1860 (Strands)	1670	210000
Grade 75	517.2	200100
Grade 80	551.7	200100
Grade 150	1034.5	200100
Strands 270 ksi	1862.1	200100
S410	410	210000
S500	500	210000
B450C	450	210000

Wood

Name	Ultimate Bending (MPa)	Ultimate Tensile Strength (MPa)	Ultimate Shear Strength (MPa)	Density g (kN/m3)	Elastic E (MPa)
Construction	11	9.7	5.5	7.8576	6900
Regular grade	6.9	6.9	4.1	7.8576	5520

STEEL

Name=material name
 fy=fyk=characteristic resistance for steel (for all the codes)
 Fu=fuk=ultimate resistance for steel (for all the codes)
 Elastic E=Elastic modulus
 Density g=specific weight

CONCRETE

Name=material name
 f'c=fck=cylindrical resistance for concrete (for all the codes)
 Elastic E=Elastic modulus
 Density g=specific weight
 Tension strength=ft=fctk=characteristic tension resistance for concrete

STEEL REBARS

Name=material name
 fy=fyk=characteristic resistance for steel (for all the codes)
 Fu=fuk=ultimate resistance for steel (for all the codes)
 Elastic E=Elastic modulus
 Density g=specific weight

WOOD

Name=material name
 Fb=fbk=Ultimate bending strength
 Ftu=ftuk=Ultimate tensile strength
 Fvu=fvuk=Ultimate shear strength
 Density g=specific weight
 Elastic E=Elastic modulus

WALL DATA

Wall section 0: P168.3x10/40

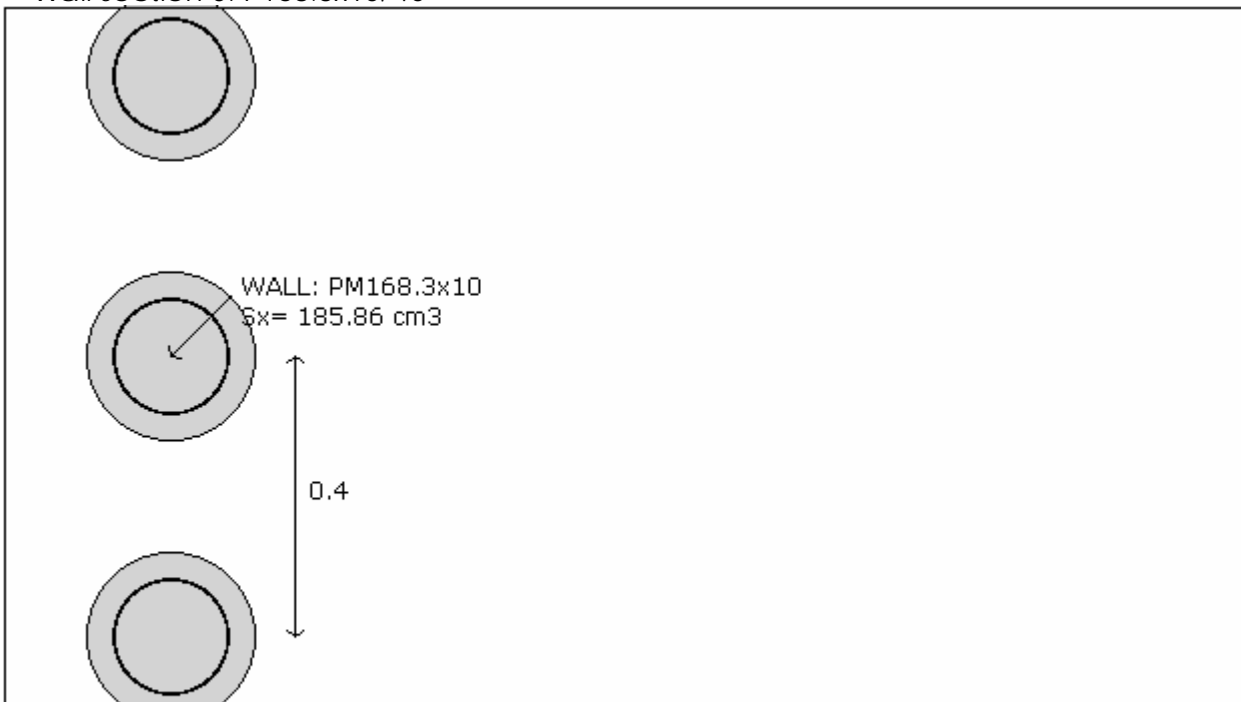

Company: My Company	Wall sketch	CeAS srl and Deep Excavation LCC
Engineer: Engineer		Paratie Plus 2010 - DeepXcar 2010
C:\nd.28_seraLotto3\alleg\LIII_typ3_rev27oct10_EQscavo_Alleg.DEEP		10/28/2010

Wall uses wall section 0: P168.3x10/40
 Wall type: Tangent pile wall
 Top wall El: 0 m Bottom wall El: -15 m
 Hor. wall spacing: 0.4 Wall thickness = 0.24
 Passive width below exc: 0.4 Active width below exc: 0.4
 Concrete f'c = 25 Rebar Fy = 410 Econc = 31476 Concrete tension FcT = 10% of Fc'

Steel members $f_y = 355$ Esteel = 206000
 Wall friction: Percentage of Soil Friction = 50%
 Steel wall capacities are calculated with NTC 2008
 Concrete capacities are calculated with ACI 318-2002.
 Note: With ultimate capacities you may have to use a structural safety factor.
 Tangent pile wall soldier pile properties

Table: Soldier Pile Properties

Name	Section	W	A	D	tw or	bf	tf	k	Ixx	Sxx	rX	Iyy	Syy	rY	rT	Cw	fy
		(kN/m)	(cm ²)	(cm)	(cm)	(cm)	(cm)	(cm)	(cm ⁴)	(cm ³)	(cm)	(cm ⁴)	(cm ³)	(cm)	(cm)	(cm ⁶)	(MPa)
	PM16	254.7	74.85	16.8	1	16.83	1	1	3705	185.9	7.04	3705	185.9	7.04	7.04	1	355

GENERAL WALL DATA

Hor wall spacing=wall horizontal spacing
 Passive width below exc=spacing for passive thrust pressure for classic analysys
 $f'_c=f_{ck}$ =cylindrical concrete resistance
 $f_y=f_{yk}$ =steel rebar characteristic resistance
 E_{conc} =Concrete Elastic modulus
 f_{ctk} =characteristic Concrete tension
 E_{steel} =steel elastic modulus
 TABULAR DATA (principal parameters)

1) Diaphragm wall (rectangular cross section section)

N/A= data not available

$F_y=f_{yk}$

$F'_c=f_{ck}$

D=wall heigt

B=wall width

2)Steel sheet pile

DES=shape (Z or U)

W=wigth per unit of length

A=area

h=heigth

t=horiz part thickness

b=wodth of the single sheet pile part

s=inclined part thickness

I_{xx} =strong axis inertia (per unit of length)

S_{xx} =strong axis section modulus (per unit of length)

3)Secant piles wall, Tangent piles wall, soldier piles, soildier piles and timber lagging

W=weigth per unit of length

A=area

D=diameter

tw=web thickness

tp= pipe thickness

bf=flange width

tf=flange thickness

k=flange thickness+stam thickness

I_{xx} =strong axis inertia modulus (per unit of length)

S_{xx} =strong axis section modulus (per unit of length)

r_x =radius of gyration about X axis

r_y =radius of gyration about Y axis

I_{yy} =weak axis inertia modulus (per unit of length)

S_{yy} =weak axis section modulus (per unit of length)

r_T =radius of gyration for torsion

Cw=warping constant

TIEBACK DATA

Name	F_y	F'_c	Dfix	Afix	Efix	Afree	Efree	Pa STR	Pu STR	PresGr	FSgeo	UserGca	Pa	Pu	WireMod
	(MPa)	(MPa)	(cm)	(cm ²)	(MPa)	(cm ²)	(MPa)	(kN)	(kN)	(kPa)			(kN)	(kN)	Yes/No
4-Strands	1862.1	25	15	176.7	31476	2.8	200100	453.4	453.4	N/A	1.4	False	N/A	N/A	Yes
5-Strands	1862.1	25	15	176.7	31476	2.8	200100	453.4	453.4	N/A	1.4	False	N/A	N/A	Yes
6-Strands	1862.1	25	15	176.7	31476	1.4	200100	226.7	226.7	N/A	1.4	False	N/A	N/A	Yes

Tieback_	1670	25	16	201.0	31476	4.17	210000	605.2	605.2	N/A	1	False	N/A	N/A	Yes
Tieback_	1670	25	16	201.0	31476	6.95	210000	1008.7	1008.7	N/A	1.4	False	N/A	N/A	Yes
Tieback_	1670	25	16	201.0	31476	5.56	210000	807	807	N/A	1	False	N/A	N/A	Yes

EXCAVATION STAGES SKETCHES

A sequence of figures for each excavation stage is reported

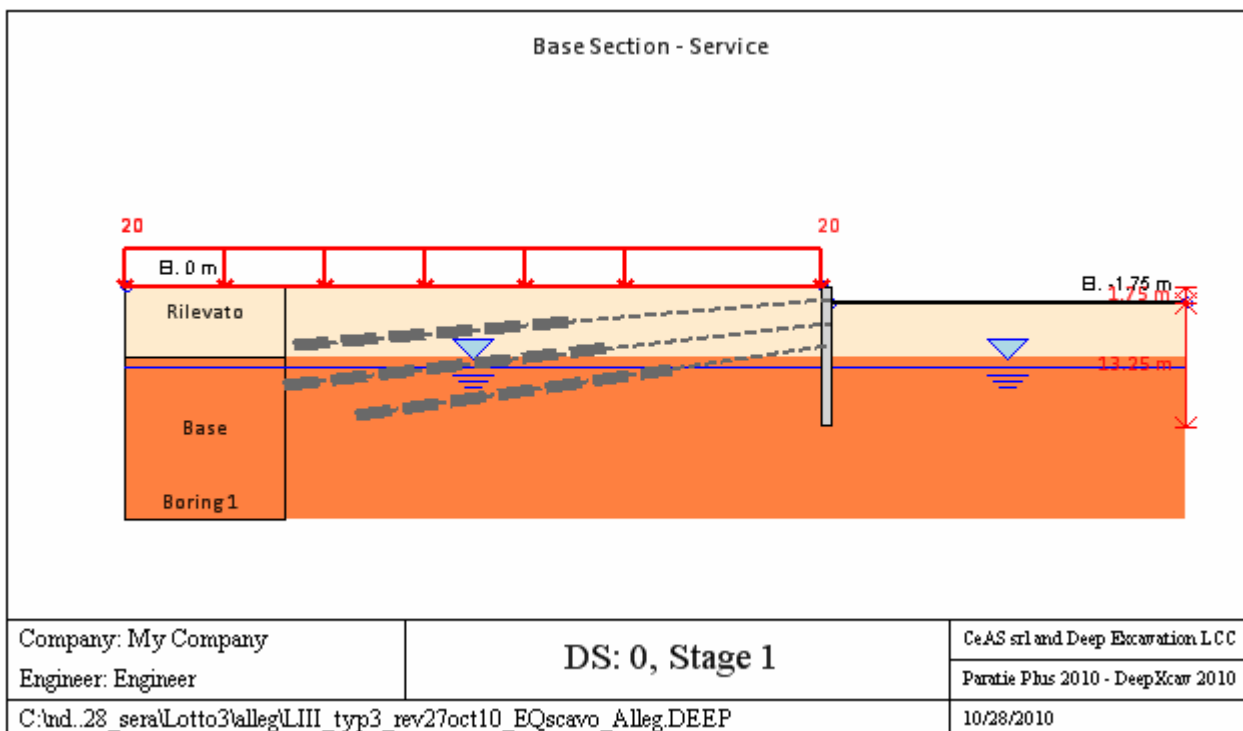
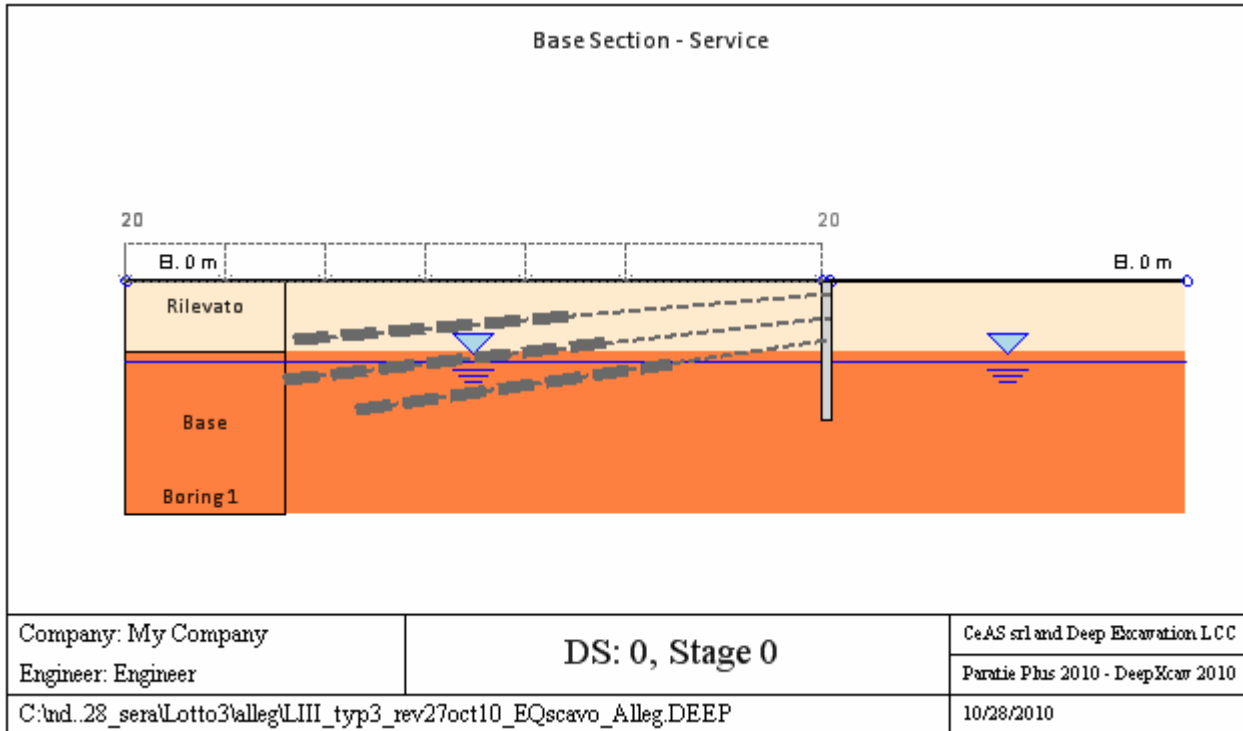

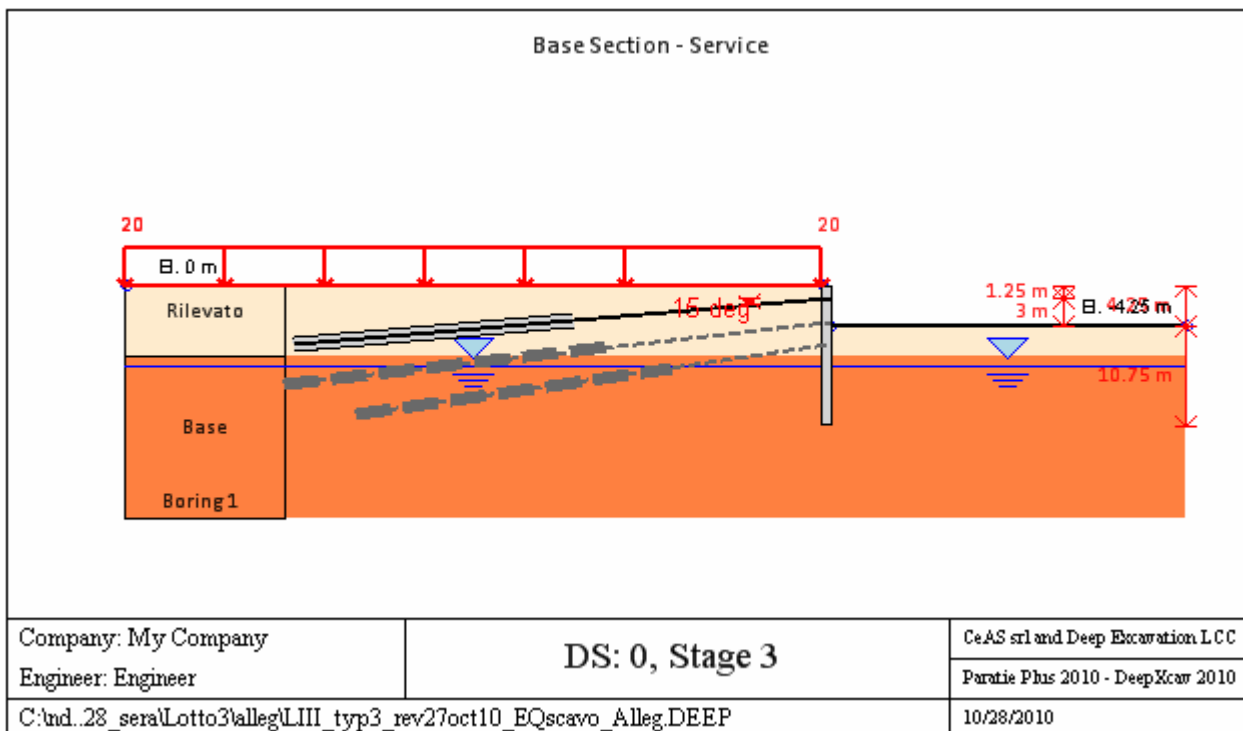
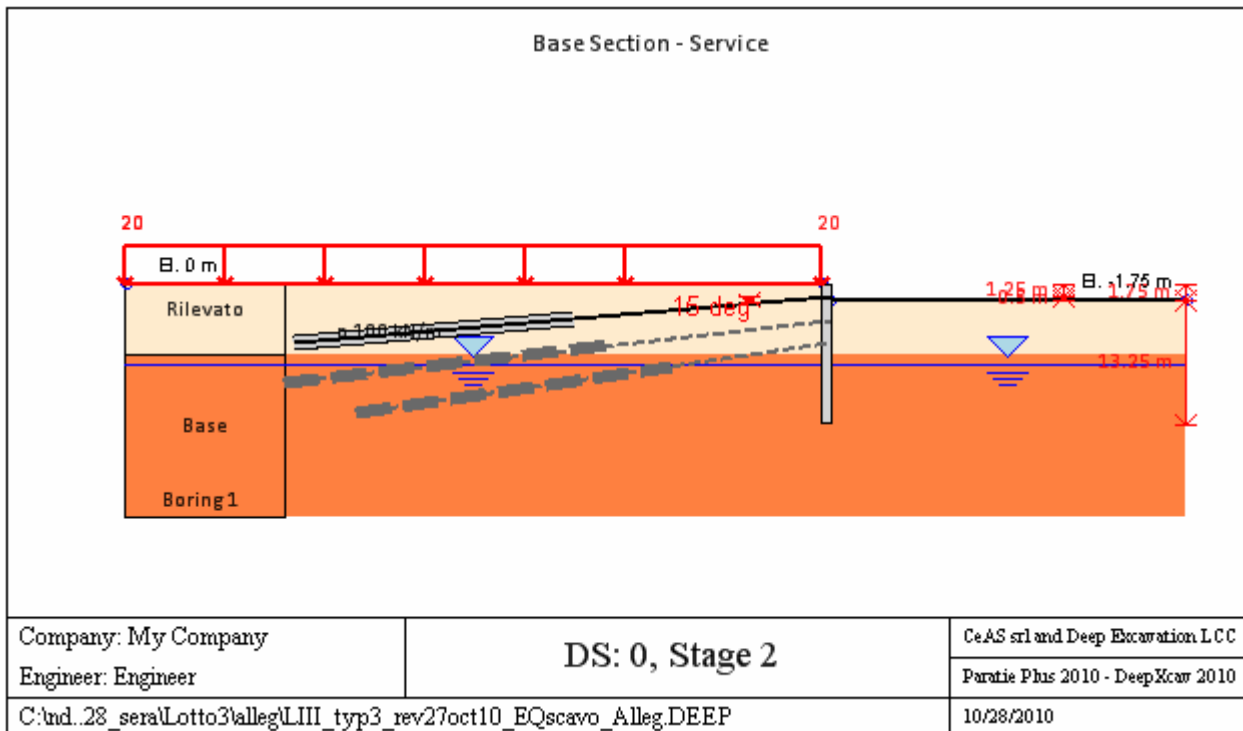

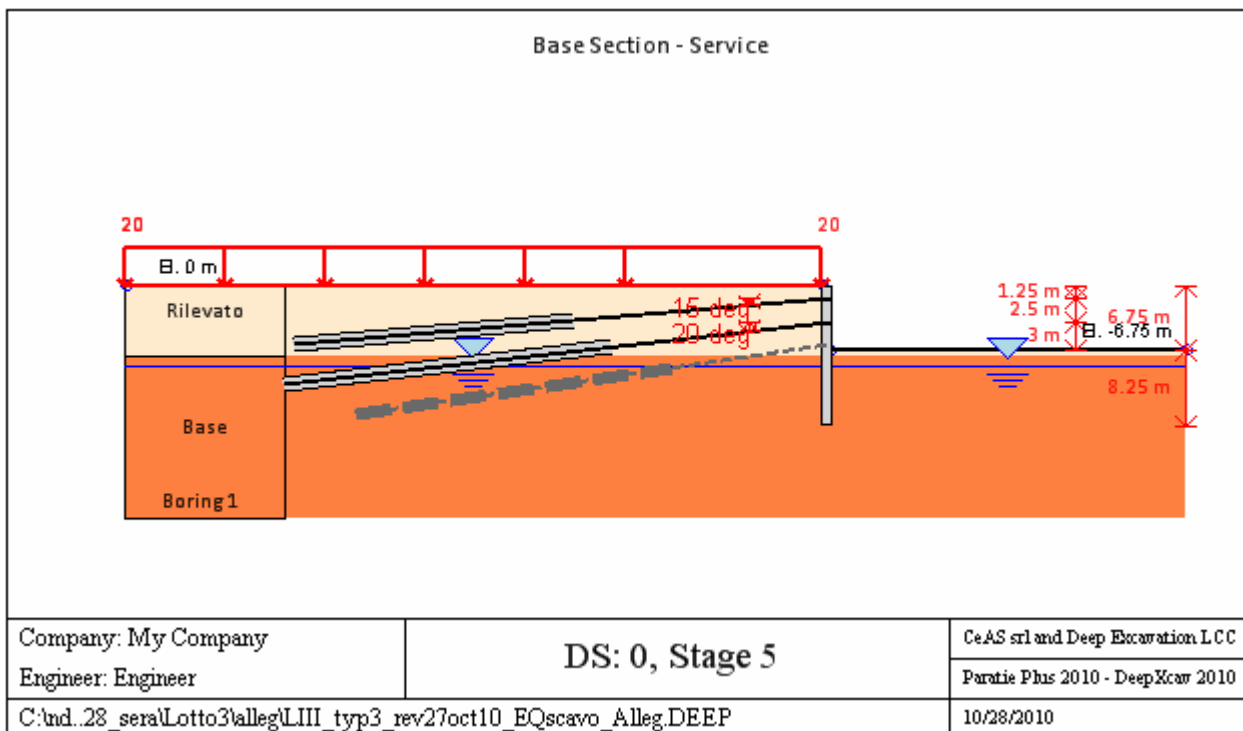
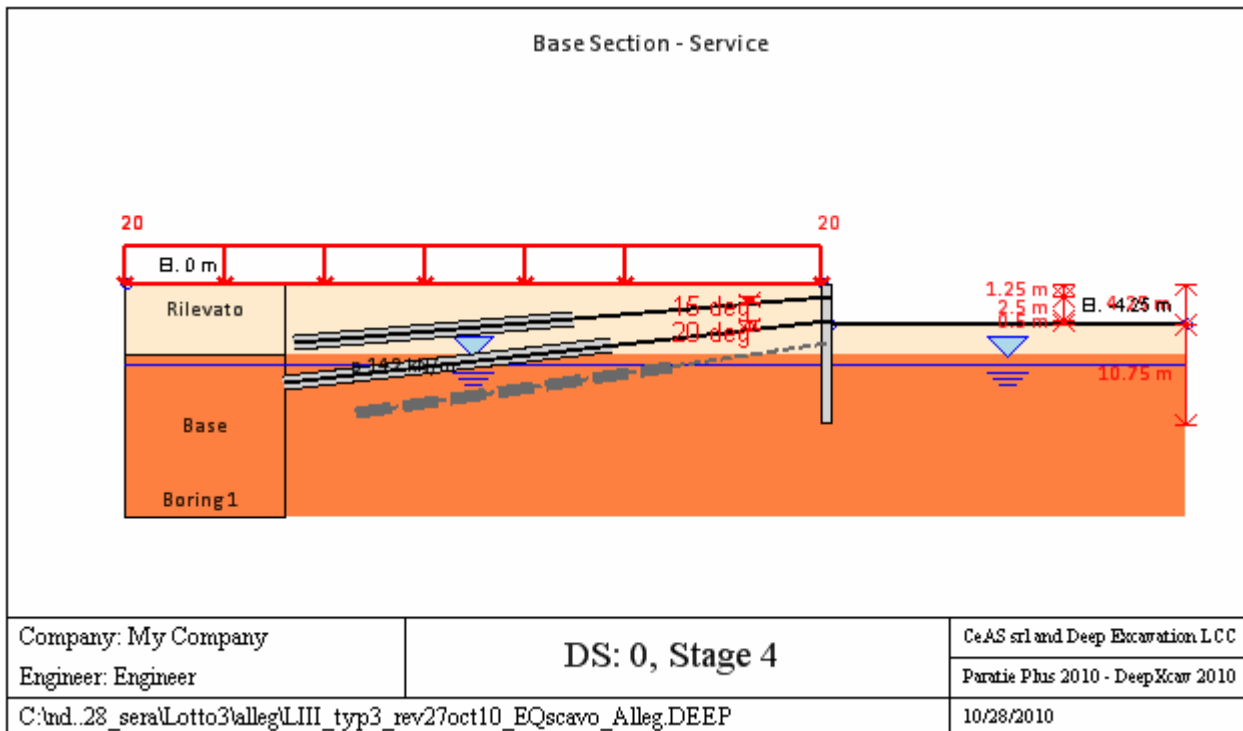

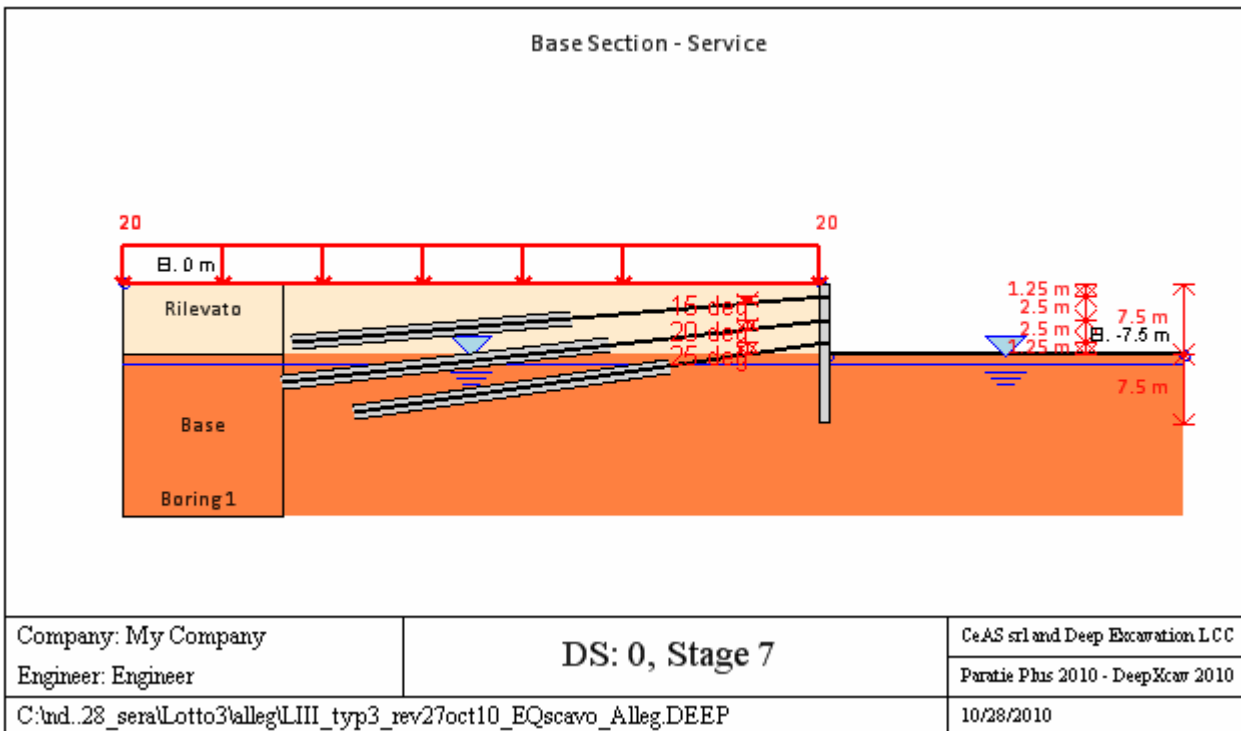
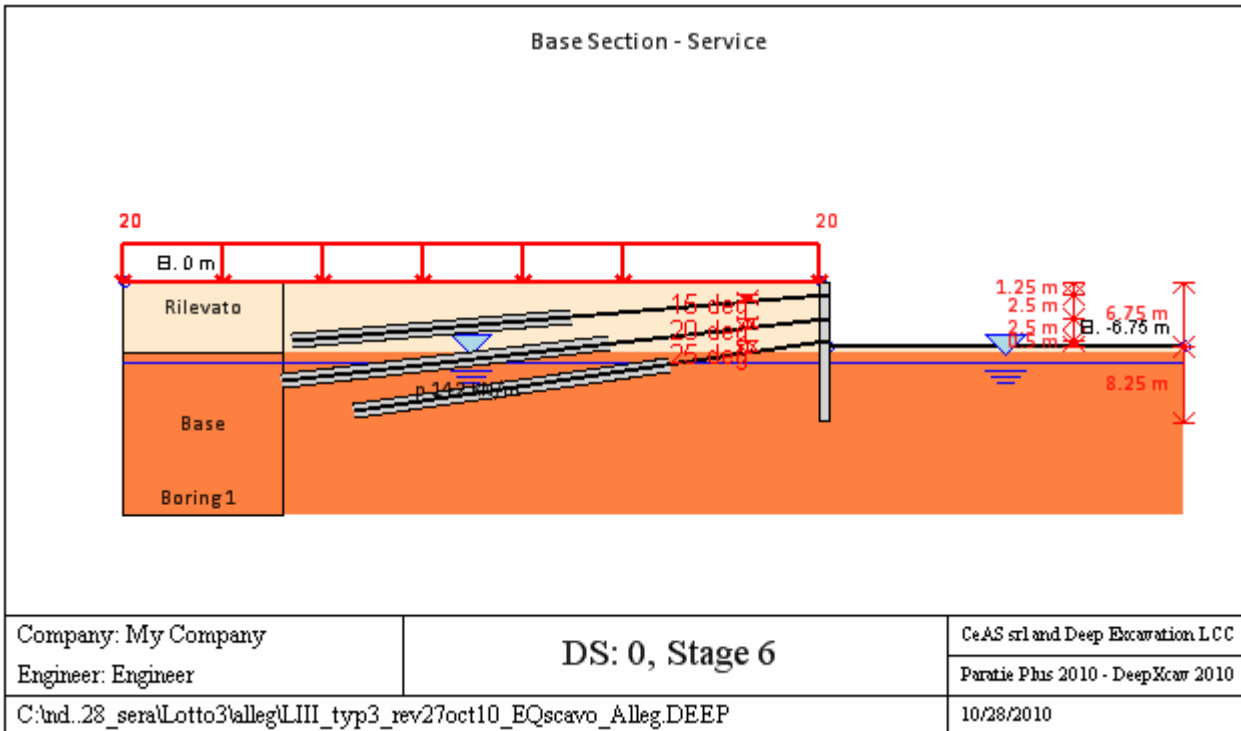

GENERAL ANALYSIS CRITERIA

Summary of stage assumptions

Name	Analysis	Drive	ka-Mult	Htr	Resist	Res	Contl	Supp	Axial	Used	Min	Toe	Toe
	Method	Press		(%)	Press	Mult	Meth	Mode	Incl	FSwall	FDtoe	FSrot	FSpas
Stage 0	Springs-Up	Ka+ d	N/A	N/A	Kp+ d	N/A		Fixed	N/A	1	11.45	13.62	11.45
Stage 1	Springs-Up	Ka+ d	N/A	N/A	Kp+ d	N/A		Fixed	N/A	1	6.974	6.974	7.255
Stage 2	Springs-Up	FHWA	1.3	m=	Kp+ d	N/A		Fixed	N/A	1	7.44	7.44	N/A
Stage 3	Springs-Up	FHWA	1.3	m=	Kp+ d	N/A		Fixed	N/A	1	4.83	4.83	N/A
Stage 4	Springs-Up	FHWA	1.3	m=	Kp+ d	N/A		Fixed	N/A	1	4.764	4.966	4.764

Stage 5	Springs-Up	FHWA	1.3	m=	Kp+ d	N/A		Fixed	N/A	1	2.688	2.688	31.72
Stage 6	Springs-Up	FHWA	1.3	m=	Kp+ d	N/A		Fixed	N/A	1	2.549	2.869	2.549
Stage 7	Springs-Up	FHWA	1.3	m=	Kp+ d	N/A		Fixed	N/A	1	2.236	2.236	26.85

Name=excavation phase name

Analysis method

springs=elasto plastic springs are used

DR=Drained condition for CLAY model

U=Undrained condition for CLAY model for all the soils

Up=Undrained condition just for selected soil

Drive press=Ka

ka mult=multiply factor for Ka

Htr T/B (%)=trapezoidal pressure scheme

Resit press=Kp

Res Mult=Multiply factor for Kp

COntle Method=cantilver method

Support Model=Fix support type

Axial Incl=Axial action is included for design

Used FS wall=Reduction factor for axial+bending resistance dominium

Min FD TOe=embedded minimum safety factor (for classic analysis)

Toe FS rot=rotation safety factor (classic for classic analysis)

Toe FSpas=driving/resistent pressure safety factor (for classic analysis)

SEISMIC DATA

Seismic action is modeled through a pseudo static approach

Summary of stage assumptions

Stage Number	Seismic g Used	Method Used	aX (g)	aY (g)	Beta	Building Code (Name)
0	No		0.026	0	1	N/A
1	No		0.026	0	1	N/A
2	No		0.026	0	1	N/A
3	No		0.026	0	1	N/A
4	No		0.026	0	1	N/A
5	No		0.026	0	1	N/A
6	No		0.026	0	1	N/A
7	No		0.026	0	1	N/A

N/A= data non available

Stage number=number of stage input

Seismic ag =value of design acceleration according to a code or input by the user

Method=the method used to evaluated the seismic thrustover the wall

ahd or khd otr axd=design horizontal acceleration

avd or kvd or ayd=design vertical acceleration

Beta=multip coeff for the semirigd approach

Buildind code=code used for design acceleration calculation

SUPPORTS PROPERTIES

Support 0: type = tieback

X = 0.24 m, Z = -1.25 m, S = 2.4 m

Lfree = 9.1 m, Lfix = 10 m, Rfix = 50 %

Walls: P168.3x10/40

Stage No	Active	Prestress	Slab live load	User add. strain
	Yes/No	(kN)	(kPa)	+expansion
0	No	-	-	-
1	No	-	-	-
2	Yes	240	-	-

0	No	-24	0	0	20	0	0	0	20
1	Yes	-24	0	0	20	0	0	0	20
2	Yes	-24	0	0	20	0	0	0	20
3	Yes	-24	0	0	20	0	0	0	20
4	Yes	-24	0	0	20	0	0	0	20
5	Yes	-24	0	0	20	0	0	0	20
6	Yes	-24	0	0	20	0	0	0	20
7	Yes	-24	0	0	20	0	0	0	20

LEGENDA

Stage No=Excavation step number

Active=load status (Yes=active)

X1=first X coordinate position of the load

Z1=first Z coordinate position of the load

qX1=first horizontal point load value

qZ1=first vertical point load value

X2=second X coordinate position of the load

Z2=second Z coordinate position of the load

qX2=second horizontal point load value

qZ2=second vertical point load value

WALL RESULTS TABLE

P168.3x10/40 Stage: 0

Wall Nod	EL (m)	Sht L (kPa)	Sht R (kPa)	Shs L (kPa)	Shs R (kPa)	q (kPa)	U L (kPa)	U R (kPa)	M (kN-)	V (kN/m)	dx (cm)
0	0	0	0	0	0	0	0	0	0	0	0
2	-0.3	2.538	2.538	2.538	2.538	0	0	0	0	0	0
4	-0.6	5.076	5.076	5.076	5.076	0	0	0	0	0	0
6	-0.9	7.614	7.614	7.614	7.614	0	0	0	0	0	0
8	-1.2	10.152	10.152	10.152	10.152	0	0	0	0	0	0
10	-1.4	11.844	11.844	11.844	11.844	0	0	0	0	0	0
12	-1.7	14.382	14.382	14.382	14.382	0	0	0	0	0	0
14	-2	16.92	16.92	16.92	16.92	0	0	0	0	0	0
16	-2.3	19.458	19.458	19.458	19.458	0	0	0	0	0	0
18	-2.6	21.996	21.996	21.996	21.996	0	0	0	0	0	0
20	-2.9	24.534	24.534	24.534	24.534	0	0	0	0	0	0
22	-3.2	27.072	27.072	27.072	27.072	0	0	0	0	0	0
24	-3.5	29.61	29.61	29.61	29.61	0	0	0	0	0	0
26	-3.75	31.725	31.725	31.725	31.725	0	0	0	0	0	0
28	-4.05	34.263	34.263	34.263	34.263	0	0	0	0	0	0
30	-4.35	36.801	36.801	36.801	36.801	0	0	0	0	0	0
32	-4.65	39.339	39.339	39.339	39.339	0	0	0	0	0	0
34	-4.95	41.877	41.877	41.877	41.877	0	0	0	0	0	0
36	-5.25	44.415	44.415	44.415	44.415	0	0	0	0	0	0
38	-5.55	46.953	46.953	46.953	46.953	0	0	0	0	0	0
40	-5.85	49.491	49.491	49.491	49.491	0	0	0	0	0	0
42	-6.15	52.029	52.029	52.029	52.029	0	0	0	0	0	0
44	-6.4	54.144	54.144	54.144	54.144	0	0	0	0	0	0
46	-6.7	56.682	56.682	56.682	56.682	0	0	0	0	0	0
48	-7	59.22	59.22	59.22	59.22	0	0	0	0	0	0
50	-7.3	61.758	61.758	61.758	61.758	0	0	0	0	0	0
52	-7.6	78.986	78.986	78.986	78.986	0	0	0	0	0	0
54	-7.9	82.103	82.103	82.103	82.103	0	0	0	0	0	0
56	-8.2	85.221	85.221	85.221	85.221	0	0	0	0	0	0
58	-8.5	88.339	88.339	88.339	88.339	0	0	0	0	0	0
60	-8.8	92.725	92.725	89.725	89.725	0	3	3	0	0	0

62	-9.1	97.111	97.111	91.111	91.111	0	6	6	0	0	0
64	-9.4	101.49	101.49	92.496	92.496	0	9	9	0	0	0
66	-9.7	105.88	105.88	93.882	93.882	0	12	12	0	0	0
68	-10	110.26	110.26	95.268	95.268	0	15	15	0	0	0
70	-10.3	114.65	114.65	96.653	96.653	0	18	18	0	0	0
72	-10.6	119.03	119.03	98.039	98.039	0	21	21	0	0	0
74	-10.9	123.42	123.42	99.425	99.425	0	24	24	0	0	0
76	-11.2	127.81	127.81	100.81	100.81	0	27	27	0	0	0
78	-11.5	132.2	132.2	102.2	102.2	0	30	30	0	0	0
80	-11.8	136.58	136.58	103.58	103.58	0	33	33	0	0	0
82	-12.1	140.97	140.97	104.97	104.97	0	36	36	0	0	0
84	-12.4	145.35	145.35	106.35	106.35	0	39	39	0	0	0
86	-12.7	149.74	149.74	107.74	107.74	0	42	42	0	0	0
88	-13	154.12	154.12	109.12	109.12	0	45	45	0	0	0
90	-13.3	158.51	158.51	110.51	110.51	0	48	48	0	0	0
92	-13.6	162.9	162.9	111.9	111.9	0	51	51	0	0	0
94	-13.9	167.28	167.28	113.28	113.28	0	54	54	0	0	0
96	-14.2	171.67	171.67	114.67	114.67	0	57	57	0	0	0
98	-14.5	176.05	176.05	116.05	116.05	0	60	60	0	0	0
100	-14.8	180.44	180.44	117.44	117.44	0	63	63	0	0	0
102	-15	183.36	183.36	118.36	118.36	0	65	65	0	0	0

P168.3x10/40 Stage: 1

Wall	EL	Sht L	Sht R	Shs L	Shs R	q	U L	U R	M	V	dx
Nod	(m)	(kPa)	(kPa)	(kPa)	(kPa)	(kPa)	(kPa)	(kPa)	(kN-	(kN/m)	(cm)
0	0	5.34	0	5.34	0	0	0	0	0	0.4	0.93
2	-0.3	6.782	0	6.782	0	0	0	0	0.26	1.31	0.83
4	-0.6	8.224	0	8.224	0	0	0	0	1.12	3.45	0.74
6	-0.9	9.665	0	9.665	0	0	0	0	2.73	6.03	0.65
8	-1.2	11.107	0	11.107	0	0	0	0	5.21	9.04	0.56
10	-1.4	12.068	0	12.068	0	0	0	0	7.41	11.28	0.5
12	-1.7	13.51	0	13.51	0	0	0	0	11.62	15.01	0.41
14	-2	14.952	22.752	14.952	22.752	0	0	0	16.85	17.8	0.33
16	-2.3	16.394	46.483	16.394	46.483	0	0	0	21.37	13.53	0.26
18	-2.6	17.836	40.632	17.836	40.632	0	0	0	23.48	5.07	0.2
20	-2.9	19.277	36.156	19.277	36.156	0	0	0	23.54	-1.3	0.15
22	-3.2	20.719	33.153	20.719	33.153	0	0	0	22.06	-6	0.1
24	-3.5	22.161	31.566	22.161	31.566	0	0	0	19.46	-9.48	0.07
26	-3.75	28.029	31.216	28.029	31.216	0	0	0	16.67	-11.59	0.06
28	-4.05	33.957	31.785	33.957	31.785	0	0	0	13.07	-12.01	0.04
30	-4.35	38.453	33.213	38.453	33.213	0	0	0	9.65	-11.1	0.03
32	-4.65	41.888	35.277	41.888	35.277	0	0	0	6.7	-9.39	0.03
34	-4.95	44.583	37.784	44.583	37.784	0	0	0	4.33	-7.38	0.03
36	-5.25	46.798	40.577	46.798	40.577	0	0	0	2.57	-5.37	0.03
38	-5.55	48.726	43.539	48.726	43.539	0	0	0	1.37	-3.57	0.03
40	-5.85	50.498	46.59	50.498	46.59	0	0	0	0.63	-2.11	0.04
42	-6.15	52.198	49.681	52.198	49.681	0	0	0	0.25	-1.04	0.04
44	-6.4	53.59	52.268	53.59	52.268	0	0	0	0.1	-0.47	0.04
46	-6.7	55.25	55.377	55.25	55.377	0	0	0	0.03	-0.18	0.05
48	-7	56.907	58.484	56.907	58.484	0	0	0	-0.05	-0.33	0.05
50	-7.3	58.57	61.585	58.57	61.585	0	0	0	-0.27	-0.91	0.05
52	-7.6	80.795	77.202	80.795	77.202	0	0	0	-0.76	-1.92	0.06
54	-7.9	83.36	80.795	83.36	80.795	0	0	0	-1.11	-0.92	0.06
56	-8.2	86.011	84.315	86.011	84.315	0	0	0	-1.22	-0.22	0.06
58	-8.5	88.758	87.755	88.758	87.755	0	0	0	-1.18	0.23	0.07
60	-8.8	92.865	92.376	89.865	89.376	0	3	3	-1.05	0.49	0.07
62	-9.1	97.056	96.929	91.056	90.929	0	6	6	-0.88	0.61	0.07
64	-9.4	101.31	101.42	92.316	92.425	0	9	9	-0.69	0.62	0.07

66	-9.7	105.63	105.87	93.631	93.877	0	12	12	-0.51	0.58	0.07
68	-10	109.98	110.29	94.986	95.295	0	15	15	-0.35	0.5	0.07
70	-10.3	114.36	114.69	96.369	96.69	0	18	18	-0.22	0.41	0.07
72	-10.6	118.77	119.07	97.771	98.07	0	21	21	-0.12	0.31	0.07
74	-10.9	123.18	123.44	99.183	99.442	0	24	24	-0.05	0.22	0.07
76	-11.2	127.6	127.81	100.6	100.81	0	27	27	0	0.15	0.07
78	-11.5	132.02	132.18	102.02	102.18	0	30	30	0.03	0.09	0.07
80	-11.8	136.43	136.55	103.43	103.55	0	33	33	0.05	0.04	0.07
82	-12.1	140.84	140.92	104.84	104.92	0	36	36	0.05	0.01	0.07
84	-12.4	145.25	145.29	106.25	106.29	0	39	39	0.05	-0.01	0.07
86	-12.7	149.65	149.67	107.65	107.67	0	42	42	0.05	-0.02	0.07
88	-13	154.05	154.05	109.05	109.05	0	45	45	0.04	-0.03	0.07
90	-13.3	158.44	158.44	110.44	110.44	0	48	48	0.03	-0.03	0.07
92	-13.6	162.83	162.82	111.83	111.82	0	51	51	0.02	-0.03	0.07
94	-13.9	167.23	167.21	113.23	113.21	0	54	54	0.01	-0.02	0.07
96	-14.2	171.62	171.6	114.62	114.6	0	57	57	0.01	-0.02	0.07
98	-14.5	176.01	175.98	116.01	115.98	0	60	60	0	-0.01	0.07
100	-14.8	180.4	180.37	117.4	117.37	0	63	63	0	-0.01	0.07
102	-15	183.32	183.3	118.32	118.3	0	65	65	0	0	0.07

P168.3x10/40 Stage: 2

Wall	EL	Sht L	Sht R	Shs L	Shs R	q	U L	U R	M	V	dx
Nod	(m)	(kPa)	(kPa)	(kPa)	(kPa)	(kPa)	(kPa)	(kPa)	(kN-	(kN/m)	(cm)
0	0	39.648	0	39.648	0	0	0	0	0	2.97	0.78
2	-0.3	42.808	0	42.808	0	0	0	0	1.82	9.16	0.68
4	-0.6	45.76	0	45.76	0	0	0	0	7.49	22.23	0.58
6	-0.9	47.977	0	47.977	0	0	0	0	17.28	36.15	0.48
8	-1.2	48.563	0	48.563	0	0	0	0	31.37	50.62	0.4
10	-1.4	47.503	0	47.503	0	0	0	0	28.7	-36.27	0.35
12	-1.7	44.086	0	44.086	0	0	0	0	21	-22.24	0.28
14	-2	39.612	7.598	39.612	7.598	0	0	0	17.24	-9.42	0.23
16	-2.3	35.055	35.015	35.055	35.015	0	0	0	16.17	-2.49	0.18
18	-2.6	31.036	32.52	31.036	32.52	0	0	0	15.41	-2.59	0.14
20	-2.9	27.878	30.871	27.878	30.871	0	0	0	14.52	-3.15	0.11
22	-3.2	25.692	30.097	25.692	30.097	0	0	0	13.36	-4.16	0.08
24	-3.5	24.451	30.159	24.451	30.159	0	0	0	11.8	-5.58	0.06
26	-3.75	28.726	30.788	28.726	30.788	0	0	0	10.14	-6.87	0.05
28	-4.05	33.388	32.134	33.388	32.134	0	0	0	8	-7.16	0.04
30	-4.35	37.174	33.998	37.174	33.998	0	0	0	5.96	-6.62	0.04
32	-4.65	40.304	36.25	40.304	36.25	0	0	0	4.2	-5.59	0.04
34	-4.95	42.971	38.775	42.971	38.775	0	0	0	2.8	-4.35	0.04
36	-5.25	45.327	41.481	45.327	41.481	0	0	0	1.78	-3.11	0.04
38	-5.55	47.484	44.302	47.484	44.302	0	0	0	1.1	-2	0.04
40	-5.85	49.517	47.193	49.517	47.193	0	0	0	0.71	-1.11	0.04
42	-6.15	51.471	50.128	51.471	50.128	0	0	0	0.52	-0.48	0.04
44	-6.4	53.054	52.598	53.054	52.598	0	0	0	0.46	-0.19	0.05
46	-6.7	54.907	55.587	54.907	55.587	0	0	0	0.42	-0.13	0.05
48	-7	56.715	58.602	56.715	58.602	0	0	0	0.32	-0.43	0.05
50	-7.3	58.49	61.634	58.49	61.634	0	0	0	0.05	-1.09	0.05
52	-7.6	80.792	77.205	80.792	77.205	0	0	0	-0.5	-2.13	0.06
54	-7.9	83.392	80.769	83.392	80.769	0	0	0	-0.91	-1.12	0.06
56	-8.2	86.061	84.274	86.061	84.274	0	0	0	-1.08	-0.4	0.06
58	-8.5	88.815	87.709	88.815	87.709	0	0	0	-1.08	0.08	0.07
60	-8.8	92.922	92.33	89.922	89.33	0	3	3	-0.99	0.37	0.07
62	-9.1	97.107	96.887	91.107	90.887	0	6	6	-0.85	0.52	0.07
64	-9.4	101.35	101.39	92.359	92.39	0	9	9	-0.68	0.56	0.07
66	-9.7	105.66	105.84	93.665	93.849	0	12	12	-0.51	0.54	0.07
68	-10	110.01	110.27	95.012	95.274	0	15	15	-0.37	0.48	0.07

70	-10.3	114.38	114.67	96.388	96.675	0	18	18	-0.24	0.4	0.07
72	-10.6	118.78	119.06	97.783	98.061	0	21	21	-0.14	0.31	0.07
74	-10.9	123.19	123.43	99.19	99.436	0	24	24	-0.07	0.23	0.07
76	-11.2	127.6	127.81	100.6	100.81	0	27	27	-0.01	0.16	0.07
78	-11.5	132.02	132.18	102.02	102.18	0	30	30	0.02	0.1	0.07
80	-11.8	136.43	136.55	103.43	103.55	0	33	33	0.04	0.05	0.07
82	-12.1	140.84	140.92	104.84	104.92	0	36	36	0.05	0.02	0.07
84	-12.4	145.24	145.3	106.24	106.3	0	39	39	0.05	0	0.07
86	-12.7	149.64	149.68	107.64	107.68	0	42	42	0.04	-0.02	0.07
88	-13	154.04	154.06	109.04	109.06	0	45	45	0.04	-0.02	0.07
90	-13.3	158.44	158.44	110.44	110.44	0	48	48	0.03	-0.03	0.07
92	-13.6	162.83	162.82	111.83	111.82	0	51	51	0.02	-0.03	0.07
94	-13.9	167.22	167.21	113.22	113.21	0	54	54	0.01	-0.02	0.07
96	-14.2	171.62	171.6	114.62	114.6	0	57	57	0.01	-0.02	0.07
98	-14.5	176.01	175.98	116.01	115.98	0	60	60	0	-0.01	0.07
100	-14.8	180.4	180.37	117.4	117.37	0	63	63	0	-0.01	0.07
102	-15	183.32	183.3	118.32	118.3	0	65	65	0	0	0.07

P168.3x10/40 Stage: 3

Wall Nod	EL (m)	Sht L (kPa)	Sht R (kPa)	Shs L (kPa)	Shs R (kPa)	q (kPa)	U L (kPa)	U R (kPa)	M (kN)	V (kN/m)	dx (cm)
0	0	48.408	0	48.408	0	0	0	0	0	3.63	0.69
2	-0.3	46.015	0	46.015	0	0	0	0	2.15	10.71	0.64
4	-0.6	43.397	0	43.397	0	0	0	0	8.44	24.33	0.6
6	-0.9	40.003	0	40.003	0	0	0	0	18.64	37.12	0.57
8	-1.2	34.92	0	34.92	0	0	0	0	32.42	48.78	0.54
10	-1.4	30.055	0	30.055	0	0	0	0	28.34	-44.63	0.53
12	-1.7	20.963	0	20.963	0	0	0	0	16.88	-36.26	0.52
14	-2	14.952	0	14.952	0	0	0	0	7.31	-30.72	0.53
16	-2.3	16.394	0	16.394	0	0	0	0	-0.88	-26.12	0.53
18	-2.6	17.836	0	17.836	0	0	0	0	-7.6	-21.1	0.54
20	-2.9	19.277	0	19.277	0	0	0	0	-12.71	-15.64	0.54
22	-3.2	20.719	0	20.719	0	0	0	0	-16.08	-9.75	0.54
24	-3.5	22.161	0	22.161	0	0	0	0	-17.59	-3.42	0.52
26	-3.75	23.362	0	23.362	0	0	0	0	-17.33	2.76	0.51
28	-4.05	24.804	0	24.804	0	0	0	0	-15.08	9.29	0.48
30	-4.35	26.246	9.101	26.246	9.101	0	0	0	-10.6	16.84	0.45
32	-4.65	27.688	36.403	27.688	36.403	0	0	0	-4.68	20.05	0.41
34	-4.95	29.13	40.502	29.13	40.502	0	0	0	0.68	17.05	0.37
36	-5.25	30.572	41.855	30.572	41.855	0	0	0	5.03	13.64	0.33
38	-5.55	32.013	43.119	32.013	43.119	0	0	0	8.36	10.27	0.29
40	-5.85	33.455	44.475	33.455	44.475	0	0	0	10.69	6.94	0.26
42	-6.15	34.897	46.031	34.897	46.031	0	0	0	12.03	3.63	0.23
44	-6.4	37.27	47.528	37.27	47.528	0	0	0	12.38	0.84	0.21
46	-6.7	41.159	49.592	41.159	49.592	0	0	0	11.96	-2.09	0.19
48	-7	44.485	51.949	44.485	51.949	0	0	0	10.78	-4.53	0.18
50	-7.3	47.31	54.574	47.31	54.574	0	0	0	8.93	-6.74	0.17
52	-7.6	73.159	66.543	73.159	66.543	0	0	0	6.41	-8.94	0.17
54	-7.9	76.005	70.131	76.005	70.131	0	0	0	4.17	-7.01	0.17
56	-8.2	78.754	73.771	78.754	73.771	0	0	0	2.45	-5.31	0.17
58	-8.5	81.472	77.413	81.472	77.413	0	0	0	1.19	-3.88	0.17
60	-8.8	85.467	82.198	82.467	79.198	0	3	3	0.29	-2.73	0.18
62	-9.1	89.498	86.95	83.498	80.95	0	6	6	-0.32	-1.8	0.18
64	-9.4	93.577	91.66	84.577	82.66	0	9	9	-0.69	-1.09	0.18
66	-9.7	97.711	96.322	85.711	84.322	0	12	12	-0.9	-0.55	0.18
68	-10	101.89	100.93	86.898	85.939	0	15	15	-0.97	-0.17	0.19
70	-10.3	106.13	105.51	88.133	87.513	0	18	18	-0.96	0.09	0.19
72	-10.6	110.41	110.05	89.411	89.05	0	21	21	-0.9	0.26	0.19

74	-10.9	114.72	114.55	90.725	90.555	0	24	24	-0.8	0.35	0.19
76	-11.2	119.06	119.03	92.068	92.035	0	27	27	-0.68	0.39	0.19
78	-11.5	123.43	123.49	93.434	93.493	0	30	30	-0.57	0.39	0.19
80	-11.8	127.81	127.93	94.818	94.935	0	33	33	-0.45	0.37	0.19
82	-12.1	132.21	132.36	96.215	96.364	0	36	36	-0.35	0.33	0.19
84	-12.4	136.62	136.78	97.622	97.784	0	39	39	-0.26	0.29	0.19
86	-12.7	141.03	141.19	99.034	99.197	0	42	42	-0.19	0.24	0.19
88	-13	145.45	145.61	100.45	100.61	0	45	45	-0.13	0.19	0.19
90	-13.3	149.87	150.01	101.87	102.01	0	48	48	-0.08	0.14	0.19
92	-13.6	154.29	154.41	103.29	103.41	0	51	51	-0.05	0.1	0.19
94	-13.9	158.71	158.81	104.71	104.81	0	54	54	-0.02	0.07	0.19
96	-14.2	163.13	163.21	106.13	106.21	0	57	57	-0.01	0.04	0.19
98	-14.5	167.56	167.61	107.56	107.61	0	60	60	0	0.02	0.19
100	-14.8	171.98	172	108.98	109	0	63	63	0	0.01	0.19
102	-15	174.93	174.93	109.93	109.93	0	65	65	0	0	0.19

P168.3x10/40 Stage: 4

Wall	EL	Sht L	Sht R	Shs L	Shs R	q	U L	U R	M	V	dx
Nod	(m)	(kPa)	(kPa)	(kPa)	(kPa)	(kPa)	(kPa)	(kPa)	(kN-	(kN/m)	(cm)
0	0	38.459	0	38.459	0	0	0	0	0	2.88	0.79
2	-0.3	40.076	0	40.076	0	0	0	0	1.75	8.78	0.71
4	-0.6	41.489	0	41.489	0	0	0	0	7.1	20.91	0.62
6	-0.9	42.186	0	42.186	0	0	0	0	16.19	33.43	0.54
8	-1.2	41.304	0	41.304	0	0	0	0	29.06	46.06	0.47
10	-1.4	39.32	0	39.32	0	0	0	0	24.94	-44.2	0.43
12	-1.7	34.673	0	34.673	0	0	0	0	14.28	-32.73	0.38
14	-2	33.218	0	33.218	0	0	0	0	6.75	-22.73	0.33
16	-2.3	39.233	0	39.233	0	0	0	0	2.24	-12.31	0.29
18	-2.6	45.099	0	45.099	0	0	0	0	1.26	-0.1	0.25
20	-2.9	50.554	0	50.554	0	0	0	0	4.34	13.85	0.21
22	-3.2	55.228	0	55.228	0	0	0	0	11.96	29.39	0.17
24	-3.5	58.625	0	58.625	0	0	0	0	24.55	46.24	0.14
26	-3.75	60.025	0	60.025	0	0	0	0	39.05	62.49	0.12
28	-4.05	59.623	0	59.623	0	0	0	0	21.45	-54.15	0.12
30	-4.35	57.56	0.481	57.56	0.481	0	0	0	9.21	-36.39	0.12
32	-4.65	54.588	19.872	54.588	19.872	0	0	0	2.02	-20.13	0.13
34	-4.95	51.296	26.88	51.296	26.88	0	0	0	-1.82	-10.67	0.14
36	-5.25	48.102	31.082	48.102	31.082	0	0	0	-3.46	-3.92	0.15
38	-5.55	45.277	34.968	45.277	34.968	0	0	0	-3.56	0.67	0.15
40	-5.85	42.982	38.621	42.982	38.621	0	0	0	-2.74	3.3	0.16
42	-6.15	41.284	42.106	41.284	42.106	0	0	0	-1.51	4.21	0.16
44	-6.4	41.505	44.925	41.505	44.925	0	0	0	-0.53	3.81	0.17
46	-6.7	43.34	48.252	43.34	48.252	0	0	0	0.37	2.67	0.17
48	-7	45.133	51.551	45.133	51.551	0	0	0	0.82	1.09	0.17
50	-7.3	46.873	54.843	46.873	54.843	0	0	0	0.7	-0.96	0.18
52	-7.6	72.324	67.221	72.324	67.221	0	0	0	-0.15	-3.46	0.18
54	-7.9	74.867	71.055	74.867	71.055	0	0	0	-0.86	-2.03	0.18
56	-8.2	77.479	74.806	77.479	74.806	0	0	0	-1.22	-0.98	0.19
58	-8.5	80.178	78.463	80.178	78.463	0	0	0	-1.35	-0.25	0.19
60	-8.8	84.24	83.194	81.24	80.194	0	3	3	-1.31	0.21	0.19
62	-9.1	88.389	87.85	82.389	81.85	0	6	6	-1.19	0.48	0.19
64	-9.4	92.617	92.439	83.617	83.439	0	9	9	-1.01	0.61	0.2
66	-9.7	96.91	96.972	84.91	84.972	0	12	12	-0.82	0.65	0.2
68	-10	101.25	101.46	86.253	86.462	0	15	15	-0.63	0.62	0.2
70	-10.3	105.63	105.91	87.634	87.918	0	18	18	-0.46	0.55	0.2
72	-10.6	110.04	110.35	89.042	89.35	0	21	21	-0.31	0.46	0.2
74	-10.9	114.46	114.76	90.466	90.765	0	24	24	-0.2	0.37	0.2
76	-11.2	118.90	119.17	91.901	92.17	0	27	27	-0.11	0.28	0.2

78	-11.5	123.33	123.57	93.339	93.57	0	30	30	-0.04	0.2	0.2
80	-11.8	127.77	127.96	94.779	94.967	0	33	33	0.01	0.14	0.19
82	-12.1	132.21	132.36	96.216	96.364	0	36	36	0.03	0.08	0.19
84	-12.4	136.65	136.76	97.65	97.761	0	39	39	0.05	0.04	0.19
86	-12.7	141.08	141.16	99.081	99.16	0	42	42	0.05	0.01	0.19
88	-13	145.51	145.56	100.51	100.56	0	45	45	0.05	-0.01	0.19
90	-13.3	149.93	149.96	101.93	101.96	0	48	48	0.05	-0.03	0.19
92	-13.6	154.35	154.36	103.35	103.36	0	51	51	0.04	-0.03	0.19
94	-13.9	158.77	158.77	104.77	104.77	0	54	54	0.03	-0.04	0.19
96	-14.2	163.19	163.17	106.19	106.17	0	57	57	0.01	-0.03	0.19
98	-14.5	167.6	167.57	107.6	107.57	0	60	60	0.01	-0.03	0.19
100	-14.8	172.02	171.97	109.02	108.97	0	63	63	0	-0.01	0.19
102	-15	174.96	174.9	109.96	109.9	0	65	65	0	0	0.19

P168.3x10/40 Stage: 5

Wall Nod	EL (m)	Sht L (kPa)	Sht R (kPa)	Shs L (kPa)	Shs R (kPa)	q (kPa)	U L (kPa)	U R (kPa)	M (kN)	V (kN/m)	dx (cm)
0	0	45.251	0	45.251	0	0	0	0	0	3.39	0.68
2	-0.3	45.952	0	45.952	0	0	0	0	2.04	10.24	0.61
4	-0.6	46.44	0	46.44	0	0	0	0	8.22	24.06	0.54
6	-0.9	46.179	0	46.179	0	0	0	0	18.58	38	0.48
8	-1.2	44.27	0	44.27	0	0	0	0	33.08	51.75	0.42
10	-1.4	41.541	0	41.541	0	0	0	0	30.36	-36.82	0.39
12	-1.7	35.641	0	35.641	0	0	0	0	22.06	-24.77	0.36
14	-2	32.712	0	32.712	0	0	0	0	16.96	-14.59	0.34
16	-2.3	36.965	0	36.965	0	0	0	0	14.84	-4.45	0.33
18	-2.6	40.711	0	40.711	0	0	0	0	16.05	6.94	0.32
20	-2.9	43.628	0	43.628	0	0	0	0	20.91	19.39	0.33
22	-3.2	45.296	0	45.296	0	0	0	0	29.69	32.63	0.34
24	-3.5	45.186	0	45.186	0	0	0	0	42.54	46.25	0.37
26	-3.75	43.276	0	43.276	0	0	0	0	56.35	58.56	0.4
28	-4.05	38.47	0	38.47	0	0	0	0	33.96	-71.55	0.47
30	-4.35	31.654	0	31.654	0	0	0	0	15.02	-60.49	0.55
32	-4.65	27.688	0	27.688	0	0	0	0	-1.08	-51.58	0.64
34	-4.95	29.13	0	29.13	0	0	0	0	-14.66	-43.16	0.73
36	-5.25	30.572	0	30.572	0	0	0	0	-25.63	-34.31	0.81
38	-5.55	32.013	0	32.013	0	0	0	0	-33.84	-25.04	0.88
40	-5.85	33.455	0	33.455	0	0	0	0	-39.18	-15.32	0.94
42	-6.15	34.897	0	34.897	0	0	0	0	-41.5	-5.18	0.98
44	-6.4	36.098	0	36.098	0	0	0	0	-41.04	3.61	0.99
46	-6.7	37.54	0	37.54	0	0	0	0	-37.51	14.54	0.99
48	-7	38.982	22.752	38.982	22.752	0	0	0	-30.8	24.55	0.98
50	-7.3	40.424	50.054	40.424	50.054	0	0	0	-22.63	27.48	0.95
52	-7.6	56.291	50.857	56.291	50.857	0	0	0	-15.29	22.89	0.9
54	-7.9	58.23	68.807	58.23	68.807	0	0	0	-8.24	23.32	0.86
56	-8.2	60.168	73.264	60.168	73.264	0	0	0	-2	19.83	0.8
58	-8.5	62.107	75.847	62.107	75.847	0	0	0	3.05	15.85	0.75
60	-8.8	65.969	79.002	62.969	76.002	0	3	3	6.89	11.78	0.7
62	-9.1	69.83	82.188	63.83	76.188	0	6	6	9.55	7.92	0.65
64	-9.4	74.857	85.459	65.857	76.459	0	9	9	11.1	4.26	0.6
66	-9.7	80.898	88.853	68.898	76.853	0	12	12	11.69	1.29	0.56
68	-10	86.735	92.391	71.735	77.391	0	15	15	11.57	-0.92	0.53
70	-10.3	92.359	96.081	74.359	78.081	0	18	18	10.94	-2.47	0.5
72	-10.6	97.777	99.921	76.777	78.921	0	21	21	9.96	-3.46	0.48
74	-10.9	103	103.90	79	79.901	0	24	24	8.79	-4	0.46
76	-11.2	108.04	108.00	81.049	81.009	0	27	27	7.54	-4.2	0.44
78	-11.5	112.94	112.22	82.944	82.227	0	30	30	6.3	-4.13	0.43
80	-11.8	117.70	116.53	84.709	83.538	0	33	33	5.11	-3.88	0.43

82	-12.1	122.36	120.92	86.368	84.924	0	36	36	4.03	-3.5	0.42
84	-12.4	126.94	125.36	87.94	86.369	0	39	39	3.08	-3.06	0.42
86	-12.7	131.44	129.85	89.446	87.859	0	42	42	2.27	-2.58	0.41
88	-13	135.90	134.37	90.903	89.379	0	45	45	1.6	-2.11	0.41
90	-13.3	140.32	138.91	92.324	90.919	0	48	48	1.07	-1.66	0.41
92	-13.6	144.72	143.47	93.721	92.472	0	51	51	0.67	-1.25	0.41
94	-13.9	149.10	148.02	95.102	94.029	0	54	54	0.37	-0.89	0.41
96	-14.2	153.47	152.58	96.475	95.587	0	57	57	0.18	-0.58	0.41
98	-14.5	157.84	157.14	97.843	97.141	0	60	60	0.06	-0.33	0.41
100	-14.8	162.21	161.69	99.21	98.691	0	63	63	0.01	-0.13	0.41
102	-15	165.12	164.72	100.12	99.722	0	65	65	0	-0.01	0.42

P168.3x10/40 Stage: 6

Wall	EL	Sht L	Sht R	Shs L	Shs R	q	U L	U R	M	V	dx
Nod	(m)	(kPa)	(kPa)	(kPa)	(kPa)	(kPa)	(kPa)	(kPa)	(kN-	(kN/m)	(cm)
0	0	41.213	0	41.213	0	0	0	0	0	3.09	0.75
2	-0.3	42.395	0	42.395	0	0	0	0	1.87	9.36	0.67
4	-0.6	43.37	0	43.37	0	0	0	0	7.55	22.16	0.59
6	-0.9	43.616	0	43.616	0	0	0	0	17.13	35.21	0.52
8	-1.2	42.256	0	42.256	0	0	0	0	30.63	48.24	0.46
10	-1.4	39.929	0	39.929	0	0	0	0	27.03	-41.5	0.42
12	-1.7	34.716	0	34.716	0	0	0	0	17.22	-29.88	0.38
14	-2	32.613	0	32.613	0	0	0	0	10.53	-19.92	0.34
16	-2.3	37.872	0	37.872	0	0	0	0	6.82	-9.74	0.31
18	-2.6	42.852	0	42.852	0	0	0	0	6.51	2.01	0.29
20	-2.9	47.273	0	47.273	0	0	0	0	10.06	15.21	0.27
22	-3.2	50.752	0	50.752	0	0	0	0	17.85	29.67	0.25
24	-3.5	52.787	0	52.787	0	0	0	0	30.21	45.08	0.24
26	-3.75	52.931	0	52.931	0	0	0	0	44.12	59.64	0.24
28	-4.05	50.897	0	50.897	0	0	0	0	24.14	-62.69	0.26
30	-4.35	47.129	0	47.129	0	0	0	0	8.73	-47.68	0.29
32	-4.65	46.385	0	46.385	0	0	0	0	-2.44	-33.88	0.33
34	-4.95	51.082	0	51.082	0	0	0	0	-9.43	-19.61	0.37
36	-5.25	55.625	0	55.625	0	0	0	0	-11.81	-3.94	0.4
38	-5.55	59.769	0	59.769	0	0	0	0	-9.19	13.06	0.42
40	-5.85	63.207	0	63.207	0	0	0	0	-1.19	31.27	0.44
42	-6.15	65.56	0	65.56	0	0	0	0	12.48	50.43	0.47
44	-6.4	66.389	0	66.389	0	0	0	0	9.11	-61.54	0.49
46	-6.7	66.109	0	66.109	0	0	0	0	-4.87	-41.62	0.52
48	-7	64.895	6.828	64.895	6.828	0	0	0	-12.92	-21.94	0.55
50	-7.3	63.163	36.081	63.163	36.081	0	0	0	-15.93	-6.84	0.57
52	-7.6	70.333	39.459	70.333	39.459	0	0	0	-16.46	-0.82	0.58
54	-7.9	69.845	59.379	69.845	59.379	0	0	0	-14.86	6.91	0.59
56	-8.2	69.489	65.699	69.489	65.699	0	0	0	-12.17	9.42	0.59
58	-8.5	69.338	69.977	69.338	69.977	0	0	0	-9.14	10.21	0.58
60	-8.8	71.359	74.626	68.359	71.626	0	3	3	-6.15	9.81	0.57
62	-9.1	73.646	79.09	67.646	73.09	0	6	6	-3.45	8.66	0.56
64	-9.4	77.365	83.423	68.365	74.423	0	9	9	-1.24	6.89	0.55
66	-9.7	82.351	87.674	70.351	75.674	0	12	12	0.42	5.13	0.53
68	-10	87.364	91.881	72.364	76.881	0	15	15	1.61	3.59	0.52
70	-10.3	92.369	96.073	74.369	78.073	0	18	18	2.39	2.29	0.5
72	-10.6	97.342	100.27	76.342	79.273	0	21	21	2.84	1.24	0.49
74	-10.9	102.26	104.49	78.269	80.495	0	24	24	3.02	0.42	0.48
76	-11.2	107.13	108.74	80.139	81.747	0	27	27	3	-0.2	0.47
78	-11.5	111.95	113.03	81.95	83.034	0	30	30	2.84	-0.64	0.46
80	-11.8	116.70	117.35	83.703	84.355	0	33	33	2.58	-0.94	0.45
82	-12.1	121.40	121.70	85.401	85.709	0	36	36	2.26	-1.1	0.44
84	-12.4	126.05	126.09	87.05	87.092	0	39	39	1.91	-1.17	0.44

86	-12.7	130.65	130.49	88.657	88.499	0	42	42	1.55	-1.17	0.43
88	-13	135.23	134.92	90.23	89.925	0	45	45	1.22	-1.11	0.43
90	-13.3	139.77	139.36	91.775	91.365	0	48	48	0.9	-1.01	0.42
92	-13.6	144.3	143.81	93.3	92.814	0	51	51	0.63	-0.88	0.42
94	-13.9	148.81	148.26	94.81	94.267	0	54	54	0.4	-0.73	0.42
96	-14.2	153.31	152.72	96.311	95.72	0	57	57	0.22	-0.57	0.42
98	-14.5	157.80	157.17	97.807	97.171	0	60	60	0.09	-0.39	0.41
100	-14.8	162.3	161.61	99.3	98.618	0	63	63	0.01	-0.19	0.41
102	-15	165.3	164.58	100.3	99.58	0	65	65	0	-0.02	0.41

P168.3x10/40 Stage: 7

Wall	EL	Sht L	Sht R	Shs L	Shs R	q	U L	U R	M	V	dx
Nod	(m)	(kPa)	(kPa)	(kPa)	(kPa)	(kPa)	(kPa)	(kPa)	(kN-	(kN/m)	(cm)
0	0	41.507	0	41.507	0	0	0	0	0	3.11	0.74
2	-0.3	42.761	0	42.761	0	0	0	0	1.88	9.43	0.66
4	-0.6	43.806	0	43.806	0	0	0	0	7.61	22.35	0.58
6	-0.9	44.121	0	44.121	0	0	0	0	17.28	35.53	0.51
8	-1.2	42.826	0	42.826	0	0	0	0	30.91	48.71	0.45
10	-1.4	40.54	0	40.54	0	0	0	0	27.46	-40.65	0.41
12	-1.7	35.377	0	35.377	0	0	0	0	17.95	-28.84	0.37
14	-2	33.304	0	33.304	0	0	0	0	11.62	-18.68	0.33
16	-2.3	38.566	0	38.566	0	0	0	0	8.33	-8.29	0.3
18	-2.6	43.511	0	43.511	0	0	0	0	8.5	3.66	0.28
20	-2.9	47.845	0	47.845	0	0	0	0	12.59	17.06	0.26
22	-3.2	51.172	0	51.172	0	0	0	0	20.97	31.68	0.24
24	-3.5	52.977	0	52.977	0	0	0	0	33.96	47.2	0.24
26	-3.75	52.855	0	52.855	0	0	0	0	48.41	61.79	0.24
28	-4.05	50.402	0	50.402	0	0	0	0	29.05	-60.63	0.27
30	-4.35	46.09	0	46.09	0	0	0	0	14.22	-45.81	0.31
32	-4.65	44.661	0	44.661	0	0	0	0	3.53	-32.37	0.36
34	-4.95	48.522	0	48.522	0	0	0	0	-3.12	-18.68	0.41
36	-5.25	52.069	0	52.069	0	0	0	0	-5.41	-3.85	0.46
38	-5.55	55.054	0	55.054	0	0	0	0	-3.01	12.01	0.51
40	-5.85	57.176	0	57.176	0	0	0	0	4.33	28.71	0.56
42	-6.15	58.073	0	58.073	0	0	0	0	16.82	45.95	0.6
44	-6.4	57.605	0	57.605	0	0	0	0	11.21	-72.88	0.65
46	-6.7	55.727	0	55.727	0	0	0	0	-6.78	-55.71	0.71
48	-7	52.966	0	52.966	0	0	0	0	-19.77	-39.19	0.77
50	-7.3	49.863	0	49.863	0	0	0	0	-27.98	-23.53	0.81
52	-7.6	59.914	5.983	59.914	5.983	0	0	0	-31.71	-8.8	0.85
54	-7.9	58.929	23.933	58.929	23.933	0	0	0	-30.93	5.95	0.87
56	-8.2	60.168	41.882	60.168	41.882	0	0	0	-26.98	15.14	0.87
58	-8.5	62.107	59.832	62.107	59.832	0	0	0	-21.38	19.42	0.86
60	-8.8	65.969	70.81	62.969	67.81	0	3	3	-15.48	19.57	0.85
62	-9.1	69.83	78.378	63.83	72.378	0	6	6	-10.01	17.6	0.82
64	-9.4	73.692	82.523	64.692	73.523	0	9	9	-5.31	15.01	0.79
66	-9.7	77.553	86.491	65.553	74.491	0	12	12	-1.41	12.35	0.76
68	-10	81.415	90.358	66.415	75.358	0	15	15	1.69	9.67	0.73
70	-10.3	85.277	94.188	67.277	76.188	0	18	18	3.99	6.99	0.7
72	-10.6	90.369	98.029	69.369	77.029	0	21	21	5.49	4.37	0.67
74	-10.9	95.916	101.91	71.916	77.914	0	24	24	6.31	2.2	0.64
76	-11.2	101.34	105.86	74.347	78.864	0	27	27	6.58	0.51	0.61
78	-11.5	106.65	109.89	76.653	79.89	0	30	30	6.44	-0.74	0.59
80	-11.8	111.83	113.99	78.834	80.992	0	33	33	6.02	-1.63	0.57
82	-12.1	116.89	118.16	80.897	82.169	0	36	36	5.39	-2.21	0.56
84	-12.4	121.85	122.41	82.854	83.414	0	39	39	4.65	-2.53	0.54
86	-12.7	126.71	126.71	84.717	84.716	0	42	42	3.86	-2.65	0.53
88	-13	131.50	131.06	86.504	86.065	0	45	45	3.07	-2.62	0.52

90	-13.3	136.22	135.44	88.228	87.449	0	48	48	2.32	-2.46	0.52
92	-13.6	140.90	139.85	89.906	88.858	0	51	51	1.64	-2.21	0.51
94	-13.9	145.55	144.28	91.551	90.281	0	54	54	1.05	-1.87	0.5
96	-14.2	150.17	148.71	93.174	91.71	0	57	57	0.58	-1.48	0.5
98	-14.5	154.78	153.13	94.786	93.138	0	60	60	0.23	-1.02	0.49
100	-14.8	159.39	157.56	96.392	94.56	0	63	63	0.04	-0.52	0.49
102	-15	162.46	160.50	97.462	95.504	0	65	65	0	-0.05	0.48

LEGENDA

Wall node=number of the node

EL=elevation

Sht L=Total horizontal soil pressure (on the left side of the wall)

Sht R=Total horizontal soil pressure (on the right side of the wall)

Shs L=Effective horizontal soil pressure (on the left side of the wall)

Shs R=Effective horizontal soil pressure (on the right side of the wall)

q=pressure given by the surcharge

U L=Water pressure (on the left side of the wall)

U R=pressione acqua (on the right side of the wall)

M=bending moment (per meter)

V=shear (per metro)

dx=wall deflection

McapL=Ultimate bending moment (on the left side of the wall)

McapR=Ultimate bending moment (on the right side of the wall)

VcapL=Ultimate resistance shear (on the left side of the wall)

VcapR=Ultimate resistance shear (on the right side of the wall)

SUPPORTS REACTIONS (TIEBACKS, STRUTS, SLABS, RAKERS)**Support 0**

Stage No	R
	(kN)
0	0
1	0
2	240
3	249.168
4	244.704
5	241.92
6	243.84
7	243.192

Support 1

Stage No	R
	(kN)
0	0
1	0
2	0
3	0
4	340.08
5	361.896
6	349.32
7	349.44

Support 2

Stage No	R
	(kN)
0	0
1	0

0	DM08_ITA	1: A1+M1+R1	1	1	1	0	1.3	1.5	1.2	1.1	1.3	1	1.3	1	1.35	0.9	1	1
1	DM08_ITA	1: A1+M1+R1	1	1	1	0	1.3	1.5	1.2	1.1	1.3	1	1.3	1	1.35	0.9	1	1
2	DM08_ITA	1: A1+M1+R1	1	1	1	0	1.3	1.5	1.2	1.1	1.3	1	1.3	1	1.35	0.9	1	1
3	DM08_ITA	1: A1+M1+R1	1	1	1	0	1.3	1.5	1.2	1.1	1.3	1	1.3	1	1.35	0.9	1	1
4	DM08_ITA	1: A1+M1+R1	1	1	1	0	1.3	1.5	1.2	1.1	1.3	1	1.3	1	1.35	0.9	1	1
5	DM08_ITA	1: A1+M1+R1	1	1	1	0	1.3	1.5	1.2	1.1	1.3	1	1.3	1	1.35	0.9	1	1
6	DM08_ITA	1: A1+M1+R1	1	1	1	0	1.3	1.5	1.2	1.1	1.3	1	1.3	1	1.35	0.9	1	1
7	DM08_ITA	1: A1+M1+R1	1	1	1	0	1.3	1.5	1.2	1.1	1.3	1	1.3	1	1.35	0.9	1	1

SOIL DATA

Name	g tot (kN/m3)	g dry (kN/m3)	Frict (deg)	C' (kPa)	Su (kPa)	FRp (deg)	FRcv (deg)	Eload (kPa)	Eur (kPa)	kAp Springs	kPp Springs	kAcv Springs	kPcv Springs	Vary	Spring Model	Color
F	20	19	30	0	N/A	N/A	N/A	15000	45000	0.33	3	N/A	N/A	True	Linear	
O1	16.5	14	22	2	20	22	22	2874	8622	0.46	2.2	0.46	2.2	True	Linear	
O2	19	16.5	28	2	N/A	N/A	N/A	7185	21555	0.36	2.77	N/A	N/A	True	Linear	
S1	21	19	34	0	N/A	N/A	N/A	25000	75000	0.28	3.54	N/A	N/A	True	Linear	
Clay	20	19	28	0	150	28	28	20000	60000	0.36	2.77	0.36	2.77	True	Linear	
GT	22	20	36	10	N/A	N/A	N/A	30000	90000	0.26	3.85	N/A	N/A	True	Linear	
Rock	27	25	30	100	N/A	N/A	N/A	479000	143700	0.33	3	N/A	N/A	True	Linear	
Rileva	18	18	32	0	N/A	N/A	N/A	30000	30000	0.31	3.26	N/A	N/A	True	Linear	
Base	18	18	25	0	N/A	N/A	N/A	25000	25000	0.41	2.46	N/A	N/A	True	Linear	

gtot=total soil specific weight

gdry=dry weight of the soil

Frict=friction angle

C'=effective cohesion

Su = Undrained cohesion (only for CLAY soils in undrained conditions)

Dilat=Soil Dilatancy (only for non linear analysis)

Evc=Virgin compression elastic module

Eur=unloading/reloading elastic module

Kap= Peak active thrust coeff

Kpp= Peak passive thrust coeff

Kacv= Constant volume active thrust coeff

Kpcv= Constant volume passive thrust coeff

Spring models= spring model (LIN=constant over the soil layer height , EXP=exponential ,

SIMC=simplified winkler)

LIN= Linear-Elastic-Perfectly Plastic,

EXP: Exponential, SUB: Modulus of Subgrade Reaction

SOIL BORINGS

Top Elev= superior SOil level

Soil type=type of the soil (sand , clay , etc)

OCR=overconsolidation ratio

K0=at rest coefficient

Name: Boring 1, pos: (-20, 0)

Top elev.	Soil type	OCR	Ko
0	Rilevato	1	0.47
-7.5	Base	1	0.58

STRUCTURAL MATERIALS DATA

Steel

Name	Strength Fy (MPa)	Fu (MPa)	Elastic E (MPa)	Density g (kN/m3)
Fe360	235	360	206000	77
Fe510	355	510	206000	77
A36	248.3	400	206000	77
A50	355	500	206000	77
New steel 4	241.4	413.8	206000	77

Concrete

Name	Strength f_c' (MPa)	Elastic E (MPa)	Density g (kN/m ³)	Tension Strength (MPa)
C20/25	20	29962	25	10
C25/30	25	31476	25	10
f_c 3ksi	20.7	21541.8	23.573	10

Steel rebar

Name	Strength f_y (MPa)	Elastic E (MPa)
S1860 (Strands)	1670	210000
Grade 75	517.2	200100
Grade 80	551.7	200100
Grade 150	1034.5	200100
Strands 270 ksi	1862.1	200100
S410	410	210000
S500	500	210000
B450C	450	210000

Wood

Name	Ultimate Bending (MPa)	Ultimate Tensile Strength (MPa)	Ultimate Shear Strength (MPa)	Density g (kN/m ³)	Elastic E (MPa)
Construction	11	9.7	5.5	7.8576	6900
Regular grade	6.9	6.9	4.1	7.8576	5520

STEEL

Name=material name

$f_y=f_{yk}$ =characteristic resistance for steel (for all the codes)

$F_u=f_{uk}$ =ultimate resistance for steel (for all the codes)

Elastic E=Elastic modulus

Density g=specific weight

CONCRETE

Name=material name

$f'_c=f_{ck}$ =cylindrical resistance for concrete (for all the codes)

Elastic E=Elastic modulus

Density g=specific weight

Tension strength= $f_t=f_{ctk}$ =characteristic tension resistance for concrete

STEEL REBARS

Name=material name

$f_y=f_{yk}$ =characteristic resistance for steel (for all the codes)

$F_u=f_{uk}$ =ultimate resistance for steel (for all the codes)

Elastic E=Elastic modulus

Density g=specific weight

WOOD

Name=material name

$F_b=f_{bk}$ =Ultimate bending strength

$F_t=f_{tk}$ =Ultimate tensile strength

$F_v=f_{vk}$ =Ultimate shear strength

Density g=specific weight

Elastic E=Elastic modulus

WALL DATA

Wall section 0: P168.3x10/40

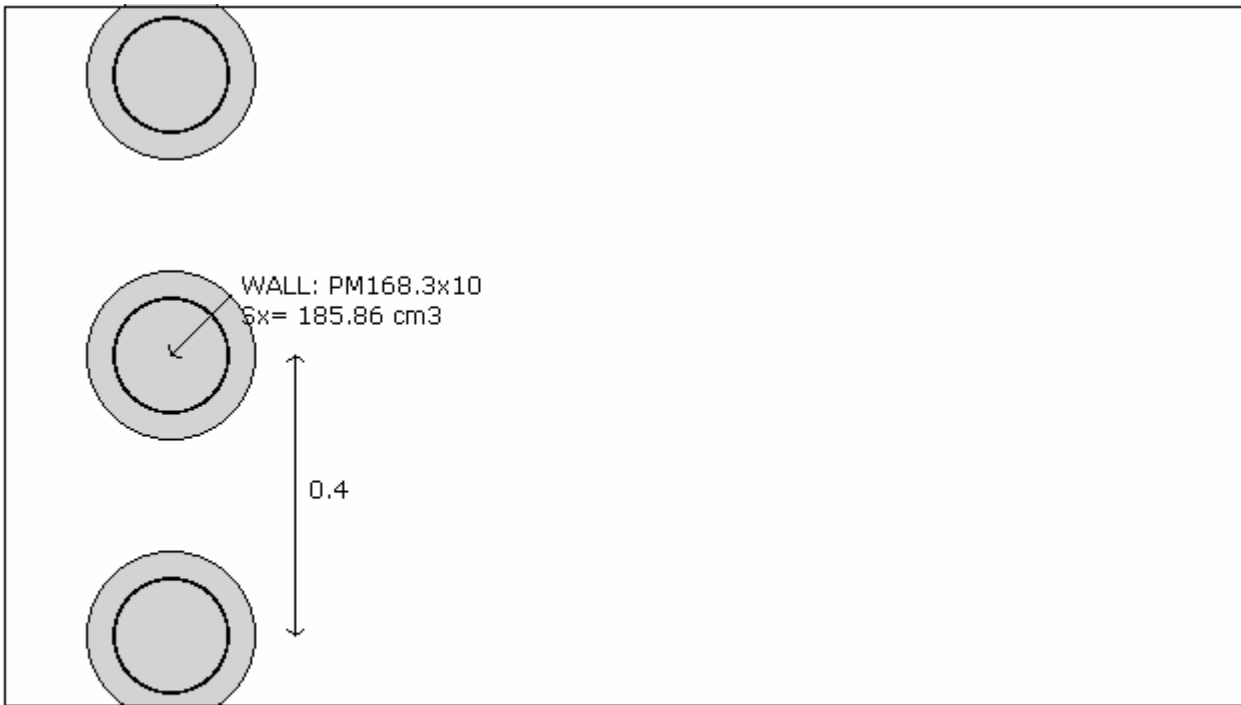

Company: My Company	Wall sketch	CeAS srl and Deep Excavation LCC
Engineer: Engineer		Paratie Plus 2010 - DeepXcar 2010
C:\nd.28_sera\otto3\alleg\LIII_typ3_rev27oct10_EQscavo_Alleg.DEEP		10/28/2010

Wall uses wall section 0: P168.3x10/40

Wall type: Tangent pile wall

Top wall El: 0 m Bottom wall El: -15 m

Hor. wall spacing: 0.4 Wall thickness = 0.24

Passive width below exc: 0.4 Active width below exc: 0.4

Concrete $f_c' = 25$ Rebar $F_y = 410$ $E_{conc} = 31476$ Concrete tension $F_{cT} = 10\%$ of F_c'

Steel members $f_y = 355$ $E_{steel} = 206000$

Wall friction: Percentage of Soil Friction = 50%

Steel wall capacities are calculated with NTC 2008

Concrete capacities are calculated with ACI 318-2002.

Note: With ultimate capacities you may have to use a structural safety factor.

Tangent pile wall soldier pile properties

Table: Soldier Pile Properties

Name	Section	W	A	D	tw or	bf	tf	k	Ixx	Sxx	rX	Iyy	Syy	rY	rT	Cw	fy
		(kN/m)	(cm ²)	(cm)	(cm)	(cm)	(cm)	(cm)	(cm ⁴)	(cm ³)	(cm)	(cm ⁴)	(cm ³)	(cm)	(cm)	(cm ⁶)	(MPa)
	PM16	254.7	74.85	16.8	1	16.83	1	1	3705	185.9	7.04	3705	185.9	7.04	7.04	1	355

GENERAL WALL DATA

Hor wall spacing=wall horizontal spacing

Passive width below exc=spacing for passive thrust pressure for classic analysis

$f'c=fck$ =cylindrical concrete resistance

$fyk=fyk$ =steel rebar characteristic resistance

E_{conc} =Concrete Elastic modulus

f_{ctk} =characteristic Concrete tension

E_{steel} =steel elastic modulus

TABULAR DATA (principal parameters)

1) Diaphragm wall (rectangular cross section section)

N/A= data not available

$F_y=fyk$

$F'c=fck$

D=wall height

B=wall width

2)Steel sheet pile

DES=shape (Z or U)

W=width per unit of length

A=area

h=height

t=horiz part thickness

b=width of the single sheet pile part

s=inclined part thickness

I_{xx} =strong axis inertia (per unit of length)

S_{xx} =strong axis section modulus (per unit of length)

3)Secant piles wall, Tangent piles wall, soldier piles, soldier piles and timber lagging

W=weight per unit of length

A=area

D=diameter

tw=web thickness

tp= pipe thickness

bf=flange width

tf=flange thickness

k=flange thickness+stem thickness

I_{xx} =strong axis inertia modulus (per unit of length)

S_{xx} =strong axis section modulus (per unit of length)

r_x =radius of gyration about X axis

r_y =radius of gyration about Y axis

I_{yy} =weak axis inertia modulus (per unit of length)

S_{yy} =weak axis section modulus (per unit of length)

r_T =radius of gyration for torsion

C_w =warping constant

TIEBACK DATA

Name	F_y	$F'c$	D_{fix}	A_{fix}	E_{fix}	A_{free}	E_{free}	Pa STR	Pu STR	PresGr	FSgeo	UserGca	Pa	Pu	WireMod
	(MPa)	(MPa)	(cm)	(cm ²)	(MPa)	(cm ²)	(MPa)	(kN)	(kN)	(kPa)			(kN)	(kN)	Yes/No
4-Strands	1862.1	25	15	176.7	31476	2.8	200100	453.4	453.4	N/A	1.4	False	N/A	N/A	Yes
5-Strands	1862.1	25	15	176.7	31476	2.8	200100	453.4	453.4	N/A	1.4	False	N/A	N/A	Yes
6-Strands	1862.1	25	15	176.7	31476	1.4	200100	226.7	226.7	N/A	1.4	False	N/A	N/A	Yes
Tieback_	1670	25	16	201.0	31476	4.17	210000	605.2	605.2	N/A	1	False	N/A	N/A	Yes
Tieback_	1670	25	16	201.0	31476	6.95	210000	1008.7	1008.7	N/A	1.4	False	N/A	N/A	Yes
Tieback_	1670	25	16	201.0	31476	5.56	210000	807	807	N/A	1	False	N/A	N/A	Yes

EXCAVATION STAGES SKETCHES

A sequence of figures for each excavation stage is reported

GENERAL ANALYSIS CRITERIA

Summary of stage assumptions

Name	Analysis	Drive	ka-Mult	Htr	Resist	Res	Contl	Supp	Axial	Used	Min	Toe	Toe
	Method	Press		(%)	Press	Mult	Meth	Mode	Incl	FSwall	FDtoe	FSrot	FSpas
Stage 0	Springs-Up	Ka+ d	N/A	N/A	Kp+ d	N/A		Fixed	N/A	1	8.809	10.47	8.809
Stage 1	Springs-Up	Ka+ d	N/A	N/A	Kp+ d	N/A		Fixed	N/A	1	5.196	5.196	5.467
Stage 2	Springs-Up	FHWA	1.3	m=	Kp+ d	N/A		Fixed	N/A	1	5.65	5.65	N/A
Stage 3	Springs-Up	FHWA	1.3	m=	Kp+ d	N/A		Fixed	N/A	1	3.667	3.667	N/A
Stage 4	Springs-Up	FHWA	1.3	m=	Kp+ d	N/A		Fixed	N/A	1	3.613	3.777	3.613
Stage 5	Springs-Up	FHWA	1.3	m=	Kp+ d	N/A		Fixed	N/A	1	2.044	2.044	19.63
Stage 6	Springs-Up	FHWA	1.3	m=	Kp+ d	N/A		Fixed	N/A	1	2.185	2.185	149.2
Stage 7	Springs-Up	FHWA	1.3	m=	Kp+ d	N/A		Fixed	N/A	1	1.703	1.703	12.80

Name=excavation phase name

Analysis method

springs=elasto plastic springs are used

DR=Drained condition for CLAY model

U=Undrained condition for CLAY model for all the soils

Up=Undrained condition just for selected soil

Drive press=Ka

ka mult=multiply factor for Ka

Htr T/B (%)=trapezoidal pressure scheme

Resit press=Kp

Res Mult=Multiply factor for Kp

COntle Method=cantilver method

Support Model=Fix support type

Axial Incl=Axial action is included for design

Used FS wall=Reduction factor for axial+bending resistance dominium

Min FD TOe=embedded minimum safety factor (for classic analysis)

Toe FS rot=rotation safety factor (classic for classic analysis)

Toe FSpas=driving/resistent pressure safety factor (for classic analysis)

SEISMIC DATA

Seismic action is modeled through a pseudo static approach

Summary of stage assumptions

Stage	Seismic g	Method	aX	aY	Beta	Building Code
Number	Used	Used	(g)	(g)		(Name)
0	No		0.026	0	1	N/A
1	No		0.026	0	1	N/A
2	No		0.026	0	1	N/A
3	No		0.026	0	1	N/A
4	No		0.026	0	1	N/A
5	No		0.026	0	1	N/A
6	No		0.026	0	1	N/A
7	No		0.026	0	1	N/A

N/A= data non available

Stage number=number of stage input

Seismic ag =value of design acceleration according to a code or input by the user

Method=the method used to evaluated the seismic thrustover the wall

ahd or khd otr axd=design horizontal acceleration

avd or kvd or ayd=design vertical acceleration

Beta=multip coeff for the semirigd approach

Buildind code=code used for design acceleration calculation

SUPPORTS PROPERTIES

Support 0: type = tieback

X = 0.24 m, Z = -1.25 m, S = 2.4 m

Lfree = 9.1 m, Lfix = 10 m, Rfix = 50 %

Walls: P168.3x10/40

Stage No	Active	Prestress	Slab live load	User add. strain
	Yes/No	(kN)	(kPa)	+expansion
0	No	-	-	-
1	No	-	-	-
2	Yes	240	-	-
3	Yes	-	-	-
4	Yes	-	-	-
5	Yes	-	-	-
6	Yes	-	-	-
7	Yes	-	-	-

Support 1: type = tieback

X = 0.24 m, Z = -3.75 m, S = 2.4 m

Lfree = 8 m, Lfix = 12 m, Rfix = 50 %

Walls: P168.3x10/40

Stage No	Active	Prestress	Slab live load	User add. strain
	Yes/No	(kN)	(kPa)	+expansion
0	No	-	-	-
1	No	-	-	-
2	No	-	-	-
3	No	-	-	-
4	Yes	340	-	-
5	Yes	-	-	-
6	Yes	-	-	-
7	Yes	-	-	-
8	Yes	-	-	-

Support 2: type = tieback

X = 0.24 m, Z = -6.25 m, S = 2.4 m

Lfree = 6 m, Lfix = 12 m, Rfix = 50 %

Walls: P168.3x10/40

Stage No	Active	Prestress	Slab live load	User add. strain
	Yes/No	(kN)	(kPa)	+expansion
0	No	-	-	-
1	No	-	-	-
2	No	-	-	-
3	No	-	-	-
4	No	-	-	-
5	No	-	-	-
6	Yes	340	-	-
7	Yes	-	-	-
8	Yes	-	-	-

Support type

LEGENDA for TIEBACKS

General data

Z=support level

S=horizontal distance between each tieback

Lfree=free length

Lfix=rigid body length

Rfix=% effective part of the rigid body length

Stage No=excavation steps number

Active=tieback status (YES=active)

Post stress= tieback preload (Load considering the horiz distance bewteen the tiebacks)

SURFACE LOADS

Surcharge 0: X1 = -24, X2 = 0

Variable surcharge

Stage No	Active	X1	Z1	qX1	qZ1	X2	Z2	qX2	qZ2
	Yes/No	(m)	(m)	(kPa)	(kPa)	(m)	(m)	(kPa)	(kPa)
0	No	-24	0	0	20	0	0	0	20
1	Yes	-24	0	0	20	0	0	0	20
2	Yes	-24	0	0	20	0	0	0	20
3	Yes	-24	0	0	20	0	0	0	20
4	Yes	-24	0	0	20	0	0	0	20
5	Yes	-24	0	0	20	0	0	0	20
6	Yes	-24	0	0	20	0	0	0	20
7	Yes	-24	0	0	20	0	0	0	20

LEGENDA

Stage No=Excavation step number

Active=load status (Yes=active)

X1=first X coordinate position of the load

Z1=first Z coordinate position of the load

qX1=first horizontal point load value

qZ1=first vertical point load value

X2=second X coordinate position of the load

Z2=second Z coordinate position of the load

qX2=second horizontal point load value

qZ2=second vertical point load value

WALL RESULTS TABLE

LEGENDA

Wall node=number of the node

EL=elevation

Sht L=Total horizontal soil pressure (on the left side of the wall)

Sht R=Total horizontal soil pressure (on the right side of the wall)

Shs L=Effective horizontal soil pressure (on the left side of the wall)

Shs R=Effective horizontal soil pressure (on the right side of the wall)

q=pressure given by the surcharge

U L=Water pressure (on the left side of the wall)

U R=pressione acqua (on the right side of the wall)

M=bending moment (per meter)

V=shear (per metro)

dx=wall deflection

McapL=Ultimate bending moment (on the left side of the wall)

McapR=Ultimate bending moment (on the right side of the wall)

VcapL=Ultimate resistance shear (on the left side of the wall)

VcapR=Ultimate resistance shear (on the right side of the wall)

SUPPORTS REACTIONS (TIEBACKS, STRUTS, SLABS, RAKERS)

Support 0

Stage No	R (kN)
0	0
1	0
2	312
3	325.385
4	319.613
5	315.775
6	318.24
7	317.366

Support 1

Stage No	R (kN)
0	0
1	0
2	0
3	0
4	442.104
5	472.68
6	456.331
7	456.425

Support 2

Stage No	R (kN)
0	0
1	0
2	0
3	0
4	0
5	0
6	442.104
7	459.826

Project: My Project
Results for Design Section 2: DM08_ITA: Comb. 2:
A2+M2+R1

DESIGN APPROACHES AND COMBINATION FACTORS

The Design Approaches (from Codes or Customized by the user) and related safety factors are the following:

Ftan fr=mult factor for friction angle

F C'=mult factor for effective cohesion

F Su'=mult factof for undrained cohesion

F EQ=mult factor for seismic action

F perm load=mult factor for perm loads

F temp load=mult factor for live loads

F perm supp=reduct factor for resistance for pull out checking

F temp supp=fattore di riduzione resistance per verifica pull out tirante

F earth Dstab=mult factor for active press coeff , unfavorable

F earth stab=mult factor for passive pressure , favorable

F GWT Dstab (ground water)=mult factor for hydrostatic pressure , unfavorable

F GWT stab (ground water)=mult factor for hydrostatic pressure, favorable

F HYD Dstab=mult factor for hydrodynamic pressure, unfavorable

F HYD stab=mult factor for hydrodynamic pressure, favorable

F UPL Dstab=mult factor for hydraulic heave, unfavorable

Stage	Design Name	Design Case	F(tan fr)	F (c')	F (Su)	F (EO)	F(perm load)	F(temp load)	F(perm sup)	F(temp sup)	F Earth (Dstab)	F Earth (stab)	F GWT (Dstab)	F GWT (stab)	F HYD (Dstab)	F HYD (stab)	F UPL (Dstab)	F UPL (stab)
0	DM08_ITA	2: A2+M2+R1	1.25	1.25	1.4	0	1	1.3	1.2	1.1	1	1	1	1	1.35	0.9	1	1
1	DM08_ITA	2: A2+M2+R1	1.25	1.25	1.4	0	1	1.3	1.2	1.1	1	1	1	1	1.35	0.9	1	1
2	DM08_ITA	2: A2+M2+R1	1.25	1.25	1.4	0	1	1.3	1.2	1.1	1	1	1	1	1.35	0.9	1	1
3	DM08_ITA	2: A2+M2+R1	1.25	1.25	1.4	0	1	1.3	1.2	1.1	1	1	1	1	1.35	0.9	1	1
4	DM08_ITA	2: A2+M2+R1	1.25	1.25	1.4	0	1	1.3	1.2	1.1	1	1	1	1	1.35	0.9	1	1
5	DM08_ITA	2: A2+M2+R1	1.25	1.25	1.4	0	1	1.3	1.2	1.1	1	1	1	1	1.35	0.9	1	1
6	DM08_ITA	2: A2+M2+R1	1.25	1.25	1.4	0	1	1.3	1.2	1.1	1	1	1	1	1.35	0.9	1	1
7	DM08_ITA	2: A2+M2+R1	1.25	1.25	1.4	0	1	1.3	1.2	1.1	1	1	1	1	1.35	0.9	1	1

SOIL DATA

Name	g tot (kN/m3)	g dry (kN/m3)	Frict (deg)	C' (kPa)	Su (kPa)	FRp (deg)	FRcv (deg)	Eload (kPa)	Eur (kPa)	kAp Springs	kPp Springs	kAcv Springs	kPcv Springs	Vary	Spring Model	Color
F	20	19	30	0	N/A	N/A	N/A	15000	45000	0.33	3	N/A	N/A	True	Linear	
O1	16.5	14	22	2	20	22	22	2874	8622	0.46	2.2	0.46	2.2	True	Linear	
O2	19	16.5	28	2	N/A	N/A	N/A	7185	21555	0.36	2.77	N/A	N/A	True	Linear	
S1	21	19	34	0	N/A	N/A	N/A	25000	75000	0.28	3.54	N/A	N/A	True	Linear	
Clay	20	19	28	0	150	28	28	20000	60000	0.36	2.77	0.36	2.77	True	Linear	
GT	22	20	36	10	N/A	N/A	N/A	30000	90000	0.26	3.85	N/A	N/A	True	Linear	
Rock	27	25	30	100	N/A	N/A	N/A	479000	143700	0.33	3	N/A	N/A	True	Linear	
Rileva	18	18	32	0	N/A	N/A	N/A	30000	30000	0.31	3.26	N/A	N/A	True	Linear	
Base	18	18	25	0	N/A	N/A	N/A	25000	25000	0.41	2.46	N/A	N/A	True	Linear	

gtot=total soil specific weight

gdry=dry weight of the soil

Frict=friction angle

C'=effective cohesion

Su = Undrained cohesiona (only for CLAY soils in undrained conditions)

Dilat=SOil Dilatancy (only for non linear analysis)

Evc=Virgin compression elastic module

Eur=unloading/reloading elastic module

Kap= Peak active thrust coeff

Kpp= Peak passive thrust coeff

Kacv= Constant volume active thrust coeff

Kpcv= Constant volume passive thrust coeff

Spring models= spring model (LIN=constant over the soil layer height , EXP=exponential , SIMC=simplified winkler)

LIN= Linear-Elastic-Perfectly Plastic,

EXP: Exponential, SUB: Modulus of Subgrade Reaction

SOIL BORINGS

Top Elev= superior SOil level

Soil type=type of the soil (sand , clay , etc)

OCR=overconsolidation ratio

K0=at rest coefficient

Name: Boring 1, pos: (-20, 0)

Top elev.	Soil type	OCR	Ko
0	Rilevato	1	0.47
-7.5	Base	1	0.58

STRUCTURAL MATERIALS DATA

Steel

Name	Strength Fy (MPa)	Fu (MPa)	Elastic E (MPa)	Density g (kN/m3)
Fe360	235	360	206000	77
Fe510	355	510	206000	77
A36	248.3	400	206000	77
A50	355	500	206000	77
New steel 4	241.4	413.8	206000	77

Concrete

Name	Strength Fc' (MPa)	Elastic E (MPa)	Density g (kN/m3)	Tension Strength (MPa)
C20/25	20	29962	25	10
C25/30	25	31476	25	10
Fc 3ksi	20.7	21541.8	23.573	10

Steel rebar

Name	Strength Fy (MPa)	Elastic E (MPa)
S1860 (Strands)	1670	210000
Grade 75	517.2	200100
Grade 80	551.7	200100
Grade 150	1034.5	200100
Strands 270 ksi	1862.1	200100
S410	410	210000
S500	500	210000
B450C	450	210000

Wood

Name	Ultimate Bending (MPa)	Ultimate Tensile Strength (MPa)	Ultimate Shear Strength (MPa)	Density g (kN/m ³)	Elastic E (MPa)
Construction	11	9.7	5.5	7.8576	6900
Regular grade	6.9	6.9	4.1	7.8576	5520

STEEL

Name=material name

fy=fyk=characteristic resistance for steel (for all the codes)

Fu=fuk=ultimate resistance for steel (for all the codes)

Elastic E=Elastic modulus

Density g=specific weight

CONCRETE

Name=material name

f'c=fck=cylindrical resistance for concrete (for all the codes)

Elastic E=Elastic modulus

Density g=specific weight

Tension strength=ft=fctk=characteristic tension resistance for concrete

STEEL REBARS

Name=material name

fy=fyk=characteristic resistance for steel (for all the codes)

Fu=fuk=ultimate resistance for steel (for all the codes)

Elastic E=Elastic modulus

Density g=specific weight

WOOD

Name=material name

Fb=fbk=Ultimate bending strength

Ftu=ftuk=Ultimate tensile strength

Fvu=fvuk=Ultimate shear strength

Density g=specific weight

Elastic E=Elastic modulus

WALL DATA

Wall section 0: P168.3x10/40

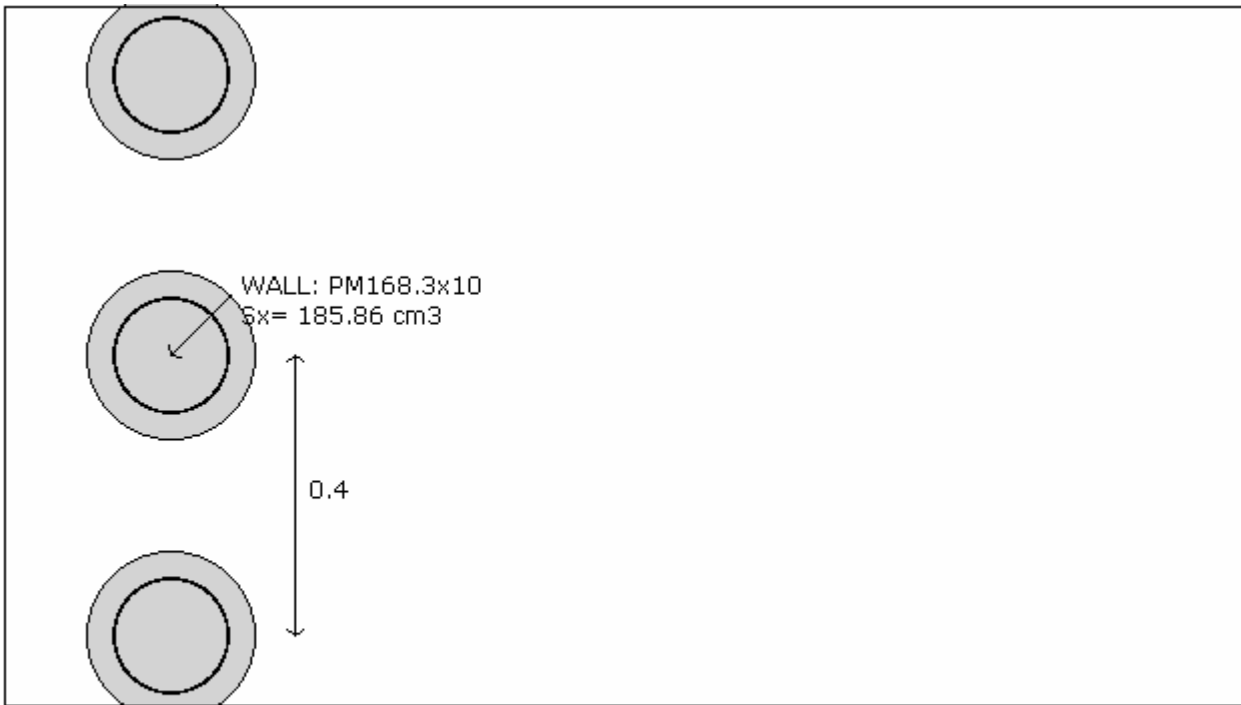

Company: My Company	Wall sketch	CeAS srl and Deep Excavation LCC
Engineer: Engineer		Paratie Plus 2010 - DeepXcar 2010
C:\nd.28_sera\otto3\alleg\LIII_typ3_rev27oct10_EQscavo_Alleg.DEEP		10/28/2010

Wall uses wall section 0: P168.3x10/40

Wall type: Tangent pile wall

Top wall El: 0 m Bottom wall El: -15 m

Hor. wall spacing: 0.4 Wall thickness = 0.24

Passive width below exc: 0.4 Active width below exc: 0.4

Concrete $f_c' = 25$ Rebar $F_y = 410$ $E_{conc} = 31476$ Concrete tension $F_{cT} = 10\%$ of F_c'

Steel members $f_y = 355$ $E_{steel} = 206000$

Wall friction: Percentage of Soil Friction = 50%

Steel wall capacities are calculated with NTC 2008

Concrete capacities are calculated with ACI 318-2002.

Note: With ultimate capacities you may have to use a structural safety factor.

Tangent pile wall soldier pile properties

Table: Soldier Pile Properties

Name	Section	W	A	D	tw or	bf	tf	k	Ixx	Sxx	rX	Iyy	Syy	rY	rT	Cw	fy
		(kN/m)	(cm ²)	(cm)	(cm)	(cm)	(cm)	(cm)	(cm ⁴)	(cm ³)	(cm)	(cm ⁴)	(cm ³)	(cm)	(cm)	(cm ⁶)	(MPa)
	PM16	254.7	74.85	16.8	1	16.83	1	1	3705	185.9	7.04	3705	185.9	7.04	7.04	1	355

GENERAL WALL DATA

Hor wall spacing=wall horizontal spacing

Passive width below exc=spacing for passive thrust pressure for classic analysis

$f'c=fck$ =cylindrical concrete resistance

$fyk=fyk$ =steel rebar characteristic resistance

E_{conc} =Concrete Elastic modulus

f_{ctk} =characteristic Concrete tension

E_{steel} =steel elastic modulus

TABULAR DATA (principal parameters)

1) Diaphragm wall (rectangular cross section section)

N/A= data not available

$F_y=fyk$

$F'c=fck$

D=wall height

B=wall width

2)Steel sheet pile

DES=shape (Z or U)

W=width per unit of length

A=area

h=height

t=horiz part thickness

b=width of the single sheet pile part

s=inclined part thickness

I_{xx} =strong axis inertia (per unit of length)

S_{xx} =strong axis section modulus (per unit of length)

3)Secant piles wall, Tangent piles wall, soldier piles, soldier piles and timber lagging

W=weight per unit of length

A=area

D=diameter

tw=web thickness

tp= pipe thickness

bf=flange width

tf=flange thickness

k=flange thickness+stem thickness

I_{xx} =strong axis inertia modulus (per unit of length)

S_{xx} =strong axis section modulus (per unit of length)

r_x =radius of gyration about X axis

r_y =radius of gyration about Y axis

I_{yy} =weak axis inertia modulus (per unit of length)

S_{yy} =weak axis section modulus (per unit of length)

r_T =radius of gyration for torsion

Cw=warping constant

TIEBACK DATA

Name	F_y	$F'c$	D_{fix}	A_{fix}	E_{fix}	A_{free}	E_{free}	Pa STR	Pu STR	PresGr	FSgeo	UserGca	Pa	Pu	WireMod
	(MPa)	(MPa)	(cm)	(cm ²)	(MPa)	(cm ²)	(MPa)	(kN)	(kN)	(kPa)			(kN)	(kN)	Yes/No
4-Strands	1862.1	25	15	176.7	31476	2.8	200100	453.4	453.4	N/A	1.4	False	N/A	N/A	Yes
5-Strands	1862.1	25	15	176.7	31476	2.8	200100	453.4	453.4	N/A	1.4	False	N/A	N/A	Yes
6-Strands	1862.1	25	15	176.7	31476	1.4	200100	226.7	226.7	N/A	1.4	False	N/A	N/A	Yes
Tieback_	1670	25	16	201.0	31476	4.17	210000	605.2	605.2	N/A	1	False	N/A	N/A	Yes
Tieback_	1670	25	16	201.0	31476	6.95	210000	1008.7	1008.7	N/A	1.4	False	N/A	N/A	Yes
Tieback_	1670	25	16	201.0	31476	5.56	210000	807	807	N/A	1	False	N/A	N/A	Yes

EXCAVATION STAGES SKETCHES

A sequence of figures for each excavation stage is reported

GENERAL ANALYSIS CRITERIA

Summary of stage assumptions

Name	Analysis	Drive	ka-Mult	Htr	Resist	Res	Contl	Supp	Axial	Used	Min	Toe	Toe
	Method	Press		(%)	Press	Mult	Meth	Mode	Incl	FSwall	FDtoe	FSrot	FSpas
Stage 0	Springs-Up	Ka+ d	N/A	N/A	Kp+ d	N/A		Fixed	N/A	1	7.084	8.181	7.084
Stage 1	Springs-Up	Ka+ d	N/A	N/A	Kp+ d	N/A		Fixed	N/A	1	4.168	4.168	4.472
Stage 2	Springs-Up	FHWA	1.3	m=	Kp+ d	N/A		Fixed	N/A	1	4.679	4.679	N/A
Stage 3	Springs-Up	FHWA	1.3	m=	Kp+ d	N/A		Fixed	N/A	1	3.052	3.052	N/A
Stage 4	Springs-Up	FHWA	1.3	m=	Kp+ d	N/A		Fixed	N/A	1	3.001	3.152	3.001
Stage 5	Springs-Up	FHWA	1.3	m=	Kp+ d	N/A		Fixed	N/A	1	1.714	1.714	10.55
Stage 6	Springs-Up	FHWA	1.3	m=	Kp+ d	N/A		Fixed	N/A	1	1.834	1.834	37.72
Stage 7	Springs-Up	FHWA	1.3	m=	Kp+ d	N/A		Fixed	N/A	1	1.43	1.43	7.055

Name=excavation phase name

Analysis method

springs=elasto plastic springs are used

DR=Drained condition for CLAY model

U=Undrained condition for CLAY model for all the soils

Up=Undrained condition just for selected soil

Drive press=Ka

ka mult=multiply factor for Ka

Htr T/B (%)=trapezoidal pressure scheme

Resit press=Kp

Res Mult=Multiply factor for Kp

COntle Method=cantilver method

Support Model=Fix support type

Axial Incl=Axial action is included for design

Used FS wall=Reduction factor for axial+bending resistance dominium

Min FD TOe=embedded minimum safety factor (for classic analysis)

Toe FS rot=rotation safety factor (classic for classic analysis)

Toe FSpas=driving/resistent pressure safety factor (for classic analysis)

SEISMIC DATA

Seismic action is modeled through a pseudo static approach

Summary of stage assumptions

Stage	Seismic g	Method	aX	aY	Beta	Building Code
Number	Used	Used	(g)	(g)		(Name)
0	No		0.026	0	1	N/A
1	No		0.026	0	1	N/A
2	No		0.026	0	1	N/A
3	No		0.026	0	1	N/A
4	No		0.026	0	1	N/A
5	No		0.026	0	1	N/A
6	No		0.026	0	1	N/A
7	No		0.026	0	1	N/A

N/A= data non available

Stage number=number of stage input

Seismic ag =value of design acceleration according to a code or input by the user

Method=the method used to evaluated the seismic thrustover the wall

ahd or khd otr axd=design horizontal acceleration

avd or kvd or ayd=design vertical acceleration

Beta=multip coeff for the semirigd approach

Buildind code=code used for design acceleration calculation

SUPPORTS PROPERTIES

Support 0: type = tieback

X = 0.24 m, Z = -1.25 m, S = 2.4 m

Lfree = 9.1 m, Lfix = 10 m, Rfix = 50 %

Walls: P168.3x10/40

Stage No	Active	Prestress	Slab live load	User add. strain
	Yes/No	(kN)	(kPa)	+expansion
0	No	-	-	-
1	No	-	-	-
2	Yes	240	-	-
3	Yes	-	-	-
4	Yes	-	-	-
5	Yes	-	-	-
6	Yes	-	-	-
7	Yes	-	-	-

Support 1: type = tieback

X = 0.24 m, Z = -3.75 m, S = 2.4 m

Lfree = 8 m, Lfix = 12 m, Rfix = 50 %

Walls: P168.3x10/40

Stage No	Active	Prestress	Slab live load	User add. strain
	Yes/No	(kN)	(kPa)	+expansion
0	No	-	-	-
1	No	-	-	-
2	No	-	-	-
3	No	-	-	-
4	Yes	340	-	-
5	Yes	-	-	-
6	Yes	-	-	-
7	Yes	-	-	-
8	Yes	-	-	-

Support 2: type = tieback

X = 0.24 m, Z = -6.25 m, S = 2.4 m

Lfree = 6 m, Lfix = 12 m, Rfix = 50 %

Walls: P168.3x10/40

Stage No	Active	Prestress	Slab live load	User add. strain
	Yes/No	(kN)	(kPa)	+expansion
0	No	-	-	-
1	No	-	-	-
2	No	-	-	-
3	No	-	-	-
4	No	-	-	-
5	No	-	-	-
6	Yes	340	-	-
7	Yes	-	-	-
8	Yes	-	-	-

Support type

LEGENDA for TIEBACKS

General data

Z=support level

S=horizontal distance between each tieback

Lfree=free length

Lfix=rigid body length

Rfix=% effective part of the rigid body length

Stage No=excavation steps number

Active=tieback status (YES=active)

Post stress= tieback preload (Load considering the horiz distance bewteen the tiebacks)

SURFACE LOADS

Surcharge 0: X1 = -24, X2 = 0

Variable surcharge

Stage No	Active	X1	Z1	qX1	qZ1	X2	Z2	qX2	qZ2
	Yes/No	(m)	(m)	(kPa)	(kPa)	(m)	(m)	(kPa)	(kPa)
0	No	-24	0	0	20	0	0	0	20
1	Yes	-24	0	0	20	0	0	0	20
2	Yes	-24	0	0	20	0	0	0	20
3	Yes	-24	0	0	20	0	0	0	20
4	Yes	-24	0	0	20	0	0	0	20
5	Yes	-24	0	0	20	0	0	0	20
6	Yes	-24	0	0	20	0	0	0	20
7	Yes	-24	0	0	20	0	0	0	20

LEGENDA

Stage No=Excavation step number

Active=load status (Yes=active)

X1=first X coordinate position of the load

Z1=first Z coordinate position of the load

qX1=first horizontal point load value

qZ1=first vertical point load value

X2=second X coordinate position of the load

Z2=second Z coordinate position of the load

qX2=second horizontal point load value

qZ2=second vertical point load value

WALL RESULTS TABLE

LEGENDA

Wall node=number of the node

EL=elevation

Sht L=Total horizontal soil pressure (on the left side of the wall)

Sht R=Total horizontal soil pressure (on the right side of the wall)

Shs L=Effective horizontal soil pressure (on the left side of the wall)

Shs R=Effective horizontal soil pressure (on the right side of the wall)

q=pressure given by the surcharge

U L=Water pressure (on the left side of the wall)

U R=pressione acqua (on the right side of the wall)

M=bending moment (per meter)

V=shear (per metro)

dx=wall deflection

McapL=Ultimate bending moment (on the left side of the wall)

McapR=Ultimate bending moment (on the right side of the wall)

VcapL=Ultimate resistance shear (on the left side of the wall)

VcapR=Ultimate resistance shear (on the right side of the wall)

SUPPORTS REACTIONS (TIEBACKS, STRUTS, SLABS, RAKERS)

Support 0

Stage No	R (kN)
0	0
1	0
2	240
3	261.528
4	256.368
5	248.64
6	250.704
7	248.376

Support 1

Stage No	R (kN)
0	0
1	0
2	0
3	0
4	340.08
5	412.104
6	397.848
7	394.08

Support 2

Stage No	R (kN)
0	0
1	0
2	0
3	0
4	0
5	0
6	340.08
7	381

Project: My Project

Results for Design Section 3: DM08_ITA: EQK - Seismic

DESIGN APPROACHES AND COMBINATION FACTORS

The Design Approaches (from Codes or Customized by the user) and related safety factors are the following:

Ftan fr=mult factor for friction angle

F C'=mult factor for effective cohesion

F Su'=mult factof for undrained cohesion

F EQ=mult factor for seismic action

F perm load=mult factor for perm loads

F temp load=mult factor for live loads

F perm supp=reduct factor for resistance for pull out checking

F temp supp=fattore di riduzione resistance per verifica pull out tirante

F earth Dstab=mult factor for active press coeff , unfavorable

F earth stab=mult factor for passive pressure , favorable

F GWT Dstab (ground water)=mult factor for hydrostatic pressure , unfavorable

F GWT stab (ground water)=mult factor for hydrostatic pressure, favorable

F HYD Dstab=mult factor for hydrodynamic pressure, unfavorable

F HYD stab=mult factor for hydrodynamic pressure, favorable

F UPL Dstab=mult factor for hydraulic heave, unfavorable

Stage	Design Name	Design Case	F(tan fr)	F (c')	F (Su)	F (EQ)	F(perm load)	F(temp load)	F(perm sup)	F(temp sup)	F Earth (Dstab)	F Earth (stab)	F GWT (Dstab)	F GWT (stab)	F HYD (Dstab)	F HYD (stab)	F UPL (Dstab)	F UPL (stab)
0	DM08_ITA	EQK - Seismic	1.25	1.25	1.4	1	1	1	1.2	1.1	1	1	1	1	1.35	0.9	1	1
1	DM08_ITA	EQK - Seismic	1.25	1.25	1.4	1	1	1	1.2	1.1	1	1	1	1	1.35	0.9	1	1
2	DM08_ITA	EQK - Seismic	1.25	1.25	1.4	1	1	1	1.2	1.1	1	1	1	1	1.35	0.9	1	1
3	DM08_ITA	EQK - Seismic	1.25	1.25	1.4	1	1	1	1.2	1.1	1	1	1	1	1.35	0.9	1	1
4	DM08_ITA	EQK - Seismic	1.25	1.25	1.4	1	1	1	1.2	1.1	1	1	1	1	1.35	0.9	1	1
5	DM08_ITA	EQK - Seismic	1.25	1.25	1.4	1	1	1	1.2	1.1	1	1	1	1	1.35	0.9	1	1
6	DM08_ITA	EQK - Seismic	1.25	1.25	1.4	1	1	1	1.2	1.1	1	1	1	1	1.35	0.9	1	1
7	DM08_ITA	EQK - Seismic	1.25	1.25	1.4	1	1	1	1.2	1.1	1	1	1	1	1.35	0.9	1	1
8	DM08_ITA	EQK - Seismic	1.25	1.25	1.4	1	1	1	1.2	1.1	1	1	1	1	1.35	0.9	1	1

SOIL DATA

Name	g tot (kN/m3)	g dry (kN/m3)	Frict (deg)	C' (kPa)	Su (kPa)	FRp (deg)	FRcv (deg)	Eload (kPa)	Eur (kPa)	kAp Springs	kPp Springs	kAcv Springs	kPcv Springs	Vary	Spring Model	Color
F	20	19	30	0	N/A	N/A	N/A	15000	45000	0.33	3	N/A	N/A	True	Linear	
O1	16.5	14	22	2	20	22	22	2874	8622	0.46	2.2	0.46	2.2	True	Linear	
O2	19	16.5	28	2	N/A	N/A	N/A	7185	21555	0.36	2.77	N/A	N/A	True	Linear	
S1	21	19	34	0	N/A	N/A	N/A	25000	75000	0.28	3.54	N/A	N/A	True	Linear	
Clay	20	19	28	0	150	28	28	20000	60000	0.36	2.77	0.36	2.77	True	Linear	
GT	22	20	36	10	N/A	N/A	N/A	30000	90000	0.26	3.85	N/A	N/A	True	Linear	
Rock	27	25	30	100	N/A	N/A	N/A	479000	143700	0.33	3	N/A	N/A	True	Linear	
Rileva	18	18	32	0	N/A	N/A	N/A	30000	30000	0.31	3.26	N/A	N/A	True	Linear	
Base	18	18	25	0	N/A	N/A	N/A	25000	25000	0.41	2.46	N/A	N/A	True	Linear	

gtot=total soil specific weight

gdry=dry weight of the soil

Frict=friction angle

C'=effective cohesion

Su = Undrained cohesiona (only for CLAY soils in undrained conditions)

Dilat=SOil Dilatancy (only for non linear analysis)

Evc=Virgin compression elastic module

Eur=unloading/reloading elastic module

Kap= Peak active thrust coeff

Kpp= Peak passive thrust coeff

Kacv= Constant volume active thrust coeff

Kpcv= Constant volume passive thrust coeff

Spring models= spring model (LIN=constant over the soil layer height , EXP=exponential ,

SIMC=simplified winkler)

LIN= Linear-Elastic-Perfectly Plastic,

EXP: Exponential, SUB: Modulus of Subgrade Reaction

SOIL BORINGS

Top Elev= superior SOil level

Soil type=type of the soil (sand , clay , etc)

OCR=overconsolidation ratio

K0=at rest coefficient

Name: Boring 1, pos: (-20, 0)

Top elev.	Soil type	OCR	Ko
0	Rilevato	1	0.47
-7.5	Base	1	0.58

STRUCTURAL MATERIALS DATA

Steel

Name	Strength Fy (MPa)	Fu (MPa)	Elastic E (MPa)	Density g (kN/m3)
Fe360	235	360	206000	77
Fe510	355	510	206000	77
A36	248.3	400	206000	77
A50	355	500	206000	77
New steel 4	241.4	413.8	206000	77

Concrete

Name	Strength Fc' (MPa)	Elastic E (MPa)	Density g (kN/m3)	Tension Strength (MPa)
C20/25	20	29962	25	10
C25/30	25	31476	25	10
Fc 3ksi	20.7	21541.8	23.573	10

Steel rebar

Name	Strength Fy	Elastic E
------	-------------	-----------

	(MPa)	(MPa)
S1860 (Strands)	1670	210000
Grade 75	517.2	200100
Grade 80	551.7	200100
Grade 150	1034.5	200100
Strands 270 ksi	1862.1	200100
S410	410	210000
S500	500	210000
B450C	450	210000

Wood

Name	Ultimate Bending (MPa)	Ultimate Tensile Strength (MPa)	Ultimate Shear Strength (MPa)	Density g (kN/m ³)	Elastic E (MPa)
Construction	11	9.7	5.5	7.8576	6900
Regular grade	6.9	6.9	4.1	7.8576	5520

STEEL

Name=material name

$f_y=f_{yk}$ =characteristic resistance for steel (for all the codes)

$F_u=f_{uk}$ =ultimate resistance for steel (for all the codes)

Elastic E=Elastic modulus

Density g=specific weight

CONCRETE

Name=material name

$f'_c=f_{ck}$ =cylindrical resistance for concrete (for all the codes)

Elastic E=Elastic modulus

Density g=specific weight

Tension strength= $f_t=f_{ctk}$ =characteristic tension resistance for concrete

STEEL REBARS

Name=material name

$f_y=f_{yk}$ =characteristic resistance for steel (for all the codes)

$F_u=f_{uk}$ =ultimate resistance for steel (for all the codes)

Elastic E=Elastic modulus

Density g=specific weight

WOOD

Name=material name

$F_b=f_{bk}$ =Ultimate bending strength

$F_t=f_{tk}$ =Ultimate tensile strength

$F_v=f_{vk}$ =Ultimate shear strength

Density g=specific weight

Elastic E=Elastic modulus

WALL DATA

Wall section 0: P168.3x10/40

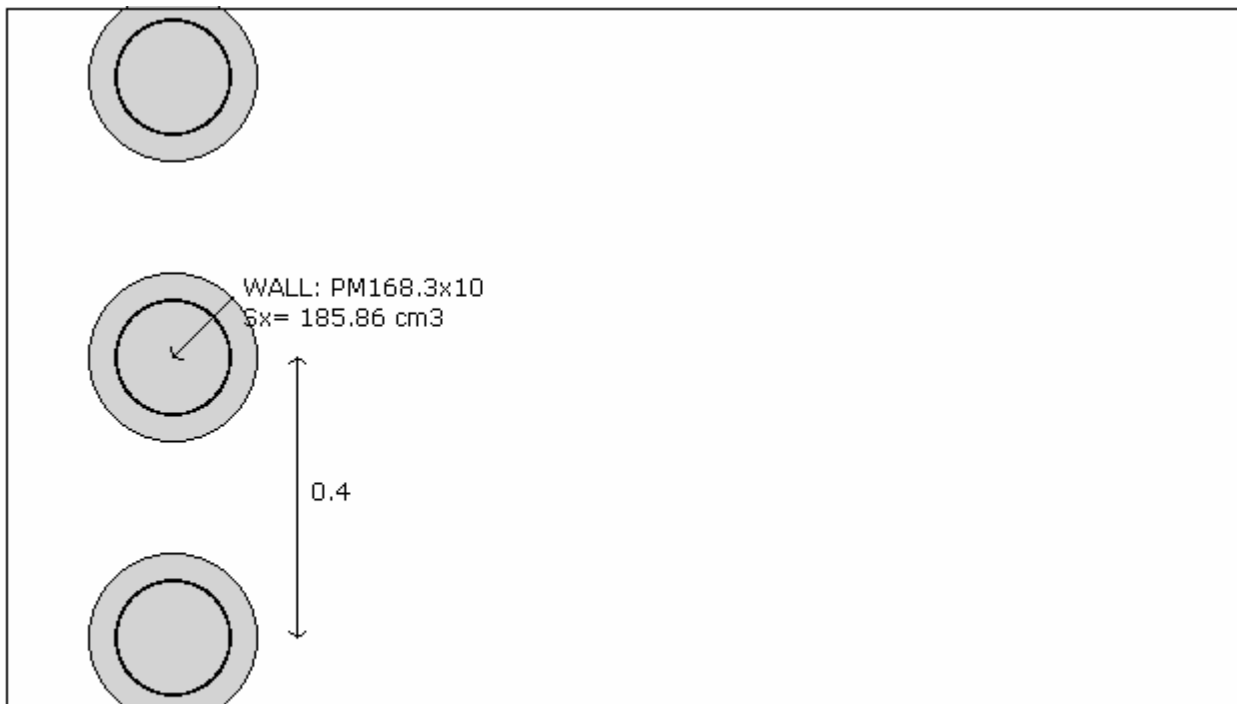

Company: My Company	Wall sketch	CeAS srl and Deep Excavation LCC
Engineer: Engineer		Paratie Plus 2010 - DeepXcar 2010
C:\nd.28_sera\otto3\alleg\LIII_typ3_rev27oct10_EQscavo_Alleg.DEEP		10/28/2010

Wall uses wall section 0: P168.3x10/40
 Wall type: Tangent pile wall
 Top wall El: 0 m Bottom wall El: -15 m
 Hor. wall spacing: 0.4 Wall thickness = 0.24
 Passive width below exc: 0.4 Active width below exc: 0.4
 Concrete $f_c' = 25$ Rebar $F_y = 410$ $E_{conc} = 31476$ Concrete tension $F_{cT} = 10\%$ of F_c'
 Steel members $f_y = 355$ $E_{steel} = 206000$
 Wall friction: Percentage of Soil Friction = 50%
 Steel wall capacities are calculated with NTC 2008
 Concrete capacities are calculated with ACI 318-2002.
 Note: With ultimate capacities you may have to use a structural safety factor.
 Tangent pile wall soldier pile properties

Table: Soldier Pile Properties

Name	Section	W	A	D	tw or	bf	tf	k	Ixx	Sxx	rX	Iyy	Syy	rY	rT	Cw	fy
		(kN/m)	(cm ²)	(cm)	(cm)	(cm)	(cm)	(cm)	(cm ⁴)	(cm ³)	(cm)	(cm ⁴)	(cm ³)	(cm)	(cm)	(cm ⁶)	(MPa)
	PM16	254.7	74.85	16.8	1	16.83	1	1	3705	185.9	7.04	3705	185.9	7.04	7.04	1	355

GENERAL WALL DATA

Hor wall spacing=wall horizontal spacing

Passive width below exc=spacing for passive thrust pressure for classic analysis

$f'c=fck$ =cylindrical concrete resistance

$fyk=fy$ =steel rebar characteristic resistance

E_{conc} =Concrete Elastic modulus

f_{ctk} =characteristic Concrete tension

E_{steel} =steel elastic modulus

TABULAR DATA (principal parameters)

1) Diaphragm wall (rectangular cross section section)

N/A= data not available

$Fy=fyk$

$F'c=fck$

D=wall height

B=wall width

2)Steel sheet pile

DES=shape (Z or U)

W=width per unit of length

A=area

h=height

t=horiz part thickness

b=width of the single sheet pile part

s=inclined part thickness

I_{xx} =strong axis inertia (per unit of length)

S_{xx} =strong axis section modulus (per unit of length)

3)Secant piles wall, Tangent piles wall, soldier piles, soldier piles and timber lagging

W=weight per unit of length

A=area

D=diameter

tw=web thickness

tp= pipe thickness

bf=flange width

tf=flange thickness

k=flange thickness+stem thickness

I_{xx} =strong axis inertia modulus (per unit of length)

S_{xx} =strong axis section modulus (per unit of length)

r_x =radius of gyration about X axis

r_y =radius of gyration about Y axis

I_{yy} =weak axis inertia modulus (per unit of length)

S_{yy} =weak axis section modulus (per unit of length)

r_T =radius of gyration for torsion

Cw=warping constant

TIEBACK DATA

Name	Fy	Fc'	Dfix	Afix	Efix	Afree	Efree	Pa STR	Pu STR	PresGr	FSgeo	UserGca	Pa	Pu	WireMod
	(MPa)	(MPa)	(cm)	(cm ²)	(MPa)	(cm ²)	(MPa)	(kN)	(kN)	(kPa)			(kN)	(kN)	Yes/No
4-Strands	1862.1	25	15	176.7	31476	2.8	200100	453.4	453.4	N/A	1.4	False	N/A	N/A	Yes
5-Strands	1862.1	25	15	176.7	31476	2.8	200100	453.4	453.4	N/A	1.4	False	N/A	N/A	Yes
6-Strands	1862.1	25	15	176.7	31476	1.4	200100	226.7	226.7	N/A	1.4	False	N/A	N/A	Yes
Tieback_	1670	25	16	201.0	31476	4.17	210000	605.2	605.2	N/A	1	False	N/A	N/A	Yes
Tieback_	1670	25	16	201.0	31476	6.95	210000	1008.7	1008.7	N/A	1.4	False	N/A	N/A	Yes
Tieback_	1670	25	16	201.0	31476	5.56	210000	807	807	N/A	1	False	N/A	N/A	Yes

EXCAVATION STAGES SKETCHES

A sequence of figures for each excavation stage is reported

GENERAL ANALYSIS CRITERIA

Summary of stage assumptions

Name	Analysis	Drive	ka-Mult	Htr	Resist	Res	Contl	Supp	Axial	Used	Min	Toe	Toe
	Method	Press		(%)	Press	Mult	Meth	Mode	Incl	FSwall	FDtoe	FSrot	FSpas
Stage 0	Springs-Up	Ka+ d	N/A	N/A	Kp+ d	N/A		Fixed	N/A	1	7.084	8.181	7.084
Stage 1	Springs-Up	Ka+ d	N/A	N/A	Kp+ d	N/A		Fixed	N/A	1	4.391	4.391	4.625
Stage 2	Springs-Up	FHWA	1.3	m=	Kp+ d	N/A		Fixed	N/A	1	4.779	4.779	N/A
Stage 3	Springs-Up	FHWA	1.3	m=	Kp+ d	N/A		Fixed	N/A	1	3.118	3.118	N/A
Stage 4	Springs-Up	FHWA	1.3	m=	Kp+ d	N/A		Fixed	N/A	1	3.07	3.211	3.07
Stage 5	Springs-Up	FHWA	1.3	m=	Kp+ d	N/A		Fixed	N/A	1	1.747	1.747	11.89
Stage 6	Springs-Up	FHWA	1.3	m=	Kp+ d	N/A		Fixed	N/A	1	1.864	1.864	44.06
Stage 7	Springs-Up	FHWA	1.3	m=	Kp+ d	N/A		Fixed	N/A	1	1.454	1.454	7.504
Stage 8	Springs-Up	FHWA	1.3	m=	Kp+ d	N/A		Fixed	N/A	1	1.54	1.54	10.15

Name=excavation phase name

Analysis method

springs=elasto plastic springs are used

DR=Drained condition for CLAY model

U=Undrained condition for CLAY model for all the soils

Up=Undrained condition just for selected soil

Drive press=Ka

ka mult=multiply factor for Ka

Htr T/B (%)=trapezoidal pressure scheme

Resit press=Kp

Res Mult=Multiply factor for Kp

COntle Method=cantilver method

Support Model=Fix support type

Axial Incl=Axial action is included for design

Used FS wall=Reduction factor for axial+bending resistance dominium

Min FD TOe=embedded minimum safety factor (for classic analysis)

Toe FS rot=rotation safety factor (classic for classic analysis)

Toe FSpas=driving/resistent pressure safety factor (for classic analysis)

SEISMIC DATA

Seismic action is modeled through a pseudo static approach

Summary of stage assumptions

Stage	Seismic g	Method	aX	aY	Beta	Building Code
Number	Used	Used	(g)	(g)		(Name)
0	No		0.026	0	1	N/A
1	No		0.026	0	1	N/A
2	No		0.026	0	1	N/A
3	No		0.026	0	1	N/A
4	No		0.026	0	1	N/A
5	No		0.026	0	1	N/A
6	No		0.026	0	1	N/A
7	No		0.026	0	1	N/A
8	Yes		0.026	0	1	N/A

N/A= data non available

Stage number=number of stage input

Seismic ag =value of design acceleration according to a code or input by the user

Method=the method used to evaluated the seismic thrustover the wall

ahd or khd otr axd=design horizontal acceleration

avd or kvd or ayd=design vertical acceleration

Beta=multip coeff for the semirigd approach

Buildind code=code used for design acceleration calculation

SUPPORTS PROPERTIES

Support 0: type = tieback

X = 0.24 m, Z = -1.25 m, S = 2.4 m

Lfree = 9.1 m, Lfix = 10 m, Rfix = 50 %

Walls: P168.3x10/40

Stage No	Active	Prestress	Slab live load	User add. strain
	Yes/No	(kN)	(kPa)	+expansion
0	No	-	-	-
1	No	-	-	-
2	Yes	240	-	-
3	Yes	-	-	-
4	Yes	-	-	-
5	Yes	-	-	-
6	Yes	-	-	-
7	Yes	-	-	-
8	Yes	-	-	-

Support 1: type = tieback

X = 0.24 m, Z = -3.75 m, S = 2.4 m

Lfree = 8 m, Lfix = 12 m, Rfix = 50 %

Walls: P168.3x10/40

Stage No	Active	Prestress	Slab live load	User add. strain
	Yes/No	(kN)	(kPa)	+expansion
0	No	-	-	-
1	No	-	-	-
2	No	-	-	-
3	No	-	-	-
4	Yes	340	-	-
5	Yes	-	-	-
6	Yes	-	-	-
7	Yes	-	-	-
8	Yes	-	-	-

Support 2: type = tieback

X = 0.24 m, Z = -6.25 m, S = 2.4 m

Lfree = 6 m, Lfix = 12 m, Rfix = 50 %

Walls: P168.3x10/40

Stage No	Active	Prestress	Slab live load	User add. strain
	Yes/No	(kN)	(kPa)	+expansion
0	No	-	-	-
1	No	-	-	-
2	No	-	-	-
3	No	-	-	-
4	No	-	-	-
5	No	-	-	-
6	Yes	340	-	-
7	Yes	-	-	-
8	Yes	-	-	-

Support type

LEGENDA for TIEBACKS

General data

Z=support level

S=horizontal distance between each tieback

Lfree=free length

Lfix=rigid body length

Rfix=% effective part of the rigid body length

Stage No=excavation steps number

Active=tieback status (YES=active)

Post stress= tieback preload (Load considering the horiz distance bewteen the tiebacks)

SURFACE LOADS

Surcharge 0: X1 = -24, X2 = 0

Variable surcharge

Stage No	Active	X1	Z1	qX1	qZ1	X2	Z2	qX2	qZ2
	Yes/No	(m)	(m)	(kPa)	(kPa)	(m)	(m)	(kPa)	(kPa)
0	No	-24	0	0	20	0	0	0	20
1	Yes	-24	0	0	20	0	0	0	20
2	Yes	-24	0	0	20	0	0	0	20
3	Yes	-24	0	0	20	0	0	0	20
4	Yes	-24	0	0	20	0	0	0	20
5	Yes	-24	0	0	20	0	0	0	20
6	Yes	-24	0	0	20	0	0	0	20
7	Yes	-24	0	0	20	0	0	0	20
8	No	-24	0	0	20	0	0	0	20

LEGENDA

Stage No=Excavation step number

Active=load status (Yes=active)

X1=first X coordinate position of the load

Z1=first Z coordinate position of the load

qX1=first horizontal point load value

qZ1=first vertical point load value

X2=second X coordinate position of the load

Z2=second Z coordinate position of the load

qX2=second horizontal point load value

qZ2=second vertical point load value

WALL RESULTS TABLE

LEGENDA

Wall node=number of the node

EL=elevation

Sht L=Total horizontal soil pressure (on the left side of the wall)

Sht R=Total horizontal soil pressure (on the right side of the wall)

Shs L=Effective horizontal soil pressure (on the left side of the wall)

Shs R=Effective horizontal soil pressure (on the right side of the wall)

q=pressure given by the surcharge

U L=Water pressure (on the left side of the wall)

U R=pressione acqua (on the right side of the wall)

M=bending moment (per meter)

V=shear (per metro)

dx=wall deflection

McapL=Ultimate bending moment (on the left side of the wall)

McapR=Ultimate bending moment (on the right side of the wall)

VcapL=Ultimate resistance shear (on the left side of the wall)

VcapR=Ultimate resistance shear (on the right side of the wall)

SUPPORTS REACTIONS (TIEBACKS, STRUTS, SLABS, RAKERS)

Support 0

Stage No	R
	(kN)
0	0
1	0
2	240
3	256.848
4	251.688
5	244.824
6	246.888
7	244.968
8	219.89

Support 1

Stage No	R
	(kN)
0	0
1	0
2	0
3	0
4	340.08
5	398.736
6	384.48
7	381.456
8	374.424

Support 2

Stage No	R
	(kN)
0	0
1	0
2	0
3	0
4	0
5	0
6	340.08

7	374.064
8	387.072

DeepXcav 2010: Report Output

Copyright©2009 - 2010 Deep Excavation LLC: www.deepexcavation.com
A program for the evaluation of deep excavations

Project: My Project

Company: My Company
Prepared by engineer: Engineer
File number: 1
Time: 10/28/2010 9:14:38 PM

THIS PROGRAM IS PROTECTED BY U.S. COPYRIGHT LAWS AS DESCRIBED IN THE EULA. UNAUTHORIZED COPYING IS PROHIBITED. LICENSED TO: Deep Excavation LLC BY DEEP EXCAVATION LLC UNDER SPECIFIC LICENCE. This report has printed because the user has accepted responsibility as described in the disclaimer and EULA
File: C:\nda\paratie\10.10.28_sera\Lotto3\alleg\LIH_typ4_rev27oct10_EQscavo_Alleg.DEEP

DeepXcav 2010: Report Output

Copyright©2009 - 2010 Deep Excavation LLC: www.deepexcavation.com
A program for the evaluation of deep excavations

Project: My Project

Company: My Company
Prepared by engineer: Engineer
File number: 1
Time: 10/28/2010 9:14:38 PM

THIS PROGRAM IS PROTECTED BY U.S. COPYRIGHT LAWS AS DESCRIBED IN THE EULA. UNAUTHORIZED COPYING IS PROHIBITED. LICENSED TO: Deep Excavation LLC BY DEEP EXCAVATION LLC UNDER SPECIFIC LICENCE. This report has printed because the user has accepted responsibility as described in the disclaimer and EULA
File: C:\nda\paratie\10.10.28_sera\Lotto3\alleg\LIII_typ4_rev27oct10_EQscavo_Alleg.DEEP

OBJECTIVES

The objective of this document is to report the most important results of the calculations

BIBLIOGRAPHIC REFERENCES

BECCI,B.,NOVA,R. (1987) "Un metodo di calcolo automatico per il progetto di paratie", Rivista Italiana di

GENERAL CALCULATION ASSUMPTIONS

DEEP EXC is a program to simulate the behavior of flexible diaphragms. It is possible to simulate all the different stages of excavation.

The program is able to perform both classic and non linear analysis.

For the non linear analysis a FEM model is used. The FEM model follows the well known beam on elasto plastic foundation approach. The wall is modeled using BEAM elements, the soil is simulated using a double system (for each part of the wall) of elasto plastic springs,

An elasto plastic spring is connected on each node of the beam elements.

The excavation procedure is performed through 2 types of analysis:

1) Classic analysis

2) Non linear analysis : every step represents an excavation phase with a defined configuration of excavations, loads, etc.

The non linear analysis has been performed using a full Newton Raphson approach.

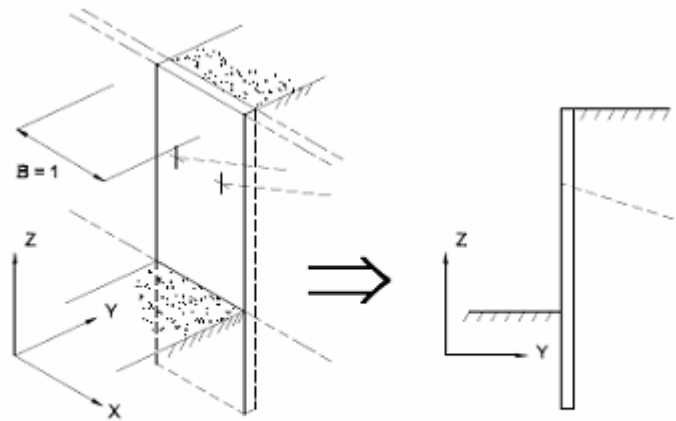

CONVENTIONS AND REFERENCE COORDINATE SYSTEMS

Loads, anelastic displacements, support reactions and displacements, are all referred to a righthand coordinate system

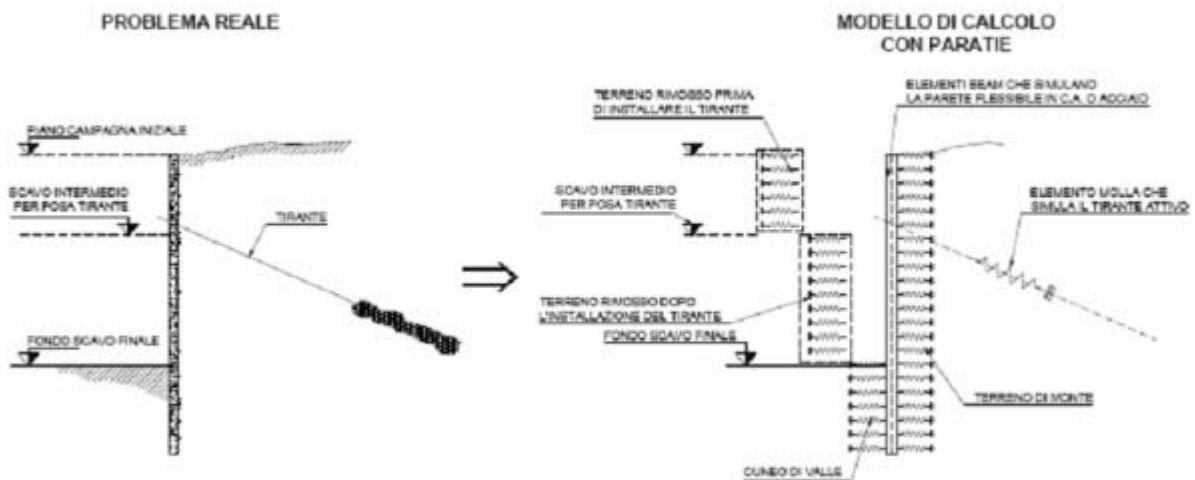

ELEMENTO TRUSS

1. FORCE : FORZA NELL'ELEMENTO PER UNITÀ DI PROFONDITÀ
2. STRESS : SPORZO

ELEMENTO BEAM (vedi figura 11-1)

1. VA : TAGLIO AL PRIMO ESTREMO
2. VB : TAGLIO AL SECONDO ESTREMO
3. MA : MOMENTO AL PRIMO ESTREMO
4. MB : MOMENTO AL SECONDO ESTREMO
(tutti per unità di profondità)

ELEMENTO ELPL (MOLLA ELASTOPLASTICA)

1. FORCE : FORZA NELL'ELEMENTO PER UNITÀ DI PROFONDITÀ
2. PLASTIC: DEFORMAZIONE PLASTICA

ELEMENTO WIRE (TIRANTE)

1. FORCE : FORZA NELL'ELEMENTO PER UNITÀ DI PROFONDITÀ

ELEMENTO CELAS (MOLLA ELASTICA)

1. FORCE : FORZA NELL'ELEMENTO PER UNITÀ DI PROFONDITÀ
2. MOMENT : MOMENTO NELL'ELEMENTO PER UNITÀ DI PROFONDITÀ

ELEMENTO SLAB (SOLETTA FRA DUE PARETI)

1. VA : TAGLIO AL PRIMO ESTREMO
2. VB : TAGLIO AL SECONDO ESTREMO
3. MA : MOMENTO AL PRIMO ESTREMO
4. MB : MOMENTO AL SECONDO ESTREMO
5. AXIAL : AZIONE ASSIALE
(tutti per unità di profondità)



Figura 11-1: convenzioni di segno per l'elemento BEAM

Checking of cross sections is performed according to the coordinate systems showed in the next figure

- X axis follow the 2 nodes direction of the beam elements , positive going from the first to the secondo node

ELEMENTO TRUSS

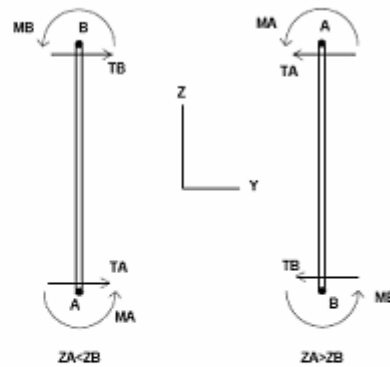
1. FORCE : FORZA NELL'ELEMENTO PER UNITÀ DI PROFONDITÀ
2. STRESS : SPORZO

ELEMENTO BEAM (vedi figura 11-1)

1. VA : TAGLIO AL PRIMO ESTREMO
2. VB : TAGLIO AL SECONDO ESTREMO
3. MA : MOMENTO AL PRIMO ESTREMO
4. MB : MOMENTO AL SECONDO ESTREMO
(tutti per unità di profondità)

ELEMENTO ELPL (MOLLA ELASTOPLASTICA)

1. FORCE : FORZA NELL'ELEMENTO PER UNITÀ DI PROFONDITÀ
2. PLASTIC: DEFORMAZIONE PLASTICA

ELEMENTO WIRE (TIRANTE)

1. FORCE : FORZA NELL'ELEMENTO PER UNITÀ DI PROFONDITÀ

ELEMENTO CELAS (MOLLA ELASTICA)

1. FORCE : FORZA NELL'ELEMENTO PER UNITÀ DI PROFONDITÀ
2. MOMENT : MOMENTO NELL'ELEMENTO PER UNITÀ DI PROFONDITÀ

ELEMENTO SLAB (SOLETTA FRA DUE PARETI)

1. VA : TAGLIO AL PRIMO ESTREMO
2. VB : TAGLIO AL SECONDO ESTREMO
3. MA : MOMENTO AL PRIMO ESTREMO
4. MB : MOMENTO AL SECONDO ESTREMO
5. AXIAL : AZIONE ASSIALE
(tutti per unità di profondità)



Figura 11-1: convenzioni di segno per l'elemento BEAM

DESIGN CODES

Reference codes are:

- DM 2008 - "Norme tecniche per le costruzioni"
- CSLP, "Istruzioni per l'applicazione delle Norme tecniche per le costruzioni di cui al DM 14/1/2008"
- EC2 1-1 :2004, Eurocode 2 - Design of concrete structures
- Ec3 1-1:2005, Eurocodice 3 - Design of steel structures
- Ec3 5:2002, Eurocodice 3 - Design of steel sheet piles walls
- Ec8:2004 - Seismic design of structures
- AISC ASD 9th Edition, 1989
- AISC LRFD 2nd Edition, 2003
- ACI 318-2002
- AASHTO 2000 ADS / LRFD

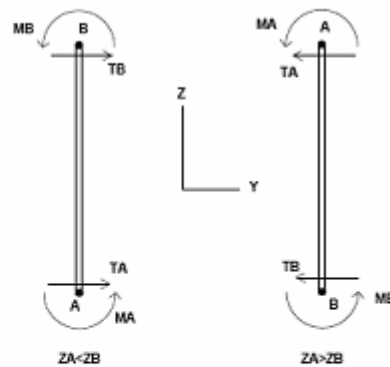
DESIGN PARAMETERS

Project: My Project

Results for Design Section 0: Base Section - Service

DESIGN APPROACHES AND COMBINATION FACTORS

The Design Approaches (from Codes or Customized by the user) and related safety factors are the following:

Ftan fr=mult factor for friction angle

F C'=mult factor for effective cohesion

F Su'=mult factof for undrained cohesion

F EQ=mult factor for seismic action

F perm load=mult factor for perm loads

F temp load=mult factor for live loads

F perm supp=reduct factor for resistance for pull out checking

F temp supp=fattore di riduzione resistance per verifica pull out tirante

F earth Dstab=mult factor for active press coeff , unfavorable

F earth stab=mult factor for passive pressure , favorable

F GWT Dstab (ground water)=mult factor for hydrostatic pressure , unfavorable

F GWT stab (ground water)=mult factor for hydrostatic pressure, favorable

F HYD Dstab=mult factor for hydrodynamic pressure, unfavorable

F HYD stab=mult factor for hydrodynamic pressure, favorable

F UPL Dstab=mult factor for hydraulic heave, unfavorable

Stage	Design Name	Design Case	F(tan fr)	F (c')	F (Su)	F (EQ)	F(perm load)	F(temp load)	F(perm sup)	F(temp sup)	F Earth (Dstab)	F Earth (stab)	F GWT (Dstab)	F GWT (stab)	F HYD (Dstab)	F HYD (stab)	F UPL (Dstab)	F UPL (stab)
0	Default	Service	1	1	1	1	1	1	1	1	1	1	1	1	1	1	1	1
1	Default	Service	1	1	1	1	1	1	1	1	1	1	1	1	1	1	1	1
2	Default	Service	1	1	1	1	1	1	1	1	1	1	1	1	1	1	1	1
3	Default	Service	1	1	1	1	1	1	1	1	1	1	1	1	1	1	1	1
4	Default	Service	1	1	1	1	1	1	1	1	1	1	1	1	1	1	1	1
5	Default	Service	1	1	1	1	1	1	1	1	1	1	1	1	1	1	1	1
6	Default	Service	1	1	1	1	1	1	1	1	1	1	1	1	1	1	1	1
7	Default	Service	1	1	1	1	1	1	1	1	1	1	1	1	1	1	1	1
8	Default	Service	1	1	1	1	1	1	1	1	1	1	1	1	1	1	1	1
9	Default	Service	1	1	1	1	1	1	1	1	1	1	1	1	1	1	1	1

SOIL DATA

Name	g tot (kN/m3)	g dry (kN/m3)	Frict (deg)	C' (kPa)	Su (kPa)	FRp (deg)	FRcv (deg)	Eload (kPa)	Eur (kPa)	kAp Springs	kPp Springs	kAcv Springs	kPcv Springs	Vary	Spring Model	Color
F	20	19	30	0	N/A	N/A	N/A	15000	45000	0.33	3	N/A	N/A	True	Linear	
O1	16.5	14	22	2	20	22	22	2874	8622	0.46	2.2	0.46	2.2	True	Linear	
O2	19	16.5	28	2	N/A	N/A	N/A	7185	21555	0.36	2.77	N/A	N/A	True	Linear	
S1	21	19	34	0	N/A	N/A	N/A	25000	75000	0.28	3.54	N/A	N/A	True	Linear	
Clay	20	19	28	0	150	28	28	20000	60000	0.36	2.77	0.36	2.77	True	Linear	
GT	22	20	36	10	N/A	N/A	N/A	30000	90000	0.26	3.85	N/A	N/A	True	Linear	
Rock	27	25	30	100	N/A	N/A	N/A	479000	143700	0.33	3	N/A	N/A	True	Linear	
Rileva	18	18	32	0	N/A	N/A	N/A	30000	30000	0.31	3.26	N/A	N/A	True	Linear	
Base	18	18	25	0	N/A	N/A	N/A	25000	25000	0.41	2.46	N/A	N/A	True	Linear	

gtot=total soil specific weighth

gdry=dry weighth of the soil

Frict=friction angle

C'=effective cohesion

Su = Undrained cohesiona (only for CLAY soils in undrained conditions)

Dilat=SOil Dilatancy (only for non linear analysis)

Evc=Virgin compression elastic module

Eur=unloading/reloading elastic module

Kap= Peak active thrust coeff

Kpp= Peak passive thrust coeff

Kacv= Constant volume active thrust coeff

Kpcv= Constant volume passive thrust coeff

Spring models= spring model (LIN=constant over the soil layer heigth , EXP=exponential ,

SIMC=simplified winkler)

LIN= Linear-Elastic-Perfectly Plastic,

EXP: Exponential, SUB: Modulus of Subgrade Reaction

SOIL BORINGS

Top Elev= superior Soil level

Soil type=type of the soil (sand , clay , etc)

OCR=overconsolidation ratio

K0=at rest coefficient

Name: Boring 1, pos: (-20, 0)

Top elev.	Soil type	OCR	Ko
0	Rilevato	1	0.47
-10	Base	1	0.58

STRUCTURAL MATERIALS DATA

Steel

Name	Strength Fy (MPa)	Fu (MPa)	Elastic E (MPa)	Density g (kN/m3)
Fe360	235	360	206000	77
Fe510	355	510	206000	77
A36	248.3	400	206000	77
A50	355	500	206000	77
New steel 4	241.4	413.8	206000	77

Concrete

Name	Strength Fc' (MPa)	Elastic E (MPa)	Density g (kN/m3)	Tension Strength (MPa)
C20/25	20	29962	25	10
C25/30	25	31476	25	10
Fc 3ksi	20.7	21541.8	23.573	10

Steel rebar

Name	Strength Fy (MPa)	Elastic E (MPa)
S1860 (Strands)	1670	210000
Grade 75	517.2	200100
Grade 80	551.7	200100
Grade 150	1034.5	200100
Strands 270 ksi	1862.1	200100
S410	410	210000
S500	500	210000
B450C	450	210000

Wood

Name	Ultimate Bending (MPa)	Ultimate Tensile Strength (MPa)	Ultimate Shear Strength (MPa)	Density g (kN/m3)	Elastic E (MPa)
Construction	11	9.7	5.5	7.8576	6900
Regular grade	6.9	6.9	4.1	7.8576	5520

STEEL

Name=material name
 fy=fyk=characteristic resistance for steel (for all the codes)
 Fu=fuk=ultimate resistance for steel (for all the codes)
 Elastic E=Elastic modulus
 Density g=specific weight

CONCRETE

Name=material name
 f'c=fck=cylindrical resistance for concrete (for all the codes)
 Elastic E=Elastic modulus
 Density g=specific weight
 Tension strength=ft=fctk=characteristic tension resistance for concrete

STEEL REBARS

Name=material name
 fy=fyk=characteristic resistance for steel (for all the codes)
 Fu=fuk=ultimate resistance for steel (for all the codes)
 Elastic E=Elastic modulus
 Density g=specific weight

WOOD

Name=material name
 Fb=fbk=Ultimate bending strength
 Ftu=ftuk=Ultimate tensile strength
 Fvu=fvuk=Ultimate shear strength
 Density g=specific weight
 Elastic E=Elastic modulus

WALL DATA

Wall section 0: P177.8x12.5/40

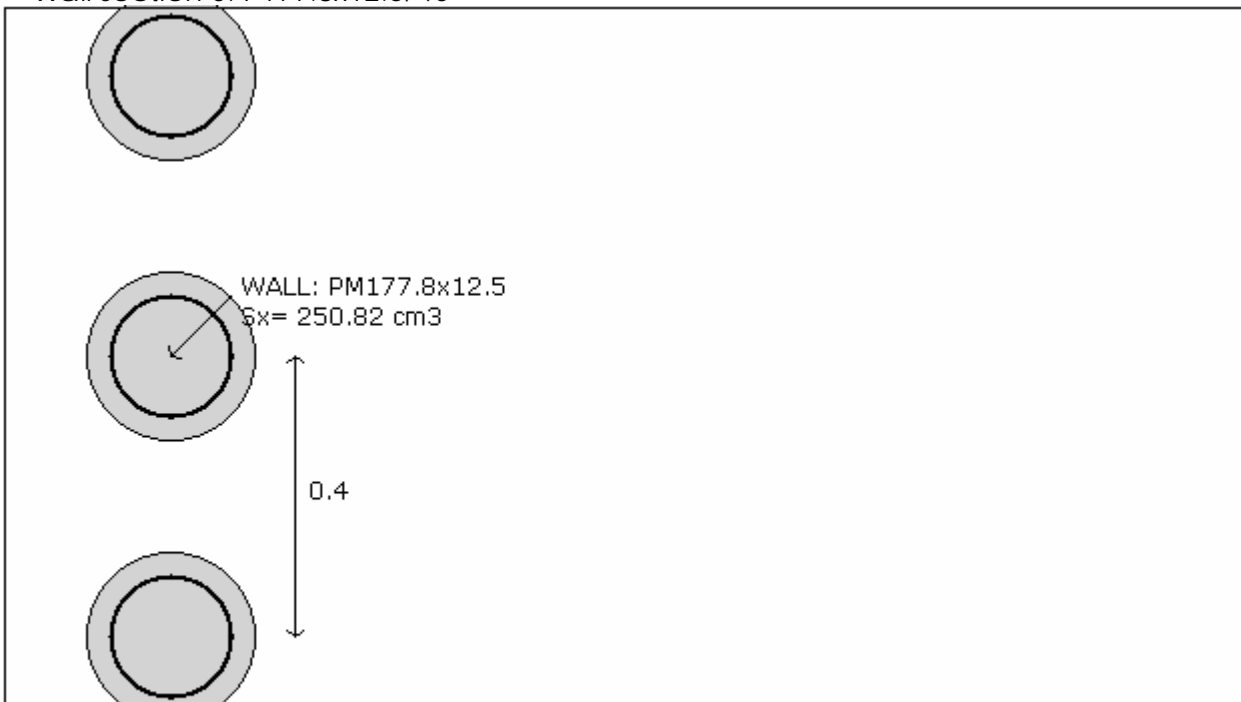

Company: My Company	Wall sketch	CeAS srl and Deep Excavation LCC
Engineer: Engineer		Paratie Plus 2010 - DeepXcar 2010
C:\nd.28_seraLotto3\alleg\LIII_typ4_rev27oct10_EQscavo_Alleg.DEEP		10/28/2010

Wall uses wall section 2: P177.8x12.5
 Wall type: Tangent pile wall
 Top wall El: 0 m Bottom wall El: -18 m
 Hor. wall spacing: 0.4 Wall thickness = 0.24
 Passive width below exc: 0.4 Active width below exc: 0.4
 Concrete f'c = 25 Rebar Fy = 410 Econc = 31476 Concrete tension FcT = 10% of Fc'

Steel members $f_y = 355$ Esteel = 206000
 Wall friction: Percentage of Soil Friction = 50%
 Steel wall capacities are calculated with NTC 2008
 Concrete capacities are calculated with ACI 318-2002.
 Note: With ultimate capacities you may have to use a structural safety factor.
 Tangent pile wall soldier pile properties

Table: Soldier Pile Properties

Name	Section	W	A	D	tw or	bf	tf	k	Ixx	Sxx	rX	Iyy	Syy	rY	rT	Cw	fy
		(kN/m)	(cm ²)	(cm)	(cm)	(cm)	(cm)	(cm)	(cm ⁴)	(cm ³)	(cm)	(cm ⁴)	(cm ³)	(cm)	(cm)	(cm ⁶)	(MPa)
	PM17	311.6	91.58	17.8	1.25	17.78	1.25	1.25	4274	250.8	6.83	4274	250.8	6.83	6.83	1	355

GENERAL WALL DATA

Hor wall spacing=wall horizontal spacing
 Passive width below exc=spacing for passive thrust pressure for classic analysys
 $f'_c=f_{ck}$ =cylindrical concrete resistance
 $f_y=f_{yk}$ =steel rebar characteristic resistance
 E_{conc} =Concrete Elastic modulus
 f_{ctk} =characteristic Concrete tension
 E_{steel} =steel elastic modulus
 TABULAR DATA (principal parameters)

1) Diaphragm wall (rectangular cross section section)
 N/A= data not available

$F_y=f_{yk}$
 $F'_c=f_{ck}$
 D=wall heigt
 B=wall width
 2)Steel sheet pile
 DES=shape (Z or U)
 W=wigth per unit of length
 A=area
 h=heigth
 t=horiz part thickness
 b=wodth of the single sheet pile part
 s=inclined part thickness
 Ixx=strong axis inertia (per unit of length)
 Sxx=strong axis section modulus (per unit of length)

3)Secant piles wall, Tangent piles wall, soldier piles, soildier piles and timber lagging
 W=weigth per unit of length
 A=area
 D=diameter
 tw=web thickness
 tp= pipe thickness
 bf=flange width
 tf=flange thickness
 k=flange thickness+stam thickness
 Ixx=strong axis inertia modulus (per unit of length)
 Sxx=strong axis section modulus (per unit of length)
 rx=radius of gyration about X axis
 ry=radius of gyration about Y axis
 Iyy=weak axis inertia modulus (per unit of length)
 Syy=weak axis section modulus (per unit of length)
 rT=radius of gyration for torsion
 Cw=warping constant

TIEBACK DATA

Name	Fy	Fc'	Dfix	Afix	Efix	Afree	Efree	Pa STR	Pu STR	PresGr	FSgeo	UserGca	Pa	Pu	WireMod
	(MPa)	(MPa)	(cm)	(cm ²)	(MPa)	(cm ²)	(MPa)	(kN)	(kN)	(kPa)			(kN)	(kN)	Yes/No
4-Strands	1862.1	25	15	176.7	31476	2.8	200100	453.4	453.4	N/A	1.4	False	N/A	N/A	Yes
5-Strands	1862.1	25	15	176.7	31476	2.8	200100	453.4	453.4	N/A	1.4	False	N/A	N/A	Yes
6-Strands	1862.1	25	15	176.7	31476	1.4	200100	226.7	226.7	N/A	1.4	False	N/A	N/A	Yes

Tieback_	1670	25	16	201.0	31476	4.17	210000	605.2	605.2	150	1	False	N/A	N/A	Yes
Tieback_	1670	25	16	201.0	31476	6.95	210000	1008.7	1008.7	180	1	False	N/A	N/A	Yes
Tieback_	1670	25	16	201.0	31476	5.56	210000	807	807	N/A	1.4	False	N/A	N/A	Yes

EXCAVATION STAGES SKETCHES

A sequence of figures for each excavation stage is reported

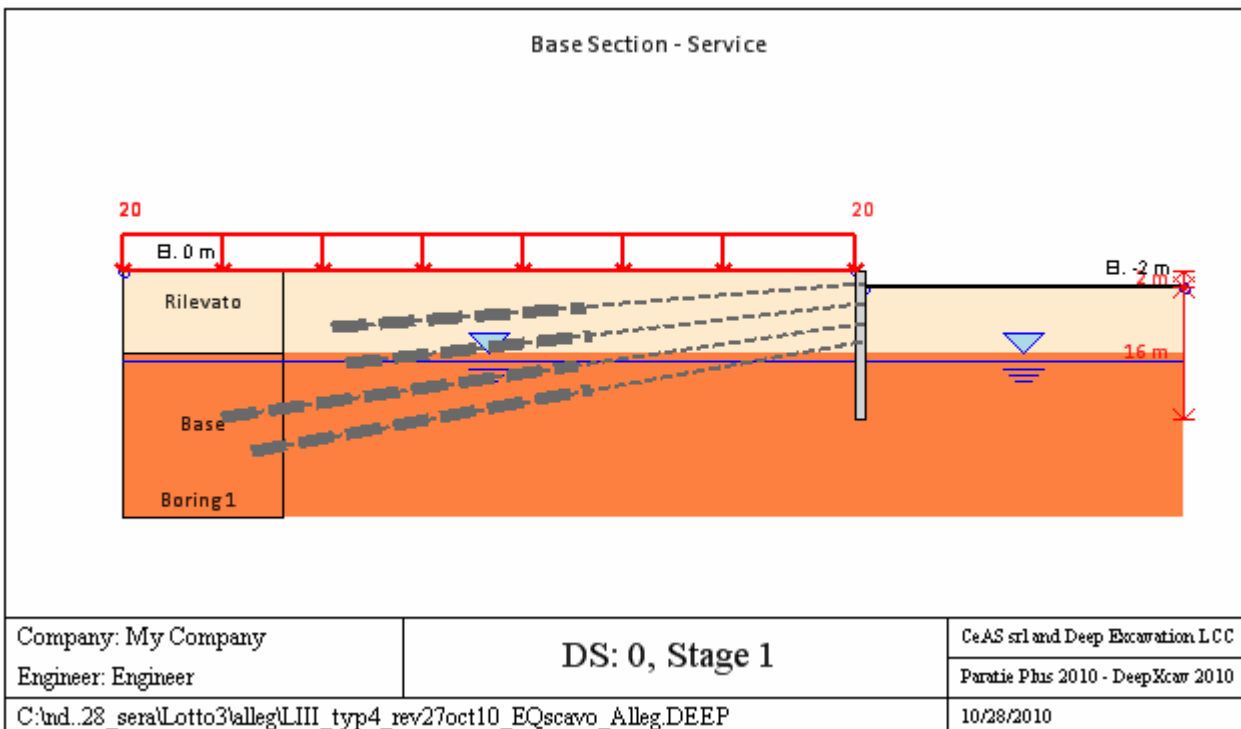
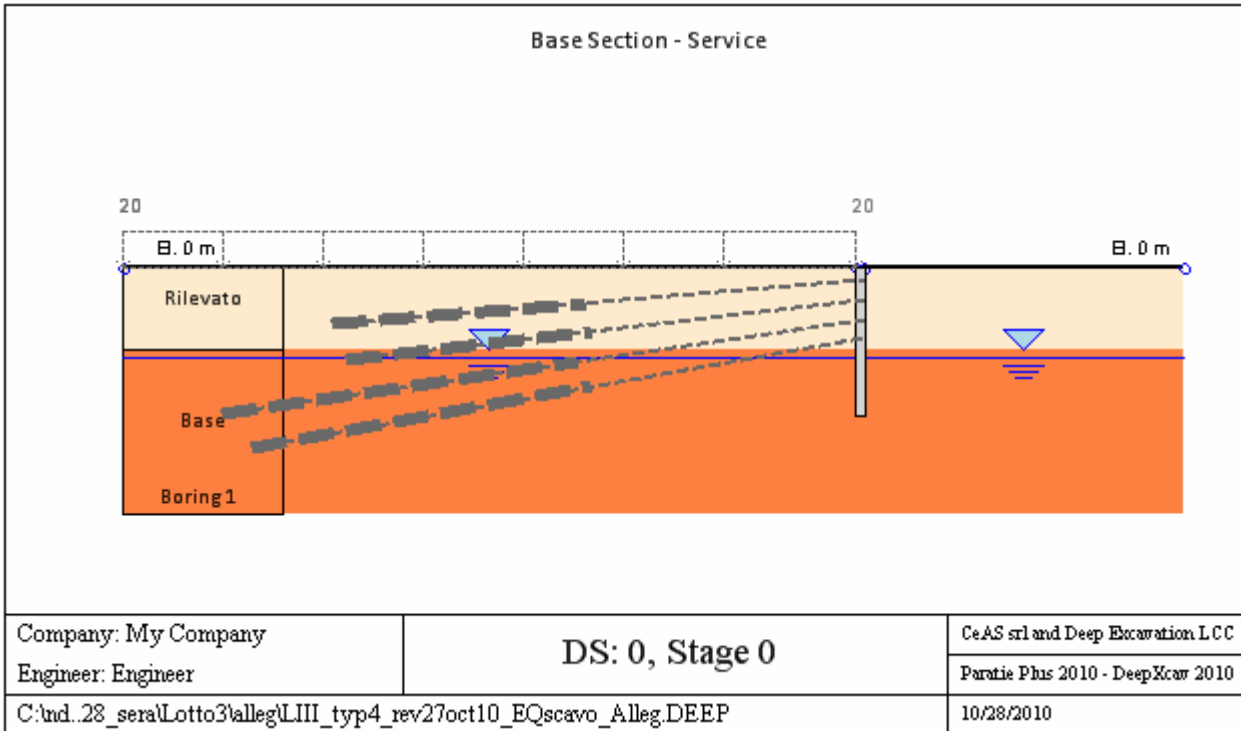

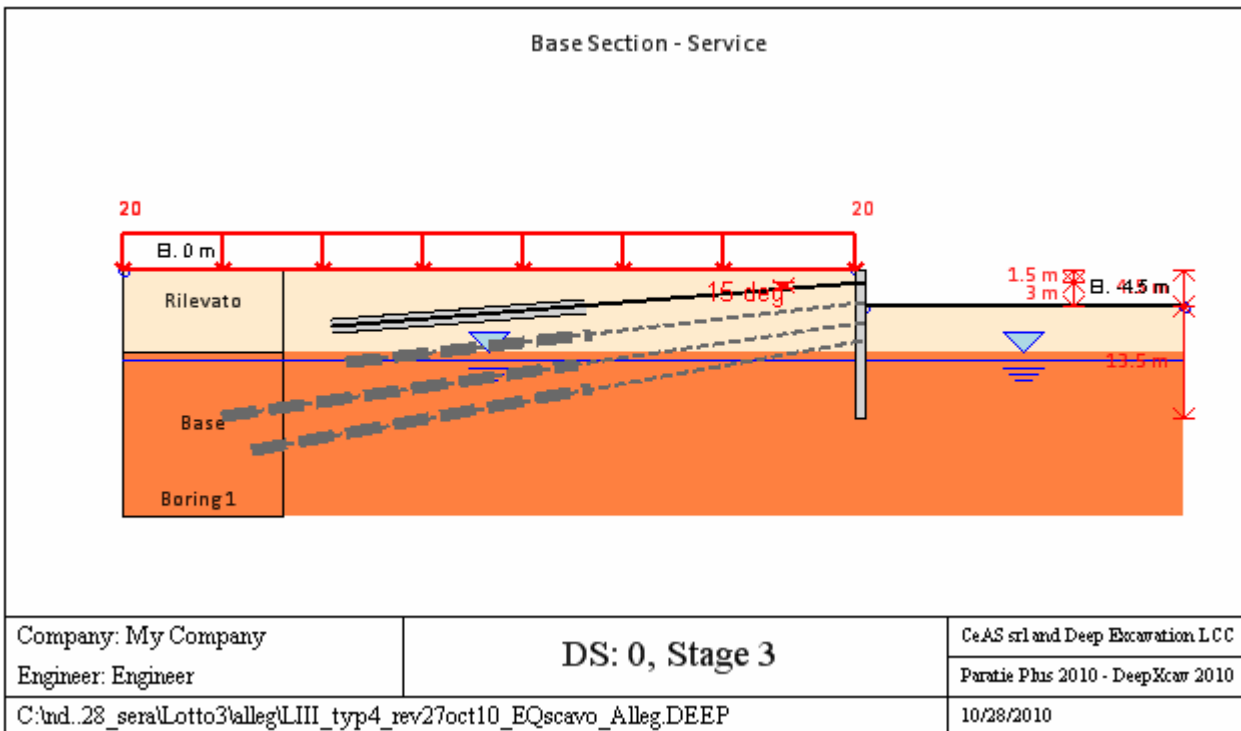
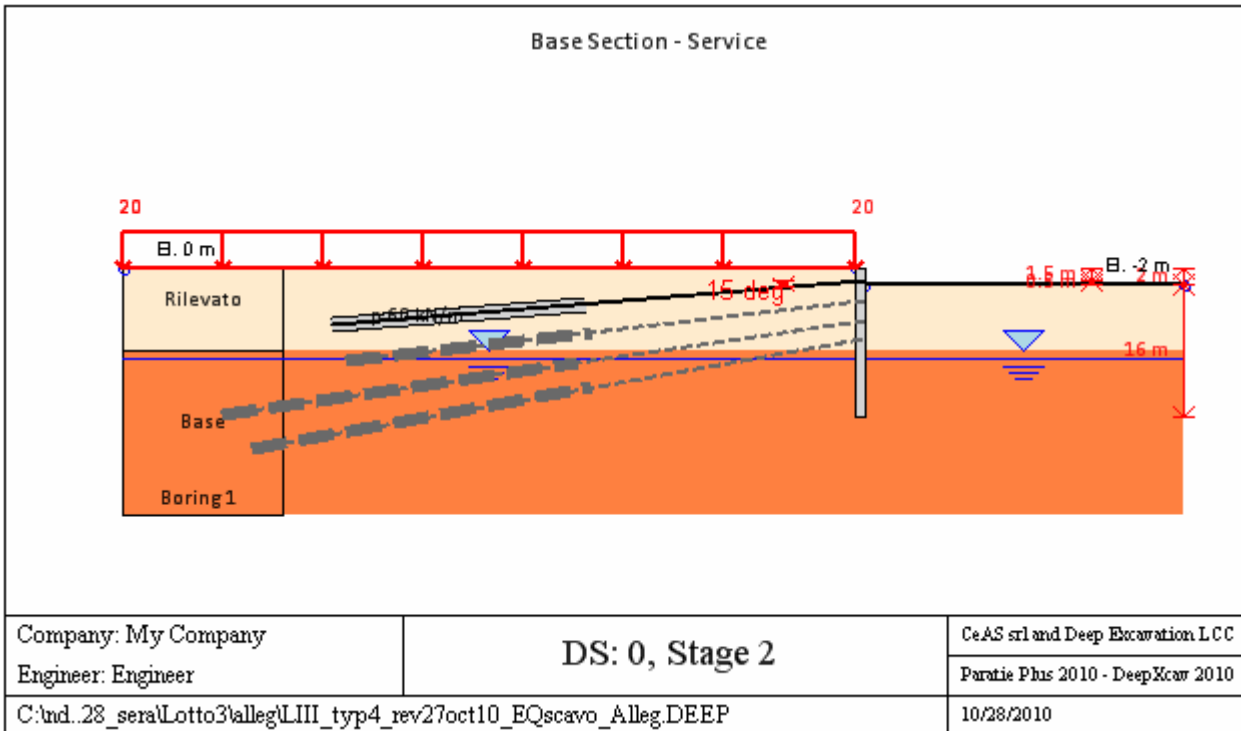

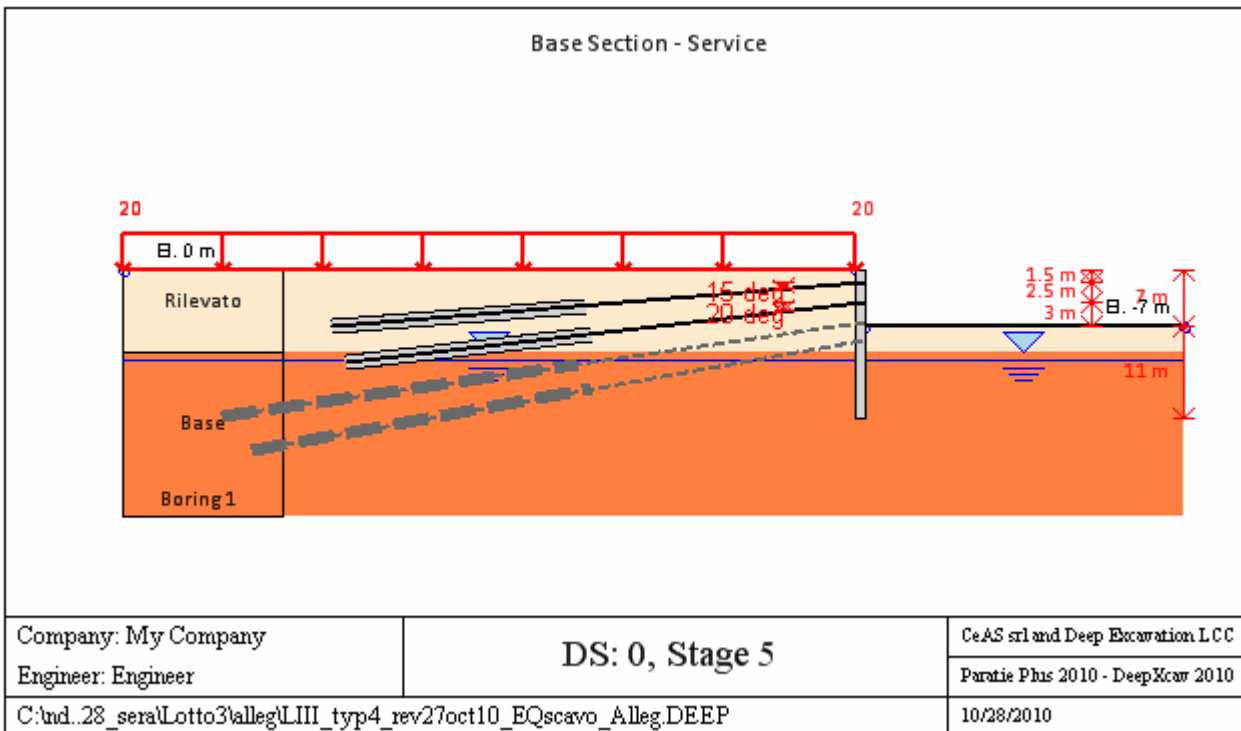
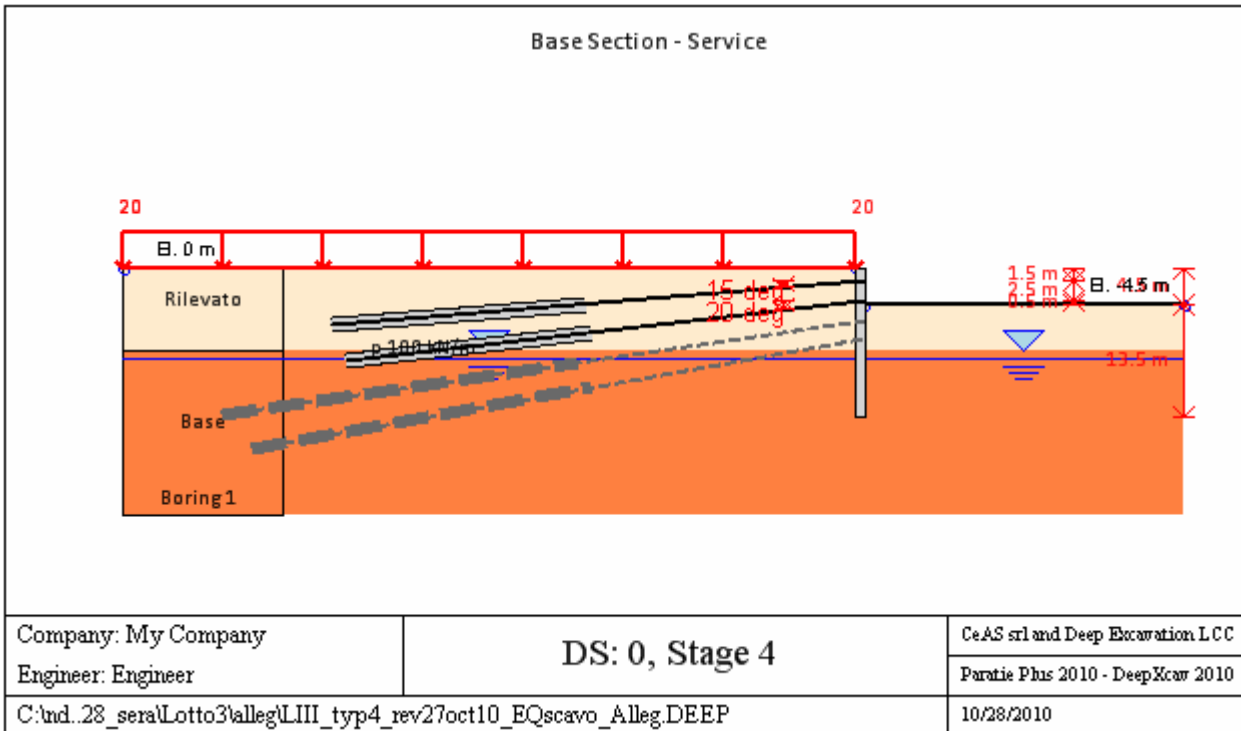

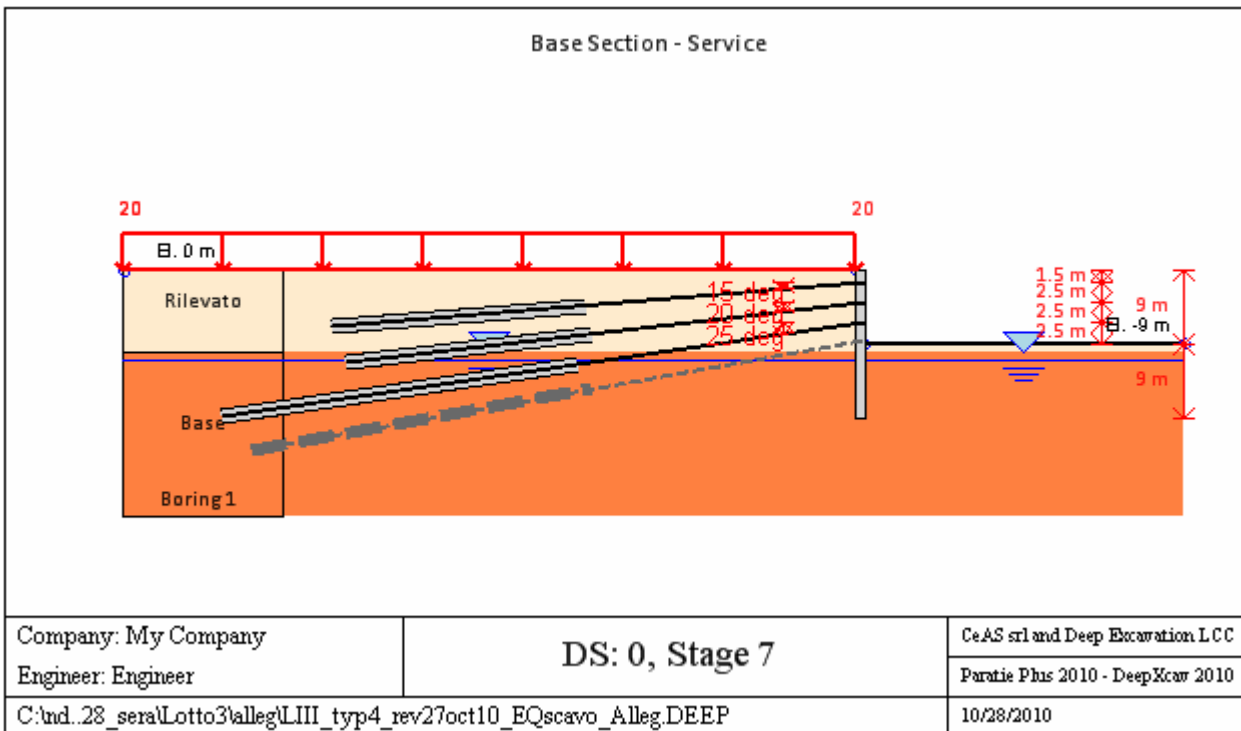
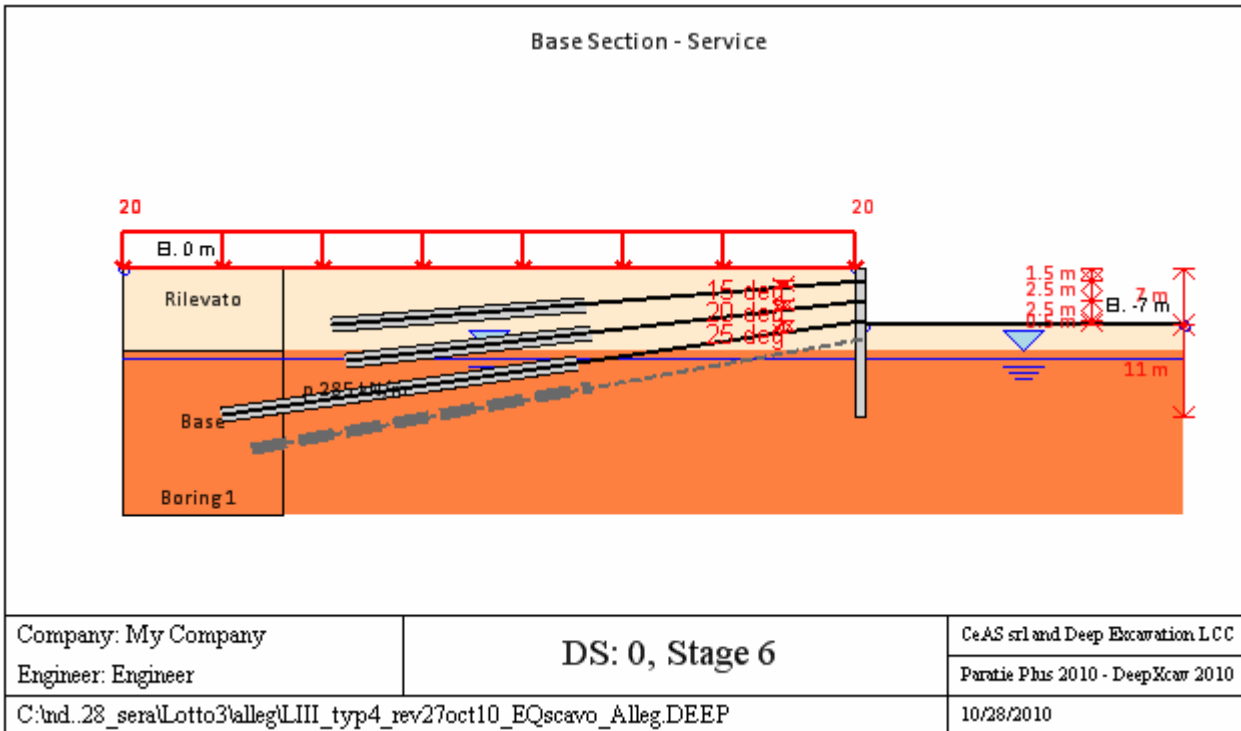

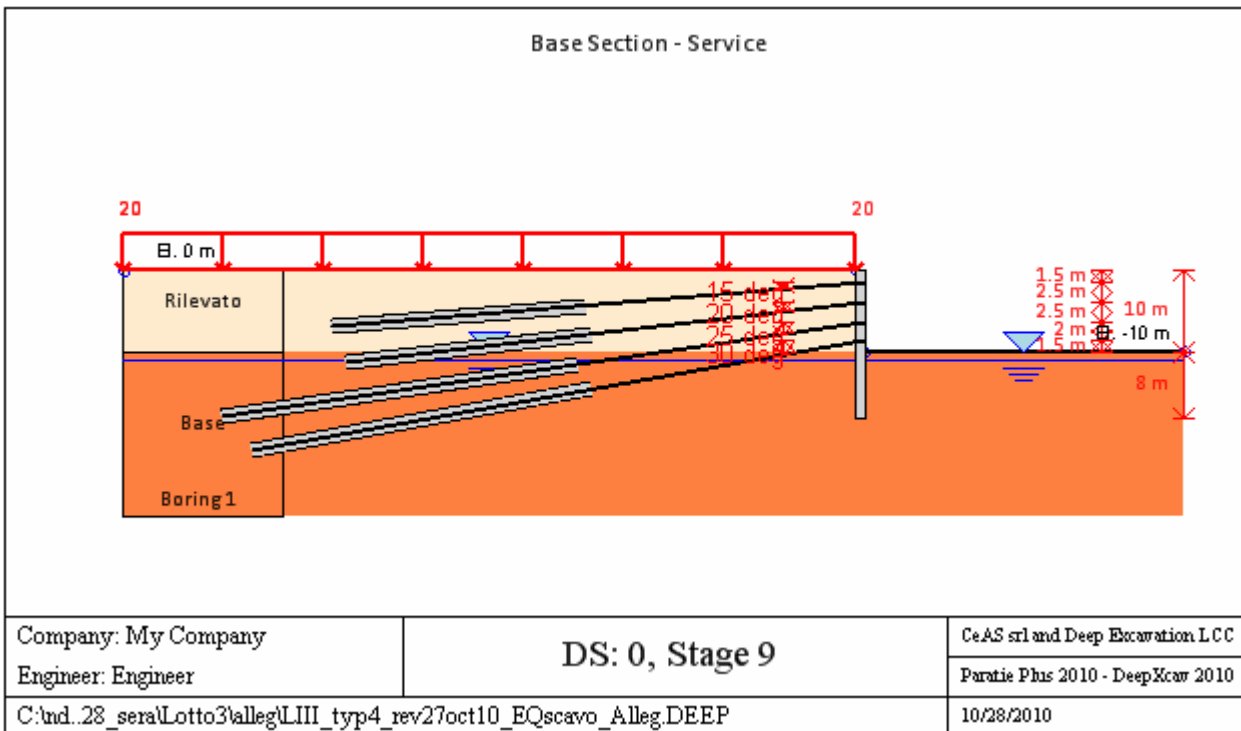
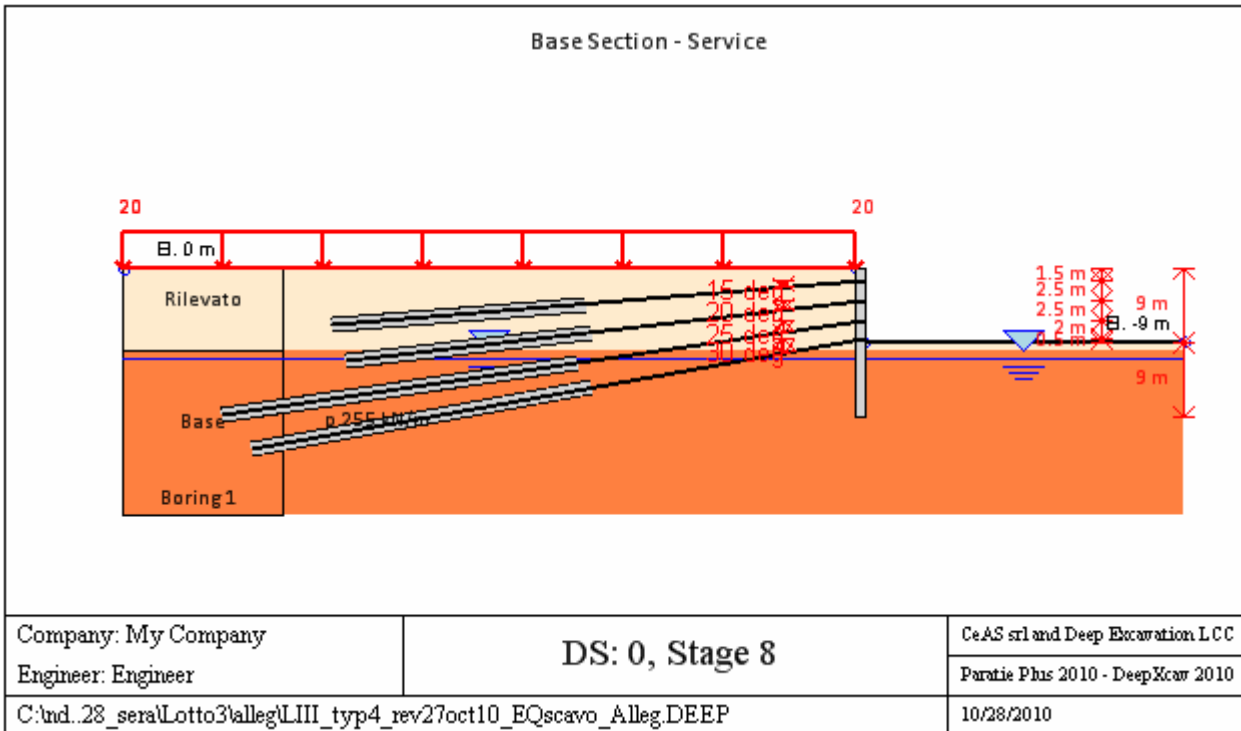

GENERAL ANALYSIS CRITERIA

Summary of stage assumptions

Name	Analysis Method	Drive Press	ka-Mult	Htr (%)	Resist Press	Res Mult	Contl Meth	Supp Mode	Axial Incl	Used FSwall	Min FDtoe	Toe FSrot	Toe FSpas
Stage 0	Springs-Up	Ka+ d	N/A	N/A	Kp+ d	N/A		Fixed	N/A	1	11.97	14.39	11.97
Stage 1	Springs-Up	Ka+ d	N/A	N/A	Kp+ d	N/A		Fixed	N/A	1	7.273	7.822	7.942
Stage 2	Springs-Up	FHWA	1.3	m=	Kp+ d	N/A		Fixed	N/A	1	7.976	7.976	N/A
Stage 3	Springs-Up	FHWA	1.3	m=	Kp+ d	N/A		Fixed	N/A	1	5.717	5.717	N/A
Stage 4	Springs-Up	FHWA	1.3	m=	Kp+ d	N/A		Fixed	N/A	1	5.718	5.791	5.718

Stage 5	Springs-Up	FHWA	1.3	m=	Kp+ d	N/A		Fixed	N/A	1	3.776	3.776	79.55
Stage 6	Springs-Up	FHWA	1.3	m=	Kp+ d	N/A		Fixed	N/A	1	3.688	3.897	3.688
Stage 7	Springs-Up	FHWA	1.3	m=	Kp+ d	N/A		Fixed	N/A	1	2.45	2.45	35.45
Stage 8	Springs-Up	FHWA	1.3	m=	Kp+ d	N/A		Fixed	N/A	1	2.569	2.569	215.1
Stage 9	Springs-Up	FHWA	1.3	m=	Kp+ d	N/A		Fixed	N/A	1	1.889	1.889	15.93

Name=excavation phase name

Analysis method

springs=elasto plastic springs are used

DR=Drained condition for CLAY model

U=Undrained condition for CLAY model for all the soils

Up=Undrained condition just for selected soil

Drive press=Ka

ka mult=multiply factor for Ka

Htr T/B (%)=trapezoidal pressure scheme

Resit press=Kp

Res Mult=Multiply factor for Kp

COntle Method=cantilver method

Support Model=Fix support type

Axial Incl=Axial action is included for design

Used FS wall=Reduction factor for axial+bending resistance dominium

Min FD TOe=embedded minimum safety factor (for classic analysis)

Toe FS rot=rotation safety factor (classic for classic analysis)

Toe FSpas=driving/resistent pressure safety factor (for classic analysis)

SEISMIC DATA

Seismic action is modeled through a pseudo static approach

Summary of stage assumptions

Stage Number	Seismic g Used	Method Used	aX (g)	aY (g)	Beta	Building Code (Name)
0	No		0.021	0	1	N/A
1	No		0.021	0	1	N/A
2	No		0.021	0	1	N/A
3	No		0.021	0	1	N/A
4	No		0.021	0	1	N/A
5	No		0.021	0	1	N/A
6	No		0.021	0	1	N/A
7	No		0.021	0	1	N/A
8	No		0.021	0	1	N/A
9	No		0.021	0	1	N/A

N/A= data non available

Stage number=number of stage input

Seismic ag =value of design acceleration according to a code or input by the user

Method=the method used to evaluated the seismic thrustover the wall

ahd or khd otr axd=design horizontal acceleration

avd or kvd or ayd=design vertical acceleration

Beta=multip coeff for the semirigd approach

Buildind code=code used for design acceleration calculation

SUPPORTS PROPERTIES

Support 0: type = tieback

X = 0.24 m, Z = -1.5 m, S = 2.4 m

Lfree = 11 m, Lfix = 10 m, Rfix = 50 %

Walls: P177.8x12.5/40

Stage No	Active	Prestress	Slab live load	User add. strain
----------	--------	-----------	----------------	------------------

	Yes/No	(kN)	(kPa)	+expansion
0	No	-	-	-
1	No	-	-	-
2	Yes	145	-	-
3	Yes	-	-	-
4	Yes	-	-	-
5	Yes	-	-	-
6	Yes	-	-	-
7	Yes	-	-	-
8	Yes	-	-	-
9	Yes	-	-	-

Support 1: type = tieback

X = 0.24 m, Z = -4 m, S = 2.4 m

Lfree = 11 m, Lfix = 10 m, Rfix = 50 %

Walls: P177.8x12.5/40

Stage No	Active	Prestress	Slab live load	User add. strain
	Yes/No	(kN)	(kPa)	+expansion
0	No	-	-	-
1	No	-	-	-
2	No	-	-	-
3	No	-	-	-
4	Yes	240	-	-
5	Yes	-	-	-
6	Yes	-	-	-
7	Yes	-	-	-
8	Yes	-	-	-
9	Yes	-	-	-
10	Yes	-	-	-
11	Yes	-	-	-

Support 2: type = tieback

X = 0.24 m, Z = -6.5 m, S = 2 m

Lfree = 12 m, Lfix = 15 m, Rfix = 50 %

Walls: P177.8x12.5/40

Stage No	Active	Prestress	Slab live load	User add. strain
	Yes/No	(kN)	(kPa)	+expansion
0	No	-	-	-
1	No	-	-	-
2	No	-	-	-
3	No	-	-	-
4	No	-	-	-
5	No	-	-	-
6	Yes	570	-	-
7	Yes	-	-	-
8	Yes	-	-	-
9	Yes	-	-	-
10	Yes	-	-	-
11	Yes	-	-	-

Support 3: type = tieback

X = 0.24 m, Z = -8.5 m, S = 2 m

Lfree = 12 m, Lfix = 15 m, Rfix = 50 %

Walls: P177.8x12.5/40

Stage No	Active	Prestress	Slab live load	User add. strain
----------	--------	-----------	----------------	------------------

	Yes/No	(kN)	(kPa)	+expansion
0	No	-	-	-
1	No	-	-	-
2	No	-	-	-
3	No	-	-	-
4	No	-	-	-
5	No	-	-	-
6	No	-	-	-
7	No	-	-	-
8	Yes	510	-	-
9	Yes	-	-	-
10	Yes	-	-	-
11	Yes	-	-	-

Support type

LEGENDA for TIEBACKS

General data

Z=support level

S=horizontal distance between each tieback

Lfree=free length

Lfix=rigid body length

Rfix=% effective part of the rigid body length

Stage No=excavation steps number

Active=tieback status (YES=active)

Post stress= tieback preload (Load considering the horiz distance bewteen the tiebacks)

SURFACE LOADS

Surcharge 0: X1 = -28, X2 = 0

Variable surcharge

Stage No	Active	X1	Z1	qX1	qZ1	X2	Z2	qX2	qZ2
	Yes/No	(m)	(m)	(kPa)	(kPa)	(m)	(m)	(kPa)	(kPa)
0	No	-28	0	0	20	0	0	0	20
1	Yes	-28	0	0	20	0	0	0	20
2	Yes	-28	0	0	20	0	0	0	20
3	Yes	-28	0	0	20	0	0	0	20
4	Yes	-28	0	0	20	0	0	0	20
5	Yes	-28	0	0	20	0	0	0	20
6	Yes	-28	0	0	20	0	0	0	20
7	Yes	-28	0	0	20	0	0	0	20
8	Yes	-28	0	0	20	0	0	0	20
9	Yes	-28	0	0	20	0	0	0	20

LEGENDA

Stage No=Excavation step number

Active=load status (Yes=active)

X1=first X coordinate position of the load

Z1=first Z coordinate position of the load

qX1=first horizontal point load value

qZ1=first vertical point load value

X2=second X coordinate position of the load

Z2=second Z coordinate position of the load

qX2=second horizontal point load value

qZ2=second vertical point load value

WALL RESULTS TABLE

P177.8x12.5/40 Stage: 0

Wall Nod	EL (m)	Sht L (kPa)	Sht R (kPa)	Shs L (kPa)	Shs R (kPa)	q (kPa)	U L (kPa)	U R (kPa)	M (kN-)	V (kN/m)	dx (cm)
0	0	0	0	0	0	0	0	0	0	0	0
2	-0.3	2.538	2.538	2.538	2.538	0	0	0	0	0	0
4	-0.6	5.076	5.076	5.076	5.076	0	0	0	0	0	0
6	-0.9	7.614	7.614	7.614	7.614	0	0	0	0	0	0
8	-1.2	10.152	10.152	10.152	10.152	0	0	0	0	0	0
10	-1.5	12.69	12.69	12.69	12.69	0	0	0	0	0	0
12	-1.8	15.228	15.228	15.228	15.228	0	0	0	0	0	0
14	-2.1	17.766	17.766	17.766	17.766	0	0	0	0	0	0
16	-2.4	20.304	20.304	20.304	20.304	0	0	0	0	0	0
18	-2.7	22.842	22.842	22.842	22.842	0	0	0	0	0	0
20	-3	25.38	25.38	25.38	25.38	0	0	0	0	0	0
22	-3.3	27.918	27.918	27.918	27.918	0	0	0	0	0	0
24	-3.6	30.456	30.456	30.456	30.456	0	0	0	0	0	0
26	-3.9	32.994	32.994	32.994	32.994	0	0	0	0	0	0
28	-4.15	35.109	35.109	35.109	35.109	0	0	0	0	0	0
30	-4.45	37.647	37.647	37.647	37.647	0	0	0	0	0	0
32	-4.75	40.185	40.185	40.185	40.185	0	0	0	0	0	0
34	-5.05	42.723	42.723	42.723	42.723	0	0	0	0	0	0
36	-5.35	45.261	45.261	45.261	45.261	0	0	0	0	0	0
38	-5.65	47.799	47.799	47.799	47.799	0	0	0	0	0	0
40	-5.95	50.337	50.337	50.337	50.337	0	0	0	0	0	0
42	-6.25	52.875	52.875	52.875	52.875	0	0	0	0	0	0
44	-6.5	54.99	54.99	54.99	54.99	0	0	0	0	0	0
46	-6.8	57.528	57.528	57.528	57.528	0	0	0	0	0	0
48	-7.1	60.066	60.066	60.066	60.066	0	0	0	0	0	0
50	-7.4	62.604	62.604	62.604	62.604	0	0	0	0	0	0
52	-7.7	65.142	65.142	65.142	65.142	0	0	0	0	0	0
54	-8	67.68	67.68	67.68	67.68	0	0	0	0	0	0
56	-8.3	70.218	70.218	70.218	70.218	0	0	0	0	0	0
58	-8.5	71.91	71.91	71.91	71.91	0	0	0	0	0	0
60	-8.8	74.448	74.448	74.448	74.448	0	0	0	0	0	0
62	-9.1	76.986	76.986	76.986	76.986	0	0	0	0	0	0
64	-9.4	79.524	79.524	79.524	79.524	0	0	0	0	0	0
66	-9.7	82.062	82.062	82.062	82.062	0	0	0	0	0	0
68	-10	103.93	103.93	103.93	103.93	0	0	0	0	0	0
70	-10.3	107.05	107.05	107.05	107.05	0	0	0	0	0	0
72	-10.6	110.16	110.16	110.16	110.16	0	0	0	0	0	0
74	-10.9	113.28	113.28	113.28	113.28	0	0	0	0	0	0
76	-11.2	117.25	117.25	115.25	115.25	0	2	2	0	0	0
78	-11.5	121.63	121.63	116.63	116.63	0	5	5	0	0	0
80	-11.8	126.02	126.02	118.02	118.02	0	8	8	0	0	0
82	-12.1	130.4	130.4	119.4	119.4	0	11	11	0	0	0
84	-12.4	134.79	134.79	120.79	120.79	0	14	14	0	0	0
86	-12.7	139.17	139.17	122.17	122.17	0	17	17	0	0	0
88	-13	143.56	143.56	123.56	123.56	0	20	20	0	0	0
90	-13.3	147.95	147.95	124.95	124.95	0	23	23	0	0	0
92	-13.6	152.33	152.33	126.33	126.33	0	26	26	0	0	0
94	-13.9	156.72	156.72	127.72	127.72	0	29	29	0	0	0
96	-14.2	161.1	161.1	129.1	129.1	0	32	32	0	0	0
98	-14.5	165.49	165.49	130.49	130.49	0	35	35	0	0	0
100	-14.8	169.87	169.87	131.87	131.87	0	38	38	0	0	0
102	-15.1	174.26	174.26	133.26	133.26	0	41	41	0	0	0
104	-15.4	178.65	178.65	134.65	134.65	0	44	44	0	0	0

106	-15.7	183.03	183.03	136.03	136.03	0	47	47	0	0	0
108	-16	187.42	187.42	137.42	137.42	0	50	50	0	0	0
110	-16.3	191.8	191.8	138.8	138.8	0	53	53	0	0	0
112	-16.6	196.19	196.19	140.19	140.19	0	56	56	0	0	0
114	-16.9	200.57	200.57	141.57	141.57	0	59	59	0	0	0
116	-17.2	204.96	204.96	142.96	142.96	0	62	62	0	0	0
118	-17.5	209.35	209.35	144.35	144.35	0	65	65	0	0	0
120	-17.8	213.73	213.73	145.73	145.73	0	68	68	0	0	0
122	-18	216.65	216.65	146.65	146.65	0	70	70	0	0	0

P177.8x12.5/40 Stage: 1

Wall	EL	Sht L	Sht R	Shs L	Shs R	q	U L	U R	M	V	dx
Nod	(m)	(kPa)	(kPa)	(kPa)	(kPa)	(kPa)	(kPa)	(kPa)	(kN-	(kN/m)	(cm)
0	0	5.34	0	5.34	0	0	0	0	0	0.4	1.29
2	-0.3	6.782	0	6.782	0	0	0	0	0.26	1.31	1.17
4	-0.6	8.224	0	8.224	0	0	0	0	1.12	3.45	1.05
6	-0.9	9.665	0	9.665	0	0	0	0	2.73	6.03	0.94
8	-1.2	11.107	0	11.107	0	0	0	0	5.21	9.04	0.82
10	-1.5	12.549	0	12.549	0	0	0	0	8.68	12.48	0.71
12	-1.8	13.991	0	13.991	0	0	0	0	13.29	16.35	0.6
14	-2.1	15.433	9.101	15.433	9.101	0	0	0	19.16	20.65	0.49
16	-2.4	16.874	36.403	16.874	36.403	0	0	0	25.49	20.61	0.4
18	-2.7	18.316	50.599	18.316	50.599	0	0	0	30.06	12.82	0.31
20	-3	19.758	44.405	19.758	44.405	0	0	0	31.82	3.73	0.24
22	-3.3	21.2	39.668	21.2	39.668	0	0	0	31.35	-3.17	0.18
24	-3.6	22.642	36.432	22.642	36.432	0	0	0	29.2	-8.34	0.13
26	-3.9	24.083	34.624	24.083	34.624	0	0	0	25.81	-12.2	0.09
28	-4.15	30.145	34.097	30.145	34.097	0	0	0	22.28	-14.52	0.07
30	-4.45	36.414	34.468	36.414	34.468	0	0	0	17.74	-15.21	0.05
32	-4.75	41.209	35.723	41.209	35.723	0	0	0	13.35	-14.32	0.04
34	-5.05	44.893	37.645	44.893	37.645	0	0	0	9.45	-12.52	0.04
36	-5.35	47.786	40.04	47.786	40.04	0	0	0	6.19	-10.28	0.03
38	-5.65	50.16	42.744	50.16	42.744	0	0	0	3.63	-7.97	0.03
40	-5.95	52.227	45.629	52.227	45.629	0	0	0	1.73	-5.8	0.04
42	-6.25	54.146	48.597	54.146	48.597	0	0	0	0.42	-3.9	0.04
44	-6.5	55.712	51.087	55.712	51.087	0	0	0	-0.29	-2.44	0.04
46	-6.8	57.612	54.058	57.612	54.058	0	0	0	-0.75	-1.25	0.05
48	-7.1	59.573	56.987	59.573	56.987	0	0	0	-0.9	-0.26	0.05
50	-7.4	61.606	59.869	61.606	59.869	0	0	0	-0.82	0.45	0.05
52	-7.7	63.705	62.706	63.705	62.706	0	0	0	-0.57	0.91	0.05
54	-8	65.852	65.512	65.852	65.512	0	0	0	-0.24	1.16	0.06
56	-8.3	68.018	68.304	68.018	68.304	0	0	0	0.12	1.21	0.06
58	-8.5	69.458	70.167	69.458	70.167	0	0	0	0.35	1.11	0.06
60	-8.8	71.592	72.975	71.592	72.975	0	0	0	0.64	0.88	0.06
62	-9.1	73.673	75.814	73.673	75.814	0	0	0	0.81	0.41	0.06
64	-9.4	75.689	78.691	75.689	78.691	0	0	0	0.78	-0.29	0.07
66	-9.7	77.643	81.606	77.643	81.606	0	0	0	0.48	-1.26	0.07
68	-10	105.01	101.45	105.01	101.45	0	0	0	-0.18	-2.53	0.07
70	-10.3	107.68	104.95	107.68	104.95	0	0	0	-0.71	-1.52	0.07
72	-10.6	110.4	108.41	110.4	108.41	0	0	0	-0.99	-0.76	0.08
74	-10.9	113.18	111.82	113.18	111.82	0	0	0	-1.09	-0.21	0.08
76	-11.2	116.86	116.02	114.86	114.02	0	2	2	-1.07	0.15	0.08
78	-11.5	121.04	120.58	116.04	115.58	0	5	5	-0.97	0.38	0.08
80	-11.8	125.27	125.1	117.27	117.1	0	8	8	-0.83	0.49	0.08
82	-12.1	129.55	129.58	118.55	118.58	0	11	11	-0.67	0.52	0.08
84	-12.4	133.87	134.02	119.87	120.02	0	14	14	-0.52	0.5	0.08
86	-12.7	138.22	138.44	121.22	121.44	0	17	17	-0.38	0.45	0.08
88	-13	142.6	142.84	122.6	122.84	0	20	20	-0.26	0.38	0.09

90	-13.3	146.99	147.23	123.99	124.23	0	23	23	-0.16	0.31	0.08
92	-13.6	151.39	151.61	125.39	125.61	0	26	26	-0.09	0.23	0.08
94	-13.9	155.79	155.99	126.79	126.99	0	29	29	-0.03	0.17	0.08
96	-14.2	160.2	160.36	128.2	128.36	0	32	32	0.01	0.11	0.08
98	-14.5	164.61	164.73	129.61	129.73	0	35	35	0.03	0.07	0.08
100	-14.8	169.02	169.11	131.02	131.11	0	38	38	0.04	0.03	0.08
102	-15.1	173.42	173.48	132.42	132.48	0	41	41	0.05	0.01	0.08
104	-15.4	177.82	177.86	133.82	133.86	0	44	44	0.05	-0.01	0.08
106	-15.7	182.22	182.24	135.22	135.24	0	47	47	0.04	-0.02	0.08
108	-16	186.61	186.62	136.61	136.62	0	50	50	0.03	-0.02	0.08
110	-16.3	191.01	191.01	138.01	138.01	0	53	53	0.03	-0.03	0.08
112	-16.6	195.4	195.39	139.4	139.39	0	56	56	0.02	-0.02	0.08
114	-16.9	199.79	199.78	140.79	140.78	0	59	59	0.01	-0.02	0.08
116	-17.2	204.18	204.16	142.18	142.16	0	62	62	0.01	-0.02	0.08
118	-17.5	208.57	208.55	143.57	143.55	0	65	65	0	-0.01	0.08
120	-17.8	212.96	212.94	144.96	144.94	0	68	68	0	-0.01	0.08
122	-18	215.89	215.86	145.89	145.86	0	70	70	0	0	0.08

P177.8x12.5/40 Stage: 2

Wall Nod	EL (m)	Sht L (kPa)	Sht R (kPa)	Shs L (kPa)	Shs R (kPa)	q (kPa)	U L (kPa)	U R (kPa)	M (kN)	V (kN/m)	dx (cm)
0	0	20.171	0	20.171	0	0	0	0	0	1.51	1.22
2	-0.3	23.252	0	23.252	0	0	0	0	0.94	4.77	1.09
4	-0.6	26.263	0	26.263	0	0	0	0	3.98	11.97	0.97
6	-0.9	29.023	0	29.023	0	0	0	0	9.37	20.07	0.84
8	-1.2	31.217	0	31.217	0	0	0	0	17.38	28.95	0.72
10	-1.5	32.385	0	32.385	0	0	0	0	28.19	38.43	0.61
12	-1.8	32.161	0	32.161	0	0	0	0	24.4	-10.21	0.51
14	-2.1	31.002	0.481	31.002	0.481	0	0	0	23.5	-0.64	0.42
16	-2.4	29.464	28.667	29.464	28.667	0	0	0	25.04	6.37	0.34
18	-2.7	27.947	44.681	27.947	44.681	0	0	0	26.66	4.3	0.26
20	-3	26.7	40.139	26.7	40.139	0	0	0	26.86	-0.46	0.2
22	-3.3	25.857	36.806	25.857	36.806	0	0	0	25.85	-4.28	0.15
24	-3.6	25.464	34.698	25.464	34.698	0	0	0	23.84	-7.43	0.12
26	-3.9	25.512	33.746	25.512	33.746	0	0	0	21	-10.11	0.09
28	-4.15	30.718	33.745	30.718	33.745	0	0	0	18.1	-11.92	0.07
30	-4.45	36.275	34.554	36.275	34.554	0	0	0	14.38	-12.43	0.05
32	-4.75	40.636	36.075	40.636	36.075	0	0	0	10.8	-11.67	0.04
34	-5.05	44.098	38.134	44.098	38.134	0	0	0	7.63	-10.18	0.04
36	-5.35	46.922	40.571	46.922	40.571	0	0	0	4.99	-8.34	0.04
38	-5.65	49.327	43.256	49.327	43.256	0	0	0	2.91	-6.45	0.04
40	-5.95	51.486	46.084	51.486	46.084	0	0	0	1.38	-4.67	0.04
42	-6.25	53.527	48.978	53.527	48.978	0	0	0	0.33	-3.11	0.04
44	-6.5	55.201	51.401	55.201	51.401	0	0	0	-0.23	-1.92	0.05
46	-6.8	57.227	54.294	57.227	54.294	0	0	0	-0.58	-0.94	0.05
48	-7.1	59.3	57.155	59.3	57.155	0	0	0	-0.68	-0.12	0.05
50	-7.4	61.427	59.979	61.427	59.979	0	0	0	-0.58	0.47	0.05
52	-7.7	63.601	62.771	63.601	62.771	0	0	0	-0.35	0.85	0.05
54	-8	65.803	65.542	65.803	65.542	0	0	0	-0.04	1.06	0.06
56	-8.3	68.008	68.31	68.008	68.31	0	0	0	0.29	1.1	0.06
58	-8.5	69.467	70.161	69.467	70.161	0	0	0	0.5	0.99	0.06
60	-8.8	71.619	72.959	71.619	72.959	0	0	0	0.75	0.77	0.06
62	-9.1	73.709	75.792	73.709	75.792	0	0	0	0.88	0.32	0.06
64	-9.4	75.728	78.668	75.728	78.668	0	0	0	0.83	-0.37	0.07
66	-9.7	77.681	81.583	77.681	81.583	0	0	0	0.51	-1.32	0.07
68	-10	105.03	101.43	105.03	101.43	0	0	0	-0.16	-2.57	0.07
70	-10.3	107.7	104.93	107.7	104.93	0	0	0	-0.7	-1.55	0.07
72	-10.6	110.42	108.4	110.42	108.4	0	0	0	-0.99	-0.78	0.08

74	-10.9	113.19	111.81	113.19	111.81	0	0	0	-1.1	-0.22	0.08
76	-11.2	116.87	116.01	114.87	114.01	0	2	2	-1.08	0.15	0.08
78	-11.5	121.04	120.58	116.04	115.58	0	5	5	-0.98	0.38	0.08
80	-11.8	125.27	125.1	117.27	117.1	0	8	8	-0.84	0.49	0.08
82	-12.1	129.55	129.58	118.55	118.58	0	11	11	-0.68	0.53	0.08
84	-12.4	133.87	134.02	119.87	120.02	0	14	14	-0.53	0.51	0.08
86	-12.7	138.22	138.44	121.22	121.44	0	17	17	-0.39	0.45	0.08
88	-13	142.59	142.84	122.59	122.84	0	20	20	-0.26	0.38	0.09
90	-13.3	146.99	147.23	123.99	124.23	0	23	23	-0.17	0.31	0.08
92	-13.6	151.39	151.61	125.39	125.61	0	26	26	-0.09	0.24	0.08
94	-13.9	155.79	155.99	126.79	126.99	0	29	29	-0.03	0.17	0.08
96	-14.2	160.2	160.36	128.2	128.36	0	32	32	0	0.12	0.08
98	-14.5	164.61	164.73	129.61	129.73	0	35	35	0.03	0.07	0.08
100	-14.8	169.01	169.11	131.01	131.11	0	38	38	0.04	0.04	0.08
102	-15.1	173.42	173.48	132.42	132.48	0	41	41	0.05	0.01	0.08
104	-15.4	177.82	177.86	133.82	133.86	0	44	44	0.05	-0.01	0.08
106	-15.7	182.22	182.24	135.22	135.24	0	47	47	0.04	-0.02	0.08
108	-16	186.61	186.62	136.61	136.62	0	50	50	0.03	-0.02	0.08
110	-16.3	191.01	191.01	138.01	138.01	0	53	53	0.03	-0.03	0.08
112	-16.6	195.4	195.39	139.4	139.39	0	56	56	0.02	-0.02	0.08
114	-16.9	199.79	199.78	140.79	140.78	0	59	59	0.01	-0.02	0.08
116	-17.2	204.18	204.16	142.18	142.16	0	62	62	0.01	-0.02	0.08
118	-17.5	208.57	208.55	143.57	143.55	0	65	65	0	-0.01	0.08
120	-17.8	212.96	212.94	144.96	144.94	0	68	68	0	-0.01	0.08
122	-18	215.89	215.86	145.89	145.86	0	70	70	0	0	0.08

P177.8x12.5/40 Stage: 3

Wall Nod	EL (m)	Sht L (kPa)	Sht R (kPa)	Shs L (kPa)	Shs R (kPa)	q (kPa)	U L (kPa)	U R (kPa)	M (kN-	V (kN/m)	dx (cm)
0	0	28.916	0	28.916	0	0	0	0	0	2.17	1.12
2	-0.3	24.353	0	24.353	0	0	0	0	1.25	6.16	1.08
4	-0.6	19.709	0	19.709	0	0	0	0	4.69	13.12	1.04
6	-0.9	14.789	0	14.789	0	0	0	0	9.9	18.68	1
8	-1.2	11.107	0	11.107	0	0	0	0	16.45	22.72	0.97
10	-1.5	12.549	0	12.549	0	0	0	0	24.03	26.16	0.94
12	-1.8	13.991	0	13.991	0	0	0	0	13.14	-35.31	0.92
14	-2.1	15.433	0	15.433	0	0	0	0	3.5	-31	0.91
16	-2.4	16.874	0	16.874	0	0	0	0	-4.74	-26.26	0.9
18	-2.7	18.316	0	18.316	0	0	0	0	-11.46	-21.09	0.88
20	-3	19.758	0	19.758	0	0	0	0	-16.54	-15.49	0.86
22	-3.3	21.2	0	21.2	0	0	0	0	-19.84	-9.46	0.84
24	-3.6	22.642	0	22.642	0	0	0	0	-21.22	-2.99	0.81
26	-3.9	24.083	0	24.083	0	0	0	0	-20.58	3.91	0.76
28	-4.15	25.285	0	25.285	0	0	0	0	-18.39	9.99	0.72
30	-4.45	26.727	0	26.727	0	0	0	0	-13.66	17.69	0.67
32	-4.75	28.169	22.752	28.169	22.752	0	0	0	-6.74	24.45	0.61
34	-5.05	29.61	46.885	29.61	46.885	0	0	0	0.67	24.14	0.54
36	-5.35	31.052	47.184	31.052	47.184	0	0	0	6.75	19.03	0.48
38	-5.65	32.494	47.359	32.494	47.359	0	0	0	11.39	14.29	0.42
40	-5.95	33.936	47.634	33.936	47.634	0	0	0	14.69	9.92	0.36
42	-6.25	35.377	48.123	35.377	48.123	0	0	0	16.75	5.89	0.31
44	-6.5	36.579	48.744	36.579	48.744	0	0	0	17.59	2.43	0.27
46	-6.8	40.381	49.771	40.381	49.771	0	0	0	17.6	-0.83	0.23
48	-7.1	45.434	51.117	45.434	51.117	0	0	0	16.76	-3.35	0.2
50	-7.4	49.901	52.773	49.901	52.773	0	0	0	15.4	-4.83	0.18
52	-7.7	53.828	54.724	53.828	54.724	0	0	0	13.78	-5.53	0.16
54	-8	57.262	56.945	57.262	56.945	0	0	0	12.08	-5.69	0.15
56	-8.3	60.252	59.413	60.252	59.413	0	0	0	10.4	-5.55	0.14

58	-8.5	62.022	61.183	62.022	61.183	0	0	0	9.32	-5.34	0.14
60	-8.8	64.375	64.007	64.375	64.007	0	0	0	7.76	-5.15	0.14
62	-9.1	66.408	67.012	66.408	67.012	0	0	0	6.23	-5.11	0.14
64	-9.4	68.172	70.168	68.172	70.168	0	0	0	4.64	-5.38	0.15
66	-9.7	69.729	73.439	69.729	73.439	0	0	0	2.88	-6.11	0.16
68	-10	98.914	90.519	98.914	90.519	0	0	0	0.77	-7.36	0.16
70	-10.3	101.21	94.438	101.21	94.438	0	0	0	-0.89	-4.96	0.17
72	-10.6	103.55	98.311	103.55	98.311	0	0	0	-1.94	-3.05	0.18
74	-10.9	105.98	102.11	105.98	102.11	0	0	0	-2.51	-1.58	0.19
76	-11.2	109.35	106.62	107.35	104.62	0	2	2	-2.74	-0.51	0.2
78	-11.5	113.25	111.44	108.25	106.44	0	5	5	-2.72	0.23	0.2
80	-11.8	117.26	116.18	109.26	108.18	0	8	8	-2.54	0.72	0.21
82	-12.1	121.36	120.84	110.36	109.84	0	11	11	-2.26	1	0.21
84	-12.4	125.55	125.43	111.55	111.43	0	14	14	-1.93	1.12	0.21
86	-12.7	129.8	129.96	112.8	112.96	0	17	17	-1.59	1.13	0.21
88	-13	134.11	134.45	114.11	114.45	0	20	20	-1.26	1.07	0.21
90	-13.3	138.47	138.9	115.47	115.9	0	23	23	-0.97	0.96	0.22
92	-13.6	142.85	143.32	116.85	117.32	0	26	26	-0.71	0.83	0.22
94	-13.9	147.26	147.73	118.26	118.73	0	29	29	-0.49	0.69	0.22
96	-14.2	151.68	152.12	119.68	120.12	0	32	32	-0.32	0.55	0.21
98	-14.5	156.11	156.5	121.11	121.5	0	35	35	-0.18	0.42	0.21
100	-14.8	160.55	160.88	122.55	122.88	0	38	38	-0.08	0.31	0.21
102	-15.1	164.98	165.26	123.98	124.26	0	41	41	-0.01	0.21	0.21
104	-15.4	169.42	169.64	125.42	125.64	0	44	44	0.04	0.13	0.21
106	-15.7	173.85	174.02	126.85	127.02	0	47	47	0.06	0.07	0.21
108	-16	178.28	178.4	128.28	128.4	0	50	50	0.07	0.02	0.21
110	-16.3	182.7	182.79	129.7	129.79	0	53	53	0.07	-0.02	0.21
112	-16.6	187.12	187.17	131.12	131.17	0	56	56	0.06	-0.04	0.21
114	-16.9	191.54	191.56	132.54	132.56	0	59	59	0.04	-0.05	0.21
116	-17.2	195.96	195.94	133.96	133.94	0	62	62	0.03	-0.05	0.21
118	-17.5	200.38	200.33	135.38	135.33	0	65	65	0.01	-0.04	0.21
120	-17.8	204.8	204.71	136.8	136.71	0	68	68	0	-0.03	0.21
122	-18	207.74	207.64	137.74	137.64	0	70	70	0	0	0.21

P177.8x12.5/40 Stage: 4

Wall	EL	Sht L	Sht R	Shs L	Shs R	q	U L	U R	M	V	dx
Nod	(m)	(kPa)	(kPa)	(kPa)	(kPa)	(kPa)	(kPa)	(kPa)	(kN-	(kN/m)	(cm)
0	0	22.256	0	22.256	0	0	0	0	0	1.67	1.19
2	-0.3	20.152	0	20.152	0	0	0	0	0.98	4.85	1.12
4	-0.6	17.979	0	17.979	0	0	0	0	3.77	10.73	1.06
6	-0.9	15.565	0	15.565	0	0	0	0	8.18	15.96	0.99
8	-1.2	14.452	0	14.452	0	0	0	0	13.98	20.42	0.93
10	-1.5	18.553	0	18.553	0	0	0	0	21.13	25.06	0.87
12	-1.8	22.756	0	22.756	0	0	0	0	10.77	-32.98	0.82
14	-2.1	27.043	0	27.043	0	0	0	0	2.46	-25.83	0.78
16	-2.4	31.365	0	31.365	0	0	0	0	-3.42	-17.4	0.73
18	-2.7	35.632	0	35.632	0	0	0	0	-6.47	-7.67	0.69
20	-3	39.71	0	39.71	0	0	0	0	-6.32	3.33	0.64
22	-3.3	43.404	0	43.404	0	0	0	0	-2.59	15.53	0.59
24	-3.6	46.454	0	46.454	0	0	0	0	5.03	28.8	0.54
26	-3.9	48.527	0	48.527	0	0	0	0	16.84	42.91	0.49
28	-4.15	49.237	0	49.237	0	0	0	0	15.9	-38.87	0.46
30	-4.45	48.956	0	48.956	0	0	0	0	7.56	-24.1	0.42
32	-4.75	47.885	10.636	47.885	10.636	0	0	0	3.61	-9.56	0.39
34	-5.05	46.421	36.554	46.421	36.554	0	0	0	2.92	-0.67	0.36
36	-5.35	44.865	38.696	44.865	38.696	0	0	0	3.34	2.01	0.32
38	-5.65	43.426	40.641	43.426	40.641	0	0	0	4.32	3.6	0.3
40	-5.95	42.243	42.529	42.243	42.529	0	0	0	5.55	4.2	0.27

42	-6.25	41.392	44.428	41.392	44.428	0	0	0	6.76	3.9	0.24
44	-6.5	40.961	46.051	40.961	46.051	0	0	0	7.57	2.91	0.22
46	-6.8	43.14	48.075	43.14	48.075	0	0	0	8.11	1.38	0.2
48	-7.1	46.919	50.204	46.919	50.204	0	0	0	8.22	0.04	0.19
50	-7.4	50.427	52.451	50.427	52.451	0	0	0	8.02	-0.85	0.17
52	-7.7	53.665	54.823	53.665	54.823	0	0	0	7.64	-1.38	0.16
54	-8	56.638	57.328	56.638	57.328	0	0	0	7.15	-1.69	0.16
56	-8.3	59.349	59.967	59.349	59.967	0	0	0	6.6	-1.88	0.15
58	-8.5	61.013	61.803	61.013	61.803	0	0	0	6.2	-2.05	0.15
60	-8.8	63.301	64.667	63.301	64.667	0	0	0	5.54	-2.28	0.15
62	-9.1	65.352	67.662	65.352	67.662	0	0	0	4.76	-2.76	0.16
64	-9.4	67.188	70.773	67.188	70.773	0	0	0	3.76	-3.54	0.16
66	-9.7	68.849	73.98	68.849	73.98	0	0	0	2.44	-4.73	0.17
68	-10	98.365	90.965	98.365	90.965	0	0	0	0.66	-6.39	0.17
70	-10.3	100.75	94.81	100.75	94.81	0	0	0	-0.78	-4.28	0.18
72	-10.6	103.18	98.61	103.18	98.61	0	0	0	-1.68	-2.6	0.19
74	-10.9	105.69	102.34	105.69	102.34	0	0	0	-2.16	-1.33	0.19
76	-11.2	109.13	106.79	107.13	104.79	0	2	2	-2.35	-0.4	0.2
78	-11.5	113.1	111.57	108.1	106.57	0	5	5	-2.32	0.24	0.2
80	-11.8	117.16	116.26	109.16	108.26	0	8	8	-2.15	0.65	0.21
82	-12.1	121.3	120.89	110.3	109.89	0	11	11	-1.91	0.88	0.21
84	-12.4	125.52	125.45	111.52	111.45	0	14	14	-1.62	0.97	0.21
86	-12.7	129.8	129.96	112.8	112.96	0	17	17	-1.32	0.98	0.21
88	-13	134.13	134.44	114.13	114.44	0	20	20	-1.04	0.91	0.21
90	-13.3	138.49	138.88	115.49	115.88	0	23	23	-0.79	0.82	0.21
92	-13.6	142.89	143.3	116.89	117.3	0	26	26	-0.57	0.7	0.21
94	-13.9	147.3	147.7	118.3	118.7	0	29	29	-0.39	0.57	0.21
96	-14.2	151.72	152.09	119.72	120.09	0	32	32	-0.25	0.45	0.21
98	-14.5	156.15	156.48	121.15	121.48	0	35	35	-0.14	0.35	0.21
100	-14.8	160.58	160.86	122.58	122.86	0	38	38	-0.05	0.25	0.21
102	-15.1	165.01	165.24	124.01	124.24	0	41	41	0	0.17	0.21
104	-15.4	169.44	169.62	125.44	125.62	0	44	44	0.04	0.1	0.21
106	-15.7	173.86	174.01	126.86	127.01	0	47	47	0.06	0.05	0.21
108	-16	178.29	178.39	128.29	128.39	0	50	50	0.06	0.01	0.21
110	-16.3	182.71	182.78	129.71	129.78	0	53	53	0.06	-0.02	0.21
112	-16.6	187.13	187.17	131.13	131.17	0	56	56	0.05	-0.04	0.21
114	-16.9	191.55	191.55	132.55	132.55	0	59	59	0.04	-0.05	0.21
116	-17.2	195.96	195.94	133.96	133.94	0	62	62	0.02	-0.05	0.21
118	-17.5	200.38	200.33	135.38	135.33	0	65	65	0.01	-0.04	0.21
120	-17.8	204.79	204.72	136.79	136.72	0	68	68	0	-0.02	0.21
122	-18	207.74	207.65	137.74	137.65	0	70	70	0	0	0.21

P177.8x12.5/40 Stage: 5

Wall	EL	Sht L	Sht R	Shs L	Shs R	q	U L	U R	M	V	dx
Nod	(m)	(kPa)	(kPa)	(kPa)	(kPa)	(kPa)	(kPa)	(kPa)	(kN-	(kN/m)	(cm)
0	0	31.875	0	31.875	0	0	0	0	0	2.39	1.03
2	-0.3	28.238	0	28.238	0	0	0	0	1.39	6.9	0.99
4	-0.6	24.52	0	24.52	0	0	0	0	5.33	15.1	0.94
6	-0.9	20.523	0	20.523	0	0	0	0	11.47	22.16	0.91
8	-1.2	17.747	0	17.747	0	0	0	0	19.45	27.99	0.87
10	-1.5	20.055	0	20.055	0	0	0	0	29.07	33.48	0.85
12	-1.8	22.275	0	22.275	0	0	0	0	21.48	-23.7	0.83
14	-2.1	24.326	0	24.326	0	0	0	0	15.9	-16.86	0.83
16	-2.4	26.094	0	26.094	0	0	0	0	12.51	-9.42	0.83
18	-2.7	27.431	0	27.431	0	0	0	0	11.46	-1.48	0.83
20	-3	28.155	0	28.155	0	0	0	0	12.88	6.81	0.84
22	-3.3	28.042	0	28.042	0	0	0	0	16.82	15.27	0.86
24	-3.6	26.829	0	26.829	0	0	0	0	23.28	23.61	0.88

26	-3.9	24.211	0	24.211	0	0	0	0	32.16	31.5	0.91
28	-4.15	25.285	0	25.285	0	0	0	0	25.8	-65.39	0.95
30	-4.45	26.727	0	26.727	0	0	0	0	7.9	-57.7	1
32	-4.75	28.169	0	28.169	0	0	0	0	-7.58	-49.57	1.06
34	-5.05	29.61	0	29.61	0	0	0	0	-20.54	-41.01	1.11
36	-5.35	31.052	0	31.052	0	0	0	0	-30.82	-32.02	1.16
38	-5.65	32.494	0	32.494	0	0	0	0	-38.32	-22.6	1.19
40	-5.95	33.936	0	33.936	0	0	0	0	-42.89	-12.74	1.21
42	-6.25	35.377	0	35.377	0	0	0	0	-44.4	-2.45	1.21
44	-6.5	36.579	0	36.579	0	0	0	0	-43.24	7.37	1.19
46	-6.8	38.021	0	38.021	0	0	0	0	-38.82	17.54	1.16
48	-7.1	39.463	9.101	39.463	9.101	0	0	0	-30.97	29.05	1.11
50	-7.4	40.904	36.403	40.904	36.403	0	0	0	-20.5	36.22	1.05
52	-7.7	42.346	61.65	42.346	61.65	0	0	0	-9.62	35.63	0.98
54	-8	43.788	63.303	43.788	63.303	0	0	0	-0.24	29.81	0.91
56	-8.3	45.23	64.579	45.23	64.579	0	0	0	7.39	23.97	0.84
58	-8.5	46.191	65.362	46.191	65.362	0	0	0	11.51	19.14	0.79
60	-8.8	47.633	66.568	47.633	66.568	0	0	0	16.25	14.37	0.72
62	-9.1	49.075	67.925	49.075	67.925	0	0	0	19.28	8.7	0.66
64	-9.4	50.516	69.51	50.516	69.51	0	0	0	20.62	3.04	0.61
66	-9.7	51.958	71.359	51.958	71.359	0	0	0	20.24	-2.69	0.56
68	-10	83.471	82.903	83.471	82.903	0	0	0	18.12	-8.55	0.53
70	-10.3	87.384	85.925	87.384	85.925	0	0	0	15.61	-8.31	0.5
72	-10.6	91.057	89.083	91.057	89.083	0	0	0	13.22	-7.82	0.48
74	-10.9	94.551	92.339	94.551	92.339	0	0	0	11.01	-7.21	0.46
76	-11.2	98.757	96.362	96.757	94.362	0	2	2	9	-6.53	0.45
78	-11.5	103.28	100.80	98.288	95.801	0	5	5	7.2	-5.81	0.44
80	-11.8	107.75	105.29	99.75	97.291	0	8	8	5.63	-5.06	0.43
82	-12.1	112.16	109.81	101.16	98.813	0	11	11	4.27	-4.33	0.43
84	-12.4	116.54	114.36	102.54	100.36	0	14	14	3.13	-3.64	0.43
86	-12.7	120.9	118.91	103.9	101.91	0	17	17	2.19	-2.99	0.43
88	-13	125.25	123.47	105.25	103.47	0	20	20	1.42	-2.41	0.43
90	-13.3	129.59	128.03	106.59	105.03	0	23	23	0.81	-1.89	0.43
92	-13.6	133.93	132.58	107.93	106.58	0	26	26	0.35	-1.44	0.43
94	-13.9	138.27	137.13	109.27	108.13	0	29	29	0.01	-1.05	0.43
96	-14.2	142.62	141.67	110.62	109.67	0	32	32	-0.23	-0.72	0.43
98	-14.5	146.97	146.2	111.97	111.2	0	35	35	-0.39	-0.45	0.43
100	-14.8	151.33	150.72	113.33	112.72	0	38	38	-0.47	-0.23	0.43
102	-15.1	155.7	155.23	114.7	114.23	0	41	41	-0.5	-0.06	0.43
104	-15.4	160.08	159.74	116.08	115.74	0	44	44	-0.49	0.07	0.43
106	-15.7	164.46	164.23	117.46	117.23	0	47	47	-0.45	0.17	0.44
108	-16	168.84	168.72	118.84	118.72	0	50	50	-0.38	0.23	0.44
110	-16.3	173.24	173.19	120.24	120.19	0	53	53	-0.31	0.26	0.44
112	-16.6	177.63	177.67	121.63	121.67	0	56	56	-0.23	0.26	0.44
114	-16.9	182.03	182.14	123.03	123.14	0	59	59	-0.15	0.25	0.44
116	-17.2	186.43	186.6	124.43	124.6	0	62	62	-0.09	0.21	0.44
118	-17.5	190.83	191.06	125.83	126.06	0	65	65	-0.04	0.15	0.44
120	-17.8	195.23	195.52	127.23	127.52	0	68	68	-0.01	0.08	0.44
122	-18	198.17	198.49	128.17	128.49	0	70	70	0	0.01	0.44

P177.8x12.5/40 Stage: 6

Wall	EL	Sht L	Sht R	Shs L	Shs R	q	U L	U R	M	V	dx
Nod	(m)	(kPa)	(kPa)	(kPa)	(kPa)	(kPa)	(kPa)	(kPa)	(kN-	(kN/m)	(cm)
0	0	23.521	0	23.521	0	0	0	0	0	1.76	1.17
2	-0.3	20.926	0	20.926	0	0	0	0	1.03	5.1	1.11
4	-0.6	18.261	0	18.261	0	0	0	0	3.94	11.18	1.05
6	-0.9	15.35	0	15.35	0	0	0	0	8.5	16.44	1
8	-1.2	13.733	0	13.733	0	0	0	0	14.43	20.81	0.94

10	-1.5	17.319	0	17.319	0	0	0	0	21.64	25.19	0.89
12	-1.8	20.996	0	20.996	0	0	0	0	11.09	-33.71	0.85
14	-2.1	24.75	0	24.75	0	0	0	0	2.44	-27.13	0.82
16	-2.4	28.539	0	28.539	0	0	0	0	-3.99	-19.42	0.78
18	-2.7	32.289	0	32.289	0	0	0	0	-7.84	-10.58	0.75
20	-3	35.881	0	35.881	0	0	0	0	-8.8	-0.62	0.71
22	-3.3	39.15	0	39.15	0	0	0	0	-6.52	10.4	0.67
24	-3.6	41.869	0	41.869	0	0	0	0	-0.73	22.36	0.62
26	-3.9	43.749	0	43.749	0	0	0	0	8.83	35.08	0.58
28	-4.15	48.991	0	48.991	0	0	0	0	5.48	-49.37	0.54
30	-4.45	55.866	0	55.866	0	0	0	0	-5.94	-34.16	0.5
32	-4.75	63.062	0	63.062	0	0	0	0	-12.34	-16.87	0.46
34	-5.05	70.363	0	70.363	0	0	0	0	-13.06	2.6	0.41
36	-5.35	77.478	0	77.478	0	0	0	0	-7.45	24.25	0.36
38	-5.65	84.028	0	84.028	0	0	0	0	5.13	48	0.3
40	-5.95	89.537	0	89.537	0	0	0	0	25.26	73.64	0.25
42	-6.25	93.418	0	93.418	0	0	0	0	53.45	100.83	0.21
44	-6.5	94.904	0	94.904	0	0	0	0	83.34	126.66	0.19
46	-6.8	94.187	0	94.187	0	0	0	0	49.54	-105.54	0.19
48	-7.1	91.363	0.481	91.363	0.481	0	0	0	24.21	-77.47	0.22
50	-7.4	87.218	7.943	87.218	7.943	0	0	0	7.04	-50.6	0.25
52	-7.7	82.403	37.035	82.403	37.035	0	0	0	-3.19	-29.51	0.29
54	-8	77.421	42.635	77.421	42.635	0	0	0	-9.1	-16.7	0.33
56	-8.3	72.637	47.737	72.637	47.737	0	0	0	-11.88	-7.02	0.36
58	-8.5	69.685	50.924	69.685	50.924	0	0	0	-12.43	-1.26	0.38
60	-8.8	65.736	55.443	65.736	55.443	0	0	0	-11.92	2.78	0.41
62	-9.1	62.45	59.706	62.45	59.706	0	0	0	-10.48	5.28	0.43
64	-9.4	59.864	63.766	59.864	63.766	0	0	0	-8.79	5.59	0.45
66	-9.7	57.972	67.663	57.972	67.663	0	0	0	-7.44	3.97	0.46
68	-10	85.889	80.94	85.889	80.94	0	0	0	-6.97	0.67	0.47
70	-10.3	88.289	85.19	88.289	85.19	0	0	0	-6.45	2.01	0.48
72	-10.6	90.829	89.268	90.829	89.268	0	0	0	-5.66	2.82	0.48
74	-10.9	93.514	93.18	93.514	93.18	0	0	0	-4.72	3.19	0.48
76	-11.2	97.182	97.64	95.182	95.64	0	2	2	-3.75	3.22	0.48
78	-11.5	101.39	102.33	96.395	97.338	0	5	5	-2.82	3.05	0.48
80	-11.8	105.71	106.94	97.711	98.946	0	8	8	-1.97	2.74	0.48
82	-12.1	110.11	111.48	99.11	100.48	0	11	11	-1.24	2.35	0.48
84	-12.4	114.57	115.96	100.57	101.96	0	14	14	-0.62	1.94	0.47
86	-12.7	119.08	120.39	102.08	103.39	0	17	17	-0.14	1.53	0.47
88	-13	123.61	124.8	103.61	104.8	0	20	20	0.23	1.14	0.46
90	-13.3	128.16	129.19	105.16	106.19	0	23	23	0.5	0.8	0.46
92	-13.6	132.71	133.57	106.71	107.57	0	26	26	0.67	0.5	0.46
94	-13.9	137.26	137.95	108.26	108.95	0	29	29	0.76	0.25	0.45
96	-14.2	141.8	142.33	109.8	110.33	0	32	32	0.79	0.06	0.45
98	-14.5	146.33	146.72	111.33	111.72	0	35	35	0.78	-0.09	0.45
100	-14.8	150.85	151.11	112.85	113.11	0	38	38	0.73	-0.19	0.44
102	-15.1	155.36	155.51	114.36	114.51	0	41	41	0.65	-0.26	0.44
104	-15.4	159.85	159.92	115.85	115.92	0	44	44	0.56	-0.3	0.44
106	-15.7	164.33	164.33	117.33	117.33	0	47	47	0.47	-0.32	0.44
108	-16	168.8	168.75	118.8	118.75	0	50	50	0.37	-0.32	0.44
110	-16.3	173.26	173.17	120.26	120.17	0	53	53	0.28	-0.3	0.44
112	-16.6	177.72	177.6	121.72	121.6	0	56	56	0.2	-0.27	0.43
114	-16.9	182.17	182.02	123.17	123.02	0	59	59	0.13	-0.23	0.43
116	-17.2	186.62	186.44	124.62	124.44	0	62	62	0.07	-0.18	0.43
118	-17.5	191.07	190.87	126.07	125.87	0	65	65	0.03	-0.13	0.43
120	-17.8	195.51	195.29	127.51	127.29	0	68	68	0	-0.06	0.43
122	-18	198.48	198.24	128.48	128.24	0	70	70	0	-0.01	0.43

Wall	EL	Sht L	Sht R	Shs L	Shs R	q	U L	U R	M	V	dx
Nod	(m)	(kPa)	(kPa)	(kPa)	(kPa)	(kPa)	(kPa)	(kPa)	(kN-	(kN/m)	(cm)
0	0	23.959	0	23.959	0	0	0	0	0	1.8	1.16
2	-0.3	21.508	0	21.508	0	0	0	0	1.05	5.21	1.1
4	-0.6	18.985	0	18.985	0	0	0	0	4.04	11.47	1.04
6	-0.9	16.216	0	16.216	0	0	0	0	8.73	16.97	0.98
8	-1.2	14.735	0	14.735	0	0	0	0	14.88	21.6	0.92
10	-1.5	18.449	0	18.449	0	0	0	0	22.4	26.3	0.87
12	-1.8	22.24	0	22.24	0	0	0	0	12.42	-31.73	0.83
14	-2.1	26.082	0	26.082	0	0	0	0	4.45	-24.77	0.79
16	-2.4	29.923	0	29.923	0	0	0	0	-1.18	-16.65	0.75
18	-2.7	33.672	0	33.672	0	0	0	0	-4.11	-7.39	0.72
20	-3	37.196	0	37.196	0	0	0	0	-4.02	2.98	0.68
22	-3.3	40.307	0	40.307	0	0	0	0	-0.58	14.38	0.64
24	-3.6	42.758	0	42.758	0	0	0	0	6.49	26.67	0.6
26	-3.9	44.237	0	44.237	0	0	0	0	17.4	39.63	0.57
28	-4.15	49.026	0	49.026	0	0	0	0	15.23	-44.58	0.54
30	-4.45	55.19	0	55.19	0	0	0	0	5.23	-29.41	0.52
32	-4.75	61.469	0	61.469	0	0	0	0	0.2	-12.38	0.49
34	-5.05	67.623	0	67.623	0	0	0	0	0.71	6.53	0.47
36	-5.35	73.337	0	73.337	0	0	0	0	7.3	27.25	0.45
38	-5.65	78.215	0	78.215	0	0	0	0	20.48	49.64	0.43
40	-5.95	81.77	0	81.77	0	0	0	0	40.7	73.4	0.42
42	-6.25	83.413	0	83.413	0	0	0	0	68.26	98.1	0.43
44	-6.5	82.825	0	82.825	0	0	0	0	96.96	121.02	0.46
46	-6.8	79.402	0	79.402	0	0	0	0	58.24	-122.93	0.52
48	-7.1	73.713	0	73.713	0	0	0	0	26.66	-99.5	0.61
50	-7.4	66.66	0	66.66	0	0	0	0	1.71	-77.9	0.71
52	-7.7	59.039	0	59.039	0	0	0	0	-17.24	-58.47	0.81
54	-8	51.507	0	51.507	0	0	0	0	-30.88	-41.33	0.9
56	-8.3	45.23	0	45.23	0	0	0	0	-39.89	-26.41	0.99
58	-8.5	46.191	0	46.191	0	0	0	0	-43.58	-15.04	1.03
60	-8.8	47.633	0	47.633	0	0	0	0	-45.65	-3.38	1.08
62	-9.1	49.075	9.101	49.075	9.101	0	0	0	-43.44	11.02	1.12
64	-9.4	50.516	36.403	50.516	36.403	0	0	0	-37.72	21.07	1.14
66	-9.7	51.958	63.706	51.958	63.706	0	0	0	-30.74	23.37	1.14
68	-10	71.8	59.832	71.8	59.832	0	0	0	-24.6	19.34	1.13
70	-10.3	73.739	77.782	73.739	77.782	0	0	0	-18.17	21.73	1.11
72	-10.6	75.677	83.754	75.677	83.754	0	0	0	-11.99	20.08	1.08
74	-10.9	77.616	87.667	77.616	87.667	0	0	0	-6.53	17.5	1.05
76	-11.2	80.836	91.675	78.836	89.675	0	2	2	-1.97	14.39	1.01
78	-11.5	85.306	95.759	80.306	90.759	0	5	5	1.61	11.1	0.97
80	-11.8	90.718	99.777	82.718	91.777	0	8	8	4.25	8.07	0.94
82	-12.1	96.13	103.76	85.13	92.767	0	11	11	6.07	5.46	0.9
84	-12.4	101.50	107.76	87.508	93.761	0	14	14	7.21	3.27	0.87
86	-12.7	106.82	111.78	89.825	94.782	0	17	17	7.78	1.49	0.84
88	-13	112.06	115.84	92.066	95.845	0	20	20	7.91	0.1	0.82
90	-13.3	117.21	119.96	94.219	96.96	0	23	23	7.7	-0.96	0.8
92	-13.6	122.28	124.13	96.281	98.132	0	26	26	7.24	-1.71	0.78
94	-13.9	127.25	128.36	98.252	99.362	0	29	29	6.61	-2.21	0.76
96	-14.2	132.14	132.65	100.14	100.65	0	32	32	5.88	-2.49	0.75
98	-14.5	136.94	136.98	101.94	101.98	0	35	35	5.1	-2.61	0.73
100	-14.8	141.68	141.36	103.68	103.36	0	38	38	4.32	-2.59	0.73
102	-15.1	146.35	145.78	105.35	104.78	0	41	41	3.57	-2.47	0.72
104	-15.4	150.98	150.23	106.98	106.23	0	44	44	2.87	-2.29	0.71
106	-15.7	155.55	154.71	108.55	107.71	0	47	47	2.23	-2.06	0.71
108	-16	160.1	159.2	110.1	109.2	0	50	50	1.68	-1.8	0.7
110	-16.3	164.62	163.7	111.62	110.7	0	53	53	1.2	-1.52	0.7

112	-16.6	169.12	168.21	113.12	112.21	0	56	56	0.8	-1.25	0.7
114	-16.9	173.61	172.73	114.61	113.73	0	59	59	0.49	-0.98	0.69
116	-17.2	178.09	177.24	116.09	115.24	0	62	62	0.26	-0.71	0.69
118	-17.5	182.57	181.75	117.57	116.75	0	65	65	0.1	-0.46	0.69
120	-17.8	187.04	186.25	119.04	118.25	0	68	68	0.02	-0.22	0.69
122	-18	190.03	189.25	120.03	119.25	0	70	70	0	-0.02	0.69

P177.8x12.5/40 Stage: 8

Wall Nod	EL (m)	Sht L (kPa)	Sht R (kPa)	Shs L (kPa)	Shs R (kPa)	q (kPa)	U L (kPa)	U R (kPa)	M (kN-)	V (kN/m)	dx (cm)
0	0	22.722	0	22.722	0	0	0	0	0	1.7	1.19
2	-0.3	20.1	0	20.1	0	0	0	0	0.99	4.92	1.13
4	-0.6	17.408	0	17.408	0	0	0	0	3.79	10.75	1.07
6	-0.9	14.475	0	14.475	0	0	0	0	8.16	15.76	1.01
8	-1.2	12.841	0	12.841	0	0	0	0	13.83	19.85	0.96
10	-1.5	16.421	0	16.421	0	0	0	0	20.69	23.97	0.91
12	-1.8	20.111	0	20.111	0	0	0	0	9.59	-35.62	0.87
14	-2.1	23.905	0	23.905	0	0	0	0	0.31	-29.31	0.84
16	-2.4	27.774	0	27.774	0	0	0	0	-6.83	-21.85	0.8
18	-2.7	31.656	0	31.656	0	0	0	0	-11.46	-13.22	0.76
20	-3	35.448	0	35.448	0	0	0	0	-13.25	-3.44	0.72
22	-3.3	38.998	0	38.998	0	0	0	0	-11.85	7.47	0.67
24	-3.6	42.096	0	42.096	0	0	0	0	-6.94	19.41	0.62
26	-3.9	44.471	0	44.471	0	0	0	0	1.75	32.23	0.56
28	-4.15	50.224	0	50.224	0	0	0	0	-2.21	-51.6	0.51
30	-4.45	57.841	0	57.841	0	0	0	0	-14.22	-35.98	0.46
32	-4.75	65.933	0	65.933	0	0	0	0	-21.01	-18.02	0.39
34	-5.05	74.289	0	74.289	0	0	0	0	-21.88	2.38	0.32
36	-5.35	82.621	0	82.621	0	0	0	0	-16.06	25.29	0.24
38	-5.65	90.546	0	90.546	0	0	0	0	-2.8	50.69	0.16
40	-5.95	97.574	0	97.574	0	0	0	0	18.6	78.4	0.07
42	-6.25	103.1	0	103.1	0	0	0	0	48.78	108.12	-0.01
44	-6.5	106.02	0	106.02	0	0	0	0	80.98	136.72	-0.06
46	-6.8	107.05	0	107.05	0	0	0	0	53.16	-84.73	-0.09
48	-7.1	105.9	0	105.9	0	0	0	0	34.96	-52.67	-0.1
50	-7.4	103.24	0	103.24	0	0	0	0	26.28	-21.07	-0.1
52	-7.7	99.544	0	99.544	0	0	0	0	26.89	9.64	-0.09
54	-8	95.118	0	95.118	0	0	0	0	36.45	39.18	-0.06
56	-8.3	90.699	0	90.699	0	0	0	0	54.57	67.35	-0.02
58	-8.5	91.96	0	91.96	0	0	0	0	71.22	90.12	0.02
60	-8.8	92.232	0	92.232	0	0	0	0	36.84	-107.67	0.1
62	-9.1	90.974	0.481	90.974	0.481	0	0	0	10.76	-80.07	0.19
64	-9.4	88.709	12.933	88.709	12.933	0	0	0	-7.2	-53.18	0.29
66	-9.7	85.87	42.866	85.87	42.866	0	0	0	-18.4	-32.9	0.39
68	-10	93.113	42.532	93.113	42.532	0	0	0	-25.53	-21.04	0.48
70	-10.3	91.783	63.134	91.783	63.134	0	0	0	-28.67	-7.52	0.56
72	-10.6	90.59	71.649	90.59	71.649	0	0	0	-29.12	0.21	0.62
74	-10.9	89.623	77.921	89.623	77.921	0	0	0	-27.87	5.34	0.68
76	-11.2	90.22	84.058	88.22	82.058	0	2	2	-25.54	8.38	0.72
78	-11.5	92.379	90.018	87.379	85.018	0	5	5	-22.66	9.89	0.76
80	-11.8	95.803	95.649	87.803	87.649	0	8	8	-19.57	10.42	0.78
82	-12.1	99.545	100.99	88.545	89.995	0	11	11	-16.45	10.34	0.8
84	-12.4	103.55	106.10	89.553	92.101	0	14	14	-13.46	9.81	0.81
86	-12.7	107.77	111.01	90.776	94.01	0	17	17	-10.7	8.99	0.81
88	-13	112.17	115.76	92.17	95.76	0	20	20	-8.22	7.98	0.81
90	-13.3	116.69	120.38	93.692	97.388	0	23	23	-6.07	6.9	0.81
92	-13.6	121.30	124.92	95.306	98.923	0	26	26	-4.25	5.79	0.81
94	-13.9	125.98	129.39	96.984	100.39	0	29	29	-2.76	4.72	0.8

96	-14.2	130.70	133.81	98.702	101.81	0	32	32	-1.57	3.72	0.79
98	-14.5	135.44	138.2	100.44	103.2	0	35	35	-0.66	2.81	0.78
100	-14.8	140.18	142.58	102.18	104.58	0	38	38	0	2.01	0.77
102	-15.1	144.93	146.94	103.93	105.94	0	41	41	0.45	1.32	0.76
104	-15.4	149.66	151.3	105.66	107.3	0	44	44	0.71	0.74	0.75
106	-15.7	154.38	155.66	107.38	108.66	0	47	47	0.83	0.28	0.74
108	-16	159.08	160.03	109.08	110.03	0	50	50	0.83	-0.08	0.73
110	-16.3	163.77	164.39	110.77	111.39	0	53	53	0.74	-0.34	0.73
112	-16.6	168.45	168.76	112.45	112.76	0	56	56	0.6	-0.51	0.72
114	-16.9	173.12	173.13	114.12	114.13	0	59	59	0.43	-0.58	0.71
116	-17.2	177.78	177.5	115.78	115.5	0	62	62	0.26	-0.56	0.7
118	-17.5	182.43	181.86	117.43	116.86	0	65	65	0.11	-0.45	0.69
120	-17.8	187.09	186.22	119.09	118.22	0	68	68	0.02	-0.26	0.69
122	-18	190.19	189.12	120.19	119.12	0	70	70	0	-0.03	0.68

P177.8x12.5/40 Stage: 9

Wall	EL	Sht L	Sht R	Shs L	Shs R	q	U L	U R	M	V	dx
Nod	(m)	(kPa)	(kPa)	(kPa)	(kPa)	(kPa)	(kPa)	(kPa)	(kN-	(kN/m)	(cm)
0	0	22.454	0	22.454	0	0	0	0	0	1.68	1.19
2	-0.3	19.927	0	19.927	0	0	0	0	0.98	4.86	1.13
4	-0.6	17.33	0	17.33	0	0	0	0	3.76	10.65	1.07
6	-0.9	14.493	0	14.493	0	0	0	0	8.09	15.64	1.01
8	-1.2	12.956	0	12.956	0	0	0	0	13.73	19.75	0.96
10	-1.5	16.635	0	16.635	0	0	0	0	20.57	23.91	0.91
12	-1.8	20.426	0	20.426	0	0	0	0	9.5	-35.51	0.87
14	-2.1	24.323	0	24.323	0	0	0	0	0.27	-29.09	0.83
16	-2.4	28.295	0	28.295	0	0	0	0	-6.78	-21.5	0.79
18	-2.7	32.28	0	32.28	0	0	0	0	-11.27	-12.71	0.75
20	-3	36.171	0	36.171	0	0	0	0	-12.86	-2.73	0.7
22	-3.3	39.812	0	39.812	0	0	0	0	-11.2	8.4	0.65
24	-3.6	42.991	0	42.991	0	0	0	0	-5.95	20.59	0.6
26	-3.9	45.426	0	45.426	0	0	0	0	3.16	33.69	0.54
28	-4.15	51.21	0	51.21	0	0	0	0	-0.33	-49.48	0.49
30	-4.45	58.833	0	58.833	0	0	0	0	-11.63	-33.55	0.43
32	-4.75	66.881	0	66.881	0	0	0	0	-17.63	-15.3	0.37
34	-5.05	75.132	0	75.132	0	0	0	0	-17.62	5.38	0.3
36	-5.35	83.28	0	83.28	0	0	0	0	-10.84	28.53	0.23
38	-5.65	90.924	0	90.924	0	0	0	0	3.43	54.1	0.15
40	-5.95	97.557	0	97.557	0	0	0	0	25.88	81.9	0.07
42	-6.25	102.55	0	102.55	0	0	0	0	57.09	111.58	0
44	-6.5	104.91	0	104.91	0	0	0	0	90.14	139.99	-0.03
46	-6.8	105.12	0	105.12	0	0	0	0	63	-82.57	-0.05
48	-7.1	102.97	0	102.97	0	0	0	0	45.3	-51.16	-0.04
50	-7.4	99.112	0	99.112	0	0	0	0	36.86	-20.53	-0.01
52	-7.7	94.028	0	94.028	0	0	0	0	37.34	8.84	0.03
54	-8	88.021	0	88.021	0	0	0	0	46.27	36.61	0.09
56	-8.3	81.84	0	81.84	0	0	0	0	63.12	62.52	0.17
58	-8.5	81.839	0	81.839	0	0	0	0	78.49	82.99	0.24
60	-8.8	80.115	0	80.115	0	0	0	0	39.53	-123.77	0.36
62	-9.1	76.814	0	76.814	0	0	0	0	7.78	-99.96	0.5
64	-9.4	72.563	0	72.563	0	0	0	0	-17.07	-77.22	0.65
66	-9.7	67.921	0	67.921	0	0	0	0	-35.39	-55.8	0.79
68	-10	79.016	0	79.016	0	0	0	0	-47.6	-35.77	0.91
70	-10.3	76.894	17.95	76.894	17.95	0	0	0	-53.23	-13.58	1.01
72	-10.6	75.677	35.899	75.677	35.899	0	0	0	-53.54	2.62	1.09
74	-10.9	77.616	53.849	77.616	53.849	0	0	0	-50.25	13.36	1.15
76	-11.2	80.836	67.15	78.836	65.15	0	2	2	-44.79	19.51	1.19
78	-11.5	84.698	78.128	79.698	73.128	0	5	5	-38.09	23.08	1.21

80	-11.8	88.56	89.106	80.56	81.106	0	8	8	-30.81	24.52	1.22
82	-12.1	92.421	100.08	81.421	89.083	0	11	11	-23.57	23.82	1.21
84	-12.4	96.283	105.44	82.283	91.44	0	14	14	-16.97	21.35	1.2
86	-12.7	100.14	109.82	83.144	92.826	0	17	17	-11.18	18.56	1.17
88	-13	104.00	114.01	84.006	94.019	0	20	20	-6.28	15.63	1.15
90	-13.3	107.86	118.08	84.868	95.087	0	23	23	-2.27	12.6	1.12
92	-13.6	112.18	122.08	86.183	96.086	0	26	26	0.82	9.53	1.08
94	-13.9	117.63	126.06	88.637	97.061	0	29	29	3.03	6.67	1.05
96	-14.2	123.05	130.04	91.054	98.043	0	32	32	4.48	4.25	1.02
98	-14.5	128.41	134.05	93.41	99.053	0	35	35	5.3	2.26	1
100	-14.8	133.69	138.11	95.694	100.11	0	38	38	5.61	0.66	0.97
102	-15.1	138.9	142.21	97.9	101.21	0	41	41	5.52	-0.58	0.95
104	-15.4	144.03	146.35	100.03	102.35	0	44	44	5.14	-1.5	0.92
106	-15.7	149.08	150.55	102.08	103.55	0	47	47	4.54	-2.13	0.9
108	-16	154.08	154.78	104.08	104.78	0	50	50	3.81	-2.51	0.89
110	-16.3	159.01	159.04	106.01	106.04	0	53	53	3.02	-2.67	0.87
112	-16.6	163.91	163.33	107.91	107.33	0	56	56	2.23	-2.63	0.86
114	-16.9	168.77	167.63	109.77	108.63	0	59	59	1.48	-2.41	0.84
116	-17.2	173.61	171.94	111.61	109.94	0	62	62	0.84	-2.03	0.83
118	-17.5	178.44	176.24	113.44	111.24	0	65	65	0.35	-1.49	0.82
120	-17.8	183.27	180.54	115.27	112.54	0	68	68	0.06	-0.79	0.8
122	-18	186.48	183.4	116.48	113.4	0	70	70	0	-0.08	0.8

LEGENDA

Wall node=number of the node

EL=elevation

Sht L=Total horizontal soil pressure (on the left side of the wall)

Sht R=Total horizontal soil pressure (on the right side of the wall)

Shs L=Effective horizontal soil pressure (on the left side of the wall)

Shs R=Effective horizontal soil pressure (on the right side of the wall)

q=pressure given by the surcharge

U L=Water pressure (on the left side of the wall)

U R=pressione acqua (on the right side of the wall)

M=bending moment (per meter)

V=shear (per metro)

dx=wall deflection

McapL=Ultimate bending moment (on the left side of the wall)

McapR=Ultimate bending moment (on the right side of the wall)

VcapL=Ultimate resistance shear (on the left side of the wall)

VcapR=Ultimate resistance shear (on the right side of the wall)

SUPPORTS REACTIONS (TIEBACKS, STRUTS, SLABS, RAKERS)

Support 0

Stage No	R
	(kN)
0	0
1	0
2	145.008
3	162.336
4	158.82
5	157.452
6	159.943
7	158.621
8	160.994
9	160.745

Support 1

Stage No	R
	(kN)
0	0
1	0
2	0
3	0
4	240
5	263.016
6	244.248
7	243.888
8	243.216
9	242.112

Support 2

Stage No	R
	(kN)
0	0
1	0
2	0
3	0
4	0
5	0
6	570
7	588.16
8	553.3
9	554.96

Support 3

Stage No	R
	(kN)
0	0
1	0
2	0
3	0
4	0
5	0
6	0
7	0
8	510
9	524.54

Project: My Project

Results for Design Section 1: 0: DM08_ITA: Comb. 1: A1+M1+R1

DESIGN APPROACHES AND COMBINATION FACTORS

The Design Approaches (from Codes or Customized by the user) and related safety factors are the following:

Ftan fr=mult factor for friction angle

F C'=mult factor for effective cohesion

F Su'=mult factof for undrained cohesion

F EQ=mult factor for seismic action

F perm load=mult factor for perm loads

F temp load=mult factor for live loads

F perm supp=reduct factor for resistance for pull out checking

F temp supp=fattore di riduzione resistance per verifica pull out tirante

F earth Dstab=mult factor for active press coeff , unfavorable

F earth stab=mult factor for passive pressure , favorable

F GWT Dstab (ground water)=mult factor for hydrostatic pressure , unfavorable

F GWT stab (ground water)=mult factor for hydrostatic pressure, favorable

F HYD Dstab=mult factor for hydrodynamic pressure, unfavorable

F HYD stab=mult factor for hydrodynamic pressure, favorable

F UPL Dstab=mult factor for hydraulic heave, unfavorable

Stage	Design Name	Design Case	F(tan fr)	F (c')	F (Su)	F (EO)	F(perm load)	F(temp load)	F(perm sup)	F(temp sup)	F Earth (Dstab)	F Earth (stab)	F GWT (Dstab)	F GWT (stab)	F HYD (Dstab)	F HYD (stab)	F UPL (Dstab)	F UPL (stab)
0	DM08_ITA	1: A1+M1+R1	1	1	1	0	1.3	1.5	1.2	1.1	1.3	1	1.3	1	1.35	0.9	1	1
1	DM08_ITA	1: A1+M1+R1	1	1	1	0	1.3	1.5	1.2	1.1	1.3	1	1.3	1	1.35	0.9	1	1
2	DM08_ITA	1: A1+M1+R1	1	1	1	0	1.3	1.5	1.2	1.1	1.3	1	1.3	1	1.35	0.9	1	1
3	DM08_ITA	1: A1+M1+R1	1	1	1	0	1.3	1.5	1.2	1.1	1.3	1	1.3	1	1.35	0.9	1	1
4	DM08_ITA	1: A1+M1+R1	1	1	1	0	1.3	1.5	1.2	1.1	1.3	1	1.3	1	1.35	0.9	1	1
5	DM08_ITA	1: A1+M1+R1	1	1	1	0	1.3	1.5	1.2	1.1	1.3	1	1.3	1	1.35	0.9	1	1
6	DM08_ITA	1: A1+M1+R1	1	1	1	0	1.3	1.5	1.2	1.1	1.3	1	1.3	1	1.35	0.9	1	1
7	DM08_ITA	1: A1+M1+R1	1	1	1	0	1.3	1.5	1.2	1.1	1.3	1	1.3	1	1.35	0.9	1	1
8	DM08_ITA	1: A1+M1+R1	1	1	1	0	1.3	1.5	1.2	1.1	1.3	1	1.3	1	1.35	0.9	1	1
9	DM08_ITA	1: A1+M1+R1	1	1	1	0	1.3	1.5	1.2	1.1	1.3	1	1.3	1	1.35	0.9	1	1

SOIL DATA

Name	g tot (kN/m3)	g dry (kN/m3)	Frict (deg)	C' (kPa)	Su (kPa)	FRp (deg)	FRcv (deg)	Eload (kPa)	Eur (kPa)	kAp Springs	kPp Springs	kAcv Springs	kPcv Springs	Vary	Spring Model	Color
F	20	19	30	0	N/A	N/A	N/A	15000	45000	0.33	3	N/A	N/A	True	Linear	
O1	16.5	14	22	2	20	22	22	2874	8622	0.46	2.2	0.46	2.2	True	Linear	
O2	19	16.5	28	2	N/A	N/A	N/A	7185	21555	0.36	2.77	N/A	N/A	True	Linear	
S1	21	19	34	0	N/A	N/A	N/A	25000	75000	0.28	3.54	N/A	N/A	True	Linear	
Clay	20	19	28	0	150	28	28	20000	60000	0.36	2.77	0.36	2.77	True	Linear	
GT	22	20	36	10	N/A	N/A	N/A	30000	90000	0.26	3.85	N/A	N/A	True	Linear	
Rock	27	25	30	100	N/A	N/A	N/A	479000	143700	0.33	3	N/A	N/A	True	Linear	
Rileva	18	18	32	0	N/A	N/A	N/A	30000	30000	0.31	3.26	N/A	N/A	True	Linear	
Base	18	18	25	0	N/A	N/A	N/A	25000	25000	0.41	2.46	N/A	N/A	True	Linear	

gtot=total soil specific weight

gdry=dry weight of the soil

Frict=friction angle

C'=effective cohesion

Su = Undrained cohesion (only for CLAY soils in undrained conditions)

Dilat=SOil Dilatancy (only for non linear analysis)

Evc=Virgin compression elastic module

Eur=unloading/reloading elastic module

Kap= Peak active thrust coeff

Kpp= Peak passive thrust coeff

Kacv= Constant volume active thrust coeff

Kpcv= Constant volume passive thrust coeff

Spring models= spring model (LIN=constant over the soil layer height , EXP=exponential ,

SIMC=simplified winkler)

LIN= Linear-Elastic-Perfectly Plastic,

EXP: Exponential, SUB: Modulus of Subgrade Reaction

SOIL BORINGS

Top Elev= superior SOil level

Soil type=type of the soil (sand , clay , etc)

OCR=overconsolidation ratio

K0=at rest coefficient

Name: Boring 1, pos: (-20, 0)

Top elev.	Soil type	OCR	Ko
0	Rilevato	1	0.47
-10	Base	1	0.58

STRUCTURAL MATERIALS DATA

Steel

Name	Strength Fy (MPa)	Fu (MPa)	Elastic E (MPa)	Density g (kN/m3)
Fe360	235	360	206000	77
Fe510	355	510	206000	77
A36	248.3	400	206000	77
A50	355	500	206000	77
New steel 4	241.4	413.8	206000	77

Concrete

Name	Strength Fc' (MPa)	Elastic E (MPa)	Density g (kN/m3)	Tension Strength (MPa)
C20/25	20	29962	25	10
C25/30	25	31476	25	10

Fc 3ksi	20.7	21541.8	23.573	10
---------	------	---------	--------	----

Steel rebar

Name	Strength Fy (MPa)	Elastic E (MPa)
S1860 (Strands)	1670	210000
Grade 75	517.2	200100
Grade 80	551.7	200100
Grade 150	1034.5	200100
Strands 270 ksi	1862.1	200100
S410	410	210000
S500	500	210000
B450C	450	210000

Wood

Name	Ultimate Bending (MPa)	Ultimate Tensile Strength (MPa)	Ultimate Shear Strength (MPa)	Density g (kN/m ³)	Elastic E (MPa)
Construction	11	9.7	5.5	7.8576	6900
Regular grade	6.9	6.9	4.1	7.8576	5520

STEEL

Name=material name

fy=fyk=characteristic resistance for steel (for all the codes)

Fu=fuk=ultimate resistance for steel (for all the codes)

Elastic E=Elastic modulus

Density g=specific weight

CONCRETE

Name=material name

f'c=fck=cylindrical resistance for concrete (for all the codes)

Elastic E=Elastic modulus

Density g=specific weight

Tension strength=ft=fctk=characteristic tension resistance for concrete

STEEL REBARS

Name=material name

fy=fyk=characteristic resistance for steel (for all the codes)

Fu=fuk=ultimate resistance for steel (for all the codes)

Elastic E=Elastic modulus

Density g=specific weight

WOOD

Name=material name

Fb=fbk=Ultimate bending strength

Ftu=ftuk=Ultimate tensile strength

Fvu=fvuk=Ultimate shear strength

Density g=specific weight

Elastic E=Elastic modulus

WALL DATA

Wall section 0: P177.8x12.5/40

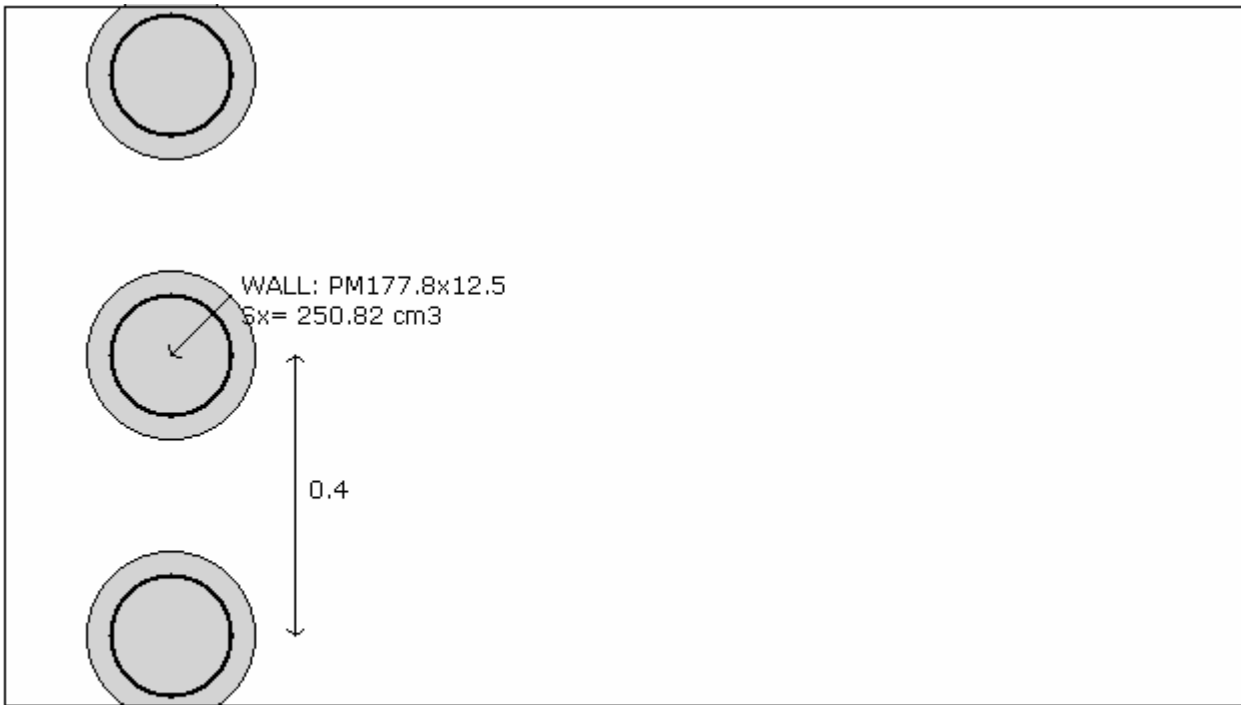

Company: My Company	Wall sketch	CeAS srl and Deep Excavation LCC
Engineer: Engineer		Paratie Plus 2010 - DeepXcar 2010
C:\nd.28_sera\otto3\alleg\LIII_typ4_rev27oct10_EQscavo_Alleg.DEEP		10/28/2010

Wall uses wall section 2: P177.8x12.5

Wall type: Tangent pile wall

Top wall El: 0 m Bottom wall El: -18 m

Hor. wall spacing: 0.4 Wall thickness = 0.24

Passive width below exc: 0.4 Active width below exc: 0.4

Concrete $f_c' = 25$ Rebar $F_y = 410$ $E_{conc} = 31476$ Concrete tension $F_{cT} = 10\%$ of F_c'

Steel members $f_y = 355$ $E_{steel} = 206000$

Wall friction: Percentage of Soil Friction = 50%

Steel wall capacities are calculated with NTC 2008

Concrete capacities are calculated with ACI 318-2002.

Note: With ultimate capacities you may have to use a structural safety factor.

Tangent pile wall soldier pile properties

Table: Soldier Pile Properties

Name	Section	W	A	D	tw or	bf	tf	k	Ixx	Sxx	rX	Iyy	Syy	rY	rT	Cw	fy
		(kN/m)	(cm ²)	(cm)	(cm)	(cm)	(cm)	(cm)	(cm ⁴)	(cm ³)	(cm)	(cm ⁴)	(cm ³)	(cm)	(cm)	(cm ⁶)	(MPa)
	PM17	311.6	91.58	17.8	1.25	17.78	1.25	1.25	4274	250.8	6.83	4274	250.8	6.83	6.83	1	355

GENERAL WALL DATA

Hor wall spacing=wall horizontal spacing

Passive width below exc=spacing for passive thrust pressure for classic analysis

f'c=fck=cylindrical concrete resistance

fyk=fyk=steel rebar characteristic resistance

Econc=Concrete Elastic modulus

fctk=characteristic Concrete tension

Esteel=steel elastic modulus

TABULAR DATA (principal parameters)

1) Diaphragm wall (rectangular cross section section)

N/A= data not available

Fy=fyk

F'c=fck

D=wall height

B=wall width

2)Steel sheet pile

DES=shape (Z or U)

W=width per unit of length

A=area

h=height

t=horiz part thickness

b=width of the single sheet pile part

s=inclined part thickness

Ixx=strong axis inertia (per unit of length)

Sxx=strong axis section modulus (per unit of length)

3)Secant piles wall, Tangent piles wall, soldier piles, soldier piles and timber lagging

W=weight per unit of length

A=area

D=diameter

tw=web thickness

tp= pipe thickness

bf=flange width

tf=flange thickness

k=flange thickness+stem thickness

Ixx=strong axis inertia modulus (per unit of length)

Sxx=strong axis section modulus (per unit of length)

rx=radius of gyration about X axis

ry=radius of gyration about Y axis

Iyy=weak axis inertia modulus (per unit of length)

Syy=weak axis section modulus (per unit of length)

rT=radius of gyration for torsion

Cw=warping constant

TIEBACK DATA

Name	Fy	Fc'	Dfix	Afix	Efix	Afree	Efree	Pa STR	Pu STR	PresGr	FSgeo	UserGca	Pa	Pu	WireMod
	(MPa)	(MPa)	(cm)	(cm ²)	(MPa)	(cm ²)	(MPa)	(kN)	(kN)	(kPa)			(kN)	(kN)	Yes/No
4-Strands	1862.1	25	15	176.7	31476	2.8	200100	453.4	453.4	N/A	1.4	False	N/A	N/A	Yes
5-Strands	1862.1	25	15	176.7	31476	2.8	200100	453.4	453.4	N/A	1.4	False	N/A	N/A	Yes
6-Strands	1862.1	25	15	176.7	31476	1.4	200100	226.7	226.7	N/A	1.4	False	N/A	N/A	Yes
Tieback_	1670	25	16	201.0	31476	4.17	210000	605.2	605.2	150	1	False	N/A	N/A	Yes
Tieback_	1670	25	16	201.0	31476	6.95	210000	1008.7	1008.7	180	1	False	N/A	N/A	Yes
Tieback_	1670	25	16	201.0	31476	5.56	210000	807	807	N/A	1.4	False	N/A	N/A	Yes

EXCAVATION STAGES SKETCHES

A sequence of figures for each excavation stage is reported

GENERAL ANALYSIS CRITERIA

Summary of stage assumptions

Name	Analysis	Drive	ka-Mult	Htr	Resist	Res	Contl	Supp	Axial	Used	Min	Toe	Toe
	Method	Press		(%)	Press	Mult	Meth	Mode	Incl	FSwall	FDtoe	FSrot	FSpas
Stage 0	Springs-Up	Ka+ d	N/A	N/A	Kp+ d	N/A		Fixed	N/A	1	9.21	11.07	9.21
Stage 1	Springs-Up	Ka+ d	N/A	N/A	Kp+ d	N/A		Fixed	N/A	1	5.846	5.846	6.002
Stage 2	Springs-Up	FHWA	1.3	m=	Kp+ d	N/A		Fixed	N/A	1	6.071	6.071	N/A
Stage 3	Springs-Up	FHWA	1.3	m=	Kp+ d	N/A		Fixed	N/A	1	4.351	4.351	N/A
Stage 4	Springs-Up	FHWA	1.3	m=	Kp+ d	N/A		Fixed	N/A	1	4.364	4.413	4.364
Stage 5	Springs-Up	FHWA	1.3	m=	Kp+ d	N/A		Fixed	N/A	1	2.877	2.877	48.88
Stage 6	Springs-Up	FHWA	1.3	m=	Kp+ d	N/A		Fixed	N/A	1	2.824	2.973	2.824
Stage 7	Springs-Up	FHWA	1.3	m=	Kp+ d	N/A		Fixed	N/A	1	1.869	1.869	18.27
Stage 8	Springs-Up	FHWA	1.3	m=	Kp+ d	N/A		Fixed	N/A	1	1.961	1.961	73.36
Stage 9	Springs-Up	FHWA	1.3	m=	Kp+ d	N/A		Fixed	N/A	1	1.442	1.442	6.634

Name=excavation phase name

Analysis method

springs=elasto plastic springs are used

DR=Drained condition for CLAY model

U=Undrained condition for CLAY model for all the soils

Up=Undrained condition just for selected soil

Drive press=Ka

ka mult=multiply factor for Ka

Htr T/B (%)=trapezoidal pressure scheme

Resit press=Kp

Res Mult=Multiply factor for Kp

COntle Method=cantilver method

Support Model=Fix support type

Axial Incl=Axial action is included for design

Used FS wall=Reduction factor for axial+bending resistance dominium

Min FD TOe=embedded minimum safety factor (for classic analysis)

Toe FS rot=rotation safety factor (classic for classic analysis)

Toe FSpas=driving/resistent pressure safety factor (for classic analysis)

SEISMIC DATA

Seismic action is modeled through a pseudo static approach

Summary of stage assumptions

Stage	Seismic g	Method	aX	aY	Beta	Building Code
Number	Used	Used	(g)	(g)		(Name)
0	No		0.021	0	1	N/A
1	No		0.021	0	1	N/A
2	No		0.021	0	1	N/A
3	No		0.021	0	1	N/A
4	No		0.021	0	1	N/A
5	No		0.021	0	1	N/A
6	No		0.021	0	1	N/A
7	No		0.021	0	1	N/A
8	No		0.021	0	1	N/A
9	No		0.021	0	1	N/A

N/A= data non available

Stage number=number of stage input

Seismic ag =value of design acceleration according to a code or input by the user

Method=the method used to evaluated the seismic thrustover the wall

ahd or khd otr axd=design horizontal acceleration

avd or kvd or ayd=design vertical acceleration

Beta=multip coeff for the semirigd approach

Buildind code=code used for design acceleration calculation

SUPPORTS PROPERTIES

Support 0: type = tieback

X = 0.24 m, Z = -1.5 m, S = 2.4 m

Lfree = 11 m, Lfix = 10 m, Rfix = 50 %

Walls: P177.8x12.5/40

Stage No	Active	Prestress	Slab live load	User add. strain
	Yes/No	(kN)	(kPa)	+expansion
0	No	-	-	-
1	No	-	-	-
2	Yes	145	-	-
3	Yes	-	-	-
4	Yes	-	-	-
5	Yes	-	-	-
6	Yes	-	-	-
7	Yes	-	-	-
8	Yes	-	-	-
9	Yes	-	-	-

Support 1: type = tieback

X = 0.24 m, Z = -4 m, S = 2.4 m

Lfree = 11 m, Lfix = 10 m, Rfix = 50 %

Walls: P177.8x12.5/40

Stage No	Active	Prestress	Slab live load	User add. strain
	Yes/No	(kN)	(kPa)	+expansion
0	No	-	-	-
1	No	-	-	-
2	No	-	-	-
3	No	-	-	-
4	Yes	240	-	-
5	Yes	-	-	-
6	Yes	-	-	-
7	Yes	-	-	-
8	Yes	-	-	-
9	Yes	-	-	-
10	Yes	-	-	-
11	Yes	-	-	-

Support 2: type = tieback

X = 0.24 m, Z = -6.5 m, S = 2 m

Lfree = 12 m, Lfix = 15 m, Rfix = 50 %

Walls: P177.8x12.5/40

Stage No	Active	Prestress	Slab live load	User add. strain
	Yes/No	(kN)	(kPa)	+expansion
0	No	-	-	-
1	No	-	-	-
2	No	-	-	-

3	No	-	-	-
4	No	-	-	-
5	No	-	-	-
6	Yes	570	-	-
7	Yes	-	-	-
8	Yes	-	-	-
9	Yes	-	-	-
10	Yes	-	-	-
11	Yes	-	-	-

Support 3: type = tieback

X = 0.24 m, Z = -8.5 m, S = 2 m

Lfree = 12 m, Lfix = 15 m, Rfix = 50 %

Walls: P177.8x12.5/40

Stage No	Active	Prestress	Slab live load	User add. strain
	Yes/No	(kN)	(kPa)	+expansion
0	No	-	-	-
1	No	-	-	-
2	No	-	-	-
3	No	-	-	-
4	No	-	-	-
5	No	-	-	-
6	No	-	-	-
7	No	-	-	-
8	Yes	510	-	-
9	Yes	-	-	-
10	Yes	-	-	-
11	Yes	-	-	-

Support type

LEGENDA for TIEBACKS

General data

Z=support level

S=horizontal distance between each tieback

Lfree=free length

Lfix=rigid body length

Rfix=% effective part of the rigid body length

Stage No=excavation steps number

Active=tieback status (YES=active)

Post stress= tieback preload (Load considering the horiz distance bewteen the tiebacks)

SURFACE LOADS

Surcharge 0: X1 = -28, X2 = 0

Variable surcharge

Stage No	Active	X1	Z1	qX1	qZ1	X2	Z2	qX2	qZ2
	Yes/No	(m)	(m)	(kPa)	(kPa)	(m)	(m)	(kPa)	(kPa)
0	No	-28	0	0	20	0	0	0	20
1	Yes	-28	0	0	20	0	0	0	20
2	Yes	-28	0	0	20	0	0	0	20
3	Yes	-28	0	0	20	0	0	0	20
4	Yes	-28	0	0	20	0	0	0	20
5	Yes	-28	0	0	20	0	0	0	20
6	Yes	-28	0	0	20	0	0	0	20
7	Yes	-28	0	0	20	0	0	0	20
8	Yes	-28	0	0	20	0	0	0	20

9	Yes	-28	0	0	20	0	0	0	20
---	-----	-----	---	---	----	---	---	---	----

LEGENDA

Stage No=Excavation step number

Active=load status (Yes=active)

X1=first X coordinate position of the load

Z1=first Z coordinate position of the load

qX1=first horizontal point load value

qZ1=first vertical point load value

X2=second X coordinate position of the load

Z2=second Z coordinate position of the load

qX2=second horizontal point load value

qZ2=second vertical point load value

WALL RESULTS TABLE

LEGENDA

Wall node=number of the node

EL=elevation

Sht L=Total horizontal soil pressure (on the left side of the wall)

Sht R=Total horizontal soil pressure (on the right side of the wall)

Shs L=Effective horizontal soil pressure (on the left side of the wall)

Shs R=Effective horizontal soil pressure (on the right side of the wall)

q=pressure given by the surcharge

U L=Water pressure (on the left side of the wall)

U R=pressione acqua (on the right side of the wall)

M=bending moment (per meter)

V=shear (per metro)

dx=wall deflection

McapL=Ultimate bending moment (on the left side of the wall)

McapR=Ultimate bending moment (on the right side of the wall)

VcapL=Ultimate resistance shear (on the left side of the wall)

VcapR=Ultimate resistance shear (on the right side of the wall)

SUPPORTS REACTIONS (TIEBACKS, STRUTS, SLABS, RAKERS)

Support 0

Stage No	R
	(kN)
0	0
1	0
2	188.51
3	213.892
4	209.318
5	207.558
6	210.8
7	208.984
8	212.073
9	211.736

Support 1

Stage No	R
	(kN)
0	0
1	0
2	0

3	0
4	312
5	344.448
6	320.05
7	319.55
8	318.677
9	317.148

Support 2

Stage No	R
	(kN)
0	0
1	0
2	0
3	0
4	0
5	0
6	741
7	765.882
8	720.564
9	722.696

Support 3

Stage No	R
	(kN)
0	0
1	0
2	0
3	0
4	0
5	0
6	0
7	0
8	663
9	682.734

Project: My Project

Results for Design Section 2: 0: DM08_ITA: Comb. 2: A2+M2+R1

DESIGN APPROACHES AND COMBINATION FACTORS

The Design Approaches (from Codes or Customized by the user) and related safety factors are the following:

Ftan fr=mult factor for friction angle

F C'=mult factor for effective cohesion

F Su'=mult factof for undrained cohesion

F EQ=mult factor for seismic action

F perm load=mult factor for perm loads

F temp load=mult factor for live loads

F perm supp=reduct factor for resistance for pull out checking

F temp supp=fattore di riduzione resistance per verifica pull out tirante

F earth Dstab=mult factor for active press coeff , unfavorable

F earth stab=mult factor for passive pressure , favorable

F GW Dstab (ground water)=mult factor for hydrostatic pressure , unfavorable

F GW stab (ground water)=mult factor for hydrostatic pressure, favorable

F HYD Dstab=mult factor for hydrodynamic pressure, unfavorable

F HYD stab=mult factor for hydrodynamic pressure, favorable

F UPL Dstab=mult factor for hydraulic heave, unfavorable

Stage	Design Name	Design Case	F(tan fr)	F (c')	F (Su')	F (EQ)	F(perm load)	F(temp load)	F(perm sup)	F(temp sup)	F Earth (Dstab)	F Earth (stab)	F GW Dstab (stab)	F GW (stab)	F HYD (Dstab)	F HYD (stab)	F UPL (Dstab)	F UPL (stab)
0	DM08_ITA	2: A2+M2+R1	1.25	1.25	1.4	0	1	1.3	1.2	1.1	1	1	1	1	1.35	0.9	1	1
1	DM08_ITA	2: A2+M2+R1	1.25	1.25	1.4	0	1	1.3	1.2	1.1	1	1	1	1	1.35	0.9	1	1
2	DM08_ITA	2: A2+M2+R1	1.25	1.25	1.4	0	1	1.3	1.2	1.1	1	1	1	1	1.35	0.9	1	1
3	DM08_ITA	2: A2+M2+R1	1.25	1.25	1.4	0	1	1.3	1.2	1.1	1	1	1	1	1.35	0.9	1	1
4	DM08_ITA	2: A2+M2+R1	1.25	1.25	1.4	0	1	1.3	1.2	1.1	1	1	1	1	1.35	0.9	1	1
5	DM08_ITA	2: A2+M2+R1	1.25	1.25	1.4	0	1	1.3	1.2	1.1	1	1	1	1	1.35	0.9	1	1
6	DM08_ITA	2: A2+M2+R1	1.25	1.25	1.4	0	1	1.3	1.2	1.1	1	1	1	1	1.35	0.9	1	1
7	DM08_ITA	2: A2+M2+R1	1.25	1.25	1.4	0	1	1.3	1.2	1.1	1	1	1	1	1.35	0.9	1	1
8	DM08_ITA	2: A2+M2+R1	1.25	1.25	1.4	0	1	1.3	1.2	1.1	1	1	1	1	1.35	0.9	1	1
9	DM08_ITA	2: A2+M2+R1	1.25	1.25	1.4	0	1	1.3	1.2	1.1	1	1	1	1	1.35	0.9	1	1

SOIL DATA

Name	g tot (kN/m3)	g dry (kN/m3)	Frict (deg)	C' (kPa)	Su (kPa)	FRp (deg)	FRcv (deg)	Eload (kPa)	Eur (kPa)	kAp Springs	kPp Springs	kAcv Springs	kPcv Springs	Vary	Spring Model	Color
F	20	19	30	0	N/A	N/A	N/A	15000	45000	0.33	3	N/A	N/A	True	Linear	
O1	16.5	14	22	2	20	22	22	2874	8622	0.46	2.2	0.46	2.2	True	Linear	
O2	19	16.5	28	2	N/A	N/A	N/A	7185	21555	0.36	2.77	N/A	N/A	True	Linear	
S1	21	19	34	0	N/A	N/A	N/A	25000	75000	0.28	3.54	N/A	N/A	True	Linear	
Clay	20	19	28	0	150	28	28	20000	60000	0.36	2.77	0.36	2.77	True	Linear	
GT	22	20	36	10	N/A	N/A	N/A	30000	90000	0.26	3.85	N/A	N/A	True	Linear	
Rock	27	25	30	100	N/A	N/A	N/A	479000	143700	0.33	3	N/A	N/A	True	Linear	
Rileva	18	18	32	0	N/A	N/A	N/A	30000	30000	0.31	3.26	N/A	N/A	True	Linear	
Base	18	18	25	0	N/A	N/A	N/A	25000	25000	0.41	2.46	N/A	N/A	True	Linear	

gtot=total soil specific weight

gdry=dry weight of the soil

Frict=friction angle

C'=effective cohesion

Su = Undrained cohesiona (only for CLAY soils in undrained conditions)

Dilat=SOil Dilatancy (only for non linear analysis)

Evc=Virgin compression elastic module

Eur=unloading/reloading elastic module

Kap= Peak active thrust coeff

Kpp= Peak passive thrust coeff

Kacv= Constant volume active thrust coeff

Kpcv= Constant volume passive thrust coeff

Spring models= spring model (LIN=constant over the soil layer height , EXP=exponential ,

SIMC=simplified winkler)

LIN= Linear-Elastic-Perfectly Plastic,

EXP: Exponential, SUB: Modulus of Subgrade Reaction

SOIL BORINGS

Top Elev= superior SOil level

Soil type=type of the soil (sand , clay , etc)

OCR=overconsolidation ratio

K0=at rest coefficient

Name: Boring 1, pos: (-20, 0)

Top elev.	Soil type	OCR	Ko
0	Rilevato	1	0.47
-10	Base	1	0.58

STRUCTURAL MATERIALS DATA

Steel

Name	Strength Fy (MPa)	Fu (MPa)	Elastic E (MPa)	Density g (kN/m3)
Fe360	235	360	206000	77
Fe510	355	510	206000	77
A36	248.3	400	206000	77
A50	355	500	206000	77
New steel 4	241.4	413.8	206000	77

Concrete

Name	Strength Fc' (MPa)	Elastic E (MPa)	Density g (kN/m3)	Tension Strength (MPa)
C20/25	20	29962	25	10
C25/30	25	31476	25	10

Fc 3ksi	20.7	21541.8	23.573	10
---------	------	---------	--------	----

Steel rebar

Name	Strength Fy (MPa)	Elastic E (MPa)
S1860 (Strands)	1670	210000
Grade 75	517.2	200100
Grade 80	551.7	200100
Grade 150	1034.5	200100
Strands 270 ksi	1862.1	200100
S410	410	210000
S500	500	210000
B450C	450	210000

Wood

Name	Ultimate Bending (MPa)	Ultimate Tensile Strength (MPa)	Ultimate Shear Strength (MPa)	Density g (kN/m ³)	Elastic E (MPa)
Construction	11	9.7	5.5	7.8576	6900
Regular grade	6.9	6.9	4.1	7.8576	5520

STEEL

Name=material name

fy=fyk=characteristic resistance for steel (for all the codes)

Fu=fuk=ultimate resistance for steel (for all the codes)

Elastic E=Elastic modulus

Density g=specific weight

CONCRETE

Name=material name

f'c=fck=cylindrical resistance for concrete (for all the codes)

Elastic E=Elastic modulus

Density g=specific weight

Tension strength=ft=fctk=characteristic tension resistance for concrete

STEEL REBARS

Name=material name

fy=fyk=characteristic resistance for steel (for all the codes)

Fu=fuk=ultimate resistance for steel (for all the codes)

Elastic E=Elastic modulus

Density g=specific weight

WOOD

Name=material name

Fb=fbk=Ultimate bending strength

Ftu=ftuk=Ultimate tensile strength

Fvu=fvuk=Ultimate shear strength

Density g=specific weight

Elastic E=Elastic modulus

WALL DATA

Wall section 0: P177.8x12.5/40

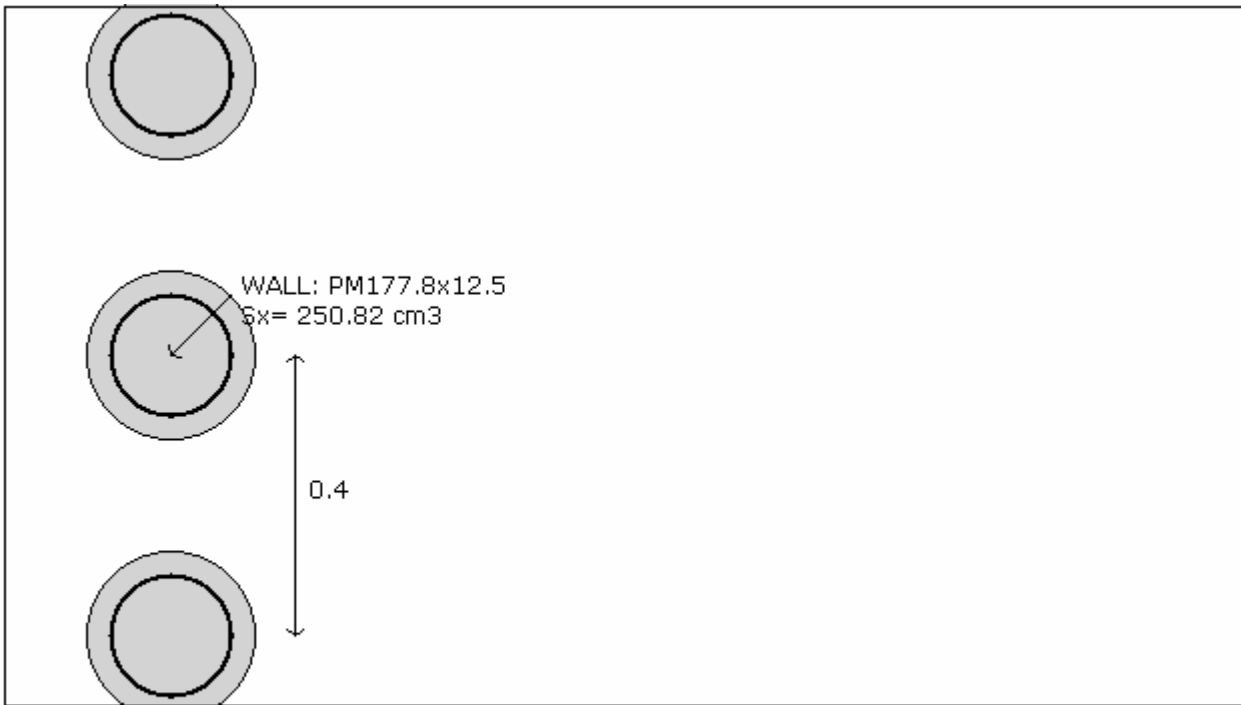

Company: My Company	Wall sketch	CeAS srl and Deep Excavation LCC
Engineer: Engineer		Paratie Plus 2010 - DeepXcar 2010
C:\nd.28_sera\otto3\alleg\LIII_typ4_rev27oct10_EQscavo_Alleg.DEEP		10/28/2010

Wall uses wall section 2: P177.8x12.5
 Wall type: Tangent pile wall
 Top wall El: 0 m Bottom wall El: -18 m
 Hor. wall spacing: 0.4 Wall thickness = 0.24
 Passive width below exc: 0.4 Active width below exc: 0.4
 Concrete $f_c' = 25$ Rebar $F_y = 410$ $E_{conc} = 31476$ Concrete tension $F_{cT} = 10\%$ of F_c'
 Steel members $f_y = 355$ $E_{steel} = 206000$
 Wall friction: Percentage of Soil Friction = 50%
 Steel wall capacities are calculated with NTC 2008
 Concrete capacities are calculated with ACI 318-2002.
 Note: With ultimate capacities you may have to use a structural safety factor.
 Tangent pile wall soldier pile properties

Table: Soldier Pile Properties

Name	Section	W	A	D	tw or	bf	tf	k	Ixx	Sxx	rX	Iyy	Syy	rY	rT	Cw	fy
		(kN/m)	(cm ²)	(cm)	(cm)	(cm)	(cm)	(cm)	(cm ⁴)	(cm ³)	(cm)	(cm ⁴)	(cm ³)	(cm)	(cm)	(cm ⁶)	(MPa)
	PM17	311.6	91.58	17.8	1.25	17.78	1.25	1.25	4274	250.8	6.83	4274	250.8	6.83	6.83	1	355

GENERAL WALL DATA

Hor wall spacing=wall horizontal spacing

Passive width below exc=spacing for passive thrust pressure for classic analysis

f'c=fck=cylindrical concrete resistance

fyk=fyk=steel rebar characteristic resistance

Econc=Concrete Elastic modulus

fctk=characteristic Concrete tension

Esteel=steel elastic modulus

TABULAR DATA (principal parameters)

1) Diaphragm wall (rectangular cross section section)

N/A= data not available

Fy=fyk

F'c=fck

D=wall height

B=wall width

2)Steel sheet pile

DES=shape (Z or U)

W=width per unit of length

A=area

h=height

t=horiz part thickness

b=width of the single sheet pile part

s=inclined part thickness

Ixx=strong axis inertia (per unit of length)

Sxx=strong axis section modulus (per unit of length)

3)Secant piles wall, Tangent piles wall, soldier piles, soldier piles and timber lagging

W=weight per unit of length

A=area

D=diameter

tw=web thickness

tp= pipe thickness

bf=flange width

tf=flange thickness

k=flange thickness+stem thickness

Ixx=strong axis inertia modulus (per unit of length)

Sxx=strong axis section modulus (per unit of length)

rx=radius of gyration about X axis

ry=radius of gyration about Y axis

Iyy=weak axis inertia modulus (per unit of length)

Syy=weak axis section modulus (per unit of length)

rT=radius of gyration for torsion

Cw=warping constant

TIEBACK DATA

Name	Fy	Fc'	Dfix	Afix	Efix	Afree	Efree	Pa STR	Pu STR	PresGr	FSgeo	UserGca	Pa	Pu	WireMod
	(MPa)	(MPa)	(cm)	(cm ²)	(MPa)	(cm ²)	(MPa)	(kN)	(kN)	(kPa)			(kN)	(kN)	Yes/No
4-Strands	1862.1	25	15	176.7	31476	2.8	200100	453.4	453.4	N/A	1.4	False	N/A	N/A	Yes
5-Strands	1862.1	25	15	176.7	31476	2.8	200100	453.4	453.4	N/A	1.4	False	N/A	N/A	Yes
6-Strands	1862.1	25	15	176.7	31476	1.4	200100	226.7	226.7	N/A	1.4	False	N/A	N/A	Yes
Tieback_	1670	25	16	201.0	31476	4.17	210000	605.2	605.2	150	1	False	N/A	N/A	Yes
Tieback_	1670	25	16	201.0	31476	6.95	210000	1008.7	1008.7	180	1	False	N/A	N/A	Yes
Tieback_	1670	25	16	201.0	31476	5.56	210000	807	807	N/A	1.4	False	N/A	N/A	Yes

EXCAVATION STAGES SKETCHES

A sequence of figures for each excavation stage is reported

GENERAL ANALYSIS CRITERIA

Summary of stage assumptions

Name	Analysis	Drive	ka-Mult	Htr	Resist	Res	Contl	Supp	Axial	Used	Min	Toe	Toe
	Method	Press		(%)	Press	Mult	Meth	Mode	Incl	FSwall	FDtoe	FSrot	FSpas
Stage 0	Springs-Up	Ka+ d	N/A	N/A	Kp+ d	N/A		Fixed	N/A	1	7.349	8.568	7.349
Stage 1	Springs-Up	Ka+ d	N/A	N/A	Kp+ d	N/A		Fixed	N/A	1	4.633	4.633	4.862
Stage 2	Springs-Up	FHWA	1.3	m=	Kp+ d	N/A		Fixed	N/A	1	4.991	4.991	N/A
Stage 3	Springs-Up	FHWA	1.3	m=	Kp+ d	N/A		Fixed	N/A	1	3.591	3.591	N/A
Stage 4	Springs-Up	FHWA	1.3	m=	Kp+ d	N/A		Fixed	N/A	1	3.654	3.654	2827.
Stage 5	Springs-Up	FHWA	1.3	m=	Kp+ d	N/A		Fixed	N/A	1	2.394	2.394	32.74
Stage 6	Springs-Up	FHWA	1.3	m=	Kp+ d	N/A		Fixed	N/A	1	2.48	2.48	415.2
Stage 7	Springs-Up	FHWA	1.3	m=	Kp+ d	N/A		Fixed	N/A	1	1.564	1.564	10.16
Stage 8	Springs-Up	FHWA	1.3	m=	Kp+ d	N/A		Fixed	N/A	1	1.644	1.644	23.20
Stage 9	Springs-Up	FHWA	1.3	m=	Kp+ d	N/A		Fixed	N/A	1	1.209	1.209	3.129

Name=excavation phase name

Analysis method

springs=elasto plastic springs are used

DR=Drained condition for CLAY model

U=Undrained condition for CLAY model for all the soils

Up=Undrained condition just for selected soil

Drive press=Ka

ka mult=multiply factor for Ka

Htr T/B (%)=trapezoidal pressure scheme

Resit press=Kp

Res Mult=Multiply factor for Kp

COntle Method=cantilver method

Support Model=Fix support type

Axial Incl=Axial action is included for design

Used FS wall=Reduction factor for axial+bending resistance dominium

Min FD TOe=embedded minimum safety factor (for classic analysis)

Toe FS rot=rotation safety factor (classic for classic analysis)

Toe FSpas=driving/resistent pressure safety factor (for classic analysis)

SEISMIC DATA

Seismic action is modeled through a pseudo static approach

Summary of stage assumptions

Stage	Seismic g	Method	aX	aY	Beta	Building Code
Number	Used	Used	(g)	(g)		(Name)
0	No		0.021	0	1	N/A
1	No		0.021	0	1	N/A
2	No		0.021	0	1	N/A
3	No		0.021	0	1	N/A
4	No		0.021	0	1	N/A
5	No		0.021	0	1	N/A
6	No		0.021	0	1	N/A
7	No		0.021	0	1	N/A
8	No		0.021	0	1	N/A
9	No		0.021	0	1	N/A

N/A= data non available

Stage number=number of stage input

Seismic ag =value of design acceleration according to a code or input by the user

Method=the method used to evaluated the seismic thrustover the wall

ahd or khd otr axd=design horizontal acceleration

avd or kvd or ayd=design vertical acceleration

Beta=multip coeff for the semirigd approach

Buildind code=code used for design acceleration calculation

SUPPORTS PROPERTIES

Support 0: type = tieback

X = 0.24 m, Z = -1.5 m, S = 2.4 m

Lfree = 11 m, Lfix = 10 m, Rfix = 50 %

Walls: P177.8x12.5/40

Stage No	Active	Prestress	Slab live load	User add. strain
	Yes/No	(kN)	(kPa)	+expansion
0	No	-	-	-
1	No	-	-	-
2	Yes	145	-	-
3	Yes	-	-	-
4	Yes	-	-	-
5	Yes	-	-	-
6	Yes	-	-	-
7	Yes	-	-	-
8	Yes	-	-	-
9	Yes	-	-	-

Support 1: type = tieback

X = 0.24 m, Z = -4 m, S = 2.4 m

Lfree = 11 m, Lfix = 10 m, Rfix = 50 %

Walls: P177.8x12.5/40

Stage No	Active	Prestress	Slab live load	User add. strain
	Yes/No	(kN)	(kPa)	+expansion
0	No	-	-	-
1	No	-	-	-
2	No	-	-	-
3	No	-	-	-
4	Yes	240	-	-
5	Yes	-	-	-
6	Yes	-	-	-
7	Yes	-	-	-
8	Yes	-	-	-
9	Yes	-	-	-
10	Yes	-	-	-
11	Yes	-	-	-

Support 2: type = tieback

X = 0.24 m, Z = -6.5 m, S = 2 m

Lfree = 12 m, Lfix = 15 m, Rfix = 50 %

Walls: P177.8x12.5/40

Stage No	Active	Prestress	Slab live load	User add. strain
	Yes/No	(kN)	(kPa)	+expansion
0	No	-	-	-
1	No	-	-	-
2	No	-	-	-

3	No	-	-	-
4	No	-	-	-
5	No	-	-	-
6	Yes	570	-	-
7	Yes	-	-	-
8	Yes	-	-	-
9	Yes	-	-	-
10	Yes	-	-	-
11	Yes	-	-	-

Support 3: type = tieback

X = 0.24 m, Z = -8.5 m, S = 2 m

Lfree = 12 m, Lfix = 15 m, Rfix = 50 %

Walls: P177.8x12.5/40

Stage No	Active	Prestress	Slab live load	User add. strain
	Yes/No	(kN)	(kPa)	+expansion
0	No	-	-	-
1	No	-	-	-
2	No	-	-	-
3	No	-	-	-
4	No	-	-	-
5	No	-	-	-
6	No	-	-	-
7	No	-	-	-
8	Yes	510	-	-
9	Yes	-	-	-
10	Yes	-	-	-
11	Yes	-	-	-

Support type

LEGENDA for TIEBACKS

General data

Z=support level

S=horizontal distance between each tieback

Lfree=free length

Lfix=rigid body length

Rfix=% effective part of the rigid body length

Stage No=excavation steps number

Active=tieback status (YES=active)

Post stress= tieback preload (Load considering the horiz distance bewteen the tiebacks)

SURFACE LOADS

Surcharge 0: X1 = -28, X2 = 0

Variable surcharge

Stage No	Active	X1	Z1	qX1	qZ1	X2	Z2	qX2	qZ2
	Yes/No	(m)	(m)	(kPa)	(kPa)	(m)	(m)	(kPa)	(kPa)
0	No	-28	0	0	20	0	0	0	20
1	Yes	-28	0	0	20	0	0	0	20
2	Yes	-28	0	0	20	0	0	0	20
3	Yes	-28	0	0	20	0	0	0	20
4	Yes	-28	0	0	20	0	0	0	20
5	Yes	-28	0	0	20	0	0	0	20
6	Yes	-28	0	0	20	0	0	0	20
7	Yes	-28	0	0	20	0	0	0	20
8	Yes	-28	0	0	20	0	0	0	20

9	Yes	-28	0	0	20	0	0	0	20
---	-----	-----	---	---	----	---	---	---	----

LEGENDA

Stage No=Excavation step number

Active=load status (Yes=active)

X1=first X coordinate position of the load

Z1=first Z coordinate position of the load

qX1=first horizontal point load value

qZ1=first vertical point load value

X2=second X coordinate position of the load

Z2=second Z coordinate position of the load

qX2=second horizontal point load value

qZ2=second vertical point load value

WALL RESULTS TABLE**LEGENDA**

Wall node=number of the node

EL=elevation

Sht L=Total horizontal soil pressure (on the left side of the wall)

Sht R=Total horizontal soil pressure (on the right side of the wall)

Shs L=Effective horizontal soil pressure (on the left side of the wall)

Shs R=Effective horizontal soil pressure (on the right side of the wall)

q=pressure given by the surcharge

U L=Water pressure (on the left side of the wall)

U R=pressione acqua (on the right side of the wall)

M=bending moment (per meter)

V=shear (per metro)

dx=wall deflection

McapL=Ultimate bending moment (on the left side of the wall)

McapR=Ultimate bending moment (on the right side of the wall)

VcapL=Ultimate resistance shear (on the left side of the wall)

VcapR=Ultimate resistance shear (on the right side of the wall)

SUPPORTS REACTIONS (TIEBACKS, STRUTS, SLABS, RAKERS)**Support 0**

Stage No	R
	(kN)
0	0
1	0
2	145.008
3	186.506
4	182.585
5	184.325
6	186.898
7	182.244
8	184.97
9	184.133

Support 1

Stage No	R
	(kN)
0	0
1	0
2	0

3	0
4	240
5	301.968
6	280.704
7	277.416
8	276.168
9	269.088

Support 2

Stage No	R (kN)
0	0
1	0
2	0
3	0
4	0
5	0
6	570
7	625.52
8	587.22
9	585.42

Support 3

Stage No	R (kN)
0	0
1	0
2	0
3	0
4	0
5	0
6	0
7	0
8	510
9	573.2

Project: My Project

Results for Design Section 3: 0: DM08_ITA: EQK - Seismic

DESIGN APPROACHES AND COMBINATION FACTORS

The Design Approaches (from Codes or Customized by the user) and related safety factors are the following:

Ftan fr=mult factor for friction angle

F C'=mult factor for effective cohesion

F Su'=mult factof for undrained cohesion

F EQ=mult factor for seismic action

F perm load=mult factor for perm loads

F temp load=mult factor for live loads

F perm supp=reduct factor for resistance for pull out checking

F temp supp=fattore di riduzione resistance per verifica pull out tirante

F earth Dstab=mult factor for active press coeff , unfavorable

F earth stab=mult factor for passive pressure , favorable

F GW Dstab (ground water)=mult factor for hydrostatic pressure , unfavorable

F GW stab (ground water)=mult factor for hydrostatic pressure, favorable

F HYD Dstab=mult factor for hydrodynamic pressure, unfavorable

F HYD stab=mult factor for hydrodynamic pressure, favorable

F UPL Dstab=mult factor for hydraulic heave, unfavorable

Stage	Design Name	Design Case	F(tan fr)	F (c')	F (Su)	F (EQ)	F(perm load)	F(temp load)	F(perm sup)	F(temp sup)	F Earth (Dstab)	F Earth (stab)	F GW Dstab (stab)	F GW (stab)	F HYD (Dstab)	F HYD (stab)	F UPL (Dstab)	F UPL (stab)
0	DM08_ITA	EQK - Seismic	1.25	1.25	1.4	1	1	1	1.2	1.1	1	1	1	1	1.35	0.9	1	1
1	DM08_ITA	EQK - Seismic	1.25	1.25	1.4	1	1	1	1.2	1.1	1	1	1	1	1.35	0.9	1	1
2	DM08_ITA	EQK - Seismic	1.25	1.25	1.4	1	1	1	1.2	1.1	1	1	1	1	1.35	0.9	1	1
3	DM08_ITA	EQK - Seismic	1.25	1.25	1.4	1	1	1	1.2	1.1	1	1	1	1	1.35	0.9	1	1
4	DM08_ITA	EQK - Seismic	1.25	1.25	1.4	1	1	1	1.2	1.1	1	1	1	1	1.35	0.9	1	1
5	DM08_ITA	EQK - Seismic	1.25	1.25	1.4	1	1	1	1.2	1.1	1	1	1	1	1.35	0.9	1	1
6	DM08_ITA	EQK - Seismic	1.25	1.25	1.4	1	1	1	1.2	1.1	1	1	1	1	1.35	0.9	1	1
7	DM08_ITA	EQK - Seismic	1.25	1.25	1.4	1	1	1	1.2	1.1	1	1	1	1	1.35	0.9	1	1
8	DM08_ITA	EQK - Seismic	1.25	1.25	1.4	1	1	1	1.2	1.1	1	1	1	1	1.35	0.9	1	1
9	DM08_ITA	EQK - Seismic	1.25	1.25	1.4	1	1	1	1.2	1.1	1	1	1	1	1.35	0.9	1	1
10	DM08_ITA	EQK - Seismic	1.25	1.25	1.4	1	1	1	1.2	1.1	1	1	1	1	1.35	0.9	1	1

SOIL DATA

Name	g tot (kN/m ³)	g dry (kN/m ³)	Frict (deg)	C' (kPa)	Su (kPa)	FRp (deg)	FRcv (deg)	Eload (kPa)	Eur (kPa)	kAp Springs	kPp Springs	kAcv Springs	kPcv Springs	Vary	Spring Model	Color
F	20	19	30	0	N/A	N/A	N/A	15000	45000	0.33	3	N/A	N/A	True	Linear	
O1	16.5	14	22	2	20	22	22	2874	8622	0.46	2.2	0.46	2.2	True	Linear	
O2	19	16.5	28	2	N/A	N/A	N/A	7185	21555	0.36	2.77	N/A	N/A	True	Linear	
S1	21	19	34	0	N/A	N/A	N/A	25000	75000	0.28	3.54	N/A	N/A	True	Linear	
Clay	20	19	28	0	150	28	28	20000	60000	0.36	2.77	0.36	2.77	True	Linear	
GT	22	20	36	10	N/A	N/A	N/A	30000	90000	0.26	3.85	N/A	N/A	True	Linear	
Rock	27	25	30	100	N/A	N/A	N/A	479000	143700	0.33	3	N/A	N/A	True	Linear	
Rileva	18	18	32	0	N/A	N/A	N/A	30000	30000	0.31	3.26	N/A	N/A	True	Linear	
Base	18	18	25	0	N/A	N/A	N/A	25000	25000	0.41	2.46	N/A	N/A	True	Linear	

gtot=total soil specific weight

gdry=dry weight of the soil

Frict=friction angle

C'=effective cohesion

Su = Undrained cohesion (only for CLAY soils in undrained conditions)

Dilat=SOil Dilatancy (only for non linear analysis)

Evc=Virgin compression elastic module

Eur=unloading/reloading elastic module

Kap= Peak active thrust coeff

Kpp= Peak passive thrust coeff

Kacv= Constant volume active thrust coeff

Kpcv= Constant volume passive thrust coeff

Spring models= spring model (LIN=constant over the soil layer height , EXP=exponential ,

SIMC=simplified winkler)

LIN= Linear-Elastic-Perfectly Plastic,

EXP: Exponential, SUB: Modulus of Subgrade Reaction

SOIL BORINGS

Top Elev= superior SOil level

Soil type=type of the soil (sand , clay , etc)

OCR=overconsolidation ratio

K0=at rest coefficient

Name: Boring 1, pos: (-20, 0)

Top elev.	Soil type	OCR	Ko
0	Rilevato	1	0.47
-10	Base	1	0.58

STRUCTURAL MATERIALS DATA

Steel

Name	Strength Fy (MPa)	Fu (MPa)	Elastic E (MPa)	Density g (kN/m ³)
Fe360	235	360	206000	77
Fe510	355	510	206000	77
A36	248.3	400	206000	77
A50	355	500	206000	77
New steel 4	241.4	413.8	206000	77

Concrete

Name	Strength Fc' (MPa)	Elastic E (MPa)	Density g (kN/m ³)	Tension Strength (MPa)
C20/25	20	29962	25	10
C25/30	25	31476	25	10

Fc 3ksi	20.7	21541.8	23.573	10
---------	------	---------	--------	----

Steel rebar

Name	Strength Fy (MPa)	Elastic E (MPa)
S1860 (Strands)	1670	210000
Grade 75	517.2	200100
Grade 80	551.7	200100
Grade 150	1034.5	200100
Strands 270 ksi	1862.1	200100
S410	410	210000
S500	500	210000
B450C	450	210000

Wood

Name	Ultimate Bending (MPa)	Ultimate Tensile Strength (MPa)	Ultimate Shear Strength (MPa)	Density g (kN/m ³)	Elastic E (MPa)
Construction	11	9.7	5.5	7.8576	6900
Regular grade	6.9	6.9	4.1	7.8576	5520

STEEL

Name=material name

fy=fyk=characteristic resistance for steel (for all the codes)

Fu=fuk=ultimate resistance for steel (for all the codes)

Elastic E=Elastic modulus

Density g=specific weight

CONCRETE

Name=material name

f'c=fck=cylindrical resistance for concrete (for all the codes)

Elastic E=Elastic modulus

Density g=specific weight

Tension strength=ft=fctk=characteristic tension resistance for concrete

STEEL REBARS

Name=material name

fy=fyk=characteristic resistance for steel (for all the codes)

Fu=fuk=ultimate resistance for steel (for all the codes)

Elastic E=Elastic modulus

Density g=specific weight

WOOD

Name=material name

Fb=fbk=Ultimate bending strength

Ftu=ftuk=Ultimate tensile strength

Fvu=fvuk=Ultimate shear strength

Density g=specific weight

Elastic E=Elastic modulus

WALL DATA

Wall section 0: P177.8x12.5/40

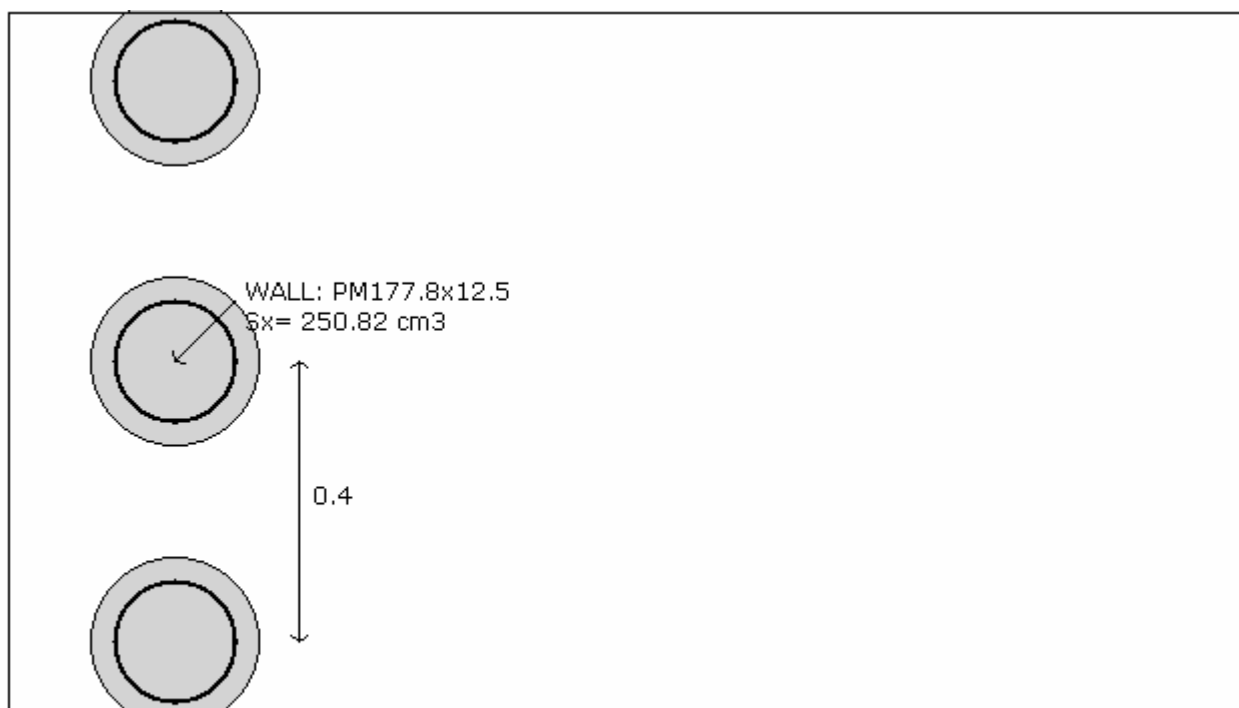

Company: My Company	Wall sketch	CeAS srl and Deep Excavation LCC
Engineer: Engineer		Paratie Plus 2010 - DeepXcar 2010
C:\nd.28_sera\otto3\alleg\LIII_typ4_rev27oct10_EQscavo_Alleg.DEEP		10/28/2010

Wall uses wall section 2: P177.8x12.5

Wall type: Tangent pile wall

Top wall El: 0 m Bottom wall El: -18 m

Hor. wall spacing: 0.4 Wall thickness = 0.24

Passive width below exc: 0.4 Active width below exc: 0.4

Concrete $f_c' = 25$ Rebar $F_y = 410$ $E_{conc} = 31476$ Concrete tension $F_{cT} = 10\%$ of F_c'

Steel members $f_y = 355$ $E_{steel} = 206000$

Wall friction: Percentage of Soil Friction = 50%

Steel wall capacities are calculated with NTC 2008

Concrete capacities are calculated with ACI 318-2002.

Note: With ultimate capacities you may have to use a structural safety factor.

Tangent pile wall soldier pile properties

Table: Soldier Pile Properties

Name	Section	W	A	D	tw or	bf	tf	k	Ixx	Sxx	rX	Iyy	Syy	rY	rT	Cw	fy
		(kN/m)	(cm ²)	(cm)	(cm)	(cm)	(cm)	(cm)	(cm ⁴)	(cm ³)	(cm)	(cm ⁴)	(cm ³)	(cm)	(cm)	(cm ⁶)	(MPa)
	PM17	311.6	91.58	17.8	1.25	17.78	1.25	1.25	4274	250.8	6.83	4274	250.8	6.83	6.83	1	355

GENERAL WALL DATA

Hor wall spacing=wall horizontal spacing

Passive width below exc=spacing for passive thrust pressure for classic analysis

f'c=fck=cylindrical concrete resistance

fyk=fy=steel rebar characteristic resistance

Econc=Concrete Elastic modulus

fctk=characteristic Concrete tension

Esteel=steel elastic modulus

TABULAR DATA (principal parameters)

1) Diaphragm wall (rectangular cross section section)

N/A= data not available

Fy=fyk

F'c=fck

D=wall height

B=wall width

2)Steel sheet pile

DES=shape (Z or U)

W=width per unit of length

A=area

h=height

t=horiz part thickness

b=width of the single sheet pile part

s=inclined part thickness

Ixx=strong axis inertia (per unit of length)

Sxx=strong axis section modulus (per unit of length)

3)Secant piles wall, Tangent piles wall, soldier piles, soldier piles and timber lagging

W=weight per unit of length

A=area

D=diameter

tw=web thickness

tp= pipe thickness

bf=flange width

tf=flange thickness

k=flange thickness+stem thickness

Ixx=strong axis inertia modulus (per unit of length)

Sxx=strong axis section modulus (per unit of length)

rx=radius of gyration about X axis

ry=radius of gyration about Y axis

Iyy=weak axis inertia modulus (per unit of length)

Syy=weak axis section modulus (per unit of length)

rT=radius of gyration for torsion

Cw=warping constant

TIEBACK DATA

Name	Fy	Fc'	Dfix	Afix	Efix	Afree	Efree	Pa STR	Pu STR	PresGr	FSgeo	UserGca	Pa	Pu	WireMod
	(MPa)	(MPa)	(cm)	(cm ²)	(MPa)	(cm ²)	(MPa)	(kN)	(kN)	(kPa)			(kN)	(kN)	Yes/No
4-Strands	1862.1	25	15	176.7	31476	2.8	200100	453.4	453.4	N/A	1.4	False	N/A	N/A	Yes
5-Strands	1862.1	25	15	176.7	31476	2.8	200100	453.4	453.4	N/A	1.4	False	N/A	N/A	Yes
6-Strands	1862.1	25	15	176.7	31476	1.4	200100	226.7	226.7	N/A	1.4	False	N/A	N/A	Yes
Tieback_	1670	25	16	201.0	31476	4.17	210000	605.2	605.2	150	1	False	N/A	N/A	Yes
Tieback_	1670	25	16	201.0	31476	6.95	210000	1008.7	1008.7	180	1	False	N/A	N/A	Yes
Tieback_	1670	25	16	201.0	31476	5.56	210000	807	807	N/A	1.4	False	N/A	N/A	Yes

EXCAVATION STAGES SKETCHES

A sequence of figures for each excavation stage is reported

GENERAL ANALYSIS CRITERIA

Summary of stage assumptions

Name	Analysis	Drive	ka-Mult	Htr	Resist	Res	Contl	Supp	Axial	Used	Min	Toe	Toe
	Method	Press		(%)	Press	Mult	Meth	Mode	Incl	FWall	FDtoe	FSrot	FSpas
Stage 0	Springs-Up	Ka+ d	N/A	N/A	Kp+ d	N/A		Fixed	N/A	1	7.349	8.568	7.349
Stage 1	Springs-Up	Ka+ d	N/A	N/A	Kp+ d	N/A		Fixed	N/A	1	4.855	4.855	5.004
Stage 2	Springs-Up	FHWA	1.3	m=	Kp+ d	N/A		Fixed	N/A	1	5.077	5.077	N/A
Stage 3	Springs-Up	FHWA	1.3	m=	Kp+ d	N/A		Fixed	N/A	1	3.654	3.654	N/A
Stage 4	Springs-Up	FHWA	1.3	m=	Kp+ d	N/A		Fixed	N/A	1	3.711	3.711	40486
Stage 5	Springs-Up	FHWA	1.3	m=	Kp+ d	N/A		Fixed	N/A	1	2.431	2.431	36.28
Stage 6	Springs-Up	FHWA	1.3	m=	Kp+ d	N/A		Fixed	N/A	1	2.514	2.514	507.0
Stage 7	Springs-Up	FHWA	1.3	m=	Kp+ d	N/A		Fixed	N/A	1	1.586	1.586	10.67
Stage 8	Springs-Up	FHWA	1.3	m=	Kp+ d	N/A		Fixed	N/A	1	1.664	1.664	23.86
Stage 9	Springs-Up	FHWA	1.3	m=	Kp+ d	N/A		Fixed	N/A	1	1.225	1.225	3.286
Stage	Springs-Up	FHWA	1.3	m=	Kp+ d	N/A		Fixed	N/A	1	1.28	1.28	4.365

Name=excavation phase name

Analysis method

springs=elasto plastic springs are used

DR=Drained condition for CLAY model

U=Undrained condition for CLAY model for all the soils

Up=Undrained condition just for selected soil

Drive press=Ka

ka mult=multiply factor for Ka

Htr T/B (%)=trapezoidal pressure scheme

Resit press=Kp

Res Mult=Multiply factor for Kp

COntle Method=cantilver method

Support Model=Fix support type

Axial Incl=Axial action is included for design

Used FS wall=Reduction factor for axial+bending resistance dominium

Min FD TOe=embedded minimum safety factor (for classic analysis)

Toe FS rot=rotation safety factor (classic for classic analysis)

Toe FSpas=driving/resistent pressure safety factor (for classic analysis)

SEISMIC DATA

Seismic action is modeled through a pseudo static approach

Summary of stage assumptions

Stage	Seismic g	Method	aX	aY	Beta	Building Code
Number	Used	Used	(g)	(g)		(Name)
0	No		0.021	0	1	N/A
1	No		0.021	0	1	N/A
2	No		0.021	0	1	N/A
3	No		0.021	0	1	N/A
4	No		0.021	0	1	N/A
5	No		0.021	0	1	N/A
6	No		0.021	0	1	N/A
7	No		0.021	0	1	N/A
8	No		0.021	0	1	N/A
9	No		0.021	0	1	N/A
10	Yes		0.021	0	1	N/A

N/A= data non available

Stage number=number of stage input

Seismic ag =value of design acceleration according to a code or input by the user

Method=the method used to evaluated the seismic thrustover the wall

ahd or khd otr axd=design horizontal acceleration

avd or kvd or ayd=design vertical acceleration

Beta=multip coeff for the semirigd approach

Buildind code=code used for design acceleration calculation

SUPPORTS PROPERTIES

Support 0: type = tieback

X = 0.24 m, Z = -1.5 m, S = 2.4 m

Lfree = 11 m, Lfix = 10 m, Rfix = 50 %

Walls: P177.8x12.5/40

Stage No	Active	Prestress	Slab live load	User add. strain
	Yes/No	(kN)	(kPa)	+expansion
0	No	-	-	-
1	No	-	-	-
2	Yes	145	-	-
3	Yes	-	-	-
4	Yes	-	-	-
5	Yes	-	-	-
6	Yes	-	-	-
7	Yes	-	-	-
8	Yes	-	-	-
9	Yes	-	-	-
10	Yes	-	-	-

Support 1: type = tieback

X = 0.24 m, Z = -4 m, S = 2.4 m

Lfree = 11 m, Lfix = 10 m, Rfix = 50 %

Walls: P177.8x12.5/40

Stage No	Active	Prestress	Slab live load	User add. strain
	Yes/No	(kN)	(kPa)	+expansion
0	No	-	-	-
1	No	-	-	-
2	No	-	-	-
3	No	-	-	-
4	Yes	240	-	-
5	Yes	-	-	-
6	Yes	-	-	-
7	Yes	-	-	-
8	Yes	-	-	-
9	Yes	-	-	-
10	Yes	-	-	-
11	Yes	-	-	-

Support 2: type = tieback

X = 0.24 m, Z = -6.5 m, S = 2 m

Lfree = 12 m, Lfix = 15 m, Rfix = 50 %

Walls: P177.8x12.5/40

Stage No	Active	Prestress	Slab live load	User add. strain
	Yes/No	(kN)	(kPa)	+expansion
0	No	-	-	-
1	No	-	-	-

2	No	-	-	-
3	No	-	-	-
4	No	-	-	-
5	No	-	-	-
6	Yes	570	-	-
7	Yes	-	-	-
8	Yes	-	-	-
9	Yes	-	-	-
10	Yes	-	-	-
11	Yes	-	-	-

Support 3: type = tieback

X = 0.24 m, Z = -8.5 m, S = 2 m

Lfree = 12 m, Lfix = 15 m, Rfix = 50 %

Walls: P177.8x12.5/40

Stage No	Active	Prestress	Slab live load	User add. strain
	Yes/No	(kN)	(kPa)	+expansion
0	No	-	-	-
1	No	-	-	-
2	No	-	-	-
3	No	-	-	-
4	No	-	-	-
5	No	-	-	-
6	No	-	-	-
7	No	-	-	-
8	Yes	510	-	-
9	Yes	-	-	-
10	Yes	-	-	-
11	Yes	-	-	-

Support type

LEGENDA for TIEBACKS

General data

Z=support level

S=horizontal distance between each tieback

Lfree=free length

Lfix=rigid body length

Rfix=% effective part of the rigid body length

Stage No=excavation steps number

Active=tieback status (YES=active)

Post stress= tieback preload (Load considering the horiz distance bewteen the tiebacks)

SURFACE LOADS

Surcharge 0: X1 = -28, X2 = 0

Variable surcharge

Stage No	Active	X1	Z1	qX1	qZ1	X2	Z2	qX2	qZ2
	Yes/No	(m)	(m)	(kPa)	(kPa)	(m)	(m)	(kPa)	(kPa)
0	No	-28	0	0	20	0	0	0	20
1	Yes	-28	0	0	20	0	0	0	20
2	Yes	-28	0	0	20	0	0	0	20
3	Yes	-28	0	0	20	0	0	0	20
4	Yes	-28	0	0	20	0	0	0	20
5	Yes	-28	0	0	20	0	0	0	20
6	Yes	-28	0	0	20	0	0	0	20

7	Yes	-28	0	0	20	0	0	0	20
8	Yes	-28	0	0	20	0	0	0	20
9	Yes	-28	0	0	20	0	0	0	20
10	No	-28	0	0	20	0	0	0	20

LEGENDA

Stage No=Excavation step number

Active=load status (Yes=active)

X1=first X coordinate position of the load

Z1=first Z coordinate position of the load

qX1=first horizontal point load value

qZ1=first vertical point load value

X2=second X coordinate position of the load

Z2=second Z coordinate position of the load

qX2=second horizontal point load value

qZ2=second vertical point load value

WALL RESULTS TABLE

LEGENDA

Wall node=number of the node

EL=elevation

Sht L=Total horizontal soil pressure (on the left side of the wall)

Sht R=Total horizontal soil pressure (on the right side of the wall)

Shs L=Effective horizontal soil pressure (on the left side of the wall)

Shs R=Effective horizontal soil pressure (on the right side of the wall)

q=pressure given by the surcharge

U L=Water pressure (on the left side of the wall)

U R=pressione acqua (on the right side of the wall)

M=bending moment (per meter)

V=shear (per metro)

dx=wall deflection

McapL=Ultimate bending moment (on the left side of the wall)

McapR=Ultimate bending moment (on the right side of the wall)

VcapL=Ultimate resistance shear (on the left side of the wall)

VcapR=Ultimate resistance shear (on the right side of the wall)

SUPPORTS REACTIONS (TIEBACKS, STRUTS, SLABS, RAKERS)

Support 0

Stage No	R
	(kN)
0	0
1	0
2	145.008
3	177.876
4	173.868
5	173.995
6	176.568
7	172.598
8	175.322
9	174.631
10	166.522

Support 1

Stage No	R
	(kN)

0	0
1	0
2	0
3	0
4	240
5	291.624
6	270.36
7	267.552
8	266.304
9	260.304
10	251.472

Support 2

Stage No	R
	(kN)
0	0
1	0
2	0
3	0
4	0
5	0
6	570
7	617.38
8	579.08
9	577.34
10	570.48

Support 3

Stage No	R
	(kN)
0	0
1	0
2	0
3	0
4	0
5	0
6	0
7	0
8	510
9	563.1
10	596.96