

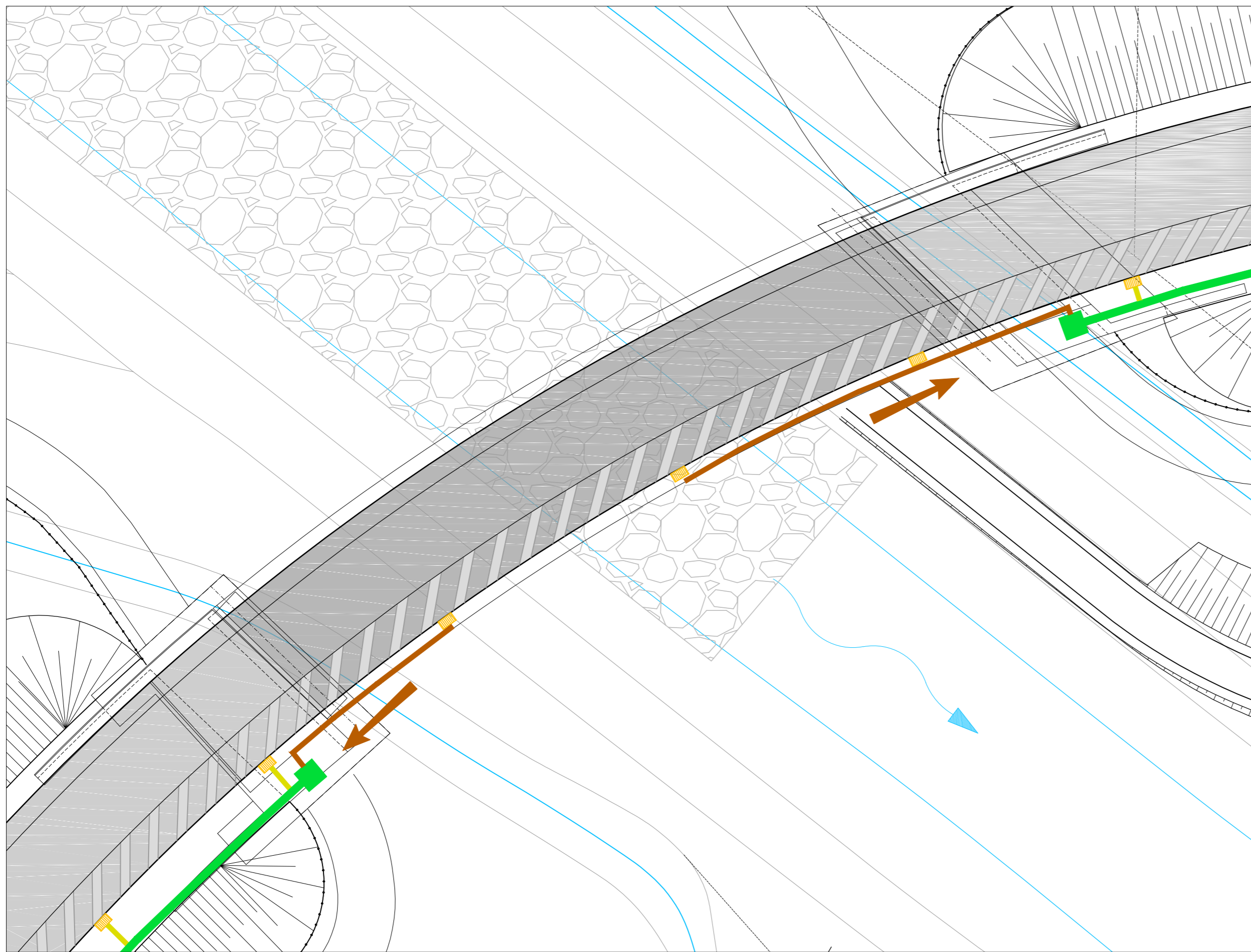



PIANTA PONTE EST "FIUME DESE"
scala 1:500



LEGENDA

-  CADITOIO IN GHISA D400 CON TUBAZIONE DI RACCORDO IN ACCIAIO Ø 160 INTERASSE 10 m
-  POZZETTI PREFABBRICATI IN C.A. m 0.80x0.80
-  CONDOTTA DN 250 IN ACCIAIO INOX PER SMALTIMENTO ACQUE PONTI (pend min 1%)

SEZIONE SPALLA PONTE
scala 1:100

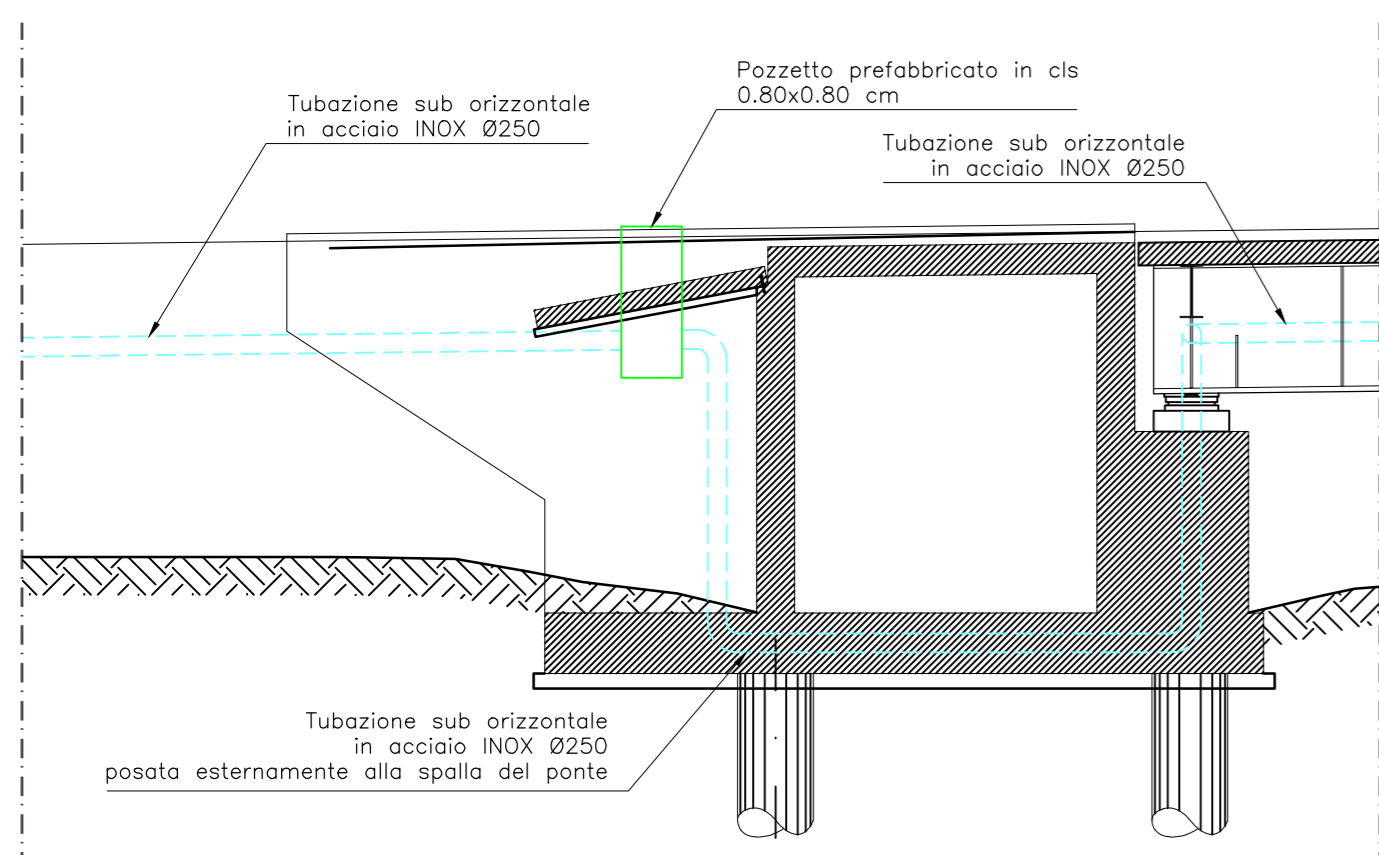

PROSPETTO TRASVERSALE PONTE
scala 1:100

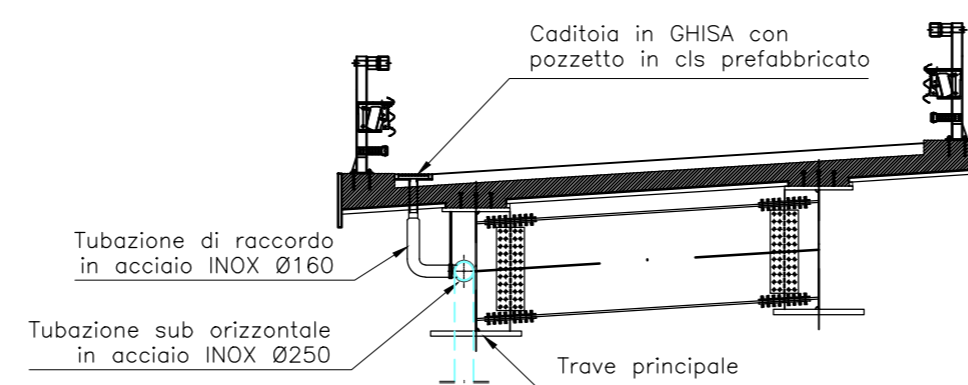

PARTICOLARE CADITOIO
scala 1:20

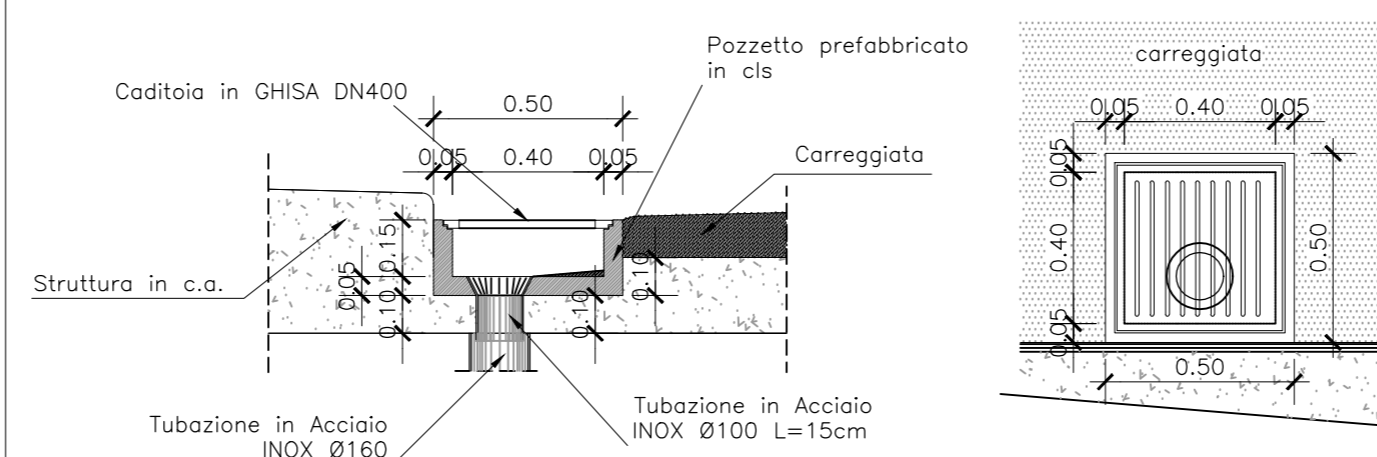

ANAS S.P.A.



AUTOSTRADA A4 - VARIANTE DI MESTRE

**PASSANTE
AUTOSTRADALE**

(L.443/2001 D.Lgs. 20.08.2002 N°190)

PROGETTO ESECUTIVO
C.U.P. D51B04000060001

IL RESPONSABILE
DEL PROCEDIMENTO

GENERAL CONTRACTOR

Passante di Mestre s.c.p.a.

DIREZIONE LAVORI



PROGETTAZIONE ESECUTIVA



IMPIANTI DI RACCOLTA E SMALTIMENTO ACQUE DI PIATTAFORMA
CASELLO DI MARTELLAGO-SCORZE' E VIABILITA' DI COLLEGAMENTO
PONTE SUL DESE RAMPA EST - PARTICOLARI SMALTIMENTO ACQUE DI PIATTAFORMA

CODICE DOCUMENTO **ZLT.SE2.B35106.PE.PZ.002.00**

CODIFICA WBS **B35106**

REV.	DATA	DESCRIZIONE	REDATTO	CONTROLLATO	APPROVATO	TAVOLA
00	05/12	EMISSIONE UFFICIALE	DAVARZAN	ZANCHETTIN	ZOLLET	B35106.PE.PZ.002
01						SCALA VARIE
02						EAD
03						ACAD2004
04						NOME FILE ZLT.SE2.B35106.PE.PZ.002.00.dwg