



ANAS S.P.A.



AUTOSTRADA A4 - VARIANTE DI MESTRE

PASSANTE AUTOSTRADALE

(L.443/2001 D.Lgs. 20.08.2002 N°190)

PROGETTO ESECUTIVO
C.U.P D51B04000060001

IL RESPONSABILE
DEL PROCEDIMENTO

GENERAL CONTRACTOR

 **Passante di Mestre s.c.p.a.**

DIREZIONE LAVORI



PROGETTAZIONE ESECUTIVA



RESPONSABILE DEL PROGETTO:
DOTT. ING. LUCIO ZOLLET



PROGETTO STRADALE
CASELLO DI MARTELLAGO-SCORZE¹ E VIABILITA¹ DI COLLEGAMENTO
SEZIONI TRASVERSALI - DA SEZ.A11 A SEZ.A24

CODICE DOCUMENTO

ZLT.5E2.B3521.PE.SV.001.00

CODIFICA WBS

B3521

REV.	DATA	DESCRIZIONE	REDATTO	CONTROLLATO	APPROVATO	TAVOLA
00	07/12	EMISSIONE UFFICIALE	TARULLI	ZANCHETTIN	ZOLLET	B3521.PE.SV.001
01						SCALA
02						-
03						CAD
04						NOME FILE ZLT.5E2.B3521.PE.SV.001.00.dwg

PROFILO A
 SEZIONE A11
 PROGRESSIVA 251.72

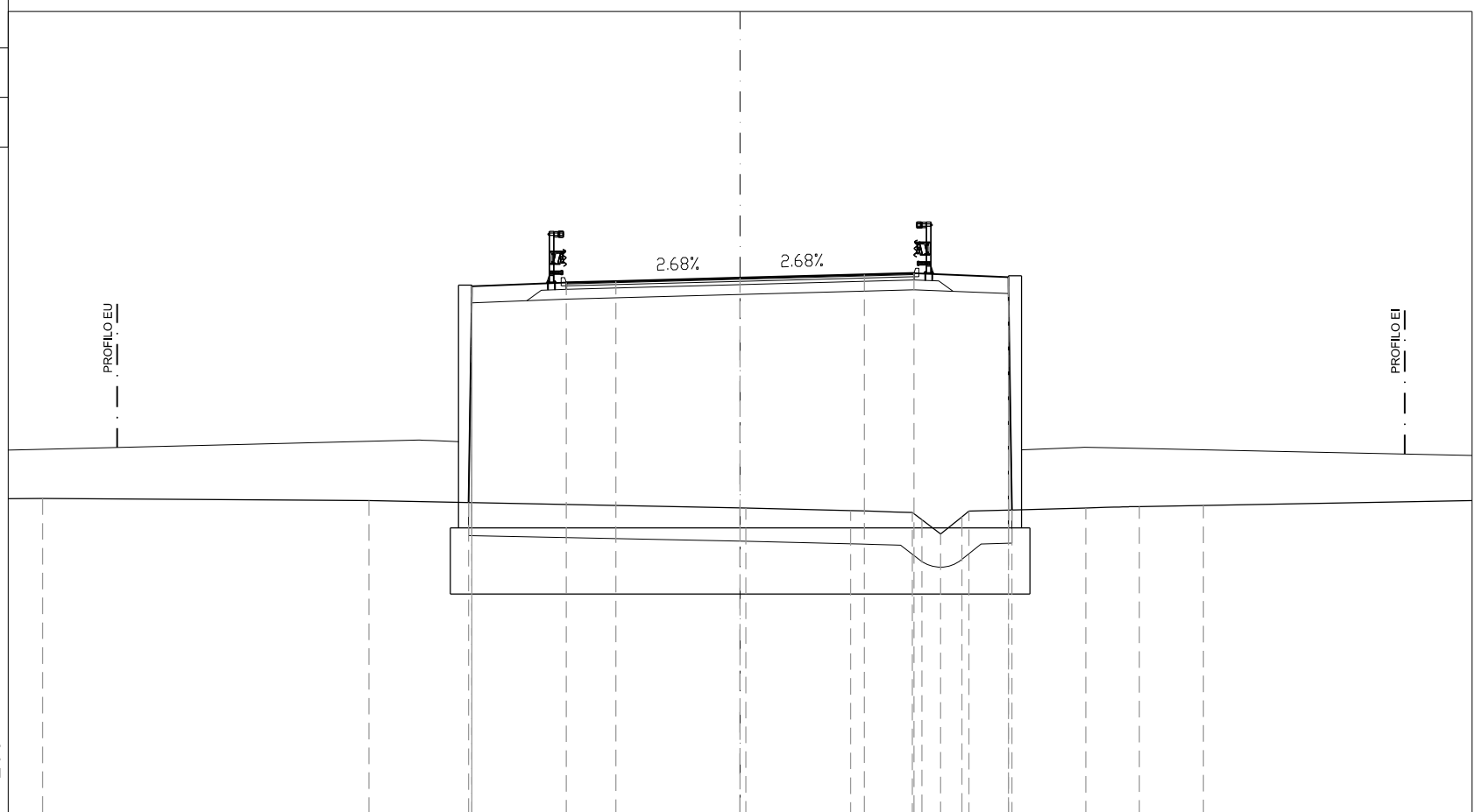

200
 200



PROGRESSIVE TERRENO	21.06	11.21				0.17	3.34	5.20	5.49	6.05	6.70	6.91	10.44	12.05	13.99
PARZIALI TERRENO	10.89	11.38			3.17	1.86	0.29	0.56	0.65	0.21	3.53	1.61	1.94	8.11	
QUOTE TERRENO	10.49	10.43			10.20	10.12	10.06	9.84	9.41	9.93	10.10	10.20	10.25	10.28	
PROGRESSIVE PROGETTO			-8.20	-8.10	-8.10	5.25	3.75	0.00	3.75	5.25	8.10	8.10	8.21		
PARZIALI PROGETTO			0.10	2.85	1.50	3.75	3.75	1.50	2.85	0.11					
QUOTE PROGETTO			10.37	16.69	16.90	17.01	17.05	17.15	17.25	17.29	16.90	17.18	10.14		

PROFILO A
 SEZIONE A12
 PROGRESSIVA 256.02

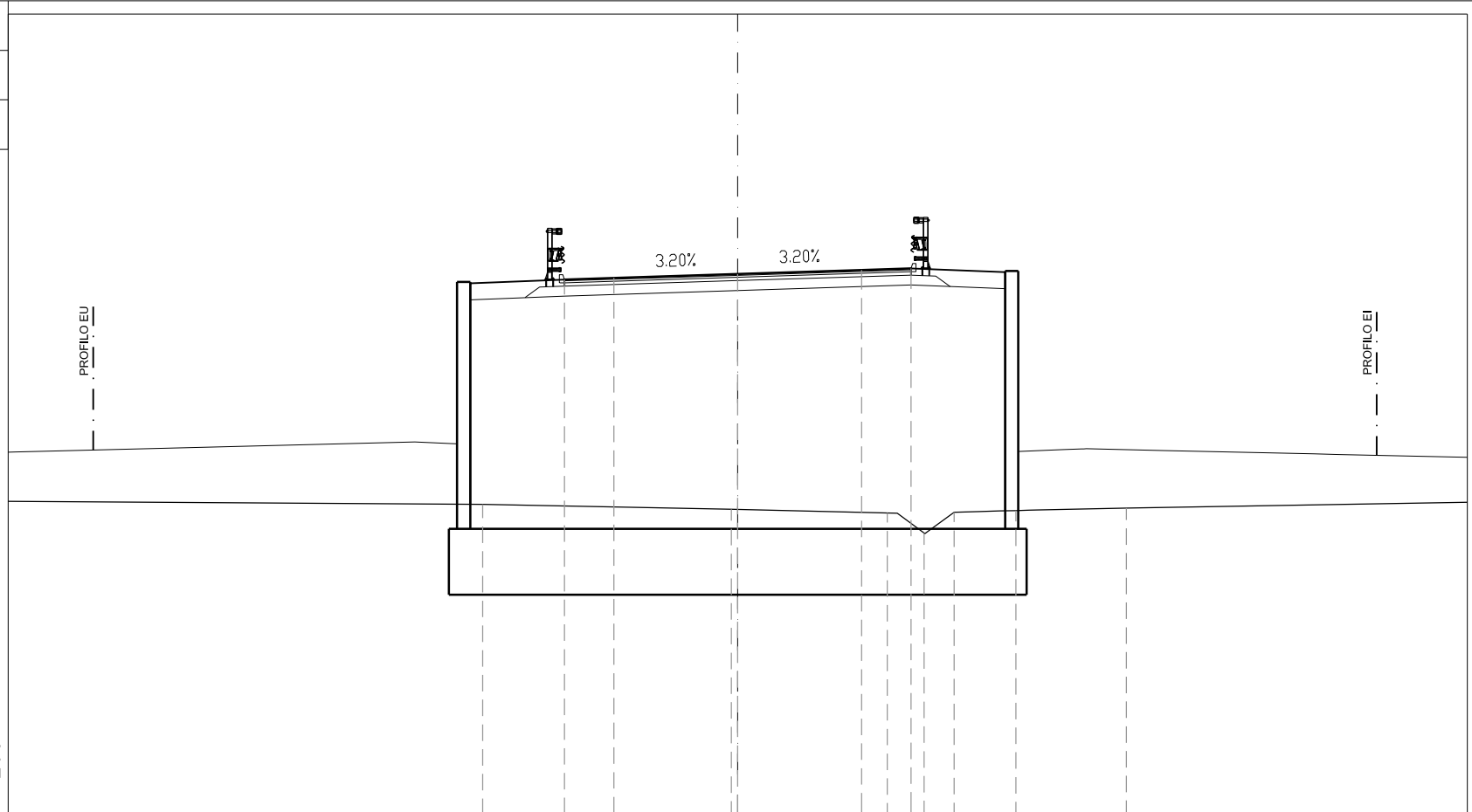

PROGRESSIVE TERRENO		7.73		-0.19		4.53	5.65	6.55	8.43	11.77	
PARZIALI TERRENO	14.37		7.54		4.72	1.12	0.90	1.88	3.34		10.33
QUOTE TERRENO		10.34		10.19		10.08	9.47	10.10	10.15	10.23	
PROGRESSIVE PROGETTO			5.25	3.75	0.00	3.75	5.25				
PARZIALI PROGETTO			1.50	3.75		3.75	1.50				
QUOTE PROGETTO			17.15	17.20	17.32	17.44	17.49				

PROFILO A
 SEZIONE S1
 PROGRESSIVA 257.32

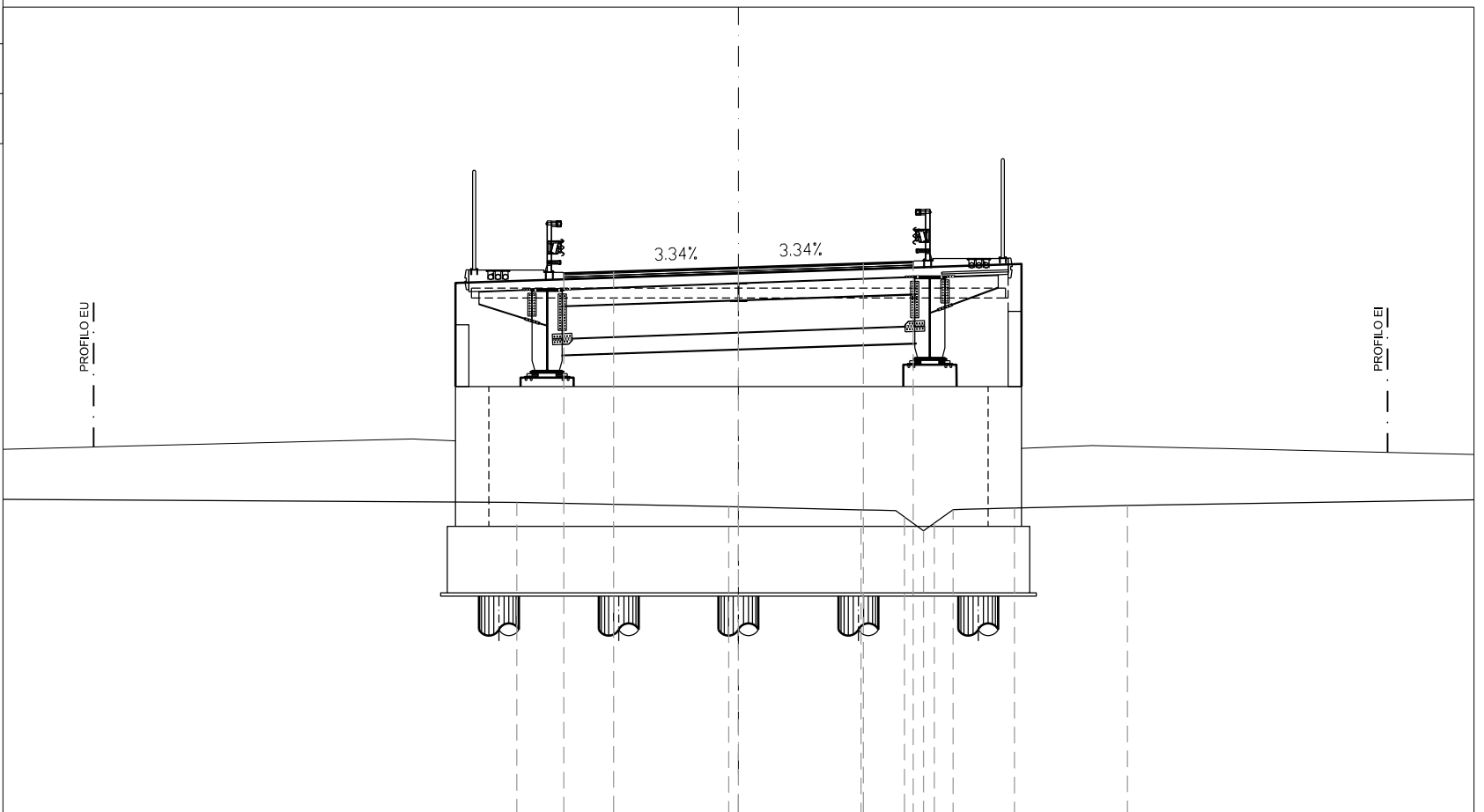

200
 200

PROGRESSIVE TERRENO		6.66		0.29		3.68	4.99	5.56	5.89	6.45	8.29	11.69	
PARZIALI TERRENO	15.44		6.37		3.97	1.31	0.57	0.33	0.56	1.84	3.40		10.41
QUOTE TERRENO		10.32		10.19		10.09	9.88	9.47	9.70	10.10	10.15	10.23	
PROGRESSIVE PROGETTO			5.25		0.00	3.75		5.25					
PARZIALI PROGETTO			1.50		3.75		3.75	1.50					
QUOTE PROGETTO		17.20		17.25		17.37		17.50		17.55			

PROFILO A
 SEZIONE A13
 PROGRESSIVA 275.00

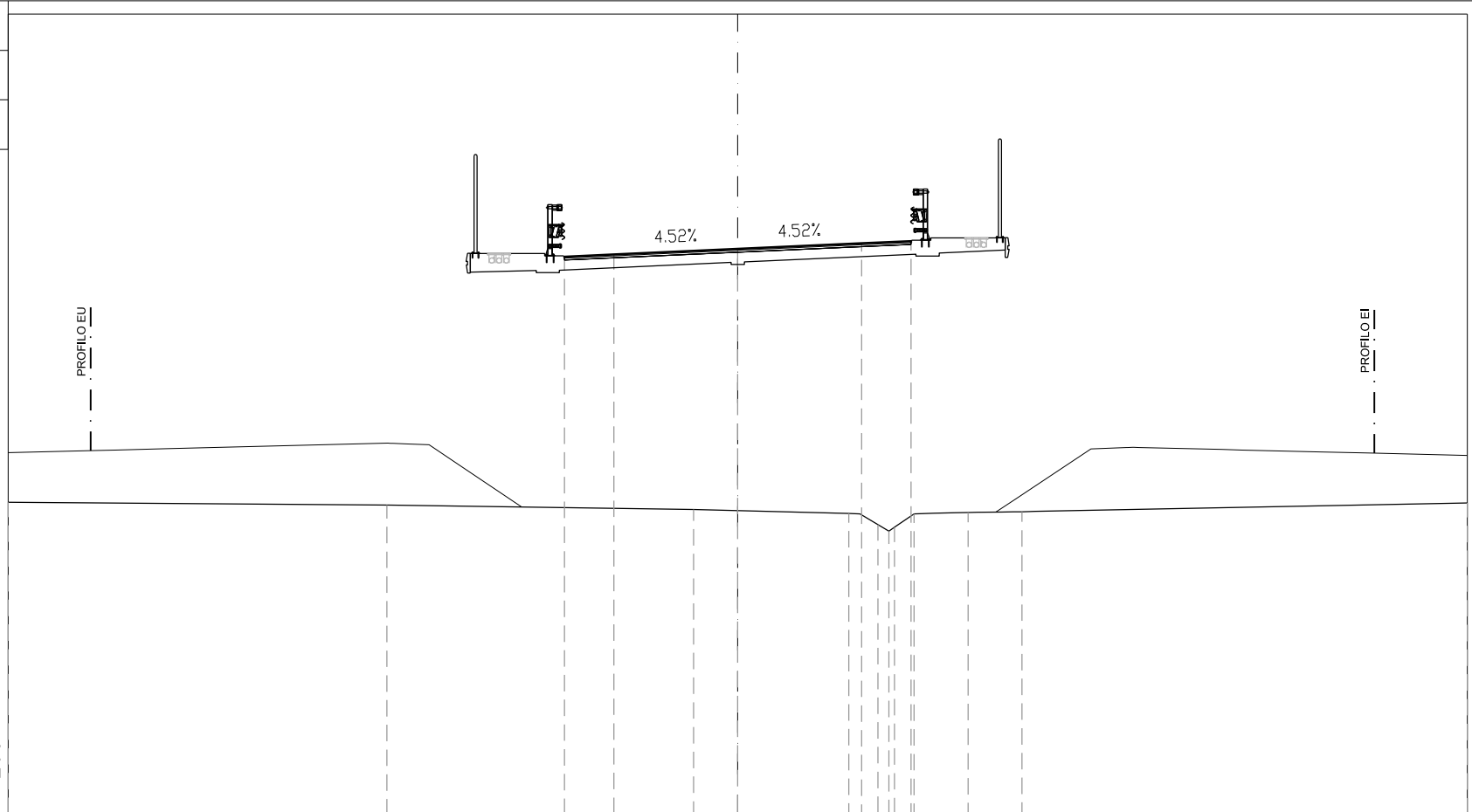

PROGRESSIVE TERRENO	-22.10	10.63	1.34	10.06	9.73	9.53	9.65	10.05	10.10	10.12	22.10
PARZIALI TERRENO	11.47	9.29	4.71	0.88	0.33	0.17	0.59	1.64	1.63	13.49	
QUOTE TERRENO	10.40	10.32	10.19	10.06	9.73	9.53	9.65	10.05	10.10	10.12	10.38
PROGRESSIVE PROGETTO		5.25	3.75	0.00	3.75	5.25					
PARZIALI PROGETTO		1.50	3.75	3.75	1.50						
QUOTE PROGETTO		17.84	17.91	18.08	18.25	18.32					

PROFILO A
 SEZIONE P1
 PROGRESSIVA 302.32

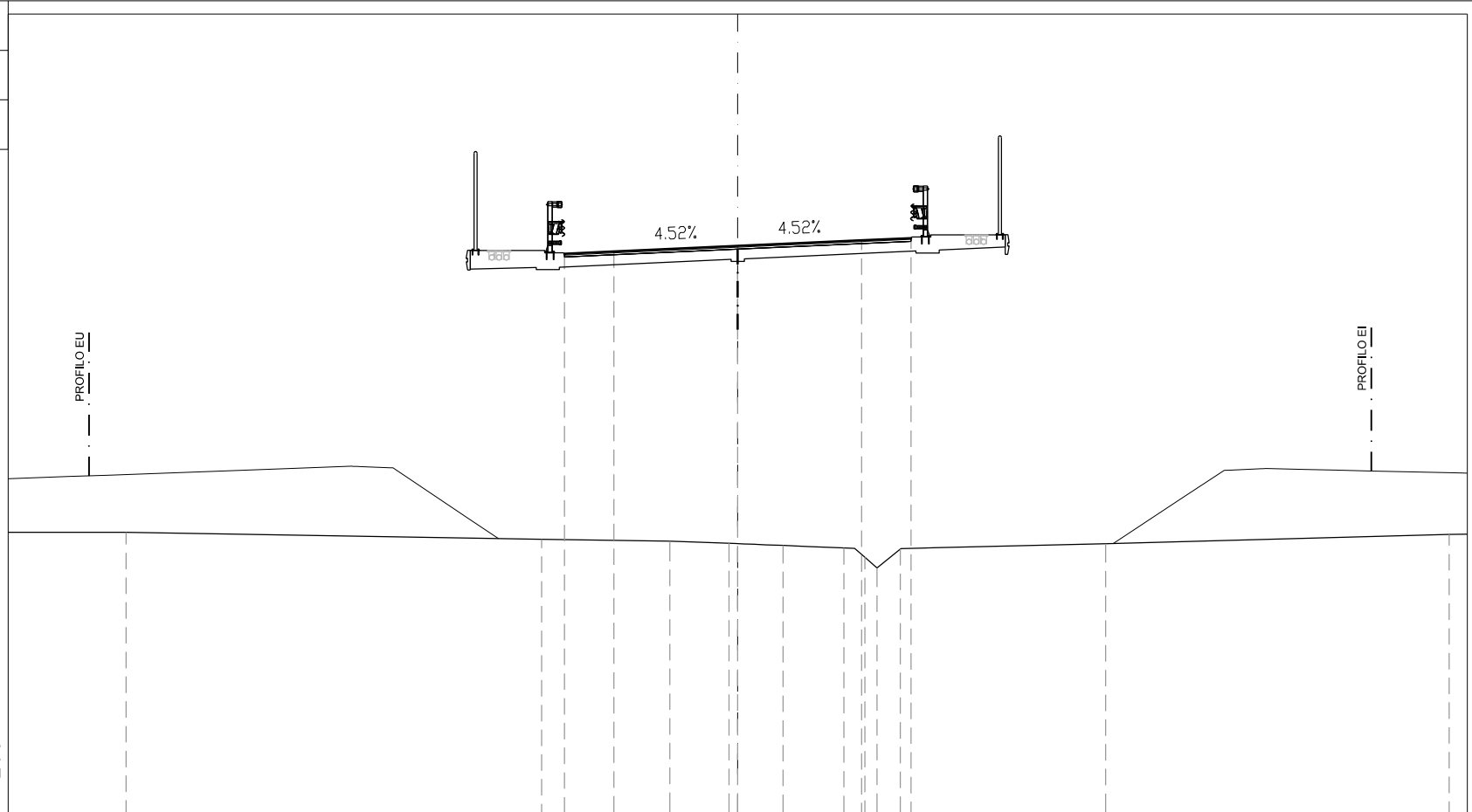

200
 200

PROGRESSIVE TERRENO	18.52	5.94	2.06	0.26	1.37	3.21	3.85	4.22	4.92	11.14	21.55	
PARZIALI TERRENO	3.58	12.58	3.88	1.80	1.63	1.84	0.64	0.37	0.70	6.22	10.41	0.55
QUOTE TERRENO	10.50	10.28	10.22	10.16	10.09	10.02	9.74	9.42	9.98	10.15	10.43	
PROGRESSIVE PROGETTO		5.25	3.75	0.00		3.75	3.75	5.25				
PARZIALI PROGETTO		1.50	3.75		3.75		1.50					
QUOTE PROGETTO		18.94	19.00	19.17		19.34	19.41					

PROFILO A
 SEZIONE A14
 PROGRESSIVA 325.00

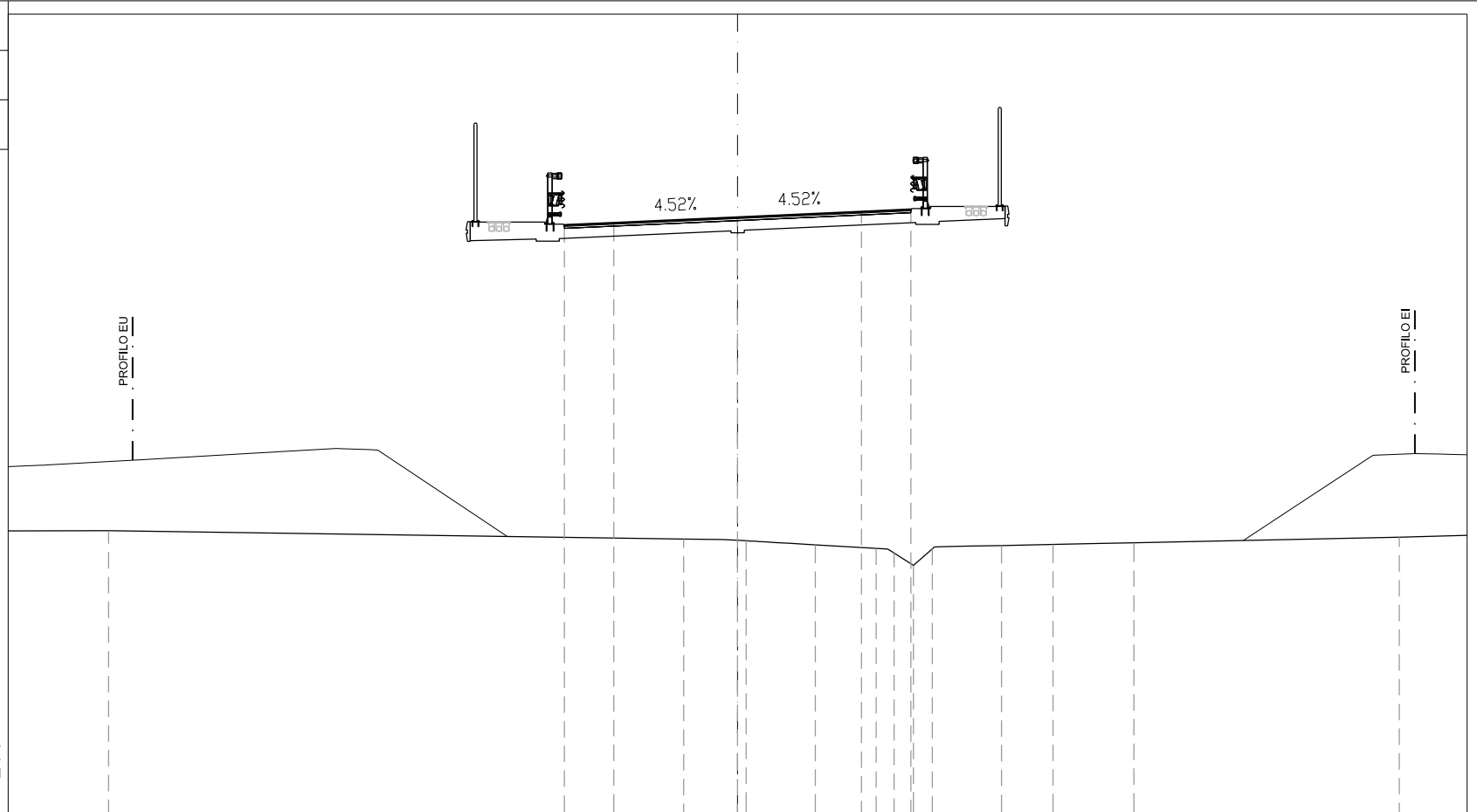

PROGRESSIVE TERRENO	19.05			-1.63	0.26	2.36	4.20	4.74	5.33	5.90	8.00	9.56	12.01	20.05
PARZIALI TERRENO	3.05	17.42		1.89	2.10	1.84	0.54	0.59	0.57	2.10	1.56	2.45	8.04	2.05
QUOTE TERRENO	10.54			10.29	10.24	10.11	10.01	9.87	9.49	10.00	10.09	10.13	10.18	10.35
PROGRESSIVE PROGETTO		5.25	3.75		0.00		3.75		5.25					
PARZIALI PROGETTO		1.50	3.75			3.75	1.50							
QUOTE PROGETTO		19.80	19.87		20.04		20.21		20.28					

PROFILO A
 SEZIONE A15
 PROGRESSIVA 375.00

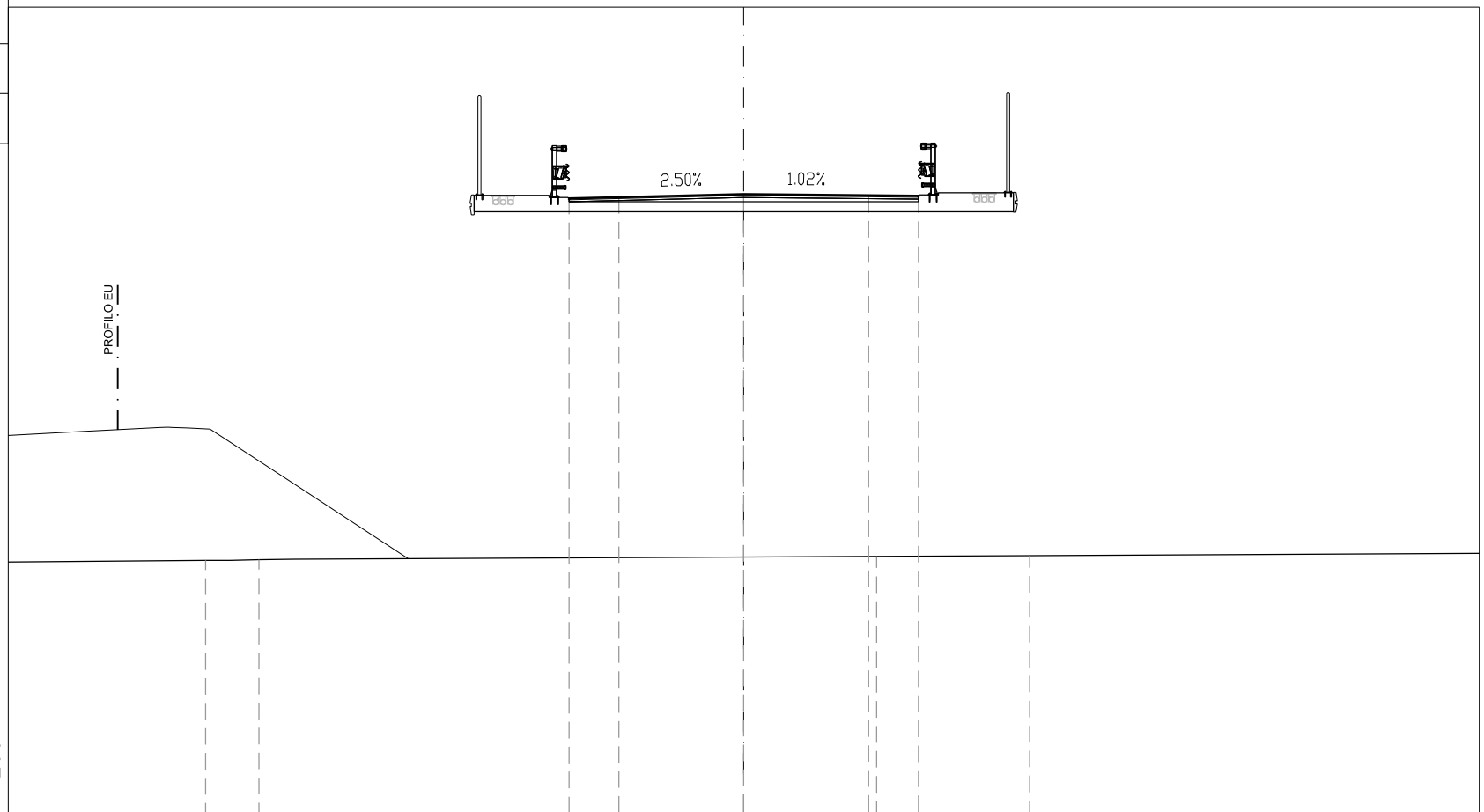

PROGRESSIVE TERRENO		16.17	14.57			3.99	8.59	
PARZIALI TERRENO	5.93	1.60		18.56		4.60	13.51	
QUOTE TERRENO		10.58	10.60			10.69	10.71	
PROGRESSIVE PROGETTO				5.25	3.75	0.00	3.75	5.25
PARZIALI PROGETTO				1.50	3.75		3.75	1.50
QUOTE PROGETTO				21.45	21.49	21.58	21.55	21.53

PROFILO A
 SEZIONE P3
 PROGRESSIVA 392.32

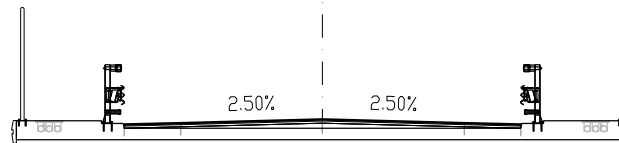

3

200
 200

PROGRESSIVE TERRENO	-22.10	12.35	6.65		6.52	15.76	22.10
PARZIALI TERRENO	9.75	5.70	13.17	9.24	6.34		
QUOTE TERRENO	10.19	10.34	10.38	10.50	10.58	10.59	
PROGRESSIVE PROGETTO		5.25	3.75	0.00	3.75	5.25	
PARZIALI PROGETTO		1.50	3.75	3.75	1.50		
QUOTE PROGETTO		21.87	21.91	22.00	21.91	21.87	

PROFILO A
 SEZIONE A16
 PROGRESSIVA 425.00

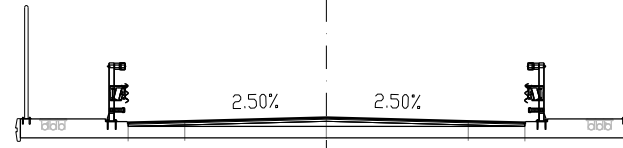

200
 200

PROGRESSIVE TERRENO	22.10	21.69	21.47	19.78	18.83	17.15	12.26	6.09	2.24	4.45	17.80	21.48	22.10
PARZIALI TERRENO	0.26	0.18	1.69	0.95	1.68	4.89	6.17	3.85	6.69	13.35	3.68	0.62	
QUOTE TERRENO	10.17	9.95	9.82	9.72	10.17	10.25	10.38	10.44	10.65	10.71	10.81	10.79	10.79
PROGRESSIVE PROGETTO								5.25	3.75	0.00	3.75	5.25	
PARZIALI PROGETTO								1.50	3.75	3.75	1.50		
QUOTE PROGETTO								22.50	22.53	22.63	22.53	22.50	

PROFILO A
 SEZIONE P4
 PROGRESSIVA 447.32

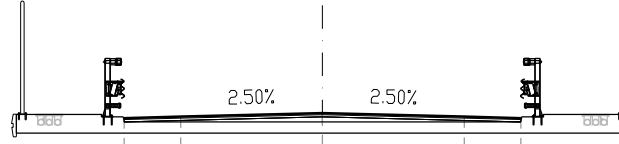

200
 200

PROGRESSIVE TERRENO	22.10	21.31	20.33	19.99	19.76	19.34	17.02	15.10	14.24	13.78	13.34	12.03	10.14	9.12	7.35	6.86	6.63	4.21	2.43	0.75	7.00	8.60	10.14	12.32	17.14	20.57	22.10
PARZIALI TERRENO	0.79	0.98	0.34	0.23	0.42	0.32	1.92	0.86	0.46	0.44	1.31	1.89	1.02	1.77	0.49	0.23	2.42	1.78	1.68	7.75	1.60	1.54	2.18	4.82	3.43	1.53	
QUOTE TERRENO	10.61	11.11	11.74	11.95	12.10	12.36	12.31	11.74	11.17	10.89	10.59	10.48	10.36	9.78	9.70	10.04	10.21	10.37	10.42	10.46	10.47	10.50	10.52	10.55	10.58	10.57	10.57
PROGRESSIVE PROGETTO															5.25	3.75				0.00		3.75	5.25				
PARZIALI PROGETTO															1.50	3.75				3.75	1.50						
QUOTE PROGETTO															22.80	22.84				22.93		22.84	22.80				

PROFILO A
 SEZIONE A20
 PROGRESSIVA 575.00

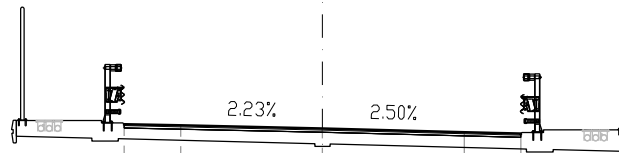

200
 200

PROGRESSIVE TERRENO	-22.10	19.77	17.74		6.14		-0.38		8.91		16.85	18.87	20.05	21.63	22.10
PARZIALI TERRENO	2.33	2.03		11.60		5.76		9.29		7.94		2.02	1.18	1.58	0.47
QUOTE TERRENO	10.71	10.76	10.89		10.90		10.81		10.79		10.84	11.01	11.50	12.40	12.46
PROGRESSIVE PROGETTO					5.25	3.75	0.00	3.75	5.25						
PARZIALI PROGETTO					1.50	3.75		3.75	1.50						
QUOTE PROGETTO					22.88	22.85	22.76	22.67	22.63						

PROFILO A
 SEZIONE P6
 PROGRESSIVA 602.32

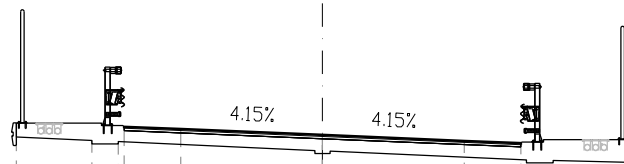

200
 200

PROGRESSIVE TERRENO	20.83	12.21		5.56		0.67		8.46	13.09	
PARZIALI TERRENO	9.89	6.65	4.89	9.13	4.63	9.01				
QUOTE TERRENO	10.92	11.05	11.13	11.13	10.98	10.93				
PROGRESSIVE PROGETTO			8.10	6.10	5.40	5.25	3.75	0.00	3.75	5.25
PARZIALI PROGETTO			2.00	1.50	3.75	3.75	1.50			
QUOTE PROGETTO			22.25	22.16	22.07	22.52	22.46	22.30	22.15	22.08

PROFILO A
 SEZIONE A21
 PROGRESSIVA 625.00

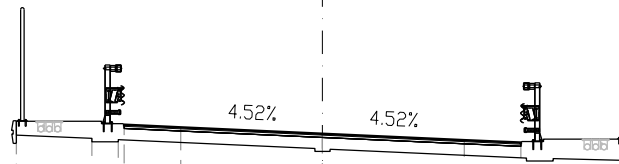

200
 200

PROGRESSIVE TERRENO	22.10	20.60	15.40		6.19	4.63		9.11	13.12	18.12	
PARZIALI TERRENO	1.50	5.20	9.21	1.56	13.74	4.01	5.00	3.98			
QUOTE TERRENO	10.64	10.64	10.56	10.63	10.64	10.70	10.68	10.87			
PROGRESSIVE PROGETTO				-8.10	-6.10	-5.40	-5.25	-3.75	0.00	3.75	5.25
PARZIALI PROGETTO				2.00	1.50	3.75	3.75	1.50			
QUOTE PROGETTO				21.77	21.68	21.59	22.04	21.98	21.81	21.64	21.57

PROFILO A
 SEZIONE P7
 PROGRESSIVA 647.32

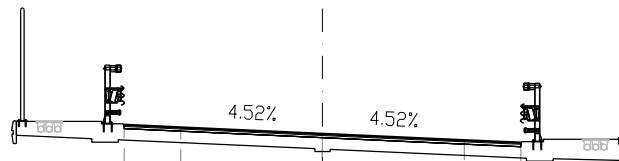

200
 200

PROGRESSIVE TERRENO	-22.10	18.23		9.42	7.54	4.55	1.88		9.20	11.84	15.40	22.10
PARZIALI TERRENO	3.87	8.81	1.88	2.99	2.67	11.08	2.64	3.56	6.70			
QUOTE TERRENO	10.98	10.99	11.01	11.01	11.02	11.02	11.01	11.01	11.03	10.97		
PROGRESSIVE PROGETTO				5.25	3.75	0.00	3.75	5.25				
PARZIALI PROGETTO			1.50	3.75	3.75	1.50						
QUOTE PROGETTO			21.46	21.39	21.22	21.05	20.98					

PROFILO A
 SEZIONE A22
 PROGRESSIVA 675.00

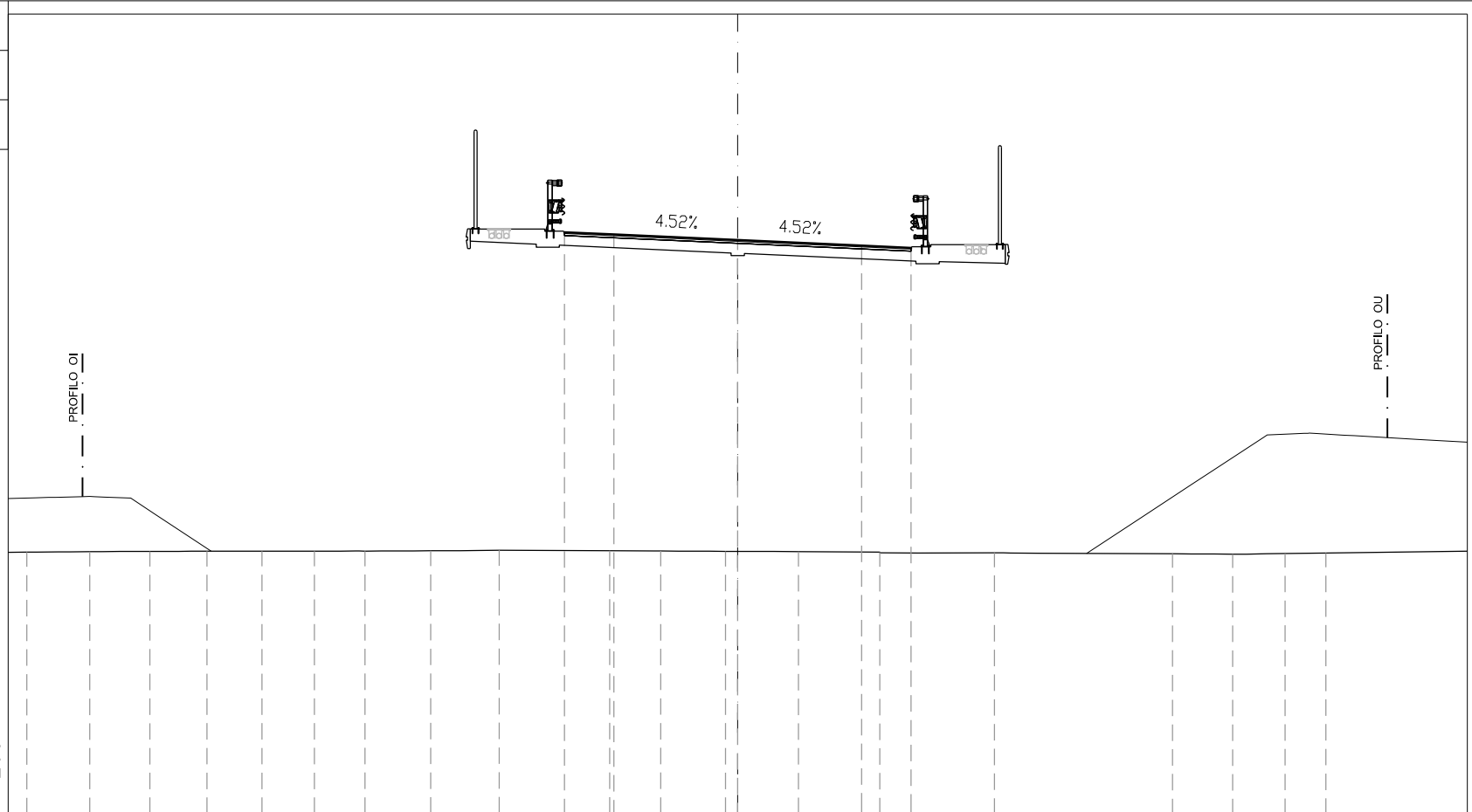

3

200
200

PROGRESSIVE TERRENO	-21.53		-19.62		-17.81		-16.07		-14.41		-12.82		-11.29		-9.30		-7.22		-3.88		-2.33		-0.37		1.84		4.30		7.78		13.17		14.99		16.58		17.82	
PARZIALI TERRENO	1.53		1.86		1.78		1.70		1.62		1.56		2.01		1.59		4.57		1.55		1.96		2.21		2.46		3.48		5.39		1.82		1.59		5.52			
QUOTE TERRENO	10.89		10.91		10.92		10.92		10.92		10.92		10.92		10.93		10.95		10.93		10.93		10.92		10.91		10.90		10.87		10.84		10.83		10.85		10.86	
PROGRESSIVE PROGETTO																	5.25		3.75		0.00				3.75		5.25											
PARZIALI PROGETTO																	1.50		3.75		0.00		3.75		1.50													
QUOTE PROGETTO																	20.59		20.52		20.35		20.18		20.11													

PROFILO A
 SEZIONE P8
 PROGRESSIVA 692.32

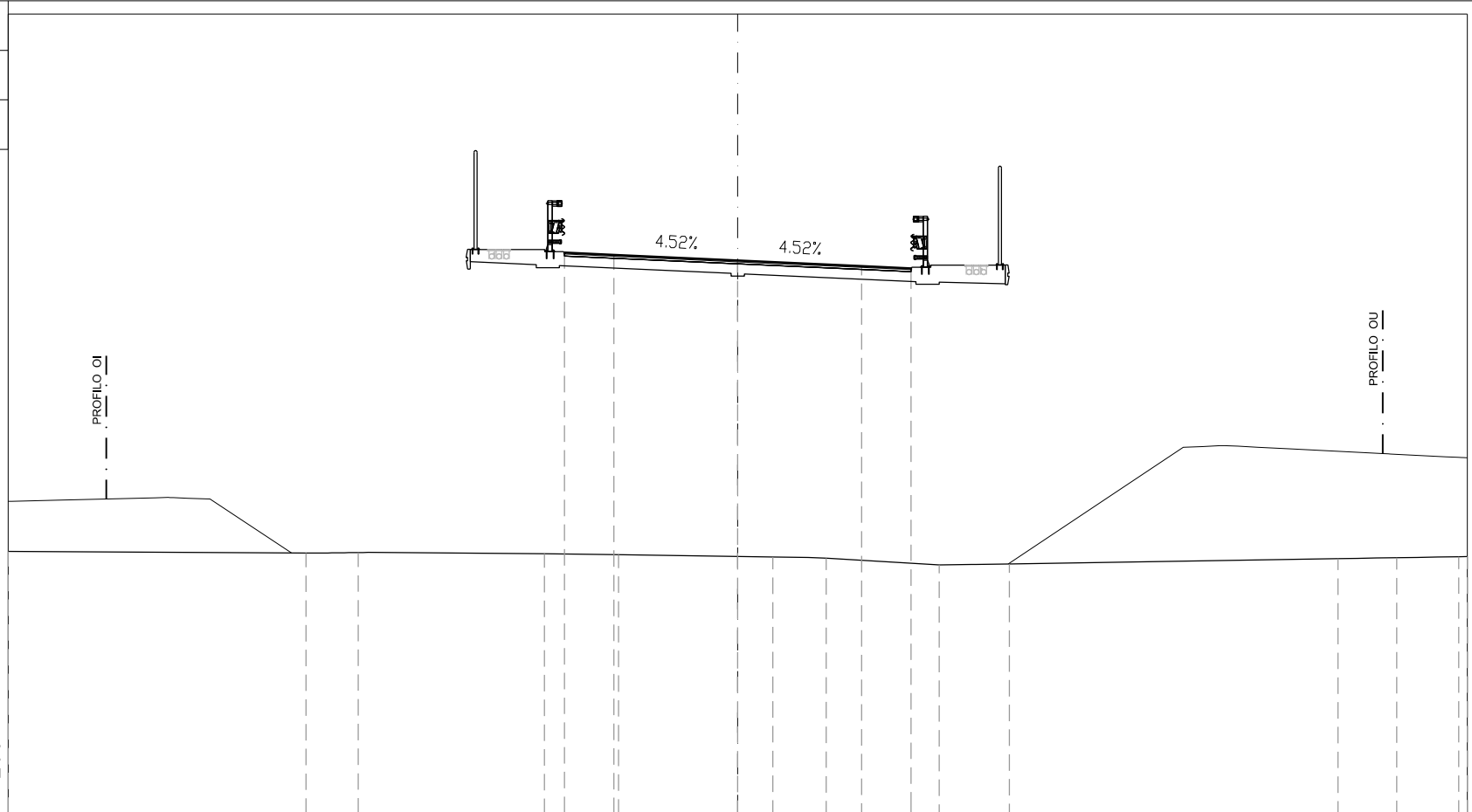

PROGRESSIVE TERRENO	22.10	13.08	11.50	5.85	3.61	1.07	2.68	6.10	8.23	18.19	19.96	21.84	22.10
PARZIALI TERRENO		9.02	1.58	5.65	2.24	4.68	1.61	3.42	2.13	9.96	1.77	1.88	0.26
QUOTE TERRENO	10.92	10.87	10.88	10.84	10.81	10.75	10.71	10.50	10.54	10.69	10.72	10.75	10.76
PROGRESSIVE PROGETTO				5.25	3.75	0.00	3.75	5.25					
PARZIALI PROGETTO				1.50	3.75		3.75	1.50					
QUOTE PROGETTO				19.97	19.90	19.73	19.56	19.49					

PROFILO A
 SEZIONE S2
 PROGRESSIVA 737.32

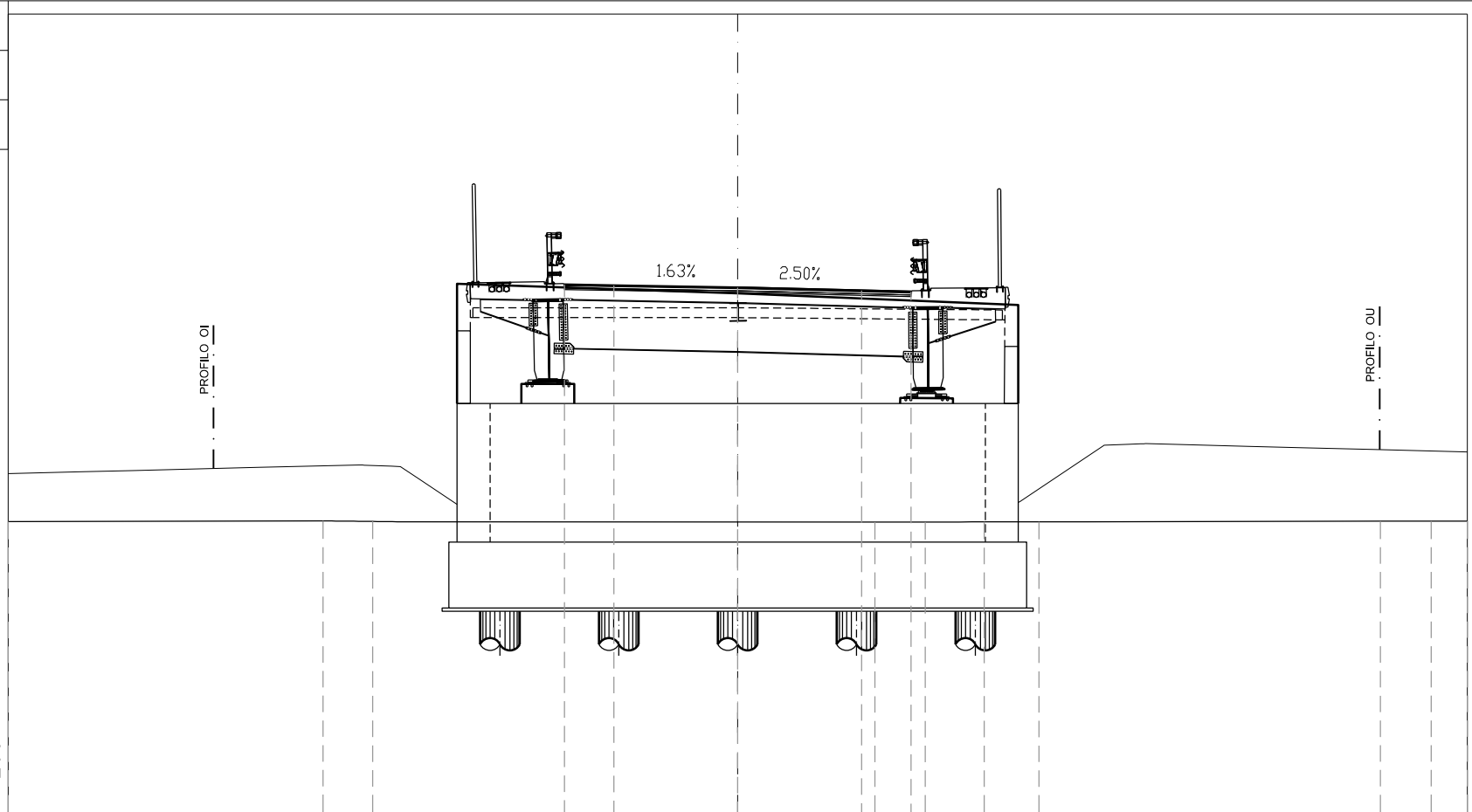

PROGRESSIVE TERRENO	-22.10	12.56	11.06		4.16	5.68	7.47	9.13	19.47	21.00	22.10
PARZIALI TERRENO		9.54	1.50	15.22	1.52	1.79	1.66	10.34	1.53	1.10	
QUOTE TERRENO	10.82	10.84	10.82		10.80	10.81	10.81	10.81	10.83	10.83	10.83
PROGRESSIVE PROGETTO				5.25	3.75	0.00	3.75	5.25			
PARZIALI PROGETTO			1.50	3.75	3.75	1.50					
QUOTE PROGETTO		18.00	17.98	17.92	17.82	17.78					

PROFILO A
 SEZIONE A24
 PROGRESSIVA 738.62

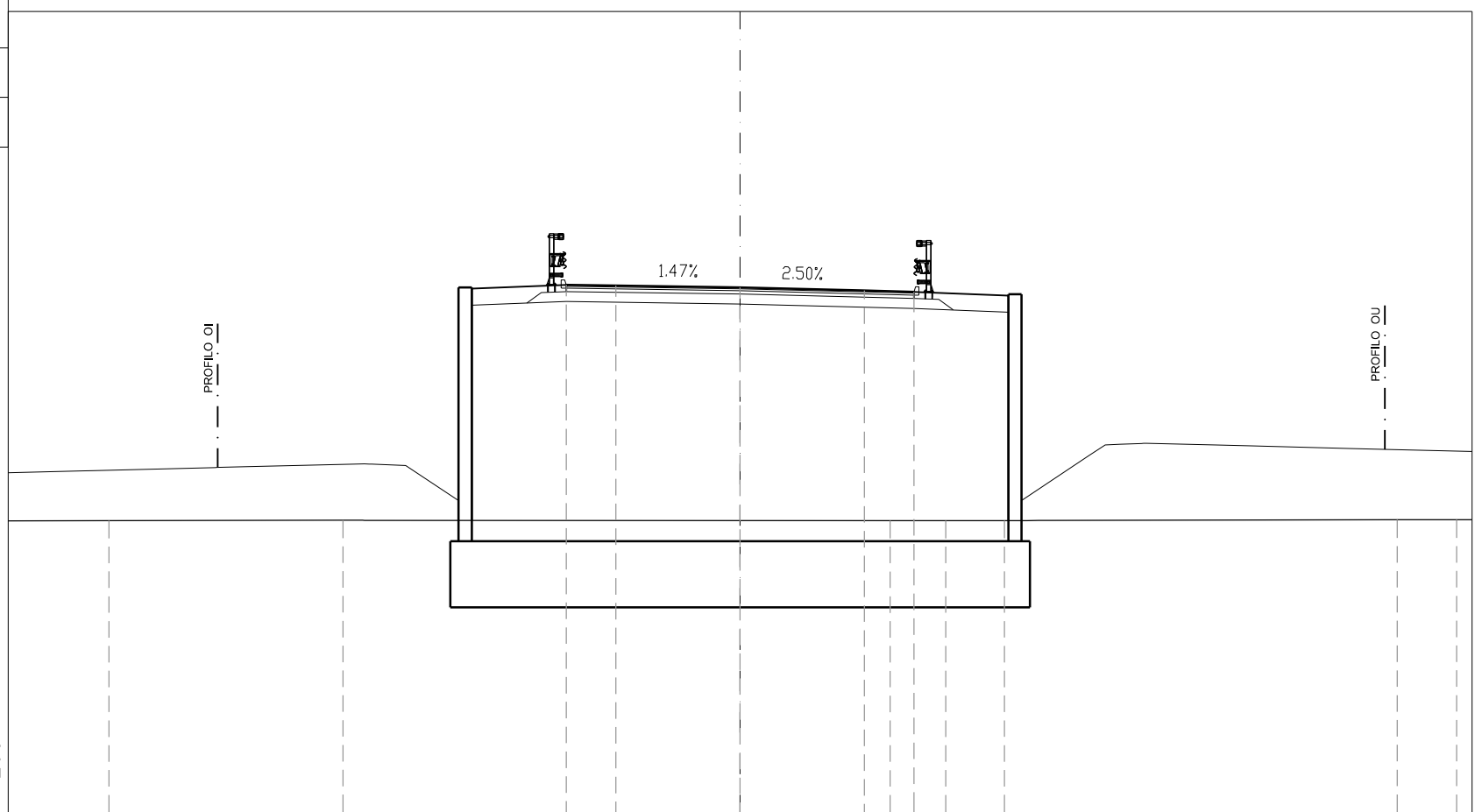

200
 200

PROGRESSIVE TERRENO		19.06		11.99				4.53	6.21	7.98			19.84	21.63
PARZIALI TERRENO	3.04		7.07			16.52		1.68	1.77		11.86		1.79	0.47
QUOTE TERRENO	10.82		10.83					10.82	10.82	10.82			10.84	10.85
PROGRESSIVE PROGETTO						5.25	3.75	0.00		3.75	5.25			
PARZIALI PROGETTO			1.50	3.75		3.75		1.50						
QUOTE PROGETTO			17.94	17.92		17.86		17.77	17.73					