

## ASSE VIARIO MARCHE-UMBRIA E QUADRILATERO DI PENETRAZIONE INTERNA MAXI LOTTO 2

LAVORI DI COMPLETAMENTO DELLA DIRETTRICE PERUGIA ANCONA:  
SS. 318 DI "VALFABBRICA", TRATTO PIANELLO - VALFABBRICA  
SS. 76 "VAL D'ESINO", TRATTI FOSSATO VICO - CANCELLI E ALBACINA - SERRA SAN QUIRICO  
"PEDEMONTANA DELLE MARCHE", TRATTO FABRIANO-MUCCIA-SFERCIA.

### PROGETTO DEFINITIVO

<p><b>CONTRAENTE GENERALE:</b></p> 	<p><i>Il responsabile del Contraente Generale:</i></p> <p style="text-align: center;">Ing. Federico Montanari</p>	<p><i>Il responsabile Integrazioni delle Prestazioni Specialistiche:</i></p> <p style="text-align: center;">Ing. Salvatore Lieto</p>
---	---	--

<p><b>PROGETTAZIONE: Associazione Temporanea di Imprese</b></p>	
<p><i>Mandatario:</i> <b>PROGETTAZIONE GRANDI INFRASTRUTTURE PROGIN S.p.A.</b></p>	<p><i>Mandanti:</i></p> <div style="display: flex; justify-content: space-around; align-items: center;"> <div style="text-align: center;">  <p>LOMBARDI SA INGEGNERI CONSULENTI</p> </div> <div style="text-align: center;">  <p>LOMBARDI-REICO INGEGNERIA S.r.l.</p> </div> <div style="text-align: center;">  <p><b>SGAI s.r.l.</b> <b>di E.Forlani &amp; C.</b> Studio di Ingegneria e Geologia Applicata <small>Via Marconi, 20 - 47833 Montano di Romagna (RN) - ITALY P. IVA 0198420453 - tel. +39 0541 541992777 - e-mail: sgai@sgai.com pec: sgai@sgai.pec.com</small></p> <p><a href="http://www.sgai.com">www.sgai.com</a></p> </div> </div>

<p>RESPONSABILE DELLA PROGETTAZIONE PER L'A.T.I. Prof. Ing. Antonio Grimaldi</p> <p>GEOLOGO Dott. Geol. Fabrizio Pontoni</p> <p>COORDINATORE DELLA SICUREZZA IN FASE DI PROGETTAZIONE Ing. Michele Curiale</p>	  	
--	--	--

<p>IL RESPONSABILE DEL PROCEDIMENTO</p> <p style="text-align: center;">Ing. Giulio Petrizzelli</p>		
--	--	--

<p><b>2.1.3 - PEDEMONTANA DELLE MARCHE</b>  <b>3° stralcio funzionale: Castelraimondo nord - Castelraimondo sud</b>  <b>4° stralcio funzionale: Castelraimondo sud - innesto S.S.77 a Muccia</b>  <b>OPERE D'ARTE MAGGIORI : GALLERIE NATURALI</b>  <b>GALLERIA NATURALE MECCIANO</b>  <b>Relazione tecnica e di calcolo della galleria naturale - Appendice 1</b></p>	<p><b>SCALA:</b> <b>VARIE</b></p> <p><b>DATA:</b> <b>Giugno 2017</b></p>
--	--

Codice Unico di Progetto (CUP) **F12C03000050021** (Assegnato CIPE 23-12-2015)

<i>Codice elaborato:</i>	Opera	Tratto	Settore	CEE	WBS	Id. doc.	N. prog.	Rev.
	L 0 7 0 3	2 1 3	E	1 3	G N 3 6 0 0	R E L	0 2	A

REV.	DATA	DESCRIZIONE	Redatto		Controllato	Approvato
A	Giugno 2017	EMISSIONE PER CONSEGNA	PROGIN	PROGIN	S. LIETO	A. GRIMALDI

## **APPENDICE:**

### **Output di calcolo FLAC**

- **Sezione tipo B2 - Parametri res min** – *Copertura di calcolo = 70 m*
- **Sezione tipo B2 - Parametri res max** – *Copertura di calcolo = 70 m*
- **Sezione tipo B0 - Parametri res min** – *Copertura di calcolo = 70 m*
- **Sezione tipo B0 - Parametri res max** – *Copertura di calcolo = 70 m*
- **Sezione tipo B2 - Parametri res min** – *Copertura di calcolo = 50 m*
- **Sezione tipo B2 - Parametri res max** – *Copertura di calcolo = 50 m*
- **Sezione tipo B0 - Parametri res min** – *Copertura di calcolo = 50 m*
- **Sezione tipo B0 - Parametri res max** – *Copertura di calcolo = 50 m*
- **Sezione tipo B2** – *Copertura di calcolo = 25 m*
- **Sezione tipo B2V** – *Copertura di calcolo = 25 m*
- **Sezione tipo B2V** – *Copertura di calcolo = 15 m*

**Output Flac – Sezione tipo B2 – Parametri res min – Copertura di calcolo = 70 m**

**Step 1 – Tensioni litostatiche**

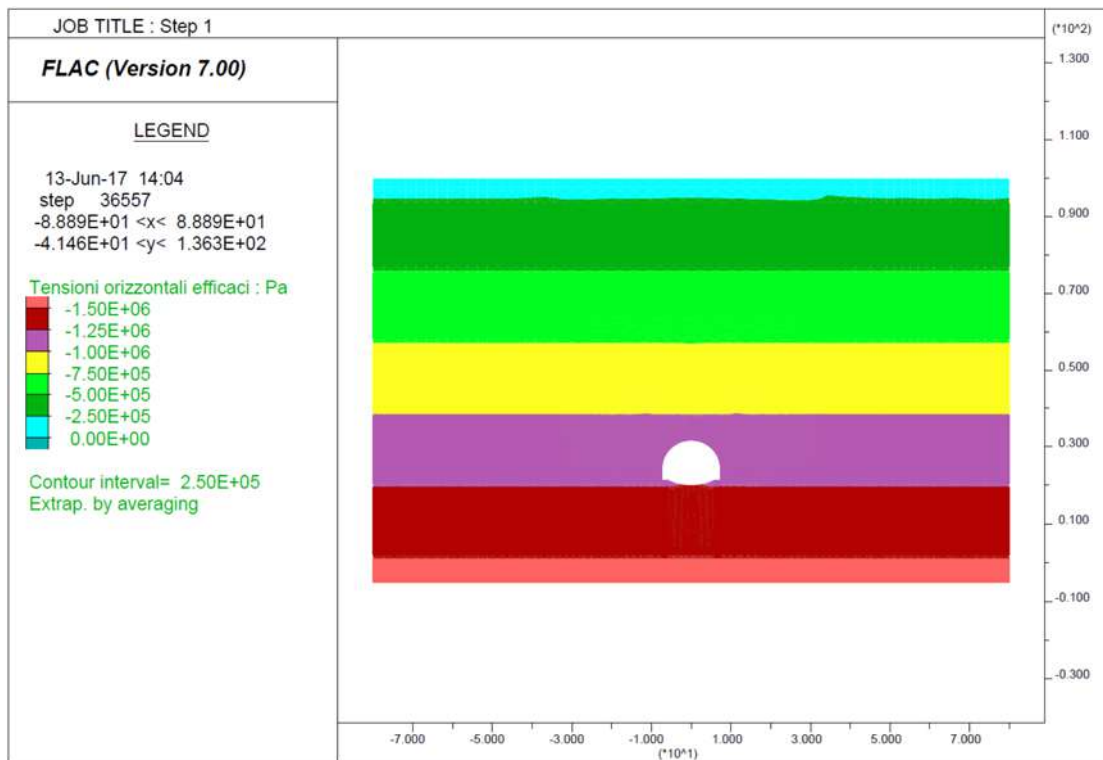
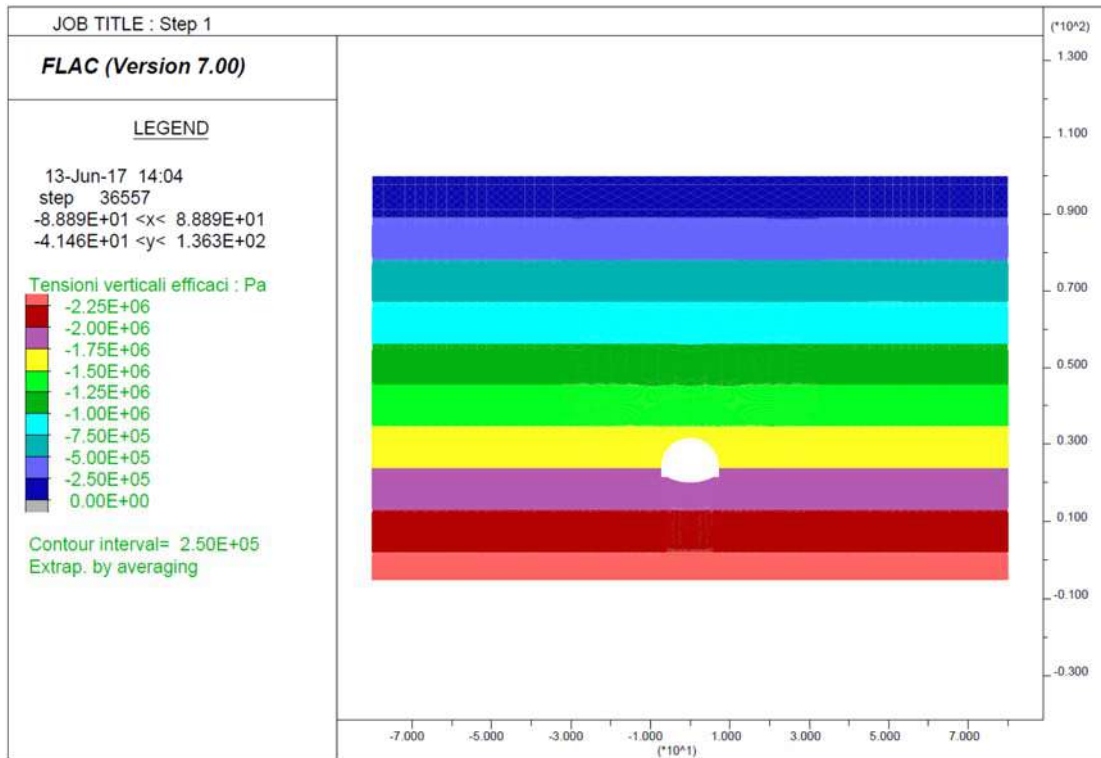

Step 6 – Avanzamento fino a 2D

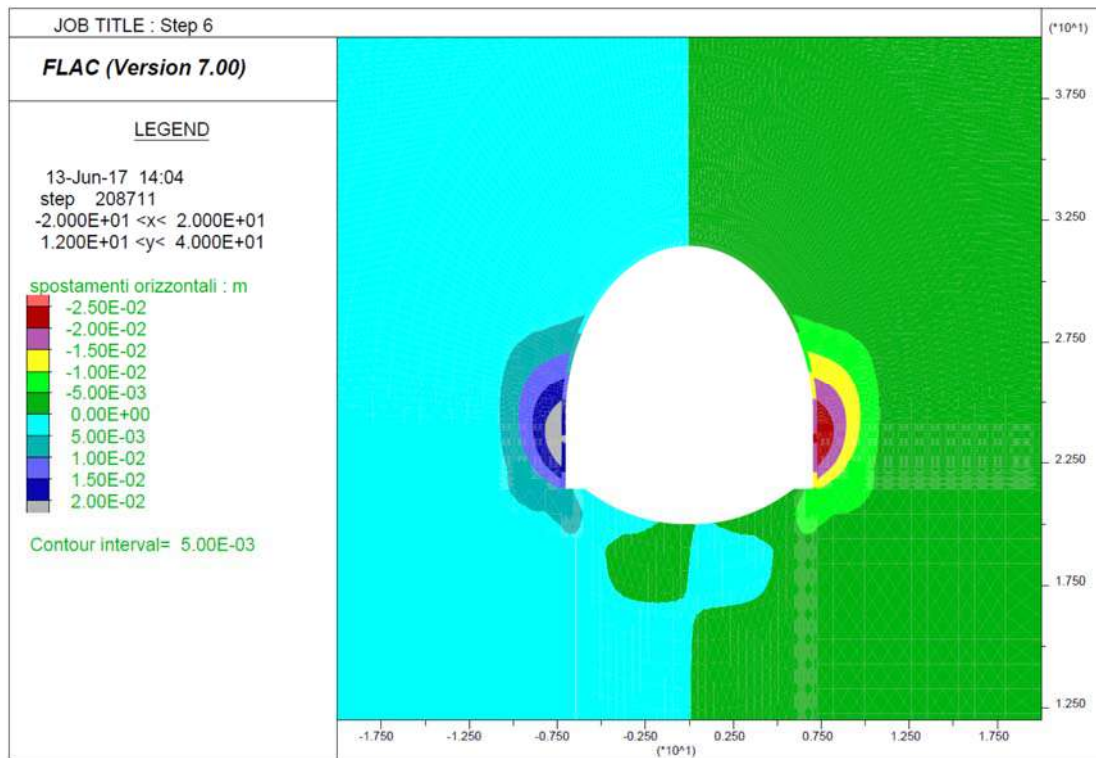
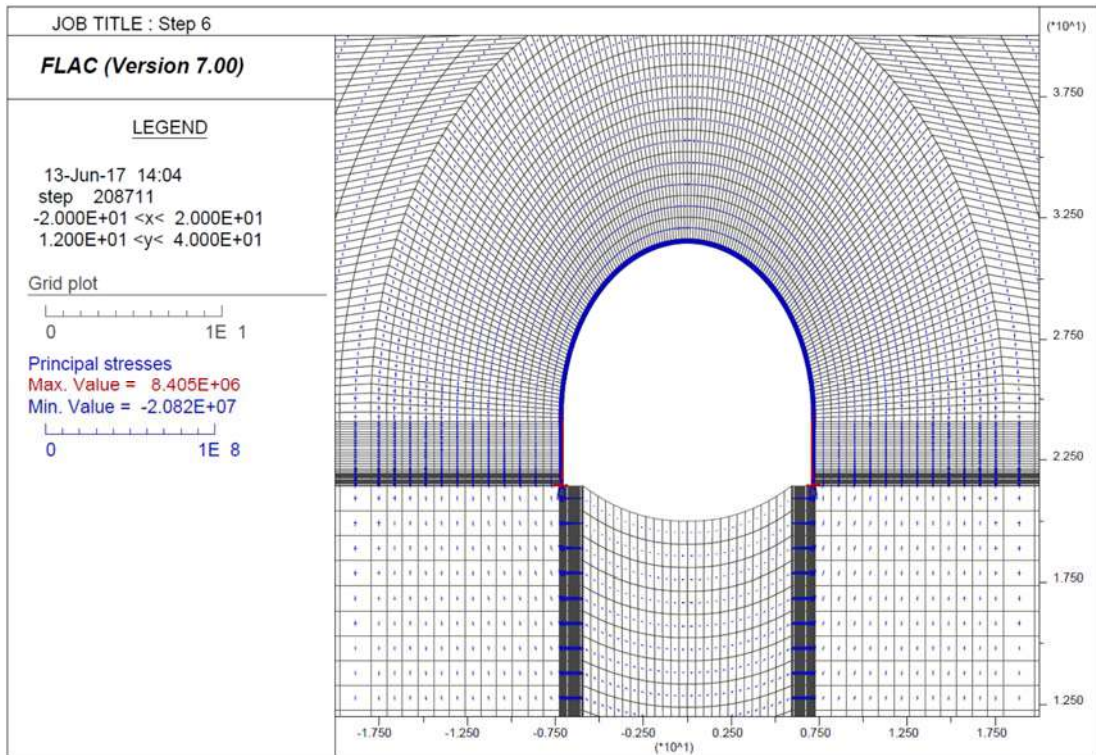



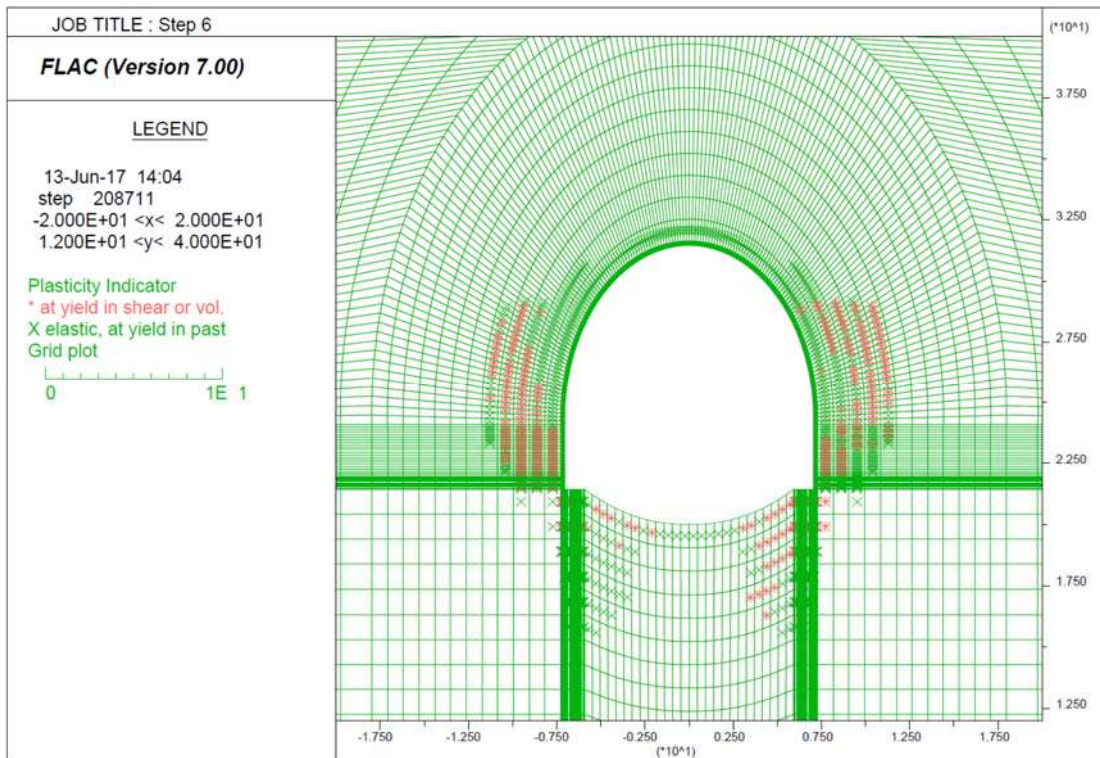
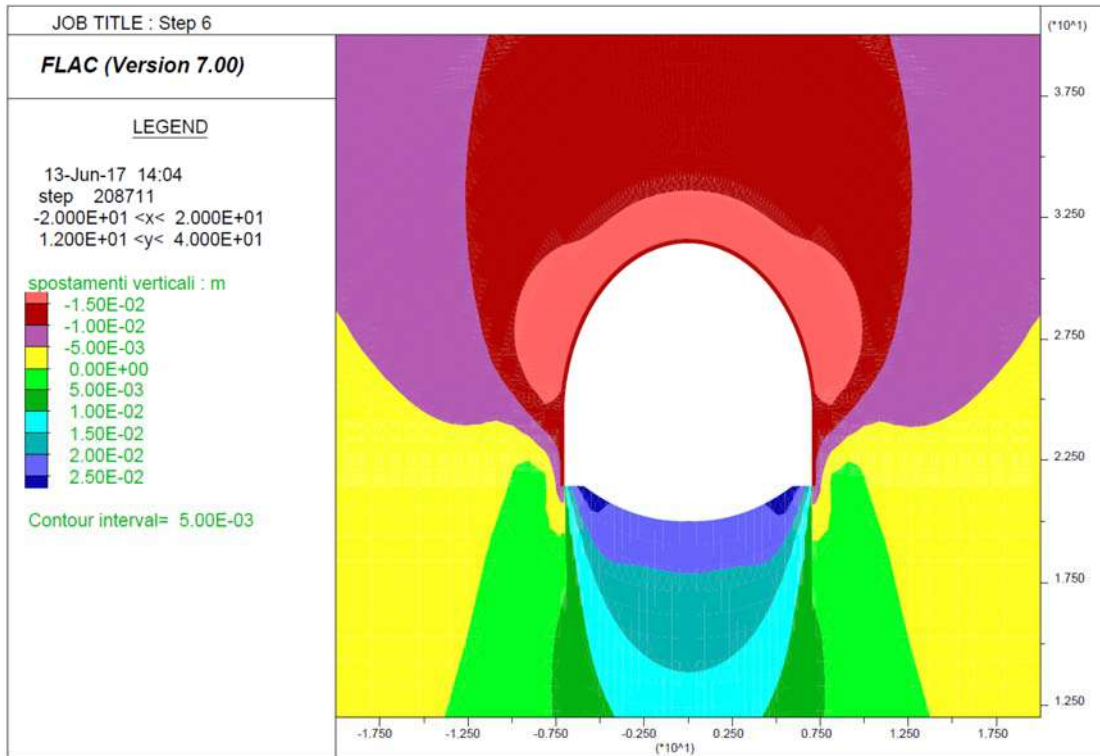

Step 7 - Getto arco rovescio e muretta a 2D e avanzamento fino a deformazioni esaurite

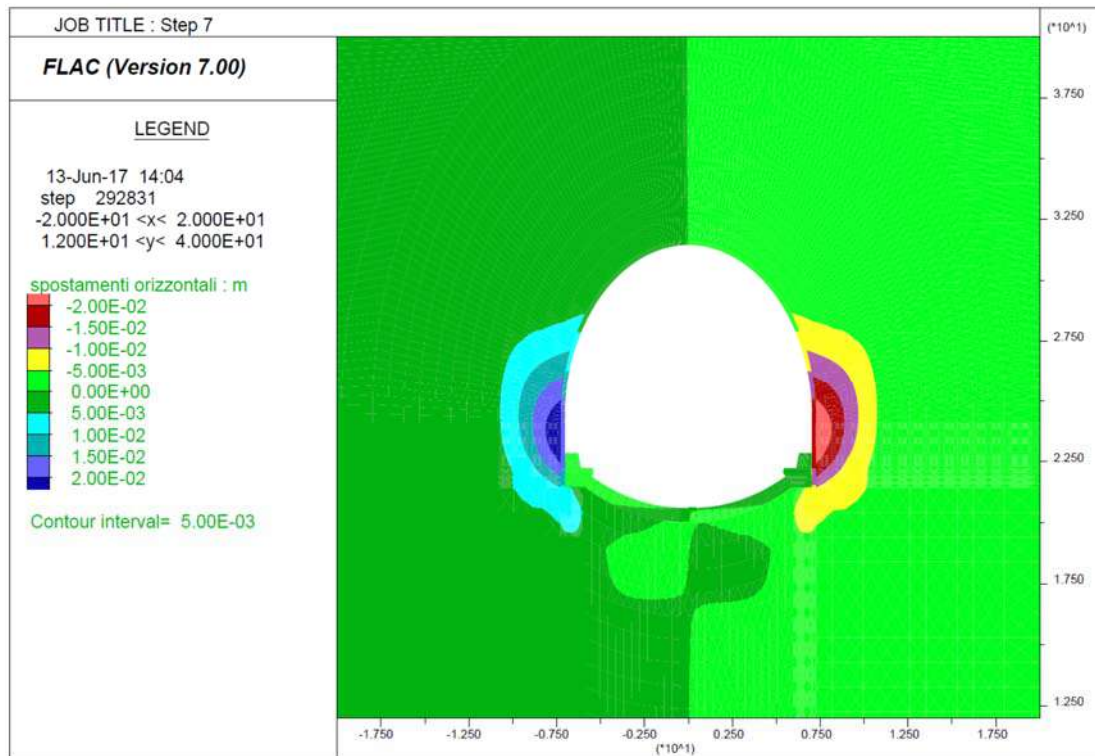
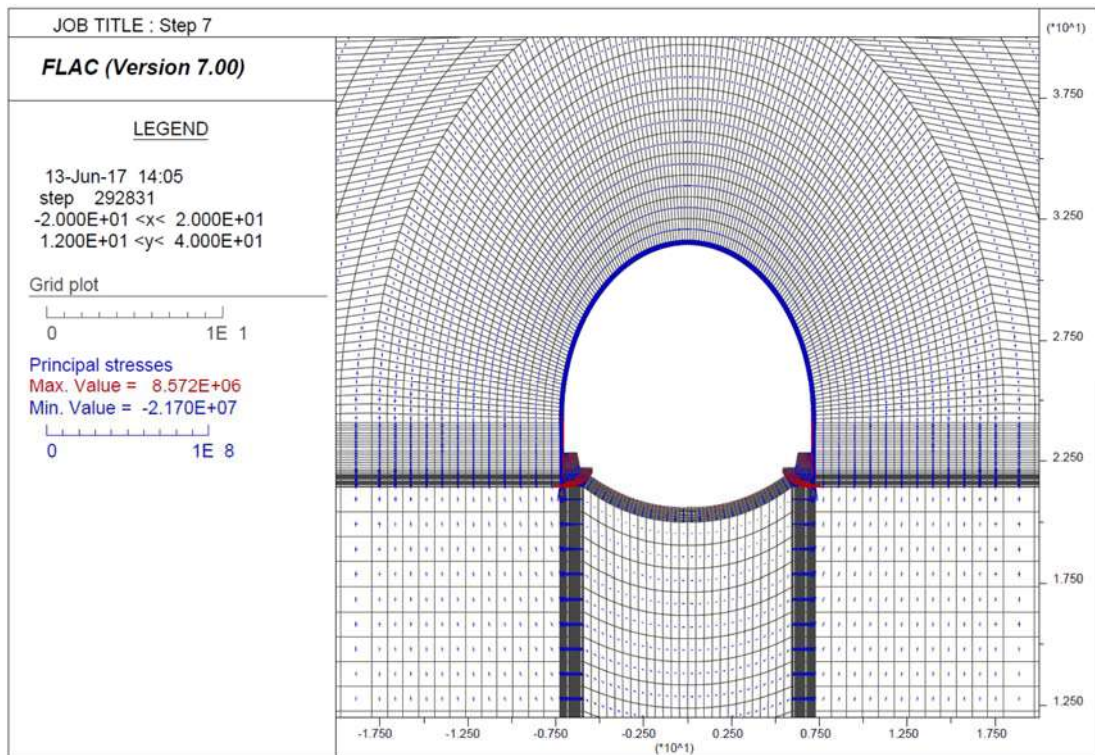



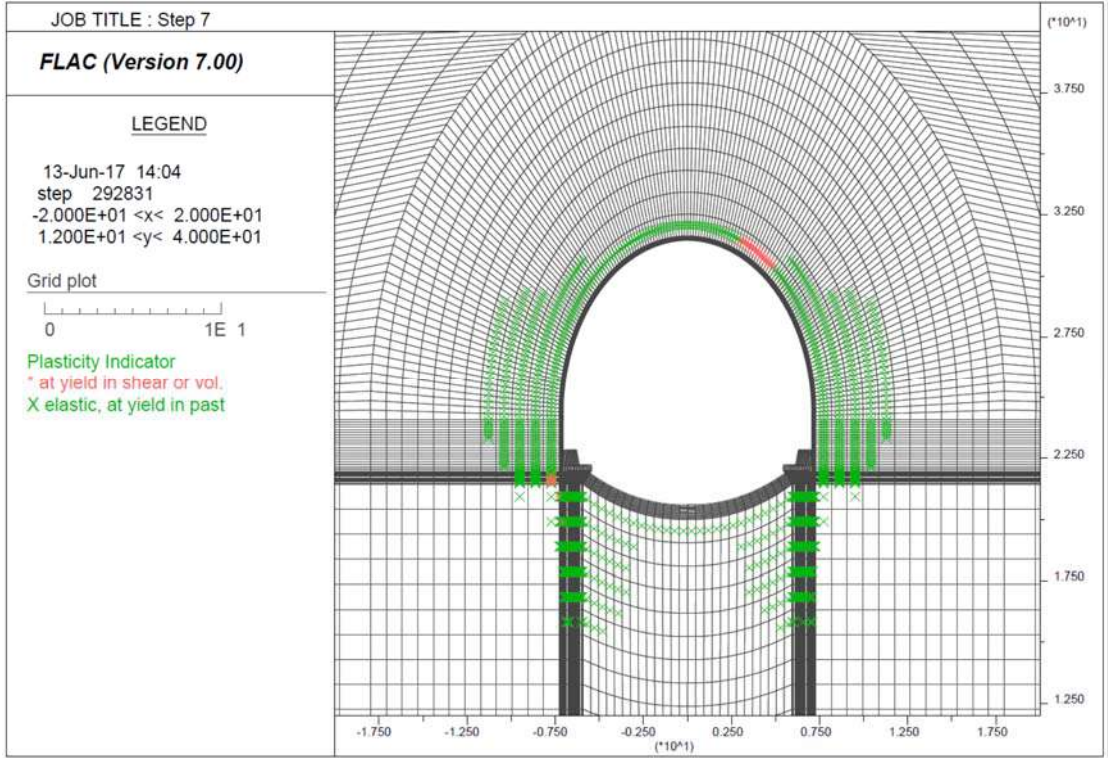
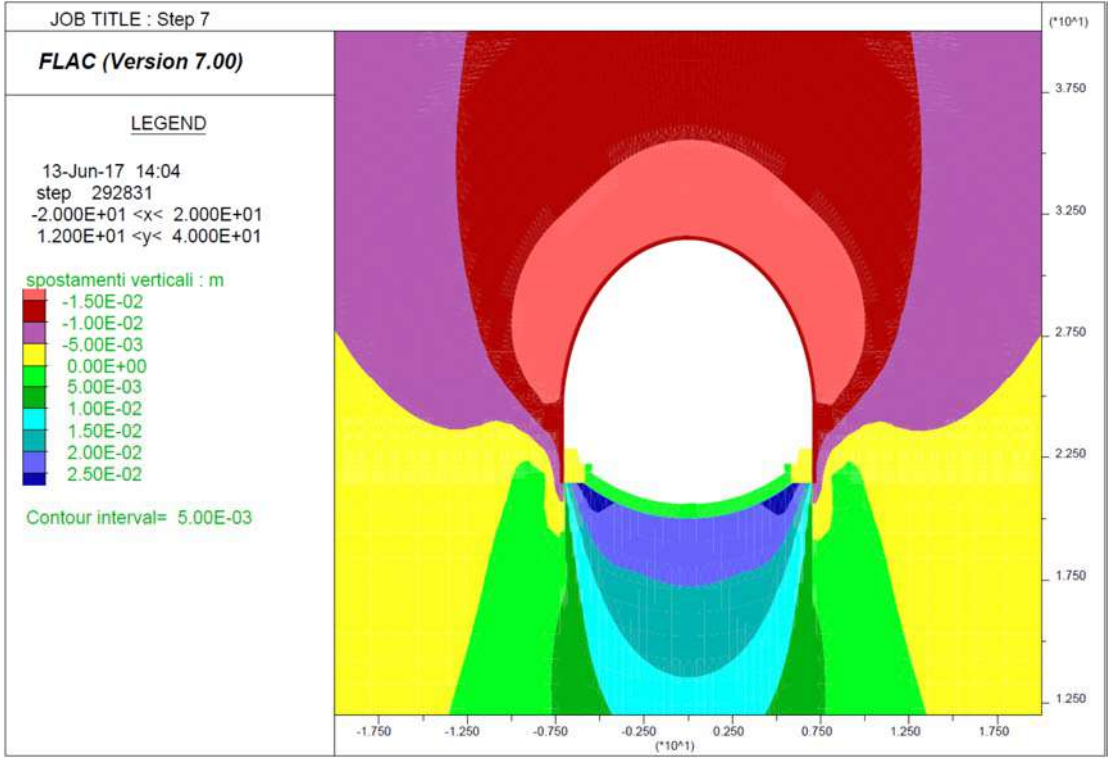

Step 8 - Getto Calotta

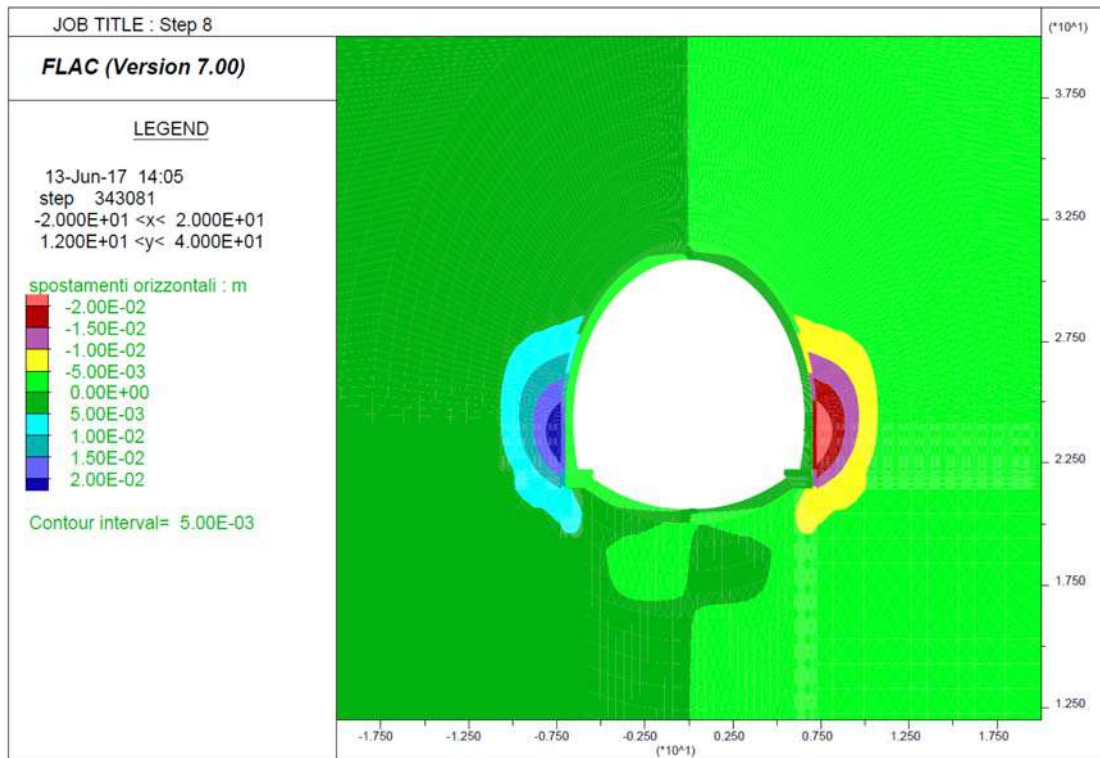
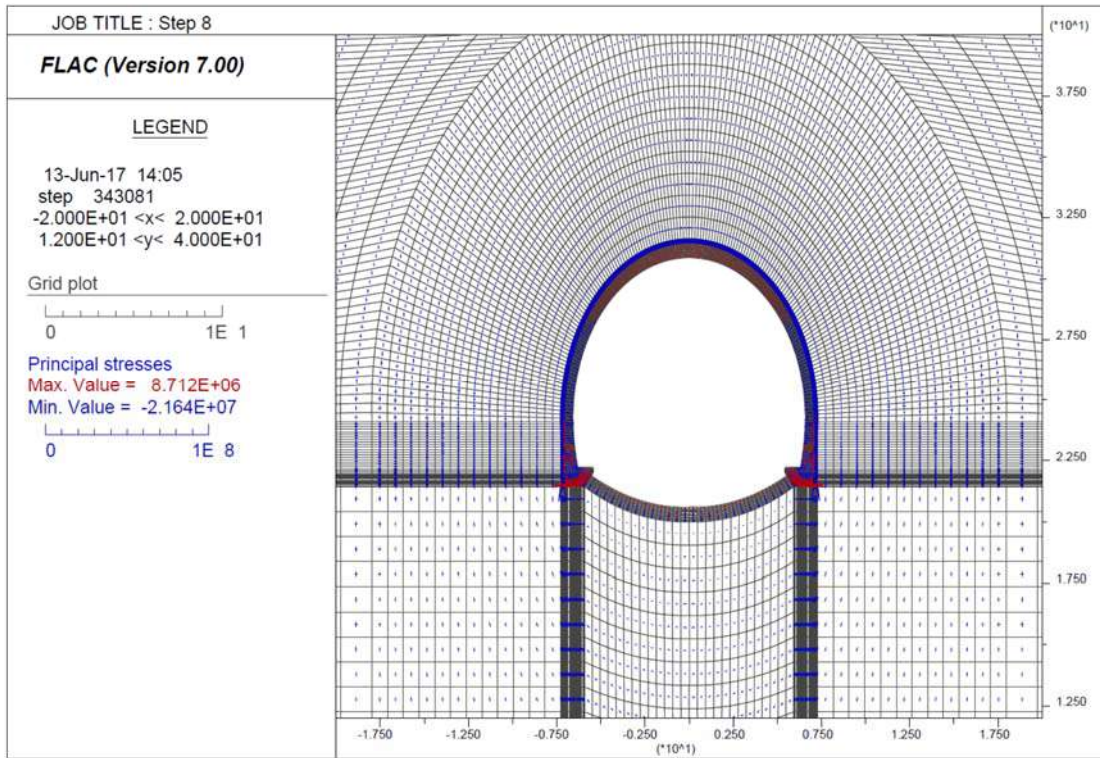



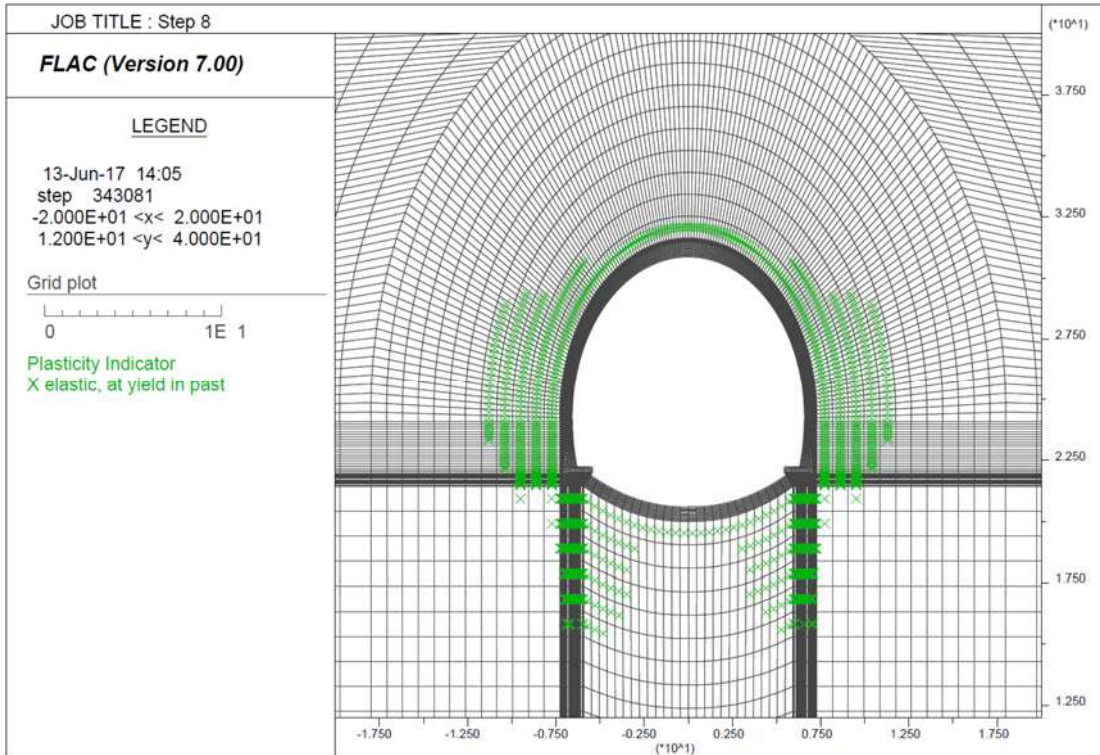
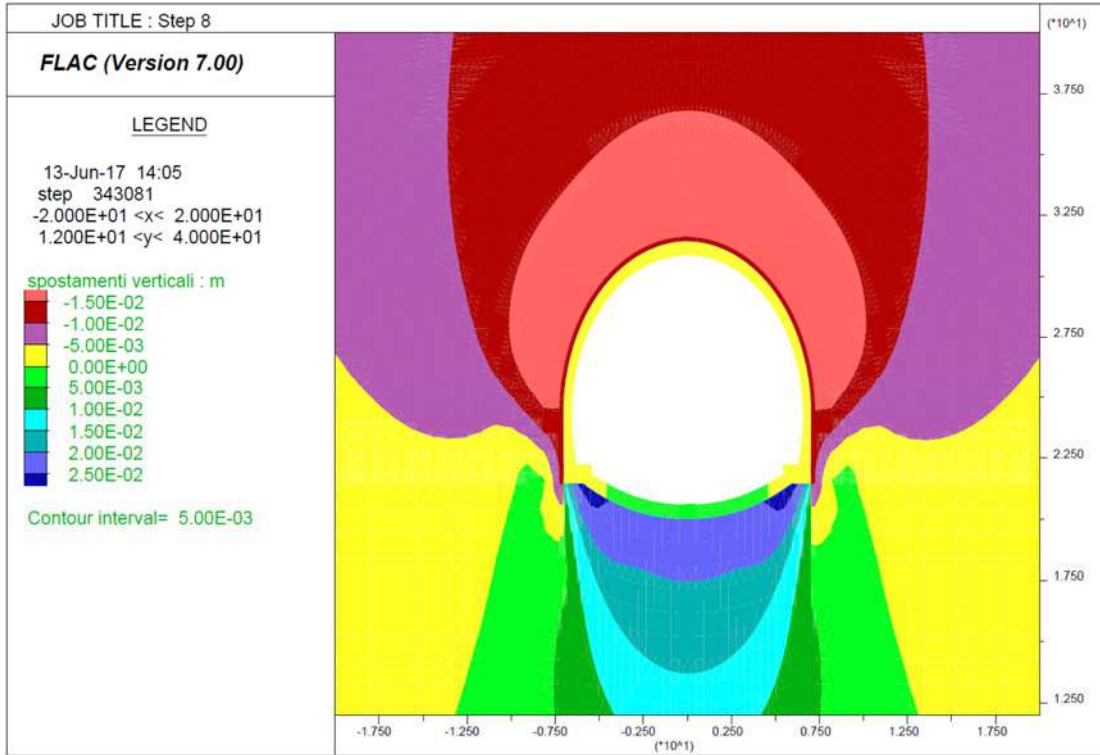



Step 9 - Decadimento dei parametri di resistenza del rivestimento provvisorio

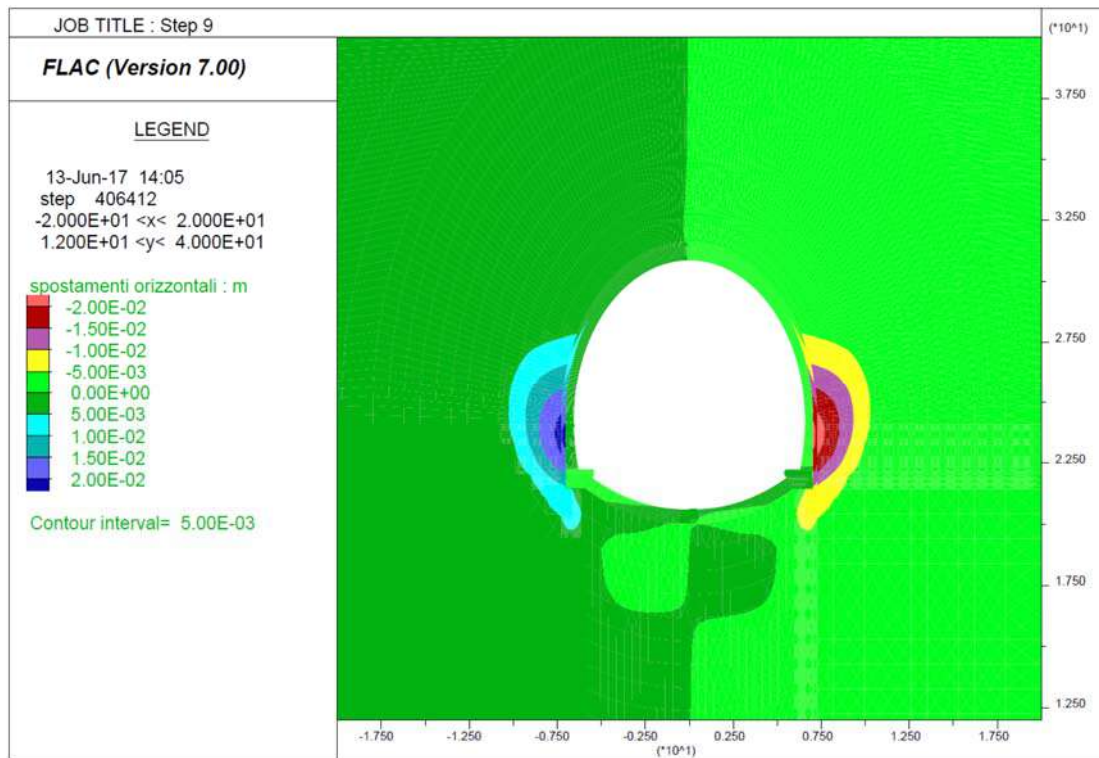
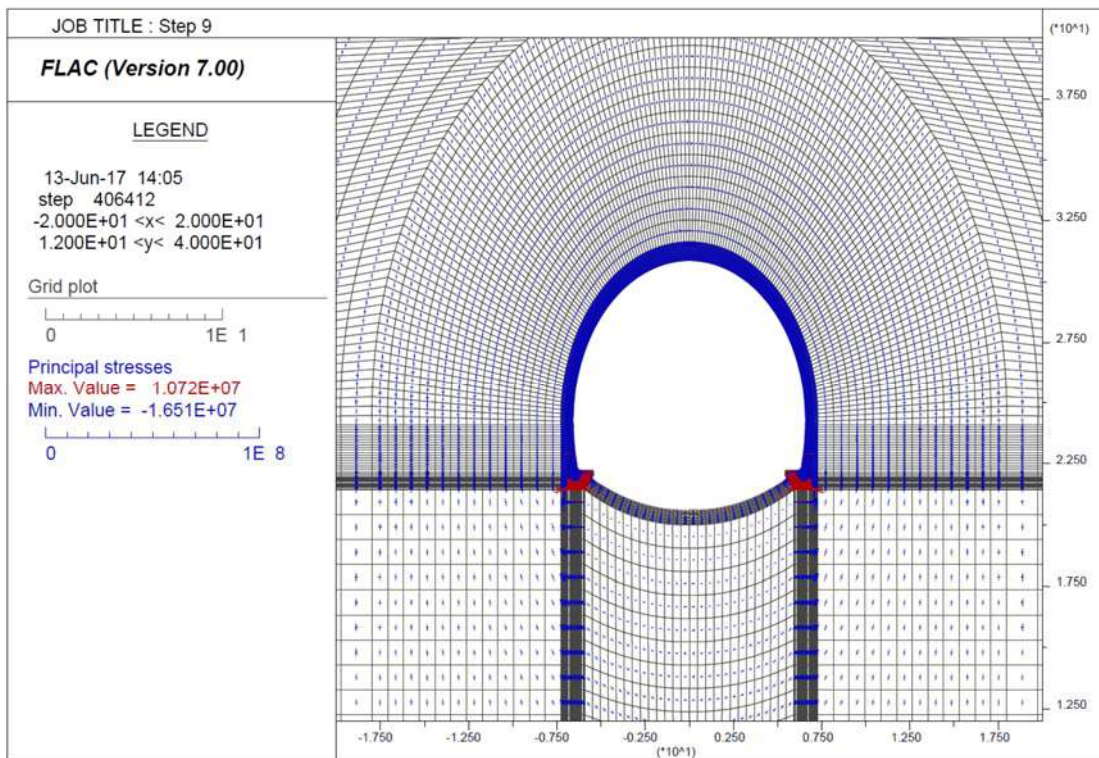

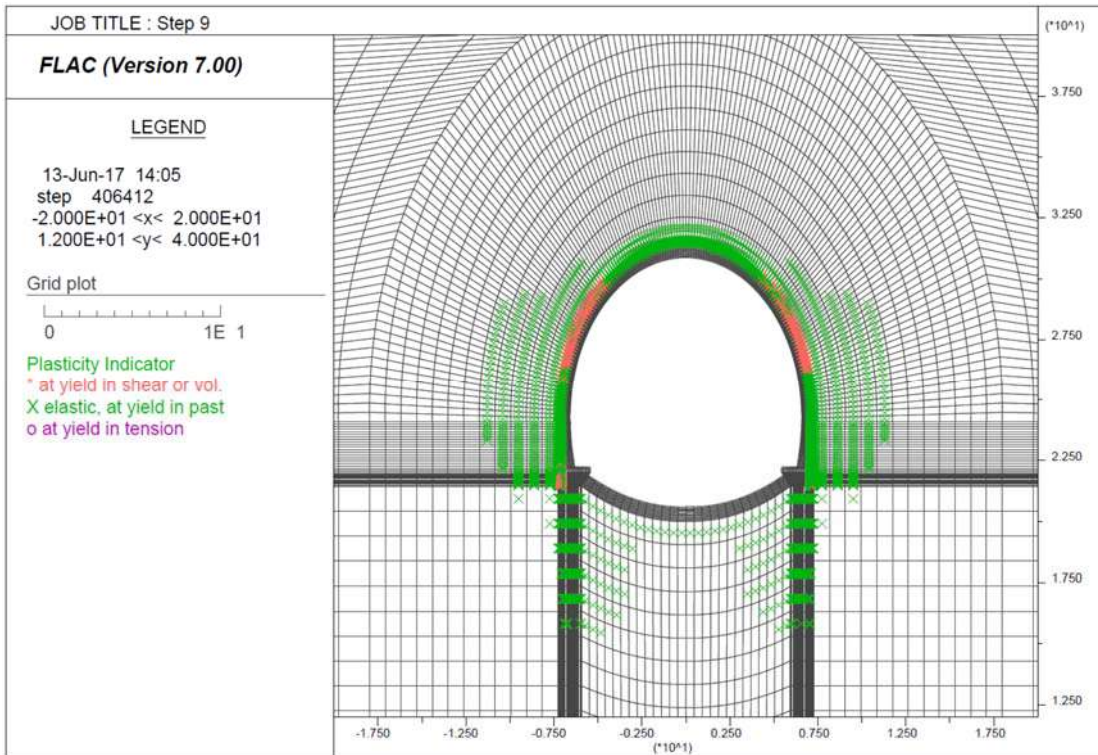
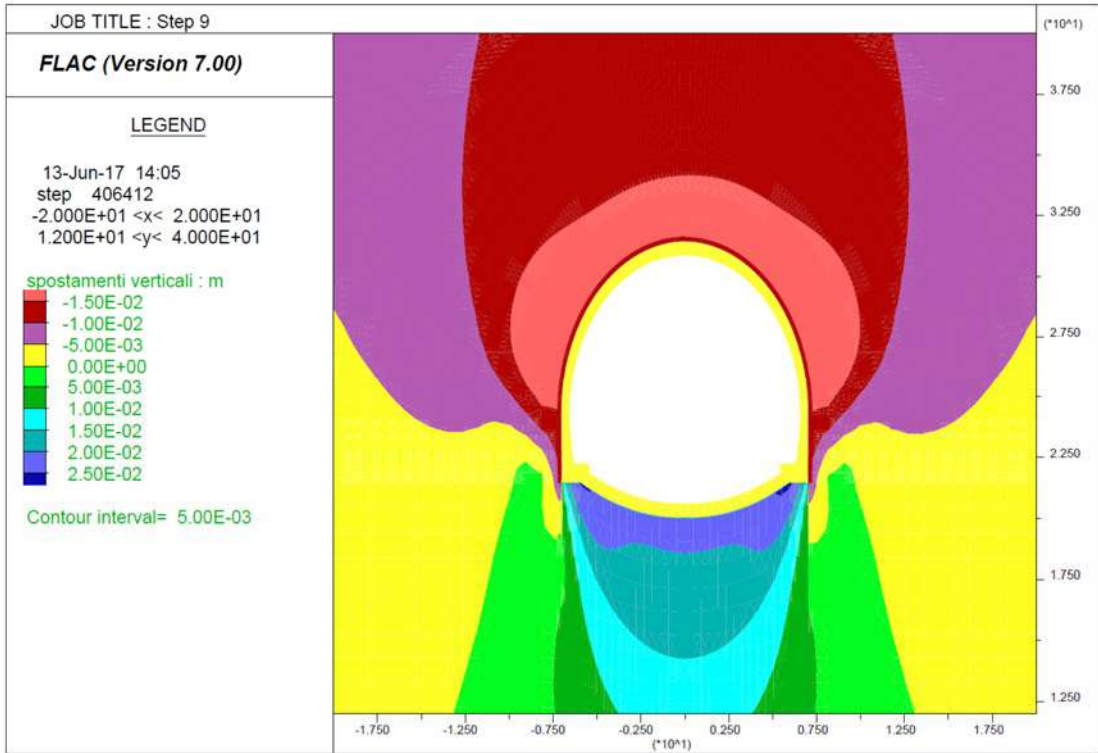

**Output Flac – Sezione tipo B2 – Parametri res max – Copertura di calcolo = 70 m**

**Step 1 – Tensioni litostatiche**

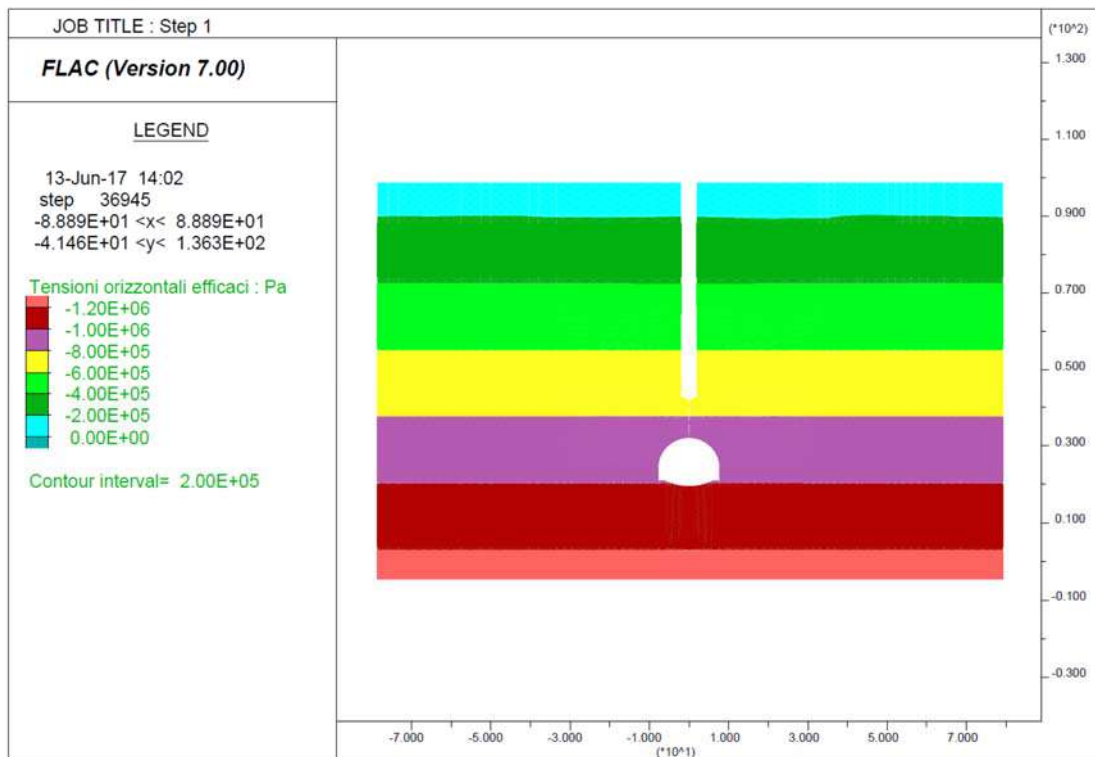
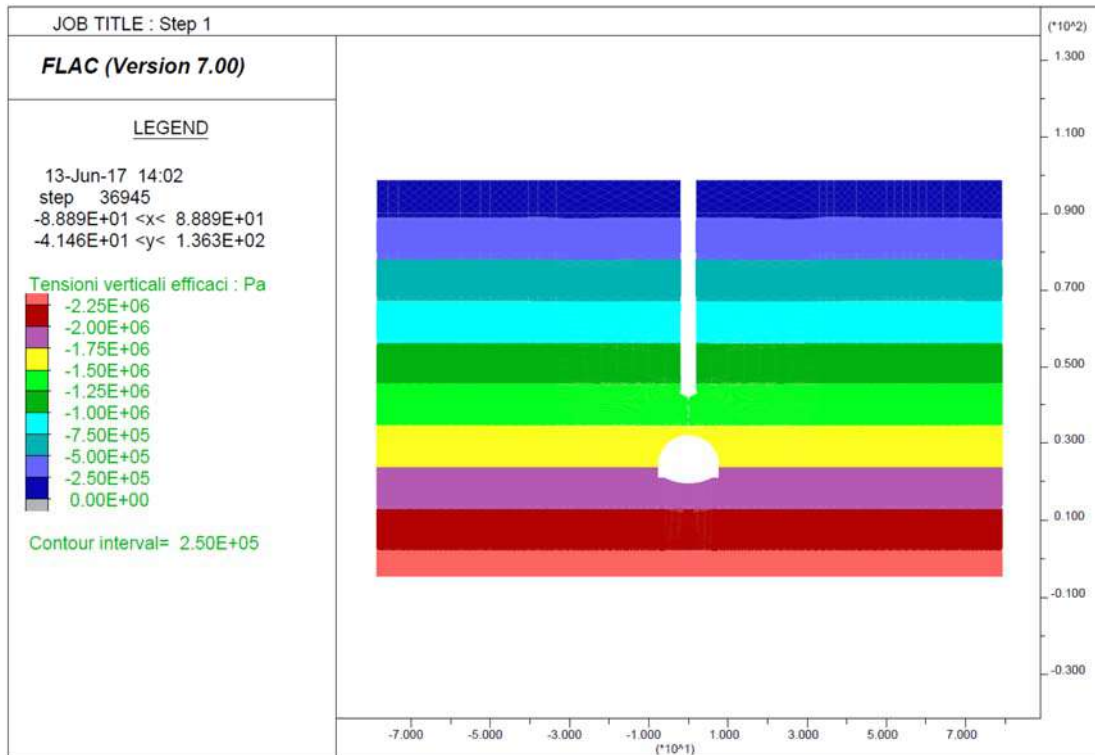



Step 6 – Avanzamento fino a 2D

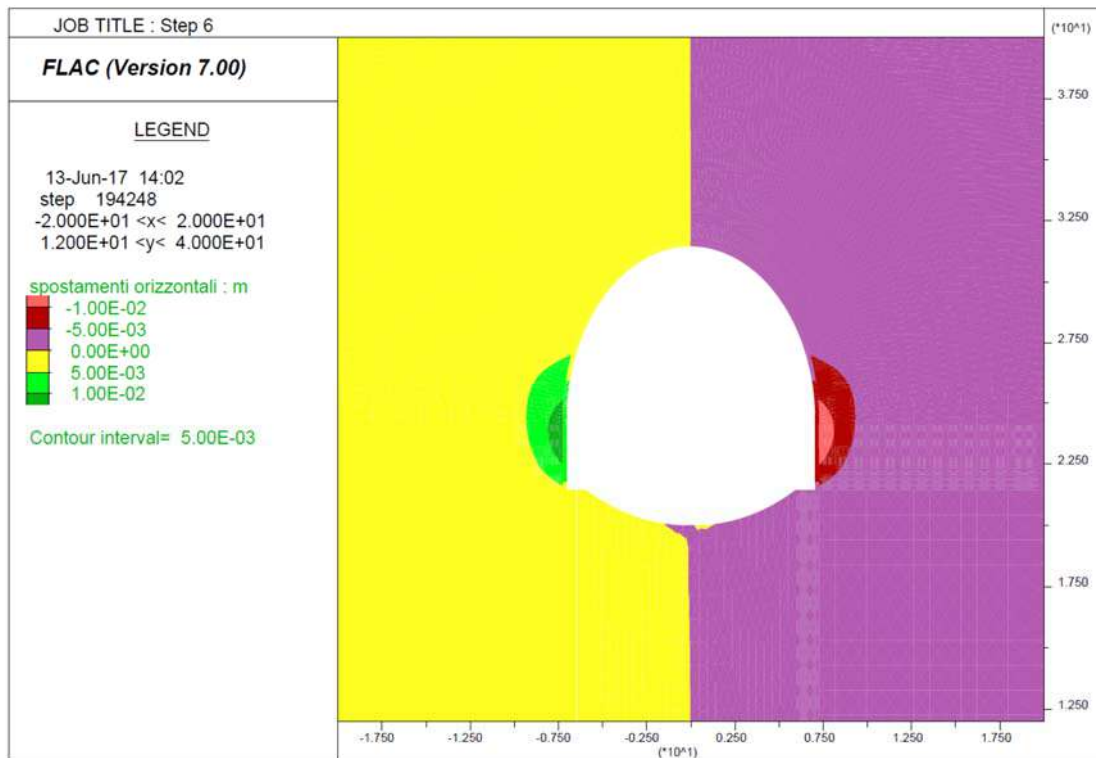
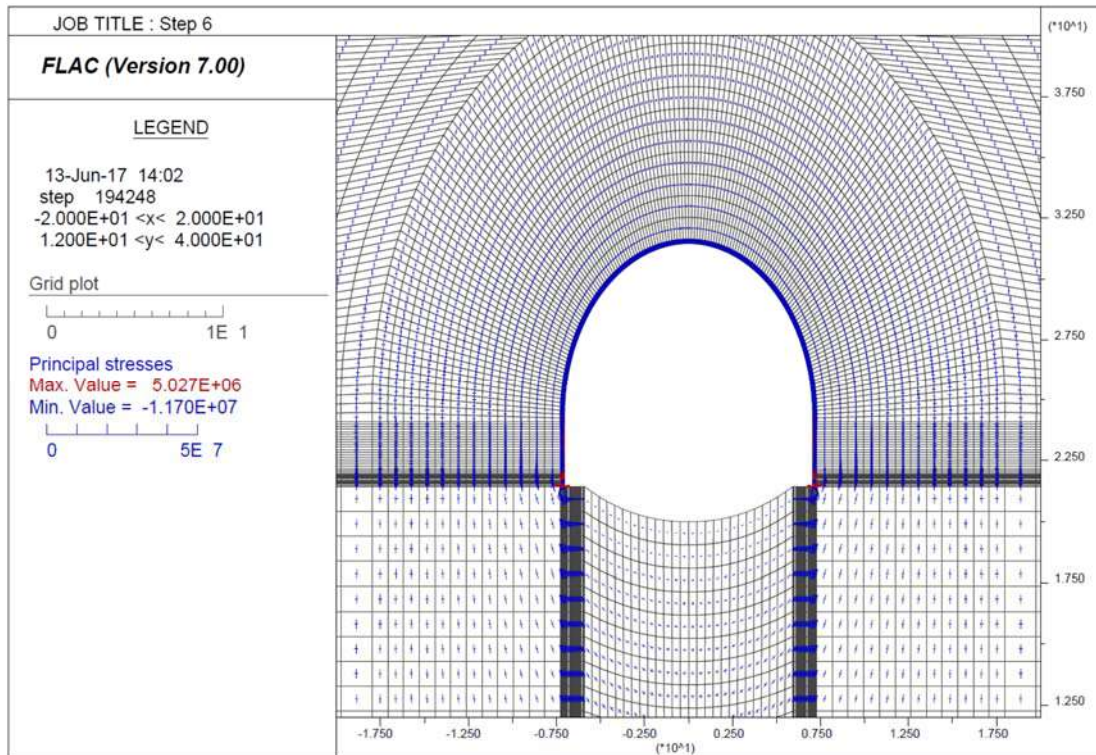

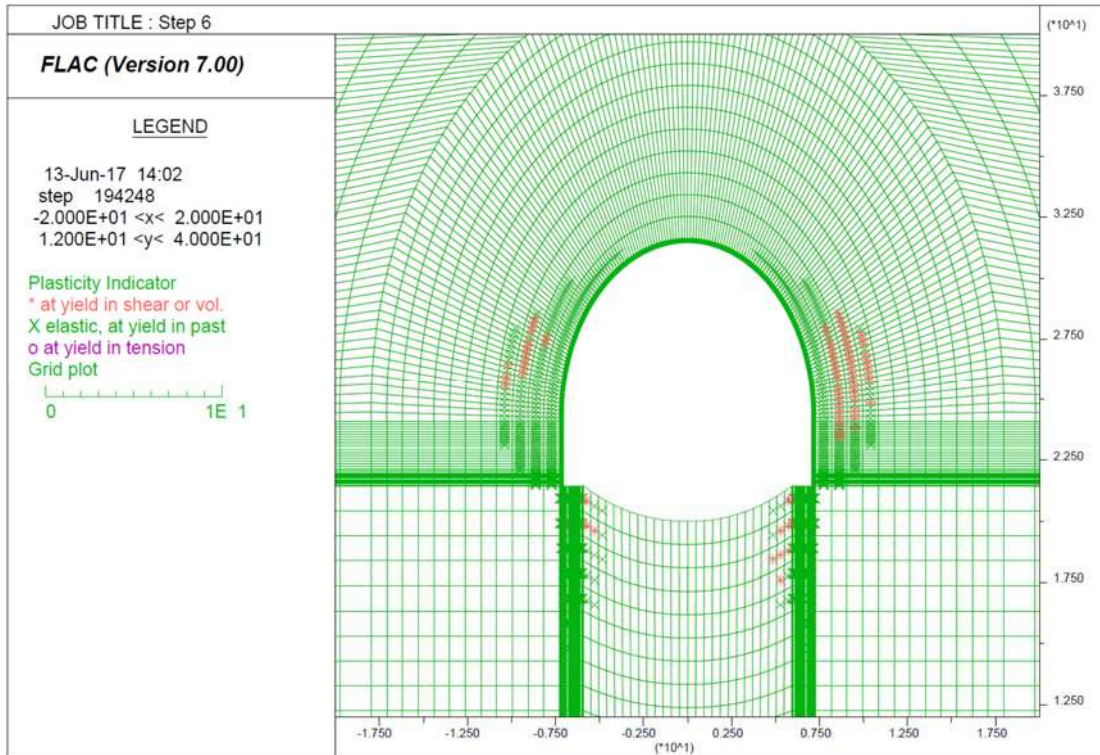
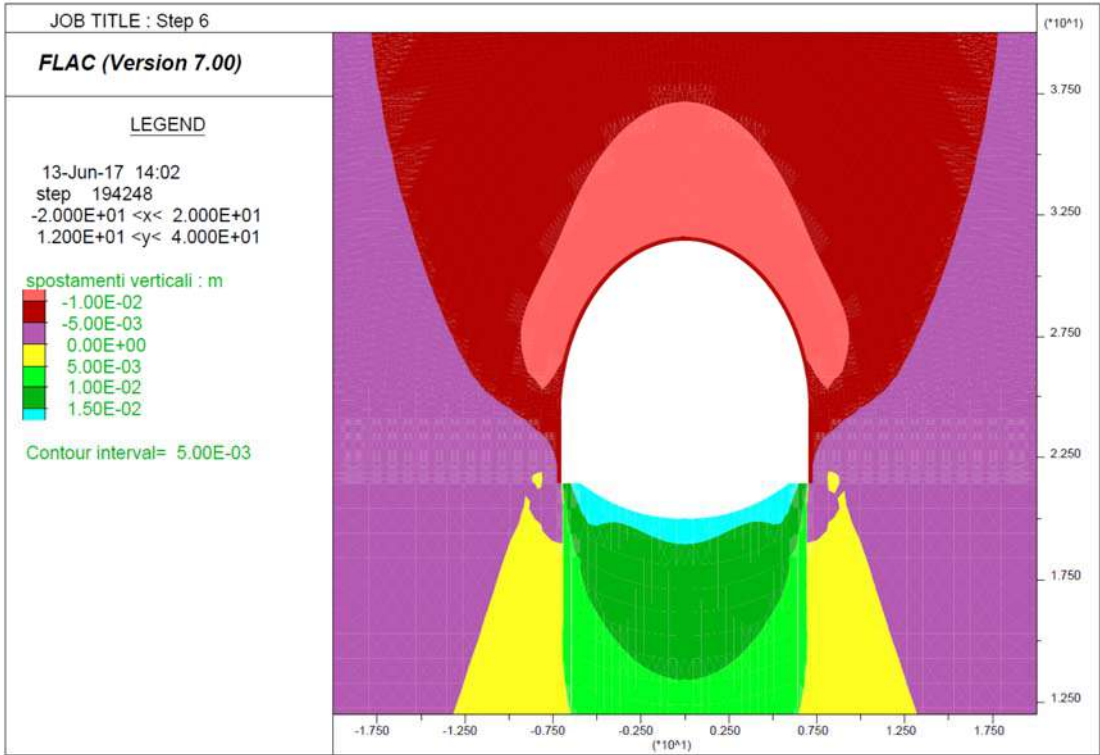



Step 7 - Getto arco rovescio e muretta a 2D e avanzamento fino a deformazioni esaurite

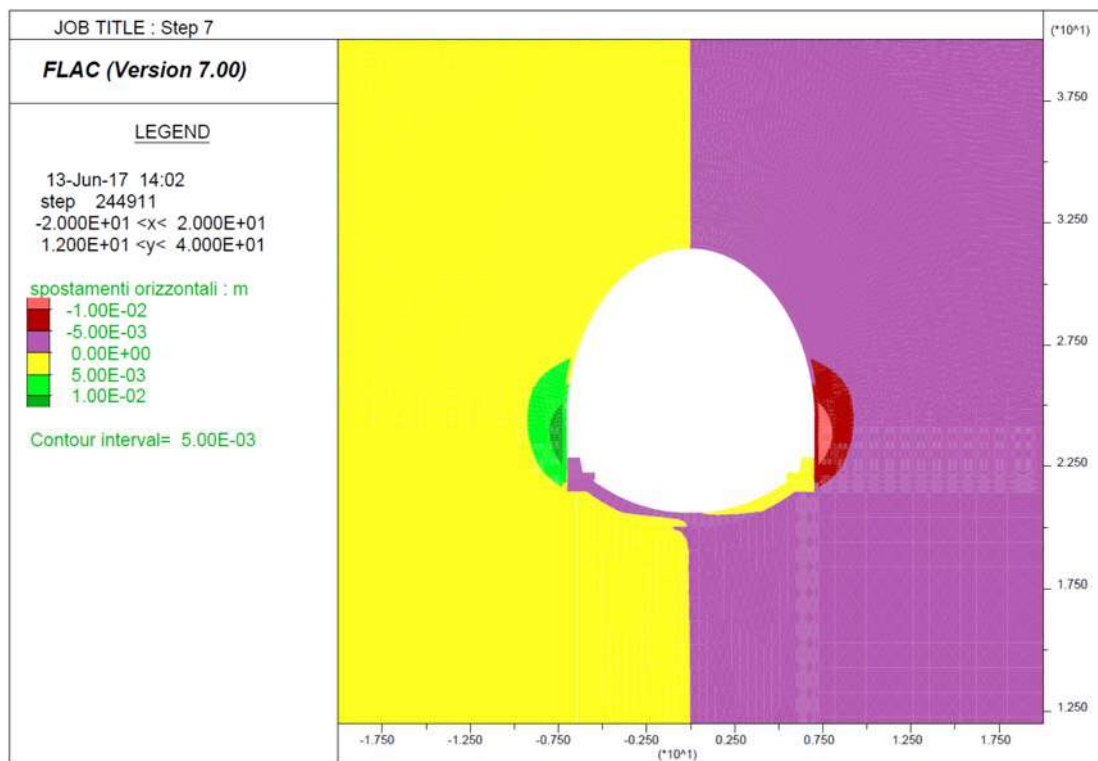
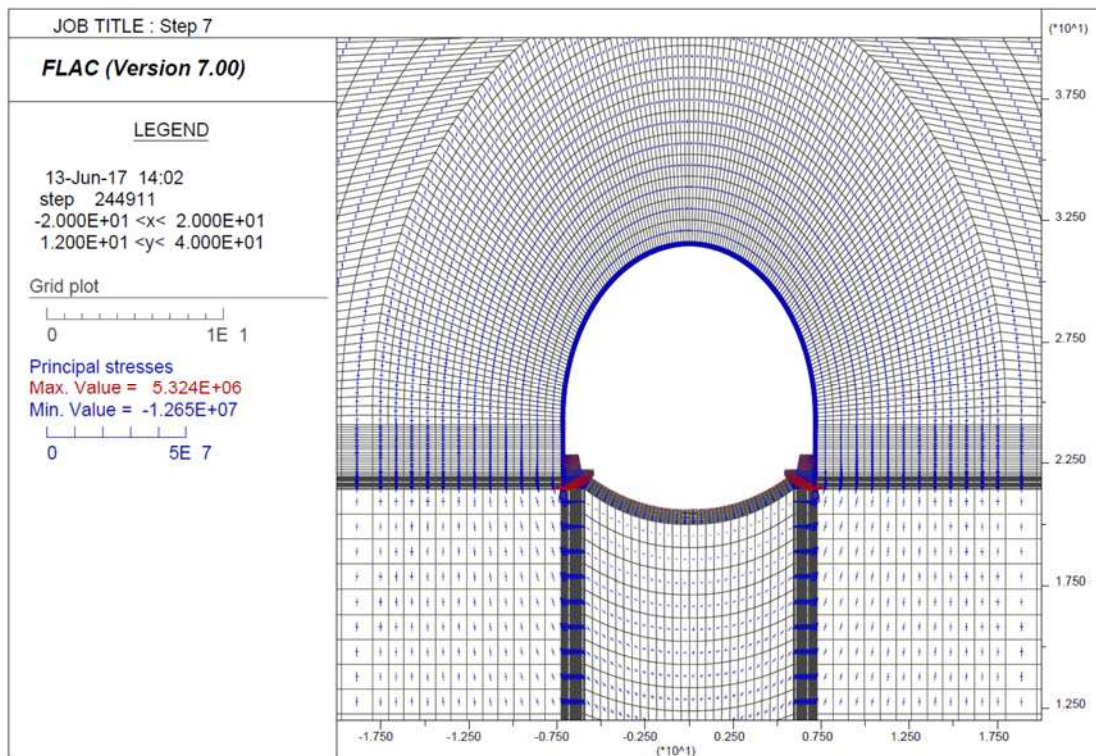

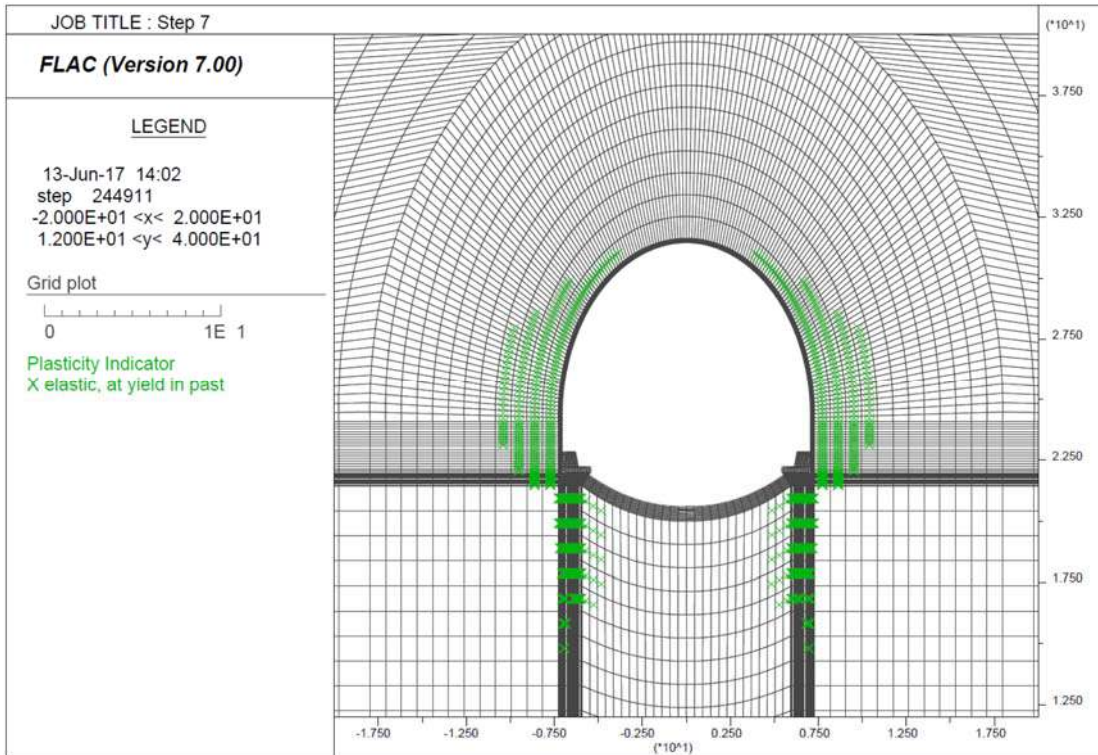
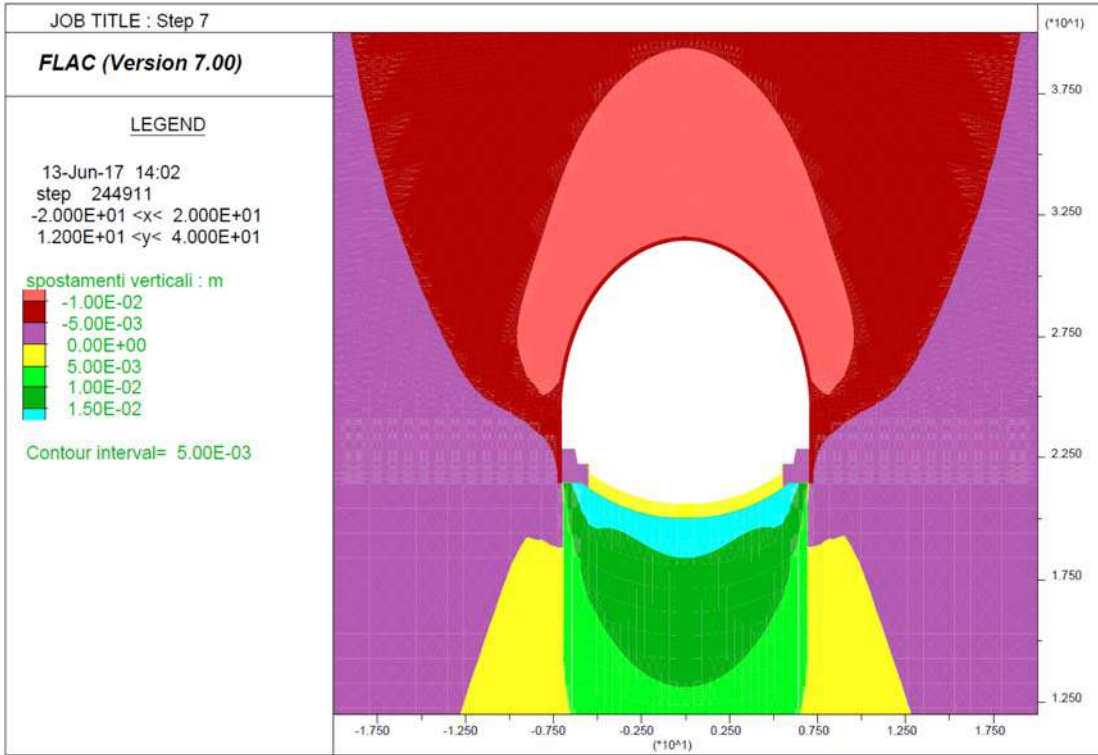



Step 8 - Getto Calotta

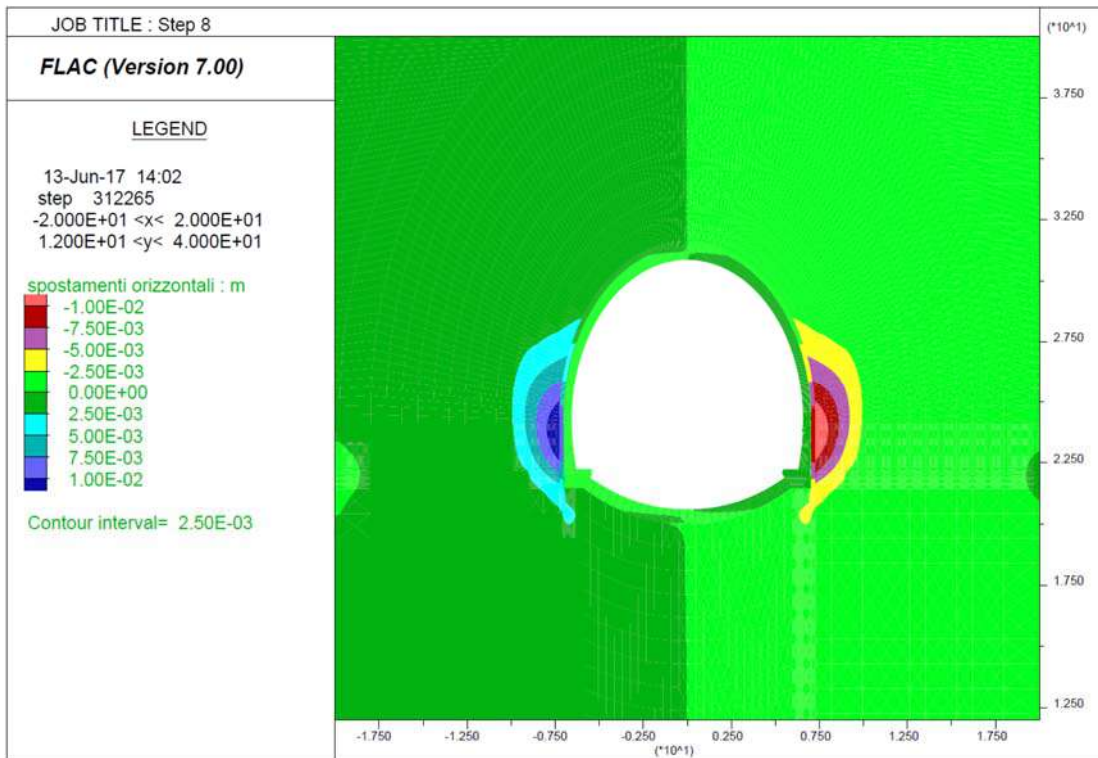
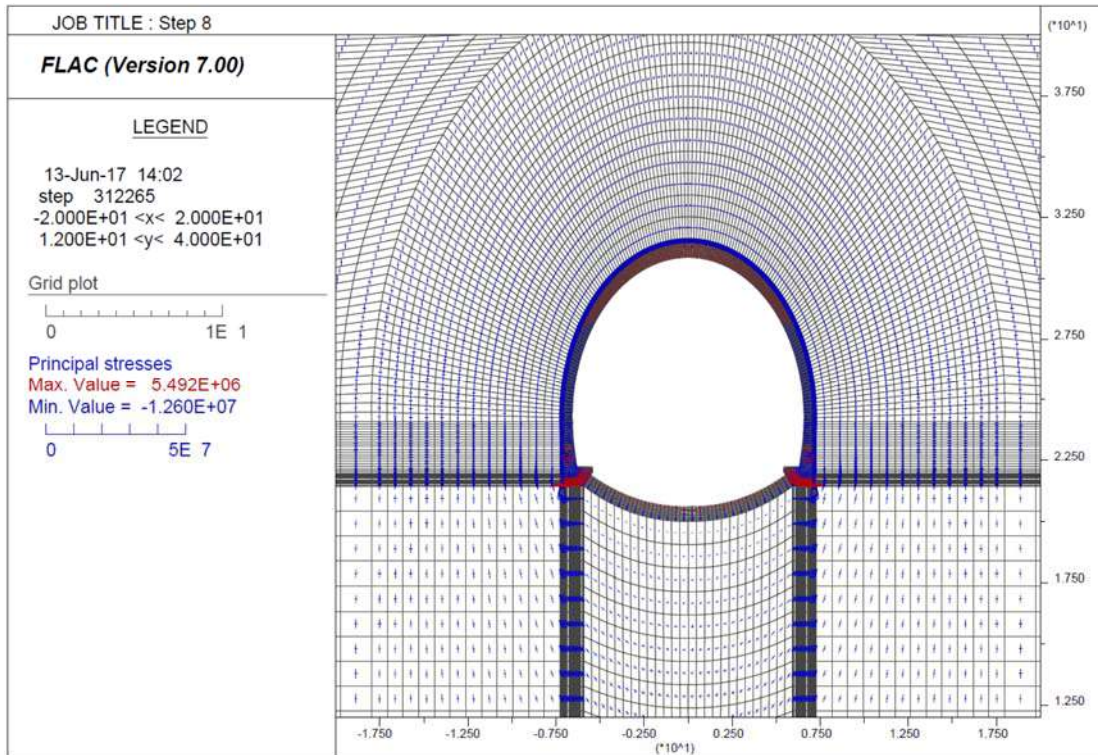

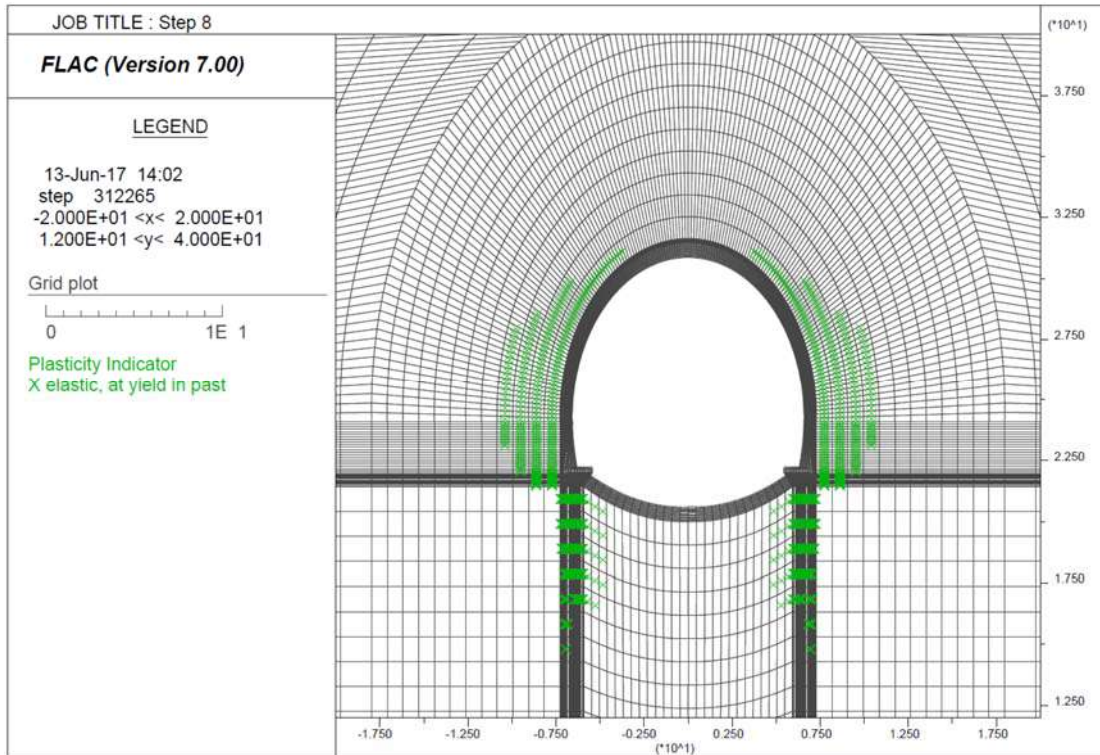
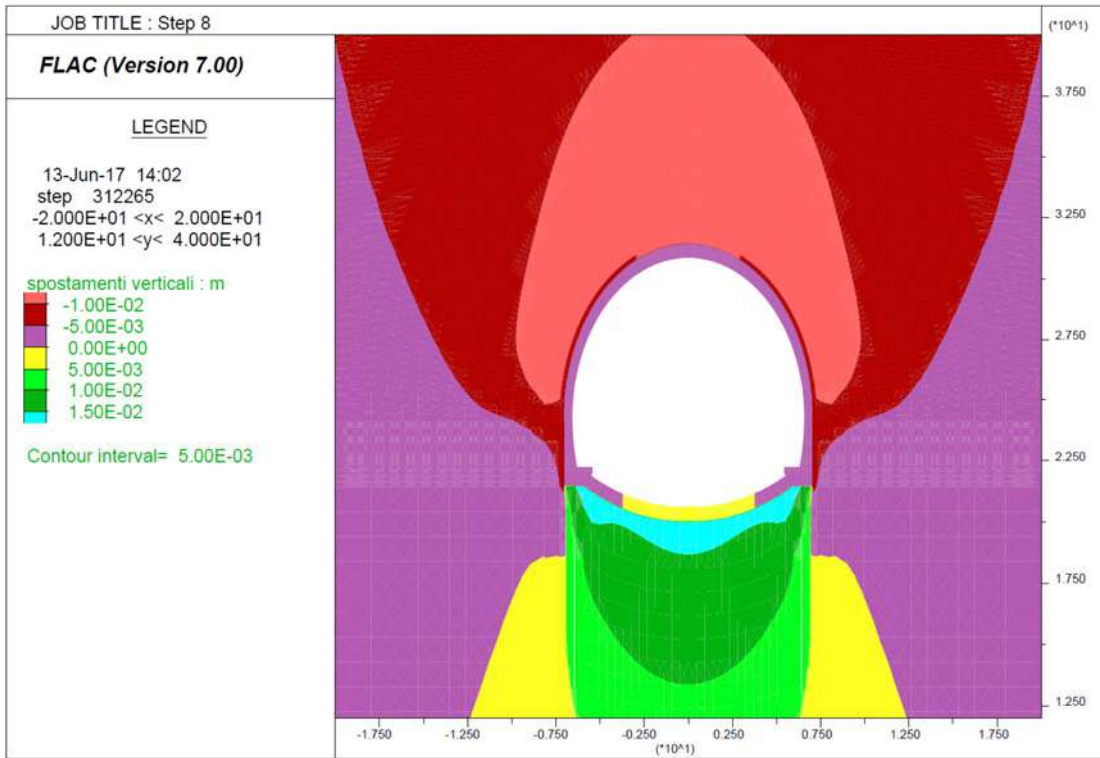



Step 9 - Decadimento dei parametri di resistenza del rivestimento provvisorio

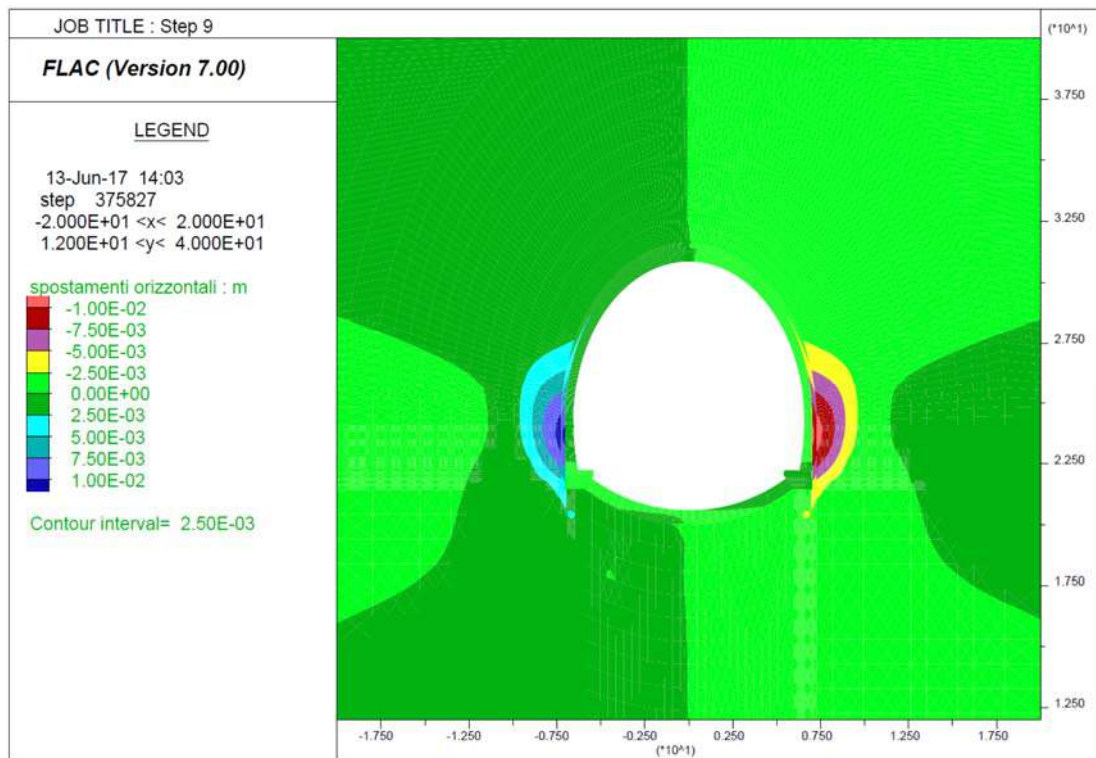
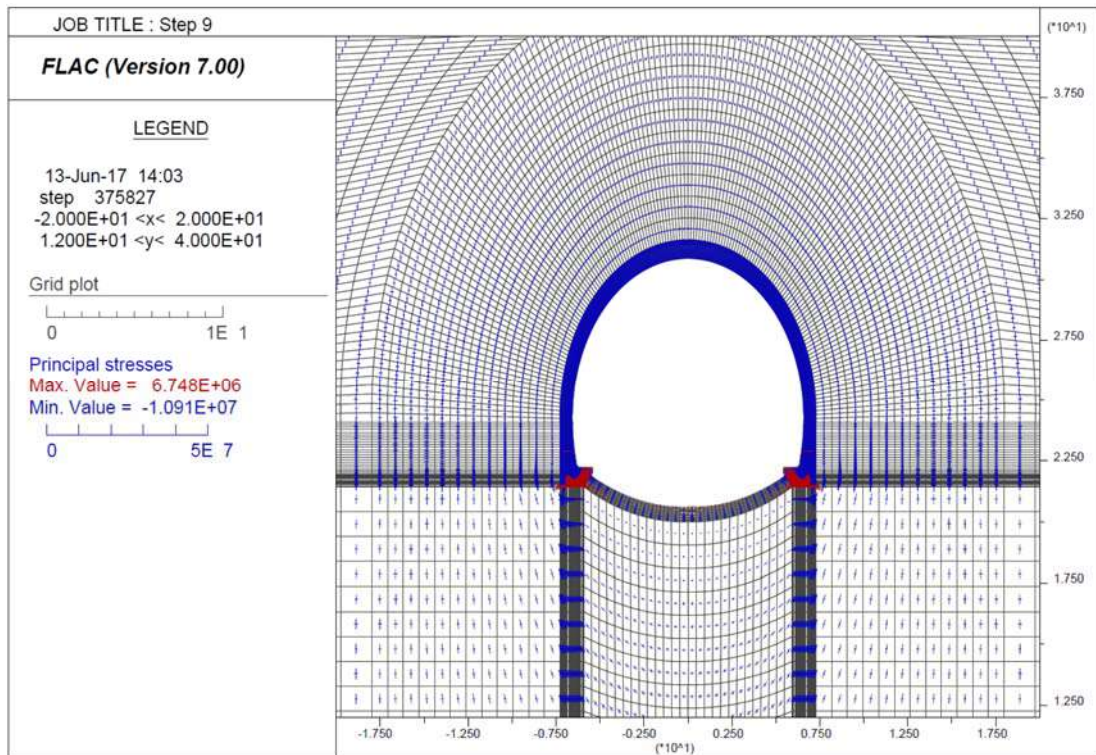



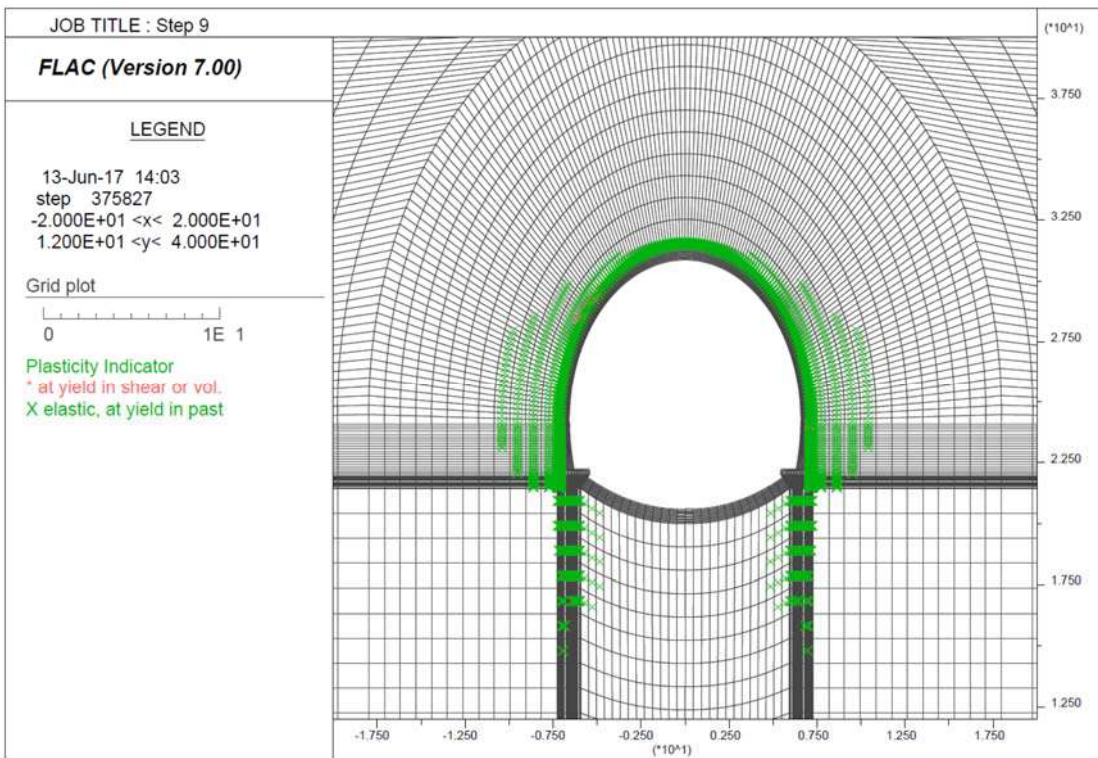
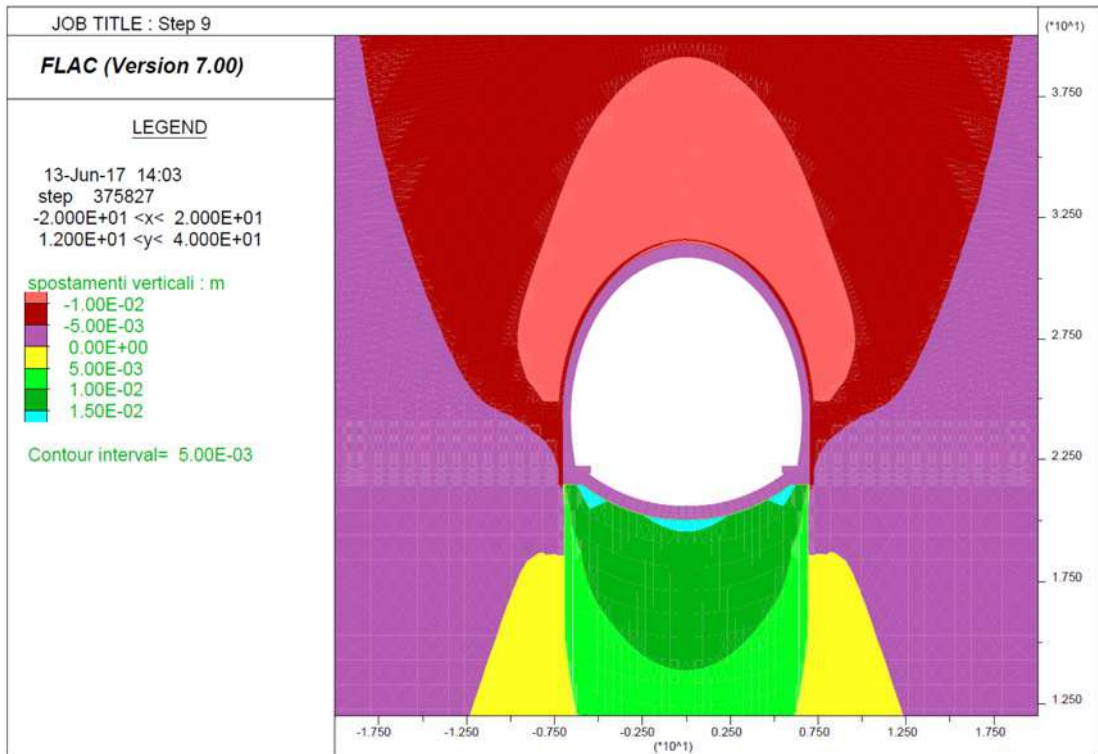

**Output Flac – Sezione tipo B0 – Parametri res min – Copertura di calcolo = 70 m**

**Step 1 – Tensioni litostatiche**

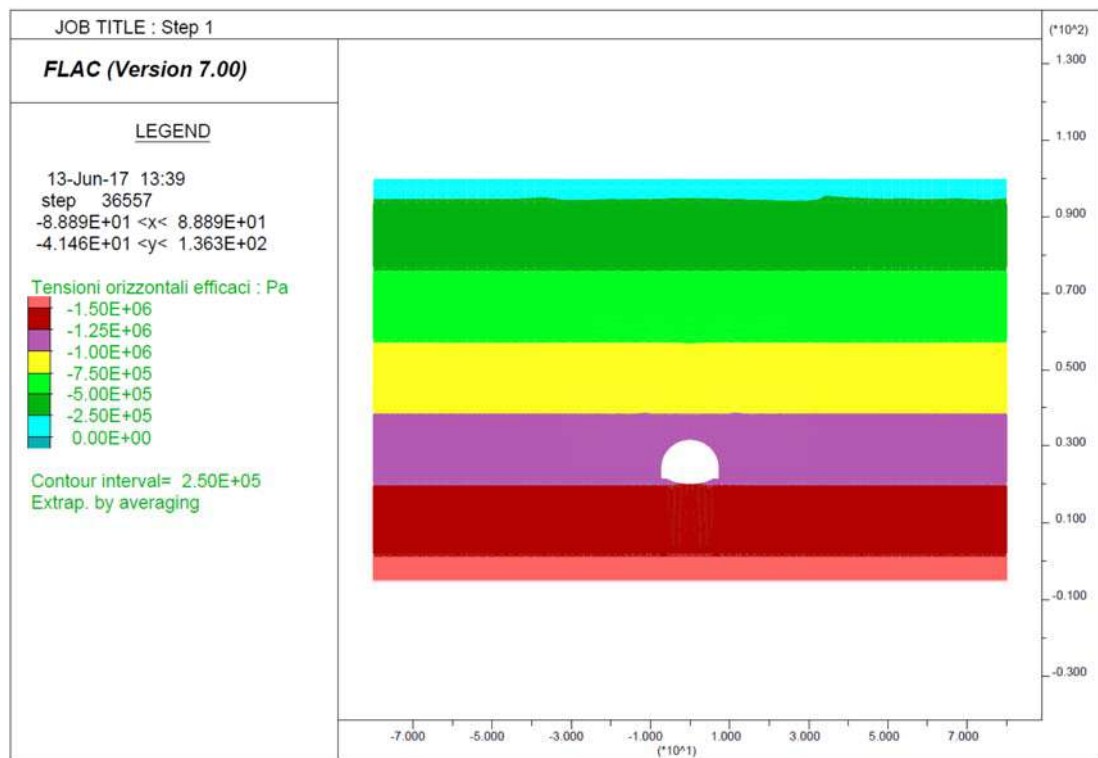
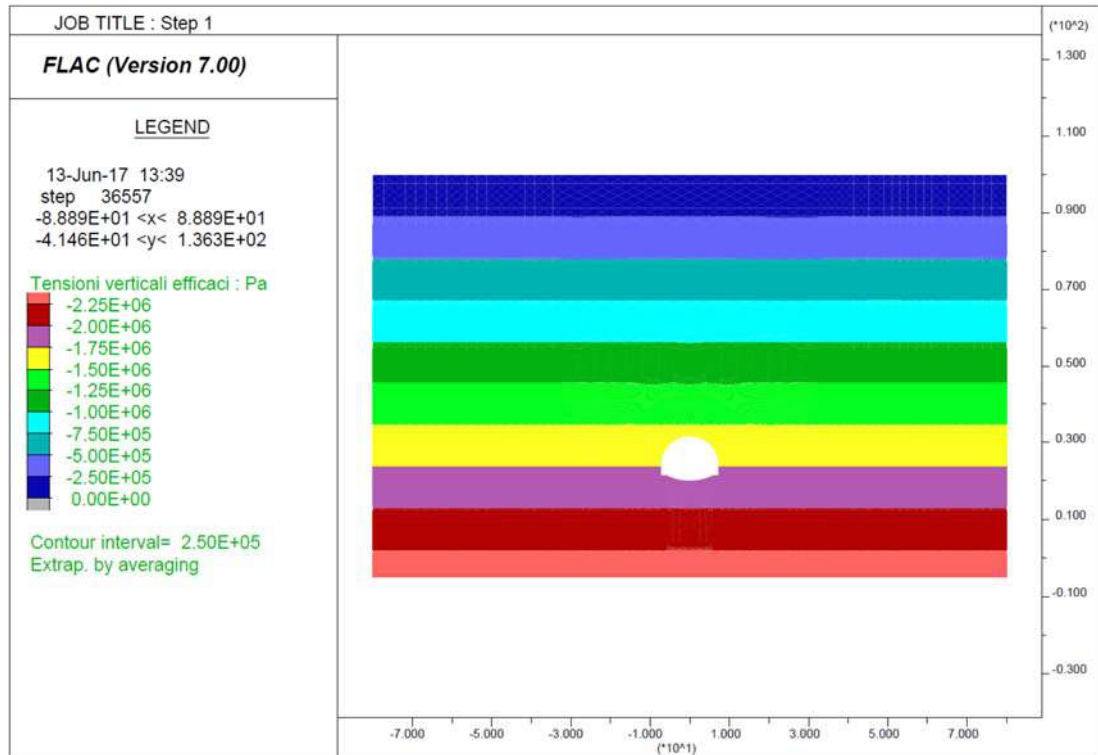

Step 6 – Avanzamento fino a deformazioni esaurite

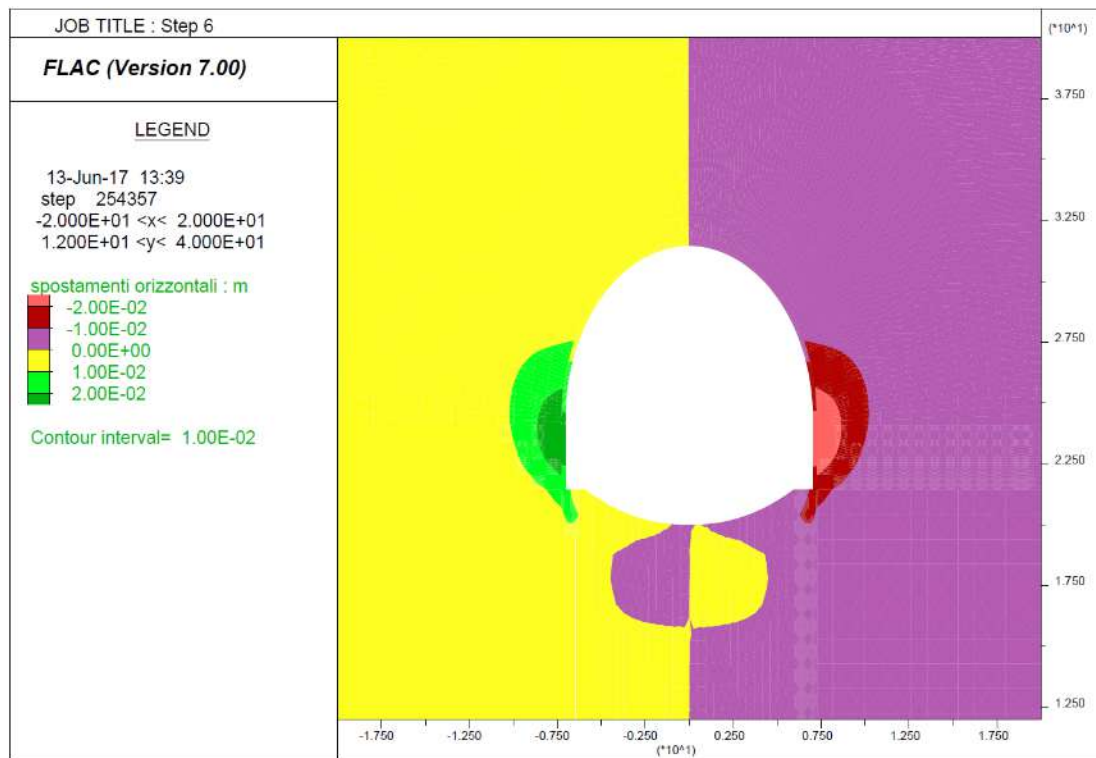
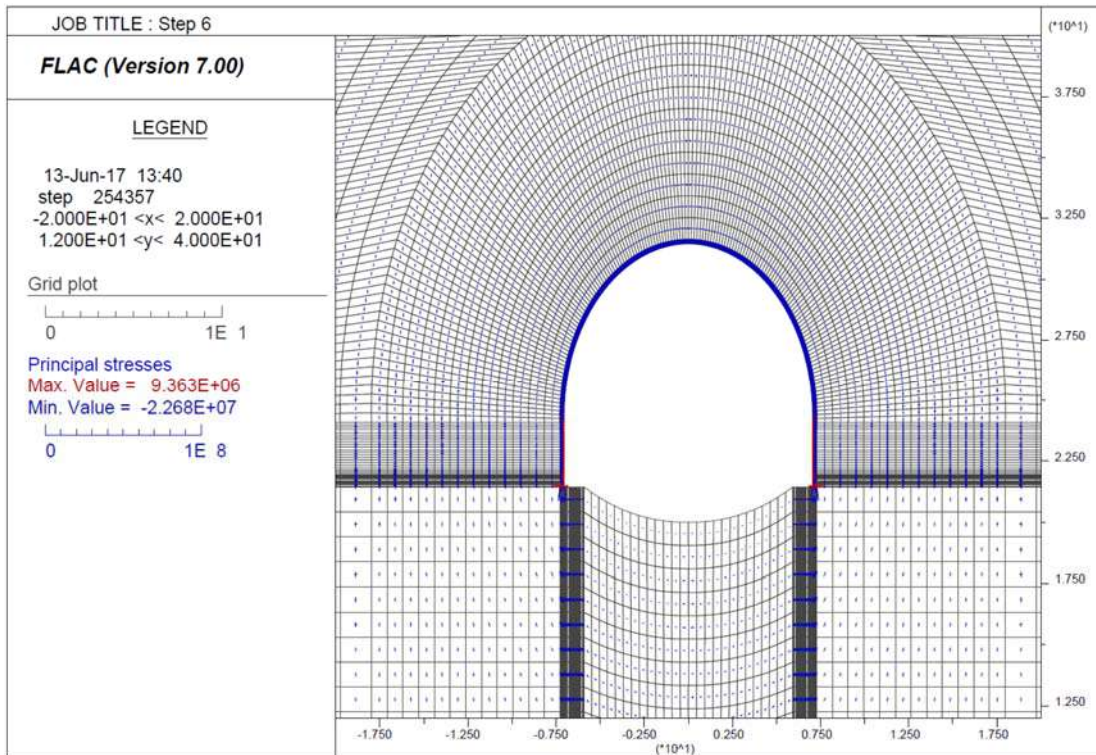



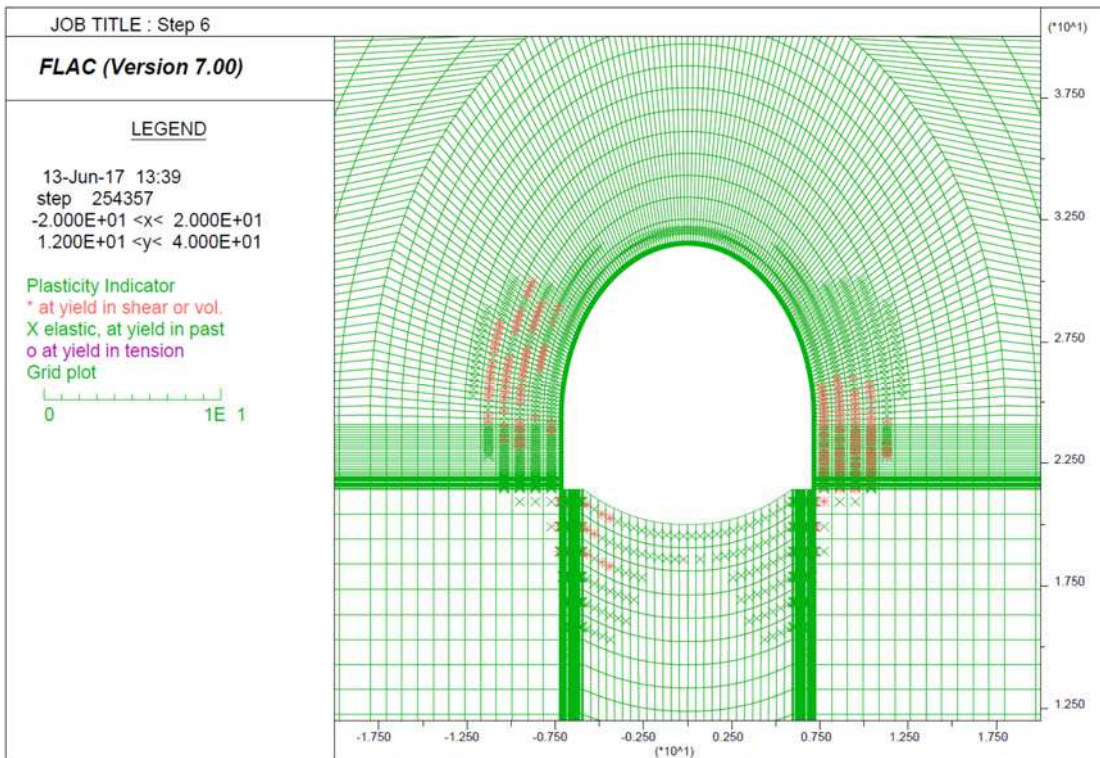
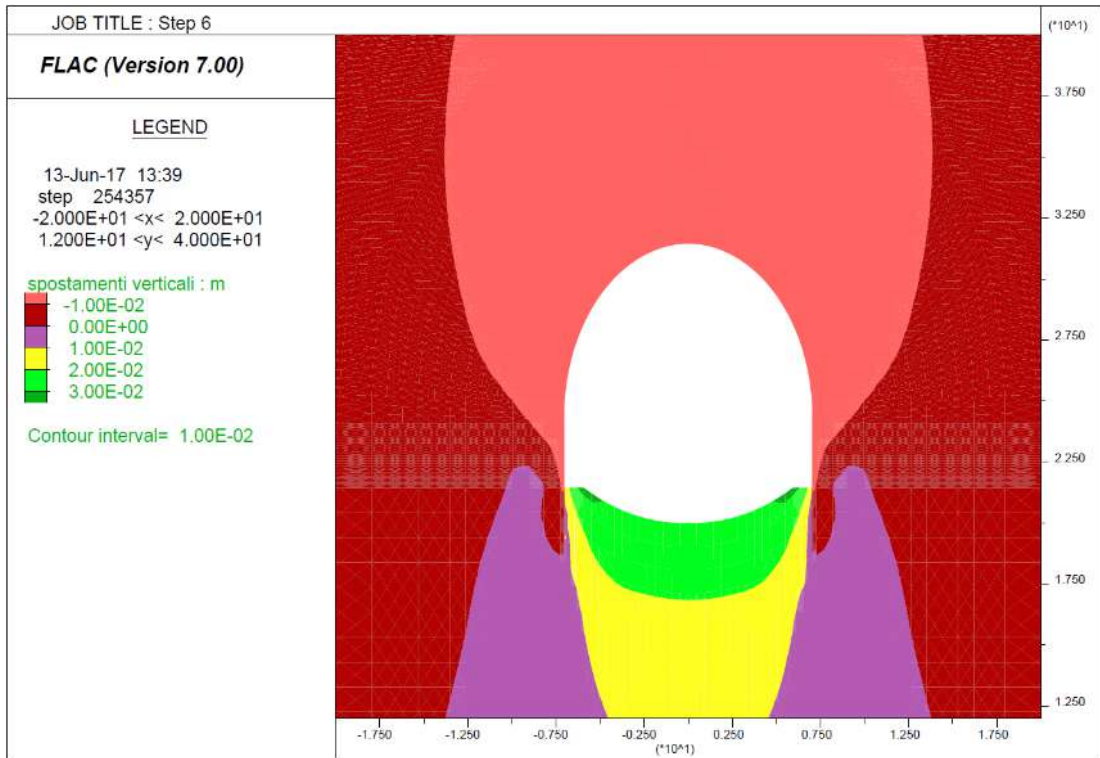

Step 7 - Getto arco rovescio e muretta

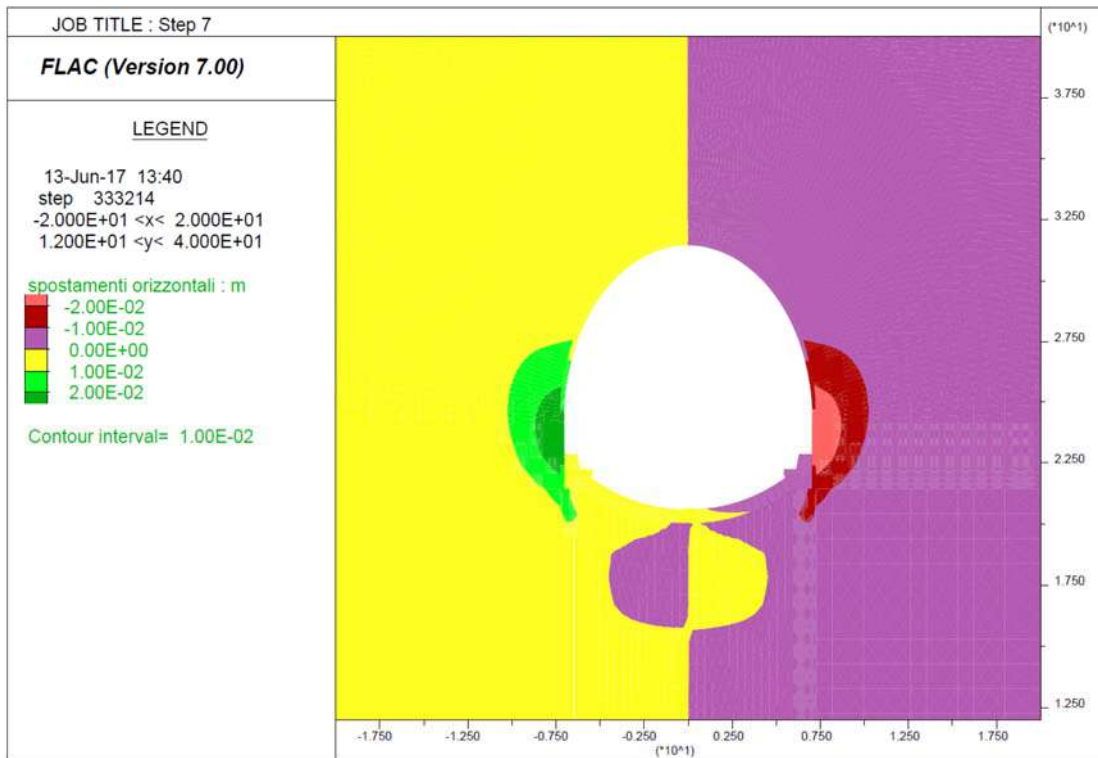
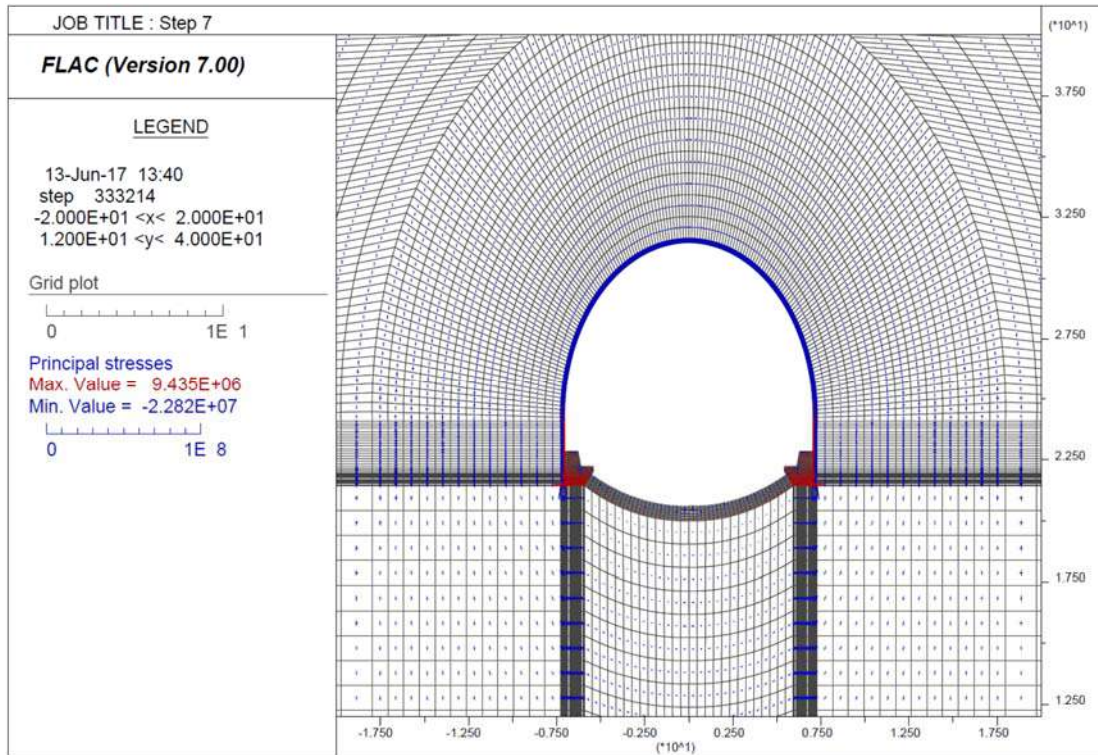



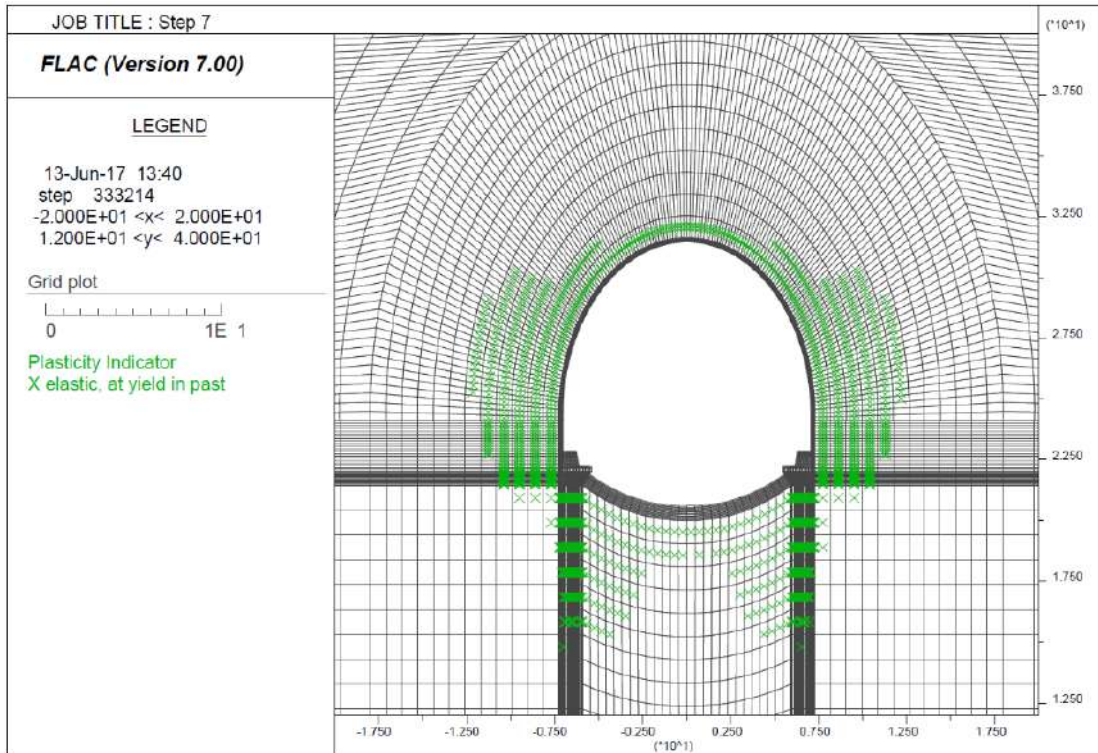
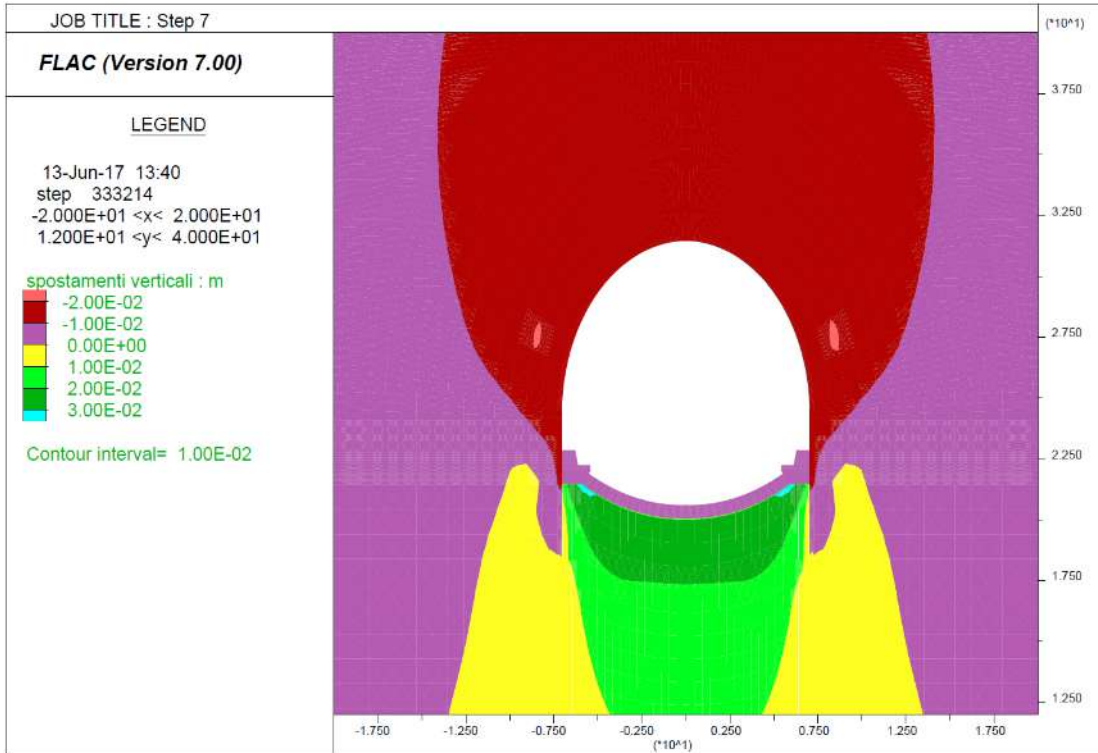

Step 8 - Getto Calotta

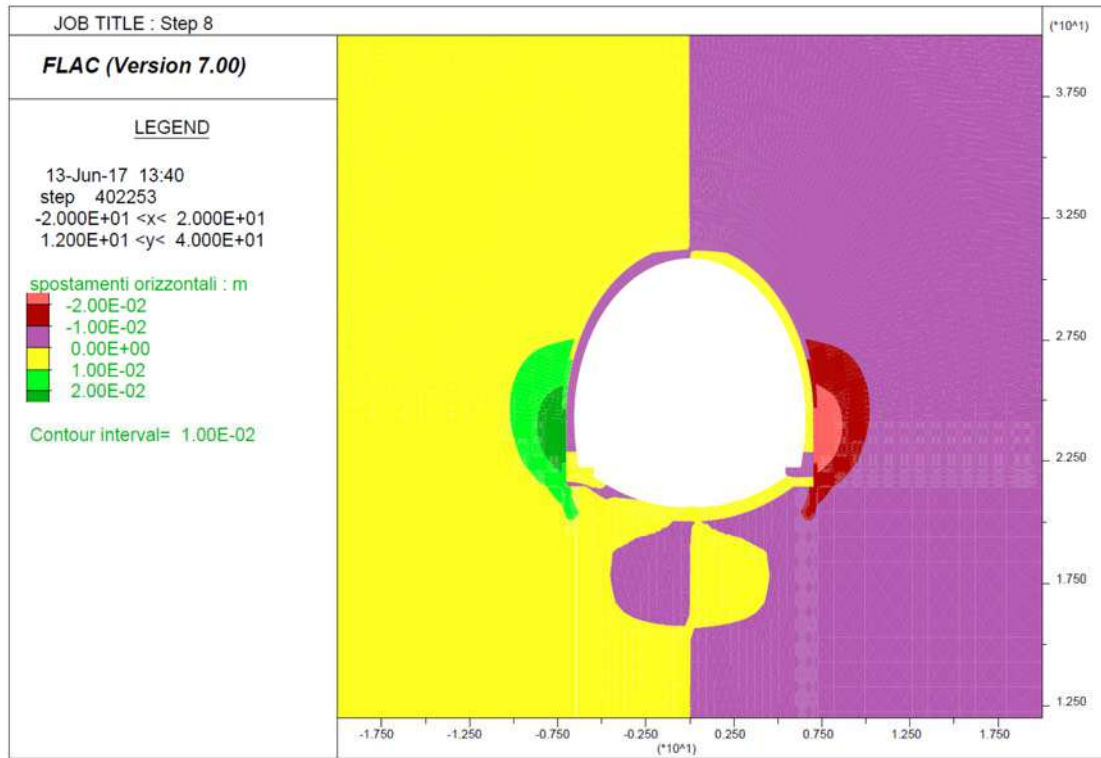
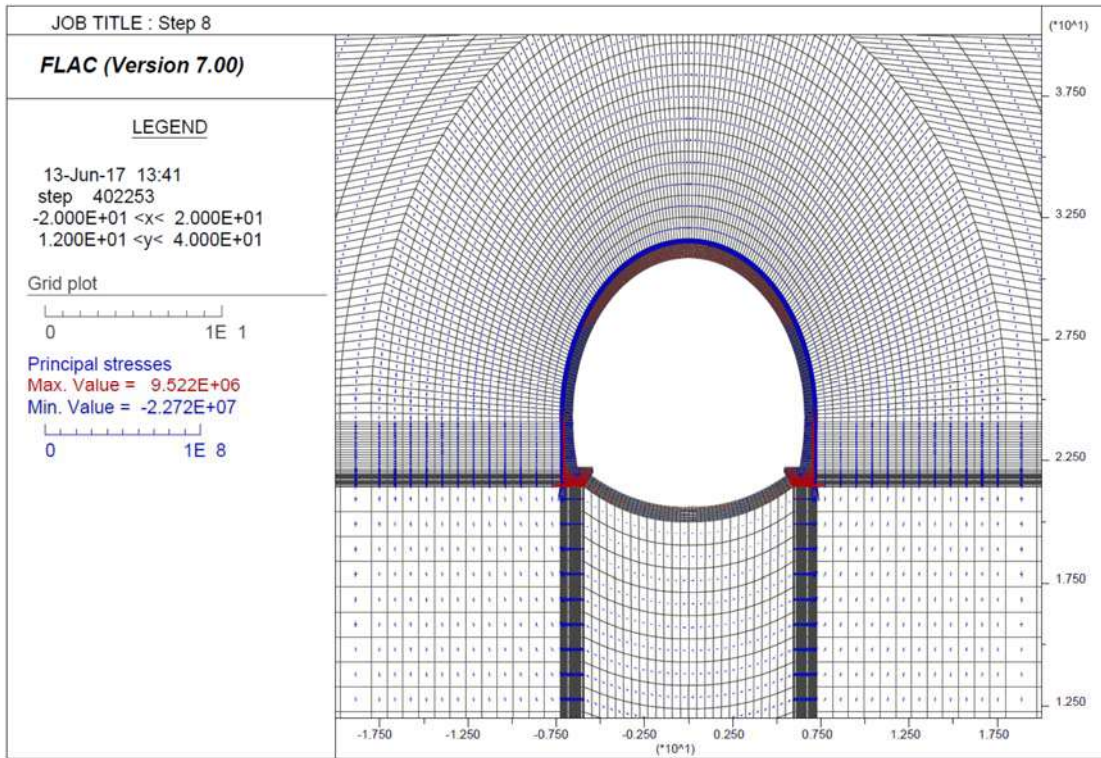

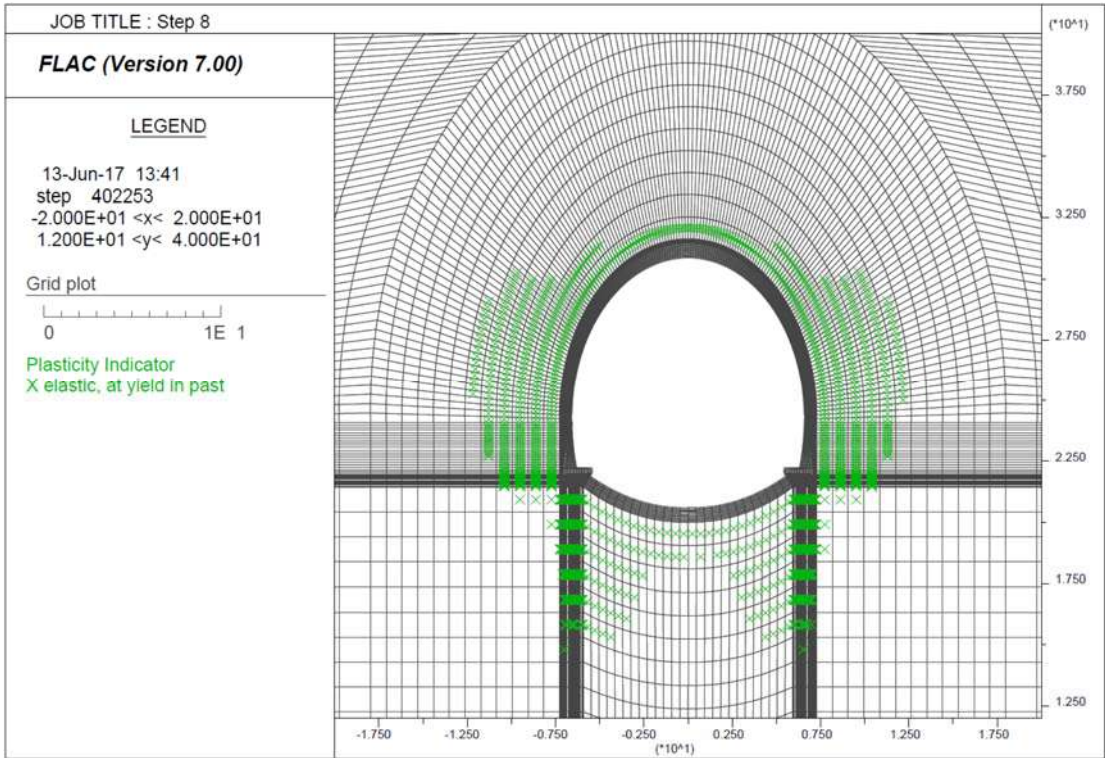
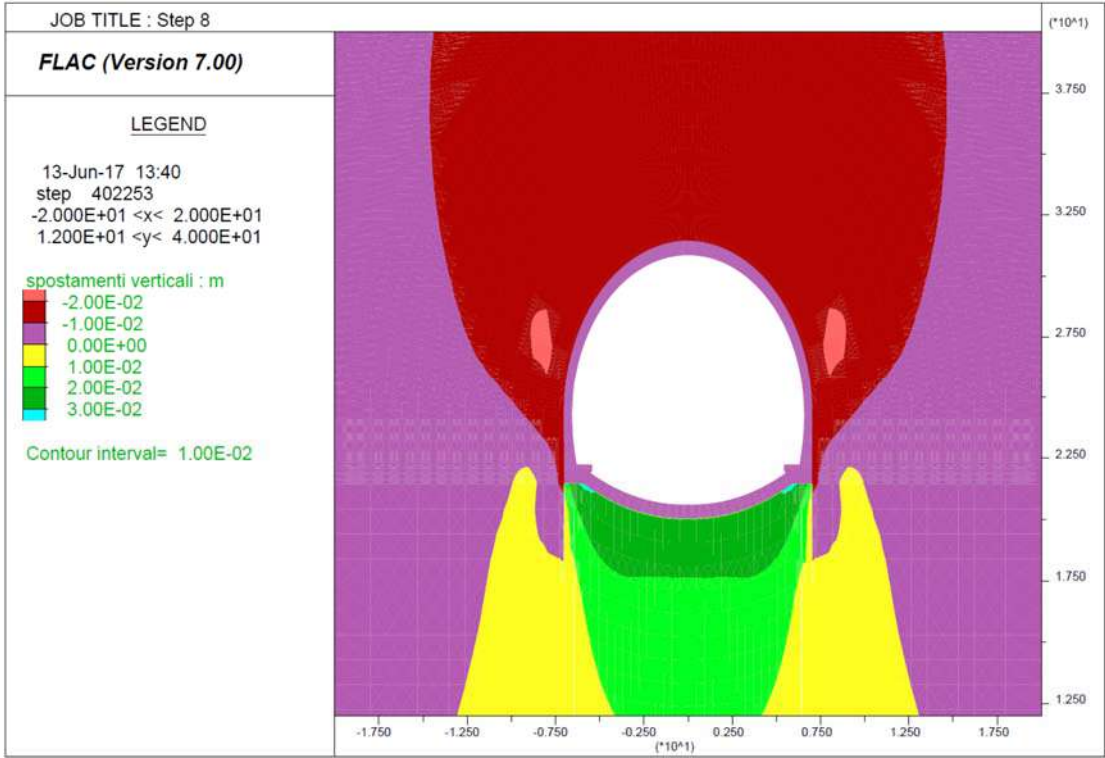



Step 9 - Decadimento dei parametri di resistenza del rivestimento provvisorio

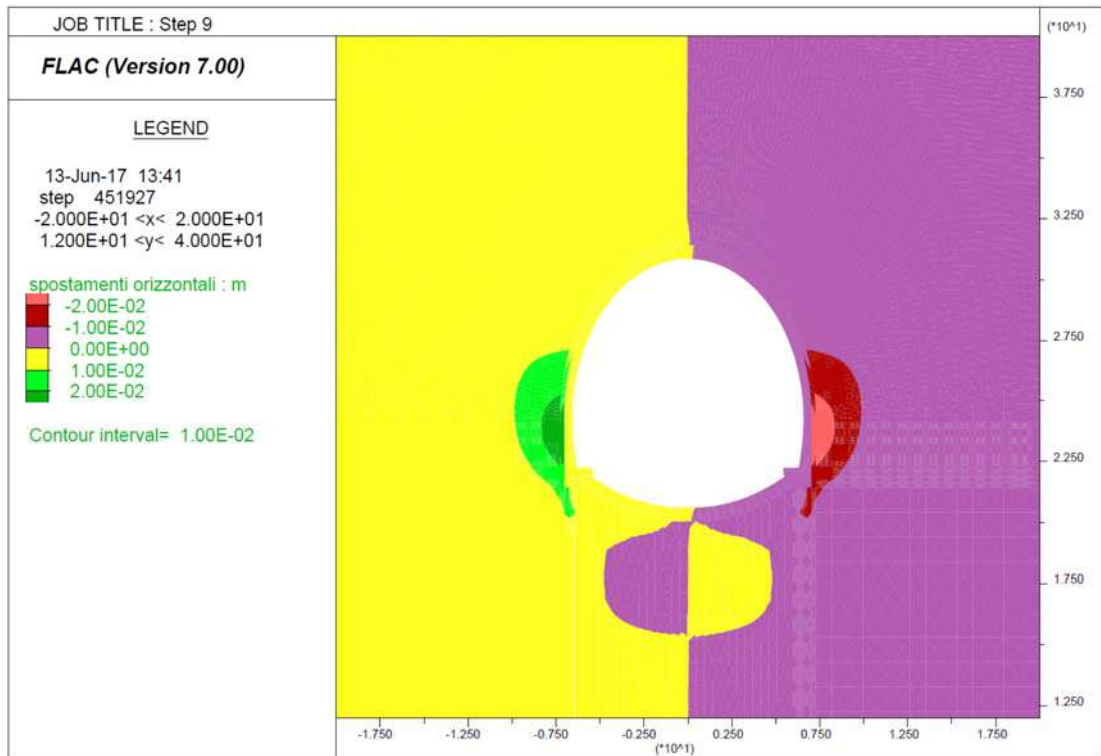
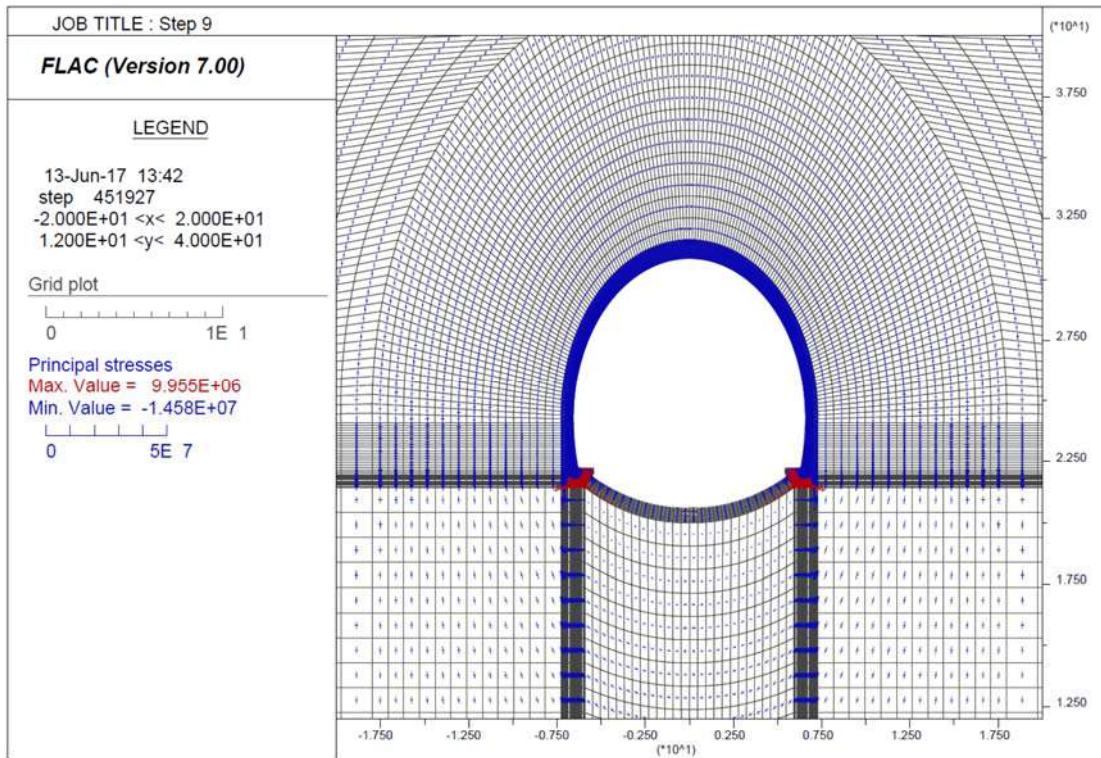

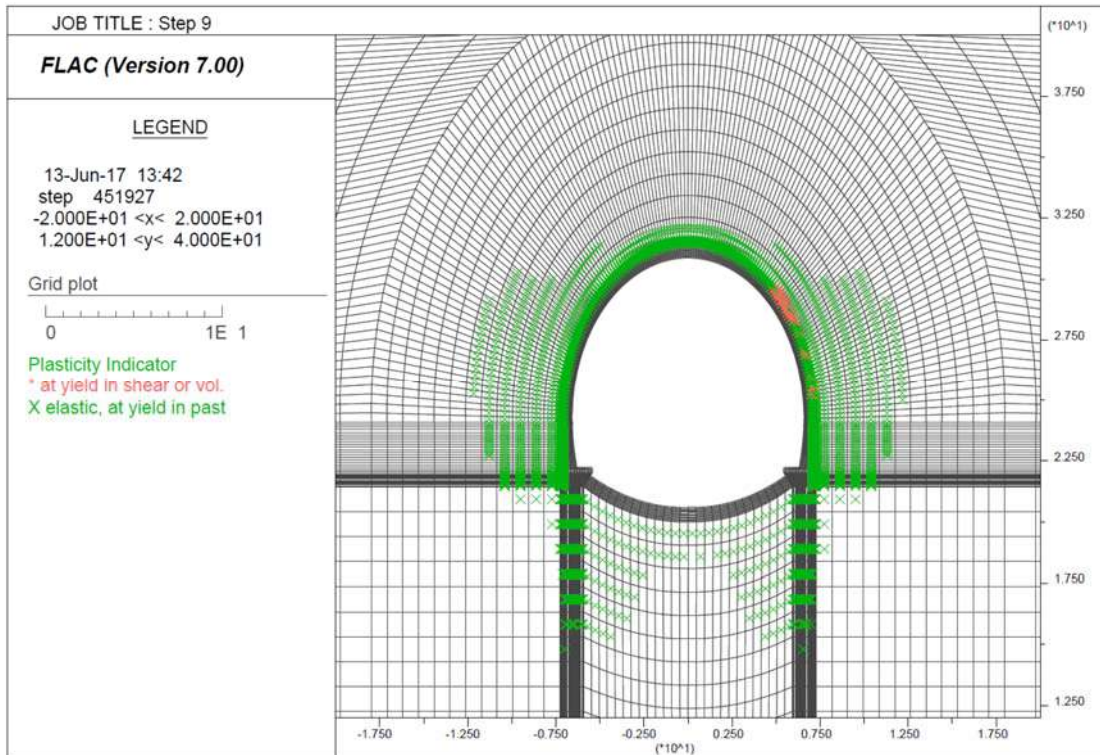
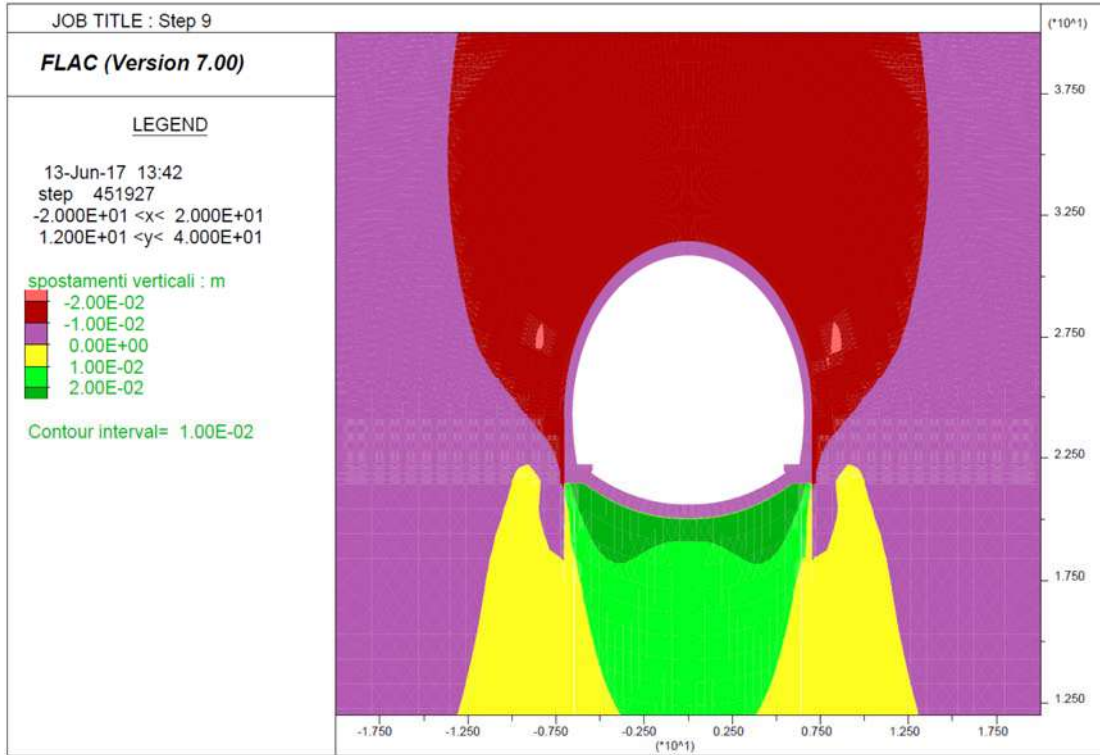

**Output Flac – Sezione tipo B0 – Parametri res max – Copertura di calcolo = 70 m**

**Step 1 – Tensioni litostatiche**

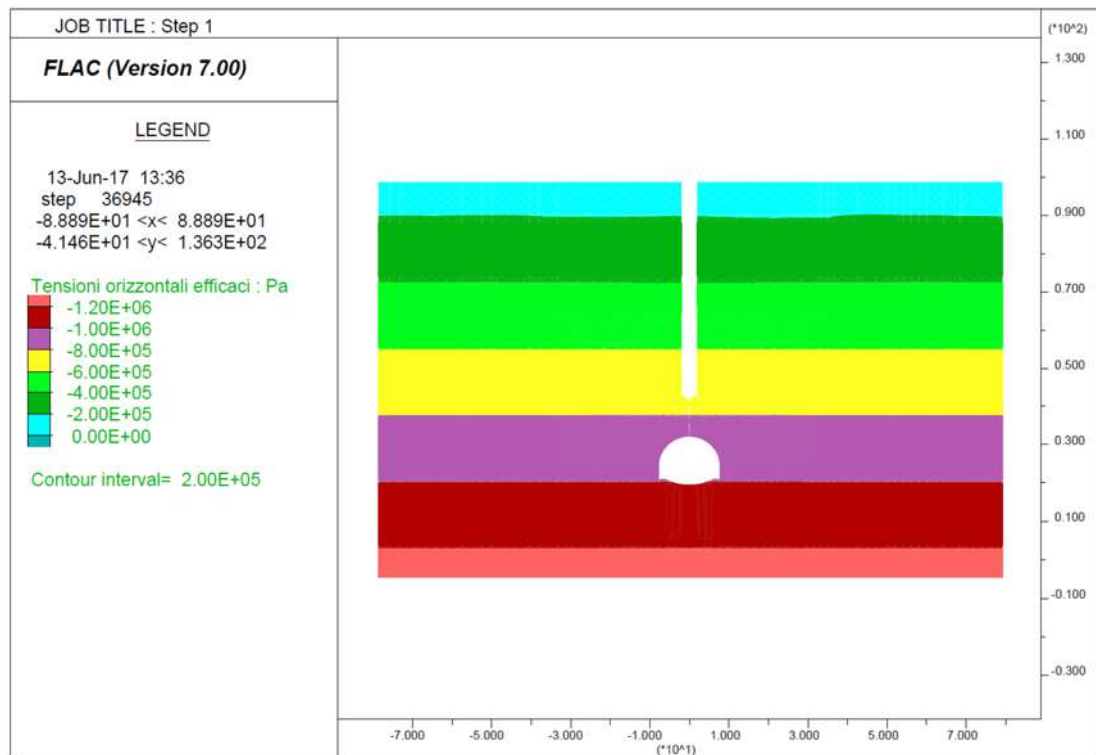
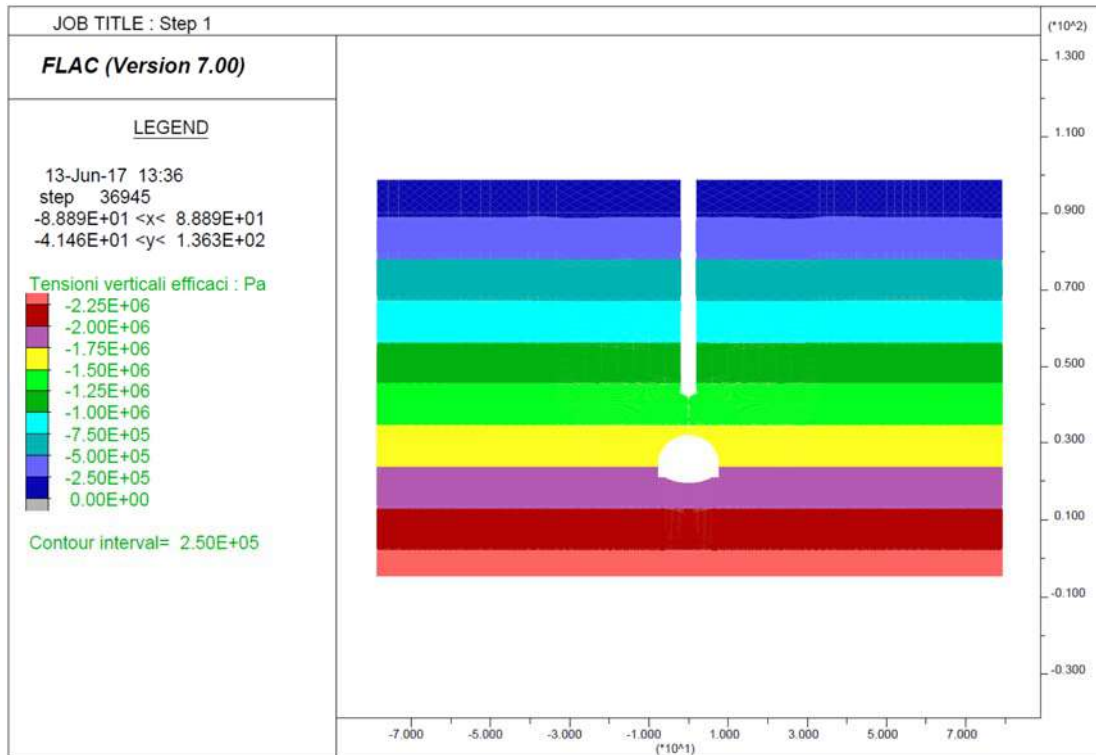



Step 6 – Avanzamento fino a deformazioni esaurite

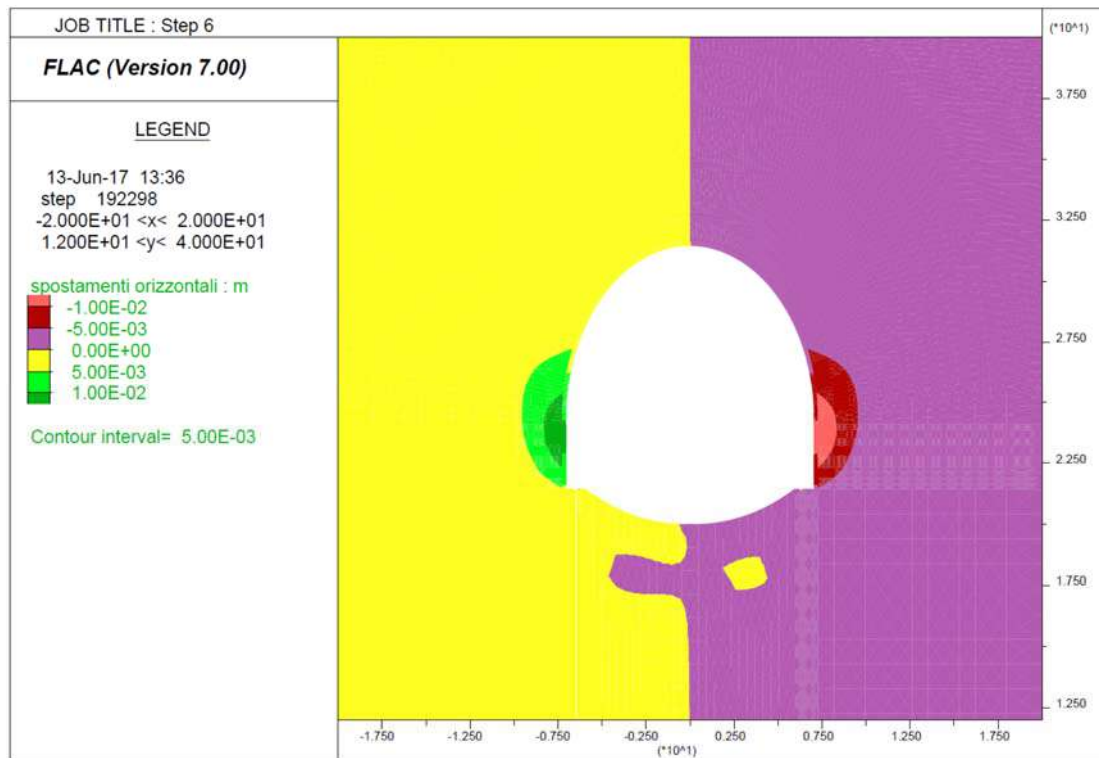
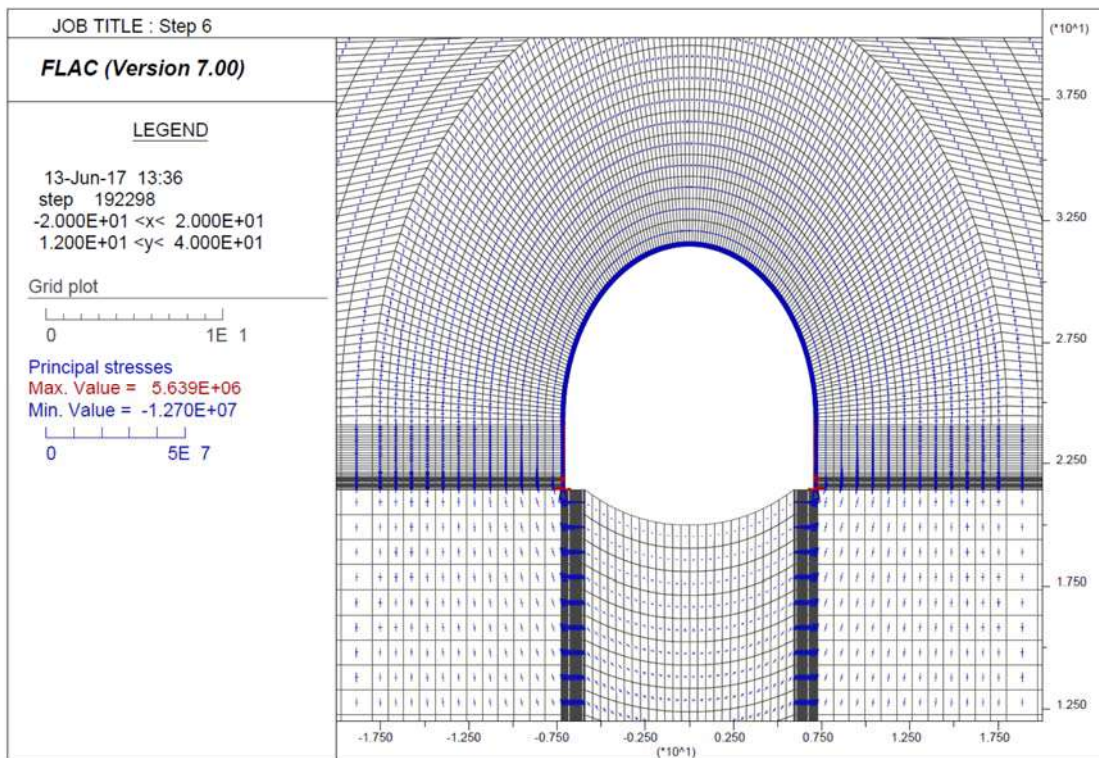

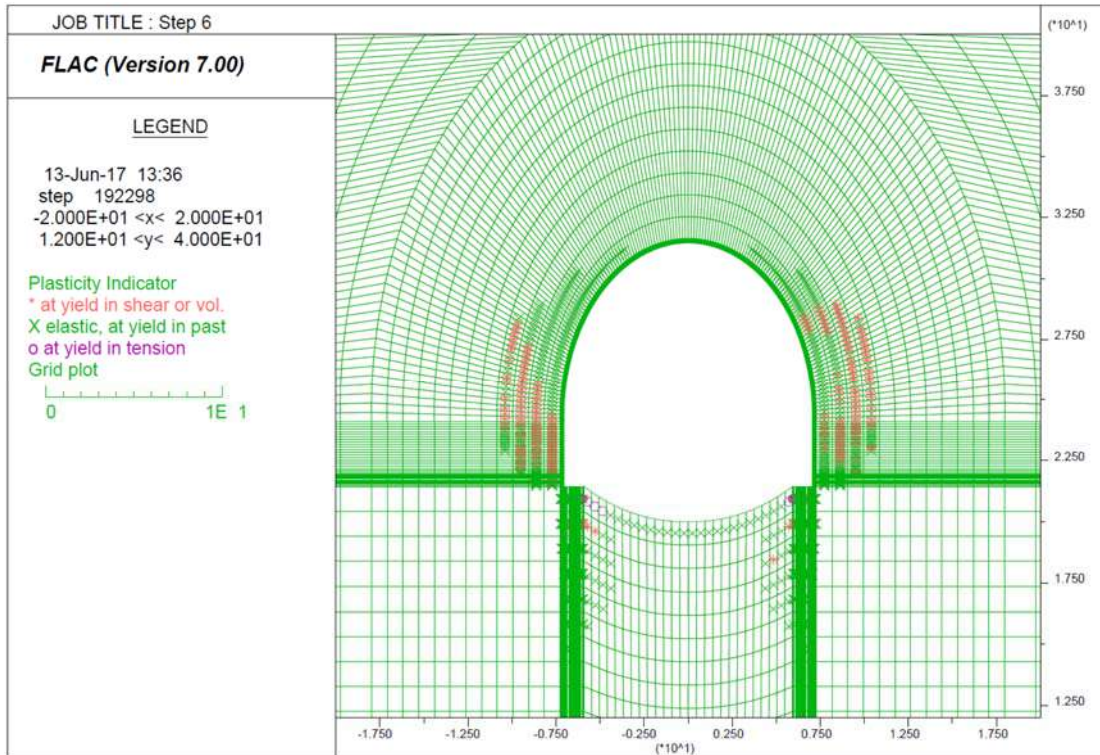
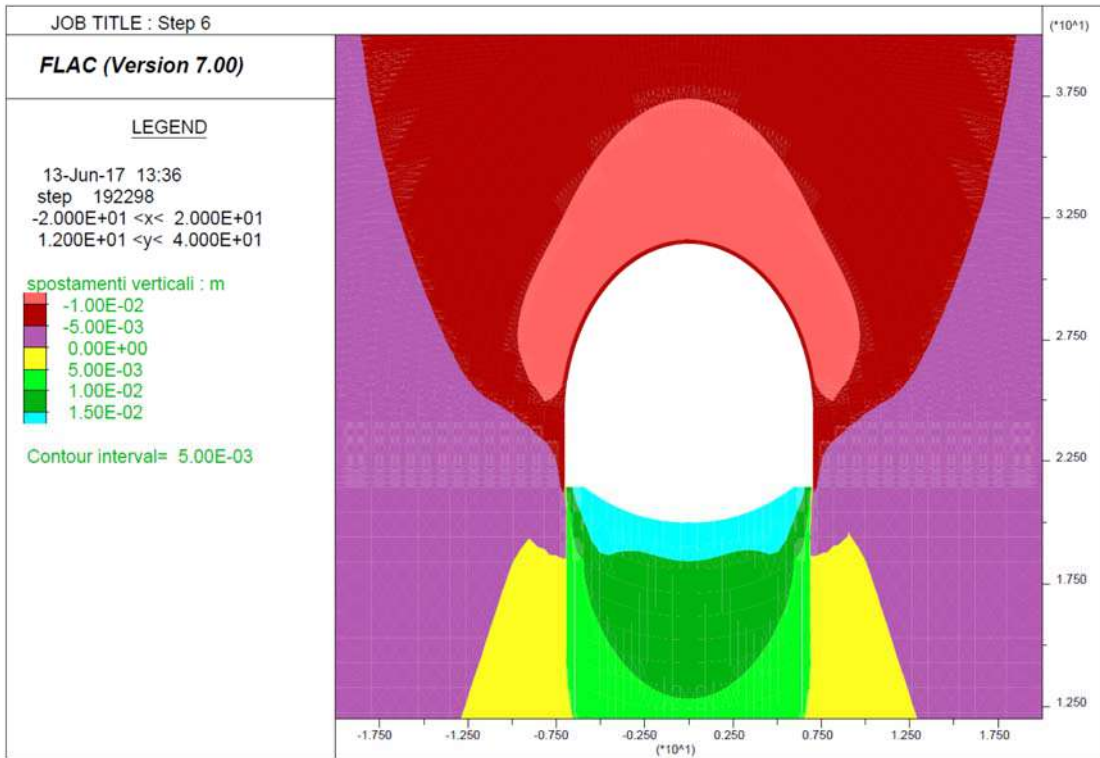



Step 7 - Getto arco rovescio e muretta

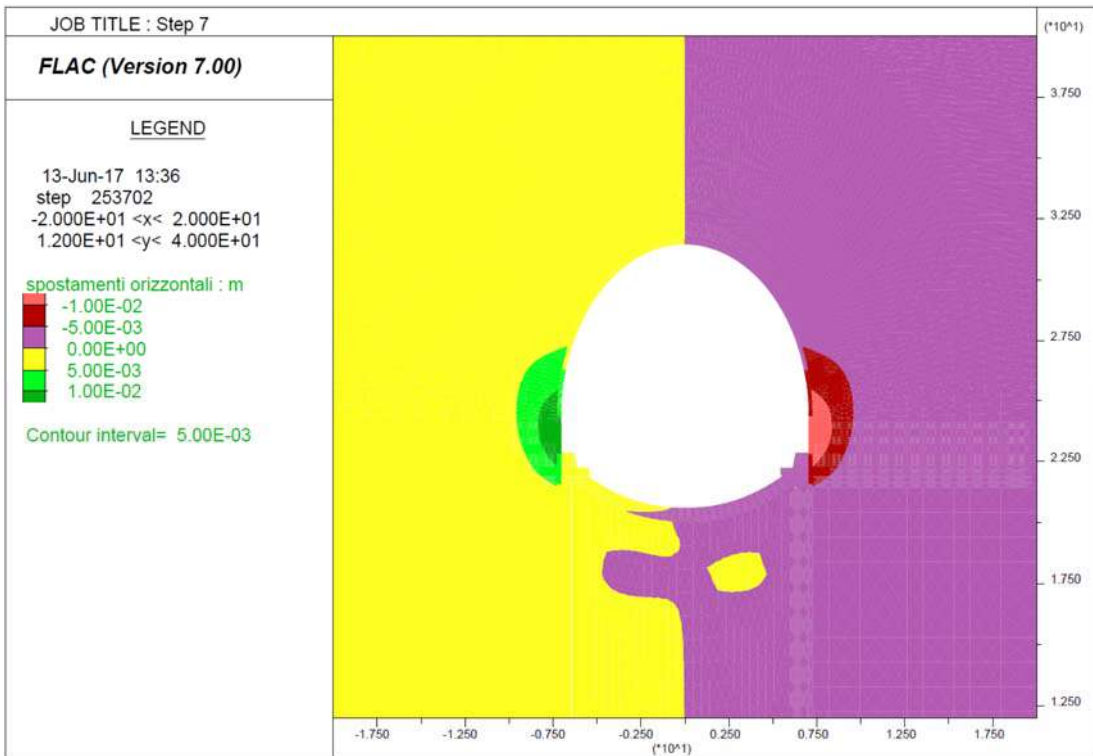
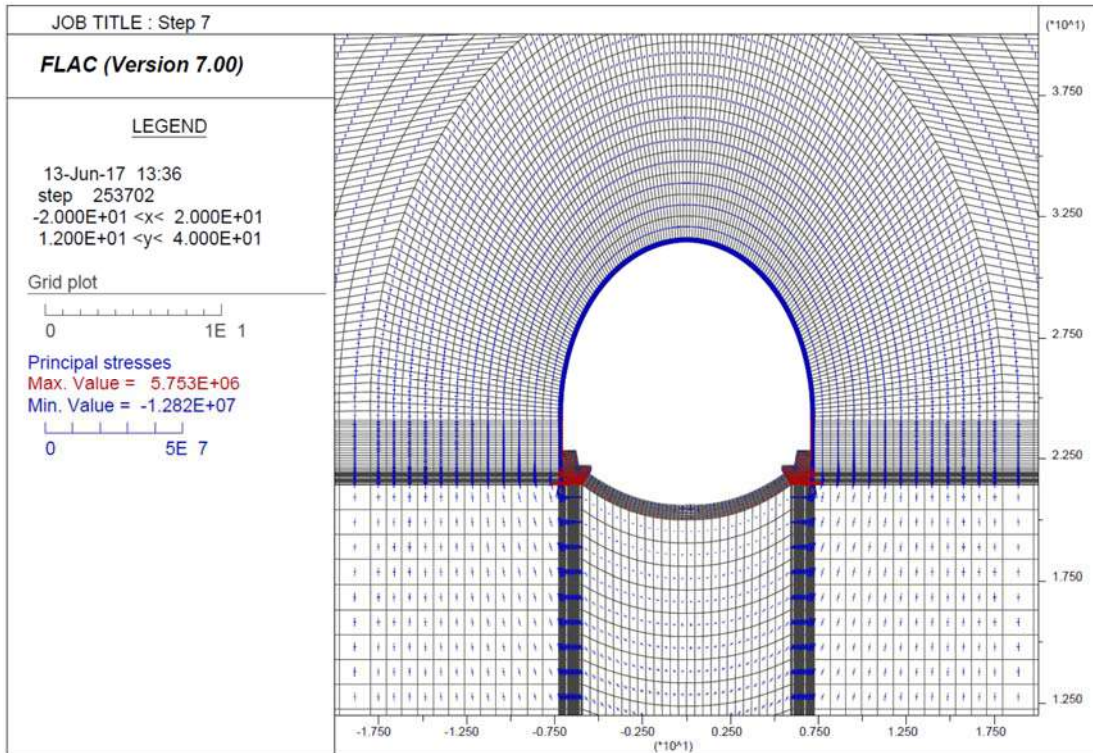



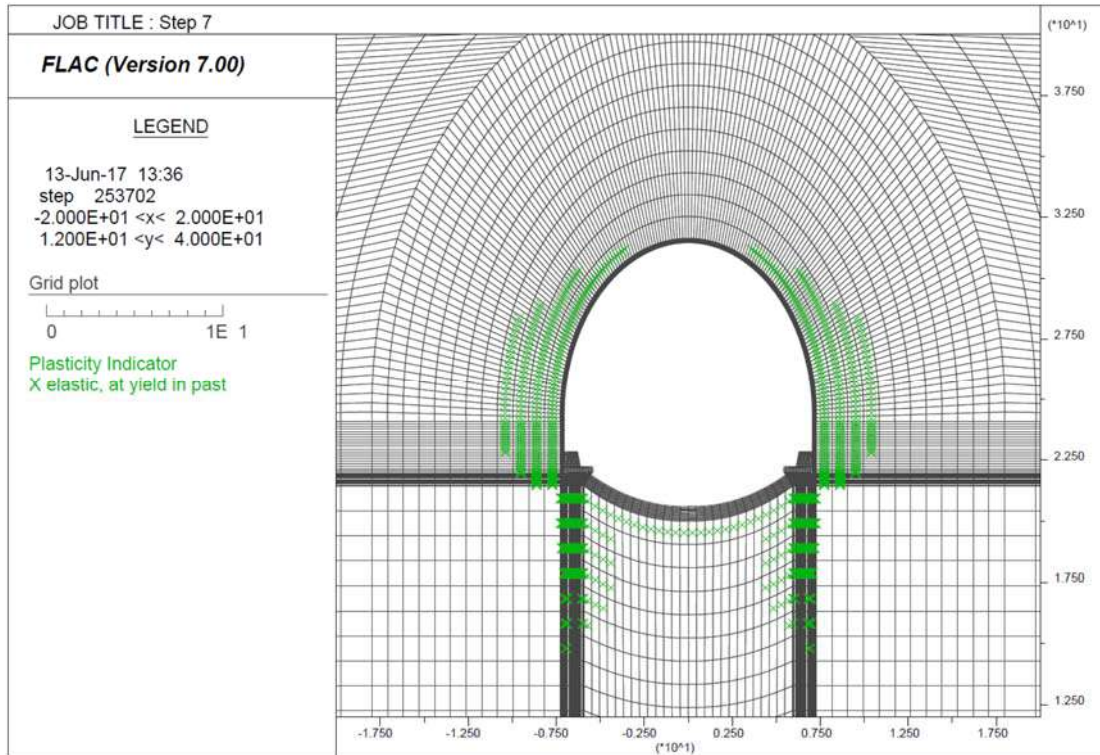
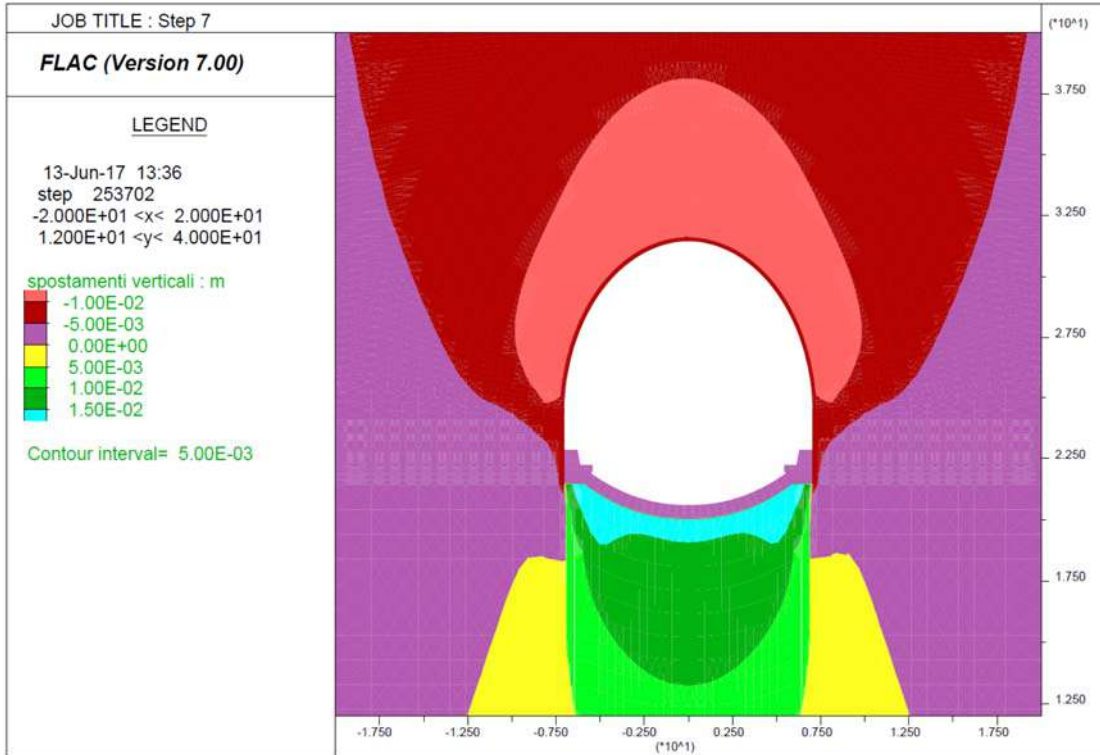

Step 8 - Getto Calotta

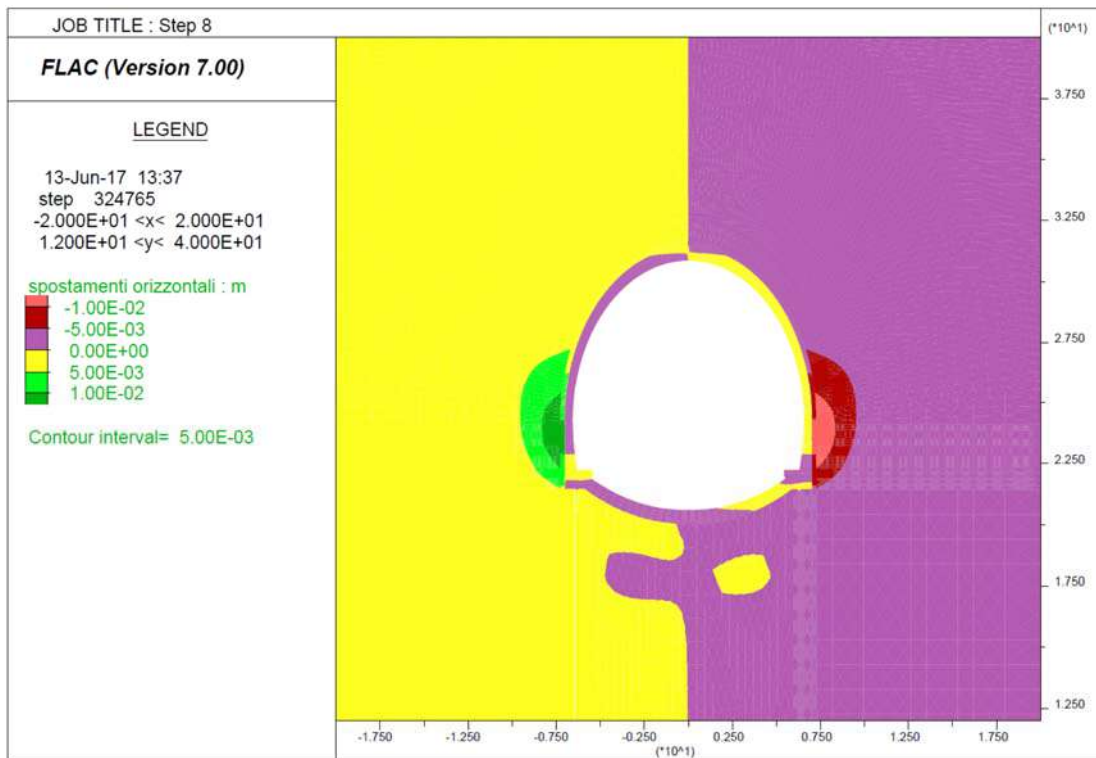
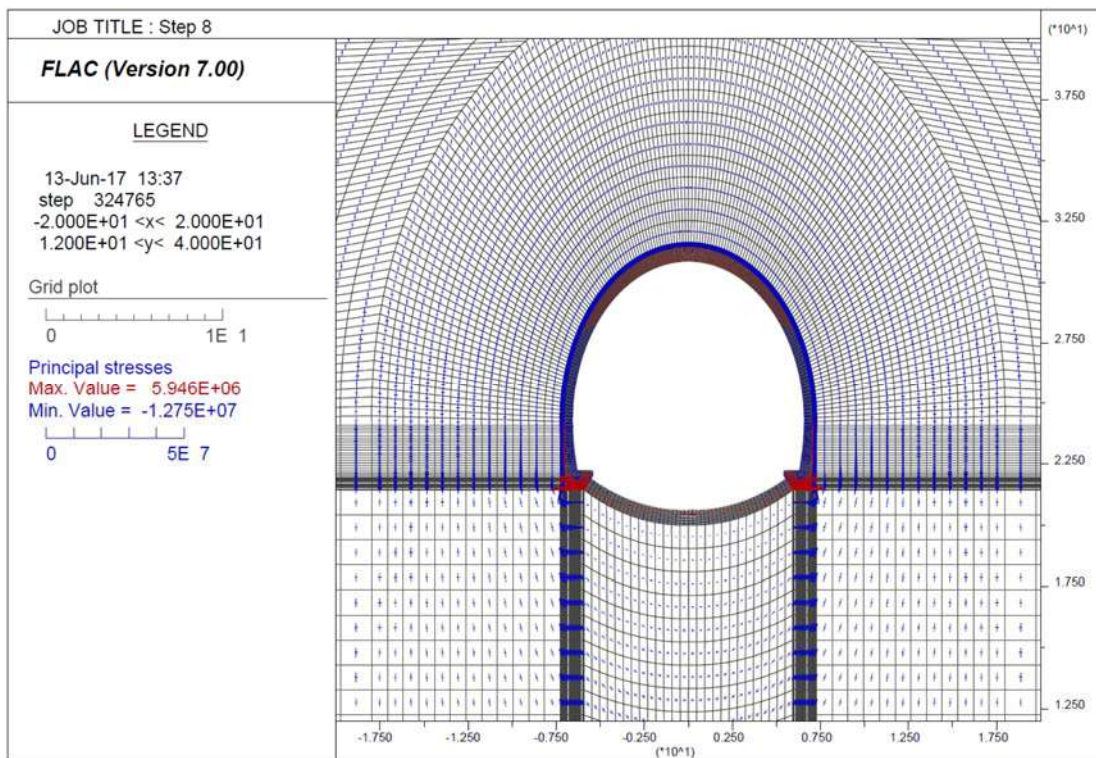

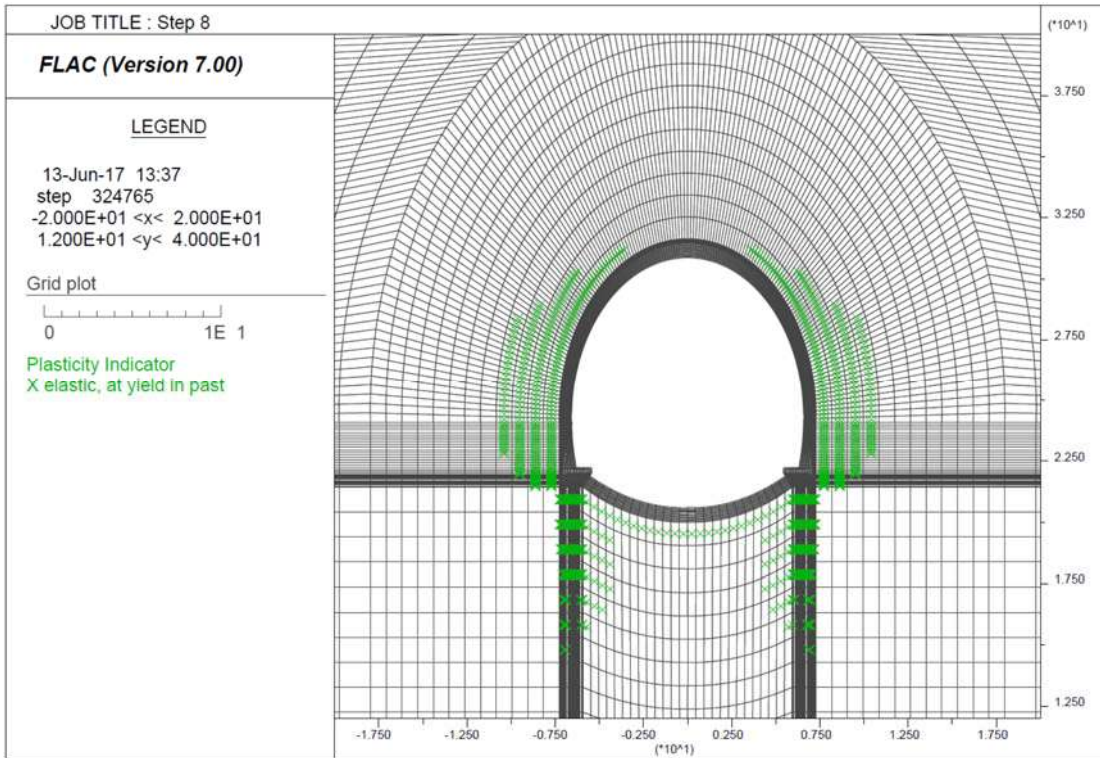
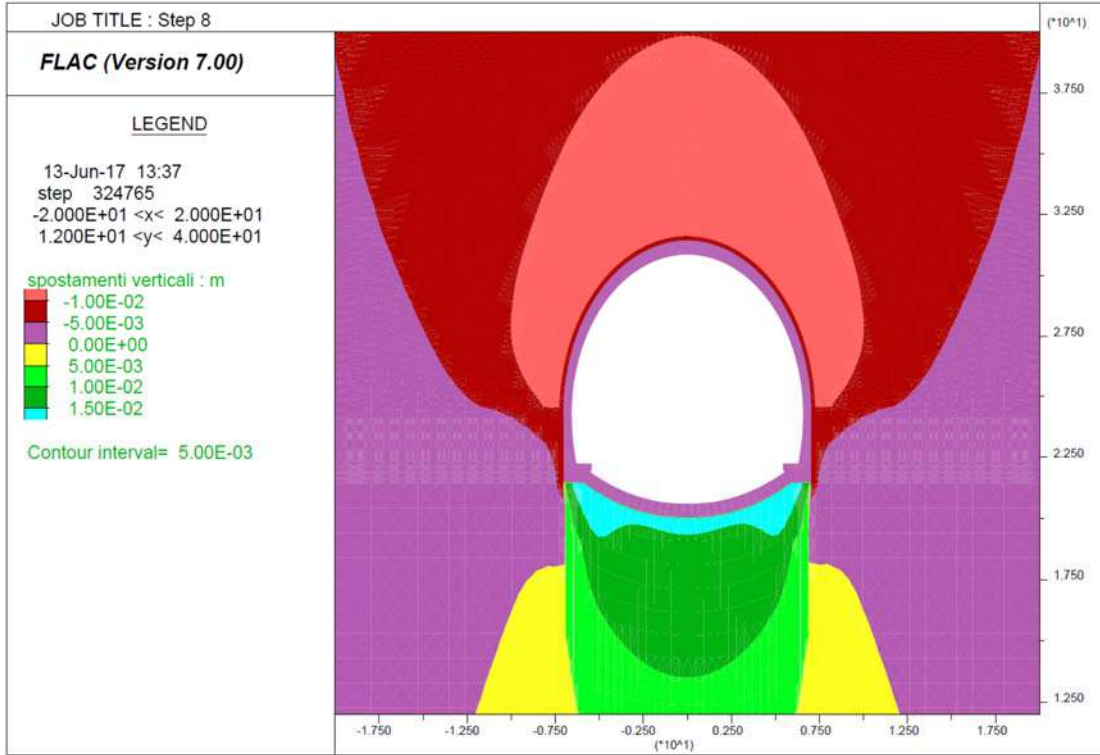



Step 9 - Decadimento dei parametri di resistenza del rivestimento provvisorio

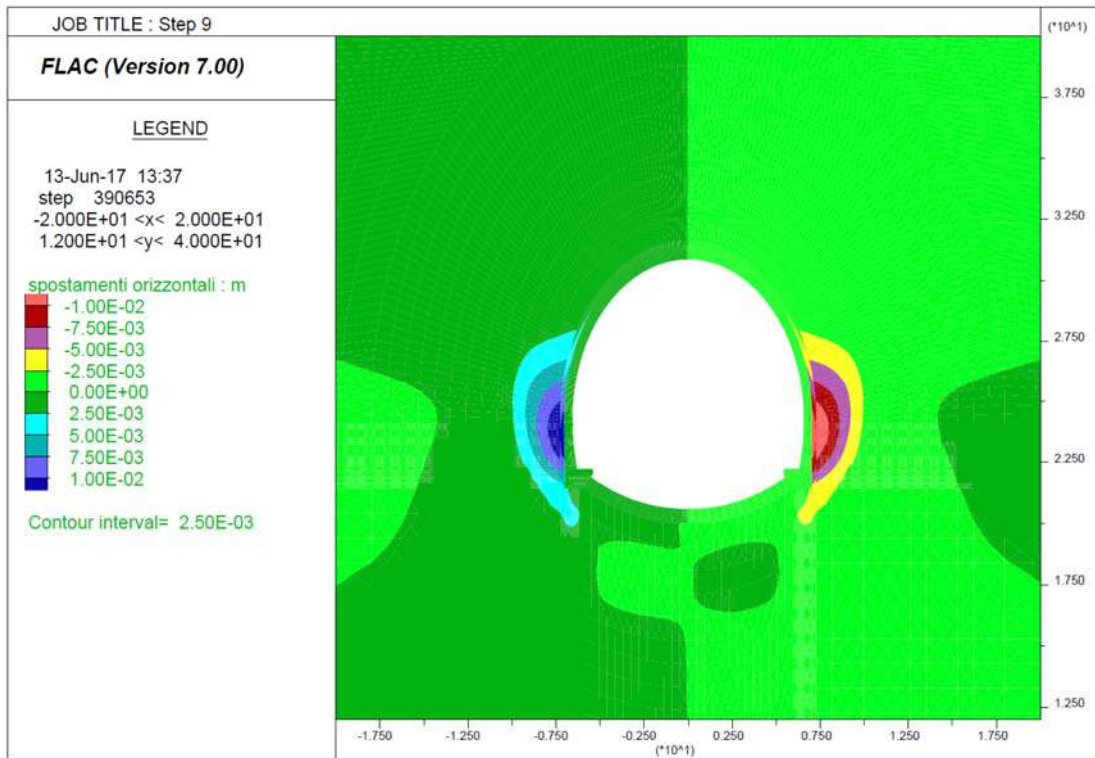
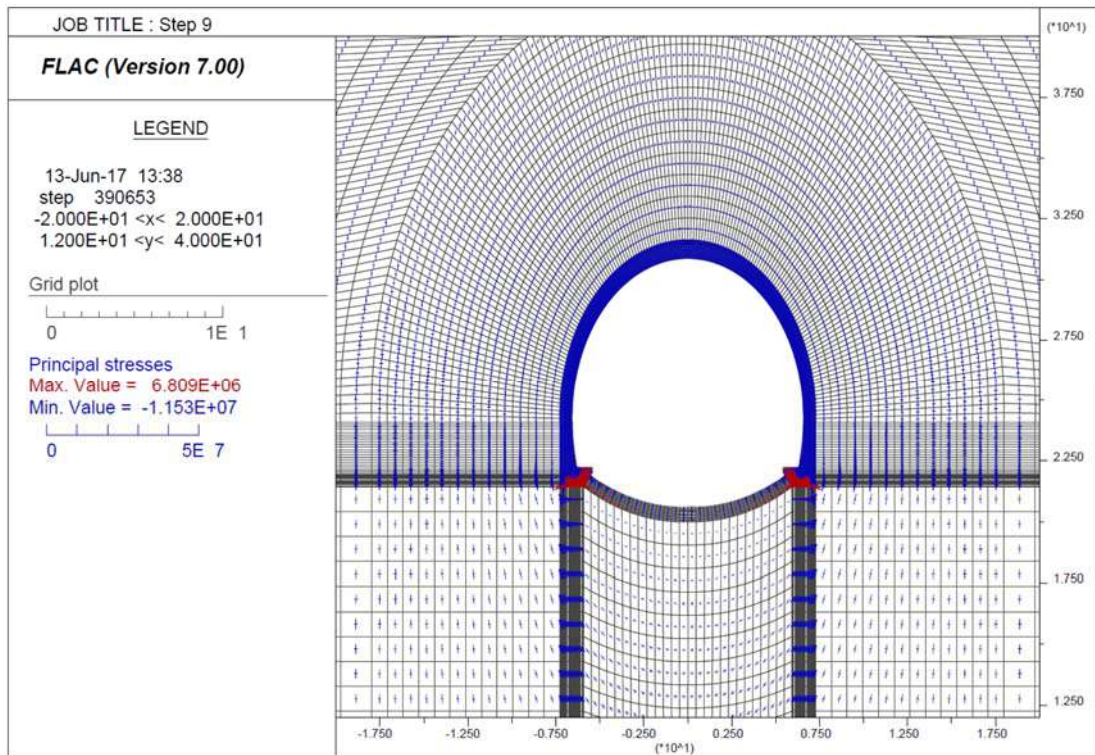

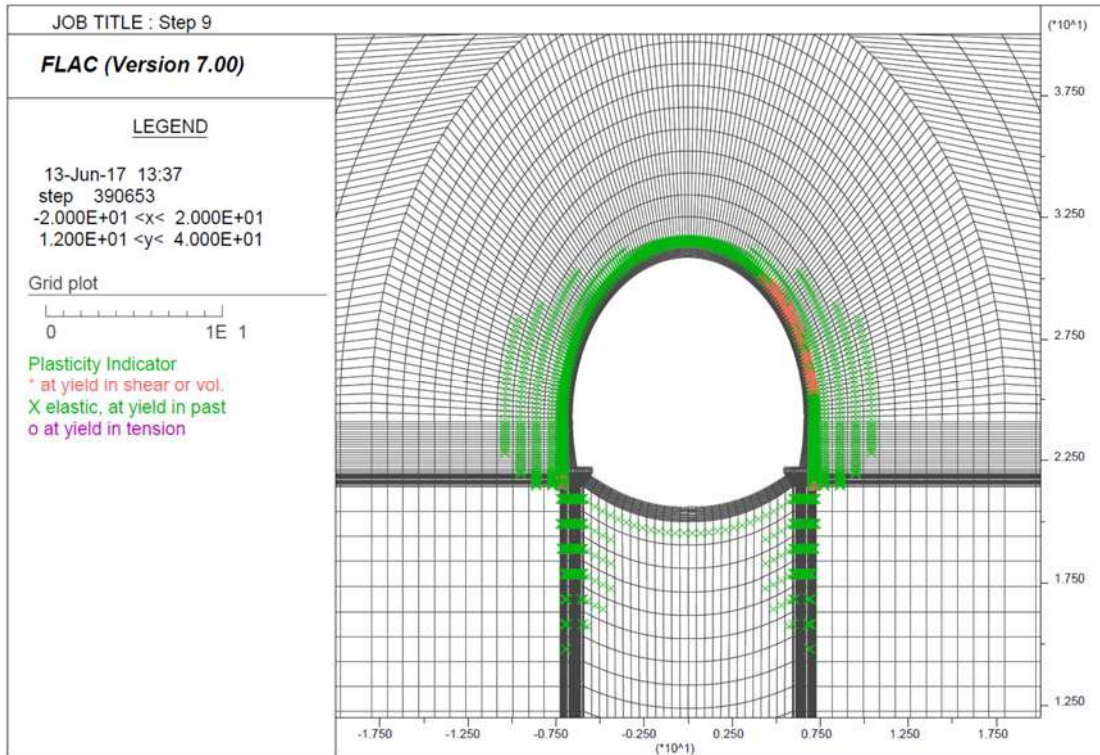
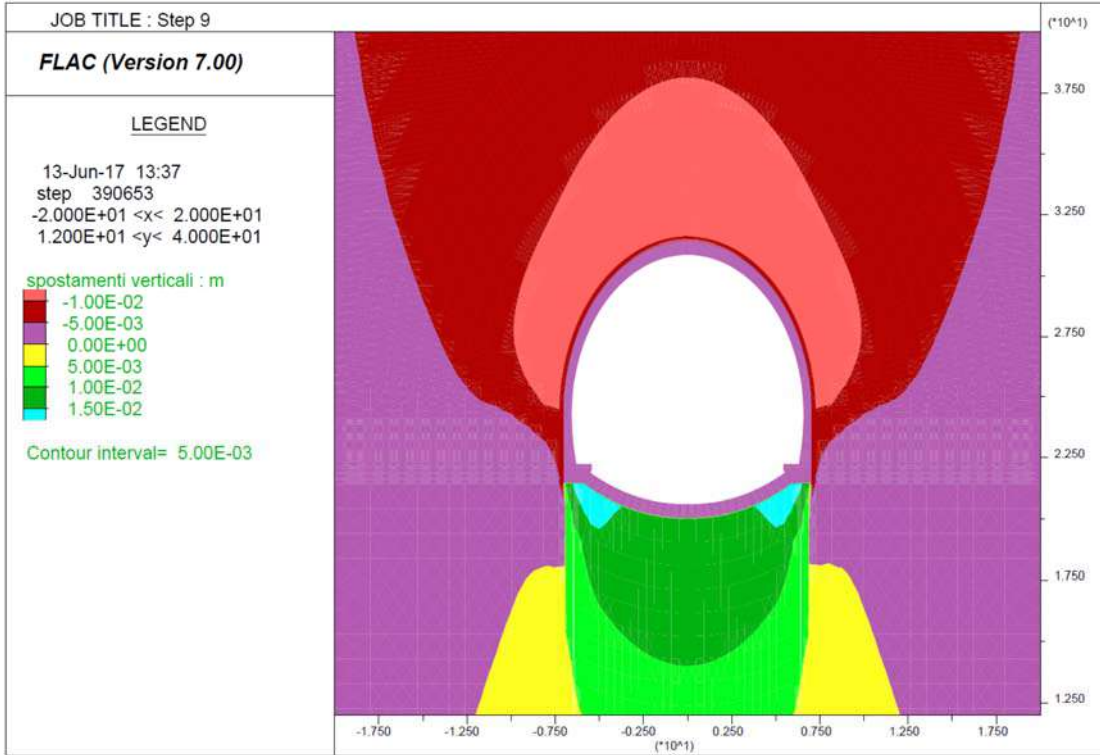

**Output Flac – Sezione tipo B2 – Parametri res min – Copertura di calcolo = 50 m**

**Step 1 – Tensioni litostatiche**

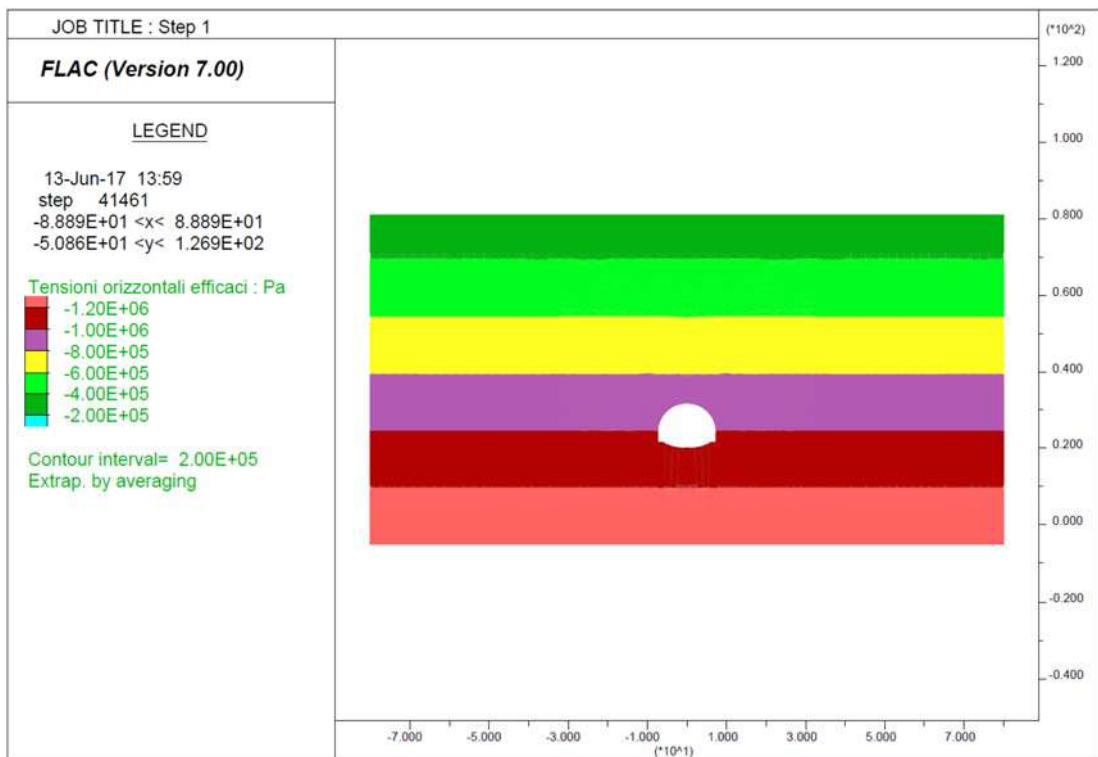
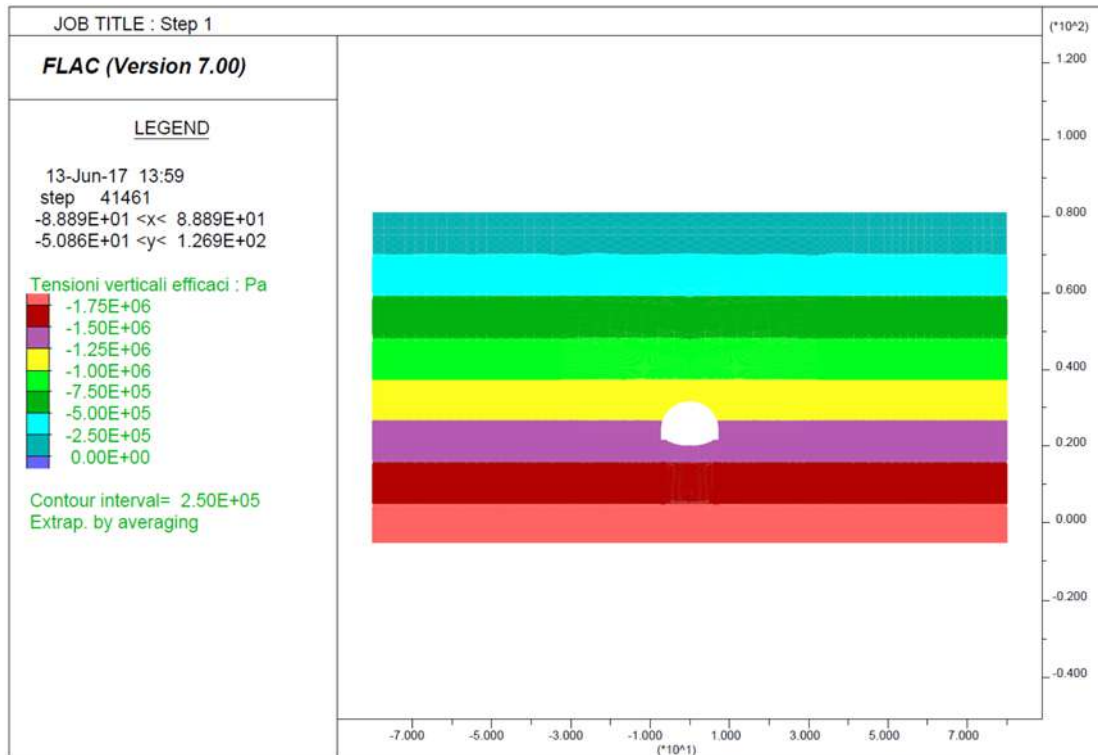



Step 6 – Avanzamento fino a 2D

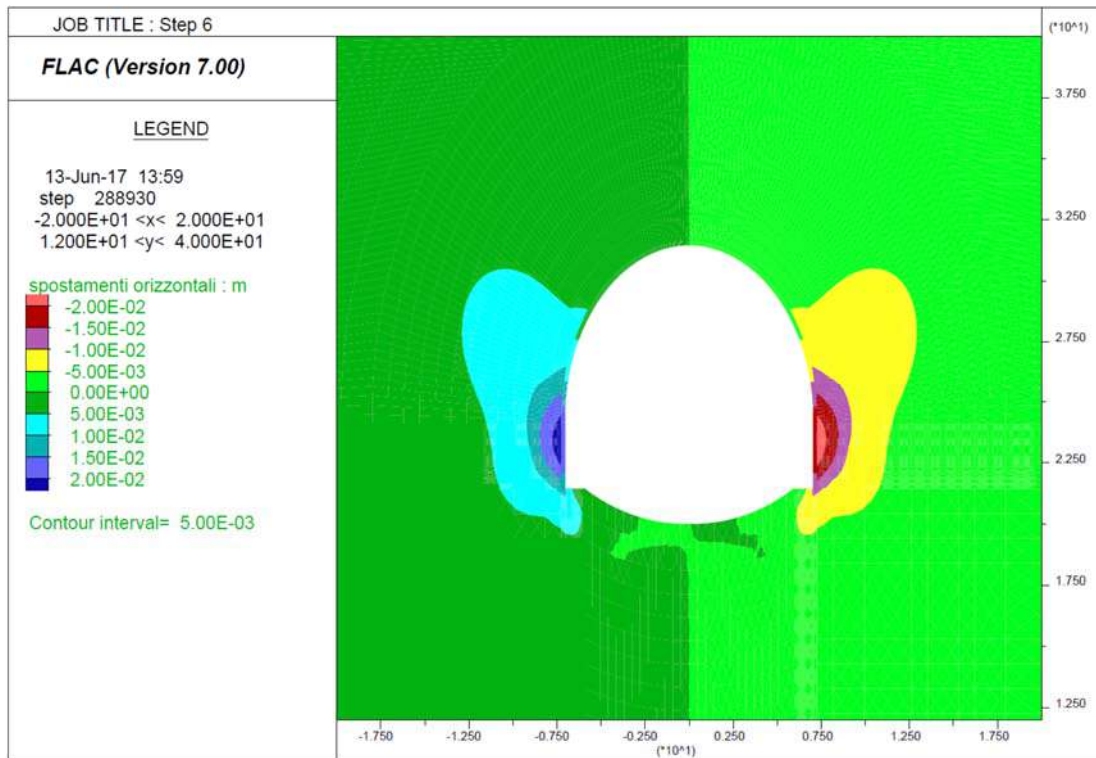
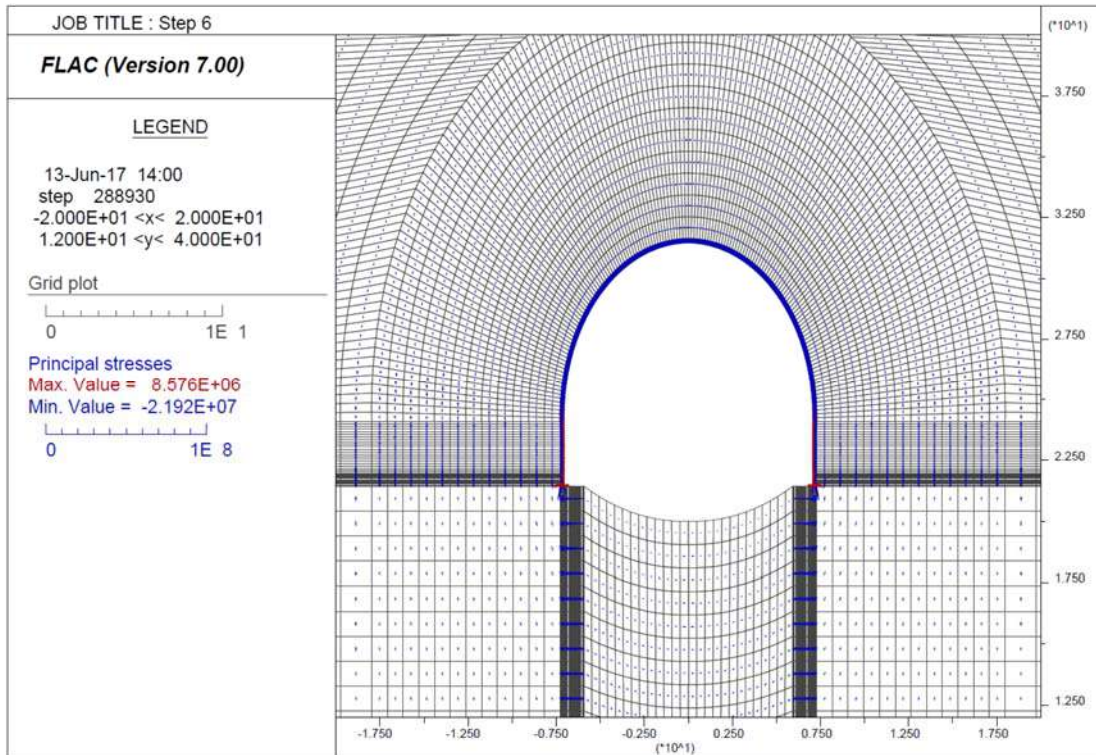

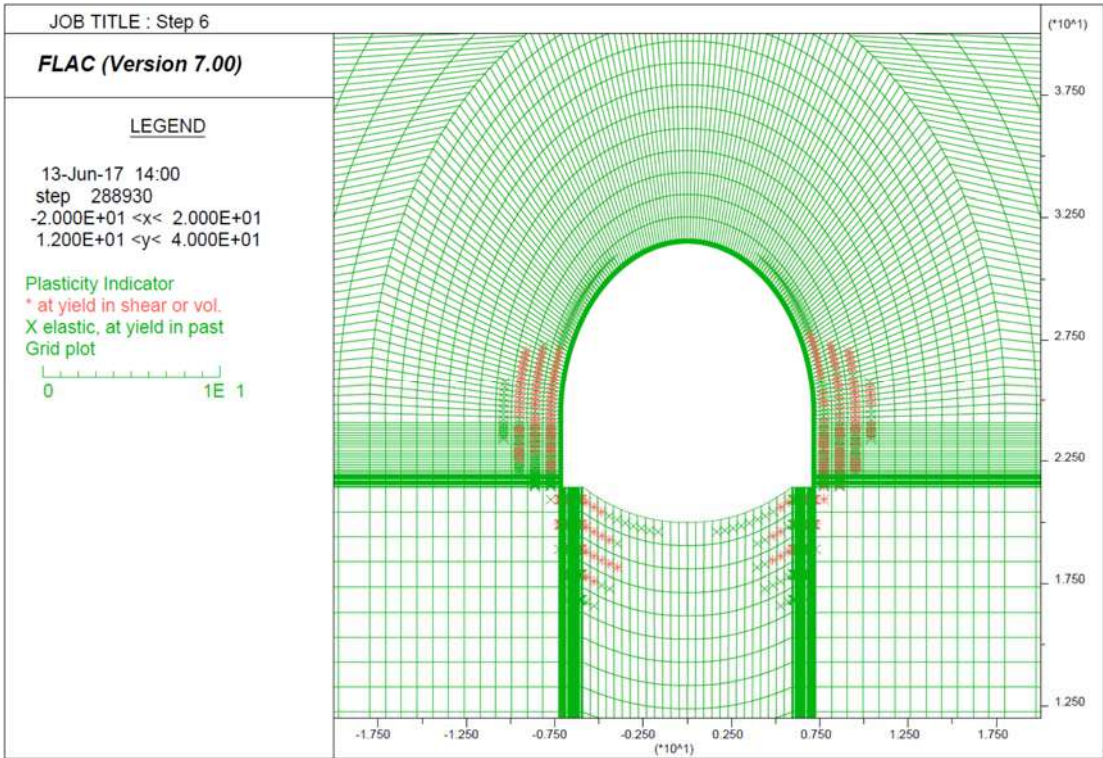
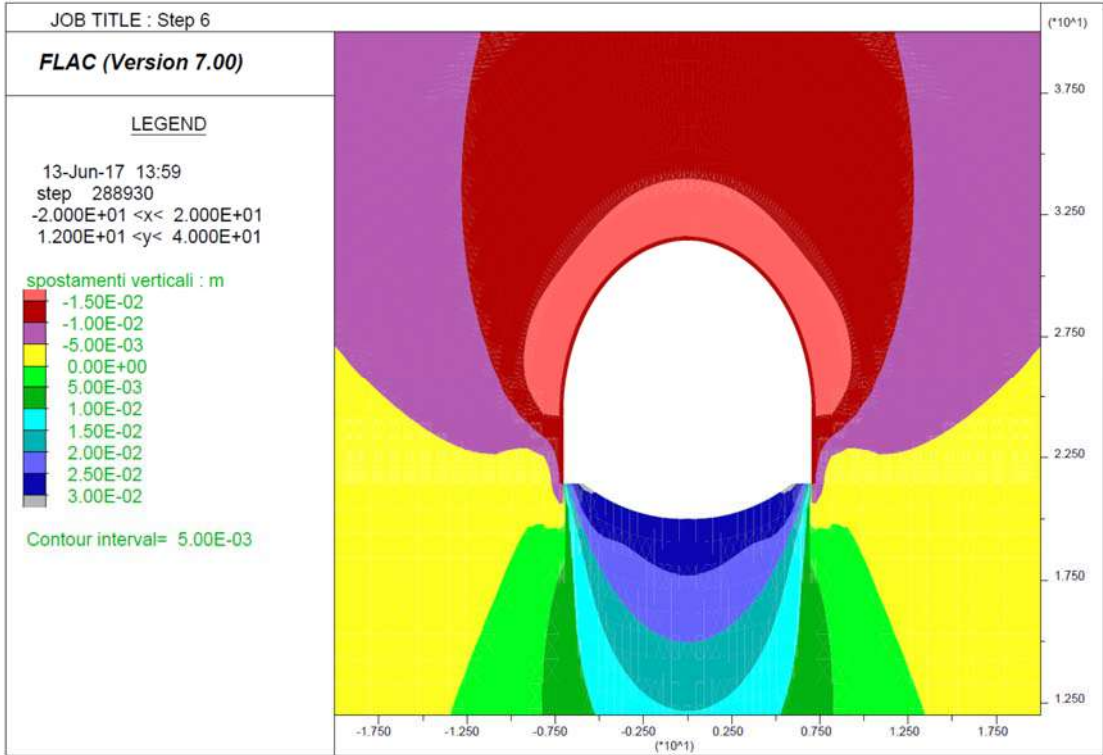



Step 7 - Getto arco rovescio e muretta a 2D e avanzamento fino a deformazioni esaurite

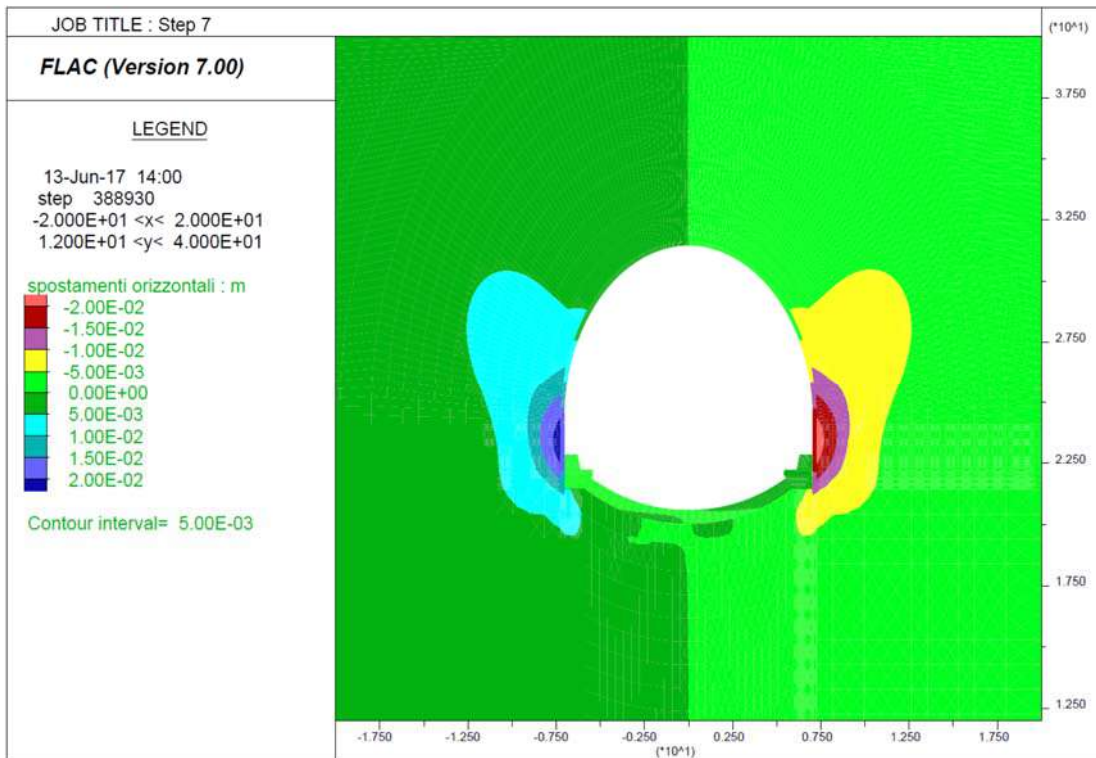
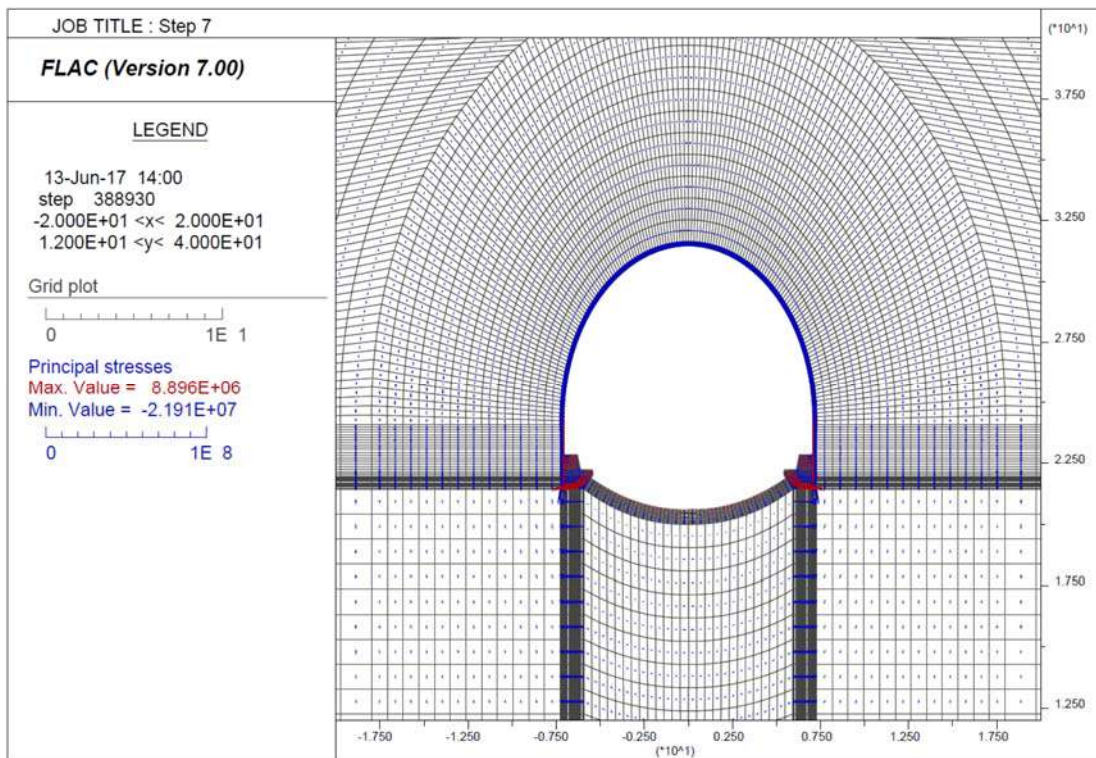



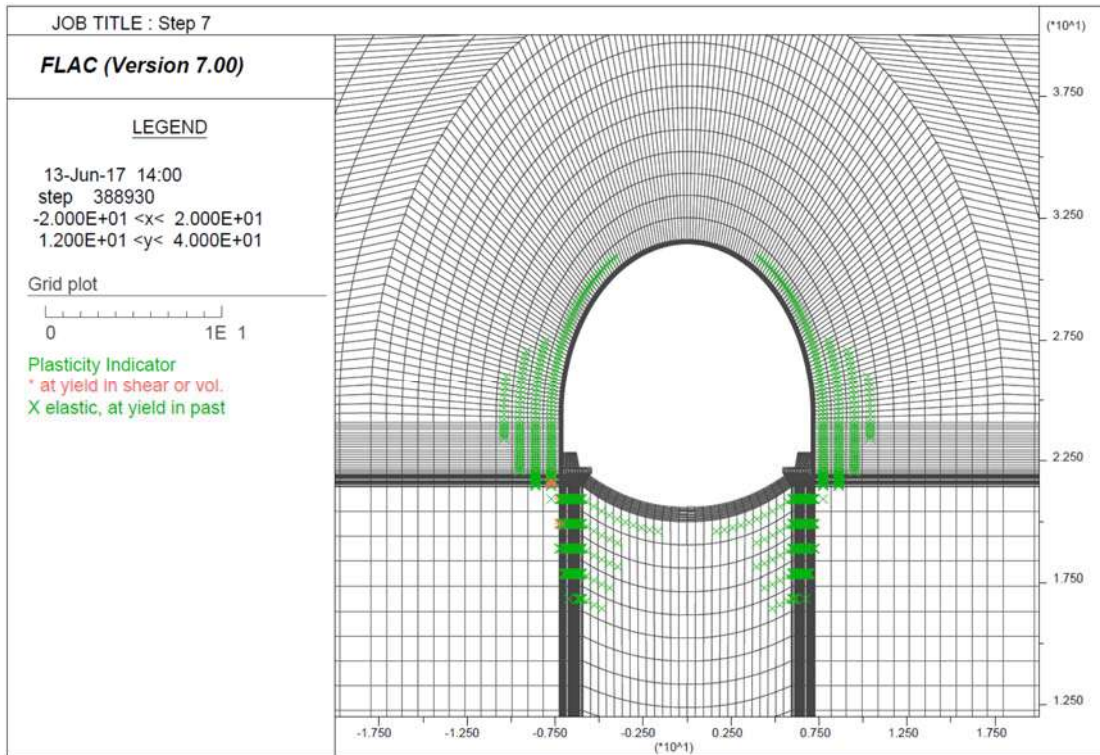
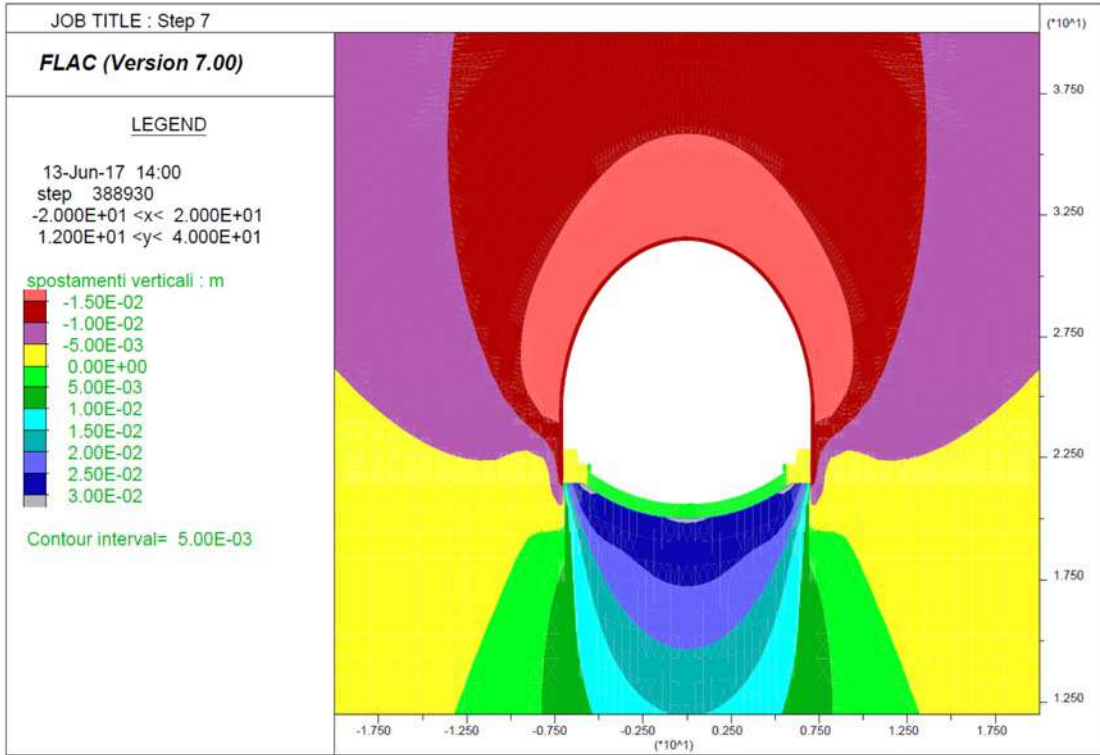

Step 8 - Getto Calotta

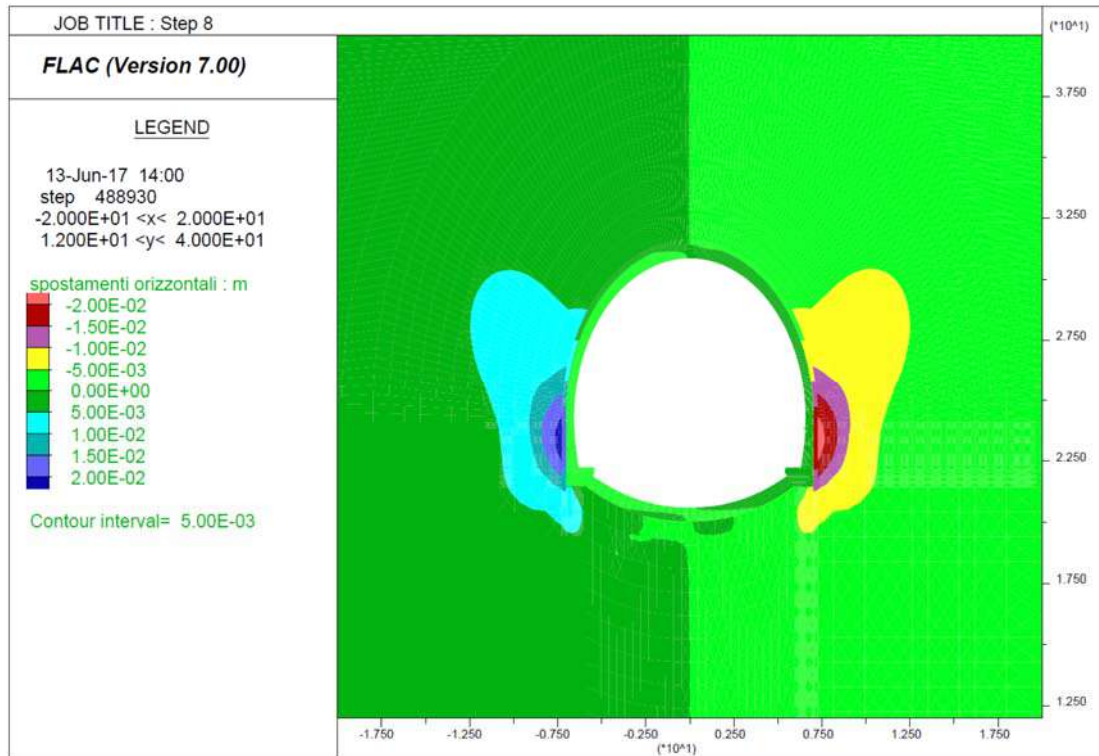
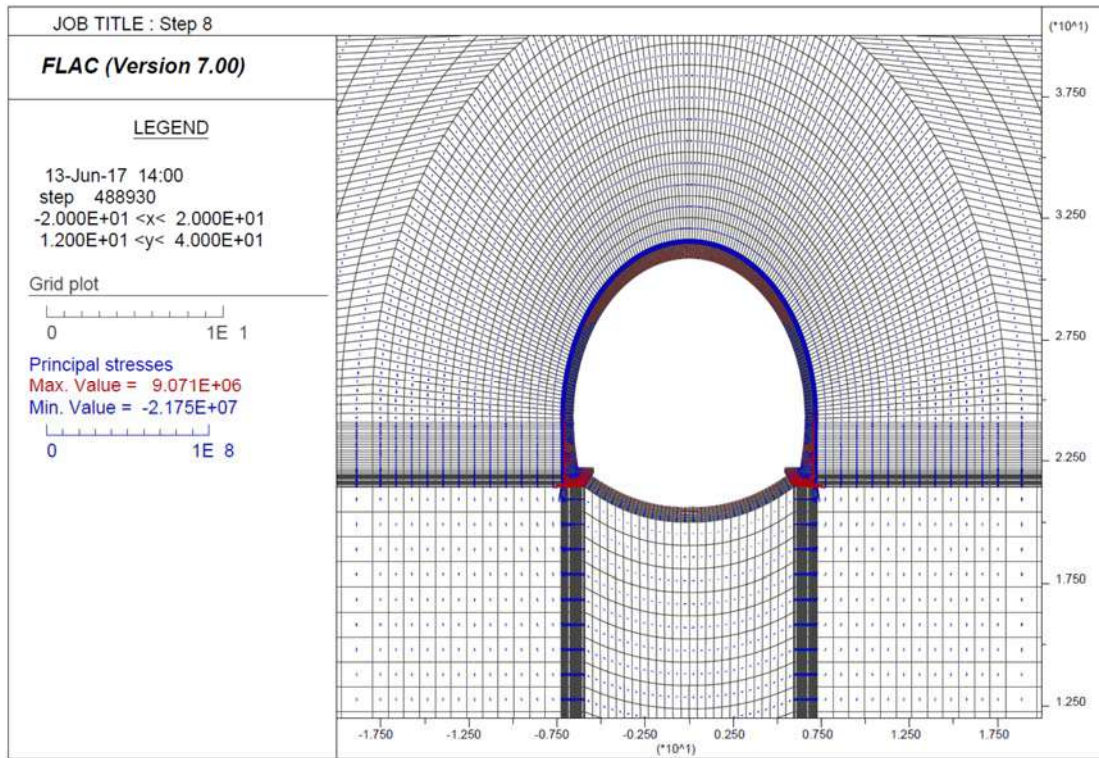

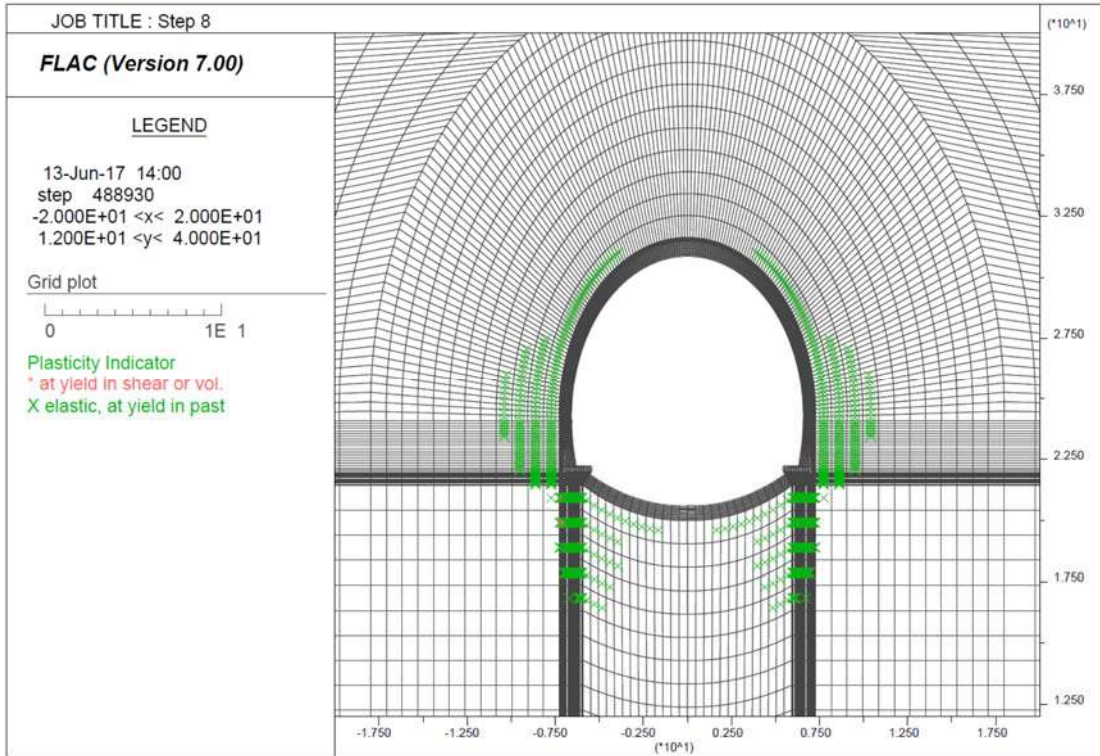
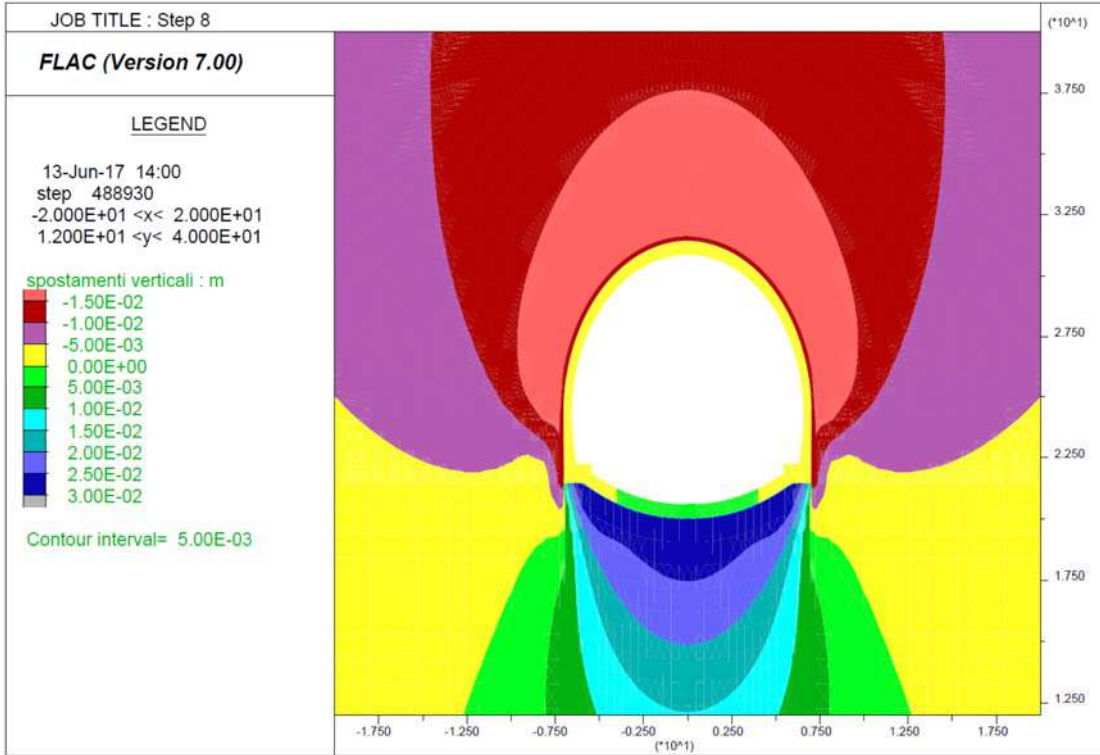



Step 9 - Decadimento dei parametri di resistenza del rivestimento provvisorio

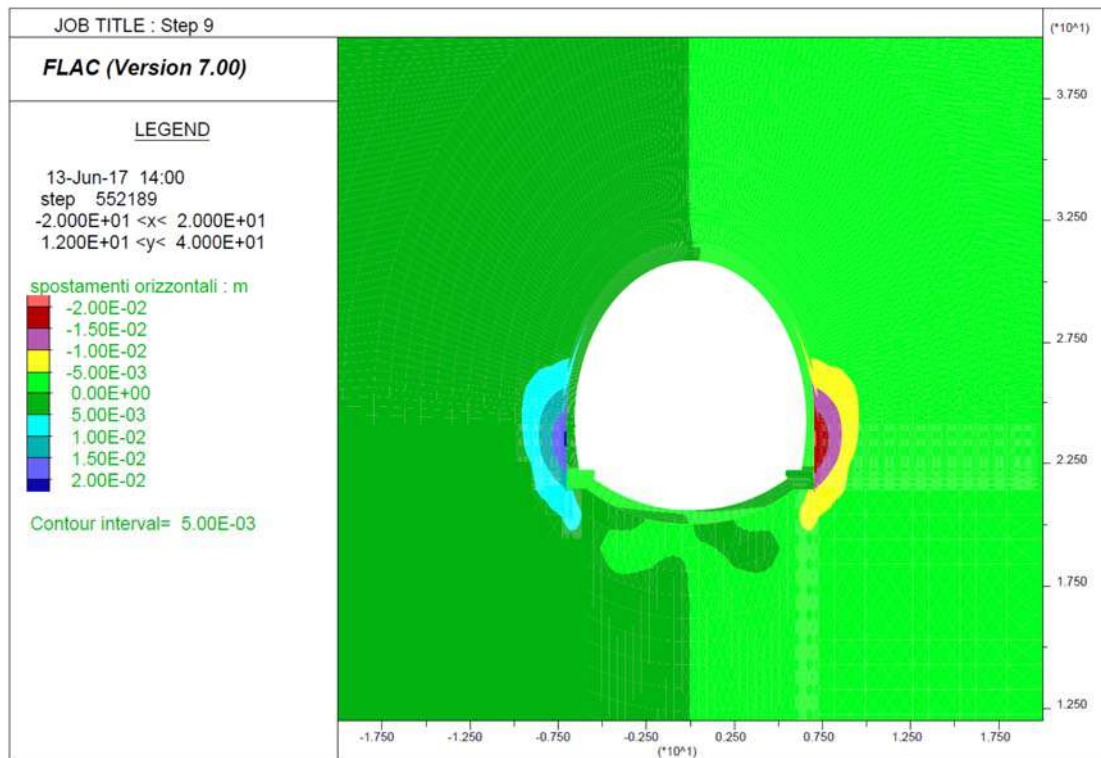
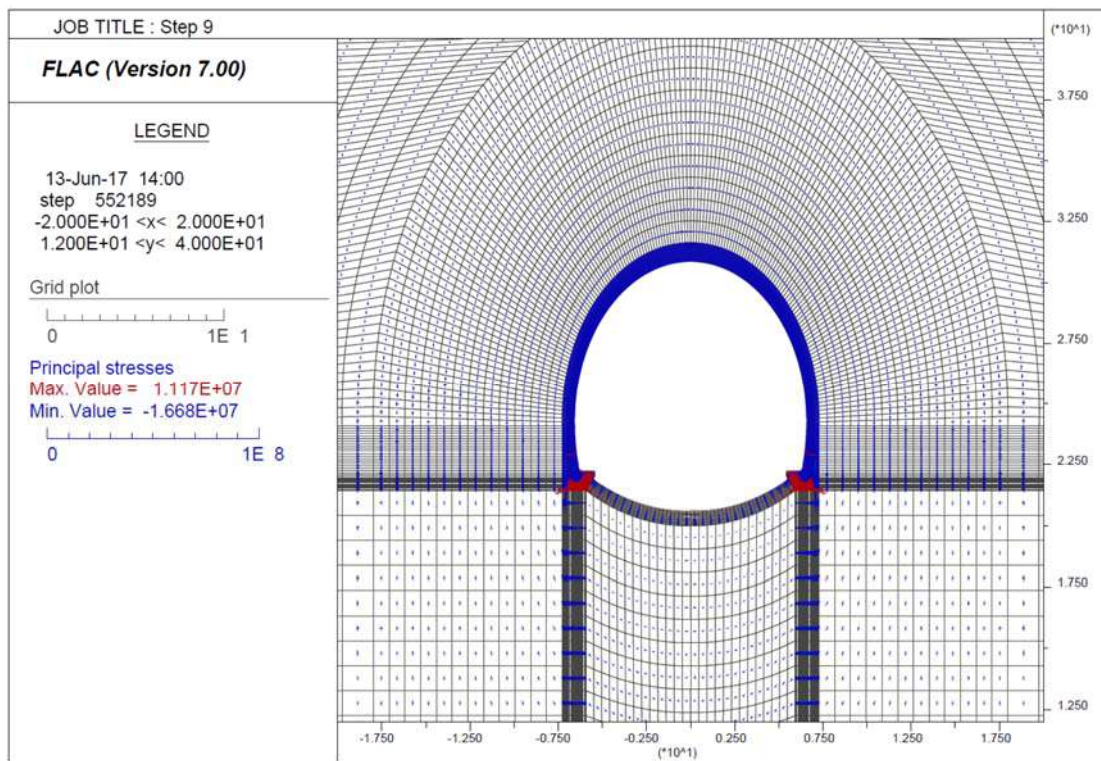

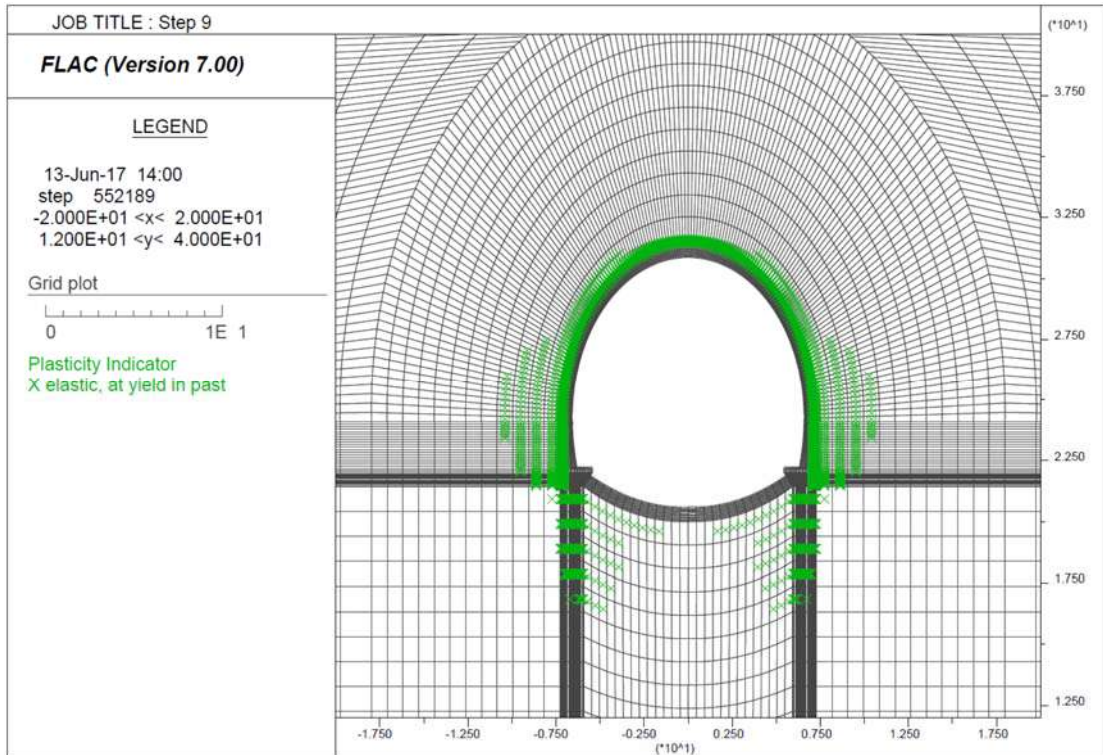
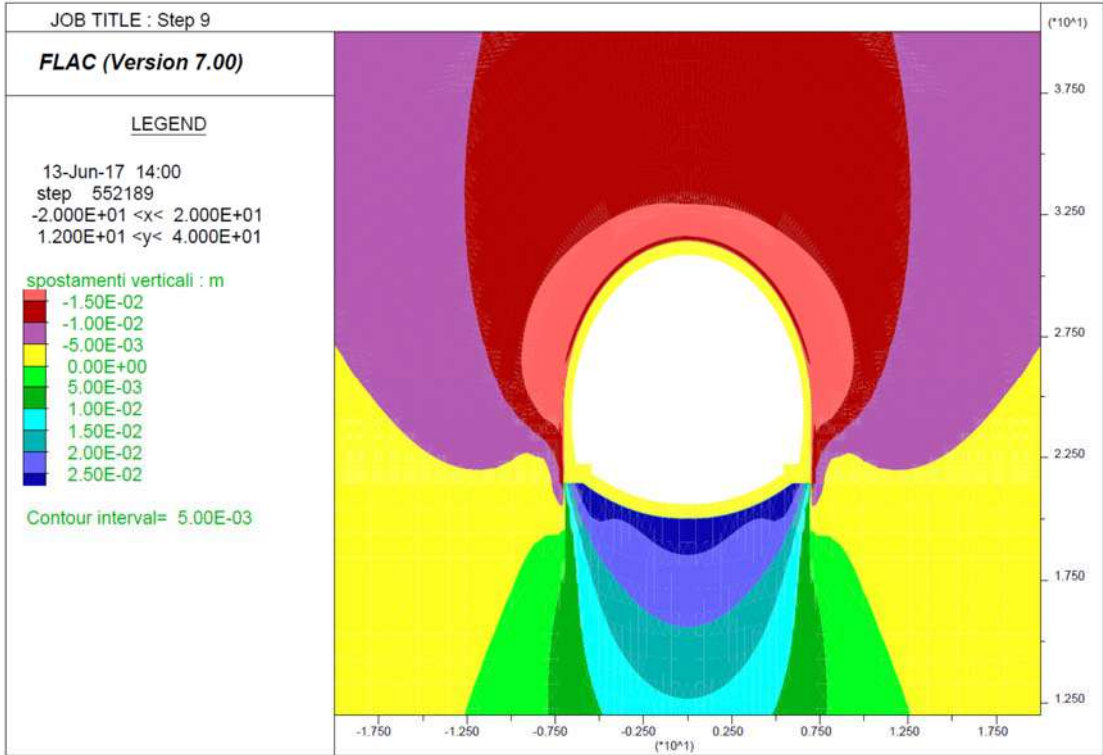

**Output Flac – Sezione tipo B2 – Parametri res max – Copertura di calcolo = 50 m**

**Step 1 – Tensioni litostatiche**

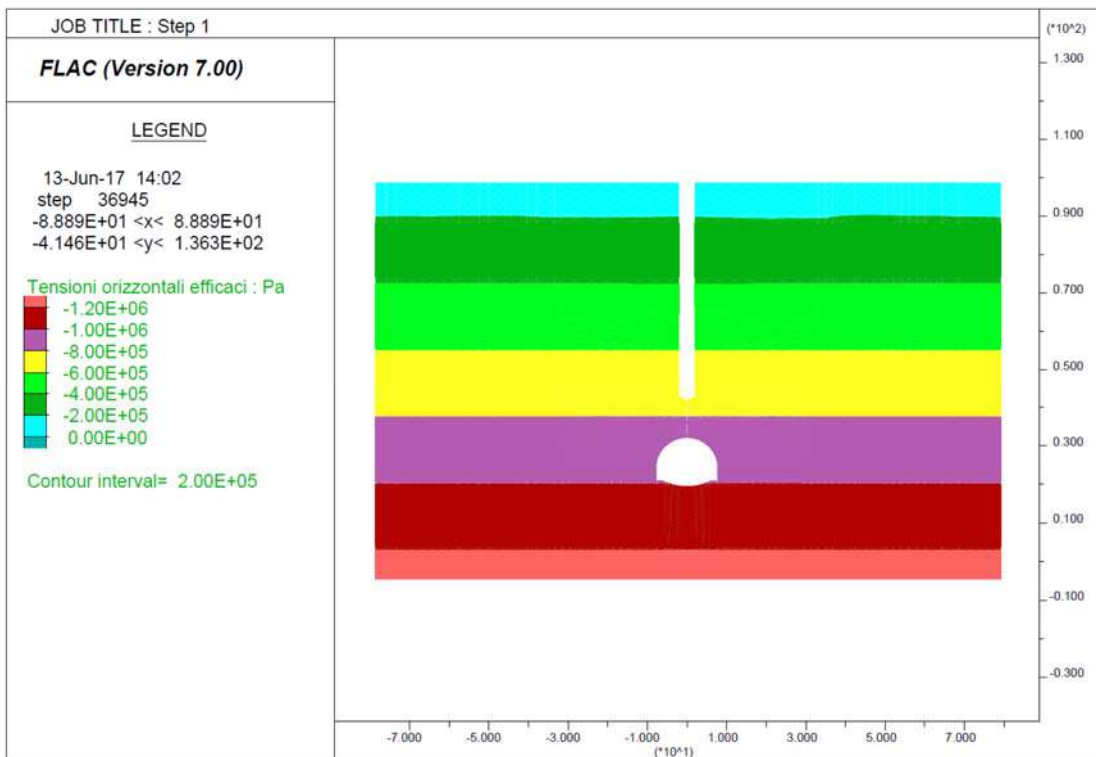
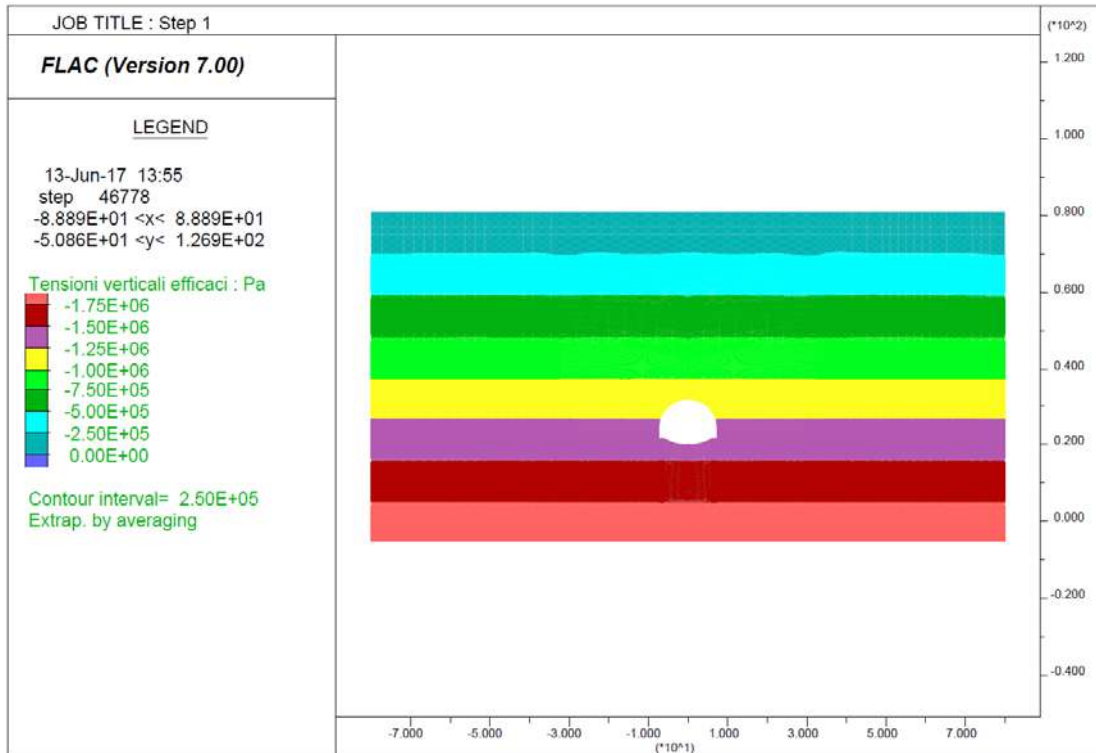



Step 6 – Avanzamento fino a 2D

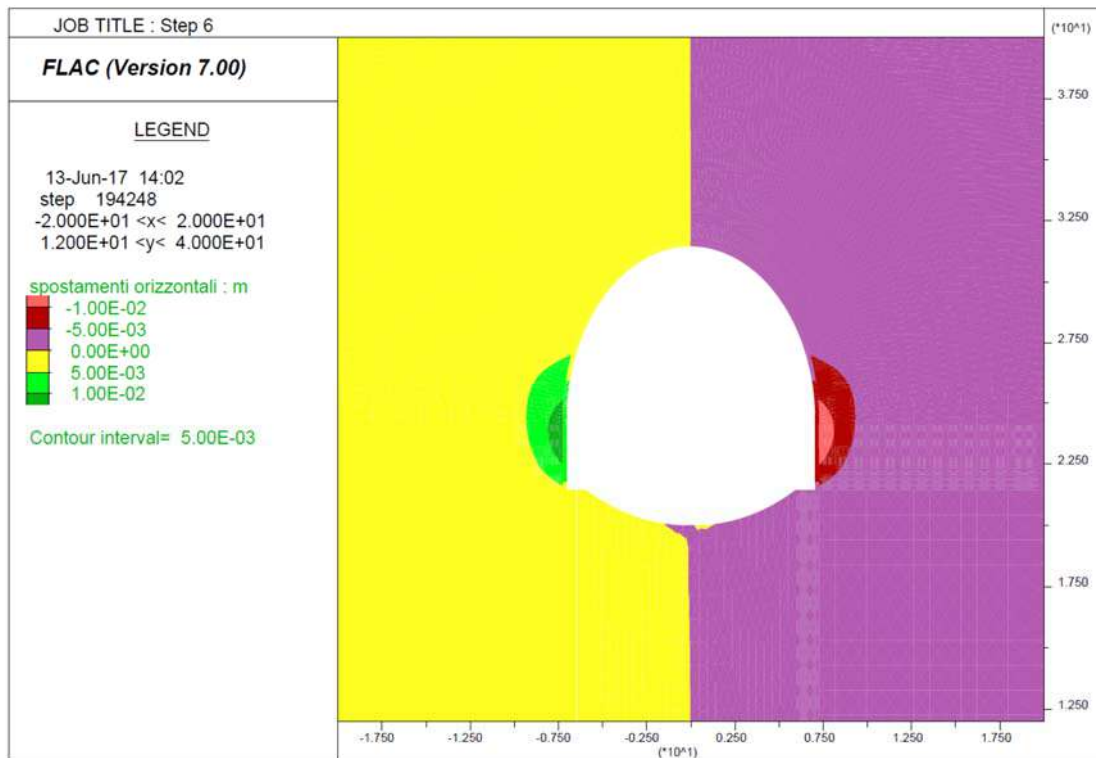
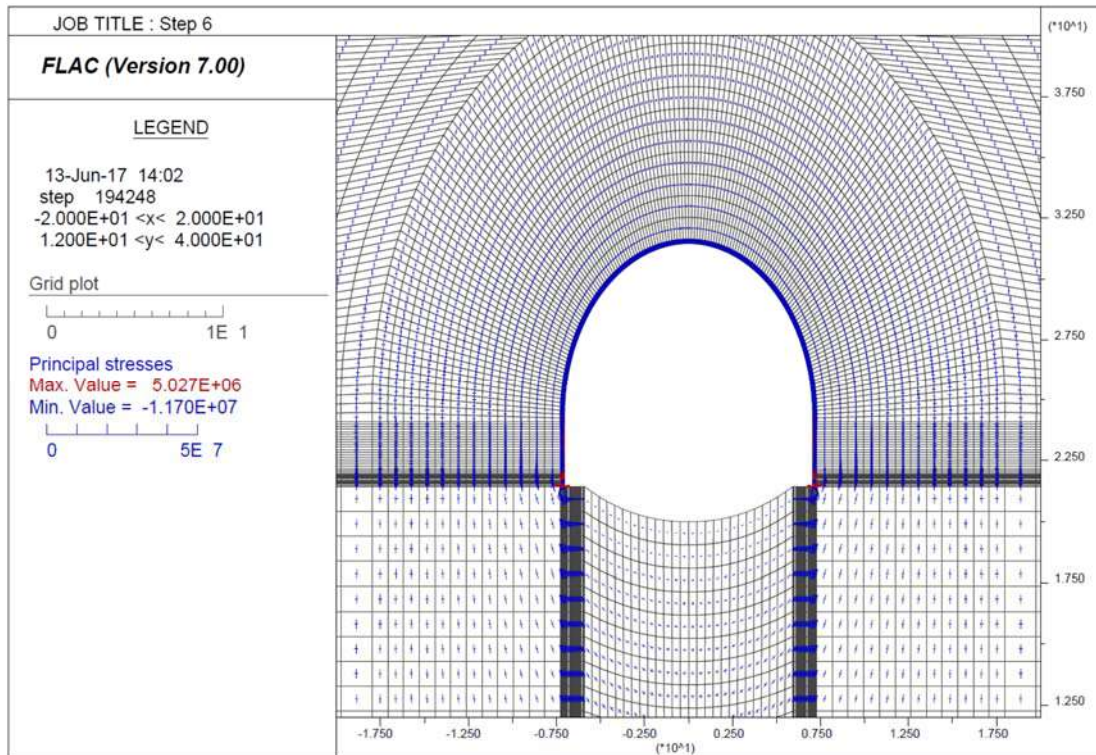

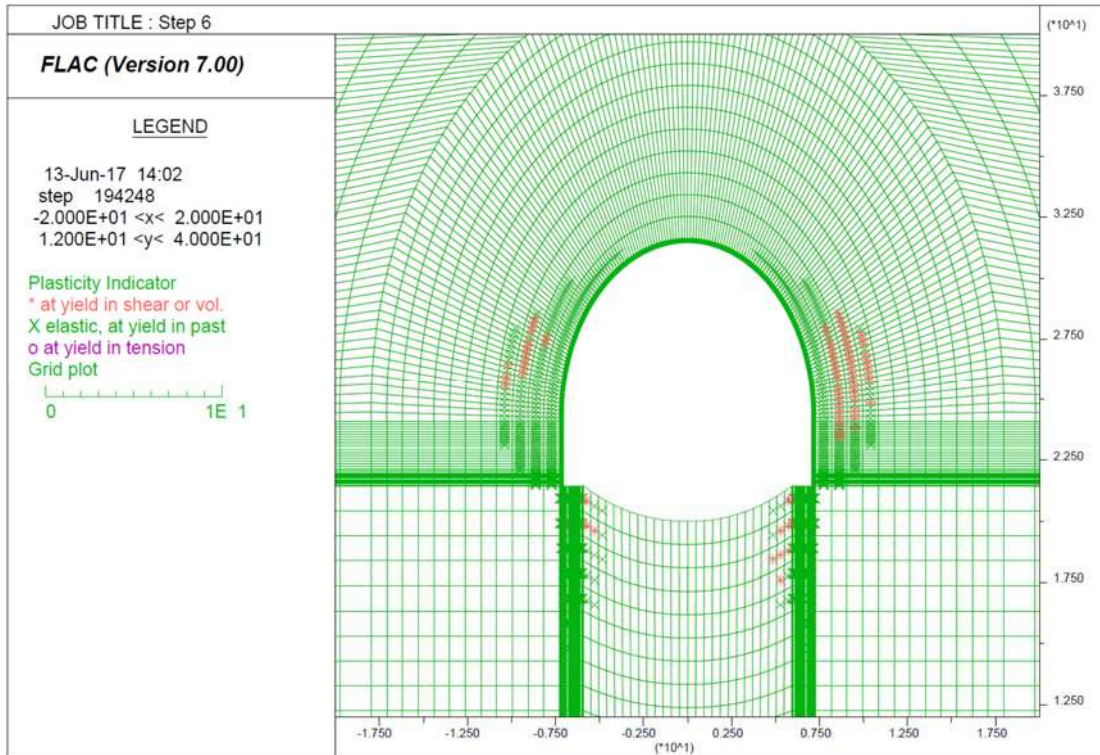
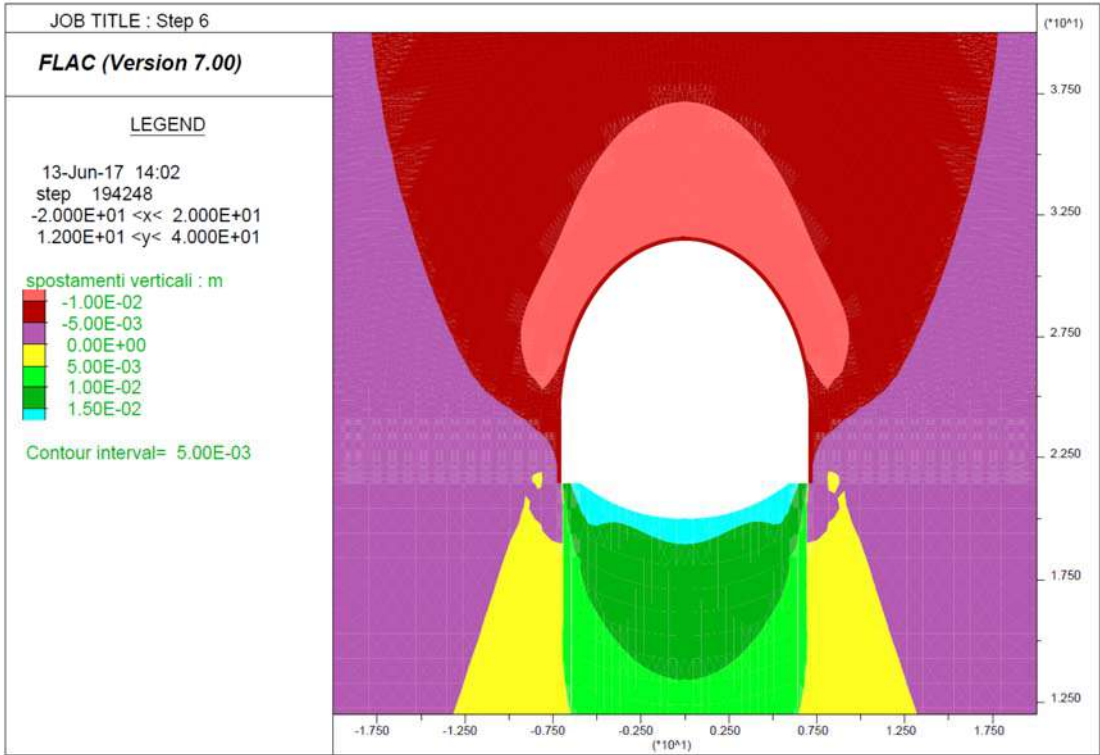



Step 7 - Getto arco rovescio e muretta a 2D e avanzamento fino a deformazioni esaurite

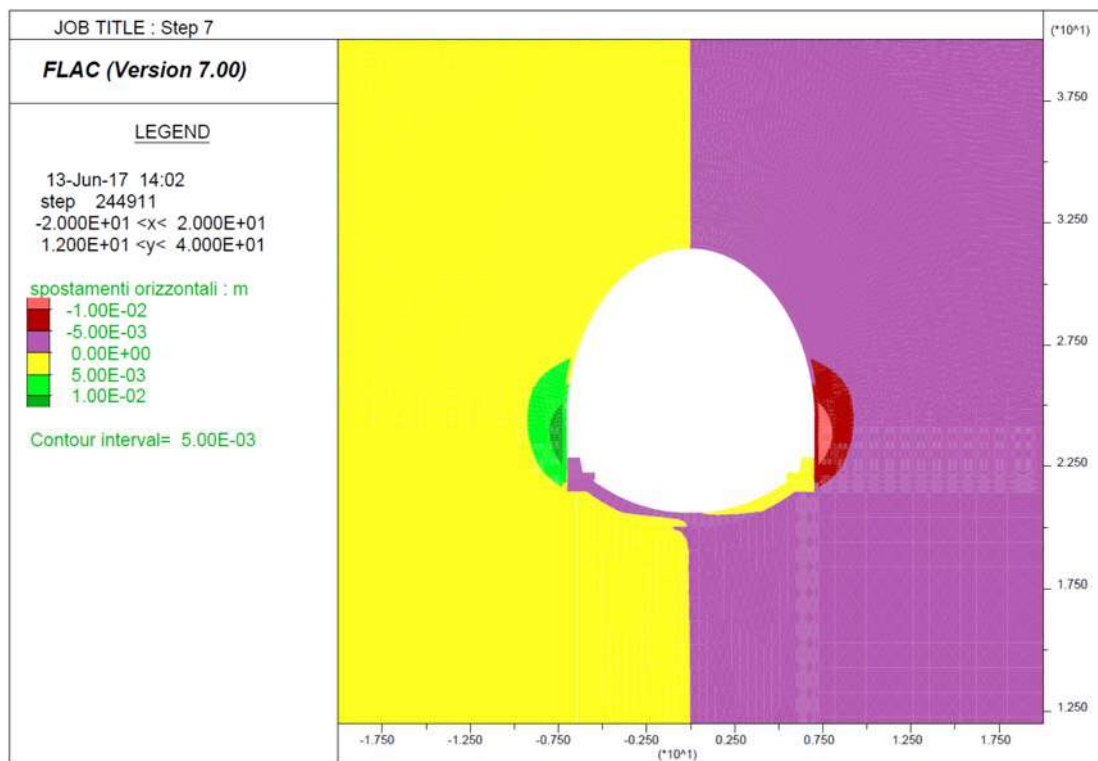
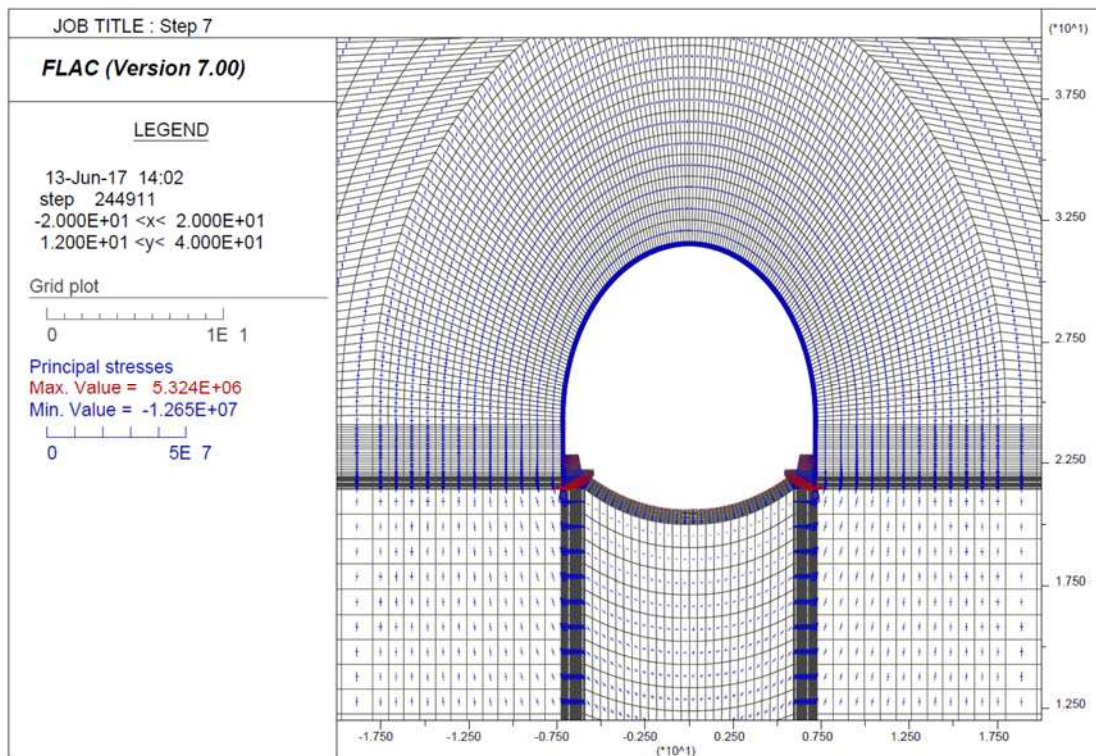



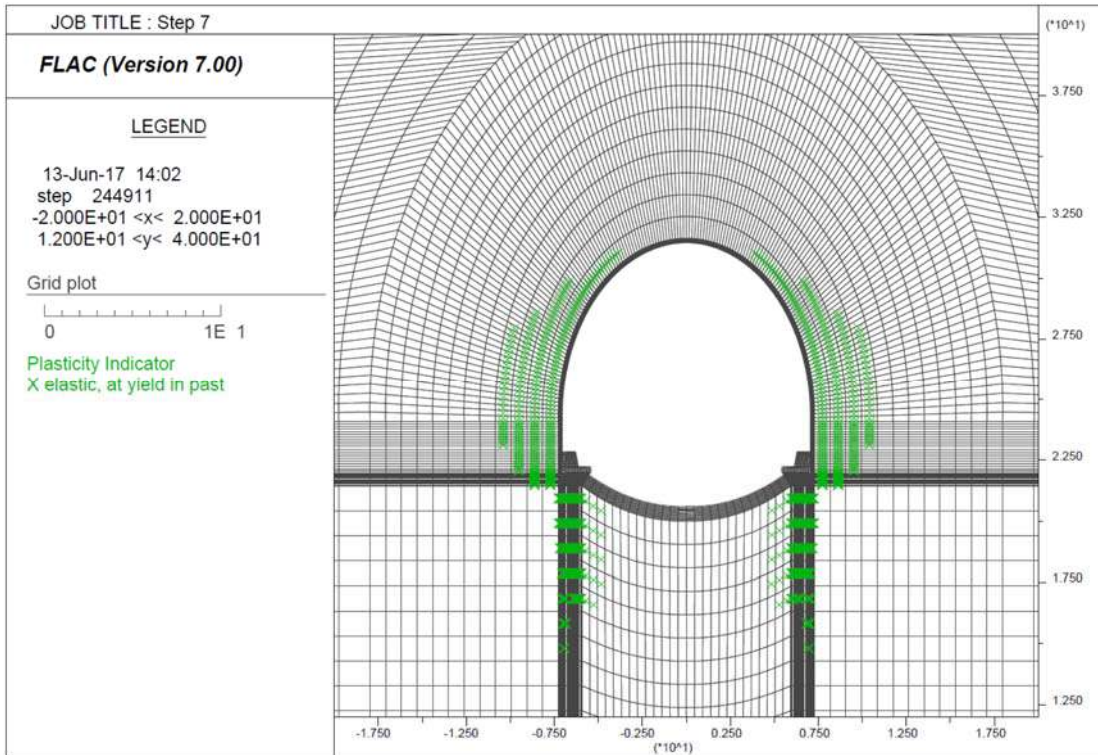
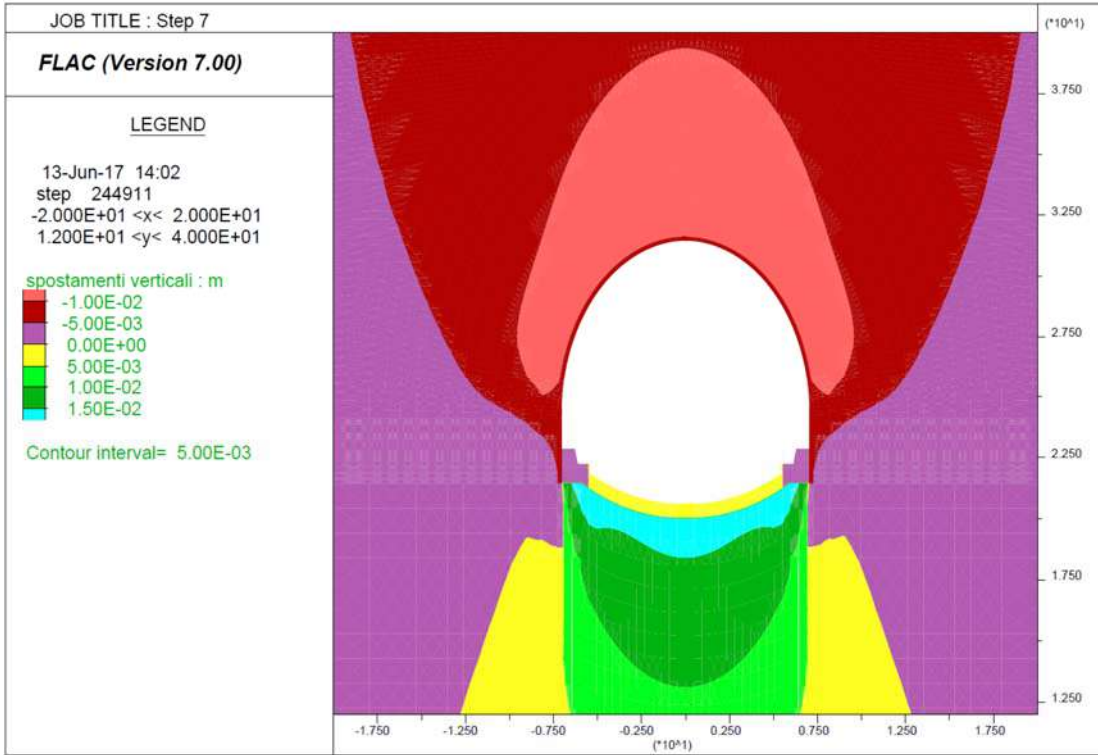

Step 8 - Getto Calotta

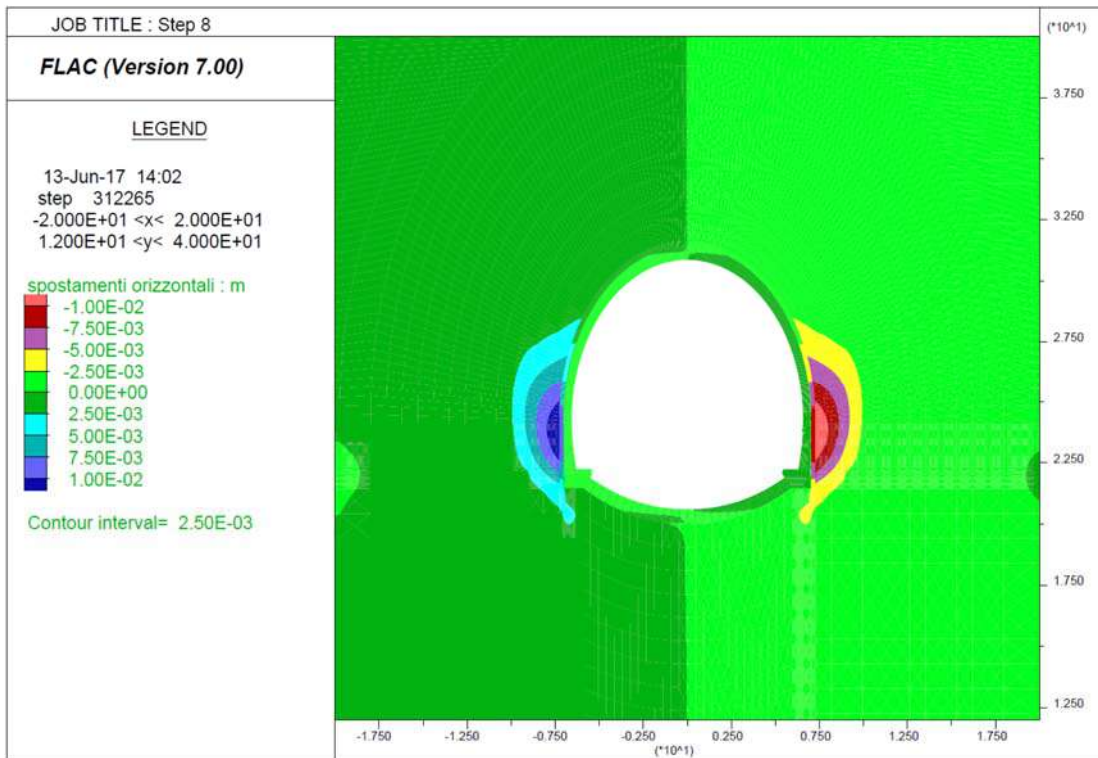
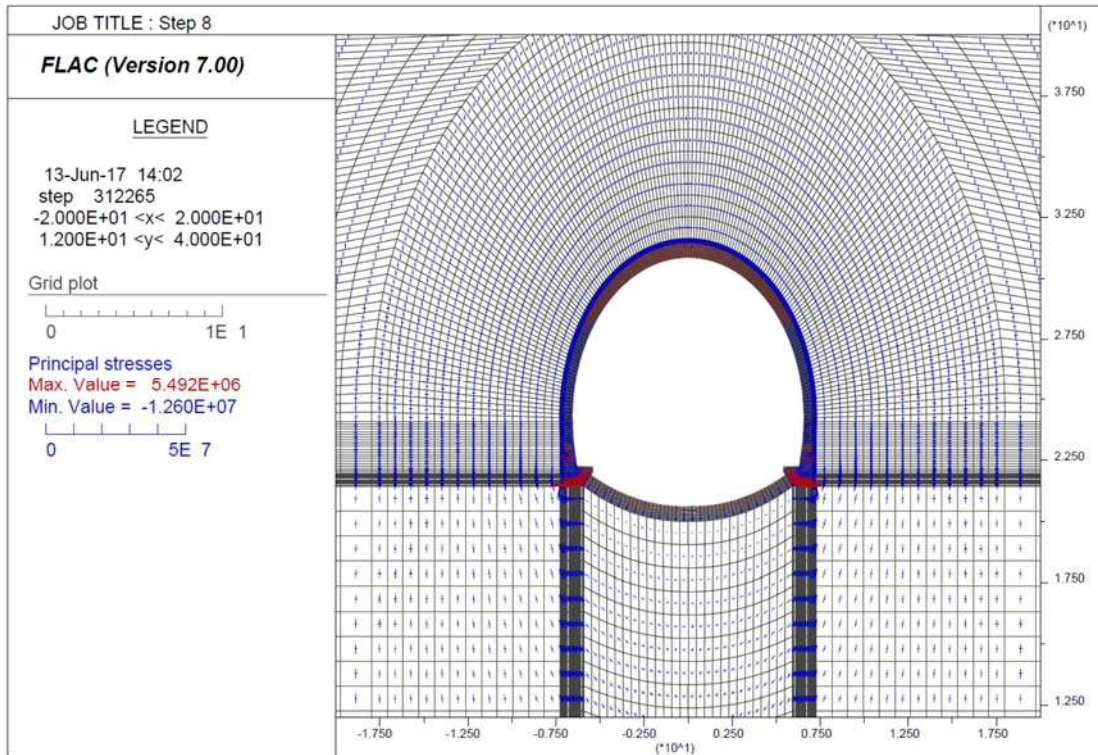



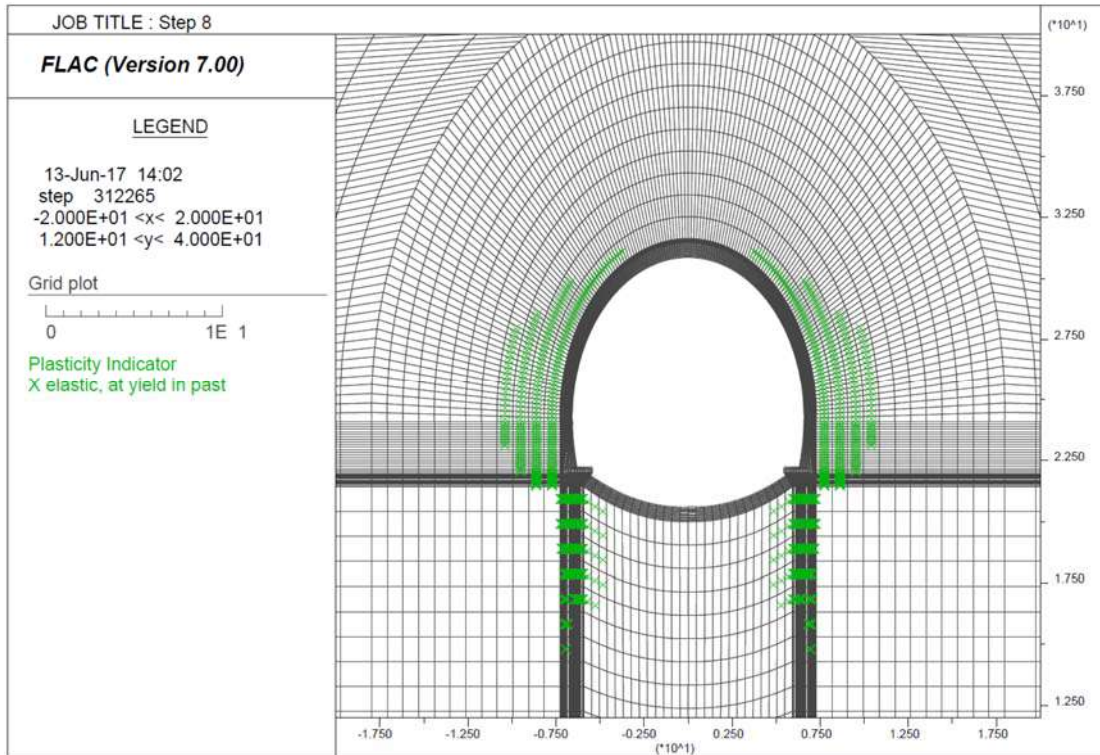
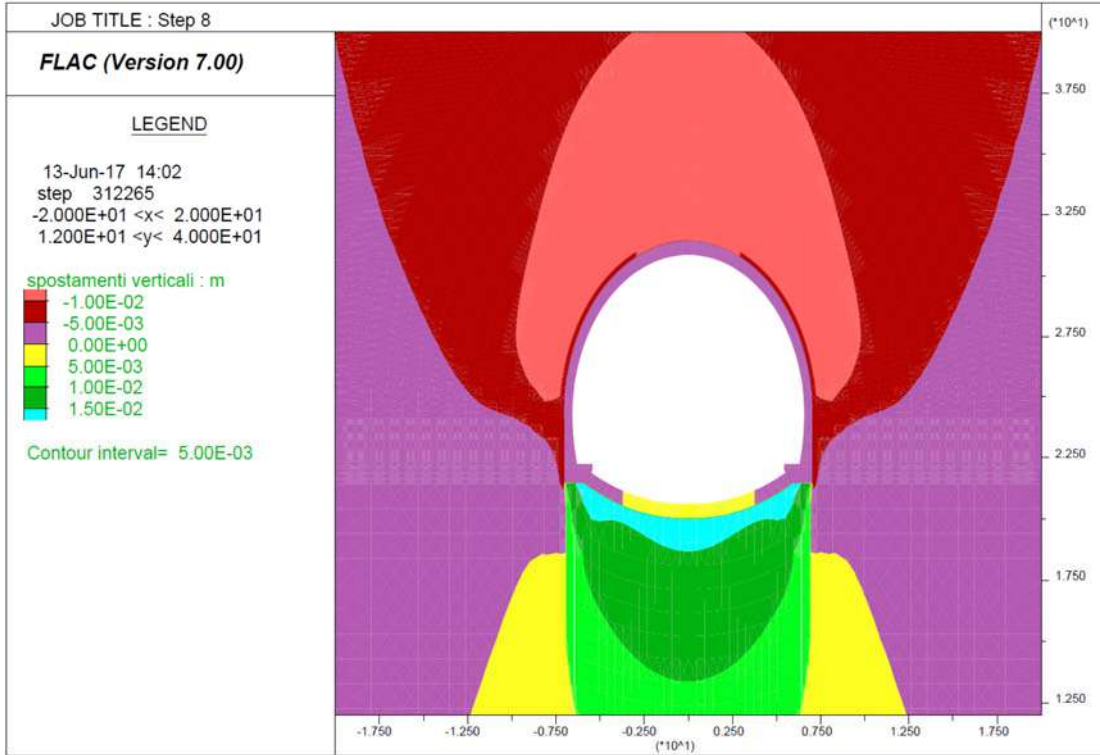



Step 9 - Decadimento dei parametri di resistenza del rivestimento provvisorio

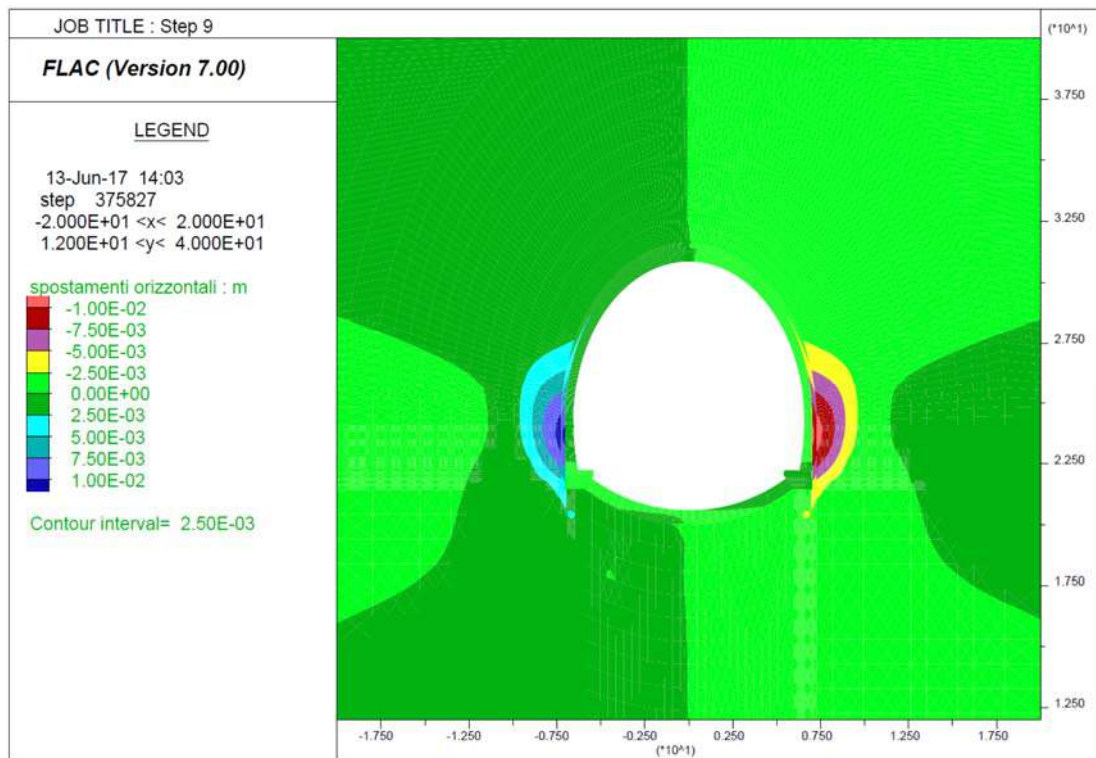
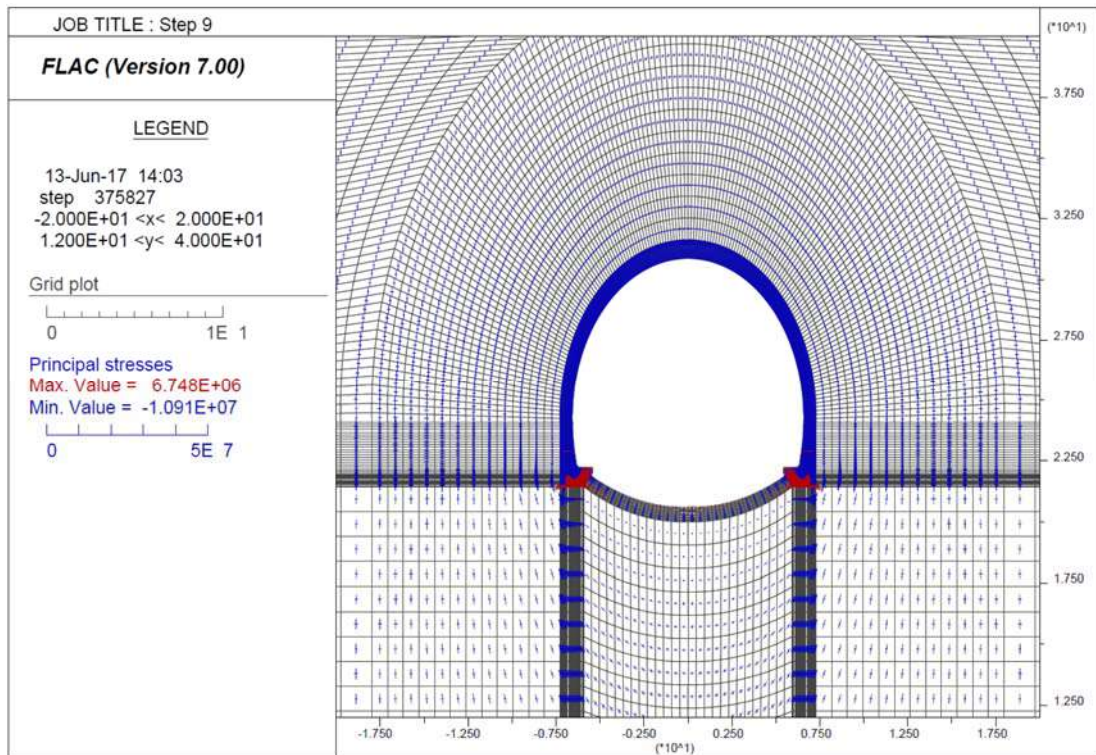

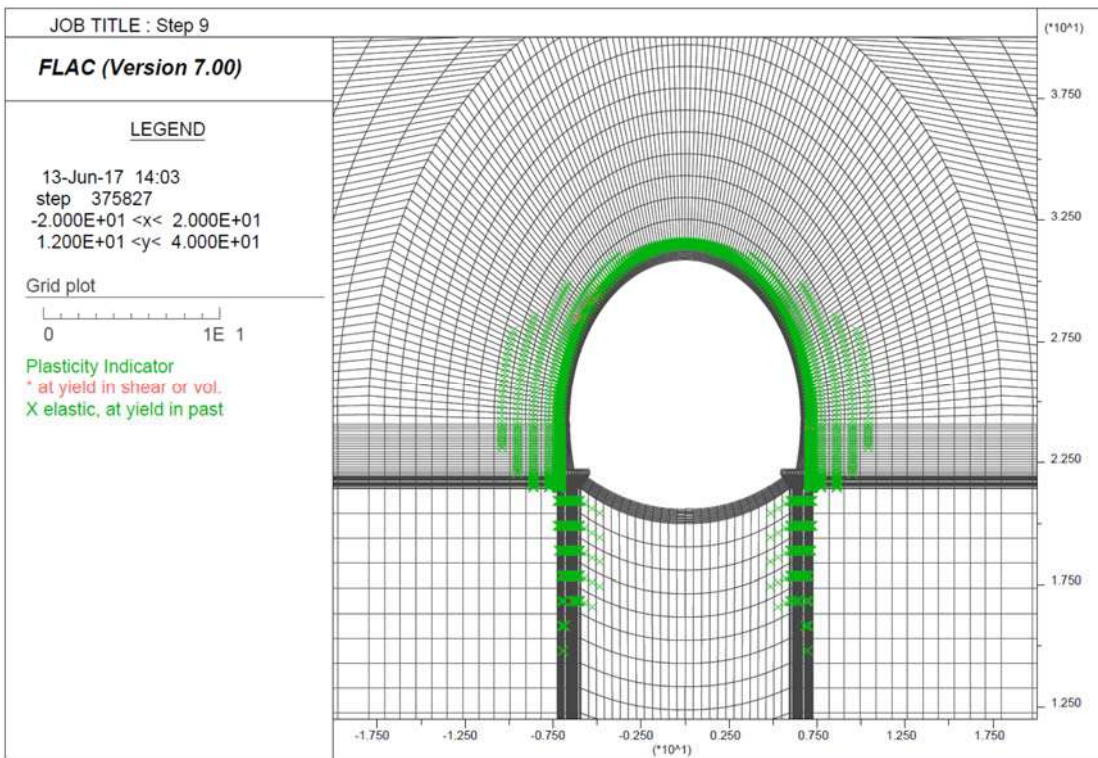
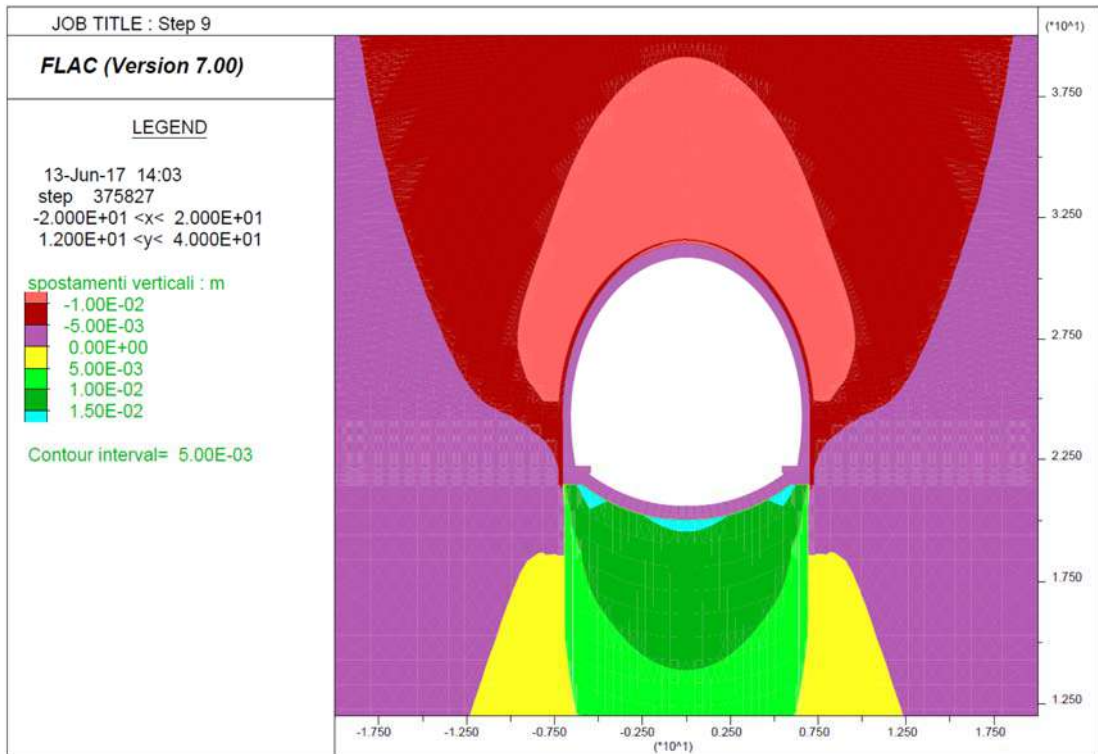

**Output Flac – Sezione tipo B0 – Parametri res min – Copertura di calcolo = 50 m**

**Step 1 – Tensioni litostatiche**

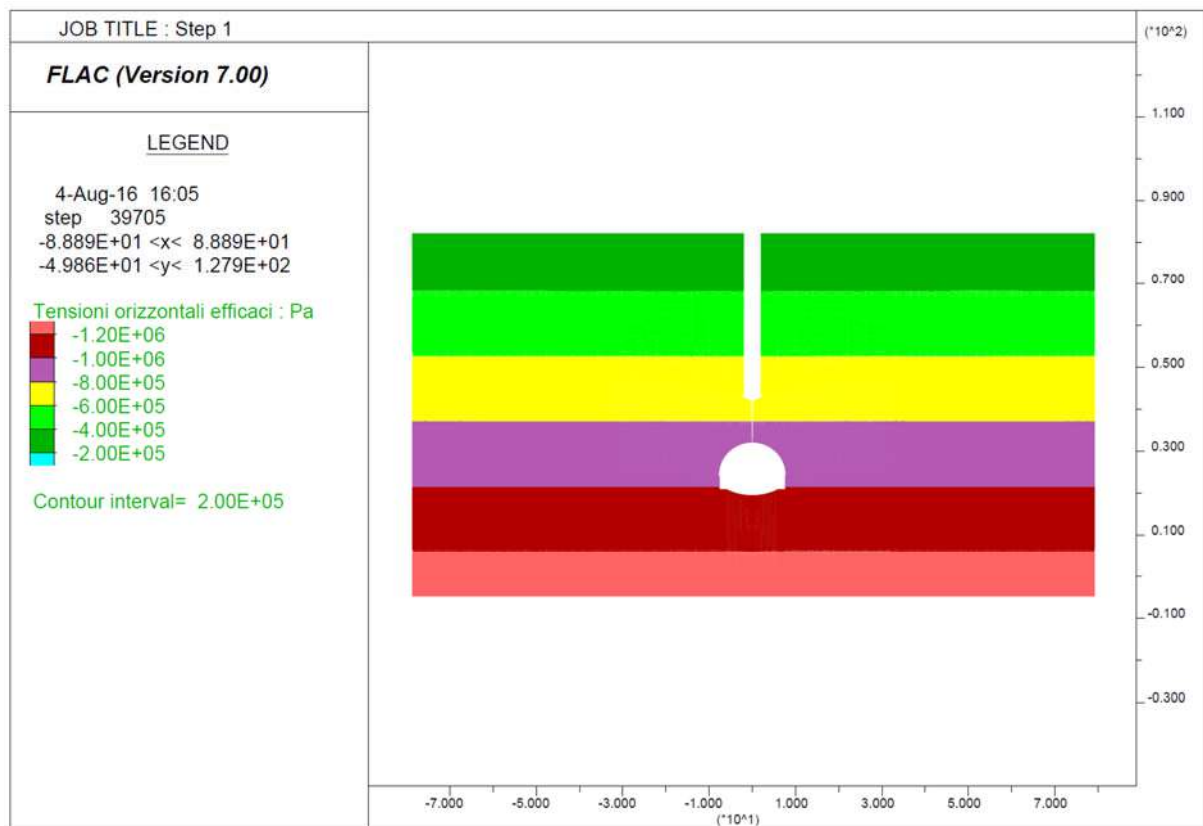
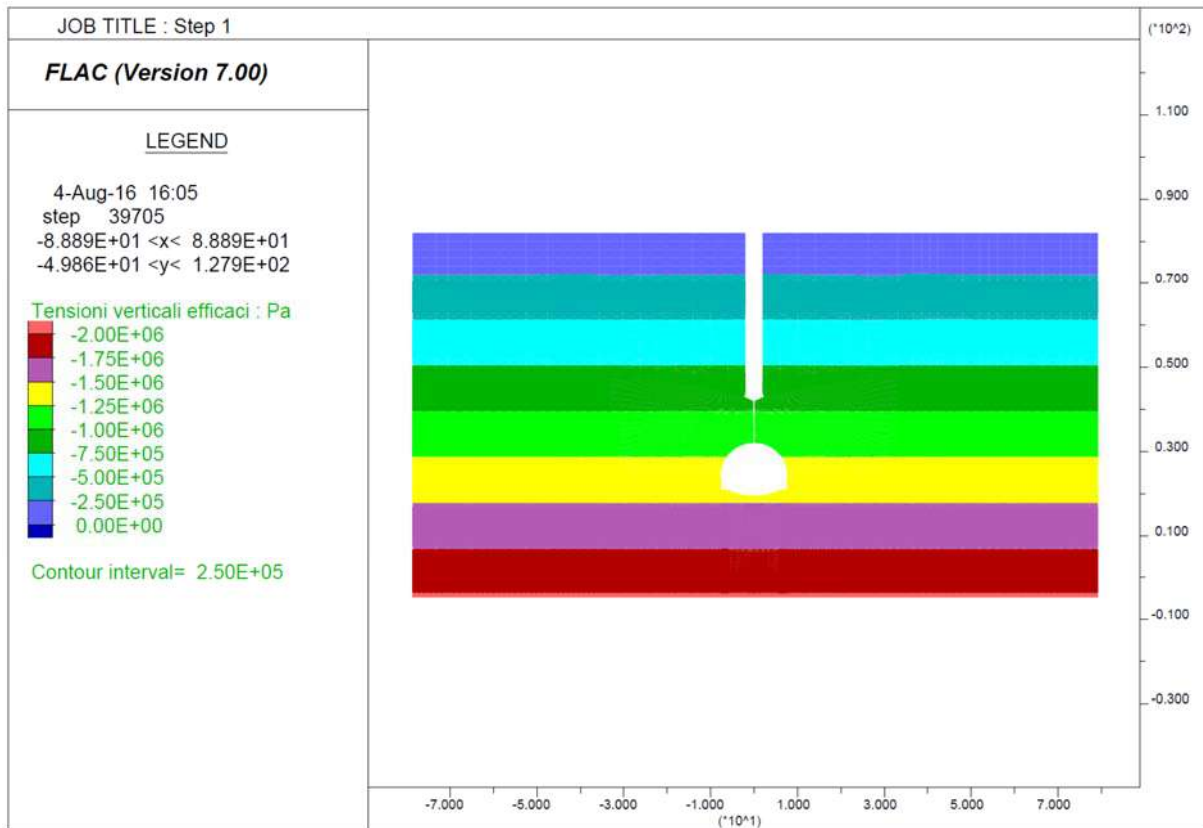



Step 6 – Avanzamento fino a deformazioni esaurite

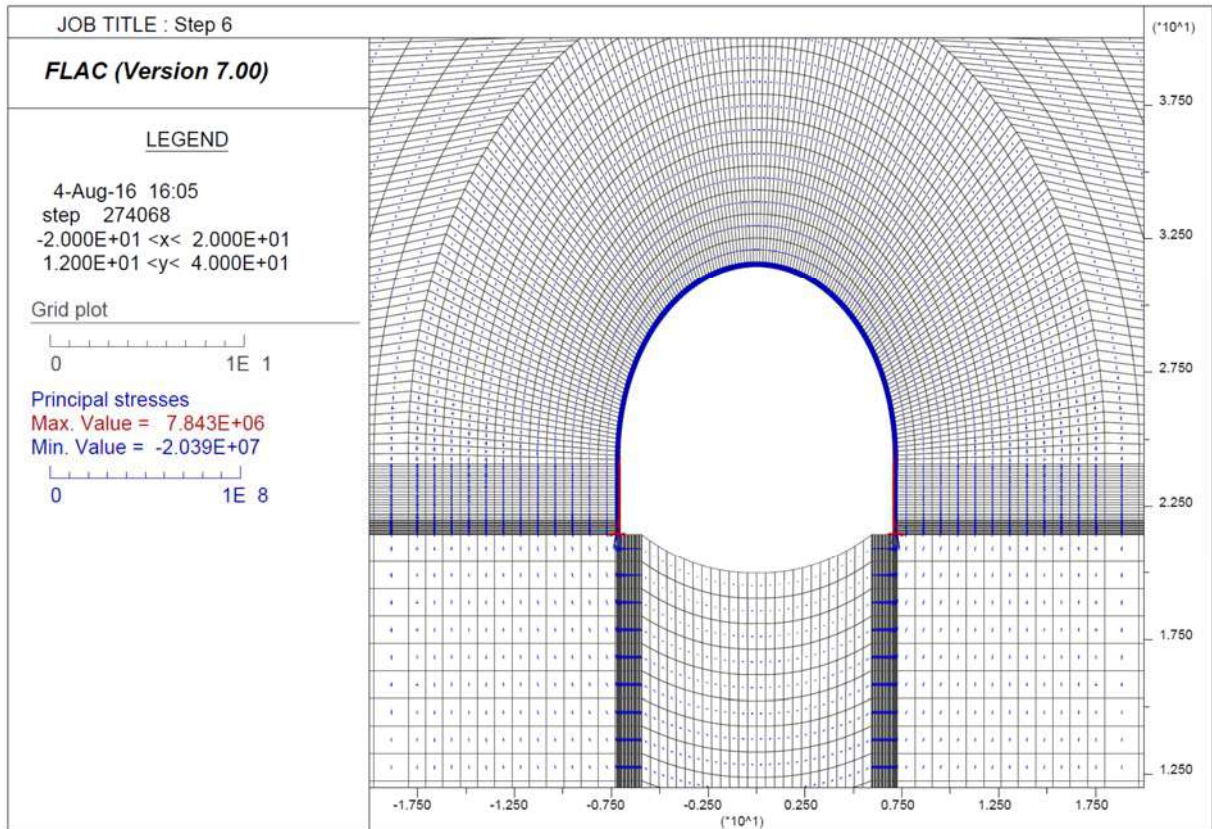

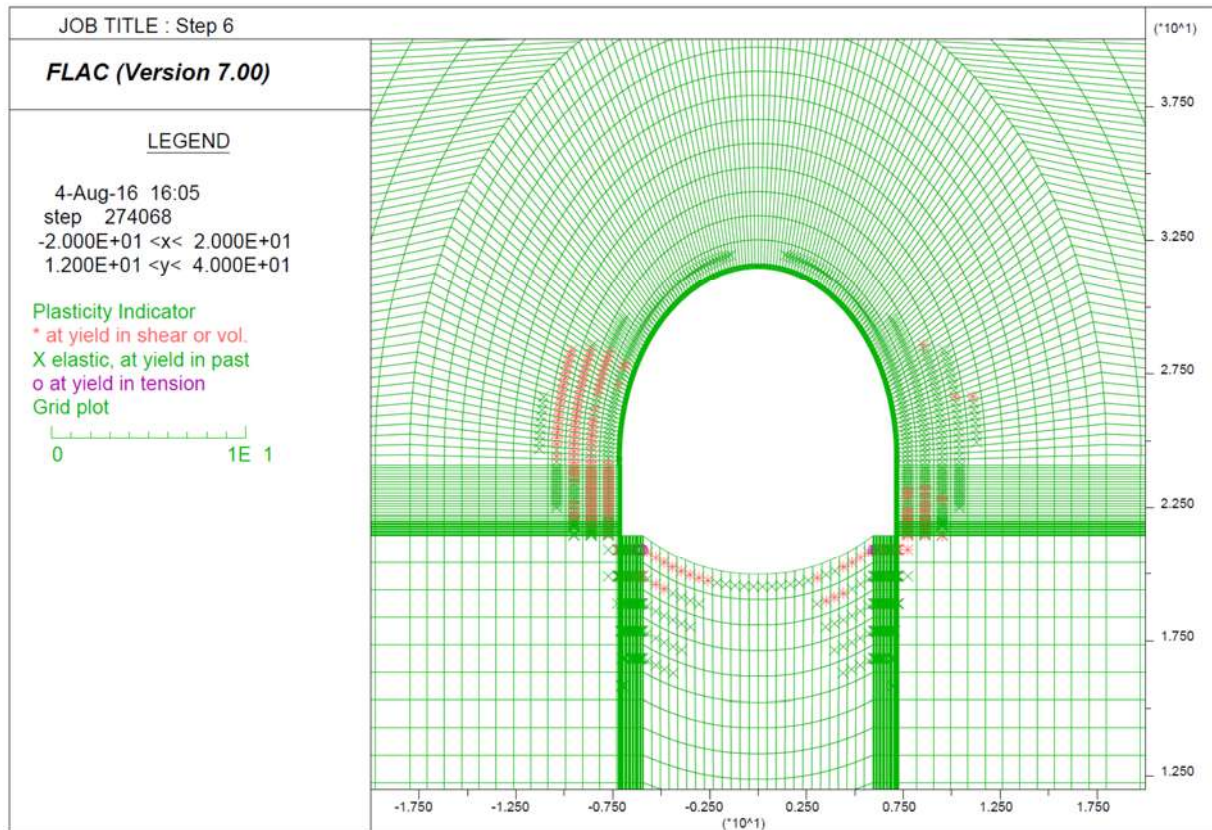
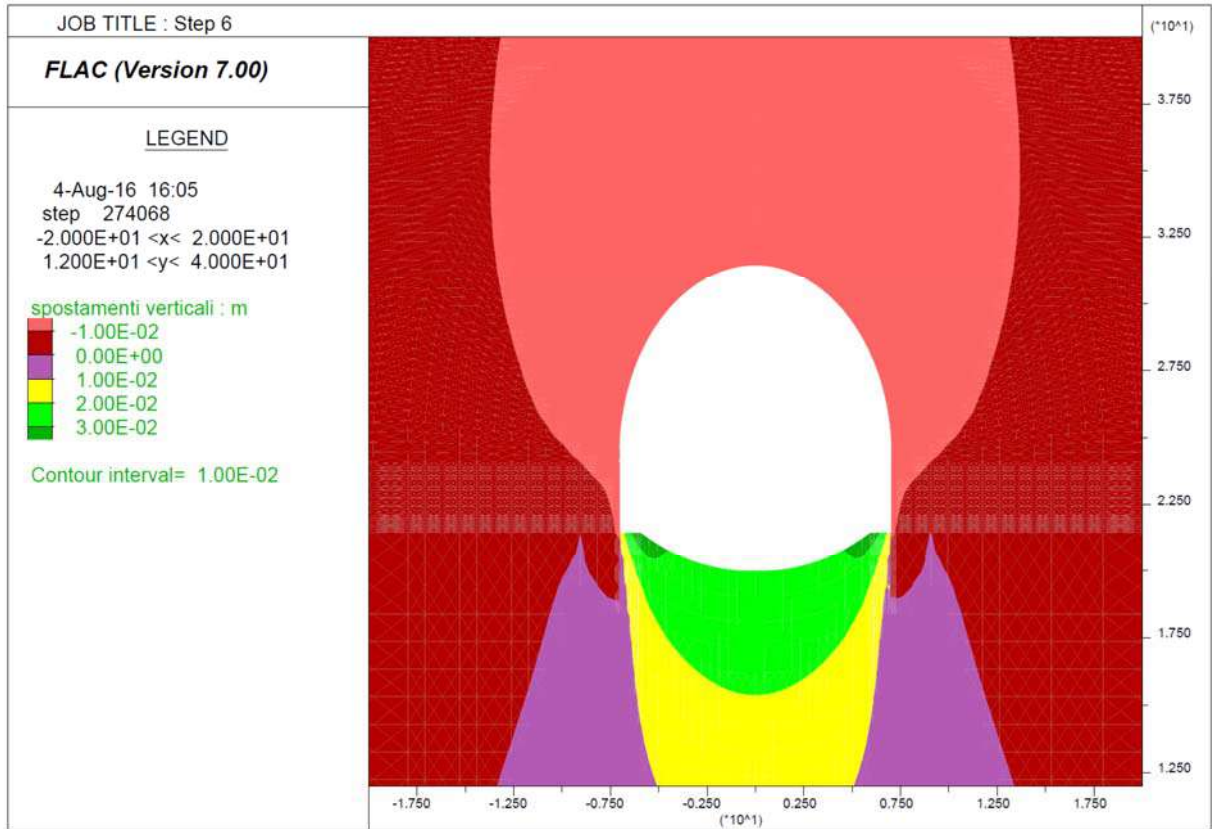



Step 7 - Getto arco rovescio e muretta

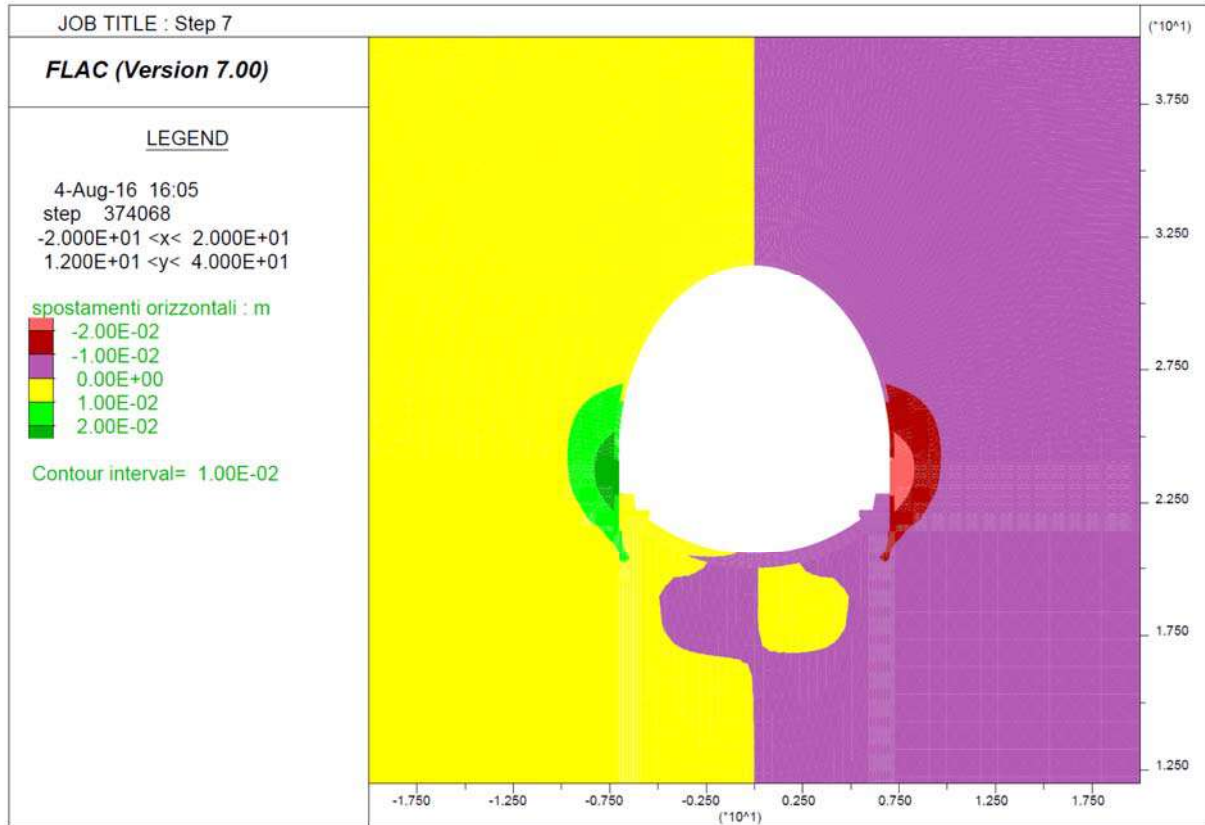
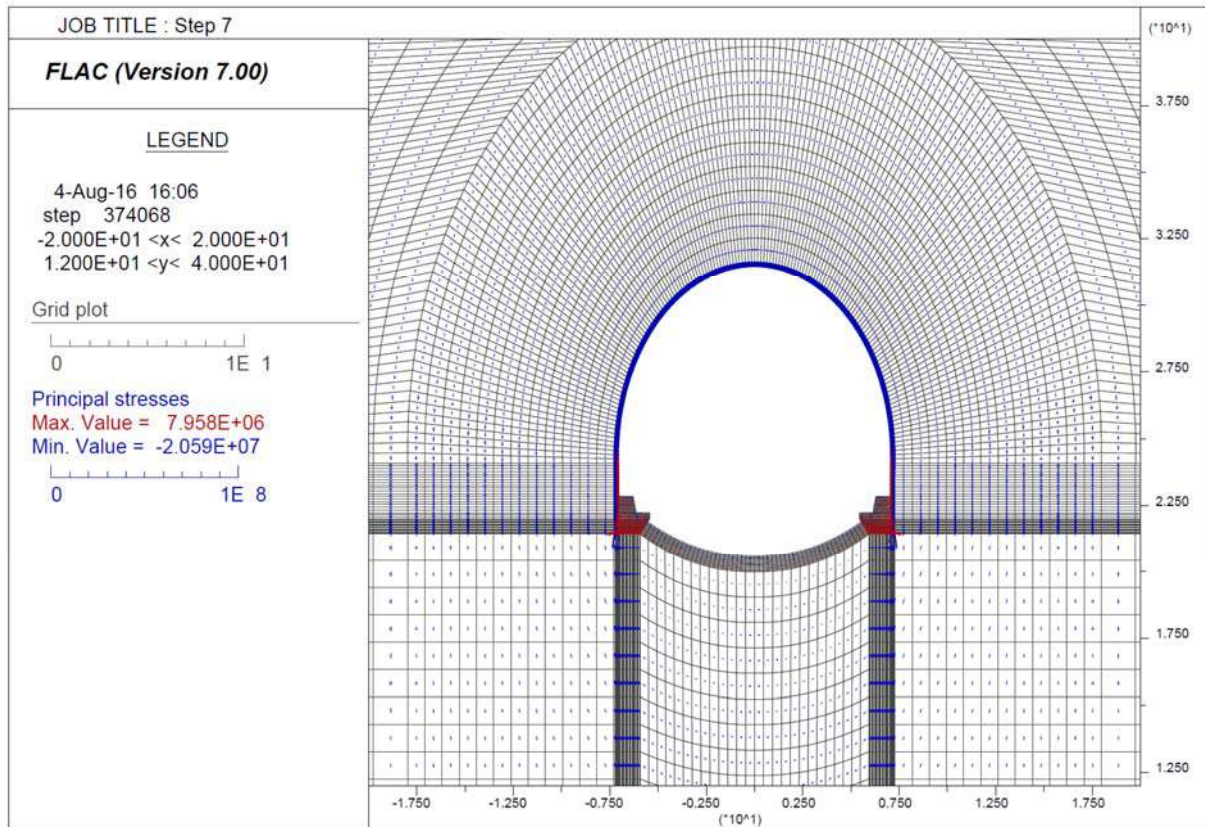



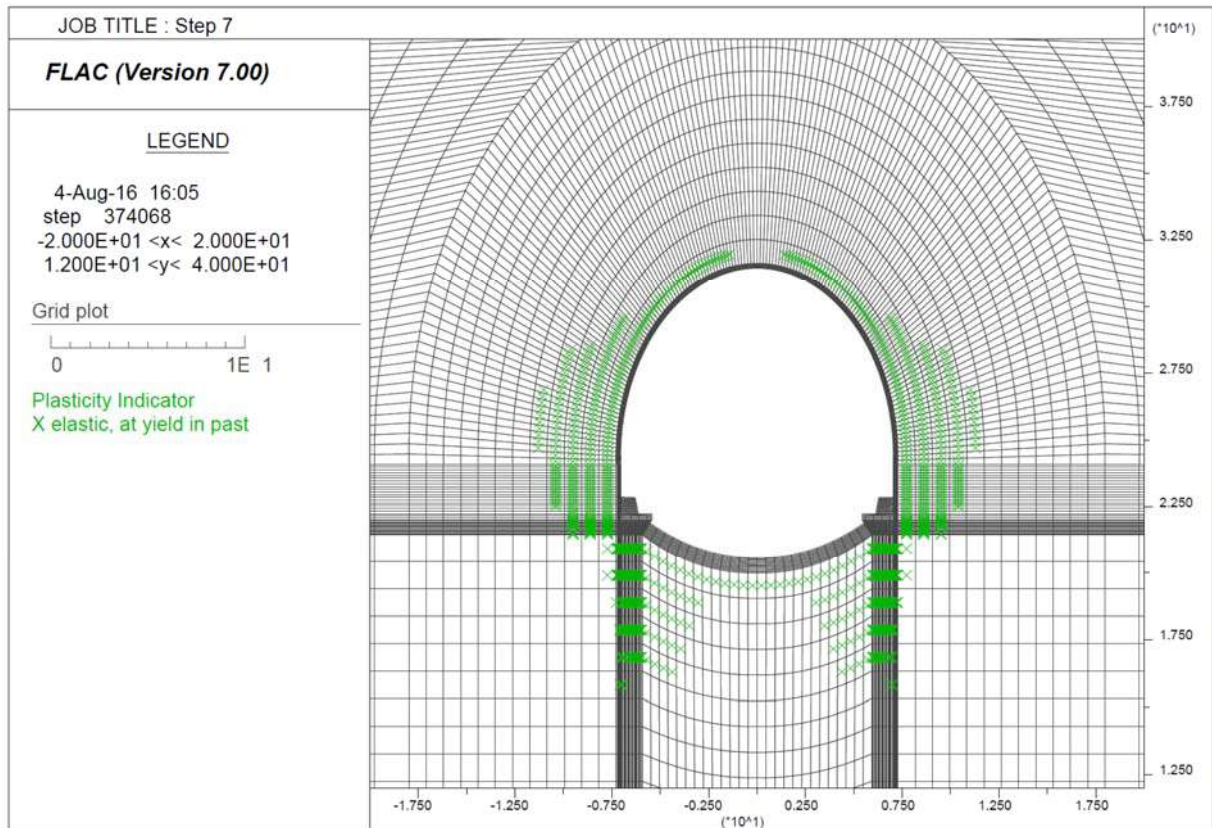
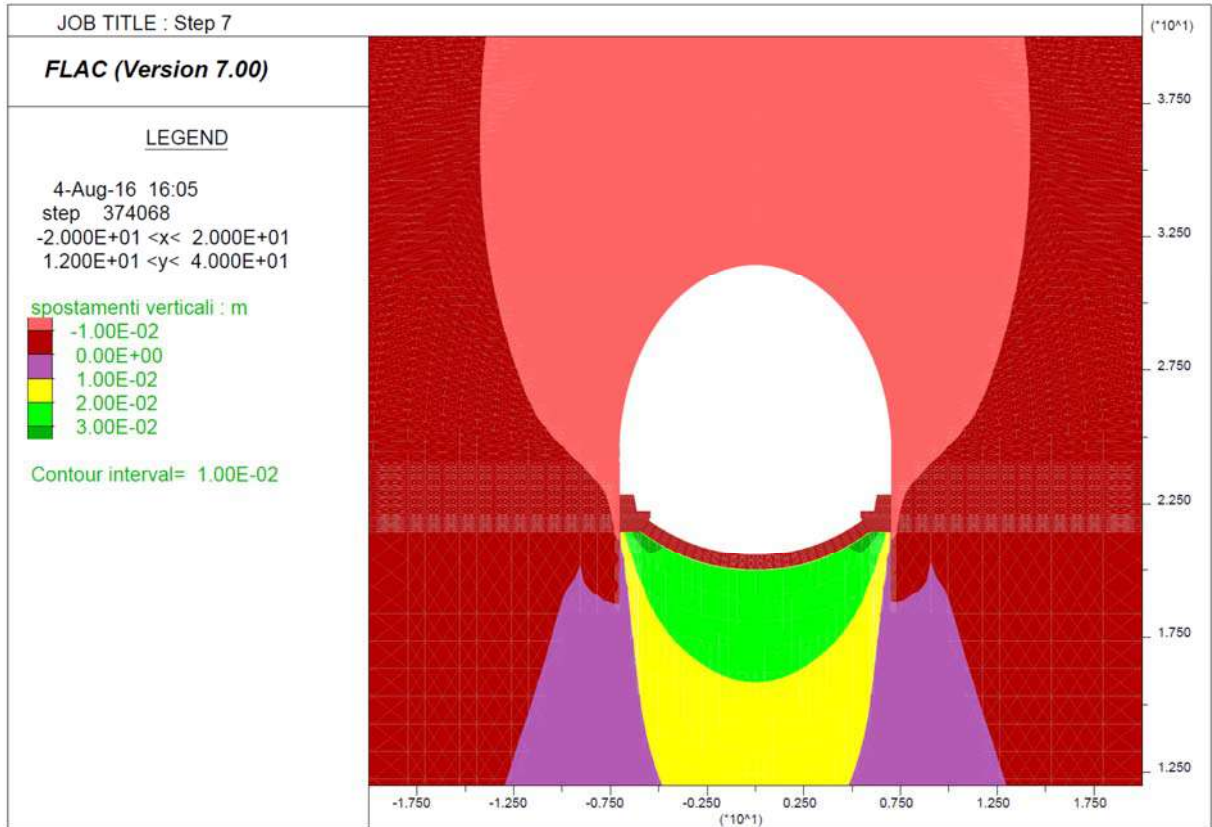

Step 8 - Getto Calotta

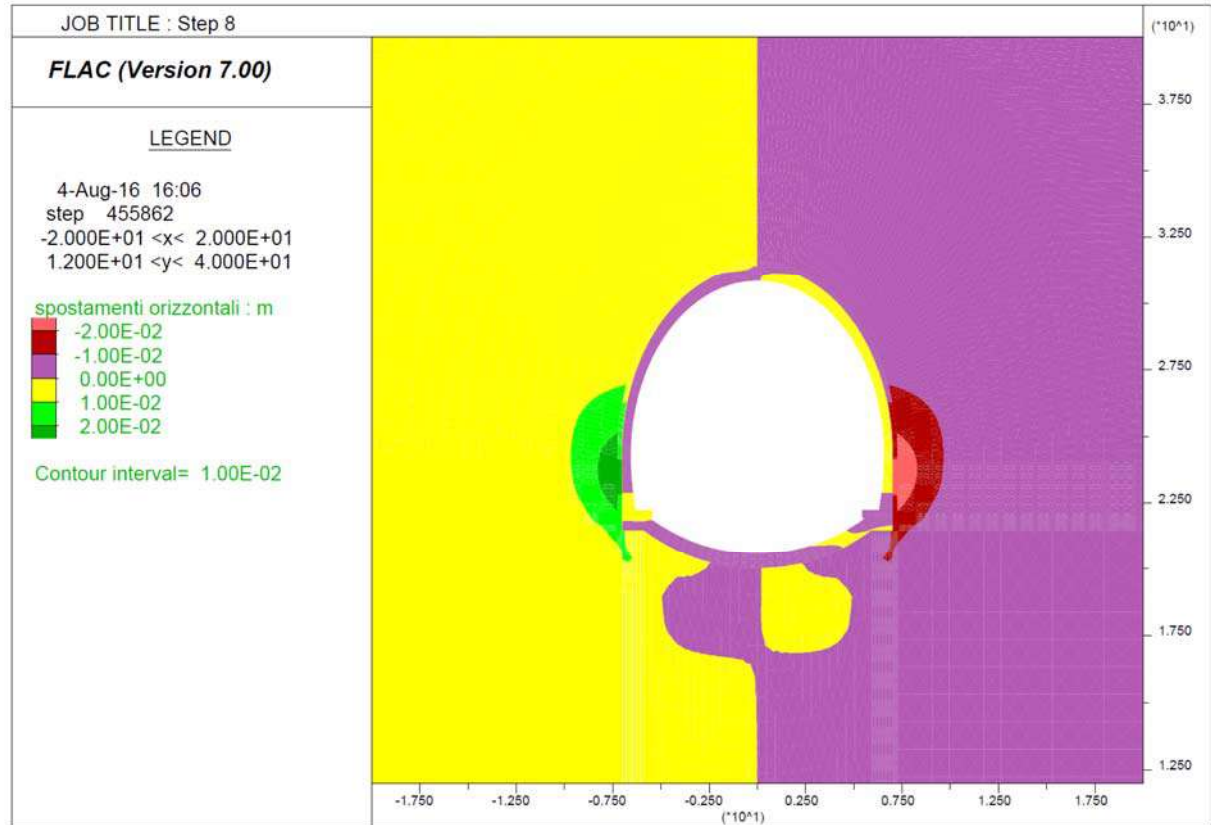
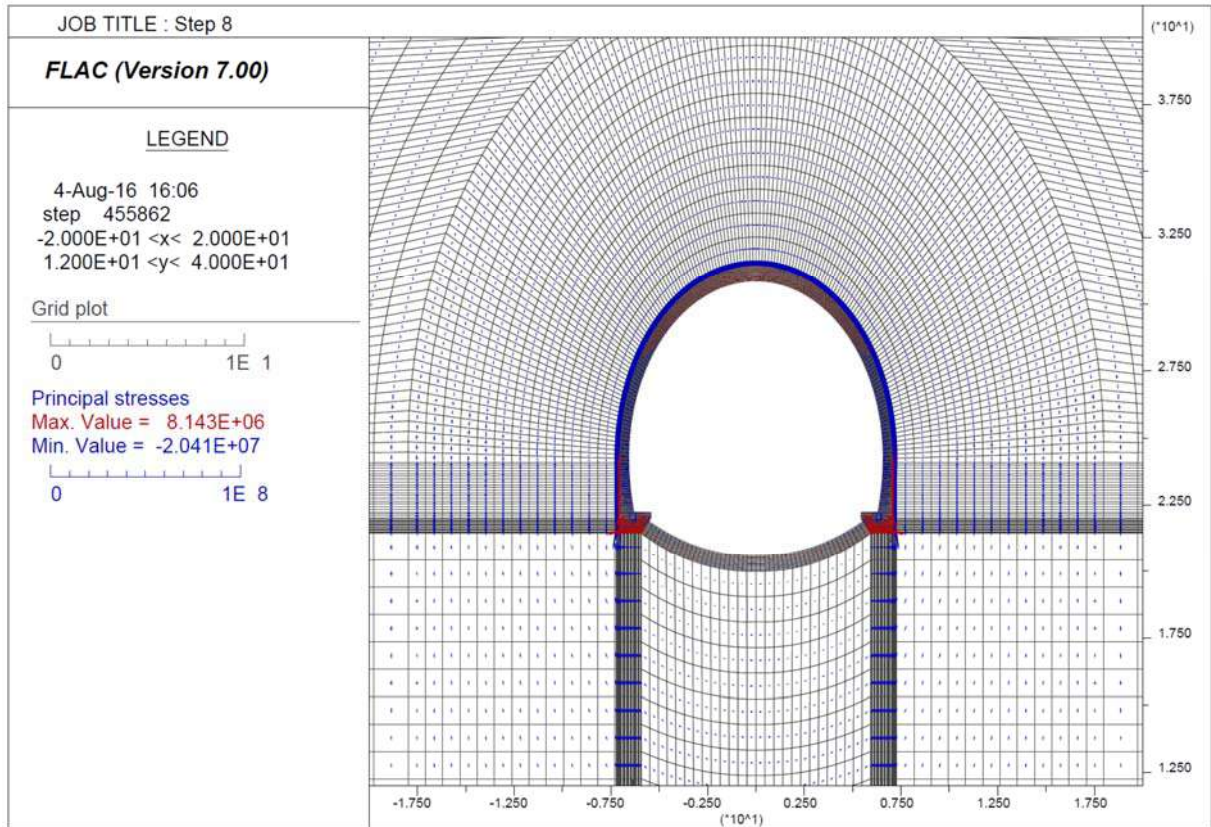



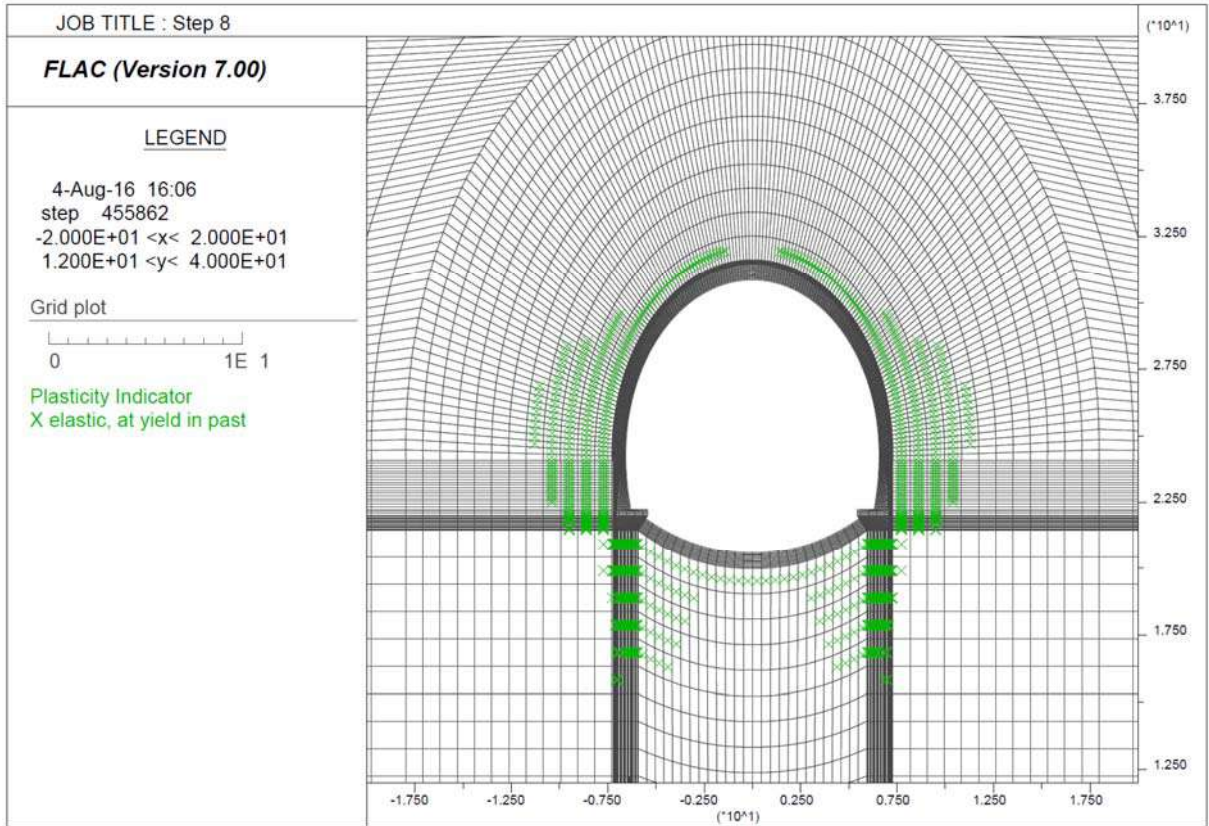
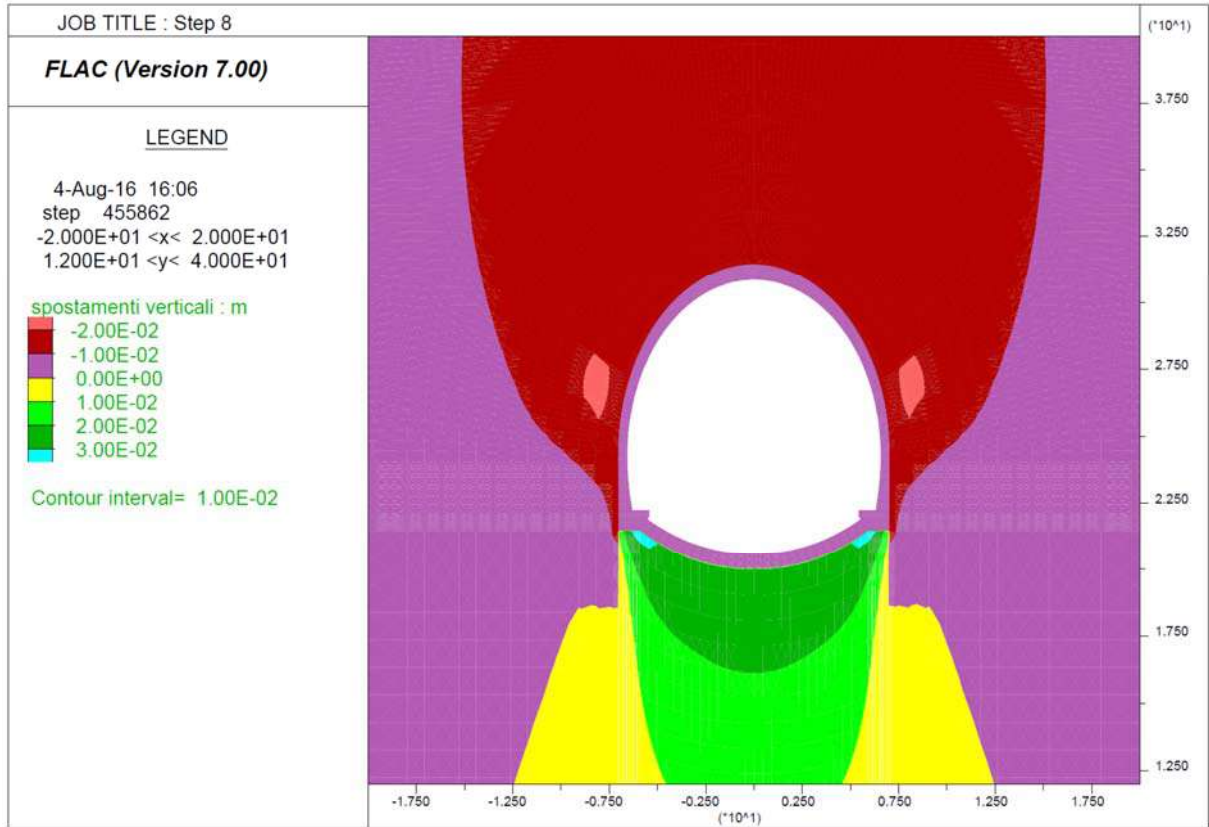



Step 9 - Decadimento dei parametri di resistenza del rivestimento provvisorio

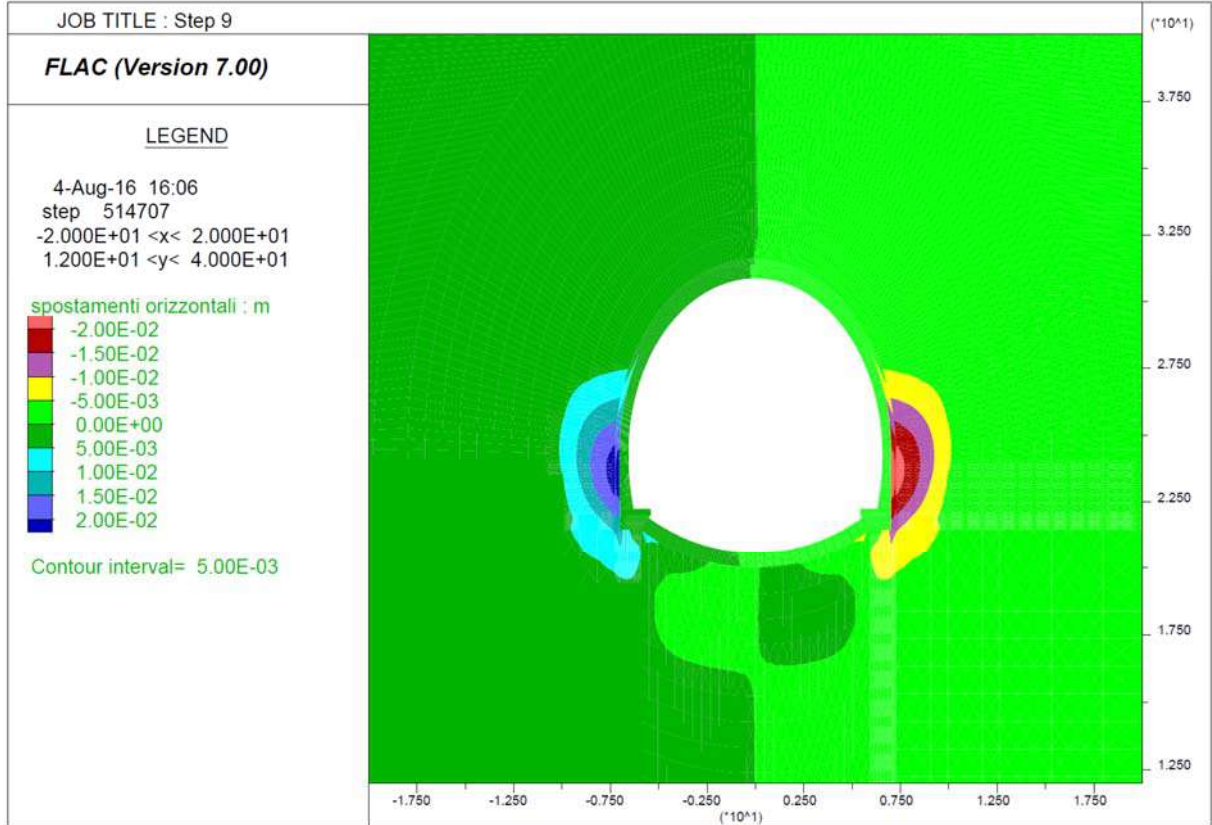
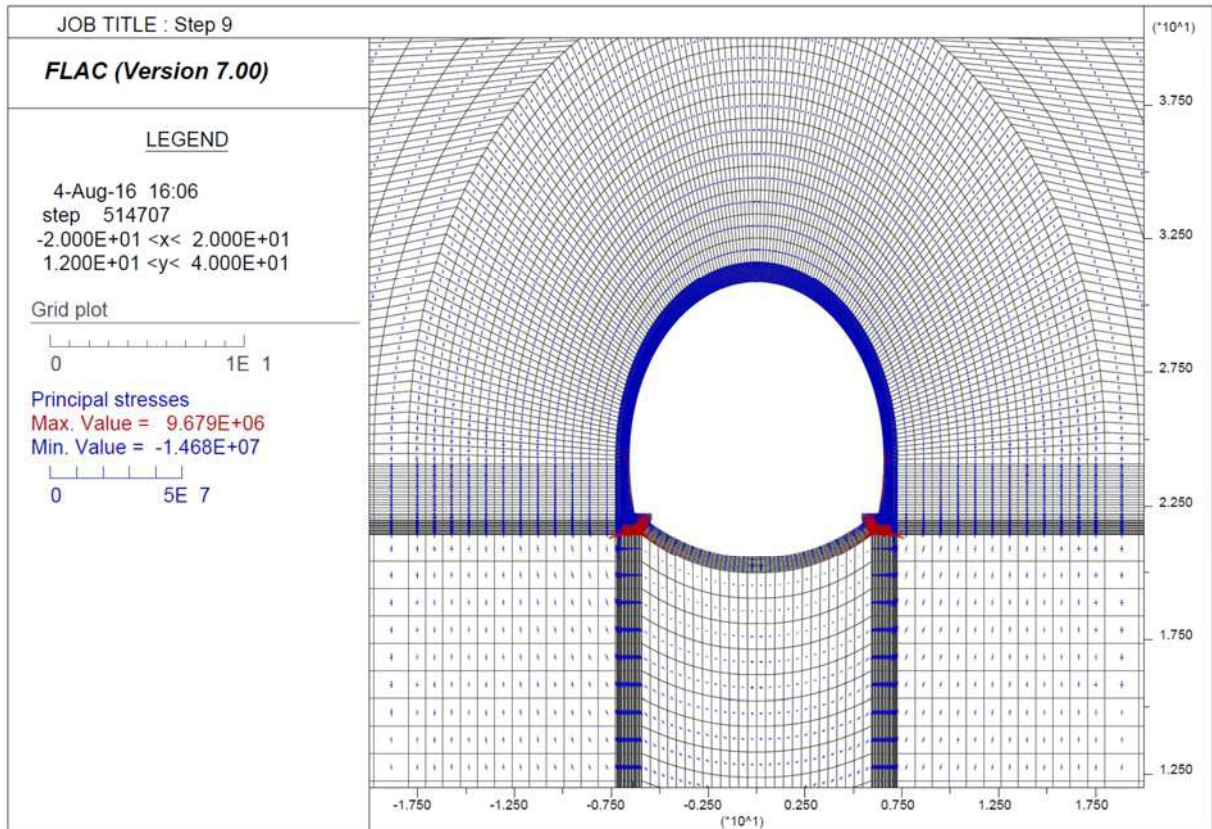

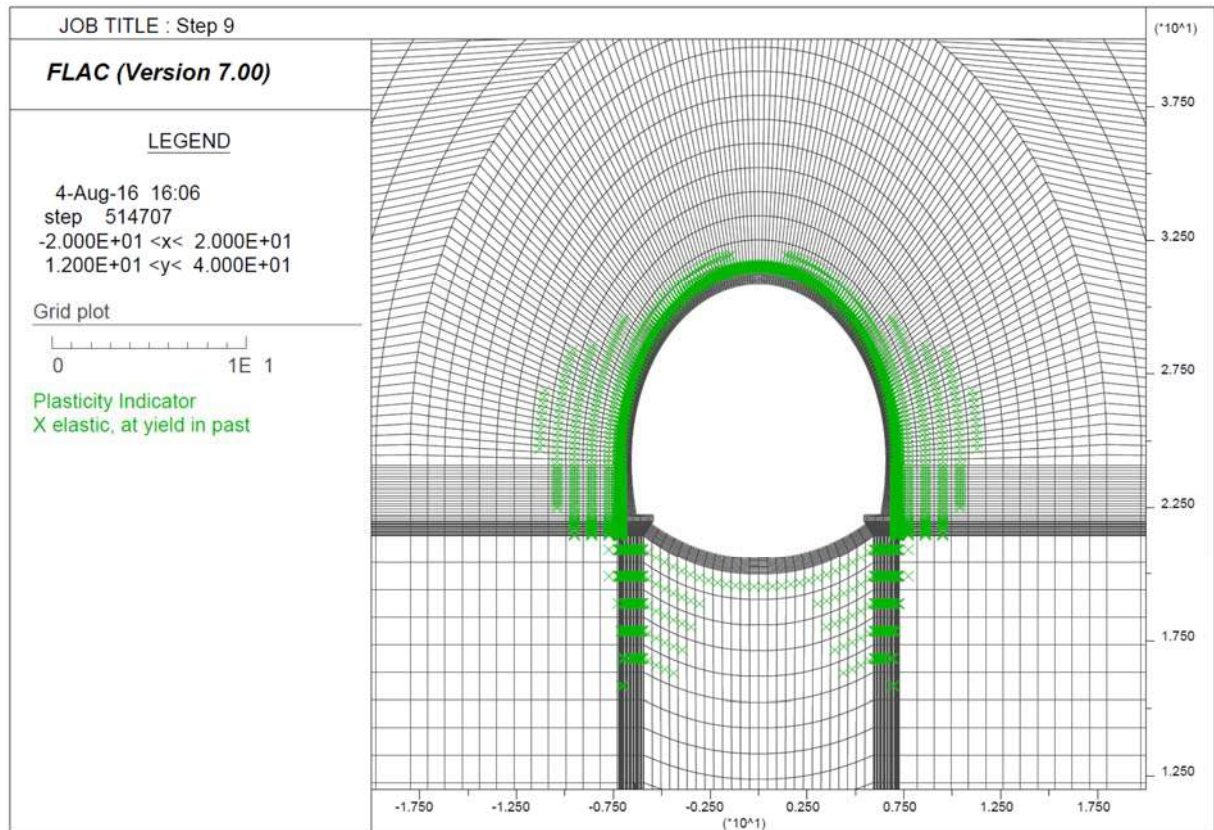
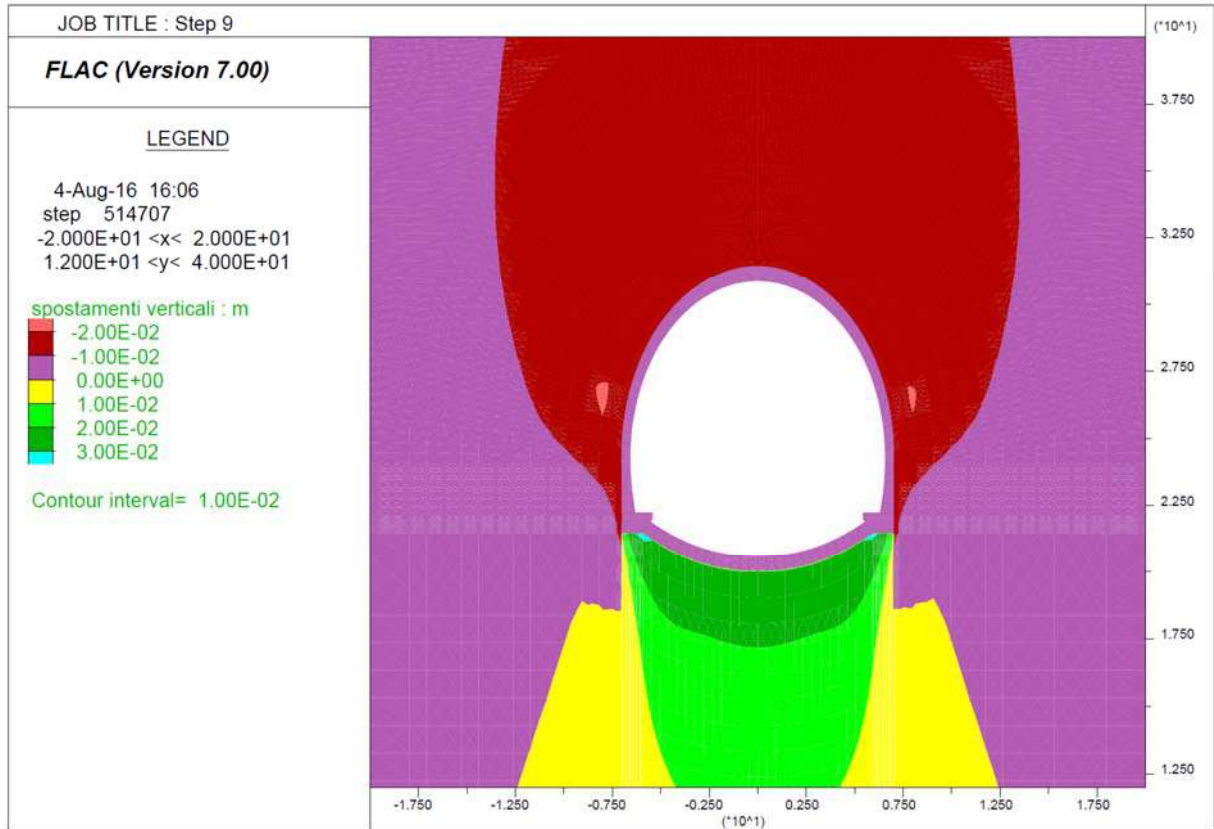

**Output Flac – Sezione tipo B0 – Parametri res max – Copertura di calcolo = 50 m**

**Step 1 – Tensioni litostatiche**

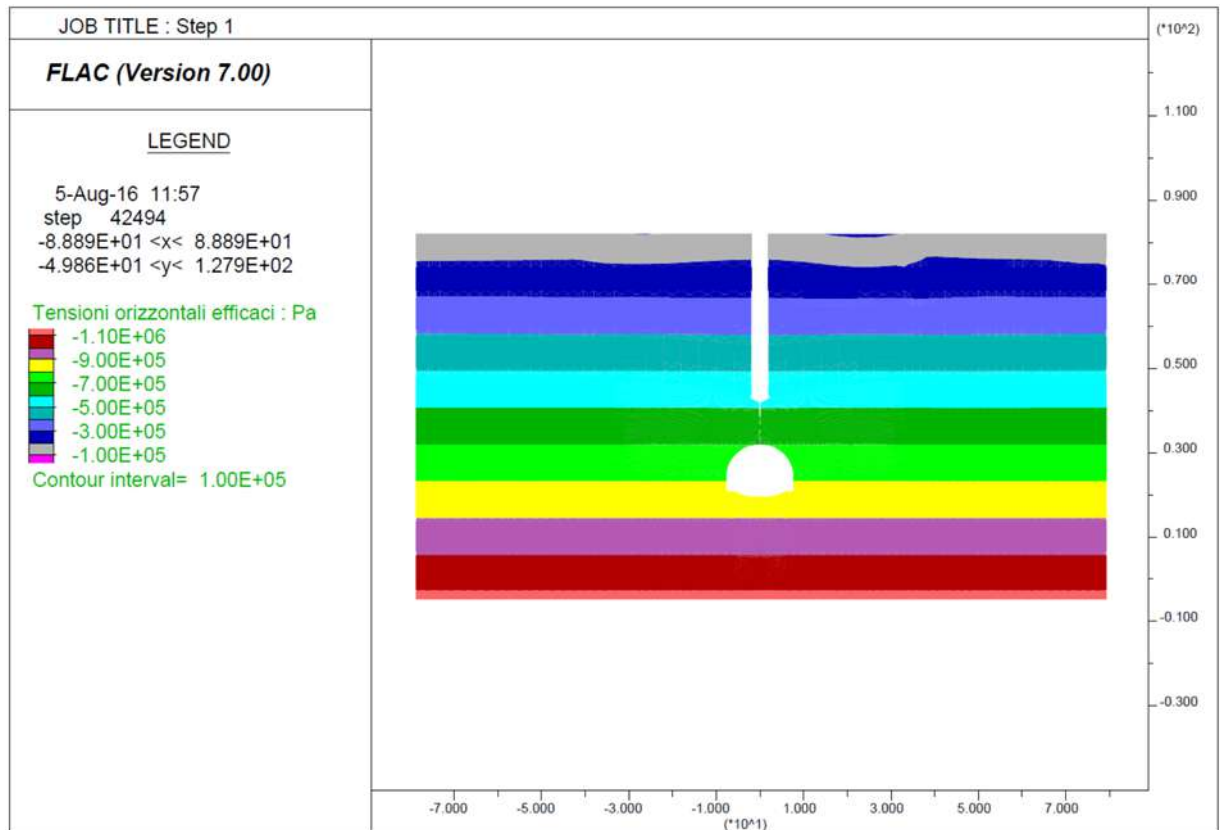
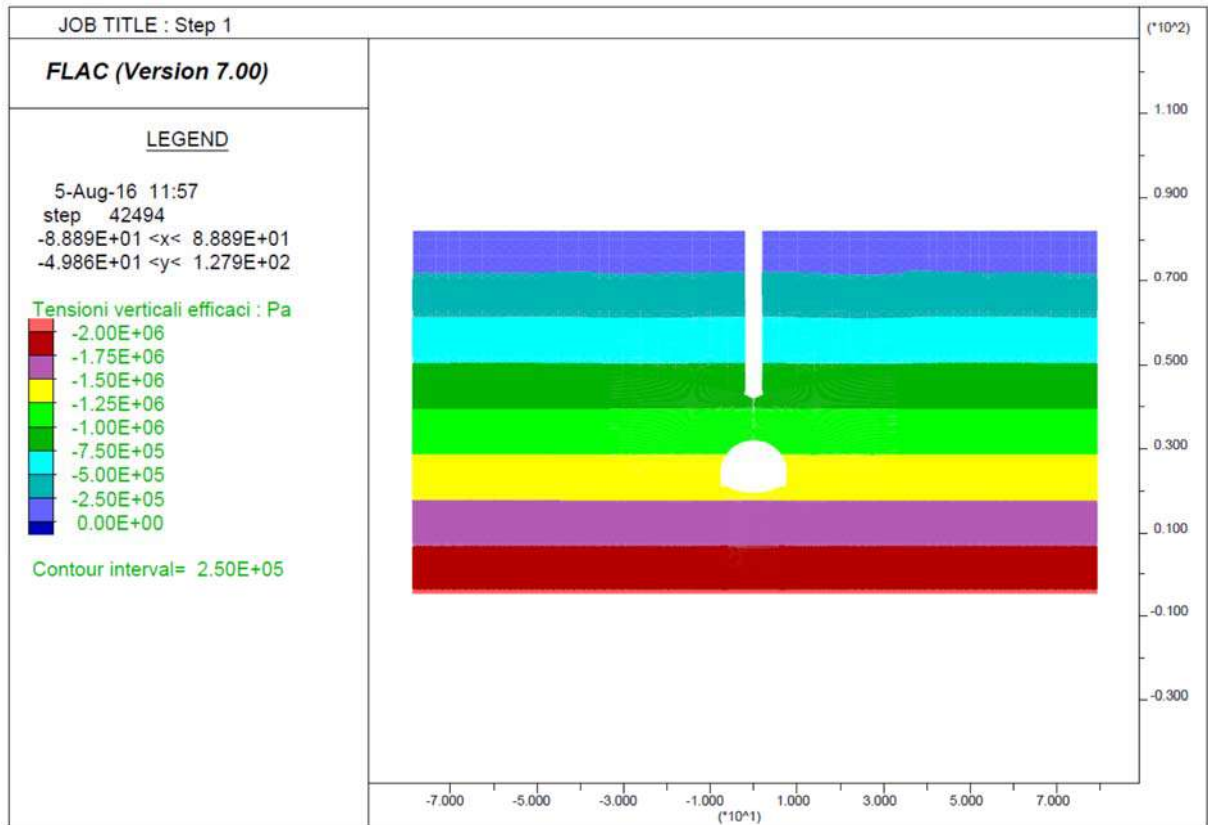



Step 6 – Avanzamento fino a 2D

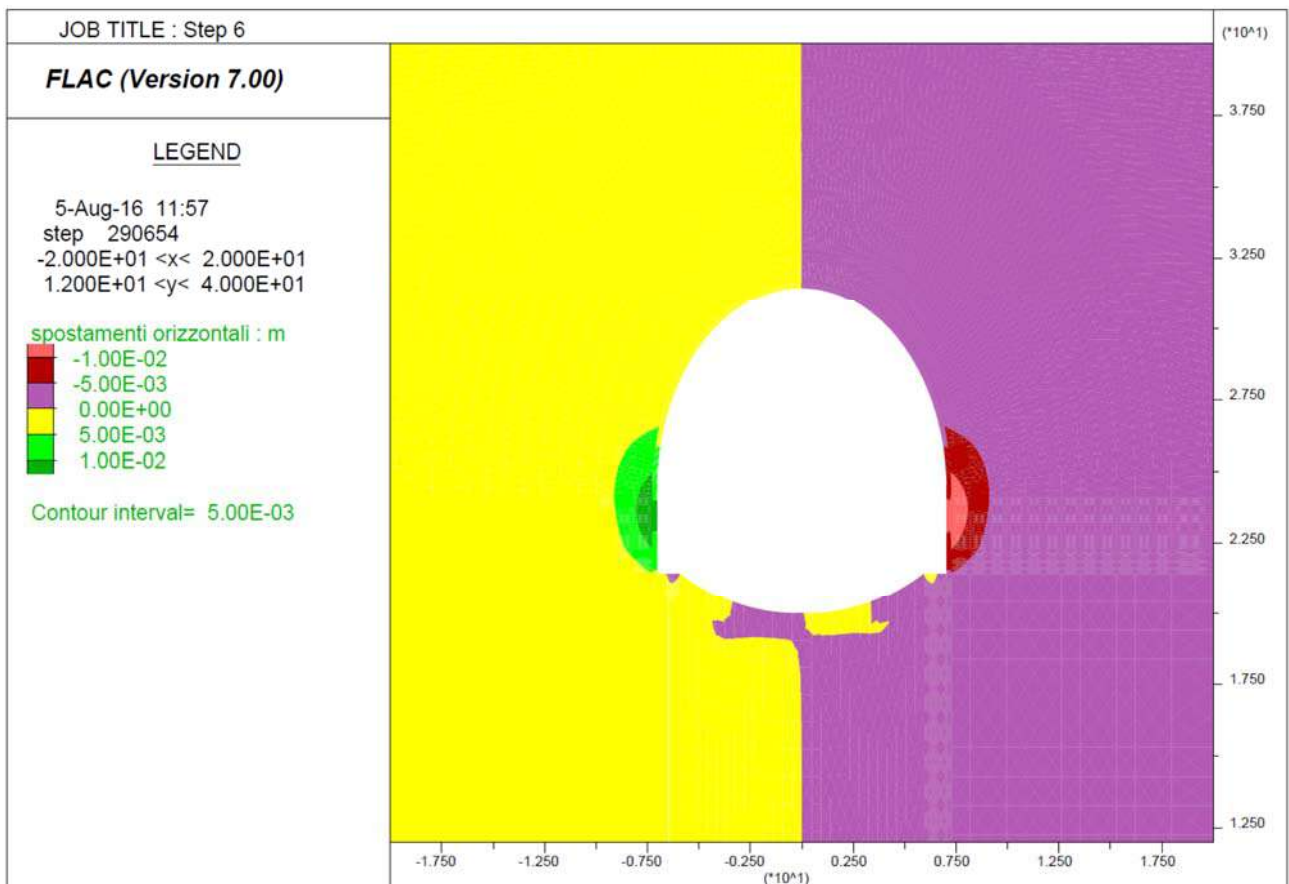
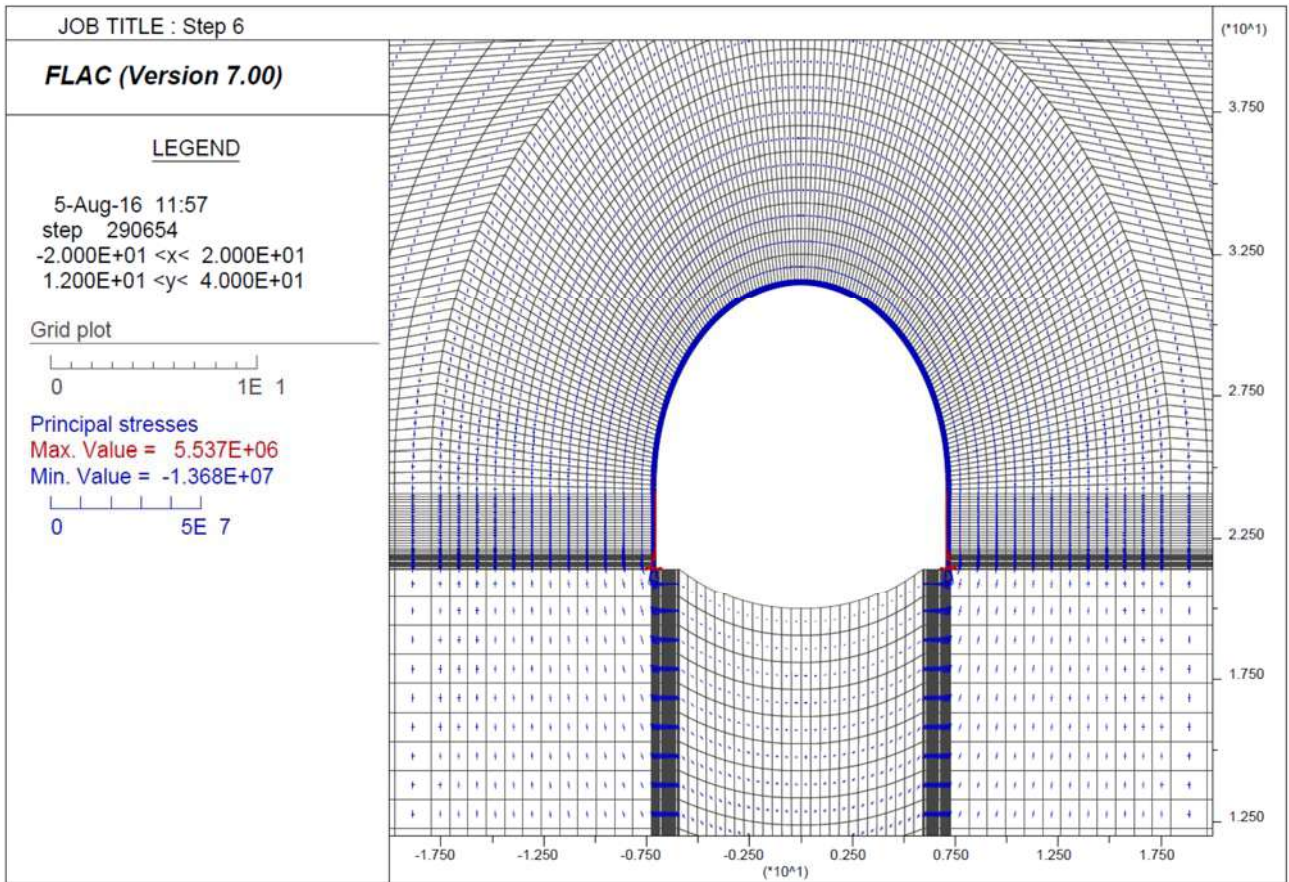

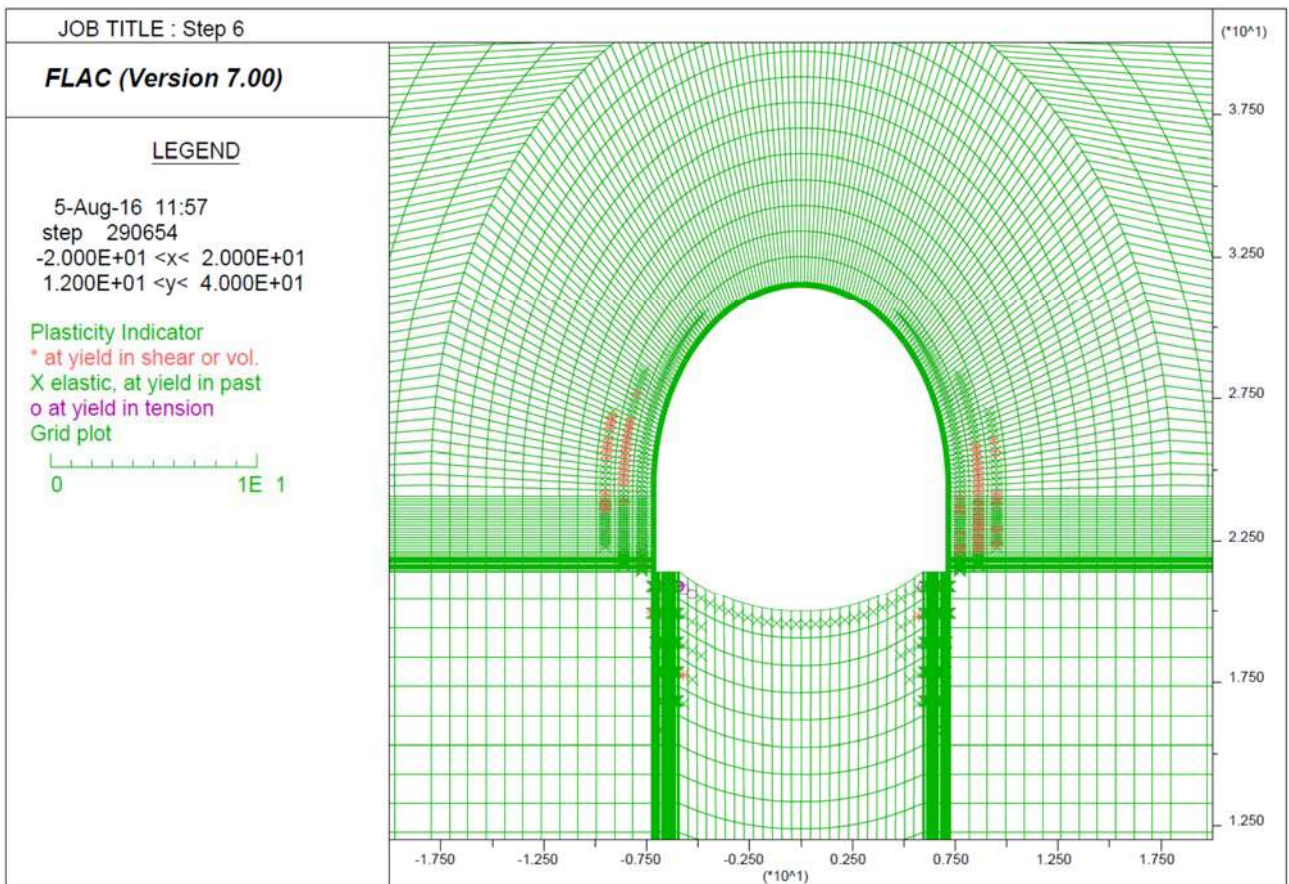
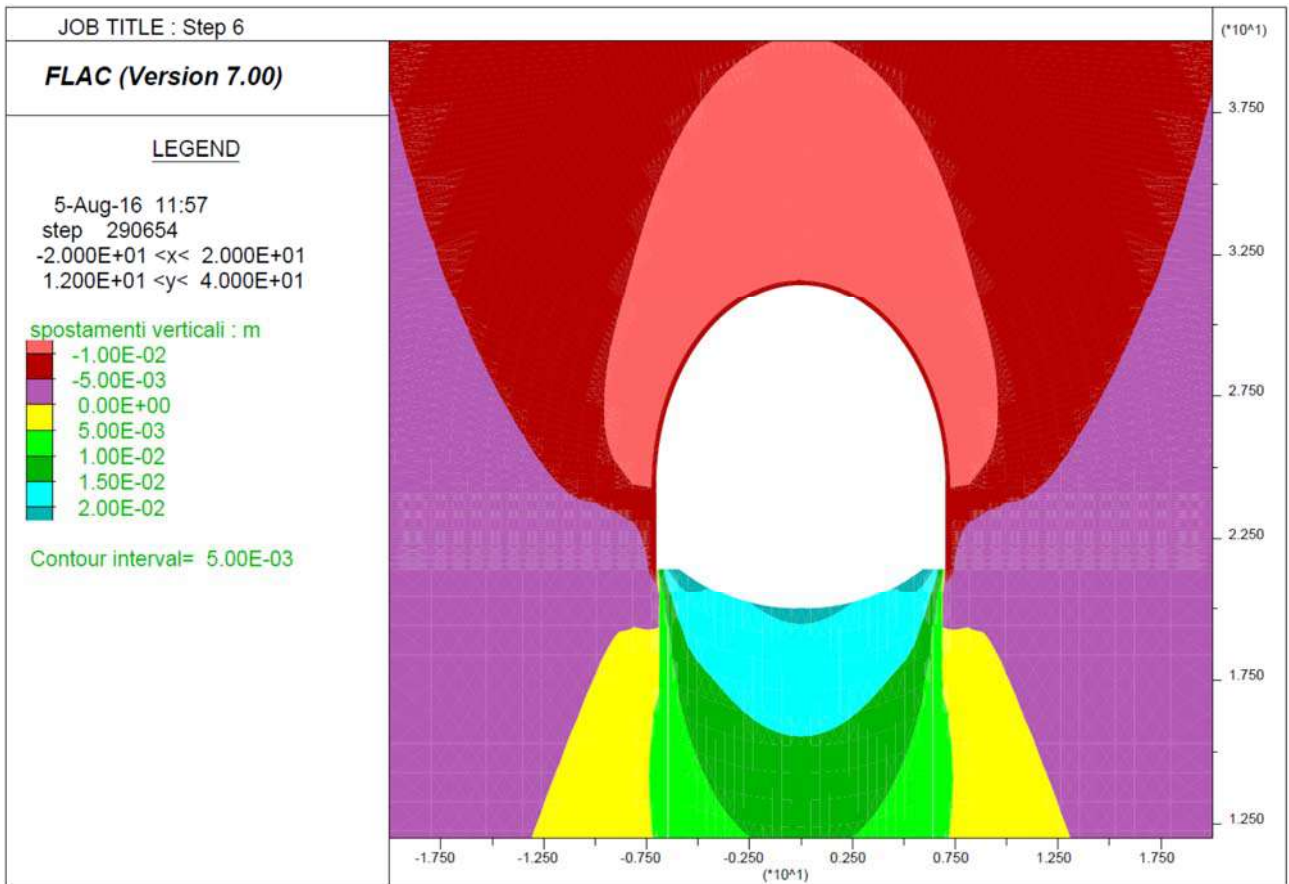



Step 7 - Getto arco rovescio e muretta a 2D e avanzamento fino a deformazioni esaurite

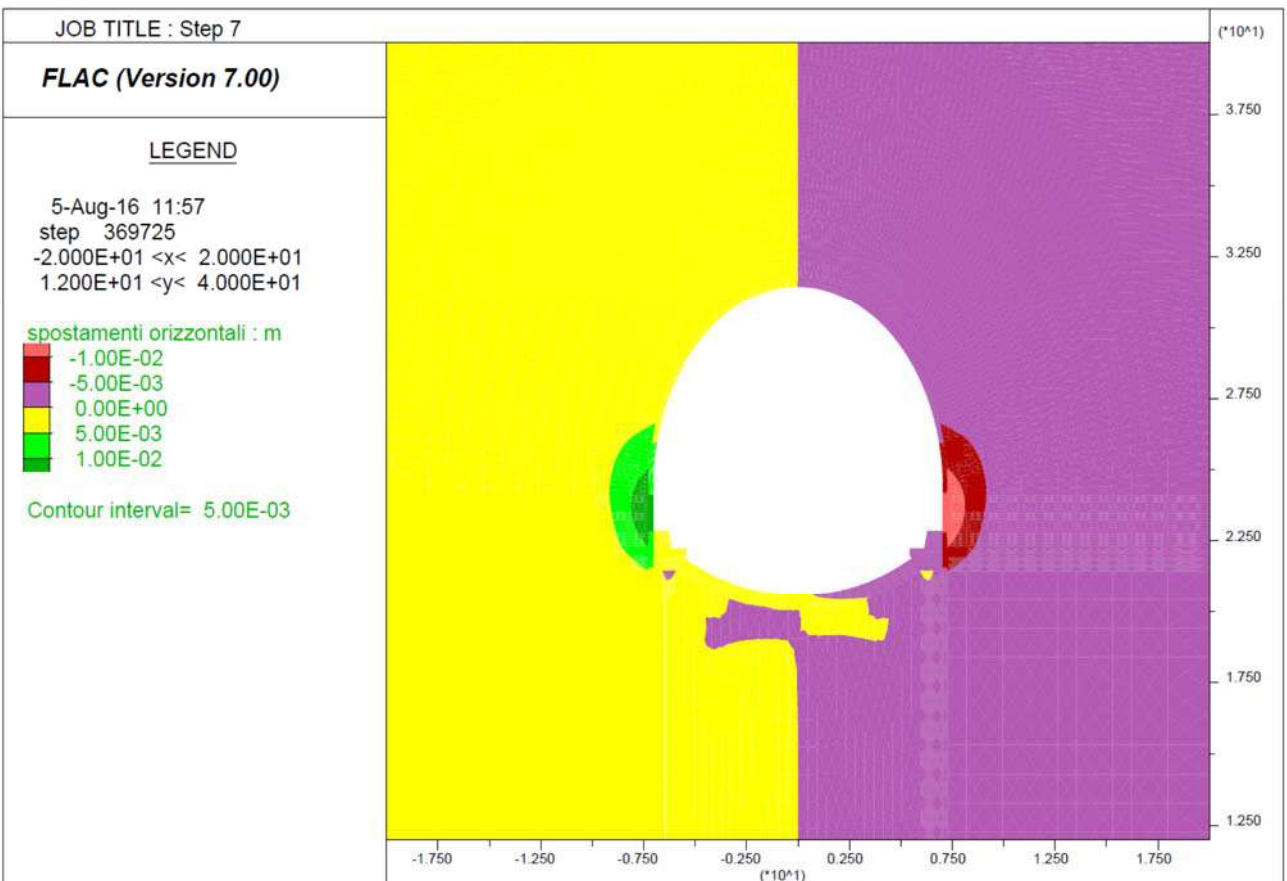
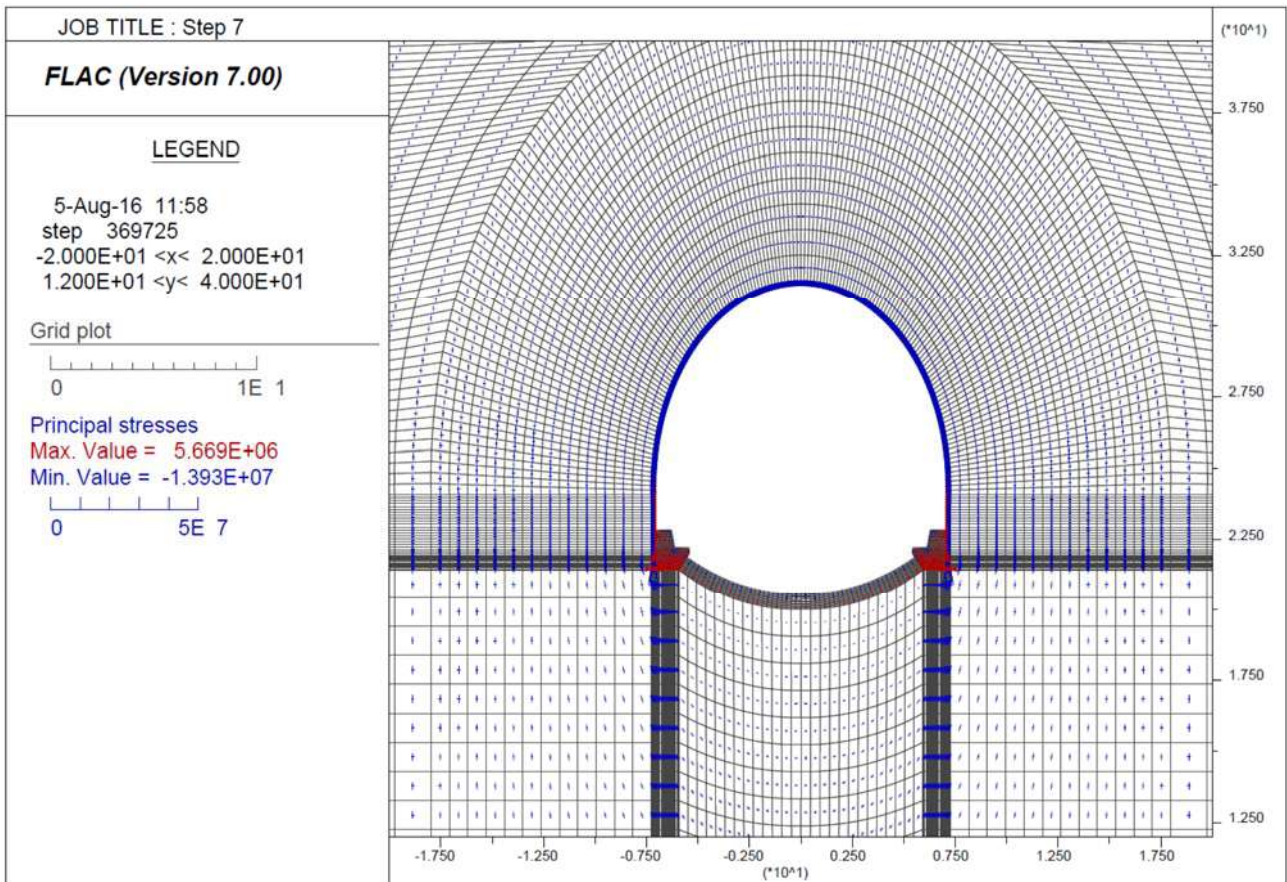



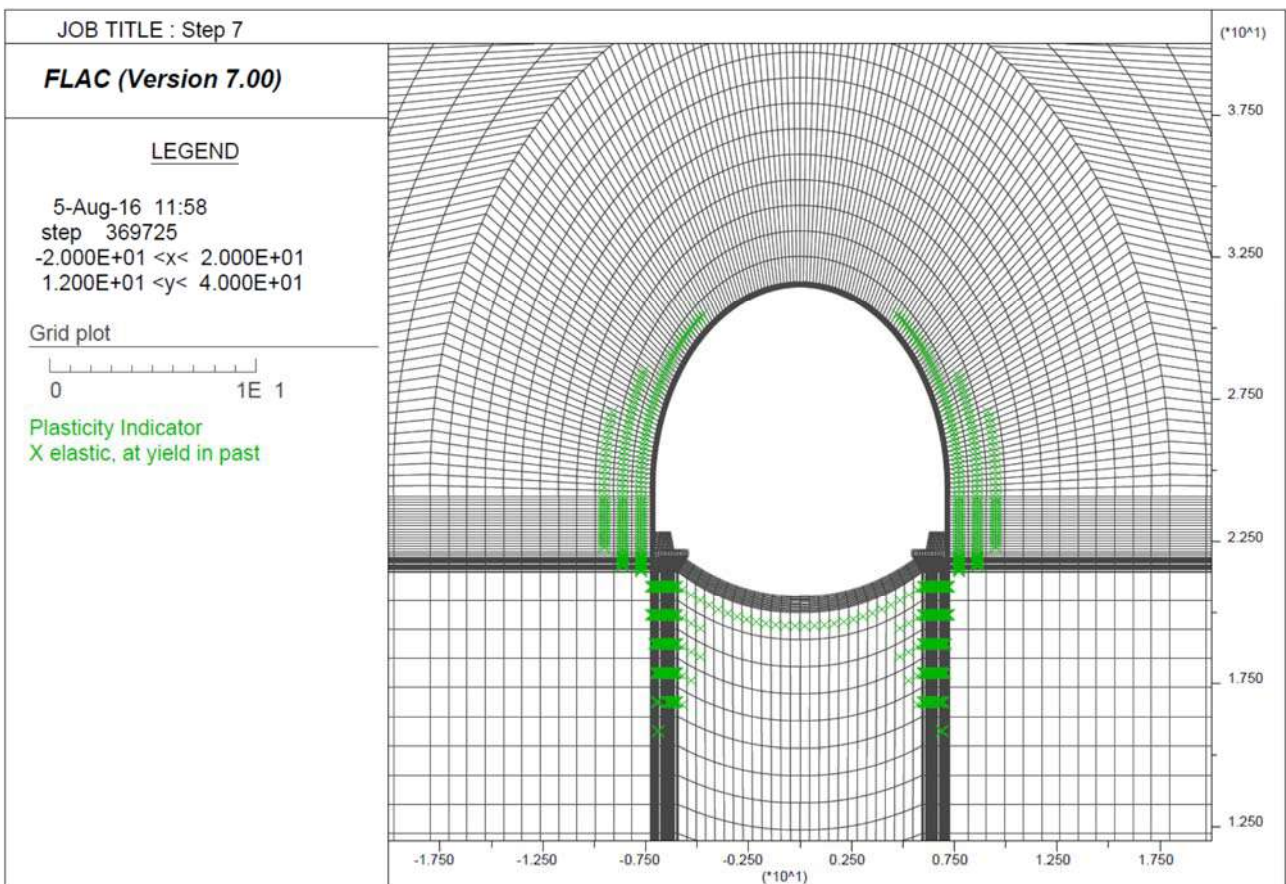
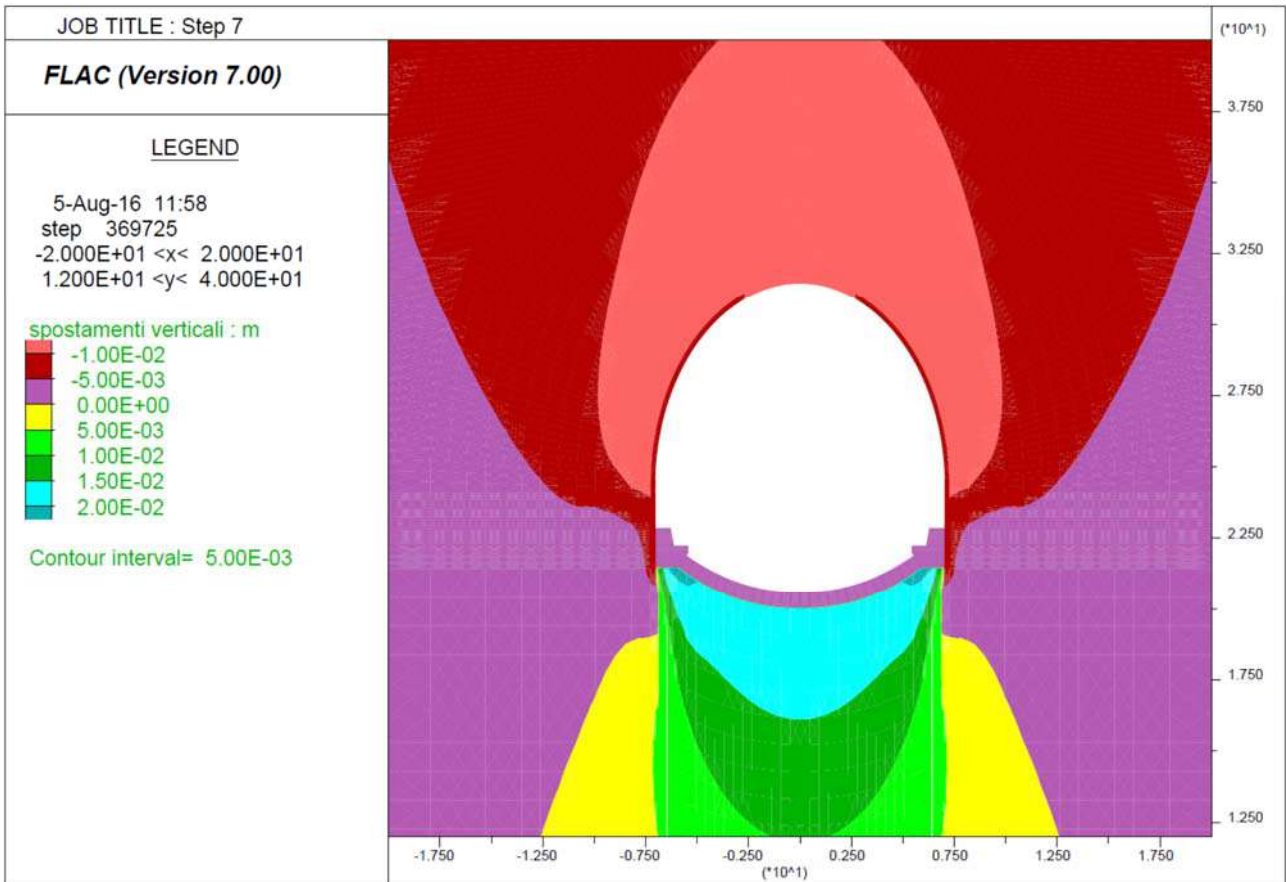

Step 8 - Getto Calotta

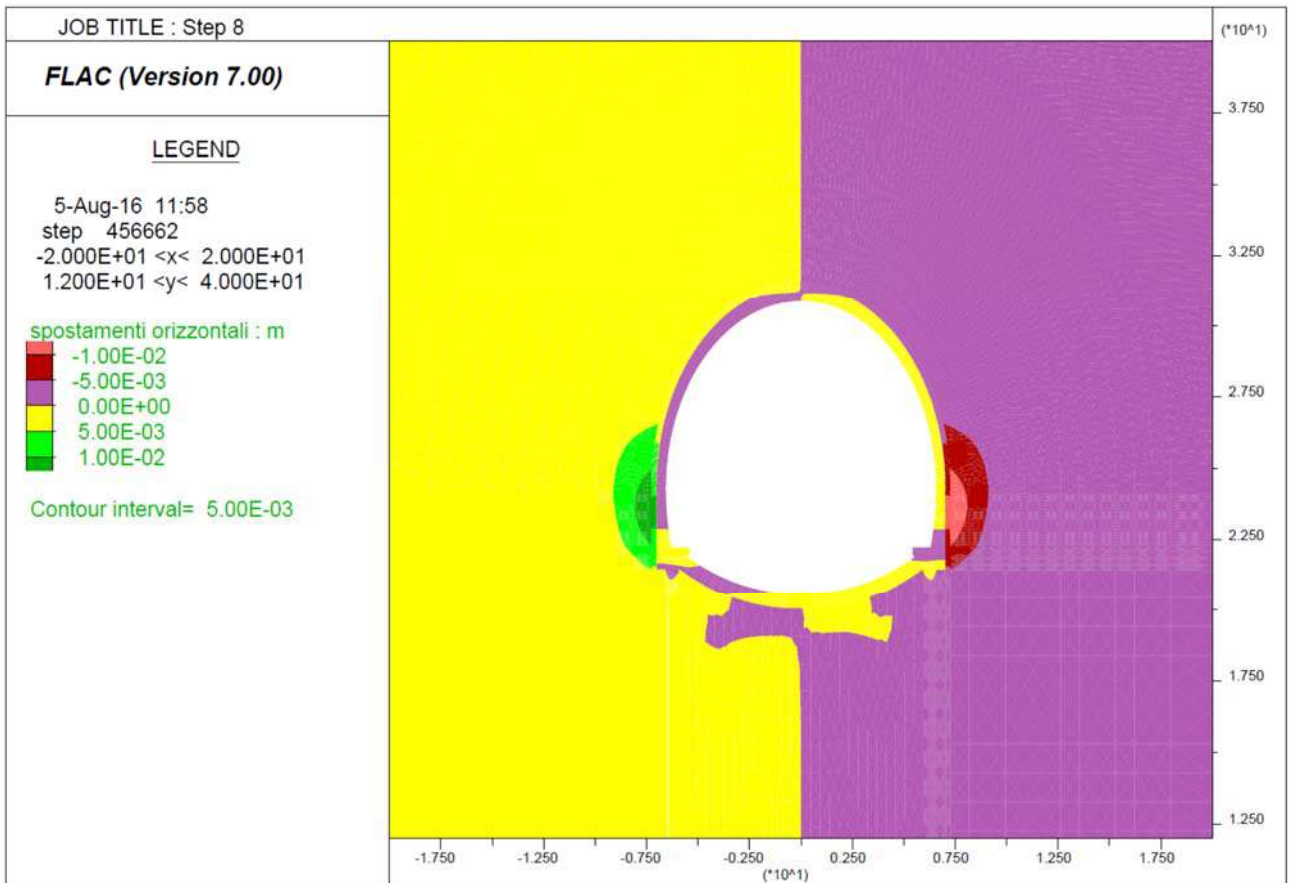
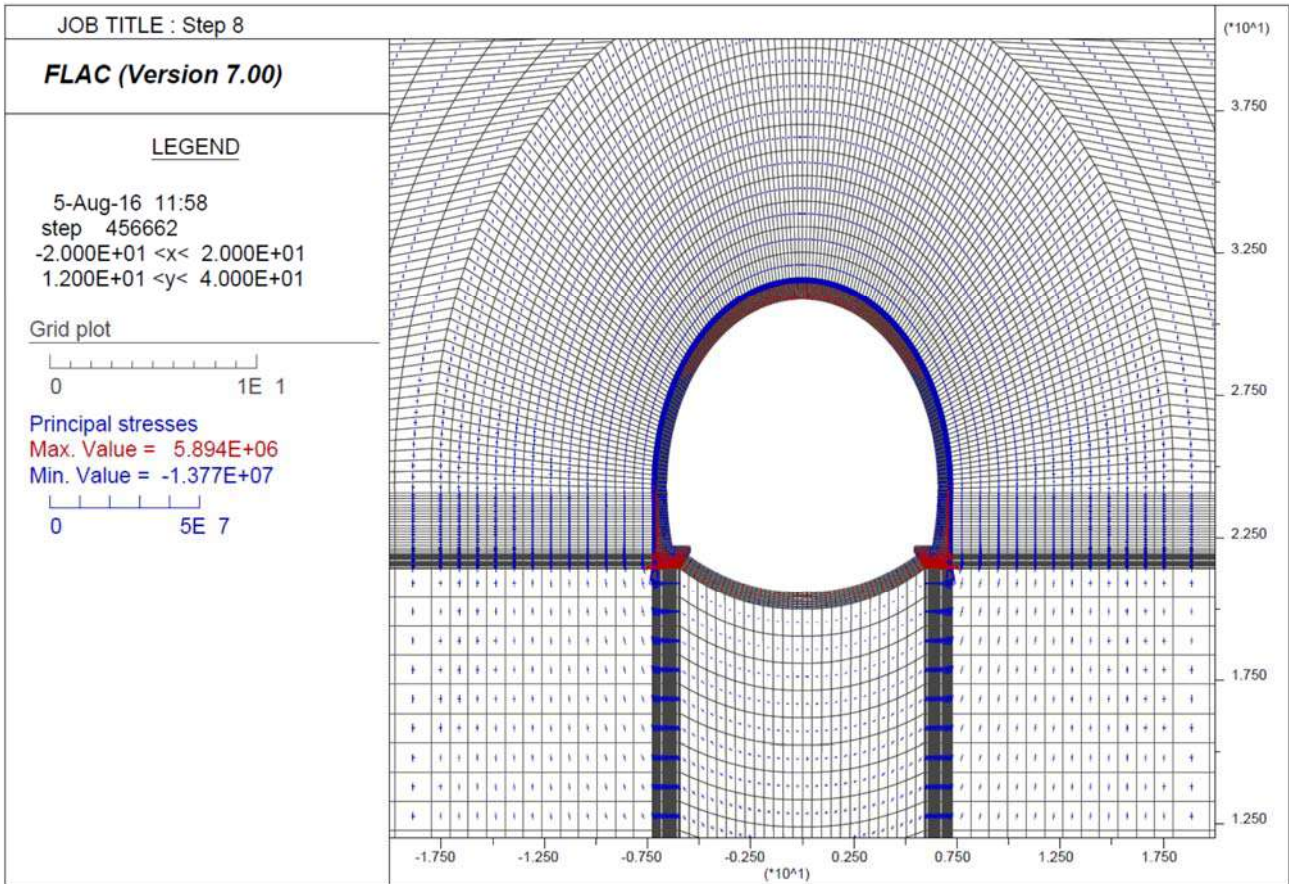



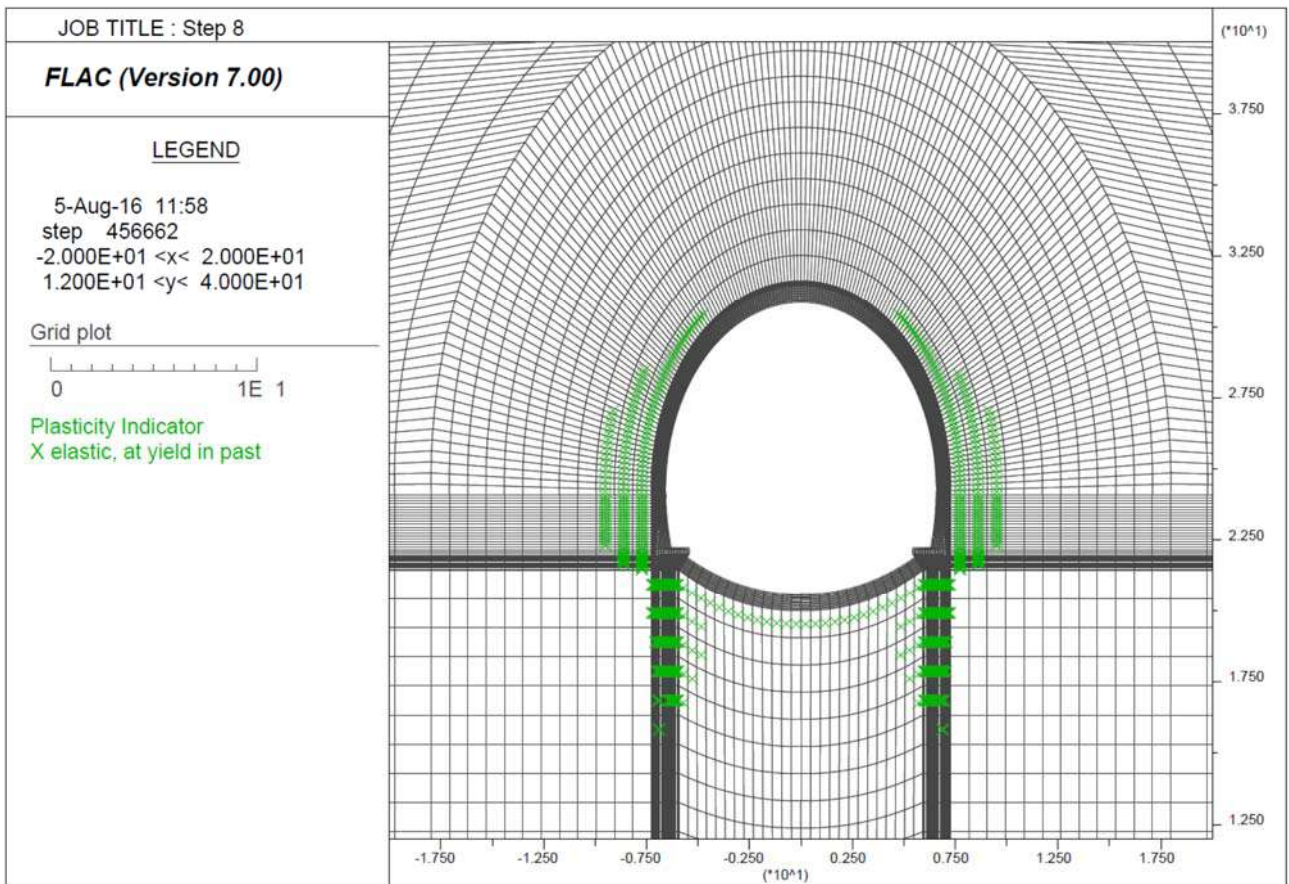
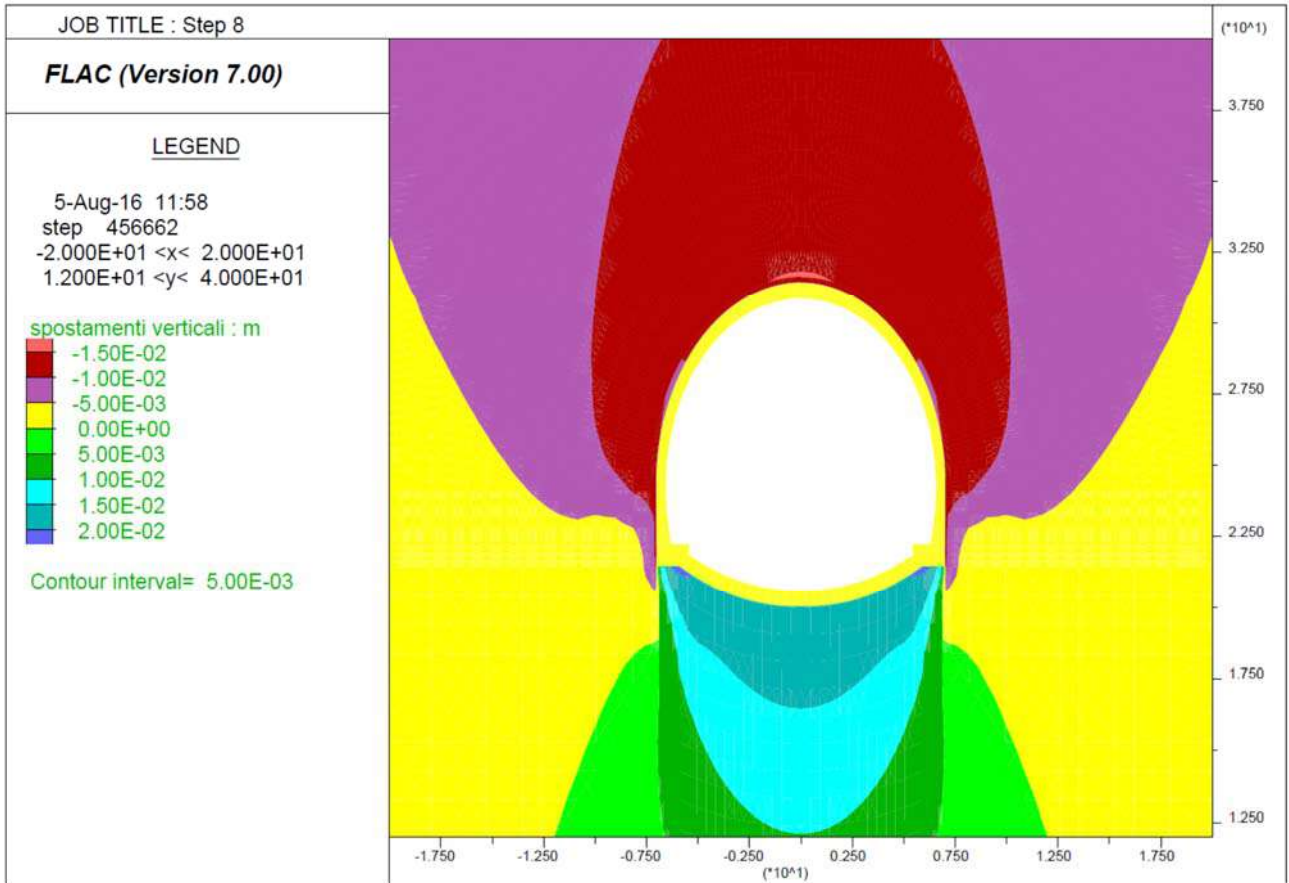



Step 9 - Decadimento dei parametri di resistenza del rivestimento provvisorio

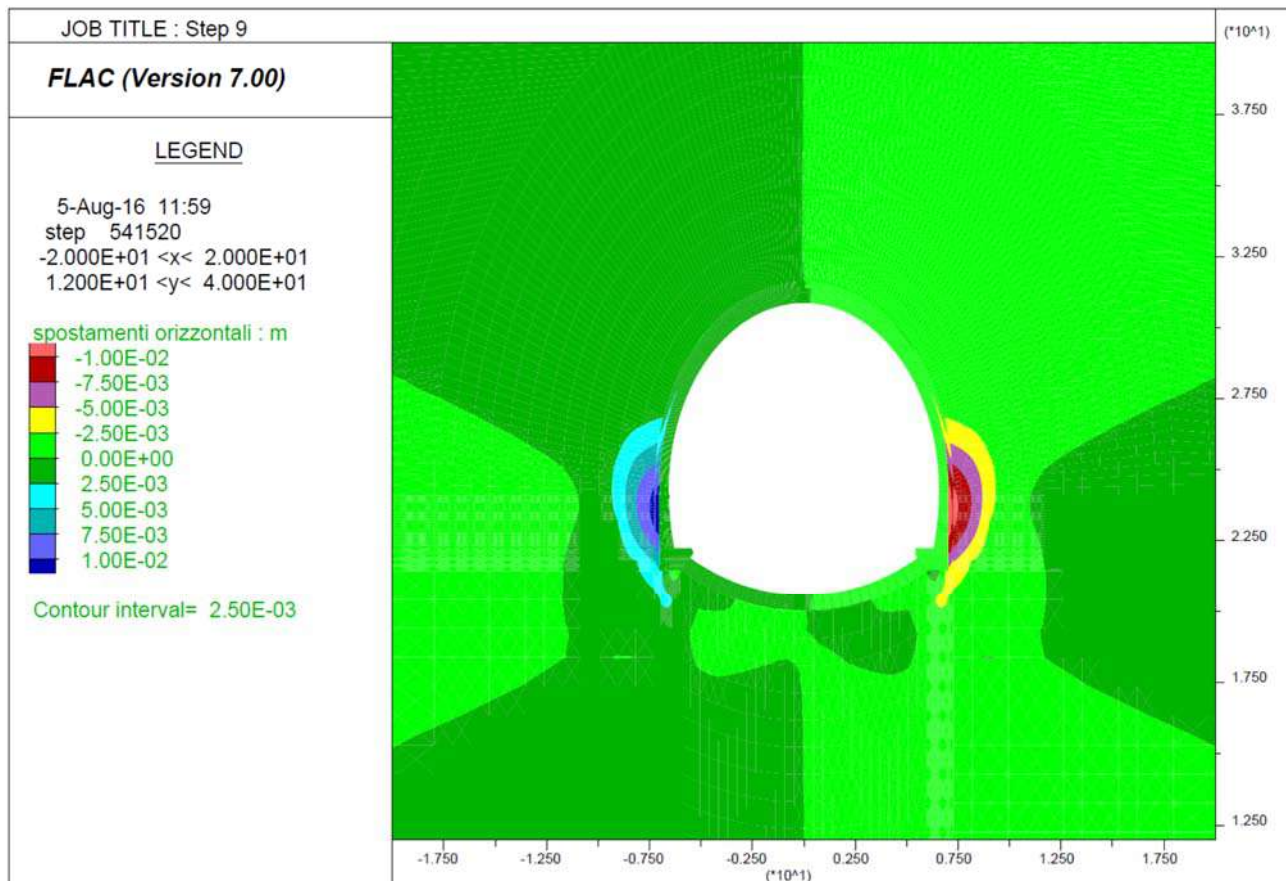
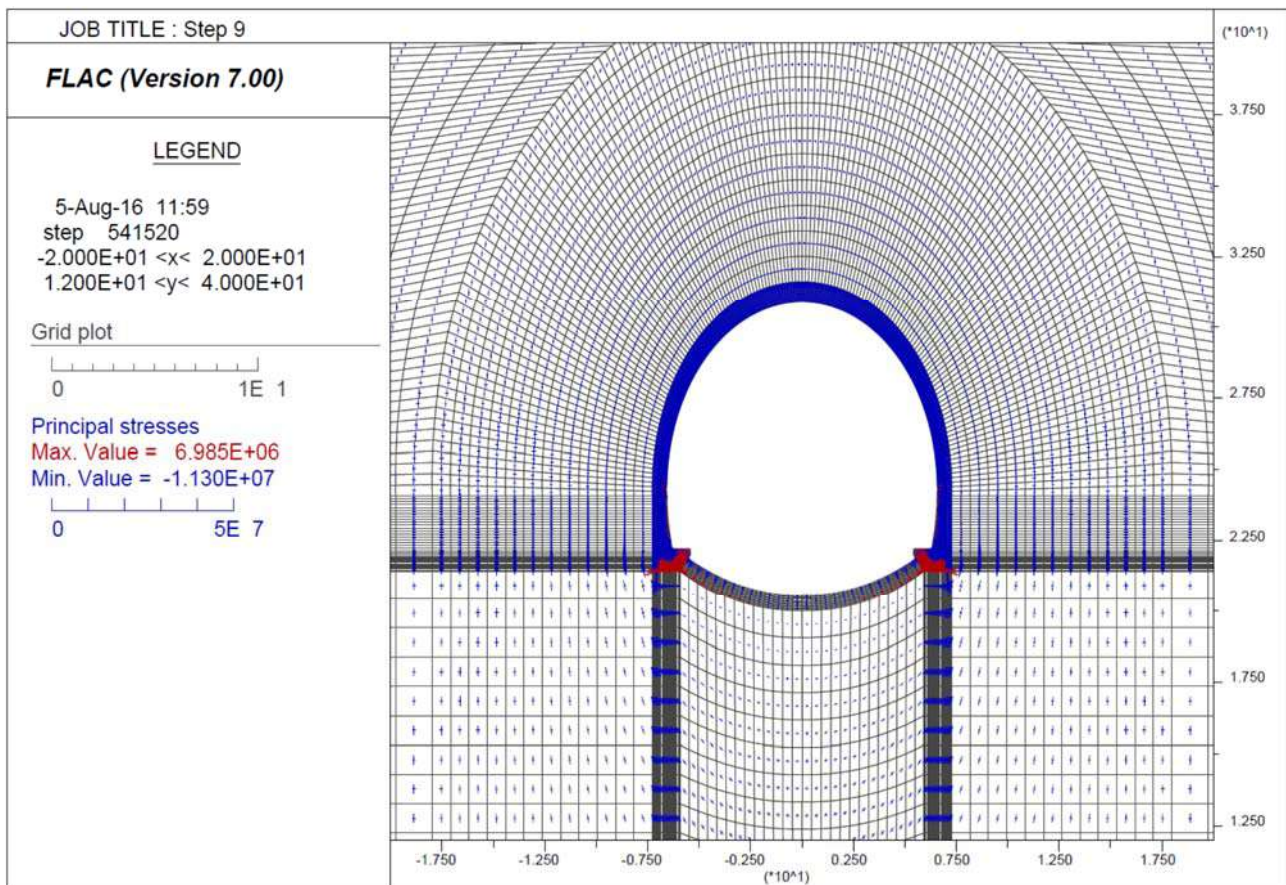

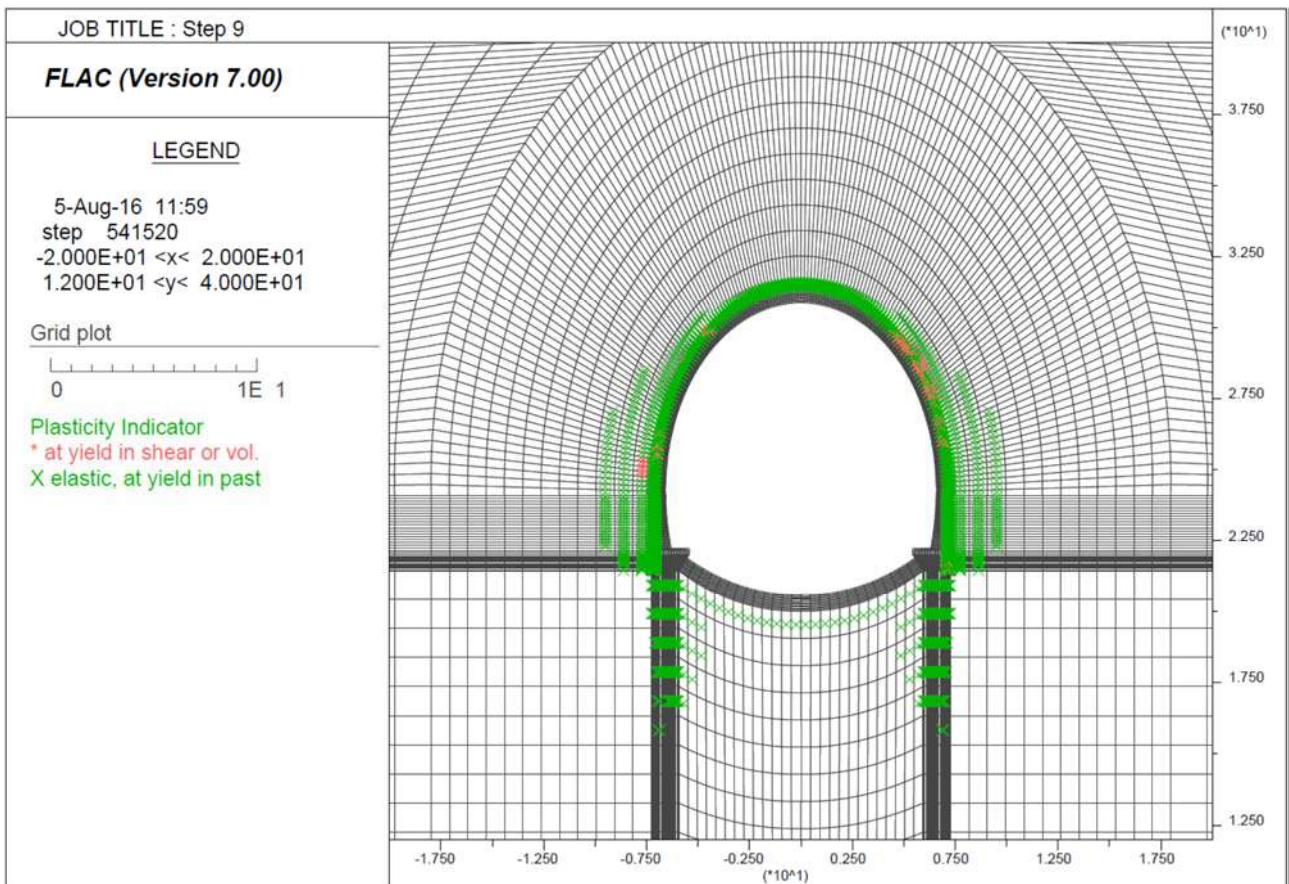
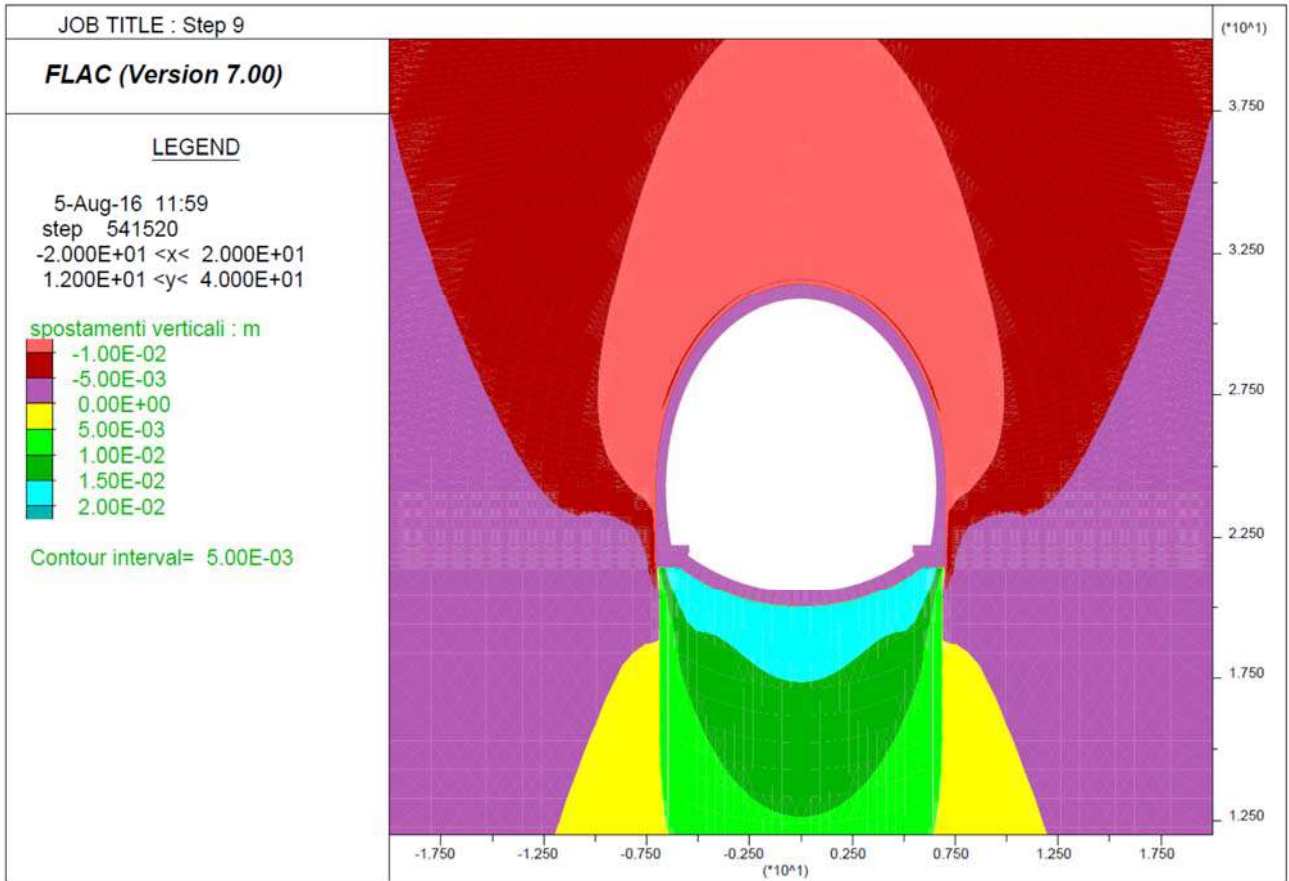



**Output Flac – Sezione tipo B2 - Copertura di calcolo = 25 m**

**Step 1 – Tensioni litostatiche**

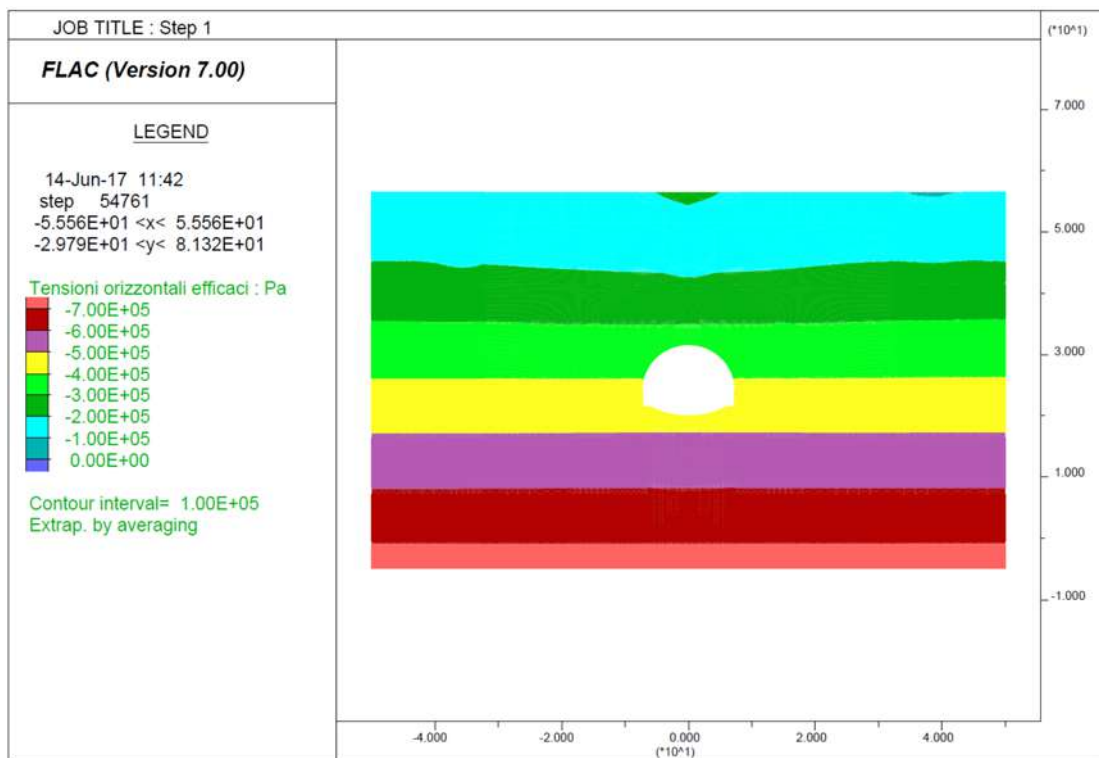
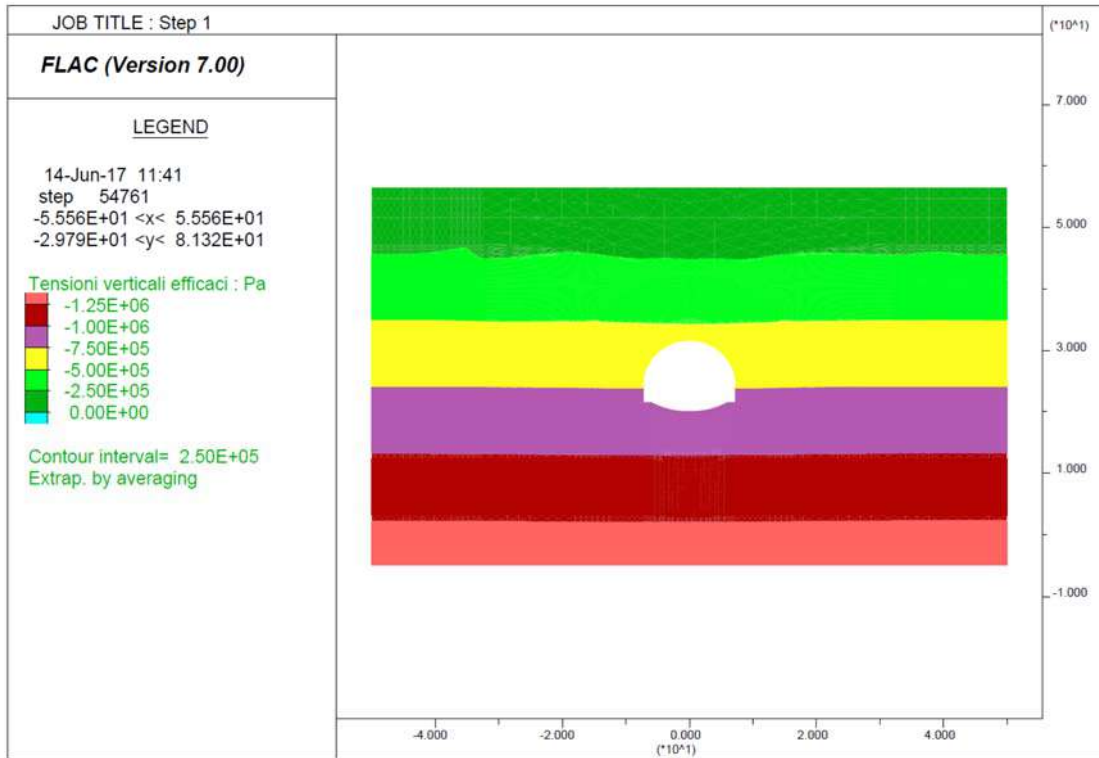



Step 6 – Avanzamento fino a 2D

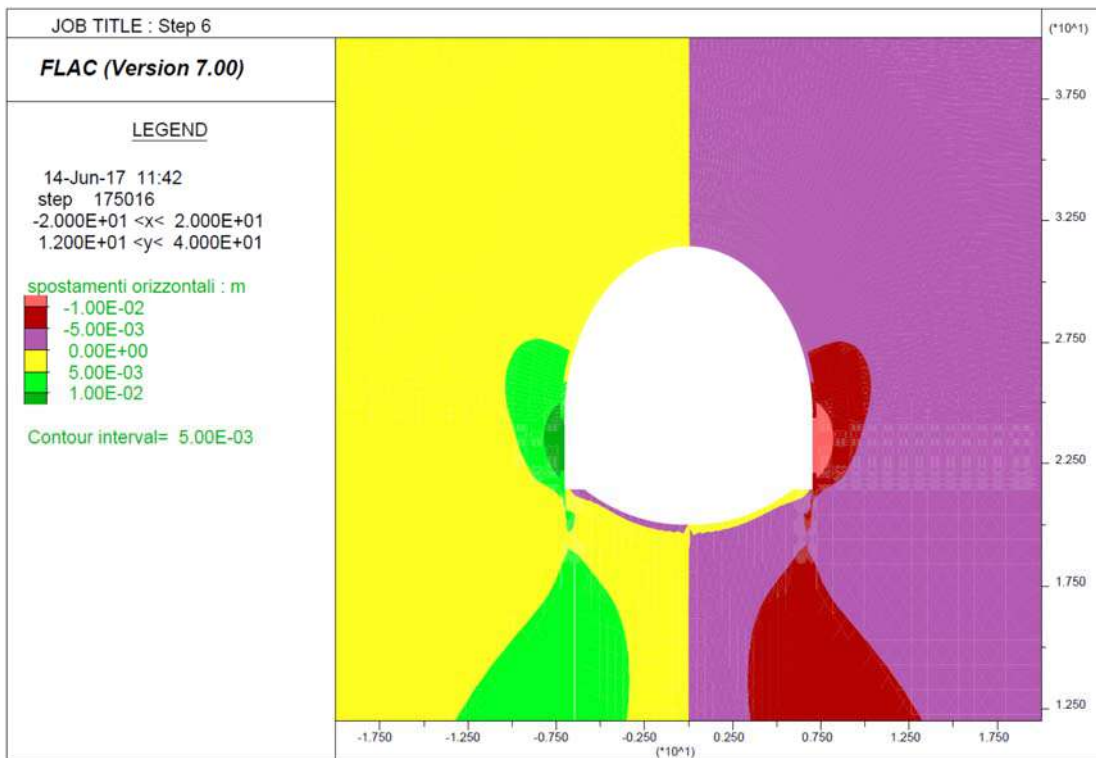
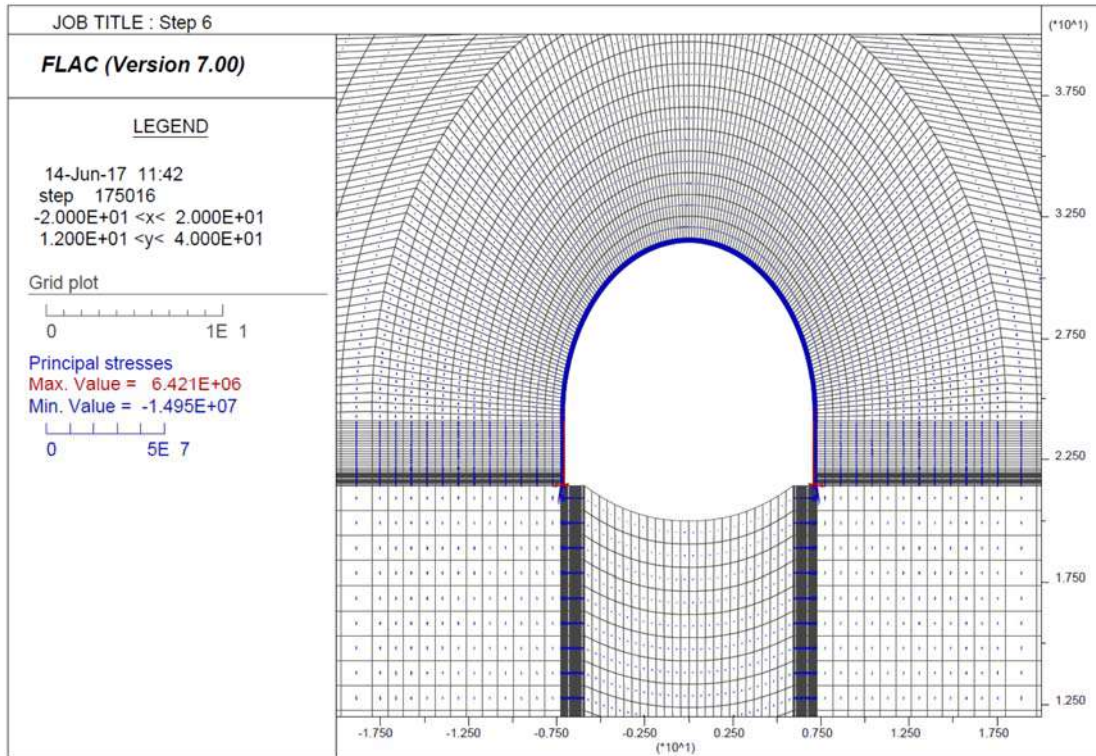

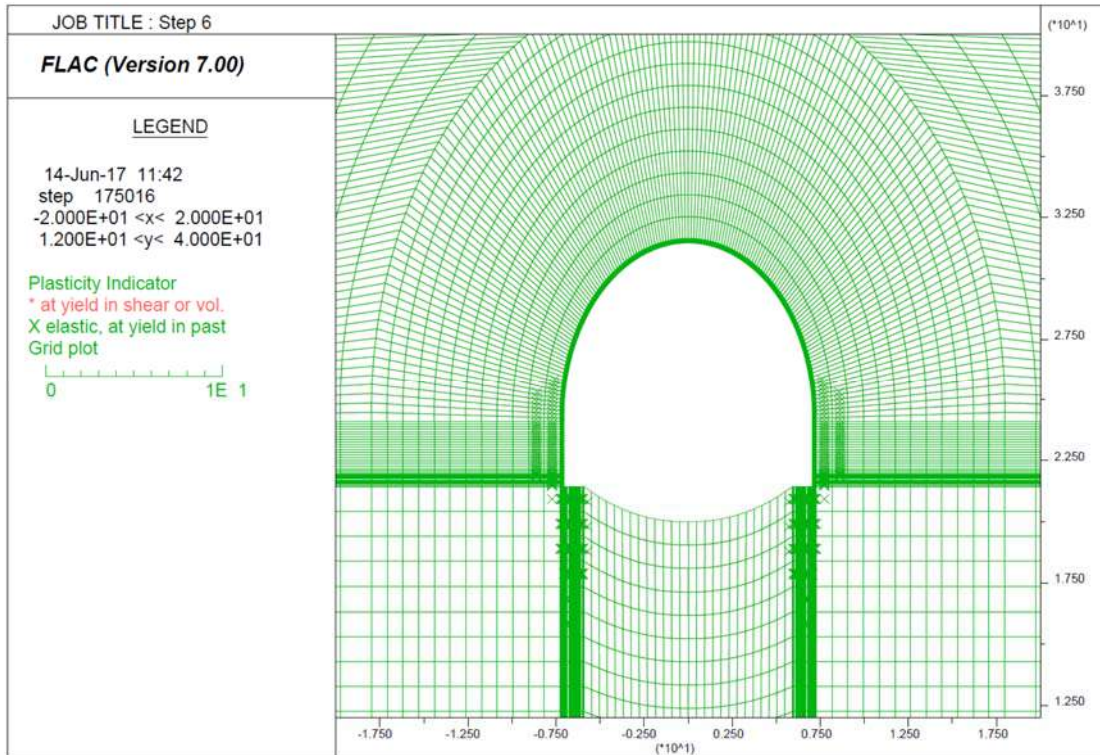
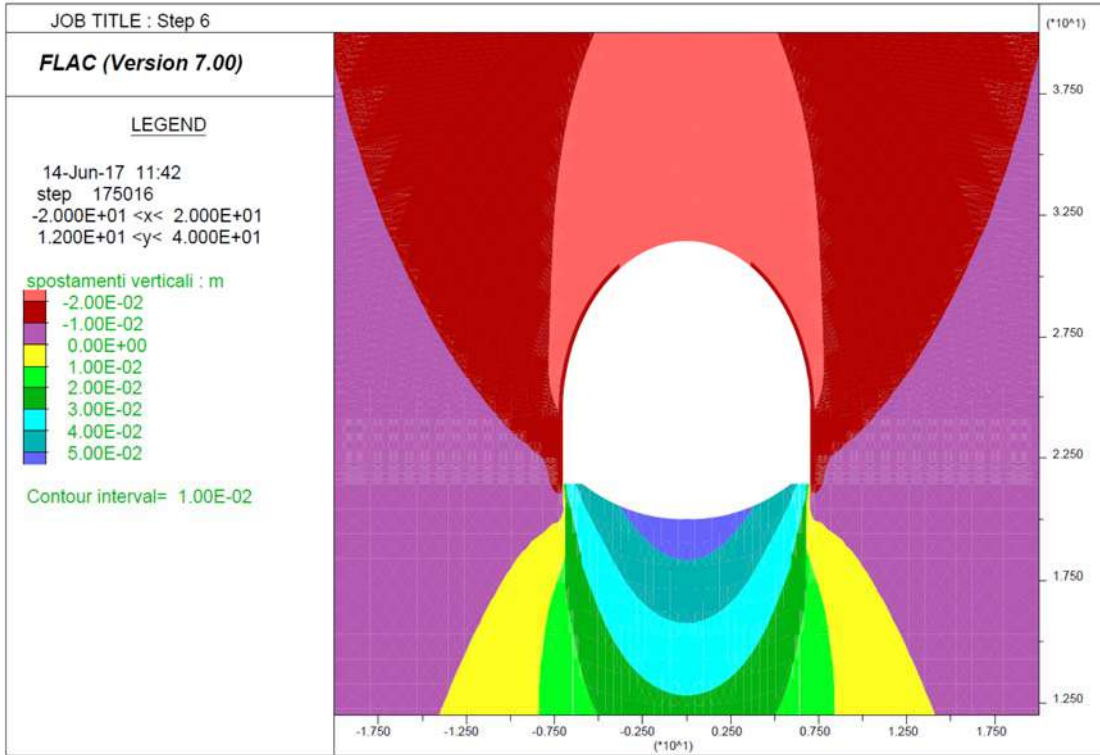

Step 7 - Getto arco rovescio e muretta a 2D e avanzamento fino a deformazioni esaurite

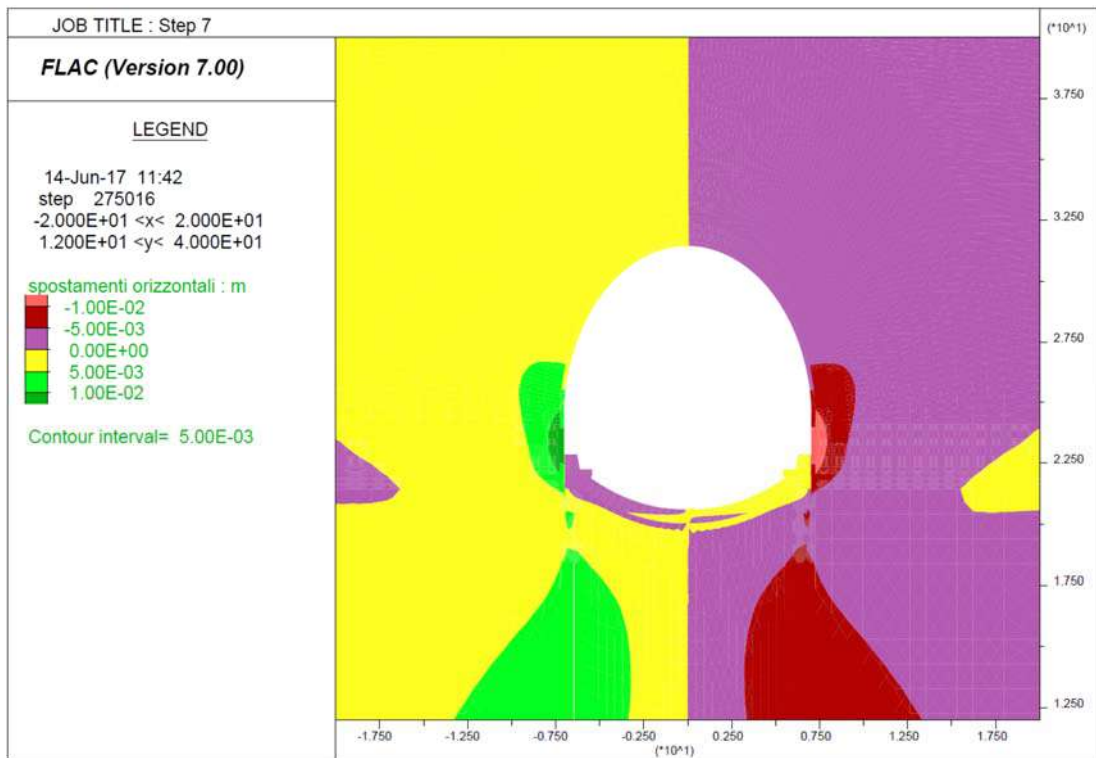
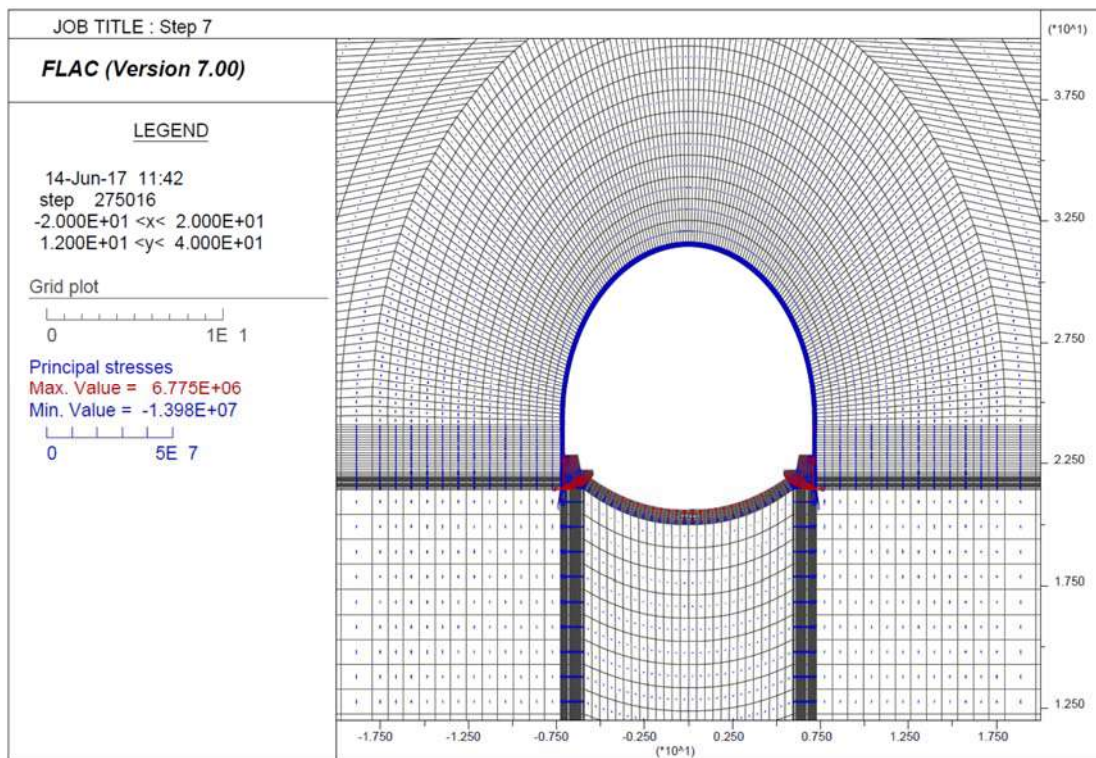



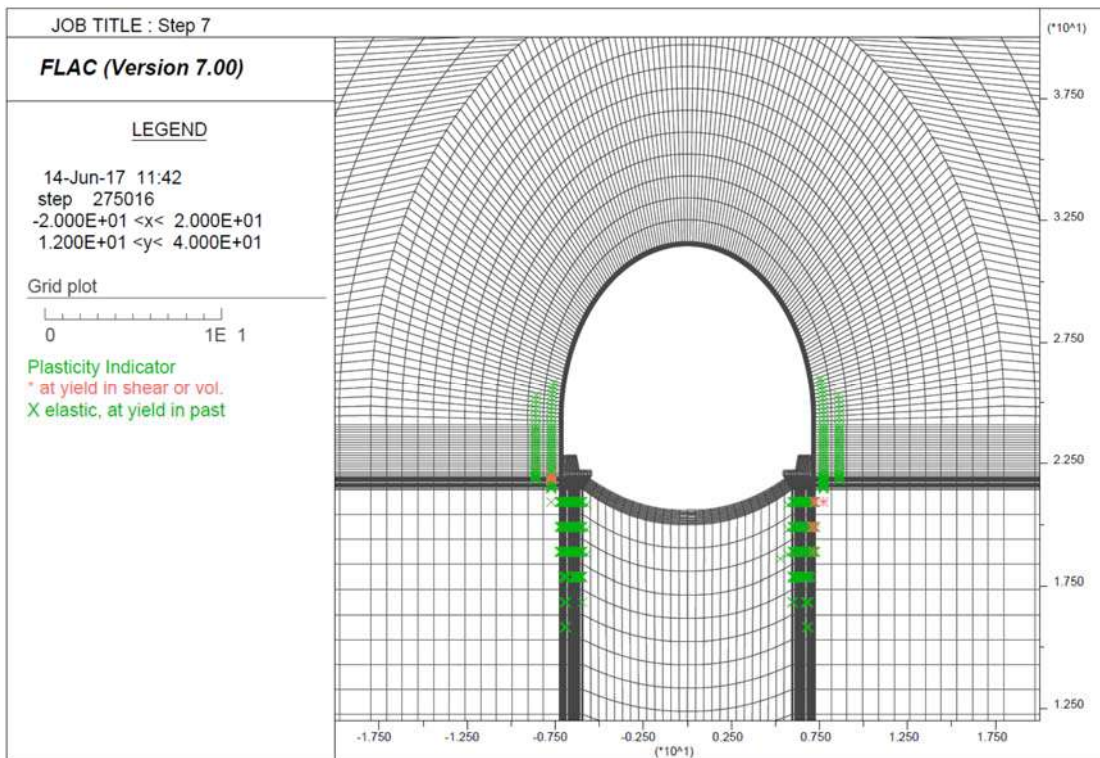
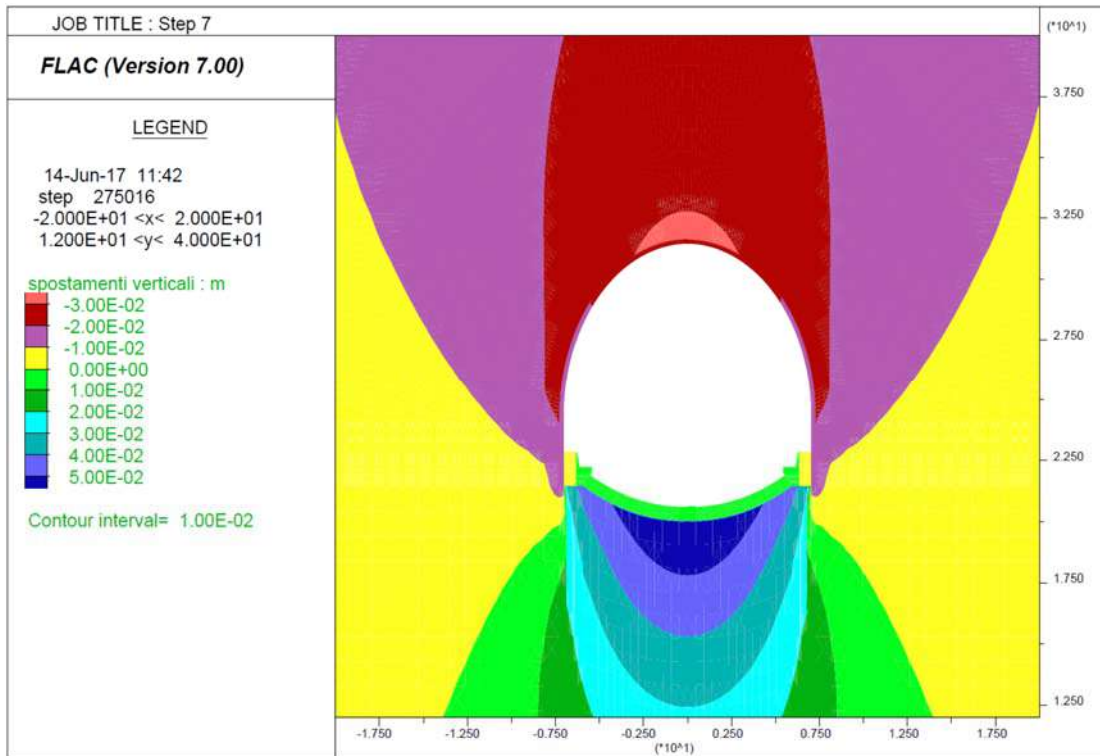

Step 8 - Getto Calotta

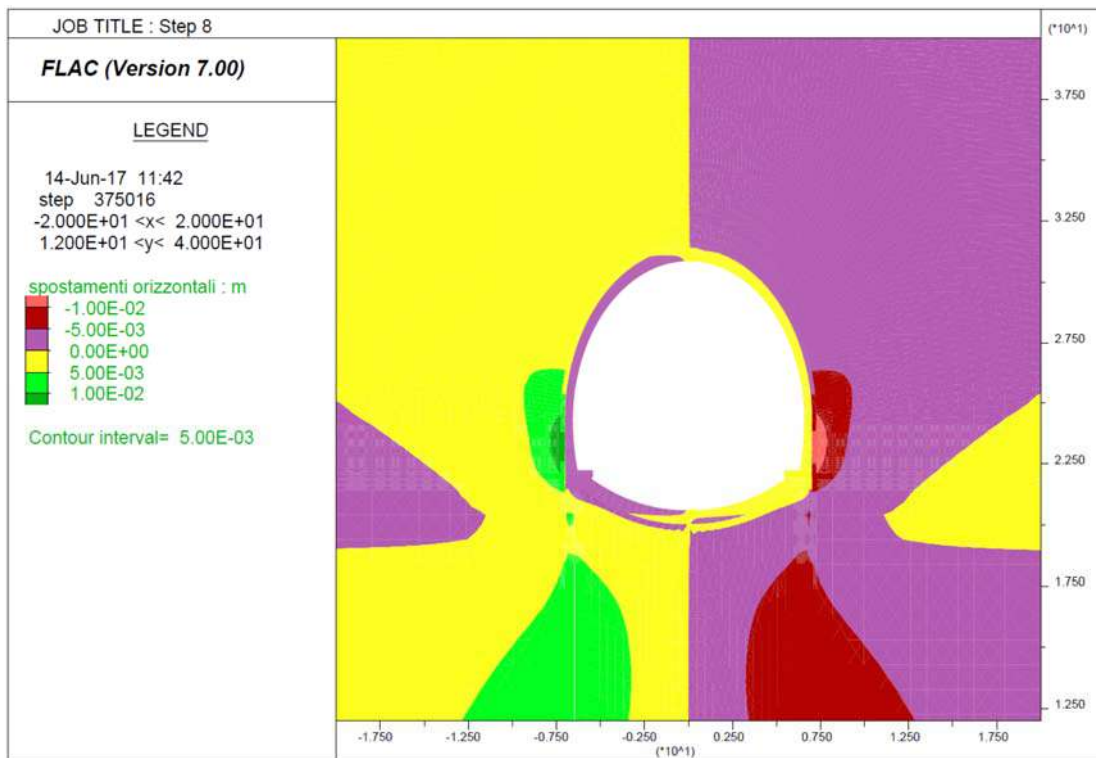
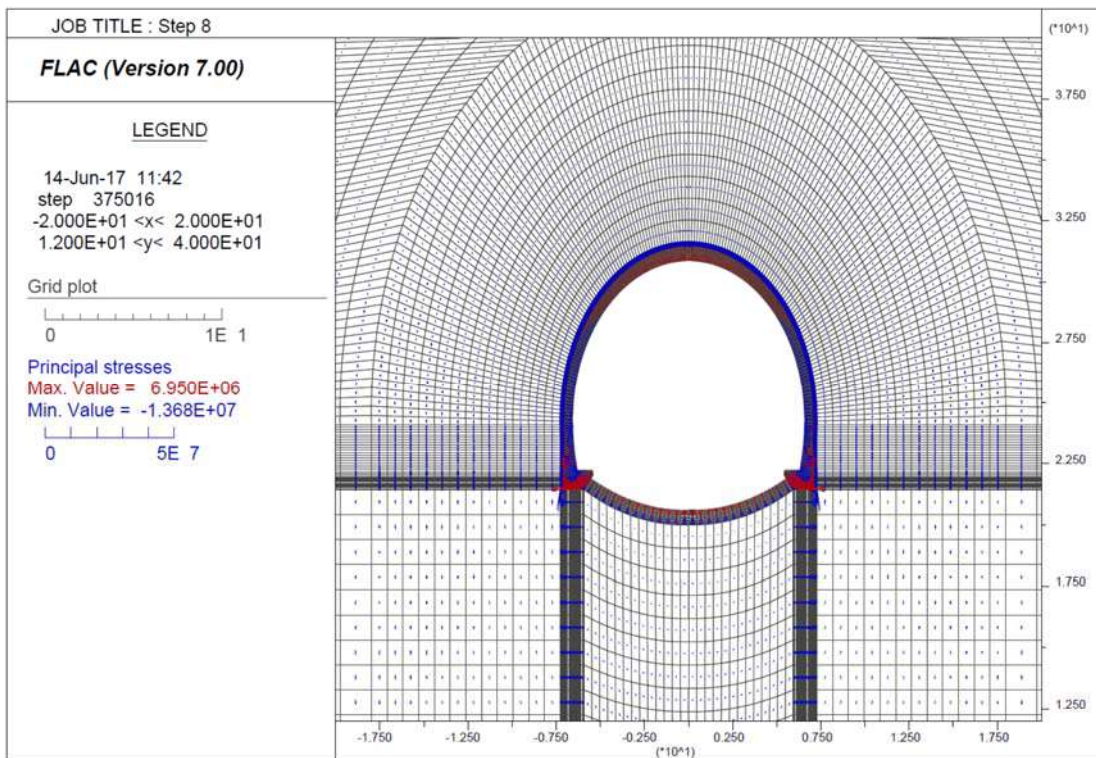

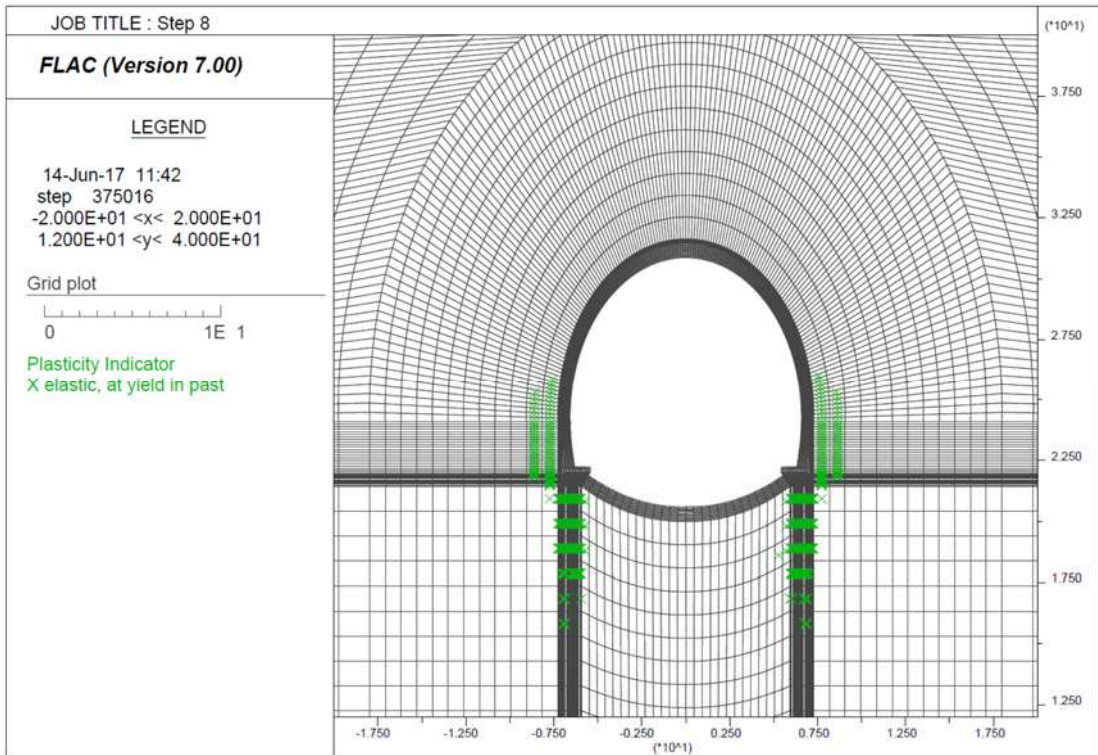
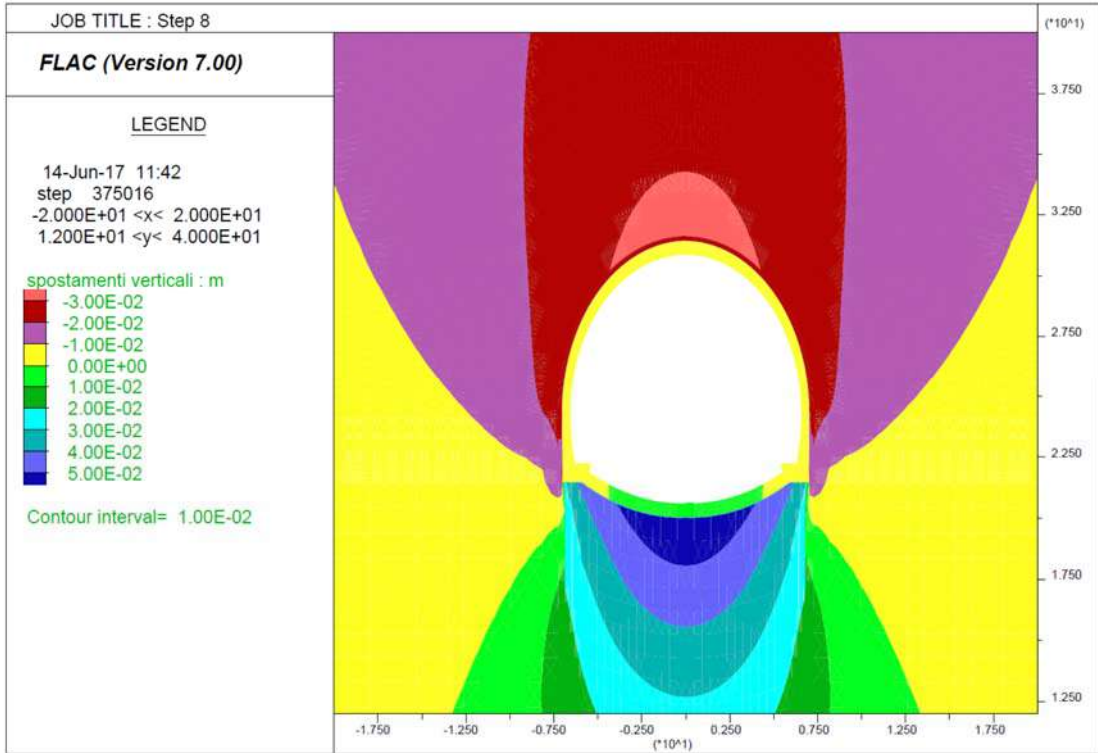



Step 9 - Decadimento dei parametri di resistenza del rivestimento provvisorio

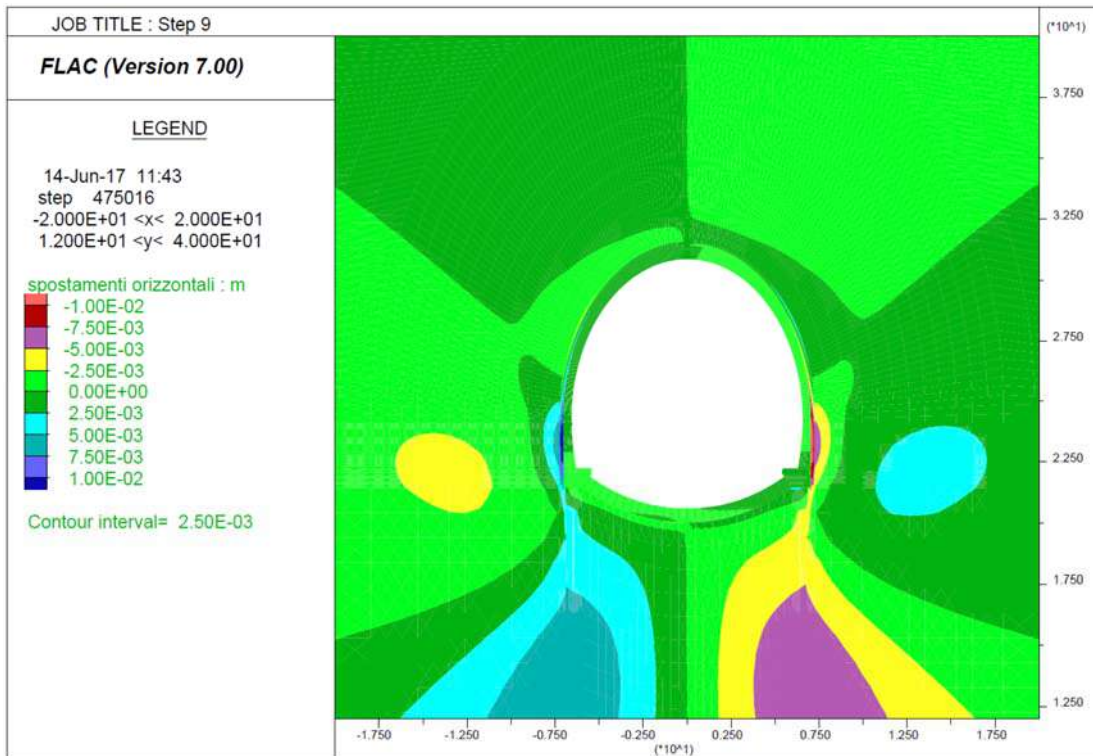
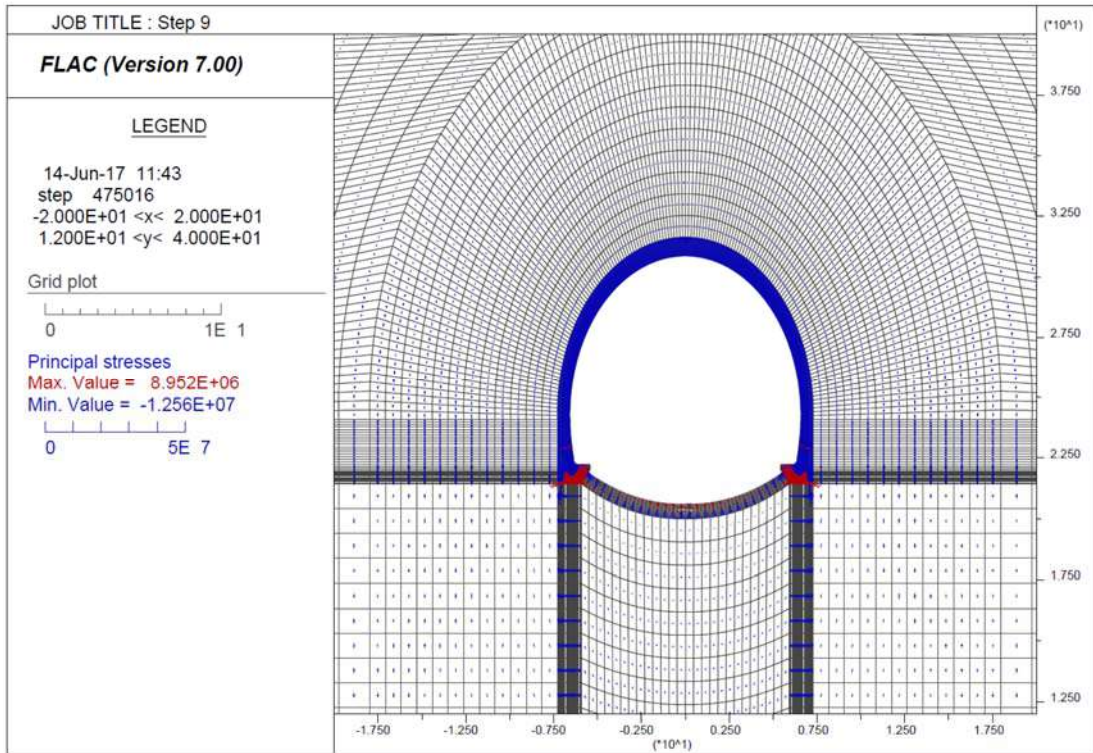

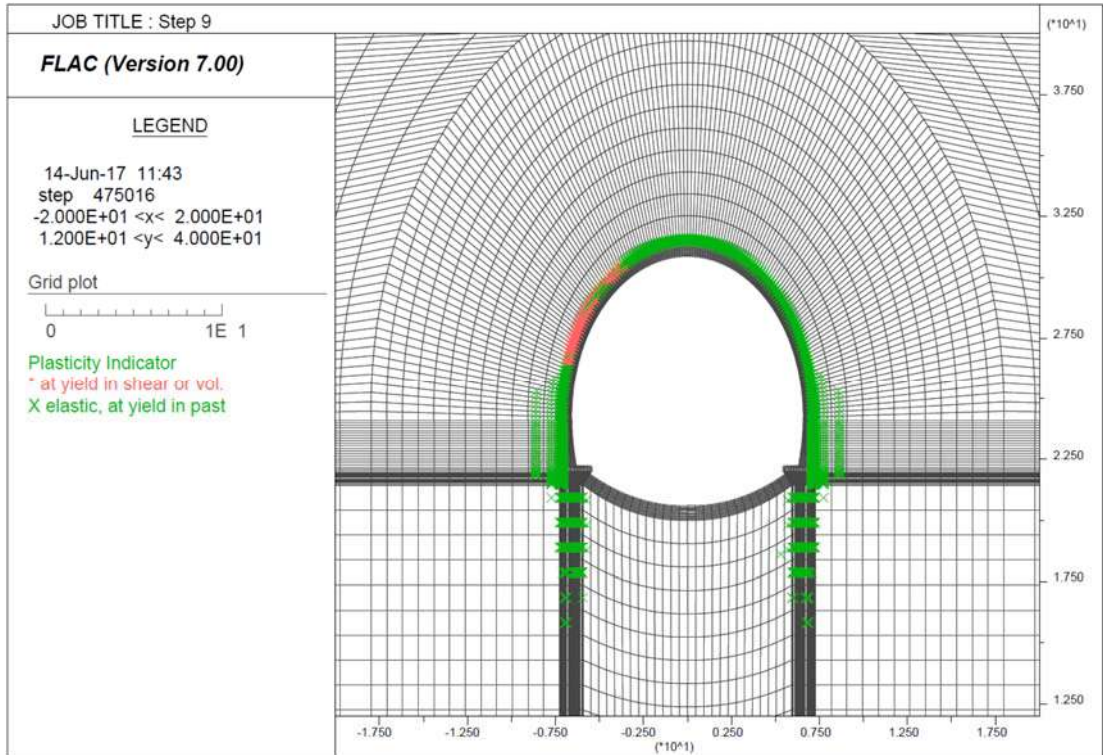
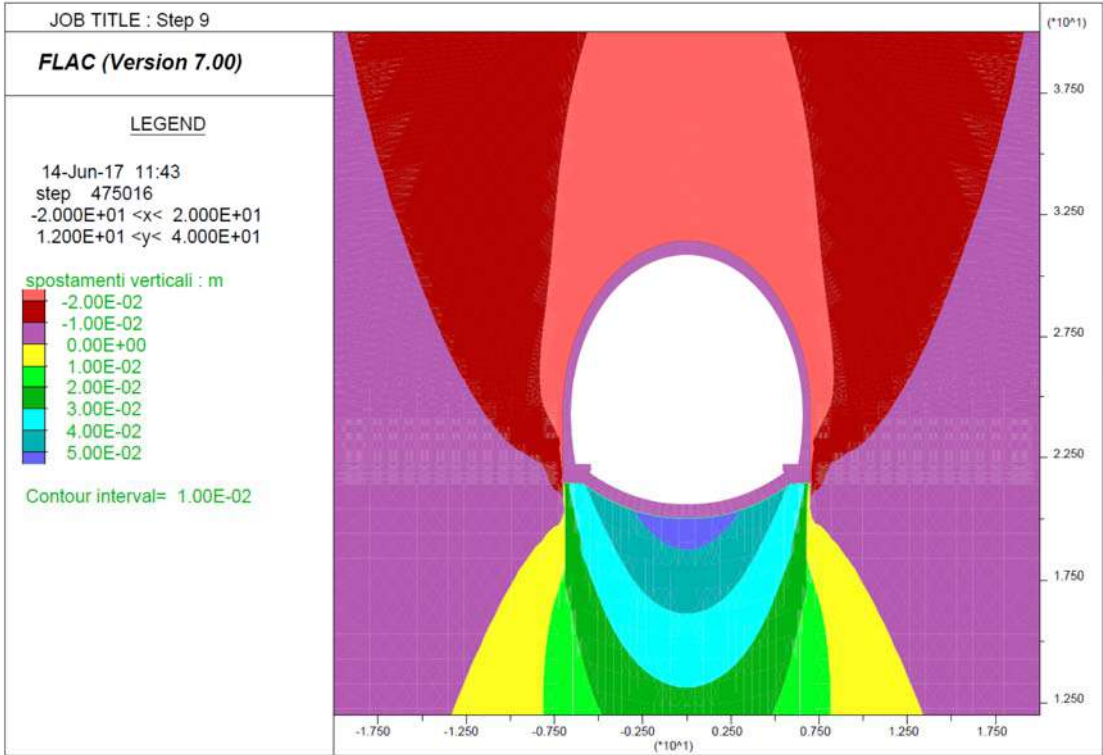

**Output Flac – Sezione tipo B2v – Copertura di calcolo = 25 m**

**Step 1 – Tensioni litostatiche**

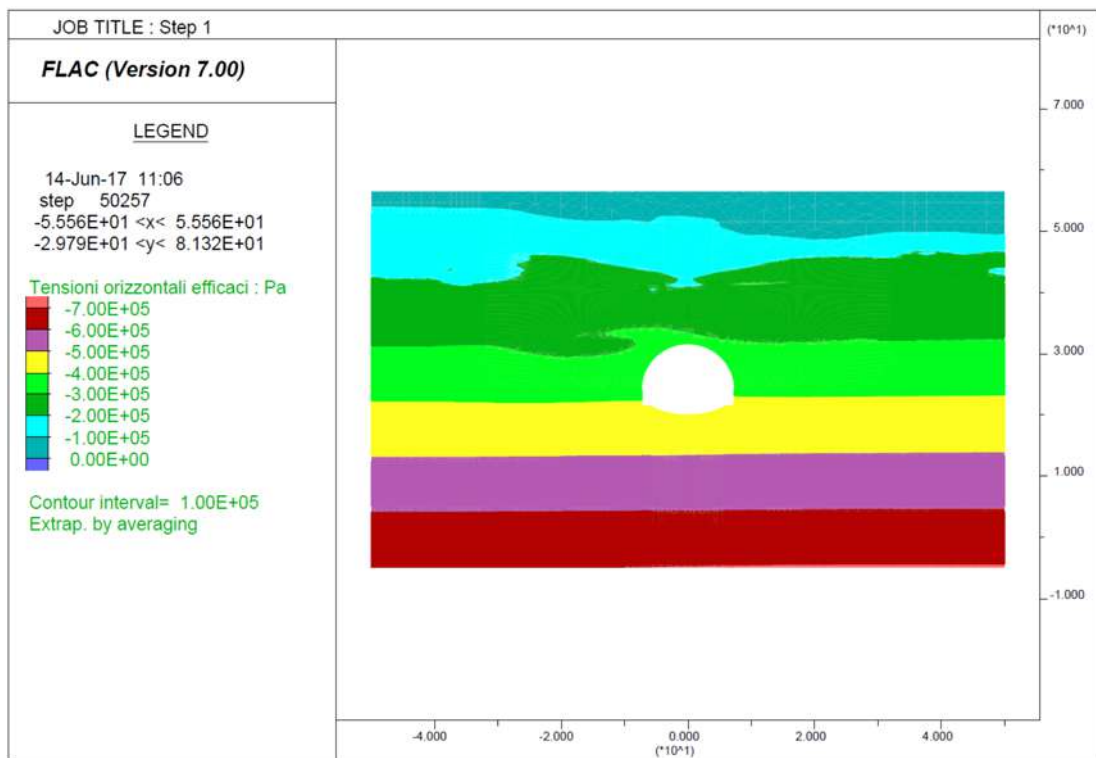
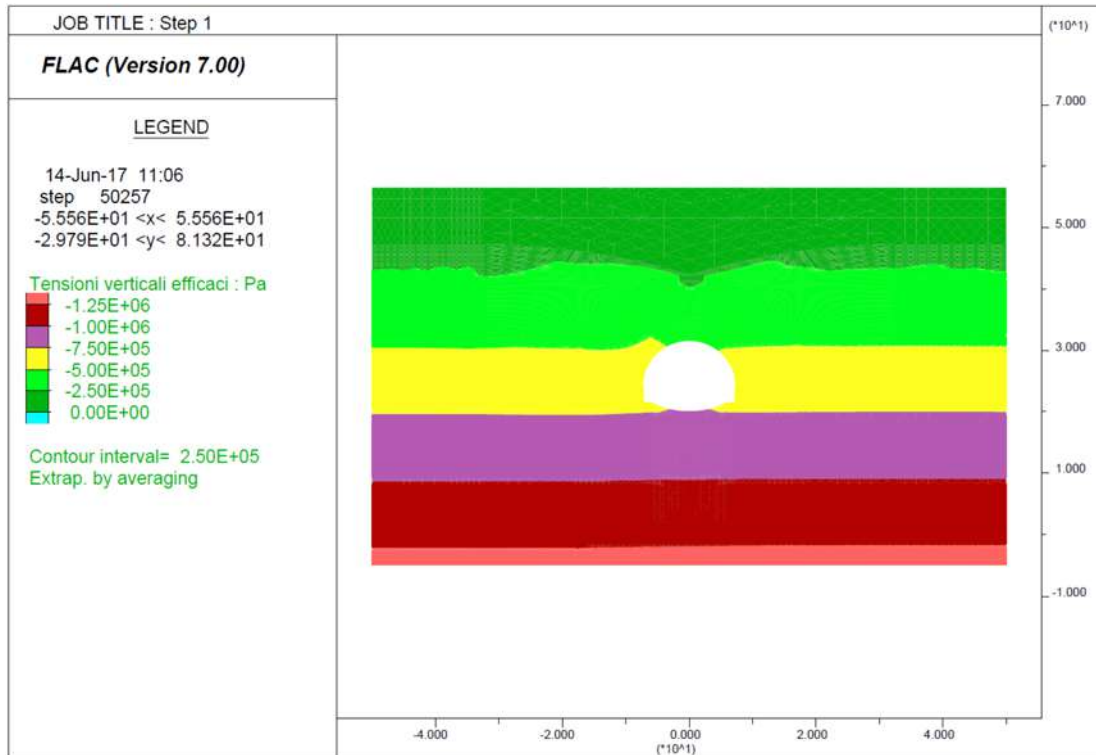



Step 6 – Avanzamento fino a 3D

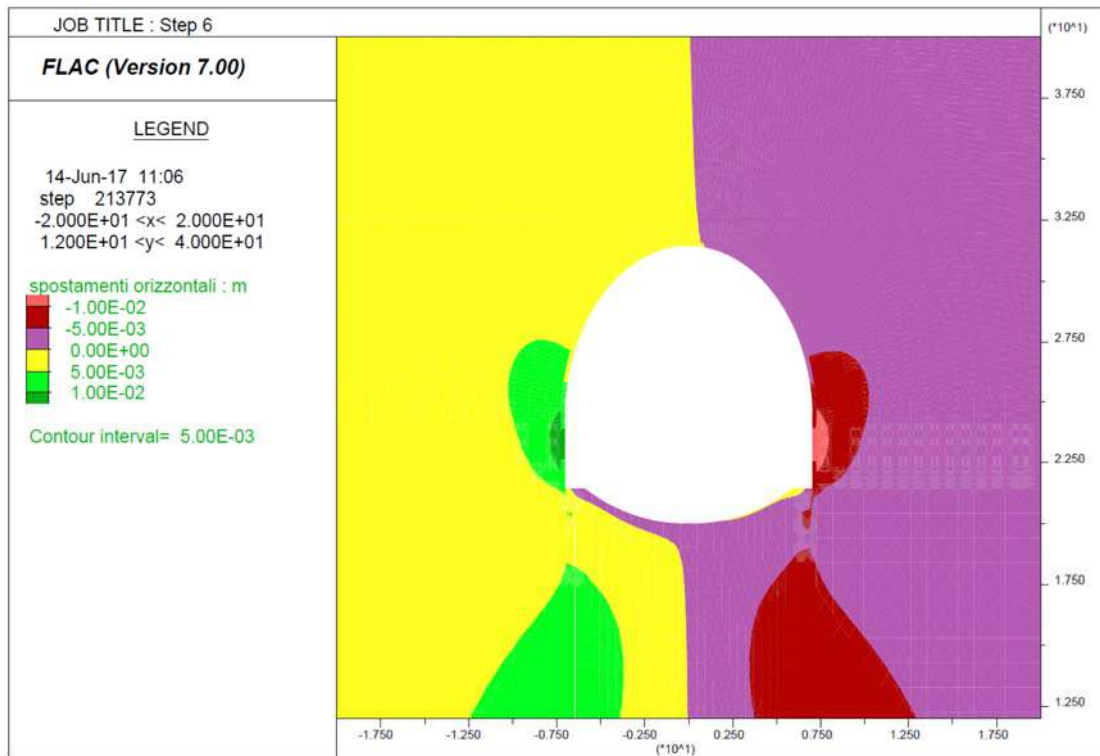
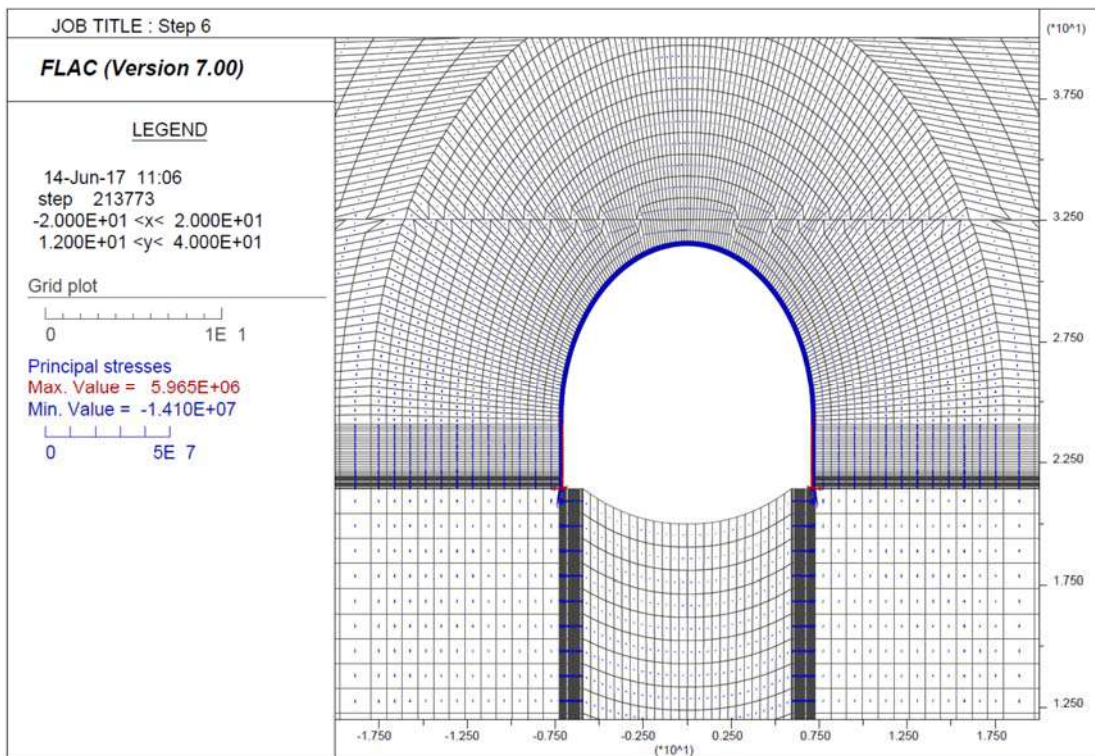

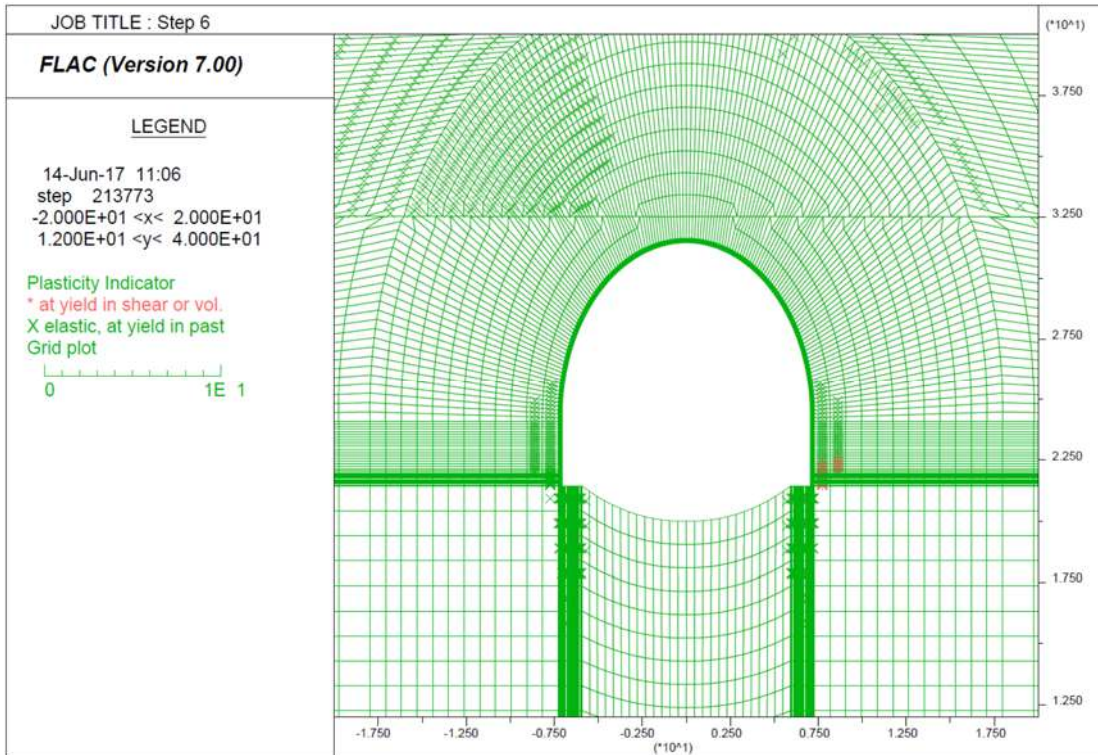
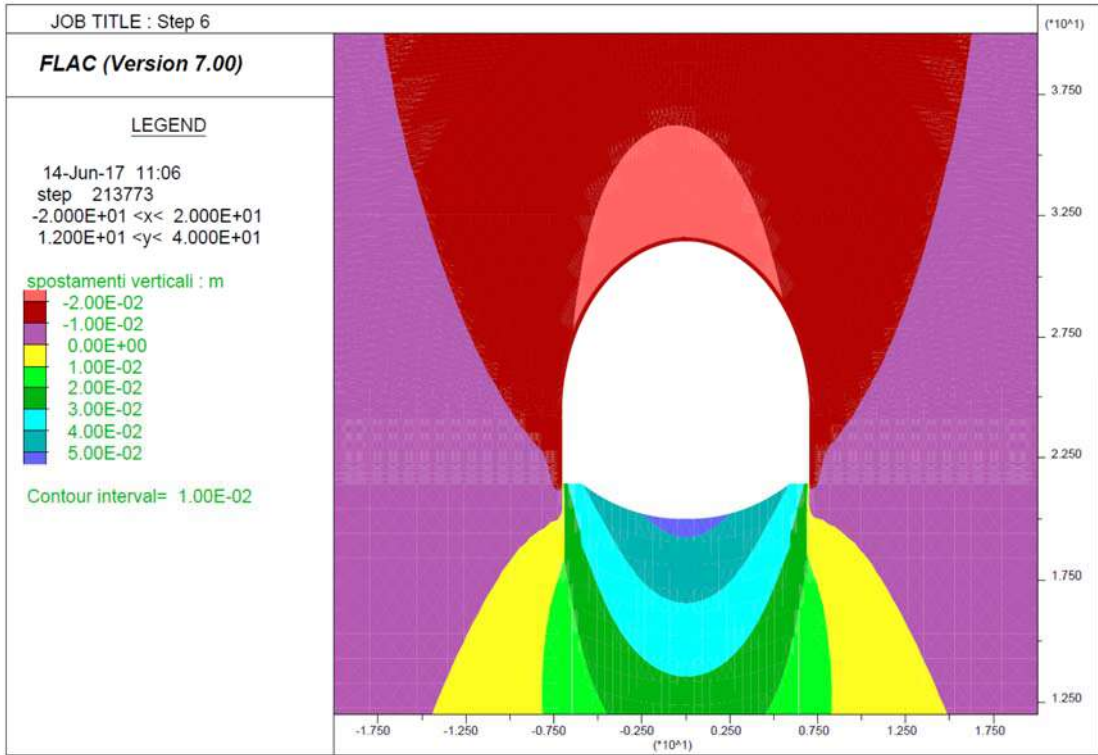



Step 7 - Getto arco rovescio e muretta a 3D e avanzamento fino a deformazioni esaurite

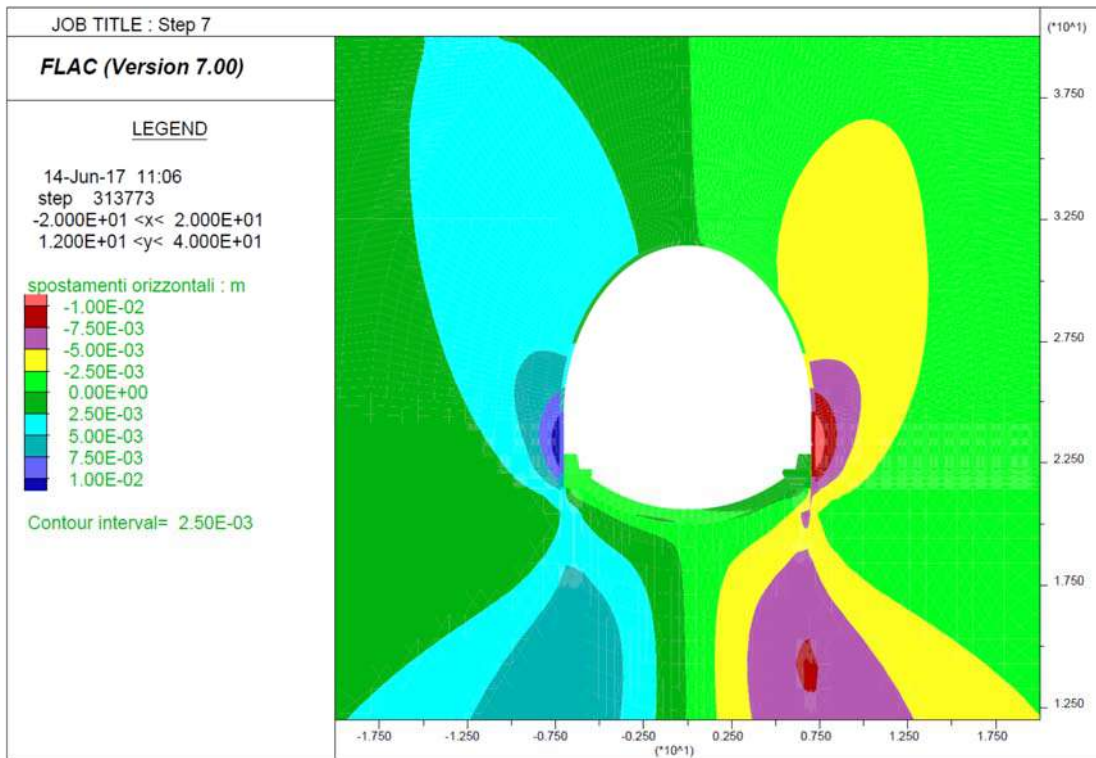
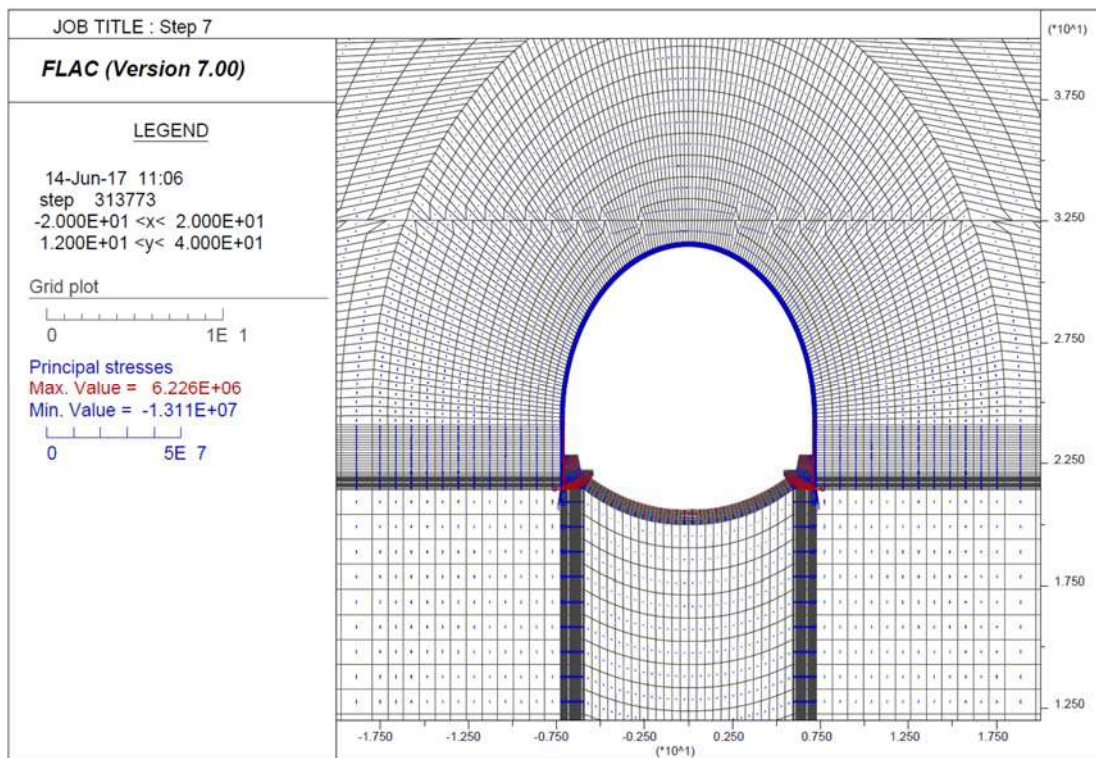



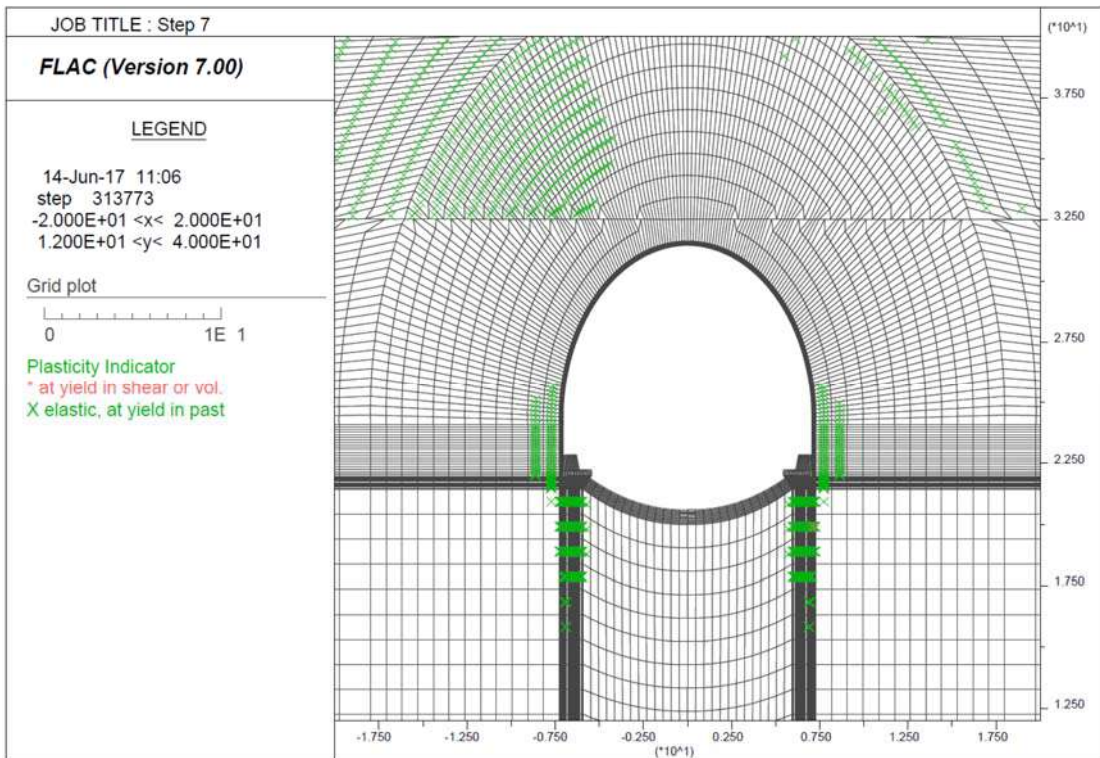
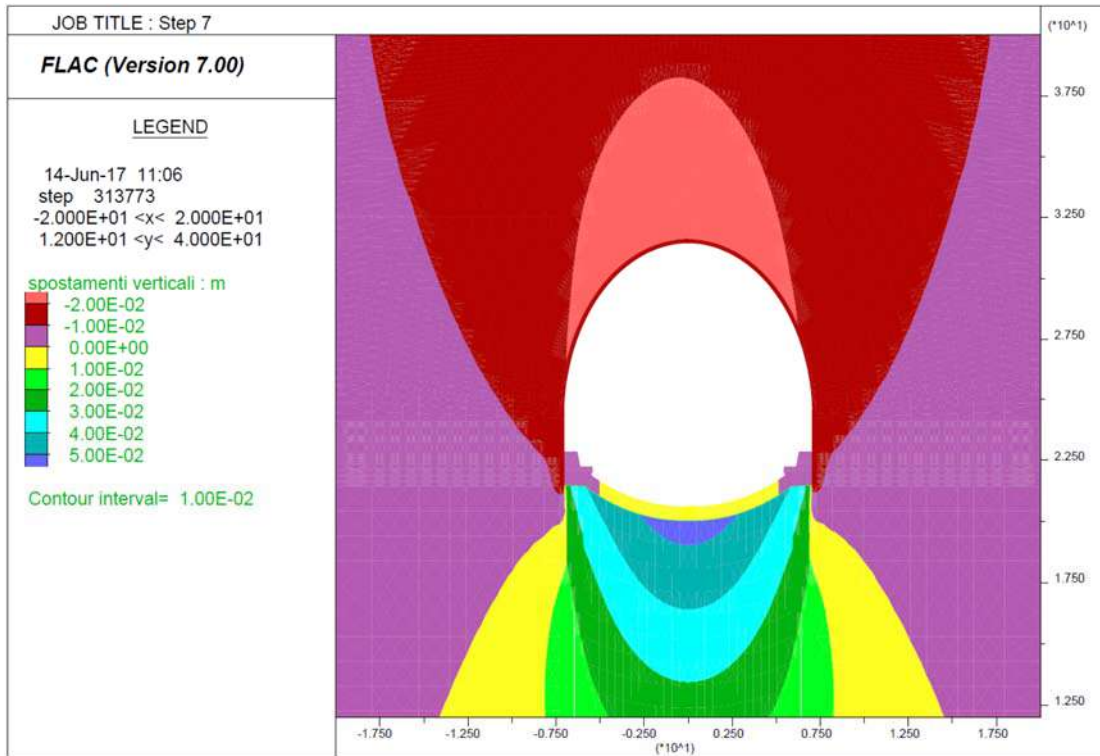

Step 8 - Getto Calotta

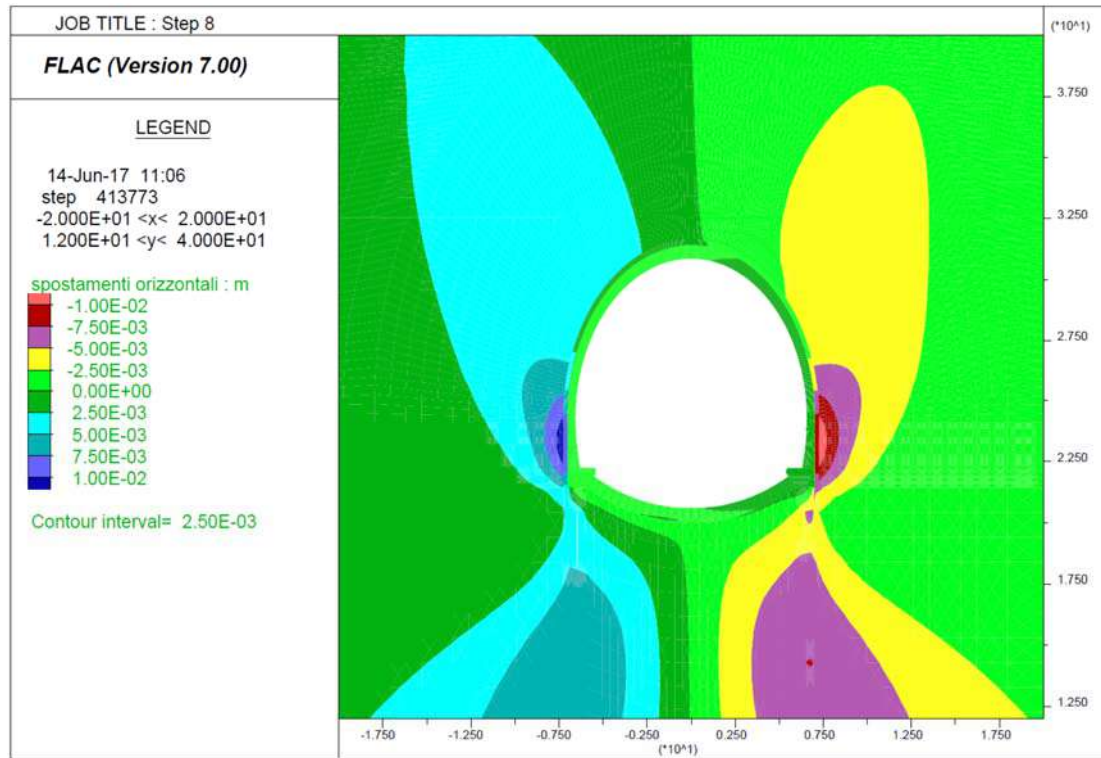
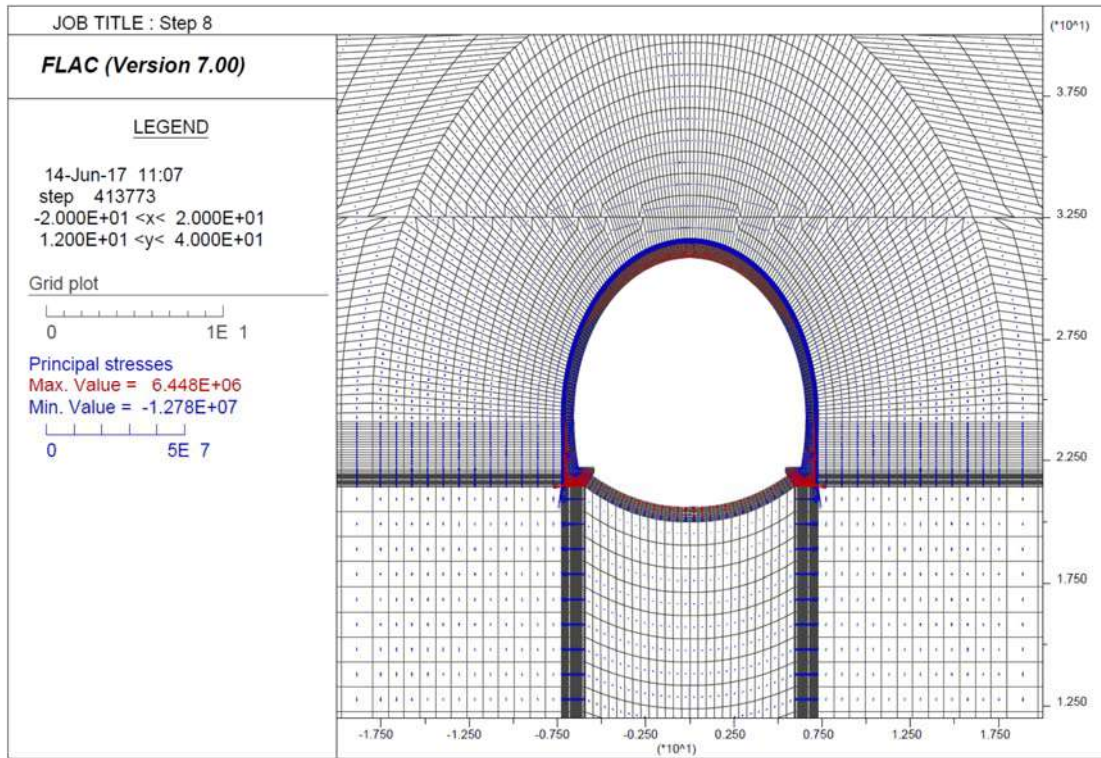



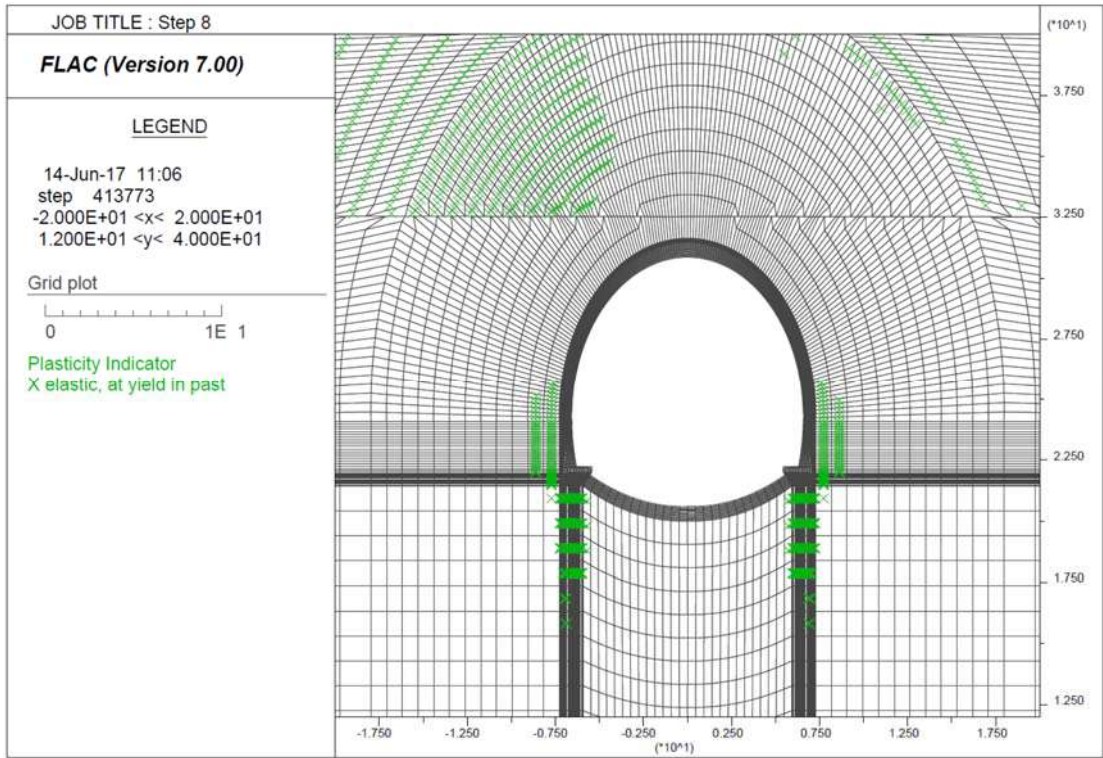
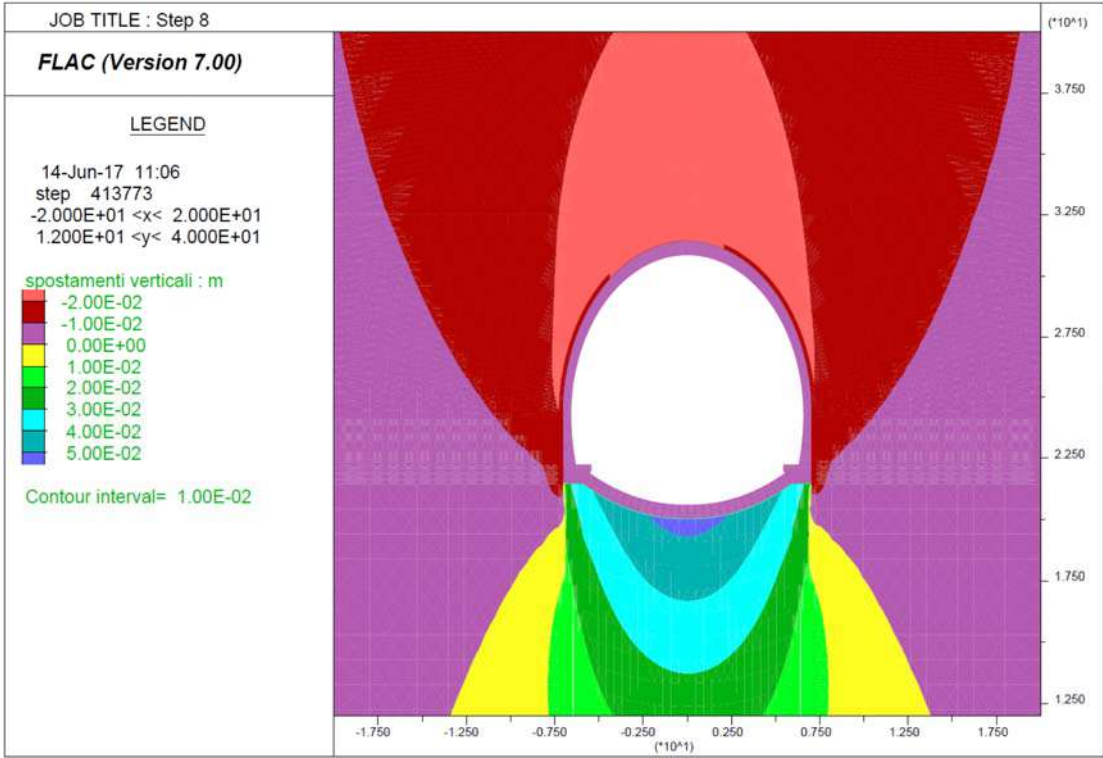



Step 9 - Decadimento dei parametri di resistenza del rivestimento provvisorio

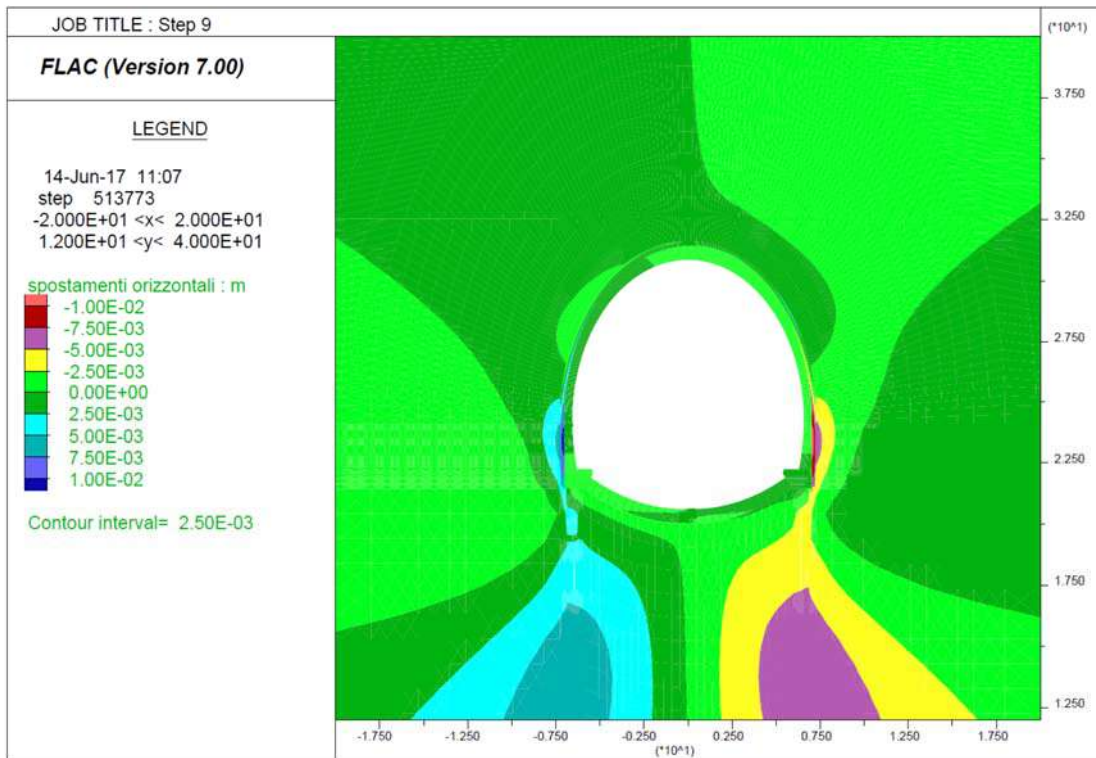
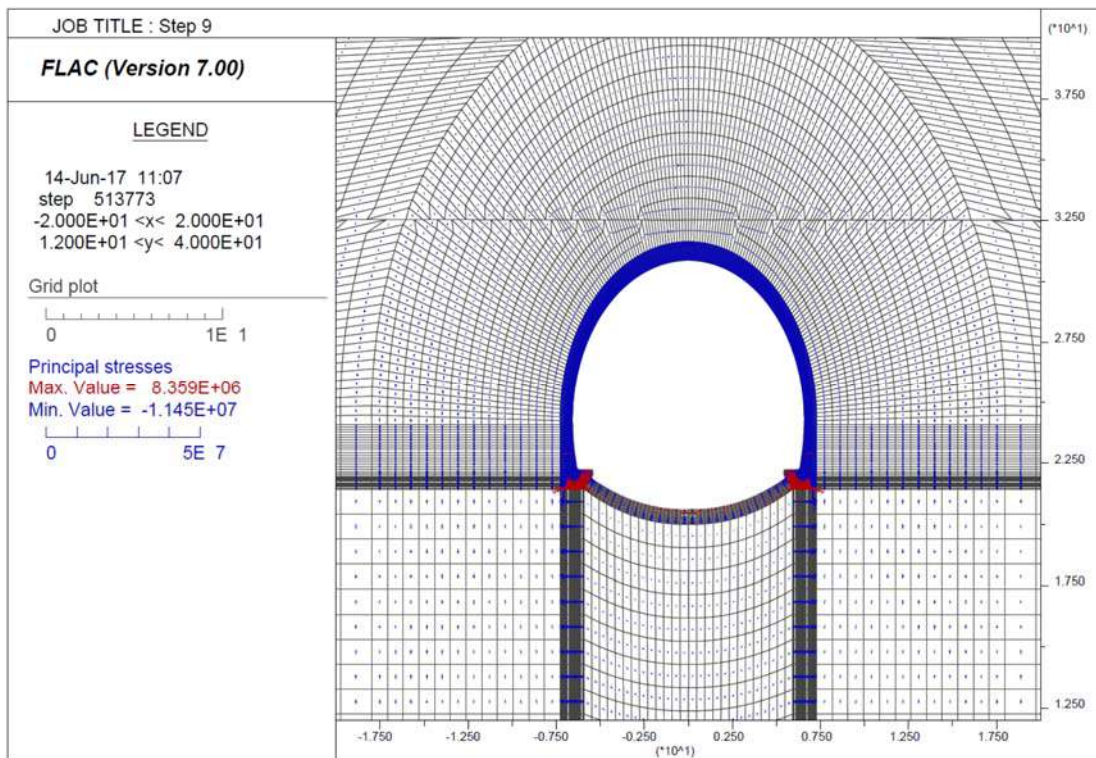

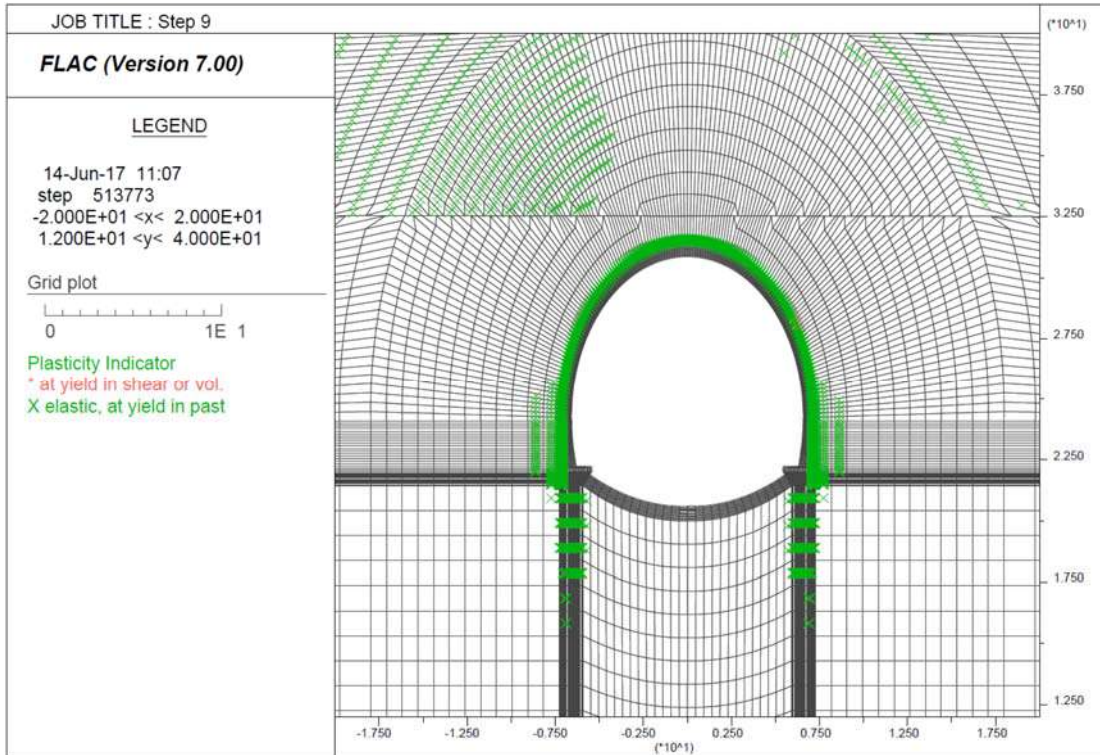
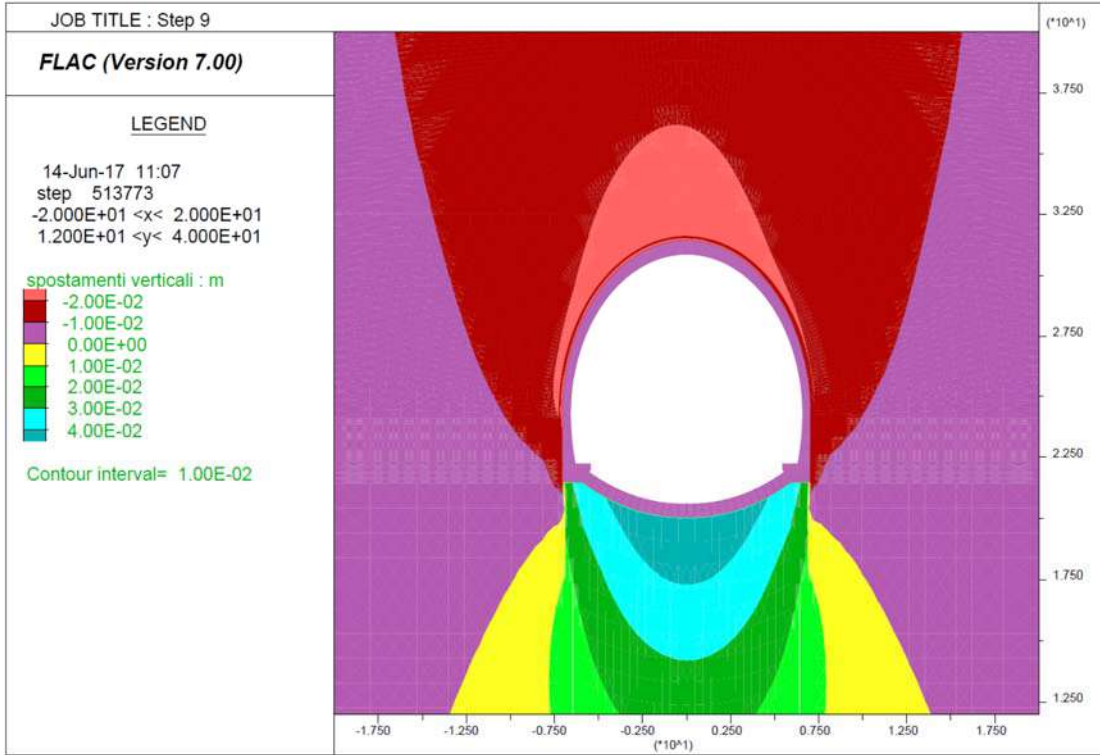

**Output Flac – Sezione tipo B2v – Copertura di calcolo = 15 m**

**Step 1 – Tensioni litostatiche**

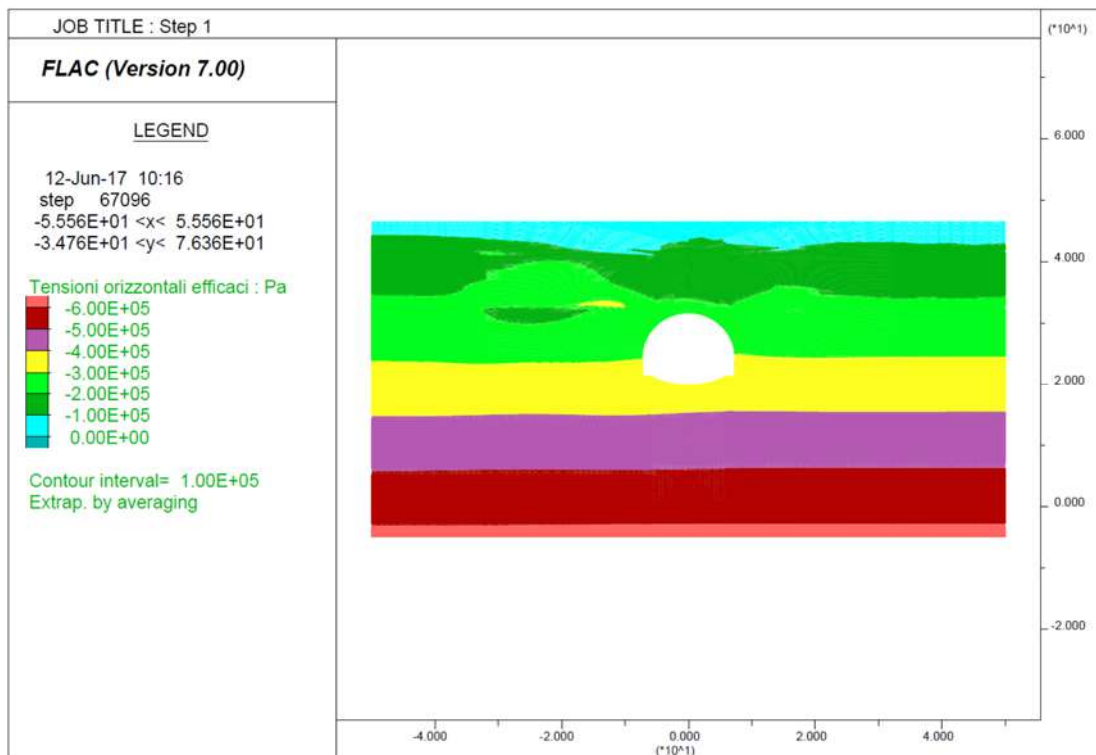
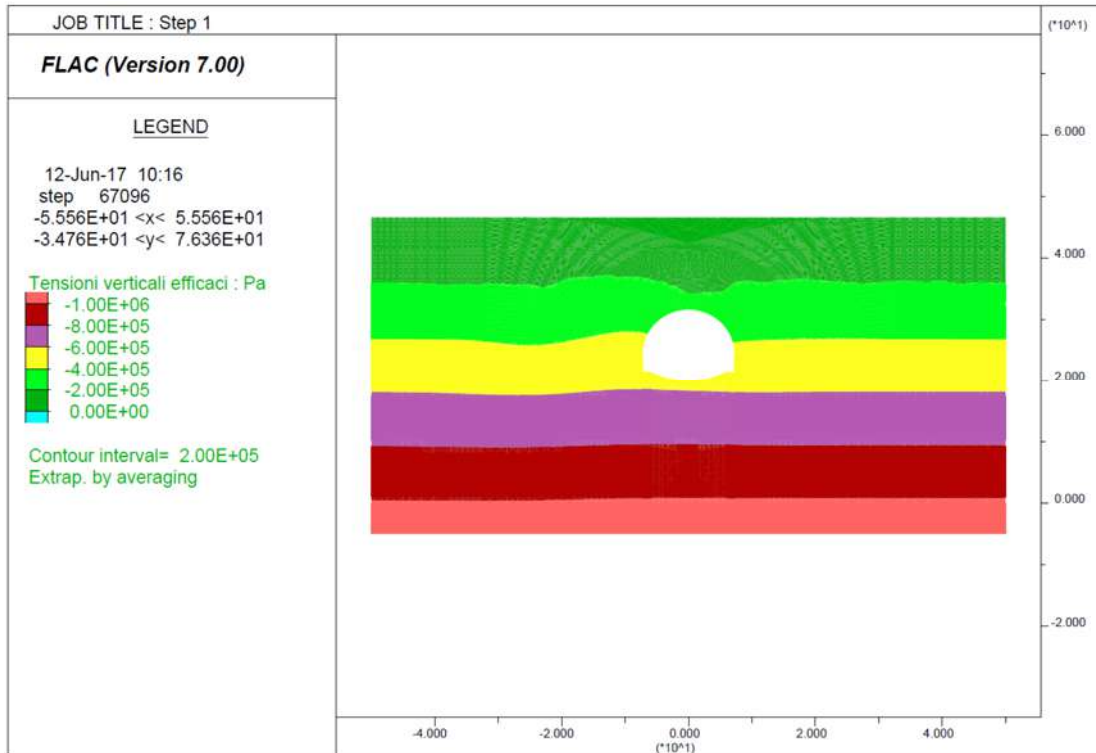



Step 6 – Avanzamento fino a 3D

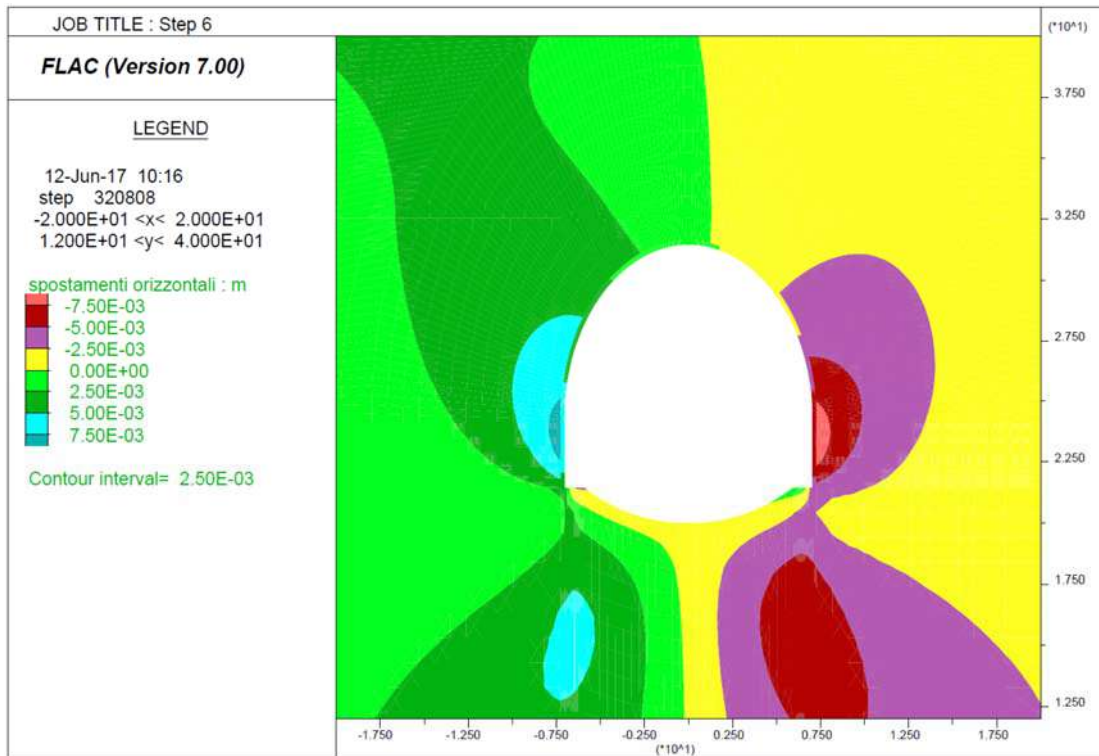
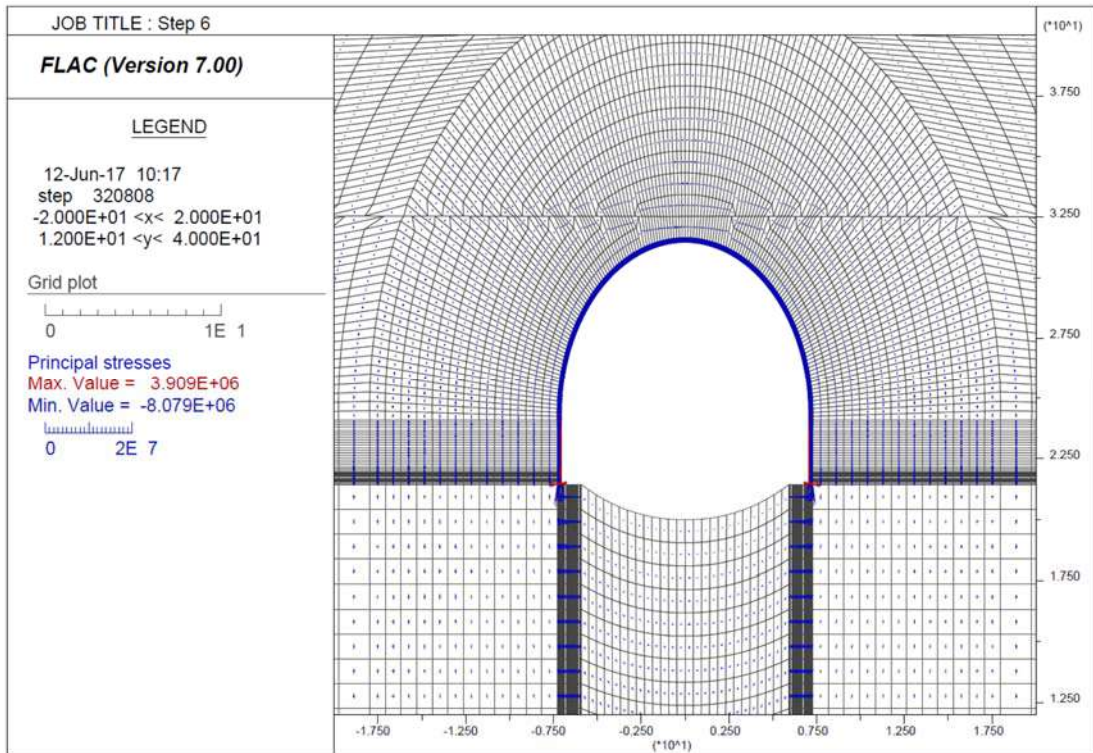

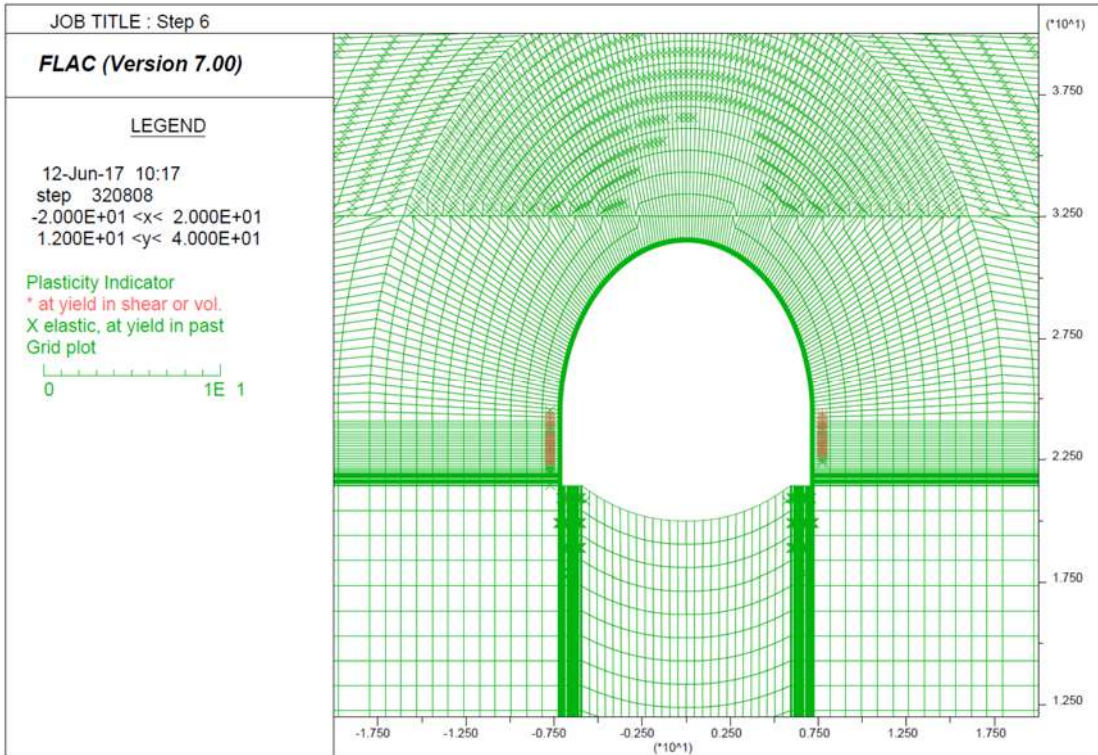
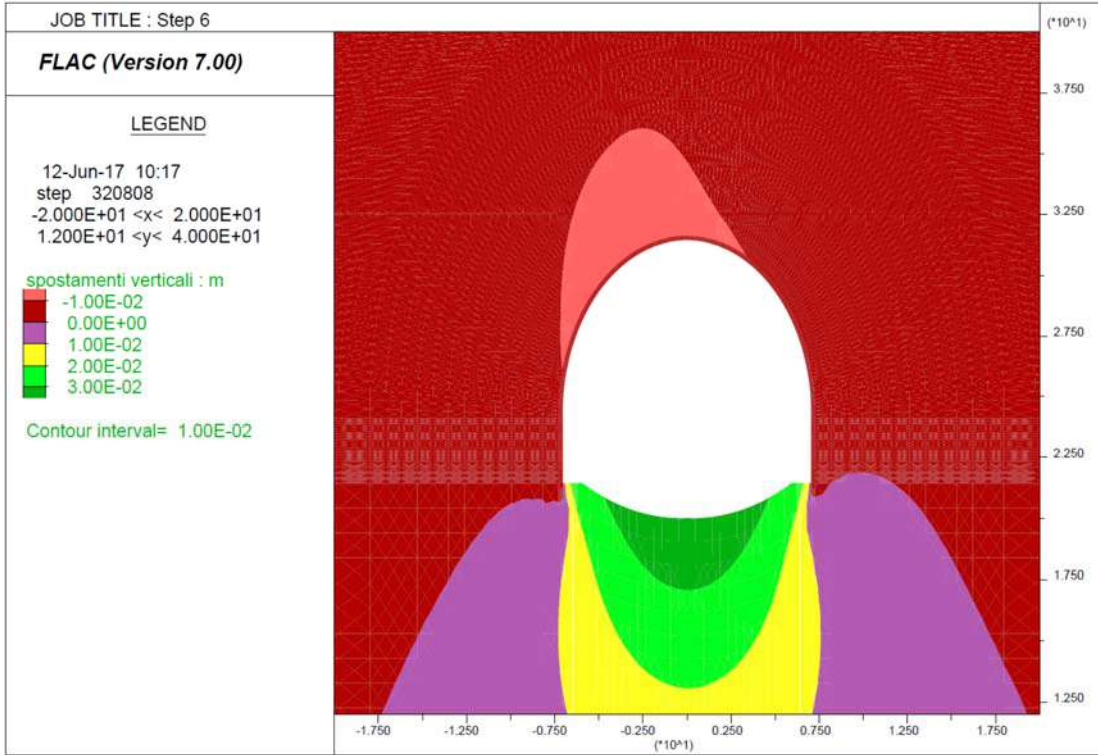



Step 7 - Getto arco rovescio e muretta a 3D e avanzamento fino a deformazioni esaurite

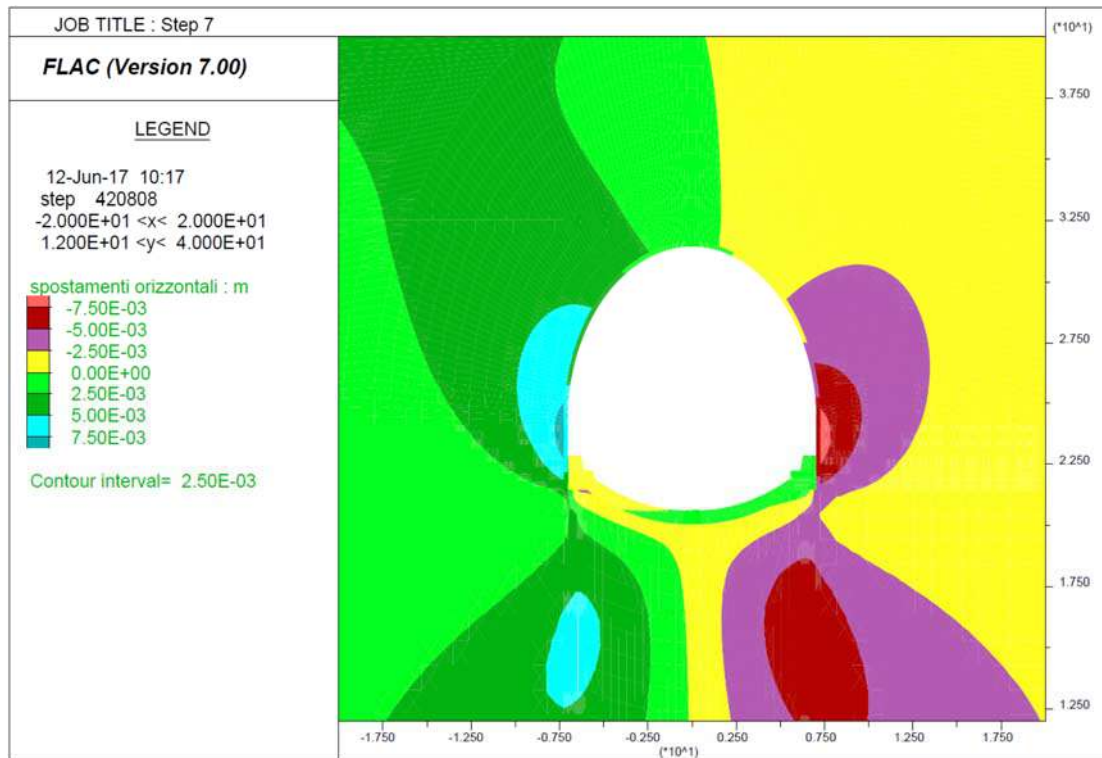
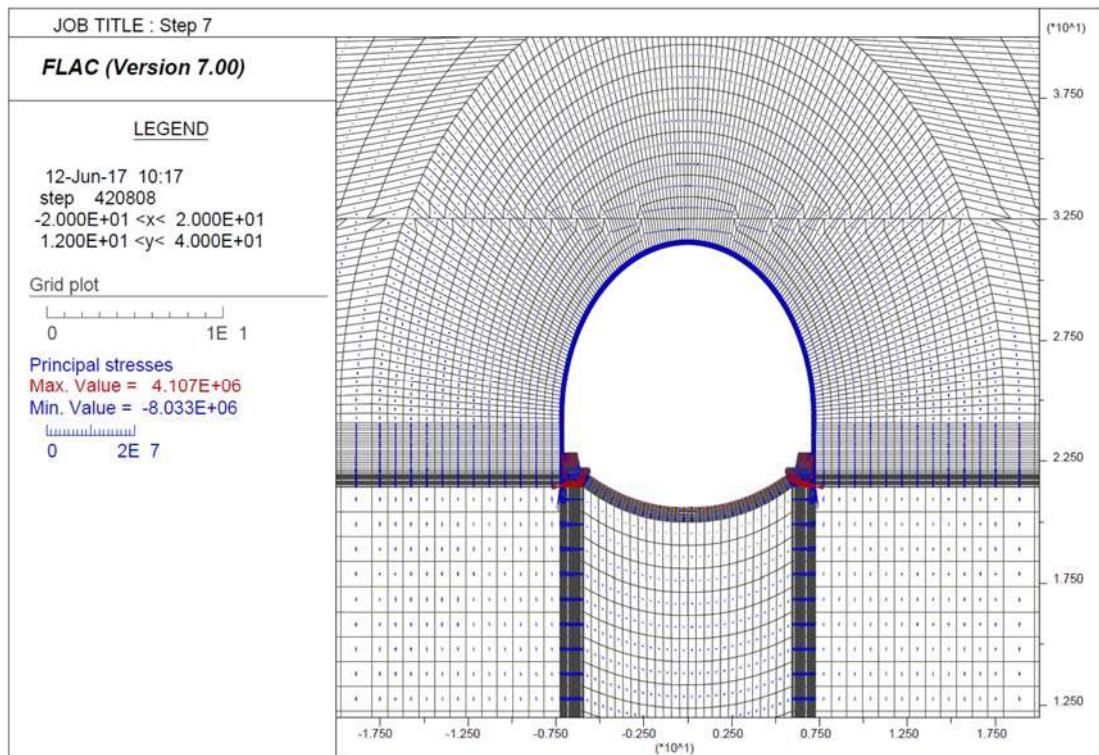



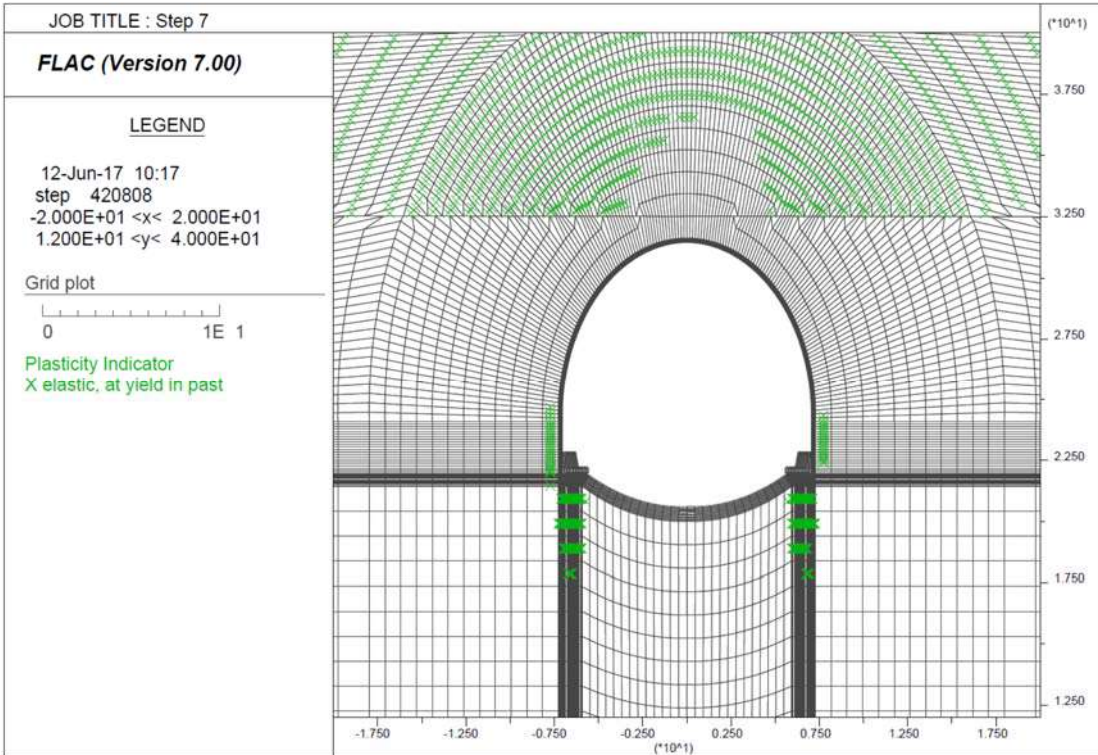
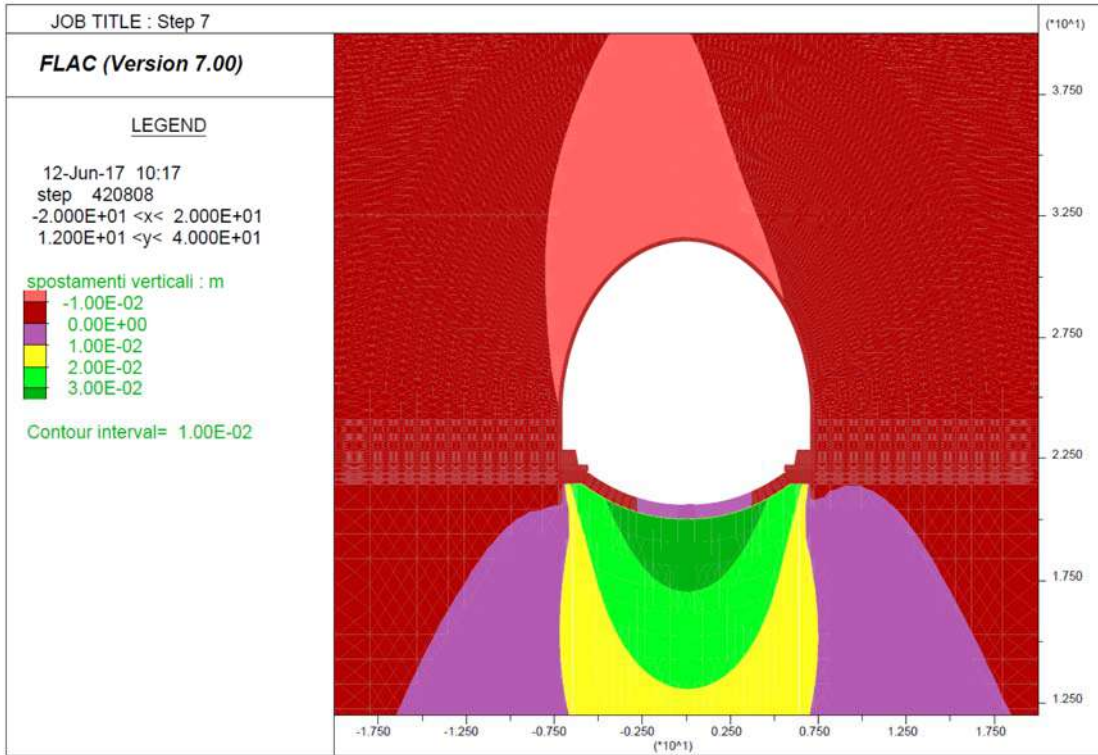

Step 8 - Getto Calotta

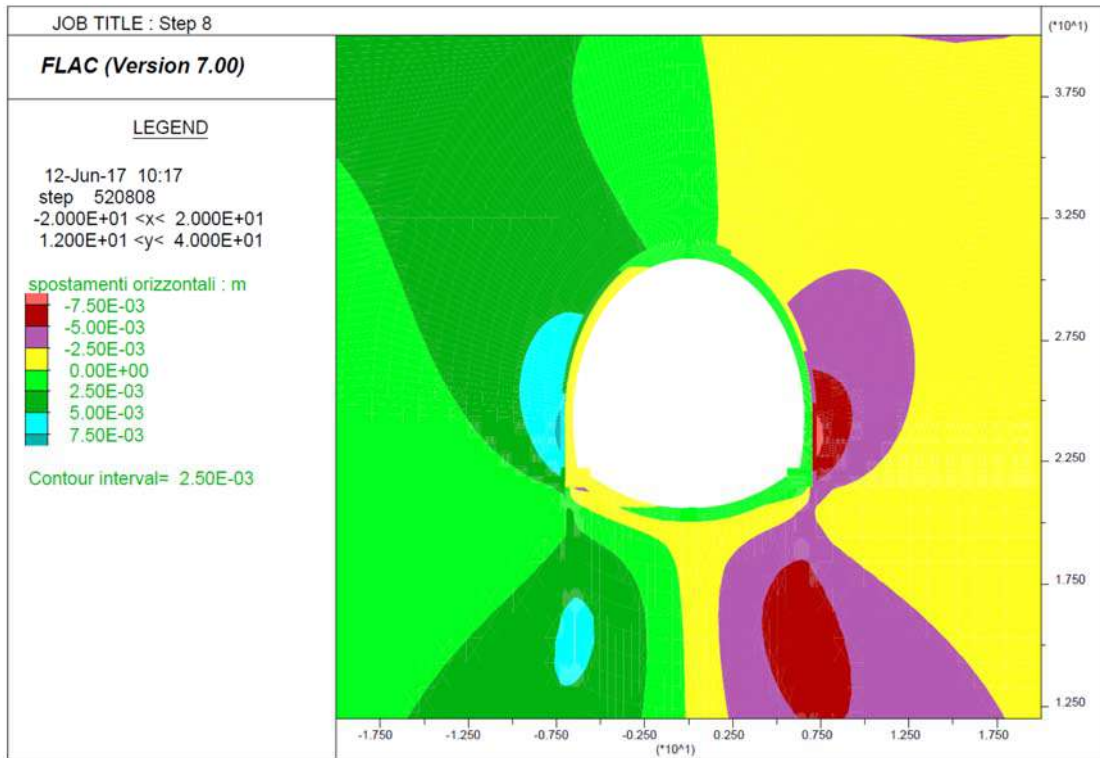
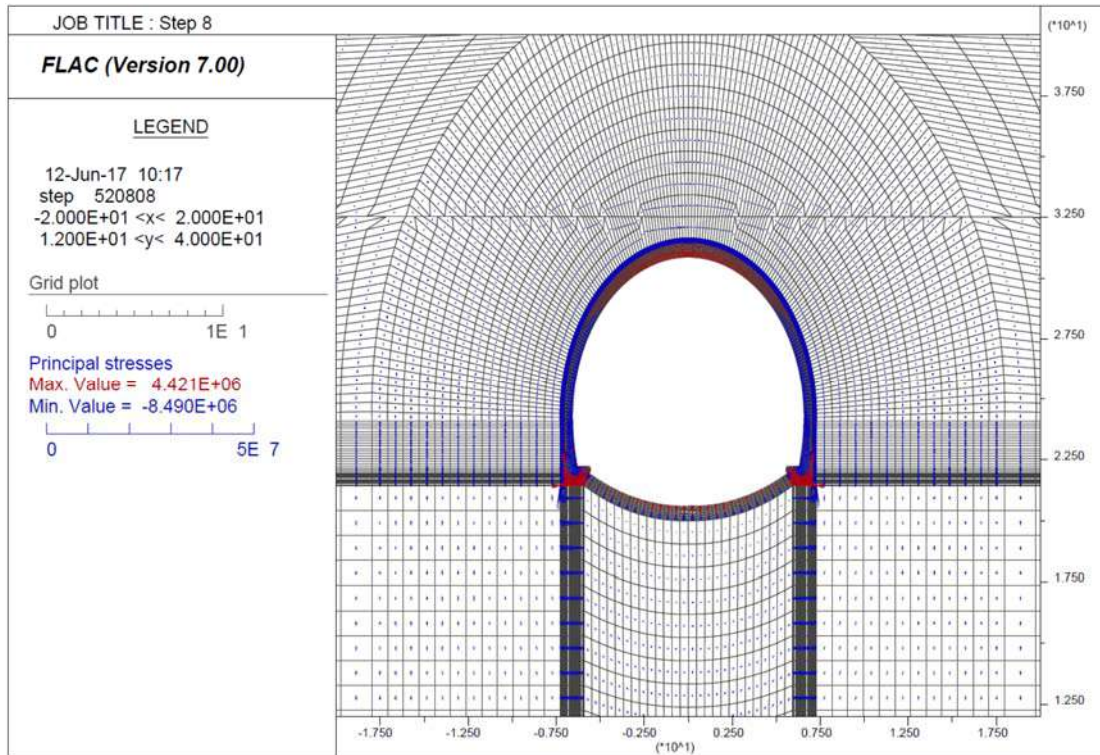



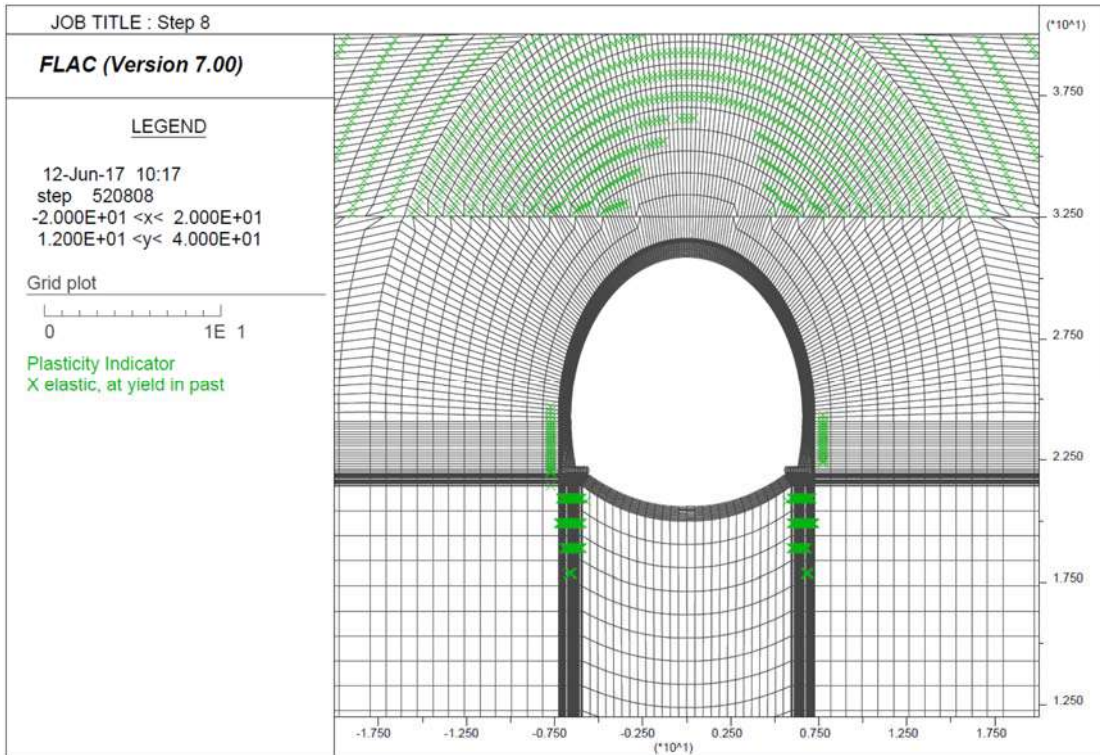
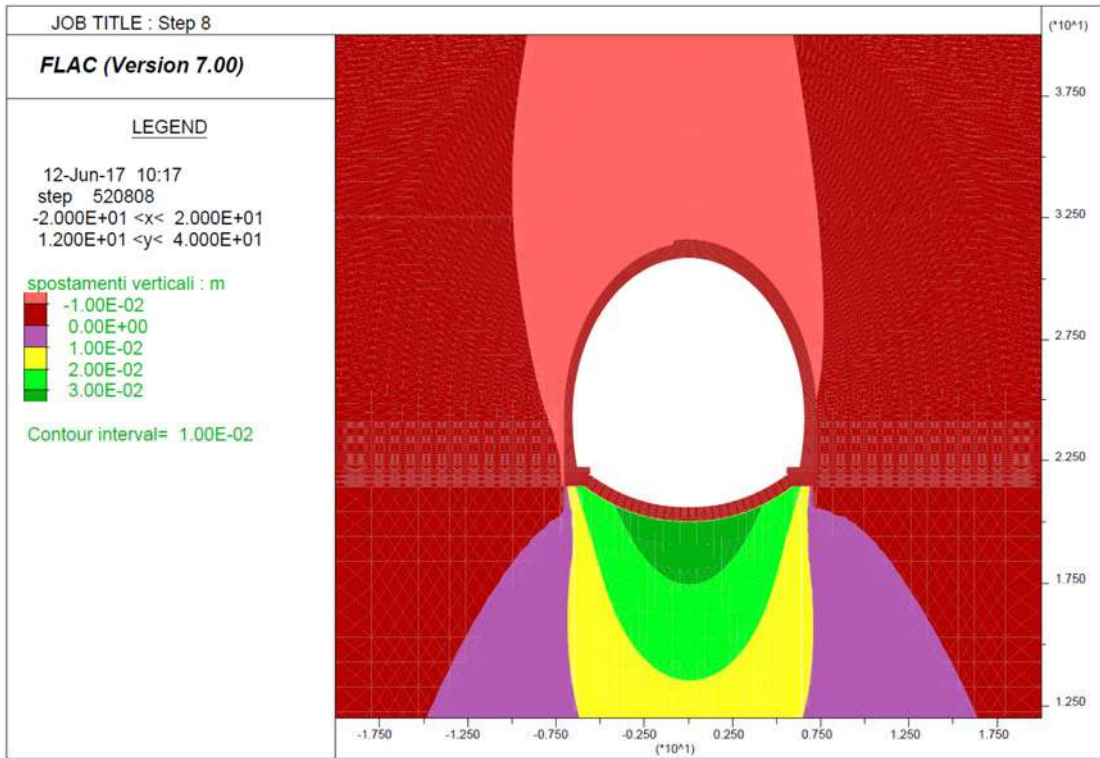



Step 9 - Decadimento dei parametri di resistenza del rivestimento provvisorio

