

SEZIONE TRASVERSALE

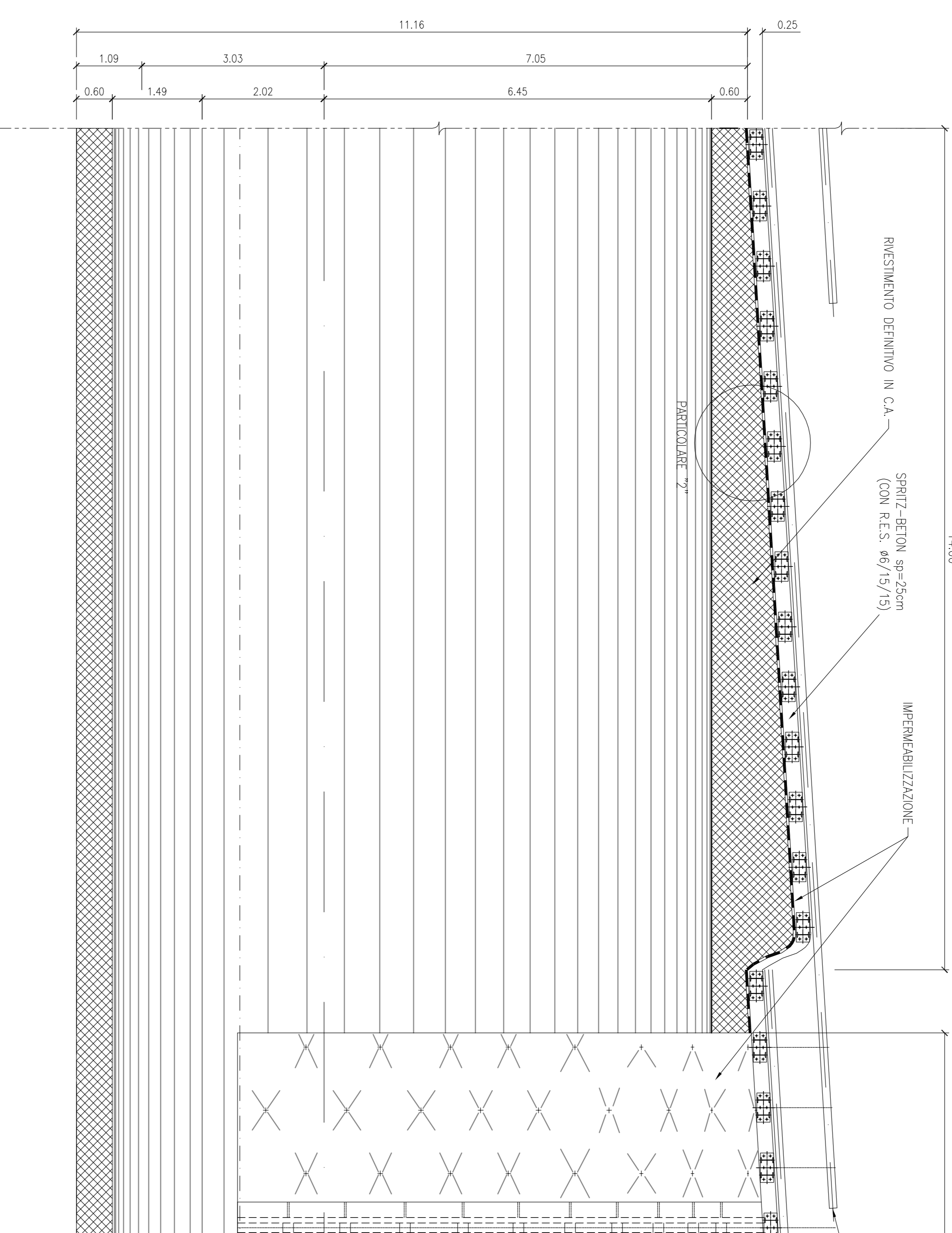

PROFLO LONGITUDINALE

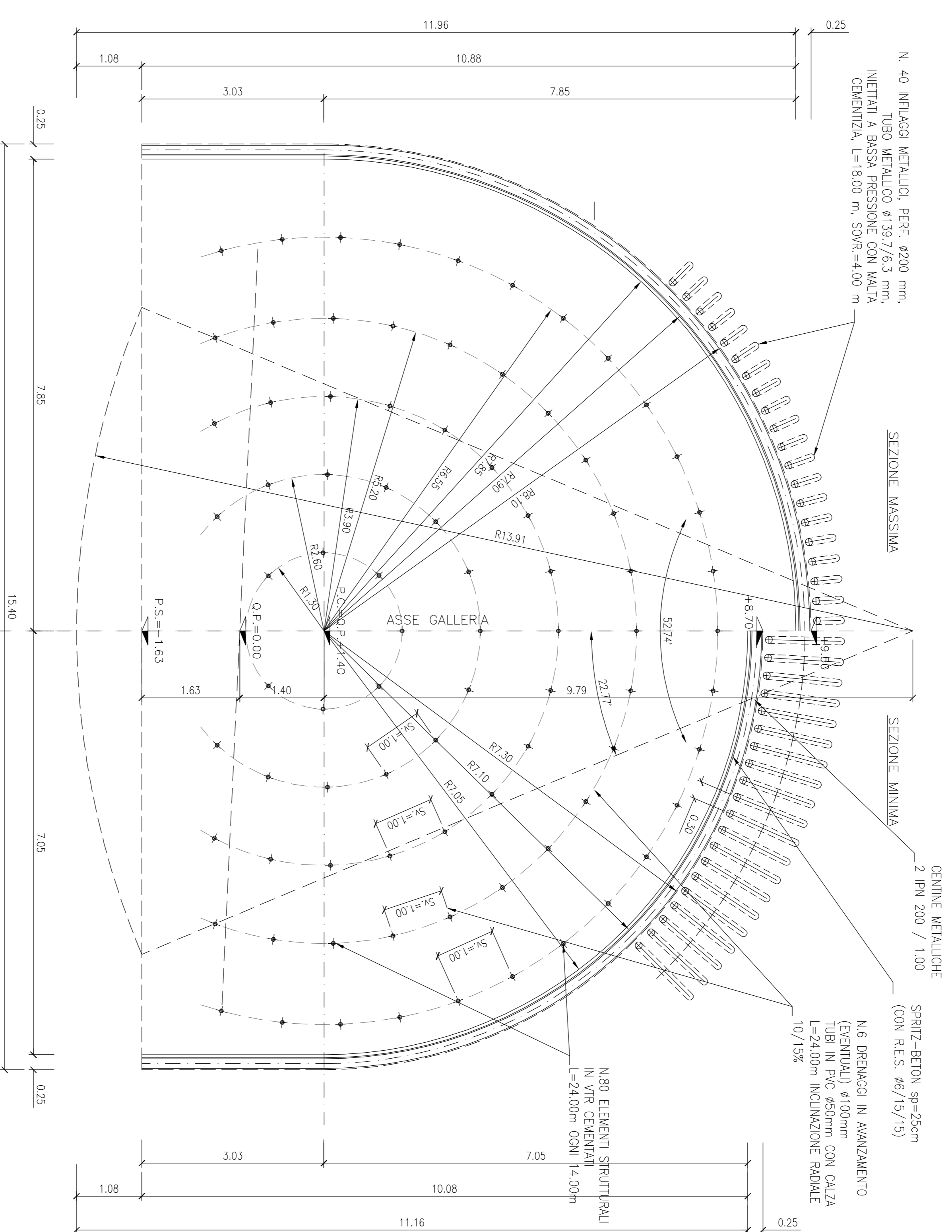
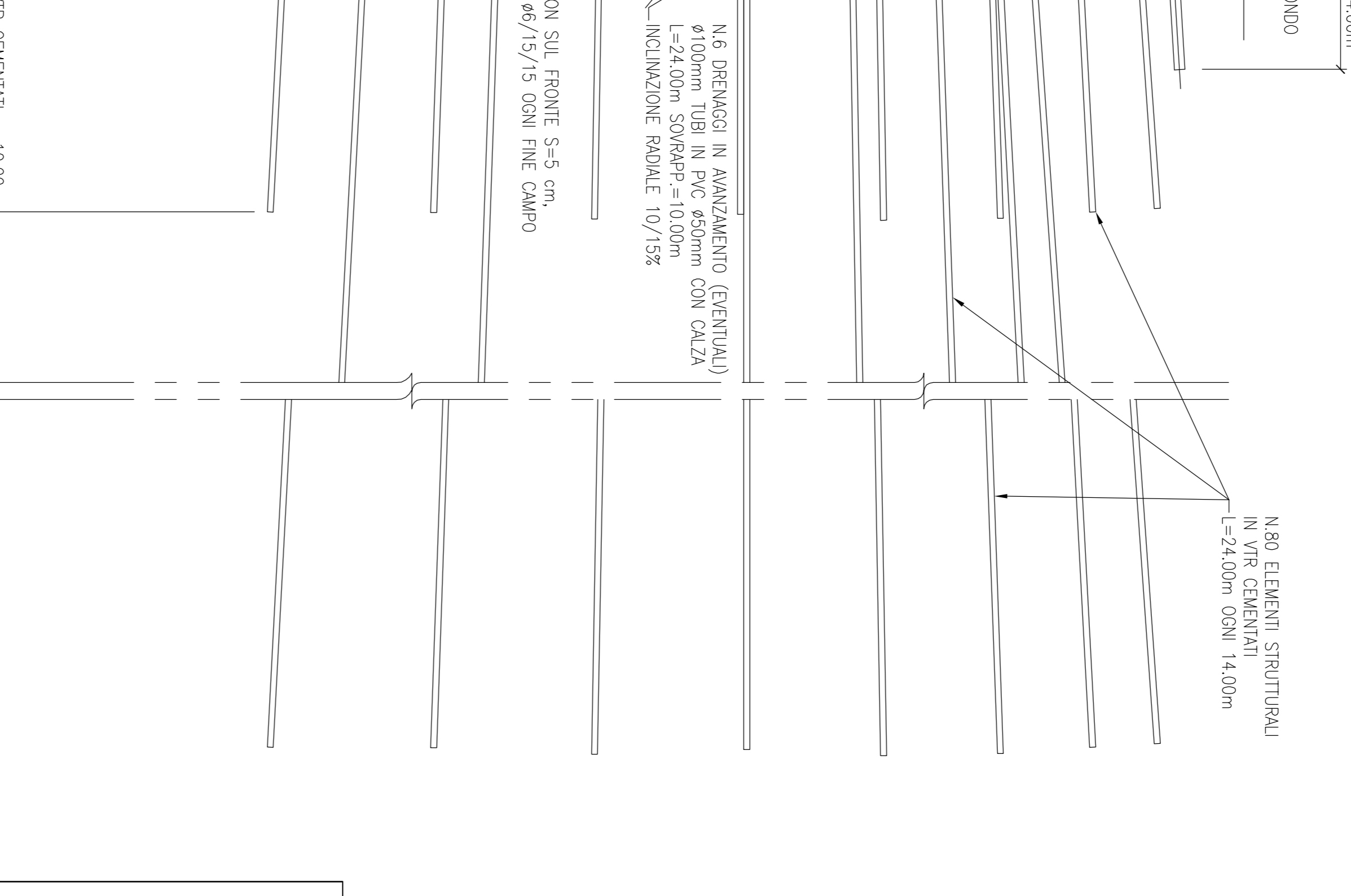
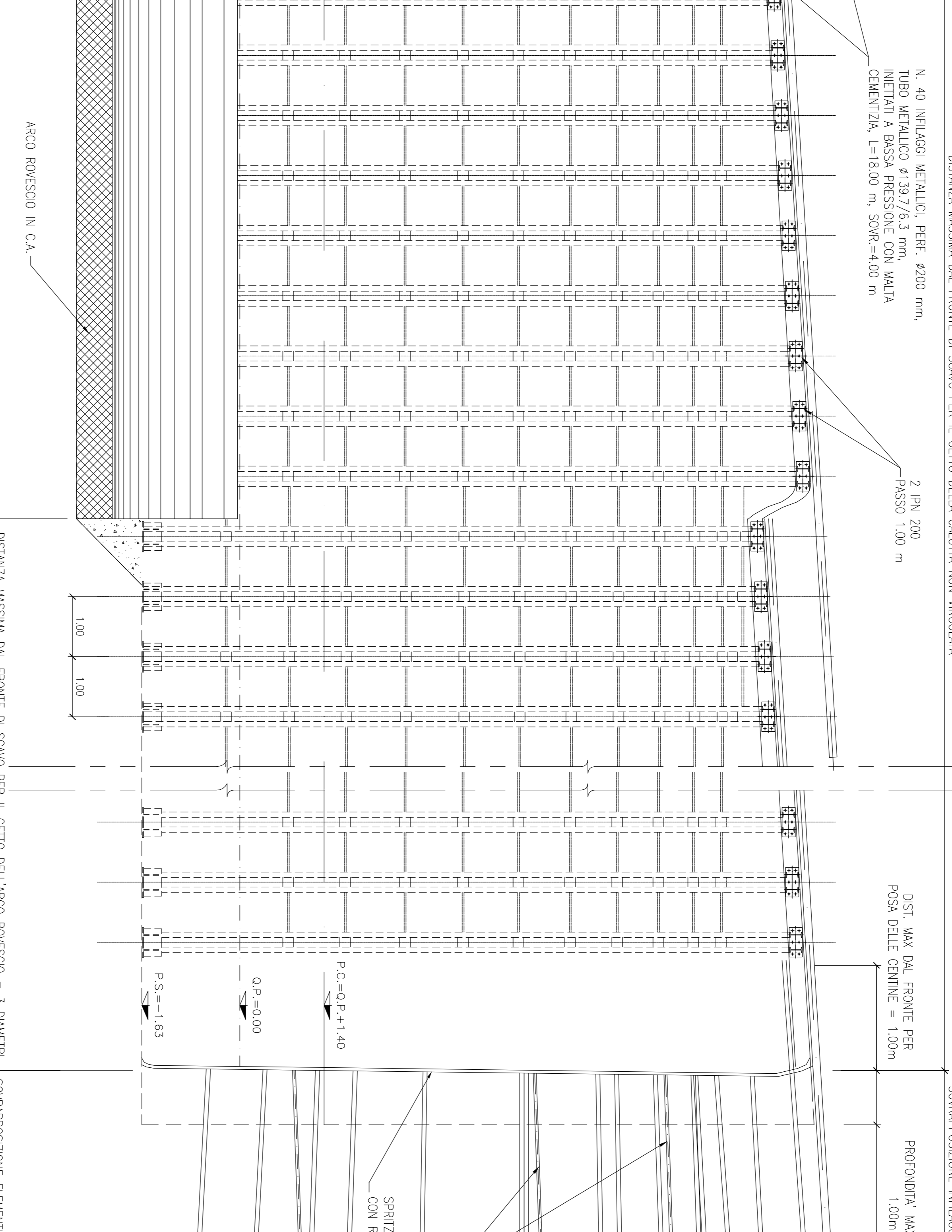

DETTAGLIO ELEMENTO STRUTTURALE IN VITE

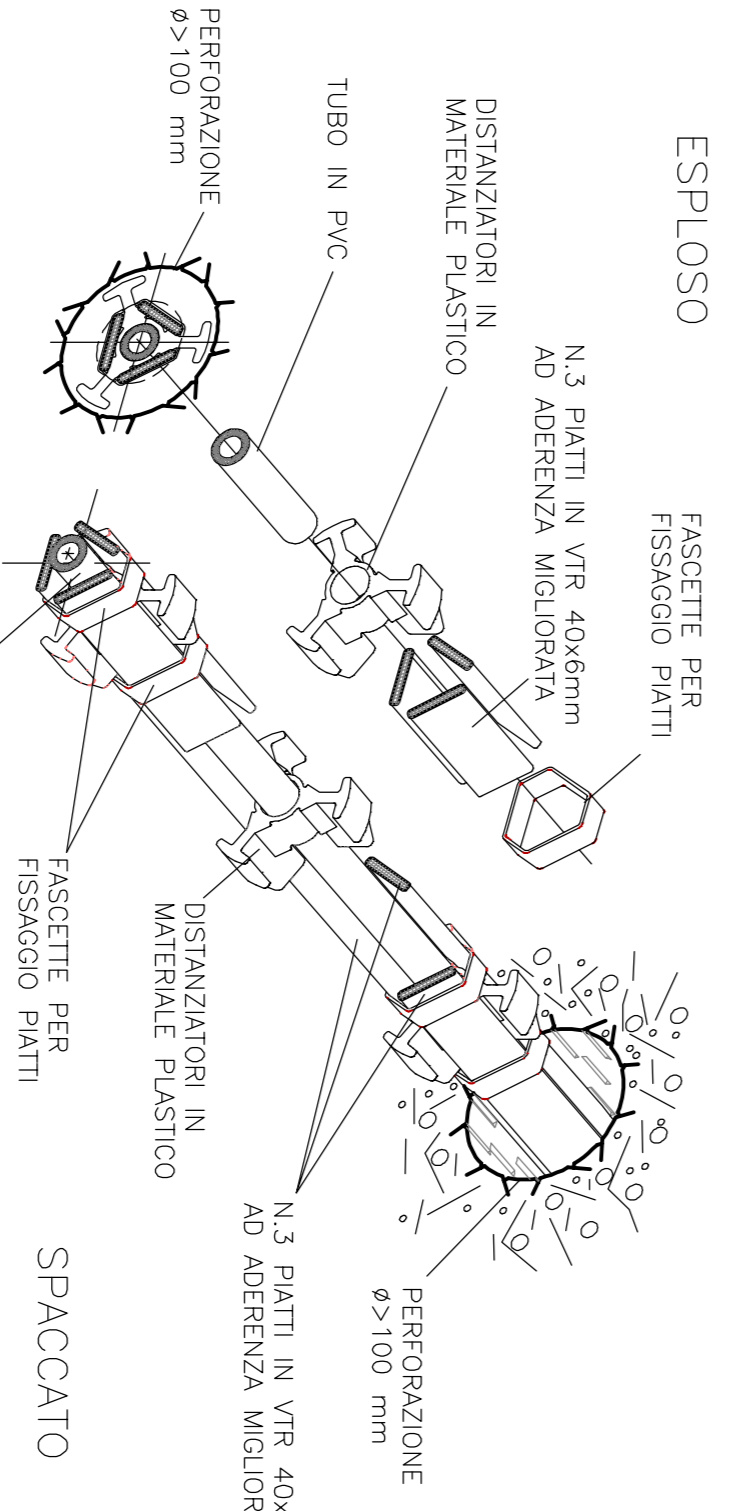

PARTICOLARE "2"

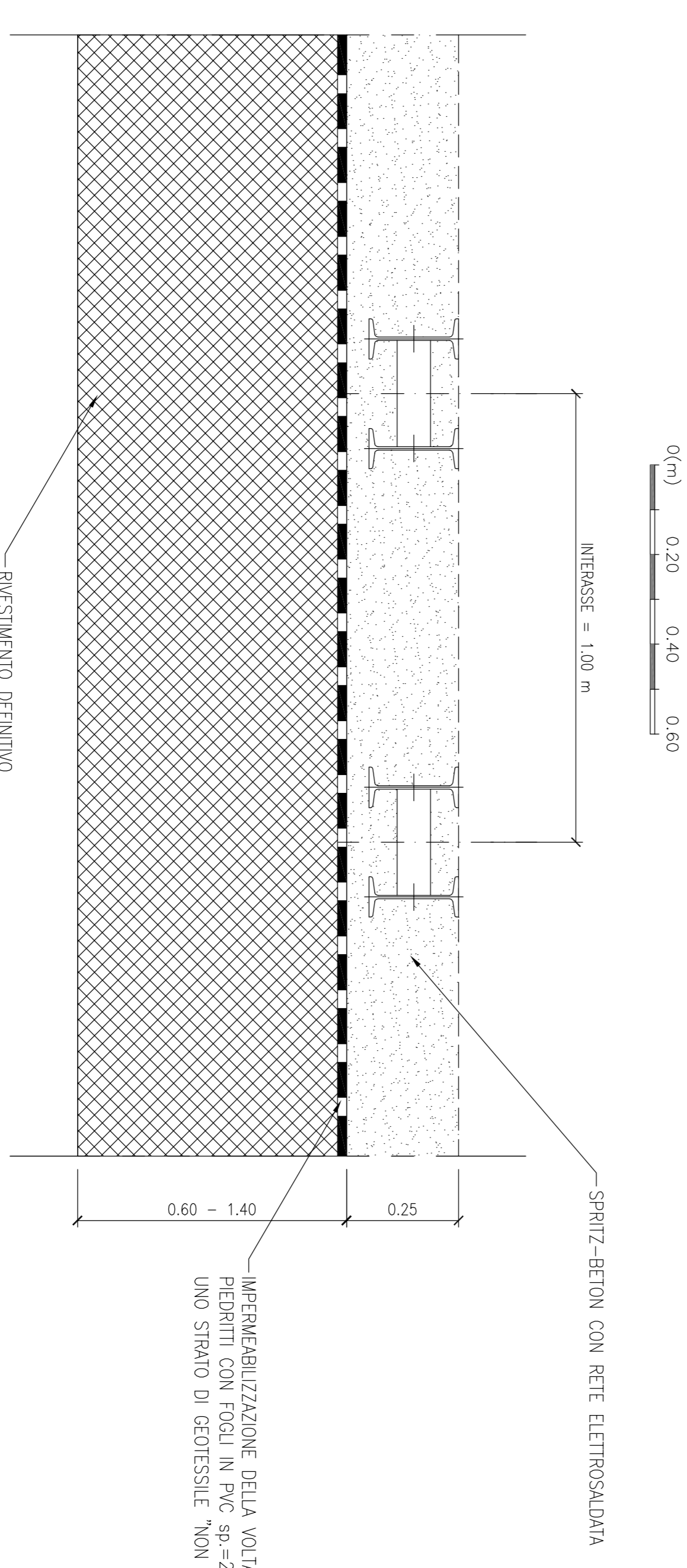

NOTA

IL PASSO DELLE CERNIE "NOTA" VARIEGA DA 0,80 A 1,20 m

TABELLA MATERIALI

Table listing materials and their specifications, including concrete, reinforcement, and other structural components.

GUABRILATERO

ASSE VIARIO MARCHE-PIEMONTE F. QUABRILATERO DI PENETRAZIONE INTERNA MANILOTTO 2

LAUREA IN INGEGNERIA CIVILE E AMBIENTALE - UNIVERSITA' DEGLI STUDI DI TRIESTE

PROGETTO DEFINITIVO

DIRPA 2

Administrative and technical information block containing logos, dates, and project details.