

DETTAGLIO "1"

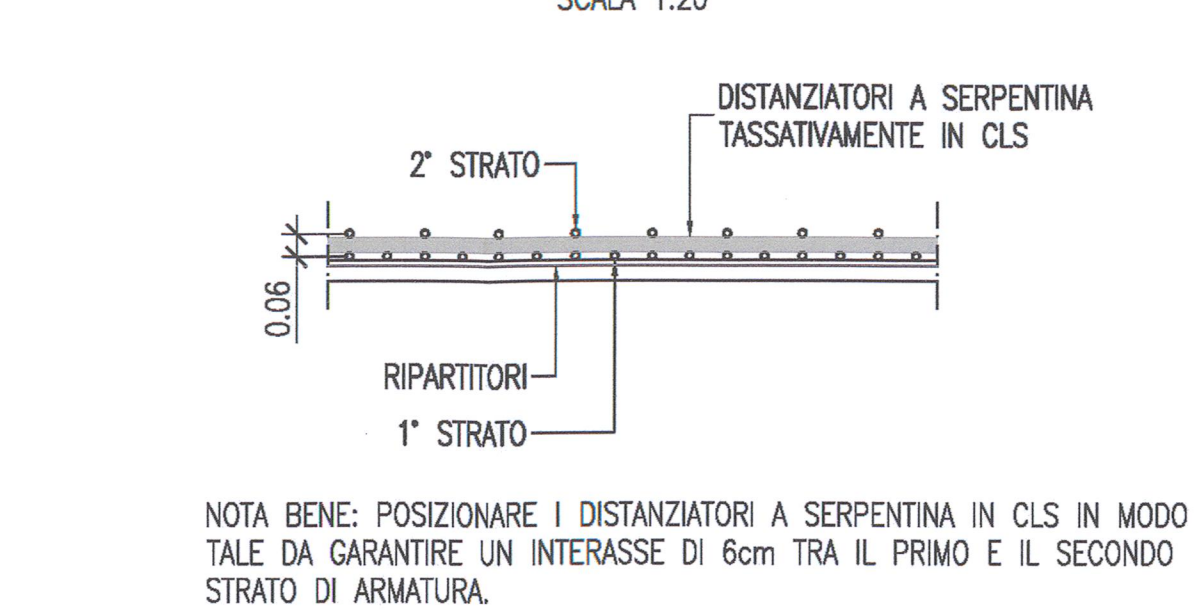

NOTA BENE: POSIZIONARE I DISTANZIATORI A SERPENTINA TASSARIAMENTE IN CLS
TALE DA GARANTIRE UN INTERASSE DI 6cm TRA IL PRIMO E IL SECONDO STRATO DI ARMATURA.

SCHEMA RIPARTITORI

L. CONCIO

L. CONCIO	27,56m
LUNGEZZE (cm)	
A	1200
B	900
C	780

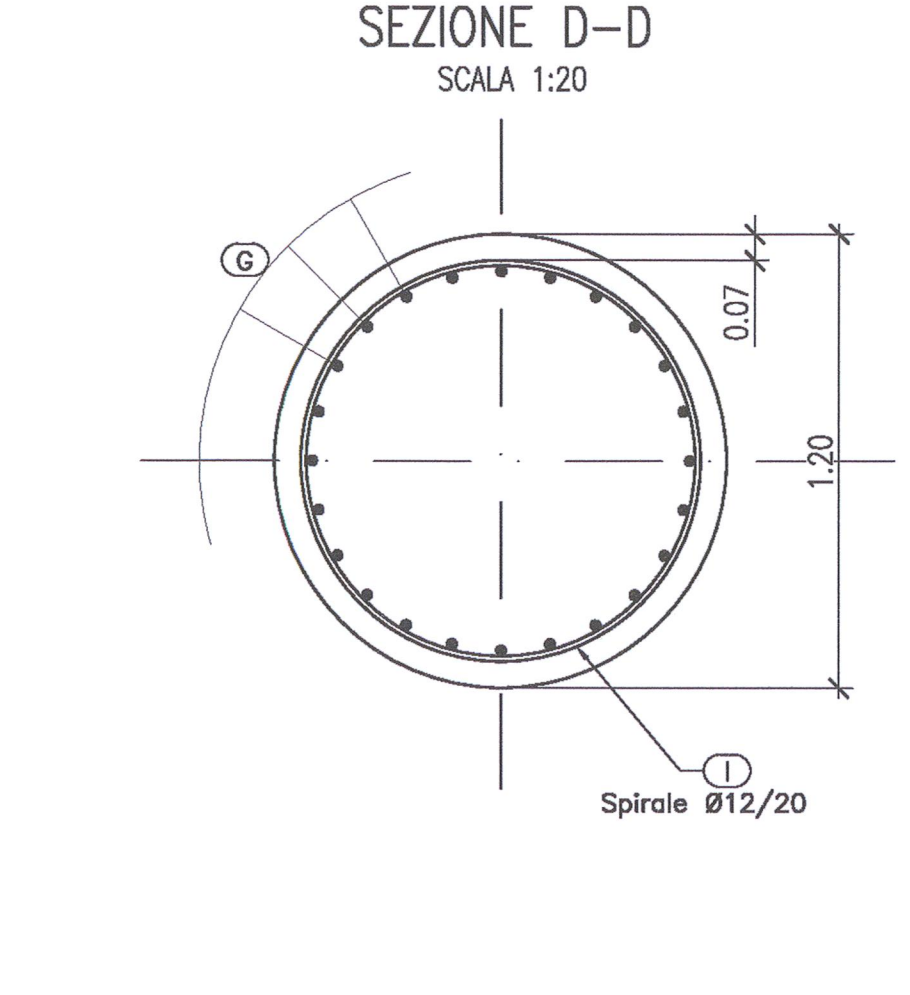
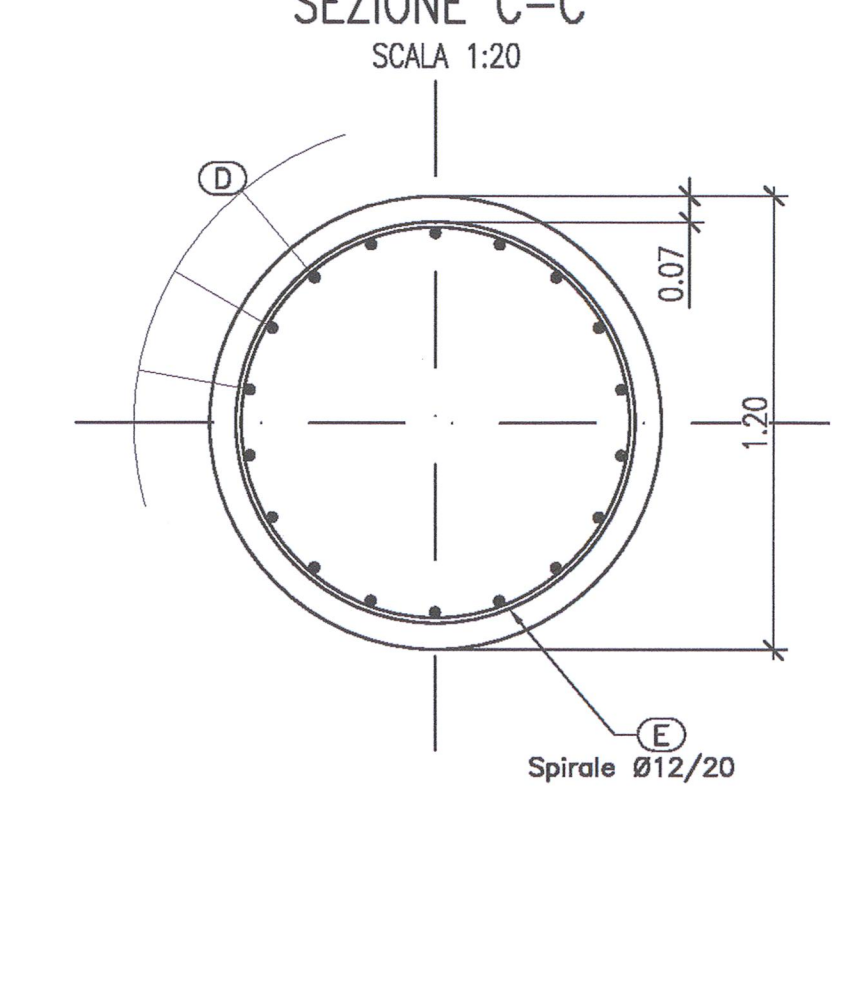
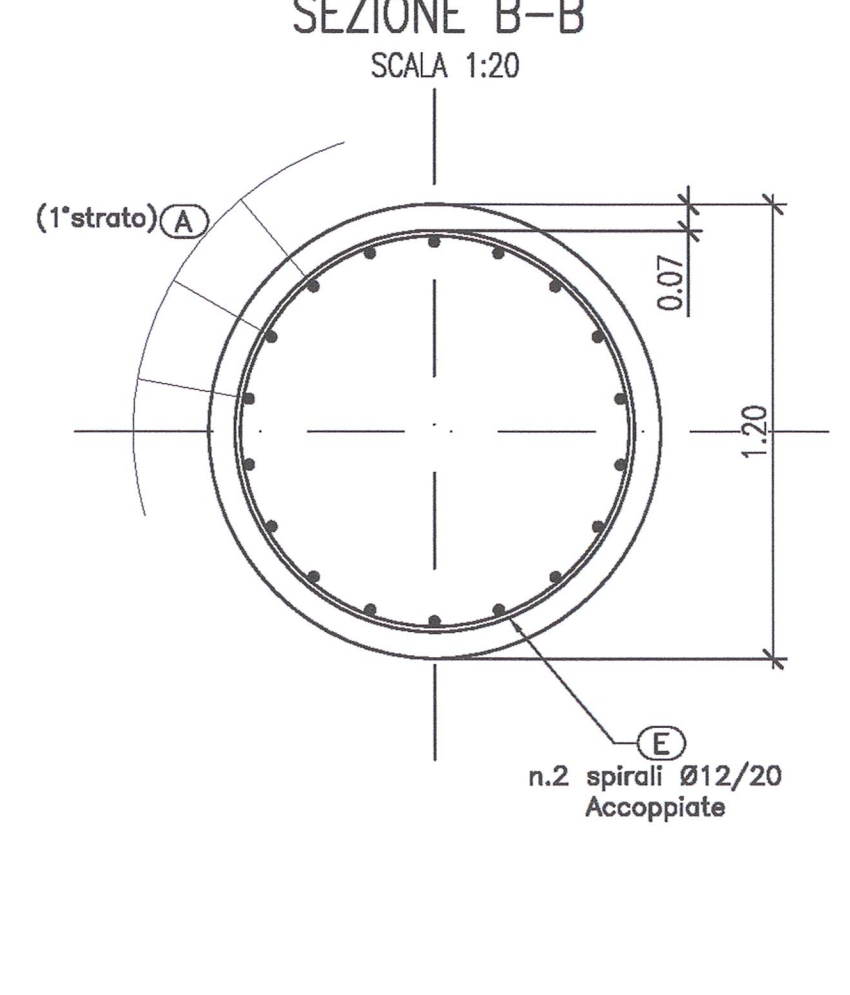
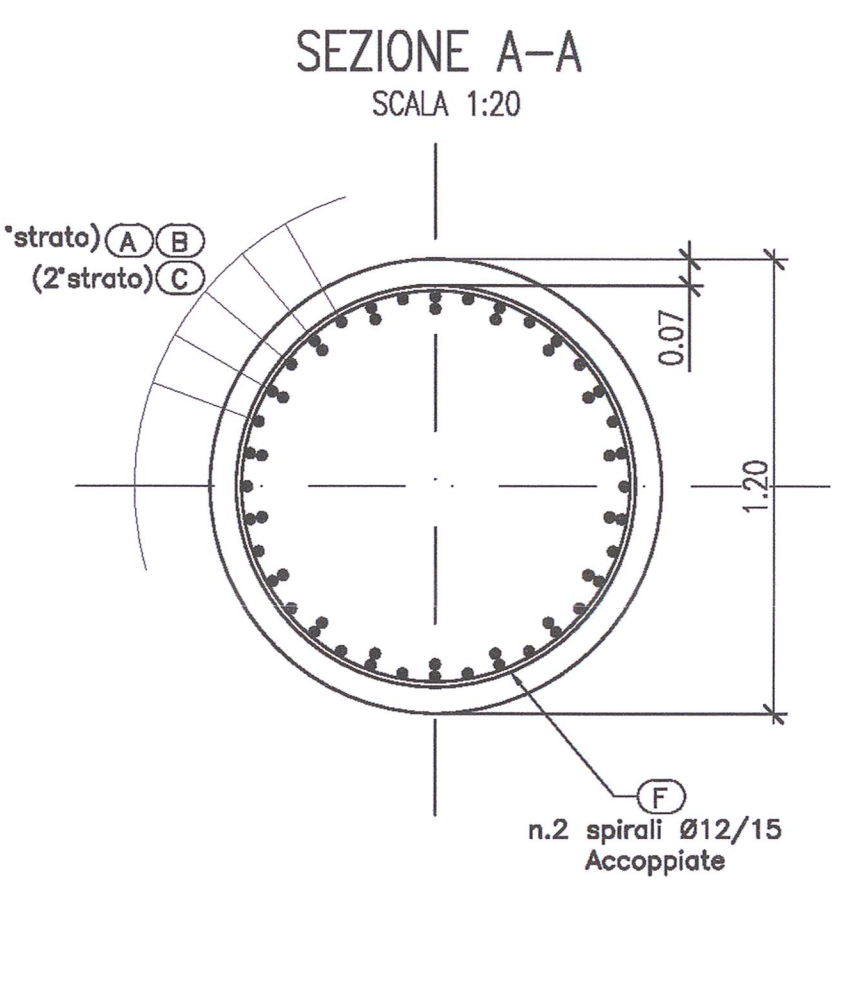
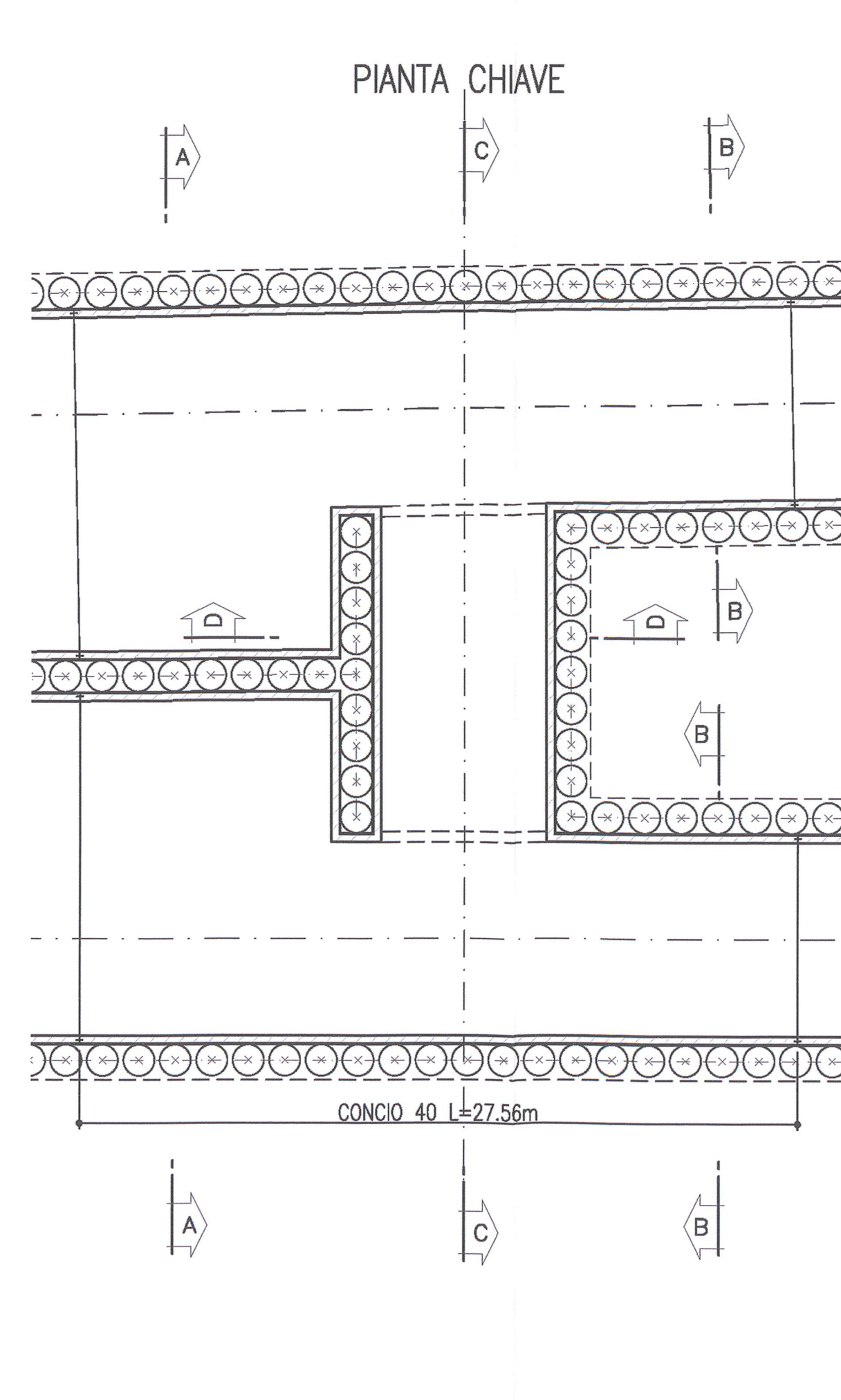
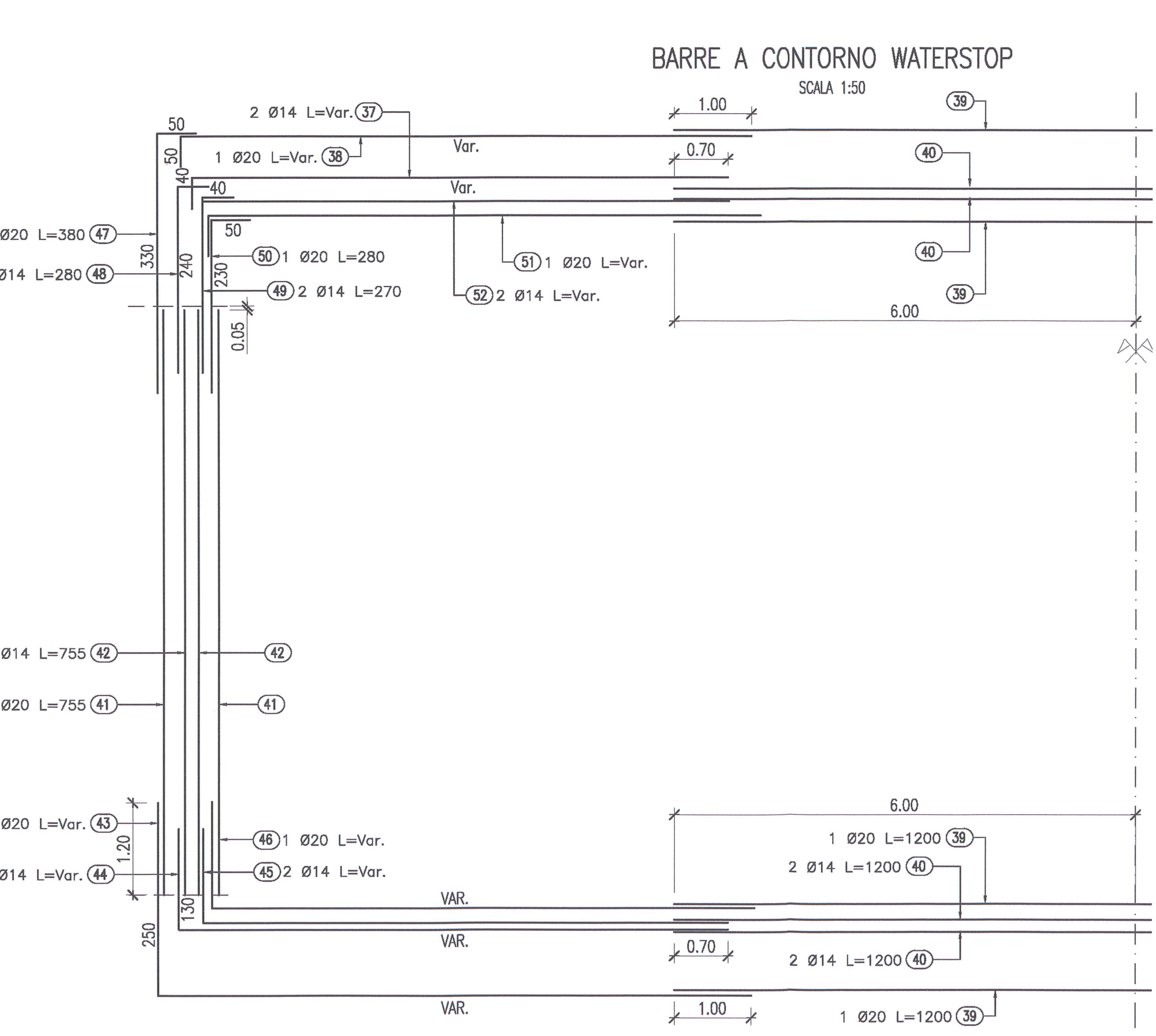
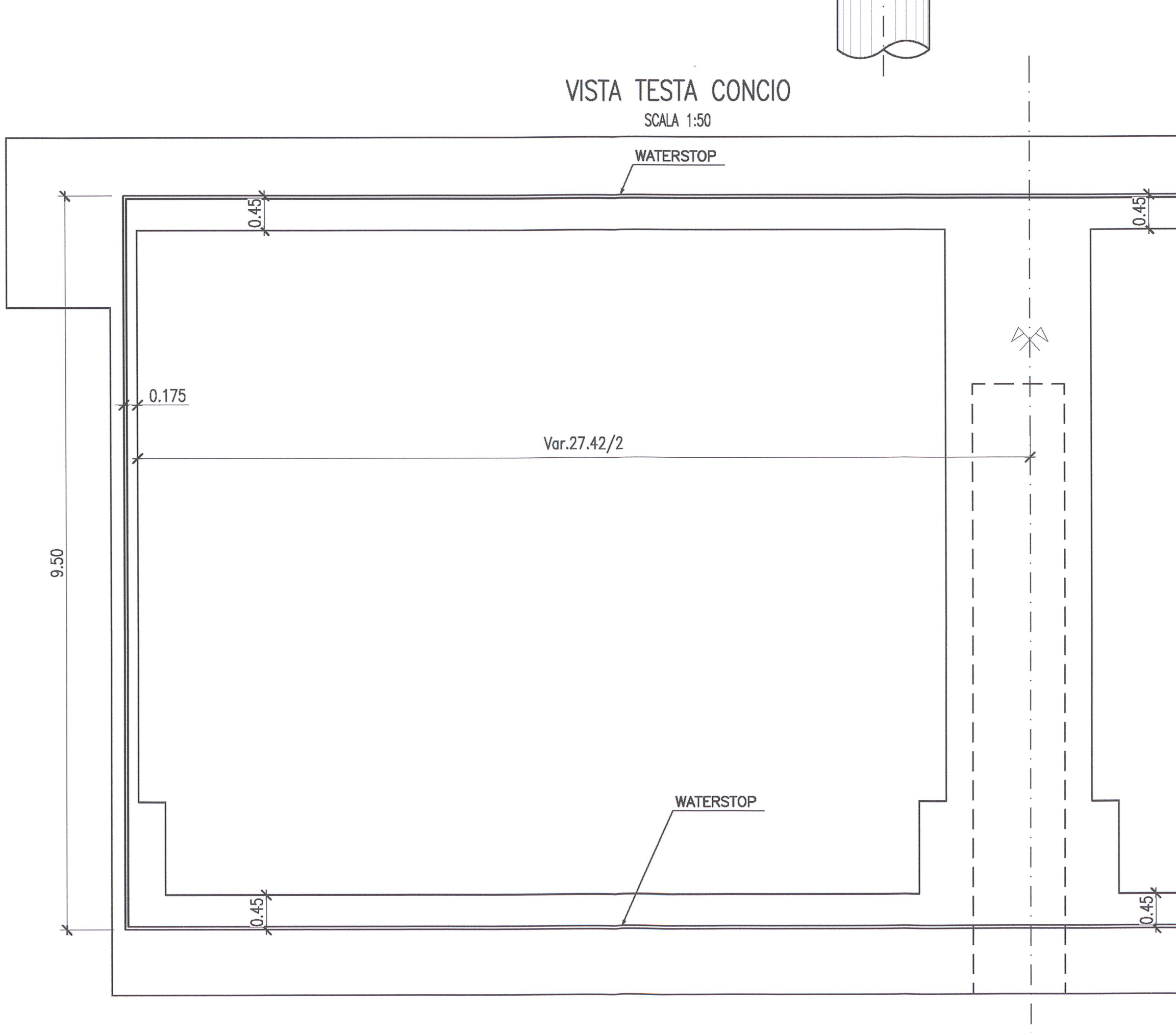
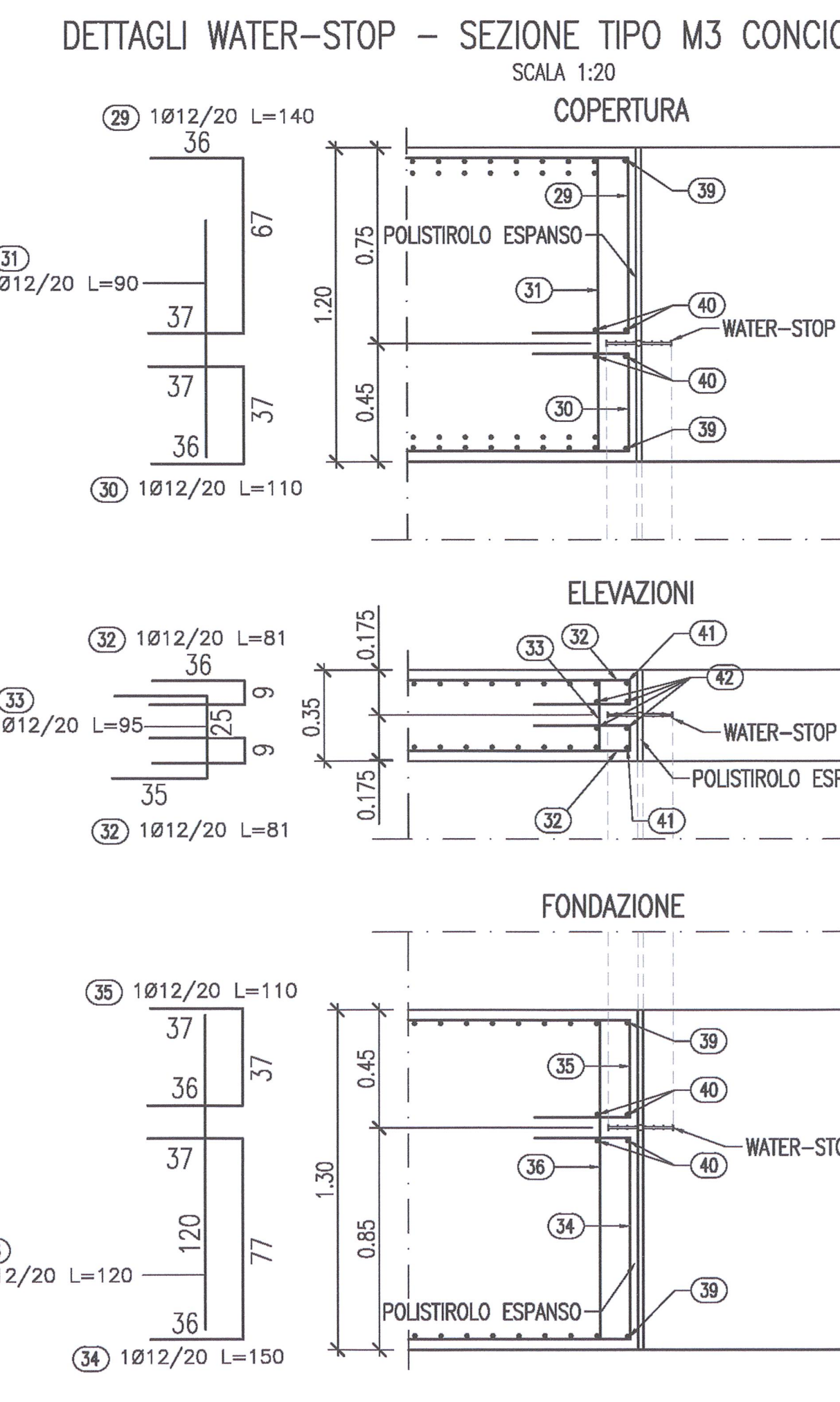
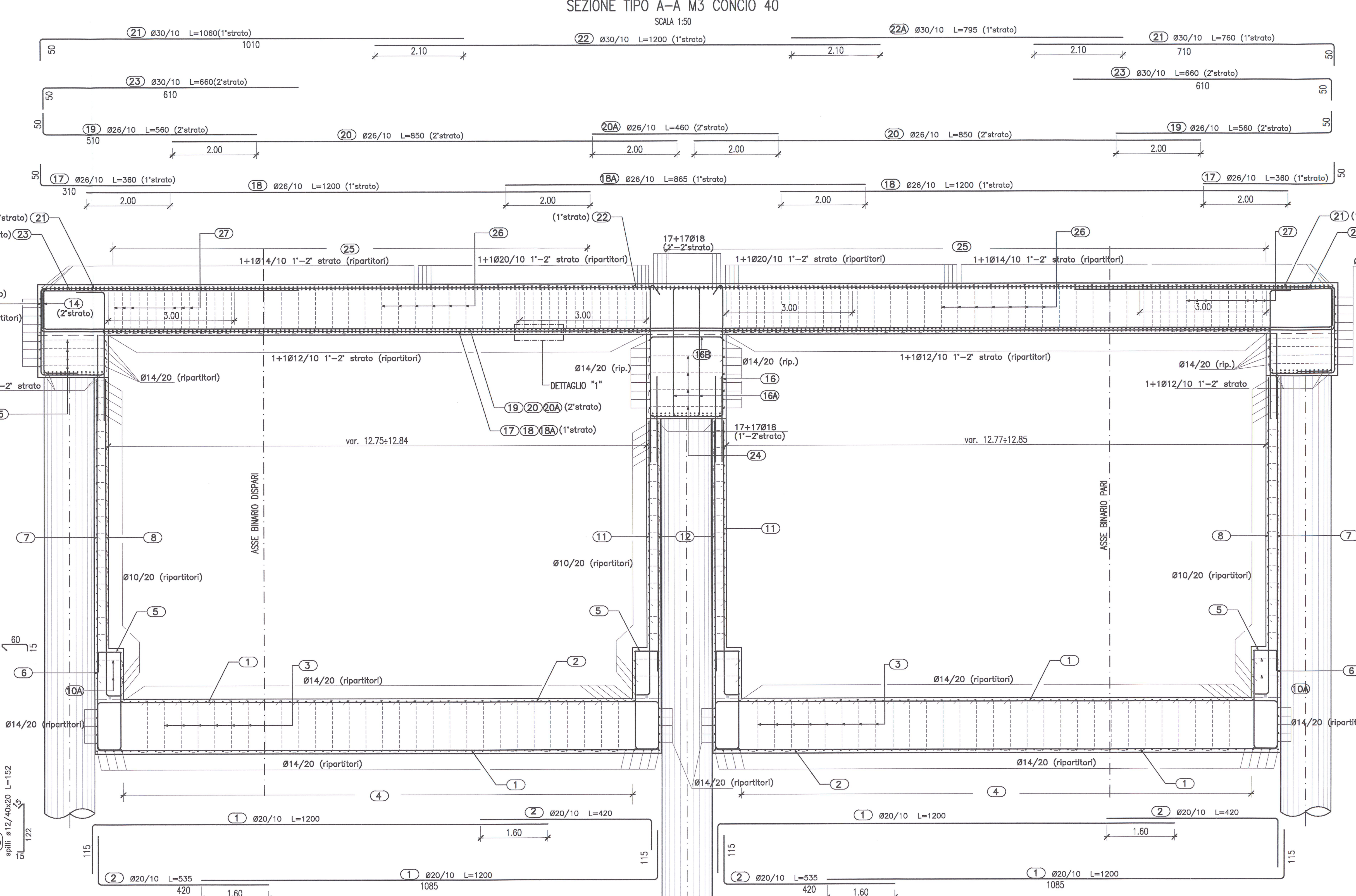
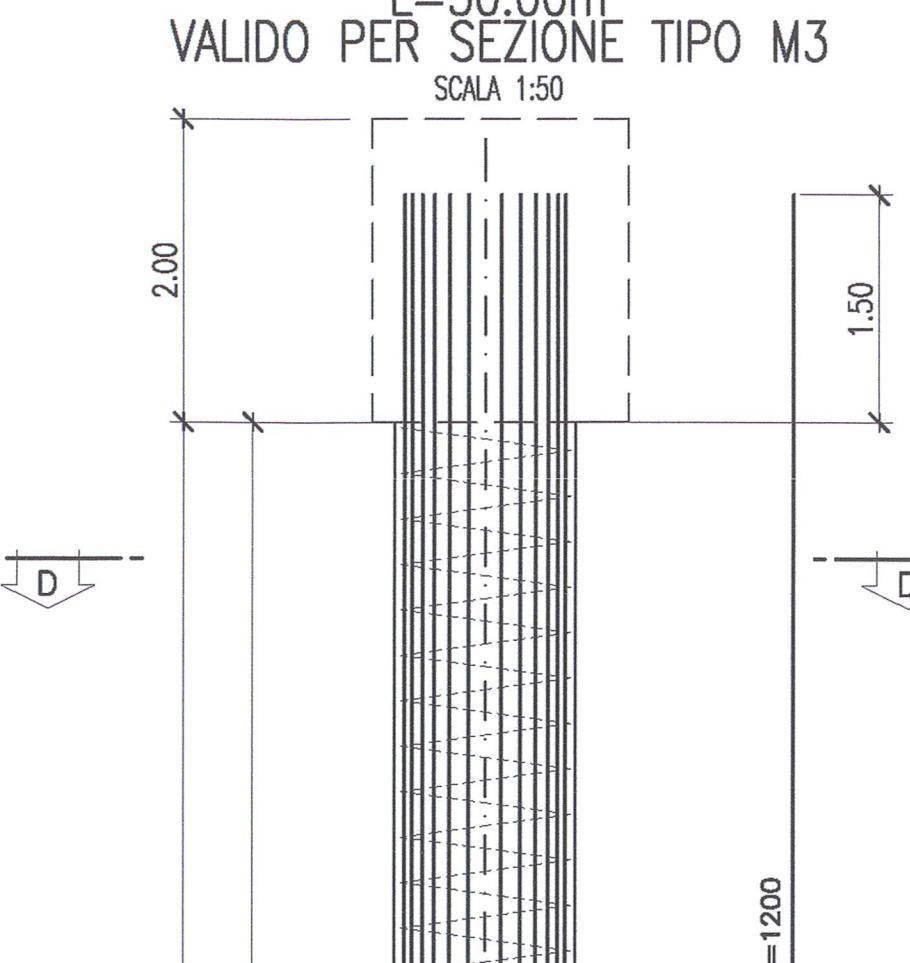
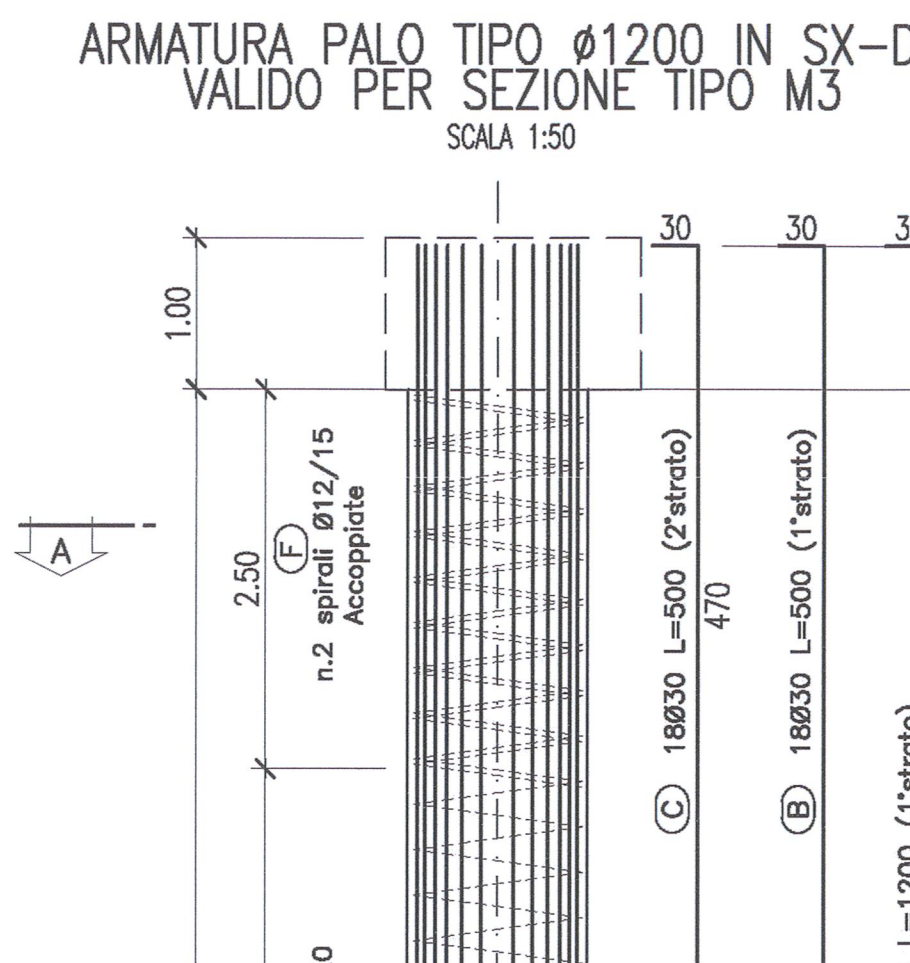

DESEGNI DI RIFERIMENTO

DESCRIZIONE	CODICE
GA06 - Bypass 1 - Concio n°40 - Carpenteria (Tav. 1/2)	INR1EE2B2GA0600030
CA06 - Bypass 1 - Concio n°40 - Carpenteria (Tav. 2/2)	INR1EE2B2GA0600048
GA06 - Tabella materiali	INR1EE2A2GA0600001

NOTE

- EVENTUALI DIFFERENZE TRA LE MISURE TOTALI E LE SOMMATORIE DELLE MISURE PARZIALI SONO DOVUTE AGLI ARROTONDAMENTI AUTOMATICI DI AUTOCAD.

LEGENDA

- P.C. PIANO DEL CENTRO
- P.F. PIANO DEL FERRO
- P.S. PIANO DI SCOVO

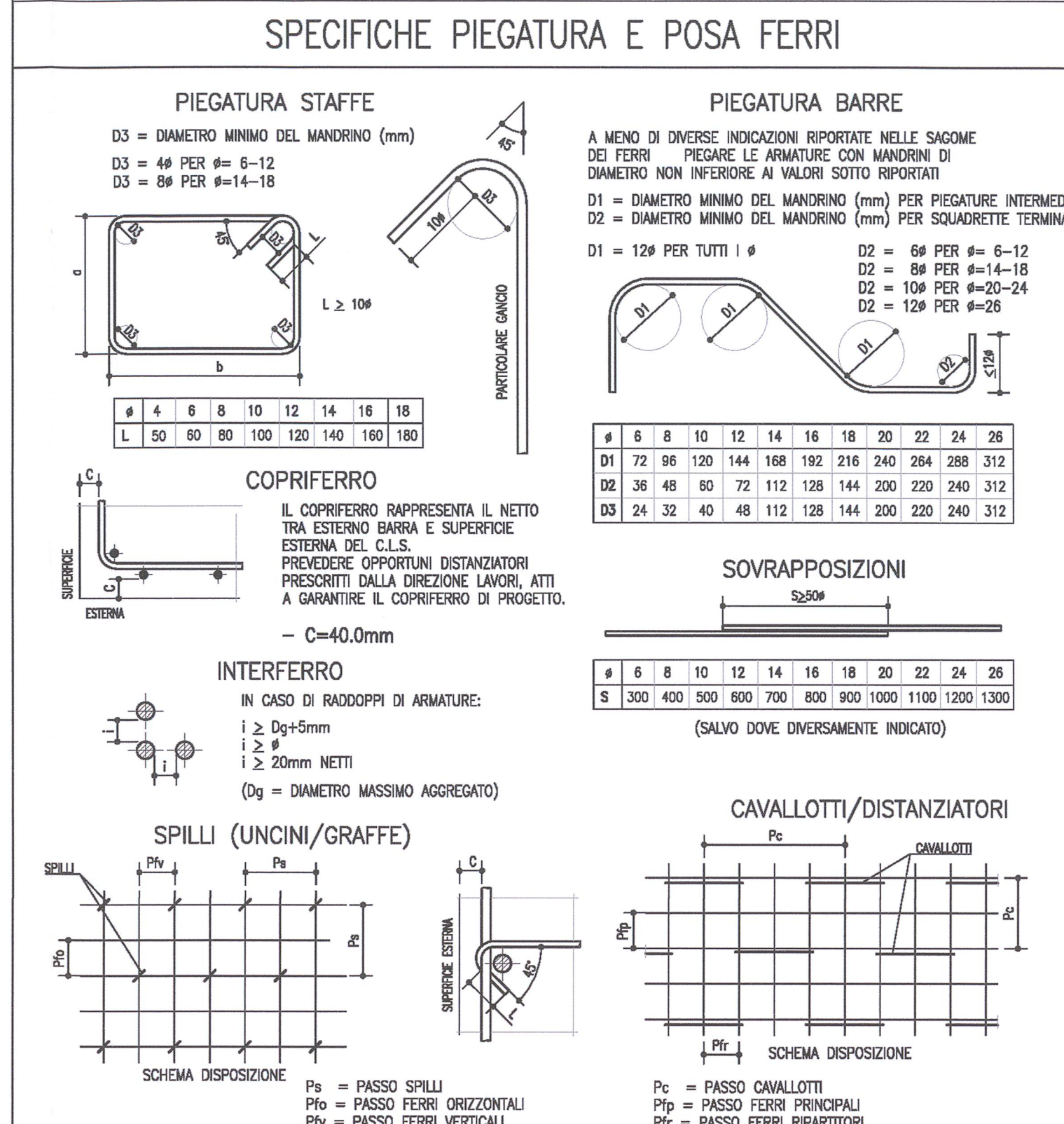

I FERRI RIPORTATI NEL PRESENTE ELABORATO SONO APPROSSIMATI A MENO DEGLI SLACCI DI PIEGATURA CON IL MANDRINO. LE MISURE PARZIALI RIPORTATE SONO RELATIVE ALLA SPEZZATA A SPIGLI V.M.

COMMITTENTE: RFI INFRASTRUTTURE FERROVIARIE ITALIANE GRUPPO FERROVIE DELLO STATO																	
ALTA SOVRVEGLIANZA: ITALFERR GRUPPO FERROVIE DELLO STATO																	
GENERAL CONTRACTOR: Cepav due Consorzio ENI per l'Alta Velocità																	
INFRASTRUTTURE FERROVIARIE STRATEGICHE DEFINITE DALLA LEGGE OBIETTIVO N. 443/01																	
LINEA A.V. I.A.C. TORINO - VENEZIA Tratta MILANO - VERONA Lotto funzionale Brescia-Verona PROGETTO ESECUTIVO																	
GALLERIA ARTIFICIALE LONATO EST (GA06) DA PK 114+565.00 A PK 115+990.00 Bypass 1 - Concio n°40 Armatura tav. (1/2)																	
CONTRATTORE: Cepav due Consorzio Cepav due Il Direttore del Consorzio (Ing. F. Tolentino)	DIRETTORE LAVORI: SCALE: Varie																
<table border="1"> <tr> <th>COMMESSA</th> <th>LOTTO</th> <th>FASE</th> <th>ENTE</th> <th>TIPO DOC.</th> <th>OPERA/DISCIPLINA</th> <th>PROG.</th> <th>REV.</th> </tr> <tr> <td>INOR</td> <td>11</td> <td>E</td> <td>E2</td> <td>B2</td> <td>GA0600</td> <td>040</td> <td>A</td> </tr> </table>		COMMESSA	LOTTO	FASE	ENTE	TIPO DOC.	OPERA/DISCIPLINA	PROG.	REV.	INOR	11	E	E2	B2	GA0600	040	A
COMMESSA	LOTTO	FASE	ENTE	TIPO DOC.	OPERA/DISCIPLINA	PROG.	REV.										
INOR	11	E	E2	B2	GA0600	040	A										
PROGETTAZIONE: Data: _____ Firma: _____ Firma: _____																	