

SEZIONE camerone di manovra CM2

scala 1:50

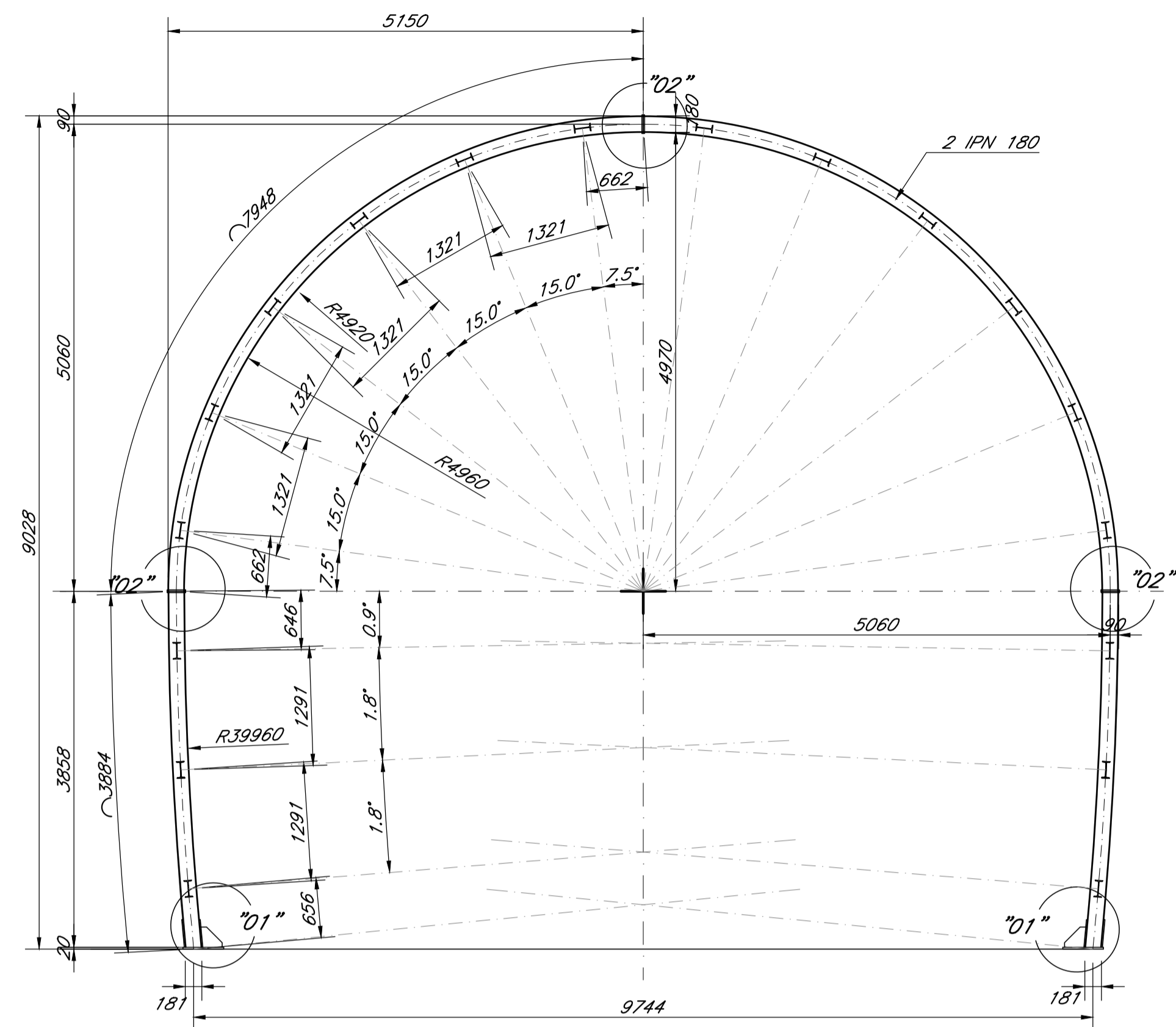

VISTA ASSONOMETRICA CATENE

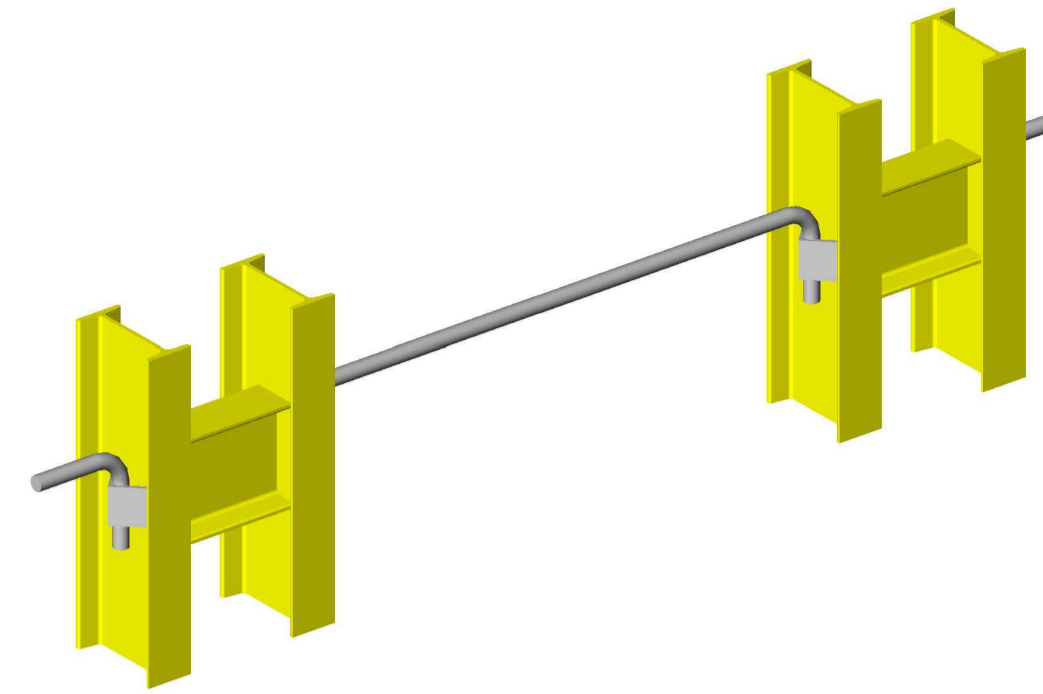

VISTA ASSONOMETRICA PARTICOLARE "01"

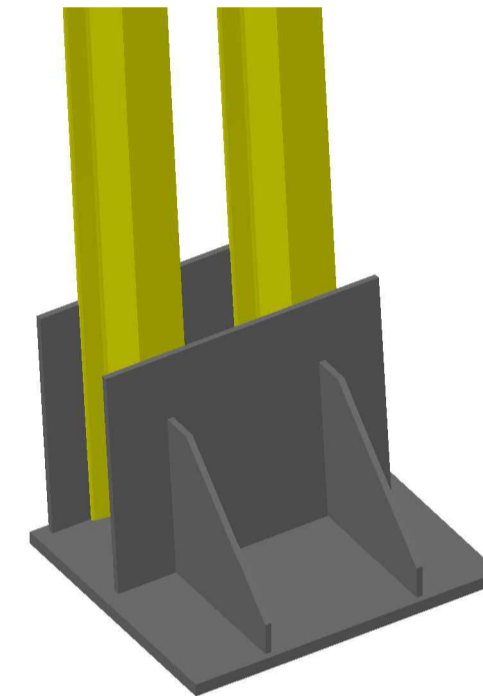

VISTA ASSONOMETRICA PARTICOLARE "02"

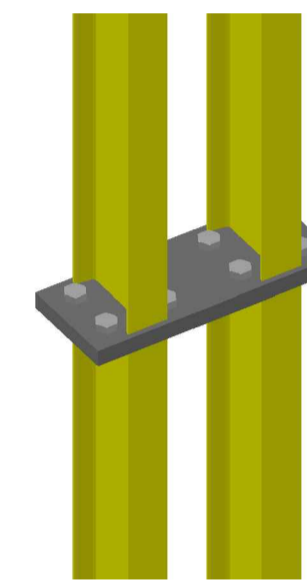

NOTE GENERALI

Per le caratteristiche dei materiali si rimanda all'elaborato "Caratteristiche dei Materiali, note e prescrizioni - IF1N 01 E ZZ SP GN0000 001 D"

PARTICOLARE "01" scala 1:10

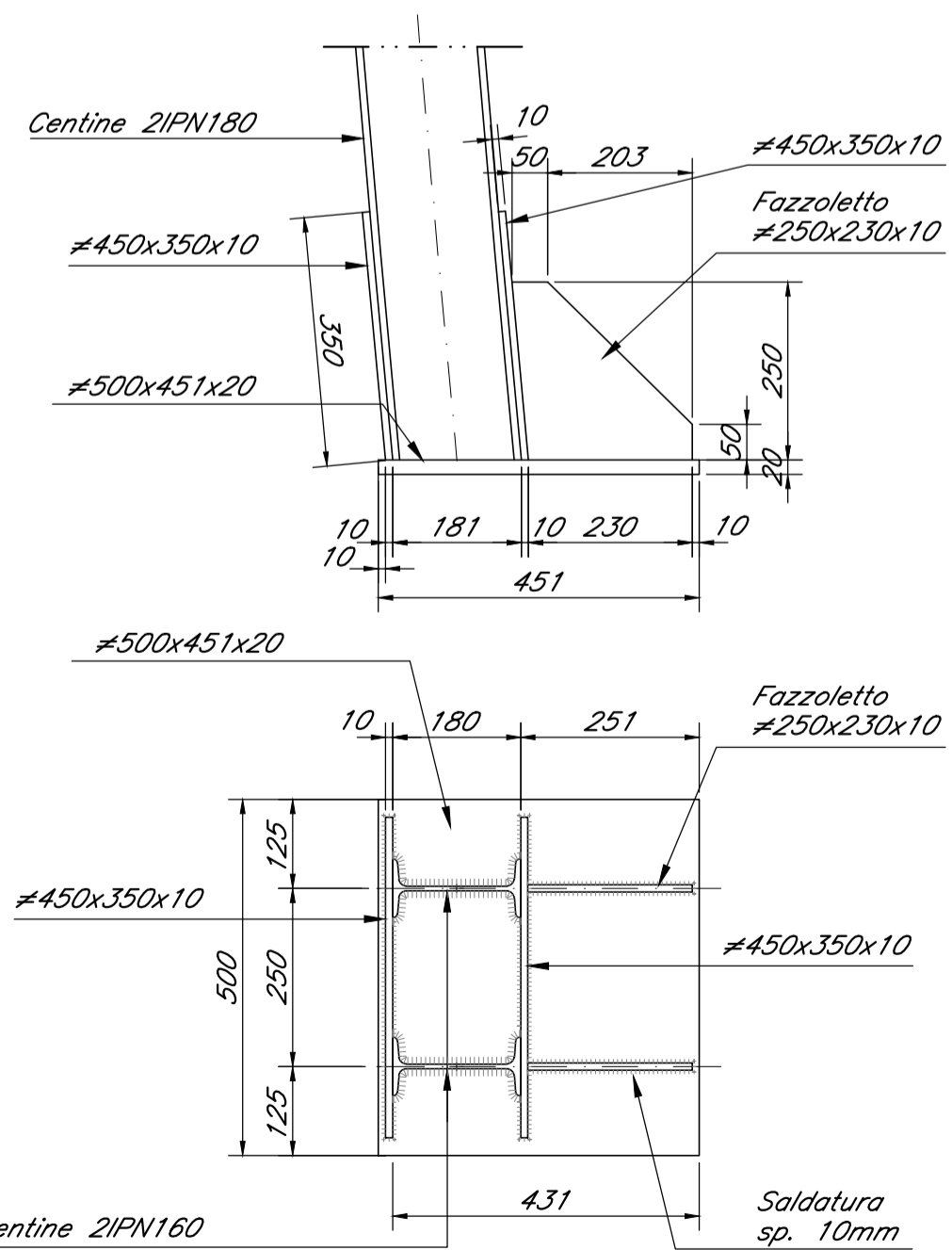

PARTICOLARE "02" scala 1:10

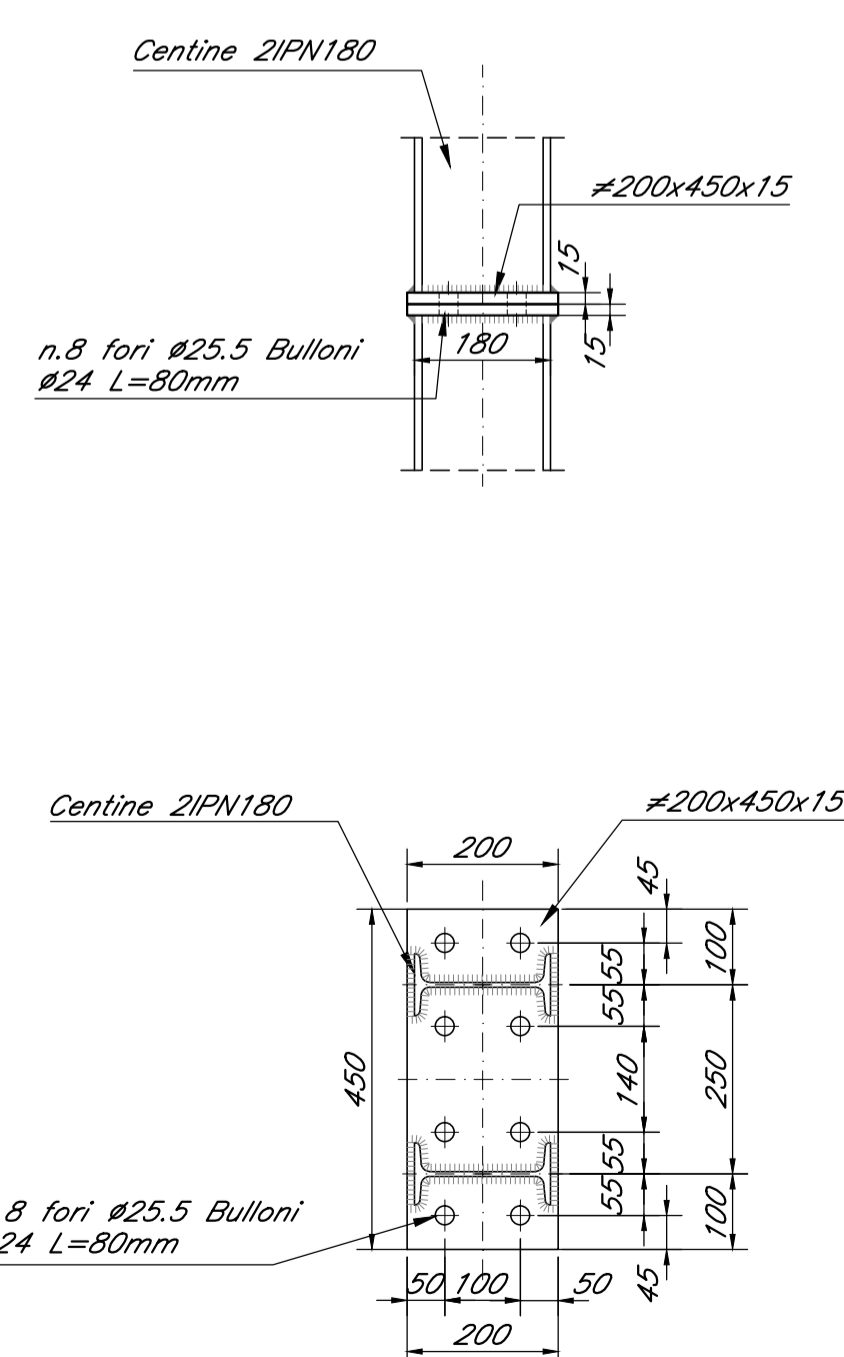

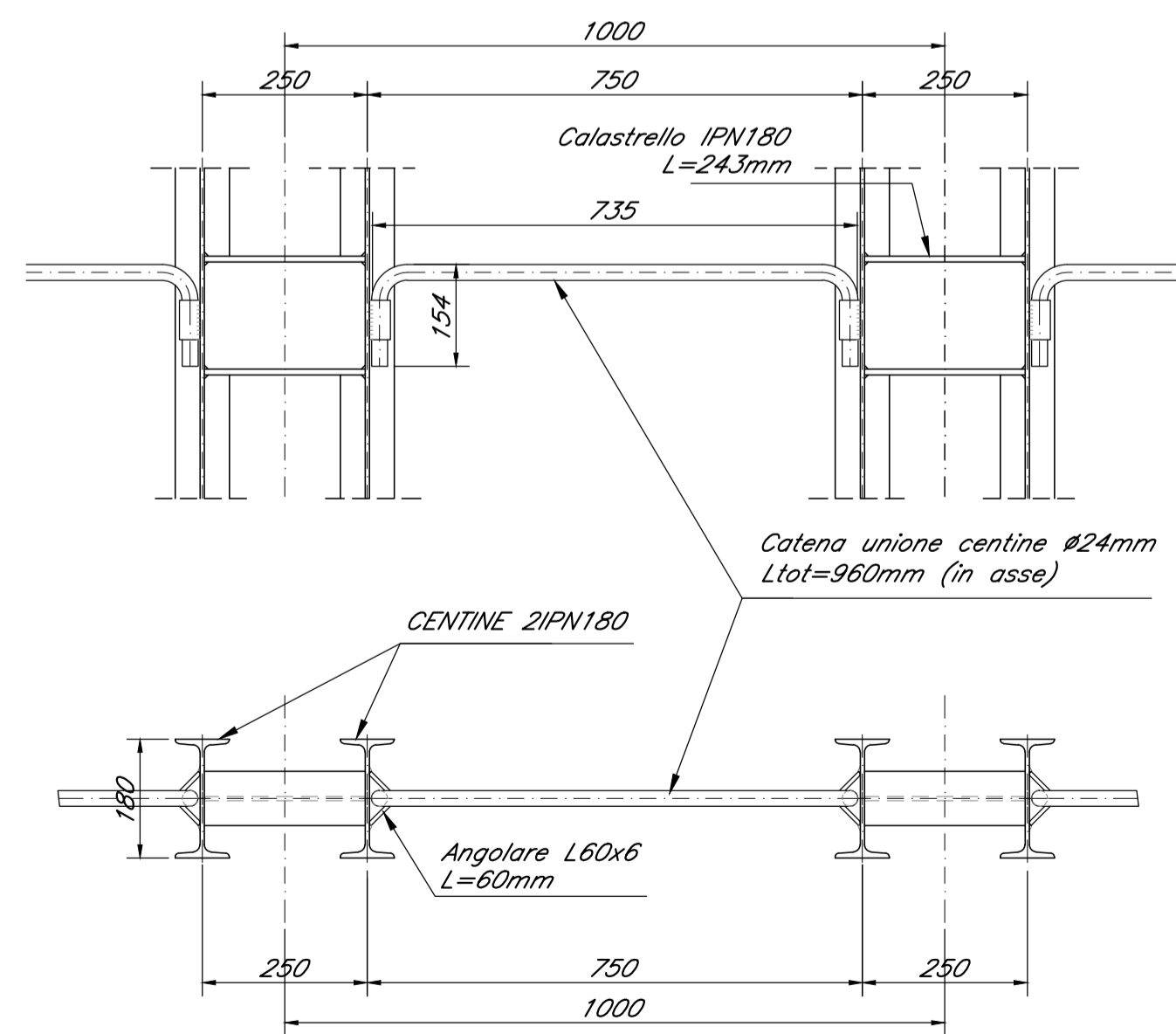

PARTICOLARE CATENE scala 1:10



COMMITTENTE:  
  
**RFI**  
 RETE FERROVIARIA ITALIANA  
 GRUPPO FERROVIE DELLO STATO ITALIANE

DIREZIONE LAVORI:  
  
**ITALFERR**  
 GRUPPO FERROVIE DELLO STATO ITALIANE

APPALTATORE:  
    
**CONSORZIO CFT**

PROGETTAZIONE: RAGGRUPPAMENTO TEMPORANEO PROGETTISTI   	PROGETTISTA: Ing. G.S. KALAMARAS	DIRETTORE DELLA PROGETTAZIONE: Ing. PIETRO MAZZOLI Responsabile integrazione fra le varie prestazioni specialistiche
--	-------------------------------------	--

PROGETTO ESECUTIVO

ITINERARIO NAPOLI-BARI  
 RADDOPPIO TRATTA CANCELLO-BENEVENTO  
 1° LOTTO FUNZIONALE CANCELLO-FRASSO TELESINO E VARIANTE ALLA LINEA ROMA-NAPOLI VIA CASSINO NEL COMUNE MADDALONI

CUNICOLO DI SFOLLAMENTO  
 Sezione tipo camerone di manovra CM2  
 Carpenteria centine

APPALTATORE CONSORZIO CFT IL DIRETTORE TECNICO Geom. G. Bianchi 03/12/2018	SCALA: 1:50
--	----------------

COMMESSA	LOTTO	FASE	ENTE	TIPO DOC.	OPERA/DISCIPLINA	PROGR.	REV.
IF1N	01	E	ZZ	BB	GN0400	031	B

Rev.	Descrizione	Redatto	Data	Verificato	Data	Approvato	Data	Autorizzato Data
A	Emissione	F. Loberto	10/07/2018	G. Kalamaras	10/07/2018	P. Mazzoli	10/07/2018	G. Kalamaras
B	Rev. Istruttoria ITF 29/08/18	F. Loberto	13/09/2018	G. Kalamaras	13/09/2018	P. Mazzoli	13/09/2018	
C	Agg. a seguito osservazioni ITF	F. Loberto	03/12/2018	G. Kalamaras	03/12/2018	P. Mazzoli	03/12/2018	
								03/12/2018