

COMMITTENTE:



DIREZIONE LAVORI:



APPALTATORE:



PROGETTAZIONE:	PROGETTISTA:	DIRETTORE DELLA PROGETTAZIONE
RAGGRUPPAMENTO TEMPORANEO PROGETTISTI	Ing. LUCA NANI	Ing. PIETRO MAZZOLI Responsabile integrazione fra le varie prestazioni specialistiche

PROGETTO ESECUTIVO

**ITINERARIO NAPOLI-BARI
RADDOPPIO TRATTA CANCELLO-BENEVENTO
I° LOTTO FUNZIONALE CANCELLO-FRASSO TELESINO E VARIANTE
ALLA LINEA ROMA-NAPOLI VIA CASSINO NEL COMUNE DI MADDALONI**

IMPIANTI LUCE E FORZA MOTRICE

**FERMATA DUGENTA
VERIFICA DELLA SELETTIVITA' FRA LE PROTEZIONI ELETTRICHE**

APPALTATORE	SCALA:
Consorzio CFT IL DIRETTORE TECNICO Geom. C. BIANCHI 10-07-2018	-

COMMESSA LOTTO FASE ENTE TIPO DOC. OPERA/DISCIPLINA PROGR. REV.

IF1N 01 E ZZ RO LF0500 003 A

Rev.	Descrizione	Redatto	Data	Verificato	Data	Approvato	Data	Autorizzato Data
A	Emissione	F.Checucci	10-07-2018	L.Nani	10-07-2018	P. Mazzoli	10-07-2018	L.Nani
								10-07-2018

File: IF1N.0.1.E.ZZ.RO.LF.05.0.0.003.A.doc n. Elab.:

Curve tempo corrente: FERMATA DUGENTA
Fornitura: Fornitura

Fornitura

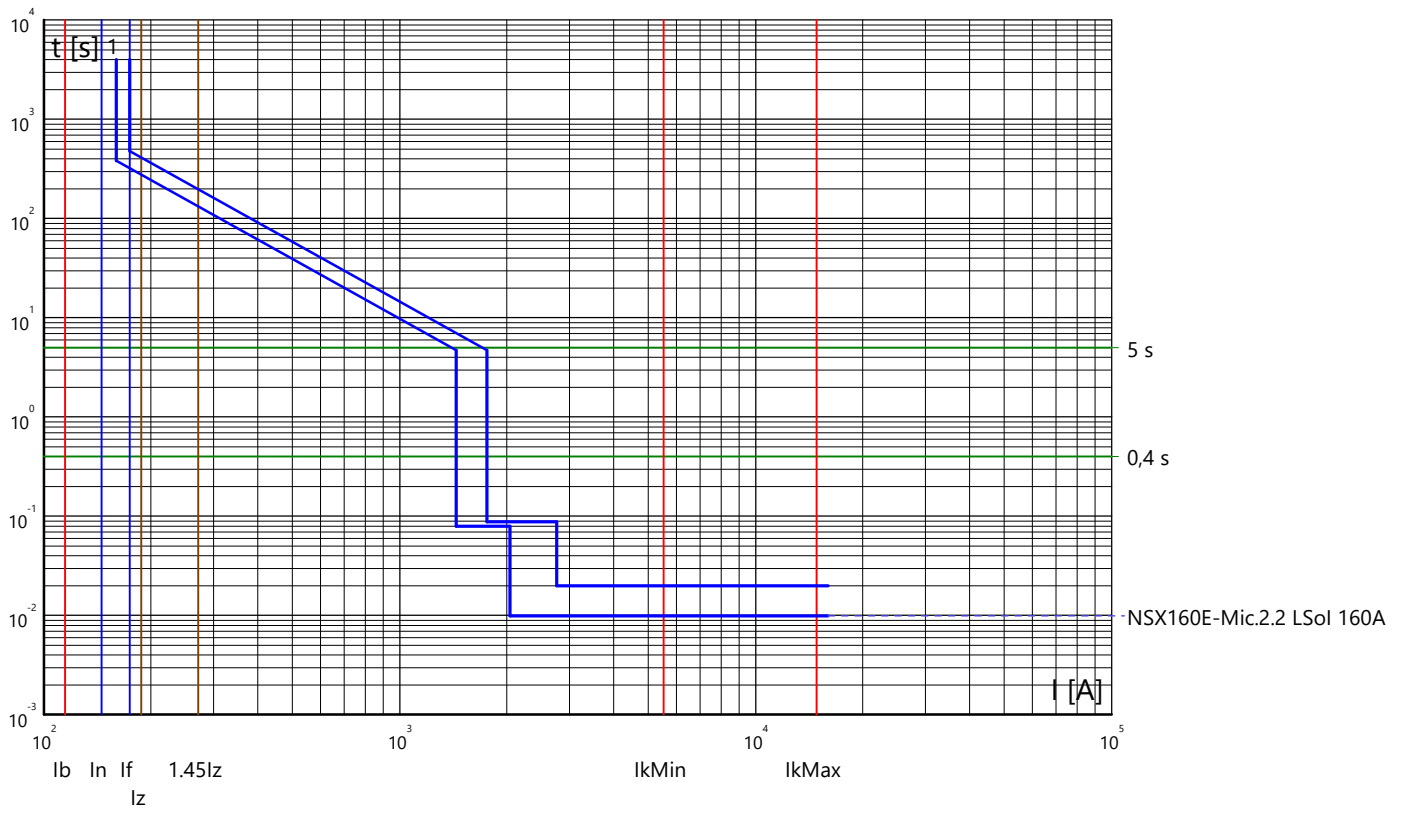

Curve tempo corrente: FERMATA DUGENTA
 Quadro: QUADRO VANO CONTATORI

Arrivo: IG

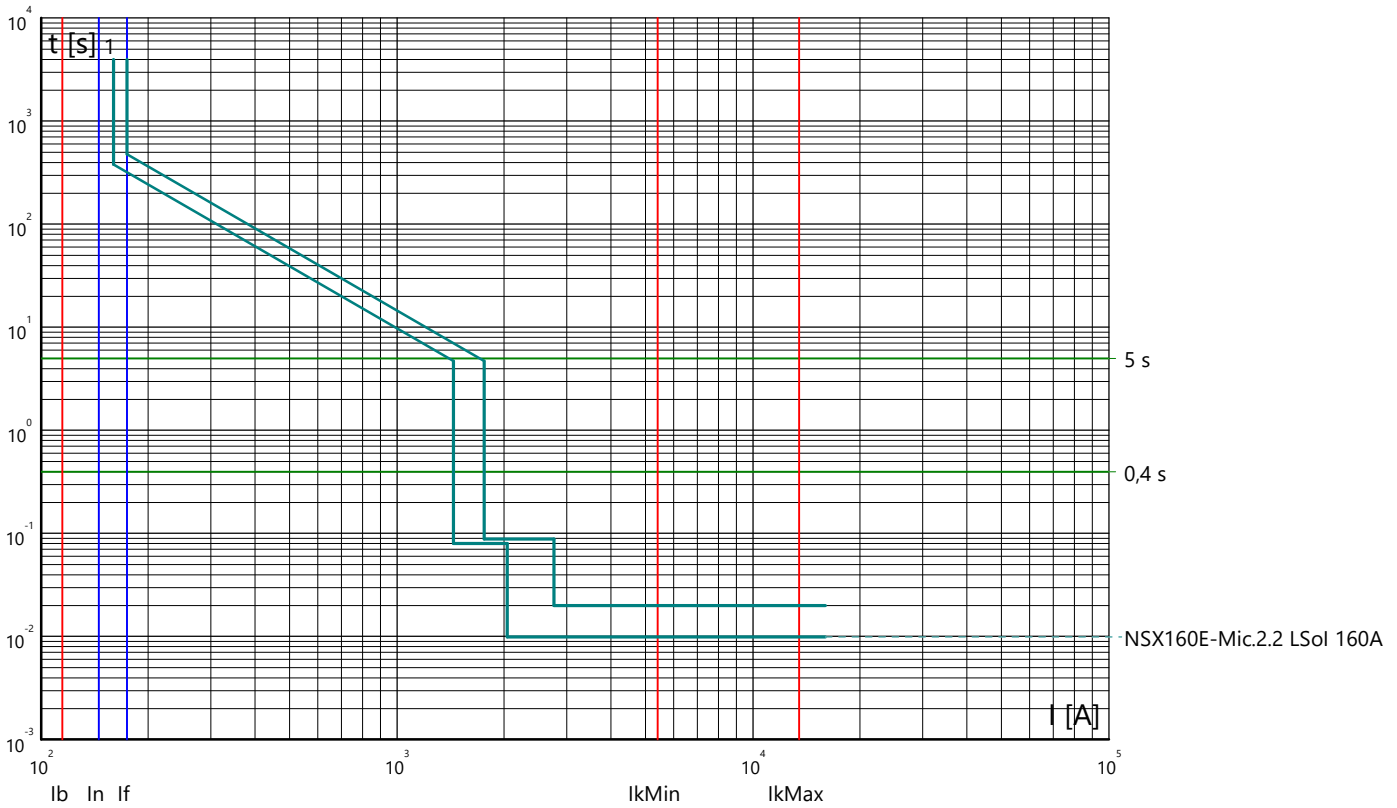

Partenza: PT

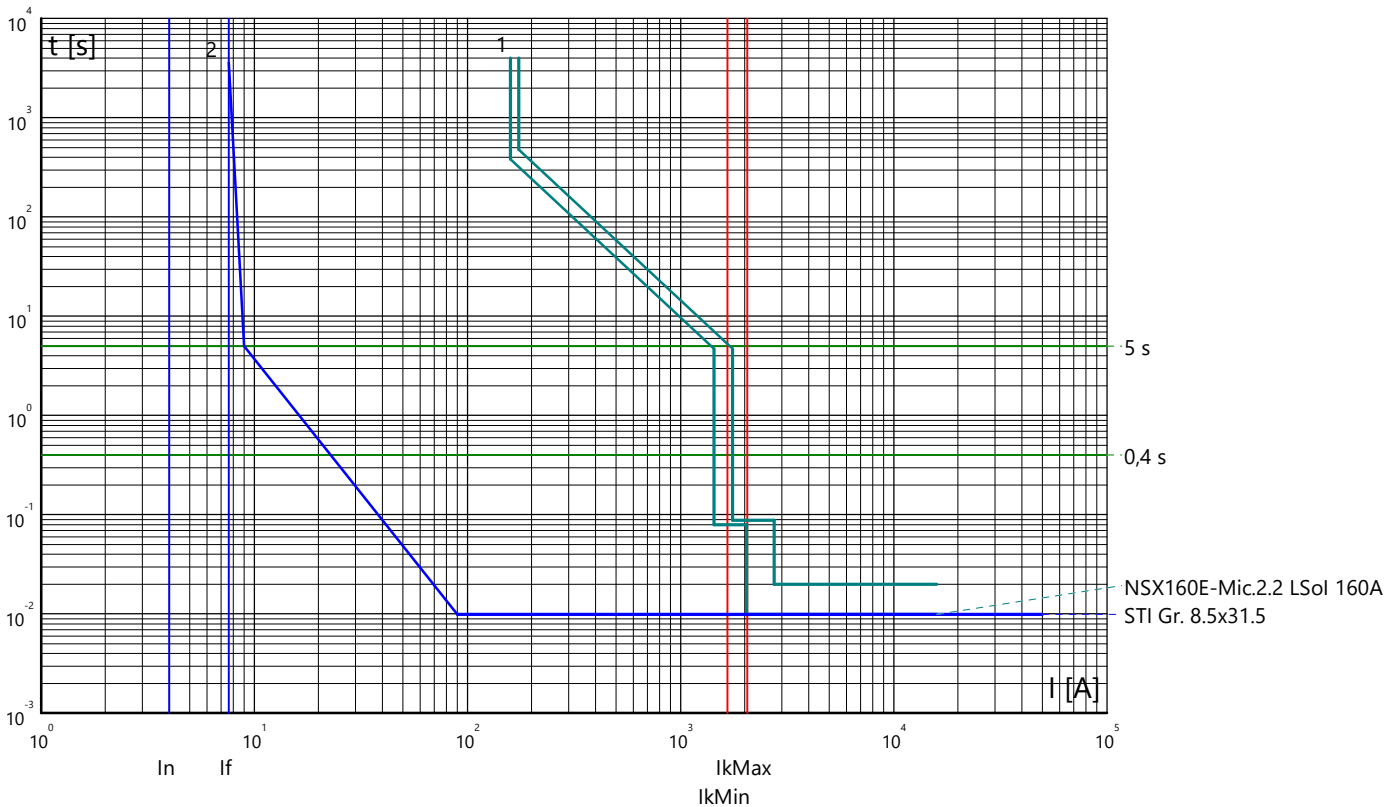

Curve tempo corrente: FERMATA DUGENTA
 Quadro: QUADRO VANO CONTATORI

Partenza: 1.0N

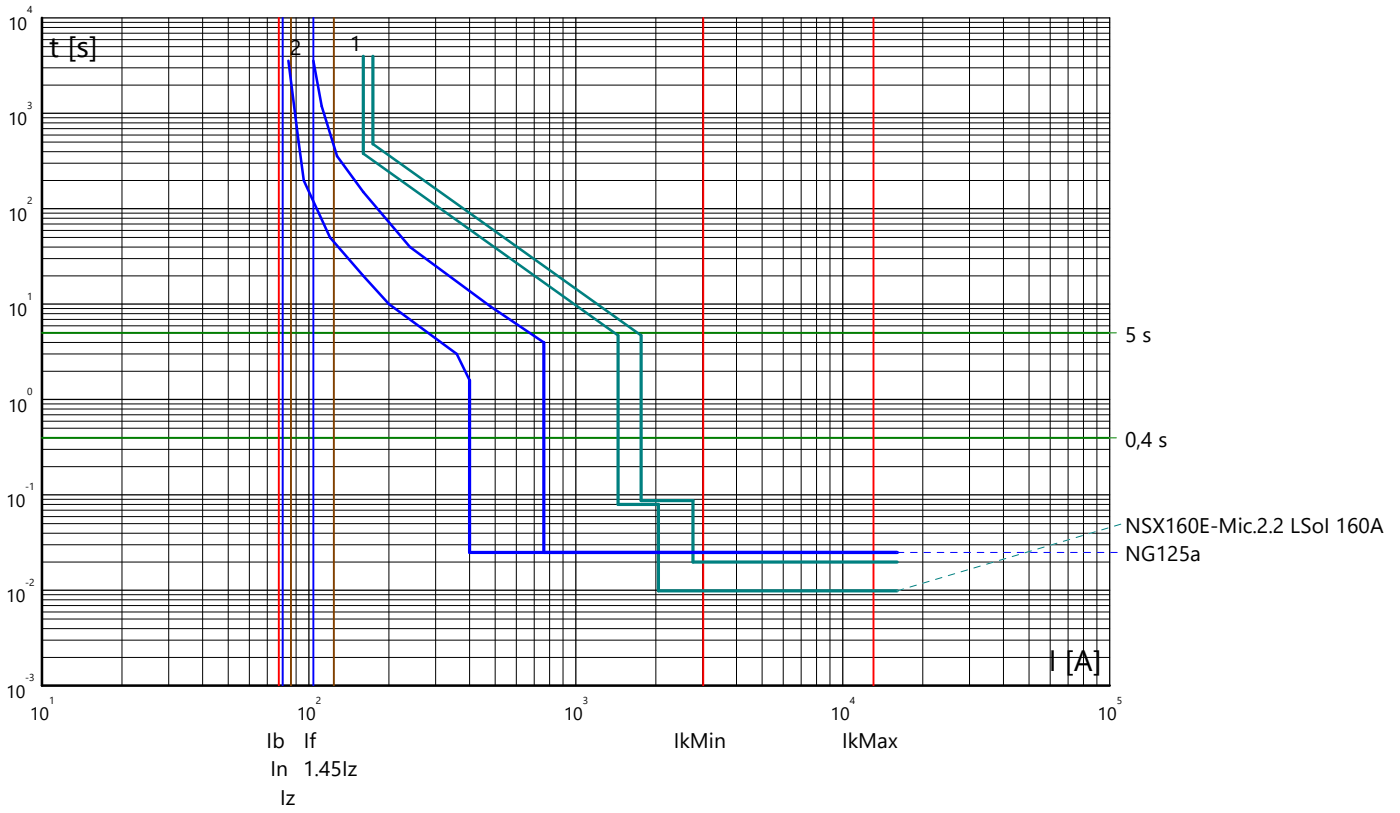

Partenza: 2.0N

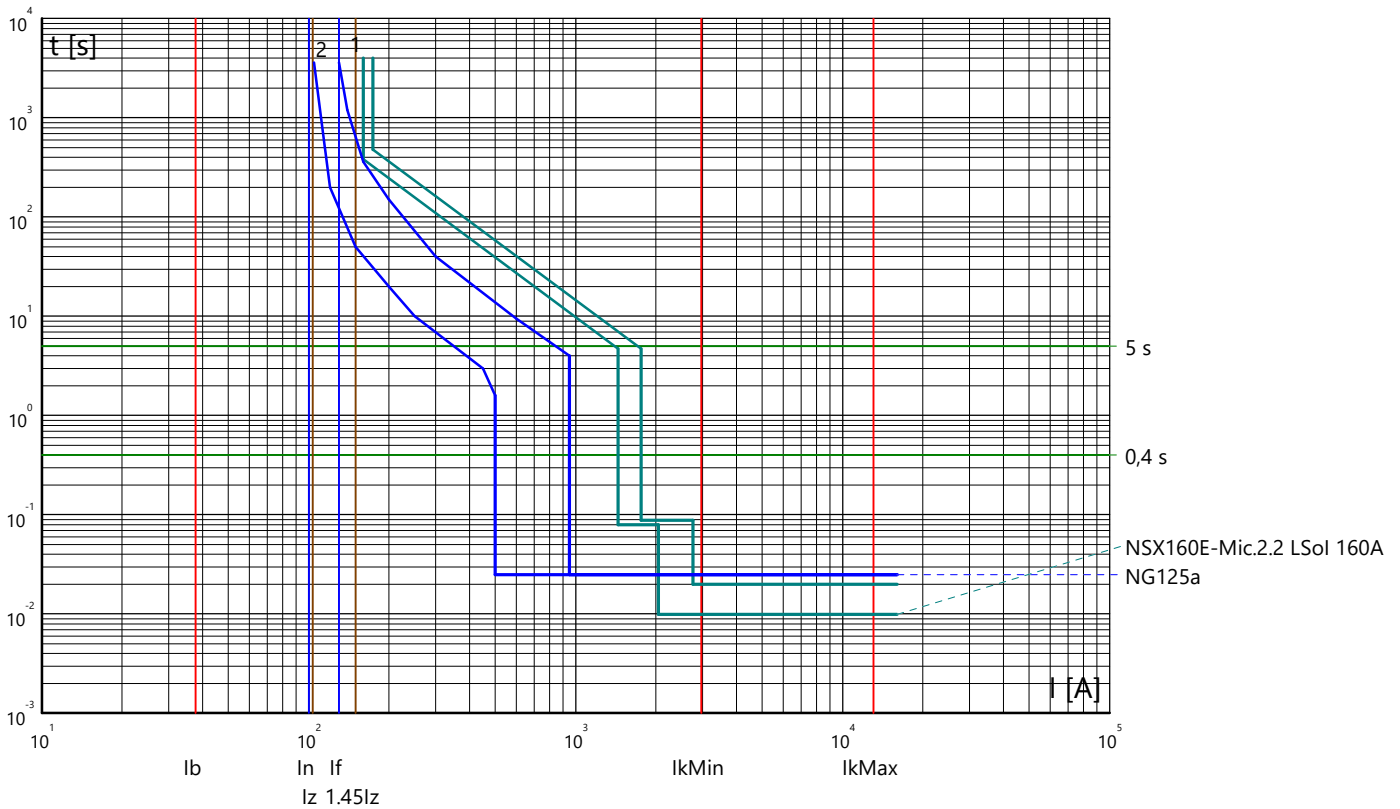

Curve tempo corrente: FERMATA DUGENTA
 Quadro: QUADRO GENERALE B.T.

Arrivo: IGN

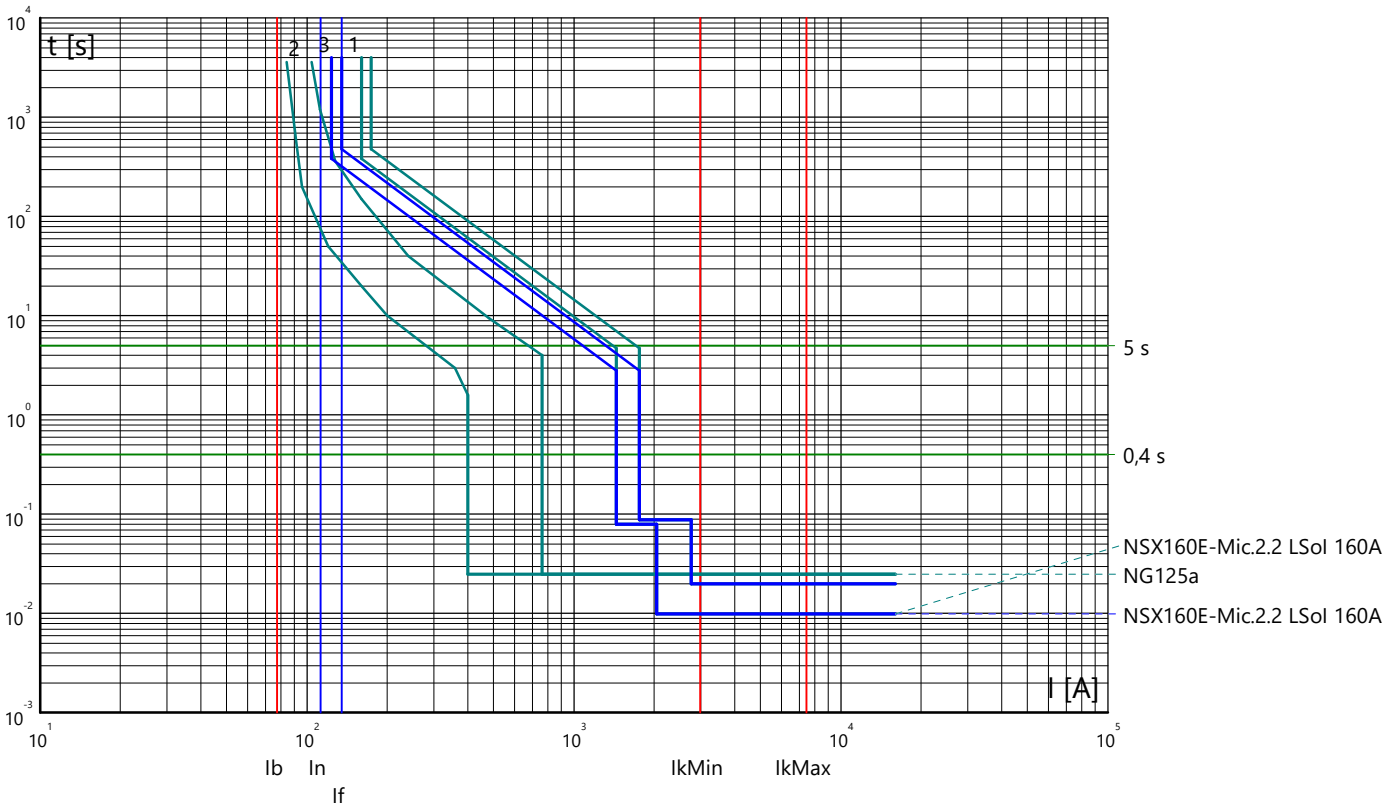

Partenza: PT

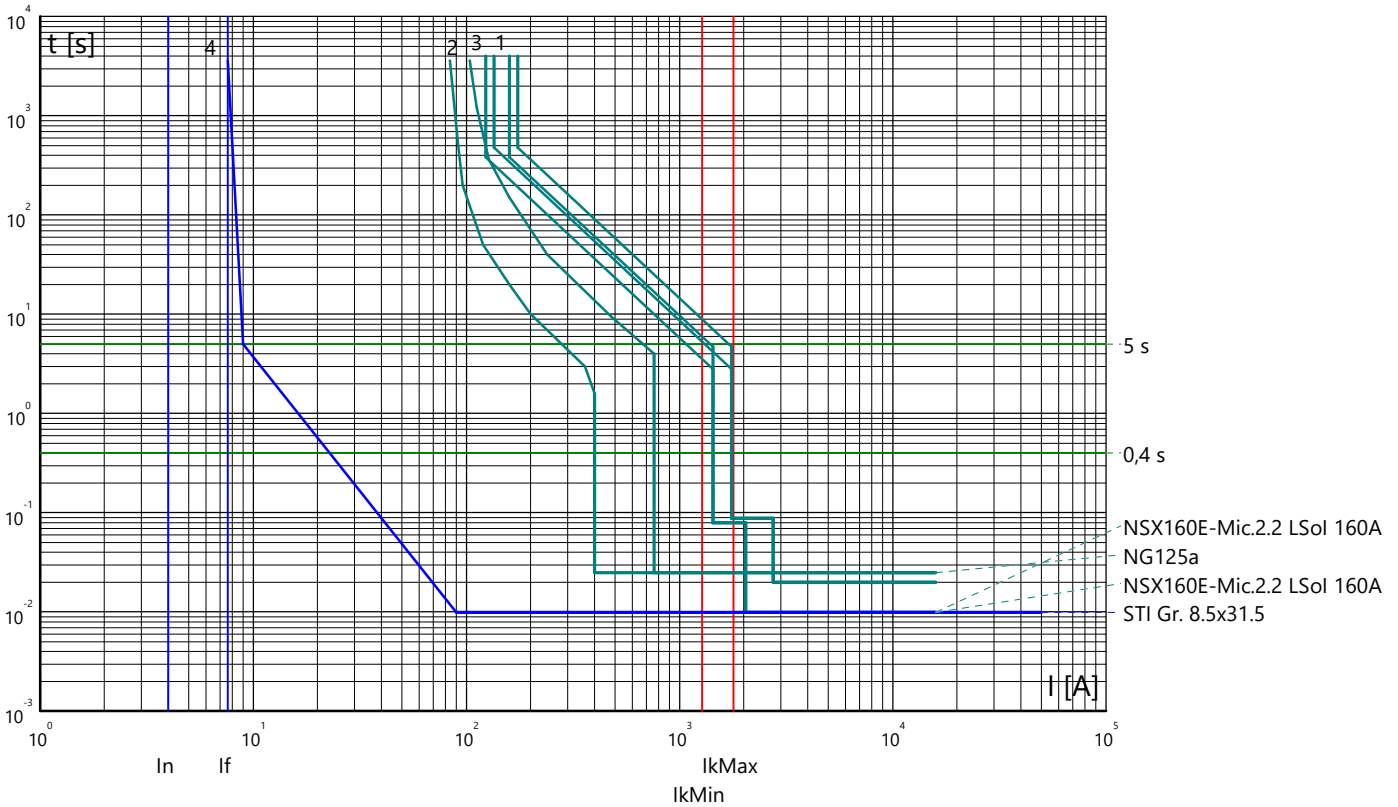

Curve tempo corrente: FERMATA DUGENTA
 Quadro: QUADRO GENERALE B.T.

Partenza: SPD

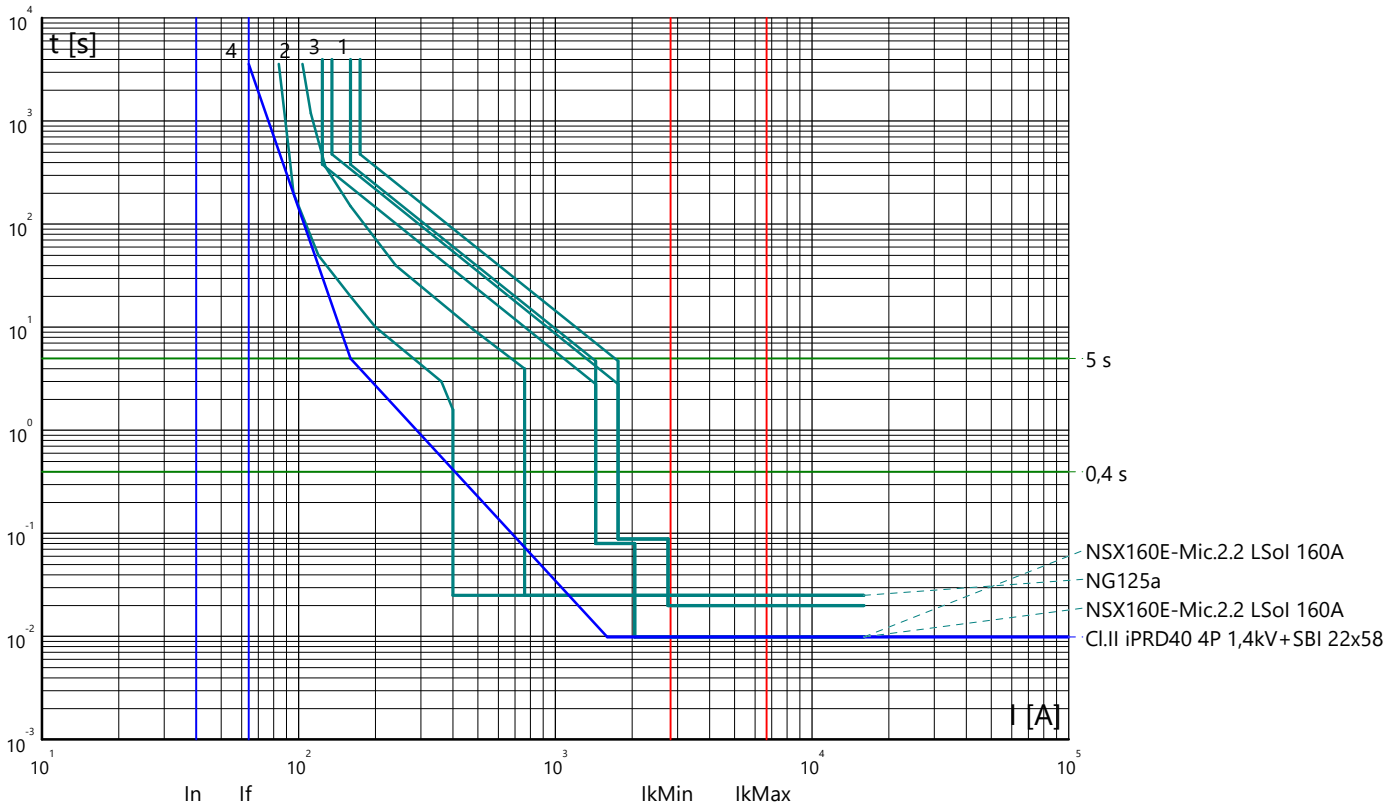

Partenza: MIS

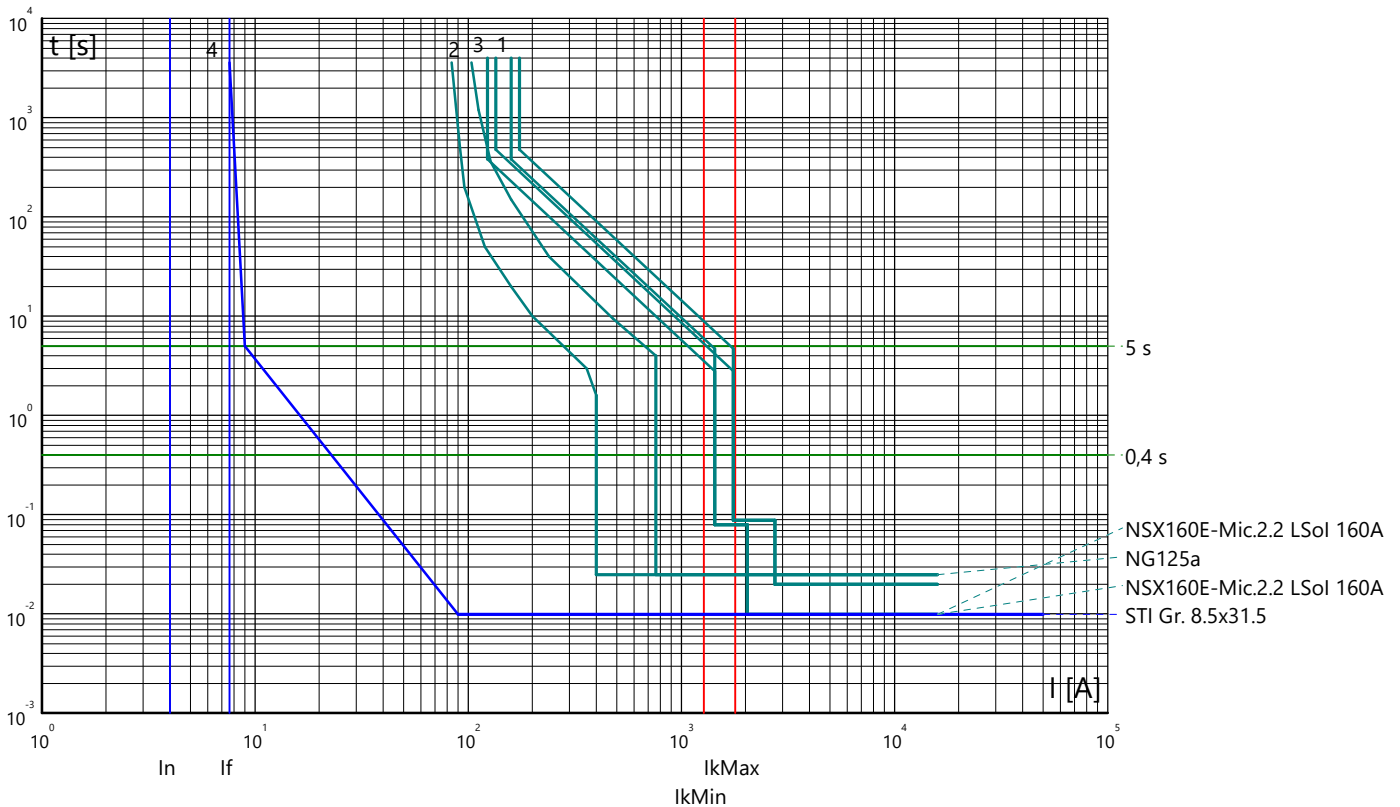

Curve tempo corrente: FERMATA DUGENTA
 Quadro: QUADRO GENERALE B.T.

Partenza: 1.1N

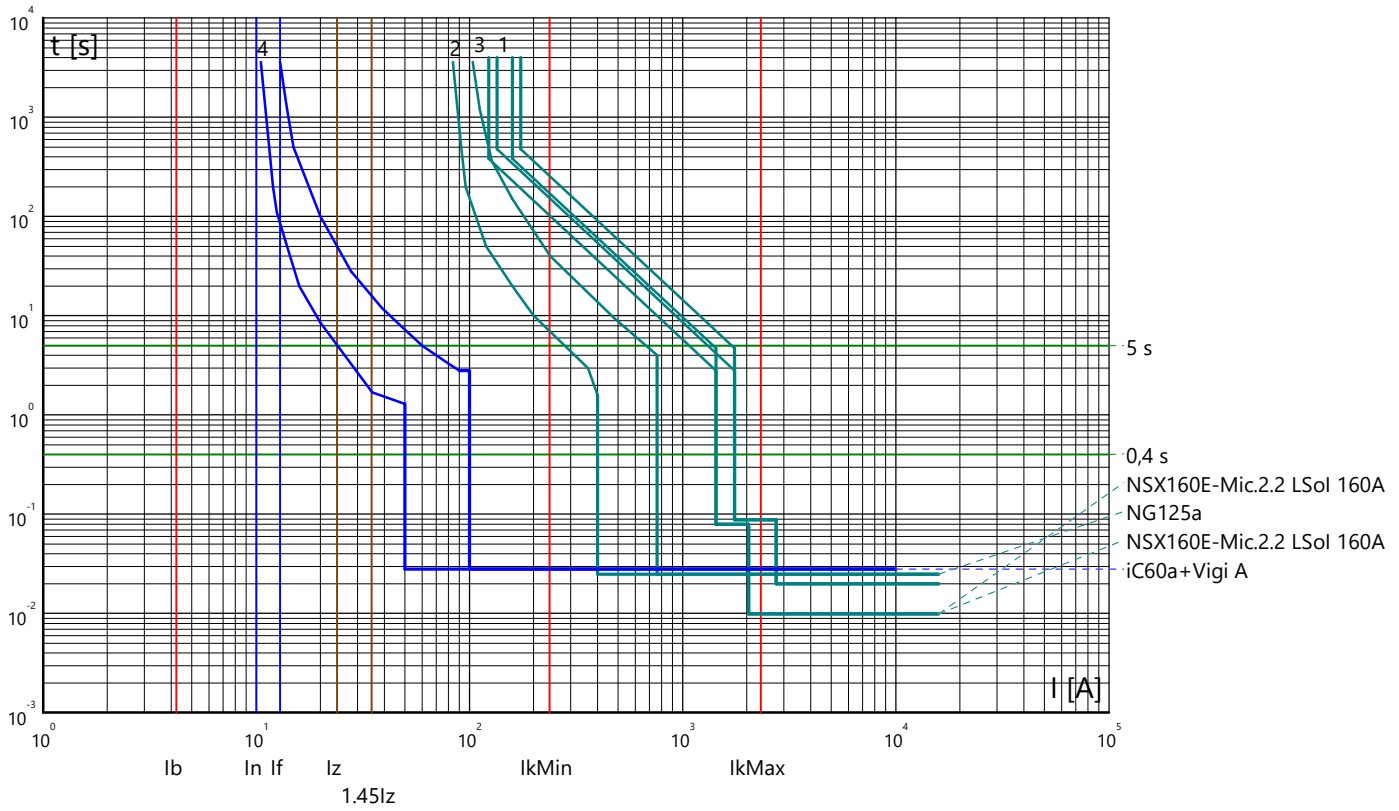

Partenza: 1.2N

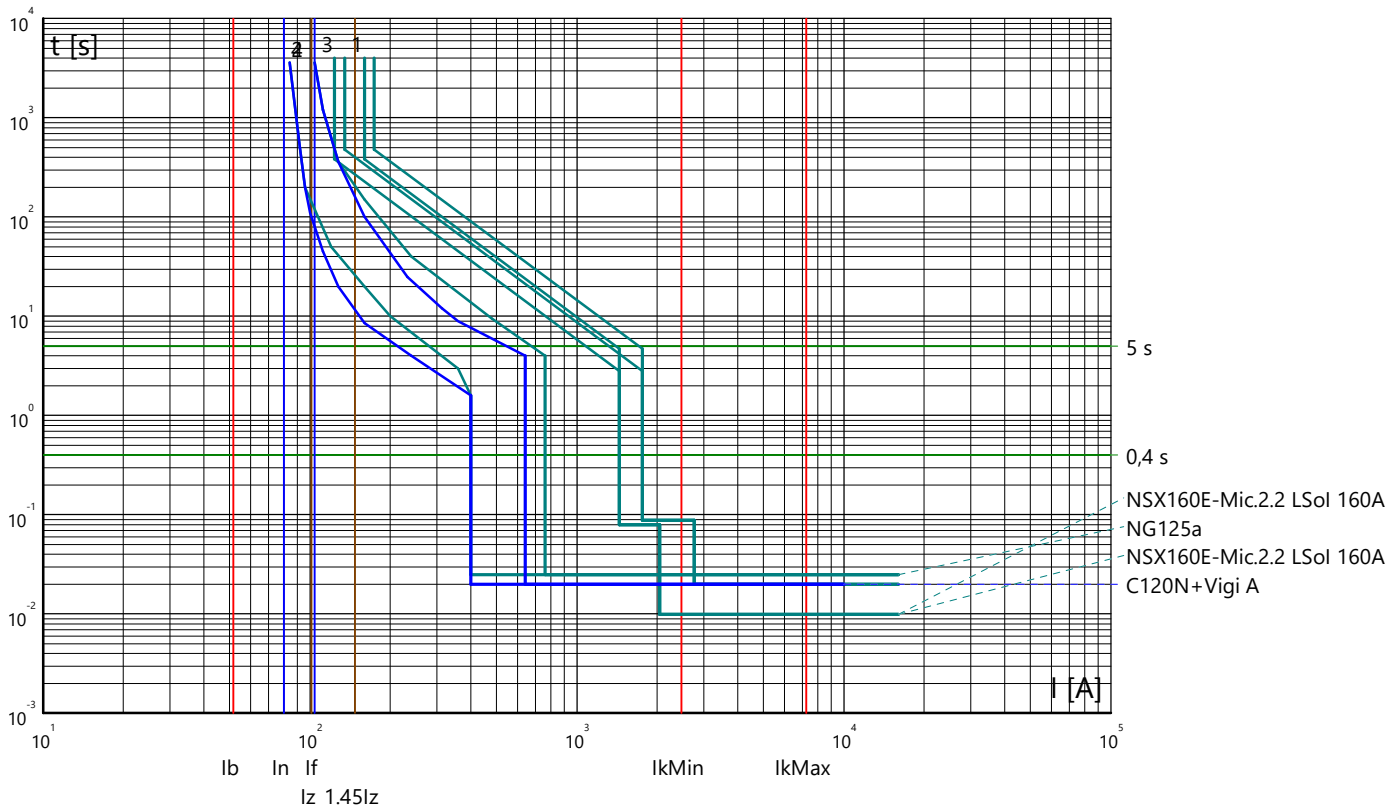

Curve tempo corrente: FERMATA DUGENTA
 Quadro: QUADRO GENERALE B.T.

Partenza: 1.3N

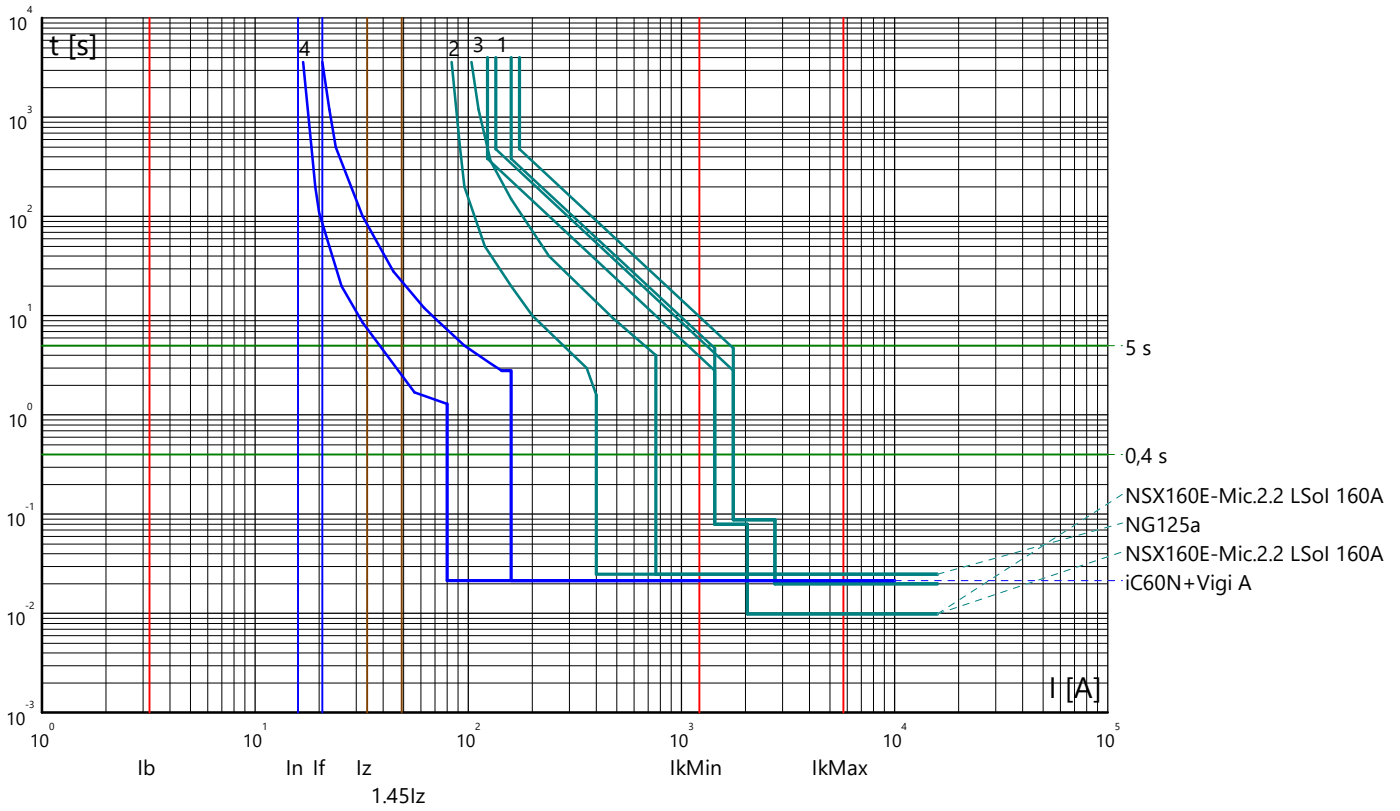

Partenza: 1.4N

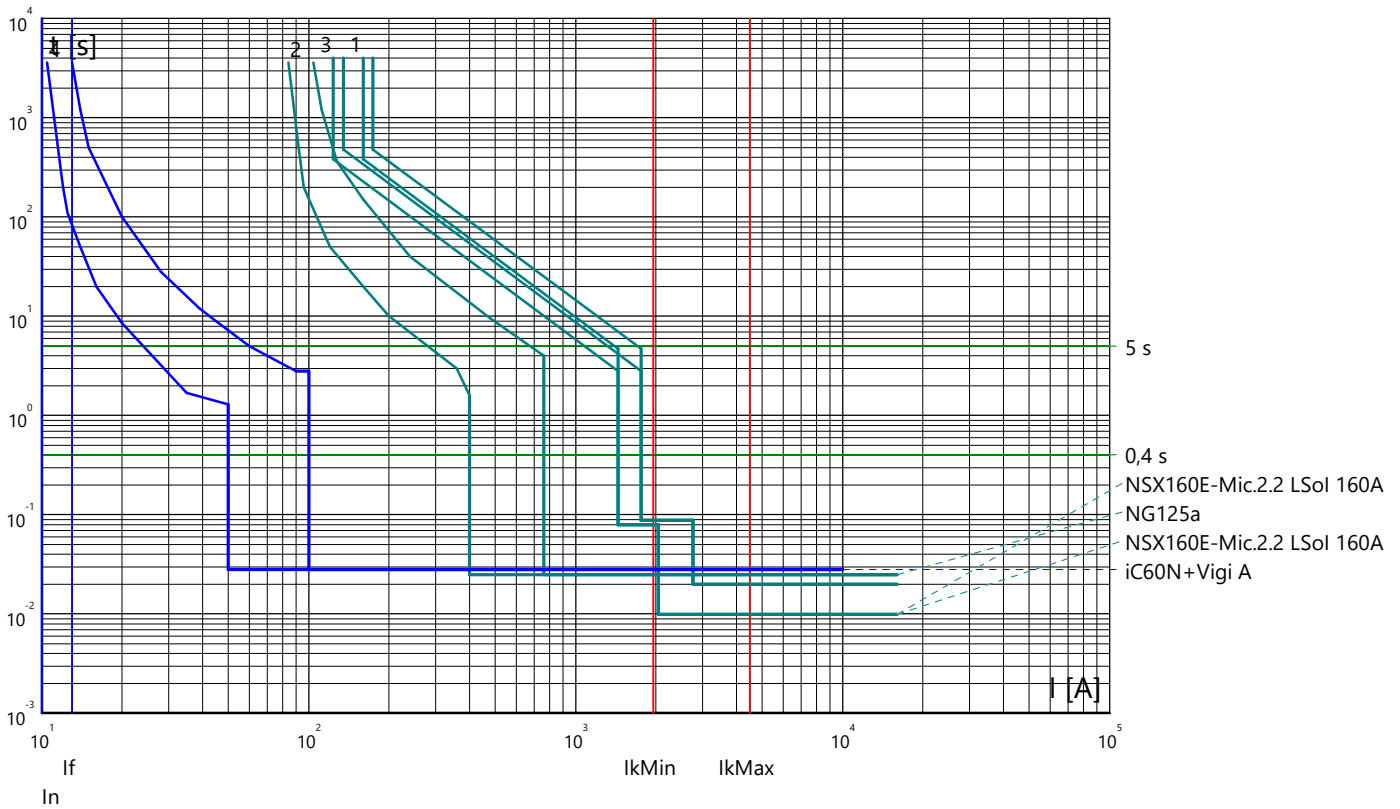

Curve tempo corrente: FERMATA DUGENTA
 Quadro: QUADRO GENERALE B.T.

Partenza: 1.5N

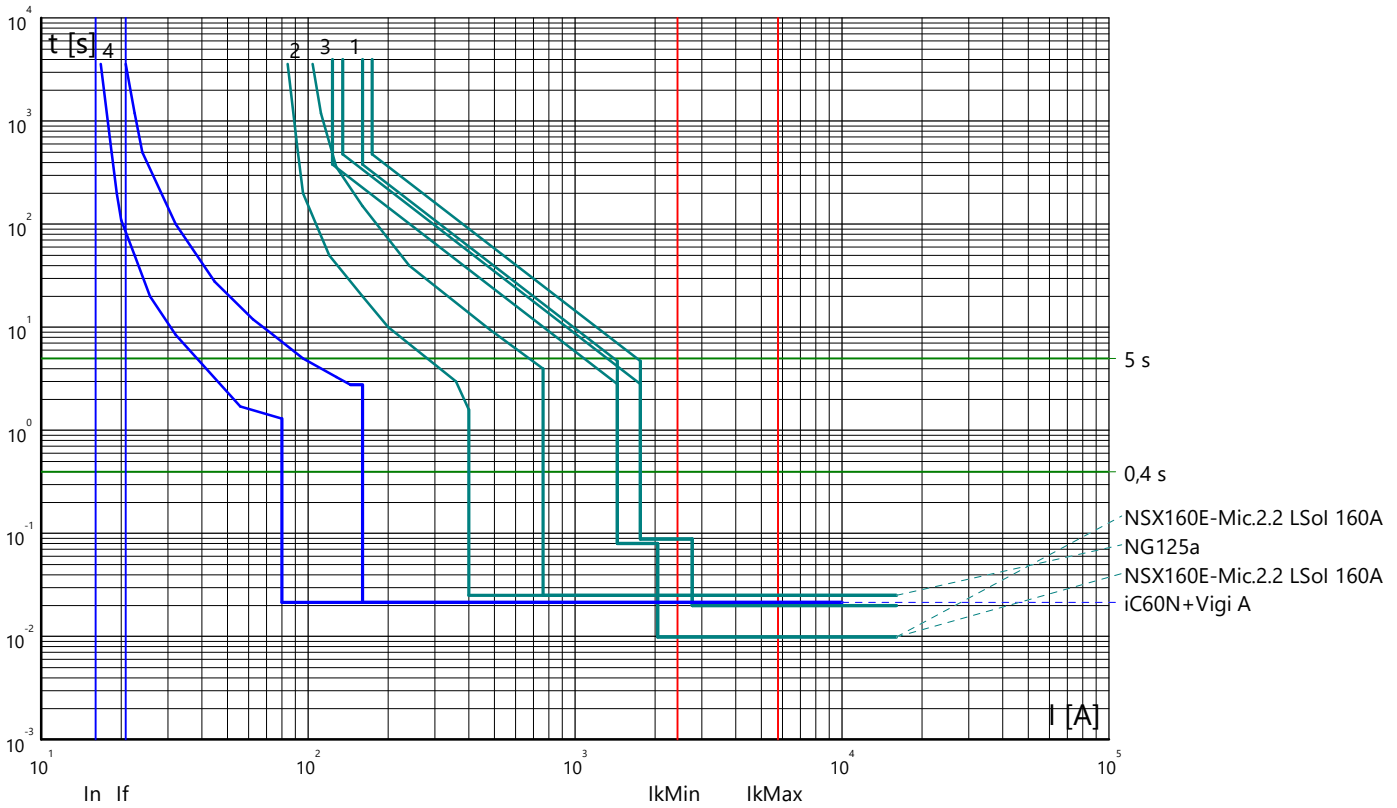

Partenza: S1.N

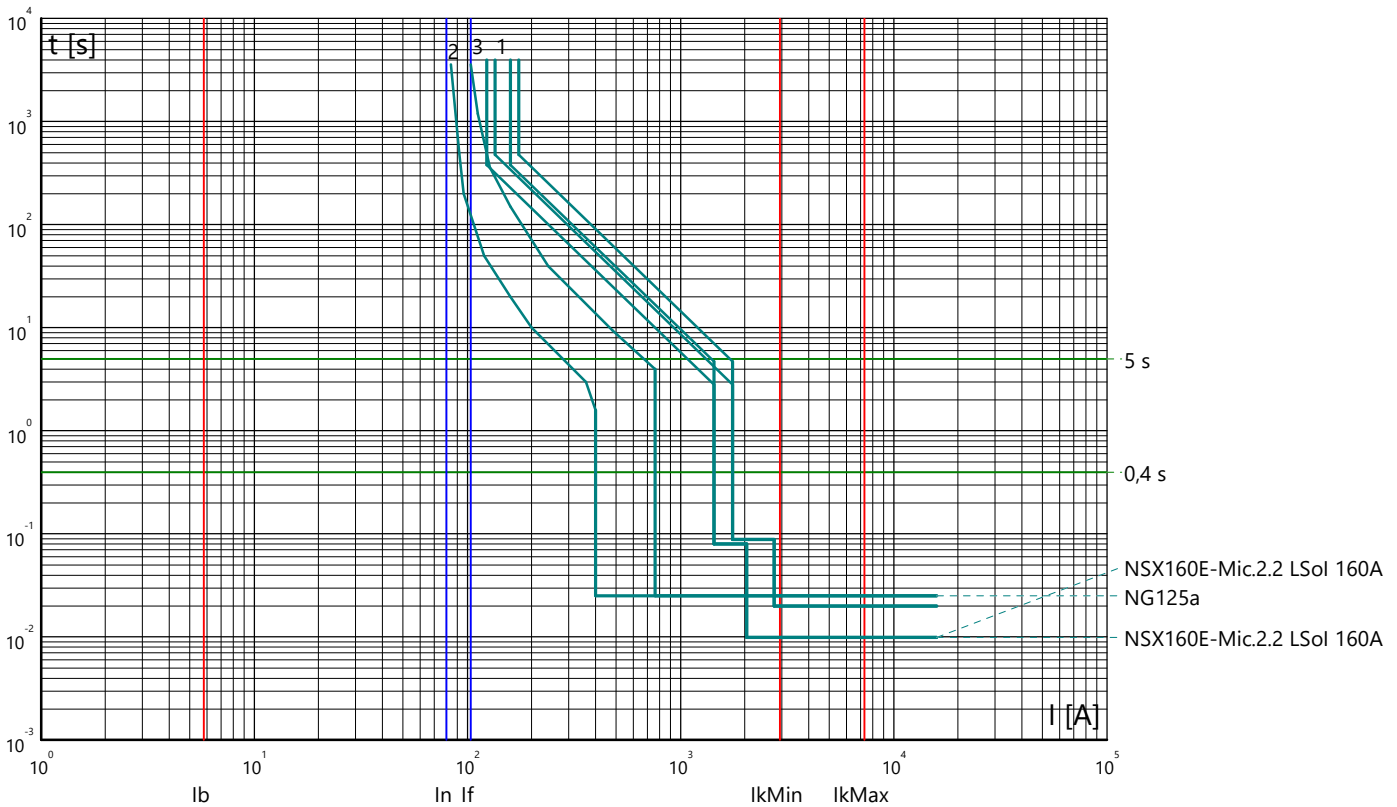

Curve tempo corrente: FERMATA DUGENTA
 Quadro: QUADRO GENERALE B.T.

Partenza: 1.6N

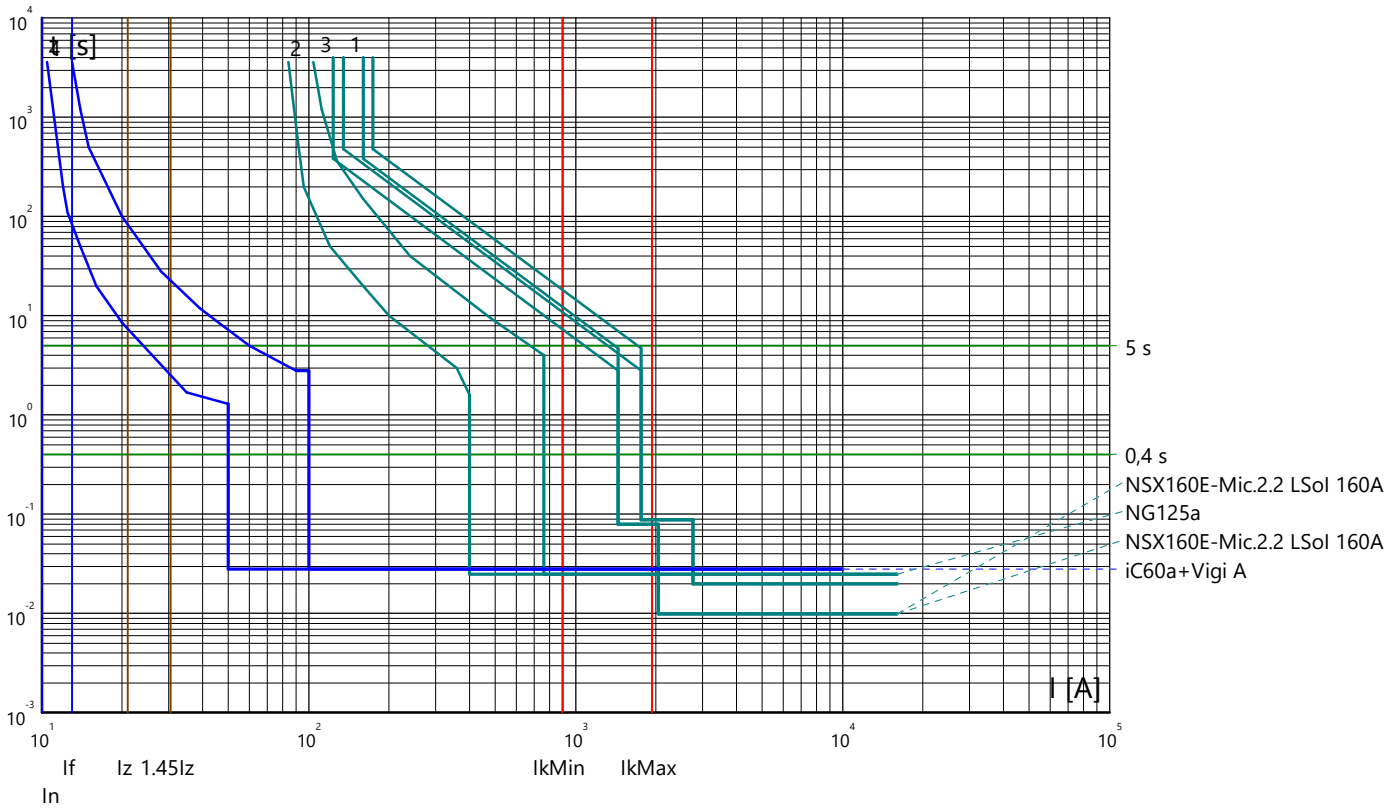

Partenza: 1.7N

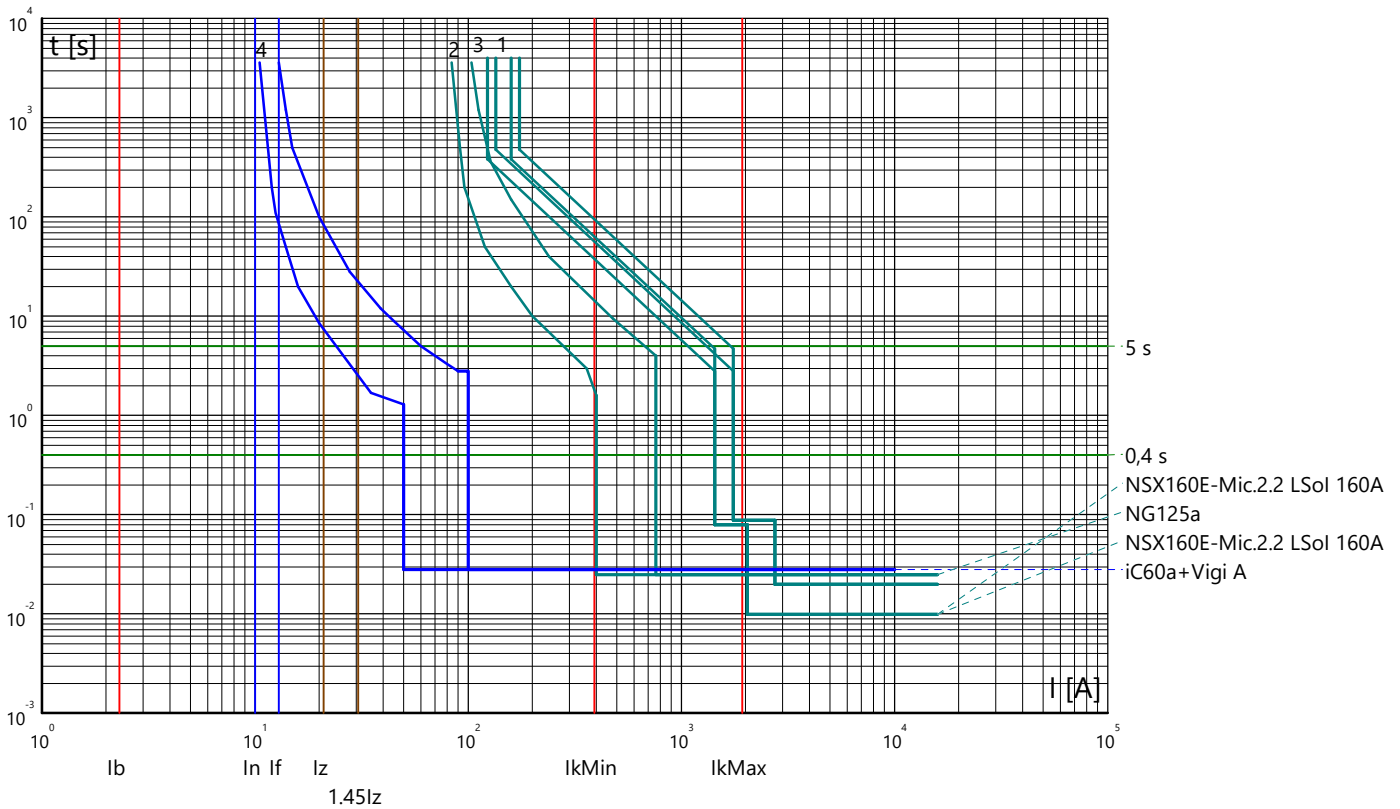

Curve tempo corrente: FERMATA DUGENTA
 Quadro: QUADRO GENERALE B.T.

Partenza: 1.8N

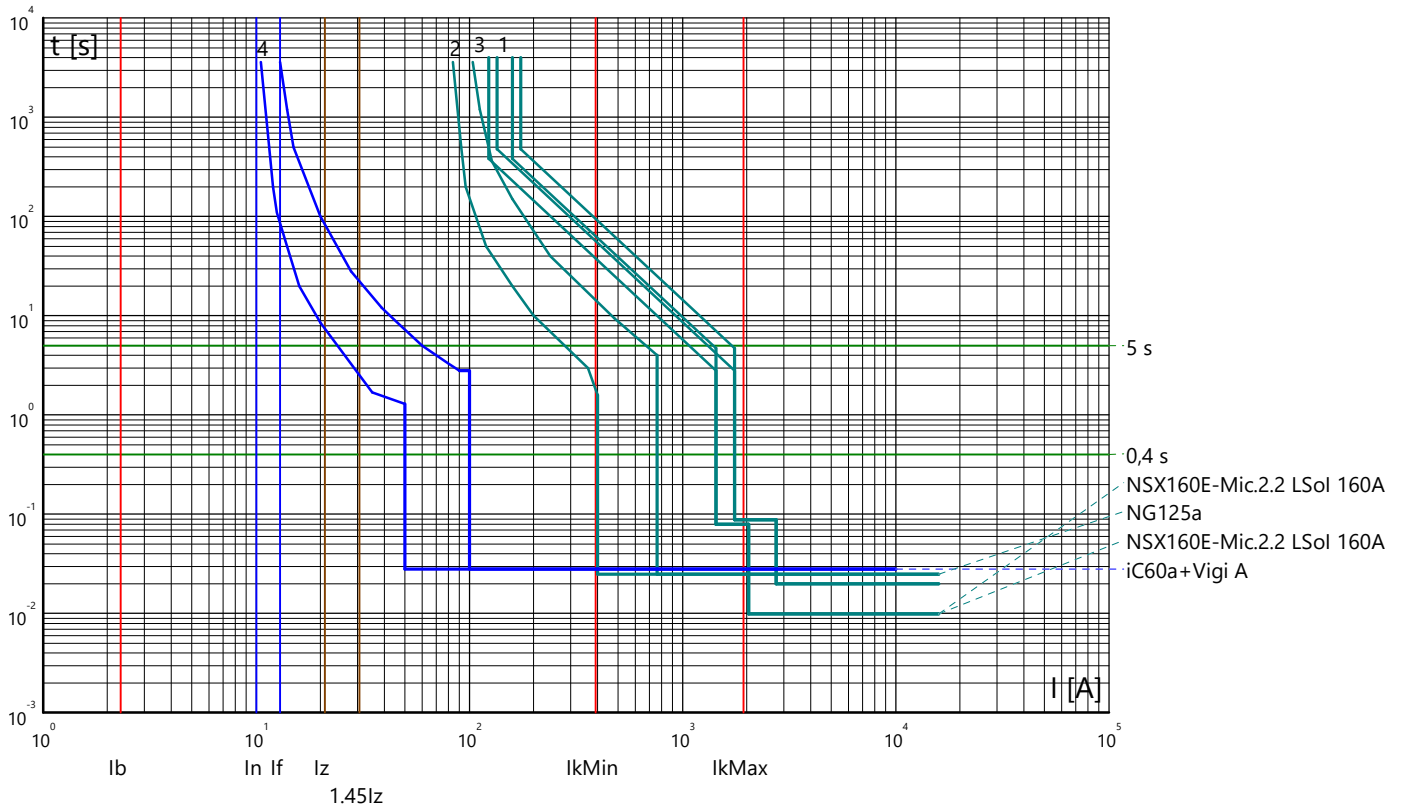

Partenza: 1.9N

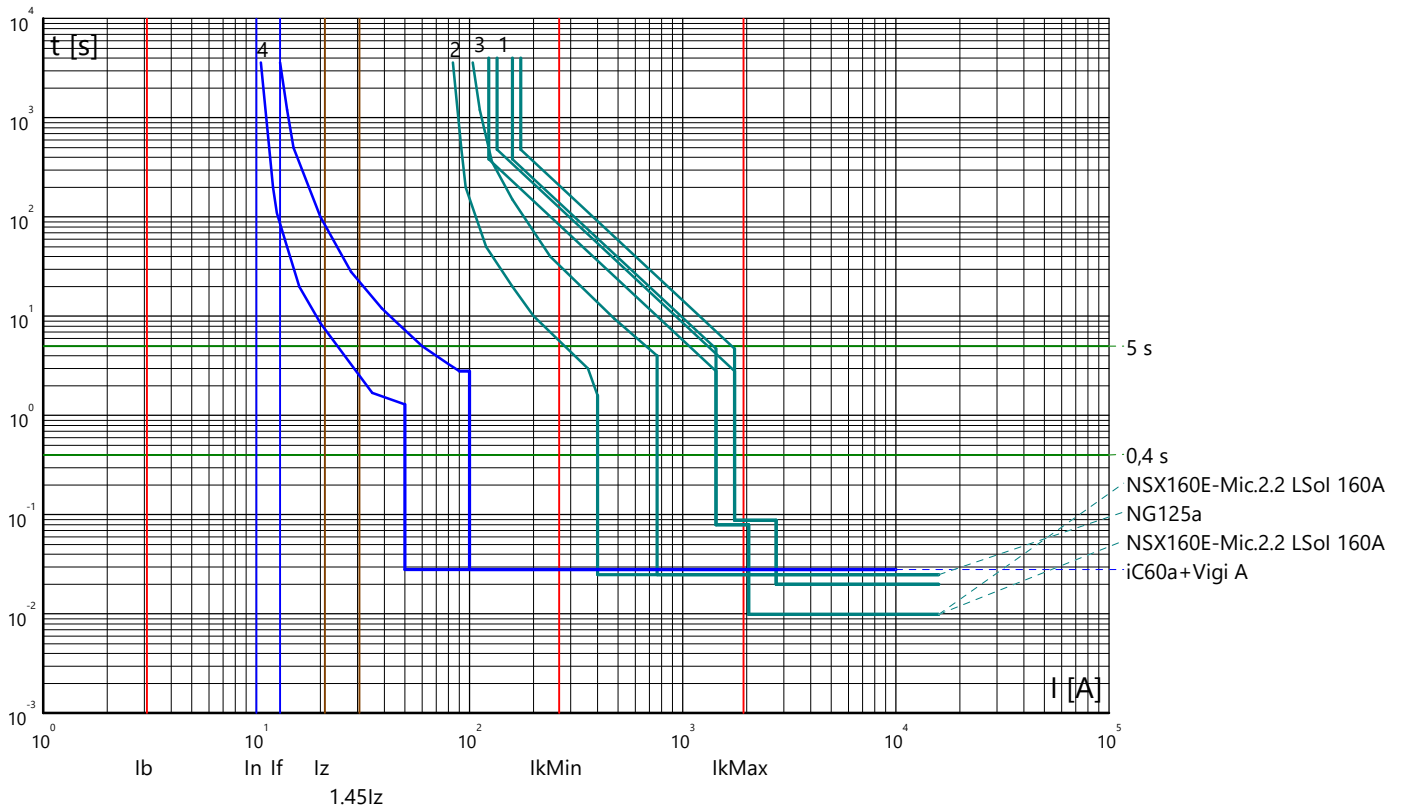

Curve tempo corrente: FERMATA DUGENTA
 Quadro: QUADRO GENERALE B.T.

Partenza: 1.10N

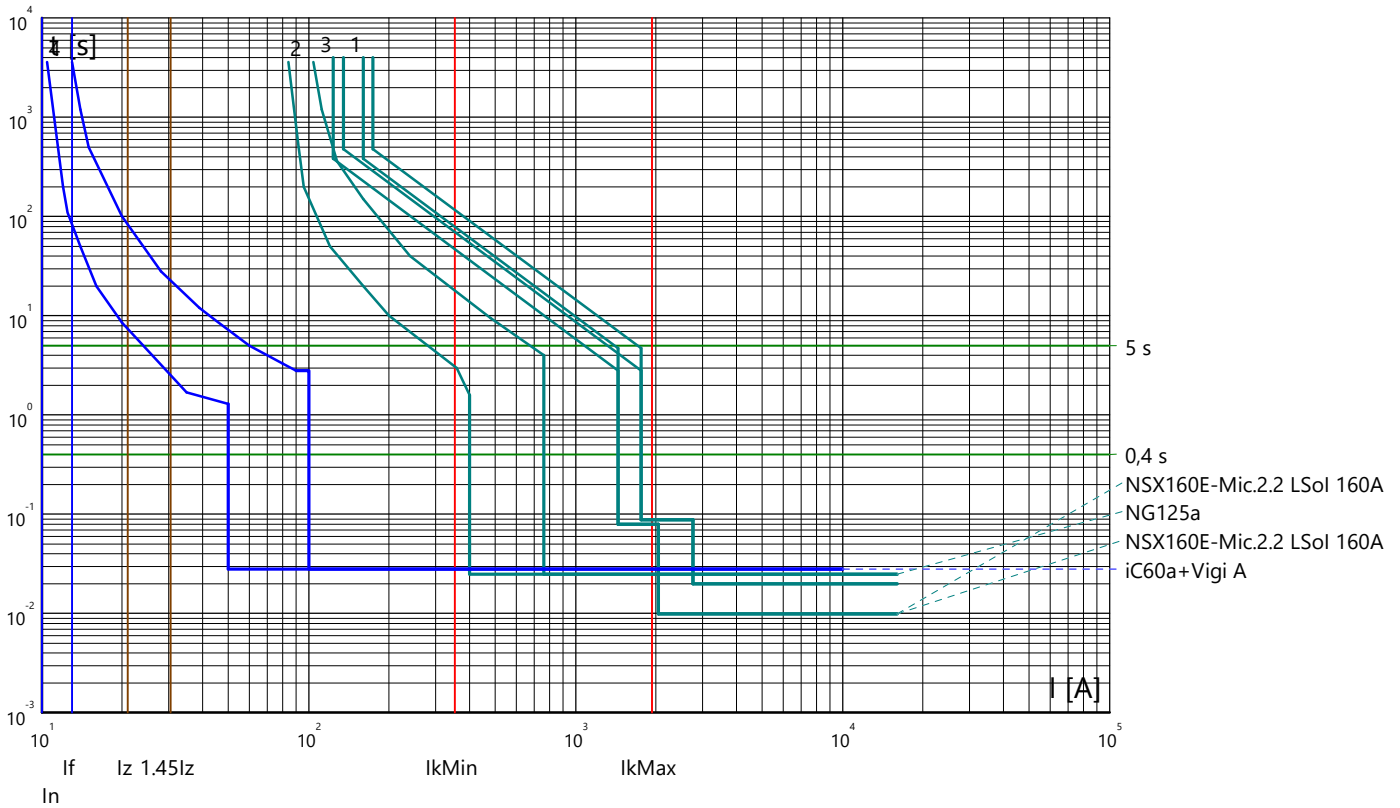

Partenza: 1.11N

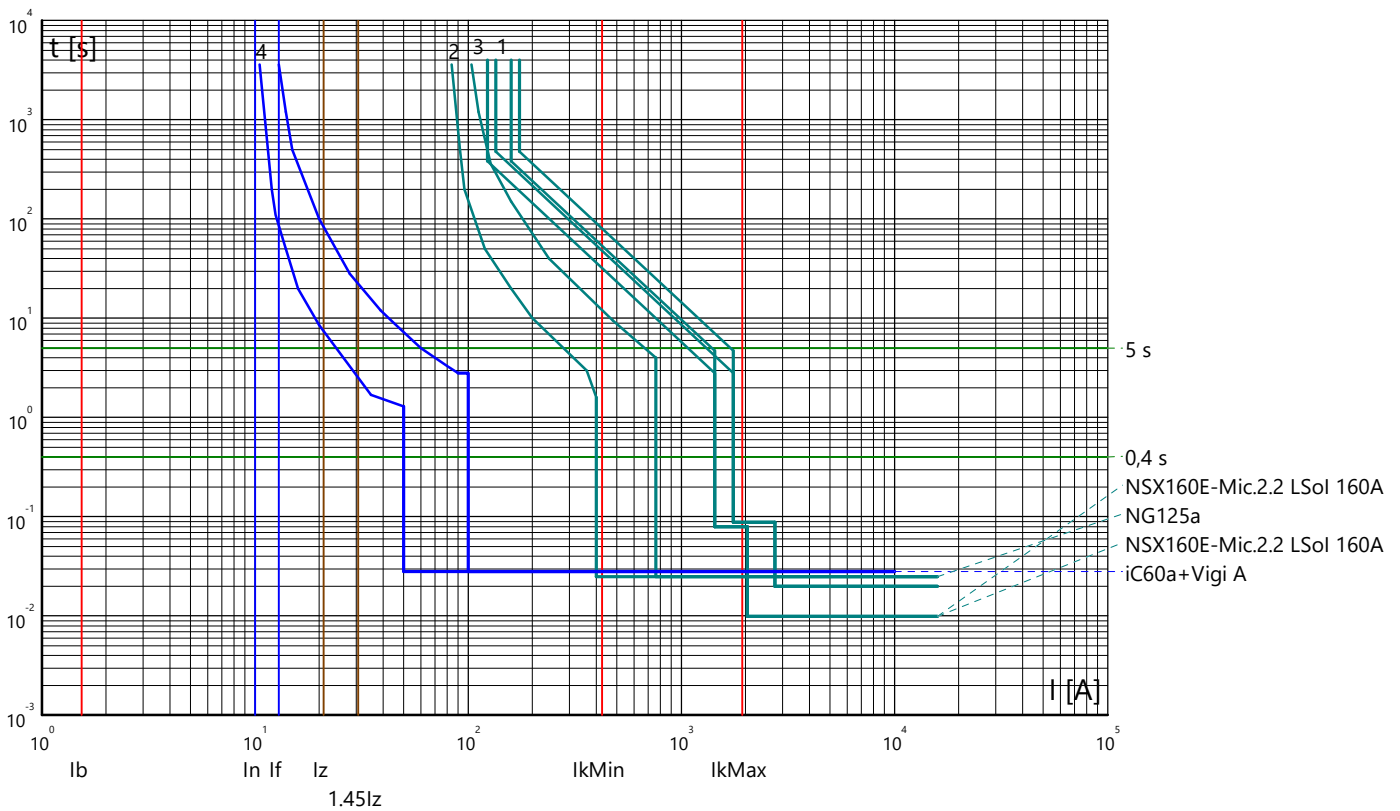

Curve tempo corrente: FERMATA DUGENTA
 Quadro: QUADRO GENERALE B.T.

Partenza: 1.12N

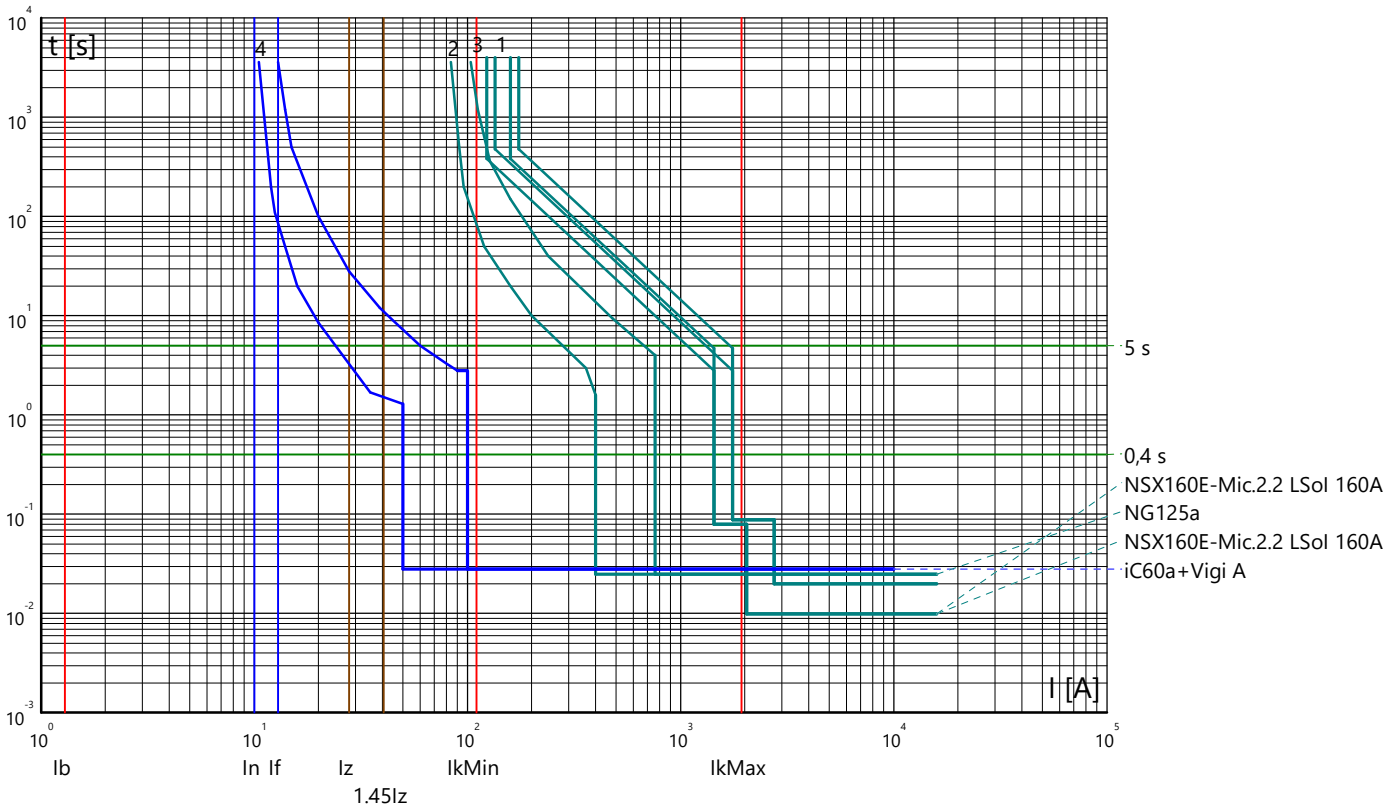

Partenza: 1.13N

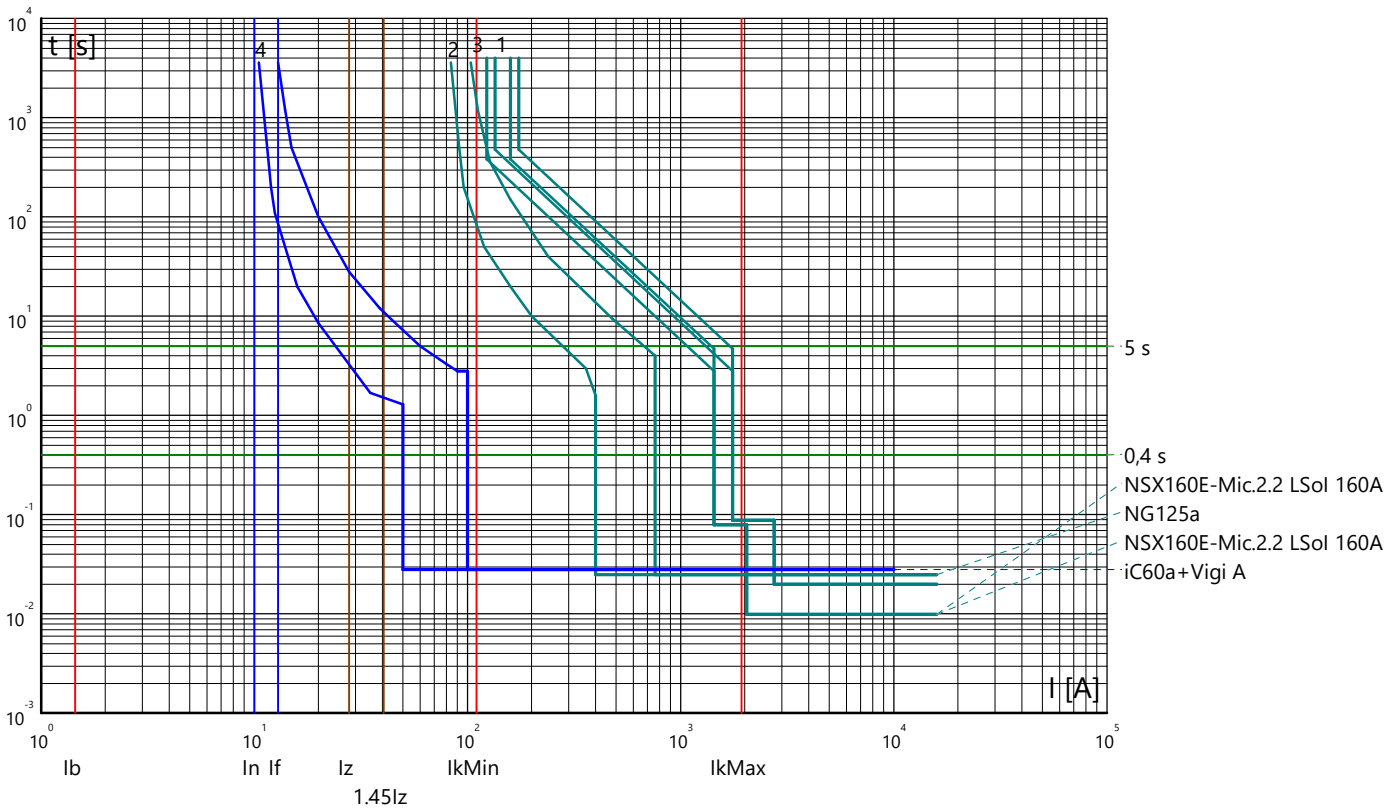

Curve tempo corrente: FERMATA DUGENTA
 Quadro: QUADRO GENERALE B.T.

Partenza: 1.14N

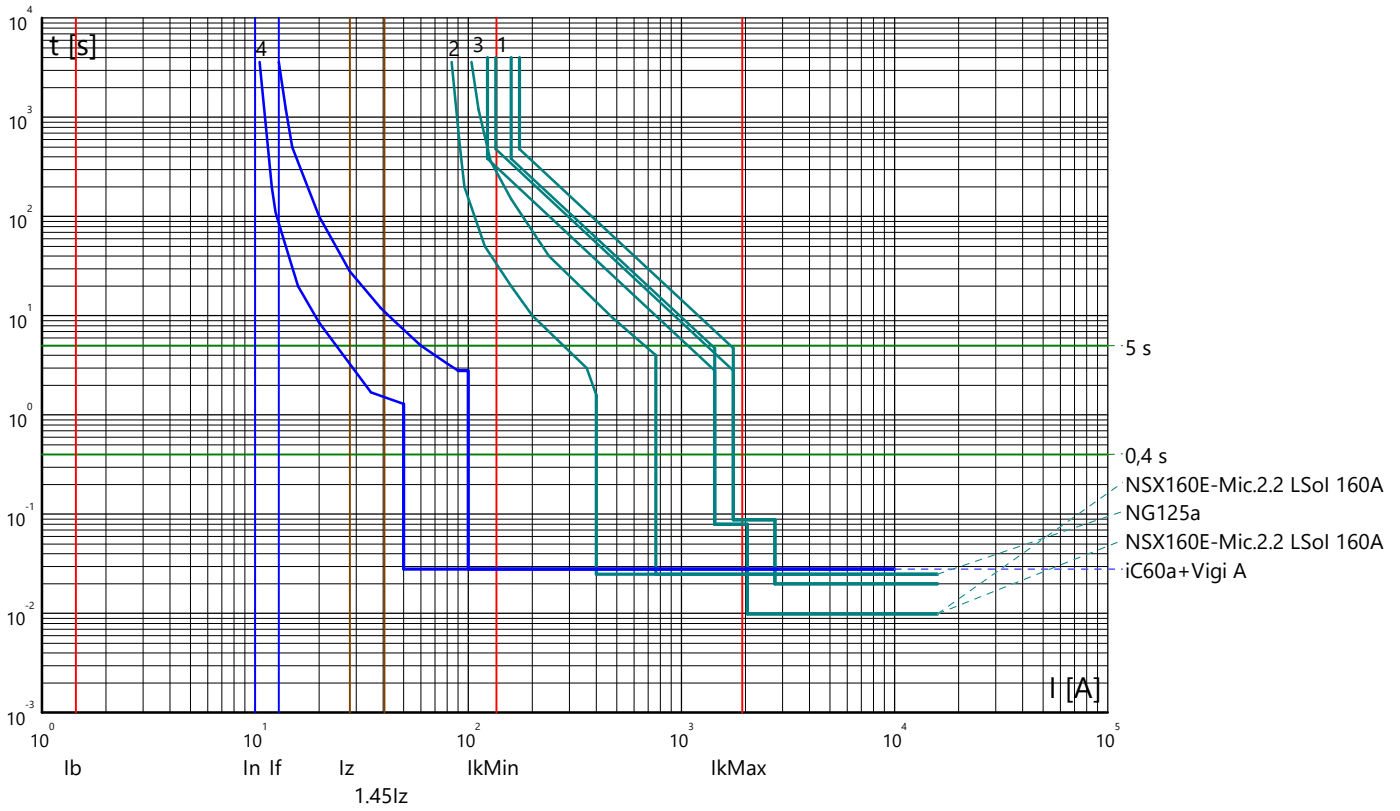

Partenza: 1.15N

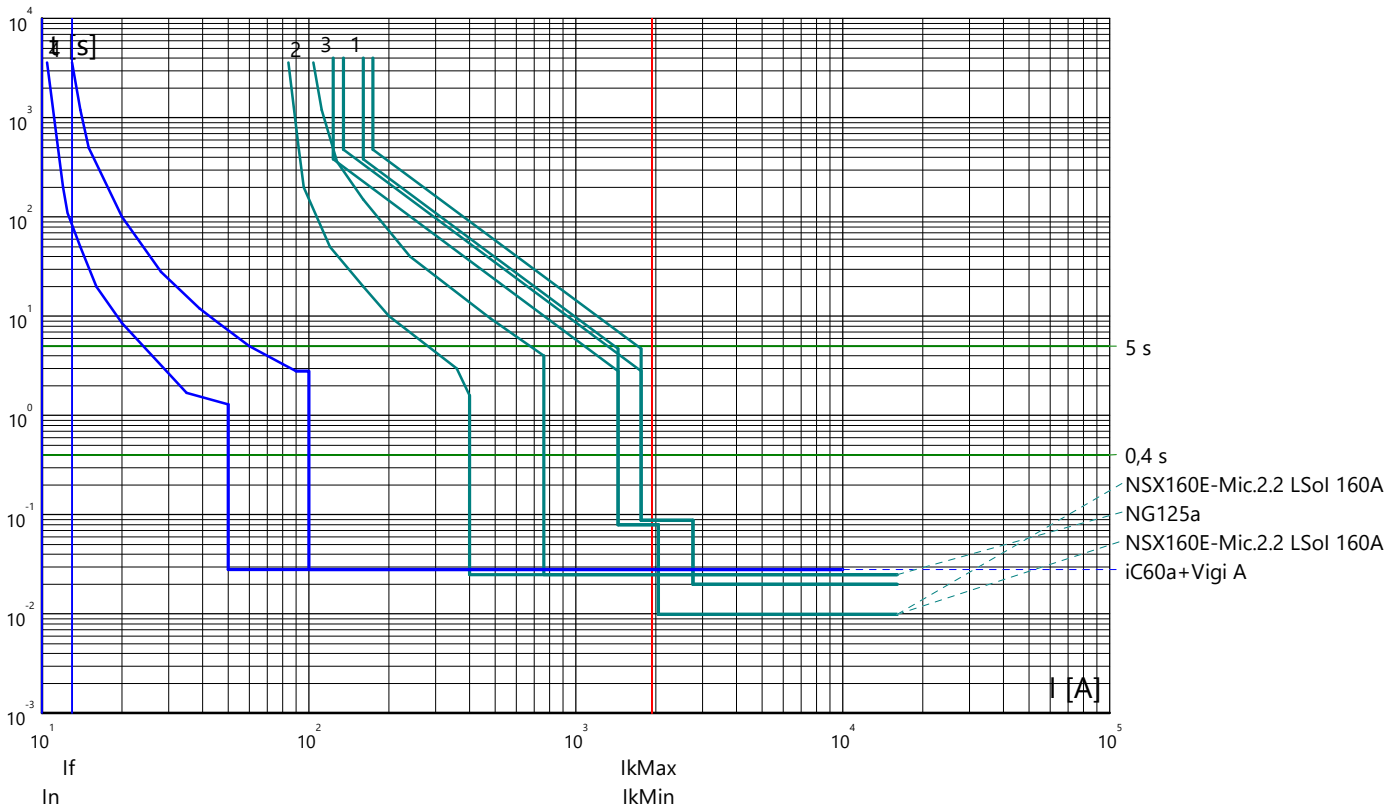

Curve tempo corrente: FERMATA DUGENTA
 Quadro: QUADRO GENERALE B.T.

Partenza: 1.16N

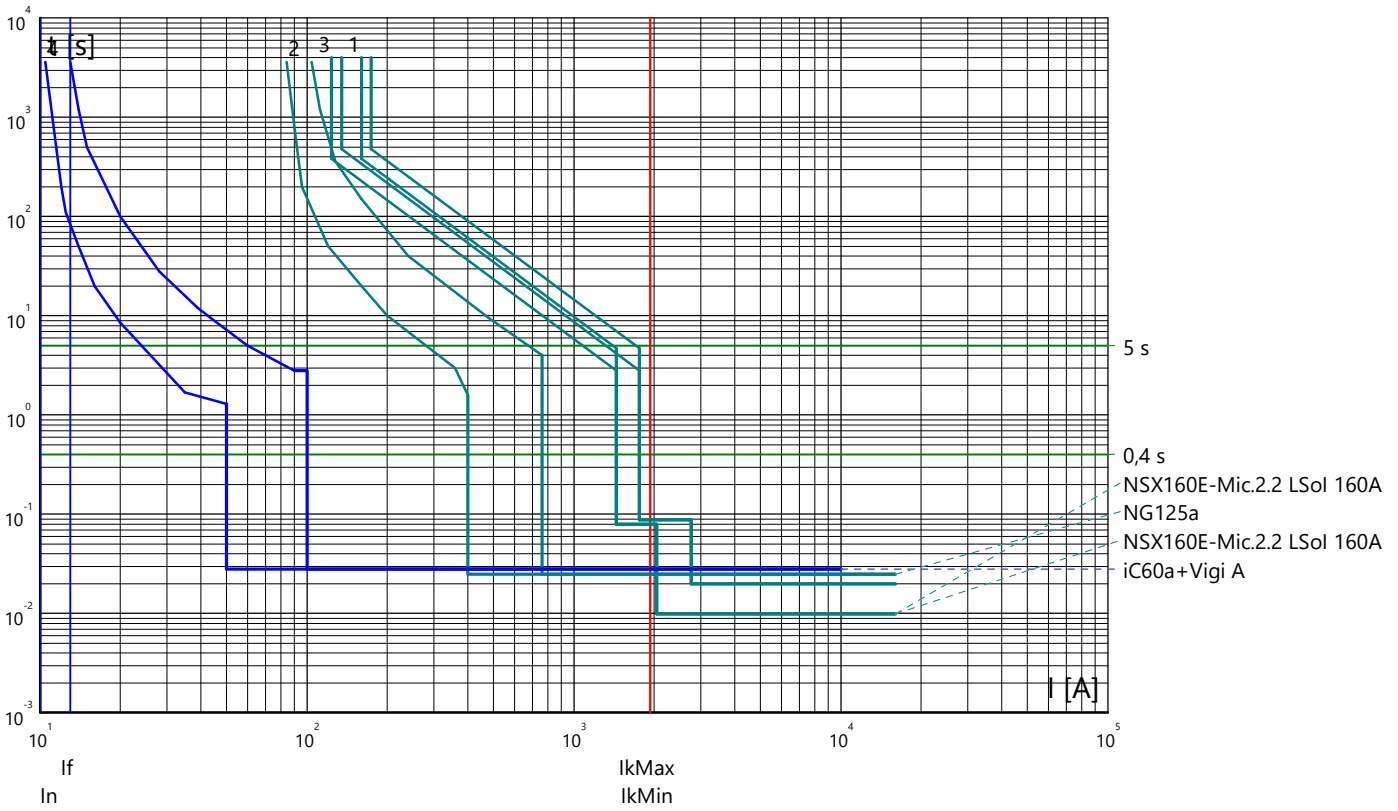

Partenza: S2.N

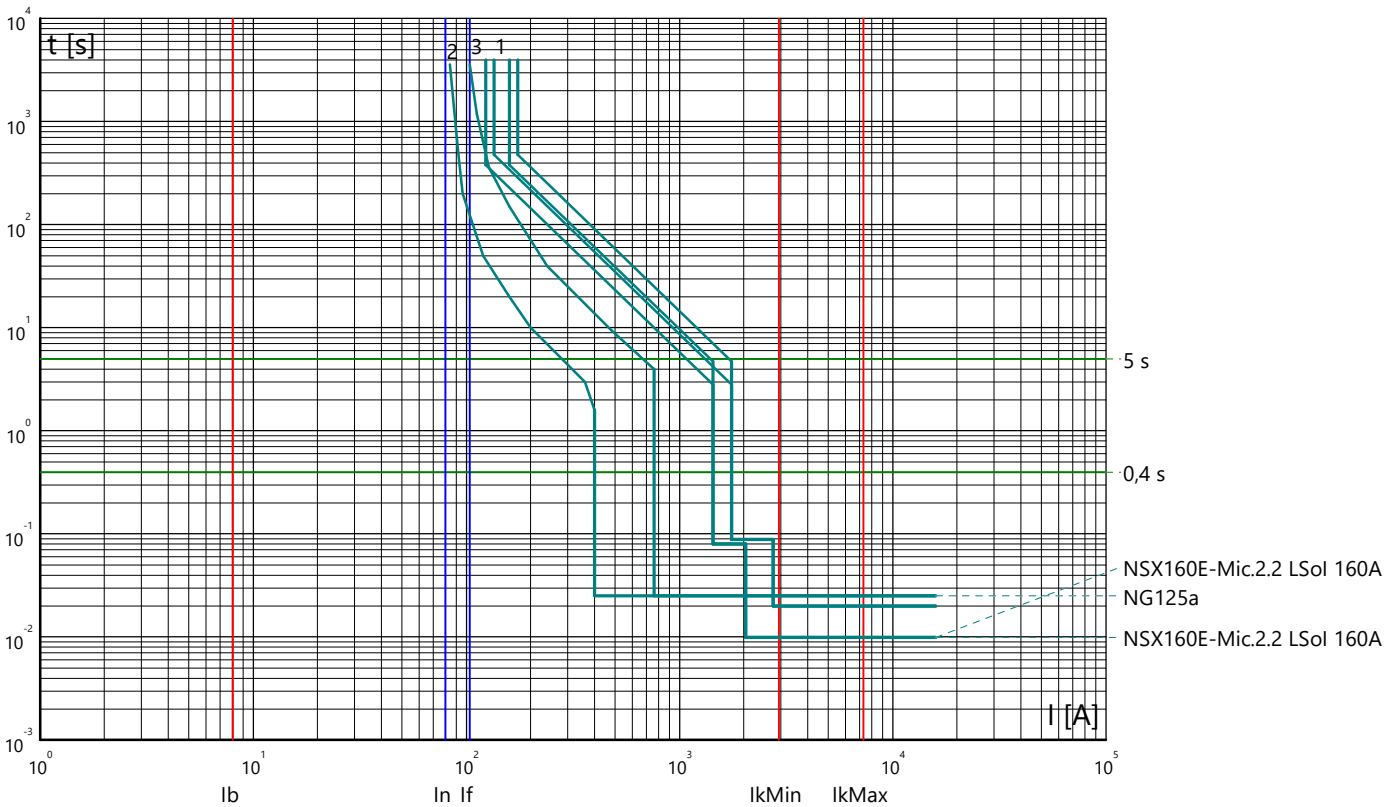

Curve tempo corrente: FERMATA DUGENTA
 Quadro: QUADRO GENERALE B.T.

Partenza: 1.17N

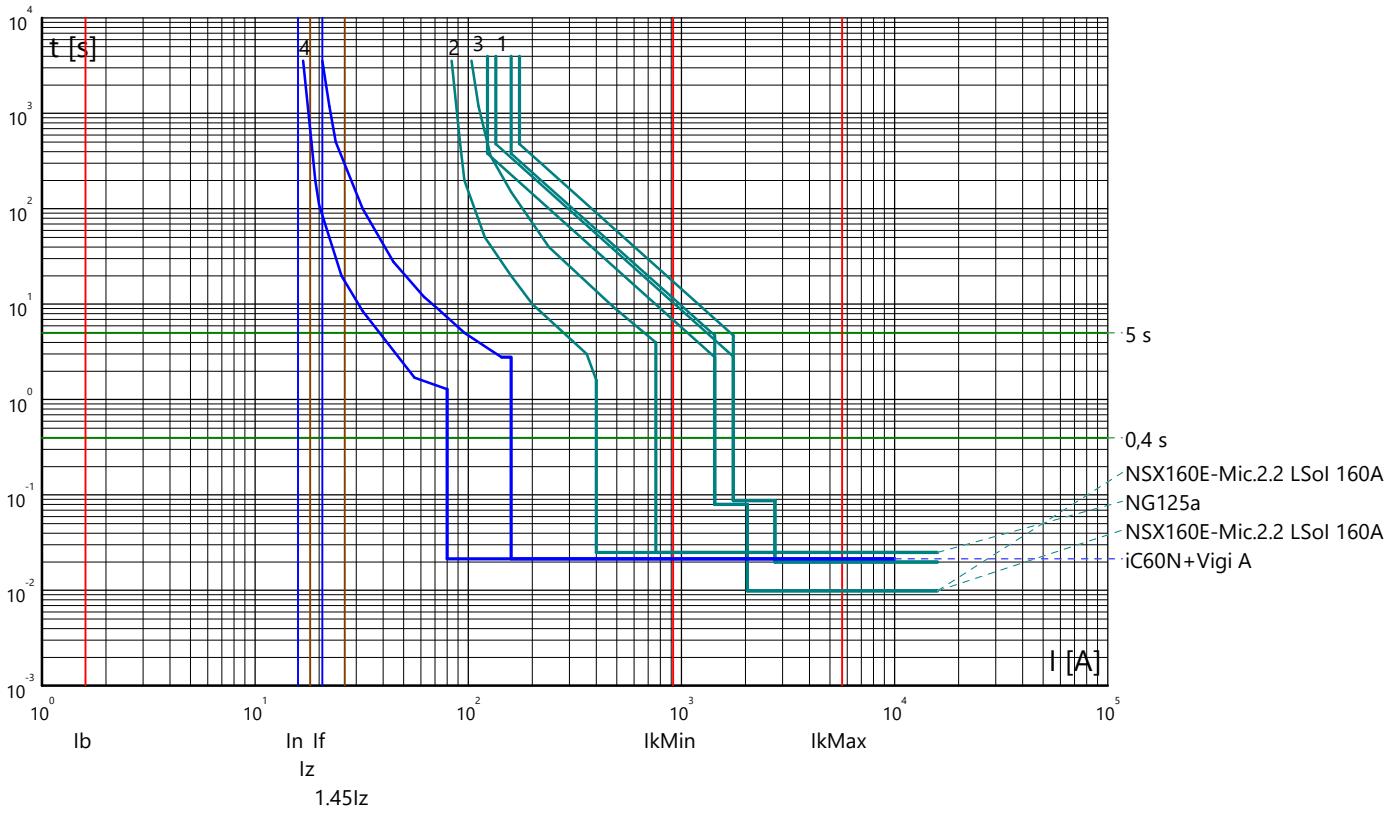

Partenza: 1.18N

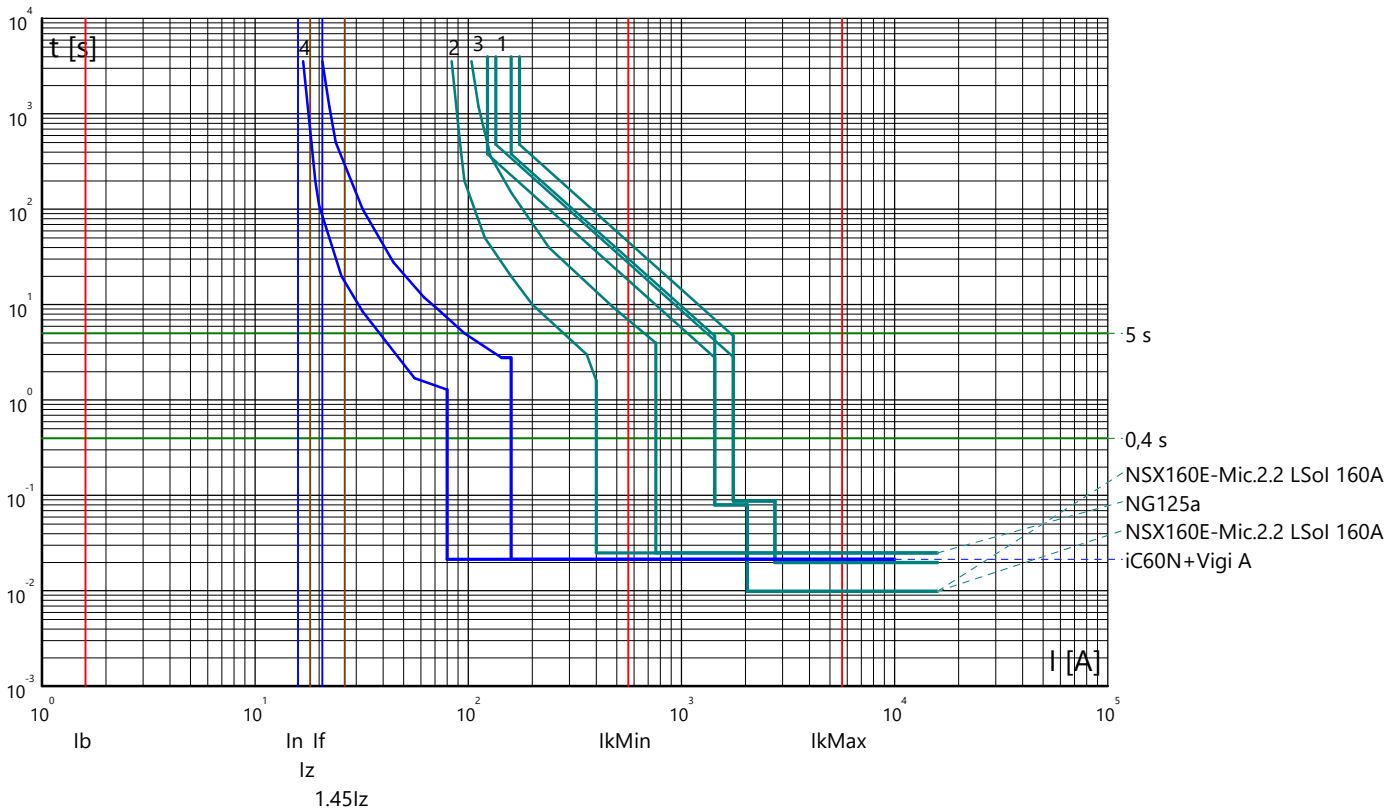

Curve tempo corrente: FERMATA DUGENTA
 Quadro: QUADRO GENERALE B.T.

Partenza: 1.19N

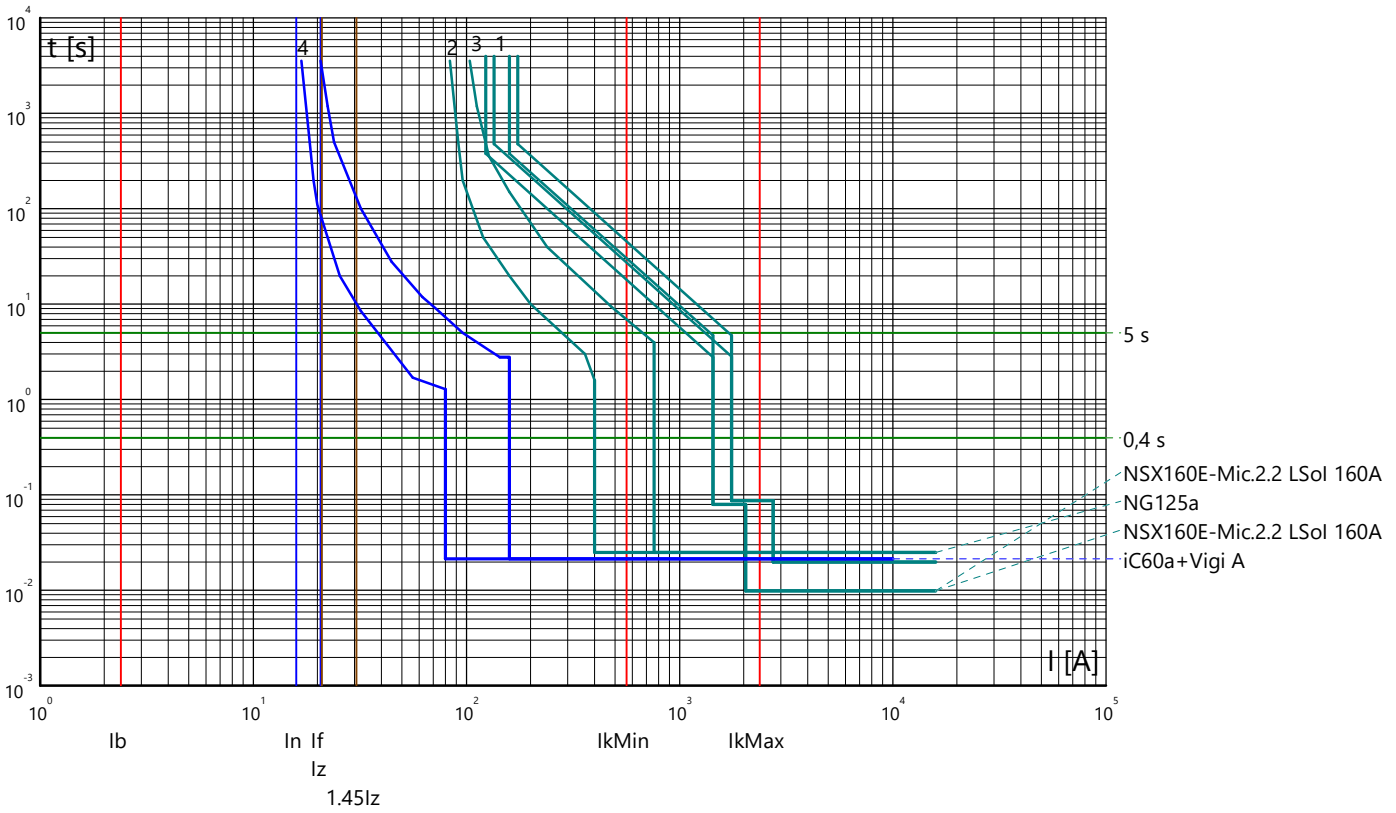

Partenza: 1.20N

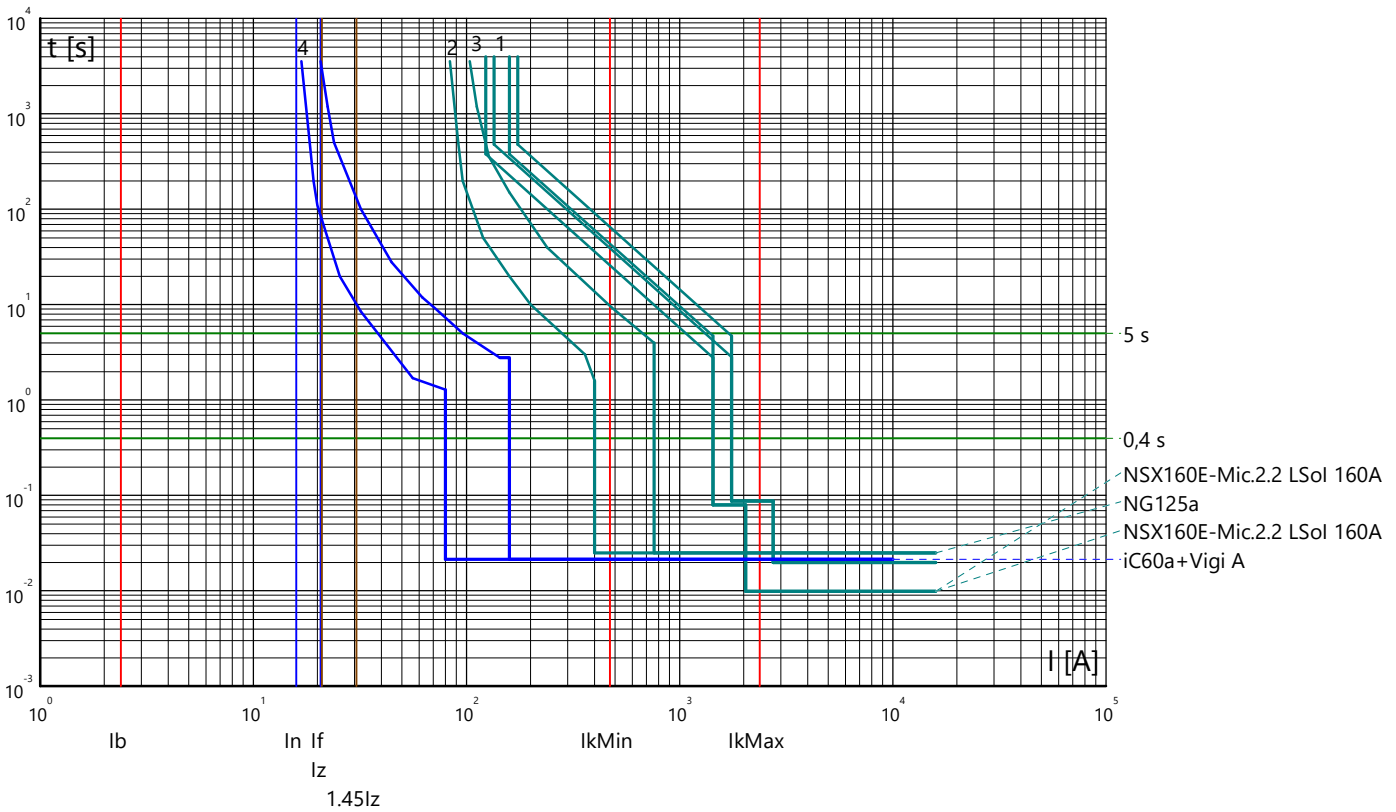

Curve tempo corrente: FERMATA DUGENTA
 Quadro: QUADRO GENERALE B.T.

Partenza: 1.21N

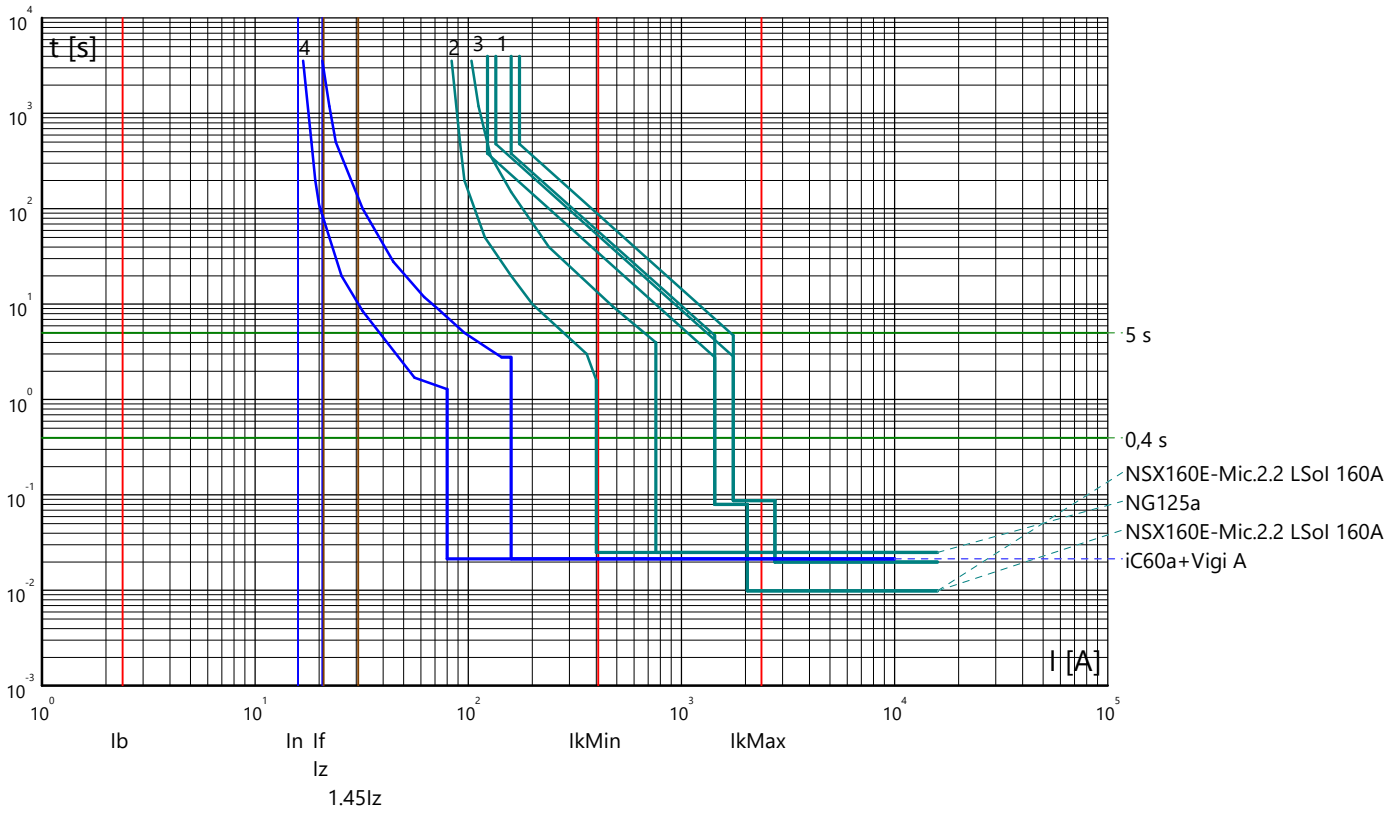

Partenza: 1.22N

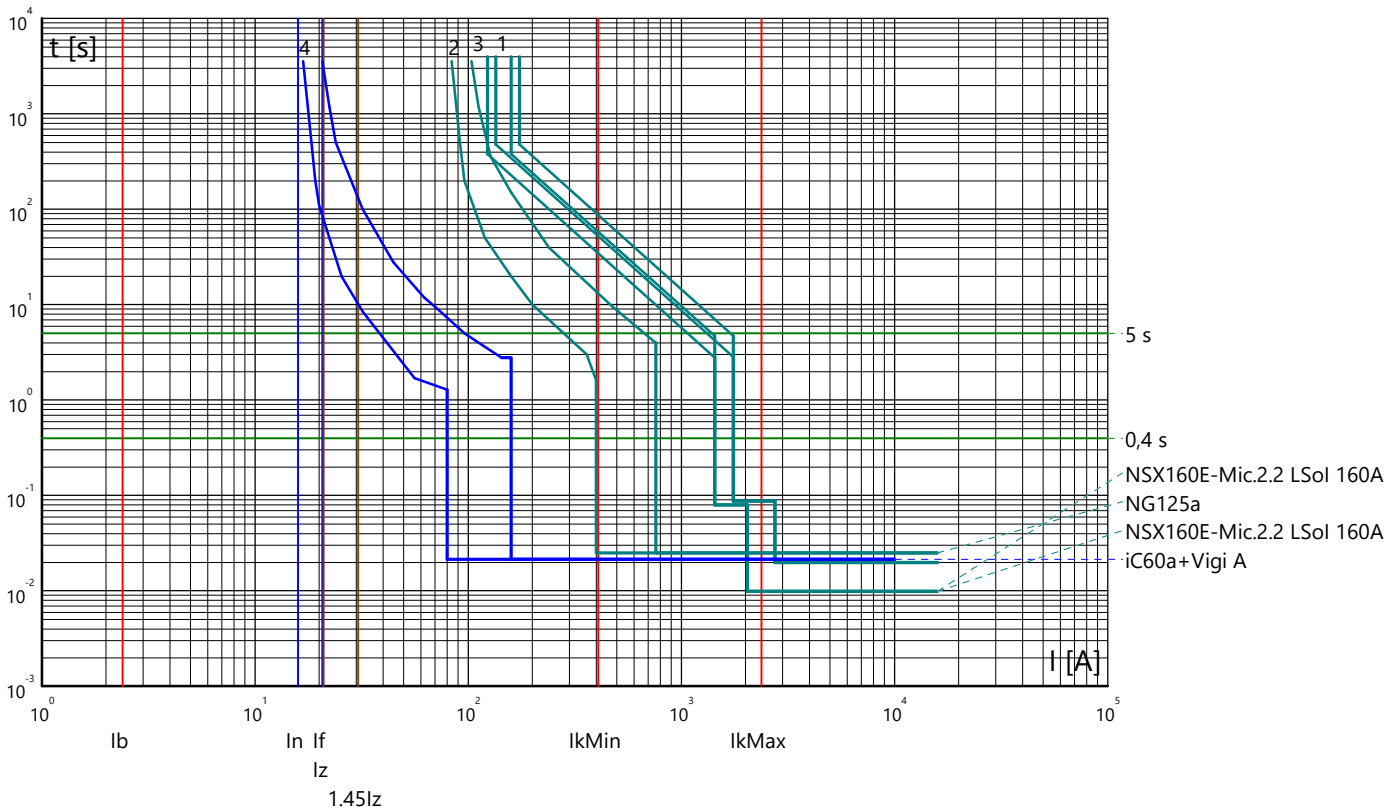

Curve tempo corrente: FERMATA DUGENTA
 Quadro: QUADRO GENERALE B.T.

Partenza: 1.23N

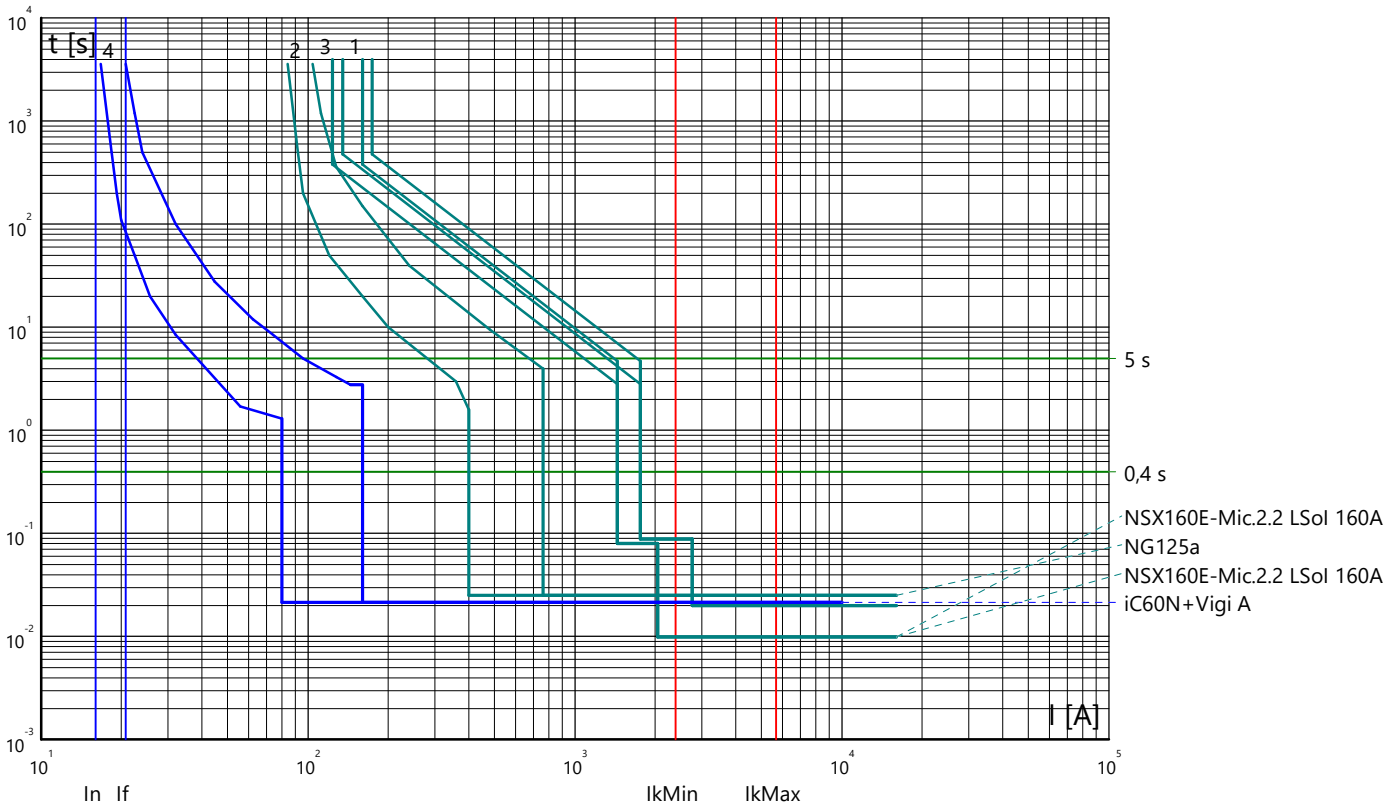

Partenza: 1.24N

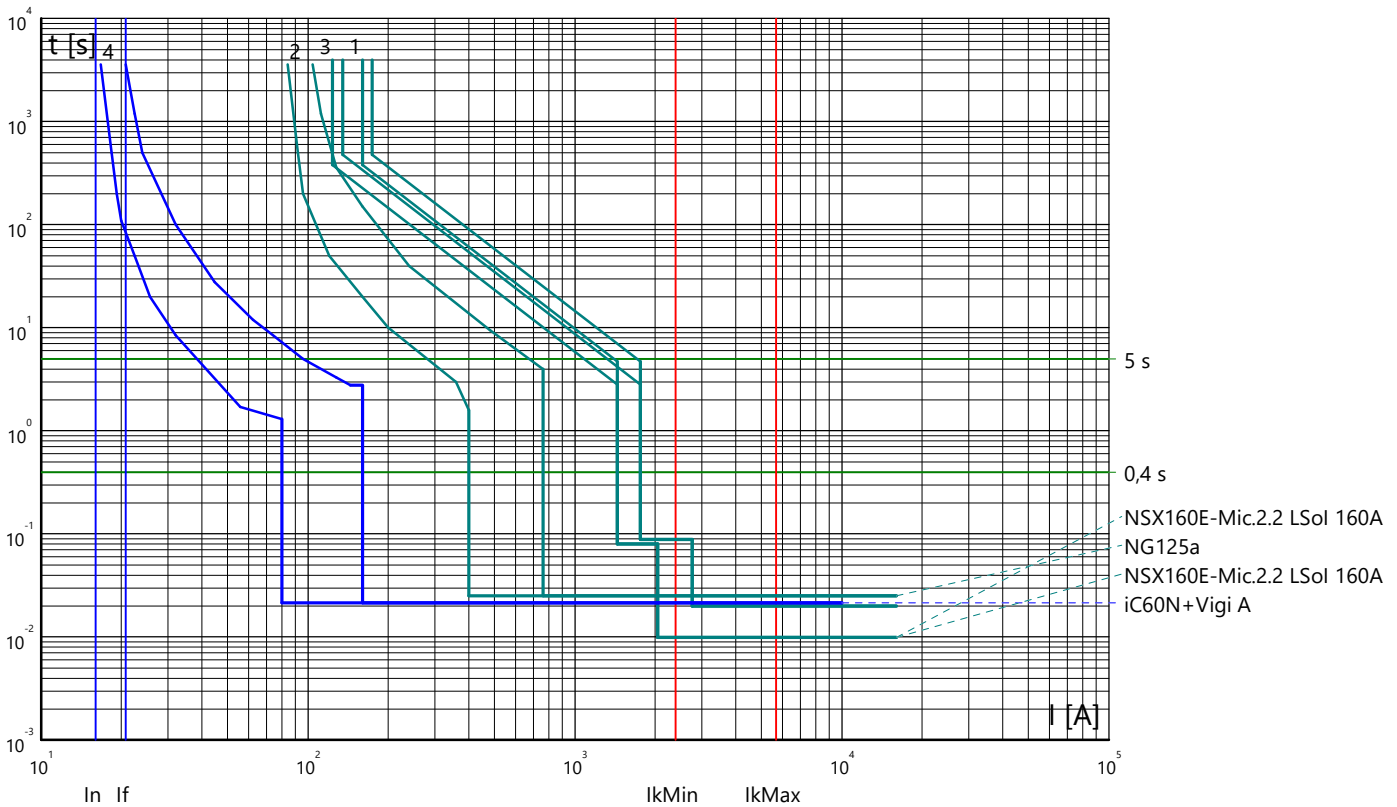

Curve tempo corrente: FERMATA DUGENTA
 Quadro: QUADRO GENERALE B.T.

Partenza: 1.25N

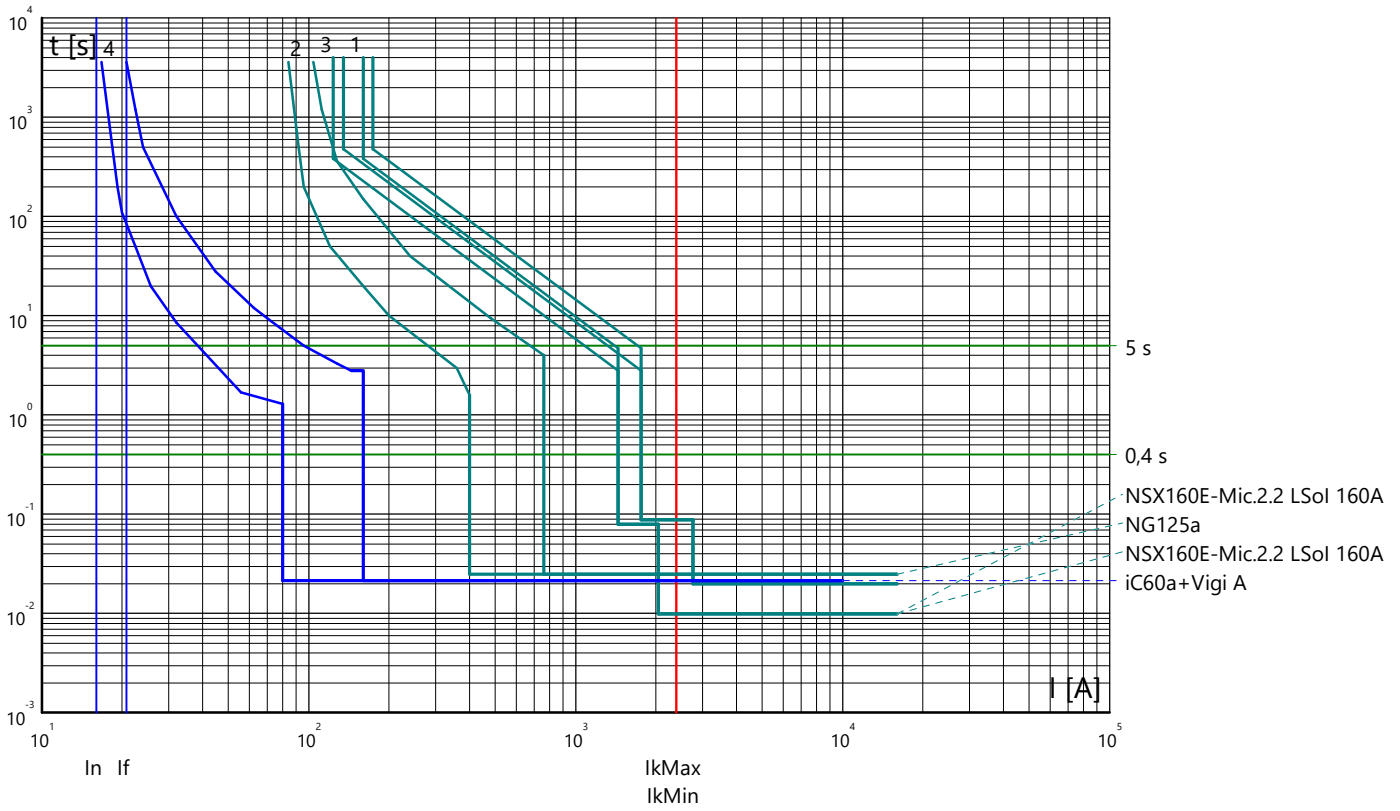

Partenza: S3.N

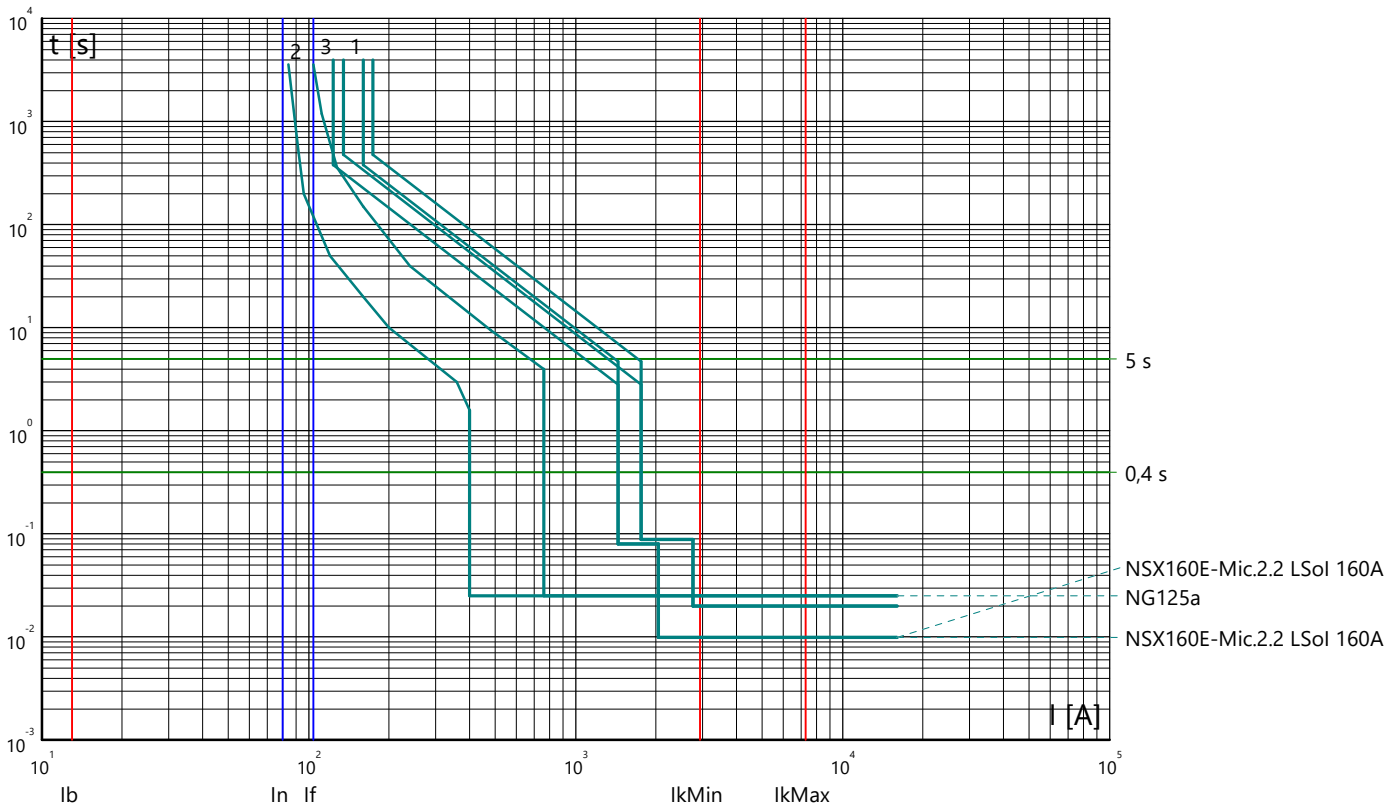

Curve tempo corrente: FERMATA DUGENTA
 Quadro: QUADRO GENERALE B.T.

Partenza: 1.26N

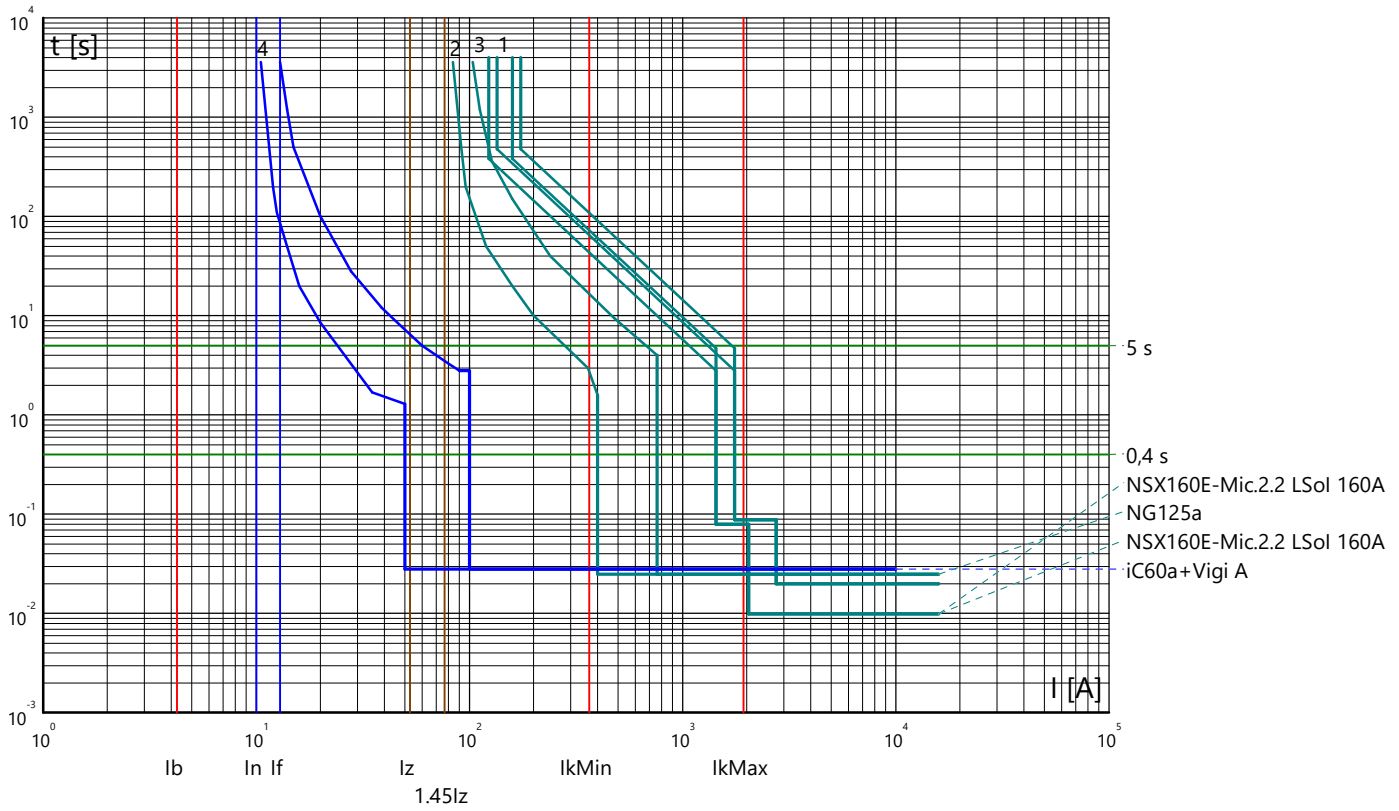

Partenza: 1.27N

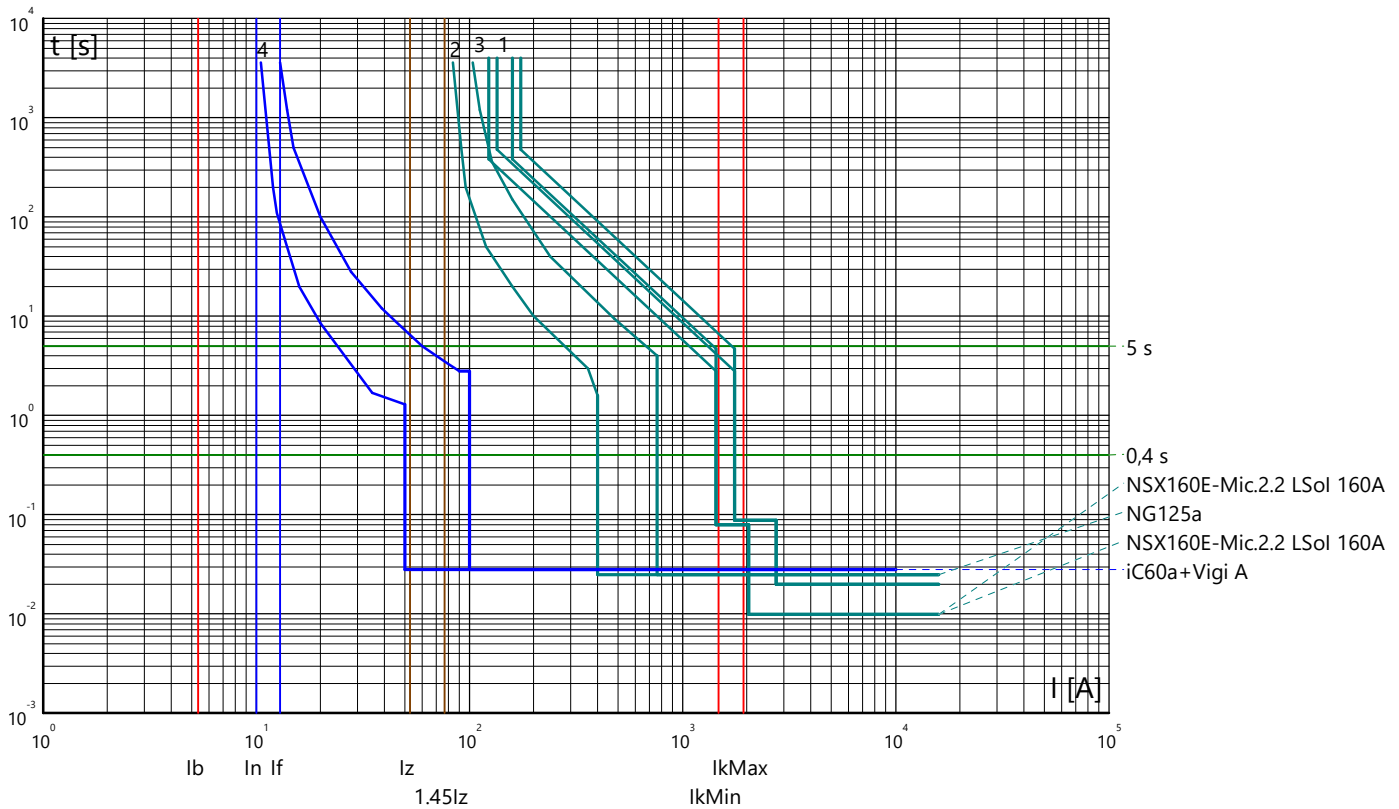

Curve tempo corrente: FERMATA DUGENTA
 Quadro: QUADRO GENERALE B.T.

Partenza: 1.28N

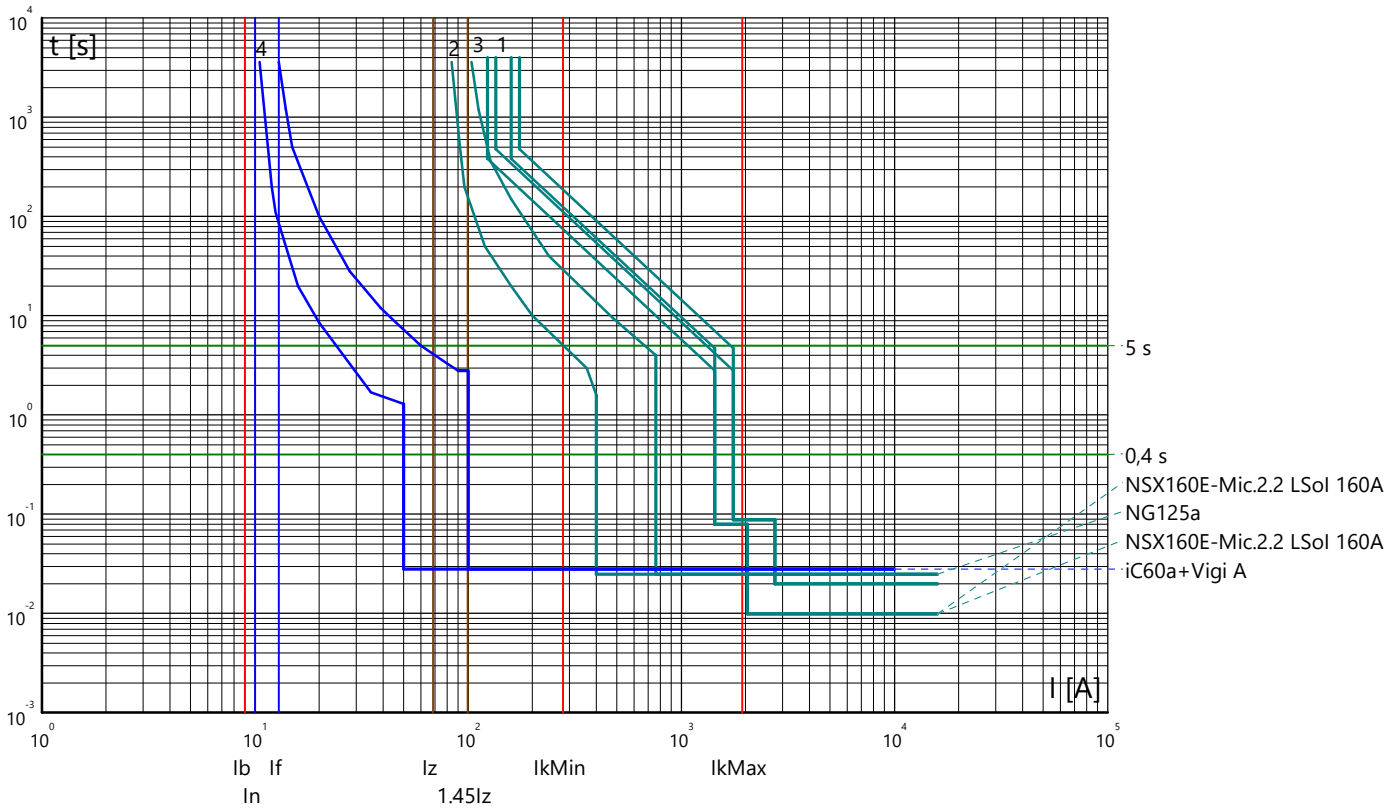

Partenza: 1.29N

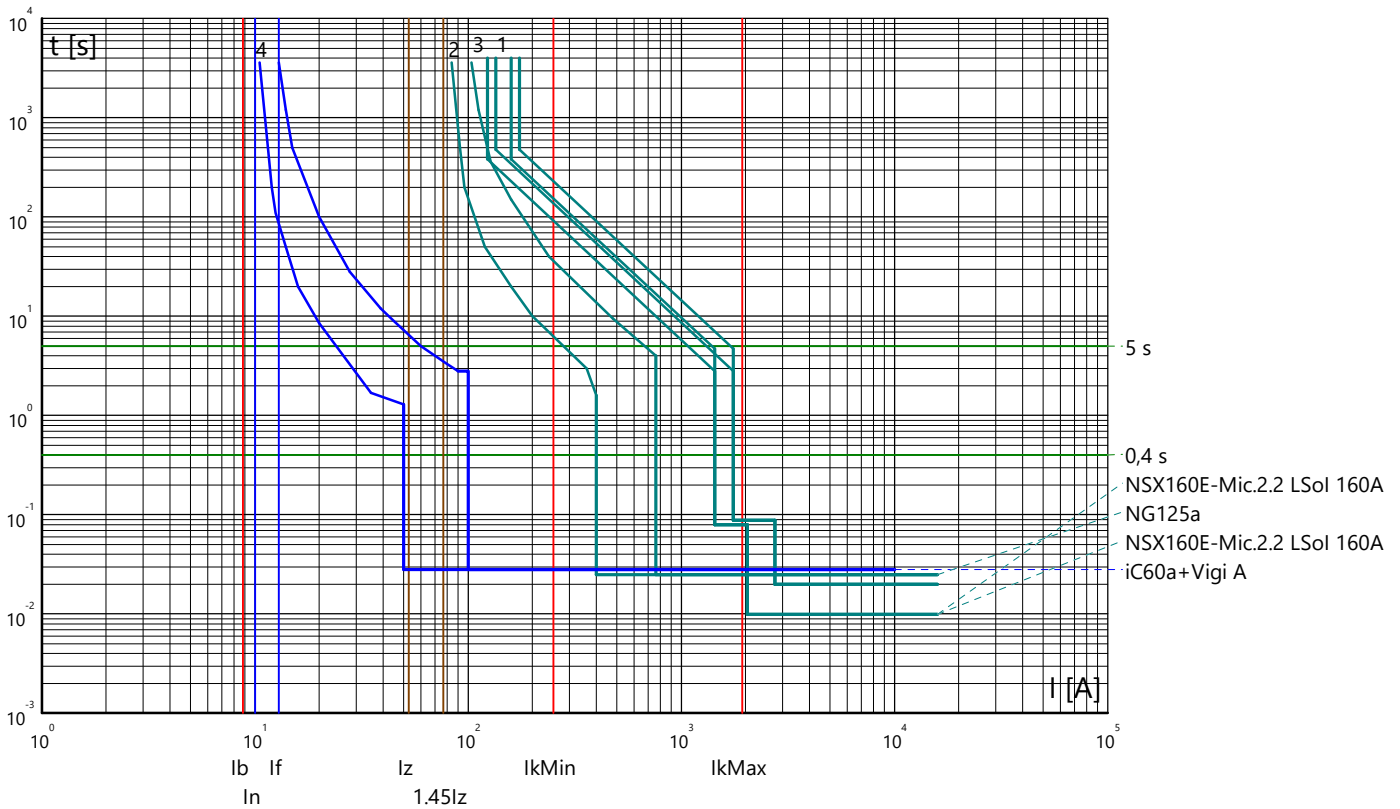

Curve tempo corrente: FERMATA DUGENTA
 Quadro: QUADRO GENERALE B.T.

Partenza: 1.30N

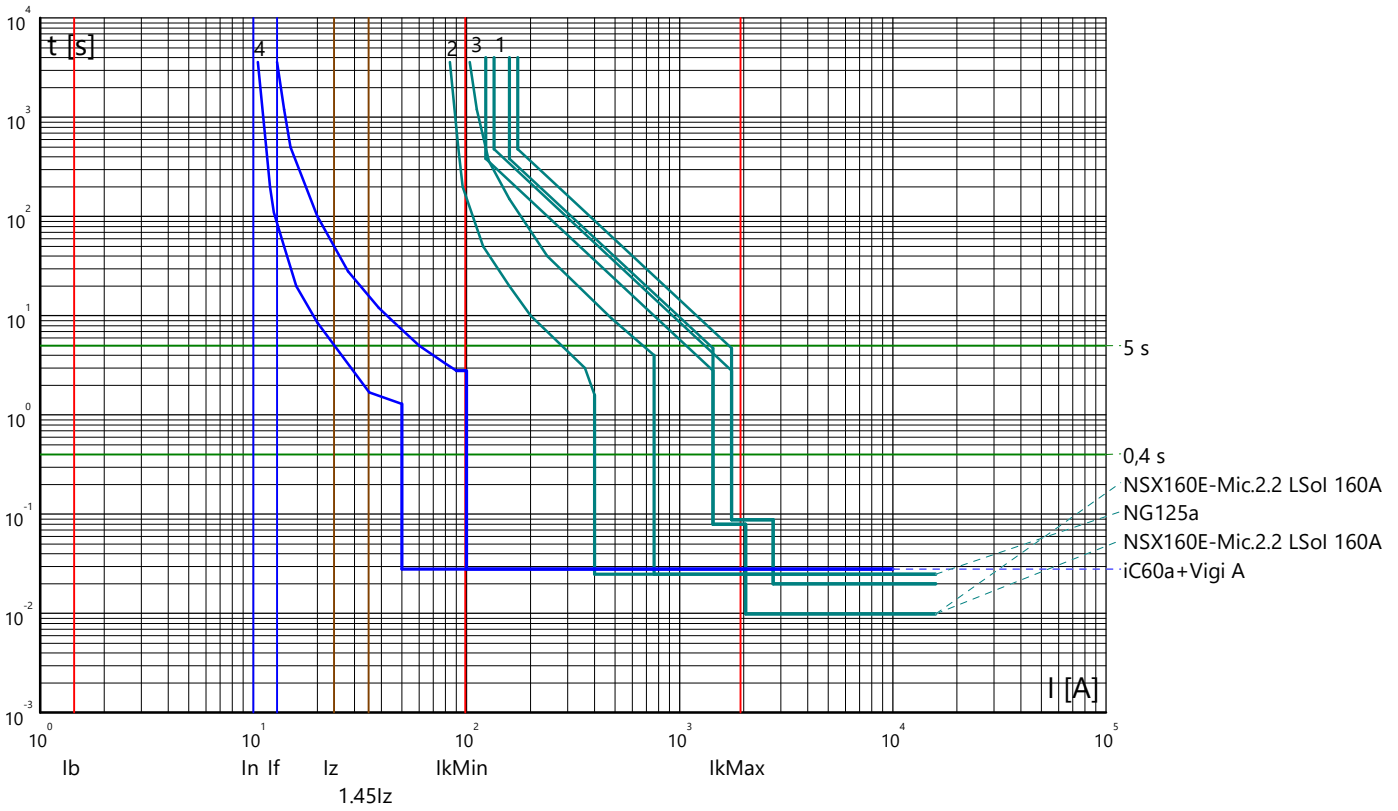

Partenza: 1.31N

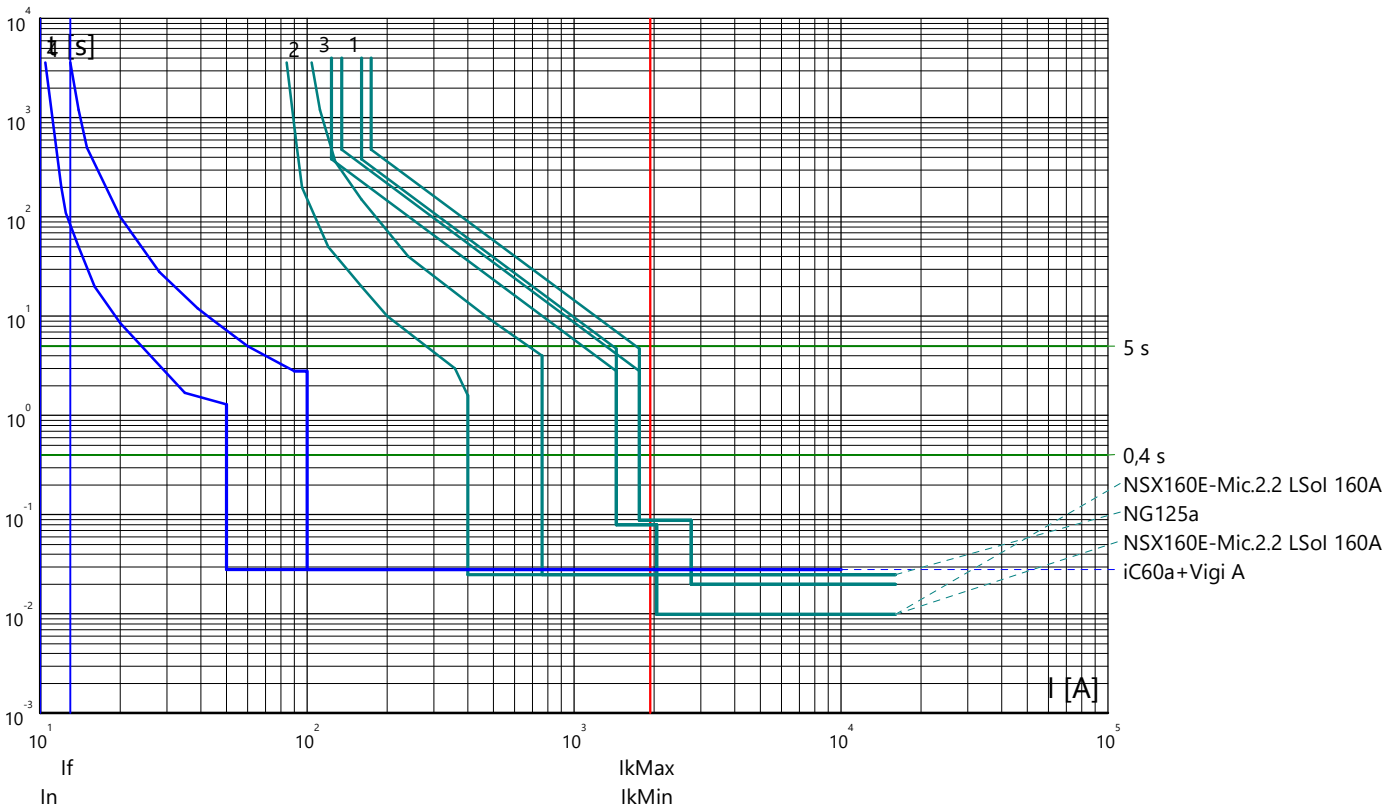

Curve tempo corrente: FERMATA DUGENTA
 Quadro: QUADRO GENERALE B.T.

Partenza: 1.32N

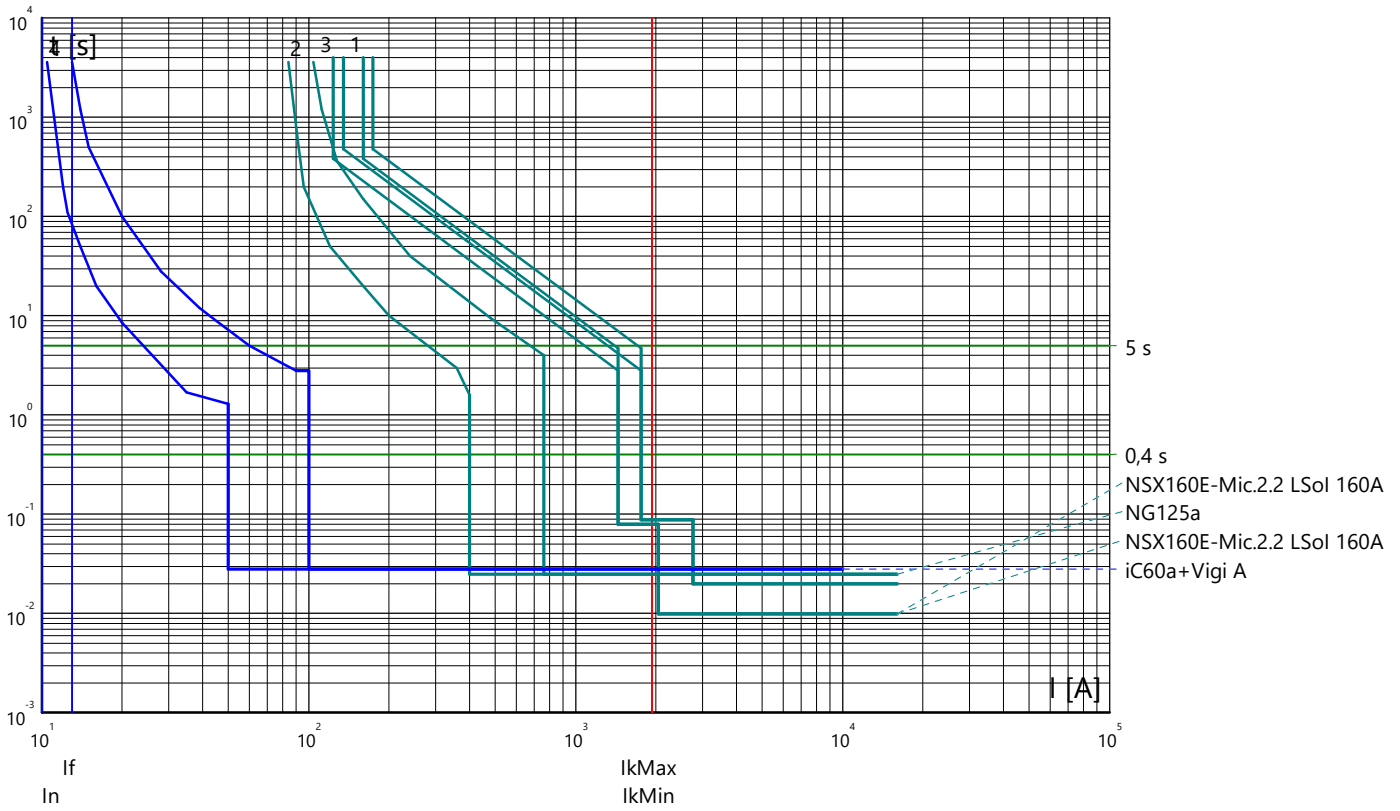

Partenza: 1.33N

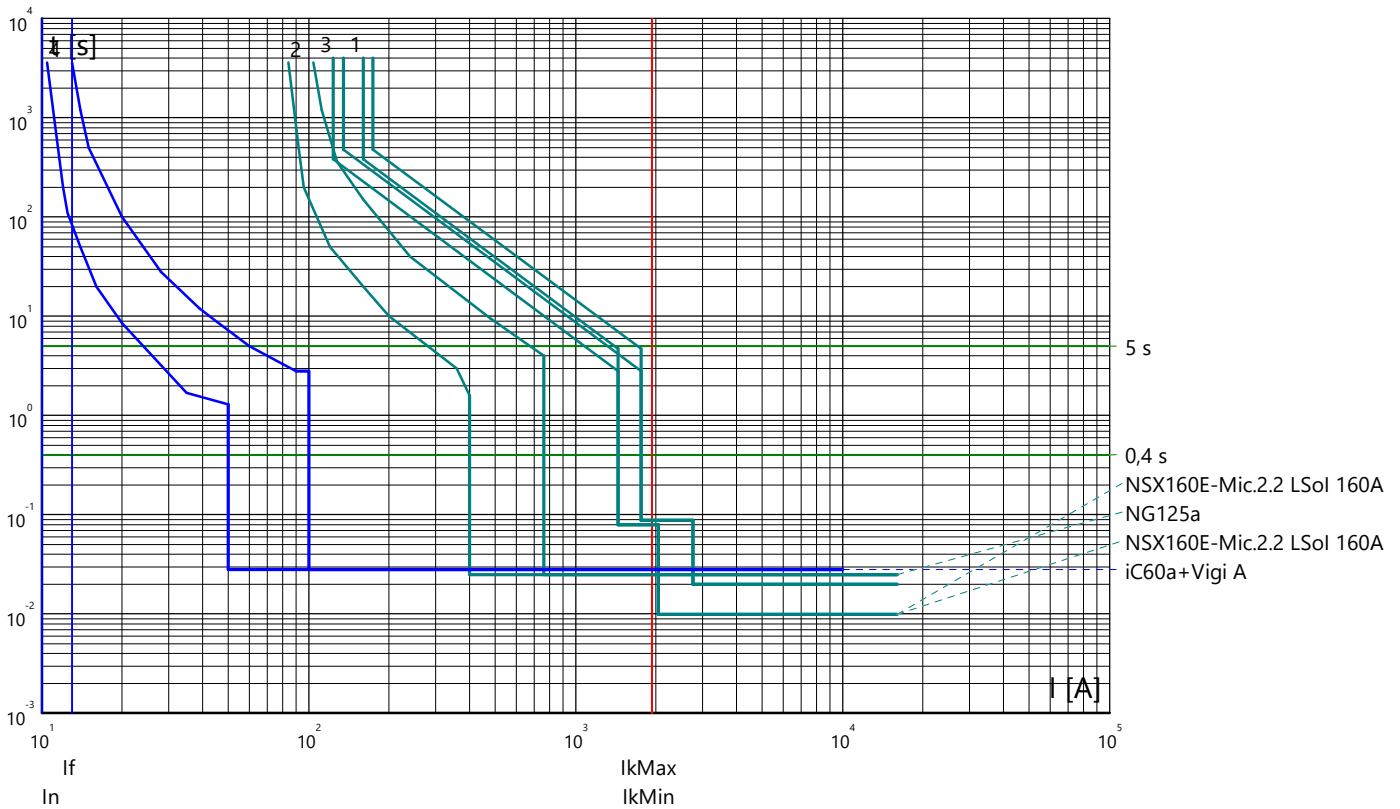

Curve tempo corrente: FERMATA DUGENTA
 Quadro: QUADRO SIAP

Arrivo: 0.0

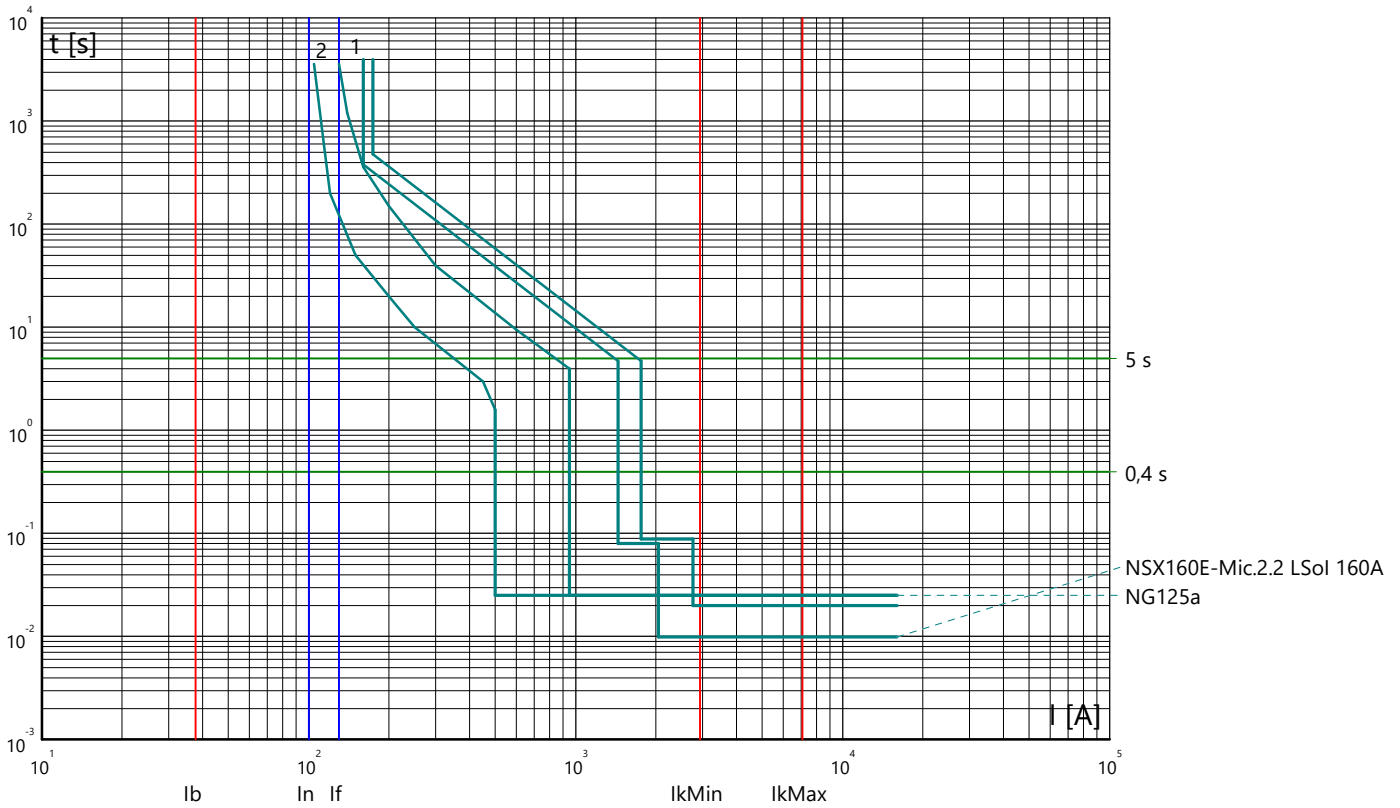

Partenza: 1.0P

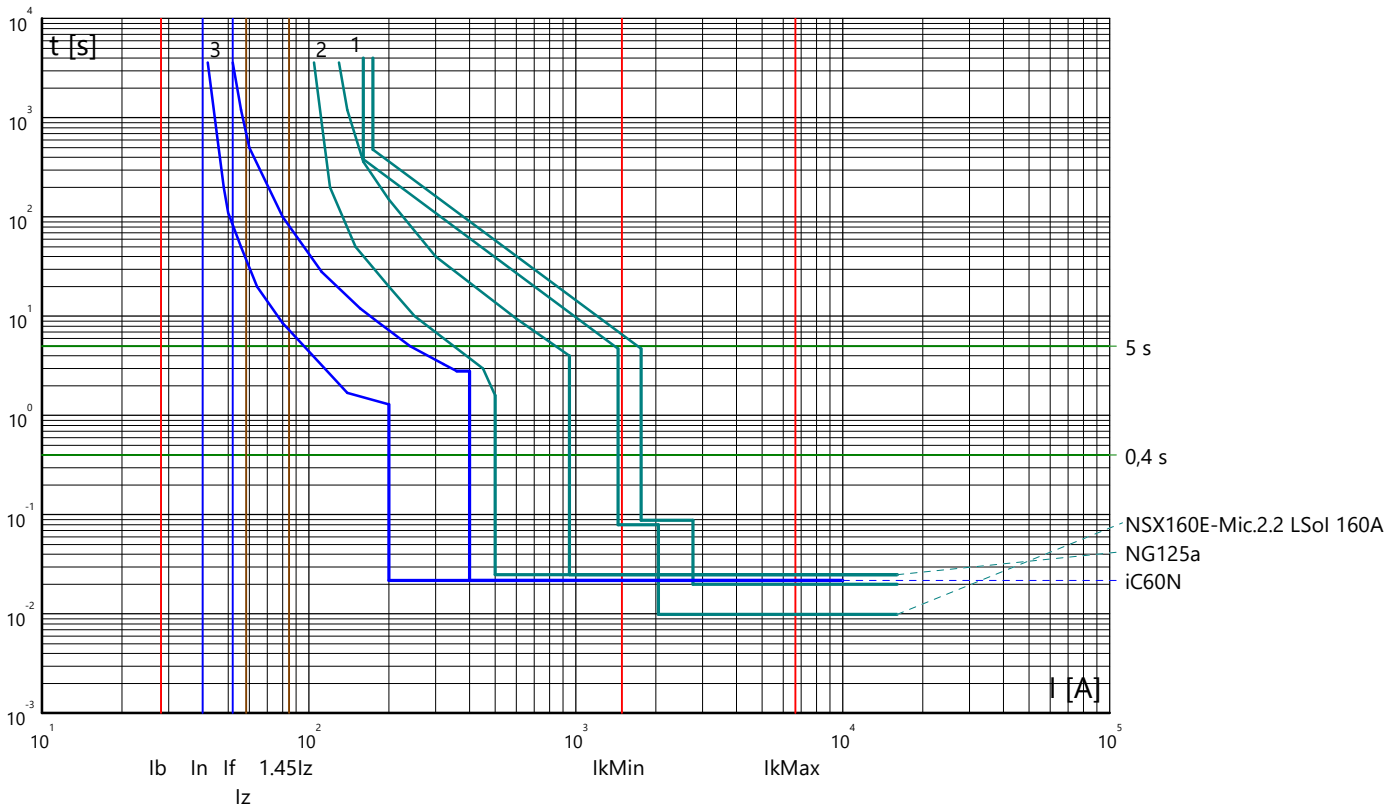

Curve tempo corrente: FERMATA DUGENTA
 Quadro: QUADRO SIAP

Partenza: 1.0S

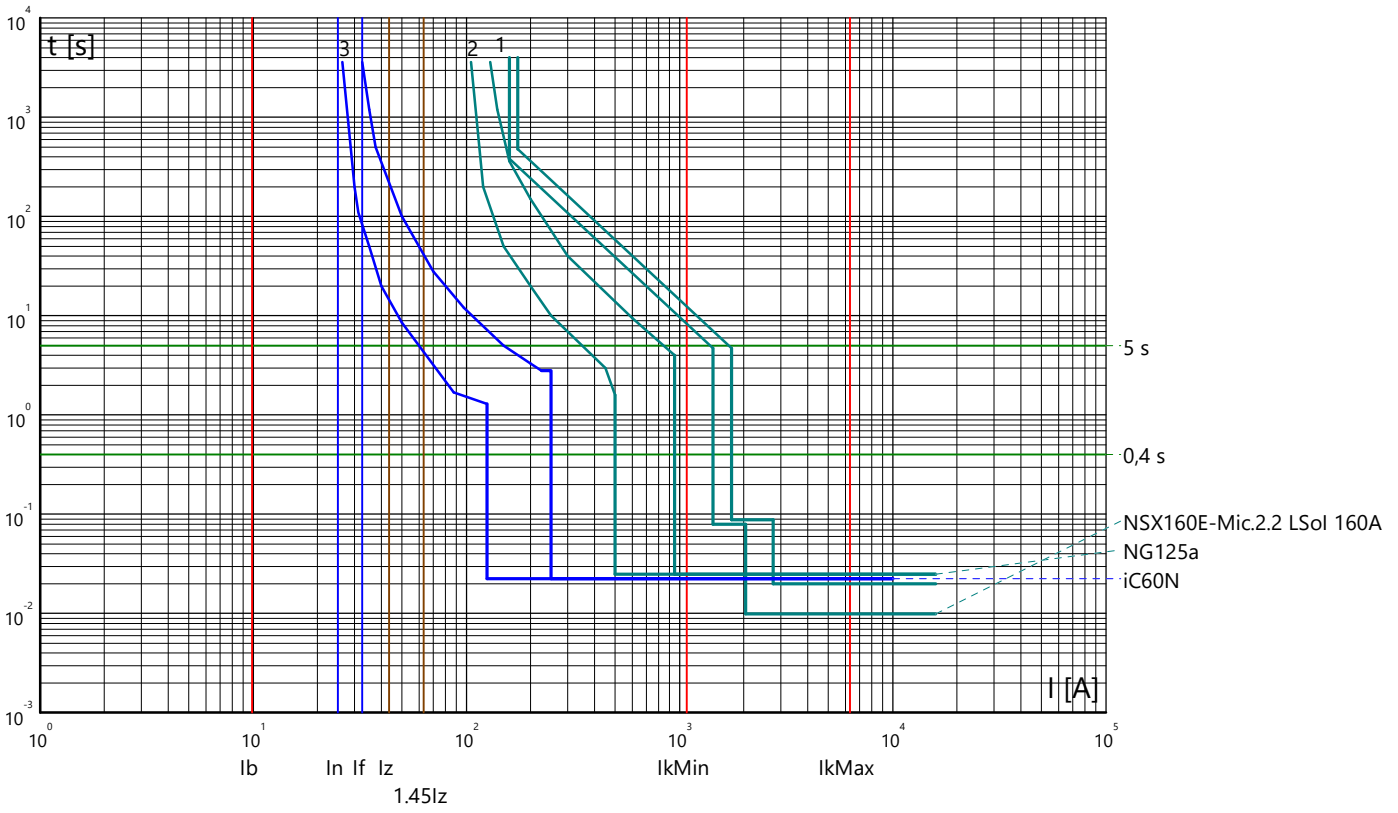

Curve tempo corrente: FERMATA DUGENTA
 Quadro: QUADRO GENERALE B.T.

Arrivo: IGP

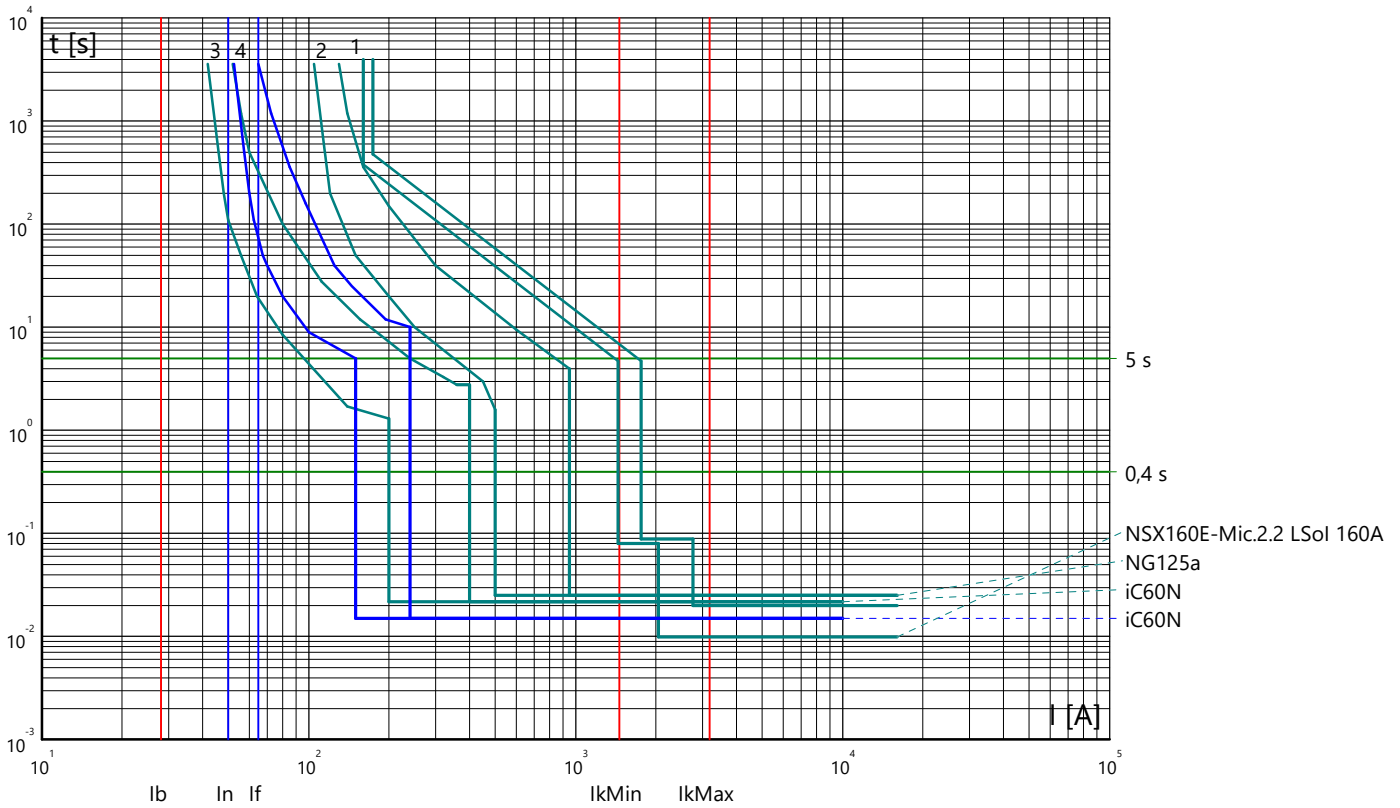

Partenza: PT

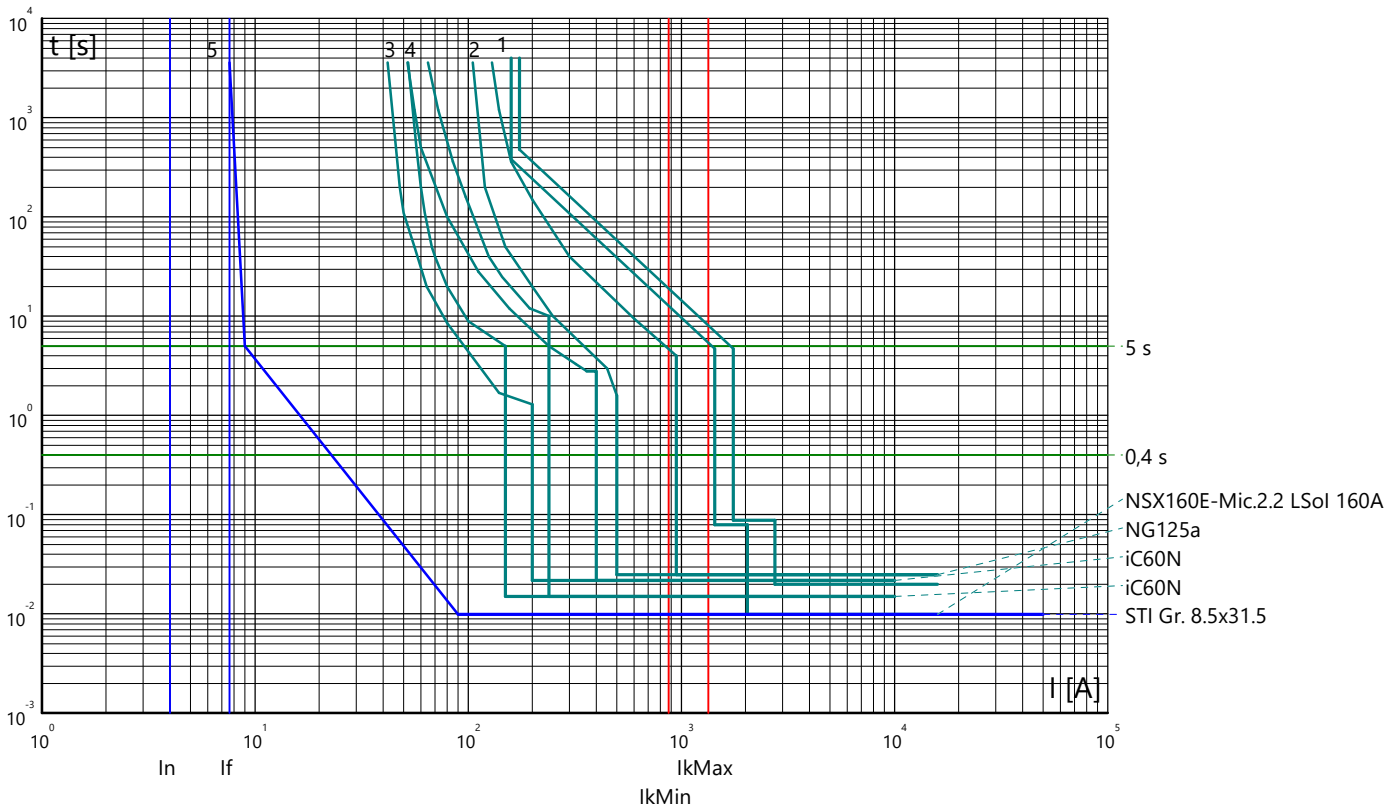

Curve tempo corrente: FERMATA DUGENTA
 Quadro: QUADRO GENERALE B.T.

Partenza: MIS

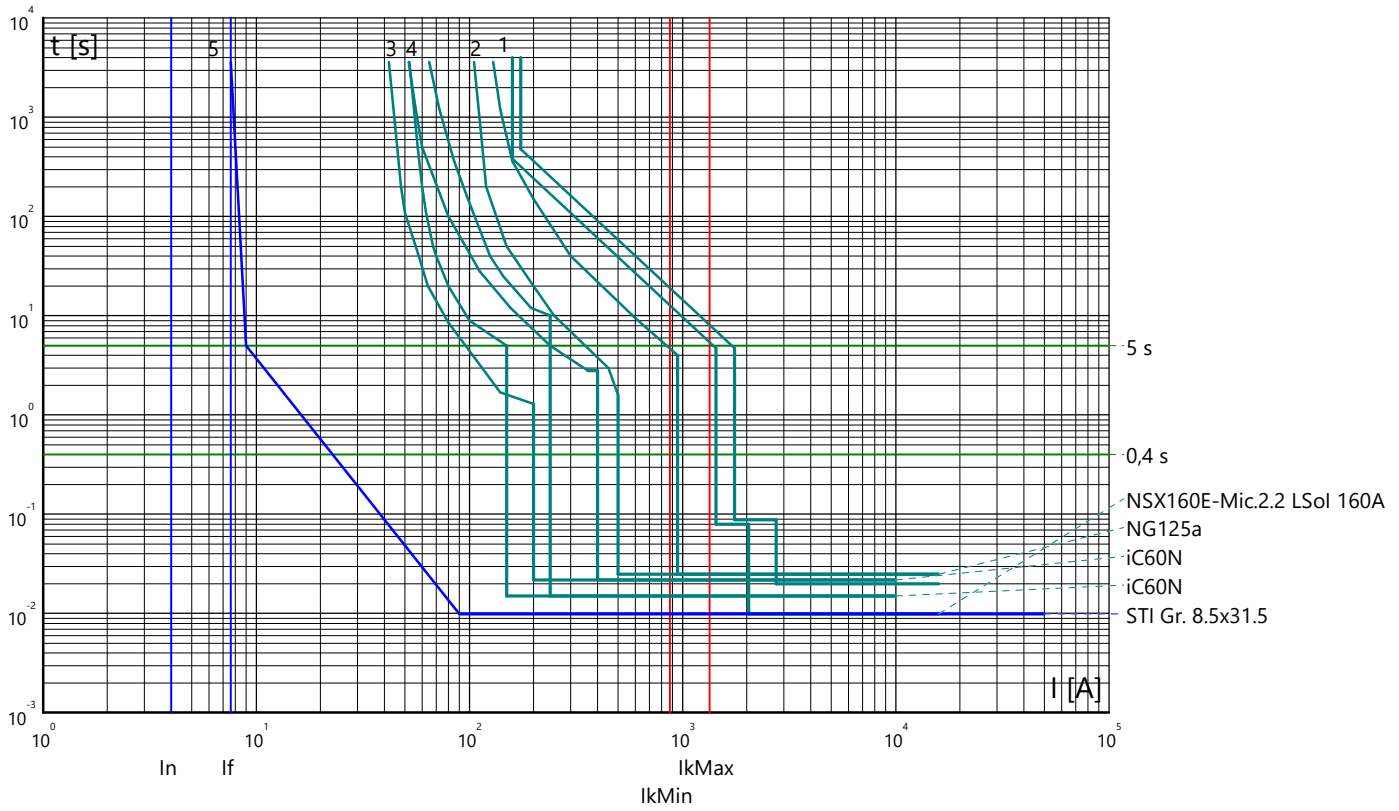

Partenza: 1.1P

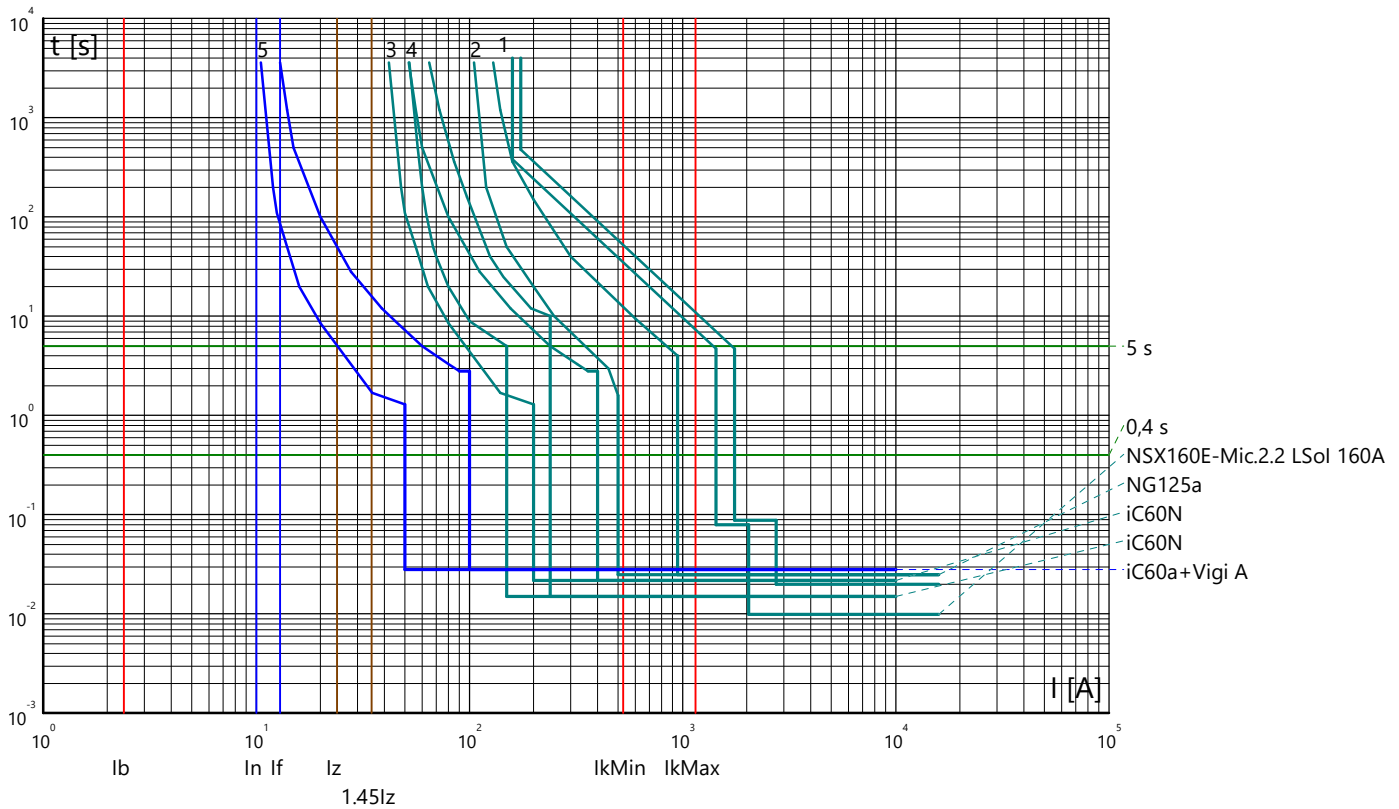

Curve tempo corrente: FERMATA DUGENTA
 Quadro: QUADRO GENERALE B.T.

Partenza: 1.2P

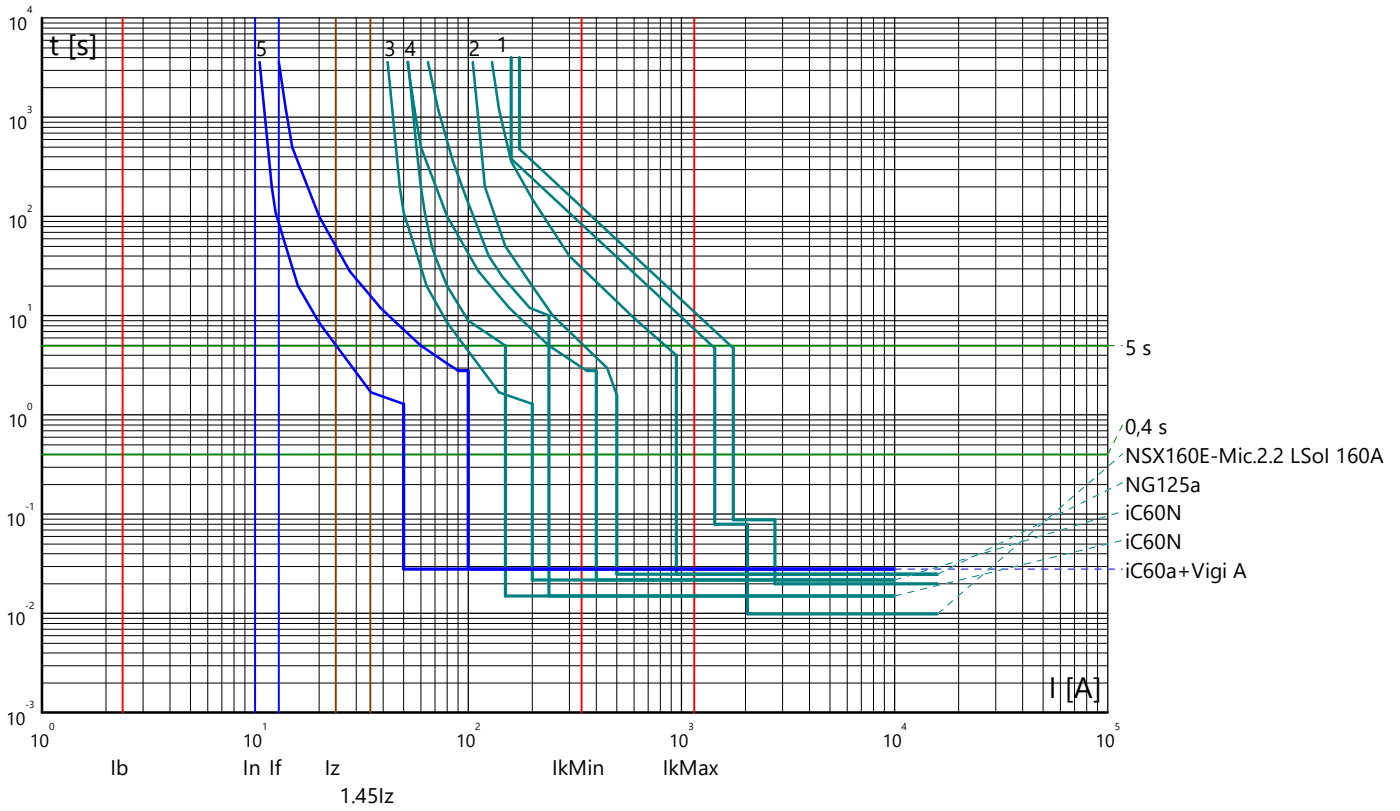

Partenza: 1.3P

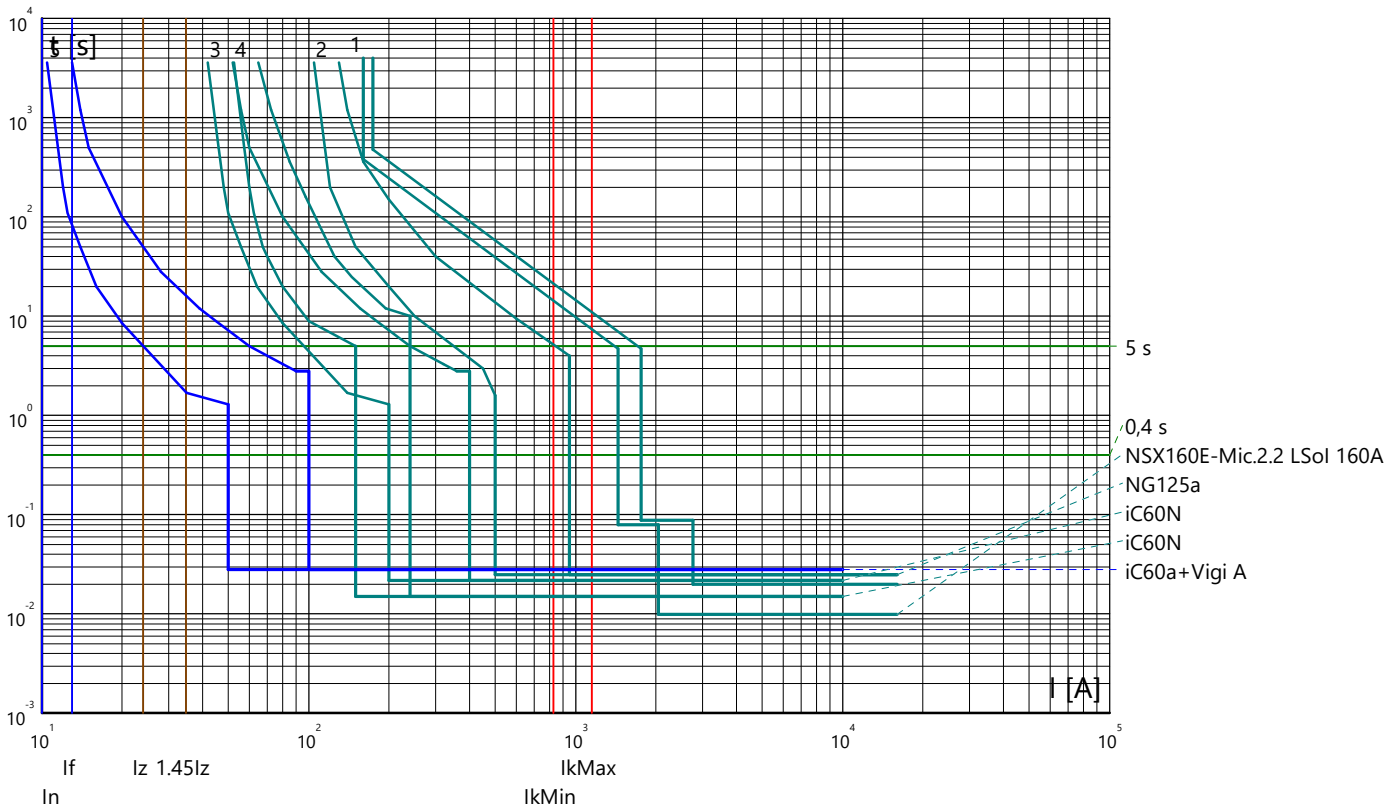

Curve tempo corrente: FERMATA DUGENTA
 Quadro: QUADRO GENERALE B.T.

Partenza: 1.4P

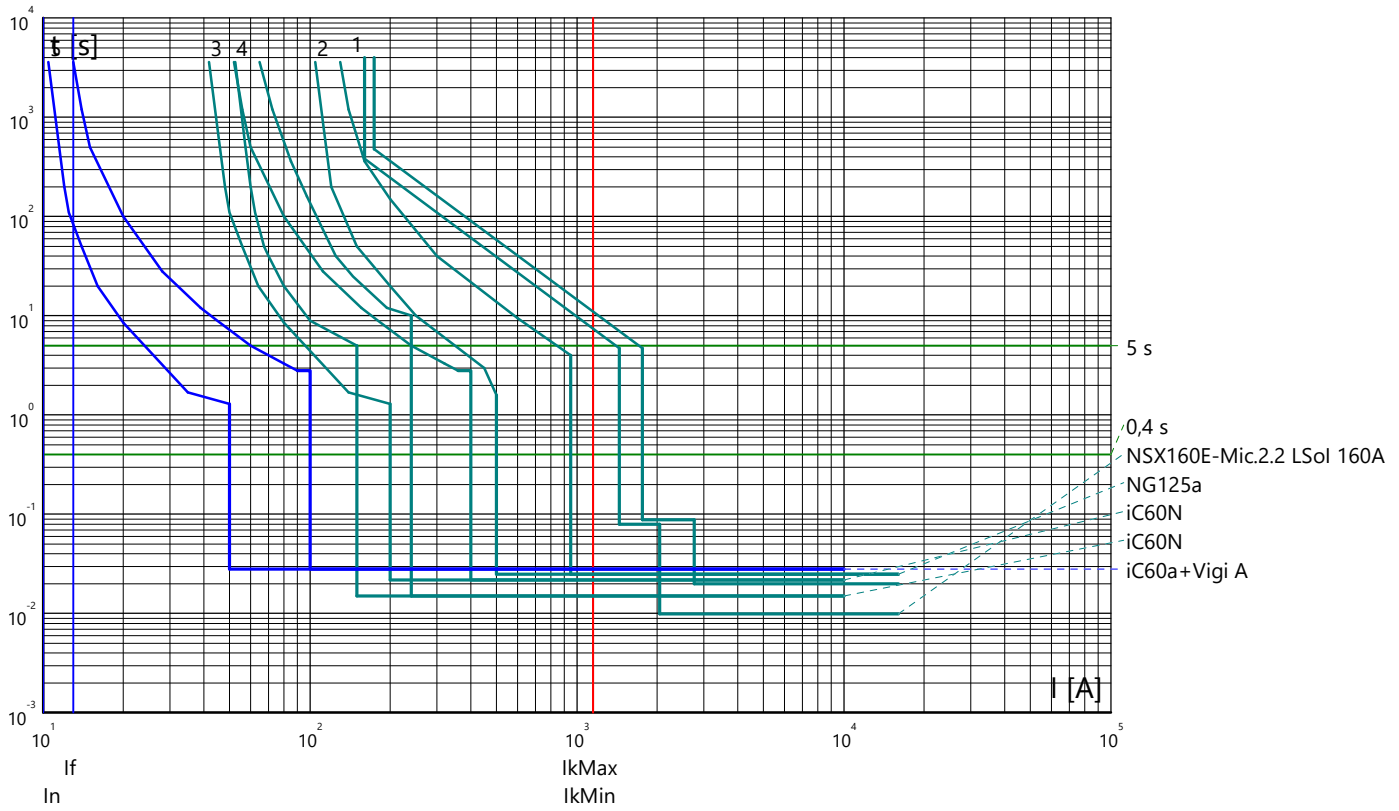

Partenza: 1.5P

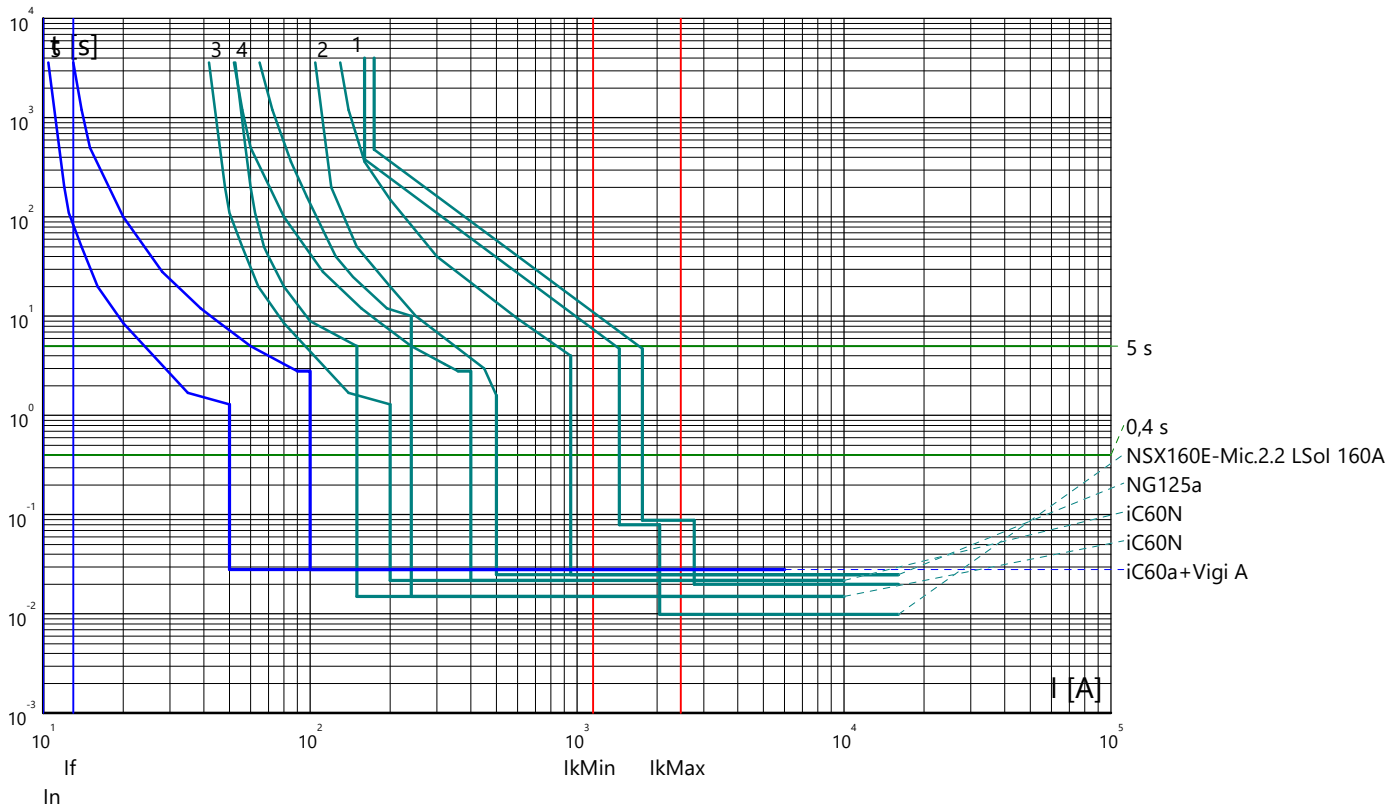

Curve tempo corrente: FERMATA DUGENTA
 Quadro: QUADRO GENERALE B.T.

Partenza: 1.6P

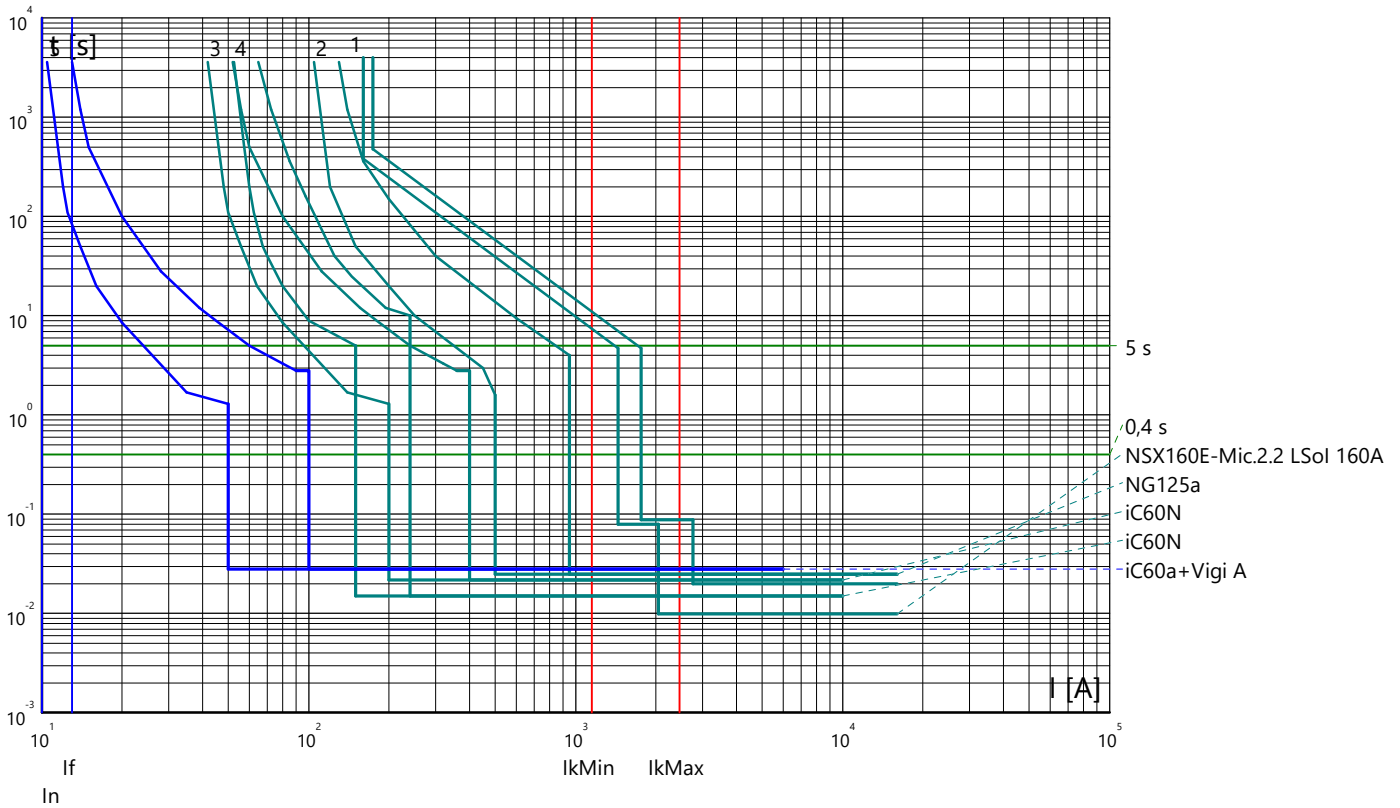

Partenza: 1.7P

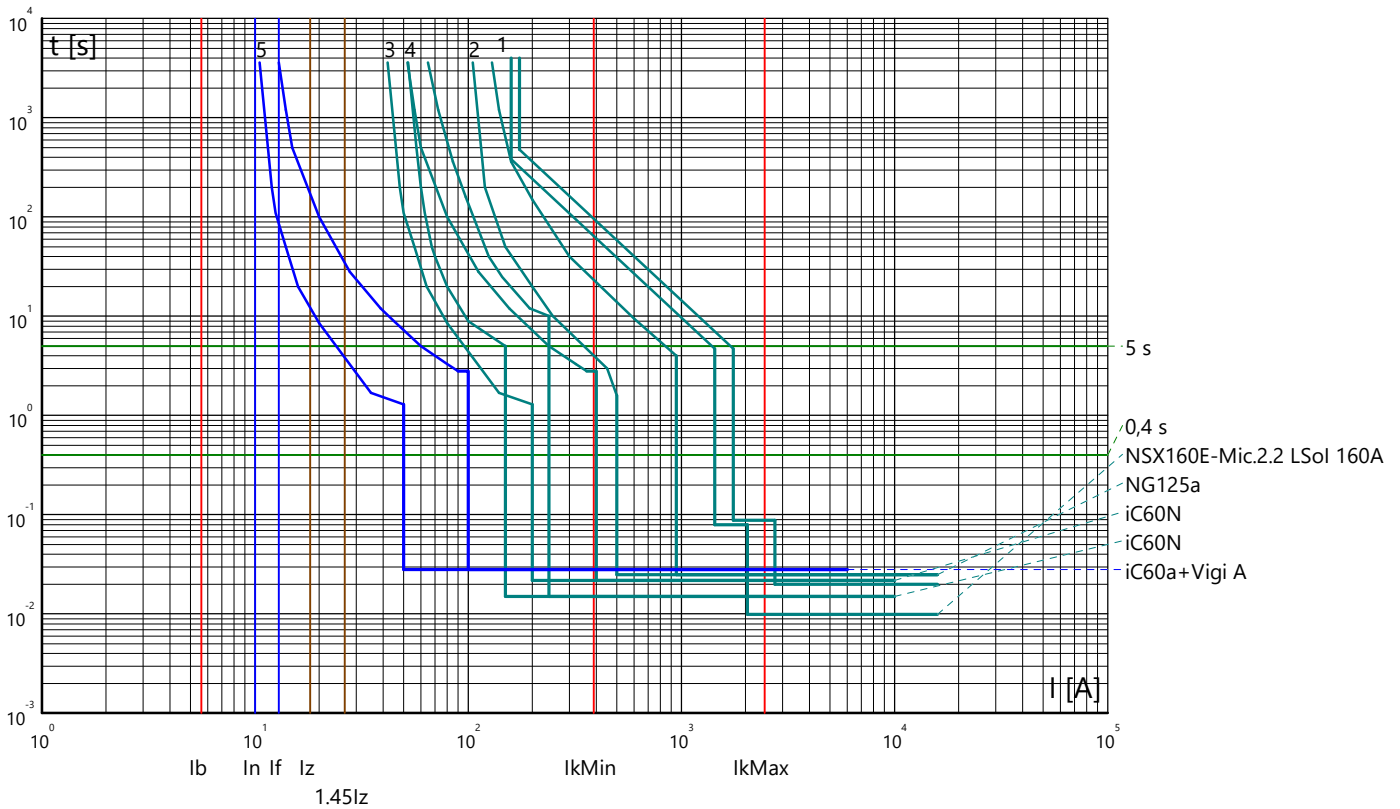

Curve tempo corrente: FERMATA DUGENTA
 Quadro: QUADRO GENERALE B.T.

Partenza: 1.8P

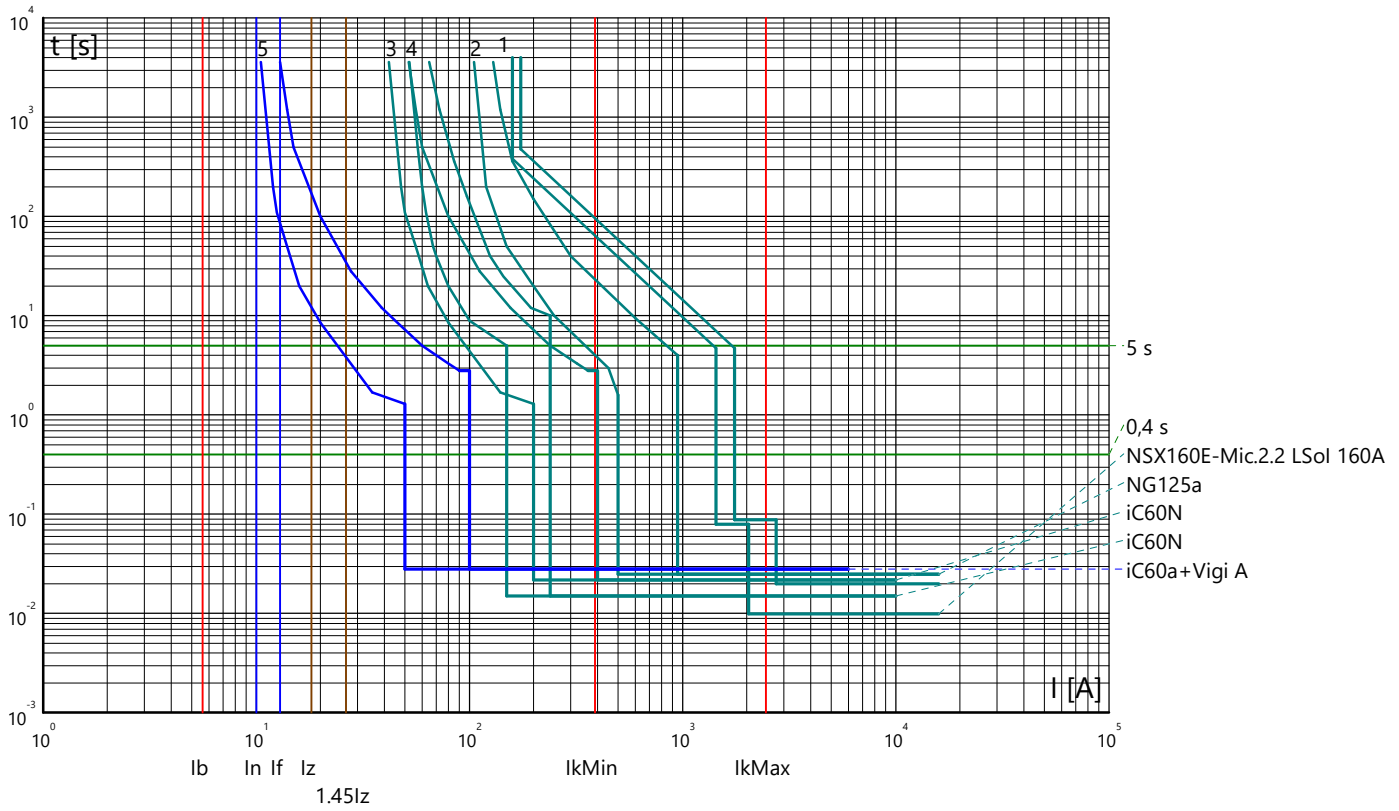

Partenza: 1.9P

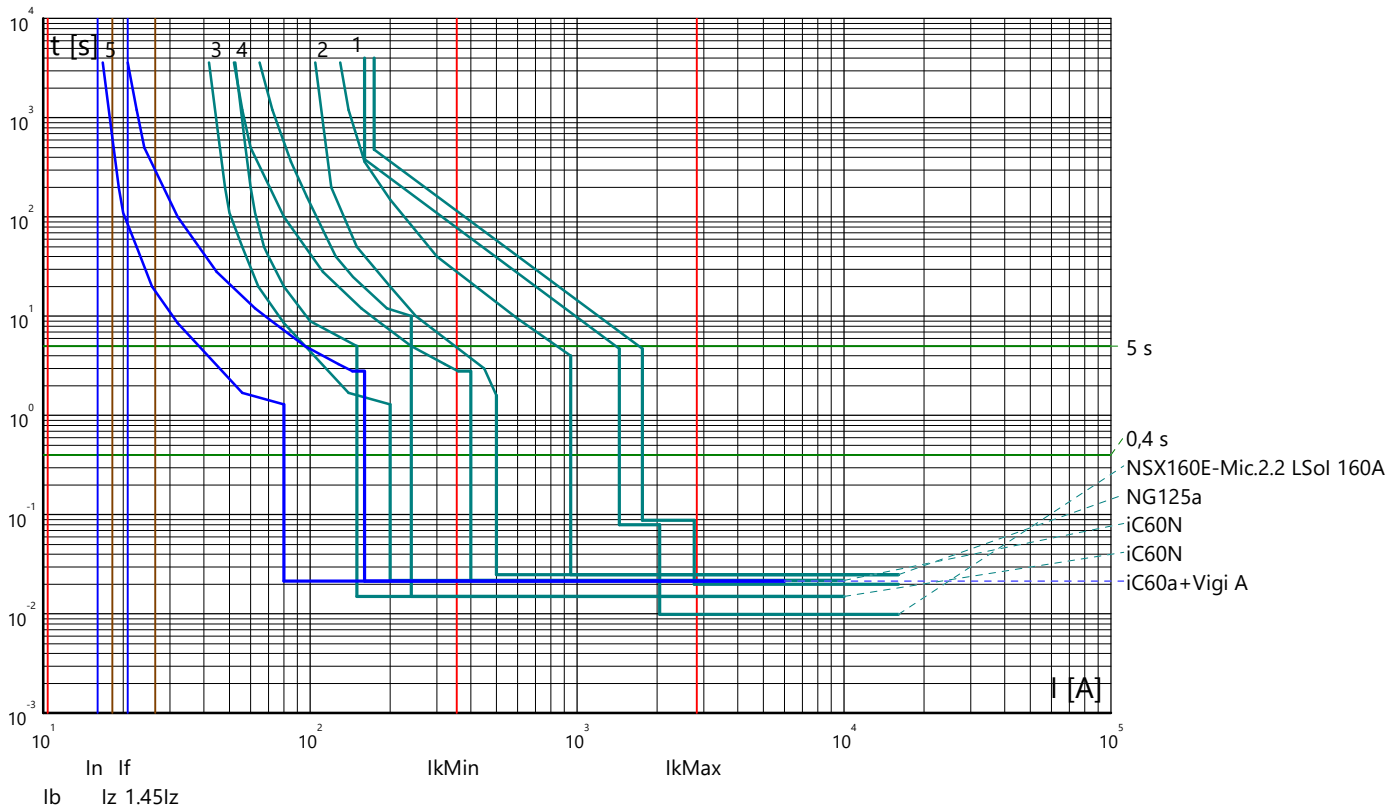

Curve tempo corrente: FERMATA DUGENTA
 Quadro: QUADRO GENERALE B.T.

Partenza: 1.10P

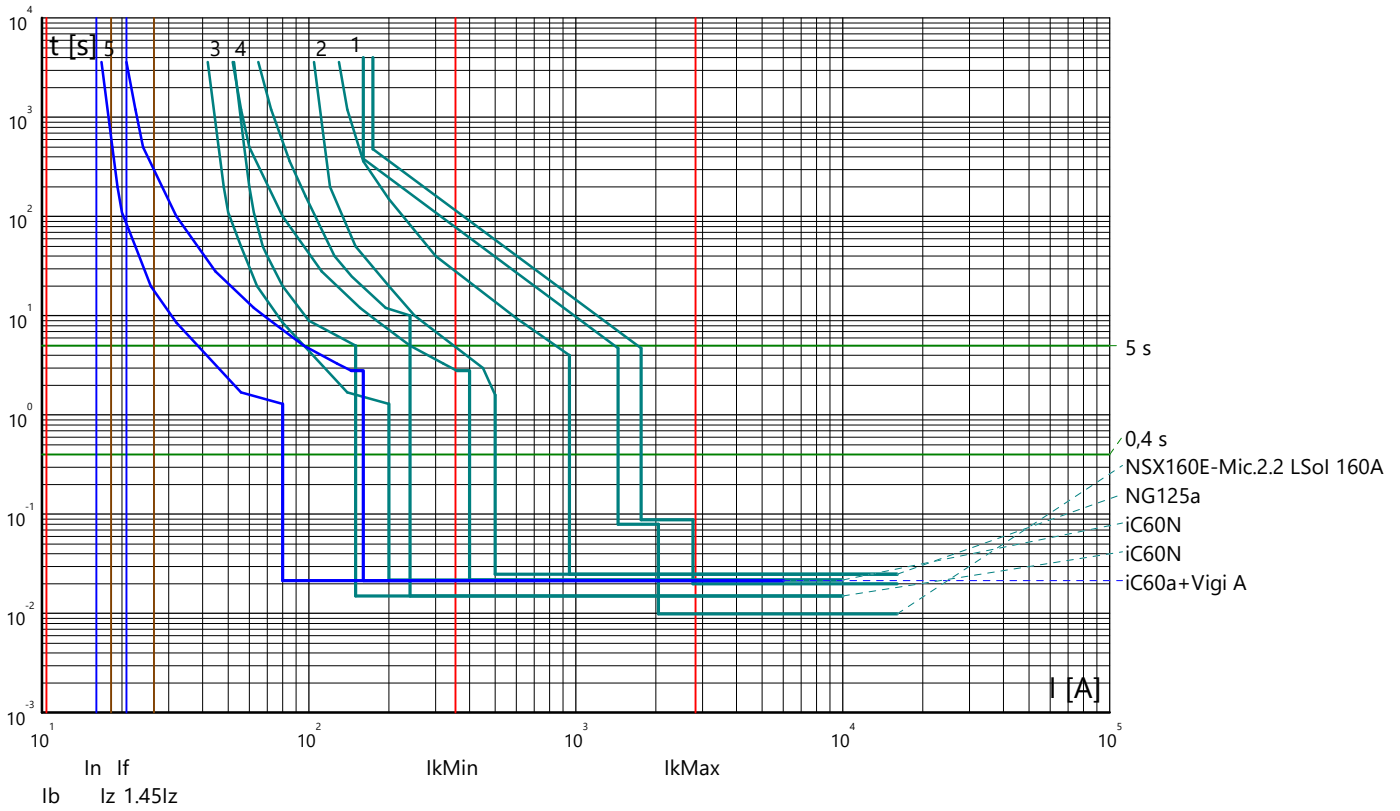

Partenza: 1.11P

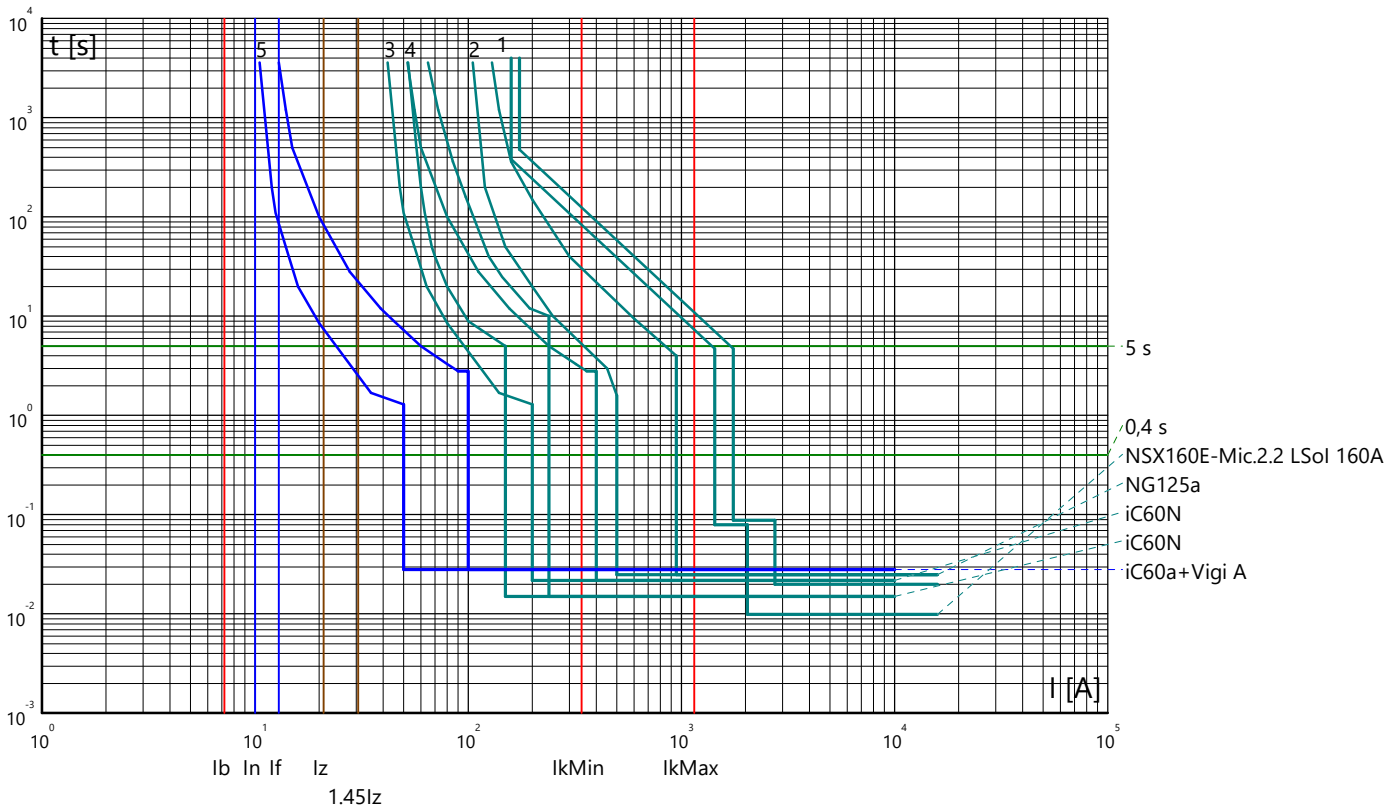

Curve tempo corrente: FERMATA DUGENTA
 Quadro: QUADRO GENERALE B.T.

Partenza: 1.12P

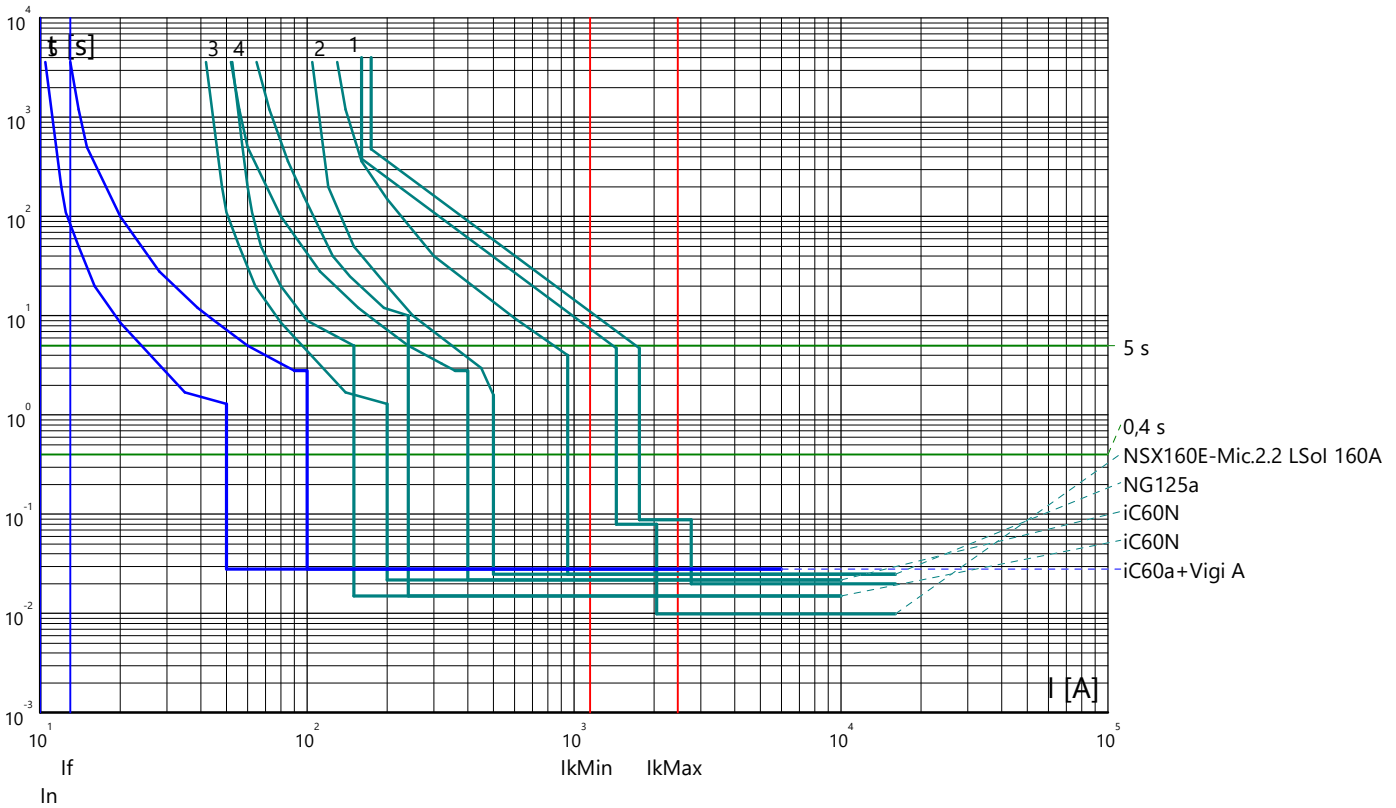

Partenza: 1.13P

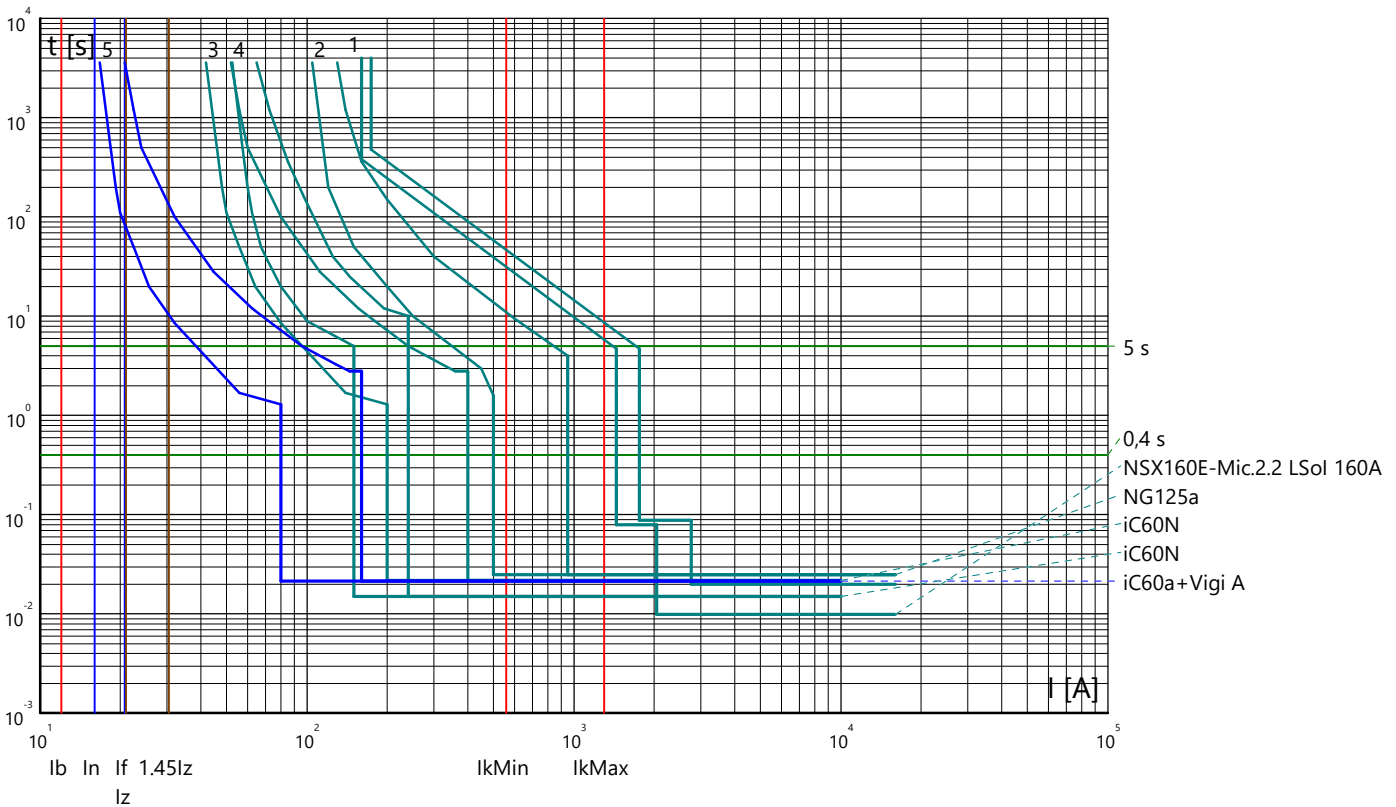

Curve tempo corrente: FERMATA DUGENTA
 Quadro: QUADRO GENERALE B.T.

Partenza: 1.14P

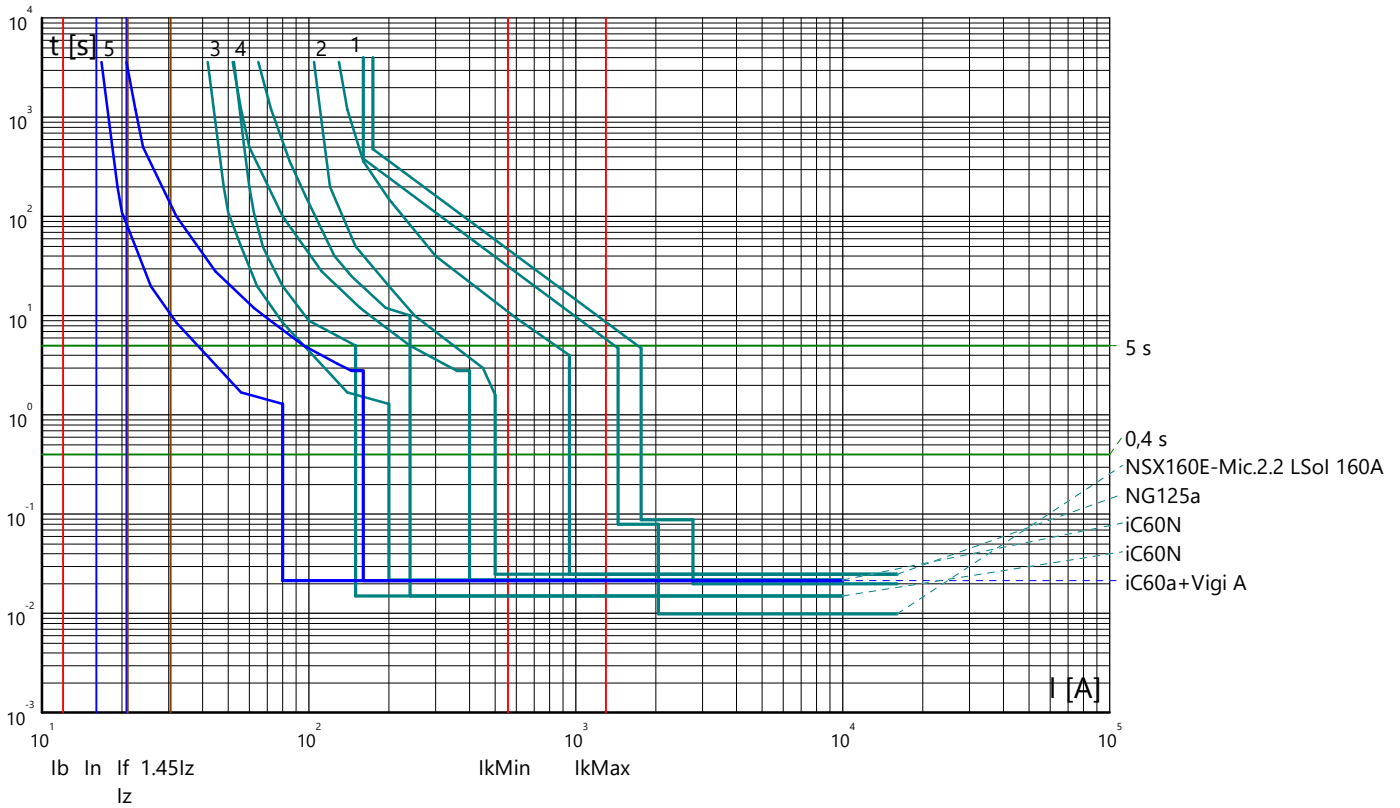

Partenza: 1.15P

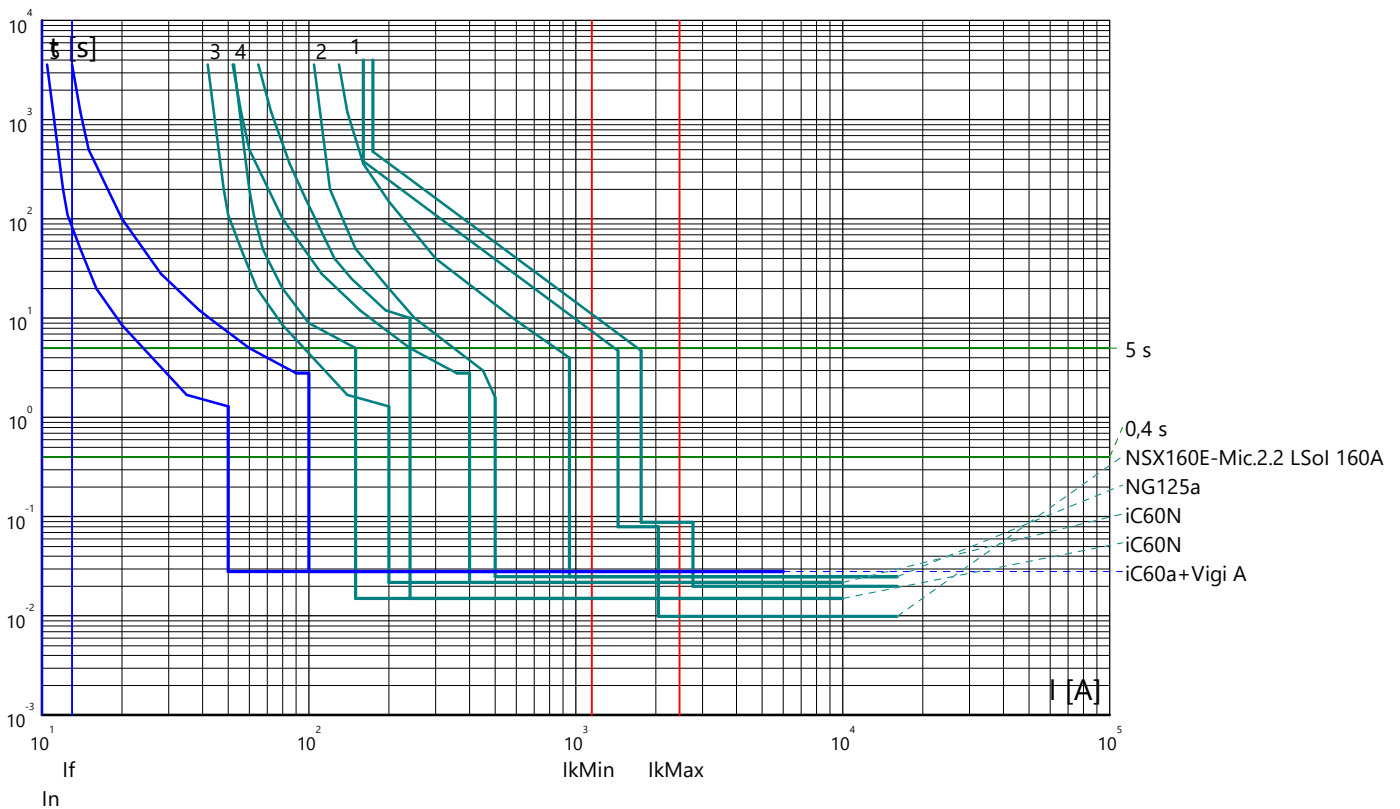

Curve tempo corrente: FERMATA DUGENTA
 Quadro: QUADRO GENERALE B.T.

Partenza: 1.16P

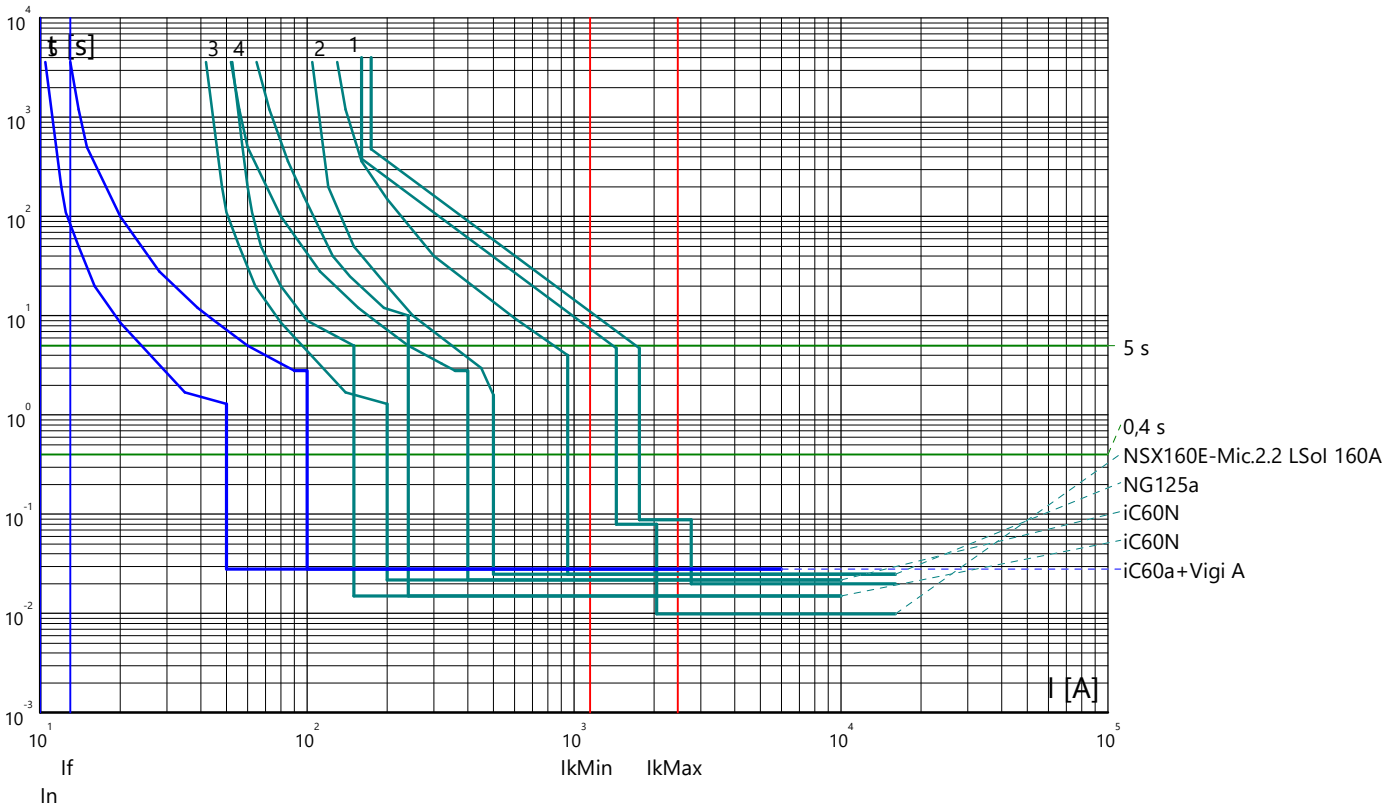

Partenza: 1.17P

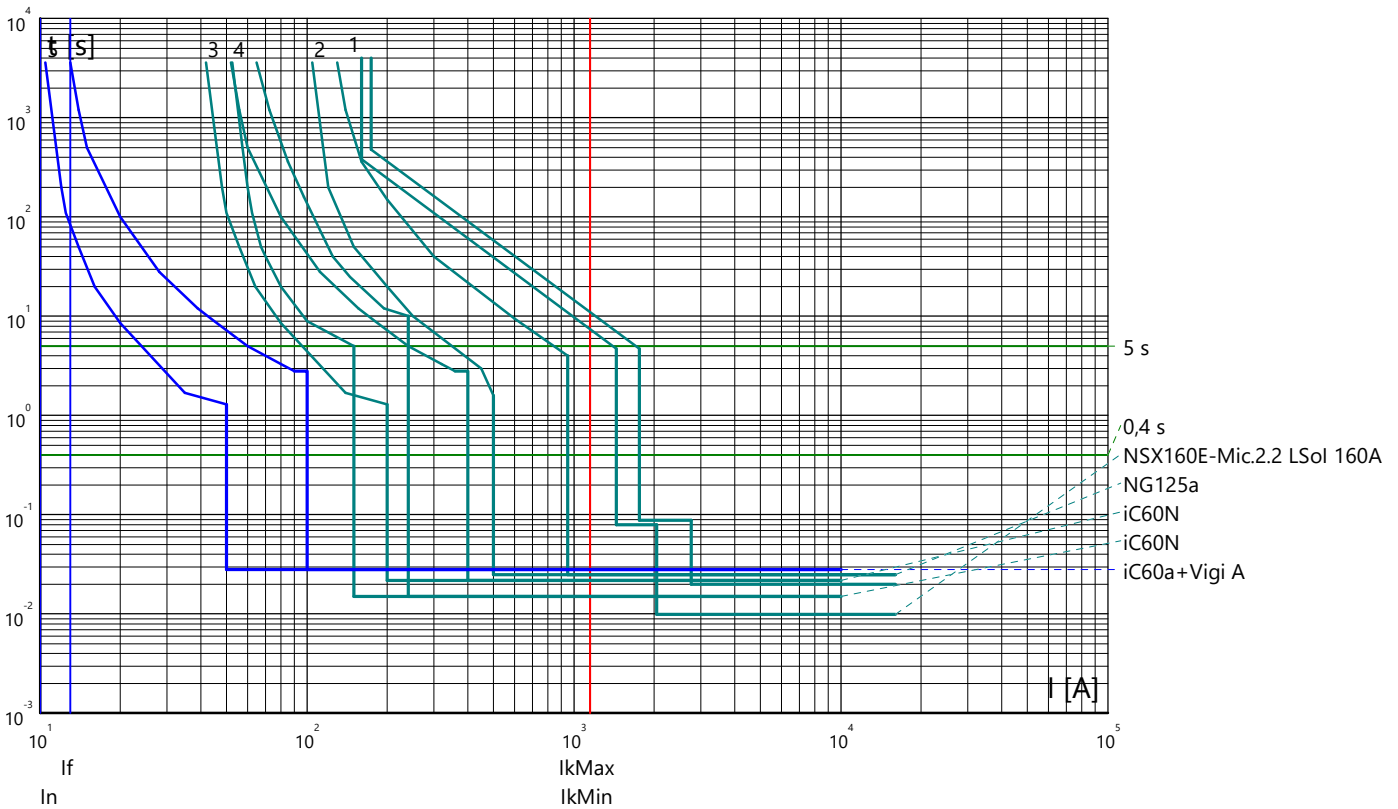

Curve tempo corrente: FERMATA DUGENTA
 Quadro: QUADRO GENERALE B.T.

Partenza: 1.18P

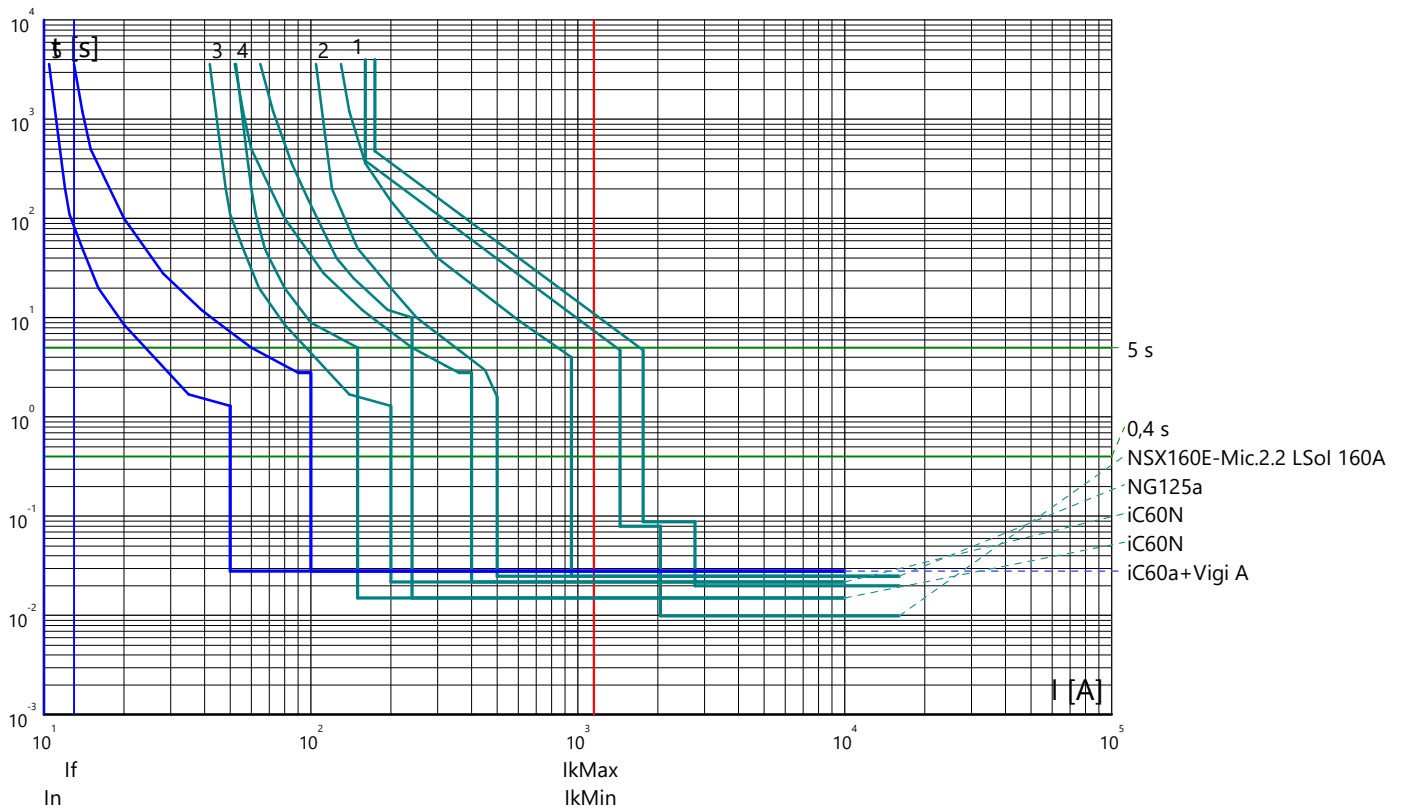

Partenza: 1.19P

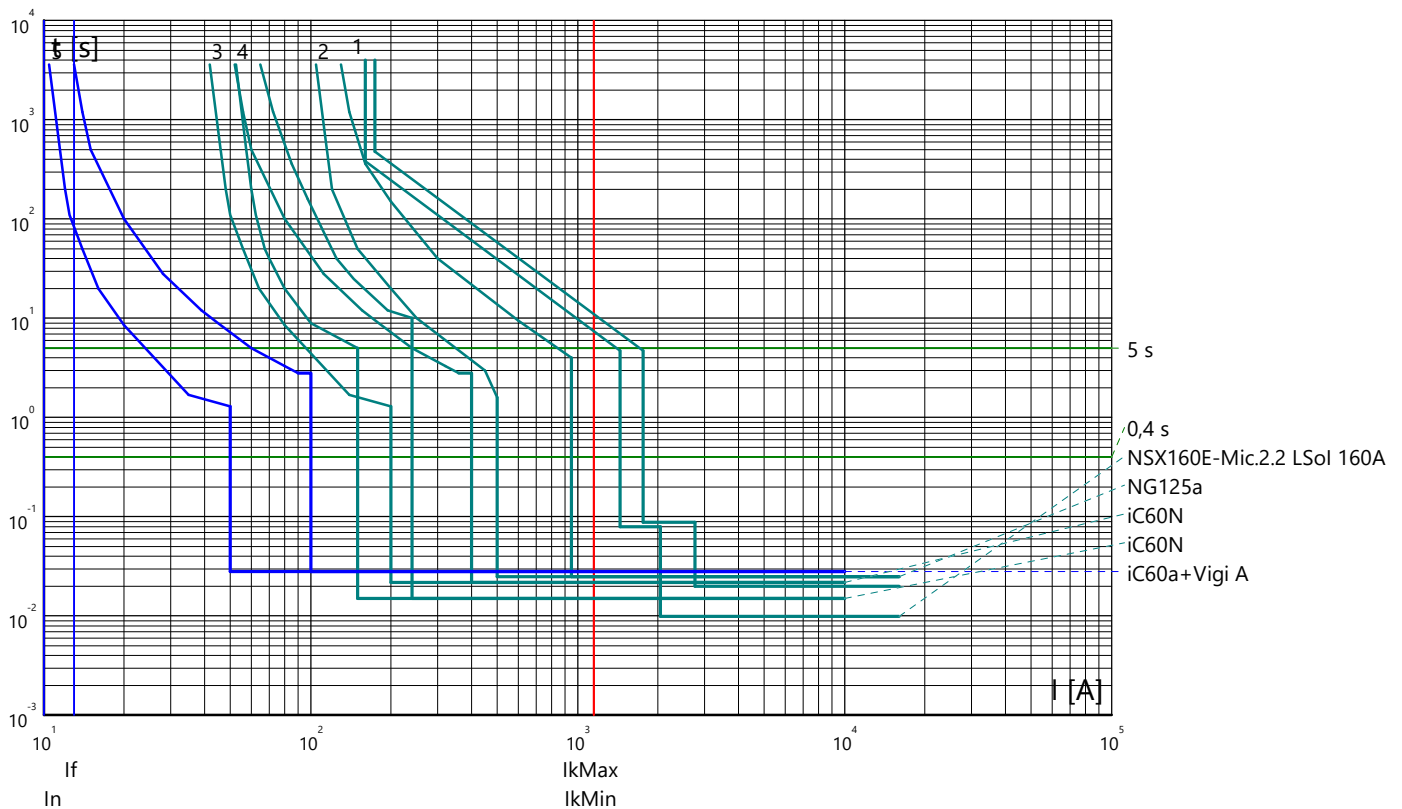

Curve tempo corrente: FERMATA DUGENTA
 Quadro: QUADRO GENERALE B.T.

Partenza: S1.P

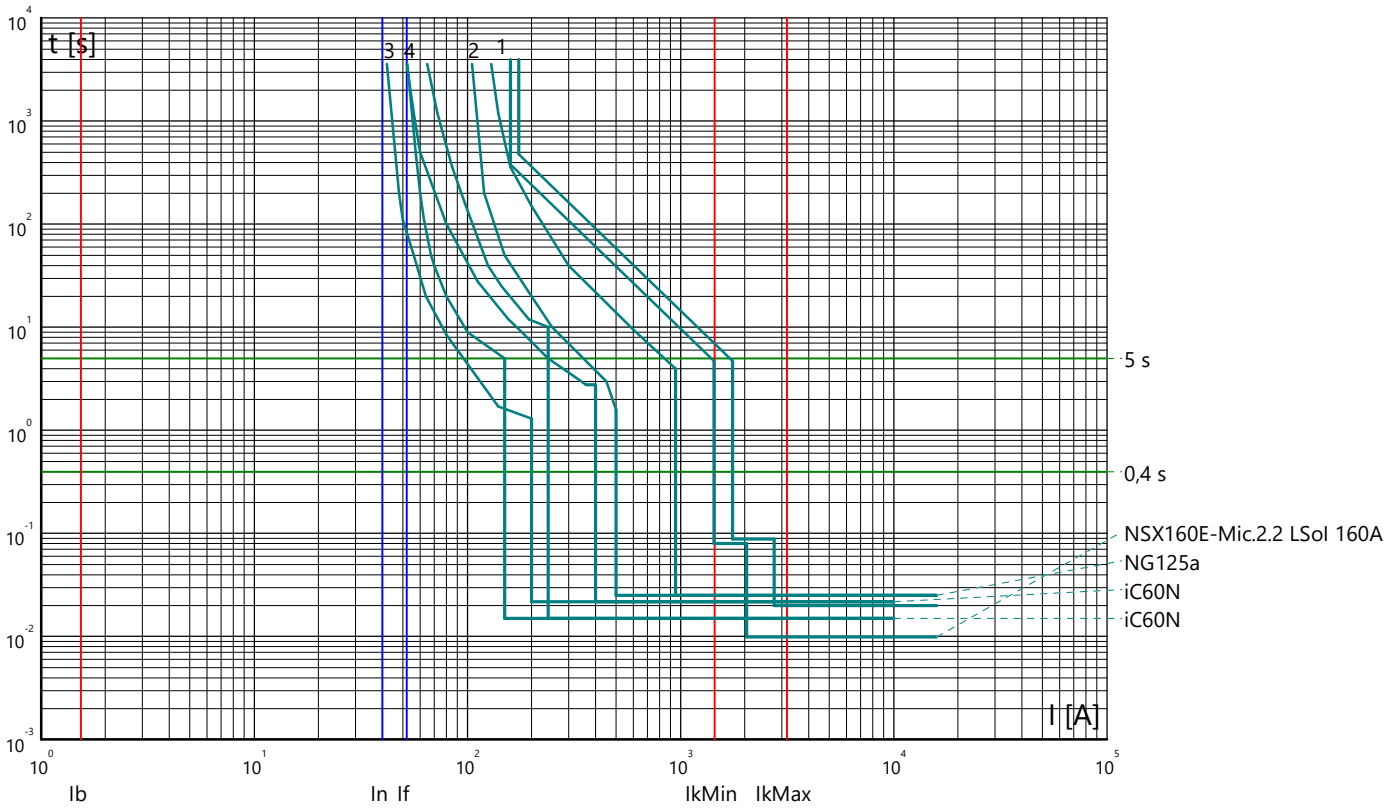

Partenza: 1.20P

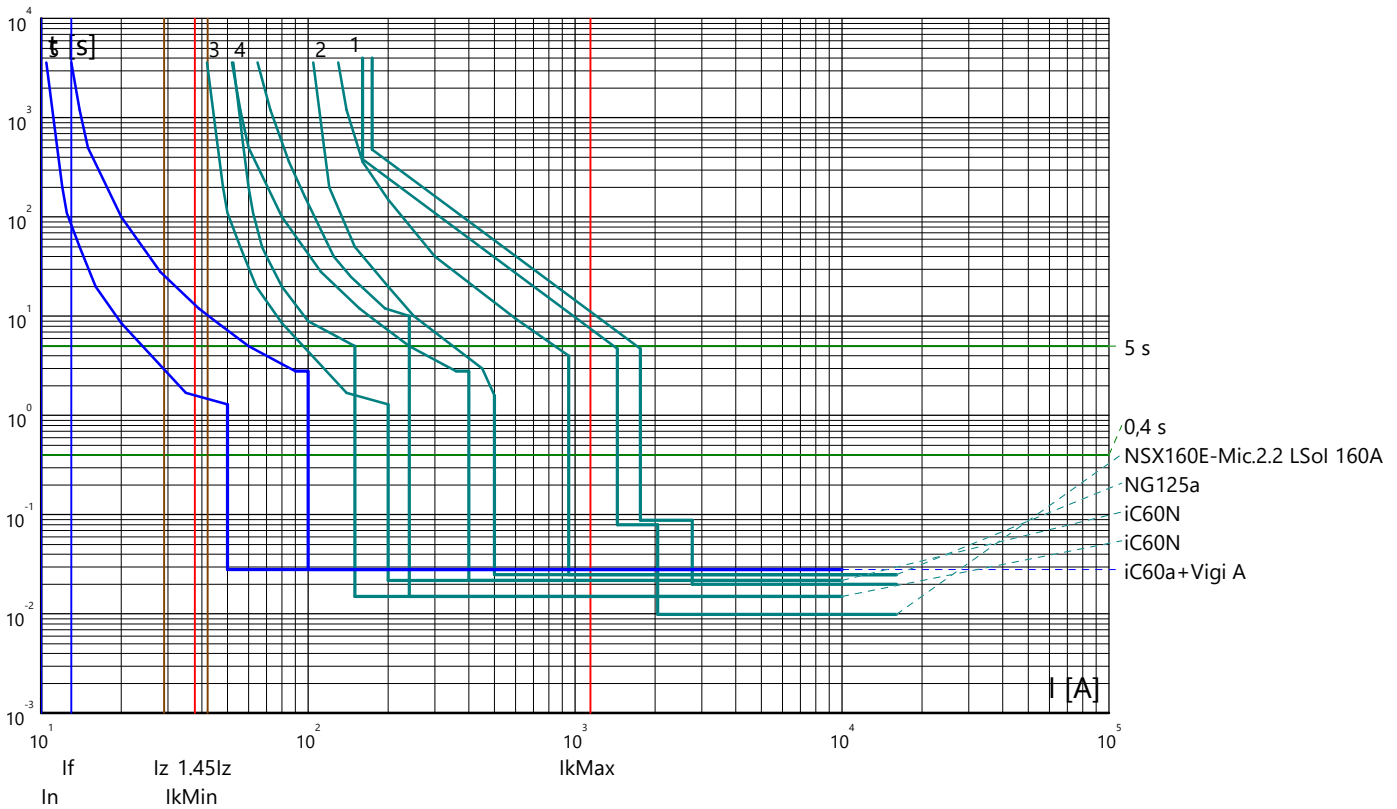

Curve tempo corrente: FERMATA DUGENTA
 Quadro: QUADRO GENERALE B.T.

Partenza: 1.21P

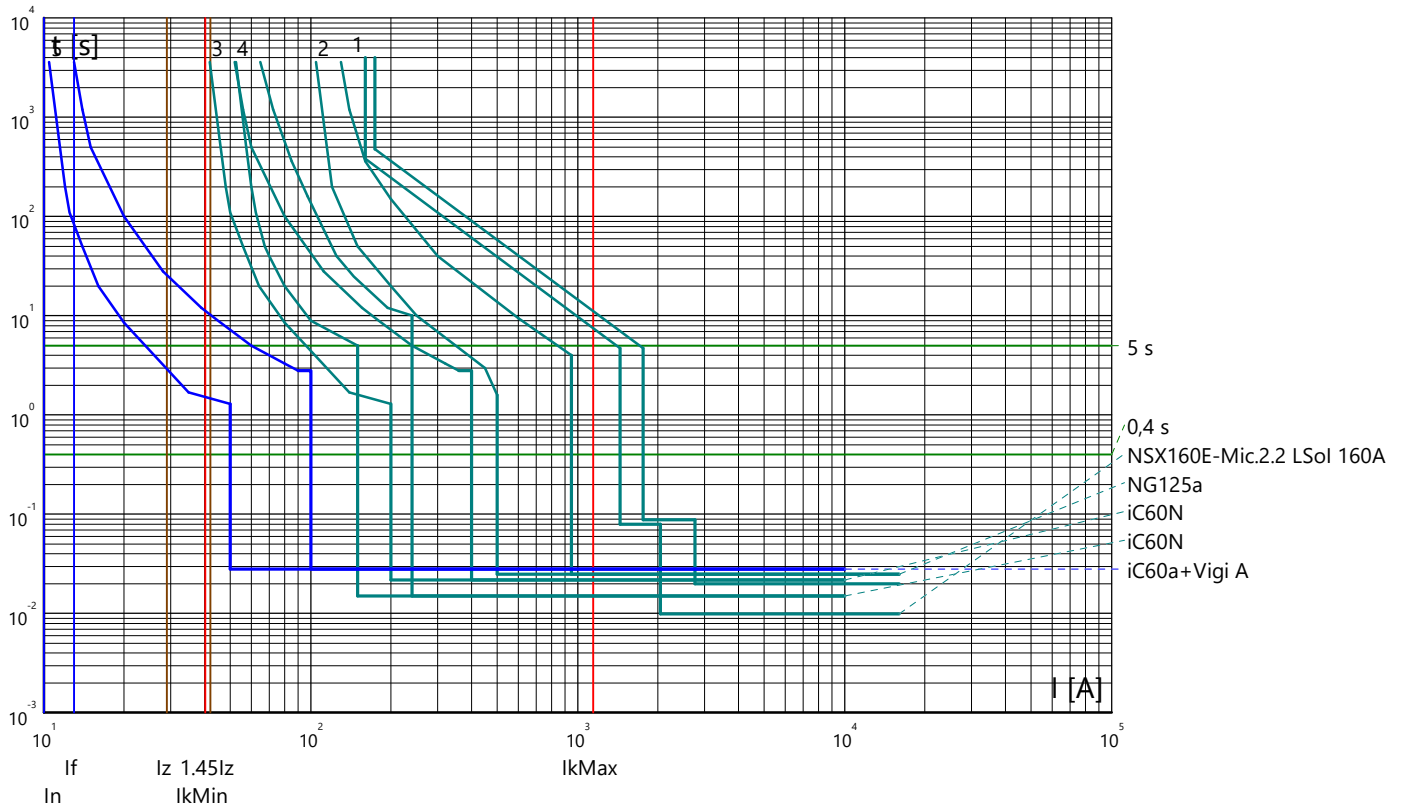

Partenza: 1.22P

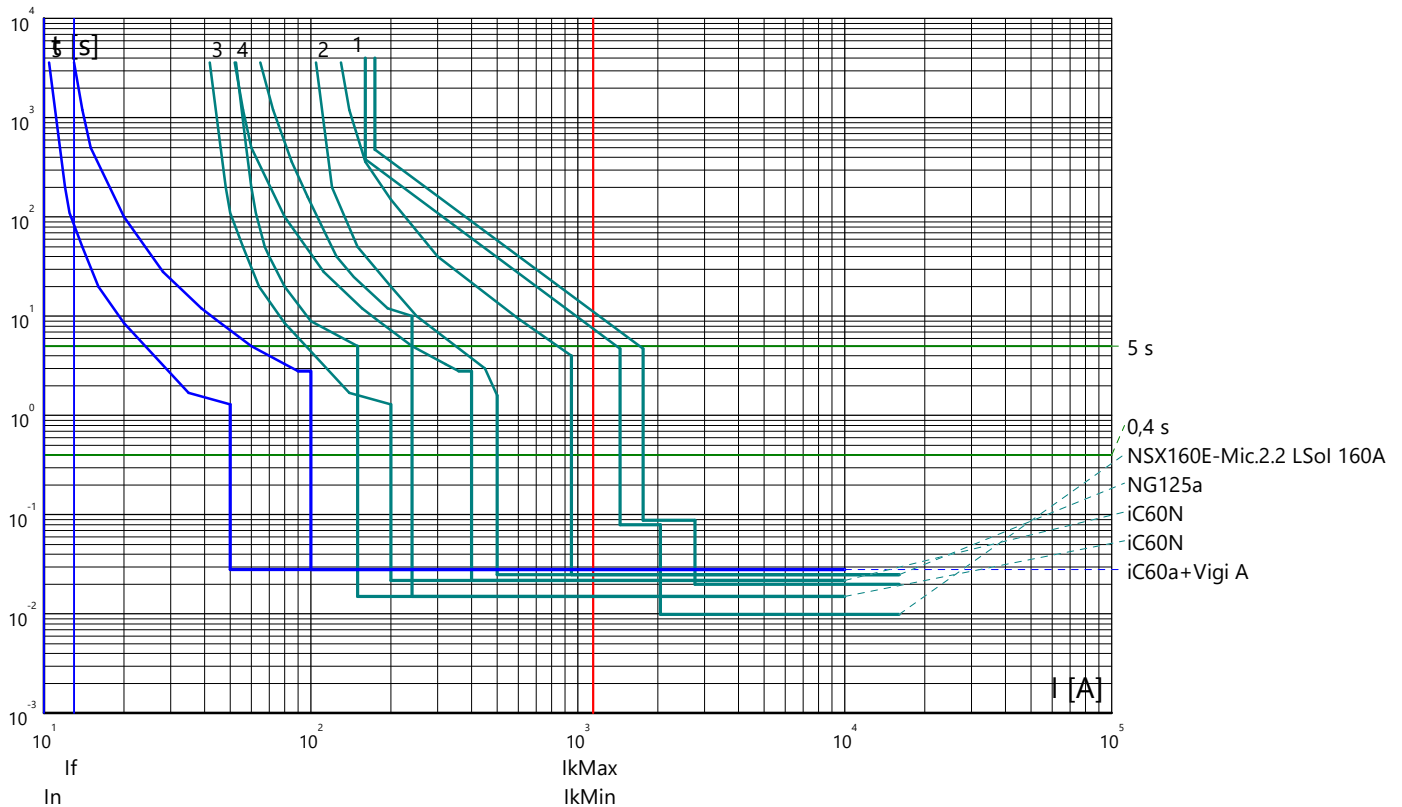

Curve tempo corrente: FERMATA DUGENTA
 Quadro: QUADRO GENERALE B.T.

Partenza: 1.23P

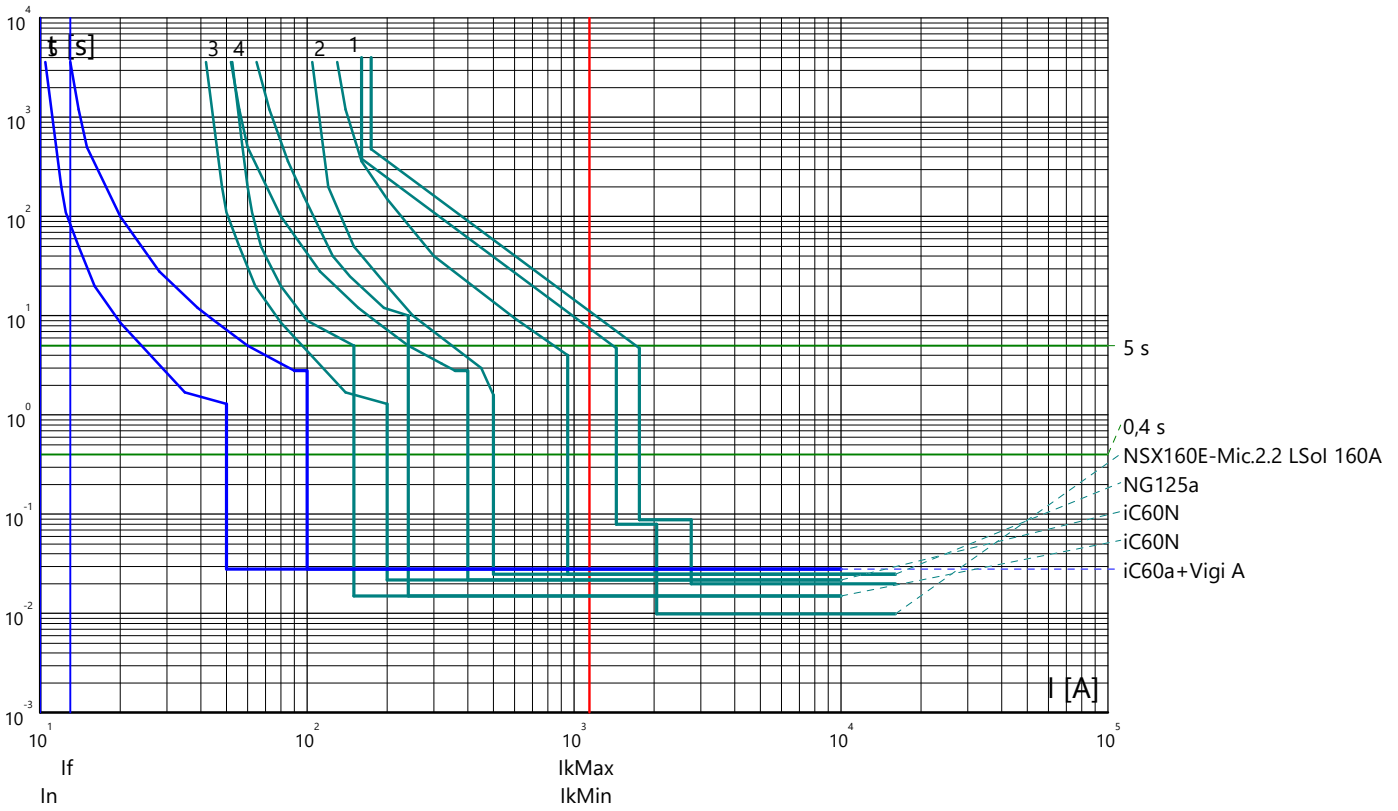

Partenza: 1.24P

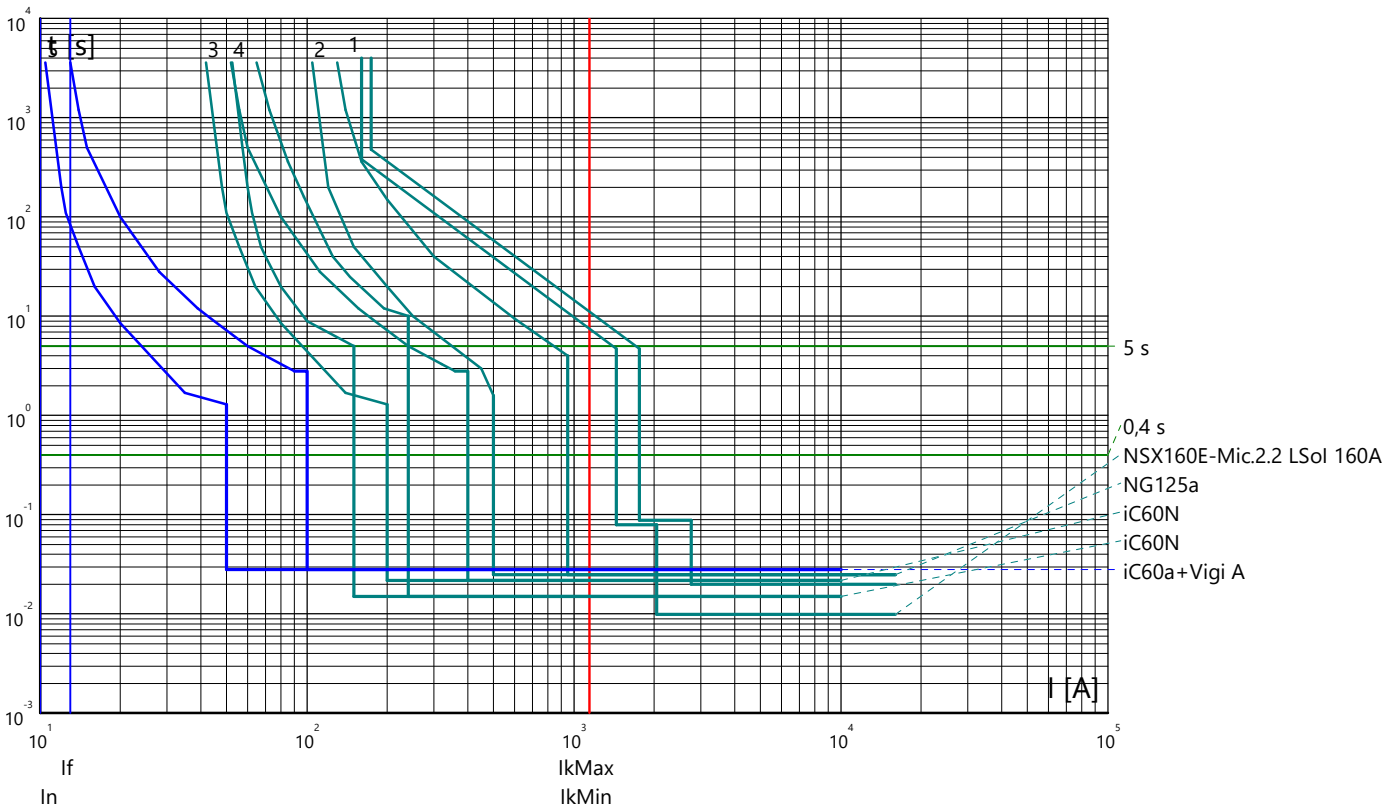

Curve tempo corrente: FERMATA DUGENTA
 Quadro: QUADRO GENERALE B.T.

Arrivo: IGS

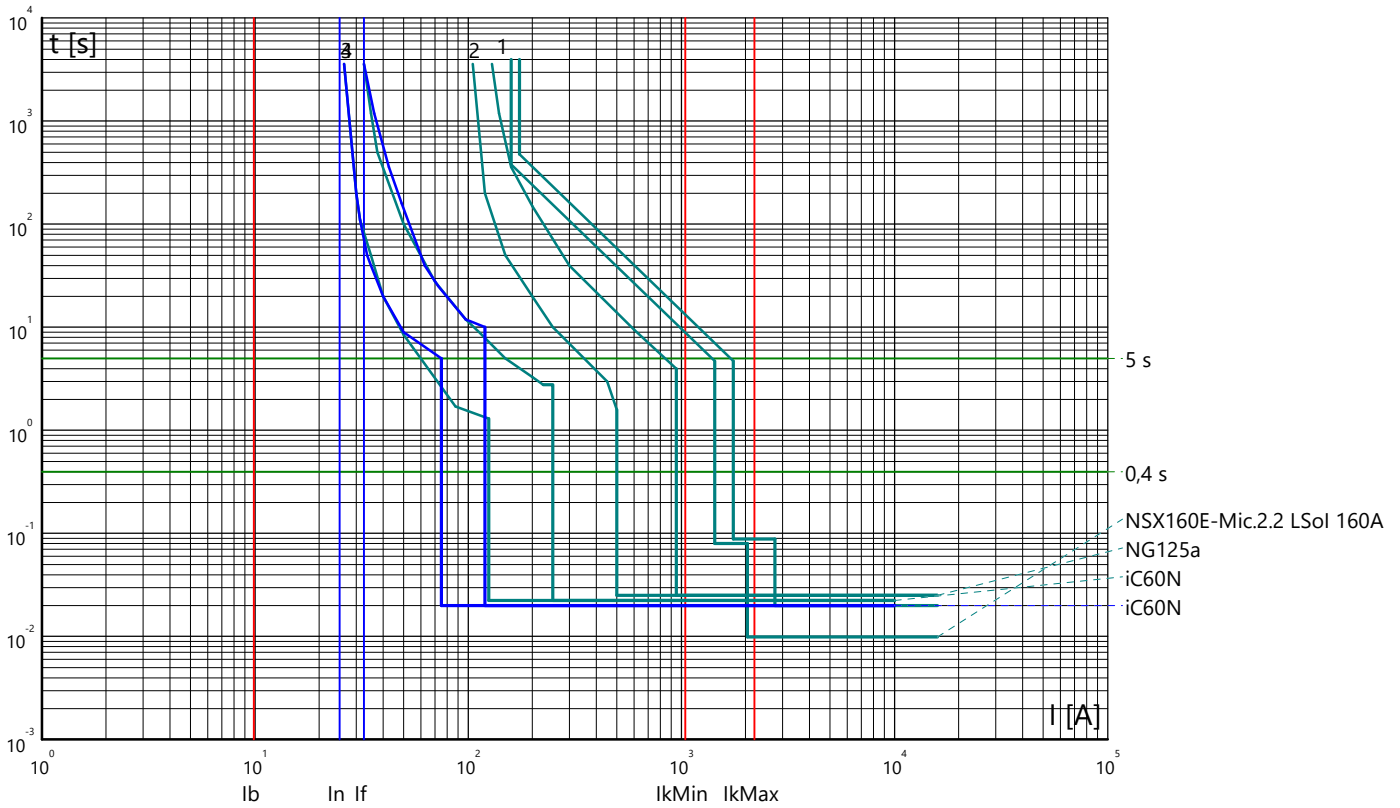

Partenza: PT

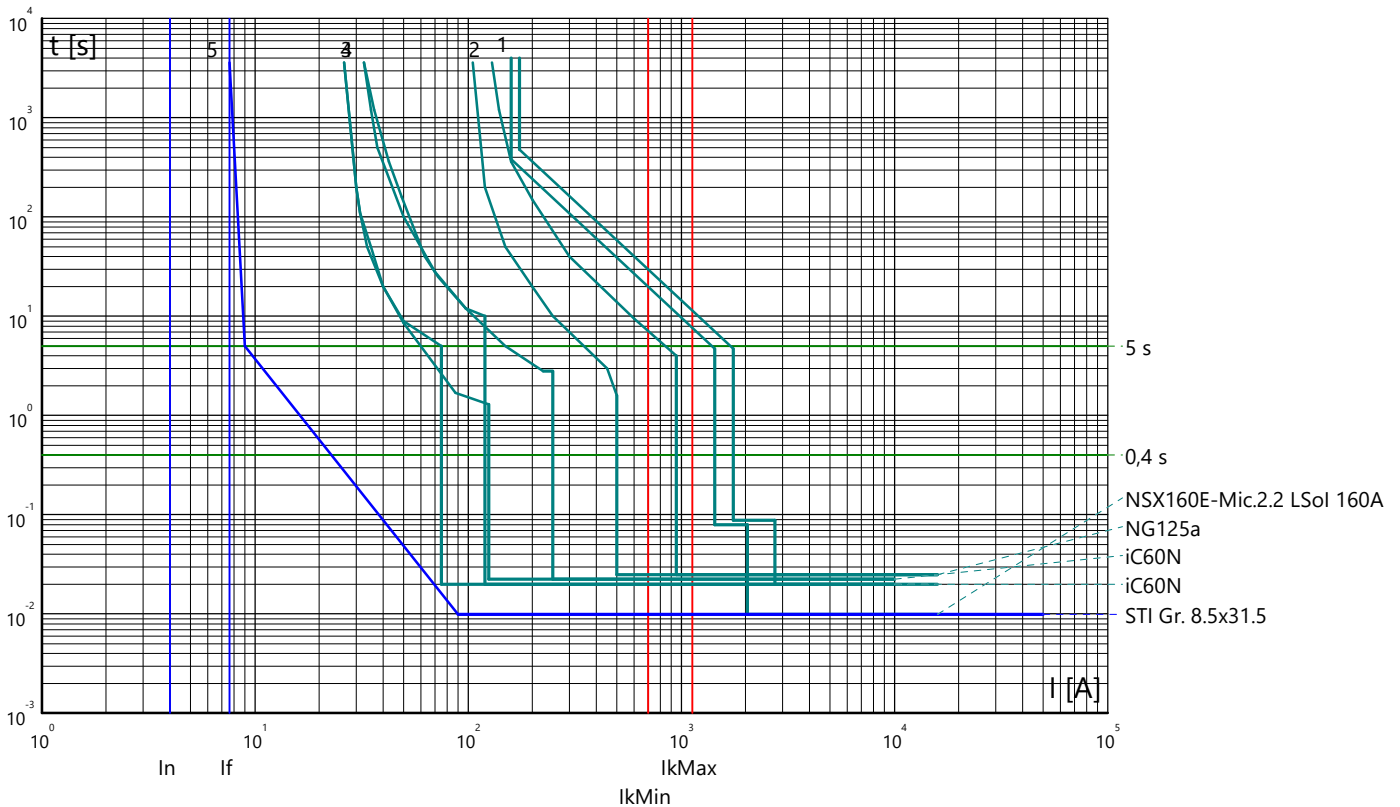

Curve tempo corrente: FERMATA DUGENTA
 Quadro: QUADRO GENERALE B.T.

Partenza: MIS

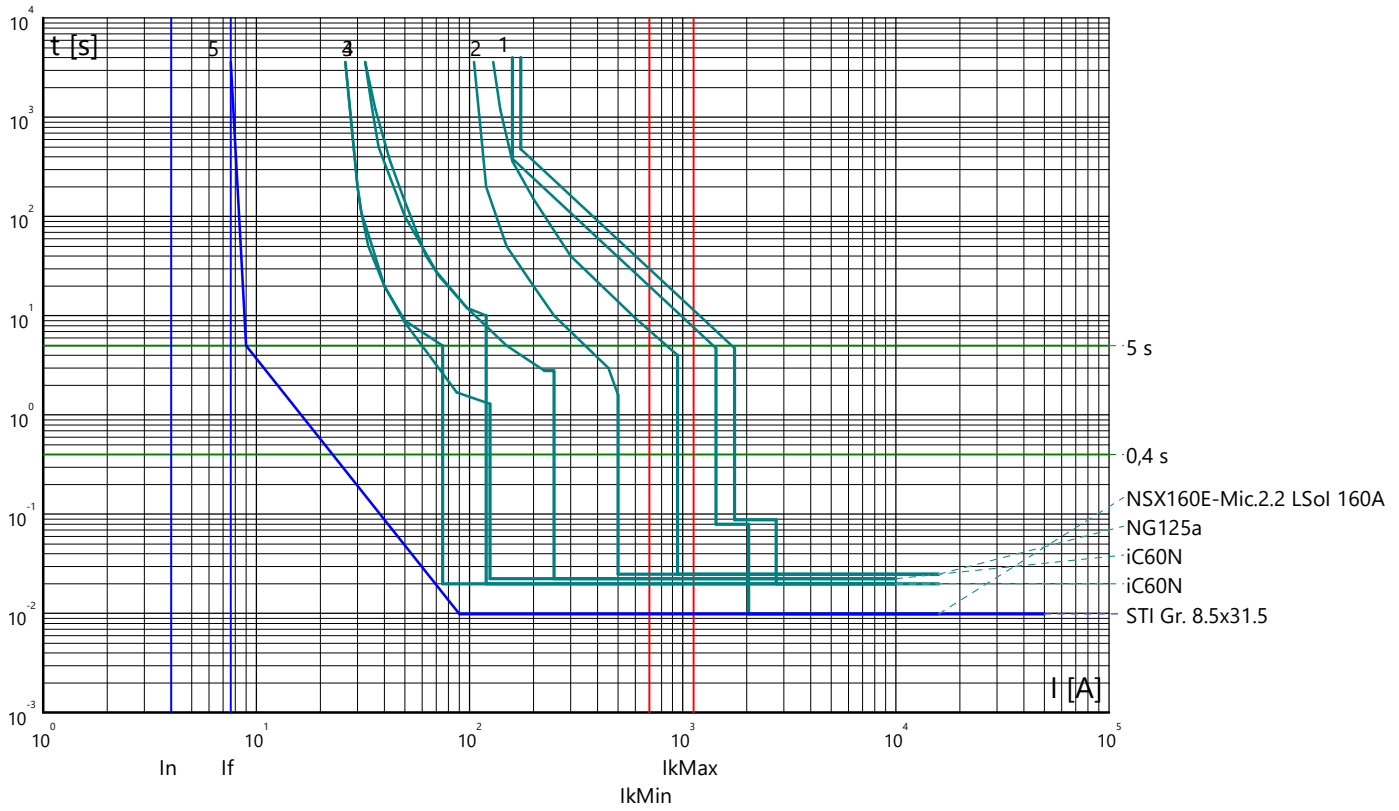

Partenza: 1.1S

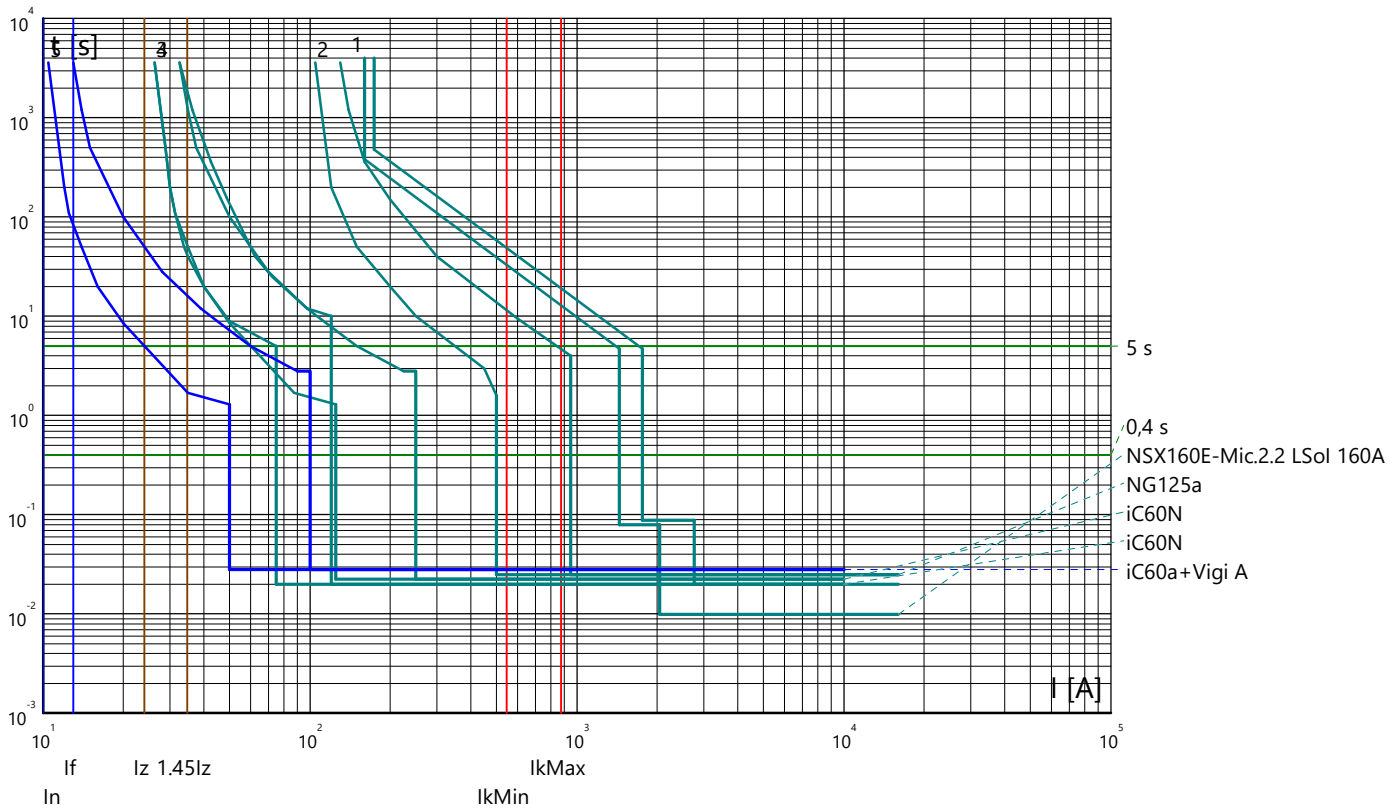

Curve tempo corrente: FERMATA DUGENTA
 Quadro: QUADRO GENERALE B.T.

Partenza: 1.2S

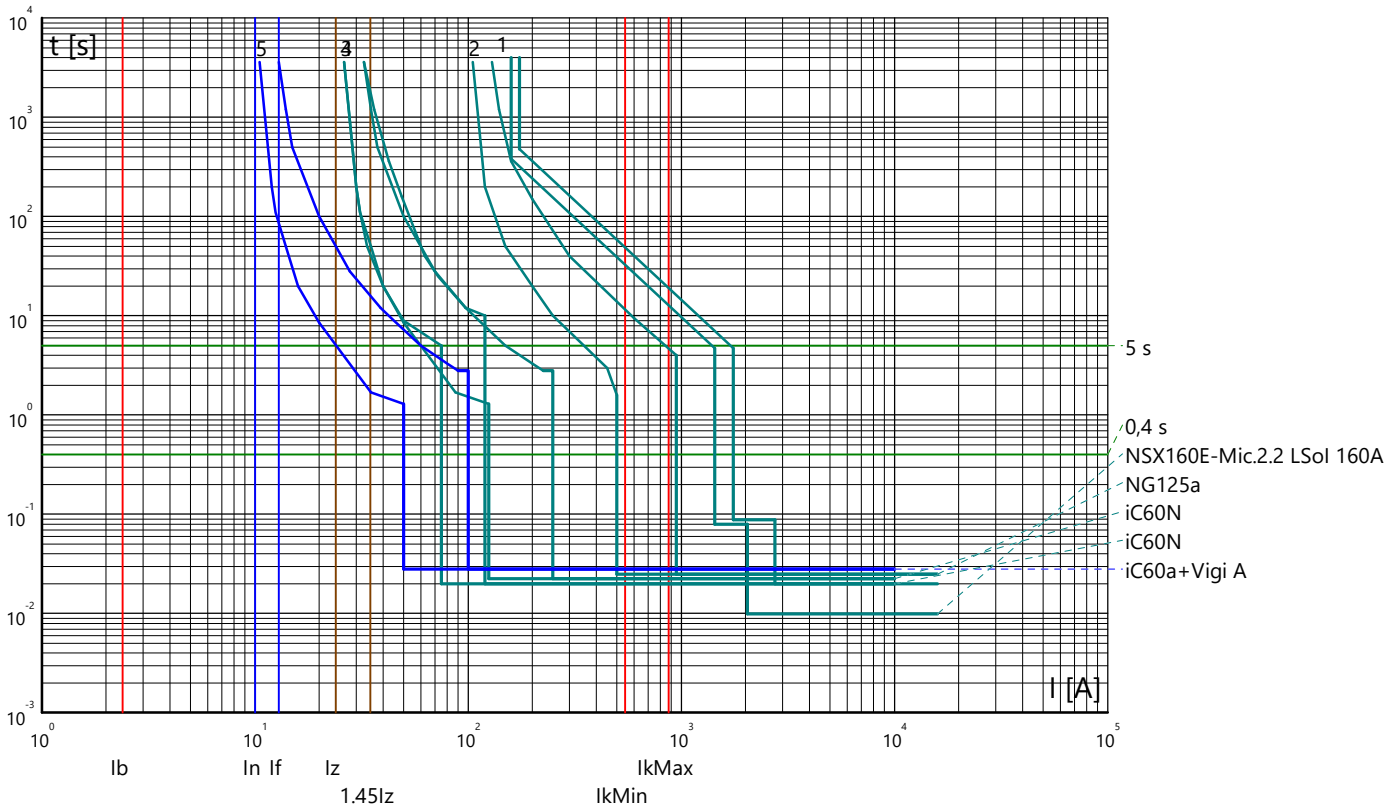

Partenza: 1.3S

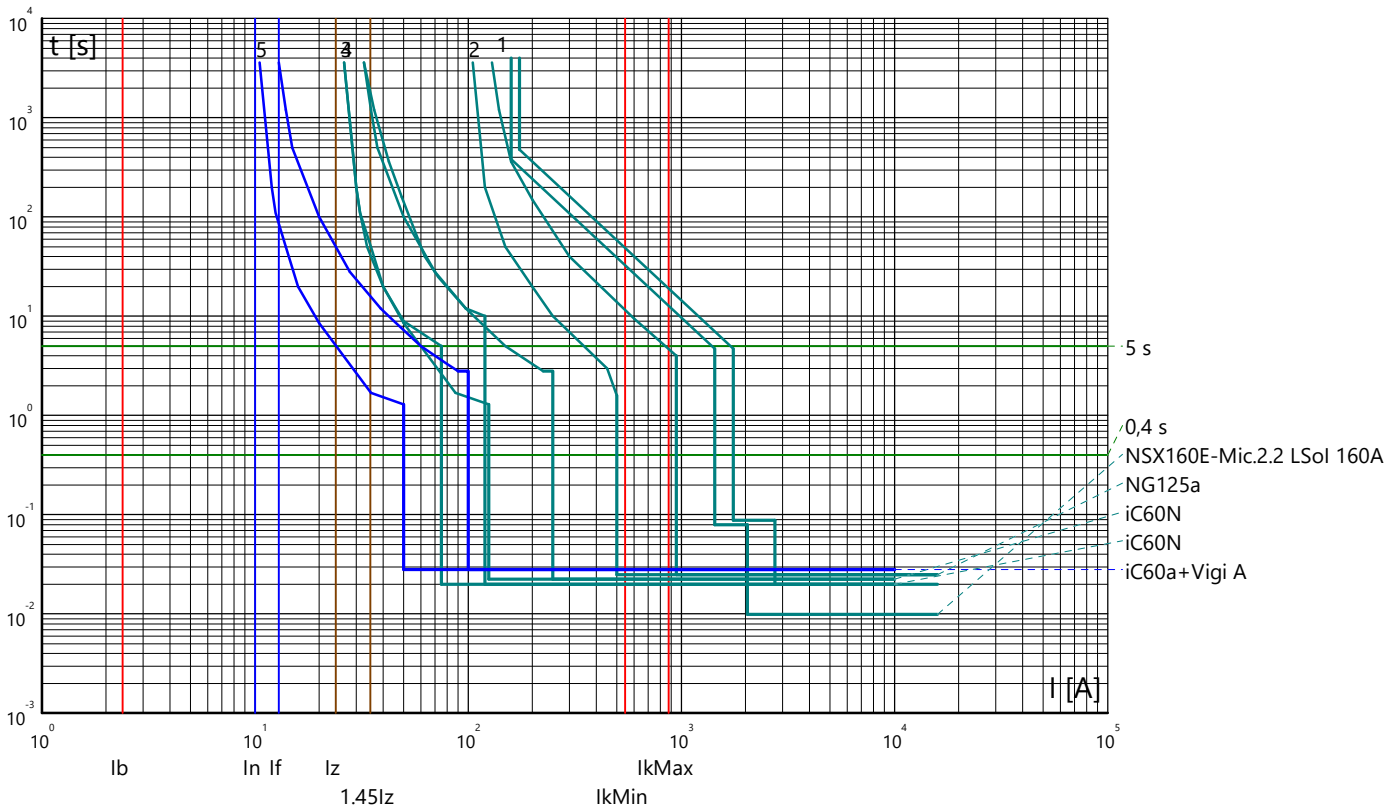

Curve tempo corrente: FERMATA DUGENTA
 Quadro: QUADRO GENERALE B.T.

Partenza: 1.4S

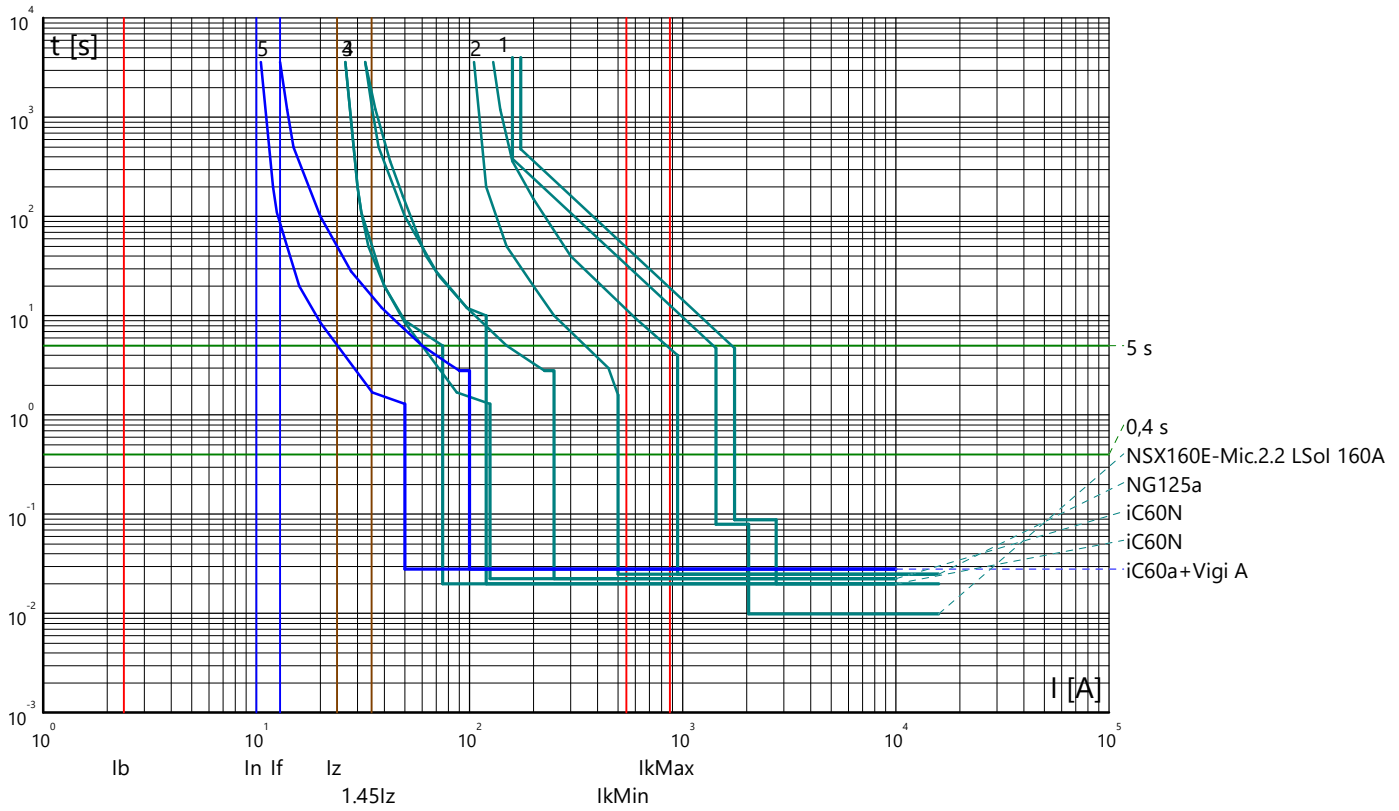

Partenza: 1.5S

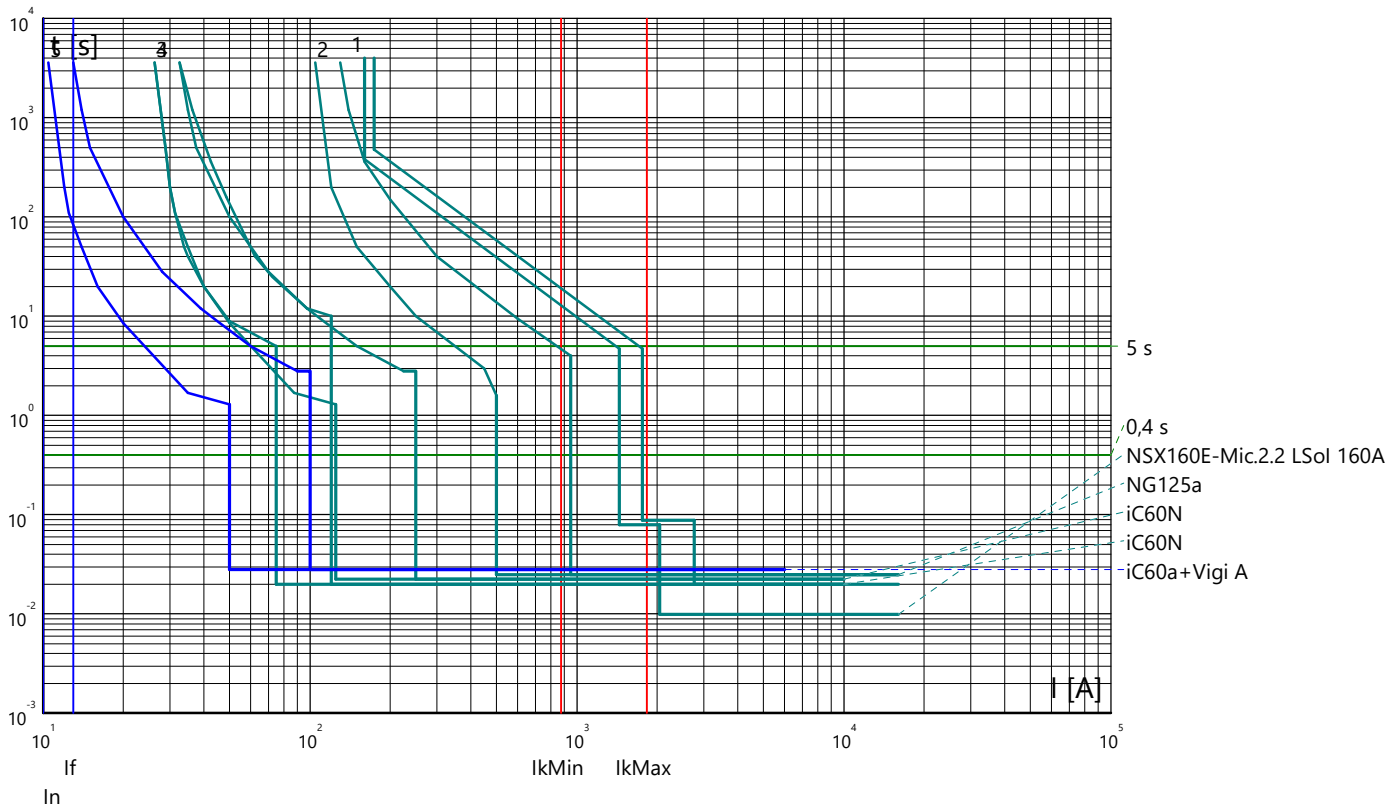

Curve tempo corrente: FERMATA DUGENTA
 Quadro: QUADRO GENERALE B.T.

Partenza: 1.6S

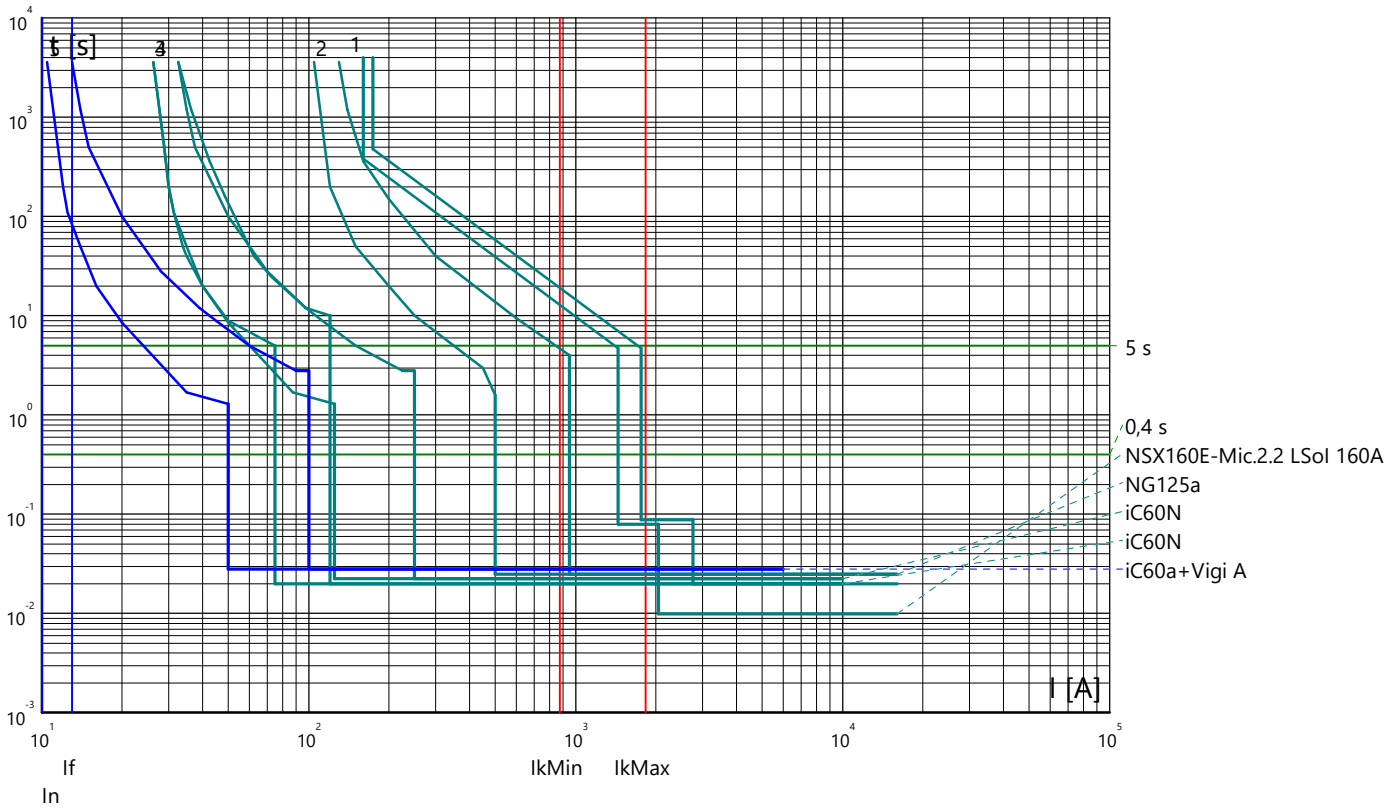

Partenza: 1.7S

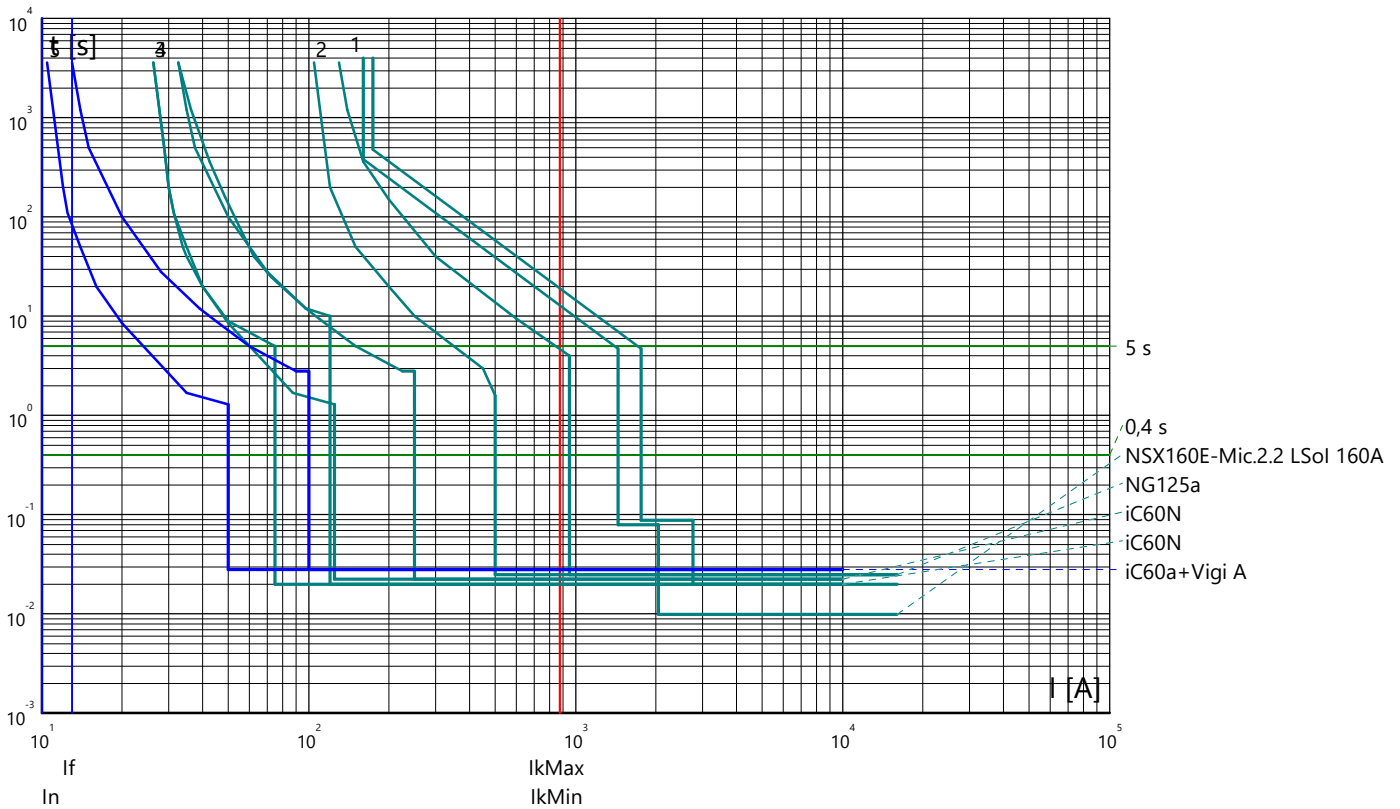

Curve tempo corrente: FERMATA DUGENTA
 Quadro: QUADRO GENERALE B.T.

Partenza: 1.8S

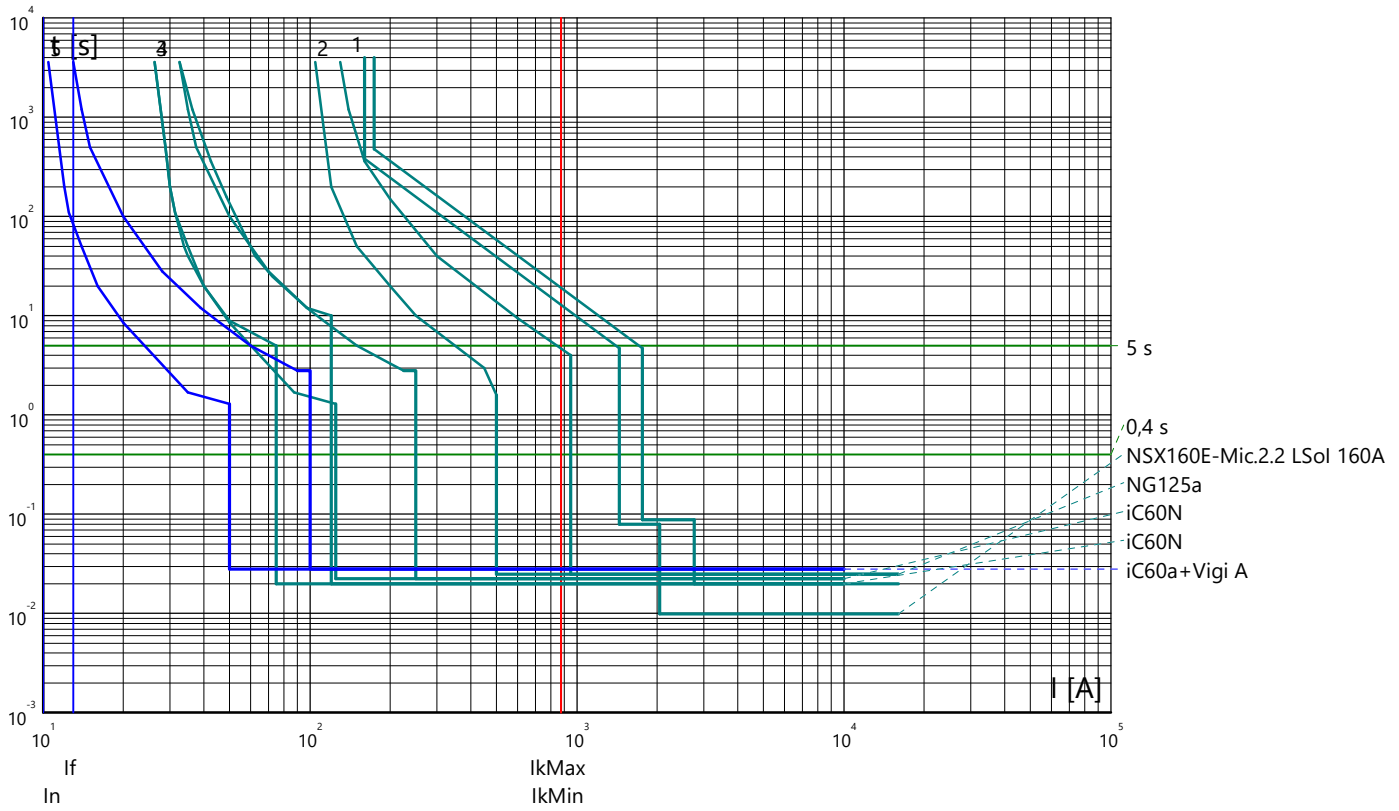

Partenza: S1.S

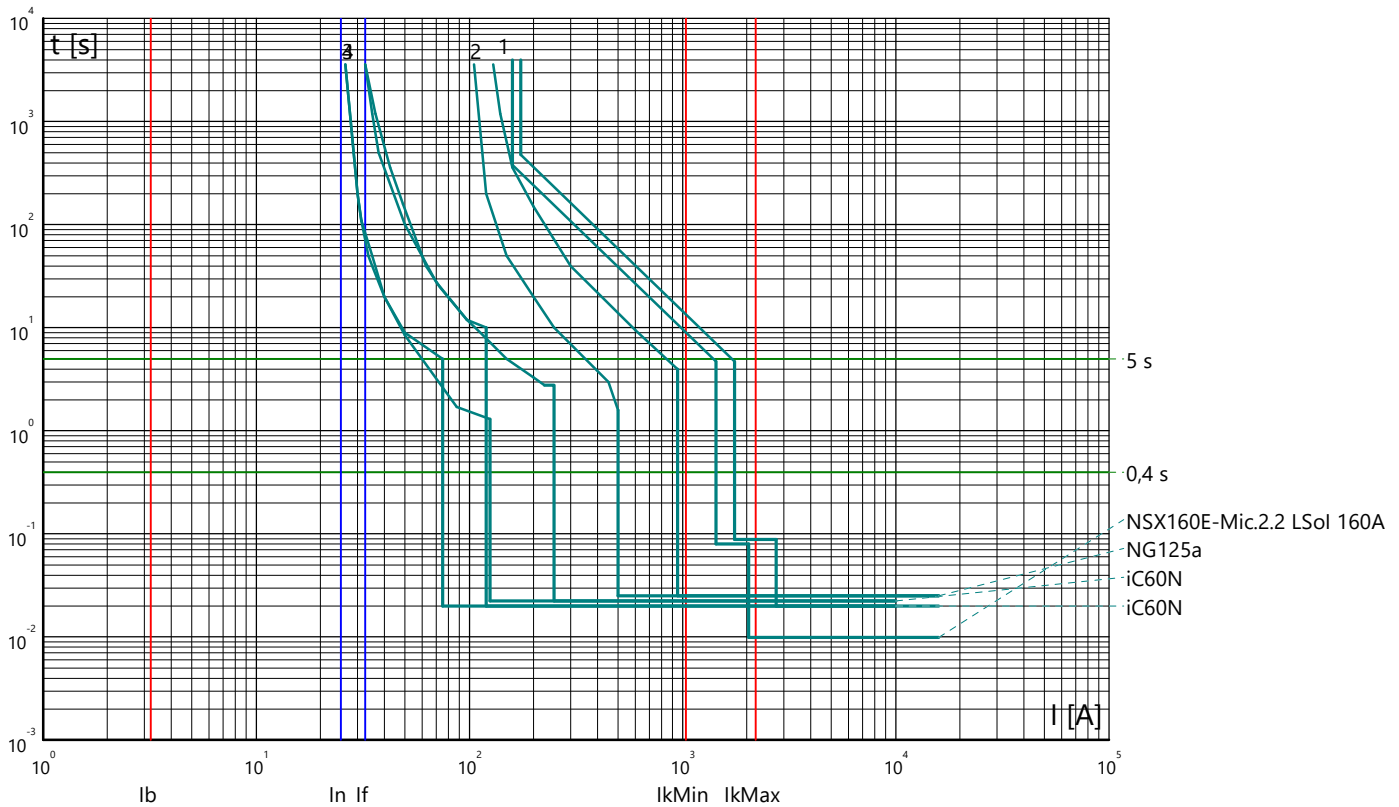

Curve tempo corrente: FERMATA DUGENTA
 Quadro: QUADRO GENERALE B.T.

Partenza: 1.9S

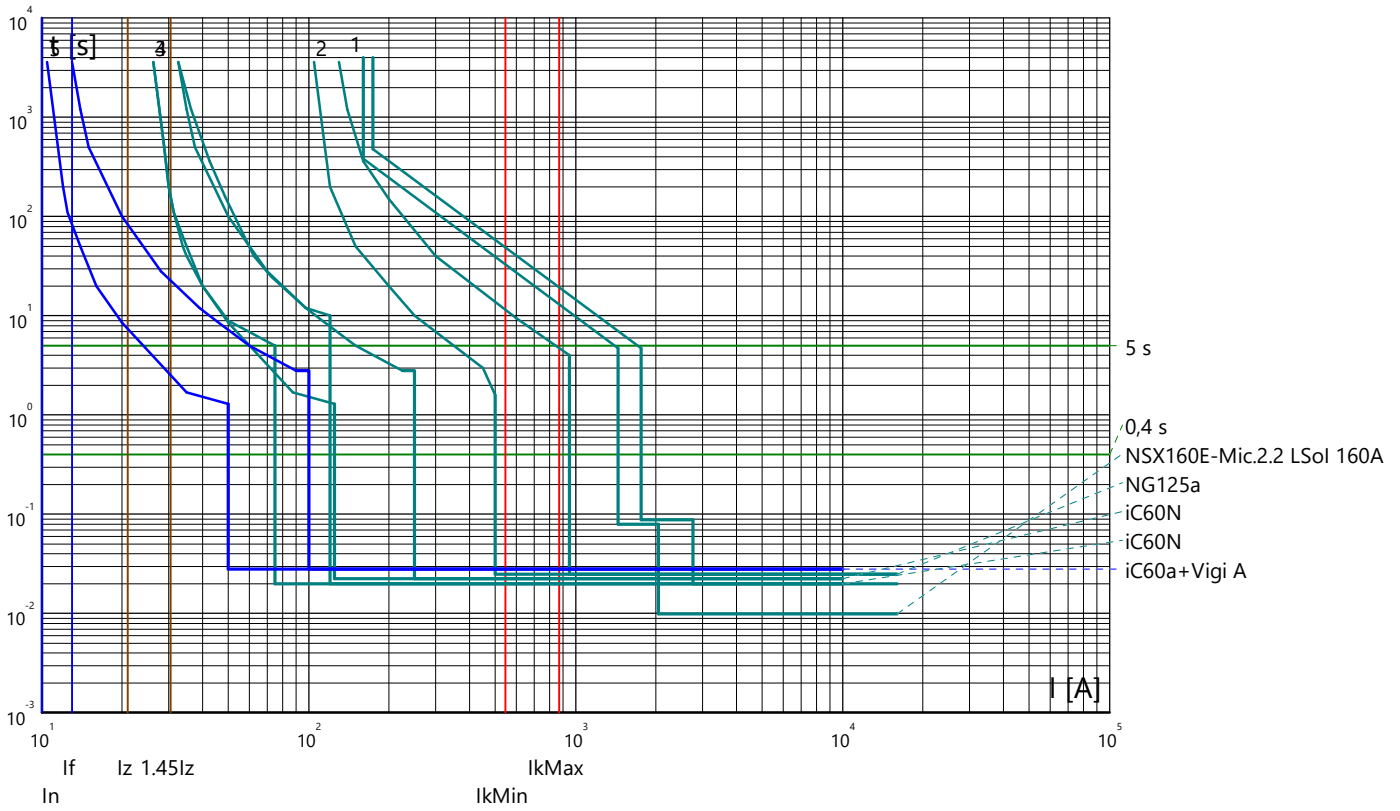

Partenza: 1.10S

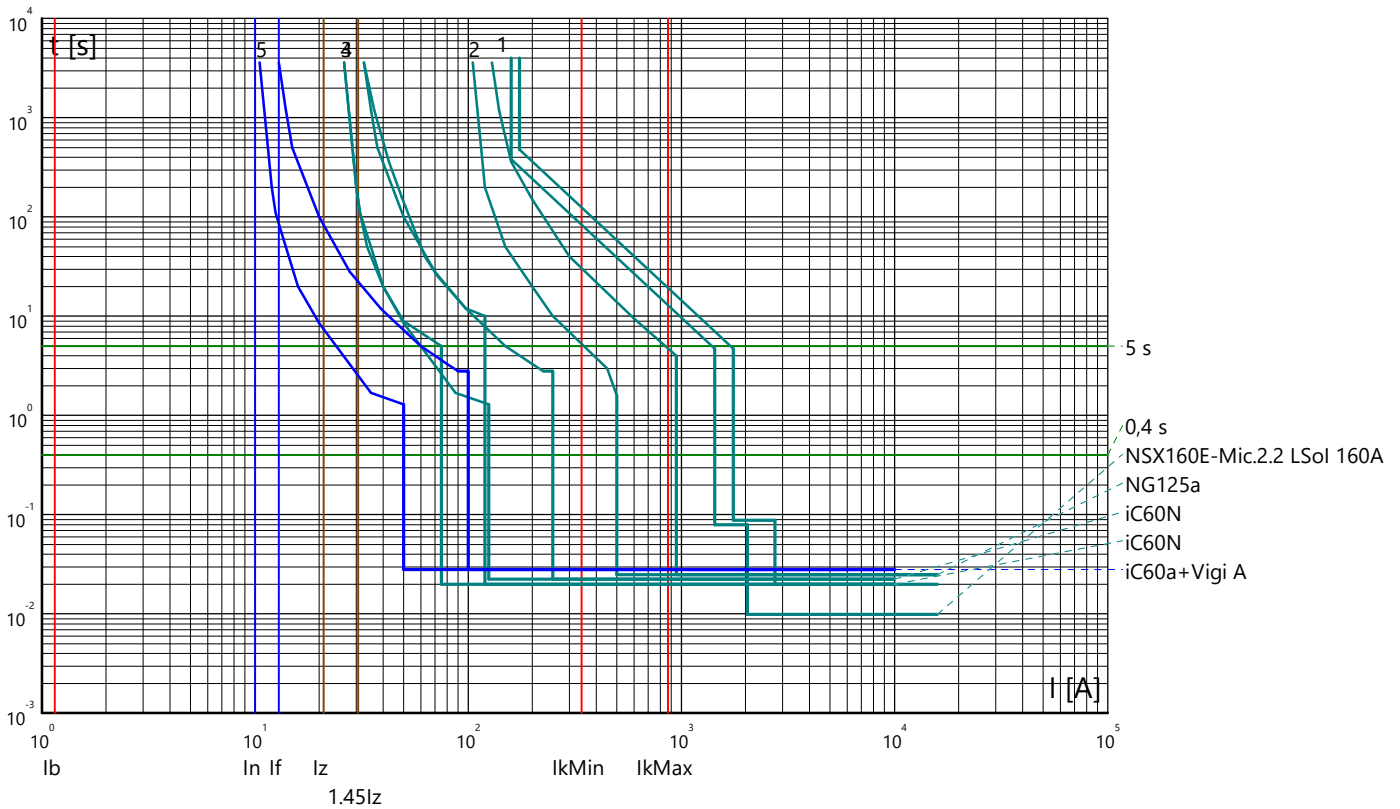

Curve tempo corrente: FERMATA DUGENTA
 Quadro: QUADRO GENERALE B.T.

Partenza: 1.11S

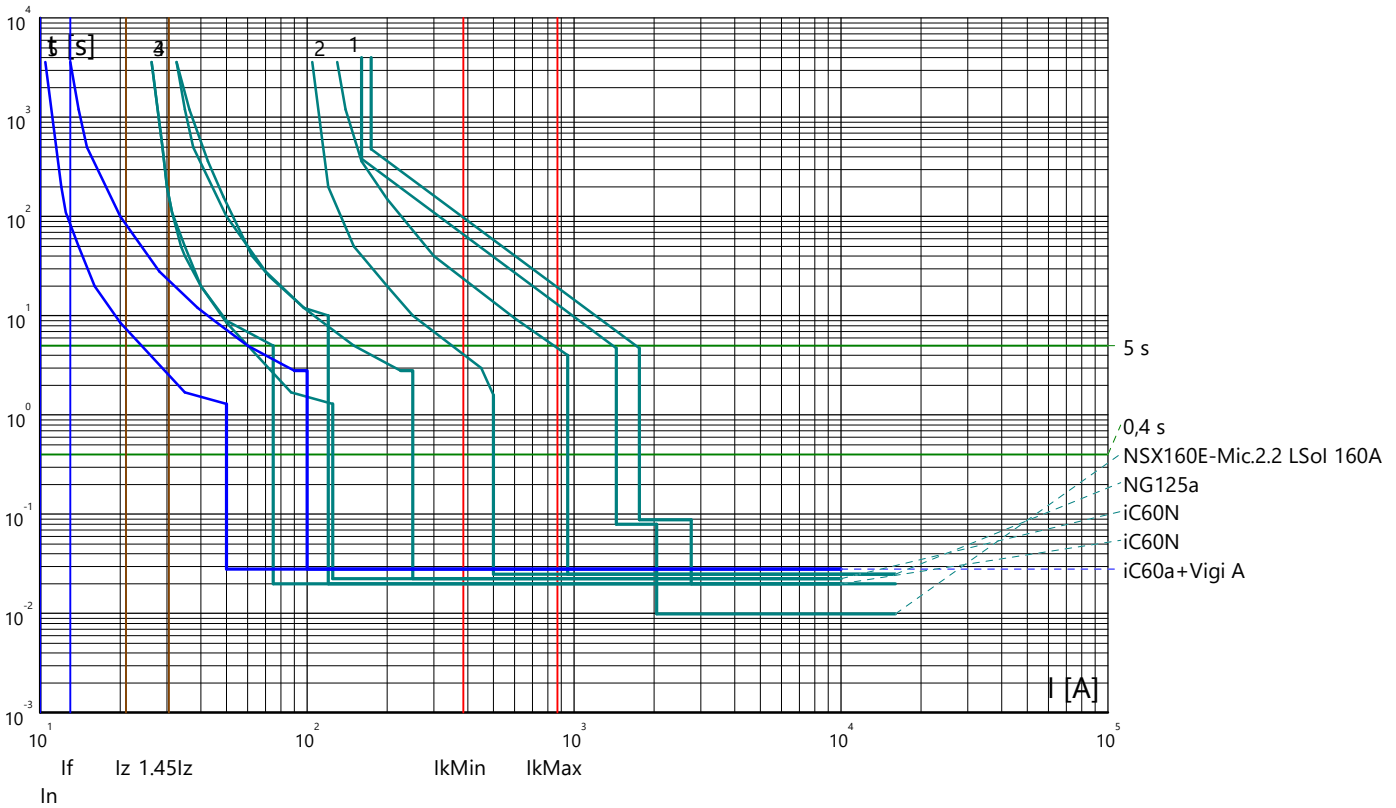

Partenza: 1.12S

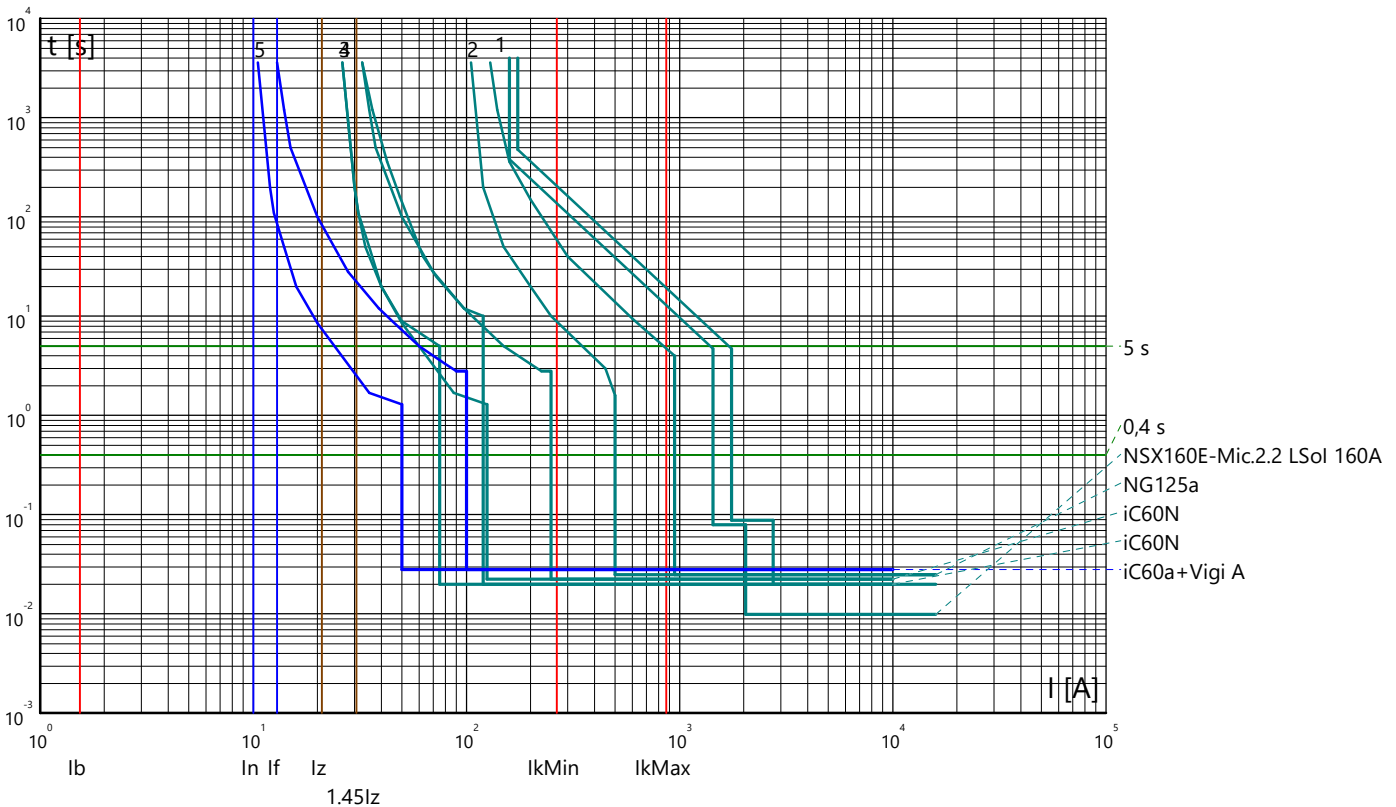

Curve tempo corrente: FERMATA DUGENTA
 Quadro: QUADRO GENERALE B.T.

Partenza: 1.13S

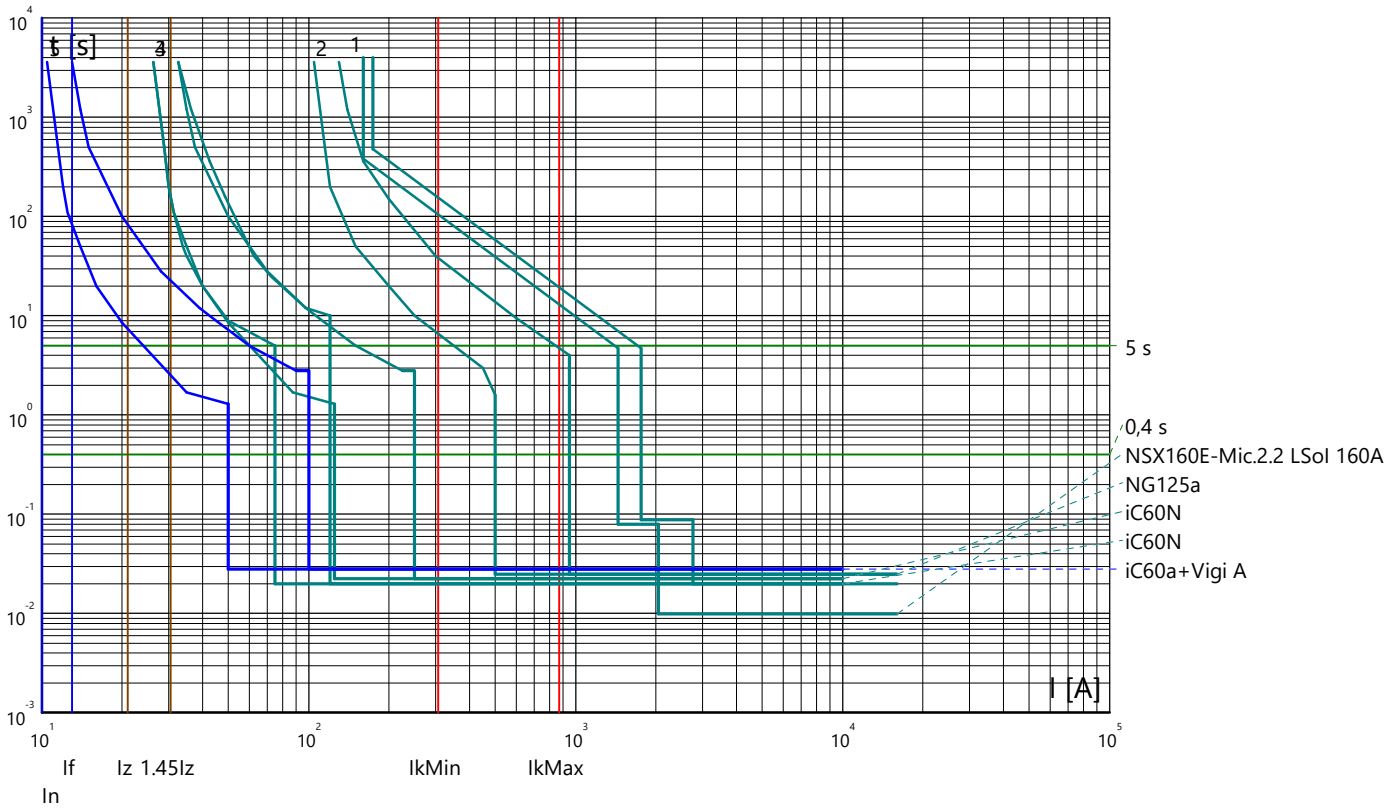

Partenza: 1.14S

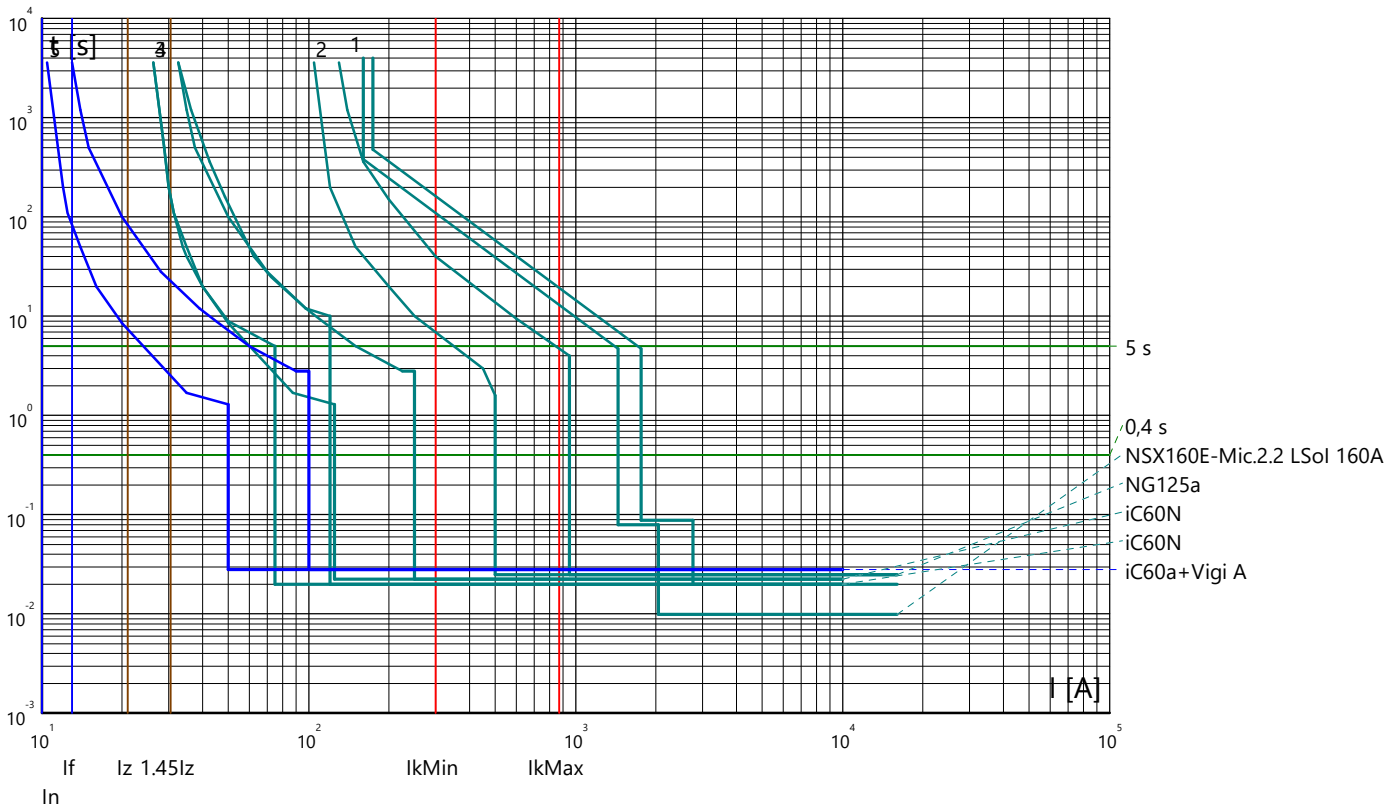

Curve tempo corrente: FERMATA DUGENTA
 Quadro: QUADRO GENERALE B.T.

Partenza: 1.15S

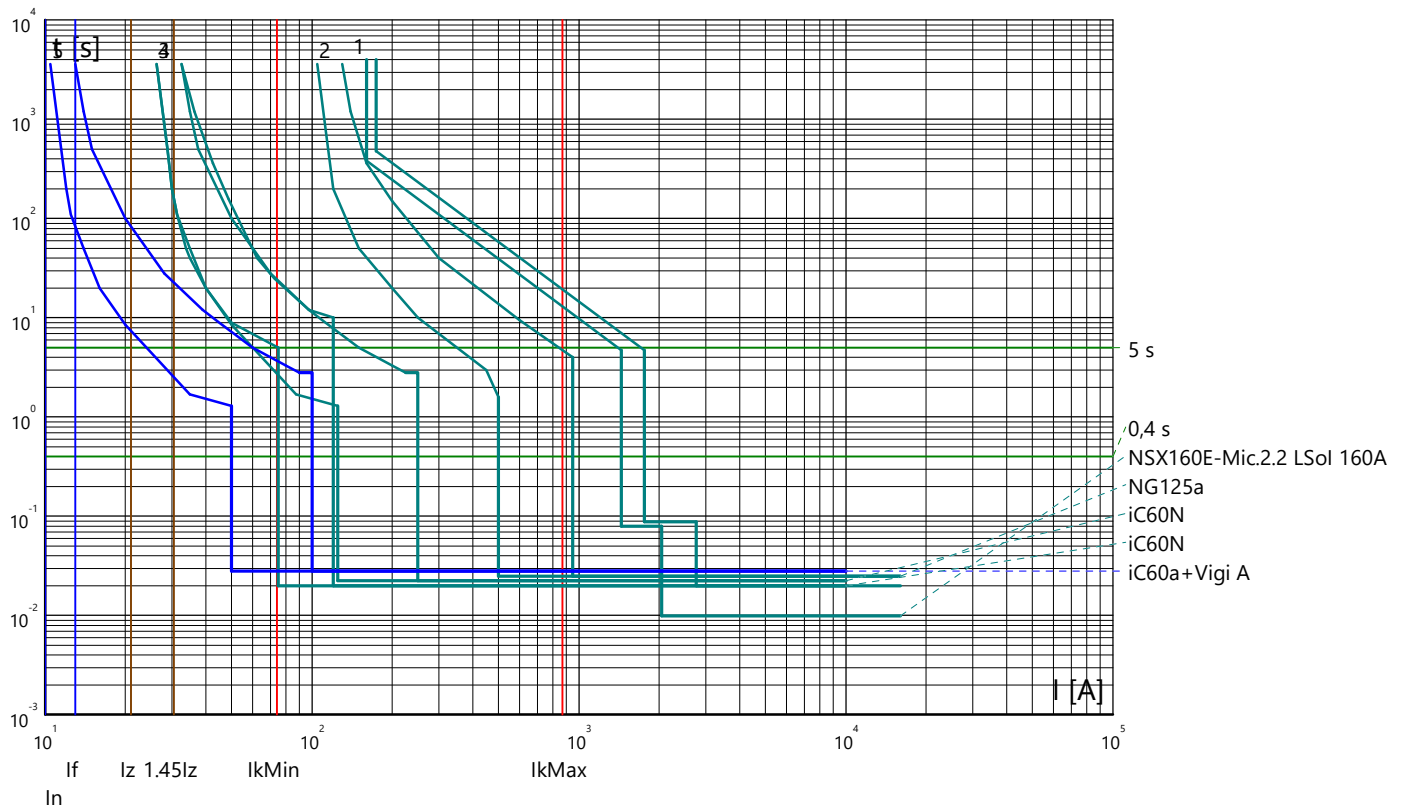

Partenza: 1.16S

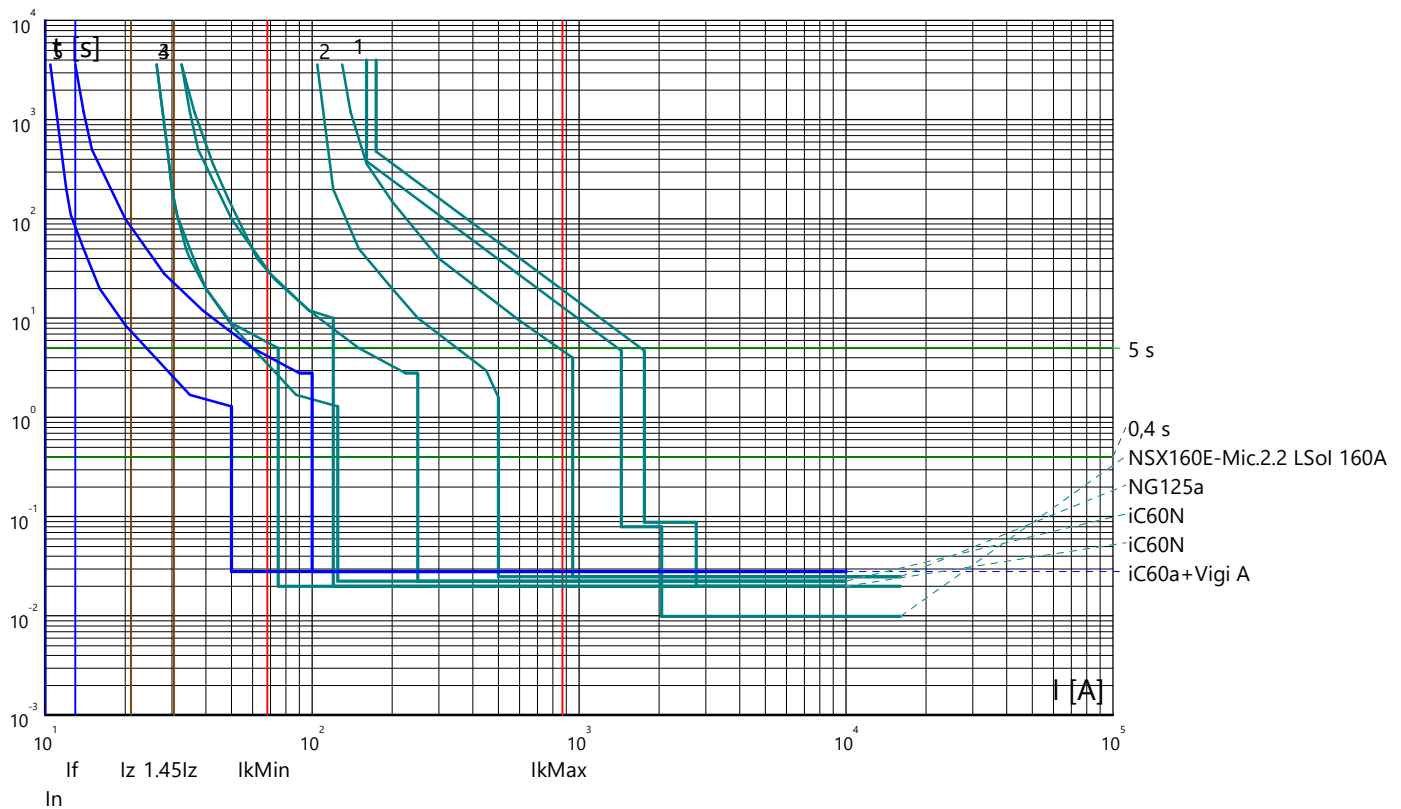

Curve tempo corrente: FERMATA DUGENTA
 Quadro: QUADRO GENERALE B.T.

Partenza: 1.17S

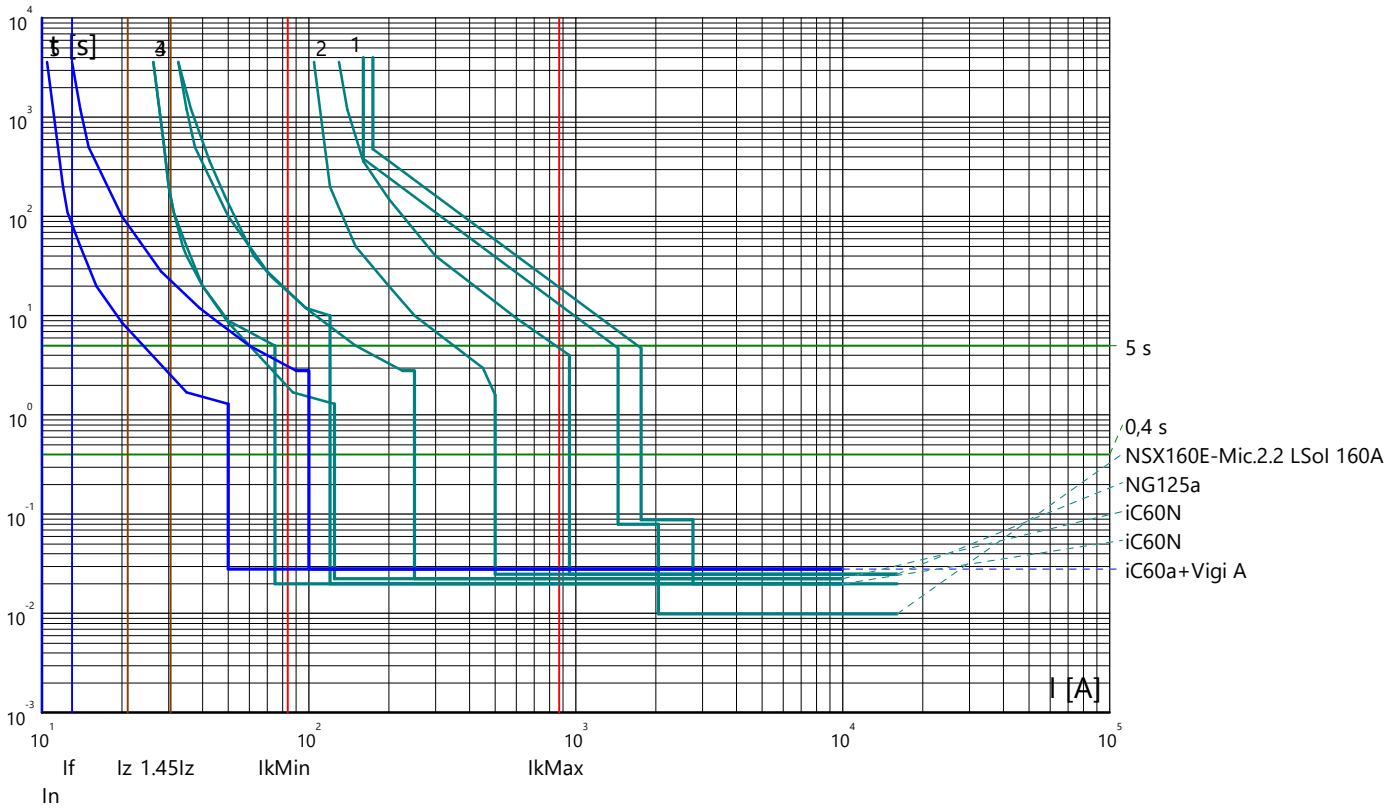

Partenza: 1.18S

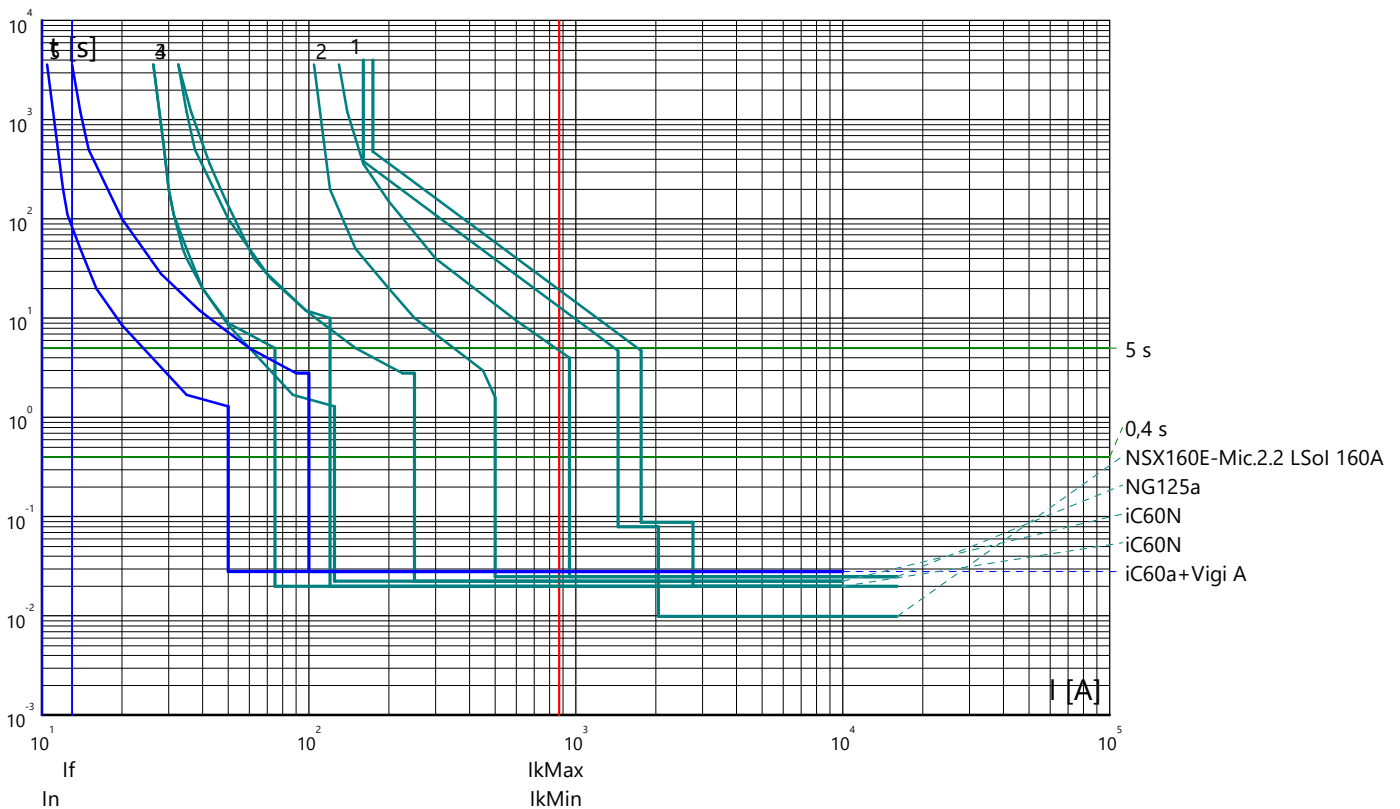

Curve tempo corrente: FERMATA DUGENTA
 Quadro: QUADRO GENERALE B.T.

Partenza: 1.19S

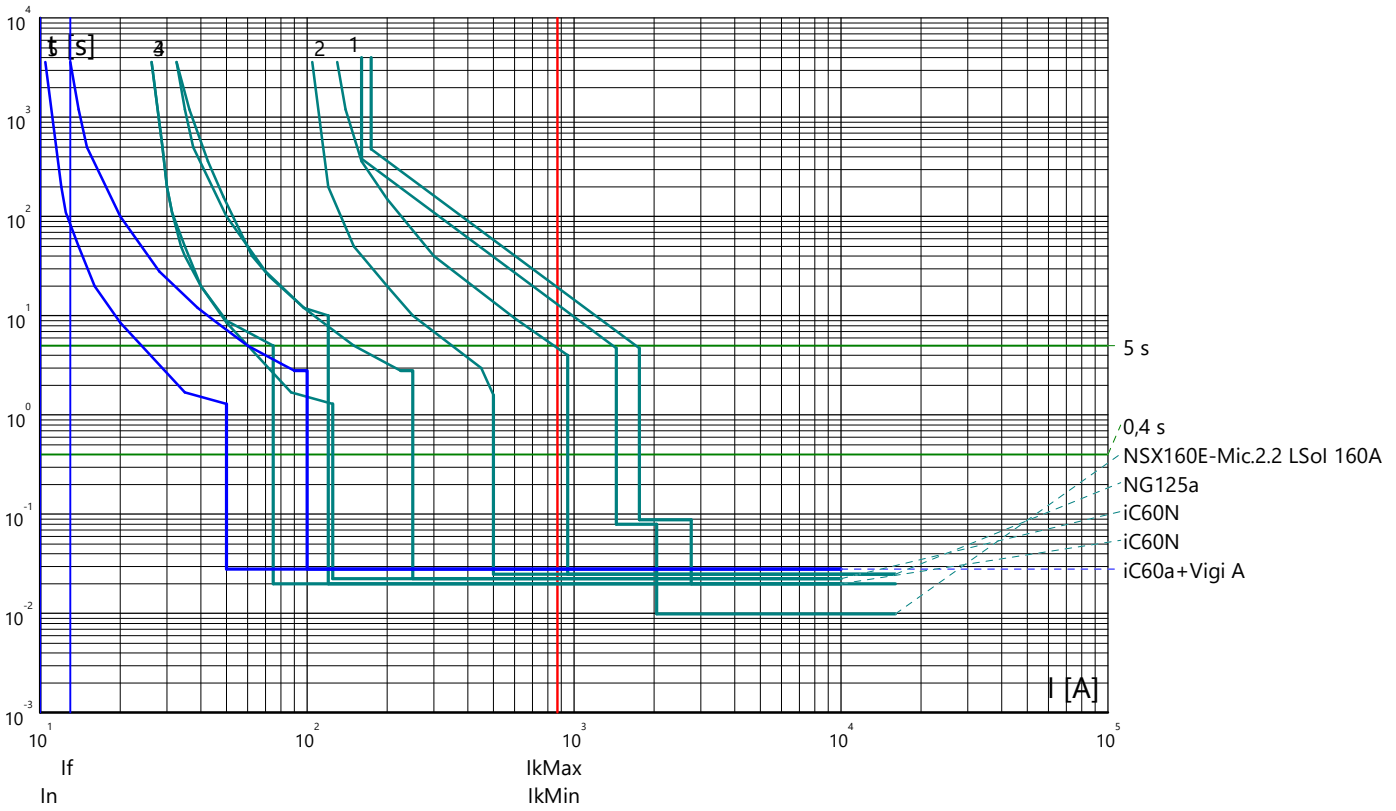

Partenza: 1.20S

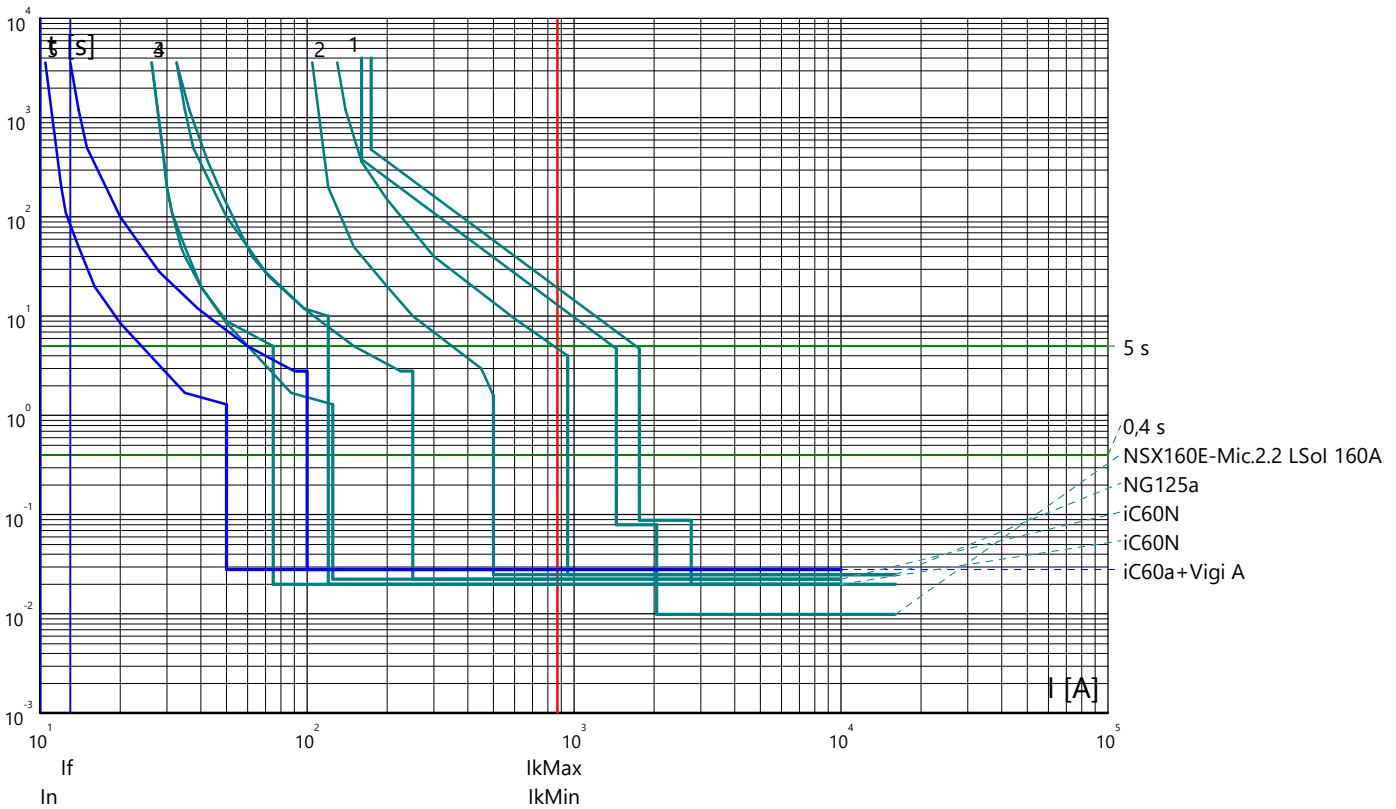

Curve tempo corrente: FERMATA DUGENTA
 Quadro: QUADRO GENERALE B.T.

Partenza: S2.S

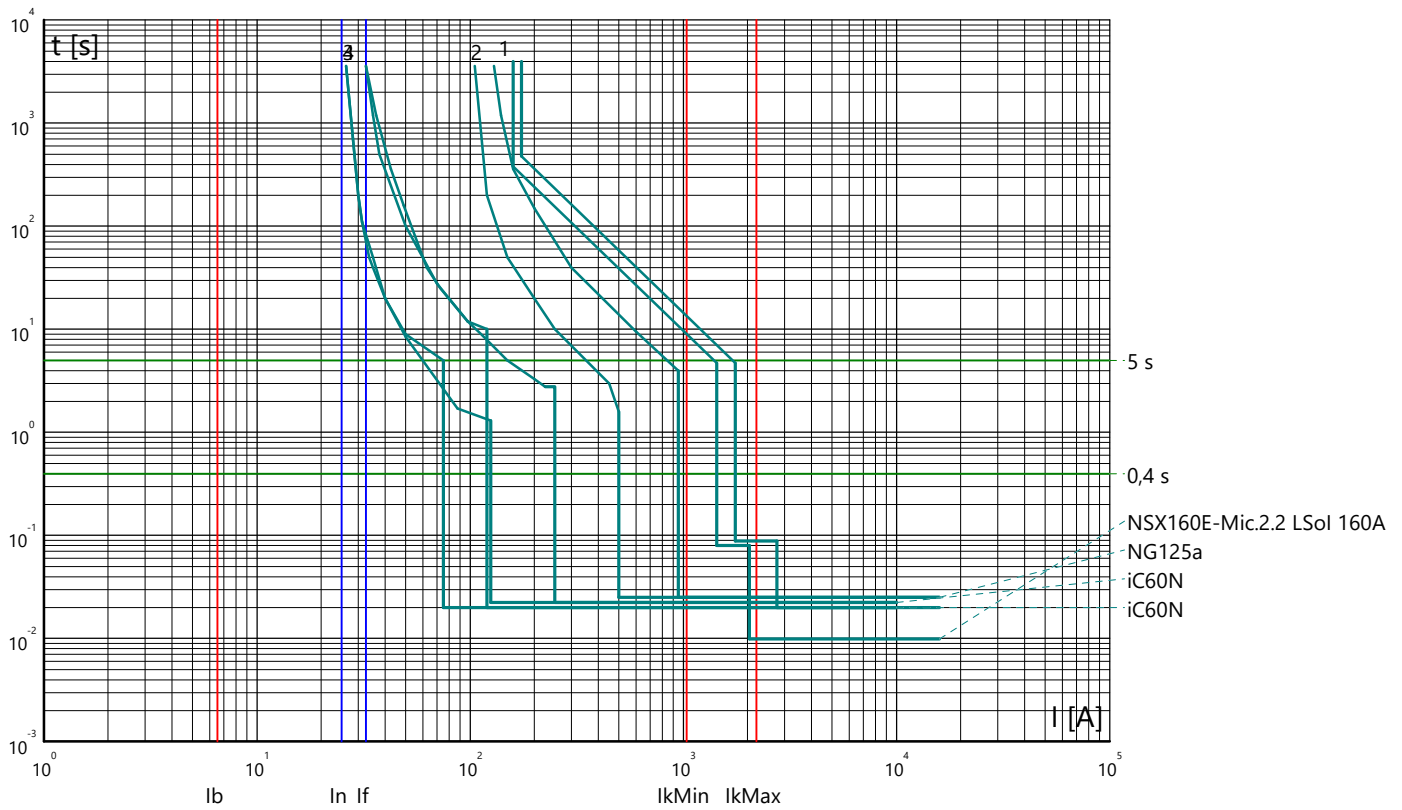

Partenza: 1.21S

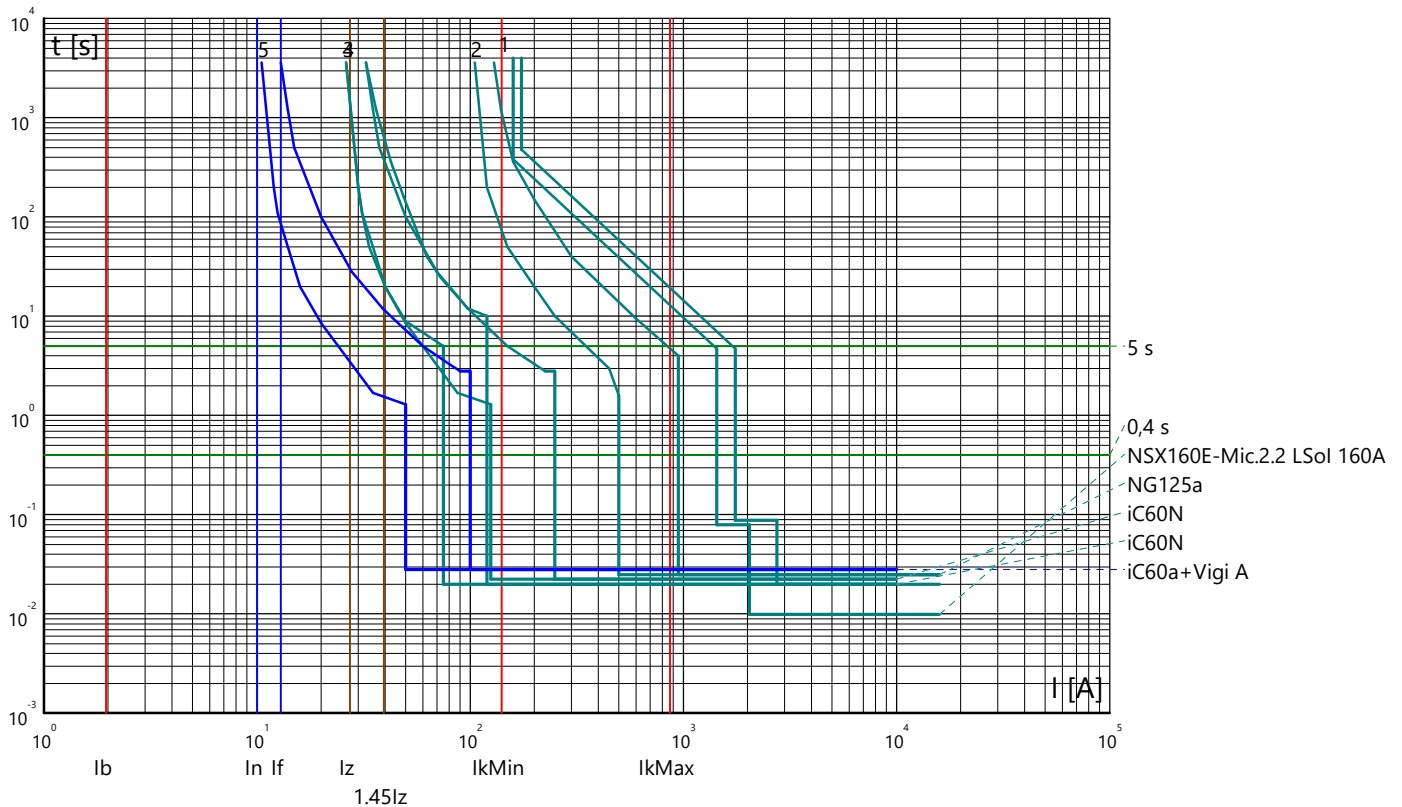

Curve tempo corrente: FERMATA DUGENTA
 Quadro: QUADRO GENERALE B.T.

Partenza: 1.22S

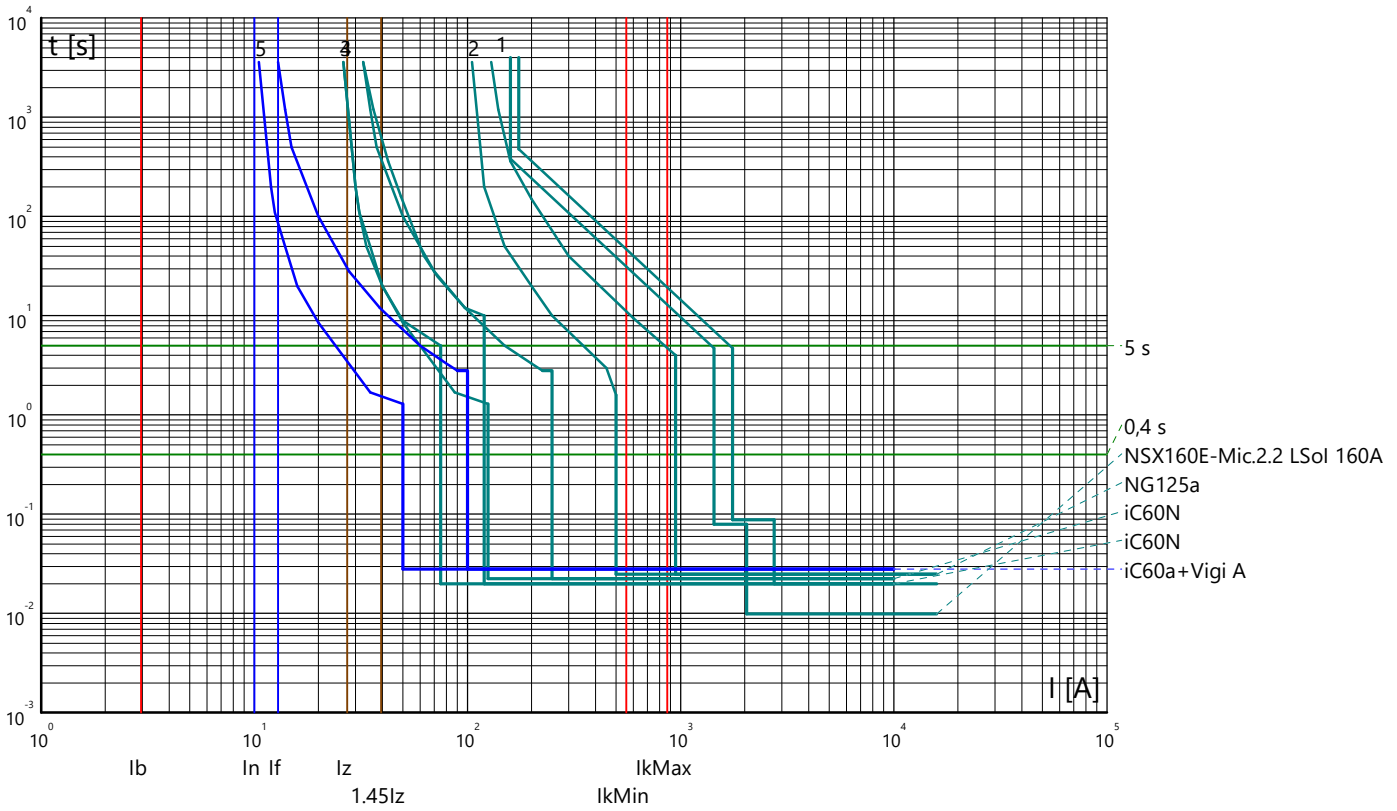

Partenza: 1.23S

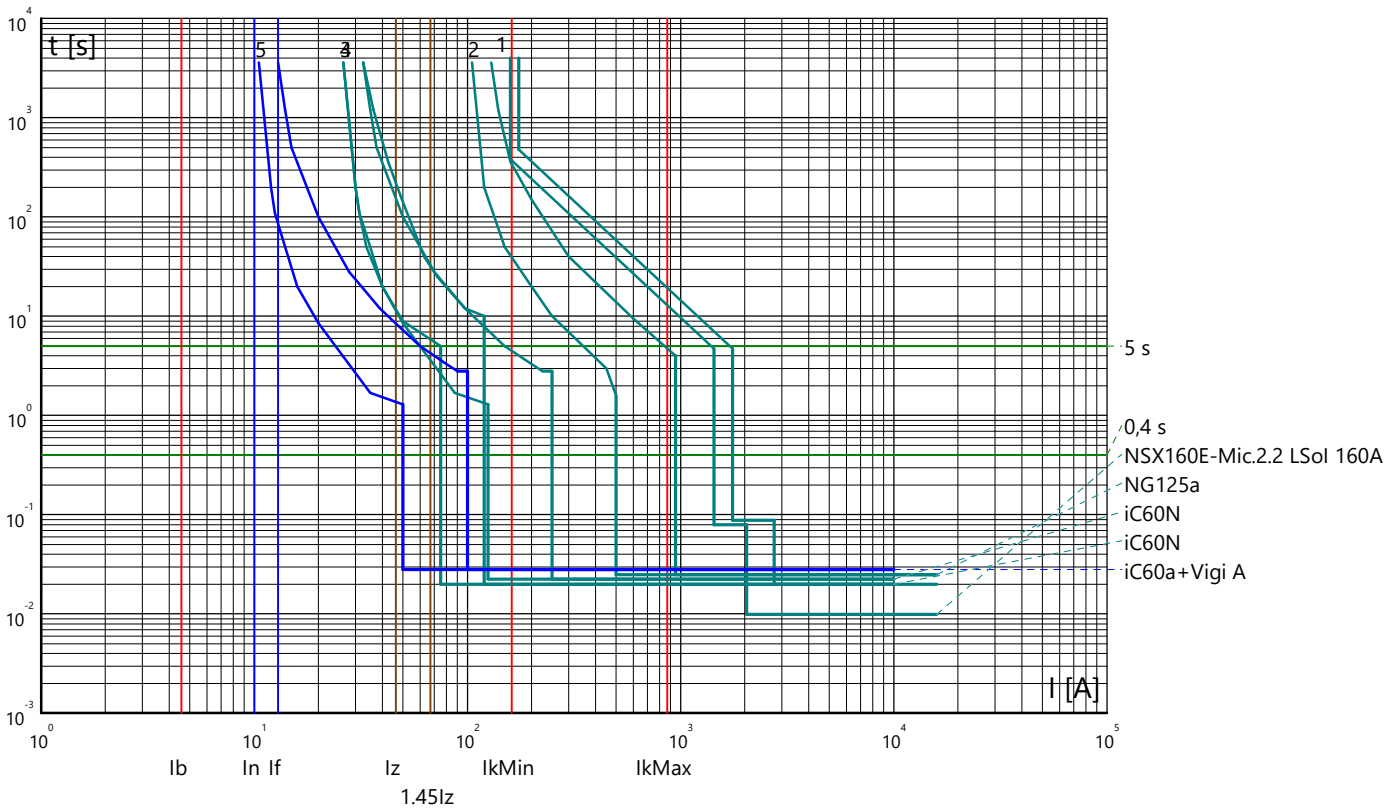

Curve tempo corrente: FERMATA DUGENTA
 Quadro: QUADRO GENERALE B.T.

Partenza: 1.24S

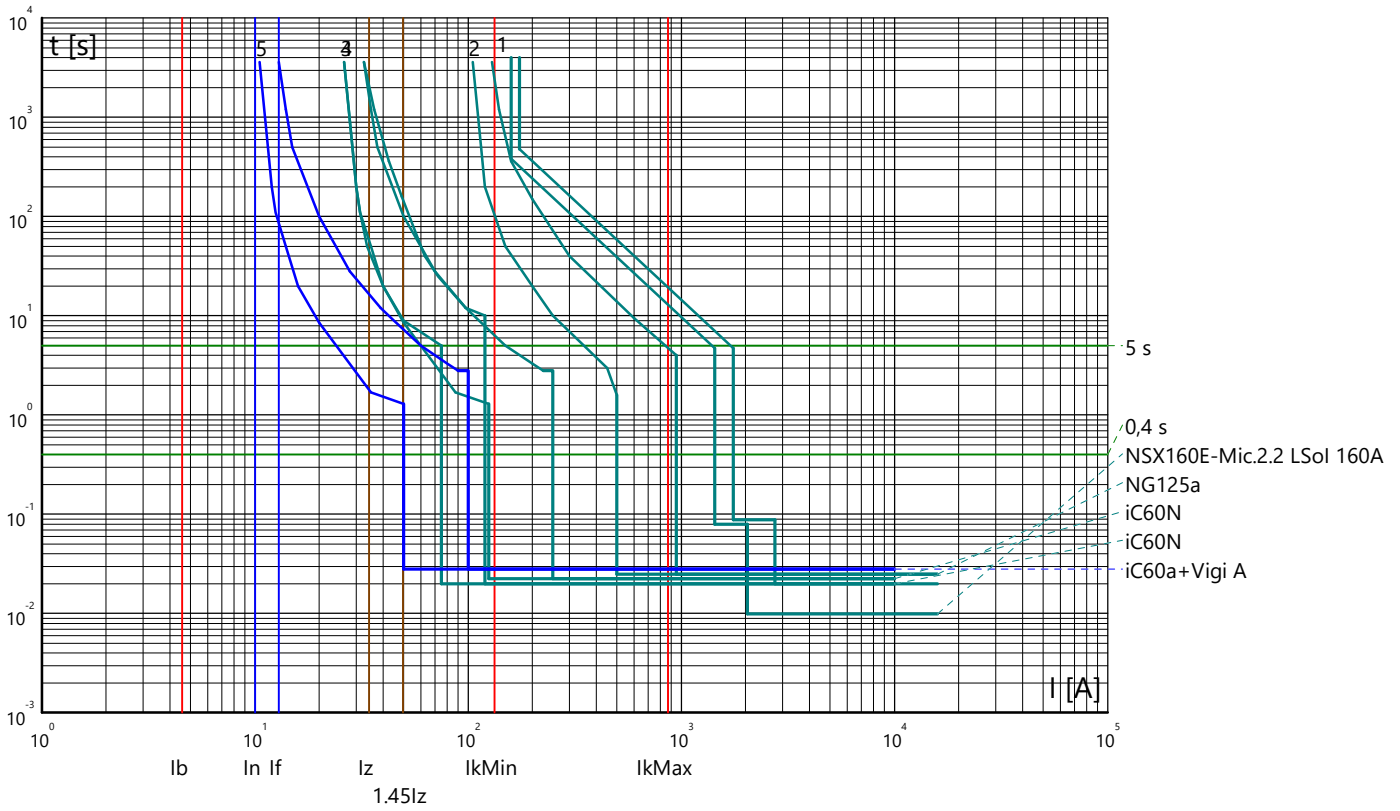

Partenza: 1.25S

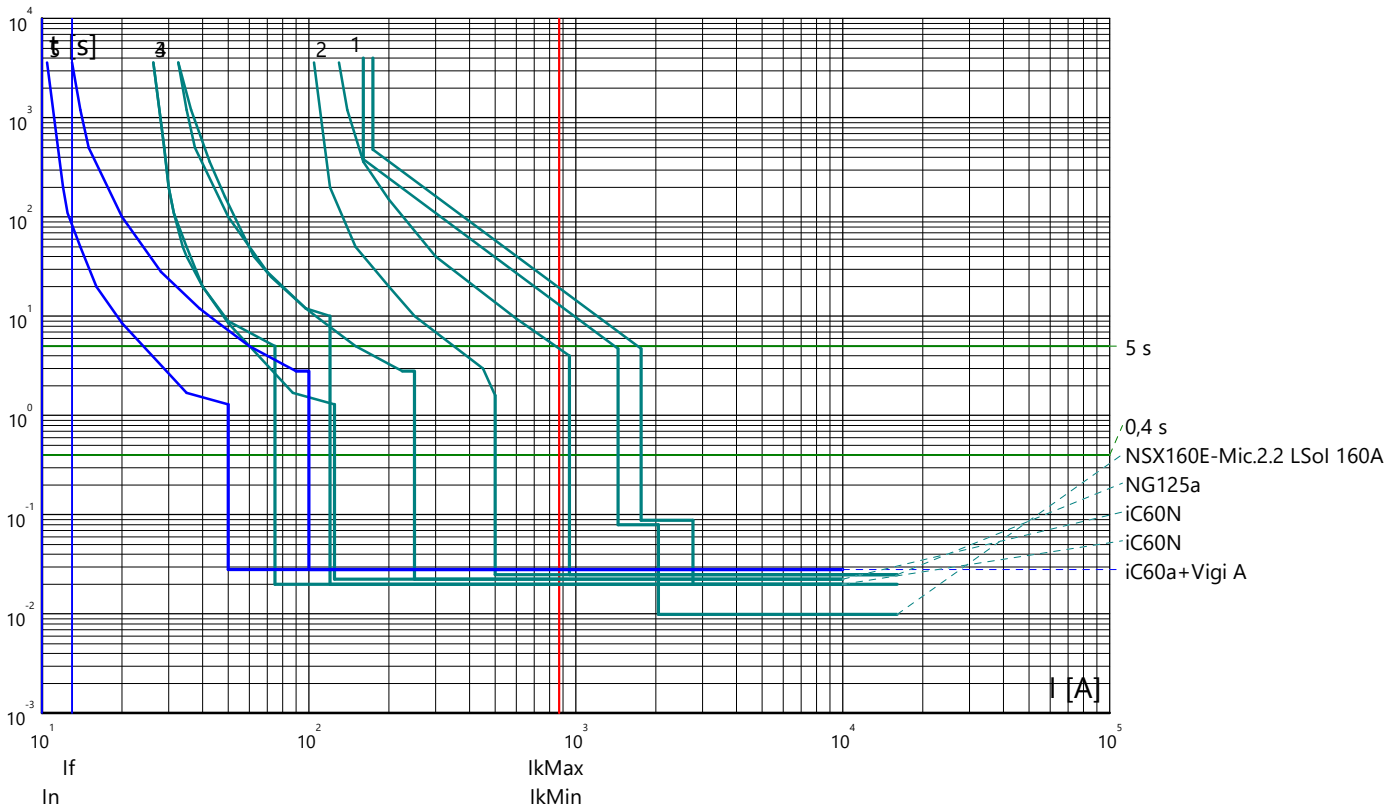

Curve tempo corrente: FERMATA DUGENTA
 Quadro: QUADRO GENERALE B.T.

Partenza: 1.26S

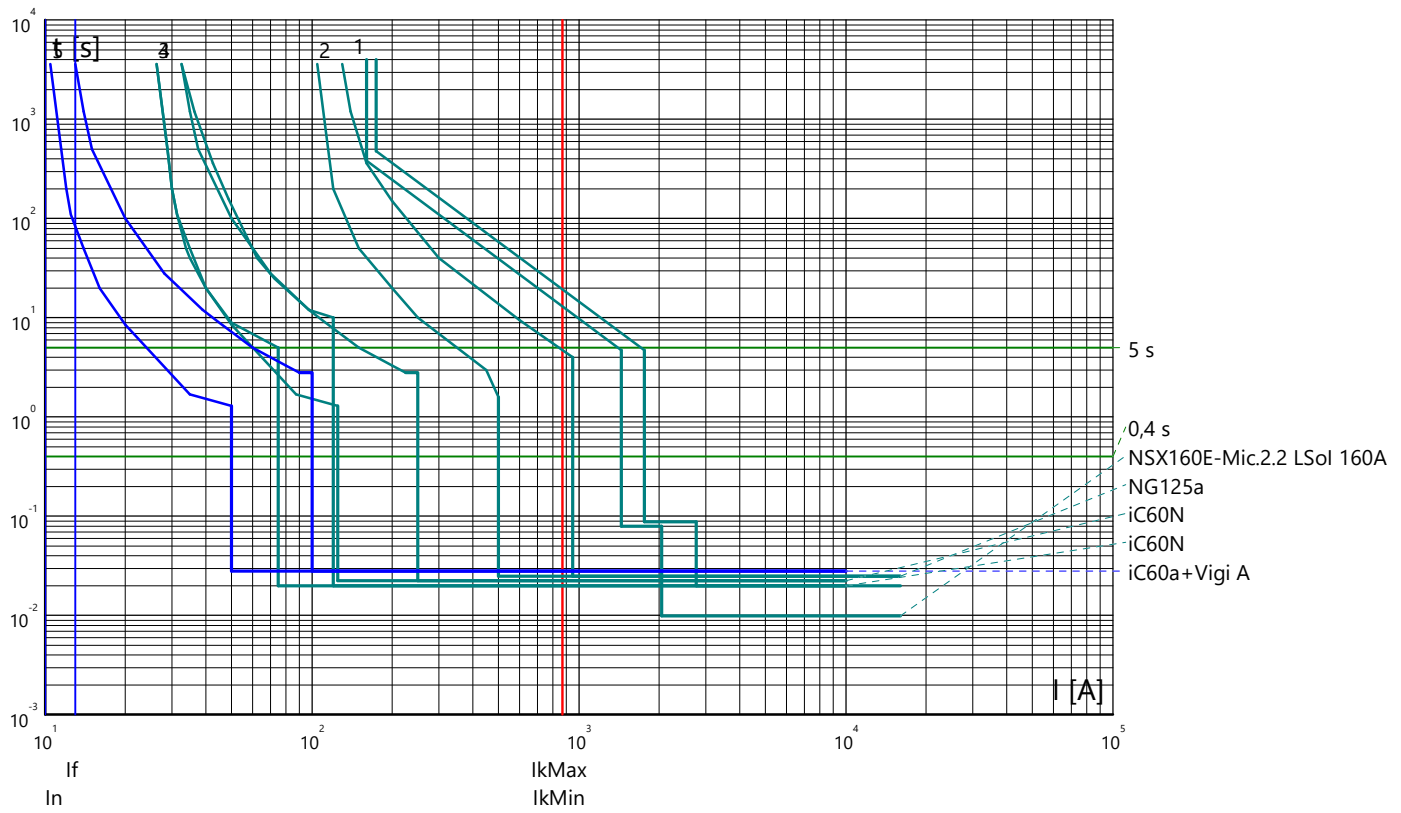

Partenza: 1.27S

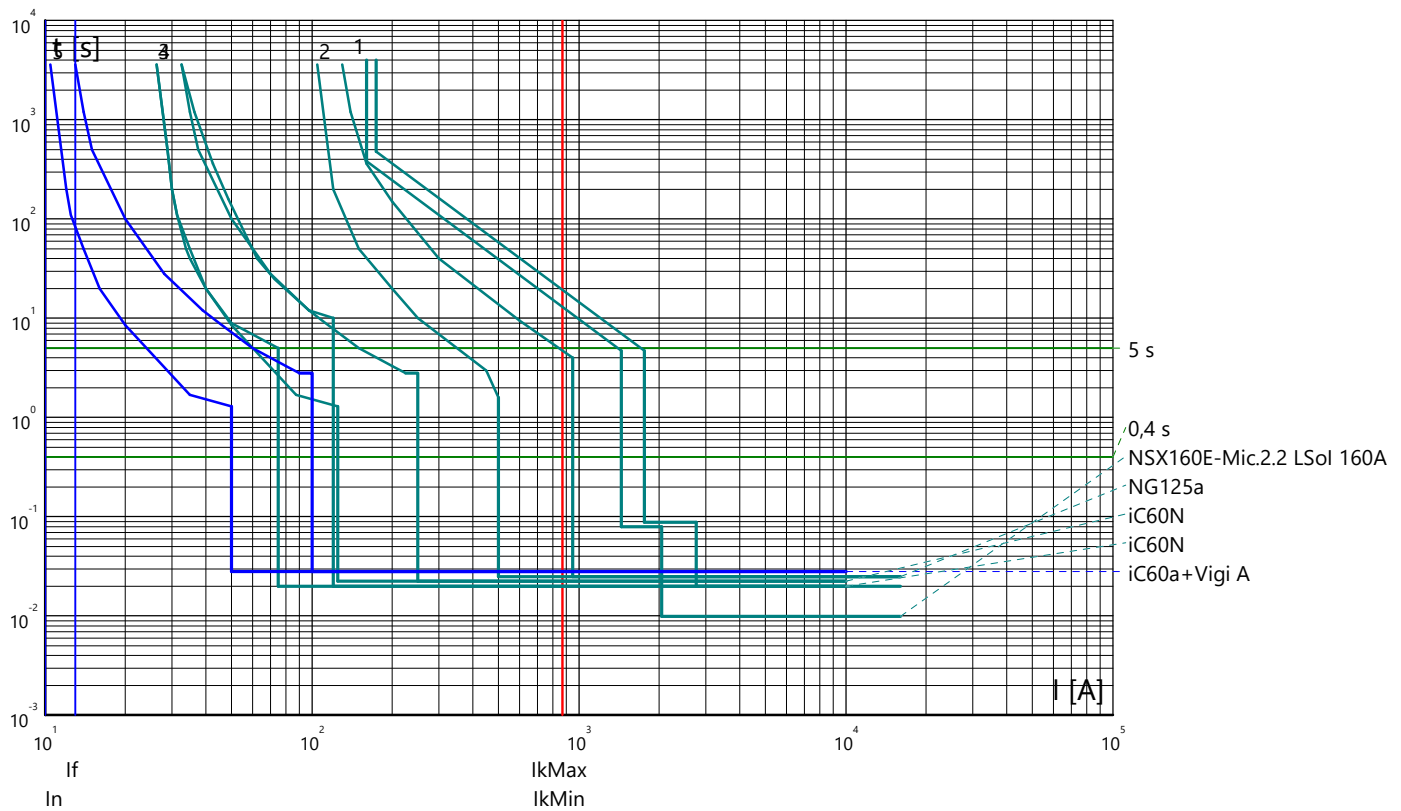

Curve tempo corrente: FERMATA DUGENTA
 Quadro: QUADRO RED

Arrivo: 1.2N

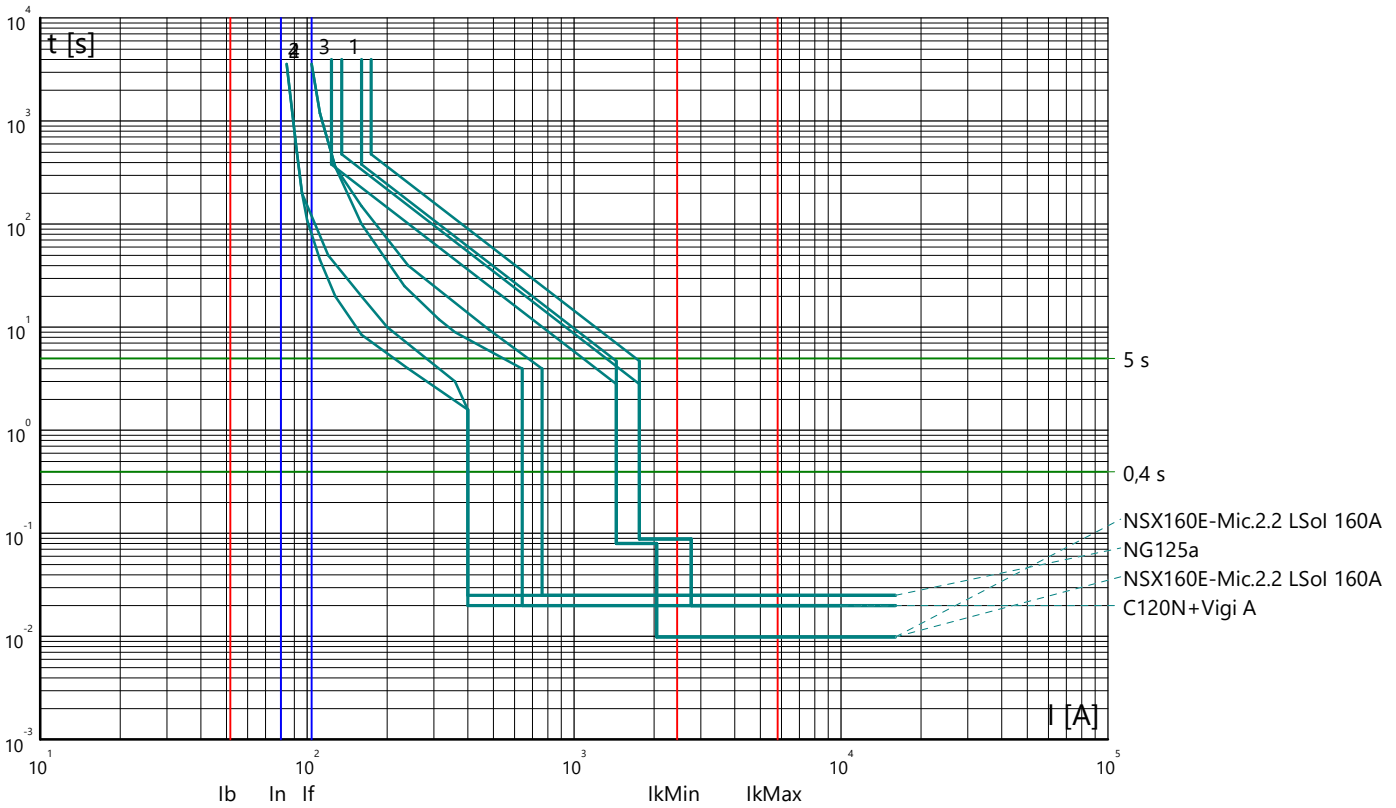

Partenza: PT

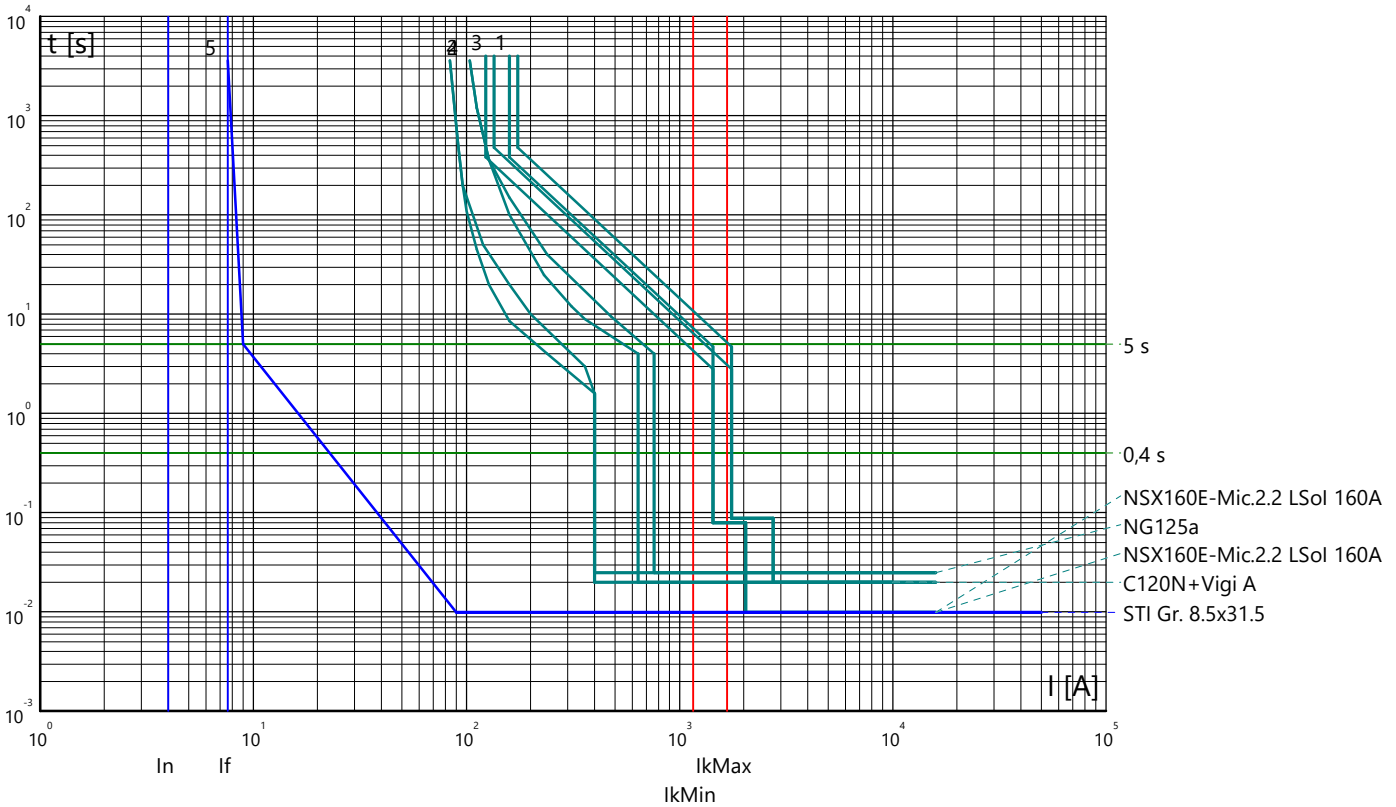

Curve tempo corrente: FERMATA DUGENTA
 Quadro: QUADRO RED

Partenza: MIS

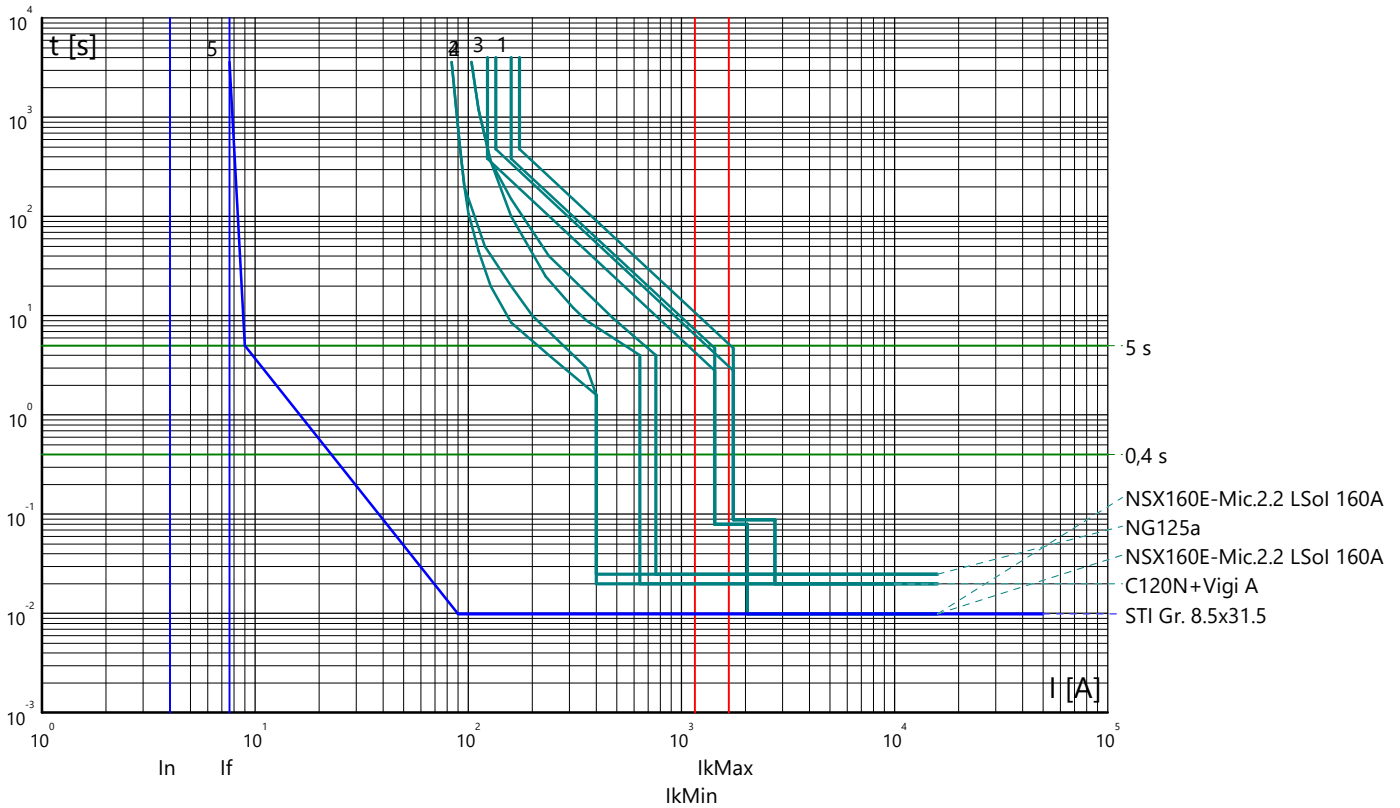

Partenza: 1.2N.1

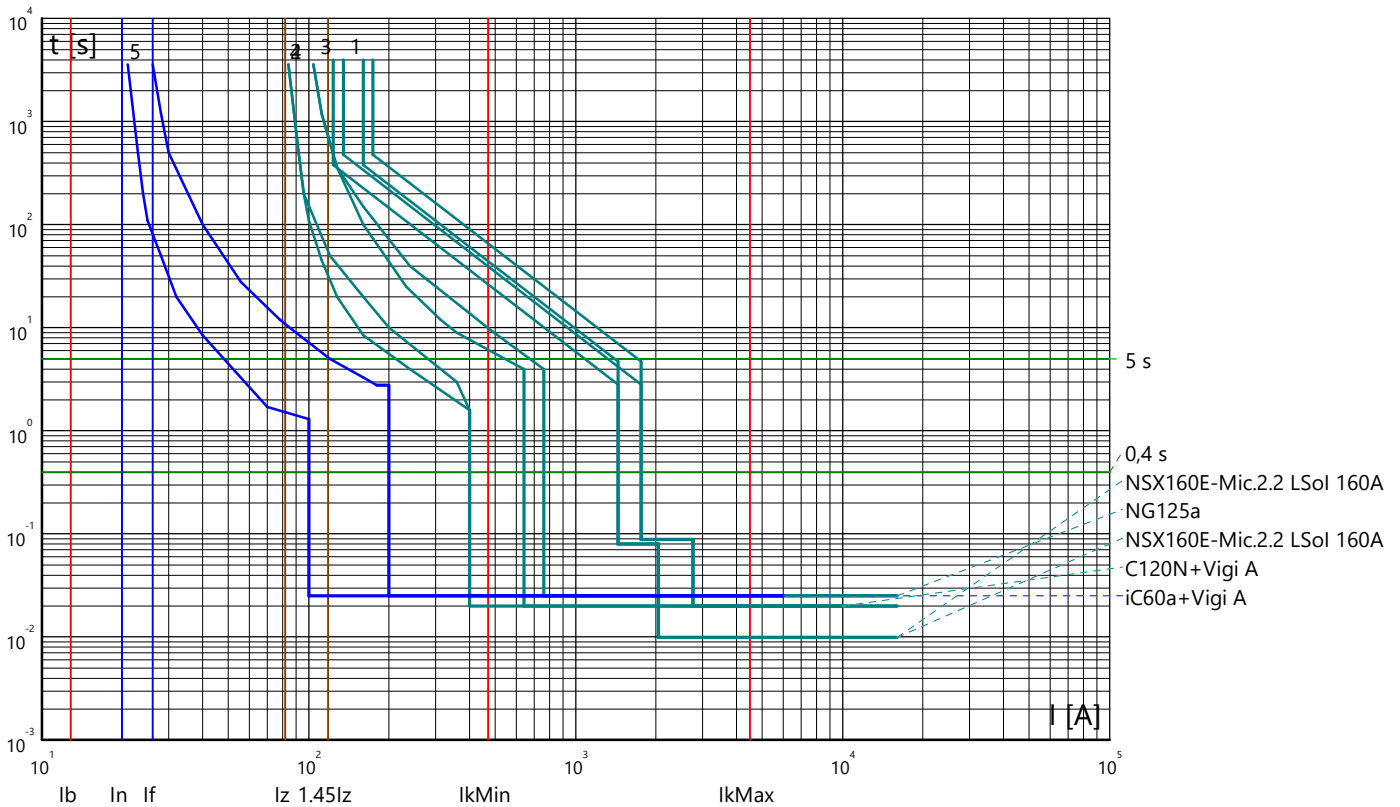

Curve tempo corrente: FERMATA DUGENTA
Quadro: QUADRO RED

Partenza: 1.2N.2

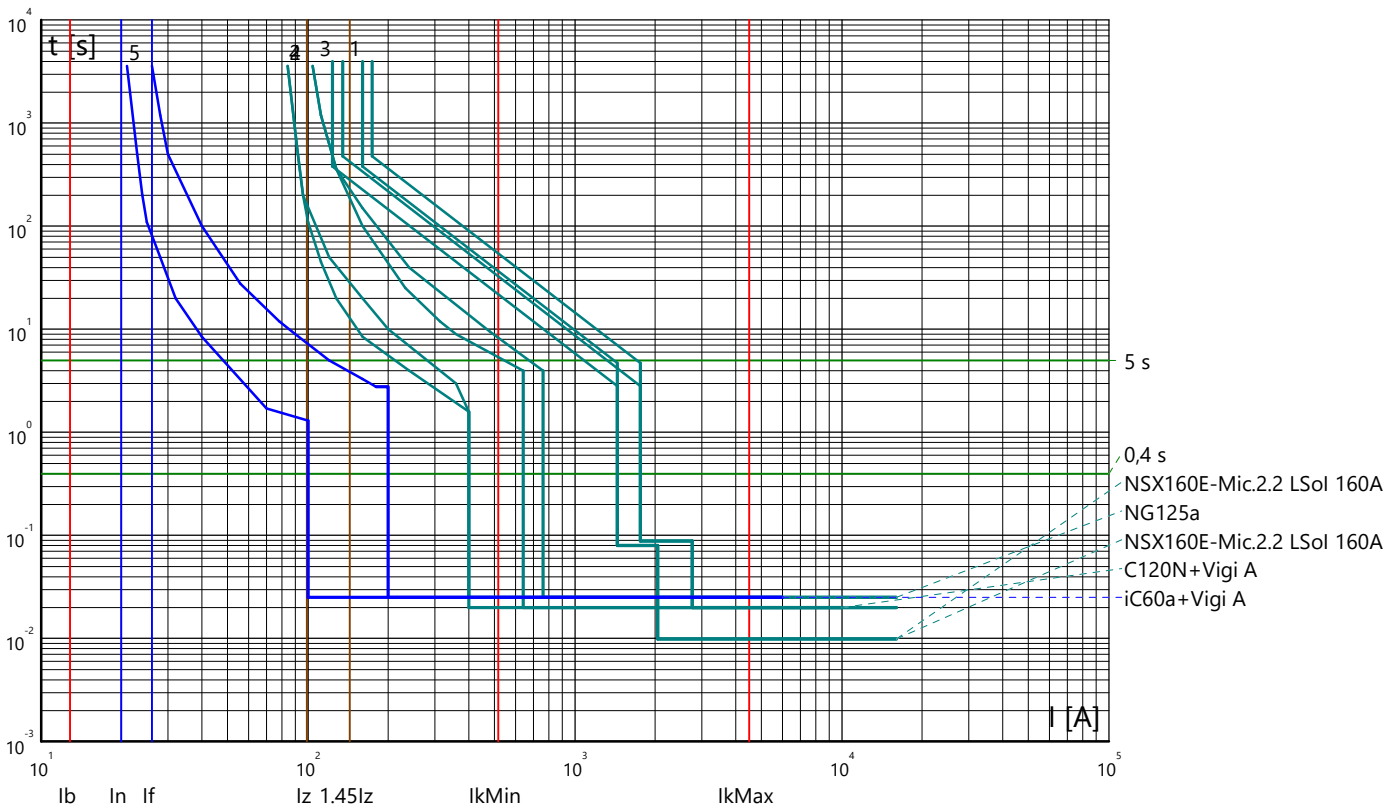

Partenza: 1.2N.3

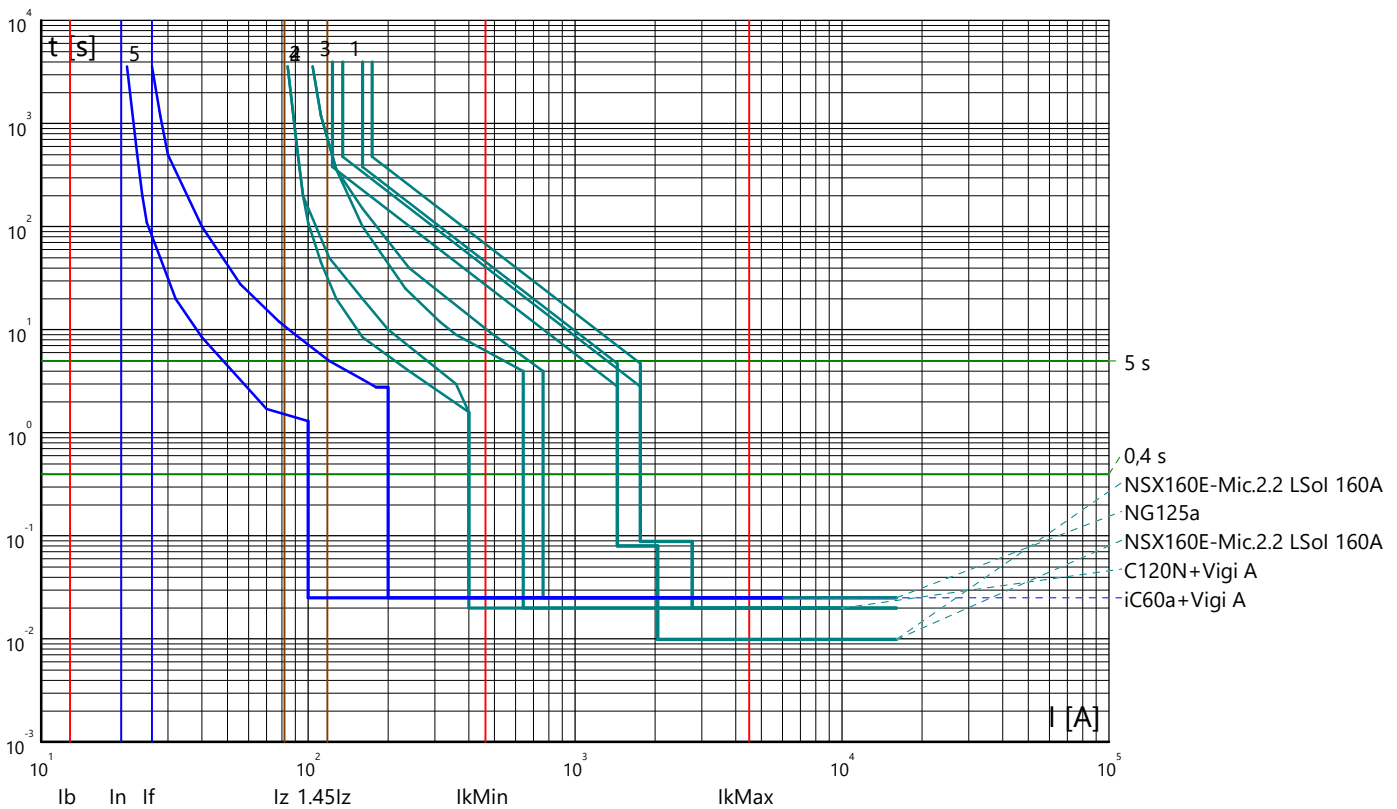

Curve tempo corrente: FERMATA DUGENTA
 Quadro: QUADRO RED

Partenza: 1.2N.4

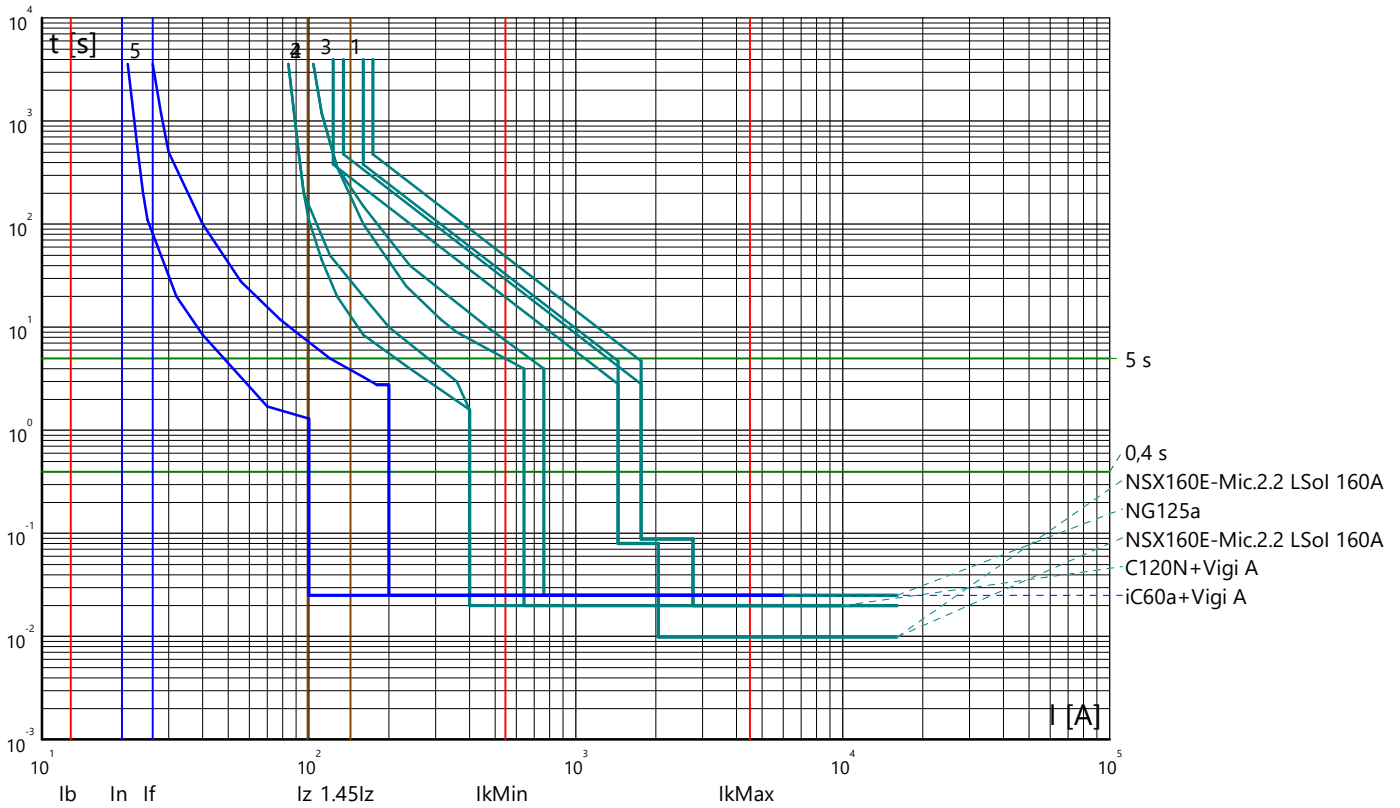

Partenza: 1.2N.5

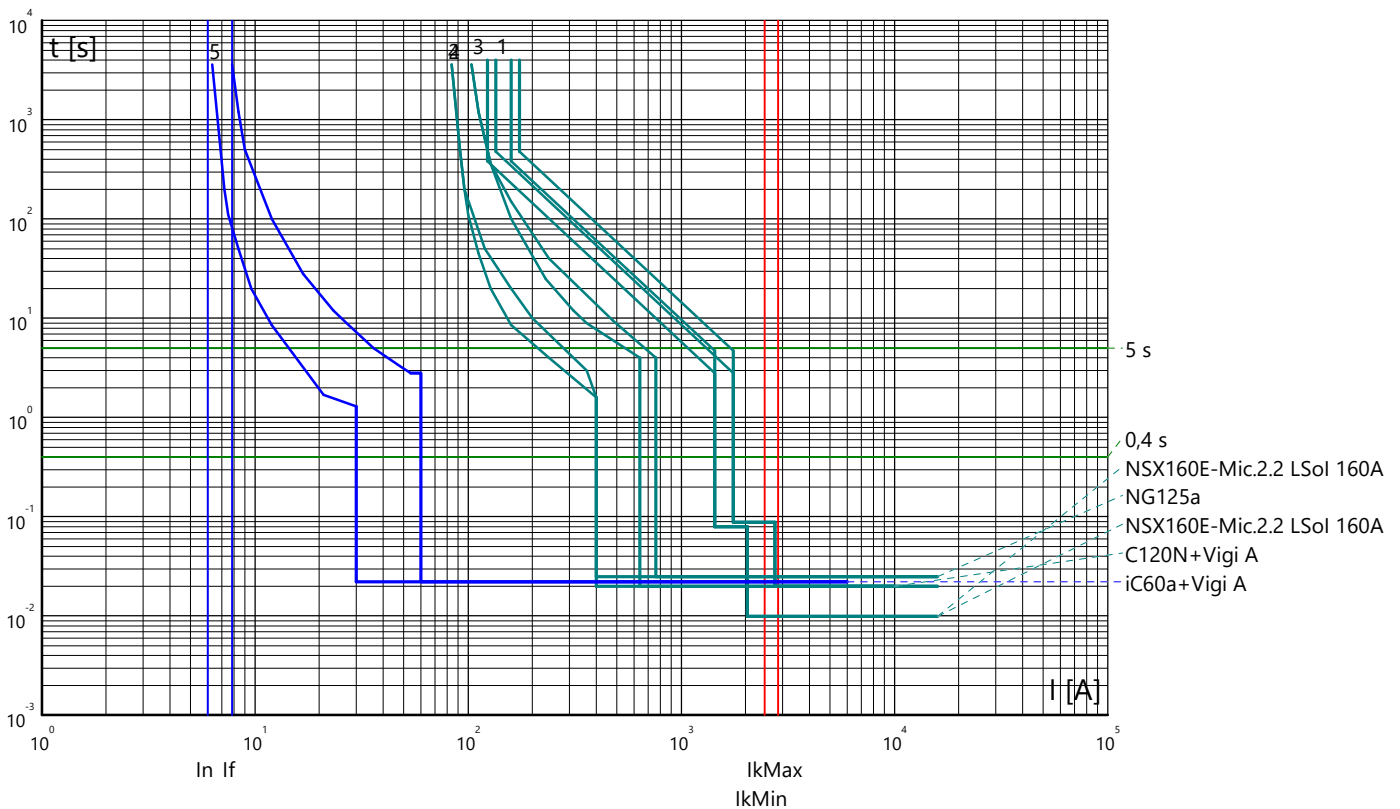

Curve tempo corrente: FERMATA DUGENTA
 Quadro: QUADRO RED

Partenza: 1.2N.6

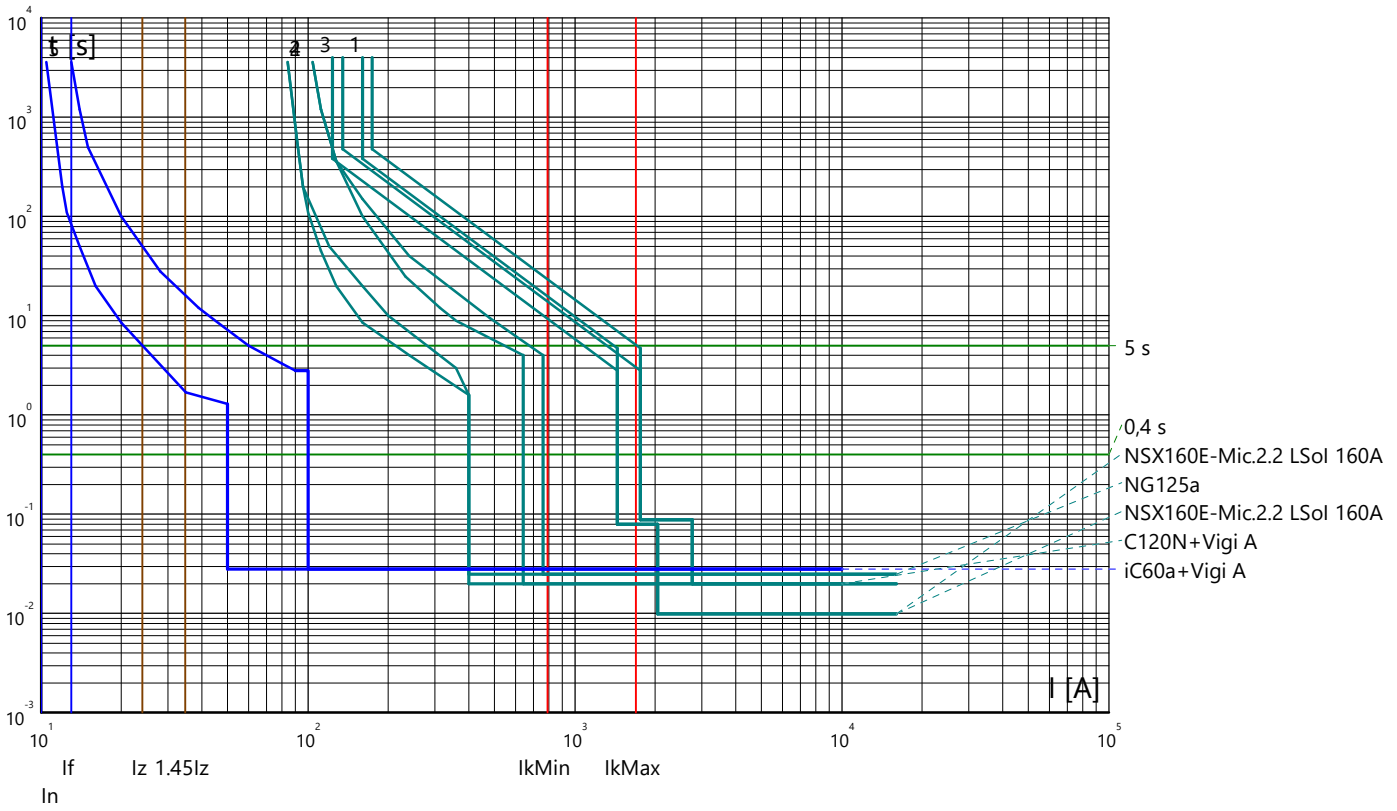

Curve tempo corrente: FERMATA DUGENTA
Fornitura: Fornitura

Fornitura

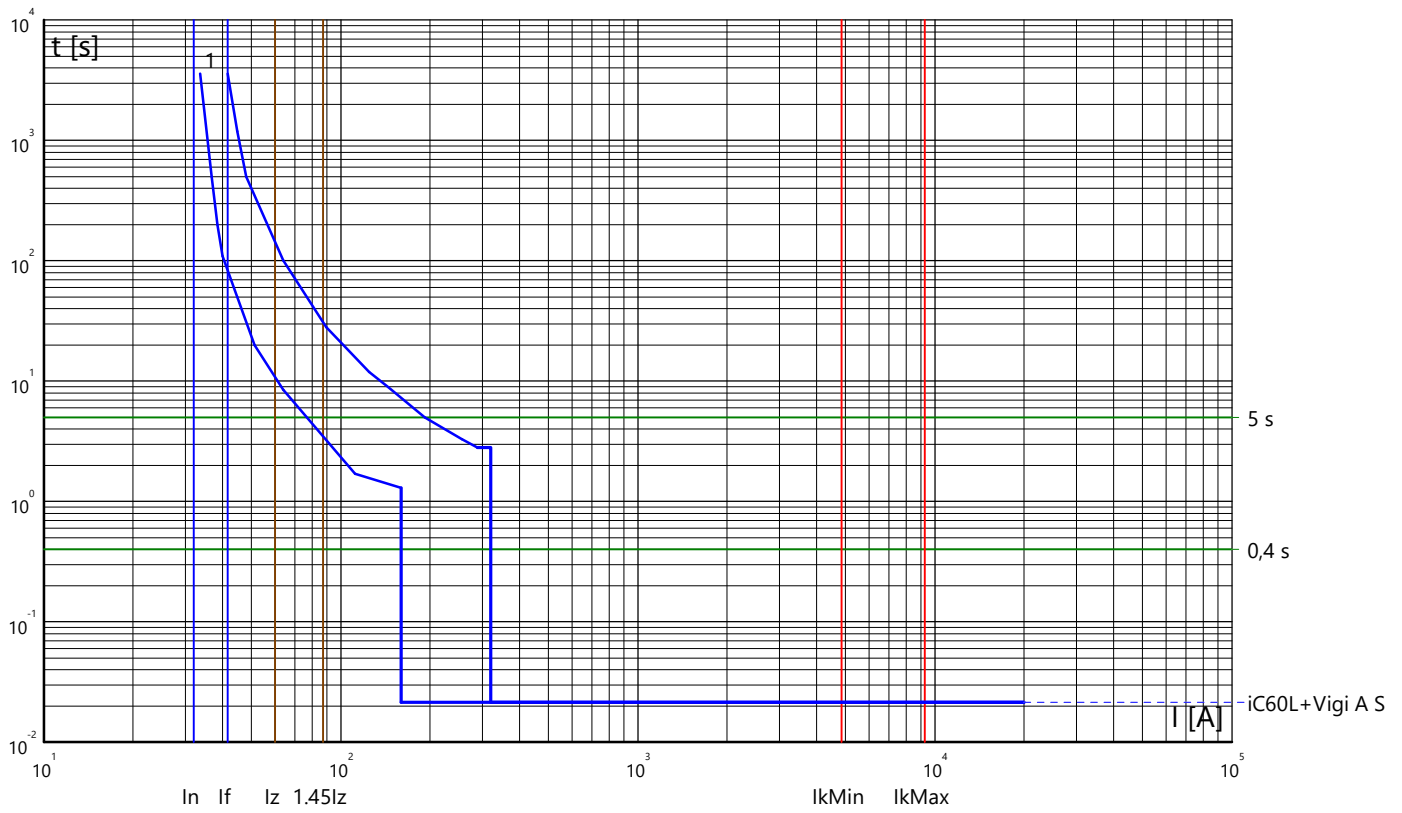

Curve tempo corrente: FERMATA DUGENTA
 Quadro: QUADRO ELETTRICO PARCHEGGIO

Arrivo: IG

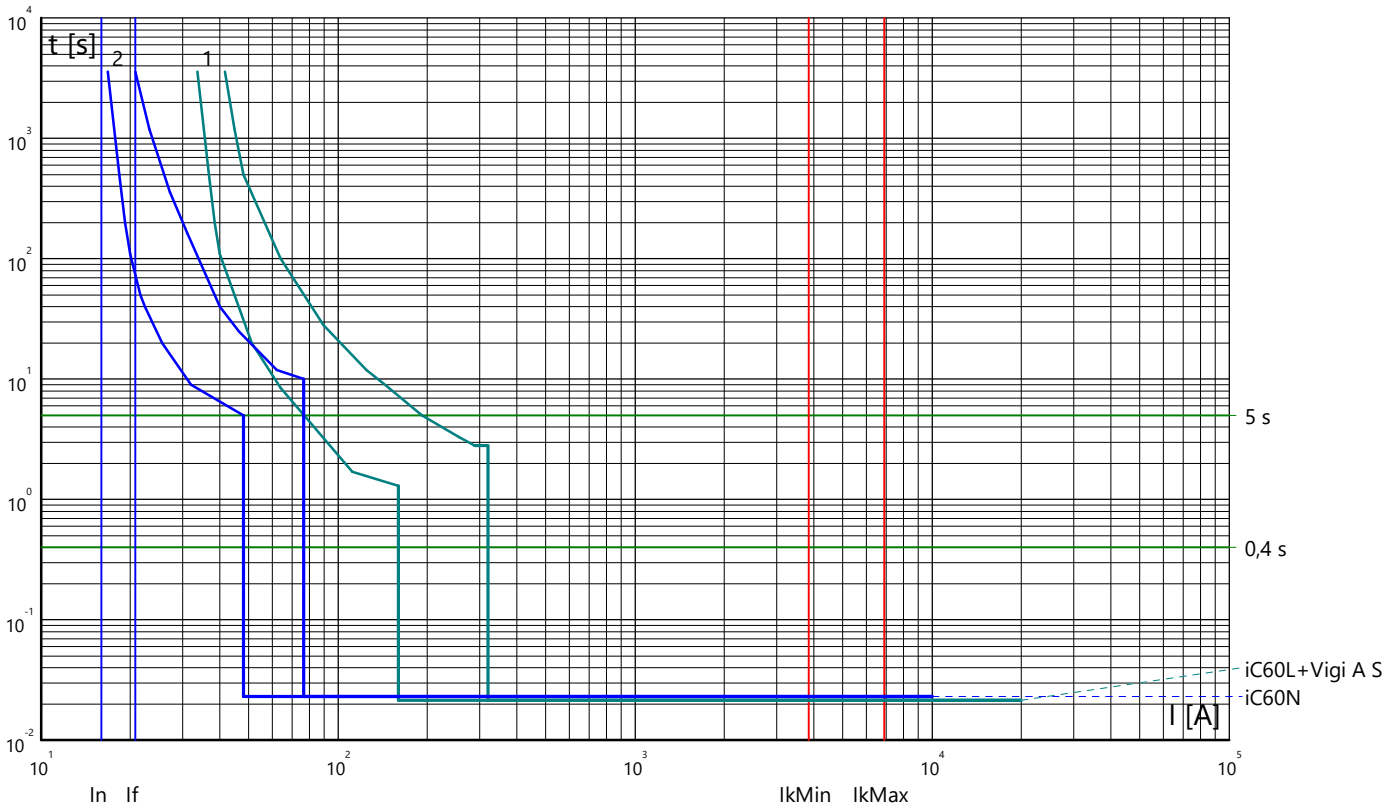

Partenza: PT

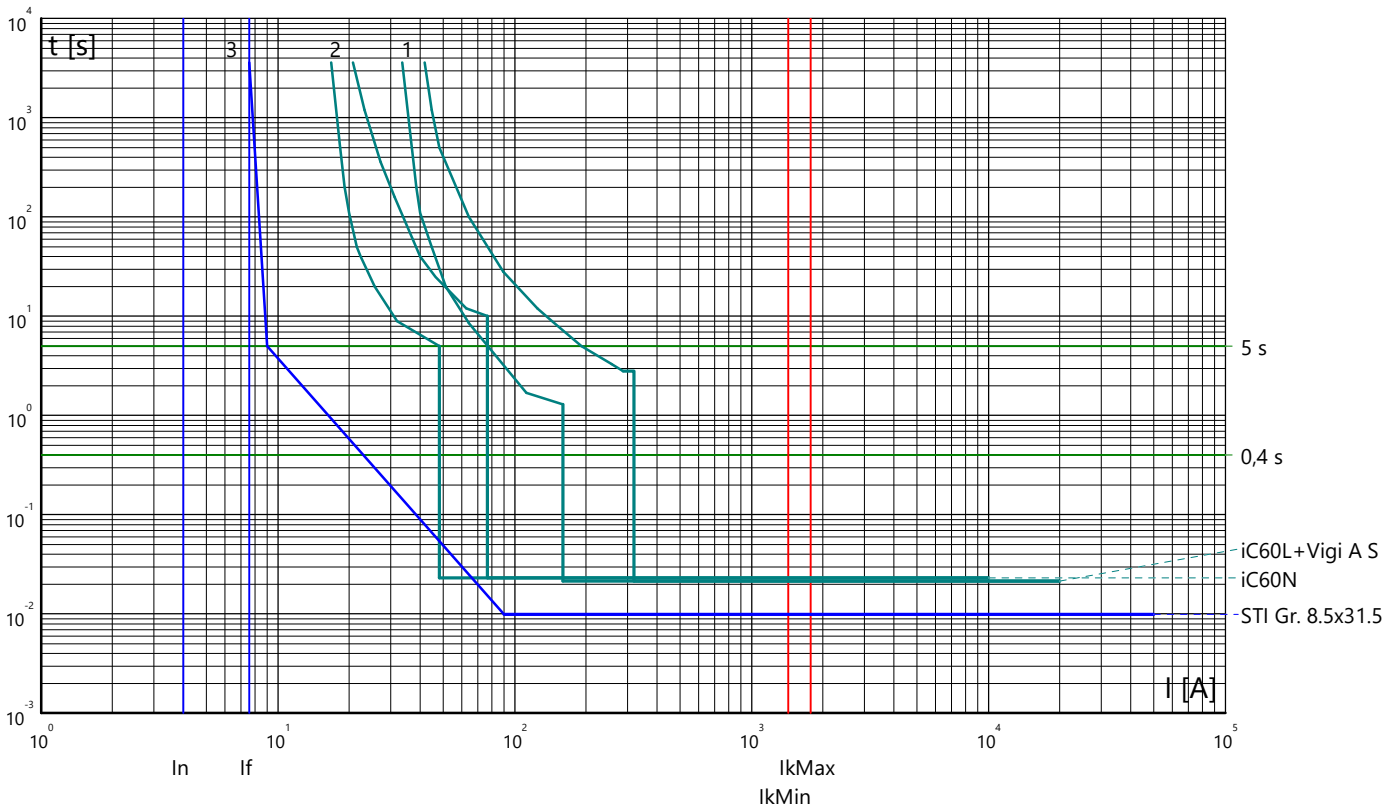

Curve tempo corrente: FERMATA DUGENTA
 Quadro: QUADRO ELETTRICO PARCHEGGIO

Partenza: SPD

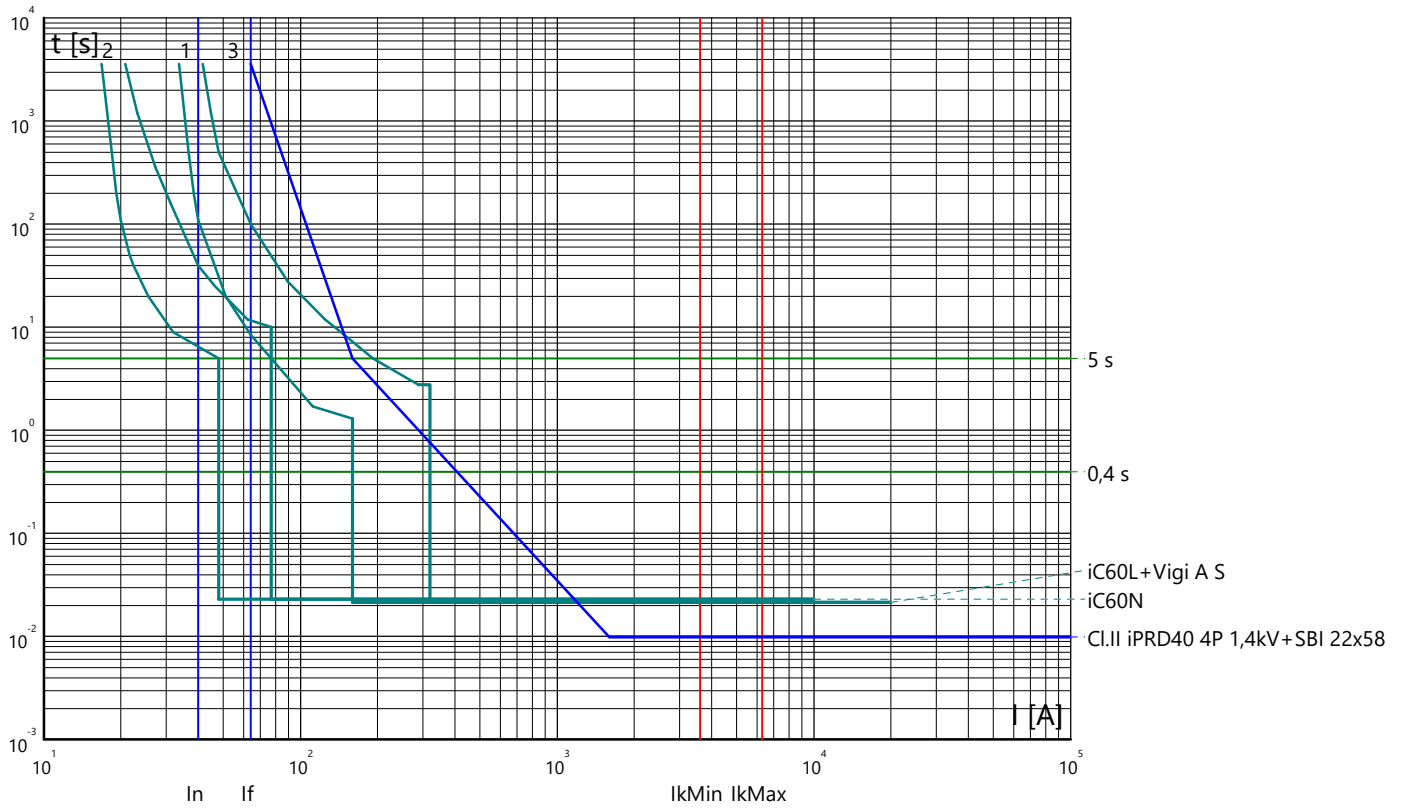

Partenza: MIS

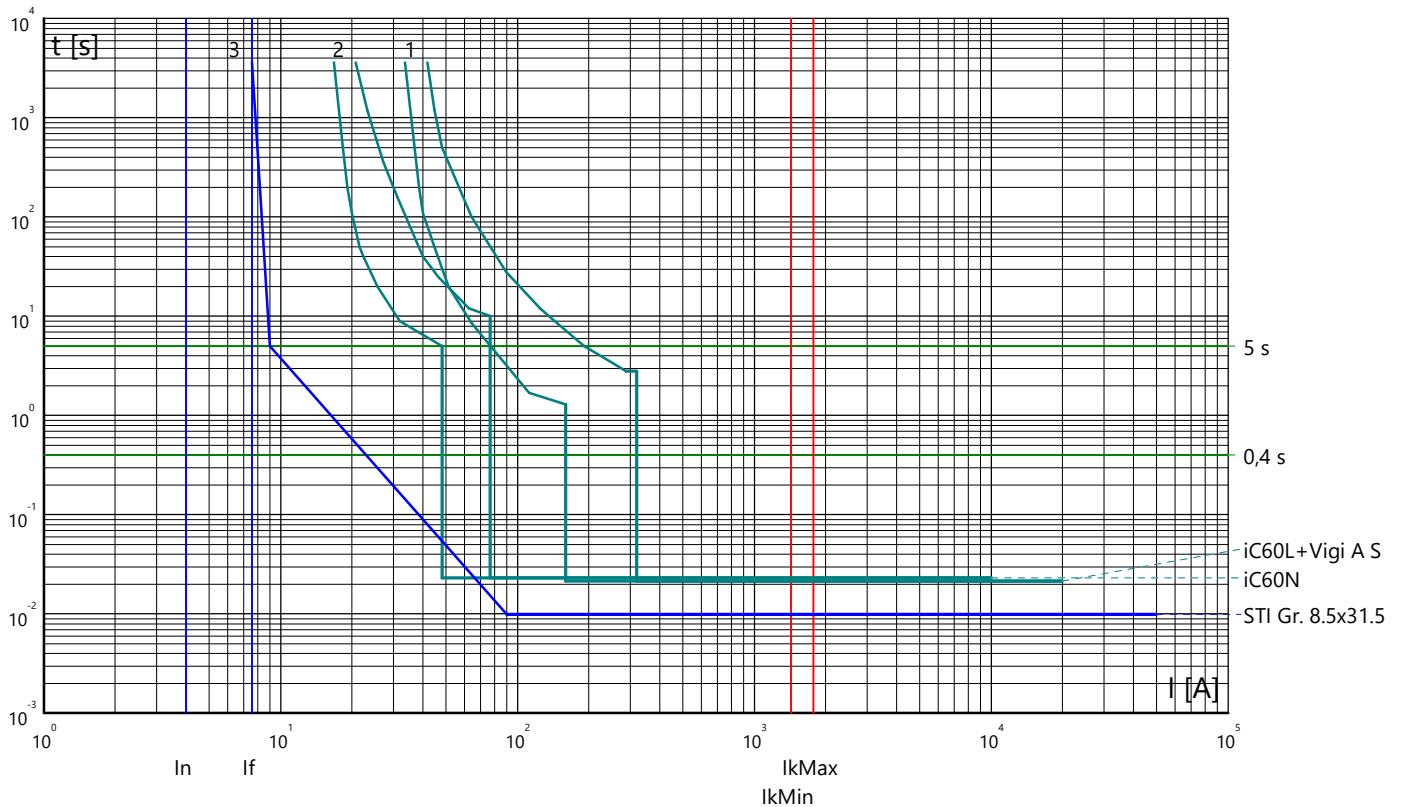

Curve tempo corrente: FERMATA DUGENTA
 Quadro: QUADRO ELETTRICO PARCHEGGIO

Partenza: 1.1

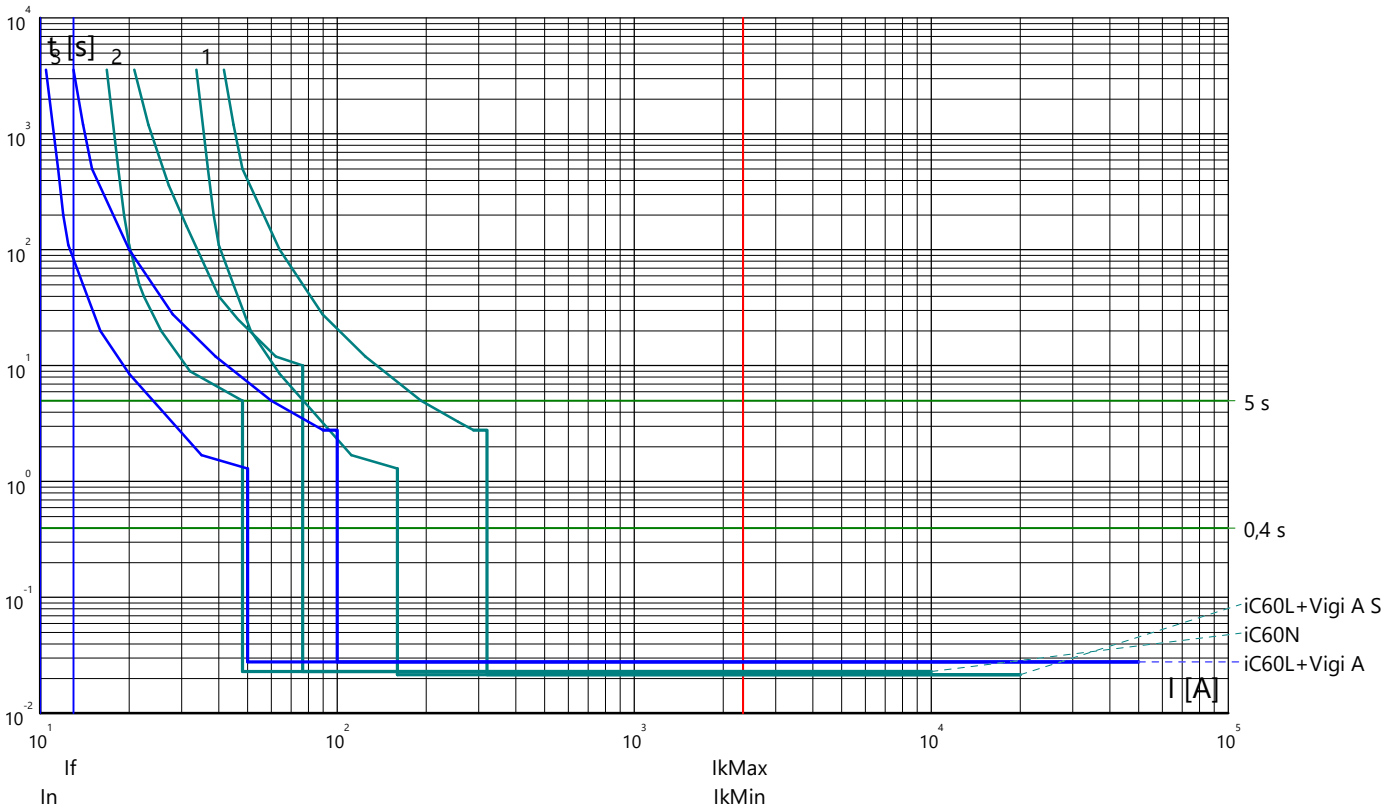

Partenza: S1

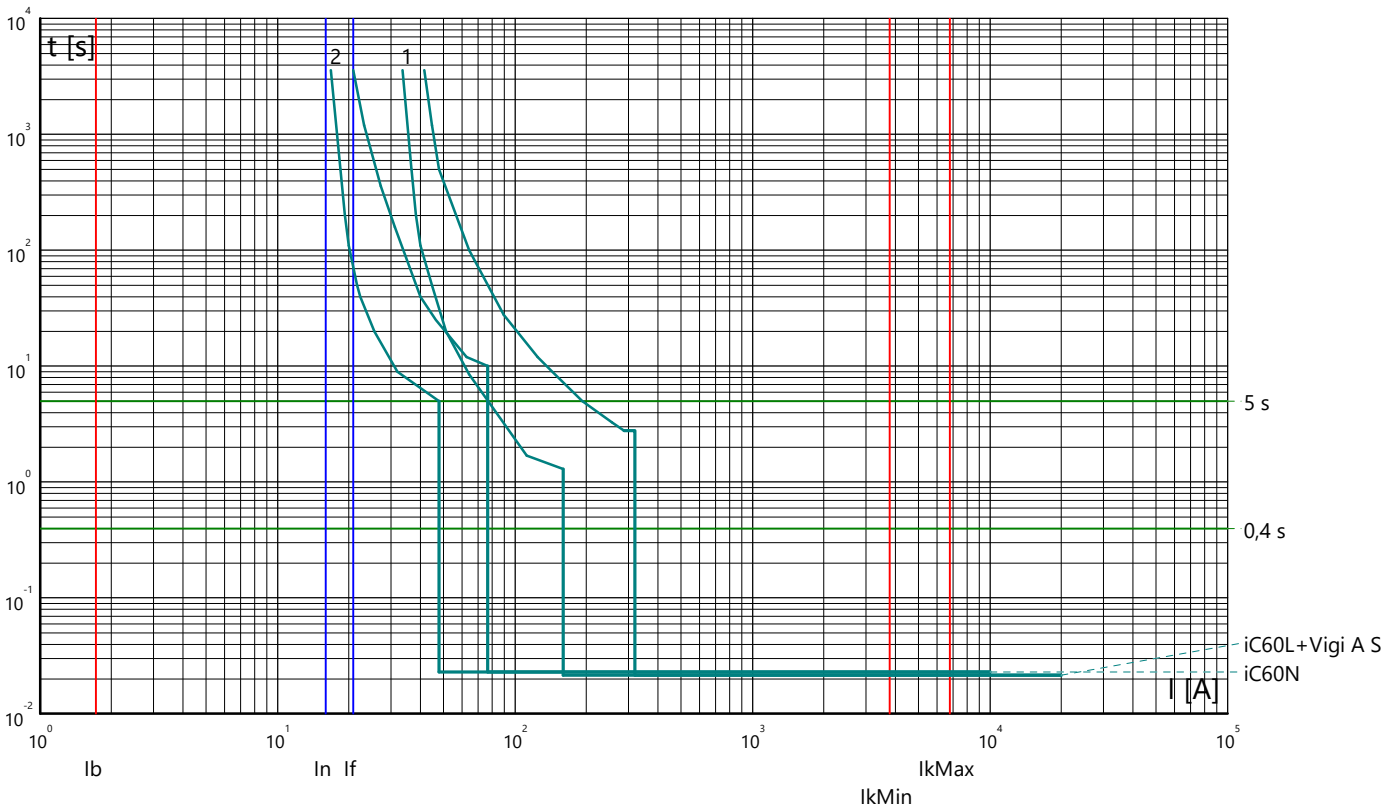

Curve tempo corrente: FERMATA DUGENTA
 Quadro: QUADRO ELETTRICO PARCHEGGIO

Partenza: 1.2

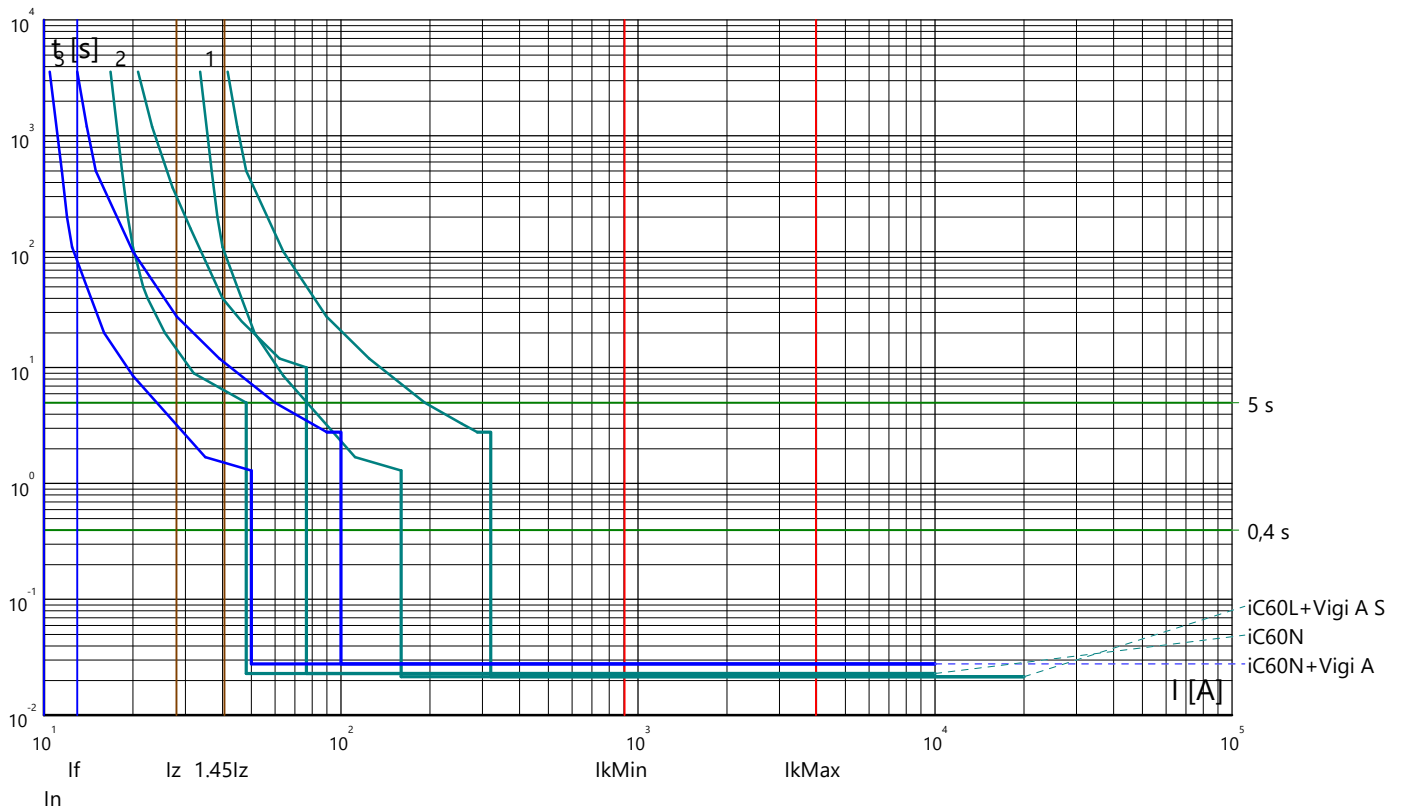

Partenza: 1.3

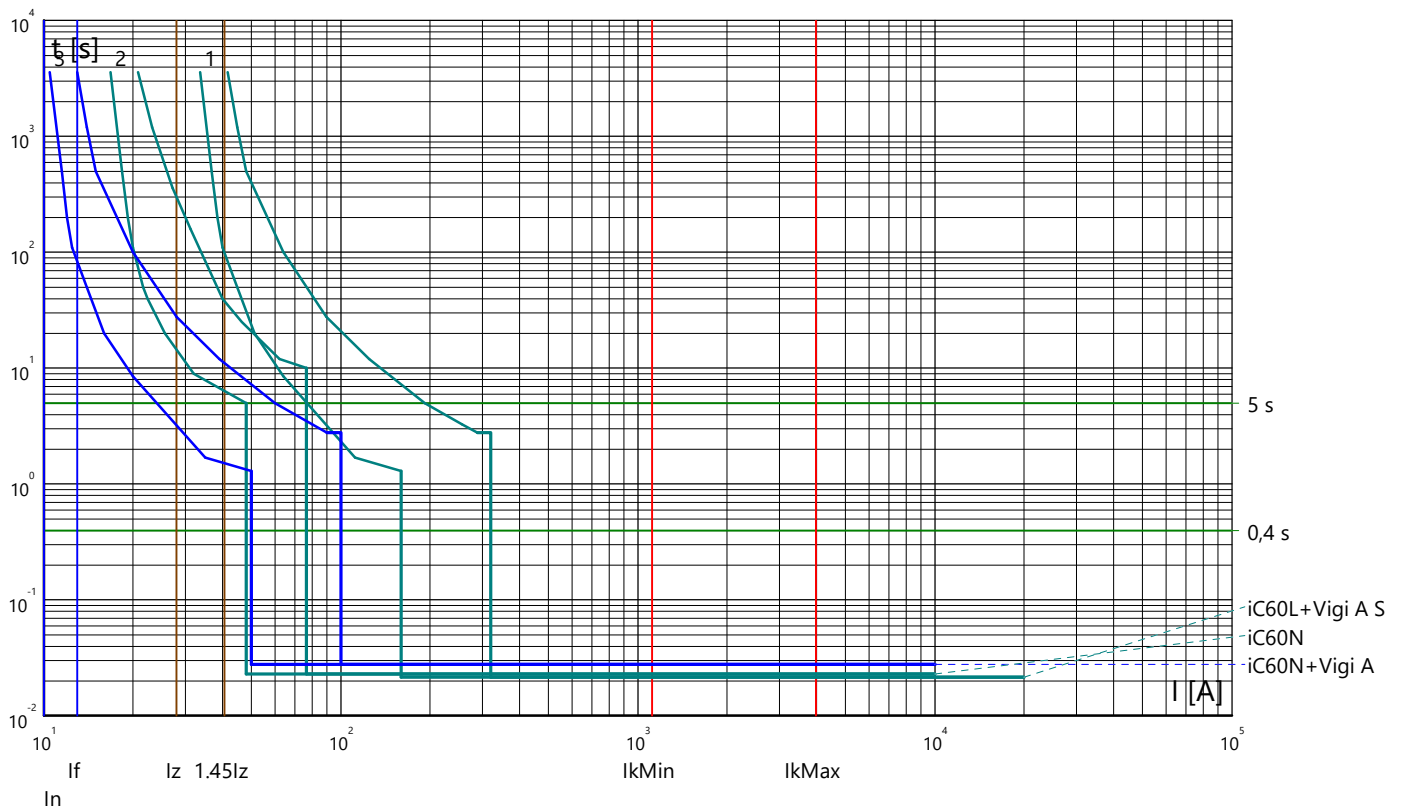

Curve tempo corrente: FERMATA DUGENTA
 Quadro: QUADRO ELETTRICO PARCHEGGIO

Partenza: 1.4

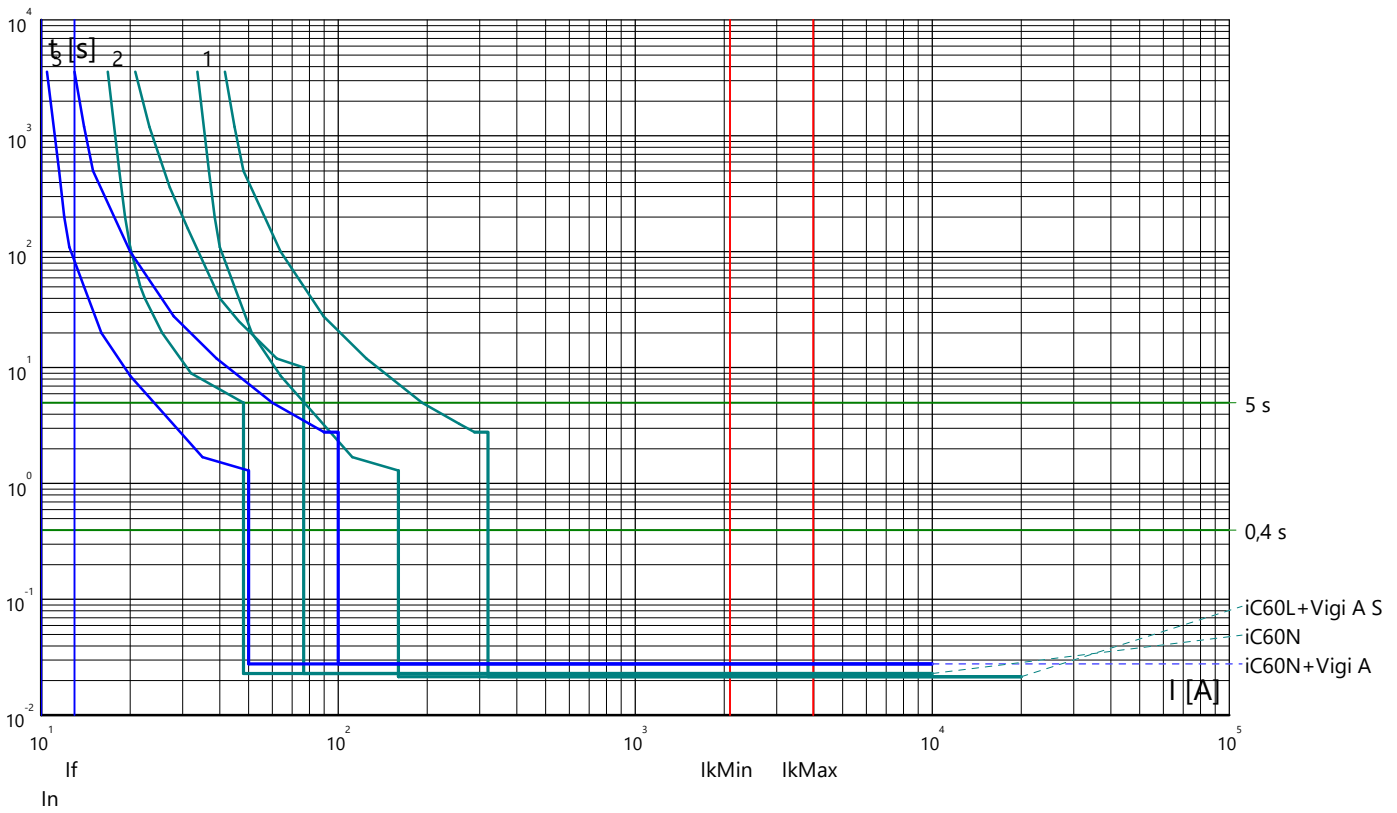

Partenza: 1.5

