

STAZIONE 6408
MAX. D. SPANDO 412,73m
MINORI: 112+125,00

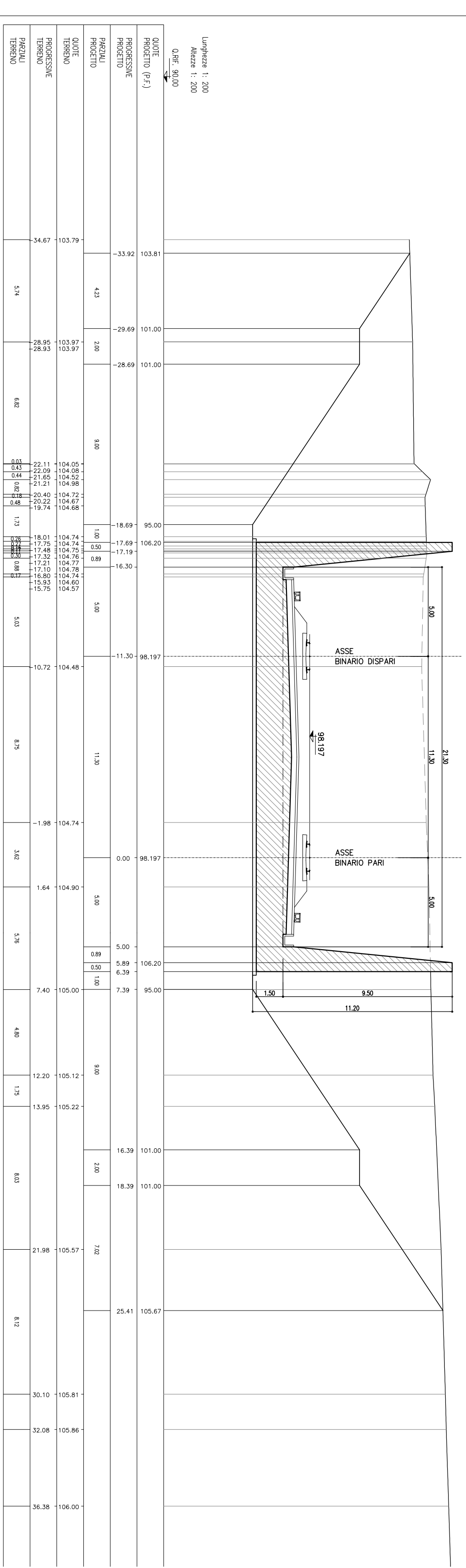

STAZIONE 6409
MAX. D. SPANDO 341,15m
MINORI: 112+143,00

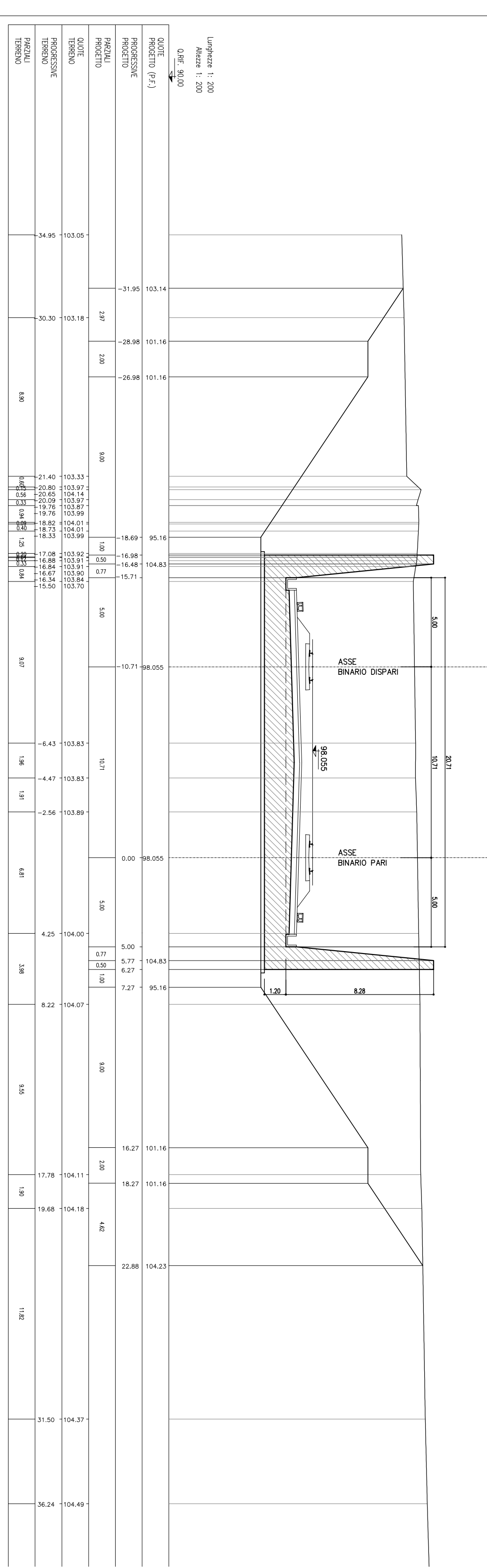

STAZIONE 6406
MAX. D. SPANDO 223,79m
MINORI: 112+182,00

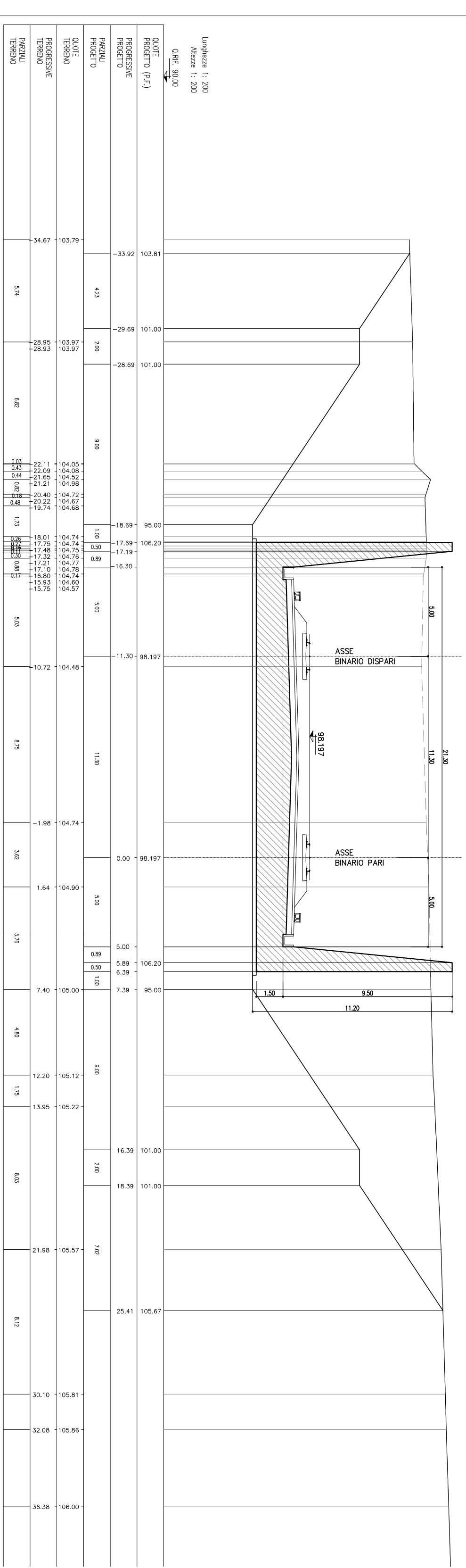

STAZIONE 6409
MAX. D. SPANDO 201,43m
MINORI: 112+193,00

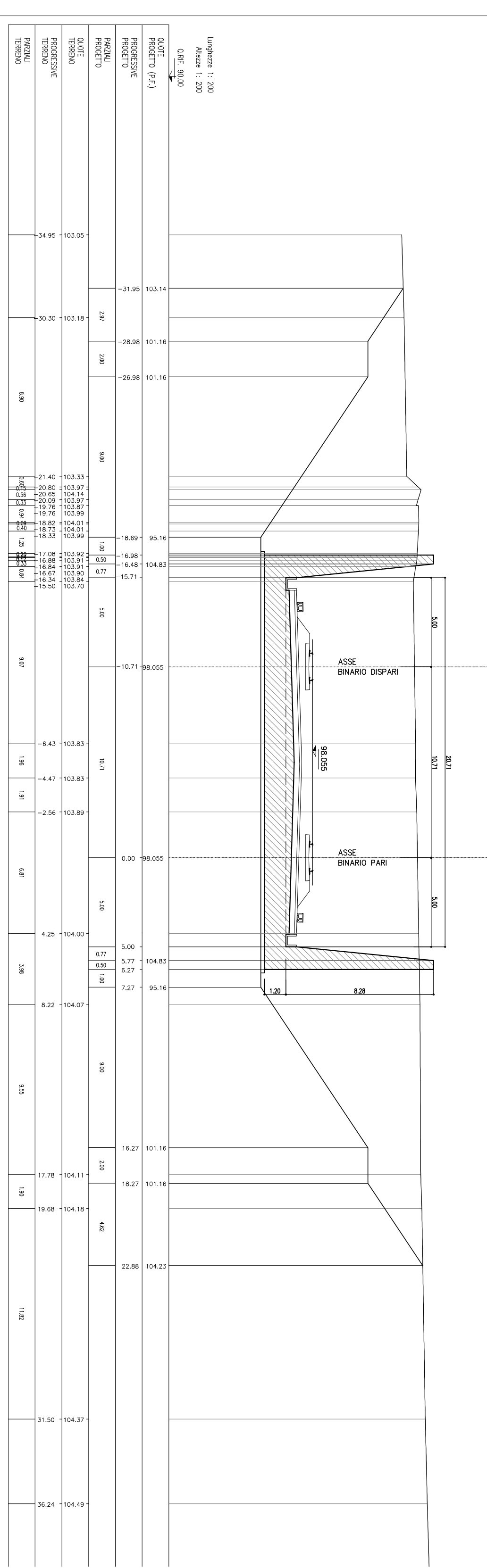

CARATTERISTICHE DEI MATERIALI

NOTE GENERALI

COMITENTE:



ALTA SORREGGIANZA



GENERAL CONTRACTOR:



INFRASTRUTTURE FERROVIARIE STRATEGICHE DEFINITE DALLA
LEGGE OBIETTIVO N. 443/01
LINEA A.V./A.C. TORINO - VENEZIA Tratta MILANO - VERONA
Lotto funzionale Brescia-Verona
PROGETTO DEFINITIVO

GALLERIE ARTIFICIALI
G. A. LONARO EST - PK. 110+787.00
A PK. 112+444.50 - MURO AD "U"
PK. 112+111.50 A PK. 112+193.10
SEZIONI TRASVERSALI



PROGETTAZIONE	DATA	REVISIONE	REDAZIONE	DATA
0	31/03/14	EMMISSIONE PER C.A.S.	ITALEN	31/03/14
1			ITALEN	31/03/14
2			ITALEN	31/03/14
3			ITALEN	31/03/14

Scala di riferimento: 1:3

Logo of the European Union and the text 'Funding provided by the European Union'.

Solebani S.p.A. COMM. 032121
Capow d'Ingegnieri
Via F. Lombardi