

SEZIONE LONGITUDINALE
SCALA 1:200

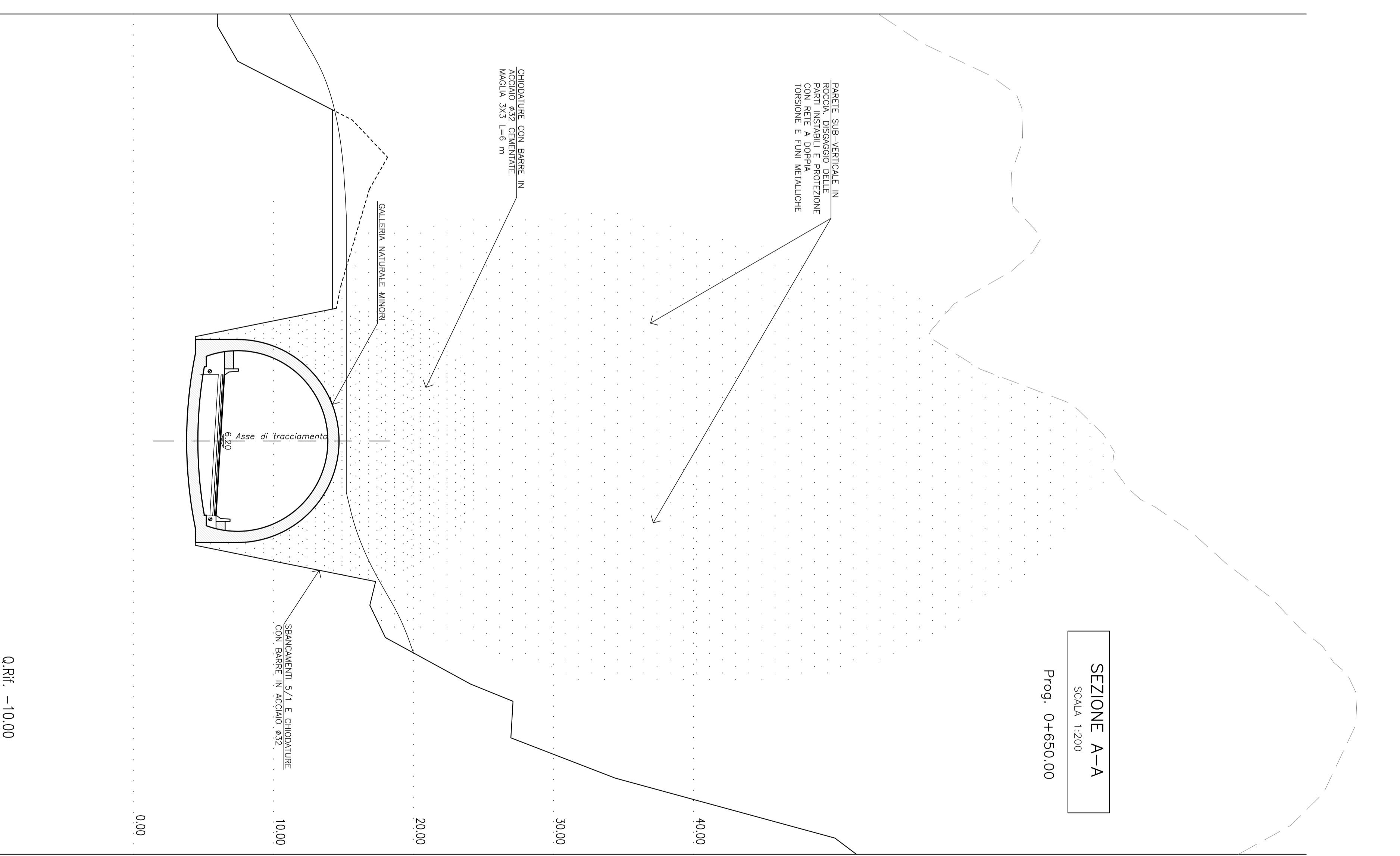

SEZIONE B-B
SCALA 1:200
Prog. 0+660.00

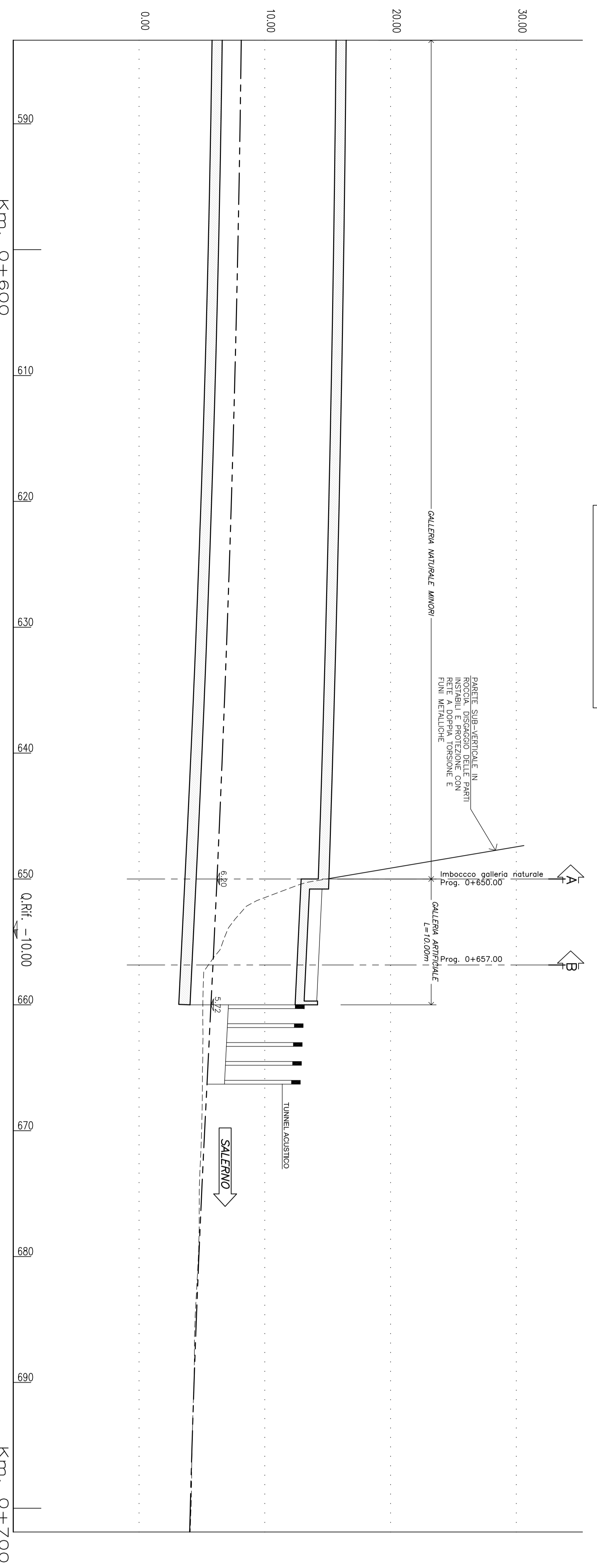

TABELLA MATERIALI — OPERE DI IMBOCCO

DESCRIZIONE DEL MATERIALE

- Acciaio laminato a caldo S235JR, S275JR, S355JR, S355K2, S460ML, S460MLK2, S550ML, S550MLK2, S690ML, S690MLK2, S690MLK3, S690MLK4, S690MLK5, S690MLK6, S690MLK7, S690MLK8, S690MLK9, S690MLK10, S690MLK11, S690MLK12, S690MLK13, S690MLK14, S690MLK15, S690MLK16, S690MLK17, S690MLK18, S690MLK19, S690MLK20, S690MLK21, S690MLK22, S690MLK23, S690MLK24, S690MLK25, S690MLK26, S690MLK27, S690MLK28, S690MLK29, S690MLK30, S690MLK31, S690MLK32, S690MLK33, S690MLK34, S690MLK35, S690MLK36, S690MLK37, S690MLK38, S690MLK39, S690MLK40, S690MLK41, S690MLK42, S690MLK43, S690MLK44, S690MLK45, S690MLK46, S690MLK47, S690MLK48, S690MLK49, S690MLK50, S690MLK51, S690MLK52, S690MLK53, S690MLK54, S690MLK55, S690MLK56, S690MLK57, S690MLK58, S690MLK59, S690MLK60, S690MLK61, S690MLK62, S690MLK63, S690MLK64, S690MLK65, S690MLK66, S690MLK67, S690MLK68, S690MLK69, S690MLK70, S690MLK71, S690MLK72, S690MLK73, S690MLK74, S690MLK75, S690MLK76, S690MLK77, S690MLK78, S690MLK79, S690MLK80, S690MLK81, S690MLK82, S690MLK83, S690MLK84, S690MLK85, S690MLK86, S690MLK87, S690MLK88, S690MLK89, S690MLK90, S690MLK91, S690MLK92, S690MLK93, S690MLK94, S690MLK95, S690MLK96, S690MLK97, S690MLK98, S690MLK99, S690MLK100.

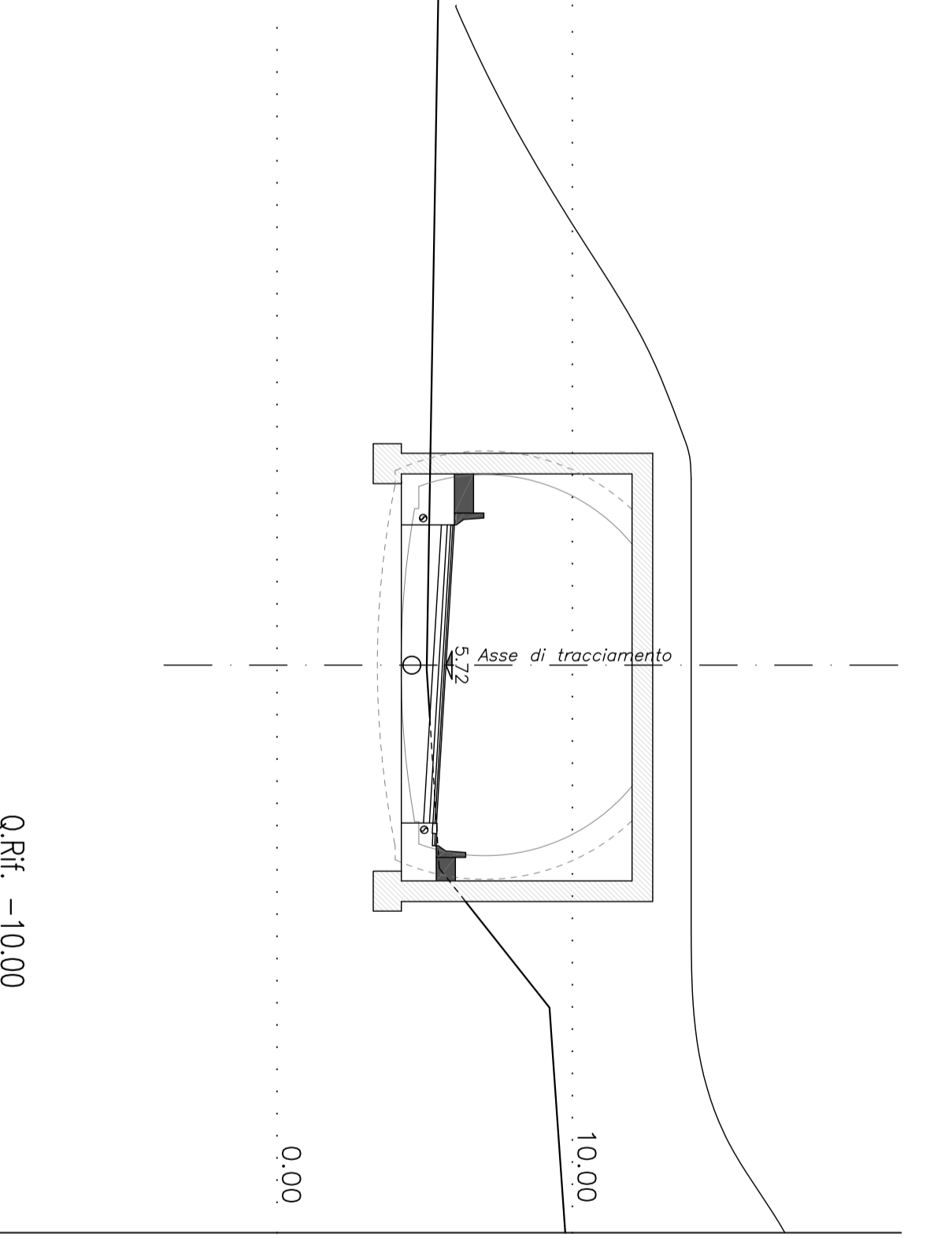

anas
Gruppo FS Italiane
Direzione Progettazione e Realizzazione Lavori

S.S. 163 — "AMALFITANA"
Realizzazione di una vorante in galleria in località "Torre Mezzocopo" tra gli abitati di Minori e Maiori

PROGETTO DI FATIBILITÀ TECNICO ECONOMICA COO. 144-288

PROGETTAZIONE: ANAS - DIREZIONE PROGETTAZIONE E REALIZZAZIONE LAVORI
PROGETTO: Ing. ACCIARIOTTI ANDREOTTI
Disegn. Ing. di Roma n. 18643

COLLABORATORI:
Ing. GAZZONI MAURIZIO
Disegn. Ing. di Roma n. 1872

VESTITO IL RESPONSABILE DEL PROCESSIONO
Disegn. Ing. di Roma n. 411731

GALLERIA NATURALE

Planimetria, profilo e sezioni imbocco lato Maiori

| STATO DEL PROGETTO | NUMERO DEL PROGETTO | REVISIONE | SCALA |
|--------------------|---------------------|-----------|-----------|
| A | DPNA0286 P 18 | A | 1:30 |
| B | | | |
| C | | | |
| A | ELABORAZIONE | REV. 2018 | |
| B | DATA | REVISIONE | VERSIONE |
| REV. | DESCRIZIONE | DATA | REVISIONE |