

## SCHEMA PLANIMETRICO

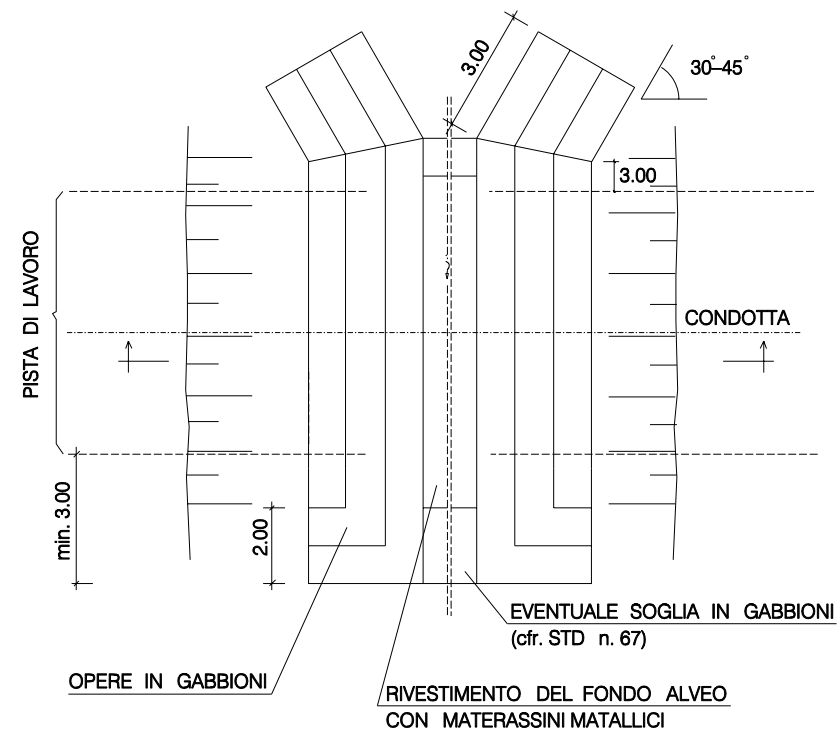

TIPOLOGIA	
1	Senza messa a dimora di talee
2	Con messa a dimora di talee

SEZIONE	B (m)	H (m)
A	1.00	1.00
B	2.00	2.00
C	3.00	3.00

Le caratteristiche geometriche e dimensionali riportate in tabella sono da considerarsi orientative; e verranno definite in appositi elaborati di progetto.

## SEZIONE A

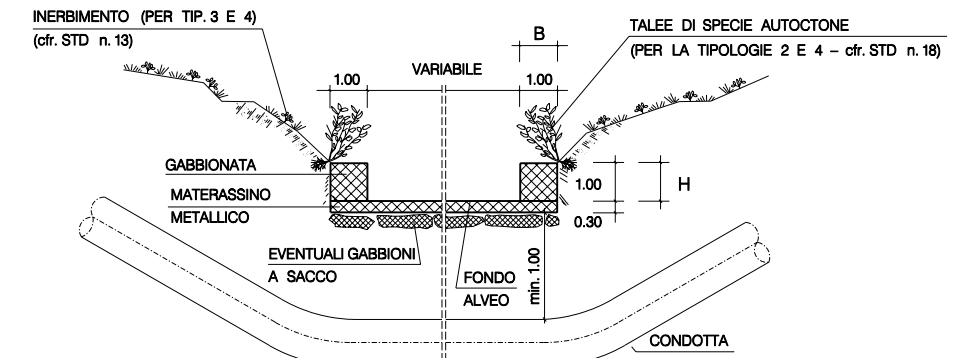

## SEZIONE B

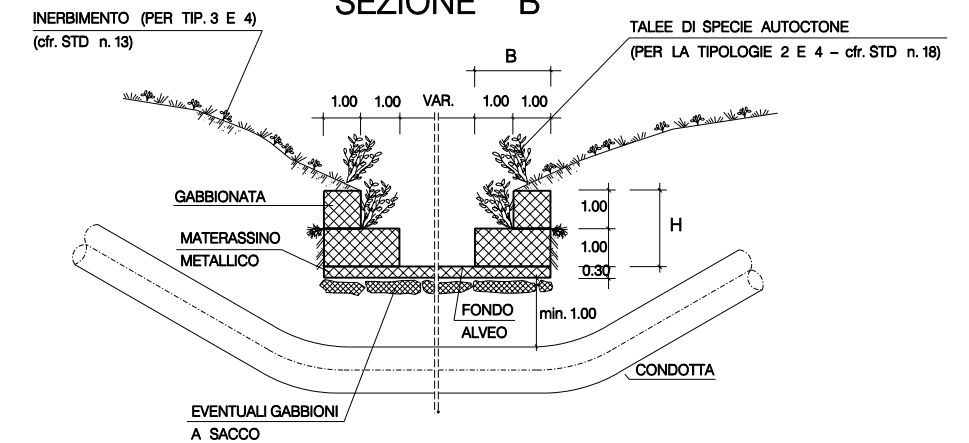

## SEZIONE C

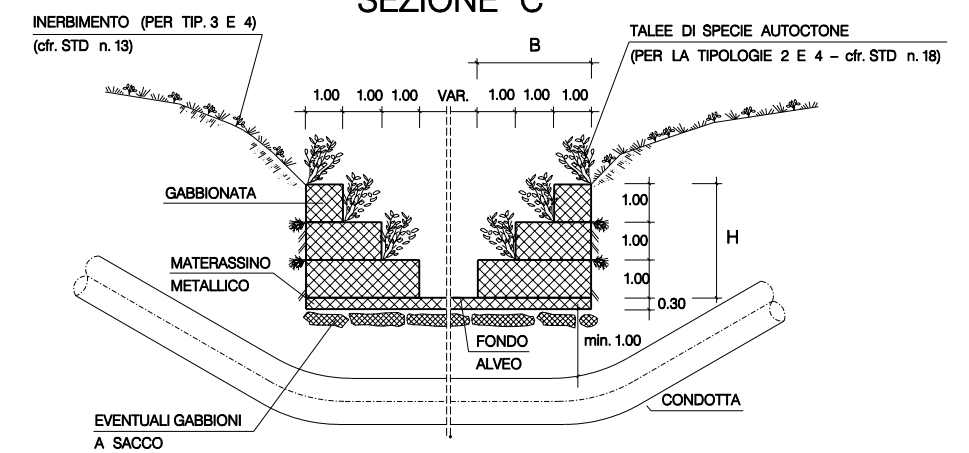

1	15-03-04	Revisione generale	MARIOTTI	CASATI	SOIA
0	23-02-04	EMISSIONE	MARIOTTI	MARIOTTI	SOIA
Rev.	DATA	DESCRIZIONE	ELABORATO	VERIFICATO	APPROVATO
 		 	COMMESSA 659750	UNITA' N. 10	
Metanodotto: SULMONA - ORICOLA DN 1200 (48") - P 75 bar			LC-D-83472		
RICOSTITUZIONE ALVEO IN GABBIONI ED IN MATERASSI METALLICI			REVISIONE	1	
			FG.	1	DI 1
			SCALA		