

SEZIONE A
Q. PROGETTO: 16.62
DIST.PROG.: 2-380.02

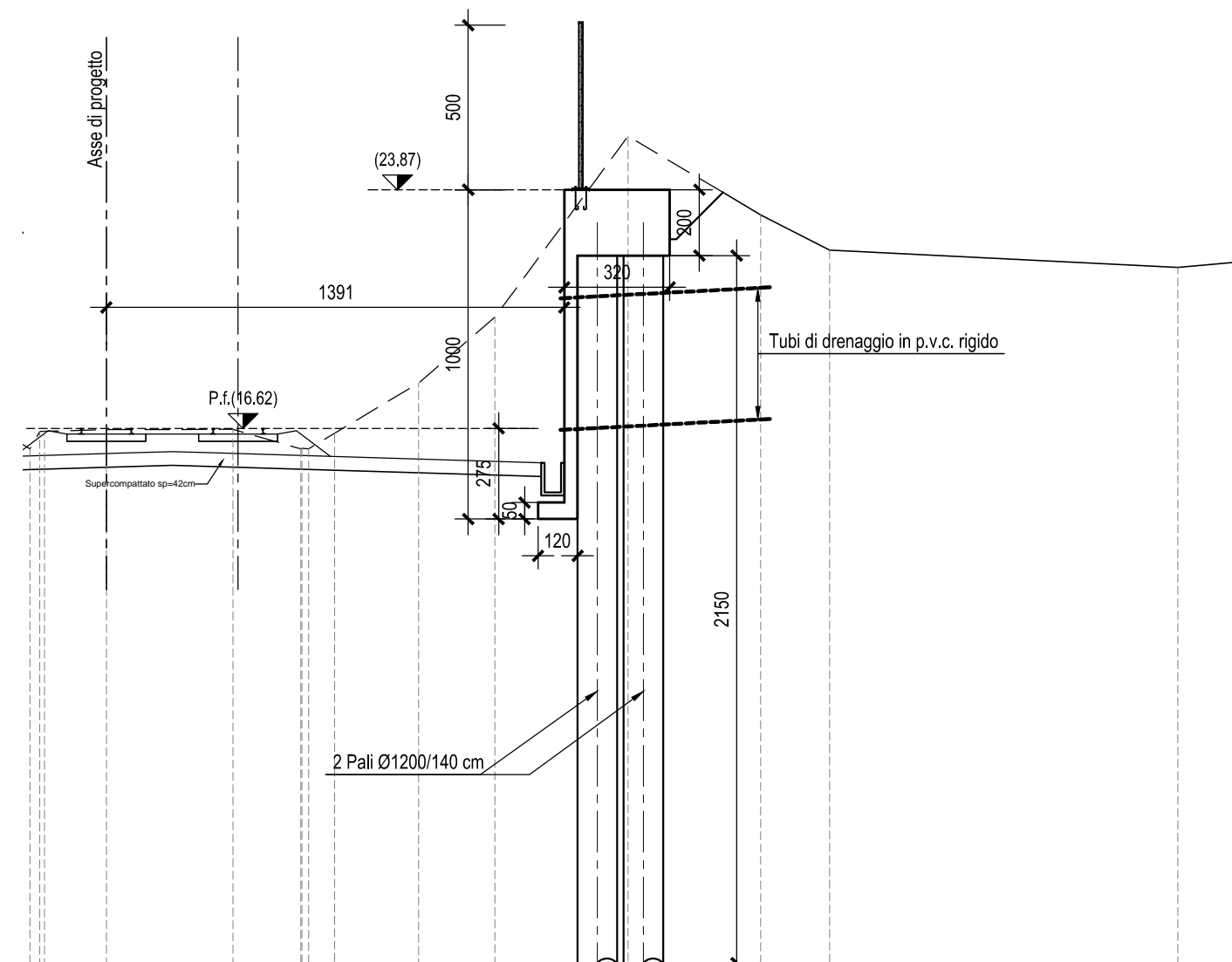

SCALA 1:200

QUOTE TERRENO	18.05	18.86	19.59	20.05	20.60	21.03	22.00	23.51
DIST.PARZIALI TERRENO	1.88	3.85	2.00	1.17	2.55	2.31	4.04	4.03
	2.10	1.52	1.34	1.72	1.67			

SEZIONE B
Q. PROGETTO: 16.53
DIST.PROG.: 2-380.03

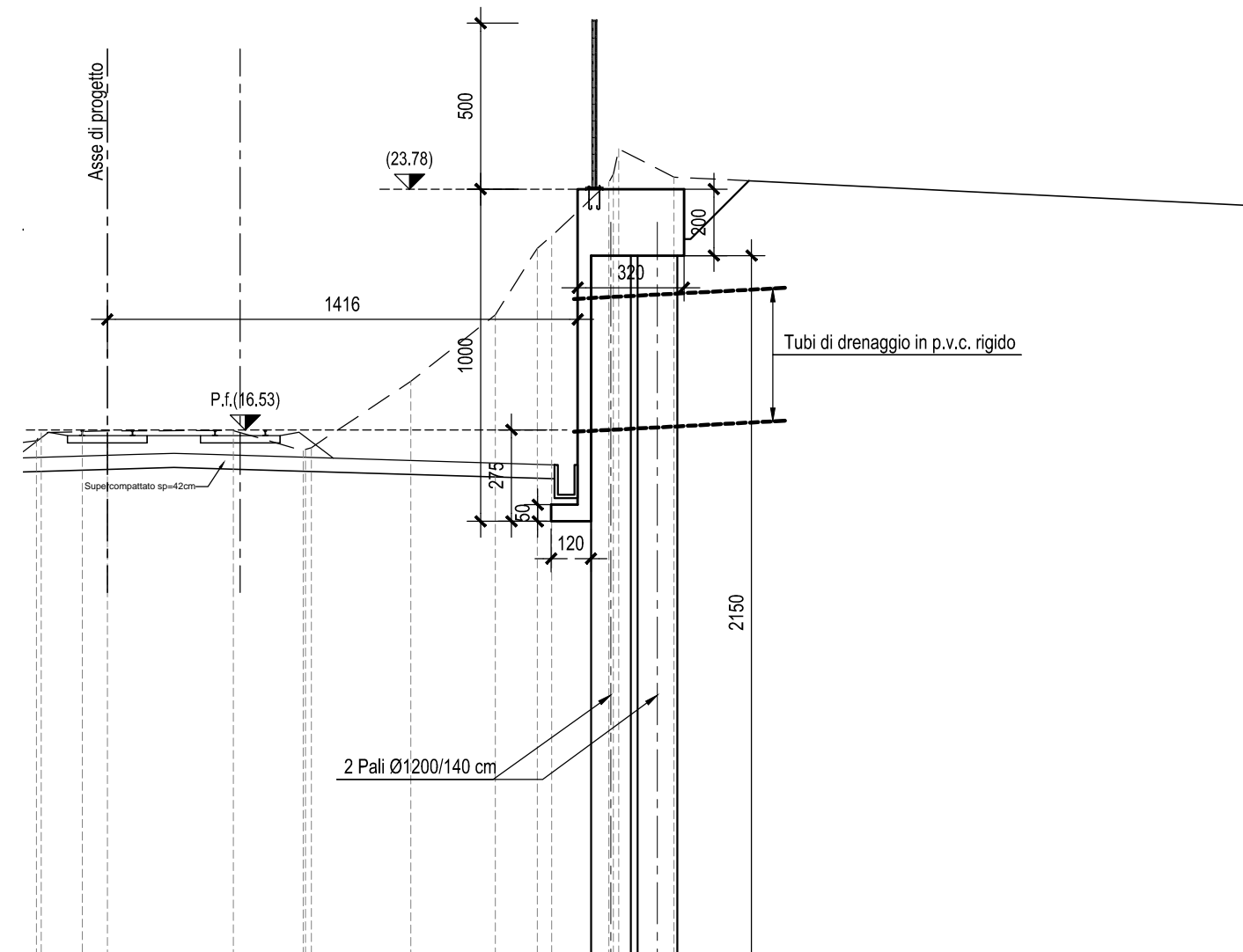

SCALA 1:200

QUOTE TERRENO	17.02	18.06	18.51	19.08	19.90	20.29	20.74	22.01
DIST.PARZIALI TERRENO	1.91	1.24	3.79	2.10	3.00	2.54	1.28	1.72
	1.67							

SEZIONE N - D
Q. PROGETTO: 16.35
DIST.PROG.: 2-493.00

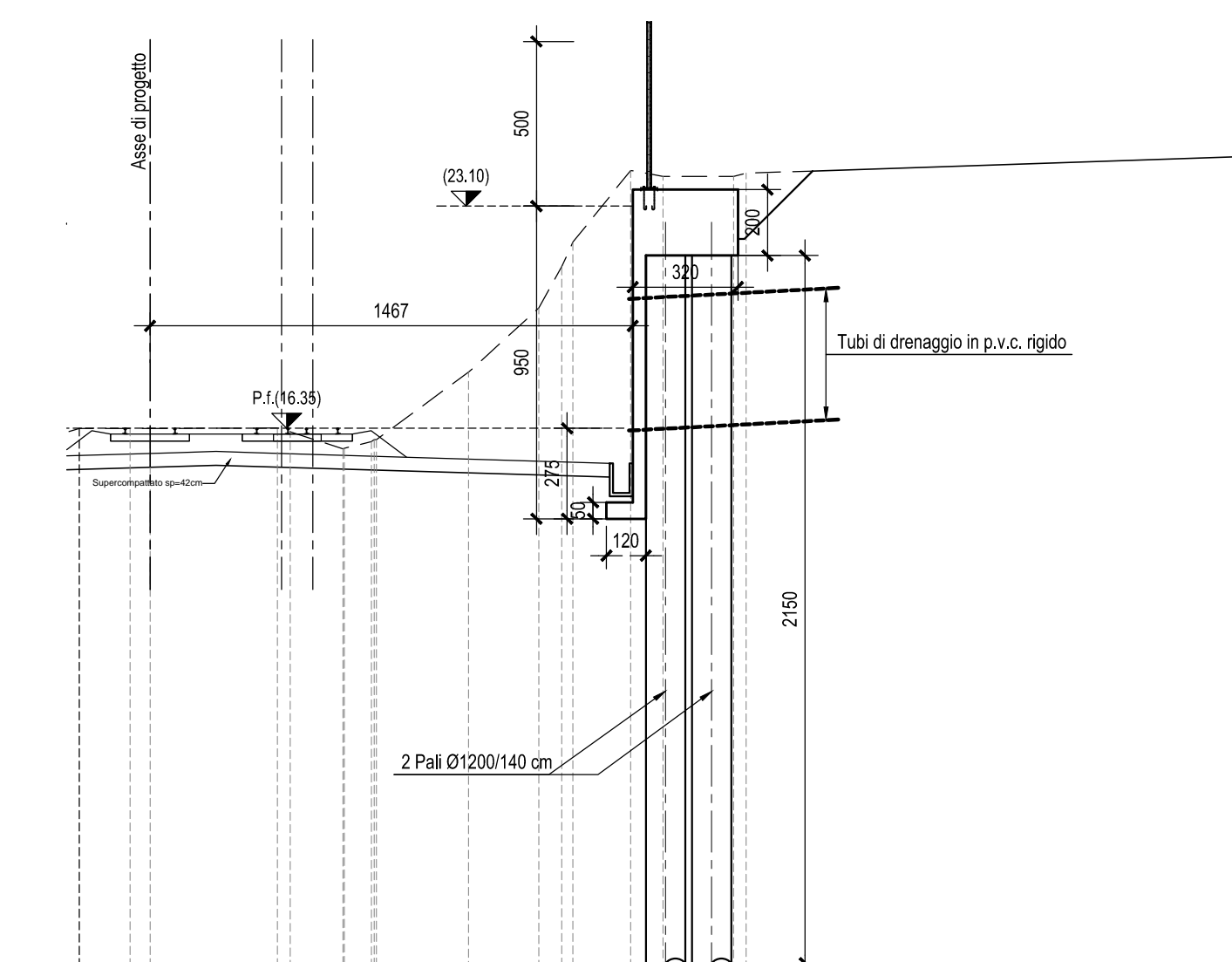

SCALA 1:200

QUOTE TERRENO	18.34	19.18	19.34	19.92	20.76	21.32	21.45	22.05
DIST.PARZIALI TERRENO	1.54	1.11	3.87	1.61	2.80	2.14	2.48	2.14
	1.99	3.95	1.93	2.38	1.33	2.17	1.50	2.28

SEZIONE G
Q. PROGETTO: 16.07
DIST.PROG.: 2-440.00

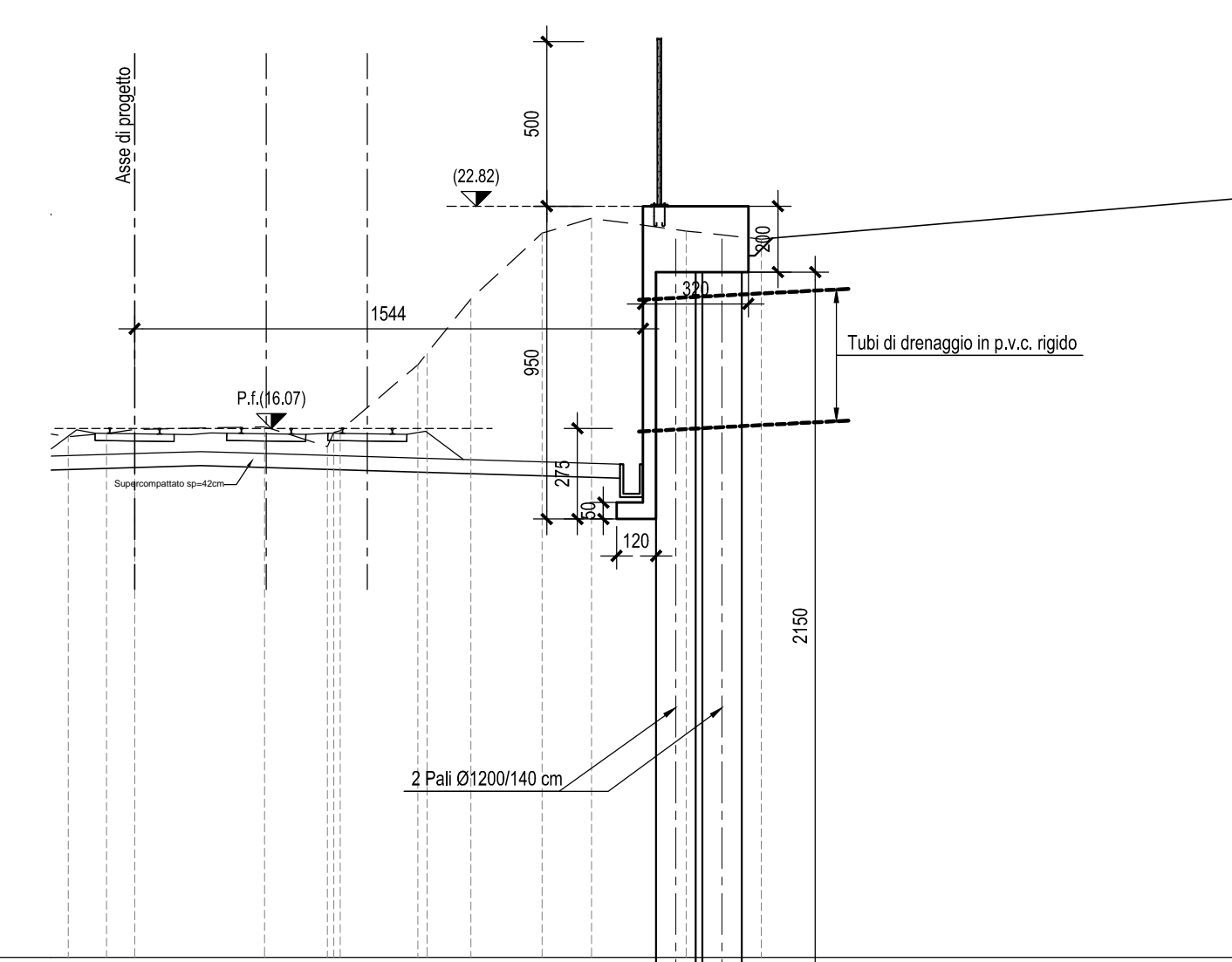

SCALA 1:200

QUOTE TERRENO	18.52	19.03	19.54	20.05	20.56	21.07	21.58	22.09
DIST.PARZIALI TERRENO	1.16	1.81	1.86	1.52	1.59	1.99	2.38	2.28
	2.99	1.50	1.30	1.32	2.45	2.87	1.50	2.28

SEZIONE E
Q. PROGETTO: 16.25
DIST.PROG.: 2-420.00

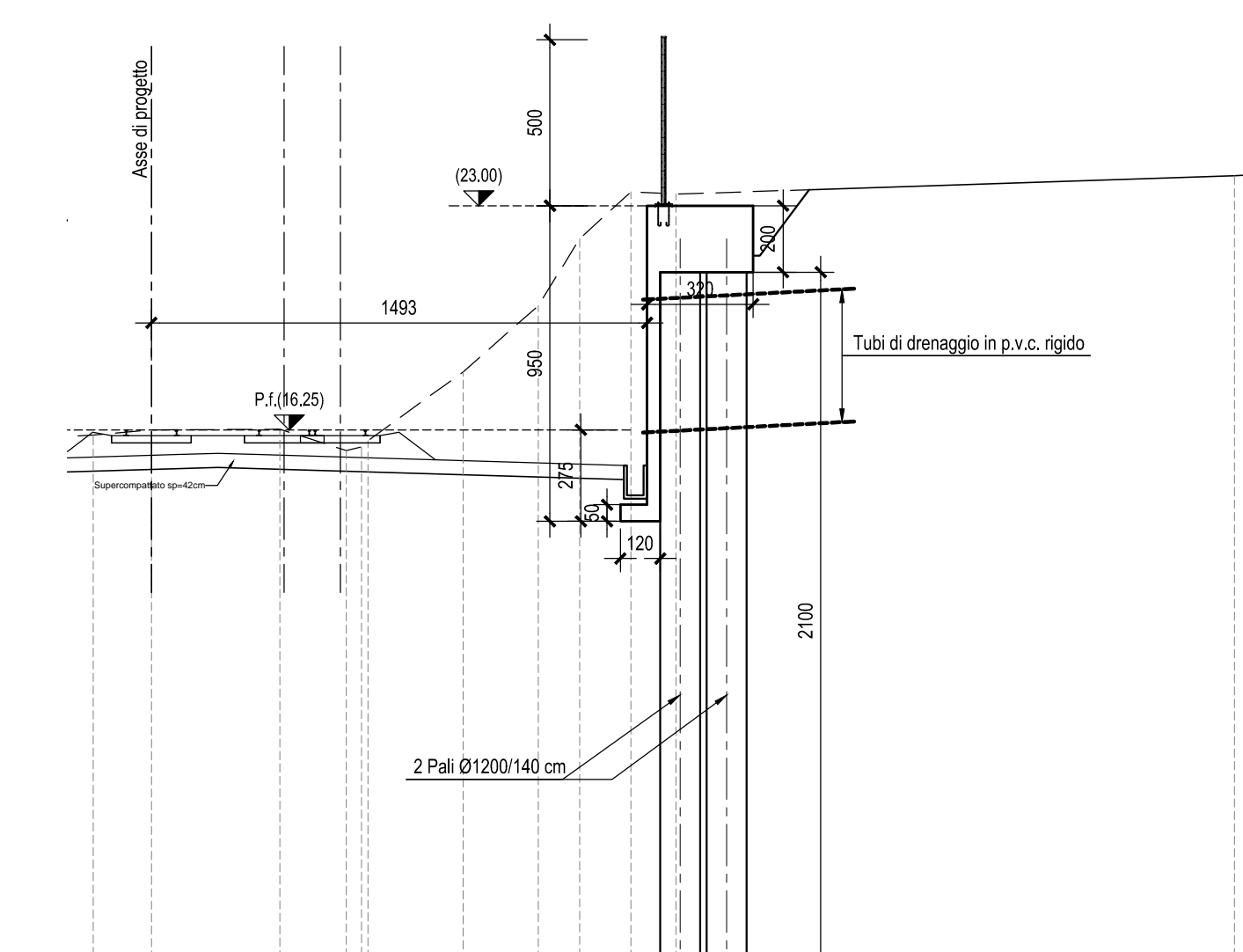

SCALA 1:200

QUOTE TERRENO	18.10	18.55	19.07	19.25	19.80	20.00	20.42	21.24
DIST.PARZIALI TERRENO	1.75	3.87	2.89	2.86	2.27	1.25	1.54	1.36
								16.83

SEZIONE N - H
Q. PROGETTO: 15.97
DIST.PROG.: 2-440.00

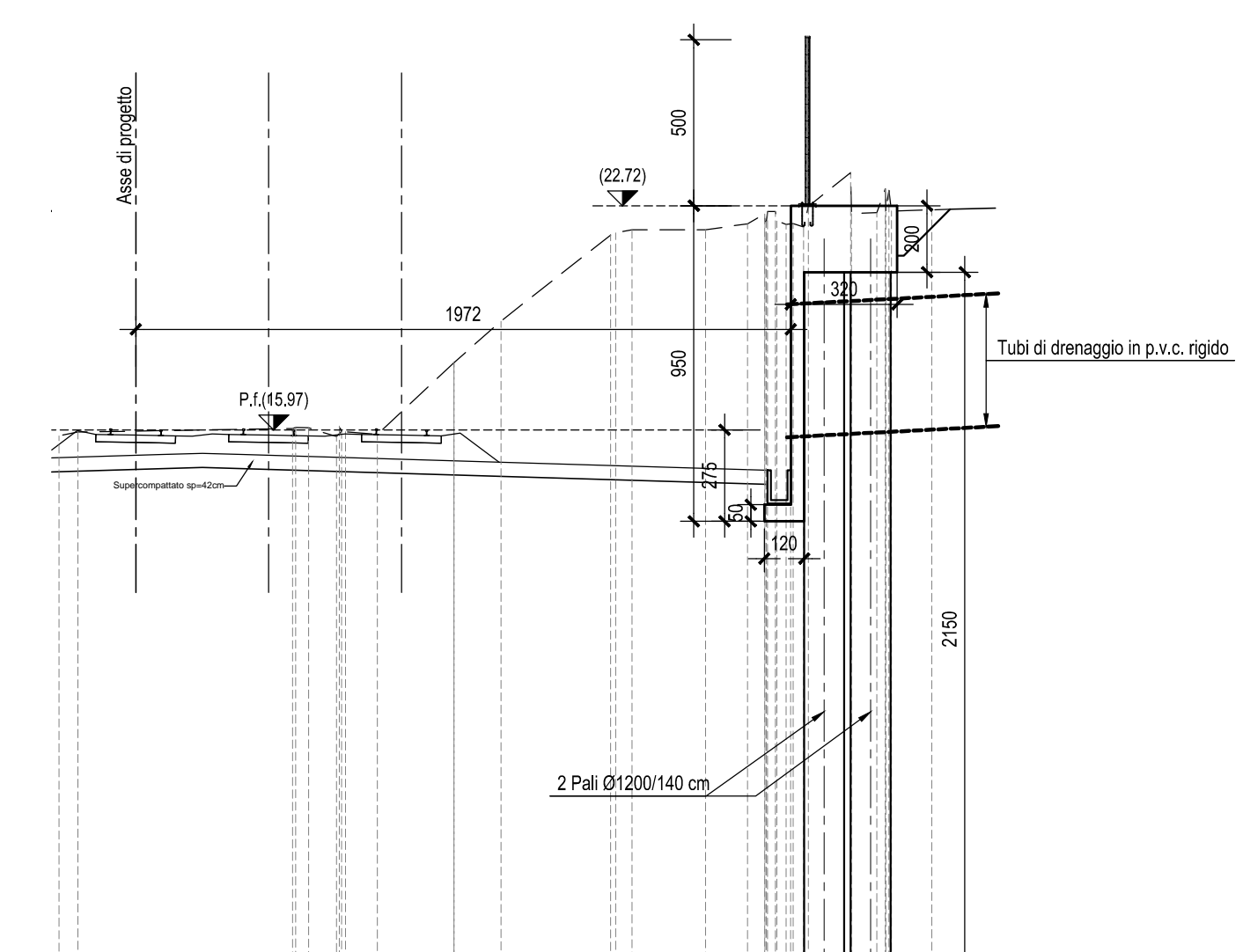

SCALA 1:200

QUOTE TERRENO	17.80	18.10	18.78	19.22	19.95	20.29	20.78	21.47
DIST.PARZIALI TERRENO	3.02	1.73	4.71	4.44	3.30	2.21	2.48	3.21
								1.21

SEZIONE C
Q. PROGETTO: 16.44
DIST.PROG.: 2-480.00

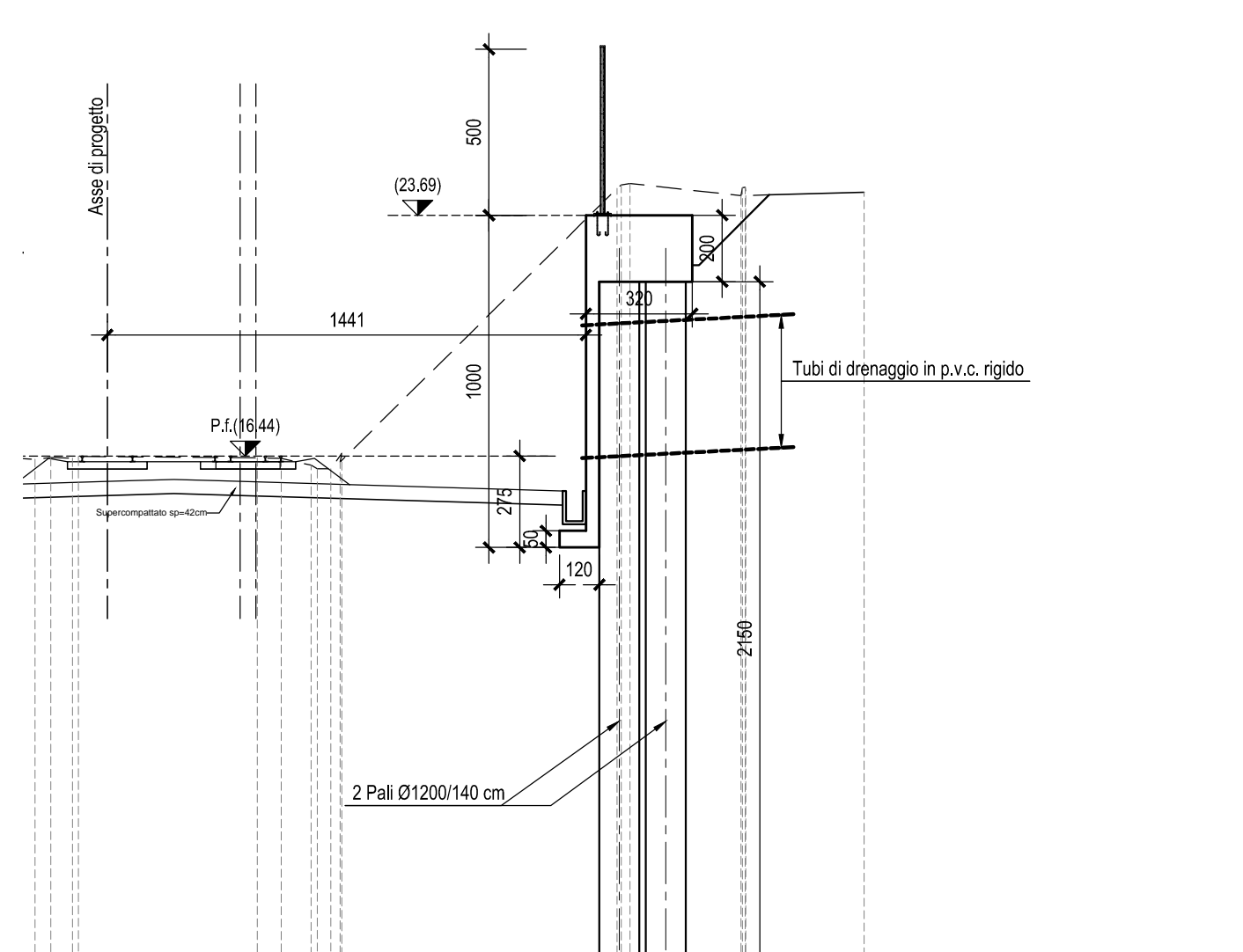

SCALA 1:200

QUOTE TERRENO	18.02	18.53	18.55	19.09	19.90	20.39	20.74	21.25
DIST.PARZIALI TERRENO	1.41	1.34	4.51	1.38	8.28	3.34	3.56	
								2.81

SEZIONE F
Q. PROGETTO: 16.16
DIST.PROG.: 2-493.00

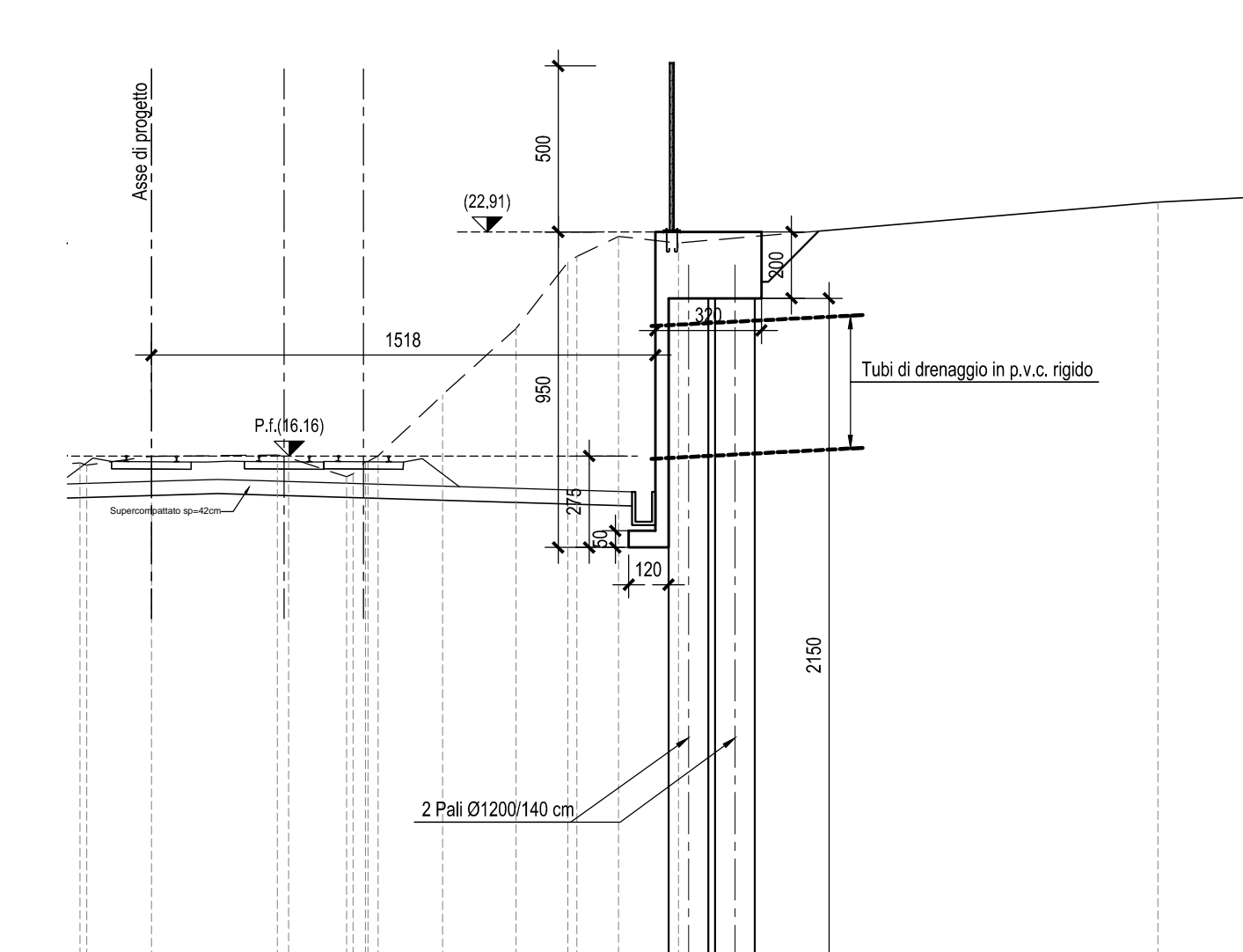

SCALA 1:200

QUOTE TERRENO	18.58	19.15	19.16	19.95	20.30	20.50	20.97	21.58
DIST.PARZIALI TERRENO	1.16	1.95	3.80	1.75	1.94	2.21	1.58	1.81
								14.41

SEZIONE I
Q. PROGETTO: 15.88
DIST.PROG.: 2-460.00

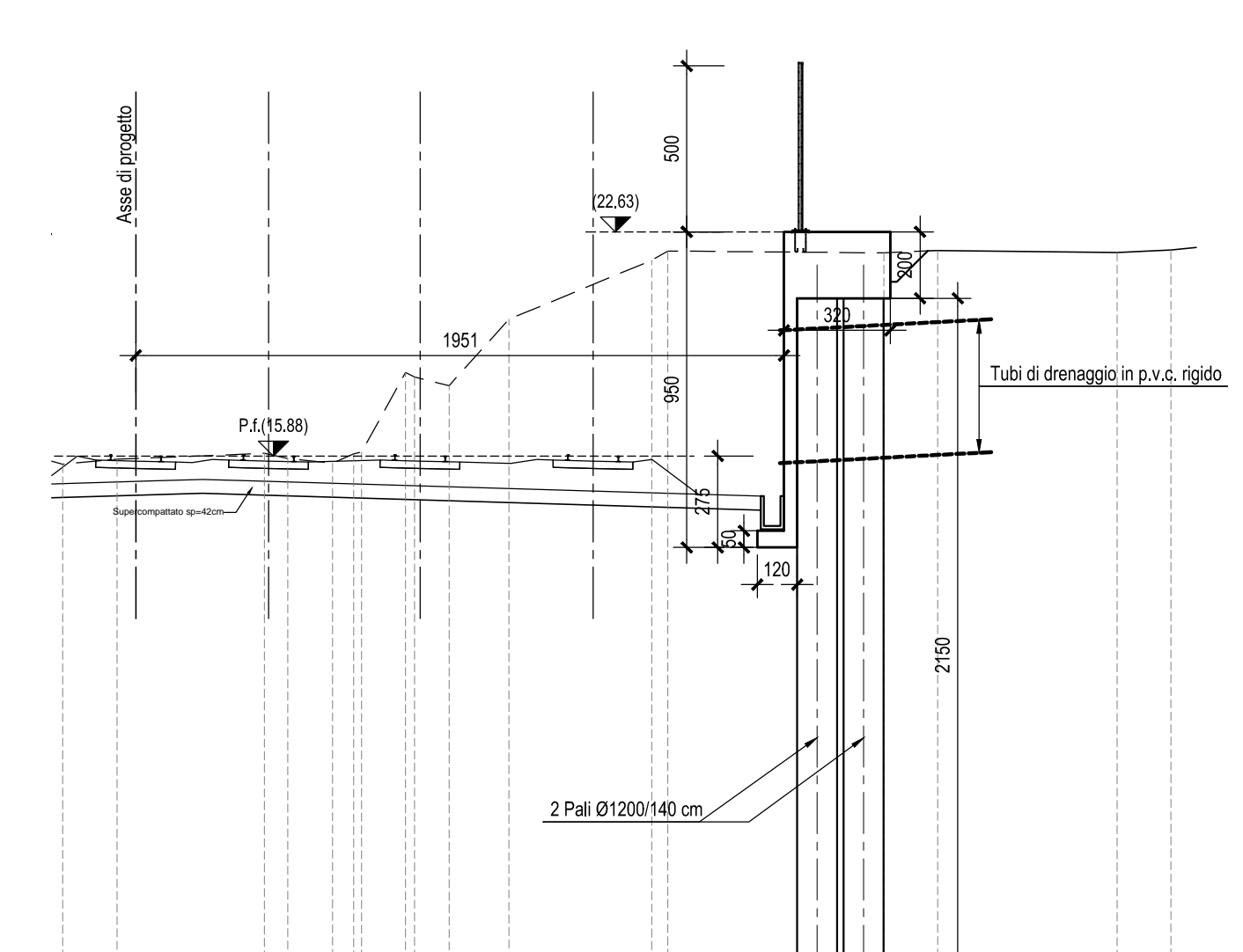

SCALA 1:200

QUOTE TERRENO	18.64	19.18	19.28	19.95	20.38	20.76	21.37	22.00
DIST.PARZIALI TERRENO	1.64	1.96	3.87	1.50	1.32	1.54	1.80	4.30
								6.51

SEZIONE L
Q. PROGETTO: 15.77
DIST.PROG.: 2-472.05

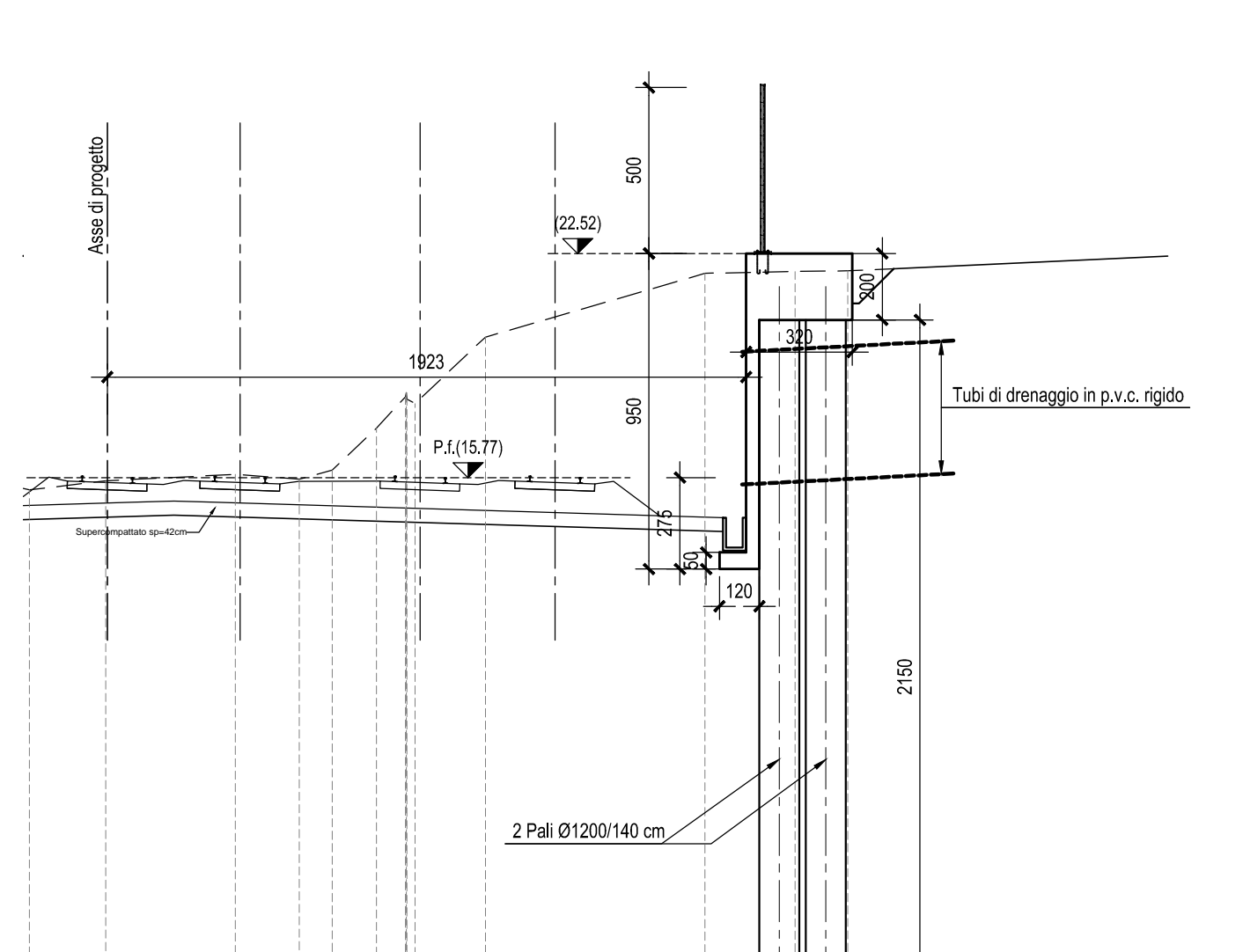

SCALA 1:200

QUOTE TERRENO	18.49	19.07	19.07	19.52	19.99	20.39	20.81	21.52
DIST.PARZIALI TERRENO	2.30	3.85	1.93	1.86	1.33	2.12	6.61	2.71
								1.58

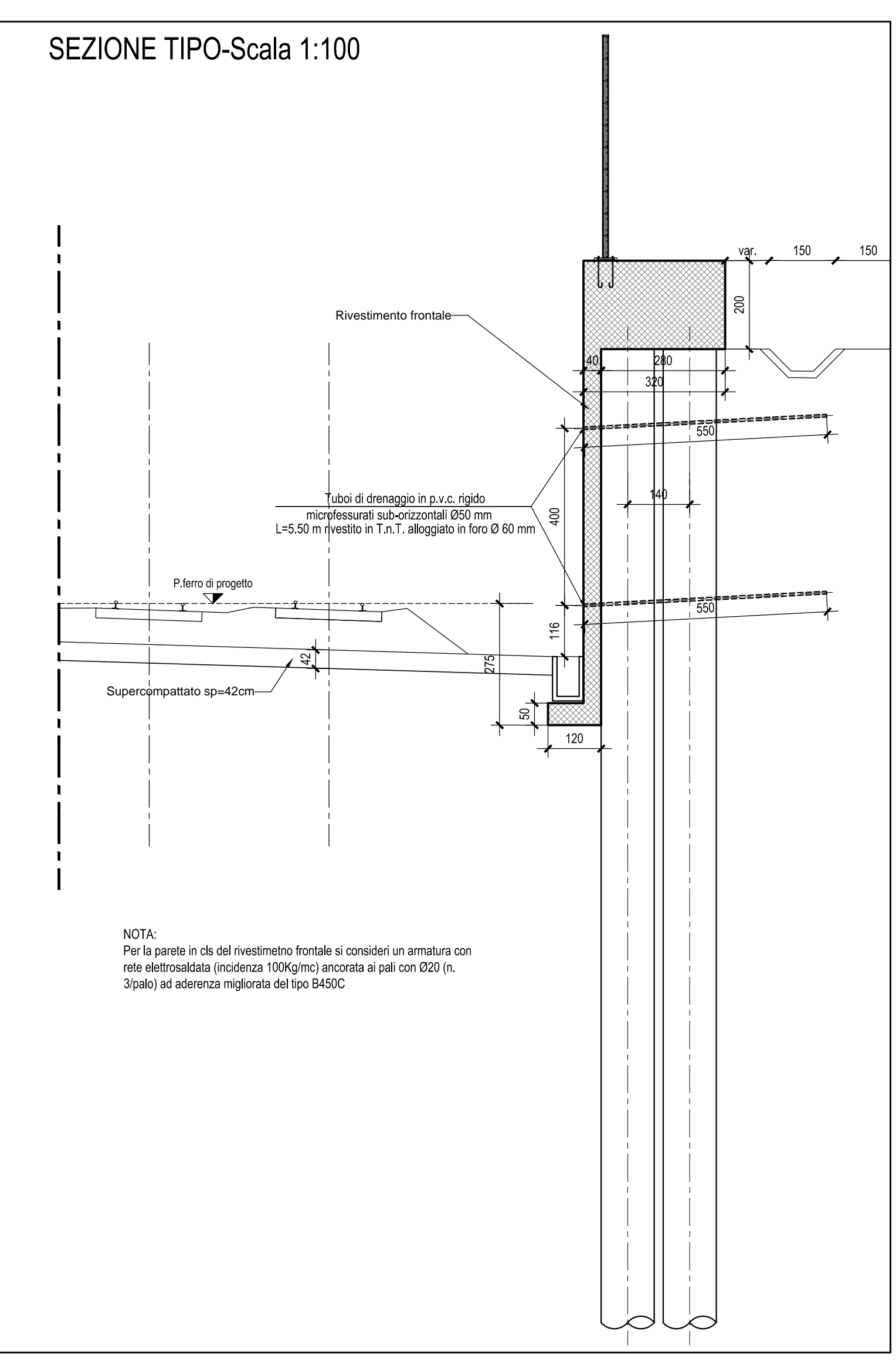
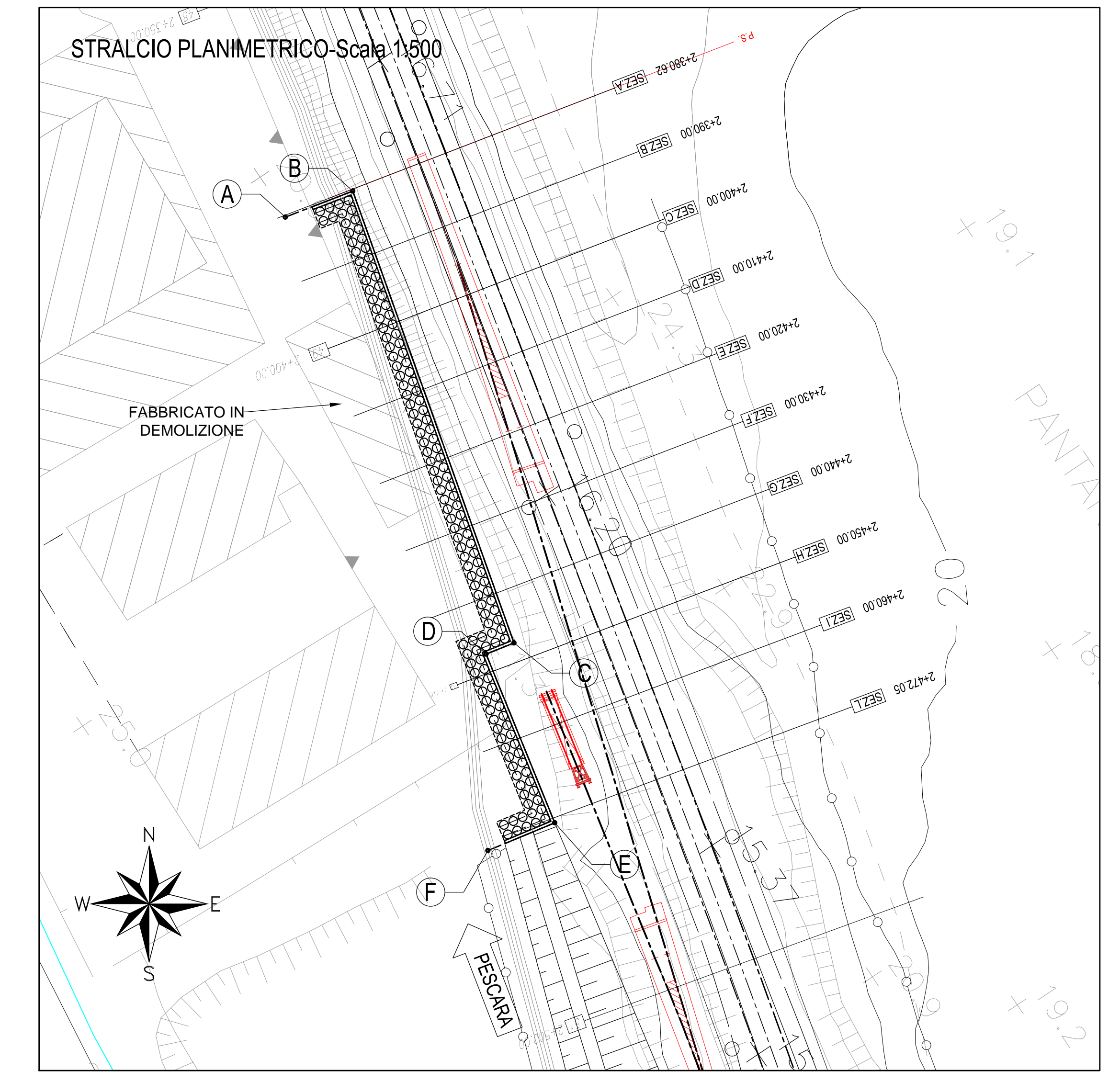

N.B.: Per la tabella materiali e incidenza armature delle Opere Civili si rimanda all'elaborato LI0202 D78 RH OC0000 001

BND

COMMITTENTE:		RFI RETE FERROVIARIA ITALIANA GRUPPO FERROVIE DELLO STATO ITALIANE	
PROGETTAZIONE:		ITALFERR GRUPPO FERROVIE DELLO STATO ITALIANE	
INFRASTRUTTURE FERROVIARIE STRATEGICHE DEFINITE DALLA LEGGE OBIETTIVO N.443/01			
U.O. INFRASTRUTTURE SUD			
PROGETTO DEFINITIVO			
LINEA PESCARA - BARI			
RADDOPPIO DELLA TRATTA FERROVIARIA TERMOLI - LESINA			
LOTTI 2 e 3 - RADDOPPIO TERMOLI - RIPALTA			
Opere di Sostegno di linea			
TR02 - Paratia BP KM 2+380.00			
Sezioni trasversali			
COMMESSA		LOTTO	
FASE		ENTE	
TIPO DOC.		OPERA/DISCIPLINA	
PROGR.		REV.	
LI0202		D78 W9	
TR0205		001 A	
Rev.	Descrizione	Redatto	Data
Verificato	Data	Approvato	Data
A	Emissione Conoscenza	M. Perrotti	Ottobre 2019
		A. Favini	Ottobre 2019
		B. Bianchi	Ottobre 2019
		D. Totari	Ottobre 2019