

VISTA A-A
Scala 1:50

SEZIONE B-B
Scala 1:50

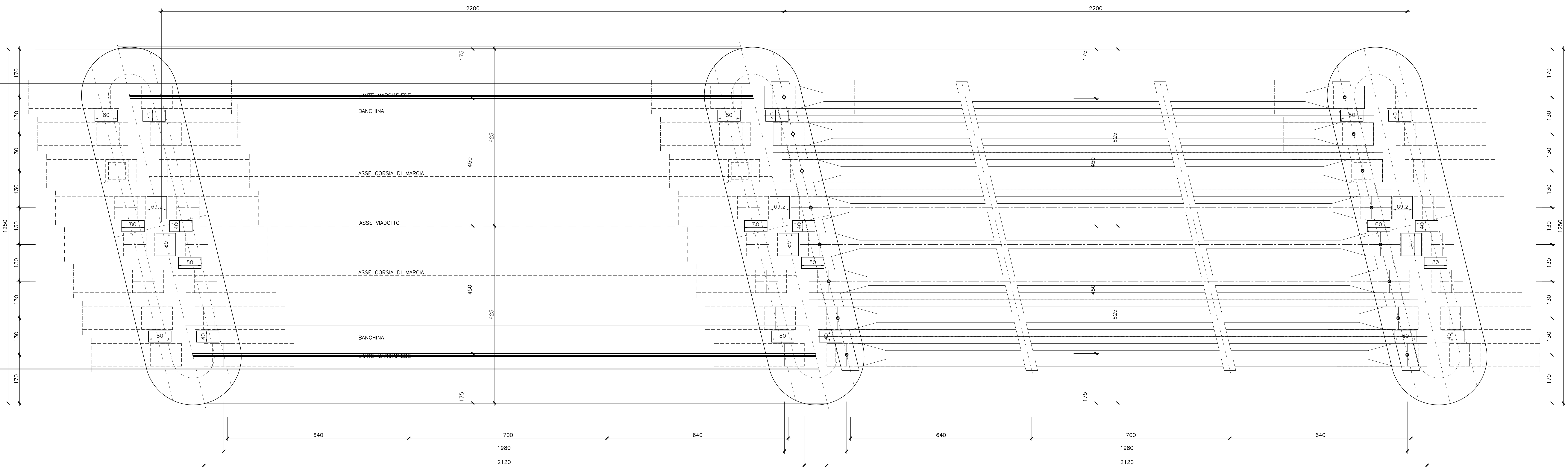

SEZIONE C-C
Scala 1:50

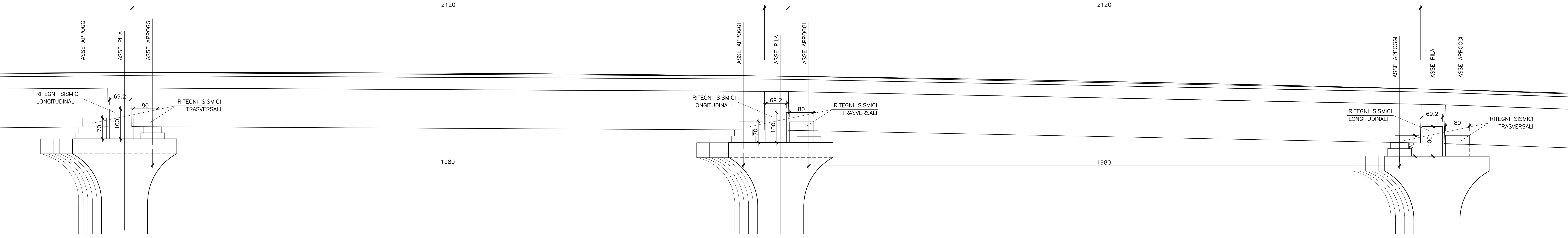

DETTAGLIO '1'
Scala 1:20

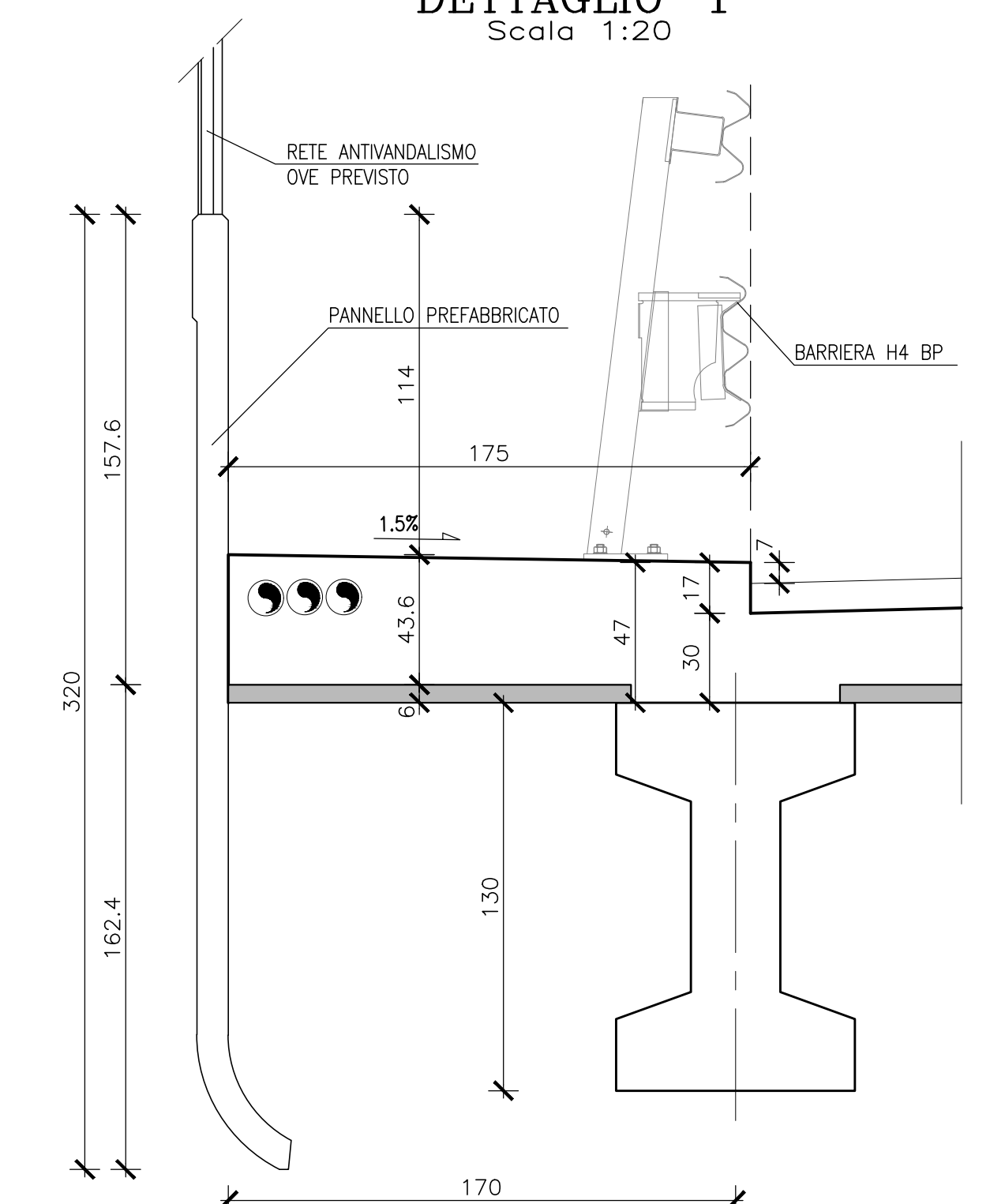

SEZIONE TRASVERSALE
Scala 1:50

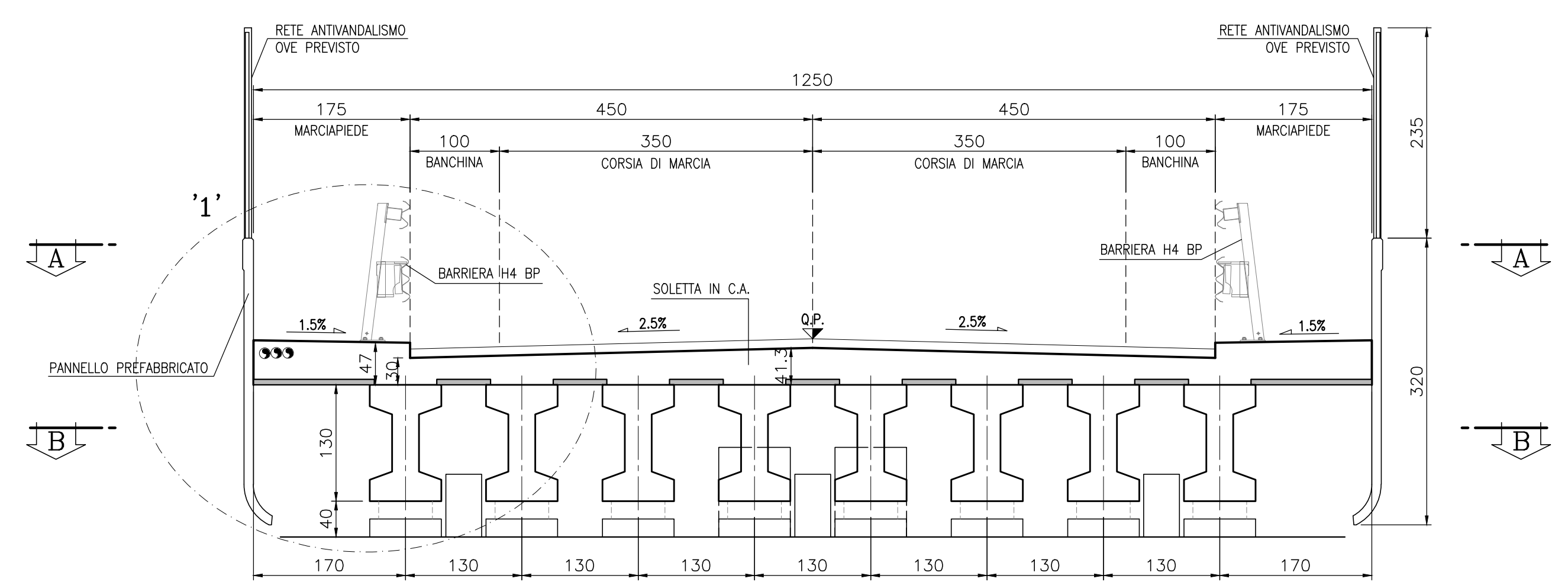

MATERIALI
PER I MATERIALI SI RIMANDA AD ELABORATO SPECIFICO :
NMO220026TTC000001

COMMITTENTE:

PROGETTAZIONE:

CUP: J47109000030009

U.O. INFRASTRUTTURE NORD
PROGETTO DEFINITIVO
POTENZIAMENTO DELLA LINEA MILANO - GENOVA
QUADRUPPLICAMENTO TRATTA MILANO ROGOREDO - PAVIA
FASE 2 - QUADRUPPLICAMENTO PIEVE EMANUELE - PAVIA
OPERE PRINCIPALI - PONTI E VIADOTTI
Nuovo cavalcavia SP40 km 12+373,85
Carpenteria impalcato

SCALA: 1:50

Rev.	Descrizione	Redatto	Data	Verificato	Data	Approvato	Data	Autografo
A	IMPALESTAZIONE ESACUTA

Fab: ... n. Etab: ...