

REGIONE CALABRIA



Comune di Squillace (CZ)



Comune di Borgia (CZ)



Comune di Maida (CZ)



Committente:

RWE

RWE RENEWABLES ITALIA S.R.L.
via Andrea Doria, 41/G - 00192 Roma
P.IVA/C.F. 06400370968

Titolo del Progetto:

PARCO EOLICO "BOLINA"

Documento:

PROGETTO DEFINITIVO

N° Documento:

PEBO-P15.04

ID PROGETTO:

PEBO

DISCIPLINA:

P

TIPOLOGIA:

FORMATO:

A4

Elaborato:

**RELAZIONE DI CALCOLO PRELIMINARE DELLE
FONDAZIONI DELL'AEROGENERATORE G8**

FOGLIO:

SCALA:

Nome file:

PEBO-P15.04_RELAZIONE DI CALCOLO PRELIMINARE DELLE FONDAZIONI
DELL'AEROGENERATORE G8

Progettazione:



Ing. Saverio Pagliuso

Ing. Claudio Coscarella

Ing. Mario Francesco Perri

Ing. Giorgio Salatino

Rev:	Data Revisione	Descrizione Revisione	Redatto	Controllato	Approvato
00	21/10/2019	PRIMA EMISSIONE	GEMSA	GEMSA	RWE



Relazione di calcolo strutturale impostata e redatta secondo le modalità previste nel D.M. 17 Gennaio 2018 cap. 10 “Redazione dei progetti strutturali esecutivi e delle relazioni di calcolo”.

2S.I. Software e Servizi per l'Ingegneria S.r.l.

Via Garibaldi, 90

44121 Ferrara FE (Italy)

Tel. +39 0532 200091

www.2si.it

info@2si.it

D.M. 17/01/18 cap. 10.2 Affidabilità dei codici utilizzati

<https://www.2si.it/it/prodotti/affidabilita/>

INTESTAZIONE E CONTENUTI DELLA RELAZIONE

Progetto

**RELAZIONE DI CALCOLO PRELIMINARE DELLE
FONDAZIONI DEGLI AEROGENERATORI G8 – G12 DA
INSTALLARSI NEI COMUNI DI BORGIA (CZ) E SQUILLACE
(CZ) E INERENTI IL PARCO EOLICO "BOLINA"**

Contenuti della relazione:

RELAZIONE DI CALCOLO STRUTTURALE

- *Origine e Caratteristiche dei Codici di Calcolo*
- *Affidabilità dei codici utilizzati*
- *Validazione dei codici*
- *Tipo di analisi svolta*
- *Modalità di presentazione dei risultati*
- *Informazioni generali sull'elaborazione*
- *Giudizio motivato di accettabilità dei risultati*

STAMPA DEI DATI DI INGRESSO

- *Normative prese a riferimento*
- *Criteri adottati per le misure di sicurezza*
- *Criteri seguiti nella schematizzazione della struttura, dei vincoli e delle sconessioni*
- *Interazione tra terreno e struttura*
- *Legami costitutivi adottati per la modellazione dei materiali e dei terreni*
- *Schematizzazione delle azioni, condizioni e combinazioni di carico*
- *Metodologie numeriche utilizzate per l'analisi strutturale*
- *Metodologie numeriche utilizzate per la progettazione e la verifica degli elementi strutturali*

STAMPA DEI RISULTATI

Il Progettista:

Indice

INTESTAZIONE E CONTENUTI DELLA RELAZIONE.....	2
Progetto.....	2
RELAZIONE DI CALCOLO STRUTTURALE.....	5
Premessa.....	5
Descrizione generale dell'opera.....	5
Quadro normativo di riferimento adottato.....	6
Azioni di progetto sulla costruzione.....	7
Modello numerico.....	7
Modellazione delle azioni.....	9
Combinazioni e/o percorsi di carico.....	10
Verifiche agli stati limite ultimi.....	11
Verifiche agli stati limite di esercizio.....	11
RELAZIONE SUI MATERIALI.....	11
NORMATIVA DI RIFERIMENTO.....	12
CARATTERISTICHE MATERIALI UTILIZZATI.....	13
LEGENDA TABELLA DATI MATERIALI.....	13
MODELLAZIONE DELLE SEZIONI.....	18
LEGENDA TABELLA DATI SEZIONI.....	18
MODELLAZIONE STRUTTURA: NODI.....	20
LEGENDA TABELLA DATI NODI.....	20
TABELLA DATI NODI.....	20
MODELLAZIONE STRUTTURA: ELEMENTI SHELL.....	23
LEGENDA TABELLA DATI SHELL.....	23
MODELLAZIONE DELLE AZIONI.....	30
LEGENDA TABELLA DATI AZIONI.....	30
SCHEMATIZZAZIONE DEI CASI DI CARICO.....	32
LEGENDA TABELLA CASI DI CARICO.....	32
DEFINIZIONE DELLE COMBINAZIONI.....	33
LEGENDA TABELLA COMBINAZIONI DI CARICO.....	33
AZIONE SISMICA.....	37
VALUTAZIONE DELL' AZIONE SISMICA.....	37
Parametri della struttura.....	37

RISULTATI ANALISI SISMICHE	38
LEGENDA TABELLA ANALISI SISMICHE.....	38
RISULTATI NODALI	43
LEGENDA RISULTATI NODALI.....	43
RISULTATI OPERE DI FONDAZIONE	91
LEGENDA RISULTATI OPERE DI FONDAZIONE.....	91
RISULTATI ELEMENTI TIPO SHELL	102
LEGENDA RISULTATI ELEMENTI TIPO SHELL.....	102
VERIFICHE ELEMENTI PARETE E/O GUSCIO IN C.A.	279
LEGENDA TABELLA VERIFICHE ELEMENTI PARETE E GUSCIO IN C.A.	279
PROGETTAZIONE DELLE FONDAZIONI	281
STATI LIMITE D' ESERCIZIO	292
LEGENDA TABELLA STATI LIMITE D' ESERCIZIO	292
RELAZIONE GEOTECNICA E DELLE FONDAZIONI	298
RELAZIONE GEOTECNICA E DELLE FONDAZIONI SUPERFICIALI	318
VERIFICHE PALI DI FONDAZIONE	334

RELAZIONE DI CALCOLO STRUTTURALE

Premessa

La presente relazione di calcolo strutturale preliminare, in conformità al §10.1 del DM 17/01/18, è comprensiva di una descrizione generale dell'opera e dei criteri generali di analisi e verifica. Segue inoltre le indicazioni fornite al §10.2 del DM stesso per quanto concerne analisi e verifiche svolte con l'ausilio di codici di calcolo. La seguente relazione descrive le analisi compiute per il dimensionamento preliminare delle strutture di fondazione di un aerogeneratore tipo Vestas V150 –5.0 MW da installare in numero pari a nei Comuni di Borgia (CZ) e Squillace (CZ). Il proponente è la società E.ON CLIMATE & RENEWABLES ITALIA S.R.L. con sede a via Andrea Doria, 41/G - 00192 Roma. Gli aerogeneratori, costituenti il parco eolico denominato "Bolina", saranno installati su 'area costituita da una serie di rilievi collinari posti tra i centri abitati di Borgia (a nord dell'area interessata dal parco) e di Squillace (a sud-est dell'area). Le quote sono comprese tra i 170 m s.l.m. del sito G10, in località Gironda ed i 315 m s.l.m. in corrispondenza dell'aerogeneratore G1, all'altezza del vertice nordovest dell'area del PE.

Nella presente parte sono riportati i principali elementi di inquadramento del progetto riguardante le strutture, in relazione agli strumenti urbanistici, al progetto architettonico, al progetto delle componenti tecnologiche in generale ed alle prestazioni attese dalla struttura.

I tabulati di calcolo sono stati concepiti tenendo conto

- delle valutazioni geologiche e geotecniche inerenti gli elaborati di merito redatti dal geol. Pasquale Greco e
- dei carichi applicati in fondazioni dedotti dall'elaborato di riferimento (Combine Tower loads V150 Mk3E HH105 IEC3B) rilasciato dalla Vestas che devono ritenersi parte integrante della presente.

A seguito di quanto riportato nella relazione geologica, le fondazioni di seguito calcolate sono di tipo profonde e più precisamente piastre su pali.

Si precisa che l'elaborazione presente è da ritenersi PRELIMINARE, quindi passibile di variazioni in fase di progettazione esecutiva, soprattutto in relazione a eventuali scelte diverse relativamente agli aerogeneratori da utilizzare ed a una più diretta condivisione dei calcoli e di esigenze realizzative con i fornitori degli stessi. Inoltre dovranno essere fatte valutazioni più puntuali a seguito di indagini geologiche più accurate che potrebbero portare a valutazioni anche abbastanza diverse.

Descrizione generale dell'opera

La presente relazione è riferita al calcolo delle opere di fondazioni del tipo di aerogeneratori Vestas V150-5.0 MW che dovranno essere installati nel parco eolico Bolina. In particolare, si è ritenuto opportuno suddividere la relazione di calcolo in relazione alla classificazione del sottosuolo nell'area in funzione dei valori geotecnici dei terreni, identificate nella relazione geologica. La presente parte fa riferimento a 2 aerogeneratori denominati G7 e G12.

La singola piastra di fondazione sarà prevista di forma circolare (in fase esecutiva potrà essere ipotizzata anche di forma circolare tronco-conica ossia con un'altezza perimetrale inferiore a quella più interna) di diametro pari a 23,00 m e spessore pari a 2,50 m. Inoltre per le caratteristiche del terreno sono stati ipotizzati 24 pali di fondazione trivellati per ogni singolo aerogeneratore, di diametro pari a 1,20 m e profondità di infissione uguale a 14,00 m. Il calcolo si è avvalso dei carichi in fondazione comunicati dal produttore Vestas con un elaborato preliminare (Combine Tower loads V150 Mk3E HH105 IEC3B), passibili di variazione in fase esecutiva, che sono i seguenti:

- Fx: 3570.18 [daN];
- Fy: 3570.18 [daN];
- Fz: -223721.0 [daN];
- Mx: 569275200.0 [daN cm];
- My: 569275200.0 [daN cm];
- Mz: -4886500.0 [daN cm].

Descrizione generale dell'opera	
Fabbricato ad uso	
Ubicazione	Comune di SQUILLACE (CZ) (Regione CALABRIA)
	Località SQUILLACE (CZ)
	Longitudine 16.492, Latitudine 38.780
Numero di piani	
Numero vani scale	
Numero vani ascensore	

Parco Eolico "Bolina" – Progetto Definitivo
Relazione di calcolo preliminare delle fondazioni degli aerogeneratori G8 e G12

Tipo di fondazione	FONDAZIONE SU PALI
--------------------	--------------------

Principali caratteristiche della struttura	
Struttura regolare in pianta	SI
Struttura regolare in altezza	SI
Classe di duttilità	B
Travi: ricalate o in spessore	
Pilastri	
Pilastri in falso	
Tipo di fondazione	FONDAZIONE SU PALI
Condizioni per cui è necessario considerare la componente verticale del sisma	

Parametri della struttura			
Classe d'uso	Vita Vn [anni]	Coeff. Uso	Periodo Vr [anni]
IV	50.0	1.0	50.0

Fattore di struttura/comportamento
1

Quadro normativo di riferimento adottato

Le norme ed i documenti assunti quale riferimento per la progettazione strutturale vengono indicati di seguito.

Nel capitolo "normativa di riferimento" è comunque presente l'elenco completo delle normative disponibili.

Progetto-verifica degli elementi	
Progetto cemento armato	D.M. 17-01-2018
Progetto acciaio	D.M. 17-01-2018
Progetto legno	D.M. 17-01-2018
Progetto muratura	D.M. 17-01-2018
Azione sismica	
Norma applicata per l'azione sismica	D.M. 17-01-2018

Azioni di progetto sulla costruzione

Nei capitoli "modellazione delle azioni" e "schematizzazione dei casi di carico" sono indicate le azioni sulla costruzioni.

Nel prosieguo si indicano tipo di analisi strutturale condotta (statico,dinamico, lineare o non lineare) e il metodo adottato per la risoluzione del problema strutturale nonché le metodologie seguite per la verifica o per il progetto-verifica delle sezioni. Si riportano le combinazioni di carico adottate e, nel caso di calcoli non lineari, i percorsi di carico seguiti; le configurazioni studiate per la struttura in esame *sono risultate effettivamente esaustive per la progettazione-verifica.*

La verifica della sicurezza degli elementi strutturali avviene con i metodi della scienza delle costruzioni. L'analisi strutturale è condotta con il metodo degli spostamenti per la valutazione dello stato tensodeformativo indotto da carichi statici. L'analisi strutturale è condotta con il metodo dell'analisi modale e dello spettro di risposta in termini di accelerazione per la valutazione dello stato tensodeformativo indotto da carichi dinamici (tra cui quelli di tipo sismico).

L'analisi strutturale viene effettuata con il metodo degli elementi finiti. Il metodo sopraindicato si basa sulla schematizzazione della struttura in elementi connessi solo in corrispondenza di un numero prefissato di punti denominati nodi. I nodi sono definiti dalle tre coordinate cartesiane in un sistema di riferimento globale. Le incognite del problema (nell'ambito del metodo degli spostamenti) sono le componenti di spostamento dei nodi riferite al sistema di riferimento globale (traslazioni secondo X, Y, Z, rotazioni attorno X, Y, Z). La soluzione del problema si ottiene con un sistema di equazioni algebriche lineari i cui termini noti sono costituiti dai carichi agenti sulla struttura opportunamente concentrati ai nodi:

$$\mathbf{K} * \mathbf{u} = \mathbf{F} \quad \text{dove} \quad \mathbf{K} = \text{matrice di rigidezza}$$

\mathbf{u} = vettore spostamenti nodali

\mathbf{F} = vettore forze nodali

Dagli spostamenti ottenuti con la risoluzione del sistema vengono quindi dedotte le sollecitazioni e/o le tensioni di ogni elemento, riferite generalmente ad una terna locale all'elemento stesso.

Il sistema di riferimento utilizzato è costituito da una terna cartesiana destrorsa XYZ. Si assume l'asse Z verticale ed orientato verso l'alto.

Gli elementi utilizzati per la modellazione dello schema statico della struttura sono i seguenti:

Elemento tipo TRUSS	(biella-D2)
Elemento tipo BEAM	(trave-D2)
Elemento tipo MEMBRANE	(membrana-D3)
Elemento tipo PLATE	(piastra-guscio-D3)
Elemento tipo BOUNDARY	(molla)
Elemento tipo STIFFNESS	(matrice di rigidezza)
Elemento tipo BRICK	(elemento solido)
Elemento tipo SOLAIO	(macro elemento composto da più membrane)

Modello numerico

In questa parte viene descritto il modello numerico utilizzato (o i modelli numerici utilizzati) per l'analisi della struttura. La presentazione delle informazioni deve essere, coerentemente con le prescrizioni del paragrafo 10.2 e relativi sottoparagrafi delle NTC-18, tale da garantirne la leggibilità, la corretta interpretazione e la riproducibilità

Parco Eolico "Bolina" – Progetto Definitivo
Relazione di calcolo preliminare delle fondazioni degli aerogeneratori G8 e G12

Tipo di analisi strutturale	
Carichi verticali	SI
Statica non lineare	NO
Sismica statica lineare	SI
Sismica dinamica lineare	NO
Sismica statica non lineare (prop. masse)	NO
Sismica statica non lineare (prop. modo)	NO
Sismica statica non lineare (triangolare)	NO
Non linearità geometriche (fattore P delta)	NO

Di seguito si indicano l'origine e le caratteristiche dei codici di calcolo utilizzati riportando titolo, produttore e distributore, versione, estremi della licenza d'uso:

Informazioni sul codice di calcolo	
Titolo:	PRO_SAP PROfessional Structural Analysis Program
Versione:	19.0.0
Produttore-Distributore:	2S.I. Software e Servizi per l'Ingegneria s.r.l., Ferrara
Dati utente finale:	Ing. Claudio Coscarella
Codice Utente:	Licenza gratuita
Codice Licenza:	START-UP (build 2019-01-184)

Un attento esame preliminare della documentazione a corredo del software **ha consentito di valutarne l'affidabilità e soprattutto l'idoneità al caso specifico**. La documentazione, fornita dal produttore e distributore del software, contiene una esauriente descrizione delle basi teoriche e degli algoritmi impiegati, l'individuazione dei campi d'impiego, nonché casi prova interamente risolti e commentati, corredati dei file di input necessari a riprodurre l'elaborazione:

Affidabilità dei codici utilizzati
2S.I. ha verificato l'affidabilità e la robustezza del codice di calcolo attraverso un numero significativo di casi prova in cui i risultati dell'analisi numerica sono stati confrontati con soluzioni teoriche.
E' possibile reperire la documentazione contenente alcuni dei più significativi casi trattati al seguente link: http://www.2si.it/Software/Affidabilità.htm

Modellazione della geometria e proprietà meccaniche:	
nodi	338
elementi D2 (per aste, travi, pilastri...)	45

Parco Eolico "Bolina" – Progetto Definitivo
Relazione di calcolo preliminare delle fondazioni degli aerogeneratori G8 e G12

elementi D3 (per pareti, platee, gusci...)	320
elementi solaio	0
elementi solidi	0
Dimensione del modello strutturale [cm]:	
X min =	-1150.00
Xmax =	1150.00
Ymin =	-1150.00
Ymax =	1150.00
Zmin =	-120.00
Zmax =	-100.00
Strutture verticali:	
Elementi di tipo asta	NO
Pilastrini	SI
Pareti	NO
Setti (a comportamento membranale)	NO
Strutture non verticali:	
Elementi di tipo asta	NO
Travi	SI
Gusci	NO
Membrane	NO
Orizzontamenti:	
Solai con la proprietà piano rigido	NO
Solai senza la proprietà piano rigido	NO
Tipo di vincoli:	
Nodi vincolati rigidamente	NO
Nodi vincolati elasticamente	NO
Nodi con isolatori sismici	NO
Fondazioni puntuali (plinti/plinti su palo)	SI
Fondazioni di tipo trave	NO
Fondazioni di tipo platea	SI
Fondazioni con elementi solidi	NO

Modellazione delle azioni

Si veda il capitolo **"Schematizzazione dei casi di carico"** per le informazioni necessarie alla comprensione ed alla ricostruzione delle azioni applicate al modello numerico, coerentemente con quanto indicato nella parte **"2.6. Azioni di progetto sulla costruzione"**.

Combinazioni e/o percorsi di carico

Si veda il capitolo **“Definizione delle combinazioni”** in cui sono indicate le combinazioni di carico adottate e, nel caso di calcoli non lineari, i percorsi di carico seguiti.

Combinazioni dei casi di carico	
APPROCCIO PROGETTUALE	Approccio 2
Tensioni ammissibili	NO
SLU	SI
SLV (SLU con sisma)	SI
SLC	NO
SLD	SI
SLO	NO
SLU GEO A2 (per approccio 1)	NO
SLU EQU	SI
Combinazione caratteristica (rara)	SI
Combinazione frequente	NO
Combinazione quasi permanente (SLE)	NO
SLA (accidentale quale incendio)	NO

Principali risultati
<p>I risultati devono costituire una sintesi completa ed efficace, presentata in modo da riassumere il comportamento della struttura, per ogni tipo di analisi svolta.</p> <p>2.8.1. Risultati dell'analisi modale</p> <p>Viene riportato il tipo di analisi modale condotta, restituiti i risultati della stessa e valutate le informazioni desumibili in merito al comportamento della struttura.</p> <p>2.8.2. Deformate e sollecitazioni per condizioni di carico</p> <p>Vengono riportati i principali risultati atti a descrivere il comportamento della struttura, in termini di stati di sollecitazione e di deformazione generalizzata, distinti per condizione elementare di carico o per combinazioni omogenee delle stesse.</p> <p>2.8.3. Involuppo delle sollecitazioni maggiormente significative. L'analisi e la restituzione degli involuppi (nelle combinazioni considerate agli SLU e agli SLE) delle caratteristiche di sollecitazione devono essere finalizzate alla valutazione dello stato di sollecitazione nei diversi elementi della struttura.</p> <p>2.8.4. Reazioni vincolari</p> <p>Vengono riportate le reazioni dei vincoli nelle singole condizioni di carico e/o nelle combinazioni considerate.</p> <p>2.8.5. Altri risultati significativi</p> <p>Nella presente parte vengono riportati tutti gli altri risultati che il progettista ritiene di interesse per la descrizione e la comprensione del/i modello/i e del comportamento della struttura.</p>

La presente relazione, oltre ad illustrare in modo esaustivo i dati in ingresso ed i risultati delle analisi in forma tabellare, riporta una serie di immagini:

per i dati in ingresso:

- modello solido della struttura
- numerazione di nodi e ed elementi
- configurazioni di carico statiche
- configurazioni di carico sismiche con baricentri delle masse e eccentricità

per le combinazioni più significative (statisticamente più gravose per la struttura):

- configurazioni deformate
- diagrammi e involuipi delle azioni interne
- mappe delle tensioni
- reazioni vincolari
- mappe delle pressioni sul terreno

per il progetto-verifica degli elementi:

- diagrammi di armatura
- percentuali di sfruttamento
- mappe delle verifiche più significative per i vari stati limite

Informazioni generali sull'elaborazione e giudizio motivato di accettabilità dei risultati.

Il programma prevede una serie di controlli automatici (check) che consentono l'individuazione di errori di modellazione. Al termine dell'analisi un controllo automatico identifica la presenza di spostamenti o rotazioni abnormi. Si può pertanto asserire che l'elaborazione sia corretta e completa. I risultati delle elaborazioni sono stati sottoposti a controlli che ne comprovano l'attendibilità. Tale valutazione ha compreso il confronto con i risultati di semplici calcoli, eseguiti con metodi tradizionali e adottati, anche in fase di primo proporzionamento della struttura. Inoltre, sulla base di considerazioni riguardanti gli stati tensionali e deformativi determinati, si è valutata la validità delle scelte operate in sede di schematizzazione e di modellazione della struttura e delle azioni. Si allega al termine della presente relazione elenco sintetico dei controlli svolti (verifiche di equilibrio tra reazioni vincolari e carichi applicati, comparazioni tra i risultati delle analisi e quelli di valutazioni semplificate, etc.) .

Verifiche agli stati limite ultimi

Nel capitolo relativo alla progettazione degli elementi strutturali agli SLU vengono indicate, con riferimento alla normativa adottata, le modalità ed i criteri seguiti per valutare la sicurezza della struttura nei confronti delle possibili situazioni di crisi ed i risultati delle valutazioni svolte. In via generale, oltre alle verifiche di resistenza e di spostamento, devono essere prese in considerazione verifiche nei confronti dei fenomeni di instabilità, locale e globale, di fatica, di duttilità, di degrado.

Verifiche agli stati limite di esercizio

Nel capitolo relativo alla progettazione degli elementi strutturali agli SLS vengono indicate, con riferimento alla normativa adottata, le modalità seguite per valutare l'affidabilità della struttura nei confronti delle possibili situazioni di perdita di funzionalità (per eccessive deformazioni, fessurazioni, vibrazioni, etc.) ed i risultati delle valutazioni svolte.

RELAZIONE SUI MATERIALI

Il capitolo Materiali riporta informazioni esaustive relative all'elenco dei materiali impiegati e loro modalità di posa in opera e ai valori di calcolo.

NORMATIVA DI RIFERIMENTO

1. D.Min. Infrastrutture Min. Interni e Prot. Civile 17 Gennaio 2018 e allegate "Norme tecniche per le costruzioni".
2. D.Min. Infrastrutture Min. Interni e Prot. Civile 14 Gennaio 2008 e allegate "Norme tecniche per le costruzioni".
3. D.Min. Infrastrutture e trasporti 14 Settembre 2005 e allegate "Norme tecniche per le costruzioni".
4. D.M. LL.PP. 9 Gennaio 1996 "Norme tecniche per il calcolo, l'esecuzione ed il collaudo delle strutture in cemento armato, normale e precompresso e per le strutture metalliche".
5. D.M. LL.PP. 16 Gennaio 1996 "Norme tecniche relative ai <<Criteri generali per la verifica di sicurezza delle costruzioni e dei carichi e sovraccarichi>>".
6. D.M. LL.PP. 16 Gennaio 1996 "Norme tecniche per le costruzioni in zone sismiche".
7. Circolare 4/07/96, n.156AA.GG./STC. istruzioni per l'applicazione delle "Norme tecniche relative ai <<Criteri generali per la verifica di sicurezza delle costruzioni e dei carichi e sovraccarichi>>" di cui al D.M. 16/01/96.
8. Circolare 10/04/97, n.65AA.GG. istruzioni per l'applicazione delle "Norme tecniche per le costruzioni in zone sismiche" di cui al D.M. 16/01/96.
9. D.M. LL.PP. 20 Novembre 1987 "Norme tecniche per la progettazione, esecuzione e collaudo degli edifici in muratura e per il loro consolidamento".
10. Circolare 4 Gennaio 1989 n. 30787 "Istruzioni in merito alle norme tecniche per la progettazione, esecuzione e collaudo degli edifici in muratura e per il loro consolidamento".
11. D.M. LL.PP. 11 Marzo 1988 "Norme tecniche riguardanti le indagini sui terreni e sulle rocce, la stabilità dei pendii naturali e delle scarpate, i criteri generali e le prescrizioni per la progettazione, l'esecuzione e il collaudo delle opere di sostegno delle terre e delle opere di fondazione".
12. D.M. LL.PP. 3 Dicembre 1987 "Norme tecniche per la progettazione, esecuzione e collaudo delle costruzioni prefabbricate".
13. UNI 9502 - Procedimento analitico per valutare la resistenza al fuoco degli elementi costruttivi di conglomerato cementizio armato, normale e precompresso - edizione maggio 2001
14. Ordinanza del Presidente del Consiglio dei Ministri n. 3274 del 20 marzo 2003 "Primi elementi in materia di criteri generali per la classificazione sismica del territorio nazionale e di normative tecniche per le costruzioni in zona sismica" e successive modificazioni e integrazioni.
15. UNI EN 1990:2006 13/04/2006 Eurocodice 0 - Criteri generali di progettazione strutturale.
16. UNI EN 1991-1-1:2004 01/08/2004 Eurocodice 1 - Azioni sulle strutture - Parte 1-1: Azioni in generale - Pesì per unità di volume, pesì propri e sovraccarichi per gli edifici.
17. UNI EN 1991-2:2005 01/03/2005 Eurocodice 1 - Azioni sulle strutture - Parte 2: Carichi da traffico sui ponti.
18. UNI EN 1991-1-3:2004 01/10/2004 Eurocodice 1 - Azioni sulle strutture - Parte 1-3: Azioni in generale - Carichi da neve.
19. UNI EN 1991-1-4:2005 01/07/2005 Eurocodice 1 - Azioni sulle strutture - Parte 1-4: Azioni in generale - Azioni del vento.
20. UNI EN 1991-1-5:2004 01/10/2004 Eurocodice 1 - Azioni sulle strutture - Parte 1-5: Azioni in generale - Azioni termiche.
21. UNI EN 1992-1-1:2005 24/11/2005 Eurocodice 2 - Progettazione delle strutture di calcestruzzo - Parte 1-1: Regole generali e regole per gli edifici.
22. UNI EN 1992-1-2:2005 01/04/2005 Eurocodice 2 - Progettazione delle strutture di calcestruzzo - Parte 1-2: Regole generali - Progettazione strutturale contro l'incendio.
23. UNI EN 1993-1-1:2005 01/08/2005 Eurocodice 3 - Progettazione delle strutture di acciaio - Parte 1-1: Regole generali e regole per gli edifici.
24. UNI EN 1993-1-8:2005 01/08/2005 Eurocodice 3 - Progettazione delle strutture di acciaio - Parte 1-8: Progettazione dei collegamenti.
25. UNI EN 1994-1-1:2005 01/03/2005 Eurocodice 4 - Progettazione delle strutture composte acciaio-calcestruzzo - Parte 1-1: Regole generali e regole per gli edifici.
26. UNI EN 1994-2:2006 12/01/2006 Eurocodice 4 - Progettazione delle strutture composte acciaio-calcestruzzo - Parte 2: Regole generali e regole per i ponti.
27. UNI EN 1995-1-1:2005 01/02/2005 Eurocodice 5 - Progettazione delle strutture di legno - Parte 1-1: Regole generali – Regole comuni e regole per gli edifici.
28. UNI EN 1995-2:2005 01/01/2005 Eurocodice 5 - Progettazione delle strutture di legno - Parte 2: Ponti.
29. UNI EN 1996-1-1:2006 26/01/2006 Eurocodice 6 - Progettazione delle strutture di muratura - Parte 1-1: Regole generali per strutture di muratura armata e non armata.
30. UNI EN 1996-3:2006 09/03/2006 Eurocodice 6 - Progettazione delle strutture di muratura - Parte 3: Metodi di calcolo semplificato per strutture di muratura non armata.
31. UNI EN 1997-1:2005 01/02/2005 Eurocodice 7 - Progettazione geotecnica - Parte 1: Regole generali.
32. UNI EN 1998-1:2005 01/03/2005 Eurocodice 8 - Progettazione delle strutture per la resistenza sismica - Parte 1: Regole generali, azioni sismiche e regole per gli edifici.
33. UNI EN 1998-3:2005 01/08/2005 Eurocodice 8 - Progettazione delle strutture per la resistenza sismica - Parte 3: Valutazione e adeguamento degli edifici.
34. UNI EN 1998-5:2005 01/01/2005 Eurocodice 8 - Progettazione delle strutture per la resistenza sismica - Parte 5: Fondazioni, strutture di contenimento ed aspetti geotecnici.

NOTA sul capitolo "normativa di riferimento": riporta l'elenco delle normative implementate nel software. Le norme utilizzate per la struttura oggetto della presente relazione sono indicate nel precedente capitolo "RELAZIONE DI CALCOLO STRUTTURALE" "ANALISI E VERIFICHE SVOLTE CON L'AUSILIO DI CODICI DI CALCOLO". Laddove nei capitoli successivi vengano richiamate norme antecedenti al DM 17.01.08 è dovuto a o a progettazione simulata di edificio esistente.

CARATTERISTICHE MATERIALI UTILIZZATI

LEGENDA TABELLA DATI MATERIALI

Il programma consente l'uso di materiali diversi. Sono previsti i seguenti tipi di materiale:

1	materiale tipo cemento armato
2	materiale tipo acciaio
3	materiale tipo muratura
4	materiale tipo legno
5	materiale tipo generico

I materiali utilizzati nella modellazione sono individuati da una sigla identificativa ed un codice numerico (gli elementi strutturali richiamano quest'ultimo nella propria descrizione). Per ogni materiale vengono riportati in tabella i seguenti dati:

Young	modulo di elasticità normale E
Poisson	coefficiente di contrazione trasversale ν
G	modulo di elasticità tangenziale
Gamma	peso specifico
Alfa	coefficiente di dilatazione termica
Fattore di confidenza FC m	Fattore di confidenza specifico per materiale; (è riportato solo se diverso da quello globale della struttura)
Fattore di confidenza FC a	Fattore di confidenza specifico per l'armatura (è riportato solo se diverso da quello globale della struttura)
Elasto-plastico	Materiale elastico perfettamente plastico per aste non lineari
Massima compressione	Massima tensione di compressione per aste non lineari
Massima trazione	Massima tensione di trazione per aste non lineari
Fattore attrito	Coefficiente di attrito per aste non lineari
Rapporto HRDb	Rapporto di hardening a flessione
Rapporto HRDv	Rapporto di hardening a taglio

I dati soprariportati vengono utilizzati per la modellazione dello schema statico e per la determinazione dei carichi inerziali e termici. In relazione al tipo di materiale vengono riportati inoltre:

1	cemento armato	Resistenza Rc Resistenza fctm Coefficiente ksb	resistenza a compressione cubica resistenza media a trazione semplice Coefficiente di riduzione della resistenza a compressione da utilizzare nello stress block
2	acciaio	Tensione ft Tensione fy Resistenza fd Resistenza fd (>40) Tensione ammissibile Tensione ammissibile (>40)	Valore della tensione di rottura Valore della tensione di snervamento Resistenza di calcolo per SL CNR-UNI 10011 Resistenza di calcolo per SL CNR-UNI 10011 per spessori > 40mm Tensione ammissibile CNR-UNI 10011 Tensione ammissibile CNR-UNI 10011 per spessori > 40mm
3	muratura	Muratura consolidata Incremento resistenza Incremento rigidezza	Muratura per la quale si prevedono interventi di rinforzo" Incremento conseguito in termini di resistenza Incremento conseguito in termini di rigidezza

Resistenza f	Valore della resistenza a compressione
Resistenza fv0	Valore della resistenza a taglio in assenza di tensioni normali
Resistenza fh	Valore della resistenza a compressione orizzontale
Resistenza fb	Valore della resistenza a compressione dei blocchi
Resistenza fbh	Valore della resistenza a compressione dei blocchi in direzione orizzontale
Resistenza fv0h	Valore della resistenza a taglio in assenza di tensioni normali per le travi
Resistenza ft	Valore della resistenza a trazione per fessurazione diagonale
Resistenza fvlm	Valore della massima resistenza a taglio
Resistenza fbt	Valore della resistenza a trazione dei blocchi
Coefficiente mu	Coefficiente d'attrito utilizzato per la resistenza a taglio (tipicamente 0.4)
Coefficiente fi	Coefficiente d'ingranamento utilizzato per la resistenza a taglio
Coefficiente ksb	Coefficiente di riduzione della resistenza a compressione da utilizzare nello stress block
4 legno	
E0,05	Modulo di elasticità corrispondente ad un frattile del 5%
Resistenza fc0	Valore della resistenza a compressione parallela
Resistenza ft0	Valore della resistenza a trazione parallela
Resistenza fm	Valore della resistenza a flessione
Resistenza fv	Valore della resistenza a taglio
Resist. ft0k	Resistenza caratteristica (tensione amm. per REGLES) per trazione
Resist. fmk	Resistenza caratteristica (tensione amm. per REGLES) per flessione
Resist. fvk	Resistenza caratteristica (tensione amm. per REGLES) per taglio
Modulo E0,05	Modulo elastico parallelo caratteristico
Lamellare	lamellare o massiccio

Vengono inoltre riportate le tabelle contenenti il riassunto delle informazioni assegnate nei criteri di progetto in uso.

Con riferimento al **Documento di Affidabilità** "Test di validazione del software di calcolo PRO_SAP e dei moduli aggiuntivi PRO_SAP Modulo Geotecnico, PRO_CAD nodi acciaio e PRO_MST" - versione Maggio 2011, disponibile per il download sul sito www.2si.it, si segnalano i seguenti esempi applicativi:

Modellazione di strutture in c.a.

Test N°	Titolo
41	GERARCHIA DELLE RESISTENZE PER TRAVI IN C.A.
42	GERARCHIA DELLE RESISTENZE PER PILASTRI IN C.A.

Parco Eolico "Bolina" – Progetto Definitivo
Relazione di calcolo preliminare delle fondazioni degli aerogeneratori G8 e G12

43	VERIFICA ALLE TA DI STRUTTURE IN C.A.
44	VERIFICA AGLI SLU DI STRUTTURE IN C.A.
45	VERIFICA A PUNZONAMENTO ALLO SLU DI PIASTRE IN C.A.
46	VERIFICA A PUNZONAMENTO ALLO SLU DI TRAVI IN C.A.
47	PROGETTAZIONE A TAGLIO DI STRUTTURE IN C.A. SECONDO IL D.M. 9/1/96
48	PROGETTAZIONE A TAGLIO DI STRUTTURE IN C.A. SECONDO IL D.M. 14/1/2008
49	VERIFICA ALLO SLE (TENSIONI E FESSURAZIONE) DI STRUTTURE IN C.A.
50	VERIFICA ALLO SLE (DEFORMAZIONE) DI STRUTTURE IN C.A.
51	FATTORE DI STRUTTURA
52	SOVRARESISTENZE
53	DETTAGLI COSTRUTTIVI C.A.: LIMITI D'ARMATURA PILASTRI E NODI TRAVE-PILASTRO
54	PARETI IN C.A. SNELLE IN ZONA SISMICA
80	ANALISI PUSHOVER DI UN EDIFICIO IN C.A.
120	PROGETTO E VERIFICA DI TRAVI PREM

Modellazione di strutture in acciaio

Test N°	Titolo
55	VERIFICA DI STABILITA' DI ASTE COMPRESSE IN ACCIAIO – METODO OMEGA
56	LUCE LIBERA DI TRAVI E ASTE IN ACCIAIO
57	LUCE LIBERA DI COLONNE IN ACCIAIO
58	SVERGOLAMENTO DI TRAVI IN ACCIAIO
59	FATTORE DI STRUTTURA
60	ACCIAIO D.M.2008
61	ACCIAIO EC3
62	GERARCHIA RESISTENZE STRUTTURE IN ACCIAIO
63	STABILITA' DI ASTE COMPOSTE IN ACCIAIO
73	COLLEGAMENTI IN ACCIAIO: NODO TRAVE COLONNA FLANGIATO CON PRESENZA IRRIGIDIMENTI TRASVERSALI
74	COLLEGAMENTI IN ACCIAIO: NODO TRAVE COLONNA FLANGIATO CON PRESENZA DI UN PIATTO DI RINFORZO SALDATO ALL'ANIMA DELLA COLONNA
75	COLLEGAMENTI IN ACCIAIO: NODO TRAVE COLONNA FLANGIATO CON PRESENZA DI DUE PIATTI DI RINFORZO SALDATI ALL'ANIMA DELLA COLONNA
76	COLLEGAMENTI IN ACCIAIO: NODO TRAVE COLONNA FLANGIATO A DUE VIE SU ALI COLONNA
77	COLLEGAMENTI IN ACCIAIO: NODO TRAVE COLONNA FLANGIATO A UNA VIA CON DUE COMBINAZIONI DI CARICO
78	COLLEGAMENTI IN ACCIAIO: NODO TRAVE COLONNA FLANGIATO SU ANIMA SENZA RINFORZI A QUATTRO FILE DI BULLONI DI CUI UNA SU PIASTRA INFERIORE E UNA SU PIASTRA SUPERIORE
79	VERIFICA DELLA PIASTRA NODO TRAVE COLONNA
85	TELAIO ACCIAIO: CONTROVENTI CONCENTRICI

Modellazione di strutture in muratura

Test N°	Titolo
81	ANALISI PUSHOVER DI UNA STRUTTURA IN MURATURA
84	ANALISI ELASTO PLASTICA INCREMENTALE, PARETE IN MURATURA
86	VERIFICA NON SISMICA DELLE MURATURE (D.M. 87 TA)
87	VERIFICA NON SISMICA DELLE MURATURE (D.M. 2005 SL)
88	FATTORE DI STRUTTURA

Modellazione di strutture in legno

Parco Eolico "Bolina" – Progetto Definitivo
Relazione di calcolo preliminare delle fondazioni degli aerogeneratori G8 e G12

Test N°	Titolo
17	SOLAIO: MISTO LEGNO-CALCESTRUZZO
89	VERIFICA ALLO SLU DI STRUTTURE IN LEGNO SECONDO EC5
90	VERIFICA ALLO SLE DI STRUTTURE IN LEGNO SECONDO EC5
91	FATTORE DI STRUTTURA
92	VERIFICHE EC5
93	SNELLEZZE EC5
94	VERIFICA AL FUOCO DI STRUTTURE IN LEGNO SECONDO EC5
117	PROGETTO E VERIFICA DI GUSCI IN MATERIALE XLAM
118	PROGETTO E VERIFICA DI PARETI IN MATERIALE XLAM E RELATIVI COLLEGAMENTI
119	PROGETTO E VERIFICA DI SOLAI IN MATERIALE XLAM

Id	Tipo / Note	V. caratt.	V. medio	Young	Poisson	G	Gamma	Alfa	Altri
		daN/cm2	daN/cm2	daN/cm2		daN/cm2	daN/cm3		
1	Calcestruzzo Classe C25/30			3.145e+05	0.20	1.310e+05	2.50e-03	1.00e-05	
	Resistenza Rc	300.0							
	Resistenza fctm		25.6						
	Coefficiente ksb								0.85
	Rapporto HRDb								1.00e-05
	Rapporto HRDv								1.00e-05
75	Materiale inf. rigido no peso E = 1.000e+09			1.000e+09	0.0	5.000e+08	0.0	1.20e-05	
	Rapporto HRDb								1.00e-05
	Rapporto HRDv								1.00e-05

Gusci c.a.	1/7/..	2/8/..	3/9/..	4/10/..	5/11/..	6/12/..
Armatura						
Inclinazione Ax [gradi]	0.0	0.0				
Angolo Ax-Ay [gradi]	90.00	90.00				
Minima tesa	0.31	0.31				
Massima tesa	0.78	0.78				
Maglia unica centrale	No	No				
Copriferro [cm]	2.00	3.00				
Maglia x						
diametro	10	24				
passo	20	20				
diametro aggiuntivi	12	12				
Maglia y						
diametro	10	24				
passo	20	20				
diametro aggiuntivi	12	12				
Stati limite ultimi						
Tensione fy [daN/cm2]	4500.00	4500.00				
Tipo acciaio	tipo C	tipo C				
Coefficiente gamma s	1.15	1.15				
Coefficiente gamma c	1.50	1.50				
Verifiche con N costante	Si	Si				
Applica SLU da DIN	No	No				
Tensioni ammissibili						
Tensione amm. cls [daN/cm2]	97.50	97.50				
Tensione amm. acciaio [daN/cm2]	2600.00	2600.00				
Rapporto omogeneizzazione N	15.00	15.00				
Massimo rapporto area compressa/tesa	1.00	1.00				
Resistenza al fuoco						
3- intradosso	No	No				
3+ estradosso	No	No				
Tempo di esposizione R	15	15				

MODELLAZIONE DELLE SEZIONI

LEGENDA TABELLA DATI SEZIONI

Il programma consente l'uso di sezioni diverse. Sono previsti i seguenti tipi di sezione:

1. sezione di tipo generico
2. profilati semplici
3. profilati accoppiati e speciali

Le sezioni utilizzate nella modellazione sono individuate da una sigla identificativa ed un codice numerico (gli elementi strutturali richiamano quest'ultimo nella propria descrizione). Per ogni sezione vengono riportati in tabella i seguenti dati:

Area	area della sezione
A V2	area della sezione/fattore di taglio (per il taglio in direzione 2)
A V3	area della sezione/fattore di taglio (per il taglio in direzione 3)
Jt	fattore torsionale di rigidezza
J2-2	momento d'inerzia della sezione riferito all'asse 2
J3-3	momento d'inerzia della sezione riferito all'asse 3
W2-2	modulo di resistenza della sezione riferito all'asse 2
W3-3	modulo di resistenza della sezione riferito all'asse 3
Wp2-2	modulo di resistenza plastico della sezione riferito all'asse 2
Wp3-3	modulo di resistenza plastico della sezione riferito all'asse 3

I dati sopra riportati vengono utilizzati per la determinazione dei carichi inerziali e per la definizione delle rigidezze degli elementi strutturali; qualora il valore di Area V2 (e/o Area V3) sia nullo la deformabilità per taglio V2 (e/o V3) è trascurata. La valutazione delle caratteristiche inerziali delle sezioni è condotta nel riferimento 2-3 dell'elemento.

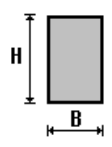
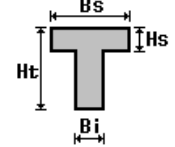
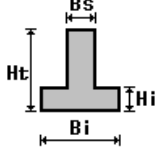
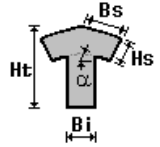
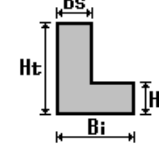
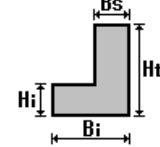
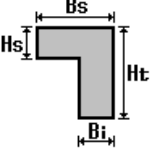
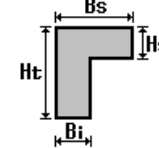
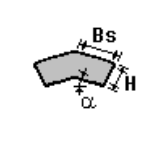
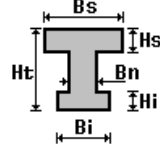
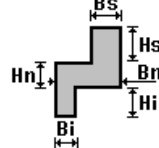
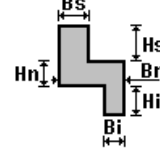
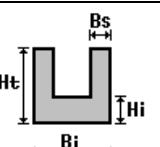
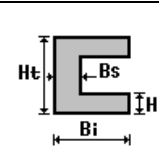
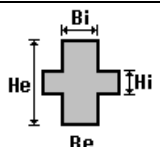
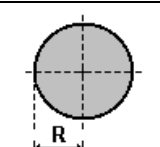
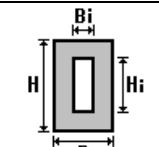
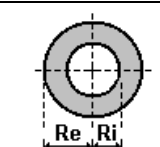
 rettangolare	 a T	 a T rovescia	 a T di colmo	 a L	 a L specchiata
 a L specchiata rovescia	 a L rovescia	 a L di colmo	 a doppio T	 a quattro specchiata	 a quattro
 a U	 a C	 a croce	 circolare	 rettangolare cava	 circolare cava

Parco Eolico "Bolina" – Progetto Definitivo
Relazione di calcolo preliminare delle fondazioni degli aerogeneratori G8 e G12

Per quanto concerne i profilati semplici ed accoppiati l'asse 2 del riferimento coincide con l'asse x riportato nei più diffusi profilati.

Per quanto concerne le sezioni di tipo generico (tipo 1.):
 i valori dimensionali con prefisso B sono riferiti all'asse 2
 i valori dimensionali con prefisso H sono riferiti all'asse 3

Con riferimento al Documento di Affidabilità "Test di validazione del software di calcolo PRO_SAP e dei moduli aggiuntivi PRO_SAP Modulo Geotecnico, PRO_CAD nodi acciaio e PRO_MST" - versione Settembre 2014, disponibile per il download sul sito www.2si.it, si segnalano i seguenti esempi applicativi:

Test N°	Titolo
1	CARATTERISTICHE GEOMETRICHE E INERZIALI
45	VERIFICA AGLI SLU DI STRUTTURE IN C.A.
48	PROGETTAZIONE A TAGLIO DI STRUTTURE IN C.A. SECONDO IL D.M. 9/1/96
49	PROGETTAZIONE A TAGLIO DI STRUTTURE IN C.A. SECONDO IL D.M. 14/1/2008
50	VERIFICA ALLO SLE (TENSIONI E FESSURAZIONE) DI STRUTTURE IN C.A.
51	VERIFICA ALLO SLE (DEFORMAZIONE) DI STRUTTURE IN C.A.
104	ANALISI DI RESISTENZA AL FUOCO

Id	Tipo	Area	A V2	A V3	Jt	J 2-2	J 3-3	W 2-2	W 3-3	Wp 2-2	Wp 3-3
		cm2	cm2	cm2	cm4	cm4	cm4	cm3	cm3	cm3	cm3
1	Rettangolare: b=30.00 h =30.00	900.00	750.00	750.00	1.139e+05	6.750e+04	6.750e+04	4500.00	4500.00	6750.00	6750.00
133	Circolare cava: re=225 ri=220	6990.04	0.0	0.0	3.461e+08	1.730e+08	1.730e+08	7.691e+05	7.691e+05	9.902e+05	9.902e+05

MODELLAZIONE STRUTTURA: NODI

LEGENDA TABELLA DATI NODI

Il programma utilizza per la modellazione nodi strutturali.

Ogni nodo è individuato dalle coordinate cartesiane nel sistema di riferimento globale (X Y Z).

Ad ogni nodo è eventualmente associato un codice di vincolamento rigido, un codice di fondazione speciale, ed un set di sei molle (tre per le traslazioni, tre per le rotazioni). Le tabelle sottoriportate riflettono le succitate possibilità. In particolare per ogni nodo viene indicato in tabella:

Nodo	numero del nodo.
X	valore della coordinata X
Y	valore della coordinata Y
Z	valore della coordinata Z

Per i nodi ai quali sia associato un codice di vincolamento rigido, un codice di fondazione speciale o un set di molle viene indicato in tabella:

Nodo	numero del nodo.
X	valore della coordinata X
Y	valore della coordinata Y
Z	valore della coordinata Z
Note	eventuale codice di vincolo (es. v=110010 sei valori relativi ai sei gradi di libertà previsti per il nodo TxTyTzRxRyRz, il valore 1 indica che lo spostamento o rotazione relativo è impedito, il valore 0 indica che lo spostamento o rotazione relativo è libero).
Note	(FS = 1, 2,...) eventuale codice del tipo di fondazione speciale (1, 2,... fanno riferimento alle tipologie: plinto, palo, plinto su pali,...) che è collegato al nodo. (ISO = "id SIGLA") indice e sigla identificativa dell' eventuale isolatore sismico assegnato al nodo
Rig. TX	valore della rigidezza dei vincoli elastici eventualmente applicati al nodo, nello specifico TX (idem per TY, TZ, RX, RY, RZ).

Per strutture sismicamente isolate viene inoltre inserita la tabella delle caratteristiche per gli isolatori utilizzati; le caratteristiche sono indicate in conformità al cap. 7.10 del D.M. 17/01/18

TABELLA DATI NODI

Nodo	X	Y	Z	Nodo	X	Y	Z	Nodo	X	Y	Z
	cm	cm	cm		cm	cm	cm		cm	cm	cm
1	-287.5	-287.5	-120.0	2	-215.6	-287.5	-120.0	3	-215.6	-215.6	-120.0
4	-287.5	-215.6	-120.0	5	-215.6	-143.8	-120.0	6	-287.5	-143.8	-120.0
7	-215.6	-71.9	-120.0	8	-287.5	-71.9	-120.0	9	-215.6	0.0	-120.0
10	-287.5	0.0	-120.0	11	-215.6	71.9	-120.0	12	-287.5	71.9	-120.0
13	-215.6	143.8	-120.0	14	-287.5	143.8	-120.0	15	-215.6	215.6	-120.0
16	-287.5	215.6	-120.0	17	-215.6	287.5	-120.0	18	-287.5	287.5	-120.0
19	-143.8	-287.5	-120.0	20	-143.8	-215.6	-120.0	21	-143.8	-143.8	-120.0
22	-143.8	-71.9	-120.0	23	-143.8	0.0	-120.0	24	-143.8	71.9	-120.0
25	-143.8	143.8	-120.0	26	-143.8	215.6	-120.0	27	-143.8	287.5	-120.0
28	-71.9	-287.5	-120.0	29	-71.9	-215.6	-120.0	30	-71.9	-143.8	-120.0
31	-71.9	-71.9	-120.0	32	-71.9	0.0	-120.0	33	-71.9	71.9	-120.0
34	-71.9	143.8	-120.0	35	-71.9	215.6	-120.0	36	-71.9	287.5	-120.0
37	0.0	-287.5	-120.0	38	0.0	-215.6	-120.0	39	0.0	-143.8	-120.0
40	0.0	-71.9	-120.0	41	0.0	0.0	-120.0	42	0.0	71.9	-120.0
43	0.0	143.8	-120.0	44	0.0	215.6	-120.0	45	0.0	287.5	-120.0
46	71.9	-287.5	-120.0	47	71.9	-215.6	-120.0	48	71.9	-143.8	-120.0
49	71.9	-71.9	-120.0	50	71.9	0.0	-120.0	51	71.9	71.9	-120.0
52	71.9	143.8	-120.0	53	71.9	215.6	-120.0	54	71.9	287.5	-120.0
55	143.8	-287.5	-120.0	56	143.8	-215.6	-120.0	57	143.8	-143.8	-120.0
58	143.8	-71.9	-120.0	59	143.8	0.0	-120.0	60	143.8	71.9	-120.0
61	143.8	143.8	-120.0	62	143.8	215.6	-120.0	63	143.8	287.5	-120.0
64	215.6	-287.5	-120.0	65	215.6	-215.6	-120.0	66	215.6	-143.8	-120.0
67	215.6	-71.9	-120.0	68	215.6	0.0	-120.0	69	215.6	71.9	-120.0
70	215.6	143.8	-120.0	71	215.6	215.6	-120.0	72	215.6	287.5	-120.0
73	287.5	-287.5	-120.0	74	287.5	-215.6	-120.0	75	287.5	-143.8	-120.0
76	287.5	-71.9	-120.0	77	287.5	0.0	-120.0	78	287.5	71.9	-120.0
79	287.5	143.8	-120.0	80	287.5	215.6	-120.0	81	287.5	287.5	-120.0
82	395.3	0.0	-120.0	83	392.6	90.9	-120.0	85	497.6	110.0	-120.0
86	610.9	0.0	-120.0	87	602.7	129.1	-120.0	88	718.8	0.0	-120.0
89	707.7	148.1	-120.0	90	826.6	0.0	-120.0	91	812.8	167.2	-120.0
93	917.8	186.2	-120.0	94	1042.2	0.0	-120.0	95	1022.9	205.3	-120.0

Parco Eolico "Bolina" – Progetto Definitivo
Relazione di calcolo preliminare delle fondazioni degli aerogeneratori G8 e G12

96	1150.0	0.0	-120.0	97	1127.9	224.4	-120.0	98	384.4	180.8	-120.0
99	481.2	217.8	-120.0	100	578.1	254.9	-120.0	101	675.0	291.9	-120.0
102	771.9	329.0	-120.0	104	965.6	403.0	-120.0	105	1062.5	440.1	-120.0
106	371.1	268.5	-120.0	107	454.7	321.4	-120.0	108	538.3	374.4	-120.0
109	621.8	427.3	-120.0	110	705.4	480.2	-120.0	111	789.0	533.1	-120.0
112	872.6	586.0	-120.0	113	956.2	638.9	-120.0	114	353.2	353.2	-120.0
116	484.6	484.6	-120.0	117	550.3	550.3	-120.0	118	616.0	616.0	-120.0
120	747.5	747.5	-120.0	121	813.2	813.2	-120.0	122	268.5	371.1	-120.0
123	321.4	454.7	-120.0	124	374.4	538.3	-120.0	125	427.3	621.8	-120.0
126	480.2	705.4	-120.0	127	533.1	789.0	-120.0	128	586.0	872.6	-120.0
129	638.9	956.2	-120.0	130	180.8	384.4	-120.0	131	217.8	481.2	-120.0
132	254.9	578.1	-120.0	133	291.9	675.0	-120.0	134	329.0	771.9	-120.0
136	403.0	965.6	-120.0	137	440.1	1062.5	-120.0	138	90.9	392.6	-120.0
139	110.0	497.6	-120.0	140	129.1	602.7	-120.0	141	148.1	707.7	-120.0
142	167.2	812.8	-120.0	143	186.2	917.8	-120.0	144	205.3	1022.9	-120.0
145	224.4	1127.9	-120.0	146	0.0	395.3	-120.0	148	0.0	610.9	-120.0
149	0.0	718.8	-120.0	150	0.0	826.6	-120.0	152	0.0	1042.2	-120.0
153	0.0	1150.0	-120.0	154	-90.9	392.6	-120.0	155	-110.0	497.6	-120.0
156	-129.1	602.7	-120.0	157	-148.1	707.7	-120.0	158	-167.2	812.8	-120.0
159	-186.2	917.8	-120.0	160	-205.3	1022.9	-120.0	161	-224.4	1127.9	-120.0
162	-180.8	384.4	-120.0	163	-217.8	481.2	-120.0	164	-254.9	578.1	-120.0
165	-291.9	675.0	-120.0	166	-329.0	771.9	-120.0	168	-403.0	965.6	-120.0
169	-440.1	1062.5	-120.0	170	-268.5	371.1	-120.0	171	-321.4	454.7	-120.0
172	-374.4	538.3	-120.0	173	-427.3	621.8	-120.0	174	-480.2	705.4	-120.0
175	-533.1	789.0	-120.0	176	-586.0	872.6	-120.0	177	-638.9	956.2	-120.0
178	-353.2	353.2	-120.0	180	-484.6	484.6	-120.0	181	-550.3	550.3	-120.0
182	-616.0	616.0	-120.0	184	-747.5	747.5	-120.0	185	-813.2	813.2	-120.0
186	-371.1	268.5	-120.0	187	-454.7	321.4	-120.0	188	-538.3	374.4	-120.0
189	-621.8	427.3	-120.0	190	-705.4	480.2	-120.0	191	-789.0	533.1	-120.0
192	-872.6	586.0	-120.0	193	-956.2	638.9	-120.0	194	-384.4	180.8	-120.0
195	-481.2	217.8	-120.0	196	-578.1	254.9	-120.0	197	-675.0	291.9	-120.0
198	-771.9	329.0	-120.0	200	-965.6	403.0	-120.0	201	-1062.5	440.1	-120.0
202	-392.6	90.9	-120.0	203	-497.6	110.0	-120.0	204	-602.7	129.1	-120.0
205	-707.7	148.1	-120.0	206	-812.8	167.2	-120.0	207	-917.8	186.2	-120.0
208	-1022.9	205.3	-120.0	209	-1127.9	224.4	-120.0	210	-395.3	0.0	-120.0
212	-610.9	0.0	-120.0	213	-718.8	0.0	-120.0	214	-826.6	0.0	-120.0
216	-1042.2	0.0	-120.0	217	-1150.0	0.0	-120.0	218	-392.6	-90.9	-120.0
219	-497.6	-110.0	-120.0	220	-602.7	-129.1	-120.0	221	-707.7	-148.1	-120.0
222	-812.8	-167.2	-120.0	223	-917.8	-186.2	-120.0	224	-1022.9	-205.3	-120.0
225	-1127.9	-224.4	-120.0	226	-384.4	-180.8	-120.0	227	-481.2	-217.8	-120.0
228	-578.1	-254.9	-120.0	229	-675.0	-291.9	-120.0	230	-771.9	-329.0	-120.0
232	-965.6	-403.0	-120.0	233	-1062.5	-440.1	-120.0	234	-371.1	-268.5	-120.0
235	-454.7	-321.4	-120.0	236	-538.3	-374.4	-120.0	237	-621.8	-427.3	-120.0
238	-705.4	-480.2	-120.0	239	-789.0	-533.1	-120.0	240	-872.6	-586.0	-120.0
241	-956.2	-638.9	-120.0	242	-353.2	-353.2	-120.0	244	-484.6	-484.6	-120.0
245	-550.3	-550.3	-120.0	246	-616.0	-616.0	-120.0	248	-747.5	-747.5	-120.0
249	-813.2	-813.2	-120.0	250	-268.5	-371.1	-120.0	251	-321.4	-454.7	-120.0
252	-374.4	-538.3	-120.0	253	-427.3	-621.8	-120.0	254	-480.2	-705.4	-120.0
255	-533.1	-789.0	-120.0	256	-586.0	-872.6	-120.0	257	-638.9	-956.2	-120.0
258	-180.8	-384.4	-120.0	259	-217.8	-481.2	-120.0	260	-254.9	-578.1	-120.0
261	-291.9	-675.0	-120.0	262	-329.0	-771.9	-120.0	264	-403.0	-965.6	-120.0
265	-440.1	-1062.5	-120.0	266	-90.9	-392.6	-120.0	267	-110.0	-497.6	-120.0
268	-129.1	-602.7	-120.0	269	-148.1	-707.7	-120.0	270	-167.2	-812.8	-120.0
271	-186.2	-917.8	-120.0	272	-205.3	-1022.9	-120.0	273	-224.4	-1127.9	-120.0
274	0.0	-395.3	-120.0	276	0.0	-610.9	-120.0	277	0.0	-718.8	-120.0
278	0.0	-826.6	-120.0	280	0.0	-1042.2	-120.0	281	0.0	-1150.0	-120.0
282	90.9	-392.6	-120.0	283	110.0	-497.6	-120.0	284	129.1	-602.7	-120.0
285	148.1	-707.7	-120.0	286	167.2	-812.8	-120.0	287	186.2	-917.8	-120.0
288	205.3	-1022.9	-120.0	289	224.4	-1127.9	-120.0	290	180.8	-384.4	-120.0
291	217.8	-481.2	-120.0	292	254.9	-578.1	-120.0	293	291.9	-675.0	-120.0
294	329.0	-771.9	-120.0	296	403.0	-965.6	-120.0	297	440.1	-1062.5	-120.0
298	268.5	-371.1	-120.0	299	321.4	-454.7	-120.0	300	374.4	-538.3	-120.0
301	427.3	-621.8	-120.0	302	480.2	-705.4	-120.0	303	533.1	-789.0	-120.0
304	586.0	-872.6	-120.0	305	638.9	-956.2	-120.0	306	353.2	-353.2	-120.0
308	484.6	-484.6	-120.0	309	550.3	-550.3	-120.0	310	616.0	-616.0	-120.0
312	747.5	-747.5	-120.0	313	813.2	-813.2	-120.0	314	371.1	-268.5	-120.0
315	454.7	-321.4	-120.0	316	538.3	-374.4	-120.0	317	621.8	-427.3	-120.0
318	705.4	-480.2	-120.0	319	789.0	-533.1	-120.0	320	872.6	-586.0	-120.0
321	956.2	-638.9	-120.0	322	384.4	-180.8	-120.0	323	481.2	-217.8	-120.0
324	578.1	-254.9	-120.0	325	675.0	-291.9	-120.0	326	771.9	-329.0	-120.0
328	965.6	-403.0	-120.0	329	1062.5	-440.1	-120.0	330	392.6	-90.9	-120.0
331	497.6	-110.0	-120.0	332	602.7	-129.1	-120.0	333	707.7	-148.1	-120.0
334	812.8	-167.2	-120.0	335	917.8	-186.2	-120.0	336	1022.9	-205.3	-120.0

Parco Eolico "Bolina" – Progetto Definitivo
Relazione di calcolo preliminare delle fondazioni degli aerogeneratori G8 e G12

337 1127.9 -224.4 -120.0 338 0.0 0.0 -100.0

Nodo	X cm	Y cm	Z cm	Note	Rig. TX daN/cm	Rig. TY daN/cm	Rig. TZ daN/cm	Rig. RX daN cm/rad	Rig. RY daN cm/rad	Rig. RZ daN cm/rad
84	503.1	0.0	-120.0	FS=5						
92	934.4	0.0	-120.0	FS=5						
103	868.7	366.0	-120.0	FS=5						
115	418.9	418.9	-120.0	FS=5						
119	681.8	681.8	-120.0	FS=5						
135	366.0	868.7	-120.0	FS=5						
147	0.0	503.1	-120.0	FS=5						
151	0.0	934.4	-120.0	FS=5						
167	-366.0	868.7	-120.0	FS=5						
179	-418.9	418.9	-120.0	FS=5						
183	-681.8	681.8	-120.0	FS=5						
199	-868.7	366.0	-120.0	FS=5						
211	-503.1	0.0	-120.0	FS=5						
215	-934.4	0.0	-120.0	FS=5						
231	-868.7	-366.0	-120.0	FS=5						
243	-418.9	-418.9	-120.0	FS=5						
247	-681.8	-681.8	-120.0	FS=5						
263	-366.0	-868.7	-120.0	FS=5						
275	0.0	-503.1	-120.0	FS=5						
279	0.0	-934.4	-120.0	FS=5						
295	366.0	-868.7	-120.0	FS=5						
307	418.9	-418.9	-120.0	FS=5						
311	681.8	-681.8	-120.0	FS=5						
327	868.7	-366.0	-120.0	FS=5						

MODELLAZIONE STRUTTURA: ELEMENTI SHELL

LEGENDA TABELLA DATI SHELL

Il programma utilizza per la modellazione elementi a tre o quattro nodi denominati in generale shell.

Ogni elemento shell è individuato dai nodi I, J, K, L (L=I per gli elementi a tre nodi).

Ogni elemento è caratterizzato da un insieme di proprietà riportate in tabella che ne completano la modellazione.

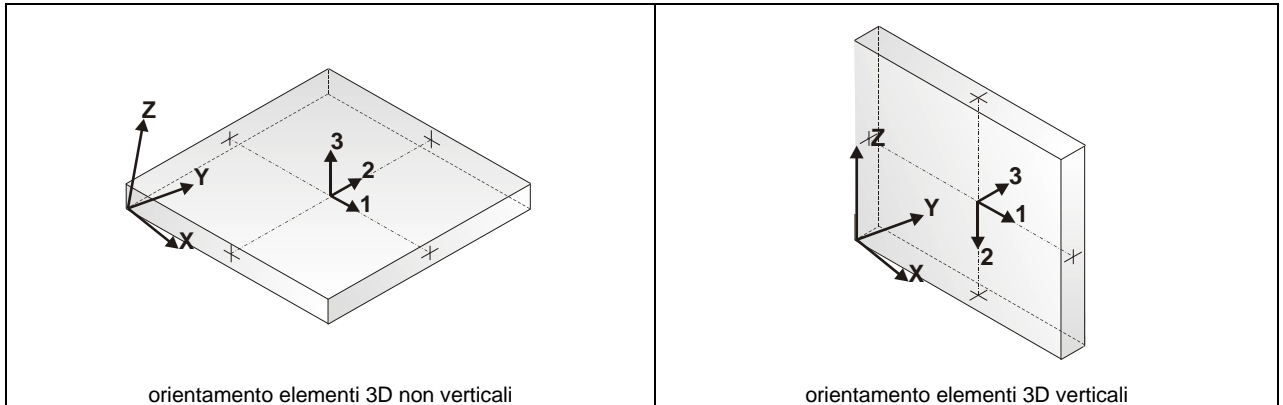

In particolare per ogni elemento viene indicato in tabella:

Elem.	numero dell'elemento
Note	codice di comportamento: <i>Guscio</i> (elemento guscio in elevazione non verticale) <i>Guscio fond.</i> (elemento guscio su suolo elastico) <i>Setto</i> (elemento guscio in elevazione verticale) <i>Membrana</i> (elemento guscio con comportamento membranale)
Nodo I (J, K, L)	numero del nodo I (J, K, L)
Mat.	codice del materiale assegnato all'elemento
Spessore	spessore dell'elemento (costante)
Wink V	costante di sottofondo (coefficiente di Winkler) per la modellazione del suolo elastico verticale
Wink O	costante di sottofondo (coefficiente di Winkler) per la modellazione del suolo elastico orizzontale

Parco Eolico "Bolina" – Progetto Definitivo
Relazione di calcolo preliminare delle fondazioni degli aerogeneratori G8 e G12

Con riferimento al **Documento di Affidabilità** "Test di validazione del software di calcolo PRO_SAP e dei moduli aggiuntivi PRO_SAP Modulo Geotecnico, PRO_CAD nodi acciaio e PRO_MST" - versione Maggio 2011, disponibile per il download sul sito www.2si.it, si segnalano i seguenti esempi applicativi:

Test N°	Titolo
8	MENSOLE CON ELEMENTI PLATE E MATERIALE ORTOTROPO
10	PIASTRA CON ELEMENTI PLATE E MATERIALE ORTOTROPO
21	DRILLING
25	TENSIONI DI ELEMENTI PLATE
31	REALIZZAZIONE DI MESH PIANA SU GEOMETRIA CON PUNTI FISSI IMPORTATA DA FILE .DXF
32	REALIZZAZIONE DI MESH PIANA SU GEOMETRIA CON SEGMENTI E FORI INTERNI IMPORTATA DA FILE .DXF
33	REALIZZAZIONE DI MESH PIANE SU GEOMETRIE COSTRUITE IN PRO_SAP
34	ANALISI DI BUCKLING DI PIASTRA ISOTROPA
35	ANALISI DI BUCKLING DI UN CILINDRO COMPRESSO INCASTRATO ALLA BASE
36	ANALISI DI PARETI FORATE
37	BIMETALLIC STRIP (NAFEMS EXERCISE 6)
38	ANALISI ELASTICA DI PIASTRA CON INTAGLIO CIRCOLARE (FLAT BAR WITH EDGE NOTCHES-NAFEMS EXERCISE 9)
39	PLATEA NERVATA
45	VERIFICA A PUNZONAMENTO ALLO SLU DI PIASTRE IN C.A.
117	PROGETTO E VERIFICA DI GUSCI IN MATERIALE XLAM
118	PROGETTO E VERIFICA DI PARETI IN MATERIALE XLAM E RELATIVI COLLEGAMENTI

Elem.	Note	Nodo I	Nodo J	Nodo K	Nodo L	Mat.	Spessore cm	Svincolo	Wink V daN/cm3	Wink O daN/cm3
1	Guscio fond.	1	2	3	4	1	250.0		3.08	3.08
2	Guscio fond.	4	3	5	6	1	250.0		2.35	2.35
3	Guscio fond.	6	5	7	8	1	250.0		2.15	2.15
4	Guscio fond.	8	7	9	10	1	250.0		2.16	2.16
5	Guscio fond.	10	9	11	12	1	250.0		2.24	2.24
6	Guscio fond.	12	11	13	14	1	250.0		2.38	2.38
7	Guscio fond.	14	13	15	16	1	250.0		2.54	2.54
8	Guscio fond.	16	15	17	18	1	250.0		2.70	2.70
9	Guscio fond.	2	19	20	3	1	250.0		3.86	3.86
10	Guscio fond.	3	20	21	5	1	250.0		2.78	2.78
11	Guscio fond.	5	21	22	7	1	250.0		2.22	2.22

Parco Eolico "Bolina" – Progetto Definitivo
Relazione di calcolo preliminare delle fondazioni degli aerogeneratori G8 e G12

12	Guscio fond.	7	22	23	9	1	250.0	2.14	2.14
13	Guscio fond.	9	23	24	11	1	250.0	2.15	2.15
14	Guscio fond.	11	24	25	13	1	250.0	2.24	2.24
15	Guscio fond.	13	25	26	15	1	250.0	2.38	2.38
16	Guscio fond.	15	26	27	17	1	250.0	2.54	2.54
17	Guscio fond.	19	28	29	20	1	250.0	3.51	3.51
18	Guscio fond.	20	29	30	21	1	250.0	3.67	3.67
19	Guscio fond.	21	30	31	22	1	250.0	2.67	2.67
20	Guscio fond.	22	31	32	23	1	250.0	2.21	2.21
21	Guscio fond.	23	32	33	24	1	250.0	2.14	2.14
22	Guscio fond.	24	33	34	25	1	250.0	2.15	2.15
23	Guscio fond.	25	34	35	26	1	250.0	2.24	2.24
24	Guscio fond.	26	35	36	27	1	250.0	2.38	2.38
25	Guscio fond.	28	37	38	29	1	250.0	2.59	2.59
26	Guscio fond.	29	38	39	30	1	250.0	3.48	3.48
27	Guscio fond.	30	39	40	31	1	250.0	3.65	3.65
28	Guscio fond.	31	40	41	32	1	250.0	2.67	2.67
29	Guscio fond.	32	41	42	33	1	250.0	2.21	2.21
30	Guscio fond.	33	42	43	34	1	250.0	2.14	2.14
31	Guscio fond.	34	43	44	35	1	250.0	2.15	2.15
32	Guscio fond.	35	44	45	36	1	250.0	2.24	2.24
33	Guscio fond.	37	46	47	38	1	250.0	2.14	2.14
34	Guscio fond.	38	47	48	39	1	250.0	2.57	2.57
35	Guscio fond.	39	48	49	40	1	250.0	3.46	3.46
36	Guscio fond.	40	49	50	41	1	250.0	3.64	3.64
37	Guscio fond.	41	50	51	42	1	250.0	2.67	2.67
38	Guscio fond.	42	51	52	43	1	250.0	2.21	2.21
39	Guscio fond.	43	52	53	44	1	250.0	2.14	2.14
40	Guscio fond.	44	53	54	45	1	250.0	2.15	2.15
41	Guscio fond.	46	55	56	47	1	250.0	1.83	1.83
42	Guscio fond.	47	56	57	48	1	250.0	2.05	2.05
43	Guscio fond.	48	57	58	49	1	250.0	2.57	2.57
44	Guscio fond.	49	58	59	50	1	250.0	3.46	3.46
45	Guscio fond.	50	59	60	51	1	250.0	3.65	3.65
46	Guscio fond.	51	60	61	52	1	250.0	2.76	2.76
47	Guscio fond.	52	61	62	53	1	250.0	2.28	2.28
48	Guscio fond.	53	62	63	54	1	250.0	2.15	2.15
49	Guscio fond.	55	64	65	56	1	250.0	1.59	1.59
50	Guscio fond.	56	65	66	57	1	250.0	1.77	1.77
51	Guscio fond.	57	66	67	58	1	250.0	2.05	2.05
52	Guscio fond.	58	67	68	59	1	250.0	2.57	2.57
53	Guscio fond.	59	68	69	60	1	250.0	3.48	3.48
54	Guscio fond.	60	69	70	61	1	250.0	3.82	3.82
55	Guscio fond.	61	70	71	62	1	250.0	2.86	2.86
56	Guscio fond.	62	71	72	63	1	250.0	2.35	2.35
57	Guscio fond.	64	73	74	65	1	250.0	1.45	1.45
58	Guscio fond.	65	74	75	66	1	250.0	1.59	1.59
59	Guscio fond.	66	75	76	67	1	250.0	1.83	1.83
60	Guscio fond.	67	76	77	68	1	250.0	2.14	2.14
61	Guscio fond.	68	77	78	69	1	250.0	2.59	2.59
62	Guscio fond.	69	78	79	70	1	250.0	3.51	3.51
63	Guscio fond.	70	79	80	71	1	250.0	3.85	3.85
64	Guscio fond.	71	80	81	72	1	250.0	3.08	3.08
65	Guscio fond.	77	82	83	78	1	250.0	2.06	2.06
66	Guscio fond.	82	84	85	83	1	250.0	1.81	1.81
67	Guscio fond.	84	86	87	85	1	250.0	1.62	1.62
68	Guscio fond.	86	88	89	87	1	250.0	1.48	1.48
69	Guscio fond.	88	90	91	89	1	250.0	1.44	1.44
70	Guscio fond.	90	92	93	91	1	250.0	1.45	1.45
71	Guscio fond.	92	94	95	93	1	250.0	1.60	1.60
72	Guscio fond.	94	96	97	95	1	250.0	2.60	2.60
73	Guscio fond.	78	83	98	79	1	250.0	2.72	2.72
74	Guscio fond.	83	85	99	98	1	250.0	2.33	2.33
75	Guscio fond.	85	87	100	99	1	250.0	2.07	2.07
76	Guscio fond.	87	89	101	100	1	250.0	1.87	1.87
77	Guscio fond.	89	91	102	101	1	250.0	1.78	1.78
78	Guscio fond.	91	93	103	102	1	250.0	1.82	1.82
79	Guscio fond.	93	95	104	103	1	250.0	2.06	2.06
80	Guscio fond.	95	97	105	104	1	250.0	3.47	3.47
81	Guscio fond.	79	98	106	80	1	250.0	3.92	3.92
82	Guscio fond.	98	99	107	106	1	250.0	3.37	3.37
83	Guscio fond.	99	100	108	107	1	250.0	3.02	3.02
84	Guscio fond.	100	101	109	108	1	250.0	2.74	2.74

Parco Eolico "Bolina" – Progetto Definitivo
Relazione di calcolo preliminare delle fondazioni degli aerogeneratori G8 e G12

85	Guscio fond.	101	102	110	109	1	250.0	2.57	2.57
86	Guscio fond.	102	103	111	110	1	250.0	2.65	2.65
87	Guscio fond.	103	104	112	111	1	250.0	3.08	3.08
88	Guscio fond.	104	105	113	112	1	250.0	5.65	5.65
89	Guscio fond.	80	106	114	81	1	250.0	3.74	3.74
90	Guscio fond.	106	107	115	114	1	250.0	4.38	4.38
91	Guscio fond.	107	108	116	115	1	250.0	5.25	5.25
92	Guscio fond.	108	109	117	116	1	250.0	4.98	4.98
93	Guscio fond.	109	110	118	117	1	250.0	4.91	4.91
94	Guscio fond.	110	111	119	118	1	250.0	5.00	5.00
95	Guscio fond.	111	112	120	119	1	250.0	5.62	5.62
96	Guscio fond.	112	113	121	120	1	250.0	7.70	7.70
97	Guscio fond.	72	81	114	122	1	250.0	2.71	2.71
98	Guscio fond.	122	114	115	123	1	250.0	3.20	3.20
99	Guscio fond.	123	115	116	124	1	250.0	4.10	4.10
100	Guscio fond.	124	116	117	125	1	250.0	4.42	4.42
101	Guscio fond.	125	117	118	126	1	250.0	4.80	4.80
102	Guscio fond.	126	118	119	127	1	250.0	5.00	5.00
103	Guscio fond.	127	119	120	128	1	250.0	4.90	4.90
104	Guscio fond.	128	120	121	129	1	250.0	4.55	4.55
105	Guscio fond.	63	72	122	130	1	250.0	2.30	2.30
106	Guscio fond.	130	122	123	131	1	250.0	2.41	2.41
107	Guscio fond.	131	123	124	132	1	250.0	2.60	2.60
108	Guscio fond.	132	124	125	133	1	250.0	2.82	2.82
109	Guscio fond.	133	125	126	134	1	250.0	3.11	3.11
110	Guscio fond.	134	126	127	135	1	250.0	3.22	3.22
111	Guscio fond.	135	127	128	136	1	250.0	3.20	3.20
112	Guscio fond.	136	128	129	137	1	250.0	3.44	3.44
113	Guscio fond.	54	63	130	138	1	250.0	2.22	2.22
114	Guscio fond.	138	130	131	139	1	250.0	2.41	2.41
115	Guscio fond.	139	131	132	140	1	250.0	2.64	2.64
116	Guscio fond.	140	132	133	141	1	250.0	2.84	2.84
117	Guscio fond.	141	133	134	142	1	250.0	3.09	3.09
118	Guscio fond.	142	134	135	143	1	250.0	3.32	3.32
119	Guscio fond.	143	135	136	144	1	250.0	3.52	3.52
120	Guscio fond.	144	136	137	145	1	250.0	3.85	3.85
121	Guscio fond.	45	54	138	146	1	250.0	2.32	2.32
122	Guscio fond.	146	138	139	147	1	250.0	2.58	2.58
123	Guscio fond.	147	139	140	148	1	250.0	2.88	2.88
124	Guscio fond.	148	140	141	149	1	250.0	3.14	3.14
125	Guscio fond.	149	141	142	150	1	250.0	3.40	3.40
126	Guscio fond.	150	142	143	151	1	250.0	3.70	3.70
127	Guscio fond.	151	143	144	152	1	250.0	3.90	3.90
128	Guscio fond.	152	144	145	153	1	250.0	4.14	4.14
129	Guscio fond.	36	45	146	154	1	250.0	2.45	2.45
130	Guscio fond.	154	146	147	155	1	250.0	2.76	2.76
131	Guscio fond.	155	147	148	156	1	250.0	3.08	3.08
132	Guscio fond.	156	148	149	157	1	250.0	3.30	3.30
133	Guscio fond.	157	149	150	158	1	250.0	3.60	3.60
134	Guscio fond.	158	150	151	159	1	250.0	3.98	3.98
135	Guscio fond.	159	151	152	160	1	250.0	4.20	4.20
136	Guscio fond.	160	152	153	161	1	250.0	4.38	4.38
137	Guscio fond.	27	36	154	162	1	250.0	2.57	2.57
138	Guscio fond.	162	154	155	163	1	250.0	2.93	2.93
139	Guscio fond.	163	155	156	164	1	250.0	3.28	3.28
140	Guscio fond.	164	156	157	165	1	250.0	3.44	3.44
141	Guscio fond.	165	157	158	166	1	250.0	3.72	3.72
142	Guscio fond.	166	158	159	167	1	250.0	4.14	4.14
143	Guscio fond.	167	159	160	168	1	250.0	4.32	4.32
144	Guscio fond.	168	160	161	169	1	250.0	4.48	4.48
145	Guscio fond.	17	27	162	170	1	250.0	2.73	2.73
146	Guscio fond.	170	162	163	171	1	250.0	3.09	3.09
147	Guscio fond.	171	163	164	172	1	250.0	3.44	3.44
148	Guscio fond.	172	164	165	173	1	250.0	3.57	3.57
149	Guscio fond.	173	165	166	174	1	250.0	3.80	3.80
150	Guscio fond.	174	166	167	175	1	250.0	4.17	4.17
151	Guscio fond.	175	167	168	176	1	250.0	4.44	4.44
152	Guscio fond.	176	168	169	177	1	250.0	4.70	4.70
153	Guscio fond.	18	17	170	178	1	250.0	2.86	2.86
154	Guscio fond.	178	170	171	179	1	250.0	3.18	3.18
155	Guscio fond.	179	171	172	180	1	250.0	3.50	3.50
156	Guscio fond.	180	172	173	181	1	250.0	3.65	3.65
157	Guscio fond.	181	173	174	182	1	250.0	3.91	3.91

Parco Eolico "Bolina" – Progetto Definitivo
Relazione di calcolo preliminare delle fondazioni degli aerogeneratori G8 e G12

158	Guscio fond.	182	174	175	183	1	250.0	4.25	4.25
159	Guscio fond.	183	175	176	184	1	250.0	4.59	4.59
160	Guscio fond.	184	176	177	185	1	250.0	4.83	4.83
161	Guscio fond.	186	16	18	178	1	250.0	2.86	2.86
162	Guscio fond.	187	186	178	179	1	250.0	3.18	3.18
163	Guscio fond.	188	187	179	180	1	250.0	3.50	3.50
164	Guscio fond.	189	188	180	181	1	250.0	3.65	3.65
165	Guscio fond.	190	189	181	182	1	250.0	3.91	3.91
166	Guscio fond.	191	190	182	183	1	250.0	4.25	4.25
167	Guscio fond.	192	191	183	184	1	250.0	4.59	4.59
168	Guscio fond.	193	192	184	185	1	250.0	4.83	4.83
169	Guscio fond.	194	14	16	186	1	250.0	2.74	2.74
170	Guscio fond.	195	194	186	187	1	250.0	3.09	3.09
171	Guscio fond.	196	195	187	188	1	250.0	3.44	3.44
172	Guscio fond.	197	196	188	189	1	250.0	3.57	3.57
173	Guscio fond.	198	197	189	190	1	250.0	3.80	3.80
174	Guscio fond.	199	198	190	191	1	250.0	4.17	4.17
175	Guscio fond.	200	199	191	192	1	250.0	4.44	4.44
176	Guscio fond.	201	200	192	193	1	250.0	4.70	4.70
177	Guscio fond.	202	12	14	194	1	250.0	2.57	2.57
178	Guscio fond.	203	202	194	195	1	250.0	2.93	2.93
179	Guscio fond.	204	203	195	196	1	250.0	3.28	3.28
180	Guscio fond.	205	204	196	197	1	250.0	3.44	3.44
181	Guscio fond.	206	205	197	198	1	250.0	3.73	3.73
182	Guscio fond.	207	206	198	199	1	250.0	4.15	4.15
183	Guscio fond.	208	207	199	200	1	250.0	4.32	4.32
184	Guscio fond.	209	208	200	201	1	250.0	4.49	4.49
185	Guscio fond.	210	10	12	202	1	250.0	2.45	2.45
186	Guscio fond.	211	210	202	203	1	250.0	2.77	2.77
187	Guscio fond.	212	211	203	204	1	250.0	3.08	3.08
188	Guscio fond.	213	212	204	205	1	250.0	3.31	3.31
189	Guscio fond.	214	213	205	206	1	250.0	3.52	3.52
190	Guscio fond.	215	214	206	207	1	250.0	3.89	3.89
191	Guscio fond.	216	215	207	208	1	250.0	4.21	4.21
192	Guscio fond.	217	216	208	209	1	250.0	4.39	4.39
193	Guscio fond.	218	8	10	210	1	250.0	2.32	2.32
194	Guscio fond.	219	218	210	211	1	250.0	2.58	2.58
195	Guscio fond.	220	219	211	212	1	250.0	2.89	2.89
196	Guscio fond.	221	220	212	213	1	250.0	3.15	3.15
197	Guscio fond.	222	221	213	214	1	250.0	3.33	3.33
198	Guscio fond.	223	222	214	215	1	250.0	3.63	3.63
199	Guscio fond.	224	223	215	216	1	250.0	3.91	3.91
200	Guscio fond.	225	224	216	217	1	250.0	4.15	4.15
201	Guscio fond.	226	6	8	218	1	250.0	2.22	2.22
202	Guscio fond.	227	226	218	219	1	250.0	2.42	2.42
203	Guscio fond.	228	227	219	220	1	250.0	2.65	2.65
204	Guscio fond.	229	228	220	221	1	250.0	2.85	2.85
205	Guscio fond.	230	229	221	222	1	250.0	3.10	3.10
206	Guscio fond.	231	230	222	223	1	250.0	3.33	3.33
207	Guscio fond.	232	231	223	224	1	250.0	3.53	3.53
208	Guscio fond.	233	232	224	225	1	250.0	3.86	3.86
209	Guscio fond.	234	4	6	226	1	250.0	2.31	2.31
210	Guscio fond.	235	234	226	227	1	250.0	2.42	2.42
211	Guscio fond.	236	235	227	228	1	250.0	2.61	2.61
212	Guscio fond.	237	236	228	229	1	250.0	2.83	2.83
213	Guscio fond.	238	237	229	230	1	250.0	3.06	3.06
214	Guscio fond.	239	238	230	231	1	250.0	3.17	3.17
215	Guscio fond.	240	239	231	232	1	250.0	3.22	3.22
216	Guscio fond.	241	240	232	233	1	250.0	3.46	3.46
217	Guscio fond.	242	1	4	234	1	250.0	2.71	2.71
218	Guscio fond.	243	242	234	235	1	250.0	3.21	3.21
219	Guscio fond.	244	243	235	236	1	250.0	4.12	4.12
220	Guscio fond.	245	244	236	237	1	250.0	4.43	4.43
221	Guscio fond.	246	245	237	238	1	250.0	4.68	4.68
222	Guscio fond.	247	246	238	239	1	250.0	4.87	4.87
223	Guscio fond.	248	247	239	240	1	250.0	4.93	4.93
224	Guscio fond.	249	248	240	241	1	250.0	4.57	4.57
225	Guscio fond.	242	250	2	1	1	250.0	3.74	3.74
226	Guscio fond.	243	251	250	242	1	250.0	4.39	4.39
227	Guscio fond.	244	252	251	243	1	250.0	5.26	5.26
228	Guscio fond.	245	253	252	244	1	250.0	4.99	4.99
229	Guscio fond.	246	254	253	245	1	250.0	4.92	4.92
230	Guscio fond.	247	255	254	246	1	250.0	5.02	5.02

Parco Eolico "Bolina" – Progetto Definitivo
Relazione di calcolo preliminare delle fondazioni degli aerogeneratori G8 e G12

231	Guscio fond.	248	256	255	247	1	250.0	5.64	5.64
232	Guscio fond.	249	257	256	248	1	250.0	7.73	7.73
233	Guscio fond.	250	258	19	2	1	250.0	3.93	3.93
234	Guscio fond.	251	259	258	250	1	250.0	3.38	3.38
235	Guscio fond.	252	260	259	251	1	250.0	3.03	3.03
236	Guscio fond.	253	261	260	252	1	250.0	2.75	2.75
237	Guscio fond.	254	262	261	253	1	250.0	2.57	2.57
238	Guscio fond.	255	263	262	254	1	250.0	2.66	2.66
239	Guscio fond.	256	264	263	255	1	250.0	3.08	3.08
240	Guscio fond.	257	265	264	256	1	250.0	5.66	5.66
241	Guscio fond.	258	266	28	19	1	250.0	2.72	2.72
242	Guscio fond.	259	267	266	258	1	250.0	2.34	2.34
243	Guscio fond.	260	268	267	259	1	250.0	2.08	2.08
244	Guscio fond.	261	269	268	260	1	250.0	1.87	1.87
245	Guscio fond.	262	270	269	261	1	250.0	1.78	1.78
246	Guscio fond.	263	271	270	262	1	250.0	1.82	1.82
247	Guscio fond.	264	272	271	263	1	250.0	2.06	2.06
248	Guscio fond.	265	273	272	264	1	250.0	3.47	3.47
249	Guscio fond.	266	274	37	28	1	250.0	2.06	2.06
250	Guscio fond.	267	275	274	266	1	250.0	1.81	1.81
251	Guscio fond.	268	276	275	267	1	250.0	1.62	1.62
252	Guscio fond.	269	277	276	268	1	250.0	1.48	1.48
253	Guscio fond.	270	278	277	269	1	250.0	1.45	1.45
254	Guscio fond.	271	279	278	270	1	250.0	1.45	1.45
255	Guscio fond.	272	280	279	271	1	250.0	1.60	1.60
256	Guscio fond.	273	281	280	272	1	250.0	2.60	2.60
257	Guscio fond.	274	282	46	37	1	250.0	1.81	1.81
258	Guscio fond.	275	283	282	274	1	250.0	1.55	1.55
259	Guscio fond.	276	284	283	275	1	250.0	1.36	1.36
260	Guscio fond.	277	285	284	276	1	250.0	1.25	1.25
261	Guscio fond.	278	286	285	277	1	250.0	1.23	1.23
262	Guscio fond.	279	287	286	278	1	250.0	1.27	1.27
263	Guscio fond.	280	288	287	279	1	250.0	1.43	1.43
264	Guscio fond.	281	289	288	280	1	250.0	2.24	2.24
265	Guscio fond.	282	290	55	46	1	250.0	1.61	1.61
266	Guscio fond.	283	291	290	282	1	250.0	1.36	1.36
267	Guscio fond.	284	292	291	283	1	250.0	1.21	1.21
268	Guscio fond.	285	293	292	284	1	250.0	1.12	1.12
269	Guscio fond.	286	294	293	285	1	250.0	1.11	1.11
270	Guscio fond.	287	295	294	286	1	250.0	1.16	1.16
271	Guscio fond.	288	296	295	287	1	250.0	1.31	1.31
272	Guscio fond.	289	297	296	288	1	250.0	2.04	2.04
273	Guscio fond.	290	298	64	55	1	250.0	1.39	1.39
274	Guscio fond.	291	299	298	290	1	250.0	1.22	1.22
275	Guscio fond.	292	300	299	291	1	250.0	1.12	1.12
276	Guscio fond.	293	301	300	292	1	250.0	1.05	1.05
277	Guscio fond.	294	302	301	293	1	250.0	1.04	1.04
278	Guscio fond.	295	303	302	294	1	250.0	1.09	1.09
279	Guscio fond.	296	304	303	295	1	250.0	1.24	1.24
280	Guscio fond.	297	305	304	296	1	250.0	1.90	1.90
281	Guscio fond.	298	306	73	64	1	250.0	1.28	1.28
282	Guscio fond.	299	307	306	298	1	250.0	1.14	1.14
283	Guscio fond.	300	308	307	299	1	250.0	1.05	1.05
284	Guscio fond.	301	309	308	300	1	250.0	1.01	1.01
285	Guscio fond.	302	310	309	301	1	250.0	1.01	1.01
286	Guscio fond.	303	311	310	302	1	250.0	1.07	1.07
287	Guscio fond.	304	312	311	303	1	250.0	1.23	1.23
288	Guscio fond.	305	313	312	304	1	250.0	1.85	1.85
289	Guscio fond.	73	306	314	74	1	250.0	1.28	1.28
290	Guscio fond.	306	307	315	314	1	250.0	1.14	1.14
291	Guscio fond.	307	308	316	315	1	250.0	1.05	1.05
292	Guscio fond.	308	309	317	316	1	250.0	1.01	1.01
293	Guscio fond.	309	310	318	317	1	250.0	1.01	1.01
294	Guscio fond.	310	311	319	318	1	250.0	1.07	1.07
295	Guscio fond.	311	312	320	319	1	250.0	1.23	1.23
296	Guscio fond.	312	313	321	320	1	250.0	1.85	1.85
297	Guscio fond.	74	314	322	75	1	250.0	1.39	1.39
298	Guscio fond.	314	315	323	322	1	250.0	1.22	1.22
299	Guscio fond.	315	316	324	323	1	250.0	1.12	1.12
300	Guscio fond.	316	317	325	324	1	250.0	1.05	1.05
301	Guscio fond.	317	318	326	325	1	250.0	1.04	1.04
302	Guscio fond.	318	319	327	326	1	250.0	1.09	1.09
303	Guscio fond.	319	320	328	327	1	250.0	1.24	1.24

Parco Eolico "Bolina" – Progetto Definitivo
Relazione di calcolo preliminare delle fondazioni degli aerogeneratori G8 e G12

304	Guscio fond.	320	321	329	328	1	250.0	1.90	1.90
305	Guscio fond.	75	322	330	76	1	250.0	1.61	1.61
306	Guscio fond.	322	323	331	330	1	250.0	1.36	1.36
307	Guscio fond.	323	324	332	331	1	250.0	1.21	1.21
308	Guscio fond.	324	325	333	332	1	250.0	1.12	1.12
309	Guscio fond.	325	326	334	333	1	250.0	1.11	1.11
310	Guscio fond.	326	327	335	334	1	250.0	1.16	1.16
311	Guscio fond.	327	328	336	335	1	250.0	1.31	1.31
312	Guscio fond.	328	329	337	336	1	250.0	2.04	2.04
313	Guscio fond.	76	330	82	77	1	250.0	1.81	1.81
314	Guscio fond.	330	331	84	82	1	250.0	1.55	1.55
315	Guscio fond.	331	332	86	84	1	250.0	1.36	1.36
316	Guscio fond.	332	333	88	86	1	250.0	1.25	1.25
317	Guscio fond.	333	334	90	88	1	250.0	1.23	1.23
318	Guscio fond.	334	335	92	90	1	250.0	1.27	1.27
319	Guscio fond.	335	336	94	92	1	250.0	1.43	1.43
320	Guscio fond.	336	337	96	94	1	250.0	2.24	2.24

MODELLAZIONE DELLE AZIONI

LEGENDA TABELLA DATI AZIONI

Il programma consente l'uso di diverse tipologie di carico (azioni). Le azioni utilizzate nella modellazione sono individuate da una sigla identificativa ed un codice numerico (gli elementi strutturali richiamano quest'ultimo nella propria descrizione). Per ogni azione applicata alla struttura viene di riportato il codice, il tipo e la sigla identificativa. Le tabelle successive dettagliano i valori caratteristici di ogni azione in relazione al tipo. Le tabelle riportano infatti i seguenti dati in relazione al tipo:

1	carico concentrato nodale 6 dati (forza F_x , F_y , F_z , momento M_x , M_y , M_z)
2	spostamento nodale impresso 6 dati (spostamento T_x , T_y , T_z , rotazione R_x , R_y , R_z)
3	carico distribuito globale su elemento tipo trave 7 dati (f_x , f_y , f_z , m_x , m_y , m_z , ascissa di inizio carico) 7 dati (f_x , f_y , f_z , m_x , m_y , m_z , ascissa di fine carico)
4	carico distribuito locale su elemento tipo trave 7 dati (f_1 , f_2 , f_3 , m_1 , m_2 , m_3 , ascissa di inizio carico) 7 dati (f_1 , f_2 , f_3 , m_1 , m_2 , m_3 , ascissa di fine carico)
5	carico concentrato globale su elemento tipo trave 7 dati (F_x , F_y , F_z , M_x , M_y , M_z , ascissa di carico)
6	carico concentrato locale su elemento tipo trave 7 dati (F_1 , F_2 , F_3 , M_1 , M_2 , M_3 , ascissa di carico)
7	variazione termica applicata ad elemento tipo trave 7 dati (variazioni termiche: uniforme, media e differenza in altezza e larghezza al nodo iniziale e finale)
8	carico di pressione uniforme su elemento tipo piastra 1 dato (pressione)
9	carico di pressione variabile su elemento tipo piastra 4 dati (pressione, quota, pressione, quota)
10	variazione termica applicata ad elemento tipo piastra 2 dati (variazioni termiche: media e differenza nello spessore)
11	carico variabile generale su elementi tipo trave e piastra 1 dato descrizione della tipologia 4 dati per segmento (posizione, valore, posizione, valore) la tipologia precisa l'ascissa di definizione, la direzione del carico, la modalità di carico e la larghezza d'influenza per gli elementi tipo trave
12	gruppo di carichi con impronta su piastra 9 dati (numero di ripetizioni in direzione X e Y, valore di ciascun carico, posizione centrale del primo, dimensioni dell'impronta, interasse tra i carichi)

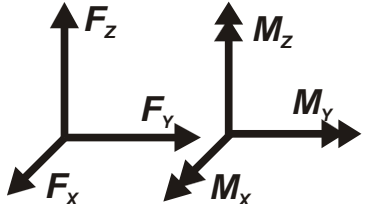
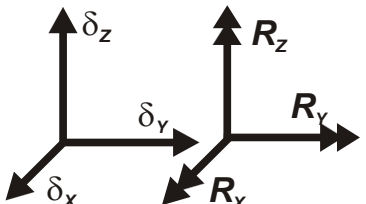
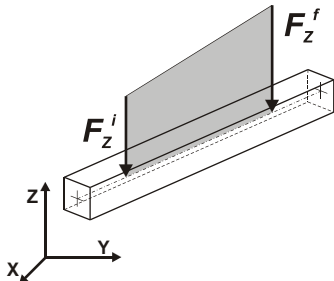
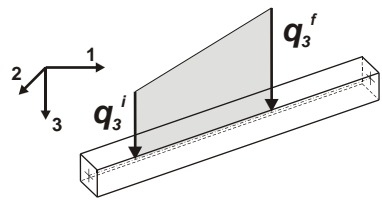
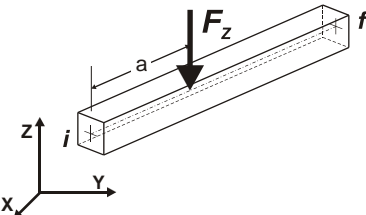
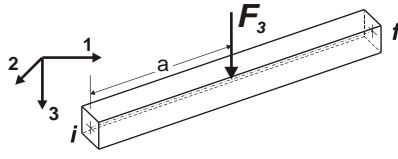
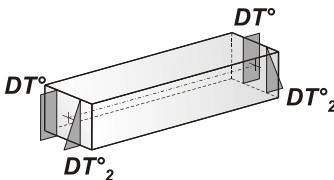
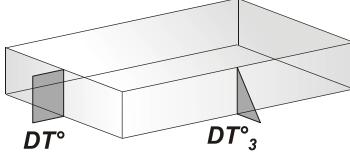
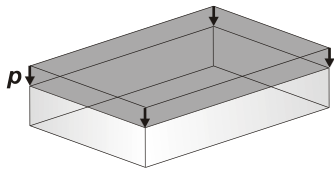
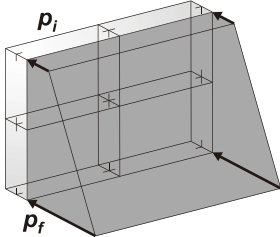
 <p>Carico concentrato nodale</p>	 <p>Spostamento impresso</p>
 <p>Carico distribuito globale</p>	 <p>Carico distribuito locale</p>
 <p>Carico concentrato globale</p>	 <p>Carico concentrato locale</p>
 <p>Carico termico 2D</p>	 <p>Carico termico 3D</p>
 <p>Carico pressione uniforme</p>	 <p>Carico pressione variabile</p>

Tipo carico concentrato nodale

Id	Tipo	Fx	Fy	Fz	Mx	My	Mz
		daN	daN	daN	daN cm	daN cm	daN cm
13	Carichi in fondazione V150-CN: Fx=3570.18 Fy=3570.18 Fz=-2.237e+05 Mx= 5.693e+08 My= 5.693e+08 Mz=-4.887e+06	3570.18	3570.18	-2.237e+05	5.693e+08	5.693e+08	-4.887e+06

SCHEMATIZZAZIONE DEI CASI DI CARICO

LEGENDA TABELLA CASI DI CARICO

Il programma consente l'applicazione di diverse tipologie di casi di carico.
Sono previsti i seguenti 11 tipi di casi di carico:

	Sigla	Tipo	Descrizione
1	Ggk	A	caso di carico comprensivo del peso proprio struttura
2	Gk	NA	caso di carico con azioni permanenti
3	Qk	NA	caso di carico con azioni variabili
4	Gsk	A	caso di carico comprensivo dei carichi permanenti sui solai e sulle coperture
5	Qsk	A	caso di carico comprensivo dei carichi variabili sui solai
6	Qnk	A	caso di carico comprensivo dei carichi di neve sulle coperture
7	Qtk	SA	caso di carico comprensivo di una variazione termica agente sulla struttura
8	Qvk	NA	caso di carico comprensivo di azioni da vento sulla struttura
9	Esk	SA	caso di carico sismico con analisi statica equivalente
10	Edk	SA	caso di carico sismico con analisi dinamica
11	Etk	NA	caso di carico comprensivo di azioni derivanti dall' incremento di spinta delle terre in condizione sismica
12	Pk	NA	caso di carico comprensivo di azioni derivanti da coazioni, cedimenti e precompressioni

Sono di tipo automatico A (ossia non prevedono introduzione dati da parte dell'utente) i seguenti casi di carico: 1-Ggk; 4-Gsk; 5-Qsk; 6-Qnk.

Sono di tipo semi-automatico SA (ossia prevedono una minima introduzione dati da parte dell'utente) i seguenti casi di carico:
7-Qtk, in quanto richiede solo il valore della variazione termica;

9-Esk e 10-Edk, in quanto richiedono il valore dell'angolo di ingresso del sisma e l'individuazione dei casi di carico partecipanti alla definizione delle masse.

Sono di tipo non automatico NA ossia prevedono la diretta applicazione di carichi generici agli elementi strutturali (si veda il precedente punto Modellazione delle Azioni) i restanti casi di carico.

Nella tabella successiva vengono riportati i casi di carico agenti sulla struttura, con l'indicazione dei dati relativi al caso di carico stesso:
Numero Tipo e Sigla identificativa, Valore di riferimento del caso di carico (se previsto).

In successione, per i casi di carico non automatici, viene riportato l'elenco di nodi ed elementi direttamente caricati con la sigla identificativa del carico.

Per i casi di carico di tipo sismico (9-Esk e 10-Edk), viene riportata la tabella di definizione delle masse: per ogni caso di carico partecipante alla definizione delle masse viene indicata la relativa aliquota (partecipazione) considerata. Si precisa che per i caso di carico 5-Qsk e 6-Qnk la partecipazione è prevista localmente per ogni elemento solaio o copertura presente nel modello (si confronti il valore Sksol nel capitolo relativo agli elementi solaio) e pertanto la loro partecipazione è di norma pari a uno.

CDC	Tipo	Sigla Id	Note
1	Ggk	CDC=Ggk (peso proprio della struttura)	
2	Esk	CDC=Es (statico SLU) alfa=0.0 (ecc. +)	partecipazione:1.00 per 1 CDC=Ggk (peso proprio della struttura)
			partecipazione:1.00 per 10 CDC=G1k (permanente generico)
3	Esk	CDC=Es (statico SLU) alfa=0.0 (ecc. -)	come precedente CDC sismico
4	Esk	CDC=Es (statico SLU) alfa=90.00 (ecc. +)	come precedente CDC sismico
5	Esk	CDC=Es (statico SLU) alfa=90.00 (ecc. -)	come precedente CDC sismico
6	Esk	CDC=Es (statico SLD) alfa=0.0 (ecc. +)	come precedente CDC sismico
7	Esk	CDC=Es (statico SLD) alfa=0.0 (ecc. -)	come precedente CDC sismico
8	Esk	CDC=Es (statico SLD) alfa=90.00 (ecc. +)	come precedente CDC sismico
9	Esk	CDC=Es (statico SLD) alfa=90.00 (ecc. -)	come precedente CDC sismico
10	Gk	CDC=G1k (permanente generico)	Nodo: 338 Azione : Carichi in fondazione V150-CN:Fx=3570.18 Fy=3570.18 Fz=-2.237e+05 Mx= 5.693e+08 My= 5.693e+08 Mz=-4.887e+06

DEFINIZIONE DELLE COMBINAZIONI

LEGENDA TABELLA COMBINAZIONI DI CARICO

Il programma combina i diversi tipi di casi di carico (CDC) secondo le regole previste dalla normativa vigente.

Le combinazioni previste sono destinate al controllo di sicurezza della struttura ed alla verifica degli spostamenti e delle sollecitazioni.

La prima tabella delle combinazioni riportata di seguito comprende le seguenti informazioni: Numero, Tipo, Sigla identificativa. Una seconda tabella riporta il peso nella combinazione assunto per ogni caso di carico.

Ai fini delle verifiche degli stati limite si definiscono le seguenti combinazioni delle azioni:

Combinazione fondamentale SLU

$$\gamma G1 \cdot G1 + \gamma G2 \cdot G2 + \gamma P \cdot P + \gamma Q1 \cdot Qk1 + \gamma Q2 \cdot \psi 02 \cdot Qk2 + \gamma Q3 \cdot \psi 03 \cdot Qk3 + \dots$$

Combinazione caratteristica (rara) SLE

$$G1 + G2 + P + Qk1 + \psi 02 \cdot Qk2 + \psi 03 \cdot Qk3 + \dots$$

Combinazione frequente SLE

$$G1 + G2 + P + \psi 11 \cdot Qk1 + \psi 22 \cdot Qk2 + \psi 23 \cdot Qk3 + \dots$$

Combinazione quasi permanente SLE

$$G1 + G2 + P + \psi 21 \cdot Qk1 + \psi 22 \cdot Qk2 + \psi 23 \cdot Qk3 + \dots$$

Combinazione sismica, impiegata per gli stati limite ultimi e di esercizio connessi all'azione sismica E

$$E + G1 + G2 + P + \psi 21 \cdot Qk1 + \psi 22 \cdot Qk2 + \dots$$

Combinazione eccezionale, impiegata per gli stati limite connessi alle azioni eccezionali

$$G1 + G2 + Ad + P + \psi 21 \cdot Qk1 + \psi 22 \cdot Qk2 + \dots$$

Dove:

NTC 2018 Tabella 2.5.I

Destinazione d'uso/azione	$\psi 0$	$\psi 1$	$\psi 2$
Categoria A residenziali	0,70	0,50	0,30
Categoria B uffici	0,70	0,50	0,30
Categoria C ambienti suscettibili di affollamento	0,70	0,70	0,60
Categoria D ambienti ad uso commerciale	0,70	0,70	0,60
Categoria E biblioteche, archivi, magazzini, ...	1,00	0,90	0,80
Categoria F Rimesse e parcheggi (autoveicoli $\leq 30kN$)	0,70	0,70	0,60
Categoria G Rimesse e parcheggi (autoveicoli $> 30kN$)	0,70	0,50	0,30
Categoria H Coperture	0,00	0,00	0,00
Vento	0,60	0,20	0,00
Neve a quota $\leq 1000 m$	0,50	0,20	0,00
Neve a quota $> 1000 m$	0,70	0,50	0,20
Variazioni Termiche	0,60	0,50	0,00

Nelle verifiche possono essere adottati in alternativa due diversi approcci progettuali:

- per l'approccio 1 si considerano due diverse combinazioni di gruppi di coefficienti di sicurezza parziali per le azioni, per i materiali e per la resistenza globale (combinazione 1 con coefficienti A1 e combinazione 2 con coefficienti A2),
- per l'approccio 2 si definisce un'unica combinazione per le azioni, per la resistenza dei materiali e per la resistenza globale (con coefficienti A1).

NTC 2018 Tabella 2.6.I

		Coefficiente	EQU	A1	A2
		γf			
Carichi permanenti	Favorevoli	$\gamma G1$	0,9	1,0	1,0
	Sfavorevoli		1,1	1,3	1,0
Carichi permanenti non strutturali (Non compiutamente definiti)	Favorevoli	$\gamma G2$	0,8	0,8	0,8
	Sfavorevoli		1,5	1,5	1,3
Carichi variabili	Favorevoli	γQi	0,0	0,0	0,0
	Sfavorevoli		1,5	1,5	1,3

Cmb	Tipo	Sigla Id	effetto P-delta
1	SLU	Comb. SLU A1 1	
2	SLU	Comb. SLU A1 2	
3	SLU (Terr. G)	Comb. SLU TIPO EQU 3	
4	SLU (Terr. G)	Comb. SLU TIPO EQU 4	

Parco Eolico "Bolina" – Progetto Definitivo
Relazione di calcolo preliminare delle fondazioni degli aerogeneratori G8 e G12

Cmb	Tipo	Sigla Id	effetto P-delta
5	SLU	Comb. SLU A1 (SLV sism.) 5	
6	SLU	Comb. SLU A1 (SLV sism.) 6	
7	SLU	Comb. SLU A1 (SLV sism.) 7	
8	SLU	Comb. SLU A1 (SLV sism.) 8	
9	SLU	Comb. SLU A1 (SLV sism.) 9	
10	SLU	Comb. SLU A1 (SLV sism.) 10	
11	SLU	Comb. SLU A1 (SLV sism.) 11	
12	SLU	Comb. SLU A1 (SLV sism.) 12	
13	SLU	Comb. SLU A1 (SLV sism.) 13	
14	SLU	Comb. SLU A1 (SLV sism.) 14	
15	SLU	Comb. SLU A1 (SLV sism.) 15	
16	SLU	Comb. SLU A1 (SLV sism.) 16	
17	SLU	Comb. SLU A1 (SLV sism.) 17	
18	SLU	Comb. SLU A1 (SLV sism.) 18	
19	SLU	Comb. SLU A1 (SLV sism.) 19	
20	SLU	Comb. SLU A1 (SLV sism.) 20	
21	SLU	Comb. SLU A1 (SLV sism.) 21	
22	SLU	Comb. SLU A1 (SLV sism.) 22	
23	SLU	Comb. SLU A1 (SLV sism.) 23	
24	SLU	Comb. SLU A1 (SLV sism.) 24	
25	SLU	Comb. SLU A1 (SLV sism.) 25	
26	SLU	Comb. SLU A1 (SLV sism.) 26	
27	SLU	Comb. SLU A1 (SLV sism.) 27	
28	SLU	Comb. SLU A1 (SLV sism.) 28	
29	SLU	Comb. SLU A1 (SLV sism.) 29	
30	SLU	Comb. SLU A1 (SLV sism.) 30	
31	SLU	Comb. SLU A1 (SLV sism.) 31	
32	SLU	Comb. SLU A1 (SLV sism.) 32	
33	SLU	Comb. SLU A1 (SLV sism.) 33	
34	SLU	Comb. SLU A1 (SLV sism.) 34	
35	SLU	Comb. SLU A1 (SLV sism.) 35	
36	SLU	Comb. SLU A1 (SLV sism.) 36	
37	SLD(sis)	Comb. SLE (SLD Danno sism.) 37	
38	SLD(sis)	Comb. SLE (SLD Danno sism.) 38	
39	SLD(sis)	Comb. SLE (SLD Danno sism.) 39	
40	SLD(sis)	Comb. SLE (SLD Danno sism.) 40	
41	SLD(sis)	Comb. SLE (SLD Danno sism.) 41	
42	SLD(sis)	Comb. SLE (SLD Danno sism.) 42	
43	SLD(sis)	Comb. SLE (SLD Danno sism.) 43	
44	SLD(sis)	Comb. SLE (SLD Danno sism.) 44	
45	SLD(sis)	Comb. SLE (SLD Danno sism.) 45	
46	SLD(sis)	Comb. SLE (SLD Danno sism.) 46	
47	SLD(sis)	Comb. SLE (SLD Danno sism.) 47	
48	SLD(sis)	Comb. SLE (SLD Danno sism.) 48	
49	SLD(sis)	Comb. SLE (SLD Danno sism.) 49	
50	SLD(sis)	Comb. SLE (SLD Danno sism.) 50	
51	SLD(sis)	Comb. SLE (SLD Danno sism.) 51	
52	SLD(sis)	Comb. SLE (SLD Danno sism.) 52	
53	SLD(sis)	Comb. SLE (SLD Danno sism.) 53	
54	SLD(sis)	Comb. SLE (SLD Danno sism.) 54	
55	SLD(sis)	Comb. SLE (SLD Danno sism.) 55	
56	SLD(sis)	Comb. SLE (SLD Danno sism.) 56	
57	SLD(sis)	Comb. SLE (SLD Danno sism.) 57	
58	SLD(sis)	Comb. SLE (SLD Danno sism.) 58	
59	SLD(sis)	Comb. SLE (SLD Danno sism.) 59	
60	SLD(sis)	Comb. SLE (SLD Danno sism.) 60	
61	SLD(sis)	Comb. SLE (SLD Danno sism.) 61	
62	SLD(sis)	Comb. SLE (SLD Danno sism.) 62	
63	SLD(sis)	Comb. SLE (SLD Danno sism.) 63	
64	SLD(sis)	Comb. SLE (SLD Danno sism.) 64	
65	SLD(sis)	Comb. SLE (SLD Danno sism.) 65	
66	SLD(sis)	Comb. SLE (SLD Danno sism.) 66	
67	SLD(sis)	Comb. SLE (SLD Danno sism.) 67	
68	SLD(sis)	Comb. SLE (SLD Danno sism.) 68	
69	SLE(r)	Comb. SLE(rara) 69	

Parco Eolico "Bolina" – Progetto Definitivo
Relazione di calcolo preliminare delle fondazioni degli aerogeneratori G8 e G12

Cmb	CDC 1/15...	CDC 2/16...	CDC 3/17...	CDC 4/18...	CDC 5/19...	CDC 6/20...	CDC 7/21...	CDC 8/22...	CDC 9/23...	CDC 10/24...	CDC 11/25...	CDC 12/26...	CDC 13/27...	CDC 14/28...
1	1.30	0.0	0.0	0.0	0.0	0.0	0.0	0.0	0.0	1.30				
2	1.00	0.0	0.0	0.0	0.0	0.0	0.0	0.0	0.0	1.00				
3	1.10	0.0	0.0	0.0	0.0	0.0	0.0	0.0	0.0	1.10				
4	0.90	0.0	0.0	0.0	0.0	0.0	0.0	0.0	0.0	0.90				
5	1.00	-1.00	0.0	-0.30	0.0	0.0	0.0	0.0	0.0	1.00				
6	1.00	-1.00	0.0	0.30	0.0	0.0	0.0	0.0	0.0	1.00				
7	1.00	1.00	0.0	-0.30	0.0	0.0	0.0	0.0	0.0	1.00				
8	1.00	1.00	0.0	0.30	0.0	0.0	0.0	0.0	0.0	1.00				
9	1.00	-1.00	0.0	0.0	-0.30	0.0	0.0	0.0	0.0	1.00				
10	1.00	-1.00	0.0	0.0	0.30	0.0	0.0	0.0	0.0	1.00				
11	1.00	1.00	0.0	0.0	-0.30	0.0	0.0	0.0	0.0	1.00				
12	1.00	1.00	0.0	0.0	0.30	0.0	0.0	0.0	0.0	1.00				
13	1.00	0.0	-1.00	-0.30	0.0	0.0	0.0	0.0	0.0	1.00				
14	1.00	0.0	-1.00	0.30	0.0	0.0	0.0	0.0	0.0	1.00				
15	1.00	0.0	1.00	-0.30	0.0	0.0	0.0	0.0	0.0	1.00				
16	1.00	0.0	1.00	0.30	0.0	0.0	0.0	0.0	0.0	1.00				
17	1.00	0.0	-1.00	0.0	-0.30	0.0	0.0	0.0	0.0	1.00				
18	1.00	0.0	-1.00	0.0	0.30	0.0	0.0	0.0	0.0	1.00				
19	1.00	0.0	1.00	0.0	-0.30	0.0	0.0	0.0	0.0	1.00				
20	1.00	0.0	1.00	0.0	0.30	0.0	0.0	0.0	0.0	1.00				
21	1.00	-0.30	0.0	-1.00	0.0	0.0	0.0	0.0	0.0	1.00				
22	1.00	-0.30	0.0	1.00	0.0	0.0	0.0	0.0	0.0	1.00				
23	1.00	0.30	0.0	-1.00	0.0	0.0	0.0	0.0	0.0	1.00				
24	1.00	0.30	0.0	1.00	0.0	0.0	0.0	0.0	0.0	1.00				
25	1.00	0.0	-0.30	-1.00	0.0	0.0	0.0	0.0	0.0	1.00				
26	1.00	0.0	-0.30	1.00	0.0	0.0	0.0	0.0	0.0	1.00				
27	1.00	0.0	0.30	-1.00	0.0	0.0	0.0	0.0	0.0	1.00				
28	1.00	0.0	0.30	1.00	0.0	0.0	0.0	0.0	0.0	1.00				
29	1.00	-0.30	0.0	0.0	-1.00	0.0	0.0	0.0	0.0	1.00				
30	1.00	-0.30	0.0	0.0	1.00	0.0	0.0	0.0	0.0	1.00				
31	1.00	0.30	0.0	0.0	-1.00	0.0	0.0	0.0	0.0	1.00				
32	1.00	0.30	0.0	0.0	1.00	0.0	0.0	0.0	0.0	1.00				
33	1.00	0.0	-0.30	0.0	-1.00	0.0	0.0	0.0	0.0	1.00				
34	1.00	0.0	-0.30	0.0	1.00	0.0	0.0	0.0	0.0	1.00				
35	1.00	0.0	0.30	0.0	-1.00	0.0	0.0	0.0	0.0	1.00				
36	1.00	0.0	0.30	0.0	1.00	0.0	0.0	0.0	0.0	1.00				
37	1.00	0.0	0.0	0.0	0.0	-1.00	0.0	-0.30	0.0	1.00				
38	1.00	0.0	0.0	0.0	0.0	-1.00	0.0	0.30	0.0	1.00				
39	1.00	0.0	0.0	0.0	0.0	1.00	0.0	-0.30	0.0	1.00				
40	1.00	0.0	0.0	0.0	0.0	1.00	0.0	0.30	0.0	1.00				
41	1.00	0.0	0.0	0.0	0.0	-1.00	0.0	0.0	-0.30	1.00				
42	1.00	0.0	0.0	0.0	0.0	-1.00	0.0	0.0	0.30	1.00				
43	1.00	0.0	0.0	0.0	0.0	1.00	0.0	0.0	-0.30	1.00				
44	1.00	0.0	0.0	0.0	0.0	1.00	0.0	0.0	0.30	1.00				
45	1.00	0.0	0.0	0.0	0.0	0.0	-1.00	-0.30	0.0	1.00				
46	1.00	0.0	0.0	0.0	0.0	0.0	-1.00	0.30	0.0	1.00				
47	1.00	0.0	0.0	0.0	0.0	0.0	1.00	-0.30	0.0	1.00				
48	1.00	0.0	0.0	0.0	0.0	0.0	1.00	0.30	0.0	1.00				
49	1.00	0.0	0.0	0.0	0.0	0.0	-1.00	0.0	-0.30	1.00				
50	1.00	0.0	0.0	0.0	0.0	0.0	-1.00	0.0	0.30	1.00				
51	1.00	0.0	0.0	0.0	0.0	0.0	1.00	0.0	-0.30	1.00				
52	1.00	0.0	0.0	0.0	0.0	0.0	1.00	0.0	0.30	1.00				
53	1.00	0.0	0.0	0.0	0.0	-0.30	0.0	-1.00	0.0	1.00				
54	1.00	0.0	0.0	0.0	0.0	-0.30	0.0	1.00	0.0	1.00				
55	1.00	0.0	0.0	0.0	0.0	0.30	0.0	-1.00	0.0	1.00				
56	1.00	0.0	0.0	0.0	0.0	0.30	0.0	1.00	0.0	1.00				
57	1.00	0.0	0.0	0.0	0.0	0.0	-0.30	-1.00	0.0	1.00				
58	1.00	0.0	0.0	0.0	0.0	0.0	-0.30	1.00	0.0	1.00				
59	1.00	0.0	0.0	0.0	0.0	0.0	0.30	-1.00	0.0	1.00				
60	1.00	0.0	0.0	0.0	0.0	0.0	0.30	1.00	0.0	1.00				
61	1.00	0.0	0.0	0.0	0.0	-0.30	0.0	0.0	-1.00	1.00				
62	1.00	0.0	0.0	0.0	0.0	-0.30	0.0	0.0	1.00	1.00				
63	1.00	0.0	0.0	0.0	0.0	0.30	0.0	0.0	-1.00	1.00				
64	1.00	0.0	0.0	0.0	0.0	0.30	0.0	0.0	1.00	1.00				
65	1.00	0.0	0.0	0.0	0.0	0.0	-0.30	0.0	-1.00	1.00				
66	1.00	0.0	0.0	0.0	0.0	0.0	-0.30	0.0	1.00	1.00				
67	1.00	0.0	0.0	0.0	0.0	0.0	0.30	0.0	-1.00	1.00				
68	1.00	0.0	0.0	0.0	0.0	0.0	0.30	0.0	1.00	1.00				
69	1.00	0.0	0.0	0.0	0.0	0.0	0.0	0.0	0.0	1.00				

AZIONE SISMICA

VALUTAZIONE DELL' AZIONE SISMICA

L'azione sismica sulle costruzioni è valutata a partire dalla "pericolosità sismica di base", in condizioni ideali di sito di riferimento rigido con superficie topografica orizzontale.

Allo stato attuale, la pericolosità sismica su reticolo di riferimento nell'intervallo di riferimento è fornita dai dati pubblicati sul sito <http://esse1.mi.ingv.it/>. Per punti non coincidenti con il reticolo di riferimento e periodi di ritorno non contemplati direttamente si opera come indicato nell' allegato alle NTC (rispettivamente media pesata e interpolazione).

L' azione sismica viene definita in relazione ad un periodo di riferimento V_r che si ricava, per ciascun tipo di costruzione, moltiplicandone la vita nominale per il coefficiente d'uso (vedi tabella Parametri della struttura). Fissato il periodo di riferimento V_r e la probabilità di superamento P_{ver} associata a ciascuno degli stati limite considerati, si ottiene il periodo di ritorno T_r e i relativi parametri di pericolosità sismica (vedi tabella successiva):

ag: accelerazione orizzontale massima del terreno;
 Fo: valore massimo del fattore di amplificazione dello spettro in accelerazione orizzontale;
 T^*c : periodo di inizio del tratto a velocità costante dello spettro in accelerazione orizzontale;

Parametri della struttura					
Classe d'uso	Vita V_n [anni]	Coeff. Uso	Periodo V_r [anni]	Tipo di suolo	Categoria topografica
IV	50.0	1.0	50.0	B	T1

Individuati su reticolo di riferimento i parametri di pericolosità sismica si valutano i parametri spettrali riportati in tabella:

S è il coefficiente che tiene conto della categoria di sottosuolo e delle condizioni topografiche mediante la relazione seguente $S = S_s * S_t$ (3.2.3)

Fo è il fattore che quantifica l'amplificazione spettrale massima, su sito di riferimento rigido orizzontale

Fv è il fattore che quantifica l'amplificazione spettrale massima verticale, in termini di accelerazione orizzontale massima del terreno ag su sito di riferimento rigido orizzontale

Tb è il periodo corrispondente all'inizio del tratto dello spettro ad accelerazione costante.

Tc è il periodo corrispondente all'inizio del tratto dello spettro a velocità costante.

Td è il periodo corrispondente all'inizio del tratto dello spettro a spostamento costante.

Id nodo	Longitudine	Latitudine	Distanza
			Km
Loc.	16.492	38.780	
42337	16.435	38.745	6.269
42338	16.499	38.744	4.031
42116	16.501	38.794	1.738
42115	16.437	38.795	5.037

SL	P_{ver}	T_r	ag	Fo	T^*c
		Anni	g		sec
SLO	81.0	30.0	0.062	2.340	0.280
SLD	63.0	50.0	0.081	2.310	0.310
SLV	10.0	475.0	0.234	2.430	0.370
SLC	5.0	975.0	0.312	2.460	0.390

SL	ag	S	Fo	Fv	Tb	Tc	Td
	g				sec	sec	sec
SLO	0.062	1.200	2.340	0.786	0.132	0.397	1.848
SLD	0.082	1.200	2.310	0.890	0.144	0.431	1.926
SLV	0.234	1.172	2.430	1.588	0.166	0.497	2.538
SLC	0.312	1.093	2.460	1.854	0.173	0.518	2.847

RISULTATI ANALISI SISMICHE

LEGENDA TABELLA ANALISI SISMICHE

Il programma consente l'analisi di diverse configurazioni sismiche.

Sono previsti, infatti, i seguenti casi di carico:

- | | |
|----------------|--|
| 9. Esk | caso di carico sismico con analisi statica equivalente |
| 10. Edk | caso di carico sismico con analisi dinamica |

Ciascun caso di carico è caratterizzato da un angolo di ingresso e da una configurazione di masse determinante la forza sismica complessiva (si rimanda al capitolo relativo ai casi di carico per chiarimenti inerenti questo aspetto).

Nella colonna Note, in funzione della norma in uso sono riportati i parametri fondamentali che caratterizzano l'azione sismica: in particolare possono essere presenti i seguenti valori:

Angolo di ingresso	Angolo di ingresso dell'azione sismica orizzontale
Fattore di importanza	Fattore di importanza dell'edificio, in base alla categoria di appartenenza
Zona sismica	Zona sismica
Accelerazione ag	Accelerazione orizzontale massima sul suolo
Categoria suolo	Categoria di profilo stratigrafico del suolo di fondazione
Fattore q	Fattore di struttura/di comportamento. Dipendente dalla tipologia strutturale
Fattore di sito S	Fattore dipendente dalla stratigrafia e dal profilo topografico
Classe di duttilità CD	Classe di duttilità della struttura – "A" duttilità alta, "B" duttilità bassa
Fattore riduz. SLD	Fattore di riduzione dello spettro elastico per lo stato limite di danno
Periodo proprio T1	Periodo proprio di vibrazione della struttura
Coefficiente Lambda	Coefficiente dipendente dal periodo proprio T1 e dal numero di piani della struttura
Ordinata spettro Sd(T1)	Valore delle ordinate dello spettro di progetto per lo stato limite ultimo, componente orizzontale (verticale Svd)
Ordinata spettro Se(T1)	Valore delle ordinate dello spettro elastico ridotta del fattore SLD per lo stato limite di danno, componente orizzontale (verticale Sve)
Ordinata spettro S (Tb-Tc)	Valore dell' ordinata dello spettro in uso nel tratto costante
numero di modi considerati	Numero di modi di vibrare della struttura considerati nell'analisi dinamica

Per ciascun caso di carico sismico viene riportato l'insieme di dati sotto riportati (le masse sono espresse in unità di forza):

- a) **analisi sismica statica equivalente:**
 - quota, posizione del centro di applicazione e azione orizzontale risultante, posizione del baricentro delle rigidezze, rapporto r/Ls (per strutture a nucleo), indici di regolarità e/r secondo EC8 4.2.3.2
 - azione sismica complessiva
- b) **analisi sismica dinamica con spettro di risposta:**
 - quota, posizione del centro di massa e massa risultante, posizione del baricentro delle rigidezze, rapporto r/Ls (per strutture a nucleo) , indici di regolarità e/r secondo EC8 4.2.3.2
 - frequenza, periodo, accelerazione spettrale, massa eccitata nelle tre direzioni globali per tutti i modi
 - massa complessiva ed aliquota di massa complessiva eccitata.

Per ciascuna combinazione sismica definita SLD o SLO viene riportato il livello di deformazione ϵ_T (dr) degli elementi strutturali verticali. Per semplicità di consultazione il livello è espresso anche in unità $1000 \cdot \epsilon_T/h$ da confrontare direttamente con i valori forniti nella norma (es. 5 per edifici con tamponamenti collegati rigidamente alla struttura, 10.0 per edifici con tamponamenti collegati elasticamente, 3 per edifici in muratura ordinaria, 4 per edifici in muratura armata).

Qualora si applichi il D.M. 96 (vedi NOTA sul capitolo "normativa di riferimento") l'analisi sismica dinamica può essere comprensiva di sollecitazione verticale contemporanea a quella orizzontale, nel qual caso è effettuata una sovrapposizione degli effetti in ragione della radice dei quadrati degli effetti stessi. Per ciascuna combinazione sismica - analisi effettuate con il D.M. 96 (vedi NOTA sul capitolo "normativa di riferimento") - viene riportato il livello di deformazione ϵ_T , ϵ_P e ϵ_D degli elementi strutturali verticali. Per semplicità di consultazione il livello è espresso in unità $1000 \cdot \epsilon_T/h$ da confrontare direttamente con il valore 2 o 4 per la verifica.

Per gli edifici sismicamente isolati si riportano di seguito le verifiche condotte sui dispositivi di isolamento. Le verifiche sono effettuate secondo la circolare 619/2009 del C.S.LL.PP nelle combinazioni in SLC come previsto dal DM 17-01-2018. Per ogni combinazione è riportato il codice di verifica ed i valori utilizzati per la verifica: spostamento d_E , area ridotta e dimensione A2, azione verticale, deformazioni di taglio dell'elastomero e tensioni nell'acciaio.

Qualora si applichi l'Ordinanza 3274 e s.m.i. le verifiche sono eseguite in accordo con l'allegato 10.A.

In particolare la tabella, per ogni combinazione di calcolo, riporta:

Nodo	Nodo di appoggio dell' isolatore
Cmb	Combinazione oggetto della verifica
Verif.	Codice di verifica ok – verifica positiva , NV – verifica negativa, ND – verifica non completata

Parco Eolico "Bolina" – Progetto Definitivo
Relazione di calcolo preliminare delle fondazioni degli aerogeneratori G8 e G12

dE	Spostamento relativo tra le due facce (amplificato del 20% per Ordinanza 3274 e smi) combinato con la regola del 30%
Ang fi	Angolo utilizzato per il calcolo dell' area ridotta Ar (per dispositivi circolari)
V	Azione verticale agente
Ar	Area ridotta efficace
Dim A2	Dimensione utile per il calcolo della deformazione per rotazione
Sig s	Tensione nell' inserto in acciaio
Gam c(a,s,t)	Deformazioni di taglio dell' elastomero
Vcr	Carico critico per instabilità

Affinché la verifica sia positiva deve essere:

- 1) $V > 0$
- 2) $Sig\ s < f_{yk}$
- 3) $Gam\ t < 5$
- 4) $Gam\ s < Gam\ * (caratteristica\ dell'\ elastomero)$
- 5) $Gam\ s < 2$
- 6) $V < 0.5\ V_{cr}$

Con riferimento al **Documento di Affidabilità** "Test di validazione del software di calcolo PRO_SAP e dei moduli aggiuntivi PRO_SAP Modulo Geotecnico, PRO_CAD nodi acciaio e PRO_MST" - versione Maggio 2011, disponibile per il download sul sito www.2si.it, si segnalano i seguenti esempi applicativi:

Test N°	Titolo
23	DM 2008: SPETTRO
29	SISMICA 1000/H, SOMMA V, EFFETTO P-δ
30	ANALISI DI UN EDIFICIO CON ISOLATORI SISMICI
70	MASSE SISMICHE
75	PROGETTO DI ISOLATORI ELASTOMERICI
76	VERIFICA DI ISOLATORI ELASTOMERICI
77	VERIFICA DI ISOLATORI FRICTION PENDULUM

CDC	Tipo	Sigla Id	Note
2	Esk	CDC=Es (statico SLU) alfa=0.0 (ecc. +)	
			categoria suolo: B
			fattore di sito S = 1.172
			ordinata spettro (tratto Tb-Tc) = 0.668 g
			angolo di ingresso:0.0
			eccentricità aggiuntiva: positiva
			periodo proprio T1: 0.300 sec.
			fattore q: 1.000
			fattore per spost. mu d: 1.000
			classe di duttilità CD: DCH
			coefficiente Lambda: 1.000
			ordinata spettro Sd(T1): 0.668

Quota	Forza Sismica	Tot. parziale	M Sismica x g	Pos. GX	Pos. GY	E agg. X-X	E agg. Y-Y	Pos. KX	Pos. KY	(r/Ls)^2	rapp. ex/rx	rapp. ey/ry
cm	daN	daN	daN	cm	cm	cm	cm	cm	cm			
-100.00	1.494e+05	1.494e+05	2.238e+05	0.0	0.0	0.0	0.0	0.0	0.0	0.0	0.0	0.0
Risulta	1.494e+05		2.238e+05									

CDC	Tipo	Sigla Id	Note
3	Esk	CDC=Es (statico SLU) alfa=0.0 (ecc. -)	
			categoria suolo: B
			fattore di sito S = 1.172
			ordinata spettro (tratto Tb-Tc) = 0.668 g

Parco Eolico "Bolina" – Progetto Definitivo
Relazione di calcolo preliminare delle fondazioni degli aerogeneratori G8 e G12

CDC	Tipo	Sigla Id	Note
			angolo di ingresso:0.0
			eccentricità aggiuntiva: negativa
			periodo proprio T1: 0.300 sec.
			fattore q: 1.000
			fattore per spost. mu d: 1.000
			classe di duttilità CD: DCH
			coefficiente Lambda: 1.000
			ordinata spettro Sd(T1): 0.668

Quota	Forza Sismica	Tot. parziale	M Sismica x g	Pos. GX	Pos. GY	E agg. X-X	E agg. Y-Y	Pos. KX	Pos. KY	(r/Ls)^2	rapp. ex/rx	rapp. ey/ry
cm	daN	daN	daN	cm	cm	cm	cm	cm	cm			
-100.00	1.494e+05	1.494e+05	2.238e+05	0.0	0.0	0.0	0.0	0.0	0.0	0.0	0.0	0.0
Risulta	1.494e+05		2.238e+05									

CDC	Tipo	Sigla Id	Note
4	Esk	CDC=Es (statico SLU) alfa=90.00 (ecc. +)	
			categoria suolo: B
			fattore di sito S = 1.172
			ordinata spettro (tratto Tb-Tc) = 0.668 g
			angolo di ingresso:90.00
			eccentricità aggiuntiva: positiva
			periodo proprio T1: 0.300 sec.
			fattore q: 1.000
			fattore per spost. mu d: 1.000
			classe di duttilità CD: DCH
			coefficiente Lambda: 1.000
			ordinata spettro Sd(T1): 0.668

Quota	Forza Sismica	Tot. parziale	M Sismica x g	Pos. GX	Pos. GY	E agg. X-X	E agg. Y-Y	Pos. KX	Pos. KY	(r/Ls)^2	rapp. ex/rx	rapp. ey/ry
cm	daN	daN	daN	cm	cm	cm	cm	cm	cm			
-100.00	1.494e+05	1.494e+05	2.238e+05	0.0	0.0	0.0	0.0	0.0	0.0	0.0	0.0	0.0
Risulta	1.494e+05		2.238e+05									

CDC	Tipo	Sigla Id	Note
5	Esk	CDC=Es (statico SLU) alfa=90.00 (ecc. -)	
			categoria suolo: B
			fattore di sito S = 1.172
			ordinata spettro (tratto Tb-Tc) = 0.668 g
			angolo di ingresso:90.00
			eccentricità aggiuntiva: negativa
			periodo proprio T1: 0.300 sec.
			fattore q: 1.000
			fattore per spost. mu d: 1.000
			classe di duttilità CD: DCH
			coefficiente Lambda: 1.000
			ordinata spettro Sd(T1): 0.668

Quota	Forza Sismica	Tot. parziale	M Sismica x g	Pos. GX	Pos. GY	E agg. X-X	E agg. Y-Y	Pos. KX	Pos. KY	(r/Ls)^2	rapp. ex/rx	rapp. ey/ry
cm	daN	daN	daN	cm	cm	cm	cm	cm	cm			

Parco Eolico "Bolina" – Progetto Definitivo
Relazione di calcolo preliminare delle fondazioni degli aerogeneratori G8 e G12

Quota	Forza Sismica	Tot. parziale	M Sismica x g	Pos. GX	Pos. GY	E agg. X-X	E agg. Y-Y	Pos. KX	Pos. KY	(r/Ls)^2	rapp. ex/rx	rapp. ey/ry
-100.00	1.494e+05	1.494e+05	2.238e+05	0.0	0.0	0.0	0.0	0.0	0.0	0.0	0.0	0.0
Risulta	1.494e+05		2.238e+05									

CDC	Tipo	Sigla Id	Note
6	Esk	CDC=Es (statico SLD) alfa=0.0 (ecc. +)	
			categoria suolo: B
			fattore di sito S = 1.200
			ordinata spettro (tratto Tb-Tc) = 0.226 g
			angolo di ingresso:0.0
			eccentricità aggiuntiva: positiva
			periodo proprio T1: 0.300 sec.
			coefficiente Lambda: 1.000
			ordinata spettro Se(T1): 0.226

Quota	Forza Sismica	Tot. parziale	M Sismica x g	Pos. GX	Pos. GY	E agg. X-X	E agg. Y-Y	Pos. KX	Pos. KY	(r/Ls)^2	rapp. ex/rx	rapp. ey/ry
cm	daN	daN	daN	cm	cm	cm	cm	cm	cm			
-100.00	5.056e+04	5.056e+04	2.238e+05	0.0	0.0	0.0	0.0	0.0	0.0	0.0	0.0	0.0
Risulta	5.056e+04		2.238e+05									

CDC	Tipo	Sigla Id	Note
7	Esk	CDC=Es (statico SLD) alfa=0.0 (ecc. -)	
			categoria suolo: B
			fattore di sito S = 1.200
			ordinata spettro (tratto Tb-Tc) = 0.226 g
			angolo di ingresso:0.0
			eccentricità aggiuntiva: negativa
			periodo proprio T1: 0.300 sec.
			coefficiente Lambda: 1.000
			ordinata spettro Se(T1): 0.226

Quota	Forza Sismica	Tot. parziale	M Sismica x g	Pos. GX	Pos. GY	E agg. X-X	E agg. Y-Y	Pos. KX	Pos. KY	(r/Ls)^2	rapp. ex/rx	rapp. ey/ry
cm	daN	daN	daN	cm	cm	cm	cm	cm	cm			
-100.00	5.056e+04	5.056e+04	2.238e+05	0.0	0.0	0.0	0.0	0.0	0.0	0.0	0.0	0.0
Risulta	5.056e+04		2.238e+05									

CDC	Tipo	Sigla Id	Note
8	Esk	CDC=Es (statico SLD) alfa=90.00 (ecc. +)	
			categoria suolo: B
			fattore di sito S = 1.200
			ordinata spettro (tratto Tb-Tc) = 0.226 g
			angolo di ingresso:90.00
			eccentricità aggiuntiva: positiva
			periodo proprio T1: 0.300 sec.
			coefficiente Lambda: 1.000
			ordinata spettro Se(T1): 0.226

Parco Eolico "Bolina" – Progetto Definitivo
Relazione di calcolo preliminare delle fondazioni degli aerogeneratori G8 e G12

Quota	Forza Sismica	Tot. parziale	M Sismica x g	Pos. GX	Pos. GY	E agg. X-X	E agg. Y-Y	Pos. KX	Pos. KY	(r/Ls)^2	rapp. ex/rx	rapp. ey/ry
cm	daN	daN	daN	cm	cm	cm	cm	cm	cm			
-100.00	5.056e+04	5.056e+04	2.238e+05	0.0	0.0	0.0	0.0	0.0	0.0	0.0	0.0	0.0
Risulta	5.056e+04		2.238e+05									

CDC	Tipo	Sigla Id	Note
9	Esk	CDC=Es (statico SLD) alfa=90.00 (ecc. -)	
			categoria suolo: B
			fattore di sito S = 1.200
			ordinata spettro (tratto Tb-Tc) = 0.226 g
			angolo di ingresso:90.00
			eccentricità aggiuntiva: negativa
			periodo proprio T1: 0.300 sec.
			coefficiente Lambda: 1.000
			ordinata spettro Se(T1): 0.226

Quota	Forza Sismica	Tot. parziale	M Sismica x g	Pos. GX	Pos. GY	E agg. X-X	E agg. Y-Y	Pos. KX	Pos. KY	(r/Ls)^2	rapp. ex/rx	rapp. ey/ry
cm	daN	daN	daN	cm	cm	cm	cm	cm	cm			
-100.00	5.056e+04	5.056e+04	2.238e+05	0.0	0.0	0.0	0.0	0.0	0.0	0.0	0.0	0.0
Risulta	5.056e+04		2.238e+05									

Cmb	Pilas. 1000 etaT/h	etaT cm	inter. h cm	Pilas. 1000 etaT/h	etaT cm	inter. h cm	Pilas. 1000 etaT/h	etaT cm	inter. h cm
37	29	0.326.34e-03	20.0						
38	29	0.326.34e-03	20.0						
39	29	0.326.36e-03	20.0						
40	29	0.326.35e-03	20.0						
41	29	0.326.34e-03	20.0						
42	29	0.326.34e-03	20.0						
43	29	0.326.36e-03	20.0						
44	29	0.326.35e-03	20.0						
45	29	0.326.34e-03	20.0						
46	29	0.326.34e-03	20.0						
47	29	0.326.36e-03	20.0						
48	29	0.326.35e-03	20.0						
49	29	0.326.34e-03	20.0						
50	29	0.326.34e-03	20.0						
51	29	0.326.36e-03	20.0						
52	29	0.326.35e-03	20.0						
53	29	0.326.35e-03	20.0						
54	29	0.326.34e-03	20.0						
55	29	0.326.36e-03	20.0						
56	29	0.326.34e-03	20.0						
57	29	0.326.35e-03	20.0						
58	29	0.326.34e-03	20.0						
59	29	0.326.36e-03	20.0						
60	29	0.326.34e-03	20.0						
61	29	0.326.35e-03	20.0						
62	29	0.326.34e-03	20.0						
63	29	0.326.36e-03	20.0						
64	29	0.326.34e-03	20.0						
65	29	0.326.35e-03	20.0						
66	29	0.326.34e-03	20.0						
67	29	0.326.36e-03	20.0						
68	29	0.326.34e-03	20.0						

Cmb 1000 etaT/h
0.32

RISULTATI NODALI

LEGENDA RISULTATI NODALI

Il controllo dei risultati delle analisi condotte, per quanto concerne i nodi strutturali, è possibile in relazione alle tabelle sottoriportate.

Una prima tabella riporta infatti per ogni nodo e per ogni combinazione (o caso di carico) gli spostamenti nodali.

Una seconda tabella riporta per ogni nodo a cui sia associato un vincolo rigido e/o elastico o una fondazione speciale e per ogni combinazione (o caso di carico) i valori delle azioni esercitate dalla struttura sui vincoli (reazioni vincolari cambiate di segno).

Una terza tabella, infine riassume per ogni nodo le sei combinazioni in cui si attingono i valori minimi e massimi della reazione Fz, della reazione Mx e della reazione My.

Nodo	Cmb	Traslazione X cm	Traslazione Y cm	Traslazione Z cm	Rotazione X	Rotazione Y	Rotazione Z
1	1	3.25e-03	-2.69e-03	-0.14	1.21e-04	1.78e-04	0.0
1	3	2.75e-03	-2.28e-03	-0.12	1.03e-04	1.51e-04	0.0
1	8	0.01	7.29e-04	-0.11	9.31e-05	1.38e-04	0.0
1	21	-1.30e-03	-0.01	-0.11	9.42e-05	1.37e-04	0.0
1	23	5.12e-03	-0.01	-0.11	9.42e-05	1.37e-04	0.0
1	40	6.18e-03	-1.12e-03	-0.11	9.32e-05	1.37e-04	0.0
1	53	1.21e-03	-5.41e-03	-0.11	9.35e-05	1.37e-04	0.0
1	55	3.38e-03	-5.45e-03	-0.11	9.36e-05	1.37e-04	0.0
1	69	2.50e-03	-2.07e-03	-0.11	9.32e-05	1.37e-04	0.0
2	1	3.24e-03	-2.73e-03	-0.16	1.28e-04	1.96e-04	0.0
2	3	2.74e-03	-2.31e-03	-0.13	1.09e-04	1.66e-04	0.0
2	8	0.01	8.79e-04	-0.12	9.85e-05	1.52e-04	0.0
2	21	-1.31e-03	-0.01	-0.12	9.96e-05	1.51e-04	0.0
2	23	5.13e-03	-0.01	-0.12	9.97e-05	1.51e-04	0.0
2	40	6.18e-03	-1.09e-03	-0.12	9.86e-05	1.51e-04	0.0
2	53	1.21e-03	-5.53e-03	-0.12	9.90e-05	1.51e-04	0.0
2	55	3.38e-03	-5.54e-03	-0.12	9.90e-05	1.51e-04	0.0
2	69	2.49e-03	-2.10e-03	-0.12	9.87e-05	1.51e-04	0.0
3	1	3.27e-03	-2.72e-03	-0.15	1.79e-04	2.16e-04	0.0
3	3	2.76e-03	-2.30e-03	-0.12	1.51e-04	1.82e-04	0.0
3	8	0.01	8.58e-04	-0.11	1.37e-04	1.67e-04	0.0
3	21	-1.19e-03	-0.01	-0.11	1.38e-04	1.66e-04	-2.54e-06
3	23	5.24e-03	-0.01	-0.11	1.38e-04	1.66e-04	-2.13e-06
3	40	6.19e-03	-1.09e-03	-0.11	1.37e-04	1.66e-04	0.0
3	53	1.26e-03	-5.52e-03	-0.11	1.38e-04	1.66e-04	-1.09e-06
3	55	3.44e-03	-5.53e-03	-0.11	1.38e-04	1.66e-04	0.0
3	69	2.51e-03	-2.09e-03	-0.11	1.37e-04	1.66e-04	0.0
4	1	3.28e-03	-2.69e-03	-0.13	1.50e-04	1.81e-04	0.0
4	3	2.77e-03	-2.27e-03	-0.11	1.27e-04	1.53e-04	0.0
4	5	-8.35e-03	-4.86e-03	-0.10	1.16e-04	1.39e-04	0.0
4	8	0.01	7.33e-04	-0.10	1.15e-04	1.40e-04	0.0
4	23	5.22e-03	-0.01	-0.10	1.17e-04	1.40e-04	0.0
4	37	-1.16e-03	-3.01e-03	-0.10	1.16e-04	1.39e-04	0.0
4	40	6.20e-03	-1.12e-03	-0.10	1.15e-04	1.40e-04	0.0
4	55	3.43e-03	-5.45e-03	-0.10	1.16e-04	1.40e-04	0.0
4	69	2.52e-03	-2.07e-03	-0.10	1.15e-04	1.39e-04	0.0
5	1	3.30e-03	-2.71e-03	-0.13	1.83e-04	2.01e-04	0.0
5	3	2.79e-03	-2.30e-03	-0.11	1.55e-04	1.70e-04	0.0
5	5	-8.23e-03	-5.00e-03	-0.10	1.41e-04	1.53e-04	0.0
5	8	0.01	8.25e-04	-0.10	1.40e-04	1.55e-04	0.0
5	23	5.39e-03	-0.01	-0.10	1.42e-04	1.55e-04	0.0
5	37	-1.11e-03	-3.07e-03	-0.10	1.41e-04	1.54e-04	0.0
5	40	6.19e-03	-1.10e-03	-0.10	1.40e-04	1.55e-04	0.0
5	55	3.50e-03	-5.53e-03	-0.10	1.41e-04	1.54e-04	0.0
5	69	2.54e-03	-2.09e-03	-0.10	1.41e-04	1.54e-04	0.0
6	1	3.31e-03	-2.68e-03	-0.12	1.91e-04	1.92e-04	0.0
6	3	2.80e-03	-2.27e-03	-0.10	1.62e-04	1.62e-04	0.0
6	5	-8.23e-03	-4.86e-03	-0.09	1.47e-04	1.46e-04	-1.91e-06
6	8	0.01	7.41e-04	-0.09	1.47e-04	1.48e-04	1.20e-06
6	23	5.37e-03	-0.01	-0.09	1.48e-04	1.48e-04	-2.23e-06
6	37	-1.10e-03	-3.01e-03	-0.09	1.47e-04	1.47e-04	0.0
6	40	6.19e-03	-1.11e-03	-0.09	1.47e-04	1.48e-04	0.0
6	55	3.50e-03	-5.46e-03	-0.09	1.48e-04	1.47e-04	0.0

Parco Eolico "Bolina" – Progetto Definitivo
Relazione di calcolo preliminare delle fondazioni degli aerogeneratori G8 e G12

6	69	2.55e-03	-2.06e-03	-0.09	1.47e-04	1.47e-04	0.0
7	1	3.35e-03	-2.71e-03	-0.12	1.95e-04	1.92e-04	0.0
7	3	2.83e-03	-2.29e-03	-0.10	1.65e-04	1.62e-04	0.0
7	5	-8.08e-03	-4.99e-03	-0.09	1.50e-04	1.46e-04	0.0
7	8	0.01	8.20e-04	-0.09	1.50e-04	1.48e-04	0.0
7	23	5.52e-03	-0.01	-0.09	1.51e-04	1.48e-04	0.0
7	37	-1.03e-03	-3.07e-03	-0.09	1.50e-04	1.47e-04	0.0
7	40	6.18e-03	-1.10e-03	-0.09	1.50e-04	1.48e-04	0.0
7	55	3.57e-03	-5.53e-03	-0.09	1.51e-04	1.48e-04	0.0
7	69	2.58e-03	-2.08e-03	-0.09	1.50e-04	1.47e-04	0.0
8	1	3.35e-03	-2.68e-03	-0.11	1.79e-04	1.65e-04	0.0
8	3	2.83e-03	-2.27e-03	-0.09	1.52e-04	1.40e-04	0.0
8	5	-8.09e-03	-4.81e-03	-0.08	1.38e-04	1.26e-04	0.0
8	8	0.01	6.92e-04	-0.08	1.38e-04	1.28e-04	0.0
8	23	5.53e-03	-0.01	-0.08	1.39e-04	1.27e-04	0.0
8	37	-1.03e-03	-2.99e-03	-0.08	1.38e-04	1.27e-04	0.0
8	40	6.18e-03	-1.13e-03	-0.08	1.38e-04	1.27e-04	0.0
8	55	3.57e-03	-5.45e-03	-0.08	1.38e-04	1.27e-04	0.0
8	69	2.57e-03	-2.06e-03	-0.08	1.38e-04	1.27e-04	0.0
9	1	3.39e-03	-2.71e-03	-0.10	1.98e-04	1.81e-04	0.0
9	3	2.87e-03	-2.29e-03	-0.09	1.68e-04	1.53e-04	0.0
9	5	-7.95e-03	-4.93e-03	-0.08	1.53e-04	1.38e-04	-2.35e-06
9	8	0.01	7.68e-04	-0.08	1.52e-04	1.40e-04	1.63e-06
9	23	5.67e-03	-0.01	-0.08	1.54e-04	1.39e-04	-2.17e-06
9	37	-9.62e-04	-3.05e-03	-0.08	1.53e-04	1.39e-04	-1.03e-06
9	40	6.18e-03	-1.12e-03	-0.08	1.52e-04	1.39e-04	0.0
9	55	3.65e-03	-5.53e-03	-0.08	1.53e-04	1.39e-04	0.0
9	69	2.61e-03	-2.08e-03	-0.08	1.53e-04	1.39e-04	0.0
10	1	3.39e-03	-2.67e-03	-0.09	1.87e-04	1.67e-04	0.0
10	3	2.87e-03	-2.26e-03	-0.08	1.58e-04	1.41e-04	0.0
10	5	-7.95e-03	-4.76e-03	-0.07	1.44e-04	1.27e-04	-2.35e-06
10	8	0.01	6.50e-04	-0.07	1.43e-04	1.29e-04	1.64e-06
10	23	5.67e-03	-0.01	-0.07	1.45e-04	1.29e-04	-2.21e-06
10	37	-9.62e-04	-2.97e-03	-0.07	1.44e-04	1.28e-04	-1.03e-06
10	40	6.18e-03	-1.14e-03	-0.07	1.43e-04	1.29e-04	0.0
10	55	3.65e-03	-5.46e-03	-0.07	1.44e-04	1.28e-04	0.0
10	69	2.61e-03	-2.06e-03	-0.07	1.44e-04	1.28e-04	0.0
11	1	3.44e-03	-2.71e-03	-0.09	1.83e-04	1.64e-04	0.0
11	3	2.91e-03	-2.29e-03	-0.07	1.55e-04	1.39e-04	0.0
11	6	-7.76e-03	1.20e-03	-0.07	1.40e-04	1.25e-04	0.0
11	7	0.01	-5.36e-03	-0.07	1.41e-04	1.27e-04	0.0
11	23	5.79e-03	-0.01	-0.07	1.42e-04	1.27e-04	0.0
11	38	-8.74e-04	-9.73e-04	-0.07	1.40e-04	1.26e-04	0.0
11	39	6.17e-03	-3.19e-03	-0.07	1.41e-04	1.27e-04	0.0
11	55	3.71e-03	-5.54e-03	-0.07	1.41e-04	1.26e-04	0.0
11	69	2.65e-03	-2.08e-03	-0.07	1.40e-04	1.26e-04	0.0
12	1	3.44e-03	-2.68e-03	-0.08	1.66e-04	1.37e-04	0.0
12	3	2.91e-03	-2.26e-03	-0.07	1.41e-04	1.16e-04	0.0
12	6	-7.76e-03	1.26e-03	-0.06	1.28e-04	1.05e-04	0.0
12	7	0.01	-5.38e-03	-0.06	1.28e-04	1.06e-04	0.0
12	23	5.79e-03	-0.01	-0.06	1.29e-04	1.06e-04	0.0
12	38	-8.72e-04	-9.37e-04	-0.06	1.28e-04	1.05e-04	0.0
12	39	6.17e-03	-3.18e-03	-0.06	1.28e-04	1.06e-04	0.0
12	55	3.71e-03	-5.46e-03	-0.06	1.28e-04	1.06e-04	0.0
12	69	2.65e-03	-2.06e-03	-0.06	1.28e-04	1.06e-04	0.0
13	1	3.49e-03	-2.71e-03	-0.08	1.63e-04	1.52e-04	0.0
13	3	2.95e-03	-2.30e-03	-0.06	1.38e-04	1.29e-04	0.0
13	6	-7.64e-03	1.20e-03	-0.06	1.25e-04	1.16e-04	0.0
13	7	0.01	-5.38e-03	-0.06	1.26e-04	1.18e-04	0.0
13	23	5.91e-03	-0.01	-0.06	1.27e-04	1.17e-04	0.0
13	38	-8.12e-04	-9.74e-04	-0.06	1.26e-04	1.17e-04	0.0
13	39	6.17e-03	-3.20e-03	-0.06	1.26e-04	1.17e-04	0.0
13	55	3.78e-03	-5.54e-03	-0.06	1.26e-04	1.17e-04	0.0
13	69	2.68e-03	-2.09e-03	-0.06	1.26e-04	1.17e-04	0.0
14	1	3.48e-03	-2.68e-03	-0.06	1.63e-04	1.37e-04	0.0
14	3	2.94e-03	-2.27e-03	-0.05	1.38e-04	1.16e-04	0.0
14	6	-7.66e-03	1.31e-03	-0.05	1.25e-04	1.04e-04	-1.45e-06
14	7	0.01	-5.43e-03	-0.05	1.26e-04	1.06e-04	0.0
14	23	5.93e-03	-0.01	-0.05	1.26e-04	1.05e-04	-2.00e-06
14	38	-8.21e-04	-9.22e-04	-0.05	1.25e-04	1.05e-04	0.0
14	39	6.17e-03	-3.20e-03	-0.05	1.25e-04	1.06e-04	0.0
14	55	3.78e-03	-5.47e-03	-0.05	1.26e-04	1.05e-04	0.0
14	69	2.68e-03	-2.06e-03	-0.05	1.25e-04	1.05e-04	0.0

Parco Eolico "Bolina" – Progetto Definitivo
Relazione di calcolo preliminare delle fondazioni degli aerogeneratori G8 e G12

15	1	3.52e-03	-2.72e-03	-0.06	1.53e-04	1.53e-04	0.0
15	3	2.98e-03	-2.30e-03	-0.05	1.29e-04	1.29e-04	0.0
15	6	-7.52e-03	1.24e-03	-0.05	1.17e-04	1.17e-04	-1.75e-06
15	7	0.01	-5.42e-03	-0.05	1.18e-04	1.19e-04	1.06e-06
15	23	6.04e-03	-0.01	-0.05	1.19e-04	1.18e-04	-1.75e-06
15	38	-7.50e-04	-9.66e-04	-0.05	1.17e-04	1.17e-04	0.0
15	39	6.17e-03	-3.22e-03	-0.05	1.18e-04	1.18e-04	0.0
15	55	3.84e-03	-5.55e-03	-0.05	1.18e-04	1.18e-04	0.0
15	69	2.71e-03	-2.09e-03	-0.05	1.18e-04	1.18e-04	0.0
16	1	3.51e-03	-2.69e-03	-0.06	1.22e-04	1.10e-04	0.0
16	3	2.97e-03	-2.27e-03	-0.05	1.03e-04	9.32e-05	0.0
16	6	-7.54e-03	1.30e-03	-0.05	9.37e-05	8.38e-05	0.0
16	7	0.01	-5.43e-03	-0.04	9.41e-05	8.57e-05	0.0
16	23	6.06e-03	-0.01	-0.04	9.49e-05	8.50e-05	0.0
16	38	-7.62e-04	-9.28e-04	-0.04	9.38e-05	8.44e-05	0.0
16	39	6.17e-03	-3.20e-03	-0.04	9.40e-05	8.51e-05	0.0
16	55	3.84e-03	-5.47e-03	-0.04	9.42e-05	8.48e-05	0.0
16	69	2.70e-03	-2.07e-03	-0.04	9.39e-05	8.48e-05	0.0
17	1	3.55e-03	-2.73e-03	-0.06	1.10e-04	1.22e-04	0.0
17	3	3.01e-03	-2.31e-03	-0.05	9.32e-05	1.03e-04	0.0
17	7	0.01	-5.46e-03	-0.04	8.49e-05	9.49e-05	0.0
17	22	-6.28e-04	8.14e-03	-0.05	8.38e-05	9.37e-05	0.0
17	23	6.10e-03	-0.01	-0.04	8.56e-05	9.42e-05	0.0
17	39	6.14e-03	-3.24e-03	-0.04	8.48e-05	9.43e-05	0.0
17	54	1.60e-03	1.36e-03	-0.04	8.44e-05	9.39e-05	0.0
17	55	3.87e-03	-5.56e-03	-0.04	8.50e-05	9.40e-05	0.0
17	69	2.73e-03	-2.10e-03	-0.04	8.47e-05	9.39e-05	0.0
18	1	3.55e-03	-2.69e-03	-0.05	9.66e-05	9.66e-05	0.0
18	3	3.00e-03	-2.28e-03	-0.04	8.18e-05	8.18e-05	0.0
18	6	-7.31e-03	1.29e-03	-0.04	7.41e-05	7.34e-05	0.0
18	7	0.01	-5.43e-03	-0.04	7.45e-05	7.52e-05	0.0
18	23	6.09e-03	-0.01	-0.04	7.52e-05	7.46e-05	0.0
18	38	-6.67e-04	-9.32e-04	-0.04	7.43e-05	7.40e-05	0.0
18	39	6.12e-03	-3.21e-03	-0.04	7.44e-05	7.46e-05	0.0
18	55	3.87e-03	-5.46e-03	-0.04	7.46e-05	7.44e-05	0.0
18	69	2.73e-03	-2.07e-03	-0.04	7.43e-05	7.43e-05	0.0
19	1	3.23e-03	-2.77e-03	-0.17	1.47e-04	2.21e-04	0.0
19	3	2.73e-03	-2.34e-03	-0.15	1.24e-04	1.87e-04	0.0
19	8	0.01	9.44e-04	-0.13	1.13e-04	1.71e-04	0.0
19	21	-1.32e-03	-0.01	-0.13	1.14e-04	1.70e-04	-2.25e-06
19	23	5.13e-03	-0.01	-0.13	1.14e-04	1.71e-04	-1.91e-06
19	40	6.18e-03	-1.09e-03	-0.13	1.13e-04	1.71e-04	0.0
19	53	1.20e-03	-5.61e-03	-0.13	1.13e-04	1.70e-04	0.0
19	55	3.38e-03	-5.61e-03	-0.13	1.13e-04	1.71e-04	0.0
19	69	2.48e-03	-2.13e-03	-0.13	1.13e-04	1.70e-04	0.0
20	1	3.26e-03	-2.76e-03	-0.16	1.61e-04	2.14e-04	0.0
20	3	2.76e-03	-2.33e-03	-0.14	1.37e-04	1.81e-04	0.0
20	8	0.01	9.27e-04	-0.12	1.24e-04	1.66e-04	0.0
20	21	-1.16e-03	-0.01	-0.12	1.25e-04	1.64e-04	0.0
20	23	5.27e-03	-0.01	-0.12	1.25e-04	1.65e-04	0.0
20	40	6.18e-03	-1.09e-03	-0.12	1.24e-04	1.65e-04	0.0
20	53	1.27e-03	-5.59e-03	-0.12	1.25e-04	1.64e-04	0.0
20	55	3.44e-03	-5.60e-03	-0.12	1.25e-04	1.65e-04	0.0
20	69	2.51e-03	-2.12e-03	-0.12	1.24e-04	1.64e-04	0.0
21	1	3.30e-03	-2.75e-03	-0.15	2.00e-04	2.29e-04	0.0
21	3	2.79e-03	-2.33e-03	-0.13	1.69e-04	1.94e-04	0.0
21	8	0.01	9.26e-04	-0.11	1.54e-04	1.77e-04	0.0
21	21	-1.01e-03	-0.01	-0.11	1.55e-04	1.76e-04	-2.53e-06
21	23	5.39e-03	-0.01	-0.11	1.55e-04	1.77e-04	-2.09e-06
21	40	6.18e-03	-1.09e-03	-0.11	1.54e-04	1.77e-04	0.0
21	53	1.34e-03	-5.59e-03	-0.11	1.54e-04	1.76e-04	-1.09e-06
21	55	3.50e-03	-5.60e-03	-0.11	1.54e-04	1.76e-04	0.0
21	69	2.54e-03	-2.12e-03	-0.11	1.54e-04	1.76e-04	0.0
22	1	3.35e-03	-2.75e-03	-0.13	2.29e-04	2.26e-04	0.0
22	3	2.83e-03	-2.33e-03	-0.11	1.94e-04	1.91e-04	0.0
22	5	-8.10e-03	-5.14e-03	-0.10	1.77e-04	1.72e-04	-2.06e-06
22	8	0.01	9.07e-04	-0.10	1.76e-04	1.75e-04	1.14e-06
22	23	5.53e-03	-0.01	-0.10	1.78e-04	1.74e-04	-2.04e-06
22	37	-1.04e-03	-3.14e-03	-0.10	1.77e-04	1.73e-04	0.0
22	40	6.18e-03	-1.09e-03	-0.10	1.76e-04	1.74e-04	0.0
22	55	3.57e-03	-5.60e-03	-0.10	1.77e-04	1.74e-04	0.0
22	69	2.57e-03	-2.12e-03	-0.10	1.77e-04	1.74e-04	0.0
23	1	3.39e-03	-2.74e-03	-0.12	2.17e-04	2.05e-04	0.0

Parco Eolico "Bolina" – Progetto Definitivo
Relazione di calcolo preliminare delle fondazioni degli aerogeneratori G8 e G12

23	3	2.87e-03	-2.32e-03	-0.10	1.84e-04	1.73e-04	0.0
23	5	-7.95e-03	-5.10e-03	-0.09	1.67e-04	1.57e-04	-2.36e-06
23	8	0.01	8.82e-04	-0.09	1.67e-04	1.59e-04	1.54e-06
23	23	5.67e-03	-0.01	-0.09	1.68e-04	1.58e-04	-2.06e-06
23	37	-9.62e-04	-3.12e-03	-0.09	1.67e-04	1.57e-04	-1.07e-06
23	40	6.18e-03	-1.10e-03	-0.09	1.67e-04	1.58e-04	0.0
23	55	3.65e-03	-5.60e-03	-0.09	1.68e-04	1.58e-04	0.0
23	69	2.61e-03	-2.11e-03	-0.09	1.67e-04	1.58e-04	0.0
24	1	3.44e-03	-2.75e-03	-0.10	2.06e-04	1.86e-04	0.0
24	3	2.91e-03	-2.33e-03	-0.08	1.74e-04	1.57e-04	0.0
24	6	-7.77e-03	1.09e-03	-0.08	1.58e-04	1.42e-04	-1.54e-06
24	7	0.01	-5.32e-03	-0.08	1.59e-04	1.44e-04	0.0
24	23	5.80e-03	-0.01	-0.08	1.59e-04	1.43e-04	-1.86e-06
24	38	-8.76e-04	-1.03e-03	-0.08	1.58e-04	1.43e-04	0.0
24	39	6.17e-03	-3.20e-03	-0.08	1.58e-04	1.43e-04	0.0
24	55	3.71e-03	-5.60e-03	-0.08	1.59e-04	1.43e-04	0.0
24	69	2.65e-03	-2.12e-03	-0.08	1.58e-04	1.43e-04	0.0
25	1	3.49e-03	-2.75e-03	-0.09	1.77e-04	1.77e-04	0.0
25	3	2.95e-03	-2.33e-03	-0.07	1.50e-04	1.50e-04	0.0
25	6	-7.64e-03	1.11e-03	-0.07	1.36e-04	1.35e-04	-1.73e-06
25	7	0.01	-5.35e-03	-0.07	1.36e-04	1.37e-04	1.01e-06
25	23	5.91e-03	-0.01	-0.07	1.37e-04	1.37e-04	-1.73e-06
25	38	-8.10e-04	-1.03e-03	-0.07	1.36e-04	1.36e-04	0.0
25	39	6.18e-03	-3.21e-03	-0.07	1.36e-04	1.37e-04	0.0
25	55	3.78e-03	-5.61e-03	-0.07	1.37e-04	1.36e-04	0.0
25	69	2.68e-03	-2.12e-03	-0.07	1.36e-04	1.36e-04	0.0
26	1	3.53e-03	-2.76e-03	-0.08	1.52e-04	1.64e-04	0.0
26	3	2.99e-03	-2.33e-03	-0.06	1.29e-04	1.38e-04	0.0
26	7	0.01	-5.35e-03	-0.06	1.17e-04	1.27e-04	0.0
26	22	-5.73e-04	8.20e-03	-0.06	1.16e-04	1.26e-04	0.0
26	23	6.00e-03	-0.01	-0.06	1.18e-04	1.26e-04	0.0
26	39	6.17e-03	-3.21e-03	-0.06	1.17e-04	1.26e-04	0.0
26	54	1.60e-03	1.37e-03	-0.06	1.17e-04	1.26e-04	0.0
26	55	3.83e-03	-5.61e-03	-0.06	1.17e-04	1.26e-04	0.0
26	69	2.72e-03	-2.12e-03	-0.06	1.17e-04	1.26e-04	0.0
27	1	3.56e-03	-2.76e-03	-0.06	1.37e-04	1.63e-04	0.0
27	3	3.02e-03	-2.34e-03	-0.05	1.16e-04	1.38e-04	0.0
27	7	0.01	-5.39e-03	-0.05	1.05e-04	1.26e-04	1.28e-06
27	22	-6.27e-04	8.21e-03	-0.05	1.04e-04	1.25e-04	0.0
27	23	6.11e-03	-0.01	-0.05	1.06e-04	1.26e-04	-1.46e-06
27	39	6.15e-03	-3.23e-03	-0.05	1.05e-04	1.26e-04	0.0
27	54	1.60e-03	1.37e-03	-0.05	1.05e-04	1.25e-04	0.0
27	55	3.88e-03	-5.62e-03	-0.05	1.06e-04	1.25e-04	0.0
27	69	2.74e-03	-2.13e-03	-0.05	1.05e-04	1.25e-04	0.0
28	1	3.23e-03	-2.80e-03	-0.19	1.18e-04	2.03e-04	0.0
28	3	2.73e-03	-2.37e-03	-0.16	9.94e-05	1.72e-04	0.0
28	8	0.01	9.96e-04	-0.14	9.02e-05	1.57e-04	0.0
28	21	-1.28e-03	-0.01	-0.15	9.14e-05	1.56e-04	0.0
28	40	6.17e-03	-1.09e-03	-0.14	9.03e-05	1.56e-04	0.0
28	53	1.21e-03	-5.68e-03	-0.14	9.07e-05	1.56e-04	0.0
28	69	2.48e-03	-2.15e-03	-0.14	9.04e-05	1.56e-04	0.0
29	1	3.25e-03	-2.80e-03	-0.18	1.55e-04	2.16e-04	0.0
29	3	2.75e-03	-2.37e-03	-0.15	1.31e-04	1.83e-04	0.0
29	8	0.01	9.97e-04	-0.14	1.19e-04	1.67e-04	0.0
29	21	-1.16e-03	-0.01	-0.14	1.20e-04	1.66e-04	0.0
29	40	6.18e-03	-1.09e-03	-0.14	1.19e-04	1.67e-04	0.0
29	53	1.26e-03	-5.68e-03	-0.14	1.19e-04	1.66e-04	0.0
29	69	2.50e-03	-2.16e-03	-0.14	1.19e-04	1.66e-04	0.0
30	1	3.30e-03	-2.80e-03	-0.17	1.97e-04	2.48e-04	0.0
30	3	2.79e-03	-2.37e-03	-0.14	1.67e-04	2.10e-04	0.0
30	8	0.01	1.00e-03	-0.13	1.51e-04	1.92e-04	0.0
30	21	-9.93e-04	-0.01	-0.13	1.53e-04	1.91e-04	-2.35e-06
30	40	6.18e-03	-1.09e-03	-0.13	1.52e-04	1.91e-04	0.0
30	53	1.34e-03	-5.68e-03	-0.13	1.52e-04	1.91e-04	-1.10e-06
30	69	2.53e-03	-2.15e-03	-0.13	1.52e-04	1.91e-04	0.0
31	1	3.34e-03	-2.79e-03	-0.15	2.36e-04	2.52e-04	0.0
31	3	2.82e-03	-2.36e-03	-0.13	1.99e-04	2.13e-04	0.0
31	8	0.01	9.96e-04	-0.12	1.81e-04	1.95e-04	0.0
31	21	-8.31e-04	-0.01	-0.12	1.83e-04	1.94e-04	-2.52e-06
31	40	6.18e-03	-1.08e-03	-0.12	1.81e-04	1.94e-04	0.0
31	53	1.42e-03	-5.67e-03	-0.12	1.82e-04	1.94e-04	-1.18e-06
31	69	2.57e-03	-2.15e-03	-0.12	1.81e-04	1.94e-04	0.0
32	1	3.39e-03	-2.79e-03	-0.13	2.44e-04	2.40e-04	0.0

Parco Eolico "Bolina" – Progetto Definitivo
Relazione di calcolo preliminare delle fondazioni degli aerogeneratori G8 e G12

32	3	2.87e-03	-2.36e-03	-0.11	2.06e-04	2.03e-04	0.0
32	5	-7.95e-03	-5.27e-03	-0.10	1.88e-04	1.83e-04	-2.43e-06
32	8	0.01	9.86e-04	-0.10	1.87e-04	1.86e-04	1.31e-06
32	21	-6.50e-04	-0.01	-0.10	1.89e-04	1.84e-04	-2.69e-06
32	37	-9.62e-04	-3.20e-03	-0.10	1.87e-04	1.84e-04	-1.19e-06
32	40	6.18e-03	-1.08e-03	-0.10	1.87e-04	1.85e-04	0.0
32	53	1.51e-03	-5.67e-03	-0.10	1.88e-04	1.84e-04	-1.28e-06
32	69	2.61e-03	-2.14e-03	-0.10	1.87e-04	1.84e-04	0.0
33	1	3.45e-03	-2.79e-03	-0.11	2.22e-04	2.22e-04	0.0
33	3	2.92e-03	-2.36e-03	-0.10	1.88e-04	1.88e-04	0.0
33	6	-7.77e-03	9.88e-04	-0.09	1.70e-04	1.69e-04	-1.71e-06
33	7	0.01	-5.28e-03	-0.09	1.71e-04	1.72e-04	0.0
33	23	5.79e-03	-0.01	-0.09	1.72e-04	1.71e-04	-1.71e-06
33	38	-8.71e-04	-1.09e-03	-0.09	1.70e-04	1.70e-04	0.0
33	39	6.18e-03	-3.21e-03	-0.09	1.71e-04	1.71e-04	0.0
33	55	3.72e-03	-5.67e-03	-0.09	1.71e-04	1.71e-04	0.0
33	69	2.66e-03	-2.15e-03	-0.09	1.70e-04	1.71e-04	0.0
34	1	3.49e-03	-2.80e-03	-0.10	1.86e-04	2.06e-04	0.0
34	3	2.96e-03	-2.37e-03	-0.08	1.57e-04	1.74e-04	0.0
34	7	0.01	-5.30e-03	-0.08	1.43e-04	1.60e-04	0.0
34	22	-5.19e-04	8.26e-03	-0.08	1.42e-04	1.58e-04	0.0
34	23	5.89e-03	-0.01	-0.08	1.44e-04	1.59e-04	-1.54e-06
34	39	6.18e-03	-3.22e-03	-0.08	1.43e-04	1.59e-04	0.0
34	54	1.60e-03	1.37e-03	-0.08	1.43e-04	1.58e-04	0.0
34	55	3.77e-03	-5.68e-03	-0.08	1.43e-04	1.58e-04	0.0
34	69	2.69e-03	-2.15e-03	-0.08	1.43e-04	1.58e-04	0.0
35	1	3.54e-03	-2.80e-03	-0.09	1.64e-04	1.83e-04	0.0
35	3	2.99e-03	-2.37e-03	-0.07	1.39e-04	1.55e-04	0.0
35	7	0.01	-5.30e-03	-0.07	1.27e-04	1.42e-04	0.0
35	22	-5.59e-04	8.25e-03	-0.07	1.25e-04	1.40e-04	0.0
35	23	6.00e-03	-0.01	-0.07	1.27e-04	1.41e-04	0.0
35	39	6.17e-03	-3.22e-03	-0.07	1.26e-04	1.41e-04	0.0
35	54	1.61e-03	1.36e-03	-0.07	1.26e-04	1.40e-04	0.0
35	55	3.83e-03	-5.68e-03	-0.07	1.27e-04	1.41e-04	0.0
35	69	2.72e-03	-2.16e-03	-0.07	1.26e-04	1.41e-04	0.0
36	1	3.57e-03	-2.80e-03	-0.08	1.37e-04	1.66e-04	0.0
36	3	3.02e-03	-2.37e-03	-0.07	1.16e-04	1.41e-04	0.0
36	7	0.01	-5.29e-03	-0.06	1.06e-04	1.29e-04	0.0
36	22	-5.73e-04	8.25e-03	-0.06	1.05e-04	1.28e-04	0.0
36	23	6.06e-03	-0.01	-0.06	1.06e-04	1.28e-04	0.0
36	39	6.15e-03	-3.22e-03	-0.06	1.06e-04	1.28e-04	0.0
36	54	1.62e-03	1.37e-03	-0.06	1.05e-04	1.28e-04	0.0
36	55	3.86e-03	-5.67e-03	-0.06	1.06e-04	1.28e-04	0.0
36	69	2.74e-03	-2.15e-03	-0.06	1.06e-04	1.28e-04	0.0
37	1	3.22e-03	-2.85e-03	-0.21	1.28e-04	1.98e-04	0.0
37	3	2.72e-03	-2.41e-03	-0.17	1.08e-04	1.67e-04	0.0
37	8	0.01	1.07e-03	-0.16	9.83e-05	1.53e-04	0.0
37	21	-1.25e-03	-0.01	-0.16	9.96e-05	1.52e-04	-1.87e-06
37	23	5.21e-03	-0.01	-0.16	9.96e-05	1.53e-04	-1.55e-06
37	40	6.17e-03	-1.09e-03	-0.16	9.85e-05	1.53e-04	0.0
37	53	1.22e-03	-5.76e-03	-0.16	9.89e-05	1.52e-04	0.0
37	55	3.40e-03	-5.74e-03	-0.16	9.89e-05	1.52e-04	0.0
37	69	2.48e-03	-2.19e-03	-0.16	9.86e-05	1.52e-04	0.0
38	1	3.25e-03	-2.85e-03	-0.20	1.47e-04	2.08e-04	0.0
38	3	2.75e-03	-2.41e-03	-0.17	1.25e-04	1.76e-04	0.0
38	8	0.01	1.07e-03	-0.15	1.13e-04	1.61e-04	0.0
38	21	-1.11e-03	-0.01	-0.15	1.14e-04	1.59e-04	-1.89e-06
38	23	5.32e-03	-0.01	-0.15	1.14e-04	1.60e-04	-1.55e-06
38	40	6.17e-03	-1.09e-03	-0.15	1.13e-04	1.60e-04	0.0
38	53	1.28e-03	-5.76e-03	-0.15	1.14e-04	1.60e-04	0.0
38	55	3.46e-03	-5.74e-03	-0.15	1.14e-04	1.60e-04	0.0
38	69	2.50e-03	-2.19e-03	-0.15	1.13e-04	1.60e-04	0.0
39	1	3.29e-03	-2.85e-03	-0.18	1.80e-04	2.24e-04	0.0
39	3	2.78e-03	-2.41e-03	-0.16	1.53e-04	1.89e-04	0.0
39	8	0.01	1.07e-03	-0.14	1.38e-04	1.73e-04	0.0
39	21	-9.73e-04	-0.01	-0.14	1.40e-04	1.72e-04	-2.00e-06
39	23	5.43e-03	-0.01	-0.14	1.40e-04	1.73e-04	-1.57e-06
39	40	6.17e-03	-1.09e-03	-0.14	1.39e-04	1.73e-04	0.0
39	53	1.34e-03	-5.76e-03	-0.14	1.39e-04	1.72e-04	0.0
39	55	3.51e-03	-5.74e-03	-0.14	1.39e-04	1.72e-04	0.0
39	69	2.53e-03	-2.19e-03	-0.14	1.39e-04	1.72e-04	0.0
40	1	3.33e-03	-2.85e-03	-0.17	2.26e-04	2.47e-04	0.0
40	3	2.82e-03	-2.41e-03	-0.14	1.91e-04	2.09e-04	0.0

Parco Eolico "Bolina" – Progetto Definitivo
Relazione di calcolo preliminare delle fondazioni degli aerogeneratori G8 e G12

40	8	0.01	1.07e-03	-0.13	1.74e-04	1.91e-04	0.0
40	21	-8.22e-04	-0.01	-0.13	1.75e-04	1.90e-04	-2.24e-06
40	23	5.55e-03	-0.01	-0.13	1.75e-04	1.90e-04	-1.63e-06
40	40	6.18e-03	-1.09e-03	-0.13	1.74e-04	1.90e-04	0.0
40	53	1.42e-03	-5.76e-03	-0.13	1.75e-04	1.90e-04	-1.13e-06
40	55	3.57e-03	-5.74e-03	-0.13	1.75e-04	1.90e-04	0.0
40	69	2.56e-03	-2.19e-03	-0.13	1.74e-04	1.90e-04	0.0
41	1	3.39e-03	-2.85e-03	-0.15	2.92e-04	2.92e-04	0.0
41	3	2.87e-03	-2.41e-03	-0.13	2.47e-04	2.47e-04	0.0
41	8	0.01	1.07e-03	-0.12	2.24e-04	2.26e-04	1.02e-06
41	21	-6.50e-04	-0.01	-0.12	2.26e-04	2.24e-04	-2.53e-06
41	23	5.67e-03	-0.01	-0.12	2.26e-04	2.25e-04	-1.71e-06
41	40	6.18e-03	-1.09e-03	-0.12	2.24e-04	2.25e-04	0.0
41	53	1.51e-03	-5.77e-03	-0.12	2.25e-04	2.24e-04	-1.35e-06
41	55	3.65e-03	-5.74e-03	-0.12	2.25e-04	2.25e-04	-1.08e-06
41	69	2.61e-03	-2.19e-03	-0.12	2.24e-04	2.24e-04	0.0
42	1	3.46e-03	-2.85e-03	-0.13	2.40e-04	2.44e-04	0.0
42	3	2.92e-03	-2.41e-03	-0.11	2.03e-04	2.06e-04	0.0
42	8	0.01	1.07e-03	-0.10	1.84e-04	1.89e-04	1.56e-06
42	21	-4.71e-04	-0.01	-0.10	1.86e-04	1.87e-04	-2.43e-06
42	24	5.79e-03	8.37e-03	-0.10	1.83e-04	1.88e-04	1.30e-06
42	40	6.19e-03	-1.09e-03	-0.10	1.84e-04	1.88e-04	0.0
42	53	1.60e-03	-5.76e-03	-0.10	1.85e-04	1.87e-04	-1.20e-06
42	56	3.72e-03	1.38e-03	-0.10	1.84e-04	1.88e-04	0.0
42	69	2.66e-03	-2.19e-03	-0.10	1.84e-04	1.87e-04	0.0
43	1	3.50e-03	-2.85e-03	-0.12	2.05e-04	2.17e-04	0.0
43	3	2.96e-03	-2.41e-03	-0.10	1.73e-04	1.84e-04	0.0
43	7	0.01	-5.25e-03	-0.09	1.58e-04	1.68e-04	1.22e-06
43	21	-3.00e-04	-0.01	-0.09	1.59e-04	1.67e-04	-2.37e-06
43	24	5.69e-03	8.37e-03	-0.09	1.57e-04	1.67e-04	1.53e-06
43	39	6.18e-03	-3.23e-03	-0.09	1.58e-04	1.68e-04	0.0
43	53	1.68e-03	-5.76e-03	-0.09	1.58e-04	1.67e-04	-1.08e-06
43	56	3.71e-03	1.38e-03	-0.09	1.57e-04	1.67e-04	0.0
43	69	2.69e-03	-2.19e-03	-0.09	1.58e-04	1.67e-04	0.0
44	1	3.54e-03	-2.85e-03	-0.10	1.81e-04	1.98e-04	0.0
44	3	2.99e-03	-2.41e-03	-0.09	1.53e-04	1.68e-04	0.0
44	7	0.01	-5.25e-03	-0.08	1.39e-04	1.54e-04	1.44e-06
44	21	-1.30e-04	-0.01	-0.08	1.40e-04	1.52e-04	-2.35e-06
44	24	5.57e-03	8.37e-03	-0.08	1.38e-04	1.53e-04	1.62e-06
44	39	6.17e-03	-3.23e-03	-0.08	1.39e-04	1.53e-04	0.0
44	53	1.76e-03	-5.76e-03	-0.08	1.39e-04	1.52e-04	-1.04e-06
44	56	3.69e-03	1.38e-03	-0.08	1.39e-04	1.53e-04	0.0
44	69	2.72e-03	-2.19e-03	-0.08	1.39e-04	1.53e-04	0.0
45	1	3.57e-03	-2.85e-03	-0.09	1.67e-04	1.87e-04	0.0
45	3	3.02e-03	-2.41e-03	-0.08	1.41e-04	1.58e-04	0.0
45	7	0.01	-5.25e-03	-0.07	1.29e-04	1.45e-04	1.49e-06
45	21	3.92e-05	-0.01	-0.07	1.29e-04	1.43e-04	-2.36e-06
45	24	5.46e-03	8.37e-03	-0.07	1.27e-04	1.44e-04	1.64e-06
45	39	6.15e-03	-3.23e-03	-0.07	1.28e-04	1.44e-04	0.0
45	53	1.83e-03	-5.76e-03	-0.07	1.28e-04	1.43e-04	-1.04e-06
45	56	3.66e-03	1.38e-03	-0.07	1.28e-04	1.44e-04	0.0
45	69	2.75e-03	-2.19e-03	-0.07	1.28e-04	1.44e-04	0.0
46	1	3.22e-03	-2.90e-03	-0.22	9.69e-05	1.69e-04	0.0
46	3	2.72e-03	-2.45e-03	-0.18	8.20e-05	1.43e-04	0.0
46	8	0.01	1.13e-03	-0.17	7.42e-05	1.31e-04	0.0
46	21	-1.20e-03	-0.01	-0.17	7.55e-05	1.30e-04	0.0
46	23	5.25e-03	-0.01	-0.17	7.55e-05	1.31e-04	0.0
46	40	6.16e-03	-1.10e-03	-0.17	7.44e-05	1.31e-04	0.0
46	53	1.23e-03	-5.84e-03	-0.17	7.48e-05	1.30e-04	0.0
46	55	3.42e-03	-5.80e-03	-0.17	7.48e-05	1.30e-04	0.0
46	69	2.48e-03	-2.23e-03	-0.17	7.45e-05	1.30e-04	0.0
47	1	3.25e-03	-2.90e-03	-0.21	1.34e-04	1.81e-04	0.0
47	3	2.75e-03	-2.45e-03	-0.18	1.14e-04	1.54e-04	0.0
47	8	0.01	1.12e-03	-0.16	1.03e-04	1.41e-04	0.0
47	21	-1.07e-03	-0.01	-0.16	1.04e-04	1.39e-04	0.0
47	23	5.37e-03	-0.01	-0.16	1.04e-04	1.40e-04	0.0
47	40	6.17e-03	-1.09e-03	-0.16	1.03e-04	1.40e-04	0.0
47	53	1.29e-03	-5.83e-03	-0.16	1.04e-04	1.39e-04	0.0
47	55	3.47e-03	-5.80e-03	-0.16	1.04e-04	1.40e-04	0.0
47	69	2.50e-03	-2.23e-03	-0.16	1.03e-04	1.40e-04	0.0
48	1	3.29e-03	-2.90e-03	-0.20	1.66e-04	2.00e-04	0.0
48	3	2.79e-03	-2.45e-03	-0.17	1.40e-04	1.69e-04	0.0
48	8	0.01	1.13e-03	-0.15	1.27e-04	1.55e-04	0.0

Parco Eolico "Bolina" – Progetto Definitivo
Relazione di calcolo preliminare delle fondazioni degli aerogeneratori G8 e G12

48	21	-9.40e-04	-0.01	-0.15	1.29e-04	1.54e-04	-1.84e-06
48	23	5.46e-03	-0.01	-0.15	1.29e-04	1.54e-04	-1.31e-06
48	40	6.17e-03	-1.10e-03	-0.15	1.27e-04	1.54e-04	0.0
48	53	1.36e-03	-5.84e-03	-0.15	1.28e-04	1.54e-04	0.0
48	55	3.52e-03	-5.80e-03	-0.15	1.28e-04	1.54e-04	0.0
48	69	2.53e-03	-2.23e-03	-0.15	1.27e-04	1.54e-04	0.0
49	1	3.33e-03	-2.91e-03	-0.19	2.13e-04	2.13e-04	0.0
49	3	2.82e-03	-2.46e-03	-0.16	1.80e-04	1.80e-04	0.0
49	8	0.01	1.13e-03	-0.14	1.63e-04	1.65e-04	0.0
49	21	-8.07e-04	-0.01	-0.14	1.65e-04	1.63e-04	-1.86e-06
49	23	5.56e-03	-0.01	-0.14	1.65e-04	1.64e-04	-1.25e-06
49	40	6.18e-03	-1.10e-03	-0.14	1.63e-04	1.64e-04	0.0
49	53	1.42e-03	-5.85e-03	-0.14	1.64e-04	1.64e-04	0.0
49	55	3.58e-03	-5.81e-03	-0.14	1.64e-04	1.64e-04	0.0
49	69	2.57e-03	-2.24e-03	-0.14	1.64e-04	1.64e-04	0.0
50	1	3.39e-03	-2.91e-03	-0.17	2.47e-04	2.26e-04	0.0
50	3	2.87e-03	-2.46e-03	-0.14	2.09e-04	1.92e-04	0.0
50	7	0.01	-5.23e-03	-0.13	1.90e-04	1.75e-04	0.0
50	8	0.01	1.14e-03	-0.13	1.90e-04	1.75e-04	1.08e-06
50	21	-6.50e-04	-0.01	-0.13	1.91e-04	1.74e-04	-2.02e-06
50	39	6.16e-03	-3.25e-03	-0.13	1.90e-04	1.75e-04	0.0
50	40	6.18e-03	-1.10e-03	-0.13	1.90e-04	1.75e-04	0.0
50	53	1.51e-03	-5.85e-03	-0.13	1.90e-04	1.74e-04	-1.08e-06
50	69	2.61e-03	-2.24e-03	-0.13	1.90e-04	1.74e-04	0.0
51	1	3.45e-03	-2.91e-03	-0.15	2.52e-04	2.36e-04	0.0
51	3	2.92e-03	-2.46e-03	-0.13	2.13e-04	1.99e-04	0.0
51	8	0.01	1.16e-03	-0.12	1.94e-04	1.83e-04	1.49e-06
51	21	-4.87e-04	-0.01	-0.12	1.95e-04	1.81e-04	-2.02e-06
51	40	6.18e-03	-1.09e-03	-0.12	1.94e-04	1.82e-04	0.0
51	53	1.59e-03	-5.85e-03	-0.12	1.94e-04	1.81e-04	-1.03e-06
51	69	2.66e-03	-2.24e-03	-0.12	1.94e-04	1.81e-04	0.0
52	1	3.50e-03	-2.90e-03	-0.13	2.26e-04	2.30e-04	0.0
52	3	2.96e-03	-2.45e-03	-0.11	1.91e-04	1.94e-04	0.0
52	7	0.01	-5.19e-03	-0.10	1.74e-04	1.78e-04	1.10e-06
52	21	-3.32e-04	-0.01	-0.10	1.75e-04	1.76e-04	-2.09e-06
52	24	5.71e-03	8.44e-03	-0.10	1.72e-04	1.77e-04	1.11e-06
52	39	6.17e-03	-3.23e-03	-0.10	1.74e-04	1.77e-04	0.0
52	53	1.67e-03	-5.84e-03	-0.10	1.74e-04	1.76e-04	-1.03e-06
52	56	3.71e-03	1.38e-03	-0.10	1.73e-04	1.77e-04	0.0
52	69	2.69e-03	-2.23e-03	-0.10	1.74e-04	1.77e-04	0.0
53	1	3.54e-03	-2.90e-03	-0.12	1.92e-04	1.95e-04	0.0
53	3	3.00e-03	-2.45e-03	-0.10	1.62e-04	1.65e-04	0.0
53	7	0.01	-5.18e-03	-0.09	1.48e-04	1.51e-04	0.0
53	21	-1.79e-04	-0.01	-0.09	1.48e-04	1.50e-04	0.0
53	24	5.63e-03	8.43e-03	-0.09	1.46e-04	1.51e-04	0.0
53	39	6.17e-03	-3.23e-03	-0.09	1.48e-04	1.51e-04	0.0
53	53	1.74e-03	-5.84e-03	-0.09	1.48e-04	1.50e-04	0.0
53	56	3.71e-03	1.38e-03	-0.09	1.47e-04	1.50e-04	0.0
53	69	2.72e-03	-2.23e-03	-0.09	1.47e-04	1.50e-04	0.0
54	1	3.57e-03	-2.90e-03	-0.11	1.65e-04	1.80e-04	0.0
54	3	3.02e-03	-2.46e-03	-0.09	1.40e-04	1.52e-04	0.0
54	7	0.01	-5.19e-03	-0.08	1.27e-04	1.39e-04	0.0
54	21	-4.74e-06	-0.01	-0.08	1.28e-04	1.38e-04	0.0
54	24	5.50e-03	8.43e-03	-0.08	1.26e-04	1.38e-04	0.0
54	39	6.14e-03	-3.23e-03	-0.08	1.27e-04	1.38e-04	0.0
54	53	1.82e-03	-5.84e-03	-0.08	1.27e-04	1.38e-04	0.0
54	56	3.68e-03	1.37e-03	-0.08	1.27e-04	1.38e-04	0.0
54	69	2.75e-03	-2.23e-03	-0.08	1.27e-04	1.38e-04	0.0
55	1	3.22e-03	-2.94e-03	-0.23	1.05e-04	1.56e-04	0.0
55	3	2.72e-03	-2.49e-03	-0.20	8.88e-05	1.32e-04	0.0
55	8	0.01	1.17e-03	-0.18	8.03e-05	1.21e-04	0.0
55	21	-1.17e-03	-0.01	-0.18	8.17e-05	1.19e-04	-1.59e-06
55	23	5.29e-03	-0.01	-0.18	8.17e-05	1.20e-04	-1.20e-06
55	40	6.16e-03	-1.10e-03	-0.18	8.06e-05	1.20e-04	0.0
55	53	1.24e-03	-5.90e-03	-0.18	8.10e-05	1.20e-04	0.0
55	55	3.43e-03	-5.85e-03	-0.18	8.10e-05	1.20e-04	0.0
55	69	2.47e-03	-2.26e-03	-0.18	8.07e-05	1.20e-04	0.0
56	1	3.25e-03	-2.95e-03	-0.22	1.27e-04	1.52e-04	0.0
56	3	2.75e-03	-2.49e-03	-0.19	1.07e-04	1.29e-04	0.0
56	8	0.01	1.18e-03	-0.17	9.70e-05	1.18e-04	0.0
56	21	-1.06e-03	-0.01	-0.17	9.84e-05	1.17e-04	0.0
56	23	5.38e-03	-0.01	-0.17	9.84e-05	1.18e-04	0.0
56	40	6.17e-03	-1.10e-03	-0.17	9.72e-05	1.18e-04	0.0

Parco Eolico "Bolina" – Progetto Definitivo
Relazione di calcolo preliminare delle fondazioni degli aerogeneratori G8 e G12

56	53	1.30e-03	-5.90e-03	-0.17	9.77e-05	1.17e-04	0.0
56	55	3.48e-03	-5.85e-03	-0.17	9.77e-05	1.17e-04	0.0
56	69	2.50e-03	-2.27e-03	-0.17	9.73e-05	1.17e-04	0.0
57	1	3.29e-03	-2.95e-03	-0.21	1.62e-04	1.62e-04	0.0
57	3	2.79e-03	-2.50e-03	-0.18	1.37e-04	1.37e-04	0.0
57	8	0.01	1.19e-03	-0.16	1.24e-04	1.26e-04	0.0
57	21	-9.24e-04	-0.01	-0.16	1.26e-04	1.24e-04	-1.49e-06
57	23	5.48e-03	-0.01	-0.16	1.25e-04	1.25e-04	0.0
57	40	6.17e-03	-1.10e-03	-0.16	1.24e-04	1.25e-04	0.0
57	53	1.36e-03	-5.91e-03	-0.16	1.25e-04	1.24e-04	0.0
57	55	3.53e-03	-5.86e-03	-0.16	1.25e-04	1.24e-04	0.0
57	69	2.53e-03	-2.27e-03	-0.16	1.24e-04	1.24e-04	0.0
58	1	3.34e-03	-2.96e-03	-0.20	2.00e-04	1.66e-04	0.0
58	3	2.83e-03	-2.50e-03	-0.17	1.69e-04	1.40e-04	0.0
58	7	0.01	-5.21e-03	-0.15	1.54e-04	1.29e-04	0.0
58	8	0.01	1.20e-03	-0.15	1.54e-04	1.29e-04	0.0
58	21	-7.88e-04	-0.01	-0.15	1.55e-04	1.27e-04	-1.72e-06
58	39	6.14e-03	-3.27e-03	-0.15	1.54e-04	1.28e-04	0.0
58	40	6.18e-03	-1.10e-03	-0.15	1.54e-04	1.28e-04	0.0
58	53	1.43e-03	-5.91e-03	-0.15	1.54e-04	1.27e-04	0.0
58	69	2.57e-03	-2.27e-03	-0.15	1.54e-04	1.28e-04	0.0
59	1	3.39e-03	-2.96e-03	-0.18	2.24e-04	1.80e-04	0.0
59	3	2.87e-03	-2.51e-03	-0.16	1.89e-04	1.53e-04	0.0
59	7	0.01	-5.18e-03	-0.14	1.73e-04	1.40e-04	0.0
59	8	0.01	1.22e-03	-0.14	1.72e-04	1.40e-04	1.10e-06
59	21	-6.50e-04	-0.01	-0.14	1.73e-04	1.39e-04	-1.60e-06
59	39	6.16e-03	-3.26e-03	-0.14	1.72e-04	1.39e-04	0.0
59	40	6.18e-03	-1.09e-03	-0.14	1.72e-04	1.39e-04	0.0
59	53	1.51e-03	-5.92e-03	-0.14	1.73e-04	1.39e-04	0.0
59	69	2.61e-03	-2.28e-03	-0.14	1.72e-04	1.39e-04	0.0
60	1	3.45e-03	-2.96e-03	-0.17	2.48e-04	1.97e-04	0.0
60	3	2.92e-03	-2.50e-03	-0.14	2.10e-04	1.67e-04	0.0
60	8	0.01	1.25e-03	-0.13	1.91e-04	1.53e-04	1.39e-06
60	21	-5.04e-04	-0.01	-0.13	1.92e-04	1.51e-04	-1.83e-06
60	40	6.18e-03	-1.08e-03	-0.13	1.91e-04	1.52e-04	0.0
60	53	1.58e-03	-5.92e-03	-0.13	1.91e-04	1.52e-04	0.0
60	69	2.65e-03	-2.27e-03	-0.13	1.91e-04	1.52e-04	0.0
61	1	3.50e-03	-2.95e-03	-0.15	2.29e-04	2.00e-04	0.0
61	3	2.96e-03	-2.50e-03	-0.13	1.94e-04	1.69e-04	0.0
61	7	0.01	-5.12e-03	-0.11	1.77e-04	1.55e-04	1.31e-06
61	8	0.01	1.28e-03	-0.11	1.76e-04	1.55e-04	1.74e-06
61	21	-3.54e-04	-0.01	-0.11	1.77e-04	1.54e-04	-1.74e-06
61	39	6.17e-03	-3.24e-03	-0.11	1.76e-04	1.54e-04	0.0
61	40	6.17e-03	-1.07e-03	-0.11	1.76e-04	1.54e-04	0.0
61	53	1.66e-03	-5.92e-03	-0.11	1.77e-04	1.54e-04	0.0
61	69	2.69e-03	-2.27e-03	-0.11	1.76e-04	1.54e-04	0.0
62	1	3.54e-03	-2.95e-03	-0.13	2.01e-04	1.83e-04	0.0
62	3	2.99e-03	-2.50e-03	-0.11	1.70e-04	1.55e-04	0.0
62	7	0.01	-5.12e-03	-0.10	1.55e-04	1.42e-04	0.0
62	21	-1.92e-04	-0.01	-0.10	1.55e-04	1.40e-04	0.0
62	24	5.63e-03	8.50e-03	-0.10	1.53e-04	1.41e-04	0.0
62	39	6.16e-03	-3.23e-03	-0.10	1.54e-04	1.41e-04	0.0
62	53	1.74e-03	-5.91e-03	-0.10	1.55e-04	1.40e-04	0.0
62	56	3.71e-03	1.38e-03	-0.10	1.54e-04	1.41e-04	0.0
62	69	2.72e-03	-2.27e-03	-0.10	1.54e-04	1.41e-04	0.0
63	1	3.58e-03	-2.94e-03	-0.12	1.92e-04	1.91e-04	0.0
63	3	3.03e-03	-2.49e-03	-0.10	1.62e-04	1.62e-04	0.0
63	7	0.01	-5.09e-03	-0.09	1.48e-04	1.48e-04	1.47e-06
63	21	-5.24e-05	-0.01	-0.09	1.48e-04	1.47e-04	-1.97e-06
63	24	5.55e-03	8.52e-03	-0.09	1.46e-04	1.47e-04	1.14e-06
63	39	6.14e-03	-3.22e-03	-0.09	1.47e-04	1.48e-04	0.0
63	53	1.80e-03	-5.91e-03	-0.09	1.48e-04	1.47e-04	0.0
63	56	3.70e-03	1.39e-03	-0.09	1.47e-04	1.47e-04	0.0
63	69	2.75e-03	-2.26e-03	-0.09	1.47e-04	1.47e-04	0.0
64	1	3.22e-03	-2.98e-03	-0.24	7.86e-05	1.04e-04	0.0
64	3	2.73e-03	-2.52e-03	-0.20	6.65e-05	8.82e-05	0.0
64	8	0.01	1.21e-03	-0.18	6.01e-05	8.12e-05	0.0
64	21	-1.16e-03	-0.01	-0.18	6.15e-05	7.98e-05	0.0
64	23	5.30e-03	-0.01	-0.18	6.14e-05	8.04e-05	0.0
64	40	6.16e-03	-1.10e-03	-0.18	6.03e-05	8.05e-05	0.0
64	53	1.25e-03	-5.95e-03	-0.18	6.08e-05	8.00e-05	0.0
64	55	3.43e-03	-5.89e-03	-0.18	6.08e-05	8.03e-05	0.0
64	69	2.48e-03	-2.29e-03	-0.18	6.04e-05	8.02e-05	0.0

Parco Eolico "Bolina" – Progetto Definitivo
Relazione di calcolo preliminare delle fondazioni degli aerogeneratori G8 e G12

65	1	3.25e-03	-2.99e-03	-0.23	1.34e-04	1.34e-04	0.0
65	3	2.75e-03	-2.53e-03	-0.20	1.13e-04	1.13e-04	0.0
65	8	0.01	1.23e-03	-0.18	1.02e-04	1.04e-04	0.0
65	21	-1.03e-03	-0.01	-0.18	1.04e-04	1.02e-04	-1.43e-06
65	23	5.41e-03	-0.01	-0.18	1.04e-04	1.03e-04	0.0
65	40	6.17e-03	-1.11e-03	-0.18	1.03e-04	1.03e-04	0.0
65	53	1.31e-03	-5.96e-03	-0.18	1.03e-04	1.03e-04	0.0
65	55	3.49e-03	-5.90e-03	-0.18	1.03e-04	1.03e-04	0.0
65	69	2.50e-03	-2.30e-03	-0.18	1.03e-04	1.03e-04	0.0
66	1	3.29e-03	-3.00e-03	-0.22	1.52e-04	1.27e-04	0.0
66	3	2.79e-03	-2.54e-03	-0.19	1.29e-04	1.07e-04	0.0
66	7	0.01	-5.18e-03	-0.17	1.17e-04	9.84e-05	0.0
66	8	0.01	1.25e-03	-0.17	1.17e-04	9.85e-05	0.0
66	21	-9.16e-04	-0.01	-0.17	1.18e-04	9.70e-05	0.0
66	39	6.12e-03	-3.28e-03	-0.17	1.17e-04	9.77e-05	0.0
66	40	6.17e-03	-1.10e-03	-0.17	1.17e-04	9.77e-05	0.0
66	53	1.37e-03	-5.97e-03	-0.17	1.18e-04	9.73e-05	0.0
66	69	2.53e-03	-2.31e-03	-0.17	1.17e-04	9.74e-05	0.0
67	1	3.34e-03	-3.00e-03	-0.21	1.81e-04	1.34e-04	0.0
67	3	2.83e-03	-2.54e-03	-0.18	1.54e-04	1.14e-04	0.0
67	7	0.01	-5.18e-03	-0.16	1.40e-04	1.05e-04	0.0
67	8	0.01	1.26e-03	-0.16	1.39e-04	1.05e-04	0.0
67	21	-7.80e-04	-0.01	-0.16	1.41e-04	1.03e-04	0.0
67	39	6.14e-03	-3.28e-03	-0.16	1.40e-04	1.04e-04	0.0
67	40	6.18e-03	-1.10e-03	-0.16	1.39e-04	1.04e-04	0.0
67	53	1.44e-03	-5.98e-03	-0.16	1.40e-04	1.03e-04	0.0
67	69	2.57e-03	-2.31e-03	-0.16	1.40e-04	1.03e-04	0.0
68	1	3.39e-03	-3.00e-03	-0.20	2.08e-04	1.47e-04	0.0
68	3	2.87e-03	-2.54e-03	-0.17	1.76e-04	1.25e-04	0.0
68	7	0.01	-5.13e-03	-0.15	1.60e-04	1.14e-04	0.0
68	8	0.01	1.30e-03	-0.15	1.59e-04	1.14e-04	1.08e-06
68	21	-6.50e-04	-0.01	-0.15	1.61e-04	1.13e-04	-1.42e-06
68	39	6.16e-03	-3.27e-03	-0.15	1.60e-04	1.14e-04	0.0
68	40	6.18e-03	-1.09e-03	-0.15	1.60e-04	1.14e-04	0.0
68	53	1.51e-03	-5.98e-03	-0.15	1.60e-04	1.13e-04	0.0
68	69	2.61e-03	-2.31e-03	-0.15	1.60e-04	1.13e-04	0.0
69	1	3.44e-03	-3.00e-03	-0.18	2.16e-04	1.55e-04	0.0
69	3	2.91e-03	-2.54e-03	-0.15	1.83e-04	1.31e-04	0.0
69	8	0.01	1.35e-03	-0.14	1.66e-04	1.20e-04	0.0
69	21	-5.05e-04	-0.01	-0.14	1.67e-04	1.19e-04	0.0
69	40	6.17e-03	-1.07e-03	-0.14	1.66e-04	1.19e-04	0.0
69	53	1.58e-03	-5.98e-03	-0.14	1.67e-04	1.19e-04	0.0
69	69	2.65e-03	-2.31e-03	-0.14	1.66e-04	1.19e-04	0.0
70	1	3.49e-03	-3.00e-03	-0.16	2.14e-04	1.61e-04	0.0
70	3	2.96e-03	-2.54e-03	-0.14	1.81e-04	1.37e-04	0.0
70	7	0.01	-5.07e-03	-0.12	1.65e-04	1.25e-04	0.0
70	8	0.01	1.36e-03	-0.12	1.64e-04	1.25e-04	0.0
70	21	-3.60e-04	-0.01	-0.12	1.65e-04	1.24e-04	0.0
70	39	6.17e-03	-3.24e-03	-0.12	1.65e-04	1.25e-04	0.0
70	40	6.16e-03	-1.07e-03	-0.12	1.64e-04	1.25e-04	0.0
70	53	1.66e-03	-5.98e-03	-0.12	1.65e-04	1.24e-04	0.0
70	69	2.69e-03	-2.31e-03	-0.12	1.64e-04	1.24e-04	0.0
71	1	3.54e-03	-2.99e-03	-0.15	2.16e-04	1.79e-04	0.0
71	3	2.99e-03	-2.53e-03	-0.12	1.82e-04	1.51e-04	0.0
71	7	0.01	-5.03e-03	-0.11	1.66e-04	1.39e-04	1.37e-06
71	8	0.01	1.41e-03	-0.11	1.66e-04	1.38e-04	1.78e-06
71	21	-2.31e-04	-0.01	-0.11	1.67e-04	1.37e-04	-1.69e-06
71	39	6.16e-03	-3.22e-03	-0.11	1.66e-04	1.38e-04	0.0
71	40	6.14e-03	-1.05e-03	-0.11	1.66e-04	1.38e-04	0.0
71	53	1.72e-03	-5.98e-03	-0.11	1.66e-04	1.37e-04	0.0
71	69	2.72e-03	-2.30e-03	-0.11	1.66e-04	1.37e-04	0.0
72	1	3.57e-03	-2.98e-03	-0.13	1.81e-04	1.50e-04	0.0
72	3	3.02e-03	-2.52e-03	-0.11	1.53e-04	1.27e-04	0.0
72	7	0.01	-4.99e-03	-0.10	1.40e-04	1.17e-04	0.0
72	21	-5.50e-05	-0.01	-0.10	1.40e-04	1.15e-04	0.0
72	24	5.54e-03	8.58e-03	-0.10	1.39e-04	1.16e-04	0.0
72	39	6.13e-03	-3.21e-03	-0.10	1.40e-04	1.16e-04	0.0
72	53	1.80e-03	-5.97e-03	-0.10	1.40e-04	1.15e-04	0.0
72	56	3.69e-03	1.39e-03	-0.10	1.39e-04	1.16e-04	0.0
72	69	2.74e-03	-2.29e-03	-0.10	1.39e-04	1.16e-04	0.0
73	1	3.22e-03	-3.03e-03	-0.24	6.91e-05	6.92e-05	0.0
73	3	2.73e-03	-2.56e-03	-0.20	5.85e-05	5.85e-05	0.0
73	8	0.01	1.29e-03	-0.18	5.28e-05	5.42e-05	0.0

Parco Eolico "Bolina" – Progetto Definitivo
Relazione di calcolo preliminare delle fondazioni degli aerogeneratori G8 e G12

73	21	-1.14e-03	-0.01	-0.18	5.42e-05	5.29e-05	0.0
73	23	5.30e-03	-0.01	-0.18	5.42e-05	5.35e-05	0.0
73	40	6.15e-03	-1.10e-03	-0.18	5.30e-05	5.36e-05	0.0
73	53	1.25e-03	-6.00e-03	-0.18	5.35e-05	5.31e-05	0.0
73	55	3.43e-03	-5.92e-03	-0.18	5.35e-05	5.33e-05	0.0
73	69	2.48e-03	-2.33e-03	-0.18	5.32e-05	5.32e-05	0.0
74	1	3.26e-03	-3.04e-03	-0.24	1.04e-04	7.86e-05	0.0
74	3	2.76e-03	-2.57e-03	-0.20	8.81e-05	6.65e-05	0.0
74	7	0.01	-5.15e-03	-0.18	8.04e-05	6.15e-05	0.0
74	8	0.01	1.30e-03	-0.18	7.98e-05	6.15e-05	0.0
74	21	-9.99e-04	-0.01	-0.18	8.12e-05	6.01e-05	0.0
74	39	6.11e-03	-3.29e-03	-0.18	8.02e-05	6.08e-05	0.0
74	40	6.17e-03	-1.11e-03	-0.18	8.00e-05	6.08e-05	0.0
74	53	1.32e-03	-6.01e-03	-0.18	8.05e-05	6.04e-05	0.0
74	69	2.50e-03	-2.34e-03	-0.18	8.01e-05	6.05e-05	0.0
75	1	3.30e-03	-3.04e-03	-0.23	1.56e-04	1.05e-04	0.0
75	3	2.79e-03	-2.57e-03	-0.20	1.32e-04	8.88e-05	0.0
75	7	0.01	-5.16e-03	-0.18	1.20e-04	8.18e-05	0.0
75	8	0.01	1.30e-03	-0.18	1.19e-04	8.18e-05	0.0
75	21	-8.92e-04	-0.01	-0.18	1.21e-04	8.04e-05	-1.41e-06
75	39	6.13e-03	-3.29e-03	-0.18	1.20e-04	8.11e-05	0.0
75	40	6.17e-03	-1.11e-03	-0.18	1.20e-04	8.11e-05	0.0
75	53	1.38e-03	-6.03e-03	-0.18	1.20e-04	8.06e-05	0.0
75	69	2.54e-03	-2.34e-03	-0.18	1.20e-04	8.07e-05	0.0
76	1	3.34e-03	-3.05e-03	-0.22	1.69e-04	9.69e-05	0.0
76	3	2.83e-03	-2.58e-03	-0.18	1.43e-04	8.20e-05	0.0
76	7	0.01	-5.12e-03	-0.17	1.30e-04	7.55e-05	0.0
76	8	0.01	1.34e-03	-0.17	1.30e-04	7.56e-05	0.0
76	21	-7.86e-04	-0.01	-0.17	1.31e-04	7.42e-05	0.0
76	39	6.14e-03	-3.28e-03	-0.17	1.30e-04	7.49e-05	0.0
76	40	6.17e-03	-1.10e-03	-0.17	1.30e-04	7.49e-05	0.0
76	53	1.43e-03	-6.03e-03	-0.17	1.31e-04	7.45e-05	0.0
76	69	2.57e-03	-2.34e-03	-0.17	1.30e-04	7.46e-05	0.0
77	1	3.39e-03	-3.05e-03	-0.21	1.98e-04	1.28e-04	0.0
77	3	2.87e-03	-2.58e-03	-0.17	1.67e-04	1.08e-04	0.0
77	7	0.01	-5.08e-03	-0.16	1.53e-04	9.96e-05	0.0
77	8	0.01	1.38e-03	-0.16	1.52e-04	9.96e-05	1.07e-06
77	21	-6.49e-04	-0.01	-0.16	1.53e-04	9.83e-05	-1.38e-06
77	39	6.16e-03	-3.27e-03	-0.16	1.52e-04	9.90e-05	0.0
77	40	6.18e-03	-1.08e-03	-0.16	1.52e-04	9.90e-05	0.0
77	53	1.51e-03	-6.03e-03	-0.16	1.53e-04	9.85e-05	0.0
77	69	2.61e-03	-2.34e-03	-0.16	1.52e-04	9.86e-05	0.0
78	1	3.45e-03	-3.05e-03	-0.19	2.03e-04	1.18e-04	0.0
78	3	2.92e-03	-2.58e-03	-0.16	1.72e-04	9.95e-05	0.0
78	8	0.01	1.42e-03	-0.15	1.56e-04	9.14e-05	0.0
78	21	-5.00e-04	-0.01	-0.14	1.57e-04	9.02e-05	0.0
78	40	6.17e-03	-1.07e-03	-0.14	1.56e-04	9.08e-05	0.0
78	53	1.58e-03	-6.03e-03	-0.14	1.56e-04	9.04e-05	0.0
78	69	2.65e-03	-2.34e-03	-0.14	1.56e-04	9.05e-05	0.0
79	1	3.49e-03	-3.04e-03	-0.17	2.21e-04	1.47e-04	0.0
79	3	2.95e-03	-2.58e-03	-0.15	1.87e-04	1.24e-04	0.0
79	7	0.01	-4.99e-03	-0.13	1.71e-04	1.14e-04	1.11e-06
79	8	0.01	1.46e-03	-0.13	1.70e-04	1.14e-04	1.44e-06
79	21	-3.88e-04	-0.01	-0.13	1.71e-04	1.13e-04	-1.55e-06
79	39	6.17e-03	-3.24e-03	-0.13	1.70e-04	1.13e-04	0.0
79	40	6.16e-03	-1.05e-03	-0.13	1.70e-04	1.13e-04	0.0
79	53	1.65e-03	-6.04e-03	-0.13	1.71e-04	1.13e-04	0.0
79	69	2.68e-03	-2.34e-03	-0.13	1.70e-04	1.13e-04	0.0
80	1	3.53e-03	-3.04e-03	-0.16	1.96e-04	1.28e-04	0.0
80	3	2.99e-03	-2.57e-03	-0.13	1.66e-04	1.09e-04	0.0
80	7	0.01	-4.97e-03	-0.12	1.51e-04	9.97e-05	0.0
80	8	0.01	1.46e-03	-0.12	1.51e-04	9.96e-05	0.0
80	21	-2.64e-04	-0.01	-0.12	1.52e-04	9.85e-05	0.0
80	39	6.16e-03	-3.23e-03	-0.12	1.51e-04	9.90e-05	0.0
80	40	6.14e-03	-1.05e-03	-0.12	1.51e-04	9.90e-05	0.0
80	53	1.71e-03	-6.03e-03	-0.12	1.51e-04	9.87e-05	0.0
80	69	2.72e-03	-2.34e-03	-0.12	1.51e-04	9.87e-05	0.0
81	1	3.56e-03	-3.04e-03	-0.14	1.78e-04	1.21e-04	0.0
81	3	3.01e-03	-2.57e-03	-0.12	1.51e-04	1.03e-04	0.0
81	7	0.01	-4.96e-03	-0.11	1.37e-04	9.43e-05	0.0
81	8	0.01	1.46e-03	-0.11	1.37e-04	9.42e-05	0.0
81	21	-5.93e-05	-0.01	-0.11	1.38e-04	9.31e-05	0.0
81	39	6.12e-03	-3.23e-03	-0.11	1.37e-04	9.36e-05	0.0

Parco Eolico "Bolina" – Progetto Definitivo
Relazione di calcolo preliminare delle fondazioni degli aerogeneratori G8 e G12

81	40	6.08e-03	-1.05e-03	-0.11	1.37e-04	9.36e-05	0.0
81	53	1.79e-03	-6.02e-03	-0.11	1.37e-04	9.32e-05	0.0
81	69	2.74e-03	-2.34e-03	-0.11	1.37e-04	9.33e-05	0.0
82	1	3.39e-03	-3.12e-03	-0.21	1.62e-04	5.61e-05	0.0
82	3	2.87e-03	-2.64e-03	-0.18	1.37e-04	4.74e-05	0.0
82	7	0.01	-5.00e-03	-0.16	1.25e-04	4.41e-05	0.0
82	8	0.01	1.48e-03	-0.16	1.25e-04	4.41e-05	0.0
82	21	-6.23e-04	-0.01	-0.16	1.26e-04	4.29e-05	0.0
82	39	6.12e-03	-3.28e-03	-0.16	1.25e-04	4.35e-05	0.0
82	40	6.14e-03	-1.09e-03	-0.16	1.25e-04	4.35e-05	0.0
82	53	1.51e-03	-6.11e-03	-0.16	1.25e-04	4.30e-05	0.0
82	69	2.61e-03	-2.40e-03	-0.16	1.25e-04	4.31e-05	0.0
83	1	3.45e-03	-3.11e-03	-0.19	1.77e-04	7.10e-05	0.0
83	3	2.92e-03	-2.63e-03	-0.16	1.50e-04	6.01e-05	0.0
83	8	0.01	1.57e-03	-0.15	1.36e-04	5.55e-05	0.0
83	21	-4.65e-04	-0.01	-0.15	1.37e-04	5.44e-05	0.0
83	40	6.14e-03	-1.05e-03	-0.15	1.36e-04	5.49e-05	0.0
83	53	1.60e-03	-6.12e-03	-0.15	1.36e-04	5.45e-05	0.0
83	69	2.65e-03	-2.39e-03	-0.15	1.36e-04	5.46e-05	0.0
84	1	3.39e-03	-3.23e-03	-0.21	1.40e-04	2.44e-05	0.0
84	3	2.87e-03	-2.73e-03	-0.17	1.18e-04	2.07e-05	0.0
84	7	0.01	-4.94e-03	-0.16	1.08e-04	2.03e-05	0.0
84	8	0.01	1.54e-03	-0.16	1.07e-04	2.03e-05	0.0
84	21	-6.00e-04	-0.01	-0.16	1.09e-04	1.84e-05	0.0
84	39	6.08e-03	-3.31e-03	-0.16	1.08e-04	1.93e-05	0.0
84	40	6.11e-03	-1.12e-03	-0.16	1.08e-04	1.93e-05	0.0
84	53	1.52e-03	-6.22e-03	-0.16	1.08e-04	1.86e-05	0.0
84	69	2.61e-03	-2.48e-03	-0.16	1.08e-04	1.88e-05	0.0
85	1	3.45e-03	-3.19e-03	-0.19	1.59e-04	4.04e-05	0.0
85	3	2.92e-03	-2.70e-03	-0.16	1.35e-04	3.42e-05	0.0
85	8	0.01	1.61e-03	-0.15	1.22e-04	3.20e-05	0.0
85	21	-4.05e-04	-0.01	-0.15	1.23e-04	3.09e-05	0.0
85	40	6.09e-03	-1.08e-03	-0.15	1.22e-04	3.14e-05	0.0
85	53	1.62e-03	-6.19e-03	-0.15	1.23e-04	3.10e-05	0.0
85	69	2.65e-03	-2.45e-03	-0.15	1.22e-04	3.11e-05	0.0
86	1	3.38e-03	-3.25e-03	-0.21	1.30e-04	8.80e-06	0.0
86	3	2.86e-03	-2.75e-03	-0.18	1.10e-04	7.45e-06	0.0
86	7	0.01	-4.83e-03	-0.16	1.01e-04	7.81e-06	0.0
86	8	0.01	1.69e-03	-0.16	9.99e-05	7.80e-06	0.0
86	21	-5.96e-04	-0.01	-0.16	1.01e-04	6.48e-06	0.0
86	39	6.06e-03	-3.29e-03	-0.16	1.00e-04	7.12e-06	0.0
86	40	6.09e-03	-1.08e-03	-0.16	1.00e-04	7.12e-06	0.0
86	53	1.52e-03	-6.27e-03	-0.16	1.00e-04	6.67e-06	0.0
86	69	2.60e-03	-2.50e-03	-0.16	1.00e-04	6.77e-06	0.0
87	1	3.45e-03	-3.24e-03	-0.19	1.48e-04	2.36e-05	0.0
87	3	2.92e-03	-2.75e-03	-0.16	1.25e-04	2.00e-05	0.0
87	7	0.01	-4.79e-03	-0.15	1.14e-04	1.91e-05	0.0
87	8	0.01	1.72e-03	-0.15	1.13e-04	1.91e-05	0.0
87	21	-3.61e-04	-0.01	-0.15	1.14e-04	1.79e-05	0.0
87	39	6.06e-03	-3.27e-03	-0.15	1.14e-04	1.85e-05	0.0
87	40	6.06e-03	-1.07e-03	-0.15	1.13e-04	1.85e-05	0.0
87	53	1.63e-03	-6.26e-03	-0.15	1.14e-04	1.81e-05	0.0
87	69	2.65e-03	-2.50e-03	-0.15	1.13e-04	1.81e-05	0.0
88	1	3.38e-03	-3.30e-03	-0.21	1.21e-04	-1.02e-06	0.0
88	3	2.86e-03	-2.80e-03	-0.18	1.02e-04	0.0	0.0
88	7	0.01	-4.74e-03	-0.16	9.32e-05	0.0	0.0
88	8	0.01	1.82e-03	-0.16	9.26e-05	0.0	0.0
88	21	-5.90e-04	-0.01	-0.16	9.37e-05	-1.08e-06	0.0
88	39	6.05e-03	-3.29e-03	-0.16	9.29e-05	0.0	0.0
88	40	6.07e-03	-1.07e-03	-0.16	9.27e-05	0.0	0.0
88	53	1.52e-03	-6.35e-03	-0.16	9.31e-05	0.0	0.0
88	69	2.60e-03	-2.54e-03	-0.16	9.28e-05	0.0	0.0
89	1	3.45e-03	-3.30e-03	-0.19	1.38e-04	1.32e-05	0.0
89	3	2.92e-03	-2.79e-03	-0.16	1.17e-04	1.12e-05	0.0
89	7	0.01	-4.70e-03	-0.15	1.07e-04	1.12e-05	0.0
89	8	0.01	1.84e-03	-0.15	1.06e-04	1.12e-05	0.0
89	21	-3.17e-04	-0.01	-0.14	1.07e-04	9.88e-06	0.0
89	39	6.04e-03	-3.27e-03	-0.14	1.07e-04	1.05e-05	0.0
89	40	6.04e-03	-1.06e-03	-0.14	1.06e-04	1.05e-05	0.0
89	53	1.65e-03	-6.34e-03	-0.14	1.07e-04	1.01e-05	0.0
89	69	2.66e-03	-2.54e-03	-0.14	1.06e-04	1.02e-05	0.0
90	1	3.37e-03	-3.37e-03	-0.21	1.13e-04	-4.61e-06	0.0
90	3	2.85e-03	-2.85e-03	-0.17	9.56e-05	-3.90e-06	0.0

Parco Eolico "Bolina" – Progetto Definitivo
Relazione di calcolo preliminare delle fondazioni degli aerogeneratori G8 e G12

90	7	0.01	-4.67e-03	-0.16	8.73e-05	-2.38e-06	0.0
90	8	0.01	1.94e-03	-0.16	8.67e-05	-2.38e-06	0.0
90	21	-5.86e-04	-0.01	-0.16	8.79e-05	-3.90e-06	0.0
90	39	6.03e-03	-3.29e-03	-0.16	8.70e-05	-3.15e-06	0.0
90	40	6.06e-03	-1.06e-03	-0.16	8.68e-05	-3.15e-06	0.0
90	53	1.52e-03	-6.44e-03	-0.16	8.72e-05	-3.67e-06	0.0
90	69	2.60e-03	-2.59e-03	-0.16	8.69e-05	-3.55e-06	0.0
91	1	3.46e-03	-3.36e-03	-0.19	1.30e-04	8.94e-06	0.0
91	3	2.93e-03	-2.85e-03	-0.16	1.10e-04	7.56e-06	0.0
91	7	0.01	-4.62e-03	-0.14	1.01e-04	7.96e-06	0.0
91	8	0.01	1.97e-03	-0.14	9.99e-05	7.96e-06	0.0
91	21	-2.76e-04	-0.01	-0.14	1.01e-04	6.55e-06	0.0
91	39	6.03e-03	-3.28e-03	-0.14	1.00e-04	7.24e-06	0.0
91	40	6.02e-03	-1.04e-03	-0.14	1.00e-04	7.24e-06	0.0
91	53	1.67e-03	-6.43e-03	-0.14	1.00e-04	6.77e-06	0.0
91	69	2.66e-03	-2.59e-03	-0.14	1.00e-04	6.88e-06	0.0
92	1	3.37e-03	-3.45e-03	-0.20	1.05e-04	0.0	0.0
92	3	2.85e-03	-2.92e-03	-0.17	8.92e-05	0.0	0.0
92	7	0.01	-4.60e-03	-0.16	8.16e-05	1.21e-06	0.0
92	8	0.01	2.05e-03	-0.16	8.06e-05	1.22e-06	0.0
92	21	-5.82e-04	-0.01	-0.16	8.26e-05	0.0	0.0
92	39	6.01e-03	-3.32e-03	-0.16	8.12e-05	0.0	0.0
92	40	6.04e-03	-1.06e-03	-0.16	8.09e-05	0.0	0.0
92	53	1.52e-03	-6.55e-03	-0.16	8.16e-05	0.0	0.0
92	69	2.59e-03	-2.66e-03	-0.16	8.11e-05	0.0	0.0
93	1	3.47e-03	-3.42e-03	-0.18	1.23e-04	9.73e-06	0.0
93	3	2.93e-03	-2.90e-03	-0.16	1.04e-04	8.23e-06	0.0
93	7	0.01	-4.54e-03	-0.14	9.54e-05	8.69e-06	0.0
93	8	0.01	2.10e-03	-0.14	9.48e-05	8.70e-06	0.0
93	21	-2.36e-04	-0.01	-0.14	9.60e-05	7.10e-06	0.0
93	39	6.02e-03	-3.28e-03	-0.14	9.51e-05	7.89e-06	0.0
93	40	6.00e-03	-1.03e-03	-0.14	9.49e-05	7.90e-06	0.0
93	53	1.69e-03	-6.52e-03	-0.14	9.53e-05	7.35e-06	0.0
93	69	2.67e-03	-2.63e-03	-0.14	9.50e-05	7.48e-06	0.0
94	1	3.37e-03	-3.48e-03	-0.21	1.04e-04	4.88e-06	0.0
94	3	2.85e-03	-2.94e-03	-0.17	8.84e-05	4.13e-06	0.0
94	7	0.01	-4.50e-03	-0.16	8.08e-05	5.08e-06	0.0
94	8	0.01	2.22e-03	-0.16	8.02e-05	5.08e-06	0.0
94	21	-5.80e-04	-0.01	-0.16	8.14e-05	3.35e-06	0.0
94	39	6.01e-03	-3.29e-03	-0.16	8.05e-05	4.20e-06	0.0
94	40	6.04e-03	-1.02e-03	-0.16	8.03e-05	4.20e-06	0.0
94	53	1.52e-03	-6.62e-03	-0.16	8.07e-05	3.61e-06	0.0
94	69	2.59e-03	-2.68e-03	-0.16	8.04e-05	3.75e-06	0.0
95	1	3.47e-03	-3.47e-03	-0.18	1.19e-04	1.23e-05	0.0
95	3	2.94e-03	-2.94e-03	-0.15	1.01e-04	1.04e-05	0.0
95	7	0.01	-4.45e-03	-0.14	9.23e-05	1.07e-05	0.0
95	8	0.01	2.26e-03	-0.14	9.17e-05	1.07e-05	0.0
95	21	-1.98e-04	-0.01	-0.14	9.29e-05	9.08e-06	0.0
95	39	6.01e-03	-3.27e-03	-0.14	9.20e-05	9.88e-06	0.0
95	40	5.99e-03	-1.00e-03	-0.14	9.18e-05	9.88e-06	0.0
95	53	1.70e-03	-6.61e-03	-0.14	9.22e-05	9.34e-06	0.0
95	69	2.67e-03	-2.67e-03	-0.14	9.19e-05	9.47e-06	0.0
96	1	3.37e-03	-3.53e-03	-0.21	1.05e-04	7.04e-06	0.0
96	3	2.85e-03	-2.98e-03	-0.17	8.88e-05	5.96e-06	0.0
96	7	0.01	-4.41e-03	-0.16	8.12e-05	6.71e-06	0.0
96	8	0.01	2.37e-03	-0.16	8.06e-05	6.71e-06	0.0
96	21	-5.80e-04	-0.01	-0.16	8.17e-05	5.03e-06	0.0
96	39	6.01e-03	-3.29e-03	-0.16	8.09e-05	5.86e-06	0.0
96	40	6.03e-03	-9.91e-04	-0.16	8.07e-05	5.86e-06	0.0
96	53	1.52e-03	-6.71e-03	-0.16	8.11e-05	5.29e-06	0.0
96	69	2.59e-03	-2.71e-03	-0.16	8.07e-05	5.42e-06	0.0
97	1	3.48e-03	-3.52e-03	-0.18	1.19e-04	1.44e-05	0.0
97	3	2.95e-03	-2.98e-03	-0.15	1.01e-04	1.22e-05	0.0
97	7	0.01	-4.36e-03	-0.14	9.22e-05	1.23e-05	0.0
97	8	0.01	2.41e-03	-0.14	9.16e-05	1.23e-05	0.0
97	21	-1.62e-04	-0.01	-0.14	9.27e-05	1.07e-05	0.0
97	39	6.00e-03	-3.26e-03	-0.14	9.19e-05	1.15e-05	0.0
97	40	5.98e-03	-9.76e-04	-0.14	9.17e-05	1.15e-05	0.0
97	53	1.72e-03	-6.70e-03	-0.14	9.21e-05	1.10e-05	0.0
97	69	2.68e-03	-2.71e-03	-0.14	9.18e-05	1.11e-05	0.0
98	1	3.50e-03	-3.11e-03	-0.17	1.82e-04	8.43e-05	0.0
98	3	2.96e-03	-2.63e-03	-0.15	1.54e-04	7.13e-05	0.0
98	7	0.01	-4.92e-03	-0.13	1.40e-04	6.58e-05	0.0

Parco Eolico "Bolina" – Progetto Definitivo
Relazione di calcolo preliminare delle fondazioni degli aerogeneratori G8 e G12

98	8	0.01	1.55e-03	-0.13	1.40e-04	6.57e-05	0.0
98	21	-2.79e-04	-0.01	-0.13	1.41e-04	6.47e-05	0.0
98	39	6.12e-03	-3.25e-03	-0.13	1.40e-04	6.52e-05	0.0
98	40	6.11e-03	-1.06e-03	-0.13	1.40e-04	6.51e-05	0.0
98	53	1.69e-03	-6.11e-03	-0.13	1.40e-04	6.48e-05	0.0
98	69	2.69e-03	-2.39e-03	-0.13	1.40e-04	6.48e-05	0.0
99	1	3.51e-03	-3.17e-03	-0.17	1.67e-04	5.71e-05	0.0
99	3	2.97e-03	-2.68e-03	-0.15	1.41e-04	4.83e-05	0.0
99	7	0.01	-4.84e-03	-0.13	1.29e-04	4.49e-05	0.0
99	8	0.01	1.62e-03	-0.13	1.28e-04	4.48e-05	0.0
99	21	-2.00e-04	-0.01	-0.13	1.29e-04	4.37e-05	0.0
99	39	6.09e-03	-3.25e-03	-0.13	1.29e-04	4.43e-05	0.0
99	40	6.07e-03	-1.07e-03	-0.13	1.28e-04	4.42e-05	0.0
99	53	1.72e-03	-6.17e-03	-0.13	1.29e-04	4.39e-05	0.0
99	69	2.70e-03	-2.44e-03	-0.13	1.28e-04	4.39e-05	0.0
100	1	3.52e-03	-3.23e-03	-0.17	1.56e-04	4.07e-05	0.0
100	3	2.98e-03	-2.73e-03	-0.14	1.32e-04	3.47e-05	0.0
100	7	0.01	-4.76e-03	-0.13	1.20e-04	3.23e-05	0.0
100	8	0.01	1.73e-03	-0.13	1.20e-04	3.22e-05	0.0
100	21	-1.17e-04	-0.01	-0.13	1.21e-04	3.11e-05	0.0
100	39	6.06e-03	-3.25e-03	-0.13	1.20e-04	3.16e-05	0.0
100	40	6.03e-03	-1.06e-03	-0.13	1.20e-04	3.16e-05	0.0
100	53	1.75e-03	-6.24e-03	-0.13	1.20e-04	3.12e-05	0.0
100	69	2.71e-03	-2.48e-03	-0.13	1.20e-04	3.13e-05	0.0
101	1	3.53e-03	-3.28e-03	-0.17	1.47e-04	2.99e-05	0.0
101	3	2.99e-03	-2.78e-03	-0.14	1.24e-04	2.53e-05	0.0
101	7	0.01	-4.68e-03	-0.13	1.13e-04	2.40e-05	0.0
101	8	0.01	1.84e-03	-0.13	1.13e-04	2.40e-05	0.0
101	21	-3.70e-05	-0.01	-0.13	1.14e-04	2.27e-05	0.0
101	39	6.03e-03	-3.25e-03	-0.13	1.13e-04	2.33e-05	0.0
101	40	6.00e-03	-1.05e-03	-0.13	1.13e-04	2.33e-05	0.0
101	53	1.78e-03	-6.31e-03	-0.13	1.13e-04	2.29e-05	0.0
101	69	2.72e-03	-2.52e-03	-0.13	1.13e-04	2.30e-05	0.0
102	1	3.54e-03	-3.34e-03	-0.16	1.38e-04	2.35e-05	0.0
102	3	3.00e-03	-2.83e-03	-0.14	1.17e-04	1.99e-05	0.0
102	7	0.01	-4.60e-03	-0.13	1.07e-04	1.92e-05	0.0
102	8	0.01	1.96e-03	-0.13	1.06e-04	1.92e-05	0.0
102	21	4.08e-05	-0.01	-0.12	1.07e-04	1.77e-05	0.0
102	39	6.01e-03	-3.26e-03	-0.12	1.06e-04	1.84e-05	0.0
102	40	5.97e-03	-1.04e-03	-0.13	1.06e-04	1.84e-05	0.0
102	53	1.82e-03	-6.40e-03	-0.12	1.07e-04	1.79e-05	0.0
102	69	2.73e-03	-2.57e-03	-0.12	1.06e-04	1.80e-05	0.0
103	1	3.56e-03	-3.43e-03	-0.16	1.28e-04	2.22e-05	0.0
103	3	3.01e-03	-2.90e-03	-0.13	1.08e-04	1.88e-05	0.0
103	7	0.01	-4.55e-03	-0.12	9.91e-05	1.87e-05	0.0
103	8	0.01	2.05e-03	-0.12	9.81e-05	1.87e-05	0.0
103	21	1.21e-04	-0.01	-0.12	1.00e-04	1.66e-05	0.0
103	39	6.00e-03	-3.28e-03	-0.12	9.87e-05	1.76e-05	0.0
103	40	5.95e-03	-1.05e-03	-0.12	9.84e-05	1.76e-05	0.0
103	53	1.85e-03	-6.50e-03	-0.12	9.91e-05	1.69e-05	0.0
103	69	2.74e-03	-2.64e-03	-0.12	9.86e-05	1.71e-05	0.0
104	1	3.57e-03	-3.44e-03	-0.16	1.26e-04	2.39e-05	0.0
104	3	3.02e-03	-2.91e-03	-0.13	1.06e-04	2.02e-05	0.0
104	7	0.01	-4.44e-03	-0.12	9.72e-05	1.96e-05	0.0
104	8	0.01	2.22e-03	-0.12	9.65e-05	1.97e-05	0.0
104	21	1.90e-04	-0.01	-0.12	9.78e-05	1.79e-05	0.0
104	39	5.99e-03	-3.25e-03	-0.12	9.69e-05	1.88e-05	0.0
104	40	5.93e-03	-9.99e-04	-0.12	9.67e-05	1.88e-05	0.0
104	53	1.88e-03	-6.56e-03	-0.12	9.71e-05	1.82e-05	0.0
104	69	2.75e-03	-2.65e-03	-0.12	9.68e-05	1.84e-05	0.0
105	1	3.59e-03	-3.48e-03	-0.15	1.26e-04	2.46e-05	0.0
105	3	3.03e-03	-2.95e-03	-0.13	1.07e-04	2.08e-05	0.0
105	7	0.01	-4.35e-03	-0.12	9.75e-05	2.01e-05	0.0
105	8	0.01	2.37e-03	-0.12	9.69e-05	2.02e-05	0.0
105	21	2.61e-04	-0.01	-0.12	9.81e-05	1.85e-05	0.0
105	39	5.98e-03	-3.24e-03	-0.12	9.73e-05	1.93e-05	0.0
105	40	5.91e-03	-9.69e-04	-0.12	9.71e-05	1.93e-05	0.0
105	53	1.91e-03	-6.64e-03	-0.12	9.75e-05	1.88e-05	0.0
105	69	2.76e-03	-2.68e-03	-0.12	9.71e-05	1.89e-05	0.0
106	1	3.55e-03	-3.10e-03	-0.15	1.76e-04	9.24e-05	0.0
106	3	3.00e-03	-2.63e-03	-0.13	1.49e-04	7.81e-05	0.0
106	7	0.01	-4.92e-03	-0.12	1.36e-04	7.20e-05	0.0
106	8	0.01	1.51e-03	-0.12	1.35e-04	7.19e-05	0.0

Parco Eolico "Bolina" – Progetto Definitivo
Relazione di calcolo preliminare delle fondazioni degli aerogeneratori G8 e G12

106	21	-1.10e-04	-0.01	-0.12	1.36e-04	7.09e-05	0.0
106	39	6.11e-03	-3.24e-03	-0.12	1.35e-04	7.14e-05	0.0
106	40	6.08e-03	-1.07e-03	-0.12	1.35e-04	7.13e-05	0.0
106	53	1.77e-03	-6.08e-03	-0.12	1.35e-04	7.10e-05	0.0
106	69	2.73e-03	-2.39e-03	-0.12	1.35e-04	7.10e-05	0.0
107	1	3.57e-03	-3.16e-03	-0.15	1.63e-04	7.12e-05	0.0
107	3	3.02e-03	-2.67e-03	-0.13	1.38e-04	6.02e-05	0.0
107	7	0.01	-4.83e-03	-0.12	1.26e-04	5.57e-05	0.0
107	8	0.01	1.61e-03	-0.12	1.25e-04	5.57e-05	0.0
107	21	1.93e-05	-0.01	-0.12	1.26e-04	5.46e-05	0.0
107	39	6.07e-03	-3.24e-03	-0.12	1.26e-04	5.51e-05	0.0
107	40	6.03e-03	-1.06e-03	-0.12	1.25e-04	5.51e-05	0.0
107	53	1.82e-03	-6.14e-03	-0.12	1.26e-04	5.47e-05	0.0
107	69	2.74e-03	-2.43e-03	-0.12	1.25e-04	5.48e-05	0.0
108	1	3.58e-03	-3.20e-03	-0.15	1.52e-04	5.70e-05	0.0
108	3	3.03e-03	-2.71e-03	-0.12	1.29e-04	4.82e-05	0.0
108	7	0.01	-4.75e-03	-0.11	1.18e-04	4.49e-05	0.0
108	8	0.01	1.70e-03	-0.11	1.17e-04	4.48e-05	0.0
108	21	1.35e-04	-0.01	-0.11	1.18e-04	4.36e-05	0.0
108	39	6.04e-03	-3.24e-03	-0.11	1.17e-04	4.42e-05	0.0
108	40	5.99e-03	-1.05e-03	-0.11	1.17e-04	4.42e-05	0.0
108	53	1.87e-03	-6.20e-03	-0.11	1.18e-04	4.38e-05	0.0
108	69	2.76e-03	-2.46e-03	-0.11	1.17e-04	4.38e-05	0.0
109	1	3.60e-03	-3.25e-03	-0.14	1.43e-04	4.64e-05	0.0
109	3	3.05e-03	-2.75e-03	-0.12	1.21e-04	3.92e-05	0.0
109	7	0.01	-4.68e-03	-0.11	1.10e-04	3.67e-05	0.0
109	8	0.01	1.80e-03	-0.11	1.10e-04	3.66e-05	0.0
109	21	2.45e-04	-0.01	-0.11	1.11e-04	3.54e-05	0.0
109	39	6.02e-03	-3.24e-03	-0.11	1.10e-04	3.60e-05	0.0
109	40	5.95e-03	-1.04e-03	-0.11	1.10e-04	3.60e-05	0.0
109	53	1.92e-03	-6.26e-03	-0.11	1.10e-04	3.56e-05	0.0
109	69	2.77e-03	-2.50e-03	-0.11	1.10e-04	3.57e-05	0.0
110	1	3.62e-03	-3.30e-03	-0.14	1.35e-04	3.90e-05	0.0
110	3	3.06e-03	-2.79e-03	-0.12	1.14e-04	3.30e-05	0.0
110	7	0.01	-4.61e-03	-0.11	1.04e-04	3.11e-05	0.0
110	8	0.01	1.91e-03	-0.11	1.03e-04	3.11e-05	0.0
110	21	3.55e-04	-0.01	-0.11	1.05e-04	2.97e-05	0.0
110	39	6.00e-03	-3.24e-03	-0.11	1.04e-04	3.04e-05	0.0
110	40	5.92e-03	-1.03e-03	-0.11	1.03e-04	3.04e-05	0.0
110	53	1.96e-03	-6.33e-03	-0.11	1.04e-04	2.99e-05	0.0
110	69	2.79e-03	-2.54e-03	-0.11	1.04e-04	3.00e-05	0.0
111	1	3.65e-03	-3.35e-03	-0.13	1.27e-04	3.52e-05	0.0
111	3	3.08e-03	-2.83e-03	-0.11	1.08e-04	2.98e-05	0.0
111	7	0.01	-4.54e-03	-0.10	9.84e-05	2.82e-05	0.0
111	8	0.01	2.01e-03	-0.10	9.78e-05	2.82e-05	0.0
111	21	4.64e-04	-0.01	-0.10	9.91e-05	2.67e-05	0.0
111	39	5.98e-03	-3.24e-03	-0.10	9.82e-05	2.74e-05	0.0
111	40	5.89e-03	-1.02e-03	-0.10	9.79e-05	2.74e-05	0.0
111	53	2.01e-03	-6.41e-03	-0.10	9.84e-05	2.69e-05	0.0
111	69	2.80e-03	-2.58e-03	-0.10	9.80e-05	2.71e-05	0.0
112	1	3.67e-03	-3.39e-03	-0.13	1.23e-04	3.35e-05	0.0
112	3	3.10e-03	-2.86e-03	-0.11	1.04e-04	2.83e-05	0.0
112	7	0.01	-4.47e-03	-0.10	9.51e-05	2.69e-05	0.0
112	8	0.01	2.13e-03	-0.10	9.45e-05	2.69e-05	0.0
112	21	5.71e-04	-0.01	-0.10	9.58e-05	2.54e-05	0.0
112	39	5.97e-03	-3.23e-03	-0.10	9.49e-05	2.61e-05	0.0
112	40	5.87e-03	-1.00e-03	-0.10	9.47e-05	2.61e-05	0.0
112	53	2.06e-03	-6.47e-03	-0.10	9.51e-05	2.56e-05	0.0
112	69	2.82e-03	-2.60e-03	-0.10	9.47e-05	2.58e-05	0.0
113	1	3.69e-03	-3.43e-03	-0.13	1.24e-04	3.42e-05	0.0
113	3	3.12e-03	-2.90e-03	-0.11	1.05e-04	2.89e-05	0.0
113	7	0.01	-4.39e-03	-0.10	9.57e-05	2.74e-05	0.0
113	8	0.01	2.26e-03	-0.10	9.50e-05	2.74e-05	0.0
113	21	6.77e-04	-0.01	-0.10	9.63e-05	2.59e-05	0.0
113	39	5.96e-03	-3.23e-03	-0.10	9.54e-05	2.66e-05	0.0
113	40	5.85e-03	-9.79e-04	-0.10	9.52e-05	2.67e-05	0.0
113	53	2.11e-03	-6.55e-03	-0.10	9.56e-05	2.61e-05	0.0
113	69	2.84e-03	-2.64e-03	-0.10	9.53e-05	2.63e-05	0.0
114	1	3.59e-03	-3.09e-03	-0.14	1.62e-04	9.66e-05	0.0
114	3	3.04e-03	-2.62e-03	-0.12	1.37e-04	8.17e-05	0.0
114	7	0.01	-4.90e-03	-0.11	1.25e-04	7.53e-05	0.0
114	8	0.01	1.51e-03	-0.11	1.25e-04	7.53e-05	0.0
114	21	9.45e-05	-0.01	-0.10	1.26e-04	7.41e-05	0.0

Parco Eolico "Bolina" – Progetto Definitivo
Relazione di calcolo preliminare delle fondazioni degli aerogeneratori G8 e G12

114	39	6.08e-03	-3.23e-03	-0.10	1.25e-04	7.47e-05	0.0
114	40	6.03e-03	-1.06e-03	-0.11	1.25e-04	7.46e-05	0.0
114	53	1.86e-03	-6.06e-03	-0.10	1.25e-04	7.42e-05	0.0
114	69	2.76e-03	-2.38e-03	-0.10	1.25e-04	7.43e-05	0.0
115	1	3.63e-03	-3.17e-03	-0.13	1.46e-04	7.89e-05	0.0
115	3	3.07e-03	-2.68e-03	-0.11	1.24e-04	6.68e-05	0.0
115	7	0.01	-4.87e-03	-0.10	1.13e-04	6.22e-05	0.0
115	8	0.01	1.54e-03	-0.10	1.12e-04	6.21e-05	0.0
115	21	2.55e-04	-0.01	-0.10	1.14e-04	6.03e-05	0.0
115	39	6.06e-03	-3.26e-03	-0.10	1.13e-04	6.12e-05	0.0
115	40	5.99e-03	-1.09e-03	-0.10	1.12e-04	6.12e-05	0.0
115	53	1.93e-03	-6.13e-03	-0.10	1.13e-04	6.06e-05	0.0
115	69	2.79e-03	-2.44e-03	-0.10	1.12e-04	6.07e-05	0.0
116	1	3.64e-03	-3.17e-03	-0.13	1.38e-04	6.87e-05	0.0
116	3	3.08e-03	-2.68e-03	-0.11	1.17e-04	5.81e-05	0.0
116	7	0.01	-4.78e-03	-0.10	1.07e-04	5.39e-05	0.0
116	8	0.01	1.64e-03	-0.10	1.06e-04	5.39e-05	0.0
116	21	3.77e-04	-0.01	-0.10	1.07e-04	5.26e-05	0.0
116	39	6.02e-03	-3.23e-03	-0.10	1.07e-04	5.32e-05	0.0
116	40	5.94e-03	-1.06e-03	-0.10	1.06e-04	5.32e-05	0.0
116	53	1.98e-03	-6.15e-03	-0.10	1.07e-04	5.28e-05	0.0
116	69	2.80e-03	-2.44e-03	-0.10	1.07e-04	5.29e-05	0.0
117	1	3.66e-03	-3.20e-03	-0.12	1.30e-04	5.85e-05	0.0
117	3	3.10e-03	-2.71e-03	-0.10	1.10e-04	4.95e-05	0.0
117	7	0.01	-4.71e-03	-0.09	1.01e-04	4.60e-05	0.0
117	8	0.01	1.73e-03	-0.09	1.00e-04	4.60e-05	0.0
117	21	5.14e-04	-0.01	-0.09	1.01e-04	4.47e-05	0.0
117	39	5.99e-03	-3.23e-03	-0.09	1.00e-04	4.53e-05	0.0
117	40	5.90e-03	-1.05e-03	-0.09	1.00e-04	4.53e-05	0.0
117	53	2.04e-03	-6.20e-03	-0.09	1.01e-04	4.49e-05	0.0
117	69	2.81e-03	-2.46e-03	-0.09	1.00e-04	4.50e-05	0.0
118	1	3.69e-03	-3.25e-03	-0.12	1.23e-04	5.04e-05	0.0
118	3	3.12e-03	-2.75e-03	-0.10	1.04e-04	4.27e-05	0.0
118	7	0.01	-4.66e-03	-0.09	9.51e-05	3.98e-05	0.0
118	8	0.01	1.80e-03	-0.09	9.44e-05	3.99e-05	0.0
118	21	6.54e-04	-0.01	-0.09	9.58e-05	3.84e-05	0.0
118	39	5.98e-03	-3.23e-03	-0.09	9.48e-05	3.91e-05	0.0
118	40	5.87e-03	-1.04e-03	-0.09	9.46e-05	3.91e-05	0.0
118	53	2.10e-03	-6.25e-03	-0.09	9.51e-05	3.87e-05	0.0
118	69	2.84e-03	-2.50e-03	-0.09	9.47e-05	3.88e-05	0.0
119	1	3.73e-03	-3.31e-03	-0.11	1.14e-04	4.47e-05	0.0
119	3	3.16e-03	-2.80e-03	-0.09	9.64e-05	3.78e-05	0.0
119	7	0.01	-4.62e-03	-0.09	8.81e-05	3.58e-05	0.0
119	8	0.01	1.87e-03	-0.09	8.72e-05	3.58e-05	0.0
119	21	8.01e-04	-0.01	-0.08	8.92e-05	3.39e-05	0.0
119	39	5.97e-03	-3.25e-03	-0.09	8.78e-05	3.49e-05	0.0
119	40	5.84e-03	-1.05e-03	-0.09	8.75e-05	3.49e-05	0.0
119	53	2.17e-03	-6.32e-03	-0.08	8.82e-05	3.42e-05	0.0
119	69	2.87e-03	-2.55e-03	-0.08	8.76e-05	3.44e-05	0.0
120	1	3.75e-03	-3.32e-03	-0.11	1.12e-04	4.33e-05	0.0
120	3	3.17e-03	-2.81e-03	-0.09	9.44e-05	3.66e-05	0.0
120	7	0.01	-4.55e-03	-0.08	8.62e-05	3.44e-05	0.0
120	8	0.01	1.98e-03	-0.08	8.55e-05	3.44e-05	0.0
120	21	9.28e-04	-0.01	-0.08	8.70e-05	3.28e-05	0.0
120	39	5.95e-03	-3.23e-03	-0.08	8.60e-05	3.36e-05	0.0
120	40	5.81e-03	-1.02e-03	-0.08	8.57e-05	3.37e-05	0.0
120	53	2.22e-03	-6.36e-03	-0.08	8.62e-05	3.31e-05	0.0
120	69	2.88e-03	-2.55e-03	-0.08	8.58e-05	3.33e-05	0.0
121	1	3.78e-03	-3.35e-03	-0.10	1.13e-04	4.41e-05	0.0
121	3	3.20e-03	-2.83e-03	-0.09	9.56e-05	3.73e-05	0.0
121	7	0.01	-4.49e-03	-0.08	8.73e-05	3.50e-05	0.0
121	8	0.01	2.08e-03	-0.08	8.66e-05	3.51e-05	0.0
121	21	1.06e-03	-0.01	-0.08	8.81e-05	3.35e-05	0.0
121	39	5.95e-03	-3.22e-03	-0.08	8.71e-05	3.43e-05	0.0
121	40	5.79e-03	-1.00e-03	-0.08	8.68e-05	3.43e-05	0.0
121	53	2.28e-03	-6.42e-03	-0.08	8.73e-05	3.38e-05	0.0
121	69	2.91e-03	-2.58e-03	-0.08	8.69e-05	3.39e-05	0.0
122	1	3.60e-03	-3.03e-03	-0.12	1.57e-04	1.18e-04	0.0
122	3	3.05e-03	-2.56e-03	-0.10	1.32e-04	9.98e-05	0.0
122	7	0.01	-4.96e-03	-0.10	1.21e-04	9.17e-05	0.0
122	21	1.57e-04	-0.01	-0.09	1.21e-04	9.05e-05	0.0
122	24	5.38e-03	8.51e-03	-0.10	1.20e-04	9.09e-05	0.0
122	39	6.09e-03	-3.22e-03	-0.10	1.21e-04	9.11e-05	0.0

Parco Eolico "Bolina" – Progetto Definitivo
Relazione di calcolo preliminare delle fondazioni degli aerogeneratori G8 e G12

122	53	1.89e-03	-6.00e-03	-0.10	1.21e-04	9.06e-05	0.0
122	56	3.65e-03	1.34e-03	-0.10	1.20e-04	9.08e-05	0.0
122	69	2.77e-03	-2.33e-03	-0.10	1.20e-04	9.07e-05	0.0
123	1	3.64e-03	-3.07e-03	-0.12	1.40e-04	9.79e-05	0.0
123	3	3.08e-03	-2.60e-03	-0.10	1.18e-04	8.28e-05	0.0
123	7	0.01	-4.91e-03	-0.09	1.08e-04	7.63e-05	0.0
123	21	3.31e-04	-0.01	-0.09	1.08e-04	7.51e-05	0.0
123	24	5.27e-03	8.46e-03	-0.09	1.06e-04	7.55e-05	0.0
123	39	6.05e-03	-3.22e-03	-0.09	1.08e-04	7.56e-05	0.0
123	53	1.96e-03	-6.02e-03	-0.09	1.08e-04	7.52e-05	0.0
123	56	3.63e-03	1.30e-03	-0.09	1.07e-04	7.53e-05	0.0
123	69	2.80e-03	-2.36e-03	-0.09	1.07e-04	7.53e-05	0.0
124	1	3.67e-03	-3.10e-03	-0.11	1.26e-04	8.36e-05	0.0
124	3	3.10e-03	-2.63e-03	-0.09	1.07e-04	7.07e-05	0.0
124	7	0.01	-4.85e-03	-0.09	9.75e-05	6.53e-05	0.0
124	21	5.10e-04	-0.01	-0.08	9.80e-05	6.41e-05	0.0
124	24	5.13e-03	8.45e-03	-0.09	9.62e-05	6.45e-05	0.0
124	39	6.02e-03	-3.22e-03	-0.09	9.72e-05	6.46e-05	0.0
124	53	2.04e-03	-6.05e-03	-0.08	9.74e-05	6.42e-05	0.0
124	56	3.60e-03	1.28e-03	-0.09	9.68e-05	6.44e-05	0.0
124	69	2.82e-03	-2.39e-03	-0.08	9.71e-05	6.43e-05	0.0
125	1	3.70e-03	-3.13e-03	-0.10	1.17e-04	7.20e-05	0.0
125	3	3.13e-03	-2.65e-03	-0.09	9.89e-05	6.09e-05	0.0
125	7	0.01	-4.80e-03	-0.08	9.03e-05	5.63e-05	0.0
125	21	6.89e-04	-0.01	-0.08	9.08e-05	5.51e-05	0.0
125	24	5.00e-03	8.46e-03	-0.08	8.89e-05	5.57e-05	0.0
125	39	5.99e-03	-3.22e-03	-0.08	9.00e-05	5.57e-05	0.0
125	53	2.12e-03	-6.08e-03	-0.08	9.02e-05	5.53e-05	0.0
125	56	3.58e-03	1.27e-03	-0.08	8.96e-05	5.55e-05	0.0
125	69	2.85e-03	-2.41e-03	-0.08	8.99e-05	5.54e-05	0.0
126	1	3.74e-03	-3.16e-03	-0.10	1.09e-04	6.22e-05	0.0
126	3	3.16e-03	-2.67e-03	-0.08	9.21e-05	5.27e-05	0.0
126	7	0.01	-4.75e-03	-0.08	8.41e-05	4.88e-05	0.0
126	21	8.69e-04	-0.01	-0.08	8.47e-05	4.76e-05	0.0
126	24	4.89e-03	8.48e-03	-0.08	8.27e-05	4.82e-05	0.0
126	39	5.97e-03	-3.21e-03	-0.08	8.39e-05	4.82e-05	0.0
126	53	2.20e-03	-6.12e-03	-0.08	8.41e-05	4.78e-05	0.0
126	56	3.56e-03	1.26e-03	-0.08	8.34e-05	4.80e-05	0.0
126	69	2.88e-03	-2.43e-03	-0.08	8.37e-05	4.79e-05	0.0
127	1	3.78e-03	-3.19e-03	-0.09	1.02e-04	5.49e-05	0.0
127	3	3.20e-03	-2.70e-03	-0.08	8.62e-05	4.65e-05	0.0
127	7	0.01	-4.70e-03	-0.07	7.87e-05	4.33e-05	0.0
127	21	1.05e-03	-0.01	-0.07	7.95e-05	4.19e-05	0.0
127	24	4.77e-03	8.51e-03	-0.07	7.72e-05	4.26e-05	0.0
127	39	5.96e-03	-3.22e-03	-0.07	7.85e-05	4.26e-05	0.0
127	53	2.28e-03	-6.17e-03	-0.07	7.87e-05	4.21e-05	0.0
127	56	3.54e-03	1.26e-03	-0.07	7.80e-05	4.24e-05	0.0
127	69	2.91e-03	-2.46e-03	-0.07	7.84e-05	4.23e-05	0.0
128	1	3.82e-03	-3.22e-03	-0.09	9.76e-05	5.06e-05	0.0
128	3	3.24e-03	-2.72e-03	-0.07	8.25e-05	4.28e-05	0.0
128	7	0.01	-4.65e-03	-0.07	7.54e-05	3.99e-05	0.0
128	21	1.23e-03	-0.01	-0.07	7.61e-05	3.86e-05	0.0
128	24	4.66e-03	8.56e-03	-0.07	7.39e-05	3.93e-05	0.0
128	39	5.96e-03	-3.21e-03	-0.07	7.52e-05	3.93e-05	0.0
128	53	2.36e-03	-6.21e-03	-0.07	7.54e-05	3.88e-05	0.0
128	56	3.52e-03	1.26e-03	-0.07	7.47e-05	3.91e-05	0.0
128	69	2.94e-03	-2.48e-03	-0.07	7.50e-05	3.89e-05	0.0
129	1	3.87e-03	-3.25e-03	-0.08	9.78e-05	5.20e-05	0.0
129	3	3.28e-03	-2.75e-03	-0.07	8.28e-05	4.40e-05	0.0
129	7	0.01	-4.61e-03	-0.06	7.56e-05	4.10e-05	0.0
129	21	1.40e-03	-0.01	-0.06	7.64e-05	3.96e-05	0.0
129	24	4.55e-03	8.62e-03	-0.06	7.42e-05	4.04e-05	0.0
129	39	5.95e-03	-3.21e-03	-0.06	7.54e-05	4.03e-05	0.0
129	53	2.44e-03	-6.26e-03	-0.06	7.56e-05	3.99e-05	0.0
129	56	3.51e-03	1.26e-03	-0.06	7.49e-05	4.01e-05	0.0
129	69	2.98e-03	-2.50e-03	-0.06	7.53e-05	4.00e-05	0.0
130	1	3.62e-03	-2.97e-03	-0.11	1.47e-04	1.37e-04	0.0
130	3	3.06e-03	-2.51e-03	-0.09	1.24e-04	1.16e-04	0.0
130	7	0.01	-5.05e-03	-0.08	1.13e-04	1.06e-04	0.0
130	21	1.84e-04	-0.01	-0.08	1.14e-04	1.05e-04	0.0
130	24	5.39e-03	8.43e-03	-0.08	1.12e-04	1.05e-04	0.0
130	39	6.11e-03	-3.22e-03	-0.08	1.13e-04	1.05e-04	0.0
130	53	1.90e-03	-5.91e-03	-0.08	1.13e-04	1.05e-04	0.0

Parco Eolico "Bolina" – Progetto Definitivo
Relazione di calcolo preliminare delle fondazioni degli aerogeneratori G8 e G12

130	56	3.66e-03	1.34e-03	-0.08	1.13e-04	1.05e-04	0.0
130	69	2.78e-03	-2.29e-03	-0.08	1.13e-04	1.05e-04	0.0
131	1	3.65e-03	-2.99e-03	-0.10	1.25e-04	1.13e-04	0.0
131	3	3.09e-03	-2.53e-03	-0.09	1.06e-04	9.59e-05	0.0
131	7	0.01	-4.99e-03	-0.08	9.66e-05	8.81e-05	0.0
131	21	4.13e-04	-0.01	-0.08	9.71e-05	8.69e-05	0.0
131	24	5.21e-03	8.39e-03	-0.08	9.54e-05	8.74e-05	0.0
131	39	6.05e-03	-3.21e-03	-0.08	9.64e-05	8.75e-05	0.0
131	53	2.00e-03	-5.92e-03	-0.08	9.65e-05	8.71e-05	0.0
131	56	3.62e-03	1.31e-03	-0.08	9.60e-05	8.72e-05	0.0
131	69	2.81e-03	-2.30e-03	-0.08	9.62e-05	8.71e-05	0.0
132	1	3.69e-03	-3.02e-03	-0.09	1.10e-04	9.64e-05	0.0
132	3	3.12e-03	-2.55e-03	-0.08	9.32e-05	8.16e-05	0.0
132	7	0.01	-4.94e-03	-0.07	8.51e-05	7.51e-05	0.0
132	21	6.29e-04	-0.01	-0.07	8.56e-05	7.39e-05	0.0
132	24	5.05e-03	8.35e-03	-0.07	8.39e-05	7.44e-05	0.0
132	39	6.02e-03	-3.21e-03	-0.07	8.49e-05	7.45e-05	0.0
132	53	2.09e-03	-5.93e-03	-0.07	8.50e-05	7.41e-05	0.0
132	56	3.58e-03	1.29e-03	-0.07	8.45e-05	7.43e-05	0.0
132	69	2.84e-03	-2.32e-03	-0.07	8.48e-05	7.42e-05	0.0
133	1	3.73e-03	-3.04e-03	-0.09	9.98e-05	8.26e-05	0.0
133	3	3.16e-03	-2.57e-03	-0.07	8.44e-05	6.99e-05	0.0
133	7	0.01	-4.90e-03	-0.07	7.71e-05	6.44e-05	0.0
133	21	8.41e-04	-0.01	-0.07	7.77e-05	6.33e-05	0.0
133	24	4.90e-03	8.33e-03	-0.07	7.58e-05	6.38e-05	0.0
133	39	5.99e-03	-3.21e-03	-0.07	7.69e-05	6.38e-05	0.0
133	53	2.18e-03	-5.95e-03	-0.07	7.71e-05	6.35e-05	0.0
133	56	3.55e-03	1.27e-03	-0.07	7.65e-05	6.36e-05	0.0
133	69	2.87e-03	-2.34e-03	-0.07	7.68e-05	6.35e-05	0.0
134	1	3.78e-03	-3.07e-03	-0.08	9.21e-05	7.11e-05	0.0
134	3	3.20e-03	-2.60e-03	-0.07	7.79e-05	6.02e-05	0.0
134	7	0.01	-4.87e-03	-0.06	7.12e-05	5.56e-05	0.0
134	21	1.05e-03	-0.01	-0.06	7.19e-05	5.44e-05	0.0
134	24	4.75e-03	8.33e-03	-0.06	6.98e-05	5.50e-05	0.0
134	39	5.97e-03	-3.21e-03	-0.06	7.10e-05	5.50e-05	0.0
134	53	2.28e-03	-5.98e-03	-0.06	7.12e-05	5.46e-05	0.0
134	56	3.53e-03	1.26e-03	-0.06	7.05e-05	5.48e-05	0.0
134	69	2.90e-03	-2.36e-03	-0.06	7.08e-05	5.47e-05	0.0
135	1	3.84e-03	-3.11e-03	-0.07	8.40e-05	6.12e-05	0.0
135	3	3.25e-03	-2.63e-03	-0.06	7.11e-05	5.18e-05	0.0
135	7	0.01	-4.84e-03	-0.06	6.51e-05	4.85e-05	0.0
135	21	1.28e-03	-0.01	-0.06	6.62e-05	4.67e-05	0.0
135	24	4.63e-03	8.32e-03	-0.06	6.31e-05	4.75e-05	0.0
135	39	5.97e-03	-3.22e-03	-0.06	6.48e-05	4.76e-05	0.0
135	53	2.39e-03	-6.02e-03	-0.06	6.52e-05	4.70e-05	0.0
135	56	3.52e-03	1.23e-03	-0.06	6.41e-05	4.72e-05	0.0
135	69	2.95e-03	-2.39e-03	-0.06	6.46e-05	4.71e-05	0.0
136	1	3.88e-03	-3.11e-03	-0.07	8.13e-05	5.72e-05	0.0
136	3	3.28e-03	-2.63e-03	-0.06	6.88e-05	4.84e-05	0.0
136	7	0.01	-4.80e-03	-0.05	6.29e-05	4.50e-05	0.0
136	21	1.48e-03	-0.01	-0.05	6.37e-05	4.36e-05	0.0
136	24	4.49e-03	8.37e-03	-0.05	6.13e-05	4.44e-05	0.0
136	39	5.95e-03	-3.21e-03	-0.05	6.26e-05	4.43e-05	0.0
136	53	2.47e-03	-6.04e-03	-0.05	6.29e-05	4.39e-05	0.0
136	56	3.49e-03	1.25e-03	-0.05	6.21e-05	4.41e-05	0.0
136	69	2.98e-03	-2.39e-03	-0.05	6.25e-05	4.40e-05	0.0
137	1	3.93e-03	-3.13e-03	-0.06	8.14e-05	5.85e-05	0.0
137	3	3.32e-03	-2.65e-03	-0.05	6.89e-05	4.95e-05	0.0
137	7	0.01	-4.76e-03	-0.05	6.30e-05	4.59e-05	0.0
137	21	1.69e-03	-0.01	-0.05	6.38e-05	4.46e-05	0.0
137	24	4.36e-03	8.41e-03	-0.05	6.15e-05	4.54e-05	0.0
137	39	5.95e-03	-3.21e-03	-0.05	6.27e-05	4.53e-05	0.0
137	53	2.57e-03	-6.07e-03	-0.05	6.30e-05	4.49e-05	0.0
137	56	3.47e-03	1.25e-03	-0.05	6.22e-05	4.51e-05	0.0
137	69	3.02e-03	-2.41e-03	-0.05	6.26e-05	4.50e-05	0.0
138	1	3.62e-03	-2.91e-03	-0.09	1.32e-04	1.45e-04	0.0
138	3	3.07e-03	-2.47e-03	-0.08	1.12e-04	1.22e-04	0.0
138	7	0.01	-5.12e-03	-0.07	1.02e-04	1.12e-04	0.0
138	21	1.93e-04	-0.01	-0.07	1.02e-04	1.11e-04	0.0
138	24	5.38e-03	8.36e-03	-0.07	1.01e-04	1.11e-04	0.0
138	39	6.11e-03	-3.22e-03	-0.07	1.02e-04	1.12e-04	0.0
138	53	1.91e-03	-5.83e-03	-0.07	1.02e-04	1.11e-04	0.0
138	56	3.67e-03	1.35e-03	-0.07	1.01e-04	1.11e-04	0.0

Parco Eolico "Bolina" – Progetto Definitivo
Relazione di calcolo preliminare delle fondazioni degli aerogeneratori G8 e G12

138	69	2.79e-03	-2.24e-03	-0.07	1.02e-04	1.11e-04	0.0
139	1	3.66e-03	-2.93e-03	-0.09	1.06e-04	1.20e-04	0.0
139	3	3.10e-03	-2.48e-03	-0.07	8.98e-05	1.02e-04	0.0
139	7	0.01	-5.09e-03	-0.07	8.20e-05	9.37e-05	0.0
139	21	4.91e-04	-0.01	-0.07	8.25e-05	9.24e-05	0.0
139	24	5.15e-03	8.26e-03	-0.07	8.08e-05	9.29e-05	0.0
139	39	6.06e-03	-3.21e-03	-0.07	8.18e-05	9.30e-05	0.0
139	53	2.03e-03	-5.81e-03	-0.07	8.19e-05	9.26e-05	0.0
139	56	3.61e-03	1.30e-03	-0.07	8.13e-05	9.27e-05	0.0
139	69	2.82e-03	-2.25e-03	-0.07	8.16e-05	9.27e-05	0.0
140	1	3.70e-03	-2.94e-03	-0.08	9.00e-05	1.02e-04	0.0
140	3	3.13e-03	-2.49e-03	-0.07	7.61e-05	8.67e-05	0.0
140	7	0.01	-5.05e-03	-0.06	6.95e-05	7.98e-05	0.0
140	21	7.29e-04	-0.01	-0.06	7.00e-05	7.86e-05	0.0
140	24	4.96e-03	8.21e-03	-0.06	6.83e-05	7.91e-05	0.0
140	39	6.02e-03	-3.21e-03	-0.06	6.93e-05	7.91e-05	0.0
140	53	2.13e-03	-5.80e-03	-0.06	6.95e-05	7.87e-05	0.0
140	56	3.56e-03	1.28e-03	-0.06	6.89e-05	7.89e-05	0.0
140	69	2.85e-03	-2.26e-03	-0.06	6.92e-05	7.88e-05	0.0
141	1	3.74e-03	-2.95e-03	-0.07	7.99e-05	8.76e-05	0.0
141	3	3.17e-03	-2.50e-03	-0.06	6.76e-05	7.41e-05	0.0
141	7	0.01	-5.02e-03	-0.06	6.18e-05	6.82e-05	0.0
141	21	9.61e-04	-0.01	-0.05	6.24e-05	6.71e-05	0.0
141	24	4.80e-03	8.17e-03	-0.06	6.06e-05	6.76e-05	0.0
141	39	5.99e-03	-3.20e-03	-0.06	6.16e-05	6.76e-05	0.0
141	53	2.23e-03	-5.80e-03	-0.06	6.18e-05	6.73e-05	0.0
141	56	3.53e-03	1.26e-03	-0.06	6.12e-05	6.74e-05	0.0
141	69	2.88e-03	-2.27e-03	-0.06	6.15e-05	6.73e-05	0.0
142	1	3.80e-03	-2.96e-03	-0.07	7.34e-05	7.53e-05	0.0
142	3	3.21e-03	-2.51e-03	-0.06	6.21e-05	6.37e-05	0.0
142	7	0.01	-5.00e-03	-0.05	5.68e-05	5.88e-05	0.0
142	21	1.20e-03	-0.01	-0.05	5.74e-05	5.76e-05	0.0
142	24	4.64e-03	8.15e-03	-0.05	5.55e-05	5.82e-05	0.0
142	39	5.97e-03	-3.20e-03	-0.05	5.66e-05	5.82e-05	0.0
142	53	2.34e-03	-5.81e-03	-0.05	5.68e-05	5.78e-05	0.0
142	56	3.50e-03	1.25e-03	-0.05	5.61e-05	5.80e-05	0.0
142	69	2.92e-03	-2.28e-03	-0.05	5.65e-05	5.79e-05	0.0
143	1	3.85e-03	-2.98e-03	-0.06	6.87e-05	6.59e-05	0.0
143	3	3.26e-03	-2.52e-03	-0.05	5.82e-05	5.58e-05	0.0
143	7	0.01	-4.97e-03	-0.05	5.32e-05	5.16e-05	0.0
143	21	1.43e-03	-0.01	-0.05	5.40e-05	5.04e-05	0.0
143	24	4.49e-03	8.14e-03	-0.05	5.18e-05	5.10e-05	0.0
143	39	5.96e-03	-3.20e-03	-0.05	5.30e-05	5.10e-05	0.0
143	53	2.44e-03	-5.82e-03	-0.05	5.33e-05	5.06e-05	0.0
143	56	3.48e-03	1.24e-03	-0.05	5.25e-05	5.08e-05	0.0
143	69	2.96e-03	-2.29e-03	-0.05	5.29e-05	5.07e-05	0.0
144	1	3.90e-03	-2.99e-03	-0.05	6.63e-05	6.01e-05	0.0
144	3	3.30e-03	-2.53e-03	-0.05	5.61e-05	5.08e-05	0.0
144	7	0.01	-4.95e-03	-0.04	5.13e-05	4.71e-05	0.0
144	21	1.66e-03	-0.01	-0.04	5.21e-05	4.59e-05	0.0
144	24	4.34e-03	8.14e-03	-0.04	4.99e-05	4.65e-05	0.0
144	39	5.95e-03	-3.20e-03	-0.04	5.11e-05	4.65e-05	0.0
144	53	2.55e-03	-5.83e-03	-0.04	5.14e-05	4.61e-05	0.0
144	56	3.46e-03	1.23e-03	-0.04	5.06e-05	4.63e-05	0.0
144	69	3.00e-03	-2.30e-03	-0.04	5.10e-05	4.62e-05	0.0
145	1	3.96e-03	-3.00e-03	-0.05	6.58e-05	6.10e-05	0.0
145	3	3.35e-03	-2.54e-03	-0.04	5.57e-05	5.17e-05	0.0
145	7	0.01	-4.93e-03	-0.04	5.10e-05	4.78e-05	0.0
145	21	1.90e-03	-0.01	-0.04	5.18e-05	4.66e-05	0.0
145	24	4.20e-03	8.15e-03	-0.04	4.95e-05	4.73e-05	0.0
145	39	5.95e-03	-3.20e-03	-0.04	5.08e-05	4.73e-05	0.0
145	53	2.66e-03	-5.85e-03	-0.04	5.10e-05	4.68e-05	0.0
145	56	3.44e-03	1.23e-03	-0.04	5.03e-05	4.71e-05	0.0
145	69	3.05e-03	-2.31e-03	-0.04	5.07e-05	4.70e-05	0.0
146	1	3.62e-03	-2.86e-03	-0.08	1.13e-04	1.42e-04	0.0
146	3	3.06e-03	-2.42e-03	-0.07	9.60e-05	1.20e-04	0.0
146	7	0.01	-5.21e-03	-0.06	8.76e-05	1.10e-04	0.0
146	21	2.98e-04	-0.01	-0.06	8.82e-05	1.09e-04	0.0
146	24	5.27e-03	8.21e-03	-0.06	8.64e-05	1.10e-04	0.0
146	39	6.10e-03	-3.22e-03	-0.06	8.74e-05	1.10e-04	0.0
146	53	1.94e-03	-5.72e-03	-0.06	8.76e-05	1.09e-04	0.0
146	56	3.62e-03	1.32e-03	-0.06	8.70e-05	1.09e-04	0.0
146	69	2.78e-03	-2.20e-03	-0.06	8.73e-05	1.09e-04	0.0

Parco Eolico "Bolina" – Progetto Definitivo
Relazione di calcolo preliminare delle fondazioni degli aerogeneratori G8 e G12

147	1	3.69e-03	-2.89e-03	-0.07	8.41e-05	1.14e-04	0.0
147	3	3.12e-03	-2.44e-03	-0.06	7.12e-05	9.67e-05	0.0
147	7	0.01	-5.20e-03	-0.05	6.52e-05	8.94e-05	0.0
147	21	5.78e-04	-0.01	-0.05	6.61e-05	8.75e-05	0.0
147	24	5.10e-03	8.08e-03	-0.05	6.33e-05	8.83e-05	0.0
147	39	6.08e-03	-3.23e-03	-0.05	6.49e-05	8.84e-05	0.0
147	53	2.07e-03	-5.71e-03	-0.05	6.52e-05	8.78e-05	0.0
147	56	3.61e-03	1.26e-03	-0.05	6.42e-05	8.81e-05	0.0
147	69	2.84e-03	-2.22e-03	-0.05	6.47e-05	8.79e-05	0.0
148	1	3.70e-03	-2.87e-03	-0.06	6.93e-05	9.87e-05	0.0
148	3	3.13e-03	-2.43e-03	-0.05	5.86e-05	8.36e-05	0.0
148	7	0.01	-5.17e-03	-0.05	5.36e-05	7.69e-05	0.0
148	21	7.97e-04	-0.01	-0.05	5.42e-05	7.57e-05	0.0
148	24	4.90e-03	8.03e-03	-0.05	5.24e-05	7.62e-05	0.0
148	39	6.02e-03	-3.21e-03	-0.05	5.34e-05	7.63e-05	0.0
148	53	2.15e-03	-5.67e-03	-0.05	5.36e-05	7.59e-05	0.0
148	56	3.54e-03	1.26e-03	-0.05	5.30e-05	7.61e-05	0.0
148	69	2.85e-03	-2.21e-03	-0.05	5.33e-05	7.60e-05	0.0
149	1	3.75e-03	-2.87e-03	-0.06	6.07e-05	8.47e-05	0.0
149	3	3.17e-03	-2.43e-03	-0.05	5.13e-05	7.17e-05	0.0
149	7	0.01	-5.15e-03	-0.04	4.70e-05	6.60e-05	0.0
149	21	1.04e-03	-0.01	-0.04	4.76e-05	6.49e-05	0.0
149	24	4.73e-03	7.97e-03	-0.05	4.58e-05	6.54e-05	0.0
149	39	5.99e-03	-3.20e-03	-0.04	4.68e-05	6.54e-05	0.0
149	53	2.26e-03	-5.65e-03	-0.04	4.70e-05	6.51e-05	0.0
149	56	3.51e-03	1.24e-03	-0.04	4.64e-05	6.52e-05	0.0
149	69	2.88e-03	-2.21e-03	-0.04	4.67e-05	6.51e-05	0.0
150	1	3.80e-03	-2.87e-03	-0.05	5.60e-05	7.33e-05	0.0
150	3	3.21e-03	-2.43e-03	-0.04	4.74e-05	6.20e-05	0.0
150	7	0.01	-5.14e-03	-0.04	4.35e-05	5.73e-05	0.0
150	21	1.28e-03	-0.01	-0.04	4.41e-05	5.61e-05	0.0
150	24	4.56e-03	7.92e-03	-0.04	4.21e-05	5.67e-05	0.0
150	39	5.97e-03	-3.20e-03	-0.04	4.32e-05	5.67e-05	0.0
150	53	2.37e-03	-5.63e-03	-0.04	4.35e-05	5.63e-05	0.0
150	56	3.48e-03	1.22e-03	-0.04	4.28e-05	5.65e-05	0.0
150	69	2.92e-03	-2.21e-03	-0.04	4.31e-05	5.64e-05	0.0
151	1	3.87e-03	-2.88e-03	-0.05	5.24e-05	6.34e-05	0.0
151	3	3.27e-03	-2.44e-03	-0.04	4.43e-05	5.37e-05	0.0
151	7	0.01	-5.13e-03	-0.04	4.08e-05	5.01e-05	0.0
151	21	1.54e-03	-0.01	-0.03	4.18e-05	4.84e-05	0.0
151	22	-6.89e-04	7.81e-03	-0.04	3.87e-05	4.84e-05	0.0
151	39	5.96e-03	-3.20e-03	-0.04	4.04e-05	4.92e-05	0.0
151	53	2.49e-03	-5.63e-03	-0.04	4.08e-05	4.87e-05	0.0
151	54	1.73e-03	1.18e-03	-0.04	3.98e-05	4.86e-05	0.0
151	69	2.97e-03	-2.21e-03	-0.04	4.03e-05	4.88e-05	0.0
152	1	3.91e-03	-2.87e-03	-0.04	5.18e-05	5.93e-05	0.0
152	3	3.31e-03	-2.43e-03	-0.04	4.39e-05	5.01e-05	0.0
152	7	0.01	-5.12e-03	-0.03	4.03e-05	4.65e-05	0.0
152	21	1.77e-03	-0.01	-0.03	4.11e-05	4.53e-05	0.0
152	22	-7.47e-04	7.80e-03	-0.03	3.87e-05	4.53e-05	0.0
152	39	5.95e-03	-3.19e-03	-0.03	4.00e-05	4.59e-05	0.0
152	53	2.59e-03	-5.61e-03	-0.03	4.03e-05	4.55e-05	0.0
152	54	1.74e-03	1.18e-03	-0.03	3.95e-05	4.55e-05	0.0
152	69	3.01e-03	-2.21e-03	-0.03	3.99e-05	4.56e-05	0.0
153	1	3.96e-03	-2.87e-03	-0.04	5.17e-05	6.01e-05	0.0
153	3	3.35e-03	-2.43e-03	-0.03	4.38e-05	5.08e-05	0.0
153	7	0.01	-5.11e-03	-0.03	4.02e-05	4.71e-05	0.0
153	21	2.01e-03	-0.01	-0.03	4.09e-05	4.59e-05	0.0
153	22	-7.94e-04	7.79e-03	-0.03	3.86e-05	4.60e-05	0.0
153	39	5.95e-03	-3.19e-03	-0.03	3.99e-05	4.65e-05	0.0
153	53	2.70e-03	-5.61e-03	-0.03	4.02e-05	4.61e-05	0.0
153	54	1.75e-03	1.18e-03	-0.03	3.94e-05	4.61e-05	0.0
153	69	3.05e-03	-2.21e-03	-0.03	3.98e-05	4.62e-05	0.0
154	1	3.61e-03	-2.80e-03	-0.07	9.62e-05	1.29e-04	0.0
154	3	3.05e-03	-2.37e-03	-0.06	8.14e-05	1.09e-04	0.0
154	7	0.01	-5.31e-03	-0.05	7.42e-05	1.00e-04	0.0
154	22	-6.56e-04	8.14e-03	-0.05	7.31e-05	9.91e-05	0.0
154	23	6.21e-03	-0.01	-0.05	7.49e-05	9.96e-05	0.0
154	39	6.11e-03	-3.22e-03	-0.05	7.41e-05	9.97e-05	0.0
154	54	1.61e-03	1.33e-03	-0.05	7.37e-05	9.92e-05	0.0
154	55	3.94e-03	-5.64e-03	-0.05	7.43e-05	9.94e-05	0.0
154	69	2.78e-03	-2.15e-03	-0.05	7.40e-05	9.93e-05	0.0
155	1	3.66e-03	-2.80e-03	-0.06	6.92e-05	1.04e-04	0.0

Parco Eolico "Bolina" – Progetto Definitivo
Relazione di calcolo preliminare delle fondazioni degli aerogeneratori G8 e G12

155	3	3.09e-03	-2.37e-03	-0.05	5.85e-05	8.81e-05	0.0
155	7	0.01	-5.28e-03	-0.04	5.35e-05	8.11e-05	0.0
155	22	-6.16e-04	8.01e-03	-0.05	5.23e-05	7.98e-05	0.0
155	23	6.24e-03	-0.01	-0.04	5.41e-05	8.04e-05	0.0
155	39	6.06e-03	-3.21e-03	-0.04	5.33e-05	8.04e-05	0.0
155	54	1.65e-03	1.28e-03	-0.04	5.29e-05	8.00e-05	0.0
155	55	3.97e-03	-5.59e-03	-0.04	5.35e-05	8.02e-05	0.0
155	69	2.81e-03	-2.15e-03	-0.04	5.32e-05	8.01e-05	0.0
156	1	3.69e-03	-2.79e-03	-0.05	5.36e-05	8.74e-05	0.0
156	3	3.13e-03	-2.36e-03	-0.04	4.54e-05	7.40e-05	0.0
156	7	0.01	-5.28e-03	-0.04	4.15e-05	6.81e-05	0.0
156	22	-6.45e-04	7.91e-03	-0.04	4.04e-05	6.70e-05	0.0
156	23	6.33e-03	-0.01	-0.04	4.21e-05	6.75e-05	0.0
156	39	6.02e-03	-3.21e-03	-0.04	4.13e-05	6.75e-05	0.0
156	54	1.66e-03	1.26e-03	-0.04	4.10e-05	6.71e-05	0.0
156	55	4.02e-03	-5.55e-03	-0.04	4.15e-05	6.73e-05	0.0
156	69	2.84e-03	-2.15e-03	-0.04	4.13e-05	6.72e-05	0.0
157	1	3.74e-03	-2.78e-03	-0.05	4.59e-05	7.52e-05	0.0
157	3	3.16e-03	-2.35e-03	-0.04	3.89e-05	6.36e-05	0.0
157	7	0.01	-5.27e-03	-0.04	3.56e-05	5.87e-05	0.0
157	22	-6.85e-04	7.84e-03	-0.04	3.44e-05	5.76e-05	0.0
157	23	6.43e-03	-0.01	-0.03	3.62e-05	5.81e-05	0.0
157	39	5.99e-03	-3.20e-03	-0.04	3.54e-05	5.81e-05	0.0
157	54	1.67e-03	1.24e-03	-0.04	3.50e-05	5.77e-05	0.0
157	55	4.08e-03	-5.52e-03	-0.04	3.56e-05	5.79e-05	0.0
157	69	2.87e-03	-2.14e-03	-0.04	3.53e-05	5.78e-05	0.0
158	1	3.78e-03	-2.77e-03	-0.04	4.26e-05	6.58e-05	0.0
158	3	3.20e-03	-2.34e-03	-0.03	3.60e-05	5.57e-05	0.0
158	7	0.01	-5.27e-03	-0.03	3.31e-05	5.15e-05	0.0
158	22	-7.25e-04	7.78e-03	-0.03	3.18e-05	5.03e-05	0.0
158	23	6.55e-03	-0.01	-0.03	3.37e-05	5.09e-05	0.0
158	39	5.97e-03	-3.19e-03	-0.03	3.29e-05	5.09e-05	0.0
158	54	1.68e-03	1.22e-03	-0.03	3.24e-05	5.05e-05	0.0
158	55	4.14e-03	-5.49e-03	-0.03	3.31e-05	5.07e-05	0.0
158	69	2.91e-03	-2.13e-03	-0.03	3.27e-05	5.06e-05	0.0
159	1	3.84e-03	-2.76e-03	-0.04	4.13e-05	5.89e-05	0.0
159	3	3.25e-03	-2.34e-03	-0.03	3.50e-05	4.98e-05	0.0
159	7	0.01	-5.27e-03	-0.03	3.22e-05	4.62e-05	0.0
159	22	-7.66e-04	7.74e-03	-0.03	3.07e-05	4.50e-05	0.0
159	23	6.67e-03	-0.01	-0.03	3.29e-05	4.56e-05	0.0
159	39	5.96e-03	-3.19e-03	-0.03	3.19e-05	4.56e-05	0.0
159	54	1.69e-03	1.21e-03	-0.03	3.14e-05	4.52e-05	0.0
159	55	4.21e-03	-5.46e-03	-0.03	3.22e-05	4.54e-05	0.0
159	69	2.95e-03	-2.12e-03	-0.03	3.18e-05	4.53e-05	0.0
160	1	3.89e-03	-2.75e-03	-0.03	4.14e-05	5.48e-05	0.0
160	3	3.29e-03	-2.33e-03	-0.03	3.51e-05	4.64e-05	0.0
160	7	0.01	-5.28e-03	-0.02	3.23e-05	4.30e-05	0.0
160	22	-8.13e-04	7.71e-03	-0.02	3.08e-05	4.19e-05	0.0
160	23	6.79e-03	-0.01	-0.02	3.30e-05	4.24e-05	0.0
160	39	5.95e-03	-3.18e-03	-0.02	3.20e-05	4.24e-05	0.0
160	54	1.70e-03	1.21e-03	-0.02	3.15e-05	4.20e-05	0.0
160	55	4.28e-03	-5.44e-03	-0.02	3.22e-05	4.22e-05	0.0
160	69	2.99e-03	-2.12e-03	-0.02	3.19e-05	4.21e-05	0.0
161	1	3.94e-03	-2.74e-03	-0.03	4.12e-05	5.54e-05	0.0
161	3	3.34e-03	-2.32e-03	-0.02	3.48e-05	4.68e-05	0.0
161	7	0.01	-5.29e-03	-0.02	3.20e-05	4.35e-05	0.0
161	22	-8.61e-04	7.68e-03	-0.02	3.05e-05	4.23e-05	0.0
161	23	6.93e-03	-0.01	-0.02	3.28e-05	4.29e-05	0.0
161	39	5.95e-03	-3.18e-03	-0.02	3.18e-05	4.29e-05	0.0
161	54	1.72e-03	1.21e-03	-0.02	3.13e-05	4.25e-05	0.0
161	55	4.35e-03	-5.42e-03	-0.02	3.20e-05	4.27e-05	0.0
161	69	3.03e-03	-2.11e-03	-0.02	3.17e-05	4.26e-05	0.0
162	1	3.61e-03	-2.75e-03	-0.06	8.42e-05	1.11e-04	0.0
162	3	3.05e-03	-2.33e-03	-0.05	7.12e-05	9.41e-05	0.0
162	7	0.01	-5.36e-03	-0.04	6.49e-05	8.65e-05	0.0
162	22	-6.43e-04	8.05e-03	-0.04	6.39e-05	8.53e-05	0.0
162	23	6.19e-03	-0.01	-0.04	6.56e-05	8.58e-05	0.0
162	39	6.12e-03	-3.21e-03	-0.04	6.48e-05	8.58e-05	0.0
162	54	1.62e-03	1.33e-03	-0.04	6.44e-05	8.54e-05	0.0
162	55	3.93e-03	-5.55e-03	-0.04	6.50e-05	8.56e-05	0.0
162	69	2.77e-03	-2.11e-03	-0.04	6.47e-05	8.55e-05	0.0
163	1	3.64e-03	-2.73e-03	-0.05	5.86e-05	8.74e-05	0.0
163	3	3.08e-03	-2.31e-03	-0.04	4.95e-05	7.40e-05	0.0

Parco Eolico "Bolina" – Progetto Definitivo
Relazione di calcolo preliminare delle fondazioni degli aerogeneratori G8 e G12

163	7	0.01	-5.37e-03	-0.04	4.53e-05	6.82e-05	0.0
163	22	-6.57e-04	7.94e-03	-0.04	4.42e-05	6.70e-05	0.0
163	23	6.25e-03	-0.01	-0.04	4.59e-05	6.75e-05	0.0
163	39	6.06e-03	-3.21e-03	-0.04	4.51e-05	6.76e-05	0.0
163	54	1.63e-03	1.29e-03	-0.04	4.48e-05	6.72e-05	0.0
163	55	3.97e-03	-5.50e-03	-0.04	4.53e-05	6.73e-05	0.0
163	69	2.80e-03	-2.10e-03	-0.04	4.50e-05	6.73e-05	0.0
164	1	3.67e-03	-2.72e-03	-0.04	4.45e-05	7.25e-05	0.0
164	3	3.11e-03	-2.30e-03	-0.04	3.77e-05	6.14e-05	0.0
164	7	0.01	-5.37e-03	-0.03	3.45e-05	5.67e-05	0.0
164	22	-6.89e-04	7.83e-03	-0.03	3.34e-05	5.55e-05	0.0
164	23	6.34e-03	-0.01	-0.03	3.51e-05	5.60e-05	0.0
164	39	6.02e-03	-3.20e-03	-0.03	3.43e-05	5.61e-05	0.0
164	54	1.64e-03	1.27e-03	-0.03	3.39e-05	5.57e-05	0.0
164	55	4.01e-03	-5.45e-03	-0.03	3.45e-05	5.59e-05	0.0
164	69	2.83e-03	-2.09e-03	-0.03	3.42e-05	5.58e-05	0.0
165	1	3.71e-03	-2.70e-03	-0.04	3.76e-05	6.24e-05	0.0
165	3	3.14e-03	-2.29e-03	-0.03	3.18e-05	5.28e-05	0.0
165	7	0.01	-5.37e-03	-0.03	2.92e-05	4.89e-05	0.0
165	22	-7.27e-04	7.75e-03	-0.03	2.80e-05	4.78e-05	0.0
165	23	6.44e-03	-0.01	-0.03	2.98e-05	4.83e-05	0.0
165	39	6.00e-03	-3.19e-03	-0.03	2.90e-05	4.83e-05	0.0
165	54	1.64e-03	1.25e-03	-0.03	2.86e-05	4.79e-05	0.0
165	55	4.07e-03	-5.40e-03	-0.03	2.92e-05	4.81e-05	0.0
165	69	2.86e-03	-2.08e-03	-0.03	2.89e-05	4.80e-05	0.0
166	1	3.76e-03	-2.68e-03	-0.03	3.49e-05	5.54e-05	0.0
166	3	3.18e-03	-2.27e-03	-0.03	2.95e-05	4.69e-05	0.0
166	7	0.01	-5.39e-03	-0.02	2.72e-05	4.35e-05	0.0
166	22	-7.65e-04	7.68e-03	-0.03	2.58e-05	4.23e-05	0.0
166	23	6.55e-03	-0.01	-0.02	2.79e-05	4.29e-05	0.0
166	39	5.98e-03	-3.19e-03	-0.02	2.70e-05	4.29e-05	0.0
166	54	1.65e-03	1.23e-03	-0.03	2.65e-05	4.25e-05	0.0
166	55	4.13e-03	-5.36e-03	-0.02	2.72e-05	4.27e-05	0.0
166	69	2.89e-03	-2.06e-03	-0.03	2.69e-05	4.26e-05	0.0
167	1	3.81e-03	-2.67e-03	-0.03	3.38e-05	4.98e-05	0.0
167	3	3.23e-03	-2.26e-03	-0.02	2.86e-05	4.21e-05	0.0
167	7	0.01	-5.40e-03	-0.02	2.65e-05	3.97e-05	0.0
167	22	-7.97e-04	7.61e-03	-0.02	2.45e-05	3.78e-05	0.0
167	23	6.66e-03	-0.01	-0.02	2.75e-05	3.88e-05	0.0
167	39	5.97e-03	-3.19e-03	-0.02	2.62e-05	3.88e-05	0.0
167	54	1.67e-03	1.22e-03	-0.02	2.55e-05	3.81e-05	0.0
167	55	4.19e-03	-5.32e-03	-0.02	2.65e-05	3.85e-05	0.0
167	69	2.93e-03	-2.05e-03	-0.02	2.60e-05	3.83e-05	0.0
168	1	3.85e-03	-2.65e-03	-0.02	3.46e-05	4.80e-05	0.0
168	3	3.26e-03	-2.24e-03	-0.02	2.93e-05	4.06e-05	0.0
168	7	0.01	-5.42e-03	-0.02	2.70e-05	3.79e-05	0.0
168	22	-8.55e-04	7.58e-03	-0.02	2.54e-05	3.66e-05	0.0
168	23	6.78e-03	-0.01	-0.02	2.78e-05	3.73e-05	0.0
168	39	5.96e-03	-3.18e-03	-0.02	2.68e-05	3.73e-05	0.0
168	54	1.67e-03	1.22e-03	-0.02	2.62e-05	3.68e-05	0.0
168	55	4.25e-03	-5.29e-03	-0.02	2.70e-05	3.71e-05	0.0
168	69	2.96e-03	-2.03e-03	-0.02	2.66e-05	3.69e-05	0.0
169	1	3.90e-03	-2.62e-03	-0.02	3.45e-05	4.86e-05	0.0
169	3	3.30e-03	-2.22e-03	-0.02	2.92e-05	4.11e-05	0.0
169	7	0.01	-5.44e-03	-0.01	2.70e-05	3.83e-05	0.0
169	22	-9.05e-04	7.55e-03	-0.01	2.54e-05	3.71e-05	0.0
169	23	6.90e-03	-0.01	-0.01	2.77e-05	3.77e-05	0.0
169	39	5.95e-03	-3.18e-03	-0.01	2.67e-05	3.77e-05	0.0
169	54	1.68e-03	1.22e-03	-0.01	2.62e-05	3.73e-05	0.0
169	55	4.32e-03	-5.26e-03	-0.01	2.69e-05	3.75e-05	0.0
169	69	3.00e-03	-2.02e-03	-0.01	2.66e-05	3.74e-05	0.0
170	1	3.59e-03	-2.70e-03	-0.05	7.52e-05	8.95e-05	0.0
170	3	3.04e-03	-2.29e-03	-0.04	6.36e-05	7.57e-05	0.0
170	7	0.01	-5.43e-03	-0.04	5.81e-05	6.98e-05	0.0
170	22	-6.30e-04	7.98e-03	-0.04	5.70e-05	6.86e-05	0.0
170	23	6.15e-03	-0.01	-0.04	5.87e-05	6.91e-05	0.0
170	39	6.09e-03	-3.21e-03	-0.04	5.79e-05	6.91e-05	0.0
170	54	1.61e-03	1.32e-03	-0.04	5.76e-05	6.88e-05	0.0
170	55	3.91e-03	-5.48e-03	-0.04	5.81e-05	6.89e-05	0.0
170	69	2.76e-03	-2.08e-03	-0.04	5.79e-05	6.88e-05	0.0
171	1	3.62e-03	-2.68e-03	-0.04	5.40e-05	6.96e-05	0.0
171	3	3.06e-03	-2.27e-03	-0.04	4.57e-05	5.89e-05	0.0
171	7	0.01	-5.43e-03	-0.03	4.17e-05	5.45e-05	0.0

Parco Eolico "Bolina" – Progetto Definitivo
Relazione di calcolo preliminare delle fondazioni degli aerogeneratori G8 e G12

171	22	-6.74e-04	7.82e-03	-0.03	4.06e-05	5.33e-05	0.0
171	23	6.24e-03	-0.01	-0.03	4.24e-05	5.38e-05	0.0
171	39	6.06e-03	-3.20e-03	-0.03	4.16e-05	5.39e-05	0.0
171	54	1.61e-03	1.28e-03	-0.03	4.12e-05	5.35e-05	0.0
171	55	3.95e-03	-5.41e-03	-0.03	4.18e-05	5.36e-05	0.0
171	69	2.78e-03	-2.06e-03	-0.03	4.15e-05	5.36e-05	0.0
172	1	3.65e-03	-2.66e-03	-0.04	4.18e-05	5.73e-05	0.0
172	3	3.09e-03	-2.25e-03	-0.03	3.54e-05	4.84e-05	0.0
172	7	0.01	-5.44e-03	-0.03	3.24e-05	4.49e-05	0.0
172	22	-7.10e-04	7.72e-03	-0.03	3.12e-05	4.38e-05	0.0
172	23	6.32e-03	-0.01	-0.03	3.31e-05	4.43e-05	0.0
172	39	6.03e-03	-3.19e-03	-0.03	3.22e-05	4.43e-05	0.0
172	54	1.62e-03	1.26e-03	-0.03	3.18e-05	4.40e-05	0.0
172	55	3.99e-03	-5.35e-03	-0.03	3.25e-05	4.41e-05	0.0
172	69	2.81e-03	-2.04e-03	-0.03	3.22e-05	4.40e-05	0.0
173	1	3.68e-03	-2.63e-03	-0.03	3.58e-05	4.95e-05	0.0
173	3	3.11e-03	-2.23e-03	-0.03	3.03e-05	4.19e-05	0.0
173	7	0.01	-5.46e-03	-0.02	2.78e-05	3.90e-05	0.0
173	22	-7.45e-04	7.63e-03	-0.03	2.66e-05	3.78e-05	0.0
173	23	6.41e-03	-0.01	-0.02	2.85e-05	3.83e-05	0.0
173	39	6.00e-03	-3.19e-03	-0.02	2.76e-05	3.84e-05	0.0
173	54	1.62e-03	1.24e-03	-0.02	2.72e-05	3.80e-05	0.0
173	55	4.04e-03	-5.29e-03	-0.02	2.78e-05	3.82e-05	0.0
173	69	2.83e-03	-2.02e-03	-0.02	2.75e-05	3.81e-05	0.0
174	1	3.72e-03	-2.60e-03	-0.03	3.33e-05	4.48e-05	0.0
174	3	3.14e-03	-2.20e-03	-0.02	2.82e-05	3.79e-05	0.0
174	7	0.01	-5.48e-03	-0.02	2.60e-05	3.54e-05	0.0
174	22	-7.84e-04	7.56e-03	-0.02	2.47e-05	3.42e-05	0.0
174	23	6.50e-03	-0.01	-0.02	2.66e-05	3.48e-05	0.0
174	39	5.98e-03	-3.18e-03	-0.02	2.58e-05	3.48e-05	0.0
174	54	1.63e-03	1.23e-03	-0.02	2.53e-05	3.44e-05	0.0
174	55	4.09e-03	-5.24e-03	-0.02	2.60e-05	3.46e-05	0.0
174	69	2.86e-03	-2.00e-03	-0.02	2.57e-05	3.45e-05	0.0
175	1	3.76e-03	-2.58e-03	-0.02	3.27e-05	4.21e-05	0.0
175	3	3.18e-03	-2.18e-03	-0.02	2.77e-05	3.57e-05	0.0
175	7	0.01	-5.50e-03	-0.02	2.55e-05	3.34e-05	0.0
175	22	-8.24e-04	7.49e-03	-0.02	2.41e-05	3.21e-05	0.0
175	23	6.60e-03	-0.01	-0.02	2.62e-05	3.28e-05	0.0
175	39	5.97e-03	-3.17e-03	-0.02	2.53e-05	3.28e-05	0.0
175	54	1.63e-03	1.22e-03	-0.02	2.48e-05	3.23e-05	0.0
175	55	4.15e-03	-5.19e-03	-0.02	2.55e-05	3.25e-05	0.0
175	69	2.89e-03	-1.98e-03	-0.02	2.52e-05	3.24e-05	0.0
176	1	3.79e-03	-2.55e-03	-0.02	3.31e-05	4.11e-05	0.0
176	3	3.21e-03	-2.16e-03	-0.02	2.80e-05	3.47e-05	0.0
176	7	0.01	-5.53e-03	-0.01	2.58e-05	3.26e-05	0.0
176	22	-8.69e-04	7.44e-03	-0.01	2.44e-05	3.12e-05	0.0
176	23	6.71e-03	-0.01	-0.01	2.65e-05	3.19e-05	0.0
176	39	5.97e-03	-3.17e-03	-0.01	2.56e-05	3.19e-05	0.0
176	54	1.64e-03	1.22e-03	-0.01	2.51e-05	3.15e-05	0.0
176	55	4.20e-03	-5.14e-03	-0.01	2.58e-05	3.17e-05	0.0
176	69	2.92e-03	-1.96e-03	-0.01	2.54e-05	3.16e-05	0.0
177	1	3.84e-03	-2.52e-03	-0.01	3.29e-05	4.14e-05	0.0
177	3	3.25e-03	-2.13e-03	-0.01	2.79e-05	3.50e-05	0.0
177	7	0.01	-5.56e-03	-9.52e-03	2.57e-05	3.28e-05	0.0
177	22	-9.16e-04	7.40e-03	-0.01	2.43e-05	3.15e-05	0.0
177	23	6.82e-03	-0.01	-9.32e-03	2.64e-05	3.22e-05	0.0
177	39	5.96e-03	-3.17e-03	-0.01	2.55e-05	3.21e-05	0.0
177	54	1.64e-03	1.22e-03	-0.01	2.50e-05	3.17e-05	0.0
177	55	4.26e-03	-5.10e-03	-1.00e-02	2.57e-05	3.19e-05	0.0
177	69	2.95e-03	-1.94e-03	-0.01	2.53e-05	3.18e-05	0.0
178	1	3.57e-03	-2.66e-03	-0.04	7.06e-05	7.07e-05	0.0
178	3	3.02e-03	-2.25e-03	-0.04	5.98e-05	5.98e-05	0.0
178	6	-7.12e-03	1.34e-03	-0.03	5.41e-05	5.34e-05	0.0
178	7	0.01	-5.44e-03	-0.03	5.46e-05	5.53e-05	0.0
178	23	6.14e-03	-0.01	-0.03	5.53e-05	5.46e-05	0.0
178	38	-5.91e-04	-9.00e-04	-0.03	5.43e-05	5.41e-05	0.0
178	39	6.09e-03	-3.20e-03	-0.03	5.44e-05	5.47e-05	0.0
178	55	3.90e-03	-5.39e-03	-0.03	5.47e-05	5.44e-05	0.0
178	69	2.75e-03	-2.05e-03	-0.03	5.43e-05	5.44e-05	0.0
179	1	3.61e-03	-2.65e-03	-0.04	5.34e-05	5.35e-05	0.0
179	3	3.05e-03	-2.24e-03	-0.03	4.52e-05	4.52e-05	0.0
179	6	-6.94e-03	1.40e-03	-0.03	4.06e-05	3.97e-05	0.0
179	7	0.01	-5.47e-03	-0.03	4.15e-05	4.25e-05	0.0

Parco Eolico "Bolina" – Progetto Definitivo
Relazione di calcolo preliminare delle fondazioni degli aerogeneratori G8 e G12

179	23	6.21e-03	-0.01	-0.03	4.25e-05	4.15e-05	0.0
179	38	-5.12e-04	-8.74e-04	-0.03	4.09e-05	4.06e-05	0.0
179	39	6.06e-03	-3.20e-03	-0.03	4.12e-05	4.16e-05	0.0
179	55	3.94e-03	-5.32e-03	-0.03	4.15e-05	4.13e-05	0.0
179	69	2.77e-03	-2.04e-03	-0.03	4.11e-05	4.11e-05	0.0
180	1	3.62e-03	-2.60e-03	-0.03	4.46e-05	4.46e-05	0.0
180	3	3.06e-03	-2.20e-03	-0.03	3.78e-05	3.78e-05	0.0
180	6	-6.81e-03	1.48e-03	-0.03	3.40e-05	3.34e-05	0.0
180	7	0.01	-5.49e-03	-0.03	3.46e-05	3.53e-05	0.0
180	23	6.27e-03	-0.01	-0.03	3.53e-05	3.46e-05	0.0
180	38	-4.62e-04	-8.24e-04	-0.03	3.42e-05	3.40e-05	0.0
180	39	6.03e-03	-3.18e-03	-0.03	3.44e-05	3.47e-05	0.0
180	55	3.96e-03	-5.25e-03	-0.03	3.47e-05	3.44e-05	0.0
180	69	2.78e-03	-2.00e-03	-0.03	3.43e-05	3.43e-05	0.0
181	1	3.64e-03	-2.57e-03	-0.03	3.94e-05	3.94e-05	0.0
181	3	3.08e-03	-2.17e-03	-0.02	3.34e-05	3.34e-05	0.0
181	6	-6.67e-03	1.56e-03	-0.02	3.00e-05	2.94e-05	0.0
181	7	0.01	-5.51e-03	-0.02	3.06e-05	3.13e-05	0.0
181	23	6.34e-03	-0.01	-0.02	3.13e-05	3.06e-05	0.0
181	38	-4.04e-04	-7.81e-04	-0.02	3.02e-05	3.00e-05	0.0
181	39	6.01e-03	-3.17e-03	-0.02	3.04e-05	3.07e-05	0.0
181	55	4.00e-03	-5.18e-03	-0.02	3.06e-05	3.04e-05	0.0
181	69	2.80e-03	-1.98e-03	-0.02	3.03e-05	3.03e-05	0.0
182	1	3.67e-03	-2.54e-03	-0.02	3.67e-05	3.68e-05	0.0
182	3	3.11e-03	-2.15e-03	-0.02	3.11e-05	3.11e-05	0.0
182	6	-6.55e-03	1.64e-03	-0.02	2.79e-05	2.72e-05	0.0
182	7	0.01	-5.54e-03	-0.02	2.86e-05	2.93e-05	0.0
182	23	6.41e-03	-0.01	-0.02	2.93e-05	2.87e-05	0.0
182	38	-3.47e-04	-7.38e-04	-0.02	2.81e-05	2.79e-05	0.0
182	39	5.99e-03	-3.17e-03	-0.02	2.84e-05	2.86e-05	0.0
182	55	4.04e-03	-5.12e-03	-0.02	2.86e-05	2.84e-05	0.0
182	69	2.82e-03	-1.95e-03	-0.02	2.83e-05	2.83e-05	0.0
183	1	3.70e-03	-2.51e-03	-0.02	3.50e-05	3.51e-05	0.0
183	3	3.13e-03	-2.13e-03	-0.02	2.96e-05	2.97e-05	0.0
183	6	-6.41e-03	1.71e-03	-0.02	2.64e-05	2.55e-05	0.0
183	7	0.01	-5.58e-03	-0.02	2.75e-05	2.85e-05	0.0
183	23	6.49e-03	-0.01	-0.02	2.84e-05	2.75e-05	0.0
183	38	-2.86e-04	-6.99e-04	-0.02	2.68e-05	2.65e-05	0.0
183	39	5.98e-03	-3.16e-03	-0.02	2.71e-05	2.75e-05	0.0
183	55	4.08e-03	-5.07e-03	-0.02	2.74e-05	2.72e-05	0.0
183	69	2.85e-03	-1.93e-03	-0.02	2.69e-05	2.70e-05	0.0
184	1	3.73e-03	-2.47e-03	-0.02	3.53e-05	3.53e-05	0.0
184	3	3.16e-03	-2.09e-03	-0.01	2.98e-05	2.99e-05	0.0
184	6	-6.32e-03	1.80e-03	-0.01	2.67e-05	2.60e-05	0.0
184	7	0.01	-5.61e-03	-0.01	2.76e-05	2.83e-05	0.0
184	23	6.57e-03	-0.01	-0.01	2.82e-05	2.76e-05	0.0
184	38	-2.39e-04	-6.48e-04	-0.01	2.70e-05	2.68e-05	0.0
184	39	5.98e-03	-3.16e-03	-0.01	2.73e-05	2.75e-05	0.0
184	55	4.12e-03	-5.01e-03	-0.01	2.75e-05	2.73e-05	0.0
184	69	2.87e-03	-1.90e-03	-0.01	2.71e-05	2.71e-05	0.0
185	1	3.76e-03	-2.44e-03	-0.01	3.54e-05	3.54e-05	0.0
185	3	3.18e-03	-2.06e-03	-0.01	3.00e-05	3.00e-05	0.0
185	6	-6.21e-03	1.89e-03	-0.01	2.68e-05	2.62e-05	0.0
185	7	0.01	-5.65e-03	-8.17e-03	2.77e-05	2.83e-05	0.0
185	23	6.66e-03	-0.01	-8.17e-03	2.83e-05	2.77e-05	0.0
185	38	-1.89e-04	-6.01e-04	-9.43e-03	2.71e-05	2.69e-05	0.0
185	39	5.97e-03	-3.15e-03	-8.80e-03	2.74e-05	2.76e-05	0.0
185	55	4.17e-03	-4.96e-03	-8.80e-03	2.76e-05	2.74e-05	0.0
185	69	2.89e-03	-1.88e-03	-9.12e-03	2.73e-05	2.73e-05	0.0
186	1	3.53e-03	-2.65e-03	-0.05	8.95e-05	7.52e-05	0.0
186	3	2.99e-03	-2.24e-03	-0.04	7.57e-05	6.37e-05	0.0
186	6	-7.34e-03	1.35e-03	-0.04	6.86e-05	5.70e-05	0.0
186	7	0.01	-5.43e-03	-0.04	6.90e-05	5.87e-05	0.0
186	23	6.07e-03	-0.01	-0.04	6.97e-05	5.81e-05	0.0
186	38	-6.86e-04	-8.89e-04	-0.04	6.87e-05	5.76e-05	0.0
186	39	6.12e-03	-3.18e-03	-0.04	6.89e-05	5.82e-05	0.0
186	55	3.85e-03	-5.37e-03	-0.04	6.91e-05	5.79e-05	0.0
186	69	2.72e-03	-2.04e-03	-0.04	6.88e-05	5.79e-05	0.0
187	1	3.55e-03	-2.61e-03	-0.04	6.96e-05	5.40e-05	0.0
187	3	3.00e-03	-2.21e-03	-0.04	5.89e-05	4.57e-05	0.0
187	6	-7.16e-03	1.45e-03	-0.03	5.33e-05	4.07e-05	0.0
187	7	0.01	-5.47e-03	-0.03	5.38e-05	4.24e-05	0.0
187	23	6.09e-03	-0.01	-0.03	5.45e-05	4.18e-05	0.0

Parco Eolico "Bolina" – Progetto Definitivo
Relazione di calcolo preliminare delle fondazioni degli aerogeneratori G8 e G12

187	38	-6.17e-04	-8.40e-04	-0.03	5.35e-05	4.12e-05	0.0
187	39	6.07e-03	-3.18e-03	-0.03	5.36e-05	4.18e-05	0.0
187	55	3.87e-03	-5.29e-03	-0.03	5.38e-05	4.16e-05	0.0
187	69	2.73e-03	-2.01e-03	-0.03	5.35e-05	4.15e-05	0.0
188	1	3.56e-03	-2.57e-03	-0.04	5.72e-05	4.18e-05	0.0
188	3	3.02e-03	-2.18e-03	-0.03	4.84e-05	3.54e-05	0.0
188	6	-7.02e-03	1.54e-03	-0.03	4.38e-05	3.13e-05	0.0
188	7	0.01	-5.50e-03	-0.03	4.42e-05	3.31e-05	0.0
188	23	6.14e-03	-0.01	-0.03	4.49e-05	3.24e-05	0.0
188	38	-5.61e-04	-7.90e-04	-0.03	4.40e-05	3.19e-05	0.0
188	39	6.04e-03	-3.17e-03	-0.03	4.41e-05	3.25e-05	0.0
188	55	3.89e-03	-5.20e-03	-0.03	4.43e-05	3.23e-05	0.0
188	69	2.74e-03	-1.98e-03	-0.03	4.40e-05	3.22e-05	0.0
189	1	3.58e-03	-2.53e-03	-0.03	4.95e-05	3.58e-05	0.0
189	3	3.03e-03	-2.14e-03	-0.03	4.19e-05	3.03e-05	0.0
189	6	-6.90e-03	1.63e-03	-0.03	3.78e-05	2.66e-05	0.0
189	7	0.01	-5.53e-03	-0.02	3.83e-05	2.85e-05	0.0
189	23	6.19e-03	-0.01	-0.02	3.89e-05	2.78e-05	0.0
189	38	-5.10e-04	-7.38e-04	-0.02	3.80e-05	2.72e-05	0.0
189	39	6.02e-03	-3.16e-03	-0.02	3.81e-05	2.79e-05	0.0
189	55	3.92e-03	-5.12e-03	-0.02	3.84e-05	2.76e-05	0.0
189	69	2.76e-03	-1.95e-03	-0.02	3.81e-05	2.75e-05	0.0
190	1	3.60e-03	-2.49e-03	-0.03	4.48e-05	3.34e-05	0.0
190	3	3.05e-03	-2.11e-03	-0.02	3.79e-05	2.82e-05	0.0
190	6	-6.79e-03	1.73e-03	-0.02	3.42e-05	2.47e-05	0.0
190	7	0.01	-5.56e-03	-0.02	3.48e-05	2.66e-05	0.0
190	23	6.24e-03	-0.01	-0.02	3.54e-05	2.60e-05	0.0
190	38	-4.64e-04	-6.85e-04	-0.02	3.44e-05	2.53e-05	0.0
190	39	6.00e-03	-3.15e-03	-0.02	3.46e-05	2.60e-05	0.0
190	55	3.95e-03	-5.04e-03	-0.02	3.48e-05	2.58e-05	0.0
190	69	2.77e-03	-1.92e-03	-0.02	3.45e-05	2.57e-05	0.0
191	1	3.62e-03	-2.46e-03	-0.02	4.21e-05	3.27e-05	0.0
191	3	3.07e-03	-2.08e-03	-0.02	3.56e-05	2.77e-05	0.0
191	6	-6.69e-03	1.83e-03	-0.02	3.20e-05	2.41e-05	0.0
191	7	0.01	-5.60e-03	-0.02	3.27e-05	2.63e-05	0.0
191	23	6.31e-03	-0.01	-0.02	3.34e-05	2.56e-05	0.0
191	38	-4.18e-04	-6.32e-04	-0.02	3.23e-05	2.48e-05	0.0
191	39	5.99e-03	-3.15e-03	-0.02	3.25e-05	2.55e-05	0.0
191	55	3.98e-03	-4.97e-03	-0.02	3.27e-05	2.53e-05	0.0
191	69	2.79e-03	-1.89e-03	-0.02	3.24e-05	2.52e-05	0.0
192	1	3.65e-03	-2.41e-03	-0.02	4.10e-05	3.31e-05	0.0
192	3	3.08e-03	-2.04e-03	-0.02	3.47e-05	2.80e-05	0.0
192	6	-6.60e-03	1.93e-03	-0.01	3.12e-05	2.44e-05	0.0
192	7	0.01	-5.65e-03	-0.01	3.19e-05	2.65e-05	0.0
192	23	6.37e-03	-0.01	-0.01	3.26e-05	2.58e-05	0.0
192	38	-3.76e-04	-5.75e-04	-0.01	3.14e-05	2.51e-05	0.0
192	39	5.98e-03	-3.14e-03	-0.01	3.17e-05	2.58e-05	0.0
192	55	4.01e-03	-4.90e-03	-0.01	3.19e-05	2.56e-05	0.0
192	69	2.80e-03	-1.86e-03	-0.01	3.16e-05	2.55e-05	0.0
193	1	3.67e-03	-2.37e-03	-0.01	4.13e-05	3.30e-05	0.0
193	3	3.11e-03	-2.01e-03	-0.01	3.50e-05	2.79e-05	0.0
193	6	-6.51e-03	2.04e-03	-0.01	3.14e-05	2.43e-05	0.0
193	7	0.01	-5.70e-03	-9.32e-03	3.22e-05	2.64e-05	0.0
193	23	6.45e-03	-0.01	-9.52e-03	3.28e-05	2.57e-05	0.0
193	38	-3.36e-04	-5.17e-04	-0.01	3.17e-05	2.50e-05	0.0
193	39	5.98e-03	-3.14e-03	-1.00e-02	3.19e-05	2.57e-05	0.0
193	55	4.05e-03	-4.84e-03	-0.01	3.21e-05	2.55e-05	0.0
193	69	2.82e-03	-1.83e-03	-0.01	3.18e-05	2.53e-05	0.0
194	1	3.49e-03	-2.63e-03	-0.06	1.11e-04	8.42e-05	0.0
194	3	2.95e-03	-2.23e-03	-0.05	9.40e-05	7.12e-05	0.0
194	6	-7.48e-03	1.39e-03	-0.04	8.53e-05	6.39e-05	0.0
194	7	0.01	-5.44e-03	-0.04	8.57e-05	6.56e-05	0.0
194	23	5.93e-03	-0.01	-0.04	8.64e-05	6.50e-05	0.0
194	38	-7.57e-04	-8.70e-04	-0.04	8.54e-05	6.45e-05	0.0
194	39	6.12e-03	-3.18e-03	-0.04	8.56e-05	6.50e-05	0.0
194	55	3.78e-03	-5.37e-03	-0.04	8.58e-05	6.48e-05	0.0
194	69	2.68e-03	-2.03e-03	-0.04	8.55e-05	6.47e-05	0.0
195	1	3.50e-03	-2.60e-03	-0.05	8.74e-05	5.86e-05	0.0
195	3	2.96e-03	-2.20e-03	-0.04	7.40e-05	4.96e-05	0.0
195	6	-7.35e-03	1.46e-03	-0.04	6.70e-05	4.42e-05	0.0
195	7	0.01	-5.45e-03	-0.04	6.75e-05	4.59e-05	0.0
195	23	5.95e-03	-0.01	-0.04	6.81e-05	4.53e-05	0.0
195	38	-7.08e-04	-8.29e-04	-0.04	6.72e-05	4.48e-05	0.0

Parco Eolico "Bolina" – Progetto Definitivo
Relazione di calcolo preliminare delle fondazioni degli aerogeneratori G8 e G12

195	39	6.09e-03	-3.17e-03	-0.04	6.73e-05	4.53e-05	0.0
195	55	3.79e-03	-5.26e-03	-0.04	6.75e-05	4.51e-05	0.0
195	69	2.69e-03	-2.00e-03	-0.04	6.72e-05	4.50e-05	0.0
196	1	3.51e-03	-2.55e-03	-0.04	7.25e-05	4.45e-05	0.0
196	3	2.97e-03	-2.16e-03	-0.04	6.13e-05	3.77e-05	0.0
196	6	-7.23e-03	1.55e-03	-0.03	5.55e-05	3.34e-05	0.0
196	7	0.01	-5.48e-03	-0.03	5.60e-05	3.51e-05	0.0
196	23	5.97e-03	-0.01	-0.03	5.66e-05	3.45e-05	0.0
196	38	-6.60e-04	-7.75e-04	-0.03	5.57e-05	3.40e-05	0.0
196	39	6.06e-03	-3.15e-03	-0.03	5.58e-05	3.45e-05	0.0
196	55	3.81e-03	-5.16e-03	-0.03	5.61e-05	3.43e-05	0.0
196	69	2.70e-03	-1.96e-03	-0.03	5.58e-05	3.42e-05	0.0
197	1	3.52e-03	-2.51e-03	-0.04	6.24e-05	3.76e-05	0.0
197	3	2.98e-03	-2.12e-03	-0.03	5.28e-05	3.18e-05	0.0
197	6	-7.12e-03	1.65e-03	-0.03	4.77e-05	2.80e-05	0.0
197	7	0.01	-5.51e-03	-0.03	4.82e-05	2.98e-05	0.0
197	23	6.00e-03	-0.01	-0.03	4.89e-05	2.92e-05	0.0
197	38	-6.18e-04	-7.17e-04	-0.03	4.79e-05	2.86e-05	0.0
197	39	6.03e-03	-3.14e-03	-0.03	4.81e-05	2.92e-05	0.0
197	55	3.82e-03	-5.07e-03	-0.03	4.83e-05	2.90e-05	0.0
197	69	2.71e-03	-1.93e-03	-0.03	4.80e-05	2.89e-05	0.0
198	1	3.53e-03	-2.47e-03	-0.03	5.54e-05	3.49e-05	0.0
198	3	2.99e-03	-2.09e-03	-0.03	4.69e-05	2.96e-05	0.0
198	6	-7.02e-03	1.76e-03	-0.03	4.23e-05	2.58e-05	0.0
198	7	0.01	-5.55e-03	-0.02	4.29e-05	2.79e-05	0.0
198	23	6.04e-03	-0.01	-0.02	4.35e-05	2.72e-05	0.0
198	38	-5.79e-04	-6.59e-04	-0.03	4.25e-05	2.65e-05	0.0
198	39	6.01e-03	-3.13e-03	-0.02	4.27e-05	2.72e-05	0.0
198	55	3.84e-03	-4.98e-03	-0.02	4.29e-05	2.70e-05	0.0
198	69	2.72e-03	-1.90e-03	-0.03	4.26e-05	2.69e-05	0.0
199	1	3.55e-03	-2.43e-03	-0.03	4.97e-05	3.39e-05	0.0
199	3	3.00e-03	-2.06e-03	-0.02	4.20e-05	2.87e-05	0.0
199	6	-6.93e-03	1.86e-03	-0.02	3.77e-05	2.46e-05	0.0
199	7	0.01	-5.60e-03	-0.02	3.87e-05	2.75e-05	0.0
199	23	6.08e-03	-0.01	-0.02	3.96e-05	2.66e-05	0.0
199	38	-5.39e-04	-6.08e-04	-0.02	3.81e-05	2.55e-05	0.0
199	39	6.00e-03	-3.13e-03	-0.02	3.84e-05	2.66e-05	0.0
199	55	3.86e-03	-4.91e-03	-0.02	3.87e-05	2.62e-05	0.0
199	69	2.73e-03	-1.87e-03	-0.02	3.82e-05	2.60e-05	0.0
200	1	3.56e-03	-2.38e-03	-0.02	4.80e-05	3.46e-05	0.0
200	3	3.01e-03	-2.01e-03	-0.02	4.06e-05	2.93e-05	0.0
200	6	-6.87e-03	1.99e-03	-0.02	3.66e-05	2.54e-05	0.0
200	7	0.01	-5.65e-03	-0.02	3.73e-05	2.78e-05	0.0
200	23	6.12e-03	-0.01	-0.02	3.79e-05	2.71e-05	0.0
200	38	-5.13e-04	-5.36e-04	-0.02	3.68e-05	2.62e-05	0.0
200	39	5.99e-03	-3.12e-03	-0.02	3.70e-05	2.70e-05	0.0
200	55	3.88e-03	-4.82e-03	-0.02	3.73e-05	2.68e-05	0.0
200	69	2.74e-03	-1.83e-03	-0.02	3.69e-05	2.66e-05	0.0
201	1	3.58e-03	-2.33e-03	-0.02	4.86e-05	3.45e-05	0.0
201	3	3.03e-03	-1.97e-03	-0.02	4.11e-05	2.92e-05	0.0
201	6	-6.81e-03	2.11e-03	-0.01	3.70e-05	2.54e-05	0.0
201	7	0.01	-5.70e-03	-0.01	3.77e-05	2.77e-05	0.0
201	23	6.17e-03	-0.01	-0.01	3.83e-05	2.70e-05	0.0
201	38	-4.85e-04	-4.70e-04	-0.01	3.73e-05	2.62e-05	0.0
201	39	5.99e-03	-3.11e-03	-0.01	3.75e-05	2.70e-05	0.0
201	55	3.91e-03	-4.75e-03	-0.01	3.77e-05	2.67e-05	0.0
201	69	2.75e-03	-1.79e-03	-0.01	3.74e-05	2.66e-05	0.0
202	1	3.44e-03	-2.63e-03	-0.07	1.29e-04	9.62e-05	0.0
202	3	2.91e-03	-2.23e-03	-0.06	1.09e-04	8.14e-05	0.0
202	6	-7.65e-03	1.41e-03	-0.05	9.90e-05	7.31e-05	0.0
202	7	0.01	-5.46e-03	-0.05	9.96e-05	7.49e-05	0.0
202	23	5.80e-03	-0.01	-0.05	1.00e-04	7.42e-05	0.0
202	38	-8.37e-04	-8.65e-04	-0.05	9.92e-05	7.37e-05	0.0
202	39	6.13e-03	-3.19e-03	-0.05	9.94e-05	7.43e-05	0.0
202	55	3.72e-03	-5.36e-03	-0.05	9.96e-05	7.41e-05	0.0
202	69	2.65e-03	-2.03e-03	-0.05	9.93e-05	7.40e-05	0.0
203	1	3.45e-03	-2.59e-03	-0.06	1.04e-04	6.92e-05	0.0
203	3	2.92e-03	-2.20e-03	-0.05	8.81e-05	5.85e-05	0.0
203	6	-7.51e-03	1.43e-03	-0.05	7.98e-05	5.23e-05	0.0
203	7	0.01	-5.43e-03	-0.04	8.03e-05	5.41e-05	0.0
203	23	5.78e-03	-0.01	-0.04	8.11e-05	5.35e-05	0.0
203	38	-7.85e-04	-8.36e-04	-0.04	8.00e-05	5.29e-05	0.0
203	39	6.09e-03	-3.16e-03	-0.04	8.02e-05	5.35e-05	0.0

Parco Eolico "Bolina" – Progetto Definitivo
Relazione di calcolo preliminare delle fondazioni degli aerogeneratori G8 e G12

203	55	3.71e-03	-5.25e-03	-0.04	8.04e-05	5.33e-05	0.0
203	69	2.65e-03	-2.00e-03	-0.04	8.01e-05	5.32e-05	0.0
204	1	3.45e-03	-2.55e-03	-0.05	8.74e-05	5.36e-05	0.0
204	3	2.92e-03	-2.15e-03	-0.04	7.39e-05	4.54e-05	0.0
204	6	-7.41e-03	1.53e-03	-0.04	6.69e-05	4.04e-05	0.0
204	7	0.01	-5.45e-03	-0.04	6.75e-05	4.21e-05	0.0
204	23	5.78e-03	-0.01	-0.04	6.81e-05	4.15e-05	0.0
204	38	-7.49e-04	-7.78e-04	-0.04	6.71e-05	4.10e-05	0.0
204	39	6.06e-03	-3.14e-03	-0.04	6.73e-05	4.15e-05	0.0
204	55	3.71e-03	-5.14e-03	-0.04	6.75e-05	4.14e-05	0.0
204	69	2.66e-03	-1.96e-03	-0.04	6.72e-05	4.13e-05	0.0
205	1	3.45e-03	-2.49e-03	-0.05	7.51e-05	4.59e-05	0.0
205	3	2.92e-03	-2.11e-03	-0.04	6.36e-05	3.89e-05	0.0
205	6	-7.32e-03	1.64e-03	-0.04	5.75e-05	3.44e-05	0.0
205	7	0.01	-5.48e-03	-0.03	5.81e-05	3.62e-05	0.0
205	23	5.79e-03	-0.01	-0.04	5.87e-05	3.56e-05	0.0
205	38	-7.20e-04	-7.14e-04	-0.04	5.77e-05	3.50e-05	0.0
205	39	6.04e-03	-3.12e-03	-0.04	5.79e-05	3.56e-05	0.0
205	55	3.72e-03	-5.04e-03	-0.04	5.81e-05	3.54e-05	0.0
205	69	2.66e-03	-1.92e-03	-0.04	5.78e-05	3.53e-05	0.0
206	1	3.46e-03	-2.45e-03	-0.04	6.57e-05	4.26e-05	0.0
206	3	2.93e-03	-2.07e-03	-0.03	5.56e-05	3.60e-05	0.0
206	6	-7.26e-03	1.75e-03	-0.03	5.03e-05	3.18e-05	0.0
206	7	0.01	-5.52e-03	-0.03	5.08e-05	3.37e-05	0.0
206	23	5.80e-03	-0.01	-0.03	5.15e-05	3.31e-05	0.0
206	38	-6.95e-04	-6.52e-04	-0.03	5.05e-05	3.24e-05	0.0
206	39	6.02e-03	-3.11e-03	-0.03	5.07e-05	3.31e-05	0.0
206	55	3.72e-03	-4.94e-03	-0.03	5.09e-05	3.29e-05	0.0
206	69	2.66e-03	-1.88e-03	-0.03	5.06e-05	3.28e-05	0.0
207	1	3.46e-03	-2.40e-03	-0.04	5.88e-05	4.14e-05	0.0
207	3	2.93e-03	-2.03e-03	-0.03	4.98e-05	3.50e-05	0.0
207	6	-7.20e-03	1.87e-03	-0.03	4.49e-05	3.07e-05	0.0
207	7	0.01	-5.57e-03	-0.03	4.55e-05	3.29e-05	0.0
207	23	5.81e-03	-0.01	-0.03	4.62e-05	3.22e-05	0.0
207	38	-6.72e-04	-5.90e-04	-0.03	4.51e-05	3.14e-05	0.0
207	39	6.00e-03	-3.11e-03	-0.03	4.53e-05	3.22e-05	0.0
207	55	3.73e-03	-4.86e-03	-0.03	4.56e-05	3.19e-05	0.0
207	69	2.66e-03	-1.85e-03	-0.03	4.52e-05	3.18e-05	0.0
208	1	3.47e-03	-2.35e-03	-0.03	5.48e-05	4.15e-05	0.0
208	3	2.94e-03	-1.99e-03	-0.03	4.63e-05	3.51e-05	0.0
208	6	-7.15e-03	2.00e-03	-0.02	4.18e-05	3.08e-05	0.0
208	7	0.01	-5.62e-03	-0.02	4.24e-05	3.30e-05	0.0
208	23	5.83e-03	-0.01	-0.02	4.30e-05	3.23e-05	0.0
208	38	-6.54e-04	-5.22e-04	-0.02	4.20e-05	3.15e-05	0.0
208	39	5.99e-03	-3.10e-03	-0.02	4.22e-05	3.23e-05	0.0
208	55	3.74e-03	-4.77e-03	-0.02	4.24e-05	3.20e-05	0.0
208	69	2.67e-03	-1.81e-03	-0.02	4.21e-05	3.19e-05	0.0
209	1	3.48e-03	-2.31e-03	-0.03	5.53e-05	4.12e-05	0.0
209	3	2.94e-03	-1.95e-03	-0.02	4.68e-05	3.48e-05	0.0
209	6	-7.12e-03	2.12e-03	-0.02	4.23e-05	3.06e-05	0.0
209	7	0.01	-5.67e-03	-0.02	4.28e-05	3.28e-05	0.0
209	23	5.85e-03	-0.01	-0.02	4.34e-05	3.21e-05	0.0
209	38	-6.38e-04	-4.55e-04	-0.02	4.25e-05	3.13e-05	0.0
209	39	5.99e-03	-3.09e-03	-0.02	4.27e-05	3.20e-05	0.0
209	55	3.75e-03	-4.69e-03	-0.02	4.29e-05	3.18e-05	0.0
209	69	2.68e-03	-1.77e-03	-0.02	4.26e-05	3.17e-05	0.0
210	1	3.40e-03	-2.63e-03	-0.08	1.42e-04	1.14e-04	0.0
210	3	2.87e-03	-2.23e-03	-0.07	1.20e-04	9.60e-05	0.0
210	5	-7.80e-03	-4.51e-03	-0.06	1.10e-04	8.64e-05	0.0
210	8	0.01	4.58e-04	-0.06	1.09e-04	8.82e-05	0.0
210	23	5.63e-03	-0.01	-0.06	1.10e-04	8.76e-05	0.0
210	37	-9.10e-04	-2.87e-03	-0.06	1.09e-04	8.70e-05	0.0
210	40	6.14e-03	-1.19e-03	-0.06	1.09e-04	8.76e-05	0.0
210	55	3.63e-03	-5.35e-03	-0.06	1.10e-04	8.74e-05	0.0
210	69	2.61e-03	-2.03e-03	-0.06	1.09e-04	8.73e-05	0.0
211	1	3.42e-03	-2.62e-03	-0.07	1.14e-04	8.41e-05	0.0
211	3	2.89e-03	-2.22e-03	-0.06	9.66e-05	7.12e-05	0.0
211	5	-7.67e-03	-4.28e-03	-0.05	8.83e-05	6.33e-05	0.0
211	8	0.01	2.44e-04	-0.05	8.75e-05	6.61e-05	0.0
211	23	5.61e-03	-0.01	-0.05	8.93e-05	6.52e-05	0.0
211	37	-8.56e-04	-2.78e-03	-0.05	8.80e-05	6.43e-05	0.0
211	40	6.11e-03	-1.25e-03	-0.05	8.77e-05	6.52e-05	0.0
211	55	3.64e-03	-5.25e-03	-0.05	8.84e-05	6.49e-05	0.0

Parco Eolico "Bolina" – Progetto Definitivo
Relazione di calcolo preliminare delle fondazioni degli aerogeneratori G8 e G12

211	69	2.63e-03	-2.02e-03	-0.05	8.79e-05	6.47e-05	0.0
212	1	3.39e-03	-2.54e-03	-0.06	9.87e-05	6.93e-05	0.0
212	3	2.87e-03	-2.15e-03	-0.05	8.35e-05	5.86e-05	0.0
212	5	-7.62e-03	-4.01e-03	-0.05	7.62e-05	5.24e-05	0.0
212	8	0.01	9.56e-05	-0.05	7.56e-05	5.42e-05	0.0
212	23	5.57e-03	-0.01	-0.05	7.69e-05	5.36e-05	0.0
212	37	-8.52e-04	-2.65e-03	-0.05	7.60e-05	5.30e-05	0.0
212	40	6.08e-03	-1.26e-03	-0.05	7.58e-05	5.36e-05	0.0
212	55	3.61e-03	-5.13e-03	-0.05	7.62e-05	5.34e-05	0.0
212	69	2.61e-03	-1.96e-03	-0.05	7.59e-05	5.33e-05	0.0
213	1	3.39e-03	-2.49e-03	-0.06	8.46e-05	6.07e-05	0.0
213	3	2.87e-03	-2.11e-03	-0.05	7.16e-05	5.14e-05	0.0
213	5	-7.57e-03	-3.76e-03	-0.05	6.54e-05	4.58e-05	0.0
213	8	0.01	-7.12e-05	-0.04	6.48e-05	4.76e-05	0.0
213	23	5.55e-03	-0.01	-0.04	6.60e-05	4.70e-05	0.0
213	37	-8.36e-04	-2.54e-03	-0.04	6.52e-05	4.64e-05	0.0
213	40	6.05e-03	-1.29e-03	-0.04	6.50e-05	4.70e-05	0.0
213	55	3.60e-03	-5.02e-03	-0.04	6.54e-05	4.68e-05	0.0
213	69	2.61e-03	-1.91e-03	-0.04	6.51e-05	4.67e-05	0.0
214	1	3.39e-03	-2.44e-03	-0.05	7.32e-05	5.61e-05	0.0
214	3	2.87e-03	-2.07e-03	-0.04	6.20e-05	4.74e-05	0.0
214	5	-7.52e-03	-3.52e-03	-0.04	5.66e-05	4.21e-05	0.0
214	8	0.01	-2.40e-04	-0.04	5.61e-05	4.42e-05	0.0
214	23	5.54e-03	-0.01	-0.04	5.73e-05	4.35e-05	0.0
214	37	-8.20e-04	-2.43e-03	-0.04	5.64e-05	4.28e-05	0.0
214	40	6.03e-03	-1.32e-03	-0.04	5.62e-05	4.35e-05	0.0
214	55	3.60e-03	-4.93e-03	-0.04	5.66e-05	4.32e-05	0.0
214	69	2.61e-03	-1.88e-03	-0.04	5.63e-05	4.31e-05	0.0
215	1	3.40e-03	-2.41e-03	-0.05	6.33e-05	5.24e-05	0.0
215	3	2.87e-03	-2.04e-03	-0.04	5.36e-05	4.43e-05	0.0
215	6	-7.41e-03	1.81e-03	-0.04	4.83e-05	3.88e-05	0.0
215	8	0.01	-4.20e-04	-0.03	4.83e-05	4.18e-05	0.0
215	23	5.53e-03	-0.01	-0.04	5.00e-05	4.08e-05	0.0
215	38	-7.79e-04	-6.16e-04	-0.04	4.85e-05	3.98e-05	0.0
215	40	6.02e-03	-1.37e-03	-0.04	4.86e-05	4.08e-05	0.0
215	55	3.60e-03	-4.85e-03	-0.04	4.91e-05	4.05e-05	0.0
215	69	2.61e-03	-1.86e-03	-0.04	4.87e-05	4.03e-05	0.0
216	1	3.39e-03	-2.35e-03	-0.04	5.92e-05	5.19e-05	0.0
216	3	2.86e-03	-1.99e-03	-0.04	5.01e-05	4.39e-05	0.0
216	6	-7.40e-03	1.95e-03	-0.03	4.53e-05	3.87e-05	0.0
216	8	0.01	-5.69e-04	-0.03	4.53e-05	4.11e-05	0.0
216	23	5.52e-03	-0.01	-0.03	4.65e-05	4.03e-05	0.0
216	38	-7.82e-04	-5.36e-04	-0.03	4.55e-05	3.95e-05	0.0
216	40	6.01e-03	-1.39e-03	-0.03	4.54e-05	4.03e-05	0.0
216	55	3.59e-03	-4.75e-03	-0.03	4.58e-05	4.00e-05	0.0
216	69	2.60e-03	-1.81e-03	-0.03	4.55e-05	3.99e-05	0.0
217	1	3.38e-03	-2.30e-03	-0.04	6.00e-05	5.17e-05	0.0
217	3	2.86e-03	-1.95e-03	-0.03	5.08e-05	4.38e-05	0.0
217	6	-7.39e-03	2.08e-03	-0.03	4.59e-05	3.86e-05	0.0
217	8	0.01	-7.30e-04	-0.03	4.59e-05	4.09e-05	0.0
217	23	5.51e-03	-0.01	-0.03	4.70e-05	4.02e-05	0.0
217	38	-7.80e-04	-4.67e-04	-0.03	4.61e-05	3.94e-05	0.0
217	40	6.01e-03	-1.42e-03	-0.03	4.61e-05	4.02e-05	0.0
217	55	3.59e-03	-4.67e-03	-0.03	4.65e-05	3.99e-05	0.0
217	69	2.60e-03	-1.77e-03	-0.03	4.62e-05	3.98e-05	0.0
218	1	3.35e-03	-2.64e-03	-0.09	1.45e-04	1.32e-04	0.0
218	3	2.83e-03	-2.23e-03	-0.08	1.22e-04	1.12e-04	0.0
218	5	-8.03e-03	-4.62e-03	-0.07	1.11e-04	1.01e-04	0.0
218	8	0.01	5.66e-04	-0.07	1.11e-04	1.02e-04	0.0
218	23	5.46e-03	-0.01	-0.07	1.12e-04	1.02e-04	0.0
218	37	-1.01e-03	-2.91e-03	-0.07	1.11e-04	1.01e-04	0.0
218	40	6.16e-03	-1.15e-03	-0.07	1.11e-04	1.02e-04	0.0
218	55	3.55e-03	-5.35e-03	-0.07	1.12e-04	1.02e-04	0.0
218	69	2.58e-03	-2.03e-03	-0.07	1.11e-04	1.02e-04	0.0
219	1	3.34e-03	-2.60e-03	-0.09	1.20e-04	1.06e-04	0.0
219	3	2.83e-03	-2.20e-03	-0.07	1.02e-04	8.98e-05	0.0
219	5	-7.95e-03	-4.32e-03	-0.07	9.29e-05	8.08e-05	0.0
219	8	0.01	3.29e-04	-0.07	9.24e-05	8.25e-05	0.0
219	23	5.40e-03	-0.01	-0.07	9.36e-05	8.20e-05	0.0
219	37	-9.89e-04	-2.78e-03	-0.07	9.27e-05	8.13e-05	0.0
219	40	6.13e-03	-1.21e-03	-0.07	9.25e-05	8.19e-05	0.0
219	55	3.53e-03	-5.24e-03	-0.07	9.30e-05	8.18e-05	0.0
219	69	2.57e-03	-2.00e-03	-0.07	9.26e-05	8.16e-05	0.0

Parco Eolico "Bolina" – Progetto Definitivo
Relazione di calcolo preliminare delle fondazioni degli aerogeneratori G8 e G12

220	1	3.33e-03	-2.54e-03	-0.08	1.02e-04	9.00e-05	0.0
220	3	2.82e-03	-2.15e-03	-0.07	8.67e-05	7.61e-05	0.0
220	5	-7.91e-03	-4.07e-03	-0.06	7.91e-05	6.83e-05	0.0
220	8	0.01	1.59e-04	-0.06	7.85e-05	7.00e-05	0.0
220	23	5.35e-03	-0.01	-0.06	7.97e-05	6.95e-05	0.0
220	37	-9.82e-04	-2.67e-03	-0.06	7.89e-05	6.89e-05	0.0
220	40	6.11e-03	-1.24e-03	-0.06	7.87e-05	6.95e-05	0.0
220	55	3.51e-03	-5.13e-03	-0.06	7.91e-05	6.93e-05	0.0
220	69	2.56e-03	-1.96e-03	-0.06	7.88e-05	6.92e-05	0.0
221	1	3.32e-03	-2.50e-03	-0.07	8.75e-05	7.99e-05	0.0
221	3	2.81e-03	-2.11e-03	-0.06	7.40e-05	6.76e-05	0.0
221	5	-7.89e-03	-3.84e-03	-0.06	6.76e-05	6.06e-05	0.0
221	8	0.01	-1.81e-06	-0.05	6.70e-05	6.24e-05	0.0
221	23	5.31e-03	-0.01	-0.06	6.82e-05	6.18e-05	0.0
221	37	-9.78e-04	-2.57e-03	-0.06	6.74e-05	6.12e-05	0.0
221	40	6.09e-03	-1.27e-03	-0.06	6.72e-05	6.18e-05	0.0
221	55	3.49e-03	-5.03e-03	-0.06	6.76e-05	6.16e-05	0.0
221	69	2.56e-03	-1.92e-03	-0.06	6.73e-05	6.15e-05	0.0
222	1	3.31e-03	-2.45e-03	-0.07	7.52e-05	7.34e-05	0.0
222	3	2.80e-03	-2.07e-03	-0.06	6.37e-05	6.21e-05	0.0
222	5	-7.88e-03	-3.61e-03	-0.05	5.82e-05	5.55e-05	0.0
222	8	0.01	-1.62e-04	-0.05	5.76e-05	5.74e-05	0.0
222	23	5.26e-03	-0.01	-0.05	5.88e-05	5.68e-05	0.0
222	37	-9.80e-04	-2.47e-03	-0.05	5.80e-05	5.61e-05	0.0
222	40	6.08e-03	-1.30e-03	-0.05	5.78e-05	5.68e-05	0.0
222	55	3.47e-03	-4.94e-03	-0.05	5.82e-05	5.66e-05	0.0
222	69	2.55e-03	-1.89e-03	-0.05	5.79e-05	5.65e-05	0.0
223	1	3.31e-03	-2.41e-03	-0.06	6.58e-05	6.88e-05	0.0
223	3	2.80e-03	-2.04e-03	-0.05	5.57e-05	5.82e-05	0.0
223	5	-7.88e-03	-3.38e-03	-0.05	5.09e-05	5.18e-05	0.0
223	8	0.01	-3.21e-04	-0.05	5.03e-05	5.40e-05	0.0
223	23	5.23e-03	-0.01	-0.05	5.16e-05	5.33e-05	0.0
223	37	-9.84e-04	-2.37e-03	-0.05	5.07e-05	5.25e-05	0.0
223	40	6.07e-03	-1.33e-03	-0.05	5.05e-05	5.33e-05	0.0
223	55	3.45e-03	-4.85e-03	-0.05	5.09e-05	5.30e-05	0.0
223	69	2.54e-03	-1.85e-03	-0.05	5.06e-05	5.29e-05	0.0
224	1	3.30e-03	-2.36e-03	-0.05	6.00e-05	6.63e-05	0.0
224	3	2.79e-03	-2.00e-03	-0.05	5.08e-05	5.61e-05	0.0
224	5	-7.90e-03	-3.15e-03	-0.04	4.65e-05	4.99e-05	0.0
224	8	0.01	-4.75e-04	-0.04	4.58e-05	5.21e-05	0.0
224	23	5.19e-03	-0.01	-0.04	4.70e-05	5.14e-05	0.0
224	37	-9.96e-04	-2.27e-03	-0.04	4.62e-05	5.06e-05	0.0
224	40	6.07e-03	-1.36e-03	-0.04	4.60e-05	5.14e-05	0.0
224	55	3.43e-03	-4.76e-03	-0.04	4.64e-05	5.11e-05	0.0
224	69	2.54e-03	-1.81e-03	-0.04	4.61e-05	5.10e-05	0.0
225	1	3.29e-03	-2.31e-03	-0.05	6.10e-05	6.59e-05	0.0
225	3	2.78e-03	-1.96e-03	-0.04	5.16e-05	5.57e-05	0.0
225	5	-7.93e-03	-2.93e-03	-0.04	4.72e-05	4.96e-05	0.0
225	8	0.01	-6.29e-04	-0.04	4.66e-05	5.18e-05	0.0
225	23	5.16e-03	-0.01	-0.04	4.78e-05	5.10e-05	0.0
225	37	-1.01e-03	-2.17e-03	-0.04	4.70e-05	5.03e-05	0.0
225	40	6.07e-03	-1.39e-03	-0.04	4.68e-05	5.10e-05	0.0
225	55	3.42e-03	-4.68e-03	-0.04	4.72e-05	5.08e-05	0.0
225	69	2.53e-03	-1.78e-03	-0.04	4.69e-05	5.07e-05	0.0
226	1	3.30e-03	-2.64e-03	-0.11	1.37e-04	1.47e-04	0.0
226	3	2.79e-03	-2.23e-03	-0.09	1.16e-04	1.24e-04	0.0
226	5	-8.18e-03	-4.63e-03	-0.08	1.05e-04	1.12e-04	0.0
226	8	0.01	5.72e-04	-0.08	1.05e-04	1.14e-04	0.0
226	23	5.30e-03	-0.01	-0.08	1.06e-04	1.13e-04	0.0
226	37	-1.09e-03	-2.91e-03	-0.08	1.05e-04	1.13e-04	0.0
226	40	6.16e-03	-1.15e-03	-0.08	1.05e-04	1.13e-04	0.0
226	55	3.47e-03	-5.35e-03	-0.08	1.05e-04	1.13e-04	0.0
226	69	2.54e-03	-2.03e-03	-0.08	1.05e-04	1.13e-04	0.0
227	1	3.29e-03	-2.60e-03	-0.10	1.13e-04	1.25e-04	0.0
227	3	2.78e-03	-2.20e-03	-0.09	9.58e-05	1.06e-04	0.0
227	5	-8.16e-03	-4.40e-03	-0.08	8.73e-05	9.54e-05	0.0
227	8	0.01	3.94e-04	-0.08	8.69e-05	9.71e-05	0.0
227	23	5.22e-03	-0.01	-0.08	8.81e-05	9.66e-05	0.0
227	37	-1.09e-03	-2.81e-03	-0.08	8.72e-05	9.60e-05	0.0
227	40	6.15e-03	-1.19e-03	-0.08	8.70e-05	9.65e-05	0.0
227	55	3.44e-03	-5.25e-03	-0.08	8.74e-05	9.64e-05	0.0
227	69	2.53e-03	-2.00e-03	-0.08	8.71e-05	9.62e-05	0.0
228	1	3.28e-03	-2.56e-03	-0.09	9.64e-05	1.10e-04	0.0

Parco Eolico "Bolina" – Progetto Definitivo
Relazione di calcolo preliminare delle fondazioni degli aerogeneratori G8 e G12

228	3	2.77e-03	-2.16e-03	-0.08	8.15e-05	9.32e-05	0.0
228	5	-8.15e-03	-4.17e-03	-0.07	7.44e-05	8.39e-05	0.0
228	8	0.01	2.41e-04	-0.07	7.39e-05	8.56e-05	0.0
228	23	5.14e-03	-0.01	-0.07	7.50e-05	8.51e-05	0.0
228	37	-1.09e-03	-2.71e-03	-0.07	7.42e-05	8.45e-05	0.0
228	40	6.13e-03	-1.22e-03	-0.07	7.40e-05	8.50e-05	0.0
228	55	3.41e-03	-5.15e-03	-0.07	7.44e-05	8.49e-05	0.0
228	69	2.52e-03	-1.97e-03	-0.07	7.41e-05	8.48e-05	0.0
229	1	3.26e-03	-2.51e-03	-0.09	8.25e-05	9.98e-05	0.0
229	3	2.76e-03	-2.13e-03	-0.07	6.98e-05	8.44e-05	0.0
229	5	-8.17e-03	-3.96e-03	-0.07	6.37e-05	7.59e-05	0.0
229	8	0.01	9.45e-05	-0.07	6.32e-05	7.77e-05	0.0
229	23	5.07e-03	-0.01	-0.07	6.44e-05	7.71e-05	0.0
229	37	-1.10e-03	-2.62e-03	-0.07	6.36e-05	7.65e-05	0.0
229	40	6.12e-03	-1.25e-03	-0.07	6.34e-05	7.71e-05	0.0
229	55	3.38e-03	-5.05e-03	-0.07	6.38e-05	7.69e-05	0.0
229	69	2.51e-03	-1.93e-03	-0.07	6.35e-05	7.68e-05	0.0
230	1	3.25e-03	-2.47e-03	-0.08	7.10e-05	9.21e-05	0.0
230	3	2.75e-03	-2.09e-03	-0.07	6.01e-05	7.79e-05	0.0
230	5	-8.19e-03	-3.75e-03	-0.06	5.49e-05	6.98e-05	0.0
230	8	0.01	-5.07e-05	-0.06	5.43e-05	7.19e-05	0.0
230	23	5.01e-03	-0.01	-0.06	5.56e-05	7.12e-05	0.0
230	37	-1.12e-03	-2.53e-03	-0.06	5.47e-05	7.05e-05	0.0
230	40	6.12e-03	-1.27e-03	-0.06	5.45e-05	7.12e-05	0.0
230	55	3.35e-03	-4.97e-03	-0.06	5.49e-05	7.10e-05	0.0
230	69	2.50e-03	-1.90e-03	-0.06	5.46e-05	7.09e-05	0.0
231	1	3.26e-03	-2.44e-03	-0.07	6.11e-05	8.41e-05	0.0
231	3	2.75e-03	-2.07e-03	-0.06	5.17e-05	7.11e-05	0.0
231	5	-8.21e-03	-3.55e-03	-0.06	4.74e-05	6.31e-05	0.0
231	8	0.01	-2.06e-04	-0.06	4.66e-05	6.62e-05	0.0
231	23	4.96e-03	-0.01	-0.06	4.83e-05	6.51e-05	0.0
231	37	-1.12e-03	-2.45e-03	-0.06	4.71e-05	6.41e-05	0.0
231	40	6.13e-03	-1.31e-03	-0.06	4.68e-05	6.52e-05	0.0
231	55	3.33e-03	-4.89e-03	-0.06	4.74e-05	6.48e-05	0.0
231	69	2.50e-03	-1.88e-03	-0.06	4.70e-05	6.47e-05	0.0
232	1	3.22e-03	-2.38e-03	-0.07	5.71e-05	8.13e-05	0.0
232	3	2.73e-03	-2.02e-03	-0.06	4.83e-05	6.88e-05	0.0
232	5	-8.29e-03	-3.34e-03	-0.05	4.43e-05	6.13e-05	0.0
232	8	0.01	-3.30e-04	-0.05	4.36e-05	6.37e-05	0.0
232	23	4.88e-03	-0.01	-0.05	4.49e-05	6.29e-05	0.0
232	37	-1.16e-03	-2.34e-03	-0.05	4.41e-05	6.21e-05	0.0
232	40	6.12e-03	-1.32e-03	-0.05	4.38e-05	6.29e-05	0.0
232	55	3.29e-03	-4.81e-03	-0.05	4.43e-05	6.26e-05	0.0
232	69	2.48e-03	-1.83e-03	-0.05	4.39e-05	6.25e-05	0.0
233	1	3.20e-03	-2.34e-03	-0.06	5.84e-05	8.14e-05	0.0
233	3	2.71e-03	-1.98e-03	-0.05	4.94e-05	6.89e-05	0.0
233	5	-8.35e-03	-3.13e-03	-0.05	4.53e-05	6.15e-05	0.0
233	8	0.01	-4.65e-04	-0.05	4.45e-05	6.38e-05	0.0
233	23	4.82e-03	-0.01	-0.05	4.58e-05	6.30e-05	0.0
233	37	-1.20e-03	-2.25e-03	-0.05	4.50e-05	6.23e-05	0.0
233	40	6.12e-03	-1.35e-03	-0.05	4.48e-05	6.30e-05	0.0
233	55	3.26e-03	-4.73e-03	-0.05	4.52e-05	6.28e-05	0.0
233	69	2.46e-03	-1.80e-03	-0.05	4.49e-05	6.26e-05	0.0
234	1	3.26e-03	-2.65e-03	-0.12	1.18e-04	1.57e-04	0.0
234	3	2.76e-03	-2.24e-03	-0.10	9.97e-05	1.32e-04	0.0
234	5	-8.34e-03	-4.65e-03	-0.10	9.09e-05	1.20e-04	0.0
234	8	0.01	5.76e-04	-0.09	9.05e-05	1.21e-04	0.0
234	23	5.14e-03	-0.01	-0.10	9.17e-05	1.21e-04	0.0
234	37	-1.16e-03	-2.92e-03	-0.10	9.07e-05	1.20e-04	0.0
234	40	6.18e-03	-1.15e-03	-0.10	9.06e-05	1.21e-04	0.0
234	55	3.40e-03	-5.36e-03	-0.10	9.10e-05	1.21e-04	0.0
234	69	2.51e-03	-2.04e-03	-0.10	9.07e-05	1.20e-04	0.0
235	1	3.25e-03	-2.62e-03	-0.12	9.78e-05	1.40e-04	0.0
235	3	2.75e-03	-2.22e-03	-0.10	8.27e-05	1.18e-04	0.0
235	5	-8.32e-03	-4.48e-03	-0.09	7.54e-05	1.06e-04	0.0
235	8	0.01	4.53e-04	-0.09	7.50e-05	1.08e-04	0.0
235	23	5.05e-03	-0.01	-0.09	7.62e-05	1.08e-04	0.0
235	37	-1.16e-03	-2.85e-03	-0.09	7.53e-05	1.07e-04	0.0
235	40	6.16e-03	-1.18e-03	-0.09	7.51e-05	1.08e-04	0.0
235	55	3.36e-03	-5.27e-03	-0.09	7.56e-05	1.08e-04	0.0
235	69	2.50e-03	-2.01e-03	-0.09	7.52e-05	1.07e-04	0.0
236	1	3.23e-03	-2.58e-03	-0.11	8.35e-05	1.26e-04	0.0
236	3	2.74e-03	-2.18e-03	-0.09	7.07e-05	1.07e-04	0.0

Parco Eolico "Bolina" – Progetto Definitivo
Relazione di calcolo preliminare delle fondazioni degli aerogeneratori G8 e G12

236	5	-8.34e-03	-4.29e-03	-0.09	6.45e-05	9.62e-05	0.0
236	8	0.01	3.28e-04	-0.08	6.40e-05	9.80e-05	0.0
236	23	4.96e-03	-0.01	-0.09	6.52e-05	9.75e-05	0.0
236	37	-1.18e-03	-2.77e-03	-0.09	6.43e-05	9.68e-05	0.0
236	40	6.15e-03	-1.20e-03	-0.08	6.42e-05	9.74e-05	0.0
236	55	3.32e-03	-5.18e-03	-0.09	6.46e-05	9.72e-05	0.0
236	69	2.49e-03	-1.98e-03	-0.08	6.42e-05	9.71e-05	0.0
237	1	3.21e-03	-2.54e-03	-0.10	7.19e-05	1.17e-04	0.0
237	3	2.71e-03	-2.15e-03	-0.09	6.09e-05	9.89e-05	0.0
237	5	-8.40e-03	-4.11e-03	-0.08	5.56e-05	8.89e-05	0.0
237	8	0.01	2.06e-04	-0.08	5.51e-05	9.08e-05	0.0
237	23	4.86e-03	-0.01	-0.08	5.63e-05	9.03e-05	0.0
237	37	-1.21e-03	-2.68e-03	-0.08	5.54e-05	8.96e-05	0.0
237	40	6.15e-03	-1.22e-03	-0.08	5.52e-05	9.02e-05	0.0
237	55	3.28e-03	-5.10e-03	-0.08	5.56e-05	9.00e-05	0.0
237	69	2.47e-03	-1.95e-03	-0.08	5.53e-05	8.99e-05	0.0
238	1	3.19e-03	-2.50e-03	-0.10	6.21e-05	1.09e-04	0.0
238	3	2.70e-03	-2.11e-03	-0.08	5.26e-05	9.21e-05	0.0
238	5	-8.46e-03	-3.93e-03	-0.08	4.81e-05	8.27e-05	0.0
238	8	0.01	8.48e-05	-0.08	4.75e-05	8.47e-05	0.0
238	23	4.77e-03	-0.01	-0.08	4.88e-05	8.41e-05	0.0
238	37	-1.24e-03	-2.60e-03	-0.08	4.79e-05	8.34e-05	0.0
238	40	6.14e-03	-1.24e-03	-0.08	4.77e-05	8.41e-05	0.0
238	55	3.24e-03	-5.02e-03	-0.08	4.81e-05	8.39e-05	0.0
238	69	2.45e-03	-1.92e-03	-0.08	4.78e-05	8.37e-05	0.0
239	1	3.17e-03	-2.46e-03	-0.09	5.48e-05	1.02e-04	0.0
239	3	2.68e-03	-2.08e-03	-0.08	4.64e-05	8.62e-05	0.0
239	5	-8.53e-03	-3.75e-03	-0.07	4.25e-05	7.73e-05	0.0
239	8	0.01	-3.47e-05	-0.07	4.18e-05	7.95e-05	0.0
239	23	4.68e-03	-0.01	-0.07	4.32e-05	7.87e-05	0.0
239	37	-1.28e-03	-2.52e-03	-0.07	4.23e-05	7.80e-05	0.0
239	40	6.15e-03	-1.27e-03	-0.07	4.20e-05	7.87e-05	0.0
239	55	3.20e-03	-4.95e-03	-0.07	4.25e-05	7.85e-05	0.0
239	69	2.44e-03	-1.89e-03	-0.07	4.22e-05	7.84e-05	0.0
240	1	3.14e-03	-2.42e-03	-0.09	5.05e-05	9.76e-05	0.0
240	3	2.66e-03	-2.05e-03	-0.07	4.27e-05	8.26e-05	0.0
240	5	-8.62e-03	-3.58e-03	-0.07	3.92e-05	7.40e-05	0.0
240	8	0.01	-1.47e-04	-0.07	3.85e-05	7.62e-05	0.0
240	23	4.59e-03	-0.01	-0.07	3.98e-05	7.54e-05	0.0
240	37	-1.32e-03	-2.44e-03	-0.07	3.90e-05	7.47e-05	0.0
240	40	6.15e-03	-1.28e-03	-0.07	3.87e-05	7.54e-05	0.0
240	55	3.15e-03	-4.88e-03	-0.07	3.92e-05	7.52e-05	0.0
240	69	2.41e-03	-1.86e-03	-0.07	3.88e-05	7.51e-05	0.0
241	1	3.11e-03	-2.38e-03	-0.08	5.19e-05	9.79e-05	0.0
241	3	2.64e-03	-2.02e-03	-0.07	4.39e-05	8.28e-05	0.0
241	5	-8.72e-03	-3.41e-03	-0.06	4.03e-05	7.42e-05	0.0
241	8	0.01	-2.60e-04	-0.06	3.95e-05	7.64e-05	0.0
241	23	4.51e-03	-0.01	-0.06	4.09e-05	7.56e-05	0.0
241	37	-1.37e-03	-2.37e-03	-0.06	4.00e-05	7.49e-05	0.0
241	40	6.16e-03	-1.30e-03	-0.06	3.98e-05	7.57e-05	0.0
241	55	3.11e-03	-4.81e-03	-0.06	4.02e-05	7.54e-05	0.0
241	69	2.40e-03	-1.83e-03	-0.06	3.99e-05	7.53e-05	0.0
242	1	3.23e-03	-2.66e-03	-0.14	9.65e-05	1.62e-04	0.0
242	3	2.73e-03	-2.25e-03	-0.12	8.17e-05	1.37e-04	0.0
242	8	0.01	6.16e-04	-0.10	7.40e-05	1.26e-04	0.0
242	21	-1.40e-03	-0.01	-0.11	7.52e-05	1.25e-04	0.0
242	23	5.01e-03	-0.01	-0.11	7.53e-05	1.25e-04	0.0
242	40	6.17e-03	-1.15e-03	-0.10	7.42e-05	1.25e-04	0.0
242	53	1.17e-03	-5.32e-03	-0.11	7.46e-05	1.25e-04	0.0
242	55	3.34e-03	-5.37e-03	-0.10	7.46e-05	1.25e-04	0.0
242	69	2.49e-03	-2.05e-03	-0.10	7.42e-05	1.25e-04	0.0
243	1	3.25e-03	-2.66e-03	-0.13	7.88e-05	1.46e-04	0.0
243	3	2.75e-03	-2.25e-03	-0.11	6.66e-05	1.24e-04	0.0
243	8	0.01	4.95e-04	-0.10	6.02e-05	1.14e-04	0.0
243	21	-1.48e-03	-0.01	-0.10	6.20e-05	1.12e-04	0.0
243	23	4.93e-03	-0.01	-0.10	6.21e-05	1.13e-04	0.0
243	40	6.19e-03	-1.18e-03	-0.10	6.05e-05	1.13e-04	0.0
243	53	1.15e-03	-5.24e-03	-0.10	6.11e-05	1.12e-04	0.0
243	55	3.32e-03	-5.31e-03	-0.10	6.11e-05	1.13e-04	0.0
243	69	2.50e-03	-2.04e-03	-0.10	6.06e-05	1.12e-04	0.0
244	1	3.19e-03	-2.60e-03	-0.13	6.86e-05	1.38e-04	0.0
244	3	2.70e-03	-2.20e-03	-0.11	5.81e-05	1.17e-04	0.0
244	8	0.01	4.17e-04	-0.10	5.25e-05	1.08e-04	0.0

Parco Eolico "Bolina" – Progetto Definitivo
Relazione di calcolo preliminare delle fondazioni degli aerogeneratori G8 e G12

244	21	-1.63e-03	-0.01	-0.10	5.38e-05	1.06e-04	0.0
244	23	4.79e-03	-0.01	-0.10	5.38e-05	1.07e-04	0.0
244	40	6.16e-03	-1.18e-03	-0.10	5.27e-05	1.07e-04	0.0
244	53	1.07e-03	-5.14e-03	-0.10	5.31e-05	1.06e-04	0.0
244	55	3.24e-03	-5.22e-03	-0.10	5.31e-05	1.07e-04	0.0
244	69	2.45e-03	-2.00e-03	-0.10	5.28e-05	1.07e-04	0.0
245	1	3.15e-03	-2.57e-03	-0.12	5.84e-05	1.30e-04	0.0
245	3	2.67e-03	-2.17e-03	-0.10	4.94e-05	1.10e-04	0.0
245	8	0.01	3.25e-04	-0.09	4.46e-05	1.01e-04	0.0
245	21	-1.76e-03	-0.01	-0.09	4.59e-05	1.00e-04	0.0
245	23	4.68e-03	-0.01	-0.09	4.59e-05	1.01e-04	0.0
245	40	6.16e-03	-1.20e-03	-0.09	4.48e-05	1.01e-04	0.0
245	53	1.01e-03	-5.06e-03	-0.09	4.53e-05	1.00e-04	0.0
245	55	3.19e-03	-5.16e-03	-0.09	4.53e-05	1.00e-04	0.0
245	69	2.43e-03	-1.97e-03	-0.09	4.49e-05	1.00e-04	0.0
246	1	3.13e-03	-2.54e-03	-0.12	5.03e-05	1.23e-04	0.0
246	3	2.65e-03	-2.15e-03	-0.10	4.25e-05	1.04e-04	0.0
246	8	0.01	2.32e-04	-0.09	3.83e-05	9.58e-05	0.0
246	21	-1.89e-03	-0.01	-0.09	3.98e-05	9.44e-05	0.0
246	23	4.57e-03	-0.01	-0.09	3.97e-05	9.51e-05	0.0
246	40	6.16e-03	-1.21e-03	-0.09	3.85e-05	9.51e-05	0.0
246	53	9.53e-04	-4.98e-03	-0.09	3.90e-05	9.46e-05	0.0
246	55	3.14e-03	-5.09e-03	-0.09	3.90e-05	9.48e-05	0.0
246	69	2.41e-03	-1.95e-03	-0.09	3.87e-05	9.47e-05	0.0
247	1	3.13e-03	-2.52e-03	-0.11	4.45e-05	1.14e-04	0.0
247	3	2.65e-03	-2.13e-03	-0.09	3.76e-05	9.64e-05	0.0
247	8	0.01	1.32e-04	-0.08	3.38e-05	8.92e-05	0.0
247	21	-2.00e-03	-0.01	-0.09	3.57e-05	8.72e-05	0.0
247	23	4.48e-03	-0.01	-0.09	3.57e-05	8.81e-05	0.0
247	40	6.18e-03	-1.24e-03	-0.08	3.40e-05	8.82e-05	0.0
247	53	9.15e-04	-4.91e-03	-0.09	3.47e-05	8.75e-05	0.0
247	55	3.11e-03	-5.04e-03	-0.08	3.47e-05	8.78e-05	0.0
247	69	2.41e-03	-1.94e-03	-0.08	3.42e-05	8.77e-05	0.0
248	1	3.07e-03	-2.47e-03	-0.11	4.31e-05	1.12e-04	0.0
248	3	2.60e-03	-2.09e-03	-0.09	3.65e-05	9.44e-05	0.0
248	8	0.01	5.48e-05	-0.08	3.27e-05	8.70e-05	0.0
248	21	-2.17e-03	-0.01	-0.08	3.43e-05	8.55e-05	0.0
248	23	4.36e-03	-0.01	-0.08	3.43e-05	8.62e-05	0.0
248	40	6.17e-03	-1.24e-03	-0.08	3.30e-05	8.63e-05	0.0
248	53	8.29e-04	-4.83e-03	-0.08	3.35e-05	8.57e-05	0.0
248	55	3.04e-03	-4.97e-03	-0.08	3.35e-05	8.60e-05	0.0
248	69	2.36e-03	-1.90e-03	-0.08	3.31e-05	8.59e-05	0.0
249	1	3.03e-03	-2.44e-03	-0.10	4.40e-05	1.13e-04	0.0
249	3	2.57e-03	-2.06e-03	-0.09	3.72e-05	9.57e-05	0.0
249	8	0.01	-2.91e-05	-0.08	3.34e-05	8.81e-05	0.0
249	21	-2.32e-03	-0.01	-0.08	3.49e-05	8.66e-05	0.0
249	23	4.25e-03	-0.01	-0.08	3.49e-05	8.73e-05	0.0
249	40	6.18e-03	-1.25e-03	-0.08	3.37e-05	8.73e-05	0.0
249	53	7.59e-04	-4.76e-03	-0.08	3.42e-05	8.69e-05	0.0
249	55	2.98e-03	-4.92e-03	-0.08	3.42e-05	8.71e-05	0.0
249	69	2.33e-03	-1.88e-03	-0.08	3.38e-05	8.70e-05	0.0
250	1	3.21e-03	-2.70e-03	-0.15	9.23e-05	1.76e-04	0.0
250	3	2.72e-03	-2.29e-03	-0.13	7.81e-05	1.49e-04	0.0
250	8	0.01	7.60e-04	-0.12	7.08e-05	1.36e-04	0.0
250	21	-1.43e-03	-0.01	-0.12	7.19e-05	1.35e-04	0.0
250	23	5.01e-03	-0.01	-0.12	7.19e-05	1.36e-04	0.0
250	40	6.17e-03	-1.12e-03	-0.12	7.09e-05	1.35e-04	0.0
250	53	1.15e-03	-5.43e-03	-0.12	7.13e-05	1.35e-04	0.0
250	55	3.33e-03	-5.46e-03	-0.12	7.13e-05	1.35e-04	0.0
250	69	2.47e-03	-2.08e-03	-0.12	7.10e-05	1.35e-04	0.0
251	1	3.19e-03	-2.68e-03	-0.15	7.11e-05	1.63e-04	0.0
251	3	2.70e-03	-2.27e-03	-0.13	6.02e-05	1.38e-04	0.0
251	8	0.01	6.58e-04	-0.12	5.45e-05	1.26e-04	0.0
251	21	-1.58e-03	-0.01	-0.12	5.56e-05	1.25e-04	0.0
251	23	4.86e-03	-0.01	-0.12	5.57e-05	1.26e-04	0.0
251	40	6.17e-03	-1.14e-03	-0.12	5.46e-05	1.26e-04	0.0
251	53	1.09e-03	-5.35e-03	-0.12	5.50e-05	1.25e-04	0.0
251	55	3.27e-03	-5.39e-03	-0.12	5.50e-05	1.26e-04	0.0
251	69	2.46e-03	-2.06e-03	-0.12	5.47e-05	1.25e-04	0.0
252	1	3.16e-03	-2.66e-03	-0.15	5.69e-05	1.52e-04	0.0
252	3	2.67e-03	-2.25e-03	-0.12	4.81e-05	1.29e-04	0.0
252	8	0.01	5.75e-04	-0.11	4.35e-05	1.18e-04	0.0
252	21	-1.74e-03	-0.01	-0.11	4.47e-05	1.17e-04	0.0

Parco Eolico "Bolina" – Progetto Definitivo
Relazione di calcolo preliminare delle fondazioni degli aerogeneratori G8 e G12

252	23	4.72e-03	-0.01	-0.11	4.48e-05	1.18e-04	0.0
252	40	6.17e-03	-1.16e-03	-0.11	4.37e-05	1.18e-04	0.0
252	53	1.02e-03	-5.28e-03	-0.11	4.41e-05	1.17e-04	0.0
252	55	3.20e-03	-5.33e-03	-0.11	4.41e-05	1.17e-04	0.0
252	69	2.43e-03	-2.05e-03	-0.11	4.38e-05	1.17e-04	0.0
253	1	3.12e-03	-2.63e-03	-0.14	4.62e-05	1.43e-04	0.0
253	3	2.64e-03	-2.23e-03	-0.12	3.91e-05	1.21e-04	0.0
253	8	0.01	5.01e-04	-0.11	3.53e-05	1.11e-04	0.0
253	21	-1.90e-03	-0.01	-0.11	3.66e-05	1.10e-04	0.0
253	23	4.58e-03	-0.01	-0.11	3.66e-05	1.10e-04	0.0
253	40	6.16e-03	-1.17e-03	-0.11	3.55e-05	1.10e-04	0.0
253	53	9.43e-04	-5.20e-03	-0.11	3.59e-05	1.10e-04	0.0
253	55	3.14e-03	-5.27e-03	-0.11	3.59e-05	1.10e-04	0.0
253	69	2.40e-03	-2.02e-03	-0.11	3.56e-05	1.10e-04	0.0
254	1	3.09e-03	-2.60e-03	-0.14	3.89e-05	1.35e-04	0.0
254	3	2.61e-03	-2.20e-03	-0.12	3.29e-05	1.14e-04	0.0
254	8	0.01	4.28e-04	-0.11	2.96e-05	1.05e-04	0.0
254	21	-2.07e-03	-0.01	-0.11	3.10e-05	1.03e-04	0.0
254	23	4.45e-03	-0.01	-0.11	3.10e-05	1.04e-04	0.0
254	40	6.17e-03	-1.18e-03	-0.11	2.98e-05	1.04e-04	0.0
254	53	8.71e-04	-5.14e-03	-0.11	3.03e-05	1.03e-04	0.0
254	55	3.08e-03	-5.21e-03	-0.11	3.03e-05	1.04e-04	0.0
254	69	2.37e-03	-2.00e-03	-0.11	2.99e-05	1.04e-04	0.0
255	1	3.05e-03	-2.58e-03	-0.13	3.50e-05	1.27e-04	0.0
255	3	2.58e-03	-2.18e-03	-0.11	2.96e-05	1.08e-04	0.0
255	8	0.01	3.56e-04	-0.10	2.66e-05	9.91e-05	0.0
255	21	-2.24e-03	-0.01	-0.10	2.81e-05	9.78e-05	0.0
255	23	4.32e-03	-0.01	-0.10	2.81e-05	9.84e-05	0.0
255	40	6.18e-03	-1.19e-03	-0.10	2.68e-05	9.84e-05	0.0
255	53	7.96e-04	-5.07e-03	-0.10	2.73e-05	9.80e-05	0.0
255	55	3.01e-03	-5.16e-03	-0.10	2.73e-05	9.82e-05	0.0
255	69	2.35e-03	-1.98e-03	-0.10	2.69e-05	9.80e-05	0.0
256	1	3.01e-03	-2.55e-03	-0.13	3.33e-05	1.23e-04	0.0
256	3	2.54e-03	-2.16e-03	-0.11	2.82e-05	1.04e-04	0.0
256	8	0.01	2.89e-04	-0.10	2.52e-05	9.58e-05	0.0
256	21	-2.43e-03	-0.01	-0.10	2.68e-05	9.45e-05	0.0
256	23	4.18e-03	-0.01	-0.10	2.67e-05	9.52e-05	0.0
256	40	6.18e-03	-1.20e-03	-0.10	2.55e-05	9.51e-05	0.0
256	53	7.09e-04	-5.01e-03	-0.10	2.60e-05	9.47e-05	0.0
256	55	2.94e-03	-5.11e-03	-0.10	2.60e-05	9.49e-05	0.0
256	69	2.31e-03	-1.96e-03	-0.10	2.56e-05	9.48e-05	0.0
257	1	2.96e-03	-2.52e-03	-0.13	3.40e-05	1.24e-04	0.0
257	3	2.51e-03	-2.13e-03	-0.11	2.88e-05	1.05e-04	0.0
257	8	0.01	2.22e-04	-0.10	2.57e-05	9.63e-05	0.0
257	21	-2.62e-03	-0.01	-0.10	2.73e-05	9.51e-05	0.0
257	23	4.03e-03	-0.01	-0.10	2.72e-05	9.57e-05	0.0
257	40	6.19e-03	-1.21e-03	-0.10	2.60e-05	9.56e-05	0.0
257	53	6.21e-04	-4.95e-03	-0.10	2.65e-05	9.52e-05	0.0
257	55	2.87e-03	-5.06e-03	-0.10	2.65e-05	9.54e-05	0.0
257	69	2.28e-03	-1.94e-03	-0.10	2.62e-05	9.53e-05	0.0
258	1	3.19e-03	-2.75e-03	-0.17	8.42e-05	1.82e-04	0.0
258	3	2.70e-03	-2.32e-03	-0.15	7.13e-05	1.54e-04	0.0
258	8	0.01	8.56e-04	-0.13	6.46e-05	1.41e-04	0.0
258	21	-1.48e-03	-0.01	-0.13	6.57e-05	1.40e-04	0.0
258	23	4.98e-03	-0.01	-0.13	6.57e-05	1.41e-04	0.0
258	40	6.17e-03	-1.11e-03	-0.13	6.47e-05	1.40e-04	0.0
258	53	1.12e-03	-5.53e-03	-0.13	6.51e-05	1.40e-04	0.0
258	55	3.31e-03	-5.54e-03	-0.13	6.51e-05	1.40e-04	0.0
258	69	2.46e-03	-2.11e-03	-0.13	6.48e-05	1.40e-04	0.0
259	1	3.17e-03	-2.73e-03	-0.17	5.70e-05	1.67e-04	0.0
259	3	2.68e-03	-2.31e-03	-0.15	4.83e-05	1.41e-04	0.0
259	8	0.01	7.96e-04	-0.13	4.37e-05	1.29e-04	0.0
259	21	-1.62e-03	-0.01	-0.13	4.48e-05	1.28e-04	0.0
259	23	4.84e-03	-0.01	-0.13	4.48e-05	1.29e-04	0.0
259	40	6.17e-03	-1.12e-03	-0.13	4.38e-05	1.29e-04	0.0
259	53	1.06e-03	-5.47e-03	-0.13	4.42e-05	1.28e-04	0.0
259	55	3.25e-03	-5.49e-03	-0.13	4.42e-05	1.29e-04	0.0
259	69	2.44e-03	-2.10e-03	-0.13	4.39e-05	1.28e-04	0.0
260	1	3.13e-03	-2.72e-03	-0.17	4.06e-05	1.56e-04	0.0
260	3	2.65e-03	-2.30e-03	-0.14	3.44e-05	1.32e-04	0.0
260	8	0.01	7.34e-04	-0.13	3.10e-05	1.21e-04	0.0
260	21	-1.80e-03	-0.01	-0.13	3.21e-05	1.20e-04	0.0
260	23	4.69e-03	-0.01	-0.13	3.22e-05	1.20e-04	0.0

Parco Eolico "Bolina" – Progetto Definitivo
Relazione di calcolo preliminare delle fondazioni degli aerogeneratori G8 e G12

260	40	6.17e-03	-1.13e-03	-0.13	3.11e-05	1.20e-04	0.0
260	53	9.85e-04	-5.41e-03	-0.13	3.15e-05	1.20e-04	0.0
260	55	3.18e-03	-5.44e-03	-0.13	3.15e-05	1.20e-04	0.0
260	69	2.41e-03	-2.09e-03	-0.13	3.12e-05	1.20e-04	0.0
261	1	3.09e-03	-2.70e-03	-0.17	2.98e-05	1.47e-04	0.0
261	3	2.62e-03	-2.28e-03	-0.14	2.52e-05	1.24e-04	0.0
261	8	0.01	6.78e-04	-0.13	2.26e-05	1.14e-04	0.0
261	21	-1.99e-03	-0.01	-0.13	2.39e-05	1.13e-04	0.0
261	23	4.53e-03	-0.01	-0.13	2.39e-05	1.13e-04	0.0
261	40	6.17e-03	-1.14e-03	-0.13	2.28e-05	1.13e-04	0.0
261	53	9.01e-04	-5.36e-03	-0.13	2.32e-05	1.13e-04	0.0
261	55	3.11e-03	-5.39e-03	-0.13	2.32e-05	1.13e-04	0.0
261	69	2.38e-03	-2.07e-03	-0.13	2.29e-05	1.13e-04	0.0
262	1	3.06e-03	-2.68e-03	-0.16	2.33e-05	1.38e-04	0.0
262	3	2.59e-03	-2.27e-03	-0.14	1.97e-05	1.17e-04	0.0
262	8	0.01	6.25e-04	-0.12	1.76e-05	1.07e-04	0.0
262	21	-2.18e-03	-0.01	-0.13	1.91e-05	1.06e-04	0.0
262	23	4.39e-03	-0.01	-0.13	1.91e-05	1.07e-04	0.0
262	40	6.18e-03	-1.15e-03	-0.12	1.78e-05	1.07e-04	0.0
262	53	8.18e-04	-5.30e-03	-0.12	1.83e-05	1.06e-04	0.0
262	55	3.04e-03	-5.35e-03	-0.12	1.83e-05	1.06e-04	0.0
262	69	2.35e-03	-2.06e-03	-0.12	1.80e-05	1.06e-04	0.0
263	1	3.05e-03	-2.66e-03	-0.16	2.20e-05	1.28e-04	0.0
263	3	2.58e-03	-2.25e-03	-0.13	1.86e-05	1.08e-04	0.0
263	8	0.01	5.70e-04	-0.12	1.65e-05	1.00e-04	0.0
263	21	-2.35e-03	-0.01	-0.12	1.85e-05	9.81e-05	0.0
263	23	4.25e-03	-0.01	-0.12	1.85e-05	9.91e-05	0.0
263	40	6.21e-03	-1.16e-03	-0.12	1.68e-05	9.91e-05	0.0
263	53	7.55e-04	-5.26e-03	-0.12	1.75e-05	9.84e-05	0.0
263	55	2.99e-03	-5.31e-03	-0.12	1.75e-05	9.87e-05	0.0
263	69	2.34e-03	-2.05e-03	-0.12	1.70e-05	9.86e-05	0.0
264	1	2.96e-03	-2.64e-03	-0.16	2.38e-05	1.26e-04	0.0
264	3	2.50e-03	-2.23e-03	-0.13	2.01e-05	1.06e-04	0.0
264	8	0.01	5.29e-04	-0.12	1.78e-05	9.79e-05	0.0
264	21	-2.59e-03	-0.01	-0.12	1.96e-05	9.66e-05	0.0
264	23	4.07e-03	-0.01	-0.12	1.95e-05	9.72e-05	0.0
264	40	6.19e-03	-1.16e-03	-0.12	1.81e-05	9.72e-05	0.0
264	53	6.29e-04	-5.21e-03	-0.12	1.87e-05	9.67e-05	0.0
264	55	2.88e-03	-5.27e-03	-0.12	1.87e-05	9.69e-05	0.0
264	69	2.28e-03	-2.03e-03	-0.12	1.83e-05	9.68e-05	0.0
265	1	2.90e-03	-2.61e-03	-0.15	2.44e-05	1.26e-04	0.0
265	3	2.46e-03	-2.21e-03	-0.13	2.07e-05	1.07e-04	0.0
265	8	0.01	4.86e-04	-0.12	1.84e-05	9.82e-05	0.0
265	21	-2.82e-03	-0.01	-0.12	2.00e-05	9.70e-05	0.0
265	23	3.90e-03	-0.01	-0.12	2.00e-05	9.76e-05	0.0
265	40	6.19e-03	-1.17e-03	-0.12	1.86e-05	9.75e-05	0.0
265	53	5.23e-04	-5.16e-03	-0.12	1.92e-05	9.71e-05	0.0
265	55	2.80e-03	-5.23e-03	-0.12	1.92e-05	9.73e-05	0.0
265	69	2.23e-03	-2.01e-03	-0.12	1.88e-05	9.72e-05	0.0
266	1	3.19e-03	-2.80e-03	-0.19	7.09e-05	1.77e-04	0.0
266	3	2.70e-03	-2.37e-03	-0.16	6.00e-05	1.50e-04	0.0
266	8	0.01	9.64e-04	-0.15	5.44e-05	1.37e-04	0.0
266	21	-1.51e-03	-0.01	-0.15	5.55e-05	1.36e-04	0.0
266	40	6.18e-03	-1.10e-03	-0.15	5.45e-05	1.37e-04	0.0
266	53	1.11e-03	-5.64e-03	-0.15	5.49e-05	1.36e-04	0.0
266	69	2.45e-03	-2.15e-03	-0.15	5.46e-05	1.36e-04	0.0
267	1	3.16e-03	-2.79e-03	-0.19	4.03e-05	1.59e-04	0.0
267	3	2.68e-03	-2.36e-03	-0.16	3.41e-05	1.35e-04	0.0
267	8	0.01	9.11e-04	-0.15	3.08e-05	1.23e-04	0.0
267	21	-1.63e-03	-0.01	-0.15	3.20e-05	1.22e-04	0.0
267	40	6.17e-03	-1.11e-03	-0.15	3.09e-05	1.23e-04	0.0
267	53	1.06e-03	-5.59e-03	-0.15	3.13e-05	1.22e-04	0.0
267	69	2.43e-03	-2.15e-03	-0.15	3.10e-05	1.22e-04	0.0
268	1	3.12e-03	-2.78e-03	-0.19	2.35e-05	1.48e-04	0.0
268	3	2.64e-03	-2.35e-03	-0.16	1.99e-05	1.25e-04	0.0
268	8	0.01	8.76e-04	-0.15	1.78e-05	1.14e-04	0.0
268	21	-1.82e-03	-0.01	-0.15	1.90e-05	1.13e-04	0.0
268	23	4.69e-03	-0.01	-0.15	1.90e-05	1.14e-04	0.0
268	40	6.17e-03	-1.12e-03	-0.15	1.80e-05	1.14e-04	0.0
268	53	9.72e-04	-5.55e-03	-0.15	1.84e-05	1.13e-04	0.0
268	55	3.17e-03	-5.55e-03	-0.15	1.84e-05	1.14e-04	0.0
268	69	2.40e-03	-2.14e-03	-0.15	1.81e-05	1.14e-04	0.0
269	1	3.07e-03	-2.77e-03	-0.19	1.31e-05	1.38e-04	0.0

Parco Eolico "Bolina" – Progetto Definitivo
Relazione di calcolo preliminare delle fondazioni degli aerogeneratori G8 e G12

269	3	2.60e-03	-2.34e-03	-0.16	1.11e-05	1.17e-04	0.0
269	8	0.01	8.43e-04	-0.14	9.80e-06	1.07e-04	0.0
269	21	-2.02e-03	-0.01	-0.15	1.11e-05	1.06e-04	0.0
269	23	4.53e-03	-0.01	-0.15	1.11e-05	1.07e-04	0.0
269	40	6.17e-03	-1.12e-03	-0.14	9.99e-06	1.07e-04	0.0
269	53	8.80e-04	-5.51e-03	-0.14	1.04e-05	1.06e-04	0.0
269	55	3.10e-03	-5.52e-03	-0.14	1.04e-05	1.07e-04	0.0
269	69	2.36e-03	-2.13e-03	-0.14	1.01e-05	1.06e-04	0.0
270	1	3.03e-03	-2.76e-03	-0.19	8.82e-06	1.30e-04	0.0
270	3	2.56e-03	-2.34e-03	-0.16	7.46e-06	1.10e-04	0.0
270	8	0.01	8.13e-04	-0.14	6.46e-06	1.01e-04	0.0
270	21	-2.23e-03	-0.01	-0.14	7.87e-06	1.00e-04	0.0
270	23	4.37e-03	-0.01	-0.14	7.87e-06	1.01e-04	0.0
270	40	6.18e-03	-1.13e-03	-0.14	6.68e-06	1.00e-04	0.0
270	53	7.88e-04	-5.48e-03	-0.14	7.15e-06	1.00e-04	0.0
270	55	3.02e-03	-5.49e-03	-0.14	7.15e-06	1.00e-04	0.0
270	69	2.33e-03	-2.12e-03	-0.14	6.79e-06	1.00e-04	0.0
271	1	2.98e-03	-2.75e-03	-0.18	9.60e-06	1.24e-04	0.0
271	3	2.52e-03	-2.33e-03	-0.16	8.12e-06	1.05e-04	0.0
271	8	0.01	7.86e-04	-0.14	7.00e-06	9.60e-05	0.0
271	21	-2.44e-03	-0.01	-0.14	8.60e-06	9.48e-05	0.0
271	23	4.20e-03	-0.01	-0.14	8.59e-06	9.54e-05	0.0
271	40	6.19e-03	-1.13e-03	-0.14	7.26e-06	9.54e-05	0.0
271	53	6.92e-04	-5.45e-03	-0.14	7.80e-06	9.49e-05	0.0
271	55	2.94e-03	-5.46e-03	-0.14	7.79e-06	9.52e-05	0.0
271	69	2.29e-03	-2.12e-03	-0.14	7.39e-06	9.50e-05	0.0
272	1	2.92e-03	-2.74e-03	-0.18	1.22e-05	1.19e-04	0.0
272	3	2.47e-03	-2.32e-03	-0.15	1.03e-05	1.01e-04	0.0
272	8	0.01	7.62e-04	-0.14	8.98e-06	9.29e-05	0.0
272	21	-2.68e-03	-0.01	-0.14	1.06e-05	9.17e-05	0.0
272	23	4.03e-03	-0.01	-0.14	1.06e-05	9.23e-05	0.0
272	40	6.19e-03	-1.14e-03	-0.14	9.24e-06	9.22e-05	0.0
272	53	5.82e-04	-5.43e-03	-0.14	9.78e-06	9.19e-05	0.0
272	55	2.85e-03	-5.44e-03	-0.14	9.78e-06	9.21e-05	0.0
272	69	2.25e-03	-2.11e-03	-0.14	9.37e-06	9.19e-05	0.0
273	1	2.86e-03	-2.73e-03	-0.18	1.43e-05	1.19e-04	0.0
273	3	2.42e-03	-2.31e-03	-0.15	1.21e-05	1.01e-04	0.0
273	8	0.01	7.40e-04	-0.14	1.06e-05	9.28e-05	0.0
273	21	-2.91e-03	-0.01	-0.14	1.22e-05	9.16e-05	0.0
273	23	3.85e-03	-0.01	-0.14	1.22e-05	9.22e-05	0.0
273	40	6.19e-03	-1.14e-03	-0.14	1.08e-05	9.21e-05	0.0
273	53	4.72e-04	-5.40e-03	-0.14	1.14e-05	9.18e-05	0.0
273	55	2.76e-03	-5.42e-03	-0.14	1.14e-05	9.20e-05	0.0
273	69	2.20e-03	-2.10e-03	-0.14	1.10e-05	9.18e-05	0.0
274	1	3.19e-03	-2.85e-03	-0.21	5.60e-05	1.62e-04	0.0
274	3	2.70e-03	-2.41e-03	-0.18	4.74e-05	1.37e-04	0.0
274	8	0.01	1.04e-03	-0.16	4.28e-05	1.26e-04	0.0
274	21	-1.42e-03	-0.01	-0.16	4.40e-05	1.25e-04	0.0
274	23	5.05e-03	-0.01	-0.16	4.41e-05	1.25e-04	0.0
274	40	6.17e-03	-1.10e-03	-0.16	4.30e-05	1.25e-04	0.0
274	53	1.14e-03	-5.73e-03	-0.16	4.34e-05	1.25e-04	0.0
274	55	3.33e-03	-5.70e-03	-0.16	4.34e-05	1.25e-04	0.0
274	69	2.45e-03	-2.19e-03	-0.16	4.31e-05	1.25e-04	0.0
275	1	3.19e-03	-2.86e-03	-0.21	2.43e-05	1.40e-04	0.0
275	3	2.70e-03	-2.42e-03	-0.17	2.06e-05	1.18e-04	0.0
275	8	0.01	1.01e-03	-0.16	1.83e-05	1.09e-04	0.0
275	21	-1.57e-03	-0.01	-0.16	2.02e-05	1.07e-04	0.0
275	23	4.92e-03	-0.01	-0.16	2.02e-05	1.08e-04	0.0
275	40	6.19e-03	-1.11e-03	-0.16	1.86e-05	1.08e-04	0.0
275	53	1.09e-03	-5.70e-03	-0.16	1.92e-05	1.08e-04	0.0
275	55	3.29e-03	-5.68e-03	-0.16	1.92e-05	1.08e-04	0.0
275	69	2.46e-03	-2.20e-03	-0.16	1.87e-05	1.08e-04	0.0
276	1	3.11e-03	-2.85e-03	-0.21	8.71e-06	1.30e-04	0.0
276	3	2.63e-03	-2.41e-03	-0.18	7.37e-06	1.10e-04	0.0
276	8	0.01	1.00e-03	-0.16	6.40e-06	1.01e-04	0.0
276	21	-1.80e-03	-0.01	-0.16	7.72e-06	9.99e-05	0.0
276	23	4.72e-03	-0.01	-0.16	7.73e-06	1.01e-04	0.0
276	40	6.16e-03	-1.11e-03	-0.16	6.60e-06	1.01e-04	0.0
276	53	9.74e-04	-5.68e-03	-0.16	7.05e-06	1.00e-04	0.0
276	55	3.18e-03	-5.66e-03	-0.16	7.05e-06	1.00e-04	0.0
276	69	2.39e-03	-2.19e-03	-0.16	6.70e-06	1.00e-04	0.0
277	1	3.06e-03	-2.85e-03	-0.21	-1.12e-06	1.21e-04	0.0
277	3	2.59e-03	-2.41e-03	-0.18	0.0	1.02e-04	0.0

Parco Eolico "Bolina" – Progetto Definitivo
Relazione di calcolo preliminare delle fondazioni degli aerogeneratori G8 e G12

277	8	0.01	9.95e-04	-0.16	-1.16e-06	9.38e-05	0.0
277	21	-2.01e-03	-0.01	-0.16	0.0	9.26e-05	0.0
277	23	4.56e-03	-0.01	-0.16	0.0	9.32e-05	0.0
277	40	6.16e-03	-1.11e-03	-0.16	0.0	9.31e-05	0.0
277	53	8.77e-04	-5.67e-03	-0.16	0.0	9.28e-05	0.0
277	55	3.10e-03	-5.64e-03	-0.16	0.0	9.30e-05	0.0
277	69	2.35e-03	-2.19e-03	-0.16	0.0	9.28e-05	0.0
278	1	3.01e-03	-2.85e-03	-0.21	-4.73e-06	1.13e-04	0.0
278	3	2.55e-03	-2.41e-03	-0.17	-4.00e-06	9.56e-05	0.0
278	8	0.01	9.88e-04	-0.16	-3.98e-06	8.80e-05	0.0
278	21	-2.22e-03	-0.01	-0.16	-2.47e-06	8.67e-05	0.0
278	23	4.40e-03	-0.01	-0.16	-2.46e-06	8.74e-05	0.0
278	40	6.17e-03	-1.12e-03	-0.16	-3.75e-06	8.73e-05	0.0
278	53	7.84e-04	-5.65e-03	-0.16	-3.24e-06	8.69e-05	0.0
278	55	3.02e-03	-5.63e-03	-0.16	-3.24e-06	8.71e-05	0.0
278	69	2.32e-03	-2.19e-03	-0.16	-3.64e-06	8.69e-05	0.0
279	1	2.99e-03	-2.85e-03	-0.20	0.0	1.05e-04	0.0
279	3	2.53e-03	-2.41e-03	-0.17	0.0	8.92e-05	0.0
279	8	0.01	9.83e-04	-0.16	-1.06e-06	8.27e-05	0.0
279	21	-2.41e-03	-0.01	-0.16	1.11e-06	8.07e-05	0.0
279	23	4.25e-03	-0.01	-0.16	1.10e-06	8.16e-05	0.0
279	40	6.19e-03	-1.12e-03	-0.16	0.0	8.16e-05	0.0
279	53	7.08e-04	-5.64e-03	-0.16	0.0	8.09e-05	0.0
279	55	2.96e-03	-5.61e-03	-0.16	0.0	8.13e-05	0.0
279	69	2.30e-03	-2.19e-03	-0.16	0.0	8.11e-05	0.0
280	1	2.90e-03	-2.85e-03	-0.21	4.75e-06	1.05e-04	0.0
280	3	2.46e-03	-2.41e-03	-0.17	4.02e-06	8.84e-05	0.0
280	8	0.01	9.80e-04	-0.16	3.25e-06	8.14e-05	0.0
280	21	-2.66e-03	-0.01	-0.16	4.99e-06	8.02e-05	0.0
280	23	4.06e-03	-0.01	-0.16	4.98e-06	8.09e-05	0.0
280	40	6.18e-03	-1.12e-03	-0.16	3.52e-06	8.08e-05	0.0
280	53	5.77e-04	-5.64e-03	-0.16	4.10e-06	8.03e-05	0.0
280	55	2.85e-03	-5.61e-03	-0.16	4.10e-06	8.06e-05	0.0
280	69	2.23e-03	-2.19e-03	-0.16	3.65e-06	8.04e-05	0.0
281	1	2.84e-03	-2.85e-03	-0.21	6.92e-06	1.05e-04	0.0
281	3	2.40e-03	-2.41e-03	-0.17	5.85e-06	8.89e-05	0.0
281	8	0.01	9.79e-04	-0.16	4.93e-06	8.18e-05	0.0
281	21	-2.90e-03	-0.01	-0.16	6.62e-06	8.06e-05	0.0
281	23	3.88e-03	-0.01	-0.16	6.61e-06	8.12e-05	0.0
281	40	6.18e-03	-1.12e-03	-0.16	5.19e-06	8.11e-05	0.0
281	53	4.64e-04	-5.63e-03	-0.16	5.76e-06	8.07e-05	0.0
281	55	2.76e-03	-5.61e-03	-0.16	5.76e-06	8.09e-05	0.0
281	69	2.18e-03	-2.19e-03	-0.16	5.32e-06	8.08e-05	0.0
282	1	3.18e-03	-2.90e-03	-0.22	4.45e-05	1.37e-04	0.0
282	3	2.69e-03	-2.45e-03	-0.19	3.76e-05	1.16e-04	0.0
282	8	0.01	1.12e-03	-0.17	3.39e-05	1.07e-04	0.0
282	21	-1.35e-03	-0.01	-0.17	3.52e-05	1.05e-04	0.0
282	23	5.14e-03	-0.01	-0.17	3.51e-05	1.06e-04	0.0
282	40	6.16e-03	-1.10e-03	-0.17	3.41e-05	1.06e-04	0.0
282	53	1.16e-03	-5.82e-03	-0.17	3.45e-05	1.05e-04	0.0
282	55	3.36e-03	-5.78e-03	-0.17	3.45e-05	1.06e-04	0.0
282	69	2.44e-03	-2.23e-03	-0.17	3.42e-05	1.06e-04	0.0
283	1	3.15e-03	-2.91e-03	-0.22	1.40e-05	1.17e-04	0.0
283	3	2.67e-03	-2.47e-03	-0.19	1.19e-05	9.94e-05	0.0
283	8	0.01	1.12e-03	-0.17	1.05e-05	9.14e-05	0.0
283	21	-1.55e-03	-0.01	-0.17	1.18e-05	9.01e-05	0.0
283	23	4.94e-03	-0.01	-0.17	1.18e-05	9.07e-05	0.0
283	40	6.16e-03	-1.11e-03	-0.17	1.07e-05	9.07e-05	0.0
283	53	1.08e-03	-5.81e-03	-0.17	1.11e-05	9.03e-05	0.0
283	55	3.28e-03	-5.77e-03	-0.17	1.11e-05	9.05e-05	0.0
283	69	2.42e-03	-2.24e-03	-0.17	1.08e-05	9.03e-05	0.0
284	1	3.10e-03	-2.93e-03	-0.23	-1.54e-06	1.04e-04	0.0
284	3	2.63e-03	-2.48e-03	-0.19	-1.31e-06	8.82e-05	0.0
284	8	0.01	1.12e-03	-0.17	-1.47e-06	8.12e-05	0.0
284	21	-1.75e-03	-0.01	-0.17	0.0	7.99e-05	0.0
284	23	4.78e-03	-0.01	-0.17	0.0	8.05e-05	0.0
284	40	6.16e-03	-1.11e-03	-0.17	-1.28e-06	8.05e-05	0.0
284	53	9.88e-04	-5.81e-03	-0.17	0.0	8.01e-05	0.0
284	55	3.20e-03	-5.76e-03	-0.17	0.0	8.03e-05	0.0
284	69	2.39e-03	-2.25e-03	-0.17	-1.19e-06	8.01e-05	0.0
285	1	3.06e-03	-2.94e-03	-0.22	-9.35e-06	9.47e-05	0.0
285	3	2.59e-03	-2.48e-03	-0.19	-7.91e-06	8.02e-05	0.0
285	8	0.01	1.14e-03	-0.17	-7.49e-06	7.39e-05	0.0

Parco Eolico "Bolina" – Progetto Definitivo
Relazione di calcolo preliminare delle fondazioni degli aerogeneratori G8 e G12

285	21	-1.95e-03	-0.01	-0.17	-6.16e-06	7.27e-05	0.0
285	23	4.62e-03	-0.01	-0.17	-6.15e-06	7.33e-05	0.0
285	40	6.16e-03	-1.11e-03	-0.17	-7.29e-06	7.32e-05	0.0
285	53	8.95e-04	-5.81e-03	-0.17	-6.84e-06	7.28e-05	0.0
285	55	3.12e-03	-5.76e-03	-0.17	-6.84e-06	7.30e-05	0.0
285	69	2.35e-03	-2.26e-03	-0.17	-7.19e-06	7.29e-05	0.0
286	1	3.01e-03	-2.94e-03	-0.22	-1.04e-05	8.85e-05	0.0
286	3	2.55e-03	-2.49e-03	-0.19	-8.77e-06	7.49e-05	0.0
286	8	0.01	1.15e-03	-0.17	-8.29e-06	6.91e-05	0.0
286	21	-2.15e-03	-0.01	-0.17	-6.85e-06	6.79e-05	0.0
286	23	4.47e-03	-0.01	-0.17	-6.85e-06	6.85e-05	0.0
286	40	6.16e-03	-1.11e-03	-0.17	-8.08e-06	6.84e-05	0.0
286	53	8.04e-04	-5.82e-03	-0.17	-7.59e-06	6.80e-05	0.0
286	55	3.04e-03	-5.76e-03	-0.17	-7.59e-06	6.82e-05	0.0
286	69	2.31e-03	-2.26e-03	-0.17	-7.97e-06	6.81e-05	0.0
287	1	2.96e-03	-2.95e-03	-0.22	-6.07e-06	8.49e-05	0.0
287	3	2.51e-03	-2.50e-03	-0.19	-5.14e-06	7.19e-05	0.0
287	8	0.01	1.17e-03	-0.17	-5.02e-06	6.64e-05	0.0
287	21	-2.36e-03	-0.01	-0.17	-3.43e-06	6.51e-05	0.0
287	23	4.31e-03	-0.01	-0.17	-3.41e-06	6.58e-05	0.0
287	40	6.17e-03	-1.11e-03	-0.17	-4.79e-06	6.57e-05	0.0
287	53	7.10e-04	-5.83e-03	-0.17	-4.25e-06	6.53e-05	0.0
287	55	2.97e-03	-5.77e-03	-0.17	-4.25e-06	6.55e-05	0.0
287	69	2.28e-03	-2.27e-03	-0.17	-4.67e-06	6.53e-05	0.0
288	1	2.90e-03	-2.97e-03	-0.22	0.0	8.37e-05	0.0
288	3	2.46e-03	-2.51e-03	-0.19	0.0	7.08e-05	0.0
288	8	0.01	1.18e-03	-0.17	0.0	6.54e-05	0.0
288	21	-2.57e-03	-0.01	-0.17	0.0	6.42e-05	0.0
288	23	4.15e-03	-0.01	-0.17	0.0	6.48e-05	0.0
288	40	6.17e-03	-1.11e-03	-0.17	0.0	6.47e-05	0.0
288	53	6.06e-04	-5.85e-03	-0.17	0.0	6.43e-05	0.0
288	55	2.88e-03	-5.78e-03	-0.17	0.0	6.45e-05	0.0
288	69	2.23e-03	-2.28e-03	-0.17	0.0	6.44e-05	0.0
289	1	2.84e-03	-2.98e-03	-0.23	2.54e-06	8.49e-05	0.0
289	3	2.41e-03	-2.52e-03	-0.19	2.15e-06	7.18e-05	0.0
289	8	0.01	1.20e-03	-0.17	1.61e-06	6.63e-05	0.0
289	21	-2.79e-03	-0.01	-0.18	3.21e-06	6.51e-05	0.0
289	23	3.99e-03	-0.01	-0.18	3.23e-06	6.57e-05	0.0
289	40	6.17e-03	-1.11e-03	-0.17	1.84e-06	6.56e-05	0.0
289	53	5.01e-04	-5.86e-03	-0.17	2.38e-06	6.52e-05	0.0
289	55	2.80e-03	-5.79e-03	-0.17	2.38e-06	6.54e-05	0.0
289	69	2.19e-03	-2.29e-03	-0.17	1.95e-06	6.53e-05	0.0
290	1	3.17e-03	-2.96e-03	-0.23	3.98e-05	1.05e-04	0.0
290	3	2.69e-03	-2.50e-03	-0.20	3.37e-05	8.91e-05	0.0
290	8	0.01	1.19e-03	-0.18	3.03e-05	8.21e-05	0.0
290	21	-1.34e-03	-0.01	-0.18	3.16e-05	8.07e-05	0.0
290	23	5.14e-03	-0.01	-0.18	3.15e-05	8.13e-05	0.0
290	40	6.15e-03	-1.10e-03	-0.18	3.05e-05	8.14e-05	0.0
290	53	1.16e-03	-5.90e-03	-0.18	3.09e-05	8.09e-05	0.0
290	55	3.35e-03	-5.84e-03	-0.18	3.09e-05	8.11e-05	0.0
290	69	2.44e-03	-2.28e-03	-0.18	3.06e-05	8.10e-05	0.0
291	1	3.15e-03	-2.98e-03	-0.24	1.16e-05	8.37e-05	0.0
291	3	2.66e-03	-2.52e-03	-0.20	9.82e-06	7.09e-05	0.0
291	8	0.01	1.21e-03	-0.18	8.61e-06	6.55e-05	0.0
291	21	-1.50e-03	-0.01	-0.18	9.89e-06	6.41e-05	0.0
291	23	4.99e-03	-0.01	-0.18	9.87e-06	6.47e-05	0.0
291	40	6.15e-03	-1.10e-03	-0.18	8.82e-06	6.48e-05	0.0
291	53	1.09e-03	-5.91e-03	-0.18	9.25e-06	6.43e-05	0.0
291	55	3.29e-03	-5.85e-03	-0.18	9.25e-06	6.45e-05	0.0
291	69	2.42e-03	-2.29e-03	-0.18	8.92e-06	6.44e-05	0.0
292	1	3.11e-03	-3.00e-03	-0.24	-2.45e-06	7.15e-05	0.0
292	3	2.63e-03	-2.54e-03	-0.20	-2.08e-06	6.05e-05	0.0
292	8	0.01	1.24e-03	-0.18	-2.19e-06	5.60e-05	0.0
292	21	-1.68e-03	-0.01	-0.18	0.0	5.48e-05	0.0
292	23	4.85e-03	-0.01	-0.18	0.0	5.54e-05	0.0
292	40	6.15e-03	-1.11e-03	-0.18	-1.99e-06	5.54e-05	0.0
292	53	1.01e-03	-5.93e-03	-0.18	-1.55e-06	5.49e-05	0.0
292	55	3.22e-03	-5.86e-03	-0.18	-1.55e-06	5.51e-05	0.0
292	69	2.39e-03	-2.31e-03	-0.18	-1.89e-06	5.50e-05	0.0
293	1	3.06e-03	-3.02e-03	-0.24	-9.14e-06	6.43e-05	0.0
293	3	2.59e-03	-2.55e-03	-0.20	-7.74e-06	5.44e-05	0.0
293	8	0.01	1.27e-03	-0.18	-7.34e-06	5.05e-05	0.0
293	21	-1.86e-03	-0.01	-0.18	-5.98e-06	4.92e-05	0.0

Parco Eolico "Bolina" – Progetto Definitivo
Relazione di calcolo preliminare delle fondazioni degli aerogeneratori G8 e G12

293	23	4.71e-03	-0.01	-0.18	-5.97e-06	4.98e-05	0.0
293	40	6.15e-03	-1.10e-03	-0.18	-7.14e-06	4.98e-05	0.0
293	53	9.30e-04	-5.95e-03	-0.18	-6.68e-06	4.94e-05	0.0
293	55	3.15e-03	-5.87e-03	-0.18	-6.67e-06	4.96e-05	0.0
293	69	2.35e-03	-2.32e-03	-0.18	-7.03e-06	4.94e-05	0.0
294	1	3.02e-03	-3.04e-03	-0.24	-1.04e-05	6.02e-05	0.0
294	3	2.55e-03	-2.57e-03	-0.20	-8.79e-06	5.10e-05	0.0
294	8	0.01	1.31e-03	-0.18	-8.31e-06	4.74e-05	0.0
294	21	-2.04e-03	-0.01	-0.18	-6.80e-06	4.61e-05	0.0
294	23	4.57e-03	-0.01	-0.18	-6.77e-06	4.68e-05	0.0
294	40	6.15e-03	-1.10e-03	-0.18	-8.10e-06	4.67e-05	0.0
294	53	8.47e-04	-5.97e-03	-0.18	-7.58e-06	4.63e-05	0.0
294	55	3.08e-03	-5.88e-03	-0.18	-7.58e-06	4.65e-05	0.0
294	69	2.32e-03	-2.34e-03	-0.18	-7.99e-06	4.63e-05	0.0
295	1	2.99e-03	-3.05e-03	-0.23	-4.40e-06	5.87e-05	0.0
295	3	2.53e-03	-2.58e-03	-0.20	-3.72e-06	4.96e-05	0.0
295	8	0.01	1.34e-03	-0.18	-3.88e-06	4.68e-05	0.0
295	21	-2.21e-03	-0.01	-0.18	-1.67e-06	4.47e-05	0.0
295	23	4.44e-03	-0.01	-0.18	-1.67e-06	4.57e-05	0.0
295	40	6.17e-03	-1.10e-03	-0.18	-3.55e-06	4.57e-05	0.0
295	53	7.73e-04	-5.99e-03	-0.18	-2.80e-06	4.50e-05	0.0
295	55	3.02e-03	-5.89e-03	-0.18	-2.80e-06	4.53e-05	0.0
295	69	2.30e-03	-2.35e-03	-0.18	-3.38e-06	4.51e-05	0.0
296	1	2.92e-03	-3.08e-03	-0.24	2.09e-06	6.10e-05	0.0
296	3	2.47e-03	-2.60e-03	-0.20	1.76e-06	5.16e-05	0.0
296	8	0.01	1.38e-03	-0.18	1.28e-06	4.80e-05	0.0
296	21	-2.42e-03	-0.01	-0.18	2.93e-06	4.67e-05	0.0
296	23	4.29e-03	-0.01	-0.18	2.98e-06	4.74e-05	0.0
296	40	6.16e-03	-1.10e-03	-0.18	1.49e-06	4.73e-05	0.0
296	53	6.68e-04	-6.03e-03	-0.18	2.05e-06	4.69e-05	0.0
296	55	2.94e-03	-5.92e-03	-0.18	2.07e-06	4.71e-05	0.0
296	69	2.25e-03	-2.37e-03	-0.18	1.60e-06	4.69e-05	0.0
297	1	2.87e-03	-3.10e-03	-0.24	4.28e-06	6.27e-05	0.0
297	3	2.42e-03	-2.62e-03	-0.20	3.62e-06	5.30e-05	0.0
297	8	0.01	1.41e-03	-0.19	2.98e-06	4.93e-05	0.0
297	21	-2.61e-03	-0.01	-0.19	4.58e-06	4.80e-05	0.0
297	23	4.15e-03	-0.01	-0.19	4.63e-06	4.87e-05	0.0
297	40	6.17e-03	-1.10e-03	-0.19	3.19e-06	4.86e-05	0.0
297	53	5.74e-04	-6.07e-03	-0.19	3.73e-06	4.82e-05	0.0
297	55	2.86e-03	-5.95e-03	-0.19	3.74e-06	4.84e-05	0.0
297	69	2.20e-03	-2.38e-03	-0.19	3.29e-06	4.82e-05	0.0
298	1	3.19e-03	-3.01e-03	-0.24	3.81e-05	7.00e-05	0.0
298	3	2.70e-03	-2.55e-03	-0.20	3.23e-05	5.92e-05	0.0
298	8	0.01	1.27e-03	-0.18	2.90e-05	5.49e-05	0.0
298	21	-1.31e-03	-0.01	-0.18	3.03e-05	5.35e-05	0.0
298	23	5.16e-03	-0.01	-0.19	3.03e-05	5.41e-05	0.0
298	40	6.15e-03	-1.10e-03	-0.18	2.92e-05	5.42e-05	0.0
298	53	1.18e-03	-5.98e-03	-0.18	2.97e-05	5.37e-05	0.0
298	55	3.37e-03	-5.91e-03	-0.18	2.97e-05	5.39e-05	0.0
298	69	2.45e-03	-2.32e-03	-0.18	2.93e-05	5.38e-05	0.0
299	1	3.15e-03	-3.04e-03	-0.24	1.68e-05	5.06e-05	0.0
299	3	2.67e-03	-2.57e-03	-0.20	1.42e-05	4.28e-05	0.0
299	8	0.01	1.31e-03	-0.19	1.26e-05	4.00e-05	0.0
299	21	-1.43e-03	-0.01	-0.19	1.40e-05	3.86e-05	0.0
299	23	5.05e-03	-0.01	-0.19	1.40e-05	3.92e-05	0.0
299	40	6.14e-03	-1.11e-03	-0.19	1.28e-05	3.93e-05	0.0
299	53	1.12e-03	-6.00e-03	-0.19	1.33e-05	3.88e-05	0.0
299	55	3.31e-03	-5.92e-03	-0.19	1.33e-05	3.90e-05	0.0
299	69	2.43e-03	-2.34e-03	-0.19	1.29e-05	3.89e-05	0.0
300	1	3.12e-03	-3.07e-03	-0.24	6.45e-06	4.12e-05	0.0
300	3	2.64e-03	-2.60e-03	-0.21	5.45e-06	3.49e-05	0.0
300	8	0.01	1.35e-03	-0.19	4.62e-06	3.28e-05	0.0
300	21	-1.58e-03	-0.01	-0.19	6.05e-06	3.14e-05	0.0
300	23	4.93e-03	-0.01	-0.19	6.04e-06	3.20e-05	0.0
300	40	6.14e-03	-1.10e-03	-0.19	4.84e-06	3.21e-05	0.0
300	53	1.05e-03	-6.04e-03	-0.19	5.33e-06	3.16e-05	0.0
300	55	3.25e-03	-5.94e-03	-0.19	5.32e-06	3.18e-05	0.0
300	69	2.40e-03	-2.36e-03	-0.19	4.96e-06	3.17e-05	0.0
301	1	3.08e-03	-3.10e-03	-0.24	0.0	3.67e-05	0.0
301	3	2.60e-03	-2.62e-03	-0.21	0.0	3.10e-05	0.0
301	8	0.01	1.41e-03	-0.19	0.0	2.93e-05	0.0
301	21	-1.73e-03	-0.01	-0.19	1.74e-06	2.80e-05	0.0
301	23	4.81e-03	-0.01	-0.19	1.75e-06	2.86e-05	0.0

Parco Eolico "Bolina" – Progetto Definitivo
Relazione di calcolo preliminare delle fondazioni degli aerogeneratori G8 e G12

301	40	6.14e-03	-1.10e-03	-0.19	0.0	2.86e-05	0.0
301	53	9.80e-04	-6.08e-03	-0.19	1.02e-06	2.81e-05	0.0
301	55	3.19e-03	-5.96e-03	-0.19	1.02e-06	2.83e-05	0.0
301	69	2.37e-03	-2.38e-03	-0.19	0.0	2.82e-05	0.0
302	1	3.04e-03	-3.13e-03	-0.24	0.0	3.53e-05	0.0
302	3	2.57e-03	-2.65e-03	-0.21	0.0	2.99e-05	0.0
302	8	0.01	1.46e-03	-0.19	0.0	2.83e-05	0.0
302	21	-1.89e-03	-0.01	-0.19	1.46e-06	2.69e-05	0.0
302	23	4.70e-03	-0.01	-0.19	1.48e-06	2.76e-05	0.0
302	40	6.15e-03	-1.10e-03	-0.19	0.0	2.75e-05	0.0
302	53	9.09e-04	-6.12e-03	-0.19	0.0	2.71e-05	0.0
302	55	3.14e-03	-5.99e-03	-0.19	0.0	2.73e-05	0.0
302	69	2.34e-03	-2.40e-03	-0.19	0.0	2.72e-05	0.0
303	1	3.00e-03	-3.16e-03	-0.25	4.06e-06	3.64e-05	0.0
303	3	2.54e-03	-2.67e-03	-0.21	3.43e-06	3.08e-05	0.0
303	8	0.01	1.51e-03	-0.19	2.81e-06	2.92e-05	0.0
303	21	-2.04e-03	-0.01	-0.19	4.37e-06	2.78e-05	0.0
303	23	4.58e-03	-0.01	-0.19	4.41e-06	2.85e-05	0.0
303	40	6.15e-03	-1.10e-03	-0.19	3.02e-06	2.84e-05	0.0
303	53	8.36e-04	-6.16e-03	-0.19	3.54e-06	2.79e-05	0.0
303	55	3.08e-03	-6.02e-03	-0.19	3.56e-06	2.82e-05	0.0
303	69	2.31e-03	-2.43e-03	-0.19	3.12e-06	2.80e-05	0.0
304	1	2.96e-03	-3.19e-03	-0.25	8.57e-06	3.87e-05	0.0
304	3	2.50e-03	-2.70e-03	-0.21	7.25e-06	3.27e-05	0.0
304	8	0.01	1.56e-03	-0.19	6.30e-06	3.09e-05	0.0
304	21	-2.20e-03	-0.01	-0.19	7.82e-06	2.95e-05	0.0
304	23	4.47e-03	-0.01	-0.19	7.87e-06	3.02e-05	0.0
304	40	6.15e-03	-1.09e-03	-0.19	6.50e-06	3.01e-05	0.0
304	53	7.59e-04	-6.20e-03	-0.19	7.01e-06	2.97e-05	0.0
304	55	3.02e-03	-6.05e-03	-0.19	7.03e-06	2.99e-05	0.0
304	69	2.27e-03	-2.45e-03	-0.19	6.59e-06	2.97e-05	0.0
305	1	2.91e-03	-3.21e-03	-0.25	1.10e-05	4.09e-05	0.0
305	3	2.46e-03	-2.72e-03	-0.21	9.27e-06	3.46e-05	0.0
305	8	0.01	1.62e-03	-0.19	8.15e-06	3.25e-05	0.0
305	21	-2.37e-03	-0.01	-0.19	9.65e-06	3.12e-05	0.0
305	23	4.36e-03	-0.01	-0.19	9.71e-06	3.19e-05	0.0
305	40	6.16e-03	-1.09e-03	-0.19	8.33e-06	3.18e-05	0.0
305	53	6.81e-04	-6.25e-03	-0.19	8.84e-06	3.14e-05	0.0
305	55	2.96e-03	-6.09e-03	-0.19	8.86e-06	3.16e-05	0.0
305	69	2.24e-03	-2.47e-03	-0.19	8.43e-06	3.14e-05	0.0
306	1	3.20e-03	-3.07e-03	-0.24	4.08e-05	4.08e-05	0.0
306	3	2.70e-03	-2.60e-03	-0.20	3.45e-05	3.46e-05	0.0
306	8	0.01	1.35e-03	-0.19	3.10e-05	3.25e-05	0.0
306	21	-1.25e-03	-0.01	-0.19	3.24e-05	3.11e-05	0.0
306	23	5.20e-03	-0.01	-0.19	3.24e-05	3.17e-05	0.0
306	40	6.14e-03	-1.11e-03	-0.19	3.13e-05	3.18e-05	0.0
306	53	1.20e-03	-6.05e-03	-0.19	3.17e-05	3.13e-05	0.0
306	55	3.39e-03	-5.95e-03	-0.19	3.17e-05	3.15e-05	0.0
306	69	2.46e-03	-2.36e-03	-0.19	3.14e-05	3.14e-05	0.0
307	1	3.17e-03	-3.11e-03	-0.24	2.62e-05	2.62e-05	0.0
307	3	2.68e-03	-2.63e-03	-0.20	2.21e-05	2.22e-05	0.0
307	7	0.01	-5.06e-03	-0.19	2.06e-05	2.18e-05	0.0
307	8	0.01	1.40e-03	-0.19	1.96e-05	2.18e-05	0.0
307	21	-1.35e-03	-0.01	-0.19	2.17e-05	1.97e-05	0.0
307	39	6.02e-03	-3.29e-03	-0.19	2.03e-05	2.07e-05	0.0
307	40	6.14e-03	-1.11e-03	-0.18	2.00e-05	2.07e-05	0.0
307	53	1.16e-03	-6.09e-03	-0.18	2.07e-05	2.00e-05	0.0
307	69	2.44e-03	-2.39e-03	-0.18	2.01e-05	2.02e-05	0.0
308	1	3.14e-03	-3.14e-03	-0.24	1.97e-05	1.98e-05	0.0
308	3	2.66e-03	-2.66e-03	-0.21	1.67e-05	1.68e-05	0.0
308	7	0.01	-5.01e-03	-0.19	1.56e-05	1.64e-05	0.0
308	8	0.01	1.47e-03	-0.19	1.49e-05	1.64e-05	0.0
308	21	-1.47e-03	-0.01	-0.19	1.63e-05	1.49e-05	0.0
308	39	6.01e-03	-3.29e-03	-0.19	1.53e-05	1.56e-05	0.0
308	40	6.14e-03	-1.10e-03	-0.19	1.51e-05	1.56e-05	0.0
308	53	1.10e-03	-6.14e-03	-0.19	1.56e-05	1.51e-05	0.0
308	69	2.41e-03	-2.42e-03	-0.19	1.52e-05	1.52e-05	0.0
309	1	3.11e-03	-3.18e-03	-0.25	1.54e-05	1.55e-05	0.0
309	3	2.63e-03	-2.69e-03	-0.21	1.31e-05	1.31e-05	0.0
309	7	0.01	-4.97e-03	-0.19	1.23e-05	1.31e-05	0.0
309	8	0.01	1.54e-03	-0.19	1.16e-05	1.30e-05	0.0
309	21	-1.59e-03	-0.01	-0.19	1.30e-05	1.17e-05	0.0
309	39	5.99e-03	-3.30e-03	-0.19	1.20e-05	1.23e-05	0.0

Parco Eolico "Bolina" – Progetto Definitivo
Relazione di calcolo preliminare delle fondazioni degli aerogeneratori G8 e G12

309	40	6.13e-03	-1.10e-03	-0.19	1.18e-05	1.23e-05	0.0
309	53	1.04e-03	-6.19e-03	-0.19	1.22e-05	1.18e-05	0.0
309	69	2.39e-03	-2.44e-03	-0.19	1.19e-05	1.19e-05	0.0
310	1	3.08e-03	-3.21e-03	-0.25	1.43e-05	1.44e-05	0.0
310	3	2.60e-03	-2.72e-03	-0.21	1.21e-05	1.22e-05	0.0
310	7	0.01	-4.94e-03	-0.19	1.15e-05	1.23e-05	0.0
310	8	0.01	1.60e-03	-0.19	1.07e-05	1.23e-05	0.0
310	21	-1.71e-03	-0.01	-0.19	1.22e-05	1.08e-05	0.0
310	39	5.97e-03	-3.30e-03	-0.19	1.12e-05	1.15e-05	0.0
310	40	6.14e-03	-1.09e-03	-0.19	1.09e-05	1.15e-05	0.0
310	53	9.88e-04	-6.24e-03	-0.19	1.14e-05	1.10e-05	0.0
310	69	2.37e-03	-2.47e-03	-0.19	1.10e-05	1.11e-05	0.0
311	1	3.04e-03	-3.25e-03	-0.24	1.77e-05	1.77e-05	0.0
311	3	2.58e-03	-2.75e-03	-0.21	1.49e-05	1.50e-05	0.0
311	7	0.01	-4.90e-03	-0.19	1.41e-05	1.54e-05	0.0
311	8	0.01	1.66e-03	-0.19	1.31e-05	1.54e-05	0.0
311	21	-1.82e-03	-0.01	-0.19	1.53e-05	1.32e-05	0.0
311	39	5.96e-03	-3.31e-03	-0.19	1.38e-05	1.42e-05	0.0
311	40	6.13e-03	-1.09e-03	-0.19	1.34e-05	1.42e-05	0.0
311	53	9.34e-04	-6.29e-03	-0.19	1.42e-05	1.35e-05	0.0
311	69	2.34e-03	-2.50e-03	-0.19	1.36e-05	1.36e-05	0.0
312	1	3.01e-03	-3.28e-03	-0.25	2.21e-05	2.22e-05	0.0
312	3	2.55e-03	-2.78e-03	-0.21	1.87e-05	1.88e-05	0.0
312	7	0.01	-4.87e-03	-0.19	1.76e-05	1.84e-05	0.0
312	8	0.01	1.74e-03	-0.19	1.68e-05	1.84e-05	0.0
312	21	-1.95e-03	-0.01	-0.19	1.83e-05	1.83e-05	0.0
312	39	5.95e-03	-3.32e-03	-0.19	1.72e-05	1.75e-05	0.0
312	40	6.14e-03	-1.08e-03	-0.19	1.69e-05	1.75e-05	0.0
312	53	8.73e-04	-6.35e-03	-0.19	1.75e-05	1.70e-05	0.0
312	69	2.32e-03	-2.52e-03	-0.19	1.70e-05	1.71e-05	0.0
313	1	2.98e-03	-3.32e-03	-0.25	2.36e-05	2.37e-05	0.0
313	3	2.52e-03	-2.81e-03	-0.21	2.00e-05	2.00e-05	0.0
313	7	0.01	-4.84e-03	-0.20	1.87e-05	1.95e-05	0.0
313	8	0.01	1.81e-03	-0.20	1.79e-05	1.94e-05	0.0
313	21	-2.07e-03	-0.01	-0.20	1.94e-05	1.80e-05	0.0
313	39	5.94e-03	-3.33e-03	-0.20	1.83e-05	1.87e-05	0.0
313	40	6.15e-03	-1.08e-03	-0.19	1.81e-05	1.86e-05	0.0
313	53	8.14e-04	-6.41e-03	-0.19	1.86e-05	1.82e-05	0.0
313	69	2.29e-03	-2.55e-03	-0.19	1.82e-05	1.82e-05	0.0
314	1	3.23e-03	-3.09e-03	-0.24	6.99e-05	3.82e-05	0.0
314	3	2.73e-03	-2.61e-03	-0.20	5.91e-05	3.23e-05	0.0
314	7	0.01	-5.08e-03	-0.19	5.40e-05	3.04e-05	0.0
314	8	0.01	1.38e-03	-0.18	5.34e-05	3.04e-05	0.0
314	21	-1.10e-03	-0.01	-0.18	5.48e-05	2.91e-05	0.0
314	39	6.07e-03	-3.29e-03	-0.18	5.39e-05	2.97e-05	0.0
314	40	6.15e-03	-1.10e-03	-0.18	5.36e-05	2.97e-05	0.0
314	53	1.27e-03	-6.07e-03	-0.18	5.41e-05	2.93e-05	0.0
314	69	2.49e-03	-2.37e-03	-0.18	5.38e-05	2.94e-05	0.0
315	1	3.21e-03	-3.13e-03	-0.24	5.05e-05	1.69e-05	0.0
315	3	2.72e-03	-2.65e-03	-0.20	4.27e-05	1.43e-05	0.0
315	7	0.01	-5.03e-03	-0.19	3.92e-05	1.40e-05	0.0
315	8	0.01	1.45e-03	-0.19	3.85e-05	1.40e-05	0.0
315	21	-1.18e-03	-0.01	-0.19	4.00e-05	1.26e-05	0.0
315	39	6.05e-03	-3.30e-03	-0.19	3.90e-05	1.33e-05	0.0
315	40	6.14e-03	-1.10e-03	-0.19	3.87e-05	1.33e-05	0.0
315	53	1.24e-03	-6.13e-03	-0.19	3.92e-05	1.29e-05	0.0
315	69	2.47e-03	-2.41e-03	-0.19	3.89e-05	1.30e-05	0.0
316	1	3.19e-03	-3.18e-03	-0.24	4.11e-05	6.53e-06	0.0
316	3	2.70e-03	-2.69e-03	-0.21	3.48e-05	5.52e-06	0.0
316	7	0.01	-4.98e-03	-0.19	3.20e-05	6.10e-06	0.0
316	8	0.01	1.53e-03	-0.19	3.13e-05	6.11e-06	0.0
316	21	-1.26e-03	-0.01	-0.19	3.27e-05	4.68e-06	0.0
316	39	6.03e-03	-3.30e-03	-0.19	3.18e-05	5.39e-06	0.0
316	40	6.13e-03	-1.10e-03	-0.19	3.15e-05	5.39e-06	0.0
316	53	1.19e-03	-6.19e-03	-0.19	3.20e-05	4.91e-06	0.0
316	69	2.45e-03	-2.44e-03	-0.19	3.16e-05	5.02e-06	0.0
317	1	3.16e-03	-3.22e-03	-0.24	3.66e-05	0.0	0.0
317	3	2.68e-03	-2.73e-03	-0.21	3.10e-05	0.0	0.0
317	7	0.01	-4.92e-03	-0.19	2.85e-05	1.82e-06	0.0
317	8	0.01	1.62e-03	-0.19	2.79e-05	1.80e-06	0.0
317	21	-1.36e-03	-0.01	-0.19	2.92e-05	0.0	0.0
317	39	6.01e-03	-3.31e-03	-0.19	2.83e-05	1.09e-06	0.0
317	40	6.13e-03	-1.09e-03	-0.19	2.81e-05	1.08e-06	0.0

Parco Eolico "Bolina" – Progetto Definitivo
Relazione di calcolo preliminare delle fondazioni degli aerogeneratori G8 e G12

317	53	1.15e-03	-6.25e-03	-0.19	2.85e-05	0.0	0.0
317	69	2.43e-03	-2.48e-03	-0.19	2.82e-05	0.0	0.0
318	1	3.14e-03	-3.27e-03	-0.24	3.52e-05	0.0	0.0
318	3	2.65e-03	-2.77e-03	-0.21	2.98e-05	0.0	0.0
318	7	0.01	-4.87e-03	-0.19	2.75e-05	1.55e-06	0.0
318	8	0.01	1.71e-03	-0.19	2.68e-05	1.52e-06	0.0
318	21	-1.45e-03	-0.01	-0.19	2.82e-05	0.0	0.0
318	39	6.00e-03	-3.31e-03	-0.19	2.72e-05	0.0	0.0
318	40	6.12e-03	-1.09e-03	-0.19	2.70e-05	0.0	0.0
318	53	1.11e-03	-6.32e-03	-0.19	2.75e-05	0.0	0.0
318	69	2.41e-03	-2.52e-03	-0.19	2.71e-05	0.0	0.0
319	1	3.11e-03	-3.32e-03	-0.25	3.63e-05	4.15e-06	0.0
319	3	2.63e-03	-2.81e-03	-0.21	3.07e-05	3.51e-06	0.0
319	7	0.01	-4.83e-03	-0.19	2.84e-05	4.48e-06	0.0
319	8	0.01	1.80e-03	-0.19	2.77e-05	4.44e-06	0.0
319	21	-1.54e-03	-0.01	-0.19	2.91e-05	2.88e-06	0.0
319	39	5.98e-03	-3.32e-03	-0.19	2.81e-05	3.63e-06	0.0
319	40	6.12e-03	-1.08e-03	-0.19	2.79e-05	3.61e-06	0.0
319	53	1.06e-03	-6.39e-03	-0.19	2.84e-05	3.09e-06	0.0
319	69	2.39e-03	-2.55e-03	-0.19	2.80e-05	3.19e-06	0.0
320	1	3.08e-03	-3.36e-03	-0.25	3.86e-05	8.67e-06	0.0
320	3	2.61e-03	-2.84e-03	-0.21	3.26e-05	7.34e-06	0.0
320	7	0.01	-4.78e-03	-0.19	3.02e-05	7.94e-06	0.0
320	8	0.01	1.89e-03	-0.19	2.94e-05	7.89e-06	0.0
320	21	-1.64e-03	-0.01	-0.19	3.08e-05	6.38e-06	0.0
320	39	5.98e-03	-3.33e-03	-0.19	2.98e-05	7.10e-06	0.0
320	40	6.13e-03	-1.07e-03	-0.19	2.96e-05	7.08e-06	0.0
320	53	1.02e-03	-6.46e-03	-0.19	3.01e-05	6.57e-06	0.0
320	69	2.37e-03	-2.58e-03	-0.19	2.97e-05	6.67e-06	0.0
321	1	3.06e-03	-3.40e-03	-0.25	4.08e-05	1.11e-05	0.0
321	3	2.59e-03	-2.88e-03	-0.21	3.45e-05	9.35e-06	0.0
321	7	0.01	-4.73e-03	-0.19	3.19e-05	9.78e-06	0.0
321	8	0.01	1.99e-03	-0.19	3.12e-05	9.73e-06	0.0
321	21	-1.74e-03	-0.01	-0.19	3.25e-05	8.22e-06	0.0
321	39	5.97e-03	-3.33e-03	-0.19	3.15e-05	8.94e-06	0.0
321	40	6.13e-03	-1.06e-03	-0.19	3.13e-05	8.92e-06	0.0
321	53	9.69e-04	-6.53e-03	-0.19	3.17e-05	8.41e-06	0.0
321	69	2.35e-03	-2.62e-03	-0.19	3.14e-05	8.50e-06	0.0
322	1	3.28e-03	-3.10e-03	-0.23	1.05e-04	3.99e-05	0.0
322	3	2.77e-03	-2.62e-03	-0.20	8.90e-05	3.37e-05	0.0
322	7	0.01	-5.08e-03	-0.18	8.13e-05	3.16e-05	0.0
322	8	0.01	1.40e-03	-0.18	8.06e-05	3.16e-05	0.0
322	21	-9.49e-04	-0.01	-0.18	8.20e-05	3.03e-05	0.0
322	39	6.09e-03	-3.30e-03	-0.18	8.10e-05	3.10e-05	0.0
322	40	6.15e-03	-1.10e-03	-0.18	8.08e-05	3.10e-05	0.0
322	53	1.35e-03	-6.10e-03	-0.18	8.13e-05	3.06e-05	0.0
322	69	2.52e-03	-2.39e-03	-0.18	8.09e-05	3.07e-05	0.0
323	1	3.26e-03	-3.16e-03	-0.24	8.37e-05	1.17e-05	0.0
323	3	2.76e-03	-2.67e-03	-0.20	7.08e-05	9.88e-06	0.0
323	7	0.01	-5.00e-03	-0.18	6.47e-05	9.93e-06	0.0
323	8	0.01	1.49e-03	-0.18	6.41e-05	9.95e-06	0.0
323	21	-9.95e-04	-0.01	-0.18	6.54e-05	8.67e-06	0.0
323	39	6.07e-03	-3.30e-03	-0.18	6.45e-05	9.31e-06	0.0
323	40	6.13e-03	-1.10e-03	-0.18	6.43e-05	9.31e-06	0.0
323	53	1.32e-03	-6.16e-03	-0.18	6.47e-05	8.88e-06	0.0
323	69	2.51e-03	-2.43e-03	-0.18	6.44e-05	8.99e-06	0.0
324	1	3.25e-03	-3.21e-03	-0.24	7.15e-05	-2.37e-06	0.0
324	3	2.75e-03	-2.72e-03	-0.20	6.05e-05	-2.00e-06	0.0
324	7	0.01	-4.93e-03	-0.18	5.53e-05	0.0	0.0
324	8	0.01	1.59e-03	-0.18	5.47e-05	0.0	0.0
324	21	-1.05e-03	-0.01	-0.18	5.60e-05	-2.13e-06	0.0
324	39	6.05e-03	-3.30e-03	-0.18	5.51e-05	-1.48e-06	0.0
324	40	6.12e-03	-1.09e-03	-0.18	5.49e-05	-1.48e-06	0.0
324	53	1.30e-03	-6.23e-03	-0.18	5.53e-05	-1.92e-06	0.0
324	69	2.50e-03	-2.47e-03	-0.18	5.50e-05	-1.82e-06	0.0
325	1	3.23e-03	-3.26e-03	-0.24	6.42e-05	-9.05e-06	0.0
325	3	2.73e-03	-2.76e-03	-0.20	5.43e-05	-7.66e-06	0.0
325	7	0.01	-4.86e-03	-0.18	4.98e-05	-5.90e-06	0.0
325	8	0.01	1.70e-03	-0.18	4.92e-05	-5.91e-06	0.0
325	21	-1.11e-03	-0.01	-0.18	5.04e-05	-7.27e-06	0.0
325	39	6.03e-03	-3.31e-03	-0.18	4.95e-05	-6.60e-06	0.0
325	40	6.11e-03	-1.09e-03	-0.18	4.93e-05	-6.61e-06	0.0
325	53	1.27e-03	-6.31e-03	-0.18	4.97e-05	-7.07e-06	0.0

Parco Eolico "Bolina" – Progetto Definitivo
Relazione di calcolo preliminare delle fondazioni degli aerogeneratori G8 e G12

325	69	2.48e-03	-2.51e-03	-0.18	4.94e-05	-6.96e-06	0.0
326	1	3.21e-03	-3.32e-03	-0.24	6.02e-05	-1.03e-05	0.0
326	3	2.71e-03	-2.81e-03	-0.20	5.09e-05	-8.71e-06	0.0
326	7	0.01	-4.80e-03	-0.18	4.67e-05	-6.70e-06	0.0
326	8	0.01	1.81e-03	-0.18	4.61e-05	-6.72e-06	0.0
326	21	-1.18e-03	-0.01	-0.18	4.74e-05	-8.23e-06	0.0
326	39	6.01e-03	-3.31e-03	-0.18	4.64e-05	-7.50e-06	0.0
326	40	6.11e-03	-1.08e-03	-0.18	4.62e-05	-7.51e-06	0.0
326	53	1.24e-03	-6.39e-03	-0.18	4.66e-05	-8.02e-06	0.0
326	69	2.47e-03	-2.55e-03	-0.18	4.63e-05	-7.91e-06	0.0
327	1	3.18e-03	-3.38e-03	-0.23	5.86e-05	-4.29e-06	0.0
327	3	2.69e-03	-2.86e-03	-0.20	4.96e-05	-3.63e-06	0.0
327	7	0.01	-4.75e-03	-0.18	4.56e-05	-1.59e-06	0.0
327	8	0.01	1.90e-03	-0.18	4.46e-05	-1.59e-06	0.0
327	21	-1.24e-03	-0.01	-0.18	4.67e-05	-3.80e-06	0.0
327	39	6.00e-03	-3.33e-03	-0.18	4.53e-05	-2.72e-06	0.0
327	40	6.10e-03	-1.08e-03	-0.18	4.49e-05	-2.72e-06	0.0
327	53	1.20e-03	-6.47e-03	-0.18	4.56e-05	-3.47e-06	0.0
327	69	2.45e-03	-2.60e-03	-0.18	4.51e-05	-3.30e-06	0.0
328	1	3.17e-03	-3.42e-03	-0.24	6.09e-05	2.19e-06	0.0
328	3	2.68e-03	-2.89e-03	-0.20	5.15e-05	1.85e-06	0.0
328	7	0.01	-4.67e-03	-0.18	4.74e-05	3.06e-06	0.0
328	8	0.01	2.03e-03	-0.18	4.67e-05	3.01e-06	0.0
328	21	-1.31e-03	-0.01	-0.18	4.80e-05	1.36e-06	0.0
328	39	6.00e-03	-3.32e-03	-0.18	4.70e-05	2.15e-06	0.0
328	40	6.11e-03	-1.05e-03	-0.18	4.68e-05	2.14e-06	0.0
328	53	1.17e-03	-6.55e-03	-0.18	4.72e-05	1.58e-06	0.0
328	69	2.44e-03	-2.63e-03	-0.18	4.69e-05	1.69e-06	0.0
329	1	3.15e-03	-3.47e-03	-0.24	6.26e-05	4.39e-06	0.0
329	3	2.67e-03	-2.93e-03	-0.20	5.30e-05	3.71e-06	0.0
329	7	0.01	-4.61e-03	-0.19	4.87e-05	4.71e-06	0.0
329	8	0.01	2.15e-03	-0.19	4.80e-05	4.66e-06	0.0
329	21	-1.37e-03	-0.01	-0.19	4.92e-05	3.06e-06	0.0
329	39	5.99e-03	-3.33e-03	-0.19	4.83e-05	3.82e-06	0.0
329	40	6.11e-03	-1.04e-03	-0.19	4.81e-05	3.81e-06	0.0
329	53	1.14e-03	-6.63e-03	-0.19	4.85e-05	3.27e-06	0.0
329	69	2.43e-03	-2.67e-03	-0.19	4.81e-05	3.37e-06	0.0
330	1	3.33e-03	-3.11e-03	-0.22	1.37e-04	4.45e-05	0.0
330	3	2.82e-03	-2.63e-03	-0.19	1.16e-04	3.77e-05	0.0
330	7	0.01	-5.08e-03	-0.17	1.06e-04	3.52e-05	0.0
330	8	0.01	1.40e-03	-0.17	1.05e-04	3.52e-05	0.0
330	21	-7.87e-04	-0.01	-0.17	1.07e-04	3.39e-05	0.0
330	39	6.11e-03	-3.30e-03	-0.17	1.06e-04	3.46e-05	0.0
330	40	6.15e-03	-1.11e-03	-0.17	1.05e-04	3.46e-05	0.0
330	53	1.43e-03	-6.10e-03	-0.17	1.06e-04	3.42e-05	0.0
330	69	2.56e-03	-2.39e-03	-0.17	1.06e-04	3.43e-05	0.0
331	1	3.32e-03	-3.18e-03	-0.22	1.17e-04	1.41e-05	0.0
331	3	2.81e-03	-2.69e-03	-0.19	9.93e-05	1.20e-05	0.0
331	7	0.01	-4.96e-03	-0.17	9.07e-05	1.18e-05	0.0
331	8	0.01	1.53e-03	-0.17	9.00e-05	1.18e-05	0.0
331	21	-8.05e-04	-0.01	-0.17	9.14e-05	1.06e-05	0.0
331	39	6.08e-03	-3.30e-03	-0.17	9.04e-05	1.12e-05	0.0
331	40	6.12e-03	-1.10e-03	-0.17	9.02e-05	1.12e-05	0.0
331	53	1.42e-03	-6.18e-03	-0.17	9.07e-05	1.08e-05	0.0
331	69	2.55e-03	-2.45e-03	-0.17	9.03e-05	1.09e-05	0.0
332	1	3.31e-03	-3.24e-03	-0.23	1.04e-04	-1.45e-06	0.0
332	3	2.80e-03	-2.74e-03	-0.19	8.81e-05	-1.23e-06	0.0
332	7	0.01	-4.88e-03	-0.17	8.05e-05	0.0	0.0
332	8	0.01	1.65e-03	-0.17	7.99e-05	0.0	0.0
332	21	-8.28e-04	-0.01	-0.17	8.11e-05	-1.40e-06	0.0
332	39	6.06e-03	-3.30e-03	-0.17	8.02e-05	0.0	0.0
332	40	6.11e-03	-1.09e-03	-0.17	8.00e-05	0.0	0.0
332	53	1.41e-03	-6.26e-03	-0.17	8.04e-05	-1.21e-06	0.0
332	69	2.55e-03	-2.49e-03	-0.17	8.01e-05	-1.12e-06	0.0
333	1	3.30e-03	-3.29e-03	-0.22	9.47e-05	-9.25e-06	0.0
333	3	2.79e-03	-2.79e-03	-0.19	8.01e-05	-7.83e-06	0.0
333	7	0.01	-4.80e-03	-0.17	7.32e-05	-6.08e-06	0.0
333	8	0.01	1.77e-03	-0.17	7.26e-05	-6.08e-06	0.0
333	21	-8.56e-04	-0.01	-0.17	7.38e-05	-7.41e-06	0.0
333	39	6.04e-03	-3.30e-03	-0.17	7.30e-05	-6.76e-06	0.0
333	40	6.10e-03	-1.08e-03	-0.17	7.28e-05	-6.77e-06	0.0
333	53	1.39e-03	-6.34e-03	-0.17	7.32e-05	-7.22e-06	0.0
333	69	2.54e-03	-2.53e-03	-0.17	7.28e-05	-7.12e-06	0.0

Parco Eolico "Bolina" – Progetto Definitivo
Relazione di calcolo preliminare delle fondazioni degli aerogeneratori G8 e G12

334	1	3.29e-03	-3.35e-03	-0.22	8.84e-05	-1.03e-05	0.0
334	3	2.78e-03	-2.84e-03	-0.19	7.48e-05	-8.68e-06	0.0
334	7	0.01	-4.73e-03	-0.17	6.84e-05	-6.77e-06	0.0
334	8	0.01	1.89e-03	-0.17	6.78e-05	-6.78e-06	0.0
334	21	-8.87e-04	-0.01	-0.17	6.90e-05	-8.21e-06	0.0
334	39	6.03e-03	-3.31e-03	-0.17	6.82e-05	-7.51e-06	0.0
334	40	6.09e-03	-1.07e-03	-0.17	6.79e-05	-7.51e-06	0.0
334	53	1.37e-03	-6.43e-03	-0.17	6.84e-05	-8.00e-06	0.0
334	69	2.53e-03	-2.58e-03	-0.17	6.80e-05	-7.89e-06	0.0
335	1	3.28e-03	-3.41e-03	-0.22	8.49e-05	-5.96e-06	0.0
335	3	2.77e-03	-2.89e-03	-0.19	7.18e-05	-5.05e-06	0.0
335	7	0.01	-4.66e-03	-0.17	6.57e-05	-3.33e-06	0.0
335	8	0.01	2.01e-03	-0.17	6.51e-05	-3.34e-06	0.0
335	21	-9.18e-04	-0.01	-0.17	6.64e-05	-4.94e-06	0.0
335	39	6.02e-03	-3.31e-03	-0.17	6.54e-05	-4.16e-06	0.0
335	40	6.08e-03	-1.06e-03	-0.17	6.52e-05	-4.17e-06	0.0
335	53	1.36e-03	-6.52e-03	-0.17	6.57e-05	-4.71e-06	0.0
335	69	2.52e-03	-2.62e-03	-0.17	6.53e-05	-4.59e-06	0.0
336	1	3.27e-03	-3.46e-03	-0.23	8.36e-05	0.0	0.0
336	3	2.77e-03	-2.93e-03	-0.19	7.07e-05	0.0	0.0
336	7	0.01	-4.58e-03	-0.17	6.48e-05	0.0	0.0
336	8	0.01	2.15e-03	-0.17	6.41e-05	0.0	0.0
336	21	-9.50e-04	-0.01	-0.17	6.53e-05	0.0	0.0
336	39	6.01e-03	-3.31e-03	-0.17	6.45e-05	0.0	0.0
336	40	6.08e-03	-1.03e-03	-0.17	6.42e-05	0.0	0.0
336	53	1.34e-03	-6.60e-03	-0.17	6.47e-05	0.0	0.0
336	69	2.52e-03	-2.66e-03	-0.17	6.43e-05	0.0	0.0
337	1	3.26e-03	-3.51e-03	-0.23	8.48e-05	2.65e-06	0.0
337	3	2.76e-03	-2.97e-03	-0.19	7.17e-05	2.25e-06	0.0
337	7	0.01	-4.50e-03	-0.18	6.57e-05	3.31e-06	0.0
337	8	0.01	2.28e-03	-0.18	6.51e-05	3.29e-06	0.0
337	21	-9.84e-04	-0.01	-0.17	6.62e-05	1.69e-06	0.0
337	39	6.01e-03	-3.31e-03	-0.17	6.54e-05	2.47e-06	0.0
337	40	6.08e-03	-1.01e-03	-0.17	6.52e-05	2.47e-06	0.0
337	53	1.33e-03	-6.69e-03	-0.17	6.56e-05	1.92e-06	0.0
337	69	2.51e-03	-2.70e-03	-0.17	6.52e-05	2.04e-06	0.0
338	1	9.23e-03	-8.68e-03	-0.15	2.92e-04	2.92e-04	0.0
338	3	7.81e-03	-7.35e-03	-0.13	2.47e-04	2.47e-04	0.0
338	8	0.02	-3.41e-03	-0.12	2.24e-04	2.26e-04	1.02e-06
338	21	3.83e-03	-0.02	-0.12	2.26e-04	2.24e-04	-2.53e-06
338	23	0.01	-0.02	-0.12	2.26e-04	2.25e-04	-1.71e-06
338	40	0.01	-5.57e-03	-0.12	2.24e-04	2.25e-04	0.0
338	53	5.99e-03	-0.01	-0.12	2.25e-04	2.24e-04	-1.36e-06
338	55	8.14e-03	-0.01	-0.12	2.25e-04	2.25e-04	-1.08e-06
338	69	7.10e-03	-6.68e-03	-0.12	2.24e-04	2.24e-04	0.0

Nodo	Traslazione X	Traslazione Y	Traslazione Z	Rotazione X	Rotazione Y	Rotazione Z
	-8.72e-03	-0.02	-0.25	-1.04e-05	-1.03e-05	-2.69e-06
	0.02	8.62e-03	-8.17e-03	2.92e-04	2.92e-04	1.78e-06

Nodo	Cmb	Azione X daN	Azione Y daN	Azione Z daN	Azione RX daN cm	Azione RY daN cm	Azione RZ daN cm
84	1	-325.77	3944.19	-1.589e+05	1.891e+06	2.422e+05	0.0
84	2	-250.60	3033.99	-1.222e+05	1.455e+06	1.863e+05	0.0
84	3	-275.65	3337.39	-1.344e+05	1.600e+06	2.050e+05	0.0
84	4	-225.54	2730.59	-1.100e+05	1.309e+06	1.677e+05	0.0
84	5	-1534.57	2530.88	-1.218e+05	1.336e+06	4.876e+05	0.0
84	6	-1525.78	3333.36	-1.218e+05	1.524e+06	4.854e+05	0.0
84	7	1024.59	2734.62	-1.226e+05	1.386e+06	-1.128e+05	0.0
84	24	147.92	4402.02	-1.223e+05	1.775e+06	9.262e+04	0.0
84	37	-685.06	2863.75	-1.221e+05	1.414e+06	2.883e+05	0.0
84	38	-682.09	3135.29	-1.221e+05	1.478e+06	2.875e+05	0.0
84	39	180.90	2932.69	-1.224e+05	1.431e+06	8.511e+04	0.0
84	56	-115.75	3496.90	-1.222e+05	1.563e+06	1.546e+05	0.0
84	69	-250.60	3033.99	-1.222e+05	1.455e+06	1.863e+05	0.0
92	1	450.95	2838.52	-1.561e+05	1.392e+06	-1.132e+05	0.0
92	2	346.88	2183.48	-1.201e+05	1.071e+06	-8.704e+04	0.0
92	3	381.57	2401.83	-1.321e+05	1.178e+06	-9.575e+04	0.0
92	4	312.19	1965.13	-1.081e+05	9.637e+05	-7.834e+04	0.0
92	6	-901.33	2417.01	-1.193e+05	1.124e+06	2.044e+05	0.0
92	7	1595.10	1949.95	-1.208e+05	1.018e+06	-3.785e+05	0.0
92	8	1604.83	2775.64	-1.208e+05	1.212e+06	-3.808e+05	0.0

Parco Eolico "Bolina" – Progetto Definitivo
Relazione di calcolo preliminare delle fondazioni degli aerogeneratori G8 e G12

92	24	739.03	3613.42	-1.202e+05	1.407e+06	-1.787e+05	0.0
92	38	-75.48	2262.50	-1.198e+05	1.089e+06	1.157e+04	0.0
92	39	769.25	2104.46	-1.203e+05	1.053e+06	-1.857e+05	0.0
92	40	772.54	2383.85	-1.203e+05	1.118e+06	-1.864e+05	0.0
92	56	479.57	2667.34	-1.201e+05	1.185e+06	-1.181e+05	0.0
92	69	346.88	2183.48	-1.201e+05	1.071e+06	-8.704e+04	0.0
103	1	-234.13	3549.86	-1.208e+05	1.716e+06	2.052e+05	0.0
103	2	-180.10	2730.66	-9.296e+04	1.320e+06	1.578e+05	0.0
103	3	-198.11	3003.73	-1.023e+05	1.452e+06	1.736e+05	0.0
103	4	-162.09	2457.60	-8.366e+04	1.188e+06	1.420e+05	0.0
103	5	-1349.62	2140.86	-9.226e+04	1.180e+06	4.307e+05	0.0
103	6	-1369.04	2959.96	-9.239e+04	1.372e+06	4.354e+05	0.0
103	8	989.42	3320.46	-9.366e+04	1.460e+06	-1.150e+05	0.0
103	24	141.30	4149.90	-9.336e+04	1.654e+06	8.318e+04	0.0
103	37	-575.84	2531.09	-9.272e+04	1.273e+06	2.502e+05	0.0
103	38	-582.41	2808.25	-9.276e+04	1.338e+06	2.518e+05	0.0
103	40	215.63	2930.24	-9.319e+04	1.368e+06	6.549e+04	0.0
103	56	-71.35	3210.90	-9.309e+04	1.433e+06	1.326e+05	0.0
103	69	-180.10	2730.66	-9.296e+04	1.320e+06	1.578e+05	0.0
115	1	-1990.62	4141.14	-9.977e+04	1.979e+06	1.010e+06	0.0
115	2	-1531.25	3185.49	-7.675e+04	1.523e+06	7.766e+05	0.0
115	3	-1684.37	3504.04	-8.442e+04	1.675e+06	8.543e+05	0.0
115	4	-1378.12	2866.94	-6.907e+04	1.370e+06	6.989e+05	0.0
115	5	-2701.67	2685.65	-7.637e+04	1.404e+06	1.051e+06	0.0
115	6	-2725.50	3480.27	-7.652e+04	1.590e+06	1.056e+06	0.0
115	8	-360.83	3685.33	-7.713e+04	1.641e+06	5.025e+05	0.0
115	24	-1216.26	4540.62	-7.710e+04	1.841e+06	7.027e+05	0.0
115	37	-1927.29	3016.36	-7.662e+04	1.482e+06	8.694e+05	0.0
115	38	-1935.35	3285.24	-7.667e+04	1.546e+06	8.712e+05	0.0
115	40	-1135.21	3354.62	-7.688e+04	1.563e+06	6.839e+05	0.0
115	56	-1424.66	3644.03	-7.687e+04	1.630e+06	7.516e+05	0.0
115	69	-1531.25	3185.49	-7.675e+04	1.523e+06	7.766e+05	0.0
119	1	-911.59	3123.34	-8.493e+04	1.518e+06	5.193e+05	0.0
119	2	-701.22	2402.57	-6.533e+04	1.168e+06	3.995e+05	0.0
119	3	-771.35	2642.83	-7.187e+04	1.285e+06	4.394e+05	0.0
119	4	-631.10	2162.31	-5.880e+04	1.051e+06	3.595e+05	0.0
119	5	-1784.62	1850.32	-6.474e+04	1.037e+06	6.522e+05	0.0
119	6	-1832.73	2653.93	-6.500e+04	1.226e+06	6.638e+05	0.0
119	8	382.17	2954.82	-6.593e+04	1.299e+06	1.468e+05	0.0
119	24	-449.18	3787.05	-6.591e+04	1.493e+06	3.414e+05	0.0
119	37	-1067.82	2215.70	-6.513e+04	1.124e+06	4.850e+05	0.0
119	38	-1084.10	2487.62	-6.522e+04	1.187e+06	4.889e+05	0.0
119	40	-334.63	2589.44	-6.554e+04	1.212e+06	3.140e+05	0.0
119	56	-615.94	2871.04	-6.553e+04	1.278e+06	3.798e+05	0.0
119	69	-701.22	2402.57	-6.533e+04	1.168e+06	3.995e+05	0.0
135	1	-1413.61	2218.12	-5.737e+04	1.099e+06	7.517e+05	0.0
135	2	-1087.39	1706.25	-4.413e+04	8.455e+05	5.782e+05	0.0
135	3	-1196.13	1876.87	-4.854e+04	9.300e+05	6.361e+05	0.0
135	4	-978.65	1535.62	-3.971e+04	7.609e+05	5.204e+05	0.0
135	6	-2189.34	2006.40	-4.406e+04	9.151e+05	8.362e+05	0.0
135	21	-1290.51	378.56	-4.348e+04	5.342e+05	6.248e+05	0.0
135	24	-884.27	3033.94	-4.477e+04	1.157e+06	5.316e+05	0.0
135	38	-1460.26	1807.81	-4.411e+04	8.690e+05	6.655e+05	0.0
135	53	-1156.12	1256.99	-4.391e+04	7.401e+05	5.940e+05	0.0
135	56	-1018.66	2155.51	-4.435e+04	9.508e+05	5.625e+05	0.0
135	69	-1087.39	1706.25	-4.413e+04	8.455e+05	5.782e+05	0.0
147	1	-3086.31	2248.70	-5.361e+04	1.107e+06	1.512e+06	0.0
147	2	-2374.09	1729.77	-4.124e+04	8.515e+05	1.163e+06	0.0
147	3	-2611.49	1902.75	-4.536e+04	9.367e+05	1.279e+06	0.0
147	4	-2136.68	1556.79	-3.711e+04	7.664e+05	1.047e+06	0.0
147	6	-3557.39	2098.49	-4.133e+04	9.378e+05	1.440e+06	0.0
147	21	-2652.39	449.28	-4.090e+04	5.504e+05	1.228e+06	0.0
147	24	-2095.78	3010.25	-4.158e+04	1.153e+06	1.098e+06	0.0
147	38	-2774.49	1854.53	-4.127e+04	8.807e+05	1.257e+06	0.0
147	53	-2468.26	1296.48	-4.112e+04	7.496e+05	1.185e+06	0.0
147	56	-2279.91	2163.05	-4.135e+04	9.534e+05	1.141e+06	0.0
147	69	-2374.09	1729.77	-4.124e+04	8.515e+05	1.163e+06	0.0
151	1	-1478.82	1260.72	-3.558e+04	6.554e+05	7.822e+05	0.0
151	2	-1137.55	969.79	-2.737e+04	5.041e+05	6.017e+05	0.0
151	3	-1251.31	1066.76	-3.011e+04	5.545e+05	6.619e+05	0.0
151	4	-1023.80	872.81	-2.463e+04	4.537e+05	5.415e+05	0.0
151	6	-2231.60	1329.10	-2.756e+04	5.879e+05	8.580e+05	0.0
151	22	-1594.64	2209.90	-2.798e+04	7.944e+05	7.095e+05	0.0

Parco Eolico "Bolina" – Progetto Definitivo
Relazione di calcolo preliminare delle fondazioni degli aerogeneratori G8 e G12

151	23	-680.46	-270.33	-2.676e+04	2.138e+05	4.939e+05	0.0
151	24	-963.71	2218.28	-2.798e+04	7.966e+05	5.619e+05	0.0
151	38	-1507.75	1091.37	-2.743e+04	5.325e+05	6.884e+05	0.0
151	54	-1292.22	1389.41	-2.758e+04	6.023e+05	6.382e+05	0.0
151	55	-982.88	550.16	-2.716e+04	4.059e+05	5.652e+05	0.0
151	56	-1078.73	1392.25	-2.758e+04	6.031e+05	5.882e+05	0.0
151	69	-1137.55	969.79	-2.737e+04	5.041e+05	6.017e+05	0.0
167	1	-1060.75	709.87	-2.123e+04	3.979e+05	5.897e+05	0.0
167	2	-815.96	546.05	-1.633e+04	3.061e+05	4.536e+05	0.0
167	3	-897.56	600.66	-1.796e+04	3.367e+05	4.990e+05	0.0
167	4	-734.37	491.45	-1.470e+04	2.755e+05	4.083e+05	0.0
167	6	-1926.40	960.24	-1.673e+04	4.030e+05	7.136e+05	0.0
167	22	-1280.28	1741.14	-1.696e+04	5.857e+05	5.629e+05	0.0
167	23	-351.65	-649.04	-1.570e+04	2.646e+04	3.444e+05	0.0
167	38	-1191.71	686.20	-1.647e+04	3.389e+05	5.416e+05	0.0
167	54	-973.08	950.44	-1.654e+04	4.007e+05	4.906e+05	0.0
167	55	-658.85	141.66	-1.612e+04	2.115e+05	4.167e+05	0.0
167	69	-815.96	546.05	-1.633e+04	3.061e+05	4.536e+05	0.0
179	1	-1201.50	1322.51	-2.921e+04	6.772e+05	6.483e+05	0.0
179	2	-924.23	1017.31	-2.247e+04	5.209e+05	4.987e+05	0.0
179	3	-1016.65	1119.04	-2.471e+04	5.730e+05	5.486e+05	0.0
179	4	-831.81	915.58	-2.022e+04	4.688e+05	4.489e+05	0.0
179	6	-2128.74	1445.48	-2.281e+04	6.219e+05	7.813e+05	0.0
179	7	280.28	589.15	-2.212e+04	4.199e+05	2.162e+05	0.0
179	22	-1352.28	2221.89	-2.281e+04	8.035e+05	5.997e+05	0.0
179	38	-1331.80	1162.19	-2.258e+04	5.551e+05	5.943e+05	0.0
179	39	-516.65	872.43	-2.235e+04	4.867e+05	4.031e+05	0.0
179	54	-1069.07	1424.91	-2.258e+04	6.165e+05	5.329e+05	0.0
179	69	-924.23	1017.31	-2.247e+04	5.209e+05	4.987e+05	0.0
183	1	-617.42	768.04	-1.577e+04	4.201e+05	3.842e+05	0.0
183	2	-474.94	590.80	-1.213e+04	3.232e+05	2.955e+05	0.0
183	3	-522.43	649.88	-1.334e+04	3.555e+05	3.251e+05	0.0
183	4	-427.44	531.72	-1.092e+04	2.909e+05	2.660e+05	0.0
183	6	-1620.00	1042.72	-1.270e+04	4.292e+05	5.633e+05	0.0
183	7	670.13	138.88	-1.156e+04	2.172e+05	2.774e+04	0.0
183	22	-926.66	1736.02	-1.270e+04	5.910e+05	4.015e+05	0.0
183	38	-862.40	743.72	-1.232e+04	3.591e+05	3.861e+05	0.0
183	39	-87.48	437.88	-1.194e+04	2.873e+05	2.049e+05	0.0
183	54	-627.79	978.31	-1.232e+04	4.138e+05	3.314e+05	0.0
183	69	-474.94	590.80	-1.213e+04	3.232e+05	2.955e+05	0.0
199	1	-598.57	1235.17	-2.123e+04	6.314e+05	3.713e+05	0.0
199	2	-460.44	950.13	-1.633e+04	4.857e+05	2.856e+05	0.0
199	3	-506.48	1045.14	-1.796e+04	5.342e+05	3.142e+05	0.0
199	4	-414.39	855.12	-1.469e+04	4.371e+05	2.571e+05	0.0
199	6	-1655.48	1414.70	-1.696e+04	5.950e+05	5.653e+05	0.0
199	7	734.61	485.55	-1.569e+04	3.763e+05	6037.26	0.0
199	22	-874.54	2060.80	-1.673e+04	7.457e+05	3.826e+05	0.0
199	38	-864.81	1107.33	-1.654e+04	5.227e+05	3.803e+05	0.0
199	39	-56.06	792.93	-1.611e+04	4.487e+05	1.910e+05	0.0
199	54	-600.56	1325.95	-1.646e+04	5.737e+05	3.184e+05	0.0
199	69	-460.44	950.13	-1.633e+04	4.857e+05	2.856e+05	0.0
211	1	-2181.72	3220.43	-5.360e+04	1.544e+06	1.091e+06	0.0
211	2	-1678.25	2477.26	-4.123e+04	1.187e+06	8.392e+05	0.0
211	3	-1846.07	2724.98	-4.535e+04	1.306e+06	9.231e+05	0.0
211	4	-1510.42	2229.53	-3.711e+04	1.069e+06	7.553e+05	0.0
211	5	-2958.80	2199.04	-4.157e+04	1.123e+06	1.140e+06	0.0
211	8	-397.69	2755.47	-4.089e+04	1.252e+06	5.381e+05	0.0
211	22	-2046.98	3660.67	-4.132e+04	1.464e+06	9.255e+05	0.0
211	37	-2111.56	2383.12	-4.134e+04	1.166e+06	9.411e+05	0.0
211	40	-1244.94	2571.40	-4.112e+04	1.209e+06	7.373e+05	0.0
211	54	-1803.02	2877.69	-4.126e+04	1.281e+06	8.684e+05	0.0
211	69	-1678.25	2477.26	-4.123e+04	1.187e+06	8.392e+05	0.0
215	1	-1195.74	1661.70	-3.557e+04	8.257e+05	6.399e+05	0.0
215	2	-919.80	1278.23	-2.736e+04	6.352e+05	4.922e+05	0.0
215	3	-1011.78	1406.05	-3.010e+04	6.987e+05	5.415e+05	0.0
215	4	-827.82	1150.41	-2.463e+04	5.717e+05	4.430e+05	0.0
215	5	-2168.41	1104.54	-2.798e+04	5.954e+05	7.847e+05	0.0
215	6	-2160.02	1735.60	-2.798e+04	7.431e+05	7.826e+05	0.0
215	7	320.43	820.86	-2.675e+04	5.273e+05	2.019e+05	0.0
215	22	-1279.15	2372.55	-2.755e+04	8.915e+05	5.760e+05	0.0
215	37	-1342.30	1219.46	-2.757e+04	6.217e+05	5.912e+05	0.0
215	38	-1339.46	1432.99	-2.757e+04	6.717e+05	5.905e+05	0.0
215	39	-500.14	1123.47	-2.716e+04	5.987e+05	3.940e+05	0.0

Parco Eolico "Bolina" – Progetto Definitivo
Relazione di calcolo preliminare delle fondazioni degli aerogeneratori G8 e G12

215	54	-1041.39	1648.52	-2.743e+04	7.219e+05	5.206e+05	0.0
215	69	-919.80	1278.23	-2.736e+04	6.352e+05	4.922e+05	0.0
231	1	-2200.27	1587.94	-5.734e+04	7.929e+05	1.095e+06	0.0
231	2	-1692.52	1221.49	-4.411e+04	6.099e+05	8.423e+05	0.0
231	3	-1861.77	1343.64	-4.852e+04	6.709e+05	9.265e+05	0.0
231	4	-1523.27	1099.34	-3.970e+04	5.489e+05	7.581e+05	0.0
231	5	-3020.36	1018.50	-4.475e+04	5.633e+05	1.154e+06	0.0
231	8	-364.68	1424.48	-4.346e+04	6.565e+05	5.310e+05	0.0
231	22	-1992.80	2323.68	-4.404e+04	8.679e+05	9.119e+05	0.0
231	37	-2141.83	1152.80	-4.432e+04	5.941e+05	9.477e+05	0.0
231	40	-1243.21	1290.18	-4.389e+04	6.257e+05	7.370e+05	0.0
231	54	-1794.13	1594.44	-4.409e+04	6.972e+05	8.659e+05	0.0
231	69	-1692.52	1221.49	-4.411e+04	6.099e+05	8.423e+05	0.0
243	1	-4131.50	2111.76	-9.975e+04	1.038e+06	1.977e+06	0.0
243	2	-3178.08	1624.43	-7.673e+04	7.985e+05	1.521e+06	0.0
243	3	-3495.89	1786.87	-8.440e+04	8.783e+05	1.673e+06	0.0
243	4	-2860.27	1461.98	-6.905e+04	7.186e+05	1.369e+06	0.0
243	5	-4533.34	1309.51	-7.708e+04	7.246e+05	1.839e+06	0.0
243	21	-3677.87	453.98	-7.711e+04	5.243e+05	1.640e+06	0.0
243	22	-3473.01	2818.75	-7.650e+04	1.078e+06	1.589e+06	0.0
243	24	-2678.29	2794.87	-7.635e+04	1.073e+06	1.402e+06	0.0
243	37	-3636.66	1517.87	-7.685e+04	7.735e+05	1.629e+06	0.0
243	53	-3347.19	1228.38	-7.686e+04	7.057e+05	1.561e+06	0.0
243	54	-3277.87	2028.56	-7.665e+04	8.931e+05	1.544e+06	0.0
243	56	-3008.96	2020.48	-7.660e+04	8.912e+05	1.481e+06	0.0
243	69	-3178.08	1624.43	-7.673e+04	7.985e+05	1.521e+06	0.0
247	1	-3146.91	1061.26	-8.488e+04	5.543e+05	1.524e+06	0.0
247	2	-2420.70	816.35	-6.529e+04	4.264e+05	1.172e+06	0.0
247	3	-2662.77	897.99	-7.182e+04	4.690e+05	1.290e+06	0.0
247	4	-2178.63	734.72	-5.877e+04	3.837e+05	1.055e+06	0.0
247	5	-3805.35	564.40	-6.588e+04	3.683e+05	1.497e+06	0.0
247	21	-2972.86	-267.14	-6.589e+04	1.737e+05	1.303e+06	0.0
247	22	-2672.28	1948.04	-6.496e+04	6.907e+05	1.230e+06	0.0
247	24	-1868.54	1899.84	-6.470e+04	6.791e+05	1.042e+06	0.0
247	37	-2889.23	731.10	-6.549e+04	4.067e+05	1.282e+06	0.0
247	53	-2607.54	449.72	-6.550e+04	3.409e+05	1.217e+06	0.0
247	54	-2505.83	1199.28	-6.518e+04	5.158e+05	1.192e+06	0.0
247	56	-2233.86	1182.98	-6.509e+04	5.119e+05	1.128e+06	0.0
247	69	-2420.70	816.35	-6.529e+04	4.264e+05	1.172e+06	0.0
263	1	-3599.57	344.22	-1.208e+05	2.307e+05	1.729e+06	0.0
263	2	-2768.90	264.78	-9.291e+04	1.774e+05	1.330e+06	0.0
263	3	-3045.79	291.26	-1.022e+05	1.952e+05	1.463e+06	0.0
263	4	-2492.01	238.31	-8.362e+04	1.597e+05	1.197e+06	0.0
263	5	-4188.31	-56.55	-9.331e+04	1.028e+05	1.663e+06	0.0
263	21	-3358.57	-904.75	-9.361e+04	-9.544e+04	1.470e+06	0.0
263	22	-2998.47	1453.78	-9.234e+04	4.551e+05	1.382e+06	0.0
263	24	-2179.23	1434.32	-9.221e+04	4.503e+05	1.190e+06	0.0
263	37	-3249.20	156.05	-9.304e+04	1.522e+05	1.443e+06	0.0
263	53	-2968.43	-130.96	-9.314e+04	8.510e+04	1.377e+06	0.0
263	54	-2846.58	667.11	-9.271e+04	2.714e+05	1.347e+06	0.0
263	56	-2569.37	660.52	-9.267e+04	2.698e+05	1.282e+06	0.0
263	69	-2768.90	264.78	-9.291e+04	1.774e+05	1.330e+06	0.0
275	1	-3950.14	390.66	-1.589e+05	2.572e+05	1.893e+06	0.0
275	2	-3038.57	300.50	-1.222e+05	1.978e+05	1.456e+06	0.0
275	3	-3342.42	330.56	-1.344e+05	2.176e+05	1.602e+06	0.0
275	4	-2734.71	270.45	-1.100e+05	1.781e+05	1.310e+06	0.0
275	5	-4406.72	-98.00	-1.223e+05	1.042e+05	1.777e+06	0.0
275	22	-3338.10	1575.64	-1.218e+05	4.969e+05	1.525e+06	0.0
275	23	-2739.03	-974.63	-1.226e+05	-1.013e+05	1.387e+06	0.0
275	24	-2535.52	1584.43	-1.218e+05	4.991e+05	1.337e+06	0.0
275	37	-3501.52	165.66	-1.222e+05	1.661e+05	1.564e+06	0.0
275	54	-3139.92	731.98	-1.221e+05	2.991e+05	1.479e+06	0.0
275	55	-2937.21	-130.97	-1.223e+05	9.664e+04	1.433e+06	0.0
275	56	-2868.35	734.95	-1.221e+05	2.998e+05	1.416e+06	0.0
275	69	-3038.57	300.50	-1.222e+05	1.978e+05	1.456e+06	0.0
279	1	-2899.02	-388.33	-1.560e+05	-9.892e+04	1.407e+06	0.0
279	2	-2230.01	-298.72	-1.200e+05	-7.609e+04	1.082e+06	0.0
279	3	-2453.02	-328.59	-1.320e+05	-8.370e+04	1.190e+06	0.0
279	4	-2007.01	-268.85	-1.080e+05	-6.848e+04	9.740e+05	0.0
279	5	-3660.15	-690.85	-1.202e+05	-1.678e+05	1.418e+06	0.0
279	21	-2822.04	-1556.62	-1.207e+05	-3.699e+05	1.223e+06	0.0
279	22	-2463.83	949.44	-1.193e+05	2.153e+05	1.135e+06	0.0
279	23	-1996.20	-1546.88	-1.208e+05	-3.675e+05	1.029e+06	0.0

Parco Eolico "Bolina" – Progetto Definitivo
Relazione di calcolo preliminare delle fondazioni degli aerogeneratori G8 e G12

279	37	-2713.94	-431.41	-1.201e+05	-1.071e+05	1.196e+06	0.0
279	53	-2430.34	-724.36	-1.203e+05	-1.755e+05	1.130e+06	0.0
279	54	-2309.13	123.63	-1.198e+05	2.252e+04	1.100e+06	0.0
279	55	-2150.90	-721.07	-1.203e+05	-1.747e+05	1.064e+06	0.0
279	69	-2230.01	-298.72	-1.200e+05	-7.609e+04	1.082e+06	0.0
295	1	-1443.41	-529.18	-1.801e+05	-1.576e+05	7.418e+05	0.0
295	2	-1110.32	-407.07	-1.385e+05	-1.213e+05	5.706e+05	0.0
295	3	-1221.35	-447.77	-1.524e+05	-1.334e+05	6.276e+05	0.0
295	4	-999.28	-366.36	-1.247e+05	-1.091e+05	5.135e+05	0.0
295	5	-2528.49	-865.63	-1.384e+05	-2.290e+05	9.033e+05	0.0
295	21	-1675.07	-1739.15	-1.392e+05	-4.327e+05	7.045e+05	0.0
295	22	-1368.91	886.16	-1.377e+05	1.807e+05	6.296e+05	0.0
295	23	-851.72	-1700.29	-1.394e+05	-4.232e+05	5.116e+05	0.0
295	37	-1590.19	-562.23	-1.385e+05	-1.577e+05	6.832e+05	0.0
295	53	-1301.41	-857.81	-1.388e+05	-2.266e+05	6.159e+05	0.0
295	54	-1197.82	30.53	-1.383e+05	-1.909e+04	5.906e+05	0.0
295	55	-1022.81	-844.66	-1.388e+05	-2.234e+05	5.506e+05	0.0
295	69	-1110.32	-407.07	-1.385e+05	-1.213e+05	5.706e+05	0.0
307	1	-409.69	415.53	-1.849e+05	2.755e+05	2.746e+05	0.0
307	2	-315.15	319.64	-1.422e+05	2.119e+05	2.113e+05	0.0
307	3	-346.66	351.60	-1.565e+05	2.331e+05	2.324e+05	0.0
307	4	-283.63	287.68	-1.280e+05	1.908e+05	1.901e+05	0.0
307	5	-1668.72	-151.33	-1.420e+05	1.012e+05	5.285e+05	0.0
307	6	-1625.96	647.90	-1.418e+05	2.885e+05	5.182e+05	0.0
307	7	995.67	-8.62	-1.427e+05	1.354e+05	-9.572e+04	0.0
307	24	155.77	1673.09	-1.420e+05	5.291e+05	1.005e+05	0.0
307	37	-773.16	160.28	-1.421e+05	1.745e+05	3.186e+05	0.0
307	38	-758.69	430.71	-1.421e+05	2.378e+05	3.151e+05	0.0
307	39	128.40	208.57	-1.424e+05	1.861e+05	1.074e+05	0.0
307	56	-155.80	777.61	-1.421e+05	3.193e+05	1.738e+05	0.0
307	69	-315.15	319.64	-1.422e+05	2.119e+05	2.113e+05	0.0
311	1	-161.17	132.80	-1.882e+05	1.502e+05	1.576e+05	0.0
311	2	-123.98	102.15	-1.448e+05	1.155e+05	1.212e+05	0.0
311	3	-136.38	112.37	-1.593e+05	1.271e+05	1.333e+05	0.0
311	4	-111.58	91.94	-1.303e+05	1.040e+05	1.091e+05	0.0
311	5	-1510.63	-417.29	-1.444e+05	-7063.29	4.457e+05	0.0
311	6	-1442.48	394.13	-1.441e+05	1.826e+05	4.291e+05	0.0
311	7	1194.52	-189.82	-1.456e+05	4.846e+04	-1.867e+05	0.0
311	24	395.38	1488.65	-1.444e+05	4.400e+05	-1374.55	0.0
311	37	-593.19	-73.61	-1.447e+05	7.405e+04	2.310e+05	0.0
311	38	-570.13	200.95	-1.446e+05	1.382e+05	2.254e+05	0.0
311	39	322.17	3.36	-1.451e+05	9.284e+04	1.703e+04	0.0
311	56	51.76	571.31	-1.447e+05	2.253e+05	7.973e+04	0.0
311	69	-123.98	102.15	-1.448e+05	1.155e+05	1.212e+05	0.0
327	1	543.02	1390.44	-1.801e+05	7.286e+05	-1.603e+05	0.0
327	2	417.71	1069.57	-1.386e+05	5.604e+05	-1.233e+05	0.0
327	3	459.48	1176.53	-1.524e+05	6.165e+05	-1.356e+05	0.0
327	4	375.94	962.62	-1.247e+05	5.044e+05	-1.110e+05	0.0
327	6	-875.67	1327.91	-1.378e+05	6.194e+05	1.787e+05	0.0
327	7	1711.08	811.24	-1.394e+05	5.015e+05	-4.253e+05	0.0
327	8	1749.90	1634.44	-1.392e+05	6.943e+05	-4.347e+05	0.0
327	24	876.23	2487.56	-1.385e+05	8.931e+05	-2.311e+05	0.0
327	38	-19.94	1156.99	-1.383e+05	5.804e+05	-2.112e+04	0.0
327	39	855.35	982.16	-1.388e+05	5.405e+05	-2.255e+05	0.0
327	40	868.49	1260.71	-1.388e+05	6.058e+05	-2.287e+05	0.0
327	56	572.86	1549.39	-1.385e+05	6.730e+05	-1.598e+05	0.0
327	69	417.71	1069.57	-1.386e+05	5.604e+05	-1.233e+05	0.0
Nodo		Azione X	Azione Y	Azione Z	Azione RX	Azione RY	Azione RZ
		-4533.34	-1739.15	-1.882e+05	-4.327e+05	-4.347e+05	0.0
		1749.90	4540.62	-1.092e+04	1.979e+06	1.977e+06	0.0
Nodo	Cmb	Azione X	Azione Y	Azione Z	Azione RX	Azione RY	Azione RZ
		daN	daN	daN	daN cm	daN cm	daN cm
84	1	-325.77	3944.19	-1.589e+05	1.891e+06	2.422e+05	0.0
	4	-225.54	2730.59	-1.100e+05	1.309e+06	1.677e+05	0.0
	21	-649.11	1665.97	-1.221e+05	1.134e+06	2.800e+05	0.0
	1	-325.77	3944.19	-1.589e+05	1.891e+06	2.422e+05	0.0
	8	1033.38	3537.10	-1.226e+05	1.574e+06	-1.150e+05	0.0
	5	-1534.57	2530.88	-1.218e+05	1.336e+06	4.876e+05	0.0
92	1	450.95	2838.52	-1.561e+05	1.392e+06	-1.132e+05	0.0
	4	312.19	1965.13	-1.081e+05	9.637e+05	-7.834e+04	0.0

Parco Eolico "Bolina" – Progetto Definitivo
Relazione di calcolo preliminare delle fondazioni degli aerogeneratori G8 e G12

	21	-45.27	753.53	-1.199e+05	7.347e+05	4636.34	0.0
	24	739.03	3613.42	-1.202e+05	1.407e+06	-1.787e+05	0.0
	8	1604.83	2775.64	-1.208e+05	1.212e+06	-3.808e+05	0.0
	5	-911.07	1591.32	-1.193e+05	9.301e+05	2.067e+05	0.0
103	1	-234.13	3549.86	-1.208e+05	1.716e+06	2.052e+05	0.0
	4	-162.09	2457.60	-8.366e+04	1.188e+06	1.420e+05	0.0
	21	-501.51	1311.42	-9.255e+04	9.867e+05	2.325e+05	0.0
	1	-234.13	3549.86	-1.208e+05	1.716e+06	2.052e+05	0.0
	7	1008.83	2501.36	-9.353e+04	1.268e+06	-1.198e+05	0.0
	6	-1369.04	2959.96	-9.239e+04	1.372e+06	4.354e+05	0.0
115	1	-1990.62	4141.14	-9.977e+04	1.979e+06	1.010e+06	0.0
	4	-1378.12	2866.94	-6.907e+04	1.370e+06	6.989e+05	0.0
	21	-1846.24	1830.36	-7.640e+04	1.204e+06	8.505e+05	0.0
	1	-1990.62	4141.14	-9.977e+04	1.979e+06	1.010e+06	0.0
	7	-337.00	2890.70	-7.697e+04	1.455e+06	4.970e+05	0.0
	6	-2725.50	3480.27	-7.652e+04	1.590e+06	1.056e+06	0.0
119	1	-911.59	3123.34	-8.493e+04	1.518e+06	5.193e+05	0.0
	4	-631.10	2162.31	-5.880e+04	1.051e+06	3.595e+05	0.0
	21	-953.27	1018.09	-6.475e+04	8.430e+05	4.576e+05	0.0
	1	-911.59	3123.34	-8.493e+04	1.518e+06	5.193e+05	0.0
	7	430.28	2151.21	-6.567e+04	1.110e+06	1.352e+05	0.0
	6	-1832.73	2653.93	-6.500e+04	1.226e+06	6.638e+05	0.0
135	1	-1413.61	2218.12	-5.737e+04	1.099e+06	7.517e+05	0.0
	4	-978.65	1535.62	-3.971e+04	7.609e+05	5.204e+05	0.0
	21	-1290.51	378.56	-4.348e+04	5.342e+05	6.248e+05	0.0
	24	-884.27	3033.94	-4.477e+04	1.157e+06	5.316e+05	0.0
	7	14.56	1406.10	-4.419e+04	7.759e+05	3.203e+05	0.0
	6	-2189.34	2006.40	-4.406e+04	9.151e+05	8.362e+05	0.0
147	1	-3086.31	2248.70	-5.361e+04	1.107e+06	1.512e+06	0.0
	4	-2136.68	1556.79	-3.711e+04	7.664e+05	1.047e+06	0.0
	21	-2652.39	449.28	-4.090e+04	5.504e+05	1.228e+06	0.0
	24	-2095.78	3010.25	-4.158e+04	1.153e+06	1.098e+06	0.0
	7	-1190.78	1361.05	-4.115e+04	7.652e+05	8.861e+05	0.0
	1	-3086.31	2248.70	-5.361e+04	1.107e+06	1.512e+06	0.0
151	1	-1478.82	1260.72	-3.558e+04	6.554e+05	7.822e+05	0.0
	4	-1023.80	872.81	-2.463e+04	4.537e+05	5.415e+05	0.0
	21	-1311.39	-278.71	-2.676e+04	2.117e+05	6.415e+05	0.0
	24	-963.71	2218.28	-2.798e+04	7.966e+05	5.619e+05	0.0
	7	-43.51	610.47	-2.719e+04	4.203e+05	3.454e+05	0.0
	6	-2231.60	1329.10	-2.756e+04	5.879e+05	8.580e+05	0.0
167	1	-1060.75	709.87	-2.123e+04	3.979e+05	5.897e+05	0.0
	4	-734.37	491.45	-1.470e+04	2.755e+05	4.083e+05	0.0
	23	-351.65	-649.04	-1.570e+04	2.646e+04	3.444e+05	0.0
	22	-1280.28	1741.14	-1.696e+04	5.857e+05	5.629e+05	0.0
	7	294.47	131.86	-1.593e+04	2.092e+05	1.937e+05	0.0
	6	-1926.40	960.24	-1.673e+04	4.030e+05	7.136e+05	0.0
179	1	-1201.50	1322.51	-2.921e+04	6.772e+05	6.483e+05	0.0
	4	-831.81	915.58	-2.022e+04	4.688e+05	4.489e+05	0.0
	23	-496.17	-187.27	-2.212e+04	2.383e+05	3.978e+05	0.0
	22	-1352.28	2221.89	-2.281e+04	8.035e+05	5.997e+05	0.0
	7	280.28	589.15	-2.212e+04	4.199e+05	2.162e+05	0.0
	6	-2128.74	1445.48	-2.281e+04	6.219e+05	7.813e+05	0.0
183	1	-617.42	768.04	-1.577e+04	4.201e+05	3.842e+05	0.0
	4	-427.44	531.72	-1.092e+04	2.909e+05	2.660e+05	0.0
	23	-23.21	-554.43	-1.156e+04	5.536e+04	1.895e+05	0.0
	22	-926.66	1736.02	-1.270e+04	5.910e+05	4.015e+05	0.0
	7	670.13	138.88	-1.156e+04	2.172e+05	2.774e+04	0.0
	6	-1620.00	1042.72	-1.270e+04	4.292e+05	5.633e+05	0.0
199	1	-598.57	1235.17	-2.123e+04	6.314e+05	3.713e+05	0.0
	4	-414.39	855.12	-1.469e+04	4.371e+05	2.571e+05	0.0
	23	-46.33	-160.54	-1.593e+04	2.256e+05	1.887e+05	0.0
	22	-874.54	2060.80	-1.673e+04	7.457e+05	3.826e+05	0.0
	7	734.61	485.55	-1.569e+04	3.763e+05	6037.26	0.0
	6	-1655.48	1414.70	-1.696e+04	5.950e+05	5.653e+05	0.0
211	1	-2181.72	3220.43	-5.360e+04	1.544e+06	1.091e+06	0.0
	4	-1510.42	2229.53	-3.711e+04	1.069e+06	7.553e+05	0.0
	23	-1309.51	1293.85	-4.114e+04	9.105e+05	7.529e+05	0.0
	1	-2181.72	3220.43	-5.360e+04	1.544e+06	1.091e+06	0.0
	8	-397.69	2755.47	-4.089e+04	1.252e+06	5.381e+05	0.0
	5	-2958.80	2199.04	-4.157e+04	1.123e+06	1.140e+06	0.0
215	1	-1195.74	1661.70	-3.557e+04	8.257e+05	6.399e+05	0.0
	4	-827.82	1150.41	-2.463e+04	5.717e+05	4.430e+05	0.0
	23	-560.45	183.91	-2.718e+04	3.788e+05	4.085e+05	0.0

Parco Eolico "Bolina" – Progetto Definitivo
Relazione di calcolo preliminare delle fondazioni degli aerogeneratori G8 e G12

	22	-1279.15	2372.55	-2.755e+04	8.915e+05	5.760e+05	0.0
	8	328.81	1451.92	-2.675e+04	6.749e+05	1.998e+05	0.0
	5	-2168.41	1104.54	-2.798e+04	5.954e+05	7.847e+05	0.0
231	1	-2200.27	1587.94	-5.734e+04	7.929e+05	1.095e+06	0.0
	4	-1523.27	1099.34	-3.970e+04	5.489e+05	7.581e+05	0.0
	23	-1392.23	119.30	-4.417e+04	3.519e+05	7.727e+05	0.0
	22	-1992.80	2323.68	-4.404e+04	8.679e+05	9.119e+05	0.0
	8	-364.68	1424.48	-4.346e+04	6.565e+05	5.310e+05	0.0
	5	-3020.36	1018.50	-4.475e+04	5.633e+05	1.154e+06	0.0
243	1	-4131.50	2111.76	-9.975e+04	1.038e+06	1.977e+06	0.0
	4	-2860.27	1461.98	-6.905e+04	7.186e+05	1.369e+06	0.0
	23	-2883.15	430.10	-7.695e+04	5.188e+05	1.453e+06	0.0
	22	-3473.01	2818.75	-7.650e+04	1.078e+06	1.589e+06	0.0
	8	-1822.82	1939.34	-7.638e+04	8.724e+05	1.202e+06	0.0
	1	-4131.50	2111.76	-9.975e+04	1.038e+06	1.977e+06	0.0
247	1	-3146.91	1061.26	-8.488e+04	5.543e+05	1.524e+06	0.0
	4	-2178.63	734.72	-5.877e+04	3.837e+05	1.055e+06	0.0
	23	-2169.12	-315.34	-6.563e+04	1.620e+05	1.115e+06	0.0
	22	-2672.28	1948.04	-6.496e+04	6.907e+05	1.230e+06	0.0
	8	-1036.05	1068.30	-6.471e+04	4.844e+05	8.474e+05	0.0
	1	-3146.91	1061.26	-8.488e+04	5.543e+05	1.524e+06	0.0
263	1	-3599.57	344.22	-1.208e+05	2.307e+05	1.729e+06	0.0
	4	-2492.01	238.31	-8.362e+04	1.597e+05	1.197e+06	0.0
	23	-2539.33	-924.21	-9.348e+04	-1.002e+05	1.277e+06	0.0
	22	-2998.47	1453.78	-9.234e+04	4.551e+05	1.382e+06	0.0
	8	-1349.49	586.12	-9.250e+04	2.521e+05	9.960e+05	0.0
	1	-3599.57	344.22	-1.208e+05	2.307e+05	1.729e+06	0.0
275	1	-3950.14	390.66	-1.589e+05	2.572e+05	1.893e+06	0.0
	4	-2734.71	270.45	-1.100e+05	1.781e+05	1.310e+06	0.0
	21	-3541.61	-983.42	-1.226e+05	-1.034e+05	1.575e+06	0.0
	24	-2535.52	1584.43	-1.218e+05	4.991e+05	1.337e+06	0.0
	8	-1670.41	699.01	-1.221e+05	2.915e+05	1.135e+06	0.0
	1	-3950.14	390.66	-1.589e+05	2.572e+05	1.893e+06	0.0
279	1	-2899.02	-388.33	-1.560e+05	-9.892e+04	1.407e+06	0.0
	4	-2007.01	-268.85	-1.080e+05	-6.848e+04	9.740e+05	0.0
	21	-2822.04	-1556.62	-1.207e+05	-3.699e+05	1.223e+06	0.0
	24	-1637.99	959.18	-1.193e+05	2.177e+05	9.416e+05	0.0
	8	-799.88	93.42	-1.198e+05	1.559e+04	7.462e+05	0.0
	5	-3660.15	-690.85	-1.202e+05	-1.678e+05	1.418e+06	0.0
295	1	-1443.41	-529.18	-1.801e+05	-1.576e+05	7.418e+05	0.0
	4	-999.28	-366.36	-1.247e+05	-1.091e+05	5.135e+05	0.0
	21	-1675.07	-1739.15	-1.392e+05	-4.327e+05	7.045e+05	0.0
	24	-545.57	925.02	-1.379e+05	1.902e+05	4.367e+05	0.0
	8	307.85	51.50	-1.387e+05	-1.348e+04	2.379e+05	0.0
	5	-2528.49	-865.63	-1.384e+05	-2.290e+05	9.033e+05	0.0
307	1	-409.69	415.53	-1.849e+05	2.755e+05	2.746e+05	0.0
	4	-283.63	287.68	-1.280e+05	1.908e+05	1.901e+05	0.0
	21	-786.07	-1033.81	-1.425e+05	-1.052e+05	3.220e+05	0.0
	24	155.77	1673.09	-1.420e+05	5.291e+05	1.005e+05	0.0
	8	1038.42	790.61	-1.425e+05	3.227e+05	-1.060e+05	0.0
	5	-1668.72	-151.33	-1.420e+05	1.012e+05	5.285e+05	0.0
311	1	-161.17	132.80	-1.882e+05	1.502e+05	1.576e+05	0.0
	4	-111.58	91.94	-1.303e+05	1.040e+05	1.091e+05	0.0
	21	-643.34	-1284.34	-1.452e+05	-2.089e+05	2.438e+05	0.0
	24	395.38	1488.65	-1.444e+05	4.400e+05	-1374.55	0.0
	8	1262.67	621.60	-1.452e+05	2.381e+05	-2.033e+05	0.0
	5	-1510.63	-417.29	-1.444e+05	-7063.29	4.457e+05	0.0
327	1	543.02	1390.44	-1.801e+05	7.286e+05	-1.603e+05	0.0
	4	375.94	962.62	-1.247e+05	5.044e+05	-1.110e+05	0.0
	21	-40.82	-348.41	-1.387e+05	2.278e+05	-1.553e+04	0.0
	24	876.23	2487.56	-1.385e+05	8.931e+05	-2.311e+05	0.0
	8	1749.90	1634.44	-1.392e+05	6.943e+05	-4.347e+05	0.0
	5	-914.49	504.70	-1.380e+05	4.266e+05	1.881e+05	0.0

RISULTATI OPERE DI FONDAZIONE

LEGENDA RISULTATI OPERE DI FONDAZIONE

Il controllo dei risultati delle analisi condotte, per quanto concerne le opere di fondazione, è possibile in relazione alle tabelle sotto riportate.

La prima tabella è riferita alle fondazioni tipo palo e plinto su pali.

Per questo tipo di fondazione vengono riportate le sei componenti di sollecitazione (espresse nel riferimento globale della struttura) per ogni palo componente l'opera.

In particolare viene riportato:

Nodo	numero del nodo a cui è applicato il plinto
Tipo	codice corrispondente al nome assegnato al tipo di plinto di fondazione: 3) palo singolo (<i>PALO</i>) 4) plinto su palo 5) plinto su due pali (<i>PL.2P</i>) 6) plinto su tre pali (<i>PL.3P</i>) 7) plinto su quattro pali (<i>PL.4P</i>) 8) plinto rettangolare su cinque pali (<i>PL.5P.R</i>) 9) plinto pentagonale su cinque pali (<i>PL.5P</i>) 10) plinto su sei pali (<i>PL.6P</i>)
Palo	numero del palo
Comb.	combinazione di carico in cui si verificano le sei componenti di sollecitazione.
Quota	quota assoluta della sezione del palo per cui si riportano le sei componenti di sollecitazione.

L'azione F_z (corrispondente allo sforzo normale nel palo) è costante poiché il peso del palo stesso non è considerato nella modellazione.

La seconda tabella è riferita alle fondazioni tipo plinto su suolo elastico.

Per questo tipo di fondazione vengono riportate le pressioni nei quattro vertici dell'impronta sul terreno.

In particolare viene riportato:

Nodo	numero del nodo a cui è applicato il plinto
Tipo	Codice identificativo del nome assegnato al plinto
area	area dell'impronta del plinto
Wink O Wink V	coefficienti di Winkler (orizzontale e verticale) adottati
Comb	Combinazione di carico in cui si verificano i valori riportati
Pt (P1 P2 P3 P4)	valori di pressione nei vertici

La terza tabella è riferita alle fondazioni tipo platea su suolo elastico.

Per questo tipo di fondazione vengono riportate le pressioni in ogni vertice (nodo) degli elementi costituenti la platea.

La quarta tabella è riferita alle fondazioni tipo trave su suolo elastico.

Per questo tipo di fondazione vengono riportate le pressioni alle estremità dell'elemento e la massima (in valore assoluto) pressione lungo lo sviluppo dell'elemento.

Vengono inoltre riportati, con funzione statistica, i valori massimo e minimo delle pressioni che compaiono nella tabella.

Parco Eolico "Bolina" – Progetto Definitivo
Relazione di calcolo preliminare delle fondazioni degli aerogeneratori G8 e G12

Con riferimento al **Documento di Affidabilità** "Test di validazione del software di calcolo PRO_SAP e dei moduli aggiuntivi PRO_SAP Modulo Geotecnico, PRO_CAD nodi acciaio e PRO_MST" - versione Settembre 2014, disponibile per il download sul sito www.2si.it, si segnalano i seguenti esempi applicativi:

Test N°	Titolo
105	PLINTO SUPERFICIALE
106	PLINTO SUPERFICIALE
107	PLINTO SUPERFICIALE
108	PLINTO SUPERFICIALE
109	PLINTO SUPERFICIALE
110	PLINTO SUPERFICIALE
111	PLINTO SUPERFICIALE
112	PLINTO SUPERFICIALE
113	PLINTO SUPERFICIALE
114	PLINTO SUPERFICIALE
115	PLINTO SUPERFICIALE
116	PLINTO SUPERFICIALE
117	PLINTO SUPERFICIALE
118	PLINTO SUPERFICIALE
119	PLINTO SUPERFICIALE
120	PLINTO SUPERFICIALE
121	PLINTO SUPERFICIALE
122	PLINTO SUPERFICIALE
123	PLINTO SUPERFICIALE
124	FONDAZIONE NASTRIFORME
125	CALCOLO DEI K DI WINKLER

Nodo	Tipo	Palo	Cmb	Quota	Fx	Fy	Fz	Mx	My	Mz
				cm	daN	daN	daN	daN cm	daN cm	daN cm
84	PALO D 120.00	1	1	-120.00	-325.77	3944.19	-1.589e+05	-1.891e+06	2.422e+05	0.0
		1	2	-120.00	-250.60	3033.99	-1.222e+05	-1.455e+06	1.863e+05	0.0
		1	3	-120.00	-275.65	3337.39	-1.344e+05	-1.600e+06	2.050e+05	0.0
		1	4	-120.00	-225.54	2730.59	-1.100e+05	-1.309e+06	1.677e+05	0.0
		1	5	-120.00	-1534.57	2530.88	-1.218e+05	-1.336e+06	4.876e+05	0.0
		1	6	-120.00	-1525.78	3333.36	-1.218e+05	-1.524e+06	4.854e+05	0.0
		1	7	-120.00	1024.59	2734.62	-1.226e+05	-1.386e+06	-1.128e+05	0.0
		1	24	-120.00	147.92	4402.02	-1.223e+05	-1.775e+06	9.262e+04	0.0
		1	37	-120.00	-685.06	2863.75	-1.221e+05	-1.414e+06	2.883e+05	0.0
		1	38	-120.00	-682.09	3135.29	-1.221e+05	-1.478e+06	2.875e+05	0.0
		1	39	-120.00	180.90	2932.69	-1.224e+05	-1.431e+06	8.511e+04	0.0
		1	56	-120.00	-115.75	3496.90	-1.222e+05	-1.563e+06	1.546e+05	0.0
		1	69	-120.00	-250.60	3033.99	-1.222e+05	-1.455e+06	1.863e+05	0.0
92	PALO D 120.00	1	1	-120.00	450.95	2838.52	-1.561e+05	-1.392e+06	-1.132e+05	0.0
		1	2	-120.00	346.88	2183.48	-1.201e+05	-1.071e+06	-8.704e+04	0.0
		1	3	-120.00	381.57	2401.83	-1.321e+05	-1.178e+06	-9.575e+04	0.0
		1	4	-120.00	312.19	1965.13	-1.081e+05	-9.637e+05	-7.834e+04	0.0
		1	6	-120.00	-901.33	2417.01	-1.193e+05	-1.124e+06	2.044e+05	0.0
		1	7	-120.00	1595.10	1949.95	-1.208e+05	-1.018e+06	-3.785e+05	0.0
		1	8	-120.00	1604.83	2775.64	-1.208e+05	-1.212e+06	-3.808e+05	0.0
		1	24	-120.00	739.03	3613.42	-1.202e+05	-1.407e+06	-1.787e+05	0.0
		1	38	-120.00	-75.48	2262.50	-1.198e+05	-1.089e+06	1.157e+04	0.0
		1	39	-120.00	769.25	2104.46	-1.203e+05	-1.053e+06	-1.857e+05	0.0
		1	40	-120.00	772.54	2383.85	-1.203e+05	-1.118e+06	-1.864e+05	0.0
		1	56	-120.00	479.57	2667.34	-1.201e+05	-1.185e+06	-1.181e+05	0.0
		1	69	-120.00	346.88	2183.48	-1.201e+05	-1.071e+06	-8.704e+04	0.0
103	PALO D 120.00	1	1	-120.00	-234.13	3549.86	-1.208e+05	-1.716e+06	2.052e+05	0.0
		1	2	-120.00	-180.10	2730.66	-9.296e+04	-1.320e+06	1.578e+05	0.0

Parco Eolico "Bolina" – Progetto Definitivo
Relazione di calcolo preliminare delle fondazioni degli aerogeneratori G8 e G12

Nodo	Tipo	Palo	Cmb	Quota	Fx	Fy	Fz	Mx	My	Mz
		1	3	-120.00	-198.11	3003.73	-1.023e+05	-1.452e+06	1.736e+05	0.0
		1	4	-120.00	-162.09	2457.60	-8.366e+04	-1.188e+06	1.420e+05	0.0
		1	5	-120.00	-1349.62	2140.86	-9.226e+04	-1.180e+06	4.307e+05	0.0
		1	6	-120.00	-1369.04	2959.96	-9.239e+04	-1.372e+06	4.354e+05	0.0
		1	8	-120.00	989.42	3320.46	-9.366e+04	-1.460e+06	-1.150e+05	0.0
		1	24	-120.00	141.30	4149.90	-9.336e+04	-1.654e+06	8.318e+04	0.0
		1	37	-120.00	-575.84	2531.09	-9.272e+04	-1.273e+06	2.502e+05	0.0
		1	38	-120.00	-582.41	2808.25	-9.276e+04	-1.338e+06	2.518e+05	0.0
		1	40	-120.00	215.63	2930.24	-9.319e+04	-1.368e+06	6.549e+04	0.0
		1	56	-120.00	-71.35	3210.90	-9.309e+04	-1.433e+06	1.326e+05	0.0
		1	69	-120.00	-180.10	2730.66	-9.296e+04	-1.320e+06	1.578e+05	0.0
115	PALO D 120.00	1	1	-120.00	-1990.62	4141.14	-9.977e+04	-1.979e+06	1.010e+06	0.0
		1	2	-120.00	-1531.25	3185.49	-7.675e+04	-1.523e+06	7.766e+05	0.0
		1	3	-120.00	-1684.37	3504.04	-8.442e+04	-1.675e+06	8.543e+05	0.0
		1	4	-120.00	-1378.12	2866.94	-6.907e+04	-1.370e+06	6.989e+05	0.0
		1	5	-120.00	-2701.67	2685.65	-7.637e+04	-1.404e+06	1.051e+06	0.0
		1	6	-120.00	-2725.50	3480.27	-7.652e+04	-1.590e+06	1.056e+06	0.0
		1	8	-120.00	-360.83	3685.33	-7.713e+04	-1.641e+06	5.025e+05	0.0
		1	24	-120.00	-1216.26	4540.62	-7.710e+04	-1.841e+06	7.027e+05	0.0
		1	37	-120.00	-1927.29	3016.36	-7.662e+04	-1.482e+06	8.694e+05	0.0
		1	38	-120.00	-1935.35	3285.24	-7.667e+04	-1.546e+06	8.712e+05	0.0
		1	40	-120.00	-1135.21	3354.62	-7.688e+04	-1.563e+06	6.839e+05	0.0
		1	56	-120.00	-1424.66	3644.03	-7.687e+04	-1.630e+06	7.516e+05	0.0
		1	69	-120.00	-1531.25	3185.49	-7.675e+04	-1.523e+06	7.766e+05	0.0
119	PALO D 120.00	1	1	-120.00	-911.59	3123.34	-8.493e+04	-1.518e+06	5.193e+05	0.0
		1	2	-120.00	-701.22	2402.57	-6.533e+04	-1.168e+06	3.995e+05	0.0
		1	3	-120.00	-771.35	2642.83	-7.187e+04	-1.285e+06	4.394e+05	0.0
		1	4	-120.00	-631.10	2162.31	-5.880e+04	-1.051e+06	3.595e+05	0.0
		1	5	-120.00	-1784.62	1850.32	-6.474e+04	-1.037e+06	6.522e+05	0.0
		1	6	-120.00	-1832.73	2653.93	-6.500e+04	-1.226e+06	6.638e+05	0.0
		1	8	-120.00	382.17	2954.82	-6.593e+04	-1.299e+06	1.468e+05	0.0
		1	24	-120.00	-449.18	3787.05	-6.591e+04	-1.493e+06	3.414e+05	0.0
		1	37	-120.00	-1067.82	2215.70	-6.513e+04	-1.124e+06	4.850e+05	0.0
		1	38	-120.00	-1084.10	2487.62	-6.522e+04	-1.187e+06	4.889e+05	0.0
		1	40	-120.00	-334.63	2589.44	-6.554e+04	-1.212e+06	3.140e+05	0.0
		1	56	-120.00	-615.94	2871.04	-6.553e+04	-1.278e+06	3.798e+05	0.0
		1	69	-120.00	-701.22	2402.57	-6.533e+04	-1.168e+06	3.995e+05	0.0
135	PALO D 120.00	1	1	-120.00	-1413.61	2218.12	-5.737e+04	-1.099e+06	7.517e+05	0.0
		1	2	-120.00	-1087.39	1706.25	-4.413e+04	-8.455e+05	5.782e+05	0.0
		1	3	-120.00	-1196.13	1876.87	-4.854e+04	-9.300e+05	6.361e+05	0.0
		1	4	-120.00	-978.65	1535.62	-3.971e+04	-7.609e+05	5.204e+05	0.0
		1	6	-120.00	-2189.34	2006.40	-4.406e+04	-9.151e+05	8.362e+05	0.0
		1	21	-120.00	-1290.51	378.56	-4.348e+04	-5.342e+05	6.248e+05	0.0
		1	24	-120.00	-884.27	3033.94	-4.477e+04	-1.157e+06	5.316e+05	0.0
		1	38	-120.00	-1460.26	1807.81	-4.411e+04	-8.690e+05	6.655e+05	0.0
		1	53	-120.00	-1156.12	1256.99	-4.391e+04	-7.401e+05	5.940e+05	0.0
		1	56	-120.00	-1018.66	2155.51	-4.435e+04	-9.508e+05	5.625e+05	0.0
		1	69	-120.00	-1087.39	1706.25	-4.413e+04	-8.455e+05	5.782e+05	0.0
147	PALO D 120.00	1	1	-120.00	-3086.31	2248.70	-5.361e+04	-1.107e+06	1.512e+06	0.0
		1	2	-120.00	-2374.09	1729.77	-4.124e+04	-8.515e+05	1.163e+06	0.0
		1	3	-120.00	-2611.49	1902.75	-4.536e+04	-9.367e+05	1.279e+06	0.0
		1	4	-120.00	-2136.68	1556.79	-3.711e+04	-7.664e+05	1.047e+06	0.0
		1	6	-120.00	-3557.39	2098.49	-4.133e+04	-9.378e+05	1.440e+06	0.0
		1	21	-120.00	-2652.39	449.28	-4.090e+04	-5.504e+05	1.228e+06	0.0
		1	24	-120.00	-2095.78	3010.25	-4.158e+04	-1.153e+06	1.098e+06	0.0
		1	38	-120.00	-2774.49	1854.53	-4.127e+04	-8.807e+05	1.257e+06	0.0
		1	53	-120.00	-2468.26	1296.48	-4.112e+04	-7.496e+05	1.185e+06	0.0
		1	56	-120.00	-2279.91	2163.05	-4.135e+04	-9.534e+05	1.141e+06	0.0
		1	69	-120.00	-2374.09	1729.77	-4.124e+04	-8.515e+05	1.163e+06	0.0
151	PALO D 120.00	1	1	-120.00	-1478.82	1260.72	-3.558e+04	-6.554e+05	7.822e+05	0.0
		1	2	-120.00	-1137.55	969.79	-2.737e+04	-5.041e+05	6.017e+05	0.0
		1	3	-120.00	-1251.31	1066.76	-3.011e+04	-5.545e+05	6.619e+05	0.0
		1	4	-120.00	-1023.80	872.81	-2.463e+04	-4.537e+05	5.415e+05	0.0
		1	6	-120.00	-2231.60	1329.10	-2.756e+04	-5.879e+05	8.580e+05	0.0
		1	22	-120.00	-1594.64	2209.90	-2.798e+04	-7.944e+05	7.095e+05	0.0
		1	23	-120.00	-680.46	-270.33	-2.676e+04	-2.138e+05	4.939e+05	0.0
		1	24	-120.00	-963.71	2218.28	-2.798e+04	-7.966e+05	5.619e+05	0.0
		1	38	-120.00	-1507.75	1091.37	-2.743e+04	-5.325e+05	6.884e+05	0.0
		1	54	-120.00	-1292.22	1389.41	-2.758e+04	-6.023e+05	6.382e+05	0.0
		1	55	-120.00	-982.88	550.16	-2.716e+04	-4.059e+05	5.652e+05	0.0

Parco Eolico "Bolina" – Progetto Definitivo
Relazione di calcolo preliminare delle fondazioni degli aerogeneratori G8 e G12

Nodo	Tipo	Palo	Cmb	Quota	Fx	Fy	Fz	Mx	My	Mz
		1	56	-120.00	-1078.73	1392.25	-2.758e+04	-6.031e+05	5.882e+05	0.0
		1	69	-120.00	-1137.55	969.79	-2.737e+04	-5.041e+05	6.017e+05	0.0
167	PALO D 120.00	1	1	-120.00	-1060.75	709.87	-2.123e+04	-3.979e+05	5.897e+05	0.0
		1	2	-120.00	-815.96	546.05	-1.633e+04	-3.061e+05	4.536e+05	0.0
		1	3	-120.00	-897.56	600.66	-1.796e+04	-3.367e+05	4.990e+05	0.0
		1	4	-120.00	-734.37	491.45	-1.470e+04	-2.755e+05	4.083e+05	0.0
		1	6	-120.00	-1926.40	960.24	-1.673e+04	-4.030e+05	7.136e+05	0.0
		1	22	-120.00	-1280.28	1741.14	-1.696e+04	-5.857e+05	5.629e+05	0.0
		1	23	-120.00	-351.65	-649.04	-1.570e+04	-2.646e+04	3.444e+05	0.0
		1	38	-120.00	-1191.71	686.20	-1.647e+04	-3.389e+05	5.416e+05	0.0
		1	54	-120.00	-973.08	950.44	-1.654e+04	-4.007e+05	4.906e+05	0.0
		1	55	-120.00	-658.85	141.66	-1.612e+04	-2.115e+05	4.167e+05	0.0
		1	69	-120.00	-815.96	546.05	-1.633e+04	-3.061e+05	4.536e+05	0.0
179	PALO D 120.00	1	1	-120.00	-1201.50	1322.51	-2.921e+04	-6.772e+05	6.483e+05	0.0
		1	2	-120.00	-924.23	1017.31	-2.247e+04	-5.209e+05	4.987e+05	0.0
		1	3	-120.00	-1016.65	1119.04	-2.471e+04	-5.730e+05	5.486e+05	0.0
		1	4	-120.00	-831.81	915.58	-2.022e+04	-4.688e+05	4.489e+05	0.0
		1	6	-120.00	-2128.74	1445.48	-2.281e+04	-6.219e+05	7.813e+05	0.0
		1	7	-120.00	280.28	589.15	-2.212e+04	-4.199e+05	2.162e+05	0.0
		1	22	-120.00	-1352.28	2221.89	-2.281e+04	-8.035e+05	5.997e+05	0.0
		1	38	-120.00	-1331.80	1162.19	-2.258e+04	-5.551e+05	5.943e+05	0.0
		1	39	-120.00	-516.65	872.43	-2.235e+04	-4.867e+05	4.031e+05	0.0
		1	54	-120.00	-1069.07	1424.91	-2.258e+04	-6.165e+05	5.329e+05	0.0
		1	69	-120.00	-924.23	1017.31	-2.247e+04	-5.209e+05	4.987e+05	0.0
183	PALO D 120.00	1	1	-120.00	-617.42	768.04	-1.577e+04	-4.201e+05	3.842e+05	0.0
		1	2	-120.00	-474.94	590.80	-1.213e+04	-3.232e+05	2.955e+05	0.0
		1	3	-120.00	-522.43	649.88	-1.334e+04	-3.555e+05	3.251e+05	0.0
		1	4	-120.00	-427.44	531.72	-1.092e+04	-2.909e+05	2.660e+05	0.0
		1	6	-120.00	-1620.00	1042.72	-1.270e+04	-4.292e+05	5.633e+05	0.0
		1	7	-120.00	670.13	138.88	-1.156e+04	-2.172e+05	2.774e+04	0.0
		1	22	-120.00	-926.66	1736.02	-1.270e+04	-5.910e+05	4.015e+05	0.0
		1	38	-120.00	-862.40	743.72	-1.232e+04	-3.591e+05	3.861e+05	0.0
		1	39	-120.00	-87.48	437.88	-1.194e+04	-2.873e+05	2.049e+05	0.0
		1	54	-120.00	-627.79	978.31	-1.232e+04	-4.138e+05	3.314e+05	0.0
		1	69	-120.00	-474.94	590.80	-1.213e+04	-3.232e+05	2.955e+05	0.0
199	PALO D 120.00	1	1	-120.00	-598.57	1235.17	-2.123e+04	-6.314e+05	3.713e+05	0.0
		1	2	-120.00	-460.44	950.13	-1.633e+04	-4.857e+05	2.856e+05	0.0
		1	3	-120.00	-506.48	1045.14	-1.796e+04	-5.342e+05	3.142e+05	0.0
		1	4	-120.00	-414.39	855.12	-1.469e+04	-4.371e+05	2.571e+05	0.0
		1	6	-120.00	-1655.48	1414.70	-1.696e+04	-5.950e+05	5.653e+05	0.0
		1	7	-120.00	734.61	485.55	-1.569e+04	-3.763e+05	6037.26	0.0
		1	22	-120.00	-874.54	2060.80	-1.673e+04	-7.457e+05	3.826e+05	0.0
		1	38	-120.00	-864.81	1107.33	-1.654e+04	-5.227e+05	3.803e+05	0.0
		1	39	-120.00	-56.06	792.93	-1.611e+04	-4.487e+05	1.910e+05	0.0
		1	54	-120.00	-600.56	1325.95	-1.646e+04	-5.737e+05	3.184e+05	0.0
		1	69	-120.00	-460.44	950.13	-1.633e+04	-4.857e+05	2.856e+05	0.0
211	PALO D 120.00	1	1	-120.00	-2181.72	3220.43	-5.360e+04	-1.544e+06	1.091e+06	0.0
		1	2	-120.00	-1678.25	2477.26	-4.123e+04	-1.187e+06	8.392e+05	0.0
		1	3	-120.00	-1846.07	2724.98	-4.535e+04	-1.306e+06	9.231e+05	0.0
		1	4	-120.00	-1510.42	2229.53	-3.711e+04	-1.069e+06	7.553e+05	0.0
		1	5	-120.00	-2958.80	2199.04	-4.157e+04	-1.123e+06	1.140e+06	0.0
		1	8	-120.00	-397.69	2755.47	-4.089e+04	-1.252e+06	5.381e+05	0.0
		1	22	-120.00	-2046.98	3660.67	-4.132e+04	-1.464e+06	9.255e+05	0.0
		1	37	-120.00	-2111.56	2383.12	-4.134e+04	-1.166e+06	9.411e+05	0.0
		1	40	-120.00	-1244.94	2571.40	-4.112e+04	-1.209e+06	7.373e+05	0.0
		1	54	-120.00	-1803.02	2877.69	-4.126e+04	-1.281e+06	8.684e+05	0.0
		1	69	-120.00	-1678.25	2477.26	-4.123e+04	-1.187e+06	8.392e+05	0.0
215	PALO D 120.00	1	1	-120.00	-1195.74	1661.70	-3.557e+04	-8.257e+05	6.399e+05	0.0
		1	2	-120.00	-919.80	1278.23	-2.736e+04	-6.352e+05	4.922e+05	0.0
		1	3	-120.00	-1011.78	1406.05	-3.010e+04	-6.987e+05	5.415e+05	0.0
		1	4	-120.00	-827.82	1150.41	-2.463e+04	-5.717e+05	4.430e+05	0.0
		1	5	-120.00	-2168.41	1104.54	-2.798e+04	-5.954e+05	7.847e+05	0.0
		1	6	-120.00	-2160.02	1735.60	-2.798e+04	-7.431e+05	7.826e+05	0.0
		1	7	-120.00	320.43	820.86	-2.675e+04	-5.273e+05	2.019e+05	0.0
		1	22	-120.00	-1279.15	2372.55	-2.755e+04	-8.915e+05	5.760e+05	0.0
		1	37	-120.00	-1342.30	1219.46	-2.757e+04	-6.217e+05	5.912e+05	0.0
		1	38	-120.00	-1339.46	1432.99	-2.757e+04	-6.717e+05	5.905e+05	0.0
		1	39	-120.00	-500.14	1123.47	-2.716e+04	-5.987e+05	3.940e+05	0.0
		1	54	-120.00	-1041.39	1648.52	-2.743e+04	-7.219e+05	5.206e+05	0.0
		1	69	-120.00	-919.80	1278.23	-2.736e+04	-6.352e+05	4.922e+05	0.0

Parco Eolico "Bolina" – Progetto Definitivo
Relazione di calcolo preliminare delle fondazioni degli aerogeneratori G8 e G12

Nodo	Tipo	Palo	Cmb	Quota	Fx	Fy	Fz	Mx	My	Mz
231	PALO D 120.00	1	1	-120.00	-2200.27	1587.94	-5.734e+04	-7.929e+05	1.095e+06	0.0
		1	2	-120.00	-1692.52	1221.49	-4.411e+04	-6.099e+05	8.423e+05	0.0
		1	3	-120.00	-1861.77	1343.64	-4.852e+04	-6.709e+05	9.265e+05	0.0
		1	4	-120.00	-1523.27	1099.34	-3.970e+04	-5.489e+05	7.581e+05	0.0
		1	5	-120.00	-3020.36	1018.50	-4.475e+04	-5.633e+05	1.154e+06	0.0
		1	8	-120.00	-364.68	1424.48	-4.346e+04	-6.565e+05	5.310e+05	0.0
		1	22	-120.00	-1992.80	2323.68	-4.404e+04	-8.679e+05	9.119e+05	0.0
		1	37	-120.00	-2141.83	1152.80	-4.432e+04	-5.941e+05	9.477e+05	0.0
		1	40	-120.00	-1243.21	1290.18	-4.389e+04	-6.257e+05	7.370e+05	0.0
		1	54	-120.00	-1794.13	1594.44	-4.409e+04	-6.972e+05	8.659e+05	0.0
1	69	-120.00	-1692.52	1221.49	-4.411e+04	-6.099e+05	8.423e+05	0.0		
243	PALO D 120.00	1	1	-120.00	-4131.50	2111.76	-9.975e+04	-1.038e+06	1.977e+06	0.0
		1	2	-120.00	-3178.08	1624.43	-7.673e+04	-7.985e+05	1.521e+06	0.0
		1	3	-120.00	-3495.89	1786.87	-8.440e+04	-8.783e+05	1.673e+06	0.0
		1	4	-120.00	-2860.27	1461.98	-6.905e+04	-7.186e+05	1.369e+06	0.0
		1	5	-120.00	-4533.34	1309.51	-7.708e+04	-7.246e+05	1.839e+06	0.0
		1	21	-120.00	-3677.87	453.98	-7.711e+04	-5.243e+05	1.640e+06	0.0
		1	22	-120.00	-3473.01	2818.75	-7.650e+04	-1.078e+06	1.589e+06	0.0
		1	24	-120.00	-2678.29	2794.87	-7.635e+04	-1.073e+06	1.402e+06	0.0
		1	37	-120.00	-3636.66	1517.87	-7.685e+04	-7.735e+05	1.629e+06	0.0
		1	53	-120.00	-3347.19	1228.38	-7.686e+04	-7.057e+05	1.561e+06	0.0
1	54	-120.00	-3277.87	2028.56	-7.665e+04	-8.931e+05	1.544e+06	0.0		
1	56	-120.00	-3008.96	2020.48	-7.660e+04	-8.912e+05	1.481e+06	0.0		
1	69	-120.00	-3178.08	1624.43	-7.673e+04	-7.985e+05	1.521e+06	0.0		
247	PALO D 120.00	1	1	-120.00	-3146.91	1061.26	-8.488e+04	-5.543e+05	1.524e+06	0.0
		1	2	-120.00	-2420.70	816.35	-6.529e+04	-4.264e+05	1.172e+06	0.0
		1	3	-120.00	-2662.77	897.99	-7.182e+04	-4.690e+05	1.290e+06	0.0
		1	4	-120.00	-2178.63	734.72	-5.877e+04	-3.837e+05	1.055e+06	0.0
		1	5	-120.00	-3805.35	564.40	-6.588e+04	-3.683e+05	1.497e+06	0.0
		1	21	-120.00	-2972.86	-267.14	-6.589e+04	-1.737e+05	1.303e+06	0.0
		1	22	-120.00	-2672.28	1948.04	-6.496e+04	-6.907e+05	1.230e+06	0.0
		1	24	-120.00	-1868.54	1899.84	-6.470e+04	-6.791e+05	1.042e+06	0.0
		1	37	-120.00	-2889.23	731.10	-6.549e+04	-4.067e+05	1.282e+06	0.0
		1	53	-120.00	-2607.54	449.72	-6.550e+04	-3.409e+05	1.217e+06	0.0
1	54	-120.00	-2505.83	1199.28	-6.518e+04	-5.158e+05	1.192e+06	0.0		
1	56	-120.00	-2233.86	1182.98	-6.509e+04	-5.119e+05	1.128e+06	0.0		
1	69	-120.00	-2420.70	816.35	-6.529e+04	-4.264e+05	1.172e+06	0.0		
263	PALO D 120.00	1	1	-120.00	-3599.57	344.22	-1.208e+05	-2.307e+05	1.729e+06	0.0
		1	2	-120.00	-2768.90	264.78	-9.291e+04	-1.774e+05	1.330e+06	0.0
		1	3	-120.00	-3045.79	291.26	-1.022e+05	-1.952e+05	1.463e+06	0.0
		1	4	-120.00	-2492.01	238.31	-8.362e+04	-1.597e+05	1.197e+06	0.0
		1	5	-120.00	-4188.31	-56.55	-9.331e+04	-1.028e+05	1.663e+06	0.0
		1	21	-120.00	-3358.57	-904.75	-9.361e+04	9.544e+04	1.470e+06	0.0
		1	22	-120.00	-2998.47	1453.78	-9.234e+04	-4.551e+05	1.382e+06	0.0
		1	24	-120.00	-2179.23	1434.32	-9.221e+04	-4.503e+05	1.190e+06	0.0
		1	37	-120.00	-3249.20	156.05	-9.304e+04	-1.522e+05	1.443e+06	0.0
		1	53	-120.00	-2968.43	-130.96	-9.314e+04	-8.510e+04	1.377e+06	0.0
1	54	-120.00	-2846.58	667.11	-9.271e+04	-2.714e+05	1.347e+06	0.0		
1	56	-120.00	-2569.37	660.52	-9.267e+04	-2.698e+05	1.282e+06	0.0		
1	69	-120.00	-2768.90	264.78	-9.291e+04	-1.774e+05	1.330e+06	0.0		
275	PALO D 120.00	1	1	-120.00	-3950.14	390.66	-1.589e+05	-2.572e+05	1.893e+06	0.0
		1	2	-120.00	-3038.57	300.50	-1.222e+05	-1.978e+05	1.456e+06	0.0
		1	3	-120.00	-3342.42	330.56	-1.344e+05	-2.176e+05	1.602e+06	0.0
		1	4	-120.00	-2734.71	270.45	-1.100e+05	-1.781e+05	1.310e+06	0.0
		1	5	-120.00	-4406.72	-98.00	-1.223e+05	-1.042e+05	1.777e+06	0.0
		1	22	-120.00	-3338.10	1575.64	-1.218e+05	-4.969e+05	1.525e+06	0.0
		1	23	-120.00	-2739.03	-974.63	-1.226e+05	1.013e+05	1.387e+06	0.0
		1	24	-120.00	-2535.52	1584.43	-1.218e+05	-4.991e+05	1.337e+06	0.0
		1	37	-120.00	-3501.52	165.66	-1.222e+05	-1.661e+05	1.564e+06	0.0
		1	54	-120.00	-3139.92	731.98	-1.221e+05	-2.991e+05	1.479e+06	0.0
1	55	-120.00	-2937.21	-130.97	-1.223e+05	-9.664e+04	1.433e+06	0.0		
1	56	-120.00	-2868.35	734.95	-1.221e+05	-2.998e+05	1.416e+06	0.0		
1	69	-120.00	-3038.57	300.50	-1.222e+05	-1.978e+05	1.456e+06	0.0		
279	PALO D 120.00	1	1	-120.00	-2899.02	-388.33	-1.560e+05	9.892e+04	1.407e+06	0.0
		1	2	-120.00	-2230.01	-298.72	-1.200e+05	7.609e+04	1.082e+06	0.0
		1	3	-120.00	-2453.02	-328.59	-1.320e+05	8.370e+04	1.190e+06	0.0
		1	4	-120.00	-2007.01	-268.85	-1.080e+05	6.848e+04	9.740e+05	0.0
		1	5	-120.00	-3660.15	-690.85	-1.202e+05	1.678e+05	1.418e+06	0.0
		1	21	-120.00	-2822.04	-1556.62	-1.207e+05	3.699e+05	1.223e+06	0.0
1	22	-120.00	-2463.83	949.44	-1.193e+05	-2.153e+05	1.135e+06	0.0		

Parco Eolico "Bolina" – Progetto Definitivo
Relazione di calcolo preliminare delle fondazioni degli aerogeneratori G8 e G12

Nodo	Tipo	Palo	Cmb	Quota	Fx	Fy	Fz	Mx	My	Mz
		1	23	-120.00	-1996.20	-1546.88	-1.208e+05	3.675e+05	1.029e+06	0.0
		1	37	-120.00	-2713.94	-431.41	-1.201e+05	1.071e+05	1.196e+06	0.0
		1	53	-120.00	-2430.34	-724.36	-1.203e+05	1.755e+05	1.130e+06	0.0
		1	54	-120.00	-2309.13	123.63	-1.198e+05	-2.252e+04	1.100e+06	0.0
		1	55	-120.00	-2150.90	-721.07	-1.203e+05	1.747e+05	1.064e+06	0.0
		1	69	-120.00	-2230.01	-298.72	-1.200e+05	7.609e+04	1.082e+06	0.0
295	PALO D 120.00	1	1	-120.00	-1443.41	-529.18	-1.801e+05	1.576e+05	7.418e+05	0.0
		1	2	-120.00	-1110.32	-407.07	-1.385e+05	1.213e+05	5.706e+05	0.0
		1	3	-120.00	-1221.35	-447.77	-1.524e+05	1.334e+05	6.276e+05	0.0
		1	4	-120.00	-999.28	-366.36	-1.247e+05	1.091e+05	5.135e+05	0.0
		1	5	-120.00	-2528.49	-865.63	-1.384e+05	2.290e+05	9.033e+05	0.0
		1	21	-120.00	-1675.07	-1739.15	-1.392e+05	4.327e+05	7.045e+05	0.0
		1	22	-120.00	-1368.91	886.16	-1.377e+05	-1.807e+05	6.296e+05	0.0
		1	23	-120.00	-851.72	-1700.29	-1.394e+05	4.232e+05	5.116e+05	0.0
		1	37	-120.00	-1590.19	-562.23	-1.385e+05	1.577e+05	6.832e+05	0.0
		1	53	-120.00	-1301.41	-857.81	-1.388e+05	2.266e+05	6.159e+05	0.0
		1	54	-120.00	-1197.82	30.53	-1.383e+05	1.909e+04	5.906e+05	0.0
		1	55	-120.00	-1022.81	-844.66	-1.388e+05	2.234e+05	5.506e+05	0.0
		1	69	-120.00	-1110.32	-407.07	-1.385e+05	1.213e+05	5.706e+05	0.0
307	PALO D 120.00	1	1	-120.00	-409.69	415.53	-1.849e+05	-2.755e+05	2.746e+05	0.0
		1	2	-120.00	-315.15	319.64	-1.422e+05	-2.119e+05	2.113e+05	0.0
		1	3	-120.00	-346.66	351.60	-1.565e+05	-2.331e+05	2.324e+05	0.0
		1	4	-120.00	-283.63	287.68	-1.280e+05	-1.908e+05	1.901e+05	0.0
		1	5	-120.00	-1668.72	-151.33	-1.420e+05	-1.012e+05	5.285e+05	0.0
		1	6	-120.00	-1625.96	647.90	-1.418e+05	-2.885e+05	5.182e+05	0.0
		1	7	-120.00	995.67	-8.62	-1.427e+05	-1.354e+05	-9.572e+04	0.0
		1	24	-120.00	155.77	1673.09	-1.420e+05	-5.291e+05	1.005e+05	0.0
		1	37	-120.00	-773.16	160.28	-1.421e+05	-1.745e+05	3.186e+05	0.0
		1	38	-120.00	-758.69	430.71	-1.421e+05	-2.378e+05	3.151e+05	0.0
		1	39	-120.00	128.40	208.57	-1.424e+05	-1.861e+05	1.074e+05	0.0
		1	56	-120.00	-155.80	777.61	-1.421e+05	-3.193e+05	1.738e+05	0.0
		1	69	-120.00	-315.15	319.64	-1.422e+05	-2.119e+05	2.113e+05	0.0
311	PALO D 120.00	1	1	-120.00	-161.17	132.80	-1.882e+05	-1.502e+05	1.576e+05	0.0
		1	2	-120.00	-123.98	102.15	-1.448e+05	-1.155e+05	1.212e+05	0.0
		1	3	-120.00	-136.38	112.37	-1.593e+05	-1.271e+05	1.333e+05	0.0
		1	4	-120.00	-111.58	91.94	-1.303e+05	-1.040e+05	1.091e+05	0.0
		1	5	-120.00	-1510.63	-417.29	-1.444e+05	7063.29	4.457e+05	0.0
		1	6	-120.00	-1442.48	394.13	-1.441e+05	-1.826e+05	4.291e+05	0.0
		1	7	-120.00	1194.52	-189.82	-1.456e+05	-4.846e+04	-1.867e+05	0.0
		1	24	-120.00	395.38	1488.65	-1.444e+05	-4.400e+05	-1374.55	0.0
		1	37	-120.00	-593.19	-73.61	-1.447e+05	-7.405e+04	2.310e+05	0.0
		1	38	-120.00	-570.13	200.95	-1.446e+05	-1.382e+05	2.254e+05	0.0
		1	39	-120.00	322.17	3.36	-1.451e+05	-9.284e+04	1.703e+04	0.0
		1	56	-120.00	51.76	571.31	-1.447e+05	-2.253e+05	7.973e+04	0.0
		1	69	-120.00	-123.98	102.15	-1.448e+05	-1.155e+05	1.212e+05	0.0
327	PALO D 120.00	1	1	-120.00	543.02	1390.44	-1.801e+05	-7.286e+05	-1.603e+05	0.0
		1	2	-120.00	417.71	1069.57	-1.386e+05	-5.604e+05	-1.233e+05	0.0
		1	3	-120.00	459.48	1176.53	-1.524e+05	-6.165e+05	-1.356e+05	0.0
		1	4	-120.00	375.94	962.62	-1.247e+05	-5.044e+05	-1.110e+05	0.0
		1	6	-120.00	-875.67	1327.91	-1.378e+05	-6.194e+05	1.787e+05	0.0
		1	7	-120.00	1711.08	811.24	-1.394e+05	-5.015e+05	-4.253e+05	0.0
		1	8	-120.00	1749.90	1634.44	-1.392e+05	-6.943e+05	-4.347e+05	0.0
		1	24	-120.00	876.23	2487.56	-1.385e+05	-8.931e+05	-2.311e+05	0.0
		1	38	-120.00	-19.94	1156.99	-1.383e+05	-5.804e+05	-2.112e+04	0.0
		1	39	-120.00	855.35	982.16	-1.388e+05	-5.405e+05	-2.255e+05	0.0
		1	40	-120.00	868.49	1260.71	-1.388e+05	-6.058e+05	-2.287e+05	0.0
		1	56	-120.00	572.86	1549.39	-1.385e+05	-6.730e+05	-1.598e+05	0.0
		1	69	-120.00	417.71	1069.57	-1.386e+05	-5.604e+05	-1.233e+05	0.0
Nodo					Fx	Fy	Fz	Mx	My	Mz
					-4533.34	-1739.15	-1.882e+05	-1.979e+06	-4.347e+05	0.0
					1749.90	4540.62	-1.092e+04	4.327e+05	1.977e+06	0.0

Nodo (G)	Pt 1/12	Pt 2/13	Pt 3...	Pt 4...							
	daN/cm2	daN/cm2	daN/cm2	daN/cm2	daN/cm2	daN/cm2	daN/cm2	daN/cm2	daN/cm2	daN/cm2	daN/cm2
1	-0.53	-0.45	-0.41	-0.41	-0.41						
2	-0.61	-0.52	-0.47	-0.47	-0.47						



Parco Eolico "Bolina" – Progetto Definitivo
Relazione di calcolo preliminare delle fondazioni degli aerogeneratori G8 e G12

3	-0.56	-0.48	-0.43	-0.43	-0.43
4	-0.40	-0.34	-0.31	-0.31	-0.31
5	-0.37	-0.31	-0.28	-0.28	-0.28
6	-0.28	-0.23	-0.21	-0.21	-0.21
7	-0.26	-0.22	-0.20	-0.20	-0.20
8	-0.24	-0.21	-0.19	-0.19	-0.19
9	-0.23	-0.19	-0.18	-0.18	-0.18
10	-0.22	-0.19	-0.17	-0.17	-0.17
11	-0.21	-0.18	-0.16	-0.16	-0.16
12	-0.20	-0.17	-0.16	-0.16	-0.15
13	-0.19	-0.16	-0.15	-0.15	-0.15
14	-0.18	-0.15	-0.14	-0.14	-0.14
15	-0.17	-0.14	-0.13	-0.13	-0.13
16	-0.17	-0.14	-0.13	-0.13	-0.13
17	-0.17	-0.14	-0.13	-0.13	-0.13
18	-0.15	-0.13	-0.12	-0.12	-0.12
19	-0.68	-0.58	-0.53	-0.52	-0.52
20	-0.62	-0.53	-0.48	-0.48	-0.48
21	-0.55	-0.46	-0.42	-0.42	-0.42
22	-0.35	-0.30	-0.27	-0.27	-0.27
23	-0.26	-0.22	-0.20	-0.20	-0.20
24	-0.22	-0.19	-0.17	-0.17	-0.17
25	-0.20	-0.17	-0.16	-0.16	-0.16
26	-0.19	-0.16	-0.15	-0.15	-0.15
27	-0.18	-0.15	-0.14	-0.14	-0.14
28	-0.66	-0.56	-0.51	-0.51	-0.51
29	-0.66	-0.55	-0.51	-0.50	-0.50
30	-0.61	-0.52	-0.47	-0.47	-0.47
31	-0.55	-0.46	-0.42	-0.42	-0.42
32	-0.35	-0.30	-0.27	-0.27	-0.27
33	-0.25	-0.21	-0.19	-0.19	-0.19
34	-0.22	-0.19	-0.17	-0.17	-0.17
35	-0.21	-0.18	-0.16	-0.16	-0.16
36	-0.20	-0.17	-0.16	-0.16	-0.15
37	-0.53	-0.45	-0.41	-0.41	-0.41
38	-0.68	-0.58	-0.52	-0.52	-0.52
39	-0.67	-0.57	-0.52	-0.52	-0.52
40	-0.62	-0.52	-0.48	-0.48	-0.48
41	-0.55	-0.47	-0.42	-0.42	-0.42
42	-0.35	-0.30	-0.27	-0.27	-0.27
43	-0.26	-0.22	-0.20	-0.20	-0.20
44	-0.23	-0.19	-0.18	-0.18	-0.18
45	-0.22	-0.19	-0.17	-0.17	-0.17
46	-0.46	-0.39	-0.36	-0.36	-0.36
47	-0.54	-0.46	-0.42	-0.42	-0.42
48	-0.69	-0.59	-0.53	-0.53	-0.53
49	-0.68	-0.58	-0.52	-0.52	-0.52
50	-0.62	-0.52	-0.48	-0.48	-0.48
51	-0.55	-0.46	-0.42	-0.42	-0.42
52	-0.37	-0.31	-0.28	-0.28	-0.28
53	-0.27	-0.23	-0.21	-0.21	-0.21
54	-0.24	-0.21	-0.19	-0.19	-0.19
55	-0.42	-0.36	-0.33	-0.32	-0.32
56	-0.46	-0.39	-0.35	-0.35	-0.35
57	-0.55	-0.46	-0.42	-0.42	-0.42
58	-0.69	-0.59	-0.53	-0.53	-0.53
59	-0.67	-0.57	-0.52	-0.52	-0.52
60	-0.63	-0.54	-0.49	-0.49	-0.49
61	-0.57	-0.48	-0.44	-0.44	-0.44
62	-0.38	-0.32	-0.29	-0.29	-0.29
63	-0.28	-0.23	-0.21	-0.21	-0.21
64	-0.38	-0.32	-0.29	-0.29	-0.29
65	-0.41	-0.35	-0.32	-0.32	-0.32
66	-0.46	-0.39	-0.35	-0.35	-0.35
67	-0.54	-0.46	-0.42	-0.42	-0.42
68	-0.68	-0.57	-0.52	-0.52	-0.52
69	-0.68	-0.58	-0.53	-0.53	-0.53
70	-0.62	-0.53	-0.48	-0.48	-0.48
71	-0.56	-0.48	-0.43	-0.43	-0.43
72	-0.40	-0.34	-0.31	-0.31	-0.31
73	-0.35	-0.29	-0.27	-0.27	-0.27
74	-0.38	-0.32	-0.29	-0.29	-0.29
75	-0.42	-0.36	-0.33	-0.32	-0.32

Parco Eolico "Bolina" – Progetto Definitivo
Relazione di calcolo preliminare delle fondazioni degli aerogeneratori G8 e G12

76	-0.46	-0.39	-0.36	-0.36	-0.36
77	-0.53	-0.45	-0.41	-0.41	-0.41
78	-0.66	-0.56	-0.51	-0.51	-0.51
79	-0.68	-0.58	-0.52	-0.52	-0.52
80	-0.61	-0.52	-0.47	-0.47	-0.47
81	-0.53	-0.45	-0.41	-0.41	-0.41
82	-0.43	-0.36	-0.33	-0.33	-0.33
83	-0.52	-0.44	-0.40	-0.40	-0.40
84	-0.37	-0.32	-0.29	-0.29	-0.29
85	-0.45	-0.38	-0.34	-0.34	-0.34
86	-0.34	-0.29	-0.26	-0.26	-0.26
87	-0.39	-0.33	-0.30	-0.30	-0.30
88	-0.31	-0.26	-0.24	-0.24	-0.24
89	-0.35	-0.30	-0.27	-0.27	-0.27
90	-0.30	-0.25	-0.23	-0.23	-0.23
91	-0.34	-0.29	-0.26	-0.26	-0.26
92	-0.32	-0.27	-0.25	-0.25	-0.25
93	-0.38	-0.32	-0.29	-0.29	-0.29
94	-0.53	-0.45	-0.41	-0.41	-0.41
95	-0.63	-0.53	-0.49	-0.49	-0.49
96	-0.53	-0.45	-0.41	-0.41	-0.41
97	-0.63	-0.53	-0.49	-0.49	-0.48
98	-0.68	-0.57	-0.52	-0.52	-0.52
99	-0.58	-0.49	-0.45	-0.45	-0.44
100	-0.51	-0.43	-0.40	-0.39	-0.39
101	-0.45	-0.38	-0.35	-0.35	-0.35
102	-0.43	-0.36	-0.33	-0.33	-0.33
103	-0.48	-0.41	-0.37	-0.37	-0.37
104	-0.88	-0.75	-0.68	-0.68	-0.68
105	-0.87	-0.74	-0.68	-0.67	-0.67
106	-0.67	-0.57	-0.52	-0.52	-0.52
107	-0.79	-0.67	-0.61	-0.61	-0.61
108	-0.77	-0.65	-0.60	-0.59	-0.59
109	-0.71	-0.60	-0.55	-0.55	-0.55
110	-0.70	-0.59	-0.54	-0.54	-0.53
111	-0.76	-0.64	-0.59	-0.58	-0.58
112	-1.01	-0.85	-0.78	-0.78	-0.77
113	-0.98	-0.83	-0.76	-0.76	-0.75
114	-0.60	-0.51	-0.46	-0.46	-0.46
115	-0.68	-0.58	-0.53	-0.52	-0.52
116	-0.66	-0.56	-0.51	-0.51	-0.51
117	-0.61	-0.51	-0.47	-0.47	-0.47
118	-0.58	-0.49	-0.45	-0.45	-0.45
119	-0.62	-0.52	-0.48	-0.48	-0.48
120	-0.82	-0.70	-0.64	-0.64	-0.63
121	-0.79	-0.67	-0.62	-0.61	-0.61
122	-0.40	-0.34	-0.31	-0.31	-0.31
123	-0.48	-0.41	-0.37	-0.37	-0.37
124	-0.49	-0.41	-0.38	-0.38	-0.38
125	-0.50	-0.42	-0.39	-0.39	-0.39
126	-0.49	-0.42	-0.38	-0.38	-0.38
127	-0.46	-0.39	-0.36	-0.36	-0.36
128	-0.43	-0.36	-0.33	-0.33	-0.33
129	-0.37	-0.32	-0.29	-0.29	-0.29
130	-0.26	-0.22	-0.20	-0.20	-0.20
131	-0.27	-0.23	-0.21	-0.21	-0.21
132	-0.27	-0.23	-0.21	-0.21	-0.21
133	-0.27	-0.23	-0.21	-0.21	-0.21
134	-0.27	-0.23	-0.21	-0.21	-0.21
135	-0.26	-0.22	-0.20	-0.20	-0.20
136	-0.27	-0.23	-0.21	-0.21	-0.21
137	-0.25	-0.21	-0.19	-0.19	-0.19
138	-0.24	-0.21	-0.19	-0.19	-0.19
139	-0.25	-0.21	-0.19	-0.19	-0.19
140	-0.25	-0.21	-0.19	-0.19	-0.19
141	-0.24	-0.21	-0.19	-0.19	-0.19
142	-0.24	-0.21	-0.19	-0.19	-0.19
143	-0.23	-0.20	-0.18	-0.18	-0.18
144	-0.23	-0.19	-0.18	-0.17	-0.17
145	-0.20	-0.17	-0.16	-0.16	-0.16
146	-0.22	-0.19	-0.17	-0.17	-0.17
147	-0.21	-0.18	-0.17	-0.17	-0.16
148	-0.21	-0.18	-0.16	-0.16	-0.16

Parco Eolico "Bolina" – Progetto Definitivo
Relazione di calcolo preliminare delle fondazioni degli aerogeneratori G8 e G12

149	-0.21	-0.18	-0.16	-0.16	-0.16
150	-0.21	-0.18	-0.16	-0.16	-0.16
151	-0.19	-0.16	-0.15	-0.15	-0.15
152	-0.18	-0.15	-0.14	-0.14	-0.14
153	-0.16	-0.13	-0.13	-0.12	-0.12
154	-0.19	-0.16	-0.15	-0.15	-0.15
155	-0.19	-0.16	-0.15	-0.15	-0.15
156	-0.18	-0.15	-0.14	-0.14	-0.14
157	-0.17	-0.15	-0.13	-0.13	-0.13
158	-0.17	-0.14	-0.13	-0.13	-0.13
159	-0.16	-0.13	-0.12	-0.12	-0.12
160	-0.14	-0.12	-0.11	-0.11	-0.11
161	-0.12	-0.10	-0.09	-0.09	-0.09
162	-0.17	-0.15	-0.13	-0.13	-0.13
163	-0.17	-0.14	-0.13	-0.13	-0.13
164	-0.15	-0.13	-0.12	-0.12	-0.12
165	-0.14	-0.12	-0.11	-0.11	-0.11
166	-0.14	-0.12	-0.11	-0.11	-0.10
167	-0.12	-0.10	-0.10	-0.10	-0.09
168	-0.11	-0.09	-0.09	-0.08	-0.08
169	-0.08	-0.07	-0.07	-0.07	-0.07
170	-0.16	-0.13	-0.12	-0.12	-0.12
171	-0.15	-0.12	-0.11	-0.11	-0.11
172	-0.13	-0.11	-0.10	-0.10	-0.10
173	-0.12	-0.11	-0.10	-0.10	-0.10
174	-0.12	-0.10	-0.09	-0.09	-0.09
175	-0.10	-0.09	-0.08	-0.08	-0.08
176	-0.09	-0.07	-0.07	-0.07	-0.07
177	-0.06	-0.05	-0.05	-0.05	-0.05
178	-0.14	-0.12	-0.11	-0.11	-0.11
179	-0.13	-0.11	-0.10	-0.10	-0.10
180	-0.12	-0.10	-0.10	-0.09	-0.09
181	-0.11	-0.10	-0.09	-0.09	-0.09
182	-0.11	-0.09	-0.08	-0.08	-0.08
183	-0.09	-0.08	-0.08	-0.07	-0.07
184	-0.08	-0.07	-0.06	-0.06	-0.06
185	-0.06	-0.05	-0.05	-0.05	-0.04
186	-0.16	-0.13	-0.12	-0.12	-0.12
187	-0.15	-0.12	-0.11	-0.11	-0.11
188	-0.13	-0.11	-0.10	-0.10	-0.10
189	-0.12	-0.11	-0.10	-0.10	-0.10
190	-0.12	-0.10	-0.09	-0.09	-0.09
191	-0.10	-0.09	-0.08	-0.08	-0.08
192	-0.09	-0.07	-0.07	-0.07	-0.07
193	-0.06	-0.05	-0.05	-0.05	-0.05
194	-0.17	-0.15	-0.13	-0.13	-0.13
195	-0.17	-0.14	-0.13	-0.13	-0.13
196	-0.15	-0.13	-0.12	-0.12	-0.12
197	-0.14	-0.12	-0.11	-0.11	-0.11
198	-0.14	-0.12	-0.11	-0.11	-0.10
199	-0.12	-0.10	-0.10	-0.10	-0.09
200	-0.11	-0.09	-0.09	-0.08	-0.08
201	-0.08	-0.07	-0.07	-0.07	-0.07
202	-0.19	-0.16	-0.15	-0.15	-0.15
203	-0.19	-0.16	-0.15	-0.15	-0.15
204	-0.18	-0.15	-0.14	-0.14	-0.14
205	-0.17	-0.15	-0.13	-0.13	-0.13
206	-0.17	-0.14	-0.13	-0.13	-0.13
207	-0.16	-0.13	-0.12	-0.12	-0.12
208	-0.14	-0.12	-0.11	-0.11	-0.11
209	-0.12	-0.10	-0.09	-0.09	-0.09
210	-0.22	-0.19	-0.17	-0.17	-0.17
211	-0.21	-0.18	-0.17	-0.17	-0.17
212	-0.21	-0.18	-0.16	-0.16	-0.16
213	-0.20	-0.17	-0.16	-0.16	-0.16
214	-0.20	-0.17	-0.16	-0.16	-0.16
215	-0.19	-0.16	-0.15	-0.15	-0.15
216	-0.18	-0.15	-0.14	-0.14	-0.14
217	-0.16	-0.13	-0.13	-0.12	-0.12
218	-0.24	-0.21	-0.19	-0.19	-0.19
219	-0.25	-0.21	-0.19	-0.19	-0.19
220	-0.25	-0.21	-0.19	-0.19	-0.19
221	-0.24	-0.20	-0.19	-0.19	-0.18

Parco Eolico "Bolina" – Progetto Definitivo
Relazione di calcolo preliminare delle fondazioni degli aerogeneratori G8 e G12

222	-0.24	-0.20	-0.19	-0.19	-0.18
223	-0.23	-0.20	-0.18	-0.18	-0.18
224	-0.23	-0.19	-0.18	-0.18	-0.17
225	-0.20	-0.17	-0.16	-0.16	-0.16
226	-0.26	-0.22	-0.20	-0.20	-0.20
227	-0.27	-0.23	-0.21	-0.21	-0.21
228	-0.27	-0.23	-0.21	-0.21	-0.21
229	-0.27	-0.23	-0.21	-0.21	-0.21
230	-0.27	-0.23	-0.21	-0.21	-0.21
231	-0.26	-0.22	-0.21	-0.20	-0.20
232	-0.27	-0.23	-0.21	-0.21	-0.21
233	-0.25	-0.21	-0.19	-0.19	-0.19
234	-0.40	-0.34	-0.31	-0.31	-0.31
235	-0.48	-0.41	-0.37	-0.37	-0.37
236	-0.49	-0.41	-0.38	-0.38	-0.38
237	-0.49	-0.41	-0.38	-0.38	-0.38
238	-0.48	-0.41	-0.37	-0.37	-0.37
239	-0.46	-0.39	-0.36	-0.35	-0.35
240	-0.43	-0.36	-0.34	-0.33	-0.33
241	-0.37	-0.32	-0.29	-0.29	-0.29
242	-0.60	-0.51	-0.46	-0.46	-0.46
243	-0.68	-0.58	-0.53	-0.53	-0.52
244	-0.66	-0.56	-0.51	-0.51	-0.51
245	-0.61	-0.51	-0.47	-0.47	-0.47
246	-0.58	-0.49	-0.45	-0.45	-0.45
247	-0.62	-0.53	-0.48	-0.48	-0.48
248	-0.83	-0.70	-0.64	-0.64	-0.64
249	-0.79	-0.67	-0.62	-0.61	-0.61
250	-0.68	-0.57	-0.52	-0.52	-0.52
251	-0.79	-0.67	-0.61	-0.61	-0.61
252	-0.77	-0.65	-0.60	-0.60	-0.59
253	-0.71	-0.60	-0.55	-0.55	-0.55
254	-0.70	-0.59	-0.54	-0.54	-0.54
255	-0.76	-0.64	-0.59	-0.59	-0.58
256	-1.01	-0.86	-0.78	-0.78	-0.78
257	-0.98	-0.83	-0.76	-0.76	-0.75
258	-0.68	-0.57	-0.52	-0.52	-0.52
259	-0.58	-0.49	-0.45	-0.45	-0.45
260	-0.51	-0.43	-0.40	-0.39	-0.39
261	-0.46	-0.39	-0.35	-0.35	-0.35
262	-0.43	-0.36	-0.33	-0.33	-0.33
263	-0.48	-0.41	-0.37	-0.37	-0.37
264	-0.88	-0.75	-0.69	-0.68	-0.68
265	-0.87	-0.74	-0.68	-0.67	-0.67
266	-0.52	-0.44	-0.40	-0.40	-0.40
267	-0.45	-0.38	-0.34	-0.34	-0.34
268	-0.39	-0.33	-0.30	-0.30	-0.30
269	-0.35	-0.30	-0.27	-0.27	-0.27
270	-0.34	-0.29	-0.26	-0.26	-0.26
271	-0.38	-0.32	-0.29	-0.29	-0.29
272	-0.63	-0.54	-0.49	-0.49	-0.49
273	-0.63	-0.53	-0.49	-0.49	-0.48
274	-0.43	-0.36	-0.33	-0.33	-0.33
275	-0.37	-0.32	-0.29	-0.29	-0.29
276	-0.34	-0.29	-0.26	-0.26	-0.26
277	-0.31	-0.26	-0.24	-0.24	-0.24
278	-0.30	-0.25	-0.23	-0.23	-0.23
279	-0.32	-0.27	-0.25	-0.25	-0.25
280	-0.53	-0.45	-0.41	-0.41	-0.41
281	-0.53	-0.45	-0.41	-0.41	-0.41
282	-0.40	-0.34	-0.31	-0.31	-0.31
283	-0.35	-0.29	-0.27	-0.27	-0.27
284	-0.31	-0.26	-0.24	-0.24	-0.24
285	-0.28	-0.24	-0.22	-0.22	-0.22
286	-0.28	-0.24	-0.22	-0.22	-0.22
287	-0.32	-0.27	-0.25	-0.25	-0.25
288	-0.50	-0.43	-0.39	-0.39	-0.39
289	-0.51	-0.43	-0.39	-0.39	-0.39
290	-0.38	-0.32	-0.29	-0.29	-0.29
291	-0.32	-0.27	-0.25	-0.25	-0.25
292	-0.29	-0.24	-0.22	-0.22	-0.22
293	-0.27	-0.22	-0.21	-0.20	-0.20
294	-0.27	-0.23	-0.21	-0.21	-0.21

Parco Eolico "Bolina" – Progetto Definitivo
Relazione di calcolo preliminare delle fondazioni degli aerogeneratori G8 e G12

295	-0.31	-0.26	-0.24	-0.24	-0.24
296	-0.49	-0.41	-0.38	-0.38	-0.37
297	-0.49	-0.42	-0.38	-0.38	-0.38
298	-0.33	-0.28	-0.26	-0.26	-0.26
299	-0.29	-0.25	-0.23	-0.23	-0.23
300	-0.27	-0.23	-0.21	-0.21	-0.21
301	-0.25	-0.22	-0.20	-0.20	-0.20
302	-0.27	-0.23	-0.21	-0.21	-0.21
303	-0.30	-0.26	-0.24	-0.23	-0.23
304	-0.47	-0.40	-0.36	-0.36	-0.36
305	-0.48	-0.40	-0.37	-0.37	-0.37
306	-0.31	-0.26	-0.24	-0.24	-0.24
307	-0.27	-0.23	-0.21	-0.21	-0.21
308	-0.26	-0.22	-0.20	-0.20	-0.20
309	-0.25	-0.21	-0.19	-0.19	-0.19
310	-0.26	-0.22	-0.20	-0.20	-0.20
311	-0.30	-0.26	-0.23	-0.23	-0.23
312	-0.46	-0.39	-0.36	-0.36	-0.36
313	-0.47	-0.40	-0.36	-0.36	-0.36
314	-0.33	-0.28	-0.26	-0.26	-0.26
315	-0.29	-0.25	-0.23	-0.23	-0.23
316	-0.27	-0.23	-0.21	-0.21	-0.21
317	-0.25	-0.22	-0.20	-0.20	-0.20
318	-0.27	-0.23	-0.21	-0.21	-0.21
319	-0.30	-0.26	-0.24	-0.23	-0.23
320	-0.47	-0.40	-0.36	-0.36	-0.36
321	-0.48	-0.40	-0.37	-0.37	-0.37
322	-0.38	-0.32	-0.29	-0.29	-0.29
323	-0.32	-0.27	-0.25	-0.25	-0.25
324	-0.29	-0.24	-0.22	-0.22	-0.22
325	-0.27	-0.22	-0.21	-0.20	-0.20
326	-0.27	-0.23	-0.21	-0.21	-0.21
327	-0.31	-0.26	-0.24	-0.24	-0.24
328	-0.49	-0.41	-0.38	-0.38	-0.37
329	-0.49	-0.42	-0.38	-0.38	-0.38
330	-0.40	-0.34	-0.31	-0.31	-0.31
331	-0.35	-0.29	-0.27	-0.27	-0.27
332	-0.31	-0.26	-0.24	-0.24	-0.24
333	-0.28	-0.24	-0.22	-0.22	-0.22
334	-0.28	-0.24	-0.22	-0.22	-0.22
335	-0.32	-0.27	-0.25	-0.25	-0.25
336	-0.50	-0.43	-0.39	-0.39	-0.39
337	-0.51	-0.43	-0.39	-0.39	-0.39

Nodo (G)	Pt 1/12	Pt 2/13	Pt 3...	Pt 4...
	-1.01			
	-0.04			

RISULTATI ELEMENTI TIPO SHELL

LEGENDA RISULTATI ELEMENTI TIPO SHELL

Il controllo dei risultati delle analisi condotte, per quanto concerne gli elementi tipo shell, è possibile in relazione alle tabelle sottoriportate. Per ogni elemento, e per ogni combinazione (o caso di carico) vengono riportati i risultati più significativi.

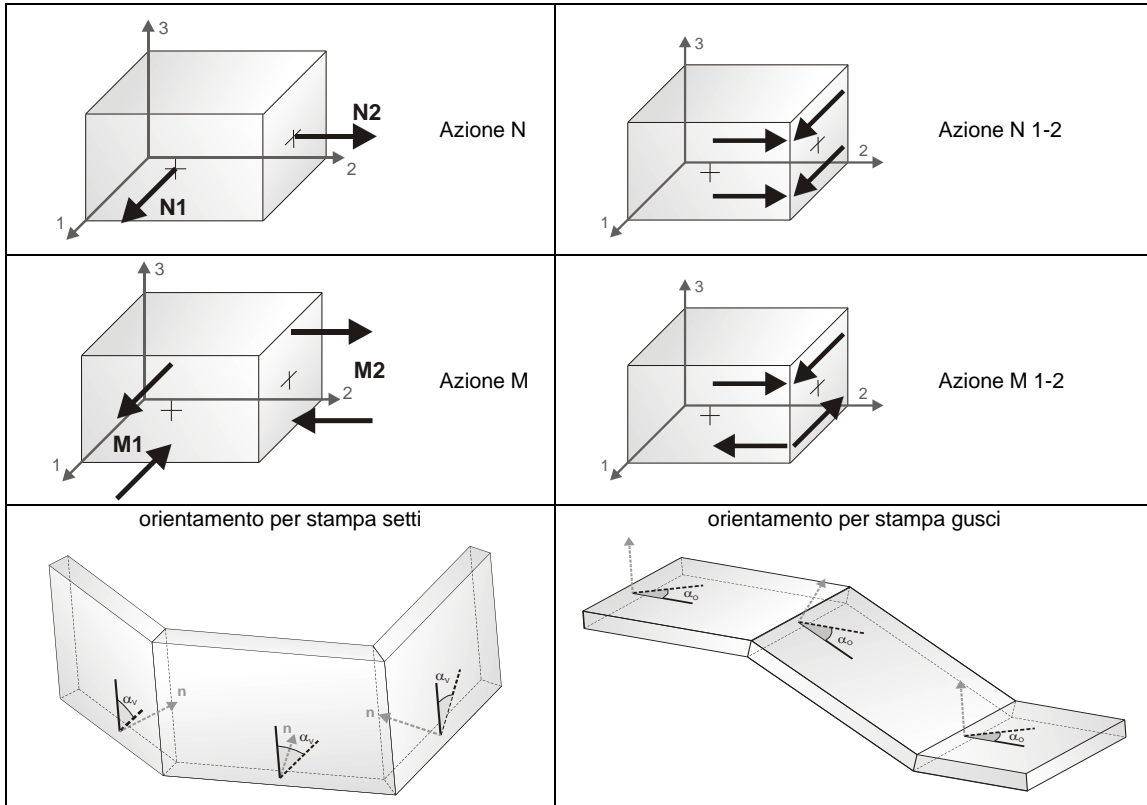

In particolare vengono riportati in ogni nodo di un elemento per ogni combinazione:

tensione di Von Mises	(valore riassuntivo del complessivo stato di sollecitazione)	
N max	sforzo membranale principale massimo	
N min	sforzo membranale principale minimo	
M max	sforzo flessionale principale massimo	
M min	sforzo flessionale principale minimo	
N1	N2	sforzi membranali e flessionali in direzione locale 1 e 2 dell'elemento (lo sforzo 2-1 è uguale allo sforzo 1-2 per la reciprocità delle tensioni tangenziali)
N1-2	M1	
M2	M1-2	

I suddetti risultati possono a scelta del progettista essere preceduti o sostituiti da valori di sollecitazione non più riferiti al sistema locale dell'elemento ma al sistema globale.

In questo caso gli elementi vengono raggruppati in gruppi (M, S: macro gusci o macro setti, raggruppati per materiale, spessore, e posizione fisica) per la valutazione dei valori mediati ai nodi appartenenti agli elementi dei gruppi stessi.

I valori di sollecitazione sono, in questo caso, riferiti ad una terna specifica del gruppo ruotata di α_0 attorno all'asse Z per i gusci e ruotata di α_v attorno alla normale (che per definizione è orizzontale) al piano del setto.

Per i setti, in particolare, se α_v è zero, l'asse '1-1 rappresenta la verticale e l'asse '2-2 l'orizzontale contenuta nel setto.

Le azioni sui setti possono essere espresse anche con formato macro, cioè riferite all'intero macroelemento.

In particolare vengono riportati per ogni quota Z dei nodi e per ogni combinazione i seguenti valori:

N memb.	Azione membranale complessiva agente sulla parete in direzione Z
V memb.	Azione complessiva di taglio agente nel piano del macroelemento
V orto	Azione complessiva di taglio agente in direzione perpendicolare al macroelemento
M memb.	Azione flessionale complessiva agente nel piano del macroelemento
M orto	Azione flessionale complessiva agente in direzione perpendicolare al macroelemento
T	Azione torsionale complessiva agente nel piano orizzontale

Parco Eolico "Bolina" – Progetto Definitivo
Relazione di calcolo preliminare delle fondazioni degli aerogeneratori G8 e G12

Macro	Tipo	Angolo 1-X (gradi)
1	Guscio	0.0

M_G	Cmb	Nodo	N max daN/cm	N min daN/cm	N 1 daN/cm	N 2 daN/cm	N 1-2 daN/cm	M max daN	M min daN	M 1 daN	M 2 daN	M 1-2 daN
1	1	1	1.73	-6.70	-5.50	0.53	-2.95	7.042e+04	-1.388e+05	6.995e+04	-1.383e+05	-9880.59
1	1	2	4.09	-8.64	-7.57	3.02	-3.53	7.210e+04	-2.075e+05	7.110e+04	-2.065e+05	1.671e+04
1	1	3	6.57	-8.68	-8.47	6.36	-1.78	5.741e+04	-1.433e+05	5.697e+04	-1.429e+05	-9392.52
1	1	4	3.93	-6.49	-6.41	3.84	-0.96	1.367e+05	-1.497e+05	1.342e+05	-1.472e+05	-2.670e+04
1	1	5	5.34	-6.15	-6.08	5.27	0.84	8.749e+04	-7.869e+04	7.857e+04	-6.977e+04	-3.746e+04
1	1	6	5.43	-8.45	-7.05	4.03	4.19	1.541e+05	-7.251e+04	1.355e+05	-5.394e+04	-6.214e+04
1	1	7	5.34	-4.17	-1.65	2.82	4.20	1.630e+05	-4.464e+04	1.548e+05	-3.650e+04	-4.030e+04
1	1	8	4.95	-6.15	-3.46	2.27	4.75	1.860e+05	-2.743e+04	1.833e+05	1.534e+04	-8.544e+04
1	1	9	6.48	-6.28	9.53e-02	0.10	6.38	2.040e+05	2.262e+04	1.370e+05	8.965e+04	-8.754e+04
1	1	10	4.93	-5.42	-0.93	0.44	5.13	2.490e+05	2.971e+04	1.946e+05	8.405e+04	-9.467e+04
1	1	11	4.02	-5.33	1.44	-2.76	4.18	2.170e+05	8.527e+04	1.752e+05	1.271e+05	-6.131e+04
1	1	12	4.62	-4.13	2.32	-1.84	3.85	2.441e+05	5.485e+04	1.849e+05	1.141e+05	-8.777e+04
1	1	13	6.00	-5.25	5.94	-5.19	0.83	2.643e+05	8.066e+04	1.841e+05	1.608e+05	-9.107e+04
1	1	14	7.82	-5.35	6.85	-4.37	3.46	2.709e+05	1.265e+05	2.001e+05	1.973e+05	-7.219e+04
1	1	15	7.95	-6.11	7.90	-6.07	-0.78	2.929e+05	1.470e+05	2.200e+05	2.199e+05	-7.299e+04
1	1	16	6.95	-4.49	6.95	-4.49	9.71e-02	2.279e+05	1.285e+05	1.822e+05	1.742e+05	-4.957e+04
1	1	17	6.82	-3.95	6.61	-3.75	-1.46	2.279e+05	1.285e+05	1.743e+05	1.821e+05	-4.958e+04
1	1	18	5.51	-1.87	5.47	-1.83	-0.55	2.375e+05	1.034e+05	1.705e+05	1.704e+05	-6.705e+04
1	1	19	9.15	-10.95	-7.63	5.83	-7.46	-2.303e+04	-2.235e+05	-3.502e+04	-2.115e+05	4.753e+04
1	1	20	5.55	-6.85	-6.41	5.11	-2.31	-3230.50	-1.556e+05	-5362.23	-1.535e+05	1.790e+04
1	1	21	3.84	-4.37	-4.37	3.84	-1.26e-02	8.113e+04	-1.542e+05	8.105e+04	-1.541e+05	-4257.17
1	1	22	7.16	-4.87	-4.05	6.35	3.03	1.276e+05	-5.805e+04	1.210e+05	-5.142e+04	-3.446e+04
1	1	23	5.67	-5.60	4.72e-02	2.77e-02	5.63	2.213e+05	3.632e+04	1.816e+05	7.598e+04	-7.591e+04
1	1	24	4.93	-7.18	4.17	-6.41	2.94	2.665e+05	9.770e+04	2.055e+05	1.586e+05	-8.106e+04
1	1	25	4.45	-3.98	4.45	-3.98	-4.09e-02	2.446e+05	1.100e+05	1.773e+05	1.773e+05	-6.730e+04
1	1	26	6.53	-5.42	6.13	-5.01	-2.17	2.643e+05	8.065e+04	1.609e+05	1.841e+05	-9.108e+04
1	1	27	8.48	-7.63	6.39	-5.53	-5.42	2.709e+05	1.265e+05	1.974e+05	2.000e+05	-7.220e+04
1	1	28	6.68	-9.57	-5.14	2.24	-7.24	-5.851e+04	-2.487e+05	-8.765e+04	-2.196e+05	6.851e+04
1	1	29	3.64	-7.00	-4.32	0.96	-4.62	-3.189e+04	-2.326e+05	-3.613e+04	-2.284e+05	2.887e+04
1	1	30	4.34	-8.09	-7.18	3.43	-3.24	-2.471e+04	-1.994e+05	-2.736e+04	-1.968e+05	2.132e+04
1	1	31	6.30	-6.78	-6.78	6.30	0.16	4.603e+04	-1.298e+05	4.575e+04	-1.295e+05	-6958.43
1	1	32	2.30	-2.36	1.38e-05	-5.40e-02	2.33	2.455e+05	1547.22	2.309e+05	1.617e+04	-5.791e+04
1	1	33	6.79	-6.42	6.78	-6.41	0.13	3.377e+05	7.632e+04	2.070e+05	2.070e+05	-1.307e+05
1	1	34	8.03	-4.60	7.25	-3.81	-3.05	2.664e+05	9.769e+04	1.587e+05	2.055e+05	-8.107e+04
1	1	35	6.55	-4.07	4.42	-1.94	-4.25	2.170e+05	8.526e+04	1.271e+05	1.752e+05	-6.132e+04
1	1	36	7.37	-6.92	3.75	-3.30	-6.22	2.441e+05	5.484e+04	1.141e+05	1.848e+05	-8.778e+04
1	1	37	5.70	-9.33	-3.52	-0.10	-7.32	-1.270e+05	-3.156e+05	-1.633e+05	-2.793e+05	7.430e+04
1	1	38	5.76	-9.05	-2.80	-0.50	-7.32	-1.112e+05	-2.560e+05	-1.716e+05	-1.956e+05	7.143e+04
1	1	39	4.81	-7.18	-1.92	-0.44	-5.95	-1.291e+05	-2.838e+05	-1.582e+05	-2.547e+05	6.043e+04
1	1	40	1.79	-2.93	-0.92	-0.22	-2.33	-9.456e+04	-3.259e+05	-1.022e+05	-3.183e+05	4.135e+04
1	1	41	0.11	-9.44e-02	5.98e-03	6.75e-03	0.10	-4.204e+04	-5.923e+04	-5.062e+04	-5.064e+04	-8596.68
1	1	42	2.88	-1.93	0.77	0.18	-2.39	2.454e+05	1539.61	1.717e+04	2.308e+05	-5.792e+04
1	1	43	6.95	-4.90	1.73	0.33	-5.88	2.213e+05	3.629e+04	7.597e+04	1.816e+05	-7.593e+04
1	1	44	8.66	-5.55	2.53	0.58	-7.04	2.040e+05	2.259e+04	8.964e+04	1.369e+05	-8.755e+04
1	1	45	7.54	-8.90	3.35	-4.70	-7.17	2.490e+05	2.968e+04	8.404e+04	1.946e+05	-9.468e+04
1	1	46	5.53	-9.46	-1.08	-2.85	-7.44	-1.464e+05	-2.969e+05	-1.837e+05	-2.596e+05	6.495e+04
1	1	47	4.30	-6.88	-0.51	-2.06	-5.54	-1.696e+05	-2.755e+05	-1.955e+05	-2.495e+05	4.558e+04
1	1	48	5.43	-6.12	3.42	-4.11	-4.38	-1.906e+05	-3.256e+05	-2.356e+05	-2.807e+05	6.360e+04
1	1	49	4.76	-6.42	4.74	-6.40	-0.49	-1.775e+05	-4.014e+05	-2.895e+05	-2.895e+05	1.120e+05
1	1	50	1.41	-1.59	-5.35e-02	-0.13	1.50	-9.461e+04	-3.260e+05	-3.183e+05	-1.022e+05	4.134e+04
1	1	51	6.06	-5.20	-5.16	6.02	-0.69	4.596e+04	-1.298e+05	-1.295e+05	4.568e+04	-6987.33
1	1	52	5.40	-5.98	-3.86	3.27	-4.43	1.276e+05	-5.808e+04	-5.144e+04	1.209e+05	-3.447e+04
1	1	53	5.57	-4.95	0.23	0.39	-5.26	1.629e+05	-4.465e+04	-3.651e+04	1.548e+05	-4.031e+04
1	1	54	5.89	-7.55	0.28	-1.95	-6.63	1.860e+05	-2.744e+04	1.534e+04	1.432e+05	-8.545e+04
1	1	55	6.52	-12.04	1.02	-6.53	-8.48	-2.230e+05	-3.257e+05	-2.765e+05	-2.723e+05	5.130e+04
1	1	56	2.59	-7.99	1.24	-6.64	-3.53	-1.709e+05	-3.193e+05	-2.341e+05	-2.561e+05	7.341e+04
1	1	57	1.40	-5.23	1.30	-5.13	-0.82	-2.040e+05	-2.977e+05	-2.508e+05	-2.508e+05	4.684e+04
1	1	58	2.58	-6.86	2.36	-6.64	1.43	-1.907e+05	-3.256e+05	-2.807e+05	-2.356e+05	6.359e+04
1	1	59	3.71	-4.24	-0.18	-0.35	3.98	-1.292e+05	-2.838e+05	-2.547e+05	-1.583e+05	6.042e+04
1	1	60	6.24	-3.75	-3.62	6.11	1.14	-2.478e+04	-1.995e+05	-1.968e+05	-2.742e+04	2.131e+04
1	1	61	3.93	-2.70	-2.64	3.88	-0.61	8.108e+04	-1.542e+05	-1.541e+05	8.100e+04	-4266.57
1	1	62	5.69	-4.84	-2.90	3.75	-4.08	8.746e+04	-7.870e+04	-6.977e+04	7.853e+04	-3.747e+04

Parco Eolico "Bolina" – Progetto Definitivo
Relazione di calcolo preliminare delle fondazioni degli aerogeneratori G8 e G12

1	1	63	5.34	-8.50	-4.13	0.97	-6.43	1.540e+05	-7.251e+04	-5.394e+04	1.355e+05	-6.214e+04
1	1	64	3.96	-8.70	0.76	-5.50	-5.50	-2.218e+05	-2.733e+05	-2.438e+05	-2.512e+05	2.548e+04
1	1	65	3.77	-9.35	2.47	-8.05	-3.92	-2.360e+05	-3.551e+05	-2.956e+05	-2.956e+05	5.952e+04
1	1	66	1.80	-6.97	1.75	-6.92	-0.70	-1.709e+05	-3.193e+05	-2.561e+05	-2.342e+05	7.340e+04
1	1	67	0.79	-4.63	-0.41	-3.44	2.25	-1.696e+05	-2.755e+05	-2.495e+05	-1.955e+05	4.557e+04
1	1	68	3.72	-4.36	-6.60e-02	-0.57	4.03	-1.112e+05	-2.560e+05	-1.956e+05	-1.716e+05	7.142e+04
1	1	69	3.66	-2.68	-1.82	2.80	2.17	-3.193e+04	-2.326e+05	-2.284e+05	-3.618e+04	2.886e+04
1	1	70	4.89	-4.41	-4.20	4.68	-1.39	-3263.52	-1.556e+05	-1.535e+05	-5394.72	1.789e+04
1	1	71	5.79	-7.71	-5.68	3.76	-4.83	5.736e+04	-1.433e+05	-1.429e+05	5.692e+04	-9391.52
1	1	72	3.23	-8.85	-5.64	1.58e-02	-5.34	1.367e+05	-1.497e+05	-1.472e+05	1.341e+05	-2.670e+04
1	1	73	3.54	-8.56	-0.31	-4.71	-5.63	-1.876e+05	-2.822e+05	-2.349e+05	-2.349e+05	4.729e+04
1	1	74	2.86	-9.12	0.87	-7.13	-4.45	-2.218e+05	-2.733e+05	-2.512e+05	-2.439e+05	2.548e+04
1	1	75	0.87	-6.17	0.57	-5.87	-1.41	-2.230e+05	-3.257e+05	-2.723e+05	-2.765e+05	5.130e+04
1	1	76	-0.84	-3.34	-1.39	-2.79	1.03	-1.465e+05	-2.969e+05	-2.596e+05	-1.837e+05	6.494e+04
1	1	77	0.53	-4.83	-3.40	-0.90	2.37	-1.271e+05	-3.156e+05	-2.793e+05	-1.633e+05	7.429e+04
1	1	78	-0.18	-2.73	-2.73	-0.18	-4.62e-02	-5.854e+04	-2.487e+05	-2.196e+05	-8.768e+04	6.850e+04
1	1	79	2.23	-5.69	-5.01	1.55	-2.22	-2.308e+04	-2.234e+05	-2.115e+05	-3.506e+04	4.752e+04
1	1	80	4.17	-9.47	-6.91	1.61	-5.33	7.205e+04	-2.074e+05	-2.064e+05	7.105e+04	1.670e+04
1	1	81	3.00	-11.30	-6.89	-1.40	-6.60	7.038e+04	-1.388e+05	-1.383e+05	6.991e+04	-9873.86
1	1	82	-1.38	-4.25	-3.37	-2.26	1.32	-8.647e+04	-2.117e+05	-1.784e+05	-1.198e+05	5.532e+04
1	1	83	3.68	-7.14	-4.05	0.59	-4.88	-4.471e+04	-2.336e+05	-1.964e+05	-8.192e+04	7.512e+04
1	1	84	-1.47	-4.59	-3.04	-3.02	-1.56	-3.111e+04	-1.240e+05	-7.827e+04	-7.639e+04	4.641e+04
1	1	85	4.42	-9.55	-9.35	4.23	-1.63	-3.539e+04	-1.403e+05	-1.050e+05	-7.063e+04	4.954e+04
1	1	86	-1.71	-4.64	-3.48	-2.88	-1.44	-3.829e+04	-1.124e+05	-6.942e+04	-8.128e+04	3.659e+04
1	1	87	2.33	-4.69	-4.03	1.67	2.05	-2.352e+04	-9.859e+04	-6.967e+04	-5.243e+04	3.653e+04
1	1	88	-1.81	-4.19	-2.95	-3.06	-1.19	-2.250e+04	-8.542e+04	-3.232e+04	-6.868e+04	2.780e+04
1	1	89	-0.75	-4.08	-3.25	-1.58	-1.45	-9222.95	-7.659e+04	-4.435e+04	-4.147e+04	3.366e+04
1	1	90	-1.56	-4.06	-2.96	-2.66	-1.24	-4866.97	-5.945e+04	-1.447e+04	-4.984e+04	2.079e+04
1	1	91	1.18	-6.04	-1.40	-3.46	-3.46	6662.70	-5.835e+04	-1.674e+04	-3.495e+04	3.120e+04
1	1	92	-0.72	-3.23	-1.48	-2.47	-1.15	3.642e+04	-2.543e+04	3.232e+04	-2.133e+04	1.539e+04
1	1	93	-0.45	-2.09	-2.08	-0.47	-0.15	7624.04	-5.196e+04	-6094.10	-3.825e+04	2.508e+04
1	1	94	-0.23	-2.43	-0.40	-2.25	0.60	6030.97	-3.223e+04	3404.72	-2.961e+04	9674.19
1	1	95	3.12	-5.02	-2.85	0.96	3.60	8980.34	-3.312e+04	2023.52	-2.616e+04	1.563e+04
1	1	96	-0.42	-2.27	-0.50	-2.19	0.38	94.88	-2.944e+04	58.84	-2.940e+04	1030.99
1	1	97	0.85	-1.19	-0.68	0.34	0.88	355.56	-2.608e+04	-1069.74	-2.465e+04	5969.94
1	1	98	0.55	-9.78	-7.63	-1.61	-4.20	-6652.58	-1.518e+05	-1.469e+05	-1.159e+04	2.631e+04
1	1	99	4.60e-02	-8.92	-8.23	-0.65	-2.39	-4388.92	-1.191e+05	-1.048e+05	-1.867e+04	3.788e+04
1	1	100	0.52	-7.13	-7.03	0.42	-0.87	3196.85	-8.938e+04	-7.363e+04	-1.255e+04	3.479e+04
1	1	101	1.13	-6.49	-6.01	0.66	-1.84	9136.09	-6.610e+04	-5.120e+04	-5761.37	2.998e+04
1	1	102	1.98	-6.65	-5.42	0.75	-3.01	1.538e+04	-4.300e+04	-3.011e+04	2494.13	2.421e+04
1	1	103	1.59	-3.75	-2.59	0.43	-2.20	3.718e+04	-1.098e+04	6752.90	1.944e+04	2.323e+04
1	1	104	1.44	-1.24	-1.10	1.29	0.61	1.170e+04	-1.606e+04	-8928.16	4566.77	1.213e+04
1	1	105	0.37	-1.77	-1.39	-4.02e-03	0.81	2.62	-8327.98	-2427.93	-5897.44	3786.87
1	1	106	2.72	-13.30	-5.77	-4.81	-8.00	3.081e+04	-1.254e+05	-1.235e+05	2.895e+04	1.696e+04
1	1	107	-1.88	-6.64	-3.60	-4.91	-2.29	3.025e+04	-9.410e+04	-9.062e+04	2.677e+04	2.051e+04
1	1	108	0.21	-12.72	-12.72	0.20	-0.17	3.521e+04	-7.073e+04	-6.726e+04	3.174e+04	1.886e+04
1	1	109	2.34	-7.38	-4.98	-6.43e-02	-4.19	3.137e+04	-5.632e+04	-5.300e+04	2.805e+04	1.672e+04
1	1	110	2.50	-5.42	-0.97	-1.95	-3.93	3.054e+04	-4.003e+04	-3.519e+04	2.570e+04	1.784e+04
1	1	111	2.58	-4.43	-3.16	1.31	-2.70	2.099e+04	-3.068e+04	-2.522e+04	1.553e+04	1.589e+04
1	1	112	4.92	-5.08	-5.07	4.92	0.16	1.620e+04	-1.393e+04	-1.130e+04	1.357e+04	8510.05
1	1	113	2.92	-2.39	-2.35	2.88	0.45	532.02	-2201.17	-1899.64	230.50	856.27
1	1	114	6.41	-15.09	-9.71	1.03	-9.32	5.858e+04	-9.647e+04	-9.627e+04	5.838e+04	-5561.52
1	1	115	3.01	-10.44	-3.43	-4.00	-6.72	7.662e+04	-5.528e+04	-5.527e+04	7.660e+04	-1248.31
1	1	116	4.37	-6.65	-5.83	3.55	-2.89	5.067e+04	-5.746e+04	-5.708e+04	5.029e+04	-6418.22
1	1	117	3.18	-6.14	-3.63	0.67	-4.13	4.373e+04	-4.608e+04	-4.591e+04	4.355e+04	-3928.84
1	1	118	3.53	-7.60	-3.33	-0.74	-5.41	4.117e+04	-3.223e+04	-3.206e+04	4.100e+04	-3549.37
1	1	119	1.44	-3.75	-1.22	-1.09	-2.60	4.898e+04	-9842.44	-9841.52	4.898e+04	232.92
1	1	120	2.77	-1.60	-1.49	2.66	0.69	2.715e+04	-1.340e+04	-1.251e+04	2.626e+04	-5949.61
1	1	121	1.08	-2.77	-2.69	1.00	0.54	9544.78	-580.55	2953.24	6011.00	-4826.29
1	1	122	5.55	-11.74	-5.84	-0.35	-8.19	8.847e+04	-9.535e+04	-9.073e+04	8.385e+04	-2.876e+04
1	1	123	8.05	-14.14	-1.04	-5.04	-10.91	7.936e+04	-7.399e+04	-7.131e+04	7.668e+04	-2.009e+04
1	1	124	16.72	-10.74	-4.85	10.83	-11.27	5.798e+04	-5.124e+04	-4.855e+04	5.528e+04	-1.695e+04
1	1	125	4.68	-5.70	-3.52	2.50	-4.23	5.129e+04	-4.469e+04	-4.101e+04	4.761e+04	-1.841e+04
1	1	126	0.63	-2.28	-1.41	-0.24	-1.34	4.562e+04	-3.642e+04	-3.391e+04	4.311e+04	-1.413e+04
1	1	127	2.21	-3.75	-1.72	0.17	-2.83	3.395e+04	-3.115e+04	-2.975e+04	3.255e+04	-9455.05
1	1	128	5.52	-4.17	-2.64	3.99	-3.54	2.361e+04	-1.775e+04	-1.654e+04	2.240e+04	-6961.42
1	1	129	2.88	-0.29	0.54	2.05	-1.39	3549.16	-519.90	540.74	2488.53	-1786.29
1	1	130	-0.48	-8.04	-4.55	-3.97	-3.77	1.107e+05	-6.749e+04	-6.031e+04	1.036e+05	-3.503e+04
1	1	131	4.94	-10.40	-3.21	-2.25	-7.66	9.731e+04	-5.643e+04	-4.332e+04	8.420e+04	-4.294e+04
1	1	132	7.51	-9.28	-1.53	-0.23	-8.37	7.588e+04	-4.803e+04	-3.495e+04	6.279e+04	-3.808e+04
1	1	133	6.28	-7.26	-0.98	7.98e-04	-6.76	5.916e+04	-4.053e+04	-2.787e+04	4.650e+04	-3.319e+04
1	1	134	4.69	-6.46	0.32	-2.09	-5.45	4.834e+04	-3.212e+04	-2.067e+04	3.689e+04	-2.811e+04
1	1	135	2.61	-2.63	0.51	-0.53	-2.57	4.697e+04	-1.729e+04	-9139.26	3.881e+04	-2.138e+04

Parco Eolico "Bolina" – Progetto Definitivo
Relazione di calcolo preliminare delle fondazioni degli aerogeneratori G8 e G12

1	1	136	3.28	-6.55e-02	0.28	2.94	-1.02	2.544e+04	-1.828e+04	-9878.49	1.704e+04	-1.722e+04
1	1	137	1.31	-0.51	8.44e-02	0.71	-0.85	5208.99	-367.27	2504.85	2336.87	-2786.87
1	1	138	-1.06	-7.41	-1.87	-6.60	-2.12	1.893e+05	-3.101e+04	1.108e+04	1.472e+05	-8.662e+04
1	1	139	6.49	-9.36	-4.04	1.17	-7.48	1.202e+05	-2.796e+04	2110.84	9.013e+04	-5.959e+04
1	1	140	6.14	-8.18	-0.70	-1.34	-7.15	9.002e+04	-3.046e+04	-678.50	6.024e+04	-5.197e+04
1	1	141	4.66	-4.65	0.89	-0.88	-4.57	6.602e+04	-3.056e+04	-3560.53	3.902e+04	-4.335e+04
1	1	142	2.35	-1.59	0.96	-0.19	-1.88	5.005e+04	-2.799e+04	-5919.89	2.798e+04	-3.515e+04
1	1	143	3.69	-2.31	2.06	-0.69	-2.67	3.392e+04	-2.565e+04	-9561.53	1.783e+04	-2.645e+04
1	1	144	5.88	-2.33	2.45	1.10	-4.05	2.163e+04	-1.654e+04	-5365.44	1.045e+04	-1.737e+04
1	1	145	4.18	0.29	3.11	1.35	-1.73	3300.60	-593.59	1589.40	1117.61	-1932.75
1	1	146	9.77	-11.58	5.35	-7.16	-8.65	1.742e+05	1.227e+04	5.940e+04	1.270e+05	-7.354e+04
1	1	147	6.63	-7.00	2.54	-2.91	-6.25	1.445e+05	1.190e+04	5.839e+04	9.806e+04	-6.328e+04
1	1	148	6.45	-3.80	0.39	2.26	-5.04	9.527e+04	-8249.11	3.785e+04	4.917e+04	-5.145e+04
1	1	149	5.38	-2.97	2.09	0.32	-4.08	6.704e+04	-1.493e+04	2.472e+04	2.738e+04	-4.096e+04
1	1	150	4.51	-3.07	3.33	-1.90	-2.75	4.838e+04	-1.645e+04	1.696e+04	1.498e+04	-3.240e+04
1	1	151	3.35	-0.84	2.77	-0.26	-1.45	3.957e+04	-1.085e+04	1.497e+04	1.376e+04	-2.520e+04
1	1	152	3.50	1.04	2.32	2.22	-1.23	2.165e+04	-1.317e+04	7617.14	863.22	-1.708e+04
1	1	153	2.79	0.23	2.35	0.67	-0.97	6212.00	59.62	5779.16	492.45	-1573.41
1	1	154	6.91	-6.09	4.35	-3.53	-5.18	2.118e+05	4.746e+04	1.153e+05	1.440e+05	-8.092e+04
1	1	155	9.95	-7.68	8.36	-6.09	-5.05	1.363e+05	2.860e+04	7.979e+04	8.510e+04	-5.378e+04
1	1	156	13.59	-5.88	7.65	5.93e-02	-8.96	8.951e+04	1.495e+04	5.924e+04	4.522e+04	-3.662e+04
1	1	157	6.67	-2.56	3.61	0.50	-4.34	6.313e+04	728.23	4.304e+04	2.082e+04	-2.916e+04
1	1	158	3.87	-0.28	2.33	1.26	-2.01	4.416e+04	-6800.37	2.951e+04	7845.88	-2.306e+04
1	1	159	3.83	-0.63	3.45	-0.25	-1.24	2.805e+04	-1.065e+04	1.735e+04	51.46	-1.731e+04
1	1	160	5.17	-0.68	4.61	-0.12	-1.72	1.722e+04	-8013.33	1.149e+04	-2285.02	-1.057e+04
1	1	161	4.17	0.84	4.11	0.90	-0.44	6541.33	244.58	6540.25	245.66	82.22
1	1	162	5.63	-2.51	4.75	-1.64	-2.53	1.797e+05	7.883e+04	1.298e+05	1.287e+05	-5.043e+04
1	1	163	7.66	-4.15	6.43	-2.91	-3.62	1.246e+05	5.169e+04	9.571e+04	8.061e+04	-3.568e+04
1	1	164	7.63	-3.00	6.10	-1.48	-3.73	8.291e+04	3.054e+04	6.943e+04	4.402e+04	-2.290e+04
1	1	165	5.81	-1.51	4.88	-0.58	-2.45	5.579e+04	1.425e+04	4.965e+04	2.038e+04	-1.474e+04
1	1	166	4.35	-1.23	4.24	-1.12	-0.76	3.805e+04	4171.99	3.515e+04	7067.48	-9471.27
1	1	167	3.29	0.30	3.22	0.37	-0.44	2.834e+04	1374.66	2.667e+04	3049.44	-6508.14
1	1	168	3.32	1.59	2.86	2.05	-0.77	1.639e+04	-4348.59	1.611e+04	-4066.52	-2402.00
1	1	169	2.80	0.78	2.80	0.78	5.96e-02	9557.95	461.22	8749.22	1269.95	2588.97
1	1	170	6.04	-3.58	5.50	-3.04	-2.22	1.768e+05	8.673e+04	1.361e+05	1.274e+05	-4.482e+04
1	1	171	6.99	-3.60	6.20	-2.81	-2.79	1.088e+05	6.426e+04	9.256e+04	8.048e+04	-2.143e+04
1	1	172	5.42	0.93	4.61	1.74	-1.73	7.080e+04	4.182e+04	6.666e+04	4.596e+04	-1.015e+04
1	1	173	4.89	0.21	3.85	1.25	-1.95	4.558e+04	2.432e+04	4.522e+04	2.468e+04	-2724.11
1	1	174	4.07	0.68	3.16	1.59	-1.50	2.999e+04	1.154e+04	2.998e+04	1.155e+04	395.24
1	1	175	2.99	0.61	2.99	0.61	5.09e-02	1.837e+04	3284.09	1.821e+04	3444.03	1544.80
1	1	176	3.78	0.85	3.64	1.00	0.63	1.234e+04	136.04	1.171e+04	774.09	2717.06
1	1	177	3.81	1.30	3.49	1.62	0.83	9905.98	407.37	7311.41	3001.94	4232.37
1	1	178	7.53	-3.76	7.45	-3.68	0.93	1.397e+05	8.378e+04	1.118e+05	1.117e+05	-2.797e+04
1	1	179	5.14	-2.33	5.11	-2.30	-0.47	9.576e+04	6.980e+04	8.277e+04	8.278e+04	-1.298e+04
1	1	180	8.54	-1.25	6.12	1.17	-4.22	5.145e+04	4.984e+04	5.065e+04	5.064e+04	-806.87
1	1	181	5.19	0.18	4.49	0.88	-1.73	3.497e+04	2.911e+04	3.204e+04	3.204e+04	2926.58
1	1	182	3.11	0.45	3.04	0.51	0.41	2.487e+04	1.514e+04	2.000e+04	2.000e+04	4864.46
1	1	183	2.61	0.93	2.61	0.93	2.86e-02	1.928e+04	8788.57	1.403e+04	1.405e+04	5247.04
1	1	184	3.23	1.60	2.75	2.08	-0.74	1.332e+04	234.96	6777.35	6774.16	6540.79
1	1	185	1.92	1.01	1.74	1.19	0.37	1.167e+04	462.15	6064.90	6069.87	5605.24
1	1	186	7.50	-4.70	7.46	-4.67	0.68	1.768e+05	8.674e+04	1.275e+05	1.361e+05	-4.482e+04
1	1	187	5.04	-1.87	4.97	-1.80	-0.70	1.088e+05	6.428e+04	8.046e+04	9.258e+04	-2.140e+04
1	1	188	6.98	-0.63	6.94	-0.59	-0.54	7.078e+04	4.191e+04	4.604e+04	6.664e+04	-1.011e+04
1	1	189	5.35	-0.12	5.15	7.29e-02	-1.01	4.557e+04	2.433e+04	2.468e+04	4.521e+04	-2722.41
1	1	190	4.55	0.16	4.38	0.33	-0.84	3.001e+04	1.151e+04	1.152e+04	3.000e+04	382.31
1	1	191	2.28	1.11	2.21	1.18	0.28	1.836e+04	3270.74	3430.64	1.820e+04	1545.23
1	1	192	2.88	1.28	1.42	2.74	0.45	1.233e+04	154.51	804.13	1.168e+04	2736.00
1	1	193	3.05	1.45	1.92	2.58	0.73	9907.41	408.31	3005.26	7310.46	4233.74
1	1	194	5.78	-1.16	5.52	-0.89	1.34	1.797e+05	7.883e+04	1.288e+05	1.297e+05	-5.043e+04
1	1	195	5.37	0.50	5.32	0.55	0.50	1.246e+05	5.170e+04	8.063e+04	9.568e+04	-3.567e+04
1	1	196	4.45	1.19	4.23	1.42	-0.82	8.289e+04	3.055e+04	4.403e+04	6.941e+04	-2.289e+04
1	1	197	3.52	1.19	3.42	1.29	-0.47	5.576e+04	1.425e+04	2.038e+04	4.963e+04	-1.473e+04
1	1	198	2.06	1.06	1.64	1.48	0.49	3.802e+04	4157.56	7045.01	3.514e+04	-9457.96
1	1	199	2.10	1.09	2.04	1.15	0.24	2.834e+04	1345.76	3024.02	2.666e+04	-6517.66
1	1	200	2.96	1.11	2.65	1.41	-0.69	1.638e+04	-4349.04	-4064.38	1.610e+04	-2412.49
1	1	201	1.50	1.07	1.07	1.50	2.27e-02	9545.87	459.23	1264.08	8741.01	2581.78
1	1	202	5.95	-2.19	3.37	0.38	3.79	2.118e+05	4.743e+04	1.440e+05	1.153e+05	-8.094e+04
1	1	203	6.42	-0.55	1.46	4.42	3.15	1.363e+05	2.860e+04	8.513e+04	7.973e+04	-5.376e+04
1	1	204	8.62	0.59	5.09	4.13	-3.99	8.946e+04	1.494e+04	4.521e+04	5.919e+04	-3.660e+04
1	1	205	4.24	0.42	4.01	0.66	-0.92	6.309e+04	703.07	2.079e+04	4.300e+04	-2.915e+04
1	1	206	3.70	-0.16	3.66	-0.12	0.37	4.414e+04	-6862.03	7805.42	2.948e+04	-2.309e+04
1	1	207	1.40	1.23	1.24	1.39	-3.35e-02	2.802e+04	-1.069e+04	18.34	1.731e+04	-1.732e+04
1	1	208	3.63	-0.26	0.48	2.90	-1.52	1.717e+04	-8001.90	-2283.79	1.145e+04	-1.055e+04

Parco Eolico "Bolina" – Progetto Definitivo
Relazione di calcolo preliminare delle fondazioni degli aerogeneratori G8 e G12

1	1	209	2.50	1.06	1.13	2.43	-0.31	6516.05	246.11	247.10	6515.06	78.43
1	1	210	4.28	-4.56	-2.66	2.37	3.64	1.741e+05	1.229e+04	1.271e+05	5.939e+04	-7.352e+04
1	1	211	3.32	-2.20	0.28	0.84	2.74	1.445e+05	1.189e+04	9.807e+04	5.836e+04	-6.328e+04
1	1	212	5.05	-1.40	4.77	-1.12	1.32	9.526e+04	-8277.30	4.918e+04	3.780e+04	-5.145e+04
1	1	213	2.37	0.46	2.33	0.49	0.26	6.700e+04	-1.498e+04	2.735e+04	2.467e+04	-4.096e+04
1	1	214	1.63	-0.32	-0.31	1.61	0.17	4.832e+04	-1.651e+04	1.490e+04	1.690e+04	-3.240e+04
1	1	215	1.28	0.50	0.75	1.02	0.37	3.954e+04	-1.091e+04	1.371e+04	1.491e+04	-2.522e+04
1	1	216	2.72	0.47	2.63	0.55	-0.43	2.163e+04	-1.319e+04	872.21	7564.23	-1.708e+04
1	1	217	1.22	0.23	0.82	0.63	-0.48	6172.09	53.47	491.44	5734.12	-1577.33
1	1	218	4.92	-11.65	-5.67	-1.06	7.96	1.893e+05	-3.101e+04	1.473e+05	1.108e+04	-8.662e+04
1	1	219	1.17	-3.98	0.53	-3.35	1.69	1.202e+05	-2.796e+04	9.013e+04	2115.63	-5.960e+04
1	1	220	0.60	-1.95	-1.12	-0.24	-1.20	9.000e+04	-3.045e+04	6.024e+04	-688.98	-5.195e+04
1	1	221	0.84	-0.48	-0.46	0.82	-0.15	6.599e+04	-3.061e+04	3.899e+04	-3608.39	-4.335e+04
1	1	222	1.63	-1.10	0.15	0.39	1.36	5.003e+04	-2.808e+04	2.794e+04	-5990.60	-3.518e+04
1	1	223	1.11	-0.58	-0.33	0.85	-0.60	3.389e+04	-2.571e+04	1.779e+04	-9614.47	-2.646e+04
1	1	224	4.11	-2.04	1.35	0.72	-3.06	2.158e+04	-1.655e+04	1.043e+04	-5399.55	-1.735e+04
1	1	225	2.27	0.35	1.28	1.34	-0.96	3271.25	-600.97	1118.02	1552.26	-1923.90
1	1	226	0.98	-4.86	-4.21	0.33	1.83	1.108e+05	-6.751e+04	1.036e+05	-6.033e+04	-3.503e+04
1	1	227	1.21	-3.87	-3.75	1.08	-0.78	9.731e+04	-5.646e+04	8.421e+04	-4.335e+04	-4.294e+04
1	1	228	2.99	-3.40	-1.31	0.90	-3.00	7.586e+04	-4.807e+04	6.277e+04	-3.499e+04	-3.808e+04
1	1	229	2.50	-2.92	-0.70	0.28	-2.66	5.912e+04	-4.059e+04	4.645e+04	-2.792e+04	-3.321e+04
1	1	230	1.88	-3.74	-2.48	0.63	-2.34	4.828e+04	-3.220e+04	3.681e+04	-2.073e+04	-2.814e+04
1	1	231	0.18	-1.02	-0.90	5.71e-02	-0.36	4.694e+04	-1.738e+04	3.878e+04	-9215.30	-2.141e+04
1	1	232	2.59	-0.94	2.56	-0.90	0.33	2.543e+04	-1.832e+04	1.705e+04	-9938.83	-1.721e+04
1	1	233	0.35	-1.46	0.34	-1.44	0.16	5169.07	-378.49	2331.17	2459.41	-2773.04
1	1	234	3.77	-6.48	-6.41	3.70	-0.84	8.850e+04	-9.541e+04	8.389e+04	-9.079e+04	-2.877e+04
1	1	235	7.26	-10.19	-8.70	5.78	-4.86	7.936e+04	-7.405e+04	7.669e+04	-7.137e+04	-2.009e+04
1	1	236	12.09	-4.51	8.39	-0.82	-6.91	5.796e+04	-5.131e+04	5.526e+04	-4.862e+04	-1.695e+04
1	1	237	0.92	-1.32	0.65	-1.05	-0.73	5.124e+04	-4.478e+04	4.757e+04	-4.111e+04	-1.842e+04
1	1	238	0.77	-2.54	-1.76	-4.35e-03	1.41	4.557e+04	-3.655e+04	4.306e+04	-3.403e+04	-1.415e+04
1	1	239	-0.39	-1.93	-0.90	-1.42	-0.72	3.391e+04	-3.124e+04	3.250e+04	-2.984e+04	-9469.79
1	1	240	3.90	-4.01	3.29	-3.41	-2.10	2.357e+04	-1.778e+04	2.237e+04	-1.658e+04	-6944.18
1	1	241	1.26	-0.75	1.25	-0.73	-0.18	3515.62	-524.98	2476.59	514.04	-1765.99
1	1	242	3.42	-8.58	-5.98	0.82	-4.94	5.860e+04	-9.651e+04	5.840e+04	-9.631e+04	-5588.21
1	1	243	4.33	-9.46	-8.56	3.43	-3.40	7.663e+04	-5.537e+04	7.661e+04	-5.536e+04	-1271.05
1	1	244	0.28	-1.49	0.28	-1.49	-2.50e-02	5.069e+04	-5.752e+04	5.031e+04	-5.714e+04	-6405.55
1	1	245	0.36	-2.95	-1.89	-0.71	-1.55	4.370e+04	-4.616e+04	4.353e+04	-4.599e+04	-3947.12
1	1	246	0.98	-5.26	-2.77	-1.51	-3.06	4.111e+04	-3.233e+04	4.094e+04	-3.216e+04	-3591.11
1	1	247	-0.17	-3.01	-2.82	-0.36	-0.71	4.895e+04	-9928.19	4.895e+04	-9927.40	215.12
1	1	248	2.35	-2.79	1.28	-1.72	2.09	2.714e+04	-1.341e+04	2.625e+04	-1.253e+04	-5930.13
1	1	249	0.51	-3.87	-0.31	-3.05	1.71	9520.14	-585.84	5999.12	2935.17	-4815.16
1	1	250	6.36	-14.10	-11.79	4.05	-6.48	3.083e+04	-1.254e+05	2.897e+04	-1.236e+05	1.695e+04
1	1	251	3.93	-10.63	-10.60	3.90	-0.69	3.029e+04	-9.417e+04	2.682e+04	-9.070e+04	2.049e+04
1	1	252	-3.22	-8.17	-3.72	-7.67	1.49	3.522e+04	-7.072e+04	3.176e+04	-6.726e+04	1.882e+04
1	1	253	0.47	-5.11	-3.23	-1.42	-2.63	3.137e+04	-5.635e+04	2.807e+04	-5.305e+04	1.670e+04
1	1	254	2.25	-5.55	-4.66	1.36	-2.48	3.054e+04	-4.007e+04	2.571e+04	-3.524e+04	1.782e+04
1	1	255	-0.19	-2.73	-1.02	-1.91	-1.19	2.097e+04	-3.069e+04	1.554e+04	-2.525e+04	1.585e+04
1	1	256	3.26	-5.28	2.93	-4.95	1.65	1.618e+04	-1.390e+04	1.357e+04	-1.129e+04	8475.23
1	1	257	1.43	-3.06	0.80	-2.43	1.56	541.38	-2181.71	249.01	-1889.35	843.01
1	1	258	3.74	-8.77	-5.43	0.41	-5.53	-6619.42	-1.519e+05	-1.155e+04	-1.469e+05	2.631e+04
1	1	259	2.21	-6.90	-5.12	0.43	-3.62	-4369.51	-1.192e+05	-1.864e+04	-1.049e+05	3.787e+04
1	1	260	-0.70	-4.17	-3.61	-1.25	-1.27	3204.81	-8.940e+04	-1.252e+04	-7.367e+04	3.477e+04
1	1	261	-0.64	-4.19	-2.76	-2.07	-1.74	9128.20	-6.611e+04	-5735.80	-5.125e+04	2.996e+04
1	1	262	5.04e-02	-5.05	-2.28	-2.73	-2.54	1.535e+04	-4.300e+04	2512.33	-3.016e+04	2.418e+04
1	1	263	-6.64e-04	-3.38	-2.32	-1.06	-1.57	3.715e+04	-1.099e+04	1.945e+04	6708.20	2.321e+04
1	1	264	0.45	-2.39	-1.29	-0.64	1.38	1.171e+04	-1.604e+04	4582.76	-8914.16	1.212e+04
1	1	265	-0.26	-3.69	-2.52	-1.43	1.62	1.21	-8308.85	-5879.18	-2428.46	3779.86
1	1	266	11.08	-11.07	-2.77	2.78	-10.72	-4.469e+04	-2.336e+05	-8.189e+04	-1.964e+05	7.513e+04
1	1	267	6.23	-7.68	0.70	-2.15	-6.81	-3.540e+04	-1.403e+05	-7.060e+04	-1.051e+05	4.952e+04
1	1	268	1.07	-1.89	-1.61	0.80	-0.86	-2.351e+04	-9.859e+04	-5.240e+04	-6.971e+04	3.653e+04
1	1	269	1.70	-6.10	-4.47	7.30e-02	-3.17	-9240.55	-7.659e+04	-4.145e+04	-4.438e+04	3.364e+04
1	1	270	3.01	-8.28	-6.08	0.81	-4.47	6639.67	-5.834e+04	-3.494e+04	-1.677e+04	3.120e+04
1	1	271	-0.57	-3.16	-3.04	-0.68	-0.54	7593.24	-5.194e+04	-3.822e+04	-6124.56	2.507e+04
1	1	272	1.84	-5.69	-1.61	-2.24	3.75	8958.77	-3.308e+04	-2.614e+04	2019.24	1.561e+04
1	1	273	1.41e-02	-2.96	-2.29	-0.66	1.24	357.09	-2.605e+04	-2.463e+04	-1066.62	5963.93
1	1	274	5.94	-10.34	-4.91	0.51	-7.68	-8.646e+04	-2.117e+05	-1.197e+05	-1.785e+05	5.533e+04
1	1	275	5.47	-10.37	-4.53	-0.38	-7.64	-3.112e+04	-1.240e+05	-7.637e+04	-7.871e+04	4.641e+04
1	1	276	3.02	-8.70	-4.26	-1.42	-5.68	-3.830e+04	-1.124e+05	-8.127e+04	-6.943e+04	3.658e+04
1	1	277	1.37	-7.28	-4.60	-1.31	-4.00	-2.252e+04	-8.540e+04	-6.866e+04	-3.926e+04	2.779e+04
1	1	278	0.33	-6.38	-4.38	-1.67	-3.07	-4911.85	-5.943e+04	-4.982e+04	-1.452e+04	2.077e+04
1	1	279	0.43	-5.42	-4.31	-0.68	-2.29	3.639e+04	-2.543e+04	-2.133e+04	3.229e+04	1.538e+04
1	1	280	-9.39e-02	-4.21	-4.21	-9.46e-02	5.38e-02	6033.65	-3.222e+04	-2.960e+04	3411.92	9665.03
1	1	281	-0.42	-4.28	-4.26	-0.43	0.24	93.28	-2.943e+04	-2.939e+04	57.22	1031.29

Parco Eolico "Bolina" – Progetto Definitivo
Relazione di calcolo preliminare delle fondazioni degli aerogeneratori G8 e G12

1	1	282	6.70	-14.91	-5.13	-3.08	-10.75	-1.353e+05	-2.423e+05	-1.844e+05	-1.931e+05	5.331e+04
1	1	283	5.68	-14.13	-9.87	1.41	-8.15	-8.894e+04	-1.645e+05	-1.492e+05	-1.042e+05	3.033e+04
1	1	284	-2.29	-8.56	-7.98	-2.87	-1.82	-5.267e+04	-1.231e+05	-1.155e+05	-6.028e+04	2.186e+04
1	1	285	0.56	-8.15	-4.84	-2.75	-4.23	-3.000e+04	-9.575e+04	-9.317e+04	-3.259e+04	1.277e+04
1	1	286	1.85	-9.55	-5.35	-2.35	-5.50	-1.849.32	-7.722e+04	-7.695e+04	-2117.97	4491.74
1	1	287	0.54	-5.94	-5.05	-0.34	-2.22	5617.39	-7.257e+04	-7.252e+04	5565.91	-2005.64
1	1	288	0.25	-6.46	-6.29	8.03e-02	1.05	1.015e+04	-5.055e+04	-5.022e+04	9821.63	-4421.69
1	1	289	-0.41	-4.08	-4.07	-0.43	-0.23	492.00	-4.218e+04	-4.082e+04	-867.39	-7494.01
1	1	290	4.44	-8.60	-2.30	-1.86	-6.51	-1.585e+05	-2.160e+05	-2.012e+05	-1.732e+05	2.511e+04
1	1	291	4.28	-9.92	-4.56	-1.08	-6.88	-1.074e+05	-1.634e+05	-1.622e+05	-1.085e+05	7991.47
1	1	292	1.83	-9.19	-5.39	-1.97	-5.24	-6.585e+04	-1.251e+05	-1.249e+05	-6.604e+04	-3374.03
1	1	293	1.07	-8.45	-5.02	-2.37	-4.57	-3.692e+04	-9.490e+04	-9.365e+04	-3.817e+04	-8444.87
1	1	294	0.65	-7.71	-4.83	-2.23	-3.97	-1.199e+04	-6.630e+04	-6.437e+04	-1.392e+04	-1.007e+04
1	1	295	0.60	-6.83	-4.58	-1.65	-3.41	3.951e+04	-3.058e+04	-2.602e+04	3.496e+04	-1.728e+04
1	1	296	-0.40	-5.70	-4.93	-1.17	-1.87	5591.46	-3.826e+04	-3.548e+04	2803.41	-1.070e+04
1	1	297	-0.49	-5.21	-4.59	-1.12	-1.60	-44.97	-3.712e+04	-3.212e+04	-5046.97	-1.267e+04
1	1	298	6.43	-11.19	0.81	-5.57	-8.21	-1.593e+05	-2.103e+05	-1.999e+05	-1.696e+05	2.050e+04
1	1	299	4.76	-9.91	-1.69	-3.46	-7.28	-1.023e+05	-1.490e+05	-1.460e+05	-1.053e+05	1.143e+04
1	1	300	2.34	-9.53	-2.91	-4.29	-5.89	-6.029e+04	-1.089e+05	-9.655e+04	-7.268e+04	-2.120e+04
1	1	301	1.27	-8.70	-3.40	-4.03	-4.97	-3.479e+04	-8.826e+04	-7.524e+04	-4.780e+04	-2.294e+04
1	1	302	1.09	-9.29	-4.14	-4.06	-5.19	-3572.39	-7.540e+04	-5.797e+04	-2.101e+04	-3.080e+04
1	1	303	1.22	-7.09	-4.00	-1.87	-4.02	3649.42	-7.386e+04	-5.487e+04	-1.534e+04	-3.334e+04
1	1	304	-0.16	-7.19	-5.62	-1.73	-2.93	9968.68	-5.221e+04	-3.612e+04	-6129.27	-2.724e+04
1	1	305	-0.56	-5.25	-3.93	-1.88	-2.11	436.51	-4.484e+04	-3.112e+04	-1.328e+04	-2.081e+04
1	1	306	5.80	-10.50	1.12	-5.81	-7.38	-1.494e+05	-1.622e+05	-1.558e+05	-1.558e+05	6395.46
1	1	307	3.53	-9.03	-0.61	-4.90	-5.90	-5.650e+04	-8.677e+04	-7.163e+04	-7.164e+04	-1.513e+04
1	1	308	0.64	-8.19	-2.37	-5.19	-4.19	-5.843e+04	-8.973e+04	-7.407e+04	-7.409e+04	-1.565e+04
1	1	309	0.96	-8.28	-2.71	-4.60	-4.52	-3.262e+04	-7.679e+04	-5.469e+04	-5.471e+04	-2.208e+04
1	1	310	1.00	-7.91	-2.84	-4.08	-4.41	-1.044e+04	-5.498e+04	-3.270e+04	-3.272e+04	-2.227e+04
1	1	311	0.62	-6.83	-2.72	-3.49	-3.70	4.042e+04	-2.309e+04	8666.01	8656.32	-3.175e+04
1	1	312	-0.64	-6.02	-3.15	-3.51	-2.68	5605.18	-3.167e+04	-1.302e+04	-1.304e+04	-1.864e+04
1	1	313	-0.45	-5.41	-2.89	-2.97	-2.48	-344.57	-3.316e+04	-1.675e+04	-1.675e+04	-1.641e+04
1	1	314	3.42	-8.90	0.32	-5.80	-5.35	-1.593e+05	-2.103e+05	-1.696e+05	-1.999e+05	2.050e+04
1	1	315	3.07	-9.05	0.44	-6.42	-5.00	-1.022e+05	-1.490e+05	-1.052e+05	-1.460e+05	-1.143e+04
1	1	316	1.20	-8.45	-1.56	-5.69	-4.36	-6.028e+04	-1.090e+05	-7.266e+04	-9.657e+04	-2.120e+04
1	1	317	0.49	-7.82	-2.19	-5.14	-3.88	-3.478e+04	-8.826e+04	-4.779e+04	-7.526e+04	-2.294e+04
1	1	318	0.54	-8.53	-2.81	-5.19	-4.38	-3564.09	-7.541e+04	-2.099e+04	-5.798e+04	-3.080e+04
1	1	319	1.04	-6.61	-1.07	-4.49	-3.42	3657.28	-7.387e+04	-1.533e+04	-5.489e+04	-3.334e+04
1	1	320	-0.15	-6.80	-1.34	-5.61	-2.55	9973.24	-5.222e+04	-6107.73	-3.614e+04	-2.723e+04
1	1	321	-0.57	-4.77	-1.68	-3.66	-1.85	436.22	-4.484e+04	-1.328e+04	-3.112e+04	-2.081e+04
1	1	322	1.80	-7.26	0.14	-5.61	-3.50	-1.585e+05	-2.160e+05	-1.732e+05	-2.012e+05	2.511e+04
1	1	323	2.64	-8.50	1.77	-7.63	-2.99	-1.074e+05	-1.634e+05	-1.085e+05	-1.623e+05	7991.49
1	1	324	0.64	-7.99	-8.53e-02	-7.27	-2.39	-6.583e+04	-1.251e+05	-6.602e+04	-1.249e+05	-3371.24
1	1	325	-0.10	-7.10	-1.14	-6.06	-2.49	-3.689e+04	-9.492e+04	-3.815e+04	-9.366e+04	-8441.49
1	1	326	-0.28	-6.42	-1.47	-5.23	-2.43	-1.196e+04	-6.632e+04	-1.389e+04	-6.438e+04	-1.007e+04
1	1	327	4.03e-02	-5.69	-1.14	-4.50	-2.32	3.954e+04	-3.058e+04	3.498e+04	-2.603e+04	-1.728e+04
1	1	328	-0.48	-4.80	-0.83	-4.45	-1.18	5590.65	-3.827e+04	2807.72	-3.248e+04	-1.069e+04
1	1	329	-0.52	-4.26	-0.95	-3.84	-1.18	-44.20	-3.712e+04	-5046.38	-3.212e+04	-1.267e+04
1	1	330	-0.30	-8.41	-3.00	-5.71	-3.82	-1.353e+05	-2.423e+05	-1.931e+05	-1.844e+05	5.332e+04
1	1	331	3.09	-10.80	2.80	-10.52	-1.97	-8.893e+04	-1.645e+05	-1.042e+05	-1.492e+05	3.032e+04
1	1	332	-1.76	-9.06	-2.41	-8.42	2.07	-5.265e+04	-1.231e+05	-6.026e+04	-1.155e+05	2.188e+04
1	1	333	-1.89	-5.53	-2.63	-4.79	-1.47	-2.998e+04	-9.577e+04	-3.256e+04	-9.319e+04	1.278e+04
1	1	334	0.15	-7.37	-2.34	-4.88	-3.54	-1826.74	-7.723e+04	-2095.73	-7.696e+04	4495.45
1	1	335	-0.20	-4.35	-0.41	-4.14	-0.90	5640.34	-7.258e+04	5589.01	-7.253e+04	-2003.14
1	1	336	0.59	-5.58	2.80e-02	-5.01	1.78	1.016e+04	-5.057e+04	9837.75	-5.025e+04	-4404.44
1	1	337	-0.36	-2.62	-0.38	-2.61	0.17	490.98	-4.219e+04	-868.12	-4.083e+04	-7494.13
1	3	1	1.47	-5.67	-4.65	0.45	-2.50	5.959e+04	-1.174e+05	5.919e+04	-1.170e+05	-8360.50
1	3	2	3.46	-7.31	-6.41	2.55	-2.99	6.101e+04	-1.756e+05	6.016e+04	-1.747e+05	1.414e+04
1	3	3	5.56	-7.34	-7.16	5.38	-0.81	4.858e+04	-1.213e+05	4.820e+04	-1.209e+05	-7947.52
1	3	4	3.32	-5.49	-5.42	3.25	-1.51	1.157e+05	-1.267e+05	1.135e+05	-1.246e+05	-2.259e+04
1	3	5	4.51	-5.20	-5.15	4.46	0.71	7.403e+04	-6.659e+04	6.648e+04	-5.904e+04	-3.170e+04
1	3	6	4.60	-7.15	-5.96	3.41	3.54	1.304e+05	-6.135e+04	1.147e+05	-4.564e+04	-5.258e+04
1	3	7	4.52	-3.53	-1.40	2.39	3.55	1.379e+05	-3.777e+04	1.310e+05	-3.089e+04	-3.410e+04
1	3	8	4.19	-5.20	-2.93	1.92	4.02	1.574e+05	-2.321e+04	1.212e+05	1.298e+04	-7.230e+04
1	3	9	5.49	-5.32	8.06e-02	8.80e-02	5.40	1.726e+05	1.914e+04	1.159e+05	7.586e+04	-7.407e+04
1	3	10	4.17	-4.59	-0.79	0.37	4.34	2.107e+05	2.514e+04	1.647e+05	7.112e+04	-8.011e+04
1	3	11	3.40	-4.51	1.22	-2.33	3.54	1.836e+05	7.215e+04	1.483e+05	1.075e+05	-5.188e+04
1	3	12	3.91	-3.50	1.96	-1.55	3.26	2.066e+05	4.641e+04	1.564e+05	9.654e+04	-7.426e+04
1	3	13	5.08	-4.44	5.02	-4.39	0.70	2.236e+05	6.825e+04	1.558e+05	1.361e+05	-7.706e+04
1	3	14	6.62	-4.52	5.79	-3.69	2.92	2.292e+05	1.070e+05	1.693e+05	1.670e+05	-6.108e+04
1	3	15	6.72	-5.17	6.69	-5.14	-0.66	2.479e+05	1.244e+05	1.861e+05	1.861e+05	-6.176e+04
1	3	16	5.88	-3.80	5.88	-3.80	8.21e-02	1.929e+05	1.087e+05	1.542e+05	1.474e+05	-4.195e+04
1	3	17	5.77	-3.35	5.60	-3.17	-1.24	1.929e+05	1.087e+05	1.475e+05	1.541e+05	-4.195e+04

Parco Eolico "Bolina" – Progetto Definitivo
Relazione di calcolo preliminare delle fondazioni degli aerogeneratori G8 e G12

1	3	18	4.66	-1.58	4.63	-1.54	-0.47	2.010e+05	8.750e+04	1.442e+05	1.442e+05	-5.673e+04
1	3	19	7.74	-9.27	-6.46	4.94	-6.31	-1.949e+04	-1.891e+05	-2.963e+04	-1.789e+05	4.022e+04
1	3	20	4.70	-5.80	-5.42	4.32	-1.95	-2733.50	-1.317e+05	-4537.27	-1.299e+05	1.514e+04
1	3	21	3.25	-3.70	-3.70	3.25	-1.07e-02	6.865e+04	-1.305e+05	6.858e+04	-1.304e+05	-3602.22
1	3	22	6.06	-4.12	-3.43	5.37	2.56	1.080e+05	-4.912e+04	1.024e+05	-4.351e+04	-2.916e+04
1	3	23	4.80	-4.73	3.99e-02	2.34e-02	4.77	1.872e+05	3.074e+04	1.537e+05	6.429e+04	-6.423e+04
1	3	24	4.17	-6.07	3.53	-5.43	2.49	2.255e+05	8.267e+04	1.739e+05	1.342e+05	-6.859e+04
1	3	25	3.77	-3.37	3.77	-3.37	-3.46e-02	2.070e+05	9.307e+04	1.500e+05	1.500e+05	-5.694e+04
1	3	26	5.53	-4.59	5.18	-4.24	-1.84	2.236e+05	6.824e+04	1.361e+05	1.557e+05	-7.707e+04
1	3	27	7.18	-6.45	5.40	-4.68	-4.59	2.292e+05	1.070e+05	1.670e+05	1.692e+05	-6.109e+04
1	3	28	5.65	-8.10	-4.35	1.90	-6.12	-4.951e+04	-2.105e+05	-7.416e+04	-1.858e+05	5.797e+04
1	3	29	3.08	-5.93	-3.66	0.81	-3.91	-2.698e+04	-1.969e+05	-3.057e+04	-1.933e+05	2.443e+04
1	3	30	3.67	-6.85	-6.08	2.90	-2.74	-2.091e+04	-1.688e+05	-2.315e+04	-1.665e+05	1.804e+04
1	3	31	5.33	-5.74	-5.74	5.33	0.13	3.895e+04	-1.098e+05	3.871e+04	-1.096e+05	-5887.90
1	3	32	1.95	-1.99	1.17e-05	-4.57e-02	1.97	2.077e+05	1309.18	1.953e+05	1.368e+04	-4.900e+04
1	3	33	5.74	-5.43	5.74	-5.43	0.11	2.857e+05	6.458e+04	1.752e+05	1.751e+05	-1.106e+05
1	3	34	6.80	-3.89	6.13	-3.22	-2.58	2.254e+05	8.266e+04	1.343e+05	1.739e+05	-6.859e+04
1	3	35	5.54	-3.44	3.74	-1.65	-3.59	1.836e+05	7.214e+04	1.075e+05	1.482e+05	-5.189e+04
1	3	36	6.24	-5.85	3.17	-2.79	-5.26	2.065e+05	4.640e+04	9.655e+04	1.564e+05	-7.427e+04
1	3	37	4.82	-7.89	-2.98	-8.71e-02	-6.19	-1.075e+05	-2.670e+05	-1.382e+05	-2.363e+05	6.287e+04
1	3	38	4.87	-7.66	-2.37	-0.42	-6.19	-9.405e+04	-2.166e+05	-1.452e+05	-1.655e+05	6.044e+04
1	3	39	4.07	-6.07	-1.63	-0.37	-5.03	-1.093e+05	-2.401e+05	-1.339e+05	-2.155e+05	5.113e+04
1	3	40	1.51	-2.48	-0.78	-0.19	-1.97	-8.002e+04	-2.758e+05	-8.648e+04	-2.693e+05	3.499e+04
1	3	41	9.07e-02	-7.99e-02	5.06e-03	5.71e-03	8.53e-02	-3.557e+04	-5.012e+04	-4.283e+04	-4.285e+04	-7274.11
1	3	42	2.44	-1.63	0.65	0.15	-2.02	2.077e+05	1302.75	1.368e+04	1.953e+05	-4.901e+04
1	3	43	5.88	-4.14	1.46	0.28	-4.98	1.872e+05	3.071e+04	6.428e+04	1.536e+05	-6.425e+04
1	3	44	7.33	-4.70	2.14	0.49	-5.96	1.726e+05	1.911e+04	7.585e+04	1.158e+05	-7.408e+04
1	3	45	6.38	-7.53	2.83	-3.98	-6.07	2.107e+05	2.511e+04	7.111e+04	1.647e+05	-8.012e+04
1	3	46	4.68	-8.00	-0.92	-2.41	-6.30	-1.239e+05	-2.512e+05	-1.555e+05	-2.197e+05	5.496e+04
1	3	47	3.64	-5.82	-0.44	-1.75	-4.69	-1.435e+05	-2.331e+05	-1.654e+05	-2.111e+05	3.856e+04
1	3	48	4.60	-5.18	2.90	-3.48	-3.70	-1.613e+05	-2.755e+05	-1.993e+05	-2.375e+05	5.382e+04
1	3	49	4.03	-5.44	4.01	-5.42	-0.41	-1.502e+05	-3.397e+05	-2.449e+05	-2.449e+05	9.475e+04
1	3	50	1.19	-1.35	-4.53e-02	-0.11	1.27	-8.005e+04	-2.758e+05	-2.693e+05	-8.652e+04	3.498e+04
1	3	51	5.13	-4.40	-4.37	5.09	-0.58	3.889e+04	-1.098e+05	-1.096e+05	3.865e+04	-5912.36
1	3	52	4.57	-5.06	-3.26	2.77	-3.75	1.080e+05	-4.914e+04	-4.352e+04	1.023e+05	-2.917e+04
1	3	53	4.71	-4.19	0.19	0.33	-4.45	1.379e+05	-3.778e+04	-3.089e+04	1.310e+05	-3.411e+04
1	3	54	4.98	-6.39	0.24	-1.65	-5.61	1.574e+05	-2.322e+04	1.298e+04	1.212e+05	-7.230e+04
1	3	55	5.52	-10.18	0.86	-5.53	-7.17	-1.887e+05	-2.756e+05	-2.339e+05	-2.304e+05	4.341e+04
1	3	56	2.19	-6.76	1.05	-5.62	-2.99	-1.446e+05	-2.702e+05	-1.981e+05	-2.167e+05	6.211e+04
1	3	57	1.19	-4.42	1.10	-4.34	-0.69	-1.726e+05	-2.519e+05	-2.122e+05	-2.122e+05	3.963e+04
1	3	58	2.19	-5.81	2.00	-5.62	1.21	-1.613e+05	-2.755e+05	-2.375e+05	-1.993e+05	5.381e+04
1	3	59	3.14	-3.59	-0.16	-0.29	3.36	-1.093e+05	-2.401e+05	-2.155e+05	-1.339e+05	5.112e+04
1	3	60	5.28	-3.17	-3.06	5.17	0.97	-2.097e+04	-1.688e+05	-1.685e+05	-2.320e+04	1.803e+04
1	3	61	3.33	-2.29	-2.24	3.28	-0.51	6.861e+04	-1.305e+05	-1.304e+05	6.854e+04	-3610.18
1	3	62	4.82	-4.09	-2.45	3.17	-3.45	7.400e+04	-6.659e+04	-5.904e+04	6.645e+04	-3.170e+04
1	3	63	4.52	-7.19	-3.49	0.82	-5.44	1.303e+05	-6.136e+04	-4.565e+04	1.146e+05	-5.258e+04
1	3	64	3.35	-7.36	0.64	-4.65	-4.65	-1.877e+05	-2.312e+05	-2.063e+05	-2.126e+05	2.156e+04
1	3	65	3.19	-7.91	2.09	-6.81	-3.32	-1.997e+05	-3.005e+05	-2.501e+05	-2.501e+05	5.036e+04
1	3	66	1.53	-5.90	1.48	-5.85	-0.59	-1.446e+05	-2.702e+05	-2.167e+05	-1.981e+05	6.211e+04
1	3	67	0.67	-3.92	-0.34	-2.91	1.90	-1.435e+05	-2.331e+05	-2.111e+05	-1.655e+05	3.856e+04
1	3	68	3.15	-3.69	-5.59e-02	-0.48	3.41	-9.409e+04	-2.166e+05	-1.655e+05	-1.452e+05	6.043e+04
1	3	69	3.10	-2.27	-1.54	2.37	1.84	-2.702e+04	-1.968e+05	-1.932e+05	-3.061e+04	2.442e+04
1	3	70	4.13	-3.73	-3.55	3.96	-1.17	-2761.44	-1.317e+05	-1.299e+05	-4564.77	1.514e+04
1	3	71	4.90	-6.52	-4.80	3.18	-4.09	4.853e+04	-1.213e+05	-1.209e+05	4.816e+04	-7946.67
1	3	72	2.73	-7.49	-4.77	1.33e-02	-4.52	1.156e+05	-1.267e+05	-1.246e+05	1.135e+05	-2.259e+04
1	3	73	2.99	-7.24	-0.26	-3.99	-4.77	-1.588e+05	-2.388e+05	-1.988e+05	-1.988e+05	4.002e+04
1	3	74	2.42	-7.71	0.74	-6.04	-3.76	-1.877e+05	-2.312e+05	-2.126e+05	-2.063e+05	2.156e+04
1	3	75	0.73	-5.22	0.48	-4.97	-1.19	-1.887e+05	-2.756e+05	-2.304e+05	-2.339e+05	4.341e+04
1	3	76	-0.71	-2.82	-1.18	-2.36	0.87	-1.239e+05	-2.512e+05	-2.197e+05	-1.555e+05	5.495e+04
1	3	77	0.45	-4.09	-2.88	-0.76	2.01	-1.075e+05	-2.670e+05	-2.363e+05	-1.382e+05	6.286e+04
1	3	78	-0.15	-2.31	-2.31	-0.15	-3.91e-02	-4.953e+04	-2.104e+05	-1.858e+05	-7.419e+04	5.797e+04
1	3	79	1.89	-4.82	-4.24	1.31	-1.88	-1.953e+04	-1.891e+05	-1.789e+05	-2.967e+04	4.021e+04
1	3	80	3.53	-8.02	-5.85	1.36	-4.51	6.097e+04	-1.755e+05	-1.747e+05	6.012e+04	1.413e+04
1	3	81	2.54	-9.56	-5.83	-1.19	-5.59	5.955e+04	-1.174e+05	-1.170e+05	5.916e+04	-8354.81
1	3	82	-1.17	-3.59	-2.85	-1.91	1.12	-7.317e+04	-1.791e+05	-1.510e+05	-1.013e+05	4.681e+04
1	3	83	3.11	-6.04	-3.43	0.50	-4.13	-3.783e+04	-1.977e+05	-1.662e+05	-6.931e+04	6.356e+04
1	3	84	-1.24	-3.89	-2.58	-2.55	-1.32	-2.632e+04	-1.049e+05	-6.657e+04	-6.464e+04	3.927e+04
1	3	85	3.74	-8.08	-7.92	3.58	-1.38	-2.995e+04	-1.187e+05	-8.888e+04	-5.976e+04	4.192e+04
1	3	86	-1.45	-3.93	-2.94	-2.43	-1.22	-3.240e+04	-9.512e+04	-5.874e+04	-6.878e+04	3.096e+04
1	3	87	1.97	-3.97	-3.41	1.41	1.73	-1.990e+04	-8.342e+04	-5.895e+04	-4.436e+04	3.091e+04
1	3	88	-1.53	-3.55	-2.49	-2.59	-1.01	-1.904e+04	-7.228e+04	-3.320e+04	-5.812e+04	2.352e+04
1	3	89	-0.63	-3.46	-2.75	-1.34	-1.22	-7804.03	-6.481e+04	-3.753e+04	-3.509e+04	2.848e+04
1	3	90	-1.32	-3.43	-2.51	-2.25	-1.05	-4118.20	-5.030e+04	-1.225e+04	-4.217e+04	1.759e+04

Parco Eolico "Bolina" – Progetto Definitivo
Relazione di calcolo preliminare delle fondazioni degli aerogeneratori G8 e G12

1	3	91	1.00	-5.11	-1.18	-2.93	-2.92	5637.67	-4.937e+04	-1.416e+04	-2.957e+04	2.640e+04
1	3	92	-0.61	-2.73	-1.25	-2.09	-0.98	3.082e+04	-2.152e+04	2.735e+04	-1.805e+04	1.302e+04
1	3	93	-0.38	-1.77	-1.76	-0.40	-0.13	6451.11	-4.397e+04	-5156.54	-3.236e+04	2.123e+04
1	3	94	-0.19	-2.05	-0.34	-1.90	0.51	5103.13	-2.727e+04	2880.92	-2.505e+04	8185.86
1	3	95	2.64	-4.25	-2.41	0.81	3.05	7598.75	-2.802e+04	1712.21	-2.213e+04	1.323e+04
1	3	96	-0.36	-1.92	-0.43	-1.86	0.32	80.28	-2.491e+04	49.79	-2.488e+04	872.38
1	3	97	0.72	-1.01	-0.58	0.29	0.74	300.85	-2.206e+04	-905.17	-2.086e+04	5051.49
1	3	98	0.46	-8.28	-6.46	-1.36	-3.55	-5629.11	-1.285e+05	-1.243e+05	-9806.48	2.226e+04
1	3	99	3.89e-02	-7.55	-6.96	-0.55	-2.03	-3713.70	-1.008e+05	-8.872e+04	-1.580e+04	3.205e+04
1	3	100	0.44	-6.03	-5.95	0.35	-0.74	2705.02	-7.563e+04	-6.231e+04	-1.062e+04	2.943e+04
1	3	101	0.96	-5.49	-5.09	0.56	-1.56	7730.54	-5.593e+04	-4.333e+04	-4875.01	2.537e+04
1	3	102	1.67	-5.62	-4.59	0.64	-2.55	1.302e+04	-3.638e+04	-2.547e+04	2110.42	2.049e+04
1	3	103	1.34	-3.17	-2.20	0.37	-1.86	3.146e+04	-9294.20	5714.00	1.645e+04	1.966e+04
1	3	104	1.22	-1.05	-0.93	1.09	0.51	9899.53	-1.359e+04	-7554.60	3864.19	1.026e+04
1	3	105	0.31	-1.49	-1.18	-3.40e-03	0.69	2.21	-7046.76	-2054.40	-4990.14	3204.27
1	3	106	2.30	-11.25	-4.88	-4.07	-6.77	2.607e+04	-1.061e+05	-1.045e+05	2.449e+04	1.435e+04
1	3	107	-1.59	-5.62	-3.05	-4.16	-1.94	2.560e+04	-7.962e+04	-7.668e+04	2.265e+04	1.736e+04
1	3	108	0.17	-10.76	-10.76	0.17	-0.14	4.980e+04	-5.985e+04	-5.691e+04	2.686e+04	1.596e+04
1	3	109	1.98	-6.25	-4.22	-5.44e-02	-3.55	2.654e+04	-4.765e+04	-4.485e+04	2.374e+04	1.415e+04
1	3	110	2.11	-4.59	-0.82	-1.65	-3.33	2.584e+04	-3.387e+04	-2.977e+04	2.174e+04	1.509e+04
1	3	111	2.18	-3.75	-2.67	1.11	-2.29	1.776e+04	-2.596e+04	-2.134e+04	1.314e+04	1.344e+04
1	3	112	4.16	-4.29	-4.29	4.16	0.13	1.371e+04	-1.179e+04	-9562.57	1.148e+04	7200.82
1	3	113	2.47	-2.02	-1.99	2.44	0.38	450.17	-1862.52	-1607.39	195.04	724.54
1	3	114	5.43	-12.77	-8.21	0.87	-7.88	4.957e+04	-8.163e+04	-8.146e+04	4.940e+04	-4705.90
1	3	115	2.55	-8.83	-2.90	-3.39	-5.69	6.483e+04	-4.677e+04	-4.676e+04	6.482e+04	-1056.26
1	3	116	3.70	-5.63	-4.93	3.00	-2.45	4.288e+04	-4.862e+04	-4.830e+04	4.255e+04	-5430.80
1	3	117	2.69	-5.19	-3.07	0.57	-3.50	3.700e+04	-3.899e+04	-3.884e+04	3.685e+04	-3324.40
1	3	118	2.99	-6.43	-2.82	-0.62	-4.58	3.484e+04	-2.727e+04	-2.713e+04	3.469e+04	-3003.31
1	3	119	1.22	-3.18	-1.03	-0.92	-2.20	4.145e+04	-8328.22	-8327.44	4.145e+04	197.09
1	3	120	2.34	-1.35	-1.26	2.25	0.59	2.297e+04	-1.134e+04	-1.059e+04	2.222e+04	-5034.29
1	3	121	0.91	-2.34	-2.28	0.85	0.46	8076.36	-491.23	2498.90	5086.23	-4083.79
1	3	122	4.69	-9.93	-4.95	-0.29	-6.93	7.486e+04	-8.068e+04	-7.677e+04	7.095e+04	-2.434e+04
1	3	123	6.81	-11.96	-0.88	-4.27	-9.23	6.715e+04	-6.260e+04	-6.034e+04	6.488e+04	-1.700e+04
1	3	124	14.15	-9.09	-4.11	9.16	-9.54	4.906e+04	-4.336e+04	-4.108e+04	4.678e+04	-1.435e+04
1	3	125	3.96	-4.82	-2.98	2.11	-3.58	4.340e+04	-3.781e+04	-3.470e+04	4.029e+04	-1.558e+04
1	3	126	0.54	-1.93	-1.19	-0.21	-1.13	3.861e+04	-3.082e+04	-2.869e+04	3.648e+04	-1.196e+04
1	3	127	1.87	-3.18	-1.45	0.15	-2.39	2.873e+04	-2.636e+04	-2.517e+04	2.754e+04	-8000.43
1	3	128	4.67	-3.53	-2.23	3.38	-2.99	1.998e+04	-1.502e+04	-1.400e+04	1.895e+04	-5890.43
1	3	129	2.43	-0.24	0.46	1.73	-1.17	3003.14	-439.91	457.55	2105.68	-1511.48
1	3	130	-0.40	-6.80	-3.85	-3.36	-3.19	9.369e+04	-5.710e+04	-5.103e+04	8.762e+04	-2.964e+04
1	3	131	4.18	-8.80	-2.71	-1.91	-6.48	8.234e+04	-4.775e+04	-3.666e+04	7.124e+04	-3.633e+04
1	3	132	6.35	-7.85	-1.30	-0.20	-7.08	6.420e+04	-4.064e+04	-2.957e+04	5.313e+04	-3.223e+04
1	3	133	5.32	-6.15	-0.83	6.75e-04	-5.72	5.006e+04	-3.429e+04	-2.358e+04	3.935e+04	-2.809e+04
1	3	134	3.97	-5.47	0.27	-1.77	-4.61	4.090e+04	-2.718e+04	-1.749e+04	3.121e+04	-2.379e+04
1	3	135	2.21	-2.23	0.43	-0.45	-2.17	3.974e+04	-1.463e+04	-7733.22	3.284e+04	-1.809e+04
1	3	136	2.78	-5.55e-02	0.24	2.48	-0.86	2.152e+04	-1.546e+04	-8358.73	1.442e+04	-1.457e+04
1	3	137	1.11	-0.43	7.14e-02	0.60	-0.72	4407.61	-310.77	2119.49	1977.35	-2358.12
1	3	138	-0.90	-6.27	-1.58	-5.58	-1.79	1.602e+05	-2.624e+04	9379.58	1.246e+05	-7.329e+04
1	3	139	5.49	-7.92	-3.42	0.99	-6.33	1.017e+05	-2.366e+04	1786.10	7.627e+04	-5.042e+04
1	3	140	5.19	-6.92	-0.59	-1.13	-6.05	7.617e+04	-2.577e+04	-574.11	5.097e+04	-4.398e+04
1	3	141	3.94	-3.93	0.75	-0.74	-3.86	5.587e+04	-2.586e+04	-3012.76	3.302e+04	-3.668e+04
1	3	142	1.99	-1.34	0.81	-0.16	-1.59	4.235e+04	-2.368e+04	-5009.14	2.368e+04	-2.974e+04
1	3	143	3.12	-1.96	1.74	-0.58	-2.26	2.870e+04	-2.170e+04	-8090.53	1.509e+04	-2.238e+04
1	3	144	4.98	-1.97	2.07	0.93	-3.43	1.830e+04	-1.400e+04	-4539.99	8841.34	-1.470e+04
1	3	145	3.53	0.25	2.63	1.15	-1.47	2792.82	-502.27	1344.88	945.67	-1635.41
1	3	146	8.26	-9.80	4.52	-6.06	-7.32	1.474e+05	1.038e+04	5.026e+04	1.075e+05	-6.223e+04
1	3	147	5.61	-5.93	2.15	-2.46	-5.29	1.223e+05	1.007e+04	4.940e+04	8.298e+04	-5.355e+04
1	3	148	5.46	-3.22	0.33	1.91	-4.27	8.061e+04	-6980.02	3.202e+04	4.161e+04	-4.353e+04
1	3	149	4.55	-2.51	1.77	0.27	-3.45	5.672e+04	-1.264e+04	2.092e+04	2.317e+04	-3.466e+04
1	3	150	3.81	-2.60	2.82	-1.60	-2.32	4.094e+04	-1.392e+04	1.435e+04	1.267e+04	-2.741e+04
1	3	151	2.83	-0.71	2.34	-0.22	-1.23	3.349e+04	-9176.92	1.267e+04	1.164e+04	-2.133e+04
1	3	152	2.96	0.88	1.96	1.88	-1.04	1.832e+04	-1.114e+04	6445.28	730.41	-1.445e+04
1	3	153	2.36	0.20	1.99	0.57	-0.82	5256.31	50.44	4890.06	416.69	-1331.35
1	3	154	5.85	-5.16	3.68	-2.99	-4.38	1.792e+05	4.016e+04	9.756e+04	1.218e+05	-6.847e+04
1	3	155	8.42	-6.50	7.08	-5.16	-4.27	1.153e+05	2.420e+04	6.752e+04	7.201e+04	-4.550e+04
1	3	156	11.50	-4.97	6.47	5.02e-02	-7.58	7.574e+04	1.265e+04	5.013e+04	3.826e+04	-3.098e+04
1	3	157	5.64	-2.16	3.05	0.42	-3.67	5.342e+04	616.20	3.642e+04	1.762e+04	-2.467e+04
1	3	158	3.28	-0.24	1.98	1.06	-1.70	3.736e+04	-5754.16	2.497e+04	6638.83	-1.951e+04
1	3	159	3.24	-0.53	2.92	-0.21	-1.05	2.373e+04	-9012.86	1.468e+04	43.55	-1.465e+04
1	3	160	4.37	-0.57	3.90	-0.10	-1.45	1.457e+04	-6780.51	9722.25	-1933.48	-8943.68
1	3	161	3.53	0.71	3.48	0.77	-0.38	5534.97	206.95	5534.06	207.86	69.57
1	3	162	4.76	-2.13	4.02	-1.38	-2.14	1.520e+05	6.671e+04	1.098e+05	1.089e+05	-4.267e+04
1	3	163	6.49	-3.51	5.44	-2.46	-3.06	1.055e+05	4.373e+04	8.098e+04	6.821e+04	-3.019e+04

Parco Eolico "Bolina" – Progetto Definitivo
Relazione di calcolo preliminare delle fondazioni degli aerogeneratori G8 e G12

1	3	164	6.46	-2.54	5.16	-1.25	-3.15	7.016e+04	2.584e+04	5.875e+04	3.725e+04	-1.938e+04
1	3	165	4.92	-1.28	4.13	-0.49	-2.07	4.720e+04	1.205e+04	4.201e+04	1.725e+04	-1.247e+04
1	3	166	3.68	-1.04	3.59	-0.95	-0.64	3.219e+04	3530.15	2.974e+04	5980.17	-8014.15
1	3	167	2.78	0.26	2.73	0.31	-0.38	2.398e+04	1163.18	2.256e+04	2580.29	-5506.89
1	3	168	2.81	1.34	2.42	1.74	-0.65	1.387e+04	-3679.58	1.363e+04	-3440.90	-2032.46
1	3	169	2.37	0.66	2.37	0.66	5.04e-02	8087.50	390.26	7403.18	1074.58	2190.67
1	3	170	5.11	-3.03	4.65	-2.57	-1.88	1.496e+05	7.339e+04	1.151e+05	1.078e+05	-3.792e+04
1	3	171	5.92	-3.05	5.25	-2.37	-2.36	9.204e+04	5.437e+04	7.832e+04	6.809e+04	-1.813e+04
1	3	172	4.59	0.79	3.90	1.47	-1.46	5.991e+04	3.538e+04	5.640e+04	3.889e+04	-8586.86
1	3	173	4.14	0.18	3.26	1.06	-1.65	3.856e+04	2.058e+04	3.826e+04	2.088e+04	-2305.02
1	3	174	3.44	0.58	2.68	1.34	-1.27	2.538e+04	9764.53	2.537e+04	9771.69	334.43
1	3	175	2.53	0.52	2.53	0.52	4.30e-02	1.554e+04	2778.85	1.540e+04	2914.18	1307.14
1	3	176	3.20	0.72	3.08	0.84	0.53	1.045e+04	115.11	9905.34	655.00	2299.05
1	3	177	3.22	1.10	2.96	1.37	0.71	8381.98	344.70	6186.58	2540.10	3581.24
1	3	178	6.37	-3.18	6.31	-3.12	0.78	1.182e+05	7.089e+04	9.458e+04	9.454e+04	-2.367e+04
1	3	179	4.35	-1.98	4.32	-1.95	-0.40	8.103e+04	5.906e+04	7.004e+04	7.005e+04	-1.098e+04
1	3	180	7.23	-1.06	5.18	0.99	-3.57	4.354e+04	4.217e+04	4.286e+04	4.285e+04	-682.73
1	3	181	4.39	0.15	3.80	0.74	-1.47	2.959e+04	2.463e+04	2.711e+04	2.711e+04	2476.33
1	3	182	2.63	0.38	2.58	0.43	0.34	2.104e+04	1.281e+04	1.693e+04	1.692e+04	4116.08
1	3	183	2.21	0.79	2.21	0.79	2.42e-02	1.632e+04	7436.48	1.187e+04	1.189e+04	4439.80
1	3	184	2.74	1.35	2.33	1.76	-0.63	1.127e+04	198.81	5734.68	5731.98	5534.50
1	3	185	1.63	0.85	1.47	1.01	0.31	9876.84	391.05	5131.84	5136.05	4742.92
1	3	186	6.35	-3.98	6.31	-3.95	0.57	1.496e+05	7.340e+04	1.079e+05	1.151e+05	-3.792e+04
1	3	187	4.27	-1.59	4.21	-1.53	-0.59	9.203e+04	5.439e+04	6.808e+04	7.834e+04	-1.811e+04
1	3	188	5.90	-0.54	5.87	-0.50	-0.46	5.989e+04	3.546e+04	3.896e+04	5.639e+04	-8557.20
1	3	189	4.52	-0.10	4.36	6.17e-02	-0.86	3.856e+04	2.059e+04	2.089e+04	3.826e+04	-2303.58
1	3	190	3.85	0.13	3.71	0.28	-0.71	2.539e+04	9742.61	9749.31	2.538e+04	323.49
1	3	191	1.93	0.94	1.87	1.00	0.24	1.554e+04	2767.55	2902.85	1.540e+04	1307.50
1	3	192	2.44	1.08	1.20	2.32	0.38	1.043e+04	130.74	680.42	9881.10	2315.07
1	3	193	2.58	1.22	1.62	2.18	0.62	8383.19	345.50	2542.91	6185.77	3582.39
1	3	194	4.89	-0.98	4.67	-0.75	1.13	1.520e+05	6.671e+04	1.090e+05	1.098e+05	-4.267e+04
1	3	195	4.54	0.42	4.50	0.47	0.43	1.054e+05	4.375e+04	6.822e+04	8.096e+04	-3.018e+04
1	3	196	3.76	1.01	3.58	1.20	-0.70	7.014e+04	2.585e+04	3.726e+04	5.873e+04	-1.937e+04
1	3	197	2.98	1.01	2.89	1.09	-0.39	4.718e+04	1.206e+04	1.724e+04	4.200e+04	-1.246e+04
1	3	198	1.74	0.90	1.39	1.25	0.41	3.217e+04	3517.93	5961.16	2.973e+04	-8002.89
1	3	199	1.78	0.92	1.72	0.97	0.20	2.398e+04	1138.72	2558.78	2.256e+04	-5514.94
1	3	200	2.50	0.94	2.25	1.20	-0.58	1.386e+04	-3679.96	-3439.09	1.362e+04	-2041.34
1	3	201	1.27	0.90	0.90	1.27	1.92e-02	8077.27	388.58	1069.61	7396.24	2184.59
1	3	202	5.03	-1.86	2.85	0.32	3.20	1.792e+05	4.013e+04	1.218e+05	9.753e+04	-6.848e+04
1	3	203	5.43	-0.46	1.23	3.74	2.67	1.153e+05	2.420e+04	7.204e+04	6.747e+04	-4.549e+04
1	3	204	7.30	0.50	4.30	3.49	-3.37	7.570e+04	1.264e+04	3.825e+04	5.009e+04	-3.097e+04
1	3	205	3.59	0.36	3.39	0.56	-0.78	5.339e+04	594.91	1.760e+04	3.638e+04	-2.467e+04
1	3	206	3.13	-0.14	3.10	-0.11	0.31	3.735e+04	-5806.33	6604.59	2.494e+04	-1.953e+04
1	3	207	1.18	1.04	1.05	1.18	-2.83e-02	2.371e+04	-9047.13	15.52	1.465e+04	-1.465e+04
1	3	208	3.07	-0.22	0.41	2.45	-1.29	1.453e+04	-6770.84	-1932.43	9691.76	-8924.84
1	3	209	2.12	0.90	0.96	2.06	-0.26	5513.58	208.25	209.08	5512.75	66.37
1	3	210	3.62	-3.86	-2.25	2.01	3.08	1.474e+05	1.040e+04	1.075e+05	5.025e+04	-6.221e+04
1	3	211	2.81	-1.86	0.24	0.71	2.32	1.223e+05	1.006e+04	8.298e+04	4.938e+04	-5.355e+04
1	3	212	4.28	-1.19	4.04	-0.95	1.12	8.060e+04	-7003.87	4.161e+04	3.199e+04	-4.354e+04
1	3	213	2.00	0.39	1.97	0.42	0.22	5.669e+04	-1.267e+04	2.314e+04	2.088e+04	-3.466e+04
1	3	214	1.38	-0.27	-0.26	1.36	0.14	4.088e+04	-1.397e+04	1.261e+04	1.430e+04	-2.741e+04
1	3	215	1.08	0.42	0.64	0.86	0.31	3.346e+04	-9233.51	1.160e+04	1.262e+04	-2.134e+04
1	3	216	2.30	0.40	2.23	0.47	-0.37	1.830e+04	-1.116e+04	738.02	6400.50	-1.446e+04
1	3	217	1.03	0.20	0.70	0.53	-0.41	5222.54	45.25	415.84	4851.94	-1334.66
1	3	218	4.16	-9.86	-4.79	-0.90	6.73	1.602e+05	-2.624e+04	1.246e+05	9375.28	-7.330e+04
1	3	219	0.99	-3.37	0.45	-2.83	1.43	1.017e+05	-2.366e+04	7.626e+04	1790.15	-5.043e+04
1	3	220	0.50	-1.65	-0.94	-0.20	-1.01	7.615e+04	-2.576e+04	5.097e+04	-582.98	-4.396e+04
1	3	221	0.71	-0.40	-0.39	0.69	-0.13	5.584e+04	-2.590e+04	3.299e+04	-3053.25	-3.668e+04
1	3	222	1.38	-0.93	0.12	0.33	1.15	4.233e+04	-2.376e+04	2.364e+04	-5068.97	-2.976e+04
1	3	223	0.94	-0.49	-0.28	0.72	-0.51	2.867e+04	-2.175e+04	1.506e+04	-8135.32	-2.239e+04
1	3	224	3.48	-1.72	1.14	0.61	-2.59	1.826e+04	-1.400e+04	8824.58	-4568.85	-1.468e+04
1	3	225	1.92	0.30	1.08	1.14	-0.81	2767.98	-508.52	946.02	1313.45	-1627.92
1	3	226	0.83	-4.11	-3.56	0.28	1.55	9.372e+04	-5.712e+04	8.765e+04	-5.105e+04	-2.964e+04
1	3	227	1.02	-3.28	-3.17	0.92	-0.66	8.234e+04	-4.777e+04	7.125e+04	-3.668e+04	-3.633e+04
1	3	228	2.53	-2.88	-1.11	0.76	-2.54	6.419e+04	-4.068e+04	5.312e+04	-2.961e+04	-3.223e+04
1	3	229	2.11	-2.47	-0.59	0.23	-2.25	5.002e+04	-3.435e+04	3.930e+04	-2.363e+04	-2.810e+04
1	3	230	1.59	-3.16	-2.10	0.53	-1.98	4.085e+04	-2.725e+04	3.115e+04	-1.754e+04	-2.381e+04
1	3	231	0.15	-0.86	-0.76	4.84e-02	-0.31	3.972e+04	-1.470e+04	3.281e+04	-7797.57	-1.811e+04
1	3	232	2.19	-0.79	2.17	-0.77	0.28	2.152e+04	-1.550e+04	1.443e+04	-8409.78	-1.456e+04
1	3	233	0.30	-1.23	0.29	-1.22	0.14	4373.83	-320.26	1972.53	2081.04	-2346.42
1	3	234	3.19	-5.48	-5.42	3.13	-0.71	7.489e+04	-8.073e+04	7.098e+04	-7.683e+04	-2.434e+04
1	3	235	6.14	-8.62	-7.37	4.89	-4.11	6.715e+04	-6.266e+04	6.489e+04	-6.039e+04	-1.700e+04
1	3	236	10.23	-3.82	7.10	-0.69	-5.84	4.904e+04	-4.342e+04	4.676e+04	-4.114e+04	-1.434e+04

Parco Eolico "Bolina" – Progetto Definitivo
Relazione di calcolo preliminare delle fondazioni degli aerogeneratori G8 e G12

1	3	237	0.78	-1.12	0.55	-0.89	-0.62	4.336e+04	-3.789e+04	4.025e+04	-3.478e+04	-1.559e+04
1	3	238	0.66	-2.15	-1.49	-3.68e-03	1.19	3.856e+04	-3.093e+04	3.643e+04	-2.880e+04	-1.198e+04
1	3	239	-0.33	-1.63	-0.76	-1.20	-0.61	2.869e+04	-2.644e+04	2.750e+04	-2.525e+04	-8012.90
1	3	240	3.30	-3.40	2.79	-2.89	-1.78	1.994e+04	-1.504e+04	1.893e+04	-1.403e+04	-5875.84
1	3	241	1.07	-0.63	1.05	-0.62	-0.15	2974.75	-444.21	2095.58	434.96	-1494.30
1	3	242	2.89	-7.26	-5.06	0.69	-4.18	4.958e+04	-8.166e+04	4.941e+04	-8.149e+04	-4728.49
1	3	243	3.66	-8.00	-7.25	2.90	-2.87	6.484e+04	-4.685e+04	6.483e+04	-4.684e+04	-1075.51
1	3	244	0.24	-1.26	0.24	-1.26	-2.11e-02	4.289e+04	-4.867e+04	4.257e+04	-4.835e+04	-5420.08
1	3	245	0.30	-2.50	-1.60	-0.60	-1.31	3.698e+04	-3.906e+04	3.683e+04	-3.891e+04	-3339.87
1	3	246	0.83	-4.45	-2.34	-1.28	-2.59	3.479e+04	-2.736e+04	3.464e+04	-2.721e+04	-3038.63
1	3	247	-0.14	-2.55	-2.39	-0.30	-0.60	4.142e+04	-8400.77	4.142e+04	-8400.11	182.02
1	3	248	1.99	-2.36	1.09	-1.46	1.77	2.296e+04	-1.135e+04	2.221e+04	-1.060e+04	-5017.80
1	3	249	0.43	-3.28	-0.27	-2.58	1.45	8055.50	-495.71	5076.18	2483.61	-4074.36
1	3	250	5.38	-11.93	-9.97	3.43	-5.48	2.609e+04	-1.061e+05	2.452e+04	-1.045e+05	1.435e+04
1	3	251	3.33	-9.00	-8.97	3.30	-0.59	2.563e+04	-7.968e+04	2.269e+04	-7.674e+04	1.734e+04
1	3	252	-2.72	-6.91	-3.15	-6.49	1.26	2.980e+04	-5.984e+04	2.688e+04	-5.691e+04	1.593e+04
1	3	253	0.39	-4.32	-2.73	-1.20	-2.23	2.655e+04	-4.768e+04	2.375e+04	-4.489e+04	1.413e+04
1	3	254	1.90	-4.69	-3.94	1.15	-2.10	2.584e+04	-3.390e+04	2.175e+04	-2.982e+04	1.508e+04
1	3	255	-0.16	-2.31	-0.86	-1.61	-1.01	1.775e+04	-2.597e+04	1.315e+04	-2.137e+04	1.341e+04
1	3	256	2.76	-4.47	2.48	-4.19	1.39	1.369e+04	-1.176e+04	1.148e+04	-9552.23	7171.35
1	3	257	1.21	-2.59	0.68	-2.05	1.32	458.09	-1846.07	210.70	-1598.68	713.32
1	3	258	3.17	-7.42	-4.60	0.35	-4.68	-5601.04	-1.285e+05	-9774.22	-1.243e+05	2.226e+04
1	3	259	1.87	-5.84	-4.33	0.36	-3.06	-3697.28	-1.008e+05	-1.577e+04	-8.875e+04	3.204e+04
1	3	260	-0.59	-3.53	-3.06	-1.06	-1.08	2711.76	-7.564e+04	-1.059e+04	-6.234e+04	2.942e+04
1	3	261	-0.54	-3.54	-2.33	-1.75	-1.47	7723.86	-5.594e+04	-4853.37	-4.336e+04	2.535e+04
1	3	262	4.26e-02	-4.28	-1.93	-2.31	-2.15	1.299e+04	-3.639e+04	2125.81	-2.552e+04	2.046e+04
1	3	263	-5.62e-04	-2.86	-1.96	-0.90	-1.33	3.143e+04	-9296.84	1.646e+04	5676.17	1.964e+04
1	3	264	0.38	-2.02	-1.09	-0.55	1.17	9907.66	-1.357e+04	3877.72	-7542.75	1.026e+04
1	3	265	-0.22	-3.12	-2.13	-1.21	1.37	1.02	-7030.56	-4974.69	-2054.85	3198.35
1	3	266	9.37	-9.36	-2.35	2.36	-9.07	-3.781e+04	-1.977e+05	-6.929e+04	-1.662e+05	6.357e+04
1	3	267	5.27	-6.50	0.59	-1.82	-5.76	-2.995e+04	-1.187e+05	-5.974e+04	-8.891e+04	4.191e+04
1	3	268	0.91	-1.60	-1.36	0.68	-0.73	-1.990e+04	-8.342e+04	-4.434e+04	-5.898e+04	3.091e+04
1	3	269	1.44	-5.16	-3.78	6.18e-02	-2.68	-7818.92	-6.481e+04	-3.507e+04	-3.755e+04	2.847e+04
1	3	270	2.54	-7.00	-5.14	0.68	-3.78	5618.18	-4.937e+04	-2.956e+04	-1.419e+04	2.640e+04
1	3	271	-0.48	-2.67	-2.57	-0.58	-0.46	6425.05	-4.395e+04	-3.234e+04	-5182.32	2.121e+04
1	3	272	1.55	-4.82	-1.36	-1.90	3.18	7580.50	-2.799e+04	-2.212e+04	1708.59	1.321e+04
1	3	273	1.19e-02	-2.50	-1.94	-0.56	1.05	302.16	-2.204e+04	-2.084e+04	-902.52	5046.40
1	3	274	5.03	-8.75	-4.15	0.43	-6.50	-7.316e+04	-1.792e+05	-1.013e+05	-1.510e+05	4.681e+04
1	3	275	4.63	-8.78	-3.83	-0.32	-6.47	-2.633e+04	-1.049e+05	-6.462e+04	-6.660e+04	3.927e+04
1	3	276	2.55	-7.36	-3.61	-1.20	-4.81	-3.240e+04	-9.511e+04	-6.877e+04	-5.875e+04	3.095e+04
1	3	277	1.16	-6.16	-3.89	-1.11	-3.38	-1.906e+04	-7.226e+04	-5.810e+04	-3.322e+04	2.351e+04
1	3	278	0.28	-5.40	-3.71	-1.41	-2.60	-4156.18	-5.029e+04	-4.216e+04	-1.229e+04	1.758e+04
1	3	279	0.36	-4.58	-3.65	-0.57	-1.94	3.079e+04	-2.151e+04	-1.805e+04	2.732e+04	1.301e+04
1	3	280	-7.94e-02	-3.56	-3.56	-8.00e-02	4.55e-02	5105.40	-2.726e+04	-2.504e+04	2887.01	8178.10
1	3	281	-0.35	-3.62	-3.61	-0.37	0.20	78.93	-2.490e+04	-2.487e+04	48.41	872.63
1	3	282	5.67	-12.61	-4.34	-2.60	-9.10	-1.145e+05	-2.050e+05	-1.560e+05	-1.634e+05	4.511e+04
1	3	283	4.81	-11.96	-8.35	1.20	-6.89	-7.623e+04	-1.392e+05	-1.262e+05	-8.818e+04	2.566e+04
1	3	284	-1.94	-7.25	-6.76	-2.43	-1.54	-4.457e+04	-1.042e+05	-9.771e+04	-5.101e+04	1.850e+04
1	3	285	0.48	-6.89	-4.10	-2.32	-3.58	-2.539e+04	-8.102e+04	-7.884e+04	-2.757e+04	1.081e+04
1	3	286	1.56	-8.08	-4.53	-1.99	-4.65	-1564.81	-6.534e+04	-6.511e+04	-1792.13	3800.71
1	3	287	0.46	-5.02	-4.27	-0.29	-1.88	4753.18	-6.140e+04	-6.136e+04	4709.61	-1697.08
1	3	288	0.21	-5.46	-5.32	6.80e-02	0.89	8584.64	-4.277e+04	-4.250e+04	8310.61	-3741.43
1	3	289	-0.35	-3.45	-3.44	-0.36	-0.20	416.31	-3.569e+04	-3.454e+04	-733.94	-6341.09
1	3	290	3.76	-7.27	-1.94	-1.57	-5.51	-1.341e+05	-1.827e+05	-1.702e+05	-1.466e+05	2.125e+04
1	3	291	3.62	-8.39	-3.86	-0.91	-5.82	-9.086e+04	-1.383e+05	-1.373e+05	-9.184e+04	6762.01
1	3	292	1.55	-7.78	-4.56	-1.67	-4.43	-5.572e+04	-1.059e+05	-1.057e+05	-5.588e+04	-2854.95
1	3	293	0.90	-7.15	-4.25	-2.00	-3.87	-3.124e+04	-8.030e+04	-7.924e+04	-3.230e+04	-7145.66
1	3	294	0.55	-6.52	-4.09	-1.88	-3.36	-1.014e+04	-5.610e+04	-5.447e+04	-1.178e+04	-8521.82
1	3	295	0.51	-5.78	-3.87	-1.40	-2.89	3.343e+04	-2.587e+04	-2.202e+04	2.958e+04	-1.462e+04
1	3	296	-0.34	-4.82	-4.17	-0.99	-1.58	4731.23	-3.238e+04	-3.002e+04	2372.12	-9054.12
1	3	297	-0.42	-4.41	-3.88	-0.94	-1.35	-38.05	-3.141e+04	-2.717e+04	-4270.51	-1.072e+04
1	3	298	5.44	-9.47	0.68	-4.71	-6.95	-1.348e+05	-1.779e+05	-1.692e+05	-1.435e+05	1.735e+04
1	3	299	4.03	-8.38	-1.43	-2.93	-6.16	-8.653e+04	-1.260e+05	-1.235e+05	-8.906e+04	-9670.88
1	3	300	1.98	-8.06	-2.46	-3.63	-4.99	-5.101e+04	-9.218e+04	-8.170e+04	-6.150e+04	-1.794e+04
1	3	301	1.08	-7.36	-2.87	-3.41	-4.21	-2.944e+04	-7.468e+04	-6.367e+04	-4.045e+04	-1.941e+04
1	3	302	0.92	-7.86	-3.50	-3.44	-4.39	-3022.79	-6.380e+04	-4.905e+04	-1.778e+04	-2.606e+04
1	3	303	1.04	-6.00	-3.38	-1.58	-3.40	3087.97	-6.250e+04	-4.643e+04	-1.298e+04	-2.821e+04
1	3	304	-0.13	-6.09	-4.75	-1.47	-2.48	8435.04	-4.418e+04	-3.056e+04	-5186.30	-2.305e+04
1	3	305	-0.47	-4.44	-3.33	-1.59	-1.79	369.35	-3.794e+04	-2.633e+04	-1.124e+04	-1.761e+04
1	3	306	4.91	-8.88	0.94	-4.92	-6.24	-1.264e+05	-1.372e+05	-1.318e+05	-1.318e+05	5411.54
1	3	307	2.98	-7.64	-0.51	-4.15	-4.99	-4.781e+04	-7.342e+04	-6.061e+04	-6.062e+04	-1.280e+04
1	3	308	0.54	-6.93	-2.00	-4.39	-3.54	-4.944e+04	-7.593e+04	-6.268e+04	-6.269e+04	-1.324e+04
1	3	309	0.82	-7.00	-2.29	-3.89	-3.83	-2.760e+04	-6.497e+04	-4.628e+04	-4.629e+04	-1.869e+04

Parco Eolico "Bolina" – Progetto Definitivo
Relazione di calcolo preliminare delle fondazioni degli aerogeneratori G8 e G12

1	3	310	0.84	-6.69	-2.40	-3.45	-3.73	-8830.85	-4.652e+04	-2.767e+04	-2.768e+04	-1.885e+04
1	3	311	0.53	-5.78	-2.30	-2.96	-3.13	3.420e+04	-1.954e+04	7332.78	7324.58	-2.687e+04
1	3	312	-0.54	-5.09	-2.67	-2.97	-2.27	4742.84	-2.679e+04	-1.102e+04	-1.103e+04	-1.577e+04
1	3	313	-0.38	-4.57	-2.45	-2.51	-2.09	-291.56	-2.806e+04	-1.417e+04	-1.417e+04	-1.388e+04
1	3	314	2.89	-7.53	0.27	-4.91	-4.52	-1.348e+05	-1.779e+05	-1.435e+05	-1.692e+05	1.735e+04
1	3	315	2.60	-7.66	0.37	-5.43	-4.23	-8.652e+04	-1.260e+05	-8.905e+04	-1.235e+05	-9671.20
1	3	316	1.02	-7.15	-1.32	-4.81	-3.69	-5.101e+04	-9.219e+04	-6.148e+04	-8.171e+04	-1.794e+04
1	3	317	0.41	-6.61	-1.85	-4.35	-3.28	-2.943e+04	-7.468e+04	-4.043e+04	-6.368e+04	-1.941e+04
1	3	318	0.46	-7.22	-2.37	-4.39	-3.70	-3015.77	-6.380e+04	-1.776e+04	-4.906e+04	-2.606e+04
1	3	319	0.88	-5.59	-0.91	-3.80	-2.90	3094.62	-6.251e+04	-1.297e+04	-4.644e+04	-2.821e+04
1	3	320	-0.13	-5.75	-1.14	-4.75	-2.16	8438.90	-4.418e+04	-5168.08	-3.058e+04	-2.304e+04
1	3	321	-0.48	-4.03	-1.42	-3.10	-1.56	369.11	-3.794e+04	-1.124e+04	-2.634e+04	-1.761e+04
1	3	322	1.52	-6.14	0.12	-4.75	-2.96	-1.341e+05	-1.827e+05	-1.466e+05	-1.703e+05	2.125e+04
1	3	323	2.23	-7.19	1.50	-6.45	-2.53	-9.084e+04	-1.383e+05	-9.183e+04	-1.373e+05	6762.03
1	3	324	0.54	-6.76	-7.22e-02	-6.15	-2.02	-5.570e+04	-1.059e+05	-5.586e+04	-1.057e+05	-2852.59
1	3	325	-8.61e-02	-6.01	-0.97	-5.13	-2.11	-3.122e+04	-8.031e+04	-3.228e+04	-7.925e+04	-7142.80
1	3	326	-0.24	-5.43	-1.25	-4.43	-2.05	-1.012e+04	-5.611e+04	-1.76e+04	-5.448e+04	-8519.68
1	3	327	3.41e-02	-4.81	-0.97	-3.81	-1.96	3.345e+04	-2.588e+04	2.960e+04	-2.202e+04	-1.462e+04
1	3	328	-0.41	-4.06	-0.70	-3.76	-1.00	4730.55	-3.238e+04	2375.76	-3.003e+04	-9046.66
1	3	329	-0.44	-3.60	-0.80	-3.25	-1.00	-37.40	-3.141e+04	-4270.01	-2.718e+04	-1.072e+04
1	3	330	-0.25	-7.12	-2.54	-4.83	-3.24	-1.145e+05	-2.050e+05	-1.634e+05	-1.561e+05	4.511e+04
1	3	331	2.61	-9.14	2.37	-8.90	-1.67	-7.525e+04	-1.392e+05	-8.815e+04	-1.263e+05	2.566e+04
1	3	332	-1.49	-7.67	-2.04	-7.12	1.75	-4.455e+04	-1.042e+05	-5.099e+04	-9.773e+04	1.851e+04
1	3	333	-1.60	-4.68	-2.23	-4.05	-1.24	-2.537e+04	-8.104e+04	-2.755e+04	-7.885e+04	1.081e+04
1	3	334	0.13	-6.24	-1.98	-4.13	-2.99	-1545.71	-6.535e+04	-1773.31	-6.512e+04	3803.85
1	3	335	-0.17	-3.68	-0.35	-3.50	-0.76	4772.59	-6.142e+04	4729.16	-6.137e+04	-1694.97
1	3	336	0.50	-4.72	2.37e-02	-4.24	1.50	8595.99	-4.279e+04	8324.25	-4.252e+04	-3726.84
1	3	337	-0.31	-2.22	-0.32	-2.21	0.14	415.45	-3.570e+04	-734.56	-3.455e+04	-6341.19
1	7	1	31.12	-10.39	24.28	-3.54	15.41	5.448e+04	-1.068e+05	5.411e+04	-1.065e+05	-7652.75
1	7	2	22.58	-16.27	16.00	-9.69	14.57	5.587e+04	-1.598e+05	5.510e+04	-1.590e+05	1.286e+04
1	7	3	20.03	-17.79	14.27	-12.03	13.59	4.464e+04	-1.102e+05	4.430e+04	-1.099e+05	-7211.21
1	7	4	34.93	-13.88	32.21	-11.17	11.19	1.056e+05	-1.153e+05	1.037e+05	-1.133e+05	-2.059e+04
1	7	5	12.93	-22.41	9.91	-19.39	9.88	6.777e+04	-6.039e+04	6.091e+04	-5.354e+04	-2.884e+04
1	7	6	35.76	-19.67	35.08	-19.00	6.08	1.191e+05	-5.558e+04	1.048e+05	-4.128e+04	-4.788e+04
1	7	7	13.02	-33.99	12.08	-33.05	6.58	1.260e+05	-3.413e+04	1.198e+05	-2.787e+04	-3.104e+04
1	7	8	33.96	-26.91	33.44	-26.39	5.61	1.436e+05	-2.091e+04	1.107e+05	1.203e+04	-6.584e+04
1	7	9	-7.47	-37.71	-7.51	-37.67	-1.09	1.575e+05	1.780e+04	1.059e+05	6.945e+04	-6.745e+04
1	7	10	63.59	-44.84	63.46	-44.71	-3.85	1.922e+05	2.324e+04	1.503e+05	6.512e+04	-7.295e+04
1	7	11	13.57	-40.58	11.74	-38.75	-9.79	1.676e+05	6.598e+04	1.354e+05	9.814e+04	-7.272e+04
1	7	12	40.21	-31.29	36.17	-27.24	-16.52	1.883e+05	4.250e+04	1.427e+05	8.810e+04	-6.761e+04
1	7	13	19.76	-37.30	10.35	-27.90	-21.17	2.039e+05	6.236e+04	1.422e+05	1.241e+05	-7.020e+04
1	7	14	46.81	-25.58	39.29	-18.06	-22.08	2.090e+05	9.777e+04	1.545e+05	1.523e+05	-5.561e+04
1	7	15	39.03	-36.27	16.47	-13.71	-34.49	2.260e+05	1.135e+05	1.698e+05	1.696e+05	-5.625e+04
1	7	16	57.32	-24.99	41.17	-8.84	-32.69	1.757e+05	9.913e+04	1.406e+05	1.342e+05	-3.816e+04
1	7	17	49.33	-25.29	18.18	5.86	-36.80	1.757e+05	9.907e+04	1.345e+05	1.402e+05	-3.820e+04
1	7	18	65.43	-19.74	33.92	11.77	-41.12	1.829e+05	7.977e+04	1.315e+05	1.312e+05	-5.158e+04
1	7	19	22.38	-20.80	15.79	-14.20	15.53	-1.739e+04	-1.720e+05	-2.664e+04	-1.627e+05	3.668e+04
1	7	20	10.63	-13.41	6.62	-9.40	8.96	-2143.15	-1.197e+05	-3804.22	-1.181e+05	1.388e+04
1	7	21	4.64	-12.10	4.17	-11.63	2.77	6.297e+04	-1.186e+05	6.291e+04	-1.185e+05	-3228.04
1	7	22	8.06	-25.35	5.18	-22.47	9.37	9.886e+04	-4.440e+04	9.377e+04	-3.931e+04	-2.652e+04
1	7	23	-4.20	-26.48	-4.20	-26.48	-0.14	1.710e+05	2.840e+04	1.405e+05	5.891e+04	-5.850e+04
1	7	24	11.38	-36.37	6.66	-31.65	-14.25	2.058e+05	7.561e+04	1.589e+05	1.225e+05	-6.250e+04
1	7	25	2.25	-19.94	0.20	-17.89	-6.42	1.888e+05	8.495e+04	1.370e+05	1.367e+05	-5.193e+04
1	7	26	17.87	-32.00	-1.25	-12.88	-24.25	2.039e+05	6.222e+04	1.242e+05	1.419e+05	-7.027e+04
1	7	27	44.32	-34.33	12.05	-2.06	-38.69	2.090e+05	9.750e+04	1.523e+05	1.541e+05	-5.572e+04
1	7	28	17.09	-14.57	11.88	-9.36	11.73	-4.479e+04	-1.915e+05	-6.732e+04	-1.690e+05	5.290e+04
1	7	29	11.56	-7.51	9.49	-5.45	5.93	-2.428e+04	-1.792e+05	-2.757e+04	-1.759e+05	2.233e+04
1	7	30	9.20	-7.90	6.89	-5.59	5.85	-1.867e+04	-1.535e+05	-2.073e+04	-1.515e+05	1.653e+04
1	7	31	4.31	-10.91	2.81	-9.41	4.54	3.597e+04	-9.969e+04	3.577e+04	-9.949e+04	-5223.85
1	7	32	-2.74	-12.98	-2.78	-12.94	-0.67	1.899e+05	1452.40	1.787e+05	1.269e+04	-4.463e+04
1	7	33	7.30	-21.02	4.00	-17.72	-9.08	2.607e+05	5.903e+04	1.600e+05	1.597e+05	-1.008e+05
1	7	34	15.44	-24.25	-0.51	-8.30	-19.46	2.056e+05	7.540e+04	1.226e+05	1.584e+05	-6.258e+04
1	7	35	14.65	-24.75	-8.32	-1.78	-19.43	1.674e+05	6.575e+04	9.817e+04	1.350e+05	-4.736e+04
1	7	36	34.87	-30.18	-1.04	5.73	-32.35	1.883e+05	4.218e+04	8.804e+04	1.424e+05	-6.779e+04
1	7	37	19.95	-20.70	15.55	-16.30	12.62	-9.763e+04	-2.431e+05	-1.257e+05	-2.150e+05	5.740e+04
1	7	38	18.25	-3.32	12.47	2.46	9.55	-8.538e+04	-1.973e+05	-1.321e+05	-1.506e+05	5.521e+04
1	7	39	13.05	-3.30	8.41	1.34	7.37	-9.930e+04	-2.187e+05	-1.218e+05	-1.962e+05	4.671e+04
1	7	40	7.68	-2.87	3.92	0.88	5.05	-7.274e+04	-2.511e+05	-7.867e+04	-2.452e+05	3.196e+04
1	7	41	0.17	-0.19	-2.51e-02	7.30e-03	0.18	-3.229e+04	-4.558e+04	-3.891e+04	-3.896e+04	-6645.56
1	7	42	7.18	-11.16	-3.30	-0.68	-9.07	1.892e+05	1196.74	1.254e+04	1.779e+05	-4.476e+04
1	7	43	14.01	-21.41	-6.44	-0.96	-17.49	1.707e+05	2.787e+04	5.860e+04	1.399e+05	-5.868e+04
1	7	44	17.44	-28.10	-8.94	-1.72	-22.48	1.574e+05	1.723e+04	6.912e+04	1.055e+05	-6.767e+04
1	7	45	32.87	-27.39	-10.22	15.71	-27.20	1.920e+05	2.271e+04	6.481e+04	1.499e+05	-7.316e+04

Parco Eolico "Bolina" – Progetto Definitivo
Relazione di calcolo preliminare delle fondazioni degli aerogeneratori G8 e G12

1	7	46	19.12	-18.77	8.48	-8.14	17.03	-1.127e+05	-2.287e+05	-1.415e+05	-1.999e+05	5.015e+04
1	7	47	19.12	-5.83	13.52	-0.23	10.41	-1.306e+05	-2.123e+05	-1.507e+05	-1.922e+05	3.520e+04
1	7	48	19.07	-6.48	9.91	2.68	12.26	-1.469e+05	-2.510e+05	-1.817e+05	-2.163e+05	4.909e+04
1	7	49	14.76	-1.93	5.44	7.39	8.29	-1.369e+05	-3.097e+05	-2.234e+05	-2.232e+05	8.640e+04
1	7	50	13.60	1.75	2.69	12.66	3.21	-7.304e+04	-2.518e+05	-2.459e+05	-7.889e+04	3.182e+04
1	7	51	20.07	-11.73	-10.83	19.17	-5.26	3.524e+04	-1.004e+05	-1.002e+05	3.502e+04	-5566.37
1	7	52	17.26	-18.62	-12.74	11.38	-13.28	9.827e+04	-4.500e+04	-3.983e+04	9.310e+04	-2.671e+04
1	7	53	16.82	-17.94	-8.93	7.82	-15.23	1.256e+05	-3.459e+04	-2.827e+04	1.192e+05	-3.118e+04
1	7	54	28.59	-28.00	-10.76	11.35	-26.05	1.434e+05	-2.136e+04	1.175e+04	1.102e+05	-6.600e+04
1	7	55	19.59	-24.15	0.70	-5.26	21.67	-1.718e+05	-2.510e+05	-2.131e+05	-2.097e+05	3.957e+04
1	7	56	23.29	-9.51	9.06	4.73	16.26	-1.317e+05	-2.461e+05	-1.805e+05	-1.973e+05	5.660e+04
1	7	57	13.54	2.00	5.31	10.23	5.22	-1.573e+05	-2.295e+05	-1.935e+05	-1.933e+05	3.614e+04
1	7	58	28.19	-8.62	-0.15	19.73	15.49	-1.471e+05	-2.512e+05	-2.167e+05	-1.817e+05	4.900e+04
1	7	59	27.05	2.18	3.98	25.24	6.45	-9.985e+04	-2.190e+05	-1.967e+05	-1.222e+05	4.652e+04
1	7	60	33.17	-10.90	-9.71	31.98	-7.16	-1.931e+04	-1.541e+05	-1.520e+05	-2.133e+04	1.635e+04
1	7	61	19.35	-7.67	-7.06	18.73	-4.02	6.239e+04	-1.191e+05	-1.190e+05	6.233e+04	-3386.91
1	7	62	25.36	-17.01	-9.67	18.02	-16.03	6.735e+04	-6.088e+04	-5.394e+04	6.042e+04	-2.900e+04
1	7	63	37.32	-36.33	-19.79	20.78	-30.73	1.186e+05	-5.611e+04	-4.175e+04	1.043e+05	-4.799e+04
1	7	64	17.53	-30.52	-4.96	-8.02	23.98	-1.709e+05	-2.104e+05	-1.879e+05	-1.933e+05	1.959e+04
1	7	65	25.09	-23.58	-3.12	4.63	24.02	-1.820e+05	-2.736e+05	-2.279e+05	-2.277e+05	4.582e+04
1	7	66	27.73	-11.58	-1.31	17.45	17.27	-1.318e+05	-2.461e+05	-1.975e+05	-1.805e+05	5.652e+04
1	7	67	34.97	-11.74	-7.95	31.18	12.75	-1.308e+05	-2.125e+05	-1.925e+05	-1.508e+05	3.510e+04
1	7	68	37.38	5.18	6.88	35.68	7.18	-8.596e+04	-1.975e+05	-1.510e+05	-1.325e+05	5.499e+04
1	7	69	36.65	-11.80	-11.62	36.47	-2.90	-2.479e+04	-1.795e+05	-1.763e+05	-2.804e+04	2.219e+04
1	7	70	31.68	-17.44	-14.13	28.37	-12.32	-2645.92	-1.201e+05	-1.185e+05	-4269.22	1.371e+04
1	7	71	30.95	-30.44	-20.84	21.34	-22.30	4.405e+04	-1.107e+05	-1.103e+05	4.371e+04	-7298.35
1	7	72	26.74	-35.13	-21.14	12.75	-25.88	1.053e+05	-1.155e+05	-1.136e+05	1.033e+05	-2.062e+04
1	7	73	13.61	-42.00	-18.50	-9.89	27.47	-1.446e+05	-2.172e+05	-1.809e+05	-1.808e+05	3.629e+04
1	7	74	15.58	-36.06	-23.58	3.09	22.11	-1.709e+05	-2.104e+05	-1.936e+05	-1.877e+05	1.956e+04
1	7	75	19.31	-31.90	-24.79	12.19	17.72	-1.720e+05	-2.510e+05	-2.099e+05	-2.131e+05	3.947e+04
1	7	76	27.67	-31.56	-27.66	23.76	14.70	-1.130e+05	-2.288e+05	-2.001e+05	-1.416e+05	4.997e+04
1	7	77	42.67	-55.52	-55.16	42.30	6.01	-9.816e+04	-2.432e+05	-2.153e+05	-1.261e+05	5.719e+04
1	7	78	28.32	-31.84	-31.33	27.82	-5.48	-4.525e+04	-1.917e+05	-1.693e+05	-6.767e+04	5.273e+04
1	7	79	25.33	-38.64	-37.07	23.77	-9.89	-1.798e+04	-1.723e+05	-1.631e+05	-2.719e+04	3.656e+04
1	7	80	24.12	-43.93	-36.80	16.99	-20.84	5.549e+04	-1.600e+05	-1.925e+05	5.472e+04	1.283e+04
1	7	81	19.98	-45.17	-29.41	4.22	-27.90	5.422e+04	-1.070e+05	-1.066e+05	5.385e+04	-7621.44
1	7	82	42.26	-64.99	-64.74	42.00	5.26	-6.669e+04	-1.628e+05	-1.370e+05	-9.248e+04	4.260e+04
1	7	83	25.55	-58.31	-57.57	24.81	-7.86	-3.455e+04	-1.795e+05	-1.510e+05	-6.305e+04	5.761e+04
1	7	84	22.67	-45.02	-44.98	22.63	1.66	-2.382e+04	-9.519e+04	-6.021e+04	-5.881e+04	3.568e+04
1	7	85	28.19	-54.74	-54.33	27.78	-5.78	-2.706e+04	-1.080e+05	-8.075e+04	-5.432e+04	3.826e+04
1	7	86	19.41	-35.11	-35.11	19.41	0.37	-2.953e+04	-8.640e+04	-5.352e+04	-6.240e+04	2.809e+04
1	7	87	24.65	-38.49	-38.17	24.34	-4.44	-1.820e+04	-7.570e+04	-5.347e+04	-4.043e+04	2.800e+04
1	7	88	20.58	-28.36	-28.36	20.58	-0.31	-1.714e+04	-6.558e+04	-2.991e+04	-5.281e+04	2.135e+04
1	7	89	22.14	-29.56	-28.30	20.88	-7.95	-6962.12	-5.873e+04	-3.384e+04	-3.185e+04	2.586e+04
1	7	90	22.67	-23.33	-23.32	22.65	-0.73	-3179.07	-4.558e+04	-1.042e+04	-3.834e+04	1.595e+04
1	7	91	20.85	-20.81	-18.84	18.88	-8.83	5302.58	-4.457e+04	-1.255e+04	-2.671e+04	2.391e+04
1	7	92	23.09	-14.09	-14.07	23.08	-0.78	2.851e+04	-1.932e+04	2.541e+04	-1.622e+04	1.178e+04
1	7	93	23.82	-14.81	-13.63	22.64	-6.66	6190.62	-3.991e+04	-4286.90	-2.943e+04	1.932e+04
1	7	94	23.87	-4.92	-4.91	23.86	0.48	4441.43	-2.464e+04	2417.19	-2.261e+04	7400.57
1	7	95	25.50	-8.02	-7.68	25.16	-3.36	7050.56	-2.552e+04	1696.72	-2.017e+04	1.207e+04
1	7	96	24.60	-2.08	-2.07	24.58	0.61	102.87	-2.253e+04	75.57	-2.250e+04	785.59
1	7	97	26.20	-1.74	-1.16	25.63	-3.97	242.73	-2.006e+04	-852.02	-1.896e+04	4585.42
1	7	98	10.47	-56.07	-53.25	7.66	-13.39	-5147.49	-1.169e+05	-1.131e+05	-8938.92	2.023e+04
1	7	99	19.64	-58.02	-52.64	14.27	-19.70	-3362.77	-9.166e+04	-8.062e+04	-1.440e+04	2.920e+04
1	7	100	23.98	-41.64	-36.57	18.91	-17.52	2519.55	-6.870e+04	-5.652e+04	-9666.26	2.682e+04
1	7	101	24.21	-32.07	-26.68	18.82	-16.56	7188.08	-5.068e+04	-3.912e+04	-4368.67	2.313e+04
1	7	102	24.85	-26.20	-20.35	19.00	-16.26	1.217e+04	-3.274e+04	-2.259e+04	2012.44	1.879e+04
1	7	103	23.49	-16.14	-11.12	18.47	-13.18	2.889e+04	-8089.34	5667.93	1.514e+04	1.787e+04
1	7	104	22.32	-5.73	-2.69	19.28	-8.72	8907.56	-1.226e+04	-6965.87	3616.66	9164.32
1	7	105	20.22	-3.18	-1.26	18.29	-6.43	25.05	-6246.69	-1812.51	-4409.14	2854.48
1	7	106	25.37	-55.84	-37.25	6.78	-34.12	2.375e+04	-9.654e+04	-9.510e+04	2.231e+04	1.307e+04
1	7	107	23.36	-46.53	-33.02	9.84	-27.60	2.316e+04	-7.208e+04	-6.934e+04	2.042e+04	1.591e+04
1	7	108	21.46	-38.25	-28.74	11.95	-21.85	2.727e+04	-5.489e+04	-5.215e+04	2.453e+04	1.475e+04
1	7	109	22.29	-28.95	-18.60	11.94	-20.57	2.424e+04	-4.321e+04	-4.065e+04	2.169e+04	1.287e+04
1	7	110	20.25	-20.54	-11.00	10.72	-17.26	2.354e+04	-3.044e+04	-2.675e+04	1.985e+04	1.362e+04
1	7	111	20.77	-16.11	-7.87	12.54	-15.36	1.630e+04	-2.338e+04	-1.911e+04	1.203e+04	1.230e+04
1	7	112	20.12	-9.08	-3.67	14.71	-11.35	1.261e+04	-1.073e+04	-8667.86	1.054e+04	6627.32
1	7	113	16.67	-4.66	-2.15	14.16	-6.88	411.50	-1679.76	-1470.50	202.24	627.57
1	7	114	29.21	-56.07	-38.71	11.85	-34.33	4.530e+04	-7.434e+04	-7.420e+04	4.515e+04	-4144.77
1	7	115	21.22	-39.71	-24.65	6.15	-26.28	5.903e+04	-4.215e+04	-4.214e+04	5.902e+04	-859.20
1	7	116	20.38	-28.38	-18.37	10.37	-19.69	3.907e+04	-4.422e+04	-4.390e+04	3.875e+04	-5104.61
1	7	117	19.01	-24.16	-13.05	7.89	-18.88	3.376e+04	-3.530e+04	-3.517e+04	3.362e+04	-3022.59
1	7	118	18.02	-21.48	-9.61	6.14	-18.11	3.187e+04	-2.450e+04	-2.438e+04	3.175e+04	-2583.82

Parco Eolico "Bolina" – Progetto Definitivo
Relazione di calcolo preliminare delle fondazioni degli aerogeneratori G8 e G12

1	7	119	14.12	-12.98	-4.57	5.70	-12.54	3.779e+04	-7199.40	-7198.31	3.779e+04	221.48
1	7	120	11.16	-3.44	0.44	7.28	-6.45	2.094e+04	-1.031e+04	-9580.41	2.020e+04	-4732.06
1	7	121	9.14	-4.00	-1.74	6.88	-4.96	7505.97	-419.39	2393.67	4692.91	-3792.26
1	7	122	31.49	-48.18	-29.88	13.19	-33.52	6.814e+04	-7.325e+04	-6.970e+04	6.459e+04	-2.212e+04
1	7	123	24.55	-40.88	-20.93	4.61	-30.12	6.114e+04	-5.674e+04	-5.464e+04	5.904e+04	-1.560e+04
1	7	124	27.00	-30.63	-16.57	12.94	-24.75	4.502e+04	-3.933e+04	-3.721e+04	4.290e+04	-1.321e+04
1	7	125	16.98	-21.68	-11.75	7.05	-16.89	3.956e+04	-3.422e+04	-3.139e+04	3.673e+04	-1.416e+04
1	7	126	11.99	-14.55	-7.55	4.99	-11.70	3.505e+04	-2.773e+04	-2.581e+04	3.312e+04	-1.083e+04
1	7	127	10.03	-10.36	-3.58	3.24	-9.61	2.619e+04	-2.384e+04	-2.277e+04	2.512e+04	-7239.17
1	7	128	9.43	-5.15	-0.19	4.46	-6.91	1.834e+04	-1.370e+04	-1.275e+04	1.740e+04	-5423.02
1	7	129	8.80	-0.99	3.47	4.35	-4.87	2793.54	-399.45	458.84	1935.25	-1415.57
1	7	130	14.55	-30.71	-17.91	1.75	-20.38	8.528e+04	-5.210e+04	-4.656e+04	7.974e+04	-2.702e+04
1	7	131	21.02	-31.09	-15.76	5.68	-23.75	7.502e+04	-4.351e+04	-3.337e+04	6.489e+04	-3.315e+04
1	7	132	20.45	-24.86	-10.61	6.20	-21.04	5.853e+04	-3.698e+04	-2.685e+04	4.841e+04	-2.940e+04
1	7	133	16.14	-18.73	-7.44	4.85	-16.32	4.562e+04	-3.114e+04	-2.137e+04	3.586e+04	-2.558e+04
1	7	134	11.47	-13.76	-4.19	1.90	-12.24	3.728e+04	-2.464e+04	-1.582e+04	2.846e+04	-2.164e+04
1	7	135	7.45	-7.36	-1.91	2.00	-7.15	3.611e+04	-1.315e+04	-6899.87	2.986e+04	-1.639e+04
1	7	136	5.11	-1.58	0.27	3.26	-2.99	1.956e+04	-1.399e+04	-7502.00	1.308e+04	-1.325e+04
1	7	137	3.67	-1.62	0.38	1.67	-2.56	4056.83	-252.56	2012.01	1792.26	-2151.89
1	7	138	26.97	-27.58	-10.69	10.08	-25.22	1.456e+05	-2.406e+04	8329.09	1.132e+05	-6.667e+04
1	7	139	33.34	-28.72	-10.74	15.37	-28.15	9.268e+04	-2.183e+04	1317.16	6.953e+04	-4.599e+04
1	7	140	22.42	-20.36	-7.24	9.30	-19.73	6.937e+04	-2.372e+04	-660.41	4.631e+04	-4.018e+04
1	7	141	16.46	-14.75	-5.35	7.07	-14.32	5.081e+04	-2.354e+04	-2730.10	3.000e+04	-3.338e+04
1	7	142	11.38	-10.21	-4.40	5.57	-9.57	3.835e+04	-2.139e+04	-4488.99	2.145e+04	-2.690e+04
1	7	143	6.61	-6.03	-2.21	2.79	-5.81	2.608e+04	-1.972e+04	-7321.48	1.368e+04	-2.035e+04
1	7	144	4.13	-3.07	-0.84	1.91	-3.32	1.678e+04	-1.284e+04	-4129.70	8069.82	-1.350e+04
1	7	145	3.32	-2.57	-1.11	1.86	-2.54	2570.39	-449.64	1254.92	865.83	-1497.43
1	7	146	40.68	-31.77	-8.42	17.34	-33.86	1.343e+05	9213.98	4.582e+04	9.770e+04	-5.691e+04
1	7	147	35.01	-25.08	-4.19	14.12	-28.62	1.113e+05	9060.64	4.496e+04	7.538e+04	-4.879e+04
1	7	148	27.89	-18.10	-4.93	14.72	-20.79	7.329e+04	-6318.58	2.910e+04	3.788e+04	-3.956e+04
1	7	149	20.13	-13.53	-4.19	10.79	-15.07	5.159e+04	-1.156e+04	1.902e+04	2.100e+04	-3.156e+04
1	7	150	13.17	-10.19	-3.91	6.88	-10.36	3.716e+04	-1.279e+04	1.306e+04	1.132e+04	-2.496e+04
1	7	151	8.08	-7.65	-4.57	5.00	-6.25	3.028e+04	-8374.76	1.147e+04	1.043e+04	-1.932e+04
1	7	152	4.54	-6.01	-5.21	3.74	-2.80	1.661e+04	-1.007e+04	5817.55	722.46	-1.310e+04
1	7	153	2.51	-6.56	-5.49	1.44	-2.93	4736.78	47.83	4414.05	370.56	-1187.07
1	7	154	46.17	-22.79	1.09	22.28	-32.81	1.633e+05	3.661e+04	8.901e+04	1.109e+05	-6.237e+04
1	7	155	40.75	-22.35	2.25	16.15	-30.78	1.050e+05	2.208e+04	6.178e+04	6.527e+04	-4.141e+04
1	7	156	35.79	-17.47	1.31	17.01	-25.45	6.927e+04	1.136e+04	4.584e+04	3.479e+04	-2.842e+04
1	7	157	25.80	-14.93	-2.50	13.37	-18.75	4.854e+04	464.15	3.310e+04	1.590e+04	-2.244e+04
1	7	158	18.23	-13.01	-4.62	9.83	-13.85	3.371e+04	-5222.94	2.255e+04	5945.77	-1.761e+04
1	7	159	10.78	-11.08	-6.54	6.24	-8.87	2.148e+04	-8298.69	1.333e+04	-148.19	-1.328e+04
1	7	160	5.39	-10.02	-7.92	3.28	-5.29	1.333e+04	-6319.68	8883.39	-1869.77	-8225.10
1	7	161	2.90	-10.34	-8.27	0.84	-4.81	5019.60	201.95	5019.01	202.54	53.42
1	7	162	51.98	-3.89	18.39	29.70	-27.35	1.384e+05	6.075e+04	1.001e+05	9.907e+04	-3.883e+04
1	7	163	53.38	-14.48	13.84	25.07	-33.46	9.597e+04	3.970e+04	7.377e+04	6.191e+04	-2.750e+04
1	7	164	40.73	-18.07	5.67	16.99	-28.85	6.379e+04	2.336e+04	5.344e+04	3.371e+04	-1.765e+04
1	7	165	30.53	-16.98	0.81	12.74	-23.00	4.279e+04	1.079e+04	3.813e+04	1.545e+04	-1.129e+04
1	7	166	21.79	-15.96	-3.07	8.90	-17.90	2.906e+04	2883.07	2.694e+04	5006.82	-7147.40
1	7	167	13.92	-15.21	-6.61	5.31	-13.29	2.152e+04	848.14	2.029e+04	2078.85	-4891.55
1	7	168	7.02	-14.80	-9.94	2.16	-9.08	1.249e+04	-3243.70	1.225e+04	-3006.43	-1917.33
1	7	169	3.22	-14.63	-10.18	-1.23	-7.73	7217.58	339.31	6599.93	956.97	1966.44
1	7	170	71.28	-32.61	30.88	7.79	-50.64	1.359e+05	6.676e+04	1.046e+05	9.805e+04	-3.442e+04
1	7	171	59.84	-25.46	22.54	11.84	-42.31	8.358e+04	4.922e+04	7.113e+04	6.167e+04	-1.652e+04
1	7	172	44.63	-19.60	12.84	12.20	-32.11	5.430e+04	3.206e+04	5.112e+04	3.524e+04	-7784.18
1	7	173	34.10	-19.80	6.46	7.84	-26.94	3.485e+04	1.858e+04	3.460e+04	1.884e+04	-2032.22
1	7	174	24.70	-19.04	1.56	4.10	-21.83	2.276e+04	8770.76	2.275e+04	8779.63	352.01
1	7	175	15.98	-18.85	-4.19	1.33	-17.20	1.402e+04	2255.70	1.387e+04	2409.17	1334.87
1	7	176	8.27	-18.60	-8.99	-1.34	-12.88	9516.65	-63.61	9022.21	430.83	2119.52
1	7	177	3.59	-18.61	-10.08	-4.94	-10.80	7597.17	341.24	5619.81	2318.61	3230.74
1	7	178	74.31	-25.90	40.78	7.63	-47.28	1.072e+05	6.473e+04	8.608e+04	8.581e+04	-2.122e+04
1	7	179	54.63	-21.85	28.03	4.76	-36.42	7.308e+04	5.359e+04	6.327e+04	6.340e+04	-9741.07
1	7	180	44.94	-22.21	19.18	3.55	-32.65	3.982e+04	3.810e+04	3.899e+04	3.893e+04	-856.87
1	7	181	35.08	-22.00	12.54	0.55	-27.90	2.679e+04	2.215e+04	2.447e+04	2.447e+04	2319.67
1	7	182	26.58	-22.09	6.55	-2.07	-23.95	1.908e+04	1.092e+04	1.499e+04	1.501e+04	4077.46
1	7	183	17.43	-21.88	0.66	-5.11	-19.44	1.461e+04	6246.10	1.035e+04	1.050e+04	4180.82
1	7	184	8.56	-21.82	-5.69	-7.57	-15.16	1.005e+04	410.87	5219.36	5236.53	4817.07
1	7	185	3.71	-20.79	-7.35	-9.74	-12.19	8774.69	324.23	4534.51	4564.40	4225.20
1	7	186	76.25	-29.80	43.02	3.42	-49.19	1.359e+05	6.685e+04	9.819e+04	1.046e+05	-3.440e+04
1	7	187	67.60	-28.58	40.84	-1.83	-43.10	8.349e+04	4.936e+04	6.152e+04	7.133e+04	-1.634e+04
1	7	188	51.68	-24.76	30.81	-3.89	-34.05	5.418e+04	3.265e+04	3.573e+04	5.111e+04	-7537.06
1	7	189	39.58	-23.48	22.90	-6.80	-27.81	3.486e+04	1.859e+04	1.885e+04	3.460e+04	-2019.46
1	7	190	28.66	-22.82	15.21	-9.38	-22.62	2.285e+04	8574.24	8579.52	2.285e+04	274.55
1	7	191	19.26	-23.74	7.19	-11.67	-19.32	1.403e+04	2140.83	2300.14	1.387e+04	1367.04

Parco Eolico "Bolina" – Progetto Definitivo
Relazione di calcolo preliminare delle fondazioni degli aerogeneratori G8 e G12

1	7	192	10.17	-24.34	-0.62	-13.55	-16.00	9486.14	-22.40	525.09	8938.64	2214.97
1	7	193	3.94	-23.94	-4.24	-15.76	-12.69	7621.15	349.91	2337.90	5633.16	3240.84
1	7	194	73.72	-4.69	67.83	1.19	-20.66	1.384e+05	6.081e+04	9.923e+04	9.998e+04	-3.880e+04
1	7	195	76.41	-17.21	64.90	-5.69	-30.75	9.586e+04	3.985e+04	6.199e+04	7.372e+04	-2.739e+04
1	7	196	56.48	-24.01	45.26	-12.78	-27.89	6.369e+04	2.346e+04	3.373e+04	5.342e+04	-1.754e+04
1	7	197	42.71	-24.33	33.21	-14.83	-23.38	4.270e+04	1.076e+04	1.536e+04	3.810e+04	-1.121e+04
1	7	198	31.68	-24.63	23.73	-16.68	-19.60	2.894e+04	2688.82	4733.01	2.690e+04	-7035.14
1	7	199	20.28	-24.46	14.01	-18.18	-15.54	2.148e+04	591.56	1820.57	2.025e+04	-4914.90
1	7	200	9.64	-24.71	4.56	-19.63	-12.19	1.249e+04	-3221.65	-2961.44	1.223e+04	-2005.15
1	7	201	4.16	-23.98	-3.34e-02	-19.78	-10.02	7166.36	321.21	920.22	6567.35	1934.30
1	7	202	73.81	-23.60	71.23	-21.02	-15.65	1.633e+05	3.646e+04	1.109e+05	8.887e+04	-6.244e+04
1	7	203	63.88	-21.66	61.22	-19.00	-14.84	1.047e+05	2.221e+04	6.539e+04	6.155e+04	-4.122e+04
1	7	204	54.42	-21.94	50.29	-17.81	-17.28	6.912e+04	1.136e+04	3.471e+04	4.576e+04	-2.835e+04
1	7	205	41.33	-23.17	38.10	-19.94	-14.06	4.841e+04	342.89	1.573e+04	3.303e+04	-2.243e+04
1	7	206	29.73	-23.01	27.33	-20.60	-11.01	3.368e+04	-5537.57	5710.31	2.243e+04	-1.774e+04
1	7	207	19.75	-24.04	17.64	-21.93	-9.38	2.137e+04	-8478.76	-409.55	1.330e+04	-1.326e+04
1	7	208	10.27	-24.80	8.25	-22.78	-8.18	1.321e+04	-6280.25	-1927.21	8859.45	-8118.11
1	7	209	3.99	-24.46	2.55	-23.01	-6.25	5002.21	222.42	222.92	5001.71	48.65
1	7	210	75.00	-43.92	74.53	-43.44	-7.50	1.341e+05	9564.62	9.762e+04	4.605e+04	-5.668e+04
1	7	211	55.63	-23.82	54.94	-23.14	-7.35	1.111e+05	9066.93	7.522e+04	4.496e+04	-4.873e+04
1	7	212	47.43	-21.60	46.87	-21.05	-6.15	7.333e+04	-6367.09	3.800e+04	2.896e+04	-3.959e+04
1	7	213	37.24	-21.58	36.77	-21.12	-5.22	5.143e+04	-1.169e+04	2.080e+04	1.895e+04	-3.154e+04
1	7	214	27.87	-22.25	27.57	-21.95	-3.87	3.686e+04	-1.310e+04	1.076e+04	1.299e+04	-2.495e+04
1	7	215	18.14	-22.63	18.00	-22.49	-2.38	3.006e+04	-8733.68	1.004e+04	1.128e+04	-1.939e+04
1	7	216	8.90	-23.15	8.84	-23.08	-1.44	1.661e+04	-1.010e+04	874.99	5644.09	-1.314e+04
1	7	217	3.82	-22.80	3.75	-22.72	-1.38	4615.05	9.11	349.37	4274.79	-1204.75
1	7	218	61.00	-24.31	60.72	-24.02	4.89	1.456e+05	-2.374e+04	1.133e+05	8557.30	-6.652e+04
1	7	219	58.35	-25.72	58.34	-25.71	-0.85	9.267e+04	-2.170e+04	6.937e+04	1602.11	-4.607e+04
1	7	220	43.36	-21.59	43.35	-21.59	-0.52	6.919e+04	-2.337e+04	4.626e+04	-441.36	-3.996e+04
1	7	221	33.08	-19.95	33.02	-19.90	1.72	5.062e+04	-2.369e+04	2.975e+04	-2815.82	-3.340e+04
1	7	222	23.88	-19.91	23.67	-19.70	3.02	3.818e+04	-2.175e+04	2.120e+04	-4767.61	-2.700e+04
1	7	223	15.75	-20.81	15.46	-20.52	3.24	2.586e+04	-1.994e+04	1.331e+04	-7385.40	-2.043e+04
1	7	224	8.30	-21.76	8.07	-21.54	2.59	1.666e+04	-1.286e+04	7917.55	-4117.74	-1.347e+04
1	7	225	3.15	-22.08	2.80	-21.72	2.98	2547.14	-436.62	892.85	1217.67	-1483.01
1	7	226	52.01	-7.79	51.26	-7.05	6.64	8.540e+04	-5.192e+04	7.986e+04	-4.638e+04	-2.701e+04
1	7	227	53.31	-14.48	51.24	-12.40	11.67	7.498e+04	-4.346e+04	6.481e+04	-3.329e+04	-3.317e+04
1	7	228	38.73	-17.64	37.32	-16.23	8.81	5.839e+04	-3.705e+04	4.823e+04	-2.688e+04	-2.944e+04
1	7	229	28.86	-17.84	27.48	-16.46	7.88	4.539e+04	-3.138e+04	3.552e+04	-2.151e+04	-2.569e+04
1	7	230	20.28	-18.04	18.64	-16.39	7.77	3.685e+04	-2.507e+04	2.779e+04	-2.601e+04	-2.188e+04
1	7	231	13.02	-18.64	10.91	-16.53	7.89	3.576e+04	-1.357e+04	2.940e+04	-7214.64	-1.653e+04
1	7	232	6.80	-19.54	4.42	-17.16	7.55	1.957e+04	-1.402e+04	1.325e+04	-7699.12	-1.313e+04
1	7	233	2.01	-20.78	-0.15	-18.62	6.68	3891.23	-312.71	1745.78	1832.73	-2101.52
1	7	234	43.55	-15.98	34.82	-7.25	21.07	6.826e+04	-7.343e+04	6.468e+04	-6.985e+04	-2.223e+04
1	7	235	35.38	-13.90	29.81	-8.33	15.60	6.080e+04	-5.680e+04	5.867e+04	-5.467e+04	-1.567e+04
1	7	236	33.18	-13.47	30.65	-10.94	10.57	4.521e+04	-3.963e+04	4.304e+04	-3.746e+04	-1.338e+04
1	7	237	23.52	-15.04	19.78	-11.31	11.41	3.940e+04	-3.454e+04	3.654e+04	-3.168e+04	-1.425e+04
1	7	238	16.34	-15.24	12.12	-11.02	10.75	3.476e+04	-2.812e+04	3.283e+04	-2.619e+04	-1.084e+04
1	7	239	10.14	-15.70	6.12	-11.68	9.37	2.588e+04	-2.411e+04	2.475e+04	-2.298e+04	-7425.88
1	7	240	5.63	-16.49	2.22	-13.07	7.99	1.825e+04	-1.380e+04	1.727e+04	-1.283e+04	-5508.86
1	7	241	1.80	-16.55	-1.76	-12.99	7.26	2768.96	-379.10	1950.00	439.86	-1381.10
1	7	242	38.12	-16.26	32.40	-10.54	16.68	4.532e+04	-7.449e+04	4.515e+04	-7.432e+04	-4505.77
1	7	243	25.72	-10.48	21.11	-5.87	12.06	5.863e+04	-4.262e+04	5.862e+04	-4.261e+04	-1148.81
1	7	244	23.35	-11.69	19.23	-7.56	11.30	3.905e+04	-4.426e+04	3.876e+04	-4.398e+04	-4831.52
1	7	245	16.80	-10.26	13.26	-6.73	9.12	3.354e+04	-3.559e+04	3.341e+04	-3.545e+04	-3103.80
1	7	246	11.39	-9.92	8.36	-6.90	7.43	3.143e+04	-2.506e+04	3.127e+04	-2.490e+04	-2973.64
1	7	247	7.80	-10.40	3.83	-6.42	7.52	3.732e+04	-7664.96	3.732e+04	-7664.87	63.21
1	7	248	5.80	-11.39	0.91	-6.49	7.76	2.086e+04	-1.025e+04	2.021e+04	-9592.81	-4463.93
1	7	249	4.23	-11.36	1.55	-8.68	5.88	7239.46	-459.49	4537.73	2242.24	-3674.39
1	7	250	28.13	-15.97	21.71	-9.55	15.55	2.365e+04	-9.652e+04	2.224e+04	-9.511e+04	1.296e+04
1	7	251	24.85	-11.66	18.61	-5.42	13.75	2.315e+04	-7.247e+04	2.044e+04	-6.976e+04	1.586e+04
1	7	252	20.39	-13.52	16.72	-9.84	10.54	2.706e+04	-5.483e+04	2.437e+04	-5.214e+04	1.460e+04
1	7	253	14.94	-7.43	13.17	-5.65	6.05	2.402e+04	-4.340e+04	2.150e+04	-4.088e+04	1.278e+04
1	7	254	10.60	-5.17	9.16	-3.72	4.55	2.322e+04	-3.067e+04	1.954e+04	-2.700e+04	1.359e+04
1	7	255	7.99	-5.18	6.87	-4.06	3.67	1.602e+04	-2.359e+04	1.189e+04	-1.946e+04	1.210e+04
1	7	256	5.77	-5.39	4.49	-4.11	3.55	1.257e+04	-1.086e+04	1.056e+04	-8854.23	6561.72
1	7	257	6.18	-7.41	4.33	-5.56	4.66	433.88	-1677.89	207.78	-1451.80	652.95
1	7	258	19.08	-7.79	16.07	-4.78	8.47	-4874.45	-1.169e+05	-8656.12	-1.131e+05	2.023e+04
1	7	259	19.71	-10.97	17.02	-8.29	8.67	-3238.38	-9.176e+04	-1.422e+04	-8.078e+04	2.918e+04
1	7	260	17.49	-9.69	15.32	-7.52	7.35	2515.67	-6.886e+04	-9594.04	-5.675e+04	2.679e+04
1	7	261	14.28	-7.33	13.28	-6.32	4.55	7002.88	-5.089e+04	-4406.97	-3.948e+04	2.303e+04
1	7	262	11.56	-5.79	11.29	-5.53	2.13	1.176e+04	-3.310e+04	1929.66	-2.326e+04	1.856e+04
1	7	263	9.03	-3.45	8.93	-3.35	1.14	2.844e+04	-8333.55	1.490e+04	5204.75	1.773e+04
1	7	264	6.55	-1.56	6.45	-1.46	0.87	8961.36	-1.227e+04	3495.76	-6804.14	9282.67

Parco Eolico "Bolina" – Progetto Definitivo
Relazione di calcolo preliminare delle fondazioni degli aerogeneratori G8 e G12

1	7	265	4.00	-2.97	3.22	-2.19	2.20	-13.28	-6376.59	-4542.35	-1847.53	2882.26
1	7	266	18.07	-15.53	14.66	-12.12	10.15	-3.418e+04	-1.795e+05	-6.272e+04	-1.510e+05	5.774e+04
1	7	267	20.59	-19.00	17.12	-15.54	11.19	-2.695e+04	-1.080e+05	-5.391e+04	-8.101e+04	3.817e+04
1	7	268	17.39	-11.91	14.93	-9.45	8.13	-1.777e+04	-7.586e+04	-4.008e+04	-5.355e+04	2.825e+04
1	7	269	12.94	-8.18	12.13	-7.37	4.04	-7080.05	-5.884e+04	-3.182e+04	-3.410e+04	2.585e+04
1	7	270	9.95	-5.15	9.77	-4.97	1.65	4972.71	-4.464e+04	-2.688e+04	-1.279e+04	2.379e+04
1	7	271	10.35	-4.00	10.25	-3.90	1.19	5857.15	-3.988e+04	-2.937e+04	-4648.17	1.924e+04
1	7	272	9.48	-3.07	9.31	-2.91	1.43	6976.29	-2.548e+04	-2.002e+04	1519.69	1.214e+04
1	7	273	7.18	-0.87	7.10	-0.79	0.82	270.76	-2.001e+04	-1.891e+04	-825.54	4585.55
1	7	274	22.46	-25.59	16.77	-19.90	15.53	-6.629e+04	-1.631e+05	-9.216e+04	-1.372e+05	4.284e+04
1	7	275	16.38	-19.19	11.75	-14.55	11.97	-2.384e+04	-9.533e+04	-5.871e+04	-6.046e+04	3.573e+04
1	7	276	13.61	-14.66	11.31	-12.36	7.73	-2.953e+04	-8.635e+04	-6.243e+04	-5.345e+04	2.805e+04
1	7	277	12.51	-11.31	11.33	-10.14	5.15	-1.726e+04	-6.562e+04	-5.276e+04	-3.013e+04	2.137e+04
1	7	278	12.15	-9.14	11.61	-8.60	3.34	-3603.14	-4.563e+04	-3.827e+04	-1.096e+04	1.597e+04
1	7	279	11.37	-5.38	11.12	-5.13	2.02	2.809e+04	-1.938e+04	-1.629e+04	2.500e+04	1.171e+04
1	7	280	10.62	-2.07	10.46	-1.91	1.42	4556.39	-2.466e+04	-2.267e+04	2565.33	7362.17
1	7	281	9.52	-1.01	9.24	-0.72	1.71	77.39	-2.255e+04	-2.253e+04	51.61	763.39
1	7	282	12.64	-28.47	6.18	-22.01	14.96	-1.042e+05	-1.866e+05	-1.421e+05	-1.487e+05	4.103e+04
1	7	283	12.63	-23.29	5.54	-16.20	14.30	-6.834e+04	-1.267e+05	-1.151e+05	-7.994e+04	2.330e+04
1	7	284	12.51	-20.92	7.25	-15.66	12.17	-4.042e+04	-9.502e+04	-8.905e+04	-4.638e+04	1.703e+04
1	7	285	12.55	-15.14	9.64	-12.23	8.49	-2.299e+04	-7.358e+04	-7.161e+04	-2.496e+04	9784.69
1	7	286	11.21	-10.15	9.49	-8.43	5.82	-1370.71	-5.916e+04	-5.898e+04	-1554.31	3252.20
1	7	287	13.01	-6.60	11.59	-5.19	5.07	4498.93	-5.577e+04	-5.573e+04	4454.77	-1630.84
1	7	288	13.24	-3.89	11.92	-2.57	4.57	7906.11	-3.889e+04	-3.866e+04	7672.23	-3300.03
1	7	289	14.12	-1.11	12.82	0.20	4.26	362.66	-3.241e+04	-3.137e+04	-679.62	-5750.85
1	7	290	1.76	-32.71	-6.84	-24.11	14.91	-1.220e+05	-1.662e+05	-1.550e+05	-1.333e+05	1.929e+04
1	7	291	8.76	-33.11	-2.81	-21.54	18.72	-8.250e+04	-1.258e+05	-1.249e+05	-8.339e+04	6135.08
1	7	292	12.68	-24.27	3.25	-14.84	16.11	-5.051e+04	-9.622e+04	-9.607e+04	-5.066e+04	-2619.01
1	7	293	13.51	-18.26	6.43	-11.18	13.22	-2.816e+04	-7.291e+04	-7.192e+04	-2.915e+04	-6589.42
1	7	294	14.50	-14.09	8.85	-8.45	11.38	-8755.73	-5.091e+04	-4.937e+04	-1.030e+04	-7921.96
1	7	295	14.87	-8.29	10.59	-4.01	8.99	3.074e+04	-2.332e+04	-1.974e+04	2.715e+04	-1.346e+04
1	7	296	15.44	-3.26	12.21	-3.12e-02	7.06	4158.47	-2.927e+04	-2.712e+04	2014.75	-8188.76
1	7	297	15.88	-1.44	12.47	1.97	6.89	-16.68	-2.842e+04	-2.457e+04	-3866.88	-9722.74
1	7	298	20.20	-44.27	-14.52	-9.54	32.14	-1.226e+05	-1.615e+05	-1.536e+05	-1.305e+05	1.563e+04
1	7	299	15.52	-35.53	-8.90	-11.10	25.50	-7.845e+04	-1.144e+05	-1.121e+05	-8.075e+04	-8808.32
1	7	300	13.35	-25.91	-2.87	-9.69	19.33	-4.616e+04	-8.365e+04	-7.406e+04	-5.575e+04	-1.636e+04
1	7	301	14.41	-19.38	1.04	-6.02	16.52	-2.652e+04	-6.778e+04	-5.765e+04	-3.665e+04	-1.776e+04
1	7	302	13.92	-13.21	3.32	-2.61	13.24	-2528.14	-5.781e+04	-4.423e+04	-1.611e+04	-2.380e+04
1	7	303	16.79	-8.76	7.78	0.25	12.20	3153.94	-5.683e+04	-4.206e+04	-1.161e+04	-2.584e+04
1	7	304	17.87	-4.88	10.65	2.34	10.59	7820.18	-4.019e+04	-2.783e+04	-4541.72	-2.099e+04
1	7	305	20.18	-1.35	12.77	6.06	10.23	309.61	-3.450e+04	-2.396e+04	-1.023e+04	-1.599e+04
1	7	306	17.11	-47.39	-20.88	-9.41	31.73	-1.152e+05	-1.243e+05	-1.199e+05	-1.197e+05	4557.19
1	7	307	13.95	-33.31	-13.94	-5.42	23.24	-4.277e+04	-6.666e+04	-5.459e+04	-5.484e+04	-1.194e+04
1	7	308	14.40	-24.23	-7.22	-2.62	19.18	-4.513e+04	-6.883e+04	-5.697e+04	-5.699e+04	-1.185e+04
1	7	309	15.81	-19.57	-3.82	5.95e-02	17.58	-2.481e+04	-5.900e+04	-4.187e+04	-4.194e+04	-1.710e+04
1	7	310	17.75	-16.18	-0.69	2.26	16.90	-7279.21	-4.229e+04	-2.474e+04	-2.483e+04	-1.750e+04
1	7	311	18.69	-9.83	3.24	5.62	14.21	3.166e+04	-1.757e+04	7157.52	6927.88	-2.461e+04
1	7	312	19.82	-3.59	7.99	8.23	11.70	4089.07	-2.421e+04	-1.003e+04	-1.009e+04	-1.415e+04
1	7	313	20.53	-1.59	8.87	10.08	11.04	-232.20	-2.535e+04	-1.277e+04	-1.281e+04	-1.256e+04
1	7	314	20.11	-50.21	-24.58	-5.52	33.85	-1.227e+05	-1.616e+05	-1.305e+05	-1.538e+05	1.562e+04
1	7	315	18.78	-43.05	-24.13	-0.14	28.49	-7.813e+04	-1.148e+05	-8.049e+04	-1.124e+05	-8993.50
1	7	316	17.67	-30.80	-15.54	2.40	22.52	-4.629e+04	-8.408e+04	-5.623e+04	-7.414e+04	-1.663e+04
1	7	317	16.79	-23.00	-11.90	5.70	17.84	-2.650e+04	-6.785e+04	-3.661e+04	-5.775e+04	-1.777e+04
1	7	318	16.30	-15.73	-7.55	8.12	13.97	-2448.74	-5.782e+04	-1.583e+04	-4.443e+04	-2.371e+04
1	7	319	20.11	-10.85	-1.79	11.05	14.08	3280.15	-5.688e+04	-1.145e+04	-4.215e+04	-2.587e+04
1	7	320	22.29	-6.07	3.53	12.69	13.42	7862.35	-4.029e+04	-4655.98	-2.777e+04	-2.112e+04
1	7	321	24.87	-1.49	6.44	16.94	12.09	301.95	-3.457e+04	-1.027e+04	-2.400e+04	-1.603e+04
1	7	322	2.41	-49.73	-46.33	-0.99	12.88	-1.221e+05	-1.662e+05	-1.333e+05	-1.549e+05	1.925e+04
1	7	323	11.59	-50.41	-42.68	3.86	20.48	-8.253e+04	-1.258e+05	-8.339e+04	-1.249e+05	6021.13
1	7	324	17.30	-36.29	-29.30	10.31	18.04	-5.045e+04	-9.632e+04	-5.061e+04	-9.616e+04	-2728.09
1	7	325	18.67	-27.23	-21.47	12.90	15.21	-2.801e+04	-7.301e+04	-2.902e+04	-7.199e+04	-6668.16
1	7	326	20.59	-21.34	-16.20	15.45	13.75	-8422.44	-5.100e+04	-9999.01	-4.943e+04	-8040.33
1	7	327	21.35	-12.60	-8.42	17.18	11.15	3.100e+04	-2.334e+04	2.745e+04	-1.979e+04	-1.343e+04
1	7	328	22.79	-4.51	-0.45	18.73	9.72	4082.97	-2.929e+04	1980.83	-2.719e+04	-8108.18
1	7	329	24.06	-1.98	1.77	20.31	9.14	-0.37	-2.844e+04	-3834.30	-2.460e+04	-9712.49
1	7	330	19.27	-56.38	-55.29	18.17	9.03	-1.040e+05	-1.865e+05	-1.485e+05	-1.420e+05	4.113e+04
1	7	331	16.55	-44.54	-43.19	15.21	8.97	-6.849e+04	-1.265e+05	-7.999e+04	-1.150e+05	2.312e+04
1	7	332	17.54	-37.57	-35.76	15.72	9.84	-4.035e+04	-9.496e+04	-4.624e+04	-8.907e+04	1.694e+04
1	7	333	19.16	-28.18	-27.10	18.08	7.06	-2.280e+04	-7.361e+04	-2.476e+04	-7.166e+04	9769.91
1	7	334	18.70	-19.43	-18.90	18.16	4.48	-1095.20	-5.920e+04	-1295.35	-5.900e+04	3404.26
1	7	335	22.41	-13.17	-12.07	21.30	6.17	4771.16	-5.587e+04	4726.06	-5.583e+04	-1653.14
1	7	336	24.73	-7.19	-5.24	22.77	7.66	7977.73	-3.899e+04	7720.88	-3.874e+04	-3463.83
1	7	337	26.94	-1.75	-0.48	25.67	5.90	344.09	-3.250e+04	-702.56	-3.145e+04	-5768.70

Parco Eolico "Bolina" – Progetto Definitivo
Relazione di calcolo preliminare delle fondazioni degli aerogeneratori G8 e G12

1	23	1	16.50	-39.11	0.82	-23.43	-25.02	5.425e+04	-1.070e+05	5.388e+04	-1.067e+05	-7626.62
1	23	2	18.04	-37.47	10.06	-29.49	-19.47	5.553e+04	-1.600e+05	5.476e+04	-1.592e+05	1.284e+04
1	23	3	23.30	-22.97	11.88	-11.55	-19.95	4.409e+04	-1.107e+05	4.375e+04	-1.104e+05	-7299.13
1	23	4	22.09	-27.99	8.06	-13.96	-22.49	1.053e+05	-1.156e+05	1.034e+05	-1.136e+05	-2.062e+04
1	23	5	17.60	-10.52	10.44	-3.37	-12.25	6.738e+04	-6.087e+04	6.045e+04	-5.394e+04	-2.900e+04
1	23	6	27.11	-26.04	14.53	-13.46	-22.59	1.187e+05	-5.611e+04	1.043e+05	-4.175e+04	-4.799e+04
1	23	7	9.99	-10.67	6.25	-6.92	-7.96	1.256e+05	-3.458e+04	1.193e+05	-2.826e+04	-3.118e+04
1	23	8	20.33	-19.36	10.22	-9.25	-17.30	1.434e+05	-2.135e+04	1.103e+05	1.175e+04	-6.600e+04
1	23	9	6.47	-19.36	-2.08	-10.80	-12.16	1.574e+05	1.726e+04	1.055e+05	6.913e+04	-6.766e+04
1	23	10	26.63	-20.50	18.59	-12.45	-17.73	1.920e+05	2.273e+04	1.499e+05	6.481e+04	-7.315e+04
1	23	11	8.34	-21.37	0.81	-13.83	-12.93	1.674e+05	6.576e+04	1.350e+05	9.815e+04	-4.736e+04
1	23	12	28.16	-23.40	10.10	-5.34	-24.60	1.883e+05	4.220e+04	1.424e+05	8.803e+04	-6.778e+04
1	23	13	14.89	-29.30	-4.49	-9.91	-21.93	2.039e+05	6.223e+04	1.419e+05	1.242e+05	-7.027e+04
1	23	14	37.47	-26.24	7.35	3.88	-31.81	2.090e+05	9.752e+04	1.542e+05	1.523e+05	-5.572e+04
1	23	15	36.15	-33.40	-3.06	5.82	-34.49	2.260e+05	1.135e+05	1.696e+05	1.698e+05	-5.625e+04
1	23	16	47.74	-23.68	14.61	9.45	-35.62	1.757e+05	9.907e+04	1.403e+05	1.345e+05	-3.820e+04
1	23	17	53.69	-21.39	-8.10e-02	32.38	-33.85	1.757e+05	9.913e+04	1.343e+05	1.406e+05	-3.816e+04
1	23	18	64.44	-18.72	16.87	28.85	-41.14	1.829e+05	7.977e+04	1.313e+05	1.314e+05	-5.158e+04
1	23	19	20.56	-32.64	16.64	-28.72	-13.89	-1.795e+04	-1.724e+05	-2.716e+04	-1.631e+05	3.656e+04
1	23	20	25.11	-12.24	19.81	-6.95	-13.03	-2620.61	-1.201e+05	-4244.30	-1.185e+05	1.372e+04
1	23	21	13.20	-2.88	12.37	-2.05	-3.56	6.243e+04	-1.191e+05	6.237e+04	-1.190e+05	-3379.68
1	23	22	9.66	-8.80	5.74	-4.88	-7.55	9.831e+04	-4.497e+04	9.315e+04	-3.981e+04	-2.670e+04
1	23	23	4.79	-13.69	-1.17	-7.73	-8.64	1.707e+05	2.789e+04	1.400e+05	5.861e+04	-5.867e+04
1	23	24	8.90	-22.07	-2.18	-11.00	-14.85	2.056e+05	7.541e+04	1.585e+05	1.226e+05	-6.258e+04
1	23	25	-1.91	-15.76	-11.42	-6.25	-6.42	1.888e+05	8.495e+04	1.367e+05	1.370e+05	-5.193e+04
1	23	26	17.14	-34.39	-19.24	1.98	-23.48	2.039e+05	6.235e+04	1.422e+05	1.422e+05	-7.020e+04
1	23	27	45.09	-25.13	-9.90	29.86	-28.94	2.090e+05	9.775e+04	1.523e+05	1.545e+05	-5.561e+04
1	23	28	26.23	-29.78	23.99	-27.54	-10.99	-4.523e+04	-1.917e+05	-6.764e+04	-1.693e+05	5.273e+04
1	23	29	32.54	-11.04	30.98	-9.47	-8.11	-2.475e+04	-1.795e+05	-2.800e+04	-1.763e+05	2.219e+04
1	23	30	25.47	-8.00	21.74	-4.28	-10.53	-1.926e+04	-1.540e+05	-2.128e+04	-1.520e+05	1.636e+04
1	23	31	10.96	-3.65	9.33	-2.01	-4.61	3.530e+04	-1.004e+05	3.507e+04	-1.001e+05	-5544.13
1	23	32	3.29	-8.04	-0.81	-3.93	-5.44	1.892e+05	1202.60	1.779e+05	1.254e+04	-4.475e+04
1	23	33	2.25	-15.97	-7.57	-6.14	-9.08	2.607e+05	5.903e+04	1.598e+05	1.600e+05	-1.008e+05
1	23	34	11.45	-32.07	-21.16	0.54	-18.86	2.058e+05	7.560e+04	1.225e+05	1.588e+05	-6.250e+04
1	23	35	14.69	-38.78	-33.24	9.15	-16.29	1.676e+05	6.597e+04	9.816e+04	1.354e+05	-4.727e+04
1	23	36	41.03	-32.15	-22.94	31.82	-24.27	1.883e+05	4.249e+04	8.811e+04	1.427e+05	-6.762e+04
1	23	37	40.29	-52.64	40.26	-52.61	-1.42	-9.813e+04	-2.432e+05	-1.260e+05	-2.153e+05	5.719e+04
1	23	38	34.05	6.46	33.96	6.55	-1.55	-8.593e+04	-1.975e+05	-1.324e+05	-1.510e+05	5.500e+04
1	23	39	24.09	3.72	24.02	3.79	-1.18	-9.981e+04	-2.190e+05	-1.222e+05	-1.967e+05	4.653e+04
1	23	40	12.06	2.55	12.05	2.56	0.26	-7.300e+04	-2.518e+05	-7.886e+04	-2.459e+05	3.183e+04
1	23	41	0.17	-0.19	6.77e-03	-2.46e-02	0.18	-3.229e+04	-4.558e+04	-3.894e+04	-3.893e+04	-6645.57
1	23	42	-1.01	-13.94	-12.30	-2.65	-4.30	1.899e+05	1446.49	1.269e+04	1.786e+05	-4.463e+04
1	23	43	-0.68	-28.49	-25.18	-3.99	-9.00	1.710e+05	2.837e+04	5.890e+04	1.405e+05	-5.851e+04
1	23	44	-3.16	-39.80	-35.81	-7.14	-11.41	1.575e+05	1.777e+04	6.944e+04	1.059e+05	-6.747e+04
1	23	45	62.28	-44.17	-42.48	60.58	-13.32	1.922e+05	2.322e+04	6.511e+04	1.503e+05	-7.296e+04
1	23	46	26.29	-29.96	25.06	-28.74	8.20	-1.130e+05	-2.288e+05	-1.416e+05	-2.001e+05	4.997e+04
1	23	47	34.47	-10.29	33.42	-9.24	6.78	-1.308e+05	-2.125e+05	-1.08e+05	-1.925e+05	3.510e+04
1	23	48	30.84	-8.52	27.47	-5.14	11.02	-1.471e+05	-2.512e+05	-1.817e+05	-2.167e+05	4.901e+04
1	23	49	19.06	-6.23	15.96	-3.13	8.29	-1.369e+05	-3.097e+05	-2.232e+05	-2.234e+05	8.640e+04
1	23	50	10.96	-5.42	1.01	4.53	8.00	-7.278e+04	-2.511e+05	-2.452e+05	-7.870e+04	3.195e+04
1	23	51	13.13	-18.70	-18.22	12.65	3.88	3.592e+04	-9.972e+04	-9.952e+04	3.572e+04	-5246.10
1	23	52	11.13	-30.64	-30.32	10.81	3.64	9.882e+04	-4.442e+04	-3.933e+04	9.372e+04	-2.653e+04
1	23	53	13.65	-35.06	-35.05	13.64	-0.70	1.260e+05	-3.414e+04	-2.787e+04	1.197e+05	-3.105e+04
1	23	54	34.79	-28.07	-27.91	34.63	-3.14	1.436e+05	-2.092e+04	1.203e+04	1.106e+05	-6.584e+04
1	23	55	20.54	-33.28	17.56	-30.29	12.31	-1.720e+05	-2.510e+05	-2.131e+05	-2.099e+05	3.947e+04
1	23	56	29.81	-13.85	23.76	-7.80	15.10	-1.318e+05	-2.461e+05	-1.805e+05	-1.975e+05	5.653e+04
1	23	57	16.84	-1.30	15.18	0.35	5.22	-1.573e+05	-2.295e+05	-1.933e+05	-1.935e+05	3.614e+04
1	23	58	21.86	-12.02	7.67	2.17	16.72	-1.469e+05	-2.510e+05	-2.163e+05	-1.817e+05	4.908e+04
1	23	59	21.12	-9.95	1.54	9.62	15.00	-9.934e+04	-2.187e+05	-1.962e+05	-1.219e+05	4.669e+04
1	23	60	19.87	-13.76	-11.00	17.11	9.22	-1.872e+04	-1.535e+05	-1.515e+05	-2.078e+04	1.652e+04
1	23	61	10.70	-16.80	-16.61	10.51	2.31	6.293e+04	-1.186e+05	-1.186e+05	6.287e+04	-3235.29
1	23	62	18.30	-26.49	-25.65	17.45	6.10	6.774e+04	-6.040e+04	-5.354e+04	6.088e+04	-2.884e+04
1	23	63	41.32	-25.28	-25.22	41.25	-2.10	1.190e+05	-5.558e+04	-4.128e+04	1.047e+05	-4.788e+04
1	23	64	18.67	-37.73	8.98	-28.04	21.28	-1.709e+05	-2.105e+05	-1.877e+05	-1.936e+05	1.956e+04
1	23	65	27.62	-26.11	12.79	-11.27	24.02	-1.820e+05	-2.736e+05	-2.277e+05	-2.279e+05	4.582e+04
1	23	66	25.89	-11.92	11.21	2.76	18.43	-1.317e+05	-2.461e+05	-1.973e+05	-1.805e+05	5.660e+04
1	23	67	23.33	-11.00	1.05	11.28	16.38	-1.306e+05	-2.123e+05	-1.922e+05	-1.508e+05	3.519e+04
1	23	68	27.64	-10.65	2.79	14.20	18.28	-8.541e+04	-1.973e+05	-1.506e+05	-1.321e+05	5.520e+04
1	23	69	19.56	-12.17	-7.59	14.98	11.15	-2.431e+04	-1.791e+05	-1.758e+05	-2.760e+04	2.233e+04
1	23	70	17.86	-19.26	-16.54	15.14	9.67	-2168.58	-1.197e+05	-1.181e+05	-3829.23	1.387e+04
1	23	71	26.30	-23.89	-21.23	23.64	11.24	4.460e+04	-1.102e+05	-1.098e+05	4.426e+04	-7210.48
1	23	72	38.52	-19.63	-18.56	37.45	7.82	1.056e+05	-1.153e+05	-1.133e+05	1.037e+05	-2.059e+04
1	23	73	14.45	-42.86	-6.11	-22.29	27.49	-1.446e+05	-2.172e+05	-1.808e+05	-1.810e+05	3.629e+04

Parco Eolico "Bolina" – Progetto Definitivo
Relazione di calcolo preliminare delle fondazioni degli aerogeneratori G8 e G12

1	23	74	17.86	-32.28	-3.54	-10.87	24.80	-1.709e+05	-2.104e+05	-1.933e+05	-1.879e+05	1.959e+04
1	23	75	24.97	-29.37	0.28	-4.67	27.06	-1.718e+05	-2.510e+05	-2.097e+05	-2.131e+05	3.957e+04
1	23	76	24.65	-24.52	-7.06	7.19	23.53	-1.127e+05	-2.287e+05	-1.999e+05	-1.415e+05	5.014e+04
1	23	77	26.47	-27.72	-18.84	17.59	20.06	-9.765e+04	-2.431e+05	-2.150e+05	-1.257e+05	5.740e+04
1	23	78	23.77	-21.26	-13.21	15.72	17.25	-4.481e+04	-1.915e+05	-1.690e+05	-6.734e+04	5.289e+04
1	23	79	30.11	-29.76	-22.47	22.82	19.58	-1.742e+04	-1.720e+05	-1.627e+05	-2.668e+04	3.667e+04
1	23	80	27.04	-21.43	-17.53	23.15	13.18	5.583e+04	-1.597e+05	-1.590e+05	5.506e+04	1.286e+04
1	23	81	31.10	-12.93	-9.01	27.18	12.53	5.444e+04	-1.068e+05	-1.065e+05	5.408e+04	-7647.64
1	23	82	28.59	-32.67	-22.89	18.81	22.43	-6.630e+04	-1.631e+05	-1.372e+05	-9.219e+04	4.284e+04
1	23	83	22.61	-22.73	-17.37	17.24	14.64	-3.420e+04	-1.795e+05	-1.510e+05	-6.274e+04	5.773e+04
1	23	84	20.39	-24.09	-16.61	12.91	16.64	-2.383e+04	-9.532e+04	-6.043e+04	-5.873e+04	3.574e+04
1	23	85	24.86	-26.09	-21.08	19.85	15.16	-2.695e+04	-1.080e+05	-8.098e+04	-5.393e+04	3.818e+04
1	23	86	16.36	-17.93	-13.95	12.38	10.98	-2.953e+04	-8.636e+04	-5.344e+04	-6.244e+04	2.806e+04
1	23	87	20.63	-16.34	-13.16	17.46	10.35	-1.778e+04	-7.586e+04	-5.353e+04	-4.011e+04	2.826e+04
1	23	88	14.57	-13.45	-11.40	12.52	7.30	-1.725e+04	-6.564e+04	-3.011e+04	-5.277e+04	2.138e+04
1	23	89	15.48	-11.06	-9.93	14.35	5.35	-7066.64	-5.884e+04	-3.407e+04	-3.184e+04	2.586e+04
1	23	90	13.89	-10.55	-9.60	12.93	4.74	-3568.65	-4.565e+04	-1.093e+04	-3.829e+04	1.598e+04
1	23	91	12.09	-6.97	-6.66	11.78	2.42	4990.44	-4.465e+04	-1.277e+04	-2.689e+04	2.379e+04
1	23	92	12.98	-6.19	-5.75	12.53	2.88	2.812e+04	-1.939e+04	2.503e+04	-1.630e+04	1.171e+04
1	23	93	12.34	-5.10	-4.97	12.22	1.48	5880.82	-3.990e+04	-4624.72	-2.939e+04	1.925e+04
1	23	94	12.20	-2.38	-2.14	11.96	1.83	4554.29	-2.467e+04	2559.79	-2.267e+04	7369.18
1	23	95	11.39	-3.49	-3.37	11.28	1.31	6992.89	-2.551e+04	1523.02	-2.004e+04	1.216e+04
1	23	96	11.10	-1.06	-0.78	10.82	1.82	78.62	-2.256e+04	52.86	-2.254e+04	763.17
1	23	97	9.15	-0.84	-0.81	9.12	0.54	269.58	-2.003e+04	-827.95	-1.893e+04	4590.16
1	23	98	21.81	-13.74	-11.02	19.09	9.45	-4900.01	-1.169e+05	-1.131e+05	-8685.46	2.024e+04
1	23	99	22.89	-17.41	-14.97	20.46	9.60	-3253.40	-9.174e+04	-8.075e+04	-1.425e+04	2.919e+04
1	23	100	20.25	-13.78	-11.97	18.43	7.64	2509.44	-6.885e+04	-5.672e+04	-9619.85	2.680e+04
1	23	101	16.67	-10.12	-9.36	15.91	4.45	7008.82	-5.089e+04	-3.945e+04	-4426.66	2.305e+04
1	23	102	13.76	-7.74	-7.60	13.62	1.75	1.179e+04	-3.309e+04	-2.322e+04	1915.64	1.859e+04
1	23	103	11.06	-4.54	-4.52	11.03	0.64	2.846e+04	-8331.08	5239.17	1.489e+04	1.775e+04
1	23	104	8.43	-1.81	-1.80	8.42	0.26	8953.92	-1.229e+04	-6814.87	3483.45	9287.77
1	23	105	5.47	-2.48	-2.16	5.14	1.57	-12.15	-6391.32	-1847.12	-4556.36	2887.64
1	23	106	31.31	-21.25	-16.97	27.03	14.37	2.363e+04	-9.650e+04	-9.508e+04	2.222e+04	1.297e+04
1	23	107	27.10	-15.25	-11.18	23.02	12.49	2.312e+04	-7.242e+04	-6.970e+04	2.041e+04	1.588e+04
1	23	108	22.14	-16.12	-13.74	19.76	9.24	2.705e+04	-5.484e+04	-5.214e+04	2.435e+04	1.463e+04
1	23	109	16.56	-9.33	-8.40	15.63	4.82	2.401e+04	-4.337e+04	-4.084e+04	2.149e+04	1.280e+04
1	23	110	11.91	-6.17	-5.51	11.25	3.40	2.322e+04	-3.064e+04	-2.696e+04	1.953e+04	1.360e+04
1	23	111	9.08	-5.44	-5.00	8.65	2.48	1.603e+04	-2.358e+04	-1.943e+04	1.188e+04	1.213e+04
1	23	112	6.54	-4.73	-4.19	6.00	2.40	1.258e+04	-1.089e+04	-8863.50	1.056e+04	6588.41
1	23	113	7.06	-6.64	-5.49	5.91	3.80	426.69	-1692.80	-1459.69	193.59	663.11
1	23	114	40.94	-21.69	-18.71	37.96	13.33	4.531e+04	-7.446e+04	-7.429e+04	4.514e+04	-4485.30
1	23	115	27.05	-13.50	-11.14	24.69	9.49	5.862e+04	-4.255e+04	-4.254e+04	5.861e+04	-1131.39
1	23	116	24.15	-13.26	-10.91	21.80	9.08	3.904e+04	-4.422e+04	-4.394e+04	3.875e+04	-4841.38
1	23	117	17.21	-10.89	-8.96	15.28	7.10	3.356e+04	-3.553e+04	-3.539e+04	3.342e+04	-3089.86
1	23	118	11.52	-9.86	-8.28	9.94	5.59	3.148e+04	-2.498e+04	-2.483e+04	3.132e+04	-2941.64
1	23	119	7.63	-9.54	-7.06	5.15	6.04	3.735e+04	-7598.98	-7598.85	3.735e+04	76.83
1	23	120	5.67	-10.01	-6.30	1.96	6.66	2.087e+04	-1.024e+04	-9581.16	2.021e+04	-4478.97
1	23	121	4.46	-10.31	-8.39	2.54	4.97	7258.49	-455.45	2256.15	4546.89	-3682.98
1	23	122	43.41	-18.62	-14.52	39.31	15.41	6.823e+04	-7.338e+04	-6.981e+04	6.466e+04	-2.222e+04
1	23	123	35.06	-16.08	-13.60	32.58	10.98	6.079e+04	-5.675e+04	-5.462e+04	5.866e+04	-1.568e+04
1	23	124	33.65	-15.12	-14.04	32.56	7.21	4.523e+04	-3.958e+04	-3.741e+04	4.306e+04	-1.338e+04
1	23	125	23.33	-15.28	-13.20	21.25	8.72	3.943e+04	-3.447e+04	-3.161e+04	3.657e+04	-1.424e+04
1	23	126	15.95	-14.74	-12.08	13.30	8.63	3.480e+04	-2.802e+04	-2.610e+04	3.288e+04	-1.083e+04
1	23	127	9.68	-14.65	-11.87	6.91	7.73	2.591e+04	-2.404e+04	-2.291e+04	2.479e+04	-7414.59
1	23	128	5.38	-15.09	-12.45	2.73	6.87	1.827e+04	-1.378e+04	-1.280e+04	1.729e+04	-5522.08
1	23	129	1.75	-14.88	-11.98	-1.15	6.31	2794.80	-375.28	460.36	1959.15	-1396.69
1	23	130	51.58	-11.00	-10.91	51.49	2.38	8.537e+04	-5.190e+04	-4.636e+04	7.984e+04	-2.701e+04
1	23	131	53.01	-16.26	-15.67	52.42	6.36	7.497e+04	-4.344e+04	-3.327e+04	6.480e+04	-3.317e+04
1	23	132	38.57	-18.47	-18.09	38.19	4.66	5.841e+04	-3.701e+04	-2.685e+04	4.824e+04	-2.944e+04
1	23	133	28.55	-17.91	-17.42	28.06	4.73	4.542e+04	-3.133e+04	-2.147e+04	3.556e+04	-2.568e+04
1	23	134	19.75	-17.42	-16.62	18.95	5.38	3.690e+04	-2.500e+04	-1.596e+04	2.785e+04	-2.186e+04
1	23	135	12.52	-17.50	-16.16	11.17	6.21	3.578e+04	-1.351e+04	-7156.28	2.943e+04	-1.651e+04
1	23	136	6.55	-18.08	-16.21	4.69	6.52	1.958e+04	-1.399e+04	-7652.82	1.324e+04	-1.314e+04
1	23	137	1.92	-19.21	-17.42	0.13	5.89	3921.85	-304.06	1867.63	1750.16	-2112.14
1	23	138	60.11	-24.77	-24.68	60.01	-2.86	1.456e+05	-2.374e+04	8561.07	1.133e+05	-6.652e+04
1	23	139	59.62	-26.97	-26.25	58.89	-7.92	9.267e+04	-2.170e+04	1598.25	6.937e+04	-4.606e+04
1	23	140	43.63	-22.33	-21.93	43.23	-5.12	6.921e+04	-2.338e+04	-433.53	4.626e+04	-3.998e+04
1	23	141	32.81	-19.89	-19.83	32.75	-1.70	5.065e+04	-2.365e+04	-2779.28	2.978e+04	-3.339e+04
1	23	142	23.44	-19.24	-19.24	23.43	0.52	3.820e+04	-2.168e+04	-4713.51	2.123e+04	-2.698e+04
1	23	143	15.25	-19.65	-19.57	15.17	1.65	2.589e+04	-1.989e+04	-7344.97	1.334e+04	-2.042e+04
1	23	144	7.99	-20.29	-20.18	7.87	1.81	1.669e+04	-1.285e+04	-4091.72	7932.73	-1.349e+04
1	23	145	3.09	-20.57	-20.33	2.85	2.38	2569.53	-430.94	1246.06	892.52	-1489.78
1	23	146	73.60	-43.67	-41.17	71.10	-16.95	1.341e+05	9548.82	4.606e+04	9.760e+04	-5.670e+04

Parco Eolico "Bolina" – Progetto Definitivo
Relazione di calcolo preliminare delle fondazioni degli aerogeneratori G8 e G12

1	23	147	55.18	-24.48	-21.83	52.53	-14.27	1.111e+05	9077.35	4.499e+04	7.521e+04	-4.873e+04
1	23	148	46.83	-21.72	-19.89	45.00	-11.05	7.333e+04	-6345.58	2.899e+04	3.799e+04	-3.958e+04
1	23	149	36.60	-21.19	-19.89	35.29	-8.57	5.146e+04	-1.165e+04	1.898e+04	2.082e+04	-3.154e+04
1	23	150	27.16	-21.41	-20.63	26.38	-6.11	3.691e+04	-1.305e+04	1.304e+04	1.082e+04	-2.495e+04
1	23	151	17.57	-21.50	-21.13	17.20	-3.77	3.009e+04	-8682.70	1.133e+04	1.007e+04	-1.937e+04
1	23	152	8.64	-21.83	-21.69	8.50	-2.05	1.663e+04	-1.008e+04	5684.43	868.01	-1.313e+04
1	23	153	3.75	-21.46	-21.34	3.63	-1.75	4645.38	13.92	4309.14	350.15	-1201.75
1	23	154	71.67	-23.62	-17.94	65.99	-22.56	1.633e+05	3.648e+04	8.890e+04	1.108e+05	-6.243e+04
1	23	155	61.23	-21.74	-15.95	55.44	-21.14	1.048e+05	2.221e+04	6.160e+04	6.537e+04	-4.123e+04
1	23	156	53.00	-21.64	-15.10	46.46	-21.10	6.915e+04	1.136e+04	4.580e+04	3.472e+04	-2.836e+04
1	23	157	40.26	-22.48	-17.68	35.46	-16.68	4.844e+04	362.02	3.306e+04	1.575e+04	-2.243e+04
1	23	158	28.96	-22.16	-18.71	25.51	-12.82	3.369e+04	-5490.53	2.246e+04	5741.09	-1.772e+04
1	23	159	19.18	-23.03	-20.35	16.50	-10.28	2.139e+04	-8447.99	1.332e+04	-384.31	-1.325e+04
1	23	160	9.97	-23.63	-21.44	7.78	-8.30	1.325e+04	-6289.19	8886.90	-1928.20	-8135.28
1	23	161	3.94	-23.26	-21.69	2.37	-6.35	5021.41	221.25	5020.85	221.80	51.52
1	23	162	70.80	-2.77	5.75	62.28	-23.54	1.384e+05	6.081e+04	1.000e+05	9.921e+04	-3.880e+04
1	23	163	73.90	-16.55	-1.22	58.58	-33.93	9.588e+04	3.984e+04	7.374e+04	6.198e+04	-2.740e+04
1	23	164	55.02	-23.30	-9.18	40.90	-30.11	6.371e+04	2.345e+04	5.343e+04	3.372e+04	-1.755e+04
1	23	165	41.68	-23.59	-12.07	30.16	-24.89	4.271e+04	1.076e+04	3.811e+04	1.536e+04	-1.122e+04
1	23	166	30.91	-23.85	-14.56	21.62	-20.56	2.896e+04	2700.12	2.691e+04	4750.19	-7045.34
1	23	167	19.81	-23.67	-16.59	12.74	-16.05	2.148e+04	613.68	2.025e+04	1840.06	-4907.61
1	23	168	9.46	-23.87	-18.52	4.10	-12.24	1.250e+04	-3221.16	1.224e+04	-2963.15	-1997.11
1	23	169	4.11	-23.14	-18.77	-0.25	-9.99	7175.59	322.75	6573.62	924.73	1939.81
1	23	170	76.03	-29.60	11.11	35.32	-51.41	1.359e+05	6.685e+04	1.046e+05	9.817e+04	-3.440e+04
1	23	171	66.87	-27.50	4.37	34.99	-44.63	8.350e+04	4.934e+04	7.131e+04	6.153e+04	-1.636e+04
1	23	172	50.89	-23.94	0.11	26.84	-34.95	5.420e+04	3.258e+04	5.111e+04	3.567e+04	-7563.95
1	23	173	38.92	-22.90	-3.89	19.91	-28.52	3.486e+04	1.859e+04	3.461e+04	1.884e+04	-2020.72
1	23	174	28.17	-22.30	-7.19	13.07	-23.11	2.284e+04	8594.11	2.284e+04	8599.80	284.51
1	23	175	18.96	-23.27	-10.27	5.96	-19.49	1.403e+04	2151.04	1.387e+04	2310.40	1366.71
1	23	176	10.04	-23.85	-12.87	-0.94	-15.86	9498.85	-36.16	8960.67	502.01	2200.43
1	23	177	3.92	-23.44	-15.06	-4.47	-12.62	7620.08	349.18	5633.91	2335.35	3239.81
1	23	178	72.09	-23.71	16.41	31.97	-47.26	1.072e+05	6.473e+04	8.585e+04	8.604e+04	-2.122e+04
1	23	179	53.28	-20.50	10.49	22.28	-36.41	7.308e+04	5.359e+04	6.339e+04	6.328e+04	-9741.04
1	23	180	44.25	-21.50	7.38	15.37	-32.64	3.982e+04	3.811e+04	3.894e+04	3.898e+04	-856.82
1	23	181	34.63	-21.53	3.33	9.76	-27.89	2.679e+04	2.215e+04	2.447e+04	2.447e+04	2319.70
1	23	182	26.30	-21.81	-0.12	4.61	-23.94	1.908e+04	1.092e+04	1.502e+04	1.499e+04	4077.48
1	23	183	17.28	-21.73	-3.82	-0.63	-19.44	1.461e+04	6246.37	1.048e+04	1.037e+04	4180.83
1	23	184	8.54	-21.79	-7.05	-6.20	-15.16	1.005e+04	410.86	5239.01	5216.90	4817.09
1	23	185	3.67	-20.75	-9.32	-7.76	-12.19	8774.70	324.24	4560.59	4538.35	4225.22
1	23	186	67.91	-29.19	15.53	23.19	-48.40	1.359e+05	6.677e+04	9.807e+04	1.046e+05	-3.442e+04
1	23	187	57.80	-23.71	17.74	16.36	-40.74	8.357e+04	4.923e+04	6.166e+04	7.114e+04	-1.650e+04
1	23	188	43.93	-18.89	16.19	8.85	-31.19	5.428e+04	3.213e+04	3.530e+04	5.111e+04	-7757.23
1	23	189	33.66	-19.26	10.84	3.57	-26.21	3.485e+04	1.859e+04	1.884e+04	3.459e+04	-2030.91
1	23	190	24.42	-18.77	6.25	-0.61	-21.32	2.277e+04	8750.98	8759.33	2.276e+04	342.09
1	23	191	15.98	-19.01	2.55	-5.58	-17.02	1.402e+04	2245.49	2398.92	1.386e+04	1335.20
1	23	192	8.37	-19.05	-1.01	-9.67	-13.01	9503.45	-49.34	453.91	9000.19	2134.07
1	23	193	3.55	-19.03	-4.71	-10.77	-10.88	7598.26	341.96	2321.16	5619.07	3231.78
1	23	194	51.28	-2.13	35.28	13.86	-24.46	1.384e+05	6.075e+04	9.909e+04	1.001e+05	-3.883e+04
1	23	195	52.59	-11.81	31.41	9.37	-30.26	9.595e+04	3.972e+04	6.192e+04	7.375e+04	-2.749e+04
1	23	196	40.02	-16.57	21.37	2.08	-26.60	6.377e+04	2.337e+04	3.372e+04	5.342e+04	-1.764e+04
1	23	197	30.16	-16.28	15.80	-1.93	-21.46	4.278e+04	1.079e+04	1.544e+04	3.812e+04	-1.128e+04
1	23	198	21.68	-15.84	11.01	-5.17	-16.93	2.904e+04	2871.84	4989.57	2.693e+04	-7137.18
1	23	199	13.95	-15.54	6.58	-8.18	-12.77	2.152e+04	825.99	2059.36	2.028e+04	-4898.85
1	23	200	7.10	-15.53	2.61	-11.04	-9.02	1.248e+04	-3244.13	-3004.76	1.224e+04	-1925.38
1	23	201	3.18	-15.37	-1.01	-11.18	-7.76	7208.27	337.80	952.46	6593.61	1960.92
1	23	202	42.58	-17.00	27.54	-1.96	-25.89	1.633e+05	3.659e+04	1.109e+05	8.898e+04	-6.238e+04
1	23	203	37.56	-16.39	21.95	-0.79	-24.46	1.050e+05	2.208e+04	6.529e+04	6.174e+04	-4.140e+04
1	23	204	34.04	-14.56	20.87	-1.39	-21.60	6.923e+04	1.135e+04	3.478e+04	4.580e+04	-2.841e+04
1	23	205	24.81	-13.51	16.04	-4.74	-16.10	4.851e+04	444.86	1.588e+04	3.307e+04	-2.244e+04
1	23	206	17.64	-12.47	11.66	-6.48	-12.02	3.370e+04	-5270.22	5914.77	2.252e+04	-1.763e+04
1	23	207	10.73	-11.46	7.37	-8.10	-7.95	2.146e+04	-8329.72	-173.59	1.330e+04	-1.328e+04
1	23	208	5.55	-11.03	3.75	-9.23	-5.16	1.330e+04	-6310.89	-1868.81	8855.73	-8208.00
1	23	209	2.81	-11.37	1.01	-9.58	-4.71	5000.20	203.12	203.65	4999.66	50.51
1	23	210	34.08	-23.99	20.78	-10.70	-24.40	1.343e+05	9229.63	9.771e+04	4.582e+04	-5.690e+04
1	23	211	29.86	-18.79	16.56	-5.49	-21.68	1.113e+05	9050.08	7.538e+04	4.494e+04	-4.879e+04
1	23	212	24.79	-14.25	16.64	-6.09	-15.87	7.329e+04	-6340.25	3.789e+04	2.906e+04	-3.957e+04
1	23	213	18.13	-11.23	12.31	-5.41	-11.71	5.155e+04	-1.160e+04	2.097e+04	1.898e+04	-3.156e+04
1	23	214	11.93	-9.06	8.09	-5.23	-8.11	3.711e+04	-1.284e+04	1.126e+04	1.301e+04	-2.496e+04
1	23	215	7.54	-7.67	5.78	-5.91	-4.86	3.025e+04	-8426.13	1.040e+04	1.143e+04	-1.933e+04
1	23	216	4.50	-7.02	4.06	-6.58	-2.20	1.660e+04	-1.009e+04	729.39	5776.86	-1.311e+04
1	23	217	2.28	-7.56	1.56	-6.84	-2.56	4706.02	43.17	369.78	4379.41	-1190.07
1	23	218	20.70	-19.99	10.76	-10.06	-17.48	1.456e+05	-2.406e+04	1.132e+05	8325.11	-6.667e+04
1	23	219	26.85	-22.19	14.87	-10.22	-21.07	9.268e+04	-2.183e+04	6.953e+04	1320.76	-4.599e+04

Parco Eolico "Bolina" – Progetto Definitivo
Relazione di calcolo preliminare delle fondazioni degli aerogeneratori G8 e G12

1	23	220	18.47	-15.90	9.45	-6.89	-15.12	6.935e+04	-2.371e+04	4.631e+04	-668.53	-4.017e+04
1	23	221	13.60	-11.65	7.37	-5.42	-10.89	5.078e+04	-2.358e+04	2.997e+04	-2766.97	-3.339e+04
1	23	222	9.35	-8.38	5.83	-4.86	-7.07	3.833e+04	-2.145e+04	2.142e+04	-4543.44	-2.693e+04
1	23	223	5.22	-5.30	3.08	-3.16	-4.23	2.605e+04	-1.977e+04	1.364e+04	-7362.28	-2.036e+04
1	23	224	3.30	-3.40	2.10	-2.20	-2.57	1.675e+04	-1.285e+04	8054.61	-4156.03	-1.348e+04
1	23	225	2.56	-3.24	1.81	-2.49	-1.95	2547.67	-455.23	866.15	1226.29	-1490.62
1	23	226	11.56	-24.19	1.62	-14.25	-16.02	8.530e+04	-5.212e+04	7.977e+04	-4.658e+04	-2.702e+04
1	23	227	16.36	-24.25	4.54	-12.44	-18.44	7.503e+04	-4.353e+04	6.489e+04	-3.340e+04	-3.315e+04
1	23	228	16.60	-19.97	5.35	-8.73	-16.87	5.851e+04	-3.701e+04	4.839e+04	-2.689e+04	-2.940e+04
1	23	229	13.12	-15.29	4.29	-6.46	-13.14	4.559e+04	-3.119e+04	3.582e+04	-2.142e+04	-2.559e+04
1	23	230	9.05	-11.42	1.59	-3.96	-9.85	3.723e+04	-2.470e+04	2.840e+04	-1.587e+04	-2.166e+04
1	23	231	5.55	-6.10	1.74	-2.29	-5.47	3.609e+04	-1.322e+04	2.983e+04	-6958.56	-1.641e+04
1	23	232	3.84	-1.53	2.98	-0.67	-1.97	1.956e+04	-1.402e+04	1.308e+04	-7548.58	-1.325e+04
1	23	233	2.38	-1.81	1.39	-0.81	-1.78	4025.69	-260.90	1787.85	1976.94	-2141.21
1	23	234	24.77	-38.90	8.36	-22.49	-27.85	6.817e+04	-7.330e+04	6.461e+04	-6.975e+04	-2.213e+04
1	23	235	19.91	-33.85	1.76	-15.70	-25.42	6.115e+04	-5.679e+04	5.905e+04	-5.468e+04	-1.560e+04
1	23	236	23.43	-25.83	11.06	-13.46	-21.36	4.501e+04	-3.938e+04	4.289e+04	-3.726e+04	-1.320e+04
1	23	237	14.03	-18.26	5.62	-9.85	-14.17	3.952e+04	-3.430e+04	3.669e+04	-3.147e+04	-1.417e+04
1	23	238	9.54	-12.21	3.82	-6.49	-9.58	3.501e+04	-2.783e+04	3.308e+04	-2.590e+04	-1.084e+04
1	23	239	8.03	-8.98	2.43	-3.39	-7.99	2.616e+04	-2.391e+04	2.509e+04	-2.284e+04	-7250.50
1	23	240	7.83	-4.71	3.93	-0.80	-5.81	1.832e+04	-1.372e+04	1.737e+04	-1.278e+04	-5409.74
1	23	241	7.10	-0.89	3.73	2.48	-3.95	2767.39	-403.16	1926.03	438.19	-1399.89
1	23	242	24.05	-48.28	6.56	-30.78	-30.97	4.531e+04	-7.437e+04	4.516e+04	-7.423e+04	-4165.29
1	23	243	17.76	-34.53	2.64	-19.42	-23.70	5.904e+04	-4.222e+04	5.903e+04	-4.221e+04	-876.68
1	23	244	17.29	-24.48	7.85	-15.05	-17.47	3.908e+04	-4.426e+04	3.876e+04	-4.395e+04	-5094.84
1	23	245	16.35	-21.26	5.91	-10.81	-16.84	3.374e+04	-3.536e+04	3.361e+04	-3.523e+04	-3036.66
1	23	246	15.66	-19.32	4.58	-8.23	-16.27	3.183e+04	-2.458e+04	3.171e+04	-2.446e+04	-2615.96
1	23	247	12.04	-11.63	4.38	-3.96	-11.08	3.776e+04	-7265.52	3.776e+04	-7264.56	207.77
1	23	248	9.39	-2.93	6.23	0.22	-5.38	2.093e+04	-1.032e+04	2.020e+04	-9592.11	-4717.04
1	23	249	7.59	-3.75	5.87	-2.03	-4.07	7486.88	-423.41	4683.73	2379.74	-3783.66
1	23	250	22.29	-50.45	1.33	-29.49	-32.94	2.376e+04	-9.657e+04	2.233e+04	-9.513e+04	1.307e+04
1	23	251	20.20	-41.89	5.49	-27.17	-26.40	2.319e+04	-7.213e+04	2.046e+04	-6.940e+04	1.590e+04
1	23	252	18.64	-34.56	8.92	-24.85	-20.55	2.727e+04	-5.488e+04	2.454e+04	-5.215e+04	1.472e+04
1	23	253	19.95	-26.32	9.49	-15.86	-19.35	2.425e+04	-4.323e+04	2.170e+04	-4.069e+04	1.285e+04
1	23	254	18.13	-18.72	8.62	-9.22	-16.12	2.354e+04	-3.047e+04	1.986e+04	-2.679e+04	1.361e+04
1	23	255	18.61	-14.80	10.75	-6.94	-14.17	1.629e+04	-2.339e+04	1.204e+04	-1.914e+04	1.227e+04
1	23	256	17.99	-8.41	13.18	-3.60	-10.19	1.259e+04	-1.071e+04	1.054e+04	-8658.52	6600.49
1	23	257	14.69	-4.37	12.55	-2.23	-6.02	419.05	-1665.11	216.51	-1462.57	617.33
1	23	258	8.60	-50.86	4.84	-47.10	-14.47	-5122.03	-1.169e+05	-8909.64	-1.131e+05	2.023e+04
1	23	259	17.50	-52.70	10.80	-46.00	-20.62	-3347.94	-9.167e+04	-1.437e+04	-8.065e+04	2.919e+04
1	23	260	21.70	-38.03	15.80	-32.13	-17.82	2525.54	-6.872e+04	-9640.47	-5.655e+04	2.681e+04
1	23	261	22.11	-29.58	16.18	-23.65	-16.47	7181.80	-5.069e+04	-4349.02	-3.916e+04	2.312e+04
1	23	262	22.81	-24.43	16.66	-18.28	-15.89	1.214e+04	-3.275e+04	2026.42	-2.263e+04	1.876e+04
1	23	263	21.47	-15.07	16.35	-9.95	-12.69	2.887e+04	-8091.53	1.514e+04	5633.49	1.786e+04
1	23	264	20.21	-5.27	17.29	-2.35	-8.12	8914.97	-1.224e+04	3628.96	-6955.08	9159.10
1	23	265	18.08	-3.03	16.34	-1.29	-5.80	23.97	-6231.95	-4395.07	-1812.91	2849.08
1	23	266	24.23	-54.28	22.24	-52.29	-12.34	-3.453e+04	-1.795e+05	-6.302e+04	-1.510e+05	5.762e+04
1	23	267	26.33	-50.07	25.06	-48.81	-9.76	-2.706e+04	-1.080e+05	-5.430e+04	-8.078e+04	3.825e+04
1	23	268	22.59	-35.24	21.81	-34.47	-6.67	-1.819e+04	-7.570e+04	-4.040e+04	-5.349e+04	2.800e+04
1	23	269	20.52	-27.61	18.66	-25.75	-9.27	-6975.86	-5.872e+04	-3.183e+04	-3.387e+04	2.585e+04
1	23	270	19.39	-19.67	16.86	-17.15	-9.61	5284.68	-4.456e+04	-2.670e+04	-1.258e+04	2.390e+04
1	23	271	22.05	-13.96	20.65	-12.56	-6.95	6166.76	-3.989e+04	-2.941e+04	-4310.36	1.931e+04
1	23	272	23.51	-7.55	23.17	-7.21	-3.24	7033.97	-2.549e+04	-2.015e+04	1693.41	1.205e+04
1	23	273	24.13	-1.68	23.59	-1.14	-3.68	243.91	-2.004e+04	-1.895e+04	-849.61	4580.79
1	23	274	39.98	-61.78	39.95	-61.75	-1.65	-6.668e+04	-1.629e+05	-9.245e+04	-1.371e+05	4.260e+04
1	23	275	21.60	-43.06	21.46	-42.92	-3.01	-2.383e+04	-9.520e+04	-5.879e+04	-6.024e+04	3.568e+04
1	23	276	18.50	-33.69	18.34	-33.53	-2.90	-2.953e+04	-8.639e+04	-6.239e+04	-5.353e+04	2.808e+04
1	23	277	19.52	-27.23	19.39	-27.10	-2.47	-1.715e+04	-6.557e+04	-5.279e+04	-2.993e+04	2.134e+04
1	23	278	21.42	-22.43	21.32	-22.33	-2.14	-3213.85	-4.556e+04	-3.832e+04	-1.045e+04	1.594e+04
1	23	279	21.73	-13.53	21.66	-13.45	-1.66	2.848e+04	-1.932e+04	-1.622e+04	2.538e+04	1.177e+04
1	23	280	22.34	-4.67	22.34	-4.67	5.63e-02	4443.45	-2.463e+04	-2.261e+04	2422.73	7393.47
1	23	281	22.99	-2.02	22.98	-2.01	0.51	101.64	-2.252e+04	-2.249e+04	74.31	785.81
1	23	282	18.78	-55.56	18.59	-55.37	3.72	-1.040e+05	-1.865e+05	-1.420e+05	-1.486e+05	4.113e+04
1	23	283	15.98	-44.54	15.69	-44.24	4.22	-6.850e+04	-1.265e+05	-1.150e+05	-8.001e+04	2.312e+04
1	23	284	16.93	-36.99	16.05	-36.11	6.85	-4.037e+04	-9.493e+04	-8.905e+04	-4.626e+04	1.693e+04
1	23	285	18.57	-27.73	18.03	-27.19	4.94	-2.282e+04	-7.359e+04	-7.164e+04	-2.478e+04	9764.09
1	23	286	18.03	-19.14	17.79	-18.90	2.97	-1112.64	-5.919e+04	-5.899e+04	-1312.53	3401.31
1	23	287	21.39	-12.81	20.60	-12.01	5.15	4753.47	-5.586e+04	-5.582e+04	4708.24	-1655.12
1	23	288	23.54	-6.95	21.78	-5.20	7.10	7967.44	-3.898e+04	-3.872e+04	7708.47	-3477.09
1	23	289	25.73	-1.71	24.54	-0.52	5.59	344.88	-3.249e+04	-3.144e+04	-701.99	-5768.62
1	23	290	3.52	-49.96	1.38	-47.82	10.49	-1.221e+05	-1.662e+05	-1.549e+05	-1.333e+05	1.925e+04
1	23	291	11.67	-50.27	6.25	-44.85	17.50	-8.255e+04	-1.258e+05	-1.249e+05	-8.340e+04	6021.07
1	23	292	17.01	-36.00	11.75	-30.74	15.85	-5.046e+04	-9.631e+04	-9.615e+04	-5.063e+04	-2730.29

Parco Eolico "Bolina" – Progetto Definitivo
Relazione di calcolo preliminare delle fondazioni degli aerogeneratori G8 e G12

1	23	293	18.25	-26.96	13.70	-22.41	13.60	-2.803e+04	-7.299e+04	-7.198e+04	-2.904e+04	-6670.82
1	23	294	20.04	-21.07	15.75	-16.78	12.56	-8445.01	-5.099e+04	-4.942e+04	-1.002e+04	-8042.32
1	23	295	20.71	-12.41	17.11	-8.81	10.31	3.098e+04	-2.334e+04	-1.978e+04	2.743e+04	-1.343e+04
1	23	296	22.06	-4.41	18.35	-0.71	9.19	4083.58	-2.929e+04	-2.718e+04	1977.48	-8115.03
1	23	297	23.31	-1.95	19.73	1.64	8.81	-0.96	-2.844e+04	-2.460e+04	-3834.77	-9712.11
1	23	298	19.95	-49.67	-0.35	-29.37	31.64	-1.227e+05	-1.616e+05	-1.537e+05	-1.305e+05	1.562e+04
1	23	299	18.89	-42.66	3.45	-27.22	26.68	-7.814e+04	-1.148e+05	-1.124e+05	-8.050e+04	-8993.24
1	23	300	17.50	-30.59	4.54	-17.64	21.34	-4.630e+04	-8.407e+04	-7.413e+04	-5.624e+04	-1.663e+04
1	23	301	16.66	-22.95	7.03	-13.32	16.99	-2.651e+04	-6.785e+04	-5.774e+04	-3.662e+04	-1.777e+04
1	23	302	16.15	-15.74	8.92	-8.51	13.35	-2455.16	-5.782e+04	-4.443e+04	-1.584e+04	-2.371e+04
1	23	303	19.79	-10.76	11.43	-2.41	13.62	3274.08	-5.688e+04	-4.215e+04	-1.146e+04	-2.587e+04
1	23	304	21.91	-5.99	12.68	3.23	13.12	7858.89	-4.029e+04	-2.776e+04	-4672.54	-2.113e+04
1	23	305	24.49	-1.48	16.73	6.28	11.89	302.17	-3.457e+04	-2.400e+04	-1.027e+04	-1.603e+04
1	23	306	18.40	-48.66	-4.26	-26.00	31.72	-1.152e+05	-1.243e+05	-1.197e+05	-1.199e+05	4557.14
1	23	307	14.75	-34.10	-2.15	-17.19	23.24	-4.277e+04	-6.666e+04	-5.483e+04	-5.460e+04	-1.194e+04
1	23	308	14.76	-24.60	-0.47	-9.37	19.17	-4.513e+04	-6.883e+04	-5.697e+04	-5.698e+04	-1.185e+04
1	23	309	16.02	-19.78	1.51	-5.27	17.58	-2.481e+04	-5.900e+04	-4.193e+04	-4.188e+04	-1.710e+04
1	23	310	17.85	-16.29	3.21	-1.65	16.89	-7279.25	-4.229e+04	-2.481e+04	-2.475e+04	-1.750e+04
1	23	311	18.75	-9.89	6.22	2.64	14.21	3.166e+04	-1.757e+04	6935.31	7149.96	-2.461e+04
1	23	312	19.82	-3.60	8.50	7.72	11.70	4089.06	-2.421e+04	-1.008e+04	-1.004e+04	-1.415e+04
1	23	313	20.53	-1.59	10.13	8.81	11.04	-232.20	-2.535e+04	-1.281e+04	-1.277e+04	-1.256e+04
1	23	314	22.91	-47.36	-4.75	-19.69	34.33	-1.226e+05	-1.615e+05	-1.305e+05	-4.523e+05	1.563e+04
1	23	315	17.11	-37.66	-8.05	-12.51	27.29	-7.844e+04	-1.144e+05	-8.074e+04	-1.121e+05	-8808.69
1	23	316	14.24	-26.86	-7.60	-5.02	20.51	-4.615e+04	-8.366e+04	-5.574e+04	-7.407e+04	-1.636e+04
1	23	317	15.04	-19.94	-4.60	-0.30	17.36	-2.651e+04	-6.778e+04	-3.664e+04	-5.766e+04	-1.776e+04
1	23	318	14.44	-13.58	-1.64	2.50	13.86	-2521.82	-5.781e+04	-1.610e+04	-4.523e+04	-2.380e+04
1	23	319	17.20	-8.94	0.86	7.40	12.66	3159.98	-5.683e+04	-1.160e+04	-4.207e+04	-2.584e+04
1	23	320	18.24	-4.94	2.64	10.65	10.88	7823.75	-4.020e+04	-4525.24	-2.785e+04	-2.099e+04
1	23	321	20.56	-1.37	6.22	12.98	10.43	309.39	-3.450e+04	-1.023e+04	-2.396e+04	-1.599e+04
1	23	322	2.62	-34.49	-22.65	-9.23	17.30	-1.220e+05	-1.663e+05	-1.333e+05	-1.550e+05	1.929e+04
1	23	323	10.53	-35.11	-19.38	-5.20	21.69	-8.248e+04	-1.258e+05	-8.337e+04	-1.249e+05	6135.03
1	23	324	14.01	-25.60	-13.39	1.80	18.29	-5.049e+04	-9.624e+04	-5.064e+04	-9.609e+04	-2616.93
1	23	325	14.50	-19.11	-10.24	5.63	14.82	-2.814e+04	-7.293e+04	-2.913e+04	-7.194e+04	-6586.88
1	23	326	15.34	-14.66	-7.87	8.54	12.56	-8733.20	-5.092e+04	-1.028e+04	-4.938e+04	-7920.07
1	23	327	15.65	-8.63	-3.62	10.64	9.83	3.075e+04	-2.333e+04	2.717e+04	-1.974e+04	-1.345e+04
1	23	328	16.19	-3.38	0.23	12.58	7.59	4157.82	-2.927e+04	2018.05	-2.713e+04	-8182.01
1	23	329	16.62	-1.48	2.11	13.04	7.21	-16.09	-2.842e+04	-3866.44	-2.457e+04	-9723.17
1	23	330	16.44	-32.62	-21.93	5.74	20.26	-1.042e+05	-1.865e+05	-1.486e+05	-1.421e+05	4.103e+04
1	23	331	16.51	-26.60	-15.15	5.05	19.04	-6.833e+04	-1.267e+05	-7.991e+04	-1.152e+05	2.329e+04
1	23	332	14.59	-22.99	-15.31	6.92	15.15	-4.040e+04	-9.504e+04	-4.636e+04	-8.907e+04	1.704e+04
1	23	333	13.98	-16.45	-12.15	9.68	10.61	-2.297e+04	-7.360e+04	-2.494e+04	-7.163e+04	9790.40
1	23	334	12.42	-11.00	-8.42	9.85	7.32	-1353.37	-5.917e+04	-1537.21	-5.899e+04	3255.03
1	23	335	14.19	-7.15	-5.24	12.29	6.08	4516.56	-5.579e+04	4472.53	-5.574e+04	-1628.97
1	23	336	14.44	-4.15	-2.61	12.89	5.13	7916.48	-3.891e+04	7684.60	-3.867e+04	-3286.85
1	23	337	15.32	-1.15	0.24	13.94	4.57	361.88	-3.242e+04	-680.19	-3.138e+04	-5750.95
1	39	1	7.13	-2.64	5.42	-0.93	3.71	5.427e+04	-1.068e+05	5.391e+04	-1.064e+05	-7618.15
1	39	2	3.45	-3.63	1.56	-1.74	3.14	5.560e+04	-1.597e+05	5.483e+04	-1.589e+05	1.285e+04
1	39	3	3.59	-3.91	0.52	-0.84	3.69	4.432e+04	-1.102e+05	4.398e+04	-1.099e+05	-7220.34
1	39	4	8.68	-2.86	7.64	-1.82	3.30	1.053e+05	-1.152e+05	1.034e+05	-1.133e+05	-2.056e+04
1	39	5	2.49	-6.11	0.26	-3.88	3.77	6.746e+04	-6.049e+04	6.060e+04	-5.363e+04	-2.882e+04
1	39	6	9.54	-5.64	8.29	-4.38	4.19	1.187e+05	-5.571e+04	1.044e+05	-4.142e+04	-4.783e+04
1	39	7	4.58	-11.08	3.25	-9.74	4.37	1.256e+05	-3.427e+04	1.193e+05	-2.801e+04	-3.101e+04
1	39	8	10.57	-8.79	9.55	-7.78	4.32	1.433e+05	-2.103e+04	1.104e+05	1.188e+04	-6.576e+04
1	39	9	-1.74	-13.45	-2.49	-12.69	2.88	1.571e+05	1.754e+04	1.055e+05	6.913e+04	-6.738e+04
1	39	10	21.05	-14.95	21.00	-14.90	1.31	1.917e+05	2.298e+04	1.499e+05	6.481e+04	-7.287e+04
1	39	11	4.78	-14.59	4.70	-14.52	-1.18	1.672e+05	6.572e+04	1.350e+05	9.788e+04	-4.720e+04
1	39	12	13.97	-10.70	13.42	-10.15	-3.63	1.880e+05	4.230e+04	1.424e+05	8.788e+04	-6.754e+04
1	39	13	8.71	-14.27	6.53	-12.08	-6.74	2.035e+05	6.215e+04	1.418e+05	1.239e+05	-7.010e+04
1	39	14	18.02	-9.57	16.78	-8.33	-5.71	2.086e+05	9.747e+04	1.541e+05	1.520e+05	-5.556e+04
1	39	15	15.79	-13.92	9.60	-7.73	-12.07	2.256e+05	1.132e+05	1.694e+05	1.693e+05	-5.618e+04
1	39	16	21.92	-9.73	17.47	-5.27	-11.01	1.755e+05	9.893e+04	1.403e+05	1.341e+05	-3.814e+04
1	39	17	18.81	-9.22	9.52	7.27e-02	-13.20	1.755e+05	9.891e+04	1.342e+05	1.401e+05	-3.816e+04
1	39	18	23.92	-6.60	14.26	3.05	-14.20	1.828e+05	7.962e+04	1.312e+05	1.311e+05	-5.158e+04
1	39	19	2.01	-2.39	1.46	-1.84	1.46	-1.761e+04	-1.719e+05	-2.684e+04	-1.627e+05	3.660e+04
1	39	20	1.07	-2.67	-1.02	-0.58	1.86	-2369.34	-1.197e+05	-4016.32	-1.181e+05	1.380e+04
1	39	21	-0.30	-2.50	-0.81	-1.98	0.93	6.260e+04	-1.186e+05	6.254e+04	-1.185e+05	-3258.94
1	39	22	2.79	-7.47	-0.31	-4.37	4.71	9.841e+04	-4.457e+04	9.331e+04	-3.947e+04	-2.651e+04
1	39	23	-0.46	-9.88	-1.40	-8.95	2.82	1.705e+05	2.810e+04	1.400e+05	5.861e+04	-5.843e+04
1	39	24	4.96	-14.56	4.38	-13.97	-3.32	2.052e+05	7.531e+04	1.584e+05	1.222e+05	-6.240e+04
1	39	25	2.78	-8.52	2.33	-8.08	-2.19	1.884e+05	8.472e+04	1.366e+05	1.365e+05	-5.182e+04
1	39	26	8.37	-12.58	2.70	-6.91	-9.31	2.035e+05	6.210e+04	1.239e+05	1.417e+05	-7.013e+04
1	39	27	18.66	-14.84	7.33	-3.51	-15.85	2.086e+05	9.737e+04	1.520e+05	1.540e+05	-5.560e+04
1	39	28	1.43	-2.05	1.40	-2.03	0.29	-4.493e+04	-1.914e+05	-6.739e+04	-1.689e+05	5.277e+04

Parco Eolico "Bolina" – Progetto Definitivo
Relazione di calcolo preliminare delle fondazioni degli aerogeneratori G8 e G12

1	39	29	1.06	-1.40	1.01	-1.35	-0.35	-2.444e+04	-1.790e+05	-2.772e+04	-1.757e+05	2.225e+04
1	39	30	-5.86e-02	-1.41	-1.32	-0.15	0.33	-1.890e+04	-1.535e+05	-2.094e+04	-1.514e+05	1.645e+04
1	39	31	0.81	-3.29	-2.50	2.12e-02	1.62	3.560e+04	-9.979e+04	3.539e+04	-9.958e+04	-5309.06
1	39	32	-0.70	-4.65	-0.94	-4.40	0.96	1.892e+05	1278.92	1.780e+05	1.252e+04	-4.457e+04
1	39	33	5.42	-9.88	4.81	-9.26	-3.01	2.601e+05	5.882e+04	1.595e+05	1.594e+05	-1.006e+05
1	39	34	8.51	-9.74	3.52	-4.75	-8.14	2.052e+05	7.523e+04	1.222e+05	1.582e+05	-6.243e+04
1	39	35	7.67	-9.83	-0.56	-1.59	-8.74	1.671e+05	6.564e+04	9.790e+04	1.348e+05	-4.724e+04
1	39	36	15.03	-13.22	1.56	0.26	-14.11	1.879e+05	4.218e+04	8.786e+04	1.423e+05	-6.761e+04
1	39	37	3.50	-5.60	3.47	-5.57	0.55	-9.768e+04	-2.429e+05	-1.256e+05	-2.149e+05	5.724e+04
1	39	38	2.90	0.48	2.80	0.58	-0.49	-8.546e+04	-1.971e+05	-1.320e+05	-1.505e+05	5.504e+04
1	39	39	2.02	7.09e-02	1.86	0.23	-0.53	-9.932e+04	-2.184e+05	-1.217e+05	-1.960e+05	4.656e+04
1	39	40	1.15	-9.96e-02	0.86	0.18	0.52	-7.274e+04	-2.508e+05	-7.864e+04	-2.449e+05	3.186e+04
1	39	41	0.11	-0.11	-5.45e-03	5.90e-03	0.11	-3.232e+04	-4.557e+04	-3.893e+04	-3.896e+04	-6623.91
1	39	42	3.86	-4.73	-0.73	-0.14	-4.29	1.889e+05	1188.54	1.247e+04	1.776e+05	-4.462e+04
1	39	43	8.20	-9.66	-1.30	-0.16	-8.91	1.704e+05	2.790e+04	5.849e+04	1.398e+05	-5.850e+04
1	39	44	10.20	-12.23	-1.74	-0.29	-11.19	1.571e+05	1.733e+04	6.901e+04	1.054e+05	-6.746e+04
1	39	45	13.65	-12.48	-1.76	2.92	-12.85	1.917e+05	2.279e+04	6.470e+04	1.497e+05	-7.295e+04
1	39	46	2.87	-4.76	2.32	-4.21	1.97	-1.127e+05	-2.285e+05	-1.414e+05	-1.998e+05	5.022e+04
1	39	47	4.40	-1.22	4.31	-1.13	0.70	-1.305e+05	-2.120e+05	-1.505e+05	-1.920e+05	3.510e+04
1	39	48	5.64	-1.73	5.10	-1.19	1.92	-1.467e+05	-2.507e+05	-1.814e+05	-2.161e+05	4.898e+04
1	39	49	5.33	-1.83	4.25	-0.76	2.56	-1.366e+05	-3.091e+05	-2.229e+05	-2.228e+05	8.623e+04
1	39	50	5.04	6.14e-02	0.88	4.22	1.85	-7.286e+04	-2.511e+05	-2.452e+05	-7.873e+04	3.181e+04
1	39	51	9.83	-6.57	-6.29	9.55	-2.13	3.532e+04	-1.000e+05	-9.982e+04	3.510e+04	-5439.67
1	39	52	8.58	-9.34	-6.27	5.52	-6.75	9.818e+04	-4.478e+04	-3.966e+04	9.305e+04	-2.658e+04
1	39	53	8.31	-8.37	-2.91	2.84	-7.83	1.254e+05	-3.443e+04	-2.815e+04	1.191e+05	-3.107e+04
1	39	54	12.27	-12.92	-3.50	2.85	-12.19	1.432e+05	-2.119e+04	1.178e+04	1.102e+05	-6.582e+04
1	39	55	2.03	-6.38	0.75	-5.11	3.02	-1.716e+05	-2.507e+05	-2.128e+05	-2.095e+05	3.950e+04
1	39	56	5.56	-3.65	3.70	-1.78	3.70	-1.315e+05	-2.458e+05	-1.802e+05	-1.971e+05	5.651e+04
1	39	57	3.23	8.22e-02	2.46	0.85	1.35	-1.570e+05	-2.292e+05	-1.931e+05	-1.930e+05	3.607e+04
1	39	58	8.29	-3.84	1.15	3.30	5.97	-1.468e+05	-2.507e+05	-2.162e+05	-1.814e+05	4.895e+04
1	39	59	10.32	-0.70	1.25	8.37	4.20	-9.954e+04	-2.186e+05	-1.962e+05	-1.219e+05	4.649e+04
1	39	60	14.10	-5.30	-5.13	13.93	-1.84	-1.915e+04	-1.536e+05	-1.516e+05	-2.117e+04	1.638e+04
1	39	61	8.54	-3.96	-3.73	8.31	-1.67	6.238e+04	-1.188e+05	-1.187e+05	6.232e+04	-3317.48
1	39	62	11.48	-8.22	-4.75	8.01	-7.50	6.730e+04	-6.065e+04	-5.376e+04	6.041e+04	-2.888e+04
1	39	63	15.29	-16.56	-8.80	7.52	-13.67	1.185e+05	-5.589e+04	-4.158e+04	1.042e+05	-4.787e+04
1	39	64	2.32	-9.12	-1.29	-5.51	5.31	-1.707e+05	-2.103e+05	-1.877e+05	-1.933e+05	1.960e+04
1	39	65	5.12	-7.45	0.20	-2.53	6.13	-1.817e+05	-2.733e+05	-2.275e+05	-2.275e+05	4.579e+04
1	39	66	6.99	-4.16	0.45	2.38	5.49	-1.316e+05	-2.458e+05	-1.971e+05	-1.802e+05	5.648e+04
1	39	67	10.95	-5.05	-2.90	8.80	5.46	-1.306e+05	-2.121e+05	-1.922e+05	-1.505e+05	3.507e+04
1	39	68	13.57	0.51	2.29	11.78	4.48	-8.568e+04	-1.971e+05	-1.506e+05	-1.322e+05	5.496e+04
1	39	69	13.77	-4.86	-4.86	13.77	0.12	-2.464e+04	-1.791e+05	-1.759e+05	-2.790e+04	2.220e+04
1	39	70	13.16	-8.10	-6.92	11.98	-4.88	-2556.27	-1.198e+05	-1.182e+05	-4190.20	1.375e+04
1	39	71	13.42	-14.22	-9.94	9.14	-10.00	4.410e+04	-1.104e+05	-1.101e+05	4.376e+04	-7249.32
1	39	72	10.68	-16.38	-10.02	4.32	-11.48	1.052e+05	-1.153e+05	-1.134e+05	1.032e+05	-2.057e+04
1	39	73	0.36	-12.52	-6.42	-5.75	6.43	-1.444e+05	-2.171e+05	-1.808e+05	-1.808e+05	3.635e+04
1	39	74	0.71	-10.83	-7.53	-2.58	5.22	-1.707e+05	-2.103e+05	-1.934e+05	-1.876e+05	1.959e+04
1	39	75	3.53	-10.49	-8.10	1.14	5.28	-1.717e+05	-2.507e+05	-2.128e+05	-2.128e+05	3.946e+04
1	39	76	8.27	-11.71	-10.06	6.62	5.50	-1.128e+05	-2.285e+05	-1.998e+05	-1.414e+05	4.996e+04
1	39	77	14.16	-20.70	-20.40	13.85	3.24	-9.788e+04	-2.429e+05	-2.150e+05	-1.258e+05	5.716e+04
1	39	78	9.49	-12.15	-11.99	9.32	-1.88	-4.510e+04	-1.915e+05	-1.690e+05	-6.752e+04	5.271e+04
1	39	79	9.64	-15.91	-15.10	8.83	-4.47	-1.783e+04	-1.720e+05	-1.628e+05	-2.705e+04	3.656e+04
1	39	80	10.21	-19.61	-15.97	6.57	-9.76	5.545e+04	-1.597e+05	-1.589e+05	5.468e+04	1.284e+04
1	39	81	8.26	-21.00	-13.46	0.71	-12.80	5.417e+04	-1.068e+05	-1.065e+05	5.381e+04	-7604.13
1	39	82	13.22	-23.78	-23.62	13.06	2.45	-6.657e+04	-1.628e+05	-1.372e+05	-9.224e+04	4.257e+04
1	39	83	9.55	-22.39	-21.54	8.70	-5.15	-3.445e+04	-1.796e+05	-1.510e+05	-6.302e+04	5.773e+04
1	39	84	6.12	-16.77	-16.77	6.12	-0.23	-2.389e+04	-9.530e+04	-6.041e+04	-5.878e+04	3.569e+04
1	39	85	11.78	-23.37	-23.15	11.56	-2.78	-2.717e+04	-1.079e+05	-8.078e+04	-5.433e+04	3.816e+04
1	39	86	5.12	-13.67	-13.65	5.10	-0.61	-2.948e+04	-8.645e+04	-5.344e+04	-6.249e+04	2.812e+04
1	39	87	9.09	-14.98	-14.97	9.08	-0.46	-1.813e+04	-7.579e+04	-5.355e+04	-4.036e+04	2.807e+04
1	39	88	5.44	-11.13	-11.09	5.41	-0.71	-1.725e+04	-6.566e+04	-3.009e+04	-5.282e+04	2.137e+04
1	39	89	6.91	-11.88	-11.23	6.26	-3.42	-7049.81	-5.885e+04	-3.402e+04	-3.188e+04	2.588e+04
1	39	90	6.36	-9.45	-9.40	6.31	-0.88	-3553.19	-4.568e+04	-1.089e+04	-3.834e+04	1.598e+04
1	39	91	6.31	-8.77	-7.09	4.63	-4.75	5185.15	-4.478e+04	-1.277e+04	-2.683e+04	2.397e+04
1	39	92	6.61	-5.57	-5.51	6.55	-0.85	2.818e+04	-1.948e+04	2.505e+04	-1.635e+04	1.182e+04
1	39	93	7.82	-6.07	-5.67	7.42	-2.33	5974.82	-3.995e+04	-4552.12	-2.942e+04	1.930e+04
1	39	94	6.95	-1.89	-1.87	6.93	0.47	4572.26	-2.474e+04	2550.72	-2.272e+04	7427.77
1	39	95	9.04	-4.09	-4.05	9.00	0.70	6956.20	-2.549e+04	1603.98	-2.014e+04	1.204e+04
1	39	96	7.22	-0.98	-0.96	7.20	0.40	83.10	-2.261e+04	55.52	-2.258e+04	790.54
1	39	97	8.93	-0.82	-0.74	8.85	-0.90	263.09	-2.006e+04	-832.74	-1.896e+04	4589.94
1	39	98	3.52	-23.65	-21.90	1.77	-6.67	-5127.56	-1.168e+05	-1.130e+05	-8923.08	2.024e+04
1	39	99	6.67	-24.17	-22.00	4.50	-7.89	-3371.60	-9.164e+04	-8.064e+04	-1.438e+04	2.916e+04
1	39	100	8.29	-17.63	-15.95	6.61	-6.37	2479.54	-6.874e+04	-5.660e+04	-9659.88	2.678e+04
1	39	101	8.75	-14.14	-12.09	6.70	-6.54	7081.95	-5.079e+04	-3.930e+04	-4410.46	2.309e+04

Parco Eolico "Bolina" – Progetto Definitivo
Relazione di calcolo preliminare delle fondazioni degli aerogeneratori G8 e G12

1	39	102	9.41	-12.24	-9.64	6.81	-7.04	1.195e+04	-3.296e+04	-2.297e+04	1950.33	1.868e+04
1	39	103	8.72	-7.34	-5.08	6.47	-5.58	2.870e+04	-8327.36	5354.73	1.502e+04	1.787e+04
1	39	104	7.92	-2.21	-1.47	7.18	-2.64	8968.14	-1.232e+04	-6900.99	3548.01	9274.30
1	39	105	6.59	-1.54	-1.13	6.19	-1.76	9.81	-6352.19	-1848.98	-4493.40	2893.18
1	39	106	9.56	-25.26	-15.54	-0.15	-15.62	2.372e+04	-9.648e+04	-9.504e+04	2.228e+04	1.306e+04
1	39	107	6.49	-18.67	-13.00	0.83	-10.50	2.323e+04	-7.228e+04	-6.958e+04	2.053e+04	1.583e+04
1	39	108	6.60	-18.65	-16.20	4.15	-7.48	2.715e+04	-5.457e+04	-5.188e+04	2.445e+04	1.459e+04
1	39	109	8.72	-13.54	-8.83	4.01	-9.09	2.417e+04	-4.328e+04	-4.073e+04	2.162e+04	1.287e+04
1	39	110	7.77	-9.35	-4.22	2.63	-7.84	2.351e+04	-3.067e+04	-2.696e+04	1.980e+04	1.369e+04
1	39	111	8.33	-7.70	-4.27	4.91	-6.57	1.620e+04	-2.352e+04	-1.930e+04	1.197e+04	1.225e+04
1	39	112	8.62	-4.96	-3.82	7.48	-3.76	1.251e+04	-1.072e+04	-8684.66	1.047e+04	6573.64
1	39	113	6.76	-2.43	-1.92	6.26	-2.10	409.88	-1688.52	-1464.39	185.74	648.14
1	39	114	13.12	-26.63	-18.04	4.53	-16.36	4.514e+04	-7.425e+04	-7.410e+04	4.499e+04	-4232.98
1	39	115	8.30	-18.33	-10.09	4.59e-02	-12.31	5.897e+04	-4.240e+04	-4.239e+04	5.896e+04	-926.05
1	39	116	8.96	-12.83	-9.18	5.32	-8.14	3.901e+04	-4.421e+04	-4.391e+04	3.871e+04	-4993.78
1	39	117	8.05	-11.30	-6.26	3.01	-8.49	3.368e+04	-3.540e+04	-3.526e+04	3.354e+04	-3022.32
1	39	118	7.86	-11.11	-4.94	1.70	-8.88	3.174e+04	-2.469e+04	-2.457e+04	3.161e+04	-2680.72
1	39	119	5.44	-6.24	-2.17	1.37	-5.56	3.772e+04	-7445.32	-7444.49	3.772e+04	193.49
1	39	120	4.47	-1.27	-0.61	3.82	-1.83	2.090e+04	-1.031e+04	-9608.95	2.020e+04	-4629.22
1	39	121	3.22	-2.34	-1.96	2.84	-1.41	7397.51	-437.31	2312.99	4647.21	-3739.51
1	39	122	13.38	-22.18	-13.09	4.29	-15.51	6.808e+04	-7.331e+04	-6.976e+04	6.453e+04	-2.212e+04
1	39	123	11.78	-20.40	-7.61	-1.01	-15.75	6.108e+04	-5.685e+04	-5.284e+04	5.900e+04	-1.550e+04
1	39	124	17.63	-15.82	-8.08	9.89	-14.11	4.474e+04	-3.939e+04	-3.730e+04	4.265e+04	-1.310e+04
1	39	125	8.11	-10.23	-5.77	3.66	-7.87	3.949e+04	-3.432e+04	-3.150e+04	3.666e+04	-1.416e+04
1	39	126	4.38	-6.08	-3.27	1.56	-4.64	3.508e+04	-2.792e+04	-2.599e+04	3.315e+04	-1.086e+04
1	39	127	4.52	-5.42	-2.08	1.19	-4.69	2.614e+04	-2.392e+04	-2.284e+04	2.507e+04	-7261.63
1	39	128	5.89	-3.75	-1.41	3.54	-4.14	1.822e+04	-1.367e+04	-1.274e+04	1.729e+04	-5377.98
1	39	129	4.40	-0.43	1.45	2.51	-2.36	2751.52	-399.70	430.47	1921.36	-1388.11
1	39	130	4.58	-14.38	-8.37	-1.43	-8.82	8.521e+04	-5.198e+04	-4.645e+04	7.968e+04	-2.697e+04
1	39	131	9.45	-15.64	-6.96	0.78	-11.93	7.491e+04	-4.344e+04	-3.334e+04	6.481e+04	-3.307e+04
1	39	132	10.62	-13.01	-4.37	1.98	-11.38	5.842e+04	-3.696e+04	-2.687e+04	4.834e+04	-2.933e+04
1	39	133	8.57	-9.95	-3.02	1.64	-8.96	4.555e+04	-3.116e+04	-2.141e+04	3.580e+04	-2.555e+04
1	39	134	6.09	-7.77	-1.26	-0.42	-6.91	3.722e+04	-2.468e+04	-1.587e+04	2.840e+04	-2.163e+04
1	39	135	3.76	-3.74	-0.39	0.41	-3.72	3.612e+04	-1.325e+04	-6986.10	2.986e+04	-1.643e+04
1	39	136	3.35	-0.52	0.23	2.60	-1.53	1.957e+04	-1.404e+04	-7566.07	1.310e+04	-1.325e+04
1	39	137	1.91	-0.80	0.17	0.93	-1.30	4023.70	-272.28	1955.64	1795.79	-2146.50
1	39	138	7.63	-12.15	-4.57	5.31e-02	-9.61	1.456e+05	-2.392e+04	8459.96	1.132e+05	-6.664e+04
1	39	139	14.57	-14.47	-5.69	5.79	-13.33	9.253e+04	-2.161e+04	1519.99	6.940e+04	-4.589e+04
1	39	140	10.48	-10.82	-2.80	2.46	-10.32	6.929e+04	-2.353e+04	-568.78	4.633e+04	-4.005e+04
1	39	141	7.65	-7.07	-1.36	1.95	-7.17	5.079e+04	-2.352e+04	-2735.90	3.001e+04	-3.335e+04
1	39	142	4.81	-4.03	-1.00	1.78	-4.20	3.845e+04	-2.148e+04	-4531.84	2.150e+04	-2.699e+04
1	39	143	3.77	-2.88	0.30	0.59	-3.32	2.609e+04	-1.973e+04	-7343.67	1.370e+04	-2.035e+04
1	39	144	4.27	-2.11	0.96	1.21	-3.19	1.668e+04	-1.276e+04	-4128.09	8048.49	-1.341e+04
1	39	145	3.01	-0.48	1.21	1.32	-1.74	2549.56	-454.24	1233.55	861.78	-1490.35
1	39	146	16.95	-14.86	-0.13	2.22	-15.86	1.341e+05	9364.11	4.574e+04	9.771e+04	-5.669e+04
1	39	147	14.56	-11.39	-0.13	3.30	-12.86	1.112e+05	9124.57	4.493e+04	7.542e+04	-4.872e+04
1	39	148	12.66	-8.00	-1.47	6.13	-9.60	7.329e+04	-6336.37	2.911e+04	3.784e+04	-3.957e+04
1	39	149	9.20	-5.74	-0.35	3.81	-7.18	5.157e+04	-1.151e+04	1.902e+04	2.104e+04	-3.153e+04
1	39	150	5.80	-4.06	0.37	1.36	-4.90	3.720e+04	-1.270e+04	1.305e+04	1.145e+04	-2.494e+04
1	39	151	3.69	-2.26	-0.14	1.56	-2.85	3.039e+04	-8353.50	1.150e+04	1.053e+04	-1.936e+04
1	39	152	3.07	-1.26	-0.58	2.40	-1.57	1.664e+04	-1.011e+04	5845.20	683.79	-1.312e+04
1	39	153	1.74	-1.57	-0.66	0.83	-1.48	4764.35	46.53	4434.86	376.02	-1202.45
1	39	154	17.99	-9.67	2.58	5.74	-13.74	1.630e+05	3.654e+04	8.880e+04	1.108e+05	-6.229e+04
1	39	155	16.74	-9.36	5.02	2.36	-12.98	1.049e+05	2.203e+04	6.152e+04	6.540e+04	-4.138e+04
1	39	156	18.25	-8.13	4.34	5.79	-13.17	6.899e+04	1.145e+04	4.566e+04	3.478e+04	-2.825e+04
1	39	157	11.65	-5.88	0.99	4.78	-8.56	4.855e+04	527.70	3.310e+04	1.598e+04	-2.243e+04
1	39	158	7.90	-4.31	-0.37	3.97	-5.71	3.388e+04	-5228.30	2.265e+04	6005.00	-1.770e+04
1	39	159	4.60	-3.07	-0.46	1.99	-3.64	2.154e+04	-8229.03	1.334e+04	-23.95	-1.330e+04
1	39	160	3.11	-2.39	-0.33	1.05	-2.66	1.327e+04	-6216.74	8853.63	-1795.63	-8162.59
1	39	161	2.01	-1.97	-0.71	0.74	-1.85	5027.66	192.82	5026.92	193.56	59.92
1	39	162	19.47	-1.62	8.64	9.22	-10.54	1.383e+05	6.068e+04	9.992e+04	9.905e+04	-3.880e+04
1	39	163	20.65	-5.69	7.95	7.00	-13.16	9.590e+04	3.974e+04	7.367e+04	6.197e+04	-2.747e+04
1	39	164	16.67	-6.65	5.02	5.00	-11.66	6.378e+04	2.344e+04	5.342e+04	3.381e+04	-1.763e+04
1	39	165	12.44	-5.66	2.76	4.02	-9.03	4.287e+04	1.090e+04	3.817e+04	1.560e+04	-1.132e+04
1	39	166	8.26	-4.70	1.12	2.44	-6.44	2.920e+04	3099.22	2.701e+04	5291.12	-7238.83
1	39	167	5.59	-4.20	-0.59	1.99	-4.72	2.171e+04	986.75	2.044e+04	2255.42	-4967.45
1	39	168	3.86	-3.99	-1.91	1.77	-3.46	1.257e+04	-3310.63	1.234e+04	-3086.93	-1871.26
1	39	169	1.75	-3.79	-2.02	-1.74e-02	-2.58	7306.69	349.55	6686.10	970.15	1983.03
1	39	170	26.42	-12.08	13.25	1.09	-18.27	1.360e+05	6.673e+04	1.047e+05	9.804e+04	-3.446e+04
1	39	171	22.94	-9.58	10.78	2.58	-15.74	8.364e+04	4.936e+04	7.118e+04	6.182e+04	-1.649e+04
1	39	172	17.63	-5.93	6.69	5.01	-11.75	5.441e+04	3.213e+04	5.122e+04	3.532e+04	-7798.77
1	39	173	13.83	-6.40	4.15	3.29	-10.11	3.499e+04	1.867e+04	3.472e+04	1.893e+04	-2074.07
1	39	174	10.32	-5.98	2.14	2.20	-8.15	2.297e+04	8840.99	2.296e+04	8848.26	320.27

Parco Eolico "Bolina" – Progetto Definitivo
Relazione di calcolo preliminare delle fondazioni degli aerogeneratori G8 e G12

1	39	175	6.24	-5.37	0.10	0.76	-5.79	1.409e+04	2435.02	1.396e+04	2568.02	1237.90
1	39	176	3.52	-4.65	-1.19	5.42e-02	-4.04	9502.76	47.72	9010.73	539.75	2100.02
1	39	177	2.02	-4.49	-1.63	-0.85	-3.23	7612.27	322.80	5622.69	2312.37	3247.24
1	39	178	26.83	-8.53	17.59	0.71	-15.53	1.074e+05	6.454e+04	8.601e+04	8.590e+04	-2.141e+04
1	39	179	20.11	-7.59	12.08	0.44	-12.57	7.346e+04	5.366e+04	6.353e+04	6.359e+04	-9901.52
1	39	180	19.47	-8.06	9.61	1.80	-13.20	3.966e+04	3.826e+04	3.897e+04	3.895e+04	-700.59
1	39	181	14.32	-7.16	6.53	0.63	-10.32	2.686e+04	2.231e+04	2.459e+04	2.458e+04	2274.38
1	39	182	9.84	-6.51	3.77	-0.44	-7.90	1.911e+04	1.140e+04	1.525e+04	1.526e+04	3855.44
1	39	183	6.86	-6.56	1.55	-1.25	-6.56	1.476e+04	6586.51	1.064e+04	1.070e+04	4085.12
1	39	184	4.52	-6.54	-0.52	-1.50	-5.51	1.018e+04	258.61	5215.38	5219.57	4958.86
1	39	185	1.83	-6.12	-1.60	-2.69	-3.94	8909.82	344.92	4621.05	4633.69	4282.45
1	39	186	27.58	-10.44	18.36	-1.22	-16.30	1.360e+05	6.677e+04	9.810e+04	1.046e+05	-3.445e+04
1	39	187	24.82	-10.00	16.35	-1.54	-14.94	8.360e+04	4.941e+04	6.177e+04	7.125e+04	-1.642e+04
1	39	188	20.31	-7.97	13.96	-1.62	-11.80	5.436e+04	3.237e+04	3.552e+04	5.121e+04	-7697.32
1	39	189	15.82	-7.71	10.37	-2.27	-9.93	3.499e+04	1.867e+04	1.894e+04	3.472e+04	-2068.89
1	39	190	11.79	-7.42	7.38	-3.01	-8.08	2.300e+04	8761.27	8767.08	2.300e+04	287.48
1	39	191	7.37	-7.17	3.56	-3.35	-6.40	1.409e+04	2389.46	2524.31	1.396e+04	1249.01
1	39	192	4.17	-6.84	0.51	-3.19	-5.18	9483.57	71.23	586.93	8967.87	2141.95
1	39	193	2.07	-6.55	-0.46	-4.02	-3.92	7621.11	326.21	2320.59	5626.72	3251.35
1	39	194	27.22	-1.51	25.76	-4.95e-02	-6.31	1.383e+05	6.070e+04	9.912e+04	9.986e+04	-3.879e+04
1	39	195	28.12	-5.10	24.66	-1.64	-10.15	9.586e+04	3.980e+04	6.201e+04	7.364e+04	-2.742e+04
1	39	196	21.36	-7.50	17.46	-3.60	-9.86	6.374e+04	2.349e+04	3.382e+04	5.340e+04	-1.758e+04
1	39	197	16.21	-7.59	12.98	-4.36	-8.15	4.283e+04	1.089e+04	1.557e+04	3.815e+04	-1.129e+04
1	39	198	11.37	-7.40	8.86	-4.89	-6.38	2.915e+04	3026.86	5187.03	2.699e+04	-7194.07
1	39	199	7.76	-7.55	5.78	-5.57	-5.14	2.169e+04	885.31	2155.09	2.042e+04	-4980.19
1	39	200	4.77	-7.80	2.89	-5.92	-4.47	1.256e+04	-3303.06	-3070.61	1.233e+04	-1906.31
1	39	201	1.98	-7.38	0.53	-5.93	-3.38	7283.21	342.42	954.73	6670.90	1968.50
1	39	202	26.16	-7.26	25.82	-6.92	-3.37	1.631e+05	3.647e+04	1.108e+05	8.873e+04	-6.232e+04
1	39	203	21.91	-4.63	21.46	-4.18	-3.42	1.048e+05	2.207e+04	6.546e+04	6.141e+04	-4.131e+04
1	39	204	22.00	-6.32	19.60	-3.93	-7.88	6.892e+04	1.145e+04	4.561e+04	4.561e+04	-2.822e+04
1	39	205	16.14	-7.62	14.93	-6.41	-5.23	4.849e+04	473.90	1.591e+04	3.306e+04	-2.242e+04
1	39	206	11.78	-7.70	11.11	-7.03	-3.54	3.386e+04	-5366.14	5904.74	2.259e+04	-1.775e+04
1	39	207	7.32	-7.44	6.60	-6.71	-3.19	2.149e+04	-8310.31	-129.25	1.331e+04	-1.330e+04
1	39	208	4.23	-7.43	3.03	-6.23	-3.54	1.321e+04	-6197.49	-1814.44	8827.19	-8115.05
1	39	209	2.04	-7.15	1.44	-6.55	-2.27	5008.91	200.53	201.19	5008.25	56.38
1	39	210	23.88	-13.51	23.87	-13.49	-0.69	1.340e+05	9493.16	9.769e+04	4.581e+04	-5.660e+04
1	39	211	18.78	-7.45	18.73	-7.40	-1.09	1.112e+05	9119.74	7.536e+04	4.492e+04	-4.870e+04
1	39	212	18.37	-7.77	18.29	-7.69	-1.41	7.329e+04	-6367.07	3.789e+04	2.904e+04	-3.958e+04
1	39	213	13.76	-7.02	13.63	-6.89	-1.64	5.071e+04	-1.158e+04	2.096e+04	1.897e+04	-3.152e+04
1	39	214	9.27	-6.70	9.17	-6.61	-1.22	3.706e+04	-1.284e+04	1.123e+04	1.300e+04	-2.493e+04
1	39	215	6.50	-7.12	6.47	-7.09	-0.62	3.029e+04	-8508.86	1.038e+04	1.141e+04	-1.939e+04
1	39	216	4.37	-7.57	4.33	-7.53	-0.71	1.663e+04	-1.013e+04	739.98	5759.57	-1.314e+04
1	39	217	1.74	-7.43	1.69	-7.37	-0.71	4702.83	30.32	368.34	4364.82	-1210.43
1	39	218	18.84	-9.85	17.66	-8.67	5.71	1.456e+05	-2.381e+04	1.133e+05	8534.60	-6.660e+04
1	39	219	20.02	-10.41	20.01	-10.40	0.57	9.254e+04	-2.157e+04	6.934e+04	1618.85	-4.592e+04
1	39	220	14.13	-7.46	14.10	-7.43	-0.79	6.922e+04	-2.340e+04	4.631e+04	-499.99	-3.996e+04
1	39	221	10.96	-6.33	10.94	-6.32	0.50	5.071e+04	-2.360e+04	2.991e+04	-2789.26	-3.336e+04
1	39	222	8.28	-6.67	8.09	-6.47	1.71	3.838e+04	-2.165e+04	2.140e+04	-4662.11	-2.704e+04
1	39	223	5.12	-6.56	5.06	-6.51	0.79	2.600e+04	-1.983e+04	1.356e+04	-7392.25	-2.038e+04
1	39	224	3.46	-6.96	3.42	-6.92	-0.68	1.662e+04	-1.277e+04	7986.88	-4141.40	-1.339e+04
1	39	225	1.63	-6.70	1.60	-6.66	0.52	2526.77	-453.60	871.13	1202.04	-1480.97
1	39	226	15.76	-2.78	15.20	-2.21	3.18	8.527e+04	-5.192e+04	7.974e+04	-4.640e+04	-2.697e+04
1	39	227	16.07	-4.28	15.43	-3.65	3.55	7.490e+04	-4.344e+04	6.479e+04	-3.333e+04	-3.308e+04
1	39	228	12.08	-5.16	11.96	-5.03	1.46	5.837e+04	-3.700e+04	4.827e+04	-2.690e+04	-2.935e+04
1	39	229	9.06	-5.55	8.94	-5.43	1.31	4.545e+04	-3.128e+04	3.566e+04	-2.149e+04	-2.559e+04
1	39	230	5.24	-5.42	5.04	-5.23	1.44	3.704e+04	-2.487e+04	2.814e+04	-1.597e+04	-2.172e+04
1	39	231	3.89	-6.22	3.24	-5.56	2.49	3.599e+04	-1.344e+04	2.968e+04	-7131.31	-1.649e+04
1	39	232	3.55	-7.02	2.80	-6.27	2.72	1.956e+04	-1.407e+04	1.316e+04	-7663.48	-1.320e+04
1	39	233	0.82	-7.73	0.12	-7.03	2.34	3947.45	-298.44	1777.16	1871.85	-2122.42
1	39	234	12.07	-4.12	8.52	-0.57	6.70	6.814e+04	-7.341e+04	6.458e+04	-6.985e+04	-2.216e+04
1	39	235	6.83	-1.05	5.66	0.12	2.80	6.096e+04	-5.690e+04	5.888e+04	-5.482e+04	-1.553e+04
1	39	236	14.64	-4.12	14.64	-4.12	6.09e-02	4.480e+04	-3.952e+04	4.269e+04	-3.742e+04	-1.316e+04
1	39	237	8.01	-5.34	7.02	-4.36	3.49	3.941e+04	-3.448e+04	3.657e+04	-3.164e+04	-1.420e+04
1	39	238	5.30	-5.83	3.20	-3.73	4.35	3.496e+04	-2.812e+04	3.302e+04	-2.618e+04	-1.087e+04
1	39	239	2.68	-5.74	1.62	-4.67	2.80	2.602e+04	-2.406e+04	2.492e+04	-2.296e+04	-7332.31
1	39	240	2.73	-6.46	2.43	-6.16	1.64	1.817e+04	-1.372e+04	1.723e+04	-1.278e+04	-5398.24
1	39	241	1.01	-5.74	3.82e-02	-4.77	2.36	2726.18	-395.45	1920.27	410.46	-1366.11
1	39	242	8.75	-3.97	7.92	-3.15	3.13	4.516e+04	-7.432e+04	4.500e+04	-7.416e+04	-4368.72
1	39	243	4.07	-1.52	2.78	-0.24	2.35	5.884e+04	-4.260e+04	5.883e+04	-4.259e+04	-1035.62
1	39	244	7.94	-4.60	6.65	-3.32	3.81	3.901e+04	-4.425e+04	3.872e+04	-4.396e+04	-4894.92
1	39	245	4.29	-3.40	3.53	-2.64	2.30	3.359e+04	-3.554e+04	3.346e+04	-3.540e+04	-3059.11
1	39	246	1.62	-3.30	1.42	-3.10	0.96	3.156e+04	-2.493e+04	3.142e+04	-2.479e+04	-2833.87
1	39	247	1.20	-3.70	-0.14	-2.35	2.18	3.754e+04	-7646.46	3.754e+04	-7646.08	130.87

Parco Eolico "Bolina" – Progetto Definitivo
Relazione di calcolo preliminare delle fondazioni degli aerogeneratori G8 e G12

1	39	248	3.15	-5.26	0.96	-3.07	3.69	2.087e+04	-1.029e+04	2.020e+04	-9620.83	-4528.57
1	39	249	1.69	-5.81	0.36	-4.49	2.86	7294.84	-453.63	4588.66	2252.55	-3693.96
1	39	250	2.42	-2.24	1.35	-1.17	1.97	2.370e+04	-9.649e+04	2.227e+04	-9.507e+04	1.301e+04
1	39	251	4.84	-3.79	0.90	0.15	4.30	2.325e+04	-7.245e+04	2.057e+04	-6.977e+04	1.580e+04
1	39	252	5.26	-8.73	3.76	-7.23	4.33	2.708e+04	-5.455e+04	2.441e+04	-5.188e+04	1.452e+04
1	39	253	2.90	-2.72	2.81	-2.63	0.71	2.409e+04	-4.336e+04	2.156e+04	-4.083e+04	1.283e+04
1	39	254	0.78	-0.63	0.73	-0.57	0.28	2.340e+04	-3.077e+04	1.970e+04	-2.707e+04	1.367e+04
1	39	255	1.90	-2.44	1.81	-2.34	0.63	1.610e+04	-2.360e+04	1.193e+04	-1.944e+04	1.216e+04
1	39	256	3.57	-4.47	3.01	-3.91	2.04	1.249e+04	-1.075e+04	1.048e+04	-8741.50	6533.73
1	39	257	2.82	-4.06	1.87	-3.12	2.37	422.34	-1678.12	197.04	-1452.82	649.98
1	39	258	2.67	-1.41	2.67	-1.41	5.24e-02	-5018.30	-1.168e+05	-8807.98	-1.130e+05	2.023e+04
1	39	259	3.36	-2.79	3.16	-2.59	1.09	-3319.62	-9.169e+04	-1.430e+04	-8.071e+04	2.915e+04
1	39	260	3.83	-3.67	3.35	-3.18	1.84	2482.30	-6.880e+04	-9618.36	-5.670e+04	2.676e+04
1	39	261	3.16	-3.26	3.09	-3.19	0.65	7015.32	-5.087e+04	-4410.40	-3.944e+04	2.304e+04
1	39	262	2.72	-3.31	2.66	-3.26	-0.57	1.180e+04	-3.309e+04	1931.58	-2.322e+04	1.858e+04
1	39	263	1.89	-1.72	1.84	-1.67	-0.41	2.853e+04	-8411.70	1.494e+04	5175.24	1.781e+04
1	39	264	1.89	-1.19	1.53	-0.82	1.00	8991.53	-1.232e+04	3515.24	-6839.14	9310.93
1	39	265	0.86	-2.53	-0.19	-1.47	1.57	-3.91	-6386.37	-4529.18	-1861.10	2899.02
1	39	266	4.15	-3.28	3.55	-2.69	-2.02	-3.431e+04	-1.797e+05	-6.290e+04	-1.511e+05	5.778e+04
1	39	267	6.16	-6.36	6.15	-6.35	0.32	-2.714e+04	-1.079e+05	-5.417e+04	-8.089e+04	3.812e+04
1	39	268	4.93	-3.48	4.23	-2.79	2.31	-1.798e+04	-7.585e+04	-4.023e+04	-5.360e+04	2.815e+04
1	39	269	1.85	-2.47	1.83	-2.46	-0.25	-7098.62	-5.889e+04	-3.186e+04	-3.413e+04	2.587e+04
1	39	270	1.34	-2.40	0.21	-1.27	-1.72	5061.79	-4.480e+04	-2.688e+04	-1.286e+04	2.393e+04
1	39	271	1.92	-1.67	1.92	-1.67	0.13	5846.43	-3.993e+04	-2.939e+04	-4689.87	1.927e+04
1	39	272	3.37	-3.17	2.33	-2.12	2.39	6919.98	-2.546e+04	-2.008e+04	1541.90	1.205e+04
1	39	273	1.61	-0.98	1.24	-0.60	0.91	273.36	-2.003e+04	-1.893e+04	-822.19	4586.93
1	39	274	3.36	-6.66	3.18	-6.47	1.35	-6.643e+04	-1.629e+05	-9.212e+04	-1.373e+05	4.265e+04
1	39	275	1.67	-5.12	1.67	-5.12	0.16	-2.391e+04	-9.535e+04	-5.873e+04	-6.052e+04	3.571e+04
1	39	276	1.67	-4.92	1.66	-4.91	-0.28	-2.948e+04	-8.643e+04	-6.249e+04	-5.342e+04	2.811e+04
1	39	277	1.51	-4.11	1.49	-4.10	-0.29	-1.730e+04	-6.567e+04	-5.280e+04	-3.018e+04	2.137e+04
1	39	278	1.73	-3.80	1.70	-3.76	-0.43	-3719.08	-4.569e+04	-3.831e+04	-1.110e+04	1.598e+04
1	39	279	1.63	-2.15	1.57	-2.08	-0.49	2.802e+04	-1.950e+04	-1.637e+04	2.489e+04	1.179e+04
1	39	280	1.51	-0.81	1.40	-0.69	0.51	4612.54	-2.474e+04	-2.273e+04	2604.51	7410.12
1	39	281	1.24	-0.75	0.96	-0.46	0.70	73.66	-2.261e+04	-2.258e+04	46.58	783.18
1	39	282	-0.50	-9.03	-0.52	-9.01	-0.41	-1.041e+05	-1.864e+05	-1.419e+05	-1.486e+05	4.102e+04
1	39	283	-2.89	-5.02	-3.15	-4.76	0.69	-6.839e+04	-1.266e+05	-1.149e+05	-8.009e+04	2.332e+04
1	39	284	-8.34e-02	-8.29	-1.61	-6.76	3.19	-4.048e+04	-9.480e+04	-8.890e+04	-4.638e+04	1.689e+04
1	39	285	0.88	-5.62	0.80	-5.54	0.72	-2.305e+04	-7.363e+04	-7.165e+04	-2.503e+04	9809.88
1	39	286	0.63	-4.20	0.48	-4.05	-0.83	-1405.15	-5.932e+04	-5.912e+04	-1603.86	3386.50
1	39	287	1.45	-2.03	1.35	-1.93	0.58	4381.22	-5.581e+04	-5.576e+04	4340.11	-1572.59
1	39	288	2.24	-2.24	0.83	-0.83	2.08	7838.64	-3.889e+04	-3.864e+04	7594.73	-3367.03
1	39	289	2.85	-0.73	2.27	-0.15	1.32	373.12	-3.243e+04	-3.139e+04	-671.42	-5759.96
1	39	290	-2.99	-9.60	-3.48	-9.11	1.73	-1.219e+05	-1.662e+05	-1.548e+05	-1.333e+05	1.931e+04
1	39	291	-1.92	-9.19	-3.27	-7.84	2.83	-8.256e+04	-1.257e+05	-1.248e+05	-8.346e+04	6143.15
1	39	292	-0.29	-7.38	-1.65	-6.02	2.78	-5.060e+04	-9.624e+04	-9.609e+04	-5.075e+04	-2603.40
1	39	293	0.47	-5.83	-0.38	-4.99	2.15	-2.832e+04	-7.297e+04	-7.200e+04	-2.929e+04	-6527.65
1	39	294	1.19	-4.64	0.54	-3.99	1.83	-9063.99	-5.097e+04	-4.946e+04	-1.057e+04	-7806.28
1	39	295	1.69	-2.64	1.25	-2.20	1.30	3.051e+04	-2.345e+04	-1.992e+04	2.698e+04	-1.335e+04
1	39	296	2.33	-1.31	1.62	-0.61	1.44	4252.84	-2.938e+04	-2.723e+04	2108.52	-8216.72
1	39	297	2.75	-0.77	1.88	0.10	1.52	-28.54	-2.851e+04	-2.466e+04	-3877.07	-9736.01
1	39	298	1.46	-12.02	-4.50	-6.06	6.70	-1.226e+05	-1.617e+05	-1.537e+05	-1.305e+05	1.572e+04
1	39	299	0.30	-9.69	-3.87	-5.52	4.92	-7.859e+04	-1.145e+05	-1.122e+05	-8.089e+04	-8797.33
1	39	300	-0.11	-7.80	-2.45	-5.46	3.54	-4.630e+04	-8.375e+04	-7.420e+04	-5.585e+04	-1.632e+04
1	39	301	0.61	-6.08	-1.38	-4.09	3.06	-2.668e+04	-6.785e+04	-5.780e+04	-3.673e+04	-1.769e+04
1	39	302	0.12	-4.05	-0.98	-2.95	1.84	-2673.75	-5.794e+04	-4.447e+04	-1.614e+04	-2.373e+04
1	39	303	2.07	-2.34	0.60	-0.87	2.08	2924.53	-5.682e+04	-4.216e+04	-1.174e+04	-2.571e+04
1	39	304	2.46	-1.80	0.74	-8.79e-02	2.09	7719.61	-4.017e+04	-2.780e+04	-4656.25	-2.097e+04
1	39	305	4.17	-0.76	2.32	1.09	2.39	326.92	-3.449e+04	-2.395e+04	-1.022e+04	-1.600e+04
1	39	306	0.67	-13.30	-6.50	-6.14	6.98	-1.150e+05	-1.246e+05	-1.199e+05	-1.198e+05	4796.96
1	39	307	0.19	-9.55	-5.03	-4.33	4.86	-4.323e+04	-6.671e+04	-5.492e+04	-5.502e+04	-1.174e+04
1	39	308	0.77	-7.95	-3.65	-3.53	4.36	-4.501e+04	-6.896e+04	-5.698e+04	-5.699e+04	-1.197e+04
1	39	309	1.15	-6.15	-2.67	-2.32	3.65	-2.499e+04	-5.904e+04	-4.200e+04	-4.204e+04	-1.703e+04
1	39	310	1.98	-4.97	-1.68	-1.31	3.47	-7774.66	-4.229e+04	-2.501e+04	-2.505e+04	-1.726e+04
1	39	311	2.85	-3.01	-0.29	0.13	2.92	3.128e+04	-1.770e+04	6832.43	6749.79	-2.449e+04
1	39	312	3.65	-1.55	1.10	1.00	2.60	4236.35	-2.431e+04	-1.002e+04	-1.005e+04	-1.427e+04
1	39	313	4.20	-0.77	1.53	1.90	2.48	-253.94	-2.545e+04	-1.285e+04	-1.286e+04	-1.260e+04
1	39	314	2.40	-15.38	-8.15	-4.82	8.73	-1.226e+05	-1.617e+05	-1.305e+05	-1.538e+05	1.572e+04
1	39	315	1.84	-13.09	-7.94	-3.32	7.10	-7.848e+04	-1.147e+05	-8.079e+04	-1.123e+05	-8860.18
1	39	316	1.69	-9.82	-6.05	-2.08	5.40	-4.634e+04	-8.390e+04	-5.601e+04	-7.424e+04	-1.642e+04
1	39	317	1.72	-7.55	-5.14	-0.69	4.06	-2.667e+04	-6.788e+04	-3.671e+04	-5.784e+04	-1.769e+04
1	39	318	1.29	-5.17	-3.98	0.10	2.50	-2642.52	-5.794e+04	-1.604e+04	-4.454e+04	-2.369e+04
1	39	319	3.44	-3.14	-1.15	1.45	3.02	2971.27	-5.684e+04	-1.168e+04	-4.220e+04	-2.572e+04
1	39	320	4.25	-2.30	0.51	1.44	3.24	7736.20	-4.021e+04	-4683.95	-2.779e+04	-2.101e+04

Parco Eolico "Bolina" – Progetto Definitivo
Relazione di calcolo preliminare delle fondazioni degli aerogeneratori G8 e G12

1	39	321	5.99	-0.80	1.33	3.87	3.15	324.18	-3.452e+04	-1.023e+04	-2.396e+04	-1.601e+04
1	39	322	-2.68	-16.12	-15.60	-3.19	2.58	-1.220e+05	-1.662e+05	-1.333e+05	-1.548e+05	1.929e+04
1	39	323	-0.36	-15.76	-13.54	-2.58	5.41	-8.256e+04	-1.257e+05	-8.345e+04	-1.249e+05	6104.61
1	39	324	1.82	-11.99	-9.96	-0.21	4.89	-5.057e+04	-9.628e+04	-5.073e+04	-9.613e+04	-2638.88
1	39	325	2.71	-9.27	-7.85	1.28	3.88	-2.825e+04	-7.301e+04	-2.924e+04	-7.203e+04	-6552.57
1	39	326	3.74	-7.40	-6.23	2.56	3.42	-8936.34	-5.101e+04	-1.045e+04	-4.949e+04	-7845.04
1	39	327	4.38	-4.29	-3.43	3.52	2.59	3.061e+04	-2.346e+04	2.709e+04	-1.994e+04	-1.334e+04
1	39	328	5.30	-1.80	-0.57	4.07	2.69	4226.89	-2.939e+04	2099.23	-2.726e+04	-8184.96
1	39	329	5.98	-0.94	0.12	4.92	2.49	-22.62	-2.851e+04	-3865.74	-2.467e+04	-9732.81
1	39	330	3.29	-20.29	-20.24	3.24	1.11	-1.040e+05	-1.864e+05	-1.485e+05	-1.419e+05	4.105e+04
1	39	331	0.10	-13.50	-13.19	-0.21	2.03	-6.844e+04	-1.265e+05	-8.009e+04	-1.148e+05	2.326e+04
1	39	332	2.27	-14.56	-13.32	1.03	4.38	-4.045e+04	-9.479e+04	-4.632e+04	-8.892e+04	1.687e+04
1	39	333	3.87	-10.70	-10.51	3.68	1.64	-2.297e+04	-7.365e+04	-2.495e+04	-7.167e+04	9808.70
1	39	334	3.67	-7.59	-7.59	3.66	-0.28	-1300.31	-5.933e+04	-1504.92	-5.913e+04	3439.84
1	39	335	5.38	-4.57	-4.29	5.10	1.63	4485.01	-5.585e+04	4443.66	-5.581e+04	-1578.87
1	39	336	6.61	-3.22	-1.76	5.15	3.50	7869.74	-3.893e+04	7619.40	-3.868e+04	-3413.68
1	39	337	7.88	-0.88	-0.35	7.36	2.08	366.31	-3.247e+04	-679.55	-3.142e+04	-5766.06
1	55	1	5.20	-15.38	-2.52	-7.66	-9.97	5.420e+04	-1.069e+05	5.384e+04	-1.065e+05	-7609.31
1	55	2	4.84	-13.74	-0.45	-8.44	-8.39	5.548e+04	-1.597e+05	5.471e+04	-1.590e+05	1.285e+04
1	55	3	7.18	-8.14	-0.29	-0.67	-7.66	4.414e+04	-1.104e+05	4.380e+04	-1.101e+05	-7250.09
1	55	4	6.52	-9.82	-0.53	-2.77	-8.10	1.052e+05	-1.153e+05	1.033e+05	-1.134e+05	-2.057e+04
1	55	5	4.75	-2.77	0.44	1.54	-3.71	6.733e+04	-6.065e+04	6.044e+04	-5.376e+04	-2.888e+04
1	55	6	5.25	-6.43	1.33	-2.51	-5.51	1.186e+05	-5.589e+04	1.043e+05	-4.158e+04	-4.787e+04
1	55	7	1.41	-1.04	1.27	-0.91	-0.56	1.254e+05	-3.442e+04	1.192e+05	-2.814e+04	-3.106e+04
1	55	8	3.75	-4.04	1.69	-1.98	-3.44	1.432e+05	-2.118e+04	1.102e+05	1.178e+04	-6.582e+04
1	55	9	-0.42	-3.84	-0.66	-3.60	-0.86	1.571e+05	1.735e+04	1.054e+05	6.902e+04	-6.745e+04
1	55	10	6.87	-5.05	5.82	-3.99	-3.39	1.917e+05	2.281e+04	1.498e+05	6.471e+04	-7.294e+04
1	55	11	1.66	-6.73	1.01	-6.08	-2.25	1.671e+05	6.565e+04	1.349e+05	9.788e+04	-4.723e+04
1	55	12	8.28	-6.42	4.60	-2.74	-6.37	1.879e+05	4.220e+04	1.423e+05	8.786e+04	-6.760e+04
1	55	13	5.69	-10.18	1.50	-5.99	-7.00	2.035e+05	6.211e+04	1.417e+05	1.239e+05	-7.013e+04
1	55	14	12.17	-7.11	5.97	-0.91	-9.00	2.086e+05	9.738e+04	1.540e+05	1.520e+05	-5.559e+04
1	55	15	13.17	-11.31	2.99	-1.12	-12.07	2.256e+05	1.132e+05	1.694e+05	1.694e+05	-5.618e+04
1	55	16	17.28	-7.89	8.48	0.91	-12.00	1.755e+05	9.892e+04	1.402e+05	1.342e+05	-3.816e+04
1	55	17	18.72	-6.34	3.34	9.05	-12.20	1.755e+05	9.893e+04	1.341e+05	1.403e+05	-3.814e+04
1	55	18	22.87	-5.54	8.49	8.83	-14.20	1.828e+05	7.962e+04	1.312e+05	1.312e+05	-5.158e+04
1	55	19	7.00	-12.00	1.75	-6.75	-8.50	-1.780e+04	-1.721e+05	-2.701e+04	-1.628e+05	3.656e+04
1	55	20	7.65	-3.96	3.44	0.25	-5.58	-2530.90	-1.198e+05	-4165.23	-1.182e+05	1.375e+04
1	55	21	2.87	0.35	1.96	1.26	-1.21	6.242e+04	-1.188e+05	6.236e+04	-1.187e+05	-3310.25
1	55	22	2.05	-0.59	-0.12	1.58	-1.01	9.822e+04	-4.476e+04	9.310e+04	-3.964e+04	-2.657e+04
1	55	23	-0.37	-2.60	-0.37	-2.60	-5.56e-02	1.704e+05	2.792e+04	1.398e+05	5.850e+04	-5.849e+04
1	55	24	2.67	-8.27	1.38	-6.99	-3.53	2.052e+05	7.524e+04	1.582e+05	1.222e+05	-6.243e+04
1	55	25	-0.34	-5.41	-1.60	-4.14	-2.19	1.884e+05	8.472e+04	1.365e+05	1.366e+05	-5.182e+04
1	55	26	6.44	-11.72	-3.39	-1.88	-9.05	2.035e+05	6.214e+04	1.239e+05	1.418e+05	-7.011e+04
1	55	27	16.68	-9.49	-9.84e-02	7.29	-12.55	2.086e+05	9.745e+04	1.520e+05	1.541e+05	-5.556e+04
1	55	28	8.74	-11.41	5.50	-8.18	-7.40	-4.508e+04	-1.915e+05	-6.750e+04	-1.690e+05	5.271e+04
1	55	29	10.28	-4.71	8.28	-2.72	-5.10	-2.460e+04	-1.791e+05	-2.786e+04	-1.759e+05	2.220e+04
1	55	30	7.48	-3.48	3.70	0.30	-5.21	-1.910e+04	-1.536e+05	-2.112e+04	-1.516e+05	1.639e+04
1	55	31	3.16	-0.93	-0.29	2.52	-1.48	3.537e+04	-1.000e+05	3.515e+04	-9.980e+04	-5417.43
1	55	32	3.43e-02	-1.67	-0.28	-1.36	-0.66	1.890e+05	1194.39	1.777e+05	1.247e+04	-4.461e+04
1	55	33	2.10	-6.56	0.89	-5.34	-3.01	2.601e+05	5.882e+04	1.594e+05	1.595e+05	-1.006e+05
1	55	34	5.37	-10.59	-3.47	-1.76	-7.93	2.052e+05	7.530e+04	1.222e+05	1.583e+05	-6.241e+04
1	55	35	6.03	-12.92	-9.00	2.11	-7.67	1.671e+05	6.571e+04	9.789e+04	1.350e+05	-4.720e+04
1	55	36	15.23	-11.99	-5.85	9.09	-11.38	1.880e+05	4.228e+04	8.789e+04	1.424e+05	-6.755e+04
1	55	37	12.41	-18.44	11.83	-17.86	-4.20	-9.785e+04	-2.429e+05	-1.257e+05	-2.150e+05	5.717e+04
1	55	38	11.89	0.15	10.07	1.96	-4.25	-8.565e+04	-1.971e+05	-1.321e+05	-1.506e+05	5.497e+04
1	55	39	8.69	-0.48	7.15	1.06	-3.43	-9.950e+04	-2.185e+05	-1.219e+05	-1.962e+05	4.650e+04
1	55	40	3.98	0.38	3.61	0.75	-1.10	-7.283e+04	-2.511e+05	-7.870e+04	-2.452e+05	3.182e+04
1	55	41	0.11	-0.11	5.34e-03	-4.88e-03	0.11	-3.232e+04	-4.557e+04	-3.894e+04	-3.895e+04	-6623.91
1	55	42	0.77	-5.34	-3.77	-0.80	-2.67	1.891e+05	1273.05	1.252e+04	1.779e+05	-4.458e+04
1	55	43	2.43	-11.26	-7.64	-1.18	-6.04	1.705e+05	2.807e+04	5.860e+04	1.399e+05	-5.844e+04
1	55	44	2.15	-15.10	-10.83	-2.12	-7.44	1.571e+05	1.751e+04	6.912e+04	1.055e+05	-6.739e+04
1	55	45	20.13	-14.70	-12.67	18.11	-8.16	1.917e+05	2.296e+04	6.481e+04	1.499e+05	-7.288e+04
1	55	46	7.98	-11.23	7.93	-11.18	-1.01	-1.128e+05	-2.285e+05	-1.414e+05	-1.998e+05	4.997e+04
1	55	47	11.07	-4.19	11.05	-4.18	-0.53	-1.306e+05	-2.121e+05	-1.505e+05	-1.922e+05	3.507e+04
1	55	48	11.19	-3.98	11.04	-3.83	1.50	-1.468e+05	-2.507e+05	-1.814e+05	-2.162e+05	4.895e+04
1	55	49	8.33	-4.83	7.81	-4.32	2.56	-1.366e+05	-3.091e+05	-2.228e+05	-2.229e+05	8.623e+04
1	55	50	4.41	-2.62	0.31	1.47	3.47	-7.278e+04	-2.509e+05	-2.450e+05	-7.867e+04	3.185e+04
1	55	51	7.40	-8.85	-8.79	7.34	0.96	3.554e+04	-9.981e+04	-9.960e+04	3.533e+04	-5331.30
1	55	52	5.38	-12.28	-12.22	5.32	-1.03	9.837e+04	-4.459e+04	-3.949e+04	9.326e+04	-2.652e+04
1	55	53	5.31	-12.24	-11.74	4.81	-2.91	1.256e+05	-3.428e+04	-2.801e+04	1.193e+05	-3.102e+04
1	55	54	11.66	-10.24	-9.30	10.72	-4.44	1.432e+05	-2.105e+04	1.188e+04	1.103e+05	-6.577e+04
1	55	55	6.46	-13.58	6.46	-13.58	-0.15	-1.717e+05	-2.507e+05	-2.128e+05	-2.096e+05	3.947e+04
1	55	56	9.38	-6.73	8.67	-6.02	3.31	-1.316e+05	-2.458e+05	-1.802e+05	-1.971e+05	5.649e+04

Parco Eolico "Bolina" – Progetto Definitivo
Relazione di calcolo preliminare delle fondazioni degli aerogeneratori G8 e G12

1	55	57	6.01	-2.71	5.80	-2.49	1.35	-1.570e+05	-2.292e+05	-1.930e+05	-1.931e+05	3.607e+04
1	55	58	7.73	-6.58	3.80	-2.65	6.39	-1.468e+05	-2.507e+05	-2.161e+05	-1.814e+05	4.898e+04
1	55	59	8.98	-5.47	0.43	3.08	7.10	-9.936e+04	-2.184e+05	-1.960e+05	-1.218e+05	4.655e+04
1	55	60	9.79	-6.46	-5.57	8.90	3.70	-1.895e+04	-1.535e+05	-1.514e+05	-2.098e+04	1.644e+04
1	55	61	5.55	-6.98	-6.97	5.53	0.47	6.256e+04	-1.186e+05	-1.185e+05	6.250e+04	-3266.18
1	55	62	7.82	-10.15	-10.15	7.82	-1.47e-02	6.743e+04	-6.049e+04	-5.362e+04	6.057e+04	-2.883e+04
1	55	63	15.07	-11.25	-10.63	14.45	-3.99	1.187e+05	-5.571e+04	-4.142e+04	1.044e+05	-4.783e+04
1	55	64	4.58	-13.43	3.43	-12.29	4.40	-1.707e+05	-2.103e+05	-1.876e+05	-1.934e+05	1.959e+04
1	55	65	7.95	-10.28	5.58	-7.91	6.13	-1.817e+05	-2.733e+05	-2.275e+05	-2.275e+05	4.579e+04
1	55	66	7.96	-5.87	4.68	-2.59	5.88	-1.315e+05	-2.458e+05	-1.971e+05	-1.803e+05	5.651e+04
1	55	67	7.86	-5.65	0.15	2.07	6.69	-1.305e+05	-2.121e+05	-1.920e+05	-1.505e+05	3.510e+04
1	55	68	11.15	-5.72	0.91	4.51	8.24	-8.549e+04	-1.971e+05	-1.505e+05	-1.320e+05	5.503e+04
1	55	69	8.48	-5.48	-3.50	6.49	4.88	-2.448e+04	-1.790e+05	-1.375e+05	-2.775e+04	2.224e+04
1	55	70	7.92	-8.15	-7.73	7.50	2.57	-2394.75	-1.197e+05	-1.180e+05	-4041.32	1.380e+04
1	55	71	10.00	-10.16	-10.07	9.91	1.35	4.428e+04	-1.102e+05	-1.099e+05	4.394e+04	-7219.59
1	55	72	12.68	-9.15	-9.15	12.68	-6.95e-02	1.053e+05	-1.152e+05	-1.133e+05	1.033e+05	-2.056e+04
1	55	73	1.42	-13.59	-2.23	-9.94	6.43	-1.444e+05	-2.171e+05	-1.807e+05	-1.808e+05	3.635e+04
1	55	74	2.92	-10.98	-0.75	-7.31	6.13	-1.707e+05	-2.103e+05	-1.639e+05	-1.877e+05	1.960e+04
1	55	75	6.70	-10.89	0.38	-4.57	8.44	-1.716e+05	-2.507e+05	-2.095e+05	-2.128e+05	3.950e+04
1	55	76	7.69	-9.77	-3.10	1.01	8.49	-1.127e+05	-2.285e+05	-1.998e+05	-1.414e+05	5.002e+04
1	55	77	9.19	-11.80	-8.11	5.49	8.00	-9.771e+04	-2.428e+05	-2.149e+05	-1.257e+05	5.723e+04
1	55	78	7.72	-8.35	-5.86	5.23	5.82	-4.495e+04	-1.914e+05	-1.689e+05	-6.741e+04	5.276e+04
1	55	79	10.01	-11.65	-10.15	8.51	5.50	-1.764e+04	-1.719e+05	-1.627e+05	-2.687e+04	3.660e+04
1	55	80	8.82	-9.62	-9.45	8.65	1.75	5.556e+04	-1.596e+05	-1.589e+05	5.479e+04	1.285e+04
1	55	81	8.53	-6.61	-6.56	8.48	0.88	5.424e+04	-1.068e+05	-1.064e+05	5.388e+04	-7613.00
1	55	82	8.93	-13.17	-9.46	5.21	8.26	-6.44e+04	-1.629e+05	-1.341e+05	-9.215e+04	4.265e+04
1	55	83	6.56	-8.36	-7.94	6.14	2.47	-3.433e+04	-1.796e+05	-1.510e+05	-6.292e+04	5.777e+04
1	55	84	4.79	-9.12	-7.17	2.83	4.83	-2.390e+04	-9.534e+04	-6.049e+04	-5.875e+04	3.571e+04
1	55	85	9.73	-12.75	-11.90	8.87	4.30	-2.713e+04	-1.079e+05	-8.086e+04	-5.420e+04	3.813e+04
1	55	86	3.61	-7.37	-6.49	2.72	2.98	-2.948e+04	-8.643e+04	-5.341e+04	-6.250e+04	2.811e+04
1	55	87	8.16	-7.91	-6.50	6.76	4.55	-1.798e+04	-7.584e+04	-5.357e+04	-4.025e+04	2.815e+04
1	55	88	3.09	-5.77	-5.36	2.68	1.87	-1.729e+04	-6.568e+04	-3.016e+04	-5.281e+04	2.138e+04
1	55	89	4.18	-5.14	-5.01	4.05	1.07	-7085.12	-5.889e+04	-3.410e+04	-3.188e+04	2.588e+04
1	55	90	3.15	-4.87	-4.75	3.03	0.97	-3684.57	-4.570e+04	-1.106e+04	-3.832e+04	1.599e+04
1	55	91	2.39	-3.13	-2.96	2.23	-0.94	5079.51	-4.481e+04	-1.284e+04	-2.689e+04	2.393e+04
1	55	92	3.01	-2.72	-2.70	2.98	0.39	2.805e+04	-1.950e+04	2.492e+04	-1.637e+04	1.180e+04
1	55	93	3.92	-2.77	-2.74	3.90	0.42	5870.11	-3.995e+04	-4666.44	-2.941e+04	1.928e+04
1	55	94	3.11	-1.14	-0.93	2.90	0.92	4610.47	-2.475e+04	2598.97	-2.274e+04	7417.15
1	55	95	4.99	-3.27	-2.59	4.30	2.28	6936.58	-2.549e+04	1545.20	-2.009e+04	1.207e+04
1	55	96	2.75	-0.72	-0.52	2.55	0.81	74.88	-2.262e+04	47.84	-2.259e+04	782.95
1	55	97	3.36	-0.72	-0.62	3.26	0.63	272.18	-2.005e+04	-824.59	-1.895e+04	4591.55
1	55	98	5.72	-7.70	-7.61	5.64	1.06	-5043.83	-1.168e+05	-1.130e+05	-8837.32	2.024e+04
1	55	99	6.85	-9.51	-9.25	6.59	2.03	-3334.58	-9.167e+04	-8.068e+04	-1.433e+04	2.916e+04
1	55	100	6.77	-7.95	-7.63	6.45	2.14	2476.14	-6.879e+04	-5.667e+04	-9644.17	2.677e+04
1	55	101	5.75	-6.26	-6.23	5.72	0.57	7021.35	-5.086e+04	-3.941e+04	-4430.08	2.306e+04
1	55	102	5.08	-5.41	-5.33	4.99	-0.94	1.182e+04	-3.308e+04	-2.318e+04	1917.57	1.861e+04
1	55	103	4.07	-2.97	-2.85	3.95	-0.90	2.855e+04	-8409.28	5209.64	1.493e+04	1.783e+04
1	55	104	3.54	-1.20	-1.17	3.51	0.40	8984.12	-1.233e+04	-6849.90	3502.94	9316.08
1	55	105	2.00	-1.70	-1.44	1.74	0.94	-2.81	-6401.10	-1860.69	-4543.21	2904.40
1	55	106	6.74	-8.72	-8.68	6.70	0.79	2.368e+04	-9.646e+04	-9.504e+04	2.225e+04	1.302e+04
1	55	107	6.09	-6.42	-5.61	5.29	3.06	2.322e+04	-7.239e+04	-6.170e+04	2.053e+04	1.581e+04
1	55	108	7.29	-11.62	-11.12	6.79	3.04	2.708e+04	-5.455e+04	-5.187e+04	2.440e+04	1.455e+04
1	55	109	5.28	-5.40	-5.38	5.26	-0.50	2.409e+04	-4.334e+04	-4.079e+04	2.155e+04	1.284e+04
1	55	110	2.95	-2.50	-2.36	2.82	-0.85	2.340e+04	-3.074e+04	-2.703e+04	1.969e+04	1.368e+04
1	55	111	3.63	-3.34	-3.30	3.59	-0.54	1.611e+04	-2.359e+04	-1.941e+04	1.192e+04	1.219e+04
1	55	112	4.62	-4.09	-4.00	4.53	0.89	1.250e+04	-1.078e+04	-8750.86	1.048e+04	6560.48
1	55	113	3.80	-3.39	-3.06	3.46	1.51	415.15	-1693.07	-1460.73	182.82	660.17
1	55	114	13.37	-11.27	-11.27	13.37	-0.23	4.515e+04	-7.429e+04	-7.413e+04	4.499e+04	-4348.21
1	55	115	6.32	-5.52	-5.52	6.32	-0.21	5.883e+04	-4.253e+04	-4.252e+04	5.882e+04	-1018.15
1	55	116	9.34	-6.82	-6.66	9.18	1.60	3.900e+04	-4.421e+04	-4.392e+04	3.871e+04	-4904.71
1	55	117	5.52	-4.89	-4.88	5.51	0.30	3.361e+04	-3.547e+04	-3.534e+04	3.348e+04	-3045.08
1	55	118	3.09	-4.59	-4.50	2.99	-0.86	3.160e+04	-2.486e+04	-2.472e+04	3.147e+04	-2801.80
1	55	119	1.31	-3.13	-3.01	1.19	0.72	3.757e+04	-7580.49	-7580.02	3.757e+04	144.54
1	55	120	3.14	-4.02	-2.89	2.01	2.61	2.088e+04	-1.029e+04	-9609.21	2.020e+04	-4543.58
1	55	121	1.99	-4.83	-4.21	1.37	1.96	7313.82	-449.57	2266.45	4597.80	-3702.53
1	55	122	13.18	-7.94	-7.89	13.13	1.04	6.812e+04	-7.336e+04	-6.980e+04	6.456e+04	-2.216e+04
1	55	123	8.70	-5.38	-5.13	8.46	-1.84	6.096e+04	-5.686e+04	-5.477e+04	5.888e+04	-1.553e+04
1	55	124	16.98	-7.67	-7.22	16.53	-3.30	4.481e+04	-3.947e+04	-3.737e+04	4.271e+04	-1.316e+04
1	55	125	8.50	-6.30	-6.26	8.46	0.80	3.944e+04	-3.441e+04	-3.157e+04	3.661e+04	-1.419e+04
1	55	126	4.89	-5.32	-4.80	4.38	2.24	3.500e+04	-2.802e+04	-2.609e+04	3.307e+04	-1.086e+04
1	55	127	2.61	-5.08	-4.89	2.43	1.18	2.605e+04	-2.399e+04	-2.289e+04	2.495e+04	-7320.99
1	55	128	2.99	-5.59	-5.56	2.96	0.52	1.820e+04	-1.370e+04	-1.275e+04	1.725e+04	-5411.49
1	55	129	1.08	-4.20	-3.78	0.66	1.43	2752.00	-391.58	430.98	1929.44	-1381.73

Parco Eolico "Bolina" – Progetto Definitivo
Relazione di calcolo preliminare delle fondazioni degli aerogeneratori G8 e G12

1	55	130	15.46	-6.06	-6.00	15.40	-1.11	8.524e+04	-5.191e+04	-4.638e+04	7.972e+04	-2.697e+04
1	55	131	16.72	-7.06	-6.93	16.59	-1.75	7.489e+04	-4.342e+04	-3.330e+04	6.478e+04	-3.308e+04
1	55	132	13.16	-7.26	-6.90	12.80	-2.68	5.838e+04	-3.697e+04	-2.687e+04	4.828e+04	-2.934e+04
1	55	133	9.71	-6.61	-6.40	9.50	-1.84	4.548e+04	-3.123e+04	-2.145e+04	3.570e+04	-2.558e+04
1	55	134	5.43	-5.55	-5.46	5.35	-0.95	3.709e+04	-2.481e+04	-1.592e+04	2.820e+04	-2.170e+04
1	55	135	3.58	-5.28	-5.21	3.51	0.79	3.601e+04	-1.337e+04	-7072.86	2.971e+04	-1.647e+04
1	55	136	3.40	-5.67	-5.34	3.08	1.69	1.957e+04	-1.404e+04	-7617.11	1.315e+04	-1.321e+04
1	55	137	0.77	-6.22	-5.85	0.41	1.56	3978.13	-289.81	1906.78	1781.54	-2133.05
1	55	138	17.11	-9.46	-9.30	16.95	-2.05	1.456e+05	-2.382e+04	8538.45	1.132e+05	-6.659e+04
1	55	139	21.80	-12.22	-10.94	20.52	-6.49	9.253e+04	-2.157e+04	1615.11	6.935e+04	-4.591e+04
1	55	140	15.20	-9.03	-7.78	13.95	-5.37	6.923e+04	-2.341e+04	-492.01	4.631e+04	-3.998e+04
1	55	141	11.12	-6.74	-6.26	10.64	-2.90	5.074e+04	-2.356e+04	-2752.54	2.994e+04	-3.336e+04
1	55	142	7.87	-6.07	-6.02	7.83	-0.78	3.840e+04	-2.158e+04	-4607.82	2.143e+04	-2.702e+04
1	55	143	4.85	-5.63	-5.57	4.78	-0.80	2.602e+04	-1.978e+04	-7351.62	1.359e+04	-2.037e+04
1	55	144	3.46	-5.81	-5.58	3.23	-1.45	1.665e+04	-1.277e+04	-4115.24	8002.10	-1.340e+04
1	55	145	1.65	-5.29	-5.29	1.65	-7.70e-02	2549.28	-447.92	1230.55	870.81	-1487.77
1	55	146	23.38	-14.18	-11.21	20.41	-10.14	1.340e+05	9477.47	4.582e+04	9.768e+04	-5.661e+04
1	55	147	18.86	-8.67	-6.10	16.29	-8.01	1.112e+05	9130.26	4.494e+04	7.536e+04	-4.870e+04
1	55	148	18.00	-8.15	-6.53	16.38	-6.31	7.330e+04	-6345.45	2.907e+04	3.788e+04	-3.958e+04
1	55	149	13.40	-6.96	-5.67	12.11	-4.98	5.153e+04	-1.154e+04	1.901e+04	2.098e+04	-3.152e+04
1	55	150	8.81	-6.14	-5.29	7.96	-3.46	3.711e+04	-1.279e+04	1.304e+04	1.128e+04	-2.493e+04
1	55	151	6.03	-6.09	-5.74	5.69	-2.01	3.032e+04	-8457.57	1.145e+04	1.041e+04	-1.938e+04
1	55	152	4.17	-6.33	-6.16	4.01	-1.32	1.664e+04	-1.011e+04	5800.16	733.04	-1.313e+04
1	55	153	1.72	-6.17	-6.02	1.57	-1.08	4733.41	35.07	4399.37	369.11	-1207.42
1	55	154	24.28	-7.61	-3.86	20.53	-10.27	1.630e+05	3.650e+04	8.876e+04	1.108e+05	-6.231e+04
1	55	155	20.11	-5.59	-1.14	15.66	-9.72	1.048e+05	2.207e+04	6.145e+04	6.543e+04	-4.132e+04
1	55	156	21.72	-7.18	-1.22	15.75	-11.70	6.895e+04	1.145e+04	4.565e+04	3.476e+04	-2.823e+04
1	55	157	15.41	-7.30	-4.15	12.25	-7.86	4.852e+04	493.17	3.309e+04	1.592e+04	-2.243e+04
1	55	158	11.05	-6.92	-5.14	9.27	-5.36	3.387e+04	-5318.84	2.262e+04	5935.74	-1.773e+04
1	55	159	6.87	-6.54	-5.13	5.46	-4.11	2.151e+04	-8279.29	1.334e+04	-103.85	-1.329e+04
1	55	160	4.08	-6.42	-4.91	2.57	-3.68	1.325e+04	-6206.34	8854.82	-1815.40	-8132.20
1	55	161	2.04	-6.02	-5.25	1.26	-2.37	5028.27	199.35	5027.54	200.08	59.28
1	55	162	24.49	0.11	4.36	20.24	-9.25	1.383e+05	6.070e+04	9.989e+04	9.910e+04	-3.879e+04
1	55	163	26.01	-4.81	2.86	18.34	-13.32	9.587e+04	3.978e+04	7.366e+04	6.200e+04	-2.743e+04
1	55	164	20.29	-7.20	-6.93e-04	13.09	-12.08	6.376e+04	2.347e+04	5.342e+04	3.381e+04	-1.759e+04
1	55	165	15.40	-7.10	-1.60	9.91	-9.67	4.285e+04	1.089e+04	3.817e+04	1.557e+04	-1.130e+04
1	55	166	10.74	-6.76	-2.77	6.74	-7.34	2.916e+04	3038.03	2.700e+04	5204.28	-7204.30
1	55	167	7.33	-6.80	-3.97	4.50	-5.66	2.169e+04	907.51	2.042e+04	2174.62	-4972.88
1	55	168	4.61	-6.99	-4.81	2.43	-4.53	1.257e+04	-3302.67	1.234e+04	-3072.28	-1898.25
1	55	169	1.95	-6.56	-4.93	0.31	-3.35	7292.48	343.95	6677.19	959.24	1974.02
1	55	170	27.10	-10.14	6.56	10.40	-18.52	1.360e+05	6.676e+04	1.047e+05	9.808e+04	-3.445e+04
1	55	171	24.30	-9.25	4.63	10.41	-16.52	8.362e+04	4.940e+04	7.124e+04	6.178e+04	-1.644e+04
1	55	172	19.44	-7.09	2.38	9.97	-12.71	5.437e+04	3.231e+04	5.122e+04	3.546e+04	-7724.25
1	55	173	15.17	-7.15	0.64	7.38	-10.64	3.499e+04	1.867e+04	3.472e+04	1.893e+04	-2070.18
1	55	174	11.30	-6.90	-0.82	5.23	-8.58	2.299e+04	8781.18	2.299e+04	8787.41	297.42
1	55	175	7.10	-6.72	-1.95	2.33	-6.57	1.409e+04	2399.71	1.396e+04	2534.59	1248.68
1	55	176	4.07	-6.38	-2.50	0.19	-5.05	9496.56	57.18	8989.90	563.83	2127.40
1	55	177	2.06	-6.06	-3.32	-0.69	-3.84	7620.02	325.48	5627.46	2318.04	3250.30
1	55	178	24.67	-6.38	9.35	8.94	-15.52	1.074e+05	6.454e+04	8.593e+04	8.598e+04	-2.141e+04
1	55	179	18.82	-6.31	6.15	6.37	-12.56	7.346e+04	5.366e+04	6.358e+04	6.354e+04	-9901.51
1	55	180	18.90	-7.49	5.61	5.80	-13.19	3.966e+04	3.826e+04	3.896e+04	3.896e+04	-700.58
1	55	181	13.90	-6.74	3.41	3.75	-10.32	2.686e+04	2.231e+04	2.459e+04	2.458e+04	2274.39
1	55	182	9.56	-6.23	1.51	1.82	-7.90	1.911e+04	1.140e+04	1.526e+04	1.525e+04	3855.45
1	55	183	6.71	-6.41	3.76e-02	0.26	-6.56	1.476e+04	6586.61	1.069e+04	1.066e+04	4085.13
1	55	184	4.50	-6.52	-0.98	-1.04	-5.51	1.018e+04	258.61	5222.03	5212.93	4958.87
1	55	185	1.79	-6.08	-2.27	-2.02	-3.94	8909.83	344.92	4629.87	4624.88	4282.45
1	55	186	23.39	-8.87	9.05	5.47	-16.03	1.360e+05	6.674e+04	9.806e+04	1.046e+05	-3.446e+04
1	55	187	20.85	-7.70	8.53	4.62	-14.14	8.363e+04	4.937e+04	6.181e+04	7.119e+04	-1.648e+04
1	55	188	17.13	-5.43	9.01	2.69	-10.83	5.439e+04	3.220e+04	3.538e+04	5.121e+04	-7771.82
1	55	189	13.48	-5.95	6.29	1.24	-9.38	3.498e+04	1.867e+04	1.894e+04	3.472e+04	-2072.76
1	55	190	10.10	-5.80	4.35	-3.88e-02	-7.64	2.298e+04	8821.12	8827.93	2.297e+04	310.33
1	55	191	6.20	-5.50	1.99	-1.29	-5.62	1.409e+04	2424.77	2557.73	1.396e+04	1238.23
1	55	192	3.57	-5.07	0.38	-1.88	-4.17	9489.60	61.94	562.85	8988.70	2114.58
1	55	193	1.94	-4.89	-0.62	-2.33	-3.31	7613.36	323.52	2314.93	5621.95	3248.28
1	55	194	18.73	0.26	14.75	4.24	-7.60	1.383e+05	6.068e+04	9.907e+04	9.990e+04	-3.880e+04
1	55	195	19.53	-2.74	13.33	3.45	-9.98	9.589e+04	3.975e+04	6.199e+04	7.365e+04	-2.746e+04
1	55	196	15.63	-4.82	9.38	1.42	-9.42	6.376e+04	2.346e+04	3.382e+04	5.340e+04	-1.761e+04
1	55	197	11.84	-4.75	7.09	5.51e-03	-7.50	4.285e+04	1.090e+04	1.560e+04	3.816e+04	-1.131e+04
1	55	198	7.92	-4.36	4.56	-1.00	-5.48	2.918e+04	3088.08	5273.85	2.699e+04	-7228.60
1	55	199	5.54	-4.46	3.26	-2.18	-4.20	2.170e+04	964.54	2235.89	2.043e+04	-4974.76
1	55	200	3.91	-4.69	2.23	-3.02	-3.40	1.256e+04	-3311.01	-3085.27	1.233e+04	-1879.32
1	55	201	1.66	-4.48	0.20	-3.02	-2.61	7297.39	348.03	965.63	6679.79	1977.50
1	55	202	14.21	-3.65	11.03	-0.47	-6.83	1.631e+05	3.652e+04	1.108e+05	8.877e+04	-6.230e+04

Parco Eolico "Bolina" – Progetto Definitivo
Relazione di calcolo preliminare delle fondazioni degli aerogeneratori G8 e G12

1	55	203	12.43	-2.28	8.17	1.98	-6.67	1.049e+05	2.203e+04	6.542e+04	6.147e+04	-4.137e+04
1	55	204	15.80	-4.52	9.65	1.63	-9.34	6.895e+04	1.145e+04	3.478e+04	4.562e+04	-2.824e+04
1	55	205	10.45	-4.26	7.47	-1.27	-5.92	4.852e+04	508.36	1.596e+04	3.308e+04	-2.243e+04
1	55	206	7.37	-3.82	5.81	-2.26	-3.88	3.387e+04	-5275.68	5973.92	2.262e+04	-1.772e+04
1	55	207	4.29	-3.19	3.13	-2.03	-2.71	2.152e+04	-8260.14	-49.41	1.331e+04	-1.331e+04
1	55	208	2.91	-3.04	1.51	-1.65	-2.52	1.324e+04	-6207.95	-1794.67	8825.93	-8145.47
1	55	209	1.74	-2.82	0.92	-2.00	-1.75	5008.23	193.99	194.67	5007.55	57.01
1	55	210	9.21	-5.94	5.68	-2.41	-6.41	1.341e+05	9379.75	9.772e+04	4.573e+04	-5.667e+04
1	55	211	9.10	-4.78	5.75	-1.43	-5.94	1.112e+05	9114.00	7.542e+04	4.491e+04	-4.872e+04
1	55	212	9.83	-4.40	8.06	-2.63	-4.70	7.328e+04	-6358.04	3.785e+04	2.907e+04	-3.958e+04
1	55	213	7.05	-3.28	5.35	-1.58	-3.83	5.154e+04	-1.155e+04	2.102e+04	1.898e+04	-3.153e+04
1	55	214	4.01	-2.37	2.58	-0.95	-2.66	3.715e+04	-1.275e+04	1.140e+04	1.300e+04	-2.493e+04
1	55	215	2.83	-1.97	2.34	-1.48	-1.46	3.036e+04	-8404.92	1.050e+04	1.146e+04	-1.938e+04
1	55	216	2.90	-2.14	2.71	-1.95	-0.96	1.662e+04	-1.013e+04	690.71	5804.50	-1.313e+04
1	55	217	1.32	-2.37	0.95	-1.99	-1.11	4733.63	41.83	375.24	4400.22	-1205.46
1	55	218	1.41	-4.59	0.76	-3.94	-1.86	1.456e+05	-2.392e+04	1.133e+05	8456.03	-6.665e+04
1	55	219	8.23	-8.09	5.30	-5.16	-6.27	9.254e+04	-2.162e+04	6.940e+04	1523.65	-4.589e+04
1	55	220	6.35	-6.18	2.63	-2.45	-5.73	6.927e+04	-2.352e+04	4.633e+04	-576.86	-4.003e+04
1	55	221	4.61	-3.76	2.26	-1.42	-3.76	5.077e+04	-2.356e+04	2.998e+04	-2772.73	-3.336e+04
1	55	222	2.74	-2.14	2.05	-1.45	-1.70	3.843e+04	-2.155e+04	2.147e+04	-4586.25	-2.701e+04
1	55	223	2.02	-1.78	0.87	-0.63	-1.74	2.606e+04	-1.977e+04	1.367e+04	-7384.42	-2.036e+04
1	55	224	3.09	-2.07	1.40	-0.38	-2.42	1.665e+04	-1.277e+04	8033.26	-4154.35	-1.339e+04
1	55	225	1.90	-0.80	1.26	-0.16	-1.15	2526.94	-459.89	862.09	1204.96	-1483.54
1	55	226	1.62	-7.87	-1.60	-4.65	-4.49	8.523e+04	-5.199e+04	7.971e+04	-4.647e+04	-2.697e+04
1	55	227	4.82	-8.85	-0.37	-3.66	-6.64	7.491e+04	-4.347e+04	6.481e+04	-3.337e+04	-3.307e+04
1	55	228	6.79	-8.14	1.15	-2.50	-7.23	5.841e+04	-3.699e+04	4.832e+04	-2.691e+04	-2.938e+04
1	55	229	5.54	-6.49	1.10	-2.05	-5.80	4.552e+04	-3.121e+04	3.576e+04	-2.146e+04	-2.556e+04
1	55	230	3.65	-5.40	-0.73	-1.02	-4.52	3.717e+04	-2.475e+04	2.834e+04	-1.592e+04	-2.165e+04
1	55	231	1.77	-2.39	0.13	-0.74	-2.04	3.610e+04	-1.332e+04	2.983e+04	-7044.66	-1.645e+04
1	55	232	2.39	-0.77	2.31	-0.69	-0.50	1.956e+04	-1.407e+04	1.311e+04	-7612.54	-1.324e+04
1	55	233	0.79	-1.16	0.64	-1.01	-0.52	3992.85	-280.81	1791.39	1920.65	-2135.85
1	55	234	7.12	-13.28	-0.43	-5.72	-9.85	6.811e+04	-7.336e+04	6.456e+04	-6.981e+04	-2.213e+04
1	55	235	8.00	-14.20	-3.83	-2.37	-11.08	6.108e+04	-5.690e+04	5.901e+04	-5.483e+04	-1.550e+04
1	55	236	14.07	-11.03	8.01	-4.97	-10.74	4.473e+04	-3.944e+04	4.264e+04	-3.735e+04	-1.310e+04
1	55	237	5.18	-6.82	2.23	-3.87	-5.17	3.945e+04	-3.440e+04	3.663e+04	-3.157e+04	-1.417e+04
1	55	238	1.94	-3.74	0.40	-2.20	-2.52	3.504e+04	-2.802e+04	3.311e+04	-2.609e+04	-1.087e+04
1	55	239	2.52	-4.02	0.37	-1.87	-3.07	2.611e+04	-2.399e+04	2.503e+04	-2.291e+04	-7272.96
1	55	240	4.43	-3.44	3.01	-2.01	-3.03	1.819e+04	-1.369e+04	1.726e+04	-1.276e+04	-5364.71
1	55	241	2.78	-0.42	1.90	0.47	-1.43	2725.60	-403.54	1912.16	409.89	-1372.47
1	55	242	8.37	-19.19	-0.82	-10.00	-13.00	4.516e+04	-7.428e+04	4.500e+04	-7.413e+04	-4253.51
1	55	243	5.63	-13.92	-3.46	-4.82	-9.75	5.897e+04	-4.246e+04	5.897e+04	-4.245e+04	-943.54
1	55	244	5.81	-8.86	2.80	-5.85	-5.92	3.902e+04	-4.425e+04	3.872e+04	-4.395e+04	-4984.02
1	55	245	5.47	-8.45	1.04	-4.02	-6.49	3.366e+04	-3.546e+04	3.353e+04	-3.533e+04	-3036.39
1	55	246	5.59	-9.01	0.14	-3.55	-7.06	3.169e+04	-2.477e+04	3.156e+04	-2.464e+04	-2712.84
1	55	247	3.44	-4.92	4.38e-02	-1.52	-4.11	3.769e+04	-7511.34	3.769e+04	-7510.62	179.79
1	55	248	2.92	-0.95	2.76	-0.80	-0.76	2.089e+04	-1.032e+04	2.020e+04	-9620.60	-4614.22
1	55	249	1.89	-2.30	1.83	-2.24	-0.51	7378.50	-441.36	4638.06	2299.08	-3730.93
1	55	250	7.76	-21.22	-5.55	-7.92	-14.44	2.373e+04	-9.651e+04	2.230e+04	-9.507e+04	1.305e+04
1	55	251	4.09	-14.84	-3.54	-7.21	-9.29	2.326e+04	-7.233e+04	2.057e+04	-6.964e+04	1.581e+04
1	55	252	3.54	-14.73	1.13	-12.31	-6.19	2.715e+04	-5.456e+04	2.447e+04	-5.188e+04	1.456e+04
1	55	253	6.51	-11.03	1.57	-6.09	-7.89	2.417e+04	-4.331e+04	2.163e+04	-4.077e+04	1.285e+04
1	55	254	5.94	-7.82	0.55	-2.43	-6.72	2.351e+04	-3.070e+04	1.981e+04	-2.700e+04	1.367e+04
1	55	255	6.19	-6.39	3.12	-3.32	-5.40	1.619e+04	-2.353e+04	1.198e+04	-1.933e+04	1.222e+04
1	55	256	6.61	-4.40	5.95	-3.74	-2.61	1.250e+04	-1.070e+04	1.047e+04	-8675.28	6546.84
1	55	257	4.88	-2.21	4.65	-1.99	-1.24	417.20	-1673.67	200.00	-1456.47	637.93
1	55	258	2.19	-19.05	-1.13	-15.73	-7.71	-5102.07	-1.169e+05	-8893.77	-1.131e+05	2.023e+04
1	55	259	4.89	-19.19	1.05	-15.35	-8.82	-3356.70	-9.166e+04	-1.435e+04	-8.067e+04	2.915e+04
1	55	260	6.05	-14.05	3.51	-11.51	-6.68	2485.62	-6.875e+04	-9634.08	-5.663e+04	2.677e+04
1	55	261	6.72	-11.70	4.07	-9.05	-6.46	7075.81	-5.080e+04	-4390.79	-3.933e+04	2.307e+04
1	55	262	7.44	-10.54	4.48	-7.58	-6.67	1.192e+04	-3.297e+04	1964.32	-2.301e+04	1.865e+04
1	55	263	6.78	-6.33	4.35	-3.91	-5.09	2.867e+04	-8329.68	1.502e+04	5320.32	1.785e+04
1	55	264	5.80	-1.73	5.19	-1.12	-2.04	8975.53	-1.231e+04	3560.31	-6890.22	9269.12
1	55	265	4.48	-1.39	4.25	-1.17	-1.14	8.72	-6337.46	-4479.34	-1849.39	2887.79
1	55	266	9.69	-19.85	6.11	-16.28	-9.63	-3.443e+04	-1.797e+05	-6.300e+04	-1.511e+05	5.774e+04
1	55	267	10.47	-19.24	8.84	-17.61	-6.77	-2.717e+04	-1.079e+05	-5.431e+04	-8.081e+04	3.815e+04
1	55	268	6.96	-11.65	6.56	-11.26	-2.69	-1.812e+04	-7.579e+04	-4.034e+04	-5.358e+04	2.806e+04
1	55	269	5.62	-10.26	4.04	-8.68	-4.75	-7063.41	-5.885e+04	-3.186e+04	-3.405e+04	2.587e+04
1	55	270	5.43	-8.21	2.61	-5.39	-5.53	5167.37	-4.477e+04	-2.682e+04	-1.279e+04	2.397e+04
1	55	271	6.09	-5.24	5.44	-4.60	-2.63	5951.07	-3.993e+04	-2.940e+04	-4575.57	1.929e+04
1	55	272	7.08	-3.64	7.02	-3.58	0.81	6939.61	-2.546e+04	-2.012e+04	1600.69	1.202e+04
1	55	273	6.87	-0.77	6.82	-0.72	-0.61	264.27	-2.004e+04	-1.894e+04	-830.33	4585.32
1	55	274	11.64	-21.25	11.02	-20.64	-4.47	-6.656e+04	-1.629e+05	-9.222e+04	-1.372e+05	4.257e+04
1	55	275	6.11	-15.87	4.96	-14.72	-4.91	-2.390e+04	-9.530e+04	-5.876e+04	-6.044e+04	3.569e+04

Parco Eolico "Bolina" – Progetto Definitivo
Relazione di calcolo preliminare delle fondazioni degli aerogeneratori G8 e G12

1	55	276	4.92	-12.95	4.04	-12.07	-3.87	-2.948e+04	-8.644e+04	-6.247e+04	-5.345e+04	2.812e+04
1	55	277	4.78	-10.40	4.22	-9.84	-2.87	-1.727e+04	-6.565e+04	-5.281e+04	-3.011e+04	2.136e+04
1	55	278	5.36	-8.78	4.98	-8.40	-2.29	-3587.80	-4.566e+04	-3.832e+04	-1.093e+04	1.597e+04
1	55	279	5.42	-5.19	5.13	-4.90	-1.73	2.816e+04	-1.948e+04	-1.634e+04	2.502e+04	1.181e+04
1	55	280	5.42	-1.63	5.42	-1.63	4.64e-02	4574.31	-2.473e+04	-2.271e+04	2556.26	7420.71
1	55	281	5.62	-0.91	5.61	-0.90	0.29	81.87	-2.260e+04	-2.257e+04	54.26	790.76
1	55	282	4.40	-21.02	3.68	-20.30	-4.21	-1.041e+05	-1.864e+05	-1.419e+05	-1.486e+05	4.105e+04
1	55	283	0.78	-14.74	0.29	-14.25	-2.72	-6.845e+04	-1.265e+05	-1.148e+05	-8.011e+04	2.326e+04
1	55	284	1.49	-13.81	1.37	-13.68	1.39	-4.047e+04	-9.477e+04	-8.890e+04	-4.633e+04	1.686e+04
1	55	285	3.65	-10.61	3.64	-10.60	-0.48	-2.299e+04	-7.364e+04	-7.166e+04	-2.497e+04	9802.91
1	55	286	3.58	-7.88	3.29	-7.59	-1.79	-1317.70	-5.933e+04	-5.912e+04	-1522.05	3436.96
1	55	287	4.44	-4.28	4.40	-4.24	0.61	4467.34	-5.583e+04	-5.579e+04	4425.88	-1580.80
1	55	288	5.38	-2.93	4.17	-1.72	2.94	7859.43	-3.892e+04	-3.866e+04	7607.00	-3426.95
1	55	289	6.68	-0.84	6.24	-0.39	1.77	367.10	-3.246e+04	-3.141e+04	-678.99	-5765.98
1	55	290	-0.70	-17.13	-0.70	-17.13	0.23	-1.220e+05	-1.661e+05	-1.548e+05	-1.333e+05	1.929e+04
1	55	291	0.16	-16.09	-0.21	-15.73	2.42	-8.258e+04	-1.257e+05	-1.248e+05	-8.346e+04	6104.58
1	55	292	1.78	-11.96	1.23	-11.41	2.70	-5.059e+04	-9.627e+04	-9.612e+04	-5.074e+04	-2641.05
1	55	293	2.54	-9.25	2.08	-8.79	2.28	-2.827e+04	-7.300e+04	-7.202e+04	-2.925e+04	-6555.19
1	55	294	3.36	-7.30	2.87	-6.81	2.23	-8958.92	-5.100e+04	-4.948e+04	-1.048e+04	-7847.00
1	55	295	3.86	-4.22	3.46	-3.82	1.75	3.059e+04	-2.346e+04	-1.994e+04	2.707e+04	-1.334e+04
1	55	296	4.56	-1.70	3.70	-0.83	2.16	4227.50	-2.939e+04	-2.725e+04	2095.91	-8191.77
1	55	297	5.24	-0.91	4.34	-1.45e-02	2.17	-23.21	-2.851e+04	-2.467e+04	-3866.20	-9732.41
1	55	298	2.99	-15.48	0.29	-12.77	6.53	-1.226e+05	-1.617e+05	-1.538e+05	-1.305e+05	1.572e+04
1	55	299	2.43	-13.09	0.31	-10.97	5.32	-7.849e+04	-1.146e+05	-1.123e+05	-8.081e+04	-8859.90
1	55	300	1.84	-9.93	5.70e-02	-8.15	4.22	-4.635e+04	-8.389e+04	-7.422e+04	-5.602e+04	-1.642e+04
1	55	301	1.88	-7.79	0.65	-6.56	3.22	-2.668e+04	-6.788e+04	-5.783e+04	-3.672e+04	-1.769e+04
1	55	302	1.46	-5.50	0.91	-4.95	1.88	-2648.92	-5.794e+04	-4.453e+04	-1.605e+04	-2.369e+04
1	55	303	3.16	-3.10	1.83	-1.77	2.56	2965.21	-5.684e+04	-4.219e+04	-1.169e+04	-2.572e+04
1	55	304	3.83	-2.19	1.43	0.21	2.95	7732.71	-4.021e+04	-2.777e+04	-4700.51	-2.101e+04
1	55	305	5.61	-0.79	3.66	1.17	2.95	324.41	-3.452e+04	-2.396e+04	-1.023e+04	-1.601e+04
1	55	306	2.53	-15.16	-0.87	-11.75	6.98	-1.150e+05	-1.246e+05	-1.198e+05	-1.199e+05	4796.94
1	55	307	1.40	-10.74	-1.04	-8.31	4.86	-4.323e+04	-6.671e+04	-5.501e+04	-5.494e+04	-1.174e+04
1	55	308	1.30	-8.48	-1.36	-5.81	4.36	-4.501e+04	-6.896e+04	-5.698e+04	-5.699e+04	-1.197e+04
1	55	309	1.50	-6.49	-0.87	-4.13	3.65	-2.499e+04	-5.904e+04	-4.202e+04	-4.202e+04	-1.703e+04
1	55	310	2.16	-5.15	-0.36	-2.63	3.47	-7774.68	-4.229e+04	-2.504e+04	-2.503e+04	-1.726e+04
1	55	311	2.95	-3.11	0.72	-0.88	2.92	3.128e+04	-1.770e+04	6757.24	6824.94	-2.449e+04
1	55	312	3.65	-1.56	1.27	0.83	2.60	4236.34	-2.431e+04	-1.004e+04	-1.003e+04	-1.427e+04
1	55	313	4.20	-0.77	1.96	1.47	2.48	-253.94	-2.545e+04	-1.286e+04	-1.285e+04	-1.260e+04
1	55	314	4.26	-15.32	-1.45	-9.62	8.90	-1.226e+05	-1.617e+05	-1.305e+05	-1.548e+05	1.572e+04
1	55	315	2.15	-12.14	-2.50	-7.50	6.69	-7.858e+04	-1.145e+05	-8.088e+04	-1.122e+05	-8797.65
1	55	316	0.78	-8.74	-3.36	-4.59	4.72	-4.630e+04	-8.376e+04	-5.584e+04	-7.421e+04	-1.632e+04
1	55	317	1.21	-6.59	-2.67	-2.72	3.90	-2.667e+04	-6.786e+04	-3.672e+04	-5.781e+04	-1.769e+04
1	55	318	0.57	-4.35	-1.98	-1.79	2.46	-2667.38	-5.794e+04	-1.613e+04	-4.447e+04	-2.373e+04
1	55	319	2.53	-2.57	-0.26	0.22	2.54	2930.58	-5.683e+04	-1.173e+04	-4.217e+04	-2.571e+04
1	55	320	2.88	-1.92	0.21	0.75	2.38	7723.14	-4.018e+04	-4639.71	-2.781e+04	-2.096e+04
1	55	321	4.56	-0.78	1.25	2.53	2.59	326.70	-3.450e+04	-1.022e+04	-2.395e+04	-1.600e+04
1	55	322	-2.63	-10.94	-7.59	-5.98	4.07	-1.219e+05	-1.662e+05	-1.332e+05	-1.548e+05	1.931e+04
1	55	323	0.17	-11.47	-5.66	-5.64	5.82	-8.255e+04	-1.257e+05	-8.344e+04	-1.248e+05	6143.15
1	55	324	1.20	-8.86	-4.57	-3.09	4.97	-5.059e+04	-9.625e+04	-5.074e+04	-9.610e+04	-2601.27
1	55	325	1.40	-6.62	-4.04	-1.18	3.75	-2.830e+04	-7.298e+04	-2.927e+04	-7.201e+04	-6525.06
1	55	326	1.93	-5.11	-3.41	0.23	3.01	-9041.42	-5.098e+04	-1.055e+04	-4.948e+04	-7804.35
1	55	327	2.40	-2.90	-1.81	1.31	2.15	3.053e+04	-2.346e+04	2.700e+04	-1.993e+04	-1.335e+04
1	55	328	3.11	-1.46	-0.35	1.99	1.97	4252.21	-2.938e+04	2111.82	-2.724e+04	-8209.95
1	55	329	3.50	-0.80	0.23	2.46	1.84	-27.94	-2.851e+04	-3876.62	-2.466e+04	-9736.42
1	55	330	1.37	-11.28	-8.95	-0.96	4.91	-1.041e+05	-1.864e+05	-1.486e+05	-1.420e+05	4.102e+04
1	55	331	1.77	-9.11	-3.70	-3.64	5.44	-6.838e+04	-1.266e+05	-8.006e+04	-1.149e+05	2.331e+04
1	55	332	2.40	-10.75	-6.41	-1.94	6.18	-4.046e+04	-9.482e+04	-4.636e+04	-8.893e+04	1.690e+04
1	55	333	1.93	-6.54	-5.45	0.84	2.84	-2.303e+04	-7.365e+04	-2.501e+04	-7.167e+04	9815.63
1	55	334	0.94	-4.13	-4.04	0.85	0.68	-1387.80	-5.933e+04	-1586.76	-5.913e+04	3389.35
1	55	335	2.61	-2.54	-1.98	2.05	1.60	4398.87	-5.582e+04	4357.87	-5.578e+04	-1570.69
1	55	336	3.43	-2.49	-0.87	1.81	2.64	7848.98	-3.890e+04	7607.12	-3.866e+04	-3353.80
1	55	337	4.03	-0.75	-0.11	3.39	1.63	372.33	-3.244e+04	-671.98	-3.140e+04	-5760.06
1	69	1	1.33	-5.16	-4.23	0.41	-2.27	5.417e+04	-1.068e+05	5.381e+04	-1.064e+05	-7600.46
1	69	2	3.14	-6.65	-5.82	2.32	-2.71	5.546e+04	-1.596e+05	5.469e+04	-1.588e+05	1.285e+04
1	69	3	5.05	-6.68	-6.51	4.89	-1.37	4.416e+04	-1.103e+05	4.382e+04	-1.099e+05	-7225.01
1	69	4	3.02	-5.00	-4.93	2.95	-0.74	1.052e+05	-1.152e+05	1.032e+05	-1.133e+05	-2.054e+04
1	69	5	4.10	-4.73	-4.68	4.06	0.65	6.730e+04	-6.053e+04	6.044e+04	-5.367e+04	-2.882e+04
1	69	6	4.18	-6.50	-5.42	3.10	3.22	1.185e+05	-5.578e+04	1.042e+05	-4.150e+04	-4.780e+04
1	69	7	4.11	-3.21	-1.27	2.17	3.23	1.254e+05	-3.434e+04	1.191e+05	-2.808e+04	-3.100e+04
1	69	8	3.81	-4.73	-2.66	1.74	3.65	1.431e+05	-2.110e+04	1.102e+05	1.180e+04	-6.573e+04
1	69	9	4.99	-4.83	7.33e-02	8.00e-02	4.91	1.569e+05	1.740e+04	1.053e+05	6.896e+04	-6.734e+04
1	69	10	3.79	-4.17	-0.72	0.34	3.95	1.915e+05	2.285e+04	1.497e+05	6.465e+04	-7.282e+04
1	69	11	3.09	-4.10	1.11	-2.12	3.22	1.669e+05	6.559e+04	1.348e+05	9.775e+04	-4.717e+04

Parco Eolico "Bolina" – Progetto Definitivo
Relazione di calcolo preliminare delle fondazioni degli aerogeneratori G8 e G12

1	69	12	3.55	-3.18	1.79	-1.41	2.96	1.878e+05	4.220e+04	1.422e+05	8.777e+04	-6.751e+04
1	69	13	4.61	-4.04	4.57	-3.99	0.64	2.033e+05	6.205e+04	1.416e+05	1.237e+05	-7.006e+04
1	69	14	6.02	-4.11	5.27	-3.36	2.66	2.084e+05	9.731e+04	1.539e+05	1.518e+05	-5.553e+04
1	69	15	6.11	-4.70	6.08	-4.67	-0.60	2.253e+05	1.130e+05	1.692e+05	1.692e+05	-5.615e+04
1	69	16	5.35	-3.45	5.35	-3.45	7.47e-02	1.753e+05	9.883e+04	1.401e+05	1.340e+05	-3.813e+04
1	69	17	5.24	-3.04	5.09	-2.89	-1.13	1.753e+05	9.883e+04	1.341e+05	1.401e+05	-3.814e+04
1	69	18	4.24	-1.44	4.21	-1.40	-0.43	1.827e+05	7.955e+04	1.311e+05	1.311e+05	-5.157e+04
1	69	19	7.04	-8.42	-5.87	4.49	-5.74	-1.772e+04	-1.719e+05	-2.694e+04	-1.627e+05	3.656e+04
1	69	20	4.27	-5.27	-4.93	3.93	-1.78	-2485.00	-1.197e+05	-4124.79	-1.181e+05	1.377e+04
1	69	21	2.95	-3.36	-3.36	2.95	-9.69e-03	6.241e+04	-1.186e+05	6.235e+04	-1.185e+05	-3274.75
1	69	22	5.51	-3.74	-3.11	4.88	2.33	9.818e+04	-4.465e+04	9.308e+04	-3.955e+04	-2.651e+04
1	69	23	4.36	-4.30	3.63e-02	2.13e-02	4.33	1.702e+05	2.794e+04	1.397e+05	5.845e+04	-5.839e+04
1	69	24	3.79	-5.52	3.21	-4.93	2.26	2.050e+05	7.515e+04	1.581e+05	1.220e+05	-6.235e+04
1	69	25	3.42	-3.06	3.42	-3.06	-3.15e-02	1.881e+05	8.461e+04	1.364e+05	1.364e+05	-5.177e+04
1	69	26	5.03	-4.17	4.71	-3.86	-1.67	2.033e+05	6.204e+04	1.237e+05	1.416e+05	-7.006e+04
1	69	27	6.53	-5.87	4.91	-4.25	-4.17	2.084e+05	9.729e+04	1.518e+05	1.539e+05	-5.554e+04
1	69	28	5.14	-7.36	-3.96	1.73	-5.57	-4.501e+04	-1.913e+05	-6.742e+04	-1.689e+05	5.270e+04
1	69	29	2.80	-5.39	-3.33	0.74	-3.55	-2.453e+04	-1.790e+05	-2.779e+04	-1.757e+05	2.221e+04
1	69	30	3.34	-6.22	-5.52	2.64	-2.49	-1.901e+04	-1.534e+05	-2.104e+04	-1.514e+05	1.640e+04
1	69	31	4.84	-5.22	-5.21	4.84	0.12	3.541e+04	-9.983e+04	3.519e+04	-9.962e+04	-5352.64
1	69	32	1.77	-1.81	1.06e-05	-4.15e-02	1.79	1.888e+05	1190.17	1.776e+05	1.244e+04	-4.454e+04
1	69	33	5.22	-4.94	5.22	-4.93	0.10	2.598e+05	5.871e+04	1.592e+05	1.592e+05	-1.005e+05
1	69	34	6.18	-3.54	5.57	-2.93	-2.34	2.050e+05	7.515e+04	1.221e+05	1.580e+05	-6.236e+04
1	69	35	5.04	-3.13	3.40	-1.50	-3.27	1.669e+05	6.558e+04	9.776e+04	1.347e+05	-4.717e+04
1	69	36	5.67	-5.32	2.88	-2.54	-4.78	1.878e+05	4.218e+04	8.778e+04	1.422e+05	-6.752e+04
1	69	37	4.38	-7.17	-2.71	-7.92e-02	-5.63	-9.771e+04	-2.427e+05	-1.256e+05	-2.149e+05	5.715e+04
1	69	38	4.43	-6.96	-2.15	-0.38	-5.63	-8.550e+04	-1.969e+05	-1.320e+05	-1.505e+05	5.495e+04
1	69	39	3.70	-5.52	-1.48	-0.34	-4.58	-9.933e+04	-2.183e+05	-1.217e+05	-1.959e+05	4.649e+04
1	69	40	1.37	-2.25	-0.71	-0.17	-1.79	-7.274e+04	-2.507e+05	-7.862e+04	-2.448e+05	3.181e+04
1	69	41	8.24e-02	-7.27e-02	4.60e-03	5.19e-03	7.75e-02	-3.234e+04	-4.556e+04	-3.894e+04	-3.896e+04	-6612.83
1	69	42	2.22	-1.49	0.59	0.14	-1.84	1.888e+05	1184.31	1.244e+04	1.775e+05	-4.455e+04
1	69	43	5.34	-3.77	1.33	0.25	-4.52	1.702e+05	2.792e+04	5.844e+04	1.397e+05	-5.840e+04
1	69	44	6.66	-4.27	1.95	0.44	-5.41	1.569e+05	1.738e+04	6.896e+04	1.053e+05	-6.735e+04
1	69	45	5.80	-6.85	2.58	-3.62	-5.51	1.915e+05	2.283e+04	6.465e+04	1.497e+05	-7.283e+04
1	69	46	4.25	-7.28	-0.83	-2.19	-5.72	-1.126e+05	-2.284e+05	-1.413e+05	-1.997e+05	4.996e+04
1	69	47	3.31	-5.29	-0.40	-1.59	-4.26	-1.304e+05	-2.119e+05	-1.504e+05	-1.920e+05	3.506e+04
1	69	48	4.18	-4.71	2.63	-3.16	-3.37	-1.467e+05	-2.505e+05	-1.812e+05	-2.159e+05	4.892e+04
1	69	49	3.66	-4.94	3.64	-4.92	-0.38	-1.365e+05	-3.088e+05	-2.227e+05	-2.227e+05	8.614e+04
1	69	50	1.08	-1.22	-4.12e-02	-9.78e-02	1.15	-7.277e+04	-2.507e+05	-2.449e+05	-7.865e+04	3.180e+04
1	69	51	4.66	-4.00	-3.97	4.63	-0.53	3.535e+04	-9.986e+04	-9.964e+04	3.514e+04	-5374.87
1	69	52	4.15	-4.60	-2.97	2.52	-3.41	9.814e+04	-4.467e+04	-3.957e+04	9.303e+04	-2.652e+04
1	69	53	4.28	-3.81	0.18	0.30	-4.05	1.253e+05	-3.435e+04	-2.808e+04	1.191e+05	-3.101e+04
1	69	54	4.53	-5.81	0.22	-1.50	-5.10	1.431e+05	-2.111e+04	1.180e+04	1.102e+05	-6.573e+04
1	69	55	5.02	-9.26	0.78	-5.03	-6.52	-1.716e+05	-2.505e+05	-2.127e+05	-2.094e+05	3.947e+04
1	69	56	1.99	-6.15	0.95	-5.11	-2.72	-1.315e+05	-2.456e+05	-1.801e+05	-1.970e+05	5.647e+04
1	69	57	1.08	-4.02	1.00	-3.94	-0.63	-1.569e+05	-2.290e+05	-1.929e+05	-1.929e+05	3.603e+04
1	69	58	1.99	-5.28	1.82	-5.11	1.10	-1.467e+05	-2.505e+05	-2.159e+05	-1.812e+05	4.892e+04
1	69	59	2.85	-3.26	-0.14	-0.27	3.06	-9.938e+04	-2.183e+05	-1.959e+05	-1.217e+05	4.647e+04
1	69	60	4.80	-2.89	-2.78	4.70	0.88	-1.906e+04	-1.534e+05	-1.514e+05	-2.109e+04	1.639e+04
1	69	61	3.03	-2.08	-2.03	2.98	-0.47	6.237e+04	-1.186e+05	-1.185e+05	6.231e+04	-3281.98
1	69	62	4.38	-3.72	-2.23	2.89	-3.14	6.727e+04	-6.054e+04	-5.367e+04	6.041e+04	-2.882e+04
1	69	63	4.11	-6.54	-3.18	0.75	-4.95	1.185e+05	-5.578e+04	-4.150e+04	1.042e+05	-4.780e+04
1	69	64	3.05	-6.69	0.59	-4.23	-4.23	-1.706e+05	-2.102e+05	-1.876e+05	-1.932e+05	1.960e+04
1	69	65	2.90	-7.19	1.90	-6.19	-3.01	-1.816e+05	-2.731e+05	-2.274e+05	-2.274e+05	4.578e+04
1	69	66	1.39	-5.37	1.34	-5.32	-0.54	-1.315e+05	-2.456e+05	-1.970e+05	-1.801e+05	5.646e+04
1	69	67	0.61	-3.56	-0.31	-2.64	1.73	-1.304e+05	-2.119e+05	-1.920e+05	-1.504e+05	3.505e+04
1	69	68	2.86	-3.35	-5.08e-02	-0.44	3.10	-8.553e+04	-1.970e+05	-1.505e+05	-1.320e+05	5.494e+04
1	69	69	2.82	-2.06	-1.40	2.15	1.67	-2.457e+04	-1.789e+05	-1.757e+05	-2.783e+04	2.220e+04
1	69	70	3.76	-3.39	-3.23	3.60	-1.07	-2510.40	-1.197e+05	-1.180e+05	-4149.79	1.376e+04
1	69	71	4.46	-5.93	-4.37	2.89	-3.71	4.412e+04	-1.103e+05	-1.099e+05	4.378e+04	-7224.24
1	69	72	2.48	-6.81	-4.34	1.21e-02	-4.11	1.051e+05	-1.152e+05	-1.132e+05	1.032e+05	-2.054e+04
1	69	73	2.72	-6.58	-0.24	-3.62	-4.33	-1.443e+05	-2.171e+05	-1.807e+05	-1.807e+05	3.638e+04
1	69	74	2.20	-7.01	0.67	-5.49	-3.42	-1.706e+05	-2.102e+05	-1.932e+05	-1.876e+05	1.960e+04
1	69	75	0.67	-4.74	0.44	-4.52	-1.09	-1.716e+05	-2.505e+05	-2.094e+05	-2.127e+05	3.946e+04
1	69	76	-0.65	-2.57	-1.07	-2.15	0.79	-1.127e+05	-2.284e+05	-1.997e+05	-1.413e+05	4.996e+04
1	69	77	0.41	-3.72	-2.62	-0.69	1.82	-9.773e+04	-2.427e+05	-2.148e+05	-1.256e+05	5.715e+04
1	69	78	-0.14	-2.10	-2.10	-0.14	-3.55e-02	-4.503e+04	-1.913e+05	-1.689e+05	-6.745e+04	5.270e+04
1	69	79	1.72	-4.38	-3.86	1.19	-1.71	-1.775e+04	-1.719e+05	-1.627e+05	-2.697e+04	3.655e+04
1	69	80	3.21	-7.29	-5.32	1.24	-4.10	5.542e+04	-1.596e+05	-1.588e+05	5.465e+04	1.285e+04
1	69	81	2.31	-8.69	-5.30	-1.08	-5.08	5.414e+04	-1.067e+05	-1.064e+05	5.378e+04	-7595.28
1	69	82	-1.06	-3.27	-2.59	-1.74	1.02	-6.652e+04	-1.628e+05	-1.372e+05	-9.213e+04	4.256e+04
1	69	83	2.83	-5.49	-3.12	0.46	-3.76	-3.439e+04	-1.797e+05	-1.511e+05	-6.301e+04	5.779e+04
1	69	84	-1.13	-3.53	-2.34	-2.32	-1.20	-2.393e+04	-9.535e+04	-6.052e+04	-5.876e+04	3.570e+04

Parco Eolico "Bolina" – Progetto Definitivo
Relazione di calcolo preliminare delle fondazioni degli aerogeneratori G8 e G12

1	69	85	3.40	-7.34	-7.20	3.26	-1.25	-2.723e+04	-1.079e+05	-8.080e+04	-5.433e+04	3.811e+04
1	69	86	-1.31	-3.57	-2.67	-2.21	-1.10	-2.945e+04	-8.647e+04	-5.340e+04	-6.253e+04	2.814e+04
1	69	87	1.79	-3.61	-3.10	1.28	1.58	-1.809e+04	-7.584e+04	-5.359e+04	-4.033e+04	2.810e+04
1	69	88	-1.40	-3.23	-2.27	-2.36	-0.91	-1.731e+04	-6.571e+04	-3.018e+04	-5.283e+04	2.138e+04
1	69	89	-0.58	-3.14	-2.50	-1.22	-1.11	-7094.58	-5.892e+04	-3.411e+04	-3.190e+04	2.589e+04
1	69	90	-1.20	-3.12	-2.28	-2.04	-0.95	-3743.82	-4.573e+04	-1.113e+04	-3.834e+04	1.599e+04
1	69	91	0.91	-4.64	-1.07	-2.66	-2.66	5125.15	-4.489e+04	-1.287e+04	-2.689e+04	2.400e+04
1	69	92	-0.55	-2.49	-1.14	-1.90	-0.89	2.802e+04	-1.956e+04	2.486e+04	-1.641e+04	1.184e+04
1	69	93	-0.35	-1.61	-1.60	-0.36	-0.12	5864.65	-3.997e+04	-4687.77	-2.942e+04	1.930e+04
1	69	94	-0.17	-1.87	-0.31	-1.73	0.46	4639.21	-2.479e+04	2619.01	-2.277e+04	7441.69
1	69	95	2.40	-3.86	-2.19	0.74	2.77	6907.95	-2.547e+04	1556.55	-2.012e+04	1.203e+04
1	69	96	-0.33	-1.75	-0.39	-1.69	0.29	72.98	-2.265e+04	45.26	-2.262e+04	793.07
1	69	97	0.65	-0.91	-0.53	0.26	0.68	273.50	-2.006e+04	-822.88	-1.896e+04	4592.26
1	69	98	0.42	-7.53	-5.87	-1.24	-3.23	-5117.37	-1.168e+05	-1.130e+05	-8914.98	2.024e+04
1	69	99	3.54e-02	-6.86	-6.33	-0.50	-1.84	-3376.09	-9.164e+04	-8.065e+04	-1.436e+04	2.914e+04
1	69	100	0.40	-5.48	-5.41	0.32	-0.67	2459.11	-6.876e+04	-5.664e+04	-9656.61	2.676e+04
1	69	101	0.87	-4.99	-4.63	0.51	-1.42	7027.77	-5.085e+04	-3.939e+04	-4431.83	2.306e+04
1	69	102	1.52	-5.11	-4.17	0.58	-2.32	1.183e+04	-3.307e+04	-2.316e+04	1918.56	1.863e+04
1	69	103	1.22	-2.88	-2.00	0.33	-1.69	2.860e+04	-8449.27	5194.54	1.496e+04	1.787e+04
1	69	104	1.11	-0.96	-0.84	0.99	0.47	8999.58	-1.235e+04	-6867.81	3512.90	9330.55
1	69	105	0.28	-1.36	-1.07	-3.09e-03	0.62	2.01	-6406.14	-1867.64	-4536.49	2912.97
1	69	106	2.09	-10.23	-4.44	-3.70	-6.15	2.370e+04	-9.645e+04	-9.501e+04	2.227e+04	1.305e+04
1	69	107	-1.44	-5.11	-2.77	-3.78	-1.76	2.327e+04	-7.238e+04	-6.971e+04	2.059e+04	1.578e+04
1	69	108	0.16	-9.79	-9.78	0.16	-0.13	2.709e+04	-5.441e+04	-5.174e+04	2.442e+04	1.451e+04
1	69	109	1.80	-5.68	-3.83	-4.94e-02	-3.23	2.413e+04	-4.332e+04	-4.077e+04	2.158e+04	1.287e+04
1	69	110	1.92	-4.17	-0.75	-1.50	-3.02	2.349e+04	-3.079e+04	-2.707e+04	1.978e+04	1.372e+04
1	69	111	1.99	-3.41	-2.43	1.01	-2.08	1.615e+04	-2.360e+04	-1.940e+04	1.194e+04	1.222e+04
1	69	112	3.78	-3.90	-3.90	3.78	0.12	1.246e+04	-1.072e+04	-8693.24	1.044e+04	6546.20
1	69	113	2.24	-1.84	-1.81	2.22	0.34	409.25	-1693.20	-1461.26	177.31	658.67
1	69	114	4.93	-11.61	-7.47	0.79	-7.17	4.506e+04	-7.421e+04	-7.405e+04	4.491e+04	-4278.09
1	69	115	2.32	-8.03	-2.64	-3.08	-5.17	5.893e+04	-4.252e+04	-4.251e+04	5.893e+04	-960.24
1	69	116	3.36	-5.12	-4.49	2.73	-2.22	3.898e+04	-4.420e+04	-4.391e+04	3.869e+04	-4937.09
1	69	117	2.45	-4.72	-2.79	0.52	-3.18	3.364e+04	-3.544e+04	-3.531e+04	3.350e+04	-3022.18
1	69	118	2.72	-5.84	-2.56	-0.57	-4.16	3.167e+04	-2.479e+04	-2.466e+04	3.154e+04	-2730.28
1	69	119	1.11	-2.89	-0.94	-0.84	-2.00	3.768e+04	-7571.11	-7570.40	3.768e+04	179.17
1	69	120	2.13	-1.23	-1.14	2.04	0.53	2.088e+04	-1.031e+04	-9623.55	2.020e+04	-4576.62
1	69	121	0.83	-2.13	-2.07	0.77	0.41	7342.14	-446.57	2271.72	4623.84	-3712.53
1	69	122	4.27	-9.03	-4.50	-0.27	-6.30	6.805e+04	-7.335e+04	-6.980e+04	6.450e+04	-2.212e+04
1	69	123	6.19	-10.87	-0.80	-3.88	-8.39	6.104e+04	-5.691e+04	-5.485e+04	5.898e+04	-1.545e+04
1	69	124	12.86	-8.26	-3.73	8.33	-8.67	4.460e+04	-3.942e+04	-3.734e+04	4.253e+04	-1.304e+04
1	69	125	3.60	-4.39	-2.71	1.92	-3.25	3.945e+04	-3.437e+04	-3.155e+04	3.663e+04	-1.416e+04
1	69	126	0.49	-1.76	-1.08	-0.19	-1.03	3.510e+04	-2.801e+04	-2.608e+04	3.316e+04	-1.087e+04
1	69	127	1.70	-2.89	-1.32	0.13	-2.18	2.612e+04	-2.396e+04	-2.288e+04	2.504e+04	-7273.12
1	69	128	4.25	-3.21	-2.03	3.07	-2.72	1.816e+04	-1.365e+04	-1.272e+04	1.723e+04	-5354.94
1	69	129	2.21	-0.22	0.41	1.58	-1.07	2730.13	-399.92	415.96	1914.25	-1374.07
1	69	130	-0.37	-6.18	-3.50	-3.05	-2.90	8.518e+04	-5.191e+04	-4.639e+04	7.966e+04	-2.695e+04
1	69	131	3.80	-8.00	-2.47	-1.73	-5.89	7.485e+04	-4.341e+04	-3.332e+04	6.477e+04	-3.303e+04
1	69	132	5.78	-7.14	-1.18	-0.18	-6.44	5.837e+04	-3.695e+04	-2.688e+04	4.830e+04	-2.930e+04
1	69	133	4.83	-5.59	-0.76	6.14e-04	-5.20	4.551e+04	-3.117e+04	-2.144e+04	3.577e+04	-2.553e+04
1	69	134	3.61	-4.97	0.24	-1.61	-4.19	3.718e+04	-2.471e+04	-1.590e+04	2.837e+04	-2.162e+04
1	69	135	2.01	-2.02	0.39	-0.41	-1.97	3.613e+04	-1.330e+04	-7030.20	2.986e+04	-1.645e+04
1	69	136	2.52	-5.04e-02	0.22	2.26	-0.78	1.957e+04	-1.406e+04	-7598.84	1.311e+04	-1.325e+04
1	69	137	1.01	-0.39	6.49e-02	0.55	-0.66	4006.92	-282.52	1926.81	1797.59	-2143.74
1	69	138	-0.82	-5.70	-1.44	-5.07	-1.63	1.456e+05	-2.386e+04	8526.89	1.132e+05	-6.663e+04
1	69	139	4.99	-7.20	-3.11	0.90	-5.76	9.246e+04	-2.151e+04	1623.73	6.933e+04	-4.584e+04
1	69	140	4.72	-6.29	-0.54	-1.03	-5.50	6.925e+04	-2.343e+04	-521.92	4.634e+04	-3.998e+04
1	69	141	3.58	-3.57	0.68	-0.67	-3.51	5.079e+04	-2.351e+04	-2738.87	3.002e+04	-3.334e+04
1	69	142	1.81	-1.22	0.74	-0.15	-1.45	3.850e+04	-2.153e+04	-4553.76	2.153e+04	-2.704e+04
1	69	143	2.84	-1.78	1.58	-0.53	-2.05	2.609e+04	-1.973e+04	-7355.02	1.372e+04	-2.034e+04
1	69	144	4.53	-1.79	1.88	0.85	-3.12	1.663e+04	-1.272e+04	-4127.26	8037.58	-1.336e+04
1	69	145	3.21	0.22	2.39	1.04	-1.33	2538.93	-456.61	1222.61	859.70	-1486.73
1	69	146	7.51	-8.91	4.11	-5.51	-6.65	1.340e+05	9440.77	4.569e+04	9.772e+04	-5.657e+04
1	69	147	5.10	-5.39	1.95	-2.24	-4.81	1.112e+05	9157.24	4.491e+04	7.543e+04	-4.868e+04
1	69	148	4.96	-2.93	0.30	1.74	-3.88	7.328e+04	-6345.47	2.911e+04	3.782e+04	-3.957e+04
1	69	149	4.14	-2.28	1.61	0.25	-3.14	5.157e+04	-1.149e+04	1.902e+04	2.106e+04	-3.151e+04
1	69	150	3.47	-2.36	2.56	-1.46	-2.11	3.722e+04	-1.265e+04	1.305e+04	1.152e+04	-2.492e+04
1	69	151	2.58	-0.65	2.13	-0.20	-1.12	3.044e+04	-8342.65	1.152e+04	1.058e+04	-1.939e+04
1	69	152	2.69	0.80	1.78	1.71	-0.95	1.665e+04	-1.013e+04	5859.34	664.01	-1.314e+04
1	69	153	2.15	0.18	1.81	0.52	-0.74	4778.46	45.86	4445.51	378.81	-1210.32
1	69	154	5.32	-4.69	3.34	-2.71	-3.98	1.629e+05	3.651e+04	8.869e+04	1.108e+05	-6.225e+04
1	69	155	7.66	-5.91	6.43	-4.69	-3.88	1.048e+05	2.200e+04	6.138e+04	6.546e+04	-4.137e+04
1	69	156	10.45	-4.52	5.89	4.56e-02	-6.89	6.885e+04	1.150e+04	4.557e+04	3.478e+04	-2.817e+04
1	69	157	5.13	-1.97	2.77	0.39	-3.34	4.856e+04	560.18	3.311e+04	1.602e+04	-2.243e+04

Parco Eolico "Bolina" – Progetto Definitivo
Relazione di calcolo preliminare delle fondazioni degli aerogeneratori G8 e G12

1	69	158	2.98	-0.22	1.80	0.97	-1.54	3.397e+04	-5231.05	2.270e+04	6035.30	-1.774e+04
1	69	159	2.95	-0.48	2.65	-0.19	-0.96	2.158e+04	-8193.51	1.334e+04	39.59	-1.332e+04
1	69	160	3.98	-0.52	3.55	-9.48e-02	-1.32	1.324e+04	-6164.10	8838.41	-1757.71	-8130.62
1	69	161	3.21	0.65	3.16	0.70	-0.34	5031.79	188.14	5030.96	188.97	63.24
1	69	162	4.33	-1.93	3.65	-1.26	-1.94	1.382e+05	6.064e+04	9.983e+04	9.904e+04	-3.879e+04
1	69	163	5.90	-3.19	4.94	-2.24	-2.78	9.587e+04	3.976e+04	7.362e+04	6.201e+04	-2.745e+04
1	69	164	5.87	-2.31	4.69	-1.13	-2.87	6.378e+04	2.349e+04	5.341e+04	3.386e+04	-1.762e+04
1	69	165	4.47	-1.16	3.75	-0.44	-1.88	4.291e+04	1.096e+04	3.819e+04	1.568e+04	-1.134e+04
1	69	166	3.35	-0.95	3.26	-0.86	-0.58	2.927e+04	3209.23	2.704e+04	5436.52	-7285.59
1	69	167	2.53	0.23	2.48	0.29	-0.34	2.180e+04	1057.43	2.051e+04	2345.72	-5006.26
1	69	168	2.56	1.22	2.20	1.58	-0.59	1.261e+04	-3345.07	1.239e+04	-3128.09	-1847.69
1	69	169	2.16	0.60	2.16	0.60	4.58e-02	7352.27	354.79	6730.17	976.89	1991.52
1	69	170	4.65	-2.76	4.23	-2.34	-1.71	1.360e+05	6.672e+04	1.047e+05	9.803e+04	-3.448e+04
1	69	171	5.38	-2.77	4.77	-2.16	-2.15	8.368e+04	4.943e+04	7.120e+04	6.190e+04	-1.648e+04
1	69	172	4.17	0.71	3.54	1.34	-1.33	5.446e+04	3.217e+04	5.127e+04	3.536e+04	-7806.24
1	69	173	3.76	0.16	2.96	0.97	-1.50	3.506e+04	1.871e+04	3.478e+04	1.898e+04	-2095.47
1	69	174	3.13	0.53	2.43	1.22	-1.15	2.307e+04	8876.84	2.306e+04	8883.36	304.03
1	69	175	2.30	0.47	2.30	0.47	3.91e-02	1.413e+04	2526.23	1.400e+04	2649.25	1188.31
1	69	176	2.91	0.66	2.80	0.77	0.48	9495.66	104.65	9004.85	595.45	2090.04
1	69	177	2.93	1.00	2.69	1.25	0.64	7619.99	313.36	5624.16	2309.18	3255.67
1	69	178	5.79	-2.89	5.73	-2.83	0.71	1.075e+05	6.445e+04	8.598e+04	8.594e+04	-2.151e+04
1	69	179	3.95	-1.80	3.93	-1.77	-0.36	7.366e+04	5.369e+04	6.367e+04	6.368e+04	-9983.58
1	69	180	6.57	-0.96	4.71	0.90	-3.25	3.958e+04	3.834e+04	3.896e+04	3.895e+04	-620.67
1	69	181	3.99	0.14	3.45	0.68	-1.33	2.690e+04	2.239e+04	2.465e+04	2.464e+04	2251.21
1	69	182	2.39	0.34	2.34	0.39	0.31	1.913e+04	1.164e+04	1.539e+04	1.538e+04	3741.89
1	69	183	2.01	0.72	2.01	0.72	2.20e-02	1.483e+04	6760.44	1.079e+04	1.080e+04	4036.18
1	69	184	2.49	1.23	2.12	1.60	-0.57	1.024e+04	180.74	5213.34	5210.89	5031.38
1	69	185	1.48	0.77	1.34	0.92	0.28	8978.94	355.50	4665.31	4669.13	4311.72
1	69	186	5.77	-3.62	5.74	-3.59	0.52	1.360e+05	6.672e+04	9.805e+04	1.047e+05	-3.448e+04
1	69	187	3.88	-1.44	3.83	-1.39	-0.54	8.366e+04	4.944e+04	6.189e+04	7.121e+04	-1.646e+04
1	69	188	5.37	-0.49	5.34	-0.46	-0.42	5.445e+04	3.223e+04	3.541e+04	5.127e+04	-7779.28
1	69	189	4.11	-9.35e-02	3.96	5.61e-02	-0.78	3.505e+04	1.871e+04	1.899e+04	3.478e+04	-2094.16
1	69	190	3.50	0.12	3.37	0.25	-0.65	2.308e+04	8856.92	8863.01	2.307e+04	294.09
1	69	191	1.75	0.85	1.70	0.91	0.21	1.413e+04	2515.96	2638.95	1.400e+04	1188.64
1	69	192	2.22	0.98	1.09	2.11	0.35	9482.53	118.85	618.56	8982.82	2104.61
1	69	193	2.35	1.11	1.48	1.99	0.56	7621.08	314.09	2311.74	5623.43	3256.72
1	69	194	4.45	-0.89	4.24	-0.68	1.03	1.382e+05	6.064e+04	9.906e+04	9.980e+04	-3.879e+04
1	69	195	4.13	0.39	4.09	0.43	0.39	9.585e+04	3.977e+04	6.202e+04	7.360e+04	-2.744e+04
1	69	196	3.42	0.92	3.25	1.09	-0.63	6.376e+04	2.350e+04	3.387e+04	5.539e+04	-1.760e+04
1	69	197	2.71	0.92	2.63	0.99	-0.36	4.289e+04	1.096e+04	1.567e+04	3.818e+04	-1.133e+04
1	69	198	1.58	0.82	1.26	1.14	0.38	2.925e+04	3198.12	5419.24	2.703e+04	-7275.36
1	69	199	1.61	0.84	1.57	0.88	0.18	2.180e+04	1035.20	2326.17	2.051e+04	-5013.58
1	69	200	2.28	0.85	2.04	1.09	-0.53	1.260e+04	-3345.42	-3126.44	1.238e+04	-1855.76
1	69	201	1.15	0.82	0.82	1.15	1.74e-02	7342.97	353.25	972.37	6723.86	1985.99
1	69	202	4.57	-1.69	2.59	0.29	2.91	1.629e+05	3.648e+04	1.108e+05	8.866e+04	-6.226e+04
1	69	203	4.94	-0.42	1.12	3.40	2.43	1.048e+05	2.200e+04	6.549e+04	6.133e+04	-4.136e+04
1	69	204	6.63	0.46	3.91	3.17	-3.07	6.881e+04	1.150e+04	3.478e+04	5.539e+04	-2.815e+04
1	69	205	3.26	0.33	3.08	0.51	-0.71	4.853e+04	540.82	1.600e+04	3.308e+04	-2.242e+04
1	69	206	2.84	-0.12	2.82	-9.59e-02	0.28	3.396e+04	-5278.48	6004.17	2.267e+04	-1.776e+04
1	69	207	1.08	0.95	0.95	1.07	-2.58e-02	2.156e+04	-8224.66	14.11	1.332e+04	-1.332e+04
1	69	208	2.80	-0.20	0.37	2.23	-1.17	1.321e+04	-6155.31	-1756.76	8810.69	-8113.49
1	69	209	1.92	0.82	0.87	1.87	-0.24	5012.34	189.32	190.07	5011.59	60.33
1	69	210	3.29	-3.51	-2.04	1.82	2.80	1.340e+05	9456.41	9.773e+04	4.569e+04	-5.655e+04
1	69	211	2.55	-1.69	0.21	0.65	2.11	1.112e+05	9146.66	7.544e+04	4.489e+04	-4.868e+04
1	69	212	3.89	-1.08	3.67	-0.86	1.02	7.328e+04	-6367.15	3.783e+04	2.908e+04	-3.958e+04
1	69	213	1.82	0.35	1.79	0.38	0.20	5.154e+04	-1.152e+04	2.104e+04	1.898e+04	-3.151e+04
1	69	214	1.25	-0.25	-0.24	1.24	0.13	3.717e+04	-1.270e+04	1.146e+04	1.300e+04	-2.492e+04
1	69	215	0.98	0.38	0.58	0.79	0.28	3.041e+04	-8394.10	1.055e+04	1.147e+04	-1.940e+04
1	69	216	2.09	0.36	2.02	0.43	-0.33	1.664e+04	-1.015e+04	670.93	5818.64	-1.314e+04
1	69	217	0.94	0.18	0.63	0.48	-0.37	4747.76	41.13	378.03	4410.86	-1213.33
1	69	218	3.78	-8.96	-4.36	-0.82	6.12	1.457e+05	-2.385e+04	1.133e+05	8522.98	-6.663e+04
1	69	219	0.90	-3.06	0.41	-2.58	1.30	9.247e+04	-2.151e+04	6.933e+04	1627.41	-4.584e+04
1	69	220	0.46	-1.50	-0.86	-0.19	-0.92	6.923e+04	-2.342e+04	4.634e+04	-529.98	-3.996e+04
1	69	221	0.64	-0.37	-0.35	0.63	-0.12	5.076e+04	-2.355e+04	2.999e+04	-2775.68	-3.335e+04
1	69	222	1.25	-0.84	0.11	0.30	1.05	3.848e+04	-2.160e+04	2.150e+04	-4608.15	-2.706e+04
1	69	223	0.85	-0.45	-0.25	0.66	-0.47	2.607e+04	-1.978e+04	1.369e+04	-7395.75	-2.035e+04
1	69	224	3.16	-1.57	1.04	0.56	-2.35	1.660e+04	-1.273e+04	8022.34	-4153.50	-1.334e+04
1	69	225	1.75	0.27	0.98	1.03	-0.74	2516.35	-462.29	860.02	1194.05	-1479.92
1	69	226	0.75	-3.74	-3.24	0.26	1.41	8.520e+04	-5.193e+04	7.968e+04	-4.641e+04	-2.695e+04
1	69	227	0.93	-2.98	-2.89	0.83	-0.60	7.486e+04	-4.343e+04	6.477e+04	-3.335e+04	-3.303e+04
1	69	228	2.30	-2.62	-1.01	0.69	-2.31	5.835e+04	-3.698e+04	4.829e+04	-2.692e+04	-2.930e+04
1	69	229	1.92	-2.25	-0.54	0.21	-2.05	4.548e+04	-3.122e+04	3.573e+04	-2.148e+04	-2.554e+04
1	69	230	1.45	-2.87	-1.91	0.48	-1.80	3.714e+04	-2.477e+04	2.831e+04	-1.595e+04	-2.164e+04

Parco Eolico "Bolina" – Progetto Definitivo
Relazione di calcolo preliminare delle fondazioni degli aerogeneratori G8 e G12

1	69	231	0.14	-0.78	-0.69	4.40e-02	-0.28	3.611e+04	-1.337e+04	2.983e+04	-7088.70	-1.647e+04
1	69	232	1.99	-0.72	1.97	-0.70	0.25	1.956e+04	-1.409e+04	1.312e+04	-7645.25	-1.324e+04
1	69	233	0.27	-1.12	0.26	-1.11	0.12	3976.21	-291.15	1793.21	1891.86	-2133.11
1	69	234	2.90	-4.98	-4.93	2.85	-0.65	6.808e+04	-7.339e+04	6.453e+04	-6.984e+04	-2.213e+04
1	69	235	5.59	-7.84	-6.70	4.45	-3.74	6.105e+04	-5.696e+04	5.899e+04	-5.490e+04	-1.545e+04
1	69	236	9.30	-3.47	6.46	-0.63	-5.31	4.458e+04	-3.947e+04	4.251e+04	-3.740e+04	-1.304e+04
1	69	237	0.71	-1.02	0.50	-0.81	-0.56	3.942e+04	-3.445e+04	3.659e+04	-3.162e+04	-1.417e+04
1	69	238	0.60	-1.96	-1.36	-3.35e-03	1.08	3.506e+04	-2.811e+04	3.312e+04	-2.618e+04	-1.089e+04
1	69	239	-0.30	-1.48	-0.69	-1.09	-0.56	2.608e+04	-2.403e+04	2.500e+04	-2.295e+04	-7284.45
1	69	240	3.00	-3.09	2.53	-2.62	-1.61	1.813e+04	-1.367e+04	1.721e+04	-1.275e+04	-5341.67
1	69	241	0.97	-0.57	0.96	-0.56	-0.14	2704.32	-403.83	1905.07	395.42	-1358.45
1	69	242	2.63	-6.60	-4.60	0.63	-3.80	4.508e+04	-7.424e+04	4.492e+04	-7.408e+04	-4298.62
1	69	243	3.33	-7.27	-6.59	2.64	-2.61	5.894e+04	-4.259e+04	5.893e+04	-4.258e+04	-977.73
1	69	244	0.22	-1.14	0.22	-1.14	-1.92e-02	3.899e+04	-4.424e+04	3.870e+04	-4.395e+04	-4927.35
1	69	245	0.27	-2.27	-1.45	-0.55	-1.19	3.362e+04	-3.551e+04	3.349e+04	-3.537e+04	-3036.25
1	69	246	0.75	-4.05	-2.13	-1.16	-2.35	3.163e+04	-2.487e+04	3.149e+04	-2.474e+04	-2762.39
1	69	247	-0.13	-2.32	-2.17	-0.28	-0.55	3.765e+04	-7637.07	3.765e+04	-7636.46	165.48
1	69	248	1.81	-2.15	0.99	-1.32	1.61	2.088e+04	-1.032e+04	2.019e+04	-9635.16	-4561.64
1	69	249	0.39	-2.98	-0.24	-2.35	1.31	7323.18	-450.65	4614.71	2257.83	-3703.97
1	69	250	4.90	-10.84	-9.07	3.12	-4.98	2.372e+04	-9.648e+04	2.229e+04	-9.504e+04	1.304e+04
1	69	251	3.03	-8.18	-8.15	3.00	-0.53	2.330e+04	-7.244e+04	2.063e+04	-6.977e+04	1.577e+04
1	69	252	-2.48	-6.28	-2.86	-5.90	1.15	2.709e+04	-5.440e+04	2.443e+04	-5.174e+04	1.448e+04
1	69	253	0.36	-3.93	-2.48	-1.09	-2.03	2.413e+04	-4.335e+04	2.159e+04	-4.081e+04	1.285e+04
1	69	254	1.73	-4.27	-3.58	1.04	-1.91	2.349e+04	-3.082e+04	1.978e+04	-2.711e+04	1.371e+04
1	69	255	-0.15	-2.10	-0.78	-1.47	-0.92	1.613e+04	-2.361e+04	1.195e+04	-1.943e+04	1.219e+04
1	69	256	2.51	-4.06	2.26	-3.81	1.27	1.245e+04	-1.070e+04	1.044e+04	-8683.85	6519.41
1	69	257	1.10	-2.35	0.62	-1.87	1.20	416.45	-1678.24	191.55	-1453.34	648.47
1	69	258	2.88	-6.74	-4.18	0.31	-4.25	-5091.86	-1.168e+05	-8885.65	-1.130e+05	2.024e+04
1	69	259	1.70	-5.31	-3.94	0.33	-2.78	-3361.16	-9.166e+04	-1.434e+04	-8.068e+04	2.913e+04
1	69	260	-0.54	-3.21	-2.78	-0.96	-0.98	2465.24	-6.877e+04	-9630.80	-5.667e+04	2.675e+04
1	69	261	-0.49	-3.22	-2.12	-1.59	-1.34	7021.69	-5.085e+04	-4412.16	-3.942e+04	2.304e+04
1	69	262	3.88e-02	-3.89	-1.75	-2.10	-1.96	1.181e+04	-3.308e+04	1932.56	-2.320e+04	1.860e+04
1	69	263	-5.11e-04	-2.60	-1.78	-0.82	-1.20	2.857e+04	-8451.67	1.496e+04	5160.16	1.785e+04
1	69	264	0.35	-1.84	-0.99	-0.50	1.06	9006.96	-1.234e+04	3525.20	-6857.04	9325.38
1	69	265	-0.20	-2.84	-1.94	-1.10	1.25	0.93	-6391.42	-4522.45	-1868.04	2907.59
1	69	266	8.52	-8.51	-2.13	2.14	-8.25	-3.437e+04	-1.797e+05	-6.299e+04	-1.511e+05	5.780e+04
1	69	267	4.79	-5.91	0.54	-1.65	-5.24	-2.723e+04	-1.079e+05	-5.431e+04	-8.083e+04	3.810e+04
1	69	268	0.83	-1.45	-1.24	0.61	-0.66	-1.809e+04	-7.584e+04	-4.030e+04	-5.362e+04	2.810e+04
1	69	269	1.31	-4.69	-3.44	5.62e-02	-2.44	-7108.11	-5.891e+04	-3.188e+04	-3.414e+04	2.588e+04
1	69	270	2.31	-6.37	-4.68	0.62	-3.44	5107.44	-4.488e+04	-2.687e+04	-1.290e+04	2.400e+04
1	69	271	-0.44	-2.43	-2.34	-0.53	-0.41	5840.95	-3.995e+04	-2.940e+04	-4711.20	1.928e+04
1	69	272	1.41	-4.38	-1.24	-1.73	2.89	6891.36	-2.544e+04	-2.011e+04	1553.26	1.200e+04
1	69	273	1.08e-02	-2.28	-1.76	-0.51	0.96	274.69	-2.004e+04	-1.894e+04	-820.47	4587.63
1	69	274	4.57	-7.95	-3.78	0.39	-5.91	-6.650e+04	-1.629e+05	-9.210e+04	-1.373e+05	4.256e+04
1	69	275	4.21	-7.98	-3.48	-0.29	-5.88	-2.394e+04	-9.536e+04	-5.875e+04	-6.055e+04	3.570e+04
1	69	276	2.32	-6.69	-3.28	-1.09	-4.37	-2.946e+04	-8.647e+04	-6.251e+04	-5.341e+04	2.814e+04
1	69	277	1.05	-5.60	-3.54	-1.01	-4.07	-1.733e+04	-6.569e+04	-5.282e+04	-3.020e+04	2.138e+04
1	69	278	0.26	-4.91	-3.37	-1.29	-2.36	-3778.35	-4.572e+04	-3.833e+04	-1.117e+04	1.598e+04
1	69	279	0.33	-4.17	-3.31	-0.52	-1.76	2.799e+04	-1.956e+04	-1.641e+04	2.484e+04	1.183e+04
1	69	280	-7.22e-02	-3.24	-3.24	-7.27e-02	4.14e-02	4641.27	-2.478e+04	-2.277e+04	2624.55	7434.64
1	69	281	-0.32	-3.29	-3.28	-0.33	0.18	71.76	-2.264e+04	-2.261e+04	44.01	793.30
1	69	282	5.15	-11.47	-3.95	-2.37	-8.27	-1.041e+05	-1.864e+05	-1.419e+05	-1.486e+05	4.101e+04
1	69	283	4.37	-10.87	-7.59	1.09	-6.27	-6.842e+04	-1.265e+05	-1.148e+05	-8.016e+04	2.333e+04
1	69	284	-1.77	-6.59	-6.14	-2.21	-1.40	-4.052e+04	-9.468e+04	-8.883e+04	-4.637e+04	1.682e+04
1	69	285	0.43	-6.27	-3.72	-2.11	-3.25	-2.308e+04	-7.366e+04	-7.167e+04	-2.507e+04	9822.77
1	69	286	1.42	-7.35	-4.12	-1.81	-4.23	-1422.55	-5.940e+04	-5.919e+04	-1629.21	3455.19
1	69	287	0.42	-4.57	-3.89	-0.26	-1.71	4321.07	-5.582e+04	-5.578e+04	4281.47	-1542.80
1	69	288	0.19	-4.97	-4.84	6.18e-02	0.81	7804.22	-3.888e+04	-3.863e+04	7555.10	-3401.30
1	69	289	-0.32	-3.14	-3.13	-0.33	-0.18	378.46	-3.245e+04	-3.140e+04	-667.22	-5764.63
1	69	290	3.41	-6.61	-1.77	-1.43	-5.01	-1.219e+05	-1.661e+05	-1.548e+05	-1.333e+05	1.932e+04
1	69	291	3.29	-7.63	-3.51	-0.83	-5.29	-8.260e+04	-1.257e+05	-1.248e+05	-8.349e+04	6147.28
1	69	292	1.41	-7.07	-4.15	-1.52	-4.03	-5.065e+04	-9.625e+04	-9.610e+04	-5.080e+04	-2595.41
1	69	293	0.82	-6.50	-3.86	-1.82	-3.52	-2.840e+04	-7.300e+04	-7.204e+04	-2.936e+04	-6496.06
1	69	294	0.50	-5.93	-3.71	-1.71	-3.05	-9221.54	-5.100e+04	-4.951e+04	-1.071e+04	-7747.11
1	69	295	0.46	-5.25	-3.52	-1.27	-2.63	3.039e+04	-2.352e+04	-2.002e+04	2.689e+04	-1.329e+04
1	69	296	-0.31	-4.39	-3.79	-0.90	-1.44	4301.12	-2.943e+04	-2.729e+04	2156.47	-8231.02
1	69	297	-0.38	-4.01	-3.53	-0.86	-1.23	-34.59	-2.855e+04	-2.470e+04	-3882.28	-9742.79
1	69	298	4.94	-8.61	0.62	-4.29	-6.32	-1.225e+05	-1.618e+05	-1.538e+05	-1.305e+05	1.577e+04
1	69	299	3.66	-7.62	-1.30	-2.66	-5.60	-7.867e+04	-1.146e+05	-1.123e+05	-8.097e+04	-8791.71
1	69	300	1.80	-7.33	-2.24	-3.30	-4.53	-4.638e+04	-8.380e+04	-7.427e+04	-5.591e+04	-1.631e+04
1	69	301	0.98	-6.69	-2.61	-3.10	-3.83	-2.676e+04	-6.789e+04	-5.788e+04	-3.677e+04	-1.765e+04
1	69	302	0.84	-7.14	-3.18	-3.13	-3.99	-2747.99	-5.800e+04	-4.459e+04	-1.616e+04	-2.369e+04
1	69	303	0.94	-5.46	-3.08	-1.44	-3.09	2807.24	-5.682e+04	-4.221e+04	-1.180e+04	-2.564e+04

Parco Eolico "Bolina" – Progetto Definitivo
Relazione di calcolo preliminare delle fondazioni degli aerogeneratori G8 e G12

1	69	304	-0.12	-5.53	-4.32	-1.33	-2.25	7668.21	-4.016e+04	-2.778e+04	-4714.82	-2.095e+04
1	69	305	-0.43	-4.04	-3.02	-1.45	-1.62	335.78	-3.449e+04	-2.394e+04	-1.022e+04	-1.601e+04
1	69	306	4.46	-8.07	0.86	-4.47	-5.67	-1.149e+05	-1.248e+05	-1.198e+05	-1.199e+05	4919.58
1	69	307	2.71	-6.95	-0.47	-3.77	-4.54	-4.346e+04	-6.674e+04	-5.510e+04	-5.511e+04	-1.164e+04
1	69	308	0.49	-6.30	-1.82	-3.99	-3.22	-4.495e+04	-6.903e+04	-5.698e+04	-5.699e+04	-1.204e+04
1	69	309	0.74	-6.37	-2.09	-3.54	-3.48	-2.509e+04	-5.907e+04	-4.207e+04	-4.208e+04	-1.699e+04
1	69	310	0.77	-6.09	-2.18	-3.14	-3.39	-8028.04	-4.229e+04	-2.515e+04	-2.517e+04	-1.713e+04
1	69	311	0.48	-5.25	-2.09	-2.69	-2.85	3.109e+04	-1.776e+04	6666.16	6658.71	-2.443e+04
1	69	312	-0.49	-4.63	-2.43	-2.70	-2.06	4311.67	-2.436e+04	-1.002e+04	-1.003e+04	-1.434e+04
1	69	313	-0.35	-4.16	-2.22	-2.28	-1.90	-265.05	-2.551e+04	-1.289e+04	-1.289e+04	-1.262e+04
1	69	314	2.63	-6.85	0.24	-4.46	-4.11	-1.225e+05	-1.618e+05	-1.305e+05	-1.538e+05	1.577e+04
1	69	315	2.36	-6.96	0.34	-4.94	-3.84	-7.865e+04	-1.146e+05	-8.095e+04	-1.123e+05	-8792.00
1	69	316	0.92	-6.50	-1.20	-4.37	-3.35	-4.637e+04	-8.381e+04	-5.589e+04	-7.428e+04	-1.631e+04
1	69	317	0.37	-6.01	-1.68	-3.96	-2.98	-2.676e+04	-6.789e+04	-3.676e+04	-5.789e+04	-1.765e+04
1	69	318	0.41	-6.57	-2.16	-3.99	-3.37	-2741.61	-5.800e+04	-1.615e+04	-4.460e+04	-2.369e+04
1	69	319	0.80	-5.08	-0.83	-3.46	-2.63	2813.29	-5.682e+04	-1.179e+04	-4.222e+04	-2.565e+04
1	69	320	-0.12	-5.23	-1.03	-4.31	-1.96	7671.72	-4.017e+04	-4698.25	-2.780e+04	-2.095e+04
1	69	321	-0.44	-3.67	-1.29	-2.82	-1.42	335.55	-3.449e+04	-1.022e+04	-2.394e+04	-1.601e+04
1	69	322	1.38	-5.59	0.11	-4.32	-2.69	-1.219e+05	-1.661e+05	-1.332e+05	-1.548e+05	1.932e+04
1	69	323	2.03	-6.54	1.36	-5.87	-2.30	-8.258e+04	-1.257e+05	-8.348e+04	-1.248e+05	6147.30
1	69	324	0.49	-6.15	-6.56e-02	-5.59	-1.84	-5.064e+04	-9.626e+04	-5.079e+04	-9.611e+04	-2593.26
1	69	325	-7.82e-02	-5.46	-0.88	-4.66	-1.91	-2.838e+04	-7.301e+04	-2.935e+04	-7.205e+04	-6493.45
1	69	326	-0.22	-4.94	-1.13	-4.03	-1.87	-9198.95	-5.101e+04	-1.069e+04	-4.952e+04	-7745.16
1	69	327	3.10e-02	-4.37	-0.88	-3.46	-1.78	3.041e+04	-2.352e+04	2.691e+04	-2.002e+04	-1.329e+04
1	69	328	-0.37	-3.69	-0.64	-3.42	-0.91	4300.50	-2.944e+04	2159.78	-2.730e+04	-8224.23
1	69	329	-0.40	-3.27	-0.73	-2.95	-0.91	-34.00	-2.855e+04	-3881.83	-2.471e+04	-9743.20
1	69	330	-0.23	-6.47	-2.31	-4.40	-2.94	-1.041e+05	-1.864e+05	-1.485e+05	-1.419e+05	4.101e+04
1	69	331	2.37	-8.31	2.16	-8.09	-1.52	-6.841e+04	-1.265e+05	-8.014e+04	-1.148e+05	2.333e+04
1	69	332	-1.36	-6.97	-1.85	-6.48	1.59	-4.050e+04	-9.471e+04	-4.636e+04	-8.885e+04	1.683e+04
1	69	333	-1.45	-4.26	-2.02	-3.68	-1.13	-2.306e+04	-7.367e+04	-2.505e+04	-7.168e+04	9828.54
1	69	334	0.11	-5.67	-1.80	-3.76	-2.72	-1405.19	-5.940e+04	-1612.10	-5.920e+04	3458.04
1	69	335	-0.16	-3.34	-0.31	-3.19	-0.69	4338.72	-5.583e+04	4299.24	-5.579e+04	-1540.88
1	69	336	0.46	-4.29	2.15e-02	-3.86	1.37	7814.54	-3.890e+04	7567.50	-3.865e+04	-3388.03
1	69	337	-0.28	-2.02	-0.29	-2.01	0.13	377.68	-3.245e+04	-667.78	-3.141e+04	-5764.71

M_G	N max	N min	N 1	N 2	N 1-2	M max	M min	M 1	M 2	M 1-2
	76.41	-64.99	-64.74	-61.75	-51.41		-4.014e+05	-3.183e+05	-3.183e+05	-1.307e+05
			74.53	71.10	34.33	3.377e+05		2.309e+05	2.308e+05	1.120e+05

Elem. Cmb	Nodo	Von Mises daN/cm ²	N max daN/cm	N min daN/cm	N 1 daN/cm	N 2 daN/cm	N 1-2 daN/cm	M max daN	M min daN	M 1 daN	M 2 daN	M 1-2 daN
1	1	18.70	-1.21	-7.94	-6.16	-2.99	-2.97	7.218e+04	-1.483e+05	7.122e+04	-1.473e+05	-
1.449e+04												
	2	18.86	13.75	-9.00	-6.43	11.18	-7.20	2.966e+04	-1.793e+05	2.902e+04	-1.786e+05	1.159e+04
	3	38.95	7.48	-14.14	-13.63	6.98	-3.27	1.637e+05	-2.975e+05	1.611e+05	-2.949e+05	-
3.480e+04												
	4	16.39	5.45	-5.67	-5.41	5.20	-1.65	1.114e+05	-8.462e+04	1.105e+05	-8.365e+04	-
1.378e+04												
1	3	15.82	-1.02	-6.72	-5.21	-2.53	-2.52	6.107e+04	-1.255e+05	6.027e+04	-1.247e+05	-
1.226e+04												
	2	15.96	11.63	-7.61	-5.44	9.46	-6.09	2.510e+04	-1.517e+05	2.455e+04	-1.511e+05	9809.88
	3	32.95	6.33	-11.96	-11.53	5.90	-2.77	1.385e+05	-2.518e+05	1.363e+05	-2.495e+05	-
2.945e+04												
	4	13.86	4.62	-4.79	-4.58	4.40	-1.40	9.430e+04	-7.160e+04	9.347e+04	-7.078e+04	-
1.166e+04												
1	23	14.59	-7.04	-66.29	-17.14	-56.19	-22.28	5.559e+04	-1.143e+05	5.485e+04	-1.136e+05	-
1.119e+04												
	2	14.63	82.61	-23.35	21.82	37.45	-52.40	2.281e+04	-1.382e+05	2.232e+04	-1.378e+05	8916.47
	3	30.16	11.96	-62.47	-7.49	-43.03	-32.70	1.260e+05	-2.297e+05	1.240e+05	-2.277e+05	-
2.698e+04												
	4	12.80	78.19	-22.46	48.35	7.37	-45.97	8.584e+04	-6.530e+04	8.509e+04	-6.454e+04	-
1.064e+04												
1	54	14.43	17.07	-1.68	-0.54	15.93	4.48	5.550e+04	-1.140e+05	5.476e+04	-1.133e+05	-
1.113e+04												
	2	14.47	4.57	-19.74	-14.00	-1.16	10.32	2.282e+04	-1.378e+05	2.232e+04	-1.373e+05	8918.61
	3	30.00	23.44	-13.19	-11.50	21.74	7.70	1.259e+05	-2.286e+05	1.239e+05	-2.266e+05	-
2.670e+04												
	4	12.67	9.05	-28.13	-21.94	2.86	13.85	8.568e+04	-6.502e+04	8.494e+04	-6.428e+04	-
1.059e+04												
1	69	14.38	-0.93	-6.11	-4.74	-2.30	-2.29	5.552e+04	-1.141e+05	5.479e+04	-1.133e+05	-
1.114e+04												
	2	14.51	10.57	-6.92	-4.95	8.60	-5.53	2.282e+04	-1.379e+05	2.232e+04	-1.374e+05	8918.07

Parco Eolico "Bolina" – Progetto Definitivo
Relazione di calcolo preliminare delle fondazioni degli aerogeneratori G8 e G12

2.677e+04	3	29.96	5.76	-10.88	-10.49	5.37	-2.52	1.259e+05	-2.289e+05	1.239e+05	-2.269e+05	-
1.060e+04	4	12.60	4.20	-4.36	-4.17	4.00	-1.27	8.572e+04	-6.509e+04	8.497e+04	-6.434e+04	-
2.047e+04	2 1 4	35.24	4.41	-8.83	-8.55	4.13	-1.88	1.884e+05	-2.341e+05	1.874e+05	-2.331e+05	-
1.230e+05	3	25.08	5.21	-11.31	-10.88	4.78	2.63	2.120e+05	-7.917e+04	1.444e+05	-1.155e+04	-
3.861e+04	5	6.64	6.88	-8.39	-8.33	6.82	-0.93	5.358e+04	-2.453e+04	2.040e+04	8643.34	-
1.732e+04	2 3 6	22.48	4.58	-4.67	-4.16	4.06	2.13	5.819e+04	-1.995e+05	3.957e+04	-1.809e+05	6.671e+04
1.040e+05	4	29.82	3.73	-7.47	-7.24	3.50	-1.59	1.594e+05	-1.981e+05	1.586e+05	-1.973e+05	-
3.267e+04	3	21.22	4.41	-9.57	-9.21	4.05	2.22	1.794e+05	-6.699e+04	1.222e+05	-9771.32	-
1.566e+04	5	5.62	5.82	-7.10	-7.05	5.77	-0.79	4.533e+04	-2.076e+04	1.726e+04	7313.60	-
9.436e+04	6	19.03	3.88	-3.96	-3.52	3.44	1.80	4.924e+04	-1.688e+05	3.349e+04	-1.530e+05	5.644e+04
2.949e+04	2 24 4	27.27	16.25	-59.05	-57.20	14.40	-11.65	1.450e+05	-1.796e+05	1.443e+05	-1.788e+05	-
1.571e+04	3	19.49	45.46	-56.70	6.21	-17.45	49.69	1.634e+05	-6.036e+04	1.116e+05	-8572.80	-
9.451e+04	5	5.15	-18.77	-34.60	-30.59	-22.78	6.88	4.125e+04	-1.843e+04	1.597e+04	6853.00	-
2.963e+04	6	17.26	73.04	-30.04	2.10	40.90	47.75	4.510e+04	-1.527e+05	3.075e+04	-1.383e+05	5.131e+04
1.574e+04	2 56 4	27.16	7.74	-24.47	-23.71	6.98	-4.90	1.450e+05	-1.799e+05	1.442e+05	-1.792e+05	-
9.459e+04	3	19.36	14.70	-21.60	-3.43	-3.47	18.15	1.632e+05	-6.072e+04	1.113e+05	-8778.05	-
2.970e+04	5	5.13	-3.92	-14.91	-14.59	-4.24	1.86	4.122e+04	-1.872e+04	1.579e+04	6717.85	-
1.574e+04	2 69 6	17.27	26.54	-12.04	-1.41	15.91	17.24	4.488e+04	-1.532e+05	3.055e+04	-1.388e+05	5.131e+04
9.459e+04	4	27.11	3.39	-6.79	-6.58	3.18	-1.44	1.449e+05	-1.801e+05	1.442e+05	-1.793e+05	-
2.970e+04	3	19.30	4.01	-8.70	-8.37	3.68	2.02	1.631e+05	-6.090e+04	1.111e+05	-8883.02	-
2.003e+04	5	5.11	5.29	-6.45	-6.41	5.24	-0.72	4.121e+04	-1.887e+04	1.569e+04	6648.72	-
6.104e+04	6	17.30	3.52	-3.60	-3.20	3.12	1.64	4.476e+04	-1.534e+05	3.044e+04	-1.391e+05	5.131e+04
4.598e+04	3 1 6	8.40	6.92	-8.68	-7.52	5.77	4.08	9.710e+04	2.472e+04	3.077e+04	9.104e+04	-
7.955e+04	5	21.04	4.45	-12.48	-11.38	3.35	4.17	1.248e+05	-1.276e+05	1.091e+05	-1.119e+05	-
1.695e+04	7	19.47	11.96	-3.14	1.91	6.91	7.12	1.672e+05	-5.804e+04	1.574e+05	-4.822e+04	-
5.165e+04	8	21.11	3.49	-0.18	3.49	-0.17	-0.10	2.113e+05	-1.617e+04	1.788e+05	1.629e+04	-
3.891e+04	3 3 6	7.11	5.86	-7.34	-6.36	4.88	3.45	8.216e+04	2.092e+04	2.604e+04	7.704e+04	-
6.732e+04	5	17.81	3.76	-10.56	-9.63	2.83	3.53	1.056e+05	-1.080e+05	9.228e+04	-9.465e+04	-
1.538e+04	7	16.48	10.12	-2.66	1.62	5.85	6.03	1.414e+05	-4.911e+04	1.331e+05	-4.080e+04	-
4.720e+04	8	17.86	2.95	-0.15	2.95	-0.15	-0.09	1.788e+05	-1.368e+04	1.513e+05	1.379e+04	-
3.554e+04	3 23 6	6.49	32.95	2.50	31.20	4.24	-7.07	7.487e+04	1.900e+04	2.362e+04	7.025e+04	-
6.148e+04	5	16.33	15.28	-23.00	9.55	-17.26	-13.66	9.617e+04	-9.868e+04	8.397e+04	-8.649e+04	-
1.539e+04	7	15.07	13.18	-13.14	6.55	-6.51	-11.42	1.288e+05	-4.489e+04	1.212e+05	-3.729e+04	-
4.704e+04	8	16.28	-0.40	-21.66	-13.41	-8.65	-10.36	1.628e+05	-1.267e+04	1.376e+05	1.248e+04	-
3.542e+04	3 53 6	6.49	21.52	2.51	6.84	17.18	7.97	7.466e+04	1.895e+04	2.358e+04	7.002e+04	-
6.129e+04	5	16.16	0.56	-12.87	-8.49	-3.83	-6.30	9.595e+04	-9.839e+04	8.381e+04	-8.625e+04	-
1.541e+04	3 69 7	14.96	5.77	4.46	4.63	5.59	-0.44	1.285e+05	-4.478e+04	1.210e+05	-3.721e+04	-
	8	16.26	11.30	-16.20	-8.76	3.86	-12.22	1.625e+05	-1.258e+04	1.374e+05	1.246e+04	-
	6	6.46	5.33	-6.67	-5.79	4.44	3.14	7.469e+04	1.901e+04	2.367e+04	7.003e+04	-

Parco Eolico "Bolina" – Progetto Definitivo
Relazione di calcolo preliminare delle fondazioni degli aerogeneratori G8 e G12

4.696e+04	5	16.19	3.42	-9.60	-8.76	2.57	3.21	9.600e+04-9.816e+04	8.389e+04-8.605e+04	-
3.537e+04	7	14.98	9.20	-2.41	1.47	5.32	5.48	1.286e+05-4.465e+04	1.210e+05-3.710e+04	-
6.120e+04	8	16.24	2.68	-0.14	2.68	-0.13	-0.08	1.625e+05-1.244e+04	1.375e+05 1.253e+04	-
9.744e+04	4 1	8	24.43	15.94	-3.80	6.33	5.81	9.87 2.334e+05-3.735e+04	1.920e+05 4055.76	-
3.751e+04	7	18.24	3.02	-8.32	-2.97	-2.33	5.66	1.651e+05-4.234e+04	1.581e+05-3.532e+04	-
7.461e+04	9	15.78	10.03	-2.82	3.60	3.61	6.43	1.687e+05 9691.22	1.167e+05 6.171e+04	-
8.245e+04	4 3	10	11.42	3.66	-7.92	-6.54	2.27	3.75 1.069e+05-2.086e+04	1.049e+05-1.890e+04	1.573e+04
3.174e+04	8	20.67	13.49	-3.22	5.36	4.91	8.35	1.975e+05-3.160e+04	1.625e+05 3431.80	-
6.313e+04	7	15.44	2.56	-7.04	-2.51	-1.97	4.79	1.397e+05-3.582e+04	1.338e+05-2.988e+04	-
7.510e+04	9	13.35	8.49	-2.39	3.04	3.06	5.44	1.428e+05 8200.26	9.875e+04 5.221e+04	-
2.888e+04	10	9.66	3.09	-6.70	-5.53	1.92	3.18	9.044e+04-1.765e+04	8.878e+04-1.599e+04	1.331e+04
5.755e+04	8	19.08	34.19	-58.30	6.26	-30.36	-42.46	1.802e+05-2.856e+04	1.483e+05 3335.77	-
7.501e+04	7	14.17	33.58	-68.02	17.36	-51.80	37.22	1.277e+05-3.236e+04	1.223e+05-2.697e+04	-
2.886e+04	9	12.21	-14.46	-36.86	-14.65	-36.68	2.04	1.304e+05 7764.39	9.027e+04 4.790e+04	-
5.744e+04	10	9.18	78.51	-83.47	43.04	-48.00	66.99	8.258e+04-1.575e+04	8.104e+04-1.421e+04	1.220e+04
7.496e+04	4 39	8	18.85	10.30	-12.28	5.34	-7.32	1.798e+05-2.867e+04	1.479e+05 3192.89	-
2.885e+04	7	14.06	12.13	-26.48	4.36	-18.71	15.48	1.272e+05-3.250e+04	1.218e+05-2.710e+04	-
5.739e+04	9	12.16	-1.41	-12.29	-3.13	-10.57	3.96	1.300e+05 7559.55	8.994e+04 4.761e+04	-
7.278e+04	10	8.89	25.96	-29.80	11.24	-15.08	24.58	8.234e+04-1.595e+04	8.082e+04-1.443e+04	1.213e+04
1.385e+05	4 69	8	18.79	12.26	-2.93	4.87	7.59	1.795e+05-2.873e+04	1.477e+05 3119.81	-
8.062e+04	7	14.03	2.32	-6.40	-2.29	-1.79	4.36	1.270e+05-3.257e+04	1.216e+05-2.717e+04	-
6.577e+04	9	12.14	7.72	-2.17	2.77	2.78	4.94	1.298e+05 7454.78	8.977e+04 4.747e+04	-
1.172e+05	5 1	10	8.78	2.81	-6.09	-5.03	2.89	8.222e+04-1.605e+04	8.071e+04-1.454e+04	1.210e+04
6.159e+04	10	27.75	7.40	-4.23	4.82	-1.65	4.83	2.945e+05 1.188e+04	1.250e+05 1.814e+05	-
6.821e+04	9	17.12	3.23	-9.25	-2.67	-3.36	6.23	1.978e+05 5.065e+04	1.349e+05 1.135e+05	-
5.565e+04	11	20.92	7.26	-3.36	1.80	2.10	5.31	2.436e+05 6.803e+04	1.906e+05 1.211e+05	-
1.068e+05	12	20.26	2.45	-13.90	-6.59	-4.86	8.13	2.374e+05 7.316e+04	2.044e+05 1.061e+05	-
5.602e+04	5 3	10	23.48	6.26	-3.58	4.08	4.09	2.492e+05 1.005e+04	1.057e+05 1.535e+05	-
6.214e+04	9	14.49	2.73	-7.83	-2.26	-2.84	5.27	1.673e+05 4.285e+04	1.142e+05 9.604e+04	-
5.065e+04	11	17.70	6.14	-2.84	1.53	1.78	4.49	2.061e+05 5.756e+04	1.613e+05 1.024e+05	-
1.066e+05	12	17.14	2.07	-11.76	-5.58	-4.11	6.88	2.008e+05 6.191e+04	1.730e+05 8.979e+04	-
5.600e+04	5 7	10	21.78	91.93	-82.95	49.78	-40.80	2.273e+05 9337.19	9.648e+04 1.401e+05	-
6.206e+04	9	13.24	-18.39	-44.15	-18.93	-43.60	-3.72	1.527e+05 3.944e+04	1.043e+05 8.782e+04	-
5.061e+04	11	16.36	42.34	-75.29	23.84	-56.78	-42.83	1.881e+05 5.268e+04	1.473e+05 9.350e+04	-
	12	15.75	22.84	-59.13	-2.69	-33.61	37.96	1.832e+05 5.660e+04	1.578e+05 8.194e+04	-
	5 39	10	21.46	30.79	-26.14	19.30	-22.85	2.268e+05 9206.45	9.624e+04 1.397e+05	-
	9	13.19	-7.36	-16.86	-7.77	-16.46	1.91	1.523e+05 3.912e+04	1.040e+05 8.748e+04	-
	11	16.16	13.39	-22.55	8.98	-18.14	-11.79	1.876e+05 5.245e+04	1.468e+05 9.325e+04	-
	12	15.64	8.59	-26.70	-4.26	-13.84	16.98	1.828e+05 5.639e+04	1.574e+05 8.173e+04	-

Parco Eolico "Bolina" – Progetto Definitivo
Relazione di calcolo preliminare delle fondazioni degli aerogeneratori G8 e G12

5	69	10	21.34	5.69	-3.25	3.71	-1.27	3.72	2.265e+05	9139.58	9.612e+04	1.395e+05	-
1.065e+05		9	13.17	2.48	-7.12	-2.05	-2.58	4.79	1.521e+05	3.896e+04	1.038e+05	8.731e+04	-
5.599e+04		11	16.09	5.59	-2.58	1.39	1.62	4.08	1.874e+05	5.233e+04	1.466e+05	9.312e+04	-
6.201e+04		12	15.59	1.89	-10.69	-5.07	-3.74	6.25	1.826e+05	5.628e+04	1.572e+05	8.163e+04	-
5.059e+04	6	1	12	28.53	0.35	-3.31	-3.23	0.27	-0.53	3.185e+05	4.863e+04	2.507e+05	1.164e+05
1.170e+05		11	14.02	3.11	-12.37	-2.43	-6.83	7.42	1.680e+05	9.254e+04	1.496e+05	1.109e+05	-
3.239e+04		13	27.03	11.50	-4.04	10.66	-3.20	3.52	3.178e+05	1.001e+05	1.852e+05	2.327e+05	-
1.062e+05		14	14.20	7.87	-7.35	6.68	-6.17	4.07	1.446e+05	-5811.54	9.016e+04	4.861e+04	7.227e+04
9.904e+04	6	3	12	24.14	0.29	-2.80	-2.74	0.23	-0.44	2.695e+05	4.115e+04	2.121e+05	9.852e+04
2.741e+04		11	11.86	2.63	-10.47	-2.06	-5.78	6.28	1.421e+05	7.830e+04	1.265e+05	9.387e+04	-
8.987e+04		13	22.87	9.73	-3.42	9.02	-2.71	2.98	2.689e+05	8.474e+04	1.567e+05	1.969e+05	-
		14	12.02	6.66	-6.22	5.66	-5.22	3.44	1.223e+05	-4917.46	7.629e+04	4.113e+04	6.115e+04
9.033e+04	6	23	12	22.26	54.49	-32.17	32.81	-10.49	-37.54	2.455e+05	3.741e+04	1.931e+05	8.983e+04
2.507e+04		11	10.79	4.25	-21.10	-11.45	-5.40	-12.31	1.296e+05	7.139e+04	1.152e+05	8.573e+04	-
8.196e+04		13	21.01	39.81	-14.93	6.94	17.94	-26.81	2.452e+05	7.720e+04	1.427e+05	1.797e+05	-
		14	10.96	-20.18	-56.48	-34.64	-42.03	17.77	1.115e+05	-4429.33	6.962e+04	3.745e+04	5.568e+04
9.013e+04	6	55	12	22.05	17.50	-11.45	9.46	-3.41	-12.97	2.452e+05	3.741e+04	1.929e+05	8.966e+04
2.497e+04		11	10.79	-4.81	-5.60	-5.11	-5.30	-0.39	1.293e+05	7.125e+04	1.151e+05	8.547e+04	-
8.179e+04		13	20.85	13.57	-1.36	7.77	4.44	-7.28	2.447e+05	7.709e+04	1.426e+05	1.792e+05	-
		14	10.94	-3.58	-22.10	-8.32	-17.36	8.08	1.113e+05	-4456.51	6.944e+04	3.741e+04	5.562e+04
9.003e+04	6	69	12	21.95	0.27	-2.55	-2.49	0.21	-0.40	2.450e+05	3.741e+04	1.928e+05	8.956e+04
2.491e+04		11	10.79	2.40	-9.52	-1.87	-5.25	5.71	1.292e+05	7.119e+04	1.150e+05	8.534e+04	-
8.170e+04		13	20.79	8.85	-3.11	8.20	-2.46	2.71	2.445e+05	7.703e+04	1.425e+05	1.790e+05	-
		14	10.93	6.05	-5.65	5.14	-4.74	3.13	1.112e+05	-4470.42	6.936e+04	3.739e+04	5.559e+04
6.753e+04	7	1	14	29.04	3.71	-4.36	3.43	-4.08	1.47	3.393e+05	9.886e+04	1.196e+05	3.186e+05
8.986e+04		13	18.89	8.22	-6.85	8.21	-6.85	-0.33	2.088e+05	2.704e+04	1.316e+05	1.043e+05	-
7.595e+04		15	31.22	9.67	-5.46	9.27	-5.06	2.43	3.603e+05	8.944e+04	3.370e+05	1.127e+05	-
6.301e+04		16	22.88	9.84	-4.41	9.77	-4.33	-1.00	2.747e+05	1.486e+05	2.091e+05	2.142e+05	-
5.714e+04	7	3	14	24.57	3.14	-3.69	2.90	-3.46	1.24	2.871e+05	8.365e+04	1.012e+05	2.696e+05
7.604e+04		13	15.99	6.96	-5.80	6.95	-5.79	-0.28	1.767e+05	2.288e+04	1.113e+05	8.825e+04	-
6.427e+04		15	26.42	8.18	-4.62	7.84	-4.29	2.05	3.049e+05	7.568e+04	2.852e+05	9.540e+04	-
5.332e+04		16	19.36	8.32	-3.73	8.27	-3.67	-0.85	2.325e+05	1.257e+05	1.769e+05	1.813e+05	-
5.213e+04	7	7	14	22.57	70.63	-31.58	18.70	20.34	-51.10	2.617e+05	7.640e+04	9.246e+04	2.456e+05
6.927e+04		13	14.59	7.20	-56.32	5.55	-54.67	-10.12	1.611e+05	2.100e+04	1.016e+05	8.056e+04	-
5.840e+04		15	24.36	59.65	-55.21	41.07	-36.64	-42.30	2.781e+05	6.925e+04	2.602e+05	8.711e+04	-
4.854e+04		16	17.74	2.89	-34.31	-16.93	-14.49	18.56	2.117e+05	1.146e+05	1.614e+05	1.650e+05	-
5.201e+04	7	39	14	22.40	23.06	-10.18	8.08	4.80	-16.54	2.612e+05	7.617e+04	9.217e+04	2.452e+05
6.918e+04		13	14.55	6.51	-22.43	6.06	-21.98	-3.59	1.608e+05	2.087e+04	1.013e+05	8.034e+04	-
5.842e+04		15	24.13	23.11	-19.46	18.62	-14.97	-13.08	2.775e+05	6.895e+04	2.596e+05	8.686e+04	-

Parco Eolico "Bolina" – Progetto Definitivo
Relazione di calcolo preliminare delle fondazioni degli aerogeneratori G8 e G12

4.850e+04	16	17.63	2.65	-10.52	-0.76	-7.11	5.77 2.115e+05 1.144e+05 1.610e+05 1.649e+05	-
7 69	14	22.34	2.85	-3.35	2.64	-3.14	1.13 2.610e+05 7.605e+04 9.202e+04 2.451e+05	-
5.195e+04	13	14.53	6.32	-5.27	6.32	-5.27	-0.25 1.606e+05 2.080e+04 1.012e+05 8.023e+04	-
6.912e+04	15	24.02	7.44	-4.20	7.13	-3.90	1.87 2.772e+05 6.880e+04 2.592e+05 8.672e+04	-
5.842e+04	16	17.60	7.57	-3.39	7.51	-3.33	-0.77 2.113e+05 1.143e+05 1.608e+05 1.648e+05	-
4.847e+04	16	15.19	6.26	-5.52	6.26	-5.52	-0.05 1.818e+05 1.058e+05 1.731e+05 1.145e+05	-
8 1	15	50.00	12.74	-6.87	12.53	-6.66	-2.04 5.744e+05 1.334e+05 3.540e+05 3.539e+05	-
2.422e+04	17	15.19	5.50	-9.20	4.38	-8.09	-3.89 1.817e+05 1.058e+05 1.145e+05 1.730e+05	-
2.205e+05	18	24.41	6.57	0.10	6.42	0.26	-0.99 2.895e+05 1.034e+05 1.965e+05 1.965e+05	-
2.422e+04	16	12.86	5.30	-4.67	5.30	-4.67	-0.04 1.538e+05 8.951e+04 1.464e+05 9.688e+04	-
9.305e+04	15	42.31	10.78	-5.82	10.60	-5.63	-1.72 4.860e+05 1.129e+05 2.995e+05 2.994e+05	-
8 3	17	12.85	4.65	-7.79	3.71	-6.84	-3.30 1.538e+05 8.952e+04 9.691e+04 1.464e+05	-
2.049e+04	18	20.66	5.56	0.09	5.43	0.22	-0.84 2.450e+05 8.752e+04 1.663e+05 1.662e+05	-
1.866e+05	16	11.78	37.03	-137.82	-63.05	-37.74	-86.51 1.402e+05 8.158e+04 1.336e+05 8.824e+04	-
2.049e+04	15	38.97	111.66	-12.25	71.47	27.94	-58.01 4.430e+05 1.030e+05 2.733e+05 2.727e+05	-
7.874e+04	17	11.82	42.30	-145.60	-16.54	-86.76	-87.14 1.400e+05 8.166e+04 8.839e+04 1.332e+05	-
8 7	18	19.16	108.23	30.83	84.24	54.82	-35.80 2.230e+05 7.976e+04 1.515e+05 1.513e+05	-
1.861e+04	16	11.70	12.46	-46.19	-18.15	-15.58	-29.30 1.400e+05 8.144e+04 1.333e+05 8.813e+04	-
1.700e+05	15	38.64	42.33	-5.71	30.56	6.07	-20.67 4.422e+05 1.028e+05 2.726e+05 2.724e+05	-
1.863e+04	17	11.73	16.46	-53.30	-3.37	-33.47	-31.47 1.399e+05 8.148e+04 8.820e+04 1.331e+05	-
7.162e+04	18	18.91	39.44	11.01	31.77	18.68	-12.62 2.228e+05 7.963e+04 1.513e+05 1.512e+05	-
8 39	16	11.69	4.81	-4.25	4.81	-4.25	-0.04 1.398e+05 8.137e+04 1.331e+05 8.808e+04	-
1.862e+04	15	38.47	9.80	-5.29	9.64	-5.12	-1.57 4.419e+05 1.026e+05 2.723e+05 2.722e+05	-
1.697e+05	17	11.69	4.23	-7.08	3.37	-6.22	-3.00 1.398e+05 8.138e+04 8.810e+04 1.331e+05	-
1.863e+04	18	18.78	5.05	0.08	4.93	0.20	-0.76 2.227e+05 7.956e+04 1.512e+05 1.511e+05	-
7.159e+04	16	11.69	4.81	-4.25	4.81	-4.25	-0.04 1.398e+05 8.137e+04 1.331e+05 8.808e+04	-
8 69	15	38.47	9.80	-5.29	9.64	-5.12	-1.57 4.419e+05 1.026e+05 2.723e+05 2.722e+05	-
1.863e+04	17	11.69	4.23	-7.08	3.37	-6.22	-3.00 1.398e+05 8.138e+04 8.810e+04 1.331e+05	-
1.696e+05	18	18.78	5.05	0.08	4.93	0.20	-0.76 2.227e+05 7.956e+04 1.512e+05 1.511e+05	-
7.158e+04	2	35.14	12.36	-7.24	-6.98	12.10	2.24 1.430e+05-2.723e+05 1.429e+05-2.721e+05	7453.71
9 1	19	18.71	4.91	-13.84	-11.11	2.17	-6.62 1.007e+05-1.238e+05 5.807e+04-8.122e+04	-
8.804e+04	20	7.90	9.85	-5.92	-5.90	9.83	0.62-5.197e+04-9.475e+04-6.918e+04-7.753e+04	-
2.098e+04	3	29.80	9.39	-8.30	-4.41	5.50	-7.33 2376.42-3.087e+05-3.596e+04-2.704e+05	-
1.023e+05	2	29.74	10.46	-6.13	-5.91	10.24	1.90 1.210e+05-2.304e+05 1.209e+05-2.303e+05	6306.99
9 3	19	15.83	4.15	-11.71	-9.40	1.83	-5.60 8.519e+04-1.048e+05 4.913e+04-6.872e+04	-
7.449e+04	20	6.68	8.34	-5.01	-4.99	8.32	0.52-4.397e+04-8.017e+04-5.854e+04-6.560e+04	-
1.775e+04	3	25.22	7.94	-7.03	-3.73	4.65	-6.20 2010.82-2.612e+05-3.043e+04-2.288e+05	-
8.652e+04	2	27.24	59.92	-26.44	-25.24	58.72	10.11 1.094e+05-2.094e+05 1.093e+05-2.093e+05	5689.45
9 5	19	14.52	28.64	-77.93	-48.41	-0.88	-47.69 7.665e+04-9.562e+04 4.381e+04-6.278e+04	-
6.767e+04	20	6.19	34.61	14.42	16.60	32.44	-6.26-4.041e+04-7.298e+04-5.347e+04-5.991e+04	-
1.596e+04	3	23.04	56.79	-49.46	15.99	-8.66	-51.68 1324.54-2.377e+05-2.800e+04-2.084e+05	-
7.842e+04	2	27.10	26.57	-12.63	-12.09	26.03	4.56 1.098e+05-2.094e+05 1.097e+05-2.093e+05	5718.68
9 37	19	14.43	11.99	-33.22	-22.03	0.81	-19.51 7.718e+04-9.537e+04 4.438e+04-6.258e+04	-

Parco Eolico "Bolina" – Progetto Definitivo
Relazione di calcolo preliminare delle fondazioni degli aerogeneratori G8 e G12

6.770e+04												
1.608e+04	20	6.12	16.22	2.37	2.61	15.98	-1.80-4.012e+04-7.291e+04-5.330e+04-5.973e+04					
7.858e+04	3	22.96	22.80	-19.76	3.17	-0.13	-21.22 1657.62-2.375e+05-2.778e+04-2.081e+05					
9 69	2	27.03	9.51	-5.57	-5.37	9.31	1.73 1.100e+05-2.094e+05 1.099e+05-2.093e+05	5733.62				
6.772e+04	19	14.39	3.77	-10.65	-8.54	1.67	-5.09 7.744e+04-9.525e+04 4.467e+04-6.247e+04	-				
1.614e+04	20	6.08	7.58	-4.56	-4.54	7.56	0.47-3.998e+04-7.288e+04-5.322e+04-5.964e+04					
7.866e+04	3	22.93	7.22	-6.39	-3.39	4.23	-5.64 1828.01-2.375e+05-2.766e+04-2.080e+05					
10 1	3	5.25	8.23	-5.00	-4.94	8.18	0.84 1.132e+04-4.773e+04-4.165e+04	5233.87	1.795e+04			
	20	19.51	0.87	-8.77	-8.73	0.83	0.61-2.144e+04-2.129e+05-2.145e+04-2.129e+05	1472.54				
	21	31.22	4.23	-4.25	-4.25	4.23	0.03 1.560e+05-2.175e+05 1.560e+05-2.175e+05	3010.60				
	5	15.13	7.58	-4.95	-4.29	6.93	-2.79 1.177e+05-6.102e+04 1.126e+05-5.595e+04	-				
2.966e+04	10 3	3	4.44	6.97	-4.23	-4.18	6.92	0.71 9574.72-4.039e+04-3.524e+04	4428.66	1.519e+04		
	20	16.51	0.74	-7.42	-7.39	0.70	0.52-1.814e+04-1.801e+05-1.815e+04-1.801e+05	1246.00				
	21	26.42	3.58	-3.60	-3.60	3.58	0.02 1.320e+05-1.840e+05 1.320e+05-1.840e+05	2547.43				
	5	12.80	6.41	-4.18	-3.63	5.86	-2.36 9.957e+04-5.163e+04 9.529e+04-4.734e+04	-				
2.510e+04	10 7	3	4.09	-0.67	-33.17	-2.90	-30.94	-8.22 8873.44-3.655e+04-3.194e+04	4271.00	1.371e+04		
	20	15.01	14.33	-11.68	2.01	0.64	12.98-1.619e+04-1.638e+05-1.620e+04-1.638e+05	1234.66				
	21	24.12	8.98	-10.27	6.66	-7.95	6.26 1.207e+05-1.676e+05 1.207e+05-1.675e+05	2278.39				
	5	11.72	18.55	-28.59	10.73	-20.77	17.54 9.114e+04-4.671e+04 8.727e+04-4.284e+04	-				
2.279e+04	10 39	3	4.02	-2.16	-7.64	-3.50	-6.31	-2.35 8761.45-3.666e+04-3.201e+04	4108.94	1.377e+04		
	20	15.01	3.63	-6.76	-3.76	0.64	4.71-1.639e+04-1.638e+05-1.640e+04-1.638e+05	1167.22				
	21	24.02	1.93	-2.38	0.09	-0.54	2.13 1.202e+05-1.674e+05 1.202e+05-1.674e+05	2303.17				
	5	11.64	4.12	-6.18	1.45	-3.50	4.52 9.073e+04-4.686e+04 8.684e+04-4.297e+04	-				
2.281e+04	10 69	3	4.04	6.33	-3.84	-3.80	6.29	0.65 8704.29-3.672e+04-3.204e+04	4026.05	1.381e+04		
	20	15.01	0.67	-6.75	-6.72	0.64	0.47-1.649e+04-1.638e+05-1.650e+04-1.638e+05	1132.73				
	21	24.02	3.25	-3.27	-3.27	3.25	0.02 1.200e+05-1.673e+05 1.200e+05-1.673e+05	2315.85				
	5	11.64	5.83	-3.80	-3.30	5.33	-2.14 9.052e+04-4.694e+04 8.662e+04-4.304e+04	-				
2.282e+04	11 1	5	16.51	5.47	-1.80	-0.34	4.00	2.92 7.436e+04-1.221e+05 7.219e+04-1.199e+05	-			
2.053e+04	21	24.52	3.39	-8.17	-7.95	3.17	1.60 1.994e+05-8.793e+04 1.576e+05-4.606e+04	-				
1.014e+05	22	30.11	4.44	-3.13	-1.82	3.14	2.86 1.428e+05-2.166e+05 1.304e+05-2.042e+05	-				
6.546e+04	7	17.90	8.07	-5.09	-4.77	7.75	2.03 1.960e+05 2.146e+04 1.648e+05 5.258e+04	-				
6.680e+04	11 3	5	13.97	4.63	-1.52	-0.28	3.39	2.47 6.292e+04-1.033e+05 6.108e+04-1.015e+05	-			
1.737e+04	21	20.75	2.87	-6.91	-6.72	2.68	1.35 1.687e+05-7.440e+04 1.333e+05-3.897e+04	-				
8.579e+04	22	25.48	3.76	-2.65	-1.54	2.65	2.42 1.208e+05-1.832e+05 1.104e+05-1.728e+05	-				
5.539e+04	7	15.15	6.83	-4.31	-4.04	6.56	1.71 1.658e+05 1.816e+04 1.395e+05 4.449e+04	-				
5.653e+04	11 7	5	12.77	-7.23	-20.23	-7.35	-20.12	1.22 5.764e+04-9.394e+04 5.597e+04-9.227e+04	-			
1.581e+04	21	18.94	13.45	-14.54	13.02	-14.11	3.44 1.543e+05-6.738e+04 1.220e+05-3.512e+04	-				
7.817e+04	22	23.26	11.51	-31.69	3.95	-24.12	16.42 1.105e+05-1.668e+05 1.009e+05-1.573e+05	-				
5.053e+04	7	13.90	23.64	-13.58	22.93	-12.87	-5.08 1.514e+05 1.694e+04 1.275e+05 4.090e+04	-				
5.147e+04	11 53	5	12.70	8.80	1.06	5.44	4.42	-3.84 5.711e+04-9.406e+04 5.543e+04-9.238e+04	-			
1.583e+04	21	18.87	7.48	-6.43	-6.10	7.15	-2.13 1.534e+05-6.788e+04 1.211e+05-3.561e+04	-				
7.808e+04	22	23.18	10.66	-2.06	-4.00e-03	8.60	-4.69 1.098e+05-1.669e+05 1.003e+05-1.573e+05	-				
5.042e+04	7	13.76	1.91	-5.08	-4.80	1.63	-1.37 1.507e+05 1.636e+04 1.267e+05 4.037e+04	-				
5.147e+04	11 69	5	12.70	4.21	-1.39	-0.26	3.08	2.24 5.720e+04-9.391e+04 5.553e+04-9.224e+04	-			
1.579e+04	21	18.86	2.61	-6.29	-6.11	2.44	1.23 1.534e+05-6.764e+04 1.212e+05-3.543e+04	-				
7.799e+04												

Parco Eolico "Bolina" – Progetto Definitivo
Relazione di calcolo preliminare delle fondazioni degli aerogeneratori G8 e G12

5.035e+04	22	23.16	3.42	-2.41	-1.40	2.41	2.20	1.098e+05-1.666e+05	1.003e+05-1.571e+05	-				
5.139e+04	7	13.77	6.21	-3.92	-3.67	5.96	1.56	1.507e+05	1.651e+04	1.268e+05	4.045e+04	-		
1.091e+04	12	1	7	21.24	1.08	-2.89	-0.78	-1.03	1.98	1.396e+05-1.155e+05	1.391e+05-1.150e+05	-		
1.869e+05	22	36.09	9.31	-6.33	-5.36	8.33	3.78	3.625e+05-2.505e+04	2.198e+05	1.176e+05	-			
4.798e+04	23	12.18	8.95	-1.86	0.71	6.38	4.60	1.261e+05	-830.00	1.042e+05	2.108e+04	-		
1.091e+05	9	22.70	8.07	-4.75	0.88	2.44	6.36	2.367e+05	1249.92	1.633e+05	7.469e+04	-		
1.582e+05	12	3	7	17.97	0.92	-2.45	-0.66	-0.87	1.68	1.181e+05-9.774e+04	1.177e+05-9.735e+04	-9230.12		
4.060e+04	22	30.54	7.88	-5.36	-4.53	7.05	3.20	3.067e+05-2.119e+04	1.860e+05	9.953e+04	-			
4.060e+04	23	10.30	7.57	-1.57	0.60	5.40	3.89	1.067e+05	-702.30	8.820e+04	1.784e+04	-		
9.230e+04	9	19.21	6.83	-4.02	0.75	2.07	5.38	2.003e+05	1057.62	1.382e+05	6.320e+04	-		
1.441e+05	12	7	7	16.60	12.32	-50.94	11.51	-50.13	-7.13	1.080e+05-8.885e+04	1.076e+05-8.849e+04	-8360.11		
3.704e+04	22	27.92	17.22	-29.63	8.62	-21.03	18.13	2.799e+05-1.885e+04	1.699e+05	9.115e+04	-			
3.704e+04	23	9.41	-7.69	-25.67	-7.84	-25.53	1.59	9.778e+04	-316.55	8.089e+04	1.658e+04	-		
8.415e+04	9	17.63	12.43	-47.00	-0.21	-34.37	24.32	1.829e+05	1250.78	1.262e+05	5.792e+04	-		
1.439e+05	12	39	7	16.43	3.59	-17.58	3.50	-17.49	-1.40	1.076e+05-8.885e+04	1.072e+05-8.849e+04	-8380.56		
3.695e+04	22	27.82	6.86	-9.55	0.19	-2.88	8.06	2.792e+05-1.913e+04	1.694e+05	9.071e+04	-			
3.695e+04	23	9.38	-0.57	-7.11	-2.29	-5.39	2.88	9.729e+04	-529.53	8.042e+04	1.634e+04	-		
8.399e+04	9	17.52	7.67	-17.67	0.38	-10.38	11.47	1.824e+05	1059.37	1.258e+05	5.761e+04	-		
1.438e+05	12	69	7	16.34	0.83	-2.23	-0.60	-0.79	1.53	1.073e+05-8.886e+04	1.070e+05-8.850e+04	-8391.02		
3.691e+04	22	27.76	7.16	-4.87	-4.12	6.41	2.91	2.789e+05-1.927e+04	1.691e+05	9.048e+04	-			
3.691e+04	23	9.37	6.89	-1.43	0.54	4.91	3.54	9.704e+04	-638.46	8.019e+04	1.621e+04	-		
8.391e+04	9	17.46	6.21	-3.65	0.68	1.88	4.89	1.821e+05	961.47	1.256e+05	5.745e+04	-		
9.368e+04	13	1	9	19.56	4.67	-8.38	-1.43	-2.28	6.51	2.153e+05	2.635e+04	1.329e+05	1.087e+05	-
5.414e+04	23	20.39	1.78	-8.62	-0.58	-6.26	4.36	2.418e+05	8.616e+04	2.199e+05	1.081e+05	-		
1.432e+05	24	27.32	6.50	-9.44	5.46	-8.41	3.92	2.793e+05	-9850.57	1.545e+05	1.149e+05	-		
5.962e+04	11	18.79	2.71	-0.09	1.51	1.11	1.39	2.257e+05	1.029e+05	1.790e+05	1.497e+05	-		
7.927e+04	13	3	9	16.55	3.95	-7.09	-1.21	-1.93	5.51	1.822e+05	2.229e+04	1.125e+05	9.199e+04	-
4.581e+04	23	17.25	1.51	-7.30	-0.49	-5.30	3.69	2.046e+05	7.290e+04	1.860e+05	9.145e+04	-		
1.212e+05	24	23.11	5.50	-7.99	4.62	-7.11	3.32	2.363e+05	-8335.10	1.307e+05	9.722e+04	-		
5.045e+04	11	15.90	2.29	-0.07	1.28	0.94	1.17	1.910e+05	8.709e+04	1.515e+05	1.266e+05	-		
7.242e+04	13	23	9	15.19	21.88	-22.69	7.98	-8.79	-20.65	1.661e+05	2.009e+04	1.023e+05	8.386e+04	-
4.181e+04	23	15.73	-2.45	-19.96	-11.84	-10.57	-8.73	1.866e+05	6.651e+04	1.696e+05	8.346e+04	-		
1.108e+05	24	21.17	17.03	-5.96	10.02	1.05	-10.59	2.155e+05	-8072.26	1.189e+05	8.856e+04	-		
4.600e+04	11	14.53	-3.57	-33.17	-4.20	-32.55	-4.26	1.741e+05	7.949e+04	1.379e+05	1.157e+05	-		
7.213e+04	13	37	9	15.08	18.33	-8.79	-1.04	10.57	12.25	1.655e+05	2.002e+04	1.020e+05	8.347e+04	-
4.168e+04	23	15.66	7.53	0.73	2.69	5.57	3.08	1.858e+05	6.612e+04	1.689e+05	8.302e+04	-		
1.102e+05	24	21.05	9.66	-7.36	-0.20	2.50	8.40	2.147e+05	-7913.78	1.186e+05	8.815e+04	-		
4.584e+04	11	14.46	18.61	-2.85	-2.74	18.50	-1.52	1.735e+05	7.912e+04	1.375e+05	1.151e+05	-		
4.584e+04	13	69	9	15.05	3.59	-6.45	-1.10	-1.76	5.01	1.656e+05	2.027e+04	1.022e+05	8.363e+04	-

Parco Eolico "Bolina" – Progetto Definitivo
Relazione di calcolo preliminare delle fondazioni degli aerogeneratori G8 e G12

7.207e+04														
4.165e+04	23	15.69	1.37	-6.63	-0.44	-4.82	3.35	1.860e+05	6.627e+04	1.691e+05	8.314e+04	-		
1.101e+05	24	21.01	5.00	-7.26	4.20	-6.47	3.02	2.148e+05	-7577.36	1.189e+05	8.838e+04	-		
4.586e+04	11	14.46	2.09	-0.07	1.16	0.86	1.07	1.736e+05	7.917e+04	1.377e+05	1.151e+05	-		
7.263e+04	14 1	11	19.65	5.40	-7.94	4.87	-7.41	2.61	2.319e+05	7.649e+04	1.817e+05	1.266e+05	-	
7.878e+04	24	21.24	3.21	-4.19	2.30	-3.28	2.43	2.520e+05	9.080e+04	1.543e+05	1.885e+05	-		
7.260e+04	25	22.91	8.07	-3.42	7.73	-3.09	1.93	2.753e+05	1.283e+05	2.133e+05	1.902e+05	-		
5.813e+04	13	17.61	1.66	-4.88	0.79	-4.02	2.22	2.112e+05	9.236e+04	1.640e+05	1.396e+05	-		
6.146e+04	14 3	11	16.63	4.57	-6.72	4.12	-6.27	2.20	1.962e+05	6.472e+04	1.538e+05	1.071e+05	-	
6.666e+04	24	17.97	2.71	-3.55	1.94	-2.78	2.05	2.132e+05	7.683e+04	1.306e+05	1.595e+05	-		
6.143e+04	25	19.39	6.83	-2.90	6.54	-2.61	1.64	2.329e+05	1.085e+05	1.805e+05	1.610e+05	-		
4.918e+04	13	14.90	1.40	-4.13	0.67	-3.40	1.88	1.787e+05	7.815e+04	1.387e+05	1.181e+05	-		
5.597e+04	14 7	11	15.22	27.68	-12.67	27.61	-12.60	1.71	1.791e+05	5.933e+04	1.405e+05	9.794e+04	-	
6.061e+04	24	16.39	13.92	-47.11	3.47	-36.66	-22.99	1.943e+05	7.031e+04	1.193e+05	1.453e+05	-		
5.589e+04	25	17.72	22.37	-26.39	21.47	-25.49	-6.58	2.126e+05	9.932e+04	1.650e+05	1.469e+05	-		
4.480e+04	13	13.61	-10.09	-31.39	-16.77	-24.71	-9.88	1.629e+05	7.131e+04	1.266e+05	1.076e+05	-		
5.591e+04	14 39	11	15.14	12.00	-8.22	11.82	-8.03	1.91	1.786e+05	5.900e+04	1.400e+05	9.758e+04	-	
6.061e+04	24	16.34	4.63	-16.37	2.34	-14.08	-6.54	1.940e+05	7.000e+04	1.189e+05	1.451e+05	-		
5.586e+04	25	17.65	11.27	-10.27	11.20	-10.20	-1.24	2.120e+05	9.890e+04	1.644e+05	1.465e+05	-		
4.474e+04	13	13.57	-4.45	-11.23	-5.27	-10.41	-2.22	1.626e+05	7.114e+04	1.263e+05	1.074e+05	-		
5.587e+04	14 69	11	15.11	4.16	-6.11	3.75	-5.70	2.00	1.783e+05	5.884e+04	1.398e+05	9.740e+04	-	
6.060e+04	24	16.34	2.47	-3.22	1.77	-2.53	1.87	1.939e+05	6.984e+04	1.187e+05	1.450e+05	-		
5.585e+04	25	17.62	6.21	-2.63	5.95	-2.37	1.49	2.118e+05	9.868e+04	1.641e+05	1.463e+05	-		
4.471e+04	13	13.55	1.27	-3.76	0.61	-3.09	1.71	1.624e+05	7.105e+04	1.261e+05	1.073e+05	-		
1.101e+05	15 1	13	28.31	4.48	-7.09	4.09	-6.70	-2.09	3.299e+05	9.251e+04	2.556e+05	1.668e+05	-	
2.453e+04	25	14.93	4.71	-4.47	4.71	-4.46	-0.16	1.741e+05	1.251e+05	1.496e+05	1.496e+05	-		
1.101e+05	26	28.30	7.84	-0.82	7.74	-0.72	0.95	3.299e+05	9.250e+04	1.668e+05	2.556e+05	-		
9.316e+04	15 3	13	15.25	5.90	-7.96	5.86	-7.92	0.80	1.567e+05	-4283.85	7.618e+04	7.619e+04	8.047e+04	-
2.076e+04	25	12.63	3.98	-3.78	3.98	-3.78	-0.14	1.473e+05	1.058e+05	1.266e+05	1.265e+05	-		
9.316e+04	26	23.95	6.64	-0.70	6.55	-0.61	0.80	2.792e+05	7.827e+04	1.412e+05	2.163e+05	-		
8.493e+04	15 23	13	12.91	5.00	-6.74	4.96	-6.70	0.68	1.326e+05	-3624.79	6.446e+04	6.447e+04	6.809e+04	-
1.886e+04	25	11.54	11.24	-16.25	-4.69	-0.31	-13.57	1.343e+05	9.659e+04	1.152e+05	1.157e+05	-		
8.490e+04	26	22.03	37.58	-47.17	-24.89	15.31	-37.30	2.546e+05	7.151e+04	1.288e+05	1.974e+05	-		
8.477e+04	15 55	13	11.79	-25.40	-59.79	-47.23	-37.96	16.56	1.209e+05	-3207.81	5.891e+04	5.882e+04	6.207e+04	-
1.887e+04	25	11.50	4.15	-5.72	0.81	-2.38	-4.67	1.341e+05	9.633e+04	1.151e+05	1.153e+05	-		
	26	21.85	13.16	-12.83	-4.49	4.82	-12.14	2.541e+05	7.128e+04	1.285e+05	1.969e+05	-		

Parco Eolico "Bolina" – Progetto Definitivo
Relazione di calcolo preliminare delle fondazioni degli aerogeneratori G8 e G12

8.476e+04		15	11.75	-8.62	-21.25	-13.00	-16.87	6.01	1.207e+05	-3265.67	5.871e+04	5.868e+04	6.196e+04	-
15 69		13	21.78	3.45	-5.45	3.14	-5.15	-1.61	2.538e+05	7.116e+04	1.966e+05	1.283e+05	-	
8.469e+04		25	11.48	3.62	-3.44	3.62	-3.43	-0.13	1.339e+05	9.620e+04	1.151e+05	1.150e+05	-	
1.887e+04		26	21.77	6.03	-0.63	5.95	-0.55	0.73	2.538e+05	7.116e+04	1.283e+05	1.966e+05	-	
8.469e+04		15	11.73	4.54	-6.12	4.51	-6.09	0.62	1.205e+05	-3295.27	5.860e+04	5.861e+04	6.190e+04	-
16 1		15	31.20	5.75	-6.43	3.96	-4.64	-4.32	3.603e+05	8.941e+04	1.127e+05	3.369e+05	-	
7.599e+04		26	18.89	6.22	-9.48	6.22	-9.48	-0.24	2.088e+05	2.703e+04	1.043e+05	1.315e+05	-	
8.987e+04		27	29.06	9.95	-3.25	9.03	-2.33	-3.36	3.394e+05	9.887e+04	3.186e+05	1.196e+05	-	
6.751e+04		17	22.87	8.14	-9.54	8.10	-9.50	0.85	2.747e+05	1.486e+05	2.143e+05	2.090e+05	-	
6.301e+04		15	26.40	4.87	-5.44	3.35	-3.93	-3.65	3.048e+05	7.566e+04	9.540e+04	2.851e+05	-	
16 3		26	15.99	5.26	-8.02	5.26	-8.02	-0.21	1.767e+05	2.287e+04	8.825e+04	1.113e+05	-	
6.430e+04		27	24.59	8.42	-2.75	7.64	-1.97	-2.85	2.871e+05	8.366e+04	2.696e+05	1.012e+05	-	
7.604e+04		17	19.35	6.89	-8.07	6.85	-8.04	0.72	2.325e+05	1.257e+05	1.813e+05	1.769e+05	-	
5.712e+04		15	24.25	52.54	-60.17	-19.14	11.50	-54.23	2.778e+05	6.898e+04	8.706e+04	2.597e+05	-	
5.332e+04		26	14.60	-18.80	-37.46	-23.25	-33.01	-7.95	1.611e+05	2.083e+04	8.047e+04	1.015e+05	-	
16 7		27	22.69	81.23	-30.28	47.70	3.26	-51.14	2.619e+05	7.642e+04	2.460e+05	9.232e+04	-	
5.871e+04		17	17.73	22.10	-62.62	20.52	-61.04	11.47	2.118e+05	1.145e+05	1.655e+05	1.609e+05	-	
6.935e+04		15	24.08	19.30	-22.23	-4.46	1.53	-20.55	2.773e+05	6.885e+04	8.684e+04	2.594e+05	-	
4.856e+04		26	14.55	-4.04	-16.66	-4.70	-15.99	-2.82	1.608e+05	2.080e+04	8.031e+04	1.013e+05	-	
16 39		27	22.47	32.01	-11.35	20.74	-0.09	-19.02	2.613e+05	7.618e+04	2.454e+05	9.211e+04	-	
5.854e+04		17	17.64	11.57	-25.99	11.06	-25.49	4.31	2.115e+05	1.144e+05	1.651e+05	1.608e+05	-	
6.920e+04		15	24.00	4.43	-4.95	3.05	-3.57	-3.32	2.771e+05	6.878e+04	8.672e+04	2.592e+05	-	
5.192e+04		26	14.53	4.78	-7.29	4.78	-7.29	-0.19	1.606e+05	2.079e+04	8.023e+04	1.012e+05	-	
4.850e+04		27	22.36	7.66	-2.50	6.95	-1.79	-2.59	2.610e+05	7.605e+04	2.451e+05	9.200e+04	-	
16 69		17	17.59	6.26	-7.34	6.23	-7.31	0.65	2.113e+05	1.143e+05	1.649e+05	1.608e+05	-	
5.845e+04		19	14.45	10.98	-4.92	-4.67	10.73	-1.98	-3.549e+04	-1.650e+05	-1.366e+05	-6.390e+04	-	
6.913e+04		28	25.23	-1.45	-9.25	-3.54	-7.16	-3.45	-7.690e+04	-2.926e+05	-8.996e+04	-2.795e+05	-	
5.193e+04		29	21.96	2.72	-11.59	-7.29	-1.58	-6.56	-7388.41	-2.322e+05	-1.742e+04	-2.221e+05	-	
4.847e+04		20	19.49	12.27	-9.37	-6.69	9.58	-7.14	2.094e+04	-1.911e+05	1.486e+04	-1.850e+05	3.538e+04	-
17 3		19	12.23	9.29	-4.17	-3.95	9.08	-1.67	-3.003e+04	-1.397e+05	-1.156e+05	-5.407e+04	-	
4.536e+04		28	21.35	-1.22	-7.83	-2.99	-6.06	-2.92	-6.507e+04	-2.476e+05	-7.612e+04	-2.365e+05	-	
4.353e+04		29	18.58	2.30	-9.81	-6.17	-1.34	-5.55	-6251.73	-1.964e+05	-1.474e+04	-1.880e+05	-	
3.927e+04		20	16.49	10.38	-7.93	-5.66	8.10	-6.04	1.772e+04	-1.617e+05	1.258e+04	-1.565e+05	2.993e+04	-
17 21		19	11.17	80.97	6.22	60.86	26.33	33.15	-2.761e+04	-1.274e+05	-1.055e+05	-4.950e+04	-	
4.130e+04		28	19.49	52.91	-65.77	27.62	-40.48	-48.60	-5.956e+04	-2.255e+05	-6.954e+04	-2.155e+05	-	
3.944e+04		29	16.96	23.64	-1.88	11.94	9.82	-12.72	-6079.02	-1.791e+05	-1.376e+04	-1.714e+05	-	
3.565e+04		20	15.00	17.90	-43.88	-11.51	-14.46	-30.85	1.563e+04	-1.475e+05	1.100e+04	-1.428e+05	2.710e+04	-
17 53		19	11.13	26.68	5.90	18.21	14.37	10.21	-2.740e+04	-1.271e+05	-1.052e+05	-4.927e+04	-	
4.126e+04		28	19.44	17.15	-26.95	7.55	-17.34	-18.20	-5.930e+04	-2.252e+05	-6.932e+04	-2.152e+05	-	

Parco Eolico "Bolina" – Progetto Definitivo
Relazione di calcolo preliminare delle fondazioni degli aerogeneratori G8 e G12

3.953e+04													
3.568e+04	29	16.92	9.15	-6.30	0.33	2.52	-7.64	-5817.27-1.788e+05-1.352e+04-1.711e+05					
17 69	20	14.99	10.88	-18.19	-7.30	-0.02	-14.07	1.595e+04-1.471e+05 1.129e+04-1.425e+05 2.717e+04					
4.124e+04	19	11.12	8.45	-3.79	-3.59	8.25	-1.52-2.730e+04-1.270e+05-1.051e+05-4.915e+04						
3.957e+04	28	19.41	-1.11	-7.12	-2.72	-5.51	-2.66-5.916e+04-2.251e+05-6.920e+04-2.150e+05						
3.570e+04	29	16.89	2.10	-8.92	-5.61	-1.22	-5.05	-5683.39-1.786e+05-1.340e+04-1.709e+05					
18 1	20	14.99	9.43	-7.21	-5.14	7.37	-5.49	1.611e+04-1.470e+05 1.143e+04-1.423e+05 2.721e+04					
5.058e+04	20	16.71	1.96	-6.07	-4.31	0.20	-3.33	5.530e+04-1.395e+05 5.432e+04-1.385e+05 1.376e+04					
	29	21.74	4.51	-10.79	-10.10	3.83	-3.17-1.135e+05-2.606e+05-1.336e+05-2.404e+05						
	30	29.01	2.69	-4.56	-3.30	1.42	-2.75	1.443e+05-2.028e+05 1.324e+05-1.908e+05 6.322e+04					
8.765e+04	21	26.31	6.66	-4.04	-3.56	6.18	-2.22	-367.09-2.739e+05-3.214e+04-2.422e+05					
18 3	20	14.14	1.66	-5.14	-3.65	0.17	-2.81	4.679e+04-1.180e+05 4.596e+04-1.172e+05 1.164e+04					
4.280e+04	29	18.40	3.82	-9.13	-8.54	3.24	-2.68-9.601e+04-2.205e+05-1.131e+05-2.034e+05						
	30	24.55	2.27	-3.86	-2.79	1.20	-2.33	1.221e+05-1.716e+05 1.120e+05-1.615e+05 5.350e+04					
7.416e+04	21	22.27	5.64	-3.42	-3.01	5.23	-1.88	-310.61-2.318e+05-2.719e+04-2.049e+05					
18 7	20	12.93	13.57	-11.91	8.81	-7.15	9.94	4.297e+04-1.073e+05 4.221e+04-1.066e+05 1.064e+04					
3.910e+04	29	16.78	16.77	-11.64	13.87	-8.74	8.60-8.719e+04-2.007e+05-1.028e+05-1.851e+05						
	30	22.41	4.00	-7.91	0.81	-4.72	5.27	1.118e+05-1.562e+05 1.026e+05-1.469e+05 4.885e+04					
6.771e+04	21	20.30	1.16	-8.37	-1.89	-5.32	4.44	163.38-2.111e+05-2.440e+04-1.865e+05					
18 40	20	12.86	-0.82	-7.53	-3.41	-4.94	3.27	4.270e+04-1.072e+05 4.195e+04-1.065e+05 1.062e+04					
3.898e+04	29	16.72	3.51	-2.89	-2.81	3.43	0.70-8.714e+04-2.004e+05-1.027e+05-1.849e+05						
	30	22.33	1.69	-9.36	-7.39	-0.28	4.23	1.113e+05-1.559e+05 1.021e+05-1.467e+05 4.870e+04					
6.751e+04	21	20.24	4.66	-6.80	-6.62	4.49	1.41	-39.29-2.107e+05-2.452e+04-1.862e+05					
18 69	20	12.85	1.51	-4.67	-3.31	0.15	-2.56	4.254e+04-1.073e+05 4.178e+04-1.066e+05 1.058e+04					
3.891e+04	29	16.72	3.47	-8.30	-7.77	2.94	-2.44-8.728e+04-2.004e+05-1.028e+05-1.849e+05						
	30	22.32	2.07	-3.51	-2.54	1.10	-2.12	1.110e+05-1.560e+05 1.018e+05-1.468e+05 4.863e+04					
6.742e+04	21	20.24	5.13	-3.11	-2.74	4.76	-1.71	-282.38-2.107e+05-2.472e+04-1.863e+05					
19 1	21	13.22	1.85	-1.82	-1.73	1.77	0.54	4.306e+04-1.109e+05 4.280e+04-1.107e+05 -6303.71					
7.147e+04	30	24.00	6.05	-6.27	-4.70	4.48	-4.10	7.483e+04-2.039e+05 5.511e+04-1.842e+05 -					
	31	21.66	10.33	-10.87	-10.87	10.32	0.37	9.019e+04-1.658e+05 9.015e+04-1.657e+05 -3493.65					
19 3	22	22.24	5.14	-5.99	-5.16	4.31	2.92	1.110e+05-1.551e+05 9.393e+04-1.380e+05 6.519e+04					
	21	11.19	1.56	-1.54	-1.47	1.49	0.46	3.644e+04-9.386e+04 3.622e+04-9.364e+04 -5333.91					
6.047e+04	30	20.31	5.12	-5.30	-3.98	3.79	-3.47	6.332e+04-1.725e+05 4.663e+04-1.559e+05 -					
	31	18.33	8.74	-9.20	-9.20	8.73	0.31	7.632e+04-1.403e+05 7.628e+04-1.402e+05 -2956.17					
19 21	22	18.82	4.35	-5.07	-4.36	3.65	2.47	9.392e+04-1.312e+05 7.948e+04-1.168e+05 5.516e+04					
	21	10.19	28.18	14.36	24.45	18.09	6.14	3.278e+04-8.587e+04 3.256e+04-8.564e+04 -5151.12					
5.504e+04	30	18.61	27.44	-15.76	13.59	-1.91	-20.16	5.708e+04-1.578e+05 4.190e+04-1.426e+05 -					
	31	16.64	15.19	-1.42	7.80	5.97	-8.26	6.902e+04-1.282e+05 6.897e+04-1.282e+05 -2994.22					
19 53	22	17.23	27.71	-16.00	-0.23	11.93	-20.99	8.485e+04-1.201e+05 7.168e+04-1.069e+05 5.027e+04					
5.500e+04	21	10.18	9.57	4.84	7.39	7.02	2.35	3.301e+04-8.551e+04 3.280e+04-8.530e+04 -4951.24					
	30	18.50	10.83	-6.99	2.21	1.64	-8.91	5.740e+04-1.572e+05 4.223e+04-1.420e+05 -					
	31	16.65	7.90	-3.52	-2.89	7.27	-2.61	6.926e+04-1.278e+05 6.922e+04-1.277e+05 -2791.24					
19 69	22	17.15	8.94	-5.41	-2.70	6.23	-5.62	8.520e+04-1.195e+05 7.206e+04-1.064e+05 5.019e+04					
5.498e+04	21	10.17	1.42	-1.40	-1.33	1.36	0.42	3.312e+04-8.532e+04 3.293e+04-8.513e+04 -4849.01					
	30	18.46	4.65	-4.82	-3.62	3.45	-3.16	5.756e+04-1.569e+05 4.239e+04-1.417e+05 -					
	31	16.66	7.94	-8.37	-8.36	7.94	0.28	6.938e+04-1.275e+05 6.934e+04-1.275e+05 -2687.43					
20 1	22	17.11	3.96	-4.60	-3.97	3.32	2.25	8.538e+04-1.193e+05 7.225e+04-1.061e+05 5.015e+04					
1.864e+05	22	8.86	10.07	-4.33	-3.86	9.60	2.55	7.979e+04-2.107e+04 3.980e+04 1.892e+04 4.934e+04					
	31	39.19	3.14	-13.84	-11.92	1.22	5.39	3.093e+05-1.525e+05 2.147e+05-5.798e+04 -					
	32	16.22	9.49	3.48	4.26	8.71	2.02	1.195e+05-7.370e+04 1.195e+05-7.367e+04 2319.88					
1.379e+05	23	30.49	10.31	-5.01	-0.80	6.09	6.84	3.116e+05-1.076e+04 2.339e+05 6.701e+04 -					
20 3	22	7.50	8.52	-3.66	-3.26	8.12	2.16	6.752e+04-1.783e+04 3.368e+04 1.601e+04 4.175e+04					

Parco Eolico "Bolina" – Progetto Definitivo
Relazione di calcolo preliminare delle fondazioni degli aerogeneratori G8 e G12

1.577e+05	31	33.16	2.66	-11.71	-10.08	1.03	4.56 2.617e+05-1.291e+05 1.817e+05-4.906e+04	-
	32	13.73	8.03	2.95	3.61	7.37	1.71 1.011e+05-6.236e+04 1.011e+05-6.234e+04	1962.98
	23	25.80	8.72	-4.24	-0.67	5.15	5.79 2.637e+05 -9103.85 1.979e+05 5.670e+04	-
1.167e+05	20 23	22	6.83	16.45	-13.10	14.34	-11.00 -7.60 6.126e+04-1.632e+04 3.041e+04 1.454e+04 3.797e+04	-
	31	30.24	5.80	-1.02	3.21	1.56	-3.31 2.386e+05-1.181e+05 1.655e+05-4.496e+04	-
1.440e+05	32	12.51	4.51	-6.87	2.18	-4.55	-4.59 9.188e+04-5.701e+04 9.187e+04-5.699e+04	1657.56
	23	23.52	-1.06	-13.12	-5.35	-8.83	-5.77 2.404e+05 -8491.32 1.803e+05 5.164e+04	-
1.065e+05	20 39	22	6.83	-1.43	-6.55	-1.48	-6.50 0.52 6.166e+04-1.614e+04 3.083e+04 1.469e+04 3.805e+04	-
	31	30.17	3.18	-9.20	-4.75	-1.27	5.94 2.383e+05-1.173e+05 1.655e+05-4.448e+04	-
1.435e+05	32	12.49	1.75	-0.12	0.81	0.82	0.94 9.221e+04-5.662e+04 9.219e+04-5.660e+04	1815.89
	23	23.49	5.55	-9.89	-0.38	-3.96	7.51 2.401e+05 -8187.84 1.802e+05 5.171e+04	-
1.062e+05	20 69	22	6.81	7.74	-3.33	-2.97	7.39 1.96 6.138e+04-1.621e+04 3.062e+04 1.455e+04 3.795e+04	-
	31	30.14	2.42	-10.65	-9.17	0.94	4.14 2.379e+05-1.173e+05 1.652e+05-4.460e+04	-
1.434e+05	32	12.48	7.30	2.68	3.28	6.70	1.55 9.191e+04-5.669e+04 9.189e+04-5.667e+04	1784.53
	23	23.45	7.93	-3.86	-0.61	4.68	5.26 2.397e+05 -8276.23 1.799e+05 5.154e+04	-
1.061e+05	21 1	23	17.73	4.95	-10.20	0.85	-6.10 6.73 2.087e+05 6.767e+04 1.686e+05 1.078e+05	-
6.360e+04	32	27.32	-3.48	-9.56	-4.22	-8.82	1.99 3.176e+05 8.638e+04 2.631e+05 1.409e+05	-
9.813e+04	33	28.30	13.74	-3.22	11.86	-1.33	5.33 3.304e+05 9.456e+04 2.089e+05 2.160e+05	-
1.179e+05	24	25.44	4.33	-10.10	3.87	-9.64	2.55 2.943e+05 7.450e+04 2.495e+05 1.193e+05	-
8.850e+04	21 3	23	15.00	4.19	-8.63	0.72	-5.16 5.70 1.766e+05 5.726e+04 1.426e+05 9.118e+04	-
5.382e+04	32	23.12	-2.95	-8.09	-3.57	-7.46	1.68 2.687e+05 7.309e+04 2.226e+05 1.192e+05	-
8.303e+04	33	23.95	11.63	-2.72	10.03	-1.13	4.51 2.796e+05 8.001e+04 1.768e+05 1.828e+05	-
9.973e+04	24	21.53	3.66	-8.55	3.27	-8.15	2.16 2.490e+05 6.304e+04 2.111e+05 1.009e+05	-
7.489e+04	21 23	23	13.73	15.69	-12.91	7.55	-4.77 -12.91 1.609e+05 5.198e+04 1.298e+05 8.315e+04	-
4.923e+04	32	21.07	-0.85	-11.16	-7.24	-4.77	-5.00 2.451e+05 6.683e+04 2.030e+05 1.089e+05	-
7.571e+04	33	21.90	8.34	-11.35	3.21	-6.22	-8.64 2.552e+05 7.266e+04 1.609e+05 1.669e+05	-
9.120e+04	24	19.65	-6.59	-21.50	-16.23	-11.86	-7.13 2.271e+05 5.757e+04 1.926e+05 9.207e+04	-
6.825e+04	21 55	23	13.64	3.10	-4.83	2.99	-4.72 -0.94 1.606e+05 5.203e+04 1.297e+05 8.298e+04	-
4.903e+04	32	21.03	-4.34	-6.37	-4.60	-6.10	-0.68 2.445e+05 6.658e+04 2.026e+05 1.086e+05	-
7.556e+04	33	21.80	7.13	-2.79	7.12	-2.78	-0.21 2.545e+05 7.271e+04 1.608e+05 1.664e+05	-
9.085e+04	24	19.59	-3.30	-9.14	-3.52	-8.92	-1.11 2.266e+05 5.739e+04 1.922e+05 9.185e+04	-
6.814e+04	21 69	23	13.64	3.81	-7.84	0.66	-4.69 5.18 1.605e+05 5.205e+04 1.297e+05 8.290e+04	-
4.892e+04	32	21.02	-2.68	-7.35	-3.25	-6.79	1.53 2.443e+05 6.645e+04 2.024e+05 1.084e+05	-
7.548e+04	33	21.77	10.57	-2.47	9.12	-1.02	4.10 2.541e+05 7.274e+04 1.607e+05 1.662e+05	-
9.066e+04	24	19.57	3.33	-7.77	2.97	-7.41	1.96 2.264e+05 5.731e+04 1.919e+05 9.174e+04	-
6.808e+04	22 1	24	23.35	5.85	-5.13	5.05	-4.33 2.87 2.671e+05 2.085e+05 2.637e+05 2.120e+05	-
1.376e+04	33	28.88	10.87	-10.42	10.86	-10.41	0.32 3.178e+05 3.744e+04 1.776e+05 1.776e+05	-
1.402e+05	34	23.35	6.00	-6.03	4.66	-4.69	-3.79 2.671e+05 2.086e+05 2.120e+05 2.636e+05	-
1.374e+04	25	22.31	2.15	-2.01	2.12	-1.97	0.37 2.554e+05 5.656e+04 1.560e+05 1.560e+05	-
9.944e+04	22 3	24	19.76	4.95	-4.34	4.27	-3.66 2.42 2.260e+05 1.765e+05 2.231e+05 1.794e+05	-
1.164e+04								

Parco Eolico "Bolina" – Progetto Definitivo
Relazione di calcolo preliminare delle fondazioni degli aerogeneratori G8 e G12

1.186e+05	33	24.43	9.20	-8.81	9.19	-8.81	0.27	2.689e+05	3.168e+04	1.503e+05	1.503e+05	-	
1.162e+04	34	19.75	5.08	-5.11	3.94	-3.97	-3.21	2.260e+05	1.765e+05	1.794e+05	2.231e+05	-	
8.414e+04	25	18.88	1.82	-1.70	1.79	-1.67	0.31	2.161e+05	4.786e+04	1.320e+05	1.320e+05	-	
1.066e+04	22 7	24	18.04	16.67	-27.93	10.14	-21.40	-15.77	2.064e+05	1.609e+05	2.038e+05	1.635e+05	-
1.081e+05	33	22.32	12.63	-27.44	10.51	-25.32	-8.97	2.453e+05	2.903e+04	1.374e+05	1.370e+05	-	
1.045e+04	34	18.02	21.28	-33.86	-5.20	-7.37	-27.55	2.060e+05	1.613e+05	1.639e+05	2.034e+05	-	
7.679e+04	25	17.32	-12.92	-32.14	-15.58	-29.49	6.63	1.973e+05	4.367e+04	1.206e+05	1.204e+05	-	
1.061e+04	22 39	24	17.99	6.92	-10.36	6.00	-9.44	-3.88	2.058e+05	1.606e+05	2.031e+05	1.632e+05	-
1.079e+05	33	22.25	9.44	-14.22	9.09	-13.87	-2.87	2.447e+05	2.888e+04	1.369e+05	1.367e+05	-	
1.053e+04	34	17.98	9.45	-13.72	0.61	-4.88	-11.25	2.056e+05	1.607e+05	1.634e+05	2.030e+05	-	
7.659e+04	25	17.22	-3.41	-11.76	-4.19	-10.98	2.43	1.967e+05	4.356e+04	1.202e+05	1.201e+05	-	
1.058e+04	22 69	24	17.96	4.50	-3.95	3.88	-3.33	2.20	2.055e+05	1.604e+05	2.028e+05	1.631e+05	-
1.078e+05	33	22.21	8.36	-8.01	8.36	-8.01	0.25	2.444e+05	2.880e+04	1.366e+05	1.366e+05	-	
1.057e+04	34	17.96	4.62	-4.64	3.59	-3.61	-2.91	2.054e+05	1.605e+05	1.631e+05	2.028e+05	-	
7.649e+04	25	17.16	1.65	-1.54	1.63	-1.52	0.29	1.965e+05	4.351e+04	1.200e+05	1.200e+05	-	
7.262e+04	23 1	25	22.91	3.77	-6.93	3.24	-6.40	-2.31	2.753e+05	1.282e+05	1.902e+05	2.133e+05	-
7.880e+04	34	21.24	4.83	-2.86	3.96	-1.99	-2.44	2.521e+05	9.078e+04	1.885e+05	1.543e+05	-	
7.265e+04	35	19.65	9.74	-5.62	9.02	-4.90	-3.25	2.318e+05	7.646e+04	1.266e+05	1.817e+05	-	
5.813e+04	26	17.62	6.37	-1.75	4.72	-0.10	-3.27	2.111e+05	9.237e+04	1.396e+05	1.639e+05	-	
6.145e+04	23 3	25	19.38	3.19	-5.86	2.74	-5.42	-1.95	2.329e+05	1.085e+05	1.610e+05	1.805e+05	-
6.668e+04	34	17.98	4.09	-2.42	3.35	-1.68	-2.06	2.133e+05	7.681e+04	1.595e+05	1.306e+05	-	
6.147e+04	35	16.63	8.24	-4.76	7.63	-4.15	-2.75	1.962e+05	6.469e+04	1.071e+05	1.537e+05	-	
4.919e+04	26	14.91	5.39	-1.48	3.99	-0.08	-2.76	1.787e+05	7.816e+04	1.181e+05	1.387e+05	-	
5.617e+04	23 7	25	17.70	4.33	-20.98	-11.75	-4.90	-12.19	2.125e+05	9.880e+04	1.469e+05	1.644e+05	-
6.084e+04	34	16.46	12.79	-34.22	-15.54	-5.90	-23.01	1.947e+05	7.004e+04	1.458e+05	1.189e+05	-	
5.613e+04	35	15.22	26.25	-5.83	21.00	-0.57	-11.87	1.788e+05	5.883e+04	9.768e+04	1.400e+05	-	
4.484e+04	26	13.63	14.42	-31.79	0.31	-17.69	-21.28	1.629e+05	7.133e+04	1.079e+05	1.264e+05	-	
5.597e+04	23 39	25	17.65	1.83	-9.07	-2.32	-4.92	-5.30	2.120e+05	9.870e+04	1.465e+05	1.642e+05	-
6.069e+04	34	16.38	5.90	-12.15	-3.24	-3.01	-9.02	1.942e+05	6.990e+04	1.453e+05	1.188e+05	-	
5.597e+04	35	15.15	13.66	-4.65	11.69	-2.69	-5.67	1.785e+05	5.882e+04	9.749e+04	1.398e+05	-	
4.476e+04	26	13.58	8.07	-11.60	2.51	-6.03	-8.86	1.626e+05	7.115e+04	1.075e+05	1.262e+05	-	
5.587e+04	23 69	25	17.62	2.90	-5.33	2.50	-1.77	2.118e+05	9.864e+04	1.463e+05	1.641e+05	-	
6.062e+04	34	16.34	3.72	-2.20	3.05	-1.53	-1.87	1.939e+05	6.983e+04	1.450e+05	1.187e+05	-	
5.588e+04	35	15.12	7.49	-4.32	6.94	-3.77	-2.50	1.783e+05	5.881e+04	9.740e+04	1.397e+05	-	
4.472e+04	26	13.55	4.90	-1.34	3.63	-0.07	-2.51	1.624e+05	7.105e+04	1.074e+05	1.261e+05	-	
1.062e+05	24 1	26	27.05	7.95	-11.87	5.83	-9.76	-6.12	3.178e+05	1.001e+05	2.328e+05	1.852e+05	-
	35	14.01	11.65	-3.03	7.67	0.94	-6.52	1.679e+05	9.254e+04	1.110e+05	1.495e+05	-	

Parco Eolico "Bolina" – Progetto Definitivo
Relazione di calcolo preliminare delle fondazioni degli aerogeneratori G8 e G12

9.126e+04	38	24.41	3.73	-10.83	-5.04	-2.05	-7.12-9.339e+04-2.876e+05-1.574e+05-2.236e+05	
4.118e+04	39	16.90	1.93	-10.00	-7.63	-0.43	-4.75-8.717e+04-2.025e+05-1.045e+05-1.852e+05	
1.664e+05	30	36.70	4.81	-10.74	-9.90	3.97	-3.52-6.870e+04-4.118e+05-1.986e+05-2.819e+05	
26	3	29	19.35	2.31	-1.76	0.04	-2.02 3.554e+04-1.814e+05 3.554e+04-1.814e+05	-1073.26
7.722e+04	38	20.66	3.16	-9.16	-4.27	-1.74	-6.03-7.902e+04-2.433e+05-1.331e+05-1.892e+05	
3.485e+04	39	14.30	1.63	-8.46	-6.46	-0.37	-4.02-7.376e+04-1.713e+05-8.840e+04-1.567e+05	
1.408e+05	30	31.05	4.07	-9.09	-8.38	3.36	-2.98-5.813e+04-3.484e+05-1.680e+05-2.385e+05	
26	23	29	17.80	49.46	-9.68	49.09	4.65 3.230e+04-1.655e+05 3.230e+04-1.655e+05	-1059.78
7.038e+04	38	18.94	43.94	-13.24	31.05	-0.35	-23.90-7.216e+04-2.219e+05-1.215e+05-1.725e+05	
3.175e+04	39	13.09	24.19	7.94	23.76	8.37	-2.62-6.740e+04-1.564e+05-8.072e+04-1.431e+05	
1.282e+05	30	28.37	26.46	-17.11	18.10	-8.75	-17.15-5.330e+04-3.177e+05-1.534e+05-2.176e+05	
26	55	29	17.66	16.64	-2.86	16.64	0.36 3.231e+04-1.651e+05 3.231e+04-1.651e+05	-1004.14
7.026e+04	38	18.84	15.95	-9.18	7.94	-1.16	-11.71-7.195e+04-2.214e+05-1.212e+05-1.722e+05	
3.170e+04	39	13.03	6.78	-0.01	4.15	2.61	-3.31-6.717e+04-1.560e+05-8.048e+04-1.427e+05	
1.281e+05	30	28.28	7.73	-7.59	1.08	-0.94	-7.59-5.300e+04-3.171e+05-1.530e+05-2.171e+05	
26	69	29	17.59	2.10	-1.60	0.04	-1.84 3.231e+04-1.649e+05 3.231e+04-1.649e+05	-975.69
7.020e+04	38	18.78	2.87	-8.33	-3.88	-1.58	-5.48-7.184e+04-2.212e+05-1.210e+05-1.720e+05	
3.168e+04	39	13.00	1.48	-7.69	-5.87	-0.33	-3.66-6.705e+04-1.558e+05-8.036e+04-1.424e+05	
1.280e+05	30	28.23	3.70	-8.26	-7.62	3.05	-2.71-5.285e+04-3.168e+05-1.528e+05-2.168e+05	
27	1	30	16.58	4.27	-11.26	-10.82	-2.58-3.972e+04-1.889e+05-9.835e+04-1.303e+05	-
7.287e+04	39	33.18	4.32	-11.72	-7.55	0.15	-7.03-7.498e+04-3.766e+05-1.514e+05-3.002e+05	
1.312e+05	40	19.78	-3.67	-9.84	-9.22	-4.30	-1.86-1.561e+04-2.134e+05-1.665e+04-2.124e+05	-
1.432e+04	31	39.46	13.12	-3.39	-1.49	11.22	-5.26 5.709e+04-3.789e+05-3.064e+04-2.912e+05	
1.748e+05	30	14.03	3.61	-9.53	-9.16	3.24	-2.18-3.361e+04-1.599e+05-8.322e+04-1.103e+05	-
27	3	39	28.07	3.65	-9.92	-6.39	-5.95-6.344e+04-3.186e+05-1.281e+05-2.540e+05	
6.166e+04	40	16.74	-3.11	-8.33	-7.80	-3.64	-1.58-1.321e+04-1.806e+05-1.409e+04-1.797e+05	-
1.110e+05	31	33.39	11.10	-2.86	-1.26	9.50	-4.45 4.831e+04-3.206e+05-2.593e+04-2.464e+05	
1.479e+05	30	12.76	14.34	-15.37	12.82	-13.85	6.54-3.035e+04-1.453e+05-7.558e+04-1.000e+05	-
27	7	39	25.57	12.57	2.53	9.63	4.57-5.747e+04-2.903e+05-1.165e+05-2.313e+05	
5.614e+04	40	15.24	7.10	-4.37	4.87	-2.15	4.54-1.166e+04-1.641e+05-1.245e+04-1.633e+05	-
1.013e+05	31	30.44	1.11	-4.74	-0.51	-3.13	2.62 4.465e+04-2.921e+05-2.316e+04-2.243e+05	
1.095e+04	30	12.77	5.36	1.75	4.98	2.13	-1.11-3.060e+04-1.456e+05-7.579e+04-1.004e+05	-
1.351e+05	39	25.56	8.99	-6.58	2.57	-0.16	-7.66-5.777e+04-2.900e+05-1.166e+05-2.312e+05	
27	55	40	15.24	-0.03	-2.12	-1.32	-1.01-1.207e+04-1.645e+05-1.288e+04-1.637e+05	-
5.617e+04	31	30.38	8.97	-3.09	1.40	4.48	-5.83 4.385e+04-2.918e+05-2.368e+04-2.243e+05	
1.010e+05	30	12.75	3.28	-8.66	-8.32	2.94	-1.98-3.056e+04-1.453e+05-7.565e+04-1.002e+05	-
1.106e+04	39	25.52	3.32	-9.02	-5.81	0.11	-5.41-5.767e+04-2.897e+05-1.164e+05-2.309e+05	
1.346e+05	40	15.22	-2.83	-7.57	-7.09	-3.31	-1.43-1.201e+04-1.642e+05-1.281e+04-1.634e+05	-
27	69	31	30.36	10.09	-2.60	-1.15	-4.05 4.392e+04-2.915e+05-2.357e+04-2.240e+05	
5.605e+04								

Parco Eolico "Bolina" – Progetto Definitivo
Relazione di calcolo preliminare delle fondazioni degli aerogeneratori G8 e G12

1.345e+05	28	1	31	8.89	2.43	-2.84	-2.84	2.42	0.14	-1308.76	-9.305e+04	-9.124e+04	-3125.13	-
1.278e+04			40	34.61	1.48	-10.32	-9.72	0.88	-2.60	-988.68	-3.607e+05	-6690.34	-3.550e+05	4.493e+04
			41	52.61	0.51	-0.49	-0.48	0.51	0.05	2.641e+05	-3.659e+05	2.640e+05	-3.658e+05	-8184.04
			32	31.86	9.83	-1.76	-1.10	9.18	2.68	2.801e+05	-8.589e+04	2.726e+05	-7.839e+04	-
5.185e+04	28	3	31	7.52	2.05	-2.41	-2.40	2.05	0.12	-1107.41	-7.874e+04	-7.720e+04	-2644.34	-
1.081e+04			40	29.28	1.25	-8.73	-8.22	0.74	-2.20	-836.57	-3.052e+05	-5661.05	-3.004e+05	3.802e+04
			41	44.51	0.43	-0.41	-0.41	0.43	0.04	2.234e+05	-3.096e+05	2.234e+05	-3.095e+05	-6924.96
			32	26.96	8.32	-1.49	-0.93	7.77	2.26	2.370e+05	-7.268e+04	2.307e+05	-6.633e+04	-
4.388e+04	28	23	31	6.93	14.37	-0.11	14.22	0.04	-1.47	-1178.95	-7.218e+04	-7.072e+04	-2641.32	-
1.008e+04			40	26.72	7.96	-2.64	5.63	-0.31	-4.40	-835.51	-2.787e+05	-5213.96	-2.743e+05	3.460e+04
			41	40.61	1.54	-0.53	0.47	0.54	1.03	2.034e+05	-2.829e+05	2.033e+05	-2.828e+05	-6672.74
			32	24.55	0.31	-8.62	-4.06	-4.26	-4.47	2.159e+05	-6.636e+04	2.101e+05	-6.053e+04	-
4.013e+04	28	55	31	6.85	3.45	1.16	3.37	1.25	-0.43	-1065.14	-7.178e+04	-7.036e+04	-2484.27	-9916.92
			40	26.65	1.93	-4.63	-3.04	0.34	-2.81	-785.90	-2.779e+05	-5169.27	-2.735e+05	3.457e+04
			41	40.51	0.63	-0.28	-0.09	0.44	0.37	2.032e+05	-2.819e+05	2.031e+05	-2.819e+05	-6423.09
			32	24.52	3.24	-1.94	-1.93	3.23	-0.15	2.156e+05	-6.617e+04	2.098e+05	-6.038e+04	-
3.997e+04	28	69	31	6.84	1.87	-2.19	-2.18	1.86	0.11	-1006.74	-7.158e+04	-7.018e+04	-2403.94	-9831.24
			40	26.62	1.14	-7.94	-7.47	0.68	-2.00	-760.52	-2.775e+05	-5146.41	-2.731e+05	3.456e+04
			41	40.47	0.39	-0.37	-0.37	0.39	0.04	2.031e+05	-2.815e+05	2.030e+05	-2.814e+05	-6295.42
			32	24.51	7.56	-1.35	-0.85	7.06	2.06	2.155e+05	-6.607e+04	2.097e+05	-6.030e+04	-
3.989e+04	29	1	32	26.90	1.70	-9.92	1.06	-9.29	2.64	2.998e+05	4.438e+04	2.683e+05	7.586e+04	-
8.396e+04			41	55.43	0.55	-0.55	0.55	-0.55	-6.50e-03	6.227e+05	1.051e+05	3.639e+05	3.638e+05	-
2.588e+05			42	26.90	10.20	-1.57	9.61	-0.98	-2.57	2.997e+05	4.438e+04	7.589e+04	2.682e+05	-
8.398e+04			33	32.62	2.93	-2.54	2.93	-2.54	0.08	3.723e+05	7.871e+04	2.255e+05	2.255e+05	-
1.468e+05	29	3	32	22.76	1.44	-8.39	0.90	-7.86	2.23	2.537e+05	3.755e+04	2.270e+05	6.419e+04	-
7.104e+04			41	46.90	0.46	-0.47	0.46	-0.47	-5.50e-03	5.269e+05	8.894e+04	3.080e+05	3.079e+05	-
2.190e+05			42	22.76	8.63	-1.33	8.13	-0.83	-2.18	2.536e+05	3.755e+04	6.421e+04	2.269e+05	-
7.106e+04			33	27.61	2.48	-2.15	2.48	-2.15	0.07	3.150e+05	6.660e+04	1.908e+05	1.908e+05	-
1.242e+05	29	7	32	20.84	6.05	-16.58	4.51	-15.04	-5.70	2.318e+05	3.446e+04	2.076e+05	5.861e+04	-
6.467e+04			41	42.80	1.10	-2.99	-0.34	-1.54	1.95	4.808e+05	8.133e+04	2.816e+05	2.806e+05	-
1.997e+05			42	20.78	20.73	-4.08	12.37	4.28	-11.73	2.310e+05	3.435e+04	5.875e+04	2.066e+05	-
6.484e+04			33	25.22	-6.14	-21.45	-6.62	-20.97	-2.68	2.876e+05	6.087e+04	1.741e+05	1.743e+05	-
1.133e+05	29	39	32	20.74	2.10	-9.84	2.07	-9.81	-0.59	2.310e+05	3.425e+04	2.068e+05	5.844e+04	-
6.461e+04			41	42.69	0.50	-1.14	0.16	-0.80	0.66	4.796e+05	8.102e+04	2.805e+05	2.801e+05	-
1.993e+05			42	20.72	11.67	-1.65	9.08	0.95	-5.28	2.307e+05	3.421e+04	5.850e+04	2.064e+05	-
6.468e+04			33	25.14	-0.65	-8.48	-0.75	-8.39	-0.87	2.868e+05	6.066e+04	1.737e+05	1.737e+05	-
1.131e+05	29	69	32	20.70	1.31	-7.63	0.82	-7.14	2.03	2.306e+05	3.414e+04	2.064e+05	5.836e+04	-
6.459e+04			41	42.64	0.42	-0.43	0.42	-0.43	-5.00e-03	4.790e+05	8.086e+04	2.800e+05	2.799e+05	-
1.991e+05			42	20.69	7.85	-1.21	7.39	-0.76	-1.98	2.305e+05	3.414e+04	5.838e+04	2.063e+05	-
6.460e+04			33	25.10	2.26	-1.95	2.26	-1.95	0.06	2.864e+05	6.055e+04	1.735e+05	1.735e+05	-
1.129e+05	30	1	33	28.31	3.32	-13.22	1.49	-11.38	-5.20	3.304e+05	9.448e+04	2.161e+05	2.088e+05	-
1.179e+05			42	27.32	9.82	3.62	9.15	4.28	-1.91	3.175e+05	8.639e+04	1.409e+05	2.630e+05	-
9.812e+04														

Parco Eolico "Bolina" – Progetto Definitivo
Relazione di calcolo preliminare delle fondazioni degli aerogeneratori G8 e G12

6.364e+04	43	17.73	10.99	-4.27	7.20	-0.47	-6.60	2.086e+05	6.761e+04	1.078e+05	1.685e+05	-
8.848e+04	34	25.44	11.34	-4.36	10.90	-3.91	-2.60	2.942e+05	7.451e+04	1.193e+05	2.495e+05	-
9.977e+04	33	23.95	2.81	-11.18	1.26	-9.63	-4.40	2.796e+05	7.994e+04	1.828e+05	1.767e+05	-
8.303e+04	42	23.12	8.31	3.06	7.75	3.62	-1.62	2.687e+05	7.310e+04	1.192e+05	2.225e+05	-
5.385e+04	43	15.00	9.30	-3.61	6.09	-0.40	-5.58	1.765e+05	5.721e+04	9.118e+04	1.426e+05	-
7.487e+04	34	21.52	9.60	-3.69	9.22	-3.31	-2.20	2.490e+05	6.304e+04	1.009e+05	2.111e+05	-
9.071e+04	33	21.89	11.60	-21.06	-7.77	-1.69	-16.04	2.550e+05	7.349e+04	1.669e+05	1.616e+05	-
7.572e+04	42	21.10	-1.58	-9.67	-6.14	-5.12	-4.02	2.454e+05	6.686e+04	1.089e+05	2.034e+05	-
4.884e+04	43	13.75	18.26	-29.55	-15.68	4.39	-21.70	1.611e+05	5.272e+04	8.343e+04	1.304e+05	-
6.844e+04	34	19.67	-10.14	-29.41	-28.33	-11.22	-4.43	2.274e+05	5.760e+04	9.225e+04	1.928e+05	-
9.070e+04	33	21.81	4.26	-12.50	-1.87	-6.36	-8.07	2.544e+05	7.295e+04	1.664e+05	1.610e+05	-
7.556e+04	42	21.04	4.08	-1.05	2.58	0.45	-2.33	2.446e+05	6.659e+04	1.085e+05	2.027e+05	-
4.892e+04	43	13.68	10.60	-11.00	-1.64	1.24	-10.70	1.607e+05	5.225e+04	8.307e+04	1.299e+05	-
6.819e+04	34	19.60	-1.96	-7.87	-4.04	-5.79	-2.82	2.267e+05	5.741e+04	9.191e+04	1.922e+05	-
9.070e+04	33	21.78	2.56	-10.17	1.14	-8.75	-4.00	2.542e+05	7.268e+04	1.662e+05	1.606e+05	-
7.548e+04	42	21.01	7.55	2.79	7.04	3.29	-1.47	2.443e+05	6.645e+04	1.084e+05	2.023e+05	-
4.895e+04	43	13.64	8.46	-3.28	5.54	-0.37	-5.07	1.605e+05	5.201e+04	8.289e+04	1.296e+05	-
6.806e+04	34	19.57	8.72	-3.35	8.38	-3.01	-2.00	2.263e+05	5.731e+04	9.173e+04	1.919e+05	-
1.432e+05	34	27.32	10.23	-5.42	9.46	-4.66	-3.36	2.793e+05	-9941.15	1.149e+05	1.545e+05	-
5.416e+04	43	20.39	9.74	-1.63	7.50	0.61	-4.52	2.418e+05	8.615e+04	1.081e+05	2.198e+05	-
9.371e+04	44	19.56	9.04	-3.05	4.48	1.51	-5.86	2.153e+05	2.630e+04	1.087e+05	1.328e+05	-
5.962e+04	35	18.80	2.35	-3.09	0.89	-1.64	-2.41	2.257e+05	1.029e+05	1.497e+05	1.790e+05	-
1.212e+05	34	23.11	8.65	-4.58	8.01	-3.94	-2.85	2.363e+05	-8411.74	9.719e+04	1.307e+05	-
4.582e+04	43	17.25	8.24	-1.38	6.35	0.51	-3.83	2.046e+05	7.289e+04	9.146e+04	1.860e+05	-
7.929e+04	44	16.55	7.65	-2.58	3.79	1.28	-4.96	1.821e+05	2.225e+04	9.199e+04	1.124e+05	-
5.045e+04	35	15.90	1.99	-2.62	0.75	-1.38	-2.04	1.910e+05	8.710e+04	1.267e+05	1.514e+05	-
1.103e+05	34	21.20	25.60	-25.77	-10.69	10.52	-23.39	2.156e+05	-7089.42	8.901e+04	1.195e+05	-
4.167e+04	43	15.75	-7.71	-28.88	-23.04	-13.55	-9.46	1.868e+05	6.678e+04	8.361e+04	1.700e+05	-
7.211e+04	44	15.24	28.53	-53.31	-30.82	6.03	-36.54	1.662e+05	2.073e+04	8.414e+04	1.028e+05	-
4.599e+04	35	14.58	5.44	-61.32	-61.28	5.40	1.61	1.743e+05	7.949e+04	1.155e+05	1.383e+05	-
1.104e+05	34	21.08	13.30	-5.08	9.82	-1.60	-7.20	2.151e+05	-7814.47	8.842e+04	1.188e+05	-
4.171e+04	43	15.70	8.59	-8.17	3.82	-3.39	-7.57	1.862e+05	6.634e+04	8.325e+04	1.693e+05	-
7.220e+04	44	15.12	15.95	-10.64	1.07	4.24	-13.20	1.658e+05	2.017e+04	8.370e+04	1.022e+05	-
4.591e+04	35	14.47	-1.60	-12.11	-10.63	-3.08	-3.65	1.738e+05	7.929e+04	1.153e+05	1.377e+05	-
1.102e+05	34	21.01	7.87	-4.17	7.28	-3.58	-2.59	2.148e+05	-7647.03	8.836e+04	1.188e+05	-
4.166e+04	43	15.69	7.49	-1.26	5.77	0.47	-3.48	1.860e+05	6.627e+04	8.314e+04	1.691e+05	-
	44	15.05	6.96	-2.34	3.45	1.16	-4.51	1.656e+05	2.023e+04	8.362e+04	1.022e+05	-

Parco Eolico "Bolina" – Progetto Definitivo
Relazione di calcolo preliminare delle fondazioni degli aerogeneratori G8 e G12

4.238e+04	38	16.07	13.71	4.97	12.42	6.27	-3.10-1.075e+05-1.924e+05-1.522e+05-1.476e+05
33 69 1.187e+05	37	25.38	4.45	-7.68	0.55	-3.78	-5.66-3.894e+04-2.814e+05-1.848e+05-1.355e+05
2.726e+04	46	19.49	10.45	-5.61	1.39	3.45	-7.96-1.261e+05-2.339e+05-1.335e+05-2.265e+05
5.464e+04	47	19.70	3.51	-9.67	-5.01	-1.14	-6.30-1.109e+05-2.367e+05-1.426e+05-2.049e+05
4.239e+04	38	16.03	6.06	-4.92	-0.37	1.51	-5.41-1.073e+05-1.922e+05-1.520e+05-1.475e+05
34 1 7.846e+04	38	22.37	8.72	-7.78	-0.53	1.47	-8.19-1.101e+05-2.672e+05-1.849e+05-1.924e+05
4.394e+04	47	24.00	-1.55	-7.17	-6.54	-2.18	-1.78-1.883e+05-2.835e+05-2.176e+05-2.542e+05
1.262e+05	48	29.23	8.76	-6.64	6.81	-4.70	-5.12-8.359e+04-3.373e+05-1.976e+05-2.233e+05
3.063e+04	39	25.44	6.51	-3.57	3.53	-0.59	-4.60-1.806e+05-3.041e+05-1.888e+05-2.960e+05
34 3 6.639e+04	38	18.92	7.37	-6.58	-0.45	1.24	-6.93-9.317e+04-2.261e+05-1.564e+05-1.628e+05
3.718e+04	47	20.31	-1.31	-6.07	-5.53	-1.85	-1.50-1.593e+05-2.399e+05-1.841e+05-2.151e+05
1.068e+05	48	24.74	7.41	-5.62	5.76	-3.97	-4.33-7.073e+04-2.854e+05-1.672e+05-1.889e+05
2.592e+04	39	21.53	5.51	-3.02	2.99	-0.50	-3.89-1.528e+05-2.574e+05-1.597e+05-2.505e+05
34 7 6.064e+04	38	17.28	21.51	-16.02	10.73	-5.24	16.98-8.455e+04-2.060e+05-1.424e+05-1.481e+05
3.388e+04	47	18.53	29.20	2.92	28.87	3.25	2.93-1.452e+05-2.185e+05-1.679e+05-1.958e+05
9.763e+04	48	22.60	7.37	-13.14	0.83	-6.60	9.56-6.385e+04-2.601e+05-1.522e+05-1.718e+05
2.367e+04	39	19.63	17.22	2.56	10.21	9.57	7.32-1.392e+05-2.345e+05-1.455e+05-2.282e+05
34 56 6.044e+04	38	17.20	8.04	-18.54	-11.32	0.81	-11.82-8.444e+04-2.055e+05-1.421e+05-1.478e+05
3.379e+04	47	18.47	1.46	-19.94	-19.91	1.43	0.82-1.448e+05-2.179e+05-1.674e+05-1.953e+05
9.719e+04	48	22.50	6.96	-9.80	-2.91	0.07	-8.25-6.396e+04-2.593e+05-1.518e+05-1.715e+05
2.361e+04	39	19.56	-1.23	-8.48	-6.56	-3.16	-3.20-1.388e+05-2.338e+05-1.451e+05-2.275e+05
34 69 6.036e+04	38	17.20	6.70	-5.98	-0.41	1.13	-6.30-8.470e+04-2.056e+05-1.422e+05-1.480e+05
3.380e+04	47	18.46	-1.19	-5.52	-5.03	-1.68	-1.37-1.448e+05-2.181e+05-1.674e+05-1.955e+05
9.708e+04	48	22.49	6.73	-5.11	5.24	-3.61	-3.94-6.430e+04-2.595e+05-1.520e+05-1.718e+05
2.357e+04	39	19.57	5.01	-2.75	2.71	-0.45	-3.54-1.389e+05-2.340e+05-1.452e+05-2.277e+05
35 1 3.874e+04	39	21.83	9.32	-6.26	3.96	-0.89	-7.40-1.670e+05-2.587e+05-1.883e+05-2.374e+05
7.899e+04	48	30.81	7.41	-5.30	6.48	-4.37	-3.31-1.644e+05-3.698e+05-2.015e+05-3.328e+05
9.785e+04	49	32.48	2.32	-13.56	-0.18	-11.05	-5.79-1.946e+05-3.907e+05-2.986e+05-2.867e+05
7.644e+04	40	32.42	8.22	2.75	7.30	3.66	-2.04-1.918e+05-3.896e+05-2.279e+05-3.535e+05
35 3 3.278e+04	39	18.47	7.89	-5.29	3.35	-0.76	-6.26-1.413e+05-2.189e+05-1.593e+05-2.009e+05
6.684e+04	48	26.07	6.27	-4.48	5.49	-3.70	-2.80-1.391e+05-3.129e+05-1.705e+05-2.816e+05
8.279e+04	49	27.48	1.96	-11.47	-0.16	-9.35	-4.90-1.647e+05-3.306e+05-2.526e+05-2.426e+05
6.468e+04	40	27.43	6.95	2.32	6.18	3.10	-1.73-1.623e+05-3.297e+05-1.928e+05-2.991e+05
35 7 3.004e+04	39	16.83	12.22	-12.41	5.51	-5.71	10.96-1.284e+05-1.993e+05-1.450e+05-1.827e+05
6.088e+04	48	23.78	18.64	6.65	11.41	13.88	5.87-1.267e+05-2.851e+05-1.553e+05-2.566e+05
7.574e+04	49	25.08	10.05	-6.57	5.11	-1.64	7.59-1.497e+05-3.014e+05-2.303e+05-2.208e+05
	40	24.99	9.93	0.63	4.31	6.25	4.55-1.479e+05-3.004e+05-1.758e+05-2.725e+05

Parco Eolico "Bolina" – Progetto Definitivo
Relazione di calcolo preliminare delle fondazioni degli aerogeneratori G8 e G12

5.896e+04																					
35 39	39	16.79	3.88	-2.39	3.88	-2.39	-0.06-1.284e+05-1.991e+05-1.449e+05-1.827e+05														
2.988e+04	48	23.73	7.18	2.45	7.16	2.47	0.30-1.265e+05-2.847e+05-1.551e+05-2.562e+05														
6.080e+04	49	25.02	1.65	-6.20	1.63	-6.18	-0.38-1.497e+05-3.008e+05-2.299e+05-2.206e+05														
7.543e+04	40	24.95	5.36	3.80	5.17	3.98	0.50-1.477e+05-3.000e+05-1.755e+05-2.721e+05														
5.885e+04																					
35 69	39	16.79	7.17	-4.81	3.04	-0.69	-5.69-1.284e+05-1.990e+05-1.448e+05-1.826e+05														
2.980e+04	48	23.70	5.70	-4.08	4.99	-3.36	-2.55-1.265e+05-2.845e+05-1.550e+05-2.560e+05														
6.077e+04	49	24.99	1.78	-10.43	-0.14	-8.50	-4.45-1.497e+05-3.005e+05-2.297e+05-2.206e+05														
7.527e+04	40	24.93	6.32	2.11	5.62	2.82	-1.57-1.475e+05-2.997e+05-1.753e+05-2.719e+05														
5.880e+04																					
36 1	40	30.90	8.77	-1.93	7.97	-1.13	-2.81-1.414e+05-3.684e+05-1.576e+05-3.522e+05														
5.837e+04	49	37.72	0.89	-2.91	0.84	-2.87	-0.42-1.785e+05-4.505e+05-3.145e+05-3.145e+05														
1.360e+05	50	30.90	1.53	-8.98	1.14	-8.59	2.00-1.415e+05-3.684e+05-3.523e+05-1.576e+05														
5.836e+04	41	59.93	0.46	-0.62	0.44	-0.60	0.14-2.237e+05-7.053e+05-4.645e+05-4.645e+05														
2.408e+05																					
36 3	40	26.15	7.42	-1.63	6.74	-0.96	-2.38-1.197e+05-3.117e+05-1.333e+05-2.980e+05														
4.939e+04	49	31.92	0.75	-2.46	0.71	-2.42	-0.36-1.511e+05-3.812e+05-2.661e+05-2.661e+05														
1.151e+05	50	26.15	1.30	-7.60	0.96	-7.26	1.69-1.197e+05-3.117e+05-2.981e+05-1.334e+05														
4.938e+04	41	50.71	0.39	-0.52	0.37	-0.51	0.12-1.893e+05-5.968e+05-3.931e+05-3.930e+05														
2.038e+05																					
36 7	40	23.84	6.30	-9.04	2.11	-4.85	6.83-1.090e+05-2.838e+05-1.215e+05-2.713e+05														
4.507e+04	49	29.14	16.27	8.47	9.46	15.28	2.59-1.377e+05-3.476e+05-2.425e+05-2.427e+05														
1.050e+05	50	23.89	8.26	-8.95	-2.26	1.58	8.39-1.091e+05-2.845e+05-2.722e+05-1.215e+05														
4.491e+04	41	46.26	2.30	-0.79	0.94	0.57	-1.54-1.726e+05-5.443e+05-3.589e+05-3.580e+05														
1.859e+05																					
36 39	40	23.79	4.88	-2.33	4.77	-2.22	0.88-1.089e+05-2.835e+05-1.213e+05-2.710e+05														
4.496e+04	49	29.06	4.33	3.01	3.63	3.71	0.66-1.374e+05-3.469e+05-2.421e+05-2.422e+05														
1.047e+05	50	23.81	2.26	-6.28	-0.19	-3.83	3.86-1.089e+05-2.838e+05-2.714e+05-1.213e+05														
4.489e+04	41	46.15	0.77	-0.34	0.54	-0.11	-0.45-1.722e+05-5.431e+05-3.579e+05-3.575e+05														
1.855e+05																					
36 69	40	23.77	6.74	-1.49	6.13	-0.87	-2.16-1.088e+05-2.834e+05-1.212e+05-2.709e+05														
4.490e+04	49	29.02	0.68	-2.24	0.65	-2.20	-0.32-1.373e+05-3.465e+05-2.419e+05-2.419e+05														
1.046e+05	50	23.77	1.18	-6.91	0.88	-6.60	1.54-1.088e+05-2.834e+05-2.710e+05-1.212e+05														
4.489e+04	41	46.10	0.35	-0.47	0.34	-0.46	0.11-1.721e+05-5.426e+05-3.573e+05-3.573e+05														
1.853e+05																					
37 1	41	52.60	0.71	-0.52	-0.48	0.67	0.22 2.639e+05-3.660e+05-3.659e+05 2.638e+05 -8246.45														
	50	34.61	8.41	-1.94	-1.68	8.14	1.62 -1042.89-3.607e+05-3.550e+05 -6743.25 4.492e+04														
	51	8.89	2.99	-0.82	-0.82	2.99	-0.13 -1354.98-9.317e+04 -3187.19-9.134e+04 -														
1.284e+04	42	31.85	1.67	-9.34	-8.36	0.69	-3.14 2.800e+05-8.591e+04-7.840e+04 2.725e+05 -														
5.186e+04																					
37 3	41	44.51	0.60	-0.44	-0.41	0.57	0.19 2.233e+05-3.097e+05-3.096e+05 2.232e+05 -6977.76														
	50	29.28	7.11	-1.64	-1.42	6.89	1.37 -882.44-3.052e+05-3.004e+05 -5705.83 3.801e+04														
	51	7.52	2.53	-0.69	-0.69	2.53	-0.11 -1146.52-7.884e+04 -2696.85-7.729e+04 -														
1.086e+04	42	26.95	1.42	-7.90	-7.07	0.59	-2.65 2.370e+05-7.269e+04-6.634e+04 2.306e+05 -														
4.388e+04																					
37 7	41	40.61	1.98	-0.84	-0.22	1.36	1.17 2.033e+05-2.830e+05-2.829e+05 2.032e+05 -6720.74														
	50	26.76	19.43	-2.33	-2.27	19.37	-1.15 -877.15-2.787e+05-2.743e+05 -5254.60 3.460e+04														
	51	6.95	18.84	-2.59	-2.46	18.71	-1.68 -1214.24-7.227e+04 -2689.04-7.080e+04 -														
1.013e+04																					

Parco Eolico "Bolina" – Progetto Definitivo
Relazione di calcolo preliminare delle fondazioni degli aerogeneratori G8 e G12

4.014e+04	42	24.59	1.48	-21.91	-17.75	-2.68	-8.94	2.159e+05-6.637e+04-6.054e+04	2.100e+05	-	
37 39	41	40.51	1.00	-0.51	-0.32	0.80	0.51	2.031e+05-2.820e+05-2.819e+05	2.030e+05	-6471.10	
	50	26.67	10.71	-1.64	-1.62	10.70	0.44	-827.58-2.779e+05-2.735e+05	-5209.95	3.457e+04	
	51	6.88	7.89	-1.29	-1.25	7.85	-0.64	-1100.60-7.187e+04	-2532.00-7.044e+04	-9962.64	
	42	24.53	1.29	-12.11	-10.26	-0.55	-4.62	2.156e+05-6.618e+04-6.039e+04	2.098e+05	-	
3.998e+04	37 69	41	40.46	0.55	-0.40	-0.37	0.52	0.17	2.030e+05-2.815e+05-2.814e+05	2.029e+05	-6343.42
	50	26.62	6.47	-1.49	-1.29	6.26	1.25	-802.22-2.775e+05-2.731e+05	-5187.12	3.456e+04	
	51	6.84	2.30	-0.63	-0.63	2.30	-0.10	-1042.29-7.167e+04	-2451.68-7.026e+04	-9876.96	
	42	24.50	1.29	-7.19	-6.43	0.53	-2.41	2.154e+05-6.608e+04-6.031e+04	2.096e+05	-	
3.989e+04	38 1	42	16.21	-2.49	-8.10	-7.32	-3.27	-1.94	1.194e+05-7.373e+04-7.370e+04	1.194e+05	2301.55
	51	39.19	12.96	-3.42	-0.58	10.11	-6.20	3.093e+05-1.526e+05-5.803e+04	2.147e+05	-	
1.864e+05		52	8.85	4.77	-6.62	-6.03	4.17	-2.54	7.971e+04-2.109e+04	1.891e+04	3.972e+04
		43	30.49	6.23	-10.17	-4.20	0.26	-7.89	3.116e+05-1.079e+04	6.699e+04	2.338e+05
1.379e+05	38 3	42	13.72	-2.11	-6.85	-6.20	-2.77	-1.64	1.010e+05-6.239e+04-6.236e+04	1.010e+05	1947.46
		51	33.16	10.96	-2.90	-0.49	8.56	-5.25	2.617e+05-1.291e+05-4.910e+04	1.817e+05	-
1.577e+05		52	7.49	4.04	-5.61	-5.10	3.53	-2.15	6.745e+04-1.784e+04	1.600e+04	3.361e+04
		43	25.80	5.27	-8.60	-3.55	0.22	-6.68	2.637e+05	-9126.98	5.668e+04
1.167e+05	38 7	42	12.53	-0.13	-20.37	-16.89	-3.61	-7.63	9.181e+04-5.703e+04-5.701e+04	9.179e+04	1643.46
		51	30.33	25.95	-5.62	0.18	20.16	-12.22	2.386e+05-1.181e+05-4.500e+04	1.655e+05	-
1.440e+05		52	6.85	23.38	-25.90	-23.04	20.52	-11.52	6.120e+04-1.633e+04	1.453e+04	3.034e+04
		43	23.59	7.51	-28.80	-16.75	-4.54	-17.10	2.404e+05	-8512.32	5.162e+04
1.065e+05	38 39	42	12.49	-1.32	-11.01	-9.44	-2.88	-3.57	9.182e+04-5.682e+04-5.680e+04	9.180e+04	1727.46
		51	30.21	15.37	-3.64	-0.24	11.97	-7.29	2.381e+05-1.176e+05-4.476e+04	1.653e+05	-
1.436e+05		52	6.82	10.34	-12.13	-10.86	9.07	-5.19	6.128e+04-1.626e+04	1.454e+04	3.048e+04
		43	23.50	5.71	-14.92	-7.80	-1.41	-9.80	2.399e+05	-8370.02	5.156e+04
1.063e+05	38 69	42	12.47	-1.92	-6.23	-5.63	-2.52	-1.49	9.183e+04-5.671e+04-5.669e+04	9.181e+04	1770.42
		51	30.14	9.97	-2.63	-0.45	7.78	-4.77	2.379e+05-1.174e+05-4.464e+04	1.651e+05	-
1.434e+05		52	6.81	3.67	-5.10	-4.64	3.21	-1.95	6.132e+04-1.622e+04	1.454e+04	3.055e+04
		43	23.45	4.79	-7.82	-3.23	0.20	-6.07	2.397e+05	-8297.26	5.153e+04
1.061e+05	39 1	43	12.17	3.70	-6.39	-3.60	0.91	-4.51	1.261e+05	-859.09	2.106e+04
4.798e+04		52	36.10	5.86	-9.28	-6.64	3.22	-5.75	3.625e+05-2.510e+04	1.176e+05	2.198e+05
1.869e+05		53	21.25	6.45	1.10	6.23	1.32	-1.07	1.395e+05-1.155e+05-1.151e+05	1.390e+05	-
1.092e+04		44	22.71	8.21	-10.21	0.23	-2.23	-9.13	2.367e+05	1215.18	7.467e+04
1.091e+05	39 3	43	10.30	3.13	-5.41	-3.05	0.77	-3.82	1.067e+05	-726.93	1.782e+04
4.060e+04		52	30.55	4.96	-7.85	-5.61	2.72	-4.86	3.067e+05-2.124e+04	9.952e+04	1.860e+05
1.582e+05		53	17.98	5.46	0.93	5.27	1.12	-0.90	1.180e+05-9.775e+04-9.735e+04	1.176e+05	-9236.10
		44	19.22	6.95	-8.64	0.20	-1.88	-7.72	2.003e+05	1028.23	6.318e+04
9.231e+04	39 8	43	9.43	22.92	-8.11	3.32	11.49	-14.97	9.666e+04	-1086.98	1.593e+04
3.706e+04		52	27.93	11.46	-25.78	-11.67	-2.65	-18.07	2.793e+05-2.000e+04	9.032e+04	1.690e+05
1.444e+05		53	16.46	39.20	4.87	38.24	5.83	-5.67	1.071e+05-8.938e+04-8.901e+04	1.067e+05	-8524.05
8.425e+04	39 40	43	9.39	9.61	-5.96	-0.71	4.35	-7.36	9.688e+04	-804.96	1.611e+04
3.696e+04		52	27.83	6.61	-13.19	-7.32	0.74	-9.04	2.790e+05-1.954e+04	9.042e+04	1.691e+05
1.440e+05		53	16.38	16.55	2.21	16.11	2.65	-2.46	1.072e+05-8.904e+04-8.867e+04	1.069e+05	-8439.63
		44	17.52	15.15	-16.76	2.91	-4.52	-15.52	1.821e+05	775.79	5.738e+04
8.403e+04	39 69	43	9.36	2.85	-4.92	-2.77	0.70	-3.47	9.699e+04	-660.84	1.620e+04
3.691e+04										8.013e+04	-

Parco Eolico "Bolina" – Progetto Definitivo
Relazione di calcolo preliminare delle fondazioni degli aerogeneratori G8 e G12

1.438e+05	52	27.77	4.51	-7.14	-5.10	2.47	-4.42	2.788e+05-1.931e+04	9.047e+04	1.691e+05	-	
	53	16.35	4.96	0.85	4.79	1.02	-0.82	1.073e+05-8.886e+04-8.850e+04	1.070e+05	-8396.46	-	
8.392e+04	44	17.47	6.32	-7.85	0.18	-1.71	-7.02	1.821e+05	934.75	5.744e+04	1.256e+05	-
40 1	44	15.79	6.53	-6.79	0.22	-0.48	-6.65	1.687e+05	9657.79	6.169e+04	1.167e+05	-
7.461e+04	53	18.22	12.70	-7.58	6.52	-1.40	-9.34	1.650e+05-4.235e+04-3.532e+04	1.580e+05	-	-	
3.752e+04	54	24.41	2.47	-9.42	-2.13	-4.82	-5.79	2.334e+05-3.735e+04	4059.13	1.919e+05	-	-
9.745e+04	45	11.41	11.59	-11.30	0.45	-0.15	-11.44	1.068e+05-2.088e+04-1.892e+04	1.049e+05	1.570e+04	-	-
40 3	44	13.36	5.53	-5.75	0.19	-0.41	-5.63	1.427e+05	8171.98	5.220e+04	9.871e+04	-
6.313e+04	53	15.42	10.75	-6.42	5.51	-1.18	-7.90	1.397e+05-3.583e+04-2.989e+04	1.337e+05	-	-	
3.175e+04	54	20.65	2.09	-7.97	-1.80	-4.07	-4.90	1.975e+05-3.161e+04	3434.65	1.624e+05	-	-
8.246e+04	45	9.66	9.81	-9.56	0.38	-0.13	-9.68	9.041e+04-1.766e+04-1.601e+04	8.875e+04	1.328e+04	-	-
40 23	44	12.17	-15.10	-41.91	-39.27	-17.75	-8.00	1.304e+05	7738.60	4.789e+04	9.024e+04	-
5.755e+04	53	14.18	27.58	-54.13	-45.07	18.52	25.66	1.276e+05-3.237e+04-2.697e+04	1.222e+05	-	-	
2.889e+04	54	19.11	37.77	-76.41	-36.40	-2.24	-54.47	1.801e+05-2.857e+04	3338.25	1.482e+05	-	-
7.511e+04	45	9.18	72.89	-74.45	-49.46	47.90	55.29	8.255e+04-1.576e+04-1.423e+04	8.102e+04	1.217e+04	-	-
40 55	44	12.15	-2.71	-16.72	-13.18	-6.25	-6.09	1.300e+05	7533.81	4.760e+04	8.991e+04	-
5.745e+04	53	14.07	6.40	-12.78	-11.93	5.55	3.93	1.272e+05-3.250e+04-2.710e+04	1.218e+05	-	-	
2.887e+04	54	18.89	13.67	-30.28	-13.40	-3.21	-21.38	1.797e+05-2.868e+04	3195.45	1.479e+05	-	-
7.501e+04	45	8.89	20.60	-20.98	-16.51	16.13	12.89	8.231e+04-1.596e+04-1.444e+04	8.080e+04	1.211e+04	-	-
40 69	44	12.14	5.02	-5.23	0.17	-0.37	-5.12	1.298e+05	7429.07	4.745e+04	8.974e+04	-
5.740e+04	53	14.02	9.77	-5.83	5.01	-1.08	-7.18	1.270e+05-3.257e+04-2.717e+04	1.216e+05	-	-	
2.886e+04	54	18.78	1.90	-7.24	-1.64	-3.70	-4.45	1.795e+05-2.873e+04	3122.41	1.477e+05	-	-
7.496e+04	45	8.78	8.92	-8.69	0.35	-0.12	-8.80	8.219e+04-1.606e+04-1.455e+04	8.068e+04	1.208e+04	-	-
41 1	46	32.89	7.14	-4.21	-3.18	6.11	-3.26	1.346e+05-3.892e+05-1.852e+05	3.386e+05	-	-	
1.016e+05	55	22.47	-0.99	-12.89	-2.91	-10.97	-4.37	1.658e+04-2.414e+05-1.233e+05	1.347e+05	-	-	
1.123e+05	56	31.49	5.90	-10.89	3.99	-8.98	-5.32	1.889e+05-3.785e+05-3.094e+05	2.580e+05	-	-	
9.125e+04	47	19.57	11.54	-7.51	4.33	-0.29	-9.24	1.751e+05-2.236e+05-1.771e+05	2.216e+05	9644.61	-	
41 3	46	27.83	6.04	-3.56	-2.69	5.17	-2.76	1.139e+05-3.293e+05-1.567e+05	2.865e+05	-	-	
8.598e+04	55	19.01	-0.84	-10.90	-2.46	-9.28	-3.70	1.403e+04-2.043e+05-1.043e+05	1.140e+05	-	-	
9.501e+04	56	26.64	4.99	-9.21	3.38	-7.60	-4.50	1.599e+05-3.203e+05-2.618e+05	2.183e+05	-	-	
7.721e+04	47	16.56	9.77	-6.35	3.66	-0.25	-7.82	1.481e+05-1.892e+05-1.498e+05	1.875e+05	8160.82	-	
41 7	46	25.47	27.87	-37.53	13.40	-23.05	27.15	1.035e+05-2.997e+05-1.426e+05	2.607e+05	-	-	
7.836e+04	55	17.29	43.07	14.57	33.47	24.17	-13.47	1.284e+04-1.860e+05-9.494e+04	1.039e+05	-	-	
8.645e+04	56	24.35	12.15	-26.82	-10.89	-3.77	19.16	1.455e+05-2.918e+05-2.386e+05	1.987e+05	-	-	
7.036e+04	47	15.09	17.92	-4.11	4.96	8.86	10.84	1.349e+05-1.722e+05-1.365e+05	1.706e+05	7536.26	-	
41 39	46	25.33	7.55	-9.32	2.92	-4.69	7.53	1.035e+05-2.995e+05-1.425e+05	2.605e+05	-	-	
7.823e+04	55	17.28	13.91	-1.47	9.85	2.59	-6.78	1.278e+04-1.858e+05-9.488e+04	1.037e+05	-	-	
8.640e+04	56	24.25	0.57	-8.07	-1.65	-5.85	3.77	1.454e+05-2.914e+05-2.382e+05	1.986e+05	-	-	
7.025e+04	47	15.06	4.52	2.21	3.88	2.85	-1.03	1.348e+05-1.721e+05-1.363e+05	1.705e+05	7458.63	-	
41 69	46	25.30	5.49	-3.24	-2.44	4.70	-2.51	1.035e+05-2.994e+05-1.424e+05	2.604e+05	-	-	
7.816e+04	55	17.28	-0.76	-9.91	-2.24	-8.44	-3.36	1.275e+04-1.857e+05-9.486e+04	1.036e+05	-	-	
8.637e+04	56	24.22	4.54	-8.37	3.07	-6.91	-4.09	1.453e+05-2.912e+05-2.380e+05	1.985e+05	-	-	

Parco Eolico "Bolina" – Progetto Definitivo
Relazione di calcolo preliminare delle fondazioni degli aerogeneratori G8 e G12

7.019e+04										
42	1	47	15.05	8.88	-5.77	3.33	-0.23	-7.11-1.347e+05-1.720e+05-1.362e+05-1.705e+05	7418.93	
5.769e+04		47	24.41	7.42	-5.04	6.67	-4.29	-2.96-1.653e+05-2.927e+05-2.020e+05-2.560e+05		
3.511e+04		56	22.04	4.99	-6.53	1.78	-3.31	-5.17-1.833e+05-2.574e+05-2.085e+05-2.322e+05		
5.550e+04		57	28.40	0.37	-8.15	-0.87	-6.92	-3.00-2.217e+05-3.357e+05-2.656e+05-2.918e+05		
5.281e+04		48	24.84	2.69	-5.73	-0.75	-2.28	-4.14-1.843e+05-2.957e+05-2.577e+05-2.222e+05		
4.882e+04	3	47	20.65	6.28	-4.26	5.65	-3.63	-2.50-1.399e+05-2.477e+05-1.709e+05-2.166e+05		
2.971e+04		56	18.65	4.23	-5.52	1.51	-2.80	-4.37-1.551e+05-2.178e+05-1.764e+05-1.965e+05		
4.696e+04		57	24.03	0.31	-6.90	-0.73	-5.85	-2.54-1.876e+05-2.841e+05-2.248e+05-2.469e+05		
4.469e+04		48	21.02	2.28	-4.85	-0.64	-1.93	-3.50-1.559e+05-2.502e+05-2.181e+05-1.881e+05		
4.442e+04	23	47	18.85	14.22	-22.78	13.89	-22.45	-3.46-1.277e+05-2.258e+05-1.559e+05-1.975e+05		
2.704e+04		56	17.04	24.86	9.78	20.60	14.04	6.79-1.413e+05-1.984e+05-1.606e+05-1.791e+05		
4.268e+04		57	21.91	21.29	-16.82	20.84	-16.37	4.10-1.712e+05-2.589e+05-2.049e+05-2.252e+05		
4.058e+04		48	19.15	38.90	-11.22	30.20	-2.52	18.98-1.423e+05-2.278e+05-1.985e+05-1.715e+05		
4.439e+04	55	47	18.80	8.49	-10.17	8.10	-9.78	-2.68-1.273e+05-2.254e+05-1.556e+05-1.971e+05		
2.702e+04		56	16.98	7.90	3.04	7.88	3.07	-0.33-1.411e+05-1.981e+05-1.605e+05-1.788e+05		
4.269e+04		57	21.86	6.61	-9.06	6.61	-9.06	-0.14-1.707e+05-2.585e+05-2.045e+05-2.247e+05		
4.061e+04		48	19.12	11.24	-3.42	9.83	-2.01	4.32-1.419e+05-2.276e+05-1.984e+05-1.711e+05		
4.438e+04	69	47	18.78	5.71	-3.88	5.13	-3.30	-2.27-1.272e+05-2.252e+05-1.554e+05-1.969e+05		
2.701e+04		56	16.95	3.84	-5.02	1.37	-2.55	-3.98-1.410e+05-1.980e+05-1.604e+05-1.786e+05		
4.269e+04		57	21.84	0.28	-6.27	-0.67	-5.32	-2.31-1.705e+05-2.583e+05-2.043e+05-2.245e+05		
4.062e+04		48	19.11	2.07	-4.41	-0.58	-1.76	-3.19-1.418e+05-2.275e+05-1.983e+05-1.710e+05		
8.023e+04	1	48	30.66	3.87	-7.82	1.15	-5.10	-4.94-2.852e+05-3.448e+05-2.854e+05-3.446e+05	-3604.60	
		57	25.66	-1.12	-3.50	-1.17	-3.45	-0.34-1.481e+05-3.085e+05-2.283e+05-2.283e+05		
1.163e+05	3	58	30.65	2.92	-6.22	2.89	-6.20	0.48-2.852e+05-3.448e+05-3.446e+05-2.854e+05	-3591.98	
6.788e+04		49	31.42	8.47	-9.35	8.47	-9.35	-0.29-1.418e+05-3.743e+05-2.580e+05-2.580e+05		
9.838e+04	23	48	25.94	3.28	-6.62	0.98	-4.32	-4.18-2.413e+05-2.918e+05-2.415e+05-2.916e+05	-3050.05	
		57	21.71	-0.95	-2.96	-0.99	-2.92	-0.29-1.253e+05-2.610e+05-1.932e+05-1.932e+05		
6.180e+04		58	25.93	2.47	-5.26	2.45	-5.24	0.41-2.413e+05-2.918e+05-2.916e+05-2.415e+05	-3039.36	
		49	26.59	7.17	-7.91	7.16	-7.91	-0.25-1.200e+05-3.167e+05-2.183e+05-2.183e+05		
8.970e+04	55	48	23.65	22.09	-12.34	18.02	-8.27	11.12-2.198e+05-2.661e+05-2.200e+05-2.660e+05	-2749.62	
6.180e+04		57	19.87	25.60	12.06	24.05	13.61	-4.32-1.141e+05-2.380e+05-1.760e+05-1.761e+05		
		58	23.66	26.72	-15.84	6.73	4.16	21.24-2.201e+05-2.658e+05-2.656e+05-2.203e+05	-2929.09	
		49	24.25	25.20	-10.74	22.82	-8.35	8.95-1.093e+05-2.887e+05-1.989e+05-1.992e+05		
6.180e+04		48	23.60	6.81	-5.52	6.68	-5.39	1.25-2.195e+05-2.656e+05-2.197e+05-2.654e+05	-2764.94	
		57	19.78	8.05	2.34	7.54	2.85	-1.63-1.140e+05-2.376e+05-1.757e+05-1.758e+05		
8.953e+04	69	58	23.60	8.92	-6.92	3.75	-1.75	7.43-2.196e+05-2.655e+05-2.653e+05-2.198e+05	-2819.24	
		49	24.20	12.44	-8.00	12.03	-7.58	2.88-1.091e+05-2.882e+05-1.986e+05-1.987e+05		
6.171e+04		48	23.58	2.98	-6.02	0.89	-3.92	-3.80-2.194e+05-2.653e+05-2.195e+05-2.651e+05	-2772.77	
		57	19.74	-0.86	-2.69	-0.90	-2.65	-0.26-1.139e+05-2.373e+05-1.756e+05-1.756e+05		
8.944e+04	1	58	23.57	2.24	-4.79	2.22	-4.77	0.37-2.194e+05-2.653e+05-2.651e+05-2.195e+05	-2763.06	
		49	24.17	6.52	-7.19	6.51	-7.19	-0.23-1.090e+05-2.879e+05-1.985e+05-1.985e+05		
		44	32.48	11.33	-3.85	9.82	-2.34	4.54-1.947e+05-3.907e+05-2.867e+05-2.986e+05		

Parco Eolico "Bolina" – Progetto Definitivo
Relazione di calcolo preliminare delle fondazioni degli aerogeneratori G8 e G12

9.781e+04										
7.901e+04	58	30.81	1.54	-8.48	1.50	-8.44	0.66-1.644e+05-3.698e+05-3.328e+05-2.015e+05			
3.871e+04	59	21.83	4.00	-8.76	0.84	-5.60	5.51-1.670e+05-2.587e+05-2.374e+05-1.883e+05			
7.643e+04	50	32.41	-3.72	-8.25	-4.03	-7.95	1.14-1.918e+05-3.896e+05-3.535e+05-2.279e+05			
8.276e+04	49	27.49	9.59	-3.26	8.31	-1.98	3.85-1.647e+05-3.306e+05-2.426e+05-2.527e+05			
6.685e+04	58	26.07	1.30	-7.18	1.27	-7.14	0.56-1.391e+05-3.129e+05-2.816e+05-1.705e+05			
3.275e+04	59	18.47	3.38	-7.41	0.71	-4.74	4.66-1.413e+05-2.189e+05-2.009e+05-1.593e+05			
6.468e+04	50	27.43	-3.15	-6.98	-3.41	-6.72	0.96-1.623e+05-3.297e+05-2.991e+05-1.929e+05			
7.519e+04	49	25.08	18.58	-9.93	1.84	6.81	14.03-1.506e+05-3.012e+05-2.215e+05-2.303e+05			
6.109e+04	58	23.81	27.71	8.62	9.08	27.25	2.92-1.268e+05-2.855e+05-2.568e+05-1.555e+05			
2.960e+04	59	16.86	27.34	-13.94	-2.93	16.32	18.26-1.292e+05-1.996e+05-1.834e+05-1.454e+05			
5.897e+04	50	25.02	9.13	2.06	4.63	6.56	3.40-1.480e+05-3.008e+05-2.730e+05-1.758e+05			
7.540e+04	49	25.02	13.98	-4.12	9.88	-0.02	7.57-1.497e+05-3.008e+05-2.207e+05-2.299e+05			
6.081e+04	58	23.73	7.90	-5.24	6.98	-4.32	3.36-1.266e+05-2.847e+05-2.562e+05-1.551e+05			
2.986e+04	59	16.81	7.68	-12.20	-1.05	-3.47	9.87-1.285e+05-1.991e+05-1.827e+05-1.449e+05			
5.885e+04	50	24.96	-0.50	-7.99	-1.94	-6.55	2.95-1.477e+05-3.000e+05-2.721e+05-1.755e+05			
7.524e+04	49	24.99	8.72	-2.96	7.56	-1.80	3.50-1.498e+05-3.005e+05-2.206e+05-2.297e+05			
6.077e+04	58	23.70	1.18	-6.52	1.15	-6.49	0.51-1.265e+05-2.845e+05-2.560e+05-1.550e+05			
2.977e+04	59	16.79	3.08	-6.74	0.65	-4.31	4.24-1.285e+05-1.990e+05-1.826e+05-1.449e+05			
5.880e+04	50	24.93	-2.86	-6.35	-3.10	-6.11	0.88-1.475e+05-2.997e+05-2.719e+05-1.753e+05			
1.433e+04	50	19.79	8.27	3.96	4.35	7.88	1.24-1.568e+04-2.135e+05-2.124e+05-1.673e+04			-
1.312e+05	59	33.17	7.11	-4.21	-1.89	4.80	4.56-7.502e+04-3.766e+05-3.002e+05-1.514e+05			
7.289e+04	60	16.58	8.82	-1.84	-1.66	8.63	1.40-3.974e+04-1.890e+05-1.303e+05-9.839e+04			-
1.748e+05	51	39.45	2.87	-12.03	-10.82	1.66	4.06 5.700e+04-3.789e+05-2.912e+05-3.073e+04			
1.213e+04	50	16.75	7.00	3.35	3.68	6.67	1.05-1.327e+04-1.806e+05-1.798e+05-1.415e+04			-
1.110e+05	59	28.07	6.02	-3.56	-1.60	4.06	3.86-6.348e+04-3.187e+05-2.540e+05-1.281e+05			
6.168e+04	60	14.03	7.46	-1.56	-1.40	7.30	1.19-3.363e+04-1.599e+05-1.103e+05-8.326e+04			-
1.479e+05	51	33.38	2.43	-10.18	-9.16	1.41	3.44 4.823e+04-3.206e+05-2.464e+05-2.600e+04			
1.096e+04	50	15.24	20.94	1.59	4.51	18.02	6.93-1.171e+04-1.642e+05-1.634e+05-1.250e+04			-
1.013e+05	59	25.61	27.01	-3.96	3.91	19.14	13.48-5.751e+04-2.903e+05-2.313e+05-1.165e+05			
5.616e+04	60	12.78	29.73	-20.00	-18.07	27.80	9.61-3.036e+04-1.453e+05-1.001e+05-7.562e+04			-
1.350e+05	51	30.52	5.64	-23.80	-20.08	1.92	9.78 4.457e+04-2.921e+05-2.243e+05-2.323e+04			
1.100e+04	50	15.22	11.28	2.57	3.74	10.11	2.97-1.194e+04-1.642e+05-1.634e+05-1.274e+04			-
1.010e+05	59	25.55	12.75	-3.47	0.36	8.92	6.89-5.764e+04-2.899e+05-2.310e+05-1.165e+05			
5.610e+04	60	12.76	14.53	-7.69	-6.96	13.80	3.97-3.050e+04-1.454e+05-1.002e+05-7.566e+04			-
1.346e+05	51	30.40	3.35	-14.15	-12.30	1.50	5.38 4.409e+04-2.917e+05-2.241e+05-2.350e+04			
1.103e+04	50	15.22	6.36	3.05	3.35	6.06	0.95-1.206e+04-1.642e+05-1.634e+05-1.287e+04			-

Parco Eolico "Bolina" – Progetto Definitivo
Relazione di calcolo preliminare delle fondazioni degli aerogeneratori G8 e G12

1.009e+05	59	25.52	5.47	-3.24	-1.46	3.69	3.51-5.771e+04-2.897e+05-2.309e+05-1.165e+05		
5.607e+04	60	12.75	6.78	-1.42	-1.27	6.64	1.08-3.057e+04-1.454e+05-1.003e+05-7.569e+04	-	
1.344e+05	51	30.35	2.21	-9.25	-8.32	1.28	3.13 4.384e+04-2.915e+05-2.240e+05-2.364e+04		
46 1	51	21.65	9.32	-8.44	-8.43	9.31	-0.49 9.015e+04-1.658e+05-1.657e+05 9.010e+04	-3505.12	
7.146e+04	60	24.01	4.71	-4.38	-4.38	4.71	-0.02 7.474e+04-2.039e+05-1.842e+05 5.503e+04	-	
61	13.21	3.83	0.38	0.74	3.46	1.06 4.301e+04-1.109e+05-1.107e+05 4.275e+04	-6337.27		
46 3	52	22.22	6.42	-5.35	-2.53	3.61	-5.02 1.109e+05-1.551e+05-1.380e+05 9.385e+04	6.520e+04	
6.047e+04	51	18.32	7.89	-7.15	-7.13	7.88	-0.42 7.628e+04-1.403e+05-1.402e+05 7.624e+04	-2965.87	
60	20.32	3.99	-3.71	-3.71	3.99	-0.01 6.324e+04-1.726e+05-1.559e+05 4.656e+04	-		
61	11.18	3.24	0.32	0.63	2.93	0.89 3.640e+04-9.387e+04-9.365e+04 3.617e+04	-5362.30		
46 8	52	18.80	5.43	-4.52	-2.14	3.05	-4.25 9.386e+04-1.312e+05-1.168e+05 7.941e+04	5.517e+04	
5.504e+04	51	16.74	25.66	-10.80	-8.46	23.33	-8.92 6.898e+04-1.282e+05-1.282e+05 6.893e+04	-3003.01	
60	18.64	28.60	-16.50	-8.73	20.83	-17.03 5.701e+04-1.578e+05-1.426e+05 4.184e+04	-		
61	10.20	31.49	14.26	17.26	28.48	6.54 3.274e+04-8.588e+04-8.565e+04 3.252e+04	-5176.95		
46 40	52	17.21	33.69	-20.51	6.67	6.51	-27.10 8.480e+04-1.201e+05-1.069e+05 7.162e+04	5.027e+04	
5.499e+04	51	16.68	13.16	-7.68	-7.15	12.63	-3.27 6.922e+04-1.278e+05-1.277e+05 6.918e+04	-2800.05	
60	18.53	11.45	-7.18	-5.18	9.45	-5.77 5.733e+04-1.572e+05-1.420e+05 4.216e+04	-		
61	10.18	12.59	5.03	6.22	11.40	2.75 3.297e+04-8.552e+04-8.531e+04 3.276e+04	-4977.05		
46 69	52	17.13	14.33	-9.32	0.97	4.04	-11.73 8.515e+04-1.196e+05-1.064e+05 7.200e+04	5.019e+04	
5.497e+04	51	16.65	7.17	-6.50	-6.48	7.16	-0.38 6.934e+04-1.275e+05-1.275e+05 6.931e+04	-2696.25	
60	18.47	3.63	-3.37	-3.37	3.63	-0.01 5.750e+04-1.569e+05-1.417e+05 4.233e+04	-		
61	10.16	2.94	0.29	0.57	2.66	0.81 3.309e+04-8.534e+04-8.514e+04 3.289e+04	-4874.82		
47 1	52	17.09	4.94	-4.11	-1.95	2.77	-3.86 8.533e+04-1.193e+05-1.062e+05 7.219e+04	5.015e+04	
6.546e+04	52	30.10	5.51	-3.65	-0.23	2.09	-4.43 1.427e+05-2.166e+05-2.042e+05 1.304e+05	-	
1.014e+05	61	24.51	5.84	-2.23	-0.55	4.16	-3.28 1.994e+05-8.796e+04-4.609e+04 1.575e+05	-	
2.053e+04	62	16.51	4.07	-3.75	-1.88	2.20	-3.33 7.432e+04-1.221e+05-1.199e+05 7.215e+04	-	
6.681e+04	53	17.89	3.16	-8.09	-6.94	2.01	-3.40 1.959e+05 2.143e+04 5.257e+04 1.648e+05	-	
47 3	52	25.47	4.66	-3.08	-0.20	1.77	-3.74 1.208e+05-1.833e+05-1.728e+05 1.103e+05	-	
5.539e+04	61	20.74	4.94	-1.88	-0.46	3.52	-2.77 1.687e+05-7.443e+04-3.900e+04 1.333e+05	-	
8.579e+04	62	13.97	3.44	-3.17	-1.59	1.86	-2.82 6.289e+04-1.033e+05-1.015e+05 6.105e+04	-	
1.737e+04	53	15.14	2.67	-6.85	-5.88	1.70	-2.88 1.658e+05 1.814e+04 4.448e+04 1.394e+05	-	
5.653e+04	47 23	52	23.29	10.15	-29.88	-26.70	6.97	10.82 1.104e+05-1.668e+05-1.573e+05 1.009e+05	-
5.053e+04	61	18.99	22.32	-17.00	-17.00	22.32	-0.31 1.542e+05-6.741e+04-3.514e+04 1.220e+05	-	
7.818e+04	62	12.80	-4.75	-25.24	-24.60	-5.39	-3.57 5.761e+04-9.393e+04-9.226e+04 5.594e+04	-	
1.582e+04	53	13.94	29.73	-25.81	-24.21	28.13	-9.29 1.514e+05 1.692e+04 4.090e+04 1.274e+05	-	
5.148e+04	47 55	52	23.20	3.58	-9.31	-9.15	3.42	1.41 1.100e+05-1.667e+05-1.572e+05 1.005e+05	-
5.041e+04	61	18.90	9.87	-6.23	-6.03	9.67	-1.77 1.537e+05-6.758e+04-3.535e+04 1.214e+05	-	
7.805e+04	62	12.73	0.19	-10.17	-9.28	-0.70	-2.90 5.732e+04-9.391e+04-9.224e+04 5.565e+04	-	
1.580e+04	53	13.82	11.56	-12.75	-11.73	10.54	-4.87 1.510e+05 1.663e+04 4.059e+04 1.270e+05	-	
5.142e+04	47 69	52	23.16	4.24	-2.80	-0.18	1.61	-3.40 1.098e+05-1.666e+05-1.571e+05 1.003e+05	-
5.035e+04	61	18.85	4.49	-1.71	-0.42	3.20	-2.52 1.534e+05-6.766e+04-3.545e+04 1.212e+05	-	
7.799e+04	62	12.70	3.13	-2.88	-1.45	1.69	-2.56 5.717e+04-9.390e+04-9.223e+04 5.550e+04	-	
1.579e+04	53	13.77	2.43	-6.22	-5.34	1.55	-2.62 1.507e+05 1.649e+04 4.044e+04 1.268e+05	-	
5.139e+04	48 1	53	19.47	4.94	-10.21	-4.88	-0.39	-7.23 1.671e+05-5.805e+04-4.823e+04 1.573e+05	-
4.599e+04									

Parco Eolico "Bolina" – Progetto Definitivo
Relazione di calcolo preliminare delle fondazioni degli aerogeneratori G8 e G12

6.104e+04	62	21.04	9.55	-9.43	-5.45	5.57	-7.73	1.248e+05	-1.276e+05	-1.119e+05	1.090e+05	-	
2.003e+04	63	8.39	9.38	2.12	2.94	8.56	2.29	9.708e+04	2.469e+04	9.104e+04	3.073e+04	-	
7.956e+04	54	21.10	6.92	-11.90	3.66	-8.64	-7.13	2.112e+05	-1.618e+04	1.629e+04	1.787e+05	-	
3.891e+04	48 3	53	16.47	4.18	-8.64	-4.13	-0.33	-6.12	1.414e+05	-4.912e+04	-4.081e+04	1.331e+05	-
5.165e+04	62	17.81	8.08	-7.98	-4.62	4.72	-6.54	1.056e+05	-1.080e+05	-9.465e+04	9.225e+04	-	
1.695e+04	63	7.10	7.94	1.80	2.49	7.24	1.94	8.215e+04	2.089e+04	7.703e+04	2.600e+04	-	
6.732e+04	54	17.85	5.86	-10.07	3.09	-7.31	-6.03	1.787e+05	-1.369e+04	1.379e+04	1.512e+05	-	
3.554e+04	48 7	53	15.11	19.26	-30.07	-15.58	4.77	-22.47	1.288e+05	-4.490e+04	-3.729e+04	1.212e+05	-
4.720e+04	62	16.42	31.89	-33.28	-24.02	22.62	-22.76	9.614e+04	-9.869e+04	-8.649e+04	8.394e+04	-	
1.538e+04	63	6.47	45.21	0.37	2.04	43.54	-8.49	7.486e+04	1.898e+04	7.025e+04	2.359e+04	-	
6.148e+04	54	16.27	3.65	-32.06	-5.72	-22.69	-15.71	1.627e+05	-1.268e+04	1.248e+04	1.376e+05	-	
3.543e+04	48 39	53	15.02	9.01	-15.35	-7.75	1.41	-11.28	1.286e+05	-4.474e+04	-3.716e+04	1.211e+05	-
4.704e+04	62	16.26	15.60	-16.01	-10.90	10.49	-11.63	9.603e+04	-9.834e+04	-8.620e+04	8.389e+04	-	
1.540e+04	63	6.46	19.26	2.02	2.19	19.09	-1.71	7.474e+04	1.899e+04	7.011e+04	2.362e+04	-	
6.130e+04	54	16.24	4.70	-16.84	-0.07	-12.07	-8.94	1.626e+05	-1.253e+04	1.251e+04	1.375e+05	-	
3.537e+04	48 69	53	14.98	3.80	-7.85	-3.75	-0.30	-5.56	1.286e+05	-4.465e+04	-3.710e+04	1.210e+05	-
4.696e+04	62	16.19	7.35	-7.26	-4.20	4.29	-5.94	9.598e+04	-9.816e+04	-8.605e+04	8.386e+04	-	
1.541e+04	63	6.46	7.21	1.63	2.26	6.59	1.76	7.468e+04	1.899e+04	7.003e+04	2.364e+04	-	
6.120e+04	54	16.23	5.33	-9.16	2.81	-6.64	-5.49	1.625e+05	-1.245e+04	1.253e+04	1.375e+05	-	
6.607e+04	49 1	55	35.02	10.52	-6.45	5.50	-1.44	-7.74	-1.472e+05	-4.150e+05	-3.976e+05	-1.646e+05	-
3.834e+04	64	28.55	-0.93	-16.84	-1.01	-16.77	1.09	-2.512e+05	-3.278e+05	-2.897e+05	-2.893e+05	-	
6.571e+04	65	37.51	5.55	-11.95	0.46	-6.86	-7.95	-1.541e+05	-4.442e+05	-1.698e+05	-4.284e+05	-	
6.862e+04	56	21.38	-1.61	-10.52	-1.63	-10.50	-0.43	-1.184e+05	-2.566e+05	-1.791e+05	-1.959e+05	-	
5.590e+04	49 3	55	29.63	8.90	-5.46	4.66	-1.22	-6.55	-1.245e+05	-3.512e+05	-3.364e+05	-1.393e+05	-
3.244e+04	64	24.16	-0.79	-14.25	-0.85	-14.19	0.93	-2.125e+05	-2.774e+05	-2.451e+05	-2.448e+05	-	
5.560e+04	65	31.74	4.70	-10.11	0.39	-5.80	-6.73	-1.304e+05	-3.758e+05	-1.437e+05	-3.625e+05	-	
5.806e+04	56	18.09	-1.36	-8.90	-1.38	-8.88	-0.37	-1.002e+05	-2.172e+05	-1.515e+05	-1.658e+05	-	
5.092e+04	49 23	55	27.05	24.49	-45.62	-8.89	-12.24	35.01	-1.136e+05	-3.197e+05	-3.063e+05	-1.271e+05	-
2.949e+04	64	22.02	26.03	-3.59	13.35	9.08	-14.65	-1.935e+05	-2.524e+05	-2.230e+05	-2.229e+05	-	
5.048e+04	65	29.08	40.99	-39.83	28.66	-27.50	29.07	-1.190e+05	-3.424e+05	-1.310e+05	-3.304e+05	-	
5.285e+04	56	16.48	43.57	-8.39	42.35	-7.17	7.86	-9.132e+04	-1.978e+05	-1.381e+05	-1.511e+05	-	
5.086e+04	49 55	55	26.94	5.70	-10.78	-0.21	-4.87	7.91	-1.134e+05	-3.194e+05	-3.060e+05	-1.268e+05	-
2.949e+04	64	21.95	5.74	-7.19	4.01	-5.46	-4.40	-1.933e+05	-2.523e+05	-2.229e+05	-2.227e+05	-	
5.052e+04	65	28.93	11.32	-14.18	9.93	-12.80	5.79	-1.187e+05	-3.419e+05	-1.307e+05	-3.298e+05	-	
5.281e+04	56	16.45	13.77	-8.05	13.50	-7.77	2.44	-9.114e+04	-1.976e+05	-1.378e+05	-1.508e+05	-	
5.082e+04	49 69	55	26.94	8.09	-4.96	4.23	-1.11	-5.96	-1.132e+05	-3.192e+05	-3.058e+05	-1.266e+05	-
	64	21.96	-0.72	-12.96	-0.77	-12.90	0.84	-1.932e+05	-2.522e+05	-2.229e+05	-2.225e+05	-	

Parco Eolico "Bolina" – Progetto Definitivo
Relazione di calcolo preliminare delle fondazioni degli aerogeneratori G8 e G12

2.949e+04										
5.055e+04	65	28.85	4.27	-9.19	0.35	-5.28	-6.12-1.185e+05-3.417e+05-1.306e+05-3.296e+05			
5.278e+04	56	16.45	-1.24	-8.09	-1.26	-8.08	-0.33-9.105e+04-1.974e+05-1.377e+05-1.507e+05			
50 1	56	33.24	2.47	-5.42	0.83	-3.78	-3.21-1.786e+05-3.991e+05-2.396e+05-3.381e+05			
9.865e+04	65	23.78	0.22	-10.35	0.12	-10.24	-1.04-1.067e+04-2.527e+05-1.317e+05-1.317e+05			-
1.210e+05	66	33.25	2.20	-12.86	-0.27	-10.39	-5.58-1.786e+05-3.991e+05-3.381e+05-2.396e+05			
9.864e+04	57	20.90	2.79	-4.64	2.71	-4.55	-0.79-2.137e+05-2.214e+05-2.175e+05-2.175e+05			-3854.10
50 3	56	28.13	2.09	-4.59	0.70	-3.20	-2.71-1.511e+05-3.377e+05-2.027e+05-2.861e+05			
8.347e+04	65	20.12	0.19	-8.75	0.10	-8.67	-0.88 -9029.25-2.138e+05-1.114e+05-1.114e+05			-
1.024e+05	66	28.14	1.86	-10.88	-0.23	-8.80	-4.72-1.511e+05-3.377e+05-2.861e+05-2.028e+05			
8.347e+04	57	17.68	2.36	-3.92	2.29	-3.85	-0.67-1.808e+05-1.873e+05-1.841e+05-1.841e+05			-3261.16
50 7	56	25.70	33.49	-23.37	15.81	-5.70	26.32-1.376e+05-3.075e+05-1.847e+05-2.604e+05			
7.604e+04	65	18.32	43.51	18.01	26.78	34.75	-12.11 -8331.63-1.948e+05-1.015e+05-1.016e+05			-
9.326e+04	66	25.73	38.18	-25.08	-9.10	22.21	27.48-1.378e+05-3.077e+05-2.607e+05-1.847e+05			
7.599e+04	57	16.12	13.94	-9.62	0.04	4.27	11.59-1.647e+05-1.707e+05-1.679e+05-1.675e+05			-3014.57
50 39	56	25.61	9.68	-7.76	5.77	-3.85	7.27-1.375e+05-3.072e+05-1.845e+05-2.602e+05			
7.593e+04	65	18.30	12.64	3.03	9.12	6.55	-4.63 -8250.11-1.946e+05-1.014e+05-1.014e+05			-
9.315e+04	66	25.62	6.51	-7.51	-3.22	2.22	6.46-1.375e+05-3.072e+05-2.603e+05-1.845e+05			
7.592e+04	57	16.09	3.96	-3.44	1.39	-0.87	3.52-1.645e+05-1.704e+05-1.675e+05-1.674e+05			-2981.57
50 69	56	25.57	1.90	-4.17	0.64	-2.91	-2.47-1.374e+05-3.070e+05-1.843e+05-2.601e+05			
7.588e+04	65	18.29	0.17	-7.96	0.09	-7.88	-0.80 -8208.41-1.944e+05-1.013e+05-1.013e+05			-
9.310e+04	66	25.58	1.69	-9.89	-0.21	-8.00	-4.29-1.374e+05-3.070e+05-2.601e+05-1.843e+05			
7.588e+04	57	16.08	2.15	-3.57	2.08	-3.50	-0.61-1.644e+05-1.703e+05-1.673e+05-1.673e+05			-2964.69
51 1	57	28.39	4.61	-5.67	4.53	-5.59	0.86-2.217e+05-3.357e+05-2.918e+05-2.656e+05			
5.549e+04	66	22.04	-1.98	-4.32	-2.45	-3.84	-0.94-1.833e+05-2.574e+05-2.322e+05-2.085e+05			
3.511e+04	67	24.41	2.29	-6.20	2.08	-5.99	1.32-1.653e+05-2.927e+05-2.560e+05-2.020e+05			
5.768e+04	58	24.84	1.25	-5.61	1.01	-5.38	1.26-1.843e+05-2.957e+05-2.223e+05-2.577e+05			
5.279e+04	57	24.02	3.90	-4.80	3.84	-4.73	0.73-1.876e+05-2.841e+05-2.469e+05-2.248e+05			
51 3	66	18.65	-1.67	-3.65	-2.08	-3.25	-0.80-1.551e+05-2.178e+05-1.965e+05-1.764e+05			
4.695e+04	67	20.65	1.94	-5.25	1.76	-5.07	1.12-1.399e+05-2.477e+05-2.166e+05-1.710e+05			
2.971e+04	58	21.02	1.06	-4.75	0.86	-4.55	1.07-1.559e+05-2.502e+05-1.881e+05-2.181e+05			
4.467e+04	57	21.89	17.56	-1.87	5.94	9.75	9.52-1.707e+05-2.589e+05-2.247e+05-2.049e+05			
51 23	66	16.99	25.92	-9.33	15.01	1.58	16.29-1.413e+05-1.984e+05-1.789e+05-1.608e+05			
4.292e+04	67	18.84	3.18	-17.56	-0.35	-14.02	7.80-1.272e+05-2.255e+05-1.971e+05-1.556e+05			
2.708e+04	58	19.17	30.82	-11.39	5.42	14.02	20.66-1.420e+05-2.282e+05-1.712e+05-1.990e+05			
4.456e+04	57	21.85	6.52	-1.76	4.32	0.45	3.66-1.706e+05-2.585e+05-2.246e+05-2.045e+05			
4.078e+04	66	16.96	6.88	-4.47	3.83	-1.42	5.03-1.411e+05-1.981e+05-1.787e+05-1.605e+05			
51 55	67	18.80	2.05	-8.91	0.94	-7.79	3.31-1.272e+05-2.253e+05-1.970e+05-1.555e+05			
4.276e+04	58	19.13	9.81	-5.46	2.35	2.01	7.63-1.418e+05-2.277e+05-1.710e+05-1.985e+05			
2.703e+04	57	21.84	3.54	-4.36	3.49	-4.30	0.66-1.705e+05-2.583e+05-2.245e+05-2.043e+05			
4.443e+04	69									
4.067e+04										
51 69										

Parco Eolico "Bolina" – Progetto Definitivo
Relazione di calcolo preliminare delle fondazioni degli aerogeneratori G8 e G12

4.268e+04									
2.701e+04	66	16.96	-1.52	-3.32	-1.89	-2.95	-0.73-1.410e+05-1.980e+05-1.786e+05-1.604e+05		
4.437e+04	67	18.78	1.76	-4.77	1.60	-4.61	1.01-1.272e+05-2.252e+05-1.969e+05-1.554e+05		
4.061e+04	58	19.11	0.96	-4.32	0.78	-4.13	0.97-1.418e+05-2.275e+05-1.710e+05-1.983e+05		
1.262e+05	52 1	58	29.22	5.01	-7.51	4.05	-6.55	3.32-8.367e+04-3.373e+05-2.233e+05-1.977e+05	
4.393e+04	67	23.99	-0.69	-1.84	-0.93	-1.60	0.46-1.883e+05-2.835e+05-2.542e+05-2.176e+05		
7.844e+04	68	22.35	3.47	-6.69	-0.67	-2.55	4.99-1.102e+05-2.672e+05-1.924e+05-1.849e+05		
3.062e+04	59	25.45	0.18	-7.72	-1.35	-6.19	3.12-1.807e+05-3.041e+05-2.960e+05-1.888e+05		
1.068e+05	52 3	58	24.73	4.24	-6.35	3.43	-5.54	2.81-7.080e+04-2.854e+05-1.889e+05-1.673e+05	
3.718e+04	67	20.30	-0.59	-1.55	-0.79	-1.35	0.39-1.593e+05-2.399e+05-2.151e+05-1.841e+05		
6.637e+04	68	18.92	2.94	-5.66	-0.56	-2.16	4.22-9.321e+04-2.261e+05-1.628e+05-1.565e+05		
2.591e+04	59	21.53	0.15	-6.53	-1.14	-5.24	2.64-1.529e+05-2.574e+05-2.505e+05-1.597e+05		
9.710e+04	52 7	58	22.62	25.51	-20.44	-7.60	12.67	20.62-6.496e+04-2.602e+05-1.724e+05-1.527e+05	
3.387e+04	67	18.57	54.25	-5.80	-5.68	54.13	-2.67-1.452e+05-2.186e+05-1.961e+05-1.677e+05		
6.029e+04	68	17.29	48.76	-20.85	-3.21	31.13	30.28-8.528e+04-2.060e+05-1.485e+05-1.427e+05		
2.351e+04	59	19.67	26.06	7.31	11.14	22.23	7.56-1.395e+05-2.347e+05-2.285e+05-1.457e+05		
9.707e+04	52 39	58	22.53	8.92	-8.48	-0.51	0.95	8.67-6.456e+04-2.597e+05-1.720e+05-1.523e+05	
3.382e+04	67	18.49	17.53	-2.42	-2.40	17.50	-0.67-1.450e+05-2.183e+05-1.957e+05-1.675e+05		
6.032e+04	68	17.23	17.76	-9.95	-1.43	9.24	12.79-8.492e+04-2.057e+05-1.482e+05-1.424e+05		
2.354e+04	59	19.59	7.92	-0.47	3.08	4.37	4.15-1.391e+05-2.342e+05-2.280e+05-1.454e+05		
9.705e+04	52 69	58	22.48	3.85	-5.77	3.12	-5.04	2.56-6.436e+04-2.595e+05-1.718e+05-1.521e+05	
3.380e+04	67	18.46	-0.53	-1.41	-0.72	-1.23	0.36-1.449e+05-2.181e+05-1.955e+05-1.674e+05		
6.034e+04	68	17.20	2.67	-5.14	-0.51	-1.96	3.84-8.474e+04-2.055e+05-1.480e+05-1.423e+05		
2.355e+04	59	19.57	0.14	-5.94	-1.04	-4.76	2.40-1.390e+05-2.340e+05-2.277e+05-1.452e+05		
4.118e+04	53 1	59	16.89	6.98	0.28	1.66	5.61	2.71-8.722e+04-2.025e+05-1.852e+05-1.045e+05	
9.126e+04	68	24.40	3.81	-2.75	-0.08	1.14	3.23-9.343e+04-2.876e+05-2.236e+05-1.574e+05		
1.664e+05	69	22.87	1.66	-1.58	-1.51	1.59	0.46 4.196e+04-2.144e+05-2.144e+05 4.195e+04	-1272.56	
3.484e+04	60	36.70	6.75	-6.89	-6.25	6.12	2.88-6.876e+04-4.118e+05-2.819e+05-1.986e+05		
7.722e+04	53 3	59	14.29	5.91	0.24	1.41	4.74	2.29-7.380e+04-1.714e+05-1.567e+05-8.844e+04	
1.408e+05	68	20.65	3.23	-2.33	-0.07	0.97	2.73-7.905e+04-2.433e+05-1.892e+05-1.332e+05		
3.180e+04	69	19.35	1.40	-1.34	-1.28	1.35	0.39 3.550e+04-1.814e+05-1.814e+05 3.550e+04	-1076.78	
7.050e+04	60	31.05	5.71	-5.83	-5.29	5.18	2.43-5.818e+04-3.484e+05-2.385e+05-1.681e+05		
1.285e+05	53 21	59	13.03	11.14	-18.25	-8.82	1.71	13.72-6.666e+04-1.554e+05-1.420e+05-8.008e+04	
3.172e+04	68	18.87	28.54	-21.56	8.82	-1.83	24.48-7.140e+04-2.214e+05-1.719e+05-1.209e+05		
7.030e+04	69	17.63	-4.66	-26.27	-6.60	-24.33	6.18 3.284e+04-1.647e+05-1.647e+05 3.284e+04	-882.78	
1.285e+05	60	28.34	22.01	-7.50	0.63	13.87	13.19-5.221e+04-3.172e+05-2.168e+05-1.526e+05		
3.172e+04	53 53	59	13.01	7.28	-5.99	-2.14	3.43	6.02-6.695e+04-1.557e+05-1.423e+05-8.029e+04	
7.030e+04	68	18.81	11.49	-8.58	2.94	-0.04	9.92-7.171e+04-2.213e+05-1.720e+05-1.210e+05		
	69	17.60	-2.01	-8.42	-3.00	-7.42	2.32 3.247e+04-1.648e+05-1.648e+05 3.246e+04	-946.37	

Parco Eolico "Bolina" – Progetto Definitivo
Relazione di calcolo preliminare delle fondazioni degli aerogeneratori G8 e G12

1.282e+05	60	28.27	10.43	-5.59	-2.97	7.81	5.93-5.266e+04-3.169e+05-2.168e+05-1.527e+05	
53 69	59	12.99	5.37	0.22	1.28	4.31	2.08-6.709e+04-1.558e+05-1.425e+05-8.040e+04	
3.167e+04	68	18.77	2.93	-2.12	-0.06	0.88	2.48-7.187e+04-2.212e+05-1.720e+05-1.211e+05	
7.020e+04	69	17.59	1.28	-1.21	-1.16	1.22	0.35 3.228e+04-1.649e+05-1.649e+05 3.227e+04	-978.90
1.280e+05	60	28.23	5.19	-5.30	-4.81	4.70	2.21-5.289e+04-3.167e+05-2.168e+05-1.528e+05	
54 1	60	29.01	4.98	-2.20	-2.19	4.96	0.31 1.443e+05-2.028e+05-1.908e+05 1.323e+05 6.322e+04	
5.057e+04	69	21.74	4.32	-5.43	-5.20	4.09	1.47-1.135e+05-2.605e+05-2.404e+05-1.337e+05	
8.763e+04	70	16.70	3.87	0.96	0.96	3.87	-6.06e-03 5.527e+04-1.395e+05-1.385e+05 5.429e+04 1.376e+04	
54 3	61	26.31	3.81	-7.21	-7.12	3.72	1.00 -432.91-2.739e+05-2.422e+05-3.220e+04	
4.279e+04	60	24.55	4.21	-1.86	-1.85	4.20	0.27 1.221e+05-1.716e+05-1.615e+05 1.120e+05 5.349e+04	
7.415e+04	69	18.39	3.66	-4.59	-4.40	3.46	1.24-9.604e+04-2.205e+05-2.034e+05-1.131e+05	
54 7	70	14.13	3.27	0.82	0.82	3.27	-5.13e-03 4.676e+04-1.180e+05-1.172e+05 4.594e+04 1.164e+04	
3.892e+04	61	22.26	3.22	-6.10	-6.03	3.15	0.84 -366.31-2.318e+05-2.049e+05-2.725e+04	
6.753e+04	60	22.44	36.79	-11.21	-6.10	31.67	-14.81 1.112e+05-1.565e+05-1.473e+05 1.020e+05 4.875e+04	
54 39	69	16.86	21.24	-28.47	-27.43	20.20	7.11-8.777e+04-2.010e+05-1.855e+05-1.033e+05	
3.891e+04	70	12.91	26.21	9.56	10.30	25.47	-3.43 4.255e+04-1.077e+05-1.069e+05 4.181e+04 1.054e+04	
6.745e+04	61	20.37	21.88	-22.69	-22.60	21.79	-2.04 -612.70-2.115e+05-1.870e+05-2.507e+04	
54 69	60	22.36	14.57	-4.50	-3.18	13.24	-4.85 1.110e+05-1.562e+05-1.470e+05 1.019e+05 4.867e+04	
3.890e+04	69	16.77	9.39	-12.40	-11.93	8.92	3.15-8.747e+04-2.006e+05-1.851e+05-1.030e+05	
6.745e+04	70	12.86	10.79	3.78	3.98	10.59	-1.16 4.253e+04-1.074e+05-1.067e+05 4.178e+04 1.057e+04	
54 69	61	20.28	9.27	-11.27	-11.27	9.26	-0.18 -427.65-2.110e+05-1.865e+05-2.487e+04	
3.890e+04	60	22.32	3.83	-1.69	-1.68	3.82	0.24 1.110e+05-1.560e+05-1.468e+05 1.018e+05 4.863e+04	
6.741e+04	69	16.72	3.32	-4.18	-4.00	3.15	1.13-8.731e+04-2.004e+05-1.849e+05-1.028e+05	
55 1	70	12.84	2.98	0.74	0.74	2.98	-4.66e-03 4.251e+04-1.073e+05-1.065e+05 4.176e+04 1.058e+04	
2.967e+04	61	20.24	2.93	-5.55	-5.48	2.86	0.77 -333.01-2.107e+05-1.863e+05-2.477e+04	
55 3	61	31.22	4.35	-3.83	-3.65	4.17	-1.21 1.560e+05-2.175e+05-2.175e+05 1.560e+05 3026.48	
2.511e+04	70	19.51	8.40	-6.46	-4.22	6.16	-5.32-2.148e+04-2.129e+05-2.128e+05-2.150e+04 1467.03	
55 8	71	5.24	11.23	-0.39	0.03	10.81	2.16 1.130e+04-4.776e+04 5223.76-4.168e+04 1.795e+04	
2.305e+04	62	15.11	1.24	-5.99	-3.64	-1.11	-3.38 1.176e+05-6.103e+04-5.596e+04 1.126e+05	-
55 40	61	26.41	3.68	-3.24	-3.09	3.52	-1.02 1.320e+05-1.840e+05-1.840e+05 1.320e+05 2560.86	
2.290e+04	70	16.51	7.11	-5.47	-3.57	5.21	-4.50-1.818e+04-1.801e+05-1.801e+05-1.819e+04 1241.33	
55 69	71	4.43	9.50	-0.33	0.03	9.15	1.83 9564.81-4.041e+04 4420.10-3.527e+04 1.519e+04	
2.282e+04	62	12.79	1.05	-5.06	-3.08	-0.94	-2.86 9.954e+04-5.164e+04-4.735e+04 9.525e+04	-
3.862e+04	61	24.08	18.66	-13.03	-5.21	10.84	-13.66 1.198e+05-1.679e+05-1.679e+05 1.198e+05 2339.70	
1.229e+05	70	15.16	55.46	-39.27	-17.84	34.02	-39.63-1.696e+04-1.644e+05-1.644e+05-1.697e+04 939.48	
2.047e+04	71	4.11	64.48	23.65	31.39	56.74	16.01 8577.96-3.712e+04 3818.37-3.236e+04 1.396e+04	
3.267e+04	62	11.65	37.15	-35.44	10.42	-8.72	-35.01 9.019e+04-4.746e+04-4.349e+04 8.622e+04	-
56 1	61	24.04	8.12	-5.96	-3.62	5.79	-5.24 1.199e+05-1.675e+05-1.675e+05 1.199e+05 2332.00	
1.229e+05	70	15.06	22.99	-16.52	-8.18	14.65	-16.12-1.667e+04-1.640e+05-1.640e+05-1.668e+04 1064.53	
2.047e+04	71	4.06	27.26	8.08	10.64	24.70	6.51 8655.54-3.687e+04 3950.63-3.216e+04 1.386e+04	
3.267e+04	62	11.63	12.89	-14.73	1.67	-3.51	-13.57 9.039e+04-4.712e+04-4.319e+04 8.646e+04	-
56 3	61	24.01	3.34	-2.95	-2.81	3.20	-0.93 1.200e+05-1.673e+05-1.673e+05 1.200e+05 2328.06	
1.229e+05	70	15.01	6.46	-4.97	-3.24	4.74	-4.10-1.653e+04-1.637e+05-1.637e+05-1.653e+04 1128.49	
2.047e+04	71	4.03	8.64	-0.30	0.02	8.32	1.66 8695.28-3.674e+04 4018.28-3.206e+04 1.381e+04	
3.267e+04	62	11.63	0.95	-4.60	-2.80	-0.85	-2.60 9.049e+04-4.695e+04-4.305e+04 8.659e+04	-
56 3	62	6.66	8.72	-0.99	-0.61	8.34	-1.89 5.357e+04-2.455e+04 8645.66 2.038e+04	-
1.229e+05	71	25.07	6.87	-8.41	-0.74	-0.80	-7.64 2.120e+05-7.919e+04-1.156e+04 1.443e+05	-
2.047e+04	72	35.25	11.89	-6.02	-5.81	11.67	1.95 1.884e+05-2.341e+05-2.331e+05 1.874e+05	-
3.267e+04	63	22.47	3.64	-14.06	-10.08	-0.34	-7.39 5.814e+04-1.995e+05-1.809e+05 3.953e+04 6.669e+04	-
3.267e+04	62	5.64	7.38	-0.84	-0.52	7.05	-1.60 4.533e+04-2.077e+04 7315.56 1.724e+04	-

Parco Eolico "Bolina" – Progetto Definitivo
Relazione di calcolo preliminare delle fondazioni degli aerogeneratori G8 e G12

1.040e+05	71	21.22	5.81	-7.12	-0.63	-0.68	-6.47	1.794e+05-6.700e+04	-9785.56	1.221e+05	-	
1.732e+04	72	29.83	10.06	-5.10	-4.91	9.88	1.65	1.594e+05-1.981e+05-1.972e+05	1.586e+05	-	-	
2.989e+04	63	19.02	3.08	-11.89	-8.53	-0.29	-6.25	4.920e+04-1.688e+05-1.530e+05	3.345e+04	5.643e+04	-	
9.490e+04	56 7	62	5.20	37.85	1.87	2.41	37.31	-4.38	4.134e+04-1.911e+04	6624.63	1.560e+04	-
1.583e+04	71	19.52	42.16	-32.66	5.08	4.42	-37.41	1.633e+05-6.126e+04	-9009.61	1.111e+05	-	
2.977e+04	72	27.43	58.84	-26.06	-26.04	58.83	1.02	1.452e+05-1.806e+05-1.798e+05	1.444e+05	-	-	
9.468e+04	63	17.39	19.23	-54.73	-39.53	4.03	-29.88	4.466e+04-1.541e+05-1.398e+05	3.033e+04	5.141e+04	-	
1.578e+04	56 39	62	5.15	17.22	0.15	0.51	16.87	-2.44	4.125e+04-1.896e+04	6641.75	1.565e+04	-
2.970e+04	71	19.37	17.76	-15.33	1.34	1.09	-16.55	1.631e+05-6.103e+04	-8934.42	1.111e+05	-	
9.457e+04	72	27.22	25.89	-11.82	-11.77	25.85	1.34	1.450e+05-1.802e+05-1.795e+05	1.442e+05	-	-	
1.575e+04	63	17.32	8.35	-25.67	-18.50	1.19	-13.87	4.470e+04-1.537e+05-1.393e+05	3.038e+04	5.134e+04	-	
7.746e+04	56 69	62	5.13	6.71	-0.76	-0.47	6.41	-1.45	4.121e+04-1.888e+04	6650.51	1.567e+04	-
2.277e+05	71	19.29	5.29	-6.47	-0.57	-0.62	-5.88	1.631e+05-6.091e+04	-8895.96	1.110e+05	-	
6.554e+04	72	27.11	9.14	-4.63	-4.47	8.98	1.50	1.449e+05-1.801e+05-1.793e+05	1.441e+05	-	-	
1.926e+05	63	17.29	2.80	-10.81	-7.75	-0.26	-5.68	4.472e+04-1.534e+05-1.391e+05	3.041e+04	5.130e+04	-	
5.952e+04	57 1	64	20.53	5.71	-21.89	-0.36	-15.82	-11.43	-1.738e+05-2.382e+05-1.738e+05	-2.381e+05	-1763.61	-
1.752e+05	73	28.46	5.08	-3.82	1.69	-0.42	-4.32	-1.867e+05-3.416e+05-2.642e+05	-2.642e+05	-	-	
9.595e+04	74	20.51	1.74	-13.68	-3.83	-8.11	-7.40	-1.738e+05-2.382e+05-2.381e+05	-1.738e+05	-1765.31	-	
6.554e+04	65	57.62	6.80	-9.44	5.66	-8.30	-4.15	-2.246e+05-6.800e+05-4.523e+05	-4.523e+05	-	-	
1.926e+05	57 3	64	17.37	4.83	-18.52	-0.31	-13.38	-9.68	-1.470e+05-2.015e+05-1.471e+05	-2.015e+05	-1492.28	-
5.952e+04	73	24.08	4.30	-3.23	1.43	-0.36	-3.66	-1.580e+05-2.891e+05-2.235e+05	-2.235e+05	-	-	
1.752e+05	74	17.35	1.47	-11.57	-3.24	-6.86	-6.26	-1.471e+05-2.015e+05-2.015e+05	-1.471e+05	-1493.72	-	
5.952e+04	65	48.76	5.75	-7.99	4.79	-7.02	-3.51	-1.901e+05-5.754e+05-3.827e+05	-3.827e+05	-	-	
1.752e+05	57 23	64	15.95	95.15	-22.83	28.55	43.77	58.49	-1.338e+05-1.836e+05-1.339e+05	-1.835e+05	-1427.06	-
5.952e+04	73	22.13	-21.65	-72.11	-37.16	-56.61	23.28	-1.439e+05-2.629e+05-2.033e+05	-2.034e+05	-	-	
1.752e+05	74	15.98	104.50	-27.16	63.38	13.96	61.02	-1.339e+05-1.833e+05-1.833e+05	-1.340e+05	-1406.92	-	
5.952e+04	65	44.66	10.59	-77.48	-15.90	-50.99	40.39	-1.732e+05-5.239e+05-3.483e+05	-3.488e+05	-	-	
1.752e+05	57 55	64	15.80	22.16	-5.92	9.48	6.76	13.97	-1.337e+05-1.833e+05-1.338e+05	-1.833e+05	-1380.46	-
5.952e+04	73	21.96	-8.69	-22.39	-11.71	-19.37	5.68	-1.437e+05-2.628e+05-2.032e+05	-2.033e+05	-	-	
1.752e+05	74	15.82	29.39	-9.30	19.50	0.60	16.88	-1.338e+05-1.832e+05-1.832e+05	-1.338e+05	-1374.51	-	
5.952e+04	65	44.42	2.96	-26.94	-2.50	-21.48	11.55	-1.729e+05-5.233e+05-3.481e+05	-3.482e+05	-	-	
1.752e+05	57 69	64	15.79	4.39	-16.84	-0.28	-12.17	-8.80	-1.337e+05-1.832e+05-1.337e+05	-1.832e+05	-1356.62	-
5.952e+04	73	21.89	3.91	-2.94	1.30	-0.32	-3.33	-1.436e+05-2.628e+05-2.032e+05	-2.032e+05	-	-	
1.752e+05	74	15.77	1.34	-10.52	-2.94	-6.24	-5.70	-1.337e+05-1.832e+05-1.832e+05	-1.337e+05	-1357.93	-	
5.952e+04	65	44.33	5.23	-7.26	4.35	-6.38	-3.19	-1.728e+05-5.231e+05-3.479e+05	-3.479e+05	-	-	
1.752e+05	58 1	65	37.52	4.21	-7.38	3.63	-6.80	-2.53	-1.541e+05-4.442e+05-4.284e+05	-1.698e+05	-	-
5.952e+04	74	28.53	-2.04	-9.53	-2.63	-8.95	-2.02	-2.512e+05-3.278e+05-2.893e+05	-2.897e+05	-	-	
1.752e+05	75	35.00	3.27	-5.45	2.39	-4.57	-2.62	-1.472e+05-4.150e+05-1.646e+05	-3.976e+05	-	-	
5.952e+04	66	21.37	2.90	-10.92	2.90	-10.92	-0.10	-1.184e+05-2.566e+05-1.959e+05	-1.791e+05	-	-	
1.752e+05	58 3	65	31.75	3.56	-6.24	3.07	-2.14	-1.304e+05-3.758e+05-3.625e+05	-1.437e+05	-	-	
5.952e+04	74	24.14	-1.73	-8.07	-2.22	-7.57	-1.71	-2.125e+05-2.774e+05-2.448e+05	-2.452e+05	-	-	
1.752e+05	75	29.61	2.76	-4.61	2.02	-3.87	-2.21	-1.245e+05-3.512e+05-1.393e+05	-3.364e+05	-	-	
5.952e+04	66	18.08	2.45	-9.24	2.45	-9.24	-0.08	-1.002e+05-2.172e+05-1.658e+05	-1.515e+05	-	-	
5.806e+04	58 23	65	28.99	45.02	-34.78	-4.45	14.69	38.74	-1.188e+05-3.421e+05-3.300e+05	-1.309e+05	-	

Parco Eolico "Bolina" – Progetto Definitivo
Relazione di calcolo preliminare delle fondazioni degli aerogeneratori G8 e G12

5.072e+04									
2.951e+04	74	22.04	46.21	-14.68	44.35	-12.82	-10.47-1.934e+05-2.525e+05-2.226e+05-2.233e+05		
5.077e+04	75	27.15	23.79	-55.53	-1.08	-30.66	36.80-1.136e+05-3.199e+05-1.270e+05-3.066e+05		
5.292e+04	66	16.51	28.75	13.65	24.39	18.02	6.85-9.117e+04-1.978e+05-1.510e+05-1.380e+05		
5.060e+04	58 55 65	28.88	12.76	-10.91	0.34	1.51	11.82-1.186e+05-3.418e+05-3.297e+05-1.307e+05		
2.950e+04	74	21.96	14.56	-9.78	13.67	-8.89	-4.57-1.933e+05-2.523e+05-2.225e+05-2.230e+05		
5.080e+04	75	27.00	7.10	-18.95	0.85	-12.70	11.12-1.134e+05-3.195e+05-1.267e+05-3.061e+05		
5.283e+04	66	16.45	10.25	0.01	9.73	0.54	2.27-9.109e+04-1.975e+05-1.508e+05-1.378e+05		
5.055e+04	58 69 65	28.86	3.24	-5.68	2.79	-5.23	-1.95-1.185e+05-3.417e+05-3.296e+05-1.306e+05		
2.949e+04	74	21.95	-1.57	-7.33	-2.02	-6.88	-1.55-1.932e+05-2.522e+05-2.225e+05-2.229e+05		
5.082e+04	75	26.92	2.51	-4.19	1.84	-3.52	-2.01-1.132e+05-3.192e+05-1.266e+05-3.058e+05		
5.278e+04	66	16.44	2.23	-8.40	2.23	-8.40	-0.08-9.106e+04-1.974e+05-1.507e+05-1.377e+05		
9.124e+04	59 1 66	31.48	8.18	-3.89	6.82	-2.52	3.82-1.889e+05-3.785e+05-2.580e+05-3.094e+05		
1.123e+05	75	22.44	1.15	-8.63	0.62	-8.10	-2.20-1.661e+04-2.414e+05-1.347e+05-1.233e+05		-
1.016e+05	76	32.87	0.55	-3.03	-2.83	0.34	0.84-1.346e+05-3.891e+05-3.385e+05-1.852e+05		
7.720e+04	59 3 67	19.58	-1.68	-8.57	-3.41	-6.84	2.99-1.751e+05-2.236e+05-2.216e+05-1.771e+05	9639.42	
9.500e+04	66	26.64	6.92	-3.29	5.77	-2.13	3.23-1.599e+05-3.203e+05-2.183e+05-2.618e+05		
8.597e+04	75	18.99	0.97	-7.30	0.53	-6.86	-1.86-1.406e+04-2.043e+05-1.140e+05-1.044e+05		-
7.022e+04	76	27.82	0.47	-2.57	-2.39	0.29	0.71-1.139e+05-3.293e+05-2.865e+05-1.567e+05		
8.643e+04	59 7 67	16.56	-1.42	-7.25	-2.89	-5.79	2.53-1.481e+05-1.892e+05-1.875e+05-1.498e+05	8156.44	
7.819e+04	66	24.35	15.14	-32.72	-14.02	-3.55	23.35-1.458e+05-2.916e+05-1.990e+05-2.384e+05		
7.020e+04	75	17.40	72.40	-4.21	13.89	54.31	-32.54-1.311e+04-1.862e+05-1.040e+05-9.531e+04		-
8.638e+04	76	25.55	52.91	-51.43	-32.16	33.64	40.49-1.038e+05-2.998e+05-2.609e+05-1.428e+05		
7.817e+04	59 39 67	15.12	20.95	-1.48	7.02	12.44	10.88-1.350e+05-1.726e+05-1.710e+05-1.366e+05	7424.42	
7.018e+04	66	24.26	7.98	-11.75	-1.28	-2.49	9.85-1.455e+05-2.913e+05-1.987e+05-2.382e+05		
8.636e+04	75	17.31	22.61	-3.35	5.02	14.25	-12.13-1.289e+04-1.859e+05-1.037e+05-9.503e+04		-
7.815e+04	76	25.38	18.12	-18.88	-12.32	11.56	14.13-1.036e+05-2.995e+05-2.606e+05-1.426e+05		
7.018e+04	59 69 67	15.06	5.89	-4.52	0.64	0.73	5.20-1.348e+05-1.722e+05-1.707e+05-1.363e+05	7418.15	
8.636e+04	66	24.21	6.29	-2.99	5.24	-1.94	2.94-1.453e+05-2.912e+05-1.985e+05-2.380e+05		
7.815e+04	75	17.26	0.88	-6.64	0.48	-6.23	-1.69-1.278e+04-1.857e+05-1.036e+05-9.488e+04		-
7.102e+04	76	25.29	0.42	-2.33	-2.17	0.26	0.64-1.035e+05-2.993e+05-2.604e+05-1.425e+05		
3.543e+04	60 1 67	15.06	-1.29	-6.59	-2.62	-5.26	2.30-1.347e+05-1.720e+05-1.705e+05-1.362e+05	7414.94	
1.543e+05	67	25.61	4.87	-3.55	0.64	0.67	4.21-1.442e+05-3.076e+05-2.664e+05-1.855e+05		
5.510e+04	76	25.33	-3.30	-8.42	-6.31	-5.41	2.52-1.639e+05-3.040e+05-2.944e+05-1.736e+05		
6.009e+04	77	32.98	5.82	-4.16	1.38	0.28	4.96-5.065e+04-3.658e+05-1.762e+05-2.403e+05		
2.998e+04	68	20.84	1.05	-7.39	-2.09	-4.24	4.08-1.395e+05-2.499e+05-1.917e+05-1.977e+05		
1.305e+05	60 3 67	21.67	4.12	-3.01	0.54	0.57	3.56-1.220e+05-2.603e+05-2.254e+05-1.569e+05		
	76	21.43	-2.79	-7.13	-5.34	-4.58	2.13-1.387e+05-2.573e+05-2.491e+05-1.469e+05		
	77	27.91	4.93	-3.52	1.17	0.24	4.20-4.286e+04-3.095e+05-1.491e+05-2.033e+05		
	68	17.64	0.89	-6.25	-1.77	-3.59	3.45-1.180e+05-2.114e+05-1.622e+05-1.673e+05		

Parco Eolico "Bolina" – Progetto Definitivo
Relazione di calcolo preliminare delle fondazioni degli aerogeneratori G8 e G12

3.926e+04									
4.352e+04	78	21.34	1.62	-5.53	-1.32	-2.59	-3.51-6.510e+04-2.475e+05-2.365e+05-7.615e+04		
4.535e+04	79	12.23	8.44	-1.67	-0.08	6.85	3.68-3.006e+04-1.397e+05-5.409e+04-1.156e+05		
62 8	70	16.46	-0.09	-7.88	-7.87	-0.09	-0.18 1.769e+04-1.616e+05-1.565e+05 1.254e+04 2.993e+04		
3.564e+04	69	16.93	23.77	11.89	13.12	22.54	-3.62 -6117.82-1.791e+05-1.714e+05-1.380e+04		
3.944e+04	78	19.47	54.53	-63.00	-36.24	27.78	-49.28-5.959e+04-2.255e+05-2.155e+05-6.956e+04		
4.129e+04	79	11.18	90.86	-1.90	18.05	70.91	38.11-2.763e+04-1.274e+05-4.952e+04-1.055e+05		
62 55	70	15.00	10.15	-45.81	-29.06	-6.60	-25.63 1.560e+04-1.474e+05-1.428e+05 1.097e+04 2.709e+04		
3.573e+04	69	16.92	15.11	-4.14	1.32	9.65	8.68 -5629.03-1.786e+05-1.709e+05-1.335e+04		
3.964e+04	78	19.42	3.79	2.01	3.71	2.10	-0.38-5.912e+04-2.251e+05-2.150e+05-6.919e+04		
4.121e+04	79	11.12	11.01	-12.87	-11.25	9.39	6.01-2.733e+04-1.270e+05-4.914e+04-1.052e+05		
62 69	70	15.03	8.02	-14.60	-13.33	6.76	5.19 1.625e+04-1.470e+05-1.423e+05 1.156e+04 2.727e+04		
3.569e+04	69	16.89	7.73	-0.79	2.05	4.90	4.02 -5722.26-1.786e+05-1.709e+05-1.344e+04		
3.957e+04	78	19.40	1.47	-5.02	-1.20	-2.36	-3.19-5.918e+04-2.250e+05-2.150e+05-6.923e+04		
4.123e+04	79	11.12	7.67	-1.52	-0.07	6.23	3.35-2.732e+04-1.270e+05-4.917e+04-1.051e+05		
63 1	70	14.97	-0.08	-7.16	-7.16	-0.08	-0.17 1.608e+04-1.469e+05-1.423e+05 1.140e+04 2.721e+04		
2.097e+04	70	7.89	8.78	-4.23	-4.23	8.78	1.49e-03-5.198e+04-9.474e+04-7.752e+04-6.920e+04		
8.801e+04	79	18.73	3.20	-8.92	-3.40	-2.32	-6.04 1.006e+05-1.238e+05-8.124e+04 5.800e+04		-
1.022e+05	80	35.08	3.37	-0.92	-0.70	3.14	0.96 1.429e+05-2.722e+05-2.721e+05 1.428e+05	7452.56	
63 3	71	29.76	8.05	-10.43	-8.56	6.18	-5.56 2330.60-3.087e+05-2.703e+05-3.600e+04		
1.774e+04	70	6.68	7.43	-3.58	-3.58	7.43	1.26e-03-4.398e+04-8.017e+04-6.560e+04-5.855e+04		
7.447e+04	79	15.85	2.71	-7.55	-2.88	-1.97	-5.11 8.512e+04-1.048e+05-6.874e+04 4.908e+04		-
8.650e+04	80	29.68	2.85	-0.78	-0.59	2.66	0.81 1.209e+05-2.303e+05-2.302e+05 1.208e+05	6306.01	
1.624e+04	71	25.18	6.81	-8.82	-7.24	5.23	-4.71 1972.04-2.612e+05-2.287e+05-3.046e+04		
6.787e+04	70	6.12	11.93	-31.04	-30.93	11.83	2.08-3.978e+04-7.289e+04-5.953e+04-5.314e+04		
7.892e+04	79	14.43	36.40	-13.80	-8.51	31.10	15.42 7.806e+04-9.519e+04-6.240e+04 4.528e+04		-
63 55	80	27.30	31.97	-42.62	-42.62	31.96	0.72 1.105e+05-2.097e+05-2.096e+05 1.104e+05	5740.62	
1.617e+04	71	23.05	19.73	-29.12	-11.65	2.25	23.42 2106.72-2.377e+05-2.081e+05-2.753e+04		
6.776e+04	70	6.08	8.50	-12.64	-12.62	8.47	0.70-3.992e+04-7.288e+04-5.960e+04-5.320e+04		
7.873e+04	79	14.41	9.67	-4.93	-4.61	9.34	2.14 7.762e+04-9.524e+04-6.246e+04 4.484e+04		-
1.613e+04	80	27.09	12.43	-14.80	-14.78	12.41	0.73 1.101e+05-2.095e+05-2.094e+05 1.100e+05	5735.41	
6.770e+04	71	22.95	5.75	-10.14	-8.30	3.91	5.09 1898.99-2.375e+05-2.080e+05-2.764e+04		
7.864e+04	70	6.07	6.76	-3.25	-3.25	6.76	1.15e-03-3.999e+04-7.288e+04-5.963e+04-5.323e+04		
3.480e+04	79	14.41	2.46	-6.86	-2.61	-1.79	-4.64 7.739e+04-9.526e+04-6.249e+04 4.462e+04		-
1.448e+04	80	26.98	2.59	-0.71	-0.54	2.42	0.74 1.099e+05-2.094e+05-2.093e+05 1.098e+05	5732.74	
1.378e+04	71	22.89	6.19	-8.02	-6.59	4.75	-4.28 1792.77-2.374e+05-2.080e+05-2.769e+04		
2.944e+04	64 1	71	38.93	3.00	-17.59	-13.43	-1.16 -8.26 1.636e+05-2.975e+05-2.949e+05 1.610e+05		-
1.448e+04	80	18.80	15.52	-6.01	4.84	4.67	-10.76 2.962e+04-1.792e+05-1.786e+05 2.897e+04 1.159e+04		
1.378e+04	81	18.71	-3.73	-16.82	-12.58	-7.97	-6.12 7.214e+04-1.483e+05-1.473e+05 7.119e+04		-
2.944e+04	72	16.41	22.09	-8.54	-0.86	14.41	-13.28 1.114e+05-8.461e+04-8.364e+04 1.104e+05		-
2.944e+04	64 3	71	32.94	2.54	-14.88	-11.37	-0.98 -6.99 1.385e+05-2.517e+05-2.495e+05 1.362e+05		-
2.944e+04	80	15.91	13.13	-5.08	4.09	3.95	-9.11 2.506e+04-1.517e+05-1.511e+05 2.451e+04	9809.96	
2.944e+04	81	15.83	-3.16	-14.23	-10.65	-6.74	-5.18 6.104e+04-1.255e+05-1.246e+05 6.023e+04		-

Parco Eolico "Bolina" – Progetto Definitivo
Relazione di calcolo preliminare delle fondazioni degli aerogeneratori G8 e G12

1.225e+04												
1.166e+04	72	13.89	18.69	-7.23	-0.73	12.19	-11.24	9.426e+04	-7.159e+04	-7.077e+04	9.343e+04	-
64 24	71	29.89	8.21	-109.49	-38.89	-62.39	-57.66	1.250e+05	-2.293e+05	-2.272e+05	1.229e+05	-
2.704e+04												
	80	14.77	135.98	-39.98	76.47	19.53	-83.24	2.248e+04	-1.380e+05	-1.375e+05	2.198e+04	8945.96
	81	14.37	-31.98	-108.60	-57.83	-82.75	-36.23	5.517e+04	-1.141e+05	-1.134e+05	5.444e+04	-
1.112e+04												
	72	12.80	139.77	-39.49	30.66	69.62	-87.49	8.525e+04	-6.523e+04	-6.449e+04	8.451e+04	-
1.056e+04												
64 56	71	29.93	2.88	-44.58	-19.99	-21.70	-23.72	1.256e+05	-2.290e+05	-2.269e+05	1.235e+05	-
2.686e+04												
	80	14.57	53.67	-16.35	28.34	8.99	-33.64	2.268e+04	-1.379e+05	-1.374e+05	2.218e+04	8927.56
	81	14.38	-13.34	-44.69	-25.97	-32.06	-15.38	5.538e+04	-1.141e+05	-1.133e+05	5.465e+04	-
1.113e+04												
	72	12.68	58.26	-17.43	9.94	30.89	-36.36	8.554e+04	-6.513e+04	-6.439e+04	8.479e+04	-
1.059e+04												
64 69	71	29.94	2.31	-13.53	-10.33	-0.89	-6.36	1.259e+05	-2.289e+05	-2.268e+05	1.238e+05	-
2.677e+04												
	80	14.47	11.94	-4.62	3.72	3.59	-8.28	2.278e+04	-1.379e+05	-1.374e+05	2.229e+04	8918.14
	81	14.40	-2.87	-12.94	-9.68	-6.13	-4.71	5.549e+04	-1.140e+05	-1.133e+05	5.476e+04	-
1.114e+04												
	72	12.63	16.99	-6.57	-0.66	11.08	-10.22	8.569e+04	-6.508e+04	-6.434e+04	8.494e+04	-
1.060e+04												
65 1	77	32.86	0.33	-2.93	0.08	-2.69	0.86	-1.076e+05	-3.832e+05	-3.761e+05	-1.146e+05	-
4.349e+04												
	82	19.75	0.55	-7.42	-7.41	0.53	-0.38	-7.256e+04	-2.320e+05	-1.480e+05	-1.566e+05	-
7.962e+04												
	83	18.76	3.65	-0.82	-0.57	3.40	1.04	-6.039e+04	-2.185e+05	-1.779e+05	-1.009e+05	-
6.902e+04												
	78	21.39	-1.66	-10.48	-9.58	-2.56	2.67	-4.244e+04	-2.407e+05	-1.672e+05	-1.159e+05	-
9.573e+04												
65 3	77	27.81	0.28	-2.48	0.07	-2.27	0.73	-9.103e+04	-3.242e+05	-3.183e+05	-9.699e+04	-
3.680e+04												
	82	16.71	0.46	-6.28	-6.27	0.45	-0.32	-6.140e+04	-1.963e+05	-1.252e+05	-1.325e+05	-
6.737e+04												
	83	15.88	3.09	-0.70	-0.48	2.87	0.88	-5.110e+04	-1.849e+05	-1.506e+05	-8.539e+04	-
5.840e+04												
	78	18.10	-1.41	-8.87	-8.11	-2.17	2.26	-3.591e+04	-2.036e+05	-1.415e+05	-9.804e+04	-
8.100e+04												
65 23	77	25.41	27.41	-22.85	-16.92	21.48	16.22	-8.277e+04	-2.950e+05	-2.895e+05	-8.829e+04	-
3.377e+04												
	82	15.32	26.63	-38.72	-21.71	9.62	28.67	-5.572e+04	-1.784e+05	-1.137e+05	-1.204e+05	-
6.124e+04												
	83	14.55	30.05	-20.65	-13.07	22.47	18.08	-4.630e+04	-1.681e+05	-1.368e+05	-7.763e+04	-
5.325e+04												
	78	16.68	25.72	-48.74	-30.23	7.21	32.18	-3.238e+04	-1.853e+05	-1.287e+05	-8.901e+04	-
7.385e+04												
65 55	77	25.32	8.39	-8.17	-5.68	5.90	5.92	-8.276e+04	-2.948e+05	-2.894e+05	-8.821e+04	-
3.356e+04												
	82	15.23	8.20	-15.80	-11.12	3.52	9.51	-5.578e+04	-1.785e+05	-1.138e+05	-1.205e+05	-
6.125e+04												
	83	14.47	11.98	-7.36	-4.71	9.33	6.64	-4.640e+04	-1.681e+05	-1.369e+05	-7.763e+04	-
5.314e+04												
	78	16.53	7.71	-21.68	-15.11	1.14	12.25	-3.255e+04	-1.852e+05	-1.287e+05	-8.909e+04	-
7.371e+04												
65 69	77	25.28	0.25	-2.25	0.06	-2.07	0.66	-8.276e+04	-2.947e+05	-2.893e+05	-8.818e+04	-
3.346e+04												
	82	15.19	0.42	-5.71	-5.70	0.41	-0.29	-5.582e+04	-1.785e+05	-1.138e+05	-1.205e+05	-
6.125e+04												
	83	14.43	2.81	-0.63	-0.44	2.61	0.80	-4.646e+04	-1.680e+05	-1.369e+05	-7.763e+04	-
5.309e+04												
	78	16.46	-1.28	-8.06	-7.37	-1.97	2.05	-3.264e+04	-1.851e+05	-1.286e+05	-8.913e+04	-
7.364e+04												
66 1	82	18.89	0.73	-20.50	0.16	-19.94	3.41	-8.759e+04	-2.250e+05	-1.832e+05	-1.294e+05	-
6.321e+04												
	84	13.67	42.00	-12.87	-3.12	32.25	-20.97	-2.479e+04	-1.514e+05	-7.163e+04	-1.045e+05	-
6.112e+04												
	85	11.67	1.61	-12.95	-11.62	0.28	4.20	-3.766e+04	-1.355e+05	-9.396e+04	-7.921e+04	-
4.837e+04												
	83	19.55	16.37	-10.40	-5.65	11.63	-10.22	-3.816e+04	-2.197e+05	-1.685e+05	-8.929e+04	-
8.164e+04												
66 3	82	15.98	0.61	-17.35	0.14	-16.87	2.89	-7.411e+04	-1.904e+05	-1.551e+05	-1.095e+05	-

Parco Eolico "Bolina" – Progetto Definitivo
Relazione di calcolo preliminare delle fondazioni degli aerogeneratori G8 e G12

5.349e+04								
5.172e+04	84	11.57	35.54	-10.89	-2.64	27.29	-17.75-2.098e+04-1.281e+05-6.061e+04-8.846e+04	
4.093e+04	85	9.88	1.36	-10.96	-9.83	0.24	3.55-3.186e+04-1.147e+05-7.950e+04-6.702e+04	
6.908e+04	83	16.54	13.85	-8.80	-4.78	9.84	-8.65-3.229e+04-1.859e+05-1.426e+05-7.555e+04	
4.826e+04	66 6 82	14.58	50.58	-59.85	50.13	-59.40	-7.04-6.714e+04-1.726e+05-1.411e+05-9.863e+04	
4.902e+04	84	10.95	69.08	-15.07	49.27	4.74	-35.70-1.908e+04-1.200e+05-5.758e+04-8.148e+04	
3.668e+04	85	8.86	31.38	-5.25	30.58	-4.45	5.37-2.899e+04-1.031e+05-7.116e+04-6.089e+04	
6.336e+04	83	15.31	75.35	-55.84	75.01	-55.50	-6.64-2.920e+04-1.698e+05-1.300e+05-6.902e+04	
4.850e+04	66 38 82	14.52	17.05	-30.26	17.04	-30.25	-0.65-6.730e+04-1.729e+05-1.410e+05-9.921e+04	
4.769e+04	84	10.66	39.35	-6.25	15.08	18.02	-22.75-1.908e+04-1.176e+05-5.594e+04-8.078e+04	
3.703e+04	85	8.92	6.44	-3.36	4.43	-1.36	3.95-2.897e+04-1.038e+05-7.190e+04-6.091e+04	
6.299e+04	83	15.13	24.01	-14.37	22.51	-12.86	-7.45-2.930e+04-1.693e+05-1.298e+05-6.880e+04	
4.863e+04	66 69 82	14.53	0.56	-15.77	0.13	-15.34	2.62-6.738e+04-1.731e+05-1.410e+05-9.951e+04	
4.701e+04	84	10.52	32.31	-9.90	-2.40	24.81	-16.13-1.907e+04-1.164e+05-5.510e+04-8.042e+04	
3.721e+04	85	8.98	1.24	-9.96	-8.94	0.22	3.23-2.897e+04-1.042e+05-7.227e+04-6.093e+04	
6.280e+04	83	15.04	12.59	-8.00	-4.35	8.94	-7.86-2.935e+04-1.690e+05-1.296e+05-6.868e+04	
3.200e+04	67 1 84	9.99	41.18	-10.32	0.43	30.42	20.93-5.078e+04-1.197e+05-7.248e+04-9.797e+04	
3.469e+04	86	9.25	-2.15	-22.16	-3.47	-20.84	-4.96-3.864e+04-1.094e+05-6.711e+04-8.092e+04	
3.453e+04	87	8.10	10.06	-5.16	-0.82	5.72	6.87-2.446e+04-9.360e+04-6.067e+04-5.738e+04	
5.299e+04	85	12.45	5.16	-14.09	-11.94	3.01	-6.06-3.721e+04-1.441e+05-9.738e+04-8.389e+04	
2.708e+04	67 3 84	8.46	34.84	-8.73	0.37	25.74	17.71-4.296e+04-1.013e+05-6.133e+04-8.290e+04	
2.936e+04	86	7.83	-1.82	-18.75	-2.94	-17.63	-4.20-3.270e+04-9.256e+04-5.678e+04-6.847e+04	
2.922e+04	87	6.85	8.51	-4.37	-0.69	4.84	5.82-2.070e+04-7.920e+04-5.134e+04-4.856e+04	
4.484e+04	85	10.53	4.37	-11.92	-10.10	2.55	-5.13-3.149e+04-1.219e+05-8.240e+04-7.098e+04	
2.322e+04	67 22 84	7.76	24.18	8.98	9.55	23.62	2.87-4.093e+04-9.241e+04-5.557e+04-7.778e+04	
2.703e+04	86	7.12	15.36	-40.83	7.07	-32.55	-19.92-2.894e+04-8.383e+04-5.159e+04-6.117e+04	
2.618e+04	87	6.21	9.57	-11.84	8.11	-10.38	-5.40-1.954e+04-7.195e+04-4.693e+04-4.456e+04	
4.097e+04	85	9.69	17.57	-29.86	0.96	-13.26	-22.62-2.853e+04-1.111e+05-7.481e+04-6.479e+04	
2.414e+04	67 54 84	7.71	28.81	-1.88	3.45	23.48	11.62-3.971e+04-9.216e+04-5.569e+04-7.618e+04	
2.680e+04	86	7.09	3.98	-24.97	0.63	-21.62	-9.27-2.946e+04-8.404e+04-5.161e+04-6.188e+04	
2.643e+04	87	6.21	3.09	-1.36	2.33	-0.60	1.67-1.906e+04-7.198e+04-4.676e+04-4.428e+04	
4.083e+04	85	9.61	6.48	-15.18	-5.75	-2.95	-10.74-2.859e+04-1.109e+05-7.487e+04-6.462e+04	
2.462e+04	67 69 84	7.69	31.67	-7.94	0.33	23.40	16.10-3.906e+04-9.205e+04-5.575e+04-7.536e+04	
2.669e+04	86	7.11	-1.65	-17.04	-2.67	-16.03	-3.82-2.972e+04-8.415e+04-5.162e+04-6.225e+04	
2.656e+04	87	6.23	7.74	-3.97	-0.63	4.40	5.29-1.882e+04-7.200e+04-4.667e+04-4.414e+04	
4.076e+04	85	9.57	3.97	-10.84	-9.19	2.32	-4.66-2.863e+04-1.108e+05-7.491e+04-6.453e+04	
3.268e+04	68 1 86	9.20	-4.03e-03	-3.49	-2.75	-0.75	1.43-3.829e+04-1.089e+05-6.023e+04-8.698e+04	

Parco Eolico "Bolina" – Progetto Definitivo
Relazione di calcolo preliminare delle fondazioni degli aerogeneratori G8 e G12

2.488e+04	88	7.34	-2.50	-5.16	-3.06	-4.60	-1.08-2.241e+04-8.502e+04-3.471e+04-7.272e+04
3.359e+04	89	6.98	-0.28	-3.63	-3.39	-0.52	-0.86 -9074.19-7.683e+04-3.850e+04-4.741e+04
3.820e+04	87	8.69	-1.09	-3.35	-3.32	-1.12	-0.27-2.305e+04-9.975e+04-6.472e+04-5.809e+04
2.766e+04	86	7.78	-3.41e-03	-2.96	-2.32	-0.64	1.21-3.240e+04-9.216e+04-5.096e+04-7.359e+04
2.105e+04	88	6.21	-2.12	-4.36	-2.59	-3.89	-0.92-1.896e+04-7.194e+04-2.937e+04-6.153e+04
2.842e+04	89	5.91	-0.23	-3.07	-2.87	-0.44	-0.73 -7678.16-6.501e+04-3.258e+04-4.011e+04
3.233e+04	87	7.35	-0.92	-2.84	-2.81	-0.95	-0.23-1.951e+04-8.440e+04-5.476e+04-4.915e+04
2.535e+04	86	7.12	15.16	-9.54	6.88	-1.26	11.66-2.909e+04-8.379e+04-4.619e+04-6.669e+04
1.914e+04	88	5.68	10.69	-8.37	5.63	-3.32	8.42-1.731e+04-6.543e+04-2.679e+04-5.595e+04
2.586e+04	89	5.43	18.15	-7.24	7.80	3.11	12.48 -6979.53-5.913e+04-2.972e+04-3.639e+04
2.952e+04	87	6.74	21.08	-7.28	10.83	2.97	13.62-1.756e+04-7.682e+04-4.979e+04-4.459e+04
2.521e+04	86	7.09	4.82	-4.70	0.93	-0.81	4.68-2.933e+04-8.378e+04-4.628e+04-6.683e+04
1.914e+04	88	5.66	1.43	-4.54	0.35	-3.46	2.30-1.726e+04-6.541e+04-2.673e+04-5.594e+04
2.584e+04	89	5.39	4.64	-2.93	0.91	0.79	3.78 -6979.98-5.911e+04-2.965e+04-3.644e+04
2.943e+04	87	6.70	5.75	-3.33	1.97	0.44	4.47-1.767e+04-7.676e+04-4.978e+04-4.465e+04
2.514e+04	86	7.07	-3.10e-03	-2.69	-2.11	-0.58	1.10-2.945e+04-8.378e+04-4.633e+04-6.690e+04
1.914e+04	88	5.64	-1.92	-3.97	-2.35	-3.54	-0.83-1.723e+04-6.540e+04-2.670e+04-5.594e+04
2.584e+04	89	5.37	-0.21	-2.79	-2.61	-0.40	-0.66 -6980.15-5.910e+04-2.962e+04-3.647e+04
2.939e+04	87	6.68	-0.84	-2.58	-2.56	-0.86	-0.20-1.773e+04-7.673e+04-4.978e+04-4.468e+04
2.479e+04	88	7.35	-2.38	-4.64	-2.87	-4.15	-0.93-2.254e+04-8.519e+04-3.471e+04-7.301e+04
2.988e+04	90	5.79	-0.14	-3.64	-2.77	-1.01	-1.52 -1425.16-6.092e+04 -8522.25-5.382e+04 1.928e+04
3.349e+04	91	6.04	0.05	-5.51	-2.30	-3.17	-2.75 5815.89-5.972e+04-1.350e+04-4.041e+04
2.098e+04	89	6.97	1.07	-3.93	-2.57	-0.29	-2.22 -9019.92-7.655e+04-3.849e+04-4.709e+04
2.528e+04	88	6.22	-2.02	-3.92	-2.43	-3.51	-0.78-1.907e+04-7.208e+04-2.937e+04-6.178e+04
2.834e+04	90	4.90	-0.11	-3.08	-2.34	-0.86	-1.28 -1205.90-5.155e+04 -7211.13-4.554e+04 1.632e+04
1.914e+04	91	5.11	0.04	-4.66	-1.94	-2.68	-2.32 4921.14-5.053e+04-1.142e+04-3.419e+04
2.300e+04	89	5.89	0.90	-3.33	-2.18	-0.25	-1.88 -7632.24-6.478e+04-3.257e+04-3.984e+04
2.582e+04	88	5.71	22.57	-21.46	22.52	-21.41	-1.45-1.747e+04-6.564e+04-2.694e+04-5.618e+04
1.906e+04	90	4.52	18.87	-21.23	18.71	-21.06	-2.55 -1623.35-4.703e+04 -7266.34-4.139e+04 1.498e+04
2.302e+04	91	4.74	19.57	-20.61	18.42	-19.46	6.70 4230.56-4.616e+04-1.068e+04-3.125e+04
2.576e+04	89	5.42	25.72	-19.41	24.39	-18.08	7.63 -7064.07-5.908e+04-2.991e+04-3.624e+04
1.907e+04	88	5.65	-0.54	-7.44	-4.57	-3.42	-3.40-1.733e+04-6.551e+04-2.668e+04-5.616e+04
2.298e+04	90	4.47	1.79	-6.22	-4.28	-0.15	-3.43 -1034.06-4.693e+04 -6488.92-4.147e+04 1.485e+04
2.576e+04	91	4.67	1.99	-9.79	-4.14	-3.66	-5.88 4538.64-4.593e+04-1.035e+04-3.105e+04
2.298e+04	89	5.38	2.54	-9.10	-5.38	-1.18	-5.43 -6927.31-5.888e+04-2.957e+04-3.625e+04
2.576e+04	88	5.65	-1.83	-3.57	-2.21	-3.19	-0.71-1.734e+04-6.553e+04-2.670e+04-5.616e+04
2.298e+04	90	4.45	-0.10	-2.80	-2.13	-0.78	-1.17 -1096.27-4.686e+04 -6555.58-4.140e+04 1.483e+04
2.576e+04	91	4.65	0.04	-4.24	-1.77	-2.44	-2.11 4473.77-4.594e+04-1.038e+04-3.108e+04
2.576e+04	89	5.36	0.82	-3.02	-1.98	-0.23	-1.71 -6938.40-5.889e+04-2.961e+04-3.622e+04

Parco Eolico "Bolina" – Progetto Definitivo
Relazione di calcolo preliminare delle fondazioni degli aerogeneratori G8 e G12

70	1	90	5.64	-2.62	-11.13	-2.67	-11.09	-0.60	-3726.51-6.021e+04-1.314e+04-5.080e+04
2.105e+04		92	6.57	20.04	-7.96	-5.13	17.21	-8.44	4.040e+04-3.741e+04 3.602e+04-3.303e+04 1.794e+04
		93	5.19	-1.15	-7.24	-3.08	-5.31	2.83	6788.35-5.005e+04 -1919.13-4.134e+04 2.047e+04
		91	6.19	6.93	-2.77	0.34	3.82	-4.53	8296.34-5.953e+04 -9527.83-4.170e+04 2.985e+04
70	3	90	4.77	-2.22	-9.42	-2.26	-9.38	-0.51	-3153.20-5.095e+04-1.112e+04-4.298e+04
1.782e+04		92	5.56	16.95	-6.74	-4.34	14.56	-7.14	3.419e+04-3.166e+04 3.048e+04-2.795e+04 1.518e+04
		93	4.39	-0.97	-6.13	-2.61	-4.50	2.40	5743.99-4.235e+04 -1623.88-3.498e+04 1.732e+04
		91	5.23	5.86	-2.35	0.28	3.23	-3.83	7019.98-5.037e+04 -8062.01-3.529e+04 2.526e+04
70	24	90	4.27	-3.59	-15.75	-7.06	-12.27	-5.49	-2683.18-4.564e+04 -9939.30-3.839e+04 1.610e+04
		92	5.40	30.00	-15.34	-10.48	25.15	-14.02	3.193e+04-3.118e+04 2.831e+04-2.757e+04 1.466e+04
		93	3.93	-2.98	-11.89	-7.11	-7.76	-4.45	5218.96-3.797e+04 -1365.56-3.138e+04 1.552e+04
		91	4.86	12.16	-14.79	-6.02	3.39	-12.62	6445.64-4.628e+04 -7370.32-3.246e+04 2.318e+04
70	56	90	4.31	-3.05	-10.49	-3.75	-9.80	-2.17	-2804.58-4.609e+04-1.005e+04-3.884e+04
1.616e+04		92	5.17	20.35	-9.24	-6.16	17.27	-9.04	3.137e+04-2.959e+04 2.791e+04-2.614e+04 1.409e+04
		93	3.96	-3.97	-5.33	-3.97	-5.33	-0.06	5220.84-3.832e+04 -1438.80-3.166e+04 1.567e+04
		91	4.79	7.64	-6.41	-1.87	3.09	-6.58	6403.39-4.595e+04 -7343.05-3.221e+04 2.304e+04
70	69	90	4.34	-2.02	-8.56	-2.05	-8.53	-0.46	-2866.55-4.632e+04-1.011e+04-3.907e+04
1.620e+04		92	5.05	15.41	-6.13	-3.95	13.23	-6.49	3.108e+04-2.878e+04 2.771e+04-2.541e+04 1.380e+04
		93	3.99	-0.88	-5.57	-2.37	-4.09	2.18	5221.81-3.850e+04 -1476.26-3.180e+04 1.575e+04
		91	4.76	5.33	-2.13	0.26	2.94	-3.48	6381.80-4.579e+04 -7329.10-3.208e+04 2.296e+04
71	1	92	5.34	27.87	-2.68	5.76	19.43	13.66	3.149e+04-3.216e+04 3.146e+04-3.213e+04 1385.97
		94	2.72	-1.40	-13.56	-1.40	-13.56	0.19	2165.55-2.664e+04 1954.91-2.643e+04 2454.39
		95	3.75	11.10	-1.17	1.56	8.37	5.10	8763.03-3.378e+04 6075.81-3.109e+04 1.035e+04
		93	5.62	-2.01	-13.27	-8.66	-6.62	-5.54	1.061e+04-5.229e+04 6.61-4.168e+04 2.355e+04
71	3	92	4.52	23.58	-2.27	4.87	16.44	11.56	2.664e+04-2.721e+04 2.662e+04-2.718e+04 1172.75
		94	2.30	-1.18	-11.48	-1.19	-11.47	0.16	1832.39-2.255e+04 1654.16-2.237e+04 2076.79
		95	3.17	9.39	-0.99	1.32	7.08	4.31	7414.87-2.858e+04 5141.07-2.631e+04 8756.83
		93	4.76	-1.70	-11.23	-7.33	-5.60	-4.69	8979.64-4.424e+04 5.59-3.527e+04 1.993e+04
71	8	92	4.17	48.33	-7.13	1.20	40.00	19.82	2.287e+04-2.554e+04 2.287e+04-2.553e+04 -455.81
		94	2.04	10.38	-6.40	-5.77	9.75	3.19	1510.92-1.999e+04 1324.82-1.980e+04 1991.44
		95	3.00	29.18	-6.51	-6.48	29.15	-1.11	6654.36-2.612e+04 4801.45-2.426e+04 7568.93
		93	4.55	19.12	-27.24	-22.45	14.32	-14.12	9679.57-4.031e+04 1226.75-3.185e+04 1.874e+04
71	40	92	4.12	30.33	-3.57	3.33	23.43	13.66	2.375e+04-2.500e+04 2.375e+04-2.499e+04 551.15
		94	2.04	-1.87	-4.40	-2.66	-3.60	1.18	1613.12-2.032e+04 1443.22-2.015e+04 1923.00
		95	2.92	14.43	-1.71	-1.40	14.12	2.22	6710.12-2.603e+04 4716.93-2.403e+04 7828.17
		93	4.40	4.89	-15.42	-12.00	1.48	-7.60	8676.37-4.025e+04 418.46-3.199e+04 1.833e+04
71	69	92	4.10	21.44	-2.06	4.43	14.95	10.51	2.422e+04-2.474e+04 2.420e+04-2.471e+04 1066.13
		94	2.09	-1.08	-10.43	-1.08	-10.43	0.15	1665.81-2.050e+04 1503.78-2.033e+04 1888.00
		95	2.88	8.53	-0.90	1.20	6.44	3.92	6740.80-2.598e+04 4673.70-2.392e+04 7960.76
		93	4.32	-1.55	-10.21	-6.66	-5.09	-4.26	8163.31-4.022e+04 5.08-3.206e+04 1.812e+04
72	1	94	3.37	1.98	-2.09	0.71	-0.83	1.88	6351.84-3.143e+04 5976.78-3.105e+04 3745.48
		96	2.78	-0.05	-4.91	-0.17	-4.79	0.75	17.08-2.878e+04 -187.99-2.857e+04 -2421.41
		97	2.54	1.70	-0.95	-0.89	1.64	0.38	400.42-2.622e+04 -167.85-2.565e+04 3847.61
		95	3.47	0.92	-1.78	-0.44	-0.43	1.35	6642.98-3.228e+04 2968.43-2.860e+04 1.138e+04
72	3	94	2.85	1.67	-1.77	0.60	-0.70	1.59	5374.63-2.659e+04 5057.28-2.628e+04 3169.25
		96	2.35	-0.04	-4.15	-0.14	-4.05	0.64	14.45-2.435e+04 -159.07-2.418e+04 -2048.89
		97	2.15	1.44	-0.80	-0.75	1.39	0.32	338.81-2.219e+04 -142.03-2.170e+04 3255.67
		95	2.93	0.78	-1.51	-0.37	-0.36	1.14	5620.98-2.731e+04 2511.75-2.420e+04 9629.47
72	6	94	2.72	5.04	-26.10	4.36	-25.42	-4.54	5133.09-2.435e+04 4816.66-2.404e+04 3038.19
		96	2.25	0.74	-29.68	0.08	-29.03	-4.42	-15.51-2.225e+04 -172.01-2.210e+04 -1858.93
		97	2.06	2.55	-26.16	1.66	-25.28	4.96	339.96-2.018e+04 -105.05-1.973e+04 2988.76
		95	2.78	5.00	-27.84	3.34	-26.18	7.18	4986.25-2.488e+04 2095.92-2.199e+04 8829.79
72	38	94	2.64	1.87	-9.06	1.84	-9.02	-0.58	4969.52-2.424e+04 4671.67-2.394e+04 2934.28
		96	2.18	0.04	-12.36	-0.06	-12.26	-1.11	3.44-2.218e+04 -153.88-2.202e+04 -1861.37
		97	1.99	0.53	-8.14	0.11	-7.72	1.87	318.82-2.017e+04 -120.97-1.973e+04 2969.53
		95	2.71	1.80	-9.97	0.91	-9.08	3.12	5068.01-2.485e+04 2219.97-2.200e+04 8779.69
72	69	94	2.59	1.52	-1.61	0.55	-0.64	1.45	4886.03-2.418e+04 4597.53-2.389e+04 2881.14
		96	2.14	-0.04	-3.78	-0.13	-3.68	0.58	13.13-2.214e+04 -144.61-2.198e+04 -1862.62
		97	1.96	1.31	-0.73	-0.68	1.26	0.29	308.01-2.017e+04 -129.12-1.973e+04 2959.70
		95	2.67	0.71	-1.37	-0.34	-0.33	1.04	5109.98-2.483e+04 2283.41-2.200e+04 8754.06
73	1	78	13.64	3.27	-6.39	-5.89	2.77	-2.14	-6.288e+04-1.627e+05-1.108e+05-1.147e+05
4.986e+04		83	26.69	-3.12	-4.89	-3.16	-4.85	0.26	-3.727e+04-2.946e+05-1.687e+05-1.632e+05
1.286e+05		98	16.16	2.89	-11.67	-10.54	1.75	-3.90	7.617e+04-1.163e+05-1.145e+05 7.429e+04 1.896e+04
		79	49.09	1.79	-13.02	-11.65	0.43	4.28	-4.025e+04-5.299e+05-2.942e+05-2.760e+05
2.447e+05									
73	3	78	11.55	2.77	-5.41	-4.99	2.34	-1.81	-5.321e+04-1.376e+05-9.377e+04-9.709e+04
4.219e+04									

Parco Eolico "Bolina" – Progetto Definitivo
Relazione di calcolo preliminare delle fondazioni degli aerogeneratori G8 e G12

1.089e+05	83	22.58	-2.64	-4.14	-2.67	-4.10	0.22-3.154e+04-2.493e+05-1.428e+05-1.381e+05	
	98	13.67	2.44	-9.87	-8.91	1.48	-3.30 6.445e+04-9.845e+04-9.685e+04 6.286e+04 1.604e+04	
	79	41.54	1.51	-11.01	-9.86	0.36	3.62-3.406e+04-4.484e+05-2.489e+05-2.335e+05	
2.070e+05	73 7	78	10.57	56.54	-56.86	-56.00	55.68 -9.87-4.863e+04-1.254e+05-8.552e+04-8.853e+04	
3.836e+04	83	20.74	2.96	-55.85	-26.37	-26.52	29.41-2.881e+04-2.267e+05-1.299e+05-1.256e+05	
9.890e+04	98	12.67	11.77	-68.10	-65.29	8.96	-14.72 5.873e+04-8.962e+04-8.817e+04 5.729e+04 1.456e+04	
	79	38.11	41.11	-94.76	-81.21	27.56	40.72-3.125e+04-4.085e+05-2.269e+05-2.129e+05	
1.885e+05	73 39	78	10.52	20.71	-22.41	-21.95	20.25 -4.43-4.846e+04-1.252e+05-8.534e+04-8.835e+04	
3.836e+04	83	20.60	-0.89	-21.08	-10.53	-11.44	10.08-2.872e+04-2.266e+05-1.298e+05-1.255e+05	
9.894e+04	98	12.51	5.40	-28.93	-27.45	3.92	-6.97 5.864e+04-8.954e+04-8.809e+04 5.719e+04 1.458e+04	
	79	37.88	14.82	-38.69	-33.41	9.54	15.96-3.106e+04-4.079e+05-2.265e+05-2.125e+05	
1.883e+05	73 69	78	10.50	2.51	-4.92	-4.53	2.13 -1.64-4.837e+04-1.251e+05-8.525e+04-8.826e+04	
3.835e+04	83	20.53	-2.40	-3.76	-2.43	-3.73	0.20-2.867e+04-2.266e+05-1.298e+05-1.255e+05	
9.895e+04	98	12.43	2.22	-8.98	-8.10	1.35	-3.00 5.859e+04-8.950e+04-8.805e+04 5.714e+04 1.458e+04	
	79	37.76	1.38	-10.01	-8.97	0.33	3.29-3.096e+04-4.076e+05-2.263e+05-2.123e+05	
1.882e+05	74 1	83	17.82	2.00	-16.64	-13.00	-1.63 -7.39-4.181e+04-2.028e+05-1.412e+05-1.035e+05	
7.827e+04	85	12.54	8.85	-7.70	-7.26	8.41	2.66-3.354e+04-1.441e+05-7.611e+04-1.015e+05	
5.379e+04	99	11.12	-0.48	-9.84	-9.68	-0.64	-1.24 -288.76-1.158e+05-7.859e+04-3.753e+04	
5.400e+04	98	16.53	2.10	-6.98	-6.43	1.55	-2.16-1.856e+04-1.807e+05-1.303e+05-6.898e+04	
7.506e+04	74 3	83	15.08	1.69	-14.08	-11.00	-1.38 -6.25-3.537e+04-1.716e+05-1.194e+05-8.755e+04	
6.623e+04	85	10.61	7.49	-6.51	-6.14	7.12	2.25-2.838e+04-1.219e+05-6.440e+04-8.590e+04	
4.552e+04	99	9.41	-0.40	-8.33	-8.19	-0.55	-1.05 -244.33-9.801e+04-6.650e+04-3.176e+04	
4.569e+04	98	13.99	1.77	-5.90	-5.44	1.31	-1.83-1.570e+04-1.529e+05-1.102e+05-5.837e+04	
6.351e+04	74 23	83	13.79	8.99	-18.36	-12.70	3.33 11.08-3.195e+04-1.560e+05-1.087e+05-7.934e+04	
6.029e+04	85	9.78	28.40	-33.46	-11.12	6.06	29.71-2.547e+04-1.106e+05-5.850e+04-7.760e+04	
4.149e+04	99	8.67	35.12	-14.20	-8.45	29.37	15.83 -111.45-8.923e+04-6.053e+04-2.881e+04	
4.164e+04	98	12.92	22.93	-45.78	-4.35	-18.51	33.62-1.407e+04-1.391e+05-1.002e+05-5.292e+04	
5.785e+04	74 55	83	13.72	0.30	-10.92	-10.92	0.30 -0.01-3.209e+04-1.560e+05-1.086e+05-7.951e+04	
6.024e+04	85	9.69	12.77	-13.89	-7.46	6.33	11.41-2.569e+04-1.108e+05-5.853e+04-7.792e+04	
4.142e+04	99	8.59	10.81	-8.98	-7.79	9.61	4.72 -184.67-8.915e+04-6.048e+04-2.885e+04	
4.158e+04	98	12.78	5.17	-15.39	-4.74	-5.47	10.28-1.421e+04-1.390e+05-1.002e+05-5.302e+04	
5.777e+04	74 69	83	13.71	1.54	-12.80	-10.00	-1.26 -5.68-3.216e+04-1.560e+05-1.086e+05-7.959e+04	
6.021e+04	85	9.65	6.81	-5.92	-5.58	6.47	2.05-2.580e+04-1.108e+05-5.854e+04-7.809e+04	
4.138e+04	99	8.55	-0.37	-7.57	-7.44	-0.50	-0.96 -222.12-8.910e+04-6.045e+04-2.887e+04	
4.154e+04	98	12.72	1.61	-5.37	-4.94	1.19	-1.66-1.427e+04-1.390e+05-1.002e+05-5.307e+04	
5.774e+04	75 1	85	11.95	5.54	-6.92	-6.28	4.90 2.75-3.304e+04-1.376e+05-7.758e+04-9.304e+04	
5.170e+04	87	8.73	0.28	-6.58	-5.41	-0.90	2.59-2.358e+04-1.002e+05-4.899e+04-7.481e+04	
3.608e+04	100	8.74	1.41	-6.87	-6.52	1.06	1.66 3518.75-8.900e+04-5.083e+04-3.466e+04	
4.555e+04	99	11.39	0.90	-8.64	-8.54	0.79	-0.98 -5306.47-1.211e+05-7.978e+04-4.663e+04	

Parco Eolico "Bolina" – Progetto Definitivo
Relazione di calcolo preliminare delle fondazioni degli aerogeneratori G8 e G12

5.548e+04 75 3	85	10.11	4.69	-5.85	-5.31	4.15	2.33-2.795e+04-1.164e+05-6.565e+04-7.872e+04
4.375e+04	87	7.39	0.24	-5.57	-4.58	-0.76	2.19-1.995e+04-8.480e+04-4.145e+04-6.330e+04
3.053e+04	100	7.39	1.19	-5.81	-5.52	0.89	1.41 2977.40-7.531e+04-4.301e+04-2.933e+04
3.854e+04	99	9.64	0.76	-7.31	-7.22	0.67	-0.83 -4490.09-1.025e+05-6.751e+04-3.946e+04
4.694e+04 75 23	85	9.29	24.14	-22.25	-9.43	11.32	20.75-2.497e+04-1.058e+05-5.965e+04-7.113e+04
4.001e+04	87	6.78	18.68	-18.85	-7.23	7.05	17.35-1.796e+04-7.714e+04-3.765e+04-5.745e+04
2.788e+04	100	6.82	24.51	-14.45	-5.54	15.60	16.36 2783.49-6.855e+04-3.913e+04-2.664e+04
3.512e+04	99	8.87	21.99	-16.41	-6.71	12.30	16.68 -3992.32-9.327e+04-6.142e+04-3.584e+04
4.277e+04 75 55	85	9.23	10.52	-10.58	-6.38	6.32	8.42-2.526e+04-1.058e+05-5.967e+04-7.142e+04
3.985e+04	87	6.74	6.39	-9.66	-5.20	1.93	7.19-1.808e+04-7.711e+04-3.767e+04-5.751e+04
2.780e+04	100	6.75	8.74	-8.12	-5.19	5.82	6.38 2732.70-6.849e+04-3.911e+04-2.665e+04
3.507e+04	99	8.80	6.57	-8.63	-6.62	4.57	5.15 -4051.59-9.320e+04-6.139e+04-3.586e+04
4.271e+04 75 69	85	9.20	4.26	-5.32	-4.83	3.77	2.11-2.541e+04-1.058e+05-5.968e+04-7.157e+04
3.977e+04	87	6.72	0.22	-5.06	-4.16	-0.69	1.99-1.814e+04-7.709e+04-3.769e+04-5.754e+04
2.775e+04	100	6.72	1.08	-5.28	-5.01	0.81	1.28 2706.73-6.846e+04-3.910e+04-2.666e+04
3.504e+04	99	8.76	0.69	-6.65	-6.57	0.61	-0.75 -4081.90-9.316e+04-6.137e+04-3.587e+04
4.267e+04 76 1	87	8.80	1.21	-4.80	-3.33	-0.25	2.58-2.293e+04-1.008e+05-5.017e+04-7.359e+04
3.714e+04	89	6.93	-1.70	-4.41	-4.28	-1.82	-0.57 -9591.16-7.654e+04-2.678e+04-5.935e+04
2.924e+04	101	6.78	1.62	-6.41	-6.41	1.61	0.27 8881.60-6.565e+04-3.213e+04-2.464e+04
3.708e+04	100	8.75	1.40	-7.10	-7.10	1.40	-3.77e-03 2829.82-8.965e+04-5.142e+04-3.539e+04
4.554e+04 76 3	87	7.45	1.02	-4.06	-2.82	-0.22	2.18-1.940e+04-8.531e+04-4.245e+04-6.227e+04
3.143e+04	89	5.87	-1.44	-3.73	-3.62	-1.54	-0.48 -8115.60-6.476e+04-2.266e+04-5.022e+04
2.474e+04	101	5.73	1.37	-5.43	-5.42	1.36	0.22 7515.20-5.555e+04-2.719e+04-2.085e+04
3.137e+04	100	7.41	1.18	-6.01	-6.01	1.18	-3.19e-03 2394.47-7.585e+04-4.351e+04-2.995e+04
3.853e+04 76 21	87	6.83	21.04	-9.32	15.25	-3.53	11.92-1.733e+04-7.764e+04-3.853e+04-5.644e+04
2.879e+04	89	5.39	15.20	-8.78	11.22	-4.79	8.93 -7474.09-5.891e+04-2.074e+04-4.565e+04
2.250e+04	101	5.30	24.87	-10.43	13.35	1.09	16.55 6700.31-5.065e+04-2.497e+04-1.898e+04
2.852e+04	100	6.81	27.35	-9.20	17.18	0.97	16.38 2164.98-6.911e+04-3.976e+04-2.718e+04
3.508e+04 76 53	87	6.79	6.93	-4.79	3.46	-1.32	5.35-1.754e+04-7.759e+04-3.857e+04-5.655e+04
2.865e+04	89	5.35	2.97	-3.90	1.62	-2.55	2.73 -7410.41-5.889e+04-2.065e+04-4.565e+04
2.250e+04	101	5.24	6.96	-4.51	1.26	1.19	5.74 6787.38-5.055e+04-2.480e+04-1.896e+04
2.852e+04	100	6.76	7.19	-3.95	2.20	1.04	5.54 2172.75-6.901e+04-3.962e+04-2.721e+04
3.505e+04 76 69	87	6.77	0.93	-3.69	-2.56	-0.20	1.98-1.764e+04-7.756e+04-3.859e+04-5.661e+04
2.857e+04	89	5.33	-1.31	-3.39	-3.29	-1.40	-0.44 -7377.82-5.888e+04-2.060e+04-4.566e+04
2.249e+04	101	5.21	1.25	-4.93	-4.93	1.24	0.20 6832.00-5.050e+04-2.471e+04-1.895e+04
2.852e+04	100	6.73	1.07	-5.46	-5.46	1.07	-2.90e-03 2176.79-6.896e+04-3.956e+04-2.722e+04
3.503e+04							

Parco Eolico "Bolina" – Progetto Definitivo
Relazione di calcolo preliminare delle fondazioni degli aerogeneratori G8 e G12

77	1	89	6.94	-1.93	-4.53	-4.33	-2.13	-0.70	-9203.58-7.646e+04-2.663e+04-5.903e+04
2.947e+04		91	5.77	0.81	-4.75	-3.53	-0.41	-2.30	3675.24-5.800e+04 -4130.59-5.019e+04 2.051e+04
		102	4.94	0.56	-8.02	-7.13	-0.33	-2.61	1.622e+04-4.121e+04-1.311e+04-1.188e+04
2.871e+04		101	6.78	3.21	-5.73	-5.57	3.05	-1.20	8178.37-6.616e+04-3.255e+04-2.543e+04
3.700e+04									
2.493e+04	3	89	5.87	-1.63	-3.83	-3.66	-1.80	-0.59	-7787.64-6.469e+04-2.253e+04-4.995e+04
		91	4.88	0.69	-4.02	-2.99	-0.35	-1.95	3109.82-4.907e+04 -3495.11-4.247e+04 1.735e+04
		102	4.18	0.47	-6.79	-6.03	-0.28	-2.21	1.372e+04-3.487e+04-1.110e+04-1.005e+04
2.429e+04		101	5.74	2.72	-4.85	-4.71	2.58	-1.01	6920.16-5.598e+04-2.754e+04-2.152e+04
3.131e+04									
2.269e+04	21	89	5.39	13.59	-7.70	10.14	-4.25	7.85	-7165.50-5.887e+04-2.063e+04-4.541e+04
		91	4.46	10.12	-6.93	7.79	-4.61	5.85	2610.00-4.454e+04 -3359.54-3.858e+04 1.568e+04
		102	3.84	17.85	-9.27	8.86	-0.28	12.77	1.190e+04-3.188e+04-1.061e+04 -9358.01 2.188e+04
		101	5.28	20.40	-6.66	12.58	1.16	12.27	6198.57-5.102e+04-2.530e+04-1.953e+04
2.846e+04									
2.268e+04	53	89	5.36	2.32	-3.62	1.23	-2.52	2.30	-7108.74-5.883e+04-2.053e+04-4.541e+04
		91	4.43	1.07	-2.00	0.84	-1.77	0.81	2753.64-4.459e+04 -3239.02-3.860e+04 1.574e+04
		102	3.80	2.55	-3.44	-0.63	-0.26	2.99	1.228e+04-3.176e+04-1.027e+04 -9212.71 2.201e+04
		101	5.24	5.23	-1.87	1.42	1.94	3.54	6259.68-5.094e+04-2.513e+04-1.955e+04
2.846e+04									
2.267e+04	69	89	5.34	-1.48	-3.48	-3.33	-1.64	-0.54	-7079.68-5.881e+04-2.049e+04-4.541e+04
		91	4.43	0.62	-3.66	-2.71	-0.32	-1.77	2827.10-4.461e+04 -3177.37-3.861e+04 1.577e+04
		102	3.80	0.43	-6.17	-5.49	-0.25	-2.01	1.247e+04-3.170e+04-1.009e+04 -9138.39 2.208e+04
		101	5.22	2.47	-4.41	-4.28	2.34	-0.92	6291.06-5.089e+04-2.504e+04-1.956e+04
2.846e+04									
	1	91	5.88	-1.47	-12.71	-5.32	-8.86	-5.33	8912.05-5.621e+04 75.52-4.737e+04 2.230e+04
		93	5.21	10.49	-4.22	2.63	3.65	7.33	5095.43-5.147e+04 3273.45-4.965e+04 9987.01
		103	5.11	3.13	-34.62	-7.03	-24.46	-16.74	4.738e+04 -8115.39 2.185e+04 1.742e+04 2.766e+04
		102	4.55	12.89	-6.27	-6.14	12.76	-1.60	8747.84-4.219e+04-1.619e+04-1.725e+04
2.546e+04									
	3	91	4.97	-1.24	-10.75	-4.50	-7.50	-4.51	7540.96-4.756e+04 63.90-4.009e+04 1.887e+04
		93	4.41	8.87	-3.57	2.22	3.09	6.21	4311.51-4.355e+04 2769.85-4.201e+04 8450.55
		103	4.32	2.65	-29.29	-5.95	-20.70	-14.16	4.009e+04 -6866.87 1.848e+04 1.474e+04 2.340e+04
		102	3.85	10.91	-5.31	-5.19	10.80	-1.35	7402.02-3.570e+04-1.370e+04-1.460e+04
2.154e+04									
	24	91	4.59	2.27	-22.98	-13.90	-6.80	-12.12	7504.93-4.300e+04 440.87-3.594e+04 1.752e+04
		93	4.02	11.77	-3.69	-2.12	10.20	4.67	3227.17-3.986e+04 2050.74-3.868e+04 7021.62
		103	4.39	9.74	-54.80	-17.27	-27.78	-31.84	3.986e+04 -6201.92 1.795e+04 1.571e+04 2.301e+04
		102	3.56	19.44	-21.74	-18.16	15.86	-11.59	6613.11-3.250e+04-1.193e+04-1.396e+04
1.953e+04									
	56	91	4.54	-0.29	-13.93	-7.41	-6.81	-6.81	7074.78-4.316e+04 187.61-3.627e+04 1.728e+04
		93	4.01	8.77	-2.85	0.62	5.31	5.31	3683.25-3.968e+04 2359.92-3.836e+04 7458.76
		103	4.09	4.63	-35.90	-9.42	-21.85	-19.29	3.760e+04 -6226.39 1.719e+04 1.418e+04 2.186e+04
		102	3.52	12.87	-10.28	-9.27	11.86	-4.73	6687.72-3.246e+04-1.228e+04-1.350e+04
1.957e+04									
	69	91	4.52	-1.13	-9.78	-4.09	-6.82	-4.10	6855.42-4.324e+04 58.09-3.644e+04 1.716e+04
		93	4.01	8.07	-3.24	2.02	2.81	5.64	3919.56-3.959e+04 2518.04-3.819e+04 7682.32
		103	3.93	2.40	-26.63	-5.41	-18.82	-12.87	3.645e+04 -6242.61 1.680e+04 1.340e+04 2.128e+04
		102	3.50	9.92	-4.82	-4.72	9.81	-1.23	6729.11-3.245e+04-1.245e+04-1.327e+04
1.959e+04									
	1	93	5.68	7.61	-0.39	1.92	5.30	-3.63	8251.19-5.430e+04 3807.69-4.985e+04 1.607e+04
		95	3.84	-1.33	-13.42	-4.82	-9.93	5.48	1.233e+04-3.202e+04 1.104e+04-3.073e+04 7462.25
		104	3.10	14.15	0.13	0.14	14.14	-0.37	1.323e+04-2.342e+04 -3883.17 -6307.65 1.828e+04
		103	3.66	1.89	-29.36	-1.95	-25.51	10.27	3.749e+04 -433.24 1.917e+04 1.789e+04 1.895e+04
	3	93	4.80	6.44	-0.33	1.62	4.49	-3.07	6981.77-4.594e+04 3221.89-4.218e+04 1.360e+04
		95	3.25	-1.12	-11.36	-4.08	-8.40	4.64	1.044e+04-2.709e+04 9342.44-2.600e+04 6314.21
		104	2.62	11.98	0.11	0.12	11.97	-0.31	1.119e+04-1.981e+04 -3285.76 -5337.24 1.547e+04
		103	3.10	1.60	-24.84	-1.65	-21.59	8.69	3.172e+04 -366.59 1.622e+04 1.513e+04 1.604e+04
	7	93	4.43	26.84	-15.32	-14.75	26.27	4.87	7008.45-4.111e+04 3973.84-3.807e+04 1.170e+04
		95	3.05	19.20	-11.01	-9.29	17.48	7.00	9674.17-2.502e+04 8592.48-2.393e+04 6029.40
		104	2.39	31.88	-7.96	-7.47	31.39	-4.37	1.021e+04-1.762e+04 -3144.63 -4258.13 1.390e+04
		103	2.96	9.61	-6.01	-4.45	8.04	-4.68	2.917e+04 -2631.85 1.361e+04 1.292e+04 1.590e+04
	37	93	4.35	8.41	-4.74	6.93	-3.26	-4.16	6117.84-4.186e+04 2599.93-3.834e+04 1.251e+04
		95	2.98	-0.38	-16.56	-1.13	-15.81	3.39	9373.47-2.459e+04 8394.75-2.361e+04 5681.98
		104	2.39	6.42	0.75	2.82	4.35	2.73	1.020e+04-1.802e+04 -2907.46 -4916.15 1.408e+04
		103	2.81	5.15	-31.11	0.35	-26.32	12.28	2.870e+04 30.59 1.513e+04 1.360e+04 1.432e+04

Parco Eolico "Bolina" – Progetto Definitivo
Relazione di calcolo preliminare delle fondazioni degli aerogeneratori G8 e G12

79	69	93	4.37	5.86	-0.30	1.48	4.08	-2.79	6347.07-4.177e+04	2928.99-3.835e+04	1.236e+04
		95	2.96	-1.02	-10.32	-3.71	-7.64	4.22	9487.91-2.463e+04	8493.13-2.363e+04	5740.19
		104	2.38	10.89	0.10	0.11	10.88	-0.28	1.017e+04-1.801e+04	-2987.05 -4852.04	1.406e+04
		103	2.81	1.46	-22.58	-1.50	-19.62	7.90	2.884e+04 -333.26	1.475e+04 1.376e+04	1.458e+04
80	1	95	3.83	2.67	-4.57	-1.70	-0.19	3.54	8638.53-3.484e+04	6712.96-3.292e+04	8945.25
		97	2.51	0.92	-2.35	0.36	-1.79	1.23	310.83-2.593e+04	272.46-2.589e+04	-1002.71
		105	0.94	3.96	-1.21	-1.20	3.95	0.26	114.98 -9559.01	-879.74 -8564.29	2938.27
		104	2.65	1.51	-1.66	0.36	-0.50	-1.53	1.490e+04-1.679e+04	-131.99 -1761.00	1.582e+04
80	3	95	3.24	2.26	-3.86	-1.44	-0.16	3.00	7309.52-2.948e+04	5680.19-2.785e+04	7569.06
		97	2.13	0.78	-1.99	0.30	-1.52	1.04	263.01-2.194e+04	230.54-2.191e+04	-848.45
		105	0.79	3.35	-1.03	-1.02	3.34	0.22	97.29 -8088.39	-744.39 -7246.71	2486.23
		104	2.24	1.28	-1.41	0.30	-0.43	-1.29	1.260e+04-1.421e+04	-111.69 -1490.08	1.339e+04
80	8	95	3.04	24.34	-9.00	-7.49	22.82	6.94	6831.01-2.682e+04	5359.25-2.535e+04	6881.97
		97	2.03	27.29	-1.06	0.27	25.96	6.00	210.33-1.997e+04	182.54-1.994e+04	-748.40
		105	0.81	24.05	-6.51	-4.58	22.12	-7.44	124.89 -7187.96	-648.02 -6415.05	2248.29
		104	2.12	25.37	-6.12	-1.96	21.20	-10.66	1.154e+04-1.303e+04	-340.25 -1151.87	1.228e+04
80	40	95	2.97	9.01	-4.79	-3.40	7.63	4.15	6707.94-2.681e+04	5229.94-2.533e+04	6881.30
		97	1.96	8.71	-0.56	0.27	7.87	2.66	229.36-1.995e+04	200.43-1.993e+04	-763.56
		105	0.75	9.96	-2.63	-2.16	9.49	-2.39	100.74 -7297.17	-667.01 -6529.42	2256.17
		104	2.07	8.96	-2.52	-0.48	6.92	-4.39	1.149e+04-1.295e+04	-182.31 -1286.01	1.221e+04
80	69	95	2.95	2.06	-3.51	-1.31	-0.14	2.72	6645.02-2.680e+04	5163.81-2.532e+04	6880.96
		97	1.93	0.71	-1.81	0.27	-1.38	0.95	239.10-1.995e+04	209.58-1.992e+04	-771.32
		105	0.72	3.05	-0.93	-0.92	3.04	0.20	88.44 -7353.09	-676.72 -6587.92	2260.21
		104	2.04	1.16	-1.28	0.27	-0.39	-1.18	1.146e+04-1.292e+04	-101.53 -1354.62	1.217e+04
81	1	79	32.37	5.37	-10.27	-9.30	4.40	-3.77	9.052e+04-2.827e+05	-1.921e+05 -14.28	1.600e+05
		98	14.86	-1.69	-13.11	-10.91	-3.89	4.51	-4.747e+04-1.726e+05	-9.709e+04-1.230e+05	
6.120e+04		106	13.54	6.19	-13.80	-10.69	3.08	-7.25	3.570e+04-1.195e+05	-7.602e+04 -7809.14	6.972e+04
		80	20.99	2.76	-20.92	-17.21	-0.95	8.60	5.291e+04-1.864e+05	-1.089e+05-2.465e+04	
1.120e+05		81	27.39	4.54	-8.69	-7.87	3.72	-3.19	7.660e+04-2.392e+05	-1.626e+05 -12.08	1.354e+05
		98	12.58	-1.43	-11.10	-9.23	-3.29	3.81	-4.017e+04-1.460e+05	-8.215e+04-1.041e+05	
5.179e+04		106	11.45	5.24	-11.68	-9.04	2.60	-6.14	3.020e+04-1.011e+05	-6.433e+04 -6607.74	5.899e+04
		80	17.76	2.34	-17.70	-14.56	-0.80	7.28	4.477e+04-1.577e+05	-9.211e+04-2.086e+04	
9.478e+04		81	24.98	57.21	-99.25	-80.89	38.84	-50.36	6.914e+04-2.180e+05	-1.485e+05 -379.98	1.230e+05
		98	11.79	5.09	-110.42	-76.12	-29.22	52.78	-3.666e+04-1.329e+05	-7.477e+04-9.475e+04	
4.706e+04		106	10.60	62.67	-96.26	-69.76	36.18	-59.24	2.746e+04-9.203e+04	-5.849e+04 -6080.53	5.369e+04
		80	16.75	12.07	-161.85	-120.37	-29.42	74.12	4.049e+04-1.437e+05	-8.406e+04-1.920e+04	
8.622e+04		81	24.92	22.02	-38.74	-32.10	15.38	-18.96	6.947e+04-2.176e+05	-1.480e+05 -135.84	1.230e+05
		98	11.55	0.79	-43.96	-31.31	-11.87	20.15	-3.656e+04-1.328e+05	-7.471e+04-9.465e+04	
4.707e+04		106	10.47	24.36	-39.59	-29.04	13.81	-23.74	2.746e+04-9.197e+04	-5.848e+04 -6031.90	5.365e+04
		80	16.35	5.38	-65.31	-49.49	-10.44	29.46	4.063e+04-1.435e+05	-8.384e+04-1.904e+04	
8.618e+04		81	24.90	4.13	-7.90	-7.15	3.39	-2.90	6.963e+04-2.174e+05	-1.478e+05 -10.98	1.231e+05
		98	11.43	-1.30	-10.09	-8.39	-2.99	3.47	-3.652e+04-1.328e+05	-7.468e+04-9.459e+04	
4.708e+04		106	10.41	4.76	-10.62	-8.22	2.37	-5.58	2.746e+04-9.194e+04	-5.848e+04 -6007.03	5.363e+04
		80	16.14	2.12	-16.09	-13.24	-0.73	6.62	4.070e+04-1.434e+05	-8.373e+04-1.896e+04	
8.616e+04		82	16.44	2.09	-10.57	-9.73	1.24	-3.16	-2185.08-1.723e+05	-9.817e+04-7.628e+04	
8.433e+04		99	11.11	-0.09	-10.07	-8.26	-1.90	3.84	-8371.74-1.194e+05	-5.778e+04-7.000e+04	
5.518e+04		107	10.79	-0.35	-10.42	-9.32	-1.45	-3.14	3.438e+04-9.118e+04	-4.793e+04 -8865.31	5.966e+04
		106	13.86	-3.14	-13.35	-13.30	-3.19	0.70	2.756e+04-1.283e+05	-8.307e+04-1.768e+04	
7.075e+04		82	13.91	1.77	-8.95	-8.23	1.05	-2.68	-1848.91-1.458e+05	-8.306e+04-6.455e+04	
7.136e+04		99	9.40	-0.08	-8.52	-6.99	-1.61	3.25	-7083.78-1.010e+05	-4.889e+04-5.923e+04	
4.669e+04		107	9.13	-0.30	-8.82	-7.89	-1.23	-2.66	2.909e+04-7.715e+04	-4.056e+04 -7501.41	5.048e+04
		106	11.73	-2.66	-11.30	-11.25	-2.70	0.60	2.332e+04-1.086e+05	-7.029e+04-1.496e+04	
5.987e+04		82	12.72	15.52	-49.34	-49.33	15.51	0.96	-1697.40-1.327e+05	-7.563e+04-5.874e+04	
6.494e+04		99	8.71	15.76	-63.37	-53.00	5.38	26.71	-6468.80-9.186e+04	-4.442e+04-5.391e+04	
4.243e+04		107	8.37	41.86	-52.00	-51.70	41.56	-5.29	2.645e+04-7.016e+04	-3.671e+04 -7001.63	4.596e+04

Parco Eolico "Bolina" – Progetto Definitivo
Relazione di calcolo preliminare delle fondazioni degli aerogeneratori G8 e G12

5.447e+04	106	10.95	-3.51	-82.26	-70.35	-15.42	28.22	2.120e+04-9.880e+04-6.397e+04-1.363e+04
82 39	98	12.67	5.94	-21.70	-21.64	5.88	-1.28	-1686.44-1.326e+05-7.555e+04-5.870e+04
6.490e+04	99	8.60	5.26	-26.55	-22.14	0.85	10.99	-6449.62-9.185e+04-4.444e+04-5.387e+04
4.244e+04	107	8.32	13.65	-22.56	-22.24	13.33	-3.39	2.645e+04-7.014e+04-3.682e+04 -6881.11 4.592e+04
5.444e+04	106	10.76	-3.25	-34.16	-30.57	-6.84	9.91	2.120e+04-9.874e+04-6.392e+04-1.361e+04
82 69	98	12.65	1.61	-8.13	-7.48	0.95	-2.43	-1680.83-1.325e+05-7.551e+04-5.868e+04
6.487e+04	99	8.55	-0.07	-7.75	-6.35	-1.46	2.96	-6439.80-9.185e+04-4.445e+04-5.385e+04
4.245e+04	107	8.30	-0.27	-8.02	-7.17	-1.12	-2.42	2.644e+04-7.014e+04-3.687e+04 -6819.47 4.589e+04
5.443e+04	106	10.66	-2.42	-10.27	-10.23	-2.45	0.54	2.120e+04-9.871e+04-6.390e+04-1.360e+04
83 1	99	11.40	0.76	-8.03	-7.88	0.61	1.13	-3455.91-1.203e+05-5.722e+04-6.654e+04
5.824e+04	100	8.71	-0.35	-8.67	-7.13	-1.88	3.22	3129.68-8.888e+04-3.335e+04-5.239e+04
4.501e+04	108	9.07	1.68	-7.81	-6.18	0.05	3.58	3.343e+04-7.283e+04-3.387e+04 -5530.18 5.121e+04
83 3	107	10.66	-5.80	-7.98	-7.68	-6.10	-0.76	3.260e+04-9.103e+04-4.927e+04 -9159.31 5.847e+04
4.928e+04	99	9.65	0.64	-6.80	-6.67	0.52	0.96	-2924.24-1.018e+05-4.842e+04-5.631e+04
3.808e+04	100	7.37	-0.30	-7.33	-6.04	-1.59	2.73	2648.19-7.520e+04-2.822e+04-4.433e+04
83 23	108	7.67	1.42	-6.61	-5.23	0.04	3.03	2.829e+04-6.163e+04-2.866e+04 -4679.38 4.333e+04
4.492e+04	107	9.02	-4.90	-6.75	-6.49	-5.16	-0.64	2.758e+04-7.702e+04-4.169e+04 -7750.18 4.947e+04
83 55	99	8.89	24.12	-17.25	1.12	5.75	20.55	-2526.52-9.264e+04-4.403e+04-5.113e+04
4.484e+04	100	6.79	18.29	-16.45	-0.24	2.08	17.33	2433.57-6.848e+04-2.570e+04-4.034e+04
3.469e+04	108	7.12	28.52	-15.01	3.56	9.95	21.53	2.571e+04-5.630e+04-2.614e+04 -4444.45 3.954e+04
83 55	107	8.31	23.44	-13.64	3.45	6.35	18.49	2.481e+04-7.022e+04-3.790e+04 -7508.27 4.502e+04
4.484e+04	99	8.81	7.40	-8.77	-3.63	2.26	7.53	-2613.78-9.258e+04-4.402e+04-5.117e+04
3.464e+04	100	6.73	5.72	-9.68	-3.71	-0.25	7.50	2416.28-6.840e+04-2.567e+04-4.032e+04
83 69	108	7.02	10.22	-8.76	-1.94	3.40	9.11	2.571e+04-5.612e+04-2.609e+04 -4318.43 3.944e+04
4.480e+04	107	8.24	4.09	-7.79	-2.74	-0.96	5.87	2.498e+04-7.009e+04-3.790e+04 -7202.17 4.499e+04
83 69	99	8.77	0.59	-6.18	-6.06	0.47	0.87	-2658.40-9.255e+04-4.402e+04-5.119e+04
3.462e+04	100	6.70	-0.27	-6.67	-5.49	-1.45	2.48	2407.45-6.837e+04-2.566e+04-4.030e+04
84 1	108	6.97	1.29	-6.01	-4.76	0.04	2.75	2.571e+04-5.603e+04-2.606e+04 -4253.98 3.939e+04
4.579e+04	107	8.20	-4.46	-6.14	-5.90	-4.69	-0.58	2.507e+04-7.002e+04-3.790e+04 -7045.62 4.497e+04
84 1	100	8.82	-0.07	-6.19	-5.42	-0.85	2.03	3312.94-9.002e+04-3.438e+04-5.232e+04
3.664e+04	101	6.89	0.41	-7.15	-6.40	-0.35	2.27	9987.08-6.610e+04-1.782e+04-3.829e+04
84 3	109	7.48	4.24	-7.48	-7.47	4.23	0.30	3.144e+04-5.717e+04-2.362e+04 -2104.17 4.298e+04
3.875e+04	108	8.99	0.75	-9.67	-8.97	0.05	2.60	3.343e+04-7.205e+04-3.378e+04 -4842.40 5.071e+04
84 3	100	7.46	-0.06	-5.23	-4.58	-0.72	1.72	2803.26-7.617e+04-2.909e+04-4.427e+04
3.101e+04	101	5.83	0.35	-6.05	-5.41	-0.29	1.92	8450.61-5.593e+04-1.508e+04-3.240e+04
84 23	109	6.33	3.59	-6.33	-6.32	3.58	0.26	2.661e+04-4.838e+04-1.999e+04 -1780.45 3.637e+04
3.528e+04	108	7.61	0.63	-8.18	-7.59	0.04	2.20	2.828e+04-6.096e+04-2.858e+04 -4097.42 4.291e+04
84 23	100	6.87	18.38	-13.88	-0.20	4.70	15.94	2603.65-6.931e+04-2.643e+04-4.027e+04
2.821e+04	101	5.37	15.35	-11.55	-0.61	4.41	13.22	7658.01-5.090e+04-1.378e+04-2.946e+04
84 55	109	5.86	23.06	-11.49	0.59	10.97	16.48	2.410e+04-4.400e+04-1.829e+04 -1617.49 3.301e+04
3.525e+04	108	7.02	21.28	-9.72	1.33	10.23	14.85	2.569e+04-5.577e+04-2.619e+04 -3893.93 3.917e+04
84 55	100	6.81	5.90	-7.56	-2.82	1.16	6.43	2567.11-6.927e+04-2.644e+04-4.025e+04
2.819e+04	101	5.32	5.04	-7.19	-3.46	1.32	5.62	7674.12-5.087e+04-1.374e+04-2.946e+04
84 69	109	5.79	8.57	-6.30	-3.60	5.87	5.73	2.416e+04-4.399e+04-1.821e+04 -1618.22 3.305e+04
3.523e+04	108	6.95	7.09	-7.71	-4.12	3.49	6.35	2.570e+04-5.554e+04-2.605e+04 -3782.11 3.906e+04
84 69	100	6.78	-0.06	-4.76	-4.17	-0.65	1.56	2548.42-6.924e+04-2.645e+04-4.024e+04
3.523e+04	101	5.30	0.31	-5.50	-4.92	-0.27	1.74	7682.37-5.085e+04-1.371e+04-2.946e+04

Parco Eolico "Bolina" – Progetto Definitivo
Relazione di calcolo preliminare delle fondazioni degli aerogeneratori G8 e G12

2.819e+04		109	5.76	3.26	-5.76	-5.75	3.26	0.23	2.419e+04	-4.398e+04	-1.817e+04	-1618.59	3.306e+04	
		108	6.92	0.58	-7.44	-6.90	0.04	2.00	2.571e+04	-5.542e+04	-2.598e+04	-3724.93	3.901e+04	
	85	101	6.90	-0.38	-6.99	-6.50	-0.86	1.72	9503.09	-6.649e+04	-1.857e+04	-3.842e+04		
3.668e+04		102	5.37	3.31	-6.17	-6.16	3.30	0.12	1.831e+04	-4.440e+04	-2228.25	-2.385e+04	2.943e+04	
		110	6.01	1.68	-4.90	-4.75	1.54	-0.98	3.053e+04	-4.138e+04	-1.014e+04	-711.98	3.565e+04	
		109	7.42	4.66	-6.45	-6.07	4.29	-2.00	3.154e+04	-5.652e+04	-2.322e+04	-1762.71	4.270e+04	
	85	3	101	5.84	-0.32	-5.91	-5.50	-0.73	1.45	8041.07	-5.626e+04	-1.571e+04	-3.251e+04	
3.104e+04		102	4.54	2.80	-5.22	-5.22	2.80	0.11	1.550e+04	-3.757e+04	-1885.44	-2.018e+04	2.490e+04	
		110	5.08	1.42	-4.15	-4.02	1.30	-0.83	2.584e+04	-3.502e+04	-8578.15	-602.44	3.016e+04	
		109	6.28	3.94	-5.45	-5.14	3.63	-1.69	2.669e+04	-4.782e+04	-1.965e+04	-1491.52	3.613e+04	
	85	24	101	5.34	7.94	-27.21	-25.94	6.66	-6.57	7457.25	-5.096e+04	-1.403e+04	-2.948e+04	
2.817e+04		102	4.21	13.29	-22.99	-21.90	12.20	-6.22	1.437e+04	-3.404e+04	-1231.29	-1.843e+04	2.263e+04	
		110	4.74	14.00	-30.14	-21.32	5.18	-17.65	2.377e+04	-3.171e+04	-7612.52	-325.07	2.750e+04	
		109	5.79	15.19	-32.13	-25.49	8.55	-16.44	2.446e+04	-4.333e+04	-1.760e+04	-1270.25	3.289e+04	
	85	56	101	5.30	1.95	-12.22	-12.09	1.82	-1.35	7359.83	-5.109e+04	-1.420e+04	-2.953e+04	
2.820e+04		102	4.16	6.06	-10.80	-10.55	5.81	-2.04	1.418e+04	-3.411e+04	-1550.69	-1.838e+04	2.263e+04	
		110	4.66	5.33	-12.43	-9.63	2.54	-6.47	2.358e+04	-3.179e+04	-7735.45	-472.35	2.745e+04	
		109	5.74	7.35	-13.99	-11.72	5.07	-6.58	2.433e+04	-4.343e+04	-1.777e+04	-1326.94	3.286e+04	
	85	69	101	5.31	-0.29	-5.37	-5.00	-0.66	1.32	7310.07	-5.115e+04	-1.428e+04	-2.955e+04	
2.821e+04		102	4.13	2.54	-4.74	-4.74	2.54	0.10	1.409e+04	-3.415e+04	-1714.04	-1.835e+04	2.264e+04	
		110	4.62	1.30	-3.77	-3.66	1.18	-0.75	2.349e+04	-3.183e+04	-7798.32	-547.68	2.742e+04	
		109	5.71	3.59	-4.96	-4.67	3.30	-1.54	2.426e+04	-4.348e+04	-1.786e+04	-1355.93	3.285e+04	
	86	1	102	5.40	-5.52	-9.46	-8.66	1.58	1.851e+04	-4.444e+04	-5838.16	-2.010e+04	3.066e+04	
		103	5.77	26.20	-11.68	-10.29	24.81	-7.12	4.269e+04	-2.452e+04	3.082e+04	-1.265e+04	2.563e+04	
		111	4.09	2.09	-7.38	-3.47	-1.82	4.66	1.950e+04	-2.898e+04	-5344.66	-4137.67	2.424e+04	
		110	6.02	11.71	-3.75	-1.82	9.78	-5.11	3.112e+04	-4.070e+04	-7049.13	-2529.79	3.584e+04	
	86	3	102	4.57	-4.67	-8.00	-5.34	-7.33	1.34	1.566e+04	-3.761e+04	-4939.98	-1.700e+04	2.594e+04
		103	4.88	22.17	-9.89	-8.71	20.99	-6.03	3.613e+04	-2.075e+04	2.608e+04	-1.070e+04	2.169e+04	
		111	3.46	1.77	-6.24	-2.93	-1.54	3.95	1.650e+04	-2.453e+04	-4522.40	-3501.10	2.051e+04	
		110	5.10	9.91	-3.18	-1.54	8.28	-4.33	2.633e+04	-3.444e+04	-5964.65	-2140.59	3.033e+04	
	86	22	102	4.14	-2.20	-19.96	-6.29	-15.87	-7.48	1.449e+04	-3.370e+04	-4463.86	-1.474e+04	2.354e+04
		103	4.77	32.11	-17.59	-11.79	26.31	-15.95	3.345e+04	-2.148e+04	2.394e+04	-1.197e+04	2.079e+04	
		111	3.10	-2.05	-14.81	-6.02	-10.84	-5.91	1.504e+04	-2.165e+04	-3919.88	-2694.95	1.834e+04	
		110	4.74	12.15	-14.52	-5.73	3.36	-12.54	2.396e+04	-3.185e+04	-5511.35	-2378.23	2.786e+04	
	86	54	102	4.13	-4.75	-10.37	-5.34	-9.78	-1.73	1.432e+04	-3.402e+04	-4481.74	-1.522e+04	2.357e+04
		103	4.55	23.98	-11.68	-9.23	21.53	-9.02	3.305e+04	-1.975e+04	2.379e+04	-1.049e+04	2.008e+04	
		111	3.11	-3.65	-4.74	-3.80	-4.59	0.37	1.501e+04	-2.208e+04	-4046.51	-3017.74	1.854e+04	
		110	4.67	9.81	-6.56	-2.87	6.11	-6.85	2.395e+04	-3.149e+04	-5452.51	-2092.25	2.767e+04	
	86	69	102	4.15	-4.24	-7.28	-4.86	-6.66	1.22	1.424e+04	-3.419e+04	-4490.89	-1.546e+04	2.358e+04
		103	4.44	20.15	-8.99	-7.92	19.08	-5.48	3.284e+04	-1.886e+04	2.371e+04	-9731.55	1.972e+04	
		111	3.15	1.61	-5.68	-2.67	-1.40	3.59	1.500e+04	-2.230e+04	-4111.28	-3182.82	1.864e+04	
		110	4.63	9.01	-2.89	-1.40	7.52	-3.93	2.394e+04	-3.131e+04	-5422.41	-1946.00	2.757e+04	
	87	1	103	3.23	40.42	-4.63	8.19	27.60	20.33	2.422e+04	-1.393e+04	2.227e+04	-1.199e+04	8395.14
		104	1.67	-1.06	-14.47	-1.11	-14.43	0.79	9281.52	-1.062e+04	1284.54	-2620.83	9756.17	
		112	2.11	18.00	-2.78	0.79	14.43	7.83	1.229e+04	-1.244e+04	1319.26	-1475.84	1.229e+04	
		111	4.88	1.62	-17.60	-12.55	-3.43	-8.46	2.608e+04	-3.178e+04	-1407.71	-4289.08	2.890e+04	
	87	3	103	2.73	34.20	-3.91	6.93	23.35	17.20	2.049e+04	-1.179e+04	1.885e+04	-1.014e+04	7103.58
		104	1.41	-0.90	-12.25	-0.94	-12.21	0.67	7853.60	-8984.31	1086.92	-2217.63	8255.22	
		112	1.78	15.23	-2.35	0.67	12.21	6.63	1.040e+04	-1.053e+04	1116.29	-1248.79	1.040e+04	
		111	4.13	1.37	-14.89	-10.62	-2.91	-7.16	2.207e+04	-2.689e+04	-1191.14	-3629.22	2.445e+04	
	87	24	103	2.45	47.41	-5.32	4.25	37.84	20.33	1.673e+04	-1.185e+04	1.595e+04	-1.106e+04	4665.81
		104	1.30	-3.54	-5.93	-5.92	-3.55	-0.11	7646.61	-7913.93	902.38	-1169.70	7710.98	
		112	1.56	18.84	-7.02	-6.26	18.08	-4.36	8780.54	-9446.71	949.56	-1615.73	9022.92	
		111	3.97	12.42	-34.13	-24.64	2.92	-18.76	2.167e+04	-2.443e+04	34.13	-2795.25	2.300e+04	
	87	56	103	2.45	36.46	-4.00	5.61	26.85	17.22	1.796e+04	-1.108e+04	1.673e+04	-9844.24	5851.43
		104	1.29	-2.55	-8.56	-2.57	-8.54	0.37	7307.64	-8078.19	959.10	-1729.65	7574.53	
		112	1.57	13.87	-2.12	-1.72	13.46	2.51	9223.43	-9528.54	992.73	-1297.84	9305.77	
		111	3.82	5.00	-20.48	-14.72	-0.76	-10.66	2.061e+04	-2.444e+04	-704.89	-3128.74	2.249e+04	
	87	69	103	2.48	31.09	-3.56	6.30	21.23	15.63	1.863e+04	-1.072e+04	1.713e+04	-9220.85	6457.80
		104	1.29	-0.82	-11.13	-0.85	-11.10	0.61	7139.63	-8167.55	988.11	-2016.02	7504.75	
		112	1.62	13.84	-2.14	0.61	11.10	6.03	9451.16	-9571.61	1014.81	-1135.26	9450.44	
		111	3.75	1.25	-13.54	-9.65	-2.64	-6.51	2.007e+04	-2.445e+04	-1082.85	-3299.29	2.223e+04	
	88	1	104	1.98	4.95	-2.78	0.30	1.88	3.79	9717.27	-1.374e+04	3911.77	-7937.19	1.012e+04
		105	0.70	0.12	-5.66	-0.02	-5.52	0.88	-93.19	-7113.51	-128.74	-7077.96	498.29	
		113	0.21	6.08	-1.43	-1.00	5.65	1.74	361.24	-1954.74	-598.72	-994.78	1140.93	
		112	2.33	2.92	-0.31	-0.20	2.81	0.60	1.453e+04	-1.345e+04	-672.65	1752.99	1.394e+04	
	88	3	104	1.67	4.19	-2.36	0.25	1.59	3.20	8222.31	-1.163e+04	3309.96	-6716.09	8566.37

Parco Eolico "Bolina" – Progetto Definitivo
Relazione di calcolo preliminare delle fondazioni degli aerogeneratori G8 e G12

		105	0.59	0.10	-4.79	-0.01	-4.67	0.75	-78.86	-6019.12	-108.94	-5989.04	421.63
		113	0.18	5.14	-1.21	-0.85	4.78	1.47	305.67	-1654.01	-506.61	-841.74	965.40
		112	1.97	2.47	-0.27	-0.17	2.38	0.50	1.230e+04	-1.138e+04	-569.17	1483.30	1.180e+04
88	5	104	1.58	5.79	-20.41	5.21	-19.84	-3.84	7795.77	-1.079e+04	3284.13	-6282.71	7969.75
		105	0.65	1.71	-28.57	0.63	-27.49	-5.62	-109.25	-5669.08	-134.40	-5643.94	373.06
		113	0.25	7.61	-17.65	3.46	-13.50	9.36	325.40	-1565.52	-430.90	-809.21	926.34
		112	1.88	8.46	-23.87	3.97	-19.37	11.19	1.115e+04	-1.059e+04	-723.78	1285.53	1.082e+04
88	37	104	1.54	1.97	-5.81	1.91	-5.76	0.63	7583.30	-1.065e+04	3102.13	-6165.49	7849.24
		105	0.58	0.37	-12.28	0.21	-12.11	-1.45	-84.42	-5538.62	-111.00	-5512.04	379.83
		113	0.19	3.71	-4.74	0.66	-1.69	4.05	293.87	-1524.49	-450.52	-780.10	894.12
		112	1.82	3.24	-7.13	1.24	-5.13	4.09	1.117e+04	-1.043e+04	-587.25	1327.16	1.076e+04
88	69	104	1.52	3.81	-2.14	0.23	1.44	2.91	7474.82	-1.057e+04	3009.05	-6105.53	7787.61
		105	0.54	0.09	-4.35	-0.01	-4.25	0.68	-71.69	-5471.93	-99.03	-5444.58	383.30
		113	0.16	4.67	-1.10	-0.77	4.34	1.34	277.88	-1503.65	-460.55	-765.22	877.64
		112	1.79	2.25	-0.24	-0.15	2.16	0.46	1.118e+04	-1.035e+04	-517.43	1348.45	1.072e+04
89	1	80	22.47	3.25	-18.27	-18.22	3.20	1.05	6.514e+04	-1.943e+05	-8.015e+04	-4.905e+04	
1.288e+05													
7.556e+04		106	13.52	7.00	-9.41	-9.31	6.90	-1.23	2.387e+04	-1.273e+05	-5.053e+04	-5.286e+04	
		114	13.08	2.69	-16.72	-16.69	2.66	-0.74	6.431e+04	-9.195e+04	-3.705e+04	9414.77	7.459e+04
		81	17.45	7.71	-8.67	-8.62	7.66	0.93	6.958e+04	-1.364e+05	-6.695e+04	136.76	9.737e+04
89	3	80	19.01	2.75	-15.46	-15.41	2.71	0.89	5.512e+04	-1.644e+05	-6.782e+04	-4.150e+04	
1.090e+05													
6.393e+04		106	11.44	5.92	-7.96	-7.88	5.84	-1.04	2.020e+04	-1.077e+05	-4.275e+04	-4.473e+04	
		114	11.06	2.28	-14.15	-14.12	2.25	-0.63	5.441e+04	-7.780e+04	-3.135e+04	7966.34	6.312e+04
		81	14.76	6.52	-7.34	-7.29	6.48	0.78	5.887e+04	-1.154e+05	-5.665e+04	115.72	8.239e+04
89	23	80	17.45	40.83	-22.02	28.32	-9.52	25.09	5.053e+04	-1.496e+05	-6.154e+04	-3.755e+04	
9.936e+04													
5.819e+04		106	10.51	28.34	-9.28	14.80	4.26	18.06	1.842e+04	-9.797e+04	-3.894e+04	-4.061e+04	
		114	10.24	42.20	-24.41	15.51	2.28	32.64	4.931e+04	-7.082e+04	-2.879e+04	7280.50	5.729e+04
		81	13.53	27.11	-15.07	15.61	-3.57	18.79	5.384e+04	-1.050e+05	-5.150e+04	341.78	7.507e+04
89	55	80	17.34	8.44	-9.72	0.31	-1.59	9.03	5.025e+04	-1.495e+05	-6.162e+04	-3.767e+04	
9.917e+04													
5.814e+04		106	10.43	8.58	-3.35	0.27	4.96	5.48	1.838e+04	-9.792e+04	-3.889e+04	-4.064e+04	
		114	10.12	10.44	-11.56	-3.25	2.13	10.67	4.941e+04	-7.076e+04	-2.860e+04	7255.11	5.735e+04
		81	13.46	8.68	-5.09	0.89	2.69	6.83	5.363e+04	-1.049e+05	-5.150e+04	185.25	7.495e+04
89	69	80	17.29	2.50	-14.05	-14.01	2.46	0.81	5.011e+04	-1.495e+05	-6.166e+04	-3.773e+04	
9.908e+04													
5.812e+04		106	10.40	5.38	-7.24	-7.16	5.31	-0.95	1.836e+04	-9.789e+04	-3.887e+04	-4.066e+04	
		114	10.06	2.07	-12.86	-12.84	2.05	-0.57	4.947e+04	-7.073e+04	-2.850e+04	7242.13	5.738e+04
		81	13.42	5.93	-6.67	-6.63	5.89	0.71	5.352e+04	-1.049e+05	-5.150e+04	105.20	7.490e+04
90	1	106	14.21	2.46	-18.26	-17.82	2.02	-2.98	3.616e+04	-1.265e+05	-4.512e+04	-4.520e+04	
8.132e+04													
5.769e+04		107	10.26	1.88	-8.75	-2.12	-4.76	5.15	2.276e+04	-9.323e+04	-2.933e+04	-4.115e+04	
		115	13.01	6.71	-50.02	-19.78	-23.53	-28.30	9.525e+04	-5.721e+04	-1895.61	3.994e+04	7.330e+04
		114	12.68	19.26	-14.80	-13.35	17.82	6.87	5.189e+04	-9.745e+04	-4.368e+04	-1887.66	7.169e+04
90	3	106	12.02	2.08	-15.45	-15.08	1.71	-2.52	3.060e+04	-1.070e+05	-3.818e+04	-3.825e+04	
6.881e+04													
4.882e+04		107	8.68	1.59	-7.41	-1.79	-4.03	4.36	1.925e+04	-7.889e+04	-2.481e+04	-3.482e+04	
		115	11.01	5.68	-42.33	-16.74	-19.91	-23.95	8.059e+04	-4.840e+04	-1603.98	3.379e+04	6.202e+04
		114	10.73	16.30	-12.52	-11.30	15.08	5.81	4.390e+04	-8.246e+04	-3.696e+04	-1597.25	6.066e+04
90	22	106	11.12	15.70	-54.88	-39.57	0.40	-29.08	2.828e+04	-9.729e+04	-3.432e+04	-3.469e+04	
6.279e+04													
4.406e+04		107	7.90	10.82	-25.63	-18.12	3.30	-14.74	1.698e+04	-7.154e+04	-2.303e+04	-3.152e+04	
		115	10.59	20.03	-89.62	-40.76	-28.84	-54.50	7.696e+04	-4.453e+04	-113.76	3.254e+04	5.851e+04
		114	9.66	25.97	-39.27	-33.83	20.53	-18.03	3.887e+04	-7.467e+04	-3.332e+04	-2486.65	5.464e+04
90	54	106	11.00	5.74	-27.03	-22.46	1.16	-11.36	2.798e+04	-9.729e+04	-3.458e+04	-3.474e+04	
6.263e+04													
4.427e+04		107	7.86	-0.47	-8.04	-7.21	-1.30	-2.37	1.733e+04	-7.165e+04	-2.272e+04	-3.161e+04	
		115	10.20	10.07	-55.66	-23.86	-21.73	-32.85	7.452e+04	-4.418e+04	-1003.25	3.134e+04	5.710e+04
		114	9.68	16.21	-18.44	-18.24	16.02	-2.60	3.956e+04	-7.486e+04	-3.350e+04	-1802.13	5.497e+04
90	69	106	10.93	1.89	-14.04	-13.71	1.56	-2.29	2.782e+04	-9.729e+04	-3.471e+04	-3.477e+04	
6.256e+04													
4.438e+04		107	7.89	1.44	-6.73	-1.63	-3.66	3.96	1.750e+04	-7.172e+04	-2.256e+04	-3.165e+04	

Parco Eolico "Bolina" – Progetto Definitivo
Relazione di calcolo preliminare delle fondazioni degli aerogeneratori G8 e G12

		115	10.01	5.16	-38.48	-15.22	-18.10	-21.77	7.327e+04	-4.400e+04	-1458.17	3.072e+04	5.639e+04
		114	9.75	14.82	-11.38	-10.27	13.71	5.28	3.991e+04	-7.496e+04	-3.360e+04	-1452.05	5.514e+04
91	1	107	11.55	7.64	-10.26	-5.06	2.43	-8.13	3.132e+04	-1.010e+05	-2.566e+04	-4.403e+04	
6.552e+04		108	8.82	-0.84	-26.04	-10.16	-16.72	12.17	3.892e+04	-6.491e+04	-6487.33	-1.951e+04	5.151e+04
		116	9.43	30.55	-5.83	-5.55	30.28	3.13	4.589e+04	-6.634e+04	-2.442e+04	3969.05	5.429e+04
		115	10.98	0.90	-57.29	-3.63	-52.77	15.59	8.814e+04	-4.098e+04	-6038.91	5.320e+04	5.737e+04
91	3	107	9.78	6.46	-8.69	-4.28	2.06	-6.88	2.650e+04	-8.547e+04	-2.171e+04	-3.726e+04	
5.544e+04		108	7.46	-0.71	-22.04	-8.60	-14.14	10.30	3.293e+04	-5.493e+04	-5489.28	-1.651e+04	4.358e+04
		116	7.98	25.85	-4.93	-4.70	25.62	2.65	3.883e+04	-5.613e+04	-2.066e+04	3358.43	4.594e+04
		115	9.29	0.76	-48.48	-3.07	-44.65	13.19	7.458e+04	-3.468e+04	-5109.84	4.501e+04	4.854e+04
91	24	107	8.95	19.62	-56.23	-52.32	15.71	-16.79	2.468e+04	-7.708e+04	-1.852e+04	-3.388e+04	
5.030e+04		108	6.72	0.70	-43.92	-43.92	0.70	0.20	3.021e+04	-4.974e+04	-4852.98	-1.467e+04	3.967e+04
		116	7.20	40.43	-41.03	-38.43	37.83	-14.32	3.452e+04	-5.110e+04	-1.889e+04	2307.19	4.147e+04
		115	8.80	-26.29	-46.72	-33.65	-39.36	-9.81	6.962e+04	-3.293e+04	-6551.41	4.324e+04	4.483e+04
91	56	107	8.91	9.76	-23.49	-20.28	6.55	-9.82	2.429e+04	-7.749e+04	-1.932e+04	-3.387e+04	
5.037e+04		108	6.76	-5.56	-22.74	-20.03	-8.27	6.26	3.003e+04	-4.987e+04	-4943.80	-1.489e+04	3.964e+04
		116	7.21	28.45	-16.07	-15.83	28.21	-3.25	3.503e+04	-5.105e+04	-1.882e+04	2800.71	4.166e+04
		115	8.57	-12.47	-40.94	-13.23	-40.17	4.61	6.841e+04	-3.200e+04	-5290.29	4.171e+04	4.436e+04
91	69	107	8.89	5.88	-7.90	-3.89	1.87	-6.25	2.409e+04	-7.770e+04	-1.974e+04	-3.387e+04	
5.040e+04		108	6.78	-0.64	-20.03	-7.82	-12.86	9.36	2.994e+04	-4.993e+04	-4990.25	-1.501e+04	3.962e+04
		116	7.25	23.50	-4.48	-4.27	23.29	2.41	3.530e+04	-5.103e+04	-1.879e+04	3053.11	4.176e+04
		115	8.45	0.69	-44.07	-2.79	-40.59	11.99	6.780e+04	-3.152e+04	-4645.31	4.092e+04	4.413e+04
92	1	108	9.21	2.65	-10.78	-9.37	1.24	4.11	3.509e+04	-7.314e+04	-1.200e+04	-2.604e+04	
5.366e+04		109	7.33	0.20	-7.68	-7.11	-0.37	2.04	3.109e+04	-5.582e+04	-5761.92	-1.897e+04	4.295e+04
		117	7.52	5.96	-6.69	-6.50	5.77	1.54	4.389e+04	-4.628e+04	-1.502e+04	1.262e+04	4.292e+04
		116	9.08	2.23	-5.39	-4.95	1.78	1.78	5.308e+04	-5.590e+04	-1.932e+04	1.650e+04	5.146e+04
92	3	108	7.79	2.24	-9.12	-7.93	1.05	3.48	2.969e+04	-6.188e+04	-1.016e+04	-2.204e+04	
4.540e+04		109	6.21	0.17	-6.50	-6.02	-0.31	1.72	2.630e+04	-4.723e+04	-4875.47	-1.605e+04	3.634e+04
		117	6.36	5.05	-5.66	-5.50	4.88	1.30	3.714e+04	-3.916e+04	-1.271e+04	1.068e+04	3.631e+04
		116	7.68	1.88	-4.56	-4.19	1.51	1.51	4.491e+04	-4.730e+04	-1.635e+04	1.396e+04	4.354e+04
92	7	108	7.18	22.07	-38.81	-35.16	18.42	14.44	2.721e+04	-5.650e+04	-9237.97	-2.005e+04	4.150e+04
		109	5.70	19.22	-29.68	-26.11	15.65	12.72	2.400e+04	-4.287e+04	-4351.57	-1.452e+04	3.304e+04
		117	5.86	22.27	-26.20	-25.31	21.38	6.52	3.391e+04	-3.542e+04	-1.140e+04	9894.51	3.299e+04
		116	7.08	21.86	-22.96	-22.63	21.54	3.80	4.089e+04	-4.327e+04	-1.513e+04	1.275e+04	3.971e+04
92	39	108	7.12	8.78	-18.58	-16.67	6.87	6.98	2.707e+04	-5.634e+04	-9234.57	-2.004e+04	4.135e+04
		109	5.66	6.60	-13.95	-12.46	5.11	5.34	2.394e+04	-4.291e+04	-4404.95	-1.457e+04	3.304e+04
		117	5.81	10.57	-12.27	-11.87	10.17	2.99	3.381e+04	-3.554e+04	-1.150e+04	9772.55	3.301e+04
		116	7.02	8.45	-10.44	-10.18	8.20	2.19	4.085e+04	-4.309e+04	-1.495e+04	1.271e+04	3.963e+04
92	69	108	7.08	2.04	-8.29	-7.21	0.96	3.16	2.699e+04	-5.626e+04	-9232.83	-2.003e+04	4.127e+04
		109	5.64	0.15	-5.91	-5.47	-0.28	1.57	2.391e+04	-4.294e+04	-4432.25	-1.459e+04	3.304e+04
		117	5.79	4.59	-5.14	-5.00	4.44	1.19	3.376e+04	-3.560e+04	-1.155e+04	9710.18	3.301e+04
		116	6.98	1.71	-4.15	-3.81	1.37	1.37	4.083e+04	-4.300e+04	-1.486e+04	1.269e+04	3.958e+04
93	1	109	7.34	0.65	-8.33	-8.26	0.57	0.83	3.140e+04	-5.576e+04	-5397.32	-1.896e+04	4.305e+04
		110	5.68	1.71	-5.01	-5.00	1.70	-0.30	2.830e+04	-3.962e+04	3887.40	-1.520e+04	3.259e+04
		118	6.11	2.53	-8.32	-8.21	2.42	-1.09	4.218e+04	-3.100e+04	-5833.13	1.701e+04	3.476e+04
		117	7.47	5.97	-5.05	-5.01	5.93	-0.64	4.384e+04	-4.597e+04	-1.491e+04	1.277e+04	4.272e+04
93	3	109	6.21	0.55	-7.05	-6.99	0.49	0.70	2.657e+04	-4.719e+04	-4566.97	-1.605e+04	3.643e+04
		110	4.81	1.45	-4.24	-4.23	1.44	-0.25	2.395e+04	-3.352e+04	3289.34	-1.286e+04	2.758e+04
		118	5.17	2.14	-7.04	-6.95	2.04	-0.92	3.569e+04	-2.623e+04	-4935.72	1.439e+04	2.911e+04
		117	6.32	5.05	-4.27	-4.24	5.02	-0.54	3.709e+04	-3.890e+04	-1.261e+04	1.081e+04	3.615e+04
93	23	109	5.71	10.79	-9.93	2.14	-1.27	10.22	2.401e+04	-4.296e+04	-4306.88	-1.464e+04	3.308e+04
		110	4.41	11.96	-9.23	5.66	-2.92	9.69	2.158e+04	-3.039e+04	2858.00	-1.167e+04	2.495e+04
		118	4.76	17.26	-11.43	3.67	2.16	14.32	3.195e+04	-2.396e+04	-4896.77	1.289e+04	2.650e+04
		117	5.82	18.17	-4.79	8.77	4.61	11.29	3.368e+04	-3.543e+04	-1.161e+04	9858.57	3.284e+04
93	55	109	5.67	2.41	-6.03	-3.48	-0.14	3.88	2.411e+04	-4.292e+04	-4204.27	-1.461e+04	3.311e+04
		110	4.38	2.76	-3.52	-0.63	-0.12	3.13	2.170e+04	-3.044e+04	2945.54	-1.169e+04	2.503e+04
		118	4.72	4.45	-5.43	-2.94	1.96	4.29	3.228e+04	-2.388e+04	-4625.67	1.302e+04	2.666e+04
		117	5.77	6.56	-1.57	0.42	4.58	3.49	3.371e+04	-3.539e+04	-1.152e+04	9835.85	3.286e+04
93	69	109	5.65	0.50	-6.41	-6.35	0.44	0.64	2.416e+04	-4.290e+04	-4151.79	-1.459e+04	3.312e+04
		110	4.37	1.32	-3.86	-3.85	1.31	-0.23	2.177e+04	-3.047e+04	2990.31	-1.169e+04	2.507e+04
		118	4.70	1.94	-6.40	-6.32	1.86	-0.84	3.244e+04	-2.385e+04	-4487.02	1.308e+04	2.674e+04
		117	5.75	4.59	-3.88	-3.85	4.56	-0.49	3.372e+04	-3.536e+04	-1.147e+04	9824.23	3.286e+04
94	1	110	5.91	-3.23	-9.90	-7.44	-5.69	-3.22	3.226e+04	-3.848e+04	6678.10	-1.289e+04	3.399e+04
		111	3.82	12.68	-5.58	1.84	5.26	8.97	1.629e+04	-2.856e+04	3923.48	-1.620e+04	2.004e+04
		119	6.56	1.89	-30.48	-8.85	-19.74	-15.24	6.152e+04	-9829.37	1.589e+04	3.580e+04	3.426e+04
		118	5.68	13.80	-7.03	-6.88	13.66	-1.71	3.670e+04	-3.147e+04	-7536.51	1.277e+04	3.254e+04

Parco Eolico "Bolina" – Progetto Definitivo
Relazione di calcolo preliminare delle fondazioni degli aerogeneratori G8 e G12

94	3	110	5.00	-2.73	-8.38	-6.30	-4.81	-2.72	2.730e+04	-3.256e+04	5650.70	-1.091e+04	2.876e+04	
		111	3.23	10.73	-4.72	1.56	4.45	7.59	1.378e+04	-2.417e+04	3319.87	-1.370e+04	1.696e+04	
		119	5.55	1.60	-25.79	-7.49	-16.70	-12.90	5.205e+04	-8317.16	1.345e+04	3.029e+04	2.899e+04	
		118	4.81	11.68	-5.94	-5.82	11.56	-1.45	3.106e+04	-2.663e+04	-6377.05	1.081e+04	2.753e+04	
94	22	110	4.65	3.25	-19.43	-11.48	-4.70	-10.82	2.548e+04	-2.951e+04	5431.71	-9462.81	2.647e+04	
		111	2.84	12.03	-4.21	-3.48	11.29	3.38	1.161e+04	-2.192e+04	2620.09	-1.293e+04	1.486e+04	
		119	5.50	11.63	-50.32	-14.53	-24.16	-30.60	5.060e+04	-7833.83	1.302e+04	2.974e+04	2.800e+04	
		118	4.38	18.20	-19.85	-16.60	14.95	-10.63	2.801e+04	-2.417e+04	-5358.77	9197.13	2.505e+04	
94	54	110	4.58	-0.54	-11.61	-7.67	-4.48	-5.30	2.504e+04	-2.957e+04	5236.72	-9764.65	2.625e+04	
		111	2.90	9.76	-3.50	-0.24	6.50	5.71	1.222e+04	-2.195e+04	2883.40	-1.262e+04	1.523e+04	
		119	5.20	4.82	-32.46	-9.42	-18.22	-18.11	4.843e+04	-7653.18	1.249e+04	2.828e+04	2.691e+04	
		118	4.36	12.92	-10.03	-9.12	12.01	-4.47	2.816e+04	-2.419e+04	-5648.92	9611.59	2.504e+04	
94	69	110	4.55	-2.48	-7.61	-5.72	-4.37	-2.48	2.481e+04	-2.960e+04	5137.00	-9919.02	2.614e+04	
		111	2.94	9.76	-4.30	1.42	4.04	6.90	1.253e+04	-2.197e+04	3018.06	-1.246e+04	1.542e+04	
		119	5.04	1.46	-23.45	-6.81	-15.18	-11.73	4.732e+04	-7561.05	1.222e+04	2.754e+04	2.635e+04	
		118	4.37	10.62	-5.40	-5.29	10.51	-1.32	2.823e+04	-2.421e+04	-5797.32	9823.55	2.503e+04	
95	1	111	4.67	8.00	-1.24	-1.01	7.77	-1.42	2.214e+04	-3.344e+04	5436.46	-1.674e+04	2.548e+04	
		112	2.82	-1.64	-13.80	-5.62	-9.83	5.70	1.990e+04	-1.335e+04	9332.77	-2784.01	1.548e+04	
		120	3.89	13.55	1.86	2.03	13.38	1.38	2.741e+04	-1.881e+04	-5138.31	1.374e+04	2.109e+04	
		119	5.28	2.96	-23.89	1.03	-21.96	6.94	5.256e+04	-4285.05	1.132e+04	3.695e+04	2.537e+04	
95	3	111	3.96	6.77	-1.05	-0.86	6.57	-1.20	1.873e+04	-2.829e+04	4600.08	-1.416e+04	2.156e+04	
		112	2.39	-1.39	-11.68	-4.75	-8.32	4.83	1.684e+04	-1.129e+04	7896.96	-2355.70	1.319e+04	
		120	3.29	11.46	1.58	1.72	11.32	1.17	2.319e+04	-1.592e+04	-4347.80	1.162e+04	1.785e+04	
		119	4.46	2.51	-20.22	0.87	-18.58	5.87	4.447e+04	-3625.81	9581.73	3.127e+04	2.147e+04	
95	8	111	3.53	27.48	-21.53	-20.19	26.14	7.99	1.731e+04	-2.462e+04	5274.75	-1.258e+04	1.897e+04	
		112	2.22	16.26	-18.51	-15.57	13.32	9.67	1.568e+04	-1.057e+04	7408.96	-2298.34	1.219e+04	
		120	3.01	27.24	-7.01	-6.11	26.34	-5.48	2.133e+04	-1.443e+04	-4197.98	1.111e+04	1.616e+04	
		119	4.25	11.73	-7.60	-2.68	6.81	-8.42	4.094e+04	-5401.89	7467.60	2.807e+04	2.076e+04	
95	40	111	3.57	12.99	-7.54	-7.35	12.80	1.98	1.712e+04	-2.535e+04	4551.69	-1.278e+04	1.939e+04	
		112	2.19	2.95	-11.57	-8.13	-0.49	6.17	1.543e+04	-1.037e+04	7256.83	-2194.60	1.200e+04	
		120	3.00	15.80	-1.11	-1.04	15.73	-1.15	2.117e+04	-1.445e+04	-4035.59	1.075e+04	1.620e+04	
		119	4.12	-0.33	-8.93	-0.38	-8.87	0.68	4.060e+04	-4008.59	8290.04	2.830e+04	1.994e+04	
95	69	111	3.60	6.15	-0.95	-0.78	5.98	-1.10	1.703e+04	-2.572e+04	4181.89	-1.288e+04	1.960e+04	
		112	2.17	-1.26	-10.62	-4.32	-7.56	4.39	1.531e+04	-1.027e+04	7179.05	-2141.55	1.191e+04	
		120	2.99	10.42	1.43	1.56	10.29	1.07	2.108e+04	-1.447e+04	-3952.54	1.057e+04	1.623e+04	
		119	4.06	2.28	-18.38	0.79	-16.89	5.34	4.043e+04	-3296.19	8710.66	2.842e+04	1.952e+04	
96	1	112	2.93	1.85	-4.86	-3.33	0.32	2.82	1.831e+04	-1.672e+04	5840.51	-4250.44	1.677e+04	
		113	0.30	1.31	-4.90	0.23	-3.82	2.36	722.53	-2467.31	-329.74	-1415.05	1499.76	
		121	0.97	4.57	-0.70	-0.67	4.54	0.38	9596.60	-671.61	-504.85	9429.83	1297.90	
		120	3.77	2.36	-0.06	2.06	0.24	-0.80	2.961e+04	-1.481e+04	-2411.13	1.721e+04	1.993e+04	
96	3	112	2.48	1.57	-4.11	-2.82	0.27	2.38	1.549e+04	-1.415e+04	4941.97	-3596.53	1.419e+04	
		113	0.25	1.11	-4.15	0.19	-3.23	2.00	611.37	-2087.73	-279.01	-1197.35	1269.03	
		121	0.82	3.86	-0.59	-0.57	3.84	0.32	8120.20	-568.29	-427.18	7979.09	1098.22	
		120	3.19	2.00	-0.05	1.74	0.21	-0.68	2.506e+04	-1.253e+04	-2040.19	1.456e+04	1.686e+04	
96	8	112	2.29	24.02	-12.48	-9.54	21.08	9.93	1.430e+04	-1.281e+04	4697.79	-3207.25	1.296e+04	
		113	0.27	18.40	-6.99	-2.91	14.32	9.32	584.88	-1927.30	-285.71	-1056.71	1195.48	
		121	0.83	21.87	-4.27	-2.47	20.06	-6.63	7641.37	-471.62	-352.44	7522.19	976.05	
		120	2.97	24.00	-5.13	0.22	18.65	-11.28	2.299e+04	-1.169e+04	-2147.89	1.344e+04	1.549e+04	
96	40	112	2.27	8.95	-6.58	-4.92	7.30	4.79	1.416e+04	-1.284e+04	4562.10	-3248.48	1.292e+04	
		113	0.24	5.76	-3.73	-0.87	2.90	4.36	565.46	-1907.70	-264.49	-1077.74	1167.81	
		121	0.78	9.49	-1.57	-1.18	9.10	-2.05	7469.69	-501.32	-376.20	7344.56	990.83	
		120	2.92	8.77	-1.21	1.12	6.43	-4.22	2.285e+04	-1.150e+04	-1953.92	1.331e+04	1.538e+04	
96	69	112	2.25	1.43	-3.74	-2.56	0.25	2.17	1.408e+04	-1.286e+04	4492.70	-3269.57	1.290e+04	
		113	0.23	1.01	-3.77	0.18	-2.94	1.81	555.79	-1897.93	-253.64	-1088.50	1153.66	
		121	0.75	3.51	-0.54	-0.52	3.49	0.29	7382.00	-516.62	-388.34	7253.72	998.39	
		120	2.90	1.82	-0.04	1.58	0.19	-0.62	2.278e+04	-1.139e+04	-1854.72	1.324e+04	1.533e+04	
97	1	72	23.17	4.66	-20.18	-7.55	-7.97	-12.42	1.229e+05	-1.547e+05	-1.397e+05	1.078e+05	-	
6.290e+04		81	17.04	5.08	-8.44	-3.43	0.07	-6.53	6.964e+04	-1.319e+05	-1.282e+05	6.594e+04	-	
2.705e+04		114	13.42	4.69	-16.62	-5.95	-5.98	-10.65	5.981e+04	-9.964e+04	-9.638e+04	5.655e+04	-	
2.257e+04		122	14.67	7.22	-9.23	-2.85	0.84	-8.02	8.939e+04	-8.658e+04	-7.328e+04	7.609e+04	-	
4.650e+04		97	3	72	19.61	3.94	-17.07	-6.39	-6.74	-10.51	1.040e+05	-1.309e+05	-1.182e+05	9.122e+04
5.323e+04		81	14.42	4.30	-7.14	-2.90	0.06	-5.52	5.892e+04	-1.116e+05	-1.084e+05	5.579e+04	-	
2.289e+04		114	11.35	3.97	-14.06	-5.03	-5.06	-9.01	5.060e+04	-8.431e+04	-8.155e+04	4.785e+04	-	
1.909e+04		122	12.41	6.11	-7.81	-2.41	0.71	-6.78	7.563e+04	-7.326e+04	-6.201e+04	4.439e+04	-	
3.935e+04		97	7	72	18.04	30.23	-73.57	-27.42	-15.92	-51.58	9.466e+04	-1.194e+05	-1.078e+05	8.302e+04

Parco Eolico "Bolina" – Progetto Definitivo
Relazione di calcolo preliminare delle fondazioni degli aerogeneratori G8 e G12

2.460e+04	115	7.23	65.91	-4.56	29.24	32.10	-35.21	3.688e+04	-4.809e+04	-4.024e+04	2.903e+04	-
3.983e+04	116	7.60	-3.15	-23.45	-22.77	-3.84	3.67	4.701e+04	-4.423e+04	-2.085e+04	2.364e+04	-
3.753e+04	124	7.13	31.01	-9.21	12.22	9.58	-20.07	4.465e+04	-3.961e+04	-1.663e+04	2.167e+04	-
5.320e+04	123	10.50	22.82	-78.29	16.88	-72.35	-23.77	6.809e+04	-5.763e+04	-2.826e+04	3.872e+04	-
2.239e+04	115	6.38	78.09	-43.27	24.46	10.36	-60.27	3.162e+04	-4.221e+04	-3.465e+04	2.406e+04	-
3.643e+04	116	7.05	3.23	-45.13	-11.94	-29.96	-22.43	4.284e+04	-4.073e+04	-1.941e+04	2.153e+04	-
3.396e+04	124	6.50	45.78	-43.40	24.82	-22.45	-37.81	4.051e+04	-3.567e+04	-1.482e+04	1.967e+04	-
5.327e+04	123	10.48	9.85	-42.89	8.72	-41.76	-7.65	6.744e+04	-5.792e+04	-2.828e+04	3.779e+04	-
2.237e+04	115	6.50	65.94	-17.26	25.87	22.81	-41.57	3.288e+04	-4.320e+04	-3.593e+04	2.560e+04	-
3.628e+04	116	6.95	-9.09	-21.09	-17.73	-12.45	-5.38	4.277e+04	-4.038e+04	-1.911e+04	2.150e+04	-
3.406e+04	124	6.49	33.33	-19.42	15.75	-1.83	-24.87	4.057e+04	-3.589e+04	-1.502e+04	1.969e+04	-
5.331e+04	123	10.48	4.56	-26.12	4.55	-26.11	0.60	6.710e+04	-5.808e+04	-2.829e+04	3.732e+04	-
2.236e+04	115	6.57	59.91	-4.15	26.58	29.18	-32.01	3.353e+04	-4.372e+04	-3.658e+04	2.639e+04	-
3.621e+04	116	6.91	-2.86	-21.32	-20.70	-3.49	3.34	4.274e+04	-4.021e+04	-1.896e+04	2.149e+04	-
3.412e+04	124	6.48	28.19	-8.38	11.11	8.71	-18.25	4.060e+04	-3.601e+04	-1.511e+04	1.970e+04	-
5.367e+04	124	9.22	9.23	-9.49	1.60	-1.86	-9.20	5.910e+04	-5.104e+04	-8334.80	1.640e+04	-
4.629e+04	116	8.77	5.91	-5.16	0.36	0.39	-5.54	4.888e+04	-5.606e+04	-2.830e+04	2.112e+04	-
3.951e+04	117	7.49	1.51	-7.46	-2.71	-3.25	-4.48	4.381e+04	-4.596e+04	-2.238e+04	2.022e+04	-
4.734e+04	125	8.06	7.74	-5.44	3.81	-1.51	-6.03	5.122e+04	-4.518e+04	-6051.12	1.209e+04	-
4.541e+04	124	7.81	7.81	-8.03	1.36	-1.58	-7.79	5.001e+04	-4.319e+04	-7052.52	1.387e+04	-
3.917e+04	116	7.42	5.00	-4.37	0.31	0.33	-4.69	4.136e+04	-4.744e+04	-2.394e+04	1.787e+04	-
3.343e+04	117	6.34	1.28	-6.31	-2.29	-2.75	-3.79	3.707e+04	-3.889e+04	-1.894e+04	1.711e+04	-
4.005e+04	125	6.82	6.55	-4.60	3.23	-1.27	-5.10	4.334e+04	-3.823e+04	-5120.18	1.023e+04	-
4.135e+04	124	7.20	22.25	-26.77	8.33	-12.84	-22.10	4.568e+04	-3.918e+04	-6289.06	1.279e+04	-
3.573e+04	116	6.84	18.63	-27.67	2.36	-11.41	-22.10	3.772e+04	-4.309e+04	-2.155e+04	1.618e+04	-
3.035e+04	117	5.85	17.81	-28.48	0.77	-11.43	-22.33	3.378e+04	-3.521e+04	-1.711e+04	1.568e+04	-
3.639e+04	125	6.28	22.10	-22.18	11.17	-11.25	-19.09	3.952e+04	-3.458e+04	-4480.53	9416.22	-
4.130e+04	124	7.13	12.12	-13.79	3.63	-5.29	-12.16	4.554e+04	-3.924e+04	-6369.99	1.267e+04	-
3.565e+04	116	6.77	9.22	-11.89	0.98	-3.66	-10.30	3.764e+04	-4.311e+04	-2.169e+04	1.622e+04	-
3.038e+04	117	5.79	6.76	-13.40	-1.12	-5.52	-9.83	3.373e+04	-3.531e+04	-1.718e+04	1.560e+04	-
3.641e+04	125	6.23	11.40	-10.26	5.72	-4.57	-9.53	3.944e+04	-3.470e+04	-4595.77	9340.90	-
4.128e+04	124	7.10	7.10	-7.30	1.23	-1.43	-7.08	4.546e+04	-3.926e+04	-6411.39	1.261e+04	-
3.561e+04	116	6.74	4.55	-3.97	0.28	0.30	-4.26	3.760e+04	-4.312e+04	-2.177e+04	1.625e+04	-
3.039e+04	117	5.76	1.16	-5.74	-2.08	-2.50	-3.44	3.370e+04	-3.536e+04	-1.721e+04	1.556e+04	-
3.641e+04	125	6.20	5.96	-4.18	2.93	-1.16	-4.64	3.940e+04	-3.475e+04	-4654.71	9302.38	-
4.803e+04	125	8.04	5.39	-4.12	3.13	-1.86	-4.05	5.150e+04	-4.476e+04	299.84	6443.90	-
	117	7.45	0.08	-6.16	-1.27	-4.81	-2.56	4.337e+04	-4.609e+04	-1.749e+04	1.478e+04	-

Parco Eolico "Bolina" – Progetto Definitivo
Relazione di calcolo preliminare delle fondazioni degli aerogeneratori G8 e G12

2.348e+04	119	4.71	13.80	-9.87	13.80	-9.87	-0.20	4.039e+04-1.373e+04	-108.30	2.677e+04	-
2.450e+04	127	4.10	3.49	-3.69	-0.95	0.75	-3.49	2.502e+04-2.398e+04	228.70	813.10	-
103 1	127	6.07	-0.14	-15.77	-2.75	-13.15	5.84	4.005e+04-3.226e+04	2768.17	5014.53	-
3.614e+04	119	3.63	37.90	-2.73	22.82	12.35	-19.63	3.107e+04 -9133.09	1526.86	2.041e+04	-
1.775e+04	120	3.14	1.57	-14.92	-14.51	1.16	-2.57	2.689e+04 -9543.22	1.235e+04	4991.96	-
1.784e+04	128	3.10	17.02	-3.00	12.92	1.10	-8.08	1.990e+04-1.665e+04	1181.25	2074.64	-
1.827e+04	127	5.13	-0.11	-13.35	-2.33	-11.13	4.94	3.388e+04-2.730e+04	2342.30	4243.06	-
103 3	119	3.07	32.07	-2.31	19.31	10.45	-16.61	2.629e+04 -7728.00	1291.96	1.727e+04	-
3.058e+04	120	2.66	1.33	-12.62	-12.27	0.98	-2.17	2.275e+04 -8075.03	1.045e+04	4223.96	-
1.502e+04	128	2.62	14.40	-2.54	10.93	0.93	-6.84	1.684e+04-1.409e+04	999.52	1755.46	-
1.546e+04	127	4.54	11.03	-20.87	-19.70	9.86	-5.99	2.916e+04-2.489e+04	1773.76	2495.88	-
103 21	119	3.01	9.63	-8.97	-8.93	9.59	0.92	2.682e+04 -7314.49	2272.10	1.724e+04	-
2.702e+04	120	2.43	10.94	-27.38	-27.18	10.74	2.74	2.020e+04 -7389.16	8760.60	4050.05	-
1.534e+04	128	2.48	11.37	-16.12	-12.06	7.31	-9.76	1.586e+04-1.307e+04	1317.25	1471.38	-
1.359e+04	127	4.59	-3.17	-8.25	-8.07	-3.36	0.95	3.025e+04-2.484e+04	2009.04	3396.65	-
1.447e+04	119	2.86	18.75	-0.63	8.59	9.53	-9.68	2.489e+04 -7120.97	1545.91	1.622e+04	-
103 53	120	2.42	4.23	-16.59	-16.58	4.23	-0.38	2.052e+04 -7355.68	9250.09	3911.05	-
2.753e+04	128	2.42	10.18	-4.66	2.49	3.03	-7.41	1.549e+04-1.289e+04	1046.92	1553.75	-
1.419e+04	127	4.67	-0.10	-12.13	-2.12	-10.12	4.49	3.080e+04-2.482e+04	2129.37	3857.33	-
103 69	119	2.79	29.16	-2.10	17.55	9.50	-15.10	2.390e+04 -7025.45	1174.51	1.570e+04	-
2.780e+04	120	2.42	1.21	-11.47	-11.16	0.90	-1.97	2.068e+04 -7340.94	9500.43	3839.97	-
1.365e+04	128	2.38	13.09	-2.31	9.94	0.84	-6.21	1.531e+04-1.280e+04	908.66	1595.87	-
1.372e+04	128	3.43	5.81	-3.18	3.37	-0.73	-4.00	2.267e+04-1.812e+04	4785.56	-230.45	-
1.405e+04	120	3.10	2.18	-1.88	-0.76	1.06	-1.82	2.520e+04-1.096e+04	8971.01	5270.70	-
104 1	121	0.99	0.84	-8.09	-7.67	0.42	-1.89	9652.77 -649.28	9334.36	-330.87	-1782.95
2.024e+04	129	0.49	5.01	-0.55	4.92	-0.46	-0.71	4494.91 -692.82	3612.67	189.42	-1948.97
1.712e+04	128	2.90	4.92	-2.69	2.85	-0.62	-3.38	1.918e+04-1.533e+04	4049.32	-194.99	-
1.522e+04	120	2.62	1.85	-1.59	-0.64	0.90	-1.54	2.133e+04 -9275.76	7590.85	4459.82	-
1.404e+04	121	0.83	0.71	-6.85	-6.49	0.36	-1.60	8167.73 -549.39	7898.30	-279.97	-1508.65
1.568e+04	129	0.41	4.24	-0.47	4.16	-0.39	-0.60	3803.39 -586.23	3056.87	160.28	-1649.13
104 21	128	2.69	11.21	-20.76	-17.11	7.56	-10.17	1.748e+04-1.416e+04	3720.29	-396.34	-
1.404e+04	120	2.49	3.32	-25.67	-21.65	-0.71	10.03	1.968e+04 -8499.13	6800.66	4382.37	-
1.561e+04	121	0.83	6.18	-23.90	-23.62	5.91	2.85	7192.52 -537.52	6950.32	-295.32	-1346.69
1.391e+04	129	0.39	0.69	-19.42	-17.05	-1.68	-6.48	3533.74 -527.57	2829.01	177.16	-1538.01
104 53	128	2.66	5.36	-7.25	-4.07	2.19	-5.48	1.745e+04-1.401e+04	3694.43	-251.40	-
1.557e+04	120	2.41	1.00	-8.41	-7.71	0.30	2.47	1.949e+04 -8454.62	6866.90	4165.36	-
1.384e+04	121	0.78	2.21	-11.90	-11.90	2.21	3.69e-03	7346.47 -512.33	7102.46	-268.32	-1363.10
104 69	129	0.37	0.80	-4.87	-3.27	-0.80	-2.56	3483.36 -531.10	2795.90	156.35	-1512.34
1.557e+04	128	2.64	4.47	-2.44	2.59	-0.56	-3.08	1.744e+04-1.394e+04	3681.20	-177.27	-
1.384e+04	120	2.38	1.68	-1.45	-0.59	0.82	-1.40	1.939e+04 -8432.51	6900.77	4054.38	-
	121	0.76	0.65	-6.23	-5.90	0.33	-1.45	7425.21 -499.45	7180.28	-254.51	-1371.50

Parco Eolico "Bolina" – Progetto Definitivo
Relazione di calcolo preliminare delle fondazioni degli aerogeneratori G8 e G12

	129	0.37	3.85	-0.43	3.78	-0.35	-0.55	3457.63	-532.94	2778.97	145.71	-1499.21
105 1	63	35.40	13.28	-16.90	-6.75	3.13	-14.26	1.945e+05	-2.298e+05	2.022e+05	1.669e+05	-
1.046e+05												
	72	21.16	-5.24	-21.14	-5.98	-20.40	3.35	1.261e+05	-1.277e+05	-1.133e+05	1.118e+05	-
5.858e+04												
	122	15.96	12.48	-16.12	-6.07	2.44	-13.65	8.079e+04	-1.095e+05	-9.804e+04	6.928e+04	-
4.535e+04												
	130	12.55	-3.37	-14.71	-6.08	-12.00	4.84	1.274e+05	-5507.02	2.354e+04	9.831e+04	-
5.491e+04												
105 3	63	29.95	11.24	-14.30	-5.71	2.65	-12.07	1.645e+05	-1.945e+05	-1.711e+05	1.412e+05	-
8.854e+04												
	72	17.90	-4.43	-17.89	-5.06	-17.26	2.84	1.067e+05	-1.080e+05	-9.591e+04	9.462e+04	-
4.956e+04												
	122	13.50	10.56	-13.64	-5.14	2.06	-11.55	6.836e+04	-9.269e+04	-8.296e+04	5.862e+04	-
3.838e+04												
	130	10.62	-2.85	-12.45	-5.15	-10.15	4.09	1.078e+05	-4659.79	1.992e+04	8.318e+04	-
4.646e+04												
105 24	63	27.40	55.11	-109.60	-19.57	-34.92	-82.00	1.489e+05	-1.773e+05	-1.559e+05	1.276e+05	-
8.059e+04												
	72	16.81	9.76	-165.94	5.33	-161.51	27.54	9.661e+04	-9.838e+04	-8.737e+04	8.560e+04	-
4.499e+04												
	122	12.48	59.87	-95.66	-19.14	-16.65	-77.75	6.197e+04	-8.424e+04	-7.544e+04	5.317e+04	-
3.477e+04												
	130	10.03	8.58	-116.84	2.91	-111.17	26.05	9.777e+04	-4355.71	1.794e+04	7.547e+04	-
4.219e+04												
105 56	63	27.28	24.86	-45.14	-10.05	-10.22	-35.00	1.494e+05	-1.770e+05	-1.557e+05	1.281e+05	-
8.053e+04												
	72	16.46	0.61	-66.88	-1.24	-65.03	11.02	9.689e+04	-9.827e+04	-8.725e+04	8.588e+04	-
4.504e+04												
	122	12.34	26.38	-40.34	-9.57	-4.39	-33.26	6.208e+04	-8.425e+04	-7.542e+04	5.325e+04	-
3.485e+04												
	130	9.78	0.75	-46.58	-2.11	-43.72	11.28	9.790e+04	-4276.62	1.805e+04	7.557e+04	-
4.222e+04												
105 69	63	27.23	10.22	-13.00	-5.19	2.41	-10.97	1.496e+05	-1.768e+05	-1.556e+05	1.283e+05	-
8.049e+04												
	72	16.27	-4.03	-16.26	-4.60	-15.69	2.58	9.704e+04	-9.821e+04	-8.719e+04	8.602e+04	-
4.506e+04												
	122	12.27	9.60	-12.40	-4.67	1.87	-10.50	6.214e+04	-8.426e+04	-7.541e+04	5.330e+04	-
3.489e+04												
	130	9.65	-2.59	-11.32	-4.68	-9.23	3.72	9.796e+04	-4236.17	1.811e+04	7.562e+04	-
4.224e+04												
106 1	130	17.50	3.22	-17.75	-9.92	-4.61	-10.15	1.293e+05	-7.839e+04	-3.511e+04	8.598e+04	-
8.434e+04												
	122	15.12	-1.43	-10.04	-4.48	-7.00	-4.11	9.103e+04	-9.063e+04	-6.858e+04	6.898e+04	-
5.933e+04												
	123	12.71	10.71	-14.02	2.55	-5.86	-11.63	7.832e+04	-7.419e+04	-5.642e+04	6.055e+04	-
4.893e+04												
	131	12.62	7.39	-7.89	4.09	-4.59	-6.29	9.777e+04	-5.133e+04	-1.510e+04	6.153e+04	-
6.395e+04												
106 3	130	14.81	2.73	-15.02	-8.39	-3.90	-8.58	1.094e+05	-6.633e+04	-2.971e+04	7.275e+04	-
7.137e+04												
	122	12.79	-1.21	-8.50	-3.79	-5.92	-3.48	7.703e+04	-7.669e+04	-5.803e+04	5.837e+04	-
5.020e+04												
	123	10.75	9.06	-11.86	2.16	-4.95	-9.84	6.627e+04	-6.277e+04	-4.774e+04	5.123e+04	-
4.140e+04												
	131	10.68	6.26	-6.68	3.46	-3.88	-5.32	8.273e+04	-4.344e+04	-1.278e+04	5.207e+04	-
5.411e+04												
106 23	130	13.60	41.93	-22.59	-22.17	41.50	-5.23	9.970e+04	-6.031e+04	-2.694e+04	6.633e+04	-
6.501e+04												
	122	11.91	77.06	-3.94	3.03	70.08	-22.73	7.021e+04	-6.971e+04	-5.268e+04	5.319e+04	-
4.574e+04												
	123	9.90	36.32	-31.98	-31.15	35.48	7.50	6.036e+04	-5.702e+04	-4.317e+04	4.651e+04	-
3.786e+04												
	131	9.94	62.35	-9.92	-4.51	56.94	-19.01	7.532e+04	-3.948e+04	-1.150e+04	4.734e+04	-
4.928e+04												
106 55	130	13.51	13.54	-14.39	-12.55	11.70	-6.93	9.952e+04	-6.030e+04	-2.698e+04	6.620e+04	-
6.492e+04												
	122	11.72	23.95	-5.05	-1.25	20.15	-9.78	7.009e+04	-6.971e+04	-5.273e+04	5.310e+04	-
4.567e+04												
	123	9.82	9.63	-9.85	-9.24	9.03	-3.38	6.028e+04	-5.705e+04	-4.332e+04	4.655e+04	-
3.771e+04												
	131	9.78	21.39	-3.90	0.55	16.93	-9.64	7.524e+04	-3.948e+04	-1.158e+04	4.734e+04	-
4.922e+04												

Parco Eolico "Bolina" – Progetto Definitivo
Relazione di calcolo preliminare delle fondazioni degli aerogeneratori G8 e G12

106	69	130	13.46	2.48	-13.66	-7.63	-3.54	-7.80	9.943e+04	-6.030e+04	-2.701e+04	6.614e+04	-
6.488e+04		122	11.63	-1.10	-7.72	-3.44	-5.38	-3.17	7.003e+04	-6.971e+04	-5.275e+04	5.306e+04	-
4.564e+04		123	9.78	8.24	-10.78	1.96	-4.50	-8.94	6.024e+04	-5.707e+04	-4.340e+04	4.658e+04	-
3.763e+04		131	9.70	5.69	-6.07	3.15	-3.53	-4.84	7.521e+04	-3.949e+04	-1.162e+04	4.733e+04	-
4.919e+04		131	13.10	4.94	-12.25	1.17	-8.47	-7.12	9.818e+04	-5.722e+04	-9546.33	5.050e+04	-
7.167e+04	1	123	12.37	11.44	-8.94	5.68	-3.19	-9.17	7.723e+04	-7.121e+04	-4.553e+04	5.155e+04	-
5.615e+04		124	9.61	9.58	-13.84	1.44	-5.70	-11.15	6.113e+04	-5.386e+04	-3.338e+04	4.065e+04	-
4.400e+04		132	10.42	10.35	-8.10	4.93	-2.68	-8.41	7.573e+04	-4.802e+04	-6049.13	3.376e+04	-
5.859e+04		131	11.08	4.18	-10.36	0.99	-7.17	-6.02	8.307e+04	-4.842e+04	-8077.66	4.273e+04	-
6.064e+04	3	123	10.47	9.68	-7.56	4.81	-2.70	-7.76	6.534e+04	-6.026e+04	-3.853e+04	4.362e+04	-
4.751e+04		124	8.13	8.11	-11.71	1.22	-4.82	-9.44	5.173e+04	-4.557e+04	-2.824e+04	3.440e+04	-
3.723e+04		132	8.82	8.76	-6.85	4.17	-2.26	-7.11	6.408e+04	-4.063e+04	-5118.49	2.856e+04	-
4.957e+04		131	10.24	49.18	-20.34	-17.80	46.65	-13.04	7.558e+04	-4.407e+04	-7227.17	3.873e+04	-
5.524e+04	23	123	9.65	36.80	-11.95	-11.56	36.41	-4.35	5.975e+04	-5.463e+04	-3.468e+04	3.981e+04	-
4.340e+04		124	7.51	30.37	-17.91	-17.43	29.89	-4.78	4.713e+04	-4.150e+04	-2.546e+04	3.109e+04	-
3.412e+04		132	8.15	42.35	-16.66	-12.54	38.23	-15.04	5.835e+04	-3.698e+04	-4540.38	2.591e+04	-
4.517e+04		131	10.13	14.68	-8.64	-5.43	11.47	-8.04	7.554e+04	-4.404e+04	-7304.03	3.881e+04	-
5.516e+04	55	123	9.56	13.33	-3.65	-1.02	10.70	-6.14	5.952e+04	-5.473e+04	-3.491e+04	3.970e+04	-
4.326e+04		124	7.43	10.59	-8.54	-5.16	7.22	-7.29	4.706e+04	-4.146e+04	-2.560e+04	3.121e+04	-
3.394e+04		132	8.06	16.41	-6.57	-1.74	11.57	-9.37	5.828e+04	-3.695e+04	-4615.01	2.595e+04	-
4.510e+04		131	10.08	3.80	-9.42	0.90	-6.52	-5.48	7.552e+04	-4.402e+04	-7343.33	3.885e+04	-
5.513e+04	69	123	9.52	8.80	-6.88	4.37	-2.45	-7.06	5.940e+04	-5.478e+04	-3.503e+04	3.965e+04	-
4.319e+04		124	7.39	7.37	-10.64	1.11	-4.38	-8.58	4.702e+04	-4.143e+04	-2.568e+04	3.127e+04	-
3.384e+04		132	8.02	7.96	-6.23	3.79	-2.06	-6.47	5.825e+04	-3.694e+04	-4653.17	2.597e+04	-
4.507e+04		132	10.46	6.70	-9.99	4.26	-7.56	-5.89	7.613e+04	-4.826e+04	490.07	2.738e+04	-
6.073e+04	1	124	9.40	12.53	-9.88	3.53	-0.87	-10.99	5.901e+04	-5.336e+04	-2.649e+04	3.214e+04	-
4.793e+04		125	7.98	3.61	-7.44	-2.61	-1.22	-5.48	5.119e+04	-4.432e+04	-1.841e+04	2.528e+04	-
4.247e+04		133	8.32	8.99	-7.59	5.33	-3.94	-6.87	5.879e+04	-4.019e+04	2008.99	1.659e+04	-
4.895e+04		132	8.85	5.67	-8.46	3.61	-6.39	-4.99	6.442e+04	-4.084e+04	414.67	2.316e+04	-
5.138e+04	3	124	7.96	10.60	-8.36	2.98	-0.74	-9.30	4.993e+04	-4.515e+04	-2.242e+04	2.720e+04	-
4.055e+04		125	6.75	3.05	-6.30	-2.21	-1.03	-4.64	4.331e+04	-3.750e+04	-1.557e+04	2.139e+04	-
3.593e+04		133	7.04	7.60	-6.42	4.51	-3.33	-5.81	4.974e+04	-3.400e+04	1699.91	1.404e+04	-
4.142e+04		132	8.16	19.34	-23.32	5.99	-9.97	-19.78	5.870e+04	-3.715e+04	487.29	2.106e+04	-
4.681e+04	7	124	7.34	21.49	-29.14	1.10	-8.75	-24.83	4.575e+04	-4.097e+04	-2.016e+04	2.494e+04	-
3.703e+04		125	6.24	16.50	-26.54	-3.86	-6.18	-21.49	3.946e+04	-3.396e+04	-1.404e+04	1.954e+04	-
3.264e+04		133	6.49	20.94	-19.12	8.67	-6.84	-18.47	4.535e+04	-3.087e+04	1638.28	1.284e+04	-
3.770e+04		132	8.08	9.74	-12.76	4.19	-7.22	-9.69	5.861e+04	-3.713e+04	414.30	2.106e+04	-
108	39												-

Parco Eolico "Bolina" – Progetto Definitivo
Relazione di calcolo preliminare delle fondazioni degli aerogeneratori G8 e G12

4.674e+04																					-
3.692e+04	124	7.27	13.65	-14.89	2.16	-3.41	-13.99	4.551e+04	-4.102e+04	-2.030e+04	2.480e+04										-
3.266e+04	125	6.17	7.39	-12.74	-2.64	-2.71	-10.06	3.941e+04	-3.405e+04	-1.412e+04	1.948e+04										-
3.767e+04	133	6.43	11.61	-10.28	5.65	-4.32	-9.75	4.526e+04	-3.090e+04		1576.81	1.279e+04									-
4.671e+04	108 69 132	8.04	5.15	-7.69	3.28	-5.81	-4.53	5.856e+04	-3.713e+04		376.98	2.106e+04									-
3.687e+04	124	7.23	9.64	-7.60	2.71	-0.67	-8.45	4.539e+04	-4.104e+04	-2.038e+04	2.473e+04										-
3.267e+04	125	6.14	2.78	-5.73	-2.01	-0.94	-4.22	3.938e+04	-3.409e+04	-1.416e+04	1.944e+04										-
3.765e+04	133	6.40	6.91	-5.84	4.10	-3.03	-5.29	4.522e+04	-3.091e+04		1545.37	1.276e+04									-
4.958e+04	109 1 133	8.34	7.12	-6.57	5.11	-4.57	-4.84	5.873e+04	-4.060e+04		6191.61	1.193e+04									-
4.422e+04	125	7.99	2.14	-5.97	-0.69	-3.14	-3.87	5.124e+04	-4.450e+04	-1.497e+04	2.171e+04										-
3.647e+04	126	6.68	1.44	-3.58	-0.78	-1.36	-2.49	4.408e+04	-3.595e+04	-1.239e+04	2.052e+04										-
4.035e+04	134	6.78	3.76	-6.31	3.25	-5.81	-2.19	4.922e+04	-3.148e+04		8300.56	9438.52									-
4.195e+04	109 3 133	7.05	6.02	-5.56	4.33	-3.87	-4.10	4.969e+04	-3.436e+04		5239.06	1.009e+04									-
3.742e+04	125	6.76	1.81	-5.05	-0.59	-2.66	-3.27	4.336e+04	-3.765e+04	-1.266e+04	1.837e+04										-
3.086e+04	126	5.65	1.22	-3.03	-0.66	-1.15	-2.11	3.730e+04	-3.042e+04	-1.048e+04	1.736e+04										-
3.414e+04	134	5.73	3.18	-5.34	2.75	-4.91	-1.86	4.165e+04	-2.664e+04		7023.55	7986.44									-
3.818e+04	109 7 133	6.49	16.61	-15.78	7.98	-7.15	-14.32	4.531e+04	-3.118e+04		4905.56	9230.77									-
3.400e+04	125	6.21	11.95	-21.34	0.24	-9.63	-15.90	3.952e+04	-3.410e+04	-1.139e+04	1.681e+04										-
2.798e+04	126	5.20	12.51	-19.38	-1.81	-5.07	-15.86	3.393e+04	-2.742e+04		-9319.55	1.583e+04									-
3.095e+04	134	5.27	14.54	-13.94	8.69	-8.09	-11.50	3.778e+04	-2.413e+04		6340.69	7313.70									-
3.815e+04	109 39 133	6.44	9.15	-8.59	5.30	-4.75	-7.31	4.522e+04	-3.121e+04		4811.09	9195.20									-
3.401e+04	125	6.17	5.13	-10.26	-0.27	-4.85	-7.35	3.945e+04	-3.419e+04	-1.147e+04	1.673e+04										-
2.803e+04	126	5.16	4.97	-8.38	-1.01	-2.41	-6.64	3.391e+04	-2.757e+04		-9457.41	1.580e+04									-
3.101e+04	134	5.23	6.63	-7.73	4.60	-5.69	-5.01	3.784e+04	-2.419e+04		6370.04	7278.43									-
3.814e+04	109 69 133	6.41	5.47	-5.06	3.93	-3.52	-3.72	4.517e+04	-3.123e+04		4762.78	9177.00									-
3.401e+04	125	6.14	1.65	-4.59	-0.53	-2.41	-2.98	3.941e+04	-3.423e+04	-1.151e+04	1.670e+04										-
2.806e+04	126	5.14	1.11	-2.75	-0.60	-1.05	-1.92	3.391e+04	-2.765e+04		-9527.92	1.578e+04									-
3.104e+04	134	5.21	2.89	-4.86	2.50	-4.47	-1.69	3.786e+04	-2.422e+04		6385.05	7260.40									-
3.838e+04	110 1 134	6.44	12.13	-5.92	11.74	-5.53	-2.64	4.481e+04	-3.199e+04		7527.50	5292.17									-
3.900e+04	126	6.93	-3.12	-7.90	-6.76	-4.25	2.03	4.776e+04	-3.513e+04		-7716.39	2.035e+04									-
2.648e+04	127	4.90	12.67	-5.51	2.78	4.38	-9.06	2.904e+04	-2.915e+04	-1.212e+04	1.201e+04										-
3.748e+04	135	6.64	0.56	-22.61	-13.38	-8.67	11.35	5.808e+04	-1.706e+04	2.311e+04	1.792e+04										-
3.248e+04	110 3 134	5.45	10.27	-5.01	9.93	-4.68	-2.23	3.792e+04	-2.707e+04		6369.43	4477.99									-
3.300e+04	126	5.86	-2.64	-6.68	-5.72	-3.59	1.72	4.042e+04	-2.972e+04		-6529.25	1.722e+04									-
2.240e+04	127	4.14	10.72	-4.66	2.35	3.71	-7.66	2.457e+04	-2.467e+04	-1.025e+04	1.016e+04										-
3.171e+04	135	5.62	0.48	-19.13	-11.32	-7.34	9.60	4.915e+04	-1.443e+04	1.955e+04	1.516e+04										-
2.947e+04	110 22 134	4.98	28.98	-26.78	27.95	-25.75	7.51	3.445e+04	-2.450e+04		5235.31	4712.94									-

Parco Eolico "Bolina" – Progetto Definitivo
Relazione di calcolo preliminare delle fondazioni degli aerogeneratori G8 e G12

3.034e+04	126	5.41	8.84	-16.31	8.81	-16.28	0.80	3.749e+04	-2.688e+04	-5442.24	1.605e+04	-
1.971e+04	127	3.64	24.43	-9.41	21.17	-6.15	-9.98	2.125e+04	-2.223e+04	-9673.84	8687.23	-
3.046e+04	135	5.52	12.71	-39.68	-2.86	-24.11	23.94	4.798e+04	-1.309e+04	1.954e+04	1.535e+04	-
2.950e+04	110 38 134	4.93	8.42	-3.53	8.42	-3.53	0.18	3.432e+04	-2.470e+04	5556.17	4057.45	-
3.007e+04	126	5.36	1.66	-9.41	-6.31	-1.43	4.97	3.686e+04	-2.703e+04	-5856.66	1.568e+04	-
2.028e+04	127	3.74	7.86	-0.67	2.65	4.53	-4.16	2.217e+04	-2.248e+04	-9486.95	9174.58	-
2.914e+04	135	5.19	2.75	-23.05	-14.94	-5.36	11.98	4.527e+04	-1.320e+04	1.835e+04	1.372e+04	-
2.953e+04	110 69 134	4.95	9.33	-4.55	9.03	-4.25	-2.03	3.447e+04	-2.461e+04	5790.39	4070.90	-
3.000e+04	126	5.33	-2.40	-6.07	-5.20	-3.27	1.56	3.674e+04	-2.702e+04	-5935.68	1.566e+04	-
2.037e+04	127	3.77	9.75	-4.24	2.14	3.37	-6.97	2.234e+04	-2.242e+04	-9321.55	9237.93	-
2.883e+04	135	5.11	0.43	-17.39	-10.29	-6.67	8.73	4.468e+04	-1.312e+04	1.777e+04	1.378e+04	-
3.056e+04	111 1 135	5.49	4.97	-14.81	-13.03	3.19	-5.66	4.839e+04	-1.444e+04	2.425e+04	9703.27	-
3.110e+04	127	5.52	3.83	-0.99	3.81	-0.97	-0.34	3.427e+04	-3.210e+04	-1.049e+04	1.266e+04	-
2.063e+04	128	3.64	-0.66	-8.52	-5.60	-3.58	-3.80	2.635e+04	-1.684e+04	-1615.94	1.113e+04	-
2.332e+04	136	3.98	10.74	2.48	10.46	2.76	-1.50	2.555e+04	-2.208e+04	6587.01	-3109.35	-
2.586e+04	111 3 135	4.65	4.20	-12.53	-11.03	2.70	-4.79	4.095e+04	-1.222e+04	2.052e+04	8210.46	-
2.631e+04	127	4.67	3.24	-0.84	3.22	-0.82	-0.28	2.900e+04	-2.716e+04	-8876.58	1.071e+04	-
1.746e+04	128	3.08	-0.56	-7.21	-4.74	-3.03	-3.22	2.230e+04	-1.425e+04	-1367.34	9416.57	-
1.973e+04	136	3.37	9.09	2.10	8.85	2.34	-1.27	2.162e+04	-1.868e+04	5573.62	-2630.99	-
2.215e+04	111 5 135	4.07	8.93	-36.33	-32.71	5.31	-12.27	3.698e+04	-8733.14	1.977e+04	8476.05	-
2.455e+04	127	4.38	17.61	-13.75	-8.85	12.72	11.38	2.619e+04	-2.586e+04	-8477.31	8802.61	-
1.554e+04	128	2.73	3.55	-20.55	-20.04	3.03	3.49	2.003e+04	-1.247e+04	-959.32	8521.12	-
1.809e+04	136	3.07	7.74	-5.65	-5.31	7.39	-2.12	1.947e+04	-1.733e+04	4410.61	-2274.97	-
2.305e+04	111 37 135	4.17	5.55	-19.83	-17.70	3.42	-7.03	3.714e+04	-1.030e+04	1.903e+04	7806.49	-
2.413e+04	127	4.29	5.79	-3.04	-1.06	3.81	3.68	2.630e+04	-2.509e+04	-8207.57	9423.12	-
1.576e+04	128	2.78	-0.73	-9.70	-9.63	-0.79	-0.75	2.019e+04	-1.279e+04	-1147.03	8547.19	-
1.799e+04	136	3.06	5.21	2.23	3.53	3.91	-1.48	1.959e+04	-1.710e+04	4844.85	-2352.27	-
2.351e+04	111 69 135	4.22	3.82	-11.39	-10.02	2.45	-4.35	3.723e+04	-1.110e+04	1.866e+04	7464.05	-
2.392e+04	127	4.25	2.95	-0.77	2.93	-0.75	-0.26	2.636e+04	-2.469e+04	-8069.62	9740.46	-
1.587e+04	128	2.80	-0.51	-6.56	-4.31	-2.75	-2.92	2.027e+04	-1.295e+04	-1243.03	8560.52	-
1.794e+04	136	3.06	8.26	1.91	8.05	2.12	-1.15	1.966e+04	-1.698e+04	5066.93	-2391.81	-
2.272e+04	112 1 136	3.93	2.23	1.35	1.73	1.85	-0.43	2.733e+04	-1.967e+04	9819.62	-2155.27	-
2.205e+04	128	3.77	0.78	-2.84	0.40	-2.46	-1.12	2.561e+04	-1.950e+04	-1674.57	7786.86	-
	129	0.28	1.77	-1.05	-0.45	1.17	-1.16	2660.93	-404.48	2093.01	163.43	-1190.95
	137	0.70	4.42	-0.67	4.32	-0.58	-0.67	6380.51	-1250.59	5087.90	42.01	-2862.37
1.923e+04	112 3 136	3.32	1.88	1.14	1.46	1.57	-0.37	2.313e+04	-1.664e+04	8308.91	-1823.69	-
1.866e+04	128	3.19	0.66	-2.41	0.34	-2.08	-0.94	2.167e+04	-1.650e+04	-1416.95	6588.88	-
	129	0.24	1.50	-0.89	-0.38	0.99	-0.98	2251.56	-342.26	1771.01	138.29	-1007.73

Parco Eolico "Bolina" – Progetto Definitivo
Relazione di calcolo preliminare delle fondazioni degli aerogeneratori G8 e G12

		137	0.59	3.74	-0.57	3.66	-0.49	-0.57	5398.89	-1058.19	4305.15	35.55	-2422.00		
112	24	136	3.07	25.57	-5.32	23.35	-3.11	7.97	2.116e+04	-1.533e+04	7731.63	-1901.32	-		
1.759e+04															
		128	2.95	27.19	-7.76	24.51	-5.08	-9.30	1.985e+04	-1.495e+04	-1302.66	6198.58	-		
1.699e+04															
		129	0.32	25.89	-3.60	24.59	-2.31	-6.03	2046.07	-358.56	1588.94	98.57	-943.54		
		137	0.59	26.85	-2.18	25.66	-0.99	5.75	5033.40	-914.42	4056.73	62.26	-2203.45		
112	56	136	3.04	9.42	-0.75	8.78	-0.11	2.48	2.107e+04	-1.520e+04	7613.81	-1740.27	-		
1.752e+04															
		128	2.91	9.60	-4.07	8.50	-2.97	-3.72	1.975e+04	-1.498e+04	-1293.05	6060.51	-		
1.697e+04															
		129	0.25	8.86	-0.95	8.09	-0.19	-2.63	2046.58	-327.17	1602.88	116.53	-925.40		
		137	0.55	11.10	-0.85	10.88	-0.63	1.60	4950.42	-945.83	3962.14	42.45	-2202.37		
112	69	136	3.02	1.71	1.04	1.33	1.43	-0.33	2.102e+04	-1.513e+04	7553.56	-1657.90	-		
1.748e+04															
		128	2.90	0.60	-2.19	0.31	-1.89	-0.86	1.970e+04	-1.500e+04	-1288.13	5989.89	-		
1.696e+04															
		129	0.22	1.36	-0.81	-0.35	0.90	-0.89	2046.87	-311.14	1610.01	125.72	-916.12		
		137	0.54	3.40	-0.52	3.33	-0.45	-0.52	4908.08	-961.99	3913.77	32.32	-2201.82		
113	1	54	12.62	8.24	-1.79	3.40	3.05	-5.01	1.181e+05	-2.305e+04	2.086e+04	7.418e+04	-		
6.534e+04															
		63	44.49	3.71	-13.81	0.38	-10.48	-6.87	4.342e+05	-5.326e+04	1.140e+05	2.670e+05	-		
2.314e+05															
		130	19.87	0.47	-4.04	-0.96	-2.61	-2.10	7.691e+04	-1.575e+05	-1.571e+05	7.660e+04	8497.85		
		138	25.48	-1.40	-7.39	-4.77	-4.02	-2.97	2.430e+05	-3.999e+04	3.643e+04	1.666e+05	-		
1.257e+05															
		113	3	54	10.68	6.97	-1.52	2.88	2.58	-4.24	9.992e+04	-1.950e+04	1.765e+04	6.277e+04	-
5.529e+04															
		63	37.64	3.14	-11.68	0.32	-8.87	-5.82	3.674e+05	-4.507e+04	9.646e+04	2.259e+05	-		
1.958e+05															
		130	16.81	0.39	-3.42	-0.81	-2.21	-1.77	6.508e+04	-1.332e+05	-1.330e+05	6.482e+04	7190.49		
		138	21.56	-1.19	-6.25	-4.03	-3.40	-2.51	2.056e+05	-3.384e+04	3.082e+04	1.410e+05	-		
1.063e+05															
		113	23	54	9.75	64.56	-49.24	-42.23	57.54	27.36	9.123e+04	-1.751e+04	1.633e+04	5.739e+04	-
5.035e+04															
		63	34.61	88.54	-44.33	-38.97	83.18	-26.15	3.351e+05	-4.072e+04	8.819e+04	2.062e+05	-		
1.784e+05															
		130	15.45	61.82	-1.15	6.91	53.76	21.04	5.933e+04	-1.213e+05	-1.210e+05	5.909e+04	6559.84		
		138	19.90	66.99	-14.81	9.34	42.83	-37.32	1.871e+05	-3.067e+04	2.814e+04	1.283e+05	-		
9.669e+04															
		113	55	54	9.70	22.31	-13.85	-12.56	21.02	6.71	9.097e+04	-1.765e+04	1.615e+04	5.717e+04	-
5.029e+04															
		63	34.35	26.66	-16.84	-12.99	22.81	-12.35	3.344e+05	-4.089e+04	8.786e+04	2.057e+05	-		
1.782e+05															
		130	15.34	19.00	-0.29	1.85	16.86	6.05	5.922e+04	-1.212e+05	-1.209e+05	5.898e+04	6544.60		
		138	19.70	21.89	-8.71	0.74	12.45	-14.14	1.870e+05	-3.073e+04	2.806e+04	1.282e+05	-		
9.667e+04															
		113	69	54	9.71	6.34	-1.38	2.62	2.34	-3.85	9.084e+04	-1.773e+04	1.605e+04	5.706e+04	-
5.026e+04															
		63	34.22	2.85	-10.62	0.29	-8.06	-5.29	3.340e+05	-4.097e+04	8.769e+04	2.054e+05	-		
1.780e+05															
		130	15.28	0.36	-3.11	-0.74	-2.01	-1.61	5.916e+04	-1.211e+05	-1.209e+05	5.893e+04	6536.81		
		138	19.60	-1.08	-5.68	-3.67	-3.09	-2.28	1.869e+05	-3.076e+04	2.802e+04	1.282e+05	-		
9.666e+04															
		114	1	138	17.10	0.69	-14.04	-5.75	-7.59	-7.31	1.589e+05	-3.316e+04	1.206e+04	1.137e+05	-
8.148e+04															
		130	16.67	10.07	-7.96	4.23	-2.11	-8.44	1.377e+05	-5.690e+04	-1.996e+04	1.007e+05	-		
7.632e+04															
		131	13.13	2.96	-13.13	-7.12	-3.05	-7.79	9.444e+04	-6.181e+04	-3.854e+04	7.117e+04	-		
5.562e+04															
		139	13.57	5.24	-7.17	0.44	-2.37	-6.04	1.268e+05	-2.510e+04	2.549e+04	7.619e+04	-		
7.159e+04															
		114	3	138	14.47	0.59	-11.88	-4.87	-6.43	-6.18	1.344e+05	-2.806e+04	1.020e+04	9.617e+04	-
6.895e+04															
		130	14.10	8.52	-6.73	3.58	-1.78	-7.14	1.165e+05	-4.815e+04	-1.689e+04	8.525e+04	-		
6.457e+04															
		131	11.11	2.50	-11.11	-6.02	-2.58	-6.59	7.991e+04	-5.230e+04	-3.261e+04	6.022e+04	-		
4.707e+04															
		139	11.48	4.43	-6.07	0.37	-2.00	-5.11	1.073e+05	-2.124e+04	2.157e+04	6.447e+04	-		
6.057e+04															
		114	7	138	13.32	22.98	-35.88	-10.36	-2.54	-29.17	1.223e+05	-2.572e+04	9094.94	8.751e+04	-
6.278e+04															
		130	13.07	66.14	-33.27	23.05	9.82	-49.26	1.060e+05	-4.396e+04	-1.544e+04	7.752e+04	-		

Parco Eolico "Bolina" – Progetto Definitivo
Relazione di calcolo preliminare delle fondazioni degli aerogeneratori G8 e G12

3.875e+04	133	7.13	4.46	-6.69	0.46	-2.69	-5.35 5.050e+04-3.435e+04	-9184.56 2.533e+04	-
4.108e+04	141	7.01	6.09	-4.11	3.66	-1.68	-4.35 5.587e+04-2.636e+04	1.301e+04 1.650e+04	-
4.613e+04	140	8.15	21.36	-18.13	2.55	0.69	-19.72 6.886e+04-2.404e+04	1.690e+04 2.792e+04	-
4.221e+04	132	8.11	17.61	-23.89	-2.57	-3.70	-20.74 5.847e+04-3.678e+04-1.121e+04	3.290e+04	-
3.527e+04	133	6.58	15.38	-22.01	-4.14	-2.49	-18.68 4.601e+04-3.118e+04	-8263.04 2.309e+04	-
3.736e+04	141	6.48	21.88	-15.33	5.16	1.39	-18.51 5.082e+04-2.397e+04	1.187e+04 1.499e+04	-
4.601e+04	140	8.06	10.01	-9.89	2.21	-2.09	-9.71 6.879e+04-2.389e+04	1.692e+04 2.798e+04	-
4.214e+04	132	8.04	9.10	-12.39	-0.19	-3.10	-10.64 5.835e+04-3.676e+04-1.125e+04	3.284e+04	-
3.524e+04	133	6.51	7.77	-11.35	-1.12	-2.46	-9.54 4.594e+04-3.121e+04	-8320.31 2.305e+04	-
3.735e+04	141	6.41	10.86	-7.45	3.95	-0.54	-8.88 5.080e+04-2.396e+04	1.184e+04 1.500e+04	-
4.595e+04	140	8.02	4.64	-6.10	2.04	-3.51	-4.60 6.875e+04-2.382e+04	1.693e+04 2.800e+04	-
4.211e+04	132	8.00	4.92	-6.69	1.03	-2.80	-5.48 5.829e+04-3.676e+04-1.127e+04	3.280e+04	-
3.523e+04	133	6.48	4.06	-6.08	0.42	-2.44	-4.87 4.591e+04-3.123e+04	-8349.60 2.303e+04	-
3.734e+04	141	6.37	5.54	-3.74	3.33	-1.53	-3.95 5.079e+04-2.396e+04	1.183e+04 1.500e+04	-
4.847e+04	141	8.26	5.46	-4.47	3.99	-3.00	-3.53 6.612e+04-3.082e+04	1.803e+04 1.727e+04	-
4.685e+04	133	8.40	3.78	-7.02	0.68	-3.91	-4.89 5.946e+04-4.073e+04	-8369.31 2.710e+04	-
3.885e+04	134	6.90	4.54	-6.26	2.21	-3.93	-4.45 4.951e+04-3.260e+04	-4806.05 2.171e+04	-
3.931e+04	142	6.64	5.05	-2.80	2.86	-0.61	-3.52 4.982e+04-2.882e+04	1.155e+04 9441.62	-
4.101e+04	141	6.99	4.62	-3.78	3.37	-2.53	-2.99 5.595e+04-2.608e+04	1.526e+04 1.461e+04	-
3.964e+04	133	7.11	3.20	-5.94	0.57	-3.31	-4.14 5.031e+04-3.446e+04	-7081.73 2.293e+04	-
3.288e+04	134	5.84	3.84	-5.30	1.87	-3.32	-3.76 4.189e+04-2.759e+04	-4066.65 1.837e+04	-
3.326e+04	142	5.62	4.27	-2.37	2.42	-0.52	-2.97 4.215e+04-2.439e+04	9774.18 7989.07	-
3.731e+04	141	6.44	16.29	-11.79	4.00	0.50	-13.93 5.091e+04-2.372e+04	1.393e+04 1.326e+04	-
3.608e+04	133	6.54	11.78	-18.18	-1.66	-4.74	-14.90 4.583e+04-3.132e+04	-6406.61 2.091e+04	-
2.980e+04	134	5.36	11.23	-17.31	-2.62	-3.47	-14.27 3.815e+04-2.480e+04	-3457.70 1.681e+04	-
3.016e+04	142	5.17	17.18	-11.27	5.02	0.90	-14.08 3.823e+04-2.211e+04	8856.66 7262.84	-
3.729e+04	141	6.38	7.94	-5.91	3.38	-1.35	-6.51 5.088e+04-2.371e+04	1.389e+04 1.328e+04	-
3.605e+04	133	6.49	5.81	-9.62	-0.21	-3.59	-7.53 4.577e+04-3.133e+04	-6427.33 2.087e+04	-
2.986e+04	134	5.32	5.83	-8.76	0.24	-3.17	-7.09 3.811e+04-2.498e+04	-3616.00 1.674e+04	-
3.021e+04	142	5.13	8.31	-5.17	3.15	-7.63e-03	-6.55 3.829e+04-2.215e+04	8875.82 7262.81	-
3.729e+04	141	6.35	4.20	-3.44	3.07	-2.30	-2.72 5.086e+04-2.371e+04	1.387e+04 1.329e+04	-
3.604e+04	133	6.46	2.91	-5.40	0.52	-3.01	-3.76 4.574e+04-3.133e+04	-6437.93 2.085e+04	-
2.989e+04	134	5.30	3.49	-4.82	1.70	-3.02	-3.42 3.808e+04-2.508e+04	-3696.96 1.670e+04	-
3.023e+04	142	5.11	3.88	-2.15	2.20	-0.47	-2.70 3.832e+04-2.217e+04	8885.62 7262.79	-
3.924e+04	142	6.62	6.53	-0.43	6.21	-0.11	-1.47 5.007e+04-2.847e+04	1.235e+04 9254.52	-
4.002e+04	134	6.92	-0.93	-8.11	-3.84	-5.19	-3.53 4.988e+04-3.247e+04	-995.54 1.840e+04	-
	135	6.11	14.08	-9.83	14.02	-9.77	-1.21 4.935e+04-2.207e+04	-1702.23 2.898e+04	-

Parco Eolico "Bolina" – Progetto Definitivo
Relazione di calcolo preliminare delle fondazioni degli aerogeneratori G8 e G12

3.225e+04													
2.953e+04	143	4.97	6.23	-2.24	1.88	2.11	-4.23	3.295e+04-2.630e+04	5721.48	927.43	-		
118 3	142	5.61	5.53	-0.37	5.25	-0.09	-1.24	4.237e+04-2.409e+04	1.045e+04	7830.75	-		
3.320e+04	134	5.85	-0.78	-6.86	-3.25	-4.39	-2.98	4.221e+04-2.747e+04	-842.38	1.557e+04	-		
3.386e+04	135	5.17	11.91	-8.32	11.86	-8.27	-1.02	4.176e+04-1.868e+04	-1440.34	2.452e+04	-		
2.729e+04	143	4.20	5.27	-1.89	1.59	1.79	-3.58	2.788e+04-2.225e+04	4841.25	784.75	-		
2.498e+04	142	5.08	16.78	-12.13	16.08	-11.43	-4.43	3.863e+04-2.123e+04	9967.40	7432.84	-		
118 8	134	5.39	15.62	-25.01	10.52	-19.91	-13.46	3.855e+04-2.504e+04	-1164.94	1.467e+04	-		
2.990e+04	135	4.54	20.36	-27.08	13.86	-20.58	-16.31	3.804e+04-1.417e+04	424.76	2.344e+04	-		
3.079e+04	143	3.91	17.45	-5.90	16.99	-5.44	-3.25	2.552e+04-2.111e+04	4113.72	290.11	-		
2.343e+04	142	5.09	8.99	-4.31	8.60	-3.92	-2.25	3.856e+04-2.167e+04	9657.53	7225.10	-		
2.324e+04	134	5.34	4.51	-12.28	1.61	-9.38	-6.35	3.843e+04-2.500e+04	-900.86	1.433e+04	-		
118 40	135	4.62	13.32	-13.43	11.83	-11.94	-6.13	3.799e+04-1.603e+04	-722.60	2.268e+04	-		
3.009e+04	143	3.85	7.92	-1.98	6.71	-0.77	-3.25	2.540e+04-2.053e+04	4303.88	570.18	-		
2.434e+04	142	5.10	5.02	-0.33	4.77	-0.08	-1.13	3.852e+04-2.190e+04	9499.05	7118.86	-		
2.289e+04	134	5.32	-0.71	-6.24	-2.96	-3.99	-2.71	3.837e+04-2.498e+04	-765.80	1.416e+04	-		
118 69	135	4.70	10.83	-7.56	10.78	-7.52	-0.93	3.796e+04-1.698e+04	-1309.40	2.229e+04	-		
3.019e+04	143	3.82	4.79	-1.72	1.44	1.63	-3.25	2.535e+04-2.023e+04	4401.14	713.41	-		
3.078e+04	143	5.46	1.88	-11.00	0.63	-9.75	3.81	3.843e+04-2.655e+04	6790.33	5088.56	-		
2.481e+04	135	4.28	30.19	-2.65	17.34	10.21	-16.03	3.288e+04-1.644e+04	-1488.54	1.793e+04	-		
2.271e+04	136	3.34	1.90	-8.64	-8.51	1.77	-1.14	2.476e+04-1.496e+04	4848.21	4944.67	-		
119 1	144	2.93	15.68	-2.46	11.80	1.42	-7.44	1.892e+04-1.558e+04	2848.29	490.92	-		
3.248e+04	143	4.62	1.59	-9.30	0.53	-8.25	3.22	3.252e+04-2.247e+04	5745.67	4305.71	-		
2.267e+04	135	3.62	25.55	-2.24	14.67	8.64	-13.56	2.782e+04-1.391e+04	-1259.53	1.518e+04	-		
1.986e+04	136	2.83	1.61	-7.31	-7.20	1.50	-0.96	2.095e+04-1.266e+04	4102.33	4183.95	-		
1.721e+04	144	2.48	13.26	-2.08	9.98	1.20	-6.29	1.601e+04-1.318e+04	2410.09	415.39	-		
119 3	143	4.11	12.48	-19.03	-16.50	9.95	-8.56	2.814e+04-2.048e+04	4893.83	2768.98	-		
2.748e+04	135	3.51	10.82	-13.95	-13.92	10.78	-0.92	2.804e+04-1.285e+04	164.17	1.503e+04	-		
1.918e+04	136	2.56	8.06	-24.27	-24.18	7.97	1.72	1.866e+04-1.163e+04	3076.32	3954.53	-		
1.680e+04	144	2.35	13.88	-17.24	-12.02	8.66	-11.63	1.514e+04-1.220e+04	2611.99	320.58	-		
1.456e+04	143	4.14	-1.36	-5.50	-5.26	-1.60	-0.96	2.908e+04-2.044e+04	5111.84	3526.74	-		
119 23	135	3.37	15.27	-2.31	4.11	8.85	-8.47	2.622e+04-1.271e+04	-702.03	1.421e+04	-		
2.429e+04	136	2.56	3.60	-12.51	-12.51	3.60	5.38e-03	1.891e+04-1.155e+04	3508.41	3854.66	-		
1.905e+04	144	2.29	10.56	-4.98	1.94	3.65	-7.72	1.475e+04-1.206e+04	2333.45	358.33	-		
1.514e+04	143	4.20	1.45	-8.46	0.49	-7.50	2.93	2.956e+04-2.043e+04	5223.33	3914.28	-		
1.362e+04	135	3.29	23.23	-2.04	13.34	7.85	-12.33	2.529e+04-1.264e+04	-1145.03	1.380e+04	-		
119 55	136	2.57	1.46	-6.64	-6.55	1.36	-0.87	1.904e+04-1.151e+04	3729.39	3803.59	-		
2.475e+04													
1.798e+04													
1.523e+04													
1.337e+04													
119 69													
2.499e+04													
1.743e+04													
1.528e+04													

Parco Eolico "Bolina" – Progetto Definitivo
Relazione di calcolo preliminare delle fondazioni degli aerogeneratori G8 e G12

	144	2.25	12.06	-1.89	9.07	1.09	-5.72	1.455e+04	-1.198e+04	2190.99	377.63	-	
1.323e+04													
120	1	144	3.22	5.90	-1.88	4.70	-0.67	-2.81	2.131e+04	-1.706e+04	4984.11	-733.22	-
1.897e+04													
	136	3.43	3.36	-0.56	1.37	1.42	-1.96	2.428e+04	-1.657e+04	1989.14	5720.19	-	
2.034e+04													
	137	0.43	0.56	-2.71	-2.69	0.54	-0.23	4430.59	122.93	4195.05	358.47	-979.36	
	145	0.55	6.96	-0.36	6.45	0.15	-1.86	4543.73	-1471.11	3023.16	49.46	-2614.16	
120	3	144	2.72	4.99	-1.59	3.97	-0.57	-2.38	1.803e+04	-1.444e+04	4217.33	-620.42	-
1.606e+04													
	136	2.90	2.84	-0.48	1.16	1.20	-1.66	2.054e+04	-1.402e+04	1683.12	4840.16	-	
1.721e+04													
	137	0.36	0.47	-2.29	-2.28	0.46	-0.19	3748.96	104.02	3549.66	303.32	-828.69	
	145	0.46	5.89	-0.30	5.46	0.12	-1.57	3844.69	-1244.78	2558.06	41.85	-2211.98	
120	21	144	2.53	8.51	-24.29	-20.96	5.18	-9.90	1.640e+04	-1.332e+04	3847.83	-768.16	-
1.468e+04													
	136	2.71	5.72	-24.93	-23.16	3.95	7.14	1.896e+04	-1.287e+04	1419.42	4671.76	-	
1.583e+04													
	137	0.43	3.64	-28.29	-27.22	2.57	5.73	3259.04	55.83	3075.82	239.06	-743.87	
	145	0.42	4.35	-21.90	-19.33	1.78	-7.81	3544.47	-1131.81	2343.63	69.03	-2042.90	
120	53	144	2.49	4.03	-7.32	-4.70	1.41	-4.78	1.640e+04	-1.319e+04	3838.64	-633.10	-
1.462e+04													
	136	2.65	2.28	-7.35	-7.14	2.06	1.42	1.877e+04	-1.279e+04	1492.65	4492.05	-	
1.571e+04													
	137	0.36	1.42	-10.86	-10.58	1.15	1.82	3357.67	81.48	3175.82	263.33	-750.14	
	145	0.42	2.80	-5.38	-3.26	0.68	-3.59	3511.83	-1131.66	2331.64	48.53	-2021.72	
120	69	144	2.48	4.54	-1.44	3.61	-0.52	-2.16	1.640e+04	-1.313e+04	3833.93	-564.02	-
1.460e+04													
	136	2.64	2.59	-0.43	1.06	1.10	-1.51	1.868e+04	-1.275e+04	1530.11	4400.14	-	
1.565e+04													
	137	0.33	0.43	-2.08	-2.07	0.42	-0.18	3408.15	94.56	3226.96	275.75	-753.36	
	145	0.42	5.35	-0.28	4.96	0.11	-1.43	3495.17	-1131.62	2325.50	38.05	-2010.89	
121	1	45	27.20	8.34	-14.49	3.02	-9.17	-9.65	2.820e+05	-2524.65	1.752e+04	2.619e+05	-
7.280e+04													
	54	20.13	8.39	-9.59	-2.99	1.79	-8.67	1.870e+05	-3.885e+04	3.011e+04	1.180e+05	-	
1.040e+05													
	138	18.11	5.85	-3.20	5.82	-3.17	-0.48	1.746e+05	-2.523e+04	1.650e+04	1.328e+05	-	
8.122e+04													
	146	18.02	5.96	-9.93	3.81	-7.78	-5.44	1.959e+05	1.809e+04	9.677e+04	1.172e+05	-	
8.830e+04													
121	3	45	23.01	7.05	-12.26	2.56	-7.76	-8.16	2.386e+05	-2136.24	1.482e+04	2.216e+05	-
6.160e+04													
	54	17.04	7.10	-8.12	-2.53	1.52	-7.33	1.582e+05	-3.288e+04	2.548e+04	9.987e+04	-	
8.801e+04													
	138	15.32	4.95	-2.71	4.93	-2.68	-0.40	1.477e+05	-2.135e+04	1.396e+04	1.124e+05	-	
6.873e+04													
	146	15.25	5.05	-8.40	3.23	-6.58	-4.60	1.657e+05	1.530e+04	8.188e+04	9.915e+04	-	
7.472e+04													
121	7	45	21.12	26.75	-29.89	-19.25	16.11	-22.12	2.173e+05	-2084.24	1.354e+04	2.017e+05	-
5.641e+04													
	54	15.80	55.57	-36.42	-12.29	31.44	-40.47	1.441e+05	-3.018e+04	2.308e+04	9.086e+04	-	
8.029e+04													
	138	14.07	23.83	-13.10	-5.39	16.12	-15.01	1.345e+05	-1.959e+04	1.272e+04	1.022e+05	-	
6.272e+04													
	146	14.09	45.61	-31.85	-0.82	14.58	-37.96	1.507e+05	1.381e+04	7.442e+04	9.006e+04	-	
6.799e+04													
121	39	45	20.98	10.63	-14.82	-4.98	0.78	-12.40	2.170e+05	-1990.05	1.349e+04	2.015e+05	-
5.614e+04													
	54	15.59	22.98	-17.11	-5.68	11.55	-18.10	1.439e+05	-2.999e+04	2.314e+04	9.081e+04	-	
8.011e+04													
	138	13.96	7.98	-3.00	1.14	3.84	-5.32	1.344e+05	-1.947e+04	1.270e+04	1.022e+05	-	
6.256e+04													
	146	13.94	16.93	-14.30	1.66	0.97	-15.61	1.507e+05	1.388e+04	7.443e+04	9.011e+04	-	
6.795e+04													
121	69	45	20.92	6.41	-11.14	2.32	-7.05	-7.42	2.169e+05	-1942.04	1.347e+04	2.015e+05	-
5.600e+04													
	54	15.49	6.46	-7.38	-2.30	1.38	-6.67	1.438e+05	-2.989e+04	2.316e+04	9.079e+04	-	
8.001e+04													
	138	13.93	4.50	-2.46	4.48	-2.44	-0.37	1.343e+05	-1.941e+04	1.269e+04	1.022e+05	-	
6.248e+04													
	146	13.86	4.59	-7.64	2.93	-5.98	-4.18	1.507e+05	1.391e+04	7.444e+04	9.014e+04	-	
6.792e+04													
122	1	146	16.86	24.87	-12.44	19.78	-7.35	-12.80	1.788e+05	7844.87	5.986e+04	1.268e+05	-

Parco Eolico "Bolina" – Progetto Definitivo
Relazione di calcolo preliminare delle fondazioni degli aerogeneratori G8 e G12

7.867e+04																				-
8.729e+04	138	18.98	-0.23	-14.15	-0.87	-13.51	2.91	1.822e+05-2.712e+04	1.980e+04	1.353e+05										-
5.722e+04	139	12.14	18.26	-12.94	-6.18	11.49	-12.86	1.087e+05-2.848e+04	2305.42	7.788e+04										-
7.766e+04	147	15.90	-1.58	-42.64	-23.22	-21.00	20.50	1.700e+05	1.294e+04	7.981e+04	1.031e+05									-
6.656e+04	146	14.26	21.04	-10.52	16.74	-6.22	-10.83	1.513e+05	6637.97	5.065e+04	1.073e+05									-
7.386e+04	138	16.06	-0.20	-11.97	-0.74	-11.43	2.46	1.542e+05-2.294e+04	1.675e+04	1.145e+05										-
4.842e+04	139	10.27	15.45	-10.95	-5.23	9.72	-10.88	9.195e+04-2.410e+04	1950.74	6.590e+04										-
6.571e+04	147	13.45	-1.34	-36.08	-19.65	-17.77	17.34	1.438e+05	1.095e+04	6.753e+04	8.727e+04									-
5.998e+04	146	13.04	62.38	-69.35	62.37	-69.34	1.18	1.368e+05	5848.25	4.506e+04	9.759e+04									-
6.766e+04	138	14.97	62.04	-100.97	62.03	-100.97	0.72	1.410e+05-2.096e+04	1.553e+04	1.045e+05										-
4.344e+04	139	9.16	-0.65	-41.38	-2.28	-39.75	-7.99	8.214e+04-2.170e+04	1783.38	5.866e+04										-
6.173e+04	147	12.86	17.08	-99.31	-0.02	-82.21	41.21	1.347e+05	9711.40	6.247e+04	8.193e+04									-
6.033e+04	146	12.94	31.81	-27.84	31.17	-27.20	-6.11	1.373e+05	5972.29	4.571e+04	9.756e+04									-
6.732e+04	138	14.72	20.59	-41.09	20.55	-41.04	1.73	1.404e+05-2.089e+04	1.533e+04	1.042e+05										-
4.382e+04	139	9.24	3.67	-15.19	-3.92	-7.60	-9.25	8.310e+04-2.184e+04	1776.78	5.948e+04										-
6.041e+04	147	12.44	2.62	-52.95	-11.83	-38.50	24.38	1.321e+05	9873.45	6.176e+04	8.021e+04									-
6.051e+04	146	12.97	19.13	-9.57	15.22	-5.66	-9.84	1.376e+05	6034.52	4.605e+04	9.755e+04									-
6.715e+04	138	14.60	-0.18	-10.88	-0.67	-10.39	2.24	1.402e+05-2.086e+04	1.523e+04	1.041e+05										-
4.402e+04	139	9.34	14.04	-9.96	-4.75	8.84	-9.89	8.359e+04-2.191e+04	1773.40	5.991e+04										-
5.974e+04	147	12.23	-1.22	-32.80	-17.86	-16.15	15.77	1.308e+05	9955.79	6.139e+04	7.934e+04									-
6.344e+04	147	13.11	16.15	-27.98	-24.28	12.46	-12.22	1.435e+05	1.648e+04	7.732e+04	8.264e+04									-
6.643e+04	139	13.63	1.87	-9.93	-0.72	-7.34	-4.88	1.243e+05-3.026e+04	7538.03	8.648e+04										-
5.486e+04	140	10.44	5.42	-11.21	-3.57	-2.22	-8.29	9.099e+04-2.872e+04	7185.33	5.508e+04										-
5.334e+04	148	9.73	17.40	-0.96	15.59	0.85	-5.48	9.371e+04-1.307e+04	3.806e+04	4.258e+04										-
5.368e+04	147	11.10	13.67	-23.67	-20.54	10.54	-10.34	1.214e+05	1.395e+04	6.543e+04	6.992e+04									-
5.621e+04	139	11.53	1.58	-8.40	-0.61	-6.21	-4.13	1.052e+05-2.560e+04	6378.33	7.317e+04										-
4.642e+04	140	8.83	4.59	-9.48	-3.02	-1.88	-7.01	7.700e+04-2.431e+04	6079.90	4.661e+04										-
4.514e+04	148	8.23	14.73	-0.82	13.19	0.72	-4.64	7.930e+04-1.106e+04	3.221e+04	3.603e+04										-
4.961e+04	147	10.20	1.34	-33.65	-2.03	-30.28	10.33	1.103e+05	1.111e+04	6.015e+04	6.129e+04									-
5.076e+04	139	10.68	25.39	-68.00	25.36	-67.97	-1.55	9.614e+04-2.278e+04	5715.89	6.765e+04										-
4.238e+04	140	8.10	17.80	-44.82	17.63	-44.65	-3.28	7.008e+04-2.238e+04	5366.48	4.233e+04										-
4.082e+04	148	7.49	31.85	-45.30	30.95	-44.40	8.27	7.179e+04	-9935.68	2.911e+04	3.275e+04									-
4.853e+04	147	10.12	28.01	-29.25	-24.31	23.07	-16.08	1.104e+05	1.320e+04	5.925e+04	6.434e+04									-
5.121e+04	139	10.54	16.24	-10.12	-9.33	15.44	-4.50	9.541e+04-2.345e+04	5826.43	6.614e+04										-
4.214e+04	140	8.06	15.06	-11.87	-9.64	12.82	-7.42	6.997e+04-2.200e+04	5581.55	4.239e+04										-
4.110e+04	148	7.53	20.63	0.84	5.58	15.90	-8.44	7.219e+04-1.009e+04	2.934e+04	3.276e+04										-
4.880e+04	147	10.09	12.43	-21.52	-18.68	9.58	-9.40	1.104e+05	1.268e+04	5.948e+04	6.357e+04									-

Parco Eolico "Bolina" – Progetto Definitivo
Relazione di calcolo preliminare delle fondazioni degli aerogeneratori G8 e G12

5.110e+04	139	10.48	1.43	-7.64	-0.56	-5.65	-3.75	9.560e+04-2.328e+04	5798.48	6.652e+04	-		
4.220e+04	140	8.03	4.17	-8.62	-2.75	-1.71	-6.38	7.000e+04-2.210e+04	5527.18	4.237e+04	-		
4.103e+04	148	7.49	13.39	-0.74	11.99	0.65	-4.21	7.209e+04-1.005e+04	2.928e+04	3.276e+04	-		
5.139e+04	124 1	148	9.58	7.22	-5.11	0.60	1.51	-6.15	9.561e+04	-7192.50	4.522e+04	4.319e+04	-
5.622e+04	140	10.49	4.45	-6.23	1.34	-3.11	-4.86	9.012e+04-3.110e+04	6871.15	5.215e+04	-		
4.566e+04	141	8.18	3.85	-5.11	0.08	-1.33	-4.42	6.580e+04-3.009e+04	3216.84	3.249e+04	-		
4.121e+04	149	7.35	8.07	-2.95	5.09	0.03	-4.89	6.720e+04-1.562e+04	2.989e+04	2.170e+04	-		
4.348e+04	124 3	148	8.11	6.11	-4.32	0.51	1.28	-5.20	8.090e+04	-6085.96	3.827e+04	3.655e+04	-
4.757e+04	140	8.88	3.77	-5.27	1.13	-2.63	-4.11	7.625e+04-2.631e+04	5814.05	4.413e+04	-		
3.863e+04	141	6.92	3.26	-4.32	0.07	-1.13	-3.74	5.568e+04-2.546e+04	2721.94	2.749e+04	-		
3.487e+04	149	6.22	6.82	-2.49	4.31	0.03	-4.14	5.686e+04-1.321e+04	2.529e+04	1.836e+04	-		
3.972e+04	124 7	148	7.51	27.26	-16.20	-0.73	11.79	-20.81	7.370e+04	-5756.96	3.468e+04	3.326e+04	-
4.336e+04	140	8.19	18.58	-18.92	-5.49	5.15	-17.98	6.940e+04-2.402e+04	5302.12	4.007e+04	-		
3.517e+04	141	6.39	16.18	-18.03	-7.12	5.28	-15.94	5.063e+04-2.321e+04	2463.07	2.496e+04	-		
3.172e+04	149	5.76	25.66	-13.47	2.70	9.50	-19.27	5.171e+04-1.205e+04	2.306e+04	1.661e+04	-		
3.960e+04	124 39	148	7.42	12.85	-8.03	0.06	4.76	-10.17	7.360e+04	-5608.56	3.475e+04	3.324e+04	-
4.328e+04	140	8.11	8.07	-9.09	-1.18	0.16	-8.55	6.935e+04-2.396e+04	5291.13	4.010e+04	-		
3.514e+04	141	6.33	7.21	-8.47	-2.37	1.11	-7.65	5.062e+04-2.317e+04	2470.63	2.498e+04	-		
3.170e+04	149	5.69	12.38	-5.64	3.50	3.23	-9.01	5.170e+04-1.202e+04	2.301e+04	1.666e+04	-		
3.953e+04	124 69	148	7.37	5.56	-3.93	0.46	1.16	-4.73	7.355e+04	-5532.69	3.479e+04	3.322e+04	-
4.325e+04	140	8.07	3.43	-4.79	1.03	-2.39	-3.74	6.932e+04-2.392e+04	5285.50	4.011e+04	-		
3.512e+04	141	6.29	2.96	-3.93	0.06	-1.03	-3.40	5.061e+04-2.315e+04	2474.49	2.499e+04	-		
3.170e+04	149	5.66	6.20	-2.27	3.91	0.02	-3.76	5.169e+04-1.201e+04	2.299e+04	1.669e+04	-		
4.090e+04	125 1	149	7.32	5.98	-2.67	3.86	-0.54	-3.72	6.716e+04-1.519e+04	3.079e+04	2.117e+04	-	
4.611e+04	141	8.21	2.27	-4.30	0.59	-2.62	-2.86	6.614e+04-3.019e+04	4054.92	3.190e+04	-		
3.668e+04	142	6.45	2.26	-1.75	0.89	-0.38	-1.90	4.884e+04-2.757e+04	-25.85	2.130e+04	-		
3.233e+04	150	5.71	4.92	-3.05	3.95	-2.09	-2.60	4.927e+04-1.644e+04	2.229e+04	1.054e+04	-		
3.460e+04	125 3	149	6.19	5.06	-2.26	3.26	-0.46	-3.15	5.683e+04-1.286e+04	2.606e+04	1.791e+04	-	
3.901e+04	141	6.94	1.92	-3.64	0.50	-2.22	-2.42	5.597e+04-2.554e+04	3431.08	2.699e+04	-		
3.104e+04	142	5.45	1.91	-1.48	0.76	-0.32	-1.61	4.132e+04-2.332e+04	-21.87	1.802e+04	-		
2.735e+04	150	4.83	4.16	-2.58	3.35	-1.77	-2.20	4.169e+04-1.391e+04	1.886e+04	8921.86	-		
3.152e+04	125 7	149	5.71	19.76	-10.78	0.43	8.55	-14.72	5.172e+04-1.176e+04	2.374e+04	1.621e+04	-	
3.549e+04	141	6.39	11.73	-14.08	-5.21	2.86	-12.26	5.087e+04-2.327e+04	3105.72	2.450e+04	-		
2.815e+04	142	5.02	11.22	-13.49	-6.69	4.41	-11.04	3.750e+04-2.111e+04	59.05	1.633e+04	-		
2.476e+04	150	4.45	18.81	-10.53	2.48	5.79	-14.58	3.762e+04-1.274e+04	1.700e+04	7878.32	-		
3.148e+04	125 39	149	5.66	9.25	-4.52	2.11	2.62	-6.88	5.168e+04-1.171e+04	2.371e+04	1.626e+04	-	
	141	6.34	4.72	-6.55	-1.46	-0.37	-5.61	5.088e+04-2.324e+04	3114.62	2.453e+04	-		

Parco Eolico “Bolina” – Progetto Definitivo
Relazione di calcolo preliminare delle fondazioni degli aerogeneratori G8 e G12

3.548e+04																						-	
2.820e+04	142	4.98	4.70	-5.21	-1.81	1.30	-4.70	3.754e+04-2.117e+04	6.83	1.637e+04												-	
2.483e+04	150	4.41	8.21	-4.46	2.85	0.90	-6.26	3.781e+04-1.268e+04	1.710e+04	8032.12												-	
125 69	149	5.63	4.60	-2.05	2.97	-0.42	-2.87	5.166e+04-1.169e+04	2.369e+04	1.629e+04												-	
3.146e+04	141	6.31	1.74	-3.31	0.46	-2.02	-2.20	5.088e+04-2.322e+04	3119.17	2.454e+04												-	
3.547e+04	142	4.96	1.74	-1.34	0.69	-0.30	-1.46	3.757e+04-2.120e+04	-19.88	1.638e+04												-	
2.822e+04	150	4.39	3.78	-2.35	3.04	-1.61	-2.00	3.790e+04-1.264e+04	1.715e+04	8110.78												-	
2.487e+04	150	5.43	9.86	-3.15	9.42	-2.71	-2.36	4.611e+04-1.657e+04	2.019e+04	9345.20												-	
126 1	150	5.43	9.86	-3.15	9.42	-2.71	-2.36	4.611e+04-1.657e+04	2.019e+04	9345.20												-	
3.087e+04	142	6.65	-1.70	-4.10	-3.11	-2.70	1.18	5.151e+04-2.712e+04	1941.33	2.244e+04												-	
3.795e+04	143	4.55	10.19	-2.76	3.62	3.81	-6.48	3.011e+04-2.391e+04	-4903.77	1.110e+04												-	
2.580e+04	151	5.32	0.87	-13.23	-7.37	-4.99	6.95	4.834e+04-1.119e+04	2.483e+04	1.232e+04												-	
2.910e+04	150	4.59	8.35	-2.67	7.97	-2.29	-2.00	3.902e+04-1.402e+04	1.709e+04	7907.48												-	
126 3	150	4.59	8.35	-2.67	7.97	-2.29	-2.00	3.902e+04-1.402e+04	1.709e+04	7907.48												-	
2.612e+04	142	5.63	-1.44	-3.47	-2.63	-2.28	1.00	4.358e+04-2.295e+04	1642.66	1.899e+04												-	
3.211e+04	143	3.85	8.63	-2.34	3.07	3.22	-5.48	2.548e+04-2.023e+04	-4149.34	9394.46												-	
2.183e+04	151	4.50	0.74	-11.20	-6.23	-4.22	5.88	4.091e+04 -9466.92	2.101e+04	1.043e+04												-	
2.462e+04	150	4.15	14.72	-11.33	13.15	-9.77	6.19	3.511e+04-1.279e+04	1.491e+04	7419.05												-	
126 6	150	4.15	14.72	-11.33	13.15	-9.77	6.19	3.511e+04-1.279e+04	1.491e+04	7419.05												-	
2.366e+04	142	5.21	6.86	-11.14	1.03	-5.32	8.42	4.015e+04-2.079e+04	1871.09	1.748e+04												-	
2.945e+04	143	3.40	11.39	1.22	11.16	1.46	-1.54	2.239e+04-1.837e+04	-4187.44	8203.35												-	
1.941e+04	151	4.43	8.68	-30.31	-12.29	-9.34	19.44	3.971e+04 -8743.83	2.097e+04	9994.17												-	
2.360e+04	150	4.15	9.30	-4.74	9.25	-4.68	0.89	3.535e+04-1.276e+04	1.532e+04	7266.59												-	
126 38	150	4.15	9.30	-4.74	9.25	-4.68	0.89	3.535e+04-1.276e+04	1.532e+04	7266.59												-	
2.372e+04	142	5.15	1.38	-5.79	-1.23	-3.17	3.45	3.980e+04-2.084e+04	1621.15	1.734e+04												-	
2.928e+04	143	3.46	8.16	-0.11	5.62	2.43	-3.82	2.290e+04-1.839e+04	-3912.66	8426.36												-	
1.970e+04	151	4.21	3.37	-16.98	-7.91	-5.70	10.11	3.804e+04 -8652.07	1.973e+04	9653.92												-	
2.280e+04	150	4.17	7.59	-2.43	7.25	-2.08	-1.82	3.547e+04-1.275e+04	1.553e+04	7188.62												-	
126 69	150	4.17	7.59	-2.43	7.25	-2.08	-1.82	3.547e+04-1.275e+04	1.553e+04	7188.62												-	
2.375e+04	142	5.12	-1.31	-3.16	-2.39	-2.07	0.91	3.962e+04-2.086e+04	1493.33	1.727e+04												-	
2.919e+04	143	3.50	7.84	-2.12	2.79	2.93	-4.98	2.316e+04-1.839e+04	-3772.13	8540.41												-	
1.984e+04	151	4.09	0.67	-10.18	-5.67	-3.84	5.35	3.719e+04 -8606.29	1.910e+04	9479.90												-	
2.239e+04	151	4.55	5.17	-8.35	-7.16	3.98	-3.83	4.133e+04-1.021e+04	2.449e+04	6623.66												-	
127 1	151	4.55	5.17	-8.35	-7.16	3.98	-3.83	4.133e+04-1.021e+04	2.449e+04	6623.66												-	
2.417e+04	143	5.02	4.34	-1.16	4.23	-1.06	-0.75	3.425e+04-2.588e+04	-4542.59	1.290e+04												-	
2.877e+04	144	3.27	0.50	-4.08	-1.77	-1.81	-2.29	2.323e+04-1.571e+04	-767.18	8284.35												-	
1.894e+04	152	3.13	10.29	2.26	9.50	3.04	-2.39	2.153e+04-1.565e+04	8858.49	-2978.19												-	
1.762e+04	151	3.85	4.37	-7.07	-6.06	3.36	-3.24	3.497e+04 -8642.11	2.072e+04	5604.63												-	
127 3	151	3.85	4.37	-7.07	-6.06	3.36	-3.24	3.497e+04 -8642.11	2.072e+04	5604.63												-	
2.045e+04	143	4.24	3.67	-0.98	3.58	-0.89	-0.64	2.898e+04-2.190e+04	-3843.73	1.092e+04												-	
2.435e+04	144	2.77	0.42	-3.46	-1.50	-1.53	-1.94	1.966e+04-1.330e+04	-649.15	7009.83												-	
1.603e+04	152	2.65	8.71	1.91	8.04	2.58	-2.02	1.822e+04-1.324e+04	7495.65	-2520.01												-	
1.491e+04	151	3.38	5.23	-26.95	-24.04	2.32	-9.23	3.190e+04 -5753.19	2.037e+04	5773.90												-	
127 5	151	3.38	5.23	-26.95	-24.04	2.32	-9.23	3.190e+04 -5753.19	2.037e+04	5773.90												-	
1.735e+04	143	3.97	13.21	-6.28	-2.77	9.70	7.49	2.629e+04-2.093e+04	-3898.67	9256.97												-	
2.268e+04																							-

Parco Eolico "Bolina" – Progetto Definitivo
Relazione di calcolo preliminare delle fondazioni degli aerogeneratori G8 e G12

1.428e+04	144	2.46	1.51	-12.04	-11.75	1.23	1.95	1.778e+04	-1.155e+04	-234.65	6468.07	-
1.374e+04	152	2.40	6.08	0.40	0.41	6.07	-0.11	1.632e+04	-1.243e+04	6151.82	-2261.60	-
1.817e+04	127 37 151	3.46	4.40	-13.37	-11.78	2.81	-5.07	3.182e+04	-7140.59	1.936e+04	5324.80	-
2.232e+04	143	3.90	4.26	-0.30	1.22	2.74	2.15	2.632e+04	-2.026e+04	-3631.13	9699.89	-
1.447e+04	144	2.50	-0.45	-4.94	-4.88	-0.51	-0.51	1.784e+04	-1.191e+04	-469.85	6404.89	-
1.362e+04	152	2.40	5.72	2.86	4.97	3.60	-1.25	1.648e+04	-1.217e+04	6590.08	-2280.99	-
1.859e+04	127 69 151	3.50	3.97	-6.42	-5.51	3.06	-2.95	3.179e+04	-7856.46	1.884e+04	5095.12	-
2.213e+04	143	3.86	3.34	-0.89	3.25	-0.81	-0.58	2.634e+04	-1.991e+04	-3494.30	9926.42	-
1.457e+04	144	2.52	0.39	-3.14	-1.36	-1.40	-1.76	1.787e+04	-1.209e+04	-590.14	6372.57	-
1.356e+04	152	2.41	7.92	1.74	7.31	2.34	-1.84	1.656e+04	-1.204e+04	6814.22	-2290.92	-
1.747e+04	128 1 152	3.12	3.27	1.49	3.05	1.71	-0.59	2.296e+04	-1.411e+04	1.063e+04	-1778.03	-
2.006e+04	144	3.41	2.40	-1.84	2.28	-1.72	-0.71	2.308e+04	-1.785e+04	-1431.97	6658.35	-
1.478e+04	128 3 152	0.22	1.40	0.94	1.33	1.00	-0.16	2252.43	88.98	1975.27	366.14	-723.05
1.697e+04	153	0.75	6.21	-0.27	5.76	0.18	-1.65	7119.23	-837.28	6186.11	95.83	-2560.01
1.356e+04	128 3 152	2.64	2.77	1.26	2.58	1.45	-0.50	1.943e+04	-1.194e+04	8994.71	-1504.49	-
1.356e+04	144	2.89	2.03	-1.56	1.93	-1.45	-0.60	1.953e+04	-1.511e+04	-1211.66	5633.99	-
1.356e+04	145	0.18	1.18	0.79	1.13	0.85	-0.14	1905.90	75.29	1671.38	309.81	-611.81
1.356e+04	153	0.64	5.26	-0.23	4.88	0.15	-1.39	6023.96	-708.47	5234.40	81.09	-2166.16
1.356e+04	128 24 152	2.44	28.61	-4.03	26.02	-1.44	8.83	1.779e+04	-1.109e+04	8308.93	-1609.01	-
1.547e+04	144	2.67	28.27	-9.04	26.62	-7.39	-7.67	1.790e+04	-1.370e+04	-1104.14	5301.91	-
1.348e+04	145	0.28	28.02	-2.29	26.61	-0.87	-6.40	1742.69	23.40	1513.24	252.85	-584.67
1.348e+04	153	0.65	27.69	-3.08	26.85	-2.25	5.00	5598.80	-589.53	4903.63	105.64	-1954.14
1.544e+04	128 56 152	2.41	11.04	-0.29	10.36	0.38	2.69	1.770e+04	-1.093e+04	8221.65	-1449.36	-
1.544e+04	144	2.64	10.79	-3.99	10.17	-3.38	-2.96	1.780e+04	-1.372e+04	-1102.40	5182.75	-
1.344e+04	145	0.20	10.19	-0.29	9.68	0.21	-2.25	1736.02	53.23	1517.34	271.90	-565.83
1.344e+04	153	0.60	12.08	-0.73	12.02	-0.67	0.85	5517.69	-625.53	4807.64	84.52	-1964.13
1.543e+04	128 69 152	2.40	2.52	1.14	2.35	1.32	-0.45	1.766e+04	-1.085e+04	8177.01	-1367.71	-
7.579e+04	144	2.63	1.85	-1.42	1.75	-1.32	-0.55	1.775e+04	-1.373e+04	-1101.51	5121.81	-
1.851e+05	145	0.17	1.07	0.72	1.02	0.77	-0.12	1732.64	68.44	1519.44	281.64	-556.19
4.392e+04	153	0.58	4.78	-0.21	4.43	0.14	-1.27	5476.33	-644.06	4758.55	73.72	-1969.24
1.003e+05	129 1 36	18.10	8.18	-16.92	2.92	-11.65	-10.22	2.091e+05	5.312e+04	1.127e+05	1.495e+05	-
6.413e+04	45	39.16	7.39	-5.81	4.14	-2.56	-5.69	4.190e+05	2.375e+04	1.522e+05	2.906e+05	-
1.567e+05	146	13.20	7.68	-12.76	4.21	-9.28	-7.68	1.356e+05	-3398.89	1.223e+04	1.200e+05	-
3.717e+04	154	21.54	8.56	-5.52	5.43	-2.39	-5.85	2.403e+05	3.707e+04	1.223e+05	1.550e+05	-
5.835e+04	129 3 36	15.32	6.93	-14.31	2.47	-9.86	-8.65	1.769e+05	4.495e+04	9.539e+04	1.265e+05	-
1.427e+05	45	33.14	6.26	-4.92	3.50	-2.16	-4.82	3.546e+05	2.009e+04	1.288e+05	2.459e+05	-
3.385e+04	146	11.17	6.50	-10.80	3.56	-7.86	-6.50	1.148e+05	-2875.98	1.035e+04	1.015e+05	-
5.835e+04	154	18.23	7.24	-4.67	4.60	-2.02	-4.95	2.033e+05	3.137e+04	1.035e+05	1.312e+05	-
1.427e+05	129 23 36	14.12	57.76	2.47	8.00	52.23	-16.59	1.613e+05	4.118e+04	8.705e+04	1.154e+05	-
3.385e+04	45	30.58	93.49	-52.90	-40.23	80.82	-41.16	3.233e+05	1.862e+04	1.176e+05	2.243e+05	-
1.427e+05	146	10.49	85.75	-45.56	-45.35	85.54	-5.25	1.042e+05	-2493.26	9620.37	9.207e+04	-
3.385e+04	154	16.65	37.06	-76.06	-74.82	35.83	11.77	1.852e+05	2.859e+04	9.439e+04	1.194e+05	-

Parco Eolico "Bolina" – Progetto Definitivo
Relazione di calcolo preliminare delle fondazioni degli aerogeneratori G8 e G12

131 23	155	9.61	57.13	-25.91	-22.06	53.27	-17.47	1.071e+05	2.100e+04	5.535e+04	7.280e+04	-	
4.218e+04	147	9.04	63.62	-9.20	-3.93	58.36	-18.87	9.627e+04	1.014e+04	3.194e+04	7.447e+04	-	
3.745e+04	148	7.54	47.63	-32.03	-31.85	47.45	-3.76	7.515e+04	-4921.56	2.876e+04	4.147e+04	-	
3.953e+04	156	6.12	59.50	-17.08	-9.22	51.64	-23.24	6.732e+04	1.257e+04	4.213e+04	3.776e+04	-	
2.729e+04	131 55	155	9.56	10.73	-6.35	-4.01	8.39	-5.87	1.080e+05	2.097e+04	5.519e+04	7.374e+04	-
4.249e+04	147	8.73	47.63	-3.33	13.29	31.00	-23.89	9.371e+04	1.041e+04	3.133e+04	7.279e+04	-	
3.613e+04	148	7.53	17.21	-19.19	-19.15	17.16	-1.26	7.557e+04	-4938.49	2.917e+04	4.146e+04	-	
3.978e+04	156	6.00	30.42	-6.12	3.62	20.68	-16.16	6.672e+04	1.272e+04	4.183e+04	3.762e+04	-	
2.692e+04	131 69	155	9.58	5.23	-14.57	5.23	-14.57	0.06	1.084e+05	2.096e+04	5.511e+04	7.422e+04	-
4.265e+04	147	8.58	46.14	-7.02	22.10	17.02	-26.46	9.241e+04	1.055e+04	3.103e+04	7.193e+04	-	
3.545e+04	148	7.53	1.67	-12.65	-12.65	1.67	0.02	7.578e+04	-4947.73	2.938e+04	4.146e+04	-	
3.991e+04	156	5.95	20.33	-5.30	10.18	4.85	-12.54	6.642e+04	1.280e+04	4.167e+04	3.755e+04	-	
2.673e+04	132 1	156	8.19	9.52	-5.99	3.37	0.16	-7.59	9.104e+04	1.434e+04	5.514e+04	5.024e+04	-
3.827e+04	148	9.35	9.97	-3.65	2.34	3.98	-6.76	9.344e+04	-6523.72	3.032e+04	5.659e+04	-	
4.822e+04	149	7.25	4.34	-3.88	-0.79	1.25	-3.99	6.698e+04	-1.447e+04	1.972e+04	3.279e+04	-	
4.020e+04	157	6.10	10.05	-2.93	5.11	2.01	-6.30	6.320e+04	253.10	3.875e+04	2.470e+04	-	
3.068e+04	132 3	156	6.93	8.06	-5.07	2.85	0.14	-6.42	7.703e+04	1.213e+04	4.666e+04	4.251e+04	-
3.238e+04	148	7.91	8.43	-3.09	1.98	3.36	-5.72	7.906e+04	-5520.07	2.566e+04	4.788e+04	-	
4.081e+04	149	6.14	3.68	-3.29	-0.67	1.06	-3.37	5.667e+04	-1.225e+04	1.669e+04	2.774e+04	-	
3.401e+04	157	5.16	8.50	-2.48	4.32	1.70	-5.33	5.348e+04	214.16	3.279e+04	2.090e+04	-	
2.596e+04	132 7	156	6.42	33.61	-16.71	-2.21	19.11	-22.79	7.021e+04	1.091e+04	4.247e+04	3.865e+04	-
2.959e+04	148	7.32	25.64	-16.57	-7.52	16.59	-17.32	7.225e+04	-5082.20	2.348e+04	4.369e+04	-	
3.732e+04	149	5.67	20.23	-17.26	-10.36	13.34	-14.53	5.150e+04	-1.123e+04	1.511e+04	2.516e+04	-	
3.096e+04	157	4.80	31.39	-14.53	-0.12	16.98	-21.31	4.864e+04	107.29	2.984e+04	1.891e+04	-	
2.364e+04	132 39	156	6.34	15.66	-8.15	0.97	6.55	-11.57	7.009e+04	1.099e+04	4.243e+04	3.864e+04	-
2.949e+04	148	7.23	13.47	-7.19	-1.36	7.64	-9.30	7.200e+04	-5039.88	2.338e+04	4.358e+04	-	
3.717e+04	149	5.61	8.91	-7.67	-3.91	5.15	-6.94	5.151e+04	-1.116e+04	1.515e+04	2.520e+04	-	
3.093e+04	157	4.73	15.29	-5.97	2.56	6.77	-10.42	4.862e+04	165.13	2.982e+04	1.897e+04	-	
2.361e+04	132 69	156	6.30	7.33	-4.61	2.59	0.12	-5.84	7.003e+04	1.103e+04	4.242e+04	3.864e+04	-
2.944e+04	148	7.19	7.67	-2.81	1.80	3.06	-5.20	7.188e+04	-5018.25	2.333e+04	4.353e+04	-	
3.710e+04	149	5.58	3.34	-2.99	-0.61	0.96	-3.07	5.152e+04	-1.113e+04	1.517e+04	2.522e+04	-	
3.092e+04	157	4.69	7.73	-2.26	3.93	1.54	-4.85	4.861e+04	194.69	2.981e+04	1.900e+04	-	
2.360e+04	133 1	157	6.11	7.13	-2.71	3.51	0.91	-4.74	6.351e+04	529.74	3.843e+04	2.561e+04	-
3.083e+04	149	7.23	3.45	-2.69	0.48	0.27	-3.07	6.682e+04	-1.445e+04	1.872e+04	3.365e+04	-	
3.995e+04	150	5.67	3.92	-2.55	2.13	-0.76	-2.90	4.886e+04	-1.644e+04	1.198e+04	2.044e+04	-	
3.237e+04	158	4.68	6.96	-1.57	3.30	2.08	-4.22	4.425e+04	-7501.42	2.573e+04	1.102e+04	-	
2.481e+04	133 3	157	5.17	6.03	-2.29	2.97	0.77	-4.01	5.374e+04	448.24	3.252e+04	2.167e+04	-

Parco Eolico "Bolina" – Progetto Definitivo
Relazione di calcolo preliminare delle fondazioni degli aerogeneratori G8 e G12

1.877e+04	151	3.39	21.67	-0.65	12.52	8.51	-10.98	2.862e+04	-9700.65	5631.45	1.328e+04	-
1.612e+04	152	2.75	2.59	-4.81	-4.79	2.57	-0.31	2.144e+04	-1.105e+04	7194.44	3200.19	-
1.052e+04	160	1.98	13.32	-1.64	9.76	1.92	-6.37	1.535e+04	-7303.26	8225.83	-176.51	-
1.766e+04	135 3 159	3.12	1.95	-5.28	1.64	-4.97	1.46	2.658e+04	-9523.83	1.227e+04	4786.52	-
1.588e+04	151	2.87	18.34	-0.55	10.59	7.20	-9.29	2.421e+04	-8208.24	4765.07	1.124e+04	-
1.364e+04	152	2.33	2.19	-4.07	-4.06	2.18	-0.26	1.815e+04	-9350.04	6087.60	2707.85	-
1.547e+04	160 135 23 159	1.67	11.27	-1.38	8.25	1.63	-5.39	1.299e+04	-6179.68	6960.31	-149.36	-8901.60
1.580e+04	151	2.81	13.10	-18.54	-18.08	12.64	3.79	2.435e+04	-7942.43	4886.02	1.152e+04	-
1.230e+04	152	2.14	10.90	-26.27	-25.74	10.36	4.43	1.620e+04	-8522.35	5034.82	2644.85	-
1.587e+04	160 135 39 159	1.58	15.51	-21.33	-17.36	11.53	-11.42	1.225e+04	-5956.77	6574.20	-279.71	-8434.40
1.489e+04	151	2.67	11.59	-1.99	3.25	6.34	-6.61	2.282e+04	-7463.69	4905.15	1.045e+04	-
1.234e+04	152	2.10	3.33	-6.16	-6.08	3.25	-0.88	1.631e+04	-8535.89	5300.79	2468.42	-
1.605e+04	160 135 69 159	1.55	9.92	-3.43	4.10	2.39	-6.62	1.201e+04	-5644.97	6462.88	-95.74	-8196.90
1.444e+04	151	2.61	16.67	-0.50	9.63	6.55	-8.44	2.201e+04	-7462.04	4331.88	1.022e+04	-
1.240e+04	152	2.11	1.99	-3.70	-3.69	1.98	-0.24	1.650e+04	-8500.03	5534.18	2461.68	-
1.189e+04	160 136 1 160	1.52	10.24	-1.26	7.50	1.48	-4.90	1.181e+04	-5617.89	6327.56	-135.78	-8092.36
1.640e+04	152	2.76	2.10	0.97	1.95	1.13	-0.39	2.080e+04	-1.200e+04	4510.16	4284.27	-
1.006e+04	153 161 160 136 3 160	0.56	0.83	-0.72	-0.63	0.74	0.35	5918.00	343.29	5856.20	405.09	-583.68
1.388e+04	152	2.34	1.78	0.82	1.65	0.95	-0.33	1.760e+04	-1.016e+04	3816.29	3625.15	-
1.278e+04	153 161 160 136 23 152	0.47	0.70	-0.61	-0.54	0.63	0.30	5007.54	290.48	4955.25	342.77	-493.88
1.267e+04	153 161 160 136 55 152	0.64	5.84	-0.15	5.21	0.48	-1.84	6231.65	-294.96	5811.04	125.65	-1602.57
1.262e+04	153 161 160 136 69 152	1.72	9.91	-24.53	-21.17	6.56	-10.21	1.330e+04	-6651.82	7100.49	-449.11	-9235.88
9.515e+04	152	2.22	5.74	-25.54	-23.13	3.33	8.35	1.624e+04	-9313.85	3370.33	3559.92	-
9.048e+04	153 161 160 136 55 152	0.52	4.27	-26.21	-24.95	3.01	6.07	4399.70	230.85	4354.84	275.71	-430.10
7.470e+04	153 161 160 136 69 152	0.61	5.46	-22.23	-18.97	2.20	-8.92	5679.16	-257.41	5276.75	145.00	-1492.32
5.664e+04	153 161 160 136 69 152	1.70	4.81	-7.42	-4.85	2.24	-4.98	1.329e+04	-6511.66	7111.46	-328.84	-9177.65
8.051e+04	152	2.15	2.44	-7.58	-6.84	1.70	2.63	1.608e+04	-9260.84	3435.85	3385.03	-
7.656e+04	153 161 160 136 69 152	0.46	1.87	-9.24	-8.77	1.40	2.23	4500.67	252.83	4454.04	299.46	-442.59
	153 161 160 136 69 152	0.56	3.53	-5.78	-3.28	1.03	-4.12	5669.82	-264.45	5280.73	124.64	-1468.87
	153 161 160 136 69 152	1.69	4.64	-1.11	3.50	0.03	-2.30	1.329e+04	-6440.01	7117.07	-267.33	-9147.87
	152	2.13	1.62	0.75	1.50	0.87	-0.30	1.600e+04	-9234.17	3469.36	3295.59	-
	153 161 160 136 69 152	0.43	0.64	-0.55	-0.49	0.57	0.27	4552.31	264.07	4504.77	311.61	-448.99
	153 161 160 136 69 152	0.58	5.31	-0.14	4.74	0.43	-1.67	5665.14	-268.15	5282.76	114.23	-1456.88
	137 1 27	33.43	10.26	-7.93	3.51	-1.18	-8.78	3.705e+05	5.046e+04	8.183e+04	3.391e+05	-
	36	19.68	3.58	-10.88	3.52	-10.83	-0.87	2.204e+05	3.561e+04	1.093e+05	1.467e+05	-
	154	18.41	9.02	-8.25	2.51	-1.74	-8.37	2.128e+05	5.483e+04	1.082e+05	1.594e+05	-
	162	17.63	0.81	-2.03	0.79	-2.01	0.26	2.100e+05	7.902e+04	1.773e+05	1.117e+05	-
	137 3 27	28.29	8.68	-6.71	2.97	-1.00	-7.43	3.135e+05	4.270e+04	6.924e+04	2.869e+05	-
	36	16.66	3.03	-9.21	2.98	-9.16	-0.74	1.865e+05	3.013e+04	9.250e+04	1.241e+05	-

Parco Eolico "Bolina" – Progetto Definitivo
Relazione di calcolo preliminare delle fondazioni degli aerogeneratori G8 e G12

6.321e+04	154	15.57	7.63	-6.98	2.12	-1.47	-7.08	1.800e+05	4.639e+04	9.152e+04	1.349e+05	-	
4.792e+04	162	14.92	0.69	-1.72	0.67	-1.70	0.22	1.777e+05	6.687e+04	1.500e+05	9.448e+04	-	
7.318e+04	137 23	27	26.22	116.38	-36.49	-36.13	116.02	-7.44	2.858e+05	3.930e+04	6.338e+04	2.617e+05	-
6.972e+04	36	15.43	49.83	-67.26	-47.42	29.98	-43.93	1.700e+05	2.764e+04	8.443e+04	1.132e+05	-	
5.759e+04	154	14.23	50.71	21.91	26.54	46.08	10.58	1.640e+05	4.227e+04	8.344e+04	1.228e+05	-	
4.361e+04	162	13.75	77.59	-12.45	3.73	61.40	-34.57	1.617e+05	6.090e+04	1.366e+05	8.604e+04	-	
7.319e+04	137 55	27	25.88	39.64	-11.41	-10.44	38.66	-6.99	2.853e+05	3.898e+04	6.309e+04	2.611e+05	-
6.964e+04	36	15.23	13.18	-22.80	-14.25	4.63	-15.31	1.697e+05	2.748e+04	8.420e+04	1.130e+05	-	
5.750e+04	154	14.18	14.81	10.16	10.26	14.71	-0.68	1.638e+05	4.221e+04	8.328e+04	1.227e+05	-	
4.358e+04	162	13.63	25.39	-3.97	1.66	19.76	-11.57	1.616e+05	6.083e+04	1.365e+05	8.594e+04	-	
7.319e+04	137 69	27	25.71	7.89	-6.10	2.70	-0.91	-6.76	2.850e+05	3.882e+04	6.295e+04	2.608e+05	-
6.960e+04	36	15.14	2.75	-8.37	2.71	-8.33	-0.67	1.695e+05	2.739e+04	8.409e+04	1.128e+05	-	
5.746e+04	154	14.16	6.94	-6.35	1.93	-1.34	-6.44	1.637e+05	4.217e+04	8.320e+04	1.226e+05	-	
4.357e+04	162	13.56	0.62	-1.56	0.61	-1.54	0.20	1.615e+05	6.079e+04	1.364e+05	8.589e+04	-	
5.549e+04	138 1	162	16.24	6.31	-13.78	-3.15	-4.31	-10.03	1.932e+05	7.350e+04	1.109e+05	1.558e+05	-
6.837e+04	154	17.24	3.38	-3.27	1.93	-1.83	-2.74	1.994e+05	5.079e+04	9.603e+04	1.541e+05	-	
4.997e+04	155	11.77	11.42	-9.86	6.70	-5.15	-8.84	1.341e+05	2.897e+04	6.525e+04	9.780e+04	-	
3.698e+04	163	10.65	11.68	-1.64	10.24	-0.19	-4.14	1.271e+05	5.307e+04	9.172e+04	8.844e+04	-	
4.695e+04	138 3	162	13.74	5.34	-11.66	-2.67	-3.65	-8.49	1.635e+05	6.219e+04	9.384e+04	1.319e+05	-
5.786e+04	154	14.58	2.86	-2.77	1.63	-1.55	-2.32	1.687e+05	4.297e+04	8.126e+04	1.304e+05	-	
4.228e+04	155	9.96	9.66	-8.34	5.67	-4.35	-7.48	1.135e+05	2.452e+04	5.522e+04	8.275e+04	-	
3.129e+04	163	9.01	9.88	-1.38	8.66	-0.16	-3.51	1.075e+05	4.490e+04	7.761e+04	7.483e+04	-	
4.271e+04	138 23	162	12.66	48.34	-27.97	-22.23	42.60	-20.13	1.488e+05	5.670e+04	8.551e+04	1.200e+05	-
5.265e+04	154	13.84	143.51	-6.49	32.41	104.61	-65.74	1.537e+05	3.922e+04	7.405e+04	1.188e+05	-	
3.858e+04	155	9.14	60.48	-52.40	-52.40	60.48	2.44e-03	1.032e+05	2.223e+04	5.044e+04	7.500e+04	-	
2.839e+04	163	8.45	88.30	-6.82	13.44	68.04	-38.94	9.780e+04	4.095e+04	7.066e+04	6.810e+04	-	
4.269e+04	138 55	162	12.55	17.54	-14.45	-9.13	12.22	-11.91	1.487e+05	5.659e+04	8.537e+04	1.199e+05	-
5.261e+04	154	13.45	49.39	-2.98	11.95	34.47	-23.64	1.535e+05	3.912e+04	7.393e+04	1.186e+05	-	
3.849e+04	155	9.08	18.46	-14.93	-14.32	17.85	-4.50	1.032e+05	2.227e+04	5.028e+04	7.515e+04	-	
2.843e+04	163	8.28	32.99	-0.30	9.76	22.93	-15.29	9.778e+04	4.086e+04	7.059e+04	6.805e+04	-	
4.269e+04	138 69	162	12.50	4.86	-10.60	-2.43	-3.32	-7.71	1.486e+05	5.654e+04	8.531e+04	1.199e+05	-
5.260e+04	154	13.26	2.60	-2.52	1.49	-1.41	-2.11	1.534e+05	3.907e+04	7.387e+04	1.185e+05	-	
3.844e+04	155	9.05	8.78	-7.59	5.16	-3.96	-6.80	1.031e+05	2.229e+04	5.020e+04	7.523e+04	-	
2.844e+04	163	8.19	8.99	-1.26	7.87	-0.15	-3.19	9.776e+04	4.082e+04	7.055e+04	6.803e+04	-	
3.685e+04	139 1	163	10.54	6.97	-6.02	4.23	-3.28	-5.31	1.258e+05	5.117e+04	8.269e+04	9.425e+04	-
4.789e+04	155	11.72	13.09	-5.33	7.58	0.18	-8.43	1.342e+05	3.115e+04	6.365e+04	1.017e+05	-	
	156	8.12	8.56	-6.08	2.50	-0.03	-7.21	9.041e+04	1.434e+04	4.583e+04	5.892e+04	-	

Parco Eolico "Bolina" – Progetto Definitivo
Relazione di calcolo preliminare delle fondazioni degli aerogeneratori G8 e G12

1.504e+04	165	3.75	6.56	-1.78	3.94	0.84	-3.87	4.303e+04	1.082e+04	3.267e+04	2.118e+04	-	
141	1	165	4.87	6.54	-2.08	4.21	0.25	-3.83	5.597e+04	1.405e+04	4.126e+04	2.877e+04	-
2.001e+04	157	6.01	4.02	-2.06	0.79	1.17	-3.03	6.296e+04	1143.60	2.862e+04	3.549e+04	-	
3.072e+04	158	4.50	3.63	-0.07	0.90	2.67	-1.62	4.321e+04	-6471.55	1.778e+04	1.896e+04	-	
2.483e+04	166	3.57	5.50	-1.51	4.10	-0.11	-2.80	3.875e+04	4055.80	2.966e+04	1.314e+04	-	
1.525e+04	165	4.12	5.54	-1.76	3.57	0.21	-3.24	4.736e+04	1.189e+04	3.491e+04	2.434e+04	-	
141	3	165	4.12	5.54	-1.76	3.57	0.21	-3.24	4.736e+04	1.189e+04	3.491e+04	2.434e+04	-
1.693e+04	157	5.09	3.40	-1.74	0.67	0.99	-2.57	5.327e+04	967.66	2.422e+04	3.003e+04	-	
2.599e+04	158	3.81	3.07	-0.06	0.76	2.26	-1.37	3.656e+04	-5475.92	1.504e+04	1.605e+04	-	
2.101e+04	166	3.02	4.66	-1.28	3.47	-0.10	-2.37	3.278e+04	3431.83	2.509e+04	1.112e+04	-	
1.291e+04	165	3.80	17.26	-8.77	6.48	2.01	-12.82	4.308e+04	1.076e+04	3.175e+04	2.208e+04	-	
141	8	165	3.80	17.26	-8.77	6.48	2.01	-12.82	4.308e+04	1.076e+04	3.175e+04	2.208e+04	-
1.542e+04	157	4.69	12.44	-13.54	1.11	-2.21	-12.88	4.846e+04	874.80	2.200e+04	2.734e+04	-	
2.364e+04	158	3.52	11.65	-12.52	-1.29	0.42	-12.05	3.320e+04	-4859.04	1.374e+04	1.460e+04	-	
1.902e+04	166	2.78	17.40	-9.05	7.85	0.51	-12.70	2.956e+04	3093.28	2.263e+04	1.003e+04	-	
1.164e+04	165	3.77	9.10	-3.96	4.34	0.81	-6.29	4.306e+04	1.079e+04	3.174e+04	2.211e+04	-	
141	40	165	3.77	9.10	-3.96	4.34	0.81	-6.29	4.306e+04	1.079e+04	3.174e+04	2.211e+04	-
1.540e+04	157	4.64	6.24	-5.61	0.78	-0.15	-5.90	4.844e+04	878.04	2.201e+04	2.731e+04	-	
2.363e+04	158	3.48	5.72	-4.20	0.02	1.50	-4.91	3.323e+04	-4937.82	1.370e+04	1.459e+04	-	
1.908e+04	166	2.76	8.60	-3.75	4.74	0.11	-5.73	2.972e+04	3110.86	2.275e+04	1.008e+04	-	
1.170e+04	165	3.75	5.03	-1.60	3.24	0.19	-2.95	4.306e+04	1.081e+04	3.174e+04	2.213e+04	-	
141	69	165	3.75	5.03	-1.60	3.24	0.19	-2.95	4.306e+04	1.081e+04	3.174e+04	2.213e+04	-
1.539e+04	157	4.62	3.09	-1.58	0.61	0.90	-2.33	4.843e+04	879.69	2.201e+04	2.730e+04	-	
2.363e+04	158	3.47	2.80	-0.05	0.69	2.05	-1.25	3.324e+04	-4978.11	1.367e+04	1.459e+04	-	
1.910e+04	166	2.74	4.23	-1.16	3.16	-0.09	-2.16	2.980e+04	3119.85	2.281e+04	1.011e+04	-	
1.173e+04	166	3.38	7.62	-1.82	6.81	-1.01	-2.65	3.682e+04	4133.08	2.748e+04	1.348e+04	-	
142	1	166	3.38	7.62	-1.82	6.81	-1.01	-2.65	3.682e+04	4133.08	2.748e+04	1.348e+04	-
1.477e+04	158	4.64	0.45	-1.79	-1.53	0.19	0.73	4.488e+04	-6223.45	1.760e+04	2.106e+04	-	
2.549e+04	159	3.00	8.24	-0.29	3.18	4.77	-4.19	2.510e+04	-9500.43	7616.24	7986.43	-	
1.730e+04	167	3.27	0.84	-6.32	-2.58	-2.89	3.58	3.441e+04	1130.85	2.541e+04	1.013e+04	-	
1.478e+04	166	2.86	6.45	-1.54	5.76	-0.86	-2.24	3.116e+04	3497.22	2.325e+04	1.140e+04	-	
142	3	166	2.86	6.45	-1.54	5.76	-0.86	-2.24	3.116e+04	3497.22	2.325e+04	1.140e+04	-
1.250e+04	158	3.93	0.38	-1.52	-1.29	0.16	0.61	3.797e+04	-5266.00	1.489e+04	1.782e+04	-	
2.157e+04	159	2.54	6.97	-0.25	2.69	4.04	-3.55	2.124e+04	-8038.82	6444.51	6757.75	-	
1.464e+04	167	2.77	0.71	-5.34	-2.18	-2.45	3.03	2.912e+04	956.87	2.150e+04	8572.46	-	
1.251e+04	166	2.56	21.89	-20.01	19.64	-17.76	9.44	2.811e+04	3409.64	2.066e+04	1.086e+04	-	
142	6	166	2.56	21.89	-20.01	19.64	-17.76	9.44	2.811e+04	3409.64	2.066e+04	1.086e+04	-
1.134e+04	158	3.66	11.32	-12.78	10.32	-11.78	4.81	3.519e+04	-4677.90	1.401e+04	1.651e+04	-	
1.990e+04	159	2.21	19.45	-4.30	19.19	-4.03	-2.48	1.838e+04	-7137.26	5522.38	5723.20	-	
1.276e+04	167	2.88	14.20	-29.52	0.76	-16.08	20.18	2.940e+04	902.98	2.141e+04	8886.08	-	
1.280e+04	166	2.58	10.31	-6.73	10.11	-6.52	1.84	2.825e+04	3258.91	2.098e+04	1.053e+04	-	
142	38	166	2.58	10.31	-6.73	10.11	-6.52	1.84	2.825e+04	3258.91	2.098e+04	1.053e+04	-
1.135e+04	158	3.60	3.27	-4.45	2.71	-3.89	2.00	3.475e+04	-4750.21	1.370e+04	1.630e+04	-	
1.971e+04	159	2.28	9.20	-0.02	8.11	1.06	-2.97	1.900e+04	-7250.23	5744.86	6001.22	-	
1.312e+04	167	2.64	5.14	-13.11	-1.06	-6.91	8.65	2.746e+04	881.82	2.018e+04	8162.97	-	

Parco Eolico "Bolina" – Progetto Definitivo
Relazione di calcolo preliminare delle fondazioni degli aerogeneratori G8 e G12

1.185e+04															
142	69	166	2.60	5.86	-1.40	5.24	-0.78	-2.04	2.832e+04	3179.29	2.114e+04	1.037e+04			-
1.136e+04															
1.961e+04		158	3.57	0.35	-1.38	-1.18	0.14	0.56	3.452e+04	-4787.27	1.354e+04	1.620e+04			-
1.331e+04		159	2.31	6.34	-0.22	2.45	3.67	-3.22	1.931e+04	-7308.02	5858.65	6143.41			-
1.137e+04		167	2.52	0.65	-4.86	-1.99	-2.22	2.75	2.647e+04	869.88	1.955e+04	7793.15			-
143	1	167	2.96	5.61	-2.67	-2.16	5.10	-1.99	3.043e+04	-687.31	2.429e+04	5453.29			-
1.238e+04		159	3.28	3.27	-1.02	3.20	-0.95	-0.55	2.798e+04	-1.004e+04	7099.78	1.084e+04			-
1.892e+04		160	2.20	0.92	-0.31	0.51	0.10	-0.58	1.815e+04	-7597.11	5667.32	4882.73			-
1.287e+04		168	1.94	7.92	1.94	6.55	3.31	-2.51	1.648e+04	-5752.64	1.262e+04	-1895.07		-8418.12	
143	3	167	2.50	4.75	-2.26	-1.83	4.32	-1.68	2.575e+04	-581.57	2.055e+04	4614.32			-
1.048e+04		159	2.77	2.76	-0.86	2.70	-0.80	-0.46	2.368e+04	-8493.30	6007.51	9174.29			-
1.601e+04		160	1.86	0.78	-0.26	0.44	0.08	-0.49	1.536e+04	-6428.32	4795.42	4131.54			-
1.089e+04		168	1.64	6.70	1.64	5.54	2.80	-2.12	1.394e+04	-4867.62	1.068e+04	-1603.52		-7123.03	
143	21	167	2.20	13.10	-32.62	-27.94	8.42	-13.86	2.325e+04	1528.77	1.947e+04	5306.31		-8233.59	
159		159	2.66	19.20	-19.52	-16.83	16.51	9.85	2.146e+04	-8935.50	5194.72	7329.70			-
1.516e+04		160	1.69	9.58	-22.44	-21.70	8.84	4.82	1.375e+04	-5473.88	4631.49	3642.19		-9597.99	
143	53	168	1.47	11.29	-15.05	-13.51	9.75	-6.18	1.236e+04	-4482.06	9177.24	-1294.61		-6598.36	
167		167	2.24	7.27	-12.38	-10.56	5.45	-5.70	2.335e+04	172.06	1.895e+04	4570.93		-9088.86	
159		159	2.56	6.03	-4.99	-4.07	5.10	3.05	2.150e+04	-8130.73	5371.14	7998.31			-
1.476e+04		160	1.69	3.22	-7.25	-7.08	3.04	1.34	1.389e+04	-5718.24	4451.52	3717.45		-9795.85	
143	69	168	1.47	6.46	-2.71	-1.24	4.98	-3.37	1.257e+04	-4442.81	9527.01	-1402.54		-6517.06	
167		167	2.27	4.32	-2.06	-1.66	3.93	-1.53	2.341e+04	-528.70	1.868e+04	4194.84		-9526.28	
159		159	2.52	2.51	-0.79	2.46	-0.73	-0.42	2.152e+04	-7721.18	5461.37	8340.26			-
1.455e+04		160	1.70	0.71	-0.24	0.40	0.08	-0.45	1.396e+04	-5843.93	4359.47	3755.95		-9897.04	
144	1	168	1.49	6.09	1.49	5.04	2.55	-1.93	1.267e+04	-4425.11	9705.90	-1457.74		-6475.48	
168		168	1.95	3.88	1.11	2.99	1.99	-1.29	1.726e+04	-4902.60	1.313e+04	-767.68		-8633.89	
160		160	2.28	2.52	-1.44	2.41	-1.33	0.67	1.810e+04	-8783.15	4824.94	4490.71			-
1.344e+04		161	0.59	2.36	0.94	2.08	1.23	0.57	6253.11	302.63	6239.95	315.78		-279.46	
144	3	169	0.98	5.66	-0.24	4.97	0.45	-1.90	9935.39	-4.79	9712.73	217.86		-1470.94	
168		168	1.65	3.28	0.94	2.53	1.69	-1.09	1.460e+04	-4148.35	1.111e+04	-649.58		-7305.60	
160		160	1.93	2.14	-1.22	2.04	-1.12	0.57	1.531e+04	-7431.90	4082.64	3799.83			-
1.137e+04		161	0.50	2.00	0.79	1.76	1.04	0.48	5291.09	256.07	5279.96	267.20		-236.47	
144	22	169	0.83	4.79	-0.20	4.21	0.38	-1.61	8406.86	-4.06	8218.46	184.34		-1244.64	
168		168	1.56	29.90	-4.99	27.38	-2.48	9.03	1.349e+04	-4050.32	1.027e+04	-833.90		-6787.43	
160		160	1.83	29.59	-8.02	27.96	-6.39	-7.66	1.406e+04	-6685.09	3723.49	3648.52			-
1.037e+04		161	0.57	29.20	-2.25	28.05	-1.10	-5.90	4821.05	201.12	4808.06	214.12		-244.68	
144	55	169	0.85	28.94	-3.00	27.85	-1.92	5.79	7807.90	32.86	7642.53	198.24		-1121.81	
168		168	1.48	4.66	-7.96	-6.18	2.89	-4.38	1.321e+04	-3676.93	1.004e+04	-508.17		-6592.06	
160		160	1.78	1.99	-8.18	-6.98	0.79	3.28	1.388e+04	-6780.54	3707.43	3388.70			-
1.033e+04		161	0.48	2.33	-8.05	-7.36	1.64	2.59	4806.45	243.43	4797.22	252.65		-204.92	
144	69	169	0.74	3.16	-6.36	-4.31	1.11	-3.91	7586.72	-16.11	7413.40	157.21		-1134.77	
168		168	1.50	2.98	0.85	2.30	1.53	-0.99	1.328e+04	-3771.23	1.010e+04	-590.53		-6641.45	
160		160	1.76	1.94	-1.11	1.85	-1.02	0.51	1.392e+04	-6756.27	3711.49	3454.39			-
1.034e+04		161	0.46	1.82	0.72	1.60	0.94	0.44	4810.08	232.79	4799.96	242.91		-214.97	
145	1	169	0.75	4.36	-0.19	3.82	0.35	-1.46	7642.60	-3.69	7471.33	167.59		-1131.49	
17		17	16.33	8.40	3.88	7.42	4.86	1.87	1.939e+05	1.229e+05	1.570e+05	1.598e+05			-
3.545e+04		27	42.41	10.22	-11.70	5.95	-7.44	-8.68	4.849e+05	1.068e+05	2.990e+05	2.927e+05			-
1.890e+05		162	11.56	9.39	1.83	7.21	4.01	3.42	1.380e+05	5.442e+04	6.098e+04	1.314e+05			-
2.247e+04		170	17.28	8.43	-6.70	5.25	-3.52	-6.17	2.066e+05	8.638e+04	1.501e+05	1.429e+05			-
6.001e+04		145	13.82	7.11	3.28	6.28	4.12	1.58	1.640e+05	1.040e+05	1.328e+05	1.352e+05			-
2.999e+04	3	17													-

Parco Eolico "Bolina" – Progetto Definitivo
Relazione di calcolo preliminare delle fondazioni degli aerogeneratori G8 e G12

1.599e+05	27	35.88	8.64	-9.90	5.04	-6.29	-7.34	4.103e+05	9.035e+04	2.530e+05	2.477e+05	-
1.902e+04	162	9.78	7.94	1.55	6.10	3.39	2.90	1.167e+05	4.605e+04	5.159e+04	1.112e+05	-
5.078e+04	170	14.62	7.14	-5.67	4.45	-2.98	-5.22	1.748e+05	7.309e+04	1.270e+05	1.209e+05	-
145 23	17	12.83	166.31	-6.84	-2.44	161.92	27.24	1.494e+05	9.490e+04	1.210e+05	1.233e+05	-
2.724e+04	27	33.15	108.53	-61.90	18.30	28.33	-85.07	3.738e+05	8.256e+04	2.304e+05	2.259e+05	-
1.456e+05	162	9.23	118.16	-4.46	1.46	112.24	26.29	1.063e+05	4.203e+04	4.707e+04	1.013e+05	-
1.727e+04	170	13.66	97.15	-63.84	20.31	13.00	-80.41	1.590e+05	6.661e+04	1.155e+05	1.101e+05	-
4.609e+04	17	12.65	59.11	1.11	2.95	57.26	10.17	1.492e+05	9.467e+04	1.208e+05	1.231e+05	-
145 55	17	12.65	59.11	1.11	2.95	57.26	10.17	1.492e+05	9.467e+04	1.208e+05	1.231e+05	-
2.726e+04	27	32.80	40.76	-25.73	9.22	5.80	-33.20	3.733e+05	8.228e+04	2.301e+05	2.254e+05	-
1.455e+05	162	9.00	42.94	1.24	4.16	40.02	10.64	1.062e+05	4.192e+04	4.696e+04	1.011e+05	-
1.728e+04	170	13.42	36.62	-24.47	9.55	2.61	-30.35	1.589e+05	6.650e+04	1.155e+05	1.100e+05	-
4.614e+04	17	12.56	6.47	2.98	5.71	3.74	1.44	1.491e+05	9.455e+04	1.208e+05	1.229e+05	-
145 69	17	12.56	6.47	2.98	5.71	3.74	1.44	1.491e+05	9.455e+04	1.208e+05	1.229e+05	-
2.727e+04	27	32.62	7.86	-9.00	4.58	-5.72	-6.67	3.730e+05	8.213e+04	2.300e+05	2.251e+05	-
1.454e+05	162	8.89	7.22	1.41	5.54	3.09	2.63	1.061e+05	4.186e+04	4.690e+04	1.011e+05	-
1.729e+04	170	13.29	6.49	-5.15	4.04	-2.71	-4.74	1.589e+05	6.645e+04	1.155e+05	1.099e+05	-
4.616e+04	170	13.64	5.82	-6.99	3.21	-4.38	-5.15	1.639e+05	8.587e+04	1.095e+05	1.403e+05	-
146 1	170	13.64	5.82	-6.99	3.21	-4.38	-5.15	1.639e+05	8.587e+04	1.095e+05	1.403e+05	-
3.586e+04	162	17.15	13.64	-3.71	9.91	0.02	-7.13	2.045e+05	8.155e+04	1.212e+05	1.648e+05	-
5.744e+04	163	10.01	5.59	-5.61	0.22	-0.25	-5.59	1.196e+05	4.988e+04	7.538e+04	9.414e+04	-
3.359e+04	171	9.43	8.23	-2.01	6.12	0.10	-4.14	1.126e+05	6.528e+04	8.840e+04	8.951e+04	-
2.367e+04	170	11.54	4.92	-5.91	2.72	-3.71	-4.36	1.387e+05	7.266e+04	9.265e+04	1.187e+05	-
146 3	170	11.54	4.92	-5.91	2.72	-3.71	-4.36	1.387e+05	7.266e+04	9.265e+04	1.187e+05	-
3.034e+04	162	14.51	11.54	-3.14	8.39	0.01	-6.03	1.730e+05	6.900e+04	1.025e+05	1.395e+05	-
4.861e+04	163	8.47	4.73	-4.75	0.19	-0.21	-4.73	1.012e+05	4.221e+04	6.379e+04	7.965e+04	-
2.843e+04	171	7.98	6.96	-1.70	5.18	0.08	-3.50	9.530e+04	5.524e+04	7.480e+04	7.574e+04	-
2.003e+04	170	10.71	63.16	11.24	24.58	49.82	-22.69	1.262e+05	6.612e+04	8.432e+04	1.080e+05	-
146 7	170	10.71	63.16	11.24	24.58	49.82	-22.69	1.262e+05	6.612e+04	8.432e+04	1.080e+05	-
2.759e+04	162	13.52	93.95	-20.36	41.04	32.55	-57.00	1.575e+05	6.281e+04	9.345e+04	1.269e+05	-
4.430e+04	163	7.85	47.85	-24.79	-18.73	41.80	-20.07	9.220e+04	3.833e+04	5.813e+04	7.240e+04	-
2.598e+04	171	7.43	72.02	-36.31	4.18	31.53	-52.41	8.628e+04	5.005e+04	6.764e+04	6.868e+04	-
1.811e+04	170	10.57	22.85	1.73	9.95	14.63	-10.30	1.261e+05	6.608e+04	8.426e+04	1.079e+05	-
146 39	170	10.57	22.85	1.73	9.95	14.63	-10.30	1.261e+05	6.608e+04	8.426e+04	1.079e+05	-
2.759e+04	162	13.30	38.23	-8.28	18.93	11.02	-22.92	1.574e+05	6.276e+04	9.329e+04	1.268e+05	-
4.423e+04	163	7.75	17.87	-10.08	-6.23	14.02	-9.64	9.209e+04	3.836e+04	5.803e+04	7.241e+04	-
2.589e+04	171	7.31	27.70	-12.46	4.53	10.72	-19.84	8.651e+04	5.016e+04	6.788e+04	6.880e+04	-
1.817e+04	170	10.49	4.47	-5.37	2.47	-3.37	-3.96	1.261e+05	6.606e+04	8.423e+04	1.079e+05	-
146 69	170	10.49	4.47	-5.37	2.47	-3.37	-3.96	1.261e+05	6.606e+04	8.423e+04	1.079e+05	-
2.758e+04	162	13.19	10.50	-2.86	7.63	0.01	-5.48	1.573e+05	6.273e+04	9.320e+04	1.268e+05	-
4.419e+04	163	7.70	4.30	-4.31	0.17	-0.19	-4.30	9.203e+04	3.837e+04	5.799e+04	7.241e+04	-
2.584e+04	171	7.25	6.33	-1.55	4.71	0.07	-3.18	8.664e+04	5.022e+04	6.800e+04	6.886e+04	-
1.821e+04	171	9.08	6.54	-2.43	2.75	1.36	-4.43	1.084e+05	6.408e+04	8.046e+04	9.204e+04	-
147 1	171	9.08	6.54	-2.43	2.75	1.36	-4.43	1.084e+05	6.408e+04	8.046e+04	9.204e+04	-
2.140e+04	163	10.57	7.22	-4.12	3.97	-0.87	-5.13	1.262e+05	5.241e+04	7.599e+04	1.027e+05	-

Parco Eolico “Bolina” – Progetto Definitivo
Relazione di calcolo preliminare delle fondazioni degli aerogeneratori G8 e G12

3.442e+04																				
2.563e+04	164	6.92	7.03	-2.55	2.29	2.19	-4.79	8.198e+04	3.058e+04	5.437e+04	5.819e+04									
1.395e+04	172	5.95	7.88	-2.05	5.26	0.57	-4.38	7.076e+04	4.239e+04	5.914e+04	5.402e+04									
147 3	171	7.69	5.53	-2.06	2.32	1.15	-3.75	9.174e+04	5.423e+04	6.808e+04	7.788e+04									
1.810e+04	163	8.94	6.11	-3.48	3.36	-0.73	-4.34	1.068e+05	4.435e+04	6.430e+04	8.686e+04									
2.913e+04	164	5.85	5.95	-2.16	1.93	1.85	-4.05	6.937e+04	2.587e+04	4.600e+04	4.924e+04									
2.169e+04	172	5.03	6.67	-1.74	4.45	0.48	-3.70	5.987e+04	3.587e+04	5.004e+04	4.571e+04									
1.180e+04	171	7.14	56.07	-20.13	0.62	35.32	-33.92	8.339e+04	4.907e+04	6.157e+04	7.090e+04									
147 7	163	8.31	52.29	-18.33	-6.64	40.60	-26.25	9.717e+04	4.026e+04	5.857e+04	7.885e+04									
1.652e+04	164	5.43	40.97	-21.04	-13.33	33.26	-20.46	6.307e+04	2.340e+04	4.180e+04	4.467e+04									
2.659e+04	172	4.68	49.09	-20.41	-0.77	29.45	-31.30	5.432e+04	3.237e+04	4.541e+04	4.128e+04									
1.078e+04	171	7.04	21.93	-7.67	1.61	12.65	-13.73	8.340e+04	4.922e+04	6.178e+04	7.083e+04									
147 39	163	8.19	19.87	-6.80	-0.22	13.30	-11.49	9.712e+04	4.030e+04	5.849e+04	7.893e+04									
1.648e+04	164	5.36	16.73	-7.71	-3.35	12.37	-9.36	6.306e+04	2.348e+04	4.182e+04	4.473e+04									
2.651e+04	172	4.61	19.74	-7.07	2.42	10.25	-12.82	5.439e+04	3.253e+04	4.546e+04	4.146e+04									
1.075e+04	171	6.99	5.03	-1.87	2.11	1.05	-3.41	8.340e+04	4.930e+04	6.189e+04	7.080e+04									
147 69	163	8.13	5.56	-3.17	3.06	-0.67	-3.94	9.710e+04	4.031e+04	5.845e+04	7.896e+04									
1.646e+04	164	5.32	5.41	-1.96	1.76	1.68	-3.68	6.306e+04	2.352e+04	4.182e+04	4.476e+04									
2.648e+04	172	4.57	6.06	-1.58	4.05	0.44	-3.37	5.443e+04	3.261e+04	4.549e+04	4.155e+04									
1.971e+04	172	5.92	5.94	-0.48	3.90	1.57	-2.99	7.058e+04	4.186e+04	5.736e+04	5.509e+04									
1.073e+04	172	5.92	5.94	-0.48	3.90	1.57	-2.99	7.058e+04	4.186e+04	5.736e+04	5.509e+04									
148 1	164	6.98	5.73	-2.88	2.19	0.66	-4.24	8.281e+04	3.100e+04	5.180e+04	6.201e+04									
1.431e+04	165	4.82	5.07	-0.83	2.03	2.21	-2.95	5.559e+04	1.437e+04	3.672e+04	3.324e+04									
2.540e+04	173	3.85	6.91	-0.61	3.46	2.84	-3.74	4.598e+04	2.397e+04	4.129e+04	2.867e+04	-9015.47								
2.054e+04	172	5.01	5.03	-0.40	3.30	1.33	-2.53	5.972e+04	3.542e+04	4.853e+04	4.661e+04									
148 3	164	5.91	4.85	-2.44	1.85	0.56	-3.58	7.007e+04	2.623e+04	4.383e+04	5.247e+04									
1.211e+04	165	4.08	4.29	-0.71	1.72	1.87	-2.50	4.704e+04	1.216e+04	3.107e+04	2.812e+04									
2.149e+04	173	3.25	5.84	-0.51	2.92	2.40	-3.17	3.891e+04	2.028e+04	3.494e+04	2.426e+04	-7628.47								
1.738e+04	172	4.64	43.63	-19.14	-6.35	30.85	-25.28	5.416e+04	3.208e+04	4.404e+04	4.220e+04									
148 7	164	5.47	36.47	-17.91	-13.40	31.96	-15.00	6.372e+04	2.370e+04	3.983e+04	4.758e+04									
1.100e+04	165	3.76	31.54	-19.20	-15.45	27.80	-13.26	4.263e+04	1.088e+04	2.820e+04	2.531e+04									
1.963e+04	173	3.00	38.23	-19.52	-6.83	25.53	-23.91	3.518e+04	1.831e+04	3.164e+04	2.186e+04	-6875.84								
1.581e+04	172	4.58	17.11	-6.04	-0.16	11.23	-10.08	5.425e+04	3.216e+04	4.409e+04	4.232e+04									
148 39	164	5.40	14.13	-6.40	-3.42	11.15	-7.23	6.371e+04	2.380e+04	3.984e+04	4.766e+04									
1.101e+04	165	3.72	12.66	-6.32	-4.20	10.53	-5.99	4.272e+04	1.099e+04	2.823e+04	2.548e+04									
1.957e+04	173	2.97	16.09	-6.56	-0.55	10.09	-10.00	3.531e+04	1.840e+04	3.172e+04	2.199e+04	-6914.97								
1.580e+04	172	4.55	4.57	-0.37	3.00	1.20	-2.30	5.429e+04	3.220e+04	4.412e+04	4.238e+04									
148 69	164	5.37	4.41	-2.21	1.68	0.51	-3.26	6.370e+04	2.385e+04	3.985e+04	4.770e+04									
1.101e+04	165	3.71	3.90	-0.64	1.56	1.70	-2.27	4.276e+04	1.105e+04	2.825e+04	2.557e+04									
1.954e+04	173	2.96	5.31	-0.47	2.66	2.19	-2.88	3.537e+04	1.844e+04	3.176e+04	2.205e+04	-6934.98								
1.580e+04	173	3.84	5.45	-0.63	2.93	1.89	-3.00	4.601e+04	2.418e+04	4.032e+04	2.986e+04	-9579.20								
149 1	173	3.84	5.45	-0.63	2.93	1.89	-3.00	4.601e+04	2.418e+04	4.032e+04	2.986e+04									

Parco Eolico "Bolina" – Progetto Definitivo
Relazione di calcolo preliminare delle fondazioni degli aerogeneratori G8 e G12

2.057e+04	165	4.81	3.20	-0.92	1.49	0.80	-2.03	5.565e+04	1.450e+04	3.495e+04	3.519e+04	-
1.656e+04	166	3.48	3.69	-0.34	2.32	1.03	-1.91	3.808e+04	4392.30	2.430e+04	1.817e+04	-
	174	2.57	6.42	-0.39	3.06	2.96	-3.40	3.035e+04	1.098e+04	2.772e+04	1.361e+04	-6637.71
149	3	173	3.25	4.61	-0.54	2.48	-2.54	3.893e+04	2.046e+04	3.412e+04	2.526e+04	-8105.47
	165	4.07	2.71	-0.78	1.26	0.68	-1.72	4.708e+04	1.227e+04	2.957e+04	2.978e+04	-
1.741e+04	166	2.94	3.12	-0.29	1.96	0.87	-1.62	3.222e+04	3716.56	2.056e+04	1.538e+04	-
1.401e+04	174	2.18	5.43	-0.33	2.59	2.51	-2.88	2.568e+04	9291.22	2.345e+04	1.152e+04	-5616.52
149	8	173	2.99	20.31	-9.78	1.87	-14.65	3.530e+04	1.852e+04	3.096e+04	2.286e+04	-7347.09
	165	3.75	11.93	-10.38	-2.29	3.84	-10.73	4.277e+04	1.105e+04	2.680e+04	2.703e+04	-
1.586e+04	166	2.71	12.07	-12.37	-4.63	4.33	-11.37	2.924e+04	3477.34	1.878e+04	1.394e+04	-
1.265e+04	174	2.00	19.85	-10.46	2.85	6.54	-15.04	2.315e+04	8455.25	2.118e+04	1.043e+04	-5015.35
149	40	173	2.97	9.55	-3.54	2.12	-6.48	3.536e+04	1.857e+04	3.100e+04	2.293e+04	-7361.33
	165	3.72	5.59	-3.90	-0.02	1.71	-4.66	4.279e+04	1.112e+04	2.686e+04	2.706e+04	-
1.584e+04	166	2.69	5.77	-4.16	-0.39	1.99	-4.82	2.927e+04	3412.12	1.872e+04	1.396e+04	-
1.271e+04	174	1.99	9.97	-3.73	2.52	3.72	-6.82	2.328e+04	8449.52	2.127e+04	1.046e+04	-5075.28
149	69	173	2.96	4.19	-0.49	2.25	-2.31	3.539e+04	1.860e+04	3.102e+04	2.297e+04	-7368.61
	165	3.70	2.46	-0.71	1.14	0.61	-1.56	4.280e+04	1.115e+04	2.689e+04	2.707e+04	-
1.583e+04	166	2.68	2.84	-0.26	1.78	0.79	-1.47	2.929e+04	3378.69	1.869e+04	1.398e+04	-
1.274e+04	174	1.98	4.94	-0.30	2.36	2.28	-2.62	2.335e+04	8446.56	2.132e+04	1.047e+04	-5105.93
150	1	174	2.55	5.51	-0.08	3.30	-2.74	3.023e+04	1.167e+04	2.701e+04	1.489e+04	-7028.18
	166	3.53	0.76	-1.42	0.19	-0.84	-0.96	3.856e+04	4094.67	2.386e+04	1.879e+04	-
1.705e+04	167	2.58	6.34	-3.46	6.03	-3.14	-1.74	2.790e+04	2581.93	1.566e+04	1.482e+04	-
1.265e+04	175	1.77	6.32	1.20	3.23	4.28	-2.51	1.891e+04	1244.02	1.720e+04	2949.38	-5216.35
150	3	174	2.16	4.67	-0.07	2.79	-2.31	2.558e+04	9876.14	2.286e+04	1.260e+04	-5946.92
	166	2.98	0.64	-1.20	0.16	-0.71	-0.81	3.263e+04	3464.72	2.019e+04	1.590e+04	-
1.442e+04	167	2.18	5.37	-2.92	5.10	-2.65	-1.47	2.361e+04	2184.71	1.325e+04	1.254e+04	-
1.070e+04	175	1.50	5.35	1.01	2.74	3.62	-2.12	1.600e+04	1052.63	1.455e+04	2495.63	-4413.83
150	22	174	2.01	25.82	-21.60	24.71	7.16	2.346e+04	9498.30	2.113e+04	1.183e+04	-5205.45
	166	2.78	27.27	-29.41	26.42	-28.57	-6.88	2.996e+04	3590.80	1.834e+04	1.521e+04	-
1.309e+04	167	1.97	30.01	-31.25	27.81	-29.06	-11.40	2.164e+04	4305.33	1.259e+04	1.335e+04	-8658.99
	175	1.49	28.19	-12.91	26.19	-10.91	8.84	1.481e+04	213.22	1.325e+04	1771.08	-4506.49
150	54	174	1.98	10.11	-5.92	10.04	-5.85	2.332e+04	9154.50	2.090e+04	1.158e+04	-5338.33
	166	2.74	9.44	-10.50	9.04	-10.10	-2.81	2.976e+04	3300.20	1.835e+04	1.471e+04	-
1.311e+04	167	1.98	13.38	-12.33	12.48	-11.43	-4.74	2.152e+04	2776.88	1.223e+04	1.206e+04	-9368.69
	175	1.40	10.75	-1.75	10.51	-1.51	1.72	1.463e+04	706.19	1.324e+04	2100.35	-4179.70
150	69	174	1.96	4.24	-0.06	2.54	-2.10	2.326e+04	8978.30	2.078e+04	1.146e+04	-5406.29
	166	2.71	0.58	-1.09	0.14	-0.65	-0.74	2.966e+04	3149.75	1.836e+04	1.446e+04	-
1.311e+04	167	1.98	4.88	-2.66	4.63	-2.41	-1.34	2.146e+04	1986.10	1.205e+04	1.140e+04	-9731.65
	175	1.36	4.86	0.92	2.49	3.29	-1.93	1.454e+04	956.94	1.323e+04	2268.76	-4012.57
151	1	175	1.82	2.45	-2.89	2.40	0.48	2.029e+04	3312.30	1.697e+04	6638.16	-6739.19
	167	1.99	13.31	0.72	7.16	6.86	-6.29	2.109e+04	2002.56	1.432e+04	8774.22	-9131.93
	168	1.78	3.52	-1.50	-1.47	3.49	0.41	1.645e+04	-3474.80	1.177e+04	1206.65	-8448.88
	176	1.13	9.53	-1.13	6.87	1.53	-4.62	1.162e+04	454.23	1.124e+04	832.80	-2020.46
151	3	175	1.54	2.07	-2.45	2.03	0.41	1.717e+04	2802.71	1.436e+04	5616.90	-5702.39
	167	1.68	11.26	0.61	6.06	5.81	-5.32	1.784e+04	1694.47	1.211e+04	7424.34	-7727.01
	168	1.51	2.98	-1.27	-1.25	2.95	0.34	1.392e+04	-2940.22	9962.09	1021.02	-7149.06
	176	0.95	8.07	-0.96	5.81	1.30	-3.91	9829.02	384.35	9508.69	704.67	-1709.62
151	7	175	1.32	17.94	-17.03	-12.46	-11.79	1.461e+04	2191.40	1.264e+04	4154.32	-4529.50
	167	1.81	8.61	-21.11	-20.47	7.98	4.31	1.880e+04	1273.25	1.230e+04	7766.52	-8463.23
	168	1.35	9.41	-16.76	-16.72	9.37	0.98	1.201e+04	-2620.17	8359.56	1031.64	-6332.13
	176	0.93	11.55	-17.86	-13.44	7.13	-10.51	9399.56	223.08	8990.76	631.89	-1893.21
151	40	175	1.58	3.13	-1.09	1.62	-2.02	1.533e+04	2522.16	1.290e+04	4945.40	-5015.53
	167	1.59	6.83	-1.72	0.57	4.55	-3.78	1.699e+04	1480.89	1.158e+04	6894.75	-7393.73
	168	1.35	3.61	-2.30	-2.18	3.49	-0.83	1.243e+04	-2677.70	8837.12	919.85	-6436.24
	176	0.88	7.42	-2.73	3.41	1.28	-4.96	9084.38	377.14	8765.47	696.04	-1635.57
151	69	175	1.40	1.88	-2.23	1.85	-2.19	1.561e+04	2547.92	1.305e+04	5106.28	-5183.99

Parco Eolico "Bolina" – Progetto Definitivo
Relazione di calcolo preliminare delle fondazioni degli aerogeneratori G8 e G12

		167	1.53	10.24	0.55	5.51	5.28	-4.84	1.622e+04	1540.43	1.101e+04	6749.40	-7024.56
		168	1.37	2.71	-1.16	-1.13	2.68	0.31	1.266e+04	-2672.92	9056.44	928.20	-6499.14
		176	0.87	7.33	-0.87	5.28	1.18	-3.55	8935.47	349.41	8644.27	640.61	-1554.20
152	1	176	1.22	5.51	-1.34	3.87	0.30	-2.92	1.254e+04	24.62	1.178e+04	790.16	-2999.26
		168	1.68	2.24	0.56	1.81	0.99	0.73	1.553e+04	-3437.77	9879.33	2217.47	-8678.22
		169	0.92	1.90	-0.15	0.74	1.01	1.02	9731.51	376.24	9731.43	376.32	-28.33
		177	1.00	6.05	-0.10	5.21	0.74	-2.11	1.029e+04	126.33	1.023e+04	179.93	-735.95
152	3	176	1.04	4.66	-1.14	3.28	0.25	-2.47	1.061e+04	20.83	9963.57	668.60	-2537.83
		168	1.42	1.89	0.47	1.53	0.84	0.62	1.314e+04	-2908.88	8359.43	1876.32	-7343.11
		169	0.78	1.61	-0.13	0.63	0.85	0.86	8234.36	318.36	8234.28	318.43	-23.98
		177	0.85	5.12	-0.09	4.41	0.62	-1.79	8703.16	106.90	8657.81	152.25	-622.72
152	23	176	1.00	9.48	-27.00	-23.23	5.71	-11.11	9652.08	-202.11	9043.06	406.91	-2372.86
		168	1.41	7.41	-26.70	-23.46	4.18	10.00	1.203e+04	-2647.20	7414.00	1967.66	-6814.03
		169	0.79	4.93	-25.39	-23.37	2.91	7.56	7302.19	257.44	7302.16	257.46	-12.73
		177	0.84	5.10	-25.05	-22.58	2.63	-8.27	7913.95	119.52	7867.23	166.25	-601.68
152	55	176	0.94	4.69	-8.49	-5.89	2.08	-5.25	9648.50	-55.86	9052.81	539.83	-2329.36
		168	1.33	3.29	-8.39	-7.02	1.92	3.76	1.198e+04	-2644.34	7536.72	1794.37	-6722.41
		169	0.73	2.45	-8.48	-7.53	1.50	3.08	7423.65	278.60	7423.60	278.65	-18.73
		177	0.77	3.12	-6.84	-4.99	1.27	-3.88	7912.59	104.78	7869.55	147.83	-578.15
152	69	176	0.94	4.24	-1.03	2.98	0.23	-2.25	9646.67	18.94	9057.79	607.82	-2307.12
		168	1.29	1.72	0.43	1.39	0.76	0.56	1.195e+04	-2644.44	7599.49	1705.75	-6675.55
		169	0.71	1.46	-0.12	0.57	0.77	0.78	7485.78	289.41	7485.71	289.48	-21.80
		177	0.77	4.66	-0.08	4.01	0.57	-1.63	7911.96	97.18	7870.73	138.41	-566.11
153	1	18	17.62	5.84	-2.82	5.81	-2.79	-0.53	2.119e+05	1.030e+05	1.389e+05	1.759e+05	-
5.119e+04		17	22.95	8.93	-4.66	5.66	-1.40	-5.81	2.752e+05	1.229e+05	1.882e+05	2.099e+05	-
7.538e+04		170	13.63	6.30	1.64	6.24	1.70	-0.54	1.638e+05	8.472e+04	1.146e+05	1.339e+05	-
3.834e+04		178	11.93	6.75	-5.53	6.67	-5.46	-0.96	1.426e+05	8.534e+04	1.119e+05	1.160e+05	-
2.854e+04		153	14.91	4.95	-2.39	4.92	-2.36	-0.44	1.793e+05	8.716e+04	1.176e+05	1.489e+05	-
4.331e+04	3	17	19.42	7.55	-3.95	4.79	-1.18	-4.91	2.328e+05	1.040e+05	1.592e+05	1.776e+05	-
6.378e+04		170	11.54	5.33	1.39	5.28	1.44	-0.46	1.386e+05	7.168e+04	9.695e+04	1.133e+05	-
3.244e+04		178	10.10	5.71	-4.68	5.64	-4.62	-0.81	1.206e+05	7.221e+04	9.467e+04	9.818e+04	-
2.415e+04		153	13.71	40.16	-44.13	-11.49	7.52	-41.06	1.632e+05	7.945e+04	1.070e+05	1.356e+05	-
3.935e+04	23	17	18.15	136.14	-26.14	22.34	87.66	-74.27	2.121e+05	9.483e+04	1.450e+05	1.619e+05	-
5.801e+04		170	10.67	53.39	-59.20	-18.68	12.86	-54.04	1.260e+05	6.534e+04	8.822e+04	1.032e+05	-
2.942e+04		178	9.41	88.33	-20.68	11.64	56.00	-49.79	1.092e+05	6.574e+04	8.587e+04	8.907e+04	-
2.167e+04		153	13.61	14.30	-14.10	-0.93	1.12	-14.16	1.630e+05	7.931e+04	1.069e+05	1.354e+05	-
3.937e+04	55	17	17.82	49.27	-9.88	10.44	28.95	-28.09	2.118e+05	9.462e+04	1.448e+05	1.616e+05	-
5.799e+04		170	10.55	20.06	-17.99	-3.14	5.22	-18.56	1.260e+05	6.523e+04	8.817e+04	1.031e+05	-
2.947e+04		178	9.26	29.64	-6.14	7.33	16.17	-17.34	1.095e+05	6.568e+04	8.600e+04	8.919e+04	-
2.186e+04		153	13.55	4.50	-2.17	4.47	-2.15	-0.40	1.630e+05	7.924e+04	1.069e+05	1.353e+05	-
3.938e+04	69	17	17.65	6.87	-3.59	4.36	-1.08	-4.47	2.117e+05	9.452e+04	1.447e+05	1.614e+05	-
5.798e+04		170	10.49	4.85	1.26	4.80	1.31	-0.41	1.260e+05	6.517e+04	8.814e+04	1.030e+05	-
2.949e+04		178	9.18	5.19	-4.26	5.13	-4.20	-0.74	1.097e+05	6.564e+04	8.607e+04	8.925e+04	-
2.196e+04		154	11.49	9.52	-4.64	8.89	-4.01	-2.92	1.372e+05	8.189e+04	9.347e+04	1.257e+05	-
2.251e+04	1	170	14.45	4.53	-3.21	3.74	-2.42	-2.34	1.737e+05	8.901e+04	1.122e+05	1.505e+05	-
3.778e+04		171	8.58	13.15	-2.84	3.85	6.46	-7.89	1.017e+05	6.326e+04	7.621e+04	8.874e+04	-
1.816e+04		179	8.87	1.34	-14.60	-5.08	-8.18	7.82	1.042e+05	7.001e+04	8.128e+04	9.293e+04	-
1.607e+04		154	9.72	8.05	-3.93	7.52	-3.40	-2.47	1.161e+05	6.929e+04	7.909e+04	1.063e+05	-
1.905e+04	3	178											-

Parco Eolico "Bolina" – Progetto Definitivo
Relazione di calcolo preliminare delle fondazioni degli aerogeneratori G8 e G12

3.197e+04	170	12.23	3.84	-2.72	3.17	-2.05	-1.98	1.470e+05	7.532e+04	9.496e+04	1.274e+05	-
1.537e+04	171	7.26	11.13	-2.40	3.26	5.47	-6.67	8.604e+04	5.353e+04	6.449e+04	7.509e+04	-
1.360e+04	179	7.51	1.14	-12.35	-4.29	-6.92	6.62	8.817e+04	5.924e+04	6.877e+04	7.864e+04	-
1.741e+04	154 6 178	9.01	33.66	-56.51	9.27	-32.11	40.06	1.058e+05	6.220e+04	7.090e+04	9.706e+04	-
2.937e+04	170	11.40	28.79	-73.40	8.39	-53.01	40.85	1.341e+05	6.851e+04	8.671e+04	1.159e+05	-
1.334e+04	171	6.61	19.11	-39.69	5.82	-26.40	24.59	7.720e+04	4.889e+04	5.832e+04	6.776e+04	-
1.429e+04	179	7.30	21.12	-80.45	-23.41	-35.92	50.40	8.371e+04	5.425e+04	6.543e+04	7.253e+04	-
1.735e+04	154 38 178	8.89	13.23	-18.48	7.66	-12.91	12.07	1.056e+05	6.272e+04	7.156e+04	9.679e+04	-
2.917e+04	170	11.21	10.18	-24.60	4.74	-19.17	12.63	1.338e+05	6.849e+04	8.646e+04	1.158e+05	-
1.376e+04	171	6.56	5.58	-7.30	3.93	-5.64	4.31	7.787e+04	4.874e+04	5.852e+04	6.809e+04	-
1.302e+04	179	6.98	7.82	-34.64	-10.50	-16.32	21.03	8.134e+04	5.401e+04	6.350e+04	7.184e+04	-
1.732e+04	154 69 178	8.83	7.32	-3.57	6.84	-3.09	-2.25	1.056e+05	6.299e+04	7.190e+04	9.665e+04	-
2.906e+04	170	11.12	3.49	-2.47	2.88	-1.87	-1.80	1.336e+05	6.847e+04	8.633e+04	1.158e+05	-
1.397e+04	171	6.60	10.12	-2.18	2.96	4.97	-6.07	7.822e+04	4.866e+04	5.862e+04	6.826e+04	-
1.236e+04	179	6.83	1.03	-11.23	-3.90	-6.29	6.01	8.015e+04	5.385e+04	6.252e+04	7.149e+04	-
1.176e+04	155 1 179	7.81	22.14	-0.90	-0.83	22.08	1.23	9.017e+04	6.635e+04	7.638e+04	8.014e+04	-
1.929e+04	171	9.42	4.18	-11.24	3.09	-10.16	-3.94	1.127e+05	6.405e+04	7.355e+04	1.032e+05	-
1.530e+04	172	5.97	7.52	2.53	2.53	7.52	0.05	7.141e+04	4.080e+04	5.631e+04	5.589e+04	-
1.632e+04	180	4.88	10.41	-3.67	3.38	3.36	-7.04	5.112e+04	5.031e+04	5.035e+04	5.108e+04	-172.40
1.295e+04	155 3 179	6.61	18.74	-0.76	-0.70	18.68	1.04	7.630e+04	5.614e+04	6.463e+04	6.781e+04	-9952.44
1.071e+04	171	7.97	3.53	-9.51	2.62	-8.60	-3.34	9.539e+04	5.420e+04	6.224e+04	8.735e+04	-
1.457e+04	172	5.06	6.37	2.14	2.14	6.37	0.05	6.042e+04	3.452e+04	4.765e+04	4.729e+04	-
1.253e+04	180	4.13	8.81	-3.10	2.86	2.84	-5.95	4.325e+04	4.257e+04	4.260e+04	4.322e+04	-145.88
1.475e+04	155 22 179	5.92	36.26	-26.41	17.97	-8.12	28.49	6.905e+04	4.761e+04	5.864e+04	5.803e+04	-
1.203e+04	171	7.58	26.63	-77.26	26.03	-76.66	7.87	8.827e+04	4.972e+04	5.638e+04	8.161e+04	-
1.484e+04	172	4.67	27.75	-40.74	25.38	-38.36	12.54	5.530e+04	3.022e+04	4.309e+04	4.243e+04	-
1.177e+04	180	3.83	17.86	-35.05	15.92	-33.11	9.95	4.004e+04	3.893e+04	3.941e+04	3.956e+04	548.35
1.393e+04	155 54 179	5.95	17.44	-3.29	5.66	8.49	10.27	6.922e+04	4.992e+04	5.871e+04	6.042e+04	-9611.70
1.203e+04	171	7.35	10.39	-31.12	10.38	-31.11	0.66	8.724e+04	4.943e+04	5.651e+04	8.016e+04	-
1.475e+04	172	4.60	10.79	-10.07	9.87	-9.15	4.27	5.505e+04	3.099e+04	4.324e+04	4.280e+04	-
1.177e+04	180	3.77	7.11	-9.50	7.11	-9.49	-0.22	3.940e+04	3.894e+04	3.896e+04	3.938e+04	97.80
1.484e+04	155 69 179	6.01	17.03	-0.69	-0.64	16.98	0.95	6.936e+04	5.104e+04	5.875e+04	6.165e+04	-9047.67
1.177e+04	171	7.24	3.21	-8.65	2.38	-7.82	-3.03	8.672e+04	4.927e+04	5.658e+04	7.941e+04	-
1.177e+04	172	4.60	5.79	1.94	1.94	5.79	0.04	5.493e+04	3.138e+04	4.332e+04	4.299e+04	-
1.393e+04	180	3.76	8.01	-2.82	2.60	2.58	-5.41	3.932e+04	3.870e+04	3.873e+04	3.929e+04	-132.62
1.179e+04	156 1 180	4.88	8.34	-0.54	2.05	5.74	-4.04	5.208e+04	4.919e+04	5.012e+04	5.114e+04	-1351.34
1.179e+04	172	5.91	3.30	0.76	1.17	2.89	-0.94	7.048e+04	4.220e+04	5.392e+04	5.876e+04	-
1.179e+04	173	3.76	5.26	0.58	1.14	4.70	-1.52	4.499e+04	2.444e+04	3.822e+04	3.121e+04	-9659.70
1.179e+04	181	3.13	6.42	-0.20	3.10	3.12	-3.31	3.502e+04	2.914e+04	3.467e+04	2.949e+04	1386.20
1.179e+04	156 3 180	4.13	7.06	-0.46	1.74	4.86	-3.42	4.406e+04	4.162e+04	4.241e+04	4.327e+04	-1143.44
1.179e+04	172	5.00	2.79	0.64	0.99	2.44	-0.79	5.963e+04	3.571e+04	4.562e+04	4.972e+04	-
1.179e+04	173	3.18	4.45	0.49	0.97	3.98	-1.28	3.807e+04	2.068e+04	3.234e+04	2.641e+04	-8173.59
1.179e+04	181	2.65	5.43	-0.17	2.62	2.64	-2.80	2.963e+04	2.466e+04	2.934e+04	2.495e+04	1172.94
1.179e+04	156 6 180	3.77	21.15	-31.78	12.35	-22.98	19.71	3.988e+04	3.792e+04	3.874e+04	3.906e+04	-967.62

Parco Eolico "Bolina" – Progetto Definitivo
Relazione di calcolo preliminare delle fondazioni degli aerogeneratori G8 e G12

1.080e+04	172	4.63	21.50	-35.22	18.41	-32.14	12.87	5.441e+04	3.247e+04	4.154e+04	4.533e+04	-
	173	2.92	22.24	-27.79	19.57	-25.12	11.26	3.481e+04	1.891e+04	2.953e+04	2.419e+04	-7486.19
	181	2.43	22.36	-29.37	14.45	-21.46	18.62	2.703e+04	2.268e+04	2.678e+04	2.293e+04	1000.21
156	39	180	3.77	19.20	-7.58	-2.06	-10.83	4.013e+04	3.780e+04	3.849e+04	3.943e+04	-1063.81
	172	4.57	15.24	-6.42	-5.02	13.84	-5.32	5.415e+04	3.246e+04	4.145e+04	4.515e+04	-
1.069e+04	173	2.90	14.76	-6.87	-5.45	13.34	-5.37	3.454e+04	1.876e+04	2.935e+04	2.395e+04	-7411.71
	181	2.40	15.85	-7.07	-1.70	10.48	-9.71	2.691e+04	2.232e+04	2.663e+04	2.260e+04	1088.67
156	69	180	3.76	6.42	-0.42	1.58	-3.11	4.006e+04	3.784e+04	3.856e+04	3.934e+04	-1039.49
	172	4.54	2.54	0.58	0.90	2.22	-0.72	5.421e+04	3.246e+04	4.147e+04	4.520e+04	-
1.072e+04	173	2.89	4.05	0.45	0.88	3.61	-1.17	3.461e+04	1.880e+04	2.940e+04	2.401e+04	-7430.54
	181	2.41	4.94	-0.16	2.38	2.40	-2.55	2.694e+04	2.241e+04	2.667e+04	2.268e+04	1066.31
157	1	181	3.12	5.64	-0.65	2.36	-3.14	3.495e+04	2.905e+04	3.478e+04	2.923e+04	998.71
	173	3.78	2.81	0.65	0.68	2.78	-0.26	4.533e+04	2.469e+04	3.708e+04	3.294e+04	-
1.011e+04	174	2.46	4.44	0.84	0.89	4.39	-0.43	2.932e+04	1.162e+04	2.505e+04	1.589e+04	-7570.64
	182	2.11	4.33	0.06	3.33	1.06	-1.80	2.502e+04	1.536e+04	2.464e+04	1.574e+04	1879.23
157	3	181	2.64	4.77	-0.55	2.00	-2.66	2.957e+04	2.458e+04	2.943e+04	2.473e+04	845.06
	173	3.20	2.38	0.55	0.57	2.35	-0.22	3.835e+04	2.089e+04	3.138e+04	2.787e+04	-8551.05
	174	2.08	3.76	0.71	0.76	3.71	-0.37	2.481e+04	9830.84	2.120e+04	1.344e+04	-6405.93
	182	1.78	3.66	0.05	2.82	0.90	-1.53	2.117e+04	1.300e+04	2.085e+04	1.332e+04	1590.11
157	6	181	2.43	22.75	-27.59	17.54	15.33	2.697e+04	2.257e+04	2.685e+04	2.270e+04	728.79
	173	2.94	20.99	-25.08	20.17	-24.25	6.10	3.510e+04	1.912e+04	2.867e+04	2.555e+04	-7839.49
	174	1.94	22.26	-19.72	21.26	-18.72	6.40	2.281e+04	9048.69	1.945e+04	1.241e+04	-5909.91
	182	1.70	23.55	-25.84	17.63	-19.92	16.04	1.942e+04	1.256e+04	1.922e+04	1.276e+04	1160.57
157	56	181	2.41	7.33	-3.59	6.98	-1.90	2.692e+04	2.238e+04	2.678e+04	2.252e+04	762.20
	173	2.92	6.25	-6.41	5.75	-5.91	-2.47	3.490e+04	1.901e+04	2.854e+04	2.537e+04	-7787.19
	174	1.98	6.09	-3.73	5.08	-2.73	-2.98	2.258e+04	9002.30	1.932e+04	1.226e+04	-5801.55
	182	1.64	8.15	-4.62	8.05	-4.52	-1.10	1.923e+04	1.194e+04	1.894e+04	1.223e+04	1431.90
157	69	181	2.40	4.34	-0.50	1.82	-2.42	2.689e+04	2.235e+04	2.675e+04	2.248e+04	768.24
	173	2.91	2.16	0.50	0.52	2.14	-0.20	3.487e+04	1.899e+04	2.852e+04	2.534e+04	-7773.68
	174	1.89	3.42	0.65	0.69	3.38	-0.33	2.255e+04	8937.13	1.927e+04	1.222e+04	-5823.57
	182	1.62	3.33	0.05	2.56	0.82	-1.39	1.924e+04	1.182e+04	1.895e+04	1.211e+04	1445.56
158	1	182	2.08	4.07	-0.84	3.08	-1.97	2.476e+04	1.490e+04	2.442e+04	1.524e+04	1793.51
	174	2.52	2.60	-0.34	0.14	2.11	1.09	3.009e+04	1.187e+04	2.463e+04	1.733e+04	-8342.15
	175	1.50	5.78	1.78	2.35	5.22	-1.39	1.686e+04	3027.64	1.479e+04	5096.30	-4932.89
	183	1.67	2.45	-2.71	2.14	-2.39	1.24	1.991e+04	1.133e+04	1.991e+04	1.134e+04	-204.10
158	3	182	1.76	3.44	-0.71	2.60	-1.67	2.095e+04	1.261e+04	2.067e+04	1.289e+04	1517.59
	174	2.13	2.20	-0.29	0.12	1.78	0.93	2.546e+04	1.005e+04	2.084e+04	1.466e+04	-7058.75
	175	1.27	4.89	1.51	1.99	4.41	-1.18	1.427e+04	2561.85	1.252e+04	4312.25	-4173.98
	183	1.41	2.08	-2.29	1.81	-2.03	1.05	1.685e+04	9587.74	1.685e+04	9591.85	-172.70
158	22	182	1.70	26.30	-21.96	24.78	8.43	1.927e+04	1.215e+04	1.903e+04	1.239e+04	1277.47
	174	2.02	23.73	-22.19	23.36	-21.82	-4.11	2.345e+04	9253.19	1.915e+04	1.355e+04	-6519.92
	175	1.25	26.13	-13.77	24.63	-12.27	-7.59	1.277e+04	2373.41	1.149e+04	3655.28	-3418.80
158	38	183	1.36	28.30	-25.81	25.74	11.49	1.538e+04	1.024e+04	1.525e+04	1.037e+04	-831.24
	182	1.62	9.90	-7.57	9.22	-6.89	3.38	1.897e+04	1.170e+04	1.871e+04	1.196e+04	1336.52
	174	1.97	6.75	-4.72	6.55	-4.52	1.51	2.337e+04	9169.60	1.912e+04	1.343e+04	-6508.05
	175	1.16	9.95	-0.62	9.75	-0.42	-1.42	1.273e+04	2337.36	1.129e+04	3781.19	-3595.26
	183	1.34	8.68	-10.98	5.51	-7.81	7.23	1.591e+04	9147.99	1.585e+04	9210.24	-645.98
158	69	182	1.60	3.13	-0.65	2.37	-1.52	1.905e+04	1.146e+04	1.879e+04	1.172e+04	1379.63
	174	1.94	2.00	-0.27	0.11	1.62	0.84	2.314e+04	9132.61	1.895e+04	1.333e+04	-6417.04
	175	1.16	4.45	1.37	1.81	4.01	-1.07	1.297e+04	2328.96	1.138e+04	3920.23	-3794.53
	183	1.28	1.89	-2.09	1.64	-1.84	0.95	1.532e+04	8716.12	1.531e+04	8719.86	-157.00
159	1	183	1.66	7.42	2.68	3.14	1.41	1.923e+04	5275.05	1.917e+04	5331.61	-886.49
	175	1.52	1.97	-2.16	1.86	-2.05	-0.66	1.774e+04	5218.24	1.452e+04	8431.30	-5467.90
	176	1.21	4.30	0.23	2.97	1.56	1.91	1.267e+04	89.42	1.038e+04	2386.01	-4860.30
	184	1.32	5.14	0.65	2.41	3.37	-2.19	1.366e+04	-127.46	1.361e+04	-73.62	859.93
159	3	183	1.40	6.28	2.26	2.66	1.19	1.627e+04	4463.50	1.622e+04	4511.36	-750.11
	175	1.29	1.66	-1.83	1.57	-1.74	-0.56	1.501e+04	4415.44	1.229e+04	7134.17	-4626.69
	176	1.03	3.64	0.19	2.51	1.32	1.61	1.072e+04	75.66	8779.14	2018.93	-4112.57
	184	1.12	4.35	0.55	2.04	2.85	-1.86	1.156e+04	-107.85	1.151e+04	-62.29	727.63
159	23	183	1.41	13.44	-30.00	-25.12	8.56	1.534e+04	5404.36	1.530e+04	5447.01	649.61
	175	1.32	19.56	-23.57	-21.45	17.44	9.32	1.370e+04	2525.64	1.092e+04	5312.88	-4835.75
	176	1.03	12.24	-24.19	-23.17	11.22	6.01	9672.46	200.48	8223.43	1649.51	-3409.62
	184	1.05	11.72	-21.22	-18.99	9.49	-8.28	9955.87	135.25	9922.73	168.39	569.52
159	55	183	1.30	7.50	-7.97	-6.90	-3.92	1.494e+04	4551.46	1.493e+04	4556.62	-231.36
	175	1.21	5.53	-6.98	-6.31	4.86	2.82	1.366e+04	3510.57	1.109e+04	6088.79	-4419.15
	176	0.96	5.36	-7.10	-6.33	4.59	3.00	9718.86	116.69	8063.06	1772.49	-3627.35
	184	1.03	6.26	-6.54	-5.20	4.93	-3.92	1.032e+04	-19.06	1.028e+04	19.51	630.36
159	69	183	1.27	5.70	2.06	2.42	1.08	1.479e+04	4057.73	1.475e+04	4101.24	-681.92
	175	1.17	1.51	-1.66	1.43	-1.58	-0.51	1.364e+04	4014.03	1.117e+04	6485.61	-4206.08

Parco Eolico "Bolina" – Progetto Definitivo
Relazione di calcolo preliminare delle fondazioni degli aerogeneratori G8 e G12

		176	0.93	3.31	0.18	2.29	1.20	1.47	9747.64	68.78	7981.04	1835.39	-3738.70
		184	1.01	3.95	0.50	1.86	2.59	-1.69	1.051e+04	-98.05	1.047e+04	-56.63	661.48
160	1	184	1.25	3.85	0.76	2.40	2.21	-1.54	1.321e+04	404.78	1.321e+04	411.17	285.93
		176	1.21	3.56	-2.13	2.47	-1.04	2.24	1.258e+04	-55.81	1.017e+04	2358.51	-4967.79
		177	0.95	3.69	0.60	2.90	1.38	1.34	9941.83	272.99	9935.80	279.03	241.47
		185	1.14	3.78	-0.53	2.79	0.45	-1.81	1.190e+04	240.69	1.189e+04	249.28	-316.32
160	3	184	1.06	3.25	0.64	2.03	1.87	-1.30	1.118e+04	342.51	1.118e+04	347.91	241.94
		176	1.03	3.02	-1.80	2.09	-0.88	1.90	1.064e+04	-47.23	8602.07	1995.66	-4203.52
		177	0.80	3.12	0.50	2.46	1.17	1.14	8412.32	231.00	8407.21	236.10	204.32
		185	0.97	3.20	-0.45	2.36	0.38	-1.53	1.007e+04	203.66	1.006e+04	210.93	-267.66
160	22	184	1.09	28.80	-2.33	26.07	0.39	8.80	1.029e+04	22.04	1.029e+04	22.23	44.18
		176	1.05	27.43	-8.25	26.44	-7.26	-5.86	9787.98	59.56	7824.02	2023.51	-3905.01
		177	0.83	27.30	-1.62	26.17	-0.49	-5.60	7628.86	181.22	7625.85	184.23	149.69
		185	0.99	26.41	-2.77	25.66	-2.01	4.63	9370.11	223.21	9364.47	228.85	-227.07
160	55	184	0.98	4.13	-8.34	-6.35	2.14	-4.56	1.012e+04	407.74	1.012e+04	415.78	279.42
		176	0.97	3.29	-8.30	-6.40	1.39	4.29	9640.58	-78.43	7818.72	1743.42	-3793.08
		177	0.75	2.82	-7.11	-5.87	1.58	3.28	7653.97	219.65	7648.70	224.93	197.95
		185	0.89	2.55	-7.21	-5.81	1.15	-3.43	9079.56	172.24	9072.61	179.20	-248.82
160	69	184	0.97	2.96	0.59	1.85	1.70	-1.18	1.017e+04	311.37	1.016e+04	316.28	219.94
		176	0.93	2.74	-1.64	1.90	-0.80	1.72	9677.23	-42.93	7820.06	1814.24	-3821.38
		177	0.73	2.84	0.46	2.23	1.06	1.03	7647.56	210.00	7642.92	214.64	185.75
		185	0.88	2.91	-0.41	2.15	0.35	-1.39	9153.00	185.14	9146.40	191.75	-243.32
161	1	186	13.63	3.99	-5.62	2.33	-3.95	3.64	1.638e+05	8.473e+04	1.630e+05	8.558e+04	-8150.35
		16	22.92	7.57	-3.46	1.73	2.38	5.50	2.752e+05	1.229e+05	2.715e+05	1.266e+05	-
2.336e+04													
		18	17.62	4.35	-3.11	2.52	-1.28	3.20	2.119e+05	1.030e+05	2.116e+05	1.033e+05	-5862.27
		178	11.93	8.21	-4.90	2.40	0.91	6.51	1.426e+05	8.535e+04	1.405e+05	8.742e+04	-
1.069e+04													
161	3	186	11.53	3.38	-4.76	1.97	-3.35	3.08	1.386e+05	7.169e+04	1.379e+05	7.241e+04	-6896.45
		16	19.40	6.40	-2.93	1.46	2.02	4.66	2.328e+05	1.040e+05	2.297e+05	1.071e+05	-
1.977e+04													
		18	14.91	3.68	-2.63	2.14	-1.09	2.71	1.793e+05	8.716e+04	1.790e+05	8.742e+04	-4960.38
		178	10.10	6.95	-4.15	2.03	0.77	5.51	1.206e+05	7.222e+04	1.189e+05	7.397e+04	-9041.88
161	7	186	10.66	51.07	-65.92	50.75	-65.59	-6.17	1.261e+05	6.535e+04	1.254e+05	6.599e+04	-6200.65
		16	18.13	134.42	-21.64	134.19	-21.41	6.04	2.121e+05	9.483e+04	2.093e+05	9.762e+04	-
1.786e+04													
		18	13.72	40.86	-48.15	40.61	-47.90	-4.77	1.632e+05	7.945e+04	1.630e+05	7.968e+04	-4423.52
		178	9.41	91.95	-21.16	91.31	-20.52	8.52	1.092e+05	6.574e+04	1.076e+05	6.731e+04	-8086.98
161	39	186	10.54	18.36	-24.21	18.36	-24.21	-0.23	1.260e+05	6.523e+04	1.254e+05	6.588e+04	-6246.20
		16	17.80	46.73	-6.48	46.28	-6.03	4.85	2.118e+05	9.463e+04	2.090e+05	9.744e+04	-
1.793e+04													
		18	13.61	15.02	-16.86	15.02	-16.86	0.02	1.631e+05	7.931e+04	1.628e+05	7.955e+04	-4480.36
		178	9.26	33.09	-7.45	32.12	-6.48	6.20	1.095e+05	6.568e+04	1.079e+05	6.726e+04	-8174.92
161	69	186	10.48	3.07	-4.33	1.79	-3.04	2.80	1.260e+05	6.517e+04	1.253e+05	6.583e+04	-6269.50
		16	17.63	5.82	-2.66	1.33	1.83	4.23	2.117e+05	9.452e+04	2.088e+05	9.735e+04	-
1.797e+04													
		18	13.56	3.34	-2.39	1.94	-0.99	2.46	1.630e+05	7.923e+04	1.627e+05	7.948e+04	-4509.43
		178	9.18	6.31	-3.77	1.84	0.70	5.01	1.097e+05	6.565e+04	1.081e+05	6.724e+04	-8219.89
162	1	187	8.57	12.43	0.97	11.78	1.62	2.64	1.017e+05	6.330e+04	9.962e+04	6.535e+04	-8642.82
		186	14.46	8.32	-10.79	-0.40	-2.07	9.52	1.738e+05	8.902e+04	1.714e+05	9.133e+04	-
1.379e+04													
		178	11.49	5.87	-0.18	1.99	3.70	2.90	1.372e+05	8.180e+04	1.368e+05	8.223e+04	-4889.86
		179	8.89	5.88	-20.96	-11.72	-3.36	12.76	1.043e+05	7.014e+04	1.025e+05	7.196e+04	-7661.84
162	3	187	7.25	10.52	0.82	9.97	1.37	2.24	8.603e+04	5.356e+04	8.429e+04	5.530e+04	-7313.16
		186	12.23	7.04	-9.13	-0.34	-1.75	8.05	1.470e+05	7.533e+04	1.451e+05	7.728e+04	-
1.167e+04													
		178	9.72	4.97	-0.15	1.68	3.13	2.46	1.161e+05	6.921e+04	1.158e+05	6.958e+04	-4137.57
		179	7.52	4.98	-17.74	-9.92	-2.85	10.79	8.823e+04	5.935e+04	8.669e+04	6.089e+04	-6483.10
162	22	187	6.61	23.05	-41.37	-38.89	20.58	12.37	7.718e+04	4.891e+04	7.572e+04	5.038e+04	-6265.80
		186	11.42	28.88	-76.09	-72.99	25.77	17.79	1.341e+05	6.852e+04	1.323e+05	7.038e+04	-
1.091e+04													
		178	9.01	36.02	-58.18	-52.76	30.60	21.94	1.058e+05	6.213e+04	1.055e+05	6.239e+04	-3341.74
		179	7.31	23.05	-83.84	-67.96	7.17	38.01	8.378e+04	5.433e+04	8.146e+04	5.665e+04	-7929.72
162	54	187	6.56	9.61	-8.99	-7.16	7.79	5.53	7.786e+04	4.877e+04	7.632e+04	5.031e+04	-6518.89
		186	11.22	10.96	-28.19	-24.90	7.67	10.86	1.338e+05	6.849e+04	1.320e+05	7.030e+04	-
1.071e+04													
		178	8.89	14.75	-19.35	-16.84	12.24	8.90	1.056e+05	6.265e+04	1.053e+05	6.296e+04	-3619.42
		179	6.99	10.27	-38.51	-28.96	0.72	19.35	8.140e+04	5.410e+04	7.971e+04	5.579e+04	-6582.66
162	69	187	6.59	9.56	0.75	9.06	1.25	2.03	7.821e+04	4.869e+04	7.663e+04	5.027e+04	-6648.33
		186	11.12	6.40	-8.30	-0.31	-1.59	7.32	1.337e+05	6.848e+04	1.319e+05	7.025e+04	-
1.061e+04													
		178	8.84	4.52	-0.14	1.53	2.85	2.23	1.056e+05	6.292e+04	1.052e+05	6.326e+04	-3761.43
		179	6.84	4.53	-16.13	-9.01	-2.59	9.81	8.021e+04	5.395e+04	7.881e+04	5.535e+04	-5893.72

Parco Eolico "Bolina" – Progetto Definitivo
Relazione di calcolo preliminare delle fondazioni degli aerogeneratori G8 e G12

163	1	188	5.96	11.83	-1.66	7.04	3.13	6.45	7.138e+04	4.099e+04	6.369e+04	4.868e+04	-
1.321e+04		187	9.42	1.13	-7.29	-6.91	0.75	1.75	1.127e+05	6.400e+04	1.108e+05	6.581e+04	-9231.26
		179	7.82	26.57	-8.28	21.11	-2.82	12.67	9.015e+04	6.693e+04	8.592e+04	7.117e+04	-8963.51
		180	4.87	8.12	-0.66	8.02	-0.55	-0.94	5.111e+04	5.007e+04	5.111e+04	5.007e+04	15.63
163	3	188	5.04	10.01	-1.40	5.96	2.65	5.46	6.040e+04	3.468e+04	5.389e+04	4.119e+04	-
1.118e+04		187	7.97	0.96	-6.17	-5.85	0.64	1.48	9.533e+04	5.415e+04	9.379e+04	5.569e+04	-7811.07
		179	6.61	22.49	-7.00	17.87	-2.38	10.72	7.628e+04	5.664e+04	7.270e+04	6.022e+04	-7584.50
		180	4.12	6.87	-0.55	6.79	-0.47	-0.79	4.325e+04	4.237e+04	4.325e+04	4.237e+04	13.22
163	6	188	4.68	27.46	-40.49	-40.47	27.43	-1.31	5.527e+04	3.038e+04	4.884e+04	3.681e+04	-
1.090e+04		187	7.57	25.21	-74.88	-73.25	23.58	-12.67	8.822e+04	4.968e+04	8.717e+04	5.073e+04	-6261.41
		179	5.94	36.30	-28.87	-19.85	27.28	22.51	6.904e+04	4.806e+04	6.355e+04	5.354e+04	-9218.68
		180	3.82	17.40	-33.89	-33.89	17.40	0.12	3.990e+04	3.888e+04	3.926e+04	3.951e+04	493.77
163	38	188	4.61	11.26	-10.49	-10.11	10.88	2.84	5.503e+04	3.114e+04	4.894e+04	3.723e+04	-
1.041e+04		187	7.35	8.67	-28.62	-28.30	8.36	-3.40	8.718e+04	4.939e+04	8.591e+04	5.066e+04	-6816.88
		179	5.95	20.10	-8.28	4.03	7.80	14.06	6.920e+04	5.037e+04	6.523e+04	5.434e+04	-7681.28
		180	3.76	5.62	-7.40	-7.38	5.60	-0.44	3.936e+04	3.879e+04	3.930e+04	3.886e+04	175.03
163	69	188	4.59	9.10	-1.27	5.41	2.41	4.96	5.491e+04	3.153e+04	4.900e+04	3.744e+04	-
1.016e+04		187	7.25	0.87	-5.61	-5.31	0.58	1.34	8.667e+04	4.923e+04	8.527e+04	5.063e+04	-7100.97
		179	6.01	20.44	-6.37	16.24	-2.17	9.74	6.935e+04	5.149e+04	6.609e+04	5.474e+04	-6895.00
		180	3.75	6.25	-0.50	6.17	-0.43	-0.72	3.932e+04	3.852e+04	3.931e+04	3.852e+04	12.02
164	1	189	3.75	7.04	-0.60	4.99	1.45	3.39	4.499e+04	2.445e+04	3.483e+04	3.461e+04	-
1.027e+04		188	5.90	7.07	-2.47	3.36	1.23	4.65	7.046e+04	4.224e+04	6.350e+04	4.920e+04	-
1.216e+04		180	4.88	8.15	-0.99	7.91	-0.75	1.45	5.207e+04	4.922e+04	5.160e+04	4.969e+04	-1061.79
		181	3.13	5.31	0.61	5.22	0.71	0.65	3.501e+04	2.914e+04	2.917e+04	3.499e+04	391.23
164	3	189	3.17	5.96	-0.51	4.22	1.23	2.87	3.807e+04	2.069e+04	2.947e+04	2.929e+04	-8687.68
1.029e+04		188	4.99	5.98	-2.09	2.84	1.04	3.94	5.962e+04	3.574e+04	5.373e+04	4.163e+04	-
		180	4.13	6.90	-0.84	6.70	-0.64	1.22	4.406e+04	4.165e+04	4.366e+04	4.205e+04	-898.44
		181	2.65	4.49	0.52	4.41	0.60	0.55	2.963e+04	2.466e+04	2.468e+04	2.960e+04	331.04
164	22	189	2.93	23.31	-28.44	-27.75	22.62	5.93	3.481e+04	1.892e+04	2.698e+04	2.674e+04	-7943.02
		188	4.64	22.49	-35.77	-34.87	21.58	7.21	5.439e+04	3.250e+04	4.901e+04	3.788e+04	-9424.27
		180	3.77	21.94	-33.09	-28.10	16.95	15.80	3.988e+04	3.795e+04	3.941e+04	3.842e+04	-829.85
		181	2.43	22.90	-30.12	-26.11	18.89	14.02	2.702e+04	2.268e+04	2.270e+04	2.700e+04	262.57
164	54	189	2.90	9.26	-7.72	-6.85	8.39	3.73	3.467e+04	1.885e+04	2.686e+04	2.667e+04	-7913.16
		188	4.57	9.13	-11.29	-10.09	7.93	4.81	5.426e+04	3.250e+04	4.890e+04	3.786e+04	-9378.18
		180	3.75	8.08	-8.21	-5.48	5.35	6.08	3.999e+04	3.789e+04	3.960e+04	3.829e+04	-821.19
		181	2.41	8.51	-7.93	-6.18	6.75	5.08	2.696e+04	2.251e+04	2.252e+04	2.694e+04	287.96
164	69	189	2.88	5.42	-0.47	3.84	1.11	2.61	3.461e+04	1.881e+04	2.679e+04	2.663e+04	-7897.89
		188	4.54	5.44	-1.90	2.58	0.95	3.58	5.420e+04	3.249e+04	4.885e+04	3.784e+04	-9354.61
		180	3.76	6.27	-0.76	6.09	-0.58	1.11	4.006e+04	3.786e+04	3.969e+04	3.823e+04	-816.77
		181	2.41	4.08	0.47	4.01	0.54	0.50	2.693e+04	2.241e+04	2.243e+04	2.691e+04	300.95
165	1	190	2.46	6.29	-0.47	4.21	1.62	3.12	2.932e+04	1.161e+04	1.774e+04	2.318e+04	-8428.67
1.031e+04		189	3.78	5.91	-1.89	3.13	0.88	3.73	4.532e+04	2.470e+04	3.531e+04	3.472e+04	-
		181	3.12	3.80	0.53	3.79	0.54	0.20	3.494e+04	2.906e+04	2.908e+04	3.492e+04	344.41
		182	2.11	2.78	1.05	2.28	1.55	0.79	2.504e+04	1.537e+04	1.543e+04	2.498e+04	795.33
165	3	190	2.08	5.33	-0.40	3.56	1.37	2.64	2.481e+04	9820.85	1.501e+04	1.962e+04	-7131.96
		189	3.20	5.00	-1.60	2.65	0.74	3.16	3.835e+04	2.090e+04	2.988e+04	2.938e+04	-8720.08
		181	2.64	3.22	0.45	3.21	0.46	0.17	2.957e+04	2.459e+04	2.460e+04	2.955e+04	291.42
		182	1.78	2.35	0.89	1.93	1.31	0.67	2.119e+04	1.300e+04	1.306e+04	2.113e+04	672.97
165	22	190	1.93	23.15	-20.22	-19.83	22.76	4.08	2.281e+04	9039.50	1.386e+04	1.799e+04	-6566.32
		189	2.95	21.45	-25.10	-24.80	21.15	3.74	3.510e+04	1.913e+04	2.739e+04	2.684e+04	-7982.86
		181	2.43	23.08	-28.45	-25.02	19.65	12.84	2.697e+04	2.258e+04	2.259e+04	2.695e+04	240.28
		182	1.70	23.71	-26.41	-22.48	19.78	13.47	1.944e+04	1.256e+04	1.258e+04	1.942e+04	377.95
165	54	190	1.90	9.17	-5.21	-4.57	8.53	2.97	2.264e+04	8965.80	1.372e+04	1.789e+04	-6511.59
		189	2.92	8.27	-7.46	-6.80	7.60	3.16	3.494e+04	1.905e+04	2.724e+04	2.675e+04	-7946.13
		181	2.45	8.26	-7.88	-6.54	6.92	4.45	2.691e+04	2.243e+04	2.244e+04	2.689e+04	256.59
		182	1.65	9.07	-8.04	-6.45	7.48	4.96	1.932e+04	1.207e+04	1.211e+04	1.928e+04	532.66
165	69	190	1.89	4.84	-0.36	3.24	1.24	2.40	2.255e+04	8928.05	1.365e+04	1.783e+04	-6483.60
		189	2.91	4.54	-1.46	2.41	0.68	2.87	3.486e+04	1.900e+04	2.716e+04	2.671e+04	-7927.35
		181	2.40	2.93	0.41	2.92	0.42	2.16	2.688e+04	2.235e+04	2.237e+04	2.686e+04	264.93
		182	1.62	2.14	0.81	1.75	1.20	0.61	1.926e+04	1.182e+04	1.187e+04	1.921e+04	611.79
166	1	191	1.49	5.36	2.97	5.23	3.11	0.55	1.674e+04	3047.65	5772.17	1.402e+04	-5466.65
		190	2.54	5.26	-2.82	2.29	0.15	3.90	3.016e+04	1.188e+04	1.849e+04	2.355e+04	-8787.73
		182	2.07	2.34	0.44	0.44	2.33	-0.05	2.466e+04	1.491e+04	1.505e+04	2.452e+04	1179.10
		183	1.69	2.57	-4.67	-1.67	-0.43	3.57	2.029e+04	1.127e+04	1.138e+04	2.018e+04	-962.05

Parco Eolico "Bolina" – Progetto Definitivo
Relazione di calcolo preliminare delle fondazioni degli aerogeneratori G8 e G12

166	3	191	1.26	4.54	2.51	4.42	2.63	0.47	1.417e+04	2578.78	4884.14	1.186e+04	-4625.63
		190	2.15	4.45	-2.38	1.94	0.13	3.30	2.552e+04	1.005e+04	1.565e+04	1.993e+04	-7435.77
		182	1.75	1.98	0.37	0.37	1.97	-0.05	2.087e+04	1.261e+04	1.274e+04	2.075e+04	997.70
		183	1.43	2.17	-3.95	-1.42	-0.36	3.02	1.717e+04	9537.27	9625.14	1.708e+04	-814.04
166	6	191	1.24	26.17	-13.22	-11.23	24.17	-8.64	1.268e+04	2387.52	4126.88	1.094e+04	-3857.84
		190	2.02	23.09	-21.37	-20.80	22.52	-5.01	2.350e+04	9255.73	1.446e+04	1.830e+04	-6860.52
		182	1.69	26.37	-22.38	-21.36	25.35	6.96	1.919e+04	1.216e+04	1.226e+04	1.909e+04	834.01
		183	1.38	27.01	-25.91	-23.88	24.98	10.17	1.570e+04	1.016e+04	1.049e+04	1.538e+04	-1294.11
166	40	191	1.15	8.48	-2.40	7.34	-1.27	3.33	1.281e+04	2327.11	4458.10	1.068e+04	-4217.90
		190	1.98	9.48	-7.34	6.84	-4.70	6.13	2.323e+04	9110.59	1.420e+04	1.814e+04	-6781.34
		182	1.58	4.14	-2.86	4.12	-2.85	-0.28	1.883e+04	1.135e+04	1.146e+04	1.871e+04	922.13
		183	1.36	4.39	-8.49	3.42	-7.51	3.40	1.599e+04	8320.62	8413.09	1.590e+04	-837.12
166	69	191	1.14	4.12	2.29	4.02	2.39	0.43	1.288e+04	2344.35	4440.13	1.078e+04	-4205.12
		190	1.95	4.05	-2.17	1.76	0.12	3.00	2.320e+04	9135.17	1.422e+04	1.811e+04	-6759.79
		182	1.59	1.80	0.34	0.34	1.80	-0.04	1.897e+04	1.147e+04	1.158e+04	1.886e+04	907.00
		183	1.30	1.98	-3.59	-1.29	-0.33	2.74	1.561e+04	8670.25	8750.12	1.553e+04	-740.04
167	1	192	1.22	4.85	-1.03	0.88	2.93	2.76	1.271e+04	182.75	2707.17	1.019e+04	-5025.51
		191	1.52	2.85	-1.12	-0.84	2.56	1.02	1.773e+04	5031.34	8644.16	1.412e+04	-5728.80
		183	1.69	6.54	-0.10	6.10	0.35	1.67	1.957e+04	5406.24	5484.87	1.950e+04	-1052.54
		184	1.31	4.63	1.50	4.16	1.97	-1.12	1.353e+04	-136.82	-122.07	1.351e+04	448.64
167	3	192	1.03	4.10	-0.87	0.75	2.48	2.33	1.076e+04	154.64	2290.69	8620.04	-4252.35
		191	1.29	2.41	-0.95	-0.71	2.17	0.86	1.500e+04	4257.29	7314.29	1.194e+04	-4847.44
		183	1.43	5.54	-0.08	5.16	0.30	1.41	1.656e+04	4574.51	4641.05	1.650e+04	-890.61
		184	1.11	3.92	1.27	3.52	1.67	-0.95	1.145e+04	-115.77	-103.29	1.143e+04	379.62
167	8	192	1.00	7.99	-15.93	5.65	-13.59	7.11	9875.80	447.02	2069.32	8253.50	-3558.71
		191	1.29	17.64	-13.42	13.56	-9.34	10.49	1.369e+04	2493.36	5761.22	1.042e+04	-5089.36
		183	1.50	6.60	-25.56	4.53	-23.49	-7.88	1.652e+04	5117.77	5145.23	1.650e+04	558.95
		184	0.99	8.55	-10.55	8.36	-10.36	-1.92	9721.19	0.55	5.29	9716.44	214.73
167	40	192	0.96	4.31	-5.06	2.36	-3.11	3.81	9808.23	247.31	2078.00	7977.54	-3761.87
		191	1.20	6.21	-3.91	4.16	-1.85	4.07	1.365e+04	3404.51	6348.83	1.071e+04	-4637.74
		183	1.36	4.90	-8.03	4.64	-7.77	-1.82	1.551e+04	4521.57	4532.50	1.550e+04	-346.55
		184	1.00	5.14	-2.70	4.95	-2.50	-1.22	1.017e+04	-69.19	-60.34	1.017e+04	300.99
167	69	192	0.94	3.73	-0.80	0.68	2.26	2.12	9778.26	140.58	2082.44	7836.40	-3865.78
		191	1.17	2.19	-0.86	-0.64	1.97	0.78	1.364e+04	3870.26	6649.35	1.086e+04	-4406.77
		183	1.30	5.03	-0.07	4.69	0.27	1.28	1.506e+04	4158.65	4219.13	1.500e+04	-809.65
		184	1.00	3.56	1.15	3.20	1.51	-0.86	1.041e+04	-105.24	-93.90	1.040e+04	345.11
168	1	193	0.95	4.45	-7.98e-03	0.94	3.51	1.82	9946.45	274.42	281.92	9938.95	269.18
		192	1.21	4.16	-1.70	-0.21	2.68	2.55	1.257e+04	-39.52	2330.80	1.020e+04	-4926.16
		184	1.25	2.75	0.06	1.43	1.38	-1.34	1.324e+04	421.80	430.55	1.323e+04	334.80
		185	1.14	2.79	-0.17	0.98	1.64	-1.44	1.189e+04	237.18	244.50	1.189e+04	-291.95
168	3	193	0.81	3.77	-6.75e-03	0.79	2.97	1.54	8416.23	232.20	238.55	8409.88	227.77
		192	1.03	3.52	-1.44	-0.18	2.26	2.16	1.064e+04	-33.44	1972.22	8629.39	-4168.29
		184	1.06	2.33	0.05	1.21	1.17	-1.14	1.120e+04	356.91	364.31	1.119e+04	283.29
		185	0.96	2.36	-0.14	0.83	1.39	-1.22	1.006e+04	200.69	206.88	1.006e+04	-247.03
168	6	193	0.83	27.61	-1.81	-0.87	26.67	-5.17	7632.42	182.34	186.27	7628.49	171.03
		192	1.04	27.54	-7.57	-6.67	26.64	-5.55	9778.65	72.45	2001.77	7849.33	-3873.51
		184	1.09	28.11	-3.03	-0.15	25.24	9.02	1.031e+04	35.58	36.25	1.031e+04	82.86
		185	0.99	25.65	-2.48	-1.57	24.74	4.98	9365.40	220.53	225.26	9360.67	-207.86
168	38	193	0.77	10.87	0.12	0.18	10.81	-0.82	7644.75	201.40	206.51	7639.64	194.87
		192	0.97	10.40	-2.39	-2.37	10.38	-0.58	9705.19	4.81	1863.59	7846.40	-3817.83
		184	1.01	9.85	0.07	0.68	9.24	2.37	1.023e+04	227.45	231.39	1.022e+04	198.43
		185	0.91	9.30	-0.13	-0.03	9.21	0.95	9221.74	195.34	200.66	9216.43	-218.92
168	69	193	0.73	3.42	-6.14e-03	0.72	2.70	1.40	7651.12	211.09	216.86	7645.35	207.06
		192	0.93	3.20	-1.31	-0.17	2.06	1.96	9668.23	-30.40	1792.92	7844.90	-3789.36
		184	0.96	2.12	0.05	1.10	1.06	-1.03	1.018e+04	324.46	331.19	1.018e+04	257.54
		185	0.87	2.15	-0.13	0.75	1.26	-1.11	9148.29	182.44	188.07	9142.66	-224.58
169	1	194	11.58	4.76	-5.28	4.28	-4.80	2.15	1.380e+05	5.441e+04	1.372e+05	5.518e+04	7945.19
		14	42.37	9.38	-2.24	5.00	2.14	5.63	4.849e+05	1.068e+05	4.236e+05	1.680e+05	-
1.393e+05													
		16	16.31	4.43	-4.86	2.68	-3.11	3.63	1.939e+05	1.229e+05	1.838e+05	1.330e+05	-
2.472e+04													
		186	17.26	6.71	-1.41	4.35	0.96	3.69	2.066e+05	8.639e+04	1.852e+05	1.078e+05	-
4.601e+04													
		194	9.80	4.03	-4.47	3.62	-4.06	1.82	1.168e+05	4.604e+04	1.161e+05	4.669e+04	6722.85
		14	35.85	7.94	-1.90	4.23	1.81	4.77	4.103e+05	9.036e+04	3.585e+05	1.422e+05	-
1.179e+05													
		16	13.80	3.75	-4.11	2.27	-2.63	3.07	1.640e+05	1.040e+05	1.555e+05	1.125e+05	-
2.091e+04													
		186	14.60	5.68	-1.19	3.68	0.81	3.12	1.748e+05	7.310e+04	1.567e+05	9.124e+04	-
3.893e+04													
		194	9.24	116.78	-12.44	80.53	23.81	58.06	1.063e+05	4.203e+04	1.057e+05	4.262e+04	6127.82
		14	33.11	104.82	-50.38	89.60	-35.16	-46.15	3.738e+05	8.257e+04	3.267e+05	1.296e+05	-
1.072e+05													

Parco Eolico "Bolina" – Progetto Definitivo
Relazione di calcolo preliminare delle fondazioni degli aerogeneratori G8 e G12

1.892e+04	16	12.81	165.52	-16.80	119.52	29.20	79.19	1.494e+05	9.491e+04	1.418e+05	1.025e+05	-		
3.531e+04	186	13.64	92.79	-56.96	71.18	-35.35	-52.63	1.590e+05	6.662e+04	1.425e+05	8.305e+04	-		
169	39	194	9.02	41.43	-6.39	29.43	5.61	20.74	1.062e+05	4.192e+04	1.056e+05	4.250e+04	6117.14	
1.072e+05	14	32.76	36.31	-14.26	32.86	-10.81	-12.75	3.732e+05	8.229e+04	3.262e+05	1.294e+05	-		
1.898e+04	16	12.63	58.24	-8.13	41.81	8.30	28.64	1.492e+05	9.468e+04	1.415e+05	1.024e+05	-		
3.537e+04	186	13.40	32.12	-17.29	26.30	-11.47	-15.93	1.589e+05	6.651e+04	1.425e+05	8.298e+04	-		
169	69	194	8.91	3.66	-4.06	3.29	-3.69	1.65	1.062e+05	4.186e+04	1.056e+05	4.244e+04	6111.69	
1.071e+05	14	32.59	7.22	-1.73	3.85	1.65	4.33	3.730e+05	8.215e+04	3.259e+05	1.292e+05	-		
1.901e+04	16	12.55	3.41	-3.74	2.07	-2.39	2.79	1.491e+05	9.457e+04	1.414e+05	1.023e+05	-		
3.539e+04	186	13.27	5.17	-1.08	3.35	0.74	2.84	1.589e+05	6.646e+04	1.425e+05	8.294e+04	-		
170	1	195	10.00	7.92	2.90	5.68	5.15	2.49	1.196e+05	4.990e+04	1.094e+05	6.007e+04	-	
2.461e+04	194	17.13	5.85	-8.43	-0.63	-1.94	7.11	2.045e+05	8.156e+04	1.903e+05	9.572e+04	-		
3.925e+04	186	13.64	12.11	-2.13	6.75	3.23	6.90	1.639e+05	8.588e+04	1.560e+05	9.384e+04	-		
2.363e+04	187	9.40	5.19	-4.81	4.18	-3.80	3.00	1.126e+05	6.532e+04	1.011e+05	7.687e+04	-		
2.032e+04	170	3	195	8.46	6.70	2.46	4.80	4.35	2.11	1.012e+05	4.222e+04	9.261e+04	5.083e+04	-
2.083e+04	194	14.50	4.95	-7.13	-0.54	-1.64	6.01	1.730e+05	6.901e+04	1.610e+05	8.100e+04	-		
3.321e+04	186	11.54	10.25	-1.81	5.71	2.73	5.84	1.387e+05	7.267e+04	1.320e+05	7.941e+04	-		
1.999e+04	187	7.96	4.39	-4.07	3.54	-3.22	2.54	9.530e+04	5.527e+04	8.553e+04	6.504e+04	-		
1.719e+04	170	23	195	7.84	50.39	-18.50	50.24	-18.35	3.23	9.219e+04	3.833e+04	8.426e+04	4.627e+04	-
1.909e+04	194	13.47	78.90	-15.77	57.27	5.86	-39.75	1.575e+05	6.282e+04	1.465e+05	7.381e+04	-		
3.033e+04	186	10.71	65.95	18.01	65.72	18.24	-3.33	1.262e+05	6.613e+04	1.200e+05	7.227e+04	-		
1.819e+04	187	7.41	68.06	-37.41	56.72	-26.07	-32.68	8.628e+04	5.008e+04	7.752e+04	5.884e+04	-		
1.550e+04	170	54	195	7.72	11.60	-11.25	-11.15	11.51	1.47	9.196e+04	3.840e+04	8.417e+04	4.619e+04	-
1.888e+04	194	13.28	10.26	-34.27	-20.03	-3.98	20.77	1.572e+05	6.271e+04	1.463e+05	7.357e+04	-		
3.014e+04	186	10.55	1.25	-19.39	-15.29	-2.85	8.23	1.261e+05	6.604e+04	1.200e+05	7.216e+04	-		
1.817e+04	187	7.31	12.28	-22.26	-14.88	4.90	14.15	8.676e+04	5.031e+04	7.784e+04	5.923e+04	-		
1.567e+04	170	69	195	7.69	6.09	2.23	4.37	3.96	1.92	9.202e+04	3.838e+04	8.419e+04	4.621e+04	-
1.893e+04	194	13.18	4.50	-6.48	-0.49	-1.49	5.47	1.573e+05	6.274e+04	1.464e+05	7.363e+04	-		
3.019e+04	186	10.49	9.32	-1.64	5.19	2.49	5.31	1.261e+05	6.606e+04	1.200e+05	7.219e+04	-		
1.817e+04	187	7.23	3.99	-3.70	3.22	-2.93	2.31	8.664e+04	5.025e+04	7.776e+04	5.913e+04	-		
1.563e+04	171	1	196	6.89	5.63	1.01	5.10	1.54	1.47	8.196e+04	3.060e+04	6.677e+04	4.579e+04	-
2.344e+04	195	10.54	4.98	-1.14	2.49	1.34	3.01	1.262e+05	5.242e+04	1.135e+05	6.510e+04	-		
2.783e+04	187	9.07	6.89	-1.83	6.00	-0.94	2.63	1.084e+05	6.415e+04	9.897e+04	7.360e+04	-		
1.814e+04	188	5.93	4.59	0.76	4.56	0.79	0.37	7.073e+04	4.244e+04	5.889e+04	5.428e+04	-		
1.396e+04	171	3	196	5.83	4.76	0.86	4.32	1.30	1.24	6.935e+04	2.589e+04	5.650e+04	3.874e+04	-
1.983e+04	195	8.92	4.21	-0.97	2.11	1.14	2.54	1.068e+05	4.436e+04	9.607e+04	5.508e+04	-		
2.355e+04	187	7.68	5.83	-1.55	5.08	-0.80	2.22	9.174e+04	5.428e+04	8.374e+04	6.228e+04	-		
1.535e+04	188	5.02	3.89	0.64	3.86	0.67	0.31	5.985e+04	3.591e+04	4.983e+04	4.593e+04	-		

Parco Eolico "Bolina" – Progetto Definitivo
Relazione di calcolo preliminare delle fondazioni degli aerogeneratori G8 e G12

1.181e+04	171	6	196	5.38	25.65	-49.93	-49.13	24.85	-7.73	6.310e+04	2.354e+04	5.146e+04	3.518e+04	-
1.802e+04			195	8.30	25.00	-67.93	-67.71	24.77	-4.56	9.713e+04	4.028e+04	8.746e+04	4.995e+04	-
2.136e+04			187	7.12	22.44	-56.05	-54.36	20.74	11.41	8.337e+04	4.916e+04	7.599e+04	5.654e+04	-
1.408e+04			188	4.66	27.21	-48.40	-47.05	25.86	10.00	5.464e+04	3.262e+04	4.563e+04	4.163e+04	-
1.083e+04	171	38	196	5.32	9.34	-14.18	-14.03	9.19	-1.87	6.306e+04	2.354e+04	5.139e+04	3.521e+04	-
1.803e+04			195	8.17	9.07	-21.65	-21.65	9.07	-0.01	9.710e+04	4.031e+04	8.738e+04	5.003e+04	-
2.139e+04			187	7.02	7.71	-16.51	-15.34	6.54	5.20	8.339e+04	4.928e+04	7.608e+04	5.659e+04	-
1.399e+04			188	4.58	9.70	-14.15	-13.60	9.15	3.57	5.449e+04	3.264e+04	4.541e+04	4.171e+04	-
1.077e+04	171	69	196	5.30	4.33	0.78	3.93	1.18	1.13	6.304e+04	2.354e+04	5.136e+04	3.522e+04	-
1.803e+04			195	8.11	3.83	-0.88	1.91	1.03	2.31	9.708e+04	4.032e+04	8.733e+04	5.007e+04	-
2.141e+04			187	6.98	5.30	-1.40	4.62	-0.73	2.02	8.340e+04	4.935e+04	7.613e+04	5.661e+04	-
1.395e+04			188	4.56	3.53	0.58	3.51	0.61	0.28	5.441e+04	3.264e+04	4.530e+04	4.175e+04	-
1.074e+04	172	1	197	4.80	4.58	0.65	3.72	1.51	1.62	5.557e+04	1.437e+04	3.785e+04	3.209e+04	-
2.040e+04			196	6.96	3.86	0.16	3.06	0.95	1.52	8.279e+04	3.101e+04	6.753e+04	4.627e+04	-
2.360e+04			188	5.91	4.82	0.44	4.30	0.97	1.43	7.056e+04	4.193e+04	5.833e+04	5.416e+04	-
1.416e+04			189	3.83	5.40	0.65	5.39	0.65	0.10	4.598e+04	2.398e+04	3.084e+04	3.911e+04	-
1.019e+04	172	3	197	4.06	3.87	0.55	3.15	1.28	1.37	4.702e+04	1.216e+04	3.203e+04	2.715e+04	-
1.726e+04			196	5.89	3.26	0.13	2.59	0.80	1.29	7.005e+04	2.624e+04	5.714e+04	3.915e+04	-
1.997e+04			188	5.00	4.08	0.37	3.64	0.82	1.21	5.971e+04	3.548e+04	4.936e+04	4.583e+04	-
1.198e+04			189	3.24	4.57	0.55	4.56	0.55	0.09	3.890e+04	2.029e+04	2.609e+04	3.310e+04	-8624.09
1.573e+04	172	23	197	3.74	31.30	-18.17	30.86	-17.72	-4.66	4.261e+04	1.088e+04	2.886e+04	2.463e+04	-
1.826e+04			196	5.45	36.31	-16.88	35.82	-16.39	-5.08	6.370e+04	2.370e+04	5.185e+04	3.554e+04	-
1.090e+04			188	4.63	42.71	-18.34	37.58	-13.21	-16.95	5.415e+04	3.213e+04	4.470e+04	4.158e+04	-
1.090e+04			189	2.99	37.32	-18.82	31.77	-13.26	-16.76	3.518e+04	1.831e+04	2.352e+04	2.997e+04	-7789.45
1.570e+04	172	55	197	3.71	12.37	-5.26	12.33	-5.23	-0.75	4.270e+04	1.099e+04	2.903e+04	2.466e+04	-
1.819e+04			196	5.38	13.73	-5.11	13.68	-5.06	-0.95	6.369e+04	2.380e+04	5.192e+04	3.557e+04	-
1.090e+04			188	4.57	16.15	-5.22	14.90	-3.98	-5.01	5.424e+04	3.221e+04	4.481e+04	4.164e+04	-
1.569e+04			189	2.96	15.13	-5.79	13.49	-4.16	-5.62	3.530e+04	1.840e+04	2.365e+04	3.005e+04	-7822.95
1.816e+04	172	69	197	3.69	3.52	0.50	2.86	1.16	1.25	4.274e+04	1.105e+04	2.911e+04	2.468e+04	-
1.090e+04			196	5.35	2.97	0.12	2.36	0.73	1.17	6.368e+04	2.386e+04	5.195e+04	3.559e+04	-
1.090e+04			188	4.54	3.71	0.34	3.31	0.74	1.10	5.428e+04	3.225e+04	4.487e+04	4.166e+04	-
1.684e+04			189	2.95	4.15	0.50	4.15	0.50	0.08	3.537e+04	1.844e+04	2.372e+04	3.009e+04	-7840.08
2.036e+04	173	1	198	3.47	3.50	0.64	1.87	2.28	1.42	3.806e+04	4340.48	2.038e+04	2.202e+04	-
1.019e+04			197	4.80	3.60	-0.59	2.19	0.82	1.98	5.562e+04	1.451e+04	3.793e+04	3.220e+04	-
1.019e+04			189	3.83	3.66	0.75	3.64	0.76	0.24	4.600e+04	2.418e+04	3.119e+04	3.899e+04	-
1.425e+04			190	2.56	4.81	0.65	4.74	0.72	-0.56	3.036e+04	1.096e+04	1.456e+04	2.677e+04	-7533.84
1.723e+04	173	3	198	2.93	2.97	0.54	1.58	1.93	1.20	3.221e+04	3672.71	1.725e+04	1.863e+04	-
			197	4.06	3.05	-0.50	1.85	0.70	1.67	4.707e+04	1.227e+04	3.210e+04	2.725e+04	-
			189	3.24	3.10	0.63	3.08	0.65	0.20	3.892e+04	2.046e+04	2.639e+04	3.299e+04	-8619.84

Parco Eolico "Bolina" – Progetto Definitivo
Relazione di calcolo preliminare delle fondazioni degli aerogeneratori G8 e G12

		190	2.17	4.07	0.55	4.01	0.61	-0.48	2.569e+04	9276.97	1.232e+04	2.265e+04	-6374.79
173	22	198	2.70	21.91	-20.60	-20.12	21.43	4.49	2.947e+04	3604.72	1.615e+04	1.693e+04	-
1.293e+04													
1.563e+04		197	3.74	18.64	-23.05	-22.51	18.11	4.67	4.293e+04	1.135e+04	2.941e+04	2.487e+04	-
		189	3.00	20.52	-28.02	-22.88	15.39	14.93	3.557e+04	1.875e+04	2.422e+04	3.009e+04	-7880.71
		190	2.00	19.33	-21.13	-15.90	14.09	13.57	2.362e+04	8575.87	1.138e+04	2.081e+04	-5860.90
173	54	198	2.68	8.75	-6.20	-5.86	8.41	2.24	2.934e+04	3429.28	1.584e+04	1.694e+04	-
1.295e+04													
1.565e+04		197	3.71	7.04	-7.00	-6.50	6.55	2.59	4.283e+04	1.122e+04	2.925e+04	2.480e+04	-
		189	2.96	7.58	-7.88	-5.89	5.60	5.17	3.545e+04	1.865e+04	2.407e+04	3.003e+04	-7851.28
		190	1.97	7.00	-4.83	-2.97	5.14	4.31	2.344e+04	8481.76	1.126e+04	2.067e+04	-5817.47
173	69	198	2.67	2.70	0.49	1.44	1.75	1.09	2.928e+04	3338.83	1.568e+04	1.694e+04	-
1.295e+04													
1.566e+04		197	3.69	2.77	-0.45	1.68	0.63	1.52	4.279e+04	1.116e+04	2.918e+04	2.477e+04	-
		189	2.95	2.82	0.57	2.80	0.59	0.18	3.538e+04	1.860e+04	2.399e+04	2.999e+04	-7836.22
		190	1.97	3.70	0.50	3.64	0.56	-0.43	2.335e+04	8433.61	1.120e+04	2.059e+04	-5795.26
174	1	199	2.58	7.65	-2.88	-2.76	7.53	1.12	2.790e+04	2160.53	1.558e+04	1.448e+04	-
1.286e+04													
1.716e+04		198	3.53	1.53	-2.12	0.25	-0.84	1.74	3.859e+04	4134.19	1.985e+04	2.287e+04	-
		190	2.54	3.27	1.84	3.11	2.00	-0.44	3.020e+04	1.159e+04	1.532e+04	2.647e+04	-7447.98
		191	1.76	5.46	0.71	5.19	0.98	-1.10	1.892e+04	1340.37	3337.99	1.692e+04	-5579.23
174	3	199	2.19	6.47	-2.44	-2.33	6.37	0.95	2.361e+04	1828.14	1.319e+04	1.225e+04	-
1.088e+04													
1.452e+04		198	2.99	1.29	-1.79	0.21	-0.71	1.47	3.265e+04	3498.16	1.680e+04	1.935e+04	-
		190	2.15	2.76	1.56	2.63	1.69	-0.37	2.555e+04	9808.54	1.296e+04	2.239e+04	-6302.13
		191	1.49	4.62	0.60	4.39	0.83	-0.93	1.601e+04	1134.16	2824.45	1.432e+04	-4720.88
174	8	199	2.20	25.27	-12.94	17.14	-4.81	15.64	2.139e+04	-1173.27	1.052e+04	9699.11	-
1.127e+04													
1.322e+04		198	2.79	24.43	-23.41	21.90	-20.88	10.72	2.962e+04	2978.87	1.466e+04	1.794e+04	-
		190	1.97	17.99	-15.03	17.90	-14.94	-1.73	2.303e+04	8325.91	1.145e+04	1.990e+04	-6016.78
		191	1.38	14.73	-20.05	14.03	-19.36	-4.86	1.449e+04	1827.56	3052.33	1.326e+04	-3742.44
174	40	199	2.05	9.26	-2.66	4.39	2.21	5.86	2.144e+04	702.63	1.149e+04	1.065e+04	-
1.036e+04													
1.321e+04		198	2.74	8.79	-8.74	7.54	-7.49	4.51	2.966e+04	3113.94	1.506e+04	1.771e+04	-
		190	1.95	7.69	-4.10	7.64	-4.04	-0.81	2.316e+04	8717.65	1.167e+04	2.020e+04	-5826.52
		191	1.36	7.74	-6.40	7.39	-6.05	-2.20	1.453e+04	1302.77	2731.68	1.310e+04	-4105.85
174	69	199	1.99	5.89	-2.21	-2.12	5.79	0.86	2.146e+04	1661.95	1.199e+04	1.114e+04	-9892.07
1.320e+04		198	2.72	1.18	-1.63	0.19	-0.64	1.34	2.968e+04	3180.15	1.527e+04	1.759e+04	-
		190	1.95	2.51	1.42	2.39	1.54	-0.34	2.323e+04	8916.85	1.179e+04	2.036e+04	-5729.21
		191	1.35	4.20	0.55	3.99	0.76	-0.84	1.455e+04	1031.05	2567.68	1.302e+04	-4291.71
175	1	200	1.80	3.80	-2.77	3.23	-2.21	1.84	1.656e+04	-3460.08	1294.76	1.181e+04	-8519.66
		199	1.95	13.63	2.70	7.91	8.42	-5.46	2.069e+04	2022.09	8810.07	1.390e+04	-8978.48
		191	1.83	1.14	-3.83	-3.15	0.46	1.71	2.041e+04	3317.77	6747.06	1.698e+04	-6845.30
		192	1.11	8.36	-0.18	2.54	5.63	-3.98	1.153e+04	416.79	797.97	1.114e+04	-2022.23
175	3	200	1.52	3.21	-2.35	2.74	-1.87	1.56	1.401e+04	-2927.76	1095.57	9989.12	-7208.94
		199	1.65	11.53	2.29	6.69	7.13	-4.62	1.750e+04	1711.00	7454.68	1.176e+04	-7597.18
		191	1.55	0.97	-3.24	-2.66	0.39	1.45	1.727e+04	2807.34	5709.05	1.437e+04	-5792.18
		192	0.94	7.07	-0.15	2.15	4.77	-3.37	9752.83	352.67	675.21	9430.29	-1711.12
175	23	200	1.37	9.35	-17.46	9.17	-17.28	2.17	1.209e+04	-2608.28	1098.01	8385.36	-6383.23
		199	1.78	9.58	-20.30	8.70	-19.42	5.05	1.849e+04	1285.79	7806.05	1.197e+04	-8346.50
		191	1.33	16.94	-17.75	13.23	-14.04	-10.72	1.469e+04	2198.22	4232.62	1.266e+04	-4613.25
		192	0.93	11.72	-18.19	7.96	-14.44	-9.92	9329.01	195.74	607.96	8916.78	-1896.06
175	53	200	1.36	3.32	-2.77	3.31	-2.76	0.27	1.252e+04	-2666.26	987.10	8862.17	-6489.80
		199	1.56	7.10	-0.21	5.34	1.55	-3.12	1.668e+04	1496.84	6925.37	1.125e+04	-7277.44
		191	1.38	1.22	-0.90	0.21	0.11	-1.06	1.542e+04	2526.78	5027.77	1.292e+04	-5097.19
		192	0.87	6.73	-2.21	2.07	2.46	-4.46	9014.75	348.73	669.94	8693.54	-1637.20
175	69	200	1.38	2.92	-2.13	2.49	-1.70	1.41	1.274e+04	-2661.60	995.97	9081.02	-6553.58
		199	1.50	10.48	2.08	6.08	6.48	-4.20	1.591e+04	1555.45	6776.98	1.069e+04	-6906.52
		191	1.40	0.88	-2.95	-2.42	0.35	1.32	1.570e+04	2552.13	5190.04	1.306e+04	-5265.62
		192	0.86	6.43	-0.14	1.96	4.33	-3.06	8866.21	320.61	613.83	8572.99	-1555.56
176	1	201	0.92	2.30	-0.95	0.69	0.66	1.63	9725.95	377.77	379.90	9723.82	141.17
		200	1.68	3.07	0.34	1.83	1.58	1.36	1.550e+04	-3443.78	1891.54	1.017e+04	-8521.24
		192	1.22	4.31	-2.12	-0.29	2.48	-2.90	1.253e+04	26.90	676.42	1.188e+04	-2775.19
		193	0.99	4.43	0.13	1.15	3.41	-1.83	1.028e+04	126.38	155.87	1.025e+04	-546.57
176	3	201	0.78	1.95	-0.80	0.58	0.56	1.38	8229.65	319.65	321.46	8227.85	119.45

Parco Eolico "Bolina" – Progetto Definitivo
Relazione di calcolo preliminare delle fondazioni degli aerogeneratori G8 e G12

		200	1.42	2.60	0.29	1.55	1.34	1.15	1.312e+04	-2913.97	1600.54	8601.83	-7210.28
		192	1.03	3.65	-1.79	-0.25	2.10	-2.45	1.061e+04	22.76	572.36	1.006e+04	-2348.23
		193	0.84	3.75	0.11	0.97	2.89	-1.55	8702.01	106.93	131.89	8677.05	-462.49
176	7	201	0.79	4.91	-25.66	2.92	-23.67	7.54	7297.93	258.63	260.50	7296.05	114.85
		200	1.41	8.23	-27.06	5.16	-23.99	9.94	1.200e+04	-2652.02	1711.68	7639.74	-6701.50
		192	1.01	9.05	-28.09	4.92	-23.96	-11.67	9646.69	-200.33	317.04	9129.33	-2197.00
		193	0.85	5.23	-26.26	2.68	-23.71	-8.59	7912.88	119.57	146.41	7886.04	-456.58
176	39	201	0.73	2.47	-8.80	1.34	-7.67	3.38	7419.38	279.78	281.50	7417.67	110.71
		200	1.33	4.12	-8.75	2.68	-7.31	4.06	1.195e+04	-2649.03	1541.88	7758.90	-6604.44
		192	0.94	4.18	-9.51	1.51	-6.84	-5.43	9643.15	-54.09	451.54	9137.52	-2155.82
		193	0.78	3.07	-7.86	1.49	-6.29	-3.84	7911.54	104.82	128.87	7887.49	-432.67
176	69	201	0.71	1.77	-0.73	0.53	0.51	1.25	7481.50	290.59	292.23	7479.86	108.59
		200	1.30	2.36	0.26	1.41	1.22	1.05	1.192e+04	-2649.06	1455.03	7819.84	-6554.80
		192	0.94	3.31	-1.63	-0.23	1.91	-2.23	9641.34	20.69	520.33	9141.71	-2134.76
		193	0.76	3.41	0.10	0.88	2.62	-1.41	7910.92	97.21	119.90	7888.23	-420.44
177	1	202	18.39	8.99	-4.33	1.01	3.64	6.53	2.128e+05	5.483e+04	1.889e+05	7.871e+04	-
5.659e+04		12	19.69	6.82	-2.38	6.63	-2.20	1.29	2.204e+05	3.563e+04	1.835e+05	7.249e+04	-
7.384e+04		14	33.42	10.60	-7.70	4.24	-1.33	8.72	3.705e+05	5.052e+04	3.675e+05	5.357e+04	-
3.109e+04		194	17.65	7.77	2.39	6.61	3.54	-2.21	2.099e+05	7.902e+04	1.390e+05	1.499e+05	-
6.522e+04		202	15.56	7.60	-3.66	0.86	3.08	5.52	1.800e+05	4.639e+04	1.598e+05	6.660e+04	-
4.788e+04	177	12	16.66	5.77	-2.01	5.61	-1.86	1.09	1.865e+05	3.014e+04	1.553e+05	6.133e+04	-
6.248e+04		14	28.28	8.97	-6.51	3.58	-1.12	7.38	3.135e+05	4.275e+04	3.109e+05	4.533e+04	-
2.630e+04		194	14.94	6.57	2.02	5.59	3.00	-1.87	1.776e+05	6.686e+04	1.176e+05	1.269e+05	-
5.519e+04		202	14.18	62.96	12.24	39.52	35.68	25.29	1.640e+05	4.227e+04	1.455e+05	6.073e+04	-
4.366e+04	177	12	15.45	60.93	-68.83	57.98	-65.88	-19.35	1.700e+05	2.766e+04	1.416e+05	5.606e+04	-
5.689e+04		14	26.21	122.58	-42.98	112.52	-32.92	39.55	2.858e+05	3.935e+04	2.835e+05	4.167e+04	-
2.381e+04		194	13.77	85.14	-10.71	80.57	-6.14	-20.42	1.617e+05	6.090e+04	1.071e+05	1.155e+05	-
5.022e+04		202	14.14	25.78	2.03	13.89	13.93	11.88	1.638e+05	4.221e+04	1.454e+05	6.061e+04	-
4.357e+04	177	12	15.25	23.73	-24.15	22.99	-23.41	-5.89	1.697e+05	2.749e+04	1.413e+05	5.586e+04	-
5.683e+04		14	25.88	45.75	-17.33	40.23	-11.82	17.82	2.853e+05	3.903e+04	2.830e+05	4.136e+04	-
2.388e+04		194	13.64	32.59	-2.24	30.63	-0.27	-8.04	1.615e+05	6.082e+04	1.070e+05	1.154e+05	-
5.019e+04		202	14.15	6.91	-3.33	0.78	2.80	5.02	1.637e+05	4.217e+04	1.453e+05	6.055e+04	-
4.353e+04	177	12	15.14	5.24	-1.83	5.10	-1.69	0.99	1.695e+05	2.740e+04	1.412e+05	5.576e+04	-
5.680e+04		14	25.71	8.16	-5.92	3.26	-1.02	6.71	2.850e+05	3.886e+04	2.827e+05	4.121e+04	-
2.391e+04		194	13.58	5.98	1.84	5.08	2.73	-1.70	1.615e+05	6.079e+04	1.069e+05	1.153e+05	-
5.017e+04		203	11.74	8.10	0.44	1.37	7.17	2.49	1.341e+05	2.894e+04	1.116e+05	5.136e+04	-
4.306e+04	178	202	17.24	5.59	-1.16	1.51	2.92	3.30	1.994e+05	5.077e+04	1.728e+05	7.737e+04	-
5.696e+04		194	16.23	12.67	-1.23	4.13	7.32	6.77	1.932e+05	7.350e+04	1.710e+05	9.572e+04	-
4.654e+04		195	10.62	6.12	-1.70	6.12	-1.70	9.64e-04	1.271e+05	5.309e+04	9.928e+04	8.088e+04	-
3.583e+04		203	9.93	6.85	0.38	1.16	6.07	2.11	1.134e+05	2.449e+04	9.445e+04	4.346e+04	-
3.644e+04	178	202	14.58	4.73	-0.98	1.28	2.47	2.79	1.687e+05	4.296e+04	1.462e+05	6.547e+04	-
4.820e+04		194	13.73	10.72	-1.04	3.49	6.19	5.73	1.635e+05	6.219e+04	1.447e+05	8.099e+04	-
3.938e+04		195	8.99	5.17	-1.44	5.17	-1.44	8.15e-04	1.075e+05	4.492e+04	8.400e+04	6.844e+04	-
3.032e+04		203	9.11	66.88	-53.37	60.89	-47.39	26.15	1.032e+05	2.220e+04	8.569e+04	3.970e+04	-
3.333e+04	178												

Parco Eolico "Bolina" – Progetto Definitivo
Relazione di calcolo preliminare delle fondazioni degli aerogeneratori G8 e G12

4.386e+04	202	13.82	141.89	-1.64	124.03	16.22	-47.38	1.537e+05	3.921e+04	1.332e+05	5.968e+04	-
3.583e+04	194	12.63	51.47	-16.38	51.35	-16.26	2.87	1.488e+05	5.670e+04	1.317e+05	7.382e+04	-
2.752e+04	195	8.44	88.61	-11.68	81.84	-4.91	-25.17	9.779e+04	4.097e+04	7.642e+04	6.234e+04	-
178 39	203	9.04	24.11	-15.19	21.30	-12.38	10.12	1.031e+05	2.224e+04	8.581e+04	3.957e+04	-
3.319e+04	202	13.44	47.79	1.93	42.74	6.97	-14.35	1.535e+05	3.911e+04	1.330e+05	5.957e+04	-
4.383e+04	194	12.52	20.35	-2.66	19.47	-1.78	4.41	1.487e+05	5.659e+04	1.316e+05	7.369e+04	-
3.581e+04	195	8.26	32.85	-4.58	30.80	-2.53	-8.52	9.776e+04	4.088e+04	7.639e+04	6.226e+04	-
2.755e+04	203	9.03	6.23	0.34	1.05	5.52	1.92	1.031e+05	2.226e+04	8.587e+04	3.951e+04	-
178 69	202	13.26	4.30	-0.89	1.17	2.24	2.54	1.534e+05	3.906e+04	1.329e+05	5.952e+04	-
3.312e+04	194	12.48	9.75	-0.95	3.17	5.63	5.21	1.486e+05	5.654e+04	1.315e+05	7.363e+04	-
4.382e+04	195	8.17	4.70	-1.31	4.70	-1.31	7.41e-04	9.775e+04	4.084e+04	7.637e+04	6.222e+04	-
3.580e+04	204	8.09	3.45	1.51	3.35	1.61	-0.41	9.037e+04	1.434e+04	6.606e+04	3.865e+04	-
2.756e+04	203	11.69	5.67	4.36	4.48	5.54	-0.39	1.342e+05	3.113e+04	1.107e+05	5.465e+04	-
179 1	195	10.52	4.09	0.31	2.58	1.82	1.85	1.258e+05	5.119e+04	1.013e+05	7.564e+04	-
3.546e+04	196	7.03	6.39	1.25	5.89	1.75	-1.52	8.326e+04	3.032e+04	5.737e+04	5.621e+04	-
4.325e+04	204	6.84	2.92	1.28	2.84	1.36	-0.35	7.647e+04	1.214e+04	5.590e+04	3.271e+04	-
3.501e+04	203	9.89	4.80	3.69	3.79	4.69	-0.33	1.135e+05	2.634e+04	9.365e+04	4.624e+04	-
2.646e+04	195	8.90	3.46	0.26	2.19	1.54	1.57	1.064e+05	4.331e+04	8.572e+04	6.400e+04	-
179 3	196	5.94	5.40	1.06	4.98	1.48	-1.29	7.045e+04	2.566e+04	4.854e+04	4.756e+04	-
3.000e+04	204	6.30	55.29	-25.37	54.60	-24.68	7.42	6.951e+04	1.095e+04	5.064e+04	2.983e+04	-
3.660e+04	203	9.19	66.26	-15.04	66.18	-14.96	2.51	1.036e+05	2.400e+04	8.537e+04	4.225e+04	-
2.962e+04	195	8.25	68.72	-22.97	68.21	-22.45	-6.86	9.668e+04	3.944e+04	7.781e+04	5.831e+04	-
2.239e+04	196	5.51	60.38	-23.27	58.15	-21.05	-13.45	6.400e+04	2.329e+04	4.399e+04	4.330e+04	-
179 7	204	6.26	12.56	-5.43	11.67	-4.54	-3.89	6.957e+04	1.099e+04	5.080e+04	2.976e+04	-
2.737e+04	203	9.06	16.26	-1.37	14.26	0.63	-5.58	1.034e+05	2.398e+04	8.519e+04	4.217e+04	-
3.346e+04	195	8.15	16.75	-4.10	15.03	-2.38	-5.74	9.675e+04	3.935e+04	7.790e+04	5.821e+04	-
2.691e+04	196	5.45	18.61	-4.56	15.13	-1.08	-8.28	6.406e+04	2.328e+04	4.410e+04	4.325e+04	-
2.035e+04	204	6.22	2.65	1.16	2.58	1.24	-0.32	6.952e+04	1.103e+04	5.082e+04	2.973e+04	-
179 55	203	8.99	4.36	3.35	3.45	4.26	-0.30	1.032e+05	2.395e+04	8.513e+04	4.204e+04	-
2.734e+04	195	8.09	3.15	0.24	1.99	1.40	1.42	9.674e+04	3.938e+04	7.793e+04	5.818e+04	-
3.338e+04	196	5.40	4.91	0.96	4.53	1.35	-1.17	6.404e+04	2.332e+04	4.413e+04	4.324e+04	-
2.696e+04	205	5.98	4.62	-0.54	4.37	-0.29	1.10	6.281e+04	962.23	3.725e+04	2.653e+04	-
2.038e+04	204	8.07	5.20	1.62	4.86	1.96	-1.05	9.021e+04	1.445e+04	6.549e+04	3.917e+04	-
179 69	196	7.04	2.84	1.44	2.84	1.44	-0.11	8.356e+04	3.027e+04	5.805e+04	5.577e+04	-
2.727e+04	197	4.85	4.94	1.28	4.28	1.94	-1.41	5.591e+04	1.407e+04	2.998e+04	4.000e+04	-
3.327e+04	205	5.06	3.91	-0.46	3.70	-0.25	0.93	5.315e+04	814.20	3.152e+04	2.245e+04	-
2.693e+04	204	6.83	4.40	1.37	4.12	1.65	-0.89	7.633e+04	1.223e+04	5.541e+04	3.315e+04	-
2.031e+04												-
180 3												-
2.577e+04												-

Parco Eolico "Bolina" – Progetto Definitivo
Relazione di calcolo preliminare delle fondazioni degli aerogeneratori G8 e G12

1.493e+04	198	3.36	5.34	0.16	0.27	5.23	-0.76 3.671e+04	4101.94	1.385e+04	2.696e+04	-	
1.512e+04	199	3.33	2.56	-10.07	-1.40	-6.11	5.86 3.473e+04	1041.06	1.046e+04	2.532e+04	-	
182 3	207	2.52	5.50	1.53	4.51	2.52	-1.72 2.115e+04	-8054.42	7132.66	5965.82	-	
1.459e+04	206	3.95	3.10	-4.18	1.02	-2.10	3.29 3.800e+04	-5287.79	1.839e+04	1.433e+04	-	
2.155e+04	198	2.84	4.52	0.14	0.23	4.42	-0.64 3.107e+04	3470.87	1.172e+04	2.281e+04	-	
1.263e+04	199	2.82	2.17	-8.52	-1.18	-5.17	4.96 2.939e+04	880.89	8850.19	2.142e+04	-	
1.279e+04	182 22	207	2.20	19.11	-3.66	-3.60	19.05	-1.15 1.830e+04	-7151.41	6049.26	5101.74	-
1.272e+04	206	3.68	11.76	-13.27	-11.14	9.63	6.99 3.522e+04	-4697.86	1.704e+04	1.348e+04	-	
1.988e+04	198	2.56	21.53	-19.86	-17.03	18.70	10.45 2.803e+04	3384.67	1.115e+04	2.027e+04	-	
1.145e+04	199	2.93	14.35	-31.29	-15.40	-1.53	21.74 2.964e+04	835.63	9176.82	2.130e+04	-	
1.306e+04	182 54	207	2.26	8.26	1.20	1.50	7.96	-1.42 1.892e+04	-7264.40	6337.05	5314.61	-
1.308e+04	206	3.62	4.47	-5.63	-3.16	2.00	4.34 3.478e+04	-4770.07	1.683e+04	1.318e+04	-	
1.969e+04	198	2.57	9.64	-6.27	-5.62	8.99	3.15 2.817e+04	3234.62	1.082e+04	2.058e+04	-	
1.147e+04	199	2.68	5.63	-15.18	-5.92	-3.63	10.34 2.771e+04	813.36	8428.40	2.009e+04	-	
1.212e+04	182 69	207	2.29	5.00	1.39	4.10	2.29	-1.56 1.923e+04	-7322.20	6484.24	5423.48	-
1.327e+04	206	3.59	2.82	-3.80	0.92	-1.91	2.99 3.455e+04	-4807.08	1.672e+04	1.302e+04	-	
1.959e+04	198	2.59	4.11	0.12	0.21	4.02	-0.58 2.824e+04	3155.34	1.066e+04	2.074e+04	-	
1.149e+04	199	2.56	1.97	-7.74	-1.07	-4.70	4.51 2.672e+04	800.81	8045.63	1.947e+04	-	
1.163e+04	183 1	208	2.20	0.28	-0.85	-0.04	-0.53	0.51 1.813e+04	-7501.27	4823.43	5810.09	-
1.281e+04	207	3.30	3.73	-0.24	0.58	2.91	1.61 2.796e+04	-1.025e+04	1.058e+04	7124.81	-	
1.902e+04	199	2.96	5.29	-6.14	4.88	-5.73	-2.11 3.053e+04	-349.26	5480.44	2.470e+04	-	
1.208e+04	200	1.93	6.34	2.98	4.14	5.18	-1.60 1.638e+04	-5803.33	-1958.49	1.254e+04	-8397.99	
183 3	208	1.86	0.24	-0.72	-0.04	-0.45	0.43 1.534e+04	-6347.23	4081.37	4916.23	-	
1.084e+04	207	2.79	3.16	-0.20	0.49	2.46	1.36 2.366e+04	-8673.22	8953.47	6028.69	-	
1.610e+04	199	2.50	4.47	-5.20	4.13	-4.85	-1.79 2.583e+04	-295.53	4637.29	2.090e+04	-	
1.022e+04	200	1.63	5.37	2.52	3.50	4.38	-1.35 1.386e+04	-4910.51	-1657.19	1.061e+04	-7105.99	
183 8	208	1.69	9.74	-23.52	8.78	-22.56	5.55 1.374e+04	-5400.24	3598.68	4739.43	-9552.28	
207	2.68	21.16	-20.53	17.80	-17.17	11.35 2.144e+04	-9098.96	7124.86	5218.76	-		
1.524e+04	199	2.21	12.72	-35.18	8.15	-30.61	-14.07 2.334e+04	1777.97	5336.45	1.978e+04	-8003.93	
183 40	200	1.47	11.55	-15.74	10.35	-14.55	-5.59 1.230e+04	-4523.18	-1344.22	9118.38	-6585.28	
208	1.69	3.36	-8.31	2.95	-7.90	2.14 1.388e+04	-5644.54	3672.55	4560.70	-9751.06		
207	2.58	8.07	-6.08	6.32	-4.33	4.66 2.148e+04	-8294.27	7796.18	5392.01	-		
1.484e+04	199	2.25	6.93	-14.96	5.24	-13.28	-5.84 2.343e+04	428.70	4594.95	1.926e+04	-8858.38	
183 69	200	1.47	6.45	-3.12	5.61	-2.29	-2.71 1.250e+04	-4482.51	-1451.61	9467.46	-6502.39	
208	1.69	0.22	-0.66	-0.03	-0.41	0.39 1.395e+04	-5770.21	3710.33	4469.30	-9852.72		
207	2.54	2.87	-0.19	0.45	2.24	1.24 2.150e+04	-7884.75	8139.52	5480.62	-		
1.463e+04	199	2.28	4.07	-4.72	3.75	-4.41	-1.63 2.348e+04	-268.66	4215.72	1.900e+04	-9295.37	
184 1	200	1.48	4.88	2.29	3.18	3.99	-1.23 1.260e+04	-4464.10	-1506.53	9646.00	-6459.99	
209	0.59	2.53	4.50e-03	0.95	1.58	1.22 6232.30	305.46	310.45	6227.30	-171.99		
208	2.28	2.32	-1.13	-0.45	1.64	1.37 1.806e+04	-8783.29	4013.59	5264.90	-		
1.341e+04	200	1.94	2.65	-0.14	1.48	1.03	-1.38 1.726e+04	-4870.55	-1042.48	1.343e+04	-8370.08	
184 3	201	0.96	3.85	-0.08	0.87	2.90	-1.69 9917.08	-10.61	165.29	9741.18	-1309.72	
209	0.50	2.14	3.81e-03	0.80	1.34	1.03 5273.48	258.46	262.69	5269.25	-145.53		
208	1.93	1.96	-0.95	-0.38	1.39	1.16 1.528e+04	-7432.02	3396.11	4454.92	-		
1.135e+04												

Parco Eolico "Bolina" – Progetto Definitivo
Relazione di calcolo preliminare delle fondazioni degli aerogeneratori G8 e G12

		200	1.64	2.24	-0.12	1.25	0.87	-1.16	1.460e+04	-4121.23	-882.09	1.136e+04	-7082.38
		201	0.82	3.26	-0.07	0.74	2.45	-1.43	8391.38	-8.98	139.86	8242.53	-1108.23
184	6	209	0.57	28.72	-2.33	-1.53	27.92	-4.91	4804.80	203.33	208.99	4799.13	-161.35
		208	1.82	28.90	-7.23	-5.99	27.67	-6.56	1.403e+04	-6685.42	3280.29	4062.84	-
1.035e+04													
		200	1.56	28.42	-5.42	-2.51	25.51	9.48	1.349e+04	-4025.74	-1050.27	1.051e+04	-6577.11
		201	0.84	27.43	-2.76	-1.32	26.00	6.42	7793.71	28.42	158.18	7663.96	-995.35
184	39	209	0.48	2.34	-8.66	1.50	-7.82	2.92	4790.52	245.60	248.90	4787.22	-122.47
		208	1.78	2.82	-8.93	1.56	-7.68	3.63	1.385e+04	-6780.57	3022.10	4045.55	-
1.030e+04													
		200	1.48	4.19	-9.39	2.37	-7.57	-4.63	1.320e+04	-3652.25	-717.86	1.027e+04	-6391.63
		201	0.75	3.07	-7.53	1.35	-5.82	-3.91	7572.68	-20.60	116.65	7435.44	-1011.58
184	69	209	0.45	1.94	3.46e-03	0.73	1.22	0.94	4794.07	234.97	238.81	4790.23	-132.30
		208	1.76	1.78	-0.87	-0.35	1.26	1.05	1.389e+04	-6756.38	3087.37	4049.92	-
1.031e+04													
		200	1.49	2.04	-0.11	1.14	0.79	-1.06	1.328e+04	-3746.57	-801.90	1.033e+04	-6438.53
		201	0.74	2.96	-0.06	0.67	2.23	-1.30	7628.52	-8.16	127.15	7493.21	-1007.48
185	1	210	13.22	9.30	-4.50	-1.19	6.00	5.89	1.356e+05	-3434.46	1.258e+05	6426.13	-
3.570e+04													
		10	39.19	1.85	-11.30	-7.65	-1.80	5.89	4.191e+05	2.378e+04	3.166e+05	1.263e+05	-
1.732e+05													
		12	18.09	17.02	-5.10	10.75	1.17	9.97	2.091e+05	5.314e+04	1.602e+05	1.020e+05	-
7.233e+04													
		202	21.51	1.56	-2.21	1.32	-1.97	0.92	2.403e+05	3.709e+04	1.694e+05	1.080e+05	-
9.685e+04													
185	3	210	11.19	7.87	-3.81	-1.01	5.07	4.98	1.148e+05	-2906.08	1.064e+05	5437.50	-
3.020e+04													
		10	33.16	1.57	-9.56	-6.47	-1.52	4.98	3.546e+05	2.012e+04	2.679e+05	1.068e+05	-
1.466e+05													
		12	15.31	14.41	-4.32	9.10	0.99	8.44	1.769e+05	4.497e+04	1.356e+05	8.630e+04	-
6.120e+04													
		202	18.20	1.32	-1.87	1.12	-1.67	0.78	2.033e+05	3.138e+04	1.433e+05	9.139e+04	-
8.195e+04													
185	7	210	10.48	92.53	-44.87	90.79	-43.14	15.36	1.042e+05	-2520.43	9.652e+04	5142.02	-
2.755e+04													
		10	30.52	85.47	-53.25	81.62	-49.40	-22.78	3.233e+05	1.865e+04	2.444e+05	9.761e+04	-
1.335e+05													
		12	14.09	70.40	5.47	70.25	5.62	3.11	1.613e+05	4.119e+04	1.237e+05	7.878e+04	-
5.568e+04													
		202	16.68	41.19	-82.85	35.87	-77.52	25.15	1.852e+05	2.860e+04	1.305e+05	8.337e+04	-
7.469e+04													
185	38	210	10.31	20.78	-31.97	-31.95	20.77	0.87	1.044e+05	-2683.14	9.684e+04	4875.90	-
2.743e+04													
		10	30.25	18.38	-39.01	-35.49	14.86	13.77	3.220e+05	1.818e+04	2.433e+05	9.697e+04	-
1.332e+05													
		12	13.96	4.29	-17.70	-12.70	-0.70	9.22	1.607e+05	4.077e+04	1.231e+05	7.834e+04	-
5.563e+04													
		202	16.56	25.77	-12.34	-10.78	24.21	-7.56	1.847e+05	2.850e+04	1.302e+05	8.299e+04	-
7.444e+04													
185	69	210	10.17	7.16	-3.46	-0.92	4.61	4.53	1.043e+05	-2641.89	9.676e+04	4943.18	-
2.746e+04													
		10	30.15	1.42	-8.69	-5.88	-1.39	4.53	3.224e+05	1.830e+04	2.435e+05	9.713e+04	-
1.333e+05													
		12	13.92	13.10	-3.93	8.27	0.90	7.67	1.608e+05	4.088e+04	1.233e+05	7.845e+04	-
5.564e+04													
		202	16.55	1.20	-1.70	1.02	-1.51	0.71	1.848e+05	2.853e+04	1.303e+05	8.308e+04	-
7.450e+04													
186	1	211	14.04	26.97	-18.15	-17.61	26.43	4.93	1.464e+05	2220.29	1.158e+05	3.281e+04	-
5.895e+04													
		210	18.14	-0.71	-11.90	-2.56	-10.06	4.15	1.964e+05	1.660e+04	1.509e+05	6.210e+04	-
7.817e+04													
		202	16.96	8.43	-1.86	3.22	3.35	5.15	1.952e+05	4.675e+04	1.486e+05	9.327e+04	-
6.885e+04													
		203	12.01	9.75	3.79	9.73	3.81	0.34	1.361e+05	2.693e+04	9.080e+04	7.228e+04	-
5.382e+04													
186	3	211	11.88	22.82	-15.36	-14.90	22.36	4.17	1.239e+05	1878.71	9.799e+04	2.776e+04	-
4.988e+04													
		210	15.35	-0.60	-10.07	-2.17	-8.51	3.51	1.662e+05	1.405e+04	1.277e+05	5.255e+04	-
6.615e+04													
		202	14.35	7.13	-1.58	2.73	2.83	4.35	1.651e+05	3.956e+04	1.258e+05	7.892e+04	-
5.826e+04													
		203	10.16	8.25	3.21	8.23	3.23	0.29	1.152e+05	2.279e+04	7.683e+04	6.116e+04	-
4.554e+04													

Parco Eolico "Bolina" – Progetto Definitivo
Relazione di calcolo preliminare delle fondazioni degli aerogeneratori G8 e G12

186	6	211	11.01	50.08	-80.47	-80.45	50.06	-1.62	1.134e+05	2910.54	9.148e+04	2.481e+04	-
4.404e+04		210	14.15	35.63	-64.35	-64.01	35.28	5.84	1.511e+05	1.253e+04	1.161e+05	4.758e+04	-
6.024e+04		202	13.31	85.74	-102.70	-100.23	83.28	21.40	1.499e+05	3.638e+04	1.145e+05	7.174e+04	-
5.256e+04		203	9.38	2.99	-52.41	-47.93	-1.49	15.09	1.043e+05	1.987e+04	6.880e+04	5.542e+04	-
4.171e+04		211	10.87	30.45	-36.24	-36.18	30.39	1.96	1.129e+05	2122.25	8.989e+04	2.510e+04	-
4.490e+04	38	210	14.02	7.37	-23.51	-22.96	6.82	4.09	1.511e+05	1.269e+04	1.161e+05	4.770e+04	-
6.017e+04		202	13.13	31.41	-33.80	-32.28	29.88	9.86	1.500e+05	3.610e+04	1.144e+05	7.174e+04	-
5.283e+04		203	9.26	3.35	-13.18	-11.27	1.44	5.28	1.046e+05	2.043e+04	6.949e+04	5.554e+04	-
4.150e+04		211	10.80	20.75	-13.96	-13.54	20.33	3.79	1.126e+05	1707.92	8.908e+04	2.524e+04	-
4.534e+04	69	210	13.95	-0.55	-9.15	-1.97	-7.73	3.19	1.511e+05	1.277e+04	1.161e+05	4.777e+04	-
6.013e+04		202	13.05	6.49	-1.43	2.48	2.57	3.96	1.501e+05	3.596e+04	1.143e+05	7.174e+04	-
5.296e+04		203	9.24	7.50	2.92	7.48	2.93	0.26	1.047e+05	2.072e+04	6.985e+04	5.560e+04	-
4.140e+04		212	9.83	6.41	-19.31	3.88	-16.79	7.65	9.857e+04	-6408.98	5.716e+04	3.500e+04	-
5.131e+04	1	211	11.11	52.21	0.45	25.11	27.55	-25.85	1.200e+05	1.362e+04	9.646e+04	3.720e+04	-
4.420e+04		203	12.49	7.31	-15.92	-12.88	4.26	7.84	1.409e+05	2.721e+04	9.995e+04	6.813e+04	-
5.456e+04		204	7.69	21.18	-0.79	11.30	9.10	-10.93	8.626e+04	1.664e+04	5.099e+04	5.191e+04	-
3.481e+04		212	8.32	5.42	-16.34	3.29	-14.20	6.47	8.341e+04	-5422.99	4.837e+04	2.962e+04	-
4.342e+04	3	211	9.40	44.18	0.38	21.25	23.31	-21.87	1.016e+05	1.152e+04	8.162e+04	3.148e+04	-
3.740e+04		203	10.57	6.18	-13.47	-10.89	3.61	6.63	1.192e+05	2.302e+04	8.458e+04	5.765e+04	-
4.617e+04		204	6.51	17.93	-0.67	9.56	7.70	-9.25	7.299e+04	1.408e+04	4.314e+04	4.392e+04	-
2.945e+04		212	7.70	7.60	-44.06	-42.91	6.46	7.61	7.646e+04	-4960.03	4.398e+04	2.752e+04	-
3.987e+04	6	211	8.09	57.75	-32.48	-21.42	46.69	-29.59	8.848e+04	1.088e+04	7.153e+04	2.783e+04	-
3.206e+04		203	9.93	35.26	-82.43	-78.73	31.56	20.52	1.096e+05	2.087e+04	7.834e+04	5.214e+04	-
4.239e+04		204	5.78	27.02	-38.65	-38.65	27.02	0.21	6.545e+04	1.303e+04	3.898e+04	3.950e+04	-
2.621e+04		212	7.61	-2.28	-16.62	-12.54	-6.36	6.47	7.604e+04	-4939.78	4.397e+04	2.713e+04	-
3.960e+04	38	211	8.39	43.84	-8.49	5.53	29.82	-23.17	9.104e+04	1.061e+04	7.330e+04	2.835e+04	-
3.335e+04		203	9.72	15.31	-35.66	-33.19	12.85	10.93	1.088e+05	2.091e+04	7.738e+04	5.231e+04	-
4.211e+04		204	5.86	15.12	-8.67	-7.33	13.78	-5.49	6.605e+04	1.288e+04	3.914e+04	3.979e+04	-
2.658e+04		212	7.56	4.93	-14.86	2.99	-12.91	5.89	7.583e+04	-4929.99	4.397e+04	2.693e+04	-
3.947e+04	69	211	8.54	40.16	0.35	19.32	21.20	-19.89	9.234e+04	1.047e+04	7.420e+04	2.862e+04	-
3.400e+04		203	9.61	5.62	-12.24	-9.90	3.28	6.03	1.084e+05	2.093e+04	7.689e+04	5.240e+04	-
4.197e+04		204	5.92	16.30	-0.61	8.69	7.00	-8.41	6.635e+04	1.280e+04	3.922e+04	3.993e+04	-
2.677e+04		213	7.23	2.91	-1.48	2.68	-1.25	0.98	6.694e+04	-1.452e+04	3.432e+04	1.810e+04	-
3.991e+04	1	212	9.31	5.67	1.73	5.65	1.75	-0.28	9.341e+04	-6535.69	5.849e+04	2.839e+04	-
4.765e+04		204	8.15	5.31	-0.63	4.31	0.37	-2.22	9.101e+04	1.433e+04	5.173e+04	5.361e+04	-
3.833e+04		205	6.07	6.39	0.88	5.19	2.09	-2.28	6.316e+04	228.55	2.589e+04	3.750e+04	-
3.092e+04		213	6.12	2.46	-1.25	2.27	-1.06	0.83	5.664e+04	-1.228e+04	2.904e+04	1.532e+04	-
188	3												-

Parco Eolico "Bolina" – Progetto Definitivo
Relazione di calcolo preliminare delle fondazioni degli aerogeneratori G8 e G12

3.377e+04													
4.032e+04	212	7.88	4.80	1.46	4.78	1.48	-0.24	7.904e+04	-5530.20	4.949e+04	2.402e+04		-
3.243e+04	204	6.90	4.49	-0.53	3.65	0.31	-1.88	7.701e+04	1.213e+04	4.377e+04	4.536e+04		-
2.617e+04	205	5.14	5.41	0.74	4.39	1.77	-1.93	5.344e+04	193.39	2.190e+04	3.173e+04		-
3.074e+04	188 23 213	5.65	18.40	-14.64	14.85	-11.09	-10.23	5.147e+04	-1.126e+04	2.634e+04	1.386e+04		-
3.688e+04	212	7.29	22.81	-12.96	18.32	-8.47	-11.85	7.223e+04	-5091.35	4.515e+04	2.198e+04		-
2.963e+04	204	6.40	31.86	-14.04	22.95	-5.13	-18.16	7.019e+04	1.090e+04	3.980e+04	4.128e+04		-
2.383e+04	205	4.77	29.69	-12.75	20.03	-3.10	-17.79	4.861e+04	88.47	1.982e+04	2.888e+04		-
3.071e+04	188 55 213	5.59	7.15	-5.15	6.39	-4.39	-2.96	5.148e+04	-1.120e+04	2.638e+04	1.390e+04		-
3.673e+04	212	7.21	10.46	-3.36	9.07	-1.98	-4.15	7.198e+04	-5049.07	4.504e+04	2.189e+04		-
2.953e+04	204	6.32	13.48	-5.07	9.96	-1.55	-7.27	7.007e+04	1.098e+04	3.980e+04	4.125e+04		-
2.380e+04	205	4.70	13.30	-3.87	9.42	0.01	-7.18	4.859e+04	146.27	1.988e+04	2.886e+04		-
3.070e+04	188 69 213	5.56	2.24	-1.14	2.06	-0.96	0.75	5.149e+04	-1.117e+04	2.640e+04	1.392e+04		-
3.666e+04	212	7.16	4.36	1.33	4.35	1.34	-0.22	7.185e+04	-5027.46	4.499e+04	2.184e+04		-
2.948e+04	204	6.27	4.08	-0.48	3.32	0.28	-1.71	7.001e+04	1.102e+04	3.979e+04	4.124e+04		-
2.379e+04	205	4.67	4.92	0.68	3.99	1.61	-1.75	4.858e+04	175.81	1.991e+04	2.885e+04		-
3.230e+04	189 1 214	5.65	1.96	0.03	0.32	1.67	0.69	4.880e+04	-1.654e+04	2.105e+04	1.121e+04		-
3.977e+04	213	7.21	2.45	-1.06	1.71	-0.32	1.44	6.678e+04	-1.449e+04	3.446e+04	1.783e+04		-
3.096e+04	205	6.08	3.98	0.52	3.52	0.98	-1.18	6.347e+04	498.88	2.624e+04	3.773e+04		-
2.497e+04	206	4.66	4.72	0.14	4.30	0.56	-1.33	4.423e+04	-7548.43	1.151e+04	2.517e+04		-
2.733e+04	189 3 214	4.78	1.66	0.03	0.27	1.41	0.58	4.129e+04	-1.400e+04	1.781e+04	9482.34		-
3.366e+04	213	6.10	2.08	-0.90	1.45	-0.27	1.21	5.651e+04	-1.226e+04	2.916e+04	1.509e+04		-
2.619e+04	205	5.14	3.37	0.44	2.98	0.83	-1.00	5.371e+04	422.13	2.220e+04	3.193e+04		-
2.113e+04	206	3.94	4.00	0.11	3.63	0.48	-1.13	3.743e+04	-6387.14	9743.44	2.130e+04		-
2.483e+04	189 23 214	4.40	12.53	-12.40	10.34	-10.21	-7.05	3.747e+04	-1.272e+04	1.602e+04	8738.92		-
3.066e+04	213	5.61	13.94	-11.21	12.01	-9.28	-6.69	5.140e+04	-1.125e+04	2.647e+04	1.368e+04		-
2.384e+04	205	4.75	24.35	-11.88	17.93	-5.47	-13.83	4.882e+04	299.91	2.008e+04	2.904e+04		-
1.915e+04	206	3.65	22.57	-11.91	14.73	-4.07	-14.45	3.384e+04	-5866.41	8750.57	1.922e+04		-
2.485e+04	189 54 214	4.37	6.20	-4.19	-3.17	5.17	3.10	3.756e+04	-1.273e+04	1.625e+04	8580.18		-
3.057e+04	213	5.57	4.79	-4.28	-2.30	2.81	3.74	5.136e+04	-1.111e+04	2.652e+04	1.373e+04		-
2.380e+04	205	4.68	4.57	-4.15	-2.45	2.86	3.46	4.882e+04	412.10	2.022e+04	2.902e+04		-
1.923e+04	206	3.60	4.43	-3.04	-0.56	1.96	3.52	3.409e+04	-5786.21	8893.92	1.940e+04		-
2.484e+04	189 69 214	4.35	1.51	0.02	0.25	1.28	0.53	3.754e+04	-1.272e+04	1.619e+04	8620.31		-
3.060e+04	213	5.55	1.89	-0.82	1.31	-0.24	1.10	5.137e+04	-1.115e+04	2.651e+04	1.372e+04		-
2.381e+04	205	4.68	3.07	0.40	2.71	0.76	-0.91	4.882e+04	383.76	2.018e+04	2.902e+04		-
1.921e+04	206	3.58	3.63	0.10	3.30	0.43	-1.03	3.402e+04	-5806.49	8857.68	1.936e+04		-
2.581e+04	190 1 215	4.69	11.44	-5.42	-5.14	11.15	2.17	4.053e+04	-1.328e+04	2.123e+04	6024.96		-

Parco Eolico "Bolina" – Progetto Definitivo
Relazione di calcolo preliminare delle fondazioni degli aerogeneratori G8 e G12

3.264e+04	214	5.69	-0.49	-3.83	-0.84	-3.47	1.03	4.929e+04	-1.637e+04	1.999e+04	1.292e+04	-
2.499e+04	206	4.64	3.47	2.92	3.35	3.05	-0.23	4.426e+04	-7140.20	1.257e+04	2.455e+04	-
1.866e+04	207	3.39	5.97	-1.00	4.75	0.22	-2.64	2.776e+04	-1.181e+04	1394.24	1.455e+04	-
2.184e+04	190 3 215	3.97	9.68	-4.59	-4.35	9.44	1.83	3.430e+04	-1.124e+04	1.796e+04	5098.05	-
2.762e+04	214	4.82	-0.41	-3.24	-0.71	-2.94	0.87	4.171e+04	-1.386e+04	1.692e+04	1.093e+04	-
2.115e+04	206	3.92	2.94	2.47	2.83	2.58	-0.20	3.745e+04	-6041.70	1.064e+04	2.077e+04	-
1.579e+04	207	2.87	5.05	-0.84	4.02	0.19	-2.24	2.349e+04	-9992.43	1179.74	1.231e+04	-
1.869e+04	190 21 215	3.47	9.75	-15.94	-9.68	3.49	-11.03	3.105e+04	-7759.92	1.688e+04	6411.23	-
2.518e+04	214	4.43	7.48	-11.48	-8.36	4.36	-7.03	3.788e+04	-1.286e+04	1.562e+04	9391.48	-
1.897e+04	206	3.59	10.57	-4.04	-0.41	6.94	-6.31	3.412e+04	-4956.06	9887.49	1.928e+04	-
1.475e+04	207	2.70	12.16	-1.05	2.13	8.98	-5.65	2.138e+04	-9807.90	736.13	1.083e+04	-
2.025e+04	190 56 215	3.69	12.71	-4.43	-2.02	10.30	5.96	3.122e+04	-1.105e+04	1.614e+04	4033.41	-
2.509e+04	214	4.39	3.37	-6.46	1.96	-5.05	3.44	3.793e+04	-1.251e+04	1.530e+04	1.013e+04	-
1.931e+04	206	3.58	4.54	-0.17	3.59	0.79	1.90	3.402e+04	-5674.21	9595.84	1.875e+04	-
1.422e+04	207	2.58	4.26	-2.91	4.17	-2.81	-0.81	2.134e+04	-8839.39	1186.31	1.132e+04	-
1.985e+04	190 69 215	3.61	8.80	-4.17	-3.95	8.58	1.67	3.118e+04	-1.022e+04	1.633e+04	4634.59	-
2.511e+04	214	4.38	-0.38	-2.95	-0.65	-2.67	0.79	3.792e+04	-1.260e+04	1.538e+04	9940.48	-
1.922e+04	206	3.57	2.67	2.25	2.58	2.34	-0.18	3.405e+04	-5492.46	9669.58	1.888e+04	-
1.435e+04	207	2.61	4.59	-0.77	3.65	0.17	-2.03	2.135e+04	-9084.03	1072.49	1.119e+04	-
1.614e+04	191 1 216	2.77	2.71	-6.36	2.55	-6.20	1.19	2.151e+04	-1.104e+04	3149.60	7315.89	-
1.866e+04	215	3.37	21.07	1.39	9.43	13.03	-9.67	2.834e+04	-9796.99	1.318e+04	5358.58	-
2.090e+04	207	3.70	0.61	-6.85	-5.53	-0.72	2.86	3.148e+04	-1.129e+04	5576.27	1.462e+04	-
1.048e+04	208	1.96	11.63	-0.82	3.06	7.76	-5.76	1.525e+04	-7344.09	-273.46	8176.90	-
1.366e+04	191 3 216	2.34	2.29	-5.38	2.16	-5.25	1.01	1.820e+04	-9344.08	2665.05	6190.36	-
1.579e+04	215	2.85	17.83	1.17	7.98	11.02	-8.19	2.398e+04	-8289.76	1.115e+04	4534.18	-
1.769e+04	207	3.13	0.52	-5.80	-4.68	-0.61	2.42	2.664e+04	-9551.72	4718.38	1.237e+04	-
1.251e+04	191 6 216	1.66	9.84	-0.69	2.59	6.56	-4.88	1.290e+04	-6214.23	-231.39	6918.91	-8864.17
1.299e+04	215	2.41	46.24	-7.42	1.05	37.78	-19.56	1.946e+04	-7055.86	8847.29	3561.08	-
1.666e+04	207	3.00	26.11	-27.01	-22.98	22.08	14.06	2.538e+04	-8484.66	5437.74	1.146e+04	-
1.248e+04	191 54 216	1.46	30.93	-7.81	-7.69	30.80	2.20	1.129e+04	-5310.99	-65.05	6041.40	-7717.11
1.391e+04	215	2.53	22.18	1.64	7.44	16.38	-9.25	2.100e+04	-7541.62	9911.33	3546.63	-
1.627e+04	207	2.90	3.46	-10.18	-7.94	1.22	5.06	2.458e+04	-8674.32	4519.09	1.138e+04	-
1.242e+04	191 69 216	1.49	10.18	0.61	1.44	9.35	-2.69	1.153e+04	-5622.25	-249.97	6154.09	-7953.98
1.436e+04	215	2.59	16.21	1.07	7.25	10.02	0.92	1.654e+04	-8494.62	2422.77	5627.60	-
1.608e+04	207	2.85	0.47	-5.27	-4.25	-0.55	2.20	2.422e+04	-8683.38	4289.44	1.124e+04	-

Parco Eolico "Bolina" – Progetto Definitivo
Relazione di calcolo preliminare delle fondazioni degli aerogeneratori G8 e G12

		208	1.51	8.95	-0.63	2.35	5.97	-4.43	1.173e+04	-5649.30	-210.35	6289.92	-8058.33
192	1	217	0.56	0.96	-1.92	0.49	-1.45	1.06	5879.74	343.72	398.50	5824.96	-547.98
		216	2.76	2.14	0.75	1.89	1.00	0.53	2.076e+04	-1.204e+04	4058.85	4664.07	-
1.640e+04													
		208	2.20	4.42	-2.33	-0.20	2.29	-3.14	1.725e+04	-8381.24	-520.43	9385.43	-
1.182e+04													
		209	0.74	4.77	-0.17	0.99	3.61	-2.09	7337.50	-350.94	123.50	6863.07	-1850.03
192	3	217	0.47	0.81	-1.62	0.42	-1.23	0.90	4975.17	290.84	337.20	4928.81	-463.68
		216	2.34	1.81	0.64	1.60	0.85	0.45	1.757e+04	-1.019e+04	3434.41	3946.52	-
1.387e+04													
		208	1.86	3.74	-1.97	-0.17	1.93	-2.65	1.459e+04	-7091.82	-440.37	7941.52	-9999.67
		209	0.63	4.03	-0.14	0.84	3.05	-1.77	6208.66	-296.95	104.50	5807.21	-1565.41
192	7	217	0.52	4.28	-27.10	2.90	-25.72	6.43	4370.55	231.19	270.88	4330.85	-403.41
		216	2.22	6.62	-26.59	4.04	-24.01	8.88	1.621e+04	-9339.01	3384.37	3491.35	-
1.278e+04													
		208	1.71	9.70	-26.25	6.27	-22.82	-10.57	1.328e+04	-6658.74	-583.27	7204.47	-9177.45
		209	0.62	5.53	-23.97	2.43	-20.87	-9.05	5658.60	-259.30	125.29	5274.02	-1458.77
192	39	217	0.46	1.88	-10.09	1.23	-9.44	2.72	4471.33	253.16	294.48	4430.02	-415.40
		216	2.16	3.31	-8.60	2.33	-7.61	3.28	1.605e+04	-9285.91	3210.91	3555.13	-
1.267e+04													
		208	1.70	4.45	-8.99	2.02	-6.56	-5.17	1.327e+04	-6518.70	-462.23	7214.46	-9120.00
		209	0.57	3.32	-7.22	1.33	-5.23	-4.13	5649.04	-266.29	105.25	5277.50	-1435.17
192	69	217	0.43	0.74	-1.47	0.38	-1.12	0.81	4522.88	264.40	306.54	4480.74	-421.52
		216	2.12	1.65	0.58	1.46	0.77	0.41	1.597e+04	-9259.19	3122.19	3587.74	-
1.261e+04													
		208	1.69	3.40	-1.79	-0.16	1.76	-2.41	1.327e+04	-6447.10	-400.33	7219.56	-9090.61
		209	0.57	3.67	-0.13	0.76	2.77	-1.61	5644.23	-269.95	95.00	5279.28	-1423.10
193	1	218	18.12	5.41	-4.05	-1.88	3.24	3.97	1.746e+05	-2.523e+04	1.206e+05	2.880e+04	-
8.875e+04													
		8	20.17	5.53	-19.89	-12.80	-1.56	11.40	1.870e+05	-3.884e+04	1.026e+05	4.558e+04	-
1.093e+05													
		10	27.20	9.92	-1.34	5.54	3.04	5.49	2.820e+05	-2501.08	2.502e+05	2.928e+04	-
8.963e+04													
		210	18.05	2.81	-11.99	-5.05	-4.12	7.39	1.959e+05	1.808e+04	1.044e+05	1.096e+05	-
8.886e+04													
193	3	218	15.34	4.57	-3.42	-1.59	2.74	3.36	1.477e+05	-2.135e+04	1.020e+05	2.437e+04	-
7.510e+04													
		8	17.07	4.68	-16.83	-10.83	-1.32	9.64	1.583e+05	-3.286e+04	8.682e+04	3.856e+04	-
9.246e+04													
		10	23.02	8.39	-1.13	4.69	2.58	4.64	2.386e+05	-2116.30	2.117e+05	2.478e+04	-
7.584e+04													
		210	15.27	2.38	-10.14	-4.27	-3.49	6.25	1.657e+05	1.530e+04	8.830e+04	9.274e+04	-
7.519e+04													
193	7	218	14.21	44.30	-70.61	36.98	-63.29	-28.07	1.345e+05	-1.920e+04	9.286e+04	2.241e+04	-
6.829e+04													
		8	15.64	58.64	-2.96	56.50	-0.83	-11.27	1.443e+05	-2.975e+04	7.929e+04	3.529e+04	-
8.422e+04													
		10	21.28	89.65	-50.88	88.15	-49.38	14.48	2.177e+05	-1490.21	1.933e+05	2.298e+04	-
6.903e+04													
		210	14.03	85.66	-46.96	80.03	-41.33	-26.74	1.506e+05	1.387e+04	8.001e+04	8.446e+04	-
6.833e+04													
193	39	218	14.00	13.25	-21.46	11.56	-19.77	-7.48	1.344e+05	-1.934e+04	9.279e+04	2.224e+04	-
6.828e+04													
		8	15.47	12.89	-1.36	12.60	-1.07	1.99	1.440e+05	-2.983e+04	7.905e+04	3.514e+04	-
8.411e+04													
		10	21.04	33.85	-16.37	32.64	-15.16	7.69	2.172e+05	-1777.16	1.927e+05	2.268e+04	-
6.897e+04													
		210	13.88	25.19	-16.76	24.51	-16.09	-5.29	1.507e+05	1.389e+04	8.018e+04	8.436e+04	-
6.835e+04													
193	69	218	13.94	4.16	-3.11	-1.45	2.49	3.05	1.343e+05	-1.941e+04	9.275e+04	2.215e+04	-
6.827e+04													
		8	15.52	4.25	-15.30	-9.85	-1.20	8.77	1.439e+05	-2.988e+04	7.893e+04	3.506e+04	-
8.406e+04													
		10	20.92	7.63	-1.03	4.26	2.34	4.22	2.169e+05	-1923.91	1.925e+05	2.253e+04	-
6.895e+04													
		210	13.89	2.16	-9.22	-3.88	-3.17	5.68	1.507e+05	1.391e+04	8.027e+04	8.431e+04	-
6.835e+04													
194	1	219	12.09	13.40	-4.00	12.10	-2.70	-4.57	1.087e+05	-2.847e+04	7.226e+04	7963.58	-
6.058e+04													
		218	19.04	5.53	-24.85	-10.52	-8.80	15.17	1.823e+05	-2.711e+04	1.267e+05	2.846e+04	-
9.246e+04													
		210	16.80	18.45	-2.61	-2.59	18.43	-0.64	1.788e+05	7793.45	1.191e+05	6.744e+04	-
8.150e+04													

Parco Eolico "Bolina" – Progetto Definitivo
Relazione di calcolo preliminare delle fondazioni degli aerogeneratori G8 e G12

7.847e+04	211	15.96	7.59	-52.74	-14.18	-30.98	28.97	1.701e+05	1.296e+04	9.551e+04	8.754e+04	-
194 3	219	10.23	11.34	-3.38	10.24	-2.29	-3.86	9.197e+04	-2.409e+04	6.114e+04	6738.41	-
5.126e+04	218	16.11	4.68	-21.03	-8.90	-7.45	12.83	1.542e+05	-2.294e+04	1.072e+05	2.408e+04	-
7.823e+04	210	14.22	15.61	-2.20	-2.19	15.60	-0.54	1.513e+05	6594.46	1.008e+05	5.707e+04	-
6.896e+04	211	13.50	6.42	-44.63	-12.00	-26.21	24.51	1.439e+05	1.096e+04	8.082e+04	7.408e+04	-
6.640e+04	219	9.20	0.08	-38.93	-38.91	0.06	0.82	8.216e+04	-2.169e+04	5.440e+04	6076.98	-
194 6	218	15.02	57.72	-100.42	-98.46	55.76	17.48	1.410e+05	-2.096e+04	9.782e+04	2.224e+04	-
4.596e+04	210	13.07	61.98	-66.27	-64.29	60.00	15.80	1.368e+05	5807.86	9.174e+04	5.084e+04	-
7.164e+04	211	12.90	19.72	-102.65	-74.30	-8.62	51.63	1.348e+05	9722.59	7.587e+04	6.862e+04	-
6.221e+04	219	9.21	-0.69	-7.67	-7.01	-1.35	-2.05	8.312e+04	-2.183e+04	5.518e+04	6109.30	-
6.241e+04	218	14.77	17.69	-41.97	-38.67	14.39	13.63	1.405e+05	-2.089e+04	9.759e+04	2.201e+04	-
194 38	210	12.97	30.16	-23.54	-23.07	29.68	5.02	1.373e+05	5932.45	9.168e+04	5.153e+04	-
4.638e+04	211	12.49	7.41	-58.45	-32.36	-18.69	32.21	1.322e+05	9884.10	7.428e+04	6.777e+04	-
7.130e+04	219	9.30	10.31	-3.07	9.31	-2.08	-3.51	8.361e+04	-2.190e+04	5.559e+04	6125.83	-
6.253e+04	218	14.64	4.25	-19.12	-8.09	-6.77	11.67	1.402e+05	-2.086e+04	9.746e+04	2.189e+04	-
6.106e+04	210	12.93	14.19	-2.00	-1.99	14.18	-0.50	1.375e+05	5994.96	9.165e+04	5.188e+04	-
194 69	211	12.28	5.83	-40.57	-10.90	-23.83	22.28	1.308e+05	9966.14	7.347e+04	6.734e+04	-
4.660e+04	220	10.40	0.45	-4.84	-1.47	-2.92	-2.54	9.097e+04	-2.864e+04	5.161e+04	1.072e+04	-
7.112e+04	219	13.66	1.15	-8.90	-6.04	-1.71	4.53	1.243e+05	-3.034e+04	8.210e+04	1.181e+04	-
6.269e+04	211	13.05	16.56	-28.42	15.61	-27.46	-6.50	1.434e+05	1.694e+04	7.883e+04	8.155e+04	-
6.036e+04	212	9.70	13.60	3.83	4.00	13.43	1.27	9.369e+04	-1.322e+04	3.921e+04	4.126e+04	-
195 1	220	8.80	0.38	-4.10	-1.25	-2.47	-2.15	7.697e+04	-2.423e+04	4.367e+04	9069.71	-
5.620e+04	219	11.56	0.97	-7.53	-5.11	-1.44	3.84	1.051e+05	-2.567e+04	6.947e+04	9993.33	-
6.884e+04	211	11.05	14.02	-24.05	13.20	-23.24	-5.50	1.214e+05	1.434e+04	6.670e+04	6.901e+04	-
6.323e+04	212	8.21	11.50	3.24	3.38	11.36	1.08	7.927e+04	-1.118e+04	3.317e+04	3.492e+04	-
5.344e+04	220	8.12	18.02	-43.94	-43.78	17.86	3.12	7.006e+04	-2.231e+04	3.965e+04	8095.57	-
195 3	219	10.72	25.18	-67.47	-66.69	24.40	8.45	9.613e+04	-2.284e+04	6.431e+04	8982.00	-
4.755e+04	211	10.21	3.31	-35.62	-26.51	-5.80	16.48	1.103e+05	1.146e+04	5.832e+04	6.345e+04	-
5.825e+04	212	7.53	31.72	-44.34	-41.06	28.44	15.45	7.177e+04	-1.005e+04	3.017e+04	3.156e+04	-
5.350e+04	220	8.02	4.56	-15.57	-15.56	4.56	-0.24	7.000e+04	-2.212e+04	3.968e+04	8194.57	-
4.522e+04	219	10.58	8.18	-26.43	-25.64	7.39	5.17	9.576e+04	-2.317e+04	6.354e+04	9050.05	-
195 6	211	10.08	-0.69	-16.28	-1.03	-15.94	2.27	1.103e+05	1.251e+04	5.985e+04	6.298e+04	-
4.341e+04	212	7.48	17.63	-13.03	-11.86	16.46	5.88	7.197e+04	-1.013e+04	3.016e+04	3.168e+04	-
5.266e+04	220	8.00	0.34	-3.72	-1.13	-2.25	-1.96	6.997e+04	-2.203e+04	3.970e+04	8245.19	-
4.936e+04	219	10.51	0.89	-6.85	-4.65	-1.31	3.49	9.558e+04	-2.334e+04	6.316e+04	9084.84	-
4.091e+04	211	10.04	12.74	-21.86	12.00	-21.13	-5.00	1.103e+05	1.303e+04	6.064e+04	6.273e+04	-
195 38	212	7.46	10.46	2.94	3.07	10.33	0.98	7.207e+04	-1.017e+04	3.016e+04	3.174e+04	-
4.329e+04												-
5.286e+04												-
4.888e+04												-
4.104e+04												-
195 69												-
4.323e+04												-
5.296e+04												-
4.864e+04												-

Parco Eolico "Bolina" – Progetto Definitivo
Relazione di calcolo preliminare delle fondazioni degli aerogeneratori G8 e G12

4.111e+04	196	1	221	8.16	-8.73e-03	-0.40	-0.30	-0.11	0.17	6.577e+04	-3.014e+04	3.065e+04	4980.74	-
4.620e+04			220	10.48	1.47	-2.44	-2.02	1.04	1.22	9.010e+04	-3.111e+04	4.992e+04	9062.30	-
5.706e+04			212	9.55	4.60	-1.90	4.50	-1.81	-0.77	9.559e+04	-7174.17	4.120e+04	4.722e+04	-
5.130e+04			213	7.32	3.32	1.88	2.66	2.54	-0.72	6.716e+04	-1.567e+04	2.005e+04	3.144e+04	-
4.102e+04	196	3	221	6.90	-7.39e-03	-0.34	-0.25	-0.09	0.15	5.565e+04	-2.550e+04	2.593e+04	4214.47	-
3.909e+04			220	8.87	1.24	-2.07	-1.71	0.88	1.03	7.624e+04	-2.633e+04	4.224e+04	7668.10	-
4.828e+04			212	8.08	3.89	-1.61	3.81	-1.53	-0.65	8.089e+04	-6070.45	3.486e+04	3.996e+04	-
4.340e+04			213	6.20	2.81	1.59	2.25	2.15	-0.61	5.683e+04	-1.326e+04	1.696e+04	2.661e+04	-
3.471e+04	196	6	221	6.35	21.19	-34.26	-34.20	21.12	1.87	5.072e+04	-2.306e+04	2.380e+04	3854.83	-
3.551e+04			220	8.17	22.42	-43.73	-43.52	22.21	3.76	6.937e+04	-2.396e+04	3.850e+04	6917.04	-
4.391e+04			212	7.42	20.29	-38.71	-35.23	16.82	13.88	7.338e+04	-5620.57	3.141e+04	3.635e+04	-
3.942e+04			213	5.70	23.02	-36.21	-33.18	19.99	13.05	5.179e+04	-1.190e+04	1.569e+04	2.421e+04	-
3.156e+04	196	38	221	6.30	7.12	-11.75	-11.73	7.09	0.72	5.063e+04	-2.314e+04	2.365e+04	3839.29	-
3.553e+04			220	8.10	8.19	-15.90	-15.75	8.04	1.89	6.933e+04	-2.394e+04	3.843e+04	6952.74	-
4.390e+04			212	7.36	5.96	-10.82	-9.63	4.77	4.31	7.348e+04	-5553.03	3.159e+04	3.633e+04	-
3.945e+04			213	5.65	8.93	-10.75	-9.87	8.05	4.05	5.170e+04	-1.200e+04	1.551e+04	2.419e+04	-
3.155e+04	196	69	221	6.27	-6.72e-03	-0.31	-0.23	-0.09	0.13	5.059e+04	-2.318e+04	2.358e+04	3831.34	-
3.554e+04			220	8.06	1.13	-1.88	-1.55	0.80	0.94	6.931e+04	-2.393e+04	3.840e+04	6971.00	-
4.389e+04			212	7.34	3.54	-1.46	3.47	-1.39	-0.59	7.353e+04	-5518.59	3.169e+04	3.632e+04	-
3.946e+04			213	5.63	2.55	1.44	2.04	1.95	-0.55	5.166e+04	-1.205e+04	1.542e+04	2.419e+04	-
3.155e+04	197	1	222	6.45	1.91	-1.07	0.45	0.39	1.49	4.880e+04	-2.764e+04	2.047e+04	688.61	-
3.692e+04			221	8.20	0.84	-2.36	-1.42	-0.10	1.46	6.611e+04	-3.023e+04	3.088e+04	4994.92	-
4.640e+04			213	7.29	1.80	1.46	1.74	1.52	-0.13	6.711e+04	-1.524e+04	2.027e+04	3.161e+04	-
4.078e+04			214	5.69	1.22	0.02	0.06	1.18	0.22	4.923e+04	-1.651e+04	9790.66	2.294e+04	-
3.221e+04	197	3	222	5.45	1.61	-0.90	0.38	0.33	1.26	4.130e+04	-2.339e+04	1.732e+04	582.67	-
3.124e+04			221	6.94	0.71	-2.00	-1.21	-0.08	1.23	5.594e+04	-2.558e+04	2.613e+04	4226.47	-
3.926e+04			213	6.17	1.52	1.24	1.47	1.29	-0.11	5.679e+04	-1.289e+04	1.715e+04	2.674e+04	-
3.451e+04			214	4.81	1.03	0.02	0.05	1.00	0.19	4.166e+04	-1.397e+04	8284.40	1.941e+04	-
2.725e+04	197	22	222	5.05	13.95	-10.67	-4.17	7.45	10.85	3.761e+04	-2.136e+04	1.580e+04	452.23	-
2.847e+04			221	6.38	12.39	-12.72	-5.74	5.41	11.25	5.086e+04	-2.321e+04	2.380e+04	3855.20	-
3.567e+04			213	5.67	11.08	-15.00	-7.36	3.44	11.87	5.157e+04	-1.165e+04	1.567e+04	2.426e+04	-
3.132e+04			214	4.48	10.54	-16.30	-7.06	1.29	12.76	3.815e+04	-1.260e+04	7761.46	1.779e+04	-
2.488e+04	197	54	222	4.99	5.61	-4.07	-1.18	2.72	4.43	3.756e+04	-2.129e+04	1.577e+04	503.48	-
2.842e+04			221	6.34	4.62	-5.50	-2.67	1.78	4.55	5.086e+04	-2.324e+04	2.377e+04	3846.63	-
3.568e+04			213	5.62	4.50	-4.16	-1.61	1.94	3.95	5.161e+04	-1.170e+04	1.562e+04	2.429e+04	-
3.135e+04			214	4.41	4.09	-5.40	-2.36	1.04	4.43	3.797e+04	-1.266e+04	7609.16	1.769e+04	-
2.481e+04														-

Parco Eolico "Bolina" – Progetto Definitivo
Relazione di calcolo preliminare delle fondazioni degli aerogeneratori G8 e G12

197 69	222	4.96	1.47	-0.82	0.35	0.30	1.14	3.754e+04	-2.126e+04	1.575e+04	529.70	-
2.840e+04												
	221	6.31	0.65	-1.82	-1.10	-0.08	1.12	5.086e+04	-2.326e+04	2.376e+04	3842.24	-
3.569e+04												
	213	5.61	1.39	1.12	1.34	1.17	-0.10	5.163e+04	-1.172e+04	1.559e+04	2.431e+04	-
3.137e+04												
	214	4.37	0.94	0.02	0.05	0.91	0.17	3.787e+04	-1.270e+04	7531.28	1.764e+04	-
2.477e+04												
198 1	223	4.53	8.09	-0.79	4.28	3.02	-4.39	3.004e+04	-2.397e+04	1.090e+04	-4829.08	-
2.583e+04												
	222	6.67	1.46	-7.48	-1.68	-4.33	4.27	5.152e+04	-2.717e+04	2.215e+04	2201.87	-
3.806e+04												
	214	5.41	7.46	-1.17	-1.16	7.45	-0.27	4.599e+04	-1.666e+04	9063.86	2.026e+04	-
3.082e+04												
	215	5.36	2.76	-17.07	-3.01	-11.30	9.01	4.853e+04	-1.128e+04	1.200e+04	2.525e+04	-
2.916e+04												
198 3	223	3.83	6.84	-0.67	3.62	2.55	-3.72	2.542e+04	-2.028e+04	9224.12	-4086.15	-
2.186e+04												
	222	5.65	1.23	-6.33	-1.43	-3.67	3.61	4.359e+04	-2.299e+04	1.874e+04	1863.12	-
3.220e+04												
	214	4.57	6.31	-0.99	-0.98	6.31	-0.23	3.891e+04	-1.410e+04	7669.42	1.714e+04	-
2.608e+04												
	215	4.53	2.34	-14.44	-2.55	-9.56	7.62	4.106e+04	-9543.53	1.015e+04	2.137e+04	-
2.467e+04												
198 22	223	3.40	10.72	1.84	1.84	10.71	0.13	2.233e+04	-1.841e+04	8051.48	-4133.05	-
1.944e+04												
	222	5.23	8.80	-13.29	-4.50	0.02	10.81	4.016e+04	-2.083e+04	1.726e+04	2073.49	-
2.953e+04												
	214	4.16	14.39	-11.22	-8.50	11.67	7.89	3.502e+04	-1.285e+04	7203.17	1.496e+04	-
2.362e+04												
	215	4.47	9.77	-32.91	-7.72	-15.42	20.99	3.985e+04	-8815.37	9735.55	2.130e+04	-
2.364e+04												
198 54	223	3.45	6.47	1.49	2.80	5.16	-2.19	2.284e+04	-1.843e+04	8272.52	-3856.25	-
1.972e+04												
	222	5.17	3.54	-8.12	-2.38	-2.20	5.83	3.981e+04	-2.087e+04	1.711e+04	1822.24	-
2.936e+04												
	214	4.15	8.29	-4.01	-3.47	7.74	2.53	3.525e+04	-1.283e+04	7050.36	1.537e+04	-
2.368e+04												
	215	4.24	4.62	-19.73	-4.14	-10.97	11.69	3.818e+04	-8722.39	9400.98	2.006e+04	-
2.284e+04												
198 69	223	3.49	6.22	-0.61	3.29	2.32	-3.38	2.311e+04	-1.844e+04	8385.56	-3714.68	-
1.987e+04												
	222	5.13	1.12	-5.75	-1.30	-3.33	3.28	3.963e+04	-2.090e+04	1.704e+04	1693.75	-
2.928e+04												
	214	4.16	5.74	-0.90	-0.89	5.73	-0.21	3.537e+04	-1.282e+04	6972.20	1.558e+04	-
2.371e+04												
	215	4.12	2.12	-13.13	-2.32	-8.69	6.93	3.733e+04	-8675.94	9229.87	1.942e+04	-
2.243e+04												
199 1	224	3.26	-1.13	-4.05	-1.81	-3.36	-1.24	2.321e+04	-1.564e+04	8389.72	-820.73	-
1.887e+04												
	223	5.04	4.01	-0.13	0.47	3.41	1.46	3.421e+04	-2.610e+04	1.289e+04	-4781.92	-
2.883e+04												
	215	4.52	4.95	-12.02	3.99	-11.06	-3.92	4.132e+04	-9855.95	6838.07	2.462e+04	-
2.399e+04												
	216	3.12	8.18	3.39	3.99	7.58	-1.59	2.146e+04	-1.574e+04	-2903.85	8619.54	-
1.768e+04												
199 3	224	2.76	-0.96	-3.42	-1.54	-2.85	-1.05	1.964e+04	-1.323e+04	7099.00	-694.46	-
1.597e+04												
	223	4.27	3.39	-0.11	0.40	2.88	1.24	2.895e+04	-2.209e+04	1.090e+04	-4046.24	-
2.440e+04												
	215	3.82	4.19	-10.17	3.38	-9.36	-3.31	3.496e+04	-8339.65	5786.06	2.084e+04	-
2.030e+04												
	216	2.64	6.92	2.87	3.38	6.42	-1.34	1.816e+04	-1.332e+04	-2457.10	7293.46	-
1.496e+04												
199 24	224	2.46	1.77	-13.46	1.22	-12.91	2.82	1.777e+04	-1.149e+04	6547.93	-274.29	-
1.423e+04												
	223	3.99	15.37	-7.94	10.82	-3.39	9.24	2.626e+04	-2.110e+04	9245.58	-4084.90	-
2.272e+04												
	215	3.36	5.04	-29.66	2.40	-27.01	-9.21	3.190e+04	-5482.50	5933.69	2.048e+04	-
1.722e+04												
	216	2.41	6.83	-1.15	6.80	-1.12	0.53	1.626e+04	-1.250e+04	-2203.59	5967.33	-
1.379e+04												
199 56	224	2.48	-0.49	-6.10	-0.51	-6.08	0.33	1.782e+04	-1.185e+04	6485.54	-510.52	-

Parco Eolico "Bolina" – Progetto Definitivo
Relazione di calcolo preliminare delle fondazioni degli aerogeneratori G8 e G12

5.418e+04	8	9.68	20.19	-28.11	-28.10	20.19	-0.57	9.072e+04	-1.779e+04	3.358e+04	3.935e+04	-
1.088e+05	218	19.73	7.70	-31.95	-10.37	-13.87	19.75	1.869e+05	-3.079e+04	8.210e+04	7.402e+04	-
3.247e+04	201 69 226	15.29	-1.67	-4.28	-2.93	-3.03	-1.30	5.919e+04	-1.211e+05	5.314e+04	-1.151e+05	-
1.861e+05	6	34.25	5.72	-8.42	-2.62	-0.08	6.95	3.341e+05	-4.096e+04	1.238e+05	1.693e+05	-
5.421e+04	8	9.70	2.41	-6.94	-6.61	2.08	1.73	9.085e+04	-1.771e+04	3.368e+04	3.946e+04	-
1.088e+05	218	19.64	4.76	-9.00	-0.38	-3.86	6.66	1.870e+05	-3.076e+04	8.215e+04	7.406e+04	-
6.918e+04	202 1 227	13.09	4.04	-2.30	-2.22	3.97	-0.70	9.445e+04	-6.184e+04	5.264e+04	-2.003e+04	-
9.058e+04	226	16.69	1.63	-14.84	-4.87	-8.34	8.05	1.377e+05	-5.691e+04	7.598e+04	4825.26	-
9.275e+04	218	17.10	3.30	-6.75	0.94	-4.39	4.26	1.589e+05	-3.317e+04	8.780e+04	3.794e+04	-
7.586e+04	219	13.56	0.30	-8.41	-1.32	-6.78	3.39	1.268e+05	-2.509e+04	5.429e+04	4.742e+04	-
5.854e+04	202 3 227	11.08	3.42	-1.95	-1.88	3.36	-0.59	7.992e+04	-5.232e+04	4.454e+04	-1.695e+04	-
7.665e+04	226	14.12	1.38	-12.56	-4.12	-7.06	6.81	1.165e+05	-4.816e+04	6.429e+04	4082.91	-
7.848e+04	218	14.47	2.79	-5.71	0.80	-3.72	3.60	1.345e+05	-2.807e+04	7.430e+04	3.210e+04	-
6.419e+04	219	11.48	0.25	-7.11	-1.12	-5.74	2.87	1.073e+05	-2.123e+04	4.593e+04	4.012e+04	-
5.314e+04	202 24 227	10.17	59.79	0.03	41.27	18.55	27.64	7.256e+04	-4.748e+04	4.045e+04	-1.536e+04	-
6.955e+04	226	12.95	39.70	-59.07	22.56	-41.94	37.40	1.059e+05	-4.353e+04	5.854e+04	3853.61	-
7.122e+04	218	13.31	93.24	-21.75	68.20	3.29	47.46	1.223e+05	-2.523e+04	6.765e+04	2.939e+04	-
5.814e+04	219	10.47	29.13	-46.72	27.10	-44.69	12.25	9.746e+04	-1.892e+04	4.169e+04	3.685e+04	-
5.319e+04	202 56 227	10.10	19.84	1.28	12.83	8.29	9.00	7.262e+04	-4.754e+04	4.048e+04	-1.539e+04	-
6.963e+04	226	12.88	13.85	-27.13	5.15	-18.43	16.75	1.059e+05	-4.370e+04	5.848e+04	3759.74	-
7.130e+04	218	13.21	33.23	-10.79	23.56	-1.12	18.23	1.222e+05	-2.542e+04	6.758e+04	2.925e+04	-
5.828e+04	219	10.45	9.71	-19.79	8.50	-18.57	5.87	9.751e+04	-1.917e+04	4.174e+04	3.660e+04	-
5.322e+04	202 69 227	10.07	3.11	-1.77	-1.71	3.05	-0.54	7.265e+04	-4.757e+04	4.049e+04	-1.541e+04	-
6.968e+04	226	12.84	1.25	-11.42	-3.75	-6.41	6.19	1.059e+05	-4.378e+04	5.845e+04	3711.74	-
7.134e+04	218	13.15	2.54	-5.19	0.73	-3.38	3.28	1.222e+05	-2.551e+04	6.754e+04	2.918e+04	-
5.835e+04	219	10.43	0.23	-6.47	-1.02	-5.22	2.61	9.753e+04	-1.930e+04	4.176e+04	3.648e+04	-
5.782e+04	203 1 228	10.40	2.77	-4.01	-3.19	1.94	-2.22	7.586e+04	-4.811e+04	3.621e+04	-8463.32	-
7.061e+04	227	13.03	1.03	-4.42	-3.89	0.50	1.62	9.898e+04	-5.552e+04	5.306e+04	-9609.88	-
7.427e+04	219	13.20	0.14	-4.96	0.13	-4.94	0.30	1.212e+05	-2.808e+04	5.406e+04	3.907e+04	-
6.033e+04	220	10.43	2.69	-1.46	-0.62	1.85	-1.67	8.958e+04	-3.108e+04	2.871e+04	2.980e+04	-
4.892e+04	203 3 228	8.80	2.34	-3.40	-2.70	1.64	-1.88	6.419e+04	-4.071e+04	3.064e+04	-7161.27	-
5.975e+04	227	11.03	0.88	-3.74	-3.29	0.43	1.37	8.375e+04	-4.698e+04	4.490e+04	-8131.44	-
6.285e+04	219	11.17	0.12	-4.19	0.11	-4.18	0.25	1.026e+05	-2.376e+04	4.575e+04	3.306e+04	-
5.105e+04	220	8.82	2.28	-1.24	-0.52	1.56	-1.41	7.580e+04	-2.630e+04	2.429e+04	2.521e+04	-
4.459e+04	203 23 228	8.13	15.69	-23.39	-4.91	-2.79	-19.51	5.851e+04	-3.706e+04	2.789e+04	-6438.08	-
5.446e+04	227	10.15	17.60	-22.95	-6.10	0.76	-19.98	7.631e+04	-4.279e+04	4.086e+04	-7333.82	-
	219	10.33	21.82	-20.60	2.33	-1.10	-21.14	9.336e+04	-2.205e+04	4.156e+04	2.975e+04	-

Parco Eolico “Bolina” – Progetto Definitivo
Relazione di calcolo preliminare delle fondazioni degli aerogeneratori G8 e G12

5.740e+04																									
4.657e+04	220	8.18	23.93	-16.03	0.98	6.92	-19.75	6.906e+04	-2.409e+04	2.204e+04	2.293e+04		-												
4.452e+04	203 55	228	8.04	6.29	-9.53	-3.28	0.04	-7.73	5.841e+04	-3.702e+04	2.787e+04	-6485.82	-												
5.436e+04		227	10.05	4.59	-8.13	-4.04	0.51	-5.94	7.620e+04	-4.274e+04	4.083e+04	-7372.46	-												
5.722e+04		219	10.21	6.23	-8.26	0.85	-2.88	-7.00	9.328e+04	-2.175e+04	4.158e+04	2.995e+04	-												
4.646e+04		220	8.07	9.36	-6.06	0.02	3.28	-7.54	6.896e+04	-2.397e+04	2.207e+04	2.292e+04	-												
4.448e+04	203 69	228	8.00	2.13	-3.09	-2.45	1.49	-1.71	5.835e+04	-3.701e+04	2.786e+04	-6510.24	-												
5.432e+04		227	10.02	0.80	-3.40	-2.99	0.39	1.24	7.614e+04	-4.271e+04	4.082e+04	-7392.22	-												
5.713e+04		219	10.15	0.11	-3.81	0.10	-3.80	0.23	9.325e+04	-2.160e+04	4.159e+04	3.006e+04	-												
4.641e+04		220	8.02	2.07	-1.12	-0.47	1.42	-1.29	6.891e+04	-2.391e+04	2.208e+04	2.292e+04	-												
4.798e+04	204 1	229	8.40	1.55	-3.16	-2.37	0.76	-1.76	5.964e+04	-4.066e+04	2.409e+04	-5109.36	-												
5.786e+04		228	10.36	1.84	-2.93	-2.57	1.48	-1.26	7.576e+04	-4.783e+04	3.566e+04	-7726.35	-												
6.016e+04		220	10.39	0.98	-2.27	-2.16	0.87	-0.58	8.936e+04	-3.097e+04	2.900e+04	2.940e+04	-												
4.844e+04		221	8.26	2.63	-0.22	0.20	2.21	-1.01	6.600e+04	-3.121e+04	1.347e+04	2.132e+04	-												
4.060e+04	204 3	229	7.10	1.31	-2.68	-2.01	0.64	-1.49	5.046e+04	-3.440e+04	2.038e+04	-4323.31	-												
4.896e+04		228	8.77	1.56	-2.48	-2.17	1.25	-1.07	6.411e+04	-4.047e+04	3.018e+04	-6537.68	-												
5.091e+04		220	8.79	0.83	-1.92	-1.83	0.74	-0.49	7.562e+04	-2.620e+04	2.453e+04	2.488e+04	-												
4.099e+04		221	6.99	2.22	-0.19	0.17	1.87	-0.85	5.584e+04	-2.641e+04	1.139e+04	1.804e+04	-												
3.694e+04	204 23	229	6.56	12.41	-18.23	-3.58	-2.24	-15.31	4.598e+04	-3.123e+04	1.858e+04	-3839.10	-												
4.461e+04		228	8.09	13.69	-19.08	-4.78	-0.61	-16.25	5.845e+04	-3.682e+04	2.751e+04	-5874.35	-												
4.645e+04		220	8.12	17.55	-13.83	0.67	3.06	-15.65	6.885e+04	-2.405e+04	2.220e+04	2.261e+04	-												
3.728e+04		221	6.46	18.65	-12.11	1.26	5.27	-15.25	5.079e+04	-2.401e+04	1.034e+04	1.645e+04	-												
3.692e+04	204 55	229	6.49	4.77	-7.55	-2.42	-0.37	-6.08	4.591e+04	-3.126e+04	1.855e+04	-3899.43	-												
4.454e+04		228	8.01	5.19	-7.57	-2.92	0.55	-6.14	5.834e+04	-3.680e+04	2.746e+04	-5920.00	-												
4.634e+04		220	8.04	6.02	-5.41	-0.87	1.48	-5.59	6.878e+04	-2.390e+04	2.227e+04	2.261e+04	-												
3.727e+04		221	6.39	7.52	-4.08	0.53	2.91	-5.68	5.078e+04	-2.401e+04	1.035e+04	1.642e+04	-												
3.691e+04	204 69	229	6.46	1.19	-2.43	-1.82	0.58	-1.35	4.588e+04	-3.128e+04	1.853e+04	-3930.28	-												
4.451e+04		228	7.97	1.42	-2.25	-1.97	1.14	-0.97	5.828e+04	-3.679e+04	2.743e+04	-5943.35	-												
4.628e+04		220	7.99	0.75	-1.74	-1.66	0.67	-0.45	6.874e+04	-2.382e+04	2.230e+04	2.262e+04	-												
3.726e+04		221	6.35	2.02	-0.17	0.15	1.70	-0.78	5.077e+04	-2.400e+04	1.036e+04	1.640e+04	-												
3.972e+04	205 1	230	6.88	1.96	-3.17	-2.98	1.77	-0.96	4.946e+04	-3.272e+04	1.890e+04	-2165.37	-												
4.797e+04		229	8.38	0.27	-2.84	-2.65	0.09	-0.74	5.942e+04	-4.079e+04	2.376e+04	-5131.71	-												
4.834e+04		221	8.24	1.85	-0.89	-0.89	1.84	0.02	6.609e+04	-3.088e+04	1.388e+04	2.133e+04	-												
3.916e+04		222	6.62	1.77	-0.09	1.28	0.40	-0.82	4.979e+04	-2.890e+04	6668.26	1.422e+04	-												
3.361e+04	205 3	230	5.82	1.66	-2.68	-2.52	1.50	-0.81	4.185e+04	-2.769e+04	1.599e+04	-1832.24	-												
4.059e+04		229	7.09	0.23	-2.40	-2.24	0.07	-0.62	5.028e+04	-3.451e+04	2.011e+04	-4342.21	-												
4.090e+04		221	6.97	1.56	-0.75	-0.75	1.56	0.02	5.592e+04	-2.613e+04	1.174e+04	1.805e+04	-												

Parco Eolico "Bolina" – Progetto Definitivo
Relazione di calcolo preliminare delle fondazioni degli aerogeneratori G8 e G12

3.314e+04	222	5.60	1.50	-0.07	1.09	0.34	-0.69	4.213e+04-2.445e+04	5642.37	1.203e+04	-
205 23	230	5.35	8.88	-14.53	-3.48	-2.17	-11.68	3.811e+04-2.489e+04	1.465e+04	-1432.77	-
3.046e+04	229	6.53	8.82	-14.73	-4.55	-1.37	-11.67	4.580e+04-3.137e+04	1.834e+04	-3913.37	-
3.695e+04	221	6.42	13.49	-9.02	1.35	3.12	-11.22	5.088e+04-2.377e+04	1.065e+04	1.647e+04	-
3.721e+04	222	5.16	14.66	-9.25	1.56	3.84	-11.90	3.821e+04-2.217e+04	5134.70	1.090e+04	-
3.005e+04	205 55	230	5.31	3.40	-5.93	-2.70	0.17	-4.44	3.807e+04-2.508e+04	1.458e+04	-1586.86
3.052e+04	229	6.47	2.84	-6.15	-2.89	-0.42	-4.32	4.574e+04-3.137e+04	1.830e+04	-3935.93	-
3.692e+04	221	6.36	4.91	-2.91	4.20e-03	1.99	-3.78	5.085e+04-2.376e+04	1.067e+04	1.643e+04	-
3.719e+04	222	5.12	5.79	-3.10	1.18	1.51	-4.44	3.827e+04-2.221e+04	5131.21	1.093e+04	-
3.010e+04	205 69	230	5.29	1.51	-2.44	-2.29	1.37	-0.74	3.804e+04-2.517e+04	1.454e+04	-1665.67
3.055e+04	229	6.45	0.21	-2.18	-2.04	0.07	-0.57	4.571e+04-3.137e+04	1.828e+04	-3947.47	-
3.690e+04	221	6.34	1.42	-0.68	-0.68	1.42	0.02	5.084e+04-2.375e+04	1.068e+04	1.641e+04	-
3.719e+04	222	5.10	1.36	-0.07	0.99	0.31	-0.63	3.830e+04-2.223e+04	5129.43	1.094e+04	-
3.012e+04	206 1	231	6.16	14.46	-9.07	-8.87	14.26	2.18	4.936e+04-2.255e+04	2.798e+04	-1168.62
3.287e+04	230	6.90	-3.57	-5.61	-3.86	-5.32	-0.71	4.984e+04-3.249e+04	1.723e+04	116.38	-
4.027e+04	222	6.62	4.40	1.22	1.45	4.17	0.82	5.003e+04-2.862e+04	8122.52	1.329e+04	-
3.924e+04	223	4.95	4.93	-2.60	3.25	-0.92	-3.14	3.289e+04-2.622e+04	156.50	6520.55	-
2.938e+04	206 3	231	5.21	12.24	-7.68	-7.51	12.06	1.84	4.176e+04-1.908e+04	2.367e+04	-988.83
2.781e+04	230	5.84	-3.02	-4.75	-3.26	-4.51	-0.60	4.217e+04-2.749e+04	1.458e+04	98.48	-
3.407e+04	222	5.60	3.73	1.03	1.22	3.53	0.70	4.234e+04-2.422e+04	6872.90	1.124e+04	-
3.320e+04	223	4.18	4.18	-2.20	2.75	-0.78	-2.66	2.783e+04-2.218e+04	132.42	5517.39	-
2.486e+04	206 21	231	4.55	19.06	-24.94	-20.31	14.43	-13.51	3.805e+04-1.454e+04	2.271e+04	798.25
2.390e+04	230	5.38	13.34	-22.81	-19.16	9.70	-10.89	3.852e+04-2.506e+04	1.377e+04	-309.48	-
3.100e+04	222	5.08	14.78	-10.56	-10.34	14.55	-2.40	3.860e+04-2.135e+04	6569.44	1.068e+04	-
2.990e+04	223	3.90	15.08	-4.79	-4.56	14.85	-2.12	2.547e+04-2.105e+04	-317.10	4742.10	-
2.312e+04	206 53	231	4.65	12.64	-11.88	-11.39	12.14	-3.46	3.799e+04-1.640e+04	2.192e+04	-324.65
2.482e+04	230	5.33	2.12	-10.00	-8.45	0.57	-4.05	3.840e+04-2.502e+04	1.343e+04	-45.49	-
3.098e+04	222	5.08	7.06	-2.78	-2.76	7.05	-0.39	3.852e+04-2.179e+04	6356.83	1.038e+04	-
3.009e+04	223	3.84	5.54	-0.88	0.11	4.56	-2.32	2.536e+04-2.047e+04	-27.65	4923.19	-
2.278e+04	206 69	231	4.74	11.12	-6.98	-6.82	10.97	1.67	3.797e+04-1.735e+04	2.152e+04	-898.94
2.528e+04	230	5.31	-2.74	-4.32	-2.97	-4.10	-0.55	3.834e+04-2.499e+04	1.326e+04	89.53	-
3.098e+04	222	5.09	3.39	0.94	1.11	3.21	0.63	3.849e+04-2.202e+04	6248.10	1.022e+04	-
3.019e+04	223	3.80	3.80	-2.00	2.50	-0.70	-2.42	2.530e+04-2.017e+04	120.38	5015.81	-
2.260e+04	207 1	232	3.35	1.78	-10.25	1.77	-10.24	0.31	2.481e+04-1.497e+04	5105.88	4738.08
1.989e+04	231	4.26	29.17	-0.78	11.16	17.23	-14.67	3.271e+04-1.659e+04	1.809e+04	-1967.16	-
2.252e+04	223	5.47	0.20	-11.60	-9.23	-2.17	4.73	3.847e+04-2.661e+04	5298.78	6564.99	-
3.253e+04	224	2.92	13.82	-1.74	2.65	9.42	-7.01	1.883e+04-1.564e+04	560.73	2628.83	-

Parco Eolico "Bolina" – Progetto Definitivo
Relazione di calcolo preliminare delle fondazioni degli aerogeneratori G8 e G12

1.720e+04																		
207	3	232	2.83	1.50	-8.67	1.50	-8.67	0.26	2.100e+04	-1.267e+04	4320.36	4009.15	-					
1.683e+04		231	3.61	24.69	-0.66	9.44	14.58	-12.41	2.768e+04	-1.404e+04	1.531e+04	-1664.52	-					
1.905e+04		223	4.63	0.17	-9.82	-7.81	-1.83	4.00	3.255e+04	-2.251e+04	4483.58	5554.99	-					
2.753e+04		224	2.47	11.69	-1.47	2.25	7.97	-5.93	1.593e+04	-1.323e+04	474.47	2224.40	-					
1.456e+04																		
207	6	232	2.62	10.18	-5.63	-5.24	9.79	-2.45	1.948e+04	-1.141e+04	3777.62	4296.83	-					
1.545e+04		231	3.06	51.71	-5.56	5.72	40.43	-22.78	2.244e+04	-1.258e+04	1.267e+04	-2811.46	-					
1.571e+04		223	4.41	20.44	-29.64	-24.64	15.44	15.01	3.102e+04	-2.042e+04	5226.17	5374.37	-					
2.572e+04		224	2.15	28.39	-5.59	-5.59	28.38	0.44	1.390e+04	-1.181e+04	485.52	1603.62	-					
1.284e+04																		
207	38	232	2.58	-0.54	-2.23	-0.87	-1.90	-0.67	1.922e+04	-1.148e+04	3876.85	3865.35	-					
1.535e+04		231	3.21	31.92	-1.86	7.61	22.45	-15.17	2.424e+04	-1.270e+04	1.349e+04	-1952.50	-					
1.677e+04		223	4.28	6.93	-15.84	-13.04	4.12	7.49	3.007e+04	-2.045e+04	4465.18	5159.75	-					
2.526e+04		224	2.21	15.14	-1.28	-0.54	14.40	-3.42	1.429e+04	-1.195e+04	449.67	1880.55	-					
1.310e+04																		
207	69	232	2.57	1.37	-7.88	1.36	-7.88	0.24	1.909e+04	-1.152e+04	3927.60	3644.68	-					
1.530e+04		231	3.28	22.44	-0.60	8.58	13.26	-11.28	2.516e+04	-1.276e+04	1.391e+04	-1513.20	-					
1.732e+04		223	4.21	0.16	-8.92	-7.10	-1.67	3.64	2.959e+04	-2.047e+04	4075.98	5049.99	-					
2.502e+04		224	2.25	10.63	-1.34	2.04	7.25	-5.39	1.448e+04	-1.203e+04	431.33	2022.18	-					
1.323e+04																		
208	1	233	0.43	0.34	-4.12	0.27	-4.06	0.54	4390.81	119.83	394.12	4116.52	-1047.02					
2.027e+04		232	3.43	2.51	-0.35	2.15	1.44e-03	-0.94	2.426e+04	-1.662e+04	6431.71	1207.60	-					
1.906e+04		224	3.22	4.04	-2.71	-0.64	1.97	-3.11	2.128e+04	-1.709e+04	-85.21	4276.15	-					
1.715e+04																		
208	3	225	0.54	4.61	-0.33	0.67	3.60	-1.99	4516.12	-1483.19	143.14	2889.79	-2666.82					
1.613e+04		233	0.37	0.29	-3.49	0.23	-3.43	0.45	3715.30	101.40	333.49	3483.21	-885.94					
		232	2.90	2.12	-0.30	1.82	1.22e-03	-0.80	2.053e+04	-1.406e+04	5442.22	1021.82	-					
1.577e+04		224	2.72	3.42	-2.30	-0.54	1.66	-2.63	1.801e+04	-1.446e+04	-72.10	3618.28	-					
1.475e+04																		
208	8	225	0.46	3.90	-0.28	0.57	3.05	-1.69	3821.33	-1255.01	121.12	2445.21	-2256.54					
1.557e+04		233	0.43	3.63	-29.54	2.17	-28.08	6.81	3228.68	53.37	266.12	3015.94	-793.90					
1.475e+04		232	2.71	6.52	-26.26	4.20	-23.93	8.41	1.894e+04	-1.291e+04	5225.53	812.09	-					
1.475e+04		224	2.53	8.39	-26.25	5.48	-23.34	-9.61	1.637e+04	-1.334e+04	-266.73	3300.65	-					
1.475e+04																		
208	40	225	0.42	4.52	-23.88	2.40	-21.76	-7.47	3523.57	-1141.18	142.21	2240.19	-2083.17					
1.565e+04		233	0.37	1.38	-12.08	0.87	-11.57	2.58	3327.15	79.07	290.63	3115.59	-801.51					
1.469e+04		232	2.65	3.02	-8.60	2.52	-8.10	2.37	1.876e+04	-1.283e+04	5041.56	889.39	-					
1.469e+04		224	2.49	3.73	-9.10	1.53	-6.90	-4.84	1.637e+04	-1.321e+04	-133.62	3293.17	-					
1.559e+04																		
208	69	225	0.41	2.68	-7.06	1.15	-5.53	-3.54	3490.71	-1140.98	120.97	2228.76	-2062.15					
1.466e+04		233	0.33	0.26	-3.17	0.21	-3.12	0.41	3377.55	92.18	303.17	3166.56	-805.40					
1.559e+04		232	2.64	1.93	-0.27	1.66	1.11e-03	-0.72	1.866e+04	-1.278e+04	4947.47	928.93	-					
1.466e+04		224	2.48	3.11	-2.09	-0.49	1.51	-2.40	1.637e+04	-1.315e+04	-65.54	3289.35	-					
9.051e+04																		
209	1	225	0.41	3.55	-0.26	0.52	2.77	-1.53	3473.94	-1140.92	110.11	2222.91	-2051.40					
1.200e+05		234	15.91	0.89	-5.36	-4.00	-0.47	2.58	8.082e+04	-1.096e+05	1.514e+04	4.391e+04	-					
2.029e+05		4	21.13	4.15	-4.81	-3.94	3.28	2.64	1.262e+05	-1.277e+05	4.066e+04	4.216e+04	-					
6.559e+04																		
209	3	6	35.36	3.08	-9.80	-3.65	-3.08	6.43	1.945e+05	-2.299e+05	4.429e+04	7.962e+04	-					
7.659e+04		226	12.51	5.01	-2.47	-2.45	4.99	0.38	1.274e+05	-5520.88	5.029e+04	7.157e+04	-					
7.659e+04		234	13.46	0.75	-4.53	-3.38	-0.39	2.18	6.838e+04	-9.273e+04	1.281e+04	3.716e+04	-					

Parco Eolico "Bolina" – Progetto Definitivo
Relazione di calcolo preliminare delle fondazioni degli aerogeneratori G8 e G12

1.015e+05	4	17.88	3.51	-4.07	-3.34	2.78	2.24	1.068e+05-1.080e+05	3.441e+04-3.568e+04	-
1.717e+05	6	29.92	2.60	-8.30	-3.09	-2.60	5.44	1.646e+05-1.945e+05	3.748e+04-6.737e+04	-
5.550e+04	226	10.58	4.24	-2.09	-2.07	4.23	0.32	1.078e+05	-4671.51 4.255e+04 6.056e+04	-
6.963e+04	209 21	234	12.56	62.35	-85.25	-51.62	28.72	-61.91	6.215e+04-8.434e+04 1.164e+04-3.382e+04	-
9.244e+04	4	16.67	-6.01	-127.70	-100.62	-33.08	50.61	9.698e+04-9.860e+04	3.109e+04-3.271e+04	-
1.565e+05	6	27.53	61.31	-77.93	-49.35	32.73	-56.24	1.495e+05-1.777e+05	3.342e+04-6.171e+04	-
5.049e+04	226	9.90	-10.32	-80.80	-55.09	-36.03	33.93	9.799e+04	-4311.95 3.863e+04 5.505e+04	-
6.962e+04	209 56	234	12.35	27.95	-24.80	13.35	-10.20	23.60	6.217e+04-8.429e+04 1.165e+04-3.376e+04	-
9.226e+04	4	16.34	38.62	5.94	29.99	14.57	-14.40	9.710e+04-9.810e+04	3.134e+04-3.234e+04	-
1.560e+05	6	27.29	28.38	-29.68	12.94	-14.24	25.65	1.497e+05-1.765e+05	3.429e+04-6.109e+04	-
5.044e+04	226	9.71	27.83	5.62	16.12	17.33	-11.09	9.798e+04	-4224.80 3.870e+04 5.506e+04	-
6.962e+04	209 69	234	12.24	0.69	-4.12	-3.08	-0.36	1.98	6.217e+04-8.430e+04 1.164e+04-3.378e+04	-
9.231e+04	4	16.26	3.19	-3.70	-3.03	2.53	2.03	9.707e+04-9.823e+04	3.128e+04-3.243e+04	-
1.561e+05	6	27.20	2.37	-7.54	-2.81	-2.37	4.95	1.496e+05-1.768e+05	3.407e+04-6.125e+04	-
5.046e+04	226	9.62	3.86	-1.90	-1.89	3.84	0.29	9.798e+04	-4246.83 3.868e+04 5.505e+04	-
7.141e+04	210 1	235	12.71	9.60	-6.26	-6.19	9.53	1.06	7.832e+04-7.428e+04 2.891e+04-2.486e+04	-
8.552e+04	234	15.16	1.64	-12.78	-7.90	-3.24	6.82	9.107e+04-9.067e+04	3.092e+04-3.053e+04	-
1.032e+05	226	17.48	7.51	-4.61	1.49	1.40	6.06	1.293e+05-7.841e+04	3.669e+04 1.419e+04	-
7.454e+04	227	12.60	-1.52	-3.65	-3.16	-2.00	0.89	9.777e+04-5.135e+04	2.513e+04 2.128e+04	-
6.042e+04	210 3	235	10.76	8.12	-5.30	-5.24	8.06	0.90	6.627e+04-6.285e+04 2.446e+04-2.104e+04	-
7.236e+04	234	12.83	1.39	-10.81	-6.68	-2.74	5.77	7.706e+04-7.672e+04	2.616e+04-2.583e+04	-
8.736e+04	226	14.79	6.35	-3.90	1.26	1.18	5.13	1.094e+05-6.635e+04	3.104e+04 1.201e+04	-
6.307e+04	227	10.67	-1.29	-3.09	-2.68	-1.70	0.76	8.273e+04-4.345e+04	2.127e+04 1.801e+04	-
5.498e+04	210 22	235	9.97	41.78	-19.39	14.68	7.71	30.38	6.006e+04-5.753e+04 2.211e+04-1.958e+04	-
6.572e+04	234	11.80	33.49	-26.95	8.73	-2.19	29.72	6.997e+04-6.973e+04	2.376e+04-2.352e+04	-
7.924e+04	226	13.69	65.37	-28.93	24.15	12.28	46.78	9.930e+04-6.011e+04	2.824e+04 1.095e+04	-
5.719e+04	227	9.77	13.44	-27.98	7.08	-21.63	14.93	7.506e+04-3.937e+04	1.938e+04 1.631e+04	-
5.494e+04	210 54	235	9.84	15.82	-6.55	1.82	7.46	10.82	6.019e+04-5.727e+04 2.219e+04-1.928e+04	-
6.576e+04	234	11.71	11.82	-15.27	-1.06	-2.39	13.53	7.002e+04-6.974e+04	2.378e+04-2.350e+04	-
7.936e+04	226	13.53	25.92	-12.12	8.93	4.87	18.91	9.940e+04-6.025e+04	2.823e+04 1.093e+04	-
5.729e+04	227	9.72	3.37	-10.93	0.79	-8.34	5.51	7.516e+04-3.946e+04	1.935e+04 1.635e+04	-
5.493e+04	210 69	235	9.78	7.38	-4.82	-4.76	7.33	0.82	6.025e+04-5.714e+04 2.224e+04-1.913e+04	-
6.578e+04	234	11.66	1.26	-9.83	-6.08	-2.49	5.25	7.005e+04-6.975e+04	2.379e+04-2.348e+04	-
7.942e+04	226	13.45	5.77	-3.55	1.15	1.08	4.66	9.945e+04-6.032e+04	2.822e+04 1.092e+04	-
5.734e+04	227	9.70	-1.17	-2.81	-2.43	-1.54	0.69	7.521e+04-3.950e+04	1.933e+04 1.637e+04	-
5.396e+04	211 1	236	9.58	5.75	-7.75	-6.73	4.73	-3.58	6.111e+04-5.392e+04 2.350e+04-1.632e+04	-
	235	12.37	7.98	-3.20	-3.20	7.98	0.02	7.724e+04-7.129e+04	2.963e+04-2.368e+04	-

Parco Eolico "Bolina" – Progetto Definitivo
Relazione di calcolo preliminare delle fondazioni degli aerogeneratori G8 e G12

6.931e+04																					-	
7.762e+04	227	13.09	1.89	-5.75	-5.10	1.24	2.12	9.818e+04	-5.725e+04	2.441e+04	1.652e+04										-	
6.187e+04	228	10.39	4.94	-2.18	-1.37	4.13	-2.26	7.571e+04	-4.806e+04	1.268e+04	1.497e+04										-	
211	3	236	8.11	4.87	-6.56	-5.69	4.00	-3.03	5.170e+04	-4.563e+04	1.989e+04	-1.381e+04									-	
4.566e+04	235	10.46	6.76	-2.71	-2.71	6.76	0.02	6.536e+04	-6.032e+04	2.507e+04	-2.004e+04										-	
5.865e+04	227	11.07	1.60	-4.86	-4.32	1.05	1.79	8.308e+04	-4.844e+04	2.065e+04	1.398e+04										-	
6.568e+04	228	8.79	4.18	-1.84	-1.16	3.49	-1.91	6.406e+04	-4.067e+04	1.073e+04	1.266e+04										-	
5.236e+04	211	6	236	7.44	21.94	-39.32	-39.21	21.82	2.64	4.690e+04	-4.141e+04	1.834e+04	-1.285e+04								-	
4.131e+04	235	9.61	22.26	-41.22	-40.50	21.54	6.72	5.906e+04	-5.499e+04	2.270e+04	-1.862e+04										-	
5.315e+04	227	10.21	20.83	-58.42	-52.44	14.84	20.95	7.547e+04	-4.398e+04	1.892e+04	1.256e+04										-	
5.964e+04	228	8.08	19.52	-41.19	-36.69	15.02	15.90	5.814e+04	-3.693e+04	9840.61	1.137e+04										-	
4.753e+04	211	38	236	7.38	9.82	-16.72	-16.69	9.79	-0.93	4.697e+04	-4.145e+04	1.817e+04	-1.265e+04								-	
4.144e+04	235	9.54	11.55	-15.53	-15.33	11.35	2.29	5.930e+04	-5.489e+04	2.276e+04	-1.835e+04										-	
5.326e+04	227	10.12	8.01	-22.69	-20.34	5.66	8.17	7.550e+04	-4.402e+04	1.882e+04	1.266e+04										-	
5.968e+04	228	8.01	8.03	-13.96	-13.11	7.18	4.23	5.820e+04	-3.696e+04	9782.38	1.146e+04										-	
4.757e+04	211	69	236	7.37	4.42	-5.96	-5.17	3.64	-2.75	4.700e+04	-4.148e+04	1.808e+04	-1.255e+04								-	
4.151e+04	235	9.51	6.14	-2.46	-2.46	6.14	0.02	5.941e+04	-5.484e+04	2.279e+04	-1.822e+04										-	
5.332e+04	227	10.07	1.45	-4.42	-3.93	0.96	1.63	7.552e+04	-4.404e+04	1.877e+04	1.271e+04										-	
5.970e+04	228	7.99	3.80	-1.68	-1.05	3.18	-1.74	5.824e+04	-3.697e+04	9752.59	1.151e+04										-	
4.760e+04	212	1	237	7.96	0.17	-2.87	-0.55	-2.15	-1.30	5.114e+04	-4.441e+04	1.518e+04	-8450.79								-	
4.629e+04	236	9.38	8.03	-3.86	-0.98	5.15	-5.10	5.899e+04	-5.342e+04	2.068e+04	-1.511e+04										-	
5.328e+04	228	10.43	2.90	-4.97	-4.97	2.90	0.09	7.611e+04	-4.831e+04	1.346e+04	1.434e+04										-	
6.221e+04	229	8.30	4.84	-3.15	-2.29	3.97	-2.48	5.875e+04	-4.025e+04	5424.23	1.307e+04										-	
4.935e+04	212	3	237	6.74	0.15	-2.43	-0.47	-1.82	-1.10	4.328e+04	-3.758e+04	1.285e+04	-7150.67								-	
3.917e+04	236	7.93	6.80	-3.27	-0.83	4.36	-4.31	4.991e+04	-4.520e+04	1.750e+04	-1.279e+04										-	
4.508e+04	228	8.83	2.45	-4.20	-4.20	2.45	0.07	6.440e+04	-4.087e+04	1.139e+04	1.213e+04										-	
5.264e+04	229	7.02	4.09	-2.67	-1.94	3.36	-2.10	4.971e+04	-3.406e+04	4589.73	1.106e+04										-	
4.176e+04	212	6	237	6.17	14.30	-25.47	-25.12	13.96	3.69	3.941e+04	-3.405e+04	1.182e+04	-6456.71								-	
3.558e+04	236	7.19	21.67	-28.75	-28.64	21.57	-2.32	4.494e+04	-4.099e+04	1.586e+04	-1.192e+04										-	
4.066e+04	228	8.14	20.86	-44.56	-40.20	16.50	16.32	5.859e+04	-3.710e+04	1.058e+04	1.091e+04										-	
4.784e+04	229	6.44	19.29	-32.01	-29.01	16.29	12.04	4.526e+04	-3.080e+04	4470.50	9989.93										-	
3.793e+04	212	38	237	6.13	3.66	-8.81	-8.78	3.63	0.59	3.936e+04	-3.412e+04	1.173e+04	-6485.76								-	
3.560e+04	236	7.18	10.47	-10.74	-10.19	9.92	-3.38	4.523e+04	-4.106e+04	1.589e+04	-1.172e+04										-	
4.087e+04	228	8.06	8.32	-17.40	-16.13	7.06	5.57	5.856e+04	-3.714e+04	1.043e+04	1.099e+04										-	
4.785e+04	229	6.38	7.95	-11.40	-10.98	7.53	2.81	4.521e+04	-3.091e+04	4273.32	1.003e+04										-	
3.795e+04	212	69	237	6.12	0.13	-2.21	-0.42	-1.65	-1.00	3.934e+04	-3.416e+04	1.168e+04	-6500.61								-	
3.561e+04	236	7.21	6.18	-2.97	-0.75	3.96	-3.92	4.538e+04	-4.109e+04	1.591e+04	-1.162e+04										-	
4.098e+04																						-

Parco Eolico "Bolina" – Progetto Definitivo
Relazione di calcolo preliminare delle fondazioni degli aerogeneratori G8 e G12

4.785e+04	228	8.02	2.23	-3.82	-3.82	2.23	0.07	5.854e+04	-3.716e+04	1.036e+04	1.103e+04	-
3.796e+04	229	6.38	3.72	-2.43	-1.76	3.05	-1.91	4.519e+04	-3.096e+04	4172.48	1.006e+04	-
213 1	238	6.67	0.05	-1.73	-0.41	-1.27	0.79	4.402e+04	-3.607e+04	1.540e+04	-7452.73	-
3.838e+04	237	7.97	-1.21	-1.85	-1.84	-1.22	0.08	5.119e+04	-4.459e+04	1.555e+04	-8947.80	-
4.630e+04	229	8.31	3.52	-2.72	-2.50	3.30	-1.15	5.868e+04	-4.067e+04	5199.59	1.281e+04	-
4.953e+04	230	6.77	0.79	-3.76	-3.69	0.72	0.56	4.918e+04	-3.156e+04	3936.07	1.368e+04	-
4.008e+04	238	5.65	0.05	-1.47	-0.35	-1.07	0.67	3.724e+04	-3.052e+04	1.303e+04	-6306.15	-
213 3	237	6.74	-1.02	-1.56	-1.55	-1.03	0.07	4.332e+04	-3.773e+04	1.316e+04	-7571.22	-
3.247e+04	229	7.04	2.98	-2.30	-2.12	2.79	-0.98	4.965e+04	-3.442e+04	4399.65	1.084e+04	-
3.918e+04	230	5.73	0.67	-3.18	-3.12	0.61	0.47	4.162e+04	-2.671e+04	3330.52	1.158e+04	-
4.191e+04	238	5.17	18.23	-17.73	17.96	-17.47	-3.07	3.364e+04	-2.776e+04	1.164e+04	-5769.77	-
3.391e+04	237	6.17	18.62	-17.19	18.61	-17.17	-0.70	3.933e+04	-3.441e+04	1.180e+04	-6888.83	-
213 7	229	6.48	29.55	-16.92	24.99	-12.36	-13.83	4.508e+04	-3.143e+04	3710.13	9935.34	-
2.944e+04	230	5.25	22.14	-16.69	17.94	-12.49	-12.06	3.728e+04	-2.451e+04	2392.00	1.038e+04	-
3.566e+04	238	5.14	5.90	-6.59	5.87	-6.56	-0.64	3.378e+04	-2.775e+04	1.178e+04	-5745.35	-
3.813e+04	237	6.14	5.36	-6.43	5.36	-6.43	-0.20	3.936e+04	-3.434e+04	1.191e+04	-6884.92	-
3.064e+04	229	6.43	9.50	-4.81	7.18	-2.50	-5.27	4.512e+04	-3.134e+04	3901.71	9879.86	-
213 39	230	5.22	5.70	-5.37	4.19	-3.86	-3.80	3.765e+04	-2.436e+04	2812.62	1.048e+04	-
2.949e+04	238	5.13	0.04	-1.33	-0.32	-0.97	0.61	3.386e+04	-2.774e+04	1.185e+04	-5732.87	-
3.563e+04	237	6.13	-0.93	-1.42	-1.41	-0.94	0.06	3.938e+04	-3.430e+04	1.196e+04	-6882.92	-
3.811e+04	229	6.40	2.71	-2.09	-1.92	2.54	-0.89	4.514e+04	-3.129e+04	3999.69	9851.49	-
3.076e+04	230	5.21	0.61	-2.89	-2.84	0.55	0.43	3.783e+04	-2.428e+04	3027.74	1.052e+04	-
213 69	239	4.89	10.48	-3.50	4.46	2.51	-6.92	2.899e+04	-2.924e+04	1.027e+04	-1.052e+04	-
2.952e+04	238	6.95	-0.11	-10.93	-2.81	-8.23	4.68	4.774e+04	-3.523e+04	1.775e+04	-5239.94	-
3.561e+04	230	6.42	9.84	-3.90	-3.89	9.83	-0.27	4.471e+04	-3.210e+04	2749.84	9860.90	-
3.810e+04	231	6.67	2.11	-25.79	-5.90	-17.78	12.62	5.820e+04	-1.715e+04	1.536e+04	2.568e+04	-
3.083e+04	239	4.14	8.87	-2.96	3.77	2.13	-5.86	2.453e+04	-2.475e+04	8685.88	-8902.15	-
214 1	238	5.88	-0.10	-9.25	-2.38	-6.96	3.96	4.040e+04	-2.981e+04	1.502e+04	-4433.79	-
2.720e+04	230	5.43	8.32	-3.30	-3.29	8.32	-0.23	3.783e+04	-2.716e+04	2326.79	8343.83	-
3.986e+04	231	5.64	1.78	-21.82	-4.99	-15.04	10.68	4.925e+04	-1.451e+04	1.300e+04	2.173e+04	-
3.824e+04	239	3.63	23.06	-8.14	-6.27	21.19	-7.42	2.121e+04	-2.231e+04	7387.70	-8487.90	-
3.732e+04	238	5.43	8.25	-15.89	-15.28	7.63	3.81	3.747e+04	-2.696e+04	1.403e+04	-3515.80	-
214 3	230	4.99	28.03	-25.96	-23.80	25.87	10.57	3.437e+04	-2.458e+04	2759.30	7027.65	-
2.301e+04	231	5.54	12.51	-40.78	-21.00	-7.27	25.74	4.807e+04	-1.316e+04	1.328e+04	2.163e+04	-
3.373e+04	239	3.73	6.36	0.69	4.77	2.29	-2.55	2.213e+04	-2.255e+04	7838.53	-8263.82	-
3.236e+04	238	5.38	3.99	-11.79	-0.12	-7.68	6.92	3.684e+04	-2.711e+04	1.368e+04	-3946.77	-
3.158e+04	230	4.94	7.23	-2.53	-2.13	6.83	1.95	3.424e+04	-2.479e+04	2103.12	7349.80	-
214 6												
2.026e+04												
3.100e+04												
2.940e+04												
3.033e+04												
214 54												
2.084e+04												
3.073e+04												

Parco Eolico "Bolina" – Progetto Definitivo
Relazione di calcolo preliminare delle fondazioni degli aerogeneratori G8 e G12

2.940e+04	231	5.22	4.16	-25.73	-3.03	-18.53	12.78	4.536e+04	-1.327e+04	1.174e+04	2.035e+04	-
2.900e+04	214 69 239	3.76	8.06	-2.69	3.43	1.93	-5.32	2.230e+04	-2.250e+04	7896.25	-8092.86	-
2.092e+04	238	5.35	-0.09	-8.41	-2.16	-6.33	3.60	3.672e+04	-2.710e+04	1.366e+04	-4030.72	-
3.066e+04	230	4.94	7.57	-3.00	-2.99	7.56	-0.21	3.439e+04	-2.469e+04	2115.26	7585.30	-
2.941e+04	231	5.13	1.62	-19.84	-4.54	-13.68	9.71	4.477e+04	-1.319e+04	1.182e+04	1.976e+04	-
2.871e+04	215 1 240	3.63	-2.16	-8.62	-3.51	-7.27	-2.62	2.633e+04	-1.679e+04	1.098e+04	-1430.88	-
2.065e+04	239	5.55	3.84	-0.34	0.62	2.88	1.75	3.422e+04	-3.234e+04	1.224e+04	-1.036e+04	-
3.130e+04	231	5.46	4.82	-18.27	3.23	-16.69	-5.84	4.837e+04	-1.410e+04	9562.19	2.471e+04	-
3.031e+04	232	3.98	8.67	3.45	3.65	8.47	-0.99	2.550e+04	-2.218e+04	-3306.71	6628.61	-
2.332e+04	215 3 240	3.07	-1.83	-7.29	-2.97	-6.15	-2.22	2.228e+04	-1.420e+04	9288.48	-1210.74	-
1.747e+04	239	4.69	3.25	-0.29	0.52	2.44	1.48	2.895e+04	-2.737e+04	1.035e+04	-8769.99	-
2.649e+04	231	4.62	4.07	-15.46	2.73	-14.12	-4.94	4.093e+04	-1.193e+04	8091.08	2.091e+04	-
2.564e+04	232	3.37	7.33	2.92	3.09	7.17	-0.84	2.158e+04	-1.877e+04	-2797.99	5608.82	-
1.973e+04	215 24 240	2.73	3.92	-22.08	3.18	-21.33	4.33	2.002e+04	-1.243e+04	8407.42	-819.32	-
1.555e+04	239	4.40	19.73	-15.35	14.08	-9.70	12.89	2.615e+04	-2.605e+04	8470.62	-8374.93	-
2.470e+04	231	4.05	8.81	-38.96	5.28	-35.43	-12.50	3.696e+04	-8478.78	8379.01	2.010e+04	-
2.195e+04	232	3.07	8.28	-7.07	8.07	-6.86	-1.81	1.943e+04	-1.741e+04	-2428.01	4444.06	-
1.810e+04	215 56 240	2.77	-0.71	-10.92	-0.71	-10.92	0.13	2.017e+04	-1.275e+04	8431.67	-1005.47	-
1.577e+04	239	4.31	7.92	-4.65	5.08	-1.82	5.26	2.626e+04	-2.527e+04	9094.36	-8108.82	-
2.429e+04	231	4.15	5.43	-22.48	3.43	-20.48	-7.20	3.713e+04	-1.005e+04	7701.85	1.938e+04	-
2.285e+04	232	3.06	5.00	1.58	4.59	1.99	-1.12	1.955e+04	-1.718e+04	-2504.50	4877.34	-
1.799e+04	215 69 240	2.79	-1.66	-6.63	-2.70	-5.59	-2.02	2.026e+04	-1.291e+04	8444.07	-1100.67	-
1.588e+04	239	4.27	2.95	-0.26	0.48	2.21	1.35	2.632e+04	-2.488e+04	9413.36	-7972.72	-
2.408e+04	231	4.20	3.70	-14.06	2.48	-12.84	-4.49	3.721e+04	-1.085e+04	7355.53	1.900e+04	-
2.331e+04	232	3.06	6.67	2.66	2.81	6.52	-0.76	1.962e+04	-1.706e+04	-2543.63	5098.93	-
1.794e+04	216 1 241	0.28	0.99	-1.88	0.95	-1.84	-0.33	2626.72	-406.77	210.92	2009.03	-1221.57
		240	3.76	-0.89	-1.87	-1.70	-0.37	2.558e+04	-1.953e+04	8589.27	-2543.17	-
2.186e+04	232	3.93	1.81	-0.99	1.70	-0.89	-0.52	2.732e+04	-1.967e+04	-1287.28	8931.47	-
2.293e+04	233	0.69	2.06	-0.48	-0.09	1.67	-0.92	6338.74	-1268.22	146.94	4923.58	-2960.13
	216 3 241	0.24	0.84	-1.59	0.81	-1.56	-0.28	2222.61	-344.19	178.47	1699.95	-1033.63
		240	3.18	-0.76	-1.58	-1.44	-0.31	2.164e+04	-1.653e+04	7267.84	-2151.91	-
1.849e+04	232	3.32	1.53	-0.84	1.44	-0.75	-0.44	2.311e+04	-1.665e+04	-1089.24	7557.40	-
1.940e+04	233	0.58	1.74	-0.41	-0.08	1.41	-0.78	5363.55	-1073.11	124.33	4166.10	-2504.73
	216 5 241	0.31	24.68	-3.60	-2.29	23.37	-5.94	2019.78	-360.52	136.12	1523.15	-967.21
		240	2.95	25.95	-7.02	-4.18	-9.25	1.983e+04	-1.498e+04	6816.86	-1972.12	-
1.684e+04	232	3.07	23.69	-5.57	-3.54	21.66	7.44	2.115e+04	-1.533e+04	-1229.32	7043.85	-
1.776e+04	233	0.58	24.90	-1.87	-0.84	23.87	5.15	5000.86	-927.74	143.07	3930.04	-2280.75
	216 37 241	0.24	7.57	-0.89	-0.29	6.97	-2.18	2020.27	-328.99	153.40	1537.88	-948.99
		240	2.91	8.32	-3.32	-2.28	-3.32	1.973e+04	-1.501e+04	6678.10	-1961.64	-
1.682e+04	232	3.04	7.52	-0.97	-0.33	6.88	2.25	2.106e+04	-1.520e+04	-1071.12	6929.07	-

Parco Eolico "Bolina" – Progetto Definitivo
Relazione di calcolo preliminare delle fondazioni degli aerogeneratori G8 e G12

1.768e+04		233	0.54	9.10	-0.51	-0.33	8.93	1.28	4918.15	-959.31	123.20	3835.64	-2278.28		
	216	69	241	0.21	0.76	-1.45	0.73	-1.42	-0.25	2020.56	-312.90	162.24	1545.41	-939.67	
			240	2.89	-0.69	-1.44	-1.31	-0.82	-0.28	1.967e+04	-1.502e+04	6607.13	-1956.28	-	
1.681e+04			232	3.02	1.39	-0.76	1.31	-0.68	-0.40	2.101e+04	-1.513e+04	-990.22	6870.36	-	
1.764e+04			233	0.53	1.59	-0.37	-0.07	1.29	-0.71	4875.95	-975.55	113.03	3787.37	-2277.03	
	217	1	242	13.45	4.98	-12.92	-10.63	2.69	5.99	5.983e+04	-9.972e+04	-6594.84	-3.330e+04	-	
7.865e+04			1	17.04	3.63	-6.99	-6.12	2.76	2.91	6.968e+04	-1.319e+05	-1.271e+04	-4.949e+04	-	
9.909e+04			4	23.17	2.18	-7.14	-2.54	-2.43	4.66	1.229e+05	-1.547e+05	-1.797e+04	-1.385e+04	-	
1.388e+05			234	14.64	7.09	-2.26	-2.15	6.98	1.00	8.942e+04	-8.662e+04	-7511.70	1.031e+04	-	
8.757e+04			217	3	242	11.38	4.22	-10.94	-8.99	2.28	5.06	5.062e+04	-8.438e+04	-5580.25	-2.818e+04
6.655e+04			1	14.42	3.07	-5.91	-5.18	2.33	2.46	5.896e+04	-1.116e+05	-1.076e+04	-4.188e+04	-	
8.384e+04			4	19.60	1.84	-6.04	-2.15	-2.05	3.94	1.040e+05	-1.309e+05	-1.521e+04	-1.172e+04	-	
1.175e+05			234	12.39	6.00	-1.91	-1.82	5.91	0.85	7.566e+04	-7.329e+04	-6356.06	8722.52	-	
7.410e+04			217	23	242	10.46	22.84	-53.61	-42.74	11.96	-26.70	4.613e+04	-7.648e+04	-4809.82	-2.554e+04
6.042e+04			1	13.20	26.05	-32.30	-27.39	21.15	-16.19	5.368e+04	-1.017e+05	-9826.84	-3.819e+04	-	
7.638e+04			4	17.99	23.59	-57.92	-52.42	18.09	-20.45	9.470e+04	-1.194e+05	-1.401e+04	-1.073e+04	-	
1.071e+05			234	11.42	25.88	-32.17	-25.02	18.73	-19.08	6.890e+04	-6.665e+04	-5746.46	7989.85	-	
6.743e+04			217	54	242	10.41	16.51	-14.27	3.52	-1.28	15.20	4.598e+04	-7.679e+04	-5161.99	-2.564e+04
6.053e+04			1	13.14	8.55	-9.90	2.97	-4.32	8.47	5.357e+04	-1.014e+05	-9763.40	-3.803e+04	-	
7.617e+04			4	17.86	19.93	-13.43	15.12	-8.62	11.72	9.451e+04	-1.189e+05	-1.377e+04	-1.063e+04	-	
1.067e+05			234	11.31	11.51	-4.41	6.25	0.85	7.49	6.874e+04	-6.662e+04	-5788.98	7909.17	-	
6.734e+04			217	69	242	10.34	3.83	-9.94	-8.18	2.07	4.60	4.602e+04	-7.671e+04	-5072.95	-2.562e+04
6.050e+04			1	13.11	2.79	-5.38	-4.71	2.12	2.24	5.360e+04	-1.014e+05	-9779.44	-3.807e+04	-	
7.622e+04			4	17.82	1.67	-5.49	-1.95	-1.87	3.58	9.456e+04	-1.190e+05	-1.383e+04	-1.065e+04	-	
1.068e+05			234	11.26	5.45	-1.74	-1.65	5.37	0.77	6.878e+04	-6.663e+04	-5778.23	7929.56	-	
6.736e+04			218	1	243	12.83	29.36	-27.03	-21.91	24.24	16.21	8.267e+04	-6.966e+04	2.845e+04	-1.544e+04
7.293e+04			242	13.04	-5.43	-6.77	-5.72	-6.48	0.56	5.838e+04	-9.685e+04	-9200.57	-2.926e+04	-	
7.696e+04			234	15.64	8.36	-8.40	-3.38	3.33	7.68	9.274e+04	-9.478e+04	-8865.27	6821.91	-	
9.343e+04			235	12.48	4.00	1.13	1.15	3.98	0.27	7.486e+04	-7.522e+04	-5044.56	4687.78	-	
7.488e+04			218	3	243	10.86	24.84	-22.87	-18.54	20.51	13.71	6.995e+04	-5.894e+04	2.407e+04	-1.306e+04
6.171e+04			242	11.03	-4.59	-5.73	-4.84	-5.48	0.47	4.940e+04	-8.195e+04	-7785.10	-2.476e+04	-	
6.512e+04			234	13.24	7.07	-7.11	-2.86	2.82	6.50	7.847e+04	-8.020e+04	-7501.38	5772.39	-	
7.906e+04			235	10.56	3.39	0.95	0.98	3.37	0.23	6.335e+04	-6.365e+04	-4268.48	3966.58	-	
6.336e+04			218	22	243	10.36	59.23	-28.27	12.79	18.18	43.67	6.396e+04	-5.708e+04	2.052e+04	-1.364e+04
5.806e+04			242	10.07	31.66	-31.00	21.99	-21.33	22.64	4.468e+04	-7.367e+04	-7314.42	-2.167e+04	-	
5.873e+04			234	12.25	47.05	-25.46	29.57	-7.98	31.01	7.129e+04	-7.338e+04	-7148.92	5056.54	-	
7.208e+04			235	9.67	28.31	-20.13	21.01	-12.83	17.33	5.739e+04	-5.740e+04	-3379.32	3372.78	-	
5.729e+04			218	54	243	10.04	32.10	-20.44	-6.82	18.49	23.02	6.372e+04	-5.476e+04	2.142e+04	-1.247e+04

Parco Eolico "Bolina" – Progetto Definitivo
Relazione di calcolo preliminare delle fondazioni degli aerogeneratori G8 e G12

5.676e+04																					
5.904e+04	242	10.04	7.95	-13.93	4.53	-10.52	7.94	4.483e+04-7.421e+04	-7157.58-2.223e+04	-											
7.194e+04	234	12.11	18.77	-11.49	8.29	-1.00	14.40	7.132e+04-7.307e+04	-6930.93	5182.97	-										
5.750e+04	235	9.62	10.50	-5.12	7.69	-2.31	6.00	5.752e+04-5.770e+04	-3710.87	3527.07	-										
5.610e+04	243	9.87	22.58	-20.79	-16.85	18.64	12.47	6.359e+04-5.358e+04	2.188e+04-1.187e+04	-											
5.920e+04	242	10.03	-4.18	-5.21	-4.40	-4.98	0.43	4.491e+04-7.450e+04	-7077.36-2.251e+04	-											
7.187e+04	234	12.03	6.43	-6.46	-2.60	2.56	5.91	7.134e+04-7.291e+04	-6819.44	5247.63	-										
5.760e+04	235	9.60	3.08	0.87	0.89	3.06	0.20	5.759e+04-5.786e+04	-3880.43	3605.98	-										
5.392e+04	244	8.99	-0.87	-29.42	-1.16	-29.13	2.84	5.560e+04-5.226e+04	517.39	2826.19	-										
4.585e+04	243	8.53	73.23	1.57	18.60	56.21	-30.50	4.366e+04-5.704e+04	1.413e+04-2.750e+04	-											
8.139e+04	235	13.67	8.55	-33.50	-24.70	-0.25	17.10	8.722e+04-7.559e+04	7532.54	4097.44	-										
4.973e+04	236	8.40	32.08	-4.99	3.77	23.32	-15.75	5.274e+04-4.689e+04	44.35	5807.18	-										
4.562e+04	244	7.61	-0.74	-24.89	-0.98	-24.65	2.40	4.705e+04-4.422e+04	437.79	2391.39	-										
3.880e+04	243	7.22	61.97	1.33	15.74	47.56	-25.81	3.695e+04-4.826e+04	1.195e+04-2.327e+04	-											
6.887e+04	235	11.57	7.24	-28.35	-20.90	-0.21	14.47	7.380e+04-6.396e+04	6373.69	3467.07	-										
4.208e+04	236	7.11	27.15	-4.23	3.19	19.73	-13.33	4.463e+04-3.967e+04	37.53	4913.77	-										
4.188e+04	244	7.07	-7.63	-35.87	-22.85	-20.64	14.08	4.407e+04-3.976e+04	435.20	3874.86	-										
3.284e+04	243	6.20	77.21	-8.33	-0.91	69.78	-24.08	2.919e+04-4.447e+04	9039.62-2.432e+04	-											
6.359e+04	235	10.87	24.78	-77.29	-60.95	8.44	37.43	6.894e+04-5.831e+04	7399.93	3232.29	-										
3.737e+04	236	6.23	29.99	-20.96	-20.96	29.99	0.12	3.899e+04-3.583e+04	-226.41	3383.22	-										
4.161e+04	244	6.97	-5.90	-24.24	-8.32	-21.81	6.21	4.321e+04-4.005e+04	410.58	2749.52	-										
3.445e+04	243	6.44	62.69	-1.31	9.16	52.22	-23.67	3.209e+04-4.407e+04	1.025e+04-2.222e+04	-											
6.294e+04	235	10.63	12.68	-43.15	-33.20	2.73	21.37	6.772e+04-5.820e+04	6337.58	3179.09	-										
3.795e+04	236	6.39	24.18	-7.34	-5.17	22.02	-7.98	4.003e+04-3.599e+04	-54.04	4100.32	-										
4.148e+04	244	6.92	-0.67	-22.63	-0.89	-22.41	2.18	4.277e+04-4.020e+04	397.99	2173.99	-										
3.527e+04	243	6.56	56.33	1.21	14.30	43.23	-23.46	3.359e+04-4.388e+04	1.087e+04-2.115e+04	-											
6.261e+04	235	10.52	6.58	-25.77	-19.00	-0.19	13.16	6.709e+04-5.815e+04	5794.26	3151.88	-										
3.825e+04	236	6.46	24.68	-3.84	2.90	17.94	-12.12	4.057e+04-3.607e+04	34.12	4467.06	-										
4.450e+04	245	7.47	-2.12	-3.00	-2.67	-2.46	-0.43	4.379e+04-4.605e+04	4948.67	-7209.09	-										
5.205e+04	244	8.74	1.69	0.18	0.73	1.14	-0.73	4.890e+04-5.612e+04	3319.51-1.054e+04	-											
5.463e+04	236	9.20	4.84	-3.80	-0.90	1.95	-4.08	5.910e+04-5.111e+04	-3245.45	1.123e+04	-										
4.754e+04	237	8.04	3.70	-1.02	-0.09	2.77	-1.88	5.118e+04-4.528e+04	-5158.44	1.106e+04	-										
3.766e+04	245	6.32	-1.80	-2.54	-2.26	-2.08	-0.36	3.705e+04-3.896e+04	4187.33	-6100.00	-										
4.404e+04	244	7.40	1.43	0.15	0.61	0.97	-0.62	4.138e+04-4.748e+04	2808.81	-8917.75	-										
4.622e+04	236	7.78	4.10	-3.21	-0.76	1.65	-3.45	5.000e+04-4.325e+04	-2746.15	9502.30	-										
4.023e+04	237	6.80	3.13	-0.86	-0.08	2.34	-1.59	4.330e+04-3.831e+04	-4364.83	9357.38	-										
3.423e+04	245	5.82	18.90	-14.12	16.38	-11.60	-8.77	3.356e+04-3.553e+04	3649.56	-5616.21	-										

Parco Eolico "Bolina" – Progetto Definitivo
Relazione di calcolo preliminare delle fondazioni degli aerogeneratori G8 e G12

4.020e+04	244	6.80	17.71	-12.26	16.51	-11.05	-5.89	3.796e+04	-4.317e+04	2822.51	-8034.37	-
4.229e+04	236	7.21	33.37	-14.95	25.83	-7.41	-17.54	4.582e+04	-3.952e+04	-2491.94	8788.72	-
3.660e+04	237	6.27	26.11	-12.80	18.47	-5.16	-15.45	3.940e+04	-3.489e+04	-4055.09	8566.28	-
220 39	245	5.77	5.17	-6.16	4.19	-5.18	-3.18	3.364e+04	-3.546e+04	3753.51	-5569.40	-
3.423e+04	244	6.75	6.53	-3.73	5.96	-3.16	-2.36	3.773e+04	-4.317e+04	2644.50	-8082.45	-
4.009e+04	236	7.12	12.77	-6.00	8.28	-1.51	-8.01	4.558e+04	-3.939e+04	-2494.95	8689.30	-
4.211e+04	237	6.21	9.93	-4.06	6.20	-0.34	-6.18	3.938e+04	-3.485e+04	-3997.49	8526.87	-
3.658e+04	245	5.75	-1.63	-2.31	-2.05	-1.89	-0.33	3.368e+04	-3.542e+04	3806.67	-5545.46	-
220 69	244	6.72	1.30	0.14	0.56	0.88	-0.56	3.761e+04	-4.317e+04	2553.47	-8107.04	-
3.423e+04	236	7.08	3.72	-2.92	-0.70	1.50	-3.14	4.546e+04	-3.932e+04	-2496.50	8638.45	-
4.004e+04	237	6.18	2.84	-0.79	-0.07	2.13	-1.44	3.937e+04	-3.483e+04	-3968.03	8506.71	-
3.657e+04	246	6.33	1.18	-4.52	-4.50	1.16	-0.35	4.265e+04	-3.333e+04	1.041e+04	-1092.66	-
221 1	245	7.45	-1.41	-4.10	-3.28	-2.22	1.24	4.335e+04	-4.617e+04	4738.43	-7556.12	-
3.756e+04	237	8.02	1.73	-0.26	0.12	1.35	-0.79	5.146e+04	-4.486e+04	-4703.44	1.130e+04	-
4.434e+04	238	6.90	0.50	-1.28	0.42	-1.20	-0.36	4.515e+04	-3.768e+04	-1792.35	9262.84	-
4.749e+04	246	5.36	1.00	-3.82	-3.80	0.98	-0.30	3.609e+04	-2.821e+04	8808.00	-924.56	-
4.104e+04	245	6.31	-1.19	-3.47	-2.78	-1.88	1.05	3.668e+04	-3.907e+04	4009.44	-6393.64	-
221 3	237	6.79	1.47	-0.22	0.10	1.14	-0.67	4.354e+04	-3.796e+04	-3979.83	9564.52	-
3.178e+04	238	5.84	0.42	-1.08	0.36	-1.02	-0.31	3.820e+04	-3.188e+04	-1516.60	7837.79	-
3.752e+04	246	4.92	13.80	-13.14	12.13	-11.47	-6.49	3.262e+04	-2.570e+04	7628.79	-711.43	-
4.018e+04	245	5.76	10.02	-13.26	9.79	-13.03	-2.30	3.329e+04	-3.562e+04	3536.59	-5867.48	-
3.473e+04	237	6.25	25.32	-13.19	20.01	-7.88	-13.28	3.959e+04	-3.459e+04	-3742.03	8732.98	-
221 7	238	5.37	18.75	-13.52	12.99	-7.76	-12.36	3.453e+04	-2.903e+04	-1491.21	6994.96	-
2.886e+04	246	4.89	2.75	-4.22	1.82	-3.29	-2.37	3.275e+04	-2.566e+04	7879.21	-796.83	-
3.413e+04	245	5.73	1.64	-5.54	1.64	-5.54	-0.15	3.333e+04	-3.555e+04	3608.28	-5831.04	-
3.656e+04	237	6.20	9.01	-4.16	6.83	-1.98	-4.89	3.958e+04	-3.454e+04	-3659.99	8707.86	-
3.150e+04	238	5.33	6.56	-5.18	4.61	-3.24	-4.37	3.466e+04	-2.900e+04	-1416.79	7081.17	-
221 39	246	4.87	0.91	-3.48	-3.46	0.89	-0.27	3.281e+04	-2.564e+04	8007.28	-840.51	-
2.888e+04	245	5.73	-1.08	-3.15	-2.53	-1.71	0.95	3.335e+04	-3.551e+04	3644.95	-5812.40	-
3.411e+04	237	6.17	1.33	-0.20	0.09	1.04	-0.61	3.958e+04	-3.451e+04	-3618.03	8695.02	-
3.654e+04	238	5.31	0.38	-0.98	0.32	-0.92	-0.28	3.473e+04	-2.898e+04	-1378.73	7125.26	-
3.154e+04	247	6.17	18.26	-12.19	-11.42	17.49	4.77	5.251e+04	-1.826e+04	3.044e+04	3801.42	-
221 69	246	6.38	-5.21	-8.36	-5.22	-8.35	0.20	4.314e+04	-3.337e+04	7963.60	1803.42	-
2.889e+04	238	6.89	5.02	1.42	2.01	4.43	1.33	4.541e+04	-3.724e+04	118.33	8048.95	-
3.410e+04	239	5.31	3.90	-5.62	1.84	-3.56	-3.92	3.246e+04	-3.113e+04	-3186.61	4517.26	-
3.653e+04	247	5.22	15.45	-10.31	-9.66	14.80	4.04	4.443e+04	-1.545e+04	2.576e+04	3216.59	-
3.157e+04	246	5.40	-4.41	-7.08	-4.42	-7.07	0.17	3.650e+04	-2.824e+04	6738.43	1525.97	-
222 1												
3.278e+04												
3.813e+04												
4.114e+04												
3.156e+04												
222 3												
2.774e+04												

Parco Eolico "Bolina" – Progetto Definitivo
Relazione di calcolo preliminare delle fondazioni degli aerogeneratori G8 e G12

3.227e+04													
3.481e+04	238	5.83	4.25	1.20	1.70	3.75	1.13	3.842e+04-3.151e+04	100.12	6810.65	-		
2.671e+04	239	4.49	3.30	-4.75	1.55	-3.01	-3.31	2.747e+04-2.634e+04	-2696.36	3822.30	-		
2.664e+04	222 22	247	5.05	30.11	-13.89	0.82	15.40	20.76	4.053e+04-1.698e+04	2.258e+04	967.99	-	
2.936e+04	246	4.97	12.20	-20.82	8.90	-17.51	9.91	3.317e+04-2.568e+04	5710.21	1781.71	-		
3.193e+04	238	5.39	12.02	-7.86	8.94	-4.77	7.19	3.482e+04-2.930e+04	-167.00	5686.93	-		
2.379e+04	239	3.99	6.61	-14.98	6.58	-14.95	-0.80	2.482e+04-2.312e+04	-2062.05	3765.46	-		
2.570e+04	222 54	247	4.85	17.92	-9.34	-5.53	14.11	9.45	4.044e+04-1.504e+04	2.313e+04	2262.25	-	
2.934e+04	246	4.93	1.39	-11.21	0.35	-10.18	3.46	3.318e+04-2.567e+04	5985.21	1520.72	-		
3.174e+04	238	5.33	5.89	-1.21	4.05	0.64	3.11	3.489e+04-2.887e+04	3.71	6020.77	-		
2.411e+04	239	4.05	3.65	-7.36	3.16	-6.87	-2.26	2.492e+04-2.367e+04	-2319.55	3573.16	-		
2.522e+04	222 69	247	4.75	14.04	-9.37	-8.78	13.45	3.67	4.039e+04-1.405e+04	2.342e+04	2924.17	-	
2.933e+04	246	4.91	-4.01	-6.43	-4.02	-6.42	0.15	3.319e+04-2.567e+04	6125.85	1387.25	-		
3.164e+04	238	5.30	3.86	1.09	1.54	3.41	1.03	3.493e+04-2.865e+04	91.02	6191.50	-		
2.428e+04	239	4.09	3.00	-4.32	1.41	-2.74	-3.01	2.497e+04-2.395e+04	-2451.24	3474.82	-		
1.763e+04	223 1	248	3.16	1.35	-16.09	1.25	-15.98	-1.36	2.694e+04	-9538.30	4010.09	1.339e+04	
1.821e+04	247	3.62	36.61	-0.88	12.27	23.46	-17.89	3.095e+04	-9286.31	1.939e+04	2278.86	-	
3.618e+04	239	6.08	-1.47	-16.54	-12.04	-5.98	6.90	4.005e+04-3.234e+04	2908.79	4801.28	-		
1.827e+04	240	3.10	15.27	-2.39	1.83	11.05	-7.54	1.983e+04-1.673e+04	984.40	2119.62	-		
1.491e+04	223 3	248	2.67	1.15	-13.62	1.05	-13.53	-1.15	2.279e+04	-8070.87	3393.15	1.133e+04	
1.541e+04	247	3.06	30.98	-0.74	10.38	19.85	-15.13	2.619e+04	-7857.65	1.640e+04	1928.26	-	
3.062e+04	239	5.14	-1.24	-14.00	-10.19	-5.06	5.84	3.389e+04-2.737e+04	2461.29	4062.62	-		
1.546e+04	240	2.62	12.92	-2.02	1.55	9.35	-6.38	1.678e+04-1.415e+04	832.95	1793.52	-		
1.366e+04	223 5	248	2.51	5.73	-10.88	-9.18	4.02	-5.04	2.122e+04	-7302.75	2867.90	1.105e+04	
1.231e+04	247	2.56	61.30	-7.46	8.44	45.41	-28.99	2.092e+04	-6882.65	1.347e+04	559.02	-	
2.864e+04	239	4.90	18.43	-34.70	-28.68	12.41	16.84	3.246e+04-2.481e+04	3554.01	4093.33	-		
1.366e+04	240	2.29	30.32	-4.92	-4.87	30.26	-1.42	1.471e+04-1.261e+04	904.54	1198.68	-		
1.361e+04	223 38	248	2.45	-1.43	-9.08	-1.46	-9.05	-0.49	2.094e+04	-7303.26	3056.83	1.058e+04	
1.344e+04	247	2.71	37.21	-0.69	10.41	26.12	-17.24	2.283e+04	-7236.03	1.455e+04	1049.73	-	
2.811e+04	239	4.75	2.80	-19.16	-14.32	-2.05	9.10	3.135e+04-2.489e+04	2593.22	3866.61	-		
1.392e+04	240	2.35	14.75	-0.79	0.63	13.33	-4.47	1.501e+04-1.284e+04	742.47	1426.21	-		
1.356e+04	223 69	248	2.43	1.04	-12.38	0.96	-12.30	-1.05	2.072e+04	-7337.15	3084.68	1.030e+04	
1.401e+04	247	2.78	28.16	-0.67	9.44	18.05	-13.76	2.381e+04	-7143.32	1.491e+04	1752.97	-	
2.783e+04	239	4.68	-1.13	-12.73	-9.26	-4.60	5.31	3.081e+04-2.488e+04	2237.53	3693.29	-		
1.405e+04	240	2.38	11.75	-1.84	1.41	8.50	-5.80	1.525e+04-1.287e+04	757.23	1630.47	-		
1.801e+04	224 1	249	0.99	0.41	-8.62	0.34	-8.55	-0.77	9628.57	-653.23	-322.55	9297.89	-1814.01
		248	3.09	1.96	-2.40	1.78	-2.22	-0.86	2.519e+04-1.099e+04	5366.91	8834.88	-	
		240	3.43	4.22	-4.03	-0.66	0.85	-4.05	2.264e+04-1.816e+04	-151.55	4628.95	-	

Parco Eolico "Bolina" – Progetto Definitivo
Relazione di calcolo preliminare delle fondazioni degli aerogeneratori G8 e G12

2.026e+04														
	241	0.48	2.51	-0.59	-0.09	2.01	-1.14	4460.73	-699.40	201.19	3560.13	-1958.60		
	224 3	249	0.84	0.35	-7.29	0.29	-7.23	-0.66	8147.25	-552.73	-272.93	7867.45	-1534.93	
		248	2.61	1.66	-2.03	1.51	-1.88	-0.73	2.132e+04	-9301.52	4541.24	7475.67	-	
1.524e+04														
	240	2.90	3.57	-3.41	-0.56	0.72	-3.43	1.916e+04	-1.537e+04	-128.24	3916.80	-		
1.714e+04														
	241	0.40	2.12	-0.50	-0.07	1.70	-0.96	3774.46	-591.80	170.24	3012.42	-1657.28		
	224 8	249	0.83	6.31	-24.78	5.84	-24.31	3.78	7173.93	-540.56	-289.05	6922.42	-1370.05	
		248	2.50	4.16	-27.12	-0.22	-22.74	10.86	1.968e+04	-8522.82	4457.53	6694.96	-	
1.405e+04														
	240	2.70	11.11	-22.53	7.68	-19.10	-10.18	1.746e+04	-1.419e+04	-334.99	3599.44	-		
1.570e+04														
	241	0.39	0.91	-21.62	-1.36	-19.35	-6.78	3507.73	-532.75	186.41	2788.57	-1545.50		
	224 40	249	0.78	2.20	-12.63	2.15	-12.58	0.89	7327.86	-515.37	-261.97	7074.46	-1386.82	
		248	2.41	1.82	-9.81	0.83	-8.82	3.24	1.948e+04	-8478.13	4239.77	6761.85	-	
1.392e+04														
	240	2.66	5.01	-8.78	2.26	-6.03	-5.51	1.743e+04	-1.405e+04	-190.48	3573.83	-		
1.563e+04														
	241	0.36	0.80	-6.83	-0.51	-5.52	-2.87	3457.16	-536.21	165.47	2755.49	-1519.77		
	224 69	249	0.76	0.31	-6.63	0.26	-6.58	-0.60	7406.59	-502.48	-248.11	7152.22	-1395.39	
		248	2.38	1.50	-1.84	1.37	-1.71	-0.66	1.938e+04	-8455.93	4128.40	6796.06	-	
1.385e+04														
	240	2.64	3.24	-3.10	-0.51	0.65	-3.12	1.742e+04	-1.397e+04	-116.58	3560.73	-		
1.559e+04														
	241	0.37	1.93	-0.45	-0.07	1.55	-0.88	3431.33	-538.00	154.76	2738.56	-1506.62		
	225 1	242	13.12	6.07	-13.56	-10.76	3.26	-6.87	6.432e+04	-9.201e+04	6.341e+04	-9.109e+04	1.192e+04	
		250	13.54	-0.72	-10.26	-9.25	-1.73	-2.94	2.390e+04	-1.273e+05	1.569e+04	-1.191e+05	3.428e+04	
		2	22.49	6.68	-15.80	-7.29	-1.83	-10.91	6.519e+04	-1.944e+05	5.796e+04	-1.872e+05	4.269e+04	
		1	17.45	3.05	-5.44	-4.22	1.83	-2.97	6.962e+04	-1.364e+05	6.883e+04	-1.356e+05	1.270e+04	
	225 3	242	11.10	5.13	-11.48	-9.10	2.76	-5.81	5.443e+04	-7.785e+04	5.365e+04	-7.708e+04	1.009e+04	
		250	11.45	-0.61	-8.68	-7.82	-1.47	-2.49	2.023e+04	-1.077e+05	1.327e+04	-1.008e+05	2.901e+04	
		2	19.03	5.66	-13.37	-6.17	-1.55	-9.23	5.516e+04	-1.645e+05	4.905e+04	-1.584e+05	3.613e+04	
		1	14.76	2.58	-4.60	-3.57	1.55	-2.52	5.891e+04	-1.154e+05	5.824e+04	-1.148e+05	1.075e+04	
	225 23	242	10.21	19.22	-60.83	6.30	-47.90	-29.46	4.962e+04	-7.082e+04	4.873e+04	-7.012e+04	9306.93	
		250	10.43	44.21	-31.21	22.28	-9.28	-34.25	1.840e+04	-9.805e+04	1.206e+04	-9.172e+04	2.641e+04	
		2	17.45	16.78	-88.08	-6.04	-65.27	-43.27	5.019e+04	-1.499e+05	4.464e+04	-1.444e+05	3.287e+04	
		1	13.49	32.18	-20.44	18.01	-6.28	-23.34	5.363e+04	-1.052e+05	5.302e+04	-1.046e+05	9776.20	
	225 54	242	10.16	19.82	-13.46	-13.21	19.56	2.89	4.943e+04	-7.082e+04	4.873e+04	-7.012e+04	9127.74	
		250	10.41	4.72	-20.42	-17.06	1.35	8.56	1.839e+04	-9.787e+04	1.207e+04	-9.156e+04	2.636e+04	
		2	17.34	20.65	-5.90	-5.46	20.20	3.41	5.013e+04	-1.494e+05	4.457e+04	-1.438e+05	3.283e+04	
		1	13.44	5.48	-11.91	-10.44	4.01	4.83	5.353e+04	-1.049e+05	5.292e+04	-1.043e+05	9770.47	
	225 69	242	10.09	4.67	-10.43	-8.28	2.51	-5.29	4.948e+04	-7.078e+04	4.877e+04	-7.007e+04	9173.05	
		250	10.41	-0.55	-7.89	-7.11	-1.33	-2.26	1.839e+04	-9.792e+04	1.207e+04	-9.160e+04	2.637e+04	
		2	17.30	5.14	-12.15	-5.61	-1.41	-8.39	5.014e+04	-1.495e+05	4.459e+04	-1.440e+05	3.284e+04	
		1	13.42	2.35	-4.18	-3.25	1.41	-2.29	5.355e+04	-1.049e+05	5.295e+04	-1.043e+05	9771.92	
	226 1	243	13.06	13.34	-54.16	-48.47	7.66	-18.75	9.520e+04	-5.736e+04	6.509e+04	-4.724e+04	3.796e+04	
		251	10.23	1.82	-4.36	-3.66	1.11	1.96	2.284e+04	-9.325e+04	740.15	-7.115e+04	4.558e+04	
		250	14.29	6.71	-22.51	-14.30	-1.49	-13.13	3.617e+04	-1.265e+05	1.144e+04	-1.018e+05	5.841e+04	
		242	12.63	13.86	-6.84	11.11	-4.09	-7.03	5.191e+04	-9.750e+04	4.215e+04	-8.774e+04	3.693e+04	
	226 3	243	11.05	11.29	-45.83	-41.01	6.48	-15.87	8.056e+04	-4.853e+04	7.200e+04	-3.998e+04	3.212e+04	
		251	8.65	1.54	-3.69	-3.10	0.94	1.66	1.933e+04	-7.890e+04	626.28	-6.020e+04	3.857e+04	
		250	12.09	5.68	-19.04	-12.10	-1.26	-11.11	3.060e+04	-1.071e+05	9678.96	-8.614e+04	4.942e+04	
		242	10.69	11.72	-5.79	9.40	-3.46	-5.94	4.392e+04	-8.250e+04	3.566e+04	-7.424e+04	3.125e+04	
	226 6	243	10.63	24.33	-91.94	-72.93	5.32	-43.00	7.692e+04	-4.465e+04	6.868e+04	-3.641e+04	3.055e+04	
		251	7.94	15.33	-26.90	-12.21	0.64	-20.12	1.705e+04	-7.155e+04	395.49	-5.489e+04	3.462e+04	
		250	11.18	21.11	-60.10	-34.16	-4.83	-37.86	2.828e+04	-9.732e+04	9082.92	-7.812e+04	4.520e+04	
		242	9.71	27.24	-38.54	-5.01	-6.29	-32.88	3.889e+04	-7.471e+04	3.122e+04	-6.704e+04	2.850e+04	
	226 38	243	10.24	14.75	-58.40	-49.35	5.70	-24.09	7.448e+04	-4.430e+04	6.655e+04	-3.636e+04	2.966e+04	
		251	7.89	4.12	-9.33	-6.00	0.78	-5.81	1.740e+04	-7.167e+04	510.52	-5.478e+04	3.491e+04	
		250	11.05	10.54	-31.77	-18.84	-2.40	-19.49	2.798e+04	-9.733e+04	8895.11	-7.824e+04	4.502e+04	
		242	9.69	15.13	-15.39	3.96	-4.21	-14.70	3.958e+04	-7.490e+04	3.201e+04	-6.734e+04	2.844e+04	
	226 69	243	10.04	10.26	-41.66	-37.29	5.89	-14.42	7.323e+04	-4.412e+04	6.545e+04	-3.634e+04	2.920e+04	
		251	7.87	1.40	-3.36	-2.82	0.86	1.51	1.757e+04	-7.173e+04	569.34	-5.473e+04	3.506e+04	
		250	10.99	5.16	-17.31	-11.00	-1.15	-10.10	2.782e+04	-9.733e+04	8799.05	-7.831e+04	4.493e+04	
		242	9.72	10.66	-5.26	8.54	-3.15	-5.40	3.993e+04	-7.500e+04	3.242e+04	-6.749e+04	2.840e+04	
	227 1	244	9.41	27.57	-1.16	25.63	0.78	-7.21	4.587e+04	-6.648e+04	2.939e+04	-5.000e+04	3.975e+04	
		252	8.78	-2.76	-22.93	-13.62	-12.07	10.05	3.891e+04	-6.482e+04	7492.51	-3.340e+04	4.767e+04	
		251	11.62	14.95	-14.56	-6.70	7.09	-13.04	3.133e+04	-1.012e+05	-9590.01	-6.029e+04	6.124e+04	
		243	10.99	3.02	-59.86	-47.28	-9.56	25.16	8.817e+04	-4.061e+04	7.824e+04	-3.069e+04	3.435e+04	
	227 3	244	7.97	23.33	-0.98	21.68	0.66	-6.10	3.881e+04	-5.626e+04	2.486e+04	-4.231e+04	3.364e+04	
		252	7.43	-2.34	-19.40	-11.53	-10.21	8.51	3.293e+04	-5.485e+04	6339.81	-2.826e+04	4.033e+04	
		251	9.83	12.65	-12.32	-5.67	6.00	-11.04	2.651e+04	-8.565e+04	-8114.62	-5.102e+04	5.182e+04	

Parco Eolico "Bolina" – Progetto Definitivo
Relazione di calcolo preliminare delle fondazioni degli aerogeneratori G8 e G12

		243	9.30	2.56	-50.65	-40.01	-8.09	21.29	7.460e+04	-3.437e+04	6.620e+04	-2.597e+04	2.907e+04
227	22	244	7.34	26.98	6.30	6.99	26.30	-3.70	3.466e+04	-5.216e+04	2.129e+04	-3.880e+04	3.134e+04
		252	6.57	21.03	-34.98	-32.63	18.67	11.24	2.966e+04	-4.850e+04	6.177	22-2.501e+04	3.583e+04
		251	-11.82	55.94	-30.42	-28.77	54.29	-11.82	2.409e+04	-7.954e+04	-7179.06	-4.826e+04	4.757e+04
		243	8.30	20.63	-79.01	-64.46	6.08	35.19	6.826e+04	-2.729e+04	6.163e+04	-2.066e+04	2.428e+04
227	54	244	7.25	18.15	6.56	15.41	9.30	-4.92	3.507e+04	-5.149e+04	2.216e+04	-3.858e+04	3.083e+04
		252	6.69	3.82	-21.62	-17.97	0.17	8.92	2.984e+04	-4.940e+04	5903.47	-2.546e+04	3.639e+04
		251	9.03	24.95	-16.12	-13.14	21.98	-10.64	2.410e+04	-7.843e+04	-7309.97	-4.702e+04	4.726e+04
		243	8.40	8.44	-57.12	-45.87	-2.81	24.71	6.797e+04	-2.990e+04	6.018e+04	-2.261e+04	2.570e+04
227	69	244	7.24	21.21	-0.89	19.71	0.60	-5.55	3.528e+04	-5.114e+04	2.260e+04	-3.846e+04	3.058e+04
		252	6.76	-2.13	-17.64	-10.48	-9.28	7.73	2.993e+04	-4.986e+04	5763.47	-2.569e+04	3.667e+04
		251	8.94	11.50	-11.20	-5.16	5.46	-10.03	2.410e+04	-7.786e+04	-7376.93	-4.638e+04	4.710e+04
		243	8.45	2.33	-46.05	-36.37	-7.35	19.35	6.782e+04	-3.124e+04	6.018e+04	-2.361e+04	2.642e+04
228	1	245	7.51	2.70	-2.98	2.30	-2.59	-1.44	4.387e+04	-4.637e+04	2.677e+04	-2.928e+04	3.536e+04
		253	7.33	-1.75	-5.11	-2.59	-4.27	-1.45	3.110e+04	-5.585e+04	-3461.34	-2.129e+04	4.255e+04
		252	9.18	-0.56	-6.17	-0.77	-5.96	-1.05	3.509e+04	-7.315e+04	-6760.04	-3.129e+04	5.271e+04
		244	9.07	-0.58	-2.23	-1.84	-0.96	-0.70	5.309e+04	-5.592e+04	3.341e+04	-3.624e+04	4.193e+04
228	3	245	6.35	2.28	-2.52	1.95	-2.19	-1.22	3.712e+04	-3.924e+04	2.265e+04	-2.477e+04	2.992e+04
		253	6.20	-1.48	-4.32	-2.19	-3.61	-1.23	2.631e+04	-4.725e+04	-2928.82	-1.801e+04	3.600e+04
		252	7.77	-0.48	-5.22	-0.65	-5.04	-0.89	2.970e+04	-6.189e+04	-5720.03	-2.648e+04	4.460e+04
		244	7.67	-0.49	-1.89	-1.56	-0.82	-0.59	4.492e+04	-4.732e+04	2.827e+04	-3.066e+04	3.548e+04
228	23	245	5.85	19.49	-23.10	19.33	-22.94	-2.63	3.389e+04	-3.549e+04	2.077e+04	-2.236e+04	2.718e+04
		253	5.69	16.86	-26.90	16.66	-26.70	2.94	2.401e+04	-4.289e+04	-2591.00	-1.630e+04	3.274e+04
		252	7.16	19.43	-35.09	19.37	-35.03	1.80	2.721e+04	-5.650e+04	-5139.62	-2.416e+04	4.076e+04
		244	7.06	19.03	-19.85	18.35	-19.17	-5.10	4.091e+04	-4.329e+04	2.579e+04	-2.817e+04	3.231e+04
228	55	245	5.80	7.87	-9.23	7.71	-9.08	-1.62	3.379e+04	-3.561e+04	2.065e+04	-2.247e+04	2.719e+04
		253	5.65	4.32	-11.21	4.32	-11.21	0.26	2.395e+04	-4.294e+04	-2638.35	-1.635e+04	3.273e+04
		252	7.10	6.16	-14.89	6.16	-14.89	0.07	2.707e+04	-5.635e+04	-5179.59	-2.410e+04	4.062e+04
		244	7.00	5.61	-7.32	5.27	-6.98	-2.08	4.086e+04	-4.311e+04	2.573e+04	-2.797e+04	3.228e+04
228	69	245	5.77	2.07	-2.29	1.77	-1.99	-1.11	3.374e+04	-3.567e+04	2.059e+04	-2.252e+04	2.720e+04
		253	5.64	-1.35	-3.93	-1.99	-3.29	-1.12	2.392e+04	-4.296e+04	-2662.57	-1.637e+04	3.273e+04
		252	7.06	-0.43	-4.74	-0.59	-4.59	-0.81	2.700e+04	-5.627e+04	-5200.03	-2.407e+04	4.055e+04
		244	6.98	-0.44	-1.72	-1.42	-0.74	-0.54	4.084e+04	-4.302e+04	2.570e+04	-2.787e+04	3.226e+04
229	1	246	6.12	0.29	-6.34	-1.36	-4.69	-2.87	4.213e+04	-3.110e+04	2.463e+04	-1.361e+04	3.123e+04
		254	5.69	1.34	-4.79	-0.74	-2.71	-2.90	2.830e+04	-3.964e+04	-7475.55	-3867.26	3.392e+04
		253	7.36	-0.43	-6.68	-1.98	-5.12	-2.70	3.141e+04	-5.580e+04	-8909.23	-1.548e+04	4.348e+04
		245	7.48	3.57	-3.05	2.18	-1.66	-2.69	4.382e+04	-4.605e+04	2.215e+04	-2.439e+04	3.844e+04
229	3	246	5.18	0.25	-5.37	-1.15	-3.97	-2.43	3.565e+04	-2.632e+04	2.084e+04	-1.151e+04	2.642e+04
		254	4.82	1.13	-4.06	-0.63	-2.30	-2.46	2.395e+04	-3.354e+04	-6325.46	-3272.30	2.817e+04
		253	6.23	-0.36	-5.65	-1.68	-4.33	-2.29	2.658e+04	-4.721e+04	-7538.58	-1.310e+04	3.679e+04
		245	6.33	3.02	-2.58	1.85	-1.40	-2.28	3.707e+04	-3.897e+04	1.874e+04	-2.064e+04	3.253e+04
229	6	246	4.84	10.81	-25.62	-4.82	-9.99	-18.03	3.290e+04	-2.381e+04	1.920e+04	-1.011e+04	2.427e+04
		254	4.48	10.52	-18.44	1.25	-9.17	-13.51	2.196e+04	-3.058e+04	-5742.22	-2872.69	2.623e+04
		253	5.73	7.09	-19.27	-2.06	-10.12	-12.55	2.431e+04	-4.286e+04	-6788.61	-1.176e+04	3.349e+04
		245	5.82	9.68	-21.91	-1.18	-11.04	-15.01	3.375e+04	-3.536e+04	1.701e+04	-1.862e+04	2.961e+04
229	38	246	4.75	3.71	-11.80	-2.33	-5.77	-7.56	3.257e+04	-2.389e+04	1.903e+04	-1.035e+04	2.411e+04
		254	4.41	4.24	-8.68	0.05	-4.48	-6.05	2.184e+04	-3.052e+04	-5747.65	-2940.26	2.614e+04
		253	5.69	2.15	-9.89	-1.70	-6.03	-5.62	2.421e+04	-4.290e+04	-6831.38	-1.186e+04	3.346e+04
		245	5.78	5.04	-8.91	0.71	-4.58	-6.45	3.372e+04	-3.540e+04	1.703e+04	-1.871e+04	2.958e+04
229	69	246	4.71	0.22	-4.88	-1.05	-3.61	-2.21	3.240e+04	-2.393e+04	1.895e+04	-1.047e+04	2.402e+04
		254	4.38	1.03	-3.69	-0.57	-2.09	-2.23	2.177e+04	-3.049e+04	-5750.42	-2974.82	2.610e+04
		253	5.66	-0.33	-5.14	-1.52	-3.94	-2.08	2.416e+04	-4.292e+04	-6853.25	-1.191e+04	3.345e+04
		245	5.75	2.75	-2.34	1.68	-1.28	-2.07	3.370e+04	-3.543e+04	1.704e+04	-1.876e+04	2.957e+04
230	1	247	6.58	3.39	-33.13	-25.52	-4.22	-14.83	6.156e+04	-9943.17	4.039e+04	1.123e+04	3.265e+04
		255	3.82	10.50	-4.23	4.47	1.80	7.24	1.629e+04	-2.857e+04	-1.345e+04	1169.80	2.121e+04
		254	5.92	-1.05	-12.38	-8.63	-4.80	-5.33	3.227e+04	-3.848e+04	-8245.53	2035.18	3.500e+04
		246	5.68	11.14	-5.29	10.40	-4.55	-3.40	3.660e+04	-3.158e+04	1.691e+04	-1.189e+04	3.090e+04
230	3	247	5.57	2.86	-28.03	-21.60	-3.57	-12.55	5.209e+04	-8413.45	3.417e+04	9505.35	2.762e+04
		255	3.23	8.88	-3.58	3.78	1.52	6.13	1.378e+04	-2.417e+04	-1.138e+04	989.83	1.794e+04
		254	5.01	-0.89	-10.48	-7.31	-4.06	-4.51	2.731e+04	-3.256e+04	-6976.99	1722.07	2.962e+04
		246	4.80	9.42	-4.48	8.80	-3.85	-2.88	3.097e+04	-2.672e+04	1.431e+04	-1.006e+04	2.615e+04
230	6	247	5.52	12.30	-51.88	-31.10	-8.48	-30.03	5.064e+04	-7922.24	3.349e+04	9230.14	2.665e+04
		255	2.84	10.32	-3.11	10.21	-3.00	1.22	1.161e+04	-2.193e+04	-1.089e+04	575.96	1.576e+04
		254	4.66	4.51	-20.91	-8.06	-8.33	-12.71	2.549e+04	-2.952e+04	-5843.72	1817.56	2.724e+04
		246	4.39	16.79	-19.06	11.25	-13.52	-12.96	2.793e+04	-2.426e+04	1.239e+04	-8715.83	2.386e+04
230	38	247	5.21	5.71	-34.24	-23.51	-5.02	-17.71	4.847e+04	-7741.03	3.189e+04	8840.50	2.563e+04
		255	2.90	7.84	-2.22	5.73	-0.10	4.10	1.222e+04	-2.196e+04	-1.053e+04	790.25	1.613e+04
		254	4.59	0.88	-13.27	-7.12	-5.26	-7.01	2.505e+04	-2.957e+04	-6173.87	1650.81	2.703e+04
		246	4.37	11.17	-8.96	9.10	-6.89	-6.12	2.808e+04	-2.428e+04	1.280e+04	-9000.73	2.380e+04
230	69	247	5.06	2.60	-25.49	-19.63	-3.25	-11.41	4.736e+04	-7648.59	3.107e+04	8641.23	2.511e+04
		255	2.94	8.07	-3.26	3.44	1.38	5.57	1.253e+04	-2.198e+04	-1.035e+04	899.85	1.631e+04
		254	4.56	-0.81	-9.53	-6.64	-3.69	-4.10	2.483e+04	-2.960e+04	-6342.71	1565.52	2.693e+04
		246	4.37	8.57	-4.07	8.00	-3.50	-2.62	2.816e+04	-2.429e+04	1.301e+04	-9146.44	2.377e+04

Parco Eolico "Bolina" – Progetto Definitivo
Relazione di calcolo preliminare delle fondazioni degli aerogeneratori G8 e G12

231	1	248	3.88	11.18	2.94	11.05	3.07	1.03 2.735e+04-1.885e+04	1.481e+04	-6312.43	2.055e+04	
		256	2.81	-2.79	-14.34	-11.71	-5.42	4.85 1.988e+04-1.325e+04	-1813.71	8443.43	1.575e+04	
		255	4.69	7.57	-0.70	5.61	1.26	-3.52 2.211e+04-3.359e+04	-1.530e+04	3820.59	2.615e+04	
231	3	247	5.27	3.19	-27.98	-25.48	0.69	8.48 5.254e+04	-4002.17	3.853e+04	1.001e+04 2.442e+04	
		248	3.29	9.46	2.49	9.35	2.60	0.87 2.314e+04-1.595e+04	1.253e+04	-5341.28	1.739e+04	
		256	2.38	-2.36	-12.13	-9.91	-4.58	4.10 1.682e+04-1.121e+04	-1534.68	7144.44	1.333e+04	
231	21	255	3.97	6.41	-0.59	4.75	1.07	-2.98 1.871e+04-2.842e+04	-1.294e+04	3232.81	2.213e+04	
		247	4.46	2.70	-23.68	-21.56	0.58	7.17 4.446e+04	-3386.45	3.260e+04	8474.14	2.066e+04
		248	3.01	25.53	-6.31	24.18	-4.96	-6.42 2.129e+04-1.446e+04	1.193e+04	-5096.84	1.572e+04	
231	53	256	2.21	14.31	-17.91	12.11	-15.71	8.13 1.567e+04-1.049e+04	-1535.48	6708.28	1.241e+04	
		255	3.54	25.57	-19.52	24.95	-18.90	5.26 1.729e+04-2.473e+04	-1.151e+04	4066.53	1.952e+04	
		247	4.23	8.94	-7.88	3.28	-2.22	-7.95 4.093e+04	-5184.22	2.936e+04	6390.77	2.000e+04
231	69	248	2.99	13.99	-0.31	13.80	-0.11	-1.65 2.112e+04-1.449e+04	1.157e+04	-4937.31	1.578e+04	
		256	2.18	1.10	-11.04	-1.86	-8.07	5.22 1.542e+04-1.029e+04	-1442.64	6567.13	1.222e+04	
		255	3.58	11.30	-5.75	11.30	-5.75	-0.01 1.710e+04-2.546e+04	-1.168e+04	3320.47	1.991e+04	
231	21	247	4.11	-0.17	-12.08	-11.86	-0.40	1.62 4.059e+04	-3790.96	2.954e+04	7259.48	1.919e+04
		248	2.99	8.60	2.26	8.50	2.36	0.79 2.104e+04-1.450e+04	1.139e+04	-4855.71	1.580e+04	
		256	2.16	-2.14	-11.03	-9.01	-4.17	3.73 1.529e+04-1.019e+04	-1395.16	6494.94	1.212e+04	
232	1	255	3.61	5.83	-0.54	4.32	0.97	-2.71 1.701e+04-2.583e+04	-1.177e+04	2938.91	2.012e+04	
		247	4.05	2.46	-21.52	-19.60	0.53	6.52 4.042e+04	-3078.59	2.964e+04	7703.76	1.878e+04
		249	0.96	1.96	-0.49	1.68	-0.20	0.79 9569.76	-676.51	9396.01	-502.77	1322.88
232	3	257	0.30	0.51	-5.61	-5.26	0.17	1.42 734.89	-2449.80	-1395.15	-319.76	1498.82
		256	2.92	-0.17	-4.00	-1.89	-2.28	1.91 1.829e+04-1.669e+04	-4303.40	5901.30	1.673e+04	
		248	3.77	1.81	-2.51	-2.50	1.81	-0.19 2.960e+04-1.479e+04	1.710e+04	-2287.66	1.996e+04	
232	21	249	0.81	1.66	-0.41	1.42	-0.17	0.67 8097.49	-572.43	7950.47	-425.42	1119.36
		257	0.25	0.43	-4.75	-4.45	0.14	1.20 621.83	-2072.91	-1180.51	-270.57	1268.23
		256	2.47	-0.14	-3.38	-1.60	-1.93	1.61 1.548e+04-1.413e+04	-3641.34	4993.40	1.416e+04	
232	53	248	3.19	1.54	-2.12	-2.11	1.53	-0.16 2.504e+04-1.251e+04	1.447e+04	-1935.71	1.689e+04	
		249	0.82	19.71	-3.96	17.90	-2.15	-6.29 7620.65	-475.36	7496.25	-350.96	995.82
		257	0.26	16.93	-6.71	13.14	-2.92	8.67 594.80	-1914.16	-1041.52	-277.83	1194.95
232	69	256	2.29	22.14	-11.52	19.31	-8.69	9.34 1.429e+04-1.279e+04	-3248.19	4744.80	1.293e+04	
		248	2.97	21.88	-5.33	16.60	-0.04	-10.77 2.298e+04-1.167e+04	1.335e+04	-2052.16	1.552e+04	
		249	0.77	7.28	-1.20	6.91	-0.83	-1.73 7449.02	-505.08	7318.57	-374.64	1010.23
232	21	257	0.24	4.32	-3.46	1.77	-0.90	3.65 575.11	-1894.34	-1062.48	-256.75	1167.15
		256	2.26	7.10	-5.62	5.57	-4.10	4.13 1.414e+04-1.282e+04	-3289.29	4608.94	1.289e+04	
		248	2.92	6.74	-1.49	4.34	0.91	-3.74 2.284e+04-1.148e+04	1.322e+04	-1858.69	1.541e+04	
232	53	249	0.74	1.51	-0.37	1.29	-0.15	0.61 7361.35	-520.39	7227.70	-386.75	1017.60
		257	0.23	0.40	-4.32	-4.05	0.13	1.09 565.30	-1884.46	-1073.19	-245.97	1152.94
		256	2.25	-0.13	-3.08	-1.45	-1.75	1.47 1.407e+04-1.284e+04	-3310.31	4539.46	1.287e+04	
232	69	248	2.90	1.40	-1.93	-1.92	1.39	-0.14 2.277e+04-1.137e+04	1.315e+04	-1759.74	1.536e+04	
		250	13.58	10.53	-13.63	-7.24	4.15	-10.66 3.573e+04-1.196e+05	3.084e+04	-1.147e+05	2.712e+04	
		258	14.87	-4.62	-13.57	-10.82	-7.38	4.13-4.745e+04-1.726e+05	-7.728e+04	-1.428e+05		
5.332e+04	19	2	32.44	15.59	-13.06	-5.57	8.10	-12.59 9.058e+04-2.827e+05	8.376e+04	-2.759e+05	5.000e+04	
		2	20.94	-7.05	-11.91	-7.37	-11.59	1.21 5.296e+04-1.864e+05	4.091e+04	-1.744e+05	5.233e+04	
		250	11.49	8.91	-11.53	-6.12	3.51	-9.02 3.023e+04-1.012e+05	2.609e+04	-9.703e+04	2.295e+04	
4.512e+04	233	258	12.58	-3.91	-11.49	-9.15	-6.24	3.50-4.015e+04-1.461e+05	-6.539e+04	-1.208e+05		
		19	27.45	13.19	-11.05	-4.71	6.85	-10.65 7.665e+04-2.392e+05	7.088e+04	-2.334e+05	4.231e+04	
		2	17.72	-5.96	-10.08	-6.23	-9.81	1.02 4.481e+04-1.578e+05	3.462e+04	-1.476e+05	4.428e+04	
4.104e+04	233	250	10.58	36.84	-29.19	21.45	-13.80	27.92 2.756e+04-9.203e+04	2.381e+04	-8.828e+04	2.085e+04	
		258	11.47	25.63	8.35	22.78	11.20	-6.41-3.648e+04-1.328e+05	-5.942e+04	-1.099e+05		
		19	25.14	26.68	-35.12	14.52	-22.95	24.57 7.044e+04-2.176e+05	6.513e+04	-2.123e+05	3.874e+04	
4.101e+04	233	2	16.19	31.56	18.55	18.55	31.56	-0.11 4.110e+04-1.436e+05	3.183e+04	-1.343e+05	4.032e+04	
		250	10.54	28.51	-38.85	-16.22	5.89	-31.81 2.746e+04-9.197e+04	2.369e+04	-8.820e+04	2.088e+04	
		258	11.53	-10.99	-34.01	-16.66	-28.34	9.92-3.653e+04-1.328e+05	-5.948e+04	-1.098e+05		
4.102e+04	233	19	25.02	33.34	-35.79	-12.03	9.58	-32.84 6.937e+04-2.175e+05	6.415e+04	-2.123e+05	3.835e+04	
		2	16.23	-10.25	-47.75	-11.03	-46.97	5.34 4.059e+04-1.434e+05	3.133e+04	-1.342e+05	4.024e+04	
		250	10.45	8.10	-10.48	-5.57	3.19	-8.20 2.748e+04-9.197e+04	2.372e+04	-8.821e+04	2.086e+04	
5.106e+04	234	258	11.44	-3.56	-10.44	-8.32	-5.68	3.18-3.650e+04-1.328e+05	-5.945e+04	-1.098e+05		
		19	24.96	11.99	-10.04	-4.28	6.23	-9.68 6.968e+04-2.175e+05	6.443e+04	-2.122e+05	3.846e+04	
		2	16.11	-5.42	-9.17	-5.67	-8.92	0.93 4.074e+04-1.434e+05	3.147e+04	-1.342e+05	4.025e+04	
6.806e+04	234	251	10.84	0.92	-14.86	-13.28	-0.66	-4.74 3.440e+04-9.121e+04	1.799e+04	-7.480e+04	4.233e+04	
		259	11.10	3.84	-3.32	1.41	-0.90	-3.39 -8348.41	-1.194e+05	-4.203e+04	-8.575e+04	
		258	16.50	6.08	-21.36	-12.11	-3.17	-12.97 -2156.72	-1.723e+05	-3.618e+04	-1.383e+05	
234	3	250	13.89	9.54	-10.61	-4.70	3.63	-9.18 2.760e+04-1.284e+05	1.292e+04	-1.137e+05	4.553e+04	
		251	9.17	0.78	-12.57	-11.24	-0.56	-4.01 2.910e+04-7.718e+04	1.522e+04	-6.330e+04	3.582e+04	
		259	9.39	3.25	-2.81	1.20	-0.76	-2.87 -7064.04	-1.011e+05	-3.557e+04	-7.255e+04	

Parco Eolico "Bolina" – Progetto Definitivo
Relazione di calcolo preliminare delle fondazioni degli aerogeneratori G8 e G12

4.320e+04																			
5.759e+04	258	13.96	5.15	-18.08	-10.25	-2.68	-10.98	-1824.92-1.458e+05-3.062e+04-1.170e+05											
	250	11.76	8.08	-8.98	-3.98	3.07	-7.77	2.335e+04-1.086e+05	1.093e+04-9.619e+04	3.853e+04									
	234 6	251	8.51	13.82	-53.11	-37.83	-1.47	-28.10	2.684e+04-7.002e+04	1.425e+04-5.742e+04	3.258e+04								
		259	8.62	21.36	-17.49	1.32	2.55	-19.41	-6581.31-9.179e+04-3.244e+04-6.593e+04										
3.917e+04	258	12.86	23.43	-73.01	-46.32	-3.26	-43.15	-1874.77-1.324e+05-2.803e+04-1.063e+05											
5.226e+04	250	10.82	25.54	-41.44	-22.71	6.81	-30.06	2.118e+04-9.869e+04	9869.59-8.738e+04	3.503e+04									
	234 38	251	8.40	4.96	-25.35	-19.56	-0.84	-11.92	2.659e+04-7.011e+04	1.397e+04-5.750e+04	3.257e+04								
		259	8.57	9.09	-7.52	1.17	0.41	-8.29	-6475.81-9.184e+04-3.237e+04-6.595e+04										
3.924e+04	258	12.75	10.98	-35.54	-21.84	-2.72	-21.20	-1732.03-1.325e+05-2.790e+04-1.063e+05											
5.232e+04	250	10.73	13.50	-19.42	-10.08	4.15	-14.84	2.121e+04-9.872e+04	9916.29-8.742e+04	3.503e+04									
	234 69	251	8.34	0.71	-11.43	-10.21	-0.51	-3.65	2.646e+04-7.016e+04	1.384e+04-5.754e+04	3.256e+04								
		259	8.54	2.95	-2.56	1.09	-0.69	-2.61	-6421.86-9.187e+04-3.233e+04-6.596e+04										
3.928e+04	258	12.69	4.68	-16.43	-9.32	-2.44	-9.98	-1659.02-1.325e+05-2.783e+04-1.064e+05											
5.235e+04	250	10.69	7.34	-8.17	-3.62	2.79	-7.06	2.123e+04-9.873e+04	9940.18-8.744e+04	3.503e+04									
	235 1	252	9.04	-0.96	-4.11	-3.45	-1.62	1.28	3.344e+04-7.287e+04	1.104e+04-5.047e+04	4.335e+04								
		260	8.69	-2.31	-4.35	-3.31	-3.34	-1.02	3140.24-8.889e+04-3.652e+04-4.922e+04										
4.557e+04	259	11.42	2.93	-7.76	-3.25	-1.58	-5.28	-3440.57-1.203e+05-4.647e+04-7.731e+04											
5.638e+04	251	10.69	0.82	-11.52	-10.55	-0.14	-3.32	3.263e+04-9.104e+04	9529.31-6.794e+04	4.820e+04									
	235 3	252	7.65	-0.81	-3.47	-2.92	-1.37	1.08	2.830e+04-6.166e+04	9345.52-4.270e+04	3.668e+04								
		260	7.35	-1.96	-3.68	-2.80	-2.83	-0.86	2657.12-7.521e+04-3.090e+04-4.165e+04										
3.856e+04	259	9.66	2.48	-6.57	-2.75	-1.34	-4.47	-2911.25-1.018e+05-3.932e+04-6.541e+04											
4.771e+04	251	9.05	0.70	-9.75	-8.93	-0.12	-2.81	2.761e+04-7.703e+04	8063.27-5.749e+04	4.079e+04									
	235 22	252	7.00	33.50	-27.43	-25.48	31.55	10.73	2.562e+04-5.603e+04	8607.48-3.902e+04	3.316e+04								
		260	6.73	33.42	-25.22	-25.14	33.33	-2.26	2380.17-6.838e+04-2.806e+04-3.795e+04										
3.503e+04	259	8.88	48.71	-26.25	-25.89	48.36	-5.13	-2686.91-9.261e+04-3.570e+04-5.960e+04											
4.334e+04	251	8.29	36.48	-30.39	-29.55	35.64	7.44	2.521e+04-6.979e+04	7550.67-5.214e+04	3.695e+04									
	235 54	252	6.97	10.72	-11.25	-10.38	9.85	4.28	2.569e+04-5.605e+04	8533.67-3.889e+04	3.328e+04								
		260	6.70	9.66	-10.28	-10.19	9.58	-1.28	2403.58-6.838e+04-2.808e+04-3.789e+04										
3.505e+04	259	8.81	16.29	-11.15	-10.42	15.56	-4.42	-2660.26-9.258e+04-3.573e+04-5.951e+04											
4.336e+04	251	8.24	12.01	-15.39	-15.37	11.99	0.83	2.514e+04-6.995e+04	7404.83-5.222e+04	3.704e+04									
	235 69	252	6.96	-0.74	-3.16	-2.65	-1.25	0.98	2.573e+04-5.605e+04	8495.93-3.882e+04	3.335e+04								
		260	6.68	-1.78	-3.34	-2.55	-2.57	-0.78	2415.57-6.837e+04-2.809e+04-3.786e+04										
3.506e+04	259	8.78	2.25	-5.97	-2.50	-1.22	-4.06	-2646.59-9.257e+04-3.575e+04-5.947e+04											
4.337e+04	251	8.22	0.63	-8.86	-8.12	-0.11	-2.55	2.510e+04-7.003e+04	7330.24-5.226e+04	3.708e+04									
	236 1	253	7.48	1.44	-4.14	0.67	-3.37	-1.92	3.145e+04-5.721e+04	7237.13-3.300e+04	3.950e+04								
		261	6.88	-1.98	-4.15	-2.37	-3.75	-0.84	9979.00-6.611e+04-2.982e+04-2.631e+04										
3.800e+04	260	8.82	0.07	-4.57	-3.14	-1.35	-2.14	3320.84-9.004e+04-4.184e+04-4.488e+04											
4.665e+04	252	8.97	-3.32	-4.74	-3.34	-4.72	0.15	3.344e+04-7.205e+04	6152.82-4.476e+04	4.619e+04									
	236 3	253	6.33	1.22	-3.51	0.57	-2.85	-1.63	2.661e+04-4.841e+04	6123.72-2.792e+04	3.342e+04								
		261	5.82	-1.67	-3.51	-2.01	-3.18	-0.71	8443.77-5.594e+04-2.523e+04-2.226e+04										
3.216e+04	260	7.46	0.06	-3.86	-2.66	-1.14	-1.81	2809.94-7.619e+04-3.540e+04-3.798e+04											
3.948e+04	252	7.59	-2.81	-4.01	-2.83	-3.99	0.13	2.829e+04-6.097e+04	5206.24-3.788e+04	3.909e+04									
	236 7	253	5.84	21.35	-9.38	11.80	0.16	14.22	2.410e+04-4.403e+04	5555.12-2.549e+04	3.032e+04								
		261	5.36	13.13	-8.88	5.38	-1.13	10.51	7651.93-5.090e+04-2.294e+04-2.032e+04										
2.925e+04	260	6.85	15.56	-9.71	6.09	-0.24	12.23	2609.81-6.933e+04-3.220e+04-3.452e+04											
3.595e+04	252	7.01	19.26	-7.05	10.44	1.76	12.42	2.570e+04-5.577e+04	4599.54-3.467e+04	3.569e+04									
	236 39	253	5.78	6.20	-3.53	4.34	-1.66	3.83	2.416e+04-4.401e+04	5562.99-2.542e+04	3.036e+04								
		261	5.31	2.61	-4.29	0.61	-2.29	3.13	7667.95-5.087e+04-2.294e+04-2.026e+04										
2.924e+04																			

Parco Eolico "Bolina" – Progetto Definitivo
Relazione di calcolo preliminare delle fondazioni degli aerogeneratori G8 e G12

	260	6.80	2.96	-3.27	0.46	-0.77	3.05	2573.21-6.928e+04-3.219e+04-3.452e+04
3.591e+04	252	6.94	4.67	-4.64	1.83	-1.80	4.28	2.571e+04-5.554e+04 4687.80-3.452e+04 3.559e+04
236	69	253	5.75	1.11	-3.19	0.52	-2.60	-1.48 2.419e+04-4.401e+04 5567.02-2.538e+04 3.038e+04
	261	5.29	-1.52	-3.19	-1.83	-2.89	-0.65	7676.15-5.085e+04-2.294e+04-2.024e+04
2.923e+04	260	6.78	0.05	-3.51	-2.42	-1.04	-1.64	2554.49-6.926e+04-3.218e+04-3.452e+04
3.589e+04	252	6.90	-2.56	-3.64	-2.57	-3.63	0.12	2.572e+04-5.542e+04 4732.94-3.443e+04 3.553e+04
237	1	254	6.02	0.34	-3.86	-1.83	-1.70	-2.10 3.053e+04-4.142e+04 4041.06-1.493e+04 3.470e+04
	262	5.38	1.96	-5.01	1.02	-4.06	-2.39	1.829e+04-4.443e+04-1.979e+04 -6342.93 3.063e+04
	261	6.89	-1.98	-4.73	-3.05	-3.66	-1.34	9496.39-6.650e+04-3.338e+04-2.362e+04
3.768e+04	253	7.44	2.99	-4.89	0.62	-2.52	-3.61	3.154e+04-5.656e+04 3883.28-2.890e+04 4.089e+04
237	3	254	5.09	0.28	-3.27	-1.55	-1.78	2.583e+04-3.505e+04 3419.36-1.263e+04 2.936e+04
	262	4.55	1.66	-4.24	0.86	-3.44	-2.02	1.548e+04-3.759e+04-1.675e+04 -5367.09 2.592e+04
	261	5.83	-1.68	-4.00	-2.58	-3.10	-1.13	8035.41-5.627e+04-2.825e+04-1.999e+04
3.189e+04	253	6.30	2.53	-4.13	0.53	-2.13	-3.05	2.669e+04-4.786e+04 3285.85-2.445e+04 3.460e+04
237	5	254	4.75	13.37	-29.74	0.25	-16.62	-19.84 2.377e+04-3.174e+04 3341.84-1.131e+04 2.677e+04
	262	4.22	12.55	-22.40	9.48	-19.33	-9.90	1.435e+04-3.406e+04-1.531e+04 -4397.28 2.359e+04
	261	5.35	7.65	-26.41	3.82	-22.58	-10.76	7451.82-5.097e+04-2.560e+04-1.791e+04
2.896e+04	253	5.80	14.29	-31.31	3.64	-20.66	-19.29	2.446e+04-4.336e+04 3079.69-2.198e+04 3.151e+04
237	37	254	4.67	4.61	-11.94	-0.85	-7.78	2.358e+04-3.182e+04 3187.46-1.143e+04 2.672e+04
	262	4.17	5.23	-10.11	3.73	-8.61	-4.56	1.417e+04-3.414e+04-1.525e+04 -4716.11 2.357e+04
	261	5.32	1.45	-11.21	-0.26	-9.51	-4.32	7354.59-5.109e+04-2.565e+04-1.808e+04
2.898e+04	253	5.75	6.34	-13.06	1.55	-8.27	-8.37	2.433e+04-4.346e+04 3018.46-2.215e+04 3.147e+04
237	69	254	4.63	0.26	-2.97	-1.41	-1.61	2.348e+04-3.186e+04 3108.51-1.148e+04 2.669e+04
	262	4.14	1.51	-3.85	0.78	-3.12	-1.84	1.407e+04-3.417e+04-1.523e+04 -4879.17 2.356e+04
	261	5.30	-1.52	-3.64	-2.35	-2.82	-1.03	7304.92-5.115e+04-2.568e+04-1.817e+04
2.899e+04	253	5.72	2.30	-3.76	0.48	-1.94	-2.78	2.426e+04-4.351e+04 2987.14-2.223e+04 3.145e+04
238	1	255	4.08	1.34	-8.13	-4.79	-4.53	1.947e+04-2.888e+04 -2528.24 -6880.07 2.408e+04
	263	5.79	25.85	-11.38	22.81	-8.34	-10.19	4.267e+04-2.478e+04-1.111e+04 2.899e+04 2.712e+04
	262	5.39	-4.17	-11.19	-11.18	-4.19	-0.36	1.850e+04-4.442e+04-1.803e+04 -7890.83 3.105e+04
	254	6.04	10.37	-3.16	6.58	0.62	-6.07	3.111e+04-4.079e+04 -260.82 -9415.76 3.565e+04
238	3	255	3.45	1.14	-6.88	-4.05	-1.69	3.83 1.648e+04-2.444e+04 -2139.28 -5821.60 2.037e+04
	263	4.90	21.87	-9.63	19.30	-7.06	-8.62	3.610e+04-2.097e+04 -9398.12 2.453e+04 2.295e+04
	262	4.56	-3.53	-9.47	-9.46	-3.55	-0.30	1.565e+04-3.759e+04-1.526e+04 -6676.86 2.627e+04
	254	5.11	8.77	-2.67	5.57	0.53	-5.14	2.632e+04-3.451e+04 -220.69 -7967.18 3.017e+04
238	6	255	3.10	-1.52	-16.52	-13.73	-4.30	-5.83 1.501e+04-2.157e+04 -1476.95 -5080.83 1.820e+04
	263	4.79	32.41	-17.90	24.11	-9.61	-18.67	3.343e+04-2.168e+04-1.071e+04 2.246e+04 2.200e+04
	262	4.15	0.01	-22.48	-18.34	-4.13	-8.72	1.448e+04-3.368e+04-1.316e+04 -6039.31 2.382e+04
	254	4.75	11.95	-14.87	0.39	-3.30	-13.28	2.395e+04-3.191e+04 -613.91 -7350.99 2.773e+04
238	38	255	3.10	-2.45	-7.11	-7.08	-2.47	0.33 1.499e+04-2.200e+04 -1786.49 -5220.78 1.841e+04
	263	4.56	23.97	-11.70	19.77	-7.50	-11.50	3.303e+04-1.995e+04 -9278.42 2.236e+04 2.125e+04
	262	4.14	-2.49	-12.94	-11.89	-3.53	-3.13	1.431e+04-3.400e+04-1.363e+04 -6059.53 2.386e+04
	254	4.68	9.22	-6.54	3.48	-0.80	-7.59	2.394e+04-3.156e+04 -340.47 -7279.47 2.753e+04
238	69	255	3.14	1.03	-6.25	-3.69	-1.53	3.48 1.498e+04-2.222e+04 -1944.80 -5292.36 1.852e+04
	263	4.45	19.89	-8.75	17.55	-6.42	-7.84	3.282e+04-1.906e+04 -8543.75 2.230e+04 2.086e+04
	262	4.14	-3.21	-8.61	-8.60	-3.22	-0.28	1.423e+04-3.417e+04-1.387e+04 -6069.87 2.388e+04
	254	4.64	7.98	-2.43	5.06	0.48	-4.67	2.393e+04-3.137e+04 -200.63 -7242.89 2.743e+04
239	1	256	2.10	15.86	-2.24	11.41	2.20	7.79 1.225e+04-1.245e+04 -1372.38 1171.27 1.229e+04
	264	1.67	-0.92	-16.78	-16.78	-0.92	-0.15	9326.59-1.058e+04 -2474.56 1220.15 9780.87
	263	3.24	38.24	-3.07	26.06	9.11	18.84	2.422e+04-1.403e+04-1.204e+04 2.222e+04 8510.74
	255	4.88	-0.29	-17.77	-6.64	-11.42	-8.41	2.609e+04-3.177e+04 -3995.24 -1693.08 2.891e+04
239	3	256	1.78	13.42	-1.90	9.66	1.86	6.59 1.037e+04-1.054e+04 -1161.24 991.08 1.040e+04
	264	1.41	-0.78	-14.20	-14.20	-0.78	-0.13	7891.73 -8953.16 -2093.86 1032.43 8276.12
	263	2.74	32.36	-2.60	22.05	7.71	15.94	2.050e+04-1.188e+04-1.019e+04 1.881e+04 7201.40
	255	4.13	-0.25	-15.04	-5.62	-9.66	-7.12	2.207e+04-2.689e+04 -3380.59 -1432.61 2.446e+04
239	5	256	1.56	16.57	-6.03	15.64	-5.11	-4.49 8753.34 -9453.77 -1539.59 839.16 9025.53
	264	1.30	-4.66	-6.48	-5.37	-5.78	-0.89	7682.56 -7886.75 -1055.32 851.14 7726.08
	263	2.45	45.64	-4.04	36.69	4.91	19.09	1.674e+04-1.193e+04-1.112e+04 1.592e+04 4757.19
	255	3.97	10.67	-33.99	0.36	-23.67	-18.82	2.167e+04-2.442e+04 -2562.67 -191.83 2.301e+04
239	37	256	1.57	11.59	-1.10	11.10	-0.61	2.45 9196.69 -9536.05 -1219.42 880.06 9307.35
	264	1.28	-2.41	-10.37	-10.35	-2.43	-0.38	7342.75 -8050.26 -1616.50 908.99 7592.21
	263	2.45	34.74	-2.76	25.68	6.30	16.05	1.797e+04-1.116e+04 -9887.95 1.670e+04 5941.19
	255	3.82	3.34	-20.43	-3.26	-13.82	-10.65	2.061e+04-2.443e+04 -2900.49 -926.59 2.250e+04
239	69	256	1.62	12.20	-1.72	8.78	1.69	5.99 9424.64 -9579.34 -1055.68 900.98 9451.49
	264	1.28	-0.71	-12.91	-12.91	-0.71	-0.12	7174.30 -8139.24 -1903.51 938.57 7523.75
	263	2.49	29.42	-2.36	20.05	7.01	14.49	1.863e+04-1.080e+04 -9259.51 1.710e+04 6546.73

Parco Eolico "Bolina" – Progetto Definitivo
Relazione di calcolo preliminare delle fondazioni degli aerogeneratori G8 e G12

		255	3.75	-0.22	-13.67	-5.11	-8.78	-6.47	2.007e+04	-2.444e+04	-3073.26	-1302.37	2.224e+04	
240	1	257	0.22	3.38	-1.53	2.20	-0.35	2.10	367.00	-1932.75	-1009.20	-556.56	1127.38	
		265	0.71	-0.24	-7.75	-7.75	-0.24	0.14	-92.66	-7091.87	-7071.74	-112.79	374.87	
		264	1.98	3.08	-2.48	-0.58	1.18	2.64	9726.20	-1.373e+04	-8296.91	4288.98	9899.27	
		256	2.34	1.23	-1.62	-0.29	-0.10	1.43	1.453e+04	-1.344e+04	1265.48	-174.88	1.397e+04	
240	3	257	0.18	2.86	-1.29	1.86	-0.30	1.77	310.53	-1635.41	-853.94	-470.93	953.94	
		265	0.60	-0.20	-6.56	-6.55	-0.20	0.12	-78.40	-6000.82	-5983.78	-95.44	317.20	
		264	1.67	2.61	-2.10	-0.49	1.00	2.23	8229.86	-1.162e+04	-7020.46	3629.14	8376.31	
		256	1.98	1.04	-1.37	-0.25	-0.08	1.21	1.229e+04	-1.137e+04	1070.79	-147.98	1.182e+04	
240	24	257	0.25	7.79	-19.93	-16.40	4.27	9.23	329.55	-1548.43	-822.21	-396.67	914.56	
		265	0.65	1.65	-30.38	-28.94	0.21	-6.64	-108.89	-5652.46	-5638.78	-122.57	275.06	
		264	1.58	6.61	-22.41	-21.44	5.64	-5.22	7802.66	-1.079e+04	-6566.12	3580.96	7788.49	
		256	1.88	8.62	-26.33	-22.14	4.43	11.35	1.115e+04	-1.058e+04	906.59	-337.03	1.085e+04	
240	56	257	0.19	3.49	-6.65	-4.43	1.27	4.19	298.19	-1507.51	-791.84	-417.48	883.24	
		265	0.58	0.29	-14.07	-13.74	-0.05	-2.17	-84.02	-5521.99	-5507.13	-98.88	283.86	
		264	1.54	2.53	-7.57	-7.55	2.51	-0.42	7590.17	-1.064e+04	-6444.46	3394.55	7673.59	
		256	1.83	3.35	-9.54	-7.64	1.45	4.57	1.117e+04	-1.042e+04	950.82	-203.05	1.078e+04	
240	69	257	0.17	2.60	-1.18	1.69	-0.27	1.61	282.30	-1486.73	-776.31	-428.12	867.22	
		265	0.54	-0.18	-5.96	-5.96	-0.18	0.11	-71.28	-5455.29	-5439.80	-86.76	288.36	
		264	1.52	2.37	-1.91	-0.45	0.91	2.03	7481.69	-1.056e+04	-6382.24	3299.21	7614.83	
		256	1.80	0.95	-1.25	-0.22	-0.07	1.10	1.118e+04	-1.034e+04	973.44	-134.52	1.074e+04	
241	1	258	16.14	3.44	-0.93	2.74	-0.23	-1.60	7.623e+04	-1.164e+05	7.341e+04	-1.136e+05	-	
2.315e+04		266	26.74	10.21	-12.80	-4.62	2.04	-11.01	-3.725e+04	-2.947e+05	-1.085e+05	-2.234e+05	-	
1.152e+05		28	13.67	10.02	-5.16	-4.82	9.68	-2.26	-6.286e+04	-1.627e+05	-9.324e+04	-1.323e+05	-	
4.593e+04		19	49.11	7.23	-14.08	-6.17	-0.67	-10.30	-4.021e+04	-5.300e+05	-1.724e+05	-3.978e+05	-	
2.174e+05		241	3	258	13.66	2.91	-0.79	2.32	-0.20	-1.35	6.450e+04	-9.848e+04	6.211e+04	-9.609e+04
1.959e+04		266	22.63	8.64	-10.83	-3.91	1.73	-9.32	-3.152e+04	-2.493e+05	-9.180e+04	-1.890e+05	-	
9.745e+04		28	11.57	8.48	-4.37	-4.08	8.19	-1.91	-5.319e+04	-1.376e+05	-7.890e+04	-1.119e+05	-	
3.886e+04		19	41.56	6.12	-11.91	-5.22	-0.57	-8.71	-3.403e+04	-4.485e+05	-1.459e+05	-3.366e+05	-	
1.840e+05		241	23	258	12.65	12.30	-60.25	1.59	-49.53	-25.74	5.877e+04	-8.964e+04	5.659e+04	-8.745e+04
1.788e+04		266	20.69	-3.70	-44.81	-13.88	-34.63	17.75	-2.879e+04	-2.267e+05	-8.356e+04	-1.719e+05	-	
8.854e+04		28	10.59	52.50	-47.04	41.13	-35.67	-31.66	-4.861e+04	-1.254e+05	-7.199e+04	-1.020e+05	-	
3.534e+04		19	38.05	34.13	-83.99	33.93	-83.79	4.86	-3.122e+04	-4.086e+05	-1.331e+05	-3.067e+05	-	
1.675e+05		241	54	258	12.46	19.43	-0.62	2.29	16.52	7.06	5.859e+04	-8.948e+04	5.643e+04	-8.732e+04
1.778e+04		266	20.64	25.56	-11.80	-0.06	13.82	-17.34	-2.860e+04	-2.267e+05	-8.342e+04	-1.718e+05	-	
8.861e+04		28	10.49	23.69	-20.53	-18.88	22.04	8.39	-4.826e+04	-1.250e+05	-7.163e+04	-1.017e+05	-	
3.532e+04		19	37.85	30.75	-20.92	-17.84	27.66	-12.24	-3.084e+04	-4.074e+05	-1.325e+05	-3.057e+05	-	
1.672e+05		241	69	258	12.42	2.65	-0.72	2.11	-0.18	-1.23	5.864e+04	-8.952e+04	5.647e+04	-8.735e+04
1.781e+04		266	20.57	7.86	-9.84	-3.56	1.57	-8.47	-2.865e+04	-2.267e+05	-8.346e+04	-1.719e+05	-	
8.859e+04		28	10.51	7.71	-3.97	-3.71	7.45	-1.74	-4.835e+04	-1.251e+05	-7.172e+04	-1.018e+05	-	
3.533e+04		19	37.78	5.56	-10.83	-4.75	-0.52	-7.92	-3.093e+04	-4.077e+05	-1.326e+05	-3.060e+05	-	
1.673e+05		242	1	259	11.12	-0.94	-10.37	-9.57	-1.75	-2.63	-267.52	-1.159e+05	-2.268e+04	-9.344e+04
4.570e+04		267	12.59	11.96	-6.09	6.35	-0.48	-8.35	-3.354e+04	-1.441e+05	-8.530e+04	-9.234e+04	-	
5.517e+04		266	17.85	7.31	-13.89	-2.50	-4.07	-10.57	-4.178e+04	-2.029e+05	-8.149e+04	-1.631e+05	-	
6.942e+04		258	16.61	20.31	-9.44	6.39	4.48	-14.84	-1.853e+04	-1.807e+05	-4.845e+04	-1.508e+05	-	
6.291e+04		242	3	259	9.41	-0.80	-8.78	-8.10	-1.48	-2.23	-226.36	-9.803e+04	-1.919e+04	-7.906e+04
3.867e+04		267	10.65	10.12	-5.15	5.37	-0.40	-7.07	-2.838e+04	-1.219e+05	-7.217e+04	-7.814e+04	-	
4.668e+04														

Parco Eolico "Bolina" – Progetto Definitivo
Relazione di calcolo preliminare delle fondazioni degli aerogeneratori G8 e G12

5.874e+04	266	15.10	6.19	-11.75	-2.12	-3.44	-8.94-3.535e+04-1.716e+05-6.896e+04-1.380e+05	
5.323e+04	258	14.05	17.18	-7.99	5.41	3.79	-12.56-1.568e+04-1.529e+05-4.100e+04-1.276e+05	
3.510e+04	259	8.63	-3.65	-64.51	-39.79	-28.38	-29.89	-331.86-8.903e+04-1.758e+04-7.179e+04
4.232e+04	267	9.78	38.39	-29.21	25.96	-16.78	-26.18-2.616e+04-1.109e+05-6.620e+04-7.088e+04	
5.334e+04	266	13.81	17.36	-87.87	-24.42	-46.10	-51.48-3.244e+04-1.561e+05-6.302e+04-1.255e+05	
4.830e+04	258	12.89	60.19	-45.48	23.04	-8.33	-50.46-1.454e+04-1.390e+05-3.752e+04-1.160e+05	
3.514e+04	259	8.58	-2.31	-26.52	-18.33	-10.49	-11.45	-248.45-8.909e+04-1.749e+04-7.185e+04
4.240e+04	267	9.72	18.93	-12.84	12.02	-5.92	-13.11-2.592e+04-1.109e+05-6.581e+04-7.098e+04	
5.338e+04	266	13.76	9.56	-36.76	-9.54	-17.67	-22.80-3.224e+04-1.561e+05-6.280e+04-1.255e+05	
4.836e+04	258	12.81	30.55	-20.04	11.05	-0.54	-24.63-1.435e+04-1.390e+05-3.736e+04-1.160e+05	
3.515e+04	259	8.56	-0.73	-7.98	-7.36	-1.34	-2.02	-205.78-8.912e+04-1.745e+04-7.188e+04
4.244e+04	267	9.68	9.20	-4.68	4.88	-0.37	-6.43-2.580e+04-1.108e+05-6.561e+04-7.103e+04	
5.340e+04	266	13.73	5.63	-10.68	-1.93	-3.13	-8.13-3.214e+04-1.560e+05-6.269e+04-1.255e+05	
4.840e+04	258	12.78	15.62	-7.26	4.91	3.45	-11.42-1.425e+04-1.390e+05-3.727e+04-1.160e+05	
4.311e+04	260	8.72	-0.93	-3.29	-2.88	-1.34	-0.89	3526.81-8.902e+04-2.593e+04-5.956e+04
3.790e+04	268	8.72	0.09	-4.38	-2.22	-2.07	-2.23-2.359e+04-1.002e+05-6.752e+04-5.628e+04	
5.223e+04	267	11.96	5.33	-3.91	3.17	-1.74	-3.91-3.302e+04-1.376e+05-8.282e+04-8.780e+04	
5.120e+04	259	11.41	4.45	-7.59	-2.36	-0.77	-5.97	-5288.81-1.211e+05-3.614e+04-9.028e+04
3.648e+04	260	7.38	-0.79	-2.78	-2.44	-1.13	-0.75	2984.22-7.532e+04-2.194e+04-5.040e+04
3.207e+04	268	7.38	0.07	-3.70	-1.88	-1.75	-1.89-1.996e+04-8.480e+04-5.713e+04-4.762e+04	
4.419e+04	267	10.12	4.51	-3.31	2.68	-1.47	-3.31-2.794e+04-1.164e+05-7.008e+04-7.429e+04	
4.333e+04	259	9.66	3.77	-6.42	-2.00	-0.66	-5.05	-4475.15-1.025e+05-3.058e+04-7.639e+04
3.309e+04	260	6.78	9.07	-26.58	-19.77	2.26	-14.01	2636.07-6.839e+04-1.998e+04-4.577e+04
2.903e+04	268	6.75	13.83	-21.80	-12.31	4.35	-15.75-1.832e+04-7.704e+04-5.206e+04-4.330e+04	
3.998e+04	267	9.28	20.60	-22.47	-8.61	6.74	-20.13-2.584e+04-1.059e+05-6.419e+04-6.752e+04	
3.930e+04	259	8.86	15.80	-29.74	-16.77	2.83	-20.55	-4157.96-9.306e+04-2.784e+04-6.937e+04
3.314e+04	260	6.73	2.59	-10.67	-8.16	0.08	-5.19	2686.92-6.844e+04-1.996e+04-4.580e+04
2.911e+04	268	6.72	4.63	-9.51	-5.29	0.42	-6.46-1.820e+04-7.707e+04-5.198e+04-4.330e+04	
4.011e+04	267	9.23	8.95	-8.86	-1.30	1.39	-8.80-2.555e+04-1.059e+05-6.387e+04-6.753e+04	
3.936e+04	259	8.81	7.51	-13.82	-6.88	0.56	-9.99	-4098.65-9.314e+04-2.781e+04-6.942e+04
3.316e+04	260	6.71	-0.72	-2.53	-2.22	-1.03	-0.68	2712.93-6.847e+04-1.995e+04-4.582e+04
2.915e+04	268	6.71	0.07	-3.37	-1.71	-1.59	-1.72-1.814e+04-7.709e+04-5.194e+04-4.329e+04	
4.017e+04	267	9.20	4.10	-3.01	2.44	-1.34	-3.01-2.540e+04-1.058e+05-6.371e+04-6.754e+04	
3.939e+04	259	8.78	3.42	-5.84	-1.82	-0.60	-4.59	-4068.31-9.317e+04-2.780e+04-6.945e+04
3.633e+04	261	6.78	-0.44	-3.79	-1.63	-2.59	-1.60	8874.29-6.566e+04-2.007e+04-3.672e+04
3.103e+04	269	6.94	0.94	-6.50	-3.71	-1.85	-3.61	-9609.16-7.653e+04-5.560e+04-3.054e+04
	268	8.79	1.01	-3.10	-1.84	-0.25	-1.89-2.293e+04-1.008e+05-6.889e+04-5.487e+04	

Parco Eolico "Bolina" – Progetto Definitivo
Relazione di calcolo preliminare delle fondazioni degli aerogeneratori G8 e G12

	262		3.85	8.86	-3.65	8.47	-3.25	-2.19	7357.75-3.572e+04-1.403e+04-1.433e+04
2.154e+04									
	246	21	263	4.28	14.63	-45.87	-5.32	-25.92	-28.44 3.906e+04 -6092.88 1.497e+04 1.799e+04 2.252e+04
			271	4.05	25.79	-10.23	23.87	-8.30	8.11 3290.90-3.950e+04-3.810e+04 1892.27 7608.41
			270	4.62	11.29	-24.34	10.24	-23.29	-6.00 7376.74-4.300e+04-3.559e+04 -27.34 1.784e+04
			262	3.57	32.48	-28.32	29.46	-25.30	-13.23 7018.40-3.212e+04-1.286e+04-1.224e+04
1.957e+04									
	246	53	263	4.05	4.81	-32.05	-16.24	-11.00	-18.24 3.732e+04 -6185.89 1.438e+04 1.676e+04 2.172e+04
			271	4.01	11.67	-3.81	9.10	-1.24	5.76 3711.92-3.955e+04-3.801e+04 2172.04 8015.84
			270	4.55	1.02	-12.89	-2.10	-9.78	-5.80 7022.39-4.314e+04-3.583e+04 -293.60 1.771e+04
			262	3.52	16.31	-11.77	15.06	-10.52	-5.79 6799.22-3.235e+04-1.279e+04-1.276e+04
1.957e+04									
	246	69	263	3.93	3.37	-28.56	-21.82	-3.37	-13.03 3.643e+04 -6234.80 1.407e+04 1.612e+04 2.131e+04
			271	4.01	6.54	-2.63	1.54	2.37	4.57 3929.34-3.959e+04-3.797e+04 2315.13 8224.21
			270	4.52	0.70	-11.97	-8.41	-2.86	-5.70 6841.27-4.322e+04-3.595e+04 -429.77 1.764e+04
			262	3.50	8.06	-3.32	7.70	-2.96	-1.99 6688.86-3.247e+04-1.275e+04-1.303e+04
1.958e+04									
	247	1	264	3.10	11.40	1.08	11.39	1.10	-0.43 1.322e+04-2.344e+04 -6473.86 -3746.76 1.828e+04
			272	3.84	-2.30	-14.56	-12.29	-4.56	4.76 1.232e+04-3.194e+04-3.071e+04 1.109e+04 7272.69
			271	5.67	8.68	-1.97	3.41	3.30	-5.33 8173.56-5.433e+04-4.997e+04 3808.63 1.593e+04
			263	3.64	2.25	-32.65	-29.04	-1.36	10.62 3.746e+04 -149.33 1.791e+04 1.940e+04 1.879e+04
	247	3	264	2.62	9.65	0.91	9.63	0.93	-0.36 1.118e+04-1.983e+04 -5477.88 -3170.33 1.542e+04
			272	3.25	-1.94	-12.32	-10.40	-3.86	4.03 1.043e+04-2.702e+04-2.598e+04 9385.50 6153.82
			271	4.80	7.35	-1.67	2.88	2.80	-4.51 6916.09-4.597e+04-4.228e+04 3222.69 1.348e+04
			263	3.08	1.90	-27.63	-24.58	-1.15	8.99 3.170e+04 -126.35 1.515e+04 1.642e+04 1.590e+04
	247	21	264	2.45	30.32	-9.46	28.09	-7.23	-9.15 1.009e+04-1.800e+04 -4790.01 -3117.62 1.412e+04
			272	3.03	16.09	-12.53	14.67	-11.12	6.21 9816.18-2.468e+04-2.369e+04 8824.17 5765.08
			271	4.48	24.26	-13.54	24.26	-13.54	0.08 6974.04-4.154e+04-3.846e+04 3899.07 1.182e+04
			263	2.91	0.57	-9.69	-2.49	-6.62	-4.69 2.925e+04 -1221.10 1.423e+04 1.380e+04 1.523e+04
	247	37	264	2.42	11.30	-1.40	10.10	-0.21	-3.71 1.010e+04-1.822e+04 -5168.64 -2945.44 1.412e+04
			272	2.94	-2.52	-10.31	-7.50	-5.33	3.74 9590.88-2.444e+04-2.351e+04 8659.71 5551.62
			271	4.40	8.58	-3.06	4.56	0.95	-5.53 6372.31-4.198e+04-3.860e+04 2991.79 1.233e+04
			263	2.77	-1.01	-26.28	-24.38	-2.91	6.66 2.891e+04 392.26 1.449e+04 1.481e+04 1.426e+04
	247	69	264	2.38	8.77	0.83	8.76	0.85	-0.33 1.017e+04-1.803e+04 -4979.89 -2882.12 1.406e+04
			272	2.96	-1.77	-11.20	-9.46	-3.51	3.66 9477.80-2.457e+04-2.362e+04 8532.28 5594.38
			271	4.36	6.68	-1.52	2.62	2.54	-4.10 6287.35-4.179e+04-3.844e+04 2929.72 1.225e+04
			263	2.80	1.73	-25.11	-22.34	-1.04	8.17 2.882e+04 -114.87 1.378e+04 1.492e+04 1.445e+04
	248	1	265	0.92	0.99	-0.91	0.78	-0.70	0.59 111.23 -9541.97 -8647.38 -783.36 2799.18
			273	2.52	0.27	-4.31	-4.19	0.15	0.72 313.45-2.590e+04-2.582e+04 231.99 -1459.05
			272	3.84	1.02	-4.49	-2.53	-0.93	2.64 8615.81-3.481e+04-3.319e+04 6995.18 8230.88
			264	2.64	0.62	-3.73	-3.46	0.35	-1.05 1.490e+04-1.674e+04 -2280.92 438.29 1.576e+04
	248	3	265	0.78	0.83	-0.77	0.66	-0.59	0.50 94.12 -8073.98 -7317.01 -662.85 2368.53
			273	2.13	0.23	-3.64	-3.54	0.13	0.61 265.22-2.192e+04-2.185e+04 196.30 -1234.58
			272	3.25	0.86	-3.80	-2.14	-0.79	2.23 7290.30-2.945e+04-2.808e+04 5919.00 6964.59
			264	2.23	0.52	-3.16	-2.93	0.29	-0.89 1.261e+04-1.416e+04 -1930.01 370.86 1.334e+04
	248	23	265	0.79	23.73	-4.98	23.30	-4.56	-3.46 115.42 -7168.52 -6483.02 -570.08 2126.79
			273	2.01	22.61	-0.46	21.12	1.02	5.66 211.35-1.994e+04-1.988e+04 151.41 -1097.33
			272	3.03	23.64	-9.18	21.83	-7.36	7.50 6791.95-2.678e+04-2.553e+04 5539.09 6363.29
			264	2.11	24.52	-3.91	20.95	-0.33	-9.43 1.149e+04-1.305e+04 -1664.50 104.16 1.224e+04
	248	54	265	0.75	1.20	-7.46	-7.08	0.82	1.78 75.48 -7398.02 -6708.95 -613.59 2162.15
			273	1.97	-0.07	-11.58	-11.46	-0.19	-1.17 251.20-1.992e+04-1.986e+04 187.61 -1130.82
			272	2.98	1.53	-10.00	-9.99	1.53	0.18 6571.91-2.677e+04-2.553e+04 5327.38 6320.67
			264	2.04	0.85	-11.04	-10.65	0.47	2.11 1.145e+04-1.282e+04 -1785.03 415.99 1.208e+04
	248	69	265	0.71	0.76	-0.70	0.60	-0.54	0.45 85.56 -7339.98 -6651.83 -602.59 2153.21
			273	1.94	0.21	-3.31	-3.22	0.12	0.56 241.11-1.993e+04-1.986e+04 178.46 -1122.35
			272	2.95	0.79	-3.45	-1.95	-0.72	2.03 6627.54-2.678e+04-2.553e+04 5380.91 6331.44
			264	2.03	0.47	-2.87	-2.66	0.27	-0.81 1.146e+04-1.288e+04 -1754.56 337.15 1.212e+04
	249	1	266	18.78	4.19	-7.06	-4.77	1.91	-4.53-6.037e+04-2.185e+05-9.133e+04-1.875e+05
6.275e+04									
			274	19.80	12.39	-10.14	0.63	1.62	-11.25-7.256e+04-2.321e+05-1.451e+05-1.595e+05
7.943e+04									
			37	32.87	2.13	-14.78	-8.07	-4.59	-8.27-1.075e+05-3.832e+05-1.097e+05-3.811e+05
2.418e+04									
			28	21.45	19.31	-11.49	-4.05	11.87	-13.18-4.241e+04-2.407e+05-1.023e+05-1.808e+05
9.104e+04									
	249	3	266	15.89	3.55	-5.97	-4.04	1.61	-3.83-5.108e+04-1.849e+05-7.728e+04-1.587e+05
5.310e+04									
			274	16.75	10.48	-8.58	0.53	1.37	-9.52-6.140e+04-1.964e+05-1.228e+05-1.350e+05
6.721e+04									
			37	27.81	1.80	-12.51	-6.83	-3.88	-7.00-9.099e+04-3.243e+05-9.280e+04-3.224e+05
2.046e+04									
			28	18.15	16.34	-9.73	-3.43	10.04	-11.15-3.589e+04-2.036e+05-8.657e+04-1.530e+05
7.703e+04									

Parco Eolico "Bolina" – Progetto Definitivo
Relazione di calcolo preliminare delle fondazioni degli aerogeneratori G8 e G12

249	23	266	14.59	67.96	-33.34	65.39	-30.77	15.92-4.668e+04-1.681e+05-7.049e+04-1.443e+05
4.821e+04		274	15.27	42.73	-72.79	42.45	-72.50	5.73-5.580e+04-1.783e+05-1.117e+05-1.224e+05
6.104e+04		37	25.61	45.10	-75.25	39.66	-69.80	-25.01-8.318e+04-2.954e+05-8.482e+04-2.938e+05
1.858e+04		28	16.56	0.93	-48.00	0.78	-47.85	-2.71-3.280e+04-1.855e+05-7.889e+04-1.394e+05
7.009e+04		266	14.47	20.02	-9.76	19.70	-9.44	3.08-4.652e+04-1.681e+05-7.034e+04-1.443e+05
4.825e+04	55	274	15.18	15.05	-24.08	14.68	-23.71	-3.79-5.581e+04-1.785e+05-1.117e+05-1.226e+05
6.108e+04		37	25.40	13.39	-30.04	9.31	-25.96	-12.67-8.288e+04-2.950e+05-8.452e+04-2.934e+05
1.860e+04		28	16.46	2.72	-14.67	-1.80	-10.15	-7.62-3.269e+04-1.853e+05-7.876e+04-1.392e+05
7.005e+04		266	14.45	3.22	-5.43	-3.67	1.47	-3.48-4.644e+04-1.681e+05-7.026e+04-1.443e+05
4.827e+04	69	274	15.23	9.53	-7.80	0.48	1.25	-8.65-5.582e+04-1.785e+05-1.116e+05-1.227e+05
6.110e+04		37	25.28	1.63	-11.37	-6.20	-3.53	-6.36-8.272e+04-2.948e+05-8.436e+04-2.931e+05
1.860e+04		28	16.50	14.85	-8.84	-3.12	9.13	-10.14-3.263e+04-1.851e+05-7.870e+04-1.391e+05
7.003e+04		267	11.63	-0.85	-7.26	-1.28	-6.83	-1.60-3.765e+04-1.355e+05-7.457e+04-9.854e+04
4.741e+04	1	275	13.72	48.48	-16.28	29.95	2.25	-29.27-2.480e+04-1.515e+05-9.861e+04-7.774e+04
6.250e+04		274	18.87	2.02	-23.59	-22.94	1.37	-4.02-8.757e+04-2.250e+05-1.234e+05-1.892e+05
6.032e+04		266	19.62	23.49	-11.42	6.10	5.97	-17.46-3.813e+04-2.197e+05-8.162e+04-1.762e+05
7.749e+04		267	9.84	-0.72	-6.14	-1.08	-5.78	-1.35-3.186e+04-1.146e+05-6.309e+04-8.338e+04
4.012e+04	3	275	11.61	41.02	-13.78	25.35	1.90	-24.77-2.099e+04-1.282e+05-8.344e+04-6.578e+04
5.289e+04		274	15.96	1.71	-19.96	-19.41	1.16	-3.40-7.410e+04-1.904e+05-1.044e+05-1.601e+05
5.104e+04		266	16.60	19.88	-9.67	5.16	5.05	-14.77-3.227e+04-1.859e+05-6.906e+04-1.491e+05
6.557e+04		267	8.88	34.21	-5.60	-5.37	33.98	3.03-2.898e+04-1.030e+05-5.736e+04-7.464e+04
3.600e+04	22	275	10.99	75.21	-18.83	1.28	55.10	-38.56-1.908e+04-1.201e+05-7.673e+04-6.246e+04
5.000e+04		274	14.60	52.38	-63.01	-62.42	51.79	-8.20-6.713e+04-1.726e+05-9.405e+04-1.457e+05
4.598e+04		266	15.37	83.66	-59.44	-59.24	83.46	-5.34-2.919e+04-1.699e+05-6.306e+04-1.360e+05
6.016e+04		267	8.92	8.03	-2.47	-2.47	8.02	0.21-2.897e+04-1.038e+05-5.736e+04-7.541e+04
3.631e+04	54	275	10.70	45.75	-10.29	15.68	19.79	-27.94-1.908e+04-1.178e+05-7.615e+04-6.070e+04
4.873e+04		274	14.54	18.67	-33.25	-32.80	18.22	-4.82-6.729e+04-1.729e+05-9.461e+04-1.456e+05
4.626e+04		266	15.18	33.54	-19.21	-16.94	31.28	-10.69-2.928e+04-1.693e+05-6.288e+04-1.357e+05
5.980e+04		267	8.95	-0.66	-5.59	-0.99	-5.26	-1.23-2.896e+04-1.042e+05-5.736e+04-7.580e+04
3.647e+04	69	275	10.56	37.29	-12.52	23.04	1.73	-22.51-1.908e+04-1.166e+05-7.585e+04-5.980e+04
4.808e+04		274	14.51	1.55	-18.14	-17.65	1.05	-3.09-6.736e+04-1.731e+05-9.490e+04-1.456e+05
4.640e+04		266	15.09	18.07	-8.79	4.69	4.59	-13.43-2.933e+04-1.690e+05-6.278e+04-1.356e+05
5.961e+04		268	8.08	6.40	-0.35	3.04	3.01	3.37-2.444e+04-9.360e+04-5.517e+04-6.287e+04
3.437e+04	1	276	9.23	1.94	-25.17	-21.87	-1.35	-8.85-3.866e+04-1.094e+05-7.870e+04-6.933e+04
3.504e+04		275	10.01	35.82	-4.70	30.91	0.22	13.23-5.066e+04-1.197e+05-9.591e+04-7.444e+04
3.280e+04		267	12.48	9.50	-14.49	-0.32	-4.67	-11.80-3.725e+04-1.441e+05-8.052e+04-1.008e+05
5.244e+04		268	6.84	5.41	-0.29	2.57	2.55	2.85-2.068e+04-7.920e+04-4.668e+04-5.320e+04
251	3							

Parco Eolico "Bolina" – Progetto Definitivo
Relazione di calcolo preliminare delle fondazioni degli aerogeneratori G8 e G12

		278	5.79	1.68	-5.75	-2.33	-1.75	-3.71	-1465.77-6.092e+04-5.340e+04	-8985.99	1.976e+04
		277	7.34	0.93	-7.87	-5.30	-1.63	-4.00-2.256e+04-8.517e+04-7.245e+04-3.527e+04			
2.519e+04		269	6.98	3.37	-5.92	-2.88	0.33	-4.36	-9037.87-7.655e+04-4.635e+04-3.924e+04		
3.357e+04		270	5.11	1.71	-6.69	-4.86	-0.11	-3.46	4900.14-5.052e+04-3.363e+04-1.199e+04		
2.551e+04	3	278	4.90	1.42	-4.87	-1.97	-1.48	-3.14	-1240.27-5.154e+04-4.518e+04	-7603.53	1.672e+04
		277	6.21	0.79	-6.66	-4.49	-1.38	-3.38-1.909e+04-7.206e+04-6.131e+04-2.984e+04			
2.131e+04		269	5.90	2.85	-5.01	-2.44	0.28	-3.69	-7647.42-6.477e+04-3.922e+04-3.320e+04		
2.840e+04		270	4.73	20.78	-22.12	-21.24	19.90	6.07	4211.71-4.615e+04-3.074e+04-1.120e+04		
2.321e+04		278	4.52	19.86	-22.43	-22.09	19.52	-3.79	-1654.17-4.703e+04-4.106e+04	-7625.98	1.534e+04
		277	5.70	23.74	-22.54	-22.30	23.49	-3.35-1.749e+04-6.563e+04-5.575e+04-2.737e+04			
1.944e+04		269	5.41	27.31	-20.74	-19.85	26.42	6.47	-7077.56-5.908e+04-3.567e+04-3.048e+04		
2.587e+04		270	4.66	6.67	-10.11	-10.11	6.67	-0.03	4372.44-4.600e+04-3.063e+04-1.100e+04		
2.320e+04	56	278	4.46	6.38	-9.32	-8.66	5.71	-3.17	-1306.32-4.691e+04-4.107e+04	-7153.79	1.525e+04
		277	5.66	7.68	-10.81	-10.24	7.12	-3.17-1.740e+04-6.555e+04-5.574e+04-2.721e+04			
1.940e+04		269	5.36	9.11	-8.18	-8.18	9.11	-0.03	-6994.71-5.895e+04-3.566e+04-3.028e+04		
2.584e+04		270	4.65	1.55	-6.08	-4.42	-0.10	-3.15	4454.67-4.593e+04-3.057e+04-1.090e+04		
2.319e+04	69	278	4.45	1.29	-4.43	-1.79	-1.34	-2.85	-1127.52-4.686e+04-4.107e+04	-6912.30	1.520e+04
		277	5.64	0.72	-6.05	-4.08	-1.26	-3.08-1.735e+04-6.551e+04-5.573e+04-2.713e+04			
1.937e+04		269	5.37	2.59	-4.55	-2.22	0.26	-3.35	-6952.20-5.888e+04-3.566e+04-3.018e+04		
2.582e+04		271	5.18	-1.10	-8.76	-7.96	-1.90	2.34	6762.73-4.996e+04-4.115e+04	-2052.35	2.055e+04
	1	279	6.57	20.51	-8.64	16.15	-4.28	-10.39	4.035e+04-3.757e+04-3.301e+04	3.580e+04	1.828e+04
		278	5.63	-1.02	-13.30	-12.68	-1.64	-2.69	-3769.58-6.016e+04-5.059e+04-1.334e+04		
2.117e+04		270	6.19	7.78	-4.04	1.51	2.23	-5.90	8271.73-5.955e+04-4.150e+04	-9784.35	2.998e+04
		271	4.39	-0.93	-7.41	-6.73	-1.61	1.98	5722.31-4.228e+04-3.482e+04	-1736.61	1.739e+04
	3	279	5.56	17.35	-7.31	13.66	-3.62	-8.79	3.414e+04-3.179e+04-2.793e+04	3.029e+04	1.546e+04
		278	4.76	-0.86	-11.26	-10.73	-1.39	-2.28	-3189.64-5.091e+04-4.281e+04-1.129e+04		
1.791e+04		270	5.24	6.58	-3.42	1.28	1.88	-4.99	6999.15-5.039e+04-3.511e+04	-8279.06	2.536e+04
		271	3.91	-2.82	-13.19	-9.85	-6.16	-4.84	5199.17-3.790e+04-3.123e+04	-1466.46	1.558e+04
	5	279	5.41	30.34	-15.83	24.27	-9.77	-15.60	3.189e+04-3.130e+04-2.755e+04	2.813e+04	1.493e+04
		278	4.26	-1.89	-17.89	-13.54	-6.24	-7.12	-2716.33-4.560e+04-3.823e+04-1.009e+04		
1.618e+04		270	4.87	12.56	-15.52	1.54	-4.51	-13.71	6426.50-4.630e+04-3.230e+04	-7569.31	2.328e+04
		271	3.96	-3.01	-7.43	-7.38	-3.05	-0.45	5201.10-3.825e+04-3.151e+04	-1540.74	1.573e+04
	37	279	5.18	20.70	-9.75	16.43	-5.48	-10.57	3.133e+04-2.971e+04-2.612e+04	2.774e+04	1.435e+04
		278	4.31	-1.46	-12.53	-11.04	-2.95	-3.78	-2837.72-4.605e+04-3.868e+04-1.021e+04		
1.625e+04		270	4.80	8.14	-7.24	1.29	-0.39	-7.64	6384.39-4.597e+04-3.205e+04	-7540.93	2.313e+04
		271	3.99	-0.85	-6.74	-6.12	-1.46	1.80	5202.10-3.843e+04-3.165e+04	-1578.73	1.581e+04
	69	279	5.06	15.77	-6.64	12.42	-3.29	-7.99	3.104e+04-2.890e+04-2.539e+04	2.754e+04	1.406e+04
		278	4.33	-0.79	-10.23	-9.75	-1.26	-2.07	-2899.67-4.628e+04-3.891e+04-1.026e+04		
1.629e+04		270	4.76	5.98	-3.11	1.16	1.71	-4.54	6362.87-4.581e+04-3.192e+04	-7526.42	2.306e+04
		272	3.73	9.30	-1.11	5.72	2.47	4.94	8727.66-3.377e+04-3.113e+04	6089.48	1.025e+04
	1	280	2.72	-1.29	-15.43	-15.39	-1.33	-0.72	2176.62-2.660e+04-2.640e+04	1976.25	2392.86
		279	5.34	25.93	-1.49	18.23	6.22	12.33	3.150e+04-3.225e+04-3.222e+04	3.148e+04	1222.92
		271	5.61	-2.30	-14.54	-9.17	-7.66	-6.07	1.059e+04-5.225e+04-4.174e+04	79.51	2.345e+04
	3	272	3.16	7.87	-0.94	4.84	2.09	4.18	7384.94-2.857e+04-2.634e+04	5152.64	8676.87
		280	2.30	-1.09	-13.05	-13.02	-1.12	-0.61	1841.76-2.251e+04-2.234e+04	1672.21	2024.73
		279	4.52	21.94	-1.26	15.42	5.26	10.43	2.666e+04-2.729e+04-2.727e+04	2.664e+04	1034.78
		271	4.74	-1.95	-12.30	-7.76	-6.48	-5.14	8958.18-4.421e+04-3.532e+04	67.28	1.984e+04
	21	272	2.99	27.15	-5.84	27.11	-5.80	-1.17	6627.23-2.611e+04-2.429e+04	4810.29	7495.18
		280	2.03	8.76	-6.14	8.32	-5.70	2.54	1519.42-1.995e+04-1.977e+04	1341.66	1945.54
		279	4.17	46.86	-6.25	39.02	1.59	18.85	2.288e+04-2.561e+04-2.560e+04	2.288e+04	-580.06
		271	4.54	17.69	-27.02	12.39	-21.72	-14.46	9659.83-4.027e+04-3.190e+04	1285.37	1.866e+04
	53	272	2.91	12.42	-1.04	12.08	-0.70	2.12	6682.93-2.602e+04-2.406e+04	4726.88	7755.12
		280	2.04	-2.51	-5.11	-5.02	-2.60	0.49	1621.63-2.029e+04-2.013e+04	1459.78	1876.15
		279	4.13	28.85	-2.66	22.48	3.70	12.65	2.377e+04-2.507e+04-2.506e+04	2.376e+04	426.12

Parco Eolico "Bolina" – Progetto Definitivo
Relazione di calcolo preliminare delle fondazioni degli aerogeneratori G8 e G12

		271	4.39	3.77	-15.49	-0.48	-11.25	-7.98	8656.78-4.022e+04-3.204e+04	475.41	1.825e+04
255	69	272	2.87	7.15	-0.85	4.40	1.90	3.80	6713.58-2.598e+04-2.395e+04	4684.22	7888.06
		280	2.09	-0.99	-11.87	-11.84	-1.02	-0.56	1674.32-2.046e+04-2.031e+04	1520.19	1840.66
		279	4.11	19.95	-1.15	14.02	4.78	9.48	2.423e+04-2.480e+04-2.479e+04	2.421e+04	940.71
		271	4.31	-1.77	-11.18	-7.06	-5.89	-4.67	8143.80-4.019e+04-3.211e+04	61.16	1.804e+04
256	1	273	2.54	-0.20	-1.66	-1.26	-0.59	0.65	400.88-2.620e+04-2.568e+04	-115.55	3669.95
		281	2.79	-0.29	-6.70	-6.68	-0.30	0.31	16.33-2.877e+04-2.853e+04	-222.83	-2612.77
		280	3.38	1.31	-2.82	-2.57	1.07	0.98	6352.82-3.142e+04-3.110e+04	6028.15	3486.93
		272	3.47	0.45	-3.74	-3.14	-0.15	1.46	6625.90-3.224e+04-2.873e+04	3110.68	1.115e+04
256	3	273	2.15	-0.17	-1.40	-1.07	-0.50	0.55	339.21-2.217e+04-2.173e+04	-97.78	3105.35
		281	2.36	-0.24	-5.67	-5.66	-0.26	0.26	13.81-2.434e+04-2.414e+04	-188.55	-2210.80
		280	2.86	1.11	-2.38	-2.18	0.90	0.83	5375.46-2.659e+04-2.631e+04	5100.74	2950.48
		272	2.94	0.38	-3.16	-2.66	-0.12	1.24	5606.53-2.728e+04-2.431e+04	2632.11	9433.10
256	22	273	2.07	2.77	-28.38	-27.57	1.96	4.97	340.32-2.016e+04-1.976e+04	-64.42	2851.93
		281	2.26	0.69	-31.19	-30.41	-0.09	-4.93	-16.08-2.224e+04-2.206e+04	-198.76	-2006.72
		280	2.73	5.47	-27.59	-26.67	4.55	-5.43	5133.80-2.435e+04-2.407e+04	4858.29	2836.77
		272	2.79	5.14	-29.84	-28.34	3.64	7.07	4973.13-2.485e+04-2.209e+04	2206.40	8652.66
256	54	273	1.99	0.74	-10.35	-9.97	0.36	2.01	319.17-2.015e+04-1.975e+04	-80.61	2832.82
		281	2.18	-0.02	-13.86	-13.69	-0.18	-1.51	2.87-2.217e+04-2.198e+04	-180.67	-2008.77
		280	2.64	2.23	-10.48	-10.33	2.08	-1.34	4970.26-2.423e+04-2.397e+04	4711.90	2734.54
		272	2.71	1.91	-11.94	-11.19	1.16	3.14	5054.88-2.482e+04-2.210e+04	2329.75	8601.64
256	69	273	1.95	-0.15	-1.27	-0.97	-0.45	0.50	308.37-2.015e+04-1.975e+04	-88.89	2823.04
		281	2.14	-0.22	-5.15	-5.14	-0.23	0.24	12.56-2.213e+04-2.194e+04	-171.41	-2009.82
		280	2.60	1.01	-2.17	-1.98	0.82	0.75	4886.78-2.417e+04-2.392e+04	4637.04	2682.26
		272	2.67	0.34	-2.87	-2.42	-0.11	1.12	5096.85-2.480e+04-2.210e+04	2392.83	8575.55
257	1	274	13.86	7.84	-18.04	-10.13	-0.07	-11.92	-7.020e+04-1.657e+05-7.469e+04-1.613e+05		
2.022e+04		282	23.16	-3.00	-7.45	-6.58	-3.88	-1.77	-1.250e+05-2.780e+05-1.960e+05-2.070e+05		
7.634e+04		46	20.81	8.72	-21.51	-0.66	-12.14	-13.98	-1.461e+05-2.489e+05-1.848e+05-2.102e+05		
4.979e+04		37	45.11	10.79	-5.55	0.79	4.45	-7.96	-1.114e+05-5.151e+05-2.214e+05-4.051e+05		
1.797e+05		274	11.72	6.64	-15.26	-8.57	-0.06	-10.09	-5.940e+04-1.402e+05-6.320e+04-1.364e+05		
1.711e+04	3	282	19.60	-2.54	-6.31	-5.56	-3.28	-1.50	-1.057e+05-2.353e+05-1.658e+05-1.751e+05		
6.459e+04		46	17.61	7.37	-18.20	-0.56	-10.27	-11.83	-1.237e+05-2.106e+05-1.564e+05-1.779e+05		
4.213e+04		37	38.17	9.13	-4.69	0.67	3.77	-6.74	-9.427e+04-4.358e+05-1.874e+05-3.428e+05		
1.521e+05		274	10.85	39.55	-75.49	37.91	-73.85	-13.63	-5.417e+04-1.272e+05-5.765e+04-1.237e+05		
1.556e+04	23	282	17.94	66.92	-34.75	63.86	-31.70	-17.35	-9.622e+04-2.141e+05-1.511e+05-1.593e+05		
5.881e+04		46	16.14	0.57	-56.80	0.11	-56.34	-5.12	-1.128e+05-1.918e+05-1.425e+05-1.621e+05		
3.828e+04		37	34.98	47.33	-70.55	43.05	-66.27	22.05	-8.610e+04-3.969e+05-1.708e+05-3.123e+05		
1.384e+05		274	10.75	26.11	-24.44	-23.26	24.92	-7.66	-5.394e+04-1.276e+05-5.738e+04-1.242e+05		
1.555e+04	54	282	17.85	7.20	-28.84	-28.38	6.73	4.05	-9.609e+04-2.138e+05-1.507e+05-1.592e+05		
5.869e+04		46	16.04	16.10	-10.25	-0.72	6.57	-12.66	-1.123e+05-1.914e+05-1.421e+05-1.616e+05		
3.830e+04		37	34.78	32.33	-19.08	-13.76	27.01	-15.66	-8.556e+04-3.960e+05-1.702e+05-3.114e+05		
1.382e+05		274	10.66	6.03	-13.88	-7.79	-0.05	-9.17	-5.400e+04-1.275e+05-5.745e+04-1.240e+05		
1.555e+04	69	282	17.82	-2.31	-5.73	-5.06	-2.98	-1.36	-9.612e+04-2.139e+05-1.508e+05-1.592e+05		
5.872e+04		46	16.01	6.70	-16.55	-0.51	-9.34	-10.76	-1.124e+05-1.915e+05-1.422e+05-1.617e+05		
3.830e+04		37	34.70	8.30	-4.27	0.61	3.43	-6.12	-8.570e+04-3.962e+05-1.703e+05-3.116e+05		
1.383e+05		275	10.66	14.78	-50.32	-38.52	2.98	-25.08	-1.890e+04-1.180e+05-5.509e+04-8.179e+04		
4.771e+04	1	283	14.00	2.95	-7.44	-6.53	2.04	-2.94	-9.271e+04-1.680e+05-1.532e+05-1.075e+05		
2.994e+04		282	18.17	8.25	-26.95	-15.99	-2.72	-16.30	-1.265e+05-2.174e+05-1.639e+05-1.801e+05		
4.472e+04		274	19.93	14.32	-2.39	12.69	-0.76	-4.96	-1.011e+05-2.385e+05-1.375e+05-2.021e+05		
6.063e+04											

Parco Eolico "Bolina" – Progetto Definitivo
Relazione di calcolo preliminare delle fondazioni degli aerogeneratori G8 e G12

258	3	275	9.02	12.51	-42.58	-32.59	2.52	-21.22-1.599e+04-9.984e+04-4.662e+04-6.921e+04
4.037e+04		283	11.85	2.49	-6.30	-5.53	1.72	-2.49-7.845e+04-1.422e+05-1.296e+05-9.099e+04
2.533e+04		282	15.38	6.98	-22.80	-13.53	-2.30	-13.79-1.071e+05-1.840e+05-1.386e+05-1.524e+05
3.784e+04		274	16.86	12.12	-2.02	10.74	-0.64	-4.19-8.553e+04-2.018e+05-1.163e+05-1.710e+05
5.130e+04		275	8.25	57.91	-59.42	-58.07	56.57	-12.49-1.646e+04-9.118e+04-4.210e+04-6.554e+04
258	22	283	10.80	42.52	-9.05	-6.15	39.61	-11.90-7.017e+04-1.292e+05-1.177e+05-8.170e+04
3.548e+04		282	14.09	82.53	-85.29	-79.74	76.98	-30.00-9.782e+04-1.671e+05-1.261e+05-1.389e+05
2.340e+04		274	15.46	49.64	-32.64	-32.21	49.21	-5.93-7.736e+04-1.836e+05-1.055e+05-1.555e+05
3.405e+04		275	8.21	25.14	-43.74	-39.25	20.66	-16.99-1.519e+04-9.089e+04-4.228e+04-6.380e+04
4.687e+04		283	10.77	15.87	-6.84	-5.40	14.44	-5.52-7.093e+04-1.292e+05-1.178e+05-8.237e+04
258	54	282	14.02	29.90	-40.35	-35.12	24.67	-18.45-9.749e+04-1.672e+05-1.260e+05-1.387e+05
3.629e+04		274	15.37	17.21	-5.39	-4.44	16.26	-4.53-7.762e+04-1.835e+05-1.057e+05-1.555e+05
2.316e+04		275	8.20	11.37	-38.71	-29.63	2.29	-19.29-1.453e+04-9.076e+04-4.238e+04-6.292e+04
3.428e+04		283	10.77	2.27	-5.72	-5.02	1.57	-2.26-7.132e+04-1.292e+05-1.178e+05-8.272e+04
4.672e+04		282	13.98	6.34	-20.73	-12.30	-2.09	-12.54-9.733e+04-1.673e+05-1.260e+05-1.385e+05
258	69	274	15.33	11.01	-1.84	9.76	-0.58	-3.81-7.776e+04-1.834e+05-1.058e+05-1.555e+05
3.670e+04		276	10.49	18.23	-6.12	13.56	-1.45	-9.59-3.968e+04-1.229e+05-8.531e+04-7.722e+04
2.303e+04		284	9.92	-4.45	-14.84	-13.16	-6.14	3.83-4.830e+04-1.180e+05-1.081e+05-5.820e+04
3.440e+04		283	14.36	14.93	-15.83	-9.19	8.29	-12.66-8.934e+04-1.724e+05-1.499e+05-1.119e+05
4.664e+04		275	9.55	-0.34	-47.06	-39.70	-7.70	17.02-2.768e+04-1.091e+05-5.637e+04-8.039e+04
259	1	276	8.88	15.42	-5.18	11.47	-1.23	-8.11-3.357e+04-1.040e+05-7.219e+04-6.534e+04
4.139e+04		284	8.39	-3.77	-12.56	-11.14	-5.19	3.24-4.087e+04-9.984e+04-9.146e+04-4.925e+04
2.434e+04		283	12.15	12.63	-13.40	-7.78	7.01	-10.71-7.559e+04-1.459e+05-1.268e+05-9.466e+04
3.695e+04		275	8.08	-0.29	-39.82	-33.60	-6.52	14.40-2.343e+04-9.229e+04-4.770e+04-6.802e+04
3.888e+04		276	8.23	26.57	-15.90	-0.75	11.43	-20.34-3.064e+04-9.572e+04-6.695e+04-5.941e+04
259	3	284	7.56	10.43	-25.71	-24.04	8.76	-7.59-3.723e+04-8.986e+04-8.261e+04-4.449e+04
3.502e+04		283	11.14	44.32	-36.95	-22.74	30.11	-30.87-6.885e+04-1.331e+05-1.150e+05-8.690e+04
2.060e+04		275	6.99	5.95	-60.06	-58.83	4.71	8.94-2.133e+04-8.035e+04-4.091e+04-6.076e+04
3.126e+04		276	8.13	16.78	-7.01	6.65	3.13	-11.76-3.056e+04-9.491e+04-6.607e+04-5.940e+04
3.290e+04		284	7.60	-0.13	-14.86	-14.83	-0.16	-0.62-3.718e+04-9.046e+04-8.296e+04-4.468e+04
259	6	283	11.08	22.57	-20.53	-12.37	14.41	-16.89-6.877e+04-1.328e+05-1.152e+05-8.634e+04
3.232e+04		275	7.23	1.00	-43.43	-40.11	-2.32	11.69-2.131e+04-8.269e+04-4.253e+04-6.148e+04
1.814e+04		276	8.07	14.02	-4.71	10.43	-1.12	-7.37-3.052e+04-9.450e+04-6.562e+04-5.940e+04
2.888e+04		284	7.63	-3.43	-11.42	-10.12	-4.72	2.94-3.715e+04-9.077e+04-8.314e+04-4.477e+04
2.779e+04		283	11.05	11.48	-12.18	-7.07	6.37	-9.74-6.872e+04-1.326e+05-1.153e+05-8.606e+04
259	38	275	7.35	-0.27	-36.20	-30.54	-5.92	13.09-2.130e+04-8.390e+04-4.336e+04-6.184e+04
3.200e+04		277	7.42	1.90	-6.67	-3.52	-1.25	-4.13-2.242e+04-8.596e+04-6.525e+04-4.312e+04
1.853e+04								
2.858e+04								
2.919e+04								
259	69							
3.184e+04								
1.872e+04								
2.842e+04								
2.991e+04								
260	1							

Parco Eolico "Bolina" – Progetto Definitivo
Relazione di calcolo preliminare delle fondazioni degli aerogeneratori G8 e G12

267	1	284	10.48	1.08	-8.64	-7.87	0.30	-2.63-5.378e+04-1.255e+05-1.089e+05-7.041e+04	
3.027e+04		292	10.45	0.79	-8.90	-7.17	-0.94	-3.71-6.494e+04-1.254e+05-1.246e+05-6.575e+04	6946.19
		291	13.86	4.81	-11.41	-8.19	1.60	-6.46-1.081e+05-1.638e+05-1.576e+05-1.143e+05	
1.744e+04		283	13.31	2.06	-13.40	-12.24	0.90	-4.08-8.715e+04-1.598e+05-1.335e+05-1.134e+05	
3.489e+04		267	8.87	0.91	-7.31	-6.66	0.26	-2.22-4.551e+04-1.062e+05-9.215e+04-5.958e+04	
2.562e+04	3	284	8.84	0.67	-7.53	-6.07	-0.80	-3.14-5.495e+04-1.061e+05-1.054e+05-5.564e+04	5877.55
		291	11.73	4.07	-9.65	-6.93	1.35	-5.47-9.148e+04-1.386e+05-1.334e+05-9.668e+04	
1.475e+04		283	11.27	1.74	-11.34	-10.35	0.76	-3.45-7.374e+04-1.352e+05-1.130e+05-9.596e+04	
2.952e+04		267	8.07	15.05	-20.17	13.60	-18.72	7.00-4.122e+04-9.669e+04-8.386e+04-5.405e+04	
2.339e+04	7	284	8.03	11.70	-25.93	5.93	-20.16	13.56-4.983e+04-9.646e+04-9.583e+04-5.045e+04	5357.12
		291	10.68	11.92	-30.28	6.64	-25.00	13.96-8.304e+04-1.260e+05-1.213e+05-8.775e+04	
1.342e+04		283	10.32	9.13	-25.52	5.60	-21.99	10.49-6.703e+04-1.234e+05-1.031e+05-8.731e+04	
2.706e+04		267	8.06	0.75	-6.33	0.60	-6.18	1.03-4.132e+04-9.661e+04-8.380e+04-5.412e+04	
2.332e+04	39	284	8.03	-0.56	-8.38	-1.64	-7.30	2.70-4.991e+04-9.646e+04-9.584e+04-5.054e+04	5347.93
		291	10.67	-1.58	-7.99	-1.92	-7.65	1.44-8.312e+04-1.260e+05-1.213e+05-8.784e+04	
1.341e+04		283	10.27	-3.68	-7.64	-4.33	-6.98	1.47-6.703e+04-1.231e+05-1.028e+05-8.726e+04	
2.691e+04		267	8.06	0.83	-6.64	-6.05	0.23	-2.02-4.137e+04-9.656e+04-8.377e+04-5.416e+04	
2.329e+04	69	284	8.04	0.61	-6.85	-5.52	-0.72	-2.85-4.996e+04-9.646e+04-9.584e+04-5.058e+04	5343.23
		291	10.66	3.70	-8.77	-6.30	1.23	-4.97-8.317e+04-1.260e+05-1.212e+05-8.789e+04	
1.341e+04		283	10.24	1.59	-10.31	-9.41	0.69	-3.14-6.704e+04-1.229e+05-1.027e+05-8.724e+04	
2.684e+04		268	8.25	1.06	-7.99	-5.95	-0.97	-3.78-2.980e+04-9.682e+04-8.630e+04-4.032e+04	
2.438e+04	1	285	8.00	0.39	-8.22	-6.99	-0.84	-3.01-3.617e+04-9.508e+04-9.475e+04-3.649e+04	4375.85
		292	10.45	2.58	-9.43	-7.61	0.76	-4.30-6.661e+04-1.253e+05-1.238e+05-6.819e+04	9482.63
		284	10.36	-0.59	-8.55	-8.02	-1.12	-1.98-5.482e+04-1.241e+05-1.060e+05-7.289e+04	
3.042e+04		268	6.98	0.90	-6.76	-5.04	-0.82	-3.20-2.521e+04-8.192e+04-7.302e+04-3.411e+04	
2.063e+04	3	285	6.77	0.33	-6.96	-5.92	-0.71	-2.55-3.060e+04-8.045e+04-8.017e+04-3.088e+04	3702.64
		292	8.84	2.18	-7.98	-6.44	0.64	-3.64-5.636e+04-1.060e+05-1.047e+05-5.770e+04	8023.77
		284	8.76	-0.50	-7.23	-6.78	-0.95	-1.68-4.638e+04-1.050e+05-8.972e+04-6.167e+04	
2.574e+04		268	6.43	26.56	-27.54	-27.54	26.56	-0.27-2.316e+04-7.457e+04-6.642e+04-3.131e+04	
1.877e+04	22	285	6.24	27.59	-30.08	-28.01	25.52	-10.73-2.820e+04-7.314e+04-7.288e+04-2.847e+04	3458.29
		292	8.09	37.85	-30.65	-28.15	35.35	-12.86-5.143e+04-9.637e+04-9.511e+04-5.268e+04	7406.37
		284	8.00	33.96	-29.46	-29.37	33.87	2.48-4.230e+04-9.530e+04-8.141e+04-5.619e+04	
2.331e+04		268	6.38	8.68	-12.54	-12.35	8.49	-2.01-2.300e+04-7.451e+04-6.640e+04-3.111e+04	
1.876e+04	54	285	6.19	9.39	-14.23	-13.04	8.21	-5.16-2.795e+04-7.314e+04-7.288e+04-2.821e+04	3397.25
		292	8.05	13.91	-14.97	-13.40	12.35	-6.54-5.130e+04-9.639e+04-9.517e+04-5.253e+04	7332.24
		284	7.98	10.89	-14.02	-14.02	10.89	-0.17-4.221e+04-9.541e+04-8.151e+04-5.611e+04	
2.337e+04		268	6.35	0.82	-6.14	-4.58	-0.75	-2.91-2.292e+04-7.448e+04-6.638e+04-3.101e+04	
1.875e+04	69	285	6.16	0.30	-6.32	-5.38	-0.65	-2.32-2.782e+04-7.314e+04-7.288e+04-2.807e+04	3366.04
		292	8.04	1.98	-7.25	-5.85	0.58	-3.31-5.124e+04-9.641e+04-9.520e+04-5.245e+04	7294.33
		284	7.97	-0.46	-6.57	-6.17	-0.86	-1.52-4.217e+04-9.546e+04-8.156e+04-5.607e+04	
2.340e+04		269	7.41	1.48	-9.48	-7.80	-0.20	-3.95 -3363.82-7.868e+04-7.147e+04-1.058e+04	
2.216e+04	1	286	6.13	0.89	-6.73	-5.44	-0.41	-2.86 -8575.49-6.749e+04-6.710e+04 -8970.51	4808.03
		293	8.04	1.13	-9.05	-7.74	-0.18	-3.41-3.708e+04-9.565e+04-9.501e+04-3.771e+04	6069.98
		285	8.19	1.48	-7.73	-5.95	-0.29	-3.63-2.984e+04-9.616e+04-8.453e+04-4.148e+04	
2.522e+04		269	6.27	1.25	-8.02	-6.60	-0.17	-3.34 -2846.31-6.658e+04-6.047e+04 -8948.88	1.875e+04
	3	294	5.18	0.75	-5.70	-4.60	-0.35	-2.42 -7256.18-5.711e+04-5.677e+04 -7590.43	4068.33

Parco Eolico "Bolina" – Progetto Definitivo
Relazione di calcolo preliminare delle fondazioni degli aerogeneratori G8 e G12

		293	6.81	0.96	-7.66	-6.55	-0.15	-2.88-3.137e+04-8.094e+04-8.040e+04-3.191e+04	5136.13
		285	6.93	1.25	-6.54	-5.04	-0.25	-3.07-2.525e+04-8.137e+04-7.153e+04-3.510e+04	
2.134e+04									
	269	22	286	5.82	18.89	-29.05	-29.05	18.89	0.08 -2864.27-6.070e+04-5.511e+04 -8450.72 1.708e+04
			294	4.81	21.86	-30.14	-28.33	20.06	-9.52 -7334.25-5.202e+04-5.167e+04 -7678.37 3906.01
			293	6.28	27.18	-30.87	-29.11	25.42	-9.96-2.888e+04-7.360e+04-7.309e+04-2.939e+04 4750.87
			285	6.39	25.45	-27.78	-27.74	25.41	1.47-2.323e+04-7.404e+04-6.504e+04-3.223e+04
1.940e+04									
	269	54	286	5.74	6.48	-13.99	-13.80	6.29	-1.98 -2681.21-6.058e+04-5.502e+04 -8242.06 1.706e+04
			294	4.75	7.67	-13.45	-12.35	6.58	-4.68 -6846.51-5.195e+04-5.163e+04 -7163.64 3768.70
			293	6.22	9.62	-14.90	-13.79	8.51	-5.10-2.864e+04-7.358e+04-7.309e+04-2.914e+04 4696.84
			285	6.33	8.54	-12.51	-12.42	8.45	-1.35-2.305e+04-7.400e+04-6.503e+04-3.202e+04
1.940e+04									
	269	69	286	5.70	1.14	-7.29	-6.00	-0.15	-3.04 -2587.56-6.052e+04-5.498e+04 -8135.34 1.705e+04
			294	4.71	0.68	-5.18	-4.18	-0.31	-2.20 -6596.53-5.192e+04-5.161e+04 -6900.39 3698.48
			293	6.19	0.87	-6.96	-5.96	-0.14	-2.62-2.852e+04-7.358e+04-7.309e+04-2.901e+04 4669.21
			285	6.30	1.14	-5.94	-4.58	-0.22	-2.79-2.296e+04-7.397e+04-6.502e+04-3.191e+04
1.940e+04									
	270	1	287	7.18	-1.19	-9.49	-9.44	-1.23	0.61 5799.86-7.134e+04-6.760e+04 2064.71 1.656e+04
			295	6.53	9.41	-5.44	5.20	-1.23	-6.69 4.075e+04-3.742e+04-3.681e+04 4.015e+04 6850.94
			294	5.97	0.45	-12.02	-11.46	-0.11	-2.60-1.282e+04-6.718e+04-6.578e+04-1.422e+04 8612.18
			286	7.56	4.04	-5.82	-3.54	1.77	-4.15 491.23-7.847e+04-7.013e+04 -6918.47 2.303e+04
	270	3	287	6.07	-1.01	-8.03	-7.99	-1.04	0.51 4907.58-6.036e+04-5.720e+04 1747.06 1.401e+04
			295	5.53	7.96	-4.60	4.40	-1.04	-5.66 3.448e+04-3.166e+04-3.115e+04 3.397e+04 5796.95
			294	5.05	0.38	-10.17	-9.69	-0.10	-2.20-1.085e+04-5.684e+04-5.566e+04-1.204e+04 7287.23
			286	6.39	3.42	-4.92	-3.00	1.50	-3.51 415.66-6.640e+04-6.013e+04 -5854.09 1.274e+04
	270	22	287	5.63	9.70	-33.12	-32.21	8.79	6.17 4635.06-5.464e+04-5.196e+04 1961.33 1.230e+04
			295	5.00	22.37	-25.94	-20.89	17.32	-14.78 2.963e+04-2.924e+04-2.857e+04 2.896e+04 6239.95
			294	4.68	20.88	-34.76	-33.47	19.60	-8.36-1.059e+04-5.175e+04-5.063e+04-1.172e+04 6701.81
			286	5.95	18.67	-25.66	-25.65	18.66	0.40 126.62-6.070e+04-5.488e+04 -5700.24 1.790e+04
	270	54	287	5.56	2.66	-16.02	-15.70	2.35	2.39 4519.37-5.479e+04-5.199e+04 1714.48 1.259e+04
			295	4.99	10.10	-9.29	-4.42	5.24	-8.41 3.076e+04-2.893e+04-2.840e+04 3.023e+04 5598.18
			294	4.62	7.28	-17.86	-17.16	6.57	-4.15-1.011e+04-5.170e+04-5.061e+04-1.120e+04 6650.83
			286	5.86	7.43	-10.70	-10.48	7.21	-1.98 292.70-6.048e+04-5.474e+04 -5449.92 1.778e+04
	270	69	287	5.52	-0.91	-7.30	-7.26	-0.95	0.47 4461.43-5.487e+04-5.200e+04 1588.24 1.274e+04
			295	5.02	7.24	-4.18	4.00	-0.94	-5.15 3.135e+04-2.878e+04-2.832e+04 3.088e+04 5269.95
			294	4.59	0.35	-9.25	-8.81	-0.09	-2.00 -9863.91-5.167e+04-5.060e+04-1.094e+04 6624.75
			286	5.81	3.11	-4.47	-2.73	1.36	-3.19 377.87-6.036e+04-5.466e+04 -5321.90 1.771e+04
	271	1	288	5.58	2.94	-1.68	-0.63	1.89	1.94 1.125e+04-5.158e+04-5.012e+04 9796.88 9457.55
			296	3.62	-1.40	-11.70	-11.69	-1.41	-0.26 2827.73-3.575e+04-3.524e+04 2312.21 -4429.70
			295	6.20	9.79	-0.97	6.08	2.75	5.12 3.877e+04-3.564e+04-3.535e+04 3.848e+04 -4626.29
			287	7.31	-2.32	-11.23	-10.12	-3.43	-2.94 6656.88-7.234e+04-6.752e+04 1842.35 1.890e+04
	271	3	288	4.72	2.49	-1.42	-0.53	1.60	1.64 9522.83-4.364e+04-4.241e+04 8289.67 8002.54
			296	3.06	-1.19	-9.90	-9.89	-1.19	-0.22 2392.69-3.025e+04-2.981e+04 1956.48 -3748.21
			295	5.25	8.29	-0.82	5.14	2.33	4.33 3.280e+04-3.016e+04-2.991e+04 3.256e+04 -3914.56
			287	6.18	-1.97	-9.50	-8.56	-2.91	-2.49 5632.74-6.121e+04-5.714e+04 1558.91 1.599e+04
	271	23	288	4.43	27.24	-5.81	27.17	-5.74	-1.51 8787.38-3.981e+04-3.879e+04 7765.73 6991.61
			296	2.79	16.94	-6.22	15.91	-5.19	4.77 1957.37-2.716e+04-2.677e+04 1561.10 -3373.78
			295	4.83	37.08	-6.64	31.61	-1.17	14.46 2.878e+04-2.780e+04-2.739e+04 2.838e+04 -4756.75
			287	5.81	19.62	-19.73	17.27	-17.37	-9.33 6430.65-5.576e+04-5.188e+04 2548.33 1.505e+04
	271	55	288	4.33	8.90	-1.00	8.87	-0.98	0.48 8700.60-3.972e+04-3.863e+04 7613.78 7172.37
			296	2.74	0.24	-3.28	-0.57	-2.47	1.48 2101.47-2.739e+04-2.699e+04 1705.02 -3396.07
			295	4.79	17.25	-2.45	13.79	1.00	7.50 2.946e+04-2.754e+04-2.726e+04 2.919e+04 -3964.08
			287	5.66	2.78	-9.71	0.69	-7.63	-4.66 5563.81-5.568e+04-5.192e+04 1799.94 1.471e+04
	271	69	288	4.29	2.26	-1.29	-0.48	1.45	1.49 8657.12-3.968e+04-3.855e+04 7536.06 7275.06
			296	2.78	-1.08	-9.00	-8.99	-1.09	-0.20 2175.17-2.750e+04-2.710e+04 1778.62 -3407.47
			295	4.77	7.53	-0.74	4.67	2.12	3.94 2.982e+04-2.742e+04-2.719e+04 2.960e+04 -3558.69
			287	5.62	-1.79	-8.64	-7.78	-2.64	-2.26 5120.68-5.565e+04-5.194e+04 1417.19 1.454e+04
	272	1	289	4.10	-0.43	-3.44	-3.44	-0.43	0.03 541.80-4.232e+04-4.179e+04 9.34 4747.58
			297	3.59	-0.43	-6.47	-6.45	-0.45	0.34 -76.97-3.722e+04-3.673e+04 -565.12 -4230.19
			296	4.07	0.55	-4.66	-4.65	0.54	0.15 7148.16-3.814e+04-3.808e+04 7093.80 -1568.04
			288	5.26	0.31	-5.74	-5.57	0.14	1.00 7551.35-5.034e+04-4.833e+04 5542.13 1.060e+04
	272	3	289	3.47	-0.36	-2.91	-2.91	-0.36	0.03 458.45-3.581e+04-3.536e+04 7.91 4017.18
			297	3.04	-0.36	-5.47	-5.46	-0.38	0.29 -65.13-3.150e+04-3.108e+04 -478.18 -3579.39
			296	3.44	0.46	-3.94	-3.94	0.46	0.12 6048.44-3.227e+04-3.222e+04 6002.45 -1326.80
			288	4.45	0.27	-4.86	-4.72	0.12	0.85 6389.60-4.260e+04-4.090e+04 4689.50 8966.21
	272	22	289	3.27	1.37	-31.32	-30.64	0.69	4.67 452.00-3.251e+04-3.209e+04 36.35 3677.95
			297	2.89	1.14	-32.98	-32.37	0.53	-4.51 -94.72-2.875e+04-2.837e+04 -469.52 -3255.66
			296	3.26	4.07	-31.12	-30.00	2.95	-6.18 5742.68-2.941e+04-2.938e+04 5713.18 -1017.85
			288	4.16	5.80	-32.31	-31.43	4.92	5.73 5636.84-3.871e+04-3.712e+04 4051.87 8232.31
	272	54	289	3.19	0.22	-12.33	-12.12	0.02	1.60 428.69-3.254e+04-3.213e+04 17.06 3660.77
			297	2.81	0.08	-14.37	-14.24	-0.05	-1.35 -71.22-2.867e+04-2.830e+04 -446.49 -3254.56
			296	3.17	1.56	-12.81	-12.52	1.28	-2.02 5580.93-2.936e+04-2.932e+04 5543.53 -1142.46

Parco Eolico "Bolina" – Progetto Definitivo
Relazione di calcolo preliminare delle fondazioni degli aerogeneratori G8 e G12

		288	4.08	2.12	-13.86	-13.47	1.74	2.45	5750.49-3.872e+04-3.716e+04	4191.68	8178.58
272	69	289	3.16	-0.33	-2.65	-2.65	-0.33	0.03	416.77-3.256e+04-3.215e+04	7.19	3651.99
		297	2.76	-0.33	-4.98	-4.96	-0.34	0.26	-59.21-2.863e+04-2.826e+04	-434.71	-3253.99
		296	3.13	0.42	-3.58	-3.58	0.42	0.11	5498.58-2.934e+04-2.929e+04	5456.77	-1206.19
		288	4.04	0.24	-4.42	-4.29	0.11	0.77	5808.73-3.872e+04-3.718e+04	4263.18	8151.10
273	1	290	15.14	6.92	1.60	2.63	5.90	2.10-1.356e+05-1.727e+05-1.363e+05-1.720e+05			-5109.99
		298	20.71	7.80	-16.60	-1.32	-7.47	-11.80-1.584e+05-2.455e+05-2.208e+05-1.830e+05			
3.923e+04											
		64	21.64	12.36	0.75	0.77	12.34	0.46-2.120e+05-2.364e+05-2.306e+05-2.179e+05			
1.046e+04		55	47.59	7.12	-18.42	-1.26	-10.05	-11.99-1.978e+05-5.637e+05-3.820e+05-3.795e+05			
1.829e+05											
273	3	290	12.81	5.86	1.36	2.22	4.99	1.77-1.147e+05-1.462e+05-1.153e+05-1.456e+05			-4323.84
		298	17.52	6.60	-14.04	-1.12	-6.32	-9.99-1.340e+05-2.077e+05-1.869e+05-1.549e+05			
3.319e+04											
		64	18.31	10.46	0.63	0.65	10.44	0.39-1.794e+05-2.001e+05-1.951e+05-1.843e+05			8848.25
		55	40.26	6.02	-15.59	-1.06	-8.50	-10.14-1.674e+05-4.769e+05-3.232e+05-3.211e+05			
1.548e+05											
273	23	290	11.84	13.24	-78.54	10.26	-75.55	-16.28-1.045e+05-1.330e+05-1.050e+05-1.324e+05			-3999.64
		298	16.06	36.67	-59.35	-8.83	-13.85	47.94-1.220e+05-1.887e+05-1.699e+05-1.408e+05			
3.003e+04											
		64	16.82	14.21	-111.76	11.35	-108.90	-18.76-1.634e+05-1.821e+05-1.776e+05-1.679e+05			7968.69
		55	36.90	31.87	-70.95	-6.25	-32.83	49.66-1.526e+05-4.341e+05-2.942e+05-2.925e+05			
1.407e+05											
273	54	290	11.71	33.36	-2.49	-0.77	31.64	7.67-1.042e+05-1.329e+05-1.048e+05-1.323e+05			-3907.46
		298	15.98	27.78	-29.16	1.63	-3.01	-28.38-1.218e+05-1.889e+05-1.699e+05-1.408e+05			
3.022e+04											
		64	16.70	50.43	-3.92	-3.05	49.56	6.83-1.629e+05-1.818e+05-1.773e+05-1.675e+05			8069.30
		55	36.70	29.94	-28.35	0.82	0.77	-29.14-1.520e+05-4.334e+05-2.937e+05-2.917e+05			
1.407e+05											
273	69	290	11.64	5.32	1.23	2.02	4.54	1.61-1.043e+05-1.329e+05-1.048e+05-1.323e+05			-3930.77
		298	15.93	6.00	-12.77	-1.02	-5.75	-9.08-1.218e+05-1.888e+05-1.699e+05-1.408e+05			
3.017e+04											
		64	16.65	9.51	0.58	0.59	9.49	0.36-1.631e+05-1.819e+05-1.774e+05-1.676e+05			8043.87
		55	36.60	5.47	-14.17	-0.97	-7.73	-9.22-1.522e+05-4.336e+05-2.938e+05-2.919e+05			
1.407e+05											
274	1	291	13.37	2.48	-13.07	-11.61	1.02	-4.53-1.065e+05-1.573e+05-1.515e+05-1.123e+05			
1.616e+04											
		299	12.62	6.36	-10.72	-4.15	-0.20	-8.31-1.009e+05-1.485e+05-1.485e+05-1.009e+05			459.31
		298	17.41	4.75	-7.43	-2.42	-0.25	-6.00-1.602e+05-1.968e+05-1.829e+05-1.741e+05			
1.779e+04											
		290	20.58	15.02	-11.07	3.18	0.78	-12.99-1.644e+05-2.420e+05-2.041e+05-2.023e+05			
3.882e+04											
274	3	291	11.32	2.10	-11.06	-9.82	0.86	-3.84-9.013e+04-1.331e+05-1.282e+05-9.505e+04			
1.367e+04											
		299	10.68	5.38	-9.07	-3.51	-0.17	-7.03-8.540e+04-1.256e+05-1.256e+05-8.541e+04			388.65
		298	14.73	4.02	-6.29	-2.05	-0.22	-5.07-1.355e+05-1.665e+05-1.547e+05-1.473e+05			
1.505e+04											
		290	17.42	12.71	-9.36	2.69	0.66	-10.99-1.391e+05-2.048e+05-1.727e+05-1.712e+05			
3.285e+04											
274	6	291	10.29	35.39	-32.76	-29.78	32.41	-13.93-8.201e+04-1.209e+05-1.164e+05-8.645e+04			
1.236e+04											
		299	9.75	51.48	-41.26	-11.28	21.51	-43.37-7.784e+04-1.146e+05-1.146e+05-7.785e+04			518.97
		298	13.51	48.80	2.24	10.60	40.45	-17.87-1.231e+05-1.514e+05-1.406e+05-1.340e+05			
1.376e+04											
		290	15.99	72.85	-27.13	21.52	24.21	-49.97-1.264e+05-1.861e+05-1.568e+05-1.556e+05			
2.984e+04											
274	38	291	10.29	13.18	-17.68	-15.99	11.48	-7.02-8.196e+04-1.210e+05-1.165e+05-8.642e+04			
1.241e+04											
		299	9.72	20.63	-19.39	-5.93	7.17	-18.90-7.771e+04-1.144e+05-1.143e+05-7.771e+04			409.37
		298	13.43	18.64	-2.73	2.35	13.56	-9.10-1.232e+05-1.514e+05-1.406e+05-1.339e+05			
1.371e+04											
		290	15.89	32.26	-14.78	8.90	8.59	-23.52-1.264e+05-1.861e+05-1.569e+05-1.556e+05			
2.986e+04											
274	69	291	10.29	1.90	-10.05	-8.93	0.78	-3.49-8.194e+04-1.210e+05-1.165e+05-8.641e+04			
1.243e+04											
		299	9.71	4.89	-8.24	-3.19	-0.16	-6.39-7.764e+04-1.142e+05-1.142e+05-7.764e+04			353.31
		298	13.39	3.66	-5.72	-1.86	-0.20	-4.61-1.232e+05-1.514e+05-1.407e+05-1.339e+05			
1.368e+04											
		290	15.83	11.55	-8.51	2.44	0.60	-9.99-1.264e+05-1.862e+05-1.570e+05-1.556e+05			
2.986e+04											
275	1	292	10.38	1.57	-9.46	-8.22	0.33	-3.49-6.513e+04-1.245e+05-1.215e+05-6.817e+04			
1.308e+04											

Parco Eolico "Bolina" – Progetto Definitivo
Relazione di calcolo preliminare delle fondazioni degli aerogeneratori G8 e G12

1.099e+04	300	9.46	2.43	-9.09	-6.53	-0.13	-4.79-6.078e+04-1.133e+05-1.109e+05-6.319e+04	-	
	299	12.25	3.76	-9.69	-5.90	-0.03	-6.05-9.972e+04-1.436e+05-1.435e+05-9.980e+04	1964.27	
2.140e+04	291	13.92	5.21	-10.51	-7.89	2.60	-5.85-1.087e+05-1.645e+05-1.545e+05-1.187e+05		
1.107e+04	275 3	292	8.78	1.33	-8.01	-6.96	0.28	-2.95-5.511e+04-1.054e+05-1.028e+05-5.768e+04	
	300	8.00	2.06	-7.69	-5.52	-0.11	-4.05-5.143e+04-9.590e+04-9.386e+04-5.347e+04	-9302.13	
	299	10.37	3.18	-8.20	-4.99	-0.02	-5.12-8.437e+04-1.215e+05-1.214e+05-8.445e+04	1662.08	
	291	11.78	4.41	-8.89	-6.68	2.20	-4.95-9.200e+04-1.392e+05-1.307e+05-1.005e+05		
1.811e+04	275 7	292	7.98	13.78	-24.44	11.88	-22.55	8.30-4.997e+04-9.574e+04-9.340e+04-5.231e+04	
1.007e+04	300	7.28	13.69	-27.11	6.46	-19.89	15.57-4.647e+04-8.706e+04-8.521e+04-4.831e+04	-8450.78	
	299	9.40	11.19	-33.47	2.30	-24.58	17.83-7.674e+04-1.101e+05-1.100e+05-7.681e+04	1510.39	
	291	10.74	12.03	-32.62	8.64	-29.24	11.83-8.350e+04-1.266e+05-1.190e+05-9.118e+04		
1.650e+04	275 39	292	7.97	-0.02	-7.61	-0.16	-7.46	1.03-5.006e+04-9.577e+04-9.343e+04-5.239e+04	
1.007e+04	300	7.25	0.04	-7.97	-1.14	-6.80	2.83-4.666e+04-8.714e+04-8.529e+04-4.851e+04	-8454.55	
	299	9.42	-1.03	-9.53	-2.22	-8.33	2.96-7.672e+04-1.103e+05-1.103e+05-7.679e+04	1510.78	
	291	10.72	-0.96	-8.71	-1.09	-8.57	1.02-8.359e+04-1.266e+05-1.189e+05-9.128e+04		
1.647e+04	275 69	292	7.98	1.21	-7.28	-6.33	0.25	-2.68-5.010e+04-9.578e+04-9.345e+04-5.244e+04	
1.006e+04	300	7.28	1.87	-6.99	-5.02	-0.10	-3.69-4.675e+04-8.718e+04-8.533e+04-4.861e+04	-8456.48	
	299	9.42	2.89	-7.45	-4.54	-0.02	-4.65-7.670e+04-1.105e+05-1.104e+05-7.677e+04	1510.98	
	291	10.71	4.01	-8.08	-6.07	2.00	-4.50-8.364e+04-1.265e+05-1.189e+05-9.133e+04		
1.646e+04	276 1	293	7.90	1.13	-8.68	-7.62	0.08	-3.05-3.669e+04-9.404e+04-9.208e+04-3.865e+04	
1.041e+04	301	7.48	0.91	-8.45	-6.79	-0.75	-3.58-3.481e+04-8.897e+04-8.728e+04-3.651e+04	-9426.34	
	300	9.29	2.48	-9.47	-7.24	0.25	-4.66-6.251e+04-1.111e+05-1.101e+05-6.357e+04	-7126.77	
	292	10.44	2.39	-8.99	-7.94	1.34	-3.29-6.670e+04-1.253e+05-1.206e+05-7.134e+04		
1.580e+04	276 3	293	6.69	0.96	-7.35	-6.45	0.06	-2.58-3.105e+04-7.957e+04-7.791e+04-3.270e+04	8806.61
	301	6.33	0.77	-7.15	-5.74	-0.63	-3.03-2.946e+04-7.528e+04-7.385e+04-3.089e+04	-7976.14	
	300	7.86	2.10	-8.02	-6.13	0.21	-3.94-5.289e+04-9.403e+04-9.313e+04-5.379e+04	-6030.35	
	292	8.83	2.02	-7.61	-6.72	1.14	-2.79-5.644e+04-1.060e+05-1.021e+05-6.036e+04		
1.337e+04	276 22	293	6.17	27.99	-29.98	-29.87	27.88	-2.54-2.860e+04-7.233e+04-7.079e+04-3.015e+04	8068.34
	301	5.86	24.41	-29.01	-25.79	21.19	-12.72-2.705e+04-6.851e+04-6.723e+04-2.833e+04	-7177.27	
	300	7.20	33.39	-31.39	-26.72	28.72	-16.76-4.821e+04-8.525e+04-8.451e+04-4.896e+04	-5184.78	
	292	8.09	37.77	-29.71	-29.62	37.68	-2.48-5.159e+04-9.628e+04-9.268e+04-5.518e+04		
1.215e+04	276 54	293	6.11	9.72	-14.23	-13.99	9.47	-2.41-2.835e+04-7.233e+04-7.082e+04-2.987e+04	8027.10
	301	5.79	8.59	-13.99	-12.18	6.79	-6.13-2.687e+04-6.846e+04-6.717e+04-2.817e+04	-7226.07	
	300	7.16	12.42	-15.30	-12.73	9.84	-8.04-4.813e+04-8.541e+04-8.461e+04-4.892e+04	-5381.52	
	292	8.05	13.66	-14.29	-14.06	13.43	-2.51-5.140e+04-9.632e+04-9.275e+04-5.498e+04		
1.215e+04	276 69	293	6.08	0.87	-6.68	-5.86	0.06	-2.34-2.822e+04-7.233e+04-7.083e+04-2.973e+04	8006.01
	301	5.76	0.70	-6.50	-5.22	-0.58	-2.75-2.678e+04-6.844e+04-6.714e+04-2.808e+04	-7251.03	
	300	7.15	1.91	-7.29	-5.57	0.19	-3.59-4.808e+04-8.548e+04-8.466e+04-4.890e+04	-5482.13	
	292	8.03	1.84	-6.92	-6.11	1.03	-2.53-5.131e+04-9.635e+04-9.279e+04-5.487e+04		
1.216e+04	277 1	294	5.85	0.87	-9.21	-8.22	-0.13	-3.01 -9751.70-6.494e+04-6.349e+04-1.120e+04	8831.94
	302	7.07	0.50	-8.08	-7.02	-0.56	-2.82 -5820.24-7.601e+04-7.455e+04 -7280.35	-	
1.002e+04	301	7.48	1.33	-8.96	-7.50	-0.13	-3.60-3.442e+04-8.880e+04-8.795e+04-3.526e+04	-6714.65	
	293	7.97	1.69	-7.94	-7.13	0.88	-2.67-3.768e+04-9.490e+04-9.181e+04-4.076e+04		
1.292e+04	277 3	294	4.95	0.74	-7.79	-6.95	-0.11	-2.54 -8251.44-5.495e+04-5.372e+04 -9479.66	7473.18
	302	5.98	0.42	-6.84	-5.94	-0.47	-2.39 -4924.82-6.432e+04-6.308e+04 -6160.30	-8476.40	
	301	6.33	1.13	-7.59	-6.35	-0.11	-3.04-2.913e+04-7.514e+04-7.442e+04-2.984e+04	-5681.63	
	293	6.74	1.43	-6.71	-6.03	0.75	-2.26-3.188e+04-8.030e+04-7.769e+04-3.449e+04		
1.093e+04	277 22	294	4.60	21.60	-30.76	-30.75	21.59	0.60 -8355.83-5.001e+04-4.891e+04 -9453.77	6672.95
	302	5.56	16.86	-29.41	-27.70	15.16	-8.72 -4775.51-5.859e+04-5.746e+04 -5907.41	-7722.36	
	301	5.85	24.04	-29.93	-27.49	21.60	-11.21-2.678e+04-6.834e+04-6.771e+04-2.741e+04	-5083.87	
	293	6.22	27.17	-29.61	-29.61	27.16	0.17-2.935e+04-7.300e+04-7.059e+04-3.176e+04	9972.65	
	277 54	294	4.53	7.32	-14.67	-14.59	7.24	-1.33 -7790.46-4.997e+04-4.886e+04 -8900.72	6752.91
	302	5.48	5.87	-13.97	-12.95	4.84	-4.39 -4578.09-5.851e+04-5.738e+04 -5704.20	-7711.42	
	301	5.78	8.69	-14.57	-13.12	7.24	-5.63-2.658e+04-6.832e+04-6.767e+04-2.722e+04	-5137.63	

Parco Eolico "Bolina" – Progetto Definitivo
Relazione di calcolo preliminare delle fondazioni degli aerogeneratori G8 e G12

		293	6.16	9.71	-13.72	-13.65	9.64	-1.30-2.911e+04-7.300e+04-7.061e+04-3.149e+04	9950.72
277	69	294	4.50	0.67	-7.09	-6.32	-0.10	-2.31 -7501.31-4.996e+04-4.884e+04 -8617.87	6793.80
		302	5.43	0.38	-6.21	-5.40	-0.43	-2.17 -4477.11-5.847e+04-5.735e+04 -5600.27	-7705.82
		301	5.75	1.03	-6.90	-5.77	-0.10	-2.77-2.648e+04-6.830e+04-6.766e+04-2.713e+04	-5165.12
		293	6.13	1.30	-6.10	-5.48	0.68	-2.05-2.898e+04-7.300e+04-7.063e+04-3.136e+04	9939.50
278	1	295	5.47	3.23	-20.47	-17.97	0.74	-7.28 3.927e+04-2.557e+04-2.398e+043.768e+04	1.003e+04
		303	7.40	1.20	-5.92	-5.62	0.89	1.45 4491.31-7.453e+04-7.372e+04 3679.36	-7968.99
		302	7.13	1.30	-12.14	-10.52	-0.33	-4.38 -574.87-7.411e+04-7.357e+04 -1106.39	-6229.03
		294	5.81	0.91	-3.38	-2.79	0.33	-1.47-1.570e+04-6.671e+04-6.564e+04-1.419e+04	7321.29
278	3	295	4.63	2.74	-17.32	-15.20	0.62	-6.16 3.323e+04-2.163e+04-2.029e+043.189e+04	8486.75
		303	6.26	1.02	-5.01	-4.75	0.76	1.22 3800.34-6.307e+04-6.238e+04 3113.30	-6742.99
		302	6.03	1.10	-10.27	-8.90	-0.28	-3.71 -486.42-6.270e+04-6.225e+04 -936.18	-5270.71
		294	4.91	0.77	-2.86	-2.36	0.28	-1.25-1.328e+04-5.645e+04-5.554e+04-1.419e+04	6194.94
278	6	295	4.15	14.88	-43.45	-42.36	13.80	-7.89 2.918e+04-1.845e+04-1.703e+042.776e+04	8113.49
		303	5.83	8.28	-23.00	-21.85	7.12	-5.90 3528.01-5.772e+04-5.710e+04 2916.60	-6088.61
		302	5.57	14.71	-31.92	-28.26	11.05	-12.54 -601.44-5.685e+04-5.647e+04 -982.43	-4613.43
		294	4.59	13.39	-19.83	-19.75	13.31	-1.66-1.253e+04-5.193e+04-5.112e+04-1.335e+04	5611.28
278	38	295	4.19	6.40	-24.84	-23.48	5.04	-6.37 2.986e+04-1.925e+04-1.796e+042.857e+04	7849.99
		303	5.74	2.99	-10.37	-10.25	2.87	-1.26 3479.58-5.746e+04-5.684e+04 2859.49	-6115.99
		302	5.52	5.61	-16.96	-14.91	3.57	-6.47 -496.18-5.695e+04-5.655e+04 -895.52	-4731.28
		294	4.51	4.81	-8.24	-8.10	4.67	-1.31-1.223e+04-5.153e+04-5.070e+04-1.305e+04	5624.83
278	69	295	4.21	2.49	-15.74	-13.82	0.57	-5.60 3.021e+04-1.967e+04-1.844e+042.899e+04	7715.23
		303	5.69	0.92	-4.56	-4.32	0.69	1.11 3454.86-5.733e+04-5.671e+04 2830.28	-6129.99
		302	5.49	1.00	-9.34	-8.09	-0.25	-3.37 -442.20-5.700e+04-5.660e+04 -851.07	-4791.56
		294	4.47	0.70	-2.60	-2.15	0.25	-1.13-1.207e+04-5.132e+04-5.049e+04-1.290e+04	5631.76
279	1	296	4.33	0.90	-1.52	-0.43	-0.19	-1.20 5378.48-4.212e+04-3.720e+04 460.80	1.447e+04
		304	5.73	-0.79	-10.74	-10.24	-1.29	2.17 1.291e+04-5.183e+04-5.172e+041.279e+04	-2712.94
		303	7.33	5.08	-7.14	-5.17	3.11	-4.49 2848.13-7.455e+04-7.447e+04 2762.50	-2573.09
		295	5.53	0.26	-20.74	-18.62	-1.85	6.32 4.034e+04-2.477e+04-2.219e+043.776e+04	1.270e+04
279	3	296	3.66	0.76	-1.28	-0.37	-0.16	-1.02 4551.02-3.564e+04-3.148e+04 389.91	1.224e+04
		304	4.85	-0.67	-9.08	-8.66	-1.09	1.83 1.092e+04-4.386e+04-4.376e+041.083e+04	-2295.57
		303	6.20	4.30	-6.04	-4.38	2.63	-3.80 2409.96-6.308e+04-6.301e+04 2337.50	-2177.23
		295	4.68	0.22	-17.55	-15.76	-1.57	5.35 3.414e+04-2.096e+04-1.878e+043.195e+04	1.075e+04
279	23	296	3.42	26.17	-5.25	25.26	-4.34	-5.28 3937.84-3.236e+04-2.853e+04 117.63	1.114e+04
		304	4.51	20.11	-8.68	18.96	-7.53	5.64 1.025e+04-3.993e+04-3.986e+041.018e+04	-1896.61
		303	5.78	21.80	-10.07	21.41	-9.68	3.47 3150.68-5.747e+04-5.738e+04 3060.14	-2341.13
		295	4.18	9.72	-6.35	9.15	-5.78	-2.97 3.034e+04-1.890e+04-1.655e+042.798e+04	1.050e+04
279	38	296	3.38	1.28	-6.28	-6.22	1.22	-0.70 4179.48-3.270e+04-2.890e+04 382.00	1.121e+04
		304	4.43	0.02	-15.89	-15.87	4.03e-03	0.57 9953.90-3.972e+04-3.962e+04 9855.46	-2209.24
		303	5.67	8.85	-12.42	-10.19	6.62	-6.52 1818.06-5.749e+04-5.744e+04 1768.43	-1714.96
		295	4.25	1.30	-26.68	-24.21	-1.17	7.94 3.119e+04-1.829e+04-1.651e+042.941e+04	9223.81
279	69	296	3.33	0.69	-1.17	-0.33	-0.15	-0.92 4137.29-3.240e+04-2.862e+04 354.46	1.113e+04
		304	4.41	-0.61	-8.26	-7.88	-0.99	1.67 9929.07-3.987e+04-3.978e+04 9841.46	-2086.88
		303	5.64	3.91	-5.49	-3.98	2.39	-3.45 2190.87-5.735e+04-5.728e+04 2125.00	-1979.30
		295	4.25	0.20	-15.95	-14.33	-1.43	4.86 3.103e+04-1.905e+04-1.707e+042.905e+04	9773.01
280	1	297	3.58	-0.26	-4.26	-4.21	-0.30	-0.43 42.17-3.707e+04-3.642e+04 -602.45	4848.32
		305	4.36	-0.41	-5.54	-5.50	-0.45	0.47 422.90-4.496e+04-4.449e+04 -42.29	-4570.91
		304	5.48	0.30	-6.46	-6.44	0.28	0.42 7858.95-5.244e+04-5.244e+04 7858.53	-159.23
		296	4.23	-0.19	-6.38	-6.38	-0.20	0.16 8777.20-3.881e+04-3.526e+04 5222.02	1.251e+04
280	3	297	3.03	-0.22	-3.60	-3.56	-0.25	-0.36 35.68-3.137e+04-3.082e+04 -509.76	4102.42
		305	3.69	-0.35	-4.69	-4.65	-0.38	0.40 357.84-3.804e+04-3.765e+04 -35.78	-3867.69
		304	4.63	0.26	-5.47	-5.45	0.23	0.35 6649.88-4.437e+04-4.437e+04 6649.52	-134.74
		296	3.58	-0.16	-5.40	-5.40	-0.17	0.14 7426.86-3.284e+04-2.983e+04 4418.63	1.059e+04
280	22	297	2.87	1.35	-29.79	-29.17	0.73	4.33 -0.51-2.862e+04-2.813e+04 -493.37	3723.51
		305	3.47	0.78	-33.95	-33.48	0.31	-4.01 355.97-3.452e+04-3.416e+04 -6.51	-3536.96
		304	4.31	5.09	-32.49	-31.89	4.49	-4.71 5830.50-4.027e+04-4.027e+04 5829.94	-160.09
		296	3.38	3.48	-31.79	-30.76	2.45	5.93 6897.32-2.990e+04-2.726e+04 4253.11	9503.69
280	54	297	2.79	0.22	-12.14	-12.01	0.10	1.25 21.29-2.855e+04-2.806e+04 -473.55	3727.46
		305	3.39	-0.04	-14.22	-14.13	-0.12	-1.12 335.68-3.456e+04-3.420e+04 -23.72	-3523.15
		304	4.25	1.78	-14.19	-14.06	1.66	-1.38 5972.64-4.031e+04-4.031e+04 5972.25	-135.21
		296	3.30	1.03	-13.95	-13.66	0.73	2.09 6800.72-2.987e+04-2.717e+04 4096.85	9583.61
280	69	297	2.75	-0.20	-3.27	-3.24	-0.23	-0.33 32.44-2.851e+04-2.802e+04 -463.42	3729.47
		305	3.35	-0.31	-4.26	-4.23	-0.35	0.36 325.31-3.458e+04-3.422e+04 -32.53	-3516.08
		304	4.21	0.23	-4.97	-4.95	0.21	0.32 6045.35-4.033e+04-4.033e+04 6045.02	-122.49
		296	3.26	-0.15	-4.91	-4.91	-0.15	0.12 6751.69-2.985e+04-2.712e+04 4016.94	9624.49
281	1	298	17.35	4.30	-10.38	-1.58	-4.50	-7.19-1.607e+05-1.956e+05-1.843e+05-1.720e+05	
1.633e+04		306	14.84	7.02	-10.34	-0.07	-3.26	-8.53-1.459e+05-1.620e+05-1.580e+05-1.498e+05	6926.98
		73	21.86	2.22	-10.21	-2.23	-5.76	-5.95-1.874e+05-2.533e+05-2.064e+05-2.343e+05	
2.983e+04		64	27.66	12.43	-10.54	1.06	0.84	-11.48-2.136e+05-3.273e+05-2.667e+05-2.741e+05	
5.671e+04		281	14.68	3.64	-8.78	-1.33	-3.81	-6.08-1.360e+05-1.655e+05-1.559e+05-1.455e+05	

Parco Eolico "Bolina" – Progetto Definitivo
Relazione di calcolo preliminare delle fondazioni degli aerogeneratori G8 e G12

1.382e+04											
	306	12.55	5.94	-8.75	-0.06	-2.75	-7.22-1.234e+05-1.370e+05-1.337e+05-1.268e+05	5861.29			
	73	18.49	1.87	-8.64	-1.89	-4.87	-5.04-1.586e+05-2.143e+05-1.746e+05-1.982e+05				
2.524e+04											
	64	23.40	10.52	-8.92	0.89	0.71	-9.72-1.807e+05-2.769e+05-2.257e+05-2.319e+05				
4.799e+04											
281 22	298	13.35	36.83	-60.60	-23.62	-0.14	-47.28-1.234e+05-1.505e+05-1.417e+05-1.323e+05				
1.270e+04											
	306	11.54	68.70	-28.32	1.13	39.24	-44.61-1.122e+05-1.251e+05-1.217e+05-1.155e+05	5673.49			
	73	16.82	28.28	-47.55	-18.09	-1.18	-36.96-1.439e+05-1.947e+05-1.586e+05-1.800e+05				
2.305e+04											
	64	21.53	106.41	-30.08	10.42	65.91	-62.35-1.640e+05-2.515e+05-2.050e+05-2.105e+05				
4.368e+04											
281 54	298	13.35	14.35	-25.49	-8.80	-2.34	-19.66-1.236e+05-1.505e+05-1.417e+05-1.323e+05				
1.261e+04											
	306	11.45	26.22	-14.25	0.35	11.62	-19.44-1.122e+05-1.248e+05-1.216e+05-1.153e+05	5445.20			
	73	16.81	10.37	-20.95	-7.26	-3.33	-15.54-1.441e+05-1.948e+05-1.587e+05-1.801e+05				
2.298e+04											
	64	21.36	41.91	-15.12	4.06	22.73	-26.94-1.642e+05-2.517e+05-2.051e+05-2.107e+05				
4.364e+04											
281 69	298	13.35	3.31	-7.98	-1.21	-3.46	-5.53-1.236e+05-1.505e+05-1.418e+05-1.323e+05				
1.256e+04											
	306	11.41	5.40	-7.95	-0.05	-2.50	-6.56-1.122e+05-1.246e+05-1.215e+05-1.152e+05	5328.44			
	73	16.81	1.70	-7.85	-1.71	-4.43	-4.58-1.441e+05-1.948e+05-1.588e+05-1.802e+05				
2.295e+04											
	64	21.28	9.56	-8.11	0.81	0.64	-8.83-1.643e+05-2.517e+05-2.052e+05-2.109e+05				
4.363e+04											
282 1	299	12.82	1.36	-9.87	-6.25	-2.27	-5.25-1.024e+05-1.508e+05-1.508e+05-1.024e+05	931.81			
	307	7.63	9.85	-9.42	-0.45	0.88	-9.61-6.203e+04-8.949e+04-8.820e+04-6.332e+04	-5809.27			
	306	15.19	4.02	-10.94	-5.38	-1.53	-7.23-1.507e+05-1.647e+05-1.543e+05-1.610e+05	6116.18			
	298	17.75	8.95	-10.45	-2.89	1.39	-9.46-1.578e+05-2.033e+05-1.835e+05-1.777e+05				
2.255e+04											
282 3	299	10.85	1.15	-8.35	-5.28	-1.92	-4.44-8.665e+04-1.276e+05-1.276e+05-8.667e+04	788.45			
	307	6.46	8.33	-7.97	-0.38	0.74	-8.13-5.248e+04-7.572e+04-7.463e+04-5.358e+04	-4915.53			
	306	12.85	3.40	-9.26	-4.56	-1.30	-6.12-1.275e+05-1.393e+05-1.306e+05-1.363e+05	5175.23			
	298	15.02	7.57	-8.84	-2.45	1.18	-8.00-1.336e+05-1.720e+05-1.553e+05-1.503e+05				
1.908e+04											
282 6	299	9.84	33.44	-26.80	-12.00	18.64	-25.94-7.834e+04-1.157e+05-1.157e+05-7.834e+04	144.26			
	307	6.12	58.88	-26.24	12.38	20.25	-42.38-4.942e+04-7.134e+04-7.107e+04-4.969e+04	-2424.51			
	306	11.70	44.05	-38.05	-12.51	18.51	-38.01-1.151e+05-1.269e+05-1.176e+05-1.244e+05	4880.24			
	298	13.81	61.51	-34.89	-12.38	39.01	-40.78-1.213e+05-1.571e+05-1.416e+05-1.369e+05				
1.775e+04											
282 38	299	9.85	11.98	-14.06	-7.24	5.15	-11.45-7.863e+04-1.159e+05-1.159e+05-7.864e+04	523.05			
	307	5.94	24.93	-13.67	3.96	7.30	-19.23-4.835e+04-6.963e+04-6.893e+04-4.904e+04	-3776.98			
	306	11.68	16.93	-18.42	-6.97	5.49	-16.54-1.156e+05-1.267e+05-1.183e+05-1.240e+05	4764.13			
	298	13.71	25.15	-16.90	-5.66	13.91	-18.61-1.214e+05-1.566e+05-1.413e+05-1.367e+05				
1.748e+04											
282 69	299	9.86	1.05	-7.59	-4.80	-1.74	-4.04-7.877e+04-1.160e+05-1.160e+05-7.879e+04	716.78			
	307	5.87	7.57	-7.24	-0.34	0.67	-7.39-4.771e+04-6.883e+04-6.784e+04-4.870e+04	-4468.67			
	306	11.69	3.09	-8.41	-4.14	-1.18	-5.56-1.159e+05-1.267e+05-1.187e+05-1.239e+05	4704.75			
	298	13.66	6.88	-8.04	-2.23	1.07	-7.28-1.214e+05-1.564e+05-1.411e+05-1.367e+05				
1.734e+04											
283 1	300	8.71	1.76	-10.40	-7.47	-1.17	-5.20-5.413e+04-1.044e+05-1.030e+05-5.552e+04	-8263.30			
	308	7.76	0.45	-7.76	-6.13	-1.17	-3.27-6.126e+04-9.132e+04-8.260e+04-6.998e+04	-			
1.365e+04											
	307	7.22	1.24	-12.63	-4.02	-7.37	-6.73-4.885e+04-8.616e+04-8.045e+04-5.457e+04	-			
1.344e+04											
	299	13.06	7.66	-9.45	-7.09	5.31	-5.89-1.057e+05-1.533e+05-1.529e+05-1.061e+05	4333.26			
283 3	300	7.37	1.49	-8.80	-6.32	-0.99	-4.40-4.580e+04-8.830e+04-8.712e+04-4.698e+04	-6992.02			
	308	6.57	0.38	-6.56	-5.19	-0.99	-2.77-5.183e+04-7.727e+04-6.989e+04-5.921e+04	-			
1.155e+04											
	307	6.11	1.05	-10.68	-3.40	-6.24	-5.69-4.134e+04-7.291e+04-6.807e+04-4.617e+04	-			
1.137e+04											
	299	11.05	6.49	-7.99	-6.00	4.49	-4.99-8.941e+04-1.297e+05-1.294e+05-8.975e+04	3666.60			
283 22	300	6.73	30.11	-32.79	-28.56	25.88	-15.75-4.134e+04-7.966e+04-7.886e+04-4.214e+04	-5490.14			
	308	6.09	25.61	-21.87	-17.61	21.35	-13.57-4.694e+04-7.160e+04-6.435e+04-5.419e+04	-			
1.124e+04											
	307	5.47	23.40	-41.33	-22.80	4.88	-29.26-3.555e+04-6.419e+04-6.146e+04-3.828e+04	-8408.83			
	299	10.09	57.40	-29.43	-27.50	55.46	-12.83-8.375e+04-1.176e+05-1.174e+05-8.402e+04	3023.10			
283 54	300	6.71	10.78	-16.09	-13.46	8.16	-7.98-4.154e+04-8.007e+04-7.909e+04-4.252e+04	-6063.27			
	308	6.01	8.81	-11.27	-9.08	6.63	-6.25-4.706e+04-7.071e+04-6.381e+04-5.395e+04	-			
1.075e+04											
	307	5.52	7.93	-19.79	-9.76	-2.10	-13.32-3.694e+04-6.552e+04-6.174e+04-4.073e+04	-9685.11			

Parco Eolico "Bolina" – Progetto Definitivo
Relazione di calcolo preliminare delle fondazioni degli aerogeneratori G8 e G12

		299	10.06	22.97	-14.42	-12.91	21.47	-7.34-8.212e+04-1.178e+05-1.175e+05-8.241e+04	3228.32
283	69	300	6.70	1.35	-8.00	-5.74	-0.90	-4.00-4.163e+04-8.028e+04-7.920e+04-4.271e+04	-6356.38
		308	5.97	0.35	-5.97	-4.72	-0.90	-2.51-4.712e+04-7.025e+04-6.354e+04-5.383e+04	-
1.050e+04									
		307	5.55	0.95	-9.71	-3.09	-5.67	-5.18-3.758e+04-6.628e+04-6.188e+04-4.198e+04	-
1.034e+04									
		299	10.05	5.90	-7.27	-5.46	4.08	-4.53-8.128e+04-1.179e+05-1.176e+05-8.159e+04	3333.28
284	1	301	7.37	1.14	-8.88	-7.68	-0.07	-3.26-3.512e+04-8.773e+04-8.772e+04-3.513e+04	-714.69
		309	6.43	0.75	-8.15	-6.96	-0.44	-3.02-3.259e+04-7.673e+04-7.306e+04-3.625e+04	-
1.218e+04									
		308	7.51	0.69	-8.40	-6.62	-1.09	-3.61-5.451e+04-8.924e+04-8.583e+04-5.792e+04	-
1.034e+04									
		300	8.98	2.83	-9.31	-7.63	1.15	-4.20-6.356e+04-1.071e+05-1.070e+05-6.366e+04	-2063.72
284	3	301	6.24	0.96	-7.52	-6.50	-0.06	-2.76-2.972e+04-7.423e+04-7.422e+04-2.973e+04	-604.74
		309	5.44	0.63	-6.89	-5.89	-0.37	-2.56-2.757e+04-6.492e+04-6.182e+04-3.068e+04	-
1.031e+04									
		308	6.35	0.58	-7.11	-5.60	-0.92	-3.05-4.613e+04-7.551e+04-7.262e+04-4.901e+04	-8745.31
		300	7.60	2.40	-7.88	-6.45	0.97	-3.55-5.378e+04-9.064e+04-9.056e+04-5.387e+04	-1746.23
284	6	301	5.76	21.32	-28.18	-25.52	18.66	-11.15-2.724e+04-6.761e+04-6.760e+04-2.724e+04	-439.97
		309	5.04	21.47	-28.29	-21.45	14.62	-17.14-2.538e+04-5.905e+04-5.628e+04-2.815e+04	-9253.24
		308	5.84	25.16	-26.97	-18.83	17.02	-18.92-4.173e+04-6.880e+04-6.620e+04-4.433e+04	-7981.27
		300	6.97	28.59	-28.10	-24.70	25.19	-13.45-4.911e+04-8.245e+04-8.239e+04-4.917e+04	-1456.27
284	38	301	5.70	7.74	-14.00	-12.54	6.28	-5.43-2.709e+04-6.752e+04-6.752e+04-2.710e+04	-512.61
		309	4.98	7.65	-13.72	-10.80	4.73	-7.34-2.517e+04-5.903e+04-5.623e+04-2.797e+04	-9330.58
		308	5.79	8.86	-13.39	-9.74	5.20	-8.24-4.186e+04-6.870e+04-6.608e+04-4.448e+04	-7960.77
		300	6.93	11.03	-14.16	-12.24	9.11	-6.69-4.897e+04-8.242e+04-8.235e+04-4.904e+04	-1543.08
284	69	301	5.67	0.88	-6.83	-5.91	-0.05	-2.51-2.702e+04-6.748e+04-6.747e+04-2.703e+04	-549.76
		309	4.95	0.57	-6.27	-5.36	-0.34	-2.32-2.507e+04-5.902e+04-5.620e+04-2.789e+04	-9370.14
		308	5.77	0.53	-6.46	-5.09	-0.84	-2.78-4.193e+04-6.864e+04-6.602e+04-4.456e+04	-7950.28
		300	6.91	2.18	-7.16	-5.87	0.88	-3.23-4.889e+04-8.240e+04-8.233e+04-4.897e+04	-1587.48
285	1	302	7.07	0.92	-9.11	-8.41	0.22	-2.55 -6016.45-7.611e+04-7.582e+04 -6299.17	4442.53
		310	4.99	0.81	-7.56	-7.04	0.29	-2.02 -7697.95-5.510e+04-5.362e+04 -9180.10	-8249.78
		309	6.44	1.10	-8.31	-7.45	0.24	-2.72-3.265e+04-7.684e+04-7.464e+04-3.485e+04	-9614.19
		301	7.88	1.74	-8.53	-7.65	0.86	-2.88-3.479e+04-8.755e+04-8.743e+04-3.491e+04	2438.62
285	3	302	5.98	0.78	-7.71	-7.12	0.19	-2.16 -5090.84-6.440e+04-6.416e+04 -5330.06	3759.06
		310	4.22	0.68	-6.39	-5.95	0.24	-1.71 -6513.65-4.662e+04-4.537e+04 -7767.78	-6980.58
		309	5.45	0.93	-7.04	-6.30	0.20	-2.30-2.762e+04-6.502e+04-6.316e+04-2.949e+04	-8135.09
		301	6.22	1.47	-7.22	-6.47	0.73	-2.43-2.944e+04-7.408e+04-7.398e+04-2.954e+04	2063.45
285	22	302	5.56	16.52	-28.69	-28.66	16.49	-1.19 -4872.31-5.870e+04-5.838e+04 -5087.02	3392.78
		310	3.93	17.88	-30.01	-27.98	15.85	-9.66 -6660.59-4.237e+04-4.127e+04 -7763.95	-6179.47
		309	5.05	20.11	-28.79	-26.57	17.90	-10.16-2.536e+04-5.919e+04-5.750e+04-2.705e+04	-7365.61
		301	5.75	23.57	-28.58	-28.50	23.49	-2.00-2.701e+04-6.738e+04-6.729e+04-2.711e+04	1944.81
285	54	302	5.48	5.84	-14.12	-13.98	5.69	-1.70 -4710.69-5.860e+04-5.838e+04 -4927.23	3409.02
		310	3.87	6.45	-14.00	-13.05	5.51	-4.29 -6171.60-4.238e+04-4.125e+04 -7299.27	-6289.64
		309	4.99	7.34	-13.94	-12.78	6.18	-4.82-2.520e+04-5.914e+04-5.745e+04-2.689e+04	-7385.41
		301	5.69	8.60	-13.75	-13.54	8.39	-2.14-2.685e+04-6.736e+04-6.727e+04-2.694e+04	1899.19
285	69	302	5.44	0.71	-7.01	-6.47	0.17	-1.96 -4628.04-5.854e+04-5.838e+04 -4845.51	3417.33
		310	3.84	0.62	-5.81	-5.41	0.22	-1.55 -5921.50-4.238e+04-4.124e+04 -7061.62	-6345.98
		309	4.96	0.85	-6.40	-5.73	0.18	-2.09-2.511e+04-5.911e+04-5.742e+04-2.680e+04	-7395.53
		301	5.66	1.34	-6.56	-5.89	0.66	-2.21-2.677e+04-6.734e+04-6.726e+04-2.685e+04	1875.86
286	1	303	7.23	-0.14	-8.64	-8.48	-0.31	-1.17 4063.67-7.288e+04-7.229e+04 3474.91	6705.01
		311	5.33	1.26	-6.51	-6.11	0.86	-1.72 3.944e+04-2.377e+04-2.313e+04 3.880e+04	-6321.52
		310	4.87	1.16	-8.25	-7.68	0.59	-2.25-1.254e+04-5.549e+04-5.527e+04-1.276e+04	-3054.57
		302	7.19	1.66	-7.84	-7.62	1.44	-1.43 -1798.10-7.547e+04-7.485e+04 -2418.55	6732.27
286	3	303	6.12	-0.12	-7.31	-7.17	-0.26	-0.99 3438.49-6.167e+04-6.117e+04 2940.30	5673.47
		311	4.51	1.06	-5.51	-5.17	0.72	-1.45 3.337e+04-2.012e+04-1.957e+04 2.83e+04	-5348.98
		310	4.12	0.98	-6.98	-6.50	0.50	-1.90-1.061e+04-4.695e+04-4.677e+04-1.080e+04	-2584.64
		302	6.09	1.40	-6.64	-6.45	1.22	-1.21 -1521.47-6.386e+04-6.333e+04 -2046.46	5696.53
286	6	303	5.65	6.70	-31.40	-31.38	6.68	0.93 3424.61-5.556e+04-5.521e+04 3074.82	4528.98
		311	4.18	19.90	-24.90	-17.70	12.70	-16.46 2.862e+04-1.998e+04-1.976e+04 2.841e+04	-3201.58
		310	3.80	18.02	-32.16	-29.25	15.10	-11.73-1.039e+04-4.229e+04-4.214e+04-1.055e+04	-2192.71
		302	5.67	14.45	-25.18	-24.79	14.06	-3.93 -1677.22-5.864e+04-5.810e+04 -2218.69	5527.48
286	38	303	5.59	2.11	-14.94	-14.93	2.11	-0.28 3225.52-5.589e+04-5.548e+04 2808.97	4944.96
		311	4.13	7.27	-11.63	-9.10	4.73	-6.44 2.974e+04-1.885e+04-1.846e+04 2.936e+04	-4300.62
		310	3.77	6.69	-15.08	-13.81	5.41	-5.11 -9898.98-4.255e+04-4.239e+04-1.006e+04	-2296.56
		302	5.58	5.72	-12.50	-12.27	5.49	-2.06 -1483.08-5.825e+04-5.775e+04 -1981.65	5296.70
286	69	303	5.56	-0.11	-6.65	-6.52	-0.24	-0.90 3125.90-5.606e+04-5.561e+04 2673.00	5157.70
		311	4.10	0.97	-5.01	-4.70	0.66	-1.32 3.034e+04-1.829e+04-1.780e+04 2.985e+04	-4862.71
		310	3.75	0.89	-6.35	-5.91	0.45	-1.73 -9645.96-4.268e+04-4.252e+04 -9813.92	-2349.67
		302	5.53	1.28	-6.03	-5.86	1.11	-1.10 -1383.16-5.805e+04-5.758e+04 -1860.42	5178.67
287	1	304	5.77	0.74	-6.22	-6.12	0.65	-0.81 1.199e+04-5.295e+04-5.265e+04 1.169e+04	4358.06
		312	3.43	-1.14	-6.30	-6.30	-1.14	0.01 4903.66-3.280e+04-2.890e+04 1006.72	-
1.148e+04									

Parco Eolico "Bolina" – Progetto Definitivo
Relazione di calcolo preliminare delle fondazioni degli aerogeneratori G8 e G12

1.081e+04	311	5.48	0.15	-6.93	-6.35	-0.42	-1.94	4.184e+04-2.294e+04-2.108e+04	3.998e+04	-	
	303	7.26	0.68	-8.59	-8.57	0.66	0.45	3275.52-7.357e+04-7.260e+04	2302.10	8593.89	
287	3	304	4.88	0.63	-5.26	-5.18	0.55	-0.68	1.014e+04-4.480e+04-4.455e+04	9894.94	3687.59
	312	2.90	-0.96	-5.33	-5.33	-0.96	0.01	4149.25-2.775e+04-2.446e+04	851.84	-9712.03	
	311	4.64	0.13	-5.86	-5.38	-0.36	-1.64	3.540e+04-1.941e+04-1.784e+04	3.383e+04	-9150.87	
	303	6.14	0.58	-7.27	-7.25	0.56	0.38	2771.59-6.225e+04-6.143e+04	1947.93	7271.76	
287	23	304	4.57	23.34	-5.21	23.19	-5.07	-2.04	9320.55-4.110e+04-4.093e+04	9145.03	2969.75
	312	2.63	17.83	-5.09	16.83	-4.09	4.68	3584.11-2.460e+04-2.159e+04	571.63	-8708.83	
	311	4.35	28.80	-4.09	24.60	0.11	10.98	3.136e+04-1.923e+04-1.722e+04	2.934e+04	-9899.42	
	303	5.73	17.86	-15.88	16.64	-14.65	-6.31	3993.46-5.649e+04-5.558e+04	3085.32	7355.66	
287	54	304	4.47	2.38	-14.15	-14.15	2.38	-0.14	9189.45-4.060e+04-4.036e+04	8944.77	3481.82
	312	2.69	0.41	-12.37	-12.18	0.21	-1.57	3836.05-2.544e+04-2.245e+04	843.02	-8869.82	
	311	4.24	1.52	-16.85	-14.86	-0.47	-5.71	3.249e+04-1.713e+04-1.588e+04	3.123e+04	-7784.19	
	303	5.61	5.97	-14.79	-14.46	5.64	2.60	2023.71-5.663e+04-5.593e+04	1326.06	6358.61	
287	69	304	4.44	0.57	-4.78	-4.71	0.50	-0.62	9221.42-4.073e+04-4.050e+04	8995.40	3352.35
	312	2.64	-0.88	-4.85	-4.85	-0.88	0.01	3772.05-2.523e+04-2.223e+04	774.40	-8829.12	
	311	4.22	0.12	-5.33	-4.89	-0.33	-1.49	3.218e+04-1.765e+04-1.622e+04	3.075e+04	-8318.98	
	303	5.59	0.53	-6.61	-6.59	0.51	0.35	2519.63-5.659e+04-5.584e+04	1770.85	6610.69	
288	1	305	4.33	-0.41	-5.27	-5.25	-0.43	-0.32	450.13-4.472e+04-4.435e+04	80.39	4070.17
	313	3.19	-0.36	-5.51	-5.50	-0.37	0.25	-297.27-3.320e+04-3.248e+04	-1024.73	-4838.29	
	312	3.54	-0.03	-5.82	-5.79	-0.06	-0.43	7880.57-3.210e+04-3.055e+04	6335.88	-7704.95	
	304	5.43	0.49	-6.74	-6.73	0.49	0.10	7560.36-5.209e+04-5.150e+04	6979.73	5856.20	
288	3	305	3.67	-0.34	-4.46	-4.44	-0.36	-0.27	380.88-3.784e+04-3.753e+04	68.02	3443.99
	313	2.70	-0.30	-4.67	-4.66	-0.31	0.21	-251.53-2.810e+04-2.748e+04	-867.08	-4093.94	
	312	3.00	-0.02	-4.93	-4.90	-0.05	-0.37	6668.17-2.716e+04-2.585e+04	5361.13	-6519.57	
	304	4.59	0.42	-5.70	-5.70	0.42	0.08	6397.23-4.407e+04-4.358e+04	5905.92	4955.24	
288	22	305	3.44	0.49	-31.22	-30.72	-6.48e-03	3.93	382.80-3.432e+04-3.403e+04	92.56	3160.15
	313	2.58	1.32	-30.19	-29.71	0.84	-3.86	-268.63-2.572e+04-2.516e+04	-828.97	-3734.77	
	312	2.85	1.97	-30.89	-29.49	0.57	-6.64	6279.63-2.466e+04-2.356e+04	5175.94	-5738.56	
	304	4.28	5.98	-31.75	-31.38	5.61	3.72	5616.18-4.000e+04-3.953e+04	5146.57	4604.53	
288	54	305	3.37	-0.12	-13.17	-13.07	-0.22	1.17	358.61-3.437e+04-3.409e+04	72.23	3140.80
	313	2.50	0.20	-12.96	-12.85	0.10	-1.18	-242.19-2.560e+04-2.504e+04	-802.03	-3726.16	
	312	2.77	0.61	-13.37	-12.92	0.16	-2.47	6135.20-2.468e+04-2.352e+04	4976.00	-5863.16	
	304	4.21	2.25	-14.15	-14.05	2.15	1.31	5748.08-4.004e+04-3.959e+04	5293.75	4538.52	
288	69	305	3.33	-0.31	-4.05	-4.04	-0.33	-0.25	346.26-3.440e+04-3.412e+04	61.84	3130.90
	313	2.46	-0.28	-4.24	-4.23	-0.29	0.19	-228.67-2.554e+04-2.498e+04	-788.26	-3721.76	
	312	2.73	-0.02	-4.48	-4.45	-0.05	-0.33	6061.98-2.469e+04-2.350e+04	4873.75	-5926.89	
	304	4.17	0.38	-5.18	-5.18	0.38	0.07	5815.66-4.007e+04-3.962e+04	5369.02	4504.77	
289	1	73	21.85	3.41	-11.76	3.37	-11.72	0.80-1.874e+05-2.533e+05-2.532e+05	-1.874e+05	614.90	
	306	14.84	7.32	-9.59	6.97	-9.24	2.41	-1.459e+05-1.620e+05-1.583e+05	-1.495e+05	6739.72	
	314	17.37	1.41	-13.99	1.36	-13.94	-0.86	-1.607e+05-1.956e+05-1.901e+05	-1.662e+05		
1.272e+04	74	27.63	5.34	-6.53	4.81	-6.01	2.44	-2.136e+05-3.273e+05-3.230e+05	-2.179e+05		
2.164e+04	289	3	73	18.49	2.89	-9.95	2.85	-9.92	0.68-1.586e+05-2.143e+05-2.143e+05	-1.586e+05	520.30
	306	12.56	6.19	-8.11	5.89	-7.81	2.04	-1.234e+05-1.371e+05-1.340e+05	-1.265e+05	5702.84	
	314	14.69	1.20	-11.84	1.15	-11.80	-0.73	-1.360e+05-1.655e+05-1.609e+05	-1.406e+05		
1.076e+04	74	23.38	4.52	-5.52	4.07	-5.08	2.06	-1.807e+05-2.769e+05-2.733e+05	-1.844e+05		
1.831e+04	289	7	73	16.85	32.99	-24.76	-23.98	32.21	6.70-1.444e+05-1.949e+05-1.949e+05	-1.444e+05	407.10
	306	11.49	13.51	-59.40	-59.40	13.51	-0.40	-1.122e+05-1.241e+05-1.212e+05	-1.151e+05	5079.72	
	314	13.36	43.18	-32.46	-31.81	42.53	6.99	-1.238e+05-1.504e+05-1.462e+05	-1.280e+05	9738.25	
	74	21.55	16.97	-95.03	-95.03	16.97	-0.15	-1.646e+05-2.520e+05-2.487e+05	-1.679e+05		
1.655e+04	289	39	73	16.82	5.53	-7.00	-6.40	4.93	2.67-1.442e+05-1.948e+05-1.948e+05	-1.442e+05	450.70
	306	11.44	-0.06	-16.63	-16.55	-0.13	1.09	-1.122e+05-1.244e+05-1.216e+05	-1.150e+05	5148.98	
	314	13.36	7.51	-10.28	-10.07	7.30	1.93	-1.237e+05-1.505e+05-1.462e+05	-1.279e+05	9767.59	
	74	21.35	2.73	-29.75	-29.71	2.69	1.19	-1.644e+05-2.518e+05-2.485e+05	-1.677e+05		
1.662e+04	289	69	73	16.81	2.63	-9.05	2.59	-9.02	0.61-1.441e+05-1.948e+05-1.948e+05	-1.442e+05	473.00
	306	11.41	5.63	-7.37	5.36	-7.10	1.85	-1.122e+05-1.246e+05-1.218e+05	-1.150e+05	5184.40	
	314	13.36	1.09	-10.76	1.05	-10.72	-0.66	-1.236e+05-1.505e+05-1.462e+05	-1.278e+05	9782.60	
	74	21.26	4.10	-5.02	3.70	-4.62	1.87	-1.643e+05-2.517e+05-2.484e+05	-1.676e+05		
1.665e+04	290	1	306	15.19	4.95	-11.23	4.65	-10.92	2.20-1.507e+05-1.647e+05-1.644e+05	-1.510e+05	2062.60
	307	7.64	8.33	-8.39	8.04	-8.10	-2.18	-6.201e+04-8.950e+04-6.278e+04	-8.874e+04	4514.00	
	315	12.82	0.29	-7.75	-0.17	-7.30	1.86	-1.024e+05-1.508e+05-1.099e+05	-1.433e+05		
1.752e+04	314	17.75	5.70	-10.76	5.17	-10.23	2.91	-1.578e+05-2.033e+05-1.942e+05	-1.670e+05		
1.823e+04	290	3	306	12.85	4.19	-9.50	3.94	-9.24	1.86-1.275e+05-1.393e+05-1.391e+05	-1.278e+05	1745.27

Parco Eolico "Bolina" – Progetto Definitivo
Relazione di calcolo preliminare delle fondazioni degli aerogeneratori G8 e G12

		307	6.46	7.05	-7.10	6.80	-6.85	-1.85-5.247e+04-7.573e+04-5.312e+04-7.509e+04	3819.54	
		315	10.85	0.24	-6.56	-0.14	-6.17	1.57-8.664e+04-1.276e+05-9.298e+04-1.213e+05		
1.482e+04		314	15.02	4.82	-9.10	4.37	-8.66	2.46-1.335e+05-1.720e+05-1.643e+05-1.413e+05		
1.543e+04		290 22	306	11.70	43.93	-37.49	42.11	-35.67	-12.05-1.151e+05-1.269e+05-1.268e+05-1.152e+05	1177.72
			307	6.11	57.03	-24.73	49.03	-16.73	-24.29-4.941e+04-7.136e+04-5.102e+04-6.975e+04	5719.69
			315	9.84	32.09	-24.56	31.67	-24.14	-4.87-7.833e+04-1.157e+05-8.371e+04-1.103e+05	
1.312e+04		314	13.79	58.57	-34.93	58.34	-34.69	-4.72-1.213e+05-1.572e+05-1.499e+05-1.286e+05		
1.440e+04		290 54	306	11.68	16.87	-17.88	16.62	-17.63	-2.96-1.156e+05-1.267e+05-1.266e+05-1.158e+05	1448.25
			307	5.94	23.31	-12.41	20.68	-9.78	-9.33-4.834e+04-6.964e+04-4.921e+04-6.877e+04	4232.77
			315	9.86	10.65	-11.90	10.63	-11.88	-0.70-7.862e+04-1.159e+05-8.425e+04-1.103e+05	
1.335e+04		314	13.69	22.37	-16.95	22.37	-16.95	-0.12-1.214e+05-1.567e+05-1.495e+05-1.285e+05		
1.415e+04		290 69	306	11.69	3.81	-8.64	3.58	-8.40	1.69-1.159e+05-1.267e+05-1.264e+05-1.162e+05	1586.61
			307	5.88	6.41	-6.45	6.18	-6.23	-1.68-4.770e+04-6.885e+04-4.829e+04-6.826e+04	3472.31
			315	9.87	0.22	-5.96	-0.13	-5.61	1.43-7.876e+04-1.160e+05-8.453e+04-1.102e+05	
1.347e+04		314	13.65	4.38	-8.28	3.98	-7.87	2.23-1.214e+05-1.564e+05-1.494e+05-1.284e+05		
1.403e+04		291 1	307	7.22	-1.64	-9.37	-2.59	-8.43	-2.53-4.885e+04-8.618e+04-4.955e+04-8.549e+04	-5041.20
			308	7.76	0.86	-8.39	0.70	-8.23	1.19-6.126e+04-9.131e+04-6.394e+04-8.863e+04	-8563.51
			316	8.71	0.27	-8.63	0.27	-8.63	0.04-5.412e+04-1.044e+05-5.460e+04-1.039e+05	4879.76
			315	13.07	6.43	-8.95	5.89	-8.41	2.83-1.056e+05-1.533e+05-1.115e+05-1.475e+05	
1.560e+04		291 3	307	6.11	-1.39	-7.93	-2.19	-7.13	-2.14-4.134e+04-7.292e+04-4.193e+04-7.233e+04	-4265.63
			308	6.57	0.73	-7.10	0.60	-6.97	1.01-5.184e+04-7.726e+04-5.411e+04-7.500e+04	-7246.05
			316	7.37	0.23	-7.31	0.23	-7.31	0.03-4.579e+04-8.831e+04-4.620e+04-8.791e+04	4129.03
			315	11.06	5.44	-7.57	4.98	-7.11	2.40-8.939e+04-1.297e+05-9.432e+04-1.248e+05	
1.320e+04		291 6	307	5.47	22.58	-40.09	18.70	-36.21	-15.10-3.555e+04-6.420e+04-3.562e+04-6.414e+04	-1386.14
			308	6.09	25.95	-22.48	25.95	-22.48	0.28-4.694e+04-7.159e+04-4.920e+04-6.933e+04	-7111.57
			316	6.73	29.65	-32.00	29.55	-31.90	2.42-4.133e+04-7.967e+04-4.188e+04-7.912e+04	4559.87
			315	10.10	57.20	-30.00	55.01	-27.82	13.63-8.373e+04-1.176e+05-8.783e+04-1.135e+05	
1.105e+04		291 38	307	5.52	6.77	-18.30	5.01	-16.54	-6.40-3.694e+04-6.554e+04-3.727e+04-6.521e+04	-3034.71
			308	6.01	9.16	-11.82	9.14	-11.80	0.70-4.706e+04-7.070e+04-4.919e+04-6.857e+04	-6764.71
			316	6.71	10.17	-15.22	10.14	-15.19	0.84-4.153e+04-8.007e+04-4.196e+04-7.965e+04	4026.46
			315	10.07	22.62	-14.70	21.61	-13.69	6.05-8.210e+04-1.178e+05-8.645e+04-1.135e+05	
1.168e+04		291 69	307	5.55	-1.26	-7.21	-1.99	-6.48	-1.94-3.758e+04-6.629e+04-3.811e+04-6.576e+04	-3877.85
			308	5.97	0.66	-6.45	0.54	-6.33	0.91-4.713e+04-7.024e+04-4.919e+04-6.818e+04	-6587.32
			316	6.70	0.21	-6.64	0.21	-6.64	0.03-4.163e+04-8.028e+04-4.200e+04-7.992e+04	3753.66
			315	10.05	4.95	-6.88	4.53	-6.47	2.18-8.127e+04-1.179e+05-8.574e+04-1.135e+05	
1.200e+04		292 1	308	7.51	0.67	-8.34	0.66	-8.33	0.32-5.451e+04-8.924e+04-5.518e+04-8.857e+04	-4770.78
			309	6.43	0.85	-8.29	0.85	-8.28	0.16-3.259e+04-7.673e+04-3.315e+04-7.617e+04	-4938.28
			317	7.37	0.24	-7.84	0.23	-7.84	0.25-3.511e+04-8.773e+04-3.655e+04-8.630e+04	8566.49
			316	8.98	1.51	-8.07	1.47	-8.03	0.65-6.356e+04-1.071e+05-6.431e+04-1.064e+05	5687.71
		292 3	308	6.35	0.57	-7.06	0.56	-7.05	0.27-4.613e+04-7.551e+04-4.669e+04-7.494e+04	-4036.81
			309	5.44	0.72	-7.01	0.72	-7.01	0.13-2.757e+04-6.492e+04-2.805e+04-6.445e+04	-4178.54
			317	6.24	0.20	-6.64	0.19	-6.63	0.22-2.971e+04-7.423e+04-3.093e+04-7.302e+04	7248.57
			316	7.60	1.28	-6.83	1.24	-6.79	0.55-5.378e+04-9.065e+04-5.442e+04-9.001e+04	4812.68
		292 22	308	5.84	24.79	-26.56	23.03	-24.80	-9.33-4.173e+04-6.880e+04-4.223e+04-6.831e+04	-3627.60
			309	5.04	21.26	-28.11	19.82	-26.67	-8.31-2.538e+04-5.905e+04-2.579e+04-5.864e+04	-3720.20
			317	5.76	20.73	-27.47	20.70	-27.45	-1.18-2.723e+04-6.761e+04-2.836e+04-6.648e+04	6677.53
			316	6.97	27.69	-27.27	27.65	-27.23	-1.50-4.910e+04-8.246e+04-4.971e+04-8.185e+04	4473.62
		292 54	308	5.79	8.56	-13.06	8.13	-12.63	-3.00-4.187e+04-6.870e+04-4.237e+04-6.819e+04	-3655.54
			309	4.98	7.50	-13.60	7.14	-13.24	-2.73-2.517e+04-5.903e+04-2.560e+04-5.861e+04	-3772.12
			317	5.70	7.12	-13.28	7.12	-13.27	-0.27-2.708e+04-6.753e+04-2.820e+04-6.641e+04	6619.36
			316	6.93	10.10	-13.30	10.10	-13.30	-0.18-4.896e+04-8.243e+04-4.955e+04-8.183e+04	4408.48
		292 69	308	5.77	0.52	-6.42	0.51	-6.41	0.25-4.193e+04-6.864e+04-4.245e+04-6.813e+04	-3669.83
			309	4.95	0.66	-6.37	0.65	-6.37	0.12-2.507e+04-5.902e+04-2.550e+04-5.859e+04	-3798.67
			317	5.67	0.18	-6.03	0.18	-6.03	0.20-2.701e+04-6.749e+04-2.811e+04-6.638e+04	6589.61
			316	6.91	1.16	-6.21	1.13	-6.17	0.50-4.889e+04-8.241e+04-4.947e+04-8.183e+04	4375.16
		293 1	309	6.44	1.18	-8.38	1.18	-8.38	0.07-3.265e+04-7.685e+04-3.317e+04-7.632e+04	-4790.17
			310	4.99	0.96	-7.74	0.96	-7.74	0.11 -7695.21-5.510e+04 -7877.68-5.491e+04	-2935.32
			318	7.07	0.25	-8.21	0.24	-8.21	-0.20 -6005.65-7.611e+04 -8231.77-7.389e+04	1.229e+04
			317	7.36	0.83	-7.52	0.83	-7.52	0.17-3.478e+04-8.755e+04-3.616e+04-8.618e+04	8399.30
		293 3	309	5.45	1.00	-7.09	0.99	-7.09	0.06-2.762e+04-6.502e+04-2.807e+04-6.458e+04	-4053.22

Parco Eolico "Bolina" – Progetto Definitivo
Relazione di calcolo preliminare delle fondazioni degli aerogeneratori G8 e G12

		310	4.23	0.81	-6.55	0.81	-6.55	0.10	-6511.33-4.662e+04	-6665.73-4.647e+04	-2483.74
		318	5.98	0.21	-6.95	0.20	-6.95	-0.17	-5081.71-6.440e+04	-6965.34-6.252e+04	1.040e+04
		317	6.23	0.70	-6.36	0.70	-6.36	0.14	-2.943e+04-7.408e+04	-3.059e+04-7.292e+04	7107.10
293	6	309	5.05	20.20	-28.87	19.96	-28.63	-3.39	-2.536e+04-5.919e+04	-2.576e+04-5.879e+04	-3673.30
		310	3.94	17.95	-30.13	17.71	-29.88	-3.43	-6658.46-4.237e+04	-6791.21-4.224e+04	-2173.30
		318	5.56	16.38	-28.38	15.82	-27.82	5.01	-4864.02-5.870e+04	-6566.88-5.700e+04	9422.25
		317	5.75	23.41	-28.36	22.81	-27.76	5.54	-2.700e+04-6.739e+04	-2.808e+04-6.631e+04	6503.01
293	38	309	4.99	7.41	-14.01	7.35	-13.96	-1.11	-2.520e+04-5.914e+04	-2.560e+04-5.874e+04	-3680.87
		310	3.87	6.54	-14.11	6.48	-14.05	-1.10	-6169.48-4.238e+04	-6307.26-4.224e+04	-2229.30
		318	5.48	5.61	-13.72	5.47	-13.59	1.59	-4702.40-5.860e+04	-6411.56-5.689e+04	9444.51
		317	5.69	8.32	-13.40	8.14	-13.22	1.96	-2.684e+04-6.736e+04	-2.790e+04-6.630e+04	6475.22
293	69	309	4.96	0.90	-6.45	0.90	-6.45	0.06	-2.511e+04-5.911e+04	-2.552e+04-5.871e+04	-3684.75
		310	3.84	0.74	-5.96	0.74	-5.96	0.09	-5919.39-4.238e+04	-6059.75-4.224e+04	-2257.94
		318	5.44	0.19	-6.32	0.18	-6.31	-0.16	-4619.73-5.855e+04	-6332.13-5.684e+04	9455.90
		317	5.66	0.64	-5.78	0.64	-5.78	0.13	-2.676e+04-6.735e+04	-2.781e+04-6.629e+04	6461.00
294	1	310	4.87	1.11	-8.15	1.08	-8.12	-0.48	-1.253e+04-5.551e+04	-1.253e+04-5.551e+04	-183.02
		311	5.33	1.33	-6.84	1.31	-6.82	-0.33	3.943e+04-2.371e+04	3.936e+04-2.363e+04	-2174.88
		319	7.23	-0.51	-7.91	-0.51	-7.91	0.06	4078.44-7.291e+04	2252.65-7.108e+04	1.171e+04
		318	7.19	1.23	-7.25	1.20	-7.22	0.49	-1787.43-7.546e+04	-3626.55-7.362e+04	1.149e+04
294	3	310	4.12	0.94	-6.89	0.92	-6.87	-0.41	-1.060e+04-4.697e+04	-1.060e+04-4.697e+04	-154.86
		311	4.51	1.12	-5.79	1.11	-5.77	-0.28	3.337e+04-2.006e+04	3.330e+04-2.000e+04	-1840.28
		319	6.12	-0.43	-6.69	-0.43	-6.69	0.05	3450.99-6.169e+04	1906.09-6.015e+04	9912.14
		318	6.08	1.04	-6.14	1.01	-6.11	0.42	-1512.44-6.385e+04	-3068.62-6.229e+04	9725.63
294	6	310	3.86	16.75	-29.06	16.25	-28.56	-4.78	-1.034e+04-4.300e+04	-1.034e+04-4.300e+04	-76.39
		311	4.04	17.79	-33.58	17.25	-33.04	-5.22	2.849e+04-1.766e+04	2.845e+04-1.762e+04	-1341.21
		319	5.69	8.58	-29.72	7.77	-28.91	5.52	3324.69-5.614e+04	2015.72-5.483e+04	8224.83
		318	5.65	16.31	-29.14	15.73	-28.55	5.12	-1597.09-5.812e+04	-3030.94-5.668e+04	8887.32
294	38	310	3.79	6.22	-13.97	6.05	-13.80	-1.86	-9876.09-4.280e+04	-9876.52-4.280e+04	-119.00
		311	4.08	6.68	-14.83	6.51	-14.65	-1.93	2.971e+04-1.804e+04	2.966e+04-1.799e+04	-1560.72
		319	5.61	2.59	-14.02	2.37	-13.80	1.90	3200.25-5.610e+04	1828.54-5.473e+04	8914.19
		318	5.57	6.13	-13.54	5.93	-13.34	1.98	-1450.14-5.807e+04	-2871.30-5.665e+04	8857.00
294	69	310	3.75	0.85	-6.27	0.83	-6.25	-0.37	-9640.18-4.270e+04	-9640.78-4.270e+04	-140.78
		311	4.10	1.02	-5.26	1.01	-5.25	-0.25	3.033e+04-1.824e+04	3.028e+04-1.818e+04	-1672.99
		319	5.56	-0.39	-6.08	-0.39	-6.08	0.05	3137.26-5.608e+04	1732.81-5.468e+04	9011.03
		318	5.53	0.94	-5.58	0.92	-5.56	0.38	-1374.95-5.805e+04	-2789.65-5.663e+04	8841.48
295	1	311	5.48	-0.09	-7.20	-0.31	-6.99	-1.23	4.185e+04-2.285e+04	4.057e+04-2.157e+04	-9010.16
		312	3.43	-0.93	-6.37	-0.98	-6.31	0.53	4895.52-3.282e+04	1630.09-2.956e+04	-
1.061e+04		320	5.77	0.45	-5.68	0.44	-5.66	-0.34	1.200e+04-5.293e+04	1.141e+04-5.233e+04	6193.41
		319	7.26	0.82	-8.13	0.57	-7.88	1.49	3250.22-7.359e+04	1730.93-7.207e+04	1.070e+04
295	3	311	4.64	-0.08	-6.10	-0.26	-5.91	-1.04	3.541e+04-1.934e+04	3.433e+04-1.825e+04	-7623.98
		312	2.90	-0.78	-5.39	-0.83	-5.34	0.45	4142.37-2.777e+04	1379.31-2.501e+04	-8975.00
		320	4.88	0.38	-4.81	0.37	-4.79	-0.29	1.016e+04-4.479e+04	9652.59-4.428e+04	5240.58
		319	6.14	0.70	-6.88	0.48	-6.67	1.26	2750.18-6.227e+04	1464.63-6.098e+04	9051.44
295	7	311	4.34	28.71	-4.40	-0.49	24.80	10.69	3.136e+04-1.916e+04	2.988e+04-1.768e+04	-8520.92
		312	2.63	17.93	-5.08	-4.21	17.07	4.37	3577.75-2.462e+04	1045.02-2.209e+04	-8062.80
		320	4.57	23.68	-5.36	-5.12	23.44	-2.62	9332.48-4.109e+04	8945.84-4.070e+04	4398.41
		319	5.73	18.11	-15.65	-14.32	16.77	-6.59	3974.21-5.651e+04	2603.13-5.513e+04	9002.39
295	38	311	4.24	1.26	-17.00	-0.16	-15.58	-4.88	3.250e+04-1.706e+04	3.166e+04-1.623e+04	-6392.86
		312	2.69	0.49	-12.34	0.42	-12.28	-0.93	3829.83-2.546e+04	1324.60-2.296e+04	-8191.67
		320	4.46	2.20	-13.78	2.18	-13.76	0.54	9201.85-4.059e+04	8717.30-4.010e+04	4887.92
		319	5.61	6.14	-14.50	5.43	-13.79	3.77	2004.18-5.664e+04	901.19-5.554e+04	7966.74
295	69	311	4.21	-0.07	-5.54	-0.24	-5.37	-0.94	3.219e+04-1.758e+04	3.121e+04-1.659e+04	-6930.89
		312	2.64	-0.71	-4.90	-0.75	-4.86	0.41	3765.79-2.525e+04	1253.92-2.274e+04	-8159.09
		320	4.44	0.35	-4.37	0.34	-4.36	-0.26	9233.70-4.072e+04	8775.08-4.026e+04	4764.16
		319	5.58	0.63	-6.26	0.44	-6.06	1.15	2500.17-5.661e+04	1331.49-5.544e+04	8228.58
296	1	312	3.54	-0.10	-5.96	-0.10	-5.95	-0.13	7881.41-3.209e+04	6302.48-3.051e+04	-7785.62
		313	3.19	-0.27	-5.58	-0.28	-5.56	0.29	-297.89-3.321e+04	-1050.41-3.245e+04	-4919.11
		321	4.33	-0.49	-4.69	-0.52	-4.67	-0.34	450.60-4.472e+04	101.13-4.438e+04	3957.95
		320	5.43	0.50	-6.16	0.48	-6.14	0.31	7562.96-5.209e+04	7008.54-5.153e+04	5723.96
296	3	312	3.00	-0.08	-5.04	-0.08	-5.04	-0.11	6668.88-2.715e+04	5332.87-2.582e+04	-6587.83
		313	2.70	-0.23	-4.72	-0.24	-4.70	0.25	-252.06-2.810e+04	-888.81-2.746e+04	-4162.33
		321	3.67	-0.42	-3.97	-0.44	-3.95	-0.29	381.27-3.784e+04	85.57-3.755e+04	3349.03
		320	4.59	0.42	-5.21	0.41	-5.20	0.26	6399.43-4.407e+04	5930.31-4.360e+04	4843.35
296	6	312	2.85	1.85	-30.92	0.51	-29.58	-6.48	6280.46-2.465e+04	5151.24-2.353e+04	-5801.53
		313	2.58	1.38	-30.22	0.89	-29.74	-3.89	-269.11-2.572e+04	-848.79-2.514e+04	-3797.32
		321	3.44	0.42	-30.79	-0.06	-30.30	3.85	383.16-3.432e+04	108.67-3.404e+04	3074.00
		320	4.28	6.01	-31.34	5.62	-30.95	3.81	5618.26-4.000e+04	5169.25-3.955e+04	4503.63
296	38	312	2.77	0.50	-13.42	0.12	-13.04	-2.26	6135.91-2.467e+04	4950.65-2.349e+04	-5925.52
		313	2.50	0.26	-13.00	0.16	-12.89	-1.17	-242.67-2.560e+04	-821.81-2.502e+04	-3788.46
		321	3.37	-0.18	-12.73	-0.28	-12.63	1.13	358.97-3.437e+04	88.24-3.410e+04	3054.53
		320	4.21	2.28	-13.73	2.15	-13.60	1.45	5750.11-4.005e+04	5316.09-3.961e+04	4437.08
296	69	312	2.72	-0.07	-4.58	-0.08	-4.58	-0.10	6062.62-2.468e+04	4848.06-2.347e+04	-5988.94

Parco Eolico "Bolina" – Progetto Definitivo
Relazione di calcolo preliminare delle fondazioni degli aerogeneratori G8 e G12

		313	2.46	-0.20	-4.29	-0.22	-4.28	0.23	-229.14-2.554e+04	-808.01-2.496e+04	-3783.93
		321	3.33	-0.38	-3.61	-0.40	-3.59	-0.26	346.61-3.440e+04	77.79-3.414e+04	3044.58
		320	4.17	0.38	-4.74	0.37	-4.73	0.24	5817.66-4.007e+04	5391.19-3.964e+04	4403.05
297	1	74	21.62	7.84	-8.17	7.04	-7.37	3.49-2.120e+05	-2.365e+05	-2.268e+05	-2.216e+05
1.197e+04											
4.149e+04		314	20.70	1.69	-8.53	1.29	-8.13	-1.99-1.584e+05	-2.455e+05	-2.152e+05	-1.887e+05
1.599e+04		322	15.12	3.03	-6.26	3.03	-6.26	0.04-1.356e+05	-1.727e+05	-1.636e+05	-1.447e+05
1.336e+05		75	47.56	-1.07	-7.31	-1.73	-6.65	1.92-1.979e+05	-5.636e+05	-5.057e+05	-2.558e+05
1.013e+04	3	74	18.30	6.63	-6.92	5.96	-6.24	2.95-1.794e+05	-2.001e+05	-1.919e+05	-1.875e+05
3.511e+04		314	17.51	1.43	-7.22	1.09	-6.88	-1.69-1.340e+05	-2.077e+05	-1.821e+05	-1.596e+05
1.353e+04		322	12.79	2.56	-5.29	2.56	-5.29	0.03-1.147e+05	-1.462e+05	-1.384e+05	-1.225e+05
1.130e+05		75	40.24	-0.91	-6.19	-1.46	-5.63	1.62-1.674e+05	-4.769e+05	-4.279e+05	-2.165e+05
3.181e+04	7	74	16.84	9.23	-116.35	-81.98	-25.14	-55.99-1.634e+05	-1.821e+05	-1.747e+05	-1.708e+05
1.230e+04		314	16.08	43.19	-64.22	-46.33	25.30	40.02-1.220e+05	-1.887e+05	-1.655e+05	-1.453e+05
1.027e+05		322	11.85	9.46	-83.52	-53.24	-20.82	-43.57-1.045e+05	-1.330e+05	-1.259e+05	-1.115e+05
3.188e+04	39	74	16.70	-0.04	-36.38	-24.16	-12.26	-17.17-1.632e+05	-1.819e+05	-1.745e+05	-1.706e+05
1.230e+04		314	15.97	10.56	-21.16	-15.02	4.42	12.53-1.219e+05	-1.888e+05	-1.655e+05	-1.452e+05
1.027e+05		322	11.71	1.70	-28.40	-16.48	-10.23	-14.72-1.044e+05	-1.329e+05	-1.259e+05	-1.114e+05
3.191e+04	69	74	16.63	6.03	-6.29	5.41	-5.67	2.68-1.631e+05	-1.819e+05	-1.745e+05	-1.705e+05
1.230e+04		314	15.92	1.30	-6.56	0.99	-6.25	-1.53-1.218e+05	-1.888e+05	-1.655e+05	-1.451e+05
1.027e+05		322	11.63	2.33	-4.81	2.33	-4.81	0.03-1.043e+05	-1.329e+05	-1.258e+05	-1.113e+05
1.765e+04	1	314	17.41	7.14	-4.60	6.15	-3.61	3.26-1.602e+05	-1.968e+05	-1.834e+05	-1.736e+05
1.210e+04		315	12.64	3.04	-11.50	2.98	-11.44	-0.93-1.009e+05	-1.485e+05	-1.042e+05	-1.452e+05
2.372e+04		323	13.37	2.78	-7.65	2.01	-6.88	2.73-1.065e+05	-1.573e+05	-1.228e+05	-1.410e+05
3.424e+04		322	20.56	0.88	-8.57	0.81	-8.50	-0.81-1.644e+05	-2.420e+05	-2.215e+05	-1.849e+05
1.493e+04	3	314	14.73	6.04	-3.89	5.21	-3.05	2.76-1.355e+05	-1.665e+05	-1.552e+05	-1.469e+05
1.024e+04		315	10.69	2.57	-9.73	2.52	-9.68	-0.79-8.539e+04	-1.256e+05	-8.819e+04	-1.228e+05
2.007e+04		323	11.31	2.35	-6.47	1.70	-5.82	2.31-9.011e+04	-1.331e+05	-1.039e+05	-1.193e+05
2.897e+04		322	17.39	0.74	-7.25	0.68	-7.19	-0.69-1.391e+05	-2.048e+05	-1.874e+05	-1.564e+05
1.352e+04	23	314	13.50	-9.60	-42.33	-40.72	-11.21	7.09-1.233e+05	-1.513e+05	-1.410e+05	-1.336e+05
1.834e+04		315	9.68	25.50	-45.13	-35.58	15.95	24.16-7.742e+04	-1.138e+05	-7.987e+04	-1.113e+05
2.641e+04		323	10.28	17.03	-31.94	-31.88	16.97	-1.78-8.185e+04	-1.211e+05	-9.445e+04	-1.085e+05
1.356e+04	55	314	13.43	-3.37	-12.91	-10.65	-5.63	4.06-1.232e+05	-1.514e+05	-1.411e+05	-1.335e+05
1.828e+04		315	9.71	3.74	-14.68	-10.52	-0.42	7.70-7.756e+04	-1.141e+05	-8.007e+04	-1.116e+05
2.636e+04		323	10.28	2.29	-9.81	-9.76	2.24	0.78-8.190e+04	-1.211e+05	-9.445e+04	-1.085e+05
1.358e+04	69	314	13.39	5.49	-3.54	4.73	-2.78	2.51-1.232e+05	-1.514e+05	-1.411e+05	-1.335e+05
		315	9.72	2.34	-8.84	2.29	-8.80	-0.71-7.762e+04	-1.142e+05	-8.017e+04	-1.117e+05

Parco Eolico "Bolina" – Progetto Definitivo
Relazione di calcolo preliminare delle fondazioni degli aerogeneratori G8 e G12

1.824e+04	323	10.28	2.14	-5.88	1.55	-5.29	2.10-8.192e+04-1.210e+05-9.446e+04-1.085e+05		
2.634e+04	322	15.81	0.67	-6.59	0.62	-6.54	-0.62-1.264e+05-1.862e+05-1.704e+05-1.422e+05		
299	1	315	12.26	2.59	-8.06	2.58	-8.06	-0.08-9.970e+04-1.436e+05-1.018e+05-1.416e+05	9275.10
		316	9.46	1.59	-8.73	1.59	-8.72	-0.21-6.077e+04-1.133e+05-6.086e+04-1.133e+05	-2229.33
		324	10.38	0.37	-7.66	0.18	-7.47	1.22-6.511e+04-1.245e+05-7.418e+04-1.155e+05	
2.137e+04									
2.622e+04	323	13.93	2.60	-9.14	2.41	-8.94	1.50-1.087e+05-1.645e+05-1.270e+05-1.462e+05		
299	3	315	10.37	2.19	-6.82	2.19	-6.82	-0.07-8.436e+04-1.215e+05-8.610e+04-1.198e+05	7848.16
		316	8.01	1.35	-7.38	1.35	-7.38	-0.17-5.142e+04-9.591e+04-5.150e+04-9.583e+04	-1886.36
		324	8.78	0.31	-6.48	0.15	-6.32	1.03-5.509e+04-1.054e+05-6.276e+04-9.771e+04	
1.808e+04									
2.218e+04	323	11.79	2.20	-7.73	2.04	-7.57	1.27-9.198e+04-1.392e+05-1.075e+05-1.237e+05		
299	23	315	9.41	13.08	-35.15	-29.29	7.21	15.76-7.673e+04-1.101e+05-7.830e+04-1.085e+05	7060.13
		316	7.28	14.58	-28.29	-24.16	10.45	12.64-4.646e+04-8.706e+04-4.653e+04-8.699e+04	-1679.43
		324	7.98	15.36	-25.63	-25.18	14.91	4.30-4.995e+04-9.575e+04-5.693e+04-8.878e+04	
1.646e+04									
2.025e+04	323	10.75	13.72	-35.15	-33.54	12.12	8.71-8.348e+04-1.266e+05-9.759e+04-1.125e+05		
299	55	315	9.42	1.20	-11.45	-8.59	-1.66	5.29-7.670e+04-1.103e+05-7.828e+04-1.088e+05	7109.46
		316	7.25	1.14	-9.41	-7.37	-0.90	4.17-4.665e+04-8.715e+04-4.672e+04-8.708e+04	-1702.88
		324	7.97	1.67	-8.86	-8.43	1.24	2.08-5.004e+04-9.578e+04-5.702e+04-8.881e+04	
1.644e+04									
2.019e+04	323	10.73	0.81	-11.38	-10.12	-0.45	3.71-8.357e+04-1.266e+05-9.768e+04-1.125e+05		
299	69	315	9.43	1.99	-6.20	1.99	-6.20	-0.06-7.669e+04-1.105e+05-7.827e+04-1.089e+05	7134.69
		316	7.28	1.23	-6.71	1.22	-6.71	-0.16-4.674e+04-8.719e+04-4.682e+04-8.712e+04	-1714.87
		324	7.99	0.28	-5.89	0.14	-5.74	0.94-5.008e+04-9.580e+04-5.706e+04-8.882e+04	
1.644e+04									
2.017e+04	323	10.72	2.00	-7.03	1.85	-6.88	1.15-8.362e+04-1.266e+05-9.772e+04-1.125e+05		
300	1	316	9.29	1.63	-8.55	1.59	-8.51	-0.60-6.250e+04-1.111e+05-6.256e+04-1.111e+05	-1745.61
		317	7.48	0.28	-7.78	0.22	-7.72	-0.70-3.480e+04-8.897e+04-3.503e+04-8.875e+04	-3508.95
		325	7.91	-0.25	-7.06	-0.25	-7.06	0.01-3.667e+04-9.405e+04-4.163e+04-8.909e+04	
1.613e+04									
2.092e+04	324	10.45	0.94	-7.63	0.80	-7.49	1.07-6.668e+04-1.253e+05-7.547e+04-1.165e+05		
300	3	316	7.86	1.38	-7.23	1.35	-7.20	-0.51-5.288e+04-9.404e+04-5.293e+04-9.399e+04	-1477.05
		317	6.33	0.24	-6.59	0.19	-6.53	-0.60-2.945e+04-7.529e+04-2.964e+04-7.509e+04	-2969.11
		325	6.69	-0.21	-5.98	-0.21	-5.98	0.01-3.103e+04-7.958e+04-3.523e+04-7.538e+04	
1.364e+04									
1.770e+04	324	8.84	0.79	-6.46	0.68	-6.34	0.90-5.642e+04-1.060e+05-6.386e+04-9.856e+04		
300	6	316	7.20	33.03	-30.95	32.07	-30.00	-7.76-4.821e+04-8.526e+04-4.824e+04-8.523e+04	-1075.40
		317	5.86	24.21	-28.80	23.62	-28.22	-5.53-2.704e+04-6.851e+04-2.721e+04-6.834e+04	-2644.80
		325	6.17	27.58	-29.38	27.02	-28.82	5.61-2.859e+04-7.234e+04-3.245e+04-6.848e+04	
1.241e+04									
1.604e+04	324	8.09	37.36	-29.41	36.49	-28.53	7.59-5.157e+04-9.629e+04-5.836e+04-8.951e+04		
300	38	316	7.17	11.99	-14.81	11.66	-14.48	-2.93-4.812e+04-8.541e+04-4.816e+04-8.537e+04	-1252.30
		317	5.79	8.33	-13.71	8.11	-13.48	-2.23-2.686e+04-6.847e+04-2.704e+04-6.829e+04	-2680.79
		325	6.11	9.18	-13.51	9.02	-13.35	1.90-2.834e+04-7.234e+04-3.217e+04-6.851e+04	
1.241e+04									
1.608e+04	324	8.05	13.12	-13.83	12.76	-13.47	3.11-5.139e+04-9.634e+04-5.816e+04-8.957e+04		
300	69	316	7.15	1.25	-6.58	1.23	-6.55	-0.46-4.807e+04-8.549e+04-4.812e+04-8.544e+04	-1342.77
		317	5.76	0.22	-5.99	0.17	-5.94	-0.54-2.677e+04-6.844e+04-2.695e+04-6.827e+04	-2699.19
		325	6.08	-0.19	-5.43	-0.19	-5.43	9.59e-03-2.821e+04-7.235e+04-3.202e+04-6.853e+04	
1.240e+04									
1.609e+04	324	8.04	0.72	-5.87	0.62	-5.76	0.82-5.129e+04-9.636e+04-5.806e+04-8.960e+04		
301	1	317	7.48	0.66	-8.18	0.55	-8.07	-0.97-3.441e+04-8.880e+04-3.459e+04-8.862e+04	-3110.97
		318	7.06	0.08	-7.49	-0.04	-7.37	-0.94 -5814.70-7.601e+04 -6234.04-7.559e+04	-5409.22
		326	5.85	-0.34	-7.63	-0.49	-7.47	-1.06 -9724.66-6.496e+04-1.260e+04-6.208e+04	
1.227e+04									
1.624e+04	325	7.97	0.35	-6.41	0.35	-6.41	0.03-3.766e+04-9.491e+04-4.271e+04-8.986e+04		
301	3	317	6.33	0.56	-6.92	0.46	-6.83	-0.82-2.912e+04-7.514e+04-2.927e+04-7.499e+04	-2632.36
		318	5.98	0.07	-6.33	-0.03	-6.23	-0.80 -4920.13-6.432e+04 -5274.96-6.396e+04	-4577.03
		326	4.95	-0.28	-6.46	-0.42	-6.32	-0.90 -8228.56-5.496e+04-1.066e+04-5.253e+04	

Parco Eolico "Bolina" – Progetto Definitivo
Relazione di calcolo preliminare delle fondazioni degli aerogeneratori G8 e G12

		328	3.30	1.07	-13.17	0.79	-12.89	1.99	6800.46-2.988e+04	4435.19-2.752e+04	9009.46
304	69	320	4.21	0.21	-4.77	0.16	-4.72	0.52	6050.68-4.034e+04	6030.33-4.032e+04	-971.42
		321	3.35	-0.23	-3.99	-0.27	-3.95	0.39	324.51-3.458e+04	-175.66-3.408e+04	-4148.48
		329	2.75	-0.26	-2.51	-0.34	-2.44	-0.41	33.57-2.851e+04	-333.09-2.815e+04	3214.38
		328	3.25	-0.15	-4.08	-0.16	-4.07	0.21	6751.48-2.987e+04	4356.85-2.747e+04	9052.69
	305	1	75	38.75	0.44	-3.60	0.16	-3.32	1.03-1.550e+05-4.582e+05-4.580e+05-1.552e+05	-7989.82	
		322	21.74	2.60	-8.20	2.34	-7.94		-1.66-1.345e+05-2.613e+05-1.702e+05-2.255e+05		
5.704e+04											
3.391e+04		330	20.55	-1.68	-5.35	-3.28	-3.75		-1.82-1.518e+05-2.448e+05-2.301e+05-1.665e+05		
		76	22.14	0.55	-3.73	0.42	-3.61		0.72-1.206e+05-2.659e+05-2.338e+05-1.528e+05		
6.031e+04											
	305	3	75	32.79	0.37	-3.05	0.14	-2.81	0.87-1.312e+05-3.877e+05-3.875e+05-1.313e+05	-6760.62	
		322	18.39	2.20	-6.94	1.98	-6.72		-1.40-1.138e+05-2.211e+05-1.440e+05-1.908e+05		
4.827e+04											
2.870e+04		330	17.39	-1.43	-4.52	-2.78	-3.17		-1.54-1.285e+05-2.071e+05-1.947e+05-1.409e+05		
		76	18.74	0.46	-3.16	0.36	-3.05		0.61-1.021e+05-2.250e+05-1.978e+05-1.293e+05		
5.103e+04											
	305	7	75	30.19	32.41	-87.80	-81.74	26.35	-26.30-1.197e+05-3.531e+05-3.529e+05-1.199e+05	-6256.87	
		322	16.80	6.66	-55.62	-53.24	4.28		11.95-1.036e+05-2.011e+05-1.310e+05-1.736e+05		
4.386e+04											
2.618e+04		330	15.88	-6.56	-47.86	-29.34	-25.08		-20.54-1.169e+05-1.885e+05-1.771e+05-1.283e+05		
		76	17.19	55.22	-43.92	-41.78	53.08		14.41-9.309e+04-2.049e+05-1.802e+05-1.178e+05		
4.642e+04											
	305	39	75	29.94	9.14	-29.49	-27.58	7.23	-8.37-1.194e+05-3.527e+05-3.525e+05-1.196e+05	-6183.52	
		322	16.75	-1.91	-17.51	-16.82	-2.59		3.20-1.035e+05-2.010e+05-1.310e+05-1.735e+05		
4.387e+04											
2.612e+04		330	15.84	-3.10	-18.89	-11.60	-10.39		-7.88-1.168e+05-1.883e+05-1.770e+05-1.281e+05		
		76	17.09	17.01	-14.81	-13.92	16.13		5.24-9.289e+04-2.047e+05-1.800e+05-1.176e+05		
4.640e+04											
	305	69	75	29.81	0.34	-2.77	0.12	-2.55	0.79-1.192e+05-3.524e+05-3.523e+05-1.194e+05	-6146.01	
		322	16.72	2.00	-6.31	1.80	-6.11		-1.27-1.035e+05-2.010e+05-1.309e+05-1.735e+05		
4.388e+04											
2.609e+04		330	15.81	-1.30	-4.11	-2.52	-2.88		-1.40-1.168e+05-1.883e+05-1.770e+05-1.281e+05		
		76	17.03	0.42	-2.87	0.33	-2.77		0.55-9.278e+04-2.046e+05-1.798e+05-1.175e+05		
4.639e+04											
3.057e+04		306	1	322	19.39	0.93	-6.28	0.93	-6.27	-0.21-1.605e+05-2.267e+05-2.062e+05-1.810e+05	
		323	14.16	2.07	-8.85	2.04	-8.82		-0.60-1.061e+05-1.681e+05-1.154e+05-1.588e+05		
2.217e+04											
3.574e+04		331	13.18	1.31	-13.82	1.15	-13.65		1.58-8.630e+04-1.579e+05-1.199e+05-1.244e+05		
		330	19.21	5.42	-7.46	3.13	-5.17		-4.92-1.373e+05-2.294e+05-2.074e+05-1.593e+05		
3.929e+04											
2.587e+04		306	3	322	16.41	0.79	-5.31	0.78	-5.31	-0.17-1.358e+05-1.918e+05-1.745e+05-1.532e+05	
		323	11.98	1.75	-7.49	1.73	-7.46		-0.51-8.976e+04-1.422e+05-9.765e+04-1.344e+05		
1.876e+04											
3.024e+04		331	11.15	1.11	-11.69	0.97	-11.55		1.34-7.302e+04-1.336e+05-1.014e+05-1.052e+05		
		330	16.25	4.58	-6.31	2.64	-4.37		-4.17-1.161e+05-1.941e+05-1.755e+05-1.348e+05		
3.324e+04											
2.350e+04		306	7	322	14.97	13.99	-33.50	-33.46	13.95	-1.38-1.237e+05-1.744e+05-1.586e+05-1.395e+05	
		323	10.96	6.22	-58.36	-53.62	1.47		16.85-8.166e+04-1.294e+05-8.873e+04-1.223e+05		
1.696e+04											
2.764e+04		331	10.19	40.16	-47.96	-42.37	34.56		-21.49-6.617e+04-1.216e+05-9.192e+04-9.583e+04		
		330	15.11	0.78	-103.44	-91.66	-11.00		33.00-1.058e+05-1.766e+05-1.597e+05-1.227e+05		
3.022e+04											
2.352e+04		306	38	322	14.92	12.28	-11.18	12.27	-11.18	0.26-1.234e+05-1.743e+05-1.586e+05-1.392e+05	
		323	10.88	21.53	-10.86	20.24	-9.57		-6.32-8.159e+04-1.293e+05-8.879e+04-1.221e+05		
1.708e+04											
2.744e+04		331	10.16	17.35	-27.59	15.52	-25.75		8.90-6.646e+04-1.214e+05-9.229e+04-9.560e+04		
		330	14.89	40.49	-7.86	34.23	-1.60		-16.23-1.055e+05-1.764e+05-1.595e+05-1.224e+05		
3.022e+04											
	306	69	322	14.91	0.72	-4.83	0.71	-4.82	-0.16-1.235e+05-1.744e+05-1.586e+05-1.393e+05		

Parco Eolico "Bolina" – Progetto Definitivo
Relazione di calcolo preliminare delle fondazioni degli aerogeneratori G8 e G12

2.352e+04										
1.705e+04	323	10.89	1.59	-6.81	1.57	-6.78	-0.46-8.160e+04-1.293e+05-8.878e+04-1.221e+05			
2.749e+04	331	10.14	1.01	-10.63	0.88	-10.50	1.21-6.639e+04-1.215e+05-9.220e+04-9.566e+04			
3.022e+04	330	14.78	4.17	-5.74	2.40	-3.98	-3.79-1.056e+05-1.765e+05-1.596e+05-1.225e+05			
2.132e+04	307 1	323	13.86	3.25	-8.50	3.25	-8.50	-0.08-1.081e+05-1.638e+05-1.180e+05-1.538e+05		
1.254e+04	324	10.46	-0.13	-8.65	-0.15	-8.64	0.37-6.492e+04-1.254e+05-6.765e+04-1.227e+05			
3.345e+04	332	10.50	-0.31	-6.73	-0.88	-6.17	1.82-5.376e+04-1.256e+05-7.663e+04-1.027e+05			
3.619e+04	331	13.33	0.08	-12.23	-0.45	-11.69	2.51-8.713e+04-1.598e+05-1.204e+05-1.265e+05			
1.804e+04	307 3	323	11.73	2.75	-7.19	2.75	-7.19	-0.07-9.146e+04-1.386e+05-9.988e+04-1.302e+05		
1.061e+04	324	8.85	-0.11	-7.32	-0.13	-7.31	0.31-5.494e+04-1.061e+05-5.724e+04-1.038e+05			
2.831e+04	332	8.88	-0.27	-5.70	-0.74	-5.22	1.54-4.549e+04-1.062e+05-6.484e+04-8.688e+04			
3.062e+04	331	11.28	0.07	-10.35	-0.38	-9.89	2.12-7.373e+04-1.352e+05-1.018e+05-1.071e+05			
1.643e+04	307 23	323	10.68	14.82	-32.20	-27.05	9.67	14.69-8.302e+04-1.260e+05-9.066e+04-1.184e+05		
2.585e+04	324	8.02	12.81	-27.52	-22.44	7.72	13.39-4.981e+04-9.647e+04-5.191e+04-9.437e+04	9671.94		
2.810e+04	332	8.08	17.36	-22.12	-21.02	16.27	6.48-4.120e+04-9.670e+04-5.886e+04-7.904e+04			
1.641e+04	307 55	323	10.67	1.61	-10.17	-7.50	-1.06	4.93-8.311e+04-1.260e+05-9.075e+04-1.183e+05		
2.577e+04	324	8.04	0.83	-10.28	-7.67	-1.78	4.72-4.990e+04-9.647e+04-5.199e+04-9.438e+04	9655.01		
2.793e+04	332	8.07	3.26	-8.46	-7.56	2.36	3.12-4.130e+04-9.662e+04-5.892e+04-7.900e+04			
1.640e+04	307 69	323	10.67	2.50	-6.54	2.50	-6.54	-0.06-8.315e+04-1.260e+05-9.080e+04-1.183e+05		
2.573e+04	324	8.04	-0.10	-6.65	-0.11	-6.64	0.28-4.994e+04-9.647e+04-5.204e+04-9.438e+04	9646.34		
2.784e+04	332	8.07	-0.24	-5.18	-0.67	-4.75	1.40-4.135e+04-9.658e+04-5.895e+04-7.898e+04			
1.284e+04	308 1	324	10.45	1.43	-8.08	1.42	-8.08	-0.28-6.659e+04-1.253e+05-6.955e+04-1.224e+05		
2.704e+04	325	8.01	-0.49	-7.25	-0.50	-7.24	-0.21-3.615e+04-9.509e+04-3.724e+04-9.400e+04	7943.18		
3.225e+04	333	8.26	-1.50	-5.22	-1.86	-4.86	-1.10-2.977e+04-9.684e+04-4.348e+04-8.313e+04			
1.087e+04	308 3	324	8.84	1.21	-6.84	1.20	-6.83	-0.24-5.635e+04-1.061e+05-5.885e+04-1.036e+05		
2.288e+04	325	6.78	-0.42	-6.13	-0.42	-6.13	-0.18-3.058e+04-8.046e+04-3.151e+04-7.954e+04	6721.15		
2.729e+04	333	6.99	-1.27	-4.41	-1.57	-4.11	-0.93-2.519e+04-8.194e+04-3.679e+04-7.034e+04			
2.078e+04	332	8.77	-1.44	-6.37	-2.09	-5.72	1.67-4.636e+04-1.050e+05-6.494e+04-8.645e+04			
1.087e+04	308 5	324	8.09	29.16	-23.47	29.16	-23.47	0.39-5.133e+04-9.636e+04-5.366e+04-9.402e+04	9984.26	
2.479e+04	325	6.22	21.01	-22.87	21.01	-22.87	0.04-2.811e+04-7.309e+04-2.897e+04-7.224e+04	6153.64		
2.079e+04	333	6.43	22.61	-20.19	20.69	-18.26	8.87-2.313e+04-7.452e+04-3.371e+04-6.395e+04			
2.479e+04	308 37	324	8.06	10.59	-12.05	10.59	-12.05	-0.01-5.126e+04-9.640e+04-5.355e+04-9.410e+04	9915.61	
2.079e+04	325	6.18	6.86	-11.43	6.86	-11.42	-0.09-2.791e+04-7.313e+04-2.875e+04-7.228e+04	6124.86		
2.480e+04	333	6.38	6.45	-9.05	6.05	-8.65	2.44-2.298e+04-7.450e+04-3.353e+04-6.395e+04			
2.480e+04	308 69	324	8.04	1.10	-6.22	1.09	-6.21	-0.22-5.122e+04-9.642e+04-5.350e+04-9.415e+04	9880.50	
	325	6.16	-0.38	-5.58	-0.38	-5.57	-0.17-2.780e+04-7.315e+04-2.864e+04-7.231e+04	6110.14		
	333	6.35	-1.16	-4.01	-1.43	-3.74	-0.84-2.290e+04-7.449e+04-3.344e+04-6.395e+04			

Parco Eolico "Bolina" – Progetto Definitivo
Relazione di calcolo preliminare delle fondazioni degli aerogeneratori G8 e G12

2.080e+04											
	332	7.98	-1.31	-5.79	-1.90	-5.20	1.52-4.215e+04-9.548e+04-5.904e+04-7.859e+04				
2.481e+04											
	309	1	325	8.05	0.10	-7.81	0.03	-7.74	-0.74-3.705e+04-9.567e+04-3.818e+04-9.454e+04	8049.63	
			326	6.13	-0.14	-5.44	-0.33	-5.25	-0.99 -8546.00-6.750e+04 -9344.14-6.670e+04	6812.70	
			334	7.41	-0.22	-7.28	-0.95	-6.55	-2.15 -3339.25-7.869e+04-1.216e+04-6.987e+04		
2.423e+04											
	333	8.20	-0.97	-5.08	-1.29	-4.76	-1.10-2.982e+04-9.618e+04-4.325e+04-8.275e+04				
2.667e+04											
	309	3	325	6.81	0.09	-6.60	0.03	-6.55	-0.62-3.135e+04-8.095e+04-3.231e+04-8.000e+04	6811.22	
			326	5.19	-0.12	-4.60	-0.28	-4.44	-0.83 -7231.23-5.711e+04 -7906.58-5.644e+04	5764.60	
			334	6.27	-0.18	-6.16	-0.80	-5.54	-1.82 -2825.52-6.659e+04-1.029e+04-5.912e+04		
2.050e+04											
	333	6.94	-0.82	-4.30	-1.09	-4.03	-0.93-2.523e+04-8.138e+04-3.660e+04-7.002e+04				
2.256e+04											
	309	6	325	6.28	26.72	-30.24	26.04	-29.56	-6.20-2.886e+04-7.361e+04-2.975e+04-7.272e+04	6260.41	
			326	4.82	21.42	-29.49	20.57	-28.64	-6.52 -7311.60-5.202e+04 -7979.30-5.135e+04	5422.64	
			334	5.82	18.23	-28.01	18.05	-27.83	2.91 -2845.42-6.071e+04 -9673.29-5.388e+04	1.867e+04	
			333	6.39	24.80	-26.99	24.30	-26.48	5.10-2.321e+04-7.406e+04-3.360e+04-6.367e+04		
2.050e+04											
	309	38	325	6.22	9.09	-14.20	8.83	-13.94	-2.47-2.862e+04-7.360e+04-2.950e+04-7.272e+04	6215.16	
			326	4.75	7.17	-12.74	6.79	-12.36	-2.71 -6823.83-5.195e+04 -7455.62-5.132e+04	5302.16	
			334	5.74	5.62	-12.75	5.62	-12.75	-0.11 -2662.33-6.059e+04 -9463.11-5.379e+04	1.865e+04	
			333	6.33	7.64	-11.45	7.57	-11.38	1.17-2.303e+04-7.401e+04-3.338e+04-6.366e+04		
2.051e+04											
	309	69	325	6.19	0.08	-6.00	0.03	-5.95	-0.57-2.850e+04-7.359e+04-2.937e+04-7.272e+04	6192.02	
			326	4.72	-0.11	-4.18	-0.25	-4.03	-0.76 -6573.85-5.192e+04 -7187.80-5.131e+04	5240.54	
			334	5.70	-0.17	-5.60	-0.73	-5.04	-1.66 -2568.65-6.053e+04 -9355.62-5.375e+04	1.864e+04	
			333	6.30	-0.75	-3.91	-0.99	-3.66	-0.85-2.294e+04-7.399e+04-3.327e+04-6.365e+04		
2.051e+04											
	310	1	326	5.97	-0.15	-10.97	-0.21	-10.91	-0.80-1.279e+04-6.722e+04-1.443e+04-6.557e+04	9318.94	
			327	6.53	8.31	-4.28	-1.22	5.25	-5.41 4.079e+04-3.732e+04 4.000e+04-3.653e+04	7826.20	
			335	7.18	-1.55	-8.11	-1.88	-7.78	1.44 5816.56-7.138e+04 1604.90-6.717e+04	1.753e+04	
			334	7.56	2.36	-3.68	0.98	-2.31	-2.54 515.33-7.846e+04 -7522.58-7.042e+04	2.388e+04	
	310	3	326	5.06	-0.12	-9.28	-0.18	-9.23	-0.68-1.082e+04-5.688e+04-1.221e+04-5.548e+04	7885.26	
			327	5.52	7.04	-3.62	-1.03	4.44	-4.57 3.452e+04-3.158e+04 3.385e+04-3.091e+04	6622.17	
			335	6.07	-1.31	-6.87	-1.59	-6.59	1.22 4921.70-6.040e+04 1357.99-5.684e+04	1.484e+04	
			334	6.39	1.99	-3.12	0.83	-1.95	-2.15 436.04-6.639e+04 -6365.26-5.959e+04	2.021e+04	
	310	6	326	4.69	20.45	-33.97	19.69	-33.21	-6.39-1.057e+04-5.173e+04-1.137e+04-5.047e+04	7235.41	
			327	5.00	21.66	-25.19	17.58	-21.12	-13.20 2.966e+04-2.917e+04 2.882e+04-2.833e+04	6967.23	
			335	5.63	9.45	-32.09	8.14	-30.78	7.27 4647.44-5.467e+04 1619.22-5.164e+04	1.306e+04	
			334	5.95	18.06	-24.72	17.95	-24.61	2.19 145.09-6.070e+04 -6170.00-5.438e+04	1.856e+04	
	310	38	326	4.63	6.84	-17.07	6.56	-16.79	-2.57-1.008e+04-5.173e+04-1.110e+04-5.045e+04	7191.09	
			327	4.98	9.15	-8.30	5.33	-4.47	-7.22 3.079e+04-2.886e+04 3.011e+04-2.818e+04	6340.62	
			335	5.56	2.41	-14.98	1.80	-14.38	3.19 4532.05-5.483e+04 1364.71-5.166e+04	1.334e+04	
			334	5.86	6.59	-9.52	6.57	-9.50	-0.55 311.21-6.047e+04 -5916.34-5.424e+04	1.843e+04	
	310	69	326	4.60	-0.11	-8.43	-0.16	-8.39	-0.62 -9837.38-5.171e+04-1.110e+04-5.045e+04	7168.42	
			327	5.02	6.40	-3.29	-0.94	4.04	-4.16 3.138e+04-2.871e+04 3.077e+04-2.810e+04	6020.15	
			335	5.52	-1.19	-6.24	-1.44	-5.99	1.11 4474.27-5.491e+04 1234.54-5.167e+04	1.349e+04	
			334	5.81	1.81	-2.83	0.75	-1.77	-1.95 396.40-6.035e+04 -5786.60-5.417e+04	1.837e+04	
	311	1	327	6.20	10.91	-1.81	2.74	6.36	6.10 3.877e+04-3.556e+04 3.845e+04-3.524e+04	-4851.87	
			328	3.62	-1.32	-10.84	-1.34	-10.83	0.34 2820.16-3.578e+04 2273.89-3.523e+04	-4559.31	
			336	5.58	3.40	-1.09	1.40	0.91	2.23 1.128e+04-5.158e+04 9884.79-5.018e+04	9261.11	
			335	7.31	-3.08	-9.37	-3.94	-8.50	-2.17 6665.34-7.237e+04 1981.79-6.769e+04	1.866e+04	
	311	3	327	5.25	9.23	-1.53	2.32	5.38	5.16 3.280e+04-3.009e+04 3.253e+04-2.982e+04	-4105.43	
			328	3.06	-1.12	-9.18	-1.13	-9.17	0.29 2386.29-3.028e+04 1924.06-2.981e+04	-3857.88	
			336	4.72	2.88	-0.92	1.19	0.77	1.89 9544.86-4.364e+04 8364.06-4.246e+04	7836.32	
			335	6.18	-2.60	-7.93	-3.34	-7.19	-1.84 5639.90-6.124e+04 1676.90-5.727e+04	1.579e+04	
	311	7	327	4.83	37.80	-7.14	-1.10	31.76	15.32 2.878e+04-2.773e+04 2.835e+04-2.730e+04	-4926.88	
			328	2.79	17.78	-6.34	-5.10	16.54	5.33 1951.54-2.718e+04 1531.88-2.676e+04	-3471.42	
			336	4.43	28.43	-6.17	-6.13	28.39	-1.16 8807.17-3.981e+04 7831.13-3.883e+04	6818.81	
			335	5.82	20.49	-19.75	-17.82	18.57	-8.59 6437.41-5.578e+04 2659.38-5.200e+04	1.486e+04	
	311	39	327	4.79	18.02	-3.02	1.02	13.98	8.29 2.946e+04-2.748e+04 2.916e+04-2.718e+04	-4136.45	
			328	2.75	1.17	-3.50	-2.41	0.08	1.98 2095.64-2.741e+04 1675.63-2.699e+04	-3495.07	
			336	4.33	10.12	-1.41	-1.36	10.07	0.74 8720.55-3.972e+04 7680.65-3.868e+04	7020.69	
			335	5.67	3.37	-9.45	-8.04	1.95	-4.01 5570.40-5.571e+04 1908.49-5.204e+04	1.453e+04	
	311	69	327	4.77	8.39	-1.39	2.11	4.89	4.69 2.982e+04-2.736e+04 2.958e+04-2.711e+04	-3732.21	
			328	2.78	-1.02	-8.34	-1.03	-8.33	0.26 2169.35-2.752e+04 1749.15-2.710e+04	-3507.16	
			336	4.29	2.61	-0.84	1.08	0.70	1.71 8677.14-3.967e+04 7603.69-3.860e+04	7123.93	
			335	5.62	-2.37	-7.21	-3.03	-6.54	-1.67 5127.18-5.567e+04 1524.46-5.207e+04	1.435e+04	
	312	1	328	4.06	0.54	-4.01	0.44	-3.92	0.65 7149.09-3.813e+04 7027.17-3.801e+04	-2346.49	
			329	3.59	-0.31	-5.65	-0.35	-5.61	0.48 -76.85-3.723e+04 -723.96-3.658e+04	-4860.13	
			337	4.10	-0.56	-1.78	-0.57	-1.77	-0.12 541.57-4.233e+04 161.93-4.195e+04	4016.46	

Parco Eolico "Bolina" – Progetto Definitivo
Relazione di calcolo preliminare delle fondazioni degli aerogeneratori G8 e G12

		336	5.25	0.29	-4.25	0.02	-3.98	1.08	7562.52-5.036e+04	5901.81-4.870e+04	9666.01
312	3	328	3.44	0.45	-3.40	0.37	-3.31	0.55	6049.23-3.227e+04	5946.07-3.216e+04	-1985.49
		329	3.04	-0.26	-4.78	-0.30	-4.74	0.40	-65.03-3.150e+04	-612.58-3.095e+04	-4112.42
		337	3.47	-0.47	-1.51	-0.48	-1.50	-0.10	458.25-3.582e+04	137.02-3.550e+04	3398.54
		336	4.44	0.25	-3.60	0.02	-3.37	0.91	6399.06-4.261e+04	4993.84-4.121e+04	8178.93
312	6	328	3.26	3.84	-30.41	2.64	-29.21	-6.29	5743.50-2.941e+04	5668.43-2.933e+04	-1622.78
		329	2.89	1.16	-32.29	0.43	-31.55	-4.90	-94.64-2.875e+04	-591.79-2.826e+04	-3741.68
		337	3.27	1.26	-30.04	0.73	-29.51	4.04	451.83-3.252e+04	154.65-3.222e+04	3115.94
		336	4.15	5.74	-31.13	4.99	-30.37	5.23	5645.48-3.872e+04	4331.46-3.740e+04	7521.25
312	38	328	3.17	1.36	-12.12	1.12	-11.88	-1.80	5581.68-2.936e+04	5494.48-2.927e+04	-1743.34
		329	2.80	0.11	-13.68	-0.03	-13.53	-1.41	-71.14-2.868e+04	-568.70-2.818e+04	-3739.62
		337	3.19	0.11	-11.04	-0.04	-10.89	1.31	428.51-3.255e+04	134.74-3.225e+04	3098.50
		336	4.08	2.07	-12.68	1.70	-12.30	2.32	5759.10-3.873e+04	4469.34-3.744e+04	7464.45
312	69	328	3.13	0.41	-3.09	0.34	-3.01	0.50	5499.30-2.933e+04	5405.51-2.924e+04	-1804.99
		329	2.76	-0.24	-4.35	-0.27	-4.31	0.37	-59.12-2.864e+04	-556.89-2.814e+04	-3738.56
		337	3.15	-0.43	-1.37	-0.44	-1.36	-0.09	416.59-3.256e+04	124.56-3.227e+04	3089.58
		336	4.04	0.22	-3.27	0.01	-3.06	0.83	5817.32-3.874e+04	4539.85-3.746e+04	7435.39
313	1	76	20.80	3.32	-2.67	2.82	-2.17	1.65	-1.462e+05-2.489e+05-2.173e+05-1.778e+05		
4.743e+04		330	23.18	-4.24	-7.13	-5.23	-6.14	1.37	-1.250e+05-2.780e+05-2.179e+05-1.851e+05		
7.475e+04		82	13.83	1.00	-5.96	0.03	-4.98	-2.42	-7.023e+04-1.657e+05-1.637e+05-7.226e+04		
1.378e+04		77	45.10	2.34	-10.21	-9.11	1.23	3.56	-1.114e+05-5.150e+05-4.300e+05-1.965e+05		
1.646e+05		313	17.60	2.81	-2.26	2.39	-1.83	1.40	-1.237e+05-2.106e+05-1.838e+05-1.504e+05		
4.013e+04	3	76	17.60	2.81	-2.26	2.39	-1.83	1.40	-1.237e+05-2.106e+05-1.838e+05-1.504e+05		
6.325e+04		330	19.61	-3.59	-6.03	-4.43	-5.20	1.16	-1.057e+05-2.352e+05-1.844e+05-1.566e+05		
1.166e+04		82	11.71	0.85	-5.04	0.03	-4.21	-2.04	-5.942e+04-1.402e+05-1.385e+05-6.114e+04		
1.393e+05		77	38.16	1.98	-8.64	-7.71	1.04	3.01	-9.430e+04-4.358e+05-3.638e+05-1.663e+05		
3.646e+04	7	76	16.14	-0.18	-45.53	-45.28	-0.43	3.35	-1.128e+05-1.918e+05-1.675e+05-1.371e+05		
5.760e+04		330	17.93	66.30	-34.98	-30.06	61.38	-21.77	-9.622e+04-2.141e+05-1.677e+05-1.426e+05		
1.065e+04		82	10.86	42.54	-74.35	-72.43	40.61	-14.89	-5.419e+04-1.272e+05-1.256e+05-5.578e+04		
1.267e+05		77	35.05	50.74	-84.14	-80.27	46.86	22.53	-8.612e+04-3.969e+05-3.314e+05-1.516e+05		
3.648e+04	39	76	16.05	-0.95	-14.19	-13.89	-1.25	1.97	-1.125e+05-1.916e+05-1.673e+05-1.369e+05		
5.753e+04		330	17.84	19.04	-14.23	-12.83	17.64	-6.67	-9.615e+04-2.139e+05-1.676e+05-1.425e+05		
1.062e+04		82	10.71	12.28	-25.56	-24.49	11.21	-6.27	-5.408e+04-1.274e+05-1.258e+05-5.565e+04		
1.267e+05		77	34.81	18.26	-33.57	-31.80	16.49	9.43	-8.586e+04-3.964e+05-3.310e+05-1.513e+05		
3.648e+04	69	76	16.00	2.55	-2.05	2.17	-1.67	1.27	-1.124e+05-1.915e+05-1.671e+05-1.368e+05		
5.750e+04		330	17.83	-3.26	-5.48	-4.02	-4.73	1.05	-9.612e+04-2.139e+05-1.676e+05-1.424e+05		
1.060e+04		82	10.64	0.77	-4.58	0.02	-3.83	-1.86	-5.402e+04-1.275e+05-1.259e+05-5.558e+04		
1.266e+05		77	34.69	1.80	-7.86	-7.01	0.95	2.74	-8.572e+04-3.962e+05-3.308e+05-1.512e+05		
4.376e+04	1	330	18.16	2.42	-16.83	-1.30	-13.11	-7.60	-1.265e+05-2.174e+05-1.843e+05-1.596e+05		
3.198e+04		331	14.02	3.08	-9.13	1.87	-7.92	3.65	-9.275e+04-1.680e+05-1.105e+05-1.502e+05		
4.630e+04		84	10.62	8.51	-44.38	1.58	-37.45	-17.85	-1.878e+04-1.180e+05-8.616e+04-5.059e+04		
5.724e+04		82	19.92	15.06	-5.96	-5.72	14.81	2.26	-1.011e+05-2.384e+05-2.077e+05-1.318e+05		
3.703e+04	3	330	15.36	2.05	-14.24	-1.10	-11.09	-6.43	-1.070e+05-1.840e+05-1.560e+05-1.350e+05		
2.706e+04		331	11.86	2.61	-7.72	1.58	-6.70	3.09	-7.848e+04-1.422e+05-9.354e+04-1.271e+05		
3.917e+04		84	8.99	7.20	-37.55	1.34	-31.69	-15.10	-1.589e+04-9.982e+04-7.290e+04-4.280e+04		
4.843e+04		82	16.85	12.74	-5.04	-4.84	12.53	1.91	-8.556e+04-2.018e+05-1.758e+05-1.116e+05		

Parco Eolico "Bolina" – Progetto Definitivo
Relazione di calcolo preliminare delle fondazioni degli aerogeneratori G8 e G12

314 23	330	14.07	40.90	-43.98	-38.71	35.63	20.47-9.785e+04-1.674e+05-1.420e+05-1.233e+05	
3.347e+04	331	10.88	9.54	-33.27	-17.95	-5.78	20.52-7.124e+04-1.296e+05-8.511e+04-1.158e+05	
2.485e+04	84	8.06	5.50	-21.23	-19.81	4.08	5.99-1.664e+04-9.030e+04-6.552e+04-4.141e+04	
3.480e+04	82	15.43	33.44	-26.08	-19.78	27.14	18.31-7.661e+04-1.836e+05-1.599e+05-1.003e+05	
4.439e+04	314 55	330	14.00	5.86	-14.24	-13.76	5.39	3.06-9.749e+04-1.673e+05-1.418e+05-1.229e+05
3.360e+04	331	10.82	3.26	-14.36	-5.12	-5.98	8.80-7.131e+04-1.294e+05-8.506e+04-1.156e+05	
2.468e+04	84	8.08	-2.60	-20.98	-5.90	-17.68	-7.06-1.519e+04-9.059e+04-6.602e+04-3.976e+04	
3.534e+04	82	15.36	18.63	-11.51	-9.60	16.72	7.34-7.738e+04-1.835e+05-1.598e+05-1.010e+05	
4.415e+04	314 69	330	13.97	1.86	-12.94	-1.00	-10.08	-5.85-9.730e+04-1.673e+05-1.418e+05-1.228e+05
3.366e+04	331	10.79	2.37	-7.02	1.44	-6.09	2.81-7.135e+04-1.292e+05-8.504e+04-1.156e+05	
2.460e+04	84	8.17	6.55	-34.14	1.22	-28.81	-13.73-1.444e+04-9.074e+04-6.628e+04-3.891e+04	
3.561e+04	82	15.32	11.58	-4.59	-4.40	11.39	1.74-7.778e+04-1.834e+05-1.598e+05-1.014e+05	
4.403e+04	315 1	331	14.34	10.74	-10.91	9.02	-9.18	-5.87-8.929e+04-1.724e+05-1.142e+05-1.476e+05
3.806e+04	332	9.93	-1.42	-18.28	-6.66	-13.04	7.80-4.827e+04-1.180e+05-5.978e+04-1.065e+05	
2.590e+04	86	10.47	16.95	-5.30	-3.50	15.14	-6.07-3.967e+04-1.228e+05-7.982e+04-8.269e+04	
4.156e+04	84	9.60	1.97	-50.34	-12.03	-36.33	23.16-2.766e+04-1.092e+05-8.292e+04-5.397e+04	
3.813e+04	315 3	331	12.14	9.09	-9.23	7.63	-7.77	-4.96-7.555e+04-1.459e+05-9.659e+04-1.249e+05
3.221e+04	332	8.40	-1.20	-15.47	-5.64	-11.03	6.60-4.084e+04-9.989e+04-5.059e+04-9.014e+04	
2.191e+04	86	8.86	14.34	-4.48	-2.96	12.81	-5.14-3.357e+04-1.039e+05-6.754e+04-6.997e+04	
3.516e+04	84	8.12	1.67	-42.59	-10.18	-30.74	19.60-2.340e+04-9.242e+04-7.016e+04-4.567e+04	
3.226e+04	315 22	331	11.12	41.08	-33.13	31.98	-24.03	-24.34-6.882e+04-1.331e+05-8.868e+04-1.132e+05
2.970e+04	332	7.57	9.39	-24.98	9.00	-24.59	-3.64-3.722e+04-8.990e+04-4.566e+04-8.145e+04	
1.933e+04	86	8.22	22.89	-12.56	10.66	-0.33	-16.85-3.064e+04-9.571e+04-6.144e+04-6.491e+04	
3.249e+04	84	7.02	5.22	-60.07	1.61	-56.46	14.92-2.131e+04-8.046e+04-6.257e+04-3.920e+04	
2.717e+04	315 54	331	11.06	19.33	-16.72	15.41	-12.80	-11.22-6.873e+04-1.328e+05-8.811e+04-1.134e+05
2.942e+04	332	7.62	0.15	-15.46	-0.35	-14.96	2.74-3.716e+04-9.050e+04-4.588e+04-8.178e+04	
1.972e+04	86	8.11	13.96	-4.54	1.83	7.59	-8.79-3.056e+04-9.490e+04-6.141e+04-6.405e+04	
3.214e+04	84	7.26	1.65	-44.82	-5.58	-37.60	16.84-2.129e+04-8.281e+04-6.337e+04-4.073e+04	
2.860e+04	315 69	331	11.03	8.26	-8.39	6.94	-7.06	-4.51-6.869e+04-1.326e+05-8.781e+04-1.135e+05
2.928e+04	332	7.64	-1.09	-14.06	-5.12	-10.03	6.00-3.713e+04-9.080e+04-4.599e+04-8.195e+04	
1.992e+04	86	8.05	13.03	-4.08	-2.69	11.65	-4.67-3.052e+04-9.449e+04-6.140e+04-6.361e+04	
3.197e+04	84	7.38	1.52	-38.72	-9.26	-27.95	17.82-2.128e+04-8.402e+04-6.378e+04-4.152e+04	
2.933e+04	316 1	332	10.43	-2.17	-5.16	-2.32	-5.01	0.65-5.373e+04-1.248e+05-6.686e+04-1.117e+05
2.758e+04	333	8.09	-2.73	-6.02	-2.81	-5.93	-0.53-3.024e+04-9.498e+04-3.547e+04-8.975e+04	
1.764e+04	88	7.42	-0.60	-4.24	-3.20	-1.64	-1.64-2.239e+04-8.597e+04-4.427e+04-6.409e+04	
3.021e+04	86	9.25	-3.53	-5.72	-3.90	-5.35	0.83-3.607e+04-1.090e+05-7.205e+04-7.301e+04	
3.645e+04	316 3	332	8.82	-1.84	-4.36	-1.96	-4.24	0.55-4.547e+04-1.056e+05-5.658e+04-9.448e+04

Parco Eolico "Bolina" – Progetto Definitivo
Relazione di calcolo preliminare delle fondazioni degli aerogeneratori G8 e G12

2.334e+04													
1.492e+04	333	6.84	-2.31	-5.09	-2.38	-5.02	-0.45-2.559e+04-8.037e+04-3.001e+04-7.594e+04						
2.556e+04	88	6.28	-0.51	-3.58	-2.71	-1.38	-1.39-1.895e+04-7.275e+04-3.746e+04-5.423e+04						
3.085e+04	86	7.83	-2.98	-4.84	-3.30	-4.53	0.70-3.052e+04-9.222e+04-6.097e+04-6.178e+04						
2.128e+04	316 21 332	8.05	11.68	-11.70	2.08	-2.11	11.50-4.135e+04-9.601e+04-5.152e+04-8.584e+04						
1.357e+04	333	6.23	8.03	-9.58	0.87	-2.42	8.65-2.332e+04-7.305e+04-2.735e+04-6.902e+04						
2.321e+04	88	5.73	13.08	-6.49	2.37	4.22	9.74-1.728e+04-6.607e+04-3.416e+04-4.919e+04						
2.820e+04	86	7.17	15.49	-9.93	2.72	2.84	12.71-2.763e+04-8.404e+04-5.542e+04-5.625e+04						
2.123e+04	316 53 332	8.03	2.58	-6.32	-0.48	-3.26	4.22-4.134e+04-9.600e+04-5.146e+04-8.587e+04						
1.357e+04	333	6.22	0.49	-5.47	-1.14	-3.84	2.66-2.328e+04-7.306e+04-2.731e+04-6.903e+04						
2.323e+04	88	5.71	2.45	-2.68	-0.83	0.60	2.46-1.724e+04-6.611e+04-3.409e+04-4.926e+04						
2.810e+04	86	7.13	3.32	-6.15	-1.06	-1.76	4.72-2.771e+04-8.391e+04-5.542e+04-5.619e+04						
2.121e+04	316 69 332	8.02	-1.67	-3.97	-1.79	-3.85	0.50-4.133e+04-9.599e+04-5.143e+04-8.589e+04						
1.357e+04	333	6.22	-2.10	-4.63	-2.16	-4.56	-0.41-2.326e+04-7.306e+04-2.728e+04-6.904e+04						
2.324e+04	88	5.71	-0.46	-3.26	-2.46	-1.26	-1.26-1.723e+04-6.613e+04-3.406e+04-4.930e+04						
2.804e+04	86	7.12	-2.71	-4.40	-3.00	-4.12	0.63-2.775e+04-8.384e+04-5.542e+04-5.616e+04						
1.807e+04	317 1 333	8.10	-2.11	-6.05	-2.59	-5.58	-1.28-3.008e+04-9.510e+04-3.557e+04-8.961e+04						
2.282e+04	334 90	7.17	-0.76	-5.57	-2.07	-4.26	-2.14 -5010.18-7.694e+04 -6291.63-7.566e+04	9514.76					
2.981e+04	88	5.41	-0.97	-6.97	-3.25	-4.69	-2.91 -3290.40-5.785e+04-1.562e+04-4.552e+04						
1.529e+04	333	7.37	-0.64	-3.87	-2.42	-2.09	-1.61-2.265e+04-8.550e+04-4.415e+04-6.400e+04						
1.931e+04	317 3 333	6.85	-1.79	-5.12	-2.19	-4.72	-1.09-2.545e+04-8.047e+04-3.009e+04-7.583e+04						
2.523e+04	334 90	6.06	-0.64	-4.72	-1.75	-3.61	-1.81 -4239.38-6.510e+04 -5323.68-6.402e+04	8050.95					
1.390e+04	88	4.57	-0.82	-5.90	-2.75	-3.97	-2.47 -2784.19-4.895e+04-1.322e+04-3.852e+04						
2.295e+04	333	6.23	-0.54	-3.28	-2.05	-1.77	-1.36-1.917e+04-7.235e+04-3.736e+04-5.415e+04						
1.390e+04	317 5 333	6.30	20.64	-21.70	20.63	-21.69	-0.44-2.342e+04-7.319e+04-2.766e+04-6.895e+04						
1.738e+04	334 90	5.60	15.01	-21.73	14.97	-21.69	-1.21 -4167.31-5.922e+04 -5146.22-5.824e+04	7275.53					
2.295e+04	88	4.23	18.89	-21.66	17.63	-20.40	7.06 -3279.82-4.462e+04-1.276e+04-3.514e+04						
1.390e+04	333	5.73	22.73	-19.62	21.16	-18.04	8.00-1.756e+04-6.585e+04-3.422e+04-4.919e+04						
1.749e+04	317 37 333	6.25	5.70	-10.22	5.66	-10.18	-0.80-2.323e+04-7.317e+04-2.746e+04-6.894e+04						
2.294e+04	334 90	5.54	4.18	-9.67	4.01	-9.51	-1.50 -3960.01-5.920e+04 -4943.43-5.821e+04	7304.32					
1.390e+04	88	4.18	4.37	-9.35	4.31	-9.29	0.91 -2784.59-4.454e+04-1.227e+04-3.506e+04						
2.294e+04	333	5.69	6.20	-7.44	5.93	-7.17	1.89-1.747e+04-6.580e+04-3.405e+04-4.922e+04						
1.390e+04	317 69 333	6.23	-1.63	-4.66	-1.99	-4.29	-0.99-2.314e+04-7.315e+04-2.736e+04-6.893e+04						
1.755e+04	334 90	5.51	-0.58	-4.29	-1.59	-3.28	-1.65 -3853.98-5.918e+04 -4839.71-5.820e+04	7319.05					
2.293e+04	88	4.16	-0.75	-5.36	-2.50	-3.61	-2.24 -2531.08-4.450e+04-1.201e+04-3.502e+04						
1.928e+04	318 1 334	7.24	-0.57	-13.17	-2.93	-10.80	-4.92 572.75-7.486e+04 -1144.49-7.314e+04	1.125e+04					
	335	7.26	5.54	-4.87	1.88	-1.21	4.97 5086.13-7.285e+04 4992.89-7.275e+04	2694.00					
	92	5.01	3.70	-29.70	-2.39	-23.62	-12.89 3.962e+04-1.909e+04 3.024e+04	-9719.61	2.150e+04				
	90	5.30	5.99	-2.98	-2.80	5.81	-1.25-1.041e+04-5.943e+04-1.978e+04-5.005e+04						
	334 3	6.13	-0.48	-11.14	-2.48	-9.14	-4.17 484.64-6.334e+04 -968.42-6.189e+04	9520.03					
	335	6.14	4.69	-4.12	1.59	-1.02	4.20 4303.65-6.164e+04 4224.76-6.156e+04	2279.54					

Parco Eolico "Bolina" – Progetto Definitivo
Relazione di calcolo preliminare delle fondazioni degli aerogeneratori G8 e G12

		92	4.24	3.13	-25.13	-2.02	-19.98	-10.91	3.352e+04	-1.616e+04	2.559e+04	-8224.28	1.820e+04	
		90	4.48	5.07	-2.52	-2.37	4.92	-1.06	-8808.50	-5.028e+04	-1.674e+04	-4.235e+04		
1.631e+04														
	318	6	334	5.68	16.49	-32.23	15.26	-31.01	-7.63	28.36	-5.775e+04	-1258.23	-5.647e+04	8525.70
			335	5.73	10.96	-25.83	10.81	-25.68	-2.36	4301.54	-5.607e+04	4193.88	-5.596e+04	2547.04
			92	3.75	17.33	-42.88	17.29	-42.84	-1.57	2.828e+04	-1.454e+04	2.142e+04	-7671.17	1.571e+04
			90	4.14	17.66	-20.31	17.12	-19.76	4.51	-8565.82	-4.590e+04	-1.591e+04	-3.855e+04	
1.484e+04														
	318	38	334	5.61	4.91	-17.23	3.67	-15.99	-5.09	301.06	-5.764e+04	-1008.23	-5.633e+04	8610.97
			335	5.63	4.83	-9.52	4.61	-9.30	1.73	4043.29	-5.605e+04	3960.20	-5.596e+04	2232.94
			92	3.79	6.17	-28.06	4.63	-26.52	-7.09	2.973e+04	-1.464e+04	2.264e+04	-7542.45	1.626e+04
			90	4.07	4.46	-3.83	4.37	-3.73	0.89	-8197.00	-4.578e+04	-1.545e+04	-3.852e+04	
1.483e+04														
	318	69	334	5.57	-0.44	-10.13	-2.26	-8.31	-3.79	440.58	-5.758e+04	-880.38	-5.626e+04	8654.57
			335	5.59	4.26	-3.74	1.45	-0.93	3.82	3912.41	-5.604e+04	3840.69	-5.597e+04	2072.30
			92	3.85	2.84	-22.85	-1.84	-18.17	-9.92	3.047e+04	-1.469e+04	2.326e+04	-7476.62	1.654e+04
			90	4.08	4.61	-2.29	-2.16	4.47	-0.96	-8007.73	-4.571e+04	-1.522e+04	-3.850e+04	
1.483e+04														
	319	1	335	7.36	6.59	-3.36	3.43	-0.19	-4.63	5178.02	-7.392e+04	4369.86	-7.312e+04	7954.51
			336	5.54	-1.15	-13.11	-3.30	-10.96	4.59	1.353e+04	-4.938e+04	1.343e+04	-4.927e+04	2540.34
			94	4.13	8.21	-0.12	0.05	8.05	-1.17	6999.11	-3.881e+04	-1468.34	-3.034e+04	1.778e+04
			92	4.47	1.31	-28.36	-2.68	-24.38	10.12	3.618e+04	-1.507e+04	2.987e+04	-8760.84	1.684e+04
	319	3	335	6.23	5.58	-2.84	2.90	-0.16	-3.92	4381.41	-6.255e+04	3697.57	-6.187e+04	6730.74
			336	4.69	-0.97	-11.09	-2.79	-9.28	3.88	1.145e+04	-4.178e+04	1.136e+04	-4.169e+04	2149.52
			94	3.50	6.95	-0.10	0.04	6.81	-0.99	5922.33	-3.284e+04	-1242.44	-2.567e+04	1.505e+04
			92	3.78	1.11	-24.00	-2.26	-20.63	8.56	3.062e+04	-1.275e+04	2.528e+04	-7413.02	1.425e+04
	319	7	335	5.81	24.98	-12.46	-12.15	24.66	3.43	4935.13	-5.668e+04	4427.67	-5.617e+04	5568.36
			336	4.37	20.87	-10.68	-9.10	19.29	6.88	1.063e+04	-3.822e+04	1.053e+04	-3.812e+04	2205.18
			94	3.23	30.95	-6.08	-5.29	30.16	-5.37	5215.12	-2.953e+04	-1319.33	-2.300e+04	1.358e+04
			92	3.46	8.26	-6.12	-5.69	7.82	-2.47	2.753e+04	-1.266e+04	2.181e+04	-6938.15	1.404e+04
	319	38	335	5.69	9.58	-10.49	7.64	-8.54	-5.93	3663.97	-5.693e+04	3000.64	-5.627e+04	6305.13
			336	4.29	6.84e-03	-18.14	-0.32	-17.81	2.40	1.033e+04	-3.790e+04	1.026e+04	-3.783e+04	1869.15
			94	3.18	1.94	-2.02	1.84	-1.92	0.61	5441.32	-2.996e+04	-1065.25	-2.345e+04	1.371e+04
			92	3.46	3.25	-31.83	-0.83	-27.74	11.25	2.795e+04	-1.125e+04	2.337e+04	-6671.76	1.259e+04
	319	69	335	5.66	5.07	-2.58	2.64	-0.15	-3.56	3983.10	-5.686e+04	3361.43	-5.624e+04	6118.86
			336	4.26	-0.89	-10.08	-2.54	-8.43	3.53	1.041e+04	-3.798e+04	1.033e+04	-3.790e+04	1954.11
			94	3.18	6.32	-0.09	0.04	6.19	-0.90	5383.93	-2.985e+04	-1129.49	-2.334e+04	1.368e+04
			92	3.44	1.01	-21.82	-2.06	-18.75	7.78	2.783e+04	-1.159e+04	2.298e+04	-6739.11	1.295e+04
	320	1	336	5.41	0.44	-4.48	-0.46	-3.57	1.90	8661.68	-5.136e+04	8372.07	-5.107e+04	4159.14
			337	4.07	0.11	-3.74	-0.20	-3.43	1.05	440.99	-4.205e+04	76.37	-4.169e+04	-3919.32
			96	2.91	0.38	-0.81	-0.59	0.16	-0.47	223.56	-3.015e+04	-480.06	-2.945e+04	4569.11
			94	3.71	-0.29	-3.34	-0.30	-3.33	-0.15	9471.51	-3.291e+04	3463.12	-2.690e+04	1.478e+04
	320	3	336	4.58	0.37	-3.79	-0.39	-3.02	1.61	7329.12	-4.346e+04	7084.06	-4.321e+04	3519.27
			337	3.44	0.10	-3.17	-0.17	-2.90	0.89	373.15	-3.558e+04	64.62	-3.527e+04	-3316.34
			96	2.46	0.32	-0.69	-0.50	0.13	-0.40	189.17	-2.551e+04	-406.20	-2.492e+04	3866.17
			94	3.14	-0.24	-2.83	-0.25	-2.82	-0.13	8014.35	-2.785e+04	2930.34	-2.276e+04	1.251e+04
	320	6	336	4.26	5.34	-29.94	4.99	-29.60	-3.47	6474.87	-3.946e+04	6254.94	-3.924e+04	3170.78
			337	3.25	0.72	-31.51	0.15	-30.94	-4.25	371.47	-3.231e+04	86.83	-3.202e+04	-3036.63
			96	2.36	2.05	-26.43	1.42	-25.80	4.18	140.19	-2.332e+04	-402.48	-2.278e+04	3526.42
			94	2.97	3.13	-29.74	1.90	-28.51	6.22	7396.44	-2.529e+04	2898.72	-2.079e+04	1.126e+04
	320	38	336	4.19	1.46	-11.84	1.45	-11.83	-0.21	6599.23	-3.949e+04	6377.42	-3.927e+04	3189.67
			337	3.17	0.02	-12.28	-0.05	-12.21	-0.90	350.13	-3.233e+04	68.25	-3.205e+04	-3022.22
			96	2.27	0.34	-8.81	0.18	-8.65	1.18	161.22	-2.324e+04	-380.51	-2.269e+04	3518.67
			94	2.89	0.83	-11.68	0.49	-11.34	2.03	7322.96	-2.531e+04	2743.38	-2.073e+04	1.133e+04
	320	69	336	4.16	0.34	-3.44	-0.36	-2.75	1.47	6662.83	-3.951e+04	6440.06	-3.928e+04	3199.33
			337	3.13	0.09	-2.88	-0.15	-2.64	0.81	339.23	-3.235e+04	58.74	-3.207e+04	-3014.86
			96	2.24	0.29	-0.63	-0.45	0.12	-0.36	171.97	-2.319e+04	-369.28	-2.265e+04	3514.70
			94	2.85	-0.22	-2.57	-0.23	-2.56	-0.12	7285.78	-2.532e+04	2663.94	-2.070e+04	1.137e+04
Elem.			Von Mises	N max	N min	N 1	N 2	N 1-2	M max	M min	M 1	M 2	M 1-2	
2.588e+05			59.93	166.31	-165.94	-120.37	-161.51	-87.49	79.19	6.227e+05	4.236e+05	3.638e+05	2.447e+05	

VERIFICHE ELEMENTI PARETE E/O GUSCIO IN C.A.

LEGENDA TABELLA VERIFICHE ELEMENTI PARETE E GUSCIO IN C.A.

Per le pareti in c.a., in ottemperanza al cap. 7 del DM 17-01-18, viene effettuata una doppia progettazione: sia come *Singolo Elemento* sia come *Parete Sismica* o *Parete Debolmente Armata*.

Per la progettazione come *Singolo Elemento* di ogni elemento vengono riportati il codice dello stato di verifica con le sigle **Ok** e **NV**, il rapporto x/d , la verifica per sollecitazioni ultime (verifica a compressione media gli sforzi membranali, verifica a presso-flessionale e verifica a sollecitazioni taglianti), gli sforzi membranali e flessionali, il quantitativo di armatura nella direzione principale e secondaria sia inferiore che superiore e il quantitativo di armatura a taglio.

Per la progettazione come *Parete Sismica* o *Parete Debolmente Armata* vengono riportate invece le caratteristiche geometriche della parete e delle zone dissipative (quest'ultime solo nel caso di parete sismica), i coefficienti di verifica a compressione assiale, presso-flessione e sollecitazioni taglianti.

Inoltre vengono riportate per ogni quota significativa l'armatura principale e secondaria, l'armatura in zona confinata (solo per parete sismica) e non confinata, l'armatura concentrata all'estremità (per pareti debolmente armate), lo sforzo assiale aggiuntivo per q superiore a 2 e i valori di iniluppo di taglio e momento. Per le pareti debolmente armate viene riportato anche lo stato di verifica relativo alla snellezza.

Le azioni derivate dall'analisi, in ogni combinazione di calcolo, sono elaborate come previsto al punto 7.4.4.5.1: traslazione del momento, incremento e variazione diagramma taglio, incremento e decremento sforzo assiale

La progettazione nel caso dei gusci viene effettuata una progettazione come *Singolo Elemento*, riportando in tabella il rapporto x/d , la verifica per sollecitazioni ultime, (verifica a compressione media gli sforzi membranali, verifica a presso-flessionale e verifica a sollecitazioni taglianti) di ogni elemento.

Per ogni elemento, viene riportata inoltre la maglia di armatura necessaria in relazione alle risultanze della progettazione dei nodi dell'elemento stesso. Le quantità di armature necessarie sono armature (disposte rispettivamente in direzione principale e secondaria, inferiore e superiore) distribuite nell'elemento ed espresse in centimetri quadri per sviluppo lineare pari ad un metro.

Nel caso dei gusci viene effettuata, inoltre, la verifica a punzonamento, riportando in tabella il codice dello stato di verifica, il coefficiente di verifica per piastre prive di armature a taglio lungo il perimetro resistente e lungo il perimetro del pilastro, coefficiente di incremento dovuto ai momenti flettenti, fattore di amplificazione per le fondazioni, il fattore di amplificazione dell'altezza utile per individuare il perimetro di verifica lungo il quale l'armatura a taglio non è richiesta, il quantitativo di armatura a punzonamento, il numero di serie di armature, il numero di braccia di armatura ed il riferimento alla combinazione più gravosa.

Simbologia adottata nelle tabelle di verifica

Per gli elementi con progettazione "Singolo Elemento ..." è presente una tabella con i simboli di seguito descritti:

Macro Guscio	Numero del macroelemento di tipo guscio (elementi non verticali contigui ed analoghi per proprietà)
Macro Setto	Numero del macroelemento di tipo setto (elementi verticali contigui ed analoghi per proprietà)
Spessore	Spessore della parete
Id Materiale	Codice del materiale assegnato all'elemento
Id Criterio	Codice del criterio di progetto assegnato all'elemento
Progettazione	Sigla tipo di Elemento: - Singolo Elemento; - Singolo Elemento FONDAZIONE; - Singolo Elemento NON DISSIPATIVO

Per gli elementi con progettazione "Parete Sismica o Parete Debolmente Armata" è presente una tabella con i simboli di seguito descritti:

Parete	Numero della PARETE SISMICA
Parete PDA	Numero della PARETE DEBOLMENTE ARMATA
H totale	Altezza complessiva della parete
Spessore	Spessore della parete
H critica	Altezza come da punto 7.4.4.5.1 per traslazione momento (solo in Parete Sismica)
H critica V	Altezza della zona dissipativa (solo in Parete Sismica)
L totale	Larghezza di base della parete
L confinata	Lunghezza della zona dissipativa (solo in Parete Sismica)
Verif. N	Verifica di cui al punto 7.4.4.5.1 compressione semplice
Verif. N-M	Verifica di cui al punto 7.4.4.5.1 presso-flessione
Fattore V	Fattore di amplificazione del taglio di cui al punto 7.4.4.5.1
Diagramma V	Diagramma elaborato per effetto modi superiori come da fig. 7.4.4
Verif. V	Verifica di cui al punto 7.4.4.5.1 taglio (compressione cls, trazione acciaio, scorrimento in zona critica) (solo in Parete Sismica)
Verifica Snellezza	Verifica di cui al punto 7.4.4.5.1 limitazione compressione per prevenire l'instabilità (solo in Parete Debolmente Armata)
Prog. composta	Sigla per la progettazione composta

Parco Eolico "Bolina" – Progetto Definitivo
Relazione di calcolo preliminare delle fondazioni degli aerogeneratori G8 e G12

Per le verifiche degli elementi con progettazione "Singolo Elemento ..." e Progettazione Composta è presente una tabella con i simboli di seguito descritti:

Nodo	numero del nodo
Stato	codice di verifica dell'elemento ok o NV
x/d	rapporto tra posizione dell'asse neutro e altezza utile alla rottura della sezione (per sola flessione)
V N/M	Verifica delle sollecitazioni Normali (momento e sforzo normale)
Ver. rid	Rapporto Nd/Nu (Nu ottenuto con riduzione del 25% di fcd)
Af pr+	quantità di armatura richiesta in direzione principale relativa alla faccia positiva (estradosso piastre) (valore derivante da calcolo o minimo normativo)
Af pr-	quantità di armatura richiesta in direzione principale relativa alla faccia negativa (intradosso piastre) (valore derivante da calcolo o minimo normativo)
Af sec+	quantità di armatura richiesta in direzione secondaria relativa alla faccia positiva (estradosso piastre) (valore derivante da calcolo o minimo normativo)
Af sec-	quantità di armatura richiesta in direzione secondaria relativa alla faccia negativa (intradosso piastre) (valore derivante da calcolo o minimo normativo)
Nz No Nzo	Sforzi membranali per pareti e/o setti verticali
Mz Mo Mzo	Sforzi flessionali per pareti e/o setti verticali
Nx Ny Nxy	Sforzi membranali per gusci orizzontali
Mx Mx Mxy	Sforzi flessionali per gusci orizzontali

Nodo	numero del nodo
Stato	codice di verifica dell'elemento ok o NV
Max tau	Tensione tangenziale Massima
Ver V pr	Verifica a taglio nella direzione principale lato calcestruzzo
Ver V sec	Verifica a taglio nella direzione secondaria lato calcestruzzo
Af V pr	Armatura nella direzione principale
V pr-	Verifica dell'armatura nella direzione principale
Af V sec	Armatura nella direzione secondaria
V sec-	Verifica dell'armatura nella direzione secondaria

Per le verifiche degli elementi con progettazione "Parete Sismica o Parete Debolmente Armata", oltre alla tabella con le verifiche per gli elementi con progettazione "Singolo Elemento ...", è presente una tabella con i simboli di seguito descritti:

Quota	Ascissa verticale di riferimento
Af conf.	Numero e diametro armatura presente in una zona confinata
Af std	Diametro e passo armatura in zona non confinata (doppia maglia)
Af estremi	Diametro dei ferri di estremità del pannello; se posto uguale 0, viene utilizzato il diametro standard
Af V (ori)	Diametro e passo armatura orizzontale (doppia maglia)
Ver. N	Rapporto tra azione di calcolo e resistenza a compressione (normalizzato a 1 in quanto da confrontare con 40% in CDB e 35 % in CDA)
Ver. N/M	Rapporto tra azione di calcolo e resistenza a pressoflessione
Ver. V acc(7)	Rapporto tra azione di calcolo e resistenza a taglio-trazione per alfaS minore di 2 secondo paragrafo 7.4.4.5.1
Ver. V cls	Rapporto tra azione di calcolo e resistenza a taglio-compressione
Ver. V acc	Rapporto tra azione di calcolo e resistenza a taglio-trazione
Ver. V scorr.	Rapporto tra azione di calcolo e resistenza a taglio scorrimento
N add	Sforzo assiale di cui al punto 7.4.4.5.1 da sommare e sottrarre nelle verifiche quando q supera 2
N invil M invil	Involuppo del Momento e Sforzo Normale come al punto 7.4.4.5.1 (informativo) (solo in Parete Sismica)

Quota	Ascissa verticale di riferimento
N v.N	Valore dello sforzo assiale per cui Ver. N attinge il massimo valore
N v.M/N, M v.M/N	Valore dello sforzo assiale e momento per cui Ver. N/M attinge il massimo valore
N v.M/N, M v.M/N Mo v.M/N	Valore dello sforzo assiale e dei momenti per cui Ver. N/M attinge il massimo valore (per le pareti estese debolmente armate)
N v.Vcls, V v.Vcls,	Valore dello sforzo assiale e taglio per cui Ver. V. cls attinge il massimo valore
N v.Vacc, M v.Vacc, V v.Vacc,	Valore dello sforzo assiale, momento e taglio per cui Ver. V. acc attinge il massimo valore
N v.Vscorr, M v.Vscorr, V v.Vscorr,	Valore dello sforzo assiale, momento e taglio per cui Ver. V. scorr.e
N v.N	Valore dello sforzo assiale per cui Ver. N attinge il massimo valore
N v.M/N, M v.M/N	Valore dello sforzo assiale e momento per cui Ver. N/M attinge il massimo valore
N v.M/N, M v.M/N Mo v.M/N	Valore dello sforzo assiale e dei momenti per cui Ver. N/M attinge il massimo valore (per le pareti estese debolmente armate)
N v.Vcls, V v.Vcls,	Valore dello sforzo assiale e taglio per cui Ver. V. cls attinge il massimo valore

Quota	Ascissa verticale di riferimento
CtgT Vcls	Valore di ctg(teta) adottato nella verifica V compressione cls
Vrsd Vcls	Valore della resistenza a taglio trazione (armatura di calcolo)
Vrcd Vcls	Valore della resistenza a taglio compressione
CtgT Vacc	Valore di ctg(teta) adottato nella verifica V trazione armatura
Vrsd Vacc	Valore della resistenza a taglio trazione (armatura presente)
Vrcd Vacc	Valore della resistenza a taglio compressione

Parco Eolico "Bolina" – Progetto Definitivo
Relazione di calcolo preliminare delle fondazioni degli aerogeneratori G8 e G12

Vdd	Valore del contributo alla resistenza allo scorrimento come da [7.4.20]
Vid	Valore del contributo alla resistenza allo scorrimento come da [7.4.21]
A s.i.	Somma delle aree di armature
Incl.	Angolo di inclinazione delle armature
Dist.	Distanza alla base tra le armature inclinate

Quota	Ascissa verticale di riferimento
V[7.4.16]	Verifica a taglio-trazione dell'armatura dell'anima (7.4.16)
N M V	Sollecitazioni di calcolo della condizione più gravosa
Alfas	Rapporto di Taglio
Vrd,c	Resistenza a taglio degli elementi non armati
VRd,s	Resistenza a taglio nei confronti dello scorrimento
V[7.4.17]	Verifica a taglio-trazione dell'armatura dell'anima (7.4.17)
roH	Rapporto tra l'armatura orizzontale e l'area della sezione relativa di calcestruzzo
roV	Rapporto tra l'armatura verticale e l'area della sezione relativa di calcestruzzo
roN	Sforzo normale adimensionalizzato Ned/(bw fyd)

Per la verifica a Punzonamento è presente una tabella con i simboli di seguito descritti:

Nodo	numero del nodo
Stato	codice di verifica dell'elemento ok o NV
V. 6.47	Fattore di sicurezza per la verifica per piastre prive di armature a taglio lungo il perimetro resistente U1
V. 6.53	Fattore di sicurezza per la verifica per piastre prive di armature a taglio lungo il perimetro del pilastro U0
Beta	Fattore di incremento dovuto ai momenti flettenti
f. a fon	fattore di amplificazione per le fondazioni (solo per gusci di fondazione)
f. Uout	fattore di amplificazione dell'altezza utile per individuare il perimetro di verifica lungo il quale l'armatura a taglio non è richiesta
Aw tot	Quantitativo di armatura per la verifica di piastre munite di armatura (formula 6.52 dell'EC2)
Asw,min	Quantitativo minimo di armatura previsto dai dettagli costruttivi (formula 9.11 dell'EC2)
n. x serie	Numero di serie di armature
n.ser 0(R)	Numero di braccia delle armature in direzione 0 (o numero di braccia radiale)
n.ser 90	Numero di braccia delle armature in direzione 90 (solo se armatura cruciforme)
Rif. cmb	Riferimento combinazioni da cui si generano le verifiche più gravose

PROGETTAZIONE DELLE FONDAZIONI

Il D.M.17/01/2018 - par: 7.2.5 prevede:

"Sia per CD"A" sia per CD"B" il dimensionamento delle strutture di fondazione e la verifica di sicurezza del complesso fondazione-terreno devono essere eseguiti assumendo come azione in fondazione, trasmessa dagli elementi soprastanti, una tra le seguenti:

- > quella derivante dall'analisi strutturale eseguita ipotizzando comportamento strutturale non dissipativo;
- > [...];
- > quella trasferita dagli elementi soprastanti nell'ipotesi di comportamento strutturale dissipativo, amplificata di un coefficiente pari a 1,30 in CD"A" e 1,10 in CD"B";

Nel contesto visualizzazione risultati e nella stampa della relazione sulle fondazioni PRO_SAP mostra le sollecitazioni che derivano dall'analisi non incrementate sia in termini di pressioni sul terreno che in termini di sollecitazioni.

La progettazione degli elementi strutturali con proprietà fondazione è effettuata da PRO_SAP (per travi e platee) o da PRO_CAD Plinti (per plinti e pali di fondazione) incrementando le sollecitazioni delle combinazioni con sisma di un coefficiente pari 1.1 in CDB e 1.3 in CDA per pali, plinti, travi e platee.

Per i bicchieri dei plinti di fondazione prefabbricati l'incremento delle sollecitazioni ha un fattore pari a 1.2 in CDB e 1.35 in CDA.

N.B.: nel caso di comportamento strutturale non dissipativo la progettazione viene effettuata senza nessun incremento.

Le verifiche geotecniche vengono effettuate dal modulo geotecnico incrementando automaticamente le sollecitazioni del fattore 1.1 in CDB e 1.3 in CDA per pali, plinti, travi e platee.

N.B.: nel caso di comportamento strutturale non dissipativo le verifiche geotecniche vengono effettuate senza nessun incremento.

Macro Guscio	Spessore	Id Materiale	Id Criterio	Progettazione
	cm			
1	250.00	1	2	Singolo elemento

Nodo	Stato	x/d	V N/M	ver. rid	Af pr- Af pr+Af sec-Af sec+	N x daN/cm	N y daN/cm	N xy daN/cm	M x daN	M y daN	M xy daN
-------------	--------------	------------	--------------	-----------------	------------------------------------	----------------------	----------------------	-----------------------	-------------------	-------------------	--------------------



Parco Eolico "Bolina" – Progetto Definitivo
Relazione di calcolo preliminare delle fondazioni degli aerogeneratori G8 e G12

293	ok	0.03	0.1	7.45e-04	88.0	88.0	88.0	88.0	-4.0	-2.2	-4.7-9.343e+04-3.915e+04	-9051.6
294	ok	0.03	8.09e-02	8.39e-04	88.0	88.0	88.0	88.0	-1.1	-1.3	-2.1-6.268e+04-1.972e+04-1.376e+04	
295	ok	0.03	4.89e-02	1.15e-03	88.0	88.0	88.0	88.0	8.1	-4.1	-4.2-3.519e+04 3.853e+04-1.300e+04	
296	ok	0.03	5.05e-02	8.35e-04	88.0	88.0	88.0	88.0	-5.2	-1.4	-2.4-3.685e+04 6820.5	-9449.2
297	ok	0.03	4.46e-02	7.96e-04	88.0	88.0	88.0	88.0	-6.2	-0.7	-1.4-3.150e+04	-5800.0-1.341e+04
298	ok	0.03	0.3	1.73e-03	88.0	88.0	88.0	88.0	0.6	-9.4	-11.1-2.271e+05-1.768e+05	3.556e+04
299	ok	0.03	0.2	1.21e-03	88.0	88.0	88.0	88.0	-0.9	-0.9	-8.6-1.487e+05-1.102e+05-1.403e+04	
300	ok	0.03	0.1	8.02e-04	88.0	88.0	88.0	88.0	-3.4	-3.3	-5.8-1.010e+05-7.309e+04-2.226e+04	
301	ok	0.03	0.1	7.22e-04	88.0	88.0	88.0	88.0	-3.8	-3.8	-4.7-7.524e+04-4.854e+04-2.356e+04	
302	ok	0.03	9.12e-02	7.70e-04	88.0	88.0	88.0	88.0	-4.1	-3.5	-4.3-5.746e+04-2.437e+04-3.095e+04	
303	ok	0.03	8.93e-02	7.65e-04	88.0	88.0	88.0	88.0	-5.6	0.9	-1.5-5.421e+04-1.584e+04-3.454e+04	
304	ok	0.03	6.34e-02	8.41e-04	88.0	88.0	88.0	88.0	-4.0	-2.2	-3.5-3.444e+04-1.009e+04-2.722e+04	
305	ok	0.03	5.39e-02	8.20e-04	88.0	88.0	88.0	88.0	-4.8	-1.1	-1.8-3.122e+04-1.331e+04-2.085e+04	
306	ok	0.03	0.2	1.47e-03	88.0	88.0	88.0	88.0	-1.2	-5.8	-7.1-1.582e+05-1.572e+05	6964.3
307	ok	0.03	0.1	1.10e-03	88.0	88.0	88.0	88.0	-0.3	0.3	-8.4-6.843e+04-8.309e+04-1.163e+04	
308	ok	0.03	0.1	7.23e-04	88.0	88.0	88.0	88.0	-3.0	-4.3	-4.1-7.072e+04-8.186e+04-1.396e+04	
309	ok	0.03	9.21e-02	6.97e-04	88.0	88.0	88.0	88.0	-2.5	-4.8	-4.6-5.453e+04-5.496e+04-2.210e+04	
310	ok	0.03	6.65e-02	7.76e-04	88.0	88.0	88.0	88.0	-3.0	-4.1	-4.6-2.934e+04-3.870e+04-2.098e+04	
311	ok	0.03	5.02e-02	9.54e-04	88.0	88.0	88.0	88.0	-4.1	-3.2	-3.5 7746.1 1.125e+04-3.230e+04	
312	ok	0.03	3.94e-02	7.46e-04	88.0	88.0	88.0	88.0	-2.5	-4.8	-2.5-2.077e+04	-7156.3-1.759e+04
313	ok	0.03	3.98e-02	7.29e-04	88.0	88.0	88.0	88.0	-2.0	-3.8	-2.5-1.799e+04-1.551e+04-1.641e+04	
314	ok	0.03	0.3	1.57e-03	88.0	88.0	88.0	88.0	-2.2	-4.7	-5.0-2.436e+04-5.271e+05	3.556e+04
315	ok	0.03	0.2	1.25e-03	88.0	88.0	88.0	88.0	3.1	-5.6	-6.3-1.102e+05-1.488e+05-1.403e+04	
316	ok	0.03	0.1	8.08e-04	88.0	88.0	88.0	88.0	-0.6	-6.5	-4.2-7.307e+04-1.010e+05-2.226e+04	
317	ok	0.03	0.1	7.14e-04	88.0	88.0	88.0	88.0	-1.9	-5.6	-3.6-4.852e+04-7.525e+04-2.356e+04	
318	ok	0.03	9.12e-02	7.55e-04	88.0	88.0	88.0	88.0	-2.3	-5.2	-3.5-2.436e+04-5.747e+04-3.095e+04	
319	ok	0.03	8.93e-02	7.55e-04	88.0	88.0	88.0	88.0	1.7	-6.1	-1.0-1.583e+04-5.422e+04-3.452e+04	
320	ok	0.03	6.34e-02	8.33e-04	88.0	88.0	88.0	88.0	-1.8	-3.9	-3.2-1.007e+04-3.445e+04-2.722e+04	
321	ok	0.03	5.39e-02	8.12e-04	88.0	88.0	88.0	88.0	-0.9	-4.6	-1.6-1.331e+04-3.123e+04-2.085e+04	
322	ok	0.03	0.3	2.02e-03	88.0	88.0	88.0	88.0	-1.7	-6.0	-4.2-1.869e+05-2.195e+05	3.525e+04
323	ok	0.03	0.2	1.41e-03	88.0	88.0	88.0	88.0	1.0	-7.7	-3.3-1.071e+05-1.671e+05	7802.6
324	ok	0.03	0.2	9.10e-04	88.0	88.0	88.0	88.0	4.80e-03	-6.7	-2.7-6.693e+04-1.250e+05	-3778.5
325	ok	0.03	0.1	7.30e-04	88.0	88.0	88.0	88.0	-1.0	-5.1	-2.7-3.912e+04-9.344e+04	-9047.4
326	ok	0.03	8.09e-02	8.20e-04	88.0	88.0	88.0	88.0	-0.6	-1.6	-0.7-1.969e+04-6.268e+04-1.374e+04	
327	ok	0.03	4.89e-02	1.13e-03	88.0	88.0	88.0	88.0	-3.5	7.6	-3.0 3.855e+04-3.508e+04-1.304e+04	
328	ok	0.03	5.05e-02	8.17e-04	88.0	88.0	88.0	88.0	-1.0	-4.5	-1.9 6826.6-3.688e+04	-9436.0
329	ok	0.03	4.46e-02	7.79e-04	88.0	88.0	88.0	88.0	-0.5	-5.5	-0.9 -5800.6-3.150e+04-1.341e+04	
330	ok	0.03	0.3	2.50e-03	88.0	88.0	88.0	88.0	-5.0	-6.4	1.3-2.044e+05-1.986e+05	7.648e+04
331	ok	0.03	0.2	1.47e-03	88.0	88.0	88.0	88.0	7.8	-8.0	-7.4-1.077e+05-1.541e+05	3.449e+04
332	ok	0.03	0.2	9.48e-04	88.0	88.0	88.0	88.0	-2.2	-5.1	0.4-6.232e+04-1.162e+05	2.316e+04
333	ok	0.03	0.1	7.03e-04	88.0	88.0	88.0	88.0	-2.6	-4.1	-1.7-3.237e+04-9.424e+04	1.294e+04
334	ok	0.03	9.43e-02	7.78e-04	88.0	88.0	88.0	88.0	-2.5	-5.0	-3.3 -3799.5-7.823e+04	5870.9
335	ok	0.03	8.86e-02	7.79e-04	88.0	88.0	88.0	88.0	2.7	-2.1	4.6 4853.1-7.261e+04	-4255.0
336	ok	0.03	6.18e-02	8.73e-04	88.0	88.0	88.0	88.0	2.5	-0.2	1.8 1.036e+04-5.065e+04	-7558.9
337	ok	0.03	5.07e-02	7.60e-04	88.0	88.0	88.0	88.0	-0.7	-1.6	-0.4 -784.1-4.101e+04	-7421.5

Nodo	x/d	V N/M	ver. rid	Af pr-	Af pr+	Af sec-	Af sec+	N x	N y	N xy	M x	M y	M xy
								-35.15	-31.85	-30.31-4.645e+05-4.645e+05-2.226e+05			
	0.03	0.85	4.01e-03	87.96	87.96	87.96	87.96	27.50	28.24	30.00 3.540e+05 3.539e+05 2.408e+05			

Nodo	Stato	Max tau daN/cm2	Ver V pr	Ver V sec	Af V pr	Af V sec	V pr daN/cm	V sec daN/cm
1	ok	2.25						
2	ok	2.69						
3	ok	2.30						
4	ok	2.29						
5	ok	3.14						
6	ok	2.65						
7	ok	2.73						
8	ok	1.91						
9	ok	1.93						
10	ok Av	6.92	0.26	0.22	6.4	5.4	1384.2	1164.4
11	ok	2.30						
12	ok Av	4.64	0.21	6.94e-03	5.3	0.2	1136.9	37.2
13	ok Av	3.28	0.15	0.08	3.7	2.1	800.3	454.1
14	ok Av	12.42	0.53	0.38	13.1	9.4	2836.4	2019.2
15	ok Av	14.08	0.45	0.45	11.3	11.3	2441.5	2441.4
16	ok Av	6.71	0.23	0.20	5.8	5.0	1248.3	1072.6
17	ok Av	6.71	0.20	0.23	5.0	5.8	1072.7	1248.1
18	ok Av	6.67	0.22	0.22	5.4	5.4	1156.6	1156.6
19	ok Av	6.52	0.23	0.29	5.6	7.1	1211.0	1541.3
20	ok Av	3.73	0.17	3.68e-03	4.2	9.16e-02	914.1	19.8

Parco Eolico "Bolina" – Progetto Definitivo
Relazione di calcolo preliminare delle fondazioni degli aerogeneratori G8 e G12

21	ok	2.06							
22	ok	2.45							
23	ok	2.27							
24	ok	3.04							
25	ok	2.79							
26	ok Av	3.28	0.08	0.15	2.1	3.7	454.0	800.3	
27	ok Av	12.41	0.38	0.53	9.4	13.1	2019.0	2835.8	
28	ok Av	3.22	0.12	0.09	2.9	2.2	633.4	472.5	
29	ok	2.80							
30	ok	2.40							
31	ok	2.66							
32	ok Av	3.67	0.04	0.16	0.9	4.1	202.4	875.7	
33	ok	2.53							
34	ok	3.04							
35	ok	2.30							
36	ok Av	4.64	6.93e-03	0.21	0.2	5.3	37.2	1136.6	
37	ok Av	10.05	0.32	0.38	7.9	9.3	1708.8	2015.1	
38	ok	2.38							
39	ok	2.42							
40	ok Av	3.79	0.17	0.03	4.2	0.9	909.7	185.7	
41	ok	0.68							
42	ok Av	3.67	0.16	0.04	4.1	0.9	875.7	202.4	
43	ok	2.27							
44	ok	1.93							
45	ok Av	6.92	0.22	0.26	5.4	6.4	1163.8	1383.5	
46	ok Av	5.69	0.06	0.26	1.6	6.4	339.3	1389.8	
47	ok	2.28							
48	ok Av	3.21	0.09	0.12	2.2	2.9	467.4	633.6	
49	ok	2.78							
50	ok Av	3.79	0.03	0.17	0.9	4.2	185.7	909.8	
51	ok	2.66							
52	ok	2.45							
53	ok	2.73							
54	ok	1.90							
55	ok Av	15.33	0.45	0.65	11.1	16.3	2398.1	3513.4	
56	ok Av	4.07	0.10	0.17	2.6	4.3	558.3	935.8	
57	ok	3.14							
58	ok Av	3.21	0.12	0.09	2.9	2.2	633.7	467.4	
59	ok	2.43							
60	ok	2.40							
61	ok	2.06							
62	ok	3.14							
63	ok	2.65							
64	ok Av	7.97	0.23	0.28	5.8	6.9	1253.9	1498.9	
65	ok Av	16.87	0.54	0.54	13.5	13.5	2924.2	2924.2	
66	ok Av	4.07	0.17	0.10	4.3	2.6	935.8	558.4	
67	ok	2.28							
68	ok	2.38							
69	ok	2.80							
70	ok Av	3.73	3.73e-03	0.17	9.28e-02	4.2	20.0	914.9	
71	ok	2.30							
72	ok	2.29							
73	ok Av	8.31	0.27	0.27	6.7	6.7	1440.7	1440.7	
74	ok Av	7.97	0.28	0.23	6.9	5.8	1498.9	1253.9	
75	ok Av	15.33	0.65	0.45	16.3	11.1	3513.6	2398.2	
76	ok Av	5.69	0.26	0.06	6.4	1.6	1390.0	339.3	
77	ok Av	10.05	0.38	0.32	9.3	7.9	2015.4	1709.2	
78	ok Av	3.22	0.09	0.12	2.2	2.9	472.7	633.8	
79	ok Av	6.52	0.29	0.23	7.1	5.6	1541.7	1211.4	
80	ok	2.69							
81	ok	2.25							
82	ok Av	5.14	0.17	0.18	4.2	4.4	910.1	952.0	
83	ok Av	4.45	0.19	0.11	4.6	2.7	1003.0	592.8	
84	ok Av	9.23	0.33	0.27	8.2	6.7	1774.5	1444.3	
85	ok Av	4.23	0.18	0.08	4.4	2.0	940.0	441.1	
86	ok	3.04							
87	ok	1.57							
88	ok	1.54							
89	ok	1.45							
90	ok	1.88							
91	ok	1.64							
92	ok Av	4.95	0.17	0.17	4.1	4.2	894.8	916.9	
93	ok	2.17							

Parco Eolico "Bolina" – Progetto Definitivo
Relazione di calcolo preliminare delle fondazioni degli aerogeneratori G8 e G12

94	ok	0.92							
95	ok	0.85							
96	ok	0.44							
97	ok	0.47							
98	ok Av	4.58	0.07	0.21	1.8	5.2	385.3	1120.9	
99	ok	2.21							
100	ok	1.63							
101	ok	1.34							
102	ok	1.57							
103	ok Av	3.98	0.15	0.17	3.8	4.1	810.4	890.5	
104	ok	0.69							
105	ok	0.44							
106	ok	2.98							
107	ok	3.02							
108	ok	2.08							
109	ok	0.92							
110	ok	1.05							
111	ok	1.55							
112	ok	0.64							
113	ok	0.69							
114	ok	2.33							
115	ok Av	5.55	0.23	0.23	5.7	5.8	1223.8	1250.3	
116	ok	2.10							
117	ok	0.54							
118	ok	0.71							
119	ok	2.67							
120	ok	0.84							
121	ok	1.13							
122	ok	1.74							
123	ok	2.38							
124	ok	0.94							
125	ok	0.40							
126	ok	0.59							
127	ok	1.05							
128	ok	1.03							
129	ok	1.51							
130	ok Av	3.40	0.15	0.02	3.8	0.5	824.7	114.1	
131	ok	1.48							
132	ok	0.95							
133	ok	0.58							
134	ok	0.56							
135	ok	1.53							
136	ok	0.94							
137	ok	1.47							
138	ok	3.16							
139	ok	2.34							
140	ok	1.79							
141	ok	0.93							
142	ok	0.64							
143	ok	0.94							
144	ok	0.85							
145	ok	1.34							
146	ok Av	3.49	0.14	0.07	3.6	1.7	774.5	363.1	
147	ok Av	3.96	0.12	0.13	3.0	3.4	645.9	723.6	
148	ok	1.89							
149	ok	1.14							
150	ok	0.64							
151	ok	1.05							
152	ok	0.78							
153	ok	1.18							
154	ok Av	5.48	0.08	0.24	2.1	5.9	446.3	1267.3	
155	ok	3.03							
156	ok	2.01							
157	ok	1.31							
158	ok	0.92							
159	ok	0.93							
160	ok	0.73							
161	ok	1.00							
162	ok Av	4.19	0.17	0.17	4.3	4.3	935.4	933.3	
163	ok	2.67							
164	ok	1.97							
165	ok	1.39							
166	ok	0.89							

Parco Eolico "Bolina" – Progetto Definitivo
Relazione di calcolo preliminare delle fondazioni degli aerogeneratori G8 e G12

167	ok	0.74							
168	ok	0.67							
169	ok	0.81							
170	ok Av	4.59	0.14	0.16	3.5	3.9	747.3	840.4	
171	ok	2.82							
172	ok	2.17							
173	ok	1.42							
174	ok	1.02							
175	ok	0.86							
176	ok	0.61							
177	ok	0.61							
178	ok	2.97							
179	ok	2.88							
180	ok	1.88							
181	ok	1.29							
182	ok	0.84							
183	ok	0.62							
184	ok	0.56							
185	ok	0.40							
186	ok Av	4.59	0.16	0.14	3.9	3.5	840.5	747.2	
187	ok	2.82							
188	ok	2.17							
189	ok	1.42							
190	ok	1.02							
191	ok	0.86							
192	ok	0.61							
193	ok	0.61							
194	ok Av	4.19	0.17	0.17	4.3	4.3	933.5	935.4	
195	ok	2.68							
196	ok	1.97							
197	ok	1.39							
198	ok	0.89							
199	ok	0.74							
200	ok	0.67							
201	ok	0.81							
202	ok Av	5.48	0.24	0.08	5.9	2.1	1267.8	446.5	
203	ok	3.03							
204	ok	2.01							
205	ok	1.31							
206	ok	0.92							
207	ok	0.93							
208	ok	0.72							
209	ok	1.00							
210	ok Av	3.49	0.07	0.14	1.7	3.6	363.5	774.7	
211	ok Av	3.96	0.13	0.12	3.4	3.0	724.3	646.8	
212	ok	1.89							
213	ok	1.14							
214	ok	0.65							
215	ok	1.05							
216	ok	0.78							
217	ok	1.18							
218	ok	3.16							
219	ok	2.34							
220	ok	1.80							
221	ok	0.93							
222	ok	0.64							
223	ok	0.94							
224	ok	0.84							
225	ok	1.34							
226	ok Av	3.40	0.02	0.15	0.5	3.8	114.0	825.2	
227	ok	1.48							
228	ok	0.95							
229	ok	0.58							
230	ok	0.56							
231	ok	1.53							
232	ok	0.94							
233	ok	1.47							
234	ok	1.74							
235	ok	2.38							
236	ok	0.94							
237	ok	0.40							
238	ok	0.60							
239	ok	1.05							

Parco Eolico "Bolina" – Progetto Definitivo
Relazione di calcolo preliminare delle fondazioni degli aerogeneratori G8 e G12

240	ok	1.02							
241	ok	1.51							
242	ok	2.33							
243	ok Av	5.55	0.23	0.23	5.8	5.7	1249.7	1224.5	
244	ok	2.10							
245	ok	0.54							
246	ok	0.71							
247	ok	2.67							
248	ok	0.83							
249	ok	1.13							
250	ok	2.98							
251	ok	3.02							
252	ok	2.08							
253	ok	0.92							
254	ok	1.05							
255	ok	1.55							
256	ok	0.64							
257	ok	0.69							
258	ok Av	4.58	0.21	0.07	5.2	1.8	1120.7	385.2	
259	ok	2.21							
260	ok	1.63							
261	ok	1.34							
262	ok	1.57							
263	ok Av	3.98	0.17	0.15	4.1	3.7	890.5	809.5	
264	ok	0.69							
265	ok	0.44							
266	ok Av	4.45	0.11	0.19	2.7	4.6	592.9	1002.8	
267	ok Av	4.23	0.08	0.18	2.0	4.4	441.1	939.9	
268	ok	1.57							
269	ok	1.45							
270	ok	1.64							
271	ok	2.17							
272	ok	0.85							
273	ok	0.47							
274	ok Av	5.14	0.18	0.17	4.4	4.2	951.9	909.9	
275	ok Av	9.23	0.27	0.33	6.7	8.2	1444.2	1773.9	
276	ok	3.04							
277	ok	1.54							
278	ok	1.88							
279	ok Av	4.95	0.17	0.17	4.2	4.1	917.0	894.2	
280	ok	0.92							
281	ok	0.44							
282	ok Av	7.13	0.10	0.31	2.4	7.7	514.9	1670.4	
283	ok Av	5.08	0.05	0.23	1.3	5.8	280.8	1243.4	
284	ok	2.15							
285	ok	1.78							
286	ok	1.93							
287	ok	2.59							
288	ok	1.04							
289	ok	0.56							
290	ok Av	5.29	0.20	0.24	5.1	6.0	1092.7	1293.1	
291	ok Av	3.47	0.04	0.15	1.1	3.8	233.2	817.2	
292	ok	2.39							
293	ok	1.89							
294	ok	2.11							
295	ok Av	5.69	0.22	0.24	5.4	6.1	1168.2	1310.0	
296	ok	1.08							
297	ok	0.45							
298	ok Av	5.85	0.18	0.20	4.5	4.9	979.3	1062.7	
299	ok Av	6.54	0.15	0.26	3.7	6.4	796.7	1391.7	
300	ok	2.25							
301	ok	1.73							
302	ok	1.92							
303	ok	2.83							
304	ok	1.24							
305	ok	0.52							
306	ok Av	4.93	0.17	0.17	4.2	4.2	911.3	911.3	
307	ok Av	9.77	0.41	0.41	10.2	10.2	2202.3	2202.3	
308	ok	3.04							
309	ok	1.53							
310	ok	2.01							
311	ok Av	5.94	0.27	0.27	6.7	6.7	1445.8	1446.0	
312	ok	1.06							

Parco Eolico "Bolina" – Progetto Definitivo
Relazione di calcolo preliminare delle fondazioni degli aerogeneratori G8 e G12

313	ok	0.10						
314	ok Av	5.85	0.20	0.18	4.9	4.5	1062.7	979.3
315	ok Av	6.54	0.26	0.15	6.4	3.7	1391.7	796.7
316	ok	2.25						
317	ok	1.73						
318	ok	1.92						
319	ok	2.83						
320	ok	1.24						
321	ok	0.52						
322	ok Av	5.29	0.24	0.20	6.0	5.1	1293.2	1092.8
323	ok Av	3.47	0.15	0.04	3.8	1.1	817.2	233.2
324	ok	2.39						
325	ok	1.89						
326	ok	2.11						
327	ok Av	5.69	0.24	0.22	6.1	5.4	1310.2	1168.8
328	ok	1.08						
329	ok	0.45						
330	ok Av	7.13	0.31	0.10	7.7	2.4	1670.6	515.0
331	ok Av	5.08	0.23	0.05	5.8	1.3	1243.4	280.9
332	ok	2.15						
333	ok	1.78						
334	ok	1.93						
335	ok	2.59						
336	ok	1.04						
337	ok	0.56						
Nodo		Max tau	Ver V pr	Ver V sec	Af V pr	Af V sec	V pr	V sec
		16.87	0.65	0.65	16.28	16.27	3513.57	3513.43

STATI LIMITE D' ESERCIZIO

LEGENDA TABELLA STATI LIMITE D' ESERCIZIO

In tabella vengono riportati i valori di interesse per il controllo degli stati limite d'esercizio.

In particolare vengono riportati, in relazione al tipo di elemento strutturale, i risultati relativi alle tre categorie di combinazione considerate:

- Combinazioni rare
- Combinazioni frequenti
- Combinazioni quasi permanenti.

I valori di interesse sono i seguenti:

rRfck	rapporto tra la massima compressione nel calcestruzzo e la tensione fck in combinazioni rare [normalizzato a 1]
rRfyk	rapporto tra la massima tensione nell'acciaio e la tensione fyk in combinazioni rare [normalizzato a 1]
rPfck	rapporto tra la massima compressione nel calcestruzzo e la tensione fck in combinazioni quasi permanenti [normalizzato a 1]
wR	apertura caratteristica delle fessure in combinazioni rare [mm]
wF	apertura caratteristica delle fessure in combinazioni frequenti [mm]
wP	apertura caratteristica delle fessure in combinazioni quasi permanenti [mm]
dR	massima deformazione in combinazioni rare
dF	massima deformazione in combinazioni frequenti
dP	massima deformazione in combinazioni quasi permanenti

Per ognuno dei nove valori soprariportati viene indicata (Rif.cmb) la combinazione in cui si è verificato.

In relazione al tipo di elemento strutturale i valori sono selezionati nel modo seguente:

pilastr	rRfck	rRfyk	rPfck	per sezioni significative
travi	rRfck	rRfyk	rPfck	per sezioni significative
	wR	wF	wP	per sezioni significative
	dR	dF	dP	massimi in campata
	rRfck	rRfyk	rPfck	massimi nei nodi dell'elemento
setti e gusci	wR	wF	wP	massimi nei nodi dell'elemento

Si precisa che i valori di massima deformazione per travi sono riferiti al piano verticale (piano locale 1-2 con momenti flettenti 3-3).

Parco Eolico "Bolina" – Progetto Definitivo
Relazione di calcolo preliminare delle fondazioni degli aerogeneratori G8 e G12

Guscio	rRfck	rRfyk	rPfck	Rif. cmb	wR mm	wF mm	wP mm	Rif. cmb
1	0.16	0.31	0.0	69,69,0	0.0	0.0	0.0	0,0,0
2	0.12	0.25	0.0	69,69,0	0.0	0.0	0.0	0,0,0
3	0.11	0.22	0.0	69,69,0	0.0	0.0	0.0	0,0,0
4	0.12	0.25	0.0	69,69,0	0.0	0.0	0.0	0,0,0
5	0.16	0.31	0.0	69,69,0	0.0	0.0	0.0	0,0,0
6	0.17	0.33	0.0	69,69,0	0.0	0.0	0.0	0,0,0
7	0.19	0.38	0.0	69,69,0	0.03	0.0	0.0	69,0,0
8	0.31	0.60	0.0	69,69,0	0.07	0.0	0.0	69,0,0
9	0.16	0.33	0.0	69,69,0	0.0	0.0	0.0	0,0,0
10	0.12	0.23	0.0	69,69,0	0.0	0.0	0.0	0,0,0
11	0.12	0.23	0.0	69,69,0	0.0	0.0	0.0	0,0,0
12	0.19	0.38	0.0	69,69,0	0.03	0.0	0.0	69,0,0
13	0.15	0.29	0.0	69,69,0	0.0	0.0	0.0	0,0,0
14	0.15	0.29	0.0	69,69,0	0.0	0.0	0.0	0,0,0
15	0.18	0.35	0.0	69,69,0	0.03	0.0	0.0	69,0,0
16	0.19	0.38	0.0	69,69,0	0.03	0.0	0.0	69,0,0
17	0.16	0.31	0.0	69,69,0	0.0	0.0	0.0	0,0,0
18	0.15	0.29	0.0	69,69,0	0.0	0.0	0.0	0,0,0
19	0.11	0.21	0.0	69,69,0	0.0	0.0	0.0	0,0,0
20	0.17	0.33	0.0	69,69,0	0.0	0.0	0.0	0,0,0
21	0.18	0.35	0.0	69,69,0	0.03	0.0	0.0	69,0,0
22	0.17	0.33	0.0	69,69,0	0.0	0.0	0.0	0,0,0
23	0.15	0.29	0.0	69,69,0	0.0	0.0	0.0	0,0,0
24	0.17	0.34	0.0	69,69,0	0.0	0.0	0.0	0,0,0
25	0.17	0.33	0.0	69,69,0	0.0	0.0	0.0	0,0,0
26	0.22	0.43	0.0	69,69,0	0.03	0.0	0.0	69,0,0
27	0.20	0.40	0.0	69,69,0	0.03	0.0	0.0	69,0,0
28	0.19	0.38	0.0	69,69,0	0.03	0.0	0.0	69,0,0
29	0.33	0.65	0.0	69,69,0	0.08	0.0	0.0	69,0,0
30	0.18	0.35	0.0	69,69,0	0.03	0.0	0.0	69,0,0
31	0.15	0.29	0.0	69,69,0	0.0	0.0	0.0	0,0,0
32	0.16	0.31	0.0	69,69,0	0.0	0.0	0.0	0,0,0
33	0.19	0.39	0.0	69,69,0	0.03	0.0	0.0	69,0,0
34	0.18	0.36	0.0	69,69,0	0.03	0.0	0.0	69,0,0
35	0.21	0.41	0.0	69,69,0	0.03	0.0	0.0	69,0,0
36	0.38	0.74	0.0	69,69,0	0.11	0.0	0.0	69,0,0
37	0.19	0.38	0.0	69,69,0	0.03	0.0	0.0	69,0,0
38	0.17	0.33	0.0	69,69,0	0.0	0.0	0.0	0,0,0
39	0.19	0.38	0.0	69,69,0	0.03	0.0	0.0	69,0,0
40	0.12	0.25	0.0	69,69,0	0.0	0.0	0.0	0,0,0
41	0.21	0.41	0.0	69,69,0	0.03	0.0	0.0	69,0,0
42	0.18	0.35	0.0	69,69,0	0.03	0.0	0.0	69,0,0
43	0.20	0.39	0.0	69,69,0	0.03	0.0	0.0	69,0,0
44	0.21	0.41	0.0	69,69,0	0.03	0.0	0.0	69,0,0
45	0.20	0.40	0.0	69,69,0	0.03	0.0	0.0	69,0,0
46	0.11	0.21	0.0	69,69,0	0.0	0.0	0.0	0,0,0
47	0.12	0.23	0.0	69,69,0	0.0	0.0	0.0	0,0,0
48	0.11	0.22	0.0	69,69,0	0.0	0.0	0.0	0,0,0
49	0.24	0.47	0.0	69,69,0	0.04	0.0	0.0	69,0,0
50	0.21	0.42	0.0	69,69,0	0.03	0.0	0.0	69,0,0
51	0.18	0.35	0.0	69,69,0	0.03	0.0	0.0	69,0,0
52	0.18	0.35	0.0	69,69,0	0.03	0.0	0.0	69,0,0
53	0.22	0.43	0.0	69,69,0	0.03	0.0	0.0	69,0,0
54	0.15	0.29	0.0	69,69,0	0.0	0.0	0.0	0,0,0
55	0.12	0.23	0.0	69,69,0	0.0	0.0	0.0	0,0,0
56	0.12	0.25	0.0	69,69,0	0.0	0.0	0.0	0,0,0
57	0.36	0.72	0.0	69,69,0	0.10	0.0	0.0	69,0,0
58	0.24	0.47	0.0	69,69,0	0.04	0.0	0.0	69,0,0
59	0.21	0.41	0.0	69,69,0	0.03	0.0	0.0	69,0,0
60	0.19	0.38	0.0	69,69,0	0.03	0.0	0.0	69,0,0
61	0.17	0.33	0.0	69,69,0	0.0	0.0	0.0	0,0,0
62	0.16	0.31	0.0	69,69,0	0.0	0.0	0.0	0,0,0
63	0.16	0.32	0.0	69,69,0	0.0	0.0	0.0	0,0,0
64	0.16	0.31	0.0	69,69,0	0.0	0.0	0.0	0,0,0
65	0.20	0.40	0.0	69,69,0	0.03	0.0	0.0	69,0,0
66	0.12	0.24	0.0	69,69,0	0.0	0.0	0.0	0,0,0
67	0.08	0.15	0.0	69,69,0	0.0	0.0	0.0	0,0,0
68	0.06	0.11	0.0	69,69,0	0.0	0.0	0.0	0,0,0
69	0.05	0.09	0.0	69,69,0	0.0	0.0	0.0	0,0,0

Parco Eolico "Bolina" – Progetto Definitivo
Relazione di calcolo preliminare delle fondazioni degli aerogeneratori G8 e G12

70	0.03	0.06	0.0	69,69,0	0.0	0.0	0.0	0,0,0
71	0.03	0.05	0.0	69,69,0	0.0	0.0	0.0	0,0,0
72	0.02	0.03	0.0	69,69,0	0.0	0.0	0.0	0,0,0
73	0.28	0.56	0.0	69,69,0	0.06	0.0	0.0	69,0,0
74	0.11	0.21	0.0	69,69,0	0.0	0.0	0.0	0,0,0
75	0.07	0.14	0.0	69,69,0	0.0	0.0	0.0	0,0,0
76	0.05	0.11	0.0	69,69,0	0.0	0.0	0.0	0,0,0
77	0.04	0.08	0.0	69,69,0	0.0	0.0	0.0	0,0,0
78	0.03	0.06	0.0	69,69,0	0.0	0.0	0.0	0,0,0
79	0.03	0.06	0.0	69,69,0	0.0	0.0	0.0	0,0,0
80	0.02	0.04	0.0	69,69,0	0.0	0.0	0.0	0,0,0
81	0.15	0.30	0.0	69,69,0	0.0	0.0	0.0	0,0,0
82	0.09	0.18	0.0	69,69,0	0.0	0.0	0.0	0,0,0
83	0.06	0.13	0.0	69,69,0	0.0	0.0	0.0	0,0,0
84	0.05	0.09	0.0	69,69,0	0.0	0.0	0.0	0,0,0
85	0.04	0.07	0.0	69,69,0	0.0	0.0	0.0	0,0,0
86	0.02	0.05	0.0	69,69,0	0.0	0.0	0.0	0,0,0
87	0.02	0.03	0.0	69,69,0	0.0	0.0	0.0	0,0,0
88	7.69e-03	0.02	0.0	69,69,0	0.0	0.0	0.0	0,0,0
89	0.10	0.20	0.0	69,69,0	0.0	0.0	0.0	0,0,0
90	0.07	0.13	0.0	69,69,0	0.0	0.0	0.0	0,0,0
91	0.05	0.11	0.0	69,69,0	0.0	0.0	0.0	0,0,0
92	0.04	0.08	0.0	69,69,0	0.0	0.0	0.0	0,0,0
93	0.03	0.06	0.0	69,69,0	0.0	0.0	0.0	0,0,0
94	0.03	0.06	0.0	69,69,0	0.0	0.0	0.0	0,0,0
95	0.03	0.05	0.0	69,69,0	0.0	0.0	0.0	0,0,0
96	0.02	0.03	0.0	69,69,0	0.0	0.0	0.0	0,0,0
97	0.08	0.16	0.0	69,69,0	0.0	0.0	0.0	0,0,0
98	0.05	0.10	0.0	69,69,0	0.0	0.0	0.0	0,0,0
99	0.05	0.09	0.0	69,69,0	0.0	0.0	0.0	0,0,0
100	0.03	0.06	0.0	69,69,0	0.0	0.0	0.0	0,0,0
101	0.03	0.05	0.0	69,69,0	0.0	0.0	0.0	0,0,0
102	0.03	0.05	0.0	69,69,0	0.0	0.0	0.0	0,0,0
103	0.02	0.04	0.0	69,69,0	0.0	0.0	0.0	0,0,0
104	0.01	0.03	0.0	69,69,0	0.0	0.0	0.0	0,0,0
105	0.12	0.24	0.0	69,69,0	0.0	0.0	0.0	0,0,0
106	0.07	0.14	0.0	69,69,0	0.0	0.0	0.0	0,0,0
107	0.05	0.10	0.0	69,69,0	0.0	0.0	0.0	0,0,0
108	0.04	0.08	0.0	69,69,0	0.0	0.0	0.0	0,0,0
109	0.03	0.06	0.0	69,69,0	0.0	0.0	0.0	0,0,0
110	0.03	0.06	0.0	69,69,0	0.0	0.0	0.0	0,0,0
111	0.03	0.05	0.0	69,69,0	0.0	0.0	0.0	0,0,0
112	0.01	0.03	0.0	69,69,0	0.0	0.0	0.0	0,0,0
113	0.23	0.46	0.0	69,69,0	0.04	0.0	0.0	69,0,0
114	0.08	0.17	0.0	69,69,0	0.0	0.0	0.0	0,0,0
115	0.06	0.13	0.0	69,69,0	0.0	0.0	0.0	0,0,0
116	0.05	0.09	0.0	69,69,0	0.0	0.0	0.0	0,0,0
117	0.04	0.07	0.0	69,69,0	0.0	0.0	0.0	0,0,0
118	0.03	0.05	0.0	69,69,0	0.0	0.0	0.0	0,0,0
119	0.02	0.04	0.0	69,69,0	0.0	0.0	0.0	0,0,0
120	0.01	0.03	0.0	69,69,0	0.0	0.0	0.0	0,0,0
121	0.15	0.30	0.0	69,69,0	0.0	0.0	0.0	0,0,0
122	0.10	0.19	0.0	69,69,0	0.0	0.0	0.0	0,0,0
123	0.08	0.15	0.0	69,69,0	0.0	0.0	0.0	0,0,0
124	0.05	0.10	0.0	69,69,0	0.0	0.0	0.0	0,0,0
125	0.04	0.07	0.0	69,69,0	0.0	0.0	0.0	0,0,0
126	0.03	0.05	0.0	69,69,0	0.0	0.0	0.0	0,0,0
127	0.02	0.04	0.0	69,69,0	0.0	0.0	0.0	0,0,0
128	0.01	0.02	0.0	69,69,0	0.0	0.0	0.0	0,0,0
129	0.22	0.44	0.0	69,69,0	0.04	0.0	0.0	69,0,0
130	0.10	0.21	0.0	69,69,0	0.0	0.0	0.0	0,0,0
131	0.08	0.15	0.0	69,69,0	0.0	0.0	0.0	0,0,0
132	0.05	0.10	0.0	69,69,0	0.0	0.0	0.0	0,0,0
133	0.04	0.07	0.0	69,69,0	0.0	0.0	0.0	0,0,0
134	0.03	0.05	0.0	69,69,0	0.0	0.0	0.0	0,0,0
135	0.02	0.03	0.0	69,69,0	0.0	0.0	0.0	0,0,0
136	0.01	0.02	0.0	69,69,0	0.0	0.0	0.0	0,0,0
137	0.20	0.39	0.0	69,69,0	0.03	0.0	0.0	69,0,0
138	0.11	0.21	0.0	69,69,0	0.0	0.0	0.0	0,0,0
139	0.07	0.14	0.0	69,69,0	0.0	0.0	0.0	0,0,0
140	0.05	0.10	0.0	69,69,0	0.0	0.0	0.0	0,0,0
141	0.03	0.07	0.0	69,69,0	0.0	0.0	0.0	0,0,0
142	0.02	0.05	0.0	69,69,0	0.0	0.0	0.0	0,0,0

Parco Eolico "Bolina" – Progetto Definitivo
Relazione di calcolo preliminare delle fondazioni degli aerogeneratori G8 e G12

143	0.02	0.03	0.0	69,69,0	0.0	0.0	0.0	0,0,0
144	9.64e-03	0.02	0.0	69,69,0	0.0	0.0	0.0	0,0,0
145	0.26	0.51	0.0	69,69,0	0.04	0.0	0.0	69,0,0
146	0.11	0.22	0.0	69,69,0	0.0	0.0	0.0	0,0,0
147	0.07	0.13	0.0	69,69,0	0.0	0.0	0.0	0,0,0
148	0.04	0.09	0.0	69,69,0	0.0	0.0	0.0	0,0,0
149	0.03	0.06	0.0	69,69,0	0.0	0.0	0.0	0,0,0
150	0.02	0.04	0.0	69,69,0	0.0	0.0	0.0	0,0,0
151	0.01	0.02	0.0	69,69,0	0.0	0.0	0.0	0,0,0
152	8.25e-03	0.02	0.0	69,69,0	0.0	0.0	0.0	0,0,0
153	0.15	0.29	0.0	69,69,0	0.0	0.0	0.0	0,0,0
154	0.09	0.18	0.0	69,69,0	0.0	0.0	0.0	0,0,0
155	0.06	0.12	0.0	69,69,0	0.0	0.0	0.0	0,0,0
156	0.04	0.07	0.0	69,69,0	0.0	0.0	0.0	0,0,0
157	0.02	0.05	0.0	69,69,0	0.0	0.0	0.0	0,0,0
158	0.02	0.03	0.0	69,69,0	0.0	0.0	0.0	0,0,0
159	0.01	0.02	0.0	69,69,0	0.0	0.0	0.0	0,0,0
160	6.98e-03	0.01	0.0	69,69,0	0.0	0.0	0.0	0,0,0
161	0.15	0.29	0.0	69,69,0	0.0	0.0	0.0	0,0,0
162	0.09	0.18	0.0	69,69,0	0.0	0.0	0.0	0,0,0
163	0.06	0.12	0.0	69,69,0	0.0	0.0	0.0	0,0,0
164	0.04	0.07	0.0	69,69,0	0.0	0.0	0.0	0,0,0
165	0.02	0.05	0.0	69,69,0	0.0	0.0	0.0	0,0,0
166	0.02	0.03	0.0	69,69,0	0.0	0.0	0.0	0,0,0
167	0.01	0.02	0.0	69,69,0	0.0	0.0	0.0	0,0,0
168	7.02e-03	0.01	0.0	69,69,0	0.0	0.0	0.0	0,0,0
169	0.26	0.51	0.0	69,69,0	0.04	0.0	0.0	69,0,0
170	0.11	0.21	0.0	69,69,0	0.0	0.0	0.0	0,0,0
171	0.07	0.13	0.0	69,69,0	0.0	0.0	0.0	0,0,0
172	0.04	0.09	0.0	69,69,0	0.0	0.0	0.0	0,0,0
173	0.03	0.06	0.0	69,69,0	0.0	0.0	0.0	0,0,0
174	0.02	0.04	0.0	69,69,0	0.0	0.0	0.0	0,0,0
175	0.01	0.02	0.0	69,69,0	0.0	0.0	0.0	0,0,0
176	8.25e-03	0.02	0.0	69,69,0	0.0	0.0	0.0	0,0,0
177	0.20	0.39	0.0	69,69,0	0.03	0.0	0.0	69,0,0
178	0.11	0.21	0.0	69,69,0	0.0	0.0	0.0	0,0,0
179	0.07	0.14	0.0	69,69,0	0.0	0.0	0.0	0,0,0
180	0.05	0.10	0.0	69,69,0	0.0	0.0	0.0	0,0,0
181	0.03	0.07	0.0	69,69,0	0.0	0.0	0.0	0,0,0
182	0.02	0.05	0.0	69,69,0	0.0	0.0	0.0	0,0,0
183	0.02	0.03	0.0	69,69,0	0.0	0.0	0.0	0,0,0
184	9.64e-03	0.02	0.0	69,69,0	0.0	0.0	0.0	0,0,0
185	0.22	0.44	0.0	69,69,0	0.03	0.0	0.0	69,0,0
186	0.10	0.21	0.0	69,69,0	0.0	0.0	0.0	0,0,0
187	0.08	0.15	0.0	69,69,0	0.0	0.0	0.0	0,0,0
188	0.05	0.10	0.0	69,69,0	0.0	0.0	0.0	0,0,0
189	0.04	0.07	0.0	69,69,0	0.0	0.0	0.0	0,0,0
190	0.03	0.05	0.0	69,69,0	0.0	0.0	0.0	0,0,0
191	0.02	0.03	0.0	69,69,0	0.0	0.0	0.0	0,0,0
192	0.01	0.02	0.0	69,69,0	0.0	0.0	0.0	0,0,0
193	0.15	0.30	0.0	69,69,0	0.0	0.0	0.0	0,0,0
194	0.10	0.19	0.0	69,69,0	0.0	0.0	0.0	0,0,0
195	0.08	0.15	0.0	69,69,0	0.0	0.0	0.0	0,0,0
196	0.05	0.10	0.0	69,69,0	0.0	0.0	0.0	0,0,0
197	0.04	0.07	0.0	69,69,0	0.0	0.0	0.0	0,0,0
198	0.03	0.05	0.0	69,69,0	0.0	0.0	0.0	0,0,0
199	0.02	0.04	0.0	69,69,0	0.0	0.0	0.0	0,0,0
200	0.01	0.02	0.0	69,69,0	0.0	0.0	0.0	0,0,0
201	0.23	0.46	0.0	69,69,0	0.04	0.0	0.0	69,0,0
202	0.08	0.17	0.0	69,69,0	0.0	0.0	0.0	0,0,0
203	0.06	0.13	0.0	69,69,0	0.0	0.0	0.0	0,0,0
204	0.05	0.09	0.0	69,69,0	0.0	0.0	0.0	0,0,0
205	0.04	0.07	0.0	69,69,0	0.0	0.0	0.0	0,0,0
206	0.03	0.05	0.0	69,69,0	0.0	0.0	0.0	0,0,0
207	0.02	0.04	0.0	69,69,0	0.0	0.0	0.0	0,0,0
208	0.01	0.03	0.0	69,69,0	0.0	0.0	0.0	0,0,0
209	0.12	0.24	0.0	69,69,0	0.0	0.0	0.0	0,0,0
210	0.07	0.14	0.0	69,69,0	0.0	0.0	0.0	0,0,0
211	0.05	0.10	0.0	69,69,0	0.0	0.0	0.0	0,0,0
212	0.04	0.08	0.0	69,69,0	0.0	0.0	0.0	0,0,0
213	0.03	0.06	0.0	69,69,0	0.0	0.0	0.0	0,0,0
214	0.03	0.06	0.0	69,69,0	0.0	0.0	0.0	0,0,0
215	0.03	0.05	0.0	69,69,0	0.0	0.0	0.0	0,0,0

Parco Eolico "Bolina" – Progetto Definitivo
Relazione di calcolo preliminare delle fondazioni degli aerogeneratori G8 e G12

216	0.01	0.03	0.0	69,69,0	0.0	0.0	0.0	0,0,0
217	0.08	0.16	0.0	69,69,0	0.0	0.0	0.0	0,0,0
218	0.05	0.10	0.0	69,69,0	0.0	0.0	0.0	0,0,0
219	0.05	0.09	0.0	69,69,0	0.0	0.0	0.0	0,0,0
220	0.03	0.06	0.0	69,69,0	0.0	0.0	0.0	0,0,0
221	0.03	0.05	0.0	69,69,0	0.0	0.0	0.0	0,0,0
222	0.03	0.05	0.0	69,69,0	0.0	0.0	0.0	0,0,0
223	0.02	0.04	0.0	69,69,0	0.0	0.0	0.0	0,0,0
224	0.01	0.03	0.0	69,69,0	0.0	0.0	0.0	0,0,0
225	0.10	0.20	0.0	69,69,0	0.0	0.0	0.0	0,0,0
226	0.07	0.13	0.0	69,69,0	0.0	0.0	0.0	0,0,0
227	0.05	0.11	0.0	69,69,0	0.0	0.0	0.0	0,0,0
228	0.04	0.08	0.0	69,69,0	0.0	0.0	0.0	0,0,0
229	0.03	0.06	0.0	69,69,0	0.0	0.0	0.0	0,0,0
230	0.03	0.06	0.0	69,69,0	0.0	0.0	0.0	0,0,0
231	0.03	0.05	0.0	69,69,0	0.0	0.0	0.0	0,0,0
232	0.02	0.03	0.0	69,69,0	0.0	0.0	0.0	0,0,0
233	0.15	0.30	0.0	69,69,0	0.0	0.0	0.0	0,0,0
234	0.09	0.18	0.0	69,69,0	0.0	0.0	0.0	0,0,0
235	0.06	0.13	0.0	69,69,0	0.0	0.0	0.0	0,0,0
236	0.05	0.09	0.0	69,69,0	0.0	0.0	0.0	0,0,0
237	0.04	0.07	0.0	69,69,0	0.0	0.0	0.0	0,0,0
238	0.02	0.05	0.0	69,69,0	0.0	0.0	0.0	0,0,0
239	0.02	0.03	0.0	69,69,0	0.0	0.0	0.0	0,0,0
240	7.71e-03	0.02	0.0	69,69,0	0.0	0.0	0.0	0,0,0
241	0.28	0.56	0.0	69,69,0	0.06	0.0	0.0	69,0,0
242	0.11	0.21	0.0	69,69,0	0.0	0.0	0.0	0,0,0
243	0.07	0.15	0.0	69,69,0	0.0	0.0	0.0	0,0,0
244	0.05	0.11	0.0	69,69,0	0.0	0.0	0.0	0,0,0
245	0.04	0.08	0.0	69,69,0	0.0	0.0	0.0	0,0,0
246	0.03	0.06	0.0	69,69,0	0.0	0.0	0.0	0,0,0
247	0.03	0.06	0.0	69,69,0	0.0	0.0	0.0	0,0,0
248	0.02	0.04	0.0	69,69,0	0.0	0.0	0.0	0,0,0
249	0.20	0.40	0.0	69,69,0	0.03	0.0	0.0	69,0,0
250	0.12	0.24	0.0	69,69,0	0.0	0.0	0.0	0,0,0
251	0.08	0.15	0.0	69,69,0	0.0	0.0	0.0	0,0,0
252	0.06	0.11	0.0	69,69,0	0.0	0.0	0.0	0,0,0
253	0.05	0.09	0.0	69,69,0	0.0	0.0	0.0	0,0,0
254	0.03	0.06	0.0	69,69,0	0.0	0.0	0.0	0,0,0
255	0.03	0.05	0.0	69,69,0	0.0	0.0	0.0	0,0,0
256	0.02	0.03	0.0	69,69,0	0.0	0.0	0.0	0,0,0
257	0.27	0.54	0.0	69,69,0	0.05	0.0	0.0	69,0,0
258	0.13	0.25	0.0	69,69,0	0.0	0.0	0.0	0,0,0
259	0.09	0.18	0.0	69,69,0	0.0	0.0	0.0	0,0,0
260	0.07	0.13	0.0	69,69,0	0.0	0.0	0.0	0,0,0
261	0.05	0.10	0.0	69,69,0	0.0	0.0	0.0	0,0,0
262	0.04	0.08	0.0	69,69,0	0.0	0.0	0.0	0,0,0
263	0.04	0.08	0.0	69,69,0	0.0	0.0	0.0	0,0,0
264	0.03	0.05	0.0	69,69,0	0.0	0.0	0.0	0,0,0
265	0.24	0.48	0.0	69,69,0	0.04	0.0	0.0	69,0,0
266	0.12	0.24	0.0	69,69,0	0.0	0.0	0.0	0,0,0
267	0.09	0.17	0.0	69,69,0	0.0	0.0	0.0	0,0,0
268	0.07	0.13	0.0	69,69,0	0.0	0.0	0.0	0,0,0
269	0.05	0.10	0.0	69,69,0	0.0	0.0	0.0	0,0,0
270	0.04	0.08	0.0	69,69,0	0.0	0.0	0.0	0,0,0
271	0.04	0.08	0.0	69,69,0	0.0	0.0	0.0	0,0,0
272	0.03	0.05	0.0	69,69,0	0.0	0.0	0.0	0,0,0
273	0.30	0.59	0.0	69,69,0	0.07	0.0	0.0	69,0,0
274	0.13	0.26	0.0	69,69,0	0.0	0.0	0.0	0,0,0
275	0.09	0.17	0.0	69,69,0	0.0	0.0	0.0	0,0,0
276	0.07	0.13	0.0	69,69,0	0.0	0.0	0.0	0,0,0
277	0.05	0.10	0.0	69,69,0	0.0	0.0	0.0	0,0,0
278	0.04	0.08	0.0	69,69,0	0.0	0.0	0.0	0,0,0
279	0.04	0.08	0.0	69,69,0	0.0	0.0	0.0	0,0,0
280	0.03	0.05	0.0	69,69,0	0.0	0.0	0.0	0,0,0
281	0.17	0.35	0.0	69,69,0	0.03	0.0	0.0	69,0,0
282	0.11	0.21	0.0	69,69,0	0.0	0.0	0.0	0,0,0
283	0.08	0.16	0.0	69,69,0	0.0	0.0	0.0	0,0,0
284	0.06	0.11	0.0	69,69,0	0.0	0.0	0.0	0,0,0
285	0.05	0.09	0.0	69,69,0	0.0	0.0	0.0	0,0,0
286	0.04	0.08	0.0	69,69,0	0.0	0.0	0.0	0,0,0
287	0.04	0.08	0.0	69,69,0	0.0	0.0	0.0	0,0,0
288	0.03	0.05	0.0	69,69,0	0.0	0.0	0.0	0,0,0

Parco Eolico "Bolina" – Progetto Definitivo
Relazione di calcolo preliminare delle fondazioni degli aerogeneratori G8 e G12

289	0.17	0.34	0.0	69,69,0	0.03	0.0	0.0	69,0,0
290	0.11	0.21	0.0	69,69,0	0.0	0.0	0.0	0,0,0
291	0.08	0.16	0.0	69,69,0	0.0	0.0	0.0	0,0,0
292	0.06	0.11	0.0	69,69,0	0.0	0.0	0.0	0,0,0
293	0.05	0.09	0.0	69,69,0	0.0	0.0	0.0	0,0,0
294	0.04	0.08	0.0	69,69,0	0.0	0.0	0.0	0,0,0
295	0.04	0.08	0.0	69,69,0	0.0	0.0	0.0	0,0,0
296	0.03	0.05	0.0	69,69,0	0.0	0.0	0.0	0,0,0
297	0.30	0.59	0.0	69,69,0	0.07	0.0	0.0	69,0,0
298	0.13	0.25	0.0	69,69,0	0.0	0.0	0.0	0,0,0
299	0.09	0.17	0.0	69,69,0	0.0	0.0	0.0	0,0,0
300	0.07	0.13	0.0	69,69,0	0.0	0.0	0.0	0,0,0
301	0.05	0.10	0.0	69,69,0	0.0	0.0	0.0	0,0,0
302	0.04	0.08	0.0	69,69,0	0.0	0.0	0.0	0,0,0
303	0.04	0.08	0.0	69,69,0	0.0	0.0	0.0	0,0,0
304	0.03	0.05	0.0	69,69,0	0.0	0.0	0.0	0,0,0
305	0.24	0.48	0.0	69,69,0	0.04	0.0	0.0	69,0,0
306	0.12	0.24	0.0	69,69,0	0.0	0.0	0.0	0,0,0
307	0.09	0.17	0.0	69,69,0	0.0	0.0	0.0	0,0,0
308	0.07	0.13	0.0	69,69,0	0.0	0.0	0.0	0,0,0
309	0.05	0.10	0.0	69,69,0	0.0	0.0	0.0	0,0,0
310	0.04	0.08	0.0	69,69,0	0.0	0.0	0.0	0,0,0
311	0.04	0.08	0.0	69,69,0	0.0	0.0	0.0	0,0,0
312	0.03	0.05	0.0	69,69,0	0.0	0.0	0.0	0,0,0
313	0.27	0.54	0.0	69,69,0	0.05	0.0	0.0	69,0,0
314	0.13	0.25	0.0	69,69,0	0.0	0.0	0.0	0,0,0
315	0.09	0.18	0.0	69,69,0	0.0	0.0	0.0	0,0,0
316	0.07	0.13	0.0	69,69,0	0.0	0.0	0.0	0,0,0
317	0.05	0.10	0.0	69,69,0	0.0	0.0	0.0	0,0,0
318	0.04	0.08	0.0	69,69,0	0.0	0.0	0.0	0,0,0
319	0.04	0.08	0.0	69,69,0	0.0	0.0	0.0	0,0,0
320	0.03	0.05	0.0	69,69,0	0.0	0.0	0.0	0,0,0
Guscio	rRfck	rRfyk	rPFck		wR	wF	wP	
	0.38	0.74	0.0		0.11	0.0	0.0	

RELAZIONE GEOTECNICA E DELLE FONDAZIONI

NORMATIVE DI RIFERIMENTO

In quanto di seguito riportato viene fatto esplicito riferimento alle seguenti Normative:

- **LEGGE n° 64 del 02/02/1974.** "Provvedimenti per le costruzioni, con particolari prescrizioni per le zone sismiche.";
- **D.M. LL.PP. del 11/03/1988.** "Norme tecniche riguardanti le indagini sui terreni e sulle rocce, la stabilità dei pendii naturali e delle scarpate, i criteri generali e le prescrizioni per la progettazione, l'esecuzione e il collaudo delle opere di sostegno delle terre e delle opere di fondazione.";
- **D.M. LL.PP. del 16/01/1996.** "Norme tecniche per le costruzioni in zone sismiche.";
- **Circolare Ministeriale LL.PP. n° 65/AA.GG. del 10/04/1997.** "Istruzioni per l'applicazione delle "Norme Tecniche per le costruzioni in zone sismiche" di cui al D.M. 16/01/1996.";
- **Eurocodice 1 - Parte 1** - "Basi di calcolo ed azioni sulle strutture - Basi di calcolo -.";
- **Eurocodice 7 - Parte 1** - "Progettazione geotecnica - Regole generali -.";
- **Eurocodice 8 - Parte 5** - "Indicazioni progettuali per la resistenza sismica delle strutture - Fondazioni, strutture di contenimento ed aspetti geotecnici -.";
- **D.M. 17/01/2018 - NUOVE NORME TECNICHE PER LE COSTRUZIONI**
- **Circolare n. 617 del 02/02/2009**

INDAGINI IN SITO E CARATTERIZZAZIONE GEOTECNICA DEI TERRENI DI FONDAZIONE

La finalità della presente relazione è quella di definire il comportamento meccanico del volume di terreno (volume significativo) influenzato direttamente o indirettamente dalla costruzione di un manufatto e che a sua volta influenza il comportamento strutturale del manufatto stesso. Di seguito si illustrano i risultati delle indagini geologiche eseguite, nonché l'interpretazione dei risultati ottenuti. Dal quadro generale in tal modo scaturito si definiscono le caratteristiche della fondazione da adottare ed il modello da utilizzare per le elaborazioni relative alla interazione sovrastruttura-fondazione e fondazione-terreno.

Nell'area in esame sono state eseguite le seguenti indagini:

- Cinque prove penetrometriche dinamiche continue con penetrometro DPM,
- Dieci stendimenti sismici a rifrazione tipo MASW.

Le risultanze dell'indagine in sito hanno evidenziato per gli aerogeneratori oggetto della presente che il terreno di fondazione per tutta l'area in studio è caratterizzato sempre da una formazione argillosa per tutto lo spessore indagato di circa 4,7 metri, profondità oltre la quale si è avuto rifiuto delle aste alla penetrazione.

Dal punto di vista della resistenza la formazione si presenta in due spessori a resistenza crescente con la profondità (ved. la stima dei parametri geotecnici delle prova). Complessivamente si hanno valori medi di resistenza considerati fino al rifiuto alla penetrazione delle aste a circa 4.70 m di profondità.

Livello argilloso	Profondità base strato	Coesione non drenata (De Beer)	Angolo di attrito (Owasaki & Iwasaki)	Peso di volume
A	3,00 m	0,31 Kg/cmq	$\phi = 22,1^\circ$	$\gamma = 1.60 \text{ gr/cc}$
B	4,70 m	1,50 Kg/cmq	$\phi = 30,5^\circ$	$\gamma = 2.02 \text{ gr/cc}$
CATEGORIA SISMICA DEI SITI		B		

Di seguito si riportano alcuni cenni teorici relativi alle modalità di calcolo implementate e la descrizione della simbologia adottata nei tabulati.

DETERMINAZIONE DELLA PORTANZA VERTICALE DI FONDAZIONI PROFONDE

Per la determinazione della portanza verticale di fondazioni profonde si fa riferimento a due contributi: la "portanza di punta" e la "portanza per attrito laterale". Queste due componenti in genere sono calcolate in maniera autonoma dato che risulta molto difficoltoso, tranne che in poche situazioni, stabilire quanta parte del carico è assorbita dall'attrito laterale e quanta dalla resistenza alla punta. Nel seguito, ai fini del calcolo della portanza verticale, si assumeranno le seguenti espressioni generali valide per il caso di palo soggetto a compressione e per il caso di palo soggetto a trazione (nel calcolo della portanza verticale è possibile tenere in conto tutti o solo uno dei contributi su definiti):

$$Q_C = \frac{Q_P}{\eta_P} + \frac{Q_L}{\eta_L} - W_{ATT.NEG.} - W_P \quad (\text{caso di palo in compressione}) \quad Q_T$$

$$= \frac{Q_L}{\eta_L} + W_P \quad (\text{caso di palo in trazione})$$

dove i simboli su riportati hanno il seguente significato:

- Q_C resistenza a compressione del palo
- Q_T resistenza a trazione del palo
- Q_P carico limite verticale alla punta del palo
- Q_L carico limite verticale lungo la superficie laterale del palo
- $W_{ATT.NEG.}$ attrito negativo agente sul palo
- W_P peso totale del palo
- η_P coefficiente di sicurezza per carico limite verticale alla punta del palo
- η_L coefficiente di sicurezza per carico limite verticale lungo la superficie laterale del palo

I valori del carico limite verticale alla punta del palo " Q_P " e del carico limite verticale lungo la superficie laterale del palo " Q_L " sono determinati con le note "formule statiche". Queste esprimono i valori di cui sopra in funzione della geometria del palo, delle caratteristiche geotecniche del terreno in cui è immerso, della modalità esecutiva e dell'interfaccia palo-terreno.

Di seguito si illustrano le metodologie con le quali saranno determinati i valori prima citati; è necessario tenere presente che tali metodi sono riferiti al calcolo del "singolo palo" e per estendere tale modalità computazione al caso di "pali in gruppo" si farà ricorso ai "coefficienti d'efficienza", in questo modo si potrà tenere in debito conto l'interferenza reciproca che i pali esercitano.

CARICO LIMITE VERTICALE ALLA PUNTA DEL PALO

Il valore del carico limite verticale alla punta del palo, indipendentemente dal metodo utilizzato per la sua determinazione, è condizionato dalla modalità esecutiva. Esso varia notevolmente a seconda che il palo sia del tipo "infisso" o "trivellato" poiché le caratteristiche fisico-meccaniche del terreno circostante il palo variano in seguito alle operazioni d'installazione. Di conseguenza, per tenere conto della modalità esecutiva nel calcolo dei coefficienti di portanza, si propone di modificare il valore dell'angolo di resistenza a taglio secondo quanto suggerito da Kishida (1967):

$$\phi_{cor} = \frac{\phi + 40}{2} \quad (\text{per pali infissi}) \quad \phi_{cor} = \phi - 3^\circ \quad (\text{per pali trivellati})$$

Con la correzione di cui sopra si determineranno i fattori adimensionali di portanza che sono presenti nella relazione per la determinazione del carico limite verticale alla punta che assume la seguente espressione:

$$Q_P = A_P \cdot (q_P \cdot N_q^* + c \cdot N_c^*)$$

dove i simboli su riportati hanno il seguente significato:

- A_P superficie portante efficace della punta del palo
- q_P pressione del terreno presente alla punta del palo
- c coesione del terreno alla punta del palo (nel caso di condizione non drenata $c = c_u$)
- N_q^*, N_c^* fattori adimensionali di portanza funzione dell'angolo d'attrito interno ϕ_{cor} del terreno già corretti

In letteratura esistono diverse formulazioni per il calcolo dei fattori adimensionali di portanza, di seguito si riportano quelle che sono state implementate:

Formulazione di Meyerhof per base poggiate su terreni sciolti (1951)

- se $\phi \neq 0$ (condizione drenata) si ha:

$$N_q = \operatorname{tg}^2\left(\frac{\pi}{4} + \frac{\phi}{2}\right) \cdot e^{\pi \cdot \operatorname{tg}(\phi)} \quad N_c = (N_q - 1) \cdot \operatorname{ctg}(\phi)$$

$$s_q = 1 + 0.1 \cdot \operatorname{tg}^2\left(\frac{\pi}{4} + \frac{\phi}{2}\right) \quad s_c = 1 + 0.2 \cdot \operatorname{tg}^2\left(\frac{\pi}{4} + \frac{\phi}{2}\right) \quad \text{(fattori di forma)}$$

$$d_q = 1 + 0.1 \cdot \frac{L}{D} \cdot \sqrt{\operatorname{tg}^2\left(\frac{\pi}{4} + \frac{\phi}{2}\right)} \quad d_c = 1 + 0.2 \cdot \frac{L}{D} \cdot \sqrt{\operatorname{tg}^2\left(\frac{\pi}{4} + \frac{\phi}{2}\right)} \quad \text{(fattori d'approfondimento)}$$

$$N_q^* = N_q \cdot s_q \cdot d_q \quad N_c^* = N_c \cdot s_c \cdot d_c$$

se $\varphi = 0$ (condizione non drenata) si ha:

$$N_q = 1.00 \quad N_c = \pi + 2$$

$$s_q = 1.00 \quad s_c = 1.20 \quad \text{(fattori di forma)}$$

$$d_q = 1.00 \quad d_c = 1 + 0.2 \cdot \frac{L}{D} \quad \text{(fattori d'approfondimento)}$$

$$N_q^* = N_q \cdot s_q \cdot d_q \quad N_c^* = N_c \cdot s_c \cdot d_c$$

Formulazione di Hansen per base poggiate su terreni sciolti (1970)

se $\varphi \neq 0$ (condizione drenata) si ha:

$$N_q = \operatorname{tg}^2\left(\frac{\pi}{4} + \frac{\phi}{2}\right) \cdot e^{\pi \cdot \operatorname{tg}(\phi)} \quad N_c = (N_q - 1) \cdot \operatorname{ctg}(\phi)$$

$$s_q = 1 + \operatorname{tg}(\phi) \quad s_c = 1 + \frac{N_q}{N_c} \quad \text{(fattori di forma)}$$

$$d_q = 1 + 2 \cdot \operatorname{tg}(\phi) \cdot (1 - \operatorname{sen}(\phi))^2 \cdot \theta \quad d_c = 1 + 0.4 \cdot \theta \quad \text{(fattori d'approfondimento)}$$

dove: se $\frac{L}{D} \leq 1 \Rightarrow \theta = \frac{L}{D}$, se $\frac{L}{D} > 1 \Rightarrow \theta = \operatorname{arctg}\left(\frac{L}{D}\right)$

$$N_q^* = N_q \cdot s_q \cdot d_q \quad N_c^* = N_c \cdot s_c \cdot d_c$$

se $\varphi = 0$ (condizione non drenata) si ha:

$$N_q = 1.00 \quad N_c = \pi + 2$$

$$s_q = 1.00 \quad s_c = 1.20 \quad \text{(fattori di forma)}$$

$$d_q = 1.00 \quad d_c = 1 + 0.4 \cdot \theta \quad \text{(fattori d'approfondimento)}$$

$$N_q^* = N_q \cdot s_q \cdot d_q \quad N_c^* = N_c \cdot s_c \cdot d_c$$

Formulazione di Zeevaert per base poggiate su terreni sciolti (1972)

se $\varphi \neq 0$ (condizione drenata) si ha:

$$N_q^* = \frac{\cos^2(\phi)}{2 \cdot \cos^2\left(\frac{\pi}{4} + \frac{\phi}{2}\right)} \cdot e^{\left(\frac{\pi}{2} + \phi\right) \cdot \operatorname{tg}(\phi)} \quad N_c^* = (N_q - 1) \cdot \operatorname{ctg}(\phi)$$

se $\varphi = 0$ (condizione non drenata) si ha:

$$N_q^* = 1.00 \quad N_c^* = 9.00$$

Formulazione di Berezantzev per base poggiate su terreni sciolti (1970)

Berezantzev fa riferimento ad una superficie di scorrimento "alla Terzaghi" che si arresta sul piano della punta del palo. Inoltre considera il cilindro di terreno coassiale al palo (avente diametro pari all'estensione in sezione della superficie di scorrimento) in parte sostenuto da tensioni tangenziali dal rimanente terreno presente lungo la superficie laterale del cilindro. Conseguentemente il valore della pressione presente alla punta del palo è inferiore alla corrispondente pressione litostatica ed è influenzata dal rapporto tra la profondità alla quale è posta la punta "L" del palo e il diametro "D" dello stesso. Quindi il valore di N_q^* è influenzato da questo effetto "Silo". I valori che l'autore propone sono:

se $\varphi = 0$ (condizione drenata) si ha:

Valori di N_q^* per pali di diametro fino a 80.0 cm.

L/D	8°	16°	18°	20°	22°	24°	26°	28°	30°	32°	34°	36°	38°	40°	42°	44°	46°	48°	50°
4	1.07	2.18	3.15	4.72	7.15	10.73	15.85	22.95	32.62	45.56	62.69	85.18	114.53	152.71	202.32	266.82	350.86	460.79	605.36
12	1.04	1.77	2.46	3.64	5.52	8.42	12.71	18.85	27.44	39.21	55.07	76.20	104.13	140.81	188.86	251.72	334.05	442.17	584.82
20	1.03	1.63	2.20	3.20	4.82	7.38	11.22	16.82	24.76	35.79	50.83	71.06	98.01	133.65	180.59	242.29	323.39	430.21	571.48

Parco Eolico "Bolina" – Progetto Definitivo
Relazione di calcolo preliminare delle fondazioni degli aerogeneratori G8 e G12

28	1.03	1.54	2.05	2.93	4.40	6.72	10.26	15.48	22.96	33.43	47.84	67.37	93.54	128.35	174.39	235.13	315.21	420.95	561.08
36	1.02	1.49	1.94	2.75	4.10	6.26	9.57	14.49	21.60	31.64	45.53	64.48	90.00	124.10	169.36	229.27	308.46	413.26	552.38
50	1.02	1.42	1.82	2.53	3.74	5.68	8.70	13.23	19.84	29.27	42.45	60.56	85.14	118.18	162.30	220.95	298.80	402.16	539.74
75	1.02	1.35	1.69	2.30	3.33	5.02	7.69	11.74	17.73	26.37	38.58	55.55	78.82	110.38	152.84	209.67	285.53	386.74	522.01
100	1.01	1.31	1.61	2.14	3.07	4.60	7.02	10.74	16.28	24.34	35.84	51.95	74.19	104.56	145.68	201.02	275.23	374.64	507.95
200	1.01	1.22	1.44	1.84	2.54	3.71	5.60	8.56	13.05	19.73	29.43	43.30	62.82	89.95	127.29	178.30	247.63	341.59	468.90
500	1.01	1.14	1.29	1.55	2.02	2.82	4.14	6.24	9.50	14.45	21.83	32.64	48.25	70.49	101.85	145.69	206.57	290.75	406.87

Valori di N_q^* per pali di diametro maggiore a 80.0 cm.

Λ/Δ	8°	16°	18°	20°	22°	24°	26°	28°	30°	32°	34°	36°	38°	40°	42°	44°	46°	48°	50°
4	1.16	3.09	3.95	5.04	6.44	8.22	10.50	13.41	17.12	21.87	27.92	35.65	45.53	58.14	74.24	94.80	121.05	154.57	197.38
12	1.21	3.14	3.98	5.05	6.42	8.14	10.34	13.13	16.68	21.18	26.90	34.17	43.41	55.15	70.07	89.03	113.13	143.77	182.72
20	1.26	3.18	4.01	5.06	6.39	8.06	10.18	12.85	16.23	20.49	25.88	32.69	41.29	52.16	65.89	83.26	105.21	132.97	168.06
28	1.30	3.22	4.04	5.07	6.36	7.99	10.02	12.57	15.78	19.81	24.86	31.20	39.17	49.16	61.72	77.49	97.29	122.16	153.40
36	1.35	3.27	4.07	5.08	6.34	7.91	9.86	12.30	15.33	19.12	23.84	29.72	37.04	46.17	57.55	71.72	89.38	111.36	138.75
44	1.39	3.31	4.10	5.09	6.31	7.83	9.70	12.02	14.88	18.43	22.81	28.23	34.92	43.18	53.38	65.95	81.46	100.56	124.09
52	1.44	3.35	4.14	5.10	6.29	7.75	9.54	11.74	14.44	17.74	21.79	26.75	32.80	40.19	49.21	60.18	73.54	89.76	109.43
56	1.46	3.37	4.15	5.10	6.27	7.71	9.46	11.60	14.21	17.40	21.28	26.00	31.74	38.70	47.12	57.30	69.58	84.36	102.10
60	1.49	3.39	4.17	5.11	6.26	7.67	9.38	11.46	13.99	17.06	20.77	25.26	30.68	37.20	45.03	54.42	65.62	78.96	94.77
65	1.51	3.42	4.19	5.12	6.25	7.62	9.28	11.29	13.71	16.63	20.13	24.33	29.35	35.33	42.43	50.81	60.67	72.21	85.61

$$N_c^* = (N_q - 1) \cdot \text{ctg}(\phi)$$

se $\phi = 0$ (condizione non drenata) si ha:

$$N_q^* = 1.00 \qquad N_c^* = 9.00$$

Formulazione di Vesic per base poggiate su terreni sciolti (1975)

se $\phi \neq 0$ (condizione drenata) si ha:

$$N_q^* = \frac{3}{3 - \text{sen}(\phi)} \cdot \text{tg}^2\left(\frac{\pi}{4} + \frac{\phi}{2}\right) \cdot I_{rr}^{\frac{4 + \text{sen}(\phi)}{8 \cdot (1 + \text{sen}(\phi))}} \cdot e^{\left(\frac{\pi}{2} - \phi\right) \cdot \text{tg}(\phi)}$$

$$N_c^* = (N_q - 1) \cdot \text{ctg}(\phi)$$

$$I_{rr} = \frac{I_r}{1 + \varepsilon_v \cdot I_r} \qquad \varepsilon_v = \frac{q_p \cdot \alpha \cdot (1 + \nu) \cdot (1 - 2 \cdot \nu)}{E_t \cdot (1 - \nu)}$$

$$I_r = \frac{E_t}{2 \cdot (1 + \nu) \cdot (c + q_p \cdot \alpha \cdot \text{tg}(\phi))}$$

se $\phi = 0$ (condizione non drenata) si ha:

$$N_q^* = 1.00 \qquad N_c^* = \frac{4}{3} \cdot (\log_n(I_{rr}) + 1) + \frac{\pi}{2} + 1$$

dove i simboli su riportati hanno il seguente significato:

- E_t modulo elastico del terreno alla profondità della punta del palo
- ν coefficiente di Poisson del terreno alla profondità della punta del palo
- α coefficiente di riduzione della pressione del terreno presente alla profondità della punta del palo

Nel caso in cui si scelga di effettuare la riduzione della pressione del terreno presente alla profondità della punta del palo (cioè $\alpha < 1$) il coefficiente di riduzione " α " assume la seguente espressione:

$$\alpha = \frac{1 + 2 \cdot K_0}{3} \qquad \text{dove: se } \phi \neq 0 \Rightarrow K_0 = 1 - \text{sen}(\phi); \qquad \text{se } \phi = 0 \Rightarrow K_0 = \frac{\nu}{1 - \nu}$$

Formulazione di Janbu per base poggiate su terreni sciolti (1976)

se $\phi \neq 0$ (condizione drenata) si ha:

$$N_q^* = (\text{tg}(\phi) + \sqrt{1 + \text{tg}^2(\phi)})^2 \cdot e^{2 \cdot \vartheta \cdot \text{tg}(\phi)} \qquad N_c^* = (N_q - 1) \cdot \text{ctg}(\phi)$$

$$\vartheta = 60 + 0.45 \cdot Dr \qquad \text{dove "Dr" è la densità relativa del terreno.}$$

se $\phi = 0$ (condizione non drenata) si ha:

$$N_q^* = 1.00 \qquad N_c^* = 5.74$$

Formulazione di Terzaghi per base poggiate su roccia (1943)

Per la determinazione del carico limite nel caso di presenza di ammasso roccioso bisogna valutare molto attentamente il grado di solidità della roccia stessa. Tale valutazione viene in genere eseguita stimando l'indice RQD (Rock Quality Designation) che rappresenta una misura della qualità di un ammasso roccioso. Tale indice può variare da un minimo di 0 (caso in cui la lunghezza dei pezzi di roccia estratti dal carotiere è inferiore a 100 mm) ad un massimo di 1 (caso in cui la carota risulta integra) ed è calcolato nel seguente modo:

$$RQD = \frac{\sum \text{lunghezze dei pezzi di roccia intatta} > 100\text{mm}}{\text{lunghezza del carotiere}}$$

Se il valore di RQD è molto basso la roccia è molto fratturata ed il calcolo della capacità portante dell'ammasso roccioso va condotto alla stregua di un terreno sciolto utilizzando tutte le formulazioni sopra descritte.

$$N_q = \frac{e^{2 \cdot \left(\frac{3\pi - \phi}{4} - \frac{\phi}{2}\right) \cdot \text{tg}(\phi)}}{2 \cdot \cos^2\left(\frac{\pi + \phi}{4} + \frac{\phi}{2}\right)} \quad N_c = (N_q - 1) \cdot \text{ctg}(\phi) \quad \text{se } \phi = 0 \Rightarrow N_c = \frac{3}{2} \cdot \pi + 1$$

$$s_q = 1.00 \quad s_c = 1.30 \quad (\text{fattori di forma})$$

$$N_q^* = RQD^2 \cdot N_q \cdot s_q \quad N_c^* = RQD^2 \cdot N_c \cdot s_c$$

Formulazione di Stagg-Zienkiewicz per base poggiate su roccia (1968)

$$N_q = \text{tg}^6\left(\frac{90^\circ + \phi}{2}\right) \quad N_c = 5 \cdot \text{tg}^4\left(\frac{90^\circ + \phi}{2}\right)$$

$$s_q = 1.00 \quad s_c = 1.30 \quad (\text{fattori di forma})$$

$$N_q^* = RQD^2 \cdot N_q \cdot s_q \quad N_c^* = RQD^2 \cdot N_c \cdot s_c$$

CARICO LIMITE VERTICALE LUNGO LA SUPERFICIE LATERALE DEL PALO

Il valore del carico limite verticale lungo la superficie laterale del palo è dato dall'integrale esteso a tutta la superficie laterale del palo delle tensioni tangenziali che si sviluppano all'interfaccia palo-terreno in condizioni limite:

$$Q_L = \int_{\Gamma} \tau_{\text{lim}} \cdot d\Gamma = \int_0^L (c_a + \sigma_h \cdot \text{tg}(\delta)) \cdot P_{\text{lat}} \cdot dz$$

dove i simboli sopra riportati hanno il seguente significato:

- χ_a adesione all'interfaccia terreno-palo alla generica profondità "z"
- σ_h tensione orizzontale alla generica profondità "z"
- δ angolo di resistenza a taglio all'interfaccia terreno-palo alla generica profondità "z"
- P_{lat} perimetro della sezione trasversale del palo alla generica profondità "z"
- L sviluppo longitudinale del palo

Analogamente al carico limite alla punta, anche il valore del carico limite verticale lungo la superficie laterale del palo varia notevolmente a seconda che esso sia del tipo "infisso" o "trivellato" a causa del diverso comportamento del terreno circostante in palo. Conseguentemente i parametri sopra riportati possono essere correlati da leggi diverse in funzione delle modalità di esecuzione del palo. Di seguito si descrivono quelle che sono state implementate.

L'adesione " c_a " è correlata alla coesione " c " nel caso di condizioni drenate; oppure alla coesione non drenata " c_u " nel caso di condizioni non drenate, per mezzo del coefficiente d'adesione " ψ " secondo la seguente relazione:

$$c_a = c_* \cdot \psi \quad \text{dove: } c_* = c \text{ (in condizione drenata);}$$

$$c_* = c_u \text{ (in condizione non drenata).}$$

Esprimendo il valore di " c_* " in N/cm^2 , il coefficiente d'adesione " ψ " può assumere i seguenti valori:

Caquot-Kerisel (consigliato per pali trivellati)

$$\psi = \frac{100 + c_*^2}{100 + 7 \cdot c_*^2}$$

Meyerhof-Murdock (consigliato per pali trivellati)

se $c_* \leq 5.00 \text{ N/cm}^2 \Rightarrow \psi = 1.000 - 0.100 \cdot c_*$

se $c_* > 5.00 \text{ N/cm}^2 \Rightarrow \psi = 0.525 - 0.005 \cdot c_*$

Whitaker-Cooke (consigliato per pali trivellati)

se $c_* \leq 2.50 \text{ N/cm}^2 \Rightarrow \psi = 0.90$

se $2.50 < c_* \leq 5.00 \text{ N/cm}^2 \Rightarrow \psi = 0.80$

se $5.00 < c_* \leq 7.50 \text{ N/cm}^2 \Rightarrow \psi = 0.60$

se $c_* > 7.50 \text{ N/cm}^2 \Rightarrow \psi = 0.40$

Woodward (consigliato per pali trivellati)

se $c_* \leq 4.00 \text{ N/cm}^2$	⇒	ψ = 0.90
se $4.00 < c_* \leq 8.00 \text{ N/cm}^2$	⇒	ψ = 0.60
se $8.00 < c_* \leq 12.00 \text{ N/cm}^2$	⇒	ψ = 0.50
se $12.00 < c_* \leq 20.00 \text{ N/cm}^2$	⇒	ψ = 0.40
se $c_* > 20.00 \text{ N/cm}^2$	⇒	ψ = 0.30
Viggiani e altri (consigliato per pali infissi)		
se $c_* \leq 5.00 \text{ N/cm}^2$	⇒	ψ = 1.00
se $5.00 < c_* \leq 10.00 \text{ N/cm}^2$	⇒	ψ = 0.70
se $10.00 < c_* \leq 15.00 \text{ N/cm}^2$	⇒	ψ = 0.50
se $15.00 < c_* \leq 20.00 \text{ N/cm}^2$	⇒	ψ = 0.40
se $c_* > 20.00 \text{ N/cm}^2$	⇒	ψ = 0.30

Il valore della tensione orizzontale " σ_h " è correlato al valore della pressione verticale " σ_v " per mezzo del coefficiente di spinta orizzontale " K_s " secondo la seguente relazione:

$$\sigma_h = \sigma_v \cdot K_s$$

Il valore di " K_s " dipende essenzialmente dal tipo di terreno e dal suo stato d'addensamento nonché dalla tecnologia utilizzata per l'installazione.

Il programma permette di scegliere tra differenti teorie per il calcolo di K_s .

Opzione 1:

Metodo "Tomlinson (1971)"

K_s può variare da un limite inferiore pari al coefficiente di spinta a riposo " K_0 " fino a valori prossimi al coefficiente di spinta passiva " K_p "; i valori proposti sono:

pali trivellati: $K_s = K_0 = 1 - \text{sen}(\phi)$

pali infissi: $K_s =$ variabile da: $K_p = 1 + \text{tg}^2(\phi)$ in sommità fino a $K_0 = 1 - \text{sen}(\phi)$ alla punta

Opzione 2:

Metodo di "Kulhavy (1983)"

pali trivellati: $K_s = \alpha K_0$ con α variabile tra 2/3 e 1

pali infissi: $K_s = \alpha K_0$ con α variabile da 3/4, per compattazione del terreno trascurabile, fino a 2, nel caso di compattazione significativa.

Il valore dell'angolo di resistenza al taglio all'interfaccia terreno-palo " δ " è funzione della scabrezza della superficie del palo e quindi della modalità esecutiva; i valori proposti sono:

$$\delta = \text{arctg}(\text{tg}(\phi)) \quad (\text{per pali trivellati}) \quad \delta = \text{arctg}\left(\frac{3}{4} \cdot \text{tg}(\phi)\right) \quad (\text{per pali infissi})$$

SIMBOLOGIA ADOTTATA NEI TABULATI DI CALCOLO

Per maggior chiarezza nella lettura dei tabulati di calcolo viene riportata la descrizione dei simboli principali utilizzati nella stesura degli stessi. Per comodità di lettura la legenda è suddivisa in paragrafi con la stessa modalità in cui sono stampati i tabulati di calcolo.

Dati geometrici degli elementi costituenti le fondazioni profonde

- X elem. ascissa nel riferimento globale dell'elemento
- Y elem. ordinata nel riferimento globale dell'elemento
- Profon. profondità del piano di posa dell'elemento a partire dal piano campagna
- Base larghezza della sezione trasversale dell'elemento
- Lungh. dimensione dello sviluppo longitudinale dell'elemento
- Altez. altezza della sezione trasversale dell'elemento
- Rotaz. rotazione dell'elemento rispetto al suo baricentro

- Grup. ap. nel caso cui l'elemento faccia parte di una palificata, rappresenta il numero identificativo della stessa
- Ind. Strat. indice della stratigrafia associata all'elemento
- Tip. iniez. tipologia d'iniezione dei micropali ai fini del calcolo della portanza secondo le raccomandazioni di Bustamante e Doix (No iniez. = assenza d'iniezione, Iniez.uni. = iniezione unica, Iniez.rip. = iniezione ripetuta)
- Tip. ter. tipologia di terreno ai fini del calcolo della portanza secondo le raccomandazioni di Bustamante e Doix (Coes. = coesivo, Inc. = incoerente)
- Dia. P. diametro fusto del palo
- Lun. P. lunghezza totale del palo
- Lun. L. lunghezza tratto del palo senza contributo di terreno
- Dis. P. distanza del baricentro del palo dal bordo del plinto
- In. Px interasse principale del palo
- In. Py interasse secondario del palo
- Dia. B. diametro bulbo del palo
- Lun. B. lunghezza della sbulbatura del palo
- E.C.V. coefficiente d'efficienza per carico limite verticale del singolo palo
- E.C.C. coefficiente d'efficienza per carico critico verticale del singolo palo
- E.C.T. coefficiente d'efficienza per carico limite trasversale del singolo palo
- Svin. testa codice di svincolo alla rotazione in testa al palo (0 = non attivo, 1 = attivo)
- Vin. piede codici di vincolo rispettivamente alla rotazione orizzontale, traslazione orizzontale e traslazione verticale applicabili al piede del palo (0 = non attivo, 1 = attivo)
- Asc. X' ascissa del baricentro del singolo palo dell'elemento nel riferimento locale con origine nel baricentro del plinto
- Asc. Y' ordinata del baricentro del singolo palo dell'elemento nel riferimento locale con origine nel baricentro del plinto
- Peso spec. peso specifico del palo
- Mod. El. Pa. modulo elastico normale del palo

Dati di carico degli elementi costituenti le fondazioni profonde

- Cmb numero della combinazione di carico
- Tipologia tipologia della combinazione di carico
- Sismica flag per l'applicazione della riduzione sismica alle caratteristiche meccaniche del terreno di fondazione per la combinazione di carico in esame
- S. Normale sollecitazione normale agente alla quota del piano di fondazione dell'elemento (riferimento locale con origine nel baricentro del plinto)
- S. Tagliante X' sollecitazione tagliante lungo l'asse X' agente alla quota del piano di fondazione dell'elemento (riferimento locale con origine nel baricentro del plinto)
- S. Tagliante Y' sollecitazione tagliante lungo l'asse Y' agente alla quota del piano di fondazione dell'elemento (riferimento locale con origine nel baricentro del plinto)
- S. Flessionale X' sollecitazione flessionale lungo l'asse X' agente alla quota del piano di fondazione dell'elemento (riferimento locale con origine nel baricentro del plinto)
- S. Flessionale Y' sollecitazione flessionale lungo l'asse Y' agente alla quota del piano di fondazione dell'elemento (riferimento locale con origine nel baricentro del plinto)
- S. Torsionale sollecitazione torsionale agente alla quota del piano di fondazione dell'elemento (riferimento locale con origine nel baricentro del plinto)

Valori di calcolo per le fondazioni profonde

- Port. punta carico limite verticale alla punta del palo (valore su singolo palo corretto dal relativo coefficiente d'efficienza)
- Port. lat. carico limite verticale lungo la superficie laterale del fusto del palo (valore su singolo palo corretto dal relativo coefficiente d'efficienza)
- Port. bulbo carico limite verticale lungo la superficie laterale del bulbo del palo (valore su singolo palo corretto dal relativo coefficiente d'efficienza)
- C. Critico carico critico per l'instabilità del palo (valore su singolo palo corretto dal relativo coefficiente d'efficienza)
- Attr. Neg. attrito negativo agente sul palo (valore su singolo palo)

- Peso Palo peso totale del singolo palo
- Cmb numero e tipologia della combinazione di carico
- S. Norm. sollecitazione normale agente alla testa del palo in esame
- V. V. Com. resistenza a compressione del palo in esame (corretto dal relativo coefficiente di sicurezza)
- V. V. Tra. resistenza a trazione del palo in esame (corretto dal relativo coefficiente di sicurezza)
- Ver. Com. rapporto tra la sollecitazione normale agente alla testa del palo e la sua resistenza a compressione (verifica positiva se il rapporto è < 1.0)
- Ver. Tra. rapporto tra la sollecitazione normale agente alla testa del palo e la sua resistenza a trazione (verifica positiva se il rapporto è < 1.0)
- S. Tagl. sollecitazione tagliente agente alla testa del palo
- S. Fles. sollecitazione flessionale agente alla testa del palo
- V. V. Trs. resistenza trasversale del palo in esame (corretto dal relativo coefficiente di sicurezza)
- Ver. Tra. rapporto tra la sollecitazione tagliente agente alla testa del palo e la sua resistenza trasversale (verifica positiva se il rapporto è < 1.0)
- Ced. V. cedimento verticale in corrispondenza della testa del palo
- Ced. H. cedimento orizzontale in corrispondenza della testa del palo

PARAMETRI DI CALCOLO

Modalità di calcolo della portanza verticale per fondazioni profonde:

Per elementi con pali: Portanza di punta e laterale

Per elementi con micropali: Portanza di punta e laterale

Metodi di calcolo della portanza di punta per fondazioni profonde:

Per terreni sciolti: Vesic

Riduzione della tensione litostatica: No

Per terreni lapidei: Terzaghi

Riduzione di Kishida per pali battuti o trivellati: Si

Metodo di calcolo del coefficiente di spinta orizzontale Ks: Tomlinson

Coefficienti parziali e totali di sicurezza per Tensioni Ammissibili e S.L.E. nel calcolo della portanza per fondazioni profonde:

Coeff. di sicurezza alla punta: 2,50

Coeff. di sicurezza lungo il fusto: 2,50

Coeff. di sicurezza lungo il bulbo: 2,50

Coeff. di sicurezza per palo in trazione: 2,50

Combinazioni di carico:

APPROCCIO PROGETTUALE TIPO 2 - Comb. (A1+M1+R3)

Coefficienti parziali e totali di sicurezza per S.L.U. nel calcolo della portanza per pali trivellati:

I coeff. A1 risultano combinati secondo lo schema presente nella relazione di calcolo della struttura.

- Coeff. M1 per $\tan \phi$ (statico): 1

- Coeff. M1 per c' (statico): 1

- Coeff. M1 per C_u (statico): 1

- Coeff. M1 per $\tan \phi$ (sismico): 1

- Coeff. M1 per c' (sismico): 1

- Coeff. M1 per C_u sismico): 1

- Coeff. R3 base: 1,35

- Coeff. R3 laterale in compressione: 1,15

- Coeff. R3 laterale in trazione: 1,25

Fattore di correlazione: 1,70

ARCHIVIO STRATIGRAFIE

Indice / Descrizione: 004 / Stratigr. G8-G12

Parco Eolico "Bolina" – Progetto Definitivo
Relazione di calcolo preliminare delle fondazioni degli aerogeneratori G8 e G12

Numero strati: 2
Profondità falda: assente

Strato n.	Quota di riferimento	Spessore	Indice / Descrizione terreno	Attrito Neg.
1	da 0,0 a -300,0 cm	300,0 cm	007 / Argilla media Strato 1	Assente
2	da -300,0 a -4300,0 cm	4000,0 cm	008 / Argilla marnosa Strato 2	Assente

ARCHIVIO TERRENI

Indice / Descrizione terreno: **007 / Argilla media Strato 1**

Comportamento del terreno: condizione non drenata

Peso Spec.	P. Spec. Sat.	Coef.non dren.	Mod.Elast.	Mod.Edom.	Dens.Rel.	Poisson	C. Ades.
daN/cm ²	daN/cm ²	daN/cm ²	daN/cm ²	daN/cm ²	%	%	
1,600 E-3	1,800 E-3	0,310	150,000	150,000	60,0	0,500	0,69

Indice / Descrizione terreno: **008 / Argilla marnosa Strato 2**

Comportamento del terreno: condizione non drenata

Peso Spec.	P. Spec. Sat.	Coef.non dren.	Mod.Elast.	Mod.Edom.	Dens.Rel.	Poisson	C. Ades.
daN/cm ²	daN/cm ²	daN/cm ²	daN/cm ²	daN/cm ²	%	%	
2,020 E-3	2,220 E-3	1,500	250,000	250,000	60,0	0,500	0,45

DATI GEOMETRICI DEGLI ELEMENTI COSTITUENTI LE FONDAZIONI PROFONDE

Elemento: 84 - Palo singolo - Tipologia pali: trivellati

X elem.	Y elem.	Prof.	Base	Lungh.	Altez.	Rot.	Grup.ap.	Ind.strat.					Svin.testa	Vin.piede
cm	cm	cm	cm	cm	cm	Gradi°	n.	n.					codice	codice
503,1	0,0	245,0	0,0	0,0	250,0	0,00	84	004					0	0; 0; 0
Dia. P.	Lun. P.	Lun. L.	Dist.P.	In. Px	In. Py	Dia. B.	Lun. B.	E.C.V.	E.C.C.	E.C.T.			Svin.testa	Vin.piede
cm	cm	cm	cm	cm	cm	cm	cm						codice	codice
120,0	1400,0	0,0	0,0	0,0	0,0	0,0	0,0	1,00	1,00	1,00			0	0; 0; 0
Palo	Asc. X'	Ord. Y'												
n.	cm	cm												
1	0,0	0,0												

Elemento: 92 - Palo singolo - Tipologia pali: trivellati

X elem.	Y elem.	Prof.	Base	Lungh.	Altez.	Rot.	Grup.ap.	Ind.strat.					Svin.testa	Vin.piede
cm	cm	cm	cm	cm	cm	Gradi°	n.	n.					codice	codice
934,4	0,0	245,0	0,0	0,0	250,0	0,00	92	004					0	0; 0; 0
Dia. P.	Lun. P.	Lun. L.	Dist.P.	In. Px	In. Py	Dia. B.	Lun. B.	E.C.V.	E.C.C.	E.C.T.			Svin.testa	Vin.piede
cm	cm	cm	cm	cm	cm	cm	cm						codice	codice
120,0	1400,0	0,0	0,0	0,0	0,0	0,0	0,0	1,00	1,00	1,00			0	0; 0; 0
Palo	Asc. X'	Ord. Y'												
n.	cm	cm												
1	0,0	0,0												

Elemento: 103 - Palo singolo - Tipologia pali: trivellati

X elem.	Y elem.	Prof.	Base	Lungh.	Altez.	Rot.	Grup.ap.	Ind.strat.					Svin.testa	Vin.piede
cm	cm	cm	cm	cm	cm	Gradi°	n.	n.					codice	codice
868,7	366,0	245,0	0,0	0,0	250,0	0,00	103	004					0	0; 0; 0
Dia. P.	Lun. P.	Lun. L.	Dist.P.	In. Px	In. Py	Dia. B.	Lun. B.	E.C.V.	E.C.C.	E.C.T.			Svin.testa	Vin.piede
cm	cm	cm	cm	cm	cm	cm	cm						codice	codice
120,0	1400,0	0,0	0,0	0,0	0,0	0,0	0,0	1,00	1,00	1,00			0	0; 0; 0
Palo	Asc. X'	Ord. Y'												
n.	cm	cm												
1	0,0	0,0												

Elemento: 115 - Palo singolo - Tipologia pali: trivellati

X elem.	Y elem.	Prof.	Base	Lungh.	Altez.	Rot.	Grup.ap.	Ind.strat.					Svin.testa	Vin.piede
cm	cm	cm	cm	cm	cm	Gradi°	n.	n.					codice	codice
418,9	418,9	245,0	0,0	0,0	250,0	0,00	115	004					0	0; 0; 0
Dia. P.	Lun. P.	Lun. L.	Dist.P.	In. Px	In. Py	Dia. B.	Lun. B.	E.C.V.	E.C.C.	E.C.T.			Svin.testa	Vin.piede
cm	cm	cm	cm	cm	cm	cm	cm						codice	codice
120,0	1400,0	0,0	0,0	0,0	0,0	0,0	0,0	1,00	1,00	1,00			0	0; 0; 0
Palo	Asc. X'	Ord. Y'												
n.	cm	cm												
1	0,0	0,0												

Elemento: 119 - Palo singolo - Tipologia pali: trivellati

X elem.	Y elem.	Prof.	Base	Lungh.	Altez.	Rot.	Grup.ap.	Ind.strat.
cm	cm	cm	cm	cm	cm	Gradi°	n.	n.



Parco Eolico "Bolina" – Progetto Definitivo
Relazione di calcolo preliminare delle fondazioni degli aerogeneratori G8 e G12

681,8	681,8	245,0	0,0	0,0	250,0	0,00	119	004					
Dia. P. cm	Lun. P. cm	Lun. L. cm	Dist.P. cm	In. Px cm	In. Py cm	Dia. B. cm	Lun. B. cm	E.C.V.	E.C.C.	E.C.T.	Svin.testa codice	Vin.piede codice	
120,0	1400,0	0,0	0,0	0,0	0,0	0,0	0,0	1,00	1,00	1,00	0	0; 0; 0	
Palo n.	Asc. X' cm	Ord. Y' cm											
1	0,0	0,0											

Elemento: 135 - Palo singolo - Tipologia pali: trivellati

X elem. cm	Y elem. cm	Prof. cm	Base cm	Lungh. cm	Altez. cm	Rot. Gradi°	Grup.ap. n.	Ind.strat. n.					
366,0	868,7	245,0	0,0	0,0	250,0	0,00	135	004					
Dia. P. cm	Lun. P. cm	Lun. L. cm	Dist.P. cm	In. Px cm	In. Py cm	Dia. B. cm	Lun. B. cm	E.C.V.	E.C.C.	E.C.T.	Svin.testa codice	Vin.piede codice	
120,0	1400,0	0,0	0,0	0,0	0,0	0,0	0,0	1,00	1,00	1,00	0	0; 0; 0	
Palo n.	Asc. X' cm	Ord. Y' cm											
1	0,0	0,0											

Elemento: 147 - Palo singolo - Tipologia pali: trivellati

X elem. cm	Y elem. cm	Prof. cm	Base cm	Lungh. cm	Altez. cm	Rot. Gradi°	Grup.ap. n.	Ind.strat. n.					
0,0	503,1	245,0	0,0	0,0	250,0	0,00	147	004					
Dia. P. cm	Lun. P. cm	Lun. L. cm	Dist.P. cm	In. Px cm	In. Py cm	Dia. B. cm	Lun. B. cm	E.C.V.	E.C.C.	E.C.T.	Svin.testa codice	Vin.piede codice	
120,0	1400,0	0,0	0,0	0,0	0,0	0,0	0,0	1,00	1,00	1,00	0	0; 0; 0	
Palo n.	Asc. X' cm	Ord. Y' cm											
1	0,0	0,0											

Elemento: 151 - Palo singolo - Tipologia pali: trivellati

X elem. cm	Y elem. cm	Prof. cm	Base cm	Lungh. cm	Altez. cm	Rot. Gradi°	Grup.ap. n.	Ind.strat. n.					
0,0	934,4	245,0	0,0	0,0	250,0	0,00	151	004					
Dia. P. cm	Lun. P. cm	Lun. L. cm	Dist.P. cm	In. Px cm	In. Py cm	Dia. B. cm	Lun. B. cm	E.C.V.	E.C.C.	E.C.T.	Svin.testa codice	Vin.piede codice	
120,0	1400,0	0,0	0,0	0,0	0,0	0,0	0,0	1,00	1,00	1,00	0	0; 0; 0	
Palo n.	Asc. X' cm	Ord. Y' cm											
1	0,0	0,0											

Elemento: 167 - Palo singolo - Tipologia pali: trivellati

X elem. cm	Y elem. cm	Prof. cm	Base cm	Lungh. cm	Altez. cm	Rot. Gradi°	Grup.ap. n.	Ind.strat. n.					
-366,0	868,7	245,0	0,0	0,0	250,0	0,00	167	004					
Dia. P. cm	Lun. P. cm	Lun. L. cm	Dist.P. cm	In. Px cm	In. Py cm	Dia. B. cm	Lun. B. cm	E.C.V.	E.C.C.	E.C.T.	Svin.testa codice	Vin.piede codice	
120,0	1400,0	0,0	0,0	0,0	0,0	0,0	0,0	1,00	1,00	1,00	0	0; 0; 0	
Palo n.	Asc. X' cm	Ord. Y' cm											
1	0,0	0,0											

Elemento: 179 - Palo singolo - Tipologia pali: trivellati

X elem. cm	Y elem. cm	Prof. cm	Base cm	Lungh. cm	Altez. cm	Rot. Gradi°	Grup.ap. n.	Ind.strat. n.					
-418,9	418,9	245,0	0,0	0,0	250,0	0,00	179	004					
Dia. P. cm	Lun. P. cm	Lun. L. cm	Dist.P. cm	In. Px cm	In. Py cm	Dia. B. cm	Lun. B. cm	E.C.V.	E.C.C.	E.C.T.	Svin.testa codice	Vin.piede codice	
120,0	1400,0	0,0	0,0	0,0	0,0	0,0	0,0	1,00	1,00	1,00	0	0; 0; 0	
Palo n.	Asc. X' cm	Ord. Y' cm											
1	0,0	0,0											

Elemento: 183 - Palo singolo - Tipologia pali: trivellati

X elem. cm	Y elem. cm	Prof. cm	Base cm	Lungh. cm	Altez. cm	Rot. Gradi°	Grup.ap. n.	Ind.strat. n.					
-681,8	681,8	245,0	0,0	0,0	250,0	0,00	183	004					
Dia. P. cm	Lun. P. cm	Lun. L. cm	Dist.P. cm	In. Px cm	In. Py cm	Dia. B. cm	Lun. B. cm	E.C.V.	E.C.C.	E.C.T.	Svin.testa codice	Vin.piede codice	
120,0	1400,0	0,0	0,0	0,0	0,0	0,0	0,0	1,00	1,00	1,00	0	0; 0; 0	

Parco Eolico "Bolina" – Progetto Definitivo
Relazione di calcolo preliminare delle fondazioni degli aerogeneratori G8 e G12

120,0	1400,0	0,0	0,0	0,0	0,0	0,0	0,0	1,00	1,00	1,00	0	0; 0; 0
Palo	Asc. X'	Ord. Y'										
n.	cm	cm										
1	0,0	0,0										

Elemento: 199 - Palo singolo - Tipologia pali: trivellati

X elem.	Y elem.	Prof.	Base	Lungh.	Altez.	Rot.	Grup.ap.	Ind.strat.					Svin.testa	Vin.piede
cm	cm	cm	cm	cm	cm	Gradi°	n.	n.					codice	codice
-868,7	366,0	245,0	0,0	0,0	250,0	0,00	199	004					0	0; 0; 0
Dia. P.	Lun. P.	Lun. L.	Dist.P.	In. Px	In. Py	Dia. B.	Lun. B.	E.C.V.	E.C.C.	E.C.T.				
cm	cm	cm	cm	cm	cm	cm	cm	cm	cm	cm				
120,0	1400,0	0,0	0,0	0,0	0,0	0,0	0,0	1,00	1,00	1,00				
Palo	Asc. X'	Ord. Y'												
n.	cm	cm												
1	0,0	0,0												

Elemento: 211 - Palo singolo - Tipologia pali: trivellati

X elem.	Y elem.	Prof.	Base	Lungh.	Altez.	Rot.	Grup.ap.	Ind.strat.					Svin.testa	Vin.piede
cm	cm	cm	cm	cm	cm	Gradi°	n.	n.					codice	codice
-503,1	0,0	245,0	0,0	0,0	250,0	0,00	211	004					0	0; 0; 0
Dia. P.	Lun. P.	Lun. L.	Dist.P.	In. Px	In. Py	Dia. B.	Lun. B.	E.C.V.	E.C.C.	E.C.T.				
cm	cm	cm	cm	cm	cm	cm	cm	cm	cm	cm				
120,0	1400,0	0,0	0,0	0,0	0,0	0,0	0,0	1,00	1,00	1,00				
Palo	Asc. X'	Ord. Y'												
n.	cm	cm												
1	0,0	0,0												

Elemento: 215 - Palo singolo - Tipologia pali: trivellati

X elem.	Y elem.	Prof.	Base	Lungh.	Altez.	Rot.	Grup.ap.	Ind.strat.					Svin.testa	Vin.piede
cm	cm	cm	cm	cm	cm	Gradi°	n.	n.					codice	codice
-934,4	0,0	245,0	0,0	0,0	250,0	0,00	215	004					0	0; 0; 0
Dia. P.	Lun. P.	Lun. L.	Dist.P.	In. Px	In. Py	Dia. B.	Lun. B.	E.C.V.	E.C.C.	E.C.T.				
cm	cm	cm	cm	cm	cm	cm	cm	cm	cm	cm				
120,0	1400,0	0,0	0,0	0,0	0,0	0,0	0,0	1,00	1,00	1,00				
Palo	Asc. X'	Ord. Y'												
n.	cm	cm												
1	0,0	0,0												

Elemento: 231 - Palo singolo - Tipologia pali: trivellati

X elem.	Y elem.	Prof.	Base	Lungh.	Altez.	Rot.	Grup.ap.	Ind.strat.					Svin.testa	Vin.piede
cm	cm	cm	cm	cm	cm	Gradi°	n.	n.					codice	codice
-868,7	-366,0	245,0	0,0	0,0	250,0	0,00	231	004					0	0; 0; 0
Dia. P.	Lun. P.	Lun. L.	Dist.P.	In. Px	In. Py	Dia. B.	Lun. B.	E.C.V.	E.C.C.	E.C.T.				
cm	cm	cm	cm	cm	cm	cm	cm	cm	cm	cm				
120,0	1400,0	0,0	0,0	0,0	0,0	0,0	0,0	1,00	1,00	1,00				
Palo	Asc. X'	Ord. Y'												
n.	cm	cm												
1	0,0	0,0												

Elemento: 243 - Palo singolo - Tipologia pali: trivellati

X elem.	Y elem.	Prof.	Base	Lungh.	Altez.	Rot.	Grup.ap.	Ind.strat.					Svin.testa	Vin.piede
cm	cm	cm	cm	cm	cm	Gradi°	n.	n.					codice	codice
-418,9	-418,9	245,0	0,0	0,0	250,0	0,00	243	004					0	0; 0; 0
Dia. P.	Lun. P.	Lun. L.	Dist.P.	In. Px	In. Py	Dia. B.	Lun. B.	E.C.V.	E.C.C.	E.C.T.				
cm	cm	cm	cm	cm	cm	cm	cm	cm	cm	cm				
120,0	1400,0	0,0	0,0	0,0	0,0	0,0	0,0	1,00	1,00	1,00				
Palo	Asc. X'	Ord. Y'												
n.	cm	cm												
1	0,0	0,0												

Elemento: 247 - Palo singolo - Tipologia pali: trivellati

X elem.	Y elem.	Prof.	Base	Lungh.	Altez.	Rot.	Grup.ap.	Ind.strat.					Svin.testa	Vin.piede
cm	cm	cm	cm	cm	cm	Gradi°	n.	n.					codice	codice
-681,8	-681,8	245,0	0,0	0,0	250,0	0,00	247	004					0	0; 0; 0
Dia. P.	Lun. P.	Lun. L.	Dist.P.	In. Px	In. Py	Dia. B.	Lun. B.	E.C.V.	E.C.C.	E.C.T.				
cm	cm	cm	cm	cm	cm	cm	cm	cm	cm	cm				
120,0	1400,0	0,0	0,0	0,0	0,0	0,0	0,0	1,00	1,00	1,00				
Palo	Asc. X'	Ord. Y'												
n.	cm	cm												



Parco Eolico "Bolina" – Progetto Definitivo
Relazione di calcolo preliminare delle fondazioni degli aerogeneratori G8 e G12

1 0,0 0,0

Elemento: 263 - Palo singolo - Tipologia pali: trivellati

X elem.	Y elem.	Prof.	Base	Lungh.	Altez.	Rot.	Grup.ap.	Ind.strat.
cm	cm	cm	cm	cm	cm	Gradi°	n.	n.
-366,0	-868,7	245,0	0,0	0,0	250,0	0,00	263	004

Dia. P.	Lun. P.	Lun. L.	Dist.P.	In. Px	In. Py	Dia. B.	Lun. B.	E.C.V.	E.C.C.	E.C.T.	Svin.testa	Vin.piede
cm	cm	cm	cm	cm	cm	cm	cm				codice	codice
120,0	1400,0	0,0	0,0	0,0	0,0	0,0	0,0	1,00	1,00	1,00	0	0; 0; 0

Palo	Asc. X'	Ord. Y'
n.	cm	cm
1	0,0	0,0

Elemento: 275 - Palo singolo - Tipologia pali: trivellati

X elem.	Y elem.	Prof.	Base	Lungh.	Altez.	Rot.	Grup.ap.	Ind.strat.
cm	cm	cm	cm	cm	cm	Gradi°	n.	n.
0,0	-503,1	245,0	0,0	0,0	250,0	0,00	275	004

Dia. P.	Lun. P.	Lun. L.	Dist.P.	In. Px	In. Py	Dia. B.	Lun. B.	E.C.V.	E.C.C.	E.C.T.	Svin.testa	Vin.piede
cm	cm	cm	cm	cm	cm	cm	cm				codice	codice
120,0	1400,0	0,0	0,0	0,0	0,0	0,0	0,0	1,00	1,00	1,00	0	0; 0; 0

Palo	Asc. X'	Ord. Y'
n.	cm	cm
1	0,0	0,0

Elemento: 279 - Palo singolo - Tipologia pali: trivellati

X elem.	Y elem.	Prof.	Base	Lungh.	Altez.	Rot.	Grup.ap.	Ind.strat.
cm	cm	cm	cm	cm	cm	Gradi°	n.	n.
0,0	-934,4	245,0	0,0	0,0	250,0	0,00	279	004

Dia. P.	Lun. P.	Lun. L.	Dist.P.	In. Px	In. Py	Dia. B.	Lun. B.	E.C.V.	E.C.C.	E.C.T.	Svin.testa	Vin.piede
cm	cm	cm	cm	cm	cm	cm	cm				codice	codice
120,0	1400,0	0,0	0,0	0,0	0,0	0,0	0,0	1,00	1,00	1,00	0	0; 0; 0

Palo	Asc. X'	Ord. Y'
n.	cm	cm
1	0,0	0,0

Elemento: 295 - Palo singolo - Tipologia pali: trivellati

X elem.	Y elem.	Prof.	Base	Lungh.	Altez.	Rot.	Grup.ap.	Ind.strat.
cm	cm	cm	cm	cm	cm	Gradi°	n.	n.
366,0	-868,7	245,0	0,0	0,0	250,0	0,00	295	004

Dia. P.	Lun. P.	Lun. L.	Dist.P.	In. Px	In. Py	Dia. B.	Lun. B.	E.C.V.	E.C.C.	E.C.T.	Svin.testa	Vin.piede
cm	cm	cm	cm	cm	cm	cm	cm				codice	codice
120,0	1400,0	0,0	0,0	0,0	0,0	0,0	0,0	1,00	1,00	1,00	0	0; 0; 0

Palo	Asc. X'	Ord. Y'
n.	cm	cm
1	0,0	0,0

Elemento: 307 - Palo singolo - Tipologia pali: trivellati

X elem.	Y elem.	Prof.	Base	Lungh.	Altez.	Rot.	Grup.ap.	Ind.strat.
cm	cm	cm	cm	cm	cm	Gradi°	n.	n.
418,9	-418,9	245,0	0,0	0,0	250,0	0,00	307	004

Dia. P.	Lun. P.	Lun. L.	Dist.P.	In. Px	In. Py	Dia. B.	Lun. B.	E.C.V.	E.C.C.	E.C.T.	Svin.testa	Vin.piede
cm	cm	cm	cm	cm	cm	cm	cm				codice	codice
120,0	1400,0	0,0	0,0	0,0	0,0	0,0	0,0	1,00	1,00	1,00	0	0; 0; 0

Palo	Asc. X'	Ord. Y'
n.	cm	cm
1	0,0	0,0

Elemento: 311 - Palo singolo - Tipologia pali: trivellati

X elem.	Y elem.	Prof.	Base	Lungh.	Altez.	Rot.	Grup.ap.	Ind.strat.
cm	cm	cm	cm	cm	cm	Gradi°	n.	n.
681,8	-681,8	245,0	0,0	0,0	250,0	0,00	311	004

Dia. P.	Lun. P.	Lun. L.	Dist.P.	In. Px	In. Py	Dia. B.	Lun. B.	E.C.V.	E.C.C.	E.C.T.	Svin.testa	Vin.piede
cm	cm	cm	cm	cm	cm	cm	cm				codice	codice
120,0	1400,0	0,0	0,0	0,0	0,0	0,0	0,0	1,00	1,00	1,00	0	0; 0; 0

Palo	Asc. X'	Ord. Y'
n.	cm	cm
1	0,0	0,0

Elemento: 327 - Palo singolo - Tipologia pali: trivellati

X elem.	Y elem.	Prof.	Base	Lungh.	Altez.	Rot.	Grup.ap.	Ind.strat.
---------	---------	-------	------	--------	--------	------	----------	------------



Parco Eolico "Bolina" – Progetto Definitivo
Relazione di calcolo preliminare delle fondazioni degli aerogeneratori G8 e G12

cm	cm	cm	cm	cm	cm	Gradi°	n.	n.					
868,7	-366,0	245,0	0,0	0,0	250,0	0,00	327	004					
Dia. P.	Lun. P.	Lun. L.	Dist.P.	In. Px	In. Py	Dia. B.	Lun. B.	E.C.V.	E.C.C.	E.C.T.	Svin.testa	Vin.piede	
cm	cm	cm	cm	cm	cm	cm	cm				codice	codice	
120,0	1400,0	0,0	0,0	0,0	0,0	0,0	0,0	1,00	1,00	1,00	0	0; 0; 0	
Palo	Asc. X'	Ord. Y'											
n.	cm	cm											
1	0,0	0,0											

VALORI DI CALCOLO DELLA PORTANZA PER FONDAZIONI PROFONDE

Elemento: 84 - Palo singolo

$N_q = 1.000$, $\sigma_{punta} = 3.197$, $\phi = 0.0$, $N_c = 9.261$, $c_{punta} = 1.500$
 Port. lat. = 346695.9 daN, Port. punta = 193259.2 daN, P.P.Palo = 39584.1 daN

Cmb.	Tipo	Palo	coord.X	coord.Y	N	N lim	Ver.N	Stato
n.		n.	cm	cm	daN	daN		
001	SLU STR	70	0.000	0.000	-158900.0	-221962.8	0,716	Ok

Sollecitazioni:

Cmb	Tipo	Sism.	N	Tx	Ty	Mx	My
n.			daN	daN	daN	daN cm	daN cm
001	SLU STR	No	-158900.0	-325.8	3944.2	1891000.0	242200.0

Elemento: 92 - Palo singolo

$N_q = 1.000$, $\sigma_{punta} = 3.197$, $\phi = 0.0$, $N_c = 9.261$, $c_{punta} = 1.500$
 Port. lat. = 346695.9 daN, Port. punta = 193259.2 daN, P.P.Palo = 39584.1 daN

Cmb.	Tipo	Palo	coord.X	coord.Y	N	N lim	Ver.N	Stato
n.		n.	cm	cm	daN	daN		
001	SLU STR	70	0.000	0.000	-156100.0	-221962.8	0,703	Ok

Sollecitazioni:

Cmb	Tipo	Sism.	N	Tx	Ty	Mx	My
n.			daN	daN	daN	daN cm	daN cm
001	SLU STR	No	-156100.0	451.0	2838.5	1392000.0	-113200.0

Elemento: 103 - Palo singolo

$N_q = 1.000$, $\sigma_{punta} = 3.197$, $\phi = 0.0$, $N_c = 9.261$, $c_{punta} = 1.500$
 Port. lat. = 346695.9 daN, Port. punta = 193259.2 daN, P.P.Palo = 39584.1 daN

Cmb.	Tipo	Palo	coord.X	coord.Y	N	N lim	Ver.N	Stato
n.		n.	cm	cm	daN	daN		
001	SLU STR	70	0.000	0.000	-120800.0	-221962.8	0,544	Ok

Sollecitazioni:

Cmb	Tipo	Sism.	N	Tx	Ty	Mx	My
n.			daN	daN	daN	daN cm	daN cm
001	SLU STR	No	-120800.0	-234.1	3549.9	1716000.0	205200.0

Elemento: 115 - Palo singolo

$N_q = 1.000$, $\sigma_{punta} = 3.197$, $\phi = 0.0$, $N_c = 9.261$, $c_{punta} = 1.500$
 Port. lat. = 346695.9 daN, Port. punta = 193259.2 daN, P.P.Palo = 39584.1 daN

Cmb.	Tipo	Palo	coord.X	coord.Y	N	N lim	Ver.N	Stato
n.		n.	cm	cm	daN	daN		
001	SLU STR	70	0.000	0.000	-99770.0	-221962.8	0,449	Ok

Sollecitazioni:

Cmb	Tipo	Sism.	N	Tx	Ty	Mx	My
n.			daN	daN	daN	daN cm	daN cm
001	SLU STR	No	-99770.0	-1990.6	4141.1	1979000.0	1010000.0

Elemento: 119 - Palo singolo

$N_q = 1.000$, $\sigma_{punta} = 3.197$, $\phi = 0.0$, $N_c = 9.261$, $c_{punta} = 1.500$
 Port. lat. = 346695.9 daN, Port. punta = 193259.2 daN, P.P.Palo = 39584.1 daN

Cmb.	Tipo	Palo	coord.X	coord.Y	N	N lim	Ver.N	Stato
n.		n.	cm	cm	daN	daN		
001	SLU STR	70	0.000	0.000	-84930.0	-221962.8	0,383	Ok

Sollecitazioni:

Cmb	Tipo	Sism.	N	Tx	Ty	Mx	My
n.			daN	daN	daN	daN cm	daN cm
001	SLU STR	No	-84930.0	-1990.6	4141.1	1979000.0	1010000.0



Parco Eolico "Bolina" – Progetto Definitivo
Relazione di calcolo preliminare delle fondazioni degli aerogeneratori G8 e G12

001 SLU STR No -84930.0 -911.6 3123.3 1518000.0 519300.0

Elemento: 135 - Palo singolo

$N_q = 1.000$, $\sigma_{punta} = 3.197$, $\phi = 0.0$, $N_c = 9.261$, $c_{punta} = 1.500$
 Port. lat. = 346695.9 daN, Port. punta = 193259.2 daN, P.P.Palo = 39584.1 daN

Cmb.	Tipo	Palo	coord.X	coord.Y	N	N lim	Ver.N	Stato
n.		n.	cm	cm	daN	daN		
001	SLU STR	70	0.000	0.000	-57370.0	-221962.8	0,258	Ok

Sollecitazioni:

Cmb	Tipo	Sism.	N	Tx	Ty	Mx	My
n.			daN	daN	daN	daN cm	daN cm
001	SLU STR	No	-57370.0	-1413.6	2218.1	1099000.0	751700.0

Elemento: 147 - Palo singolo

$N_q = 1.000$, $\sigma_{punta} = 3.197$, $\phi = 0.0$, $N_c = 9.261$, $c_{punta} = 1.500$
 Port. lat. = 346695.9 daN, Port. punta = 193259.2 daN, P.P.Palo = 39584.1 daN

Cmb.	Tipo	Palo	coord.X	coord.Y	N	N lim	Ver.N	Stato
n.		n.	cm	cm	daN	daN		
001	SLU STR	70	0.000	0.000	-53610.0	-221962.8	0,242	Ok

Sollecitazioni:

Cmb	Tipo	Sism.	N	Tx	Ty	Mx	My
n.			daN	daN	daN	daN cm	daN cm
001	SLU STR	No	-53610.0	-3086.3	2248.7	1107000.0	1512000.0

Elemento: 151 - Palo singolo

$N_q = 1.000$, $\sigma_{punta} = 3.197$, $\phi = 0.0$, $N_c = 9.261$, $c_{punta} = 1.500$
 Port. lat. = 346695.9 daN, Port. punta = 193259.2 daN, P.P.Palo = 39584.1 daN

Cmb.	Tipo	Palo	coord.X	coord.Y	N	N lim	Ver.N	Stato
n.		n.	cm	cm	daN	daN		
001	SLU STR	70	0.000	0.000	-35580.0	-221962.8	0,160	Ok

Sollecitazioni:

Cmb	Tipo	Sism.	N	Tx	Ty	Mx	My
n.			daN	daN	daN	daN cm	daN cm
001	SLU STR	No	-35580.0	-1478.8	1260.7	655400.0	782200.0

Elemento: 167 - Palo singolo

$N_q = 1.000$, $\sigma_{punta} = 3.197$, $\phi = 0.0$, $N_c = 9.261$, $c_{punta} = 1.500$
 Port. lat. = 346695.9 daN, Port. punta = 193259.2 daN, P.P.Palo = 39584.1 daN

Cmb.	Tipo	Palo	coord.X	coord.Y	N	N lim	Ver.N	Stato
n.		n.	cm	cm	daN	daN		
001	SLU STR	70	0.000	0.000	-21230.0	-221962.8	0,096	Ok

Sollecitazioni:

Cmb	Tipo	Sism.	N	Tx	Ty	Mx	My
n.			daN	daN	daN	daN cm	daN cm
001	SLU STR	No	-21230.0	-1060.8	709.9	397900.0	589700.0

Elemento: 179 - Palo singolo

$N_q = 1.000$, $\sigma_{punta} = 3.197$, $\phi = 0.0$, $N_c = 9.261$, $c_{punta} = 1.500$
 Port. lat. = 346695.9 daN, Port. punta = 193259.2 daN, P.P.Palo = 39584.1 daN

Cmb.	Tipo	Palo	coord.X	coord.Y	N	N lim	Ver.N	Stato
n.		n.	cm	cm	daN	daN		
001	SLU STR	70	0.000	0.000	-29210.0	-221962.8	0,132	Ok

Sollecitazioni:

Cmb	Tipo	Sism.	N	Tx	Ty	Mx	My
n.			daN	daN	daN	daN cm	daN cm
001	SLU STR	No	-29210.0	-1201.5	1322.5	677200.0	648300.0

Elemento: 183 - Palo singolo

$N_q = 1.000$, $\sigma_{punta} = 3.197$, $\phi = 0.0$, $N_c = 9.261$, $c_{punta} = 1.500$
 Port. lat. = 346695.9 daN, Port. punta = 193259.2 daN, P.P.Palo = 39584.1 daN

Cmb.	Tipo	Palo	coord.X	coord.Y	N	N lim	Ver.N	Stato
n.		n.	cm	cm	daN	daN		
001	SLU STR	70	0.000	0.000	-15770.0	-221962.8	0,071	Ok

Parco Eolico "Bolina" – Progetto Definitivo
Relazione di calcolo preliminare delle fondazioni degli aerogeneratori G8 e G12

Sollecitazioni:

Cmb	Tipo	Sism.	N	Tx	Ty	Mx	My
n.			daN	daN	daN	daN cm	daN cm
001	SLU STR	No	-15770.0	-617.4	768.0	420100.0	384200.0

Elemento: 199 - Palo singolo

$N_q = 1.000$, $\sigma_{punta} = 3.197$, $\phi = 0.0$, $N_c = 9.261$, $c_{punta} = 1.500$

Port. lat. = 346695.9 daN, Port. punta = 193259.2 daN, P.P.Palo = 39584.1 daN

Cmb.	Tipo	Palo	coord.X	coord.Y	N	N lim	Ver.N	Stato
n.		n.	cm	cm	daN	daN		
001	SLU STR	70	0.000	0.000	-21230.0	-221962.8	0,096	Ok

Sollecitazioni:

Cmb	Tipo	Sism.	N	Tx	Ty	Mx	My
n.			daN	daN	daN	daN cm	daN cm
001	SLU STR	No	-21230.0	-598.6	1235.2	631400.0	371300.0

Elemento: 211 - Palo singolo

$N_q = 1.000$, $\sigma_{punta} = 3.197$, $\phi = 0.0$, $N_c = 9.261$, $c_{punta} = 1.500$

Port. lat. = 346695.9 daN, Port. punta = 193259.2 daN, P.P.Palo = 39584.1 daN

Cmb.	Tipo	Palo	coord.X	coord.Y	N	N lim	Ver.N	Stato
n.		n.	cm	cm	daN	daN		
001	SLU STR	70	0.000	0.000	-53600.0	-221962.8	0,241	Ok

Sollecitazioni:

Cmb	Tipo	Sism.	N	Tx	Ty	Mx	My
n.			daN	daN	daN	daN cm	daN cm
001	SLU STR	No	-53600.0	-2181.7	3220.4	1544000.0	1091000.0

Elemento: 215 - Palo singolo

$N_q = 1.000$, $\sigma_{punta} = 3.197$, $\phi = 0.0$, $N_c = 9.261$, $c_{punta} = 1.500$

Port. lat. = 346695.9 daN, Port. punta = 193259.2 daN, P.P.Palo = 39584.1 daN

Cmb.	Tipo	Palo	coord.X	coord.Y	N	N lim	Ver.N	Stato
n.		n.	cm	cm	daN	daN		
001	SLU STR	70	0.000	0.000	-35570.0	-221962.8	0,160	Ok

Sollecitazioni:

Cmb	Tipo	Sism.	N	Tx	Ty	Mx	My
n.			daN	daN	daN	daN cm	daN cm
001	SLU STR	No	-35570.0	-1195.7	1661.7	825700.0	639900.0

Elemento: 231 - Palo singolo

$N_q = 1.000$, $\sigma_{punta} = 3.197$, $\phi = 0.0$, $N_c = 9.261$, $c_{punta} = 1.500$

Port. lat. = 346695.9 daN, Port. punta = 193259.2 daN, P.P.Palo = 39584.1 daN

Cmb.	Tipo	Palo	coord.X	coord.Y	N	N lim	Ver.N	Stato
n.		n.	cm	cm	daN	daN		
001	SLU STR	70	0.000	0.000	-57340.0	-221962.8	0,258	Ok

Sollecitazioni:

Cmb	Tipo	Sism.	N	Tx	Ty	Mx	My
n.			daN	daN	daN	daN cm	daN cm
001	SLU STR	No	-57340.0	-2200.3	1587.9	792900.0	1095000.0

Elemento: 243 - Palo singolo

$N_q = 1.000$, $\sigma_{punta} = 3.197$, $\phi = 0.0$, $N_c = 9.261$, $c_{punta} = 1.500$

Port. lat. = 346695.9 daN, Port. punta = 193259.2 daN, P.P.Palo = 39584.1 daN

Cmb.	Tipo	Palo	coord.X	coord.Y	N	N lim	Ver.N	Stato
n.		n.	cm	cm	daN	daN		
001	SLU STR	70	0.000	0.000	-99750.0	-221962.8	0,449	Ok

Sollecitazioni:

Cmb	Tipo	Sism.	N	Tx	Ty	Mx	My
n.			daN	daN	daN	daN cm	daN cm
001	SLU STR	No	-99750.0	-4131.5	2111.8	1038000.0	1977000.0

Elemento: 247 - Palo singolo

$N_q = 1.000$, $\sigma_{punta} = 3.197$, $\phi = 0.0$, $N_c = 9.261$, $c_{punta} = 1.500$

Port. lat. = 346695.9 daN, Port. punta = 193259.2 daN, P.P.Palo = 39584.1 daN

Parco Eolico "Bolina" – Progetto Definitivo
Relazione di calcolo preliminare delle fondazioni degli aerogeneratori G8 e G12

Cmb.	Tipo	Palo	coord.X	coord.Y	N	N lim	Ver.N	Stato
n.		n.	cm	cm	daN	daN		
001	SLU STR	70	0.000	0.000	-84880.0	-221962.8	0,382	Ok

Sollecitazioni:

Cmb	Tipo	Sism.	N	Tx	Ty	Mx	My
n.			daN	daN	daN	daN cm	daN cm
001	SLU STR	No	-84880.0	-3146.9	1061.3	554300.0	1524000.0

Elemento: 263 - Palo singolo

$N_q = 1.000$, $\sigma_{punta} = 3.197$, $\phi = 0.0$, $N_c = 9.261$, $c_{punta} = 1.500$

Port. lat. = 346695.9 daN, Port. punta = 193259.2 daN, P.P.Palo = 39584.1 daN

Cmb.	Tipo	Palo	coord.X	coord.Y	N	N lim	Ver.N	Stato
n.		n.	cm	cm	daN	daN		
001	SLU STR	70	0.000	0.000	-120800.0	-221962.8	0,544	Ok

Sollecitazioni:

Cmb	Tipo	Sism.	N	Tx	Ty	Mx	My
n.			daN	daN	daN	daN cm	daN cm
001	SLU STR	No	-120800.0	-3599.6	344.2	230700.0	1729000.0

Elemento: 275 - Palo singolo

$N_q = 1.000$, $\sigma_{punta} = 3.197$, $\phi = 0.0$, $N_c = 9.261$, $c_{punta} = 1.500$

Port. lat. = 346695.9 daN, Port. punta = 193259.2 daN, P.P.Palo = 39584.1 daN

Cmb.	Tipo	Palo	coord.X	coord.Y	N	N lim	Ver.N	Stato
n.		n.	cm	cm	daN	daN		
001	SLU STR	70	0.000	0.000	-158900.0	-221962.8	0,716	Ok

Sollecitazioni:

Cmb	Tipo	Sism.	N	Tx	Ty	Mx	My
n.			daN	daN	daN	daN cm	daN cm
001	SLU STR	No	-158900.0	-3950.1	390.7	257200.0	1893000.0

Elemento: 279 - Palo singolo

$N_q = 1.000$, $\sigma_{punta} = 3.197$, $\phi = 0.0$, $N_c = 9.261$, $c_{punta} = 1.500$

Port. lat. = 346695.9 daN, Port. punta = 193259.2 daN, P.P.Palo = 39584.1 daN

Cmb.	Tipo	Palo	coord.X	coord.Y	N	N lim	Ver.N	Stato
n.		n.	cm	cm	daN	daN		
001	SLU STR	70	0.000	0.000	-156000.0	-221962.8	0,703	Ok

Sollecitazioni:

Cmb	Tipo	Sism.	N	Tx	Ty	Mx	My
n.			daN	daN	daN	daN cm	daN cm
001	SLU STR	No	-156000.0	-2899.0	-388.3	-98920.0	1407000.0

Elemento: 295 - Palo singolo

$N_q = 1.000$, $\sigma_{punta} = 3.197$, $\phi = 0.0$, $N_c = 9.261$, $c_{punta} = 1.500$

Port. lat. = 346695.9 daN, Port. punta = 193259.2 daN, P.P.Palo = 39584.1 daN

Cmb.	Tipo	Palo	coord.X	coord.Y	N	N lim	Ver.N	Stato
n.		n.	cm	cm	daN	daN		
001	SLU STR	70	0.000	0.000	-180100.0	-221962.8	0,811	Ok

Sollecitazioni:

Cmb	Tipo	Sism.	N	Tx	Ty	Mx	My
n.			daN	daN	daN	daN cm	daN cm
001	SLU STR	No	-180100.0	-1443.4	-529.2	-157600.0	741800.0

Elemento: 307 - Palo singolo

$N_q = 1.000$, $\sigma_{punta} = 3.197$, $\phi = 0.0$, $N_c = 9.261$, $c_{punta} = 1.500$

Port. lat. = 346695.9 daN, Port. punta = 193259.2 daN, P.P.Palo = 39584.1 daN

Cmb.	Tipo	Palo	coord.X	coord.Y	N	N lim	Ver.N	Stato
n.		n.	cm	cm	daN	daN		
001	SLU STR	70	0.000	0.000	-184900.0	-221962.8	0,833	Ok

Sollecitazioni:

Cmb	Tipo	Sism.	N	Tx	Ty	Mx	My
n.			daN	daN	daN	daN cm	daN cm
001	SLU STR	No	-184900.0	-409.7	415.5	275500.0	274600.0

Elemento: 311 - Palo singolo

Parco Eolico "Bolina" – Progetto Definitivo
Relazione di calcolo preliminare delle fondazioni degli aerogeneratori G8 e G12

Nq = 1.000, σ_{punta} = 3.197, ϕ = 0.0, Nc = 9.261, c punta = 1.500
 Port. lat. = 346695.9 daN, Port. punta = 193259.2 daN, P.P.Palo = 39584.1 daN

Cmb.	Tipo	Palo	coord.X	coord.Y	N	N lim	Ver.N	Stato
n.		n.	cm	cm	daN	daN		
001	SLU STR	70	0.000	0.000	-188200.0	-221962.8	0,848	Ok

Sollecitazioni:

Cmb	Tipo	Sism.	N	Tx	Ty	Mx	My
n.			daN	daN	daN	daN cm	daN cm
001	SLU STR	No	-188200.0	-161.2	132.8	150200.0	157600.0

Elemento: 327 - Palo singolo

Nq = 1.000, σ_{punta} = 3.197, ϕ = 0.0, Nc = 9.261, c punta = 1.500
 Port. lat. = 346695.9 daN, Port. punta = 193259.2 daN, P.P.Palo = 39584.1 daN

Cmb.	Tipo	Palo	coord.X	coord.Y	N	N lim	Ver.N	Stato
n.		n.	cm	cm	daN	daN		
001	SLU STR	70	0.000	0.000	-180100.0	-221962.8	0,811	Ok

Sollecitazioni:

Cmb	Tipo	Sism.	N	Tx	Ty	Mx	My
n.			daN	daN	daN	daN cm	daN cm
001	SLU STR	No	-180100.0	543.0	1390.4	728600.0	-160300.0

VALORI DI CALCOLO DEI CEDIMENTI PER FONDAZIONI PROFONDE

Elemento: 84 - Palo singolo

Cmb. (Tipo)	Palo	coord.X	coord.Y	N	Ced.Vert
n.	n.	cm	cm	daN	cm
069 (SLE rare)	1	0.000	0.000	-122200.0	0.115

Sollecitazioni:

Cmb	Tipo	Sism.	N	Tx	Ty	Mx	My
n.			daN	daN	daN	daN cm	daN cm
069	SLE rare	No	-122200.0	-250.6	3034.0	1455000.0	186300.0

Elemento: 92 - Palo singolo

Cmb. (Tipo)	Palo	coord.X	coord.Y	N	Ced.Vert
n.	n.	cm	cm	daN	cm
069 (SLE rare)	1	0.000	0.000	-120100.0	0.113

Sollecitazioni:

Cmb	Tipo	Sism.	N	Tx	Ty	Mx	My
n.			daN	daN	daN	daN cm	daN cm
069	SLE rare	No	-120100.0	346.9	2183.5	1071000.0	-87040.0

Elemento: 103 - Palo singolo

Cmb. (Tipo)	Palo	coord.X	coord.Y	N	Ced.Vert
n.	n.	cm	cm	daN	cm
069 (SLE rare)	1	0.000	0.000	-92960.0	0.087

Sollecitazioni:

Cmb	Tipo	Sism.	N	Tx	Ty	Mx	My
n.			daN	daN	daN	daN cm	daN cm
069	SLE rare	No	-92960.0	-180.1	2730.7	1320000.0	157800.0

Elemento: 115 - Palo singolo

Cmb. (Tipo)	Palo	coord.X	coord.Y	N	Ced.Vert
n.	n.	cm	cm	daN	cm
069 (SLE rare)	1	0.000	0.000	-76750.0	0.072

Sollecitazioni:

Cmb	Tipo	Sism.	N	Tx	Ty	Mx	My
n.			daN	daN	daN	daN cm	daN cm
069	SLE rare	No	-76750.0	-1531.3	3185.5	1523000.0	776600.0

Elemento: 119 - Palo singolo

Cmb. (Tipo)	Palo	coord.X	coord.Y	N	Ced.Vert
n.	n.	cm	cm	daN	cm
069 (SLE rare)	1	0.000	0.000	-65330.0	0.061

Sollecitazioni:

Cmb	Tipo	Sism.	N	Tx	Ty	Mx	My
n.			daN	daN	daN	daN cm	daN cm

Parco Eolico "Bolina" – Progetto Definitivo
Relazione di calcolo preliminare delle fondazioni degli aerogeneratori G8 e G12

069 SLE rare No -65330.0 -701.2 2402.6 1168000.0 399500.0

Elemento: 135 - Palo singolo

Cmb. (Tipo)	Palo	coord.X	coord.Y	N	Ced.Vert
n.	n.	cm	cm	daN	cm
069 (SLE rare)	1	0.000	0.000	-44130.0	0.041

Sollecitazioni:

Cmb	Tipo	Sism.	N	Tx	Ty	Mx	My
n.			daN	daN	daN	daN cm	daN cm
069	SLE rare	No	-44130.0	-1087.4	1706.3	845500.0	578200.0

Elemento: 147 - Palo singolo

Cmb. (Tipo)	Palo	coord.X	coord.Y	N	Ced.Vert
n.	n.	cm	cm	daN	cm
069 (SLE rare)	1	0.000	0.000	-41240.0	0.039

Sollecitazioni:

Cmb	Tipo	Sism.	N	Tx	Ty	Mx	My
n.			daN	daN	daN	daN cm	daN cm
069	SLE rare	No	-41240.0	-2374.1	1729.8	851500.0	1163000.0

Elemento: 151 - Palo singolo

Cmb. (Tipo)	Palo	coord.X	coord.Y	N	Ced.Vert
n.	n.	cm	cm	daN	cm
069 (SLE rare)	1	0.000	0.000	-27370.0	0.026

Sollecitazioni:

Cmb	Tipo	Sism.	N	Tx	Ty	Mx	My
n.			daN	daN	daN	daN cm	daN cm
069	SLE rare	No	-27370.0	-1137.6	969.8	504100.0	601700.0

Elemento: 167 - Palo singolo

Cmb. (Tipo)	Palo	coord.X	coord.Y	N	Ced.Vert
n.	n.	cm	cm	daN	cm
069 (SLE rare)	1	0.000	0.000	-16330.0	0.015

Sollecitazioni:

Cmb	Tipo	Sism.	N	Tx	Ty	Mx	My
n.			daN	daN	daN	daN cm	daN cm
069	SLE rare	No	-16330.0	-816.0	546.1	306100.0	453600.0

Elemento: 179 - Palo singolo

Cmb. (Tipo)	Palo	coord.X	coord.Y	N	Ced.Vert
n.	n.	cm	cm	daN	cm
069 (SLE rare)	1	0.000	0.000	-22470.0	0.021

Sollecitazioni:

Cmb	Tipo	Sism.	N	Tx	Ty	Mx	My
n.			daN	daN	daN	daN cm	daN cm
069	SLE rare	No	-22470.0	-924.2	1017.3	520900.0	498700.0

Elemento: 183 - Palo singolo

Cmb. (Tipo)	Palo	coord.X	coord.Y	N	Ced.Vert
n.	n.	cm	cm	daN	cm
069 (SLE rare)	1	0.000	0.000	-12130.0	0.011

Sollecitazioni:

Cmb	Tipo	Sism.	N	Tx	Ty	Mx	My
n.			daN	daN	daN	daN cm	daN cm
069	SLE rare	No	-12130.0	-474.9	590.8	323200.0	295500.0

Elemento: 199 - Palo singolo

Cmb. (Tipo)	Palo	coord.X	coord.Y	N	Ced.Vert
n.	n.	cm	cm	daN	cm
069 (SLE rare)	1	0.000	0.000	-16330.0	0.015

Sollecitazioni:

Cmb	Tipo	Sism.	N	Tx	Ty	Mx	My
n.			daN	daN	daN	daN cm	daN cm
069	SLE rare	No	-16330.0	-460.4	950.1	485700.0	285600.0

Elemento: 211 - Palo singolo

Cmb. (Tipo)	Palo	coord.X	coord.Y	N	Ced.Vert
n.	n.	cm	cm	daN	cm
069 (SLE rare)	1	0.000	0.000	-41230.0	0.039

Parco Eolico "Bolina" – Progetto Definitivo
Relazione di calcolo preliminare delle fondazioni degli aerogeneratori G8 e G12

Sollecitazioni:

Cmb	Tipo	Sism.	N	Tx	Ty	Mx	My
n.			daN	daN	daN	daN cm	daN cm
069	SLE rare	No	-41230.0	-1678.3	2477.3	1187000.0	839200.0

Elemento: 215 - Palo singolo

Cmb. (Tipo)	Palo	coord.X	coord.Y	N	Ced.Vert
n.	n.	cm	cm	daN	cm
069 (SLE rare)	1	0.000	0.000	-27360.0	0.026

Sollecitazioni:

Cmb	Tipo	Sism.	N	Tx	Ty	Mx	My
n.			daN	daN	daN	daN cm	daN cm
069	SLE rare	No	-27360.0	-919.8	1278.2	635200.0	492200.0

Elemento: 231 - Palo singolo

Cmb. (Tipo)	Palo	coord.X	coord.Y	N	Ced.Vert
n.	n.	cm	cm	daN	cm
069 (SLE rare)	1	0.000	0.000	-44110.0	0.041

Sollecitazioni:

Cmb	Tipo	Sism.	N	Tx	Ty	Mx	My
n.			daN	daN	daN	daN cm	daN cm
069	SLE rare	No	-44110.0	-1692.5	1221.5	609900.0	842300.0

Elemento: 243 - Palo singolo

Cmb. (Tipo)	Palo	coord.X	coord.Y	N	Ced.Vert
n.	n.	cm	cm	daN	cm
069 (SLE rare)	1	0.000	0.000	-76730.0	0.072

Sollecitazioni:

Cmb	Tipo	Sism.	N	Tx	Ty	Mx	My
n.			daN	daN	daN	daN cm	daN cm
069	SLE rare	No	-76730.0	-3178.1	1624.4	798500.0	1521000.0

Elemento: 247 - Palo singolo

Cmb. (Tipo)	Palo	coord.X	coord.Y	N	Ced.Vert
n.	n.	cm	cm	daN	cm
069 (SLE rare)	1	0.000	0.000	-65290.0	0.061

Sollecitazioni:

Cmb	Tipo	Sism.	N	Tx	Ty	Mx	My
n.			daN	daN	daN	daN cm	daN cm
069	SLE rare	No	-65290.0	-2420.7	816.4	426400.0	1172000.0

Elemento: 263 - Palo singolo

Cmb. (Tipo)	Palo	coord.X	coord.Y	N	Ced.Vert
n.	n.	cm	cm	daN	cm
069 (SLE rare)	1	0.000	0.000	-92910.0	0.087

Sollecitazioni:

Cmb	Tipo	Sism.	N	Tx	Ty	Mx	My
n.			daN	daN	daN	daN cm	daN cm
069	SLE rare	No	-92910.0	-2768.9	264.8	177400.0	1330000.0

Elemento: 275 - Palo singolo

Cmb. (Tipo)	Palo	coord.X	coord.Y	N	Ced.Vert
n.	n.	cm	cm	daN	cm
069 (SLE rare)	1	0.000	0.000	-122200.0	0.115

Sollecitazioni:

Cmb	Tipo	Sism.	N	Tx	Ty	Mx	My
n.			daN	daN	daN	daN cm	daN cm
069	SLE rare	No	-122200.0	-3038.6	300.5	197800.0	1456000.0

Elemento: 279 - Palo singolo

Cmb. (Tipo)	Palo	coord.X	coord.Y	N	Ced.Vert
n.	n.	cm	cm	daN	cm
069 (SLE rare)	1	0.000	0.000	-120000.0	0.113

Sollecitazioni:

Cmb	Tipo	Sism.	N	Tx	Ty	Mx	My
n.			daN	daN	daN	daN cm	daN cm
069	SLE rare	No	-120000.0	-2230.0	-298.7	-76090.0	1082000.0

Elemento: 295 - Palo singolo

Cmb. (Tipo)	Palo	coord.X	coord.Y	N	Ced.Vert
--------------------	-------------	----------------	----------------	----------	-----------------

Parco Eolico "Bolina" – Progetto Definitivo
Relazione di calcolo preliminare delle fondazioni degli aerogeneratori G8 e G12

n.	n.	cm	cm	daN	cm		
069 (SLE rare)	1	0.000	0.000	-138500.0	0.131		
Sollecitazioni:							
Cmb	Tipo	Sism.	N	Tx	Ty	Mx	My
n.			daN	daN	daN	daN cm	daN cm
069	SLE rare	No	-138500.0	-1110.3	-407.1	-121300.0	570600.0

Elemento: 307 - Palo singolo

Cmb. (Tipo)	Palo	coord.X	coord.Y	N	Ced.Vert		
n.	n.	cm	cm	daN	cm		
069 (SLE rare)	1	0.000	0.000	-142200.0	0.135		
Sollecitazioni:							
Cmb	Tipo	Sism.	N	Tx	Ty	Mx	My
n.			daN	daN	daN	daN cm	daN cm
069	SLE rare	No	-142200.0	-315.2	319.6	211900.0	211300.0

Elemento: 311 - Palo singolo

Cmb. (Tipo)	Palo	coord.X	coord.Y	N	Ced.Vert		
n.	n.	cm	cm	daN	cm		
069 (SLE rare)	1	0.000	0.000	-144800.0	0.137		
Sollecitazioni:							
Cmb	Tipo	Sism.	N	Tx	Ty	Mx	My
n.			daN	daN	daN	daN cm	daN cm
069	SLE rare	No	-144800.0	-124.0	102.2	115500.0	121200.0

Elemento: 327 - Palo singolo

Cmb. (Tipo)	Palo	coord.X	coord.Y	N	Ced.Vert		
n.	n.	cm	cm	daN	cm		
069 (SLE rare)	1	0.000	0.000	-138600.0	0.131		
Sollecitazioni:							
Cmb	Tipo	Sism.	N	Tx	Ty	Mx	My
n.			daN	daN	daN	daN cm	daN cm
069	SLE rare	No	-138600.0	417.7	1069.6	560400.0	-123300.0

RELAZIONE GEOTECNICA E DELLE FONDAZIONI SUPERFICIALI

NORMATIVE DI RIFERIMENTO

In quanto di seguito riportato viene fatto esplicito riferimento alle seguenti Normative:

- **LEGGE n° 64 del 02/02/1974.** "Provvedimenti per le costruzioni, con particolari prescrizioni per le zone sismiche.";
- **D.M. LL.PP. del 11/03/1988.** "Norme tecniche riguardanti le indagini sui terreni e sulle rocce, la stabilità dei pendii naturali e delle scarpate, i criteri generali e le prescrizioni per la progettazione, l'esecuzione e il collaudo delle opere di sostegno delle terre e delle opere di fondazione.";
- **D.M. LL.PP. del 16/01/1996.** "Norme tecniche per le costruzioni in zone sismiche.";
- **Circolare Ministeriale LL.PP. n° 65/AA.GG. del 10/04/1997.** "Istruzioni per l'applicazione delle "Norme Tecniche per le costruzioni in zone sismiche" di cui al D.M. 16/01/1996.";
- **Eurocodice 1 - Parte 1** - "Basi di calcolo ed azioni sulle strutture - Basi di calcolo -.";
- **Eurocodice 7 - Parte 1** - "Progettazione geotecnica - Regole generali -.";
- **Eurocodice 8 - Parte 5** - "Indicazioni progettuali per la resistenza sismica delle strutture - Fondazioni, strutture di contenimento ed aspetti geotecnici -.";
- **D.M. 17/01/2018 - NUOVE NORME TECNICHE PER LE COSTRUZIONI**
- **Circolare n. 617 del 02/02/2008**

INDAGINI IN SITO E CARATTERIZZAZIONE GEOTECNICA DEI TERRENI DI FONDAZIONE

La finalità della presente relazione è quella di definire il comportamento meccanico del volume di terreno (volume significativo) influenzato direttamente o indirettamente dalla costruzione di un manufatto e che a sua volta influenza il comportamento strutturale del manufatto stesso. Di seguito si illustrano i risultati delle indagini geologiche eseguite, nonché l'interpretazione dei risultati ottenuti. Dal quadro generale in tal modo scaturito si definiscono le caratteristiche della fondazione da adottare ed il modello da utilizzare per le elaborazioni relative alla interazione sovrastruttura-fondazione e fondazione-terreno.

Nell'area in esame sono state eseguite le seguenti indagini:

- Cinque prove penetrometriche dinamiche continue con penetrometro DPM,
- Dieci stendimenti sismici a rifrazione tipo MASW.

Le risultanze dell'indagine in sito hanno evidenziato per gli aerogeneratori oggetto della presente che il terreno di fondazione per tutta l'area in studio è caratterizzato sempre da una formazione argillosa per tutto lo spessore indagato di circa 4,7 metri, profondità oltre la quale si è avuto rifiuto delle aste alla penetrazione.

Dal punto di vista della resistenza la formazione si presenta in due spessori a resistenza crescente con la profondità (ved. la stima dei parametri geotecnici delle prova). Complessivamente si hanno valori medi di resistenza considerati fino al rifiuto alla penetrazione delle aste a circa 4.70 m di profondità.

Livello argilloso	Profondità base strato	Coesione non drenata (De Beer)	Angolo di attrito (Owasaki & Iwasaki)	Peso di volume
A	3,00 m	0,31 Kg/cmq	$\phi = 22,1^\circ$	$\gamma = 1.60 \text{ gr/cc}$
B	4,70 m	1,50 Kg/cmq	$\phi = 30,5^\circ$	$\gamma = 2.02 \text{ gr/cc}$
CATEGORIA SISMICA DEI SITI		B		

Di seguito si riportano alcuni cenni teorici relativi alle modalità di calcolo implementate e la descrizione della simbologia adottata nei tabulati.

CARICO LIMITE DI FONDAZIONI SUPERFICIALI SU TERRENI

Per la determinazione del carico limite del complesso terreno-fondazione (inteso come valore asintotico del diagramma carico-cedimento) si fa riferimento a due principali meccanismi di rottura: il "meccanismo generale" e quello di "punzonamento". Il primo è caratterizzato dalla formazione di una superficie di scorrimento: il terreno sotto-

stante la fondazione rifluisce lateralmente e verso l'alto, conseguentemente il terreno circostante la fondazione è interessato da un meccanismo di sollevamento ed emersione della superficie di scorrimento. Il secondo meccanismo è caratterizzato dall'assenza di una superficie di scorrimento ben definita: il terreno sotto la fondazione si comprime ed in corrispondenza della superficie del terreno circostante la fondazione si osserva un abbassamento generalizzato. Quest'ultimo meccanismo non consente una precisa individuazione del carico limite in quanto la curva cedimenti-carico applicato non raggiunge mai un valore asintotico ma cresce indefinitamente. Vesic ha studiato il fenomeno della rottura per punzonamento assimilando il terreno ad un mezzo elasto-plastico e la rottura per carico limite all'espansione di una cavità cilindrica. In questo caso il fenomeno risulta retto da un indice di rigidezza " I_r " così definito:

$$I_r = \frac{G}{c' + \sigma' \cdot \operatorname{tg}(\varphi)}$$

Per la determinazione del modulo di rigidezza a taglio si utilizzeranno le seguenti relazioni:

$$G = \frac{E}{2 \cdot (1 + \nu)}; \quad E = E_{ed} \frac{1 - \nu - 2 \cdot \nu^2}{1 - \nu}; \quad \nu = \frac{k_0}{1 + k_0}; \quad k_0 = 1 - \operatorname{sen}(\varphi)$$

L'indice di rigidezza viene confrontato con l'indice di rigidezza critico " $I_{r,crit}$ ":

$$I_{r,crit} = \frac{e^{\left[\left(3.3 - 0.45 \frac{B}{L} \right) c \operatorname{tg} \left(45^\circ - \frac{\varphi}{2} \right) \right]}}{2}$$

La rottura per punzonamento del terreno di fondazione avviene quando l'indice di rigidezza è minore di quello critico. Tale teoria comporta l'introduzione di coefficienti correttivi all'interno della formula trinomia del carico limite detti "coefficienti di punzonamento" i quali sono funzione dell'indice di rigidezza, dell'angolo d'attrito e della geometria dell'elemento di fondazione. La loro espressione è la seguente:

- se $I_r < I_{r,crit}$ si ha :

$$\Psi_\gamma = \Psi_q = e^{\left[\left(0.6 \frac{B}{L} - 4.4 \right) \operatorname{tg}(\varphi) + \frac{3.07 \cdot \operatorname{sen}(\varphi) \log_{10}(2 I_r)}{1 + \operatorname{sen}(\varphi)} \right]} \quad \text{se } \varphi = 0 \Rightarrow \Psi_\gamma = \Psi_q = 1$$

$$\Psi_c = \Psi_q - \frac{1 - \Psi_q}{N_c \cdot \operatorname{tg}(\varphi)} \quad \text{se } \varphi = 0 \Rightarrow \Psi_c = 0.32 + 0.12 \cdot \frac{B}{L} + 0.6 \cdot \log_{10}(I_r)$$

- se $I_r > I_{r,crit}$ si ha che $\Psi_\gamma = \Psi_q = \Psi_c = 1$.

Il significato dei simboli adottati nelle equazioni sopra riportate è il seguente:

- E_{ed} modulo edometrico del terreno sottostante la fondazione
- ν coefficiente di Poisson del terreno sottostante la fondazione
- k_0 coefficiente di spinta a riposo del terreno sottostante la fondazione
- φ angolo d'attrito efficace del terreno sottostante il piano di posa
- c' coesione (espressa in termini di tensioni efficaci)
- σ' tensione litostatica effettiva a profondità $D+B/2$
- L luce delle singole travi di fondazione
- D profondità del piano di posa della fondazione a partire dal piano campagna
- B larghezza della trave di fondazione

Definito il meccanismo di rottura, il calcolo del carico limite viene eseguito modellando il terreno come un mezzo rigido perfettamente plastico con la seguente espressione:

$$q_{ult} = \gamma_1 \cdot D \cdot N_q \cdot s_q \cdot d_q \cdot i_q \cdot \Psi_q + c \cdot N_c \cdot s_c \cdot d_c \cdot i_c \cdot \Psi_c + \gamma_2 \cdot \frac{B}{2} \cdot N_\gamma \cdot s_\gamma \cdot d_\gamma \cdot i_\gamma \cdot \Psi_\gamma \cdot r_\gamma$$

Il significato dei termini presenti nella relazione trinomia sopra riportata è il seguente:

- N_q, N_c, N_γ , fattori adimensionali di portanza funzione dell'angolo d'attrito interno φ del terreno
- s_q, s_c, s_γ , coefficienti che rappresentano il fattore di forma
- d_q, d_c, d_γ , coefficienti che rappresentano il fattore dell'approfondimento
- i_q, i_c, i_γ , coefficienti che rappresentano il fattore di inclinazione del carico
- γ_1 peso per unità di volume del terreno sovrastante il piano di posa
- γ_2 peso per unità di volume del terreno sottostante il piano di posa

Per fondazioni aventi larghezza modesta si dimostra che il terzo termine non aumenta indefinitamente e per valori elevati di "B", sia secondo Vesic che secondo de Beer, il valore limite è prossimo a quello di una fondazione profonda. Bowles per fondazioni di larghezza maggiore di 2.00 metri propone il seguente fattore riduttivo:

$$r_\gamma = 1 - 0.25 \cdot \log_{10} \left(\frac{B}{2} \right) \quad \text{dove "B" va espresso in metri.}$$

Questa relazione risulta particolarmente utile per fondazioni larghe con rapporto D/B basso (platee e simili), caso nel quale il terzo termine dell'equazione trinomia è predominante.

Nel caso di carico eccentrico Meyerhof consiglia di ridurre le dimensioni della superficie di contatto (A_f) tra fondazione e terreno (B, L) in tutte le formule del calcolo del carico limite. Tale riduzione è espressa dalle seguenti relazioni:

$$B_{rid} = B - 2 \cdot e_B \quad L_{rid} = L - 2 \cdot e_L \quad \text{dove } e_B, e_L \text{ sono le eccentricità relative alle dimensioni in esame.}$$

L'equazione trinomia del carico limite può essere risolta secondo varie formulazioni, di seguito si riportano quelle che sono state implementate:

Formulazione di Hansen (1970)

$$N_q = tg^2 \left(\frac{90^\circ + \varphi}{2} \right) \cdot e^{\pi \cdot tg(\varphi)} \quad N_\gamma = 1.5 \cdot (N_q - 1) \cdot tg(\varphi) \quad N_c = (N_q - 1) \cdot ctg(\varphi)$$

- se $\varphi \neq 0$ si ha:

$$s_q = 1 + \frac{B}{L} \cdot tg(\varphi) \quad s_\gamma = 1 - 0.4 \cdot \frac{B}{L} \quad s_c = 1 + \frac{N_q \cdot B}{N_c \cdot L}$$

$$d_q = 1 + 2 \cdot tg(\varphi) \cdot (1 - \sin(\varphi))^2 \cdot \Theta \quad d_\gamma = 1.0 \quad d_c = 1 + 0.4 \cdot \Theta$$

$$\text{dove: se } \frac{D}{B} \leq 1 \Rightarrow \Theta = \frac{D}{B}, \text{ se } \frac{D}{B} > 1 \Rightarrow \Theta = \arctg \left(\frac{D}{B} \right)$$

$$i_q = \left[1 - \frac{0.5 \cdot H}{V + A_f \cdot c_a \cdot ctg(\varphi)} \right]^{\alpha_1} \quad i_\gamma = \left[1 - \frac{0.7 \cdot H}{V + A_f \cdot c_a \cdot ctg(\varphi)} \right]^{\alpha_2} \quad i_c = i_q - \frac{1 - i_q}{N_q - 1}$$

- se $\varphi = 0$ si ha:

$$s_q = 1.0 \quad s_\gamma = 1.0 \quad s_c = 1 + 0.2 \cdot \frac{B}{L}$$

$$d_q = 1.0 \quad d_\gamma = 1.0 \quad d_c = 1 + 0.4 \cdot \Theta$$

$$i_q = 1.0 \quad i_\gamma = 1.0 \quad i_c = 0.5 \cdot \left(1 + \sqrt{1 - \frac{H}{A_f \cdot c_a}} \right)$$

Formulazione di Vesic (1975)

$$N_q = tg^2 \left(\frac{90^\circ + \varphi}{2} \right) \cdot e^{\pi \cdot tg(\varphi)} \quad N_\gamma = 2 \cdot (N_q + 1) \cdot tg(\varphi) \quad N_c = (N_q - 1) \cdot ctg(\varphi)$$

- se $\varphi \neq 0$ si ha:

$$s_q = 1 + \frac{B}{L} \cdot tg(\varphi) \quad s_\gamma = 1 - 0.4 \cdot \frac{B}{L} \quad s_c = 1 + \frac{N_q \cdot B}{N_c \cdot L}$$

$$d_q = 1 + 2 \cdot tg(\varphi) \cdot (1 - \sin(\varphi))^2 \cdot \Theta \quad d_\gamma = 1.0 \quad d_c = 1 + 0.4 \cdot \Theta$$

$$\text{dove: se } \frac{D}{B} \leq 1 \Rightarrow \Theta = \frac{D}{B}, \text{ se } \frac{D}{B} > 1 \Rightarrow \Theta = \arctg \left(\frac{D}{B} \right)$$

$$i_q = \left[1 - \frac{H}{V + A_f \cdot c_a \cdot ctg(\varphi)} \right]^m \quad i_\gamma = \left[1 - \frac{H}{V + A_f \cdot c_a \cdot ctg(\varphi)} \right]^{m+1} \quad i_c = i_q - \frac{1 - i_q}{N_q - 1}$$

$$\text{dove: } m = m_B = \frac{2 + \frac{B}{L}}{1 + \frac{B}{L}} \quad m = m_L = \frac{2 + \frac{L}{B}}{1 + \frac{L}{B}}$$

- se $\varphi = 0$ si ha:

$$s_q = 1.0 \quad s_\gamma = 1.0 \quad s_c = 1 + 0.2 \cdot \frac{B}{L}$$

$$d_q = 1.0 \quad d_\gamma = 1.0 \quad d_c = 1 + 0.4 \cdot \Theta$$

$$i_q = 1.0 \quad i_\gamma = 1.0 \quad i_c = 1 - \frac{m \cdot H}{A_f \cdot c_a \cdot N_c}$$

Formulazione di Brinch-Hansen

$$N_q = tg^2 \left(\frac{90^\circ + \varphi}{2} \right) \cdot e^{\pi \cdot tg(\varphi)} \quad N_\gamma = 2 \cdot (N_q + 1) \cdot tg(\varphi) \quad N_c = (N_q - 1) \cdot ctg(\varphi)$$

- se $\varphi \neq 0$ si ha:

$$s_q = 1 + 0.1 \cdot \frac{B \cdot (1 + \text{sen}(\varphi))}{L \cdot (1 - \text{sen}(\varphi))} \quad s_\gamma = 1 + 0.1 \cdot \frac{B \cdot (1 + \text{sen}(\varphi))}{L \cdot (1 - \text{sen}(\varphi))} \quad s_c = 1 + 0.2 \cdot \frac{B \cdot (1 + \text{sen}(\varphi))}{L \cdot (1 - \text{sen}(\varphi))}$$

$$d_q = 1 + 2 \cdot tg(\varphi) \cdot (1 - \text{sen}(\varphi))^2 \cdot \Theta \quad d_\gamma = 1.0 \quad d_c = d_q - \frac{1 - d_q}{N_c \cdot tg(\varphi)}$$

dove: se $\frac{D}{B} \leq 1 \Rightarrow \Theta = \frac{D}{B}$, se $\frac{D}{B} > 1 \Rightarrow \Theta = \text{arctg} \left(\frac{D}{B} \right)$

$$i_q = \left[1 - \frac{H}{V + A_f \cdot c_a \cdot ctg(\varphi)} \right]^m \quad i_\gamma = \left[1 - \frac{H}{V + A_f \cdot c_a \cdot ctg(\varphi)} \right]^{m+1} \quad i_c = i_q - \frac{1 - i_q}{N_q - 1}$$

dove: $m = m_B = \frac{2 + \frac{B}{L}}{1 + \frac{B}{L}}$ $m = m_L = \frac{2 + \frac{L}{B}}{1 + \frac{L}{B}}$

- se $\varphi = 0$ si ha:

$$s_q = 1.0 \quad s_\gamma = 1.0 \quad s_c = 1 + 0.2 \cdot \frac{B}{L}$$

$$d_q = 1.0 \quad d_\gamma = 1.0 \quad d_c = 1 + 0.4 \cdot \Theta$$

$$i_q = 1.0 \quad i_\gamma = 1.0 \quad i_c = 1 - \frac{m \cdot H}{A_f \cdot c_a \cdot N_c}$$

Formulazione Eurocodice 7

$$N_q = tg^2 \left(\frac{90^\circ + \varphi}{2} \right) \cdot e^{\pi \cdot tg(\varphi)} \quad N_\gamma = 2 \cdot (N_q - 1) \cdot tg(\varphi) \quad N_c = (N_q - 1) \cdot ctg(\varphi)$$

- se $\varphi \neq 0$ si ha:

$$s_q = 1 + \frac{B}{L} \cdot \text{sen}(\varphi) \quad s_\gamma = 1 - 0.3 \cdot \frac{B}{L} \quad s_c = \frac{s_q \cdot (N_q - 1)}{N_q - 1}$$

$$d_q = 1 + 2 \cdot tg(\varphi) \cdot (1 - \text{sen}(\varphi))^2 \cdot \Theta \quad d_\gamma = 1.0 \quad d_c = 1 + 0.4 \cdot \Theta$$

dove: se $\frac{D}{B} \leq 1 \Rightarrow \Theta = \frac{D}{B}$, se $\frac{D}{B} > 1 \Rightarrow \Theta = \text{arctg} \left(\frac{D}{B} \right)$

- se H è parallela al lato B si ha:

$$i_q = \left[1 - \frac{0.7 \cdot H}{V + A_f \cdot c_a \cdot ctg(\varphi)} \right]^3 \quad i_\gamma = \left[1 - \frac{H}{V + A_f \cdot c_a \cdot ctg(\varphi)} \right]^3 \quad i_c = \frac{i_q \cdot N_q - 1}{N_q - 1}$$

- se H è parallela al lato L si ha:

$$i_q = 1 - \frac{H}{V + A_f \cdot c_a \cdot ctg(\varphi)} \quad i_\gamma = 1 - \frac{H}{V + A_f \cdot c_a \cdot ctg(\varphi)} \quad i_c = \frac{i_q \cdot N_q - 1}{N_q - 1}$$

- se $\varphi = 0$ si ha:

$$s_q = 1.0 \quad s_\gamma = 1.0 \quad s_c = 1 + 0.2 \cdot \frac{B}{L}$$

$$d_q = 1.0 \quad d_\gamma = 1.0 \quad d_c = 1 + 0.4 \cdot \Theta$$

$$i_q = 1.0 \quad i_\gamma = 1.0 \quad i_c = 0.5 \cdot \left(1 + \sqrt{1 - \frac{H}{A_f \cdot c_a}} \right)$$

Si ricorda che per le relazioni sopra riportate nel caso in cui $\varphi = 0 \Rightarrow N_q = 1.0, N_\gamma = 1.0$ e $N_c = 2 + \pi$.
 Il significato dei termini presenti nelle relazioni su descritte è il seguente:

- V componente verticale del carico agente sulla fondazione
- H componente orizzontale del carico agente sulla fondazione (sia lungo B che lungo L)
- c_a adesione fondazione-terreno (valore variabile tra il 60% e 100% della coesione)
- α_1, α_2 esponenti di potenza che variano tra 2 e 5

Nel caso in cui il cuneo di fondazione sia interessato da falda idrica il valore di γ_2 nella formula trinomia assume la seguente espressione:

$$\gamma_2 = \frac{\gamma \cdot z + \gamma_{sat} \cdot (h_c - z)}{h_c} \quad h_c = \frac{B}{2} \cdot \operatorname{tg} \left(\frac{90 + \varphi}{2} \right)$$

dove i termini dell'espressione hanno il seguente significato:

- γ peso per unità di volume del terreno sottostante il piano di posa
- γ_{sat} peso per unità di volume saturo del terreno sottostante il piano di posa
- z profondità della falda dal piano di posa
- h_c altezza del cuneo di rottura della fondazione

Tutto ciò che è stato detto sopra è valido nell'ipotesi di terreno con caratteristiche geotecniche omogenee. Nella realtà i terreni costituenti il piano di posa delle fondazioni sono quasi sempre composti, o comunque riconducibili, a formazioni di terreno omogenee di spessore variabile che si sovrappongono (caso di terreni stratificati). In queste condizioni i parametri vengono determinati con la seguente procedura:

- viene determinata l'altezza del cuneo di rottura in funzione delle caratteristiche geotecniche degli strati attraversati; quindi si determina il numero degli strati interessati da esso
- in corrispondenza di ogni superficie di separazione, partendo da quella immediatamente sottostante il piano di posa della fondazione, fino a raggiungere l'altezza del cuneo di rottura, viene determinata la capacità portante di ogni singolo strato come somma di due valori: il primo dato dall'applicazione della formula trinomia alla quota i -esima dello strato; il secondo dato dalla resistenza al punzonamento del terreno sovrastante lo strato in esame
- il minimo di questi due valori sarà assunto come valore massimo della capacità portante della fondazione stratificata

Si può formulare il procedimento anche in forma analitica:

$$q_{ult} = [q_{ult}'' + q_{resT}]_{\min} = \left[q_{ult}'' + \frac{p}{A_f} (P_V \cdot K_S \cdot \operatorname{tg}(\varphi) + d \cdot c) \right]_{\min}$$

dove i termini dell'espressione hanno il seguente significato:

- q_{ult}'' carico limite per un'ipotetica fondazione posta alla quota dello strato interessato
- p perimetro della fondazione
- P_V spinta verticale del terreno dal piano di posa allo strato interessato
- K_S coefficiente di spinta laterale del terreno
- d distanza dal piano di posa allo strato interessato

CARICO LIMITE DI FONDAZIONI SUPERFICIALI SU ROCCIA

Per la determinazione del carico limite nel caso di presenza di ammasso roccioso bisogna valutare molto attentamente il grado di solidità della roccia stessa. Tale valutazione viene in genere eseguita stimando l'indice RQD (Rock Quality Designation) che rappresenta una misura della qualità di un ammasso roccioso. Tale indice può variare da un minimo di 0 (caso in cui la lunghezza dei pezzi di roccia estratti dal carotiere è inferiore a 100 mm) ad un massimo di 1 (caso in cui la carota risulta integra) ed è calcolato nel seguente modo:

$$RQD = \frac{\sum \text{lunghezze dei pezzi di roccia intatta} > 100\text{mm}}{\text{lunghezza del carotiere}}$$

Se il valore di RQD è molto basso la roccia è molto fratturata ed il calcolo della capacità portante dell'ammasso

roccioso va condotto alla stregua di un terreno sciolto utilizzando tutte le formulazioni sopra descritte. Per ricavare la capacità portante di rocce non assimilabili ad ammassi di terreno sciolto sono state implementate due formulazioni: quella di Terzaghi (1943) e quella di Stagg-Zienkiewicz (1968), entrambe correlate all'indice RQD. In definitiva il valore della capacità portante sarà espresso dalla seguente relazione:

$$q'_{ult} = q''_{ult} \cdot RQD^2$$

dove i termini dell'espressione hanno il seguente significato:

- q'_{ult} carico limite dell'ammasso roccioso
- q''_{ult} carico limite calcolato alla Terzaghi o alla Stagg-Zienkiewicz

In questo caso l'equazione trinomia del carico limite assume la seguente forma:

$$q''_{ult} = \gamma_1 \cdot D \cdot N_q + c \cdot N_c \cdot s_c + \gamma_2 \cdot \frac{B}{2} \cdot N_\gamma \cdot s_\gamma$$

I termini presenti nell'equazione hanno lo stesso significato già visto in precedenza; i coefficienti di forma assumeranno i seguenti valori:

- $s_c = 1.0$ per fondazioni di tipo nastriforme $s_c = 1.3$ per fondazioni di tipo quadrato;
- $s_\gamma = 1.0$ per fondazioni di tipo nastriforme $s_\gamma = 0.8$ per fondazioni di tipo quadrato.

I fattori adimensionali di portanza a seconda della formulazione adottata saranno:

Formulazione di Terzaghi (1943)

$$N_q = \frac{e^{2 \left(0.75 \cdot \pi - \frac{\varphi}{2} \right) \cdot \text{tg}(\varphi)}}{2 \cdot \cos^2 \left(\frac{90^\circ + \varphi}{2} \right)} \quad N_\gamma = \frac{\text{tg}(\varphi)}{2} \left(\frac{K_{py}}{\cos^2(\varphi)} - 1 \right) \quad N_c = (N_q - 1) \cdot \text{ctg}(\varphi)$$

se $\varphi = 0 \Rightarrow N_c = 1.5 \cdot \pi + 1$

φ	0	5	10	15	20	25	30	35	40	45	50
K_{py}	10.8	12.2	14.7	18.6	25.0	35.0	52.0	82.0	141.0	298.0	800.0

Formulazione di Stagg-Zienkiewicz (1968)

$$N_q = \text{tg}^6 \left(\frac{90^\circ + \varphi}{2} \right) \quad N_\gamma = N_q + 1 \quad N_c = 5 \cdot \text{tg}^4 \left(\frac{90^\circ + \varphi}{2} \right)$$

VERIFICA A ROTTURA PER SCORRIMENTO DI FONDAZIONI SUPERFICIALI

Se il carico applicato alla base della fondazione non è normale alla stessa bisogna effettuare anche una verifica per rottura a scorrimento. Rispetto al collasso per scorrimento la resistenza offerta dal sistema fondale viene valutata come somma di due componenti: la prima derivante dall'attrito fondazione-terreno, la seconda derivante dall'adesione. In generale, oltre a queste due componenti, può essere tenuto in conto anche l'effetto della spinta passiva del terreno di ricoprimento esercita sulla fondazione fino ad un massimo del 30%. La formulazione analitica della verifica può essere esposta nel seguente modo:

$$T_{Sd} \leq T_{Rd} = N_{Sd} \cdot \text{tg}(\delta) + A_f \cdot c_a + S_p \cdot f_{Sp}$$

dove i termini dell'espressione hanno il seguente significato:

- T_{Sd} componente orizzontale del carico agente sulla fondazione (sia lungo B che lungo L)
- N_{Sd} componente verticale del carico agente sulla fondazione
- c_a adesione fondazione-terreno (valore variabile tra il 60% e 100% della coesione)
- δ angolo d'attrito fondazione-terreno (valore variabile tra il 60% e 100% della coesione)
- S_p spinta passiva del terreno di ricoprimento della fondazione
- f_{Sp} percentuale di partecipazione della spinta passiva
- A_f superficie di contatto del piano di posa della fondazione

La verifica deve essere effettuata sia per componenti taglianti parallele alla base della fondazione che per quelle ortogonali.

DETERMINAZIONE DELLE TENSIONI INDOTTE NEL TERRENO

Ai fini del calcolo dei cedimenti è essenziale conoscere lo stato tensionale indotto nel terreno a varie profondità da un carico applicato in superficie. Tale determinazione viene eseguita ipotizzando che il terreno si comporti come un mezzo continuo, elastico-lineare, omogeneo e isotopo. Tale assunzione, utilizzata per la determinazione della variazione delle tensioni verticali dovuta all'applicazione di un carico in superficie, è confortata dalla letteratura (Morgenstern e Phukan) perché la non linearità del materiale poco influenza la distribuzione delle tensioni verticali. Per ottenere un profilo verticale di pressioni si possono utilizzare tre metodi di calcolo: quello di Boussinesq, quello di Westergaard oppure quello di Mindlin; tutti basati sulla teoria del continuo elastico. Il metodo di Westergaard differisce da quello di Boussinesq per la presenza del coefficiente di Poisson "ν", quindi si adatta meglio ai terreni stratificati. Il metodo di Mindlin differisce dai primi due per la possibilità di posizionare il carico all'interno del continuo elastico mentre i primi due lo pongono esclusivamente sulla frontiera quindi si presta meglio al caso di fondazioni molto profonde. Nel caso di fondazioni poste sulla frontiera del continuo elastico il metodo di Mindlin risulta equivalente a quello di Boussinesq. Le espressioni analitiche dei tre metodi di calcolo sono:

$$\text{Boussinesq} \Rightarrow \Delta\sigma_v = \frac{3 \cdot Q \cdot z^3}{2 \cdot \pi \cdot (r^2 + z^2)^{\frac{5}{2}}} \quad \text{Westergaard} \Rightarrow \Delta\sigma_v = \frac{Q}{2 \cdot \pi \cdot z^2} \cdot \frac{\sqrt{\frac{1-2 \cdot \nu}{2-2 \cdot \nu}}}{\left(\frac{1-2 \cdot \nu}{2-2 \cdot \nu} + \frac{r^2}{z^2}\right)^{\frac{3}{2}}}$$

dove i termini dell'espressioni hanno il seguente significato:

- Q carico puntiforme applicato sulla frontiera del mezzo
- r proiezione orizzontale della distanza del punto di applicazione del carico dal punto in esame
- z proiezione verticale della distanza del punto di applicazione del carico dal punto in esame

$$\text{Mindlin} \Rightarrow \Delta\sigma_v = \frac{Q}{8 \cdot \pi \cdot (1-\nu) \cdot D^2} \left(\begin{array}{l} \left[-\frac{(1-2 \cdot \nu) \cdot (m-1)}{A^3} + \frac{(1-2 \cdot \nu) \cdot (m-1)}{B^3} - \frac{3 \cdot (m-1)^3}{A^5} - \frac{30 \cdot m \cdot (m+1)^3}{B^7} \right] \\ \left[-\frac{3 \cdot (3-4 \cdot \nu) \cdot m \cdot (m+1)^2 - 3 \cdot (m+1) \cdot (5 \cdot m-1)}{B^5} \right] \end{array} \right)$$

$$n = \frac{r}{D}; \quad m = \frac{z}{D}; \quad A^2 = n^2 + (m-1)^2; \quad B^2 = n^2 + (m+1)^2$$

dove i termini dell'espressioni hanno il seguente significato:

- Q carico puntiforme applicato sulla frontiera o all'interno del mezzo
- D proiezione verticale della distanza del punto di applicazione del carico dalla frontiera del mezzo
- r proiezione orizzontale della distanza del punto di applicazione del carico dal punto in esame
- z proiezione verticale della distanza del punto di applicazione del carico dal punto in esame

Basandosi sulle ben note equazioni ricavate per un carico puntiforme, l'algoritmo implementato esegue un'integrazione delle equazioni di cui sopra lungo la verticale di ogni punto notevole degli elementi fondali estesa a tutte le aree di carico presenti sulla superficie del terreno; questo consente di determinare la variazione dello stato tensionale verticale "Δσ_v". Bisogna sottolineare che, nel caso di pressione, "Q" va definito come "pressione netta", ossia la pressione in eccesso rispetto a quella geostatica esistente che può essere sopportata con sicurezza alla profondità "D" del piano di posa delle fondazioni. Questo perché i cedimenti sono causati solo da incrementi netti di pressione che si aggiungono all'esistente pressione geostatica.

CALCOLO DEI CEDIMENTI DELLA FONDAZIONE

La determinazione dei cedimenti delle fondazioni assume una rilevanza notevole per il manufatto da realizzarsi, in special modo nella fase di esercizio. Nell'evolversi della fase di cedimento il terreno passa da uno stato di sforzo corrente dovuto al peso proprio ad uno nuovo dovuto all'effetto del carico addizionale applicato. Questa variazione dello stato tensionale produce una serie di movimenti di rotolamento e scorrimento relativo tra i granuli del terreno, nonché deformazioni elastiche e rotture delle particelle costituenti il mezzo localizzate in una limitata zona d'influenza a ridosso dell'area di carico. L'insieme di questi fenomeni costituisce il cedimento che nel caso in esame è verticale. Nonostante la frazione elastica sia modesta, l'esperienza ha dimostrato che ai fini del calcolo dei

cedimenti modellare il terreno come materiale pseudoelastico permette di ottenere risultati soddisfacenti. In letteratura sono descritti diversi metodi per il calcolo dei cedimenti ma si ricorda che, qualunque sia il metodo di calcolo, la determinazione del valore del cedimento deve intendersi come la miglior stima delle deformazioni subite dal terreno da attendersi all'applicazione dei carichi. Nel seguito vengono descritte le teorie implementate:

Metodo edometrico, che si basa sulla nota relazione:

$$w_{ed} = \sum_{i=1}^n \frac{\Delta\sigma_{v,i}}{E_{ed,i}} \cdot \Delta z_i$$

dove i termini dell'espressioni hanno il seguente significato:

- $\Delta\sigma_{v,i}$ variazione dello stato tensionale verticale alla profondità "z_i" dello strato i-esimo per l'applicazione del carico
- $E_{ed,i}$ modulo edometrico del terreno relativo allo strato i-esimo
- Δz_i spessore dello strato i-esimo

Si ricorda che questo metodo si basa sull'ipotesi edometrica quindi l'accuratezza del risultato è maggiore quando il rapporto tra lo spessore dello strato deformabile e la dimensione in pianta delle fondazioni è ridotto, tuttavia il metodo edometrico consente una buona approssimazione anche nel caso di strati deformabili di spessore notevole.

Metodo dell'elasticità, che si basa sulle note relazioni:

$$w_{Imp.} = \sum_{i=1}^n \frac{\Delta\sigma_{v,i}}{E_i} \cdot \Delta z_i \qquad w_{Lib.} = \sum_{i=1}^n \frac{\Delta\sigma_{v,i}}{E_i} \cdot \frac{1-2 \cdot \nu^2}{1-\nu} \cdot \Delta z_i$$

dove i termini dell'espressioni hanno il seguente significato:

- $w_{Imp.}$ cedimento in condizioni di deformazione laterale impedita
- $w_{Lib.}$ cedimento in condizioni di deformazione laterale libera
- $\Delta\sigma_{v,i}$ variazione stato tensionale verticale alla profondità "z_i" dello strato i-esimo per l'applicazione del carico
- E_i modulo elastico del terreno relativo allo strato i-esimo
- Δz_i spessore dello strato i-esimo

La doppia formulazione adottata consente di ottenere un intervallo di valori del cedimento elastico per la fondazione in esame (valore minimo per $w_{Imp.}$ e valore massimo per $w_{Lib.}$).

SIMBOLOGIA ADOTTATA NEI TABULATI DI CALCOLO

Per maggior chiarezza nella lettura dei tabulati di calcolo viene riportata la descrizione dei simboli principali utilizzati nella stesura degli stessi. Per comodità di lettura la legenda è suddivisa in paragrafi con la stessa modalità in cui sono stampati i tabulati di calcolo.

Dati geometrici degli elementi costituenti le fondazioni superficiali

per tipologie travi e plinti superficiali:

- Indice Strat. indice della stratigrafia associata all'elemento
- Prof. Fon. profondità del piano di posa dell'elemento a partire dal piano campagna
- Base larghezza della sezione trasversale dell'elemento
- Altezza altezza della sezione trasversale dell'elemento
- Lung. Elem. dimensione dello sviluppo longitudinale dell'elemento
- Lung. Travata nel caso l'elemento appartenga ad un macroelemento, rappresenta la dimensione dello sviluppo longitudinale del macroelemento

per tipologia platea:

- Indice Strat. indice della stratigrafia associata all'elemento
- Prof. Fon. profondità del piano di posa dell'elemento dal piano campagna
- Dia. Eq. diametro del cerchio equivalente alla superficie dell'elemento
- Spessore spessore dell'elemento
- Superficie superficie dell'elemento
- Vert. Elem. Numero dei vertici che costituiscono l'elemento
- Macro nel caso l'elemento appartenga ad un macroelemento, rappresenta il numero del macroelemento

Nel caso si avesse scelto di determinare la portanza anche per gli elementi platea è presente un'ulteriore riga nella quale sono riportate le caratteristiche geometriche del plinto equivalente alla macro/platea in esame.

Dati di carico degli elementi costituenti le fondazioni superficiali

per tipologie travi e plinti superficiali:

- Cmb numero della combinazione di carico
- Tipologia tipologia della combinazione di carico
- Sismica flag per l'applicazione della riduzione sismica alle caratteristiche meccaniche del terreno di fondazione per la combinazione di carico in esame
- Ecc. B eccentricità del carico normale agente sul piano di fondazione in direzione parallela alla sezione trasversale dell'elemento
- Ecc. L eccentricità del carico normale agente sul piano di fondazione in direzione parallela allo sviluppo longitudinale dell'elemento
- S.Taglio B sforzo di taglio agente sul piano di fondazione in direzione parallela alla sezione trasversale dell'elemento
- S.Taglio L sforzo di taglio agente sul piano di fondazione in direzione parallela allo sviluppo longitudinale dell'elemento
- S.Normale carico normale agente sul piano di fondazione
- T.T.min minimo valore della distribuzione tensionale di contatto tra terreno ed elemento fondale
- T.T.max massimo valore della distribuzione tensionale di contatto tra terreno ed elemento fondale

per tipologia platea:

- Cmb numero della combinazione di carico
- Tipologia tipologia della combinazione di carico
- Sismica flag per l'applicazione della riduzione sismica alle caratteristiche meccaniche del terreno di fondazione per la combinazione di carico in esame
- Press. N1 tensione di contatto tra terreno e fondazione nel vertice n° 1 dell'elemento
- Press. N2 tensione di contatto tra terreno e fondazione nel vertice n° 2 dell'elemento
- Press. N3 tensione di contatto tra terreno e fondazione nel vertice n° 3 dell'elemento
- Press. N4 tensione di contatto tra terreno e fondazione nel vertice n° 4 dell'elemento
- S.Taglio X sforzo di taglio agente sul piano di fondazione in direzione parallela all'asse X del riferimento globale
- S.Taglio Y sforzo di taglio agente sul piano di fondazione in direzione parallela all'asse Y del riferimento globale

Nel caso si avesse scelto di determinare la portanza anche per gli elementi platea è presente un'ulteriore riga nella quale sono riportate le macroazioni (integrale delle azioni applicate sui singoli elementi che compongono la platea) agenti sul plinto equivalente alla macro/platea in esame.

Valori di calcolo della portanza per fondazioni superficiali

- Cmb numero della combinazione di carico
- Qlim capacità portante totale data dalla somma di Qlim q, Qlim g, Qlim c e di Qres P (nel caso in cui si operi alle tensioni ammissibili corrisponde alla portanza ammissibile)
- Qlim q termine relativo al sovraccarico della formula trinomia per il calcolo della capacità portante (nel caso in cui si operi alle tensioni ammissibili corrisponde alla relativa parte della portanza ammissibile)
- Qlim g termine relativo alla larghezza della base di fondazione della formula trinomia per il calcolo della capacità portante (nel caso in cui si operi alle tensioni ammissibili corrisponde alla relativa parte della portanza ammissibile)
- Qlim c termine relativo alla coesione della formula trinomia per il calcolo della capacità portante (nel caso in cui si operi alle tensioni ammissibili corrisponde alla relativa parte della portanza ammissibile)
- Qres P termine relativo alla resistenza al punzonamento del terreno sovrastante lo strato di rottura. Diverso da zero solo nel caso di terreni stratificati dove lo strato di rottura è diverso dal primo (nel caso in cui si operi alle tensioni ammissibili corrisponde alla relativa parte della portanza ammissibile)
- Qmax / Qlim rapporto tra il massimo valore della distribuzione tensionale di contatto tra terreno ed elemento fondale ed il valore della capacità portante (verifica positiva se il rapporto è < 1.0).
- TBlim valore limite della resistenza a scorrimento in direzione parallela alla sezione trasversale dell'elemento

- TB / TBlim rapporto tra lo sforzo di taglio agente ed il valore limite della resistenza a scorrimento in direzione parallela alla sezione trasversale dell'elemento (verifica positiva se il rapporto è < 1.0)
- TLLim valore limite della resistenza a scorrimento in direzione parallela allo sviluppo longitudinale dell'elemento
- TL / TLlim rapporto tra lo sforzo di taglio agente ed il valore limite della resistenza a scorrimento in direzione parallela allo sviluppo longitudinale dell'elemento (verifica positiva se il rapporto è < 1.0)
- Sgm. Lt. tensione litostatica agente alla quota del piano di posa dell'elemento fondale

Nel caso si avesse scelto di determinare la portanza anche per gli elementi platea è presente un'ulteriore riga nella quale sono riportate le verifiche di portanza del plinto equivalente alla macro/platea in esame.

Valori di calcolo dei cedimenti per fondazioni superficiali

- Cmb numero della combinazione di carico e tipologia
- Nodo vertice dell'elemento in cui viene calcolato il cedimento
- Car. Netto valore del carico netto applicato sulla superficie del terreno
- Cedimento/i valore del cedimento (nel caso di calcolo di cedimenti elastici i valori riportati sono due, il primo corrisponde al cedimento $w_{Imp.}$, mentre il secondo al cedimento $w_{Lib.}$)

PARAMETRI DI CALCOLO

Metodi di calcolo della portanza per fondazioni superficiali:

- Per terreni sciolti: Vesic
- Per terreni lapidei: Terzaghi

Fattori utilizzati per il calcolo della portanza per fondazioni superficiali :

- Riduzione dimensioni per eccentricità: si
- Fattori di forma della fondazione: si
- Fattori di profondità del piano di posa: si
- Fattori di inclinazione del carico: si
- Fattori di punzonamento (Vesic): si
- Fattore riduzione effetto piastra (Bowles): si
- Fattore di riduzione dimensione Base equivalente platea: 20,0 %
- Fattore di riduzione dimensione Lunghezza equivalente platea: 20,0 %

Coefficienti parziali di sicurezza per Tensioni Ammissibili, SLE nel calcolo della portanza per fondazioni superficiali:

- Coeff. parziale di sicurezza F_c (statico): 2,50
- Coeff. parziale di sicurezza F_q (statico): 2,50
- Coeff. parziale di sicurezza F_g (statico): 2,50
- Coeff. parziale di sicurezza F_c (sismico): 3,00
- Coeff. parziale di sicurezza F_q (sismico): 3,00
- Coeff. parziale di sicurezza F_g (sismico): 3,00

Combinazioni di carico:

APPROCCIO PROGETTUALE TIPO 2 - Comb. (A1+M1+R3)

Coefficienti parziali di sicurezza per SLU nel calcolo della portanza per fondazioni superficiali :

I coeff. A1 risultano combinati secondo lo schema presente nella relazione di calcolo della struttura.

- Coeff. M1 per $\tan \phi$ (statico): 1
- Coeff. M1 per c' (statico): 1
- Coeff. M1 per C_u (statico): 1
- Coeff. M1 per $\tan \phi$ (sismico): 1
- Coeff. M1 per c' (sismico): 1
- Coeff. M1 per C_u (sismico): 1

- Coeff. R3 capacità portante (statico e sismico): 2,30
- Coeff. R3 scorrimento (statico e sismico): 1,10

Parametri per la verifica a scorrimento delle fondazioni superficiali:

Parco Eolico "Bolina" – Progetto Definitivo
Relazione di calcolo preliminare delle fondazioni degli aerogeneratori G8 e G12

- Fattore per l'adesione ($6 < Ca < 10$): 8
- Fattore per attrito terreno-fondazione ($5 < Delta < 10$): 7
- Frazione di spinta passiva fSp: 50,00 %
- Coeff. resistenza sulle sup. laterali: 1,30

Metodi e parametri per il calcolo dei cedimenti delle fondazioni superficiali:

- Metodo di calcolo tensioni superficiali: Boussinesq
- Modalità d'interferenza dei bulbi tensionali: sovrapposizione dei bulbi
- Metodo di calcolo dei cedimenti del terreno: cedimenti edometrici

ARCHIVIO STRATIGRAFIE

Indice / Descrizione: 004 / Stratigr. G8-G12

Numero strati: 2

Profondità falda: assente

Strato n.	Quota di riferimento	Spessore	Indice / Descrizione terreno	Attrito Neg.
1	da 0,0 a -300,0 cm	300,0 cm	007 / Argilla media Strato 1	Assente
2	da -300,0 a -4300,0 cm	4000,0 cm	008 / Argilla marnosa Strato 2	Assente

ARCHIVIO TERRENI

Indice / Descrizione terreno: **007 / Argilla media Strato 1**

Comportamento del terreno: condizione non drenata

Peso Spec.	P. Spec. Sat.	Coes.non dren.	Mod.Elast.	Mod.Edom.	Dens.Rel.	Poisson	C. Ades.
daN/cm ²	daN/cm ²	daN/cm ²	daN/cm ²	daN/cm ²	%	%	
1,600 E-3	1,800 E-3	0,310	150,000	150,000	60,0	0,500	0,69

Indice / Descrizione terreno: **008 / Argilla marnosa Strato 2**

Comportamento del terreno: condizione non drenata

Peso Spec.	P. Spec. Sat.	Coes.non dren.	Mod.Elast.	Mod.Edom.	Dens.Rel.	Poisson	C. Ades.
daN/cm ²	daN/cm ²	daN/cm ²	daN/cm ²	daN/cm ²	%	%	
2,020 E-3	2,220 E-3	1,500	250,000	250,000	60,0	0,500	0,45

DATI GEOMETRICI DEGLI ELEMENTI COSTITUENTI LE FONDAZIONI SUPERFICIALI

Elemento n.	Tipologia	Id.Strat.	Prof. Fon. cm	Dia. Eq. cm	Spessore cm	Superficie cm ²	Vertici n. per elem.	Macro n.
Platea n. 1	Platea	004	245.000	81.102	250.000	5166.016	4	1
Platea n. 2	Platea	004	245.000	81.102	250.000	5166.016	4	1
Platea n. 3	Platea	004	245.000	81.102	250.000	5166.016	4	1
Platea n. 4	Platea	004	245.000	81.102	250.000	5166.016	4	1
Platea n. 5	Platea	004	245.000	81.102	250.000	5166.016	4	1
Platea n. 6	Platea	004	245.000	81.102	250.000	5166.016	4	1
Platea n. 7	Platea	004	245.000	81.102	250.000	5166.016	4	1
Platea n. 8	Platea	004	245.000	81.102	250.000	5166.016	4	1
Platea n. 9	Platea	004	245.000	81.102	250.000	5166.016	4	1
Platea n. 10	Platea	004	245.000	81.102	250.000	5166.016	4	1
Platea n. 11	Platea	004	245.000	81.102	250.000	5166.016	4	1
Platea n. 12	Platea	004	245.000	81.102	250.000	5166.016	4	1
Platea n. 13	Platea	004	245.000	81.102	250.000	5166.016	4	1
Platea n. 14	Platea	004	245.000	81.102	250.000	5166.016	4	1
Platea n. 15	Platea	004	245.000	81.102	250.000	5166.016	4	1
Platea n. 16	Platea	004	245.000	81.102	250.000	5166.016	4	1
Platea n. 17	Platea	004	245.000	81.102	250.000	5166.016	4	1
Platea n. 18	Platea	004	245.000	81.102	250.000	5166.016	4	1
Platea n. 19	Platea	004	245.000	81.102	250.000	5166.016	4	1
Platea n. 20	Platea	004	245.000	81.102	250.000	5166.016	4	1
Platea n. 21	Platea	004	245.000	81.102	250.000	5166.016	4	1
Platea n. 22	Platea	004	245.000	81.102	250.000	5166.016	4	1
Platea n. 23	Platea	004	245.000	81.102	250.000	5166.016	4	1
Platea n. 24	Platea	004	245.000	81.102	250.000	5166.016	4	1
Platea n. 25	Platea	004	245.000	81.102	250.000	5166.016	4	1
Platea n. 26	Platea	004	245.000	81.102	250.000	5166.016	4	1
Platea n. 27	Platea	004	245.000	81.102	250.000	5166.016	4	1
Platea n. 28	Platea	004	245.000	81.102	250.000	5166.016	4	1
Platea n. 29	Platea	004	245.000	81.102	250.000	5166.016	4	1
Platea n. 30	Platea	004	245.000	81.102	250.000	5166.016	4	1
Platea n. 31	Platea	004	245.000	81.102	250.000	5166.016	4	1
Platea n. 32	Platea	004	245.000	81.102	250.000	5166.016	4	1

Parco Eolico "Bolina" – Progetto Definitivo
Relazione di calcolo preliminare delle fondazioni degli aerogeneratori G8 e G12

Platea n. 33	Platea	004	245.000	81.102	250.000	5166.016	4	1
Platea n. 34	Platea	004	245.000	81.102	250.000	5166.016	4	1
Platea n. 35	Platea	004	245.000	81.102	250.000	5166.016	4	1
Platea n. 36	Platea	004	245.000	81.102	250.000	5166.016	4	1
Platea n. 37	Platea	004	245.000	81.102	250.000	5166.016	4	1
Platea n. 38	Platea	004	245.000	81.102	250.000	5166.016	4	1
Platea n. 39	Platea	004	245.000	81.102	250.000	5166.016	4	1
Platea n. 40	Platea	004	245.000	81.102	250.000	5166.016	4	1
Platea n. 41	Platea	004	245.000	81.102	250.000	5166.016	4	1
Platea n. 42	Platea	004	245.000	81.102	250.000	5166.016	4	1
Platea n. 43	Platea	004	245.000	81.102	250.000	5166.016	4	1
Platea n. 44	Platea	004	245.000	81.102	250.000	5166.016	4	1
Platea n. 45	Platea	004	245.000	81.102	250.000	5166.016	4	1
Platea n. 46	Platea	004	245.000	81.102	250.000	5166.016	4	1
Platea n. 47	Platea	004	245.000	81.102	250.000	5166.016	4	1
Platea n. 48	Platea	004	245.000	81.102	250.000	5166.016	4	1
Platea n. 49	Platea	004	245.000	81.102	250.000	5166.016	4	1
Platea n. 50	Platea	004	245.000	81.102	250.000	5166.016	4	1
Platea n. 51	Platea	004	245.000	81.102	250.000	5166.016	4	1
Platea n. 52	Platea	004	245.000	81.102	250.000	5166.016	4	1
Platea n. 53	Platea	004	245.000	81.102	250.000	5166.016	4	1
Platea n. 54	Platea	004	245.000	81.102	250.000	5166.016	4	1
Platea n. 55	Platea	004	245.000	81.102	250.000	5166.016	4	1
Platea n. 56	Platea	004	245.000	81.102	250.000	5166.016	4	1
Platea n. 57	Platea	004	245.000	81.102	250.000	5166.016	4	1
Platea n. 58	Platea	004	245.000	81.102	250.000	5166.016	4	1
Platea n. 59	Platea	004	245.000	81.102	250.000	5166.016	4	1
Platea n. 60	Platea	004	245.000	81.102	250.000	5166.016	4	1
Platea n. 61	Platea	004	245.000	81.102	250.000	5166.016	4	1
Platea n. 62	Platea	004	245.000	81.102	250.000	5166.016	4	1
Platea n. 63	Platea	004	245.000	81.102	250.000	5166.016	4	1
Platea n. 64	Platea	004	245.000	81.102	250.000	5166.016	4	1
Platea n. 65	Platea	004	245.000	105.110	250.000	8677.205	4	1
Platea n. 66	Platea	004	245.000	116.895	250.000	10732.100	4	1
Platea n. 67	Platea	004	245.000	127.597	250.000	12786.990	4	1
Platea n. 68	Platea	004	245.000	137.467	250.000	14841.880	4	1
Platea n. 69	Platea	004	245.000	146.675	250.000	16896.770	4	1
Platea n. 70	Platea	004	245.000	155.338	250.000	18951.660	4	1
Platea n. 71	Platea	004	245.000	163.543	250.000	21006.550	4	1
Platea n. 72	Platea	004	245.000	171.356	250.000	23061.450	4	1
Platea n. 73	Platea	004	245.000	102.670	250.000	8278.992	4	1
Platea n. 74	Platea	004	245.000	114.651	250.000	10323.940	4	1
Platea n. 75	Platea	004	245.000	125.493	250.000	12368.880	4	1
Platea n. 76	Platea	004	245.000	135.471	250.000	14413.820	4	1
Platea n. 77	Platea	004	245.000	144.762	250.000	16458.760	4	1
Platea n. 78	Platea	004	245.000	153.492	250.000	18503.710	4	1
Platea n. 79	Platea	004	245.000	161.751	250.000	20548.660	4	1
Platea n. 80	Platea	004	245.000	169.609	250.000	22593.590	4	1
Platea n. 81	Platea	004	245.000	97.719	250.000	7499.757	4	1
Platea n. 82	Platea	004	245.000	110.148	250.000	9528.968	4	1
Platea n. 83	Platea	004	245.000	121.311	250.000	11558.180	4	1
Platea n. 84	Platea	004	245.000	131.529	250.000	13587.380	4	1
Platea n. 85	Platea	004	245.000	141.009	250.000	15616.590	4	1
Platea n. 86	Platea	004	245.000	149.891	250.000	17645.800	4	1
Platea n. 87	Platea	004	245.000	158.275	250.000	19675.020	4	1
Platea n. 88	Platea	004	245.000	166.237	250.000	21704.210	4	1
Platea n. 89	Platea	004	245.000	90.081	250.000	6373.153	4	1
Platea n. 90	Platea	004	245.000	103.349	250.000	8388.857	4	1
Platea n. 91	Platea	004	245.000	115.098	250.000	10404.560	4	1
Platea n. 92	Platea	004	245.000	125.754	250.000	12420.270	4	1
Platea n. 93	Platea	004	245.000	135.574	250.000	14435.960	4	1
Platea n. 94	Platea	004	245.000	144.731	250.000	16451.670	4	1
Platea n. 95	Platea	004	245.000	153.341	250.000	18467.380	4	1
Platea n. 96	Platea	004	245.000	161.493	250.000	20483.070	4	1
Platea n. 97	Platea	004	245.000	90.081	250.000	6373.153	4	1
Platea n. 98	Platea	004	245.000	103.349	250.000	8388.857	4	1
Platea n. 99	Platea	004	245.000	115.098	250.000	10404.560	4	1
Platea n. 100	Platea	004	245.000	125.754	250.000	12420.270	4	1
Platea n. 101	Platea	004	245.000	135.574	250.000	14435.960	4	1
Platea n. 102	Platea	004	245.000	144.731	250.000	16451.670	4	1
Platea n. 103	Platea	004	245.000	153.341	250.000	18467.380	4	1
Platea n. 104	Platea	004	245.000	161.493	250.000	20483.070	4	1
Platea n. 105	Platea	004	245.000	97.719	250.000	7499.757	4	1

Parco Eolico "Bolina" – Progetto Definitivo
Relazione di calcolo preliminare delle fondazioni degli aerogeneratori G8 e G12

Platea n. 106	Platea	004	245.000	110.148	250.000	9528.968	4	1
Platea n. 107	Platea	004	245.000	121.311	250.000	11558.180	4	1
Platea n. 108	Platea	004	245.000	131.529	250.000	13587.380	4	1
Platea n. 109	Platea	004	245.000	141.009	250.000	15616.590	4	1
Platea n. 110	Platea	004	245.000	149.891	250.000	17645.800	4	1
Platea n. 111	Platea	004	245.000	158.275	250.000	19675.020	4	1
Platea n. 112	Platea	004	245.000	166.237	250.000	21704.210	4	1
Platea n. 113	Platea	004	245.000	102.670	250.000	8278.992	4	1
Platea n. 114	Platea	004	245.000	114.651	250.000	10323.940	4	1
Platea n. 115	Platea	004	245.000	125.493	250.000	12368.880	4	1
Platea n. 116	Platea	004	245.000	135.471	250.000	14413.820	4	1
Platea n. 117	Platea	004	245.000	144.762	250.000	16458.760	4	1
Platea n. 118	Platea	004	245.000	153.492	250.000	18503.710	4	1
Platea n. 119	Platea	004	245.000	161.751	250.000	20548.660	4	1
Platea n. 120	Platea	004	245.000	169.609	250.000	22593.590	4	1
Platea n. 121	Platea	004	245.000	105.110	250.000	8677.205	4	1
Platea n. 122	Platea	004	245.000	116.895	250.000	10732.100	4	1
Platea n. 123	Platea	004	245.000	127.597	250.000	12786.990	4	1
Platea n. 124	Platea	004	245.000	137.467	250.000	14841.880	4	1
Platea n. 125	Platea	004	245.000	146.675	250.000	16896.770	4	1
Platea n. 126	Platea	004	245.000	155.338	250.000	18951.660	4	1
Platea n. 127	Platea	004	245.000	163.543	250.000	21006.550	4	1
Platea n. 128	Platea	004	245.000	171.356	250.000	23061.450	4	1
Platea n. 129	Platea	004	245.000	105.110	250.000	8677.205	4	1
Platea n. 130	Platea	004	245.000	116.895	250.000	10732.100	4	1
Platea n. 131	Platea	004	245.000	127.597	250.000	12786.990	4	1
Platea n. 132	Platea	004	245.000	137.467	250.000	14841.880	4	1
Platea n. 133	Platea	004	245.000	146.675	250.000	16896.770	4	1
Platea n. 134	Platea	004	245.000	155.338	250.000	18951.660	4	1
Platea n. 135	Platea	004	245.000	163.543	250.000	21006.550	4	1
Platea n. 136	Platea	004	245.000	171.356	250.000	23061.450	4	1
Platea n. 137	Platea	004	245.000	102.670	250.000	8278.992	4	1
Platea n. 138	Platea	004	245.000	114.651	250.000	10323.940	4	1
Platea n. 139	Platea	004	245.000	125.493	250.000	12368.880	4	1
Platea n. 140	Platea	004	245.000	135.471	250.000	14413.820	4	1
Platea n. 141	Platea	004	245.000	144.762	250.000	16458.760	4	1
Platea n. 142	Platea	004	245.000	153.492	250.000	18503.710	4	1
Platea n. 143	Platea	004	245.000	161.751	250.000	20548.660	4	1
Platea n. 144	Platea	004	245.000	169.609	250.000	22593.590	4	1
Platea n. 145	Platea	004	245.000	97.719	250.000	7499.757	4	1
Platea n. 146	Platea	004	245.000	110.148	250.000	9528.968	4	1
Platea n. 147	Platea	004	245.000	121.311	250.000	11558.180	4	1
Platea n. 148	Platea	004	245.000	131.529	250.000	13587.380	4	1
Platea n. 149	Platea	004	245.000	141.009	250.000	15616.590	4	1
Platea n. 150	Platea	004	245.000	149.891	250.000	17645.800	4	1
Platea n. 151	Platea	004	245.000	158.275	250.000	19675.020	4	1
Platea n. 152	Platea	004	245.000	166.237	250.000	21704.210	4	1
Platea n. 153	Platea	004	245.000	90.081	250.000	6373.153	4	1
Platea n. 154	Platea	004	245.000	103.349	250.000	8388.857	4	1
Platea n. 155	Platea	004	245.000	115.098	250.000	10404.560	4	1
Platea n. 156	Platea	004	245.000	125.754	250.000	12420.270	4	1
Platea n. 157	Platea	004	245.000	135.574	250.000	14435.960	4	1
Platea n. 158	Platea	004	245.000	144.731	250.000	16451.670	4	1
Platea n. 159	Platea	004	245.000	153.341	250.000	18467.380	4	1
Platea n. 160	Platea	004	245.000	161.493	250.000	20483.070	4	1
Platea n. 161	Platea	004	245.000	90.081	250.000	6373.153	4	1
Platea n. 162	Platea	004	245.000	103.349	250.000	8388.857	4	1
Platea n. 163	Platea	004	245.000	115.098	250.000	10404.560	4	1
Platea n. 164	Platea	004	245.000	125.754	250.000	12420.270	4	1
Platea n. 165	Platea	004	245.000	135.574	250.000	14435.960	4	1
Platea n. 166	Platea	004	245.000	144.731	250.000	16451.670	4	1
Platea n. 167	Platea	004	245.000	153.341	250.000	18467.380	4	1
Platea n. 168	Platea	004	245.000	161.493	250.000	20483.070	4	1
Platea n. 169	Platea	004	245.000	97.719	250.000	7499.757	4	1
Platea n. 170	Platea	004	245.000	110.148	250.000	9528.968	4	1
Platea n. 171	Platea	004	245.000	121.311	250.000	11558.180	4	1
Platea n. 172	Platea	004	245.000	131.529	250.000	13587.380	4	1
Platea n. 173	Platea	004	245.000	141.009	250.000	15616.590	4	1
Platea n. 174	Platea	004	245.000	149.891	250.000	17645.800	4	1
Platea n. 175	Platea	004	245.000	158.275	250.000	19675.020	4	1
Platea n. 176	Platea	004	245.000	166.237	250.000	21704.210	4	1
Platea n. 177	Platea	004	245.000	102.670	250.000	8278.992	4	1
Platea n. 178	Platea	004	245.000	114.651	250.000	10323.940	4	1

Parco Eolico "Bolina" – Progetto Definitivo
Relazione di calcolo preliminare delle fondazioni degli aerogeneratori G8 e G12

Platea n. 179	Platea	004	245.000	125.493	250.000	12368.880	4	1
Platea n. 180	Platea	004	245.000	135.471	250.000	14413.820	4	1
Platea n. 181	Platea	004	245.000	144.762	250.000	16458.760	4	1
Platea n. 182	Platea	004	245.000	153.492	250.000	18503.710	4	1
Platea n. 183	Platea	004	245.000	161.751	250.000	20548.660	4	1
Platea n. 184	Platea	004	245.000	169.609	250.000	22593.590	4	1
Platea n. 185	Platea	004	245.000	105.110	250.000	8677.205	4	1
Platea n. 186	Platea	004	245.000	116.895	250.000	10732.100	4	1
Platea n. 187	Platea	004	245.000	127.597	250.000	12786.990	4	1
Platea n. 188	Platea	004	245.000	137.467	250.000	14841.880	4	1
Platea n. 189	Platea	004	245.000	146.675	250.000	16896.770	4	1
Platea n. 190	Platea	004	245.000	155.338	250.000	18951.660	4	1
Platea n. 191	Platea	004	245.000	163.543	250.000	21006.550	4	1
Platea n. 192	Platea	004	245.000	171.356	250.000	23061.450	4	1
Platea n. 193	Platea	004	245.000	105.110	250.000	8677.205	4	1
Platea n. 194	Platea	004	245.000	116.895	250.000	10732.100	4	1
Platea n. 195	Platea	004	245.000	127.597	250.000	12786.990	4	1
Platea n. 196	Platea	004	245.000	137.467	250.000	14841.880	4	1
Platea n. 197	Platea	004	245.000	146.675	250.000	16896.770	4	1
Platea n. 198	Platea	004	245.000	155.338	250.000	18951.660	4	1
Platea n. 199	Platea	004	245.000	163.543	250.000	21006.550	4	1
Platea n. 200	Platea	004	245.000	171.356	250.000	23061.450	4	1
Platea n. 201	Platea	004	245.000	102.670	250.000	8278.992	4	1
Platea n. 202	Platea	004	245.000	114.651	250.000	10323.940	4	1
Platea n. 203	Platea	004	245.000	125.493	250.000	12368.880	4	1
Platea n. 204	Platea	004	245.000	135.471	250.000	14413.820	4	1
Platea n. 205	Platea	004	245.000	144.762	250.000	16458.760	4	1
Platea n. 206	Platea	004	245.000	153.492	250.000	18503.710	4	1
Platea n. 207	Platea	004	245.000	161.751	250.000	20548.660	4	1
Platea n. 208	Platea	004	245.000	169.609	250.000	22593.590	4	1
Platea n. 209	Platea	004	245.000	97.719	250.000	7499.757	4	1
Platea n. 210	Platea	004	245.000	110.148	250.000	9528.968	4	1
Platea n. 211	Platea	004	245.000	121.311	250.000	11558.180	4	1
Platea n. 212	Platea	004	245.000	131.529	250.000	13587.380	4	1
Platea n. 213	Platea	004	245.000	141.009	250.000	15616.590	4	1
Platea n. 214	Platea	004	245.000	149.891	250.000	17645.800	4	1
Platea n. 215	Platea	004	245.000	158.275	250.000	19675.020	4	1
Platea n. 216	Platea	004	245.000	166.237	250.000	21704.210	4	1
Platea n. 217	Platea	004	245.000	90.081	250.000	6373.153	4	1
Platea n. 218	Platea	004	245.000	103.349	250.000	8388.857	4	1
Platea n. 219	Platea	004	245.000	115.098	250.000	10404.560	4	1
Platea n. 220	Platea	004	245.000	125.754	250.000	12420.270	4	1
Platea n. 221	Platea	004	245.000	135.574	250.000	14435.960	4	1
Platea n. 222	Platea	004	245.000	144.731	250.000	16451.670	4	1
Platea n. 223	Platea	004	245.000	153.341	250.000	18467.380	4	1
Platea n. 224	Platea	004	245.000	161.493	250.000	20483.070	4	1
Platea n. 225	Platea	004	245.000	90.081	250.000	6373.153	4	1
Platea n. 226	Platea	004	245.000	103.349	250.000	8388.857	4	1
Platea n. 227	Platea	004	245.000	115.098	250.000	10404.560	4	1
Platea n. 228	Platea	004	245.000	125.754	250.000	12420.270	4	1
Platea n. 229	Platea	004	245.000	135.574	250.000	14435.960	4	1
Platea n. 230	Platea	004	245.000	144.731	250.000	16451.670	4	1
Platea n. 231	Platea	004	245.000	153.341	250.000	18467.380	4	1
Platea n. 232	Platea	004	245.000	161.493	250.000	20483.070	4	1
Platea n. 233	Platea	004	245.000	97.719	250.000	7499.757	4	1
Platea n. 234	Platea	004	245.000	110.148	250.000	9528.968	4	1
Platea n. 235	Platea	004	245.000	121.311	250.000	11558.180	4	1
Platea n. 236	Platea	004	245.000	131.529	250.000	13587.380	4	1
Platea n. 237	Platea	004	245.000	141.009	250.000	15616.590	4	1
Platea n. 238	Platea	004	245.000	149.891	250.000	17645.800	4	1
Platea n. 239	Platea	004	245.000	158.275	250.000	19675.020	4	1
Platea n. 240	Platea	004	245.000	166.237	250.000	21704.210	4	1
Platea n. 241	Platea	004	245.000	102.670	250.000	8278.992	4	1
Platea n. 242	Platea	004	245.000	114.651	250.000	10323.940	4	1
Platea n. 243	Platea	004	245.000	125.493	250.000	12368.880	4	1
Platea n. 244	Platea	004	245.000	135.471	250.000	14413.820	4	1
Platea n. 245	Platea	004	245.000	144.762	250.000	16458.760	4	1
Platea n. 246	Platea	004	245.000	153.492	250.000	18503.710	4	1
Platea n. 247	Platea	004	245.000	161.751	250.000	20548.660	4	1
Platea n. 248	Platea	004	245.000	169.609	250.000	22593.590	4	1
Platea n. 249	Platea	004	245.000	105.110	250.000	8677.205	4	1
Platea n. 250	Platea	004	245.000	116.895	250.000	10732.100	4	1
Platea n. 251	Platea	004	245.000	127.597	250.000	12786.990	4	1

Parco Eolico "Bolina" – Progetto Definitivo
Relazione di calcolo preliminare delle fondazioni degli aerogeneratori G8 e G12

Platea n. 252	Platea	004	245.000	137.467	250.000	14841.880	4	1
Platea n. 253	Platea	004	245.000	146.675	250.000	16896.770	4	1
Platea n. 254	Platea	004	245.000	155.338	250.000	18951.660	4	1
Platea n. 255	Platea	004	245.000	163.543	250.000	21006.550	4	1
Platea n. 256	Platea	004	245.000	171.356	250.000	23061.450	4	1
Platea n. 257	Platea	004	245.000	105.110	250.000	8677.205	4	1
Platea n. 258	Platea	004	245.000	116.895	250.000	10732.100	4	1
Platea n. 259	Platea	004	245.000	127.597	250.000	12786.990	4	1
Platea n. 260	Platea	004	245.000	137.467	250.000	14841.880	4	1
Platea n. 261	Platea	004	245.000	146.675	250.000	16896.770	4	1
Platea n. 262	Platea	004	245.000	155.338	250.000	18951.660	4	1
Platea n. 263	Platea	004	245.000	163.543	250.000	21006.550	4	1
Platea n. 264	Platea	004	245.000	171.356	250.000	23061.450	4	1
Platea n. 265	Platea	004	245.000	102.670	250.000	8278.992	4	1
Platea n. 266	Platea	004	245.000	114.651	250.000	10323.940	4	1
Platea n. 267	Platea	004	245.000	125.493	250.000	12368.880	4	1
Platea n. 268	Platea	004	245.000	135.471	250.000	14413.820	4	1
Platea n. 269	Platea	004	245.000	144.762	250.000	16458.760	4	1
Platea n. 270	Platea	004	245.000	153.492	250.000	18503.710	4	1
Platea n. 271	Platea	004	245.000	161.751	250.000	20548.660	4	1
Platea n. 272	Platea	004	245.000	169.609	250.000	22593.590	4	1
Platea n. 273	Platea	004	245.000	97.719	250.000	7499.757	4	1
Platea n. 274	Platea	004	245.000	110.148	250.000	9528.968	4	1
Platea n. 275	Platea	004	245.000	121.311	250.000	11558.180	4	1
Platea n. 276	Platea	004	245.000	131.529	250.000	13587.380	4	1
Platea n. 277	Platea	004	245.000	141.009	250.000	15616.590	4	1
Platea n. 278	Platea	004	245.000	149.891	250.000	17645.800	4	1
Platea n. 279	Platea	004	245.000	158.275	250.000	19675.020	4	1
Platea n. 280	Platea	004	245.000	166.237	250.000	21704.210	4	1
Platea n. 281	Platea	004	245.000	90.081	250.000	6373.153	4	1
Platea n. 282	Platea	004	245.000	103.349	250.000	8388.857	4	1
Platea n. 283	Platea	004	245.000	115.098	250.000	10404.560	4	1
Platea n. 284	Platea	004	245.000	125.754	250.000	12420.270	4	1
Platea n. 285	Platea	004	245.000	135.574	250.000	14435.960	4	1
Platea n. 286	Platea	004	245.000	144.731	250.000	16451.670	4	1
Platea n. 287	Platea	004	245.000	153.341	250.000	18467.380	4	1
Platea n. 288	Platea	004	245.000	161.493	250.000	20483.070	4	1
Platea n. 289	Platea	004	245.000	90.081	250.000	6373.153	4	1
Platea n. 290	Platea	004	245.000	103.349	250.000	8388.857	4	1
Platea n. 291	Platea	004	245.000	115.098	250.000	10404.560	4	1
Platea n. 292	Platea	004	245.000	125.754	250.000	12420.270	4	1
Platea n. 293	Platea	004	245.000	135.574	250.000	14435.960	4	1
Platea n. 294	Platea	004	245.000	144.731	250.000	16451.670	4	1
Platea n. 295	Platea	004	245.000	153.341	250.000	18467.380	4	1
Platea n. 296	Platea	004	245.000	161.493	250.000	20483.070	4	1
Platea n. 297	Platea	004	245.000	97.719	250.000	7499.757	4	1
Platea n. 298	Platea	004	245.000	110.148	250.000	9528.968	4	1
Platea n. 299	Platea	004	245.000	121.311	250.000	11558.180	4	1
Platea n. 300	Platea	004	245.000	131.529	250.000	13587.380	4	1
Platea n. 301	Platea	004	245.000	141.009	250.000	15616.590	4	1
Platea n. 302	Platea	004	245.000	149.891	250.000	17645.800	4	1
Platea n. 303	Platea	004	245.000	158.275	250.000	19675.020	4	1
Platea n. 304	Platea	004	245.000	166.237	250.000	21704.210	4	1
Platea n. 305	Platea	004	245.000	102.670	250.000	8278.992	4	1
Platea n. 306	Platea	004	245.000	114.651	250.000	10323.940	4	1
Platea n. 307	Platea	004	245.000	125.493	250.000	12368.880	4	1
Platea n. 308	Platea	004	245.000	135.471	250.000	14413.820	4	1
Platea n. 309	Platea	004	245.000	144.762	250.000	16458.760	4	1
Platea n. 310	Platea	004	245.000	153.492	250.000	18503.710	4	1
Platea n. 311	Platea	004	245.000	161.751	250.000	20548.660	4	1
Platea n. 312	Platea	004	245.000	169.609	250.000	22593.590	4	1
Platea n. 313	Platea	004	245.000	105.110	250.000	8677.205	4	1
Platea n. 314	Platea	004	245.000	116.895	250.000	10732.100	4	1
Platea n. 315	Platea	004	245.000	127.597	250.000	12786.990	4	1
Platea n. 316	Platea	004	245.000	137.467	250.000	14841.880	4	1
Platea n. 317	Platea	004	245.000	146.675	250.000	16896.770	4	1
Platea n. 318	Platea	004	245.000	155.338	250.000	18951.660	4	1
Platea n. 319	Platea	004	245.000	163.543	250.000	21006.550	4	1
Platea n. 320	Platea	004	245.000	171.356	250.000	23061.450	4	1
Elemento n.	Tipologia	Id.Strat.	Prof. Fon.	Base Eq.	Spessore	Lung. Eq.	Lung. Travata Eq.	
Macro n. 1	Macro-Platea	004	245.000	1625.420	250.000	1625.420	1625.420	

VALORI DI CALCOLO DELLA PORTANZA PER FONDAZIONI SUPERFICIALI

I coeff. A1 risultano combinati secondo lo schema presente nella relazione di calcolo della struttura. Le azioni trasmesse in fondazione, relative alle combinazioni di tipo sismico, non saranno amplificate in quanto determinate ipotizzando un comportamento non dissipativo.

La verifica nei confronti dello Stato Limite di Danno viene eseguita determinando il carico limite della fondazione per le corrispondenti azioni di SLD, impiegando i coefficienti parziali gammaR di cui alla tabella 7.11.II.

N.B. La relazione è redatta in forma sintetica. Verranno riportati solo i casi maggiormente gravosi per ogni tipo di combinazione e le relative verifiche.

Macro platea: 1

Risultati più gravosi per cmb. di tipo **SLU STR**:

Sgm. Lt (tens. litostatica) = -0.3920 daN/cm²

Qlim = Qlim c + Qlim q + Qlim g + Qres P = 0.8582 + 0.1704 + 0.0000 + 0.0000

Qmax / Qlim = 1.0105 / 1.0287 = 0,982 Ok (Cmb. n. 001)

TB / TBlim = 44633.6 / 689161.8 = 0,065 Ok (Cmb. n. 001)

TL / TLlim = 30434.8 / 689161.8 = 0,044 Ok (Cmb. n. 001)

Sollecitazioni:

Cmb n.	Tipo	Sism.	Ecc. B cm	Ecc. L cm	S. Taglio B daN	S. Taglio L daN	S. Normale daN	T.T. min daN/cm ²	T.T. max daN/cm ²
001	SLU STR	No	120.375	-101.281	44633.6	-30434.8	-1290778.0	-0.0572	-1.0105

Risultati più gravosi per cmb. di tipo **SLV A1 sism.**:

Sgm. Lt (tens. litostatica) = -0.3920 daN/cm²

Qlim = Qlim c + Qlim q + Qlim g + Qres P = 0.7986 + 0.1704 + 0.0000 + 0.0000

Qmax / Qlim = 0.7801 / 0.9691 = 0,805 Ok (Cmb. n. 007)

TB / TBlim = 156765.8 / 629607.7 = 0,249 Ok (Cmb. n. 007)

TL / TLlim = 145549.5 / 630663.9 = 0,231 Ok (Cmb. n. 021)

Sollecitazioni:

Cmb n.	Tipo	Sism.	Ecc. B cm	Ecc. L cm	S. Taglio B daN	S. Taglio L daN	S. Normale daN	T.T. min daN/cm ²	T.T. max daN/cm ²
007	SLV A1	Si	124.484	-101.903	156765.8	-49382.7	-991744.8	-0.0395	-0.7801
021	SLV A1	Si	119.234	-105.594	9109.3	-145549.5	-992280.6	-0.0416	-0.7848

Risultati più gravosi per cmb. di tipo **SLD sism.**:

Sgm. Lt (tens. litostatica) = -0.3920 daN/cm²

Qlim = Qlim c + Qlim q + Qlim g + Qres P = 0.8418 + 0.1704 + 0.0000 + 0.0000

Qmax / Qlim = 0.7767 / 1.0122 = 0,767 Ok (Cmb. n. 039)

TB / TBlim = 75761.6 / 631607.3 = 0,120 Ok (Cmb. n. 039)

TL / TLlim = 64740.0 / 631965.6 = 0,102 Ok (Cmb. n. 053)

Sollecitazioni:

Cmb n.	Tipo	Sism.	Ecc. B cm	Ecc. L cm	S. Taglio B daN	S. Taglio L daN	S. Normale daN	T.T. min daN/cm ²	T.T. max daN/cm ²
039	SLD	Si	121.764	-101.491	75761.6	-32199.5	-992513.8	-0.0425	-0.7767
053	SLD	Si	119.989	-102.740	25798.3	-64740.0	-992694.9	-0.0432	-0.7799

VALORI DI CALCOLO DEI CEDIMENTI PER FONDAZIONI SUPERFICIALI

Elemento: Platea n. 1

Sollecitazioni:

Cmb n.	Tipo	Sism.	Ecc. B cm	Ecc. L cm	S. Taglio B daN	S. Taglio L daN	S. Normale daN	T.T. min daN/cm ²	T.T. max daN/cm ²
069	SLE rare	No	120.375	-101.281	34333.5	-23411.4	-992906.8	-0.0440	-0.7773

Cedimento massimo = -0.109 cm in Cmb n. 069

Cedimento minimo = -0.003 cm in Cmb n. 069

VERIFICHE PALI DI FONDAZIONE

MATERIALI

Acciaio: B450C

E = 2060000 daN/cm², F_{yk} = 4500 daN/cm², f_{sd} = 3913 daN/cm²

Calcestruzzo pali: C25/30

R_{ck} = 300 daN/cm², E = 314470 daN/cm², f_{cd} = 141,1 daN/cm², f_{ctm} = 25,6 daN/cm², f_{ctd} = 11,9 daN/cm²

Sollecitazioni alla base del pilastro

Cmb.	Plin.	Tipo	Vx (daN)	Vy (daN)	N (daN)	Mx (daN cm)	My (daN cm)	T (daN cm)
1	151	SLU STR.	-1478,8	1260,7	-35580,0	655400,0	782200,0	0,0
2	151	SLU STR.	-1137,6	969,8	-27370,0	504100,0	601700,0	0,0
5	151	SLU A1 sism.	-2146,6	582,5	-27190,0	413100,0	837600,0	0,0
6	151	SLU A1 sism.	-2231,6	1329,1	-27560,0	587900,0	858000,0	0,0
7	151	SLU A1 sism.	-43,5	610,5	-27190,0	420300,0	345400,0	0,0
8	151	SLU A1 sism.	-128,5	1357,1	-27550,0	595200,0	365800,0	0,0
9	151	SLU A1 sism.	-2146,6	582,5	-27190,0	413100,0	837600,0	0,0
10	151	SLU A1 sism.	-2231,6	1329,1	-27560,0	587900,0	858000,0	0,0
11	151	SLU A1 sism.	-43,5	610,5	-27190,0	420300,0	345400,0	0,0
12	151	SLU A1 sism.	-128,5	1357,1	-27550,0	595200,0	365800,0	0,0
13	151	SLU A1 sism.	-2146,6	582,5	-27190,0	413100,0	837600,0	0,0
14	151	SLU A1 sism.	-2231,6	1329,1	-27560,0	587900,0	858000,0	0,0
15	151	SLU A1 sism.	-43,5	610,5	-27190,0	420300,0	345400,0	0,0
16	151	SLU A1 sism.	-128,5	1357,1	-27550,0	595200,0	365800,0	0,0
17	151	SLU A1 sism.	-2146,6	582,5	-27190,0	413100,0	837600,0	0,0
18	151	SLU A1 sism.	-2231,6	1329,1	-27560,0	587900,0	858000,0	0,0
19	151	SLU A1 sism.	-43,5	610,5	-27190,0	420300,0	345400,0	0,0
20	151	SLU A1 sism.	-128,5	1357,1	-27550,0	595200,0	365800,0	0,0
21	151	SLU A1 sism.	-1311,4	-278,7	-26760,0	211700,0	641500,0	0,0
22	151	SLU A1 sism.	-1594,6	2209,9	-27980,0	794400,0	709500,0	0,0
23	151	SLU A1 sism.	-680,5	-270,3	-26760,0	213800,0	493900,0	0,0
24	151	SLU A1 sism.	-963,7	2218,3	-27980,0	796600,0	561900,0	0,0
25	151	SLU A1 sism.	-1311,4	-278,7	-26760,0	211700,0	641500,0	0,0
26	151	SLU A1 sism.	-1594,6	2209,9	-27980,0	794400,0	709500,0	0,0
27	151	SLU A1 sism.	-680,5	-270,3	-26760,0	213800,0	493900,0	0,0
28	151	SLU A1 sism.	-963,7	2218,3	-27980,0	796600,0	561900,0	0,0
29	151	SLU A1 sism.	-1311,4	-278,7	-26760,0	211700,0	641500,0	0,0
30	151	SLU A1 sism.	-1594,6	2209,9	-27980,0	794400,0	709500,0	0,0
31	151	SLU A1 sism.	-680,5	-270,3	-26760,0	213800,0	493900,0	0,0
32	151	SLU A1 sism.	-963,7	2218,3	-27980,0	796600,0	561900,0	0,0
33	151	SLU A1 sism.	-1311,4	-278,7	-26760,0	211700,0	641500,0	0,0
34	151	SLU A1 sism.	-1594,6	2209,9	-27980,0	794400,0	709500,0	0,0
35	151	SLU A1 sism.	-680,5	-270,3	-26760,0	213800,0	493900,0	0,0
36	151	SLU A1 sism.	-963,7	2218,3	-27980,0	796600,0	561900,0	0,0
69	151	SLE Rare	-1137,6	969,8	-27370,0	504100,0	601700,0	0,0
1	103	SLU STR.	-234,1	3549,9	-120800,0	1716000,0	205200,0	0,0
2	103	SLU STR.	-180,1	2730,7	-92960,0	1320000,0	157800,0	0,0
5	103	SLU A1 sism.	-1349,6	2140,9	-92260,0	1180000,0	430700,0	0,0
6	103	SLU A1 sism.	-1369,0	2960,0	-92390,0	1372000,0	435400,0	0,0
7	103	SLU A1 sism.	1008,8	2501,4	-93530,0	1268000,0	-119800,0	0,0
8	103	SLU A1 sism.	989,4	3320,5	-93660,0	1460000,0	-115000,0	0,0
9	103	SLU A1 sism.	-1349,6	2140,9	-92260,0	1180000,0	430700,0	0,0
10	103	SLU A1 sism.	-1369,0	2960,0	-92390,0	1372000,0	435400,0	0,0
11	103	SLU A1 sism.	1008,8	2501,4	-93530,0	1268000,0	-119800,0	0,0
12	103	SLU A1 sism.	989,4	3320,5	-93660,0	1460000,0	-115000,0	0,0
13	103	SLU A1 sism.	-1349,6	2140,9	-92260,0	1180000,0	430700,0	0,0
14	103	SLU A1 sism.	-1369,0	2960,0	-92390,0	1372000,0	435400,0	0,0
15	103	SLU A1 sism.	1008,8	2501,4	-93530,0	1268000,0	-119800,0	0,0
16	103	SLU A1 sism.	989,4	3320,5	-93660,0	1460000,0	-115000,0	0,0
17	103	SLU A1 sism.	-1349,6	2140,9	-92260,0	1180000,0	430700,0	0,0
18	103	SLU A1 sism.	-1369,0	2960,0	-92390,0	1372000,0	435400,0	0,0
19	103	SLU A1 sism.	1008,8	2501,4	-93530,0	1268000,0	-119800,0	0,0
20	103	SLU A1 sism.	989,4	3320,5	-93660,0	1460000,0	-115000,0	0,0

Parco Eolico "Bolina" – Progetto Definitivo
Relazione di calcolo preliminare delle fondazioni degli aerogeneratori G8 e G12

21	103	SLU A1 sism.	-501,5	1311,4	-92550,0	986700,0	232500,0	0,0
22	103	SLU A1 sism.	-566,2	4041,8	-92980,0	1627000,0	248300,0	0,0
23	103	SLU A1 sism.	206,0	1419,6	-92930,0	1013000,0	67320,0	0,0
24	103	SLU A1 sism.	141,3	4149,9	-93360,0	1654000,0	83180,0	0,0
25	103	SLU A1 sism.	-501,5	1311,4	-92550,0	986700,0	232500,0	0,0
26	103	SLU A1 sism.	-566,2	4041,8	-92980,0	1627000,0	248300,0	0,0
27	103	SLU A1 sism.	206,0	1419,6	-92930,0	1013000,0	67320,0	0,0
28	103	SLU A1 sism.	141,3	4149,9	-93360,0	1654000,0	83180,0	0,0
29	103	SLU A1 sism.	-501,5	1311,4	-92550,0	986700,0	232500,0	0,0
30	103	SLU A1 sism.	-566,2	4041,8	-92980,0	1627000,0	248300,0	0,0
31	103	SLU A1 sism.	206,0	1419,6	-92930,0	1013000,0	67320,0	0,0
32	103	SLU A1 sism.	141,3	4149,9	-93360,0	1654000,0	83180,0	0,0
33	103	SLU A1 sism.	-501,5	1311,4	-92550,0	986700,0	232500,0	0,0
34	103	SLU A1 sism.	-566,2	4041,8	-92980,0	1627000,0	248300,0	0,0
35	103	SLU A1 sism.	206,0	1419,6	-92930,0	1013000,0	67320,0	0,0
36	103	SLU A1 sism.	141,3	4149,9	-93360,0	1654000,0	83180,0	0,0
69	103	SLE Rare	-180,1	2730,7	-92960,0	1320000,0	157800,0	0,0
1	115	SLU STR.	-1990,6	4141,1	-99770,0	1979000,0	1010000,0	0,0
2	115	SLU STR.	-1531,3	3185,5	-76750,0	1523000,0	776600,0	0,0
5	115	SLU A1 sism.	-2701,7	2685,7	-76370,0	1404000,0	1051000,0	0,0
6	115	SLU A1 sism.	-2725,5	3480,3	-76520,0	1590000,0	1056000,0	0,0
7	115	SLU A1 sism.	-337,0	2890,7	-76970,0	1455000,0	497000,0	0,0
8	115	SLU A1 sism.	-360,8	3685,3	-77130,0	1641000,0	502500,0	0,0
9	115	SLU A1 sism.	-2701,7	2685,7	-76370,0	1404000,0	1051000,0	0,0
10	115	SLU A1 sism.	-2725,5	3480,3	-76520,0	1590000,0	1056000,0	0,0
11	115	SLU A1 sism.	-337,0	2890,7	-76970,0	1455000,0	497000,0	0,0
12	115	SLU A1 sism.	-360,8	3685,3	-77130,0	1641000,0	502500,0	0,0
13	115	SLU A1 sism.	-2701,7	2685,7	-76370,0	1404000,0	1051000,0	0,0
14	115	SLU A1 sism.	-2725,5	3480,3	-76520,0	1590000,0	1056000,0	0,0
15	115	SLU A1 sism.	-337,0	2890,7	-76970,0	1455000,0	497000,0	0,0
16	115	SLU A1 sism.	-360,8	3685,3	-77130,0	1641000,0	502500,0	0,0
17	115	SLU A1 sism.	-2701,7	2685,7	-76370,0	1404000,0	1051000,0	0,0
18	115	SLU A1 sism.	-2725,5	3480,3	-76520,0	1590000,0	1056000,0	0,0
19	115	SLU A1 sism.	-337,0	2890,7	-76970,0	1455000,0	497000,0	0,0
20	115	SLU A1 sism.	-360,8	3685,3	-77130,0	1641000,0	502500,0	0,0
21	115	SLU A1 sism.	-1846,2	1830,4	-76400,0	1204000,0	850500,0	0,0
22	115	SLU A1 sism.	-1925,7	4479,1	-76920,0	1826000,0	868800,0	0,0
23	115	SLU A1 sism.	-1136,8	1891,9	-76580,0	1219000,0	684400,0	0,0
24	115	SLU A1 sism.	-1216,3	4540,6	-77100,0	1841000,0	702700,0	0,0
25	115	SLU A1 sism.	-1846,2	1830,4	-76400,0	1204000,0	850500,0	0,0
26	115	SLU A1 sism.	-1925,7	4479,1	-76920,0	1826000,0	868800,0	0,0
27	115	SLU A1 sism.	-1136,8	1891,9	-76580,0	1219000,0	684400,0	0,0
28	115	SLU A1 sism.	-1216,3	4540,6	-77100,0	1841000,0	702700,0	0,0
29	115	SLU A1 sism.	-1846,2	1830,4	-76400,0	1204000,0	850500,0	0,0
30	115	SLU A1 sism.	-1925,7	4479,1	-76920,0	1826000,0	868800,0	0,0
31	115	SLU A1 sism.	-1136,8	1891,9	-76580,0	1219000,0	684400,0	0,0
32	115	SLU A1 sism.	-1216,3	4540,6	-77100,0	1841000,0	702700,0	0,0
33	115	SLU A1 sism.	-1846,2	1830,4	-76400,0	1204000,0	850500,0	0,0
34	115	SLU A1 sism.	-1925,7	4479,1	-76920,0	1826000,0	868800,0	0,0
35	115	SLU A1 sism.	-1136,8	1891,9	-76580,0	1219000,0	684400,0	0,0
36	115	SLU A1 sism.	-1216,3	4540,6	-77100,0	1841000,0	702700,0	0,0
69	115	SLE Rare	-1531,3	3185,5	-76750,0	1523000,0	776600,0	0,0
1	119	SLU STR.	-911,6	3123,3	-84930,0	1518000,0	519300,0	0,0
2	119	SLU STR.	-701,2	2402,6	-65330,0	1168000,0	399500,0	0,0
5	119	SLU A1 sism.	-1784,6	1850,3	-64740,0	1037000,0	652200,0	0,0
6	119	SLU A1 sism.	-1832,7	2653,9	-65000,0	1226000,0	663800,0	0,0
7	119	SLU A1 sism.	430,3	2151,2	-65670,0	1110000,0	135200,0	0,0
8	119	SLU A1 sism.	382,2	2954,8	-65930,0	1299000,0	146800,0	0,0
9	119	SLU A1 sism.	-1784,6	1850,3	-64740,0	1037000,0	652200,0	0,0
10	119	SLU A1 sism.	-1832,7	2653,9	-65000,0	1226000,0	663800,0	0,0
11	119	SLU A1 sism.	430,3	2151,2	-65670,0	1110000,0	135200,0	0,0
12	119	SLU A1 sism.	382,2	2954,8	-65930,0	1299000,0	146800,0	0,0
13	119	SLU A1 sism.	-1784,6	1850,3	-64740,0	1037000,0	652200,0	0,0
14	119	SLU A1 sism.	-1832,7	2653,9	-65000,0	1226000,0	663800,0	0,0
15	119	SLU A1 sism.	430,3	2151,2	-65670,0	1110000,0	135200,0	0,0

Parco Eolico "Bolina" – Progetto Definitivo
Relazione di calcolo preliminare delle fondazioni degli aerogeneratori G8 e G12

16	119	SLU A1 sism.	382,2	2954,8	-65930,0	1299000,0	146800,0	0,0
17	119	SLU A1 sism.	-1784,6	1850,3	-64740,0	1037000,0	652200,0	0,0
18	119	SLU A1 sism.	-1832,7	2653,9	-65000,0	1226000,0	663800,0	0,0
19	119	SLU A1 sism.	430,3	2151,2	-65670,0	1110000,0	135200,0	0,0
20	119	SLU A1 sism.	382,2	2954,8	-65930,0	1299000,0	146800,0	0,0
21	119	SLU A1 sism.	-953,3	1018,1	-64750,0	843000,0	457600,0	0,0
22	119	SLU A1 sism.	-1113,7	3696,8	-65640,0	1471000,0	496500,0	0,0
23	119	SLU A1 sism.	-288,8	1108,4	-65030,0	864900,0	302500,0	0,0
24	119	SLU A1 sism.	-449,2	3787,1	-65910,0	1493000,0	341400,0	0,0
25	119	SLU A1 sism.	-953,3	1018,1	-64750,0	843000,0	457600,0	0,0
26	119	SLU A1 sism.	-1113,7	3696,8	-65640,0	1471000,0	496500,0	0,0
27	119	SLU A1 sism.	-288,8	1108,4	-65030,0	864900,0	302500,0	0,0
28	119	SLU A1 sism.	-449,2	3787,1	-65910,0	1493000,0	341400,0	0,0
29	119	SLU A1 sism.	-953,3	1018,1	-64750,0	843000,0	457600,0	0,0
30	119	SLU A1 sism.	-1113,7	3696,8	-65640,0	1471000,0	496500,0	0,0
31	119	SLU A1 sism.	-288,8	1108,4	-65030,0	864900,0	302500,0	0,0
32	119	SLU A1 sism.	-449,2	3787,1	-65910,0	1493000,0	341400,0	0,0
33	119	SLU A1 sism.	-953,3	1018,1	-64750,0	843000,0	457600,0	0,0
34	119	SLU A1 sism.	-1113,7	3696,8	-65640,0	1471000,0	496500,0	0,0
35	119	SLU A1 sism.	-288,8	1108,4	-65030,0	864900,0	302500,0	0,0
36	119	SLU A1 sism.	-449,2	3787,1	-65910,0	1493000,0	341400,0	0,0
69	119	SLE Rare	-701,2	2402,6	-65330,0	1168000,0	399500,0	0,0
1	135	SLU STR.	-1413,6	2218,1	-57370,0	1099000,0	751700,0	0,0
2	135	SLU STR.	-1087,4	1706,3	-44130,0	845500,0	578200,0	0,0
5	135	SLU A1 sism.	-2119,2	1226,0	-43720,0	732200,0	819200,0	0,0
6	135	SLU A1 sism.	-2189,3	2006,4	-44060,0	915100,0	836200,0	0,0
7	135	SLU A1 sism.	14,6	1406,1	-44190,0	775900,0	320300,0	0,0
8	135	SLU A1 sism.	-55,6	2186,5	-44540,0	958700,0	337300,0	0,0
9	135	SLU A1 sism.	-2119,2	1226,0	-43720,0	732200,0	819200,0	0,0
10	135	SLU A1 sism.	-2189,3	2006,4	-44060,0	915100,0	836200,0	0,0
11	135	SLU A1 sism.	14,6	1406,1	-44190,0	775900,0	320300,0	0,0
12	135	SLU A1 sism.	-55,6	2186,5	-44540,0	958700,0	337300,0	0,0
13	135	SLU A1 sism.	-2119,2	1226,0	-43720,0	732200,0	819200,0	0,0
14	135	SLU A1 sism.	-2189,3	2006,4	-44060,0	915100,0	836200,0	0,0
15	135	SLU A1 sism.	14,6	1406,1	-44190,0	775900,0	320300,0	0,0
16	135	SLU A1 sism.	-55,6	2186,5	-44540,0	958700,0	337300,0	0,0
17	135	SLU A1 sism.	-2119,2	1226,0	-43720,0	732200,0	819200,0	0,0
18	135	SLU A1 sism.	-2189,3	2006,4	-44060,0	915100,0	836200,0	0,0
19	135	SLU A1 sism.	14,6	1406,1	-44190,0	775900,0	320300,0	0,0
20	135	SLU A1 sism.	-55,6	2186,5	-44540,0	958700,0	337300,0	0,0
21	135	SLU A1 sism.	-1290,5	378,6	-43480,0	534200,0	624800,0	0,0
22	135	SLU A1 sism.	-1524,4	2979,9	-44630,0	1144000,0	681300,0	0,0
23	135	SLU A1 sism.	-650,4	432,6	-43630,0	547300,0	475200,0	0,0
24	135	SLU A1 sism.	-884,3	3033,9	-44770,0	1157000,0	531600,0	0,0
25	135	SLU A1 sism.	-1290,5	378,6	-43480,0	534200,0	624800,0	0,0
26	135	SLU A1 sism.	-1524,4	2979,9	-44630,0	1144000,0	681300,0	0,0
27	135	SLU A1 sism.	-650,4	432,6	-43630,0	547300,0	475200,0	0,0
28	135	SLU A1 sism.	-884,3	3033,9	-44770,0	1157000,0	531600,0	0,0
29	135	SLU A1 sism.	-1290,5	378,6	-43480,0	534200,0	624800,0	0,0
30	135	SLU A1 sism.	-1524,4	2979,9	-44630,0	1144000,0	681300,0	0,0
31	135	SLU A1 sism.	-650,4	432,6	-43630,0	547300,0	475200,0	0,0
32	135	SLU A1 sism.	-884,3	3033,9	-44770,0	1157000,0	531600,0	0,0
33	135	SLU A1 sism.	-1290,5	378,6	-43480,0	534200,0	624800,0	0,0
34	135	SLU A1 sism.	-1524,4	2979,9	-44630,0	1144000,0	681300,0	0,0
35	135	SLU A1 sism.	-650,4	432,6	-43630,0	547300,0	475200,0	0,0
36	135	SLU A1 sism.	-884,3	3033,9	-44770,0	1157000,0	531600,0	0,0
69	135	SLE Rare	-1087,4	1706,3	-44130,0	845500,0	578200,0	0,0
1	147	SLU STR.	-3086,3	2248,7	-53610,0	1107000,0	1512000,0	0,0
2	147	SLU STR.	-2374,1	1729,8	-41240,0	851500,0	1163000,0	0,0
5	147	SLU A1 sism.	-3515,2	1332,7	-41130,0	757800,0	1430000,0	0,0
6	147	SLU A1 sism.	-3557,4	2098,5	-41330,0	937800,0	1440000,0	0,0
7	147	SLU A1 sism.	-1190,8	1361,1	-41150,0	765200,0	886100,0	0,0
8	147	SLU A1 sism.	-1233,0	2126,8	-41350,0	945200,0	896100,0	0,0
9	147	SLU A1 sism.	-3515,2	1332,7	-41130,0	757800,0	1430000,0	0,0
10	147	SLU A1 sism.	-3557,4	2098,5	-41330,0	937800,0	1440000,0	0,0

Parco Eolico "Bolina" – Progetto Definitivo
Relazione di calcolo preliminare delle fondazioni degli aerogeneratori G8 e G12

11	147	SLU A1 sism.	-1190,8	1361,1	-41150,0	765200,0	886100,0	0,0
12	147	SLU A1 sism.	-1233,0	2126,8	-41350,0	945200,0	896100,0	0,0
13	147	SLU A1 sism.	-3515,2	1332,7	-41130,0	757800,0	1430000,0	0,0
14	147	SLU A1 sism.	-3557,4	2098,5	-41330,0	937800,0	1440000,0	0,0
15	147	SLU A1 sism.	-1190,8	1361,1	-41150,0	765200,0	886100,0	0,0
16	147	SLU A1 sism.	-1233,0	2126,8	-41350,0	945200,0	896100,0	0,0
17	147	SLU A1 sism.	-3515,2	1332,7	-41130,0	757800,0	1430000,0	0,0
18	147	SLU A1 sism.	-3557,4	2098,5	-41330,0	937800,0	1440000,0	0,0
19	147	SLU A1 sism.	-1190,8	1361,1	-41150,0	765200,0	886100,0	0,0
20	147	SLU A1 sism.	-1233,0	2126,8	-41350,0	945200,0	896100,0	0,0
21	147	SLU A1 sism.	-2652,4	449,3	-40900,0	550400,0	1228000,0	0,0
22	147	SLU A1 sism.	-2793,1	3001,8	-41570,0	1150000,0	1261000,0	0,0
23	147	SLU A1 sism.	-1955,1	457,8	-40910,0	552600,0	1065000,0	0,0
24	147	SLU A1 sism.	-2095,8	3010,3	-41580,0	1153000,0	1098000,0	0,0
25	147	SLU A1 sism.	-2652,4	449,3	-40900,0	550400,0	1228000,0	0,0
26	147	SLU A1 sism.	-2793,1	3001,8	-41570,0	1150000,0	1261000,0	0,0
27	147	SLU A1 sism.	-1955,1	457,8	-40910,0	552600,0	1065000,0	0,0
28	147	SLU A1 sism.	-2095,8	3010,3	-41580,0	1153000,0	1098000,0	0,0
29	147	SLU A1 sism.	-2652,4	449,3	-40900,0	550400,0	1228000,0	0,0
30	147	SLU A1 sism.	-2793,1	3001,8	-41570,0	1150000,0	1261000,0	0,0
31	147	SLU A1 sism.	-1955,1	457,8	-40910,0	552600,0	1065000,0	0,0
32	147	SLU A1 sism.	-2095,8	3010,3	-41580,0	1153000,0	1098000,0	0,0
33	147	SLU A1 sism.	-2652,4	449,3	-40900,0	550400,0	1228000,0	0,0
34	147	SLU A1 sism.	-2793,1	3001,8	-41570,0	1150000,0	1261000,0	0,0
35	147	SLU A1 sism.	-1955,1	457,8	-40910,0	552600,0	1065000,0	0,0
36	147	SLU A1 sism.	-2095,8	3010,3	-41580,0	1153000,0	1098000,0	0,0
69	147	SLE Rare	-2374,1	1729,8	-41240,0	851500,0	1163000,0	0,0
1	167	SLU STR.	-1060,8	709,9	-21230,0	397900,0	589700,0	0,0
2	167	SLU STR.	-816,0	546,1	-16330,0	306100,0	453600,0	0,0
5	167	SLU A1 sism.	-1839,9	254,2	-16390,0	237800,0	693000,0	0,0
6	167	SLU A1 sism.	-1926,4	960,2	-16730,0	403000,0	713600,0	0,0
7	167	SLU A1 sism.	294,5	131,9	-15930,0	209200,0	193700,0	0,0
8	167	SLU A1 sism.	208,0	837,9	-16270,0	374300,0	214300,0	0,0
9	167	SLU A1 sism.	-1839,9	254,2	-16390,0	237800,0	693000,0	0,0
10	167	SLU A1 sism.	-1926,4	960,2	-16730,0	403000,0	713600,0	0,0
11	167	SLU A1 sism.	294,5	131,9	-15930,0	209200,0	193700,0	0,0
12	167	SLU A1 sism.	208,0	837,9	-16270,0	374300,0	214300,0	0,0
13	167	SLU A1 sism.	-1839,9	254,2	-16390,0	237800,0	693000,0	0,0
14	167	SLU A1 sism.	-1926,4	960,2	-16730,0	403000,0	713600,0	0,0
15	167	SLU A1 sism.	294,5	131,9	-15930,0	209200,0	193700,0	0,0
16	167	SLU A1 sism.	208,0	837,9	-16270,0	374300,0	214300,0	0,0
17	167	SLU A1 sism.	-1839,9	254,2	-16390,0	237800,0	693000,0	0,0
18	167	SLU A1 sism.	-1926,4	960,2	-16730,0	403000,0	713600,0	0,0
19	167	SLU A1 sism.	294,5	131,9	-15930,0	209200,0	193700,0	0,0
20	167	SLU A1 sism.	208,0	837,9	-16270,0	374300,0	214300,0	0,0
21	167	SLU A1 sism.	-992,0	-612,3	-15840,0	35060,0	494200,0	0,0
22	167	SLU A1 sism.	-1280,3	1741,1	-16960,0	585700,0	562900,0	0,0
23	167	SLU A1 sism.	-351,7	-649,0	-15700,0	26460,0	344400,0	0,0
24	167	SLU A1 sism.	-640,0	1704,4	-16820,0	577100,0	413100,0	0,0
25	167	SLU A1 sism.	-992,0	-612,3	-15840,0	35060,0	494200,0	0,0
26	167	SLU A1 sism.	-1280,3	1741,1	-16960,0	585700,0	562900,0	0,0
27	167	SLU A1 sism.	-351,7	-649,0	-15700,0	26460,0	344400,0	0,0
28	167	SLU A1 sism.	-640,0	1704,4	-16820,0	577100,0	413100,0	0,0
29	167	SLU A1 sism.	-992,0	-612,3	-15840,0	35060,0	494200,0	0,0
30	167	SLU A1 sism.	-1280,3	1741,1	-16960,0	585700,0	562900,0	0,0
31	167	SLU A1 sism.	-351,7	-649,0	-15700,0	26460,0	344400,0	0,0
32	167	SLU A1 sism.	-640,0	1704,4	-16820,0	577100,0	413100,0	0,0
33	167	SLU A1 sism.	-992,0	-612,3	-15840,0	35060,0	494200,0	0,0
34	167	SLU A1 sism.	-1280,3	1741,1	-16960,0	585700,0	562900,0	0,0
35	167	SLU A1 sism.	-351,7	-649,0	-15700,0	26460,0	344400,0	0,0
36	167	SLU A1 sism.	-640,0	1704,4	-16820,0	577100,0	413100,0	0,0
69	167	SLE Rare	-816,0	546,1	-16330,0	306100,0	453600,0	0,0
1	179	SLU STR.	-1201,5	1322,5	-29210,0	677200,0	648300,0	0,0
2	179	SLU STR.	-924,2	1017,3	-22470,0	520900,0	498700,0	0,0
5	179	SLU A1 sism.	-2084,8	735,9	-22650,0	455500,0	770600,0	0,0

Parco Eolico "Bolina" – Progetto Definitivo
Relazione di calcolo preliminare delle fondazioni degli aerogeneratori G8 e G12

6	179	SLU A1 sism.	-2128,7	1445,5	-22810,0	621900,0	781300,0	0,0
7	179	SLU A1 sism.	280,3	589,2	-22120,0	419900,0	216200,0	0,0
8	179	SLU A1 sism.	236,3	1298,7	-22280,0	586300,0	226800,0	0,0
9	179	SLU A1 sism.	-2084,8	735,9	-22650,0	455500,0	770600,0	0,0
10	179	SLU A1 sism.	-2128,7	1445,5	-22810,0	621900,0	781300,0	0,0
11	179	SLU A1 sism.	280,3	589,2	-22120,0	419900,0	216200,0	0,0
12	179	SLU A1 sism.	236,3	1298,7	-22280,0	586300,0	226800,0	0,0
13	179	SLU A1 sism.	-2084,8	735,9	-22650,0	455500,0	770600,0	0,0
14	179	SLU A1 sism.	-2128,7	1445,5	-22810,0	621900,0	781300,0	0,0
15	179	SLU A1 sism.	280,3	589,2	-22120,0	419900,0	216200,0	0,0
16	179	SLU A1 sism.	236,3	1298,7	-22280,0	586300,0	226800,0	0,0
17	179	SLU A1 sism.	-2084,8	735,9	-22650,0	455500,0	770600,0	0,0
18	179	SLU A1 sism.	-2128,7	1445,5	-22810,0	621900,0	781300,0	0,0
19	179	SLU A1 sism.	280,3	589,2	-22120,0	419900,0	216200,0	0,0
20	179	SLU A1 sism.	236,3	1298,7	-22280,0	586300,0	226800,0	0,0
21	179	SLU A1 sism.	-1205,7	-143,2	-22280,0	249000,0	564100,0	0,0
22	179	SLU A1 sism.	-1352,3	2221,9	-22810,0	803500,0	599700,0	0,0
23	179	SLU A1 sism.	-496,2	-187,3	-22120,0	238300,0	397800,0	0,0
24	179	SLU A1 sism.	-642,8	2177,9	-22650,0	792800,0	433300,0	0,0
25	179	SLU A1 sism.	-1205,7	-143,2	-22280,0	249000,0	564100,0	0,0
26	179	SLU A1 sism.	-1352,3	2221,9	-22810,0	803500,0	599700,0	0,0
27	179	SLU A1 sism.	-496,2	-187,3	-22120,0	238300,0	397800,0	0,0
28	179	SLU A1 sism.	-642,8	2177,9	-22650,0	792800,0	433300,0	0,0
29	179	SLU A1 sism.	-1205,7	-143,2	-22280,0	249000,0	564100,0	0,0
30	179	SLU A1 sism.	-1352,3	2221,9	-22810,0	803500,0	599700,0	0,0
31	179	SLU A1 sism.	-496,2	-187,3	-22120,0	238300,0	397800,0	0,0
32	179	SLU A1 sism.	-642,8	2177,9	-22650,0	792800,0	433300,0	0,0
33	179	SLU A1 sism.	-1205,7	-143,2	-22280,0	249000,0	564100,0	0,0
34	179	SLU A1 sism.	-1352,3	2221,9	-22810,0	803500,0	599700,0	0,0
35	179	SLU A1 sism.	-496,2	-187,3	-22120,0	238300,0	397800,0	0,0
36	179	SLU A1 sism.	-642,8	2177,9	-22650,0	792800,0	433300,0	0,0
69	179	SLE Rare	-924,2	1017,3	-22470,0	520900,0	498700,0	0,0
1	183	SLU STR.	-617,4	768,0	-15770,0	420100,0	384200,0	0,0
2	183	SLU STR.	-474,9	590,8	-12130,0	323200,0	295500,0	0,0
5	183	SLU A1 sism.	-1548,7	377,0	-12440,0	273600,0	546400,0	0,0
6	183	SLU A1 sism.	-1620,0	1042,7	-12700,0	429200,0	563300,0	0,0
7	183	SLU A1 sism.	670,1	138,9	-11560,0	217200,0	27740,0	0,0
8	183	SLU A1 sism.	598,8	804,6	-11820,0	372800,0	44640,0	0,0
9	183	SLU A1 sism.	-1548,7	377,0	-12440,0	273600,0	546400,0	0,0
10	183	SLU A1 sism.	-1620,0	1042,7	-12700,0	429200,0	563300,0	0,0
11	183	SLU A1 sism.	670,1	138,9	-11560,0	217200,0	27740,0	0,0
12	183	SLU A1 sism.	598,8	804,6	-11820,0	372800,0	44640,0	0,0
13	183	SLU A1 sism.	-1548,7	377,0	-12440,0	273600,0	546400,0	0,0
14	183	SLU A1 sism.	-1620,0	1042,7	-12700,0	429200,0	563300,0	0,0
15	183	SLU A1 sism.	670,1	138,9	-11560,0	217200,0	27740,0	0,0
16	183	SLU A1 sism.	598,8	804,6	-11820,0	372800,0	44640,0	0,0
17	183	SLU A1 sism.	-1548,7	377,0	-12440,0	273600,0	546400,0	0,0
18	183	SLU A1 sism.	-1620,0	1042,7	-12700,0	429200,0	563300,0	0,0
19	183	SLU A1 sism.	670,1	138,9	-11560,0	217200,0	27740,0	0,0
20	183	SLU A1 sism.	598,8	804,6	-11820,0	372800,0	44640,0	0,0
21	183	SLU A1 sism.	-688,9	-483,0	-11820,0	72290,0	345100,0	0,0
22	183	SLU A1 sism.	-926,7	1736,0	-12700,0	591000,0	401500,0	0,0
23	183	SLU A1 sism.	-23,2	-554,4	-11560,0	55360,0	189500,0	0,0
24	183	SLU A1 sism.	-261,0	1664,6	-12440,0	574100,0	245900,0	0,0
25	183	SLU A1 sism.	-688,9	-483,0	-11820,0	72290,0	345100,0	0,0
26	183	SLU A1 sism.	-926,7	1736,0	-12700,0	591000,0	401500,0	0,0
27	183	SLU A1 sism.	-23,2	-554,4	-11560,0	55360,0	189500,0	0,0
28	183	SLU A1 sism.	-261,0	1664,6	-12440,0	574100,0	245900,0	0,0
29	183	SLU A1 sism.	-688,9	-483,0	-11820,0	72290,0	345100,0	0,0
30	183	SLU A1 sism.	-926,7	1736,0	-12700,0	591000,0	401500,0	0,0
31	183	SLU A1 sism.	-23,2	-554,4	-11560,0	55360,0	189500,0	0,0
32	183	SLU A1 sism.	-261,0	1664,6	-12440,0	574100,0	245900,0	0,0
33	183	SLU A1 sism.	-688,9	-483,0	-11820,0	72290,0	345100,0	0,0
34	183	SLU A1 sism.	-926,7	1736,0	-12700,0	591000,0	401500,0	0,0
35	183	SLU A1 sism.	-23,2	-554,4	-11560,0	55360,0	189500,0	0,0

Parco Eolico "Bolina" – Progetto Definitivo
Relazione di calcolo preliminare delle fondazioni degli aerogeneratori G8 e G12

36	183	SLU A1 sism.	-261,0	1664,6	-12440,0	574100,0	245900,0	0,0
69	183	SLE Rare	-474,9	590,8	-12130,0	323200,0	295500,0	0,0
1	199	SLU STR.	-598,6	1235,2	-21230,0	631400,0	371300,0	0,0
2	199	SLU STR.	-460,4	950,1	-16330,0	485700,0	285600,0	0,0
5	199	SLU A1 sism.	-1618,8	774,3	-16820,0	445200,0	556700,0	0,0
6	199	SLU A1 sism.	-1655,5	1414,7	-16960,0	595000,0	565300,0	0,0
7	199	SLU A1 sism.	734,6	485,6	-15690,0	376300,0	6037,3	0,0
8	199	SLU A1 sism.	698,0	1126,0	-15830,0	526100,0	14630,0	0,0
9	199	SLU A1 sism.	-1618,8	774,3	-16820,0	445200,0	556700,0	0,0
10	199	SLU A1 sism.	-1655,5	1414,7	-16960,0	595000,0	565300,0	0,0
11	199	SLU A1 sism.	734,6	485,6	-15690,0	376300,0	6037,3	0,0
12	199	SLU A1 sism.	698,0	1126,0	-15830,0	526100,0	14630,0	0,0
13	199	SLU A1 sism.	-1618,8	774,3	-16820,0	445200,0	556700,0	0,0
14	199	SLU A1 sism.	-1655,5	1414,7	-16960,0	595000,0	565300,0	0,0
15	199	SLU A1 sism.	734,6	485,6	-15690,0	376300,0	6037,3	0,0
16	199	SLU A1 sism.	698,0	1126,0	-15830,0	526100,0	14630,0	0,0
17	199	SLU A1 sism.	-1618,8	774,3	-16820,0	445200,0	556700,0	0,0
18	199	SLU A1 sism.	-1655,5	1414,7	-16960,0	595000,0	565300,0	0,0
19	199	SLU A1 sism.	734,6	485,6	-15690,0	376300,0	6037,3	0,0
20	199	SLU A1 sism.	698,0	1126,0	-15830,0	526100,0	14630,0	0,0
21	199	SLU A1 sism.	-752,4	-73,9	-16260,0	246300,0	353900,0	0,0
22	199	SLU A1 sism.	-874,5	2060,8	-16730,0	745700,0	382600,0	0,0
23	199	SLU A1 sism.	-46,3	-160,5	-15930,0	225600,0	188700,0	0,0
24	199	SLU A1 sism.	-168,5	1974,2	-16390,0	725100,0	217400,0	0,0
25	199	SLU A1 sism.	-752,4	-73,9	-16260,0	246300,0	353900,0	0,0
26	199	SLU A1 sism.	-874,5	2060,8	-16730,0	745700,0	382600,0	0,0
27	199	SLU A1 sism.	-46,3	-160,5	-15930,0	225600,0	188700,0	0,0
28	199	SLU A1 sism.	-168,5	1974,2	-16390,0	725100,0	217400,0	0,0
29	199	SLU A1 sism.	-752,4	-73,9	-16260,0	246300,0	353900,0	0,0
30	199	SLU A1 sism.	-874,5	2060,8	-16730,0	745700,0	382600,0	0,0
31	199	SLU A1 sism.	-46,3	-160,5	-15930,0	225600,0	188700,0	0,0
32	199	SLU A1 sism.	-168,5	1974,2	-16390,0	725100,0	217400,0	0,0
33	199	SLU A1 sism.	-752,4	-73,9	-16260,0	246300,0	353900,0	0,0
34	199	SLU A1 sism.	-874,5	2060,8	-16730,0	745700,0	382600,0	0,0
35	199	SLU A1 sism.	-46,3	-160,5	-15930,0	225600,0	188700,0	0,0
36	199	SLU A1 sism.	-168,5	1974,2	-16390,0	725100,0	217400,0	0,0
69	199	SLE Rare	-460,4	950,1	-16330,0	485700,0	285600,0	0,0
1	211	SLU STR.	-2181,7	3220,4	-53600,0	1544000,0	1091000,0	0,0
2	211	SLU STR.	-1678,3	2477,3	-41230,0	1187000,0	839200,0	0,0
5	211	SLU A1 sism.	-2958,8	2199,0	-41570,0	1123000,0	1140000,0	0,0
6	211	SLU A1 sism.	-2950,3	2896,4	-41560,0	1286000,0	1138000,0	0,0
7	211	SLU A1 sism.	-406,2	2058,1	-40900,0	1089000,0	540300,0	0,0
8	211	SLU A1 sism.	-397,7	2755,5	-40890,0	1252000,0	538100,0	0,0
9	211	SLU A1 sism.	-2958,8	2199,0	-41570,0	1123000,0	1140000,0	0,0
10	211	SLU A1 sism.	-2950,3	2896,4	-41560,0	1286000,0	1138000,0	0,0
11	211	SLU A1 sism.	-406,2	2058,1	-40900,0	1089000,0	540300,0	0,0
12	211	SLU A1 sism.	-397,7	2755,5	-40890,0	1252000,0	538100,0	0,0
13	211	SLU A1 sism.	-2958,8	2199,0	-41570,0	1123000,0	1140000,0	0,0
14	211	SLU A1 sism.	-2950,3	2896,4	-41560,0	1286000,0	1138000,0	0,0
15	211	SLU A1 sism.	-406,2	2058,1	-40900,0	1089000,0	540300,0	0,0
16	211	SLU A1 sism.	-397,7	2755,5	-40890,0	1252000,0	538100,0	0,0
17	211	SLU A1 sism.	-2958,8	2199,0	-41570,0	1123000,0	1140000,0	0,0
18	211	SLU A1 sism.	-2950,3	2896,4	-41560,0	1286000,0	1138000,0	0,0
19	211	SLU A1 sism.	-406,2	2058,1	-40900,0	1089000,0	540300,0	0,0
20	211	SLU A1 sism.	-397,7	2755,5	-40890,0	1252000,0	538100,0	0,0
21	211	SLU A1 sism.	-2075,3	1336,1	-41340,0	920600,0	932900,0	0,0
22	211	SLU A1 sism.	-2047,0	3660,7	-41320,0	1464000,0	925500,0	0,0
23	211	SLU A1 sism.	-1309,5	1293,9	-41140,0	910500,0	752900,0	0,0
24	211	SLU A1 sism.	-1281,2	3618,4	-41120,0	1454000,0	745500,0	0,0
25	211	SLU A1 sism.	-2075,3	1336,1	-41340,0	920600,0	932900,0	0,0
26	211	SLU A1 sism.	-2047,0	3660,7	-41320,0	1464000,0	925500,0	0,0
27	211	SLU A1 sism.	-1309,5	1293,9	-41140,0	910500,0	752900,0	0,0
28	211	SLU A1 sism.	-1281,2	3618,4	-41120,0	1454000,0	745500,0	0,0
29	211	SLU A1 sism.	-2075,3	1336,1	-41340,0	920600,0	932900,0	0,0
30	211	SLU A1 sism.	-2047,0	3660,7	-41320,0	1464000,0	925500,0	0,0

Parco Eolico "Bolina" – Progetto Definitivo
Relazione di calcolo preliminare delle fondazioni degli aerogeneratori G8 e G12

31	211	SLU A1 sism.	-1309,5	1293,9	-41140,0	910500,0	752900,0	0,0
32	211	SLU A1 sism.	-1281,2	3618,4	-41120,0	1454000,0	745500,0	0,0
33	211	SLU A1 sism.	-2075,3	1336,1	-41340,0	920600,0	932900,0	0,0
34	211	SLU A1 sism.	-2047,0	3660,7	-41320,0	1464000,0	925500,0	0,0
35	211	SLU A1 sism.	-1309,5	1293,9	-41140,0	910500,0	752900,0	0,0
36	211	SLU A1 sism.	-1281,2	3618,4	-41120,0	1454000,0	745500,0	0,0
69	211	SLE Rare	-1678,3	2477,3	-41230,0	1187000,0	839200,0	0,0
1	215	SLU STR.	-1195,7	1661,7	-35570,0	825700,0	639900,0	0,0
2	215	SLU STR.	-919,8	1278,2	-27360,0	635200,0	492200,0	0,0
5	215	SLU A1 sism.	-2168,4	1104,5	-27980,0	595400,0	784700,0	0,0
6	215	SLU A1 sism.	-2160,0	1735,6	-27980,0	743100,0	782600,0	0,0
7	215	SLU A1 sism.	320,4	820,9	-26750,0	527300,0	201900,0	0,0
8	215	SLU A1 sism.	328,8	1451,9	-26750,0	674900,0	199800,0	0,0
9	215	SLU A1 sism.	-2168,4	1104,5	-27980,0	595400,0	784700,0	0,0
10	215	SLU A1 sism.	-2160,0	1735,6	-27980,0	743100,0	782600,0	0,0
11	215	SLU A1 sism.	320,4	820,9	-26750,0	527300,0	201900,0	0,0
12	215	SLU A1 sism.	328,8	1451,9	-26750,0	674900,0	199800,0	0,0
13	215	SLU A1 sism.	-2168,4	1104,5	-27980,0	595400,0	784700,0	0,0
14	215	SLU A1 sism.	-2160,0	1735,6	-27980,0	743100,0	782600,0	0,0
15	215	SLU A1 sism.	320,4	820,9	-26750,0	527300,0	201900,0	0,0
16	215	SLU A1 sism.	328,8	1451,9	-26750,0	674900,0	199800,0	0,0
17	215	SLU A1 sism.	-2168,4	1104,5	-27980,0	595400,0	784700,0	0,0
18	215	SLU A1 sism.	-2160,0	1735,6	-27980,0	743100,0	782600,0	0,0
19	215	SLU A1 sism.	320,4	820,9	-26750,0	527300,0	201900,0	0,0
20	215	SLU A1 sism.	328,8	1451,9	-26750,0	674900,0	199800,0	0,0
21	215	SLU A1 sism.	-1307,1	269,0	-27550,0	399300,0	583300,0	0,0
22	215	SLU A1 sism.	-1279,2	2372,6	-27550,0	891500,0	576000,0	0,0
23	215	SLU A1 sism.	-560,5	183,9	-27180,0	378800,0	408500,0	0,0
24	215	SLU A1 sism.	-532,5	2287,5	-27180,0	871100,0	401200,0	0,0
25	215	SLU A1 sism.	-1307,1	269,0	-27550,0	399300,0	583300,0	0,0
26	215	SLU A1 sism.	-1279,2	2372,6	-27550,0	891500,0	576000,0	0,0
27	215	SLU A1 sism.	-560,5	183,9	-27180,0	378800,0	408500,0	0,0
28	215	SLU A1 sism.	-532,5	2287,5	-27180,0	871100,0	401200,0	0,0
29	215	SLU A1 sism.	-1307,1	269,0	-27550,0	399300,0	583300,0	0,0
30	215	SLU A1 sism.	-1279,2	2372,6	-27550,0	891500,0	576000,0	0,0
31	215	SLU A1 sism.	-560,5	183,9	-27180,0	378800,0	408500,0	0,0
32	215	SLU A1 sism.	-532,5	2287,5	-27180,0	871100,0	401200,0	0,0
33	215	SLU A1 sism.	-1307,1	269,0	-27550,0	399300,0	583300,0	0,0
34	215	SLU A1 sism.	-1279,2	2372,6	-27550,0	891500,0	576000,0	0,0
35	215	SLU A1 sism.	-560,5	183,9	-27180,0	378800,0	408500,0	0,0
36	215	SLU A1 sism.	-532,5	2287,5	-27180,0	871100,0	401200,0	0,0
69	215	SLE Rare	-919,8	1278,2	-27360,0	635200,0	492200,0	0,0
1	231	SLU STR.	-2200,3	1587,9	-57340,0	792900,0	1095000,0	0,0
2	231	SLU STR.	-1692,5	1221,5	-44110,0	609900,0	842300,0	0,0
5	231	SLU A1 sism.	-3020,4	1018,5	-44750,0	563300,0	1154000,0	0,0
6	231	SLU A1 sism.	-2966,4	1658,7	-44610,0	713000,0	1141000,0	0,0
7	231	SLU A1 sism.	-418,7	784,3	-43610,0	506800,0	544100,0	0,0
8	231	SLU A1 sism.	-364,7	1424,5	-43460,0	656500,0	531000,0	0,0
9	231	SLU A1 sism.	-3020,4	1018,5	-44750,0	563300,0	1154000,0	0,0
10	231	SLU A1 sism.	-2966,4	1658,7	-44610,0	713000,0	1141000,0	0,0
11	231	SLU A1 sism.	-418,7	784,3	-43610,0	506800,0	544100,0	0,0
12	231	SLU A1 sism.	-364,7	1424,5	-43460,0	656500,0	531000,0	0,0
13	231	SLU A1 sism.	-3020,4	1018,5	-44750,0	563300,0	1154000,0	0,0
14	231	SLU A1 sism.	-2966,4	1658,7	-44610,0	713000,0	1141000,0	0,0
15	231	SLU A1 sism.	-418,7	784,3	-43610,0	506800,0	544100,0	0,0
16	231	SLU A1 sism.	-364,7	1424,5	-43460,0	656500,0	531000,0	0,0
17	231	SLU A1 sism.	-3020,4	1018,5	-44750,0	563300,0	1154000,0	0,0
18	231	SLU A1 sism.	-2966,4	1658,7	-44610,0	713000,0	1141000,0	0,0
19	231	SLU A1 sism.	-418,7	784,3	-43610,0	506800,0	544100,0	0,0
20	231	SLU A1 sism.	-364,7	1424,5	-43460,0	656500,0	531000,0	0,0
21	231	SLU A1 sism.	-2172,7	189,6	-44520,0	368900,0	955600,0	0,0
22	231	SLU A1 sism.	-1992,8	2323,7	-44040,0	867900,0	911900,0	0,0
23	231	SLU A1 sism.	-1392,2	119,3	-44170,0	351900,0	772700,0	0,0
24	231	SLU A1 sism.	-1212,3	2253,4	-43700,0	850900,0	729000,0	0,0
25	231	SLU A1 sism.	-2172,7	189,6	-44520,0	368900,0	955600,0	0,0

Parco Eolico "Bolina" – Progetto Definitivo
Relazione di calcolo preliminare delle fondazioni degli aerogeneratori G8 e G12

26	231	SLU A1 sism.	-1992,8	2323,7	-44040,0	867900,0	911900,0	0,0
27	231	SLU A1 sism.	-1392,2	119,3	-44170,0	351900,0	772700,0	0,0
28	231	SLU A1 sism.	-1212,3	2253,4	-43700,0	850900,0	729000,0	0,0
29	231	SLU A1 sism.	-2172,7	189,6	-44520,0	368900,0	955600,0	0,0
30	231	SLU A1 sism.	-1992,8	2323,7	-44040,0	867900,0	911900,0	0,0
31	231	SLU A1 sism.	-1392,2	119,3	-44170,0	351900,0	772700,0	0,0
32	231	SLU A1 sism.	-1212,3	2253,4	-43700,0	850900,0	729000,0	0,0
33	231	SLU A1 sism.	-2172,7	189,6	-44520,0	368900,0	955600,0	0,0
34	231	SLU A1 sism.	-1992,8	2323,7	-44040,0	867900,0	911900,0	0,0
35	231	SLU A1 sism.	-1392,2	119,3	-44170,0	351900,0	772700,0	0,0
36	231	SLU A1 sism.	-1212,3	2253,4	-43700,0	850900,0	729000,0	0,0
69	231	SLE Rare	-1692,5	1221,5	-44110,0	609900,0	842300,0	0,0
1	243	SLU STR.	-4131,5	2111,8	-99750,0	1038000,0	1977000,0	0,0
2	243	SLU STR.	-3178,1	1624,4	-76730,0	798500,0	1521000,0	0,0
5	243	SLU A1 sism.	-4533,3	1309,5	-77080,0	724600,0	1839000,0	0,0
6	243	SLU A1 sism.	-4471,9	2018,9	-76900,0	890700,0	1824000,0	0,0
7	243	SLU A1 sism.	-1884,3	1229,9	-76560,0	706200,0	1218000,0	0,0
8	243	SLU A1 sism.	-1822,8	1939,3	-76380,0	872400,0	1202000,0	0,0
9	243	SLU A1 sism.	-4533,3	1309,5	-77080,0	724600,0	1839000,0	0,0
10	243	SLU A1 sism.	-4471,9	2018,9	-76900,0	890700,0	1824000,0	0,0
11	243	SLU A1 sism.	-1884,3	1229,9	-76560,0	706200,0	1218000,0	0,0
12	243	SLU A1 sism.	-1822,8	1939,3	-76380,0	872400,0	1202000,0	0,0
13	243	SLU A1 sism.	-4533,3	1309,5	-77080,0	724600,0	1839000,0	0,0
14	243	SLU A1 sism.	-4471,9	2018,9	-76900,0	890700,0	1824000,0	0,0
15	243	SLU A1 sism.	-1884,3	1229,9	-76560,0	706200,0	1218000,0	0,0
16	243	SLU A1 sism.	-1822,8	1939,3	-76380,0	872400,0	1202000,0	0,0
17	243	SLU A1 sism.	-4533,3	1309,5	-77080,0	724600,0	1839000,0	0,0
18	243	SLU A1 sism.	-4471,9	2018,9	-76900,0	890700,0	1824000,0	0,0
19	243	SLU A1 sism.	-1884,3	1229,9	-76560,0	706200,0	1218000,0	0,0
20	243	SLU A1 sism.	-1822,8	1939,3	-76380,0	872400,0	1202000,0	0,0
21	243	SLU A1 sism.	-3677,9	454,0	-77110,0	524300,0	1640000,0	0,0
22	243	SLU A1 sism.	-3473,0	2818,8	-76500,0	1078000,0	1589000,0	0,0
23	243	SLU A1 sism.	-2883,2	430,1	-76950,0	518800,0	1453000,0	0,0
24	243	SLU A1 sism.	-2678,3	2794,9	-76350,0	1073000,0	1402000,0	0,0
25	243	SLU A1 sism.	-3677,9	454,0	-77110,0	524300,0	1640000,0	0,0
26	243	SLU A1 sism.	-3473,0	2818,8	-76500,0	1078000,0	1589000,0	0,0
27	243	SLU A1 sism.	-2883,2	430,1	-76950,0	518800,0	1453000,0	0,0
28	243	SLU A1 sism.	-2678,3	2794,9	-76350,0	1073000,0	1402000,0	0,0
29	243	SLU A1 sism.	-3677,9	454,0	-77110,0	524300,0	1640000,0	0,0
30	243	SLU A1 sism.	-3473,0	2818,8	-76500,0	1078000,0	1589000,0	0,0
31	243	SLU A1 sism.	-2883,2	430,1	-76950,0	518800,0	1453000,0	0,0
32	243	SLU A1 sism.	-2678,3	2794,9	-76350,0	1073000,0	1402000,0	0,0
33	243	SLU A1 sism.	-3677,9	454,0	-77110,0	524300,0	1640000,0	0,0
34	243	SLU A1 sism.	-3473,0	2818,8	-76500,0	1078000,0	1589000,0	0,0
35	243	SLU A1 sism.	-2883,2	430,1	-76950,0	518800,0	1453000,0	0,0
36	243	SLU A1 sism.	-2678,3	2794,9	-76350,0	1073000,0	1402000,0	0,0
69	243	SLE Rare	-3178,1	1624,4	-76730,0	798500,0	1521000,0	0,0
1	247	SLU STR.	-3146,9	1061,3	-84880,0	554300,0	1524000,0	0,0
2	247	SLU STR.	-2420,7	816,4	-65290,0	426400,0	1172000,0	0,0
5	247	SLU A1 sism.	-3805,4	564,4	-65880,0	368300,0	1497000,0	0,0
6	247	SLU A1 sism.	-3715,2	1229,0	-65600,0	523400,0	1475000,0	0,0
7	247	SLU A1 sism.	-1126,2	403,8	-64990,0	329300,0	869300,0	0,0
8	247	SLU A1 sism.	-1036,1	1068,3	-64710,0	484400,0	847400,0	0,0
9	247	SLU A1 sism.	-3805,4	564,4	-65880,0	368300,0	1497000,0	0,0
10	247	SLU A1 sism.	-3715,2	1229,0	-65600,0	523400,0	1475000,0	0,0
11	247	SLU A1 sism.	-1126,2	403,8	-64990,0	329300,0	869300,0	0,0
12	247	SLU A1 sism.	-1036,1	1068,3	-64710,0	484400,0	847400,0	0,0
13	247	SLU A1 sism.	-3805,4	564,4	-65880,0	368300,0	1497000,0	0,0
14	247	SLU A1 sism.	-3715,2	1229,0	-65600,0	523400,0	1475000,0	0,0
15	247	SLU A1 sism.	-1126,2	403,8	-64990,0	329300,0	869300,0	0,0
16	247	SLU A1 sism.	-1036,1	1068,3	-64710,0	484400,0	847400,0	0,0
17	247	SLU A1 sism.	-3805,4	564,4	-65880,0	368300,0	1497000,0	0,0
18	247	SLU A1 sism.	-3715,2	1229,0	-65600,0	523400,0	1475000,0	0,0
19	247	SLU A1 sism.	-1126,2	403,8	-64990,0	329300,0	869300,0	0,0
20	247	SLU A1 sism.	-1036,1	1068,3	-64710,0	484400,0	847400,0	0,0

Parco Eolico "Bolina" – Progetto Definitivo
Relazione di calcolo preliminare delle fondazioni degli aerogeneratori G8 e G12

21	247	SLU A1 sism.	-2972,9	-267,1	-65890,0	173700,0	1303000,0	0,0
22	247	SLU A1 sism.	-2672,3	1948,0	-64960,0	690700,0	1230000,0	0,0
23	247	SLU A1 sism.	-2169,1	-315,3	-65630,0	162000,0	1115000,0	0,0
24	247	SLU A1 sism.	-1868,5	1899,8	-64700,0	679100,0	1042000,0	0,0
25	247	SLU A1 sism.	-2972,9	-267,1	-65890,0	173700,0	1303000,0	0,0
26	247	SLU A1 sism.	-2672,3	1948,0	-64960,0	690700,0	1230000,0	0,0
27	247	SLU A1 sism.	-2169,1	-315,3	-65630,0	162000,0	1115000,0	0,0
28	247	SLU A1 sism.	-1868,5	1899,8	-64700,0	679100,0	1042000,0	0,0
29	247	SLU A1 sism.	-2972,9	-267,1	-65890,0	173700,0	1303000,0	0,0
30	247	SLU A1 sism.	-2672,3	1948,0	-64960,0	690700,0	1230000,0	0,0
31	247	SLU A1 sism.	-2169,1	-315,3	-65630,0	162000,0	1115000,0	0,0
32	247	SLU A1 sism.	-1868,5	1899,8	-64700,0	679100,0	1042000,0	0,0
33	247	SLU A1 sism.	-2972,9	-267,1	-65890,0	173700,0	1303000,0	0,0
34	247	SLU A1 sism.	-2672,3	1948,0	-64960,0	690700,0	1230000,0	0,0
35	247	SLU A1 sism.	-2169,1	-315,3	-65630,0	162000,0	1115000,0	0,0
36	247	SLU A1 sism.	-1868,5	1899,8	-64700,0	679100,0	1042000,0	0,0
69	247	SLE Rare	-2420,7	816,4	-65290,0	426400,0	1172000,0	0,0
1	263	SLU STR.	-3599,6	344,2	-120800,0	230700,0	1729000,0	0,0
2	263	SLU STR.	-2768,9	264,8	-92910,0	177400,0	1330000,0	0,0
5	263	SLU A1 sism.	-4188,3	-56,6	-93310,0	102800,0	1663000,0	0,0
6	263	SLU A1 sism.	-4080,3	651,0	-92930,0	268000,0	1637000,0	0,0
7	263	SLU A1 sism.	-1457,5	-121,4	-92880,0	86910,0	1022000,0	0,0
8	263	SLU A1 sism.	-1349,5	586,1	-92500,0	252100,0	996000,0	0,0
9	263	SLU A1 sism.	-4188,3	-56,6	-93310,0	102800,0	1663000,0	0,0
10	263	SLU A1 sism.	-4080,3	651,0	-92930,0	268000,0	1637000,0	0,0
11	263	SLU A1 sism.	-1457,5	-121,4	-92880,0	86910,0	1022000,0	0,0
12	263	SLU A1 sism.	-1349,5	586,1	-92500,0	252100,0	996000,0	0,0
13	263	SLU A1 sism.	-4188,3	-56,6	-93310,0	102800,0	1663000,0	0,0
14	263	SLU A1 sism.	-4080,3	651,0	-92930,0	268000,0	1637000,0	0,0
15	263	SLU A1 sism.	-1457,5	-121,4	-92880,0	86910,0	1022000,0	0,0
16	263	SLU A1 sism.	-1349,5	586,1	-92500,0	252100,0	996000,0	0,0
17	263	SLU A1 sism.	-4188,3	-56,6	-93310,0	102800,0	1663000,0	0,0
18	263	SLU A1 sism.	-4080,3	651,0	-92930,0	268000,0	1637000,0	0,0
19	263	SLU A1 sism.	-1457,5	-121,4	-92880,0	86910,0	1022000,0	0,0
20	263	SLU A1 sism.	-1349,5	586,1	-92500,0	252100,0	996000,0	0,0
21	263	SLU A1 sism.	-3358,6	-904,8	-93610,0	-95440,0	1470000,0	0,0
22	263	SLU A1 sism.	-2998,5	1453,8	-92340,0	455100,0	1382000,0	0,0
23	263	SLU A1 sism.	-2539,3	-924,2	-93480,0	-100200,0	1277000,0	0,0
24	263	SLU A1 sism.	-2179,2	1434,3	-92210,0	450300,0	1190000,0	0,0
25	263	SLU A1 sism.	-3358,6	-904,8	-93610,0	-95440,0	1470000,0	0,0
26	263	SLU A1 sism.	-2998,5	1453,8	-92340,0	455100,0	1382000,0	0,0
27	263	SLU A1 sism.	-2539,3	-924,2	-93480,0	-100200,0	1277000,0	0,0
28	263	SLU A1 sism.	-2179,2	1434,3	-92210,0	450300,0	1190000,0	0,0
29	263	SLU A1 sism.	-3358,6	-904,8	-93610,0	-95440,0	1470000,0	0,0
30	263	SLU A1 sism.	-2998,5	1453,8	-92340,0	455100,0	1382000,0	0,0
31	263	SLU A1 sism.	-2539,3	-924,2	-93480,0	-100200,0	1277000,0	0,0
32	263	SLU A1 sism.	-2179,2	1434,3	-92210,0	450300,0	1190000,0	0,0
33	263	SLU A1 sism.	-3358,6	-904,8	-93610,0	-95440,0	1470000,0	0,0
34	263	SLU A1 sism.	-2998,5	1453,8	-92340,0	455100,0	1382000,0	0,0
35	263	SLU A1 sism.	-2539,3	-924,2	-93480,0	-100200,0	1277000,0	0,0
36	263	SLU A1 sism.	-2179,2	1434,3	-92210,0	450300,0	1190000,0	0,0
69	263	SLE Rare	-2768,9	264,8	-92910,0	177400,0	1330000,0	0,0
1	275	SLU STR.	-3950,1	390,7	-158900,0	257200,0	1893000,0	0,0
2	275	SLU STR.	-3038,6	300,5	-122200,0	197800,0	1456000,0	0,0
5	275	SLU A1 sism.	-4406,7	-98,0	-122300,0	104200,0	1777000,0	0,0
6	275	SLU A1 sism.	-4345,7	669,7	-122000,0	284300,0	1762000,0	0,0
7	275	SLU A1 sism.	-1731,5	-68,7	-122400,0	111400,0	1150000,0	0,0
8	275	SLU A1 sism.	-1670,4	699,0	-122100,0	291500,0	1135000,0	0,0
9	275	SLU A1 sism.	-4406,7	-98,0	-122300,0	104200,0	1777000,0	0,0
10	275	SLU A1 sism.	-4345,7	669,7	-122000,0	284300,0	1762000,0	0,0
11	275	SLU A1 sism.	-1731,5	-68,7	-122400,0	111400,0	1150000,0	0,0
12	275	SLU A1 sism.	-1670,4	699,0	-122100,0	291500,0	1135000,0	0,0
13	275	SLU A1 sism.	-4406,7	-98,0	-122300,0	104200,0	1777000,0	0,0
14	275	SLU A1 sism.	-4345,7	669,7	-122000,0	284300,0	1762000,0	0,0

Parco Eolico "Bolina" – Progetto Definitivo
Relazione di calcolo preliminare delle fondazioni degli aerogeneratori G8 e G12

15	275	SLU A1 sism.	-1731,5	-68,7	-122400,0	111400,0	1150000,0	0,0
16	275	SLU A1 sism.	-1670,4	699,0	-122100,0	291500,0	1135000,0	0,0
17	275	SLU A1 sism.	-4406,7	-98,0	-122300,0	104200,0	1777000,0	0,0
18	275	SLU A1 sism.	-4345,7	669,7	-122000,0	284300,0	1762000,0	0,0
19	275	SLU A1 sism.	-1731,5	-68,7	-122400,0	111400,0	1150000,0	0,0
20	275	SLU A1 sism.	-1670,4	699,0	-122100,0	291500,0	1135000,0	0,0
21	275	SLU A1 sism.	-3541,6	-983,4	-122600,0	-103400,0	1575000,0	0,0
22	275	SLU A1 sism.	-3338,1	1575,6	-121800,0	496900,0	1525000,0	0,0
23	275	SLU A1 sism.	-2739,0	-974,6	-122600,0	-101300,0	1387000,0	0,0
24	275	SLU A1 sism.	-2535,5	1584,4	-121800,0	499100,0	1337000,0	0,0
25	275	SLU A1 sism.	-3541,6	-983,4	-122600,0	-103400,0	1575000,0	0,0
26	275	SLU A1 sism.	-3338,1	1575,6	-121800,0	496900,0	1525000,0	0,0
27	275	SLU A1 sism.	-2739,0	-974,6	-122600,0	-101300,0	1387000,0	0,0
28	275	SLU A1 sism.	-2535,5	1584,4	-121800,0	499100,0	1337000,0	0,0
29	275	SLU A1 sism.	-3541,6	-983,4	-122600,0	-103400,0	1575000,0	0,0
30	275	SLU A1 sism.	-3338,1	1575,6	-121800,0	496900,0	1525000,0	0,0
31	275	SLU A1 sism.	-2739,0	-974,6	-122600,0	-101300,0	1387000,0	0,0
32	275	SLU A1 sism.	-2535,5	1584,4	-121800,0	499100,0	1337000,0	0,0
33	275	SLU A1 sism.	-3541,6	-983,4	-122600,0	-103400,0	1575000,0	0,0
34	275	SLU A1 sism.	-3338,1	1575,6	-121800,0	496900,0	1525000,0	0,0
35	275	SLU A1 sism.	-2739,0	-974,6	-122600,0	-101300,0	1387000,0	0,0
36	275	SLU A1 sism.	-2535,5	1584,4	-121800,0	499100,0	1337000,0	0,0
69	275	SLE Rare	-3038,6	300,5	-122200,0	197800,0	1456000,0	0,0
1	279	SLU STR.	-2899,0	-388,3	-156000,0	-98920,0	1407000,0	0,0
2	279	SLU STR.	-2230,0	-298,7	-120000,0	-76090,0	1082000,0	0,0
5	279	SLU A1 sism.	-3660,2	-690,9	-120200,0	-167800,0	1418000,0	0,0
6	279	SLU A1 sism.	-3552,7	61,0	-119800,0	7784,2	1392000,0	0,0
7	279	SLU A1 sism.	-907,4	-658,4	-120300,0	-160000,0	772400,0	0,0
8	279	SLU A1 sism.	-799,9	93,4	-119800,0	15590,0	746200,0	0,0
9	279	SLU A1 sism.	-3660,2	-690,9	-120200,0	-167800,0	1418000,0	0,0
10	279	SLU A1 sism.	-3552,7	61,0	-119800,0	7784,2	1392000,0	0,0
11	279	SLU A1 sism.	-907,4	-658,4	-120300,0	-160000,0	772400,0	0,0
12	279	SLU A1 sism.	-799,9	93,4	-119800,0	15590,0	746200,0	0,0
13	279	SLU A1 sism.	-3660,2	-690,9	-120200,0	-167800,0	1418000,0	0,0
14	279	SLU A1 sism.	-3552,7	61,0	-119800,0	7784,2	1392000,0	0,0
15	279	SLU A1 sism.	-907,4	-658,4	-120300,0	-160000,0	772400,0	0,0
16	279	SLU A1 sism.	-799,9	93,4	-119800,0	15590,0	746200,0	0,0
17	279	SLU A1 sism.	-3660,2	-690,9	-120200,0	-167800,0	1418000,0	0,0
18	279	SLU A1 sism.	-3552,7	61,0	-119800,0	7784,2	1392000,0	0,0
19	279	SLU A1 sism.	-907,4	-658,4	-120300,0	-160000,0	772400,0	0,0
20	279	SLU A1 sism.	-799,9	93,4	-119800,0	15590,0	746200,0	0,0
21	279	SLU A1 sism.	-2822,0	-1556,6	-120700,0	-369900,0	1223000,0	0,0
22	279	SLU A1 sism.	-2463,8	949,4	-119300,0	215300,0	1135000,0	0,0
23	279	SLU A1 sism.	-1996,2	-1546,9	-120800,0	-367500,0	1029000,0	0,0
24	279	SLU A1 sism.	-1638,0	959,2	-119300,0	217700,0	941600,0	0,0
25	279	SLU A1 sism.	-2822,0	-1556,6	-120700,0	-369900,0	1223000,0	0,0
26	279	SLU A1 sism.	-2463,8	949,4	-119300,0	215300,0	1135000,0	0,0
27	279	SLU A1 sism.	-1996,2	-1546,9	-120800,0	-367500,0	1029000,0	0,0
28	279	SLU A1 sism.	-1638,0	959,2	-119300,0	217700,0	941600,0	0,0
29	279	SLU A1 sism.	-2822,0	-1556,6	-120700,0	-369900,0	1223000,0	0,0
30	279	SLU A1 sism.	-2463,8	949,4	-119300,0	215300,0	1135000,0	0,0
31	279	SLU A1 sism.	-1996,2	-1546,9	-120800,0	-367500,0	1029000,0	0,0
32	279	SLU A1 sism.	-1638,0	959,2	-119300,0	217700,0	941600,0	0,0
33	279	SLU A1 sism.	-2822,0	-1556,6	-120700,0	-369900,0	1223000,0	0,0
34	279	SLU A1 sism.	-2463,8	949,4	-119300,0	215300,0	1135000,0	0,0
35	279	SLU A1 sism.	-1996,2	-1546,9	-120800,0	-367500,0	1029000,0	0,0
36	279	SLU A1 sism.	-1638,0	959,2	-119300,0	217700,0	941600,0	0,0
69	279	SLE Rare	-2230,0	-298,7	-120000,0	-76090,0	1082000,0	0,0
1	295	SLU STR.	-1443,4	-529,2	-180100,0	-157600,0	741800,0	0,0
2	295	SLU STR.	-1110,3	-407,1	-138500,0	-121300,0	570600,0	0,0
5	295	SLU A1 sism.	-2528,5	-865,6	-138400,0	-229000,0	903300,0	0,0
6	295	SLU A1 sism.	-2436,6	-78,0	-138000,0	-45030,0	880800,0	0,0
7	295	SLU A1 sism.	216,0	-736,1	-139100,0	-197500,0	260300,0	0,0
8	295	SLU A1 sism.	307,9	51,5	-138700,0	-13480,0	237900,0	0,0
9	295	SLU A1 sism.	-2528,5	-865,6	-138400,0	-229000,0	903300,0	0,0

Parco Eolico "Bolina" – Progetto Definitivo
Relazione di calcolo preliminare delle fondazioni degli aerogeneratori G8 e G12

10	295	SLU A1 sism.	-2436,6	-78,0	-138000,0	-45030,0	880800,0	0,0
11	295	SLU A1 sism.	216,0	-736,1	-139100,0	-197500,0	260300,0	0,0
12	295	SLU A1 sism.	307,9	51,5	-138700,0	-13480,0	237900,0	0,0
13	295	SLU A1 sism.	-2528,5	-865,6	-138400,0	-229000,0	903300,0	0,0
14	295	SLU A1 sism.	-2436,6	-78,0	-138000,0	-45030,0	880800,0	0,0
15	295	SLU A1 sism.	216,0	-736,1	-139100,0	-197500,0	260300,0	0,0
16	295	SLU A1 sism.	307,9	51,5	-138700,0	-13480,0	237900,0	0,0
17	295	SLU A1 sism.	-2528,5	-865,6	-138400,0	-229000,0	903300,0	0,0
18	295	SLU A1 sism.	-2436,6	-78,0	-138000,0	-45030,0	880800,0	0,0
19	295	SLU A1 sism.	216,0	-736,1	-139100,0	-197500,0	260300,0	0,0
20	295	SLU A1 sism.	307,9	51,5	-138700,0	-13480,0	237900,0	0,0
21	295	SLU A1 sism.	-1675,1	-1739,2	-139200,0	-432700,0	704500,0	0,0
22	295	SLU A1 sism.	-1368,9	886,2	-137700,0	180700,0	629600,0	0,0
23	295	SLU A1 sism.	-851,7	-1700,3	-139400,0	-423200,0	511600,0	0,0
24	295	SLU A1 sism.	-545,6	925,0	-137900,0	190200,0	436700,0	0,0
25	295	SLU A1 sism.	-1675,1	-1739,2	-139200,0	-432700,0	704500,0	0,0
26	295	SLU A1 sism.	-1368,9	886,2	-137700,0	180700,0	629600,0	0,0
27	295	SLU A1 sism.	-851,7	-1700,3	-139400,0	-423200,0	511600,0	0,0
28	295	SLU A1 sism.	-545,6	925,0	-137900,0	190200,0	436700,0	0,0
29	295	SLU A1 sism.	-1675,1	-1739,2	-139200,0	-432700,0	704500,0	0,0
30	295	SLU A1 sism.	-1368,9	886,2	-137700,0	180700,0	629600,0	0,0
31	295	SLU A1 sism.	-851,7	-1700,3	-139400,0	-423200,0	511600,0	0,0
32	295	SLU A1 sism.	-545,6	925,0	-137900,0	190200,0	436700,0	0,0
33	295	SLU A1 sism.	-1675,1	-1739,2	-139200,0	-432700,0	704500,0	0,0
34	295	SLU A1 sism.	-1368,9	886,2	-137700,0	180700,0	629600,0	0,0
35	295	SLU A1 sism.	-851,7	-1700,3	-139400,0	-423200,0	511600,0	0,0
36	295	SLU A1 sism.	-545,6	925,0	-137900,0	190200,0	436700,0	0,0
69	295	SLE Rare	-1110,3	-407,1	-138500,0	-121300,0	570600,0	0,0
1	307	SLU STR.	-409,7	415,5	-184900,0	274500,0	274600,0	0,0
2	307	SLU STR.	-315,2	319,6	-142200,0	211900,0	211300,0	0,0
5	307	SLU A1 sism.	-1668,7	-151,3	-142000,0	101200,0	528500,0	0,0
6	307	SLU A1 sism.	-1626,0	647,9	-141800,0	288500,0	518200,0	0,0
7	307	SLU A1 sism.	995,7	-8,6	-142700,0	135400,0	-95720,0	0,0
8	307	SLU A1 sism.	1038,4	790,6	-142500,0	322700,0	-106000,0	0,0
9	307	SLU A1 sism.	-1668,7	-151,3	-142000,0	101200,0	528500,0	0,0
10	307	SLU A1 sism.	-1626,0	647,9	-141800,0	288500,0	518200,0	0,0
11	307	SLU A1 sism.	995,7	-8,6	-142700,0	135400,0	-95720,0	0,0
12	307	SLU A1 sism.	1038,4	790,6	-142500,0	322700,0	-106000,0	0,0
13	307	SLU A1 sism.	-1668,7	-151,3	-142000,0	101200,0	528500,0	0,0
14	307	SLU A1 sism.	-1626,0	647,9	-141800,0	288500,0	518200,0	0,0
15	307	SLU A1 sism.	995,7	-8,6	-142700,0	135400,0	-95720,0	0,0
16	307	SLU A1 sism.	1038,4	790,6	-142500,0	322700,0	-106000,0	0,0
17	307	SLU A1 sism.	-1668,7	-151,3	-142000,0	101200,0	528500,0	0,0
18	307	SLU A1 sism.	-1626,0	647,9	-141800,0	288500,0	518200,0	0,0
19	307	SLU A1 sism.	995,7	-8,6	-142700,0	135400,0	-95720,0	0,0
20	307	SLU A1 sism.	1038,4	790,6	-142500,0	322700,0	-106000,0	0,0
21	307	SLU A1 sism.	-786,1	-1033,8	-142500,0	-105200,0	322000,0	0,0
22	307	SLU A1 sism.	-643,5	1630,3	-141800,0	518900,0	287800,0	0,0
23	307	SLU A1 sism.	13,3	-991,0	-142700,0	-94980,0	134700,0	0,0
24	307	SLU A1 sism.	155,8	1673,1	-142000,0	529100,0	100500,0	0,0
25	307	SLU A1 sism.	-786,1	-1033,8	-142500,0	-105200,0	322000,0	0,0
26	307	SLU A1 sism.	-643,5	1630,3	-141800,0	518900,0	287800,0	0,0
27	307	SLU A1 sism.	13,3	-991,0	-142700,0	-94980,0	134700,0	0,0
28	307	SLU A1 sism.	155,8	1673,1	-142000,0	529100,0	100500,0	0,0
29	307	SLU A1 sism.	-786,1	-1033,8	-142500,0	-105200,0	322000,0	0,0
30	307	SLU A1 sism.	-643,5	1630,3	-141800,0	518900,0	287800,0	0,0
31	307	SLU A1 sism.	13,3	-991,0	-142700,0	-94980,0	134700,0	0,0
32	307	SLU A1 sism.	155,8	1673,1	-142000,0	529100,0	100500,0	0,0
33	307	SLU A1 sism.	-786,1	-1033,8	-142500,0	-105200,0	322000,0	0,0
34	307	SLU A1 sism.	-643,5	1630,3	-141800,0	518900,0	287800,0	0,0
35	307	SLU A1 sism.	13,3	-991,0	-142700,0	-94980,0	134700,0	0,0
36	307	SLU A1 sism.	155,8	1673,1	-142000,0	529100,0	100500,0	0,0
69	307	SLE Rare	-315,2	319,6	-142200,0	211900,0	211300,0	0,0
1	311	SLU STR.	-161,2	132,8	-188200,0	150200,0	157600,0	0,0
2	311	SLU STR.	-124,0	102,2	-144800,0	115500,0	121200,0	0,0

Parco Eolico "Bolina" – Progetto Definitivo
Relazione di calcolo preliminare delle fondazioni degli aerogeneratori G8 e G12

5	311	SLU A1 sism.	-1510,6	-417,3	-144400,0	-7063,3	445700,0	0,0
6	311	SLU A1 sism.	-1442,5	394,1	-144100,0	182600,0	429100,0	0,0
7	311	SLU A1 sism.	1194,5	-189,8	-145600,0	48460,0	-186700,0	0,0
8	311	SLU A1 sism.	1262,7	621,6	-145200,0	238100,0	-203300,0	0,0
9	311	SLU A1 sism.	-1510,6	-417,3	-144400,0	-7063,3	445700,0	0,0
10	311	SLU A1 sism.	-1442,5	394,1	-144100,0	182600,0	429100,0	0,0
11	311	SLU A1 sism.	1194,5	-189,8	-145600,0	48460,0	-186700,0	0,0
12	311	SLU A1 sism.	1262,7	621,6	-145200,0	238100,0	-203300,0	0,0
13	311	SLU A1 sism.	-1510,6	-417,3	-144400,0	-7063,3	445700,0	0,0
14	311	SLU A1 sism.	-1442,5	394,1	-144100,0	182600,0	429100,0	0,0
15	311	SLU A1 sism.	1194,5	-189,8	-145600,0	48460,0	-186700,0	0,0
16	311	SLU A1 sism.	1262,7	621,6	-145200,0	238100,0	-203300,0	0,0
17	311	SLU A1 sism.	-1510,6	-417,3	-144400,0	-7063,3	445700,0	0,0
18	311	SLU A1 sism.	-1442,5	394,1	-144100,0	182600,0	429100,0	0,0
19	311	SLU A1 sism.	1194,5	-189,8	-145600,0	48460,0	-186700,0	0,0
20	311	SLU A1 sism.	1262,7	621,6	-145200,0	238100,0	-203300,0	0,0
21	311	SLU A1 sism.	-643,3	-1284,3	-145200,0	-208900,0	243800,0	0,0
22	311	SLU A1 sism.	-416,2	1420,4	-144100,0	423400,0	188300,0	0,0
23	311	SLU A1 sism.	168,2	-1216,1	-145600,0	-192300,0	54070,0	0,0
24	311	SLU A1 sism.	395,4	1488,7	-144400,0	440000,0	-1374,6	0,0
25	311	SLU A1 sism.	-643,3	-1284,3	-145200,0	-208900,0	243800,0	0,0
26	311	SLU A1 sism.	-416,2	1420,4	-144100,0	423400,0	188300,0	0,0
27	311	SLU A1 sism.	168,2	-1216,1	-145600,0	-192300,0	54070,0	0,0
28	311	SLU A1 sism.	395,4	1488,7	-144400,0	440000,0	-1374,6	0,0
29	311	SLU A1 sism.	-643,3	-1284,3	-145200,0	-208900,0	243800,0	0,0
30	311	SLU A1 sism.	-416,2	1420,4	-144100,0	423400,0	188300,0	0,0
31	311	SLU A1 sism.	168,2	-1216,1	-145600,0	-192300,0	54070,0	0,0
32	311	SLU A1 sism.	395,4	1488,7	-144400,0	440000,0	-1374,6	0,0
33	311	SLU A1 sism.	-643,3	-1284,3	-145200,0	-208900,0	243800,0	0,0
34	311	SLU A1 sism.	-416,2	1420,4	-144100,0	423400,0	188300,0	0,0
35	311	SLU A1 sism.	168,2	-1216,1	-145600,0	-192300,0	54070,0	0,0
36	311	SLU A1 sism.	395,4	1488,7	-144400,0	440000,0	-1374,6	0,0
69	311	SLE Rare	-124,0	102,2	-144800,0	115500,0	121200,0	0,0
1	327	SLU STR.	543,0	1390,4	-180100,0	728600,0	-160300,0	0,0
2	327	SLU STR.	417,7	1069,6	-138600,0	560400,0	-123300,0	0,0
5	327	SLU A1 sism.	-914,5	504,7	-138000,0	426600,0	188100,0	0,0
6	327	SLU A1 sism.	-875,7	1327,9	-137800,0	619400,0	178700,0	0,0
7	327	SLU A1 sism.	1711,1	811,2	-139400,0	501500,0	-425300,0	0,0
8	327	SLU A1 sism.	1749,9	1634,4	-139200,0	694300,0	-434700,0	0,0
9	327	SLU A1 sism.	-914,5	504,7	-138000,0	426600,0	188100,0	0,0
10	327	SLU A1 sism.	-875,7	1327,9	-137800,0	619400,0	178700,0	0,0
11	327	SLU A1 sism.	1711,1	811,2	-139400,0	501500,0	-425300,0	0,0
12	327	SLU A1 sism.	1749,9	1634,4	-139200,0	694300,0	-434700,0	0,0
13	327	SLU A1 sism.	-914,5	504,7	-138000,0	426600,0	188100,0	0,0
14	327	SLU A1 sism.	-875,7	1327,9	-137800,0	619400,0	178700,0	0,0
15	327	SLU A1 sism.	1711,1	811,2	-139400,0	501500,0	-425300,0	0,0
16	327	SLU A1 sism.	1749,9	1634,4	-139200,0	694300,0	-434700,0	0,0
17	327	SLU A1 sism.	-914,5	504,7	-138000,0	426600,0	188100,0	0,0
18	327	SLU A1 sism.	-875,7	1327,9	-137800,0	619400,0	178700,0	0,0
19	327	SLU A1 sism.	1711,1	811,2	-139400,0	501500,0	-425300,0	0,0
20	327	SLU A1 sism.	1749,9	1634,4	-139200,0	694300,0	-434700,0	0,0
21	327	SLU A1 sism.	-40,8	-348,4	-138700,0	227800,0	-15530,0	0,0
22	327	SLU A1 sism.	88,6	2395,6	-138000,0	870600,0	-47050,0	0,0
23	327	SLU A1 sism.	746,9	-256,5	-139100,0	250300,0	-199600,0	0,0
24	327	SLU A1 sism.	876,2	2487,6	-138500,0	893100,0	-231100,0	0,0
25	327	SLU A1 sism.	-40,8	-348,4	-138700,0	227800,0	-15530,0	0,0
26	327	SLU A1 sism.	88,6	2395,6	-138000,0	870600,0	-47050,0	0,0
27	327	SLU A1 sism.	746,9	-256,5	-139100,0	250300,0	-199600,0	0,0
28	327	SLU A1 sism.	876,2	2487,6	-138500,0	893100,0	-231100,0	0,0
29	327	SLU A1 sism.	-40,8	-348,4	-138700,0	227800,0	-15530,0	0,0
30	327	SLU A1 sism.	88,6	2395,6	-138000,0	870600,0	-47050,0	0,0
31	327	SLU A1 sism.	746,9	-256,5	-139100,0	250300,0	-199600,0	0,0
32	327	SLU A1 sism.	876,2	2487,6	-138500,0	893100,0	-231100,0	0,0
33	327	SLU A1 sism.	-40,8	-348,4	-138700,0	227800,0	-15530,0	0,0
34	327	SLU A1 sism.	88,6	2395,6	-138000,0	870600,0	-47050,0	0,0

Parco Eolico "Bolina" – Progetto Definitivo
Relazione di calcolo preliminare delle fondazioni degli aerogeneratori G8 e G12

35	327	SLU A1 sism.	746,9	-256,5	-139100,0	250300,0	-199600,0	0,0
36	327	SLU A1 sism.	876,2	2487,6	-138500,0	893100,0	-231100,0	0,0
69	327	SLE Rare	417,7	1069,6	-138600,0	560400,0	-123300,0	0,0
1	84	SLU STR.	-325,8	3944,2	-158900,0	1891000,0	242200,0	0,0
2	84	SLU STR.	-250,6	3034,0	-122200,0	1455000,0	186300,0	0,0
5	84	SLU A1 sism.	-1534,6	2530,9	-121800,0	1336000,0	487600,0	0,0
6	84	SLU A1 sism.	-1525,8	3333,4	-121800,0	1524000,0	485400,0	0,0
7	84	SLU A1 sism.	1024,6	2734,6	-122600,0	1386000,0	-112800,0	0,0
8	84	SLU A1 sism.	1033,4	3537,1	-122600,0	1574000,0	-115000,0	0,0
9	84	SLU A1 sism.	-1534,6	2530,9	-121800,0	1336000,0	487600,0	0,0
10	84	SLU A1 sism.	-1525,8	3333,4	-121800,0	1524000,0	485400,0	0,0
11	84	SLU A1 sism.	1024,6	2734,6	-122600,0	1386000,0	-112800,0	0,0
12	84	SLU A1 sism.	1033,4	3537,1	-122600,0	1574000,0	-115000,0	0,0
13	84	SLU A1 sism.	-1534,6	2530,9	-121800,0	1336000,0	487600,0	0,0
14	84	SLU A1 sism.	-1525,8	3333,4	-121800,0	1524000,0	485400,0	0,0
15	84	SLU A1 sism.	1024,6	2734,6	-122600,0	1386000,0	-112800,0	0,0
16	84	SLU A1 sism.	1033,4	3537,1	-122600,0	1574000,0	-115000,0	0,0
17	84	SLU A1 sism.	-1534,6	2530,9	-121800,0	1336000,0	487600,0	0,0
18	84	SLU A1 sism.	-1525,8	3333,4	-121800,0	1524000,0	485400,0	0,0
19	84	SLU A1 sism.	1024,6	2734,6	-122600,0	1386000,0	-112800,0	0,0
20	84	SLU A1 sism.	1033,4	3537,1	-122600,0	1574000,0	-115000,0	0,0
21	84	SLU A1 sism.	-649,1	1666,0	-122100,0	1134000,0	280000,0	0,0
22	84	SLU A1 sism.	-619,8	4340,9	-122100,0	1760000,0	272700,0	0,0
23	84	SLU A1 sism.	118,6	1727,1	-122400,0	1149000,0	99900,0	0,0
24	84	SLU A1 sism.	147,9	4402,0	-122300,0	1775000,0	92620,0	0,0
25	84	SLU A1 sism.	-649,1	1666,0	-122100,0	1134000,0	280000,0	0,0
26	84	SLU A1 sism.	-619,8	4340,9	-122100,0	1760000,0	272700,0	0,0
27	84	SLU A1 sism.	118,6	1727,1	-122400,0	1149000,0	99900,0	0,0
28	84	SLU A1 sism.	147,9	4402,0	-122300,0	1775000,0	92620,0	0,0
29	84	SLU A1 sism.	-649,1	1666,0	-122100,0	1134000,0	280000,0	0,0
30	84	SLU A1 sism.	-619,8	4340,9	-122100,0	1760000,0	272700,0	0,0
31	84	SLU A1 sism.	118,6	1727,1	-122400,0	1149000,0	99900,0	0,0
32	84	SLU A1 sism.	147,9	4402,0	-122300,0	1775000,0	92620,0	0,0
33	84	SLU A1 sism.	-649,1	1666,0	-122100,0	1134000,0	280000,0	0,0
34	84	SLU A1 sism.	-619,8	4340,9	-122100,0	1760000,0	272700,0	0,0
35	84	SLU A1 sism.	118,6	1727,1	-122400,0	1149000,0	99900,0	0,0
36	84	SLU A1 sism.	147,9	4402,0	-122300,0	1775000,0	92620,0	0,0
69	84	SLE Rare	-250,6	3034,0	-122200,0	1455000,0	186300,0	0,0
1	92	SLU STR.	451,0	2838,5	-156100,0	1392000,0	-113200,0	0,0
2	92	SLU STR.	346,9	2183,5	-120100,0	1071000,0	-87040,0	0,0
5	92	SLU A1 sism.	-911,1	1591,3	-119300,0	930100,0	206700,0	0,0
6	92	SLU A1 sism.	-901,3	2417,0	-119300,0	1124000,0	204400,0	0,0
7	92	SLU A1 sism.	1595,1	1950,0	-120800,0	1018000,0	-378500,0	0,0
8	92	SLU A1 sism.	1604,8	2775,6	-120800,0	1212000,0	-380800,0	0,0
9	92	SLU A1 sism.	-911,1	1591,3	-119300,0	930100,0	206700,0	0,0
10	92	SLU A1 sism.	-901,3	2417,0	-119300,0	1124000,0	204400,0	0,0
11	92	SLU A1 sism.	1595,1	1950,0	-120800,0	1018000,0	-378500,0	0,0
12	92	SLU A1 sism.	1604,8	2775,6	-120800,0	1212000,0	-380800,0	0,0
13	92	SLU A1 sism.	-911,1	1591,3	-119300,0	930100,0	206700,0	0,0
14	92	SLU A1 sism.	-901,3	2417,0	-119300,0	1124000,0	204400,0	0,0
15	92	SLU A1 sism.	1595,1	1950,0	-120800,0	1018000,0	-378500,0	0,0
16	92	SLU A1 sism.	1604,8	2775,6	-120800,0	1212000,0	-380800,0	0,0
17	92	SLU A1 sism.	-911,1	1591,3	-119300,0	930100,0	206700,0	0,0
18	92	SLU A1 sism.	-901,3	2417,0	-119300,0	1124000,0	204400,0	0,0
19	92	SLU A1 sism.	1595,1	1950,0	-120800,0	1018000,0	-378500,0	0,0
20	92	SLU A1 sism.	1604,8	2775,6	-120800,0	1212000,0	-380800,0	0,0
21	92	SLU A1 sism.	-45,3	753,5	-119900,0	734700,0	4636,3	0,0
22	92	SLU A1 sism.	-12,8	3505,8	-119800,0	1381000,0	-3165,7	0,0
23	92	SLU A1 sism.	706,6	861,1	-120300,0	761100,0	-170900,0	0,0
24	92	SLU A1 sism.	739,0	3613,4	-120200,0	1407000,0	-178700,0	0,0
25	92	SLU A1 sism.	-45,3	753,5	-119900,0	734700,0	4636,3	0,0
26	92	SLU A1 sism.	-12,8	3505,8	-119800,0	1381000,0	-3165,7	0,0
27	92	SLU A1 sism.	706,6	861,1	-120300,0	761100,0	-170900,0	0,0
28	92	SLU A1 sism.	739,0	3613,4	-120200,0	1407000,0	-178700,0	0,0
29	92	SLU A1 sism.	-45,3	753,5	-119900,0	734700,0	4636,3	0,0

Parco Eolico "Bolina" – Progetto Definitivo
Relazione di calcolo preliminare delle fondazioni degli aerogeneratori G8 e G12

30	92	SLU A1 sism.	-12,8	3505,8	-119800,0	1381000,0	-3165,7	0,0
31	92	SLU A1 sism.	706,6	861,1	-120300,0	761100,0	-170900,0	0,0
32	92	SLU A1 sism.	739,0	3613,4	-120200,0	1407000,0	-178700,0	0,0
33	92	SLU A1 sism.	-45,3	753,5	-119900,0	734700,0	4636,3	0,0
34	92	SLU A1 sism.	-12,8	3505,8	-119800,0	1381000,0	-3165,7	0,0
35	92	SLU A1 sism.	706,6	861,1	-120300,0	761100,0	-170900,0	0,0
36	92	SLU A1 sism.	739,0	3613,4	-120200,0	1407000,0	-178700,0	0,0
69	92	SLE Rare	346,9	2183,5	-120100,0	1071000,0	-87040,0	0,0

VERIFICHE PALI

Diametro palo = 120,0 cm
 Armatura corrente: 21 Ø 18 = 53,4 cmq
 Armatura aggiuntiva da quota 0 a quota -1200 + 24 Ø 18
 Armatura a taglio: spirale Ø8/14

VERIFICHE VERIFICHE STATO LIMITE ULTIMO:

Ver. N/M = rapporto Sd/Su con sollecitazioni ultime proporzionali
 Ver. (25)= rapporto Nd/Nu, dove Nu viene ottenuto con riduzione del 25% di fcd
 Ver.V = verifica a taglio, rapporto Vd/Vrd
 (Verifica positiva per valori inferiori a 1)

Plinto n. 151

Cmb.	Palo	Quota (cm)	N (daN)	V (daN)	M (daN cm)	Ver. N/M	Ver.(25)	Ver.V	Stato
34	151	0,0	-27984,0	2725,2	1065146,0	0,069	0,018	0,048	Ok
1	151	0,0	-35583,0	1943,3	1020476,0	0,046	0,023	0,034	Ok
34	151	-46,7	-27965,5	2624,0	939796,9	0,061	0,018	0,047	Ok
1	151	-46,7	-35559,5	1971,6	928983,5	0,042	0,023	0,035	Ok
34	151	-93,3	-27942,1	2486,4	818064,1	0,053	0,018	0,044	Ok
1	151	-93,3	-35529,7	1952,0	836977,0	0,038	0,023	0,035	Ok
34	151	-140,0	-27914,2	2317,0	702735,7	0,046	0,018	0,041	Ok
1	151	-140,0	-35494,2	1898,1	745888,5	0,034	0,023	0,034	Ok
34	151	-186,7	-27886,6	2132,4	595308,5	0,039	0,018	0,038	Ok
1	151	-186,7	-35459,1	1817,2	657313,9	0,030	0,023	0,032	Ok
34	151	-233,3	-27859,2	1938,3	496513,3	0,032	0,018	0,034	Ok
1	151	-233,3	-35424,3	1715,0	572511,1	0,026	0,022	0,030	Ok
34	151	-280,0	-27832,1	1740,4	406821,3	0,026	0,018	0,031	Ok
1	151	-280,0	-35389,9	1597,0	492478,4	0,022	0,022	0,028	Ok
34	151	-326,7	-27805,4	1543,0	326452,9	0,021	0,018	0,027	Ok
1	151	-326,7	-35355,9	1467,9	417955,4	0,019	0,022	0,026	Ok
35	151	-373,3	-26563,0	733,6	282447,9	0,018	0,017	0,013	Ok
1	151	-373,3	-35322,2	1332,2	349453,8	0,016	0,022	0,024	Ok
35	151	-420,0	-26537,9	693,7	249605,9	0,016	0,017	0,012	Ok
1	151	-420,0	-35288,9	1193,7	287285,6	0,013	0,022	0,021	Ok
35	151	-466,7	-26513,1	648,1	218451,3	0,014	0,017	0,011	Ok
1	151	-466,7	-35256,0	1055,4	231583,5	0,011	0,022	0,019	Ok
35	151	-513,3	-26488,7	598,4	189293,9	0,012	0,017	0,011	Ok
1	151	-513,3	-35223,4	920,0	182335,0	0,008	0,022	0,016	Ok
35	151	-560,0	-26464,4	546,3	162354,2	0,011	0,017	0,010	Ok
1	151	-560,0	-35191,2	789,7	139403,2	0,006	0,022	0,014	Ok
35	151	-606,7	-26440,5	493,0	137773,0	0,009	0,017	0,009	Ok
1	151	-606,7	-35159,3	666,1	102552,9	0,005	0,022	0,012	Ok
35	151	-653,3	-26416,8	439,8	115621,5	0,008	0,017	0,008	Ok
1	151	-653,3	-35127,9	550,5	71472,7	0,003	0,022	0,010	Ok
35	151	-700,0	-26393,4	387,7	95909,1	0,006	0,017	0,007	Ok
1	151	-700,0	-35096,7	443,8	45791,1	0,002	0,022	0,008	Ok
35	151	-746,7	-26370,3	337,5	78594,1	0,005	0,017	0,006	Ok
1	151	-746,7	-35066,0	346,6	25098,1	0,001	0,022	0,006	Ok
35	151	-793,3	-26347,4	290,0	63590,1	0,004	0,017	0,005	Ok
1	151	-793,3	-35035,6	259,3	8983,1	0,000	0,022	0,005	Ok
34	151	-840,0	-27529,9	72,9	55987,3	0,004	0,017	0,001	Ok

Parco Eolico "Bolina" – Progetto Definitivo
Relazione di calcolo preliminare delle fondazioni degli aerogeneratori G8 e G12

1	151	-840,0	-35005,6	182,2	3437,3	0,000	0,022	0,003	Ok
34	151	-886,7	-27506,6	67,8	56347,8	0,004	0,017	0,001	Ok
1	151	-886,7	-34975,9	115,3	11767,2	0,001	0,022	0,002	Ok
34	151	-933,3	-27483,5	95,0	54260,0	0,004	0,017	0,002	Ok
1	151	-933,3	-34946,6	58,5	17120,3	0,001	0,022	0,001	Ok
34	151	-980,0	-27460,8	123,5	50161,0	0,003	0,017	0,002	Ok
1	151	-980,0	-34917,7	12,0	19836,9	0,001	0,022	0,000	Ok
34	151	-1026,7	-27438,3	144,7	44522,4	0,003	0,017	0,003	Ok
1	151	-1026,7	-34889,1	25,4	20375,6	0,001	0,022	0,000	Ok
34	151	-1073,3	-27416,1	156,7	37822,0	0,002	0,017	0,003	Ok
1	151	-1073,3	-34860,9	52,5	19195,0	0,001	0,022	0,001	Ok
34	151	-1120,0	-27394,2	159,1	30532,7	0,002	0,017	0,003	Ok
1	151	-1120,0	-34833,1	70,1	16747,4	0,001	0,022	0,001	Ok
34	151	-1166,7	-27372,6	151,8	23119,7	0,002	0,017	0,003	Ok
1	151	-1166,7	-34805,6	78,3	13477,7	0,001	0,022	0,001	Ok
34	151	-1213,3	-27351,3	135,0	16039,8	0,002	0,020	0,002	Ok
1	151	-1213,3	-34778,5	77,2	9824,4	0,001	0,026	0,001	Ok
34	151	-1260,0	-27330,2	108,6	9743,1	0,001	0,020	0,002	Ok
1	151	-1260,0	-34751,7	66,9	6221,1	0,001	0,026	0,001	Ok
34	151	-1306,7	-27309,5	72,8	4675,2	0,001	0,020	0,001	Ok
1	151	-1306,7	-34725,3	47,5	3097,3	0,000	0,026	0,001	Ok
34	151	-1353,3	-27289,0	27,4	1279,7	0,000	0,020	0,000	Ok
1	151	-1353,3	-34699,2	18,9	881,1	0,000	0,026	0,000	Ok
18	151	-1400,0	-26872,5	26,1	0,0	0,015	0,020	0,000	Ok
1	151	-1400,0	-34699,2	18,9	0,0	0,000	0,026	0,000	Ok

Plinto n. 103

Cmb.	Palo	Quota (cm)	N (daN)	V (daN)	M (daN cm)	Ver. N/M	Ver.(25)	Ver.V	Stato
36	103	0,0	-93363,9	4152,3	1655976,0	0,094	0,059	0,074	Ok
1	103	0,0	-120843,3	3557,6	1728578,0	0,070	0,077	0,063	Ok
36	103	-46,7	-93302,3	4011,6	1464400,0	0,083	0,059	0,071	Ok
1	103	-46,7	-120763,6	3555,7	1562171,0	0,063	0,077	0,063	Ok
36	103	-93,3	-93224,2	3812,3	1277905,0	0,073	0,059	0,068	Ok
1	103	-93,3	-120662,5	3477,7	1396459,0	0,057	0,077	0,062	Ok
36	103	-140,0	-93131,1	3562,7	1100689,0	0,063	0,059	0,063	Ok
1	103	-140,0	-120541,9	3343,3	1234362,0	0,050	0,077	0,059	Ok
36	103	-186,7	-93038,8	3287,8	935107,9	0,053	0,059	0,058	Ok
1	103	-186,7	-120422,6	3168,2	1078521,0	0,044	0,076	0,056	Ok
36	103	-233,3	-92947,6	2996,4	782367,7	0,045	0,059	0,053	Ok
1	103	-233,3	-120304,5	2961,7	930839,5	0,038	0,076	0,053	Ok
36	103	-280,0	-92857,3	2697,4	643263,4	0,037	0,059	0,048	Ok
1	103	-280,0	-120187,7	2733,2	792787,7	0,032	0,076	0,048	Ok
36	103	-326,7	-92768,0	2397,7	518189,0	0,030	0,059	0,043	Ok
1	103	-326,7	-120072,1	2490,7	665398,3	0,027	0,076	0,044	Ok
35	103	-373,3	-92248,5	1357,3	438928,0	0,025	0,059	0,024	Ok
1	103	-373,3	-119957,7	2241,1	549331,7	0,022	0,076	0,040	Ok
35	103	-420,0	-92161,5	1252,2	375963,7	0,021	0,059	0,022	Ok
1	103	-420,0	-119844,6	1990,5	444925,5	0,018	0,076	0,035	Ok
35	103	-466,7	-92075,5	1140,5	317887,8	0,018	0,058	0,020	Ok
1	103	-466,7	-119732,7	1744,0	352231,9	0,014	0,076	0,031	Ok
35	103	-513,3	-91990,5	1025,6	265018,0	0,015	0,058	0,018	Ok
1	103	-513,3	-119622,1	1505,6	271080,1	0,011	0,076	0,027	Ok
35	103	-560,0	-91906,3	910,2	217516,9	0,012	0,058	0,016	Ok
1	103	-560,0	-119512,7	1278,5	201117,5	0,008	0,076	0,023	Ok
35	103	-606,7	-91823,2	796,6	175417,5	0,010	0,058	0,014	Ok
1	103	-606,7	-119404,6	1065,1	141867,2	0,006	0,076	0,019	Ok
35	103	-653,3	-91741,0	686,9	138647,0	0,008	0,058	0,012	Ok
1	103	-653,3	-119297,7	867,4	92809,6	0,004	0,076	0,015	Ok
35	103	-700,0	-91659,7	582,6	107045,7	0,006	0,058	0,010	Ok
1	103	-700,0	-119192,0	686,5	53586,8	0,002	0,076	0,012	Ok
35	103	-746,7	-91579,4	484,8	80391,1	0,005	0,058	0,009	Ok
1	103	-746,7	-119087,6	523,3	25169,6	0,001	0,076	0,009	Ok
36	103	-793,3	-91927,7	199,4	73267,4	0,004	0,058	0,004	Ok
1	103	-793,3	-118984,4	378,2	17015,9	0,001	0,076	0,007	Ok

Parco Eolico "Bolina" – Progetto Definitivo
Relazione di calcolo preliminare delle fondazioni degli aerogeneratori G8 e G12

36	103	-840,0	-91848,9	105,1	79716,7	0,005	0,058	0,002	Ok
1	103	-840,0	-118882,5	251,7	27670,2	0,001	0,076	0,004	Ok
36	103	-886,7	-91771,1	81,0	81607,3	0,005	0,058	0,001	Ok
1	103	-886,7	-118781,7	144,3	37504,6	0,002	0,075	0,003	Ok
36	103	-933,3	-91694,2	124,7	79504,2	0,005	0,058	0,002	Ok
1	103	-933,3	-118682,2	60,0	43228,5	0,002	0,075	0,001	Ok
36	103	-980,0	-91618,3	172,7	74120,2	0,004	0,058	0,003	Ok
1	103	-980,0	-118584,0	44,3	45007,5	0,002	0,075	0,001	Ok
36	103	-1026,7	-91543,4	208,8	66208,7	0,004	0,058	0,004	Ok
1	103	-1026,7	-118486,9	90,5	43470,4	0,002	0,075	0,002	Ok
36	103	-1073,3	-91469,3	230,0	56525,7	0,003	0,058	0,004	Ok
1	103	-1073,3	-118391,1	128,6	39342,4	0,002	0,075	0,002	Ok
36	103	-1120,0	-91396,3	236,1	45815,4	0,003	0,058	0,004	Ok
1	103	-1120,0	-118296,6	151,8	33368,5	0,001	0,075	0,003	Ok
36	103	-1166,7	-91324,1	227,0	34807,1	0,002	0,058	0,004	Ok
1	103	-1166,7	-118203,2	159,5	26292,8	0,001	0,075	0,003	Ok
36	103	-1213,3	-91253,0	203,0	24215,8	0,002	0,068	0,004	Ok
1	103	-1213,3	-118111,1	151,6	18852,8	0,001	0,088	0,003	Ok
36	103	-1260,0	-91182,7	164,0	14745,2	0,001	0,068	0,003	Ok
1	103	-1260,0	-118020,2	128,2	11779,1	0,001	0,088	0,002	Ok
36	103	-1306,7	-91113,5	110,3	7091,1	0,001	0,068	0,002	Ok
1	103	-1306,7	-117930,5	89,3	5797,2	0,000	0,088	0,002	Ok
36	103	-1353,3	-91045,1	41,7	1945,5	0,000	0,068	0,001	Ok
1	103	-1353,3	-117842,1	34,9	1629,9	0,000	0,088	0,001	Ok
33	103	-1400,0	-90250,4	13,0	0,0	0,050	0,068	0,000	Ok
1	103	-1400,0	-117842,1	34,9	0,0	0,000	0,088	0,001	Ok

Plinto n. 115

Cmb.	Palo	Quota (cm)	N (daN)	V (daN)	M (daN cm)	Ver. N/M	Ver.(25)	Ver.V	Stato
34	115	0,0	-76916,4	4875,5	2022016,0	0,119	0,049	0,086	Ok
1	115	0,0	-99773,7	4594,7	2222035,0	0,092	0,063	0,081	Ok
34	115	-46,7	-76865,7	4741,6	1795920,0	0,106	0,049	0,084	Ok
1	115	-46,7	-99707,9	4589,1	2006926,0	0,083	0,063	0,081	Ok
34	115	-93,3	-76801,4	4531,6	1574815,0	0,093	0,049	0,080	Ok
1	115	-93,3	-99624,4	4485,6	1792825,0	0,074	0,063	0,080	Ok
34	115	-140,0	-76724,6	4258,6	1363503,0	0,080	0,049	0,076	Ok
1	115	-140,0	-99524,9	4309,4	1583547,0	0,066	0,063	0,076	Ok
34	115	-186,7	-76648,7	3950,8	1164922,0	0,068	0,049	0,070	Ok
1	115	-186,7	-99426,4	4081,0	1382488,0	0,057	0,063	0,072	Ok
34	115	-233,3	-76573,5	3618,9	980707,1	0,058	0,049	0,064	Ok
1	115	-233,3	-99328,8	3812,6	1192082,0	0,050	0,063	0,068	Ok
34	115	-280,0	-76499,1	3274,0	811983,1	0,048	0,049	0,058	Ok
1	115	-280,0	-99232,4	3516,2	1014200,0	0,042	0,063	0,062	Ok
34	115	-326,7	-76425,6	2924,8	659367,9	0,039	0,049	0,052	Ok
1	115	-326,7	-99136,9	3202,1	850151,4	0,035	0,063	0,057	Ok
35	115	-373,3	-76020,3	1852,9	555042,5	0,033	0,048	0,033	Ok
1	115	-373,3	-99042,5	2879,2	700763,0	0,029	0,063	0,051	Ok
35	115	-420,0	-75948,7	1690,9	468591,4	0,028	0,048	0,030	Ok
1	115	-420,0	-98949,1	2555,4	566447,0	0,024	0,063	0,045	Ok
35	115	-466,7	-75877,8	1523,2	389700,5	0,023	0,048	0,027	Ok
1	115	-466,7	-98856,8	2237,1	447246,1	0,019	0,063	0,040	Ok
35	115	-513,3	-75807,7	1354,1	318635,4	0,019	0,048	0,024	Ok
1	115	-513,3	-98765,4	1929,4	342911,9	0,014	0,063	0,034	Ok
35	115	-560,0	-75738,4	1187,2	255461,8	0,015	0,048	0,021	Ok
1	115	-560,0	-98675,1	1636,5	252952,2	0,011	0,063	0,029	Ok
35	115	-606,7	-75669,8	1025,2	200080,9	0,012	0,048	0,018	Ok
1	115	-606,7	-98585,8	1361,5	176691,5	0,007	0,063	0,024	Ok
35	115	-653,3	-75602,1	870,7	152260,1	0,009	0,048	0,015	Ok
1	115	-653,3	-98497,6	1106,8	113332,4	0,005	0,063	0,020	Ok
35	115	-700,0	-75535,1	725,3	111657,1	0,007	0,048	0,013	Ok
1	115	-700,0	-98410,3	873,8	62053,2	0,003	0,063	0,015	Ok
35	115	-746,7	-75468,9	590,5	77847,9	0,005	0,048	0,010	Ok
1	115	-746,7	-98324,1	663,7	22664,5	0,001	0,062	0,012	Ok
36	115	-793,3	-75912,2	299,3	71719,3	0,004	0,048	0,005	Ok

Parco Eolico "Bolina" – Progetto Definitivo
Relazione di calcolo preliminare delle fondazioni degli aerogeneratori G8 e G12

1	115	-793,3	-98238,9	476,8	13997,5	0,001	0,062	0,008	Ok
34	115	-840,0	-75668,4	130,6	80622,8	0,005	0,048	0,002	Ok
1	115	-840,0	-98154,7	313,4	33848,5	0,001	0,062	0,006	Ok
34	115	-886,7	-75604,3	40,9	86015,3	0,005	0,048	0,001	Ok
1	115	-886,7	-98071,6	173,5	47978,5	0,002	0,062	0,003	Ok
34	115	-933,3	-75540,9	97,0	86051,7	0,005	0,048	0,002	Ok
1	115	-933,3	-97989,4	58,6	55817,9	0,002	0,062	0,001	Ok
34	115	-980,0	-75478,4	166,7	81717,7	0,005	0,048	0,003	Ok
1	115	-980,0	-97908,3	45,2	58257,9	0,002	0,062	0,001	Ok
34	115	-1026,7	-75416,6	218,1	73992,6	0,004	0,048	0,004	Ok
1	115	-1026,7	-97828,2	115,2	56299,3	0,002	0,062	0,002	Ok
34	115	-1073,3	-75355,6	250,1	63832,7	0,004	0,048	0,004	Ok
1	115	-1073,3	-97749,1	166,2	50949,0	0,002	0,062	0,003	Ok
34	115	-1120,0	-75295,4	262,9	52167,6	0,003	0,048	0,005	Ok
1	115	-1120,0	-97671,0	196,6	43199,6	0,002	0,062	0,003	Ok
34	115	-1166,7	-75236,0	256,8	39901,5	0,002	0,048	0,005	Ok
1	115	-1166,7	-97593,9	206,5	34026,5	0,001	0,062	0,004	Ok
34	115	-1213,3	-75177,4	232,2	27917,5	0,003	0,056	0,004	Ok
1	115	-1213,3	-97517,9	196,2	24388,7	0,002	0,073	0,003	Ok
34	115	-1260,0	-75119,5	189,2	17082,1	0,002	0,056	0,003	Ok
1	115	-1260,0	-97442,8	165,8	15232,1	0,001	0,073	0,003	Ok
34	115	-1306,7	-75062,5	128,1	8251,2	0,001	0,056	0,002	Ok
1	115	-1306,7	-97368,8	115,5	7493,7	0,001	0,073	0,002	Ok
34	115	-1353,3	-75006,2	48,7	2274,5	0,000	0,056	0,001	Ok
1	115	-1353,3	-97295,7	45,1	2106,0	0,000	0,073	0,001	Ok
36	115	-1400,0	-75183,3	47,0	0,0	0,000	0,056	0,001	Ok
1	115	-1400,0	-97295,7	45,1	0,0	0,000	0,073	0,001	Ok

Plinto n. 119

Cmb.	Palo	Quota (cm)	N (daN)	V (daN)	M (daN cm)	Ver. N/M	Ver.(25)	Ver.V	Stato
34	119	0,0	-65635,1	3860,9	1552421,0	0,093	0,042	0,068	Ok
1	119	0,0	-84933,2	3253,7	1604618,0	0,068	0,054	0,058	Ok
34	119	-46,7	-65591,8	3736,4	1373640,0	0,083	0,042	0,066	Ok
1	119	-46,7	-84877,1	3261,1	1452224,0	0,061	0,054	0,058	Ok
34	119	-93,3	-65536,9	3555,6	1199377,0	0,072	0,042	0,063	Ok
1	119	-93,3	-84806,1	3196,9	1300186,0	0,055	0,054	0,057	Ok
34	119	-140,0	-65471,4	3327,0	1033549,0	0,062	0,042	0,059	Ok
1	119	-140,0	-84721,4	3080,1	1151126,0	0,049	0,054	0,055	Ok
34	119	-186,7	-65406,6	3073,6	878386,0	0,053	0,042	0,055	Ok
1	119	-186,7	-84637,5	2924,5	1007507,0	0,043	0,054	0,052	Ok
34	119	-233,3	-65342,5	2804,0	735047,5	0,044	0,041	0,050	Ok
1	119	-233,3	-84554,5	2739,0	871138,3	0,037	0,054	0,049	Ok
34	119	-280,0	-65279,0	2526,4	604297,7	0,036	0,041	0,045	Ok
1	119	-280,0	-84472,4	2532,1	743424,9	0,031	0,054	0,045	Ok
34	119	-326,7	-65216,2	2247,4	486513,7	0,029	0,041	0,040	Ok
1	119	-326,7	-84391,1	2311,3	625366,0	0,026	0,054	0,041	Ok
35	119	-373,3	-64554,8	1232,2	414566,3	0,025	0,041	0,022	Ok
1	119	-373,3	-84310,8	2083,2	517611,8	0,022	0,054	0,037	Ok
35	119	-420,0	-64493,9	1144,7	357098,0	0,021	0,041	0,020	Ok
1	119	-420,0	-84231,3	1853,5	420510,0	0,018	0,053	0,033	Ok
35	119	-466,7	-64433,7	1049,4	303714,4	0,018	0,041	0,019	Ok
1	119	-466,7	-84152,6	1626,9	334139,5	0,014	0,053	0,029	Ok
35	119	-513,3	-64374,2	949,5	254777,6	0,015	0,041	0,017	Ok
1	119	-513,3	-84074,9	1407,2	258367,1	0,011	0,053	0,025	Ok
35	119	-560,0	-64315,3	847,9	210499,6	0,013	0,041	0,015	Ok
1	119	-560,0	-83998,0	1197,5	192883,3	0,008	0,053	0,021	Ok
35	119	-606,7	-64257,1	746,8	170964,1	0,010	0,041	0,013	Ok
1	119	-606,7	-83922,0	1000,1	137251,0	0,006	0,053	0,018	Ok
35	119	-653,3	-64199,6	648,2	136148,3	0,008	0,041	0,011	Ok
1	119	-653,3	-83846,9	816,9	90963,1	0,004	0,053	0,014	Ok
35	119	-700,0	-64142,7	553,5	105938,7	0,006	0,041	0,010	Ok
1	119	-700,0	-83772,6	649,0	53558,1	0,002	0,053	0,012	Ok
35	119	-746,7	-64086,5	464,1	80150,9	0,005	0,041	0,008	Ok
1	119	-746,7	-83699,2	497,1	25215,6	0,001	0,053	0,009	Ok

Parco Eolico "Bolina" – Progetto Definitivo
Relazione di calcolo preliminare delle fondazioni degli aerogeneratori G8 e G12

36	119	-793,3	-64900,3	201,2	68285,6	0,004	0,041	0,004	Ok
1	119	-793,3	-83626,7	361,9	12509,0	0,001	0,053	0,006	Ok
36	119	-840,0	-64844,7	117,4	73539,3	0,004	0,041	0,002	Ok
1	119	-840,0	-83555,0	243,6	21774,7	0,001	0,053	0,004	Ok
36	119	-886,7	-64789,8	90,3	74967,1	0,005	0,041	0,002	Ok
1	119	-886,7	-83484,2	142,4	31573,6	0,001	0,053	0,003	Ok
36	119	-933,3	-64735,5	120,3	72905,0	0,004	0,041	0,002	Ok
1	119	-933,3	-83414,3	60,6	37492,1	0,002	0,053	0,001	Ok
36	119	-980,0	-64681,9	160,4	67920,5	0,004	0,041	0,003	Ok
1	119	-980,0	-83345,2	32,1	39667,1	0,002	0,053	0,001	Ok
36	119	-1026,7	-64629,0	191,9	60659,9	0,004	0,041	0,003	Ok
1	119	-1026,7	-83277,0	75,3	38696,0	0,002	0,053	0,001	Ok
34	119	-1073,3	-64303,2	208,5	51944,1	0,003	0,041	0,004	Ok
1	119	-1073,3	-83209,7	112,0	35259,4	0,001	0,053	0,002	Ok
34	119	-1120,0	-64251,9	215,9	42216,6	0,003	0,041	0,004	Ok
1	119	-1120,0	-83143,2	134,8	30052,8	0,001	0,053	0,002	Ok
34	119	-1166,7	-64201,2	208,8	32141,6	0,002	0,041	0,004	Ok
1	119	-1166,7	-83077,6	143,1	23768,9	0,001	0,053	0,003	Ok
34	119	-1213,3	-64151,1	187,3	22400,1	0,002	0,048	0,003	Ok
1	119	-1213,3	-83012,9	136,9	17093,6	0,001	0,062	0,002	Ok
34	119	-1260,0	-64101,7	151,8	13659,3	0,001	0,048	0,003	Ok
1	119	-1260,0	-82949,0	116,3	10706,0	0,001	0,062	0,002	Ok
34	119	-1306,7	-64053,0	102,2	6577,2	0,001	0,048	0,002	Ok
1	119	-1306,7	-82886,0	81,3	5280,2	0,000	0,062	0,001	Ok
34	119	-1353,3	-64005,0	38,7	1806,9	0,000	0,048	0,001	Ok
1	119	-1353,3	-82823,8	31,9	1487,8	0,000	0,062	0,001	Ok
17	119	-1400,0	-63127,7	25,4	0,0	0,000	0,047	0,000	Ok
1	119	-1400,0	-82823,8	31,9	0,0	0,000	0,062	0,001	Ok

Plinto n. 135

Cmb.	Palo	Quota (cm)	N (daN)	V (daN)	M (daN cm)	Ver. N/M	Ver.(25)	Ver.V	Stato
34	135	0,0	-44629,0	3347,2	1331221,0	0,083	0,028	0,059	Ok
1	135	0,0	-57366,0	2630,3	1331595,0	0,058	0,036	0,047	Ok
34	135	-46,7	-44599,5	3233,0	1176569,0	0,074	0,028	0,057	Ok
1	135	-46,7	-57328,1	2649,6	1208123,0	0,053	0,036	0,047	Ok
34	135	-93,3	-44562,2	3071,6	1026032,0	0,064	0,028	0,054	Ok
1	135	-93,3	-57280,2	2608,1	1084535,0	0,048	0,036	0,046	Ok
34	135	-140,0	-44517,7	2869,5	883018,9	0,055	0,028	0,051	Ok
1	135	-140,0	-57222,9	2522,4	962877,6	0,042	0,036	0,045	Ok
34	135	-186,7	-44473,6	2647,1	749428,8	0,047	0,028	0,047	Ok
1	135	-186,7	-57166,3	2403,4	845211,4	0,037	0,036	0,043	Ok
34	135	-233,3	-44430,0	2411,5	626224,0	0,039	0,028	0,043	Ok
1	135	-233,3	-57110,2	2258,1	733098,0	0,032	0,036	0,040	Ok
34	135	-280,0	-44386,8	2169,8	514033,4	0,032	0,028	0,038	Ok
1	135	-280,0	-57054,8	2093,9	627760,9	0,028	0,036	0,037	Ok
34	135	-326,7	-44344,1	1927,7	413159,2	0,026	0,028	0,034	Ok
1	135	-326,7	-56999,9	1916,9	530086,8	0,023	0,036	0,034	Ok
35	135	-373,3	-43306,7	983,8	354387,0	0,022	0,028	0,017	Ok
1	135	-373,3	-56945,6	1732,8	440669,7	0,019	0,036	0,031	Ok
35	135	-420,0	-43265,9	923,9	308667,9	0,019	0,027	0,016	Ok
1	135	-420,0	-56891,9	1546,4	359847,9	0,016	0,036	0,027	Ok
35	135	-466,7	-43225,5	856,0	265726,9	0,017	0,027	0,015	Ok
1	135	-466,7	-56838,8	1361,5	287731,7	0,013	0,036	0,024	Ok
35	135	-513,3	-43185,6	782,7	225943,7	0,014	0,027	0,014	Ok
1	135	-513,3	-56786,3	1181,6	224249,3	0,010	0,036	0,021	Ok
35	135	-560,0	-43146,1	706,6	189570,2	0,012	0,027	0,013	Ok
1	135	-560,0	-56734,4	1009,3	169174,6	0,007	0,036	0,018	Ok
35	135	-606,7	-43107,0	629,4	156748,5	0,010	0,027	0,011	Ok
1	135	-606,7	-56683,0	846,5	122163,3	0,005	0,036	0,015	Ok
35	135	-653,3	-43068,4	553,1	127526,9	0,008	0,027	0,010	Ok
1	135	-653,3	-56632,3	694,9	82788,1	0,004	0,036	0,012	Ok
35	135	-700,0	-43030,3	478,9	101873,7	0,006	0,027	0,008	Ok
1	135	-700,0	-56582,1	555,6	50580,6	0,002	0,036	0,010	Ok
35	135	-746,7	-42992,6	407,9	79693,0	0,005	0,027	0,007	Ok

Parco Eolico "Bolina" – Progetto Definitivo
Relazione di calcolo preliminare delle fondazioni degli aerogeneratori G8 e G12

1	135	-746,7	-56532,5	429,2	25182,1	0,001	0,036	0,008	Ok
35	135	-793,3	-42955,3	341,2	60836,8	0,004	0,027	0,006	Ok
1	135	-793,3	-56483,6	316,2	8060,2	0,000	0,036	0,006	Ok
34	135	-840,0	-43904,8	71,0	63747,5	0,004	0,028	0,001	Ok
1	135	-840,0	-56435,2	216,9	12480,6	0,001	0,036	0,004	Ok
34	135	-886,7	-43867,6	53,3	65520,7	0,004	0,028	0,001	Ok
1	135	-886,7	-56387,3	131,3	21592,8	0,001	0,036	0,002	Ok
34	135	-933,3	-43830,9	95,9	63960,6	0,004	0,028	0,002	Ok
1	135	-933,3	-56340,1	60,0	27370,4	0,001	0,036	0,001	Ok
34	135	-980,0	-43794,6	137,4	59693,5	0,004	0,028	0,002	Ok
1	135	-980,0	-56293,5	15,7	29917,3	0,001	0,036	0,000	Ok
34	135	-1026,7	-43758,7	167,5	53353,7	0,003	0,028	0,003	Ok
1	135	-1026,7	-56247,4	50,0	29756,5	0,001	0,036	0,001	Ok
34	135	-1073,3	-43723,3	185,1	45565,6	0,003	0,028	0,003	Ok
1	135	-1073,3	-56201,9	82,5	27465,1	0,001	0,036	0,001	Ok
34	135	-1120,0	-43688,4	190,2	36938,3	0,002	0,028	0,003	Ok
1	135	-1120,0	-56157,0	103,2	23625,3	0,001	0,036	0,002	Ok
34	135	-1166,7	-43653,9	183,0	28065,1	0,002	0,028	0,003	Ok
1	135	-1166,7	-56112,7	111,7	18814,8	0,001	0,036	0,002	Ok
34	135	-1213,3	-43619,9	163,7	19525,7	0,002	0,033	0,003	Ok
1	135	-1213,3	-56069,0	108,1	13604,3	0,001	0,042	0,002	Ok
34	135	-1260,0	-43586,3	132,3	11889,1	0,001	0,033	0,002	Ok
1	135	-1260,0	-56025,8	92,6	8558,4	0,001	0,042	0,002	Ok
34	135	-1306,7	-43553,2	88,9	5717,3	0,001	0,033	0,002	Ok
1	135	-1306,7	-55983,3	65,1	4237,2	0,000	0,042	0,001	Ok
34	135	-1353,3	-43520,6	33,6	1568,5	0,000	0,033	0,001	Ok
1	135	-1353,3	-55941,3	25,7	1198,6	0,000	0,042	0,000	Ok
35	135	-1400,0	-42542,9	6,9	0,0	0,024	0,032	0,000	Ok
1	135	-1400,0	-55941,3	25,7	0,0	0,000	0,042	0,000	Ok

Plinto n. 147

Cmb.	Palo	Quota (cm)	N (daN)	V (daN)	M (daN cm)	Ver. N/M	Ver.(25)	Ver.V	Stato
18	147	0,0	-41326,2	4130,2	1718341,0	0,108	0,026	0,073	Ok
1	147	0,0	-53609,3	3818,6	1873792,0	0,083	0,034	0,068	Ok
18	147	-46,7	-41299,0	4018,7	1526826,0	0,096	0,026	0,071	Ok
1	147	-46,7	-53573,9	3824,4	1694802,0	0,075	0,034	0,068	Ok
18	147	-93,3	-41264,4	3842,3	1339480,0	0,085	0,026	0,068	Ok
1	147	-93,3	-53529,1	3746,5	1516331,0	0,067	0,034	0,066	Ok
18	147	-140,0	-41223,2	3612,5	1160356,0	0,073	0,026	0,064	Ok
1	147	-140,0	-53475,6	3607,0	1341493,0	0,059	0,034	0,064	Ok
18	147	-186,7	-41182,4	3352,7	991951,1	0,063	0,026	0,059	Ok
1	147	-186,7	-53422,7	3422,5	1173165,0	0,052	0,034	0,061	Ok
18	147	-233,3	-41142,0	3072,5	835666,2	0,053	0,026	0,054	Ok
1	147	-233,3	-53370,3	3203,2	1013449,0	0,045	0,034	0,057	Ok
18	147	-280,0	-41102,0	2780,8	692467,3	0,044	0,026	0,049	Ok
1	147	-280,0	-53318,5	2959,2	863966,7	0,038	0,034	0,052	Ok
34	147	-326,7	-41303,2	2468,9	563279,4	0,036	0,026	0,044	Ok
1	147	-326,7	-53267,2	2699,4	725869,6	0,032	0,034	0,048	Ok
19	147	-373,3	-40848,1	1554,7	475843,1	0,030	0,026	0,028	Ok
1	147	-373,3	-53216,4	2431,2	599898,8	0,027	0,034	0,043	Ok
19	147	-420,0	-40809,6	1422,7	403554,3	0,026	0,026	0,025	Ok
1	147	-420,0	-53166,3	2161,5	486441,8	0,021	0,034	0,038	Ok
19	147	-466,7	-40771,5	1285,4	337420,2	0,021	0,026	0,023	Ok
1	147	-466,7	-53116,6	1895,7	385570,7	0,017	0,034	0,034	Ok
19	147	-513,3	-40733,8	1146,3	277700,3	0,018	0,026	0,020	Ok
1	147	-513,3	-53067,6	1638,1	297107,2	0,013	0,034	0,029	Ok
19	147	-560,0	-40696,6	1008,4	224485,8	0,014	0,026	0,018	Ok
1	147	-560,0	-53019,0	1392,5	220661,0	0,010	0,034	0,025	Ok
19	147	-606,7	-40659,7	874,3	177730,2	0,011	0,026	0,016	Ok
1	147	-606,7	-52971,1	1161,5	155677,5	0,007	0,034	0,021	Ok
35	147	-653,3	-40384,2	743,8	137236,9	0,009	0,026	0,013	Ok
1	147	-653,3	-52923,6	947,0	101477,4	0,004	0,034	0,017	Ok
35	147	-700,0	-40348,4	621,3	104215,8	0,007	0,026	0,011	Ok
1	147	-700,0	-52876,8	750,6	57285,0	0,003	0,034	0,013	Ok

Parco Eolico "Bolina" – Progetto Definitivo
Relazione di calcolo preliminare delle fondazioni degli aerogeneratori G8 e G12

35	147	-746,7	-40313,0	508,3	77303,8	0,005	0,026	0,009	Ok
1	147	-746,7	-52830,4	573,0	22265,4	0,001	0,034	0,010	Ok
34	147	-793,3	-40929,1	243,7	61213,6	0,004	0,026	0,004	Ok
1	147	-793,3	-52784,7	414,9	4553,8	0,000	0,034	0,007	Ok
34	147	-840,0	-40894,0	135,1	69502,9	0,004	0,026	0,002	Ok
1	147	-840,0	-52739,4	276,2	23861,6	0,001	0,033	0,005	Ok
34	147	-886,7	-40859,3	73,9	73259,3	0,005	0,026	0,001	Ok
1	147	-886,7	-52694,7	157,0	36745,2	0,002	0,033	0,003	Ok
34	147	-933,3	-40825,1	97,4	72866,6	0,005	0,026	0,002	Ok
1	147	-933,3	-52650,6	56,9	44067,6	0,002	0,033	0,001	Ok
18	147	-980,0	-40553,6	140,1	68972,4	0,004	0,026	0,002	Ok
1	147	-980,0	-52607,0	24,4	46722,2	0,002	0,033	0,000	Ok
18	147	-1026,7	-40520,4	183,7	62494,1	0,004	0,026	0,003	Ok
1	147	-1026,7	-52564,0	87,1	45587,8	0,002	0,033	0,002	Ok
18	147	-1073,3	-40487,6	211,0	53943,1	0,003	0,026	0,004	Ok
1	147	-1073,3	-52521,5	131,8	41525,0	0,002	0,033	0,002	Ok
18	147	-1120,0	-40455,3	222,0	44105,9	0,003	0,026	0,004	Ok
1	147	-1120,0	-52479,5	158,8	35375,5	0,002	0,033	0,003	Ok
18	147	-1166,7	-40423,4	217,1	33748,9	0,002	0,026	0,004	Ok
1	147	-1166,7	-52438,1	168,5	27964,1	0,001	0,033	0,003	Ok
18	147	-1213,3	-40391,9	196,4	23621,0	0,003	0,030	0,003	Ok
1	147	-1213,3	-52397,2	161,1	20100,5	0,002	0,039	0,003	Ok
18	147	-1260,0	-40360,8	160,1	14457,7	0,002	0,030	0,003	Ok
1	147	-1260,0	-52356,9	136,7	12583,4	0,001	0,039	0,002	Ok
18	147	-1306,7	-40330,1	108,4	6985,6	0,001	0,030	0,002	Ok
1	147	-1306,7	-52317,1	95,5	6203,3	0,000	0,039	0,002	Ok
18	147	-1353,3	-40299,9	41,3	1926,2	0,000	0,030	0,001	Ok
1	147	-1353,3	-52277,9	37,4	1747,0	0,000	0,039	0,001	Ok
34	147	-1400,0	-40536,1	41,0	0,0	0,023	0,030	0,001	Ok
1	147	-1400,0	-52277,9	37,4	0,0	0,000	0,039	0,001	Ok

Plinto n. 167

Cmb.	Palo	Quota (cm)	N (daN)	V (daN)	M (daN cm)	Ver. N/M	Ver.(25)	Ver.V	Stato
18	167	0,0	-16732,2	2152,5	819562,4	0,055	0,011	0,038	Ok
1	167	0,0	-21229,6	1276,4	711422,5	0,033	0,013	0,023	Ok
18	167	-46,7	-16721,1	2065,4	720256,4	0,048	0,011	0,037	Ok
1	167	-46,7	-21215,6	1310,6	651076,6	0,030	0,013	0,023	Ok
18	167	-93,3	-16707,2	1950,8	624014,9	0,042	0,011	0,035	Ok
1	167	-93,3	-21197,8	1310,0	589913,6	0,027	0,013	0,023	Ok
18	167	-140,0	-16690,5	1811,6	533119,3	0,036	0,011	0,032	Ok
1	167	-140,0	-21176,7	1285,1	528781,0	0,025	0,013	0,023	Ok
18	167	-186,7	-16673,9	1661,4	448721,9	0,030	0,011	0,029	Ok
1	167	-186,7	-21155,7	1240,1	468808,4	0,022	0,013	0,022	Ok
18	167	-233,3	-16657,6	1504,7	371339,4	0,025	0,011	0,027	Ok
1	167	-233,3	-21134,9	1178,7	410938,0	0,019	0,013	0,021	Ok
18	167	-280,0	-16641,4	1345,8	301282,6	0,020	0,011	0,024	Ok
1	167	-280,0	-21114,4	1104,9	355931,5	0,017	0,013	0,020	Ok
18	167	-326,7	-16625,4	1188,3	238661,8	0,016	0,011	0,021	Ok
1	167	-326,7	-21094,1	1022,1	304369,4	0,014	0,013	0,018	Ok
19	167	-373,3	-15812,0	411,2	211502,7	0,014	0,010	0,007	Ok
1	167	-373,3	-21074,0	933,4	256670,5	0,012	0,013	0,017	Ok
19	167	-420,0	-15797,1	413,1	192730,1	0,013	0,010	0,007	Ok
1	167	-420,0	-21054,1	841,6	213110,3	0,010	0,013	0,015	Ok
19	167	-466,7	-15782,3	406,9	173772,5	0,012	0,010	0,007	Ok
1	167	-466,7	-21034,5	749,0	173834,9	0,008	0,013	0,013	Ok
19	167	-513,3	-15767,8	394,0	155037,8	0,010	0,010	0,007	Ok
1	167	-513,3	-21015,1	657,4	138883,9	0,006	0,013	0,012	Ok
19	167	-560,0	-15753,3	375,6	136860,1	0,009	0,010	0,007	Ok
1	167	-560,0	-20995,8	568,5	108205,4	0,005	0,013	0,010	Ok
35	167	-606,7	-15510,2	354,4	119456,2	0,008	0,010	0,006	Ok
1	167	-606,7	-20976,8	483,6	81673,5	0,004	0,013	0,009	Ok
35	167	-653,3	-15496,3	325,9	103994,7	0,007	0,010	0,006	Ok
1	167	-653,3	-20958,1	403,7	59103,8	0,003	0,013	0,007	Ok
35	167	-700,0	-15482,6	297,0	89701,9	0,006	0,010	0,005	Ok

Parco Eolico "Bolina" – Progetto Definitivo
Relazione di calcolo preliminare delle fondazioni degli aerogeneratori G8 e G12

1	167	-700,0	-20939,5	329,4	40265,1	0,002	0,013	0,006	Ok
35	167	-746,7	-15469,0	268,4	76618,3	0,005	0,010	0,005	Ok
1	167	-746,7	-20921,2	261,4	24892,3	0,001	0,013	0,005	Ok
35	167	-793,3	-15455,6	240,3	64753,9	0,004	0,010	0,004	Ok
1	167	-793,3	-20903,0	199,9	12696,3	0,001	0,013	0,004	Ok
35	167	-840,0	-15442,4	213,3	54093,0	0,004	0,010	0,004	Ok
1	167	-840,0	-20885,1	145,2	3378,7	0,000	0,013	0,003	Ok
34	167	-886,7	-16674,4	72,5	48650,4	0,003	0,011	0,001	Ok
1	167	-886,7	-20867,4	97,4	3427,8	0,000	0,013	0,002	Ok
34	167	-933,3	-16660,5	92,7	46016,1	0,003	0,011	0,002	Ok
1	167	-933,3	-20849,9	56,5	7963,3	0,000	0,013	0,001	Ok
34	167	-980,0	-16646,7	112,0	41968,7	0,003	0,011	0,002	Ok
1	167	-980,0	-20832,7	22,4	10596,1	0,000	0,013	0,000	Ok
34	167	-1026,7	-16633,0	125,6	36860,1	0,002	0,011	0,002	Ok
1	167	-1026,7	-20815,6	4,9	11640,6	0,001	0,013	0,000	Ok
34	167	-1073,3	-16619,6	132,4	31049,0	0,002	0,011	0,002	Ok
1	167	-1073,3	-20798,8	25,4	11413,2	0,001	0,013	0,000	Ok
34	167	-1120,0	-16606,3	132,1	24891,6	0,002	0,011	0,002	Ok
1	167	-1120,0	-20782,2	39,4	10226,2	0,000	0,013	0,001	Ok
34	167	-1166,7	-16593,2	124,4	18738,8	0,001	0,011	0,002	Ok
1	167	-1166,7	-20765,8	46,8	8388,2	0,000	0,013	0,001	Ok
34	167	-1213,3	-16580,3	109,6	12935,8	0,002	0,012	0,002	Ok
1	167	-1213,3	-20749,6	47,8	6203,5	0,001	0,016	0,001	Ok
34	167	-1260,0	-16567,5	87,5	7823,3	0,001	0,012	0,002	Ok
1	167	-1260,0	-20733,6	42,3	3973,6	0,000	0,016	0,001	Ok
34	167	-1306,7	-16554,9	58,3	3738,9	0,000	0,012	0,001	Ok
1	167	-1306,7	-20717,9	30,5	1997,7	0,000	0,016	0,001	Ok
34	167	-1353,3	-16542,5	21,8	1019,0	0,000	0,012	0,000	Ok
1	167	-1353,3	-20702,3	12,3	573,9	0,000	0,016	0,000	Ok
20	167	-1400,0	-15862,9	8,8	0,0	0,009	0,012	0,000	Ok
1	167	-1400,0	-20702,3	12,3	0,0	0,000	0,016	0,000	Ok

Plinto n. 179

Cmb.	Palo	Quota (cm)	N (daN)	V (daN)	M (daN cm)	Ver. N/M	Ver.(25)	Ver.V	Stato
34	179	0,0	-22811,0	2601,1	1002588,0	0,066	0,014	0,046	Ok
1	179	0,0	-29205,4	1786,8	937504,5	0,043	0,019	0,032	Ok
34	179	-46,7	-22796,0	2499,5	882912,3	0,058	0,014	0,044	Ok
1	179	-46,7	-29186,1	1812,5	853411,1	0,039	0,019	0,032	Ok
34	179	-93,3	-22776,9	2364,1	766842,0	0,050	0,014	0,042	Ok
1	179	-93,3	-29161,7	1794,1	768854,8	0,035	0,019	0,032	Ok
34	179	-140,0	-22754,1	2198,8	657078,4	0,043	0,014	0,039	Ok
1	179	-140,0	-29132,6	1744,4	685152,4	0,031	0,019	0,031	Ok
34	179	-186,7	-22731,6	2019,9	555026,7	0,036	0,014	0,036	Ok
1	179	-186,7	-29103,7	1669,9	603768,9	0,028	0,018	0,030	Ok
34	179	-233,3	-22709,3	1832,6	461346,1	0,030	0,014	0,032	Ok
1	179	-233,3	-29075,2	1575,8	525858,5	0,024	0,018	0,028	Ok
34	179	-280,0	-22687,3	1642,2	376450,3	0,025	0,014	0,029	Ok
1	179	-280,0	-29046,9	1467,2	452336,9	0,021	0,018	0,026	Ok
34	179	-326,7	-22665,4	1453,0	300516,3	0,020	0,014	0,026	Ok
1	179	-326,7	-29019,0	1348,6	383882,3	0,018	0,018	0,024	Ok
19	179	-373,3	-21958,1	647,5	260464,3	0,017	0,014	0,011	Ok
1	179	-373,3	-28991,4	1223,8	320964,0	0,015	0,018	0,022	Ok
19	179	-420,0	-21937,4	616,5	231676,1	0,015	0,014	0,011	Ok
1	179	-420,0	-28964,0	1096,5	263868,1	0,012	0,018	0,019	Ok
19	179	-466,7	-21917,0	580,0	204126,2	0,013	0,014	0,010	Ok
1	179	-466,7	-28937,0	969,4	212715,9	0,010	0,018	0,017	Ok
19	179	-513,3	-21896,7	539,3	178126,0	0,012	0,014	0,010	Ok
1	179	-513,3	-28910,3	845,1	167496,0	0,008	0,018	0,015	Ok
19	179	-560,0	-21876,7	495,8	153906,3	0,010	0,014	0,009	Ok
1	179	-560,0	-28883,8	725,4	128083,5	0,006	0,018	0,013	Ok
19	179	-606,7	-21856,9	450,7	131625,3	0,009	0,014	0,008	Ok
1	179	-606,7	-28857,7	611,8	94264,0	0,004	0,018	0,011	Ok
19	179	-653,3	-21837,3	405,1	111376,6	0,007	0,014	0,007	Ok
1	179	-653,3	-28831,8	505,6	65755,7	0,003	0,018	0,009	Ok

Parco Eolico "Bolina" – Progetto Definitivo
Relazione di calcolo preliminare delle fondazioni degli aerogeneratori G8 e G12

19	179	-700,0	-21818,0	360,0	93196,5	0,006	0,014	0,006	Ok
1	179	-700,0	-28806,3	407,6	42228,6	0,002	0,018	0,007	Ok
19	179	-746,7	-21798,9	316,1	77072,6	0,005	0,014	0,006	Ok
1	179	-746,7	-28781,1	318,3	23344,1	0,001	0,018	0,006	Ok
19	179	-793,3	-21780,0	274,2	62951,0	0,004	0,014	0,005	Ok
1	179	-793,3	-28756,1	238,2	8957,3	0,000	0,018	0,004	Ok
34	179	-840,0	-22440,9	60,7	54757,3	0,004	0,014	0,001	Ok
1	179	-840,0	-28731,5	167,5	4514,3	0,000	0,018	0,003	Ok
34	179	-886,7	-22421,9	63,9	54892,9	0,004	0,014	0,001	Ok
1	179	-886,7	-28707,1	106,1	11195,0	0,001	0,018	0,002	Ok
34	179	-933,3	-22403,1	93,4	52679,0	0,003	0,014	0,002	Ok
1	179	-933,3	-28683,1	54,3	15934,4	0,001	0,018	0,001	Ok
34	179	-980,0	-22384,5	121,1	48559,6	0,003	0,014	0,002	Ok
1	179	-980,0	-28659,4	13,5	18354,2	0,001	0,018	0,000	Ok
34	179	-1026,7	-22366,2	141,1	42996,4	0,003	0,014	0,003	Ok
1	179	-1026,7	-28635,9	24,5	18806,0	0,001	0,018	0,000	Ok
34	179	-1073,3	-22348,1	152,0	36450,1	0,002	0,014	0,003	Ok
1	179	-1073,3	-28612,7	48,7	17693,4	0,001	0,018	0,001	Ok
34	179	-1120,0	-22330,3	153,7	29372,8	0,002	0,014	0,003	Ok
1	179	-1120,0	-28589,9	64,7	15425,2	0,001	0,018	0,001	Ok
34	179	-1166,7	-22312,7	146,2	22206,9	0,001	0,014	0,003	Ok
1	179	-1166,7	-28567,3	72,1	12407,3	0,001	0,018	0,001	Ok
34	179	-1213,3	-22295,3	129,7	15385,4	0,002	0,017	0,002	Ok
1	179	-1213,3	-28545,1	71,1	9040,9	0,001	0,021	0,001	Ok
34	179	-1260,0	-22278,1	104,2	9334,0	0,001	0,017	0,002	Ok
1	179	-1260,0	-28523,1	61,6	5723,4	0,001	0,021	0,001	Ok
34	179	-1306,7	-22261,2	69,7	4473,6	0,001	0,017	0,001	Ok
1	179	-1306,7	-28501,4	43,7	2849,0	0,000	0,021	0,001	Ok
34	179	-1353,3	-22244,5	26,2	1222,9	0,000	0,017	0,000	Ok
1	179	-1353,3	-28480,0	17,4	810,3	0,000	0,021	0,000	Ok
34	179	-1400,0	-22244,5	26,2	0,0	0,012	0,017	0,000	Ok
1	179	-1400,0	-28480,0	17,4	0,0	0,000	0,021	0,000	Ok

Plinto n. 183

Cmb.	Palo	Quota (cm)	N (daN)	V (daN)	M (daN cm)	Ver. N/M	Ver.(25)	Ver.V	Stato
34	183	0,0	-12700,5	1967,9	714472,9	0,048	0,008	0,035	Ok
1	183	0,0	-15768,8	985,4	569297,6	0,027	0,010	0,017	Ok
34	183	-46,7	-12692,2	1874,0	624321,3	0,042	0,008	0,033	Ok
1	183	-46,7	-15758,4	1019,2	522678,7	0,025	0,010	0,018	Ok
34	183	-93,3	-12681,5	1758,4	537434,2	0,036	0,008	0,031	Ok
1	183	-93,3	-15745,2	1024,5	475197,3	0,022	0,010	0,018	Ok
34	183	-140,0	-12668,9	1622,0	455950,6	0,031	0,008	0,029	Ok
1	183	-140,0	-15729,5	1010,4	427454,9	0,020	0,010	0,018	Ok
34	183	-186,7	-12656,3	1478,0	380846,9	0,026	0,008	0,026	Ok
1	183	-186,7	-15713,9	979,6	380359,9	0,018	0,010	0,017	Ok
34	183	-233,3	-12643,9	1330,2	312503,0	0,021	0,008	0,024	Ok
1	183	-233,3	-15698,5	935,1	334695,5	0,016	0,010	0,017	Ok
34	183	-280,0	-12631,6	1182,3	251130,3	0,017	0,008	0,021	Ok
1	183	-280,0	-15683,3	880,1	291101,0	0,014	0,010	0,016	Ok
34	183	-326,7	-12619,5	1037,2	196782,8	0,013	0,008	0,018	Ok
1	183	-326,7	-15668,2	817,3	250071,0	0,012	0,010	0,014	Ok
19	183	-373,3	-11474,4	310,3	176986,8	0,012	0,007	0,006	Ok
1	183	-373,3	-15653,2	749,2	211970,2	0,010	0,010	0,013	Ok
19	183	-420,0	-11463,5	311,2	164946,8	0,011	0,007	0,006	Ok
1	183	-420,0	-15638,5	678,1	177046,9	0,008	0,010	0,012	Ok
19	183	-466,7	-11452,8	309,9	152190,8	0,010	0,007	0,005	Ok
1	183	-466,7	-15623,9	605,8	145444,1	0,007	0,010	0,011	Ok
19	183	-513,3	-11442,3	305,4	139038,1	0,009	0,007	0,005	Ok
1	183	-513,3	-15609,5	534,0	117218,0	0,006	0,010	0,009	Ok
19	183	-560,0	-11431,8	297,7	125774,8	0,008	0,007	0,005	Ok
1	183	-560,0	-15595,2	463,9	92349,7	0,004	0,010	0,008	Ok
19	183	-606,7	-11421,4	286,7	112648,3	0,008	0,007	0,005	Ok
1	183	-606,7	-15581,1	396,7	70759,9	0,003	0,010	0,007	Ok
19	183	-653,3	-11411,2	273,0	99866,5	0,007	0,007	0,005	Ok

Parco Eolico "Bolina" – Progetto Definitivo
Relazione di calcolo preliminare delle fondazioni degli aerogeneratori G8 e G12

1	183	-653,3	-15567,1	333,1	52322,9	0,002	0,010	0,006	Ok
19	183	-700,0	-11401,1	257,1	87598,2	0,006	0,007	0,005	Ok
1	183	-700,0	-15553,3	273,8	36877,8	0,002	0,010	0,005	Ok
19	183	-746,7	-11391,1	239,5	75976,1	0,005	0,007	0,004	Ok
1	183	-746,7	-15539,7	219,3	24248,6	0,001	0,010	0,004	Ok
19	183	-793,3	-11381,3	220,7	65099,3	0,004	0,007	0,004	Ok
1	183	-793,3	-15526,2	169,9	14281,9	0,001	0,010	0,003	Ok
19	183	-840,0	-11371,5	201,2	55037,8	0,004	0,007	0,004	Ok
1	183	-840,0	-15512,9	125,9	7022,1	0,000	0,010	0,002	Ok
34	183	-886,7	-12483,9	67,1	46195,0	0,003	0,008	0,001	Ok
1	183	-886,7	-15499,8	87,3	3828,0	0,000	0,010	0,002	Ok
34	183	-933,3	-12473,4	89,4	43424,5	0,003	0,008	0,002	Ok
1	183	-933,3	-15486,8	54,3	5463,3	0,000	0,010	0,001	Ok
34	183	-980,0	-12463,1	107,5	39388,7	0,003	0,008	0,002	Ok
1	183	-980,0	-15474,0	27,3	7381,2	0,000	0,010	0,000	Ok
34	183	-1026,7	-12452,9	119,5	34428,4	0,002	0,008	0,002	Ok
1	183	-1026,7	-15461,3	10,4	8330,3	0,000	0,010	0,000	Ok
34	183	-1073,3	-12442,8	124,8	28878,5	0,002	0,008	0,002	Ok
1	183	-1073,3	-15448,8	17,4	8330,4	0,000	0,010	0,000	Ok
34	183	-1120,0	-12432,9	123,5	23065,4	0,002	0,008	0,002	Ok
1	183	-1120,0	-15436,5	28,0	7571,2	0,000	0,010	0,000	Ok
34	183	-1166,7	-12423,1	115,7	17306,4	0,001	0,008	0,002	Ok
1	183	-1166,7	-15424,3	34,3	6276,7	0,000	0,010	0,001	Ok
34	183	-1213,3	-12413,4	101,3	11911,4	0,002	0,009	0,002	Ok
1	183	-1213,3	-15412,3	35,6	4680,4	0,000	0,012	0,001	Ok
34	183	-1260,0	-12403,8	80,6	7184,1	0,001	0,009	0,001	Ok
1	183	-1260,0	-15400,4	32,0	3018,0	0,000	0,012	0,001	Ok
34	183	-1306,7	-12394,4	53,4	3424,4	0,000	0,009	0,001	Ok
1	183	-1306,7	-15388,7	23,3	1525,9	0,000	0,012	0,000	Ok
34	183	-1353,3	-12385,1	19,9	930,5	0,000	0,009	0,000	Ok
1	183	-1353,3	-15377,2	9,4	440,9	0,000	0,012	0,000	Ok
34	183	-1400,0	-12385,1	19,9	0,0	0,007	0,009	0,000	Ok
1	183	-1400,0	-15377,2	9,4	0,0	0,000	0,012	0,000	Ok

Plinto n. 199

Cmb.	Palo	Quota (cm)	N (daN)	V (daN)	M (daN cm)	Ver. N/M	Ver.(25)	Ver.V	Stato
34	199	0,0	-16729,1	2238,7	838120,6	0,056	0,011	0,040	Ok
1	199	0,0	-21225,6	1372,6	732489,6	0,034	0,013	0,024	Ok
34	199	-46,7	-16718,1	2142,3	735069,0	0,049	0,011	0,038	Ok
1	199	-46,7	-21211,6	1396,3	668005,8	0,031	0,013	0,025	Ok
34	199	-93,3	-16704,1	2018,7	635389,4	0,042	0,011	0,036	Ok
1	199	-93,3	-21193,9	1385,6	603028,8	0,028	0,013	0,025	Ok
34	199	-140,0	-16687,4	1870,2	541477,6	0,036	0,011	0,033	Ok
1	199	-140,0	-21172,7	1350,5	538527,1	0,025	0,013	0,024	Ok
34	199	-186,7	-16670,9	1711,3	454500,6	0,030	0,011	0,030	Ok
1	199	-186,7	-21151,7	1295,8	475643,9	0,022	0,013	0,023	Ok
34	199	-233,3	-16654,5	1546,4	374956,9	0,025	0,011	0,027	Ok
1	199	-233,3	-21131,0	1225,5	415298,5	0,019	0,013	0,022	Ok
34	199	-280,0	-16638,4	1380,1	303137,9	0,020	0,011	0,024	Ok
1	199	-280,0	-21110,5	1143,5	358225,7	0,017	0,013	0,020	Ok
34	199	-326,7	-16622,4	1215,7	239134,7	0,016	0,011	0,022	Ok
1	199	-326,7	-21090,2	1053,2	304975,5	0,014	0,013	0,019	Ok
35	199	-373,3	-15809,0	423,2	210916,1	0,014	0,010	0,008	Ok
1	199	-373,3	-21070,1	957,9	255935,2	0,012	0,013	0,017	Ok
35	199	-420,0	-15794,1	423,4	191255,2	0,013	0,010	0,008	Ok
1	199	-420,0	-21050,2	860,1	211348,6	0,010	0,013	0,015	Ok
35	199	-466,7	-15779,3	415,0	171567,5	0,011	0,010	0,007	Ok
1	199	-466,7	-21030,6	762,3	171330,9	0,008	0,013	0,014	Ok
19	199	-513,3	-15535,3	417,5	152400,6	0,010	0,010	0,007	Ok
1	199	-513,3	-21011,1	666,2	135893,7	0,006	0,013	0,012	Ok
19	199	-560,0	-15521,1	386,7	135121,5	0,009	0,010	0,007	Ok
1	199	-560,0	-20991,9	573,5	104960,9	0,005	0,013	0,010	Ok
19	199	-606,7	-15507,0	355,9	118936,9	0,008	0,010	0,006	Ok
1	199	-606,7	-20972,9	485,4	78390,3	0,004	0,013	0,009	Ok

Parco Eolico "Bolina" – Progetto Definitivo
Relazione di calcolo preliminare delle fondazioni degli aerogeneratori G8 e G12

19	199	-653,3	-15493,1	325,3	103906,7	0,007	0,010	0,006	Ok
1	199	-653,3	-20954,2	402,9	55996,6	0,003	0,013	0,007	Ok
19	199	-700,0	-15479,4	295,4	90060,8	0,006	0,010	0,005	Ok
1	199	-700,0	-20935,6	326,6	37581,9	0,002	0,013	0,006	Ok
19	199	-746,7	-15465,8	266,4	77402,6	0,005	0,010	0,005	Ok
1	199	-746,7	-20917,3	257,0	23016,8	0,001	0,013	0,005	Ok
19	199	-793,3	-15452,4	238,6	65912,9	0,004	0,010	0,004	Ok
1	199	-793,3	-20899,1	194,5	12546,1	0,001	0,013	0,003	Ok
19	199	-840,0	-15439,2	212,4	55553,3	0,004	0,010	0,004	Ok
1	199	-840,0	-20881,2	139,3	7900,7	0,000	0,013	0,002	Ok
34	199	-886,7	-16443,7	56,6	49300,9	0,003	0,010	0,001	Ok
1	199	-886,7	-20863,5	91,7	9537,9	0,000	0,013	0,002	Ok
34	199	-933,3	-16430,0	86,4	46967,9	0,003	0,010	0,002	Ok
1	199	-933,3	-20846,1	52,2	12263,9	0,001	0,013	0,001	Ok
34	199	-980,0	-16416,3	110,6	43034,5	0,003	0,010	0,002	Ok
1	199	-980,0	-20828,8	24,1	13893,6	0,001	0,013	0,000	Ok
34	199	-1026,7	-16402,9	127,0	37912,5	0,003	0,010	0,002	Ok
1	199	-1026,7	-20811,8	22,6	14212,1	0,001	0,013	0,000	Ok
34	199	-1073,3	-16389,7	135,3	32003,1	0,002	0,010	0,002	Ok
1	199	-1073,3	-20794,9	37,3	13393,7	0,001	0,013	0,001	Ok
34	199	-1120,0	-16376,6	135,7	25694,8	0,002	0,010	0,002	Ok
1	199	-1120,0	-20778,3	48,9	11704,5	0,001	0,013	0,001	Ok
34	199	-1166,7	-16363,6	128,3	19364,2	0,001	0,010	0,002	Ok
1	199	-1166,7	-20761,9	54,6	9436,9	0,000	0,013	0,001	Ok
34	199	-1213,3	-16350,9	113,2	13378,0	0,002	0,012	0,002	Ok
1	199	-1213,3	-20745,7	54,0	6891,5	0,001	0,016	0,001	Ok
34	199	-1260,0	-16338,3	90,5	8095,5	0,001	0,012	0,002	Ok
1	199	-1260,0	-20729,8	47,0	4371,4	0,000	0,016	0,001	Ok
34	199	-1306,7	-16325,9	60,3	3870,7	0,000	0,012	0,001	Ok
1	199	-1306,7	-20714,0	33,4	2180,0	0,000	0,016	0,001	Ok
34	199	-1353,3	-16313,6	22,6	1055,3	0,000	0,012	0,000	Ok
1	199	-1353,3	-20698,5	13,3	621,3	0,000	0,015	0,000	Ok
33	199	-1400,0	-15860,0	7,6	0,0	0,009	0,012	0,000	Ok
1	199	-1400,0	-20698,5	13,3	0,0	0,000	0,015	0,000	Ok

Plinto n. 211

Cmb.	Palo	Quota (cm)	N (daN)	V (daN)	M (daN cm)	Ver. N/M	Ver.(25)	Ver.V	Stato
34	211	0,0	-41318,7	4194,1	1732303,0	0,109	0,026	0,074	Ok
1	211	0,0	-53599,5	3889,9	1890258,0	0,083	0,034	0,069	Ok
34	211	-46,7	-41291,4	4075,8	1537997,0	0,097	0,026	0,072	Ok
1	211	-46,7	-53564,2	3888,6	1708077,0	0,075	0,034	0,069	Ok
34	211	-93,3	-41256,9	3892,8	1348081,0	0,085	0,026	0,069	Ok
1	211	-93,3	-53519,3	3803,7	1526643,0	0,067	0,034	0,067	Ok
34	211	-140,0	-41215,7	3656,2	1166692,0	0,074	0,026	0,065	Ok
1	211	-140,0	-53465,9	3656,9	1349166,0	0,060	0,034	0,065	Ok
34	211	-186,7	-41174,9	3390,0	996338,0	0,063	0,026	0,060	Ok
1	211	-186,7	-53412,9	3465,3	1178539,0	0,052	0,034	0,061	Ok
34	211	-233,3	-41134,5	3103,7	838405,7	0,053	0,026	0,055	Ok
1	211	-233,3	-53360,5	3239,3	1016850,0	0,045	0,034	0,057	Ok
34	211	-280,0	-41094,5	2806,5	693844,6	0,044	0,026	0,050	Ok
1	211	-280,0	-53308,7	2989,2	865704,3	0,038	0,034	0,053	Ok
18	211	-326,7	-41295,9	2483,6	563554,5	0,036	0,026	0,044	Ok
1	211	-326,7	-53257,5	2723,7	726232,1	0,032	0,034	0,048	Ok
35	211	-373,3	-40840,6	1567,4	475258,4	0,030	0,026	0,028	Ok
1	211	-373,3	-53206,7	2450,4	599151,8	0,026	0,034	0,043	Ok
35	211	-420,0	-40802,1	1432,7	402255,3	0,025	0,026	0,025	Ok
1	211	-420,0	-53156,6	2176,1	484827,3	0,021	0,034	0,039	Ok
35	211	-466,7	-40764,0	1292,7	335540,5	0,021	0,026	0,023	Ok
1	211	-466,7	-53106,9	1906,1	383307,1	0,017	0,034	0,034	Ok
35	211	-513,3	-40726,4	1151,2	275360,1	0,017	0,026	0,020	Ok
1	211	-513,3	-53057,9	1645,1	294390,2	0,013	0,034	0,029	Ok
35	211	-560,0	-40689,1	1011,3	221790,5	0,014	0,026	0,018	Ok
1	211	-560,0	-53009,4	1396,4	217666,5	0,010	0,034	0,025	Ok
19	211	-606,7	-40412,8	875,6	175295,6	0,011	0,026	0,016	Ok

Parco Eolico "Bolina" – Progetto Definitivo
Relazione di calcolo preliminare delle fondazioni degli aerogeneratori G8 e G12

1	211	-606,7	-52961,4	1162,7	152566,2	0,007	0,034	0,021	Ok
19	211	-653,3	-40376,6	743,1	136290,7	0,009	0,026	0,013	Ok
1	211	-653,3	-52914,0	946,2	98408,2	0,004	0,034	0,017	Ok
19	211	-700,0	-40340,8	619,5	103807,9	0,007	0,026	0,011	Ok
1	211	-700,0	-52867,1	748,0	54462,7	0,002	0,034	0,013	Ok
19	211	-746,7	-40305,5	505,8	77593,9	0,005	0,026	0,009	Ok
1	211	-746,7	-52820,8	569,1	20302,8	0,001	0,034	0,010	Ok
34	211	-793,3	-40683,1	229,5	61651,2	0,004	0,026	0,004	Ok
1	211	-793,3	-52775,0	409,9	9929,1	0,000	0,034	0,007	Ok
34	211	-840,0	-40648,2	115,0	70997,1	0,004	0,026	0,002	Ok
1	211	-840,0	-52729,8	270,6	27269,5	0,001	0,033	0,005	Ok
34	211	-886,7	-40613,8	49,2	75171,5	0,005	0,026	0,001	Ok
1	211	-886,7	-52685,1	151,2	39584,3	0,002	0,033	0,003	Ok
34	211	-933,3	-40579,8	91,6	74870,3	0,005	0,026	0,002	Ok
1	211	-933,3	-52641,0	52,3	46483,3	0,002	0,033	0,001	Ok
34	211	-980,0	-40546,2	148,2	70895,3	0,004	0,026	0,003	Ok
1	211	-980,0	-52597,4	34,3	48755,7	0,002	0,033	0,001	Ok
34	211	-1026,7	-40513,0	190,9	64064,7	0,004	0,026	0,003	Ok
1	211	-1026,7	-52554,4	94,7	47261,4	0,002	0,033	0,002	Ok
34	211	-1073,3	-40480,3	217,5	55186,6	0,003	0,026	0,004	Ok
1	211	-1073,3	-52511,9	138,6	42859,6	0,002	0,033	0,002	Ok
34	211	-1120,0	-40447,9	227,8	45050,6	0,003	0,026	0,004	Ok
1	211	-1120,0	-52469,9	164,9	36396,1	0,002	0,033	0,003	Ok
34	211	-1166,7	-40416,0	222,0	34427,1	0,002	0,026	0,004	Ok
1	211	-1166,7	-52428,5	173,8	28701,2	0,001	0,033	0,003	Ok
34	211	-1213,3	-40384,5	200,4	24069,7	0,003	0,030	0,004	Ok
1	211	-1213,3	-52387,7	165,5	20590,8	0,002	0,039	0,003	Ok
34	211	-1260,0	-40353,4	163,1	14718,7	0,002	0,030	0,003	Ok
1	211	-1260,0	-52347,3	140,0	12870,0	0,001	0,039	0,002	Ok
34	211	-1306,7	-40322,8	110,3	7105,7	0,001	0,030	0,002	Ok
1	211	-1306,7	-52307,6	97,6	6335,9	0,001	0,039	0,002	Ok
34	211	-1353,3	-40292,5	41,9	1957,6	0,000	0,030	0,001	Ok
1	211	-1353,3	-52268,3	38,2	1781,9	0,000	0,039	0,001	Ok
36	211	-1400,0	-40096,9	38,3	0,0	0,000	0,030	0,001	Ok
1	211	-1400,0	-52268,3	38,2	0,0	0,000	0,039	0,001	Ok

Plinto n. 215

Cmb.	Palo	Quota (cm)	N (daN)	V (daN)	M (daN cm)	Ver. N/M	Ver.(25)	Ver.V	Stato
18	215	0,0	-27976,7	2770,9	1079142,0	0,070	0,018	0,049	Ok
1	215	0,0	-35573,2	2047,2	1044659,0	0,047	0,023	0,036	Ok
18	215	-46,7	-27958,2	2667,2	951440,5	0,062	0,018	0,047	Ok
1	215	-46,7	-35549,7	2065,3	948518,1	0,043	0,023	0,037	Ok
18	215	-93,3	-27934,9	2526,6	827432,6	0,054	0,018	0,045	Ok
1	215	-93,3	-35520,0	2035,5	852191,2	0,039	0,023	0,036	Ok
18	215	-140,0	-27906,9	2353,4	709981,2	0,046	0,018	0,042	Ok
1	215	-140,0	-35484,5	1970,9	757251,8	0,034	0,023	0,035	Ok
18	215	-186,7	-27879,3	2164,8	600608,7	0,039	0,018	0,038	Ok
1	215	-186,7	-35449,3	1879,9	665319,3	0,030	0,023	0,033	Ok
18	215	-233,3	-27852,0	1966,7	500047,8	0,033	0,018	0,035	Ok
1	215	-233,3	-35414,6	1768,0	577632,5	0,026	0,022	0,031	Ok
18	215	-280,0	-27824,9	1764,8	408764,3	0,027	0,018	0,031	Ok
1	215	-280,0	-35380,2	1640,9	495164,9	0,023	0,022	0,029	Ok
18	215	-326,7	-27798,2	1563,5	326964,7	0,021	0,018	0,028	Ok
1	215	-326,7	-35346,1	1503,6	418625,7	0,019	0,022	0,027	Ok
19	215	-373,3	-26555,2	763,2	281750,2	0,018	0,017	0,014	Ok
1	215	-373,3	-35312,5	1360,4	348493,8	0,016	0,022	0,024	Ok
19	215	-420,0	-26530,2	715,1	248091,0	0,016	0,017	0,013	Ok
1	215	-420,0	-35279,2	1215,1	285046,9	0,013	0,022	0,022	Ok
19	215	-466,7	-26505,4	662,8	216455,9	0,014	0,017	0,012	Ok
1	215	-466,7	-35246,3	1070,9	228383,0	0,010	0,022	0,019	Ok
19	215	-513,3	-26480,9	607,7	187097,2	0,012	0,017	0,011	Ok
1	215	-513,3	-35213,7	930,4	178455,9	0,008	0,022	0,016	Ok
19	215	-560,0	-26456,7	551,2	160183,1	0,010	0,017	0,010	Ok
1	215	-560,0	-35181,5	795,6	135097,8	0,006	0,022	0,014	Ok

Parco Eolico "Bolina" – Progetto Definitivo
Relazione di calcolo preliminare delle fondazioni degli aerogeneratori G8 e G12

19	215	-606,7	-26432,8	494,6	135807,2	0,009	0,017	0,009	Ok
1	215	-606,7	-35149,7	668,2	98047,3	0,004	0,022	0,012	Ok
19	215	-653,3	-26409,1	439,0	113997,6	0,007	0,017	0,008	Ok
1	215	-653,3	-35118,2	549,4	66976,9	0,003	0,022	0,010	Ok
19	215	-700,0	-26385,7	385,2	94724,3	0,006	0,017	0,007	Ok
1	215	-700,0	-35087,1	440,1	41526,4	0,002	0,022	0,008	Ok
19	215	-746,7	-26362,6	334,1	77908,3	0,005	0,017	0,006	Ok
1	215	-746,7	-35056,3	340,9	21413,4	0,001	0,022	0,006	Ok
19	215	-793,3	-26339,8	286,3	63427,8	0,004	0,017	0,005	Ok
1	215	-793,3	-35026,0	252,2	7462,9	0,000	0,022	0,004	Ok
18	215	-840,0	-27522,7	60,3	56415,5	0,004	0,017	0,001	Ok
1	215	-840,0	-34996,0	174,1	9013,4	0,000	0,022	0,003	Ok
18	215	-886,7	-27499,4	59,3	57024,5	0,004	0,017	0,001	Ok
1	215	-886,7	-34966,3	106,8	16062,1	0,001	0,022	0,002	Ok
18	215	-933,3	-27476,4	92,4	55037,0	0,004	0,017	0,002	Ok
1	215	-933,3	-34937,0	50,6	20699,1	0,001	0,022	0,001	Ok
18	215	-980,0	-27453,6	123,7	50943,8	0,003	0,017	0,002	Ok
1	215	-980,0	-34908,1	13,4	22825,9	0,001	0,022	0,000	Ok
18	215	-1026,7	-27431,2	146,3	45249,7	0,003	0,017	0,003	Ok
1	215	-1026,7	-34879,5	37,0	22826,6	0,001	0,022	0,001	Ok
18	215	-1073,3	-27409,0	159,0	38455,5	0,003	0,017	0,003	Ok
1	215	-1073,3	-34851,3	62,5	21146,0	0,001	0,022	0,001	Ok
18	215	-1120,0	-27387,1	161,6	31050,9	0,002	0,017	0,003	Ok
1	215	-1120,0	-34823,5	79,0	18237,8	0,001	0,022	0,001	Ok
18	215	-1166,7	-27365,5	154,3	23514,6	0,002	0,017	0,003	Ok
1	215	-1166,7	-34796,0	86,0	14553,4	0,001	0,022	0,002	Ok
18	215	-1213,3	-27344,2	137,3	16314,3	0,002	0,020	0,002	Ok
1	215	-1213,3	-34768,9	83,6	10539,8	0,001	0,026	0,001	Ok
18	215	-1260,0	-27323,1	110,5	9909,6	0,001	0,020	0,002	Ok
1	215	-1260,0	-34742,1	71,8	6639,2	0,001	0,026	0,001	Ok
18	215	-1306,7	-27302,4	74,0	4754,8	0,001	0,020	0,001	Ok
1	215	-1306,7	-34715,7	50,5	3290,7	0,000	0,026	0,001	Ok
18	215	-1353,3	-27281,9	27,9	1301,3	0,000	0,020	0,000	Ok
1	215	-1353,3	-34689,7	20,0	931,9	0,000	0,026	0,000	Ok
1	215	-1400,0	-34689,7	20,0	0,0	0,019	0,026	0,000	Ok

Plinto n. 231

Cmb.	Palo	Quota (cm)	N (daN)	V (daN)	M (daN cm)	Ver. N/M	Ver.(25)	Ver.V	Stato
18	231	0,0	-44608,8	3398,6	1345073,0	0,084	0,028	0,060	Ok
1	231	0,0	-57339,5	2713,4	1351909,0	0,059	0,036	0,048	Ok
18	231	-46,7	-44579,4	3280,6	1187937,0	0,074	0,028	0,058	Ok
1	231	-46,7	-57301,7	2725,3	1224597,0	0,054	0,036	0,048	Ok
18	231	-93,3	-44542,1	3114,9	1035040,0	0,065	0,028	0,055	Ok
1	231	-93,3	-57253,8	2676,1	1097417,0	0,048	0,036	0,047	Ok
18	231	-140,0	-44497,6	2908,1	889871,0	0,056	0,028	0,052	Ok
1	231	-140,0	-57196,5	2582,2	972534,4	0,043	0,036	0,046	Ok
18	231	-186,7	-44453,5	2680,9	754348,6	0,047	0,028	0,048	Ok
1	231	-186,7	-57139,9	2455,0	852033,7	0,037	0,036	0,044	Ok
18	231	-233,3	-44409,9	2440,7	629431,8	0,039	0,028	0,043	Ok
1	231	-233,3	-57083,9	2302,1	737465,3	0,032	0,036	0,041	Ok
18	231	-280,0	-44366,8	2194,5	515740,4	0,032	0,028	0,039	Ok
1	231	-280,0	-57028,4	2130,6	630036,0	0,028	0,036	0,038	Ok
18	231	-326,7	-44324,1	1948,1	413561,2	0,026	0,028	0,035	Ok
1	231	-326,7	-56973,6	1946,9	530609,8	0,023	0,036	0,035	Ok
19	231	-373,3	-43286,3	1005,2	353705,8	0,022	0,027	0,018	Ok
1	231	-373,3	-56919,3	1756,6	439754,7	0,019	0,036	0,031	Ok
19	231	-420,0	-43245,5	939,8	307179,9	0,019	0,027	0,017	Ok
1	231	-420,0	-56865,7	1564,5	357781,1	0,016	0,036	0,028	Ok
19	231	-466,7	-43205,1	867,2	263674,1	0,017	0,027	0,015	Ok
1	231	-466,7	-56812,6	1374,7	284769,4	0,013	0,036	0,024	Ok
19	231	-513,3	-43165,2	790,0	223536,0	0,014	0,027	0,014	Ok
1	231	-513,3	-56760,1	1190,4	220616,9	0,010	0,036	0,021	Ok
19	231	-560,0	-43125,7	710,6	186987,9	0,012	0,027	0,013	Ok
1	231	-560,0	-56708,2	1014,2	165065,0	0,007	0,036	0,018	Ok

Parco Eolico "Bolina" – Progetto Definitivo
Relazione di calcolo preliminare delle fondazioni degli aerogeneratori G8 e G12

19	231	-606,7	-43086,7	630,8	154144,5	0,010	0,027	0,011	Ok
1	231	-606,7	-56656,9	848,2	117733,8	0,005	0,036	0,015	Ok
19	231	-653,3	-43048,1	552,3	125030,1	0,008	0,027	0,010	Ok
1	231	-653,3	-56606,2	693,9	78150,8	0,003	0,036	0,012	Ok
19	231	-700,0	-43010,0	476,5	99591,6	0,006	0,027	0,008	Ok
1	231	-700,0	-56556,0	552,2	45771,2	0,002	0,036	0,010	Ok
19	231	-746,7	-42972,3	404,4	77715,2	0,005	0,027	0,007	Ok
1	231	-746,7	-56506,5	424,0	20003,0	0,001	0,036	0,008	Ok
19	231	-793,3	-42935,1	336,9	59238,4	0,004	0,027	0,006	Ok
1	231	-793,3	-56457,5	309,5	412,8	0,000	0,036	0,005	Ok
18	231	-840,0	-43885,0	60,3	64994,1	0,004	0,028	0,001	Ok
1	231	-840,0	-56409,1	208,9	14232,1	0,001	0,036	0,004	Ok
18	231	-886,7	-43847,8	46,8	66822,7	0,004	0,028	0,001	Ok
1	231	-886,7	-56361,3	122,3	23980,9	0,001	0,036	0,002	Ok
18	231	-933,3	-43811,1	96,4	65214,2	0,004	0,028	0,002	Ok
1	231	-933,3	-56314,1	49,4	29687,8	0,001	0,036	0,001	Ok
18	231	-980,0	-43774,8	139,9	60836,3	0,004	0,028	0,002	Ok
1	231	-980,0	-56267,5	10,0	31993,8	0,001	0,036	0,000	Ok
18	231	-1026,7	-43739,0	170,8	54348,6	0,003	0,028	0,003	Ok
1	231	-1026,7	-56221,4	56,0	31529,8	0,001	0,036	0,001	Ok
18	231	-1073,3	-43703,6	188,7	46393,2	0,003	0,028	0,003	Ok
1	231	-1073,3	-56176,0	89,2	28914,4	0,001	0,036	0,002	Ok
18	231	-1120,0	-43668,7	193,8	37592,4	0,002	0,028	0,003	Ok
1	231	-1120,0	-56131,1	109,6	24753,3	0,001	0,036	0,002	Ok
18	231	-1166,7	-43634,2	186,3	28550,3	0,002	0,028	0,003	Ok
1	231	-1166,7	-56086,8	117,5	19640,4	0,001	0,036	0,002	Ok
18	231	-1213,3	-43600,2	166,5	19855,6	0,002	0,033	0,003	Ok
1	231	-1213,3	-56043,1	113,0	14159,3	0,001	0,042	0,002	Ok
18	231	-1260,0	-43566,7	134,5	12085,6	0,001	0,033	0,002	Ok
1	231	-1260,0	-56000,0	96,3	8885,7	0,001	0,042	0,002	Ok
18	231	-1306,7	-43533,6	90,4	5809,7	0,001	0,033	0,002	Ok
1	231	-1306,7	-55957,4	67,5	4389,8	0,000	0,042	0,001	Ok
18	231	-1353,3	-43500,9	34,1	1593,2	0,000	0,033	0,001	Ok
1	231	-1353,3	-55915,5	26,5	1239,0	0,000	0,042	0,000	Ok
17	231	-1400,0	-43639,2	32,0	0,0	0,024	0,033	0,001	Ok
1	231	-1400,0	-55915,5	26,5	0,0	0,000	0,042	0,000	Ok

Plinto n. 243

Cmb.	Palo	Quota (cm)	N (daN)	V (daN)	M (daN cm)	Ver. N/M	Ver.(25)	Ver.V	Stato
18	243	0,0	-76895,0	4906,5	2030005,0	0,119	0,049	0,087	Ok
1	243	0,0	-99745,7	4639,9	2233106,0	0,093	0,063	0,082	Ok
18	243	-46,7	-76844,3	4770,0	1802436,0	0,106	0,049	0,085	Ok
1	243	-46,7	-99679,9	4630,3	2015899,0	0,084	0,063	0,082	Ok
18	243	-93,3	-76780,0	4557,3	1579940,0	0,093	0,049	0,081	Ok
1	243	-93,3	-99596,5	4522,6	1799833,0	0,075	0,063	0,080	Ok
18	243	-140,0	-76703,3	4281,5	1367365,0	0,080	0,049	0,076	Ok
1	243	-140,0	-99496,9	4341,9	1588788,0	0,066	0,063	0,077	Ok
18	243	-186,7	-76627,3	3970,7	1167662,0	0,069	0,049	0,070	Ok
1	243	-186,7	-99398,4	4109,2	1386174,0	0,058	0,063	0,073	Ok
18	243	-233,3	-76552,2	3636,0	982462,9	0,058	0,049	0,064	Ok
1	243	-233,3	-99301,0	3836,6	1194421,0	0,050	0,063	0,068	Ok
18	243	-280,0	-76477,8	3288,4	812885,3	0,048	0,049	0,058	Ok
1	243	-280,0	-99204,5	3536,2	1015389,0	0,042	0,063	0,063	Ok
18	243	-326,7	-76404,3	2936,6	659538,9	0,039	0,049	0,052	Ok
1	243	-326,7	-99109,1	3218,4	850374,1	0,035	0,063	0,057	Ok
19	243	-373,3	-75998,8	1863,6	554611,0	0,033	0,048	0,033	Ok
1	243	-373,3	-99014,7	2892,1	700190,8	0,029	0,063	0,051	Ok
19	243	-420,0	-75927,2	1699,0	467694,6	0,028	0,048	0,030	Ok
1	243	-420,0	-98921,3	2565,3	565234,9	0,023	0,063	0,045	Ok
19	243	-466,7	-75856,3	1529,0	388461,9	0,023	0,048	0,027	Ok
1	243	-466,7	-98829,0	2244,2	445532,0	0,019	0,063	0,040	Ok
19	243	-513,3	-75786,2	1357,9	317164,3	0,019	0,048	0,024	Ok
1	243	-513,3	-98737,7	1934,2	340815,4	0,014	0,063	0,034	Ok
19	243	-560,0	-75716,9	1189,2	253854,6	0,015	0,048	0,021	Ok

Parco Eolico "Bolina" – Progetto Definitivo
Relazione di calcolo preliminare delle fondazioni degli aerogeneratori G8 e G12

1	243	-560,0	-98647,4	1639,2	250572,5	0,010	0,063	0,029	Ok
19	243	-606,7	-75648,4	1025,9	198422,2	0,012	0,048	0,018	Ok
1	243	-606,7	-98558,2	1362,4	174101,8	0,007	0,063	0,024	Ok
19	243	-653,3	-75580,7	870,2	150625,0	0,009	0,048	0,015	Ok
1	243	-653,3	-98469,9	1106,1	110564,7	0,005	0,063	0,020	Ok
19	243	-700,0	-75513,7	723,8	110113,9	0,006	0,048	0,013	Ok
1	243	-700,0	-98382,7	871,9	59034,2	0,002	0,062	0,015	Ok
19	243	-746,7	-75447,6	588,3	76464,9	0,005	0,048	0,010	Ok
1	243	-746,7	-98296,5	660,6	18729,6	0,001	0,062	0,012	Ok
17	243	-793,3	-75891,0	294,8	70589,6	0,004	0,048	0,005	Ok
1	243	-793,3	-98211,3	472,9	13398,9	0,001	0,062	0,008	Ok
18	243	-840,0	-75647,3	125,5	81459,4	0,005	0,048	0,002	Ok
1	243	-840,0	-98127,2	308,7	34969,9	0,001	0,062	0,005	Ok
18	243	-886,7	-75583,2	32,3	86868,6	0,005	0,048	0,001	Ok
1	243	-886,7	-98044,0	168,1	49273,6	0,002	0,062	0,003	Ok
18	243	-933,3	-75519,9	97,2	86858,9	0,005	0,048	0,002	Ok
1	243	-933,3	-97961,9	51,0	57061,0	0,002	0,062	0,001	Ok
18	243	-980,0	-75457,4	168,4	82443,8	0,005	0,048	0,003	Ok
1	243	-980,0	-97880,8	46,1	59372,5	0,002	0,062	0,001	Ok
18	243	-1026,7	-75395,6	220,3	74618,2	0,004	0,048	0,004	Ok
1	243	-1026,7	-97800,7	118,5	57253,1	0,002	0,062	0,002	Ok
18	243	-1073,3	-75334,7	252,4	64348,8	0,004	0,048	0,004	Ok
1	243	-1073,3	-97721,6	169,8	51730,2	0,002	0,062	0,003	Ok
18	243	-1120,0	-75274,5	265,2	52572,7	0,003	0,048	0,005	Ok
1	243	-1120,0	-97643,6	200,1	43808,6	0,002	0,062	0,004	Ok
18	243	-1166,7	-75215,1	258,9	40200,3	0,002	0,048	0,005	Ok
1	243	-1166,7	-97566,5	209,7	34472,9	0,001	0,062	0,004	Ok
18	243	-1213,3	-75156,5	234,0	28119,6	0,003	0,056	0,004	Ok
1	243	-1213,3	-97490,5	198,9	24689,1	0,002	0,073	0,004	Ok
18	243	-1260,0	-75098,6	190,6	17202,1	0,002	0,056	0,003	Ok
1	243	-1260,0	-97415,4	167,8	15409,4	0,001	0,073	0,003	Ok
18	243	-1306,7	-75041,6	129,0	8307,4	0,001	0,056	0,002	Ok
1	243	-1306,7	-97341,4	116,8	7576,5	0,001	0,073	0,002	Ok
18	243	-1353,3	-74985,3	49,1	2289,5	0,000	0,056	0,001	Ok
1	243	-1353,3	-97268,4	45,6	2127,9	0,000	0,073	0,001	Ok
17	243	-1400,0	-75162,4	47,1	0,0	0,000	0,056	0,001	Ok
1	243	-1400,0	-97268,4	45,6	0,0	0,000	0,073	0,001	Ok

Plinto n. 247

Cmb.	Palo	Quota (cm)	N (daN)	V (daN)	M (daN cm)	Ver. N/M	Ver.(25)	Ver.V	Stato
18	247	0,0	-65596,6	3913,2	1565480,0	0,094	0,042	0,069	Ok
1	247	0,0	-84882,9	3321,0	1621688,0	0,069	0,054	0,059	Ok
18	247	-46,7	-65553,3	3784,1	1384266,0	0,083	0,042	0,067	Ok
1	247	-46,7	-84826,9	3322,9	1466114,0	0,062	0,054	0,059	Ok
18	247	-93,3	-65498,4	3598,5	1207719,0	0,073	0,042	0,064	Ok
1	247	-93,3	-84755,9	3252,8	1311086,0	0,056	0,054	0,058	Ok
18	247	-140,0	-65433,0	3364,8	1039829,0	0,062	0,042	0,060	Ok
1	247	-140,0	-84671,2	3129,4	1159327,0	0,049	0,054	0,055	Ok
18	247	-186,7	-65368,2	3106,5	882845,0	0,053	0,042	0,055	Ok
1	247	-186,7	-84587,4	2967,4	1013322,0	0,043	0,054	0,053	Ok
18	247	-233,3	-65304,1	2832,0	737917,7	0,044	0,041	0,050	Ok
1	247	-233,3	-84504,5	2775,6	874874,4	0,037	0,054	0,049	Ok
18	247	-280,0	-65240,7	2549,8	605801,3	0,036	0,041	0,045	Ok
1	247	-280,0	-84422,4	2562,7	745377,0	0,032	0,054	0,045	Ok
18	247	-326,7	-65177,9	2266,7	486857,8	0,029	0,041	0,040	Ok
1	247	-326,7	-84341,2	2336,4	625811,3	0,027	0,054	0,041	Ok
19	247	-373,3	-64516,2	1247,8	413955,3	0,025	0,041	0,022	Ok
1	247	-373,3	-84260,9	2103,2	516807,2	0,022	0,054	0,037	Ok
19	247	-420,0	-64455,4	1156,6	355724,8	0,021	0,041	0,021	Ok
1	247	-420,0	-84181,4	1868,9	418689,1	0,018	0,053	0,033	Ok
19	247	-466,7	-64395,2	1058,1	301750,7	0,018	0,041	0,019	Ok
1	247	-466,7	-84102,8	1638,1	331509,9	0,014	0,053	0,029	Ok
19	247	-513,3	-64335,8	955,3	252376,8	0,015	0,041	0,017	Ok
1	247	-513,3	-84025,1	1414,7	255108,2	0,011	0,053	0,025	Ok

Parco Eolico "Bolina" – Progetto Definitivo
Relazione di calcolo preliminare delle fondazioni degli aerogeneratori G8 e G12

19	247	-560,0	-64276,9	851,2	207796,4	0,013	0,041	0,015	Ok
1	247	-560,0	-83948,3	1201,8	189142,1	0,008	0,053	0,021	Ok
19	247	-606,7	-64218,8	747,9	168075,3	0,010	0,041	0,013	Ok
1	247	-606,7	-83872,3	1001,6	133133,0	0,006	0,053	0,018	Ok
19	247	-653,3	-64161,3	647,5	133173,2	0,008	0,041	0,011	Ok
1	247	-653,3	-83797,3	816,0	86508,7	0,004	0,053	0,014	Ok
19	247	-700,0	-64104,4	551,3	102959,7	0,006	0,041	0,010	Ok
1	247	-700,0	-83723,0	646,0	48663,8	0,002	0,053	0,011	Ok
19	247	-746,7	-64048,3	460,7	77234,1	0,005	0,041	0,008	Ok
1	247	-746,7	-83649,7	492,5	19291,1	0,001	0,053	0,009	Ok
17	247	-793,3	-64862,3	194,4	67753,5	0,004	0,041	0,003	Ok
1	247	-793,3	-83577,2	355,8	8289,3	0,000	0,053	0,006	Ok
17	247	-840,0	-64806,7	107,6	73547,2	0,004	0,041	0,002	Ok
1	247	-840,0	-83505,6	236,2	22445,6	0,001	0,053	0,004	Ok
17	247	-886,7	-64751,8	81,3	75263,2	0,005	0,041	0,001	Ok
1	247	-886,7	-83434,8	133,6	33067,6	0,001	0,053	0,002	Ok
18	247	-933,3	-64423,5	99,0	73441,8	0,004	0,041	0,002	Ok
1	247	-933,3	-83364,9	48,8	39108,7	0,002	0,053	0,001	Ok
18	247	-980,0	-64370,1	152,7	68855,0	0,004	0,041	0,003	Ok
1	247	-980,0	-83295,9	27,8	41189,5	0,002	0,053	0,000	Ok
18	247	-1026,7	-64317,5	190,5	61739,2	0,004	0,041	0,003	Ok
1	247	-1026,7	-83227,8	78,9	40033,8	0,002	0,053	0,001	Ok
18	247	-1073,3	-64265,5	212,8	52851,4	0,003	0,041	0,004	Ok
1	247	-1073,3	-83160,5	116,7	36373,5	0,002	0,053	0,002	Ok
18	247	-1120,0	-64214,1	220,0	42922,0	0,003	0,041	0,004	Ok
1	247	-1120,0	-83094,0	139,6	30931,4	0,001	0,053	0,002	Ok
18	247	-1166,7	-64163,5	212,4	32657,9	0,002	0,041	0,004	Ok
1	247	-1166,7	-83028,5	147,5	24418,3	0,001	0,053	0,003	Ok
18	247	-1213,3	-64113,5	190,4	22747,4	0,002	0,048	0,003	Ok
1	247	-1213,3	-82963,7	140,7	17533,5	0,001	0,062	0,002	Ok
18	247	-1260,0	-64064,1	154,1	13864,2	0,001	0,048	0,003	Ok
1	247	-1260,0	-82899,9	119,2	10967,0	0,001	0,062	0,002	Ok
18	247	-1306,7	-64015,4	103,7	6672,8	0,001	0,048	0,002	Ok
1	247	-1306,7	-82836,9	83,2	5402,5	0,000	0,062	0,001	Ok
18	247	-1353,3	-63967,4	39,3	1832,2	0,000	0,048	0,001	Ok
1	247	-1353,3	-82774,8	32,6	1520,4	0,000	0,062	0,001	Ok
35	247	-1400,0	-63997,3	21,5	0,0	0,000	0,048	0,000	Ok
1	247	-1400,0	-82774,8	32,6	0,0	0,000	0,062	0,001	Ok

Plinto n. 263

Cmb.	Palo	Quota (cm)	N (daN)	V (daN)	M (daN cm)	Ver. N/M	Ver.(25)	Ver.V	Stato
17	263	0,0	-93313,6	4188,7	1666447,0	0,095	0,059	0,074	Ok
1	263	0,0	-120777,9	3616,0	1743832,0	0,071	0,077	0,064	Ok
17	263	-46,7	-93252,0	4045,6	1473068,0	0,084	0,059	0,072	Ok
1	263	-46,7	-120698,3	3609,5	1574647,0	0,064	0,077	0,064	Ok
17	263	-93,3	-93174,0	3843,6	1284846,0	0,073	0,059	0,068	Ok
1	263	-93,3	-120597,3	3526,5	1406317,0	0,057	0,077	0,063	Ok
17	263	-140,0	-93080,9	3590,8	1106038,0	0,063	0,059	0,064	Ok
1	263	-140,0	-120476,8	3386,5	1241847,0	0,050	0,077	0,060	Ok
17	263	-186,7	-92988,7	3312,6	939015,3	0,054	0,059	0,059	Ok
1	263	-186,7	-120357,5	3205,9	1083900,0	0,044	0,076	0,057	Ok
17	263	-233,3	-92897,5	3018,0	784984,0	0,045	0,059	0,054	Ok
1	263	-233,3	-120239,5	2994,1	934376,2	0,038	0,076	0,053	Ok
17	263	-280,0	-92807,3	2715,8	644734,0	0,037	0,059	0,048	Ok
1	263	-280,0	-120122,7	2760,4	794735,3	0,032	0,076	0,049	Ok
17	263	-326,7	-92718,0	2413,1	518649,8	0,030	0,059	0,043	Ok
1	263	-326,7	-120007,1	2513,1	665996,6	0,027	0,076	0,045	Ok
19	263	-373,3	-92198,5	1370,1	438519,6	0,025	0,059	0,024	Ok
1	263	-373,3	-119892,9	2259,1	548802,8	0,022	0,076	0,040	Ok
19	263	-420,0	-92111,6	1262,3	374833,8	0,021	0,059	0,022	Ok
1	263	-420,0	-119779,8	2004,5	443471,7	0,018	0,076	0,036	Ok
19	263	-466,7	-92025,6	1148,1	316170,8	0,018	0,058	0,020	Ok
1	263	-466,7	-119668,0	1754,3	350033,0	0,014	0,076	0,031	Ok
19	263	-513,3	-91940,6	1030,8	262836,2	0,015	0,058	0,018	Ok

Parco Eolico "Bolina" – Progetto Definitivo
Relazione di calcolo preliminare delle fondazioni degli aerogeneratori G8 e G12

1	263	-513,3	-119557,4	1512,6	268290,5	0,011	0,076	0,027	Ok
19	263	-560,0	-91856,5	913,3	214979,6	0,012	0,058	0,016	Ok
1	263	-560,0	-119448,1	1282,6	197861,6	0,008	0,076	0,023	Ok
19	263	-606,7	-91773,4	797,9	172620,4	0,010	0,058	0,014	Ok
1	263	-606,7	-119340,0	1066,7	138229,2	0,006	0,076	0,019	Ok
19	263	-653,3	-91691,3	686,5	135671,7	0,008	0,058	0,012	Ok
1	263	-653,3	-119233,2	866,8	88807,5	0,004	0,076	0,015	Ok
19	263	-700,0	-91610,1	580,7	103959,3	0,006	0,058	0,010	Ok
1	263	-700,0	-119127,6	684,1	49093,0	0,002	0,076	0,012	Ok
19	263	-746,7	-91529,8	481,7	77246,4	0,004	0,058	0,009	Ok
1	263	-746,7	-119023,2	519,3	19749,2	0,001	0,076	0,009	Ok
17	263	-793,3	-91878,2	194,0	73587,8	0,004	0,058	0,003	Ok
1	263	-793,3	-118920,1	373,0	14452,8	0,001	0,076	0,007	Ok
17	263	-840,0	-91799,4	97,3	80331,0	0,005	0,058	0,002	Ok
1	263	-840,0	-118818,2	245,2	28179,5	0,001	0,075	0,004	Ok
17	263	-886,7	-91721,7	75,1	82343,0	0,005	0,058	0,001	Ok
1	263	-886,7	-118717,5	136,3	38696,2	0,002	0,075	0,002	Ok
17	263	-933,3	-91644,8	123,7	80262,3	0,005	0,058	0,002	Ok
1	263	-933,3	-118618,1	49,1	44553,2	0,002	0,075	0,001	Ok
17	263	-980,0	-91569,0	173,7	74840,2	0,004	0,058	0,003	Ok
1	263	-980,0	-118519,9	41,6	46274,1	0,002	0,075	0,001	Ok
17	263	-1026,7	-91494,0	210,6	66853,2	0,004	0,058	0,004	Ok
1	263	-1026,7	-118422,9	93,3	44594,5	0,002	0,075	0,002	Ok
17	263	-1073,3	-91420,1	232,2	57072,6	0,003	0,058	0,004	Ok
1	263	-1073,3	-118327,1	132,5	40285,1	0,002	0,075	0,002	Ok
17	263	-1120,0	-91347,0	238,4	46254,2	0,003	0,058	0,004	Ok
1	263	-1120,0	-118232,6	155,8	34115,9	0,001	0,075	0,003	Ok
17	263	-1166,7	-91274,9	229,2	35136,5	0,002	0,058	0,004	Ok
1	263	-1166,7	-118139,3	163,3	26847,5	0,001	0,075	0,003	Ok
17	263	-1213,3	-91203,8	204,9	24442,1	0,002	0,068	0,004	Ok
1	263	-1213,3	-118047,2	154,9	19229,9	0,001	0,088	0,003	Ok
17	263	-1260,0	-91133,6	165,6	14881,1	0,001	0,068	0,003	Ok
1	263	-1260,0	-117956,4	130,7	12003,5	0,001	0,088	0,002	Ok
17	263	-1306,7	-91064,4	111,3	7155,5	0,001	0,068	0,002	Ok
1	263	-1306,7	-117866,7	91,0	5902,6	0,000	0,088	0,002	Ok
17	263	-1353,3	-90996,1	42,1	1962,9	0,000	0,068	0,001	Ok
1	263	-1353,3	-117778,3	35,5	1658,1	0,000	0,088	0,001	Ok
18	263	-1400,0	-90625,0	41,4	0,0	0,000	0,068	0,001	Ok
1	263	-1400,0	-117778,3	35,5	0,0	0,000	0,088	0,001	Ok

Plinto n. 275

Cmb.	Palo	Quota (cm)	N (daN)	V (daN)	M (daN cm)	Ver. N/M	Ver.(25)	Ver.V	Stato
18	275	0,0	-122033,4	4397,0	1784529,0	0,097	0,078	0,078	Ok
1	275	0,0	-158857,3	3969,4	1910123,0	0,074	0,101	0,070	Ok
18	275	-46,7	-121952,9	4261,7	1580711,0	0,086	0,077	0,076	Ok
1	275	-46,7	-158752,5	3960,7	1724422,0	0,067	0,101	0,070	Ok
18	275	-93,3	-121850,8	4060,9	1381835,0	0,075	0,077	0,072	Ok
1	275	-93,3	-158619,7	3868,4	1539707,0	0,060	0,101	0,069	Ok
18	275	-140,0	-121729,1	3804,9	1192330,0	0,065	0,077	0,067	Ok
1	275	-140,0	-158461,2	3713,7	1359288,0	0,053	0,101	0,066	Ok
18	275	-186,7	-121608,5	3519,5	1014775,0	0,055	0,077	0,062	Ok
1	275	-186,7	-158304,3	3514,6	1186078,0	0,046	0,101	0,062	Ok
18	275	-233,3	-121489,3	3214,7	850534,7	0,046	0,077	0,057	Ok
1	275	-233,3	-158149,1	3281,4	1022154,0	0,040	0,100	0,058	Ok
18	275	-280,0	-121371,3	2899,9	700521,9	0,038	0,077	0,051	Ok
1	275	-280,0	-157995,5	3024,6	869106,3	0,034	0,100	0,054	Ok
18	275	-326,7	-121254,6	2582,8	565200,3	0,031	0,077	0,046	Ok
1	275	-326,7	-157843,5	2752,9	728044,2	0,028	0,100	0,049	Ok
19	275	-373,3	-121465,9	1537,5	477893,1	0,026	0,077	0,027	Ok
1	275	-373,3	-157693,2	2474,0	599665,1	0,023	0,100	0,044	Ok
19	275	-420,0	-121351,3	1410,3	406367,4	0,022	0,077	0,025	Ok
1	275	-420,0	-157544,5	2194,6	484310,6	0,019	0,100	0,039	Ok
19	275	-466,7	-121238,1	1277,2	340771,8	0,018	0,077	0,023	Ok
1	275	-466,7	-157397,5	1920,1	382007,0	0,015	0,100	0,034	Ok

Parco Eolico "Bolina" – Progetto Definitivo
Relazione di calcolo preliminare delle fondazioni degli aerogeneratori G8 e G12

19	275	-513,3	-121126,0	1141,6	281393,2	0,015	0,077	0,020	Ok
1	275	-513,3	-157252,0	1655,0	292534,2	0,011	0,100	0,029	Ok
19	275	-560,0	-121015,3	1006,8	228348,7	0,012	0,077	0,018	Ok
1	275	-560,0	-157108,3	1402,9	215467,7	0,008	0,100	0,025	Ok
19	275	-606,7	-120905,8	875,1	181614,9	0,010	0,077	0,016	Ok
1	275	-606,7	-156966,1	1166,3	150236,6	0,006	0,100	0,021	Ok
19	275	-653,3	-120797,5	748,8	141054,9	0,008	0,077	0,013	Ok
1	275	-653,3	-156825,6	947,3	96195,1	0,004	0,100	0,017	Ok
19	275	-700,0	-120690,5	629,3	106440,3	0,006	0,077	0,011	Ok
1	275	-700,0	-156686,7	747,1	52790,8	0,002	0,100	0,013	Ok
19	275	-746,7	-120584,8	518,0	77480,7	0,004	0,077	0,009	Ok
1	275	-746,7	-156549,4	566,6	20820,0	0,001	0,099	0,010	Ok
17	275	-793,3	-120398,4	224,2	74016,3	0,004	0,076	0,004	Ok
1	275	-793,3	-156413,7	406,3	16109,5	0,001	0,099	0,007	Ok
17	275	-840,0	-120295,3	117,9	81595,6	0,004	0,076	0,002	Ok
1	275	-840,0	-156279,7	266,4	31381,1	0,001	0,099	0,005	Ok
17	275	-886,7	-120193,3	79,5	84259,7	0,005	0,076	0,001	Ok
1	275	-886,7	-156147,3	147,3	42865,4	0,002	0,099	0,003	Ok
17	275	-933,3	-120092,7	122,9	82589,7	0,004	0,076	0,002	Ok
1	275	-933,3	-156016,5	52,0	49214,1	0,002	0,099	0,001	Ok
17	275	-980,0	-119993,2	175,3	77343,4	0,004	0,076	0,003	Ok
1	275	-980,0	-155887,3	46,5	51028,3	0,002	0,099	0,001	Ok
17	275	-1026,7	-119895,1	215,1	69326,5	0,004	0,076	0,004	Ok
1	275	-1026,7	-155759,8	103,5	49120,7	0,002	0,099	0,002	Ok
17	275	-1073,3	-119798,1	239,2	59349,5	0,003	0,076	0,004	Ok
1	275	-1073,3	-155633,8	146,3	44338,2	0,002	0,099	0,003	Ok
17	275	-1120,0	-119702,4	247,0	48211,4	0,003	0,076	0,004	Ok
1	275	-1120,0	-155509,5	171,7	37525,6	0,001	0,099	0,003	Ok
17	275	-1166,7	-119608,0	238,5	36695,4	0,002	0,076	0,004	Ok
1	275	-1166,7	-155386,8	179,7	29517,0	0,001	0,099	0,003	Ok
17	275	-1213,3	-119514,7	213,9	25570,0	0,002	0,089	0,004	Ok
1	275	-1213,3	-155265,7	170,3	21133,8	0,001	0,116	0,003	Ok
17	275	-1260,0	-119422,8	173,2	15591,3	0,001	0,089	0,003	Ok
1	275	-1260,0	-155146,2	143,7	13187,8	0,001	0,116	0,003	Ok
17	275	-1306,7	-119332,0	116,7	7507,5	0,001	0,089	0,002	Ok
1	275	-1306,7	-155028,3	99,9	6483,2	0,000	0,116	0,002	Ok
17	275	-1353,3	-119242,5	44,2	2062,6	0,000	0,089	0,001	Ok
1	275	-1353,3	-154912,0	39,0	1820,6	0,000	0,116	0,001	Ok
18	275	-1400,0	-119002,6	44,1	0,0	0,000	0,089	0,001	Ok
1	275	-1400,0	-154912,0	39,0	0,0	0,000	0,116	0,001	Ok

Piinto n. 279

Cmb.	Palo	Quota (cm)	N (daN)	V (daN)	M (daN cm)	Ver. N/M	Ver.(25)	Ver.V	Stato
17	279	0,0	-120189,9	3724,8	1428262,0	0,078	0,076	0,066	Ok
1	279	0,0	-156021,3	2924,9	1410415,0	0,055	0,099	0,052	Ok
17	279	-46,7	-120110,6	3577,4	1256545,0	0,068	0,076	0,063	Ok
1	279	-46,7	-155918,4	2919,0	1273747,0	0,050	0,099	0,052	Ok
17	279	-93,3	-120010,1	3381,9	1090035,0	0,059	0,076	0,060	Ok
1	279	-93,3	-155787,9	2851,6	1137781,0	0,044	0,099	0,051	Ok
17	279	-140,0	-119890,2	3143,4	932645,1	0,051	0,076	0,056	Ok
1	279	-140,0	-155632,2	2738,3	1004936,0	0,039	0,099	0,049	Ok
17	279	-186,7	-119771,5	2885,6	786383,0	0,043	0,076	0,051	Ok
1	279	-186,7	-155478,2	2592,2	877356,4	0,034	0,099	0,046	Ok
17	279	-233,3	-119654,1	2616,0	652171,5	0,035	0,076	0,046	Ok
1	279	-233,3	-155325,7	2421,1	756579,1	0,029	0,099	0,043	Ok
17	279	-280,0	-119537,8	2342,2	530578,1	0,029	0,076	0,042	Ok
1	279	-280,0	-155174,8	2232,3	643783,6	0,025	0,099	0,040	Ok
17	279	-326,7	-119422,9	2070,3	421824,3	0,023	0,076	0,037	Ok
1	279	-326,7	-155025,6	2032,6	539795,2	0,021	0,098	0,036	Ok
20	279	-373,3	-118964,6	1011,4	359022,6	0,020	0,076	0,018	Ok
1	279	-373,3	-154878,0	1827,4	445136,4	0,017	0,098	0,032	Ok
20	279	-420,0	-118852,5	947,8	311852,2	0,017	0,075	0,017	Ok
1	279	-420,0	-154731,9	1621,7	360068,6	0,014	0,098	0,029	Ok
20	279	-466,7	-118741,5	876,3	267643,6	0,015	0,075	0,016	Ok

Parco Eolico "Bolina" – Progetto Definitivo
Relazione di calcolo preliminare delle fondazioni degli aerogeneratori G8 e G12

1	279	-466,7	-154587,5	1419,7	284623,0	0,011	0,098	0,025	Ok
20	279	-513,3	-118631,8	799,6	226771,3	0,012	0,075	0,014	Ok
1	279	-513,3	-154444,7	1224,5	218652,7	0,009	0,098	0,022	Ok
20	279	-560,0	-118523,3	720,1	189478,6	0,010	0,075	0,013	Ok
1	279	-560,0	-154303,5	1038,7	161868,3	0,006	0,098	0,018	Ok
20	279	-606,7	-118416,1	639,8	155896,4	0,008	0,075	0,011	Ok
1	279	-606,7	-154163,8	864,4	113891,8	0,004	0,098	0,015	Ok
20	279	-653,3	-118310,1	560,6	126060,1	0,007	0,075	0,010	Ok
1	279	-653,3	-154025,8	703,0	74341,0	0,003	0,098	0,012	Ok
20	279	-700,0	-118205,3	483,7	99923,7	0,005	0,075	0,009	Ok
1	279	-700,0	-153889,4	555,5	43071,2	0,002	0,098	0,010	Ok
19	279	-746,7	-118531,9	406,2	78192,7	0,004	0,075	0,007	Ok
1	279	-746,7	-153754,6	422,6	21461,0	0,001	0,098	0,007	Ok
33	279	-793,3	-118873,4	221,9	74006,6	0,004	0,075	0,004	Ok
1	279	-793,3	-153621,3	304,7	16845,0	0,001	0,098	0,005	Ok
17	279	-840,0	-118239,7	63,9	78012,6	0,004	0,075	0,001	Ok
1	279	-840,0	-153489,7	202,0	24928,7	0,001	0,097	0,004	Ok
17	279	-886,7	-118139,5	78,9	78467,9	0,004	0,075	0,001	Ok
1	279	-886,7	-153359,6	115,6	32368,2	0,001	0,097	0,002	Ok
17	279	-933,3	-118040,6	129,1	75426,0	0,004	0,075	0,002	Ok
1	279	-933,3	-153231,2	50,1	36635,9	0,001	0,097	0,001	Ok
17	279	-980,0	-117942,8	171,8	69583,4	0,004	0,075	0,003	Ok
1	279	-980,0	-153104,3	42,7	37781,1	0,001	0,097	0,001	Ok
17	279	-1026,7	-117846,3	201,6	61634,1	0,003	0,075	0,004	Ok
1	279	-1026,7	-152979,0	78,7	36280,0	0,001	0,097	0,001	Ok
17	279	-1073,3	-117751,0	217,7	52256,7	0,003	0,075	0,004	Ok
1	279	-1073,3	-152855,3	108,7	32708,0	0,001	0,097	0,002	Ok
17	279	-1120,0	-117657,0	220,3	42110,0	0,002	0,075	0,004	Ok
1	279	-1120,0	-152733,2	126,9	27664,9	0,001	0,097	0,002	Ok
17	279	-1166,7	-117564,1	209,7	31833,8	0,002	0,075	0,004	Ok
1	279	-1166,7	-152612,7	132,5	21753,4	0,001	0,097	0,002	Ok
17	279	-1213,3	-117472,5	185,9	22052,1	0,002	0,088	0,003	Ok
1	279	-1213,3	-152493,8	125,5	15572,5	0,001	0,114	0,002	Ok
17	279	-1260,0	-117382,1	149,3	13376,3	0,001	0,088	0,003	Ok
1	279	-1260,0	-152376,4	105,9	9716,7	0,001	0,114	0,002	Ok
17	279	-1306,7	-117292,9	99,8	6409,8	0,001	0,088	0,002	Ok
1	279	-1306,7	-152260,6	73,6	4776,7	0,000	0,114	0,001	Ok
17	279	-1353,3	-117204,9	37,5	1751,7	0,000	0,088	0,001	Ok
1	279	-1353,3	-152146,4	28,7	1341,5	0,000	0,114	0,001	Ok
20	279	-1400,0	-116866,5	7,0	0,0	0,065	0,088	0,000	Ok
1	279	-1400,0	-152146,4	28,7	0,0	0,000	0,114	0,001	Ok

Plinto n. 295

Cmb.	Palo	Quota (cm)	N (daN)	V (daN)	M (daN cm)	Ver. N/M	Ver.(25)	Ver.V	Stato
17	295	0,0	-138439,9	2672,6	931873,4	0,049	0,088	0,047	Ok
1	295	0,0	-180112,9	1537,4	758323,9	0,029	0,114	0,027	Ok
17	295	-46,7	-138348,6	2531,3	809363,9	0,043	0,088	0,045	Ok
1	295	-46,7	-179994,1	1538,8	686984,5	0,026	0,114	0,027	Ok
17	295	-93,3	-138232,8	2363,1	691701,9	0,036	0,088	0,042	Ok
1	295	-93,3	-179843,5	1507,6	615843,1	0,023	0,114	0,027	Ok
17	295	-140,0	-138094,7	2168,2	581900,8	0,031	0,088	0,038	Ok
1	295	-140,0	-179663,8	1452,2	546085,2	0,021	0,114	0,026	Ok
17	295	-186,7	-137957,9	1965,1	481221,0	0,025	0,088	0,035	Ok
1	295	-186,7	-179485,9	1379,1	478850,7	0,018	0,114	0,024	Ok
17	295	-233,3	-137822,7	1758,7	390071,3	0,021	0,088	0,031	Ok
1	295	-233,3	-179309,9	1292,1	414988,2	0,016	0,114	0,023	Ok
17	295	-280,0	-137688,8	1553,9	308638,7	0,016	0,087	0,028	Ok
1	295	-280,0	-179135,8	1195,3	355159,6	0,013	0,114	0,021	Ok
17	295	-326,7	-137556,4	1354,6	236904,1	0,013	0,087	0,024	Ok
1	295	-326,7	-178963,5	1092,1	299840,6	0,011	0,114	0,019	Ok
20	295	-373,3	-137640,8	356,7	208976,6	0,011	0,087	0,006	Ok
1	295	-373,3	-178793,0	985,4	249347,0	0,009	0,114	0,017	Ok
20	295	-420,0	-137511,0	371,0	192333,1	0,010	0,087	0,007	Ok
1	295	-420,0	-178624,4	878,0	203856,5	0,008	0,113	0,016	Ok

Parco Eolico "Bolina" – Progetto Definitivo
Relazione di calcolo preliminare delle fondazioni degli aerogeneratori G8 e G12

20	295	-466,7	-137382,7	375,2	175023,0	0,009	0,087	0,007	Ok
1	295	-466,7	-178457,7	772,0	163426,4	0,006	0,113	0,014	Ok
20	295	-513,3	-137255,8	371,0	157516,6	0,008	0,087	0,007	Ok
1	295	-513,3	-178292,8	669,2	128023,5	0,005	0,113	0,012	Ok
20	295	-560,0	-137130,2	360,0	140205,4	0,007	0,087	0,006	Ok
1	295	-560,0	-178129,8	571,1	97547,7	0,004	0,113	0,010	Ok
20	295	-606,7	-137006,2	343,6	123407,9	0,007	0,087	0,006	Ok
1	295	-606,7	-177968,6	478,8	71869,0	0,003	0,113	0,008	Ok
20	295	-653,3	-136883,5	323,0	107376,0	0,006	0,087	0,006	Ok
1	295	-653,3	-177809,3	393,2	50885,2	0,002	0,113	0,007	Ok
19	295	-700,0	-137182,1	295,7	92500,3	0,005	0,087	0,005	Ok
1	295	-700,0	-177651,8	314,8	34631,6	0,001	0,113	0,006	Ok
19	295	-746,7	-137061,9	269,3	79440,5	0,004	0,087	0,005	Ok
1	295	-746,7	-177496,2	244,1	23483,0	0,001	0,113	0,004	Ok
33	295	-793,3	-137020,7	149,8	75345,7	0,004	0,087	0,003	Ok
1	295	-793,3	-177342,3	181,6	18057,6	0,001	0,113	0,003	Ok
33	295	-840,0	-136903,3	143,9	71800,2	0,004	0,087	0,003	Ok
1	295	-840,0	-177190,4	127,7	17496,0	0,001	0,113	0,002	Ok
33	295	-886,7	-136787,3	150,7	66864,6	0,004	0,087	0,003	Ok
1	295	-886,7	-177040,2	83,4	18848,5	0,001	0,112	0,001	Ok
17	295	-933,3	-135964,2	132,7	61566,8	0,003	0,086	0,002	Ok
1	295	-933,3	-176892,0	51,8	19951,6	0,001	0,112	0,001	Ok
17	295	-980,0	-135851,6	156,6	55455,8	0,003	0,086	0,003	Ok
1	295	-980,0	-176745,5	40,1	20053,2	0,001	0,112	0,001	Ok
17	295	-1026,7	-135740,4	171,2	48184,9	0,003	0,086	0,003	Ok
1	295	-1026,7	-176600,9	47,3	19056,7	0,001	0,112	0,001	Ok
17	295	-1073,3	-135630,7	176,7	40211,3	0,002	0,086	0,003	Ok
1	295	-1073,3	-176458,1	58,7	17109,5	0,001	0,112	0,001	Ok
17	295	-1120,0	-135522,3	173,2	31974,1	0,002	0,086	0,003	Ok
1	295	-1120,0	-176317,1	66,8	14452,3	0,001	0,112	0,001	Ok
17	295	-1166,7	-135415,4	160,9	23896,7	0,001	0,086	0,003	Ok
1	295	-1166,7	-176178,0	69,3	11364,1	0,000	0,112	0,001	Ok
17	295	-1213,3	-135309,8	140,1	16389,5	0,001	0,101	0,002	Ok
1	295	-1213,3	-176040,7	65,6	8140,6	0,000	0,132	0,001	Ok
17	295	-1260,0	-135205,7	110,8	9853,2	0,001	0,101	0,002	Ok
1	295	-1260,0	-175905,2	55,3	5084,5	0,000	0,132	0,001	Ok
17	295	-1306,7	-135103,0	73,2	4682,4	0,000	0,101	0,001	Ok
1	295	-1306,7	-175771,5	38,5	2502,5	0,000	0,132	0,001	Ok
17	295	-1353,3	-135001,6	27,2	1268,0	0,000	0,101	0,000	Ok
1	295	-1353,3	-175639,7	15,1	703,9	0,000	0,132	0,000	Ok
20	295	-1400,0	-135213,3	4,0	0,0	0,075	0,101	0,000	Ok
1	295	-1400,0	-175639,7	15,1	0,0	0,000	0,132	0,000	Ok

Plinto n. 307

Cmb.	Palo	Quota (cm)	N (daN)	V (daN)	M (daN cm)	Ver. N/M	Ver.(25)	Ver.V	Stato
34	307	0,0	-141766,8	1752,7	593344,5	0,031	0,090	0,031	Ok
1	307	0,0	-184896,7	583,5	389020,3	0,015	0,117	0,010	Ok
34	307	-46,7	-141673,3	1652,3	513568,1	0,027	0,090	0,029	Ok
1	307	-46,7	-184774,7	623,5	361042,3	0,014	0,117	0,011	Ok
34	307	-93,3	-141554,7	1536,2	437252,1	0,023	0,090	0,027	Ok
1	307	-93,3	-184620,1	642,2	331948,2	0,013	0,117	0,011	Ok
34	307	-140,0	-141413,3	1403,6	366389,8	0,019	0,090	0,025	Ok
1	307	-140,0	-184435,6	647,1	301981,2	0,011	0,117	0,011	Ok
34	307	-186,7	-141273,3	1267,0	301769,0	0,016	0,090	0,022	Ok
1	307	-186,7	-184253,0	639,0	271783,2	0,010	0,117	0,011	Ok
18	307	-233,3	-141134,7	1128,7	243642,0	0,013	0,090	0,020	Ok
1	307	-233,3	-184072,3	619,9	241965,1	0,009	0,117	0,011	Ok
18	307	-280,0	-140997,6	993,5	192082,7	0,010	0,090	0,018	Ok
1	307	-280,0	-183893,6	591,9	213038,9	0,008	0,117	0,010	Ok
18	307	-326,7	-140862,0	862,8	147099,9	0,008	0,089	0,015	Ok
1	307	-326,7	-183716,7	557,1	185416,9	0,007	0,117	0,010	Ok
19	307	-373,3	-141644,0	207,3	137131,3	0,007	0,090	0,004	Ok
1	307	-373,3	-183541,7	517,3	159418,8	0,006	0,117	0,009	Ok
19	307	-420,0	-141510,4	191,1	134154,2	0,007	0,090	0,003	Ok

Parco Eolico "Bolina" – Progetto Definitivo
Relazione di calcolo preliminare delle fondazioni degli aerogeneratori G8 e G12

1	307	-420,0	-183368,7	474,0	135280,0	0,005	0,116	0,008	Ok
19	307	-466,7	-141378,4	188,9	129451,9	0,007	0,090	0,003	Ok
1	307	-466,7	-183197,5	428,8	113158,5	0,004	0,116	0,008	Ok
19	307	-513,3	-141247,7	193,8	123275,1	0,006	0,090	0,003	Ok
1	307	-513,3	-183028,2	382,9	93146,9	0,004	0,116	0,007	Ok
19	307	-560,0	-141118,6	200,7	115908,1	0,006	0,090	0,004	Ok
1	307	-560,0	-182860,9	337,2	75280,2	0,003	0,116	0,006	Ok
19	307	-606,7	-140990,9	206,5	107638,2	0,006	0,090	0,004	Ok
1	307	-606,7	-182695,4	292,6	59545,3	0,002	0,116	0,005	Ok
19	307	-653,3	-140864,7	209,7	98738,7	0,005	0,089	0,004	Ok
1	307	-653,3	-182531,9	249,9	45890,2	0,002	0,116	0,004	Ok
19	307	-700,0	-140739,9	209,8	89459,8	0,005	0,089	0,004	Ok
1	307	-700,0	-182370,2	209,5	34230,0	0,001	0,116	0,004	Ok
19	307	-746,7	-140616,6	206,8	80024,0	0,004	0,089	0,004	Ok
1	307	-746,7	-182210,4	171,8	24455,1	0,001	0,116	0,003	Ok
19	307	-793,3	-140494,7	200,9	70625,1	0,004	0,089	0,004	Ok
1	307	-793,3	-182052,5	137,3	16436,3	0,001	0,116	0,002	Ok
20	307	-840,0	-140164,8	176,5	61747,8	0,003	0,089	0,003	Ok
1	307	-840,0	-181896,5	106,0	10030,4	0,000	0,116	0,002	Ok
20	307	-886,7	-140046,1	170,3	53984,1	0,003	0,089	0,003	Ok
1	307	-886,7	-181742,4	78,2	5084,4	0,000	0,115	0,001	Ok
20	307	-933,3	-139928,8	162,9	46344,7	0,002	0,089	0,003	Ok
1	307	-933,3	-181590,2	53,9	1441,5	0,000	0,115	0,001	Ok
36	307	-980,0	-139325,3	132,1	39660,2	0,002	0,088	0,002	Ok
1	307	-980,0	-181439,8	33,1	1088,8	0,000	0,115	0,001	Ok
36	307	-1026,7	-139211,3	132,7	33631,5	0,002	0,088	0,002	Ok
1	307	-1026,7	-181291,3	15,9	2628,0	0,000	0,115	0,000	Ok
36	307	-1073,3	-139098,7	129,3	27510,8	0,001	0,088	0,002	Ok
1	307	-1073,3	-181144,8	2,4	3370,4	0,000	0,115	0,000	Ok
36	307	-1120,0	-138987,6	121,7	21513,2	0,001	0,088	0,002	Ok
1	307	-1120,0	-181000,1	7,8	3478,2	0,000	0,115	0,000	Ok
34	307	-1166,7	-138669,6	108,0	15919,8	0,001	0,088	0,002	Ok
1	307	-1166,7	-180857,2	14,3	3116,7	0,000	0,115	0,000	Ok
34	307	-1213,3	-138561,5	93,4	10880,1	0,001	0,104	0,002	Ok
1	307	-1213,3	-180716,3	17,3	2450,4	0,000	0,135	0,000	Ok
34	307	-1260,0	-138454,9	73,5	6520,6	0,001	0,104	0,001	Ok
1	307	-1260,0	-180577,2	16,8	1642,7	0,000	0,135	0,000	Ok
34	307	-1306,7	-138349,7	48,3	3089,7	0,000	0,104	0,001	Ok
1	307	-1306,7	-180440,0	12,9	856,6	0,000	0,135	0,000	Ok
34	307	-1353,3	-138245,9	17,9	834,0	0,000	0,104	0,000	Ok
1	307	-1353,3	-180304,7	5,5	254,8	0,000	0,135	0,000	Ok
35	307	-1400,0	-139145,9	10,7	0,0	0,077	0,104	0,000	Ok
1	307	-1400,0	-180304,7	5,5	0,0	0,000	0,135	0,000	Ok

Plinto n. 311

Cmb.	Palo	Quota (cm)	N (daN)	V (daN)	M (daN cm)	Ver. N/M	Ver.(25)	Ver.V	Stato
18	311	0,0	-144061,4	1495,4	466330,5	0,024	0,091	0,027	Ok
1	311	0,0	-188249,1	208,8	217691,2	0,008	0,120	0,004	Ok
18	311	-46,7	-143966,4	1394,5	398572,0	0,021	0,091	0,025	Ok
1	311	-46,7	-188124,9	252,8	207224,5	0,008	0,119	0,004	Ok
18	311	-93,3	-143845,9	1283,6	334263,2	0,017	0,091	0,023	Ok
1	311	-93,3	-187967,5	282,9	195443,5	0,007	0,119	0,005	Ok
18	311	-140,0	-143702,2	1160,2	275203,4	0,014	0,091	0,021	Ok
1	311	-140,0	-187779,6	304,7	182255,6	0,007	0,119	0,005	Ok
18	311	-186,7	-143559,9	1035,8	222001,1	0,012	0,091	0,018	Ok
1	311	-186,7	-187593,7	317,1	168044,8	0,006	0,119	0,006	Ok
18	311	-233,3	-143419,1	912,9	174771,4	0,009	0,091	0,016	Ok
1	311	-233,3	-187409,8	321,4	153251,2	0,006	0,119	0,006	Ok
18	311	-280,0	-143279,8	793,8	133560,8	0,007	0,091	0,014	Ok
1	311	-280,0	-187227,7	318,5	138259,8	0,005	0,119	0,006	Ok
18	311	-326,7	-143142,0	680,2	98403,4	0,005	0,091	0,012	Ok
1	311	-326,7	-187047,7	309,9	123399,3	0,005	0,119	0,005	Ok
19	311	-373,3	-144485,9	209,5	99030,4	0,005	0,092	0,004	Ok
1	311	-373,3	-186869,5	296,5	108942,0	0,004	0,119	0,005	Ok

Parco Eolico "Bolina" – Progetto Definitivo
Relazione di calcolo preliminare delle fondazioni degli aerogeneratori G8 e G12

35	311	-420,0	-144349,6	155,4	103962,1	0,005	0,092	0,003	Ok
1	311	-420,0	-186693,3	279,6	95107,3	0,004	0,119	0,005	Ok
35	311	-466,7	-144214,9	115,8	106290,2	0,006	0,092	0,002	Ok
1	311	-466,7	-186519,1	259,9	82064,4	0,003	0,118	0,005	Ok
35	311	-513,3	-144081,7	104,2	106184,7	0,006	0,092	0,002	Ok
1	311	-513,3	-186346,8	238,4	69938,3	0,003	0,118	0,004	Ok
35	311	-560,0	-143949,9	114,0	103949,4	0,005	0,091	0,002	Ok
1	311	-560,0	-186176,4	215,9	58814,2	0,002	0,118	0,004	Ok
35	311	-606,7	-143819,7	131,9	99928,1	0,005	0,091	0,002	Ok
1	311	-606,7	-186007,9	192,9	48742,6	0,002	0,118	0,003	Ok
35	311	-653,3	-143690,9	149,4	94466,4	0,005	0,091	0,003	Ok
1	311	-653,3	-185841,4	170,0	39744,6	0,001	0,118	0,003	Ok
35	311	-700,0	-143563,6	163,3	87893,6	0,005	0,091	0,003	Ok
1	311	-700,0	-185676,8	147,6	31815,9	0,001	0,118	0,003	Ok
35	311	-746,7	-143437,8	172,8	80513,0	0,004	0,091	0,003	Ok
1	311	-746,7	-185514,1	126,1	24931,9	0,001	0,118	0,002	Ok
33	311	-793,3	-142974,7	164,6	72876,2	0,004	0,091	0,003	Ok
1	311	-793,3	-185353,3	105,8	19050,7	0,001	0,118	0,002	Ok
33	311	-840,0	-142852,2	168,9	65543,5	0,003	0,091	0,003	Ok
1	311	-840,0	-185194,5	86,9	14117,2	0,001	0,118	0,002	Ok
33	311	-886,7	-142731,2	169,9	57876,7	0,003	0,091	0,003	Ok
1	311	-886,7	-185037,6	69,6	10065,9	0,000	0,118	0,001	Ok
33	311	-933,3	-142611,6	167,6	50079,8	0,003	0,091	0,003	Ok
1	311	-933,3	-184882,6	54,0	6823,2	0,000	0,117	0,001	Ok
33	311	-980,0	-142493,5	162,0	42340,2	0,002	0,090	0,003	Ok
1	311	-980,0	-184729,5	40,2	4310,2	0,000	0,117	0,001	Ok
33	311	-1026,7	-142376,9	153,3	34829,6	0,002	0,090	0,003	Ok
1	311	-1026,7	-184578,4	28,2	2444,7	0,000	0,117	0,001	Ok
33	311	-1073,3	-142261,8	141,6	27705,5	0,001	0,090	0,003	Ok
1	311	-1073,3	-184429,1	18,2	1146,1	0,000	0,117	0,000	Ok
33	311	-1120,0	-142148,2	127,1	21113,5	0,001	0,090	0,002	Ok
1	311	-1120,0	-184281,8	10,1	366,9	0,000	0,117	0,000	Ok
17	311	-1166,7	-141250,6	107,6	15330,5	0,001	0,090	0,002	Ok
1	311	-1166,7	-184136,4	4,0	296,5	0,000	0,117	0,000	Ok
17	311	-1213,3	-141140,6	90,5	10314,0	0,001	0,106	0,002	Ok
1	311	-1213,3	-183992,9	1,3	416,6	0,000	0,138	0,000	Ok
17	311	-1260,0	-141031,9	69,6	6093,2	0,000	0,106	0,001	Ok
1	311	-1260,0	-183851,3	3,0	377,7	0,000	0,138	0,000	Ok
17	311	-1306,7	-140924,8	44,8	2847,9	0,000	0,106	0,001	Ok
1	311	-1306,7	-183711,6	3,3	237,7	0,000	0,138	0,000	Ok
17	311	-1353,3	-140819,1	16,2	757,0	0,000	0,105	0,000	Ok
1	311	-1353,3	-183573,8	1,8	82,0	0,000	0,137	0,000	Ok
1	311	-1400,0	-183573,8	1,8	0,0	0,102	0,137	0,000	Ok

Plinto n. 327

Cmb.	Palo	Quota (cm)	N (daN)	V (daN)	M (daN cm)	Ver. N/M	Ver.(25)	Ver.V	Stato
36	327	0,0	-138465,1	2637,4	922516,8	0,049	0,088	0,047	Ok
1	327	0,0	-180145,6	1492,7	746005,5	0,028	0,114	0,026	Ok
36	327	-46,7	-138373,8	2498,9	801646,1	0,042	0,088	0,044	Ok
1	327	-46,7	-180026,8	1497,3	676824,1	0,026	0,114	0,027	Ok
36	327	-93,3	-138258,0	2333,9	685530,9	0,036	0,088	0,041	Ok
1	327	-93,3	-179876,2	1469,7	607726,1	0,023	0,114	0,026	Ok
36	327	-140,0	-138119,8	2142,2	577135,8	0,030	0,088	0,038	Ok
1	327	-140,0	-179696,4	1418,3	539828,8	0,020	0,114	0,025	Ok
36	327	-186,7	-137983,1	1942,3	477709,3	0,025	0,088	0,034	Ok
1	327	-186,7	-179518,5	1349,3	474253,0	0,018	0,114	0,024	Ok
36	327	-233,3	-137847,8	1739,1	387663,5	0,020	0,088	0,031	Ok
1	327	-233,3	-179342,5	1266,4	411848,6	0,016	0,114	0,022	Ok
36	327	-280,0	-137713,9	1537,4	307191,8	0,016	0,087	0,027	Ok
1	327	-280,0	-179168,3	1173,5	353282,3	0,013	0,114	0,021	Ok
36	327	-326,7	-137581,4	1340,8	236284,9	0,012	0,087	0,024	Ok
1	327	-326,7	-178996,0	1074,0	299038,8	0,011	0,114	0,019	Ok
33	327	-373,3	-137665,7	345,0	209041,3	0,011	0,087	0,006	Ok
1	327	-373,3	-178825,5	970,8	249445,2	0,009	0,114	0,017	Ok

Parco Eolico "Bolina" – Progetto Definitivo
Relazione di calcolo preliminare delle fondazioni degli aerogeneratori G8 e G12

33	327	-420,0	-137535,9	361,9	192941,7	0,010	0,087	0,006	Ok
1	327	-420,0	-178656,9	866,5	204692,0	0,008	0,113	0,015	Ok
33	327	-466,7	-137407,5	368,4	176053,6	0,009	0,087	0,007	Ok
1	327	-466,7	-178490,1	763,4	164850,6	0,006	0,113	0,014	Ok
33	327	-513,3	-137280,6	366,3	158860,5	0,008	0,087	0,006	Ok
1	327	-513,3	-178325,2	663,2	129901,8	0,005	0,113	0,012	Ok
33	327	-560,0	-137155,1	357,1	141766,7	0,007	0,087	0,006	Ok
1	327	-560,0	-178162,1	567,4	99758,3	0,004	0,113	0,010	Ok
33	327	-606,7	-137031,0	342,2	125103,2	0,007	0,087	0,006	Ok
1	327	-606,7	-178000,9	477,1	74298,8	0,003	0,113	0,008	Ok
33	327	-653,3	-136908,3	323,0	109133,9	0,006	0,087	0,006	Ok
1	327	-653,3	-177841,6	393,1	53417,3	0,002	0,113	0,007	Ok
35	327	-700,0	-137206,9	296,8	94427,8	0,005	0,087	0,005	Ok
1	327	-700,0	-177684,1	316,2	37108,0	0,001	0,113	0,006	Ok
35	327	-746,7	-137086,7	271,3	81305,2	0,004	0,087	0,005	Ok
1	327	-746,7	-177528,4	246,7	25604,8	0,001	0,113	0,004	Ok
20	327	-793,3	-137045,6	152,4	75408,9	0,004	0,087	0,003	Ok
1	327	-793,3	-177374,5	185,2	19322,8	0,001	0,113	0,003	Ok
20	327	-840,0	-136928,2	146,2	71711,4	0,004	0,087	0,003	Ok
1	327	-840,0	-177222,5	132,1	17709,1	0,001	0,113	0,002	Ok
20	327	-886,7	-136812,2	152,2	66677,4	0,004	0,087	0,003	Ok
1	327	-886,7	-177072,4	88,3	18394,2	0,001	0,112	0,002	Ok
36	327	-933,3	-135988,9	130,3	60582,2	0,003	0,086	0,002	Ok
1	327	-933,3	-176924,1	56,4	19215,3	0,001	0,112	0,001	Ok
36	327	-980,0	-135876,3	153,9	54592,3	0,003	0,086	0,003	Ok
1	327	-980,0	-176777,6	42,2	19249,8	0,001	0,112	0,001	Ok
36	327	-1026,7	-135765,1	168,4	47452,4	0,003	0,086	0,003	Ok
1	327	-1026,7	-176632,9	46,5	18296,0	0,001	0,112	0,001	Ok
36	327	-1073,3	-135655,4	173,9	39613,2	0,002	0,086	0,003	Ok
1	327	-1073,3	-176490,1	56,5	16447,3	0,001	0,112	0,001	Ok
36	327	-1120,0	-135547,0	170,5	31507,9	0,002	0,086	0,003	Ok
1	327	-1120,0	-176349,1	64,1	13914,5	0,001	0,112	0,001	Ok
36	327	-1166,7	-135440,0	158,5	23554,5	0,001	0,086	0,003	Ok
1	327	-1166,7	-176210,0	66,6	10958,3	0,000	0,112	0,001	Ok
36	327	-1213,3	-135334,5	138,1	16158,7	0,001	0,101	0,002	Ok
1	327	-1213,3	-176072,6	63,2	7861,4	0,000	0,132	0,001	Ok
36	327	-1260,0	-135230,3	109,3	9716,7	0,001	0,101	0,002	Ok
1	327	-1260,0	-175937,1	53,5	4916,7	0,000	0,132	0,001	Ok
36	327	-1306,7	-135127,6	72,2	4618,5	0,000	0,101	0,001	Ok
1	327	-1306,7	-175803,5	37,3	2423,1	0,000	0,132	0,001	Ok
36	327	-1353,3	-135026,2	26,8	1251,0	0,000	0,101	0,000	Ok
1	327	-1353,3	-175671,6	14,6	682,5	0,000	0,132	0,000	Ok
34	327	-1400,0	-134611,1	24,3	0,0	0,075	0,101	0,000	Ok
1	327	-1400,0	-175671,6	14,6	0,0	0,000	0,132	0,000	Ok

Plinto n. 84

Cmb.	Palo	Quota (cm)	N (daN)	V (daN)	M (daN cm)	Ver. N/M	Ver.(25)	Ver.V	Stato
34	84	0,0	-122052,4	4384,9	1781356,0	0,096	0,078	0,078	Ok
1	84	0,0	-158882,2	3957,6	1906431,0	0,074	0,101	0,070	Ok
34	84	-46,7	-121971,9	4250,7	1578096,0	0,085	0,077	0,075	Ok
1	84	-46,7	-158777,4	3949,5	1721336,0	0,067	0,101	0,070	Ok
34	84	-93,3	-121869,9	4050,9	1379745,0	0,075	0,077	0,072	Ok
1	84	-93,3	-158644,6	3857,9	1537203,0	0,060	0,101	0,068	Ok
34	84	-140,0	-121748,1	3796,0	1190716,0	0,065	0,077	0,067	Ok
1	84	-140,0	-158486,0	3704,2	1357326,0	0,053	0,101	0,066	Ok
34	84	-186,7	-121627,5	3511,8	1013584,0	0,055	0,077	0,062	Ok
1	84	-186,7	-158329,1	3506,1	1184608,0	0,046	0,101	0,062	Ok
34	84	-233,3	-121508,3	3208,0	849714,5	0,046	0,077	0,057	Ok
1	84	-233,3	-158173,8	3274,0	1021125,0	0,040	0,100	0,058	Ok
34	84	-280,0	-121390,3	2894,2	700022,1	0,038	0,077	0,051	Ok
1	84	-280,0	-158020,2	3018,2	868469,2	0,034	0,100	0,054	Ok
34	84	-326,7	-121273,5	2578,2	564973,6	0,031	0,077	0,046	Ok
1	84	-326,7	-157868,2	2747,5	727750,3	0,028	0,100	0,049	Ok
35	84	-373,3	-121484,9	1534,6	477895,8	0,026	0,077	0,027	Ok

Parco Eolico "Bolina" – Progetto Definitivo
Relazione di calcolo preliminare delle fondazioni degli aerogeneratori G8 e G12

1	84	-373,3	-157717,9	2469,5	599668,9	0,023	0,100	0,044	Ok
35	84	-420,0	-121370,4	1407,9	406572,3	0,022	0,077	0,025	Ok
1	84	-420,0	-157569,2	2191,0	484570,8	0,019	0,100	0,039	Ok
35	84	-466,7	-121257,1	1275,2	341153,5	0,019	0,077	0,023	Ok
1	84	-466,7	-157422,1	1917,4	382487,9	0,015	0,100	0,034	Ok
35	84	-513,3	-121145,0	1140,2	281928,0	0,015	0,077	0,020	Ok
1	84	-513,3	-157276,7	1653,1	293207,2	0,011	0,100	0,029	Ok
35	84	-560,0	-121034,3	1005,9	229015,4	0,012	0,077	0,018	Ok
1	84	-560,0	-157132,8	1401,6	216315,1	0,008	0,100	0,025	Ok
35	84	-606,7	-120924,7	874,7	182395,5	0,010	0,077	0,016	Ok
1	84	-606,7	-156990,7	1165,7	151259,0	0,006	0,100	0,021	Ok
35	84	-653,3	-120816,5	748,7	141935,6	0,008	0,077	0,013	Ok
1	84	-653,3	-156850,1	947,2	97431,6	0,004	0,100	0,017	Ok
35	84	-700,0	-120709,5	629,7	107412,9	0,006	0,077	0,011	Ok
1	84	-700,0	-156711,2	747,5	54391,2	0,002	0,100	0,013	Ok
35	84	-746,7	-120603,7	518,7	78544,6	0,004	0,077	0,009	Ok
1	84	-746,7	-156573,9	567,5	23351,3	0,001	0,099	0,010	Ok
36	84	-793,3	-120417,2	226,1	74660,6	0,004	0,076	0,004	Ok
1	84	-793,3	-156438,2	407,7	17981,3	0,001	0,099	0,007	Ok
36	84	-840,0	-120314,0	121,4	81993,2	0,004	0,076	0,002	Ok
1	84	-840,0	-156304,2	268,3	31831,4	0,001	0,099	0,005	Ok
36	84	-886,7	-120212,1	84,1	84504,6	0,005	0,076	0,001	Ok
1	84	-886,7	-156171,7	149,9	42923,1	0,002	0,099	0,003	Ok
36	84	-933,3	-120111,4	125,3	82736,0	0,004	0,076	0,002	Ok
1	84	-933,3	-156040,9	56,8	49126,6	0,002	0,099	0,001	Ok
36	84	-980,0	-120012,0	176,5	77425,0	0,004	0,076	0,003	Ok
1	84	-980,0	-155911,7	49,4	50885,7	0,002	0,099	0,001	Ok
36	84	-1026,7	-119913,8	215,9	69366,4	0,004	0,076	0,004	Ok
1	84	-1026,7	-155784,1	103,8	48965,3	0,002	0,099	0,002	Ok
36	84	-1073,3	-119816,8	239,6	59363,5	0,003	0,076	0,004	Ok
1	84	-1073,3	-155658,2	146,0	44192,4	0,002	0,099	0,003	Ok
36	84	-1120,0	-119721,1	247,2	48210,7	0,003	0,076	0,004	Ok
1	84	-1120,0	-155533,8	171,2	37401,4	0,001	0,099	0,003	Ok
36	84	-1166,7	-119626,6	238,5	36688,0	0,002	0,076	0,004	Ok
1	84	-1166,7	-155411,1	179,1	29419,9	0,001	0,099	0,003	Ok
36	84	-1213,3	-119533,4	213,8	25561,1	0,002	0,090	0,004	Ok
1	84	-1213,3	-155290,0	169,7	21065,3	0,001	0,116	0,003	Ok
36	84	-1260,0	-119441,4	173,2	15584,0	0,001	0,089	0,003	Ok
1	84	-1260,0	-155170,5	143,2	13145,7	0,001	0,116	0,003	Ok
36	84	-1306,7	-119350,6	116,6	7503,2	0,001	0,089	0,002	Ok
1	84	-1306,7	-155052,6	99,6	6462,9	0,000	0,116	0,002	Ok
36	84	-1353,3	-119261,1	44,2	2061,2	0,000	0,089	0,001	Ok
1	84	-1353,3	-154936,3	38,9	1815,1	0,000	0,116	0,001	Ok
20	84	-1400,0	-119569,5	36,8	0,0	0,000	0,090	0,001	Ok
1	84	-1400,0	-154936,3	38,9	0,0	0,000	0,116	0,001	Ok

Plinto n. 92

Cmb.	Palo	Quota (cm)	N (daN)	V (daN)	M (daN cm)	Ver. N/M	Ver.(25)	Ver.V	Stato
36	92	0,0	-120234,0	3688,2	1418187,0	0,077	0,076	0,065	Ok
1	92	0,0	-156078,5	2874,1	1396649,0	0,054	0,099	0,051	Ok
36	92	-46,7	-120154,7	3543,6	1248217,0	0,068	0,076	0,063	Ok
1	92	-46,7	-155975,6	2872,0	1262419,0	0,049	0,099	0,051	Ok
36	92	-93,3	-120054,1	3351,0	1083367,0	0,059	0,076	0,059	Ok
1	92	-93,3	-155845,1	2808,7	1128760,0	0,044	0,099	0,050	Ok
36	92	-140,0	-119934,2	3115,9	927495,5	0,050	0,076	0,055	Ok
1	92	-140,0	-155689,3	2700,1	998013,7	0,039	0,099	0,048	Ok
36	92	-186,7	-119815,4	2861,4	782596,8	0,043	0,076	0,051	Ok
1	92	-186,7	-155535,2	2558,8	872305,5	0,034	0,099	0,045	Ok
36	92	-233,3	-119697,9	2595,0	649595,4	0,035	0,076	0,046	Ok
1	92	-233,3	-155382,7	2392,2	753173,3	0,029	0,099	0,042	Ok
36	92	-280,0	-119581,7	2324,5	529064,7	0,029	0,076	0,041	Ok
1	92	-280,0	-155231,7	2207,9	641803,6	0,025	0,099	0,039	Ok
36	92	-326,7	-119466,7	2055,5	421236,4	0,023	0,076	0,036	Ok
1	92	-326,7	-155082,4	2012,3	539032,8	0,021	0,098	0,036	Ok

Parco Eolico "Bolina" – Progetto Definitivo
Relazione di calcolo preliminare delle fondazioni degli aerogeneratori G8 e G12

33	92	-373,3	-119008,3	997,8	359211,0	0,020	0,076	0,018	Ok
1	92	-373,3	-154934,8	1811,0	445397,6	0,017	0,098	0,032	Ok
33	92	-420,0	-118896,1	937,4	312653,5	0,017	0,076	0,017	Ok
1	92	-420,0	-154788,7	1609,0	361176,0	0,014	0,098	0,029	Ok
33	92	-466,7	-118785,1	868,7	268913,9	0,015	0,075	0,015	Ok
1	92	-466,7	-154644,2	1410,2	286418,2	0,011	0,098	0,025	Ok
33	92	-513,3	-118675,3	794,4	228382,5	0,012	0,075	0,014	Ok
1	92	-513,3	-154501,3	1217,9	220998,6	0,009	0,098	0,022	Ok
33	92	-560,0	-118566,8	716,9	191318,5	0,010	0,075	0,013	Ok
1	92	-560,0	-154360,0	1034,7	164653,2	0,006	0,098	0,018	Ok
33	92	-606,7	-118459,5	638,4	157867,6	0,009	0,075	0,011	Ok
1	92	-606,7	-154220,4	862,6	117035,2	0,005	0,098	0,015	Ok
33	92	-653,3	-118353,5	560,7	128079,6	0,007	0,075	0,010	Ok
1	92	-653,3	-154082,3	703,1	77807,4	0,003	0,098	0,012	Ok
35	92	-700,0	-118679,3	482,2	102367,8	0,006	0,075	0,009	Ok
1	92	-700,0	-153945,8	557,3	46885,7	0,002	0,098	0,010	Ok
35	92	-746,7	-118575,4	408,8	80978,7	0,004	0,075	0,007	Ok
1	92	-746,7	-153810,9	425,8	25494,0	0,001	0,098	0,008	Ok
20	92	-793,3	-118916,9	226,6	75239,6	0,004	0,076	0,004	Ok
1	92	-793,3	-153677,7	309,1	18879,7	0,001	0,098	0,005	Ok
36	92	-840,0	-118283,0	69,6	77043,7	0,004	0,075	0,001	Ok
1	92	-840,0	-153546,0	207,7	24788,5	0,001	0,098	0,004	Ok
36	92	-886,7	-118182,8	80,3	77497,7	0,004	0,075	0,001	Ok
1	92	-886,7	-153415,9	122,5	31524,9	0,001	0,097	0,002	Ok
36	92	-933,3	-118083,8	128,0	74510,7	0,004	0,075	0,002	Ok
1	92	-933,3	-153287,4	58,5	35603,2	0,001	0,097	0,001	Ok
36	92	-980,0	-117986,1	169,7	68758,2	0,004	0,075	0,003	Ok
1	92	-980,0	-153160,5	45,5	36755,0	0,001	0,097	0,001	Ok
36	92	-1026,7	-117889,5	199,1	60920,3	0,003	0,075	0,004	Ok
1	92	-1026,7	-153035,1	76,8	35350,4	0,001	0,097	0,001	Ok
36	92	-1073,3	-117794,2	215,1	51665,4	0,003	0,075	0,004	Ok
1	92	-1073,3	-152911,4	105,7	31918,2	0,001	0,097	0,002	Ok
36	92	-1120,0	-117700,1	217,7	41643,8	0,002	0,075	0,004	Ok
1	92	-1120,0	-152789,2	123,6	27033,0	0,001	0,097	0,002	Ok
36	92	-1166,7	-117607,2	207,3	31488,6	0,002	0,075	0,004	Ok
1	92	-1166,7	-152668,7	129,4	21281,1	0,001	0,097	0,002	Ok
36	92	-1213,3	-117515,6	183,9	21817,6	0,002	0,088	0,003	Ok
1	92	-1213,3	-152549,7	122,7	15249,8	0,001	0,114	0,002	Ok
36	92	-1260,0	-117425,1	147,7	13236,6	0,001	0,088	0,003	Ok
1	92	-1260,0	-152432,3	103,7	9523,8	0,001	0,114	0,002	Ok
36	92	-1306,7	-117335,9	98,8	6344,1	0,001	0,088	0,002	Ok
1	92	-1306,7	-152316,5	72,2	4685,7	0,000	0,114	0,001	Ok
36	92	-1353,3	-117247,9	37,2	1734,2	0,000	0,088	0,001	Ok
1	92	-1353,3	-152202,2	28,2	1317,1	0,000	0,114	0,001	Ok
33	92	-1400,0	-116909,4	6,5	0,0	0,065	0,088	0,000	Ok
1	92	-1400,0	-152202,2	28,2	0,0	0,000	0,114	0,001	Ok

Sezioni maggiormente sollecitate:

Pl.	Cmb.	Palo	Quota (cm)	N (daN)	V (daN)	M (daN cm)	Ver. N/M	Ver.(25)	Ver.V
243	18	243	0,0	-76895,0	4906,5	2030005,0	0,119	0,049	0,087
311	1	311	-1213,3	-183992,9	1,3	416,6	0,000	0,138	0,000

S/Su massime:

Ver. N/M = 0,119 < 1 Ok

Ver. (25) = 0,138 < 1 Ok

Ver. V = 0,087 < 1 Ok

VERIFICHE STATO LIMITE DI ESERCIZIO:

Combinazioni di tipo: **SLE condizioni rare.**

Tensione lim. CLS = 149,4 daN/cm²

Tensione lim. acciaio = 3600,0 daN/cm²

Plinto n. 151

Cmb.	Palo	Quota	N	M	Ten.SLE C	Ten.SLE A	Stato
------	------	-------	---	---	-----------	-----------	-------



Parco Eolico "Bolina" – Progetto Definitivo
Relazione di calcolo preliminare delle fondazioni degli aerogeneratori G8 e G12

		(cm)	(daN)	(daN cm)	(daN/cmq)	(daN/cmq)	
69	151	0,0	-27371,5	784981,2	-6,7	-93,5	Ok
69	151	-46,7	-27353,5	714602,7	-5,7	-80,1	Ok
69	151	-93,3	-27330,6	643828,5	-5,3	-74,2	Ok
69	151	-140,0	-27303,3	573760,4	-4,9	-68,9	Ok
69	151	-186,7	-27276,2	505626,1	-4,5	-64,0	Ok
69	151	-233,3	-27249,5	440393,1	-4,2	-59,7	Ok
69	151	-280,0	-27223,0	378829,6	-3,9	-55,7	Ok
69	151	-326,7	-27196,8	321504,1	-3,6	-52,0	Ok
69	151	-373,3	-27170,9	268810,6	-3,4	-48,6	Ok
69	151	-420,0	-27145,3	220988,9	-3,1	-45,5	Ok
69	151	-466,7	-27120,0	178141,2	-2,9	-42,7	Ok
69	151	-513,3	-27094,9	140257,7	-2,8	-40,3	Ok
69	151	-560,0	-27070,1	107233,2	-2,6	-38,1	Ok
69	151	-606,7	-27045,6	78886,9	-2,5	-36,3	Ok
69	151	-653,3	-27021,4	54979,0	-2,3	-34,7	Ok
69	151	-700,0	-26997,5	35223,9	-2,2	-33,4	Ok
69	151	-746,7	-26973,8	19306,3	-2,2	-32,4	Ok
69	151	-793,3	-26950,5	6910,1	-2,1	-31,6	Ok
69	151	-840,0	-26927,4	2644,1	-2,1	-31,1	Ok
69	151	-886,7	-26904,6	9051,7	-2,1	-31,6	Ok
69	151	-933,3	-26882,0	13169,4	-2,1	-31,9	Ok
69	151	-980,0	-26859,8	15259,2	-2,1	-32,0	Ok
69	151	-1026,7	-26837,8	15673,5	-2,1	-32,0	Ok
69	151	-1073,3	-26816,1	14765,4	-2,1	-31,9	Ok
69	151	-1120,0	-26794,7	12882,6	-2,1	-31,8	Ok
69	151	-1166,7	-26773,5	10367,4	-2,1	-31,6	Ok
69	151	-1213,3	-26752,7	7557,3	-2,3	-33,8	Ok
69	151	-1260,0	-26732,1	4785,4	-2,2	-33,5	Ok
69	151	-1306,7	-26711,8	2382,6	-2,2	-33,2	Ok
69	151	-1353,3	-26691,7	677,8	-2,2	-33,1	Ok
69	151	-1400,0	-26691,7	0,0	-2,2	-33,1	Ok

Plinto n. 103

Cmb.	Palo	Quota	N	M	Ten.SLE C	Ten.SLE A	Stato
		(cm)	(daN)	(daN cm)	(daN/cmq)	(daN/cmq)	
69	103	0,0	-92956,4	1329676,0	-14,9	-211,6	Ok
69	103	-46,7	-92895,1	1201670,0	-12,9	-184,4	Ok
69	103	-93,3	-92817,3	1074199,0	-12,2	-176,1	Ok
69	103	-140,0	-92724,6	949509,5	-11,6	-168,0	Ok
69	103	-186,7	-92632,8	829631,3	-11,1	-160,2	Ok
69	103	-233,3	-92541,9	716030,4	-10,5	-152,8	Ok
69	103	-280,0	-92452,1	609836,7	-10,0	-145,9	Ok
69	103	-326,7	-92363,1	511844,9	-9,5	-139,5	Ok
69	103	-373,3	-92275,2	422562,9	-9,1	-133,6	Ok
69	103	-420,0	-92188,2	342250,4	-8,7	-128,4	Ok
69	103	-466,7	-92102,1	270947,6	-8,4	-123,7	Ok
69	103	-513,3	-92017,0	208523,2	-8,1	-119,6	Ok
69	103	-560,0	-91932,9	154705,7	-7,8	-116,0	Ok
69	103	-606,7	-91849,7	109128,6	-7,6	-113,0	Ok
69	103	-653,3	-91767,5	71392,0	-7,4	-110,5	Ok
69	103	-700,0	-91686,2	41220,6	-7,3	-108,5	Ok
69	103	-746,7	-91605,9	19361,2	-7,1	-107,0	Ok
69	103	-793,3	-91526,5	13089,1	-7,1	-106,5	Ok
69	103	-840,0	-91448,0	21284,8	-7,1	-106,9	Ok
69	103	-886,7	-91370,6	28849,7	-7,2	-107,3	Ok
69	103	-933,3	-91294,0	33252,7	-7,2	-107,5	Ok
69	103	-980,0	-91218,4	34621,1	-7,2	-107,5	Ok
69	103	-1026,7	-91143,8	33438,7	-7,2	-107,4	Ok
69	103	-1073,3	-91070,1	30263,4	-7,2	-107,1	Ok
69	103	-1120,0	-90997,4	25668,0	-7,1	-106,7	Ok
69	103	-1166,7	-90925,6	20225,2	-7,1	-106,3	Ok
69	103	-1213,3	-90854,7	14502,1	-7,6	-113,9	Ok
69	103	-1260,0	-90784,8	9060,8	-7,5	-112,7	Ok
69	103	-1306,7	-90715,8	4459,4	-7,5	-112,7	Ok

Parco Eolico "Bolina" – Progetto Definitivo
Relazione di calcolo preliminare delle fondazioni degli aerogeneratori G8 e G12

69	103	-1353,3	-90647,7	1253,8	-7,5	-112,6	Ok
69	103	-1400,0	-90647,7	0,0	-7,5	-112,6	Ok

Plinto n. 115

Cmb.	Palo	Quota (cm)	N (daN)	M (daN cm)	Ten.SLE C (daN/cm ²)	Ten.SLE A (daN/cm ²)	Stato
69	115	0,0	-76749,0	1709258,0	-15,6	-219,8	Ok
69	115	-46,7	-76698,4	1543789,0	-13,3	-188,5	Ok
69	115	-93,3	-76634,2	1379096,0	-12,5	-177,1	Ok
69	115	-140,0	-76557,6	1218113,0	-11,7	-166,6	Ok
69	115	-186,7	-76481,8	1063452,0	-10,9	-156,5	Ok
69	115	-233,3	-76406,8	916986,3	-10,2	-147,1	Ok
69	115	-280,0	-76332,6	780154,2	-9,6	-138,2	Ok
69	115	-326,7	-76259,2	653962,6	-9,0	-130,0	Ok
69	115	-373,3	-76186,6	539048,5	-8,4	-122,5	Ok
69	115	-420,0	-76114,7	435728,5	-7,9	-115,8	Ok
69	115	-466,7	-76043,7	344035,5	-7,5	-109,9	Ok
69	115	-513,3	-75973,4	263778,4	-7,1	-104,6	Ok
69	115	-560,0	-75904,0	194578,6	-6,8	-100,1	Ok
69	115	-606,7	-75835,3	135916,5	-6,5	-96,3	Ok
69	115	-653,3	-75767,4	87178,8	-6,2	-93,1	Ok
69	115	-700,0	-75700,3	47733,2	-6,1	-90,4	Ok
69	115	-746,7	-75633,9	17434,2	-5,9	-88,4	Ok
69	115	-793,3	-75568,4	10767,3	-5,9	-87,9	Ok
69	115	-840,0	-75503,6	26037,3	-5,9	-88,8	Ok
69	115	-886,7	-75439,7	36906,6	-6,0	-89,4	Ok
69	115	-933,3	-75376,5	42936,9	-6,0	-89,8	Ok
69	115	-980,0	-75314,1	44813,8	-6,0	-89,8	Ok
69	115	-1026,7	-75252,4	43307,2	-6,0	-89,6	Ok
69	115	-1073,3	-75191,6	39191,5	-6,0	-89,3	Ok
69	115	-1120,0	-75131,5	33230,5	-5,9	-88,9	Ok
69	115	-1166,7	-75072,2	26174,2	-5,9	-88,3	Ok
69	115	-1213,3	-75013,7	18760,5	-6,3	-94,5	Ok
69	115	-1260,0	-74956,0	11717,0	-6,3	-93,9	Ok
69	115	-1306,7	-74899,1	5764,4	-6,2	-93,0	Ok
69	115	-1353,3	-74842,9	1620,0	-6,2	-92,9	Ok
69	115	-1400,0	-74842,9	0,0	-6,2	-92,9	Ok

Plinto n. 119

Cmb.	Palo	Quota (cm)	N (daN)	M (daN cm)	Ten.SLE C (daN/cm ²)	Ten.SLE A (daN/cm ²)	Stato
69	119	0,0	-65333,2	1234322,0	-12,0	-169,9	Ok
69	119	-46,7	-65290,1	1117095,0	-10,3	-147,1	Ok
69	119	-93,3	-65235,5	1000143,0	-9,8	-139,5	Ok
69	119	-140,0	-65170,3	885481,7	-9,2	-132,1	Ok
69	119	-186,7	-65105,8	775005,2	-8,7	-124,9	Ok
69	119	-233,3	-65041,9	670106,4	-8,2	-118,1	Ok
69	119	-280,0	-64978,8	571865,3	-7,7	-111,7	Ok
69	119	-326,7	-64916,3	481050,7	-7,3	-105,8	Ok
69	119	-373,3	-64854,4	398162,9	-6,9	-100,4	Ok
69	119	-420,0	-64793,3	323469,2	-6,5	-95,6	Ok
69	119	-466,7	-64732,8	257030,4	-6,2	-91,2	Ok
69	119	-513,3	-64673,0	198743,9	-5,9	-87,4	Ok
69	119	-560,0	-64613,9	148371,7	-5,7	-84,1	Ok
69	119	-606,7	-64555,4	105577,7	-5,5	-81,3	Ok
69	119	-653,3	-64497,6	69971,6	-5,3	-78,9	Ok
69	119	-700,0	-64440,5	41198,6	-5,2	-77,0	Ok
69	119	-746,7	-64384,0	19396,6	-5,0	-75,6	Ok
69	119	-793,3	-64328,2	9622,3	-5,0	-74,9	Ok
69	119	-840,0	-64273,1	16749,8	-5,0	-75,3	Ok
69	119	-886,7	-64218,6	24287,4	-5,1	-75,7	Ok
69	119	-933,3	-64164,8	28840,1	-5,1	-75,9	Ok
69	119	-980,0	-64111,7	30513,2	-5,1	-76,0	Ok
69	119	-1026,7	-64059,3	29766,2	-5,1	-75,9	Ok
69	119	-1073,3	-64007,5	27122,6	-5,1	-75,6	Ok

Parco Eolico "Bolina" – Progetto Definitivo
Relazione di calcolo preliminare delle fondazioni degli aerogeneratori G8 e G12

69	119	-1120,0	-63956,3	23117,5	-5,0	-75,3	Ok
69	119	-1166,7	-63905,9	18283,7	-5,0	-74,9	Ok
69	119	-1213,3	-63856,1	13148,9	-5,4	-80,2	Ok
69	119	-1260,0	-63806,9	8235,4	-5,3	-79,8	Ok
69	119	-1306,7	-63758,4	4061,7	-5,3	-79,2	Ok
69	119	-1353,3	-63710,6	1144,5	-5,3	-79,1	Ok
69	119	-1400,0	-63710,6	0,0	-5,3	-79,1	Ok

Plinto n. 135

Cmb.	Palo	Quota (cm)	N (daN)	M (daN cm)	Ten.SLE C (daN/cm ²)	Ten.SLE A (daN/cm ²)	Stato
69	135	0,0	-44127,7	1024304,0	-9,2	-129,8	Ok
69	135	-46,7	-44098,6	929325,1	-7,9	-111,4	Ok
69	135	-93,3	-44061,7	834257,5	-7,4	-104,6	Ok
69	135	-140,0	-44017,6	740675,1	-6,9	-98,4	Ok
69	135	-186,7	-43974,1	650162,6	-6,5	-92,5	Ok
69	135	-233,3	-43930,9	563921,5	-6,1	-86,9	Ok
69	135	-280,0	-43888,3	482893,0	-5,7	-81,7	Ok
69	135	-326,7	-43846,1	407759,1	-5,3	-76,8	Ok
69	135	-373,3	-43804,3	338976,7	-5,0	-72,3	Ok
69	135	-420,0	-43763,0	276806,0	-4,7	-68,3	Ok
69	135	-466,7	-43722,2	221332,1	-4,4	-64,7	Ok
69	135	-513,3	-43681,8	172499,4	-4,2	-61,5	Ok
69	135	-560,0	-43641,8	130134,3	-4,0	-58,7	Ok
69	135	-606,7	-43602,3	93971,8	-3,8	-56,4	Ok
69	135	-653,3	-43563,3	63683,1	-3,7	-54,4	Ok
69	135	-700,0	-43524,7	38908,2	-3,5	-52,7	Ok
69	135	-746,7	-43486,6	19370,9	-3,4	-51,4	Ok
69	135	-793,3	-43448,9	6200,2	-3,4	-50,6	Ok
69	135	-840,0	-43411,7	9600,4	-3,4	-50,7	Ok
69	135	-886,7	-43374,9	16609,8	-3,4	-51,1	Ok
69	135	-933,3	-43338,5	21054,2	-3,4	-51,4	Ok
69	135	-980,0	-43302,7	23013,3	-3,4	-51,5	Ok
69	135	-1026,7	-43267,2	22889,6	-3,4	-51,4	Ok
69	135	-1073,3	-43232,2	21127,0	-3,4	-51,3	Ok
69	135	-1120,0	-43197,7	18173,3	-3,4	-51,0	Ok
69	135	-1166,7	-43163,6	14472,9	-3,4	-50,8	Ok
69	135	-1213,3	-43130,0	10464,9	-3,6	-54,3	Ok
69	135	-1260,0	-43096,8	6583,4	-3,6	-54,0	Ok
69	135	-1306,7	-43064,0	3259,4	-3,6	-53,5	Ok
69	135	-1353,3	-43031,7	922,0	-3,6	-53,4	Ok
69	135	-1400,0	-43031,7	0,0	-3,6	-53,4	Ok

Plinto n. 147

Cmb.	Palo	Quota (cm)	N (daN)	M (daN cm)	Ten.SLE C (daN/cm ²)	Ten.SLE A (daN/cm ²)	Stato
69	147	0,0	-41237,9	1441379,0	-11,9	-165,2	Ok
69	147	-46,7	-41210,7	1303694,0	-10,2	-141,3	Ok
69	147	-93,3	-41176,2	1166408,0	-9,2	-128,5	Ok
69	147	-140,0	-41135,1	1031918,0	-8,3	-116,9	Ok
69	147	-186,7	-41094,4	902434,9	-7,5	-106,5	Ok
69	147	-233,3	-41054,1	779575,8	-6,9	-97,6	Ok
69	147	-280,0	-41014,2	664589,8	-6,3	-90,0	Ok
69	147	-326,7	-40974,7	558361,2	-5,8	-83,1	Ok
69	147	-373,3	-40935,7	461460,6	-5,3	-76,9	Ok
69	147	-420,0	-40897,1	374186,0	-4,9	-71,2	Ok
69	147	-466,7	-40859,0	296592,8	-4,6	-66,2	Ok
69	147	-513,3	-40821,2	228544,0	-4,2	-61,8	Ok
69	147	-560,0	-40783,9	169739,3	-3,9	-58,0	Ok
69	147	-606,7	-40747,0	119751,9	-3,7	-54,7	Ok
69	147	-653,3	-40710,5	78059,5	-3,5	-52,0	Ok
69	147	-700,0	-40674,4	44065,4	-3,3	-49,8	Ok
69	147	-746,7	-40638,8	17127,2	-3,2	-48,0	Ok
69	147	-793,3	-40603,6	3502,9	-3,1	-46,9	Ok
69	147	-840,0	-40568,8	18355,0	-3,2	-48,0	Ok

Parco Eolico "Bolina" – Progetto Definitivo
Relazione di calcolo preliminare delle fondazioni degli aerogeneratori G8 e G12

69	147	-886,7	-40534,4	28265,6	-3,3	-48,6	Ok
69	147	-933,3	-40500,5	33898,2	-3,3	-48,9	Ok
69	147	-980,0	-40466,9	35940,2	-3,3	-49,0	Ok
69	147	-1026,7	-40433,8	35067,5	-3,3	-48,9	Ok
69	147	-1073,3	-40401,1	31942,3	-3,3	-48,7	Ok
69	147	-1120,0	-40368,9	27211,9	-3,2	-48,3	Ok
69	147	-1166,7	-40337,0	21510,8	-3,2	-47,9	Ok
69	147	-1213,3	-40305,6	15461,9	-3,4	-51,2	Ok
69	147	-1260,0	-40274,5	9679,5	-3,4	-50,7	Ok
69	147	-1306,7	-40243,9	4771,8	-3,3	-50,0	Ok
69	147	-1353,3	-40213,8	1343,9	-3,3	-49,9	Ok
69	147	-1400,0	-40213,8	0,0	-3,3	-49,9	Ok

Plinto n. 167

Cmb.	Palo	Quota (cm)	N (daN)	M (daN cm)	Ten.SLE C (daN/cm ²)	Ten.SLE A (daN/cm ²)	Stato
69	167	0,0	-16330,5	547248,1	-4,6	-63,2	Ok
69	167	-46,7	-16319,7	500828,2	-3,9	-54,5	Ok
69	167	-93,3	-16306,0	453779,7	-3,6	-50,2	Ok
69	167	-140,0	-16289,7	406754,6	-3,3	-46,1	Ok
69	167	-186,7	-16273,6	360621,8	-3,0	-42,4	Ok
69	167	-233,3	-16257,6	316106,2	-2,8	-39,2	Ok
69	167	-280,0	-16241,9	273793,5	-2,6	-36,3	Ok
69	167	-326,7	-16226,2	234130,3	-2,4	-33,8	Ok
69	167	-373,3	-16210,8	197438,8	-2,2	-31,4	Ok
69	167	-420,0	-16195,5	163931,0	-2,0	-29,2	Ok
69	167	-466,7	-16180,4	133719,1	-1,9	-27,3	Ok
69	167	-513,3	-16165,4	106833,8	-1,8	-25,5	Ok
69	167	-560,0	-16150,7	83235,0	-1,6	-24,0	Ok
69	167	-606,7	-16136,0	62825,8	-1,5	-22,7	Ok
69	167	-653,3	-16121,6	45464,5	-1,5	-21,5	Ok
69	167	-700,0	-16107,3	30973,2	-1,4	-20,6	Ok
69	167	-746,7	-16093,2	19147,9	-1,3	-19,8	Ok
69	167	-793,3	-16079,3	9766,4	-1,3	-19,2	Ok
69	167	-840,0	-16065,5	2599,0	-1,2	-18,7	Ok
69	167	-886,7	-16051,9	2636,8	-1,2	-18,7	Ok
69	167	-933,3	-16038,4	6125,6	-1,3	-18,9	Ok
69	167	-980,0	-16025,1	8150,8	-1,3	-19,0	Ok
69	167	-1026,7	-16012,0	8954,3	-1,3	-19,1	Ok
69	167	-1073,3	-15999,1	8779,4	-1,3	-19,0	Ok
69	167	-1120,0	-15986,3	7866,3	-1,3	-19,0	Ok
69	167	-1166,7	-15973,7	6452,5	-1,3	-18,9	Ok
69	167	-1213,3	-15961,2	4772,0	-1,3	-20,2	Ok
69	167	-1260,0	-15948,9	3056,7	-1,3	-20,0	Ok
69	167	-1306,7	-15936,8	1536,7	-1,3	-19,8	Ok
69	167	-1353,3	-15924,9	441,4	-1,3	-19,8	Ok
69	167	-1400,0	-15924,9	0,0	-1,3	-19,8	Ok

Plinto n. 179

Cmb.	Palo	Quota (cm)	N (daN)	M (daN cm)	Ten.SLE C (daN/cm ²)	Ten.SLE A (daN/cm ²)	Stato
69	179	0,0	-22465,7	721157,3	-6,0	-83,9	Ok
69	179	-46,7	-22450,9	656470,1	-5,2	-71,9	Ok
69	179	-93,3	-22432,1	591426,8	-4,7	-66,1	Ok
69	179	-140,0	-22409,7	527040,3	-4,3	-60,8	Ok
69	179	-186,7	-22387,5	464437,7	-4,0	-56,0	Ok
69	179	-233,3	-22365,5	404506,5	-3,6	-51,8	Ok
69	179	-280,0	-22343,8	347951,4	-3,4	-48,1	Ok
69	179	-326,7	-22322,3	295294,0	-3,1	-44,7	Ok
69	179	-373,3	-22301,0	246895,4	-2,9	-41,6	Ok
69	179	-420,0	-22280,0	202975,4	-2,7	-38,7	Ok
69	179	-466,7	-22259,2	163627,6	-2,5	-36,2	Ok
69	179	-513,3	-22238,7	128843,1	-2,3	-33,9	Ok
69	179	-560,0	-22218,3	98525,8	-2,2	-32,0	Ok
69	179	-606,7	-22198,2	72510,7	-2,1	-30,3	Ok

Parco Eolico "Bolina" – Progetto Definitivo
Relazione di calcolo preliminare delle fondazioni degli aerogeneratori G8 e G12

69	179	-653,3	-22178,3	50581,3	-1,9	-28,8	Ok
69	179	-700,0	-22158,7	32483,5	-1,9	-27,7	Ok
69	179	-746,7	-22139,3	17957,0	-1,8	-26,7	Ok
69	179	-793,3	-22120,1	6890,2	-1,7	-26,0	Ok
69	179	-840,0	-22101,1	3472,5	-1,7	-25,7	Ok
69	179	-886,7	-22082,4	8611,5	-1,7	-26,0	Ok
69	179	-933,3	-22063,9	12257,2	-1,8	-26,3	Ok
69	179	-980,0	-22045,7	14118,6	-1,8	-26,4	Ok
69	179	-1026,7	-22027,6	14466,2	-1,8	-26,4	Ok
69	179	-1073,3	-22009,8	13610,3	-1,8	-26,3	Ok
69	179	-1120,0	-21992,2	11865,5	-1,7	-26,1	Ok
69	179	-1166,7	-21974,9	9544,1	-1,7	-26,0	Ok
69	179	-1213,3	-21957,7	6954,6	-1,9	-27,8	Ok
69	179	-1260,0	-21940,8	4402,6	-1,8	-27,6	Ok
69	179	-1306,7	-21924,2	2191,5	-1,8	-27,2	Ok
69	179	-1353,3	-21907,7	623,3	-1,8	-27,2	Ok
69	179	-1400,0	-21907,7	0,0	-1,8	-27,2	Ok

Plinto n. 183

Cmb.	Palo	Quota (cm)	N (daN)	M (daN cm)	Ten.SLE C (daN/cm ²)	Ten.SLE A (daN/cm ²)	Stato
69	183	0,0	-12129,9	437921,2	-3,6	-50,0	Ok
69	183	-46,7	-12121,8	402060,5	-3,1	-43,4	Ok
69	183	-93,3	-12111,7	365536,4	-2,9	-39,9	Ok
69	183	-140,0	-12099,6	328811,4	-2,6	-36,5	Ok
69	183	-186,7	-12087,6	292584,5	-2,4	-33,5	Ok
69	183	-233,3	-12075,8	257458,1	-2,2	-30,7	Ok
69	183	-280,0	-12064,0	223923,8	-2,0	-28,3	Ok
69	183	-326,7	-12052,4	192362,3	-1,8	-26,3	Ok
69	183	-373,3	-12041,0	163054,0	-1,7	-24,4	Ok
69	183	-420,0	-12029,6	136189,9	-1,6	-22,6	Ok
69	183	-466,7	-12018,4	111880,1	-1,5	-21,1	Ok
69	183	-513,3	-12007,3	90167,7	-1,4	-19,6	Ok
69	183	-560,0	-11996,3	71038,2	-1,3	-18,4	Ok
69	183	-606,7	-11985,4	54430,7	-1,2	-17,3	Ok
69	183	-653,3	-11974,7	40248,4	-1,1	-16,4	Ok
69	183	-700,0	-11964,1	28367,6	-1,1	-15,6	Ok
69	183	-746,7	-11953,6	18652,8	-1,0	-15,0	Ok
69	183	-793,3	-11943,3	10986,1	-1,0	-14,5	Ok
69	183	-840,0	-11933,0	5401,6	-0,9	-14,1	Ok
69	183	-886,7	-11922,9	2944,6	-0,9	-14,0	Ok
69	183	-933,3	-11912,9	4202,5	-0,9	-14,0	Ok
69	183	-980,0	-11903,1	5677,8	-0,9	-14,1	Ok
69	183	-1026,7	-11893,3	6407,9	-0,9	-14,1	Ok
69	183	-1073,3	-11883,7	6408,0	-0,9	-14,1	Ok
69	183	-1120,0	-11874,2	5824,0	-0,9	-14,1	Ok
69	183	-1166,7	-11864,8	4828,2	-0,9	-14,0	Ok
69	183	-1213,3	-11855,6	3600,3	-1,0	-15,0	Ok
69	183	-1260,0	-11846,5	2321,5	-1,0	-14,9	Ok
69	183	-1306,7	-11837,5	1173,8	-1,0	-14,7	Ok
69	183	-1353,3	-11828,6	339,1	-1,0	-14,7	Ok
69	183	-1400,0	-11828,6	0,0	-1,0	-14,7	Ok

Plinto n. 199

Cmb.	Palo	Quota (cm)	N (daN)	M (daN cm)	Ten.SLE C (daN/cm ²)	Ten.SLE A (daN/cm ²)	Stato
69	199	0,0	-16327,4	563453,6	-4,7	-64,7	Ok
69	199	-46,7	-16316,6	513850,6	-4,0	-55,7	Ok
69	199	-93,3	-16303,0	463868,3	-3,7	-51,1	Ok
69	199	-140,0	-16286,7	414251,6	-3,3	-46,7	Ok
69	199	-186,7	-16270,6	365879,9	-3,0	-42,8	Ok
69	199	-233,3	-16254,6	319460,4	-2,8	-39,4	Ok
69	199	-280,0	-16238,8	275558,2	-2,6	-36,4	Ok
69	199	-326,7	-16223,2	234596,5	-2,4	-33,8	Ok
69	199	-373,3	-16207,8	196873,2	-2,2	-31,3	Ok

Parco Eolico "Bolina" – Progetto Definitivo
Relazione di calcolo preliminare delle fondazioni degli aerogeneratori G8 e G12

69	199	-420,0	-16192,5	162575,8	-2,0	-29,1	Ok
69	199	-466,7	-16177,4	131793,0	-1,9	-27,1	Ok
69	199	-513,3	-16162,4	104533,6	-1,7	-25,4	Ok
69	199	-560,0	-16147,6	80739,1	-1,6	-23,8	Ok
69	199	-606,7	-16133,0	60300,3	-1,5	-22,5	Ok
69	199	-653,3	-16118,6	43074,3	-1,4	-21,4	Ok
69	199	-700,0	-16104,3	28909,1	-1,4	-20,4	Ok
69	199	-746,7	-16090,2	17705,2	-1,3	-19,7	Ok
69	199	-793,3	-16076,3	9650,8	-1,3	-19,2	Ok
69	199	-840,0	-16062,5	6077,5	-1,3	-18,9	Ok
69	199	-886,7	-16048,9	7336,8	-1,3	-19,0	Ok
69	199	-933,3	-16035,4	9433,8	-1,3	-19,1	Ok
69	199	-980,0	-16022,2	10687,4	-1,3	-19,2	Ok
69	199	-1026,7	-16009,0	10932,4	-1,3	-19,2	Ok
69	199	-1073,3	-15996,1	10302,9	-1,3	-19,1	Ok
69	199	-1120,0	-15983,3	9003,5	-1,3	-19,0	Ok
69	199	-1166,7	-15970,7	7259,1	-1,3	-18,9	Ok
69	199	-1213,3	-15958,3	5301,2	-1,3	-20,2	Ok
69	199	-1260,0	-15946,0	3362,6	-1,3	-20,0	Ok
69	199	-1306,7	-15933,9	1676,9	-1,3	-19,8	Ok
69	199	-1353,3	-15921,9	477,9	-1,3	-19,8	Ok
69	199	-1400,0	-15921,9	0,0	-1,3	-19,8	Ok

Plinto n. 211

Cmb.	Palo	Quota (cm)	N (daN)	M (daN cm)	Ten.SLE C (daN/cm ²)	Ten.SLE A (daN/cm ²)	Stato
69	211	0,0	-41230,4	1454044,0	-12,0	-166,4	Ok
69	211	-46,7	-41203,2	1313906,0	-10,2	-142,3	Ok
69	211	-93,3	-41168,7	1174341,0	-9,2	-129,2	Ok
69	211	-140,0	-41127,6	1037820,0	-8,3	-117,3	Ok
69	211	-186,7	-41086,9	906568,7	-7,6	-106,9	Ok
69	211	-233,3	-41046,6	782192,0	-6,9	-97,8	Ok
69	211	-280,0	-41006,7	665926,4	-6,3	-90,1	Ok
69	211	-326,7	-40967,3	558640,1	-5,8	-83,1	Ok
69	211	-373,3	-40928,3	460886,0	-5,3	-76,8	Ok
69	211	-420,0	-40889,7	372944,1	-4,9	-71,1	Ok
69	211	-466,7	-40851,5	294851,6	-4,5	-66,1	Ok
69	211	-513,3	-40813,8	226454,0	-4,2	-61,6	Ok
69	211	-560,0	-40776,4	167435,8	-3,9	-57,8	Ok
69	211	-606,7	-40739,5	117358,6	-3,7	-54,6	Ok
69	211	-653,3	-40703,1	75698,6	-3,5	-51,8	Ok
69	211	-700,0	-40667,0	41894,4	-3,3	-49,6	Ok
69	211	-746,7	-40631,4	15617,5	-3,2	-47,9	Ok
69	211	-793,3	-40596,2	7637,8	-3,2	-47,3	Ok
69	211	-840,0	-40561,4	20976,6	-3,2	-48,2	Ok
69	211	-886,7	-40527,0	30449,4	-3,3	-48,7	Ok
69	211	-933,3	-40493,1	35756,4	-3,3	-49,0	Ok
69	211	-980,0	-40459,5	37504,4	-3,3	-49,1	Ok
69	211	-1026,7	-40426,4	36354,9	-3,3	-49,0	Ok
69	211	-1073,3	-40393,8	32968,9	-3,3	-48,7	Ok
69	211	-1120,0	-40361,5	27997,0	-3,2	-48,4	Ok
69	211	-1166,7	-40329,6	22077,8	-3,2	-48,0	Ok
69	211	-1213,3	-40298,2	15839,1	-3,4	-51,2	Ok
69	211	-1260,0	-40267,2	9900,0	-3,4	-50,7	Ok
69	211	-1306,7	-40236,6	4873,8	-3,4	-50,3	Ok
69	211	-1353,3	-40206,4	1370,7	-3,3	-49,9	Ok
69	211	-1400,0	-40206,4	0,0	-3,3	-49,9	Ok

Plinto n. 215

Cmb.	Palo	Quota (cm)	N (daN)	M (daN cm)	Ten.SLE C (daN/cm ²)	Ten.SLE A (daN/cm ²)	Stato
69	215	0,0	-27364,0	803584,0	-6,8	-95,2	Ok
69	215	-46,7	-27345,9	729629,3	-5,8	-81,4	Ok
69	215	-93,3	-27323,1	655531,7	-5,3	-75,2	Ok
69	215	-140,0	-27295,7	582501,4	-4,9	-69,5	Ok

Parco Eolico "Bolina" – Progetto Definitivo
Relazione di calcolo preliminare delle fondazioni degli aerogeneratori G8 e G12

69	215	-186,7	-27268,7	511784,1	-4,5	-64,4	Ok
69	215	-233,3	-27242,0	444332,7	-4,2	-60,0	Ok
69	215	-280,0	-27215,5	380896,1	-3,9	-55,9	Ok
69	215	-326,7	-27189,3	322019,8	-3,6	-52,1	Ok
69	215	-373,3	-27163,5	268072,2	-3,4	-48,6	Ok
69	215	-420,0	-27137,8	219266,9	-3,1	-45,4	Ok
69	215	-466,7	-27112,5	175679,2	-2,9	-42,6	Ok
69	215	-513,3	-27087,5	137273,7	-2,7	-40,1	Ok
69	215	-560,0	-27062,7	103921,4	-2,6	-37,9	Ok
69	215	-606,7	-27038,2	75421,0	-2,4	-36,1	Ok
69	215	-653,3	-27014,0	51520,7	-2,3	-34,5	Ok
69	215	-700,0	-26990,1	31943,4	-2,2	-33,2	Ok
69	215	-746,7	-26966,4	16471,8	-2,2	-32,2	Ok
69	215	-793,3	-26943,1	5740,7	-2,1	-31,5	Ok
69	215	-840,0	-26920,0	6933,4	-2,1	-31,5	Ok
69	215	-886,7	-26897,2	12355,4	-2,1	-31,8	Ok
69	215	-933,3	-26874,6	15922,4	-2,1	-32,0	Ok
69	215	-980,0	-26852,4	17558,4	-2,1	-32,1	Ok
69	215	-1026,7	-26830,4	17558,9	-2,1	-32,1	Ok
69	215	-1073,3	-26808,7	16266,2	-2,1	-32,0	Ok
69	215	-1120,0	-26787,3	14029,1	-2,1	-31,8	Ok
69	215	-1166,7	-26766,2	11195,0	-2,1	-31,6	Ok
69	215	-1213,3	-26745,3	8107,5	-2,3	-33,8	Ok
69	215	-1260,0	-26724,7	5107,0	-2,2	-33,6	Ok
69	215	-1306,7	-26704,4	2531,3	-2,2	-33,2	Ok
69	215	-1353,3	-26684,4	716,9	-2,2	-33,1	Ok
69	215	-1400,0	-26684,4	0,0	-2,2	-33,1	Ok

Plinto n. 231

Cmb.	Palo	Quota (cm)	N (daN)	M (daN cm)	Ten.SLE C (daN/cm ²)	Ten.SLE A (daN/cm ²)	Stato
69	231	0,0	-44107,3	1039930,0	-9,3	-131,1	Ok
69	231	-46,7	-44078,2	941998,0	-7,9	-112,3	Ok
69	231	-93,3	-44041,4	844167,2	-7,4	-105,3	Ok
69	231	-140,0	-43997,3	748103,4	-6,9	-98,8	Ok
69	231	-186,7	-43953,8	655410,5	-6,5	-92,8	Ok
69	231	-233,3	-43910,7	567281,0	-6,1	-87,1	Ok
69	231	-280,0	-43868,0	484643,1	-5,7	-81,7	Ok
69	231	-326,7	-43825,8	408161,4	-5,3	-76,8	Ok
69	231	-373,3	-43784,1	338272,9	-5,0	-72,3	Ok
69	231	-420,0	-43742,8	275216,2	-4,7	-68,2	Ok
69	231	-466,7	-43702,0	219053,4	-4,4	-64,5	Ok
69	231	-513,3	-43661,6	169705,3	-4,2	-61,3	Ok
69	231	-560,0	-43621,7	126973,1	-4,0	-58,5	Ok
69	231	-606,7	-43582,2	90564,4	-3,8	-56,1	Ok
69	231	-653,3	-43543,2	60116,0	-3,6	-54,1	Ok
69	231	-700,0	-43504,6	35208,6	-3,5	-52,5	Ok
69	231	-746,7	-43466,5	15386,9	-3,4	-51,2	Ok
69	231	-793,3	-43428,8	317,6	-3,3	-50,1	Ok
69	231	-840,0	-43391,6	10947,8	-3,4	-50,8	Ok
69	231	-886,7	-43354,9	18446,8	-3,4	-51,2	Ok
69	231	-933,3	-43318,6	22836,8	-3,4	-51,5	Ok
69	231	-980,0	-43282,7	24610,6	-3,4	-51,5	Ok
69	231	-1026,7	-43247,3	24253,7	-3,4	-51,5	Ok
69	231	-1073,3	-43212,3	22241,8	-3,4	-51,3	Ok
69	231	-1120,0	-43177,8	19041,0	-3,4	-51,1	Ok
69	231	-1166,7	-43143,7	15108,0	-3,4	-50,8	Ok
69	231	-1213,3	-43110,1	10891,8	-3,6	-54,3	Ok
69	231	-1260,0	-43076,9	6835,1	-3,6	-54,0	Ok
69	231	-1306,7	-43044,2	3376,7	-3,6	-53,5	Ok
69	231	-1353,3	-43011,9	953,1	-3,6	-53,4	Ok
69	231	-1400,0	-43011,9	0,0	-3,6	-53,4	Ok

Plinto n. 243

Cmb.	Palo	Quota	N	M	Ten.SLE C	Ten.SLE A	Stato
-------------	-------------	--------------	----------	----------	------------------	------------------	--------------



Parco Eolico "Bolina" – Progetto Definitivo
Relazione di calcolo preliminare delle fondazioni degli aerogeneratori G8 e G12

		(cm)	(daN)	(daN cm)	(daN/cmq)	(daN/cmq)	
69	243	0,0	-76727,4	1717774,0	-15,7	-220,5	Ok
69	243	-46,7	-76676,8	1550692,0	-13,3	-189,0	Ok
69	243	-93,3	-76612,7	1384487,0	-12,5	-177,5	Ok
69	243	-140,0	-76536,1	1222145,0	-11,7	-166,8	Ok
69	243	-186,7	-76460,3	1066288,0	-10,9	-156,7	Ok
69	243	-233,3	-76385,3	918785,3	-10,2	-147,1	Ok
69	243	-280,0	-76311,2	781068,2	-9,6	-138,2	Ok
69	243	-326,7	-76237,8	654133,9	-9,0	-130,0	Ok
69	243	-373,3	-76165,2	538608,3	-8,4	-122,5	Ok
69	243	-420,0	-76093,3	434796,1	-7,9	-115,7	Ok
69	243	-466,7	-76022,3	342716,9	-7,5	-109,8	Ok
69	243	-513,3	-75952,1	262165,7	-7,1	-104,5	Ok
69	243	-560,0	-75882,6	192748,0	-6,8	-100,0	Ok
69	243	-606,7	-75814,0	133924,5	-6,5	-96,1	Ok
69	243	-653,3	-75746,1	85049,8	-6,2	-92,9	Ok
69	243	-700,0	-75679,0	45411,0	-6,0	-90,3	Ok
69	243	-746,7	-75612,7	14407,4	-5,9	-88,2	Ok
69	243	-793,3	-75547,2	10306,8	-5,9	-87,9	Ok
69	243	-840,0	-75482,4	26899,9	-5,9	-88,9	Ok
69	243	-886,7	-75418,5	37902,8	-6,0	-89,5	Ok
69	243	-933,3	-75355,3	43893,1	-6,0	-89,8	Ok
69	243	-980,0	-75292,9	45671,1	-6,0	-89,8	Ok
69	243	-1026,7	-75231,3	44040,9	-6,0	-89,7	Ok
69	243	-1073,3	-75170,5	39792,4	-6,0	-89,3	Ok
69	243	-1120,0	-75110,4	33699,0	-5,9	-88,9	Ok
69	243	-1166,7	-75051,2	26517,6	-5,9	-88,3	Ok
69	243	-1213,3	-74992,7	18991,6	-6,3	-94,5	Ok
69	243	-1260,0	-74935,0	11853,4	-6,3	-93,9	Ok
69	243	-1306,7	-74878,0	5828,1	-6,2	-93,0	Ok
69	243	-1353,3	-74821,9	1636,9	-6,2	-92,9	Ok
69	243	-1400,0	-74821,9	0,0	-6,2	-92,9	Ok

Plinto n. 247

Cmb.	Palo	Quota	N	M	Ten.SLE C	Ten.SLE A	Stato
		(cm)	(daN)	(daN cm)	(daN/cmq)	(daN/cmq)	
69	247	0,0	-65294,5	1247452,0	-12,1	-170,8	Ok
69	247	-46,7	-65251,5	1127780,0	-10,4	-147,7	Ok
69	247	-93,3	-65196,9	1008528,0	-9,8	-140,0	Ok
69	247	-140,0	-65131,7	891790,1	-9,2	-132,4	Ok
69	247	-186,7	-65067,2	779478,3	-8,7	-125,1	Ok
69	247	-233,3	-65003,4	672980,3	-8,2	-118,2	Ok
69	247	-280,0	-64940,3	573366,9	-7,7	-111,8	Ok
69	247	-326,7	-64877,8	481393,3	-7,3	-105,8	Ok
69	247	-373,3	-64816,0	397544,0	-6,9	-100,3	Ok
69	247	-420,0	-64754,9	322068,5	-6,5	-95,4	Ok
69	247	-466,7	-64694,5	255007,6	-6,2	-91,0	Ok
69	247	-513,3	-64634,7	196237,0	-5,9	-87,2	Ok
69	247	-560,0	-64575,6	145493,9	-5,7	-83,9	Ok
69	247	-606,7	-64517,2	102410,0	-5,5	-81,0	Ok
69	247	-653,3	-64459,4	66545,2	-5,3	-78,7	Ok
69	247	-700,0	-64402,3	37433,7	-5,1	-76,7	Ok
69	247	-746,7	-64345,9	14839,3	-5,0	-75,2	Ok
69	247	-793,3	-64290,1	6376,3	-4,9	-74,2	Ok
69	247	-840,0	-64235,1	17265,9	-5,0	-75,3	Ok
69	247	-886,7	-64180,6	25436,6	-5,1	-75,7	Ok
69	247	-933,3	-64126,9	30083,6	-5,1	-76,0	Ok
69	247	-980,0	-64073,8	31684,2	-5,1	-76,0	Ok
69	247	-1026,7	-64021,3	30795,2	-5,1	-75,9	Ok
69	247	-1073,3	-63969,6	27979,6	-5,1	-75,6	Ok
69	247	-1120,0	-63918,5	23793,4	-5,0	-75,3	Ok
69	247	-1166,7	-63868,0	18783,3	-5,0	-74,9	Ok
69	247	-1213,3	-63818,3	13487,3	-5,4	-80,2	Ok
69	247	-1260,0	-63769,2	8436,2	-5,3	-79,8	Ok
69	247	-1306,7	-63720,7	4155,8	-5,3	-79,1	Ok

Parco Eolico "Bolina" – Progetto Definitivo
Relazione di calcolo preliminare delle fondazioni degli aerogeneratori G8 e G12

69	247	-1353,3	-63672,9	1169,5	-5,3	-79,1	Ok
69	247	-1400,0	-63672,9	0,0	-5,3	-79,1	Ok

Plinto n. 263

Cmb.	Palo	Quota (cm)	N (daN)	M (daN cm)	Ten.SLE C (daN/cm ²)	Ten.SLE A (daN/cm ²)	Stato
69	263	0,0	-92906,1	1341409,0	-14,9	-212,3	Ok
69	263	-46,7	-92844,8	1211267,0	-12,9	-184,9	Ok
69	263	-93,3	-92767,1	1081782,0	-12,3	-176,5	Ok
69	263	-140,0	-92674,4	955267,3	-11,7	-168,3	Ok
69	263	-186,7	-92582,7	833769,3	-11,1	-160,4	Ok
69	263	-233,3	-92491,9	718751,0	-10,5	-152,9	Ok
69	263	-280,0	-92402,1	611334,9	-10,0	-145,9	Ok
69	263	-326,7	-92313,2	512305,1	-9,5	-139,4	Ok
69	263	-373,3	-92225,3	422156,0	-9,1	-133,6	Ok
69	263	-420,0	-92138,3	341132,1	-8,7	-128,3	Ok
69	263	-466,7	-92052,3	269256,1	-8,4	-123,5	Ok
69	263	-513,3	-91967,3	206377,3	-8,1	-119,4	Ok
69	263	-560,0	-91883,2	152201,2	-7,8	-115,8	Ok
69	263	-606,7	-91800,0	106330,1	-7,6	-112,8	Ok
69	263	-653,3	-91717,8	68313,4	-7,4	-110,3	Ok
69	263	-700,0	-91636,6	37763,9	-7,2	-108,2	Ok
69	263	-746,7	-91556,3	15191,7	-7,1	-106,7	Ok
69	263	-793,3	-91477,0	11117,5	-7,1	-106,3	Ok
69	263	-840,0	-91398,6	21676,5	-7,1	-106,9	Ok
69	263	-886,7	-91321,2	29766,3	-7,2	-107,3	Ok
69	263	-933,3	-91244,7	34271,7	-7,2	-107,5	Ok
69	263	-980,0	-91169,1	35595,5	-7,2	-107,5	Ok
69	263	-1026,7	-91094,5	34303,5	-7,2	-107,4	Ok
69	263	-1073,3	-91020,9	30988,5	-7,2	-107,1	Ok
69	263	-1120,0	-90948,2	26243,0	-7,1	-106,7	Ok
69	263	-1166,7	-90876,4	20652,0	-7,1	-106,2	Ok
69	263	-1213,3	-90805,6	14792,2	-7,6	-113,8	Ok
69	263	-1260,0	-90735,7	9233,5	-7,5	-112,7	Ok
69	263	-1306,7	-90666,7	4540,5	-7,5	-112,6	Ok
69	263	-1353,3	-90598,7	1275,5	-7,5	-112,5	Ok
69	263	-1400,0	-90598,7	0,0	-7,5	-112,5	Ok

Plinto n. 275

Cmb.	Palo	Quota (cm)	N (daN)	M (daN cm)	Ten.SLE C (daN/cm ²)	Ten.SLE A (daN/cm ²)	Stato
69	275	0,0	-122198,0	1469325,0	-18,2	-259,3	Ok
69	275	-46,7	-122117,3	1326478,0	-15,7	-226,1	Ok
69	275	-93,3	-122015,2	1184390,0	-15,0	-216,9	Ok
69	275	-140,0	-121893,2	1045606,0	-14,3	-207,8	Ok
69	275	-186,7	-121772,6	912368,1	-13,7	-199,1	Ok
69	275	-233,3	-121653,1	786272,4	-13,1	-190,9	Ok
69	275	-280,0	-121535,0	668543,3	-12,5	-183,2	Ok
69	275	-326,7	-121418,1	560034,0	-12,0	-176,1	Ok
69	275	-373,3	-121302,5	461280,9	-11,5	-169,6	Ok
69	275	-420,0	-121188,1	372546,6	-11,1	-163,8	Ok
69	275	-466,7	-121075,0	293851,6	-10,7	-158,6	Ok
69	275	-513,3	-120963,1	225026,3	-10,4	-154,1	Ok
69	275	-560,0	-120852,5	165744,4	-10,1	-150,1	Ok
69	275	-606,7	-120743,2	115566,6	-9,8	-146,8	Ok
69	275	-653,3	-120635,0	73996,2	-9,6	-144,0	Ok
69	275	-700,0	-120528,2	40608,3	-9,5	-141,7	Ok
69	275	-746,7	-120422,6	16015,4	-9,3	-140,0	Ok
69	275	-793,3	-120318,3	12392,0	-9,3	-138,9	Ok
69	275	-840,0	-120215,1	24139,3	-9,4	-140,3	Ok
69	275	-886,7	-120113,3	32973,4	-9,4	-140,8	Ok
69	275	-933,3	-120012,7	37857,0	-9,4	-141,0	Ok
69	275	-980,0	-119913,3	39252,6	-9,4	-140,9	Ok
69	275	-1026,7	-119815,2	37785,1	-9,4	-140,7	Ok
69	275	-1073,3	-119718,3	34106,3	-9,4	-140,4	Ok

Parco Eolico "Bolina" – Progetto Definitivo
Relazione di calcolo preliminare delle fondazioni degli aerogeneratori G8 e G12

69	275	-1120,0	-119622,7	28865,9	-9,3	-139,9	Ok
69	275	-1166,7	-119528,3	22705,3	-9,3	-139,4	Ok
69	275	-1213,3	-119435,1	16256,8	-10,0	-149,5	Ok
69	275	-1260,0	-119343,2	10144,4	-9,9	-148,2	Ok
69	275	-1306,7	-119252,5	4987,0	-9,9	-148,1	Ok
69	275	-1353,3	-119163,1	1400,5	-9,9	-148,0	Ok
69	275	-1400,0	-119163,1	0,0	-9,9	-148,0	Ok

Plinto n. 279

Cmb.	Palo	Quota (cm)	N (daN)	M (daN cm)	Ten.SLE C (daN/cm ²)	Ten.SLE A (daN/cm ²)	Stato
69	279	0,0	-120016,4	1084935,0	-16,1	-230,5	Ok
69	279	-46,7	-119937,2	979805,6	-13,9	-201,3	Ok
69	279	-93,3	-119836,9	875216,3	-13,4	-194,5	Ok
69	279	-140,0	-119717,1	773027,5	-12,9	-187,8	Ok
69	279	-186,7	-119598,6	674889,6	-12,4	-181,4	Ok
69	279	-233,3	-119481,3	581984,0	-12,0	-175,3	Ok
69	279	-280,0	-119365,3	495218,2	-11,5	-169,6	Ok
69	279	-326,7	-119250,5	415227,1	-11,1	-164,3	Ok
69	279	-373,3	-119136,9	342412,6	-10,8	-159,5	Ok
69	279	-420,0	-119024,6	276975,9	-10,5	-155,2	Ok
69	279	-466,7	-118913,5	218940,8	-10,2	-151,3	Ok
69	279	-513,3	-118803,6	168194,4	-9,9	-147,9	Ok
69	279	-560,0	-118695,0	124514,1	-9,7	-145,0	Ok
69	279	-606,7	-118587,6	87609,1	-9,5	-142,5	Ok
69	279	-653,3	-118481,4	57185,4	-9,4	-140,4	Ok
69	279	-700,0	-118376,4	33131,7	-9,3	-138,8	Ok
69	279	-746,7	-118272,7	16508,4	-9,2	-137,6	Ok
69	279	-793,3	-118170,2	12957,7	-9,1	-136,4	Ok
69	279	-840,0	-118069,0	19175,9	-9,2	-137,5	Ok
69	279	-886,7	-117968,9	24898,6	-9,2	-137,8	Ok
69	279	-933,3	-117870,1	28181,5	-9,2	-137,9	Ok
69	279	-980,0	-117772,5	29062,4	-9,2	-137,8	Ok
69	279	-1026,7	-117676,2	27907,7	-9,2	-137,6	Ok
69	279	-1073,3	-117581,0	25160,0	-9,2	-137,3	Ok
69	279	-1120,0	-117487,1	21280,7	-9,1	-137,0	Ok
69	279	-1166,7	-117394,4	16733,4	-9,1	-136,6	Ok
69	279	-1213,3	-117302,9	11978,9	-9,7	-145,7	Ok
69	279	-1260,0	-117212,6	7474,4	-9,7	-145,6	Ok
69	279	-1306,7	-117123,6	3674,4	-9,7	-145,4	Ok
69	279	-1353,3	-117035,7	1031,9	-9,7	-145,3	Ok
69	279	-1400,0	-117035,7	0,0	-9,7	-145,3	Ok

Plinto n. 295

Cmb.	Palo	Quota (cm)	N (daN)	M (daN cm)	Ten.SLE C (daN/cm ²)	Ten.SLE A (daN/cm ²)	Stato
69	295	0,0	-138548,4	583326,1	-15,2	-221,7	Ok
69	295	-46,7	-138457,0	528449,6	-13,2	-193,7	Ok
69	295	-93,3	-138341,2	473725,5	-12,9	-190,1	Ok
69	295	-140,0	-138202,9	420065,5	-12,6	-186,5	Ok
69	295	-186,7	-138066,1	368346,7	-12,4	-183,0	Ok
69	295	-233,3	-137930,7	319221,7	-12,1	-179,7	Ok
69	295	-280,0	-137796,7	273199,7	-11,9	-176,6	Ok
69	295	-326,7	-137664,2	230646,6	-11,7	-173,7	Ok
69	295	-373,3	-137533,1	191805,4	-11,5	-171,1	Ok
69	295	-420,0	-137403,4	156812,7	-11,3	-168,7	Ok
69	295	-466,7	-137275,2	125712,6	-11,2	-166,5	Ok
69	295	-513,3	-137148,3	98479,7	-11,0	-164,6	Ok
69	295	-560,0	-137022,9	75036,7	-10,9	-163,0	Ok
69	295	-606,7	-136898,9	55283,8	-10,8	-161,6	Ok
69	295	-653,3	-136776,4	39142,4	-10,7	-160,4	Ok
69	295	-700,0	-136655,2	26639,7	-10,6	-159,4	Ok
69	295	-746,7	-136535,5	18063,8	-10,6	-158,8	Ok
69	295	-793,3	-136417,2	13890,4	-10,5	-157,5	Ok
69	295	-840,0	-136300,3	13458,5	-10,5	-157,3	Ok

Parco Eolico "Bolina" – Progetto Definitivo
Relazione di calcolo preliminare delle fondazioni degli aerogeneratori G8 e G12

69	295	-886,7	-136184,8	14498,9	-10,5	-157,2	Ok
69	295	-933,3	-136070,7	15347,4	-10,5	-157,1	Ok
69	295	-980,0	-135958,1	15425,5	-10,5	-156,9	Ok
69	295	-1026,7	-135846,8	14659,0	-10,5	-156,8	Ok
69	295	-1073,3	-135737,0	13161,1	-10,4	-156,7	Ok
69	295	-1120,0	-135628,6	11117,1	-10,4	-156,6	Ok
69	295	-1166,7	-135521,5	8741,6	-10,4	-156,4	Ok
69	295	-1213,3	-135415,9	6262,0	-11,2	-168,2	Ok
69	295	-1260,0	-135311,7	3911,1	-11,2	-168,0	Ok
69	295	-1306,7	-135208,9	1925,0	-11,2	-167,9	Ok
69	295	-1353,3	-135107,5	541,5	-11,2	-167,8	Ok
69	295	-1400,0	-135107,5	0,0	-11,2	-167,8	Ok

Plinto n. 307

Cmb.	Palo	Quota (cm)	N (daN)	M (daN cm)	Ten.SLE C (daN/cm ²)	Ten.SLE A (daN/cm ²)	Stato
69	307	0,0	-142228,2	299246,4	-14,2	-207,9	Ok
69	307	-46,7	-142134,4	277724,8	-12,3	-181,9	Ok
69	307	-93,3	-142015,5	255344,8	-12,1	-180,3	Ok
69	307	-140,0	-141873,5	232293,2	-12,0	-178,7	Ok
69	307	-186,7	-141733,1	209064,0	-11,9	-177,0	Ok
69	307	-233,3	-141594,1	186127,0	-11,8	-175,4	Ok
69	307	-280,0	-141456,6	163876,1	-11,7	-173,8	Ok
69	307	-326,7	-141320,5	142628,4	-11,6	-172,3	Ok
69	307	-373,3	-141185,9	122629,9	-11,4	-170,8	Ok
69	307	-420,0	-141052,8	104061,5	-11,3	-169,5	Ok
69	307	-466,7	-140921,2	87045,0	-11,3	-168,2	Ok
69	307	-513,3	-140791,0	71651,5	-11,2	-167,1	Ok
69	307	-560,0	-140662,2	57907,8	-11,1	-166,1	Ok
69	307	-606,7	-140534,9	45804,1	-11,0	-165,2	Ok
69	307	-653,3	-140409,1	35300,1	-11,0	-164,3	Ok
69	307	-700,0	-140284,8	26330,8	-10,9	-163,6	Ok
69	307	-746,7	-140161,8	18811,6	-10,9	-163,0	Ok
69	307	-793,3	-140040,4	12643,3	-10,8	-161,6	Ok
69	307	-840,0	-139920,4	7715,7	-10,8	-161,5	Ok
69	307	-886,7	-139801,8	3911,1	-10,8	-161,4	Ok
69	307	-933,3	-139684,7	1108,9	-10,7	-161,2	Ok
69	307	-980,0	-139569,1	837,5	-10,7	-161,1	Ok
69	307	-1026,7	-139454,9	2021,5	-10,7	-161,0	Ok
69	307	-1073,3	-139342,1	2592,6	-10,7	-160,8	Ok
69	307	-1120,0	-139230,8	2675,6	-10,7	-160,7	Ok
69	307	-1166,7	-139120,9	2397,5	-10,7	-160,6	Ok
69	307	-1213,3	-139012,5	1884,9	-11,5	-172,6	Ok
69	307	-1260,0	-138905,5	1263,6	-11,5	-172,5	Ok
69	307	-1306,7	-138800,0	658,9	-11,5	-172,4	Ok
69	307	-1353,3	-138695,9	196,0	-11,5	-172,2	Ok
69	307	-1400,0	-138695,9	0,0	-11,5	-172,2	Ok

Plinto n. 311

Cmb.	Palo	Quota (cm)	N (daN)	M (daN cm)	Ten.SLE C (daN/cm ²)	Ten.SLE A (daN/cm ²)	Stato
69	311	0,0	-144807,0	167454,8	-13,8	-202,6	Ok
69	311	-46,7	-144711,4	159403,5	-11,9	-177,3	Ok
69	311	-93,3	-144590,4	150341,1	-11,8	-176,5	Ok
69	311	-140,0	-144445,9	140196,6	-11,8	-175,7	Ok
69	311	-186,7	-144302,9	129265,2	-11,7	-174,9	Ok
69	311	-233,3	-144161,4	117885,5	-11,7	-174,0	Ok
69	311	-280,0	-144021,3	106353,7	-11,6	-173,1	Ok
69	311	-326,7	-143882,8	94922,5	-11,5	-172,2	Ok
69	311	-373,3	-143745,8	83801,6	-11,5	-171,3	Ok
69	311	-420,0	-143610,3	73159,5	-11,4	-170,5	Ok
69	311	-466,7	-143476,2	63126,5	-11,3	-169,7	Ok
69	311	-513,3	-143343,7	53798,7	-11,3	-168,9	Ok
69	311	-560,0	-143212,6	45241,7	-11,2	-168,2	Ok
69	311	-606,7	-143083,0	37494,3	-11,2	-167,6	Ok

Parco Eolico "Bolina" – Progetto Definitivo
Relazione di calcolo preliminare delle fondazioni degli aerogeneratori G8 e G12

69	311	-653,3	-142954,9	30572,8	-11,1	-167,0	Ok
69	311	-700,0	-142828,3	24473,8	-11,1	-166,4	Ok
69	311	-746,7	-142703,1	19178,4	-11,1	-166,0	Ok
69	311	-793,3	-142579,5	14654,4	-11,0	-164,6	Ok
69	311	-840,0	-142457,3	10859,4	-11,0	-164,4	Ok
69	311	-886,7	-142336,6	7743,0	-11,0	-164,3	Ok
69	311	-933,3	-142217,4	5248,6	-10,9	-164,2	Ok
69	311	-980,0	-142099,6	3315,5	-10,9	-164,0	Ok
69	311	-1026,7	-141983,4	1880,6	-10,9	-163,9	Ok
69	311	-1073,3	-141868,6	881,6	-10,9	-163,8	Ok
69	311	-1120,0	-141755,2	282,2	-10,9	-163,6	Ok
69	311	-1166,7	-141643,4	228,1	-10,9	-163,5	Ok
69	311	-1213,3	-141533,0	320,4	-11,7	-175,8	Ok
69	311	-1260,0	-141424,0	290,5	-11,7	-175,6	Ok
69	311	-1306,7	-141316,6	182,8	-11,7	-175,5	Ok
69	311	-1353,3	-141210,6	63,1	-11,7	-175,4	Ok
69	311	-1400,0	-141210,6	0,0	-11,7	-175,4	Ok

Plinto n. 327

Cmb.	Palo	Quota (cm)	N (daN)	M (daN cm)	Ten.SLE C (daN/cm ²)	Ten.SLE A (daN/cm ²)	Stato
69	327	0,0	-138573,6	573850,4	-15,2	-221,1	Ok
69	327	-46,7	-138482,1	520633,9	-13,1	-193,3	Ok
69	327	-93,3	-138366,3	467481,6	-12,9	-189,7	Ok
69	327	-140,0	-138228,0	415252,9	-12,6	-186,2	Ok
69	327	-186,7	-138091,2	364810,0	-12,4	-182,8	Ok
69	327	-233,3	-137955,7	316806,6	-12,1	-179,6	Ok
69	327	-280,0	-137821,8	271755,6	-11,9	-176,5	Ok
69	327	-326,7	-137689,2	230029,9	-11,7	-173,7	Ok
69	327	-373,3	-137558,1	191880,9	-11,5	-171,1	Ok
69	327	-420,0	-137428,4	157455,4	-11,3	-168,7	Ok
69	327	-466,7	-137300,1	126808,2	-11,2	-166,6	Ok
69	327	-513,3	-137173,2	99924,5	-11,0	-164,8	Ok
69	327	-560,0	-137047,8	76737,2	-10,9	-163,1	Ok
69	327	-606,7	-136923,8	57152,9	-10,8	-161,7	Ok
69	327	-653,3	-136801,2	41090,3	-10,7	-160,5	Ok
69	327	-700,0	-136680,0	28544,6	-10,7	-159,6	Ok
69	327	-746,7	-136560,3	19696,0	-10,6	-158,9	Ok
69	327	-793,3	-136442,0	14863,7	-10,5	-157,5	Ok
69	327	-840,0	-136325,0	13622,4	-10,5	-157,4	Ok
69	327	-886,7	-136209,5	14149,3	-10,5	-157,2	Ok
69	327	-933,3	-136095,4	14781,0	-10,5	-157,1	Ok
69	327	-980,0	-135982,8	14807,5	-10,5	-157,0	Ok
69	327	-1026,7	-135871,5	14073,9	-10,5	-156,8	Ok
69	327	-1073,3	-135761,6	12651,8	-10,4	-156,7	Ok
69	327	-1120,0	-135653,2	10703,5	-10,4	-156,6	Ok
69	327	-1166,7	-135546,1	8429,5	-10,4	-156,5	Ok
69	327	-1213,3	-135440,5	6047,2	-11,2	-168,2	Ok
69	327	-1260,0	-135336,3	3782,1	-11,2	-168,1	Ok
69	327	-1306,7	-135233,4	1863,9	-11,2	-167,9	Ok
69	327	-1353,3	-135132,0	525,0	-11,2	-167,8	Ok
69	327	-1400,0	-135132,0	0,0	-11,2	-167,8	Ok

Plinto n. 84

Cmb.	Palo	Quota (cm)	N (daN)	M (daN cm)	Ten.SLE C (daN/cm ²)	Ten.SLE A (daN/cm ²)	Stato
69	84	0,0	-122217,1	1466485,0	-18,2	-259,2	Ok
69	84	-46,7	-122136,5	1324104,0	-15,7	-226,0	Ok
69	84	-93,3	-122034,3	1182464,0	-15,0	-216,8	Ok
69	84	-140,0	-121912,3	1044097,0	-14,3	-207,7	Ok
69	84	-186,7	-121791,6	911237,0	-13,7	-199,1	Ok
69	84	-233,3	-121672,2	785481,1	-13,1	-190,9	Ok
69	84	-280,0	-121554,0	668053,2	-12,5	-183,2	Ok
69	84	-326,7	-121437,1	559807,9	-12,0	-176,1	Ok
69	84	-373,3	-121321,5	461283,8	-11,5	-169,6	Ok

Parco Eolico "Bolina" – Progetto Definitivo
Relazione di calcolo preliminare delle fondazioni degli aerogeneratori G8 e G12

69	84	-420,0	-121207,1	372746,8	-11,1	-163,8	Ok
69	84	-466,7	-121093,9	294221,5	-10,7	-158,7	Ok
69	84	-513,3	-120982,0	225544,0	-10,4	-154,1	Ok
69	84	-560,0	-120871,4	166396,2	-10,1	-150,2	Ok
69	84	-606,7	-120762,0	116353,1	-9,8	-146,9	Ok
69	84	-653,3	-120653,9	74947,4	-9,6	-144,1	Ok
69	84	-700,0	-120547,1	41839,4	-9,5	-141,8	Ok
69	84	-746,7	-120441,4	17962,5	-9,4	-140,2	Ok
69	84	-793,3	-120337,1	13831,8	-9,3	-138,9	Ok
69	84	-840,0	-120234,0	24485,7	-9,4	-140,4	Ok
69	84	-886,7	-120132,1	33017,8	-9,4	-140,8	Ok
69	84	-933,3	-120031,5	37789,7	-9,4	-141,0	Ok
69	84	-980,0	-119932,1	39142,9	-9,4	-140,9	Ok
69	84	-1026,7	-119834,0	37665,6	-9,4	-140,7	Ok
69	84	-1073,3	-119737,1	33994,1	-9,4	-140,4	Ok
69	84	-1120,0	-119641,4	28770,3	-9,3	-139,9	Ok
69	84	-1166,7	-119547,0	22630,7	-9,3	-139,4	Ok
69	84	-1213,3	-119453,8	16204,1	-10,0	-149,5	Ok
69	84	-1260,0	-119361,9	10112,1	-9,9	-148,2	Ok
69	84	-1306,7	-119271,2	4971,4	-9,9	-148,1	Ok
69	84	-1353,3	-119181,7	1396,2	-9,9	-148,0	Ok
69	84	-1400,0	-119181,7	0,0	-9,9	-148,0	Ok

Plinto n. 92

Cmb.	Palo	Quota (cm)	N (daN)	M (daN cm)	Ten.SLE C (daN/cm ²)	Ten.SLE A (daN/cm ²)	Stato
69	92	0,0	-120060,4	1074346,0	-16,0	-229,9	Ok
69	92	-46,7	-119981,2	971091,7	-13,8	-200,8	Ok
69	92	-93,3	-119880,8	868276,8	-13,3	-194,1	Ok
69	92	-140,0	-119761,0	767702,9	-12,9	-187,5	Ok
69	92	-186,7	-119642,5	671004,3	-12,4	-181,2	Ok
69	92	-233,3	-119525,1	579364,1	-11,9	-175,2	Ok
69	92	-280,0	-119409,0	493695,1	-11,5	-169,5	Ok
69	92	-326,7	-119294,2	414640,6	-11,1	-164,3	Ok
69	92	-373,3	-119180,6	342613,5	-10,8	-159,6	Ok
69	92	-420,0	-119068,2	277827,7	-10,5	-155,3	Ok
69	92	-466,7	-118957,1	220321,7	-10,2	-151,5	Ok
69	92	-513,3	-118847,2	169999,0	-10,0	-148,1	Ok
69	92	-560,0	-118738,5	126656,3	-9,7	-145,2	Ok
69	92	-606,7	-118631,0	90027,1	-9,6	-142,7	Ok
69	92	-653,3	-118524,8	59851,8	-9,4	-140,7	Ok
69	92	-700,0	-118419,9	36065,9	-9,3	-139,0	Ok
69	92	-746,7	-118316,1	19610,8	-9,2	-137,8	Ok
69	92	-793,3	-118213,6	14522,8	-9,2	-137,4	Ok
69	92	-840,0	-118112,3	19068,1	-9,2	-137,6	Ok
69	92	-886,7	-118012,2	24249,9	-9,2	-137,8	Ok
69	92	-933,3	-117913,4	27387,1	-9,2	-137,9	Ok
69	92	-980,0	-117815,7	28273,1	-9,2	-137,8	Ok
69	92	-1026,7	-117719,3	27192,6	-9,2	-137,6	Ok
69	92	-1073,3	-117624,1	24552,5	-9,2	-137,3	Ok
69	92	-1120,0	-117530,2	20794,6	-9,1	-137,0	Ok
69	92	-1166,7	-117437,4	16370,1	-9,1	-136,6	Ok
69	92	-1213,3	-117345,9	11730,6	-9,7	-145,7	Ok
69	92	-1260,0	-117255,6	7326,0	-9,7	-145,6	Ok
69	92	-1306,7	-117166,5	3604,4	-9,7	-145,5	Ok
69	92	-1353,3	-117078,6	1013,1	-9,7	-145,4	Ok
69	92	-1400,0	-117078,6	0,0	-9,7	-145,4	Ok

Sezioni maggiormente sollecitate:

PI.	Cmb.	Palo	Quota (cm)	N (daN)	M (daN cm)	Ten.SLE C (daN/cm ²)	Ten.SLE A (daN/cm ²)
275	69	275	0,0	-122198,0	1469325,0	-18,2	-259,3

Valori massimi:

Ten.massima CLS = 18,2 daN/cm² < Ten. lim. CLS Ok

Ten.massima acciaio = -259,3 daN/cm² < Ten. lim. acciaio Ok