

PAILO ILLUMINAZIONE SU RILEVATO TRINCEA
Scala 1/50

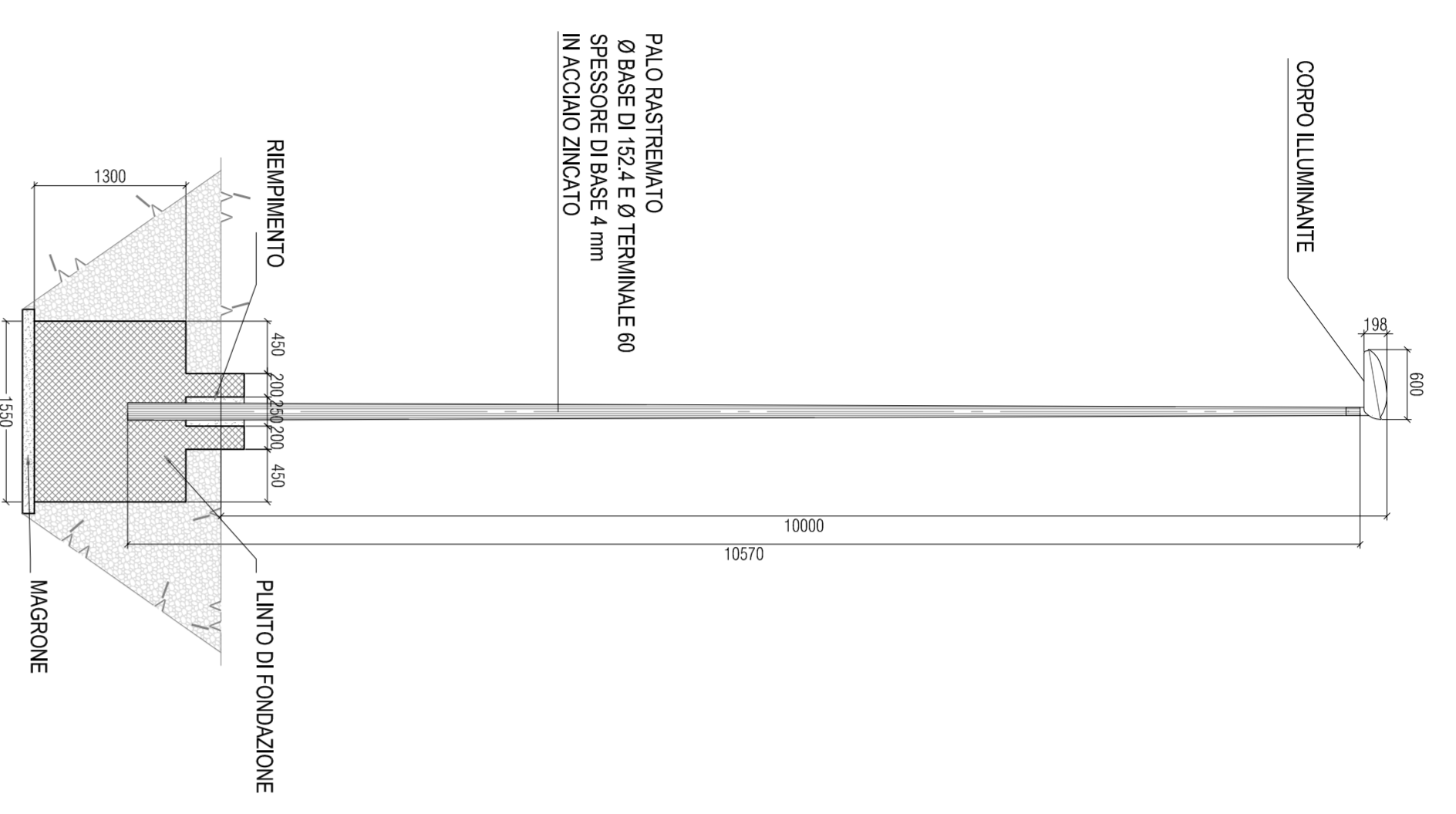

PAILO ILLUMINAZIONE SU RAIPA
Scala 1/50

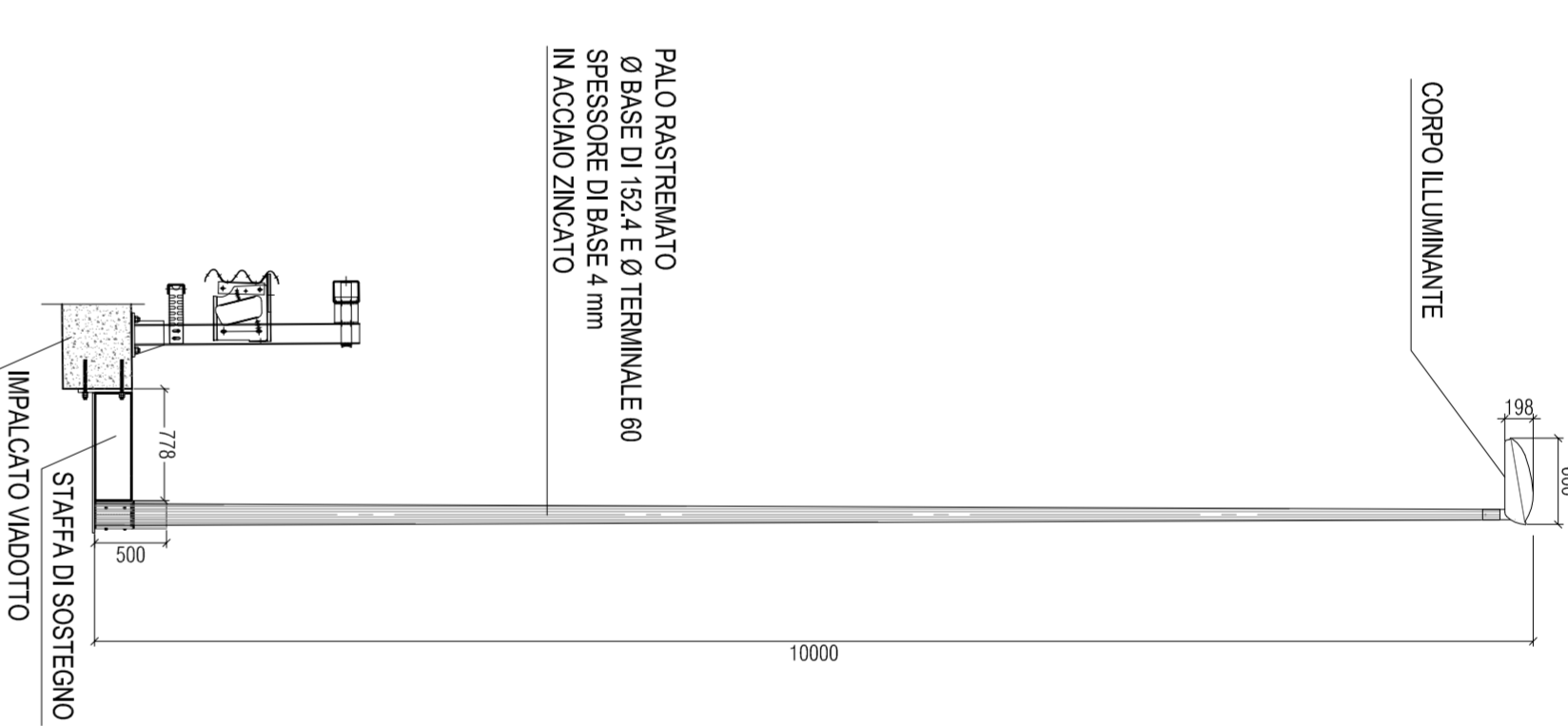

STAFFA DI SOSTEGNO PAILO ILLUMINAZIONE - PROSPETTO E SEZIONE
Scala 1/10

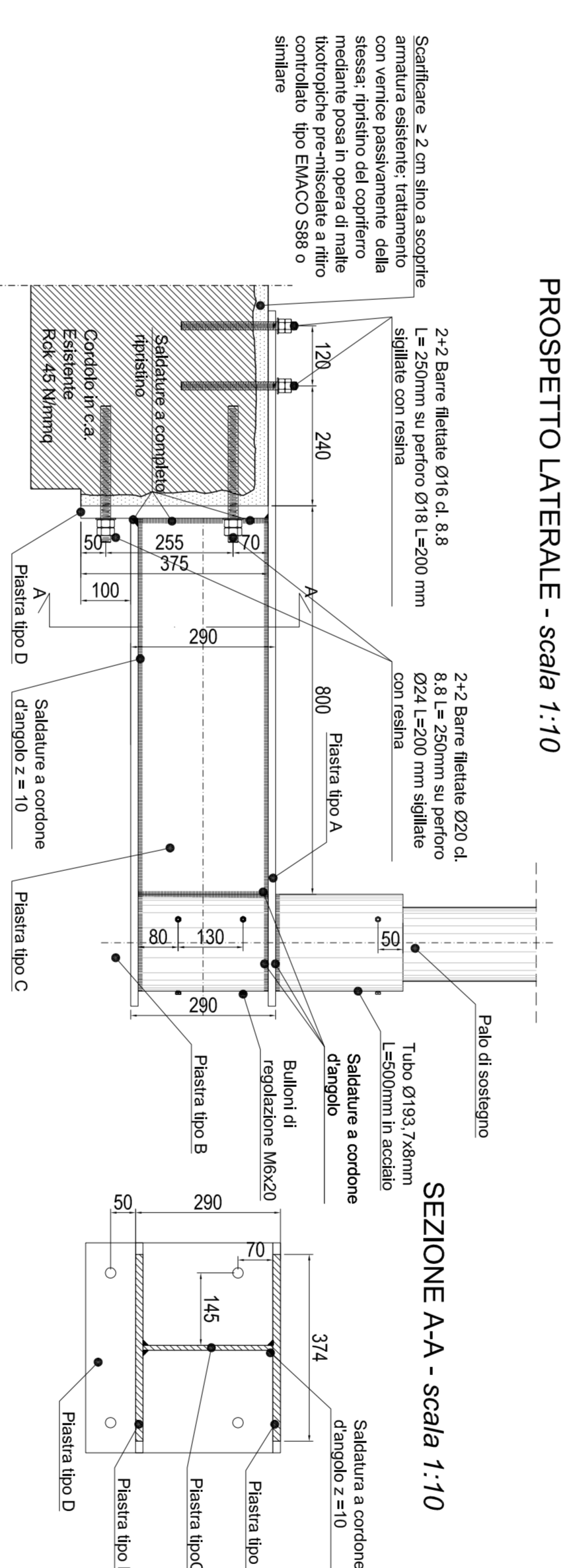

PIUNTO 155X155X130cm - CARPENTERIA E ARMATURE
1-20

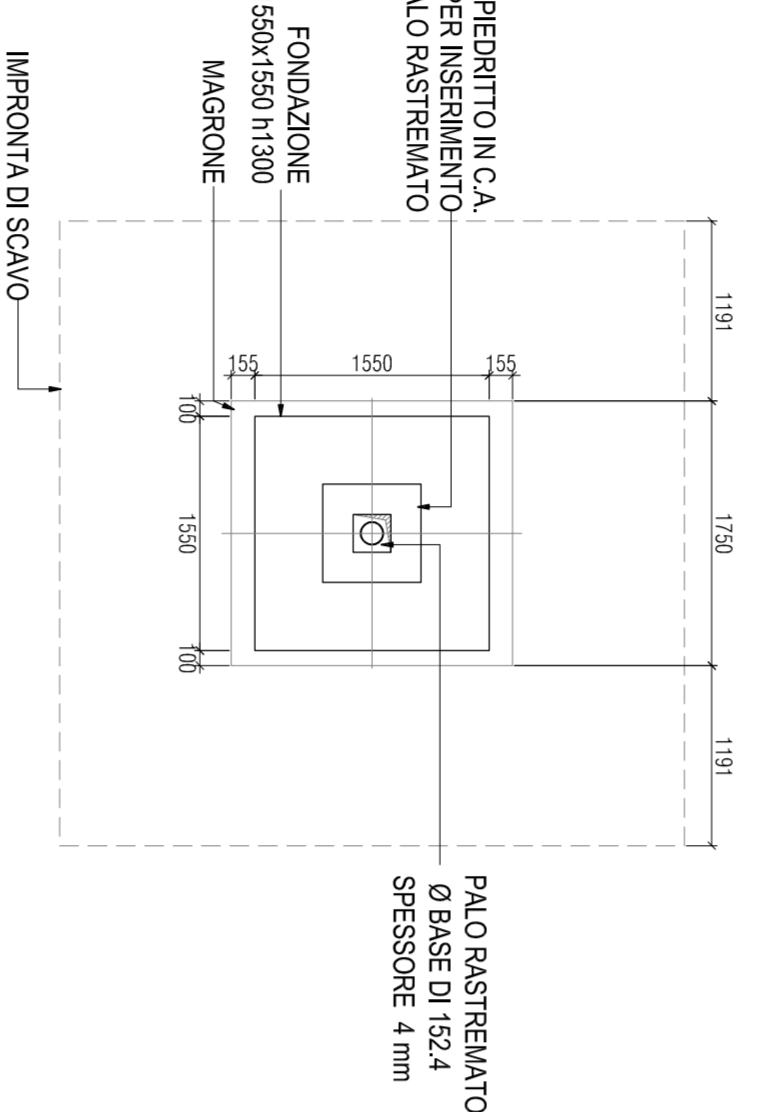

SEZIONE AA

SEZIONE BB



SEZIONE AA

SEZIONE BB

PIANTA - scala 1:10

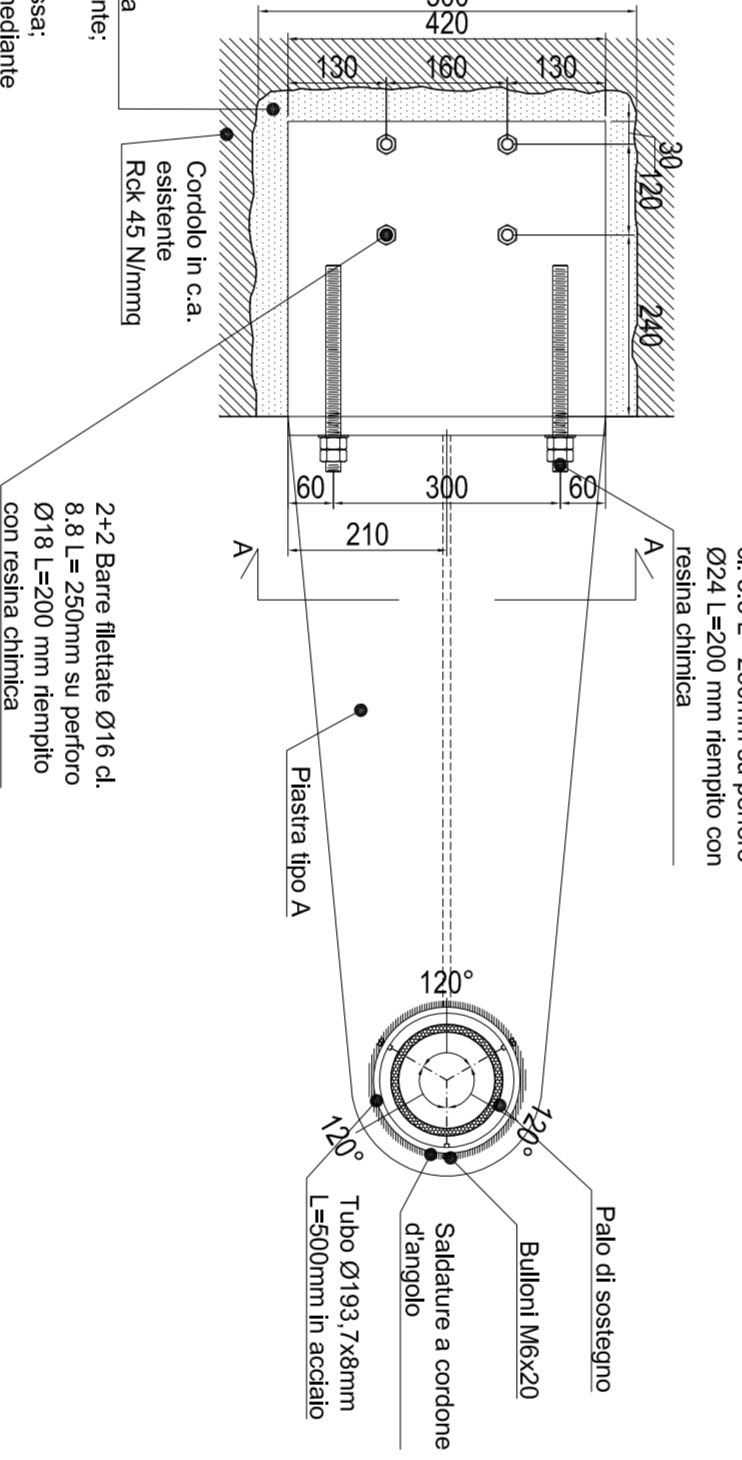

PIANTA - scala 1:10

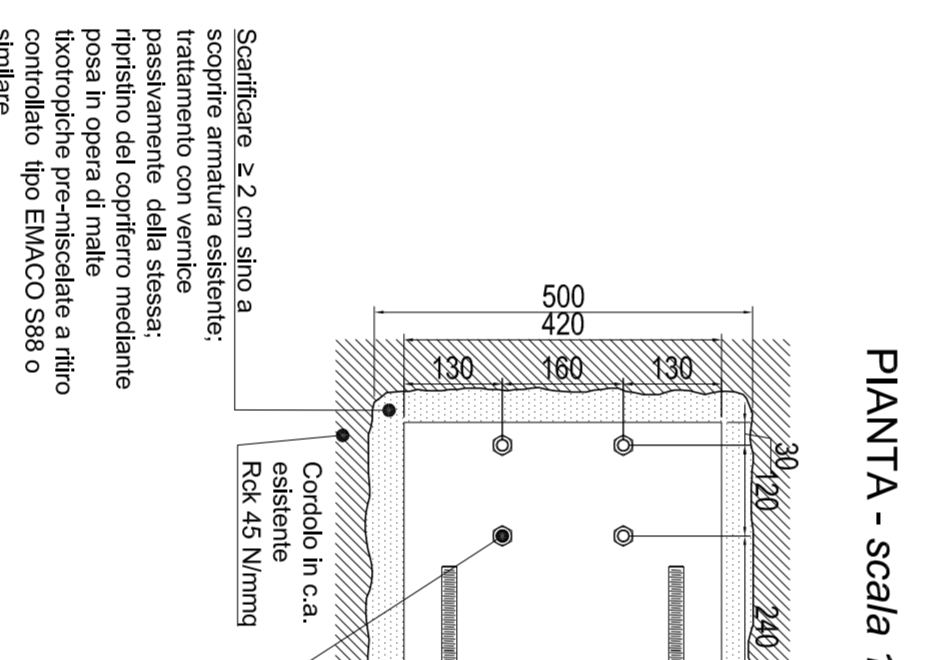

PARTICOLARI
Scala 1/10

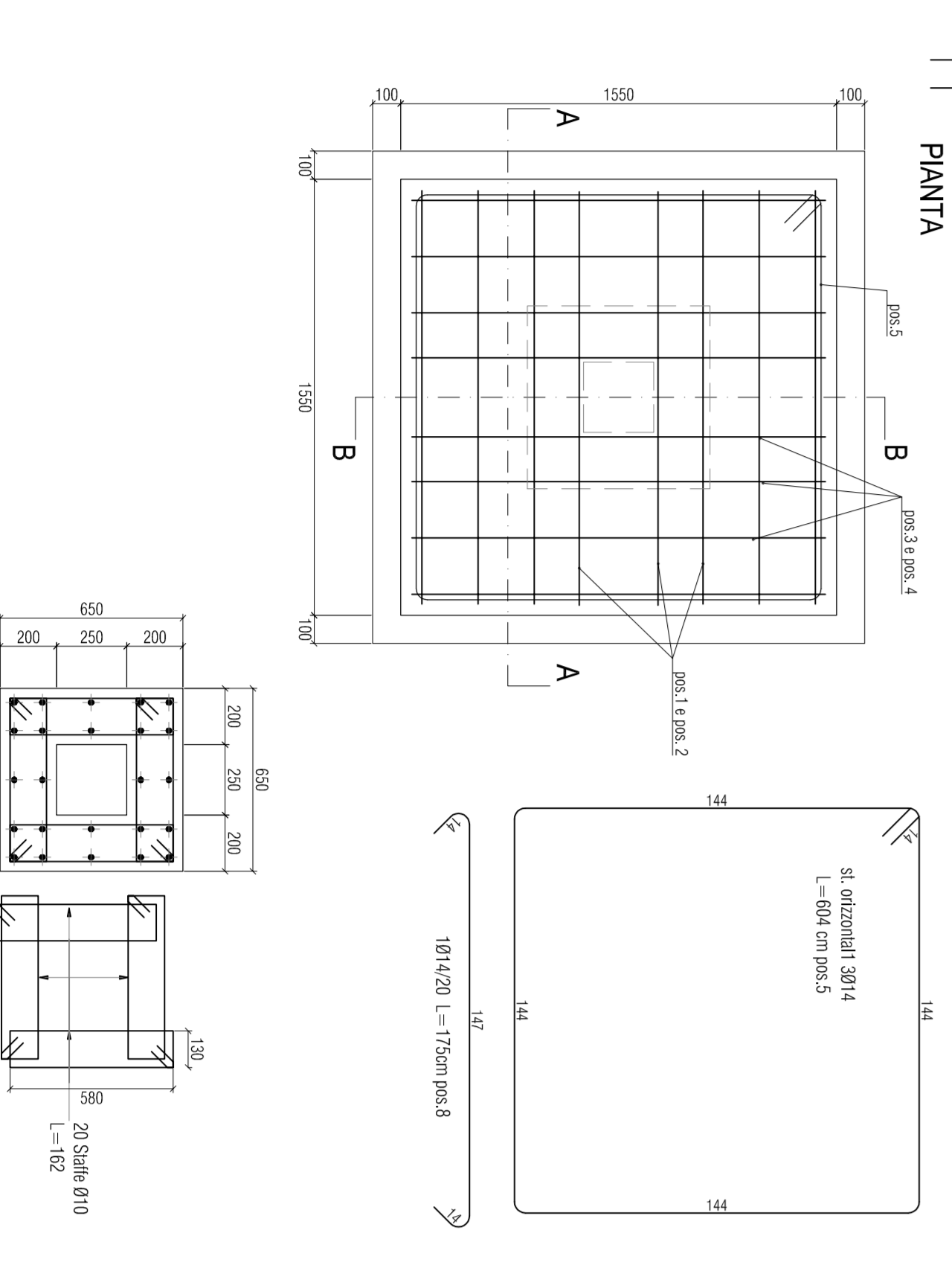
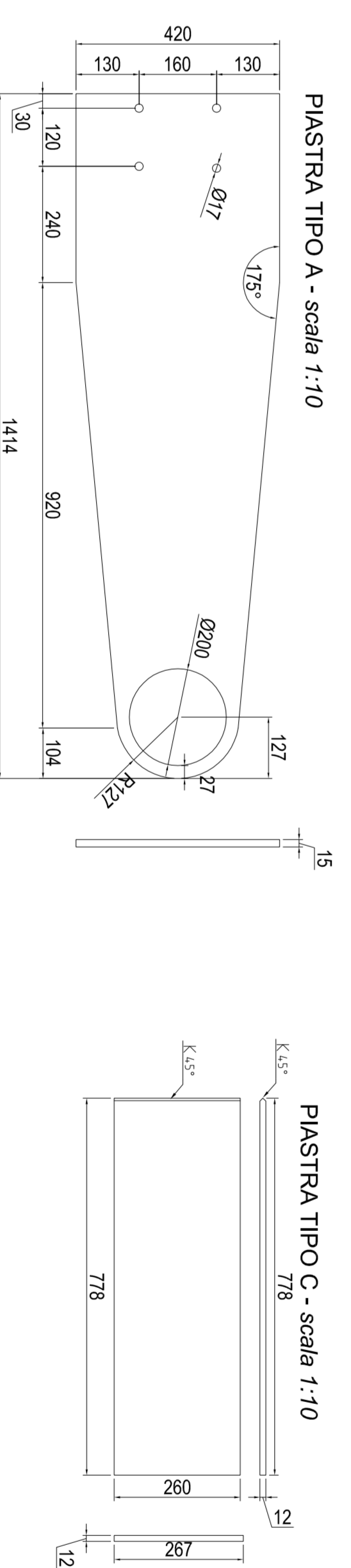

QUADRO D'UNIONE

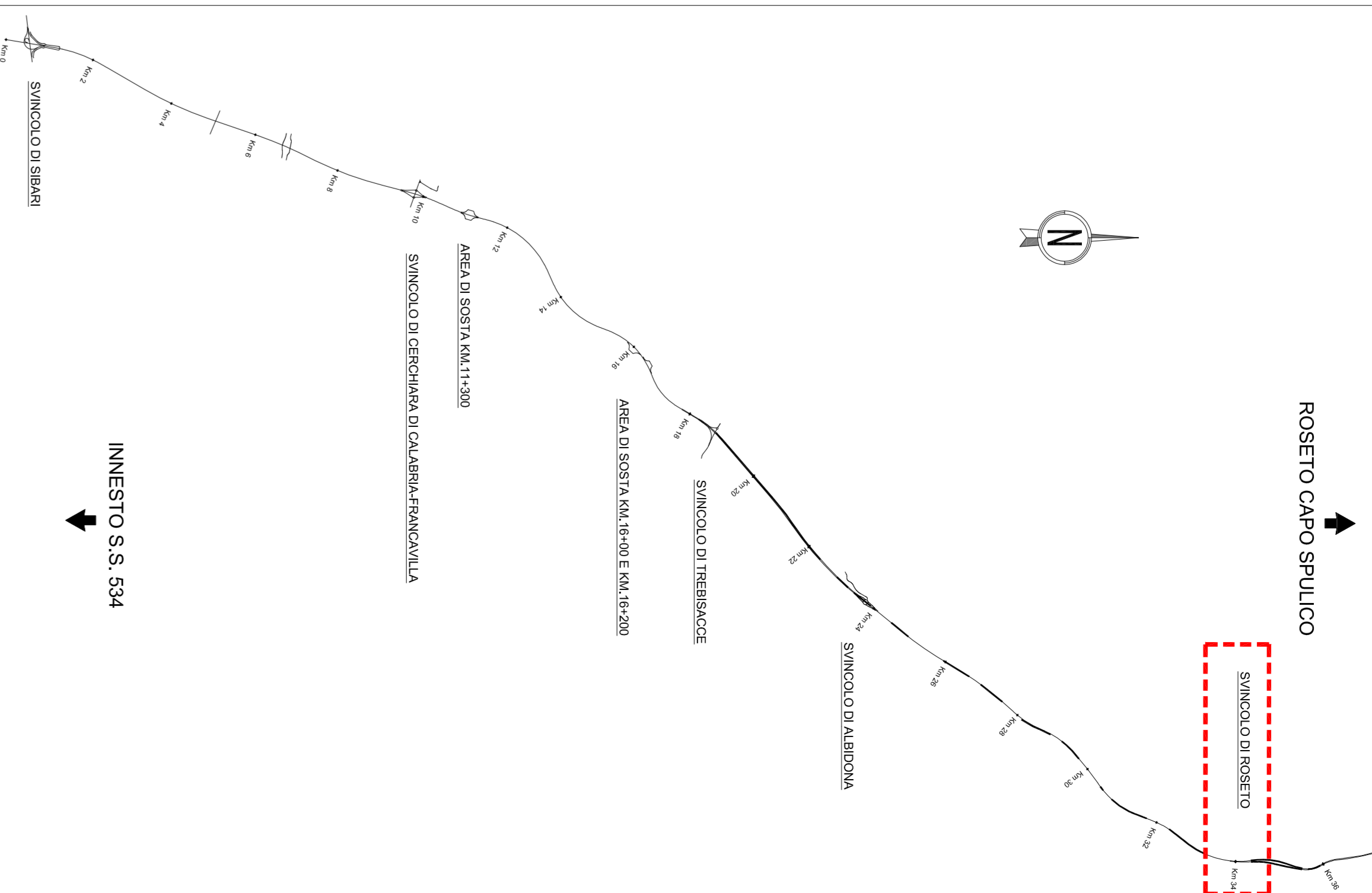

NOTE:
DOCUMENTO VALIDO AI SUOI FINI IMPUNITIVO



LAVORI DI COSTRUZIONE DEL 3° NEGOLOTTO DELLA S.S. 105 SONEVA - CAT. B - DAL PUNTO KM 0,5 A S.S. 534 (Km 30,37 - 30,37)

DG 41/08
PROGETTO ESECUTIVO

SIRJO S.C.p.A.
Dott. Arch. Maria Elena Cazzavara

IMPANTI TECNOLOGICI
SINDACATO DI ROSETO
Impianto di illuminazione
Particolari costruttivi
CONTRAENTE GENERALE:
SIRJO S.C.p.A.
Dott. Arch. Maria Elena Cazzavara



Codice Elaborato		Codice Progetto	
T	0	I	M
0	1	6	0
1	9	0	1
0	0	1	A