

### LEGENDA COLORI APPARECCHIATURE

colore 205	IMPIANTI ELETTRICI DI POTENZA MT/BT
colore 11	IMPIANTI DI ILLUMINAZIONE (IL)
colore 133	IMPIANTI DI SUPERVISIONE (SV)
colore 31	IMPIANTI SOS (SO)
colore 205	IMPIANTI TVCC (TC)
colore 151	IMPIANTI PANNELLI A MESSAGGIO VARIABILE E SEMAFORICO (PM)
colore 11	IMPIANTI ANTINCENDIO (AI)

### LEGENDA QUADRI

.../N	QUADRO LATO O DIREZIONE NORD (EVENTUALE SPECIFICAZIONE)
.../S	QUADRO LATO O DIREZIONE SUD (EVENTUALE SPECIFICAZIONE)
Q_MT	QUADRO ELETTRICO MEDIA TENSIONE
Q_GE	QUADRO ELETTRICO GENERALE BT
Q_CE	QUADRO ELETTRICO GRUPPO ELETTROGENO
Q_CPS	QUADRO ELETTRICO CPS
Q_RI	QUADRO RIFASAMENTO AUTOMATICO
Q_CA	QUADRO ELETTRICO CONTINUITA' ASSOLUTA
Q_SA	QUADRO ELETTRICO SERVIZI AUSILIARI
Q_LP (R)	QUADRO ELETTRICO ILLUMINAZIONE RINFORZO
Q_LP (P/O)	QUADRO ELETTRICO ILLUMINAZIONE PERMANENTE ORDINARIA
Q_LP (P/E)	QUADRO ELETTRICO ILLUMINAZIONE PERMANENTE EMERGENZA
Q_L/E/...	QUADRO ELETTRICO USCITE EMERGENZA
Q_AI	QUADRO ELETTRICO ANTINCENDIO

### LEGENDA CAVIDOTTI

---	CAVIDOTTO BASSA TENSIONE (GENERICO)
---	CAVIDOTTO IMPIANTI SPECIALI
---	PASSERELLA IN ACCIAIO
•	PUNTO RISALITA CAVI
☒	CAVIDOTTO CON PROFILO REDIRETTORE
☒	POZZETTO GETTATO IN OPERA/PREFABBRICATO CON CHIUSINO IN GHISA (DIM. 600x600mm)
☒	POZZETTO GETTATO IN OPERA/PREFABBRICATO CON CHIUSINO IN GHISA (DIM. 1200x1200mm)

### ANGOLI APPARECCHIATURE ILLUMINOTECNICHE

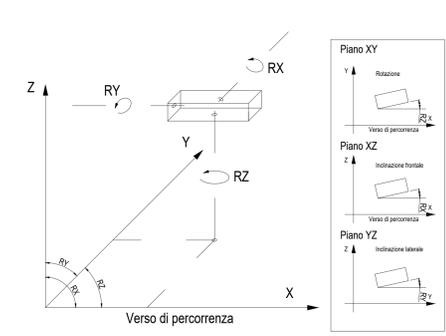

### TABELLA RIEPOLOGATIVA APPARECCHI ILLUMINAZIONE RINFORZO FORNICE DIREZIONE N

Tab. 1/3

PROGRESSIVA [m]	INTERDISTANZA [m]	QUADRO ALIMENTAZIONE	TIPO APPARECCHIO	LATO MARCIA			LATO SORPASSO				
				CIRCUITO (*)	Ang.Ind. RX [°]	Ang.Ind. RZ [°]	CIRCUITO (*)	Ang.Ind. RX [°]	Ang.Ind. RZ [°]		
10.00		CE4-Q_LPR1	LED-409W	RN-1/M/N	0	8	180	RN-1/S/N	0	8	180
21.46	11.46	CE4-Q_LPR1	LED-409W	RN-1/M/N	0	8	180	RN-1/S/N	0	8	180
32.92	11.46	CE4-Q_LPR1	LED-409W	RN-1/M/N	0	8	180	RN-1/S/N	0	8	180
44.38	11.46	CE4-Q_LPR1	LED-409W	RN-1/M/N	0	8	180	RN-1/S/N	0	8	180
55.84	11.46	CE4-Q_LPR1	LED-409W	RN-1/M/N	0	8	180	RN-1/S/N	0	8	180
67.30	11.46	CE4-Q_LPR1	LED-409W	RN-1/M/N	0	8	180	RN-1/S/N	0	8	180
78.76	11.46	CE4-Q_LPR1	LED-409W	RN-1/M/N	0	8	180	RN-1/S/N	0	8	180
89.22	10.44	CE4-Q_LPR1	LED-305W	RN-1/M/N	0	8	180	RN-1/S/N	0	8	180
99.10	9.90	CE4-Q_LPR1	LED-305W	RN-1/M/N	0	8	180	RN-1/S/N	0	8	180
110.00	10.90	CE4-Q_LPR1	LED-305W	RN-1/M/N	0	8	180	RN-1/S/N	0	8	180
123.80	13.80	CE4-Q_LPR1	LED-305W	RN-1/M/N	0	8	180	RN-1/S/N	0	8	180

### TABELLA RIEPOLOGATIVA APPARECCHI ILLUMINAZIONE RINFORZO FORNICE DIREZIONE S

Tab. 2/3

PROGRESSIVA [m]	INTERDISTANZA [m]	QUADRO ALIMENTAZIONE	TIPO APPARECCHIO	LATO MARCIA			LATO SORPASSO				
				CIRCUITO (*)	Ang.Ind. RX [°]	Ang.Ind. RZ [°]	CIRCUITO (*)	Ang.Ind. RX [°]	Ang.Ind. RZ [°]		
13.82		CE4-Q_LPR1	LED-409W	RN-2/M/N	0	8	180	RN-2/S/N	0	8	180
25.28	11.46	CE4-Q_LPR1	LED-409W	RN-2/M/N	0	8	180	RN-2/S/N	0	8	180
36.74	11.46	CE4-Q_LPR1	LED-409W	RN-2/M/N	0	8	180	RN-2/S/N	0	8	180
48.20	11.46	CE4-Q_LPR1	LED-409W	RN-2/M/N	0	8	180	RN-2/S/N	0	8	180
59.66	11.46	CE4-Q_LPR1	LED-409W	RN-2/M/N	0	8	180	RN-2/S/N	0	8	180
71.12	11.46	CE4-Q_LPR1	LED-409W	RN-2/M/N	0	8	180	RN-2/S/N	0	8	180
82.58	11.46	CE4-Q_LPR1	LED-409W	RN-2/M/N	0	8	180	RN-2/S/N	0	8	180
92.50	9.92	CE4-Q_LPR1	LED-305W	RN-2/M/N	0	8	180	RN-2/S/N	0	8	180
102.40	9.90	CE4-Q_LPR1	LED-305W	RN-2/M/N	0	8	180	RN-2/S/N	0	8	180
113.80	11.40	CE4-Q_LPR1	LED-305W	RN-2/M/N	0	8	180	RN-2/S/N	0	8	180
128.80	15.00	CE4-Q_LPR1	LED-305W	RN-2/M/N	0	8	180	RN-2/S/N	0	8	180
138.80	10.00	CE4-Q_LPR1	LED-204W	RN-2/M/N	0	8	180	RN-2/S/N	0	8	180
149.80	11.00	CE4-Q_LPR1	LED-204W	RN-2/M/N	0	8	180	RN-2/S/N	0	8	180
160.80	11.00	CE4-Q_LPR1	LED-204W	RN-2/M/N	0	8	180	RN-2/S/N	0	8	180
178.40	17.60	CE4-Q_LPR1	LED-204W	RN-2/M/N	0	8	180	RN-2/S/N	0	8	180
198.70	20.30	CE4-Q_LPR1	LED-204W	RN-2/M/N	0	8	180	RN-2/S/N	0	8	180
221.70	23.00	CE4-Q_LPR1	LED-204W	RN-2/M/N	0	8	180	RN-2/S/N	0	8	180
245.70	24.00	CE4-Q_LPR1	LED-129W	RN-2/M/N	0	8	180	RN-2/S/N	0	8	180
270.70	25.00	CE4-Q_LPR1	LED-129W	RN-2/M/N	0	8	180	RN-2/S/N	0	8	180

### TABELLA RIEPOLOGATIVA APPARECCHI ILLUMINAZIONE RINFORZO FORNICE DIREZIONE N

Tab. 3/3

PROGRESSIVA [m]	INTERDISTANZA [m]	QUADRO ALIMENTAZIONE	TIPO APPARECCHIO	LATO MARCIA			LATO SORPASSO				
				CIRCUITO (*)	Ang.Ind. RX [°]	Ang.Ind. RZ [°]	CIRCUITO (*)	Ang.Ind. RX [°]	Ang.Ind. RZ [°]		
17.64	3.82	CE4-Q_LPR1	LED-409W	RN-3/M/N	0	8	180	RN-3/S/N	0	8	180
29.10	3.82	CE4-Q_LPR1	LED-409W	RN-3/M/N	0	8	180	RN-3/S/N	0	8	180
40.56	3.82	CE4-Q_LPR1	LED-409W	RN-3/M/N	0	8	180	RN-3/S/N	0	8	180
52.02	3.82	CE4-Q_LPR1	LED-409W	RN-3/M/N	0	8	180	RN-3/S/N	0	8	180
63.48	3.82	CE4-Q_LPR1	LED-409W	RN-3/M/N	0	8	180	RN-3/S/N	0	8	180
74.94	3.82	CE4-Q_LPR1	LED-409W	RN-3/M/N	0	8	180	RN-3/S/N	0	8	180
86.90	3.32	CE4-Q_LPR1	LED-305W	RN-3/M/N	0	8	180	RN-3/S/N	0	8	180
95.80	3.30	CE4-Q_LPR1	LED-305W	RN-3/M/N	0	8	180	RN-3/S/N	0	8	180
106.20	3.80	CE4-Q_LPR1	LED-305W	RN-3/M/N	0	8	180	RN-3/S/N	0	8	180
118.80	5.00	CE4-Q_LPR1	LED-305W	RN-3/M/N	0	8	180	RN-3/S/N	0	8	180
133.80	5.00	CE4-Q_LPR1	LED-305W	RN-3/M/N	0	8	180	RN-3/S/N	0	8	180
144.30	5.50	CE4-Q_LPR1	LED-204W	RN-3/M/N	0	8	180	RN-3/S/N	0	8	180
155.30	5.50	CE4-Q_LPR1	LED-204W	RN-3/M/N	0	8	180	RN-3/S/N	0	8	180
169.60	8.80	CE4-Q_LPR1	LED-204W	RN-3/M/N	0	8	180	RN-3/S/N	0	8	180
187.20	8.80	CE4-Q_LPR1	LED-204W	RN-3/M/N	0	8	180	RN-3/S/N	0	8	180
210.20	11.50	CE4-Q_LPR1	LED-204W	RN-3/M/N	0	8	180	RN-3/S/N	0	8	180
233.20	11.50	CE4-Q_LPR1	LED-129W	RN-3/M/N	0	8	180	RN-3/S/N	0	8	180
258.20	12.50	CE4-Q_LPR1	LED-129W	RN-3/M/N	0	8	180	RN-3/S/N	0	8	180
274.40	3.70	CE4-Q_LPR1	LED-53W	RN-3/M/N	0	0	0	RN-3/S/N	0	0	0
278.40	4.00	CE4-Q_LPR1	LED-53W	RN-3/M/N	0	0	0	RN-3/S/N	0	0	0
282.70	4.30	CE4-Q_LPR1	LED-53W	RN-3/M/N	0	0	0	RN-3/S/N	0	0	0
291.00	8.30	CE4-Q_LPR1	LED-53W	RN-3/M/N	0	0	0	RN-3/S/N	0	0	0
299.30	8.30	CE4-Q_LPR1	LED-53W	RN-3/M/N	0	0	0	RN-3/S/N	0	0	0
307.60	8.30	CE4-Q_LPR1	LED-53W	RN-3/M/N	0	0	0	RN-3/S/N	0	0	0
315.90	8.30	CE4-Q_LPR1	LED-53W	RN-3/M/N	0	0	0	RN-3/S/N	0	0	0
324.20	8.30	CE4-Q_LPR1	LED-53W	RN-3/M/N	0	0	0	RN-3/S/N	0	0	0
332.50	8.30	CE4-Q_LPR1	LED-53W	RN-3/M/N	0	0	0	RN-3/S/N	0	0	0
340.80	8.30	CE4-Q_LPR1	LED-53W	RN-3/M/N	0	0	0	RN-3/S/N	0	0	0
349.10	8.30	CE4-Q_LPR1	LED-53W	RN-3/M/N	0	0	0	RN-3/S/N	0	0	0
357.40	14.00	CE4-Q_LPR1	LED-53W	RN-3/M/N	0	0	0	RN-3/S/N	0	0	0
377.10	14.00	CE4-Q_LPR1	LED-53W	RN-3/M/N	0	0	0	RN-3/S/N	0	0	0
391.10	14.00	CE4-Q_LPR1	LED-53W	RN-3/M/N	0	0	0	RN-3/S/N	0	0	0
405.10	14.00	CE4-Q_LPR1	LED-53W	RN-3/M/N	0	0	0	RN-3/S/N	0	0	0
419.10	14.00	CE4-Q_LPR1	LED-53W	RN-3/M/N	0	0	0	RN-3/S/N	0	0	0
433.10	14.00	CE4-Q_LPR1	LED-53W	RN-3/M/N	0	0	0	RN-3/S/N	0	0	0
452.10	19.00	CE4-Q_LPR1	LED-53W	RN-3/M/N	0	0	0	RN-3/S/N	0	0	0
471.10	19.00	CE4-Q_LPR1	LED-53W	RN-3/M/N	0	0	0	RN-3/S/N	0	0	0
490.10	19.00	CE4-Q_LPR1	LED-53W	RN-3/M/N	0	0	0	RN-3/S/N	0	0	0
509.10	19.00	CE4-Q_LPR1	LED-53W	RN-3/M/N	0	0	0	RN-3/S/N	0	0	0
528.10	19.00	CE4-Q_LPR1	LED-53W	RN-3/M/N	0	0	0	RN-3/S/N	0	0	0

### TABELLA RIEPOLOGATIVA APPARECCHI ILLUMINAZIONE RINFORZO FORNICE DIREZIONE S

Tab. 1/3

PROGRESSIVA [m]	INTERDISTANZA [m]	QUADRO ALIMENTAZIONE	TIPO APPARECCHIO	LATO MARCIA			LATO SORPASSO				
				CIRCUITO (*)	Ang.Ind. RX [°]	Ang.Ind. RZ [°]	CIRCUITO (*)	Ang.Ind. RX [°]	Ang.Ind. RZ [°]		
10.00		CE4-Q_LPR1	LED-409W	RN-1/M/S	0	8	180	RN-1/S/S	0	8	180
21.46	11.46	CE4-Q_LPR1	LED-409W	RN-1/M/S	0	8	180	RN-1/S/S	0	8	180
32.92	11.46	CE4-Q_LPR1	LED-409W	RN-1/M/S	0	8	180	RN-1/S/S	0	8	180
44.38	11.46	CE4-Q_LPR1	LED-409W	RN-1/M/S	0	8	180	RN-1/S/S	0	8	180
55.84	11.46	CE4-Q_LPR1	LED-409W	RN-1/M/S	0	8	180	RN-1/S/S	0	8	180
67.30	11.46	CE4-Q_LPR1	LED-409W	RN-1/M/S	0	8	180	RN-1/S/S	0	8	180
78.76	11.46	CE4-Q_LPR1	LED-409W	RN-1/M/S	0	8	180	RN-1/S/S	0	8	180
89.22	10.44	CE4-Q_LPR1	LED-305W	RN-1/M/S	0	8	180	RN-1/S/S	0	8	180
99.10	9.90	CE4-Q_LPR1	LED-305W	RN-1/M/S	0	8	180	RN-1/S/S	0	8	180
110.00	10.90	CE4-Q_LPR1	LED-305W	RN-1/M/S	0	8	180	RN-1/S/S	0	8	180
123.80	13.80	CE4-Q_LPR1	LED-305W	RN-1/M/S	0	8	180	RN-1/S/S	0	8	180

### TABELLA RIEPOLOGATIVA APPARECCHI ILLUMINAZIONE RINFORZO FORNICE DIREZIONE S

Tab. 2/3

PROGRESSIVA [m]	INTERDISTANZA [m]	QUADRO ALIMENTAZIONE	TIPO APPARECCHIO	LATO MARCIA			LATO SORPASSO				
				CIRCUITO (*)	Ang.Ind. RX [°]	Ang.Ind. RZ [°]	CIRCUITO (*)	Ang.Ind. RX [°]	Ang.Ind. RZ [°]		
13.82		CE4-Q_LPR1	LED-409W	RN-2/M/S	0	8	180	RN-2/S/S	0	8	180
25.28	11.46	CE4-Q_LPR1	LED-409W	RN-2/M/S	0	8	180	RN-2/S/S	0	8	180
36.74	11.46	CE4-Q_LPR1	LED-409W	RN-2/M/S	0	8	180	RN-2/S/S	0	8	180
48.20	11.46	CE4-Q_LPR1	LED-409W	RN-2/M/S	0	8	180	RN-2/S/S	0	8	180
59.66	11.46	CE4-Q_LPR1	LED-409W	RN-2/M/S	0	8	180	RN-2/S/S	0	8	180
71.12	11.46	CE4-Q_LPR1	LED-409W	RN-2/M/S	0	8	180	RN-2/S/S	0	8	180
82.58	11.46	CE4-Q_LPR1	LED-409W	RN-2/M/S	0	8	180	RN-2/S/S	0	8	180
92.50	9.92	CE4-Q_LPR1	LED-305W	RN-2/M/S	0	8	180	RN-2/S/S	0	8	180
102.40	9.90	CE4-Q_LPR1	LED-305W	RN-2/M/S	0	8	180	RN-2/S/S			