

Regione: **PUGLIA**

Provincia di: **FOGGIA**

Comune/i di: **VOLTURINO**

COD. ELABORATO:

**4.2.6E**

OGGETTO:

Impianto per la produzione di energia elettrica da fonte eolica "VOLTURINO" da n° 10 WTGs, da realizzarsi in agro del Comune di Volturino (FG), Regione Puglia, in località "Selva Piana-Parco Giovenco".

**PROGETTO DEFINITIVO**

**STIMA DELLA PRODUCIBILITÀ ENERGETICA ATTESA  
(A.E.P. - ANNUAL ENERGY PRODUCTION)**

PROPONENTE:



**Innogy Italia S.p.A.**

Viale Francesco Restelli, 3/1  
20124 Milano (MI) - ITALY  
Tel.: 02/69826300  
Fax: 02/69826399

PROGETTISTA:



**Ing. Michele R.G. Curtotti**

Ordine Ingegneri della Provincia di Foggia n° 1704

Viale II Giugno, 385  
71016 San Severo (FG) - ITALY  
P.E.C.: [ing.curtotti@pec.it](mailto:ing.curtotti@pec.it)  
E-mail: [studiocurtotti@gmail.com](mailto:studiocurtotti@gmail.com)

**Ing. Fabio Coccia**

Ordine Ingegneri della Provincia di Foggia n° 2697



Via Bezzecca, 39  
71016 San Severo (FG) - ITALY  
P.E.C.: [fabio.coccia2@ingpec.eu](mailto:fabio.coccia2@ingpec.eu)  
E-mail: [ing.fabiococcia@gmail.com](mailto:ing.fabiococcia@gmail.com)



Note:

<b>4.2.6E</b>	<b>R.T._SPEA</b>	<b>00/D/07</b>	<b>07/2019</b>	<b>00_07/19</b>
Cod. Elaborato:	Oggetto:	Mod. n°:	Data:	Rev. n°:

**PROPRIETÀ ESCLUSIVA DEI PROGETTISTI SOPRA INDICATI.  
UTILIZZO E DUPLICAZIONE VIETATE SENZA AUTORIZZAZIONE SCRITTA**

<b>STIMA DELLA PRODUCIBILITÀ ENERGETICA ATTESA (A.E.P. - ANNUAL ENERGY PRODUCTION)</b>  Impianto per la produzione di energia elettrica da fonte eolica "VOLTURINO" da n° 10 WTGs, da realizzarsi in agro del Comune di Volturino (FG), Regione Puglia, in località "Selva Piana-Parco Giovenco".	Cod. Elaborato: 4.2.6E	
	Oggetto: R.T._SPEA	
	Doc. n°: 01 di 02	Mod. n°: 00/D/07
	Data: 07/2019	Rev. n°: 00_07/19

## INDICE

### 1. STIMA DELLA PRODUCIBILITÀ ENERGETICA ATTESA (A.E.P. - ANNUAL ENERGY PRODUCTION)

.....	pag. 1
1.1. PREMESSA.....	pag. 1
1.2. DESCRIZIONE GENERALE DELL'INTERVENTO .....	pag. 3
1.3. ROUGHNESS COEFFICIENT & HEIGHT DATA.....	pag. 6
1.4. AIR DENSITY CORRECTION .....	pag. 9
1.5. WIND DATA .....	pag. 10
1.6. WIND ROSE .....	pag. 11
1.7. MODELLO DI TURBINA EOLICA .....	pag. 12
1.8. STIMA DELLA PRODUCIBILITÀ ENERGETICA ATTESA.....	pag. 13

PROPONENTE: **Innogy Italia S.p.A.**

Viale Francesco Restelli, 3/1  
20124 Milano (MI) - ITALY



<b>STIMA DELLA PRODUCIBILITÀ ENERGETICA ATTESA (A.E.P. - ANNUAL ENERGY PRODUCTION)</b>  Impianto per la produzione di energia elettrica da fonte eolica "VOLTURINO" da n° 10 WTGs, da realizzarsi in agro del Comune di Volturino (FG), Regione Puglia, in località "Selva Piana-Parco Giovenco".	Cod. Elaborato: <b>4.2.6E</b>	
	Oggetto: <b>R.T._SPEA</b>	
	Doc. n°: <b>01 di 02</b>	Mod. n°: <b>00/D/07</b>
	Data: <b>07/2019</b>	Rev. n°: <b>00_07/19</b>

## ALLEGATI

---

Allegato n. 1: Scheda tecnica WTG Modello NORDEX N149 da 4,8 MW della Nordex Energy GmbH

..... pag. 1

<b>STIMA DELLA PRODUCIBILITÀ ENERGETICA ATTESA (A.E.P. - ANNUAL ENERGY PRODUCTION)</b>	Cod. Elaborato: <b>4.2.6E</b>	
	Oggetto: <b>R.T._SPEA</b>	
	Doc. n°: <b>01 di 02</b>	Mod. n°: <b>00/D/07</b>
	Data: <b>07/2019</b>	Rev. n°: <b>00_07/19</b>
Impianto per la produzione di energia elettrica da fonte eolica "VOLTURINO" da n° 10 WTGs, da realizzarsi in agro del Comune di Volturino (FG), Regione Puglia, in località "Selva Piana-Parco Giovenco".		

## 1. STIMA DELLA PRODUCIBILITÀ ENERGETICA ATTESA (A.E.P. - ANNUAL ENERGY PRODUCTION)

### 1.1. PREMESSA

Il presente elaborato costituisce **STIMA DELLA PRODUCIBILITÀ ENERGETICA ATTESA (A.E.P. - ANNUAL ENERGY PRODUCTION)** (Cod. Elaborato: **4.2.6E**, Oggetto: **R.T.\_SDP**) redatta secondo i contenuti del punto 4.2.6 "Documentazione specialistica del progetto definitivo" dell'Allegato A "Istruzioni tecniche per la informatizzazione della documentazione a corredo dell'Autorizzazione Unica" alla DETERMINAZIONE DEL DIRIGENTE SERVIZIO ENERGIA, RETI E INFRASTRUTTURE MATERIALI PER LO SVILUPPO 3 gennaio 2011, n. 1 "Autorizzazione Unica ai sensi dell'art. 12 del D.Lgs. 387/2003 - DGR n. 3029 del 30.12.2010 - Approvazione delle "Istruzioni tecniche per la informatizzazione della documentazione a corredo dell'Autorizzazione Unica" e delle "Linee Guida Procedura Telematica". (pubblicata su B.U.R.P. n. 11 del 20 gennaio 2011) a corredo del progetto definitivo per la realizzazione dell'impianto per la produzione di energia elettrica da fonte eolica "VOLTURINO" che la società Innogy Italia S.p.A. intende realizzare in agro del Comune di Volturino (FG), Regione Puglia, in località "Selva Piana-Parco Giovenco".

Lo studio è stato realizzato secondo quanto richiesto da:

- DELIBERAZIONE DELLA GIUNTA REGIONALE (Regione Puglia) 30 dicembre 2010, n. 3029 "Approvazione della Disciplina del procedimento unico di autorizzazione alla realizzazione ed all'esercizio di impianti di produzione di energia elettrica" (pubblicata su B.U.R.P. n. 14 del 26 gennaio 2011).

Ai sensi del suddetto punto 4.2.6, lo "STIMA DELLA PRODUCIBILITÀ ENERGETICA ATTESA (A.E.P. - ANNUAL ENERGY PRODUCTION)" del progetto definitivo si è reso necessario "ove la progettazione implichi la soluzione di questioni specialistiche" secondo quanto esplicitato all'art. 28 del D.P.R. n. 554/1999<sup>1</sup>; laddove, a partire dal 9 giugno 2011 il riferimento legislativo è divenuto l'art. 28 del D.P.R. 207/2010<sup>2</sup>.

<sup>1</sup> DECRETO DEL PRESIDENTE DELLA REPUBBLICA 21 dicembre 1999, n. 554 "Regolamento di attuazione della legge quadro in materia di lavori pubblici 11 febbraio 1994, n. 109, e successive modificazioni" (pubblicato su G.U.R.I. n. 98 del 28 aprile 2000), **abrogato dall'8 giugno 2011 dal DECRETO DEL PRESIDENTE DELLA REPUBBLICA 5 ottobre 2010, n. 207** "Regolamento di esecuzione ed attuazione del decreto legislativo 12 aprile 2006, n. 163, recante «Codice dei contratti pubblici relativi a lavori, servizi e forniture in attuazione delle direttive 2004/17/CE e 2004/18/CE»." (pubblicato su G.U.R.I. n. 288 del 10 dicembre 2010).

<sup>2</sup> Art. 28 "Elaborati grafici del progetto definitivo" della Sezione III "Progetto definitivo", CAPO I "Progettazione", TITOLO II "PROGETTAZIONE E VERIFICA DEL PROGETTO", PARTE II "CONTRATTI PUBBLICI RELATIVI A LAVORI NEI SETTORI ORDINARI" del DECRETO DEL PRESIDENTE DELLA REPUBBLICA 5 ottobre 2010, n. 207 "Regolamento di esecuzione ed

<b>STIMA DELLA PRODUCIBILITÀ ENERGETICA ATTESA (A.E.P. - ANNUAL ENERGY PRODUCTION)</b>	Cod. Elaborato: <b>4.2.6E</b>	
	Oggetto: <b>R.T._SPEA</b>	
	Doc. n°: <b>01 di 02</b>	Mod. n°: <b>00/D/07</b>
	Data: <b>07/2019</b>	Rev. n°: <b>00_07/19</b>
<b>Impianto per la produzione di energia elettrica da fonte eolica "VOLTURINO" da n° 10 WTGs, da realizzarsi in agro del Comune di Volturino (FG), Regione Puglia, in località "Selva Piana-Parco Giovenco".</b>		

La presente Relazione Tecnica ha come oggetto la stima della producibilità energetica attesa (A.E.P. - Annual Energy Production (*di seguito*: A.E.P.) dell'impianto per la produzione di energia elettrica da fonte eolica "VOLTURINO" che la società Innogy Italia S.p.A. intende realizzare in agro del Comune di Volturino (FG), Regione Puglia, in località "Selva Piana-Parco Giovenco".

L'impianto di progetto prevede la realizzazione di **n° 10 (dieci) aerogeneratori** (WTGs) tripala ad asse orizzontale di grande taglia, **ciascuno di potenza elettrica nominale pari a 4,8 MW, per una potenza elettrica complessiva pari a 48 MW**, e delle relative opere civili ed elettriche accessorie per la connessione elettrica alla RTN, per i quali sarà impiegato il modello di turbina eolica **NORDEX N149 da 4,8 MW della Nordex Energy GmbH**, ritenuta fra le macchine più performanti ad oggi disponibili sul mercato stando le caratteristiche anemometriche proprie del sito e le esigenze di impianto.

Il modello di turbina eolica impiegato è costituito da una torre di sostegno tubolare metallica a tronco di cono sulla cui sommità è installata la navicella, il cui asse è a 145 m dal piano campagna (**hub height= 145 m s.l.t.**), con annesso il rotore di diametro pari a 149,1 m e una lunghezza della pala di 72,4 m ca. (**rotor diameter= 149,1 m**), per un'altezza massima complessiva del sistema torre-pale di 219,6 m s.l.t. (**h<sub>tip</sub>= hub height+1/2 rotor diameter= 219,6 m s.l.t.**).

Il presente studio si basa sull'acquisizione e successiva elaborazione dei dati anemometrici di velocità e direzione del vento rilevati mediante una torre anemometrica localizzata nelle vicinanze dell'area d'impianto, estesi su un range temporale di 27 mesi.

Lo studio anemologico delle serie di dati di ventosità, necessario ai fini dell'individuazione della wind rose, la successiva fase di micrositing, e infine la stima dell'A.E.P., sono stati condotti mediante l'ausilio del software windPRO (Ver. 3.2), specifico per la creazione, l'analisi e l'ottimizzazione dei layout delle wind farm.

---

attuazione del decreto legislativo 12 aprile 2006, n. 163, recante «Codice dei contratti pubblici relativi a lavori, servizi e forniture in attuazione delle direttive 2004/17/CE e 2004/18/CE».» (*pubblicato su G.U.R.I. n. 288 del 10 dicembre 2010*).

pag. 2	 <b>Studio di Ingegneria Michele R.G. Curtotti</b>	<b>PROGETTISTA: Ing. Michele R.G. Curtotti</b> <b>Ing. Fabio Coccia</b> Tecnico competente in Acustica ambientale  Viale II Giugno, 385 71016 San Severo (FG) - ITALY
	 <b>Studio di Ingegneria Coccia</b> Tecnico competente in Acustica ambientale	



<b>STIMA DELLA PRODUCIBILITÀ ENERGETICA ATTESA (A.E.P. - ANNUAL ENERGY PRODUCTION)</b>	Cod. Elaborato: 4.2.6E	
	Oggetto: R.T._SPEA	
Impianto per la produzione di energia elettrica da fonte eolica "VOLTURINO" da n° 10 WTGs, da realizzarsi in agro del Comune di Volturino (FG), Regione Puglia, in località "Selva Piana-Parco Giovenco".	Doc. n°: 01 di 02	Mod. n°: 00/D/07
	Data: 07/2019	Rev. n°: 00_07/19

## 1.2. DESCRIZIONE GENERALE DELL'INTERVENTO

La presente proposta progettuale è finalizzata alla realizzazione dell'impianto per la produzione di energia elettrica da fonte eolica "VOLTURINO" (*di seguito*: impianto di progetto), che la società Innogy Italia S.p.A. intende realizzare in agro del Comune di Volturino (FG), Regione Puglia, in località "Selva Piana-Parco Giovenco".

L'impianto di progetto in scala ampia è posizionato come indicato nella seguente ortofoto (*vedi Figura 1.2.-1.*). Di seguito alla stessa il layout d'impianto in scala più ristretta (*vedi Figura 1.2.-2.*).

Il layout dell'impianto è schematicamente indicato nelle precedenti figure, ma meglio dettagliato nelle Tavole di Progetto.

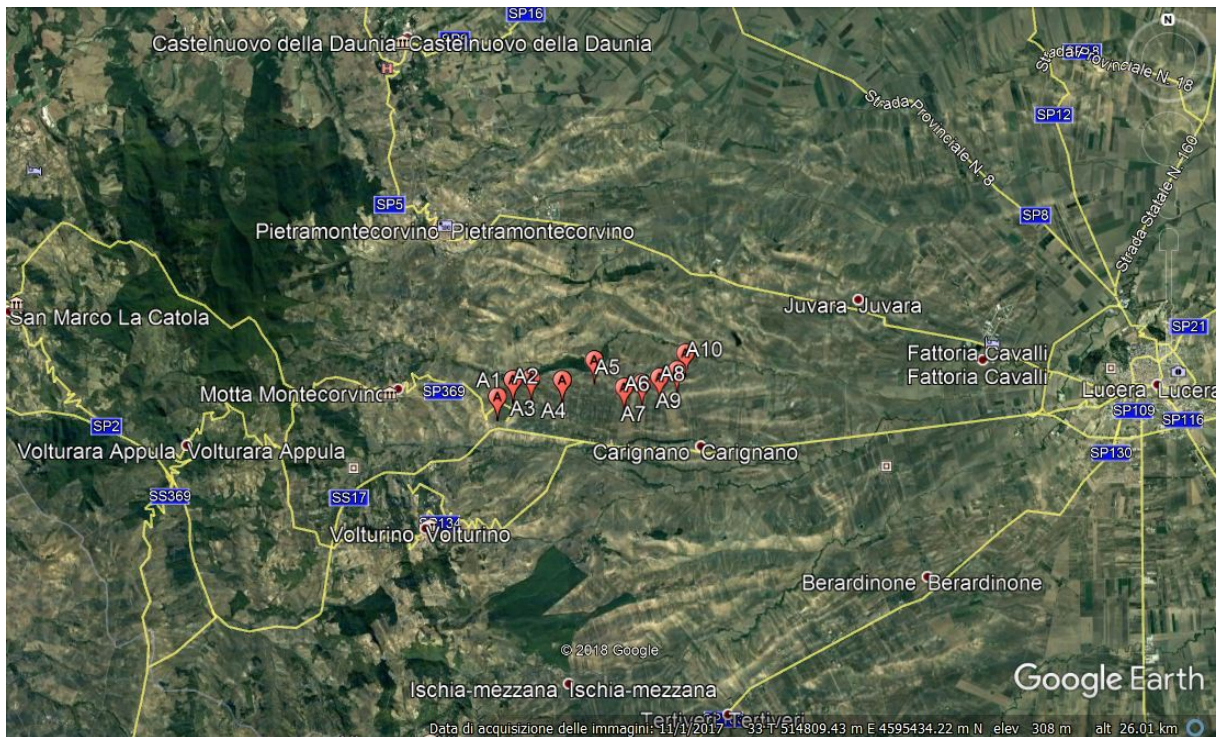

**Figura 1.2.-1.:** Layout di impianto (inquadramento ampio) (Fonte: Google Earth Pro® (data di acquisizione delle immagini: 11/1/2017)).

<b>STIMA DELLA PRODUCIBILITÀ ENERGETICA ATTESA (A.E.P. - ANNUAL ENERGY PRODUCTION)</b>	Cod. Elaborato: 4.2.6E	
	Oggetto: R.T._SPEA	
Impianto per la produzione di energia elettrica da fonte eolica "VOLTURINO" da n° 10 WTGs, da realizzarsi in agro del Comune di Volturino (FG), Regione Puglia, in località "Selva Piana-Parco Giovenco".	Doc. n°: 01 di 02	Mod. n°: 00/D/07
	Data: 07/2019	Rev. n°: 00_07/19



Figura 1.2.-2.: Layout di impianto (inquadramento di dettaglio) (Fonte: Google Earth Pro® (data di acquisizione delle immagini: 11/1/2017)).

L'impianto di progetto prevede la realizzazione di n° 10 (dieci) aerogeneratori (WTGs) tripala ad asse orizzontale di grande taglia, **ciascuno di potenza elettrica nominale pari a 4,8 MW, per una potenza elettrica complessiva pari a 48 MW**, e delle relative opere civili ed elettriche accessorie per la connessione elettrica alla RTN, per i quali sarà impiegato il modello di turbina eolica **NORDEX N149 da 4,8 MW della Nordex Energy GmbH**, ritenuta fra le macchine più performanti ad oggi disponibili sul mercato stando le caratteristiche anemometriche proprie del sito e le esigenze di impianto.

Il modello di turbina eolica impiegato è costituito da una torre di sostegno tubolare metallica a tronco di cono sulla cui sommità è installata la navicella, il cui asse è a 145 m dal piano campagna (**hub height= 145 m s.l.t.**), con annesso il rotore di diametro pari a 149,1 m e una lunghezza della pala di 72,4 m ca. (**rotor diameter= 149,1 m**), per un'altezza massima complessiva del sistema torre-pale di 219,6 m s.l.t. ( **$h_{tip} = \text{hub height} + 1/2 \text{ rotor diameter} = 219,6 \text{ m s.l.t.}$** ).

Si riportano di seguito (vedi **Tabella 1.2.-1.**) le coordinate geografiche delle n° 10 (dieci) WTGs del layout di progetto espresse nel sistema di riferimento UTM WGS84 - Fuso 33:

<b>STIMA DELLA PRODUCIBILITÀ ENERGETICA ATTESA (A.E.P. - ANNUAL ENERGY PRODUCTION)</b>	Cod. Elaborato: <b>4.2.6E</b>	
	Oggetto: <b>R.T._SPEA</b>	
	Doc. n°: <b>01 di 02</b>	Mod. n°: <b>00/D/07</b>
	Data: <b>07/2019</b>	Rev. n°: <b>00_07/19</b>
Impianto per la produzione di energia elettrica da fonte eolica "VOLTURINO" da n° 10 WTGs, da realizzarsi in agro del Comune di Volturino (FG), Regione Puglia, in località "Selva Piana-Parco Giovenco".		

**Tabella 1.2.-1.: Coordinate delle n° 10 (dieci) WTGs (ID.: A1, A2, A3, A4, A5, A6, A7, A8, A9, e A10) del layout di progetto.**

Impianto per la produzione di energia elettrica da fonte eolica "VOLTURINO" da n° 10 (dieci) WTG, da realizzarsi in agro del Comune di Volturino (FG), Regione Puglia, in località "Selva Piana-Parco Giovenco".		
Località:	<b>"Selva Piana-Parco Giovenco"</b>	
Comune/i di:	<b>Volturino</b>	
Provincia di:	<b>Foggia (FG)</b>	
Regione:	<b>PUGLIA</b>	
ID. WTGs	Coordinate WTGs (UTM WGS84 - Fuso 33)	
	Est	Nord
<b>A1</b>	512044.3273	4594317.9421
<b>A2</b>	512426.8291	4594724.8882
<b>A3</b>	512875.0876	4594764.4386
<b>A4</b>	513632.9146	4594698.3471
<b>A5</b>	514423.6304	4595169.4975
<b>A6</b>	515137.9612	4594493.4236
<b>A7</b>	515578.3877	4594585.7519
<b>A8</b>	516009.3470	4594722.3777
<b>A9</b>	516440.8097	4594890.9142
<b>A10</b>	516657.6607	4595302.3951

PROPONENTE: **Innogy Italia S.p.A.**

Viale Francesco Restelli, 3/1  
20124 Milano (MI) - ITALY





<b>STIMA DELLA PRODUCIBILITÀ ENERGETICA ATTESA (A.E.P. - ANNUAL ENERGY PRODUCTION)</b>  Impianto per la produzione di energia elettrica da fonte eolica "VOLTURINO" da n° 10 WTGs, da realizzarsi in agro del Comune di Volturino (FG), Regione Puglia, in località "Selva Piana-Parco Giovenco".	Cod. Elaborato: 4.2.6E	
	Oggetto: R.T._SPEA	
	Doc. n°: 01 di 02	Mod. n°: 00/D/07
	Data: 07/2019	Rev. n°: 00_07/19

### 1.3. ROUGHNESS COEFFICIENT & HEIGHT DATA

Un fattore non trascurabile nella valutazione della velocità media del vento è la rugosità del terreno, con la quale s'intende la capacità degli elementi orografici presenti nel rallentare i flussi di corrente.

Con l'aumento di quota tale fattore esercita un'influenza minore, permettendo una progressiva accelerazione delle velocità medie; così, se una wind farm è localizzata su un terreno completamente pianeggiante, con una rugosità uniforme, allora le caratteristiche di velocità del vento saranno le stesse su tutta la regione.

Pertanto, al fine di procedere alla stima della producibilità energetica attesa del parco eolico di progetto, è necessario calcolare la variazione della velocità del vento attraverso il paesaggio; questa variazione dipende dalla direzione del vento e dall'altezza rispetto al suolo.

I dati di orografia e di rugosità della site region sono dunque fondamentali per una corretta analisi del flusso di vento (nel seguito: "Wind Flow") sulla regione delle turbine eoliche.

Nell'eolico, il *roughness coefficient* si riferisce alla misura di scabrezza del terreno assumendo come riferimento la quota zero del suolo. Misurare questo parametro geometricamente è un'operazione particolarmente complessa che quasi mai viene fatta, nonostante la grande influenza che questo parametro ricopre nella stima della risorsa ventosa.

La determinazione dei parametri locali di rugosità, infatti, richiede sia i dati del profilo del vento osservati su un anemometro sufficientemente alto, o anche osservazioni di turbolenza o di raffiche di vento da un anemometro esposto a un livello ben sopra la media di altezza degli ostacoli vicini; tali dati sono raramente disponibili nelle situazioni di lavoro.

Per ovviare a questa impossibilità sono state definite delle tavole di riferimento riportanti i valori di *roughness* al variare del tipo di terreno presente.

Questa misura nelle applicazioni eoliche è definita come l'area frontale dell'elemento che contrasta il vento diviso per l'area che l'ostacolo stesso occupa; indicata con la lettera  $z_0$ , è solitamente espressa in metri.

Nella **Tabella 1.3-1** è riportata una classificazione per questa misura; in essa si riportano l'indice di scabrezza  $z_0$  per diversi tipi di terreno.

La più valida revisione dei parametri di rugosità ha coperto una gamma piuttosto ampia di tipologie di terreni, e usato solamente osservazioni effettuate ad altezze sufficienti; essa fu pubblicata da Deavenport nel 1960; in seguito furono pubblicate altre liste di parametri di rugosità, molte dei quali hanno usato osservazioni di qualità minore e contenevano pochi o nessun dato osservati dopo il 1969.

La ricchezza dei dati di rugosità da tutti gli esperimenti sugli strati limite pubblicati furono revisionati da Wieringa (1993) per terreni rurali omogenei, comprese le foreste. La rugosità effettiva delle tipologie reali di

<b>STIMA DELLA PRODUCIBILITÀ ENERGETICA ATTESA (A.E.P. - ANNUAL ENERGY PRODUCTION)</b>	Cod. Elaborato: <b>4.2.6E</b>	
	Oggetto: <b>R.T._SPEA</b>	
	Doc. n°: <b>01 di 02</b>	Mod. n°: <b>00/D/07</b>
	Data: <b>07/2019</b>	Rev. n°: <b>00_07/19</b>
<b>Impianto per la produzione di energia elettrica da fonte eolica "VOLTURINO" da n° 10 WTGs, da realizzarsi in agro del Comune di Volturino (FG), Regione Puglia, in località "Selva Piana-Parco Giovenco".</b>		

paesaggio, indipendentemente dall'omogeneità, fu dimostrata da lui essere molto correttamente descritta dalla Classifica Davenport del 1960.

Wieringa (1992) ha esteso quella classificazione a tipologie di terreno con minore rugosità, come il mare.

Per definire la conformazione di un terreno, in letteratura sono state individuate n° 8 classi di rugosità nell'ambito della classificazione internazionale di Davenport dell'effettiva rugosità del terreno<sup>3</sup> (aggiornata al 2001).

Per stimare la rugosità (visivamente o dalle mappe), Davenport classifica allora tutti i dati disponibili per una vasta gamma di terreni.

La descrizione di Davenport di n° 8 classi d'effettiva rugosità aerodinamica di tipologie di terreno reali è aggiornata a oggi, riassumendo oltre settantacinque attendibili esperimenti su terreni omogenei e disomogenei. È utilizzata dall'WMO e dall'ASCE, ma non ancora in Europa.

Wieringa [Bull.Am.Met.Soc., 1980; J. Wind Eng.Ind.Aer., 1992], convalida le n° 8 classi di rugosità di Davenport per terreni "aperti" ("*Open*") e moderatamente complessi e per le foreste, estendendo la propria gamma a "*Smooth terrain*" e "*Open water*".

Considerando le informazioni recenti disponibili da Grimmond e Oke [Grimmond and Oke, Bound.Layer Met., 1998; J.Appl.Met., 1999] per le città e da Davenport *et alii.* (2000) per la campagna scabra, le cinque classi più rugose dell'originale aggiornato al 1992 della classificazione di Davenport del 1960 è stata riformulata nella **Tabella 1.3.-1.**

Un anteriore aggiornamento della bozza zero delle classi da parte di Wieringa (1980) – con descrizioni delle Classi molto brevi – già ha assegnato complessivamente il giusto livello di rugosità e il presente aggiornamento non mostra che fu significativamente anticipato.

Tuttavia, l'aggiornamento di Davenport *et alii.* (2000) della classificazione di rugosità effettiva di Davenport, tengono più in conto delle differenze nel tipo di ostacolo e quindi permette maggiore precisione. Inoltre, la sua attendibilità sul lato dell'alta rugosità è incrementata perché la classificazione ora riassume più di quaranta esperimenti su terreni omogenei e trenta cinque esperimenti ad altezze sufficienti su terreni disomogenei e sulle città – quasi tutti gli esperimenti esistenti utili ben pubblicati. Gli aggiornamenti del 1980 e del 1992 furono già adottati da utenti maggiori come WMO (1996) e ASCE (1999), e da manuali come Stull (1995).

<sup>3</sup> Fonti:

1. "New Revision of Davenport Roughness Classification" – J. Wieringa, A. Davenport, C. S. B. Grimmond, T. Oke – To be presented at 3EACWE, Eindhoven, Netherlands, July 2001;
2. Alan Davenport, University of Western Ontario, London, ON, Canada; and C. S. B. Grimmond, T. Oke, and J. Wieringa.

<b>STIMA DELLA PRODUCIBILITÀ ENERGETICA ATTESA (A.E.P. - ANNUAL ENERGY PRODUCTION)</b>	Cod. Elaborato: 4.2.6E	
	Oggetto: R.T._SPEA	
	Doc. n°: 01 di 02	Mod. n°: 00/D/07
	Data: 07/2019	Rev. n°: 00_07/19
Impianto per la produzione di energia elettrica da fonte eolica "VOLTURINO" da n° 10 WTGs, da realizzarsi in agro del Comune di Volturino (FG), Regione Puglia, in località "Selva Piana-Parco Giovenco".		

La riformulazione della classificazione della rugosità di Davenport fornisce un valido strumento di lavoro, efficace per stimare la rugosità aerodinamica per tutti i tipi di terreno, per l'applicazione nel settore dell'ingegneria del vento e dello strato limite di modellazione per i terreni complessi.

Quindi è stata aggiornata la Classificazione Davenport, rendendola lo strumento più attendibile per l'effettiva rugosità aerodinamica da stimare sull'intera gamma di terreni reali del mondo.

In **Tabella 1.3.-1.** è riportata la classificazione di Davenport dell'effettiva rugosità del terreno.

**Tabella 1.3.-1.: Classificazione di Davenport dell'effettiva rugosità del terreno.**

Classificazione di Davenport dell'effettiva rugosità del terreno	
Descrizione del terreno	Scabrezza o Roughness corrispondente $Z_0$ [m]
Mare o lago aperto (indipendentemente dalle dimensioni delle onde), piatto soggetto a maree, piatto coperto di neve, deserto senza caratteristiche, con catrame e calcestruzzo, con scarico libero di alcuni chilometri.	0,0002 ("Sea")
Superficie del terreno piatta senza alcun ostacolo notevole e con vegetazione insignificante; per es. spiagge, banchisa senza catena di monti, coperta da palude e neve o campagna aperta a maggese.	0,005 ("Smooth")
Campagna piana con vegetazione bassa (per es. erba) e ostacoli isolati con separazioni di altezze di almeno 50 ostacoli; per es. terra per pascolo senza frangivento, erica, landa e tundra, pista di aeroporti. Ghiaccio con catena di monti contro vento.	0,03 ("Open")
Area naturale o coltivata con basse colture o coperture di piante, o campagne moderatamente aperte con ostacoli occasionali (per es. basse siepi, basse costruzioni isolate o alberi) a distanze orizzontali relative di altezze di almeno 20 ostacoli.	0,10 ("Roughly open")
Area naturale o coltivata con colture alte o colture di varie altezze, e ostacoli sparsi a distanze relative di altezza da 12 a 15 ostacoli per oggetti porosi (per es. frangiventi) o altezza da 8 a 12 ostacoli per oggetti bassi solidi (per es. costruzioni). (Le analisi possono aver bisogno di $Z_d$ )	0,25 ("Rough")
Paesaggio coltivato intensivamente con molti gruppi di ostacoli piuttosto larghi (grandi fattorie, ciuffi di foreste) separate da spazi aperti di altezze di circa 8 ostacoli. Bassa vegetazione più intensa densamente piantata come boscaglia, frutteto, giovani foreste. Inoltre, l'area moderatamente coperta da costruzioni basse con interspazi di altezze da 3 a 7 edifici e nessun albero alto. (Le analisi richiedono $Z_d$ )	0,5 ("Very Rough")
Paesaggio regolarmente coperto con ostacoli larghi di dimensioni simili, con spazi aperti dello stesso ordine di vastità come altezze di ostacoli; per es. foreste regolari mature, aree densamente accumulate senza variazione di molte altezze di edifici. (Le analisi richiedono $Z_d$ )	1,0 ("Skimming")
I centri cittadini con edifici misti alti e bassi, o vaste foreste di altezza irregolare con molte radure. (Analisi attraverso tunnel aerodinamico consigliato)	> 2 ("Chaotic")

La rugosità caratteristica del sito in esame è stata creata sulla base di informazioni disponibili opportunamente modificate.

L'altitudine media del sito è di circa 330 m s.l.m., con quote comprese tra i 275 m e i 385 m ca. s.l.m..

<b>STIMA DELLA PRODUCIBILITÀ ENERGETICA ATTESA (A.E.P. - ANNUAL ENERGY PRODUCTION)</b>  Impianto per la produzione di energia elettrica da fonte eolica "VOLTURINO" da n° 10 WTGs, da realizzarsi in agro del Comune di Volturino (FG), Regione Puglia, in località "Selva Piana-Parco Giovenco".	Cod. Elaborato: 4.2.6E	
	Oggetto: R.T._SPEA	
	Doc. n°: 01 di 02	Mod. n°: 00/D/07
	Data: 07/2019	Rev. n°: 00_07/19

## 1.4. AIR DENSITY CORRECTION

La densità dell'aria influisce sull'energia prodotta da una wind farm. In particolar modo, la potenza di una turbina eolica è inversamente proporzionale all'altitudine e direttamente proporzionale alla temperatura dell'aria; poiché con l'aumentare dell'altitudine l'aria diventa più leggera e la Potenza diminuisce, non appena l'aria diventa più fredda essa è più densa e la Potenza aumenta.

Generalmente, i dati di potenza e di spinta delle turbine eoliche sono specificati per la densità dell'aria determinata alle condizioni atmosferiche standard<sup>4</sup> (1,225 kg/m<sup>3</sup> ad una temperatura di 15,0 °C al livello medio del mare). La correzione della densità dell'aria è generalmente necessaria per correggere i calcoli sulla producibilità.

Di seguito si riporta la **Tabella 1.4.-1.**, desunta dalla letteratura di settore, in cui sono mostrati i principali valori di densità dell'aria al variare della temperatura.

**Tabella 1.4.-1.: Densità dell'aria al variare della temperatura.**

Temperatura [°C]	Densità dell'aria [kg/m <sup>3</sup> ] (1 atm)
-10	1,342
-5	1,316
0	1,293
5	1,269
10	1,247
15	1,225
20	1,204
25	1,184
30	1,165

Per calcolare la densità dell'aria per ciascun aerogeneratore alla rispettiva altitudine sono state usate le misure di lungo termine di temperatura e pressione rilevate da una stazione meteorologica posta nelle vicinanze (Foggia). Le curve di potenza sono state opportunamente modificate.

<sup>4</sup> Le caratteristiche dell'Atmosfera Standard Internazionale ICAO (International Civil Aviation Organization) seguono un modello ideale dell'atmosfera media reale, considerata a una latitudine di 45°: *Umidità relativa*=0%; *Pressione atmosferica* (s.l.m.)= 1 atm, *Temperatura* (s.l.m.)= 15 °C; *Densità dell'aria* (s.l.m.)=1,225 kg/m<sup>3</sup>.

<b>STIMA DELLA PRODUCIBILITÀ ENERGETICA ATTESA (A.E.P. - ANNUAL ENERGY PRODUCTION)</b>  Impianto per la produzione di energia elettrica da fonte eolica "VOLTURINO" da n° 10 WTGs, da realizzarsi in agro del Comune di Volturino (FG), Regione Puglia, in località "Selva Piana-Parco Giovenco".	Cod. Elaborato: <b>4.2.6E</b>	
	Oggetto: <b>R.T._SPEA</b>	
	Doc. n°: <b>01 di 02</b>	Mod. n°: <b>00/D/07</b>
	Data: <b>07/2019</b>	Rev. n°: <b>00_07/19</b>

## 1.5. WIND DATA

La caratterizzazione anemologica del sito di progetto è stata eseguita sulla scorta di dati anemometrici rilevati mediante l'ausilio di una torre anemometrica situata nelle vicinanze dell'area d'impianto.

I dati anemometrici rilevati dai sensori montati sulla suddetta torre anemometrica riguardano la misurazione dei valori medi, massimi, minimi, e di deviazione standard delle velocità del vento.

I risultati riportati nel presente report sono il frutto delle analisi e delle elaborazioni eseguite sui dati originali provenienti dalle registrazioni del datalogger. Le misurazioni ritenute non valide a causa di fenomeni o eventi atmosferici che hanno indotto un temporaneo malfunzionamento dei sensori (per esempio sensori ghiacciati per le basse temperature) e che quindi potrebbero alterare e falsare le stime, sono stati filtrati e pertanto esclusi dalle elaborazioni eseguite per calcolare tutti i parametri quali velocità media, valori min, max, turbolenze ecc..

Il presente studio si basa sull'acquisizione e successiva elaborazione dei dati anemometrici di velocità e direzione del vento rilevati mediante una torre anemometrica localizzata nelle vicinanze dell'area d'impianto, estesi su un range temporale di 27 mesi.



<b>STIMA DELLA PRODUCIBILITÀ ENERGETICA ATTESA (A.E.P. - ANNUAL ENERGY PRODUCTION)</b>	Cod. Elaborato: 4.2.6E	
	Oggetto: R.T._SPEA	
Impianto per la produzione di energia elettrica da fonte eolica "VOLTURINO" da n° 10 WTGs, da realizzarsi in agro del Comune di Volturino (FG), Regione Puglia, in località "Selva Piana-Parco Giovenco".	Doc. n°: 01 di 02	Mod. n°: 00/D/07
	Data: 07/2019	Rev. n°: 00_07/19

## 1.6. WIND ROSE

La distribuzione del vento avviene generalmente attorno ad un cerchio ideale suddiviso in n° 12 settori di direzione uguali, con ampiezza di 30°. All'interno della "Wind Rose" del software il dato di distribuzione è normalmente specificato come una tabella di frequenza la quale fornisce il numero di ore a ogni velocità del vento e per ogni settore.

La wind rose ottenuta indica che la direzione principale del vento è l'arco del settore Nord Nord-Ovest.

La disponibilità di dati alla torre anemometrica è stata del 91%. Per il periodo indagato si è registrata una velocità media del vento pari a 6,7 m/s a 70 m, ovvero di 7.00 m/s riferita all'altezza dell'hub.

Disponendo di tali informazioni è stato possibile elaborare la Wind Analysis e la caratterizzazione delle curve iso-vento. Si riportano a seguire la wind rose caratterizzante il regime eolico del sito.

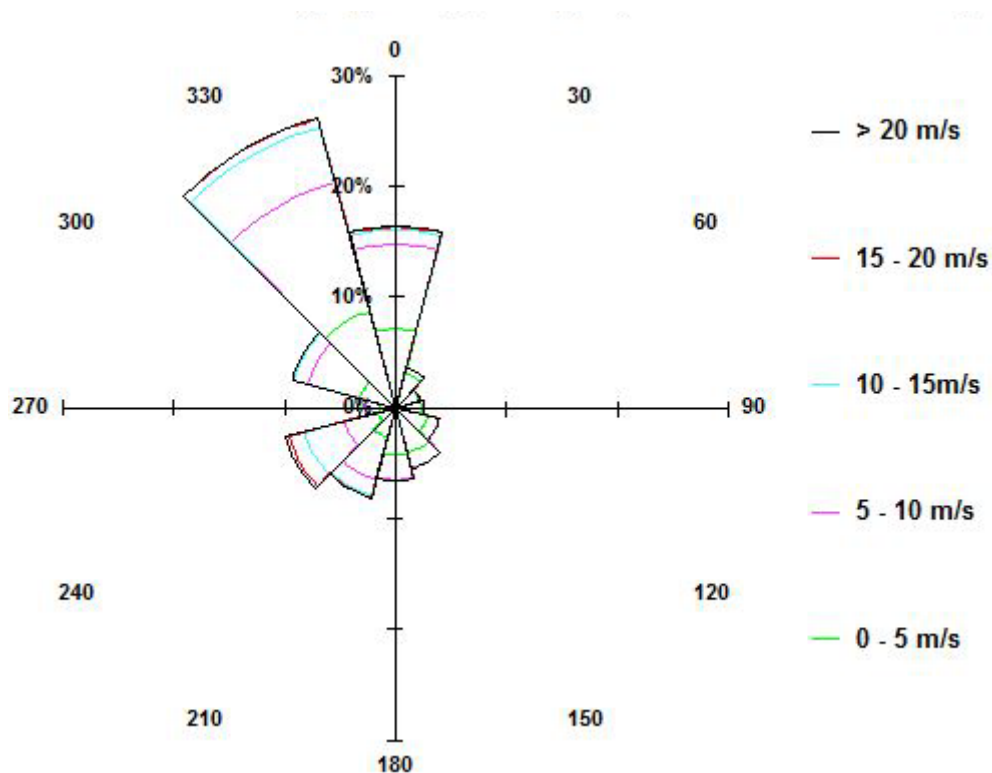

<b>STIMA DELLA PRODUCIBILITÀ ENERGETICA ATTESA (A.E.P. - ANNUAL ENERGY PRODUCTION)</b>  Impianto per la produzione di energia elettrica da fonte eolica "VOLTURINO" da n° 10 WTGs, da realizzarsi in agro del Comune di Volturino (FG), Regione Puglia, in località "Selva Piana-Parco Giovenco".	Cod. Elaborato: <b>4.2.6E</b>	
	Oggetto: <b>R.T._SPEA</b>	
	Doc. n°: <b>01 di 02</b>	Mod. n°: <b>00/D/07</b>
	Data: <b>07/2019</b>	Rev. n°: <b>00_07/19</b>

## 1.7. MODELLO DI TURBINA EOLICA

Si rammenta che per i n° 10 (dieci) aerogeneratori (WTGs) dell'impianto di progetto sarà impiegato il modello di turbina eolica **NORDEX N149 da 4,8 MW della Nordex Energy GmbH**. Il modello di turbina eolica impiegato è costituito da una torre di sostegno tubolare metallica a tronco di cono sulla cui sommità è installata la navicella, il cui asse è a 145 m dal piano campagna (**hub height= 145 m s.l.t.**), con annesso il rotore di diametro pari a 149,1 m e una lunghezza della pala di 72,4 m ca. (**rotor diameter= 149,1 m**), per un'altezza massima complessiva del sistema torre-pala di 219,6 m s.l.t. ( **$h_{tip} = \text{hub height} + 1/2 \text{ rotor diameter} = 219,6 \text{ m s.l.t.}$** ).

Nell'**Allegato n. 1** (vedi **Allegato n. 1: Scheda tecnica WTG Modello NORDEX N149 da 4,8 MW della Nordex Energy GmbH**) è riportata la scheda tecnica del modello di turbina eolica utilizzata ai fini dei calcoli, insieme ai valori della Curva di Potenza (CP) e di Thrust coefficient ( $C_t$ ) alle diverse velocità del vento per il modello di turbina eolica impiegato.

<b>STIMA DELLA PRODUCIBILITÀ ENERGETICA ATTESA (A.E.P. - ANNUAL ENERGY PRODUCTION)</b>	Cod. Elaborato: <b>4.2.6E</b>	
	Oggetto: <b>R.T._SPEA</b>	
	Doc. n°: <b>01 di 02</b>	Mod. n°: <b>00/D/07</b>
	Data: <b>07/2019</b>	Rev. n°: <b>00_07/19</b>
Impianto per la produzione di energia elettrica da fonte eolica "VOLTURINO" da n° 10 WTGs, da realizzarsi in agro del Comune di Volturino (FG), Regione Puglia, in località "Selva Piana-Parco Giovenco".		

## 1.8. STIMA DELLA PRODUCIBILITÀ ENERGETICA ATTESA

Sulla base della Wind Rose per il sito in esame e della curva di potenza del modello di turbina eolica ipotizzato ai fini delle simulazioni, mediante il software windPRO (version 3.2) è stata stimata la producibilità energia attesa dell'impianto eolico di progetto costituito da n° 10 (dieci) aerogeneratori, espressa in ore equivalenti annue.

L'efficienza dell'impianto eolico è inficiata da vari fattori di cui il software tiene conto nella simulazione: inficiano l'efficienza le turbolenze dovute all'orografia e agli ostacoli presenti nell'area d'indagine; e il cosiddetto "effetto scia", ovvero quando le turbine interagiscono tra loro tramite turbolenze e scie dovute al loro funzionamento. Dalla producibilità ottenuta sono sottratte per cautela le ulteriori perdite dovute all'efficienza elettrica, alla disponibilità delle macchine, alla degradazione aerodinamica delle pale, ecc., stimati diminuendo del 12,2% il totale di produzione del parco:

Topographic Effects % Change	Stima elaborata mediante Software windPRO
Wake effect	5.7%
Non Availability:	2.0%
Electrical losses:	3.0%
Turbine performance:	0.3%
Environmental:	1.3%
Curtailments:	0.5%
<b>Perdite Totali:</b>	<b>Total Losses= 12.2%</b>

La Net Energy Yield (P50) per l'impianto di progetto "VOLTURINO" è risultata pari a 138,945 MWh/a, per un totale di ore equivalenti annue (P50) pari a circa 3.106,8 h/a.

<b>STIMA DELLA PRODUCIBILITÀ ENERGETICA ATTESA (A.E.P. - ANNUAL ENERGY PRODUCTION)</b>  Impianto per la produzione di energia elettrica da fonte eolica "VOLTURINO" da n° 10 WTGs, da realizzarsi in agro del Comune di Volturino (FG), Regione Puglia, in località "Selva Piana-Parco Giovenco".	Cod. Elaborato: 4.2.6E	
	Oggetto: R.T._SPEA	
	Doc. n°: 01 di 02	Mod. n°: 00/D/07
	Data: 07/2019	Rev. n°: 00_07/19

Luogo e Data

San Severo, luglio 2019

**Ing. Michele R.G. Curtotti**



**Ing. Fabio Coccia**



<b>STIMA DELLA PRODUCIBILITÀ ENERGETICA ATTESA (A.E.P. - ANNUAL ENERGY PRODUCTION)</b>  Impianto per la produzione di energia elettrica da fonte eolica "VOLTURINO" da n° 10 WTGs, da realizzarsi in agro del Comune di Volturino (FG), Regione Puglia, in località "Selva Piana-Parco Giovenco".	Cod. Elaborato: 4.2.6E	
	Oggetto: R.T._SPEA_All. n. 1	
	Doc. n°: 02 di 02	Mod. n°: 00/D/07
	Data: 07/2019	Rev. n°: 00_07/19

Allegato n. 1	Scheda tecnica WTG Modello NORDEX N149 da 4,8 MW della Nordex Energy GmbH
---------------	---

PROPONENTE: **Innogy Italia S.p.A.**

Viale Francesco Restelli, 3/1  
20124 Milano (MI) - ITALY





General documentation

# Technical description

## Wind turbine class Nordex Delta4000



E0004109668

Revision 03 / 2017-10-24

- Translation of the original instructions -  
Document is published in electronic form.  
Original document at Nordex Energy GmbH, Engineering.

This document was produced by Nordex Energy GmbH and/or affiliated companies within the meaning of section 15 et seq. of the German Stock Corporation Act (AktG).

This document, including any presentation of its contents in whole or in parts, is the intellectual property of Nordex Energy GmbH and/or affiliated companies within the meaning of section 15 et seq. of the AktG. The information contained in this document must be treated as confidential and must not, neither in whole nor in part, be disclosed to third parties without the express consent of Nordex Energy GmbH.

All rights reserved.

Any disclosure, duplication, translation or other use of this document or parts thereof, regardless if in printed, handwritten, electronic or other form, without the explicit approval of Nordex Energy GmbH is prohibited.

Copyright 2017 by Nordex Energy GmbH.

### **Contact details**

For questions relating to this documentation please contact:

Nordex Energy GmbH

Langenhorner Chaussee 600

22419 Hamburg

Germany

Phone: +49 40 30030 1000

Fax: +49 40 30030 1101

<http://www.nordex-online.com>

[info@nordex-online.com](mailto:info@nordex-online.com)

# 1. Structure

The Nordex Delta4000 wind turbine class comprises speed-variable wind turbines with a rotor diameter of 149 m and a nominal power of 4500 kW, which can be adapted depending on location. The wind turbine is designed for class IIIS in accordance with IEC 61400-1 or wind zone S in accordance with DIBT 2012 and is available in 50 Hz and 60 Hz variants.

A class Nordex Delta4000 wind turbine consists of the following main components:

- Rotor, with rotor hub, three rotor blades and the pitch system
- Nacelle with drive train, generator, yaw system, medium-voltage transformer and converter
- Tubular tower or hybrid tower with MV switchgear on a foundation

## 1.1 Tower

A class Nordex Delta4000 wind turbine can be erected on a steel tower or on a hybrid tower. The steel tower is cylindrical and consists of 4 or 6 sections. This tower is bolted to the anchor cage embedded in the foundation. The bottom part of the hybrid tower consists of a concrete tower and the top part of a tubular steel tower with two sections.

Corrosion protection is ensured by a tower surface coating system in accordance with ISO 12944. A service lift, the vertical ladder with fall protection system as well as resting and working platforms inside the tower allow for a weather-protected ascent to the nacelle.

The foundation design of all towers depends on the ground conditions at the intended site.

The tower base contains a low-voltage cabinet with control units and the medium-voltage switchgear.

## 1.2 Rotor

The rotor consists of the rotor hub with three pitch bearings and three pitch drives for blade adjustment as well as three rotor blades.

The **rotor hub** consists of a base element with support structure and a spinner. The base element consists of a stiff cast structure, on which the pitch bearings and the rotor blades are assembled. The rotor hub is covered with the spinner which enables the direct access from the nacelle into the rotor hub.

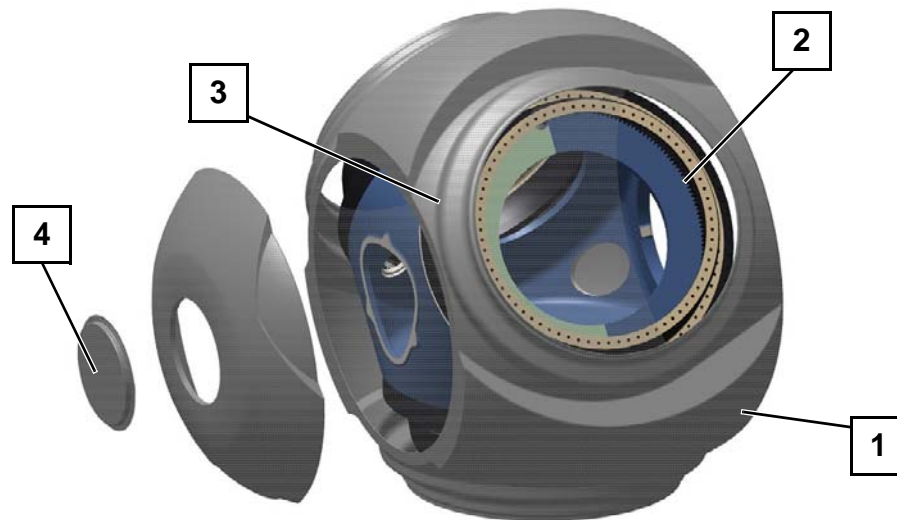

Fig.1 Rotor hub and spinner of the Nordex Delta4000

- |   |   |   |                        |
|---|---|---|------------------------|
| 1 | Spinner segment                         | 2 | Rotor hub base element |
| 3 | Spinner support structure (not visible) | 4 | Escape hatch           |

The **rotor blades** are made of high-quality glass-fiber reinforced and carbon-fiber reinforced plastics. The rotor blade is statically and dynamically tested in accordance with the guidelines IEC 61400-23 and DNVGL-ST-0376 (2015). Optionally the rotor blades can be equipped with serrations, which optimize the sound power level.

The **pitch system** serves to adjust the pitch angle of the rotor blades set by the control system. For each individual rotor blade the pitch system comprises an electromechanical drive with 3-phase motor, planetary gear and drive pinion, as well as a control unit with frequency converter and emergency power supply. Power supply and signal transfer are realized through a slip ring in the nacelle.

## 1.3 Nacelle

The nacelle contains essential mechanical and electrical components of the wind turbine. The nacelle can be pivoted on the tower.

The **rotor shaft** is mounted in the rotor bearing in the nacelle. A rotor lock is integrated in the rotor bearing, with which the rotor can be reliably locked in place mechanically.

The **gearbox** increases the rotor speed until it reaches the speed required for the generator.

The bearings and gearings are continuously lubricated with oil. A 2-stage pump enables the oil circulation. A combined filter element with integrated coarse, fine and superfine filter removes solids. The control system monitors the contamination of the filter element.

The gear oil used for lubrication also cools the gearbox. The temperatures of the gearbox bearings and the oil are continuously monitored. If the optimum operating temperature is not yet reached, a thermal bypass directs the gear oil

directly back to the gearbox. If the operating temperature of the gear oil is exceeded it is cooled down.

The gearbox cooling is realized with an oil/water cooler that is installed directly at the gearbox. The heated cooling water is cooled together with the cooling water of the generator, converter and transformer in a passive cooler on the roof of the nacelle.

The **generator** is a 6-pole doubly-fed induction machine. An air/water heat exchanger is mounted on the generator. The cooling water is recooled together with the cooling water of the other large components in a passive cooler on the nacelle roof.

The **mechanical rotor brake** is used to lock the rotor during maintenance.

The **yaw drives** optimally rotate the nacelle into the wind. The yaw drives are located on the machine frame in the nacelle. A yaw drive consists of an electric motor, multi-stage planetary gear, and a drive pinion. The drive pinions mesh with the external teeth of the yaw bearing. When the nacelle is properly positioned it is locked by means of the yaw drives.

If necessary, the oil pressure for the rotor brake is generated by a hydraulic pump.

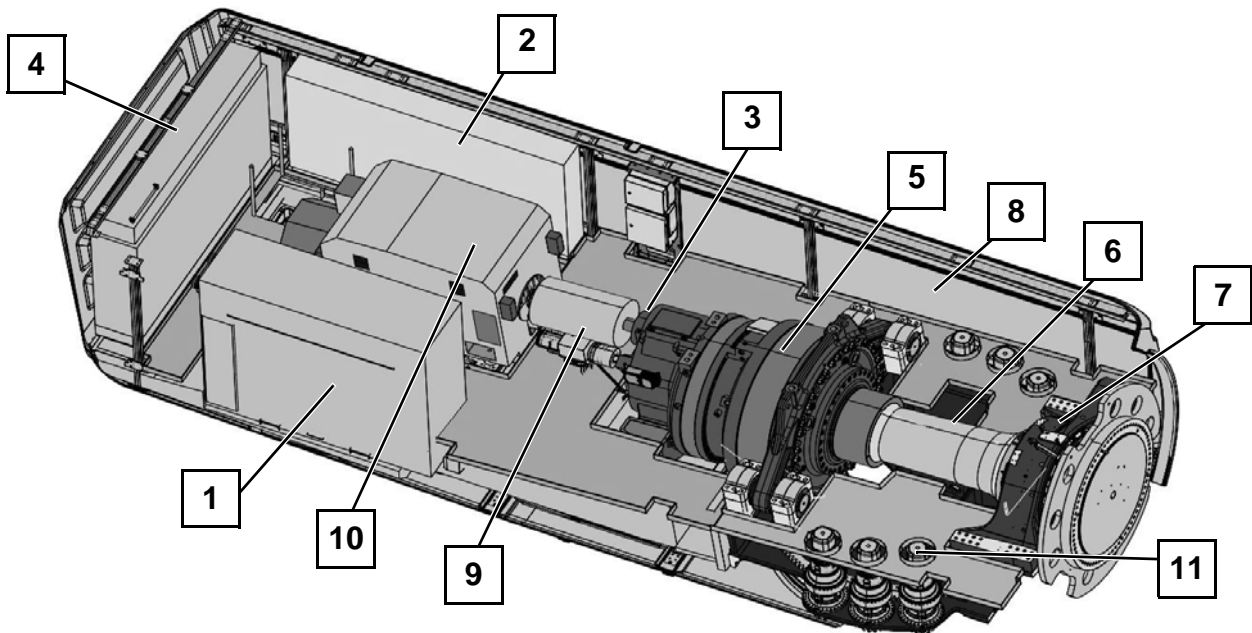

*Fig.2 Schematic representation of the nacelle*

1	Transformer	2	Switch cabinet	3	Rotor brake
4	Converter	5	Gearbox	6	Rotor shaft
7	Rotor bearing	8	Nacelle housing	9	Coupling
10	Generator	11	Yaw drives		

## 1.4 Auxiliary systems

Generator bearing, pitch gearing and yaw gearing are each equipped with an **automatic lubrication system**.



Gearbox, generator, the cooling circuit and all switch cabinets are equipped with **heaters**.

An electric **chain hoist** is installed in the nacelle which is used for lifting tools, components and other work materials from the ground into the nacelle. A second, movable **overhead crane** is used for carrying the materials within the nacelle.

Various options of additional equipment are available for the wind turbine.

### Cooling system

Gearbox, generator, converter and transformer are cooled via a coupled air/water heat exchanger. A pump conveys the mixture through the heat exchanger. At startup the lightly heated gear oil is directly fed back into the gearbox via a thermal bypass and only directed into the plate-type heat exchanger after reaching operating temperature.

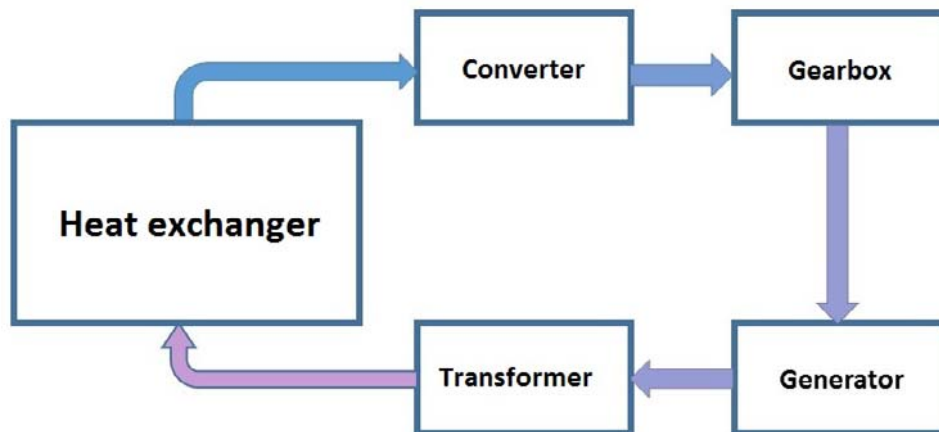

Fig.3 Schematic diagram of the cooling of the large components in the nacelle

## 2. Medium-voltage switchgear

The medium-voltage components are used to connect a WT to the medium-voltage grid in the wind farm or to the grid of the local grid operator. The **MV switchgear** is located in the tower base. It consists of a transformer panel with circuit breaker, two or three ring cable units as standard or four as option (depending on the WF configuration) and a pressure absorber duct. The transformer panel consists of a vacuum circuit breaker and the disconnecter with ground switch. The ring cable panel consist of a switch disconnecter with a ground switch. The entire MV switchgear is assembled on a support/adapter frame.

Additional properties of the MV switchgear:

- Routine tests of each switchgear in compliance with IEC 62271-200
- Type tested, SF6 insulation
- Indoor switchgear for self-contained electrical operating sites (min. IP2X)
- SF6 tank: metal-clad, metal-enclosed (min. IP65), independent of environmental influences
- Switch positions shown "On – Off – Grounded"
- Test terminal strip for secondary test
- Low-maintenance in accordance with class E2 (IEC 62271-100)

The system protection of the MV switchgear is achieved through the following items:

- Pressure relief by pressure absorber duct in case of arcing
- Improved personal safety and system protection in case of arcing by type testing in compliance with IEC 62271-200
- Protective device with inrush detection and supplied by converter current as definite-time overcurrent relay
- Actuating openings for switchgear are interlocked to preclude operation of more than one simultaneously, and can be locked as an option
- Corrosion protection of the switchgear cells through hot-dip galvanization and painted surfaces

**Transformer** and converter are located in the nacelle. The transformer has been specified in accordance with IEC 60076-16 and meets the ecodesign requirements in compliance with 548/2014/EU. The transformer protection level is IP54.

The steel components at the transformer have been designed in accordance with corrosion protection class C3 (H).

Other protection measures:

- Grounded shell
- Overtemperature protection through PT100 temperature sensors and relays

### 3. Functional principle

The turbine operates automatically. A programmable logic controller (PLC) continuously monitors the operating parameters using various sensors, compares the actual values with the corresponding setpoints and issues the required control signals to the WT components. The operating parameters are specified by Nordex and are adapted to the individual location.

When there is no wind the WT remains in idle mode. Only various auxiliary systems are operational or activated as required: e.g., heaters, gear lubrication or PLC, which monitors the data from the wind measuring system. All other systems are switched off and do not use any energy. The rotor idles. When the optional SATCOM function has been enabled, the converter remains in operation and enables reactive power supply to the grid. When the cut-in wind speed is reached, the wind turbine will change to the mode 'Ready for operation'. Now all systems are tested, the nacelle turns into the wind and the rotor blades turn into the wind. When a certain speed is reached, the generator is connected to the grid and the WT produces energy.

At low wind speeds the WT operates at part load. During this the rotor blades remain fully turned into the wind. The power produced by the WT depends on the wind speed.

When the nominal wind speed is reached, the WT switches over to the nominal load range. If the wind speed continues to increase, the speed control changes the rotor blade angle so that the rotor speed and thus the power output of the WT remain constant.

The yaw system ensures that the nacelle is always optimally aligned to the wind. To this end, two separate wind measuring systems located on the nacelle measure the wind direction. Only one wind measuring system is used for the control system, while the second system monitors the first and takes over in case the first system fails. If the measured wind direction deviates too greatly from the alignment of the nacelle, the nacelle is yawed into the wind.

The wind energy absorbed from the rotor is converted into electrical energy using a doubly-fed induction machine with slip ring rotor. Its stator is directly connected to the MV transformer, which connects the wind turbine to the grid, and its rotor via a specially controlled frequency converter. Thus only part of the power must be routed via the converter, permitting low electrical system loss.

#### Safety systems

Nordex wind turbines are equipped with extensive equipment and accessories to provide for personal and turbine safety and ensure continuous operation. The entire turbine is designed in accordance with the Machinery Directive 2006/42/EC and certified as per IEC 61400. For details on the safety devices refer to the current safety manual.

If certain parameters concerning turbine safety are exceeded, the WT will cut out immediately and is put into a safe state. Depending on the cut-out cause, different brake programs are tripped. In case of external causes, such as excessive wind speeds or if the operating temperature is not met, the wind turbine is softly braked by means of rotor blade adjustment.

### **Lightning/surge protection, electromagnetic compatibility (EMC)**

The lightning/surge protection of the wind turbine is based on the EMC-compliant lightning protection zone concept, which comprises the implementation of internal and external lightning/surge protection measures under consideration of the standard IEC 61400-24.

The wind turbine falls into lightning protection level I. All components of the internal and external lightning/surge protection are designed in accordance with lightning protection level I.

The wind turbine with the electrical equipment, consumers, the measurement, control, protection, information and telecommunication technology meets the EMC requirements according to IEC 61400-1, item 10.11.

### **Low-voltage network types**

The **660 V low voltage network** is grounded as an IT system and a three-phase system and is the primary low-voltage electrical system of the wind turbine. The elements of the electrical equipment and measuring instruments of this network are grounded directly or by means of separate protective bonding conductors. A central insulation monitor was installed as another protective measure for personal and turbine safety in the 660 V IT system.

The **400 V/230 V low-voltage network** has its neutral point grounded directly at the supplying network transformers as TN system and three-phase system. The equipment grounding conductor PE and the neutral conductor are available separately. The bodies of the electrical equipment and consumers are connected directly and straight to the neutral points of the supplying network transformers via equipment grounding conductors, including the protective equipotential bonding. The 400 V/230 V low-voltage network is the auxiliary low-voltage system of the wind turbine.

### **Auxiliary power of the wind turbine**

The auxiliary low voltage required by the wind turbine in stand-by mode and feed-in mode is requested by the following consumers:

- Wind turbine control including main converter control
- 400 V/230 V auxiliary power of the main converter
- 230 V AC UPS supply including 24 V DC supply
- Yaw system
- Pitch system

- Auxiliary drives such as pumps, fans and lubrication units
- Heaters and lighting
- Auxiliary systems such as service lift, obstacle lights

Based on measurements, simulations and existing operating experience, a coincidence factor of 0.6 can be estimated for the installed low-voltage auxiliary power for the worst load case of the auxiliary low-voltage system as well as the feed-in operation mode of the WT. In the worst load case as well as in stand-by mode of the WT, a coincidence factor of 0.2 is estimated. In addition, measurements and simulations show that the average power factor  $\cos(\phi)$  at the supply points of the auxiliary low voltage system does not permanently fall below approx. 0.97 in any WT operating point/load case.

Long-term measurements show that the average base load (average active power) of the auxiliary low-voltage system during WT feed-in operation mode is approx. 15 kW, based on one year.

Wind turbines at sites with an average annual wind speed of 6.5 m/s have an internal consumption of approx. 10,000 kWh. This value, however, depends greatly on the site. The internal consumption is defined as the energy that the WT consumes from the grid in the time period during which the WT does not feed current into the grid.

## 4. Technical data

Design	
Design temperature	Standard -20 °C to +45 °C CCV -40 °C to +45 °C
Operating temperature range	-20 °C to +40 °C <sup>1)</sup>
Operating temperature range CCV	-30 °C to +40 °C <sup>1)</sup>
Stop	Standard: -20 °C, restart at -18 °C CCV: -30 °C, restart at -28 °C
Max. height above MSL	2000 m <sup>2)</sup>
Certificate	In accordance with IEC 61400-1 and DIBt 2012
Type	3-blade rotor with horizontal axis Up-wind turbine
Output control	Active single blade adjustment
Nominal power	4500 kW <sup>1)2)3)</sup>
Nominal power starting at wind speeds of (at air density of 1.225 kg/m <sup>3</sup> )	Approx. 11.5 m/s
Operating speed range of the rotor	6.43 min <sup>-1</sup> to 12.25 min <sup>-1</sup>
Nominal speed	11.02 min <sup>-1</sup>
Cut-in wind speed	3 m/s
Cut-out wind speed	20 m/s <sup>4)</sup>
Cut-back-in wind speed	19.5 m/s <sup>4)</sup>
Calculated service life	At least 20 years

- 1) Nominal power is reached up to defined temperature ranges. Limited project-specific operating ranges are possible and must be agreed to with Nordex.
- 2) At installation altitudes above 1000 m, the nominal power is reached up to defined temperatures.
- 3) Nominal power can be adjusted depending on power factor and temperature, see diagram below. Project-specific operating ranges are possible and must be coordinated with Nordex.
- 4) Temperature-dependent adjustments are possible



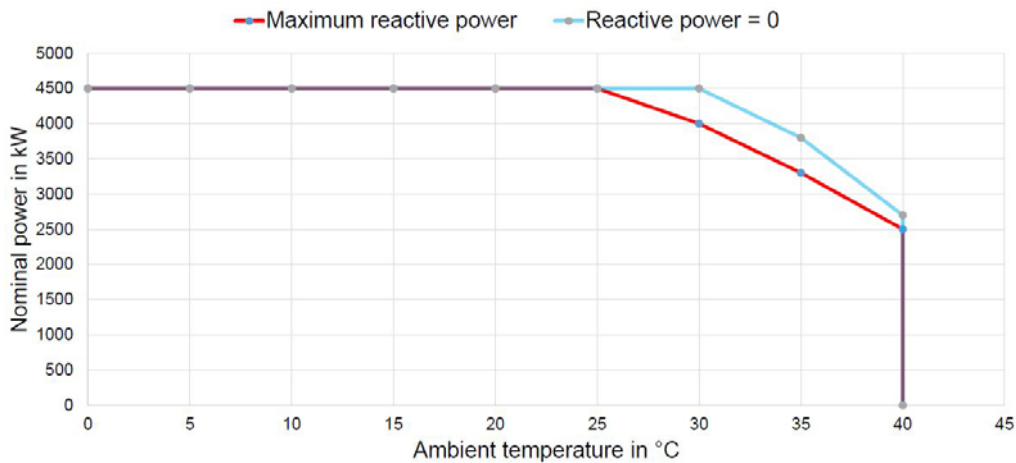

Fig.4 Power adjustment depending on reactive power and temperature (up to a height of  $\leq 1000$  m above MSL)

Towers	TS105	TS125	TCS164
Hub height	105 m	125 m	164 m
Wind class	DIBt S/ IEC S	DIBt S/ IEC S	DIBt S/ IEC S
Number of tower sections	4	6	2 steel sections 1 concrete part

Rotor	
Rotor diameter	149.1 m
Swept area	17460 m <sup>2</sup>
Nominal power/area	257.7 W/m <sup>2</sup>
Rotor shaft inclination angle	5°
Blade cone angle	3.5°

Rotor blade	
Material	Glass-fiber and carbon-fiber reinforced plastic
Total length	72.40 m

Rotor shaft/rotor bearing	
Type	Forged hollow shaft
Material	42CrMo4 or 34CrNiMo6
Bearing type	Spherical roller bearing
Lubrication	Regularly with grease

<b>Mechanical brake</b>	
Type	Actively actuated disk brake
Location	On the high-speed shaft
Number of brake calipers	1
Brake pad material	Organic pad material

<b>Gearbox</b>	
Type	Multi-stage planetary gear + spur gear stage
Gear ratio	50 Hz: $i = 113.5$ 60 Hz: $i = 136.2$
Lubrication	Forced-feed lubrication
Oil quantity including cooling circuit	Max. 650 l
Oil type	VG 320
Max. oil temperature	Approx. 77 °C
Oil change	Change, if required

<b>Electrical system</b>	
Nominal power $P_{nG}$	4500 kW*
Nominal voltage	3 x AC 660 V $\pm$ 10 % (specific to grid code)
Nominal current at full reactive current feed-in $I_{nG}$ at $S_{nG}$	4503 A
Nominal apparent power $S_{nG}$ at $P_{nG}$	5148 kVA
Power factor at $P_{nG}$	1.00 as default setting 0.869 underexcited (inductive) up to 0.885 overexcited (capacitive) possible
Frequency	50 and 60 Hz

**NOTE**

The nominal power is subject to system-specific tolerances and varies by  $\pm$  100 kW. Practice has shown that negative deviations occur rarely and in most cases are <25 kW. For precisely complying with external power specifications the nominal power of the individual wind turbine can be parameterized accordingly. Alternatively, the wind farm can be parameterized accordingly using the Wind Farm Portal®.

<b>Transformer*</b>	
Total weight	Max. 9 t
Insulating material	Cast resin or ester
Rated voltage OV, $U_r$	0.66 kV

<b>Transformer*</b>		
Maximum rated voltage OV, dependent on MV grid, $U_r$	Up to 33 kV	
Taps, overvoltage side	$\pm 2 \times 2.5 \%$	
Rated frequency, $f_r$	50/60 Hz	
Vector group	Dy5	
Power factor, $\cos(\phi)$	0.90 inductive/capacitive	
Installation altitude (above MSL)	Up to 2000 m	
Rated apparent power $S_r$	5000 kVA <sup>1)</sup>	
Impedance voltage, $u_z$	8 to 9 % $\pm 10 \%$ tolerance	
Minimum Peak Efficiency Index, $\eta$	99.483 % / 99.354 % <sup>2)</sup>	
Inrush current	$12 \times I_N$	
Power loss No load losses Short-circuit losses	Dry-type transformer (20 kV) 6700 W 38900 W	Ester transformer (33 kV) 2750 W 60750 W

1) The values apply to a nominal power of 4500 kW; project-specific adjustments are possible

2) Values for liquid-filled or dry-type transformer

All values are maximum values. The values may deviate depending on the rated voltage, rated apparent power and WT active power

<b>MV switchgear</b>	
Rated voltage (dependent on MV grid)	24 or 36 kV
Rated current	630 A
Rated short-circuit duration	1 s
Rated short-circuit current	16 kA, 20 kA, 25 kA (for 36 kV only)
Minimum/maximum ambient temperature during operation	NCV: -25 °C to +40 °C
	CCV: -30 °C to +40 °C
Connector type	Connector cone type C according to EN 50181
<b>Circuit breaker</b>	
Number of switching cycles with rated current	E2
Number of switching cycles with short-circuit breaking current	E2
Number of mechanical switching cycles	M1
Switching of capacitive currents	Min. C1 – low
<b>Disconnecter</b>	

<b>MV switchgear</b>	
Number of switching cycles with rated current	E3
Number of switching cycles with short-circuit breaking current	E3
Number of mechanical switching cycles	M1
<b>Disconnecter</b>	
Number of mechanical switching cycles	M0
<b>Ground switch</b>	
Number of switching cycles with rated short-circuit breaking current	E2
Number of mechanical switching cycles	≥1000

<b>Generator</b>	
Degree of protection	IP 54 (slip ring box IP 23)
Nominal voltage	660 V
Frequency	50 and 60 Hz
Speed range	50 Hz: 730 to 1390 min <sup>-1</sup> 60 Hz: 876 to 1668 min <sup>-1</sup>
Poles	6
Weight	approx. 10.6 t

<b>Gearbox cooling and filtration</b>	
Type	1st cooling circuit: Oil circuit with oil/water heat exchanger and thermal bypass 2nd cooling circuit: Water/air together with generator, main converter and transformer
Filter	Coarse filter 50 µm / fine filter 10 µm / super fine filter: <5 µm
Flow rate	Stage 1: approx. 100 l/min / stage 2: approx. 200 l/min

<b>Generator and converter cooling</b>	
Type	Water circuit with water/air heat exchanger and thermal bypass
Flow rate	Approx. 160 l/min
Coolant	Water/glycol-based coolant

<b>Transformer cooling</b>	
1st cooling circuit	Variant 1: Ester circuit with ester/water heat exchanger Variant 2: Closed air circuit with water/air heat exchanger
2nd cooling circuit	Water/air together with generator, converter and gearbox

<b>Pitch system</b>	
Pitch bearing	Double-row four-point contact bearing
Gearing/raceway lubrication	Regular lubrication with grease
Drive	Electric motor incl. spring-actuated brake and multi-stage planetary gear
Emergency power supply	VRLA batteries

<b>Yaw system</b>	
Yaw bearing	Double-row four-point contact bearing
Gearing/raceway lubrication	Regular lubrication with grease
Drive	Electric motor incl. spring-actuated brake and four-stage planetary gear
Number of drives	6
Yaw speed	Approx. 0.5 °/s





Nordex Energy GmbH  
Langenhorner Chaussee 600  
22419 Hamburg  
Germany  
<http://www.nordex-online.com>  
[info@nordex-online.com](mailto:info@nordex-online.com)







# Noise level, Power curves, Thrust curves

Nordex N149/4.0-4.5  
Variable Power Curve Modes

© Nordex Energy GmbH, Langenhorner Chaussee 600, D-22419 Hamburg, Germany  
All rights reserved. Observe protection notice ISO 16016.

### Nordex N149/4.0-4.5 – Noise level measurement requirements

Basis: The specified sound power levels are expected values in terms of statistics. Results of single measurements will be within the confidence interval according to IEC 61400-14 [4].

Remarks:

Verification according to: Measurements are to be carried out by a measuring institute accredited for noise emission measurements at wind turbines according to ISO/IEC 17025 [3] at the reference position as defined in IEC 61400-11 [1]. The data analysis must be carried out according to the preferred method 1 of IEC 61400-11 [1]. The tonal penalties in the vicinity of wind turbines  $K_{TN}$  based on these measurements are to be determined according to „Technische Richtlinien für Windenergieanlagen“ [2].

Tonality: The noise can be tonal in the vicinity of wind turbines. The specified sound power level includes potential tonal penalties according to „Technische Richtlinien für Windenergieanlagen“ [2], without taking into account any tonality  $K_{TN} \leq 2$  dB.

- [1] IEC 61400-11 ed. 2: Wind Turbine Generator Systems - Part 11: Acoustic Noise Measurement Techniques; 2002-12
- [2] Technische Richtlinie für Windenergieanlagen - Teil 1: Bestimmung der Schallemissionswerte, Revision 18; FGW 2008-02
- [3] ISO/IEC 17025: General requirements for the competence of testing and calibration laboratories; 2017-11
- [4] IEC 61400-14, Wind turbines - Part 14: Declaration of apparent sound power level and tonality values, first edition, 2005-03

Abbreviations

$L_{WA}$ ...	A-weighted sound power level
$v_s$ ...	wind speed converted to reference conditions (hub height 10 m, roughness length 0.05 m) using a logarithmic profile
$v_H$ ...	hub height wind speed
STE ...	Serrated Trailing Edge

**Nordex N149/4.0-4.5 – Noise level, rated power and available hub heights**

operating mode	rated power [kW]	Maximum sound power level over the complete operating range of the wind turbine		available hub heights [m]			
		L <sub>WA</sub> [dB(A)]	L <sub>WA</sub> (STE) [dB(A)]	105	125	145	164
Mode 0.b	4500	108.1	106.1	●	●	●	●
Mode 1.b	4380	107.5	105.5	●	●	●	●
Mode 2.a	4500	107.0	105.0	●	●	●	●
Mode 3.b	4200	106.6	104.6	●	●	●	●
Mode 5.a	4200	105.6	103.6	●	●	●	●
Mode 5.b	4000	105.6	103.6	●	●	●	●

● mode available



## Nordex N149/4.0-4.5 – Noise level – Mode 0.b

Standardized wind speed [m/s]	hub height 105 m			hub height 125 m		
	apparent sound power level [dB(A)]		hub height wind speed [m/s]	apparent sound power level [dB(A)]		hub height wind speed [m/s]
	L <sub>WA</sub> (w/o STE)	L <sub>WA</sub> (with STE)	v <sub>H</sub>	L <sub>WA</sub> (w/o STE)	L <sub>WA</sub> (with STE)	v <sub>H</sub>
v <sub>s</sub>						
3.0	96.0	94.0	4.3	96.0	94.0	4.4
4.0	97.0	95.0	5.8	97.4	95.4	5.9
5.0	102.3	100.3	7.2	102.8	100.8	7.4
6.0	106.3	104.3	8.7	106.8	104.8	8.9
7.0	108.1	106.1	10.1	108.1	106.1	10.3
8.0	108.1	106.1	11.6	108.1	106.1	11.8
9.0	108.1	106.1	13.0	108.1	106.1	13.3
10.0	108.1	106.1	14.4	108.1	106.1	14.8
11.0	108.1	106.1	15.9	108.1	106.1	16.2
12.0	108.1	106.1	17.3	108.1	106.1	17.7

Standardized wind speed [m/s]	hub height 145 m			hub height 164 m		
	apparent sound power level [dB(A)]		hub height wind speed [m/s]	apparent sound power level [dB(A)]		hub height wind speed [m/s]
	L <sub>WA</sub> (w/o STE)	L <sub>WA</sub> (with STE)	v <sub>H</sub>	L <sub>WA</sub> (w/o STE)	L <sub>WA</sub> (with STE)	v <sub>H</sub>
v <sub>s</sub>						
3.0	96.0	94.0	4.5	96.0	94.0	4.6
4.0	97.8	95.8	6.0	98.1	96.1	6.1
5.0	103.2	101.2	7.5	103.5	101.5	7.6
6.0	107.2	105.2	9.0	107.5	105.5	9.2
7.0	108.1	106.1	10.5	108.1	106.1	10.7
8.0	108.1	106.1	12.0	108.1	106.1	12.2
9.0	108.1	106.1	13.5	108.1	106.1	13.8
10.0	108.1	106.1	15.0	108.1	106.1	15.3
11.0	108.1	106.1	16.6	108.1	106.1	16.8
12.0	108.1	106.1	18.1	108.1	106.1	18.3

Nordex N149/4.0-4.5 – Noise level – Mode 1.b

Standardized wind speed [m/s]	hub height 105 m			hub height 125 m		
	apparent sound power level [dB(A)]		hub height wind speed [m/s]	apparent sound power level [dB(A)]		hub height wind speed [m/s]
	$L_{WA}$ (w/o STE)	$L_{WA}$ (with STE)	$v_H$	$L_{WA}$ (w/o STE)	$L_{WA}$ (with STE)	$v_H$
$v_s$						
3.0	96.0	94.0	4.3	96.0	94.0	4.4
4.0	97.0	95.0	5.8	97.4	95.4	5.9
5.0	102.3	100.3	7.2	102.8	100.8	7.4
6.0	106.3	104.3	8.7	106.8	104.8	8.9
7.0	107.5	105.5	10.1	107.5	105.5	10.3
8.0	107.5	105.5	11.6	107.5	105.5	11.8
9.0	107.5	105.5	13.0	107.5	105.5	13.3
10.0	107.5	105.5	14.4	107.5	105.5	14.8
11.0	107.5	105.5	15.9	107.5	105.5	16.2
12.0	107.5	105.5	17.3	107.5	105.5	17.7

Standardized wind speed [m/s]	hub height 145 m			hub height 164 m		
	apparent sound power level [dB(A)]		hub height wind speed [m/s]	apparent sound power level [dB(A)]		hub height wind speed [m/s]
	$L_{WA}$ (w/o STE)	$L_{WA}$ (with STE)	$v_H$	$L_{WA}$ (w/o STE)	$L_{WA}$ (with STE)	$v_H$
$v_s$						
3.0	96.0	94.0	4.5	96.0	94.0	4.6
4.0	97.8	95.8	6.0	98.1	96.1	6.1
5.0	103.2	101.2	7.5	103.5	101.5	7.6
6.0	107.2	105.2	9.0	107.3	105.3	9.2
7.0	107.5	105.5	10.5	107.5	105.5	10.7
8.0	107.5	105.5	12.0	107.5	105.5	12.2
9.0	107.5	105.5	13.5	107.5	105.5	13.8
10.0	107.5	105.5	15.0	107.5	105.5	15.3
11.0	107.5	105.5	16.6	107.5	105.5	16.8
12.0	107.5	105.5	18.1	107.5	105.5	18.3

## Nordex N149/4.0-4.5 – Noise level – Mode 2.a

Standardized wind speed [m/s]	hub height 105 m			hub height 125 m		
	apparent sound power level [dB(A)]		hub height wind speed [m/s]	apparent sound power level [dB(A)]		hub height wind speed [m/s]
	L <sub>WA</sub> (w/o STE)	L <sub>WA</sub> (with STE)	v <sub>H</sub>	L <sub>WA</sub> (w/o STE)	L <sub>WA</sub> (with STE)	v <sub>H</sub>
v <sub>s</sub>						
3.0	96.0	94.0	4.3	96.0	94.0	4.4
4.0	97.0	95.0	5.8	97.4	95.4	5.9
5.0	102.3	100.3	7.2	102.8	100.8	7.4
6.0	106.3	104.3	8.7	106.7	104.7	8.9
7.0	107.0	105.0	10.1	107.0	105.0	10.3
8.0	107.0	105.0	11.6	107.0	105.0	11.8
9.0	107.0	105.0	13.0	107.0	105.0	13.3
10.0	107.0	105.0	14.4	107.0	105.0	14.8
11.0	107.0	105.0	15.9	107.0	105.0	16.2
12.0	107.0	105.0	17.3	107.0	105.0	17.7

Standardized wind speed [m/s]	hub height 145 m			hub height 164 m		
	apparent sound power level [dB(A)]		hub height wind speed [m/s]	apparent sound power level [dB(A)]		hub height wind speed [m/s]
	L <sub>WA</sub> (w/o STE)	L <sub>WA</sub> (with STE)	v <sub>H</sub>	L <sub>WA</sub> (w/o STE)	L <sub>WA</sub> (with STE)	v <sub>H</sub>
v <sub>s</sub>						
3.0	96.0	94.0	4.5	96.0	94.0	4.6
4.0	97.8	95.8	6.0	98.1	96.1	6.1
5.0	103.2	101.2	7.5	103.5	101.5	7.6
6.0	107.0	105.0	9.0	107.0	105.0	9.2
7.0	107.0	105.0	10.5	107.0	105.0	10.7
8.0	107.0	105.0	12.0	107.0	105.0	12.2
9.0	107.0	105.0	13.5	107.0	105.0	13.8
10.0	107.0	105.0	15.0	107.0	105.0	15.3
11.0	107.0	105.0	16.6	107.0	105.0	16.8
12.0	107.0	105.0	18.1	107.0	105.0	18.3

## Nordex N149/4.0-4.5 – Noise level – Mode 3.b

Standardized wind speed [m/s]	hub height 105 m			hub height 125 m		
	apparent sound power level [dB(A)]		hub height wind speed [m/s]	apparent sound power level [dB(A)]		hub height wind speed [m/s]
	$L_{WA}$ (w/o STE)	$L_{WA}$ (with STE)	$v_H$	$L_{WA}$ (w/o STE)	$L_{WA}$ (with STE)	$v_H$
$v_s$						
3.0	96.0	94.0	4.3	96.0	94.0	4.4
4.0	97.0	95.0	5.8	97.4	95.4	5.9
5.0	102.3	100.3	7.2	102.8	100.8	7.4
6.0	106.3	104.3	8.7	106.6	104.6	8.9
7.0	106.6	104.6	10.1	106.6	104.6	10.3
8.0	106.6	104.6	11.6	106.6	104.6	11.8
9.0	106.6	104.6	13.0	106.6	104.6	13.3
10.0	106.6	104.6	14.4	106.6	104.6	14.8
11.0	106.6	104.6	15.9	106.6	104.6	16.2
12.0	106.6	104.6	17.3	106.6	104.6	17.7

Standardized wind speed [m/s]	hub height 145 m			hub height 164 m		
	apparent sound power level [dB(A)]		hub height wind speed [m/s]	apparent sound power level [dB(A)]		hub height wind speed [m/s]
	$L_{WA}$ (w/o STE)	$L_{WA}$ (with STE)	$v_H$	$L_{WA}$ (w/o STE)	$L_{WA}$ (with STE)	$v_H$
$v_s$						
3.0	96.0	94.0	4.5	96.0	94.0	4.6
4.0	97.8	95.8	6.0	98.1	96.1	6.1
5.0	103.2	101.2	7.5	103.5	101.5	7.6
6.0	106.6	104.6	9.0	106.6	104.6	9.2
7.0	106.6	104.6	10.5	106.6	104.6	10.7
8.0	106.6	104.6	12.0	106.6	104.6	12.2
9.0	106.6	104.6	13.5	106.6	104.6	13.8
10.0	106.6	104.6	15.0	106.6	104.6	15.3
11.0	106.6	104.6	16.6	106.6	104.6	16.8
12.0	106.6	104.6	18.1	106.6	104.6	18.3

## Nordex N149/4.0-4.5 – Noise level – Mode 5.a

Standardized wind speed [m/s]	hub height 105 m			hub height 125 m		
	apparent sound power level [dB(A)]		hub height wind speed [m/s]	apparent sound power level [dB(A)]		hub height wind speed [m/s]
	$L_{WA}$ (w/o STE)	$L_{WA}$ (with STE)	$v_H$	$L_{WA}$ (w/o STE)	$L_{WA}$ (with STE)	$v_H$
$v_s$						
3.0	96.0	94.0	4.3	96.0	94.0	4.4
4.0	97.0	95.0	5.8	97.4	95.4	5.9
5.0	102.3	100.3	7.2	102.8	100.8	7.4
6.0	105.6	103.6	8.7	105.6	103.6	8.9
7.0	105.6	103.6	10.1	105.6	103.6	10.3
8.0	105.6	103.6	11.6	105.6	103.6	11.8
9.0	105.6	103.6	13.0	105.6	103.6	13.3
10.0	105.6	103.6	14.4	105.6	103.6	14.8
11.0	105.6	103.6	15.9	105.6	103.6	16.2
12.0	105.6	103.6	17.3	105.6	103.6	17.7

Standardized wind speed [m/s]	hub height 145 m			hub height 164 m		
	apparent sound power level [dB(A)]		hub height wind speed [m/s]	apparent sound power level [dB(A)]		hub height wind speed [m/s]
	$L_{WA}$ (w/o STE)	$L_{WA}$ (with STE)	$v_H$	$L_{WA}$ (w/o STE)	$L_{WA}$ (with STE)	$v_H$
$v_s$						
3.0	96.0	94.0	4.5	96.0	94.0	4.6
4.0	97.8	95.8	6.0	98.1	96.1	6.1
5.0	103.2	101.2	7.5	103.5	101.5	7.6
6.0	105.6	103.6	9.0	105.6	103.6	9.2
7.0	105.6	103.6	10.5	105.6	103.6	10.7
8.0	105.6	103.6	12.0	105.6	103.6	12.2
9.0	105.6	103.6	13.5	105.6	103.6	13.8
10.0	105.6	103.6	15.0	105.6	103.6	15.3
11.0	105.6	103.6	16.6	105.6	103.6	16.8
12.0	105.6	103.6	18.1	105.6	103.6	18.3

## Nordex N149/4.0-4.5 – Noise level – Mode 5.b

Standardized wind speed [m/s]	hub height 105 m			hub height 125 m		
	apparent sound power level [dB(A)]		hub height wind speed [m/s]	apparent sound power level [dB(A)]		hub height wind speed [m/s]
	$L_{WA}$ (w/o STE)	$L_{WA}$ (with STE)	$v_H$	$L_{WA}$ (w/o STE)	$L_{WA}$ (with STE)	$v_H$
$v_s$						
3.0	96.0	94.0	4.3	96.0	94.0	4.4
4.0	97.0	95.0	5.8	97.4	95.4	5.9
5.0	102.3	100.3	7.2	102.8	100.8	7.4
6.0	105.6	103.6	8.7	105.6	103.6	8.9
7.0	105.6	103.6	10.1	105.6	103.6	10.3
8.0	105.6	103.6	11.6	105.6	103.6	11.8
9.0	105.6	103.6	13.0	105.6	103.6	13.3
10.0	105.6	103.6	14.4	105.6	103.6	14.8
11.0	105.6	103.6	15.9	105.6	103.6	16.2
12.0	105.6	103.6	17.3	105.6	103.6	17.7

Standardized wind speed [m/s]	hub height 145 m			hub height 164 m		
	apparent sound power level [dB(A)]		hub height wind speed [m/s]	apparent sound power level [dB(A)]		hub height wind speed [m/s]
	$L_{WA}$ (w/o STE)	$L_{WA}$ (with STE)	$v_H$	$L_{WA}$ (w/o STE)	$L_{WA}$ (with STE)	$v_H$
$v_s$						
3.0	96.0	94.0	4.5	96.0	94.0	4.6
4.0	97.8	95.8	6.0	98.1	96.1	6.1
5.0	103.2	101.2	7.5	103.5	101.5	7.6
6.0	105.6	103.6	9.0	105.6	103.6	9.2
7.0	105.6	103.6	10.5	105.6	103.6	10.7
8.0	105.6	103.6	12.0	105.6	103.6	12.2
9.0	105.6	103.6	13.5	105.6	103.6	13.8
10.0	105.6	103.6	15.0	105.6	103.6	15.3
11.0	105.6	103.6	16.6	105.6	103.6	16.8
12.0	105.6	103.6	18.1	105.6	103.6	18.3



### Nordex N149/4.0-4.5 – Verification conditions power curve

Basis: These power curve values according to IEC 61400-12-1 are based on aerodynamic calculations by Nordex Energy GmbH.

Determinations for the power curve verification:

Verification according to:	IEC 61400-12-1
Type of anemometer:	Thies First Class (Advanced) or Vector A100
Type of LiDAR:	Windcube V2 or Zephir 300
Measurement of power:	low voltage side, 660 VAC
Air density:	normalization to the nearest air density shown in the table
Filter of turbulence intensity:	$9\% \leq TI \leq 20\%$
Filter of wind shear:	$0 \leq \alpha \leq 0.3$ Wind shear measurement and determination according to the requirements of MEASNET power performance measurement procedure, Version 5, December - 2009, chapter 3.3 and 3.8
Filter of inflow angle:	$-2^\circ \leq \psi \leq +2^\circ$
Filter of temperature:	$\theta \leq 25^\circ\text{C}$
Ice / snow on the blades:	No (determined with ice detectors)
Filter of grid voltage U (for mode 2.a and 5.a only):	$U > 92\% U_N$ (of nominal voltage $U_N$ )
Filter of grid reactive power:	Power factor = 1.0
Status signal:	Ready for unlimited operation in the corresponding operational mode without consideration of the cut-out hysteresis

Abbreviations

TI ...	turbulence intensity
$\alpha$ ...	Hellmann exponent
$\psi$ ...	vertical inflow angle
$v_H$ ...	hub height wind speed

**Nordex N149/4.0-4.5 – Power curves – Mode 0.b**

for hub heights 105 m, 125 m, 145 m and 164 m									
wind speed $v_H$ [m/s]	Power $P_{el}$ [kW] at air density $\rho$ [kg/m <sup>3</sup> ]								
	0.900	0.925	0.950	0.975	1.000	1.025	1.050	1.075	1.100
3.0	9	11	13	14	16	18	19	21	23
3.5	77	80	84	87	91	94	98	101	105
4.0	169	175	181	187	193	199	205	211	217
4.5	282	291	300	309	318	327	336	346	355
5.0	417	430	443	455	468	481	494	507	520
5.5	576	593	611	628	645	662	680	697	714
6.0	763	786	808	831	853	875	898	920	942
6.5	982	1010	1039	1067	1095	1124	1152	1180	1208
7.0	1235	1271	1306	1341	1376	1411	1446	1481	1516
7.5	1526	1569	1612	1655	1698	1741	1784	1827	1870
8.0	1856	1908	1960	2012	2064	2115	2167	2219	2270
8.5	2228	2290	2351	2413	2475	2536	2597	2659	2720
9.0	2633	2705	2778	2850	2923	2995	3066	3137	3207
9.5	3051	3135	3218	3299	3379	3458	3530	3590	3649
10.0	3462	3551	3635	3702	3769	3836	3894	3942	3990
10.5	3816	3890	3960	4014	4068	4121	4167	4203	4238
11.0	4083	4142	4199	4239	4279	4319	4352	4376	4399
11.5	4273	4318	4360	4387	4414	4441	4460	4470	4479
12.0	4398	4429	4456	4468	4481	4493	4500	4500	4500
12.5	4470	4485	4498	4499	4500	4500	4500	4500	4500
13.0	4498	4499	4500	4500	4500	4500	4500	4500	4500
13.5	4500	4500	4500	4500	4500	4500	4500	4500	4500
14.0	4500	4500	4500	4500	4500	4500	4500	4500	4500
14.5	4500	4500	4500	4500	4500	4500	4500	4500	4500
15.0	4500	4500	4500	4500	4500	4500	4500	4500	4500
15.5	4500	4500	4500	4500	4500	4500	4500	4500	4500
16.0	4500	4500	4500	4500	4500	4500	4500	4500	4500
16.5	4500	4500	4500	4500	4500	4500	4500	4500	4500
17.0	4500	4500	4500	4500	4500	4500	4500	4500	4500
17.5	4500	4500	4500	4500	4500	4500	4500	4500	4500
18.0	4500	4500	4500	4500	4500	4500	4500	4500	4500
18.5	4500	4500	4500	4500	4500	4500	4500	4500	4500
19.0	4500	4500	4500	4500	4500	4500	4500	4500	4500
19.5	4500	4500	4500	4500	4500	4500	4500	4500	4500
20.0	4500	4500	4500	4500	4500	4500	4500	4500	4500
20.5*	4455	4455	4455	4455	4455	4455	4455	4455	4455
21.0*	4307	4307	4307	4307	4307	4307	4307	4307	4307
21.5*	4131	4131	4131	4131	4131	4131	4131	4131	4131
22.0*	3951	3951	3951	3951	3951	3951	3951	3951	3951
22.5*	3776	3776	3776	3776	3776	3776	3776	3776	3776
23.0*	3600	3600	3600	3600	3600	3600	3600	3600	3600
23.5*	3420	3420	3420	3420	3420	3420	3420	3420	3420
24.0*	3245	3245	3245	3245	3245	3245	3245	3245	3245
24.5*	3065	3065	3065	3065	3065	3065	3065	3065	3065
25.0*	2885	2885	2885	2885	2885	2885	2885	2885	2885
25.5*	2705	2705	2705	2705	2705	2705	2705	2705	2705
26.0*	2529	2529	2529	2529	2529	2529	2529	2529	2529

\* These values are based on a yield and load optimized operation that is not feasible at all sites.

### Nordex N149/4.0-4.5 – Power curves – Mode 0.b

for hub heights 105 m, 125 m, 145 m and 164 m								
wind speed $v_H$ [m/s]	Power $P_{el}$ [kW] at air density $\rho$ [kg/m <sup>3</sup> ]							
	1.125	1.150	1.175	1.200	1.225	1.250	1.275	1.300
3.0	24	26	28	29	31	32	34	36
3.5	108	112	115	119	122	126	129	133
4.0	223	229	235	241	247	253	259	265
4.5	364	373	382	391	400	409	419	428
5.0	533	545	558	571	584	597	610	622
5.5	731	748	766	783	800	817	834	852
6.0	964	987	1009	1031	1054	1076	1098	1120
6.5	1236	1265	1293	1321	1349	1377	1405	1433
7.0	1551	1586	1621	1656	1691	1726	1761	1796
7.5	1912	1955	1998	2040	2083	2125	2168	2210
8.0	2322	2373	2424	2476	2527	2578	2629	2680
8.5	2781	2842	2901	2959	3016	3072	3127	3180
9.0	3275	3339	3401	3458	3506	3553	3600	3644
9.5	3706	3759	3810	3857	3894	3930	3966	3999
10.0	4035	4077	4116	4151	4177	4203	4227	4250
10.5	4271	4301	4328	4351	4367	4381	4394	4407
11.0	4419	4437	4453	4465	4470	4474	4478	4481
11.5	4487	4493	4498	4500	4500	4500	4500	4500
12.0	4500	4500	4500	4500	4500	4500	4500	4500
12.5	4500	4500	4500	4500	4500	4500	4500	4500
13.0	4500	4500	4500	4500	4500	4500	4500	4500
13.5	4500	4500	4500	4500	4500	4500	4500	4500
14.0	4500	4500	4500	4500	4500	4500	4500	4500
14.5	4500	4500	4500	4500	4500	4500	4500	4500
15.0	4500	4500	4500	4500	4500	4500	4500	4500
15.5	4500	4500	4500	4500	4500	4500	4500	4500
16.0	4500	4500	4500	4500	4500	4500	4500	4500
16.5	4500	4500	4500	4500	4500	4500	4500	4500
17.0	4500	4500	4500	4500	4500	4500	4500	4500
17.5	4500	4500	4500	4500	4500	4500	4500	4500
18.0	4500	4500	4500	4500	4500	4500	4500	4500
18.5	4500	4500	4500	4500	4500	4500	4500	4500
19.0	4500	4500	4500	4500	4500	4500	4500	4500
19.5	4500	4500	4500	4500	4500	4500	4500	4500
20.0	4500	4500	4500	4500	4500	4500	4500	4500
20.5*	4455	4455	4455	4455	4455	4455	4455	4455
21.0*	4307	4307	4307	4307	4307	4307	4307	4307
21.5*	4131	4131	4131	4131	4131	4131	4131	4131
22.0*	3951	3951	3951	3951	3951	3951	3951	3951
22.5*	3776	3776	3776	3776	3776	3776	3776	3776
23.0*	3600	3600	3600	3600	3600	3600	3600	3600
23.5*	3420	3420	3420	3420	3420	3420	3420	3420
24.0*	3245	3245	3245	3245	3245	3245	3245	3245
24.5*	3065	3065	3065	3065	3065	3065	3065	3065
25.0*	2885	2885	2885	2885	2885	2885	2885	2885
25.5*	2705	2705	2705	2705	2705	2705	2705	2705
26.0*	2529	2529	2529	2529	2529	2529	2529	2529

\* These values are based on a yield and load optimized operation that is not feasible at all sites.

### Nordex N149/4.0-4.5 – Power curves – Mode 1.b

for hub heights 105 m, 125 m, 145 m and 164 m									
wind speed $v_H$ [m/s]	Power $P_{el}$ [kW] at air density $\rho$ [kg/m <sup>3</sup> ]								
	0.900	0.925	0.950	0.975	1.000	1.025	1.050	1.075	1.100
3.0	9	11	13	14	16	18	19	21	23
3.5	77	80	84	87	91	94	98	101	105
4.0	169	175	181	187	193	199	205	211	217
4.5	282	291	300	309	318	327	336	346	355
5.0	417	430	443	455	468	481	494	507	520
5.5	576	593	611	628	645	662	680	697	714
6.0	763	786	808	831	853	875	898	920	942
6.5	982	1010	1039	1067	1095	1124	1152	1180	1208
7.0	1235	1271	1306	1341	1376	1411	1446	1481	1516
7.5	1526	1569	1612	1655	1698	1741	1784	1827	1870
8.0	1856	1908	1960	2012	2064	2115	2167	2219	2270
8.5	2226	2288	2349	2411	2473	2534	2595	2657	2718
9.0	2619	2691	2762	2834	2906	2978	3051	3125	3199
9.5	3018	3101	3184	3268	3351	3434	3508	3572	3634
10.0	3410	3502	3594	3665	3735	3806	3866	3916	3965
10.5	3758	3835	3912	3968	4023	4079	4124	4159	4193
11.0	4015	4076	4137	4175	4214	4253	4283	4302	4322
11.5	4193	4236	4279	4301	4324	4346	4361	4366	4371
12.0	4304	4328	4354	4361	4369	4377	4380	4380	4380
12.5	4360	4369	4379	4380	4380	4380	4380	4380	4380
13.0	4378	4379	4380	4380	4380	4380	4380	4380	4380
13.5	4380	4380	4380	4380	4380	4380	4380	4380	4380
14.0	4380	4380	4380	4380	4380	4380	4380	4380	4380
14.5	4380	4380	4380	4380	4380	4380	4380	4380	4380
15.0	4380	4380	4380	4380	4380	4380	4380	4380	4380
15.5	4380	4380	4380	4380	4380	4380	4380	4380	4380
16.0	4380	4380	4380	4380	4380	4380	4380	4380	4380
16.5	4380	4380	4380	4380	4380	4380	4380	4380	4380
17.0	4380	4380	4380	4380	4380	4380	4380	4380	4380
17.5	4380	4380	4380	4380	4380	4380	4380	4380	4380
18.0	4380	4380	4380	4380	4380	4380	4380	4380	4380
18.5	4380	4380	4380	4380	4380	4380	4380	4380	4380
19.0	4380	4380	4380	4380	4380	4380	4380	4380	4380
19.5	4380	4380	4380	4380	4380	4380	4380	4380	4380
20.0	4380	4380	4380	4380	4380	4380	4380	4380	4380
20.5*	4364	4364	4364	4364	4364	4364	4364	4364	4364
21.0*	4281	4281	4281	4281	4281	4281	4281	4281	4281
21.5*	4131	4131	4131	4131	4131	4131	4131	4131	4131
22.0*	3951	3951	3951	3951	3951	3951	3951	3951	3951
22.5*	3776	3776	3776	3776	3776	3776	3776	3776	3776
23.0*	3600	3600	3600	3600	3600	3600	3600	3600	3600
23.5*	3420	3420	3420	3420	3420	3420	3420	3420	3420
24.0*	3245	3245	3245	3245	3245	3245	3245	3245	3245
24.5*	3065	3065	3065	3065	3065	3065	3065	3065	3065
25.0*	2885	2885	2885	2885	2885	2885	2885	2885	2885
25.5*	2705	2705	2705	2705	2705	2705	2705	2705	2705
26.0*	2529	2529	2529	2529	2529	2529	2529	2529	2529

\* These values are based on a yield and load optimized operation that is not feasible at all sites.

### Nordex N149/4.0-4.5 – Power curves – Mode 1.b

for hub heights 105 m, 125 m, 145 m and 164 m								
wind speed $v_H$ [m/s]	Power $P_{el}$ [kW] at air density $\rho$ [kg/m <sup>3</sup> ]							
	1.125	1.150	1.175	1.200	1.225	1.250	1.275	1.300
3.0	24	26	28	29	31	32	34	36
3.5	108	112	115	119	122	126	129	133
4.0	223	229	235	241	247	253	259	265
4.5	364	373	382	391	400	409	419	428
5.0	533	545	558	571	584	597	610	622
5.5	731	748	766	783	800	817	834	852
6.0	964	987	1009	1031	1054	1076	1098	1120
6.5	1236	1265	1293	1321	1349	1377	1405	1433
7.0	1551	1586	1621	1656	1691	1726	1761	1796
7.5	1912	1955	1998	2040	2083	2126	2168	2211
8.0	2322	2373	2424	2476	2527	2578	2629	2678
8.5	2779	2840	2900	2959	3017	3076	3132	3186
9.0	3272	3346	3401	3453	3503	3552	3599	3644
9.5	3697	3761	3803	3842	3880	3918	3952	3985
10.0	4014	4063	4094	4120	4146	4170	4192	4213
10.5	4227	4262	4279	4293	4305	4316	4327	4337
11.0	4341	4361	4366	4368	4370	4372	4374	4376
11.5	4376	4380	4380	4380	4380	4380	4380	4380
12.0	4380	4380	4380	4380	4380	4380	4380	4380
12.5	4380	4380	4380	4380	4380	4380	4380	4380
13.0	4380	4380	4380	4380	4380	4380	4380	4380
13.5	4380	4380	4380	4380	4380	4380	4380	4380
14.0	4380	4380	4380	4380	4380	4380	4380	4380
14.5	4380	4380	4380	4380	4380	4380	4380	4380
15.0	4380	4380	4380	4380	4380	4380	4380	4380
15.5	4380	4380	4380	4380	4380	4380	4380	4380
16.0	4380	4380	4380	4380	4380	4380	4380	4380
16.5	4380	4380	4380	4380	4380	4380	4380	4380
17.0	4380	4380	4380	4380	4380	4380	4380	4380
17.5	4380	4380	4380	4380	4380	4380	4380	4380
18.0	4380	4380	4380	4380	4380	4380	4380	4380
18.5	4380	4380	4380	4380	4380	4380	4380	4380
19.0	4380	4380	4380	4380	4380	4380	4380	4380
19.5	4380	4380	4380	4380	4380	4380	4380	4380
20.0	4380	4380	4380	4380	4380	4380	4380	4380
20.5*	4364	4364	4364	4364	4364	4364	4364	4364
21.0*	4281	4281	4281	4281	4281	4281	4281	4281
21.5*	4131	4131	4131	4131	4131	4131	4131	4131
22.0*	3951	3951	3951	3951	3951	3951	3951	3951
22.5*	3776	3776	3776	3776	3776	3776	3776	3776
23.0*	3600	3600	3600	3600	3600	3600	3600	3600
23.5*	3420	3420	3420	3420	3420	3420	3420	3420
24.0*	3245	3245	3245	3245	3245	3245	3245	3245
24.5*	3065	3065	3065	3065	3065	3065	3065	3065
25.0*	2885	2885	2885	2885	2885	2885	2885	2885
25.5*	2705	2705	2705	2705	2705	2705	2705	2705
26.0*	2529	2529	2529	2529	2529	2529	2529	2529

\* These values are based on a yield and load optimized operation that is not feasible at all sites.

**Nordex N149/4.0-4.5 – Power curves – Mode 2.a**

for hub heights 105 m, 125 m, 145 m and 164 m									
wind speed $v_H$ [m/s]	Power $P_{el}$ [kW] at air density $\rho$ [kg/m <sup>3</sup> ]								
	0.900	0.925	0.950	0.975	1.000	1.025	1.050	1.075	1.100
3.0	9	11	13	14	16	18	19	21	23
3.5	77	80	84	87	91	94	98	101	105
4.0	169	175	181	187	193	199	205	211	217
4.5	282	291	300	309	318	327	336	346	355
5.0	417	430	443	455	468	481	494	507	520
5.5	576	593	611	628	645	662	680	697	714
6.0	763	786	808	831	853	875	898	920	942
6.5	982	1010	1039	1067	1095	1123	1152	1180	1208
7.0	1235	1271	1306	1341	1376	1411	1446	1481	1516
7.5	1526	1569	1612	1655	1698	1741	1784	1827	1869
8.0	1857	1908	1960	2012	2064	2116	2167	2219	2270
8.5	2221	2282	2344	2405	2467	2528	2589	2650	2707
9.0	2599	2671	2742	2813	2885	2956	3027	3094	3151
9.5	2975	3056	3138	3220	3301	3380	3458	3526	3579
10.0	3341	3432	3520	3606	3691	3762	3827	3882	3923
10.5	3681	3773	3851	3922	3993	4050	4102	4145	4174
11.0	3957	4033	4097	4154	4211	4254	4293	4322	4341
11.5	4163	4224	4273	4316	4358	4389	4414	4432	4443
12.0	4311	4358	4393	4422	4450	4467	4479	4486	4491
12.5	4412	4444	4465	4479	4494	4499	4500	4500	4500
13.0	4472	4489	4497	4499	4500	4500	4500	4500	4500
13.5	4497	4500	4500	4500	4500	4500	4500	4500	4500
14.0	4500	4500	4500	4500	4500	4500	4500	4500	4500
14.5	4500	4500	4500	4500	4500	4500	4500	4500	4500
15.0	4500	4500	4500	4500	4500	4500	4500	4500	4500
15.5	4500	4500	4500	4500	4500	4500	4500	4500	4500
16.0	4500	4500	4500	4500	4500	4500	4500	4500	4500
16.5	4500	4500	4500	4500	4500	4500	4500	4500	4500
17.0	4500	4500	4500	4500	4500	4500	4500	4500	4500
17.5	4500	4500	4500	4500	4500	4500	4500	4500	4500
18.0	4500	4500	4500	4500	4500	4500	4500	4500	4500
18.5	4500	4500	4500	4500	4500	4500	4500	4500	4500
19.0	4500	4500	4500	4500	4500	4500	4500	4500	4500
19.5	4500	4500	4500	4500	4500	4500	4500	4500	4500
20.0	4500	4500	4500	4500	4500	4500	4500	4500	4500
20.5*	4455	4455	4455	4455	4455	4455	4455	4455	4455
21.0*	4307	4307	4307	4307	4307	4307	4307	4307	4307
21.5*	4131	4131	4131	4131	4131	4131	4131	4131	4131
22.0*	3951	3951	3951	3951	3951	3951	3951	3951	3951
22.5*	3776	3776	3776	3776	3776	3776	3776	3776	3776
23.0*	3600	3600	3600	3600	3600	3600	3600	3600	3600
23.5*	3420	3420	3420	3420	3420	3420	3420	3420	3420
24.0*	3245	3245	3245	3245	3245	3245	3245	3245	3245
24.5*	3065	3065	3065	3065	3065	3065	3065	3065	3065
25.0*	2885	2885	2885	2885	2885	2885	2885	2885	2885
25.5*	2705	2705	2705	2705	2705	2705	2705	2705	2705
26.0*	2529	2529	2529	2529	2529	2529	2529	2529	2529

\* These values are based on a yield and load optimized operation that is not feasible at all sites.

Nordex N149/4.0-4.5 – Power curves – Mode 2.a

for hub heights 105 m, 125 m, 145 m and 164 m								
wind speed $v_H$ [m/s]	Power $P_{el}$ [kW] at air density $\rho$ [kg/m <sup>3</sup> ]							
	1.125	1.150	1.175	1.200	1.225	1.250	1.275	1.300
3.0	24	26	28	29	31	32	34	36
3.5	108	112	115	119	122	126	129	133
4.0	223	229	235	241	247	253	259	265
4.5	364	373	382	391	400	409	419	428
5.0	533	545	558	571	584	597	610	622
5.5	731	748	766	783	800	817	834	852
6.0	964	987	1009	1031	1054	1076	1098	1120
6.5	1236	1265	1293	1321	1349	1377	1405	1433
7.0	1551	1586	1621	1656	1691	1726	1761	1796
7.5	1912	1955	1998	2041	2084	2126	2168	2209
8.0	2321	2371	2420	2468	2516	2562	2607	2650
8.5	2761	2814	2864	2912	2959	3004	3047	3088
9.0	3205	3256	3304	3349	3393	3434	3473	3510
9.5	3628	3674	3714	3749	3783	3814	3843	3870
10.0	3961	3996	4024	4049	4071	4092	4112	4130
10.5	4200	4224	4243	4259	4273	4286	4298	4309
11.0	4358	4374	4385	4394	4402	4409	4416	4422
11.5	4453	4462	4468	4471	4474	4477	4479	4482
12.0	4495	4499	4500	4500	4500	4500	4500	4500
12.5	4500	4500	4500	4500	4500	4500	4500	4500
13.0	4500	4500	4500	4500	4500	4500	4500	4500
13.5	4500	4500	4500	4500	4500	4500	4500	4500
14.0	4500	4500	4500	4500	4500	4500	4500	4500
14.5	4500	4500	4500	4500	4500	4500	4500	4500
15.0	4500	4500	4500	4500	4500	4500	4500	4500
15.5	4500	4500	4500	4500	4500	4500	4500	4500
16.0	4500	4500	4500	4500	4500	4500	4500	4500
16.5	4500	4500	4500	4500	4500	4500	4500	4500
17.0	4500	4500	4500	4500	4500	4500	4500	4500
17.5	4500	4500	4500	4500	4500	4500	4500	4500
18.0	4500	4500	4500	4500	4500	4500	4500	4500
18.5	4500	4500	4500	4500	4500	4500	4500	4500
19.0	4500	4500	4500	4500	4500	4500	4500	4500
19.5	4500	4500	4500	4500	4500	4500	4500	4500
20.0	4500	4500	4500	4500	4500	4500	4500	4500
20.5*	4455	4455	4455	4455	4455	4455	4455	4455
21.0*	4307	4307	4307	4307	4307	4307	4307	4307
21.5*	4131	4131	4131	4131	4131	4131	4131	4131
22.0*	3951	3951	3951	3951	3951	3951	3951	3951
22.5*	3776	3776	3776	3776	3776	3776	3776	3776
23.0*	3600	3600	3600	3600	3600	3600	3600	3600
23.5*	3420	3420	3420	3420	3420	3420	3420	3420
24.0*	3245	3245	3245	3245	3245	3245	3245	3245
24.5*	3065	3065	3065	3065	3065	3065	3065	3065
25.0*	2885	2885	2885	2885	2885	2885	2885	2885
25.5*	2705	2705	2705	2705	2705	2705	2705	2705
26.0*	2529	2529	2529	2529	2529	2529	2529	2529

\* These values are based on a yield and load optimized operation that is not feasible at all sites.

### Nordex N149/4.0-4.5 – Power curves – Mode 3.b

for hub heights 105 m, 125 m, 145 m and 164 m									
wind speed $v_H$ [m/s]	Power $P_{el}$ [kW] at air density $\rho$ [kg/m <sup>3</sup> ]								
	0.900	0.925	0.950	0.975	1.000	1.025	1.050	1.075	1.100
3.0	9	11	13	14	16	18	19	21	23
3.5	77	80	84	87	91	94	98	101	105
4.0	169	175	181	187	193	199	205	211	217
4.5	282	291	300	309	318	327	336	346	355
5.0	417	430	443	455	468	481	494	507	520
5.5	576	593	611	628	645	662	680	697	714
6.0	763	786	808	831	853	875	898	920	942
6.5	982	1010	1039	1067	1095	1123	1152	1180	1208
7.0	1235	1271	1306	1341	1376	1411	1446	1481	1516
7.5	1526	1569	1612	1655	1698	1741	1784	1827	1869
8.0	1856	1908	1960	2012	2064	2115	2167	2219	2270
8.5	2215	2280	2340	2402	2462	2522	2583	2644	2705
9.0	2583	2660	2730	2801	2872	2944	3017	3095	3173
9.5	2947	3038	3119	3204	3292	3379	3458	3525	3593
10.0	3307	3409	3504	3585	3660	3734	3799	3851	3901
10.5	3641	3724	3805	3870	3927	3983	4030	4062	4094
11.0	3892	3952	4014	4057	4093	4129	4156	4170	4184
11.5	4061	4100	4138	4162	4177	4193	4200	4200	4200
12.0	4158	4175	4193	4199	4200	4200	4200	4200	4200
12.5	4196	4198	4200	4200	4200	4200	4200	4200	4200
13.0	4200	4200	4200	4200	4200	4200	4200	4200	4200
13.5	4200	4200	4200	4200	4200	4200	4200	4200	4200
14.0	4200	4200	4200	4200	4200	4200	4200	4200	4200
14.5	4200	4200	4200	4200	4200	4200	4200	4200	4200
15.0	4200	4200	4200	4200	4200	4200	4200	4200	4200
15.5	4200	4200	4200	4200	4200	4200	4200	4200	4200
16.0	4200	4200	4200	4200	4200	4200	4200	4200	4200
16.5	4200	4200	4200	4200	4200	4200	4200	4200	4200
17.0	4200	4200	4200	4200	4200	4200	4200	4200	4200
17.5	4200	4200	4200	4200	4200	4200	4200	4200	4200
18.0	4200	4200	4200	4200	4200	4200	4200	4200	4200
18.5	4200	4200	4200	4200	4200	4200	4200	4200	4200
19.0	4200	4200	4200	4200	4200	4200	4200	4200	4200
19.5	4200	4200	4200	4200	4200	4200	4200	4200	4200
20.0	4200	4200	4200	4200	4200	4200	4200	4200	4200
20.5*	4200	4200	4200	4200	4200	4200	4200	4200	4200
21.0*	4185	4185	4185	4185	4185	4185	4185	4185	4185
21.5*	4102	4102	4102	4102	4102	4102	4102	4102	4102
22.0*	3951	3951	3951	3951	3951	3951	3951	3951	3951
22.5*	3776	3776	3776	3776	3776	3776	3776	3776	3776
23.0*	3600	3600	3600	3600	3600	3600	3600	3600	3600
23.5*	3420	3420	3420	3420	3420	3420	3420	3420	3420
24.0*	3245	3245	3245	3245	3245	3245	3245	3245	3245
24.5*	3065	3065	3065	3065	3065	3065	3065	3065	3065
25.0*	2885	2885	2885	2885	2885	2885	2885	2885	2885
25.5*	2705	2705	2705	2705	2705	2705	2705	2705	2705
26.0*	2529	2529	2529	2529	2529	2529	2529	2529	2529

\* These values are based on a yield and load optimized operation that is not feasible at all sites.



### Nordex N149/4.0-4.5 – Power curves – Mode 3.b

for hub heights 105 m, 125 m, 145 m and 164 m								
wind speed $v_H$ [m/s]	Power $P_{el}$ [kW] at air density $\rho$ [kg/m <sup>3</sup> ]							
	1.125	1.150	1.175	1.200	1.225	1.250	1.275	1.300
3.0	24	26	28	29	31	32	34	36
3.5	108	112	115	119	122	126	129	133
4.0	223	229	235	241	247	253	259	265
4.5	364	373	382	391	400	409	419	428
5.0	533	545	558	571	584	597	610	622
5.5	731	748	766	783	800	817	834	852
6.0	964	987	1009	1031	1054	1076	1098	1120
6.5	1236	1265	1293	1321	1349	1377	1405	1433
7.0	1551	1586	1621	1656	1691	1726	1761	1796
7.5	1912	1955	1998	2040	2083	2126	2168	2211
8.0	2322	2373	2424	2475	2526	2577	2628	2678
8.5	2766	2826	2894	2962	3029	3097	3159	3213
9.0	3250	3323	3383	3443	3502	3562	3615	3659
9.5	3659	3720	3765	3811	3856	3901	3940	3969
10.0	3952	3996	4026	4054	4083	4111	4135	4152
10.5	4127	4153	4166	4179	4191	4200	4200	4200
11.0	4198	4200	4200	4200	4200	4200	4200	4200
11.5	4200	4200	4200	4200	4200	4200	4200	4200
12.0	4200	4200	4200	4200	4200	4200	4200	4200
12.5	4200	4200	4200	4200	4200	4200	4200	4200
13.0	4200	4200	4200	4200	4200	4200	4200	4200
13.5	4200	4200	4200	4200	4200	4200	4200	4200
14.0	4200	4200	4200	4200	4200	4200	4200	4200
14.5	4200	4200	4200	4200	4200	4200	4200	4200
15.0	4200	4200	4200	4200	4200	4200	4200	4200
15.5	4200	4200	4200	4200	4200	4200	4200	4200
16.0	4200	4200	4200	4200	4200	4200	4200	4200
16.5	4200	4200	4200	4200	4200	4200	4200	4200
17.0	4200	4200	4200	4200	4200	4200	4200	4200
17.5	4200	4200	4200	4200	4200	4200	4200	4200
18.0	4200	4200	4200	4200	4200	4200	4200	4200
18.5	4200	4200	4200	4200	4200	4200	4200	4200
19.0	4200	4200	4200	4200	4200	4200	4200	4200
19.5	4200	4200	4200	4200	4200	4200	4200	4200
20.0	4200	4200	4200	4200	4200	4200	4200	4200
20.5*	4200	4200	4200	4200	4200	4200	4200	4200
21.0*	4185	4185	4185	4185	4185	4185	4185	4185
21.5*	4102	4102	4102	4102	4102	4102	4102	4102
22.0*	3951	3951	3951	3951	3951	3951	3951	3951
22.5*	3776	3776	3776	3776	3776	3776	3776	3776
23.0*	3600	3600	3600	3600	3600	3600	3600	3600
23.5*	3420	3420	3420	3420	3420	3420	3420	3420
24.0*	3245	3245	3245	3245	3245	3245	3245	3245
24.5*	3065	3065	3065	3065	3065	3065	3065	3065
25.0*	2885	2885	2885	2885	2885	2885	2885	2885
25.5*	2705	2705	2705	2705	2705	2705	2705	2705
26.0*	2529	2529	2529	2529	2529	2529	2529	2529

\* These values are based on a yield and load optimized operation that is not feasible at all sites.

Nordex N149/4.0-4.5 – Power curves – Mode 5.a

for hub heights 105 m, 125 m, 145 m and 164 m									
wind speed $v_H$ [m/s]	Power $P_{el}$ [kW] at air density $\rho$ [kg/m <sup>3</sup> ]								
	0.900	0.925	0.950	0.975	1.000	1.025	1.050	1.075	1.100
3.0	9	11	13	14	16	18	19	21	23
3.5	77	80	84	87	91	94	98	101	105
4.0	169	175	181	187	193	199	205	211	217
4.5	282	291	300	309	318	327	336	346	355
5.0	417	430	443	455	468	481	494	507	520
5.5	576	593	611	628	645	662	680	697	714
6.0	763	786	808	831	853	875	898	920	942
6.5	982	1010	1039	1067	1095	1124	1152	1180	1208
7.0	1235	1271	1306	1341	1376	1411	1446	1481	1516
7.5	1526	1570	1613	1656	1699	1741	1784	1827	1870
8.0	1850	1902	1953	2005	2058	2108	2160	2212	2263
8.5	2186	2247	2308	2368	2435	2489	2554	2613	2673
9.0	2520	2590	2659	2728	2806	2868	2945	3014	3083
9.5	2842	2922	2999	3077	3166	3240	3329	3414	3496
10.0	3146	3237	3325	3416	3514	3598	3672	3743	3815
10.5	3441	3542	3640	3718	3795	3869	3921	3974	4028
11.0	3715	3800	3881	3941	3997	4050	4084	4118	4151
11.5	3926	3988	4051	4088	4125	4157	4172	4187	4200
12.0	4073	4113	4152	4169	4185	4199	4200	4200	4200
12.5	4159	4177	4195	4197	4199	4200	4200	4200	4200
13.0	4193	4197	4200	4200	4200	4200	4200	4200	4200
13.5	4199	4200	4200	4200	4200	4200	4200	4200	4200
14.0	4200	4200	4200	4200	4200	4200	4200	4200	4200
14.5	4200	4200	4200	4200	4200	4200	4200	4200	4200
15.0	4200	4200	4200	4200	4200	4200	4200	4200	4200
15.5	4200	4200	4200	4200	4200	4200	4200	4200	4200
16.0	4200	4200	4200	4200	4200	4200	4200	4200	4200
16.5	4200	4200	4200	4200	4200	4200	4200	4200	4200
17.0	4200	4200	4200	4200	4200	4200	4200	4200	4200
17.5	4200	4200	4200	4200	4200	4200	4200	4200	4200
18.0	4200	4200	4200	4200	4200	4200	4200	4200	4200
18.5	4200	4200	4200	4200	4200	4200	4200	4200	4200
19.0	4200	4200	4200	4200	4200	4200	4200	4200	4200
19.5	4200	4200	4200	4200	4200	4200	4200	4200	4200
20.0	4200	4200	4200	4200	4200	4200	4200	4200	4200
20.5*	4200	4200	4200	4200	4200	4200	4200	4200	4200
21.0*	4185	4185	4185	4185	4185	4185	4185	4185	4185
21.5*	4102	4102	4102	4102	4102	4102	4102	4102	4102
22.0*	3951	3951	3951	3951	3951	3951	3951	3951	3951
22.5*	3776	3776	3776	3776	3776	3776	3776	3776	3776
23.0*	3600	3600	3600	3600	3600	3600	3600	3600	3600
23.5*	3420	3420	3420	3420	3420	3420	3420	3420	3420
24.0*	3245	3245	3245	3245	3245	3245	3245	3245	3245
24.5*	3065	3065	3065	3065	3065	3065	3065	3065	3065
25.0*	2885	2885	2885	2885	2885	2885	2885	2885	2885
25.5*	2705	2705	2705	2705	2705	2705	2705	2705	2705
26.0*	2529	2529	2529	2529	2529	2529	2529	2529	2529

\* These values are based on a yield and load optimized operation that is not feasible at all sites.

### Nordex N149/4.0-4.5 – Power curves – Mode 5.a

for hub heights 105 m, 125 m, 145 m and 164 m								
wind speed $v_H$ [m/s]	Power $P_{el}$ [kW] at air density $\rho$ [kg/m <sup>3</sup> ]							
	1.125	1.150	1.175	1.200	1.225	1.250	1.275	1.300
3.0	24	26	28	29	31	32	34	36
3.5	108	112	115	119	122	126	129	133
4.0	223	229	235	241	247	253	259	265
4.5	364	373	382	391	400	409	419	428
5.0	533	545	558	571	584	597	610	622
5.5	731	748	766	783	800	817	834	852
6.0	964	987	1009	1031	1054	1076	1098	1120
6.5	1236	1265	1293	1321	1349	1377	1405	1434
7.0	1551	1586	1621	1656	1691	1726	1761	1796
7.5	1913	1955	1998	2041	2083	2126	2169	2211
8.0	2314	2365	2416	2467	2518	2569	2617	2665
8.5	2733	2793	2852	2912	2978	3044	3097	3147
9.0	3158	3233	3309	3384	3444	3500	3544	3584
9.5	3563	3628	3694	3758	3803	3845	3875	3902
10.0	3865	3914	3963	4011	4040	4067	4081	4095
10.5	4060	4091	4122	4153	4166	4176	4182	4186
11.0	4166	4180	4193	4200	4200	4200	4200	4200
11.5	4200	4200	4200	4200	4200	4200	4200	4200
12.0	4200	4200	4200	4200	4200	4200	4200	4200
12.5	4200	4200	4200	4200	4200	4200	4200	4200
13.0	4200	4200	4200	4200	4200	4200	4200	4200
13.5	4200	4200	4200	4200	4200	4200	4200	4200
14.0	4200	4200	4200	4200	4200	4200	4200	4200
14.5	4200	4200	4200	4200	4200	4200	4200	4200
15.0	4200	4200	4200	4200	4200	4200	4200	4200
15.5	4200	4200	4200	4200	4200	4200	4200	4200
16.0	4200	4200	4200	4200	4200	4200	4200	4200
16.5	4200	4200	4200	4200	4200	4200	4200	4200
17.0	4200	4200	4200	4200	4200	4200	4200	4200
17.5	4200	4200	4200	4200	4200	4200	4200	4200
18.0	4200	4200	4200	4200	4200	4200	4200	4200
18.5	4200	4200	4200	4200	4200	4200	4200	4200
19.0	4200	4200	4200	4200	4200	4200	4200	4200
19.5	4200	4200	4200	4200	4200	4200	4200	4200
20.0	4200	4200	4200	4200	4200	4200	4200	4200
20.5*	4200	4200	4200	4200	4200	4200	4200	4200
21.0*	4185	4185	4185	4185	4185	4185	4185	4185
21.5*	4102	4102	4102	4102	4102	4102	4102	4102
22.0*	3951	3951	3951	3951	3951	3951	3951	3951
22.5*	3776	3776	3776	3776	3776	3776	3776	3776
23.0*	3600	3600	3600	3600	3600	3600	3600	3600
23.5*	3420	3420	3420	3420	3420	3420	3420	3420
24.0*	3245	3245	3245	3245	3245	3245	3245	3245
24.5*	3065	3065	3065	3065	3065	3065	3065	3065
25.0*	2885	2885	2885	2885	2885	2885	2885	2885
25.5*	2705	2705	2705	2705	2705	2705	2705	2705
26.0*	2529	2529	2529	2529	2529	2529	2529	2529

\* These values are based on a yield and load optimized operation that is not feasible at all sites.

**Nordex N149/4.0-4.5 – Power curves – Mode 5.b**

for hub heights 105 m, 125 m, 145 m and 164 m									
wind speed $v_H$ [m/s]	Power $P_{el}$ [kW] at air density $\rho$ [kg/m <sup>3</sup> ]								
	0.900	0.925	0.950	0.975	1.000	1.025	1.050	1.075	1.100
3.0	9	11	13	14	16	18	19	21	23
3.5	77	80	84	87	91	94	98	101	105
4.0	169	175	181	187	193	199	205	211	217
4.5	282	291	300	309	318	327	336	346	355
5.0	417	430	443	455	468	481	494	507	520
5.5	576	593	611	628	645	662	680	697	714
6.0	763	786	808	831	853	875	898	920	942
6.5	982	1010	1039	1067	1095	1124	1152	1180	1208
7.0	1235	1271	1306	1341	1376	1411	1446	1481	1516
7.5	1526	1570	1613	1656	1699	1741	1784	1827	1870
8.0	1850	1902	1953	2005	2059	2110	2160	2211	2262
8.5	2186	2247	2309	2369	2437	2496	2554	2614	2675
9.0	2520	2590	2664	2731	2812	2881	2952	3034	3115
9.5	2843	2921	3010	3091	3190	3280	3369	3440	3511
10.0	3156	3253	3359	3453	3535	3613	3688	3741	3793
10.5	3473	3562	3650	3729	3784	3841	3895	3925	3954
11.0	3725	3792	3852	3908	3939	3972	4000	4000	4000
11.5	3897	3937	3971	4000	4000	4000	4000	4000	4000
12.0	3991	4000	4000	4000	4000	4000	4000	4000	4000
12.5	4000	4000	4000	4000	4000	4000	4000	4000	4000
13.0	4000	4000	4000	4000	4000	4000	4000	4000	4000
13.5	4000	4000	4000	4000	4000	4000	4000	4000	4000
14.0	4000	4000	4000	4000	4000	4000	4000	4000	4000
14.5	4000	4000	4000	4000	4000	4000	4000	4000	4000
15.0	4000	4000	4000	4000	4000	4000	4000	4000	4000
15.5	4000	4000	4000	4000	4000	4000	4000	4000	4000
16.0	4000	4000	4000	4000	4000	4000	4000	4000	4000
16.5	4000	4000	4000	4000	4000	4000	4000	4000	4000
17.0	4000	4000	4000	4000	4000	4000	4000	4000	4000
17.5	4000	4000	4000	4000	4000	4000	4000	4000	4000
18.0	4000	4000	4000	4000	4000	4000	4000	4000	4000
18.5	4000	4000	4000	4000	4000	4000	4000	4000	4000
19.0	4000	4000	4000	4000	4000	4000	4000	4000	4000
19.5	4000	4000	4000	4000	4000	4000	4000	4000	4000
20.0	4000	4000	4000	4000	4000	4000	4000	4000	4000
20.5*	4000	4000	4000	4000	4000	4000	4000	4000	4000
21.0*	4000	4000	4000	4000	4000	4000	4000	4000	4000
21.5*	3992	3992	3992	3992	3992	3992	3992	3992	3992
22.0*	3918	3918	3918	3918	3918	3918	3918	3918	3918
22.5*	3776	3776	3776	3776	3776	3776	3776	3776	3776
23.0*	3600	3600	3600	3600	3600	3600	3600	3600	3600
23.5*	3420	3420	3420	3420	3420	3420	3420	3420	3420
24.0*	3245	3245	3245	3245	3245	3245	3245	3245	3245
24.5*	3065	3065	3065	3065	3065	3065	3065	3065	3065
25.0*	2885	2885	2885	2885	2885	2885	2885	2885	2885
25.5*	2705	2705	2705	2705	2705	2705	2705	2705	2705
26.0*	2529	2529	2529	2529	2529	2529	2529	2529	2529

\* These values are based on a yield and load optimized operation that is not feasible at all sites.

Nordex N149/4.0-4.5 – Power curves – Mode 5.b

for hub heights 105 m, 125 m, 145 m and 164 m								
wind speed $v_H$ [m/s]	Power $P_{el}$ [kW] at air density $\rho$ [kg/m <sup>3</sup> ]							
	1.125	1.150	1.175	1.200	1.225	1.250	1.275	1.300
3.0	24	26	28	29	31	32	34	36
3.5	108	112	115	119	122	126	129	133
4.0	223	229	235	241	247	253	259	265
4.5	364	373	382	391	400	409	419	428
5.0	533	545	558	571	584	597	610	622
5.5	731	748	766	783	800	817	834	852
6.0	964	987	1009	1031	1054	1076	1098	1120
6.5	1236	1265	1293	1321	1349	1377	1405	1433
7.0	1551	1586	1621	1656	1691	1726	1761	1796
7.5	1913	1955	1998	2041	2084	2126	2169	2211
8.0	2314	2365	2416	2467	2518	2569	2620	2675
8.5	2735	2798	2869	2940	3012	3083	3146	3198
9.0	3196	3271	3336	3399	3464	3526	3578	3615
9.5	3582	3646	3692	3739	3785	3832	3866	3886
10.0	3845	3888	3915	3942	3969	3996	4000	4000
10.5	3984	4000	4000	4000	4000	4000	4000	4000
11.0	4000	4000	4000	4000	4000	4000	4000	4000
11.5	4000	4000	4000	4000	4000	4000	4000	4000
12.0	4000	4000	4000	4000	4000	4000	4000	4000
12.5	4000	4000	4000	4000	4000	4000	4000	4000
13.0	4000	4000	4000	4000	4000	4000	4000	4000
13.5	4000	4000	4000	4000	4000	4000	4000	4000
14.0	4000	4000	4000	4000	4000	4000	4000	4000
14.5	4000	4000	4000	4000	4000	4000	4000	4000
15.0	4000	4000	4000	4000	4000	4000	4000	4000
15.5	4000	4000	4000	4000	4000	4000	4000	4000
16.0	4000	4000	4000	4000	4000	4000	4000	4000
16.5	4000	4000	4000	4000	4000	4000	4000	4000
17.0	4000	4000	4000	4000	4000	4000	4000	4000
17.5	4000	4000	4000	4000	4000	4000	4000	4000
18.0	4000	4000	4000	4000	4000	4000	4000	4000
18.5	4000	4000	4000	4000	4000	4000	4000	4000
19.0	4000	4000	4000	4000	4000	4000	4000	4000
19.5	4000	4000	4000	4000	4000	4000	4000	4000
20.0	4000	4000	4000	4000	4000	4000	4000	4000
20.5*	4000	4000	4000	4000	4000	4000	4000	4000
21.0*	4000	4000	4000	4000	4000	4000	4000	4000
21.5*	3992	3992	3992	3992	3992	3992	3992	3992
22.0*	3918	3918	3918	3918	3918	3918	3918	3918
22.5*	3776	3776	3776	3776	3776	3776	3776	3776
23.0*	3600	3600	3600	3600	3600	3600	3600	3600
23.5*	3420	3420	3420	3420	3420	3420	3420	3420
24.0*	3245	3245	3245	3245	3245	3245	3245	3245
24.5*	3065	3065	3065	3065	3065	3065	3065	3065
25.0*	2885	2885	2885	2885	2885	2885	2885	2885
25.5*	2705	2705	2705	2705	2705	2705	2705	2705
26.0*	2529	2529	2529	2529	2529	2529	2529	2529

\* These values are based on a yield and load optimized operation that is not feasible at all sites.

**Nordex N149/4.0-4.5 – General remarks thrust curves**

Basis:

The represented thrust coefficients are based on aerodynamical calculations by the Nordex Energy GmbH. The thrust curves are only for information and will not be warranted.

**Nordex N149/4.0-4.5 – Thrust curves – Mode 0.b**

for hub heights 105 m, 125 m, 145 m and 164 m									
wind speed $v_H$ [m/s]	Thrust coefficients $c_T$ at air density $\rho$ [kg/m <sup>3</sup> ]								
	0.900	0.925	0.950	0.975	1.000	1.025	1.050	1.075	1.100
3.0	0.827	0.827	0.827	0.827	0.827	0.827	0.827	0.827	0.827
3.5	0.826	0.826	0.826	0.826	0.826	0.826	0.826	0.826	0.826
4.0	0.817	0.817	0.817	0.817	0.817	0.817	0.817	0.817	0.817
4.5	0.808	0.808	0.808	0.808	0.808	0.808	0.808	0.808	0.808
5.0	0.800	0.800	0.800	0.800	0.800	0.800	0.800	0.800	0.800
5.5	0.794	0.794	0.794	0.794	0.794	0.794	0.794	0.794	0.794
6.0	0.791	0.791	0.791	0.791	0.791	0.791	0.791	0.791	0.791
6.5	0.789	0.789	0.789	0.789	0.789	0.789	0.789	0.789	0.789
7.0	0.788	0.788	0.788	0.788	0.788	0.788	0.788	0.788	0.788
7.5	0.787	0.787	0.787	0.787	0.787	0.787	0.788	0.787	0.787
8.0	0.783	0.783	0.783	0.783	0.783	0.783	0.783	0.783	0.783
8.5	0.767	0.767	0.767	0.767	0.767	0.767	0.767	0.764	0.762
9.0	0.744	0.743	0.743	0.741	0.738	0.736	0.734	0.729	0.724
9.5	0.712	0.709	0.706	0.702	0.698	0.694	0.690	0.684	0.679
10.0	0.671	0.667	0.663	0.658	0.652	0.647	0.642	0.636	0.629
10.5	0.626	0.621	0.616	0.610	0.604	0.598	0.593	0.586	0.579
11.0	0.580	0.574	0.568	0.562	0.555	0.549	0.543	0.536	0.528
11.5	0.533	0.527	0.521	0.514	0.507	0.500	0.494	0.486	0.479
12.0	0.487	0.480	0.474	0.467	0.459	0.453	0.446	0.438	0.431
12.5	0.442	0.435	0.428	0.421	0.413	0.406	0.400	0.392	0.384
13.0	0.398	0.391	0.384	0.377	0.369	0.362	0.356	0.348	0.340
13.5	0.358	0.350	0.343	0.336	0.328	0.321	0.315	0.307	0.299
14.0	0.321	0.314	0.307	0.299	0.292	0.285	0.278	0.271	0.264
14.5	0.288	0.281	0.274	0.267	0.259	0.252	0.246	0.240	0.234
15.0	0.259	0.251	0.244	0.238	0.231	0.225	0.219	0.214	0.209
15.5	0.232	0.225	0.219	0.213	0.207	0.202	0.197	0.193	0.188
16.0	0.209	0.203	0.197	0.192	0.187	0.183	0.178	0.174	0.171
16.5	0.190	0.184	0.180	0.175	0.171	0.166	0.163	0.159	0.156
17.0	0.174	0.169	0.164	0.160	0.156	0.153	0.149	0.146	0.143
17.5	0.160	0.156	0.152	0.148	0.145	0.141	0.138	0.135	0.132
18.0	0.149	0.145	0.141	0.138	0.134	0.131	0.128	0.126	0.123
18.5	0.139	0.136	0.132	0.129	0.126	0.123	0.120	0.118	0.115
19.0	0.131	0.128	0.124	0.122	0.119	0.116	0.114	0.111	0.109
19.5	0.124	0.121	0.118	0.115	0.112	0.110	0.108	0.105	0.103
20.0	0.118	0.115	0.112	0.110	0.107	0.105	0.103	0.101	0.098
20.5*	0.109	0.106	0.103	0.102	0.099	0.097	0.095	0.093	0.090
21.0*	0.099	0.096	0.094	0.092	0.090	0.088	0.086	0.085	0.082
21.5*	0.089	0.086	0.084	0.083	0.080	0.079	0.077	0.076	0.074
22.0*	0.080	0.078	0.076	0.074	0.072	0.071	0.070	0.068	0.066
22.5*	0.072	0.070	0.068	0.067	0.065	0.064	0.062	0.061	0.059
23.0*	0.064	0.063	0.061	0.060	0.058	0.057	0.056	0.055	0.054
23.5*	0.058	0.056	0.055	0.054	0.052	0.051	0.050	0.049	0.048
24.0*	0.052	0.051	0.049	0.048	0.047	0.046	0.045	0.044	0.043
24.5*	0.047	0.046	0.045	0.044	0.043	0.042	0.041	0.040	0.039
25.0*	0.043	0.042	0.040	0.040	0.039	0.038	0.037	0.036	0.035
25.5*	0.038	0.037	0.036	0.036	0.035	0.034	0.033	0.033	0.032
26.0*	0.035	0.034	0.033	0.032	0.032	0.031	0.030	0.030	0.029

\* These values are based on a yield and load optimized operation that is not feasible at all sites.

### Nordex N149/4.0-4.5 – Thrust curves – Mode 0.b

for hub heights 105 m, 125 m, 145 m and 164 m								
wind speed $v_H$ [m/s]	Thrust coefficients $c_T$ at air density $\rho$ [kg/m <sup>3</sup> ]							
	1.125	1.150	1.175	1.200	1.225	1.250	1.275	1.300
3.0	0.827	0.827	0.827	0.827	0.827	0.827	0.827	0.827
3.5	0.826	0.826	0.826	0.826	0.826	0.826	0.826	0.826
4.0	0.817	0.817	0.817	0.817	0.817	0.817	0.817	0.817
4.5	0.808	0.808	0.808	0.808	0.808	0.808	0.808	0.808
5.0	0.800	0.800	0.800	0.800	0.800	0.800	0.800	0.800
5.5	0.794	0.794	0.794	0.794	0.794	0.794	0.794	0.794
6.0	0.791	0.791	0.791	0.791	0.791	0.791	0.791	0.791
6.5	0.789	0.789	0.789	0.789	0.789	0.789	0.789	0.789
7.0	0.788	0.788	0.788	0.788	0.788	0.788	0.788	0.788
7.5	0.787	0.787	0.787	0.786	0.786	0.785	0.785	0.784
8.0	0.783	0.783	0.781	0.778	0.774	0.770	0.767	0.763
8.5	0.760	0.757	0.753	0.748	0.741	0.735	0.730	0.725
9.0	0.720	0.716	0.711	0.704	0.696	0.690	0.683	0.677
9.5	0.674	0.668	0.662	0.654	0.646	0.639	0.632	0.625
10.0	0.624	0.618	0.611	0.603	0.594	0.586	0.579	0.572
10.5	0.572	0.566	0.559	0.550	0.542	0.534	0.526	0.519
11.0	0.522	0.515	0.507	0.499	0.490	0.482	0.474	0.467
11.5	0.472	0.465	0.458	0.449	0.440	0.432	0.424	0.417
12.0	0.424	0.417	0.409	0.401	0.392	0.384	0.376	0.369
12.5	0.378	0.371	0.363	0.354	0.346	0.338	0.330	0.323
13.0	0.333	0.326	0.319	0.311	0.303	0.296	0.290	0.283
13.5	0.292	0.285	0.279	0.272	0.266	0.260	0.254	0.249
14.0	0.257	0.251	0.245	0.240	0.234	0.230	0.225	0.220
14.5	0.228	0.223	0.218	0.213	0.209	0.205	0.201	0.197
15.0	0.204	0.200	0.196	0.192	0.188	0.184	0.180	0.177
15.5	0.184	0.180	0.176	0.173	0.170	0.166	0.163	0.160
16.0	0.167	0.163	0.160	0.157	0.154	0.151	0.148	0.146
16.5	0.152	0.149	0.146	0.143	0.141	0.138	0.136	0.133
17.0	0.140	0.137	0.134	0.132	0.129	0.127	0.125	0.122
17.5	0.130	0.127	0.124	0.122	0.120	0.118	0.116	0.114
18.0	0.121	0.118	0.116	0.114	0.112	0.110	0.108	0.106
18.5	0.113	0.111	0.109	0.107	0.105	0.103	0.101	0.100
19.0	0.107	0.105	0.103	0.101	0.099	0.097	0.096	0.094
19.5	0.101	0.099	0.097	0.096	0.094	0.092	0.091	0.089
20.0	0.097	0.095	0.093	0.091	0.090	0.088	0.087	0.085
20.5*	0.090	0.088	0.086	0.084	0.083	0.081	0.080	0.078
21.0*	0.081	0.080	0.078	0.076	0.076	0.074	0.073	0.071
21.5*	0.073	0.071	0.070	0.068	0.068	0.066	0.065	0.064
22.0*	0.066	0.064	0.063	0.062	0.061	0.060	0.059	0.058
22.5*	0.059	0.058	0.056	0.055	0.055	0.053	0.053	0.052
23.0*	0.053	0.052	0.051	0.050	0.049	0.048	0.048	0.046
23.5*	0.047	0.046	0.045	0.044	0.044	0.043	0.042	0.041
24.0*	0.043	0.042	0.041	0.040	0.040	0.039	0.038	0.037
24.5*	0.039	0.038	0.037	0.036	0.036	0.035	0.035	0.034
25.0*	0.035	0.034	0.034	0.033	0.032	0.032	0.031	0.031
25.5*	0.031	0.031	0.030	0.029	0.029	0.028	0.028	0.027
26.0*	0.029	0.028	0.027	0.027	0.027	0.026	0.026	0.025

\* These values are based on a yield and load optimized operation that is not feasible at all sites.



**Nordex N149/4.0-4.5 – Thrust curves – Mode 1.b**

for hub heights 105 m, 125 m, 145 m and 164 m									
wind speed $v_H$ [m/s]	Thrust coefficients $c_T$ at air density $\rho$ [kg/m <sup>3</sup> ]								
	0.900	0.925	0.950	0.975	1.000	1.025	1.050	1.075	1.100
3.0	0.827	0.827	0.827	0.827	0.827	0.827	0.827	0.827	0.827
3.5	0.826	0.826	0.826	0.826	0.826	0.826	0.826	0.826	0.826
4.0	0.817	0.817	0.817	0.817	0.817	0.817	0.817	0.817	0.817
4.5	0.808	0.808	0.808	0.808	0.808	0.808	0.808	0.808	0.808
5.0	0.800	0.800	0.800	0.800	0.800	0.800	0.800	0.800	0.800
5.5	0.794	0.794	0.794	0.794	0.794	0.794	0.794	0.794	0.794
6.0	0.791	0.791	0.791	0.791	0.791	0.791	0.791	0.791	0.791
6.5	0.789	0.789	0.789	0.789	0.789	0.789	0.789	0.789	0.789
7.0	0.788	0.788	0.788	0.788	0.788	0.788	0.788	0.788	0.788
7.5	0.786	0.786	0.786	0.786	0.786	0.786	0.786	0.786	0.786
8.0	0.776	0.776	0.776	0.776	0.776	0.776	0.776	0.776	0.776
8.5	0.756	0.756	0.756	0.756	0.756	0.756	0.756	0.753	0.751
9.0	0.728	0.728	0.728	0.727	0.724	0.722	0.720	0.716	0.712
9.5	0.695	0.692	0.690	0.687	0.682	0.679	0.675	0.670	0.665
10.0	0.653	0.649	0.645	0.641	0.636	0.631	0.627	0.621	0.615
10.5	0.608	0.603	0.598	0.593	0.587	0.582	0.577	0.570	0.564
11.0	0.561	0.556	0.550	0.545	0.538	0.532	0.527	0.520	0.513
11.5	0.514	0.508	0.502	0.496	0.490	0.484	0.478	0.470	0.464
12.0	0.468	0.462	0.456	0.449	0.442	0.436	0.430	0.423	0.416
12.5	0.423	0.417	0.410	0.404	0.397	0.390	0.384	0.377	0.370
13.0	0.381	0.374	0.368	0.361	0.354	0.347	0.341	0.334	0.327
13.5	0.343	0.336	0.329	0.323	0.316	0.309	0.303	0.295	0.288
14.0	0.309	0.302	0.295	0.288	0.281	0.274	0.268	0.261	0.254
14.5	0.278	0.271	0.264	0.257	0.250	0.244	0.237	0.232	0.226
15.0	0.250	0.243	0.236	0.230	0.223	0.218	0.212	0.207	0.202
15.5	0.224	0.218	0.212	0.206	0.201	0.196	0.191	0.186	0.182
16.0	0.202	0.196	0.191	0.186	0.182	0.177	0.173	0.169	0.165
16.5	0.184	0.179	0.174	0.170	0.165	0.161	0.158	0.154	0.151
17.0	0.168	0.164	0.159	0.155	0.152	0.148	0.145	0.142	0.138
17.5	0.155	0.151	0.147	0.144	0.140	0.137	0.134	0.131	0.128
18.0	0.144	0.140	0.137	0.134	0.130	0.127	0.125	0.122	0.119
18.5	0.135	0.131	0.128	0.125	0.122	0.119	0.117	0.114	0.112
19.0	0.127	0.124	0.121	0.118	0.115	0.112	0.110	0.108	0.106
19.5	0.120	0.117	0.114	0.112	0.109	0.107	0.104	0.102	0.100
20.0	0.115	0.112	0.109	0.106	0.104	0.102	0.100	0.098	0.096
20.5*	0.106	0.103	0.101	0.098	0.096	0.094	0.092	0.090	0.089
21.0*	0.096	0.094	0.091	0.089	0.087	0.086	0.084	0.082	0.081
21.5*	0.086	0.084	0.082	0.080	0.078	0.077	0.075	0.074	0.072
22.0*	0.078	0.076	0.074	0.072	0.070	0.069	0.068	0.066	0.065
22.5*	0.070	0.068	0.066	0.064	0.063	0.062	0.061	0.059	0.058
23.0*	0.063	0.061	0.060	0.058	0.057	0.056	0.055	0.054	0.052
23.5*	0.056	0.055	0.053	0.052	0.051	0.050	0.049	0.048	0.047
24.0*	0.051	0.049	0.048	0.047	0.046	0.045	0.044	0.043	0.042
24.5*	0.046	0.045	0.043	0.042	0.041	0.041	0.040	0.039	0.038
25.0*	0.042	0.040	0.039	0.038	0.038	0.037	0.036	0.035	0.035
25.5*	0.037	0.036	0.035	0.034	0.034	0.033	0.032	0.032	0.031
26.0*	0.034	0.033	0.032	0.031	0.031	0.030	0.029	0.029	0.028

\* These values are based on a yield and load optimized operation that is not feasible at all sites.

### Nordex N149/4.0-4.5 – Thrust curves – Mode 1.b

for hub heights 105 m, 125 m, 145 m and 164 m								
wind speed $v_H$ [m/s]	Thrust coefficients $c_T$ at air density $\rho$ [kg/m <sup>3</sup> ]							
	1.125	1.150	1.175	1.200	1.225	1.250	1.275	1.300
3.0	0.827	0.827	0.827	0.827	0.827	0.827	0.827	0.827
3.5	0.826	0.826	0.826	0.826	0.826	0.826	0.826	0.826
4.0	0.817	0.817	0.817	0.817	0.817	0.817	0.817	0.817
4.5	0.808	0.808	0.808	0.808	0.808	0.808	0.808	0.808
5.0	0.800	0.800	0.800	0.800	0.800	0.800	0.800	0.800
5.5	0.794	0.794	0.794	0.794	0.794	0.794	0.794	0.794
6.0	0.791	0.791	0.791	0.791	0.791	0.791	0.791	0.791
6.5	0.789	0.789	0.789	0.789	0.789	0.789	0.789	0.789
7.0	0.788	0.788	0.788	0.788	0.788	0.788	0.788	0.788
7.5	0.786	0.786	0.786	0.786	0.786	0.785	0.784	0.782
8.0	0.776	0.776	0.776	0.773	0.770	0.766	0.763	0.759
8.5	0.749	0.748	0.745	0.740	0.734	0.729	0.724	0.718
9.0	0.708	0.705	0.700	0.694	0.687	0.681	0.675	0.668
9.5	0.660	0.656	0.650	0.644	0.636	0.629	0.623	0.615
10.0	0.609	0.604	0.598	0.591	0.583	0.576	0.569	0.562
10.5	0.558	0.552	0.546	0.539	0.530	0.523	0.516	0.508
11.0	0.507	0.501	0.495	0.487	0.479	0.471	0.464	0.456
11.5	0.457	0.451	0.444	0.437	0.429	0.421	0.414	0.406
12.0	0.409	0.403	0.396	0.388	0.380	0.372	0.365	0.358
12.5	0.363	0.357	0.350	0.342	0.334	0.327	0.320	0.313
13.0	0.320	0.314	0.307	0.300	0.292	0.286	0.279	0.273
13.5	0.281	0.275	0.269	0.262	0.256	0.251	0.245	0.240
14.0	0.248	0.242	0.237	0.231	0.226	0.222	0.217	0.213
14.5	0.221	0.216	0.211	0.206	0.202	0.198	0.194	0.190
15.0	0.198	0.193	0.189	0.185	0.182	0.178	0.175	0.171
15.5	0.178	0.174	0.171	0.167	0.164	0.161	0.158	0.155
16.0	0.162	0.158	0.155	0.152	0.149	0.146	0.144	0.141
16.5	0.148	0.144	0.142	0.139	0.136	0.134	0.131	0.129
17.0	0.136	0.133	0.130	0.128	0.125	0.123	0.121	0.119
17.5	0.126	0.123	0.120	0.118	0.116	0.114	0.112	0.110
18.0	0.117	0.115	0.112	0.110	0.108	0.106	0.104	0.103
18.5	0.110	0.108	0.105	0.103	0.102	0.100	0.098	0.096
19.0	0.103	0.101	0.100	0.098	0.096	0.094	0.093	0.091
19.5	0.098	0.096	0.094	0.093	0.091	0.090	0.088	0.086
20.0	0.094	0.092	0.090	0.088	0.087	0.086	0.084	0.083
20.5*	0.087	0.085	0.083	0.081	0.080	0.079	0.078	0.077
21.0*	0.079	0.077	0.076	0.074	0.073	0.072	0.070	0.070
21.5*	0.071	0.069	0.068	0.066	0.065	0.065	0.063	0.062
22.0*	0.064	0.062	0.061	0.060	0.059	0.058	0.057	0.056
22.5*	0.057	0.056	0.055	0.053	0.053	0.052	0.051	0.050
23.0*	0.051	0.050	0.049	0.048	0.048	0.047	0.046	0.045
23.5*	0.046	0.045	0.044	0.043	0.042	0.042	0.041	0.041
24.0*	0.041	0.040	0.040	0.039	0.038	0.038	0.037	0.037
24.5*	0.037	0.037	0.036	0.035	0.035	0.034	0.033	0.033
25.0*	0.034	0.033	0.032	0.032	0.031	0.031	0.030	0.030
25.5*	0.030	0.030	0.029	0.028	0.028	0.028	0.027	0.027
26.0*	0.028	0.027	0.027	0.026	0.026	0.025	0.025	0.024

\* These values are based on a yield and load optimized operation that is not feasible at all sites.

**Nordex N149/4.0-4.5 – Thrust curves – Mode 2.a**

for hub heights 105 m, 125 m, 145 m and 164 m									
wind speed $v_H$ [m/s]	Thrust coefficients $c_T$ at air density $\rho$ [kg/m <sup>3</sup> ]								
	0.900	0.925	0.950	0.975	1.000	1.025	1.050	1.075	1.100
3.0	0.827	0.827	0.827	0.827	0.827	0.827	0.827	0.827	0.827
3.5	0.826	0.826	0.826	0.826	0.826	0.826	0.826	0.826	0.826
4.0	0.817	0.817	0.817	0.817	0.817	0.817	0.817	0.817	0.817
4.5	0.808	0.808	0.808	0.808	0.808	0.808	0.808	0.808	0.808
5.0	0.800	0.800	0.800	0.800	0.800	0.800	0.800	0.800	0.800
5.5	0.794	0.794	0.794	0.794	0.794	0.794	0.794	0.794	0.794
6.0	0.791	0.791	0.791	0.791	0.791	0.791	0.791	0.791	0.791
6.5	0.789	0.789	0.789	0.789	0.789	0.789	0.789	0.789	0.789
7.0	0.788	0.788	0.788	0.788	0.788	0.788	0.788	0.788	0.788
7.5	0.784	0.784	0.784	0.784	0.784	0.784	0.784	0.784	0.785
8.0	0.769	0.769	0.769	0.769	0.769	0.770	0.769	0.769	0.769
8.5	0.745	0.745	0.745	0.745	0.745	0.745	0.745	0.745	0.744
9.0	0.715	0.715	0.715	0.715	0.715	0.714	0.712	0.710	0.707
9.5	0.681	0.680	0.680	0.678	0.675	0.673	0.670	0.666	0.662
10.0	0.642	0.640	0.637	0.634	0.630	0.627	0.623	0.618	0.613
10.5	0.598	0.595	0.592	0.587	0.583	0.579	0.574	0.569	0.563
11.0	0.553	0.549	0.545	0.540	0.535	0.530	0.525	0.519	0.513
11.5	0.508	0.503	0.498	0.493	0.487	0.482	0.476	0.470	0.464
12.0	0.462	0.457	0.452	0.446	0.440	0.435	0.429	0.423	0.417
12.5	0.418	0.413	0.407	0.401	0.396	0.390	0.384	0.378	0.371
13.0	0.378	0.372	0.367	0.361	0.355	0.349	0.343	0.337	0.330
13.5	0.342	0.336	0.331	0.324	0.318	0.313	0.306	0.300	0.294
14.0	0.310	0.304	0.298	0.292	0.286	0.280	0.273	0.267	0.261
14.5	0.280	0.274	0.269	0.262	0.256	0.250	0.244	0.238	0.232
15.0	0.254	0.248	0.242	0.236	0.229	0.224	0.218	0.212	0.208
15.5	0.230	0.224	0.218	0.212	0.206	0.201	0.196	0.191	0.187
16.0	0.208	0.202	0.196	0.191	0.186	0.182	0.177	0.173	0.169
16.5	0.189	0.183	0.178	0.174	0.169	0.165	0.161	0.158	0.154
17.0	0.172	0.168	0.163	0.159	0.155	0.152	0.148	0.145	0.142
17.5	0.159	0.155	0.151	0.147	0.144	0.140	0.137	0.134	0.131
18.0	0.148	0.144	0.140	0.137	0.133	0.130	0.127	0.125	0.122
18.5	0.138	0.134	0.131	0.128	0.125	0.122	0.119	0.117	0.114
19.0	0.130	0.127	0.124	0.120	0.118	0.115	0.112	0.110	0.108
19.5	0.123	0.120	0.117	0.114	0.112	0.109	0.107	0.104	0.102
20.0	0.117	0.114	0.112	0.109	0.106	0.104	0.102	0.100	0.098
20.5*	0.108	0.105	0.103	0.101	0.098	0.096	0.094	0.092	0.090
21.0*	0.098	0.096	0.094	0.091	0.089	0.087	0.086	0.084	0.082
21.5*	0.088	0.086	0.084	0.082	0.080	0.078	0.077	0.075	0.074
22.0*	0.079	0.077	0.076	0.074	0.072	0.070	0.069	0.068	0.066
22.5*	0.071	0.069	0.068	0.066	0.064	0.063	0.062	0.061	0.059
23.0*	0.064	0.062	0.061	0.060	0.058	0.057	0.056	0.055	0.054
23.5*	0.057	0.056	0.055	0.053	0.052	0.051	0.050	0.049	0.048
24.0*	0.051	0.050	0.049	0.048	0.047	0.046	0.045	0.044	0.043
24.5*	0.047	0.045	0.045	0.043	0.042	0.041	0.041	0.040	0.039
25.0*	0.042	0.041	0.040	0.039	0.038	0.038	0.037	0.036	0.035
25.5*	0.038	0.037	0.036	0.035	0.034	0.034	0.033	0.032	0.032
26.0*	0.035	0.034	0.033	0.032	0.031	0.031	0.030	0.029	0.029

\* These values are based on a yield and load optimized operation that is not feasible at all sites.

**Nordex N149/4.0-4.5 – Thrust curves – Mode 2.a**

for hub heights 105 m, 125 m, 145 m and 164 m								
wind speed $v_H$ [m/s]	Thrust coefficients $c_T$ at air density $\rho$ [kg/m <sup>3</sup> ]							
	1.125	1.150	1.175	1.200	1.225	1.250	1.275	1.300
3.0	0.827	0.827	0.827	0.827	0.827	0.827	0.827	0.827
3.5	0.826	0.826	0.826	0.826	0.826	0.826	0.826	0.826
4.0	0.817	0.817	0.817	0.817	0.817	0.817	0.817	0.817
4.5	0.808	0.808	0.808	0.808	0.808	0.808	0.808	0.808
5.0	0.800	0.800	0.800	0.800	0.800	0.800	0.800	0.800
5.5	0.794	0.794	0.794	0.794	0.794	0.794	0.794	0.794
6.0	0.791	0.791	0.791	0.791	0.791	0.791	0.791	0.791
6.5	0.789	0.789	0.789	0.789	0.789	0.789	0.789	0.789
7.0	0.788	0.788	0.787	0.787	0.787	0.786	0.785	0.783
7.5	0.784	0.781	0.778	0.776	0.773	0.770	0.767	0.763
8.0	0.766	0.762	0.757	0.752	0.748	0.744	0.739	0.733
8.5	0.740	0.733	0.727	0.720	0.714	0.708	0.702	0.695
9.0	0.701	0.693	0.686	0.678	0.670	0.664	0.656	0.648
9.5	0.655	0.646	0.638	0.629	0.621	0.614	0.606	0.598
10.0	0.606	0.596	0.587	0.578	0.570	0.562	0.554	0.545
10.5	0.555	0.546	0.536	0.527	0.519	0.510	0.502	0.493
11.0	0.505	0.495	0.486	0.477	0.468	0.460	0.451	0.442
11.5	0.456	0.446	0.437	0.427	0.419	0.410	0.402	0.394
12.0	0.408	0.399	0.390	0.381	0.372	0.364	0.357	0.350
12.5	0.363	0.354	0.346	0.338	0.331	0.324	0.317	0.311
13.0	0.322	0.315	0.308	0.301	0.294	0.288	0.282	0.276
13.5	0.287	0.280	0.274	0.267	0.262	0.256	0.250	0.246
14.0	0.255	0.249	0.243	0.238	0.232	0.228	0.223	0.218
14.5	0.226	0.221	0.216	0.212	0.207	0.203	0.199	0.195
15.0	0.203	0.198	0.194	0.190	0.186	0.182	0.179	0.175
15.5	0.183	0.179	0.175	0.171	0.168	0.165	0.162	0.158
16.0	0.165	0.162	0.159	0.155	0.152	0.149	0.147	0.144
16.5	0.151	0.148	0.145	0.142	0.139	0.136	0.134	0.132
17.0	0.139	0.136	0.133	0.130	0.128	0.126	0.123	0.121
17.5	0.128	0.126	0.123	0.121	0.118	0.116	0.114	0.112
18.0	0.119	0.117	0.115	0.113	0.110	0.108	0.106	0.105
18.5	0.112	0.110	0.108	0.106	0.104	0.102	0.100	0.098
19.0	0.106	0.104	0.102	0.100	0.098	0.096	0.094	0.093
19.5	0.100	0.098	0.096	0.095	0.093	0.091	0.090	0.088
20.0	0.096	0.094	0.092	0.090	0.089	0.087	0.086	0.084
20.5*	0.089	0.087	0.085	0.083	0.082	0.080	0.079	0.078
21.0*	0.081	0.079	0.077	0.076	0.075	0.073	0.072	0.070
21.5*	0.072	0.071	0.069	0.068	0.067	0.065	0.065	0.063
22.0*	0.065	0.064	0.062	0.061	0.060	0.059	0.058	0.057
22.5*	0.058	0.057	0.056	0.055	0.054	0.053	0.052	0.051
23.0*	0.052	0.051	0.050	0.049	0.049	0.048	0.047	0.046
23.5*	0.047	0.046	0.045	0.044	0.043	0.042	0.042	0.041
24.0*	0.042	0.041	0.040	0.040	0.039	0.038	0.038	0.037
24.5*	0.038	0.037	0.037	0.036	0.035	0.035	0.034	0.033
25.0*	0.035	0.034	0.033	0.032	0.032	0.031	0.031	0.030
25.5*	0.031	0.030	0.030	0.029	0.029	0.028	0.028	0.027
26.0*	0.028	0.028	0.027	0.027	0.026	0.026	0.025	0.025

\* These values are based on a yield and load optimized operation that is not feasible at all sites.

**Nordex N149/4.0-4.5 – Thrust curves – Mode 3.b**

for hub heights 105 m, 125 m, 145 m and 164 m									
wind speed $v_H$ [m/s]	Thrust coefficients $c_T$ at air density $\rho$ [kg/m <sup>3</sup> ]								
	0.900	0.925	0.950	0.975	1.000	1.025	1.050	1.075	1.100
3.0	0.827	0.827	0.827	0.827	0.827	0.827	0.827	0.827	0.827
3.5	0.826	0.826	0.826	0.826	0.826	0.826	0.826	0.826	0.826
4.0	0.817	0.817	0.817	0.817	0.817	0.817	0.817	0.817	0.817
4.5	0.808	0.808	0.808	0.808	0.808	0.808	0.808	0.808	0.808
5.0	0.800	0.800	0.800	0.800	0.800	0.800	0.800	0.800	0.800
5.5	0.794	0.794	0.794	0.794	0.794	0.794	0.794	0.794	0.794
6.0	0.791	0.791	0.791	0.791	0.791	0.791	0.791	0.791	0.791
6.5	0.789	0.789	0.789	0.789	0.789	0.789	0.789	0.789	0.789
7.0	0.788	0.788	0.788	0.788	0.788	0.788	0.788	0.788	0.788
7.5	0.782	0.782	0.782	0.782	0.782	0.782	0.782	0.782	0.782
8.0	0.764	0.764	0.764	0.764	0.764	0.764	0.764	0.764	0.764
8.5	0.737	0.737	0.737	0.737	0.737	0.737	0.737	0.736	0.734
9.0	0.705	0.705	0.705	0.704	0.702	0.700	0.698	0.695	0.692
9.5	0.669	0.667	0.665	0.663	0.659	0.655	0.652	0.648	0.643
10.0	0.626	0.623	0.619	0.616	0.611	0.607	0.603	0.598	0.592
10.5	0.580	0.576	0.572	0.567	0.562	0.557	0.552	0.546	0.541
11.0	0.533	0.528	0.523	0.519	0.513	0.507	0.502	0.496	0.490
11.5	0.486	0.481	0.476	0.470	0.464	0.458	0.453	0.447	0.440
12.0	0.440	0.435	0.429	0.424	0.417	0.411	0.405	0.399	0.392
12.5	0.397	0.391	0.385	0.379	0.373	0.367	0.361	0.354	0.348
13.0	0.358	0.352	0.346	0.340	0.333	0.327	0.321	0.315	0.308
13.5	0.323	0.316	0.310	0.305	0.298	0.292	0.286	0.279	0.272
14.0	0.291	0.285	0.279	0.273	0.266	0.260	0.254	0.248	0.241
14.5	0.263	0.256	0.250	0.244	0.238	0.231	0.226	0.220	0.215
15.0	0.237	0.230	0.224	0.218	0.212	0.207	0.202	0.197	0.192
15.5	0.213	0.207	0.202	0.196	0.191	0.186	0.182	0.178	0.174
16.0	0.192	0.187	0.182	0.177	0.173	0.169	0.165	0.161	0.157
16.5	0.175	0.170	0.166	0.162	0.158	0.154	0.150	0.147	0.144
17.0	0.160	0.156	0.152	0.148	0.145	0.141	0.138	0.135	0.132
17.5	0.148	0.144	0.140	0.137	0.134	0.131	0.128	0.125	0.122
18.0	0.138	0.134	0.131	0.127	0.124	0.122	0.119	0.116	0.114
18.5	0.129	0.125	0.122	0.119	0.117	0.114	0.111	0.109	0.107
19.0	0.121	0.118	0.115	0.112	0.110	0.107	0.105	0.103	0.101
19.5	0.115	0.112	0.109	0.107	0.104	0.102	0.100	0.098	0.096
20.0	0.110	0.107	0.104	0.102	0.099	0.097	0.095	0.093	0.091
20.5*	0.102	0.099	0.096	0.094	0.091	0.090	0.088	0.086	0.084
21.0*	0.092	0.090	0.087	0.086	0.083	0.081	0.080	0.078	0.076
21.5*	0.083	0.080	0.078	0.077	0.074	0.073	0.071	0.070	0.068
22.0*	0.074	0.072	0.070	0.069	0.067	0.066	0.064	0.063	0.062
22.5*	0.067	0.065	0.063	0.062	0.060	0.059	0.058	0.056	0.055
23.0*	0.060	0.058	0.057	0.056	0.054	0.053	0.052	0.051	0.050
23.5*	0.054	0.052	0.051	0.050	0.048	0.047	0.046	0.045	0.044
24.0*	0.048	0.047	0.046	0.045	0.044	0.043	0.042	0.041	0.040
24.5*	0.044	0.043	0.041	0.041	0.039	0.039	0.038	0.037	0.036
25.0*	0.040	0.039	0.038	0.037	0.036	0.035	0.034	0.034	0.033
25.5*	0.036	0.035	0.034	0.033	0.032	0.031	0.031	0.030	0.029
26.0*	0.032	0.032	0.031	0.030	0.029	0.029	0.028	0.027	0.027

\* These values are based on a yield and load optimized operation that is not feasible at all sites.

### Nordex N149/4.0-4.5 – Thrust curves – Mode 3.b

for hub heights 105 m, 125 m, 145 m and 164 m								
wind speed $v_H$ [m/s]	Thrust coefficients $c_T$ at air density $\rho$ [kg/m <sup>3</sup> ]							
	1.125	1.150	1.175	1.200	1.225	1.250	1.275	1.300
3.0	0.827	0.827	0.827	0.827	0.827	0.827	0.827	0.827
3.5	0.826	0.826	0.826	0.826	0.826	0.826	0.826	0.826
4.0	0.817	0.817	0.817	0.817	0.817	0.817	0.817	0.817
4.5	0.808	0.808	0.808	0.808	0.808	0.808	0.808	0.808
5.0	0.800	0.800	0.800	0.800	0.800	0.800	0.800	0.800
5.5	0.794	0.794	0.794	0.794	0.794	0.794	0.794	0.794
6.0	0.791	0.791	0.791	0.791	0.791	0.791	0.791	0.791
6.5	0.789	0.789	0.789	0.789	0.789	0.789	0.789	0.789
7.0	0.788	0.788	0.788	0.788	0.787	0.787	0.787	0.787
7.5	0.782	0.782	0.782	0.782	0.782	0.782	0.782	0.782
8.0	0.764	0.764	0.763	0.761	0.760	0.759	0.758	0.755
8.5	0.732	0.730	0.727	0.724	0.720	0.717	0.714	0.710
9.0	0.688	0.685	0.681	0.676	0.671	0.667	0.663	0.658
9.5	0.639	0.635	0.629	0.624	0.618	0.614	0.609	0.604
10.0	0.587	0.582	0.577	0.570	0.565	0.560	0.554	0.549
10.5	0.535	0.530	0.524	0.518	0.511	0.506	0.501	0.495
11.0	0.484	0.479	0.472	0.466	0.460	0.454	0.448	0.442
11.5	0.434	0.429	0.422	0.416	0.409	0.403	0.398	0.392
12.0	0.386	0.381	0.374	0.367	0.361	0.355	0.350	0.343
12.5	0.342	0.336	0.329	0.323	0.316	0.310	0.305	0.299
13.0	0.302	0.296	0.290	0.283	0.276	0.270	0.265	0.259
13.5	0.266	0.260	0.254	0.248	0.243	0.238	0.232	0.228
14.0	0.235	0.230	0.225	0.220	0.215	0.211	0.206	0.202
14.5	0.210	0.205	0.200	0.196	0.192	0.188	0.185	0.181
15.0	0.188	0.184	0.180	0.176	0.173	0.170	0.166	0.163
15.5	0.170	0.166	0.163	0.159	0.156	0.153	0.150	0.148
16.0	0.154	0.151	0.148	0.145	0.142	0.139	0.137	0.134
16.5	0.141	0.138	0.135	0.132	0.130	0.127	0.125	0.123
17.0	0.129	0.127	0.124	0.122	0.120	0.117	0.115	0.113
17.5	0.120	0.117	0.115	0.113	0.111	0.109	0.107	0.105
18.0	0.112	0.109	0.107	0.105	0.103	0.101	0.100	0.098
18.5	0.105	0.103	0.101	0.099	0.097	0.095	0.094	0.092
19.0	0.099	0.097	0.095	0.093	0.092	0.090	0.088	0.087
19.5	0.094	0.092	0.090	0.088	0.087	0.085	0.084	0.083
20.0	0.090	0.088	0.086	0.084	0.083	0.082	0.080	0.079
20.5*	0.083	0.081	0.079	0.078	0.077	0.076	0.074	0.073
21.0*	0.076	0.074	0.072	0.070	0.070	0.069	0.067	0.066
21.5*	0.068	0.066	0.065	0.063	0.062	0.062	0.060	0.059
22.0*	0.061	0.060	0.058	0.057	0.056	0.056	0.054	0.053
22.5*	0.055	0.053	0.052	0.051	0.050	0.050	0.048	0.048
23.0*	0.049	0.048	0.047	0.046	0.045	0.045	0.044	0.043
23.5*	0.044	0.043	0.042	0.041	0.041	0.040	0.039	0.039
24.0*	0.040	0.039	0.038	0.037	0.037	0.036	0.035	0.035
24.5*	0.036	0.035	0.034	0.033	0.033	0.033	0.032	0.031
25.0*	0.032	0.032	0.031	0.030	0.030	0.030	0.029	0.029
25.5*	0.029	0.028	0.028	0.027	0.027	0.026	0.026	0.026
26.0*	0.027	0.026	0.025	0.025	0.024	0.024	0.024	0.023

\* These values are based on a yield and load optimized operation that is not feasible at all sites.

### Nordex N149/4.0-4.5 – Thrust curves – Mode 5.a

for hub heights 105 m, 125 m, 145 m and 164 m									
wind speed $v_H$ [m/s]	Thrust coefficients $c_T$ at air density $\rho$ [kg/m <sup>3</sup> ]								
	0.900	0.925	0.950	0.975	1.000	1.025	1.050	1.075	1.100
3.0	0.827	0.827	0.827	0.827	0.827	0.827	0.827	0.827	0.827
3.5	0.826	0.826	0.826	0.826	0.826	0.826	0.826	0.826	0.826
4.0	0.817	0.817	0.817	0.817	0.817	0.817	0.817	0.817	0.817
4.5	0.808	0.808	0.808	0.808	0.808	0.808	0.808	0.808	0.808
5.0	0.800	0.800	0.800	0.800	0.800	0.800	0.800	0.800	0.800
5.5	0.794	0.794	0.794	0.794	0.794	0.794	0.794	0.794	0.794
6.0	0.791	0.791	0.791	0.791	0.791	0.791	0.791	0.791	0.791
6.5	0.789	0.789	0.789	0.789	0.789	0.789	0.789	0.789	0.789
7.0	0.786	0.786	0.786	0.786	0.786	0.786	0.786	0.786	0.786
7.5	0.770	0.770	0.770	0.770	0.770	0.770	0.770	0.770	0.770
8.0	0.744	0.744	0.744	0.744	0.744	0.744	0.744	0.744	0.744
8.5	0.712	0.712	0.712	0.712	0.712	0.712	0.712	0.712	0.712
9.0	0.675	0.675	0.675	0.675	0.675	0.675	0.674	0.672	0.670
9.5	0.636	0.636	0.636	0.635	0.633	0.631	0.629	0.626	0.623
10.0	0.595	0.594	0.592	0.589	0.586	0.584	0.580	0.576	0.573
10.5	0.550	0.548	0.545	0.542	0.538	0.535	0.531	0.526	0.522
11.0	0.505	0.501	0.498	0.494	0.490	0.486	0.482	0.477	0.472
11.5	0.459	0.455	0.451	0.447	0.442	0.438	0.433	0.428	0.423
12.0	0.416	0.412	0.407	0.403	0.398	0.393	0.388	0.382	0.377
12.5	0.377	0.372	0.368	0.363	0.358	0.353	0.348	0.342	0.337
13.0	0.342	0.337	0.332	0.327	0.322	0.317	0.312	0.306	0.301
13.5	0.310	0.305	0.300	0.295	0.290	0.285	0.279	0.274	0.268
14.0	0.282	0.277	0.271	0.266	0.261	0.256	0.250	0.245	0.239
14.5	0.256	0.251	0.245	0.240	0.235	0.230	0.224	0.219	0.214
15.0	0.232	0.227	0.222	0.217	0.211	0.206	0.201	0.196	0.191
15.5	0.211	0.206	0.200	0.195	0.190	0.185	0.181	0.177	0.173
16.0	0.192	0.186	0.181	0.176	0.172	0.168	0.164	0.160	0.156
16.5	0.174	0.170	0.165	0.161	0.157	0.153	0.149	0.146	0.143
17.0	0.160	0.155	0.151	0.148	0.144	0.140	0.137	0.134	0.131
17.5	0.147	0.143	0.140	0.136	0.133	0.130	0.127	0.124	0.121
18.0	0.137	0.133	0.130	0.127	0.124	0.121	0.118	0.116	0.113
18.5	0.128	0.125	0.122	0.119	0.116	0.113	0.111	0.108	0.106
19.0	0.121	0.118	0.115	0.112	0.109	0.107	0.104	0.102	0.100
19.5	0.114	0.111	0.109	0.106	0.104	0.101	0.099	0.097	0.095
20.0	0.109	0.106	0.104	0.101	0.099	0.097	0.094	0.092	0.091
20.5*	0.101	0.098	0.096	0.093	0.091	0.090	0.087	0.085	0.084
21.0*	0.091	0.089	0.087	0.085	0.083	0.081	0.079	0.077	0.076
21.5*	0.082	0.080	0.078	0.076	0.074	0.073	0.071	0.069	0.068
22.0*	0.074	0.072	0.070	0.068	0.067	0.066	0.064	0.062	0.062
22.5*	0.066	0.064	0.063	0.061	0.060	0.059	0.057	0.056	0.055
23.0*	0.060	0.058	0.057	0.055	0.054	0.053	0.051	0.050	0.050
23.5*	0.053	0.052	0.051	0.049	0.048	0.047	0.046	0.045	0.044
24.0*	0.048	0.047	0.046	0.044	0.044	0.043	0.041	0.040	0.040
24.5*	0.043	0.042	0.041	0.040	0.039	0.039	0.037	0.037	0.036
25.0*	0.039	0.038	0.038	0.036	0.036	0.035	0.034	0.033	0.033
25.5*	0.035	0.034	0.034	0.033	0.032	0.031	0.030	0.030	0.029
26.0*	0.032	0.031	0.031	0.030	0.029	0.029	0.028	0.027	0.027

\* These values are based on a yield and load optimized operation that is not feasible at all sites.

**Nordex N149/4.0-4.5 – Thrust curves – Mode 5.a**

for hub heights 105 m, 125 m, 145 m and 164 m								
wind speed $v_H$ [m/s]	Thrust coefficients $c_T$ at air density $\rho$ [kg/m <sup>3</sup> ]							
	1.125	1.150	1.175	1.200	1.225	1.250	1.275	1.300
3.0	0.827	0.827	0.827	0.827	0.827	0.827	0.827	0.827
3.5	0.826	0.826	0.826	0.826	0.826	0.826	0.826	0.826
4.0	0.817	0.817	0.817	0.817	0.817	0.817	0.817	0.817
4.5	0.808	0.808	0.808	0.808	0.808	0.808	0.808	0.808
5.0	0.800	0.800	0.800	0.800	0.800	0.800	0.800	0.800
5.5	0.794	0.794	0.794	0.794	0.794	0.794	0.794	0.794
6.0	0.791	0.791	0.791	0.791	0.791	0.791	0.791	0.791
6.5	0.789	0.789	0.789	0.789	0.789	0.789	0.789	0.789
7.0	0.786	0.786	0.786	0.786	0.786	0.786	0.786	0.786
7.5	0.770	0.770	0.770	0.770	0.770	0.770	0.770	0.769
8.0	0.744	0.744	0.744	0.744	0.744	0.743	0.742	0.739
8.5	0.712	0.710	0.708	0.707	0.706	0.702	0.699	0.695
9.0	0.669	0.666	0.663	0.660	0.657	0.653	0.649	0.644
9.5	0.620	0.616	0.612	0.608	0.605	0.600	0.595	0.590
10.0	0.569	0.564	0.560	0.556	0.552	0.546	0.541	0.535
10.5	0.518	0.513	0.508	0.503	0.499	0.493	0.488	0.482
11.0	0.468	0.462	0.457	0.452	0.447	0.441	0.436	0.430
11.5	0.418	0.412	0.407	0.402	0.397	0.391	0.386	0.379
12.0	0.372	0.367	0.361	0.356	0.351	0.345	0.340	0.333
12.5	0.332	0.326	0.321	0.315	0.310	0.304	0.299	0.293
13.0	0.296	0.290	0.284	0.279	0.274	0.268	0.262	0.257
13.5	0.263	0.258	0.252	0.247	0.242	0.236	0.231	0.226
14.0	0.234	0.229	0.223	0.218	0.214	0.209	0.205	0.201
14.5	0.209	0.204	0.199	0.195	0.191	0.187	0.183	0.180
15.0	0.187	0.183	0.179	0.175	0.172	0.168	0.165	0.162
15.5	0.169	0.165	0.162	0.158	0.155	0.152	0.149	0.146
16.0	0.153	0.150	0.147	0.144	0.141	0.138	0.136	0.133
16.5	0.140	0.137	0.134	0.131	0.129	0.126	0.124	0.122
17.0	0.128	0.126	0.123	0.121	0.118	0.116	0.114	0.112
17.5	0.119	0.116	0.114	0.112	0.110	0.108	0.106	0.104
18.0	0.111	0.108	0.106	0.104	0.102	0.101	0.099	0.097
18.5	0.104	0.102	0.100	0.098	0.096	0.094	0.093	0.091
19.0	0.098	0.096	0.094	0.092	0.091	0.089	0.088	0.086
19.5	0.093	0.091	0.089	0.088	0.086	0.085	0.083	0.082
20.0	0.089	0.087	0.085	0.084	0.082	0.081	0.080	0.078
20.5*	0.082	0.080	0.078	0.078	0.076	0.075	0.074	0.072
21.0*	0.075	0.073	0.071	0.070	0.069	0.068	0.067	0.065
21.5*	0.067	0.065	0.064	0.063	0.062	0.061	0.060	0.059
22.0*	0.060	0.059	0.058	0.057	0.056	0.055	0.054	0.053
22.5*	0.054	0.053	0.052	0.051	0.050	0.049	0.048	0.047
23.0*	0.049	0.048	0.046	0.046	0.045	0.044	0.044	0.043
23.5*	0.043	0.042	0.041	0.041	0.040	0.040	0.039	0.038
24.0*	0.039	0.038	0.037	0.037	0.036	0.036	0.035	0.034
24.5*	0.035	0.035	0.034	0.033	0.033	0.032	0.032	0.031
25.0*	0.032	0.031	0.031	0.030	0.030	0.029	0.029	0.028
25.5*	0.029	0.028	0.027	0.027	0.026	0.026	0.026	0.025
26.0*	0.026	0.026	0.025	0.025	0.024	0.024	0.024	0.023

\* These values are based on a yield and load optimized operation that is not feasible at all sites.



### Nordex N149/4.0-4.5 – Thrust curves – Mode 5.b

for hub heights 105 m, 125 m, 145 m and 164 m									
wind speed $v_H$ [m/s]	Thrust coefficients $c_T$ at air density $\rho$ [kg/m <sup>3</sup> ]								
	0.900	0.925	0.950	0.975	1.000	1.025	1.050	1.075	1.100
3.0	0.827	0.827	0.827	0.827	0.827	0.827	0.827	0.827	0.827
3.5	0.826	0.826	0.826	0.826	0.826	0.826	0.826	0.826	0.826
4.0	0.817	0.817	0.817	0.817	0.817	0.817	0.817	0.817	0.817
4.5	0.808	0.808	0.808	0.808	0.808	0.808	0.808	0.808	0.808
5.0	0.800	0.800	0.800	0.800	0.800	0.800	0.800	0.800	0.800
5.5	0.794	0.794	0.794	0.794	0.794	0.794	0.794	0.794	0.794
6.0	0.791	0.791	0.791	0.791	0.791	0.791	0.791	0.791	0.791
6.5	0.789	0.789	0.789	0.789	0.789	0.789	0.789	0.789	0.789
7.0	0.786	0.786	0.786	0.786	0.786	0.786	0.786	0.786	0.786
7.5	0.770	0.770	0.770	0.770	0.770	0.770	0.770	0.770	0.770
8.0	0.744	0.744	0.744	0.744	0.744	0.744	0.744	0.744	0.744
8.5	0.712	0.712	0.712	0.712	0.712	0.712	0.712	0.711	0.710
9.0	0.675	0.675	0.675	0.675	0.674	0.672	0.670	0.668	0.665
9.5	0.636	0.635	0.633	0.631	0.629	0.625	0.622	0.619	0.615
10.0	0.592	0.590	0.586	0.584	0.580	0.576	0.572	0.568	0.563
10.5	0.546	0.542	0.538	0.535	0.530	0.526	0.521	0.517	0.511
11.0	0.498	0.495	0.490	0.486	0.481	0.476	0.471	0.466	0.461
11.5	0.452	0.447	0.442	0.438	0.433	0.427	0.422	0.417	0.411
12.0	0.408	0.403	0.398	0.393	0.388	0.382	0.377	0.371	0.365
12.5	0.368	0.363	0.358	0.353	0.347	0.342	0.336	0.331	0.325
13.0	0.333	0.328	0.322	0.317	0.311	0.306	0.300	0.294	0.288
13.5	0.301	0.296	0.290	0.285	0.279	0.273	0.268	0.262	0.256
14.0	0.272	0.267	0.261	0.256	0.250	0.244	0.239	0.233	0.227
14.5	0.246	0.241	0.235	0.230	0.224	0.218	0.213	0.208	0.203
15.0	0.223	0.217	0.211	0.206	0.201	0.196	0.191	0.186	0.182
15.5	0.201	0.196	0.190	0.185	0.181	0.176	0.172	0.168	0.164
16.0	0.182	0.177	0.172	0.168	0.164	0.160	0.156	0.152	0.149
16.5	0.166	0.161	0.157	0.153	0.149	0.146	0.142	0.139	0.136
17.0	0.152	0.148	0.144	0.140	0.137	0.134	0.131	0.128	0.125
17.5	0.140	0.137	0.133	0.130	0.127	0.124	0.121	0.118	0.116
18.0	0.130	0.127	0.124	0.121	0.118	0.115	0.113	0.110	0.108
18.5	0.122	0.119	0.116	0.113	0.110	0.108	0.106	0.103	0.101
19.0	0.115	0.112	0.109	0.107	0.104	0.102	0.100	0.098	0.096
19.5	0.109	0.106	0.104	0.101	0.099	0.097	0.095	0.093	0.091
20.0	0.104	0.101	0.099	0.096	0.094	0.092	0.090	0.088	0.087
20.5*	0.096	0.093	0.091	0.089	0.087	0.085	0.083	0.081	0.080
21.0*	0.087	0.085	0.083	0.081	0.079	0.077	0.076	0.074	0.073
21.5*	0.078	0.076	0.074	0.072	0.071	0.069	0.068	0.066	0.065
22.0*	0.070	0.068	0.067	0.065	0.064	0.062	0.061	0.060	0.059
22.5*	0.063	0.061	0.060	0.058	0.057	0.056	0.055	0.053	0.053
23.0*	0.057	0.055	0.054	0.052	0.051	0.050	0.049	0.048	0.048
23.5*	0.051	0.049	0.048	0.047	0.046	0.045	0.044	0.043	0.042
24.0*	0.046	0.044	0.044	0.042	0.041	0.040	0.040	0.039	0.038
24.5*	0.041	0.040	0.039	0.038	0.037	0.037	0.036	0.035	0.035
25.0*	0.038	0.036	0.036	0.035	0.034	0.033	0.032	0.032	0.031
25.5*	0.034	0.033	0.032	0.031	0.030	0.030	0.029	0.028	0.028
26.0*	0.031	0.030	0.029	0.028	0.028	0.027	0.027	0.026	0.026

\* These values are based on a yield and load optimized operation that is not feasible at all sites.

**Nordex N149/4.0-4.5 – Thrust curves – Mode 5.b**

for hub heights 105 m, 125 m, 145 m and 164 m								
wind speed $v_H$ [m/s]	Thrust coefficients $c_T$ at air density $\rho$ [kg/m <sup>3</sup> ]							
	1.125	1.150	1.175	1.200	1.225	1.250	1.275	1.300
3.0	0.827	0.827	0.827	0.827	0.827	0.827	0.827	0.827
3.5	0.826	0.826	0.826	0.826	0.826	0.826	0.826	0.826
4.0	0.817	0.817	0.817	0.817	0.817	0.817	0.817	0.817
4.5	0.808	0.808	0.808	0.808	0.808	0.808	0.808	0.808
5.0	0.800	0.800	0.800	0.800	0.800	0.800	0.800	0.800
5.5	0.794	0.794	0.794	0.794	0.794	0.794	0.794	0.794
6.0	0.791	0.791	0.791	0.791	0.791	0.791	0.791	0.791
6.5	0.789	0.789	0.789	0.789	0.789	0.789	0.789	0.789
7.0	0.786	0.786	0.786	0.786	0.786	0.786	0.786	0.786
7.5	0.770	0.770	0.770	0.770	0.770	0.770	0.770	0.770
8.0	0.744	0.744	0.744	0.742	0.741	0.740	0.739	0.736
8.5	0.708	0.706	0.704	0.701	0.698	0.695	0.692	0.688
9.0	0.662	0.659	0.655	0.651	0.647	0.643	0.640	0.634
9.5	0.611	0.607	0.603	0.598	0.593	0.589	0.584	0.579
10.0	0.559	0.554	0.549	0.544	0.539	0.534	0.529	0.523
10.5	0.506	0.502	0.496	0.491	0.485	0.480	0.475	0.469
11.0	0.455	0.450	0.445	0.439	0.433	0.428	0.423	0.417
11.5	0.406	0.400	0.395	0.389	0.383	0.378	0.372	0.366
12.0	0.360	0.354	0.348	0.342	0.337	0.331	0.326	0.320
12.5	0.319	0.314	0.308	0.302	0.296	0.290	0.285	0.279
13.0	0.283	0.277	0.272	0.265	0.260	0.254	0.249	0.244
13.5	0.250	0.245	0.239	0.234	0.229	0.224	0.219	0.215
14.0	0.222	0.217	0.212	0.207	0.203	0.199	0.195	0.191
14.5	0.198	0.194	0.189	0.185	0.182	0.178	0.174	0.171
15.0	0.178	0.174	0.170	0.167	0.163	0.160	0.157	0.154
15.5	0.160	0.157	0.154	0.151	0.148	0.145	0.142	0.140
16.0	0.146	0.143	0.140	0.137	0.134	0.132	0.129	0.127
16.5	0.133	0.130	0.128	0.125	0.123	0.121	0.118	0.116
17.0	0.122	0.120	0.118	0.115	0.113	0.111	0.109	0.107
17.5	0.113	0.111	0.109	0.107	0.105	0.103	0.101	0.099
18.0	0.106	0.104	0.102	0.100	0.098	0.096	0.094	0.093
18.5	0.099	0.097	0.095	0.094	0.092	0.090	0.089	0.087
19.0	0.094	0.092	0.090	0.088	0.087	0.085	0.084	0.082
19.5	0.089	0.087	0.086	0.084	0.082	0.081	0.080	0.078
20.0	0.085	0.083	0.082	0.080	0.079	0.077	0.076	0.075
20.5*	0.078	0.077	0.076	0.074	0.073	0.071	0.070	0.069
21.0*	0.071	0.070	0.069	0.067	0.066	0.065	0.064	0.063
21.5*	0.064	0.062	0.062	0.060	0.059	0.058	0.057	0.056
22.0*	0.058	0.056	0.056	0.054	0.053	0.052	0.051	0.051
22.5*	0.052	0.050	0.050	0.048	0.048	0.047	0.046	0.045
23.0*	0.046	0.045	0.045	0.044	0.043	0.042	0.041	0.041
23.5*	0.041	0.041	0.040	0.039	0.039	0.038	0.037	0.037
24.0*	0.037	0.037	0.036	0.035	0.035	0.034	0.033	0.033
24.5*	0.034	0.033	0.033	0.032	0.031	0.031	0.030	0.030
25.0*	0.031	0.030	0.030	0.029	0.029	0.028	0.027	0.027
25.5*	0.027	0.027	0.026	0.026	0.026	0.025	0.025	0.024
26.0*	0.025	0.024	0.024	0.024	0.023	0.023	0.022	0.022

\* These values are based on a yield and load optimized operation that is not feasible at all sites.