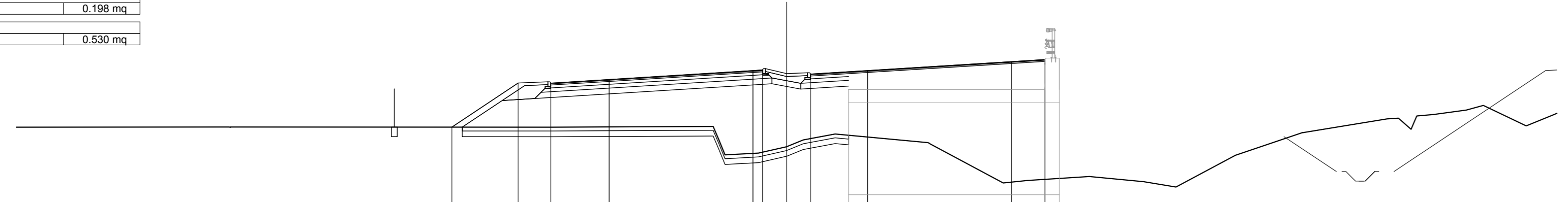

Table listing materials and quantities for SEZIONE N. : 225. Includes items like SCIAI E BONIFICHE, STERCO, BONIFICA, etc.

SEZIONE N. : 225
QT. PROGETTO : 171.210
DIST.PROG. : 46+060.000
DIST.PREC. : 20.000
DIST.SUCC. : 20.000



SCALA 1:200
QT.RIF. 160.000

QUOTE TERRENO	168.26	168.25	168.80	168.90	167.23	167.90	167.38	168.64	165.47	165.68	165.13	166.79	167.97	168.62	168.72	168.84	168.91	168.95	168.39	168.32	168.93	
QUOTE PROGETTO	168.26	170.56	170.55	171.21	171.00	171.21	171.68	171.79														
DIST.PARZIALI PROGETTO	3.46	1.70	3.04	7.50	2.50	2.97	7.50	1.75														
DIST. PROGR. PROGETTO	-17.45	-13.99	-12.29	-9.25	-1.25	1.25	4.22	11.72	13.47													

Table listing materials and quantities for SEZIONE N. : 226. Includes items like SCIAI E BONIFICHE, STERCO, BONIFICA, etc.

SEZIONE N. : 226
QT. PROGETTO : 171.320
DIST.PROG. : 46+080.000
DIST.PREC. : 20.000
DIST.SUCC. : 20.000

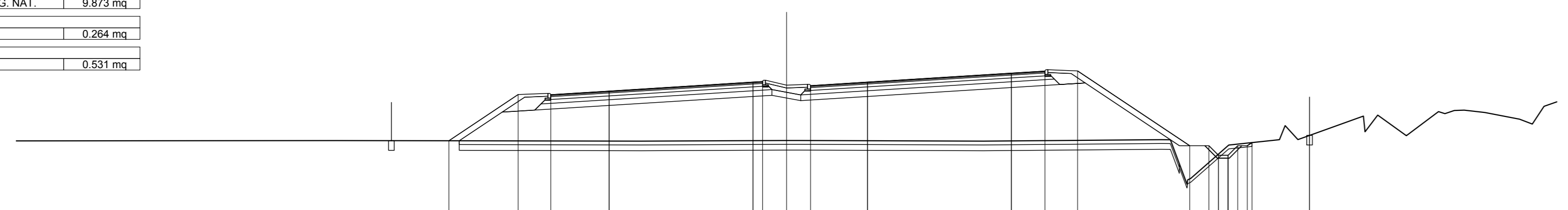

SCALA 1:200
QT.RIF. 160.000

QUOTE TERRENO	168.27	168.27	168.24	168.28	168.24	168.22	168.04	168.22	168.32	168.32	168.04	168.03	168.03	168.03	168.03	168.03	168.03	168.03	168.03	168.03	170.06	
QUOTE PROGETTO	168.26	170.67	170.66	171.32	171.14	171.32	171.90	171.90	171.90	168.00	168.00	168.00	168.00	168.00	168.00	168.00	168.00	168.00	168.00	168.00	168.00	170.06
DIST.PARZIALI PROGETTO	3.61	1.70	3.04	7.50	2.50	2.97	7.50	1.75	1.70	5.85	1.00	1.00	1.00	1.00	1.00	1.00	1.00	1.00	1.00	1.00	3.00	
DIST. PROGR. PROGETTO	-17.60	-13.99	-12.29	-9.25	-1.25	1.25	4.22	11.72	13.47	15.17	21.02	22.00	23.00	24.00	25.00	26.00	27.00	28.00	29.00	30.00	-27.26	

Table listing materials and quantities for SEZIONE N. : 227. Includes items like SCIAI E BONIFICHE, STERCO, BONIFICA, etc.

SEZIONE N. : 227
QT. PROGETTO : 171.431
DIST.PROG. : 46+100.000
DIST.PREC. : 20.000
DIST.SUCC. : 20.000

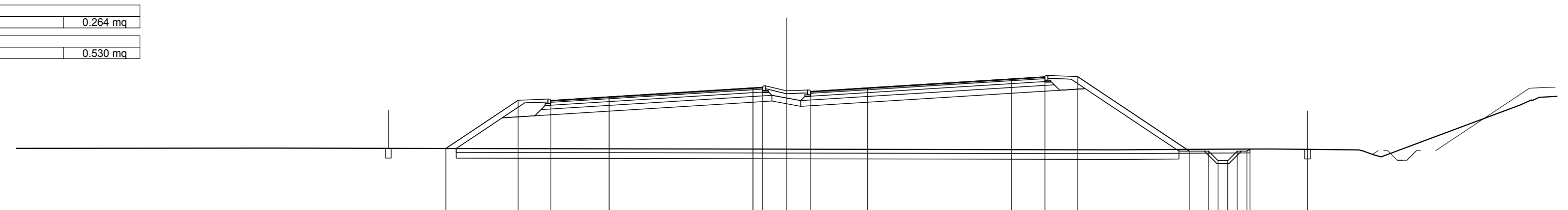

SCALA 1:200
QT.RIF. 161.000

QUOTE TERRENO	168.28	168.29	168.26	168.26	168.23	168.22	168.20	168.22	168.24	168.21	168.16	168.16	168.15	168.19	168.21	168.21	168.21	168.21	168.21	168.21	168.21	170.94
QUOTE PROGETTO	168.27	170.78	170.77	170.98	171.43	171.25	171.43	171.90	172.01	172.02	172.46	172.46	172.46	172.46	172.46	172.46	172.46	172.46	172.46	172.46	172.46	170.94
DIST.PARZIALI PROGETTO	3.77	1.70	3.04	7.50	2.50	2.97	7.50	1.75	1.70	5.83	1.00	1.00	1.00	1.00	1.00	1.00	1.00	1.00	1.00	1.00	3.00	
DIST. PROGR. PROGETTO	-17.76	-13.99	-12.29	-9.25	-1.25	1.25	4.22	11.72	13.47	15.17	21.00	22.00	23.00	24.00	25.00	26.00	27.00	28.00	29.00	30.00	-27.16	

Table listing materials and quantities for SEZIONE N. : 228. Includes items like SCIAI E BONIFICHE, STERCO, BONIFICA, etc.

SEZIONE N. : 228
QT. PROGETTO : 171.541
DIST.PROG. : 46+120.000
DIST.PREC. : 20.000
DIST.SUCC. : 20.000

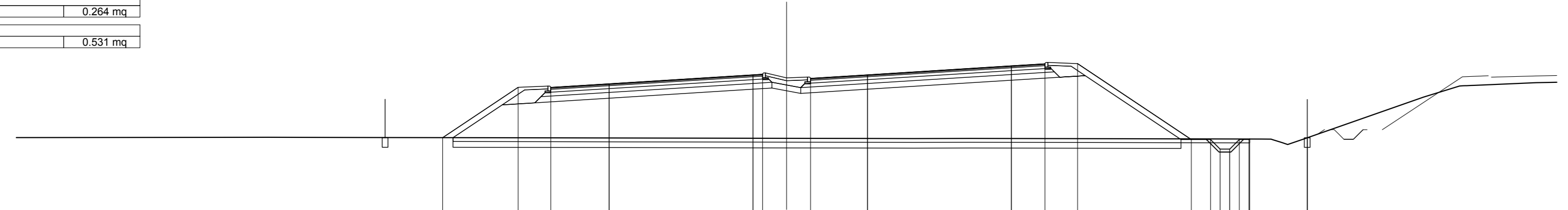

SCALA 1:200
QT.RIF. 161.000

QUOTE TERRENO	168.29	168.27	168.26	168.25	168.23	168.23	168.22	168.23	170.38	170.99	171.13
QUOTE PROGETTO	168.27	170.69	170.68	171.07	171.54	172.01	172.12	172.13	171.44	171.44	171.44
DIST.PARZIALI PROGETTO	3.94	1.70	3.04	7.50	2.50	2.97	7.50	1.75	1.70	5.93	1.00
DIST. PROGR. PROGETTO	-17.93	-13.99	-12.29	-9.25	-1.25	1.25	4.22	11.72	13.47	15.17	21.00

Table listing materials and quantities for SEZIONE N. : 229. Includes items like SCIAI E BONIFICHE, STERCO, BONIFICA, etc.

SEZIONE N. : 229
QT. PROGETTO : 171.652
DIST.PROG. : 46+140.000
DIST.PREC. : 20.000
DIST.SUCC. : 20.000

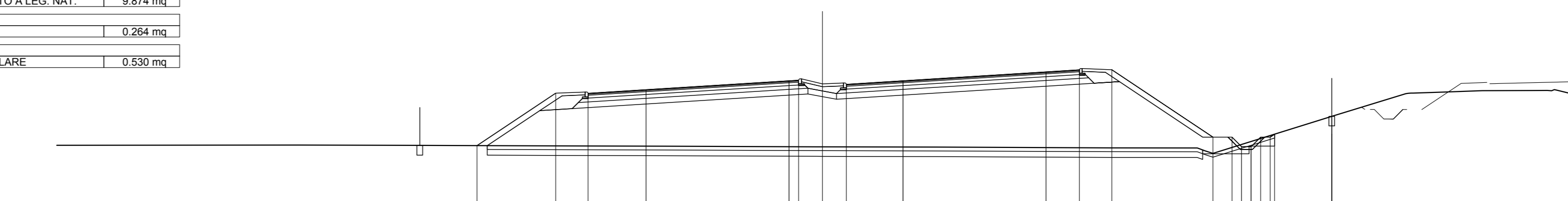

SCALA 1:200
QT.RIF. 161.000

QUOTE TERRENO	168.28	168.26	168.24	168.22	168.19	168.17	168.13	167.84	169.84	171.01	171.14	171.14	171.00
QUOTE PROGETTO	168.25	171.00	171.00	171.16	171.65	171.47	171.65	172.12	172.23	172.24	168.70	168.20	168.85
DIST.PARZIALI PROGETTO	4.12	1.70	3.04	7.50	2.50	2.97	7.50	1.75	1.70	5.30	1.00	1.00	
DIST. PROGR. PROGETTO	-18.11	-13.99	-12.29	-9.25	-1.25	1.25	4.22	11.72	13.47	15.17	20.47	21.00	

Table listing materials and quantities for SEZIONE N. : 230. Includes items like SCIAI E BONIFICHE, STERCO, BONIFICA, etc.

SEZIONE N. : 230
QT. PROGETTO : 171.762
DIST.PROG. : 46+160.000
DIST.PREC. : 20.000
DIST.SUCC. : 20.000

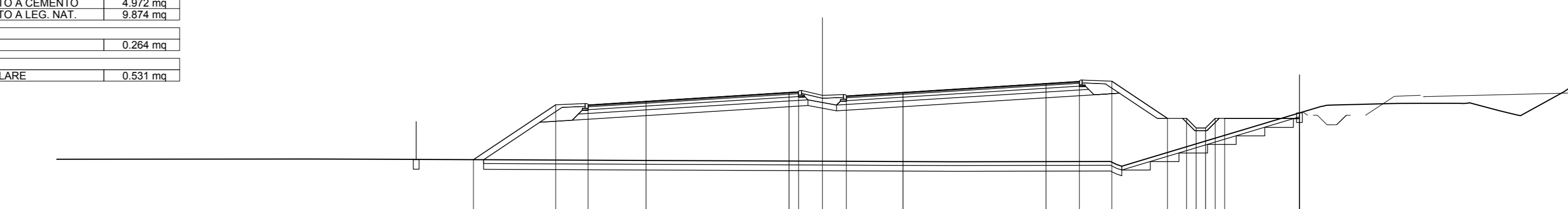

SCALA 1:200
QT.RIF. 161.000

QUOTE TERRENO	168.27	168.26	168.24	168.20	168.18	168.16	168.14	168.13	167.89	169.20	171.10	171.19	171.22	170.81	170.79
QUOTE PROGETTO	168.24	171.11	171.11	171.30	171.76	171.58	171.76	172.34	172.34	172.35	170.40	170.90	170.90	170.90	170.90
DIST.PARZIALI PROGETTO	4.31	1.70	3.04	7.50	2.50	2.97	7.50	1.75	1.70	2.92	3.92	1.00	1.00	1.00	
DIST. PROGR. PROGETTO	-18.30	-13.99	-12.29	-9.25	-1.25	1.25	4.22	11.72	13.47	15.17	18.09	19.00	20.00	21.00	22.00

Table listing materials and quantities for SEZIONE N. : 231. Includes items like SCIAI E BONIFICHE, STERCO, BONIFICA, etc.

SEZIONE N. : 231
QT. PROGETTO : 171.873
DIST.PROG. : 46+180.000
DIST.PREC. : 20.000
DIST.SUCC. : 20.000

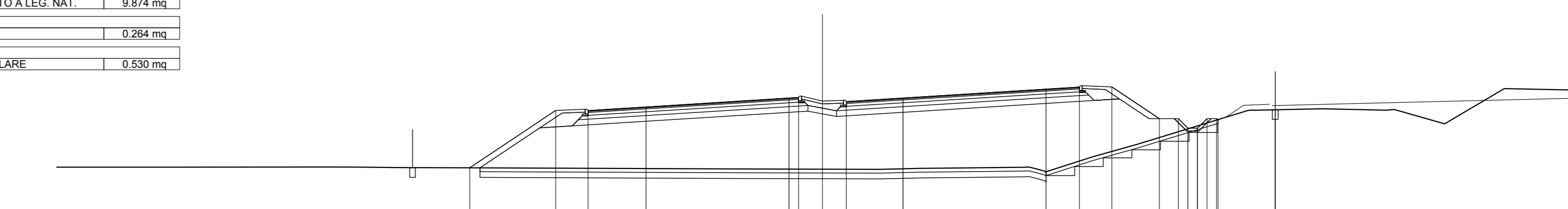

SCALA 1:200
QT.RIF. 162.000

QUOTE TERRENO	168.25	168.25	168.23	168.22	168.17	168.16	168.15	168.14	168.19	168.21	168.01	168.80	169.44	171.23	171.29	171.29	171.29	171.29	171.53	172.37
QUOTE PROGETTO	168.22	171.22	171.22	171.41	171.87	171.69	171.87	172.46	172.46	172.46	172.46	172.46	172.46	172.46	172.46	172.46	172.46	172.46	172.46	172.46
DIST.PARZIALI PROGETTO	4.51	1.70	3.04	7.50	2.50	2.97	7.50	1.75	1.70	2.49	3.00	1.00	1.00	1.00	1.00	1.00	1.00	1.00	1.00	3.00
DIST. PROGR. PROGETTO	-18.50	-13.99	-12.29	-9.25	-1.25	1.25	4.22	11.72	13.47	15.17	17.66	18.00	19.00	20.00	21.00	22.00	23.00	24.00	25.00	26.00

Table listing materials and quantities for SEZIONE N. : 232. Includes items like SCIAI E BONIFICHE, STERCO, BONIFICA, etc.

SEZIONE N. : 232
QT. PROGETTO : 171.983
DIST.PROG. : 46+200.000
DIST.PREC. : 20.000
DIST.SUCC. : 18.447

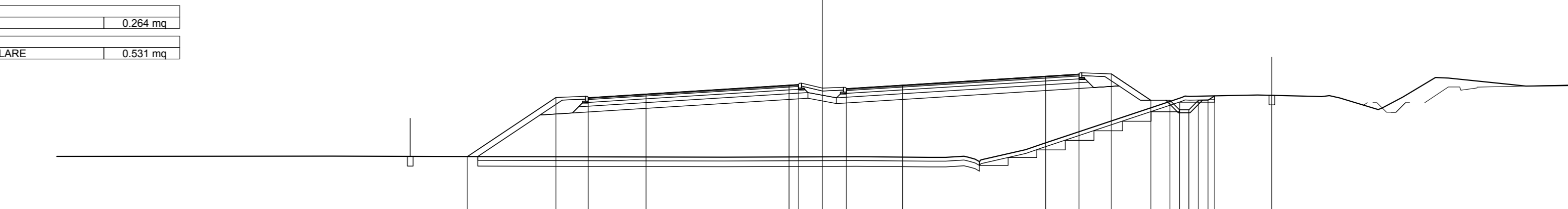

SCALA 1:200
QT.RIF. 162.000

QUOTE TERRENO	168.27	168.26	168.22	168.21	168.23	168.23	168.20	168.20	168.08	168.03	168.92	171.19	171.40	171.47	171.43	171.35	172.35	172.35	172.35	172.35	172.35
QUOTE PROGETTO	168.24	171.34	171.33	171.52	171.98	172.01	171.90	171.98	172.45	172.45	172.45	172.45	172.45	172.45	172.45	172.45	172.45	172.45	172.45	172.45	172.45
DIST.PARZIALI PROGETTO	4.63	1.70	3.03	7.50	2.50	2.95	7.50	1.75	1.70	2.07	3.00	1.00	1.00	1.00	1.00	1.00	1.00	1.00	1.00	1.00	
DIST. PROGR. PROGETTO	-18.61	-13.98	-12.28	-9.25	-1.25	1.25	4.20	11.70	13.45	15.15	17.21	18.00	19.00	20.00	21.00	22.00	23.00	24.00	25.00	26.00	



Direzione Progettazione e Realizzazione Lavori

ITINERARIO INTERNAZIONALE E78
S.G.C. GROSSETO - FANO
ADEGUAMENTO A 4 CORSIE
NEL TRATTO GROSSETO - SIENA (S.S. 223 "DI PAGANICO")
DAL KM 41+600 AL KM 53+400 - LOTTO 9

PROGETTO ESECUTIVO COD. FI15

Table with project details including Progettazione (ATI SINTAGMA - GDG - ICARIA), Gruppo di Progettazione, Progettista (Ing. Federico Durastoni), and various technical approvals.

Table with project details including Codice Progetto (L0F115), Nome File (A00-2000-06-022P), and Revisione (A) at scale 1:200.